

RADIO ENGINEERING

*A Magazine of Technical Accuracy
for the Radio Engineer, Dealer, and Manufacturer*

Edited by M.B. SLEEPER

HOW TO BUILD THE **BALLANTINE**

THREE-TUBE TUNED R. F. SET

Assembling the Silver-Marshall
Super-Heterodyne Receiver

The G-R Capacity Meter,
and how to use it

Plans for a standard test receiver
which can be made into a
splendid portable set

20c a Copy—In England, 1/-

DECEMBER, 1924

Vol. 4 No. 11

Eveready
Heavy Duty
"B" Battery,
45
volts. Three
Fahnestock
cells. Length,
8 3/16 in.;
width,
4 7/16 in.;
height,
7 3/16 in.;
weight,
13 3/4 lbs.
Price \$4.75.



*Dry "B" Batteries
are more economical
and more dependable
than any other
source of plate
current!*

REDUCE Operating Costs

THOUSANDS of people are already cutting their "B" Battery costs one-half, or even two-thirds, by using the new Eveready "B" Battery No. 770 on their heavy drain sets.

This new Eveready Heavy Duty Battery marks a marvelous advance in reducing "B" Battery costs.

If your "B" Batteries have lasted only two months on a five or six tube receiver, this Eveready Heavy Duty "B" Battery will increase the service two to three times.

Use this Eveready Heavy Duty "B" Battery on any receiving set on which the "B" Batteries last less than four months. When thus used to its full capacity, it is the cheapest as well as the best source of "B" energy ever offered.

Manufactured and guaranteed by
NATIONAL CARBON CO., INC.
Headquarters for Radio Battery Information
New York San Francisco
Canadian National Carbon Co., Limited
Toronto, Ontario

EVEREADY
Radio Batteries
—they last longer

Haynes-Griffin

RADIO SERVICE, Inc.

41 W. 43rd St., New York City

250 W. 49th St.
New York

MAIL ORDER DEPARTMENTS

111 S. Clark St.
Chicago



A. J. Haynes, Assoc. Inst. Radio Engineers, designer of the "Knock-out" Amplifier.

Mr. Haynes has prepared a complete booklet of instruction, which contains all necessary diagrams and photographs. This booklet on the "Knock-out" Amplifier is furnished free upon request.

Parts Required for the "Knock-out" Amplifier

1	10 ohm rheostat	75c.
1	20 " "	75c.
3	Haynes-Griffin panel mounting sockets	each \$1.00
1	Haynes-Griffin audio frequency transformer—Type 91	5.50
2	Daven Resisto Couplers	each 1.25
4	Daven Coupling Resistors as specified	each 50c.
2	.006 mfd. Micadon Condensers	each 75c.
1	.00025 mfd. Micadon Condenser	35c.
1	Haynes-Griffin Single open circuit jack	60c.
1	Haynes-Griffin Double circuit jack	80c.
6	Binding Posts	each 70c.
	All necessary tail washers, bus bar wire, etc.	80c.
1	7 x 10 Bakelite panel—drilled and engraved.	\$5.00

All of the above listed parts furnished at a combination price of \$20.00 per set. 7 x 10 Mahogany cabinet—\$8.25 extra. "Knock-Out" Amplifiers also furnished completely assembled in mahogany cabinet ready for use at \$35.00 each.

Prompt shipment made by our Mail Order Departments from either our New York or Chicago stores on any of the above items. Order directly from this list.

HAYNES-GRIFFIN RADIO SERVICE, Inc.

250 W. 49th Street, N. Y. City
111 S. Clark Street, Chicago

A "Knock-out" Amplifier

Audio Frequency and Resistance Coupled Amplification combined in one ideal circuit

Here at last is a real amplifier providing absolutely distortionless loud speaker reproduction.

One stage of audio frequency for volume and two stages of resistance coupled amplification to eliminate the last trace of distortion.

The new "Knock-out" Amplifier makes your loud speaker a real musical instrument. Piano music sounds like a piano—every note played by a symphony orchestra is distinguishable.

Radio fans everywhere are demanding quality of tone reproduction above all else. Here is the final answer to the most troublesome problem in radio.

New Radio Publication ABSOLUTELY FREE

"Radio Dispatch" is a radical departure from all other radio catalogs because it is always up to the minute.

Every thirty days an entirely new issue of "Radio Dispatch" brings you details of the newest radio developments—what they are, why they are better, what they cost, and how to obtain them as quickly as though you lived next door to the largest radio stores.

"Radio Dispatch" is sent free every month to everyone interested in radio. No subscription, no obligation. Mail the coupon now to our nearest store.

RE-11

HAYNES
GRIFFIN-
RADIO
SERVICE, Inc.
250 W. 49th St.
New York City.
111 So. Clark St.
Chicago

Put my name on your mailing list for Radio Dispatch.

Send me a copy of Mr. Haynes' booklet on the "Knock-Out" Amplifier.

Name

Address

HOW MANY TUBES HAVE YOU ?

Every tube is a reason why you need a KANT-BLO protector, to prevent burning out tubes from accidental short circuits. Absolutely protects one to ten tubes, of any type. One tube burned out costs at least four dollars. You can get a KANT-BLO free! With each year's subscription to Radio Engineering, new, extension, or renewal, a KANT-BLO signal tube protector is sent free, immediately. Send \$2.00, check or money order; your subscription will be entered or extended for one year and your KANT-BLO mailed at once. Address Tube Insurance Department.

LOOK FOR THE NEW, ENLARGED MAGAZINE NEXT MONTH

M. B. SLEEPER, Inc.

Technical Publisher

A-52 VANDERBILT AVENUE, NEW YORK CITY

Radio Engineering, December, 1924. Vol. 4, No. 11. Published monthly by M. B. Sleeper, Inc., 52 Vanderbilt Ave., N. Y. C. Printed in U. S. A. Yearly subscription \$2.00 in U. S. and Canada; ten shillings in foreign countries. Entered as second class matter June 15, 1924, at the post office at New York, New York, under the act of March 3, 1879. Additional entry at Albany, New York.

Modulation plus Regeneration

Gazette

RADIO SECTION

VOL. XIV-NO 132-16 PAGES**

MODULATION PLUS REGENERATION IN NEW MODEL L-2 ULTRADYNE

20 DX Stations logged on August 25th on Loud Speaker using loop aerial at Covington, Ky.

Modulation plus regeneration is the keynote of the new Model L-2 Ultradyne Receiver. Regeneration as applied to this new method of radio reception produces greater rectification than ordinary methods of detection—a vital step in radio engineering. This combination produces tremendous amplification when receiving weak signals. Allows the Ultradyne to respond to a very small amount of energy. Signals are amplified thousands of times before they are detected and made audible.

Mr. R. H. Thomas, 509 Coppin Building, Covington, Ky., writes

"The Ultradyne far surpasses any idea that I previously had as to what a radio receiver could be. On the night of August 25th, 1924, I tuned in on my Ultradyne the following stations:

- WBZ Springfield, Mass.
- WOR Newark, N. J.
- WGY Schenectady, N. Y.
- WHN New York, N. Y.
- WCAP Washington, D. C.
- WEAF New York, N. Y.
- WOO Philadelphia, Pa.
- KDKA Pittsburgh, Pa.
- WGBD Zion, Ill.
- WJAR Providence, R. I.
- WGR Buffalo, N. Y.
- WTAS Elgin, Ill.
- WAAM Newark, N. J.
- WBAB Saginaw, Mich.
- WNAC Boston, Mass.
- WLAN Providence, R. I.
- WLW Cincinnati, O.
- KSD St. Louis, Mo.
- WVJ Detroit, Mich.
- WHO Des Moines, Ia.
- WTAM Cleveland, O.
- WHAZ Troy, N. Y.
- WOS Jefferson City, Mo.

- WSB Atlanta, Ga.
- WMC Memphis, Tenn.
- WOC Davenport, Ia.
- WBAP Ft. Worth, Tex.
- WNYG New York, N. Y.
- WOAW Omaha, Neb.
- WFAA Dallas, Tex.
- WSAI Cincinnati, O.
- KFKX Hastings, Nebr.
- WCK St. Louis, Mo.
- WBT Charlotte, N. C.
- KFKB Milford, Kan.
- WGAQ Shreveport, La.
- KGO Oakland, Calif.
- KFIM Grand Forks, N. D.
- KFI Los Angeles, Calif.
- WDAF Kansas City, Mo.

"I consider the above reception remarkable as it stands, but considering it was all accomplished on a 24-inch loop, and all but WGAQ, KFJM and KFI were heard on the loud speaker, it far surpasses anything that I have heretofore experienced.

"As regards selectivity, will say that I am only four or five miles from the powerful WLW station at Cincinnati, operating on 425 meters, and his wave is so powerful that I can receive him on the loud speaker, with one stage of audio, loud enough to be heard a block away, without using an antenna, ground or loop. When WLW is on the air, I can tune him out completely, and receive WSB on 429 meters, and PWX, WDAF on 411 meters, but nominally on 400 meters, but usually somewhat above that wave.

"I know of no other receiver that will even approach this performance for extreme selectivity, volume and distance."

ULTRADYNE

MODEL L-2

This application of regeneration is the most recent development of R. E. Lacault, E.E., A.M.I.R.E., since his perfection of the "Modulation System" used exclusively in the Ultradyne and which has so revolutionized all conception of selectivity, sensitivity, volume and range.

This Model L-2 Ultradyne, without a doubt, represents the peak of present day super radio engineering skill.



ULTRADYNE KIT.

Consists of one low loss Tuning Coil, one low loss Oscillator Coil, one special low loss Coupler, one type "A" Ultraformer, three type "B" Ultraformers, four matched grid condensers. The Ultraformers are new improved long wave radio frequency transformers, especially designed by R. E. Lacault, Consulting Engineer of this Company and inventor of the Ultradyne.

To protect the public, Mr. Lacault's personal monogram seal (R. E. L.) is placed on all genuine Ultraformers. Ultraformers are guaranteed so long as this seal remains unbroken. \$30.00.

Send for the 32-page illustrated book giving latest authentic information on drilling, wiring, assembling and tuning the Model L-2 Ultradyne Receiver. 50c.



PHENIX RADIO CORPORATION

7 Beekman Street,

New York City.

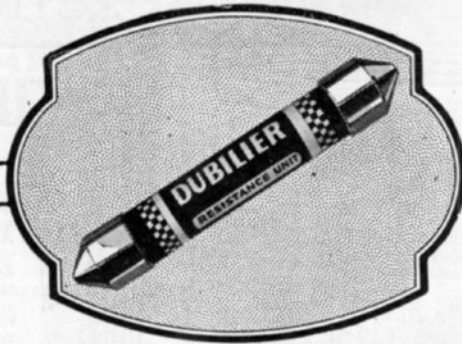

Furnished in following resistance values:
.5 .75 1. 1.5 2. 2.5
3. 4. 5. megohms
Price 50c.

The RESISTANCE UNIT

— Accurate and Efficient

A new Dubilier Product

The Dubilier engineers have perfected a resistance unit that is at once efficient, accurate *and constant*.

A good resistance unit will not change in resistance value with age. If it is marked 2 megohms it will have that same value to within commercial tolerance, after months of use.

It is easy to design a resistance unit, but it has taken us years to produce one that is right — quiet, efficient and constant.

You will find that the Dubilier Resistance Unit greatly increases the range and efficiency of your set.

For a descriptive folder, address 43-49 W. 4th St., New York

Dubilier

CONDENSER AND RADIO CORPORATION

The Ballantine R. F. Receiver

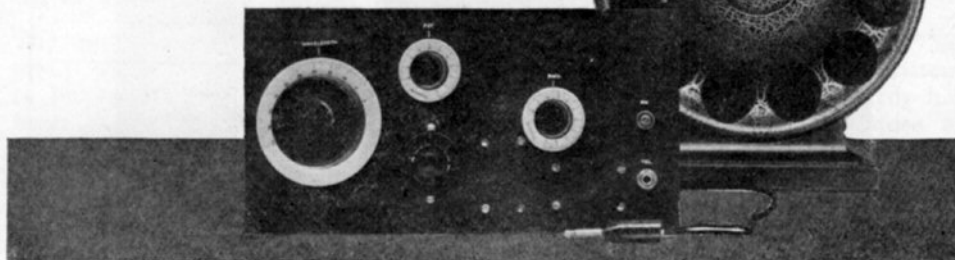

WITH all the work which is being done on reflex receivers with crystal detectors, the temptation to construct a set around the Ballantine vario-transformer was irresistible. The type 6700 receiver to be described is the result of the experiments we made.

Starting with the idea of building a receiver with one stage of vario-transformer coupled R. F. amplification, a crystal detector, and two stages of audio, we decided to work into the set a pair of Samson A. F. transformers. The preliminary set-up was made and tried out with discouraging results. The volume was only fair, and the tuning difficult because the circuit was quite unstable, breaking into oscillation without any good reason. At times it was almost impossible to stop the circuit from oscillating even with a heavy positive bias on the grid of the R. F. amplifier tube.

It seemed as if there was some peculiar combination of characteristics in the vario-transformer and in the Samson A. F. transformers, yet these two instruments are so highly efficient that we knew it should be possible to iron out the kinks. Possibly the extremely low distributed capacity of the Samson transformers was responsible. The windings on these instruments are made up of a series of pies or flat spirals only one turn thick. Therefore, there is much less difference in potential between sections than between layers in the ordinary type of coil, cutting down the distributed capacity to a very low value.

We tried one stunt after another without improving the operation of the circuit until, at last, we put a 0.0001 mfd. Mica-don across the primary of the first transformer. Immediately, the characteristics of the set changed entirely. The adjustments became perfectly stable and we got the kick from the amplifiers that we knew we should have had at the beginning. More-

over, the settings of the vario-transformer were very different from those originally obtained. For the longer wave lengths, such as station WNYC, the vario-transformer was set at only a third of its maximum wavelength range, while the medium wave stations, such as WJZ, and all stations below that wavelength, came through at the minimum setting. However, it did not appear that the results would have been improved if it had been possible to tune lower on the vario-transformer, nor was the tuning any broader on the variable condenser when the vario-transformer was at minimum.

The front view of the set shows four controls, the big dial for the variable condenser, the upper one at the center for the potentiometer, with the vario-transformer below, and a rheostat for regulating the two A. F. amplifiers at the right. With the circuit as it was finally worked out, the potentiometer was not critical. Since very little regulation of the vario-transformer is needed and no adjustment on the rheostat, once it has been set, the tuning is practically resolved into a single control. You will notice that an Accuratune micrometer dial is employed. This is necessary because of the very sharp tuning.

If you will study the accompanying illustrations, you will see that, on the front panel, the Accuratune matched controls are used, the big vernier dial for the variable condenser and the small 2-in. dials for the rheostat and potentiometer. A Walbert lock switch is used to open and close the filament circuit. Just below is an open circuit Carter jack. Behind the panel, an Eastern pickle bottle coil is mounted on a 0.0005 mfd. Bremer-Tully die-cast condenser. To the right is the Ballantine variotransformer with a Patent potentiometer of 400 ohms. The

Standard
Parts
Required

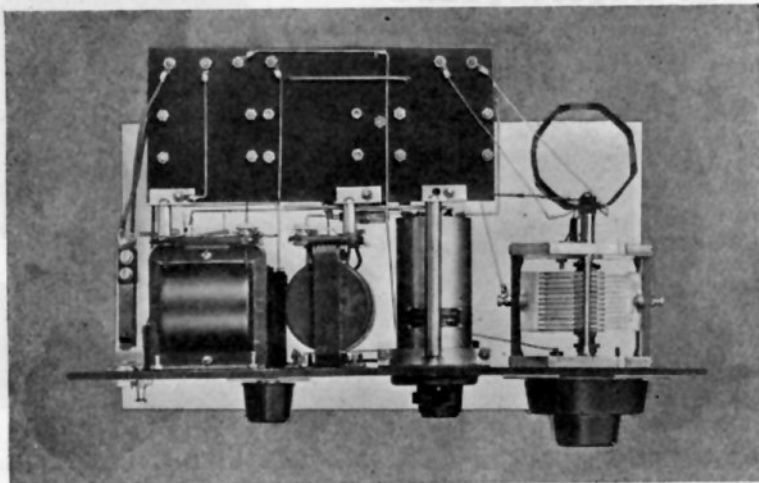

Fig. 2. You can see from this view the method employed for mounting the tube panel and the concealed wiring

Samson A. F. transformers are mounted at right angles to each other, altho that is not necessary, except to simplify the wiring, as they are thoroughly shielded. A Fil-ko-stat was chosen for fine regulation of the filament current. Just between the variotransformer and the first A. F. transformer is a Rasla fixed crystal detector and the Micadon which supplied the elusive solution to our problem of stabilizing the circuit. On the tube panel are three Benjamin sockets, a type I-A Amperite for automatically regulating the filament of the R. F. tube, and six Eby binding posts. For connections to the antenna and ground, A battery, B battery, and C battery.

These instruments are not only thoroughly good electrically and mechanically but they are so attractive in appearance that the set behind the panel is quite as handsome as the exterior.

The front panel for this outfit measures 7 by 14 by 3/16-in. and the tube panel 3 1/2 by 7 3/4 by 3-16 in. Mahogany Celeron was used for this set, altho some builders prefer polished black Formica. Panel drawings are not given here altho they can be obtained if you are going to follow exactly the construction of the original model. The full size blue prints can be used as panel patterns by putting them on the panels and punching through where the centers are indicated on the blue prints. These prints also show which holes should be countersunk for flat head screws. The only difficult operation in drilling the panels is that of making the large hole for the variotransformer.

This must be 1 5/8-in. in diameter. The hole can be made by drilling a series of small holes in a circle, altho it is far easier to use a regular adjustable panel cutter as that will give a perfectly smooth true hole.

It is important to make the hole for the shaft of the variable condenser with a 15/32-in. drill, the same size that is required for the jack. The reason for this large hole is that there is a collar at the rear of the Accurate dial which projects about 1/8-in. back from the front of the panel. If a small hole is used, it will not be possible to get the friction disc on the dial against the front of the panel.

If possible, have your panels engraved. If you cannot have this work done locally, send your panels to one of the companies that does this work. Radio sets look rather crude if they are left plain, while the engraving snaps up the appearance of the set and gives it an attractive finishing touch. Be sure to rub down the panel, if you want the grain finish, before you have it engraved for, otherwise, the bakelite dust will get into the white of the lettering.

Assembly
And
Wiring

Fig. 5 is a picture wiring diagram of the Ballantine receiver, showing the connections as they were actually put on the original model. The tube panel is tipped down so as to show the connections.

Heavy lines on the binding posts indicate the soldering lugs. Up to the present time, we have been using lugs with bent-up lips, but we have found that the wiring

can be done more neatly and more rapidly with the straight flat lugs, particularly if they are tinned. Tinned lugs of this sort are stamped out from copper sheet which is tinned before stamping.

Either Kester rosin core solder or plain soft solder with Nokorode paste, applied very sparingly, should be used for making connections. The idea of putting loops in the ends of the wire and fastening them in place with the machine screws or nuts on the various instruments is all right for those who are not able to handle a soldering iron, but the only workman-like way to build

lug under a nut on the screw which holds the condenser to the front panel.

5. Mount the two Samson A. F. transformers, using $\frac{1}{2}$ -in. 6-32 F. H. screws and nuts. The 6 to 1 ratio transformer is put on with its core vertical. Clip off the lugs on the B terminal of the 3 to 1 ratio transformer and on the B and F terminals of the other.

6. Connect 7 to 8. Terminal 7 is the F post on the transformer. Keep this wire close to the transformer terminal plate.

7. Mount the telephone jack with the bracket up.

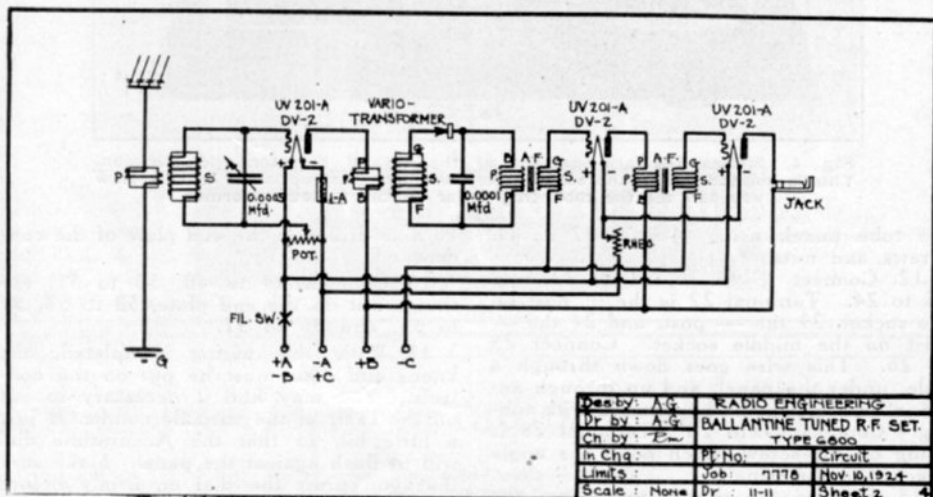

Fig. 3. This drawing shows the circuit system employed, tho it does not follow the picture wiring diagram in exact detail

radio equipment is to solder every connection.

You will notice that some of the wires are marked f. This is to indicate that flexible conductor should be used. The James Goldmark Company have a light braided cable which is excellent for this purpose. Of course, it is not absolutely necessary to use the flexible wire, but this practice is strongly recommended for all connections between instruments mounted on different panels. The purpose is to relieve the strain on the soldered connections when pressure is put on the tube panel. Varnished tubing, wherever it is necessary, is specified in the assembly instructions.

1. Mount the potentiometer, rheostat, and lock switch on the front panel. Remove the clips from the rheostat terminals.

2. Connect 1 to 2 and 3 to 4. Cover the latter wire with M-R tubing.

3. Mount the variable condenser on the front panel.

4. Connect 5 to 6. Terminal 6 is a

8. Connect 9 to 10. This should be protected by tubing.

9. Put the collar on the variotransformer, remove the pointed set screws, and use those holes for the $\frac{1}{2}$ -in. 6-32 F. H. screws and nuts to fasten the instrument to the front panel.

10. Connect 11 to 12. Run this wire straight out from the variotransformer. Connect 13 to 14 and 15 to 16. Terminals 14 and 15 are on the crystal detector, while 16 is on the B post of the transformer. Arrange these last two connections so that there will be room between the detector and the transformers for a 0.0001 mfd. Micadon. Then solder the Micadon at the bottom to wire 11 to 12 at point 17. Connect 18, the upper side of the Micadon, to 16. 11. Mount the sockets and 1A Amperite on the tube panel, using $\frac{1}{2}$ -in. 6-32 R. H. screws and nuts and put the binding posts in place, making sure that the holes run from front to rear. Also mount the three angle brackets on

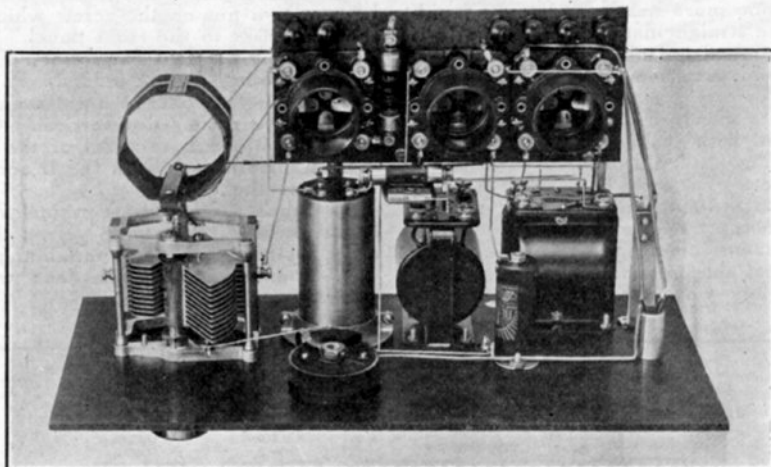

Fig. 4. Notice the arrangement of the crystal detector and Micadon. This is pointed out in the step-by-step assembly instructions. In this view you can see the mounting collar on the variotransformer

the tube panel, using $\frac{1}{2}$ -in. 6-32 F. H. screws and nuts.

12. Connect 19 to 20, 21 to 22, and 23 to 24. Terminal 22 is the + post on the socket, 23 the — post, and 24 the — post on the middle socket. Connect 25 to 26. This wire goes down through a hole, under the panel, and up through another hole. It should be covered with tubing. Connect 27 to 28. Terminal 28 is a lug on the screw which holds the angle bracket to the panel.

13. Remove the thumb nuts from the F post of the outer A. F. transformer and the G post of the inner transformer, and put coil mounting pillars, $11/16$ in.-long, in their places. Remove the nut from the lower screw holding the variotransformer to the front panel, and put a support pillar, $3\frac{3}{8}$ ins. long, in its place. Fasten the angle brackets on the tube panel to these three supports, using $\frac{1}{2}$ -in. 6-32 F. H. screws.

14. Connect 29 to 30, 31 to 32, and 4 to 22. These wires should be protected with tubing. Connect 33 to 34, 24 to 35, 36 to 37, 38 to 39, 40 to 41; 42, the P post on the transformer, to 43, 44 to 1, 45 to 46, and 47 to 48. Wire 38 to 39 should be covered with tubing.

15. Remove the screw holding the rear end plate of the variable condenser to the center post. Insert in its place a $\frac{1}{2}$ -in. 6-32 screw from which the head has been cut off. Put on the outer end of this screw a coil support pillar. Then remove one of the brackets from the pickle bottle coupler and mount that end of the clamping strips to the pillar with a $\frac{1}{2}$ -in. 6-32 R. H. screw. Fasten the other bracket with a $\frac{1}{2}$ -in. 6-32 R. H. screw and nut put through a No.

18 hole drilled in the end plate of the condenser

16. Connect 49 to 48, 50 to 51, the thumb nut on the end plate, 52 to 53, 54 to 55, and 56 to 57.

17. With the wiring completed, the knobs and dials must be put on the controls. You may find it necessary to cut off the shaft of the variable condenser just a little bit, so that the Accuratune dial will fit flush against the panel. Make sure that you press the dial on firmly before you tighten the set screw for, otherwise, the friction disc will not hold. Remove the shaft from the potentiometer, break off the handle, and file down the knurled end so that it will fit in one of the 2-in. knobs and dials. The rheostat knob must be broken off also and the shaft cut down so that, in the full-on setting, the dial will be flush with the panel.

Terminal markings for the testing and operating binding posts are given in Fig. 5. With UV-201-A or DV-2 tubes a 6-volt storage

battery should be used with a 1-A Amperite to control the R. F. amplifier. DV-3 tubes, the low-current type, can be used in this outfit. In that case, the Amperite should be changed to the 6V 199 type. The B battery should be of at least 45 volts or, better, 90 volts. Very little improvement is obtained by increasing the voltage over that value. An Eveready 3 battery is the proper type to use for the grid bias or C battery. When the set is working, you can try the various adjustments to get the correct voltage.

To put the set in operation, plug the telephones or loud speaker into the jack,

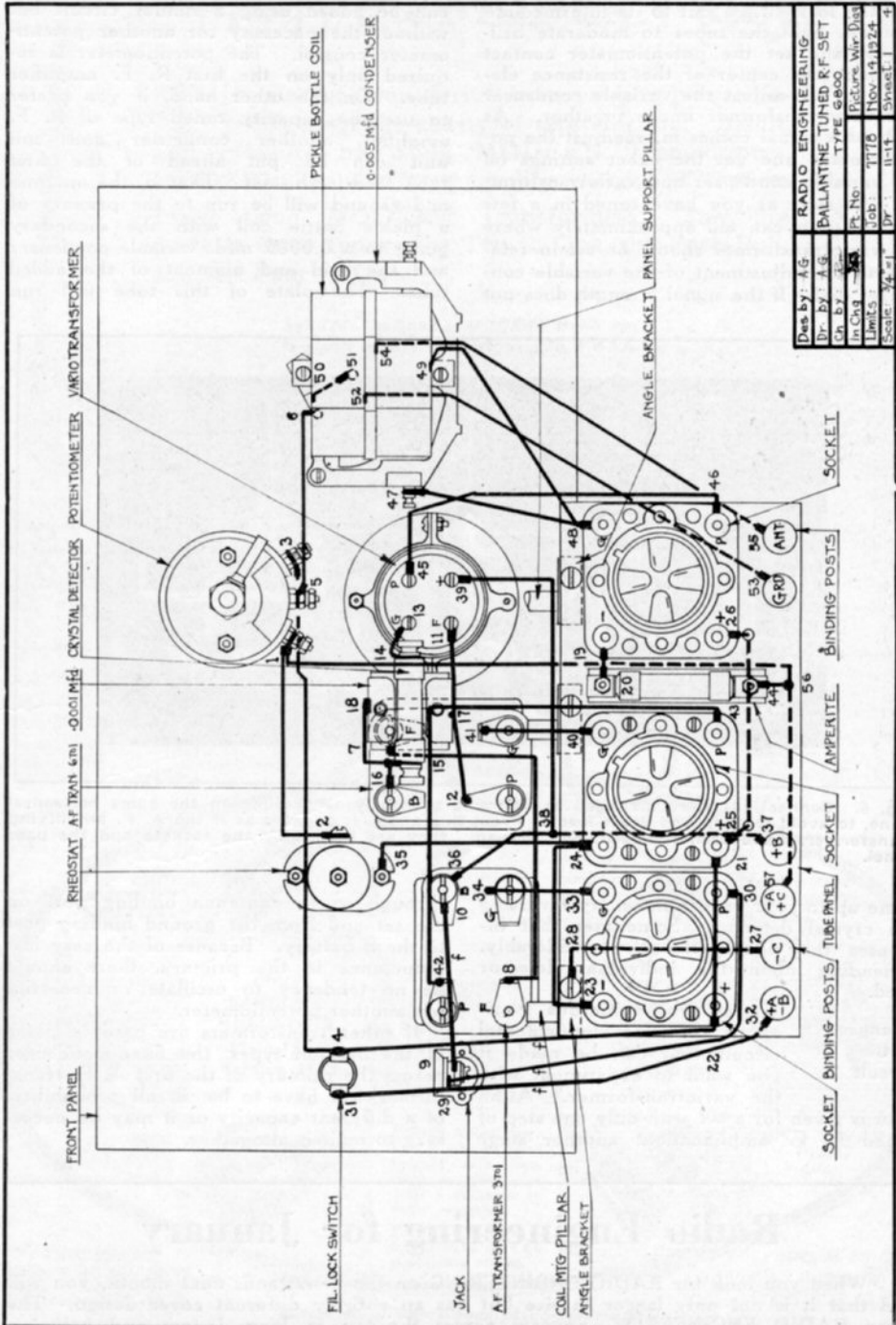

Fig. 5. Here wiring is shown as it was actually done on the original set. Numbers on the terminals correspond to those in the assembly instructions

pull the lock switch out to its intermediate position, light the tubes to moderate brilliancy, and set the potentiometer contact at about the center of the resistance element. Then adjust the variable condenser and variotransformer knobs together. As soon as a signal comes in, readjust the potentiometer and get the exact settings on the variable condenser and variotransformer. As soon as you have tuned in a few stations, you can tell approximately where the variotransformer should be set in relation to the adjustment of the variable condenser dial. If the signal strength does not

be added using a similar circuit but without the necessity for another potentiometer control. The potentiometer is required only on the first R. F. amplifier tube. On the other hand, if you prefer to use the capacity tuned type of R. F. amplifier, another condenser and coil unit can be put ahead of the first tube used in this set. That is, the antenna and ground will be run to the primary of a pickle bottle coil with the secondary going to a 0.0005 mfd. variable condenser and the grid and filament of the added tube. The plate of this tube will run

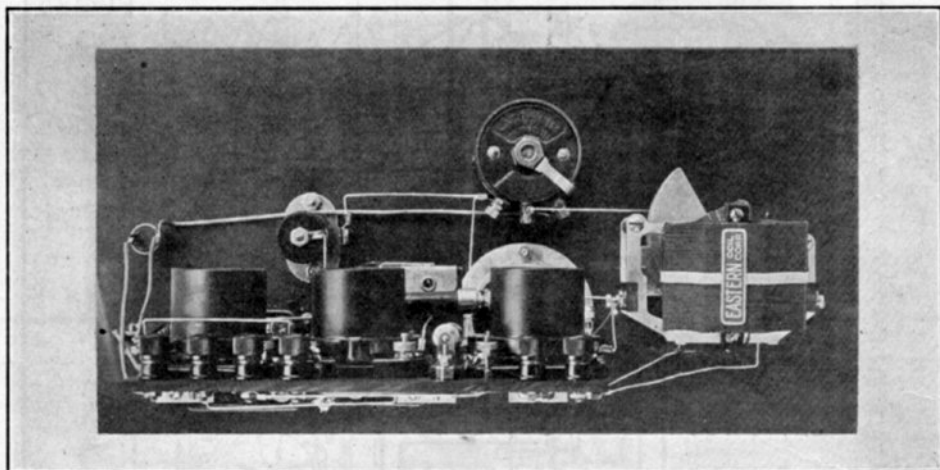

Fig. 6. Connections were arranged so as to be as nearly as possible on the same horizontal plane, to avoid long up and down leads. From this angle, it appears as if the A. F. amplifying transformers have been removed, but, actually, they are hidden by the sockets and the base panel.

come up to your expectations, try reversing the crystal detector. Sometimes that increases the signal strength considerably, depending upon the individual detector used.

Changes in the Circuit

There are numerous variations of this fundamental circuit that can be made if you want to experiment with the variotransformer. Although data is given for a set with only one step of tuned R. F. amplification, another stage

through to the antenna binding post on the set and from the ground binding post to the B battery. Because of the very low inductance in the primary, there should be no tendency to oscillate or necessity for another potentiometer.

If other transformers are used in place of the Samson types, the fixed condenser across the primary of the first A. F. transformer will have to be, in all probability, of a different capacity or it may be necessary to omit it altogether.

Radio Engineering for January

When you look for RADIO ENGINEERING on the newsstands next month, you will find that it is not only larger in size but has an entirely different cover design. The name RADIO ENGINEERING appears across the top in large letters and below a picture of a radio station. The cover design is in red and black. Although the magazine has been enlarged, there will be no increase in the price.

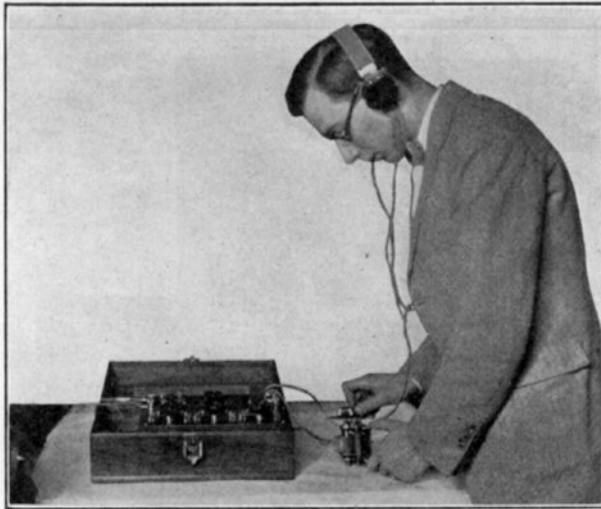

Quick and Accurate Capacity Measurements with the G-R Meter

Some data on the use of the Capacity Meter, with calibrations which were made on a few of the standard types of variable condensers

ONE of the essential instruments in every experimental or testing laboratory is a capacity meter. There is a variety of types to choose from, the particular choice depending largely upon the range of capacities to be measured, the speed with which the tests must be made, and the degree of accuracy required.

For our own use, we have chosen the General Radio type 240 as an all-round meter which can be set up, used, and put away quickly. It handles all capacities from 0.0002 to 10.0 mfd., measures power factor from 0.5 to 490, and is direct reading. You can see the meter set up and in use in Fig. 1, while Fig. 2 shows the appearance of the interior. As one would expect of Melville Eastham, the construction is thoroughly rugged, and unaffected by ordinary temperature changes or moisture.

To those unfamiliar with the design details of this type of equipment, there are two very interesting features which may be pointed out. The resistance units, the wiring of which is shown in Fig. 3, immediately catch the eye. Winding these elements

to exact values might appear to be most difficult, but the method used makes it quite simple. The resistance wire is wound in sections or strips treated to exclude moisture. Between each section, a loop of tinned copper wire, B. 16 B. & S. gauge, is put around the strip. One end is bent around and soldered to the other which, in turn, serves as a lead, as it runs straight to its corresponding switch point. The start of the resistance wire is soldered to the first loop; the end, clipped off at exactly the right point for the resistance required, is soldered to the next loop, for it is the start of the next element, also. Thus connection can be made to the copper wire at any point around the strip, wherever the resistance wire must be cut off. No special supports are needed for the units, as the lead wires hold them in place.

The buzzer used in this meter produces a clear, steady note that is much superior to that obtained by the ordinary types. Instead of having regular make-and-break contacts, a microphone button is employed. The magnetizing coil is of fairly high resistance, wound on a laminated U-shaped

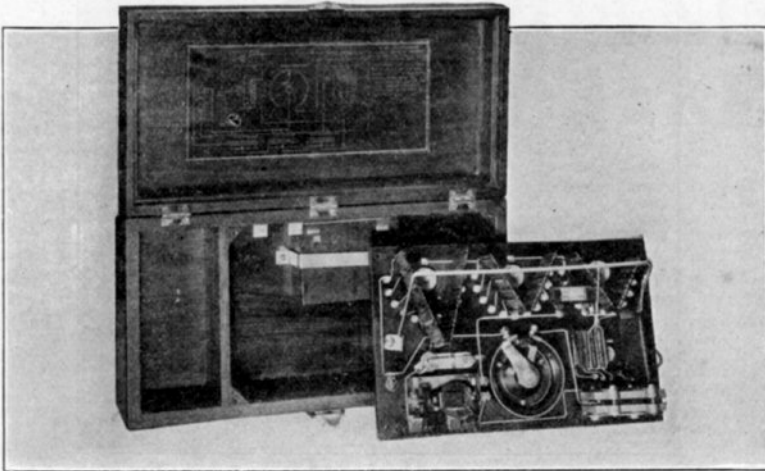

Fig. 2. The buzzer is at the lower left hand corner. Note the heavy terminal leads on the resistance units

core. Across the open side of the U a heavy steel armature is fastened. To this is bolted one side of the microphone button. The other side is not mounted at all, but merely connected thru a fine spiral spring to a terminal screw on the base. When the armature is first drawn to the core, the resistance change in the button reduces the current and the armature is released. This starts the armature vibrating at its own natural period. After that, the changing resistance of the button, as it is vibrated by the armature, is enough to serve as a regular circuit breaker. So little current is drawn that the three-cell, type 734 Eveready battery, mounted in the case, lasts indefinitely.

Using the meter is such an easy matter that, for routine inspection tests, it can be handled by a girl operator. The condenser to be measured is connected by flexible leads at the right. Then the multiplier switch is turned to the approximate value, the buzzer started, and the three switches adjusted until the buzzer sound in the telephone receivers is at minimum strength. When measuring air-dielectric condensers, the power factor knob is put at the minimum setting, tho for mica or paper condensers it may be necessary to adjust this control also to balance out the buzzer sound. Then the pointer will indicate the power factor of the condenser.

To illustrate the use of the multiplying switch—if, for example, the left hand switch reads 2, the center switch 5, and the right hand switch 9, with the multiplier switch at 1, the capacity is 2.59 mfd.; at .1, the capacity is 0.259 mfd.; at .01, it is 0.0259 mfd.; at .001, it is 0.00259 mfd.

Measurements were made with this meter on some of the standard variable condensers. These calibrations are safe to use because there is practically no difference in the calibration curves of individual condensers of the same make. Values are given in microfarads. No. 1 is an American Brand with worm gear vernier, No. 2 is a General Instrument type 56, Nos. 3 and 4 are from the National Company, and No. 5 is a Buehl.

Condenser Calibration

Condenser Scale	No. 1	No. 2
5°.....	0.000025	0.000015
10°.....	0.000045	0.000025
15°.....	0.000075	0.000045
20°.....	0.000095	0.000075
30°.....	0.000135	0.000125
40°.....	0.000180	0.000185
50°.....	0.000225	0.000235
60°.....	0.000275	0.000290
70°.....	0.000325	0.000345
80°.....	0.000370	0.000400
90°.....	0.000415	0.000455
95°.....	0.000435	0.000475

Condenser Scale	No. 3	No. 4	No. 5
5°... ..	0.000005	0.000015	0.000005
10°... ..	0.000020	0.000035	0.000015
15°... ..	0.000035	0.000055	0.000025
20°... ..	0.000055	0.000085	0.000045
30°... ..	0.000095	0.000135	0.000065
40°... ..	0.000135	0.000185	0.000085
50°... ..	0.000175	0.000235	0.000110
60°... ..	0.000215	0.000295	0.000135
70°... ..	0.000255	0.000345	0.000165
80°... ..	0.000295	0.000395	0.000195
90°... ..	0.000335	0.000445	0.000225
95°... ..	0.000345	0.000475	0.000235

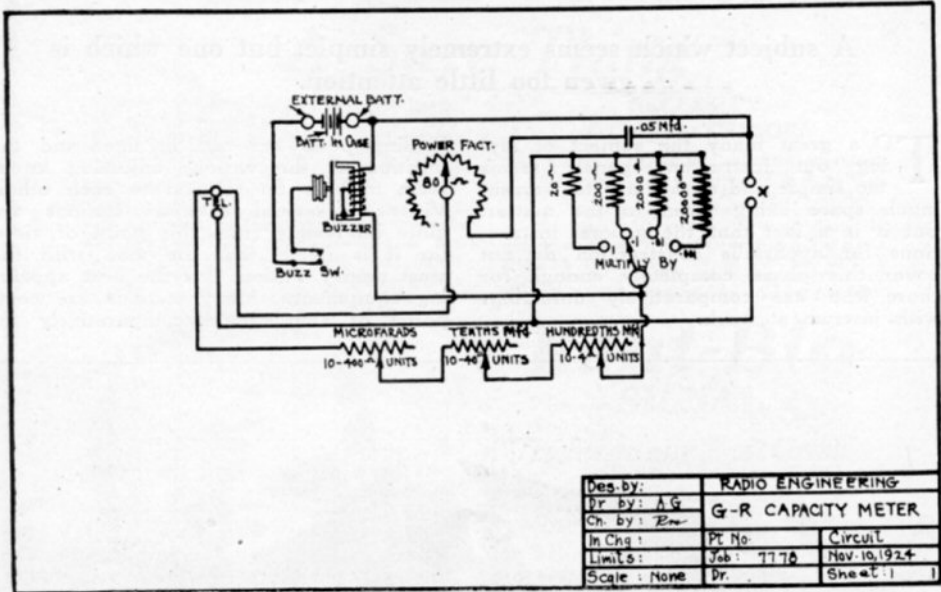

Fig. 3. Diagram of connections for the General Radio capacity meter.

If you draw curves on cross section paper to get the intermediate readings from the preceding tables, you may find the curves a little irregular in spots. This is because the capacity meter only reads to 0.0001 mfd. To get a perfectly smooth and accurate calibration curve, it is advisable to set the capacity meter at different values and tune the variable condenser until the buzzer sound in the telephones is at minimum intensity. In this way the calibration can be made very exact.

If you want to mount a calibrated variable condenser for use in the laboratory, put it on a bakelite panel about 5 ins. square, supported by terminal support pillars at each corner. It is advisable to use a vernier dial so as to get accurate settings quickly. Be sure to use a type in which there is no play. Otherwise the readings will be inaccurate.

Do not make the mistake of using a low-loss condenser and then connecting it to binding posts mounted on the panel, for the leakage across the binding posts will offset the advantage of the high efficiency of the condenser. It is all right to mount one binding post on the panel, connected

to the grounded plates of the condenser. The connection to the fixed plates, however, with a grounded rotor type, must be made directly to the plates themselves. Some condensers are so constructed that a hole can be tapped in the slotted metal strip which supports the fixed plates, and a binding post screw put into the hole. This allows an easy method of connecting on to the fixed plates without introducing any losses or creating leakage paths.

It is always advisable to test fixed condensers to make sure that they are accurate in capacity. In circuits where small variations in capacity will affect the operation, you may obtain the best results with a particular value, only to discover, when you try to reproduce the results later, that a condenser of the same rating acts differently. This is due to the differences in the two capacities of condensers, an error which seems to be inevitable in the quantity manufacture of these devices. Fortunately, however, fixed condensers manufactured by reputable concerns are held closely enough to their rated capacities so that, for ordinary use, the slight variations do not cause trouble.

Laying Out Instrument Panels

A subject which seems extremely simple, but one which is given too little attention.

TO a great many the subject of laying out instrument panels seems too simple and elementary to warrant much space being given to the matter. But it is a fact that the general instructions for apparatus construction do not cover this phase completely enough for those who are comparatively unfamiliar with instrument work.

binding posts are not in line, and the location of the various adjusting knobs seem to bear no relation to each other. Visits to several amateur stations are quite interesting from this point of view, for it is found that the man with the most money seldom has the best appearing equipment. Many stations are composed of simple and comparatively in-

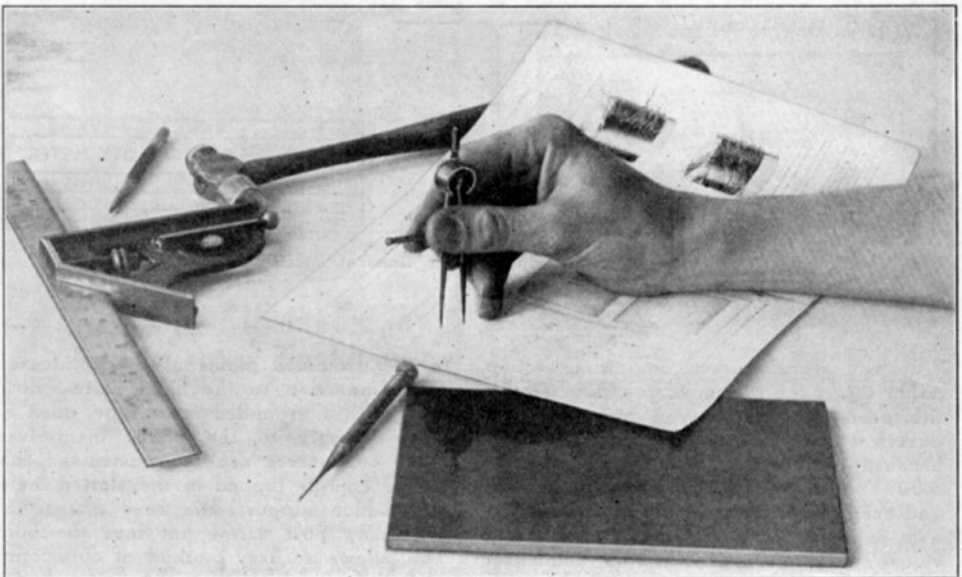

Fig. 1. Showing method of taking measurements from scale drawings.

Very frequently set builders take panels to radio stores to be laid out and drilled, quite unaware that they could save seventy-five per cent of the cost of such work by marking the position of the holes themselves. When told this, a great many take their panels back and return with the location of holes indicated by soft pencil marks one-eighth inch in diameter. Quite obviously, holes may be drilled in these places and still be a long way from the positions they should occupy.

Cases are also common where experimenters bring in instruments for repair which show the lack of proper instructions in the laying out of the panels. The distance between switch points vary,

expensive apparatus, constructed and arranged so neatly that they eclipse in appearance and working qualities the equipment of stations whose owners are not limited as to their investment. And the majority of the owners of neat and efficient outfits agree that one reason for the superiority of their equipment is the careful laying out of the instrument panels.

Some Causes Of Errors The poor appearance of some instruments is often the result of insufficient time spent in laying out the panels. This, of course, is bad economy. The use of a pencil or blunt marking tool accounts for a large number of misplaced holes and the dependence upon a mark rather than a center punch hole for starting the drill

ranks next as a cause for this error. With many, the fault lies in the fact that they are not careful or accurate in transferring dimensions from scale drawings to their work, while others can trace their trouble to the use of panels whose adjacent edges are not exactly at right angles. The latter is quite common where panels are purchased from dealers who cut their material from large pieces into any size desired by the customer. The edges are seldom straight or at right angles, and the instrument builder finds it necessary to spend considerable time squaring the edges so that he can make measurements from them to locate his holes. The ex-

Punches are often re-sharpened to points which are not truly conical, and to use them one runs the risk of centering the hole a little distance from the place where it should be located. When struck with the hammer the center punch will move slightly in the direction of that part of the tapering point which is most nearly vertical. A four-ounce ball-pein hammer is heavy enough for this class of work, altho almost any kind will serve the purpose. The hand drill is of the familiar type shown in Fig. 3. The chuck should have a drill capacity up to $\frac{1}{4}$ in. An ordinary brace is used by most experimenters for larger drills.

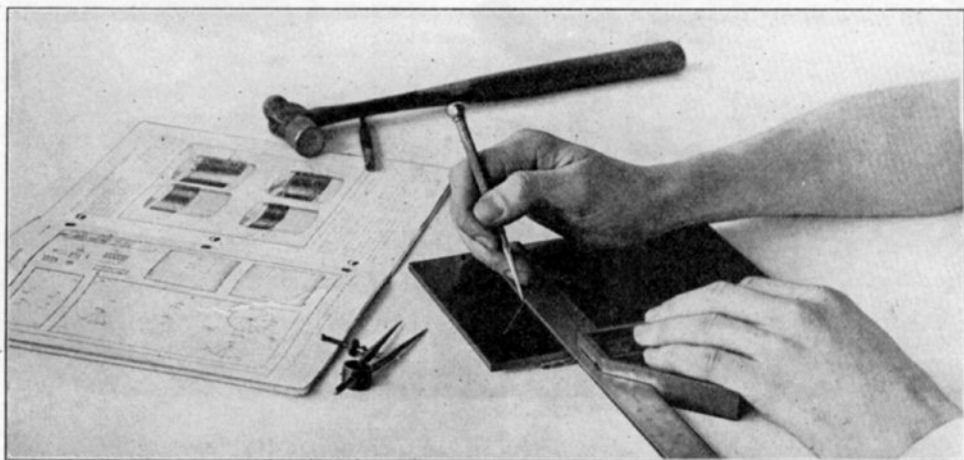

Fig. 2. Illustrating the use of the scriber.

periment building radio apparatus has much less difficulty when using accurately cut panels which have perfectly straight edges and right angle corners. With this stock to work upon, the job resolves itself into a matter of the use of tools.

The builder should provide himself with a pair of dividers, scribe, square, center-punch, hammer, and hand drill. The dividers should be capable of covering a radius of about 2 ins., the points should be sharp, and the joint firm. Errors are frequently made by an accidental change in setting of loose dividers. The only requirement of the scribe is that it should have a sharp, hard point. A combination square of the type shown in Figs. 1, 2, and 3 is recommended. The blade should be at least six inches long, with divisions to 1-32 in. or finer. A hard conical point is necessary for center punch.

Purpose Of The Tools

The dividers are used for transferring measurements made upon the drawing to the scale, and then to the panel. They should not be employed for locating a point from the edge of the panel for the reason that it is inconvenient if not impossible to set the very point of the instrument on the upper edge of the panel, as would be necessary for accurate work. The combination square should always be used for making measurements from the edge of the panel. All straight lines and points are made with the scribe used in the manner illustrated in Fig. 2. Note that the point is kept close to the scale while the square is held firmly by the left hand.

The principal functions of the combination square are the making of measurements from the panel edges, measuring the distance between the divider points when taking dimensions from drawings,

and for use as a straight edge, particularly for drawing lines parallel or at right-angles to an edge of the panel. While using the instrument as a square, care should be taken to see that the knurled nut which locks the scale is turned down tightly. The center punch is used only for marking holes to be drilled. This tool is held perpendicular to the surface of the panel at a point determined by two intersecting lines, and struck squarely with the hammer. This operation starts the hole which is easily followed by the drill. The drill should be held very firmly in a verti-

cal position by the left hand while the right is used for turning. For this class of work comparatively light pressure with high speed should be given the drill, to minimize the chances of breaking the panel out on the front, as the drill is about to come thru.

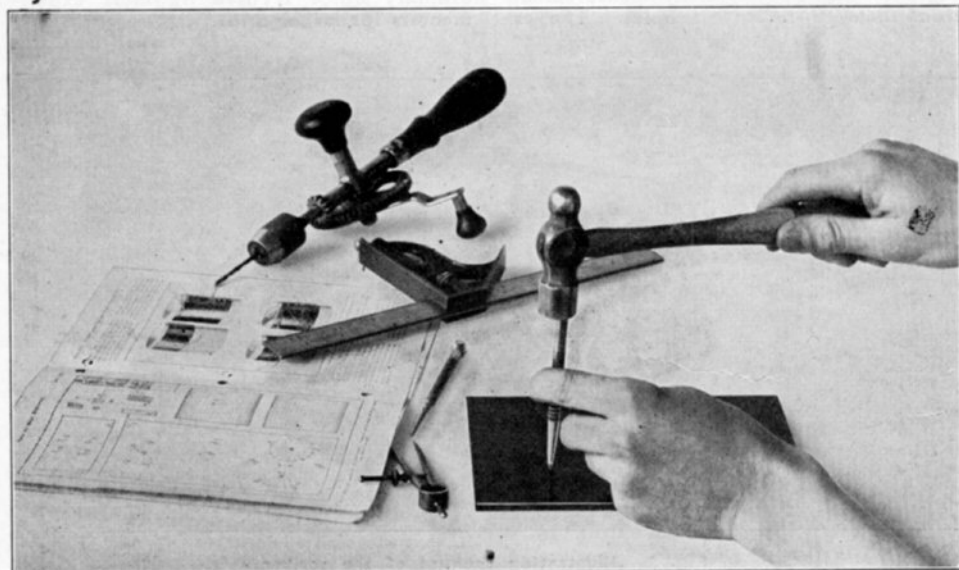

Fig. 3. A punchmark makes drilling easier.

cal position by the left hand while the right is used for turning. For this class of work comparatively light pressure with high speed should be given the drill, to minimize the chances of breaking the panel out on the front, as the drill is about to come thru.

Uses
Of The
Tools

All panels should be laid out on the reverse side so that any defacing of the panel required to locate holes will not be seen on the front of the instrument. This, of course, necessitates laying the panel out in negative, that is, the holes shown on the left of the panel drawings will be drilled on the right of the reversed panel.

Start at one end of the panel drawing, and measure the distance the first holes are located from the edge, multiply this dimension by two when the drawings are half-size, and the result will be the distance

short line crossing the first, at right angles at this point will definitely determine the location of the hole. Next place the point of the center-punch at the intersection of the two lines and hold the tool perfectly vertical while it is struck a blow with the hammer. In a similar manner all holes are located by intersecting lines, and started with a center punch to insure accurate drilling. The drill started in a center punch hole will not move along the surface of the panel as it is liable to do when no punch is used.

Every minute of time devoted to careful and accurate work in laying out panels will be amply realized in the values of the completed instrument. Experimenters who give a sufficient amount of attention to the details of this phase of apparatus construction always have a feeling of pride in the pleasing appearance of their instruments, which increases the interest in apparatus design and construction.

How to Build and Operate the Silver-Marshall Super-Heterodyne

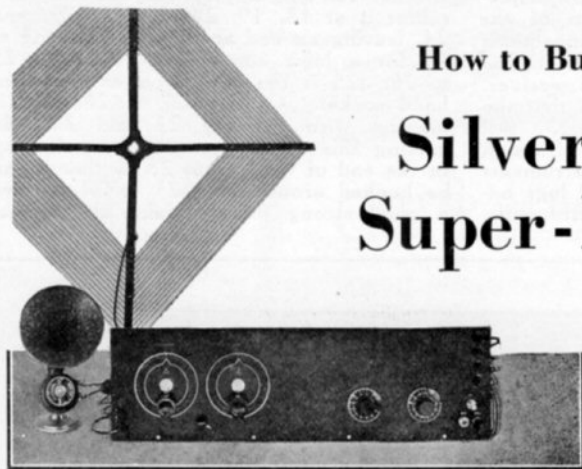

With complete step-by-step assembly instructions and picture wiring diagrams of the connections.

TO the average man, the word Super-Heterodyne instantly brings to mind a veritable collection of radio parts of all sizes and shapes with a couple of miles of wiring thrown in for good measure. Super-Heterodyne sets are gradually passing that stage, however, and are being brought down to reasonable size and simplicity. One of the most interesting results of this trend is shown in the Silver-Marshall laboratory model Super-Heterodyne. This set uses seven standard tubes and has only two controls. The wiring is much more simple than on many standard three-tube regenerative sets.

The set is designed to operate on a small 18-inch loop and is extremely sensitive. If conditions are so poor that an antenna must be used, it can be put on the set with an ordinary antenna coupler. The circuit has two stages of intermediate frequency amplification preceded by the first detector and the oscillator, and followed by the second detector with two stages of audio frequency amplification. The wavelength range of the oscillator used is about 150 to 550 meters. A center tap taken from the loop is used as the grid return on the first detector tube. The loop tuning condenser is connected across the full loop. Both this and the oscillator condenser are of the low-loss type. The three intermediate frequency transformers are enclosed in a metal case, making a single unit. All the connections between the coils are already made inside this case. A small balancing condenser is used to neutralize the capacity between the tube elements. Two C batteries are employed, one for the two A. F. tubes and the other, in conjunction with a potentiometer, for the two R. F. tubes. The C batteries are built right into

the set. One rheostat is employed for controlling the filament current of all seven tubes. A 45-volt B battery binding post is provided for the oscillator and second detector tube, and a 90-volt post for the other five tubes.

A front view of the set shown in Fig. 1. Looking from left to right we have the three-loop binding posts, oscillator condenser dial, balancing condenser, loop tuning condenser dial, potentiometer or volume control, filament rheostat, first and second A. F. stage jacks, filament switch, and battery binding posts.

A Formica panel 7 by 24 ins., 3/16-in. thick, supports the condensers, potentiometer, rheostat, jacks, filament switch and binding posts. A wooden baseboard 7 by 23 ins., 1/2-in. thick is fastened to the front panel, and has mounted on it the sockets, C batteries, A. F. transformers, I. F. transformers, fixed condensers, and oscillator coupler.

Parts required for this outfit are: Two Silver .0005 mfd. low-loss condensers and Apex vernier dials, Chelton midjet condenser, one Howard 6 1/2-ohm rheostat, and a 150-ohm potentiometer, seven binding posts, one Carter 102-A jack and one 101 jack, Silver R. F. transformer unit, Silver oscillator coupler, seven Benjamin sockets, two Thordarson 3 1/2 to 1 A. F. transformers, Cutler-Hammer battery switch, three 0.5 mfd. by-pass condensers, two .00025 condensers, one 5-megohm and one 1-megohm gridleaks, 7 by 24 by 3/16-in. Bakelite panel, 7 by 23 by 1/2-in. oak baseboard, bus-bar, screws, nuts, solder, lugs, and flexible wire.

Design
Details Of
The Set

Standard
Parts
Required

Assembly And Wiring

Figs. 3 and 4 show a picture wiring diagram of the set, in which the connections have been drawn exactly as they were arranged in the original receiver. The baseboard is tipped down so that the connections can be seen clearly. All soldering is done to lugs, some of which are already mounted on the instruments as they come in the kit. Tin all lugs before putting them on the instruments.

another full-length piece of bus bar, and solder it at 18, 19, 20, 21, 22, 23, and 24, leaving an end about $3\frac{1}{2}$ ins. long at 18 for a later connection. Connect 25 to 26. 25 is the P terminal of the right hand socket. Connect 27 to 28. 28 is on the wire between 23 and 24. In making this connection put a small loop in the end of wire 27 to 28 so that it can be hooked around wire 23 to 24 to give a good strong joint. Make all connec-

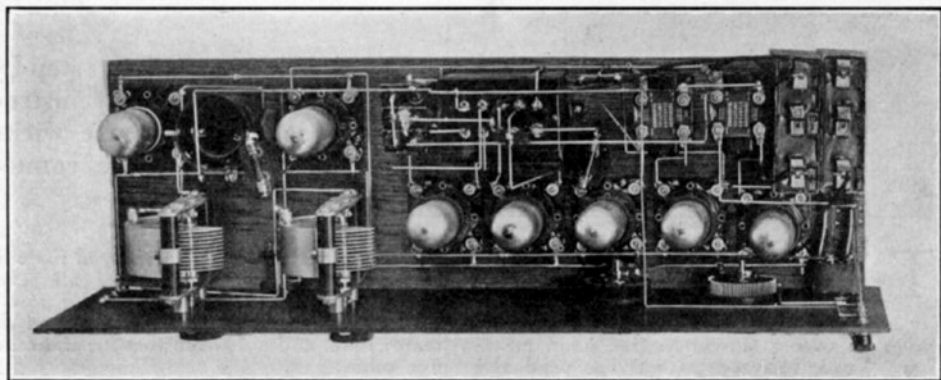

Fig. 5. This shows clearly the layout of the parts on the base panel

This will make soldering much easier later on. Use either Kester rosin core solder or plain soft solder with Nokorode paste put on sparingly. Have the iron thoroughly clean and hot enough to make the solder flow freely.

The following instructions have been prepared in the proper sequence to make the wiring as simple as possible. Read through each step before starting the work, as it may save time and extra work later on.

1. Mount the five tube sockets on the baseboard, with the terminals as shown and arranging the lugs to point in the directions indicated by the short heavy lines in the drawing. Use two wood screws for each socket. The exact location of every instrument on the baseboard can be obtained by referring to the picture wiring diagram which is drawn exactly to $\frac{3}{8}$ -scale as printed here. Mount the oscillator coupler with two wood screws, keeping the soldering lugs at the top and in the position shown.

2. Take a full-length piece of bus bar and connect it to lugs at 11, 12, 13, 14, 15, 16, and 17. These are all the + terminals on the sockets, with the exception of the last one. The connections are made at the tips of the lugs. Now bend up the lugs, on the — terminals of the five sockets on the left, until they are vertical. Take

connections of that type in this manner. Connect 29 to 30. 29 is the G terminal on this same socket. This wire runs under the oscillator coupler, near the baseboard but not touching it.

3. Snap the 5-megohm gridleak in place on one of the .00025 mfd. condensers, and place it on top of the oscillator coupler in the position shown.

4. Connect one lug of the condenser to lug 31 on the coupler, and connect 32, the other condenser lug, to 33, the G terminal of the next socket.

5. Snap the 1-megohm gridleak in place on the other .00025 mfd. condenser and slip one condenser lug over the screw on the G terminal of the third socket from the left. Screw on the nut, fastening the condenser in the position shown. Mount the R. F. transformer unit on the baseboard with the terminals as shown. The numbers on the terminals correspond with those on the picture wiring diagram. Fasten the can with two wood screws, scraping the point off the right hand foot before putting the lug under the head of the wood screw.

6. Connect 34 to 10 and 5 to 35. 35 is the G terminal of the fourth socket from the left. Connect 4 to 36. 36 is the P terminal of the fifth socket from the left. Connect 3 to 37. 37 is the G terminal

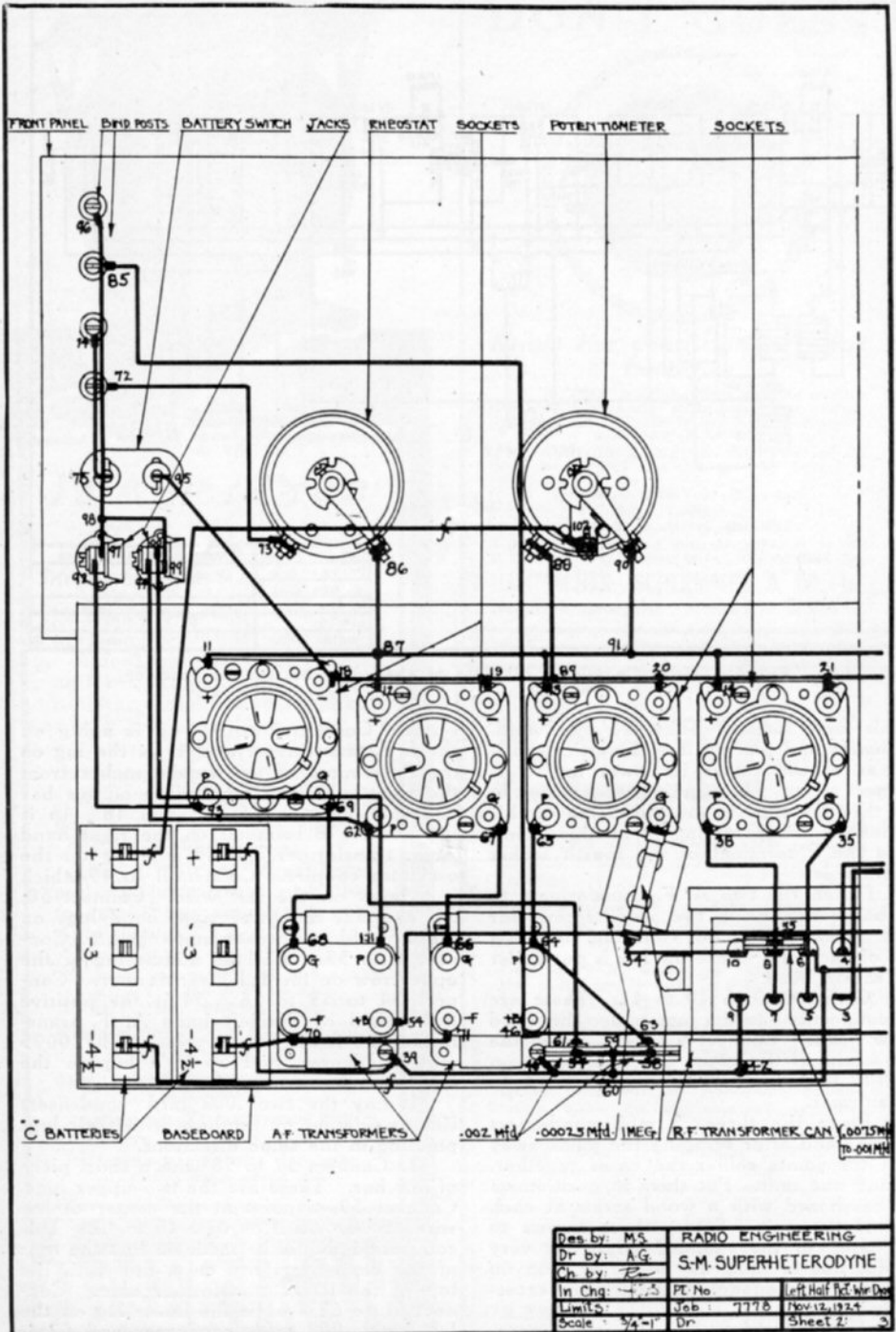

Fig. 3. Picture wiring diagram of the left hand half of the Silver-Marshall super set

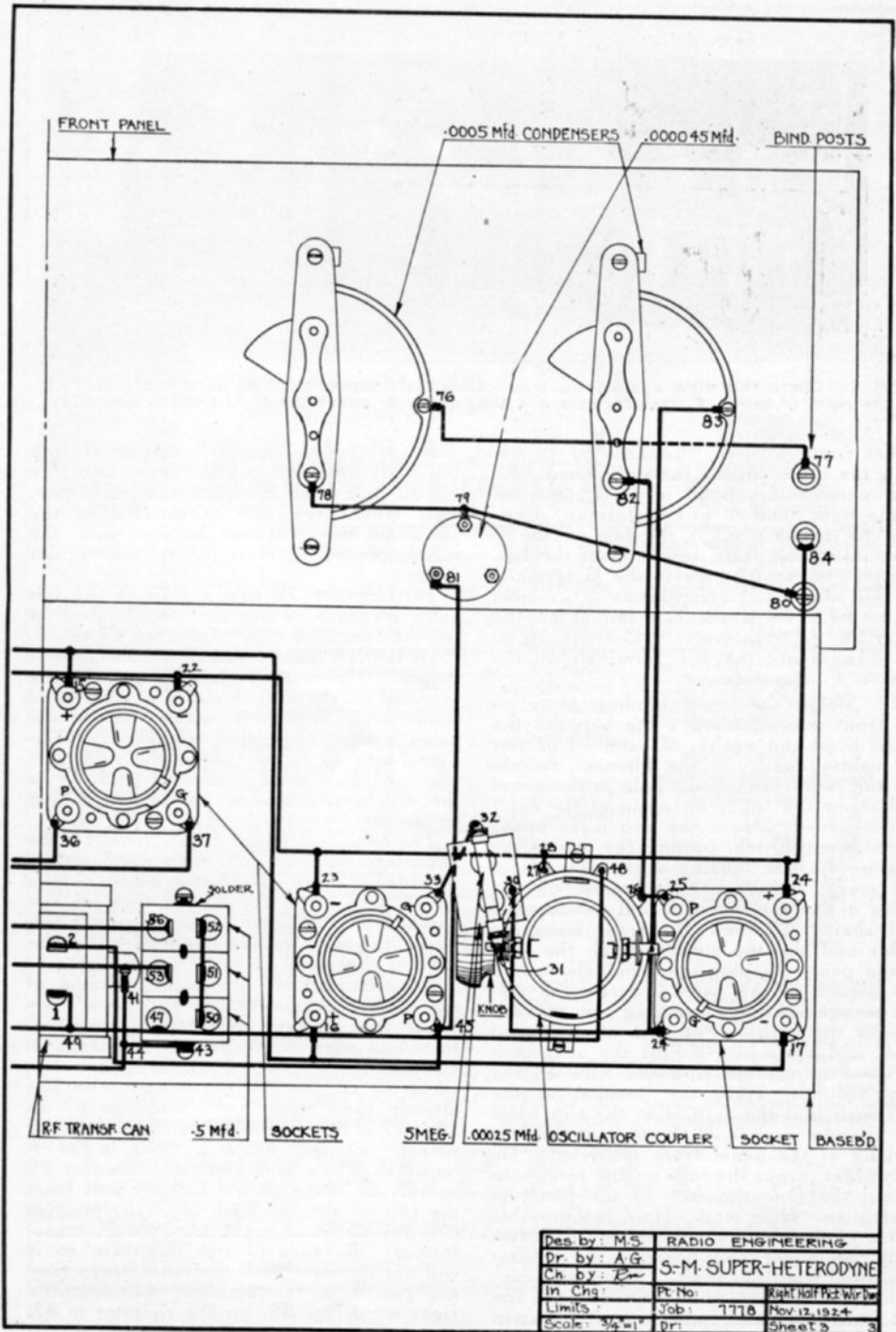

Fig. 4. Showing the right hand half. The base panel is tipped down to simplify the drawing

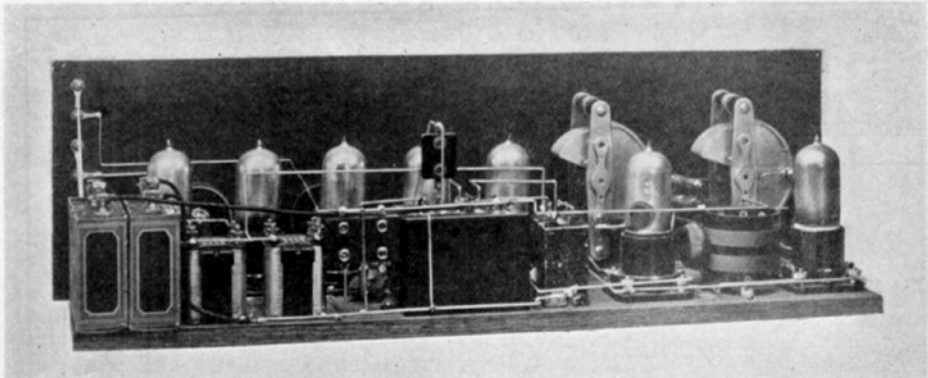

Fig. 2. Check this view against the instructions, as it shows the two fixed condensers at the right of the A. F. transformers and the condenser above the I. F. transformer unit

socket from the left. Connect 63 to 64. 63 is the lower lug on the right hand .002 mfd. condenser and 64 is the P terminal of the right hand A. F. transformer. Connect 64 to 65. 65 is the lug on the P terminal of the third socket from the left. Connect 66 to 67. 66 is the G terminal on this same A. F. transformer. Connect 68 to 69. 68 is the G terminal on the other A. F. transformer. Connect 70 to 71. These are the —F terminals on the two A. F. transformers.

13. Mount the seven binding posts on the front panel putting a lug between the screw head and washer of each. Unscrew the center collar on the filament switch, put the stem through the hole in the panel and screw the collar on again at the front of the panel. Mount the two jacks under the filament switch, putting the one-spring jack on the left, looking at the panel from the rear. Loosen the set screw on the collar of the rheostat and pull out the dial and shaft. Unscrew the front mounting collar and slip the stem through the hole in the panel, keeping the terminals toward the bottom of the panel. Screw the collar on again firmly, clamping the rheostat against the panel. Put back the dial and shaft and the arm. Adjust the arm so it makes firm contact with the wire all the way around. Have the position of the dial such that the zero is at the top when the rheostat arm is all the way to the left, looking at the panel from the front. Do not forget to put the lugs on the terminals. Mount the potentiometer on the panel in exactly the same way. Hold the movable plates of the .000045 balancing condenser with one finger and unscrew the pointer and knob from the shaft. Mount the condenser on the panel with the center nut and put back the knob and pointer. Fasten the small peg for each of the large vernier

dials for the condenser on the panel with the nut provided. This goes into the second hole from the bottom in each case. Now mount the two condensers on the panel in the positions shown, with the screws provided. Next put on the vernier dials.

14. Connect 72 to 73. 73 is the left hand terminal of the rheostat, looking at the set from the rear. Connect 47 to 75. 75 is the left hand terminal of the filament switch. Connect 76 to 77. 76 is the terminal on the dust shield of the left hand condenser. Run this wire close to the panel back of the other condenser. Connect 78 to 79 to 80. 78 is the rotor terminal of this same condenser and 79 is the upper terminal on the small midget condenser.

15. Now fasten the front panel to the baseboard with the four long wood screws provided. Keep the lower edge of the panel flush with the under face of the baseboard, and leave a 1/2-in. space between the edge of the baseboard and the edge of the panel at each end.

16. Connect 81, the lower terminal of the midget condenser, to 45, the P terminal of the second socket from the right. Run this wire down near the baseboard. Connect 82 to 26. 26 is a lug on the oscillator coupler to which one wire has already been connected. Connect 83 to 29. 29 is the G terminal of the right hand socket. Connect 84 to 24. 24 is the + terminal of the same socket. Connect 85 to 46. 85 is the second binding post from the top on the left and 46 is the positive B terminal of the right hand A. F. transformer. Be sure to run this wire so it will not interfere with the tubes when they are placed in the sockets. Connect the right hand lugs 86, on the rheostat to 87.

(Continued on page 424)

RADIO ENGINEERING

M. B. SLEEPER, Editor

F. A. SKELTON, Managing Editor

Published monthly by

M. B. SLEEPER, Inc.

Editorial and General Offices

A-52 Vanderbilt Ave., New York, N. Y.

Chicago Advertising Office

Morley Company, 157 E. Ontario Street.

Twenty cents per copy in the United States and Canada; in foreign countries one shilling. Two dollars per year, twelve numbers in the United States and Canada; ten shillings in foreign countries.

Copyright 1924 by M. B. Sleeper, Inc.

Vol. IV. DECEMBER, 1924 No. 11

EDITORIAL

AT the radio shows in our various cities—if you have seen one you have seen them all—a new price class for receiving sets is noticeable. Sixty dollars is the average, with a few in their group as low as fifty dollars and some up to seventy-five. Comparing these outfits with those available last year at prices of one hundred dollars or more, it is clear that good radio sets are available to the public this winter at a fairly reasonable cost.

Careful comparisons made between these sets and last year's models which are superseded by the new ones do not reflect much credit upon the industry, however, for most of the price reduction has been brought about at a sacrifice of attention to small details, whereas one might hope that the saving would come from improvements in design and in manufacturing methods.

Still, there is a definite indication that molded Bakelite parts are being planned with a clearer appreciation of molds and production problems. Diecastings of aluminum alloys, particularly for variable condensers, are seen in many sets. The metal panel, on the other hand, has little to justify its use, for large plates of this sort are bound to introduce losses, as a number of manufacturers have discovered already. When the coils are mounted with their axes parallel to the surface of the panel, the effect described in the October issue of Radio Engineering does not hold good, as the data given applies only to small pieces of metal. Insulating material must be used for panels.

As Mr. Gawler, of the General Radio Company, recently pointed out, there are

still too many manufacturers who are in business for a season at a time, ready in the fall to jump into radio set production or jump out of it. As a result, too many features of the outfits now available are simply talking points and not genuine developments. That accounts, more than any other single factor, for the disappointment one feels in reviewing the apparatus exhibited at the radio shows.

Some manufacturers may deny this, not realizing that many concerns, even some of the larger ones, are not as completely sold on the future of radio as they think they are. And this is probably the last season that such concerns can hold their own against those who are in radio to build up permanent organizations. Why? Because this fall the public has guaranteed, by investing heavily in the stocks of a number of radio companies, that it will keep on using and buying equipment for broadcast reception. Orders for thousands of shares in the new de Forest issue went unfilled. Trading in several radio issues has become active.

Now we must keep our eyes on the newcomers. Some will not be successful, but men experienced in the radio business are now available, and companies properly organized, with ample capital behind them, may surprise the old-timers who started two or three years ago.

It is not enough to be in the radio business to make money. We're still in the get-out-and-get-under days from which the automobile emerged years ago. So much technical knowledge is needed to operate radio sets intelligently that, if they were at all dangerous, we'd be required to take examinations and get licenses. The only successful radio sets are those which dealers can handle profitably. Right now too much of the dealers' profits go into service and express charges on outfits returned to manufacturers.

Remember, when you look for Radio Engineering next month that both the cover design and the size will be different. This marks another step in the development of the Magazine, for which we have been planning since last spring.

The change in size has been made for two reasons—to allow us to use slightly larger and more readable type, and permit the use of standard size electrotypes for advertising. Moreover, we can increase the illustrations to show more details. As for the articles themselves, there will be no change in editorial policy. I hope you will like the next issue better than ever. It will be on the news stands January first.

M. B. SLEEPER,

Editor.

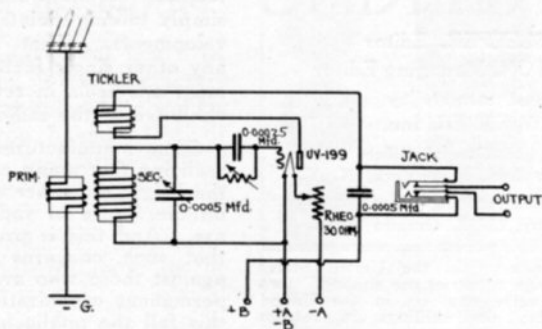

Des by: M.B.S.	RADIO ENGINEERING	
Des by: A.G.	3-CIRCUIT TESTING RECEIVER	
Ch. by: E.S.H.	TYPE G700	
In Chg:	Pt. No.	Circuit
Limits:	Job: 7776	Oct 30, 1924
Scale: None	Dr: 10-30	Sheet: 1

A Standard Receiver for Tests and Comparisons

This handy laboratory unit can be used in a dozen ways in the testing room. It also makes a first class portable receiving set

ONE of the handiest instruments we have at the Darien laboratory is the test receiver shown in the accompanying illustrations. It fits into many different experiments but it is particularly useful in checking up new types of circuits.

You probably know from your own experience that each time you try out a new receiver you guess at its merits but, unless you can check it against a standard outfit, the new circuit which you think is better may not be as good.

For example, if you have an ordinary regenerative receiver and add a step of tuned radio frequency amplification to it, the results may be improved and again the effect may be to change the tuning characteristics only. However, with a standard outfit, you can compare the set without the R. F. amplifier with the standard circuit and then check it again after the amplifier has been added.

You will notice that the standard circuit is made up with particular reference to the amount of table space it occupies. Moreover, it lines up with other test instruments which will be described separately. The connections are conveniently located so as to make the leads as simple as possible. For the output, a jack and also binding posts are provided, since we have an amplifier to use with this receiver, designed to work right along beside it. If you prefer, there is no reason for not using a standard socket except that we find it handier to have a UV199 tube run from an Eveready 3 dry battery. Most tests are of such short duration that this does not run down the little Eveready battery, although for longer tests the storage battery is hooked on.

If you will check over the photographs, you will see that the coupler is of the new General Radio type, tuned by a 0.001 mfd. Fada variable condenser. The rheostat is

of Kellogg design, the socket from the General Radio Company, the grid condenser and variable gridleak from Electrad, the jack is of the Carter 4-spring type, and the binding posts of Eby design.

For the type of circuit shown in the schematic wiring diagram, the coupling coil on the General Radio variocoupler has too many turns. Consequently, we unwound

3/16-in. down from the top. Then the panel will fit in exactly flush. To protect the controls, a cover should be provided, held in place by clasps fastened at each end. The height inside may be sufficient to clear the UV199 tube when it is in the socket or the height can be reduced if the tube is taken out of the socket and simply laid on the panel when the set is

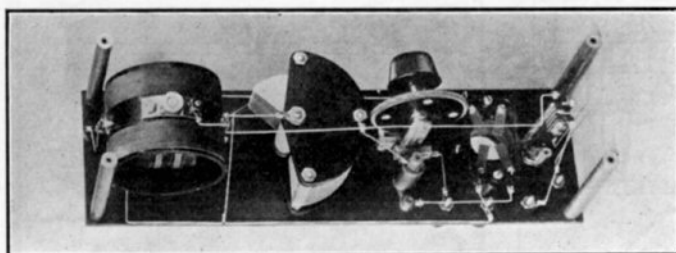

Fig. 2. A view of the under side, showing the construction details. Notice that all the leads are run as directly as possible, instead of keeping the wires in either the horizontal or vertical planes. There is space enough for a standard base socket if you prefer to use it.

a part of the coil, leaving 15 turns on each side. Then the leads were soldered to the lugs again.

The panel is of Celoron although Formica, Dilecto, of Fibroc will do as well. Hard rubber cannot be used as the weight of the instruments will cause it to sag. The dimensions of this panel are 3 1/2 by 14

being carried. A safer arrangement is to mount a General Radio or Pacent socket on the side of the top and put the tube into it, for save keeping, while the set is being carried around.

When the set is put in a cabinet, the Kellogg rheostat cannot be used. In its place a Marshall-stat should be mounted

Fig. 3. Just the type of set to have in the laboratory, for it takes up very little table space, and is planned for hooking up quickly. This view shows the reduced number of turns on the rotor or tickler coil.

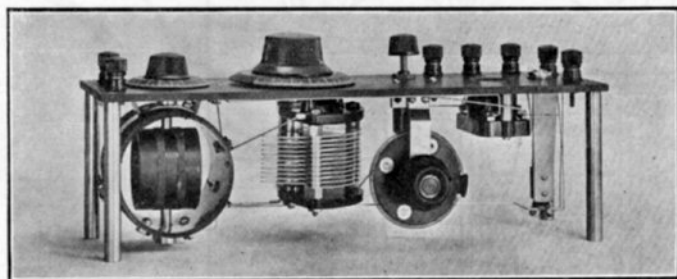

by 3/16 in. Regular terminal support pillars are used at the four corners to hold the panel. These measure 3/8-in. in diameter by 3 3/8-in. high.

No detailed dimensions are given because, if you want to make up a unit of this sort, you may find it necessary to change the instrument in some small details.

This receiver makes a splendid outfit for portable use, and its efficiency is equal to that of any good three-circuit regenerative set. For this purpose, it should be mounted in a box measuring 3 1/2 by 14 ins. inside, with a depth of 3 3/8 ins. Small triangular blocks of wood should be nailed or glued at the four corners of the box,

with the knob on the top of the panel. This is a type of rheostat particularly adaptable for use where the panel space is limited.

The wiring diagram shows loose coupling between the antenna and secondary circuits although in the set as we constructed it conductive coupling was employed. If the set is to be used where there is much interference, the antenna and ground should be connected to six turns of wire wound on top of the secondary coil. If, on the other hand, there is no trouble from local interference, the antenna should be connected to the centre tap on the secondary coil and the ground connected to the end of the secondary which runs to the filament.

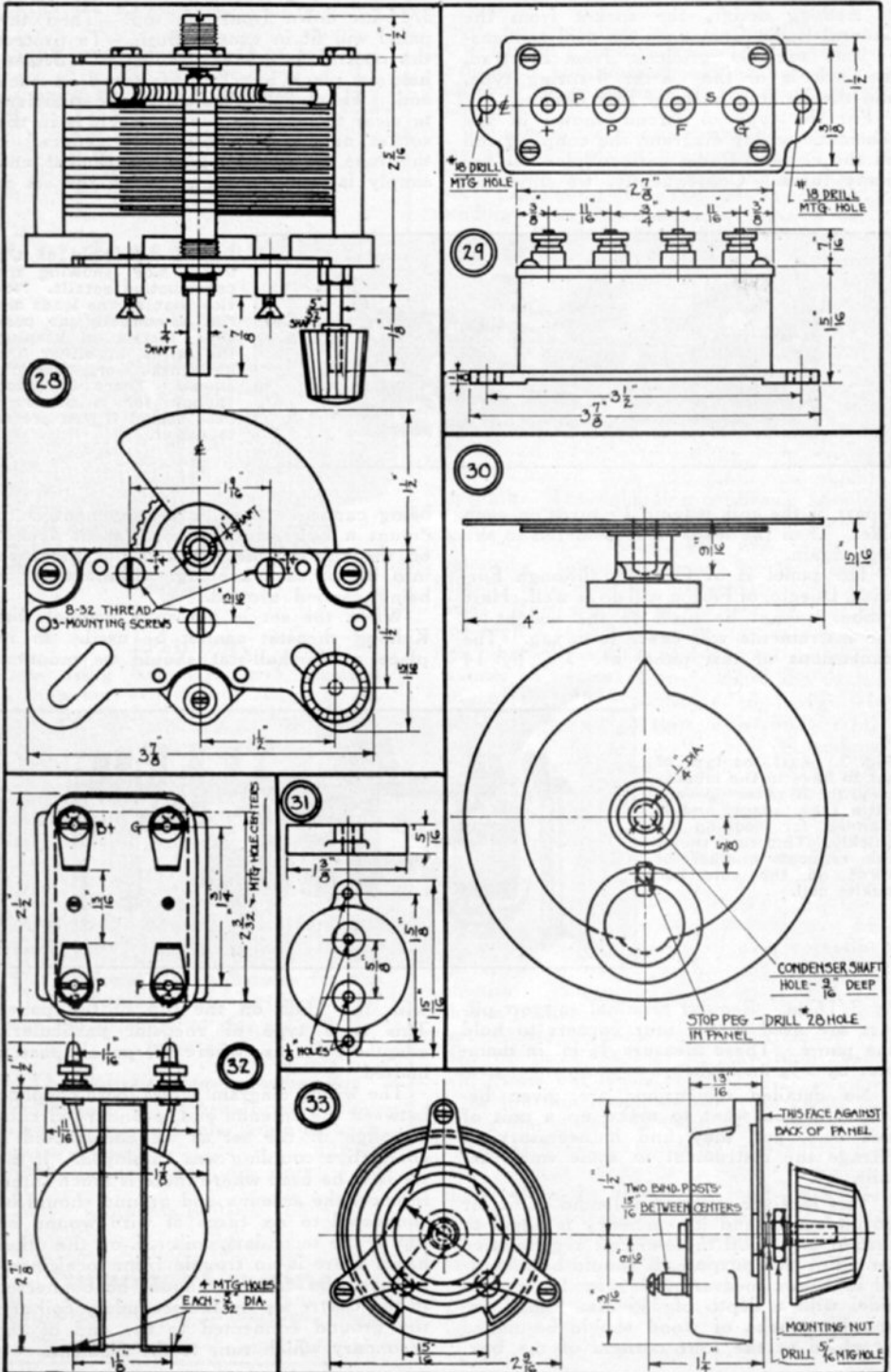

Data Sheet No. 4

28. AMERICAN BRAND VERNIER CONDENSER: This condenser is of the grounded rotor low-loss type. Very fine adjustment is secured by a 100 to 1 ratio worm-drive geared vernier control which moves all of the plates. The vernier is provided with an extra knob coming out to the front of the panel. The insulation is located outside of the electrostatic field so as to reduce losses. The metal parts are made of brass, left in their natural finish. A three-screw mounting is employed. The pig tail connection from the rotor goes to a lug on the rear end plate, while the stator is provided with a binding post. An adjustment is provided for taking up any play caused by wear on the worm gears, so there is practically no backlash. These condensers are made with or without verniers and in 0.00024, 0.00035, 0.0005, and 0.001 mfd. capacities. The dimensions given apply to the .0005 size only.

29. ACME R. F. TRANSFORMER: This iron-core transformer is made in three types, R2, R3, and R4 for the first, second, and third stages respectively. The size and terminal markings are identical for all types. The entire unit is enclosed in a neat bakelite case provided with tabs for two-hole mounting. The four binding post terminals are arranged in a line on top of the case. This transformer is very widely employed in reflex circuits. Its rugged construction and small size makes it very desirable for portable work.

30. APEX VERNIER DIAL: This 4-in. dial represents a departure from conventional vernier dials in that it is made entirely of metal. It consists of two discs and a knob. The smaller disc is anchored to the panel by a peg and carries the knob with a small gear on the shaft which meshes with an internal gear cut in the large disc. The ratio is about $11\frac{1}{2}$ to 1. The pointer on the small disc moves over a raised-letter scale on the other. The dial is made to fit on shafts $\frac{1}{4}$ -in. in diameter which project not more than $\frac{1}{2}$ -in. from the front of the panel. The front is finished

in black with nicked or gold plated scale and pointer. It is only necessary to drill a No. 28 hole in the panel for the peg to mount the dial.

31. RUSONITE FIXED MICA CONDENSER: This condenser is made in capacities of .0001 to .006 mfd. It is moulded and hermetically sealed, as an assurance against change of capacity due to variable pressure on the plates. Connection is made to the two eyelets in the center. The two outside lugs and holes are for mounting.

32. SAMSON A.F. TRANSFORMER: This transformer is known as the type HW-A2 and is made in 3 to 1 and 6 to 1 ratios. The terminal markings shown are for the 3 to 1. In the 6 to 1, the G and F terminals are interchanged. Helical windings are used for both the primary and secondary and the core is made up of very thin steel laminations. Four mounting holes are provided at the bottom. The composition shelf at the top carries the four terminals, each consisting of a binding post and an upright lug. The transformer is very ruggedly built and is shielded.

33. CICO BAKELITE RHEOSTAT: This rheostat is made in resistances of 6, 10, 20, and 30 ohms. The dimensions given are the same for all types. The resistance element is contained in a bakelite cup. It is only necessary to drill a 5/16-in. hole in the panel to mount this rheostat. The knob is of good design and has an arrow engraved on its face to indicate when the rheostat is on or off. Two binding posts are provided at the rear for connections. The usual wiping blade contact is employed. All metal parts are nicked.

NOTE: These data sheets are prepared for the use of designers and draftsmen so they can have, for quick reference, working data on the design of parts and instruments which are widely used. Keep these sheets in your note-book — you will find yourself referring to them continually.

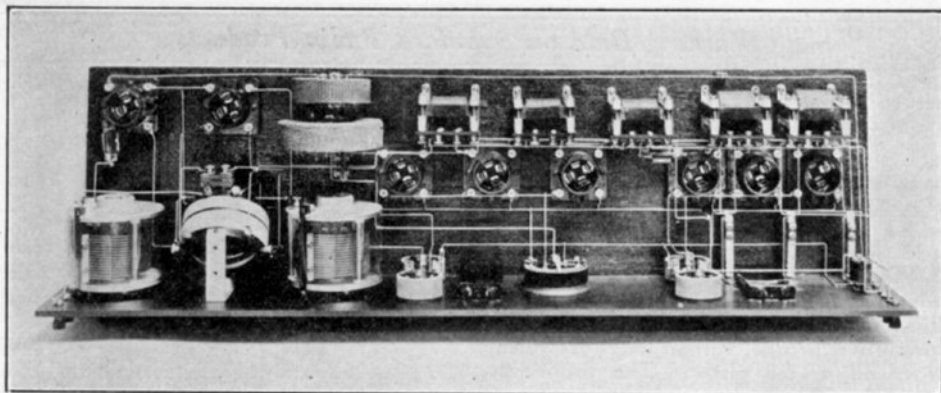

Eight-tube Super Set of Compact Design

The interesting features of this set are the transformers, using Duco Lateral coils for the tuned input transformer with closed core transformers for the intermediate frequencies.

FROM the illustration of this super-heterodyne receiver, you can see that this type of equipment is not difficult to build for, while a number of tubes and various associated instruments are employed, the set can be made without the difficulty that is so often associated with the high sounding name.

The Type of Circuit Employed

Comparing the illustration of this outfit with the wiring diagram you will see that the outfit follows the usual design for super equipment. As is the case with other outfits subsequently described, the efficiency is not dependent upon any special tricks but rather upon the correct design of the transformers and the auxiliary equipment. The input transformer is assembled from two Duo Lateral coils, one of 750 turns and one of 1250 turns for the primary and secondary respectively. The three intermediate frequency or long wave transformers are of Acme design as well as the two audio frequency types. The I. F. transformers depart from customary practice in that they employ a fairly heavy core of finely laminated iron. In practice, it has not been found necessary to shield these transformers as they have a very small exterior field. Consequently they can be

mounted as close as 1 in. apart if necessary without interfering with the operation of the set.

Another feature of the outfit is the adjustable coupling between the two coils which make up the oscillator inductance and the coupling coil. This, you will see, is so constructed as to give a coupling variation of over 180 degrees. Four rheostats are provided to allow the regulation of the filament current in the oscillator, in each detector, and in the intermediate and audio frequency stages. The first I. F. tube is provided with a potentiometer to vary the voltage on the grid. In addition, a C battery is used for a bias on the intermediate and audio frequency tubes.

The construction of the 0.0005 mfd. variable condensers, of Acme manufacture, is very interesting. These condensers, of the low-loss type, might be called the no-loss design for the losses at radio frequencies are hardly measurable. The arrangement is exceedingly rugged altho, at the same time, the weight is not excessive. The plates are soldered together and silver plated so as to give the lowest possible resistance. You can see in the photographs one of the hard rubber

Parts Required For the Set

0.0005 mfd. variable condensers, of Acme manufacture, is very interesting.

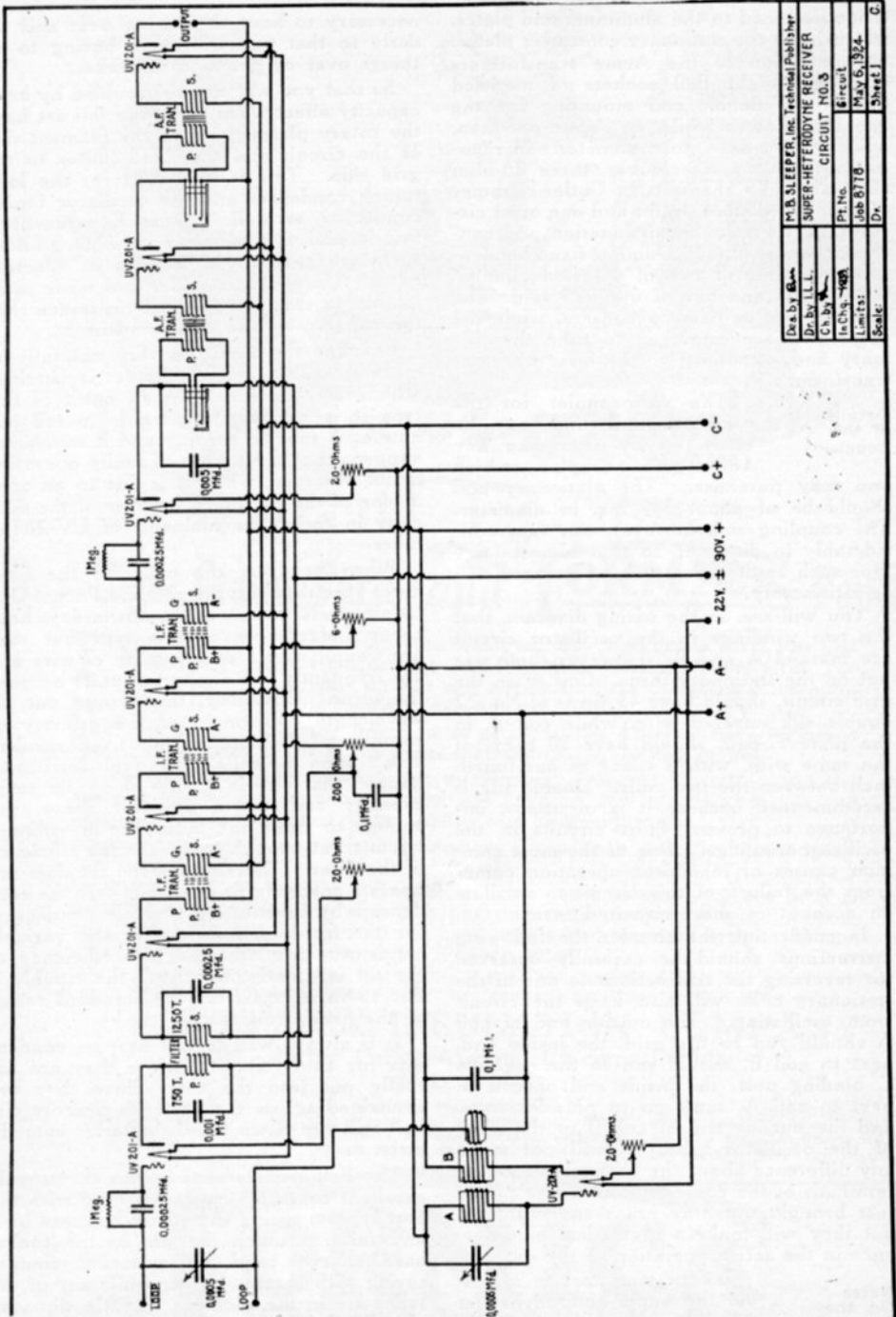

Des. by	M. W. SLEEPER, Inc. Technical Publisher
Dr. By	L. L. L.
Ch. By	W. H. W.
In Chg.	W. H. W.
Limit:	Job 6176
Scale:	May 6, 1924
	Sheet 1
	Dr.

Fig. 11. Circuit No. 3. Wiring diagram of a super-heterodyne set specially designed for use with Acme 30 K. C. transformers. The input transformer is made up with two Duo Lateral coils.

strips, fastened to the aluminum end plates, which holds the stationary condenser plates.

In addition to the Acme transformers there are eight Bell sockets of modeled Bakelite, a double coil mounting for the two Duo Lateral coils, an Acme pot-rheo, which serves as a potentiometer and rheostat for the amplifier tubes, three 20-ohm General Radio rheostats, a Cutler-Hammer switch, two double circuit and one open circuit jack, a Freshman combination grid condenser and leak, and Dubilier fixed condensers consisting of two of 0.1 mfd., one of 0.001 mfd., and one of 0.00025 mfd. The first two are by-pass condensers, while the other two are employed to tune the primary and secondary of the filter or input transformer.

Details of the Coupler The variocoupler for the oscillator coil unit can be made up by rewinding any 180-degree coupler which you may purchase. The stationary coil should be of about $3\frac{1}{2}$ ins. in diameter. The coupling coil, however, can vary considerably in diameter so that almost any type such as the Shamrock or Paragon will be satisfactory.

You will see, in the wiring diagram, that the two windings in the oscillator circuit are marked A and B. However, both are put on the stationary form. Coil A, in the grid circuit, should have 45 turns of No. 22 double silk covered wire, while coil B, in the plate circuit, should have 30 turns of the same wire, with a space of one-fourth inch between the two coils. Double silk is recommended because it is of utmost importance to prevent short circuits in the oscillator windings. One of the most common causes of inefficient operation comes from the failure of this circuit to oscillate on account of short circuited turns.

In connecting the coupler the following instructions should be carefully observed for reversing the connections to one of the stationary coils will also keep the circuit from oscillating. The outside end of coil A should run to the grid, the inside end, next to coil B, should run to the negative C binding post, the inside end of coil B, next to coil A, must go to plus 90 volts, and the outside end of coil B to the plate of the oscillator tube. It will not make any difference about the connections to the terminals of the coupling coil. These points just brought out may not seem important but they will make a great deal of difference in the actual operation of the set.

Notes On the Assembly Before you start to assemble the super-heterodyne set go over your plans carefully to make sure that the instruments will go together properly. It is very

necessary to have the wiring neat and orderly so that you will avoid having to do things over or patch up mistakes.

So that you will not be troubled by body capacity effect when you tune this set have the rotary plates going to the filament side of the circuit and the fixed plates to the grid side. This is important for the loop tuning condenser and the oscillator tuning condenser as well. Some Experimenters find it advisable to use a variable gridleak such as the Turn-it, Pudlin, or Electrad types. Usually it is easier and more satisfactory to vary the gridleak resistance than the capacity of the grid condenser.

Examine the rheostats very carefully to make sure that perfect contact is obtained all the way around. On an outfit of this type it is not always possible to tell just how each tube is burning and it sometimes happens that the source of faulty operation is not observed, when it is due to an open in one of the rheostats, because of the difficulty in seeing the filaments of UV-201-A tubes.

When you buy the coils for the filter make sure that you get genuine Patent Duo Lateral coils. Many stores now-a-days have cheap inductances of this type but they are wound with a poor quality of wire and are frequently full of short circuits between the turns. Obviously, this throws out the wavelength adjustment of the primary or secondary. Sometimes the fixed condensers around the coils are at fault for it may happen that one is a little below its rated capacity and one a little bit above, not enough to make any difference in ordinary circuits but enough to reduce the efficiency of the filter. Therefore, if the set does not operate correctly, it is well to test the condensers by substituting variable condensers for the fixed ones. If, after the variable condensers are adjusted, the efficiency of the set is greatly increased, the trouble is due to variations from the standard rating of the fixed condensers.

It is always well to test by-pass condensers for short circuits before they are actually put into the set. Since they are connected across the batteries a short circuit will run down the B. batteries immediately.

The Bell sockets used in this set provide excellent contact. However, even with the best types a spring sometimes becomes bent and fails to touch the pin in the socket base. Never bend up a socket contact spring with a screw driver while any of the tubes are in the sockets. A little slip may put the B battery voltage on to the tube filaments and burn them out. The safest thing to do is to disconnect the batteries or

ENDORSED

by radio engineers

“YOUR tubes show a greater uniformity in their characteristics than others with which they have been compared. The DV-3 is *much* less microphonic, and the DV-2 tube has a considerably lower output resistance.”

That's what *one* expert says of De Forest Tubes. Many other radio engineers have appreciated and endorsed their uniformity of excellence. The De Forest Tubes are up to the standard their name demands. They stand the severity of experimental work and laboratory tests. They deserve the leadership Dr. Lee De Forest first gave them in 1906.

Agreement is general about this. And the De Forest Company guarantees its products and backs this guarantee with a liberal replacement policy. No tube can get out of the De Forest factory without going through a whole series of tests and inspec-

tions. But the final and most significant test of all is performance when used by the purchaser.

There are two types, and only two are necessary. They are shown below — the DV-3 for dry batteries and the DV-2 for storage. The DV-3 has an average mutual conductance of 460 micro-mhos; average amplification constant (or μ) 6; plate impedance 13,000 ohms; a good radio and audio frequency amplifier and a good detector in standard regenerative circuits. It is remarkably non-microphonic. The DV-2 for storage batteries is made particularly for power amplifier work and is developed for all usual circuits. Conductance 720 micro-mhos; amplification constant (or μ) 7.2; plate impedance 10,000 ohms.

These tubes are sold by authorized dealers only and are made by the makers of De Forest D-12 Radiophones and all radio parts.

DE FOREST RADIO COMPANY
Jersey City, N. J.

DE FOREST TUBES

REG. U.S. PAT. OFF.

The "Magic Lamp" of Radio



This tube, the DV-3 consumes a filament current of only 7/100 of an ampere. It operates at a filament potential of 3 volts.

The DV-2 has a filament potential of 4-1/2 volts and a filament consumption of 25/100 of an ampere.



remove all the tubes from the sockets. To positively prevent a slip of this sort a Kant-blo should be used. This is a small unit fitted with a spiral filament lamp. When cold the resistance of the filament is very low, but the instant that a heavy current flows through it, as when the B batteries become shorted, the filament is heated and increases to a very high resistance. With a Kant-blo to protect the set you can short circuit the connections as much as you please without any danger of burning out the vacuum tubes.

The proper insulation of the various terminals is very important so that a panel of insulating material should be used. Any one of the Bakelite products is recommended such as Dielecto, Celeron, Formica, or Fibroc. Hard rubber is not satisfactory because of the weight of the instruments mounted on it. After a short time, it gradually bends more and more until, if uninsulated bus bar is employed, the wires may become short circuited. Moreover, any brass parts in contact with hard rubber soon turns green because of the action of the sulphur in the rubber.

UV201-A tubes require a 6-volt storage battery for the filaments. Twenty-two volts are indicated for the first and second detectors and an additional 90 volts for the intermediate and audio frequency amplifiers. As a matter of fact, you may find the operation improved by increasing the voltage on the detectors to as high as 45. The C battery must be regulated after the outfit is in operation. One or two Everready 3 batteries will allow an adjustment of the biasing voltage. As a rule, 4.5 volts is the correct value. Experimenters who do not realize the importance of the C battery sometimes simply short circuit the terminals provided for it. It is absolutely necessary, however, on a multi-tube set, not only because it improves the quality, but because it greatly reduces the B battery construction. Of course, B batteries cannot be expected to last as long as an 8-tube outfit as when there are only two or three tubes, but the life is quite short without the C battery. The actual function of the grid bias is explained in one of the pamphlets published by the National Carbon Company.

The loop should be about 2 feet in diameter, wound with 15 turns of annunciator wire. The spacing between turns may vary from $\frac{1}{4}$ to $\frac{1}{2}$ in. If the set does not tune high enough, the number of turns should be increased or decreased if it is not possible to get down to the lower waves. After the rheostats and potentiometer have been set it is not necessary to adjust them

further. The tubes can be cut off by means of a switch in the filament circuit. Tuning is done by moving both loop and oscillator condensers back and forth at the same time, keeping them at about the same number of divisions on the dials. As soon as possible, make out a log showing the correct settings for the condensers at various wave lengths. Then you will soon see just about how far apart the condensers should be kept while you are tuning in for a new station.

Unlike radio frequency receivers where a potentiometer is connected to the first tube, it is not necessary to adjust the potentiometer at different wavelengths for in a super-heterodyne set the potentiometer is regulated in relation to the intermediate

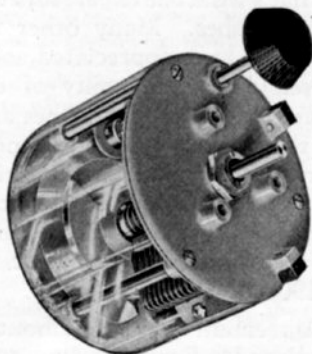

Fig. 10. The Acme low loss condenser, one of the most popular types for use in super-heterodyne receiving sets.

frequency and not to the frequency of the incoming signals. Thus the adjustments are reduced to the two variable condensers.

If the set does not oscillate properly the first point to examine is the oscillator circuit. If the adjustment of the oscillator condenser does not affect the incoming signals you can be positive that the trouble is with the oscillator. Local stations will filter through the intermediate frequency amplifier but with such poor volume compared to the signal strength when the oscillator is working that you can tell beyond a question when this trouble arises.

To test for oscillating, connect a pair of telephones between coil B and the lead running to the 90-volt battery terminal. Then touch the grid of the oscillator tube with your wet finger. If that causes a strong double plucking sound the circuit is oscillating properly but if it just makes a single ticking noise no oscillations are taking place.

Run Your Radio Direct from the Light Socket

Get All A B & C
Power From

RUN-A-RADIO

The Whole Story of Run-a-Radio In Ten Questions

1. Q. Does Run-a-Radio take the place of all batteries?
A. Yes. With Run-a-Radio you need no A B or C batteries whatever, to operate your radio set.
2. Q. Will it work with either dry cell or storage battery tubes?
A. Yes. More volume is obtained, of course, with storage battery tubes.
3. Q. How does it work?
A. You simply connect Run-a-Radio to your set, and plug it into the light socket. Turn on your radio as you turn on your light. There are models for both A C and D C current.
4. Q. How much does Run-a-Radio cost to run?
A. About as much as one electric light.
5. Q. Is it cheaper than batteries?
A. Its cost is a little more than regular battery equipment at the start, and it saves you about fifty dollars a year thereafter.
6. Q. Suppose I only want to take the place of B batteries?
A. Use Run-a-Radio B, (a separate B battery substitute.)
7. Q. Will my radio work just the same?
A. Probably better. Run-a-Radio makes it sound always just as it did when your batteries were new and in first-class condition. There is no hum or crackle as from depleted batteries. Distance as great or greater.
8. Q. Will it work on any radio set?
A. Yes. Regenerative, neutrodyne, reflex, superhet,—Run-a-Radio runs them all. Guaranteed for one year.
9. Q. Can I carry it from room to room?
A. Easily. It is about the size of a starch box and weighs only 40 pounds. Finished in rich mahogany or Brewster Green, crackle finish.
10. Q. Doesn't Run-a-Radio mean the end of all batteries in radio?
A. Of course. It is the obvious last step in radio convenience. Soon no radio set will be considered modern without Run-a-Radio.

Mr. M. B. Sleeper says "The first and only device which absolutely eliminates all noises and humming . . . should be more satisfactory than batteries. Several replacement devices have been offered before . . . but in no case has any arrangement been worked out to be of practical value. . . . This is the first one which really does what is intended."

Professor J. H. Morecroft of Columbia says ". . . exactly as represented . . . works astonishingly well . . . most ingenious and useful . . . glad to recommend it to anyone making inquiry."

There has to be one leader in every field. Send for full information regarding RUN-A-RADIO if you want to know why the day of the radio battery is past.

RADER APPLIANCE CO., INC.

Department R-E No. 2

4912 Hudson Blvd., Corner 13th St.

WEST NEW YORK

NEW JERSEY

About the Manufacturers



THE Adams-Morgan Company, whose exhibit at the New York Radio Show is pictured above, has done an about-face in revising their line of receiving sets for 1925. The new models represent unusually good values at very low prices.

Several improvements are made in the new Carter rheostats, announced as being ready for delivery on December 1st. They are made in resistances of 3, 6, 10, 20, 25, and 30 ohms.

A compass is mounted on the base of the Marion loop so that the settings for various stations can be determined quickly. In addition, there is a scale on the rotating bearing in which the loop is fastened.

The Belden Manufacturing Company is making an interesting drive for consumer business on telephone cords, hook-up wire, terminals, antenna wire, magnet wire, rosin core solder, and other special items. A very attractive package system is employed, making it easy for dealers to handle these products.

Special glass jars for radio B batteries are now offered by the Hazel-Atlas Glass Company of Wheeling W. Va. They are supplied in various sizes and with tops for corks, slip-over covers, or screw caps.

In addition to their regular lines of low-priced variable condensers, the Elgin Radio Corporation is now producing a series of low-loss type condensers.

The Splitdorf Electric Company is bringing out a 5-tube tuned R. F. receiver, sold completely assembled in a very attractive cabinet or in kit form for set builders who prefer to assemble their own equipment.

Gridleak resistances have been added to the Dubilier line. They are made in values of 0.5, 0.75, 1.0, 1.5, 2.0, 2.5, 3.0, 4.0, and 5.0 megohms. Overall dimensions are the same as for other types of gridleaks.

An exceedingly attractive variometer has just been introduced by the General Radio

Company. Unlike other types, a cross section of the winding taken parallel with the shaft shows a rectangular form instead of the usual circular form. The molded parts are of genuine Bakelite.

Following the tremendous success of the Rasla reflex set brought out last year by the Davidson Radio Corporation, a new circuit has been developed, in which the fixed detector and R. F. transformer are employed as before, with the addition of the Rasla tuner and Rasla compensating condenser.

By changing the design of the control knobs, the Accuratune dials have been made more attractive in appearance and, at the same time, they provide a better grip than was possible with the smooth finish previously employed.

The Radio Receptor Company now has a new construction kit, supplied in two styles, either with the complete set of parts, or just the essential items.

One of the latest departures from standard variable condenser design is that of the Allen-Bradley type which has been brought out just recently. These condensers are made with capacities of 0.00025, 0.0005, and 0.001 mfd.

The Martin-Copeland is manufacturing a complete line of miniature knife switches, ranging from single-pole, single-throw, to four-pole, double-throw. These are most convenient for changing connections on testing circuits or laboratory switch boards.

Jackson H. Pressley, Chief Engineer at Camp Vail, has designed a set of four I. F. transformers for super sets. These instruments are being manufactured by the Sangamo Electric Company, Springfield, Ill.

Probably the least expensive type of three-stage A. F. amplifier is the unit of the Daven Company. This resistance-coupled amplifier is well suited to complete sets or construction kits.

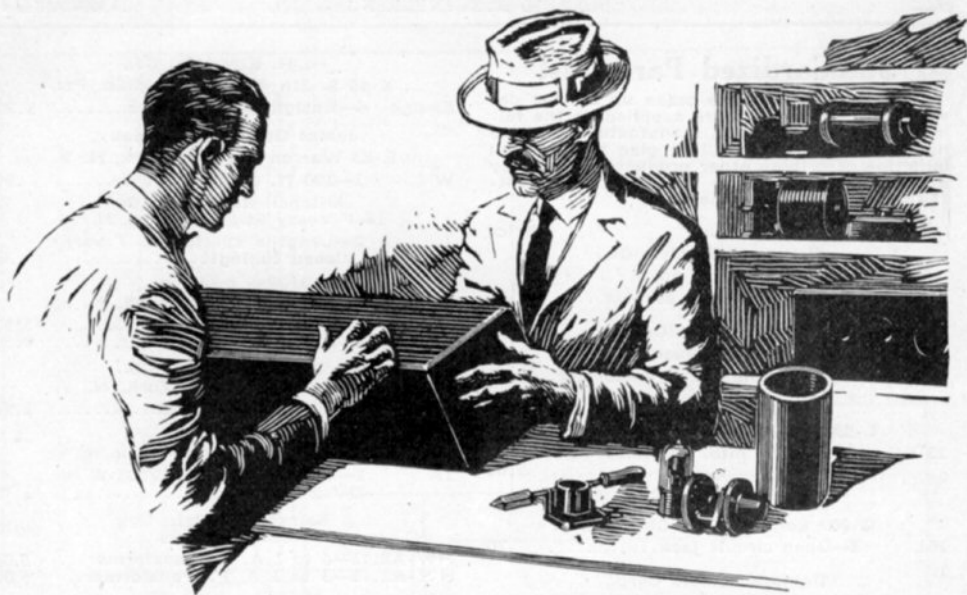

Buy High Grade Parts and **FORMICA** Panels

IF you want real results from your radio set, buy high grade parts, low loss condensers, good transformers and Formica panels! Then after you have labored over your set you will not find others using the same number of tubes who get stations you can not get.

The manufacturers of the finest radio sets built in America have endorsed Formica by using it. It is the panel material of 125 leading makes.

There are reasons for this almost unanimous choice of Formica—and the reasons are longer life, no warping and sagging, low electrical losses and fine appearance. Formica works easily with ordinary tools.

Formica is made in four splendid finishes: Gloss black, dull black, mahogany and walnut.

It is the standard radio panel material from coast to coast. More of it is used every year. In big sets incorporating radio frequency amplification, it is now regarded as essential for base panels and terminal strips. Mount everything on Formica. Don't let it touch wood.

Dealers: Formica service and quality and the universal demand for the material make it the most satisfactory and profitable panel line you can carry.

THE FORMICA INSULATION COMPANY

4653 Spring Grove Avenue, Cincinnati, Ohio

Sales Offices

50 Church St., New York, N. Y.

422 First Ave., Pittsburgh, Pa.

1142 Granite Bldg., Rochester, N. Y.

419 Ohio Bldg., Toledo, Ohio

1210 Arch St., Philadelphia, Pa.

1026 Second Ave., S. Minneapolis, Minn.

585 Mission St., San Francisco, California

Whitney Central Bldg., New Orleans, La.

516 Caxton Bldg., Cleveland, Ohio

9 S. Clinton St., Chicago, Ill.

708 Title Bldg., Baltimore, Md.

140 Victoria Street, Toronto, Ontario

FORMICA

Made from Anhydrous Bakelite Resins

SHEETS TUBES RODS

Standardized Parts List

The materials used to make up the set described in this issue were supplied by the following companies. The manufacturers whose names appear below will be glad to send you bulletins describing other products which they make. Please mention RADIO ENGINEERING when you write them.

Type	Name	Price
	Benjamin Electric Co., Chicago, Ill.	
	3—Standard base sockets.....	\$3.00
	Boonton Radio Corp., 924 Fanny Road, Boonton, N. J.	
PM.....	1—Ballentine variotransformer...	9.60
	Bremer-Tully Mfg. Co., L-532 S. Canal St., Chicago, Ill.	
23-L	1—0.0005 mfd. low-loss condenser	5.00
	Carter Radio Co., G-209 So. State St., Chicago, Ill.	
101	1—Open circuit jack.....	.70
	Davidson Radio Corp., L-222 Fulton St., New York, N. Y.	
FX	1—Rasia fixed crystal detector	1.25
	Diamond State Fibre Co., A-423 Broome St., New York, N. Y.	
	1—Mahogany Celeron panel 7 by 14 by 3/16-in.....	2.30
	1—Mahogany Celeron panel 7½ by 3½ by 3/16-in.....	.65
	Dubilier Condenser & Radio Corp., A-48 W. 4th St., New York, N. Y.	
601	1—0.0001 mfd. Micadon.....	.35
	DX Instrument Co., Harrisburgh, Pa.	
	1—Fil-ko-stat rheostat.....	2.00
	Eastern Coil Corp., A-22 Warren St., New York, N. Y.	
P-5	1—Pickle bottle coupler, 5-turn primary	2.00
	H. H. Eby Mfg. Co., X-40 S. 7th St., Philadelphia, Pa.	
Ensign	6—Ensign binding posts.....	1.20
	James Goldmark Company, E-83 Warren St., New York, N. Y.	
W	1—100 ft. spool of Wirit.....	.90
	Mitchell-Rand Mfg. Co., 18-F Vesey St., New York, N. Y.	
7	2—Lengths special N. 7 varnished tubing.....	.30
	Mydar Radio Co., 9 E. Campbell St., Newark, N. J.	
	1—4-in. vernier dial.....	3.50
	2—2-in plain dials.....	1.50
	Pacent Electric Co., A-22 Park Pl., New York, N. Y.	
88	1—400 ohm rheostat.....	1.25
	Radiall Company RE-320 W. 42 St., New York, N. Y.	
1A	1—Amperite for UV201-A or DV 2 tubes.....	1.10
	Samson Electric Co., Canton, Mass.	
HW-A2..1	1—6 to 1 A. F. transformer...	5.00
HW-A2..1	1—3 to 1 A. F. transformer...	5.00
	Walbert Mfg. Co., A-931 Wrightwood Ave., Chicago, Ill.	
	1—Filament lock switch.....	.50
	MISCELLANEOUS PARTS	
58	3—Pkgs. of 25 soldering lugs...	.60
185	3—Left hand nickeled angle brackets20
14	3—Nickeled coil support pillars	.24
151	1—Nickeled panel support.....	.30
62	2—Pkgs. 10¼-in. 6-32 F. H. nickeled screws.....	.24
63	2—Pkgs. 10½-in. 6-32 R. H. nickeled screws.....	.24
49	2—Pkgs. 10 6-32 nickeled nuts	.16
	Complete Set of Parts.....	\$48.50
	BLUE PRINTS	
	Set of four full-size blue prints for the Ballantine set.....	\$1.00

Back Issues of Radio Engineering

If you have missed any issues of RADIO and MODEL ENGINEERING for this year, check over the following list and order those that you did not get so as to make your file complete.

January—Tuska Superdyne, 4-tube Motrol, oscillating wavemeter..... 10c.

February—7-tube super-heterodyne set, Cockaday Receiver.

March-April—Portable tuned R. F. set using UV-199 tubes, Harkness circuit for Diode or crystal detector.

May—Improved Rasla reflex, the most successful I-tube receiver ever built, 100-meter Sodian receiver.

June—Sodian reflex set using UV-201—A amplifier, the Bestone V-60, tuning filter for cutting out interference.

July—Resistance coupled amplifier, Tools for the radio model shop, Crystals that oscillate.

August—Construction of 4-tube No-Loss regenerative receiver, Description of the Boonton light four receiver, The R-A-R receiving circuit.

September—R-D-X maximum modulation 1-tube regenerative reflex receiver, Assembly of the Haynes tuner, Ware type T neutrodyne, Freshman Masterpiece receiver, Ultradyn type super-heterodyne receiver.

The price of these issues is 20 cents each. They will be sent promptly upon receipt of a check, money order, or stamps to cover the cost. Postage is prepaid.

A Tuned R. F. Transformer of Technical Accuracy for the radio engineer, dealer and manufacturer

IN THESE DAYS of extravagant claims about "low loss" this and "low loss" that—and almost "minus losses"—it will interest you men to know of one instrument that is truly dependable. BALLANTINE VARIOTRANSFORMER success is founded on actual results obtained by clear-thinking technicians.

Performance that counts

BALLANTINES won't work a speaker on a crystal alone. They will, however, enable the characteristic clearness of the crystal detector to be passed on with strength sufficient for good audio treatment. Mr. Sleeper, amongst many others, has demonstrated this fact—conclusively.

Use BALLANTINES for all r. f. amplification, either in straight cascade or reflexed.

Note these specifications

Entirely self-contained; variable condensers eliminated. Metal container, only $1\frac{3}{4}$ " dia., provides perfect shielding. Treated pigtail connections assure absolutely quiet operation. Continuously variable *inductance* tuning provides for maximum amplification from 220 to 600 meters.

BOONTON RADIO CORPORATION

924 Fanny Road, Boonton, N. J.



BALLANTINE VARIOTRANSFORMER

Transformer only \$9.60
for panel or base —
At dealers or postpaid

A BOONTON
Guaranteed Product

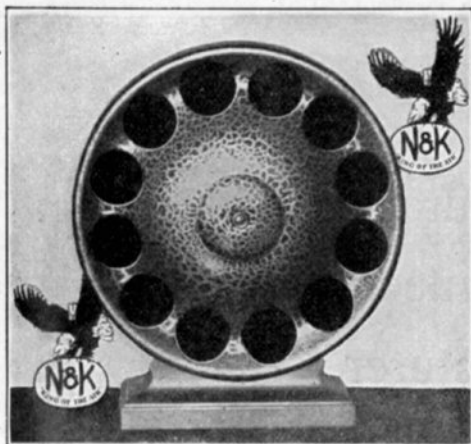

Made of a new lightweight material which eliminates rattling and rasping. Requires no batteries. Operates on all ordinary plate voltages. 14 in. high. Write for Free Descriptive Folder.

New!

AS revolutionary—in principle, in design, in tone quality—as the now famous N & K Imported Phones.

Its principle is that of *sound reflection*. The sound waves issue from the speaker in their full roundness, and are carried to every corner of the room.

Its shape is new and artistic. And it is made in handsome finishes which harmonize with all types of home decoration.

Its material is new. Burtex, a scientific product, which, unlike vibrant wood or metal, prevents counter-vibrations, thus eliminating unpleasant twanging, rasping, rattling sounds.

Its tone is surprisingly distinct, mellow, natural, with a total freedom from distortion.

Listen to this new invention on your own set. We authorize N & K dealers to put it into the homes of responsible customers on

FIVE DAYS' FREE TRIAL

Price, complete with six-foot cord, \$27.50. If your dealer has not yet been supplied, notify the Th. Goldschmidt Corporation, Dept. K12, 15 William St., New York City, and you will be given prompt opportunity to listen to this new Loudspeaker.

Made by the makers of N & K Imported Phones, price \$8.50,* and the N & K Imported Phono Unit, \$7.50.

N&K

Imported LOUDSPEAKER

TYPE W

DEALERS:—If your jobber cannot supply you, write for name of N & K authorized Distributor.

TH. GOLDSCHMIDT CORPORATION
Dept. K12, 15 William St., New York; 41 Common St., Montreal

Silver-Marshall Super-Heterodyne

(Continued from page 408)

Connect the left hand lug, 88, on the potentiometer to 89. Connect the right hand lug 90 to 91.

17. Now put the two C batteries in position on the baseboard temporarily so that the rest of the connections can be run so as to avoid them.

18. Connect 92 to 93. 92 is the left hand lug on the spring jack and 93 is the P terminal of the left hand socket. Keep this wire down near the baseboard. Connect 94 to 62. 62 is the P terminal on the next socket. Connect 95 to 18. 95 is the terminal on the right of the filament switch and 18 is the — terminal of the left hand socket. This wire is the end which was left loose before. Connect 96, the top binding post, to 97, the remaining lug on the one-spring jack. Connect 98, a point on this wire, to 99, the right hand lug on the other jack. Connect 100 to 101. 100 is the center lug on this jack and 101 is the P terminal of the left hand A. F. transformer.

19. Remove about $\frac{3}{8}$ -in. of the insulation from each end of a piece of the flexible wire $9\frac{1}{2}$ ins. long. Solder one end to 102 and after soldering the strands of the other end together, clip it on the + terminal of the left hand C battery. 102 is the center terminal of the potentiometer. Repeat this with another piece of flexible wire $7\frac{1}{2}$ ins. long, clipping it to the + terminal of the right hand C battery and soldering the other end to 39. Cut a short piece $2\frac{1}{2}$ ins. long. Clip one end to the — $4\frac{1}{2}$ terminal of the right hand C battery, and solder the other end to 70, the — F terminal of the A. F. transformer on the left. Finally, clip one end of a $7\frac{1}{2}$ -in. piece of flexible lead to the — $4\frac{1}{2}$ terminal of the left hand C battery, and solder the other end to 6, a lug on the R. F. transformer unit. The flexible wires are marked with an f in the picture wiring diagram.

This completes the wiring of the set.

After the set has been tested and operating, wired go over each connection, checking it against the picture wiring diagram. Connect a 6-volt A battery across the A+ and AB—binding posts. The A+ terminal on a storage battery is usually painted red. Insert the seven tubes in the sockets, pull out the knob on the filament switch, and turn the rheostat knob marked FIL. part way to the right. This should light all of the tubes. Leaving everything else the

(Concluded on page 426)

PARTS

FOR THE



SILVER SUPER-HETERODYNE

JUST as described by M. B. SLEEPER in this issue—These are the parts recommended by McMurdo Silver, Assoc. I. R. E., designer of the easily-built 7-Tube Wonder Sets—the Silver Supers that have amazed Editors, Engineers and Fans with their simplicity and startling performance.

PARTS for LABORATORY MODEL

	Price Each
2 Silver .0005 Low Loss Condensers No. 301.....	\$ 4.50
2 4" Moulded Dials—Tapered Knobs.....	1.00
1 Howard 6½ Ohm Rheostat.....	1.00
1 Howard 200 Ohm Potentiometer.....	1.50
7 Insulated Top Binding Posts.....	.05
1 Carter 102A Jack.....	.80
1 Carter 101 Jack.....	.70
1 Silver R. F. Transformer Unit No. 401.....	14.00
1 Silver Oscillator Coupler No. 101.....	2.50
7 Benjamin Spring Sockets (199 or 201A).....	1.00
2 Thordarson 3½:1 Audio Transformer.....	4.00
1 On-off Switch.....	.60
3 .5 MFD By-pass Condensers.....	.90
2 .0025 Mica Condensers with Leak Clips.....	.45
2 .002 Mica Condensers.....	.40
1 .0075 Mica Condensers.....	.75
1 .000045 Balancing Condensers.....	1.50
1 5 Meg Ohm Grid Leak.....	.50
1 1 Meg Ohm Grid Leak.....	.50
1 7x24x3/16" Bakelite Panel, Drilled, Grained and Engraved.....	7.00
(Specify with or without meter hole.)	
1 7x23x½" Oak Base Board, Bus-Bar, Spagetti Screws, Nuts, Solder, Lugs.....	1.50
Total	\$63.60

EXTRAS

Weston 0-8 or 0-10 Volt Meter, No. 301.....	\$ 8.00
Weston 0-7.5 and 0-150 Double Range Volt Meter.....	10.00
Carter No. 3 Jack Switch.....	1.15
National 4" Vernier Dials.....	2.50
Apex 4" Vernier Dials.....	2.50
General Radio 7 Ohm Rheostat.....	2.25
General Radio 400 Ohm Potentiometer.....	3.00

Circulars upon both Laboratory and Portable Models upon request.

GUARANTEE

S-M Products are sold on the Satisfaction or your money-back basis.

DEALERS

Write for our attractive merchandising plan.

THE BOOK

"The Portable Super-Heterodyne" tells you just how to assemble the Silver Supers with a pliers, screw driver, and a soldering iron.

Price, 50c

EASTERN DISTRIBUTOR

Twentieth Century Radio Corp., 102 Flatbush Ave., Brooklyn, N. Y.

Silver-Marshall, inc.

105 S. WABASH AVE.,

Dept. J

CHICAGO.

REASONS
not arguments have
 popularized National
VELVET
VERNIER
 Condensers and Dials

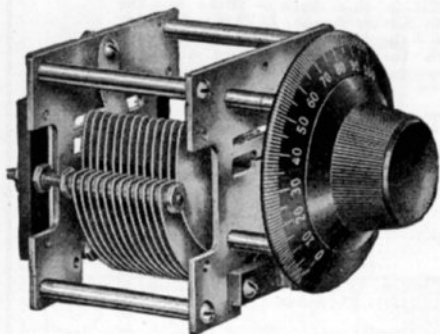

EFFICIENT

Sets using Nationals have received signals between Buenos Aires, S. A., and Hartford, Conn., 5200 miles.

DURABLE

Two National Condensers and Velvet Vernier Dials ran 324,000 Revolutions during the recent Radio World's Fair without showing the least sign of wear.

DEPENDABLE

Used in Marine and Radio Compass Work. Write for Bulletin 104.

The National Regenaformer for the Browning-Drake Receiver

The Performance of this set will surprise you.

The National Regenaformer Kit

Consisting of Regenaformer, Coil, Condensers and Dials, ready to hook up \$22.00
 Regenaformer and Coil, only 7.50

Write for Bulletin 105

Manufactured by

National Co., Inc.

110 Brookline St., Cambridge, Mass.

Silver-Marshall Super-Heterodyne

(Continued from page 424)

same, disconnect the A+ lead and connect it to the 45+ terminal and then the 90+ terminal. The tubes should not light up in either of these positions, if the set is wired correctly.

To put the set into operation, connect the outside leads of the loop to the top, and bottom binding posts on the left. Connect the center loop-tap to the middle binding post. Connect the positive terminal of the A battery to the A+ binding post and the negative terminals of both the A and B batteries to the AB— binding post. The positive terminal of the 45-volt B battery goes to the 45+ binding post and that of the 90-volt B battery goes to the 90+ binding post.

Pull out the knob of the filament switch, turn the rheostat knob three-fourths to the right and plug the speaker into the first or second jack. Adjust the loop tuning and oscillator dials for maximum signal strength. The balancing condenser should be set at the best point for each station. At the longer wavelengths the value of balancing condenser may be increased slightly with resultant strengthening of signals. This control is not critical, but if too high a capacity is used, the first detector tube will oscillate and become unstable. It may be necessary to increase the capacity of the .0075 condenser to nearly .01 mfd. It is best to start with .0075 mfd. and then build up to .01 mfd. by adding .0005 and .001 condensers in parallel with the .0075 condenser. The best value will be where the oscillator dial reading is sharpest on a comparatively strong local signal. The proper number of condensers may be bolted together with machine screws and nuts and soldered in position on the wiring. Volume control may be obtained by adjustment of the potentiometer alone or in conjunction with the rheostat. The tuning of the set is so sharp that a fraction of a degree will throw out out-of-town stations and a movement of two or three degrees on the both dials will throw out locals completely.

In the illustration showing the complete set, a Marion loop is employed. This is an excellent type, particularly convenient to use because there is a small compass mounted on the base. The loud speaker is the Amplion Dragonfly, a new type which is particularly popular because although very small in size, the volume and quality of reproduction is very good. It is just the sort of loud speaker to use on a small set where the horn is built in on the panel or mounted in the cabinet.



The
Super-Amplifier

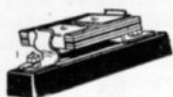

Condenser
Mounting



Grid Leak
Mounting



Combination
Mounting No. 51



The
Resisto-Coupler

Read the "RESISTOR MANUAL." A thirty-two page hand-book on Resistance Coupled Amplification with interesting data and hook-ups.

Price 25 cents
at your dealers.

DAVEN RADIO

The DAVEN SUPER AMPLIFIER

Today, more than ever, the discriminating radio fan is insisting on quality reception—the blatant reception of the past will no longer satisfy. Resistance Coupling is the ultimate method of audio amplification because of its perfect reproduction.

The *Daven Super-Amplifier* is the aristocrat of all amplification devices—it comes ready to install in any set, condensers and resistors included, and the complete unit laboratory tested and ready to give an immediate and superior service. It reproduces with fidelity the voice or musical instruments, as if the radio were not, and that the artists themselves were performing in your own home.

Sold at all good Radio Stores.

DAVEN AMPLIFIER KITS (without sockets and condensers) for those who build their own.

3-Stages \$8 00
4-Stages 10 50

Manufacturers of the Daven Grid Leak Resistors and Mountings.

DAVEN RADIO CORP.

"Resistor Specialists"

Newark, New Jersey.

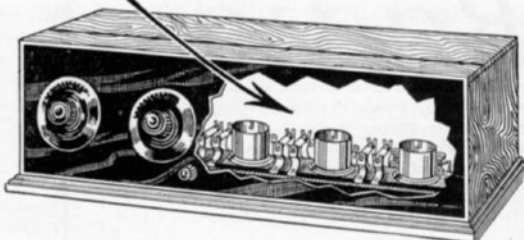

The KIT of a Thousand Possibilities

When, up to now, have you heard of *three* stages of tuned R. F.—perfectly and automatically stabilized? When, up to now, have you heard of 2, or even 3, stages of resistance-coupled A. F.—superimposed (reflexed) on the radio frequency tubes? Yet you won't have the slightest difficulty in accomplishing this with the equipment in the Telos Kit.

And you can do it with dry cell tubes—U. V. 199's or D. V. 3's throughout.

But you're not limited to that combination either. Truly, Telos is the KIT of a thousand possibilities! You can introduce a crystal detector if desired. You can use one, two or three stages of transformer A. F.; you can use W. D. 12 tubes for the R. F., with filaments connected in series, and 201 A's for the Detector and A. F.

You'll also be interested in "Unicontrol," the clever device whereby all dials turn together for rough tuning, then separately for the finer adjustment. It's in the KIT, too!

But it's impossible to tell here one-tenth of the good things you can do with Telos. Use the coupon below for your copy of "The Kit of a thousand Possibilities."



Telos Radio

Danziger-Jones, Inc.
25 Waverly Place, Dept. R.,
New York, N. Y.

Send me at once your profusely illustrated folder—"The Kit of a Thousand Possibilities"—free!

Name

Address

Tops Don't Come Off
25 Different Markings

H. H. EBY Mfg. Co.
Phila., Pa.

The buttons are arranged in a grid around the knob:

- Top row: ANT, SPEAKER +, SPEAKER -, A BAT +
- Second row: LONG ANT, A BAT -
- Third row: SHORT ANT, B BAT +
- Fourth row: LOOP, B BAT -
- Fifth row: PHONE, C BAT +
- Sixth row: GND, C BAT -
- Seventh row: INPUT, B AMP +
- Bottom row: A+ BAT B-, +, -, B DET +

MORE MONEY?

A Dollar and a Half an Hour for You

CAN you do radio installation and maintenance work? If so, have yourself officially registered in the I and M Registry in Radio Engineering, so that set owners in your town will know that you are doing this work.

¶ It costs only two dollars to have your name, address, and telephone number listed in the Registry for a whole year—less than what you are paid for a single job. Send in this data at once, so you will be all set for the big Christmas business.

PRIZE WINNERS

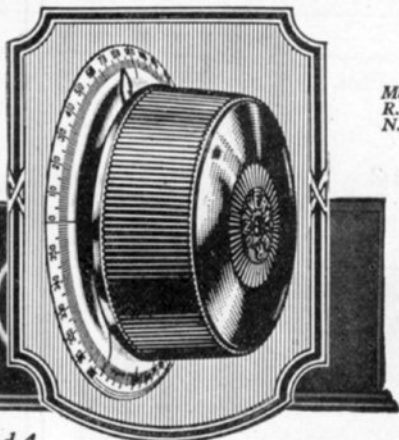

Members of
R. M. A. and
N. R. T. A.

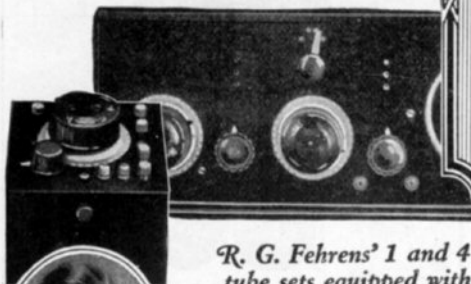

R. G. Fehrens' 1 and 4
tube sets equipped with

WALBERT UNIVERNIER

Win two prizes (1st and 6th)
at New York Radio Show

Certainly am enthused about UNIVERNIER. Took two prizes in New York Radio Show with two sets, both equipped with UNIVERNIER. Owe a great deal to their appearance and ease in tuning-in distant stations on that account. A plate vernier is passe and other geared verniers mean separate control—there's nothing like a UNIVERNIER.

Yours truly,

(R. G. Fehrens)

WHY not make your set a winner, too? Be able to tune-in those hard-to-get distant stations quickly, easily, clear and loud. Simply replace each of your dials with a UNIVERNIER, the original geared tuning dial. You'll never realize how many good stations you've been missing until you equip your set with Walbert UNIVERNIERs.

7 Features of the Improved UNIVERNIER

- 1—12-to-1 ratio—proven the right ratio.
- 2—Entire range of set under continuous vernier control. (That's why the UNIVERNIER is a record breaker—it gets the stations that are missed if "searching" has to be done by coarse adjustment.
- 3—Positive smooth action—no slipping or jerking.
- 4—Sturdier mechanism.
- 5—New attractive "dished" dial.
- 6—Cannot destroy the accuracy of low-loss condenser bearings.
- 7—Costs no more than a good dial.

Mahogany Knob and
Gold-plated dial
\$1.50

Black Knob and
Silver-plated dial
\$1.25

At your dealer or sent postpaid on receipt of purchase price.
(Please mention dealer's name.)

Jobbers and Dealers: Write for Discounts.

The WALBERT MANUFACTURING CO.
931 Wrightwood Avenue Chicago, Illinois



The Walbert Safety Rim Socket is guaranteed not to break at the slot. Our scientific bakelite design decreases inter-element capacity thereby utilizing all available grid voltage for producing signals. (New tubes have bakelite bases for same reason.) Soldering lug and double-spring contact integral. The most attractive socket on the market.

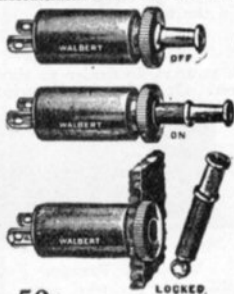

50c

Don't worry any more about someone meddling with your radio set while you are away. Simply remove key from Walbert Filament Lock Switch and take it with you just as you take the ignition key from an auto. Sturdy, compact, efficient. Shell and key handle insulated from circuit. No finer switch made, and none made with unique lock feature.



WALBERT

Parts with a Purpose

ALL WALBERT PARTS PROTECTED BY PATS. OR PATS. PEND., U. S. AND FOREIGN

FREE!
Send 2c stamp for
FREE copy of
UNIVERNIER
LOG BOOK

The
NEW



PARAGON FOUR

RADIO is revolutionized by this new receiver. A four-tube set whose range, using loudspeaker, is practically unlimited. Basically new, employing the new non-radiating Paradyne Circuit. Exquisite, natural tone. Extreme sensitiveness. And the simplest set ever to operate — one dial control.

May be used either as a three-tube or four-tube receiver. Operates successfully with any standard tubes, either dry or storage battery type. Built as only Paragon sets have been built in the past.

And priced one-third of what you would expect to pay for such value.

Ask your radio dealer to show you this new receiver. Or write for descriptive folder.



The New Paragon Four, \$65

Probably the greatest value in radio today. Employs the new Paradyne circuit—non-radiating. New type *single dial* control.

The New Paragon Three, \$48.50

An exceptionally sensitive, selective, fine-toned receiver, with amazing loudspeaker tone and volume over long distance range.

The New Paragon Two, \$27.50

Excellent tone and volume on loudspeaker from stations within moderate radius. Range for phone reception almost unlimited.

DEALERS: Write for attractive new Dealer Proposition and address of nearest Paragon Authorized Distributor

ADAMS MORGAN COMPANY, Inc.
18 Alvin Ave., Upper Montclair, N. J.

PARAGON RADIO RECEIVERS

"The Knobs Can't Come Off"

15c
each

15c
each

New
Improved
Model

12
Styles
Engraved

"Read'em"
Binding Posts

Samples of this quality terminal sent to manufacturers upon request.

The Marshall-Gerken Co.

184 Ontario St., Dept. 184, Toledo, O.

STATEMENT OF THE OWNERSHIP, MANAGEMENT, CIRCULATION, ETC., REQUIRED BY THE ACT OF CONGRESS OF AUGUST 24, 1912, OF RADIO ENGINEERING.

Published monthly at New York, N. Y., for October 1, 1924.
State of New York } ss.:
County of New York }

Before me, a Notary in and for the State and county aforesaid, personally appeared Francis A. Skelton, who, having been duly sworn according to law, deposes and says that he is the Business Manager of RADIO ENGINEERING, and that the following is, to the best of his knowledge and belief, a true statement of the ownership, management, etc., of the aforesaid publication for the date shown in the above caption, required by the Act of August 24th, 1912, embodied in section 443, Postal Laws and Regulations, to wit: 1. That the names and addresses of the publisher, editor, managing editor, and business managers are: Publisher, M. B. Sleeper, Inc., 52 Vanderbilt Avenue, New York; Editor, M. B. Sleeper, Darien, Conn.; Managing Editor, Francis A. Skelton, 52 Vanderbilt Avenue, New York; Business Manager, Francis A. Skelton, 52 Vanderbilt Avenue, New York. 2. That the owner is M. B. Sleeper, Inc., whose stockholders are: Anne F. Sleeper, Darien, Connecticut; Milton B. Sleeper, Darien, Connecticut; Francis A. Skelton, 36 East 49th St., New York, N. Y., and Mao G. Murray, Halstead Ave., Harrison, N. Y. 3. That the known bondholders, mortgagees, and other security holders owning or holding 1% or more of the total amount of bonds, mortgages, or other securities are: None. 4. That the two paragraphs next above, giving the names of the owners, stockholders, and security holders, if any, contain not only the list of stockholders and security holders as they appear upon the books of this company but also, in cases where a stockholder or security holder appears upon the books of the company as trustee or in any other fiduciary relation, the name of the person or corporation for whom such trustee is acting, is given; also that the said two paragraphs contain statements embracing affiant's full knowledge and belief as to the circumstances and conditions under which stockholders and security holders who do not appear upon the books of the company as trustees, hold stock and securities in capacity other than that of a bona fide owner; and this affiant has no reason to believe that any other person, association, or corporation has any interest direct or indirect in the said stock, bonds, or other securities than as so stated by him.

(Signed) Francis A. Skelton, Business Manager Sworn to and subscribed before me this 31st day of October, 1924.

(Seal) F. N. BUNGER, Notary Public Westchester County, New York Co. Clerk's No. 852-A. New York Co. Register's No. 6031. Commission expires March 30th, 1926.

Special Construction Kits

R-D-X One-Tube Set \$25.00

DURRANT has specialized on the R-D-X as a one-tube set for those who want an inexpensive outfit which will bring in local stations with loud speaker volume, and distant stations on the phones. All parts, as specified in this book, are furnished, with Formica panels drilled and engraved, coils wound, and everything ready to assemble.

Browning-Drake 4-Tube \$55.00

DURRANT has selected the Browning-Drake four-tube set for those who want the maximum in long distance reception coupled with tuning sharp enough to cut out all ordinary interference. Licensed B-D Regenaformer units, manufactured by the National Company, are supplied with this construction kit. All parts as specified are finished, with panels drilled and engraved.

Parts for Set Builders

All parts required for building sets described in Radio Engineering Magazine, can be obtained from DURRANT. Shipments are made promptly, and without substitution, for DURRANT handles only products of nationally known manufacturers.

Postage is paid by DURRANT, but no responsibility for safe delivery is assumed unless ten cents extra is remitted to cover the cost of registry.

DURRANT RADIO, Ltd.

C-52 Vanderbilt Avenue

New York City

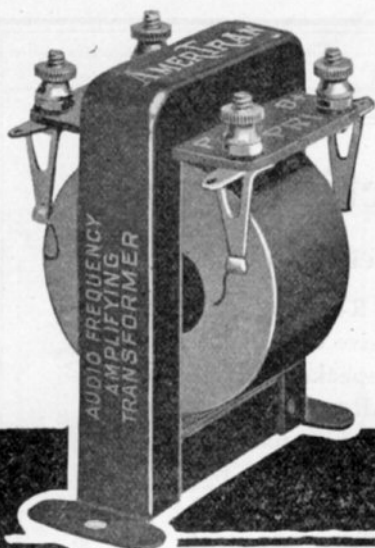

Is AmerTran The Best?

AmerTran is recommended to you as the "best" audio frequency transformer because:

AmerTran has the *most* uniform amplification. All tones are amplified nearly alike.

AmerTran insures amplification of the *highest* order—with minimum distortion.

AmerTran makes tubes deliver the *utmost* in volume, clarity and tone quality.

Use a pair of AmerTrans and you have *the* combination to get *all* two stages can possibly deliver.

AmerTran is made in two types, one quality—A F 6—Ratio 5:1 and A F 7—Ratio $3\frac{1}{2}$:1. Buy them by the pair!

Price either model \$7.00 at your Dealer's.

Send for leaflet giving useful amplifier information.

American Transformer Co.
178 Emmet St. Newark, N. J.

"Transformer builders for over twenty-three years."

AMERTRAN

TRADE MARK REG. U.S. PAT. OFF.

TEST! DON'T GUESS

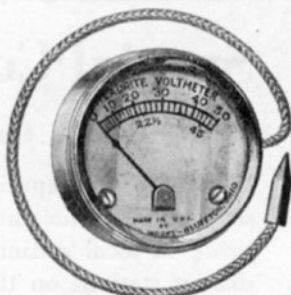

Know the condition of your batteries

NO. 50 VOLT METER—Shows accurate readings of either 22½ or 45 volt "B" batteries. Note intermediate readings. Can also be had in panel mounting. 0-50 Volts—\$1.50 each

NO. 35 VOLT AMMETER—Takes care of the large size dry cell and also the "B" battery in one meter. 0-40 Amps., 0-50 Volts—\$1.50 each

Meters Guaranteed
Accurate or Money Refunded

Either instrument sent postpaid anywhere in the U.S. on receipt of purchase price. Address Dept. 290.

HAMMACHER, SCHLEMMER & CO., Inc.
New York, since 1848 4th Ave. & 13th St.

M. B. SLEEPER

Recommends—

222 Radio Circuit Designs, a splendid book of hook-ups, 252 pages, 284 illustrations\$1.00

Radio Engineering Principles, most useful of text books, for the student and Experimenter\$3.50

How to Retail Radio, an idea book for the radio dealer who is planning ahead for his fall business.....\$2.00

ABC of Vacuum Tubes, an understandable explanation of the audion, filled with diagrams and pictures.....\$1.00

Radio Telephony for Amateurs, Ballentine's book, by an amateur and for them\$2.00

These books are selected particularly for spare time reading. They will be sent promptly, postpaid, well packed.

M. B. SLEEPER, Inc.

Technical Publisher

A-52 Vanderbilt Avenue, New York.

BMS JACK

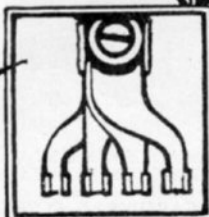
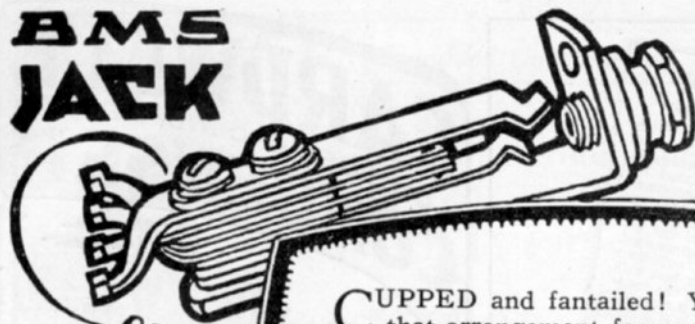

CUPPED and fantailed! You can't beat that arrangement for easy connections. The cupping is for easy soldering and the fantail makes for accessibility. You'll find this double feature only in B.M.S. JACKS. B.M.S. JACKS are made in closed and open circuit types, with and without filament control.

All good dealers sell them as well as the TRI-JACK, the TRI-COIL, the TRI-PLUG, and HET-TRI-FORMERS.

BROOKLYN METAL STAMPING Corp.
718 Atlantic Avenue, Brooklyn N.Y.

"Be Sure It's a Hammarlund"

*For
Greater Distance,
Less Interference, and
BETTER TONAL QUALITY*

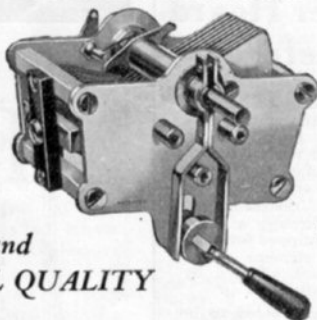

The product of 14 years' experience making the highest type of precision instruments.

**NEW
MODEL
"C"**

U. S. & For.
Patents

HAMMARLUND

VERNIER
and PLAIN CONDENSERS

Buy a Hammarlund at Your Dealer's

WRITE FOR DESCRIPTIVE FOLDER
HAMMARLUND MFG. CO., 424-438 WEST 33rd STREET, NEW YORK
Canadian Distributors, RADIO, LIMITED, Montreal

How FIL-KO-LEAK Improves Reception

Here's a typical "grid log" which shows the need of a variable grid leak in your set. A calibrated FIL-Ko-Leak was substituted for the fixed grid leak in a set (located at Harrisburg, Pa.) and was adjusted for each station tuned in until greatest volume was obtained and distortion eliminated. Of the first thirty-one, only four of the stations came in best with the FIL-Ko-Leak set at the resistance of the fixed leak it replaced.

	Megohms
WFAA ... Dallas, Texas...	.5
WMH ... Cincinnati, Ohio...	2½
WSB ... Atlanta, Ga.....	5
WGN ... Chicago, Ill.....	2
WCAI ... Cincinnati, Ohio...	1
*WSAI ... Kansas City, Mo. 1½	
WHG ... Cincinnati, Ohio...	4
WLW ... St. Louis, Mo.....	4½
KSD ... Zion City, Mo.....	4½
WCBD ... Elgin, Ill.....	3½
WTAS ... Davenport, Iowa...	5
WOC ... Oakland, Calif. 5	
KGO ... Los Angeles, Cal. 2½	
KFI ... Philadelphia, Pa. 1½	
WDAH ... Dartmouth, Mass. 4½	
WMAI ... Springfield, Mass. 1	
*WBZ ... New York ... 3	
WEAF ... Philadelphia, Pa. 4	
WOO ... Newark, N. J. ... 3½	
WOR ... Detroit, Mich. ... 4	
WWJ ... Cleveland, Ohio. 1	
*WTAM ... Jefferson City, Mo. 2	
WOS ... Oak Park, Ill. ... ¼	
WTAK ... Pittsburgh, Pa. ... ¼	
KDKA ... Chicago, Ill. ... 3½	
KYW ... Worcester, Mass. 4½	
WDBH ... Shenandoah, Iowa 5	
KFNF ... Chicago, Ill. ... 5½	
WQJ ... Kansas City, Mo. 1	
*WDAF ... Kansas City, Mo. 1½	
WHK ... Cleveland, Ohio. 1½	

\$2.00

In Canada \$2.90



Stations You Never Heard Before

YOU can "log" your FIL-KO-LEAK just as you do your other tuning units. You will get stations you never heard before. You will clear up distortion on nearby broadcasters and increase volume of weak, distant stations and get them with crystal clarity. You read FIL-KO-LEAK resistance in exact terms of the megohm through a peephole in the panel. (It's also equipped for baseboard mounting.) Resistance element is constant and accurate, and is not affected by atmospheric conditions, wear or jarring. Every FIL-KO-LEAK is guaranteed to be perfect electrically and mechanically, and to be accurately calibrated over the operating range for all tubes (¼ to 5 megohms). This calibration is doubly checked. Send 2c stamp to Dept. R E 1224 for literature on improved reception.

DX Instrument Co.
Harrisburg, Pa.

FIL-KO-LEAK
SCIENTIFICALLY CORRECT
INDIVIDUALLY CALIBRATED IN MEGOHMS

CARDWELL

LOW LOSS GROUNDED ROTOR CONDENSER

"Play safe-- Say Cardwell"

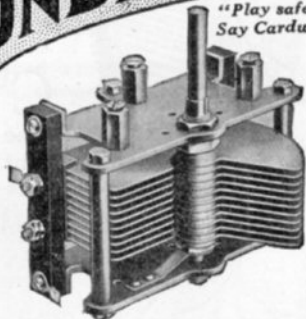

The exclusive choice of Lawrence M. Cockaday and other nationally known radio engineers. Of all the radio apparatus on the market today the CARDWELL CONDENSER is the ONLY unit which is recognized by engineers and technical Editors of National prominence as the ONE best.

A Postcard brings you an Education on Condensers.

Allen D. Cardwell Mfg. Corp.
81 Prospect St. Brooklyn, N. Y.

POSTER'S PERFECT PANELS

THE RECOGNIZED STANDARD

ENGRAVING-MACHINING

FORMICA
RADIO PANELS

"POSTER'S Perfect Panels" is more than a slogan. It is a recognized fact. POSTER today supplies panels to manufacturers of national reputation. The POSTER plant is the largest organization in the country devoted exclusively to the machining and engraving of radio panels. What the POSTER plant has learned from years of panel specialization it is ready to put at your disposal. Write us!

POSTER & CO. INC.
26-28 BARCLAY ST., N.Y. TEL. CORT. 4965-6
(WHOLESALE ONLY)

The Question of "B" Battery Current Has Been Solved With the Trans-B-Former

The Kellogg Trans-B-Former furnishes the necessary plate voltages for your radio set, from your 110 AC, 60 cycle, electric light socket, without any interference of any kind.

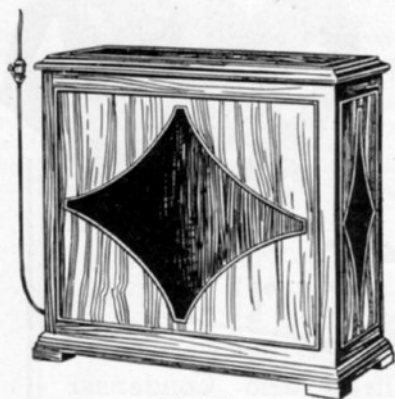

No. 502

This unvarying current is furnished at less than one-fifth cent per hour. Throw away your "B" batteries and install a Trans-B-Former and your set will operate at maximum efficiency constantly.

The Kellogg Trans-B-Former will:

- Improve reception.
- Reduce operating cost to a minimum.
- Add to the appearance of your set.
- Increase DX possibilities.

Developed, perfected and guaranteed by the Kellogg Switchboard and Supply Company.

At your dealers, each \$50.00

Kellogg Switchboard & Supply Company

1066 W. Adams St.

Chicago, Ill. 

Quality Amplification

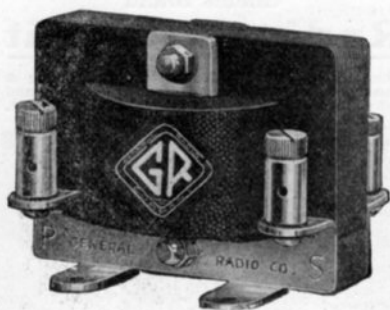

General Radio transformers give the generous volume and purity of tone which constitute quality amplification. They amplify tones of high and low pitch to approximately the same degree and have no resonant point in the audio range.

For natural reproduction of instrumental and vocal tones on phones or a loudspeaker use

General Radio transformers.
Price, \$5.

GENERAL RADIO CO.

Cambridge, Mass.

FRESHMAN MASTERPIECE

It's Easy To Build

A five tube radio frequency receiver when you use the Freshman Masterpiece Kit

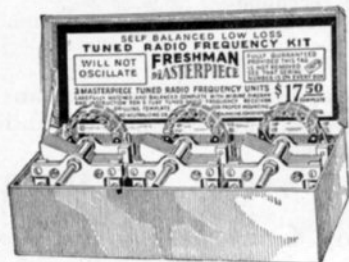

No Neutralizing or Balancing Condensers Required

With this kit you can build a radio frequency receiver that will bring in even the most distant stations with the volume and clarity of locals. So selective that stations can be brought in day after day at the same dial settings. A set that will be the equal, if not the superior, to any 5 tube receiver on the market, and what's more, it's the easiest set in the world to operate.

KIT CONSISTS OF

3 Masterpiece Tuned Radio Frequency Units carefully matched and balanced. Complete with wiring diagram and instructions for building any 5 tube tuned radio frequency receiver and also drilling tem-plate for proper mounting. **\$17.50**

Each and every Freshman Masterpiece Coil bears a serial number and Trade-mark—our guarantee of electrical and mechanical perfection. Every genuine Freshman Coil is made of specially insulated wire to prevent short-circuiting, so often caused by inferior coils. For your protection demand only the genuine.

At your dealers, otherwise send purchase price and you will be supplied without further charge.

Chas. Freshman Co. Inc.
Radio Condenser Products

106 Seventh Ave., New York

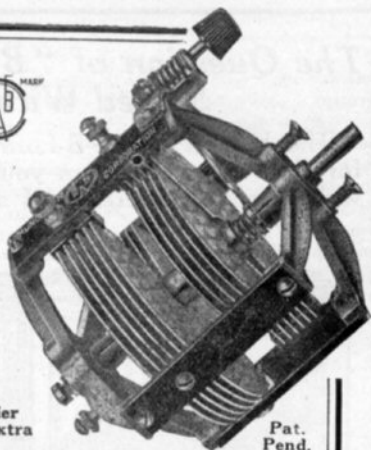

\$5.50

Vernier
\$1 Extra

Pat.
Pend.

"Bruno"³ in 1

22 Plate

Ultra Vario Condenser

A balanced precision instrument scientifically designed with

3 capacities
.0005 .00025 .00125

BRUNO RADIO CORPORATION
NEW YORK

THE IDEAL CHRISTMAS GIFT

Can you think of anything that would please your set building friend more than a

"Gnome Brand"

Radio Tool Kit

They are compact, easily portable and contain a comprehensive assortment of nationally-known and fully-guaranteed tools that give lasting satisfaction.

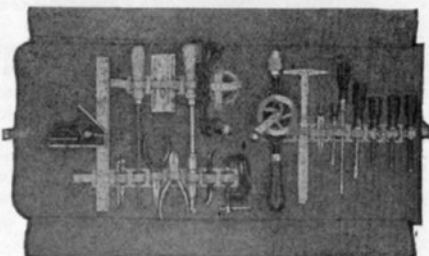

RADIO KIT NO. 1—22 Tools.....\$16.00 each
(as illustrated)

RADIO KIT No. 3—16 Tools.....\$8.00 each
Tools may be purchased individually if desired.
Also Carpenters' Tools in sets for home and general use.

SEND FOR CIRCULAR NO. 289

HAMMACHER, SCHLEMMER & CO., Inc.
New York, since 1848 4th Ave. & 13th St.

Make Your Radio Joy A Sure Thing

YOU are going to give a "radio party," or you are going on a hunt for "DX". You get yourself set for a "large" evening. Then some little unavoidable thing happens and you blow all your tubes. Money, fun and everything is lost.

The quickest way to spend \$20 is to accidentally drop a screw-driver in a five-tube set. Zip, and your money is gone as well as your fun—until the radio store opens. Either style of KANT-BLO means protection against blowing out tubes.

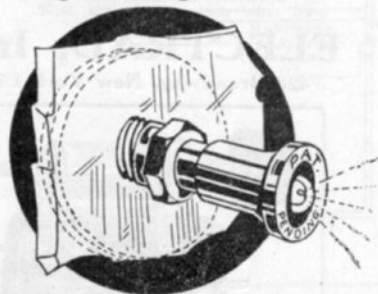

**A NECESSITY—
NOT AN ACCESSORY**

The KANT-BLO is not an extra accessory to your set. It is designed as a B battery Binding Post or as an A battery filament switch. Post Style and Switch Style—are at all the best radio stores. If your dealer is out of stock send us \$2 for a KANT-BLO Binding Post Style, or \$3 for the Switch Style, and we will ship any number of KANT-BLOS direct to you, charges prepaid.

Kant-Blo

SWITCH SIGNAL BINDING POST

"Lights on any Short Circuit"

Manufactured by
GANIO-KRAMER CO., Inc., New York

Sole Distributors
APEX RADIO CO., 503 Fifth Ave.
New York

ROYALTY

Variable High Resistances — Variable Grid Leaks

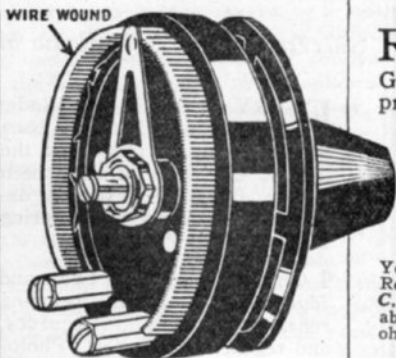

Revolutionary!

ROYALTY Variable High Resistances and the **ROYALTY** Variable Grid Leaks represent the greatest improvements ever made in this field. They are *wirewound!*

This wire winding eliminates at one stroke all the common grid leak and resistance troubles. The lever arm *cannot* scrape away the resistance element. The grid leak and the high resistance are *noiseless* and positively non-inductive. The resistance value is retained indefinitely.

Your dealer has the **ROYALTY** Variable High Resistance (*type B*, 1,500 to 100,000 ohms; *type C*, 500 to 50,000 ohms) and **ROYALTY** Variable Grid Leak (*type A*, 100,000 to 7,000,000 ohms).

any type \$1.50

FREE Write for the **ROYALTY**
Hook-Up Booklet

WIRELESS PRODUCTS CORPORATION
136 Prince Street, New York City

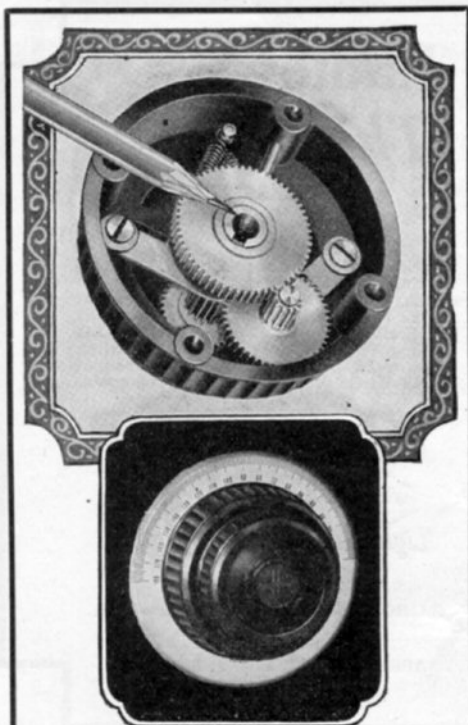

All Wobble Eliminated by Long Center Bushing

Look at that long center bushing! Watch the new model Accuratune when you tune in—how smooth it operates—how precise its movements without the slightest indication of wobble.

Few vernier dials, built as they must be to take all standard condenser shafts, are designed as the Accuratune to positively eliminate this universal objection—dial wobble.

And just this one point of refinement characterizes the complete makeup of the Accuratune Micrometer Control—features that assure most unusual tuning efficiency.

Micrometer Controls easily replace ordinary dials without any set alterations. Just tighten the set screw on the large knob.

NEW ACCURATUNE FEATURES

Geared 80-1 ratio.

No back lash.

No cutting of condenser shafts.

Flush panel mounting.

At your dealers, otherwise send purchase price and you will be supplied postpaid. Price \$3.50.

ACCURATUNE

MYDAR RADIO COMPANY

9-E Campbell Street, Newark, N. J.
Canadian Representative: Radio Ltd., Montreal.

ELECTRAD AUDIOHM Eliminates Distortion

If your radio sounds like a bad phonograph record. If the high and low tones come in "cracked" and distorted—place an Electrad Audiohm across the secondary of your audio transformer.

The effect is magical. Distortion, squeals and howls vanish immediately. The rich soprano and bass tones of voice and musical instruments are reproduced with marvelous clarity and definition.

Fits any transformer. Can be attached in a minute—without solder. Guaranteed to give perfect results. Buy an Audiohm—and hear the wonderful difference. On sale at most good radio stores. Price only \$1.50.

ELECTRAD, Inc.

428 Broadway, New York City

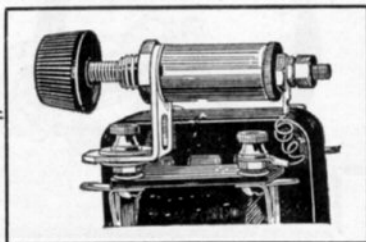

SET BUILDER'S BOOK

Success Insurance for Radio Men

EVERY design in the Radio Set Builder's Book has been thoroly tried and tested, for the designs in this book have been chosen from the best sets described in Radio Engineering Magazine.

¶ Outfits with one, two, and four tubes are shown, including reflex, straight radio frequency, and regenerative models. Photographs, scale drawings, and picture wiring diagrams. The price of this book is fifty cents, or you can get it free with a year's subscription to RADIO ENGINEERING.



When it's "Pacentized" you are sure of results

SELECTIVITY—distance—volume—these results are dependent on the parts you use. It's poor economy to slight such vital parts as jacks, rheostats, condensers, etc., when Pacent Radio Essentials, built by the pioneer radio parts manufacturer, cost no more than inferior parts.

18 years of radio experience are back of every Pacent part. Over 30 of the leading makes of receiving sets are Pacent equipped. This is convincing proof that the Pacent trade mark stands for leadership. Let the judgment of those makers be your guide in buying parts. Send for our complete catalog.

THE PACENT ELECTRIC COMPANY, Inc.
91 Seventh Avenue, New York City

Washington
Chicago

Minneapolis
Birmingham

Boston
Philadelphia

San Francisco
St. Louis

Jacksonville
Buffalo

Pacent

RADIO ESSENTIALS

PACENT Radio Essentials

Adapters
Improved Audioformer
Autoplug
Balcon
Coil Plug
Coil Plug Receptacle
Condensers, Low Loss
Detector Stand
Doojack
Dooplug
Geo-Lateral Coils
Headsets, Everytone
Jacks
Jack Set
Radio Loop
Loop Plug
Loop Jack
Multijack
Plugs
Potentiometers
Rheostats
Resistors, Laboratory
Sockets
Transformer, etc., etc.



DONT IMPROVISE - PACENTIZE

The Improved Rasla Reflex!

Write for the complete construction bulletins with full size layouts of the one and two tube Improved Rasla Reflex **FREE!**

THE Improved Rasla Reflex is the most powerful circuit so far devised. The distance, selectivity, and volume possible with it are a revelation.

Remember that RASLA Products are built by an organization of recognized reflex experts. Therein lies the secret of the Improved Rasla Reflex!



RASLA Type CR Transformer is the only radio frequency transformer designed especially to link a vacuum tube and a crystal detector.



The RASLA Fixed Detector is a permanently fixed, super-sensitive crystal detector that will give splendid results in reflex and other circuits. Everyone is a good one.

DAVIDSON RADIO CORP.
222 Fulton St., New York

RASLA

TRANSFORMER ~ FIXED DETECTOR

AMERICAN BRAND CONDENSERS

with the

~100 to 1~

**Worm Drive Vernier
Finest Condenser Made**

and the

**Greatest Radio Value
Offered the Public**

23 PLATE, only \$5⁰⁰ In Canada \$7⁰⁰

AMERICAN BRAND CORPORATION
NEWARK, N.J.

BROWNING DRAKE

The Super of R. F. Receivers

THERE is no four-tube set which offers more in range, in sharpness of tuning, or quality of reception than the Browning-Drake. The peculiar characteristics of the circuit make it as easy to tune as a one-control set. Refinements of design effect a great saving in current consumption from both A and B batteries.

¶ You can get the complete set of six blue prints for this set—free—with one year's subscription to RADIO ENGINEERING. . . . \$2.00 for both

RECEPTRAD

SUPERHETERODYNE KITS MULTIFLEX

Receptrad Kits have become favorites among fans throughout the country.



SUPER-HET KIT

Contains essential parts for a "Super-Het" set, with complete instructions for making and blue prints. Super-Het Kit with all essential parts \$53.50. Smaller Kit containing most essential parts \$33.

MULTIFLEX KIT

The Greiff Double Selector Multiflex is a 4 Tube circuit—loop operating. It can be assembled by any one in a few hours. For simplicity and ease of tuning, as well as power and quality of reception, it is far superior to a Five Tube Neutrodyne. \$29.50 containing principal parts—\$50.00 including all parts.

FREE Complete literature that's educating as well as interesting. Just ask your dealer or write direct. Kits also sent postpaid on receipt of purchase price if your dealer can't supply you.

RADIO RECEPTOR CO.
59 Bank St., New York

Amplify the MODERN way!

THE pleasure you derive from your radio set depends upon the clarity of reproduction. Insure that pleasure by using MODERN Transformers. MODERN Transformers amplify without distortion. Insist upon MODERN Transformers. They are made in three types—the Ten to One, the Push-Pull, and the Four to One.

Send for the Book of MODERN Hook-ups.
We will gladly mail it to you FREE!

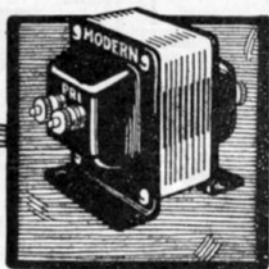

B.L. SALES CO.
218 Fulton St.
New York

CICO

CICO
BATTERY
SWITCH



NESTOR
BEND-RITE
\$1



CICO
AUTOMATIC
PLUG
75c.



CICO
BAKELITE
RHEOSTATS
Plain, \$1.00
Vernier, \$1.25



CICO
BAKELITE
POTENTIO-
METERS
\$1.15



CICO
BAKELITE
JACKS



Definite angles, perfect eyes, and straight wire from point to point does make a difference in radio reception.
The NESTOR BEND-RITE gives satisfactory results.



CICO 2-WAY
PLUG
40c.

JACK PRICES

Single open No. 30-.80
Single closed No. 31-.85
Double circuit No. 32-.90

SWITCH PRICES

"A" Battery No. 33-.90
Combination "A" & "B"
Battery No. 34-\$1.00

Write now for descriptive literature.
CONSOLIDATED INSTRUMENT COMPANY OF AMERICA, INC.
41 East 42nd Street, New York

BETTER RHEOSTATS LOWER PRICES



The Spring does it!

???

Guarantees Permanent Contact

MAKE US PROVE IT!!

Send for descriptive catalogue

**SHEFFIELD TRIMMING
& STAMPING CORP.**

211 Centre St. NEW YORK CITY

RUSONITE PRODUCTS

Price
50c

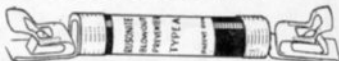

RUSONITE Blowout Preventer—Prevents tube blowouts, wire damage, excessive voltage or short-circuit risks. Indestructible.



Price
\$1.00

RUSONITE Fixed Detector—The test of detector value—Results. Try the Rusonite in your reflex and experimental work.

Price
35c
up



.0001
m.f.d.
to
.006
m.f.d

RUSONITE Fixed Mica Condenser—Moulded and hermetically sealed—Capacity absolutely constant. No losses of any kind. Accuracy predominant. Write for literature.

RUSONITE PRODUCTS CORP.
15 Park Row New York, N.Y.

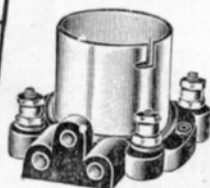
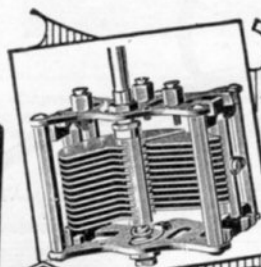

DON'T GAMBLE

in building your set by using inferior parts. You chance the loss of considerable time, money, and patience if the results aren't satisfactory. Be certain! Use only Amsco parts. Made by men who really know their business, they lead the field in all around performance.

Amsco Parts necessary for those who construct their own include the Low Loss Condenser, a laboratory instrument designed for perfection in set building. Also the Amsco Rheostat, for perfect filament control with all types of tubes and the Amsco Tube Socket with genuine Bakelite Base suitable for panel or table mounting.

At dealers everywhere. Free literature on request.

AMSCO PRODUCTS, Inc., 416 Broome Street, New York

NEW CARTER "IMP" BATTERY SWITCH

Pat. 1-30-23

Most compact Switch on the market. "OFF and ON" Name Plate and Pointer clearly indicate position at all times.

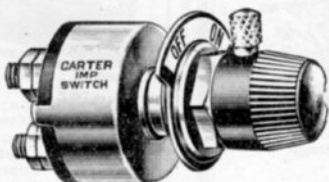

One hole mounting. Operates by turning. — just like your dial. Knob matches your other Knobs and Dials. CARTER quality.

65c

Write for Catalogue of Other CARTER products

Carter Radio Co.
209 S. STATE STREET
CHICAGO

Any dealer can supply

A constant factor in radio development

Radio design progresses rapidly—but radio's standard insulation continues to be Bakelite. For the further refinement of radio sets and parts, radio engineers rely upon Bakelite. Typical of many new Bakelite applications are the Musette Loud Speaker, the Paramount Loop and the Amsco Tube Mounting Panel.

Of all insulating materials Bakelite alone combines the many characteristics vital to efficient radio reception.

Write for our Booklet I.

Send for Our Radio Map

The Bakelite Radio Map lists the call letters, wave length and location of every broadcasting station in the world. Enclose 10 cents to cover the cost and we will send you this map. Address Map Department.

BAKELITE CORPORATION
247 Park Avenue, New York, N. Y.
Chicago Office: 636 West 22nd St.

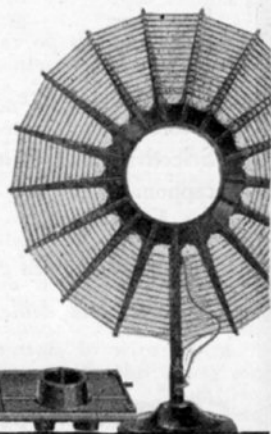

THE MATERIAL OF A THOUSAND USES

EASTERN LOW LOSS COUPLER

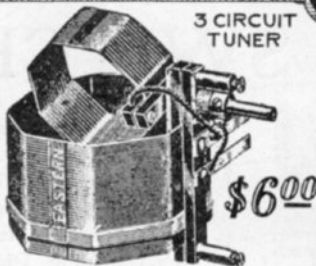

Designed by M. B. Sleeper

NEW—DISTINCTIVE!

Different from any other tuning device—maximum of inductance attained by *elimination of all tubing and winding in pickle bottle form.*

This high inductance is essential for VOLUME RECEPTION, and cannot be obtained from any other form of low loss tuner.

Results heretofore impossible absolutely guaranteed as to Selectivity and Distance Reception.

Mail orders filled promptly.

Jobbers and dealers write.

EASTERN COIL CORP.
22 WARREN ST. N.Y. CITY
Barclay 6807.

Welcome

The "SELF ADJUSTING" Rheostat

Write for
\$1.10 FREE
Everywhere Hook-Ups

No rheostat knobs on panels to turn—no meters needed—no tube worry. One AMPERITE, used in series with each tube, inside the set, automatically supplies just the right current for each individual tube's greatest efficiency. Works on thermo-electric principle. Simplifies wiring. Reduces set cost. Proven in use. Adopted by more than 50 set manufacturers. No Set is up-to-the-minute in design without it.

RADIALL COMPANY,
Dept. R. E. 3, 50 Franklin St., New York

AMPERITE
"means right amperes"

KURZ-KASCH ARISTOCRAT



DIALS
AND
KNOBS

LEADERS IN THEIR LINE

Manufacturers use them for their beauty and efficiency. Moulded of Bakelite—the quality is guaranteed. No set screws to tighten—the Patented Split Bushing eliminates the need.

Set builders use them for easy handling and recognized superiority. Assembly is simple. The Bushing is placed on the shaft, the dial goes over the bushing, and the knob is screwed on. All dials are finished in a smooth satin black, without set-screw holes to mar or scar the surface. They must be good.

The cost—4"—\$1.00, 3"—75c, 2"—35c.

ASK YOUR DEALER FOR
THE ARISTOCRAT LINE
THE KURZ - KASCH CO.
DAYTON, OHIO

HOW DO YOU KNOW?

How do you know that this coil has lower losses than another?—That this condenser has its rated capacity?—That your set covers the full wavelength range, or that it is more efficient than another set?

The equipment for a complete radio testing laboratory is so expensive that many manufacturers find that their use of such apparatus is too intermittent to justify the investment required. Until now, the Bureau of Standards has been the only laboratory available to the general public, but, because of the enormous amount of scientific investigation which the Bureau is called upon to handle, their service has been too slow for practical requirements.

The new and enlarged Radio Testing Laboratories maintained by RADIO ENGINEERING, heretofore used exclusively for the development of instruments and sets to be described in the Magazine, are now opened to the general public, so that manufacturers and experimenters can have coils and condensers measured, sets tested, and wavemeters calibrated—and they can have this work done quickly at a small cost. Following is a schedule of charges:

RADIO TESTING LABORATORIES

The Radio Testing Laboratories are for the personal information of manufacturers, and experimenters. Reports will be made directly to clients, and all data kept confidential. None of the information will be published or used in Radio Engineering Magazine. In cases where special data is required which cannot be handled by the Radio Testing Laboratories, the client will be so informed, and the remittance refunded. All checks and money orders should be made payable to M. B. Sleeper, Inc., and equipment for testing forwarded to A-52 Vanderbilt Avenue, New York City, N. Y.

SPECIAL INFORMATION AND TESTS

The Radio Testing Laboratories are equipped to handle special testing and development work. Correspondence concerning this class of work is solicited.

FIXED CONDENSERS: Capacities of 0.00005 to 1.0 mfd., tested at 1,000 cycles.....	\$50
VARIABLE CONDENSERS: Capacities of 0.00005 to 0.002 mfd., tested at 1,000 K.C. per point...	.50
VARIOMETERS: Inductance measured at 1,000 K.C., per point.....	.50
FIXED INDUCTANCES: Inductance measured at radio frequencies75
DISTRIBUTED CAPACITY: Inductances measured at radio frequencies.....	1.00
R. F. RESISTANCE: Of Inductances at radio frequencies, per setting.....	.75
D. C. RESISTANCE: Of coils or resistance elements50
WAVEMETERS: Calibration per point.....	.50
EFFICIENCY: Overall efficiency of receiving sets, output to input voltage.....	5.00

NOTE: This is one of the most important and interesting tests which shows the receiving ability of the set.

PACKING: All instruments to be tested must be securely packed and insured, for we can assume no liability for safe transportation. The name and address of the sender must be marked plainly, and a letter containing full instructions and a remittance to cover the testing charges sent separately.

RADIO TESTING LABORATORIES

(Manufacturers' and Experimenters' Service Division)

M. B. SLEEPER, Inc.

A-52 VANDERBILT AVENUE,

NEW YORK CITY

THINK OF DURRANT AS YOUR NEW YORK STOCK ROOM, FROM WHICH YOU CAN DRAW AND ORDER THE SUPPLIES YOU NEED FOR YOUR WORK.

REMEMBER, IF YOU WANT YOUR STOCK CLERK TO FILL YOUR ORDERS ACCURATELY, THAT YOU MUST WRITE OUT YOUR ORDER CAREFULLY, GIVING TYPE NUMBERS, NAMES, AND PRICES.

REMEMBER THAT YOUR NEW YORK STOCK ROOM CARRIES ONLY SUPPLIES CALLED FOR IN THE STANDARD PARTS LISTS IN THIS MAGAZINE. COILS ARE NOT WOUND, NOR ARE PANELS DRILLED OR ENGRAVED.

PRINT YOUR NAME AND ADDRESS CLEARLY. IF POSSIBLE, REMIT BY MONEY ORDER. AN EXCHANGE CHARGE OF TEN CENTS MUST BE ADDED TO OUT-OF-TOWN CHECKS. ADD TEN CENTS FOR INSURANCE.

C. O. D. ORDERS MUST BE ACCOMPANIED BY A REMITTANCE OF ONE-FOURTH THE AMOUNT.

Get-It-to-Me Quickly Mail Service

And remember that DURRANT can send you your supplies more quickly than the manufacturer who makes them, for DURRANT carries in stock at all times the supplies called for in the Standard Parts Lists in Radio Engineering. If you are in New York, call at the DURRANT office

DURRANT

AS NEAR AS YOUR MAIL BOX
C-52 Vanderbilt Avenue New York City

Special

One year's subscription or extension to *Radio Engineering*, \$2.00, and a set of six full-size blue prints \$1.50, for the Browning-Drake Receiver, including panel patterns, at the combination price of

\$2.00

BLUEPRINTS for RADIO SET BUILDERS

ONE-TUBE SETS

3 CIRCUIT REGENERATIVE RECEIVER, the famous X-1900 type, sharply tuned and very sensitive. 150 to 600 meters. Type X-1900, 3 sheets. 75c.

REINARTZ RECEIVER, one of the most popular models ever described in *Radio Engineering*. A splendid set for all around broadcast work. Type 3300, 4 sheets. \$1.00

ONE-TUBE REFLEX RECEIVER, using an Acme R-2 transformer and a crystal detector. Type 4200, 3 sheets. . . 75c.

TC CIRCUIT SET, a 2-control regenerative receiver exceptionally sharp and sensitive. Particularly adapted for indoor antennas. Type X-4000, 3 sheets. 75c.

IMPROVED RASLA REFLEX, unusually attractive in design as well as in the results produced. This set is also intended for a small antenna. Type 5900, 3 sheets. 75c.

HAYNES TUNER, known as the "One Thousand Miled for Fifteen Dollars" set. 2 sheets. 50c.

R-D-X REFLEX, brings in local stations on a loud speaker and distant stations with surprising volume. Type 6400, 3 sheets. 75c.

TWO-TUBE SETS

TUNED RADIO REFLEX, using fixed couplers tuned by variable condensers for maximum amplification. Type 5100, 3 sheets. 75c.

NO-LOSS REGENERATIVE RECEIVER, with condenser control for feed back. Equipped with 1-step AF amplifier. Type 6300, 3 sheets. 75c.

FOUR-TUBE SETS

DX RECEIVER, because of its high efficiency, owing to the use of tuned RF, this is one of the most popular sets ever described in *Radio Engineering*. Type 5300, 6 sheets. \$1.50

PORTABLE TUNED RF RECEIVER, similar in design to the Type 5300 set, but very compact and built for UV-199 tubes. Type 5800, 3 sheets. 75c.

4-TUBE REFLEX, with the standard Acme circuit in an improved design. Can be used with the Run-A-Radio battery substitute. Type 6500, 5 sheets. \$1.25

AMPLIFIERS

2-STEP AF AMPLIFIER, designed for use with any type of receiving set where additional amplification is required. Type 3100, 3 sheets. 75c.

4-TUBE AMPLIFIER, with one stage of transformer coupling and three stages of resistance coupling. Gives tremendous undistorted amplification. Type 6200, 3 sheets. 75c.

HAYNES AMPLIFIER, two stages AF. Can be used with any set, although it is designed particularly for the Haynes tuner, 2 sheets. 50c.

DEPENDABLE DESIGNS for RADIO SETS

M. B. SLEEPER, Inc. Technical Publisher
A-52 Vanderbilt Avenue New York City



**The Church
AUTOMATIC
TEMPLATE**

*Just three taps—
AND YOU'RE READY TO
DRILL ACCURATELY.*

THE Church
AUTOMATIC
TEMPLATE be-
longs in your tool
kit! It is a device
that will accu-
rately locate the holes
for anything from a
condenser to switch in
a jiffy. It absolutely
eliminates the need for
rulers, dividers or sub-
scribers.

The Church AUTO-
MATIC TEMPLATE
has myriads of uses
about the home, the
garage, or the shop.

GET ONE TODAY.
(If your dealer cannot sup-
ply you, write us, Room
302)

**New
Price
75c**

NATIONAL DISTRIBUTORS
CLARK & TILSON Inc.
552-7th Ave., N. Y. C.

Spintite WRENCHES



**Built
for
Service**

SPINTITE
STEVENS

When you buy a set of Spintites
you buy *real tools*, built for
lasting service.

Shank and head of tough drop-
forged steel that stands the gaff of
long wear; convenient one-piece
construction, giving greater strength
and durability; no separate parts to
weaken with use or get lost.

Quality tools through and through.
Heads accurately machined to size.
Handle of hard-wood, rubberoid
finish—not painted; deeply fluted to
form a sure and comfortable grip.
Substantial *steel* ferrule. Shank
firmly anchored to prevent "turning"
in handle under heavy stress.

You'll be proud to own a set of these con-
venient Spintites, which enable you to get
into the cramped corners with ease, mak-
ing joints that are as *tight as if soldered!*

SPINTITES MAKE ACCEPTABLE HOLIDAY GIFTS

Set of 3 most popular sizes for Round
or Hex nuts, as desired, in box \$1.00.

Set of 7 Hex sizes in handsomely fin-
ished metal base \$3.50.

*If your dealer can't supply
Spintites order direct
from us. Write today for
Booklet \$3, describing all
the "Speed-Up" Tools for
radio.*

Stevens & Co.
Toolsmiths since 1899
375 Broadway, New York

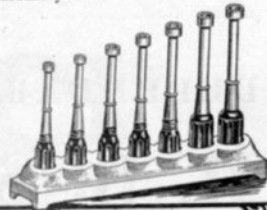

Stevens SPEED UP **Tools**

KESTER Radio SOLDER
ROSIN-CORE



Oh boy! it sure is
Safe & Simple

Here's the solder that contains the flux recom-
mended by radio engineers! The pure rosin
core inside of Kester Radio Solder is a natural
flux and can leave no harmful chemical or
electrical action on delicate parts or joints. It
requires only heat.

In developing radio frequency, it was found that
all fluxes, except rosin, spatter, fume and run
over delicate parts and joints. This causes
leakage and makes the best insulation as poor
as a grid leak!

Solder with Kester Radio Solder. You will
have no need to go over and wipe away sur-
plus flux. Leave what rosin may remain—it
is a good insulator!

There you have it: Kester Radio Solder is a
safe and simple solder with which your set can
be quickly, neatly, safely and substantially
soldered. Get a handy can of Kester from
your dealer.

CHICAGO SOLDER COMPANY
4224 Wrightwood Ave.
Chicago—U. S. A.

I^a_d M REGISTRY

A REGISTRY OF RADIO INSTALLATION and MAINTENANCE SERVICE MEN WHO INSTALL, MAINTAIN, and REPAIR RADIO EQUIPMENT

The men whose names are listed below are prepared to handle all emergency work, take care of batteries, and replace tubes. Their charge is \$1.50 per hour, not including travelling time except to unusual distances.

The charge for listing in this section is 50c. for one month, \$2.00 for six months, \$3.00 for twelve months, payable in advance. The * indicates that we have received letters from six set owners stating that the man after whose name the * appears has handled their I and M work satisfactorily.

Conn., South Norwalk—A. GHIRARDI*
White Bridge. Tel. Nor. 2724

D. C., Washington—A. C. BURG
U. S. Soldiers' Home. Tel. Col. 750 Br. 41

Ill., Oak Park—F. H. LESTER
1155 Wisconsin Ave. Park 975

Me., Bangor—JOHN FOX
120 Essex St. Tel. Ban. 7591

Md., Baltimore—OTTO U. JAHELKA
3710 No. Rd., Walbrook. Tel. Liberty 1202

Mass., Boston—H. A. NICKERSON
201 Devonshire St. Tel. Cong. 5156

Mich., Detroit—R. J. McLEOD
7725 Kellogg Ave. Tel. Bal. 9525

Mich., Detroit—WM. MILLIGAN
6545 Woodward Ave. Tel. Northway 5691W

Minn., Minneapolis—GEO. A. BECKER
4709 Wentworth Ave. Tel. Locust 6291

Mo., Kansas City—J. K. O'BRIEN
2116 Penn St. Tel. Okl. 9533

N. J., Newark—J. DUNN
13 Freeman St. Tel. New 3128

Neb., Omaha—W. J. F. SACKRIEDE
2622 Jaynes St. Tel. Kenwood 5628

N. J., Trenton—F. C. SCOBEY
478 Stuyvesant Ave. Tel. Web. 7254

N. Y., New York—APEX RADIO CO.
123 Liberty St. Tel. Rector 3176

N. Y., New York—PAUL FRANCK
317 West 119th St. Tel. Morningside 9140

N. Y.,—Brooklyn—J. McPARTLAND
932 Flatbush Ave. Tel. Fla. 1758R

N. Y., Gloversville—H. E. HOTALING
14 Gold St. Tel. Glov. 2725

N. Y., Buffalo—L. A. JEWELL
69 Leslie St. Tel. Lan. 9234

N. Y., New York—J. ROEMISCH
841 Lexington Ave. Tel. Lex. 4420

Pa., Scranton—J. J. MAHON
730 Capouse Ave. Tel. Bry. 2944

Pa., Lewistown—S. T. ROBINSON
123 S. Main St. Tel. Lew. 723

Pa., Pittsburgh—L. E. SIEGFRIED
1513 Tyndall St. Tel. Can. 8913

Tex., Fort Worth—C. L. FARRIS
500 Taylor St. Tel. Wor. 3927

Terminals — Lugs

By the thousand or million
16 Varieties

Ground Clamps

with terminal stamped
on end — one piece.

Send for samples.

**F. R. Zierick Machine
Works**

207 Canal St., N. Y. C.
Franklin 5699.

Screws — Nuts — Washers

Clean-cut, Brass, Nickel-plated

**Made by the Millions But Sold
as You Need Them.**

These items are packed 500 of each type to the box. Standard sizes carried in stock for immediate delivery. Special screws quoted on request and delivered on short notice.

GOTHAM RADIO CORP'N.
50 Park Place New York City

Made by the makers of Laboratory Equipment

NOLOSS

TRADE MARK
TYPE 51

PYREX INSULATION

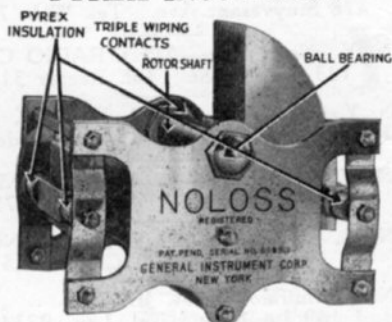

NOLOSS

TRADE MARK
TYPE 56

ISOLANTITE INSULATION

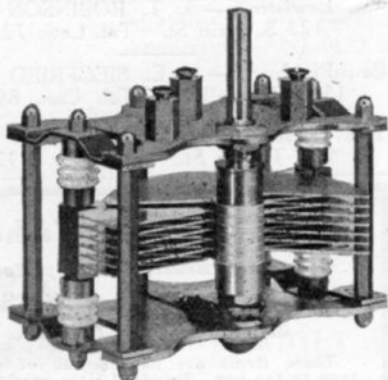

IT is now possible for the amateur to get results formerly reserved to laboratories.

The experimenter who requires every micro watt of energy to bring in heretofore inaudible signals must turn to General Instrument NOLOSS Variable Air Condensers.

They are constructed with laboratory methods, and insulated with laboratory insulations—Pyrex or Isolantite.

Products worthy of your purchase.

General Instrument apparatus costs a little more but is worth infinitely more.

General Instrument Corporation

Manufacturers of Laboratory Equipment

423 BROOME STREET
NEW YORK, U.S.A.

Which one is your tuning circuit?

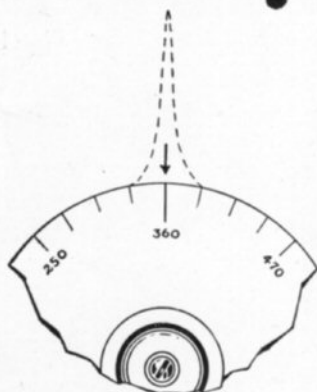
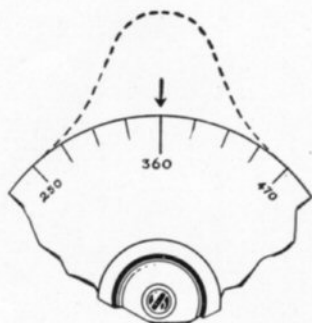

The hump or the peak?

HERE are the curves of two tuning circuits. The hump has a high loss condenser and the peak a low loss condenser. Both receive broadcasting, but the peak receives local and distant stations without interference, while the hump receives only the nearby stations with interference. The new Acme Condenser will change your tuning circuit from a hump to a peak.

The Acme Engineers have been working for two years to bring out a condenser which would give to radio experimenters sharp tuning and minimum losses. The new Acme Condenser has these fundamental advantages and also has many new improvements in structure and equipment.

Write to us for booklet, "Amplification without Distortion," which contains many diagrams and helpful hints on how to build and get the most out of a set. Enclose 10 cents in stamps.

ACME APPARATUS COMPANY

Transformer and Radio Engineers and Manufacturers

Dept. R. M. 12 Cambridge, Mass.

ACME ~for amplification

"The Best That Money Can Buy"



"GOLD SEAL" HEAD SETS

2200 Ohms

\$6.00

3200 Ohms

\$8.00

"DEVEAU GOLD SEAL" HEAD SETS are electrically and mechanically,—as well as from a radio standpoint,—as perfect as the highest-priced Head Set on the market,—and yet, with all their perfection, they retail at only \$6.00 for 2200 Ohm and \$8.00 for 3200 Ohm.

The trade mark "DEVEAU" has stood for the highest quality in telephone apparatus for thirty years,—a guarantee that every known advantage in design and manufacturing has been taken into careful consideration.

Magnets are extra-heavy one-piece units; cups are of aluminum to keep down the weight but unlike other Head Sets, every exposed metal part of the set is finished in genuine 24-karat gold,—under a protective lacquer so that the finish will last for years; the terminals of each unit are concealed,—no contact possible with user's hands.

"DEVEAU GOLD SEAL" HEAD SETS are like a piece of fine jewelry in appearance, but with all the radio niceties that the most advanced radio enthusiast can desire. DEVEAU Units exactly match each other in

tone,—each has maximum sensitivity and perfection of tone quality.

The patent design of headgear is far ahead of any Head Set on the Market,—affording as it does, instant fitting to ears and head without "re-harnessing" and without binding or pressure—the latter an admitted nuisance with all other makes of Head Sets.

Cups are of genuine Bakelite—of scientific design, and comfortable to the ear; the Bakelite never loses its jet-black lustre or highly polished surface.

"DEVEAU GOLD SEAL" HEAD SETS are never found in the cut-rate market—they are only sold to jobbers who appreciate their value.

"DEVEAU GOLD SEAL" HEAD SETS are guaranteed to be electrically and mechanically perfect—our Guarantee protects every purchaser.

Order through your regular jobber or write direct for the names of authorized Distributors throughout the country.

Send for descriptive Bulletin of Deveau Radio Apparatus and Micrometer Adjustable Air-Gap Radio Loud-Speakers.

STANLEY & PATTERSON

27 WARREN STREET

23 MURRAY STREET

NEW YORK CITY, U. S. A.