

Electronics NOW

Build the PCdrill

Thanks to our precision drilling table and your personal computer, making PC boards is easier than ever

Keep your frozen foods safe with the
Freezer Sentry
food-freezer monitor

Build a
Conductance Adapter
Measure leakage current, large resistances, and more with this add-on for your DMM

Using the
NE602
It makes designing and building RF circuits a snap



\$3.99 U.S.
\$4.50 CAN.



A GERNSBACK
PUBLICATION

Rugged.

Reliable.

High-performance
scope.

But one

feature really
stands out.



(Here's a hint.)

FLUKE®

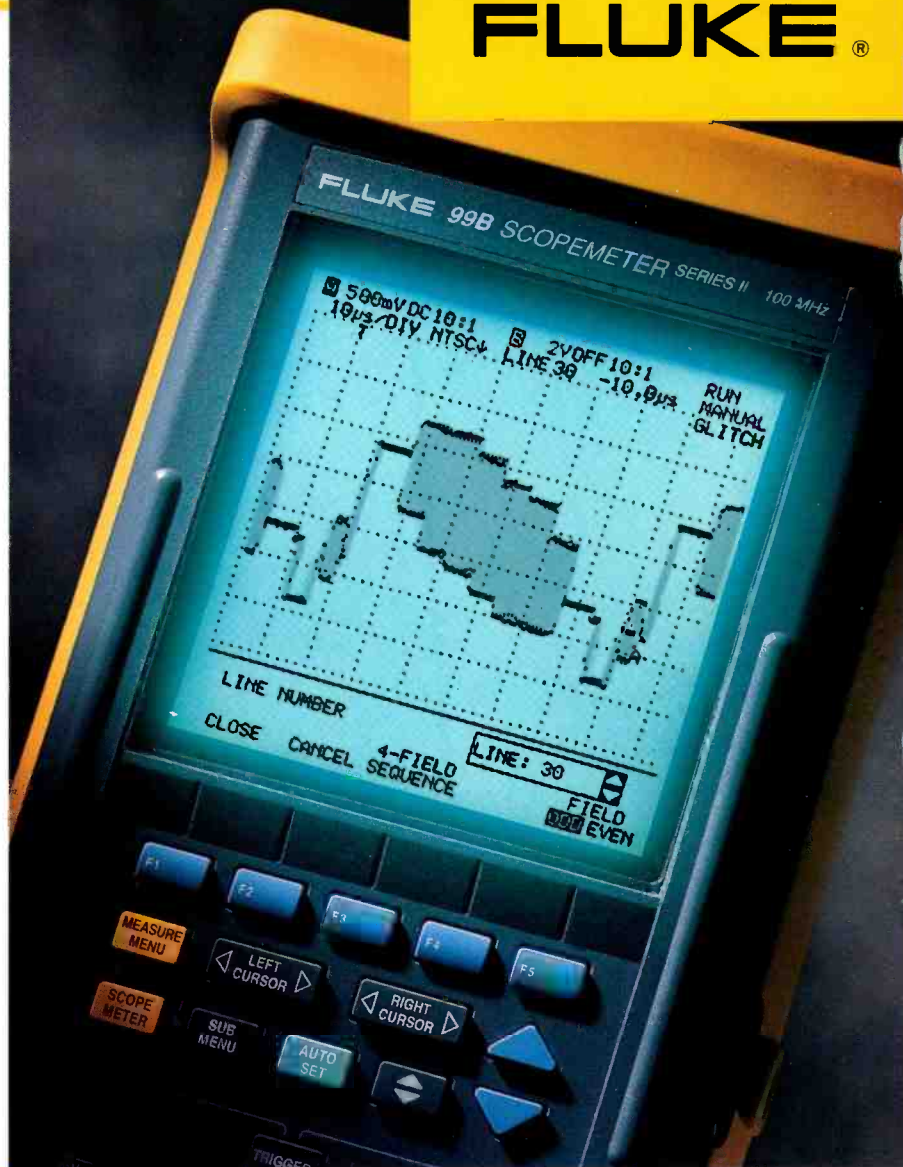

**Special
Offer.**

Only

\$945

**ScopeMeter 92B
(2ch/60 MHz)**

1-800-92-FLUKE

The ScopeMeter® 90 Series test tools—with a 10X brighter screen.

Daylight or darkness. Indoors or out. No matter where you're troubleshooting, it's easier with our ScopeMeter 90B Series. They're the same rugged, dependable, hand-held scopes you know, only much easier to read — thanks to a cold cathode fluorescent screen that's literally 10 times brighter.

They're also much more accurate, with a choice of 100 MHz or 60 MHz bandwidth and up to 5 Gigasamples/

second repetitive sampling rate. There's even video triggering, four hours of battery life and a new time and date clock feature.

And for a limited time, Fluke is offering its 92B, 60 MHz unit for only \$945. That's a savings of \$550 off the regular price of \$1,495. It's time you saw the light yourself.

To get your hands on a powerful ScopeMeter test tool, call Fluke today at 1-800-92-FLUKE.

© 1996 Fluke Corporation, P.O. Box 9090, M/S 250E, Everett, WA, USA 98206-9090. U.S. (800) 44-FLUKE or (206) 356-5400. Canada (905) 890-7600. Europe (31 40) 2 678 200. Other Countries (206) 356-5500. All rights reserved. FLU-281-104
CIRCLE 121 ON FREE INFORMATION CARD

CONTENTS

FEBRUARY 1997

ON THE COVER

35 BUILD THE PCDRILL

Except when dealing with the simplest of circuits, electronics projects invariably turn out best when a PC board is used. The problem is that making the board is often more work than building the project itself. And if you need to make several of the same board, the task can get to be overwhelming. This month, we present a project that can simplify at least one part of the task. It is a precision x/y drilling table that lets you make perfectly centered holes on even the tiniest of pads. Best of all, at under \$100 to build (including drill), it costs just a fraction of what a commercial unit would command. — *James J. Barbarello*



BUILD THIS

**55 FREEZER SENTRY
FOOD-FREEZER MONITOR**



Keep your expensive frozen meats and other foods safe from disastrous thaws with this monitor that warns you before trouble strikes. — *Dave Sweeney*

**61 CONDUCTANCE ADAPTER FOR
YOUR MULTIMETER**

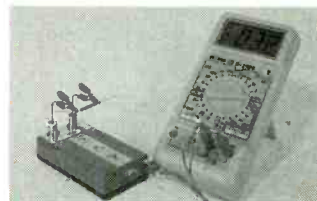

Measure very large resistances, very small leakage currents, and more with this reliable, precision add-on for your DMM. — *Skip Campisi*

As a service to readers, ELECTRONICS NOW publishes available plans or information relating to newsworthy products, techniques and scientific and technological developments. Because of possible variances in the quality and condition of materials and workmanship used by readers, ELECTRONICS NOW disclaims any responsibility for the sale and proper functioning of reader-built projects based upon or from plans or information published in this magazine.

Since some of the equipment and circuitry in ELECTRONICS NOW may relate to or be covered by U.S. patents, ELECTRONICS NOW disclaims any liability for the infringement of such patents by the making, using, or selling of any such equipment or circuitry, and suggests that anyone interested in such projects consult a patent attorney.

ELECTRONICS NOW, (ISSN 1067-9294) February 1997. Published monthly by Gernsback Publications, Inc., 500 Bi-County Boulevard, Farmingdale, NY 11735-3931. Periodicals Postage paid at Farmingdale, NY and additional mailing offices. Canada Post IPM Agreement No. 334103, authorized at Mississauga, Canada. One-year subscription rate U.S.A. and possessions \$19.97, Canada \$27.79 (includes G.S.T. Canadian Goods and Services Tax, Registration No. R125166280), all other countries \$28.97. All subscription orders payable in U.S.A. funds only, via international postal money order or check drawn on a U.S.A. bank. Single copies \$3.50. © 1996 by Gernsback Publications, Inc. All rights reserved. Printed in U.S.A.

POSTMASTER: Please send address changes to ELECTRONICS NOW, Subscription Dept., Box 55115, Boulder, CO 80321-5115.

A stamped self-address envelope must accompany all submitted manuscripts and/or artwork or photographs if their return is desired should they be rejected. We disclaim any responsibility for the loss or damage of manuscripts and/or artwork or photographs while in our possession or otherwise.

TECHNOLOGY

47 USING THE NE602
Essentially a radio-front-end on a chip, the versatile NE602 can make the task of designing and building RF circuits easier than ever.— *Joseph J. Carr*

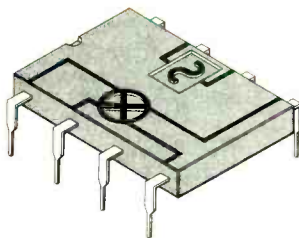

DEPARTMENTS

16 EQUIPMENT REPORT
RadioShack Probescope probe-style oscilloscope.

25 AUDIO UPDATE
Designing and using microphone splitters.— *Franklin J. Miller*

27 COMPUTER CONNECTIONS
Microsoft's biggest enemy.— *Jeff Holtzman*

65 TECH MUSINGS
Miracle energy sources, new PICs, a history of color organs, and more.— *Don Lancaster*

70 SERVICING
Troubleshooting camcorder zoom lenses.— *Ray Furlong*

73 LASER EXPERIMENTS
Special effects with a galvanic coil.— *Carl J. Bergquist*

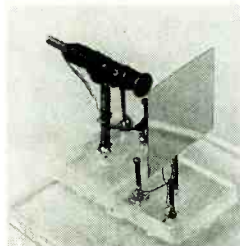
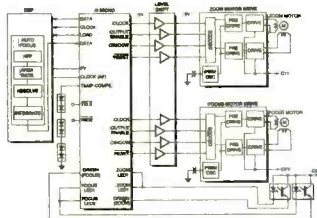

AND MORE

4 EDITORIAL	32 NEW PRODUCTS
6 WHAT'S NEWS	76 NEW LITERATURE
12 LETTERS	122 ADVERTISING INDEX
13 Q&A	122 ADVERTISING SALES OFFICE

Electronics NOW®

Hugo Gernsback (1884-1967) founder

LARRY STECKLER, EHF, CET,
Editor-in-chief and publisher

EDITORIAL DEPARTMENT

CARL LARON, editor
JOSEPH J. SUDA, associate technical editor
JULIAN S. MARTIN, associate editor
TERI SCADUTO, assistant editor
MICHAEL A. COVINGTON, N4TMI contributing editor
JEFFREY K. HOLTZMAN, computer editor
LARRY KLEIN, audio editor
DON LANCASTER, contributing editor
EVELYN ROSE, editorial assistant

ART DEPARTMENT

ANDRE DUZANT, art director
RUSSELL C. TRUELSON, illustrator

PRODUCTION DEPARTMENT

RUBY M. YEE, production director
KATHRYN R. CAMPBELL, production assistant
KEN COREN, desktop production director
LISA BAYNON, desktop production

CIRCULATION DEPARTMENT

JACQUELINE P. CHEESEBORO, circulation director
THERESA LOMBARDO, circulation assistant

REPRINT DEPARTMENT

MICHELE TORRILLO, reprint bookstore

Typography by Mates Graphics
Cover design by David Loewy

Electronics Now is indexed in *Applied Science & Technology Index*, and *Readers Guide to Periodical Literature*, *Academic Abstracts*, and *Magazine Article Summaries*.

Microfilm & Microfiche editions are available. Contact reprint bookstore for details.

Advertising Sales Offices listed on page 122.

Electronics Now Executive and Administrative Offices
1-516-293-3000.

Subscriber Customer Service:
1-800-999-7139.
7:00 AM-6:00 PM Monday-Friday MST



Audit Bureau of Circulations
Member

TraxMaker[®]

A Virtual Environment For
Growing Printed Circuit Boards

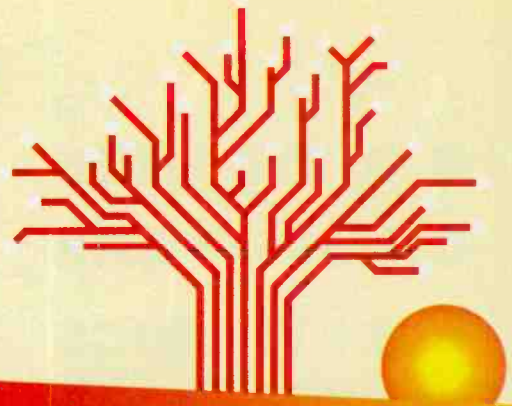

"Finally, a low cost, easy to use, professional quality, PCB design tool"

TraxMaker is a Printed Circuit Board (PCB) layout program that supports multiple layers along with full auto placement of components and autorouting of tracks. TraxMaker makes good design practice easy, according to user definable "Design Rules". It has a familiar, easy to learn Windows interface. TraxMaker is a truly cost effective package which is sure to handle your most demanding PCB design tasks. TraxMaker can be used as a standalone product or with compatible schematic capture products. When used in conjunction with CircuitMaker, TraxMaker completes a powerful beginning to end circuit design system.

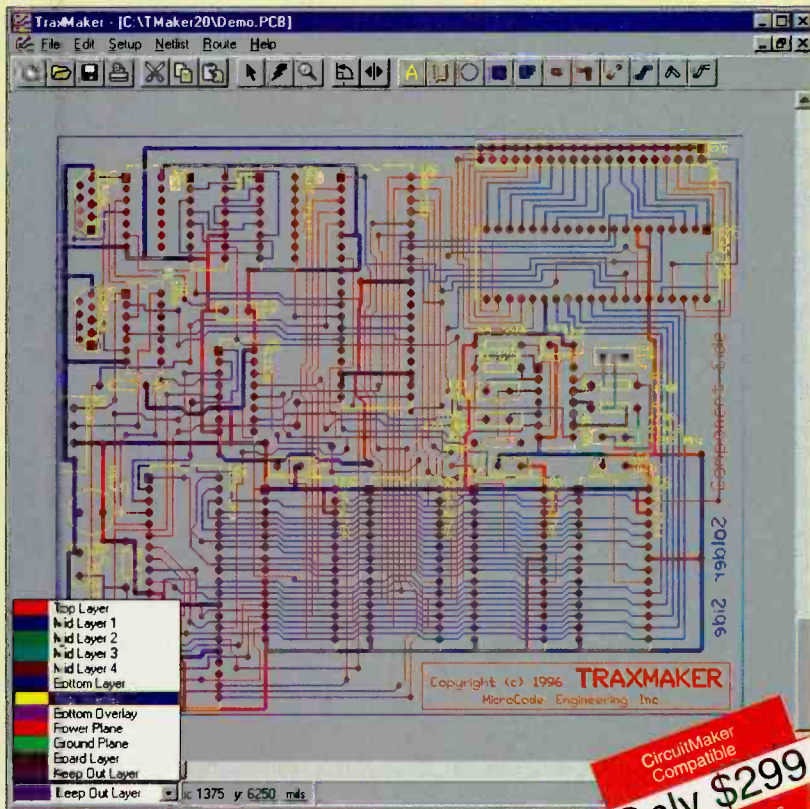

TraxMaker Features

- Exceptionally easy to learn and operate
- 6 signal layers plus power and ground planes, top and bottom overlays, and solder and paste masks
- Built-in autorouter which provides routing of entire board, individual nets, pad to pad (without net), or interactive (using ratsnest)
- Automatic component placement with user definable placement grid and keep-out areas
- Full support for both through-hole and surface mount components
- Output to any Windows compatible printing device, Gerber files, and Excellon N/C drill file
- Import CircuitMaker, Protel, and Tango netlists
- Orthogonal, curved, and any angle tracks
- Design objects include tracks, pads, vias, arcs, free text, rectangular and polygon fills
- Includes a wide selection of component patterns and new patterns can be quickly and easily created
- Choose either Metric or English units
- Maximum resolution of .001 inches (1 mil)
- Maximum board size of 32 x 32 inches

FREE Functional Demo

Product literature and a free functional TraxMaker demo are available on the Internet at <http://www.microcode.com>, on CompuServe (GO MICROCODE) and on America Online by doing a file search for TraxMaker

**Call Now to Order or
Request Additional Information**

800-419-4242



MicroCode Engineering Inc. • 573 West 1830 North Suite 4 Orem UT 84057-2030 USA • Phone 801-226-4470 Fax 801-226-6532 • Internet <http://www.microcode.com>

CIRCLE 130 ON FREE INFORMATION CARD

EARN YOUR B.S. DEGREE IN COMPUTERS OR ELECTRONICS



By Studying at Home

Grantham College of Engineering, now in our 46th year, is highly experienced in "distance education"—teaching by correspondence—through printed materials, computer materials, fax, modem, and phone.

No commuting to class. Study at your own pace, while continuing on your present job. Learn from easy-to-understand but complete and thorough lesson materials, with additional help from our instructors.

Grantham offers three separate distance-education programs, leading to the following accredited degrees;

(1) The B.S.E.T. with Major Emphasis in Electronics.

(2) The B.S.E.T. with Major Emphasis in Computers.

(3) The B.S.C.S. — the Bachelor of Science in Computer Science.

An important part of being prepared to *move up* is holding the right college degree, and the absolutely necessary part is knowing your field. Grantham can help you both ways—to learn more and to earn your degree in the process.

Write or phone for our free catalog. Toll free, 1-800-955-2527, or see mailing address below.

Accredited by
the Accrediting Commission of the
Distance Education and
Training Council

GRANTHAM
College of Engineering
Grantham College Road
Slidell, LA 70460

EDITORIAL

One of a Kind

One of the nice things about this job is that you get to meet and work with some wonderful people. High up on that list is our *Video News* editor, David Lachenbruch. That's why the news that he had passed away suddenly, shortly after the last issue went to press, was such a shock and a loss to everyone here.

David was a rare writer. A true industry "insider," his ability to gather information and rumor from many sources, distill out what was correct and what was important, and bring that information to our readers in a concise, accurate, and readable format each and every month was unmatched.

The fact that he had done it for nearly 30 years, beginning with the *Looking Ahead* column in our predecessor, **Radio Electronics**, is nothing short of extraordinary. He was one of a kind and truly will be missed.

What of his column, *Video News*? Its future is undetermined. For the time being, it will be on hiatus. The search for David's successor has already begun. It will be a hard search, because David has left behind some big shoes to fill.

And even if those shoes are filled, the man himself can never be replaced.

Carl Laron
Editor

Call for your
FREE catalog!

Your One Stop Component & Computer Source

Special Prices for
Electronics Now
Readers. Please
mention VIP #2R7!

PRECISION NAVIGATION, INC. Vector 2X Compass Module

- Pin selectable BCD or binary output format
- 3-wire serial output format (compatible with Motorola SPI and National Microwire)
- Size: 1.5"L x 1.3"W x 0.4"H



Part No.	Description	1-4	5-9
126703	Vector 2X module	\$49.95	\$44.95

Vector 2XT Gimbaled Compass Module

The Vector 2XT is a mechanically gimbaled version of the Vector 2X, where applications require some tilt compensation.

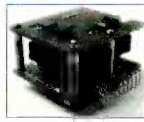

- Size: 2.5"L x 1.3"W x 0.6"H

Part No.	Description	1-4	5-9
132901	Vector 2XT module	\$99.95	\$89.95

Vector 2X Developers Kit

• Development board which allows your Vector 2X to directly communicate via the parallel port of your PC



Part No.	Description	Price
126691	Vector 2X develp kit	Special \$89.95

microEngineering Labs

"PICProto" Prototyping Boards



Part No.	Description	1-4	5-9
132644	PICProto 18	\$9.95	\$8.95
132628	PICProto Dual 18/28	14.95	13.49
132636	PICProto 3	14.95	13.49
132652	PICProto 64	16.95	14.95

CMOS PIC Microcontrollers

Part No.	Product No.	1-9	10-49
128338	PIC16C54A-04/P	\$4.49	\$4.25
128346	PIC16C54A-20/P	5.95	5.39
134156	PIC16C55/JW	14.95	13.95
134164	PIC16C55-RC/P	5.39	4.95
134172	PIC16C56-RC/P	4.95	4.49
134181	PIC16C57/JW	19.95	17.95
134199	PIC16C57-RC/P	5.95	5.39
128354	PIC16C57-XT/P	6.95	6.39
128389	PIC16C61-04/P	5.95	5.39
134201	PIC16C71-04/P	8.95	7.95
134210	PIC16C73-04/SP	12.95	11.95
134236	PIC16C84-04/P	9.95	8.95

PIC Development Kits



PICSTART Lite16C (P/N 128531) for PIC: 16C62, 16C64, 16C65, 16C74
PICSTART Lite16B (P/N 128522) for PIC: 16C54A, 16C57, 16C58A, 16C61, 16C620
 Requires 9V @ 500mA (recommend wall transformer P/N 100175)

Part No.	Description	1-4	5-9
128531	Develop. kit 16C	SALE \$119.95	
128522	Develop. kit 16B	SALE 109.95	

JAMECO 3 1/2-Digit Pocket Multimeter

- Measures: AC/DC voltage, AC/DC current, HFE and resistance
- DC voltage: 200mV, 2V, 20V, 200V, 1000V
- AC voltage: 200V, 750V
- Resistance: 200Ω, 2kΩ, 20kΩ, 200kΩ, 2MΩ
- DC current: 200mA, 2mA, 20mA, 200mA, 10A
- Diode test
- Transistor HFE
- Removable test leads

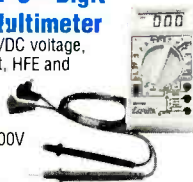

Part No.	Description	Price
119212	Pocket meter with test.....	\$17.95

Jameco Digital Lab

- Includes:
- Solderless breadboard
 - DC power supplies
 - Two 7-segment displays
 - Function generator (5 ranges)
 - Digital voltmeter (DVM) 4 ranges
 - Size: 10.6"W x 13.3"D x 5.0"H

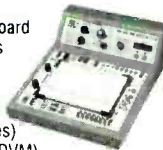

Part No.	Description	1-4	5-9
75838	Digital lab	SALE \$259.95	

Jameco E(EPROM) Programmer

- Programs EPROMs, EEPROMs
- Programs 16Kbits to 512Kbits EPROMs
- Programming speeds/algorithms: normal, intelligent, and quick pulse



Part No.	Description	1-4	5-9
101400	1 socket 16Kbits-512Kbits E(EPROM) prog.....	Special \$119.95	

80C52-Basic Microcontroller

- The 80C52-Basic chip is a custom-masked 80C52 microcontroller with a full-featured 8K-byte ROM-resident Basic-52 interpreter.
- Hardware:
- Operates DC to 12MHz
 - On-chip oscillator and clock circuit
 - 256 x 8-bit RAM
- Software:
- Full BASIC interpreter in ROM on a single chip
 - "Stand-alone" software development
 - Interrupts can be handled by BASIC or Assembly Language



Part No.	Description	1-9	10-49
125647	CPU 8-bit CMOS	\$19.95	\$17.95
126375	Microcontr. Idea Book	34.95	31.49
126252	Basic-52 Progr. Ref.	SALE 19.95	
126295	Basic-52 3.5" Disk	11.95	10.49

Serial Backpack with 2 x 16 LCD Display

- The backpack is a daughterboard with an LCD module attached that receives data serially and displays it on the 2 row, 16 column display.
- Size: 3.1"L x 1.4"W



Part No.	Description	1-4	5-9
131219	Serial pack w/ LCD	\$59.95	\$53.95

Analog Display Soldering Station

- Electronic temperature control from 200°F to 878°F
- Includes one 1/16" tip



Part No.	Description	1-4	5-9
114569	Analog disp. station	\$99.95	\$89.95

Benchtop PC Board Solder Station

- Holds PC boards up to 13" wide
- Can be adjusted by using press release and sliding support arm to hold desired size board
- Right hand soldering iron holder
- Size: 19.5"W x 8.8"D x 8.8"H



Part No.	Description	Price
133065	PC brd. solder stat.	Special \$39.95

ABS Speedy Box and Board

- 18913: Speedy Box**
- Size: 4.9"L x 2.5"W x 1.5"D
 - Weight: 3.4 oz.
- 105128: PC Board**
- Number of holes: 671
 - Size: 4.4"L x 2.0"W



Part No.	Description	1-9	10-49	50-99
18913	Speedy box	\$2.49	\$2.25	\$1.79
105128	PC board	4.95	4.49	3.95

Jameco Solderless Breadboards

- Low static plastic body - CMOS safe
- Nickel plated clips designed to withstand up to 5,000 insertion cycles



Part Number	Contact Points	Size L x W	1-9	10-49
94457	100	6.5 x 0.4	\$2.49	\$2.25
20600	400	3.3 x 2.1	4.95	4.49
20669	630	6.5 x 1.4	5.95	5.35
20722	830	6.5 x 2.1	SALE 6.95	
20757	1,360	6.5 x 3.1	SALE 11.95	
20773	1,660	6.5 x 4.3	16.95	14.95
20790	2,390	6.9 x 5.8	21.95	19.95
20811	3,220	7.3 x 7.5	29.95	27.95

Jameco 51 Piece Tool Kit

- An assortment of the most essential tools for maintenance and repair jobs. Black vinyl-covered case features removable pallets, a combination lock and a cushioned, black plastic handle.
- Weight: 11.0 lbs.
 - Size: 12.5"L x 17.5"W x 3.5"H



Part No.	Description	Price
26681	51 piece tool kit	Special \$99.95

Video Transmitter Station

- This powerful new device transmits from a source location to any number of remote locations through TVs. Excellent for security surveillance!
- Transmit/receive: channels 7-13
 - Use with a camcorder for stereo audio sound
 - Includes audio & video cables



Part No.	Description	1-4	5-9
131828	Video transmitter	\$49.95	\$44.95

Digital Voice Recorder Kit

- 20-sec. single or multiple voice/sound recorder
- Easy to use 3 button switches (start, record and play)
 - High quality, natural voice/audio reproduction
 - 100 year message retention
 - Board size: 4.6"L x 2.1"W
 - Weight: 0.2 lbs.



Part No.	Description	1-4	5-9
116484	Voice recorder kit	SALE \$49.95	

DC to Pulse Width Modulator

- This control circuit is ideal for the accurate control of DC motors, lighting levels, small heaters as well as other applications. The circuit converts a DC voltage into a series of pulses, such that the pulse duration is directly proportional to the value of the DC voltage. The great advantage of such a circuit is that almost no power is lost in the control circuit.



Part No.	Product No.	1-4	5-9
120539	K8004	Special \$19.95	

ASTECC 121 Watt Switching Power Supply

- Output:
- + 5VDC @ 5.5A
 - + 12VDC @ 2.5A
 - + 24VDC @ 1.8A
 - + 12VDC @ 0.2A
- Input: 115/230VAC @ 50/60Hz
- Input jumper selectable
 - Size: 9.4"L x 6.0"W x 2.4"H
 - Weight: 2.5 lbs.



Part No.	Product No.	1-9	10-24
114622	AA12390	\$12.95	\$11.49

Jameco Electronic Component Cabinet Kits

- Kits include the most popular components with extra space for your customized expansion. Each kit includes a 20 drawer component cabinet.



More kits available - call for details!

Part No.	Description	Price
84953	330 pc. 7400 series IC kit	\$169.95
84961	420 pc. 74LS series IC kit	\$149.95
84970	300 pc. CD4000 series IC kit	\$99.95
84988	385 pc. Linear series IC kit	\$179.95
108329	540 pc. 1/8 watt Resistor kit	\$29.95
81832	540 pc. 1/4 watt Resistor kit	\$28.95
107879	540 pc. 1/2 watt Resistor kit	\$31.95
108433	2200 pc. Electr. Hardware kit	\$39.95
81867	110 pc. Radial Capacitor kit	\$34.95
81859	320 pc. Ceramic Capacitor kit	\$29.95
81883	160 pc. Mylar Capacitor kit	\$34.95
81841	129 pc. Tantalum Capac. kit	\$49.95
82587	270 pc. Diode kit	\$39.95
82595	180 pc. Transistor kit	\$49.95

JAMECO ELECTRONIC COMPONENTS COMPUTER PRODUCTS

© 1997 Jameco 2/97
Ordering Hours:
 5:30am - 5:30pm PST

1355 Shoreway Road Belmont, CA 94002-4100
 Call for your FREE catalog!
 FAX: 1-800-237-6948 (Domestic)
 FAX: 415-592-2503 (International)
 E-mail: info@jameco.com
 http://www.jameco.com



Call 1-800-831-4242 to order today!



WHAT'S NEWS

A REVIEW OF THE LATEST HAPPENINGS IN ELECTRONICS

No Risk in Ordinary EMF Exposure

According to the U.S. National Research Council, a 16-member panel that spent three years reviewing over 500 studies on electromagnetic fields (EMF), there is no evidence that exposure to ordinary household electric and magnetic fields causes harm to humans. There is an unexplained link, however, between living near large, high-current electric power lines and the incidence of childhood leukemia.

"Research has not shown in any convincing way that electromagnetic fields common in homes can cause problems," said Dr. Charles Stevens, head of the panel and a staff member at the Salk Institute in La Jolla, California. "Extensive laboratory tests have not shown that electromagnetic fields can damage the cell in any way that is harmful to human health."

As for the leukemia link, long-term effects have not been measured, and the possibility of other risk factors have not been taken into account. In light of those problems, the U.S. National Research Council committee reported that the findings "have been inconsistent and contradictory and do not constitute reliable evidence of an association [between EMF and leukemia]."

The committee's report provided no definitive answers to the questions of potential harm from EMF exposure. Other studies of the effects of EMF are under way. Congress has ordered a five-year, \$65-million study into the possible relationships between EMF and breast cancer, nervous-system damage, and other health problems to be conducted at four federal laboratories. The federal government and the electric power industry are jointly funding another laboratory experiment in which biological samples will be exposed to electromagnetic radiation; unfavorable biological effects will be sought.

Electronics Engineers' Web Site

Eg3 Communications' Web site is a free resource for busy electronics design engineers. The EE Virtual Trade Conference (EE VTC) can be reached at <http://www.eg3.com/vtc.htm>. As part of EG3's Virtual Publishing Project, it is free to download, requires no registration, and is available worldwide via the Internet.

The EE VTC features more than 225 technical white papers on topics such as Object Oriented Programming, Virtual Distribution, DSP, the Set Top (Internet) Box, WWW for Embedded Systems, Embedded Java, Networking and Embedded Networking, Real-Time Operating Systems, and Designing with the 8051 or 68HC11.

As an experimental project, the EE VTC can be downloaded as a free software tool after registration, or it can be accessed at any of three Web sites: www.eg3.com, www.eetoolbox.com, and www.cera2.com. If you want more information, it can be obtained via e-mail at info@eg3.com.

Smithsonian Traveling Exhibition Web Site

The Smithsonian Institution Traveling Exhibition Service (SITES) has opened a World Wide Web site that lets people across the country click on a button to find the Smithsonian exhibit closest to them. The Web site, which can be reached at <http://www.si.edu/organiza/offices/sites>, gives viewers access to touring schedules, descriptions, and educational materials for SITES' many exhibits on art, history, and science.

"SITES' new Web page multiplies the possibilities of a 'Smithsonian Without Walls.' For the first time, viewers can peruse the Institution electronically and

see when SITES exhibitions will be presented in their own communities," said SITES director Anna R. Cohn.

Viewers who check out the "Ocean Planet" page, for instance, not only see where that exhibit is traveling, but can also take a virtual tour of the show itself through a link to the Ocean Planet Web site (http://seawifs.gsfc.nasa.gov/ocean_planet.html).

Teachers will find the Web site especially useful. They can click on an "Exhibition Description" page, see when the exhibit will be in their area, view a sample curriculum guide, and locate their local Geographic Alliance Coordinators to request printed versions of the resource.

Each month, the "Hot News" page will be updated to provide an insider's view of SITES. Topics will range from in-depth articles on exhibitions and stories from museums and exhibit centers in the field to special features on new programs. The "Publications" page offers sales information about catalogs, brochures, and posters produced in conjunction with SITES exhibitions.

International Broadcasting Standards Task Force Formed

Senior executives of the Society of Motion Picture and Television Engineers (SMPTE) and the European Broadcasting Union (EBU) met last fall in Amsterdam to discuss technical matters—most notably, the need for a standardized means of data exchange.

With the increasing amount of computer-based equipment being used for television production, users require the ability to exchange audio, video, and associated data easily and reliably between different systems. The multiplicity of solutions, often proprietary, being implemented or proposed adds to the

continued on page 22

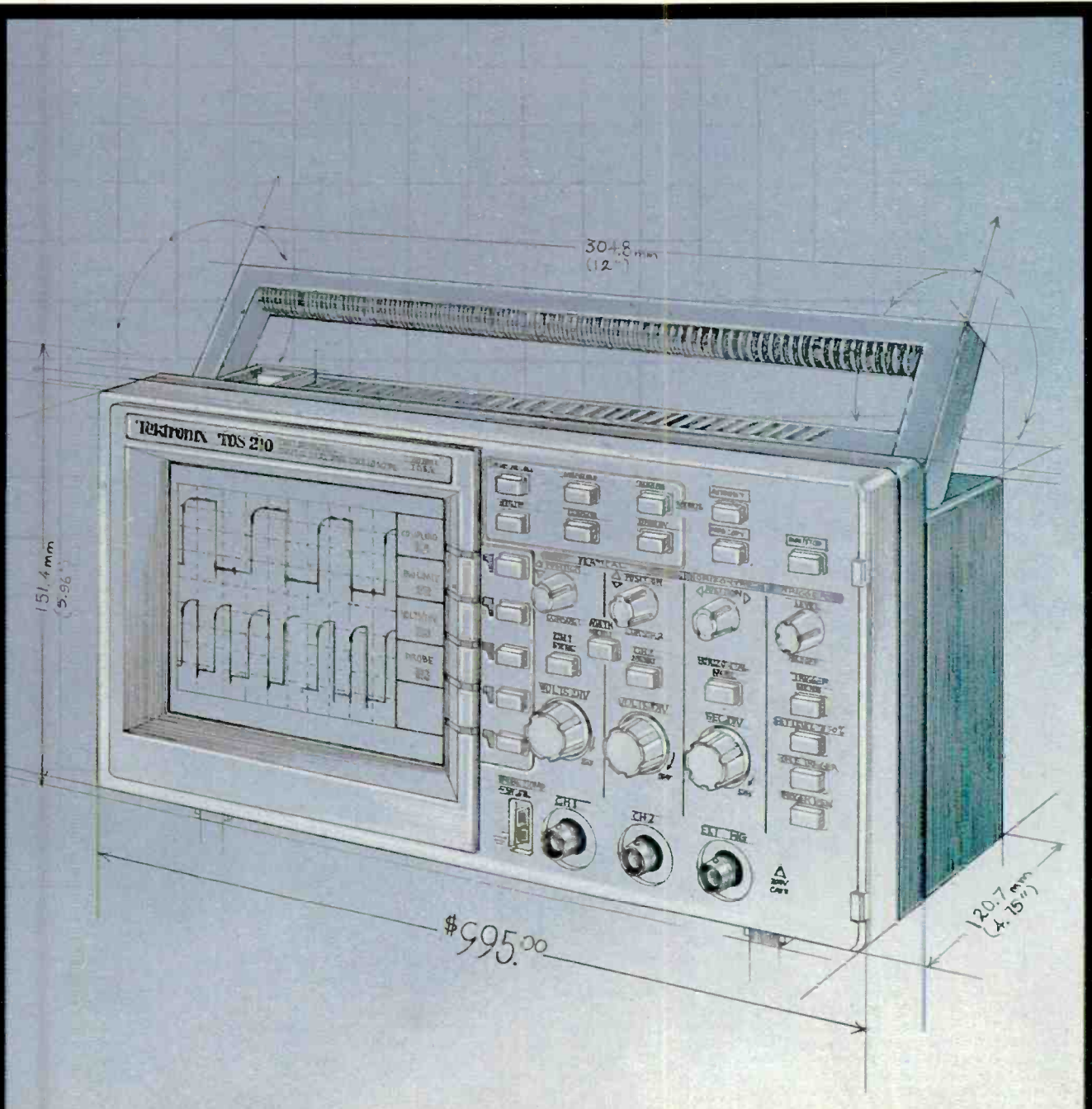

This digital scope is a major breakthrough no matter how you measure it.



It's never been easier to pick up a Tektronix digital scope. Just \$995 will get you the 60 MHz TDS 210, while \$1695 will get you its 100 MHz big brother, the TDS 220.

Both come loaded with dozens of great features like triggering and automatic setup. They'll even

store or recall your measurements at the push of a button. Yet despite all that, the actual scopes are as diminutive as their price tags. Making them easy to pick up in more ways than one. For more information, please contact your Tektronix distributor or call 1-800-479-4490, Action Code 313. Or, visit us at www.tek.com.

Tektronix

Get 3 books only \$9.95 plus 1 book FREE upon prepayment

when you join the **Electronics Engineers' Book Club®**

Values to \$269.50

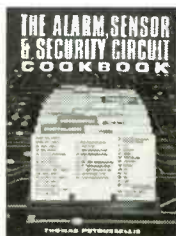

0497060 \$29.95
Construct sophisticated security, convenience, and entertainment devices with this guide. You'll find schematics, photos, and instructions for building temperature and pressure sensors, smoke and toxic gas detectors, a remote video and control system, and more!
• 304 pp. • 232 illus.

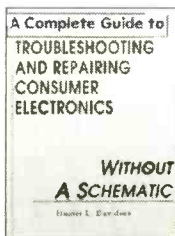

0156492 \$34.95
Tackle troublesome circuits without the benefit of a schematic with these tricks of the trade by a veteran electronics technician. See how to locate, test, and repair defective components in virtually every type of consumer electronics device imaginable.
• 304 pp. • 250 illus.

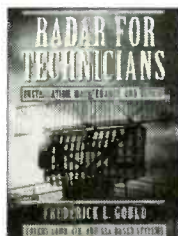

0240620 \$45.00
Examine all aspects of radar, from its history and development, through components and theory, to installation, maintenance, and repair techniques for the technician. Includes transmitters, modulation techniques, RF generators, waveguides, antennas, receivers, and more.
• 304 pp. • 232 illus.

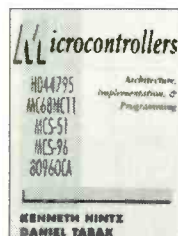

0289778-XX \$56.00
See how a controller can be used in anti-lock brakes, cash registers, and robotic systems. Get details on controllers such as the Motorola 8-bit MC68HC11, and the 32-bit Intel 8051 and 80960CA to help you use devices in your projects. • 350 pp. • 125 illus.
• Counts as 2

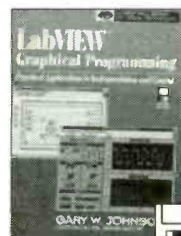

0326924 \$45.00
This book/disk package outlines a logical analysis methodology, detailing how to define each problem and then showing you how to establish a solution and design technique. The disk contains 4 LabVIEW libraries. • 546 pp. • Illustrated

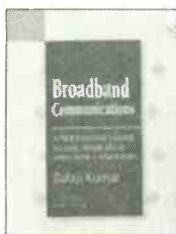

0359687 \$65.00
Keep up on the standards, services, architectures, applications, markets, and key players with this reference. Emphasizes the asynchronous transfer mode (ATM) technology, its protocol, and its switching and working environment. • 544 pp. • 300 illus.

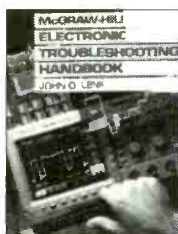

0376581 \$39.50
Pinpoint component faults and correct design flaws for virtually every type of electronic circuit with this handbook. Both circuit theory and step-by-step troubleshooting techniques are given for each circuit or component.
• 550 pp. • 170 illus.

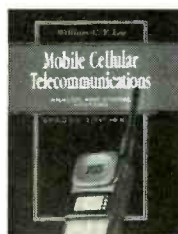

0380899-XX \$60.00
Find a complete technical description of the design, analysis, and maintenance of cellular systems in the second edition of this classic reference. Features new chapters on the CDMA standard, microcell systems, and more. • 224 pp. • 142 illus. • Counts as 2

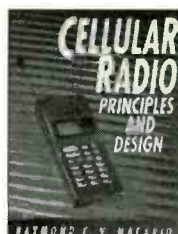

0443017-XX \$50.00
Gain a firm understanding of some of the most advanced person-to-person communications systems being installed today with this comprehensive look at modern cellular technology. Covers both analog and digital cellular systems.
• 580 pp. • 155 illus. • Counts as 2

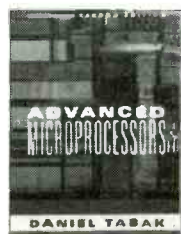

0628432 \$60.00
This newly revised edition covers the latest high-potential systems, such as Pentium, PowerPC, DEC Alpha, SuperSPARC, and others. It discusses basic architecture principles through CISC and RISC machines.
• 350 pp. • 200 illus.

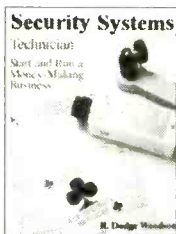

0717753 \$19.95
Become self-employed as a security systems contractor—this book shows you how. Woodson helps you decide whether you are cut out to run your own business and covers every aspect, from start-up capital to collecting past-due accounts. • 304 pp. • 150 illus.
• Softcover



0239193 \$27.95
This practical guide focuses on the specific digital circuits used in electronic power applications. It presents state-of-the-art approaches to analysis, troubleshooting, and implementation of new solid-state devices.
• 272 pp. • 197 illus.



0042144 \$39.00
Provides a solid introduction to programmable controllers. Explore how to use personal computers with programmable controllers as well as how to compare and select process control schemes.
• 304 pp. • 180 illus.

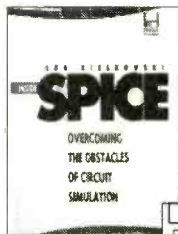

911525X \$50.00
Packed with sample circuit simulations that clearly illustrate a variety of common problems and their solutions. This in-depth guide shows you step by step how to deal with the stumbling blocks of non-convergence, numeric integration instabilities, and timestep control errors. • 208 pp. • 200 illus.



9119018 \$32.95
Offers information on everything from computer parts and tools to pricing and advertising. It covers areas of specialization, profiles auxiliary services, and even predicts future opportunities. The shareware disk packaged with the book includes a collection of diagnostic tools. • 352 pp. • 63 illus.
• Softcover

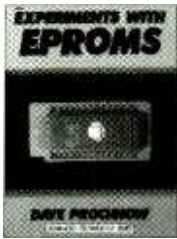

156490X \$18.95
 One of the greatest versatilities in advanced circuit design is EPROM (Erasable-Programmable Read-Only-Memory) programming. Contains in-depth look at these special integrated circuits (ICs) that can be user-programmed to perform specific applications in a microcomputer. • 230 pp. • 241 illus. • Softcover

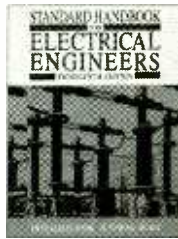

0209847-XXX \$115.00
 Since 1907, this massive handbook has been the standard by which all other electrical engineering handbooks have been measured, and with the introduction of the all-new 13th edition, the tradition continues. • 2,208 pp. • 1,421 illus. • Counts as 3

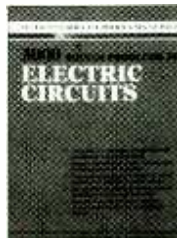

0459363 \$22.95
 Covers units and basic concepts, resistance and Ohm's Law, series and parallel resistive circuits, Kirchhoff's Laws, network theorems, waveforms and circuit relationships, complex numbers and phasors, magnetically coupled circuits. • 746 pp. • Softcover

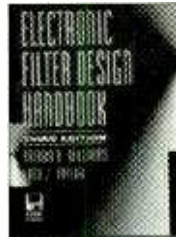

0704414 \$79.50
 Still the number one resource for designers in the field, the third edition of this classic handbook has been extensively revised and updated to reflect the enormous recent advances in electronic filter design...while maintaining the overall emphasis on practicality that made prior editions so appealing. • 704 pp. • 220 illus.



0520550 \$60.00
 This easy-to-use guide examines printed and L-C filters for RF microwave, and wireless applications, emphasizing the practical issues of filter development and integrating the PC into the design process. It also includes basic theory, element models, and discussion of computer-aided design issues. • 528 pp. • 150 illus. • Softcover



0501696 \$55.00
 Develop sophisticated electronic simulation tools capable of analyzing large, complicated circuits. Topics include Gaussian elimination, LU and Cholesky decomposition, forward- and back-substitution, pivoting for accuracy, matrix sparsity, simple RC circuits, and more. • 320 pp. • Illustrated

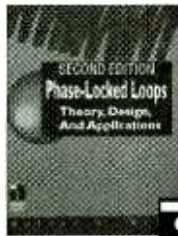

9113869 \$55.00
 Develop the expertise to design the most efficient phase-locked loops for all kinds of electronic devices. Gives design and applications information for all four types of PLLs: linear, digital (an analog/digital hybrid), all-digital, and software. • 370 pp. • 100 illus.

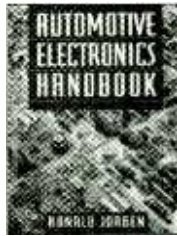

0331898-XX \$89.50
 This book examines sensors and actuators; electric cars, intelligent-vehicle highway systems, and noise cancellation; instrument panel displays, safety features, and antitheft devices; and more. • 784 pp. • Illustrated • Counts as 2

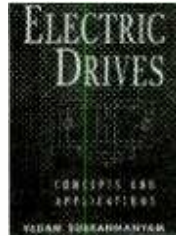

4603701 \$70.00
 Provides an exhaustive and comparative study of both conventional and static converter-based drives. It familiarizes you with the concepts of closed loop control and the dynamics of drives, as well as how to solve various technical problems. • 736 pp. • 300 illus.

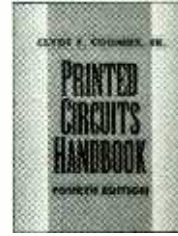

0127549-XX \$89.50
 This classic work has been refocused on producing reliable PCBs in a cost-effective fashion. Emphasizes a total solution approach for each topic, providing you with specific "how-to-do-it" information on the printed circuit processes of design, fabrication, assembly, and testing. • 900 pp. • 800 illus.

As a member of the Electronics Engineers' Book Club® ...

... you'll enjoy receiving Club bulletins every 3-4 weeks that contain exciting offers on the latest books in the field—at savings up to 50% off regular publishers' prices. If you want the Main selection, do nothing and it will be shipped automatically. If you want another book, or no book at all, simply return the reply form to us by the date specified. You'll have at least 10 days to decide. If you ever receive a book you don't want due to late delivery of the bulletin, you can return it at our expense. Plus, you'll be eligible for FREE books through the Bonus Book Program. Your only obligation is to purchase 3 more books during the next 2 years, after which you may cancel your membership at any time.

All books are hardcover unless otherwise noted. Publishers' prices shown. If you select a book that counts as 2 choices, write the book number in one box and XX in the next. If you select a counts as 3 choices, write the book number in one box and XXX in the next 2 boxes. A shipping/handling charge & sales tax will be added to all orders.

If card is missing, write to:

Electronics Engineers' Book Club®
 A Division of The McGraw-Hill Companies
 P.O. Box 549, Blacklick, OH 43004-9918
 Phone: 1-614-759-3666
 (8:30 am to 5:00 pm EST Monday-Friday)

Fax: 1-614-759-3749
 (24 Hours a day, 7 days a week)

ELECTRONICS ENGINEERS' BOOK CLUB®

A Division of The McGraw-Hill Companies, P.O. Box 549, Blacklick, OH 43004-9918

YES! Rush me the following titles(s), billing me just \$9.95 (plus shipping/handling & sales tax). Enroll me as a member of the Electronics Engineers' Book Club according to the terms outlined in this ad. If not satisfied, I may return the book(s) within 10 days for a full refund and my membership will be cancelled. I agree to purchase just 3 more selections at regular Club prices during the next 2 years and may resign anytime thereafter.

Bill me (FREE book not available with this payment option.)

Code #'s of my book(s) for \$9.95

--	--	--	--	--	--	--	--	--	--

If you select a book that counts as 2 choices, write the book number in one box and XX in the next.
 If you select a counts as 3 choices, write the book number in one box and XXX in the next 2 boxes.

SPECIAL OFFER! Prepay your order by check, money order, or credit card and receive a 4th book of your choice FREE.

Yes! I want the FREE BOOK indicated at right. My introductory payment of \$9.95 plus \$9.95 shipping/handling* and applicable sales tax is enclosed.

CODE # OF MY FREE BOOK

SINGLE TRANSACTION ONLY

Check or money order enclosed made payable to: The McGraw-Hill Companies

Please charge my: VISA Mastercard American Express Discover

Acct. No. _____ Exp. Date _____

Name _____ Signature _____

Address/Apt. # _____

City/State/ Zip _____

Offer valid for new members only, subject to acceptance by EEBC. U.S. orders are shipped 4th Class Book Post. Canada must remit in U.S. funds drawn on U.S. banks. Canadian orders are shipped International Book Post—add \$12.50 shipping/handling. Applicants outside the U.S. and Canada will receive special ordering instructions. A shipping/handling charge & sales tax will be added to all orders. DRE297C



LETTERS

SEND YOUR COMMENTS TO THE EDITORS OF ELECTRONICS NOW MAGAZINE

Fan Speed Correction

I noticed an error in the schematic diagram for my article "Build This Fan Speed Control for Your Furnace" (*Electronics Now*, December 1996). Diode D2 should be shown connected across C1, and the ground terminal of IC1 should connect to the circuit's input terminal 4. I hope that this has not caused any inconvenience.—Anthony J. Caristi

7107 Update

We have become aware of several problems in the article "Using the 7107," which appeared in the November, 1996 issue. First of all, there is a mistake in the pinout of the device as shown in Fig. 1; pins 1 and 26 are reversed. The positive 5-volt supply should connect to pin 1, and the negative supply to pin 26.

*There are also some problems with several of the application circuits. Updated information and/or corrected drawings for Figs. 4, 5, 6, 9, 10, and 12 can be found on our FTP site (<ftp.gernsback.com/pub/EN>) in a file called 7107.zip. If you cannot access the site, the information can be requested by sending a self-addressed, stamped, business-size envelope to *Electronics Now*, 7107 Update, 500 Bi-County Blvd., Farmingdale, NY 11735.*

We are sorry for any inconvenience this might have caused.—Editor

Audio Musings

I'm writing to thank you for two very interesting, informative, and well-documented articles that appeared in the October 1996 issue of *Electronics Now*: "Where Has All the Good Stuff Gone?" by Gary McClellan, and Larry Klein's "Audio Update" column titled "Hi-Fi Fixes, Stealth Squeaks, and Bio EQ." The two articles, however, gave me the impression that many so-called audiophiles are becoming less interested in the quest for true sound reproduction and are leaning more toward nostalgia or some sort of status symbol.

I decided to listen to and compare for myself the sound of tube versus transistor power amplifiers. The tube amps were the Heathkit W5-M, a version of the once highly popular ultra-linear Williamson circuit, and the Harmon Karmon D1100A Festival, a 1956 receiver that uses a pair of 5881 tubes in push-pull. The solid-state unit was a Southwest Technical Products Corporation 215/A power amp, a 25-watt-per-channel version of their Tiger .01 (the original Tiger .01 appeared in the March 1973 issue of *Radio-Electronics*). Although the difference in sound quality was very small, I found that the 215/A solid-state unit had a more clear and pleasant sound quality, while the tube units were a little mushy. Tests with a sinewave audio generator, resistive load, and oscilloscope show that the tube amplifiers distorted at very low frequencies (sometimes as high as 30 Hz) at less than full rated power output. I suspect that is due to output transformer core saturation, because the more expensive transformers would go lower in frequency before the distortion occurred. Sadly, the Peerless output transformer in the Heathkit W5-M shorted primary to secondary. The Southwest Tech 215/A has been running 24 hours a day for almost 20 years. The only problem I have had was the power supply filter capacitors opening suddenly, causing a raucous buzzing sound.

Strangely, one of the latest trends in hi-fi has been the use of single-ended triodes, without the inverse feedback usual-

ly used to reduce distortion, to purposely accentuate second-order harmonic distortion. Because those amplifiers are very inefficient, low powered, horn-loaded speakers are often used with them. To obtain loud volume, speaker sensitivities must be about 100 dBa/1 watt/1 meter.

I agree with Mr. Klein that my music system, and other audio systems that I hear regularly, sound better some days than others. Although I think it is me, not the hardware, maybe the best way to determine for sure would be to have several critical-eared people listen at the same time and see if all or most hear the same changes in sound quality simultaneously. Frankly, I would like to see an audio system designed to produce the most clear and natural rendition of speech and music, using whatever technology is best, with minimum cost, complexity, and physical bulk. Unfortunately, I still find that it takes a 12-inch woofer, in at least a four-cubic-foot ported enclosure, to faithfully reproduce full, true, bass sounds.

Mr. McClellan mentioned that once the tube equipment is snatched up, older quality solid-state units will get big tickets. The early transistor amps sounded awful and were unreliable, even for their day. Furthermore, the germanium transistors used in the early models are now scarcer and more expensive than many tubes. The Southwest Technical Tiger .01 and other units of its vintage used a fully push-pull complimentary circuit, with controlled open loop gain. That was one of the most important breakthroughs in the history of high-fidelity transistor-amplifier design, and I think most current high-end models use some variation of it. Although Southwest Technical no longer makes electronic kits, the circuit can be scratch-built and is reasonably tolerant of transistor and power transformer substitutions. Maybe the Tiger .01 will become a hot collector's item someday.

MICHAEL KILEY
Midlothian, IL

Write To:
Letters,
Electronics Now Magazine,
500 Bi-County Blvd.,
Farmingdale, NY 11735

Due to the volume of mail we receive, not all letters can be answered personally. All letters are subject to editing for clarity and length.



Q & A

READERS' QUESTIONS, EDITORS' ANSWERS

PIC Book Found

PIC microcontrollers are a "hot topic" right now, as that exciting new technology is becoming more and more accessible to experimenters.

In the November issue, a reader wrote to ask if there was a good introductory book on programming PIC microcontrollers. We've finally found one: *Easy PIC'n*, by David Benson. That 152-page paperback assumes you know some digital electronics but no assembly language. It demystifies PIC programming for beginners and includes many simple, complete example programs. The price is \$29.95 plus \$3.00 postage (and 7.25% tax if you live in California) from Square 1 Electronics, PO Box 501, Kelseyville, CA 95451.

Groundless Audio?

Q The specifications of my Audiovox car stereo read: "Output wiring: Floating-ground type designed for 4-speaker use." Why am I warned to never ground the negative output wires? Why is it that when using only 2 speakers (instead of 4) I can splice together the positive wires for the front and rear speakers without shorting out?—M. G., McAllen, TX

A Figure 1 shows the basic idea: Each stereo channel has an amplifier with two output stages that produce exactly opposite waveforms. One output stage goes to each side of the speaker. During an audio cycle, each side of the speaker swings positive, while the other swings to 0 volts. As a result, the speaker cone can undergo 24 volts' worth of movement even though the car stereo uses a 12-volt supply. The amplifier would be damaged if either of its outputs were shorted to ground.

You can't parallel the left and right channels because one of them might be swinging high while the other is swinging low. But you can join the corre-

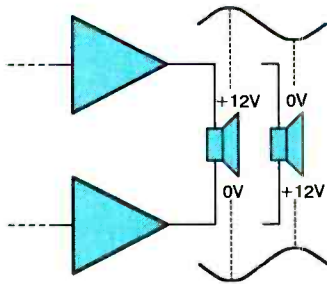

FIG. 1—IN A "FLOATING-GROUND" output stage, the two sides of the speaker are driven with opposite waveforms; neither side of the speaker is grounded.

sponding speaker wires for front and rear left or front and rear right, because the front and rear speakers carry exactly the same signal; in fact the signal is divided up between them after it leaves the amplifier.

Op-Amp Testing

Q In electronics school, we discussed op-amps but not how to test them. Can you explain how to test them? I already know the theory behind them.—R. A., Los Lunas, NM

A The circuit in Fig. 2 is a simple "dead or alive" test for an op-amp. It's an oscillator that produces a 1500-Hz squarewave, audible as a tone in the speaker. By looking at the output with

an oscilloscope, you can measure the rise time. Several op-amps can be tested at once by cascading them as shown in the diagram. That would be a handy circuit to build in a small plastic case with sockets for common single, dual, and quad op-amps.

The other op-amp parameter that you're likely to want to measure is noise. The best way to do that is build the circuit you're interested in (such as an audio amplifier) with a socket for the op-amp, then try various types. If you do that you'll find that the TL071 and TL081 outperform the old 741 in practically all applications.

Fan On Demand

Q I am designing a circuit to monitor the temperature of a heat sink and proportionally control the speed of a 12-VDC fan. I plan on using an LM34 precision temperature sensor. I would like to find a circuit to convert the output voltage from the LM34 to a change in duty cycle to control fan speed through a driver stage.—N.G., Amherst, NY

A The precision offered by a silicon temperature sensor is not needed in this application. Figure 3 shows a circuit that we breadboarded using a conventional 10K thermistor. The motor is fed with pulses whose duty cycle goes from 34% at room temperature (the mini-

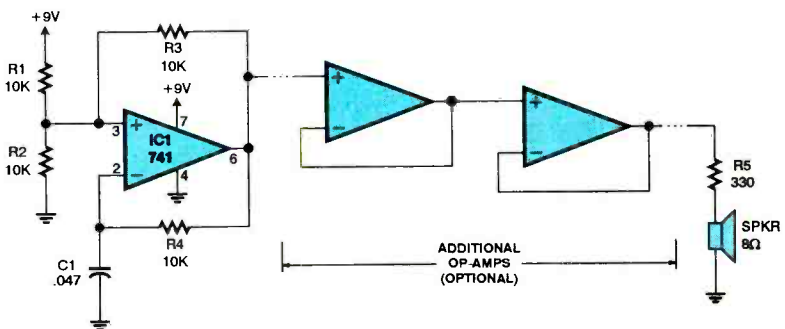

FIG. 2—THIS OP-AMP TESTER generates a 1500-Hz tone in the speaker. Any number of op-amps can be cascaded for testing at the same time.

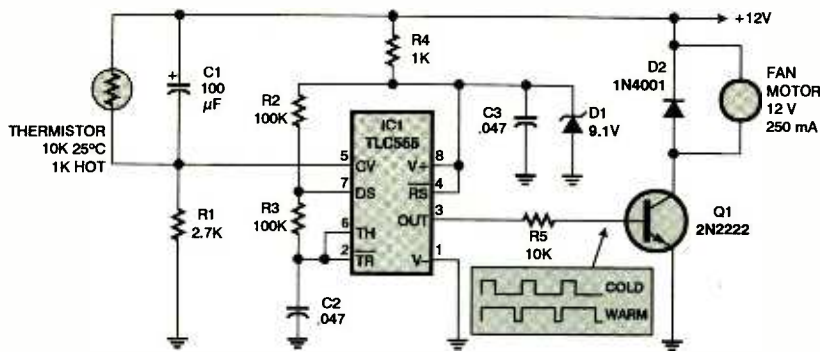

FIG. 3—THE SPEED OF THE FAN MOTOR increases as the thermistor gets warmer. The motor is fed with pulses whose duty cycle increases from 34% to 100%.

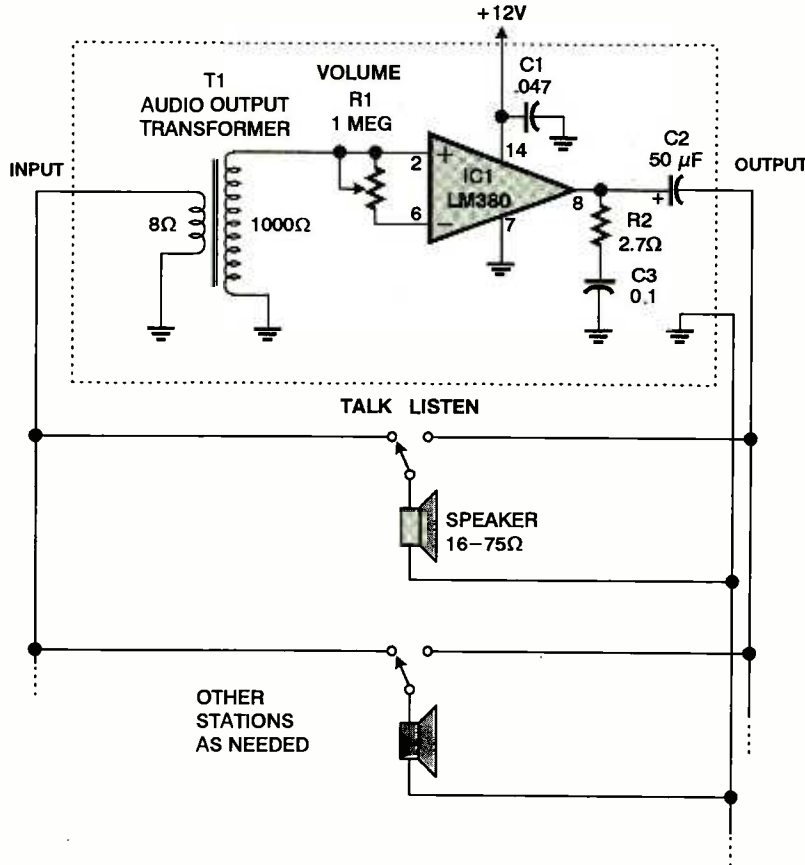

FIG. 4—TAKEN FROM A NATIONAL SEMICONDUCTOR application note, this intercom circuit is built using the LM380, though it could be easily adapted to use other op-amps. Additional stations should be wired in parallel with those shown.

mum that will run the motor reliably) to 100% at high temperatures.

The circuit design involves two subtleties. First, the TLC555 runs off its own 9.1-volt supply, regulated by a Zener diode. That ensures that the maximum control voltage from the thermistor circuit (about 9 volts) will indeed produce a 100% duty cycle. Second, the 100-µF capacitor across the thermistor simulates a high temperature for a few seconds when the circuit is turned on to ensure that the motor will start.

Make sure the fan is powerful enough

to maintain the temperature you want. Otherwise, it will run all the time and temperatures will still be too high. To adjust the temperature at which the system stabilizes, change R1.

Design An Intercom

Q I'm building a new house and would like to install a hard-wired intercom system. I've tried using 741 op-amps as well as the LM386 audio amp, and neither gives a high enough volume level to be heard comfortably.

Can you help me out with this?—J. G., Royal Oak, MI

The 741 isn't powerful enough to drive a speaker, and the LM386 is only barely so; you might want to use a more powerful amplifier chip. But your main problem is that you need more amplification and better impedance matching.

Most intercoms use speakers as microphones for two reasons. First, it allows each speaker to do double duty, so that each station doesn't need a separate microphone. Second, the low impedance of the speaker keeps the wiring from picking up crosstalk or radio interference.

But when you use a speaker as a microphone, the resulting signal is at a very low level (about 1 millivolt). You can step it up with an audio-output transformer working backward at the input to the amplifier. The transformer also matches the low-impedance speaker to the high-impedance input.

Figure 4 shows an intercom circuit based on National Semiconductor's data sheet for the LM380 audio amplifier; you can modify it to work with other ICs. With the LM380, be sure to keep all leads short, mount the 0.047-µF capacitor as close to the chip as possible, and glue a heat sink to the IC itself.

Distortion-Free CRT?

Q A colleague tells me that no one has been able to manufacture a picture tube that produces an undistorted picture. Is that a real concern? Is it going to hold up HDTV?—R. A. E., Alfred Station, NY

A Distortion is defined as an unwanted change in the shape of a picture, such as when straight lines become curved. You're probably familiar with pincushion distortion (sides of a rectangle bent inward), barrel distortion (sides of a rectangle bent outward), and keystoneing (images wider at the top than at the bottom, or vice versa).

Most large CRTs inherently produce quite a bit of distortion, but the distortion is corrected electronically so that the image comes out correct. The sweep signals are made nonlinear in a way exactly opposite to the nonlinearity of the CRT. Computer users don't tolerate distortion, and computers use even higher video resolutions than HDTV. Basically, it's a solved problem, so don't worry about it.

continued on page 18

Electronics Paperback Books

How to Use Op Amps

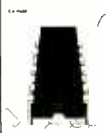

BP88—How to Use OpAmps...\$5.95. A designer's guide that covers operational amplifiers. Serving as both a source book of circuits and a reference book for design calculations. The text is non-mathematical and easy to understand by most readers.



BP113—30 Solderless Breadboard Projects-Book 2...\$5.95. Companion to BP107. Presented in exactly the same style using "Verobloc" breadboards. All the breadboard projects in this book are based on CMOS logic integrated circuits.

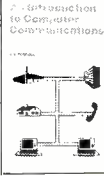

BP177—Introduction to Computer Communications...\$5.95. Details on types of modems and their suitability for specific application, plus details of connecting various computers to modems, and modems to the telephone system.



BP350—Electronic Board Games...\$6.00. Twenty novel electronic board games that you can build from the plans in this book. Some games are motor racing, searching for buried treasure or for gold in Fort Knox, —there is something for you to build and enjoy!



BP61—Beginners Guide to Digital Techniques...\$5.00. Covers the basics of digital techniques—decimal, binary, octal and hexadecimal numbering systems are covered plus insights on weighted and non-weighted binary-coded-decimal codes and alphanumeric codes. The basic building blocks of circuit logic, the common AND, OR, NAND, NOR and EXCLUSIVE-OR gates and bi-stables are thoroughly covered.



BP285—A Beginners Guide to Modern Electronics Components...\$6.50. It is easy for newcomers to electronics to become confused. There are a great many different types of components available often with numerous variations of each type. This book presents the reader with a vast amount of invaluable parts information to enable the right component to be selected every time for repairs and projects.



PCP103—Practical MIDI Handbook...\$9.95. The Musical Instrument Digital Interface (MIDI) is surrounded by a great deal of misunderstanding. This book is aimed at musicians and technicians who want to explore the vast capabilities of MIDI. It covers MIDI-based equipment you can use: keyboards, drum machines, sequencers, effects units, mixers, drum pads guitars. There's also a section on computer music.



PCP119—Electronic Music and MIDI Projects...\$14.95. Save cash by building the MIDI gadgets you need. Want a MIDI Thru box, program change pedal, Metronome, analog echo unit? Over 16 practical and very useful music and MIDI projects.



BP121—How to Design and Make Your Own PCBs...\$5.75. Simple methods for copying printed-circuit board designs from magazines and books on to copper. Covers all aspects of simple PCB construction as comprehensively as possible.



BP44—IC 555 Projects...\$5.95. Every so often a device appears that is so useful that one wonders how life went on before without it. The 555 timer integrated-circuit chip is one such device. Included are basic and general circuits used by most hobbyists.



PCP109—Everyday Electronics Data Book...\$10.00. An invaluable source of electronics information—the text contains sections that deal with the underlying theory of electronic circuits and a wide range of practical electronic uses for everyone.



BP301—Antennas for VHF and UHF...\$6.00. From installing a TV or FM antenna to setting up a multi-antenna array for shortwave listening or amateur radio, this book explains the basics of VHF and UHF antenna operation and installation. The text describes in easy-to-understand terms the essential information about how antennas work, the advantages of different antenna types, and how to get the best performance.



BP297—Loudspeakers for Musicians...\$6.25. Contains all the information that a working musician needs to know about loudspeakers; the different types, how they work, the most suitable for different instruments, for cabaret work, and for vocals. It gives tips on constructing cabinets, wiring up, available fittings, finishing and how to connect multi-speaker arrays, etc. Includes ten enclosure designs with plans.



PCP110—Electronic Power Supply Handbook...\$10.95. All types of power supplies used for electronics purposes are covered in detail, starting with cells and batteries and extending by way of rectified supplies and linear stabilizers to modern switch-mode systems. IC switch-mode regulators, DC-converters and inverters. The devices, their operating principles and typical circuits, are dealt with in detail.



BP254—From Atoms to Amperes...\$6.50. Explains in crystal-clear terms the fundamentals behind the whole of electricity and electronics. Really helps you to understand the basis of the complex subject perhaps for the first time ever.



PCP101—Practical Digital Electronics Handbook...\$9.95. An introduction to digital circuits, logic gates, bi-stables, timers, micro-processors, memory and I/O devices. A special feature of the book is the section on digital test gear projects.



BP315—Introduction to the Electromagnetic Wave...\$5.95. A fundamental and easy-to-understand approach to a complicated theory topic. The beginner requires no more than elementary mathematics and basic knowledge of electronics.



#228—Essential Theory for the Hobbyist...\$5.25. Supplies to the hobbyist background knowledge tailored to the specific requirements of the hobbyist. Relevant material is presented in a readable manner with minimum mathematics.

TEST EQUIPMENT SPECIALS

- BP239—Getting the Most from Your Multimeter...\$5.95**
Covers analog and digital gear, component and gear testing.
- BP267—How to Use Oscilloscopes & Other Testing Equipment...\$6.95**
Get with the next step to proficient troubleshooting.
- PCP111—Electronic Test Equipment Handbook...\$13.95**
The all-purpose, all-pro handbook that covers basics to in-circuit testing.

SUBSTITUTION GUIDES FOR HOBBYISTS

- BP85—International Transistor Equivalents Guide...\$7.50**
The ultimate guide to replacing foreign and domestic transistors.
- BP108—International Diode Equivalents Guide...\$5.95**
Rectifiers, Zeners, LEDs, OCIs, diacs, triacs...all hobby types.
- BP140—Digital Equivalents and Pin Connectors...\$12.50**
A master reference for builders who design projects.

ELECTRONIC TECHNOLOGY TODAY INC.
P.O. BOX 240, Massapequa, NY 11762-0240

Name _____
Address _____
City _____ State _____ Zip _____
PE6

SHIPPING CHARGES IN USA AND CANADA	
\$0.01 to \$5.00	\$2.00
\$5.01 to \$10.00	\$3.00
\$10.01 to 20.00	\$4.00
\$20.01 to 30.00	\$5.00
\$30.01 to 40.00	\$6.00
\$40.01 to 50.00	\$7.00
\$50.01 and above	\$8.50

SORRY No orders accepted outside of USA & Canada

Number of books ordered <input type="checkbox"/>	
Total price of merchandise	\$ _____
Shipping (see chart)	\$ _____
Subtotal	\$ _____
Sales Tax (NYS only)	\$ _____
Total Enclosed	\$ _____

All payments must be in U.S. funds!



EQUIPMENT REPORTS

RADIOSHACK PROBESCOPE PROBE-STYLE OSCILLOSCOPE

A hand-held, probe-style combination oscilloscope and DVM that can be used with a personal computer for detailed and expanded measurements.



CIRCLE 15 ON FREE INFORMATION CARD

The RadioShack ProbeScope Probe-Style Oscilloscope is a microprocessor-controlled oscilloscope and digital voltmeter combination housed in a small probe-style case with a backlit, miniature, liquid-crystal display (LCD). All oscilloscope parameters are menu-driven and selected by pressing one of two pushbuttons on the unit. You can quickly set all parameters while looking at the point of measurement, the probe's controls, and the display on the probe, which eliminates the need for any head movement. However, when cabled to a PC, the unit's measurement and display capabilities are greatly expanded.

In its oscilloscope mode, the ProbeScope offers the following features:

- *Ten Selectable Sampling Rates*—Displays measured signals in a wide variety of waveforms, from a small fraction of a waveform to multiple waveforms.

- *Multiple Trigger Sources*—The oscilloscope starts a measurement using either an internal or an external trigger.

- *Six Selectable Trigger Levels*—Selects both rising and falling signal events at different levels to trigger the sweep.

- *Selectable Input Voltage Ranges*—Selects the range of the measured signal for the most accurate readings.

- *Selectable Input Coupling*—Selects either DC- or AC-coupling of the signal to the oscilloscope, and provides a zero reference for zero adjustment.

The unit requires 9-13-volts. That can either be taken from the circuit under test or from an optional AC wall-plug adapter.

Probably its single most important feature is that the ProbeScope can be interfaced with your personal computer for displaying and recording measurements. The required software and an interface cable are provided in the package. To use ProbeScope's software with Microsoft Windows, you must have a computer with at least 80386 CPU, 400K bytes of available hard-disk storage space, and Windows 3.1 or later. To use ProbeScope's software with MS-DOS, your computer must have at least 800K bytes of available hard-disk storage space and DOS Version 3.3 or later.

Using the Instrument

The unit is controlled via tiny push-buttons on the body's side. The Menu button, for example, is used to select between different operating modes, to select functions within each mode, and even to turn on the backlight on the unit's tiny LCD display.

When in the Oscilloscope mode, the Menu button is used to select the unit's sampling rate. The rate can be selected between 50 nS and 1 mS in ten steps.

On the LCD, the timebase displayed is the actual sampling rate—the rate at which measurements are taken—and is in seconds. On the computer display however, the timebase shown depends on whether or not you select a grid overlay to appear (via software—more on that later). If it is not selected, the timebase displayed is again the actual sampling rate and will exactly match that on the LCD. If the grid

is displayed, the timebase on the computer's display is 10 times the LCD's sampling rate and is shown in seconds per grid division (the same as on a standard oscilloscope).

The user can also select an auto, internal or external trigger source. The trigger-source selection determines how a received pulse or signal is to be monitored or measured. The selectable trigger sources are:

- *Auto*—The ProbeScope continuously measures and records signals each time a trigger occurs regardless of its level (higher, lower, or equal to the incoming signal).

- *± External*—The ProbeScope records signals only when the defined trigger event occurs. The signal is recorded when the trigger level is equal to the incoming signal and moving in the selected direction(±). The trigger level is equal to the voltage present at the external trigger jack.

- *± Internal*—The ProbeScope records signals only when the defined trigger event occurs. The signal is recorded when the trigger level is equal to the incoming signal and moving in the selected direction(±).

The trigger mode is also selectable and determines when a new measurement is to be taken and displayed. There are two available trigger modes. The *run* mode records a new signal every time the defined trigger event occurs. That mode is used to measure or monitor a continuously running signal. The *single* mode records a new signal each time you press the *select* button and the defined trigger event occurs. That mode is used to measure or monitor a signal that occurs only once, such as a noise pulse.

Using the DVM

When the unit is placed into its DVM mode via the menu, it can be used to measure AC and DC voltages. In the AC mode, the ProbeScope rectifies the AC signal to convert it to DC. The DC is then converted to a digital value by a six-bit A/D converter and then multiplied by

0.707 to display the rms value. Since the unit does not measure true rms, any AC reading will be accurate only if the input signal is a relatively pure sinewave and at least two cycles of a waveform are measured. If you need to measure an AC signal on a DC bias, use the oscilloscope mode.

In the DC mode, the DC is directly converted to a digital value by the six-bit A/D converter. An average of up to 128 recorded values appear on the screen. A negative value is displayed when the average is below the reference line.

ProbeScope Software

While the unit can be used as a stand-alone instrument, when interfaced to a computer it begins to really shine. After you start the included ProbeScope V4.1 for Windows/DOS software, icons appear on your PC monitor's display. (You can also access the functions using keyboard shortcuts.) With the aid of icons, you can open an existing ProbeScope document, save the active document, and enter comments about the current ProbeScope document. Icons also let you show and hide the oscilloscope screen's grid, vertical cursors, horizontal cursors, and trigger-level line and more. The software makes this among the easiest-to-use pieces of test gear around.

We've barely scratched the surface of the RadioShack Probescope Probe-Style Oscilloscope's many features. In short, it offers many of the capabilities of more expensive conventional scopes, but at \$99.99, it costs just a fraction of their price. For more information on the unit, contact RadioShack (One Tandy Center, Ft. Worth, TX 76102) directly, or visit your local RadioShack store. **EN**



YAWN ALL THE WAY
TO THE BANK.

So a U.S. Savings Bond isn't the most exciting thing in the world. But wouldn't you rather have an investment that's guaranteed to grow? Sure you would. **U.S. Savings Bonds.**



GET PLUGGED

INTO THE ONLY SURFACE MOUNT BREADBOARDING SYSTEM

Global Specialties, the innovator of solderless breadboard technology, introduces the ProtoBoard Surface-Mount Breadboarding System (SMT™) designed to make life easier for circuit designers. The SMT series of protoboards provides the only quick, nondestructive and solderless method for prototyping circuits with surface-mount chip carriers. The boards are available in five models to accommodate 20, 28, 44, 68, and 84 pin PLCCs in two configurations, breadboarding sockets and header strips. The boards are also designed to easily interface with other Global Specialties Protoboards and circuit trainers which allows for maximum circuit design flexibility.

Like all Global Specialties breadboarding products, each SMT ProtoBoard breadboarding socket, comes with an unconditional lifetime guarantee and are available at fine electronics distributors everywhere. Call us for a distributor near you.

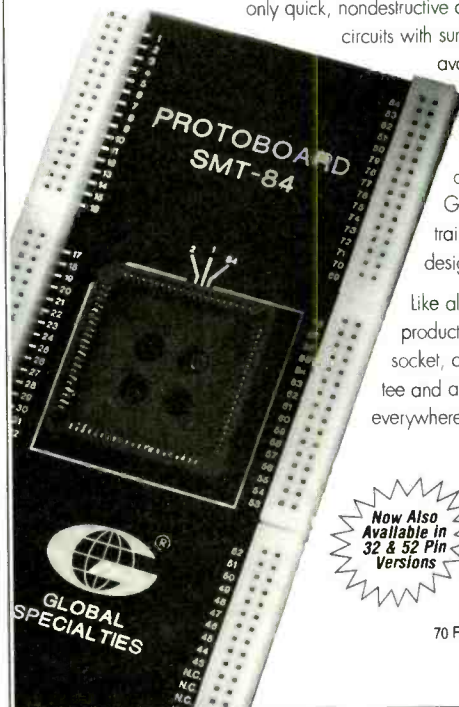

Now Also Available in 32 & 52 Pin Versions

GLOBAL SPECIALTIES

An Interplex Industries Company
70 Fulton Terrace • New Haven, CT 06512

800-572-1028

CIRCLE 122 ON FREE INFORMATION CARD

Erratic Flip-Flops

Q I designed a circuit using 7473 flip-flops as ripple counters. The input was from a Hall-effect device at about 1 Hz. The whole circuit was on a solderless breadboard inside a steel box. But the performance was not acceptable because it would skip counts or reset at various points. What steps could be taken to avoid those glitches?—V. N. H., Eprbrata, PA

A When working with TTL flip-flops, take these precautions:

(1) Ensure a clean power supply by putting a 100- μ F filter capacitor on the circuit board and a 0.1- μ F capacitor across the power supply terminals of each IC.

(2) Never leave any TTL inputs disconnected. A disconnected input is "logic high," but is very sensitive to noise. To protect it, connect it to +5V through a 10K resistor. With CMOS chips (74C, 74HC, 74HCT) you can connect inputs directly to +5V.

(3) Make sure the signal triggering the flip-flop has a good, fast rise time. Run it through a 7413 or similar Schmitt trigger to ensure that it switches on and off cleanly.

CCD Video Hacking

Q I've been thinking about trying to build a video scanner to interface with a computer, but I can't find much information about charge coupled devices (CCDs). Could you direct me to a book that might go into some detail about the subject?—J. G., Bens Run, WV

A A charge-coupled device (CCD) is a semiconductor device that picks up images optically; it's what video cameras use to pick up the image. In effect, a CCD is an array of thousands of silicon photodiodes, each of which stores a charge that depends on the amount of light that has reached it. The charges are then read out one at a time, in sequence, to create a video signal.

The most interesting CCD experiments right now are being done by amateur astronomers, many of whom build their own CCD cameras and write their own software. By using longer exposure times than a conventional camcorder,

HOW TO GET INFORMATION ABOUT ELECTRONICS

On the Internet: See our Web site at <http://www.gernsback.com> for information and files relating to our magazines (**Electronics Now** and **Popular Electronics**) and links to other useful sites.

To discuss electronics with your fellow enthusiasts, visit the newsgroups sci.electronics.repair, sci.electronics.components, sci.electronics.design, and rec.radio.amateur.homebrew. "For sale" messages are permitted only in rec.radio.swap and misc.industry.electronics.marketplace.

Many electronic component manufacturers have web pages; see the directory at <http://www.hitex.com/chipdir/>, or try addresses such as <http://www.ti.com> and <http://www.motorola.com> (substituting any company's name or abbreviation as appropriate). Many IC data sheets can be viewed online.

Books: Several good introductory electronics books are available at Radio Shack, including one on building power supplies.

An excellent general electronics textbook is *The Art of Electronics*, by Paul Horowitz and Winfield Hill, available from the publisher (Cambridge University Press, 1-800-872-7423) or on special order through any bookstore. Its 1125 pages are full of information on how to build working circuits, with a minimum of mathematics.

Also indispensable is *The ARRL Handbook for Radio Amateurs*, comprising 1000 pages of theory, radio circuits, and ready-to-build projects, available from the American Radio Relay League, Newington, CT 06111, and from ham-radio equipment dealers.

Copies of past articles: Copies of past articles in **Electronics Now** and **Popular Electronics** (post 1991 only) are available from Claggg, Inc., Reprint Department, P.O. Box 4099, Farmingdale, NY 11735; Tel: 516-293-3751.

Electronics Now and many other magazines are indexed in the *Reader's Guide to*

Periodical Literature, available at your public library. Copies of articles in other magazines can be obtained through your public library's interlibrary loan service; expect to pay about 30 cents a page.

Service manuals: Manuals for radios, TVs, VCRs, audio equipment, and some computers are available from Howard W. Sams & Co., Indianapolis, IN 46214 (1-800-428-7267). The free Sams catalog also lists addresses of manufacturers and parts dealers. Even if an item isn't listed in the catalog, it pays to call Sams; they may have a schematic on file which they can copy for you.

Manuals for older test equipment and ham radio gear are available from Hi Manuals, PO Box 802, Council Bluffs, IA 51502, and Manuals Plus, Box 637, Spanaway, WA 98387.

Replacement semiconductors: Replacement transistors, ICs, and other semiconductors, marketed by Philips ECG, NTE, and Thomson (SK), are available through most parts dealers (including Radio Shack on special order). The ECG, NTE, and SK lines contain a few hundred parts that substitute for many thousands of others; a directory (supplied as a large book and on diskette) tells you which one to use. NTE numbers usually match ECG; SK numbers are different.

Remember that the "2S" in a Japanese type number is usually omitted; a transistor marked D945 is actually a 2SD945.

Hamfests (swap meets) and local organizations: These can be located by writing to the American Radio Relay League (Newington, CT 06111; <http://www.arrl.org>). A hamfest is an excellent place to pick up used test equipment, older parts, and other items at bargain prices, as well as to meet your fellow electronics enthusiasts both amateur and professional.

they get spectacular images of faint galaxies and nebulae. Even if you're not interested in astronomy, you'll find their storehouse of CCD knowledge useful. Write to Willmann-Bell, Inc., P.O. Box 35025, Richmond, VA 23235, and ask for their catalog of books about building CCD cameras. Also look for *CCD Astronomy* magazine on newsstands or you could write to the publisher directly at 49 Bay State Road, Cambridge, MA 02138.

Writing to Q&A

As always, we welcome your questions. The most interesting ones are answered in print, usually within nine months. Please be sure to include plenty of background information (we'll shorten your letter for publication). If you are asking about a circuit, please include a complete diagram. We regret that, due to the volume of mail, we cannot give personal replies.

The Four-Year Electronics Degree Program That Really Hits Home!

Bring The Technology Home With A Bachelor Of Electronics Engineering Degree. No Hassles. No High Cost!



Now's the time to prepare for a profitable career.

We've lowered the cost of higher education.

It's true! You can earn a four-year Bachelor of Electronics Engineering Technology degree today ... and prepare yourself for a high-paying electronics career ... without quitting your job or ever leaving your home. Because World College, an affiliate of the Cleveland Institute of Electronics, offers you the total flexibility of independent study programs proven effective for people like you who truly want to succeed! World College independent study lessons help you build valuable skills

**Mail/Fax Today
or Call
1-800-696-7532**

step-by-step, and expert instructors are personally available to you with a toll-free call. What a way to earn an education!

A world of opportunity.

Where is your career headed? With a four-year bachelor's degree from World College, you call the shots, choosing from incredible, high-paying opportunities in electronics, telecommunications, computer, electrical power, and many other growing fields.

World College gives you the skills, the knowledge, the power to take advantage of your best opportunity in electronics. And you can do it all at your own pace!

Without leaving home.

World College continually works to provide its students with the most advanced education tools. From the latest equipment and reference books to breakthrough computer-simulated experiments, students are exposed to the latest technological advancements.

All the equipment, parts, and software you need are included in your affordable tuition, including more than 300 hands-on lab experiments you can complete in your home.

Choose your own pace.

Earn your bachelor's degree on your time — and at your pace — because you pay tuition to World College only as you complete the upper-level semesters close to graduation. The faster you make it through, the less you pay. So you have an incentive to make your future happen quickly — yet the freedom to choose your own pace!

Send today for your FREE course catalog — and give yourself that future you've always wanted — with an electronics degree education from World College.



Take charge of your future in electronics.

Four Powerful Reasons To Connect With World College Today:

- 1. Earn your four-year degree!**
- 2. Self-paced training!**
- 3. Independent study in your home!**
- 4. Expert instruction!**

Give Me The Power!

Send me a FREE World College course catalog today!



(Please Print Neatly)

Name _____

Address _____

City _____

State, Zip _____

Phone () _____

Age _____

**For faster service, call
1-800-696-7532,
or call
1-804-464-4600.**

**Or fax this coupon to
1-804-464-3687.**



Lake Shores Plaza
5193 Drive, Suite 113
Virginia Beach, VA 23455-2500



Affiliated with
Cleveland Institute of Electronics
WAE42

WHAT'S NEWS

continued from page 6

problems experienced by the entire motion-imaging community.

Although they do not want to limit the variety of available products, the EBU and SMPTE would like to establish an agreed-upon method to move television signals within the production chain, which would provide a surer basis for consumer choice and encourage a variety of solutions without putting limits on innovation in product design. The two organizations have identified four areas in which a single option, or at least transparent gateways between different options, are of vital importance to users. Those are compression algorithms, file formats, multiplexing of components, and interfaces.

The SMPTE and EBU have established a joint task force to formulate a definitive list of user requirements against which proposed solutions can be measured. Task force meetings will alternate between Geneva and New York. All interested parties active in these areas are

invited to participate. The task force expects to have its initial report completed by April 1997.

FCC Auctions Open Interactivity Opportunities

FCC auctions of Local Multipoint Distribution Service (LMDS) spectrum, scheduled for the end of 1996 and beginning of 1997, open the door for new interactive consumer applications. LMDS satellite systems can be used to provide a host of services, ranging from videoconferencing to messaging to wireless handheld voice and data systems. LMDS auction winners will have an easy, flexible entry into wireless, two-way, broadband interactive video, local telephony, and data services delivery.

The LMDS spectrum—found in the 28-GHz band—is especially attractive to cable operators as well as to telephone companies (also known as local exchange carriers, or LECs) because it provides a

way to compete with the successful and quickly growing direct-broadcast satellite (DBS) services, such as DSS. LMDS offers operators a broadband digital connection that can be used locally. LMDS is expected to create more telephony competition as customers are offered an alternative to standard telco services. LMDS offers greater flexibility than its counterpart Multichannel Multipoint Distribution (MMDS) frequencies, allowing operators to use the spectrum for whatever services they want to offer.

Texas Instruments already has announced plans to offer a digital LMDS platform, and Hewlett-Packard and Motorola are expected to follow suit in the near future.

Before the auctions can take place, however, the FCC faces a major decision: Should LECs, be allowed to bid for licenses in their operating areas? A decision in their favor would allow local telcos to compete in video delivery—some say with an unfair advantage—with cable television operators. The FCC also must decide whether more than one full-service LMDS operator should be allowed in a single area. **EN**

ANTIQUA RADIO CLASSIFIED Free Sample!

Antique Radio's
Largest Circulation Monthly
Articles, Ads & Classifieds.



6-Month Trial: \$18.95. 1-Yr: \$36.95 (\$53.95-1st Class).
A.R.C., P.O. Box 802-L17, Carlisle, MA 01741
Phone:(508) 371-0512 VISA/MC Fax:(508) 371-7129

SINGERS! REMOVE VOCALS

Unlimited, Low Cost, Instantly Available
Background Music from Original Standard
Recordings! Does Everything! Karaoke
does... Better and gives you the
Thompson Vocal Eliminator™
Free Brochure & Demo Tape
LT Sound Dept RL-1
7980 LT Parkway, Lithonia, GA 30058
Internet: <http://ltsound.com>
24 Hour Demo/Info Frequent Line (770) 482-2485 Ext 72
When You Want Something Better Than Karaoke!

START A CAREER IN ELECTRONICS!

Accredited home study. Repair, install, and service audio equipment, microwave ovens, alarm systems, small appliances, and more. For free career literature, send or call.

CALL 800-223-4542

Name _____
Address _____
City/State _____ Zip _____
Age _____ Phone (____) _____

The School of Electronics, Dept. ELB342
PCDI, 6065 Roswell Road, Atlanta, GA 30328

ELECTRONIC COMPONENTS

MOUSER ELECTRONICS

Call for your **FREE 332**
page catalog **TODAY!**

- 68,138 Products
- 128 Manufacturers
- All Orders Ship Same Day
- No Minimum Order

800-992-9943 FAX: 817-483-0931

<http://www.mouser.com> sales@mouser.com

958 North Main St., Mansfield, TX 76063

CIRCLE 117 ON FREE INFORMATION CARD

CABLE CONVERTER DIAGNOSTIC TEST CHIP

LOAD FULL ACTIVATION OF CABLE CONVERTER

**WE STOCK A COMPLETE LINE OF CHIPS, TOOLS,
WIRELESS QUICK INSTALL TEST BOARDS AND
DIAGNOSTIC CUBES FOR ALL CONVERTERS!**

***** ANYONE IMPLYING ILLEGAL USE WILL BE ***
DENIED SALE. WE SELL PRODUCTS ONLY!! TO
TECHNICIANS OR CABLE REPAIR FACILITIES!!**

#1 IN CUSTOMER SERVICE & TECH. SUPPORT!

***ALL ORDERS SHIP WITHIN 24HRS, UPS/ FED-X.**

***PRIORITY NEXT DAY SHIPPING AVAILABLE!**

***SALE= BUY 5 TEST BOARDS AND GET 1 FREE.**

***MON-FRI - 8AM-7PM - SAT 10AM-2PM EST.**

***WEB PAGE [HTTP://WWW.800-GOCABLE.COM](http://WWW.800-GOCABLE.COM)**

VISA MasterCard VISUAL

COMMUNICATIONS INC.

FOR ORDERS 1-800-GO-CABLE

CATALOG & TECH. SUPPORT 717-620-4363 EST. 1976

**GIVE THE POWER
TO BECOME.**



5 BOOKS FOR ONLY \$4.95

WHEN YOU JOIN THE

Electronics Book Club®

VALUES TO \$131.75

The leading source of information for electronics hobbyists for over 30 years!

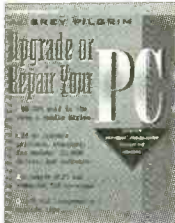

0501149 \$26.95



0650780-XX \$24.95
Counts as 2

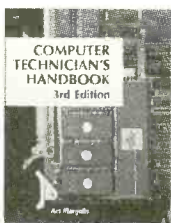

1575472 \$27.95



1574875 \$19.95

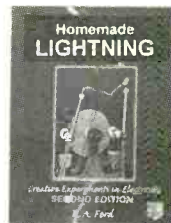

0215286 \$19.95

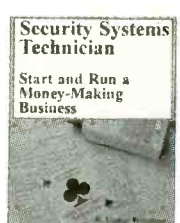

0717753 \$19.95



0376581-XX \$39.50
Counts as 2/Hardcover

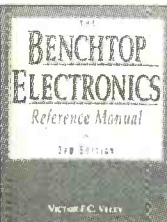

0673764-XX \$54.95
Counts as 2/Hardcover

073092X \$19.95

1577564 \$22.95

0241996-XX \$44.95
Counts as 2/Softcover

0484392 \$13.95

1554637 \$16.95

0582157-XX \$26.95
Counts as 2

1559833 \$22.95

0707618 \$19.95



0052387 \$28.95
Hardcover



1577262 \$21.95



0027994 \$19.95

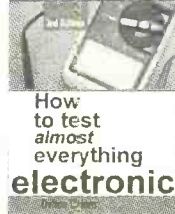

0304068 \$15.95

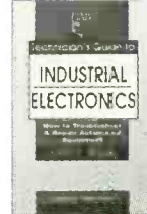

0112738-XX \$45.00
Counts as 2/Hardcover

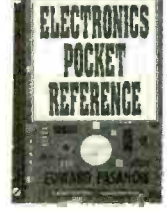

0487375 \$24.95

As a member of the ELECTRONICS BOOK CLUB . . .

you'll enjoy receiving Club bulletins every 3-4 weeks containing exciting offers on the latest books in the field at savings of up to 50% off the regular publishers' prices. If you want the Main selection, do nothing and it will be shipped automatically. If you want another book, or no book at all, simply return the reply form to us by the date specified. You'll have at least 10 days to decide. If you ever receive a book you don't want due to late delivery of the bulletin, you can return it at our expense. Your only obligation is to purchase 3 more books during the next 12 months, after which you may cancel your membership at any time. And you'll be eligible for FREE BOOKS through our Bonus Book Program.

A shipping/handling charge and sales tax will be added to all orders. All books are softcover unless otherwise noted. If you select a book that counts as 2 choices, write the book number in one box and XX in the next. (Publishers' Prices Shown) ©1996 EBC

If coupon is missing, write to:

Electronics Book Club®,
A Division The McGraw-Hill Companies,
P.O. Box 544, Blacklick, OH 43004-9918

Electronics Book Club®

A Division of The McGraw-Hill Companies, P.O. Box 549, Blacklick, OH 43004-9918

YES! Please send me the books listed below, billing me just \$4.95 plus shipping/handling & tax. Enroll me as a member of the **Electronics Book Club** according to the terms outlined in this ad. If not satisfied, I may return the books within 10 days without obligation and have my membership cancelled.

--	--	--

If you select a book that counts as 2 choices, write the book number in one box and XX in the next.

Name _____

Address/Apt. # _____

City/State _____

Zip _____ Phone _____

Valid for new members only, subject to acceptance by EBC. Canada must remit in U.S. funds drawn on U.S. banks. Applicants outside the U.S. and Canada will receive special ordering instructions. Publishers' prices shown. A shipping/handling charge & sales tax will be added to all orders. RPIE297

PHONE: 1-614-759-3666 (8:30 a.m. to 5:00 p.m. EST Monday-Friday) • FAX: 1-614-759-3749 (24 hours a day, 7 days a week)

www.americanradiohistory.com

RETAILERS THAT SELL OUR MAGAZINE MONTHLY

Alaska

Frigid North Co.
1207 W. 36th Avenue
Anchorage, AK 99503

Arizona

Dalis Electronics
2829 E. McDowell Road
Phoenix, AZ 85008

California

California Electronics
221 N. Johnson Ave.
El Cajon, CA 90202

Ford Electronics
8431 Commonwealth Avenue
Buena Park, CA 90621

All Electronics
14928 Oxnard Street
Van Nuys, CA 91411

Gateway Electronics of CA
9222 Chesapeake Drive
San Diego, CA 92123

Mac's Electronics
191 South "E" Street
San Bernardino, CA 92401

Electronics Warehouse
2691 Main Street
Riverside, CA 92501

Orvac Electronics
1645 E Orangethorpe Ave.
Fullerton, CA 92631

Sav-On Electronics
13225 Harbor Blvd.
Garden Grove, CA 92643

JK Electronics
6395 Westminster Blvd.
Westminster, CA 92683

Marvac Dow Electronics
980 S. A Street
Oxnard, CA 93030

Kandarian Electronics
1101 19th Street
Bakersfield, CA 93301

Whitcomm Electronics
105 W. Dakota #106
Clovia, CA 93612

Marvac Dow Electronics
265-B Reservation Road
Marina, CA 93933

Minuteman Electronics
37111 Post St., Suite 1
Fremont, CA 94536

HCS Electronics
6819 S. Redwood Drive
Cotati, CA 94931

Halted Specialties Co.
3500 Ryder Street
Santa Clara, CA 95051

Metro Electronics
1831 J Street
Sacramento, CA 95814

The Radio Place, Inc.
5675-A Power Inn Road
Sacramento, CA 95824

HSC Electronics
4837 Amber Lane
Sacramento, CA 95841

Colorado

Gateway Electronics of CO
2525 Federal Blvd.
Denver, CO 80211

Centennial Electronics
2324 E. Bijou
Colorado Sps., CO 80909

Connecticut

Signal Electronics Supply
589 New Park Avenue
W. Hartford, CT 06110

Cables & Connectors
2198 Berlin Turnpike
Newington, CT 06111

Electronic Service Prod.
437 Washington Avenue
North Haven, CT 06473

Georgia

Norman's Electronics, Inc.
3653 Clairmont Road
Chamblee, GA 30341

Illinois

Tri State Elec
200 W. Northwest Hwy.
Mt. Prospect, IL 60056

Maryland

Mark Elec. Supply Inc.
5015 Herzel Place
Beltsville, MD 20705

Amateur Radio Center
1117 West 36th Street
Baltimore, MD 21211

Massachusetts

U-Do-It Electronics
40 Franklin Street
Needham, MA 02194

Michigan

Purchase Radio Supply
327 East Hoover Avenue
Ann Arbor, MI 48104

Norwest Electronics
33760 Plymouth Road
Livonia, MI 48150

The Elec. Connection
37387 Ford Road
Westland, MI 48185

Elec. Parts Specialists
711 Kelso Street
Flint, MI 48506

Minnesota

Acme Electronics
224 Washington Avenue N.
Minneapolis, MN 55401

Missouri

Gateway Electronics Of MO
8123-25 Page Blvd.
St. Louis, MO 63130

William Elec & Ind Supply
803 Davis Blvd.
Sikeston, MO 63801

New Jersey

Lashen Electronics Inc.
21 Broadway
Denville, NJ 07834

New York

Sylvan Wellington Co.
269 Canal Street
New York, NY 10013

R&E Electronics
4991 Rt. 209
Accord, NY 12404

Unicorn Electronics
Valley Plaza
Johnson City, NY 13790

Ohio

Philcap Electronic Suppliers
275 E. Market Street
Akron, OH 44308

Oregon

Norvac Electronics
7940 SW Nimbus Avenue
Beaverton, OR 97005

Pennsylvania

Business & Computer Bookstore
213 N. Easton Road
Willow Grove, PA 19090

Texas

Mouser Electronics
2401 Hwy. 287 N
Mansfield, TX 76063

Tanner Electronics
1301 W Beltline
Carrollton, TX 75006

Electronic Parts Outlet
17318 Highway 3
Webster, TX 77598

Washington

Amateur Radio Supply Co.
5963 Corson Ave., Ste 140
Seattle, WA 98108

**If you'd like to sell our magazine in your store,
please circle 210 on Free Information Card.**

Design and Use of Microphone Splitters

MY COMPANY (SESCOM) HAS BEEN BUILDING AND SELLING MICROPHONE SPLITTERS TO INDUSTRIAL USERS, RADIO AND TV BROADCASTERS, SOUND-SYSTEM USERS, AND THE GENERAL PUBLIC FOR MANY YEARS. THE FIRST DESIGN THAT WE

offered was the single-input/dual-output equal-winding transformer shown in Fig. 1. You can see that it has only one electrostatic shield shared between the two outputs and one input. The transformer was built into a sturdy metal box and marketed as a Sescom model MS-1. It was also sold as a model 66J0036 audio transformer. The full schematic of the unit is shown in Fig. 2.

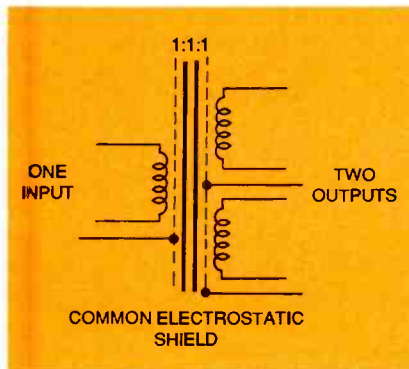

FIG. 1—THIS SINGLE-INPUT/DUAL-output transformer was one of the first microphone splitters the author designed.

A ground-lift switch was placed in the output circuit to help eliminate ground loop problems. Using that switch to open the ground connection does indeed help when ground-loop problems occur; unfortunately, it could also cause other problems. Those appear when any RFI (radio-frequency interference) or EMI (electromagnetic interference) signals are present. RFI problems are usually caused

by radio transmitters, while EMI problems are generally traced back to electronic dimmers or motors. Either type of interference is not rare, and we've all run across them at one time or another.

Therefore, a new and improved version had to be developed to solve those problems once and for all. The solution we came up with was to install separate electrostatic shields for each winding, as shown in Fig. 3. With that setup, there are no ground connections between any of the windings, which solves the RFI and EMI problems. If any interference signals do appear in the input winding, they would have a path to ground via the AC coupling of the electrostatic shields. Those shields act as capacitors whose

capacitive reactance is small and out of the audio band; they react only at the higher frequencies—just what we need to do the job.

That unit is wired as shown in Fig. 4. Note that there are no ground-lift switches in this circuit. With the new design we found that they were unnecessary more than 99% of the time. Rather than over-design our product with seldom-used features, the switches were intentionally left out. An external ground-lift switch or connector assembly could be easily added in those very few remaining instances where one was needed.

Other Problems, Other Solutions

Of course, when it comes to audio, few solutions are ever final. A new ground-loop problem did arise. It turned out to be related to the Switchcraft QG 3-pin audio connectors that were being widely used. A feature that made that connector unique was the ground solder lug that contacts the shell. Some people

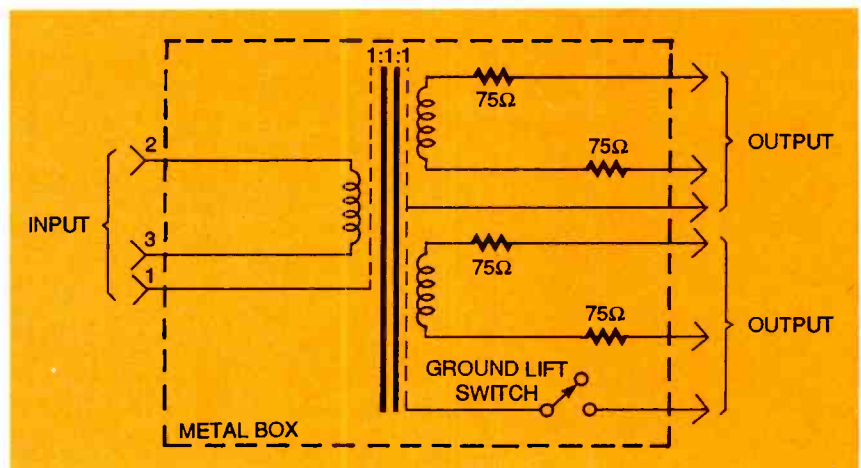

FIG. 2—THE TRANSFORMER SHOWN in Fig. 1 was installed in a metal box and a ground-lift switch was placed in the output circuit to eliminate ground-loop problems.

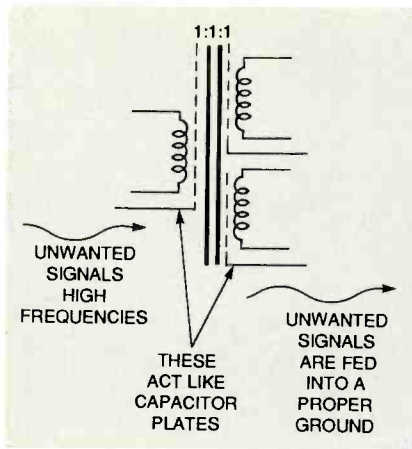

FIG. 3—USING SEPARATE electrostatic shields provides protection against most RFI and EMI signals.

made audio cables with the shield of the cable tied to pin 1 and the ground lug. Of course doing that makes the male-female cable connection RF proof, but it also makes it impossible to break the ground connection by lifting pin 1 in the box. Fortunately, a better solution appeared in the form of all-plastic male and female connectors that have no possible electrical connection from pin 1 to the shell unless you make it yourself.

In the early 1970s, we began to manufacture splitter boxes with phase-reversal switches on each input, and separate ground-lift switches; called the Sescom 9 x 3 Mike-Splitter, it is shown in Fig. 5. Those units were built in a three-rack version (5¼ inches) with nine sets of inputs and three outputs. The unit was popular with sound-rental companies that needed many splits on a temporary basis.

One consideration with that splitter is that it would not pass phantom voltage to the microphone from the main supply. That meant that if electret condenser microphones were to be used, a separate power supply would be needed

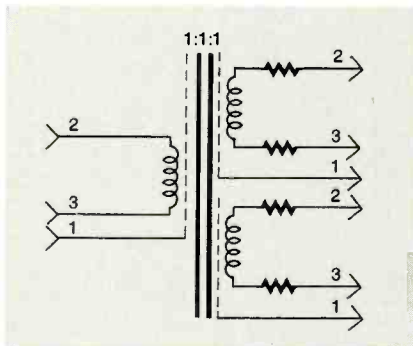

FIG. 4—THE TRANSFORMER SHOWN in Fig. 3 is wired as shown here. Note the lack of ground-lift switches; with this design they are not needed 99% of the time.

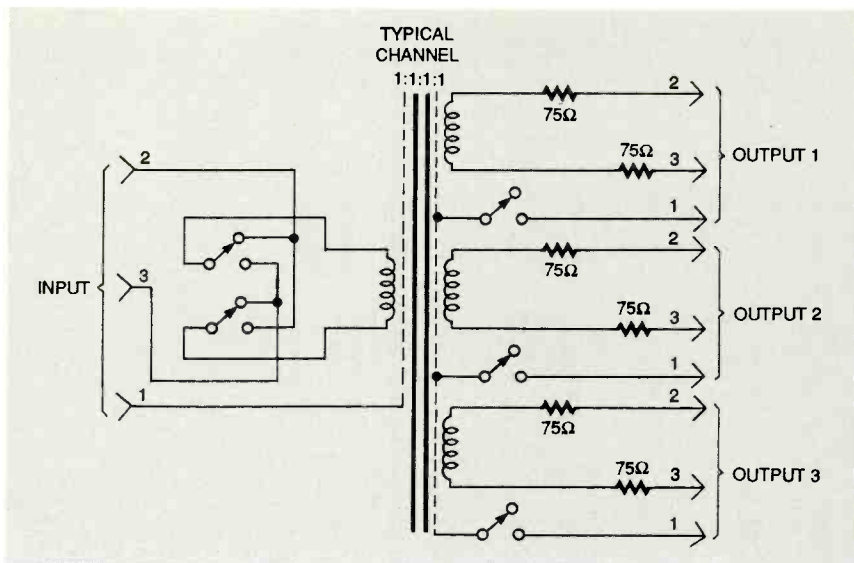

FIG. 5—PHASE-REVERSAL SWITCHES and separate ground-lift switches were used in microphone splitters of the 1970s.

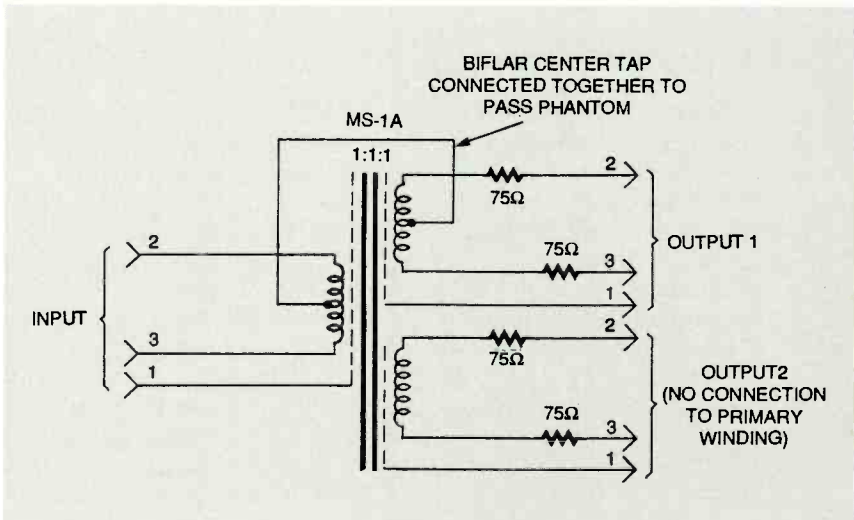

FIG. 6—TO AVOID THE NEED for an additional power source, this splitting transformer was developed to pass the phantom voltage to the microphone.

before the splitter. That could be a costly solution for the user.

Another version of the splitting transformer had to be designed to solve that new problem. Figure 6 shows the circuit that was developed. The product was marketed as our MS-1A. To meet the demand, other versions of the MS-1A were designed and built with four and even eight inputs.

Today, the newest versions of the microphone-splitting transformer boxes use printed circuits for greatest possible reliability. It also lowers the cost of construction. The previous versions are still being manufactured so that users can still design their own systems.

The Future

What comes next in microphone-

splitting technology? One possibility is the use of special materials to improve the tonal quality. However, such improvements would only be incremental and in some cases not even measurable.

More noticeable would be the improvement that could be achieved using digital technology. Using A/D converters, the analog audio could be converted to a digital signal; they could then be distributed without any loss to various devices, where they would be converted back into their original analog form.

Only time will tell what the future will bring. The only thing certain is that right now, there is a bright young engineer out there with an idea that no one else has thought of yet! Maybe it is you!

Microsoft's Biggest Enemy

MICROSOFT IS IN HOT WATER AGAIN. ONE ISSUE CONCERNS ALLEGATIONS ABOUT STRONG-ARM TACTICS USED BY THE COMPANY TO PROMOTE USE OF ITS LATEST WEB BROWSER, INTERNET EXPLORER 3. THE OTHER ISSUE CONCERNS

technical and marketing differences between NT Workstation and NT Server.

I don't have much to say about the browser issue, except that the Netscape people must be getting awfully nervous. Anybody remember a company called WordPerfect? What about Novell? Or Lotus?

The NT issue is more interesting. It appears that the core code of the workstation and server versions of NT 4.0 are essentially identical. In fact, Andrew Schulman (whose *Unauthorized Windows 95* is required reading for anyone who really wants to understand the details of how DOS still lives in Win95) noticed that doing a binary file compare on the kernel files (KERNEL32.DLL) of the two versions produces no differences. I have personally verified that the two files are identical. In fact, the OS versions distinguish themselves by entries in the system registry that affect start-up configuration.

One trade journal has blown its stack (so to speak) over the issue, because a top technical editor had questioned senior Microsoft officials in detail on that very issue, and was lied to. At the time, Microsoft claimed that common source code was used to generate both versions, but different compilation switches (using IFDEFs) were used to distinguish them, thereby generating "completely different" code. I'm not sure whether the publication in question was more angry about the substance of

the lie or about being lied to, but I suspect it was the latter.

As I see it, there are two questions: 1) Are NT customers somehow being cheated? 2) If senior Microsoft officials lied to one of the industry's top two trade journals, can we trust anything the company says?

The brief answers: No and no.

Actually, there are several other interesting questions: What are the magic registry settings, and what must be done to get NT Workstation to function as NT

Server? I fully expect those questions to be answered by the time this column reaches print.

Also, if Microsoft lies outright to the press, and indirectly to its customers, do its customers in turn owe the company anything better? I wouldn't presume to try to prescribe the behavior of other people. But I suspect that there will be a backlash. An increasingly alienated public will view Microsoft's behavior as justification for obverse kinds of abuses—such as publishing and using said registry settings.

I can draw but one conclusion from all this: Microsoft's biggest enemy is not Novell, or IBM, or the Federal Department of Justice, or . . . you name it. Microsoft's biggest enemy is . . . Microsoft.

Maybe what the company needs to

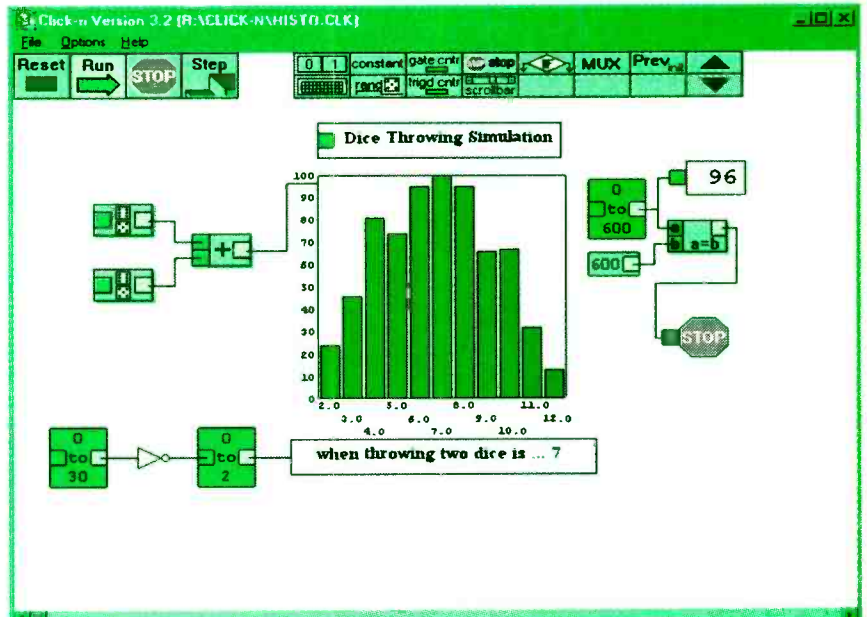

FIG. 1—CLICK-N IS A FREEWARE SIMULATOR that's both educational and fun. Here you can study probability with a dice-throwing simulation.

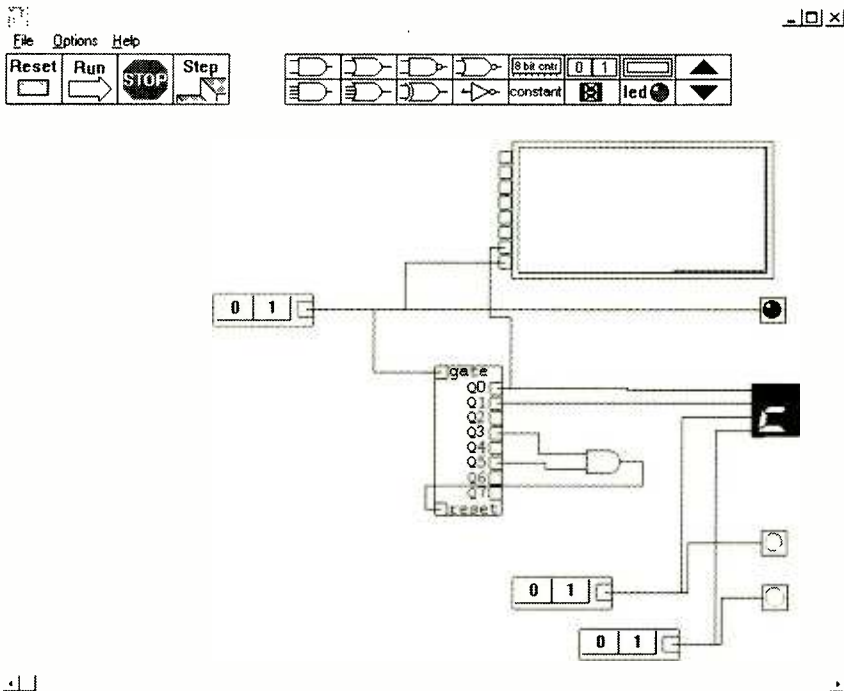

FIG. 2—HERE, CLICK-N is used to simulate a circuit and monitor its response.

learn is the old Middle Eastern saying: "The enemy of my enemy is my friend."

Click-N

Yes, it rhymes with Quicken, and no, it won't balance your checkbook. As a matter of fact, Click-n is a simulator of sorts. It's not a finished product, it's buggy, and it crashes easily and unpredictably. Despite its faults, however, Click-n is a lot of fun—and educational, too.

Click-n gives you a drag-and-drop way to create logic circuits and other types of discrete simulations. The program provides more than 60 inputs, outputs, functions, and controls. Inputs include random-number generators, scroll bars, keypads, and limited keyboard input. Outputs include 2D and 3D graphs, an eight-channel logic analyzer, a four-channel oscilloscope, a histogram, seven-segment LEDs, and discrete LEDs. Functions include logic blocks (AND, OR, NAND, NOR, XOR, NOT, and quad-input AND and OR) and mathematical functions (add, subtract, multiply, divide, sin, cos, sq, inverse, power, max, min, and more).

To create a simulation, you drag components from a palette to a workspace. Next you connect outputs to inputs as desired, and then click the Run button. You can vary run speed, and single-step through a simulation. A couple of sample simulations are shown in Figs. 1 and 2.

The program includes several inter-

esting and entertaining examples, including a game of sorts that randomly bounces a space ship and a ball around a rectangular area. Whenever their paths intersect, the spaceship blows up with both audio and visual effects.

Here are a couple of hints: 1) There is a trashcan icon for deleting components, but the mouse is restricted from reaching it. Instead, you can simply drag components off the bottom of the workspace. 2) Save often.

Why not give Click-n a try. You can get it from the author's (Ray Wilson) home page (www.csd.net/~rayw). Incidentally, version 3.2 was available when this was written; the author's home page hints at updates, though there were none all summer.

File-Print Utility

About ten years ago, I picked up a little printing utility called LJ2 from some BBS. The purpose of LJ2 is to print text files sideways, two pages per sheet, on an 8.5- × 11-inch sheet of paper. For years the utility worked fine with my trustworthy LaserJet II. But when I upgraded to a new printer (an Apple LaserWriter 360F), LJ2 stopped working. Rather, its pagination went *gaga*. The 360 is basically a PostScript printer with built-in PCL emulation, and the ability to switch between PCL and PostScript modes automatically. PCL is Hewlett-Packard's printer control language.

The print utility came with the source (in C); contributors included Joe Barnhart, Ray Duncan, Chip Rabinowitz, and Steven Stern. I thought it would be worthwhile fixing good old LJ2.

I did fix it, and updated the source to be compatible with modern file manipulation conventions, not to mention C syntax. The result is available on the Gernsback Web site; look for file LJ2A.ZIP at ftp.gernsback.com/pub/EN.

One interesting thing about the original source (included in the Zip, along with the updated source, and an executable) was its use of CP/M-derived file functions and data structures. If you don't know what a Disk Transfer Area (DTA) is, consider yourself lucky. Anyway, all that stuff is gone. If you're young enough to think that Windows or DOS just arose *ex nihilo* (from nothing)—well, here's concrete evidence (and a good reminder for us old-timers) that nothing just arises from nothing.

The program runs from a command line (DOS or DOS box under Windows or OS/2). It accepts multiple parameters, each of which specifies a file to print. Each parameter may have wildcards (? and *). So you could print all the C and H files like so:

```
C:\>lj2 *.c *.h
```

The code compiles under Microsoft C 1.52, the last 16-bit C compiler produced by Microsoft, but shouldn't be hard to adapt to Borland's product.

By the way, it turned out all I had to do to fix the program was to alter the setup string it sends to the printer. The original LJ2 set a margin of seven lines; by decreasing that to five, pagination once again lined up. Why was the change necessary at all? I suspect the LaserWriter may have a larger non-printable margin than the old LaserJet. I also added a somewhat more polite and descriptive help message. Planned enhancements (one of these days . . .) include long filename support, and a better (real) word-wrapping algorithm.

Delphi Grid Component

Before we jump into the technical stuff: Thanks to all of you Delphi fans who've been corresponding. The rapidly growing interest in Delphi actually makes me feel a bit less jaded and cynical about what it takes to succeed in the computer industry. At least in some segments, excellence is its own reward.

As part of a new Win32 coding-
continued on page 84

GET HERE.

FREE
One Year Subscription
of *Electronics Now*
When You Enroll in Any
CIE or World College
Program!

LEARN A SKILL YOU ENJOY... ...THEN FIND A JOB THAT HAS A FUTURE.

Everyone has to start somewhere.

As 150,000 CIE graduates have discovered, independent-study from

The Cleveland Institute of Electronics can get you where you want to be. In a secure, financially rewarding, exciting career field of your choice.

Since 1934, CIE has been on the forefront of an ever expanding technological revolution.



Industrial Robotics

ment. CIE's curriculum is unique from other independent-study schools in the respect that we not only provide hands-on training utilizing today's technology we also instill the knowledge and understanding of why technology works the way it does. This is the foundation upon which every CIE graduate can trace their success back to and in which CIE's reputation as a quality learning facility is based on.



Project Engineer

Independent study is not for everyone. But, if you have the desire, the basic intellect and the motivation to succeed, CIE can make it happen. Our learning program is patented and each lesson is designed for independent study while our instructors are available to assist you whenever you feel you need help. In fact, CIE's curriculum is so well respected many Fortune 1000 companies utilize it for their own employees.



Telecommunications

CIE offers personalized training to match your background with over ten career courses, an Associate Degree Program and a Bachelor Degree Program through our affiliation with World College. And every CIE graduate got started in a

successful career the same way you can...by sending for your free CIE course catalog and judging for yourself if CIE's for you.



Computer Programming

START HERE...

YES! Please send me more information on:

- CIE's Associate Degree Program
- CIE's Computer Programming Course
- CIE's 12 Career Courses
- World College's Bachelor Degree Program

AE96

Name _____

Address _____

City _____

State _____ Zip _____

Phone: _____

Check for G.I. Bill Details

Active Duty Veteran



Electronics

Back then it was radio and TV, today it's computer technology, programming and the electronics that make it all possible. Today and yesterday's similarities are uncanny... Employers are looking for qualified applicants to hire and having a hard time finding them.

Students at CIE receive the training and the education needed to get hired and to succeed in challenging fields such as computer programming, robotics, broadcast engineering, and information systems manage-



*It's More Than Just Training...
...It's an Education.*

1776 East 17th Street
Cleveland, OH 44114
(216) 781-9400 • 1-800-243-6446



NEW PRODUCTS

USE THE FREE INFORMATION CARD FOR FAST RESPONSE

Coast-to-Coast Car Navigation

THE ETAKGUIDE USA IS A DIGITAL travel guide that offers road and highway map coverage of the entire continental United States. Available on its own or bundled with Sony's NVX-F160 mobile-navigation system, the guide provides detailed digital moving maps that track the motorist's progress in real-time throughout the 48 contiguous states. The software covers more than 500,000 miles of roads, including all major highways and detailed coverage down to the street level in 32 major cities. The NVX-F160 consists of a dashboard-mounted display, a CD-ROM player, a remote control, and a global positioning system (GPS) receiver. It receives positioning signals from the Navstar network of 24 satellites and pinpoints the vehicle's location on EtakGuide USA's maps.

The software's "moving maps" use clear graphics and text to identify interstate highways, toll roads, local streets, scenic routes, exit numbers, and ramp details. A multimedia combination of audio prompts and help screens, text descriptions of attractions, icons, pho-

tographs, illustrations, and music aids the navigation process. An extensive library of travel and tourist information—drawn from a variety of guidebooks and government information services—is linked directly to the moving maps and can be accessed at the touch of a button.

The EtakGuide USA allows travelers to search for information by general topics and more specific categories. Each listing within a category is marked on the map with an icon that, when selected, displays information including a full street address and usually a phone number. A database of toll-free numbers for lodging, car rentals, airlines, and road-conditions hot lines is also provided.

The Mileage Finder shows the road miles between cities, as well as the estimated driving time based on average speed. The Address Finder shows how to get to highway intersections on the map or specific street addresses in major cities. The Attraction Finder shows the driver how to get to a desired location, such as an amusement park or museum. More than 5000 attractions are listed, including

sightseeing locations, zoos, sports arenas, RV sites, and airports.

The NVX-F160, with EtakGuide USA, has a suggested retail price of \$2995. The guide is available separately for a suggested retail price of \$149.95.

ETAK, INC.

1430 O'Brien Drive
Menlo Park, CA 94025
Tel: 415-328-3825
Fax: 415-328-3148
Web site: <http://www.etak.com>

Compact Thermal Printers

Two small, quiet thermal printers from Eltron International can be used in a wide variety of printing applications, including retail (point-of-sale), health care, home shopping/banking, and home and office labeling. The Companion, said to have the smallest footprint of any printer, can be desktop- or wall-mounted. It prints at a sharp 203 dots per inch. Its sharp resolution, which translates into less paper consumption, results in lower operating costs than traditional dot-matrix printers.

The Companion printer uses Windows-compatible Eltron Programming Language, communicates like the Epson Model TM60 and TM80/85 printers, and supports most standard bar codes. The high-end Companion Plus also supports the latest two-dimensional symbol system—MaxiCode PDF-417.

The Companion and Companion Plus thermal printers cost \$249 and \$295 respectively.

ELTRON INTERNATIONAL, INC.

41 Moreland Road



CIRCLE 20 ON FREE INFORMATION CARD



CIRCLE 21 ON FREE INFORMATION CARD

Simi Valley, CA 93056-1692
Tel: 805-579-1800
Fax: 805-579-1808
E-mail: pr@eltron.com
Compuserve: 102251,1164

Flat-Panel Display Kit

The PCI-FP-Kit from Computer Dynamics is a customizable flat-panel display subsystem that runs from your PCI bus motherboard. The complete kit includes a half-size PCI bus flat-panel interface card (PCI-FP-Card) with LVDS (low-voltage differential signaling) or TTL output, your choice of display, optional touchscreen, optional enclosure, and all interface electronics and cabling.

The PCI-FP-Card directly drives both LVDS and TTL video, and delivers up to 1280×1024 resolution and 16.7-million colors. The noise immunity of LVDS allows the display to be placed as far as 10 meters from your PC, and fewer conductors result in a smaller cable. LVDS also lowers EMI. The LVDS connection is made either via a SCSI cable from the card or through a header connector that goes to the display via a ribbon cable. For applications in which the display is close to the PC, TTL output travels from a header connector via a ribbon cable to the panel.

The PCI-FP-Card outputs NTSC video, allowing you to display images on a TV, and accepts NTSC input from video cameras, CCD cameras, videotape, or MPEG and displays it on a flat panel. The card also has two megabytes of on-board video RAM, and permits simultaneous LCD and CRT operation.

Several flat-panel displays are available, including color TFT LCDs from 6.4 to 13.8 inches in XGA, SVGA, and VGA resolution; active-matrix monochrome LCDs; electroluminescent displays; and the exclusive "Ultra-HiBrite" color LCDs for high ambient-light con-



CIRCLE 22 ON FREE INFORMATION CARD

ditions. Depending on the display, the PCI-FP-Kit is available with a guided wave, resistive, or infrared touchscreen. Power is taken from the PCI backplane for the touchscreen and display.

PCI-FP-Kits are priced starting at \$1525 for the active-matrix monochrome display-based system.

COMPUTER DYNAMICS

7640 Pelham Road
Greenville, SC 29615
Tel: 864-627-8800
Fax: 864-675-0106
E-mail: sales@cdynamics.com

Night-Time Photography Adapters

The ITT Night Cam 300 and 310 are versatile night-vision units that operate independently as night-vision monoculars, or they can be attached to a camera or camcorder to capture night experiences on film or video—opening up a previously unexplored range of photographic opportunities to photographers and videographers. Using the Night Cam creates "otherworldly" film or video in which layers of darkness are transformed into a green, glowing environment in near-daylight conditions.



CIRCLE 23 ON FREE INFORMATION CARD

As a monocular, either unit can be used for safety and security purposes or to view nocturnal wildlife without a disturbing flashlight beam. For photographic or videographic purposes, you just remove the rubber eyecap and attach the unit to a camera or camcorder using the locking adapter bracket and step-up or step-down rings. The Night Cam 300 and Night Cam 310 are designed to work with a variety of lenses as well. If they wish users, can remove the Night Cam's objective lens and attach their favorite lens to its C-mount lens.

Each Night Cam is weather resistant, weighs only 10 ounces, and features *f*/1.6 optics with a 52-degree field of view. The Night Cam 300, which costs \$1195, uses Generation II night-vision

technology, while the \$1795 model 310 features Generation III technology.

ITT NIGHT VISION

7671 Enon Drive
Roanoke, VA 24019
Tel: 1-800-448-8678
Fax: 540-362-4574

CTCSS/Burst Tone Encoder

An upgraded version of Communications Specialists' multipurpose TE-64D tone encoder now displays the actual tone frequency on a high-visibility four-digit LED display, making it well-suited for nighttime operations and mobile applications. The self-contained, fully enclosed encoder provides all EIA CTCSS tones from 67.0 to 203.5 Hz, as well as all common burst tones from 1600 to 2550 Hz, in 50-Hz increments. A front-panel dial rotary switch is used for tone selection. The TE-64D operates on 6- to 16-volts DC (it can be modified to operate from up to 30-volts DC) and measures 5.25 × 3.3 × 1.7 inches. Frequency accuracy is 0.1 Hz for sub-



CIRCLE 24 ON FREE INFORMATION CARD

audible and 1 Hz for audible tones.

The TE-64D tone encoder costs \$129.95. The digital display portion of the TE-64D can be added to an existing TE-64 with the TE-64D-MOD, which costs \$49.95. It is available as a kit, or the TE-64 can be returned for free factory installation.

COMMUNICATIONS SPECIALISTS, INC.

426 West Taft Avenue
Orange, CA 92865-4296
Tel: 1-800-854-0547
Fax: 1-800-850-0547

"CATALOG KNOCKS SOCKS OFF"

For our free Catalog, just send your name and address to:

Consumer Information Center
Department KO
Pueblo, Colorado 81009

What's better than speed reading? *Speed Learning.*

Speed Learning has replaced speed reading. It's a whole new way to read and learn. It's easy to learn...lasts a lifetime... applies to everything you read. It may be the most productive course you've ever taken.

Do you have too much to read and too little time to read it? Do you mentally pronounce each word as you read? Do you frequently have to go back and reread words, or whole paragraphs, you just finished reading? Do you have trouble concentrating? Do you quickly forget most of what you read?

If you answer "Yes" to any of these questions — then here at last is the practical help you've been waiting for. Whether you read for business or pleasure, school or college, you will build exceptional skills from this major breakthrough in effective reading, created by Dr. Russell Stauffer at the University of Delaware.

Not just "speed reading" — but speed reading — thinking — understanding — remembering — and — learning

The new *Speed Learning Program* shows you, step-by-proven step, how to increase your reading skill and speed, so you understand more, remember more and use more of everything you read. The typical remark from over one million people taking the *Speed Learning* program is, "Why didn't someone teach me this a long time ago." They were no longer held back by their lack of skills and poor reading habits. They could read almost as fast as they could think.

What makes *Speed Learning* so successful?

The new *Speed Learning Program* does not offer you a rehash of the usual eye-exercises, timing devices, and costly gadgets you've probably heard about in connection with speed reading courses, or even tried and found ineffective.

In just a few spare minutes a day of easy reading and exciting listening, you discover an entirely new way to read and think — a radical departure from anything you have ever seen or heard about. *Speed Learning* is the largest selling self-study reading program in the world. Successful with Fortune 500 corporations, colleges, government agencies and accredited by 18 professional societies. Research shows that reading is 95% *thinking* and only 5% eye movement. Yet most of today's speed reading programs spend their time teaching you rapid eye movement (5% of the problem), and ignore the most important part, (95%) *thinking*. In brief, *Speed Learning gives you what speed reading can't.*

Imagine the new freedom you'll have when you learn how to dash through all types of reading material at least twice as fast as you do now, and with greater comprehension. Think of being able to get on top of the avalanche of newspapers, magazines and correspondence you have to read...finishing a stimulating book and retaining facts and details



FOR FASTER SHIPMENT CALL 1-800-729-7323 OR FAX 1-609-273-7766

more clearly, and with greater accuracy, than ever before.

Listen — and learn — at your own pace

This is a practical, easy-to-learn program that will work for you — no matter how slow a reader you think you are now. The *Speed Learning Program* is scientifically planned to get you started quickly...to help you in spare minutes a day. It brings you a "teacher-on-cassettes" who guides you, instructs, and encourages, explaining material as you read. Interesting items taken from *Time Magazine*, *Business Week*, *Wall Street Journal*, *Money*, *Reader's Digest*, *N.Y. Times* and many others, make the program stimulating, easy and fun...and so much more effective.

Executives, students, professional people, men and women in all walks of life from 15 to 70 have benefitted from this program. *Speed Learning* is a fully accredited course...costing only 1/4 the price of less effective speed reading classroom courses. Now you can examine the same easy, practical and proven methods at home...in your spare time...without risking a penny.

Examine *Speed Learning* RISK FREE for 15 days

You will be thrilled at how quickly this program will begin to develop new thinking and reading skills. After listening to just one cassette and reading the preface, you will quickly see how you can achieve increases in both the speed at which you read, and in the amount you understand and remember.

You must be delighted with what you see, or you pay nothing. Examine this remark-

able program for 15 days. If, at the end of that time you are not convinced that you would like to master *Speed Learning*, simply return the program for a prompt refund. (See the coupon for low price and convenient credit terms.)

RISK-FREE ORDER FORM

YES! I want to try *Speed Learning* for 15 days without risk. Enclosed is the first of 4 monthly payments of \$32.25*. If I'm not completely satisfied, I may return it for a prompt refund.

SAVE 8.00! I prefer to pay the \$129.00 now, and save the \$8.00 shipping & handling charge. I may still return the program for a full refund.

Method of payment: (Federal Tax Deductible)

Check or money order payable to Learn Incorporated

Charge to: Visa MC Am Ex Discover

Card # _____ Exp. _____

Signature _____

Phone (_____) _____

Name _____

Address _____

City _____ State _____ Zip _____

*Plus \$8.00 shipping and handling. U.S. funds only. For New Jersey residents, sales tax will be added.

learn Dept. LEC-01, 113 Gaither Drive,
INCORPORATED Mt. Laurel, NJ 08054-9987

BUILD THE PCDrill

*Build a machine that lets you drill
PC board holes precisely,
effortlessly, and inexpensively.*

The printed circuit board is the foundation of many electronics projects, but creating PC boards in small quantities is always a problem. Several steps are involved in that process; those are:

- 1) Create the layout
- 2) Transfer it to the board
- 3) Etch the board
- 4) Drill the board

This project concerns Step 4.

Most people drill prototype PC-board holes manually. Typically, you use a very small, brittle drill bit that breaks easily—especially if you use a hand-held drill. Even if you use a drill stand, you must position the board for each hole. And you must prepare the board by marking each location with a center punch; otherwise you risk drill “wander” that can produce an off-center hole. In the age of 0.1-inch (and smaller) hole spacing, that can be disastrous! Further, stamping amounts to doubling the amount of work required per hole. Wouldn't it be nice to have a machine that lets you drill PC board holes precisely, effortlessly, and inexpensively?

Well, you can. For less than \$100 (which includes a \$30 mini-drill), you can build PCDrill, a computer controlled X-Y table that can locate any position on a 6-inch x 8-inch PC board with a resolution of 0.001-inch. Standard, easily available hardware is used throughout, and construction requires only hand tools, although some precise wood cutting is required for the drill caddy.

Any PC can drive PCDrill via a standard parallel port. The port controls two stepper motors, one for motion in each direction. In our design, the PC board table moves in the X direction,

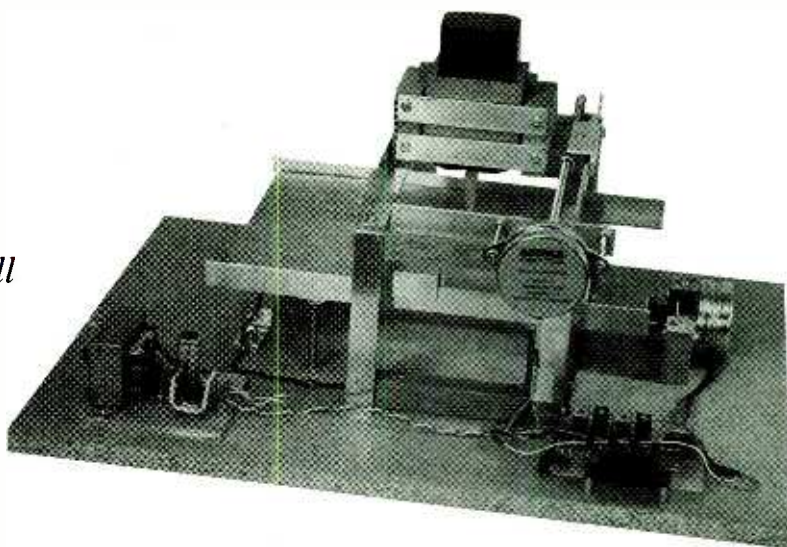

JAMES J. BARBARELLO

and the drill caddy moves in the Y direction. Also, the drill caddy is spring-loaded so that once the desired location is reached, a light downward force on the drill is all that's necessary to create a precisely located hole. The PC controls the stepper motors with a simple BASIC program that generates a series of X and Y coordinates based on input from a standard text file.

The project is straightforward to build, but there are many detailed steps. For that reason, we will go light on theory and heavy on hands-on construction details. For more detailed information on how stepper motors work, and how to control them, we refer you to the author's previous article, “Build an Automatic Parts Tray,” which appeared in the November and December 1996 issues of **Electronics Now**.

The Motor and the Motion. This project uses a standard, off-the-shelf stepper motor that costs about \$7 apiece. It is a bipolar device requiring a modest 5.75-volt DC power supply, and it has sufficient torque for this application. The motor moves 48 steps per revolution, or 7.5° per step. But how can we turn rotational motion into linear motion, and obtain 0.001-inch linear resolution in the bargain?

The secret is to couple the stepper motor's shaft to another, threaded shaft, and install a nut on that shaft, as shown in Fig. 1. If we prevent the nut from rotating while we turn the shaft, the nut will move back and forth

across the shaft. Thus we convert rotational motion (R) into linear motion (L).

Let's assume that the threaded shaft has 20 threads per inch. In that case, one rotation of the shaft will move the nut 1/20 inch (0.05 inch). However, the stepper motor can break that single rotation down into 48 discrete steps, so each step rotates the shaft 0.05 inch/48, or 0.00104 inch. A 1/4"-20 threaded rod, available at most hardware stores, contains 20 threads per inch. (Be careful not to get a 1/4"-16 rod, which contains 16 threads per inch; that 1/4"-inch rod type is even more common than the 1/4"-20 type.)

But how do we get the stepper to move in the first place? In a nutshell, a stepper has two windings. By applying DC voltages to the windings in various sequences and polarities, we can cause the shaft to move in one direc-

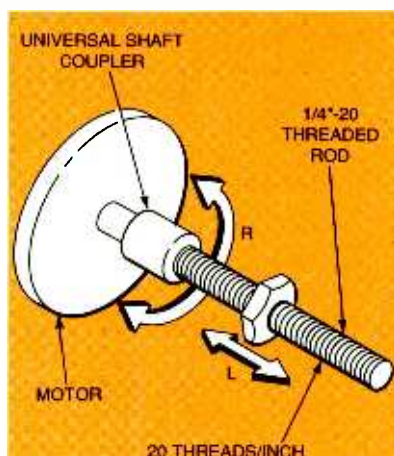

Fig. 1. The rotational motion of the threaded rod is converted to linear motion by the fixed nut.

TABLE 1—MOTION CONTROL SEQUENCE

Step	A(5)	B*(4)	B(3)	A*(2)	Decimal
1	1	0	1	0	10
2	0	0	1	1	3
3	0	1	0	1	5
4	1	1	0	0	12

tion or the other. Table 1 shows the motion-control sequence. By performing steps 1–4 sequentially, the tray rotates clockwise (CW). By performing the sequence backward (4–1), the tray rotates counterclockwise (CCW).

The Circuit. If you've seen the previous article mentioned earlier, the circuit shown in Fig. 2 should look familiar. Transistors Q1–Q12 and associated components are nearly identical to the circuits used in that project. The difference here appears in the bottom part of the figure, and involves Q13 and Q14, relay RY1, and their associated components. The purpose of the relay is simply to select one motor or the other. The remainder of the circuit serves to flip-flop the polarity of the voltage applied to the selected motor. The selected motor and polarities all depend on the states of the inputs at J1, which are of course driven by the PC's parallel port.

To give you an understanding of how the polarity-reversal mechanism works, let's examine the block consisting of Q1, Q3, Q5, R1, R2, R5, and R7. If pin 5 of J1 goes high, Q5 conducts, so its collector goes low. That low at the base of Q3 in turn forward-biases Q3, causing it to conduct, and bringing its emitter close to ground. Now look at the block consisting of Q8, Q10, Q12, R11, R12, R14, and R16. If pin 2 of J1 goes low, its collector goes high, causing Q8 to conduct and Q10 to remain off. At this point, we have a voltage difference between the emitters of Q3 and Q8, so if we connected the coil of a motor across them, the shaft would turn.

Each motor has four leads, denoted A, A*, B, and B*. Leads A and A* comprise one winding, and B and B* the other. Note that the A* ends of coil A in both stepper motors (MOT1 and MOT2) connect to the emitter of Q8. Likewise, the B* motor leads connect to Q2, and the B ends to the relay. So depending on whether the relay is

energized, one motor or the other will complete the current path from Q3 to Q8. Transistors Q13 and Q14 form a non-inverting buffer that provides enough current to drive the relay.

The remaining portion of the circuit consists of microswitches S1 and S2,

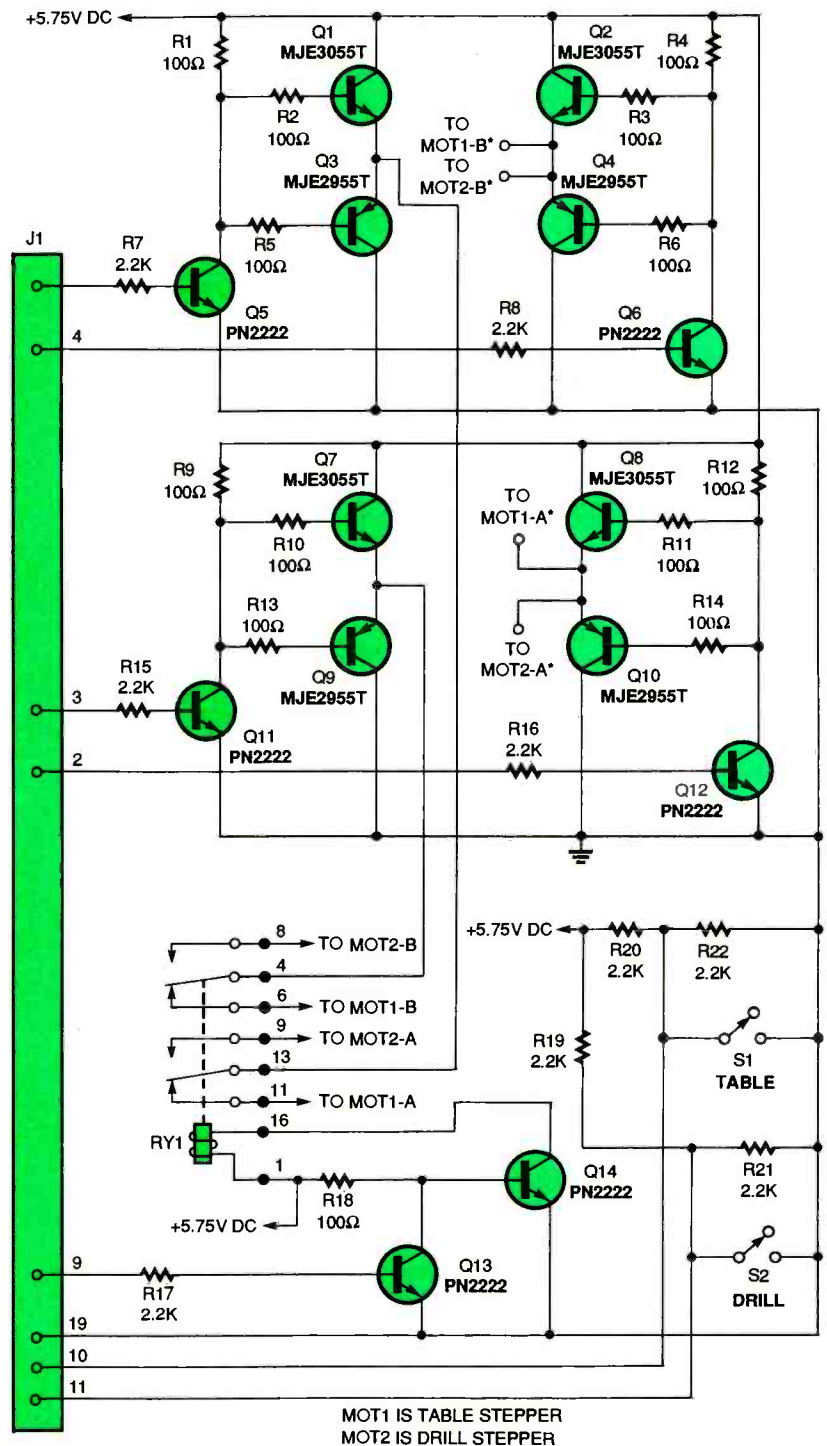

Fig. 2. The upper part of the circuit provides a digitally controllable way to swap the polarity of voltage applied to a motor. The lower portion allows one of two motors to be selected.

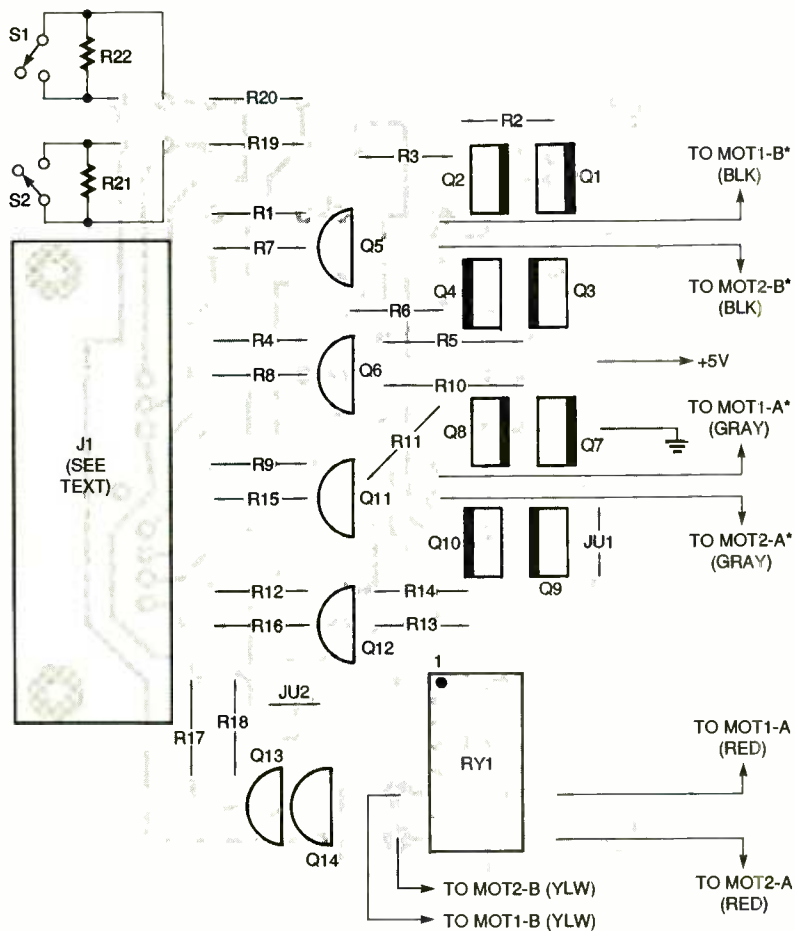
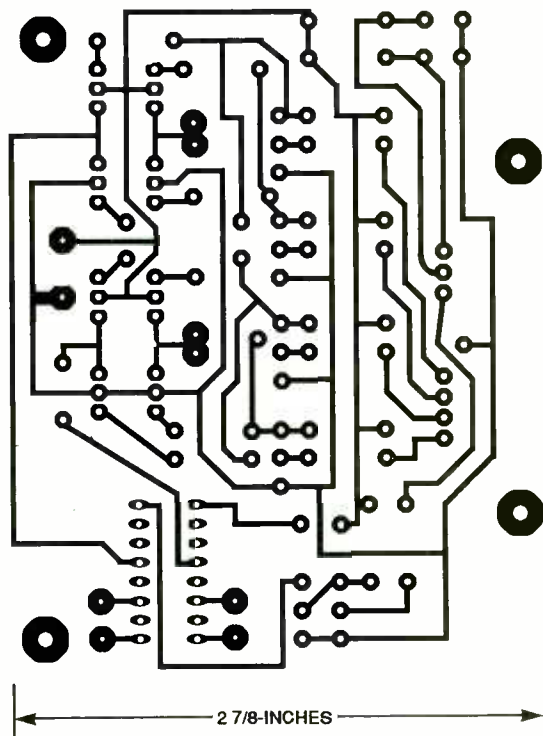

Fig. 3. Mount all components as shown here. Be careful with the orientation of all components, particularly the power transistors.



Here's the full-size PC pattern for the circuit board.

and the corresponding resistive voltage dividers. In operation, S1 and S2 function as limit switches that advise the software when the X or Y table has reached the end of travel. Both switches sit in the normally open state, providing a logic high (about 2.9-volts DC) to pins 10 and 11 of J1. When either switch closes, it grounds the associated pin on J1, indicating to the software that some action should be taken.

A note concerning current limiting: Many stepper-motor control circuits use current-limiting resistors to protect the motors against excessive current draw and consequent overheating. In our circuit, the relatively large current demand of the motor causes a measurable voltage drop across the power-providing transistors (in the example above, Q3 and Q8). Each will have a base-to-emitter drop ap-

MOTOR SPECIFICATIONS

Motor: Bipolar (2 Phase) AIRPAX Stepper Motor, P/N LB2773-MI
Mechanical: 2.25-inch D x 0.99-inch H, 0.61 lb.
Electrical: 5-volts DC, 800 mA, 6.25-ohms per coil
Resolution: 7.5°/step
Shaft: 0.25-inch D x 0.75-inch L
Mounting holes: 2 x 0.2 inch, 2.6-inches apart
Torque: 100 g-cm (detent), 1080 g-cm (holding)

proaching 1 volt. Therefore, the stepper motor coil sees only about 3.5-volts DC. With a coil resistance of 6.25 ohms, current is $3.5/6.25 = 560$ mA. That's well within the motor's ability to dissipate the heat generated. Accordingly, no current limiting resistors are required.

Construction. There are seven major steps involved in building this project: 1) PC board, 2) base, 3) table tracks, 4) table, 5) drill-caddy support, 6) drill caddy, and 7) final assembly. We'll discuss them in order. Table 2 lists all required mechanical components.

Begin by fabricating the PC board using the foil pattern accompanying this article. Then install the resistors and transistors as shown in Fig. 3. We recommend use of a 16-pin DIP socket for RY1. Note the orientation of the

PARTS LIST FOR THE PCDRILL

SEMICONDUCTORS

Q1, Q2, Q7, Q8—MJE3055T NPN transistor, TO-220 case
 Q3, Q4, Q9, Q10—MJE2955T PNP transistor, TO-220 case
 Q5, Q6, Q11-Q14—PN2222 NPN transistor, TO-92 case

RESISTORS

(All resistors are 1/4-watt, 5% units.)
 R1-R6, R9-R14, R18—100-ohm
 R7, R8, R15-R17, R19-R22—2200-ohm

ADDITIONAL PARTS AND MATERIALS

MOT1, MOT2—5-volt DC, 6.25-ohm coil, bipolar stepper motor, Airpax LB82773-M1 (Jameco 117954 or equiv.)
 RY1—DPDT relay, 5-volt coil (Jameco 115060 or equivalent)
 J1—DB-25 connector, female, PC-mount
 S1, S2—SPST microswitch (Jameco 98781 or equivalent)
 5.75-VDC, 1 amp or greater power supply (Jameco 107326 or equivalent, see text); 22-gauge stranded wire; mini drill (Jameco 26702 or equivalent); no. 64 (0.036-inch) PC drill bit (Jameco 16598 or equivalent); heat-shrink tubing; PC board; mechanical parts and materials (see Table 1); etc.

NOTE: The following are available from James J. Barbarello, 817 Tennent Road, Manalapan, NJ 07726: Enhanced software, executable on all PC platforms from XT through Pentium (CD-S, \$12, specify disk size); PCDrill PC board (PCD-PC, \$17); Drill caddy kit, consisting of spring, drill caddy sides, drill caddy slides, and drill holder (PCD-DC, \$15). The author will answer any questions sent to the address above, if accompanied by a self-addressed stamped envelope.

relay, and be sure to align the transistors as indicated. Use two excess resistor leads to form jumpers JU1 and JU2.

Prior to installing J1, enlarge the two PCB mounting holes to a diameter of 5/32 inch. Also, clip off leads 1, 6-8, 12-18, and 20-25, leaving pins 2-5, 9-11, and 19 intact. Solder the leads into place, but do not mount J1 to the PC board at this time.

The stepper-motor leads are not

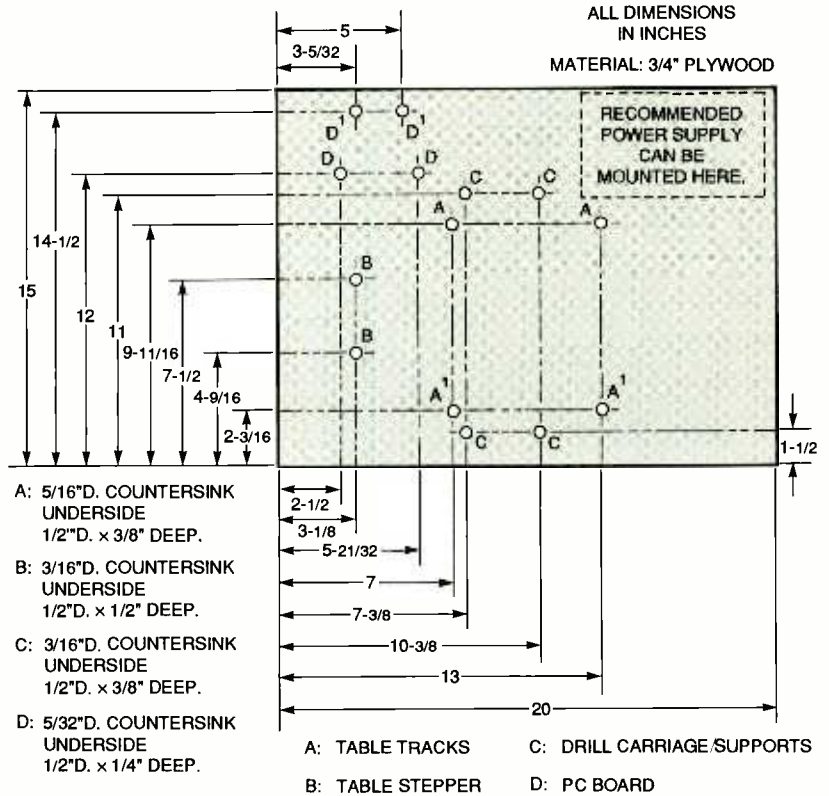

Fig. 4. The base plate has 14 holes in four groups (A, B, C, and D). Be sure to countersink all holes.

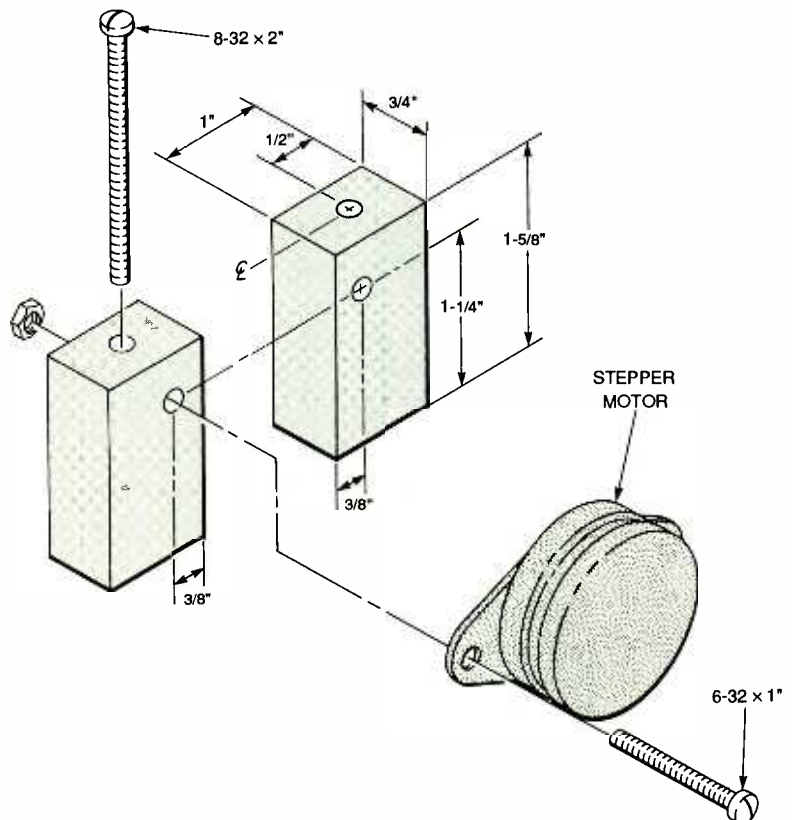

Fig. 5. The mounting blocks for the table stepper motor screw directly to the base plate.

long enough for our application, so remove the connectors on each motor. Obtain two sets of 22-gauge yellow, gray, red, and black stranded wire (each about 4" long). Extend the motor leads to about 8 inches by splicing a sufficient length of like colored wire to each lead. Solder the splice and cover it with shrink sleeving or electrical tape. Mark one motor as MOT1, and the other as MOT2. Attach the leads to the appropriate points on the PC board.

Connect your power supply's leads to the PC board. If you use the supply cited in the Parts List, clip off the connector and attach the wires to the appropriate pads on the PC board. Adjust the PC-mounted potentiometer to obtain 5.75-volts DC.

The Base. As shown in Fig. 4, the base is a piece of plywood (or similar material) measuring $15 \times 20 \times \frac{3}{4}$ inches. Drill 14 holes in the base, and countersink all 14 from the underside. That prevents mounting nuts from protruding from the bottom of the base.

Note in Fig. 4 that there are four groups of holes, denoted A, B, C, and D. Attach four threaded spacers to the D holes with 6-32 screws. Then attach the PC board to the spacers with 6-32 screws. Note that two of the screws will go through both J1 and the PC board. Also, mount the power supply in the indicated position at this time. For our prototype, we mounted the PC board and power transformer to a $4 \times 3\frac{1}{2} \times \frac{1}{4}$ -inch scrap of plywood, and attached it to the base using #8 $\times \frac{3}{4}$ -inch sheet-metal screws.

Next, fabricate two table stepper mounts as shown in Fig. 5. Attach the mounts to the base with two 8-32 \times 2-inch machine screws and nuts. Attach stepper motor MOT1 to the mounts as shown in Fig. 5. The motor's shaft should face the center of the base, and the leads should exit the top of the motor. We'll also need a support bracket for the table-zeroing switch, but we'll build it later, during the initial alignment.

Table and Tracks. Cut the table tracks from $\frac{3}{4} \times \frac{3}{4} \times \frac{1}{8}$ -inch aluminum angle stock. Cut two 12-inch lengths, then locate and drill four $\frac{1}{4}$ -inch holes as shown in Fig. 6. Countersink the holes with a $\frac{1}{2}$ -inch drill bit so that the flat heads of the machine

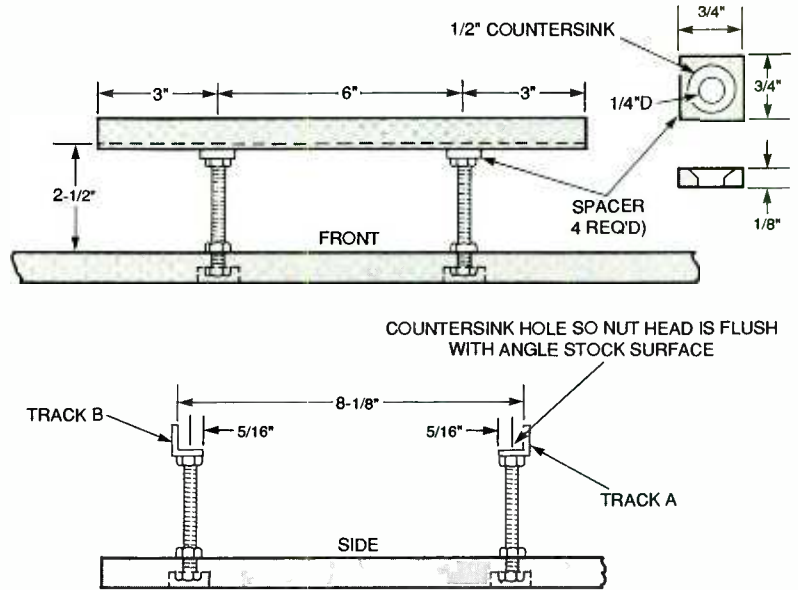

Fig. 6. Fabricate the table tracks from 12-inch lengths of $\frac{3}{4}$ -inch aluminum angle stock.

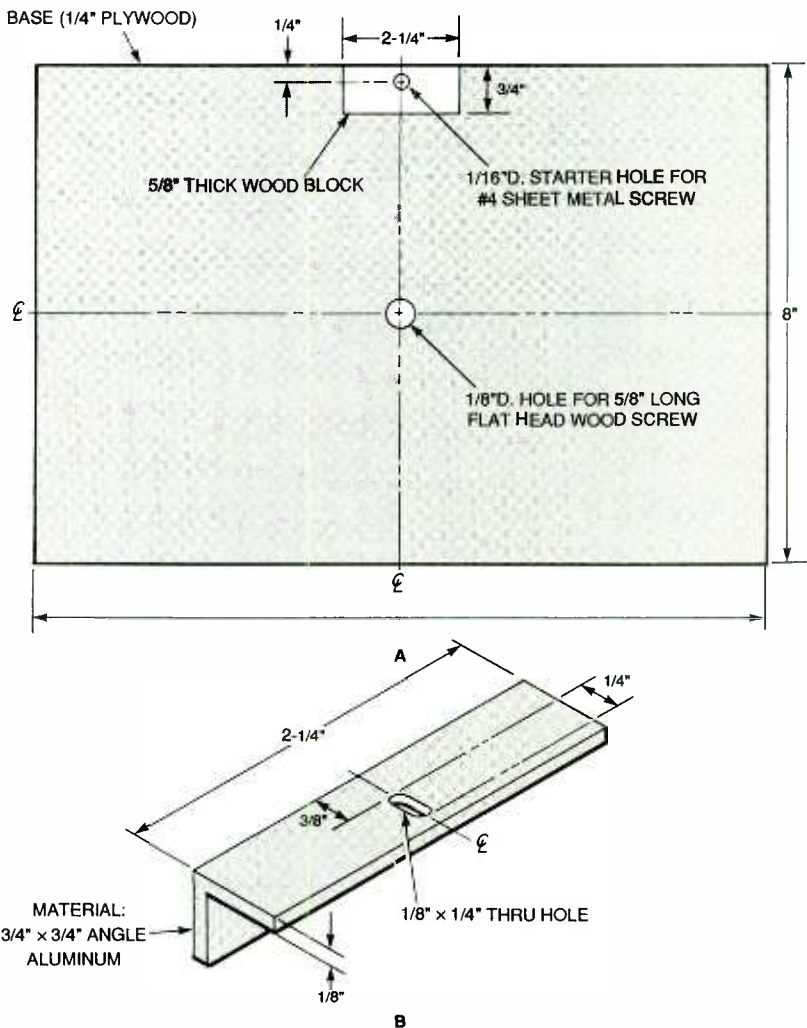

Fig. 7. As shown in A, the table base is fabricated from $\frac{1}{4}$ -inch plywood. The small block is where the table guide (B) mounts. Make two table guides; the second is used in the support assembly.

screws sit flush with the surface.

Now form four spacers from $\frac{3}{4}$ -inch flat aluminum stock, also as shown in Fig. 6. Pass a $\frac{1}{4}$ -20 \times 3-inch machine screw through each hole, place one spacer on each screw (countersunk side first), and then thread two $\frac{1}{4}$ -inch nuts onto each screw. Tighten the first nut on each screw to secure the screw to the track, making sure each screw is perpendicular to the track. Thread the remaining nut on each screw about $1\frac{1}{2}$ -inch above the bottom of the screw.

Insert the screws into the A holes on the base (Fig. 4). Then, as shown in Fig. 6, thread another nut onto each screw and adjust the nut so that the inside horizontal surface of each track (on which the Table will rest) is exactly $2\frac{1}{2}$ -inch above the base. Secure the tracks to the base by tightening the top nuts. Adjust the tracks so that the inside vertical surfaces are $8\frac{1}{8}$ -inch apart.

The table comes next. The assembly consists of the table base (Fig. 7-a), two table guides (Fig. 7-b), and the table driver (Fig. 8). Begin by cutting

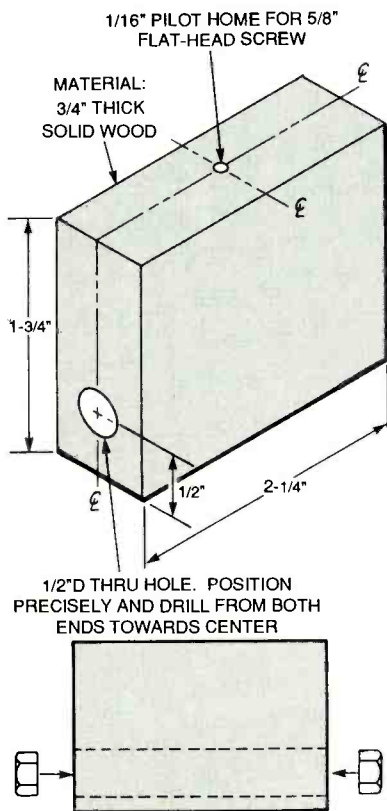

Fig. 8. The table driver has a precisely drilled $\frac{1}{2}$ -inch through-hole located $\frac{1}{2}$ -inch up from the bottom. Then press fit two $\frac{5}{16}$ -inch-20 nuts into the hole ends.

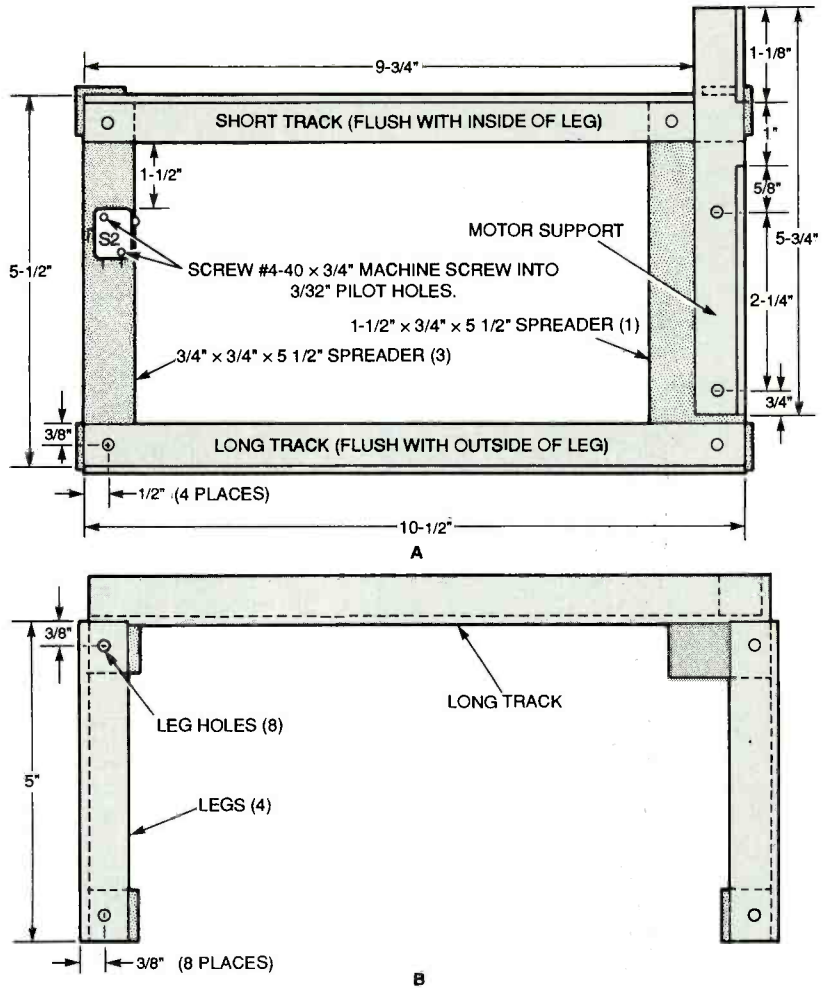

Fig. 9. The drill-caddy support framework supports the drill caddy above the table via four 5-inch legs. The top view (A) shows the short and long tracks, and the spreaders. The front view (B) shows the legs and the support track.

TABLE 2—MATERIALS LIST

QTY	DESCRIPTION	FOR
2	#4 \times $\frac{1}{2}$ -inch sheet metal screw	table/drill guides
24	#8 \times $\frac{3}{4}$ -inch sheet metal screw	drill caddy support, drill caddy
1	#2 flat washer	spring holder
1	#2-56 \times $\frac{1}{2}$ -inch machine screw and #2-56 nut	spring holder
4	#4-40 \times $\frac{3}{4}$ -inch machine screw	s1 & s2 mount
2	#4-40 nut	s1 mount
5	#6-32 \times $\frac{3}{4}$ -inch machine screw	PC board/spacers and shaft couplers
4	#6-32 \times $\frac{3}{4}$ -inch machine screw	spacers to base
2	#6-32 \times 1-inch machine screw	table stepper mounting
2	#6-32 nut	—
4	#6-32 threaded spacer, $\frac{3}{8}$ -inch long (Jameco 77551)	spacers
2	#8-32 \times 2-inch machine screw	table stepper mounts
4	#8-32 \times $1\frac{1}{4}$ -inch machine screw	drill caddy support to base
6	#8-32 nut	—
4	$\frac{1}{4}$ -20 \times 3-inch flat head machine screw	table track supports
12	$\frac{1}{4}$ -20 nut	table track supports
2	$\frac{5}{8}$ -inch \times 12-inch long threaded rod	table & drill drive
4	$\frac{5}{8}$ -inch nut	table/drill drivers
1	$\frac{3}{8}$ -inch long flat head wood screw	table mount
1	$\frac{1}{4}$ -inch \times 1-inch \times .035-inch utility compression spring	drill caddy
1	8-inch \times 12-inch \times $\frac{1}{4}$ -inch wood	table
2	2-inch \times 2 $\frac{1}{4}$ -inch \times $\frac{1}{4}$ -inch wood	table holder sides
1	2-inch \times 1 $\frac{3}{4}$ -inch \times $\frac{1}{4}$ -inch wood	drill holder side
1	1 $\frac{1}{4}$ -inch \times 1 $\frac{3}{4}$ -inch \times $\frac{1}{4}$ -inch plywood	drill holder side

the base from 1/4-inch plywood and smoothing the ends with sandpaper. Next cut a small wood block as shown in Fig. 7-a, drill the 1/16-inch starter hole, and glue the block to the table with white (or carpenter's) glue. Next, fabricate a table guide per Fig. 7-b. To create the oblong hole, drill two 1/8-inch holes and file away the material

between the holes.

After the glue dries, place the base on the table tracks with the block resting over Track A (see Fig. 6). Place the table guide on the block so it overlaps Track A. Push the block flush with the inside vertical surface of Track A. Place a piece of paper or a business card against Track A's outer surface

and pull the guide flush to it. Secure the guide to the block with a #4 sheet-metal screw, and then remove the paper (or business card). Ensure that the table slides freely but does not wobble. Adjust as necessary.

The last part of the table, the table drive, is the most important. Referring to Fig. 8, cut a piece of wood to the dimensions shown. Precisely locate a point on each end that is 1/2-inch up from the bottom, and at the halfway point between the two sides. Starting with a small drill bit (1/16 or 3/32 inch), drill in from each side to create a pilot. Gradually increase the size of the hole using larger drill bits. You should eventually end up with a 1/2-inch through-hole. Now drill the 1/16-inch pilot hole on the top. Next, place a 5/16-inch hex nut over one end of the 1/2-inch through-hole, and temporarily secure it with some masking tape. Place the nut/block assembly in a vise and gently squeeze the nut into the hole until it is flush. Remove the tape and repeat the process with another nut in the other end.

Thread a 5/16-inch threaded rod through one of the nuts. As the rod approaches the other end, it will either thread through easily or begin to bind. If it binds, use another threaded rod from the outside and gently move the unthreaded nut slightly. Do this until the rod can be threaded through easily. Apply a light coating of oil to

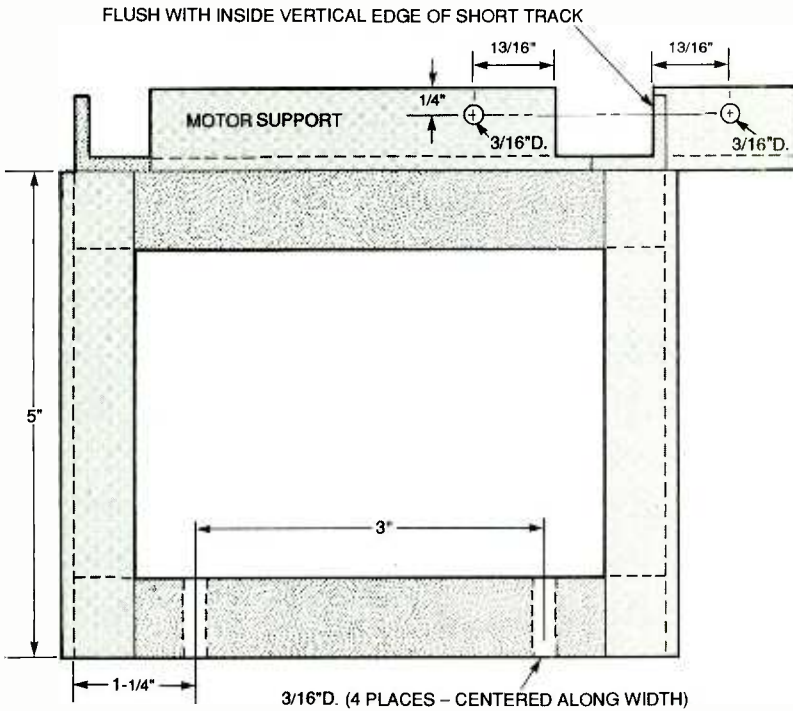

Fig. 10. This side view of the drill-caddy support details the holes where the motor mounts and the notch that provides clearance for the threaded rod.

1	15-inch × 20-inch × 3/8-inch plywood or composition board	base
2	3/8-inch aluminum stock, 3/8-inch w × 2 1/2-inch long	retaining clips
2	3/8-inch × 3/8-inch × 1/4-inch angle aluminum, 2 1/4-inch long	table/drill guide
4	3/8-inch × 3/8-inch × 1/4-inch angle aluminum, 5-inch long	drill caddy support legs
1	3/8-inch × 3/8-inch × 1/4-inch angle aluminum, 5 1/4-inch long	drill caddy motor support
1	3/8-inch × 3/8-inch × 1/4-inch angle aluminum, 9 1/4-inch long	short drill caddy track
1	3/8-inch × 3/8-inch × 1/4-inch angle aluminum, 10 1/4-inch long	long drill caddy track
2	3/8-inch × 3/8-inch × 1/4-inch angle aluminum, 12-inch long	table tracks
4	3/8-inch × 3/8-inch × 1/4-inch flat aluminum stock, 4 1/4-inch long	drill caddy side stretcher
1	3/8-inch × 3/8-inch × 1/4-inch flat aluminum stock, 4 1/4-inch long	table zeroer support
2	3/8-inch × 3/8-inch × 2-inch wood	drill caddy slide
1	3/8-inch × 3/8-inch × 2 1/4-inch wood	table base wood block
3	3/8-inch × 3/8-inch × 5 1/2-inch wood	drill caddy spreader
1	3/8-inch × 1-inch × 2 1/4-inch wood	drill driver
1	3/8-inch × 1 1/2-inch × 5 1/2-inch wood	drill caddy spreader
1	3/8-inch × 1 1/2-inch × 2 1/4-inch wood	table driver
2	3/8-inch × 2-inch × 2 1/4-inch wood	drill caddy side
4	universal shaft coupler (Jameco 106606)	motor coupler
2	rubber coupler (Jameco 106622)	motor coupler

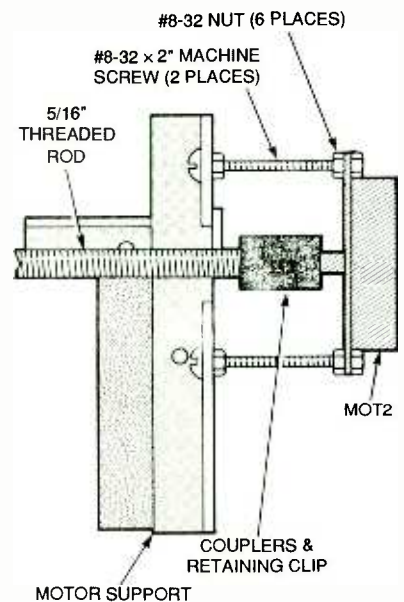

Fig. 11. As shown here, stepper motor MOT2 mounts against the motor support bracket.

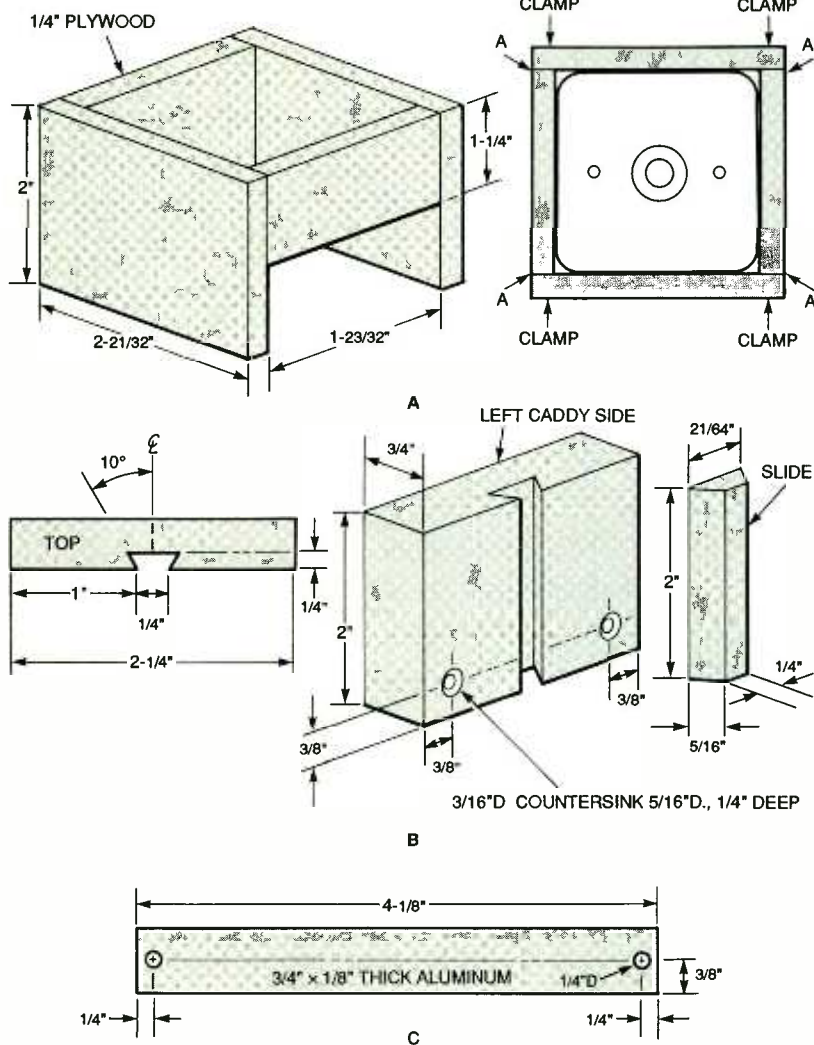

Fig. 12. The drill holder (A), the caddy sides and slide (B), and the side stretcher (C) are the drill-holder components shown here.

the rod and run the guide up and down the rod several times. You can do this quickly by chucking the rod into a variable-speed, reversible drill. The goal is for the rod to be able to move with no discernible resistance.

Place the guide on the underside of the table so both pilot holes align. Insert a 5/8-inch flat-head wood screw through the table into the guide. The screw's head should be flush with the table and the guide should be flush with the underside of the table, but the guide should be able to rotate without major resistance. That will allow the guide to move the table forward and back, but compensate for any minor misalignment of MOT1's threaded-rod drive after it is installed (during final assembly).

44 **Drill Caddy and Support.** Referring

to Fig. 9-a, cut four legs and the short and long tracks from angle stock. Next, cut the four spreaders from 3/4-inch wood stock. Drill and countersink two holes in each of the bottom spreaders as shown.

Drill two leg holes in each leg as shown in Fig. 9-b. Using #8 sheet-metal screws, connect the legs and stretchers to form two leg subassemblies, making sure they are square. Drill the track holes in each of the tracks and attach to the leg subassemblies. (Note that the short track is flush with the inside of the legs, but the long track is flush with the outside of the legs). Make sure the resulting top surface of the structure is square, and is of equal height on both ends.

Cut a 1-inch notch in the motor-support bracket and drill two spreader holes and two motor-mount

holes. Secure the motor-support bracket with #8 sheet-metal screws. Make sure the notch aligns with and is perpendicular to the short track's inside vertical surface, as shown in Fig. 10. Secure the assembly to the base with four 8-32 x 1 1/4-inch machine screws in the base holes marked C. Mount microswitch S2 on the top spreader using two 4-40 x 3/4-inch machine screws screwed into 3/32-inch pilot holes. The edge of the microswitch with the plunger should be flush with the edge of the spreader. Finally, attach motor MOT2 to the motor support as shown in Fig. 11, using two 8-32 x 2-inch machine screws and six nuts.

The Drill Caddy. The last and most critical assembly is the drill caddy. It must hold the drill in a vertical position, allow it to travel up and down, and have no slop in any direction. The assembly consists of a pair of dovetail slides and a drill holder that is custom-fit to the drill to be used. The Parts List mentions one suitable drill, though many others could be used.

Refer to Fig. 12 as we proceed. Begin by cutting two pieces of 1/4-inch wood stock to 2-inches high by 2 5/32-inches long. Cut another piece to 2-inches high by 1 23/32-inches long, and one more piece to 1 1/4-inches high by

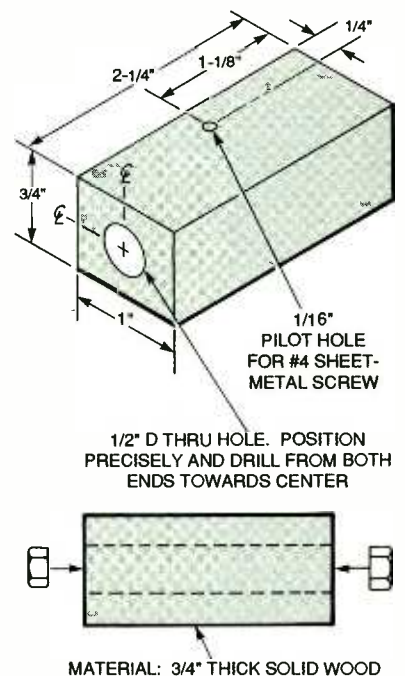

Fig. 13. The drill driver, like the table driver (Fig. 8), has a 1/2-inch through-hole.

LISTING 1—TEST PROGRAM

```

REM** PCDRL.BAS (c) 1995, JJ Barbarello, Manalapan, NJ 908-536-5499
REM** V951125
DEF SEG = 64: DEFINT A: add = 888: ON ERROR GOTO errortrap
DIM a(4), a$(5): a(1) = 5: a(2) = 3: a(3) = 10: a(4) = 12
OUT add, a(4): aseq = 4
a$(1) = "Table Towards Stepper": a$(2) = "Table Away From Stepper"
a$(3) = "Drill Towards Stepper": a$(4) = "Drill Away From Stepper"
a$(5) = "END"
start:
CLS : LOCATE 1, 25: PRINT "PC-DRILL CHECKOUT AND ALIGNMENT"
LOCATE 6, 5: PRINT "SELECT OPTION:"
FOR i = 1 TO 5
    LOCATE 8 + i, 10: PRINT USING "#. "; i;
    PRINT a$(i)
zNEXT i
getoption:
LOCATE 6, 20, 1: PRINT SPACES$(10); : LOCATE 6, 20
a$ = INPUT$(1): a = VAL(a$)
CLS
LOCATE 1, 25: PRINT "PC-DRILL CHECKOUT AND ALIGNMENT"
LOCATE 10, 16
SELECT CASE a
    CASE IS = 1
        steps = -1: which = 128: PRINT a$(1);
    CASE IS = 2
        steps = 1: which = 128: PRINT a$(2);
    CASE IS = 3
        steps = -1: which = 0: PRINT a$(3);
    CASE IS = 4
        steps = 1: which = 0: PRINT a$(4);
    CASE IS = 5
        CLS : OUT add, which: LOCATE 18, 1: END
    CASE ELSE
        BEEP: GOTO start
END SELECT
OUT add, a(4): aseq = 4
PRINT ". Press Enter to stop...";
motionloop:
    aseq = (aseq MOD 4) + steps
    IF aseq = 0 THEN aseq = 4
    IF aseq = -1 THEN aseq = 3
    OUT add, a(aseq) + which
startl = TIMER
WHILE (TIMER - startl) < .000001: WEND
    IF (INP(add + 1) AND 64) = 0 AND a = 2 AND which = 128 THEN GOTO start
    IF (INP(add + 1) AND 128) = 128 AND a = 4 AND which = 0 THEN GOTO start
    IF INKEY$ = "" THEN GOTO motionloop
OUT add, 0 + which
GOTO start
errortrap:
OUT add, 0 + which
RESUME start

```

$1\frac{23}{32}$ -inches long. Using the selected drill as a mold, arrange those pieces around the drill to form a box, and temporarily clamp the sides as shown in Fig. 12-a. The drill should be held securely, only able to move if significant pressure is applied. If that is not the case, adjust the lengths of the shorter pieces as necessary. When done, remove the clamps, apply car-

penter's glue on mating surfaces A, and re-clamp. **Note:** Make sure the box is square on all sides. Let the assembly sit for about an hour and then remove the drill, leaving the clamps in place. Let the assembly sit for another hour to ensure that the glue cures.

Cut two caddy sides from $\frac{3}{4}$ -inch wood, as shown in Fig. 12-b. Form the dovetail slot centered in the $2\frac{1}{4}$ -inch

width of each piece. Cut two caddy slides and slide them into the dovetail slots. They should slide freely, but without any side-to-side or front-to-back wobble. If necessary, lightly sand the pieces until they fit properly. Drill two holes in the left caddy side.

Place the caddy slides in the caddy sides and position on each of the shorter sides of the drill box. Apply a thin line of glue along caddy-slide-surface G and clamp the complete assembly together, making sure the assembly is square on all sides. Let the glue cure for about one hour. Remove the clamp.

Cut four side stretchers from $\frac{3}{4}$ - \times - $\frac{1}{8}$ -inch aluminum flat stock, as shown in Fig. 12-c. Screw the side stretchers onto the assembly after first drilling $\frac{3}{32}$ -inch pilot holes. When done, the drill box should slide freely in the caddy without any side-to-side or front-to-back movement. If not, adjust the stretchers or lightly sand as necessary until free sliding occurs.

Referring to Fig. 13, fabricate a drill driver using the same methods as for the table driver. Remove screws from the side stretchers and left caddy side. Position the drill driver on the bottom outside of the left caddy side and temporarily clamp in place, making sure the bottoms of the caddy side and drill driver are flush. Drill two countersunk holes in the drill driver (Fig. 12-b) and secure with two #8 \times $\frac{3}{4}$ -inch sheet-metal screws. Ensure that the ends of the screws do not protrude into the cavity of the drill driver. If there is interference, remove the screws and file their ends down as necessary. Reassemble the drill caddy.

Remove screws from the side stretchers and right caddy side. Referring to Fig. 12-d, fabricate a $\frac{5}{8}$ \times $\frac{5}{16}$ -inch square piece of wood to serve as the spring flange. After drilling the $\frac{1}{8}$ -inch hole, glue the flange to the caddy side as shown in Fig. 14. After the glue has cured, install a 1- \times $\frac{1}{4}$ -inch (diameter) spring by placing a flat washer in the end of the spring and inserting a 4-40 \times $\frac{1}{2}$ -inch machine screw through the spring, washer, and flange. Secure in place with a 4-40 nut. Make sure the spring does not angle out into the path of the drill. Reassemble the drill caddy and thread a $\frac{5}{16}$ -inch threaded rod about halfway into the drill driver.

Place the drill caddy assembly on

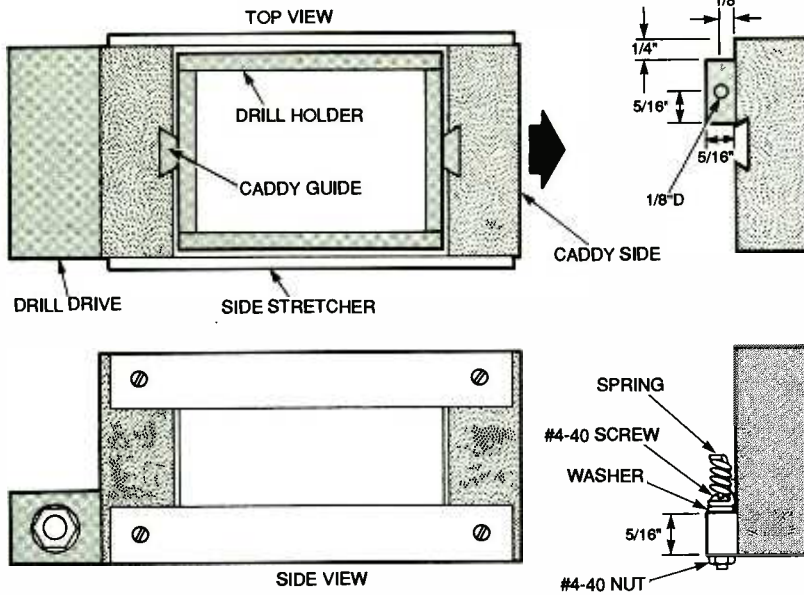

Fig. 14. The drill-caddy assembly contains all the components shown in Fig. 12 and Fig. 13.

ENLARGE 1/4" HOLE TO 5/16"D. (2 OF 4 COUPLERS)

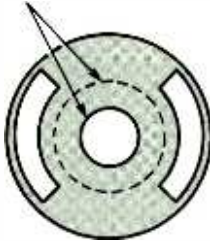

Fig. 15. You must modify the universal shaft coupler by enlarging the 1/4-inch hole to 5/16-inch on half of each coupler. Optionally, replace the set screws with 6-32 screws.

the drill caddy support so the threaded rod protrudes through the 1-inch slot on the motor support. Form another guide as shown in Fig. 7-b, and position it on top of the drill driver. Fasten with a #4 sheet-metal screw, and adjust so the drill caddy moves freely with minimum wobble.

Final Assembly. We will couple the threaded rods to the motors using 1/4-inch universal shaft couplers. First, however, we must modify the shaft couplers for our application, as shown in Fig. 15. When enlarging the 1/4-inch hole, use progressively larger drill bits, and work slowly as the couplers are brittle. For safety, clamp the couplers in place when drilling. Enlarge only two couplers for the threaded rods; unmodified couplers fit the motors as is. For convenience, you can optionally replace the set screws in the

couplers with 6-32 x 3/8-inch machine screws.

Next, form two shaft coupler retaining clips from thin aluminum stock as shown in Fig. 16. If you cannot find thin aluminum anywhere else, the top of a used electronics hobby box works well.

Install a modified coupler on one end of each threaded rod, making sure the coupler is not cocked. If it is, loosen the set screw, rotate the rod slightly, and try again. Install an un-

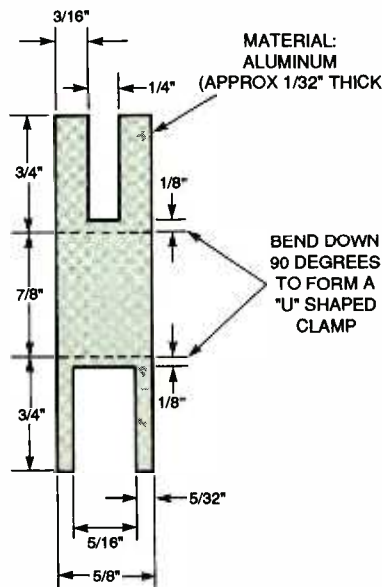

Fig. 16. The coupler retaining clip holds the universal-shaft-coupler components together. One clip is required for each motor/rod assembly.

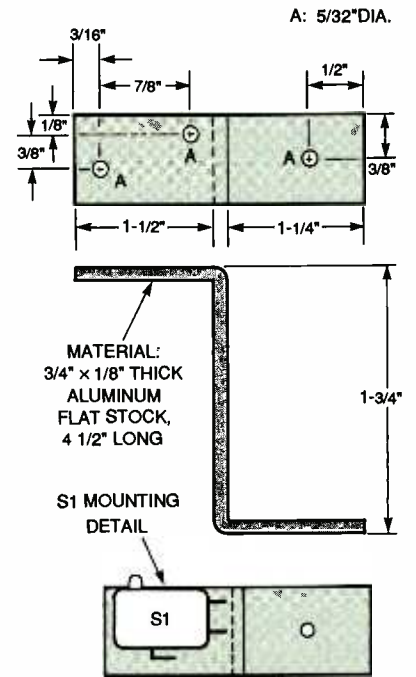

Fig. 17. The switch support bracket holds microswitch S1.

modified coupler on the shaft of each motor. Install one rubber coupler into each coupler on each motor.

Place the table on the table supports and slide toward motor MOT1. Align the rubber coupler and metal coupler on the threaded rod and push together. Snap the retaining clip over the couplers.

Slide the drill caddy assembly toward MOT2 and push onto the rubber coupler. Snap a retaining clip onto the couplers. Adjust MOT2 as necessary so it is in-line with the threaded rod. Carefully push the drill into the drill box until the bottom of the chuck is about 3/4-inch above the table.

Fabricate a support bracket for switch S1 as shown in Fig. 17, and mount S1 using two 4-40 x 5/8-inch machine screws and nuts. Cut four 22-inch lengths of 22-gage stranded wire. Connect S1 and S2 to the PC board, routing the wires so as not to interfere with table or caddy movement. Mount R21 across S2's terminals and solder it in place. Mount R22 across S1's terminals and solder it in place.

Initial Checkout. Connect J1 to your PC's parallel port, and energize PCDrill's power supply. Next we'll run a test program. Either enter the QBasic program shown in Listing 1, or execute
(Continued on page 79)

The NE602 could very well become the RF experimenter's "555" chip. Learn about this fascinating and versatile device for your next RF project.

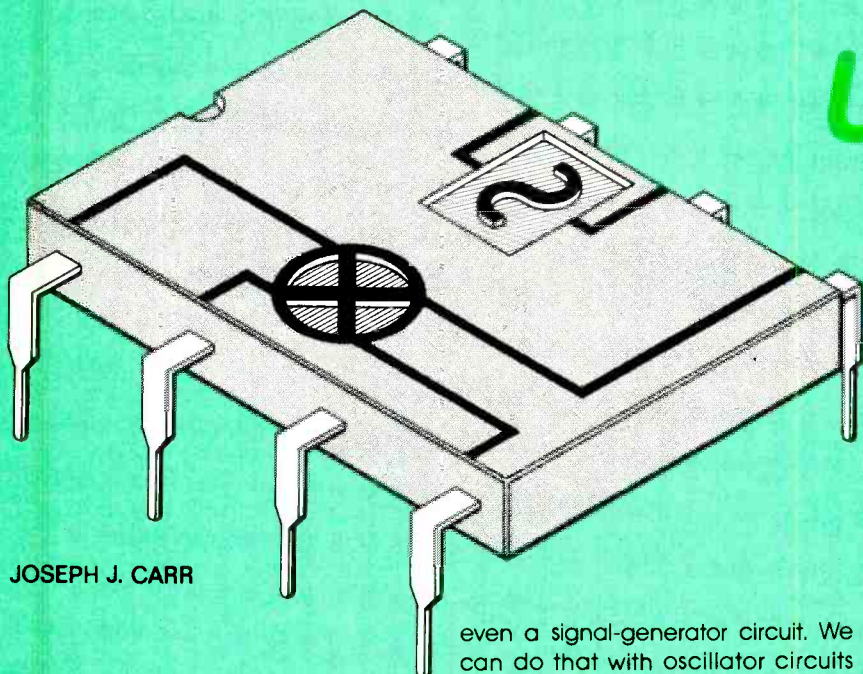

JOSEPH J. CARR

Every now and then a chip comes along that strikes the public imagination, so it gets used in a lot of projects. The 741 operational amplifier was like that in the early 1970s. Also reaching a high pitch of popularity was the 555 IC timer chip. Both of those chips reached such heights because they were both useful and well-behaved (i.e. they did what they did with little fuss or fuss). The radio frequency (RF) hobbyist, however, only recently found a chip that meets those requirements: the NE602 from Signetics.

The NE602 device is a monolithic integrated circuit containing a double-balanced mixer (DBM) and an internal oscillator circuit. The DBM has balanced inputs (pins 1 and 2), balanced outputs (pins 4 and 5), and can operate at up to 500 MHz. The internal oscillator circuit provides an emitter connection and a base connection to the outside world. Figure 1-a shows the block diagram, and Fig. 1-b the pinouts for the NE602 device.

The NE602 is meant to be used as the receiver front-end in VHF portable telephones, but a lot of amateur radio and electronics enthusiasts have used the chip for a wider variety of applications, some of which we'll talk about here. The NE602 is a strong candidate whenever you want to build a frequency converter or translator, or

even a signal-generator circuit. We can do that with oscillator circuits consisting of inductor-capacitor (L-C) variable-frequency oscillators, or piezoelectric crystals in either voltage-tuned or swept-frequency arrangements. We're going to explore some of the various configurations of circuits for the NE602 device, including the DC-power-supply connections, the RF-input configurations, the local-oscillator circuits, and the output circuits.

The NE602 version of the device operates over a temperature range of 0- to +70°C, while the related SA-602 device operates over an extended temperature range of -40- to +85°C. The most common form of the NE602, and most useful for the hobbyist and experimenter, is the NE602N, which is in an eight-pin mini-DIP package. An eight-lead surface-mount package (NE602D) is also available.

Heart of the NE602. Because the NE602 contains both a DBM and a local oscillator (LO), it can be used as the entire front-end of a radio receiver. Figure 2 shows a partial view of the internal circuit of the heart of the NE602: the double-balanced mixer stage. That configuration is known as a Gilbert transconductance cell. It consists of a pair of cross-coupled differential amplifiers. One feature of the design is that it offers a very good

USING THE NE602

noise figure, which is typically 5 dB at 45 MHz. The third-order intercept point is -15-dBm referenced to a matched input. Unfortunately, the dynamic range is not what it could be, so a good idea is to be sure that the input signal levels do not exceed -25 dBm (≈ 3.16 mW). That signal level is similar to about 12.6 mV into a 50-ohm load, or 68 mV into the 1,500-ohm input impedance of the NE602. The NE602 is capable of providing 0.2- μ V sensitivity without the need for external RF amplification. Although the straight NE602 suffers from dynamic range problems, the improved NE602A is said to solve that problem.

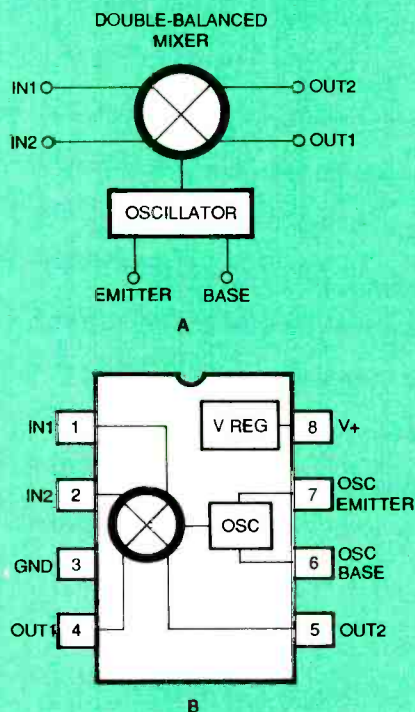

Fig. 1. The NE602 contains a double-balanced mixer and local oscillator. Here are its block diagram (A) and pinouts (B).

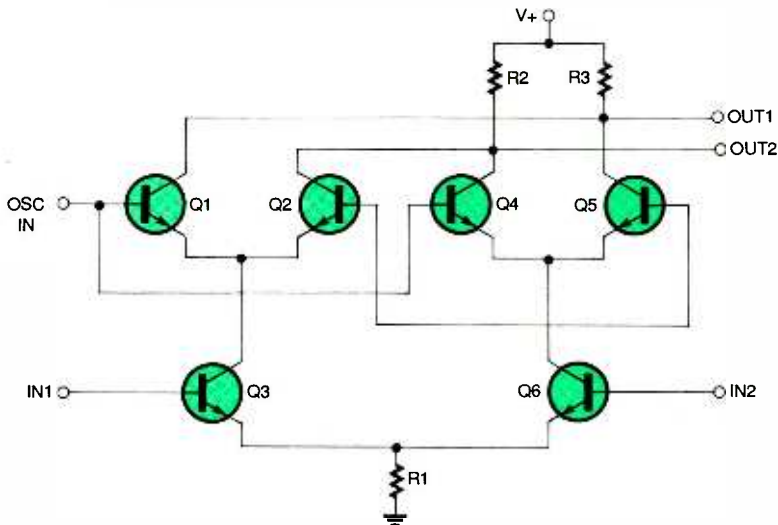

Fig. 2. The heart of the NE602: a Gilbert transconductance cell used for the double-balanced mixer.

Frequency Translation. The process of frequency translation or conversion is called heterodyning. When two frequencies (F_1 and F_2 in Fig. 3) are mixed together in a nonlinear circuit, a collection of different frequencies will appear at the output. Those frequencies are characterized as $mF_1 + /-nF_2$, where n and m are integers or zero (0, 1, 2, 3...). For the sake of simplicity, we normally consider only the cases where m and n are either 0 or 1, so the output frequencies are F_1 , F_2 , $F_1 - F_2$ (difference), and $F_1 + F_2$ (sum). To make a superheterodyne receiver (the most common modern form), select either the sum ($F_1 + F_2$) or difference ($F_1 - F_2$) frequency as the receiver's intermediate frequency (IF). The NE602 contains a double-balanced mixer, so when it is properly impedance matched, it suppresses the two input frequencies (F_1 and F_2) at the output, and only produces the sum and difference frequencies.

In order to provide frequency translation by heterodyning, it is necessary to provide an LO circuit. The LO circuit inside the NE602 consists of a transistor

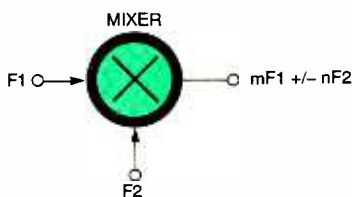

Fig. 3. In a basic mixer circuit, the sum ($F_1 + F_2$) and difference ($F_1 - F_2$) of two input frequencies appear at the output.

with its base and emitter elements available to the outside world. Oscillators using that circuit will operate up to 200 MHz. Any form of oscillator can be built, as long as the circuit does not need a connection to the collector of the oscillator transistor. Because of that restriction, both L-C and crystal variants of the Colpitts, Clapp, Hartley, Butler and other oscillator circuits can be built, while the Pierce and Miller circuits are not possible.

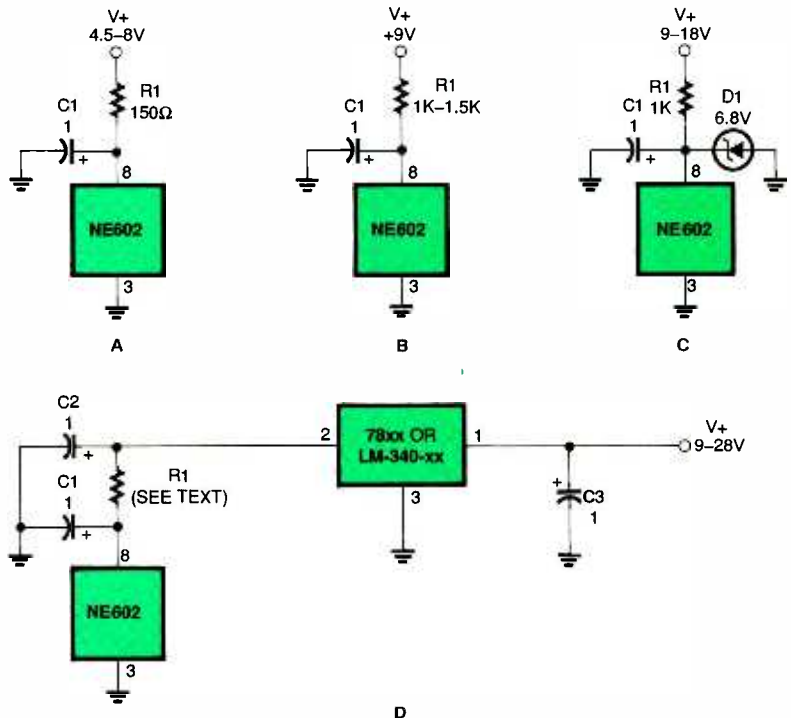

Fig. 4. There are several ways to power the NE602. A resistor should be placed in series between the power supply and the NE602 (a and b). A Zener diode (c) or a voltage regulator (d) can also be used.

DC Power Supply Connections.

The power is applied to the NE602 between pins 3 (ground) and 8 (V_+). The DC power supply voltage range is +4.5- to +8-volts DC, with a current drain ranging from 2.4 to 2.8 mA.

The DC power supply terminal (pin 8) must be decoupled with a 0.01- to 1- μ F capacitor (0.1 μ F is most common). The bypass capacitor must be mounted as close as possible to the body of the NE602, and must be capable of good performance at RF frequencies (some capacitors act like complex RLC networks at RF).

Figure 4 shows several possible DC power-supply configurations for the NE602. In Fig. 4-a, the DC power supply voltage is between +4.5 and +8-volts DC, which is the normal operating range of the device. A resistor, usually 100 to 180 ohms, is placed in series with the V_+ line to the NE602. If the circuit is operated from a 9-volt DC power supply (e.g. a 9-volt DC transistor-radio battery), then the resistor should be increased to a value between 1,000 and 1,500 ohms, as in Fig. 4-b.

If the DC power supply voltage is either unstable, or at a value higher than 9-volts DC, you might want to use some form of voltage regulation. In

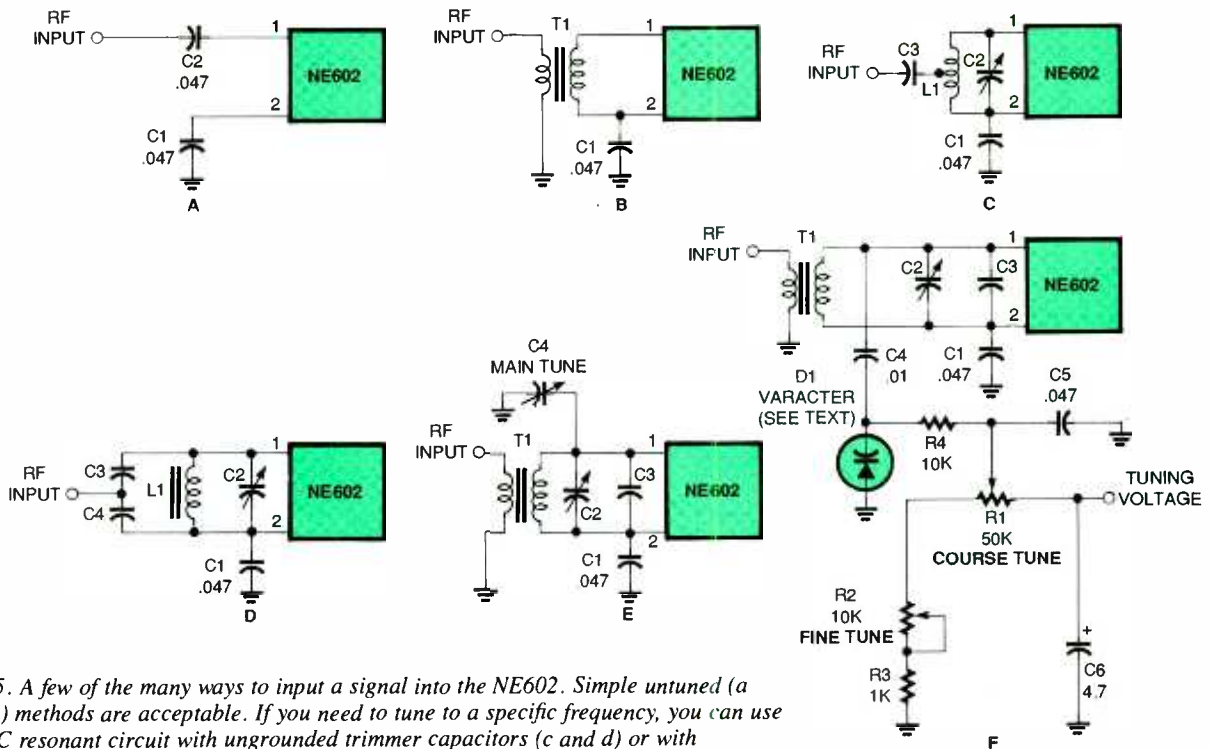

Fig. 5. A few of the many ways to input a signal into the NE602. Simple untuned (a and b) methods are acceptable. If you need to tune to a specific frequency, you can use an L-C resonant circuit with ungrounded trimmer capacitors (c and d) or with grounded variable capacitors (e). You can even use a tuning voltage in connection with a varactor (f).

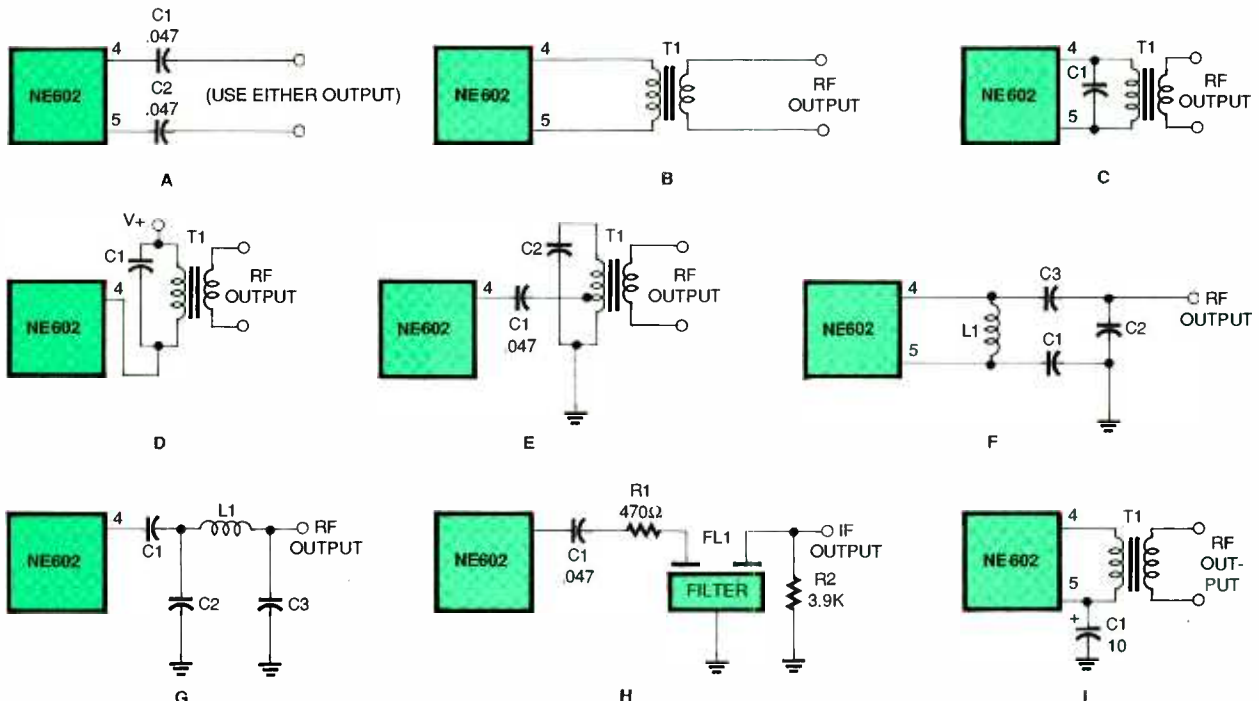

Fig. 6. The various output circuits shown here demonstrate how to either pass all the frequencies from the NE602, or allow only the sum or difference frequencies through, depending on which circuit is used.

fact, that's highly recommended. Figure 4-c shows the use of a Zener diode, rated at 6.8-volts DC, which keeps the supply voltage seen by the NE602 at that level even though the source power supply voltage might

vary from 9 to 18 volts, or so.

The use of a three-terminal voltage regulator is shown in Fig. 4-d. Those devices provide a constant output voltage for a wide range of DC input voltages. A typical voltage regulator

can accept input voltages from a minimum of about 2.5-volts higher than its rated output voltage, up to a maximum of about 30 to 38 volts. Almost any positive voltage regulator can be used in the circuit of Fig. 4-d if it

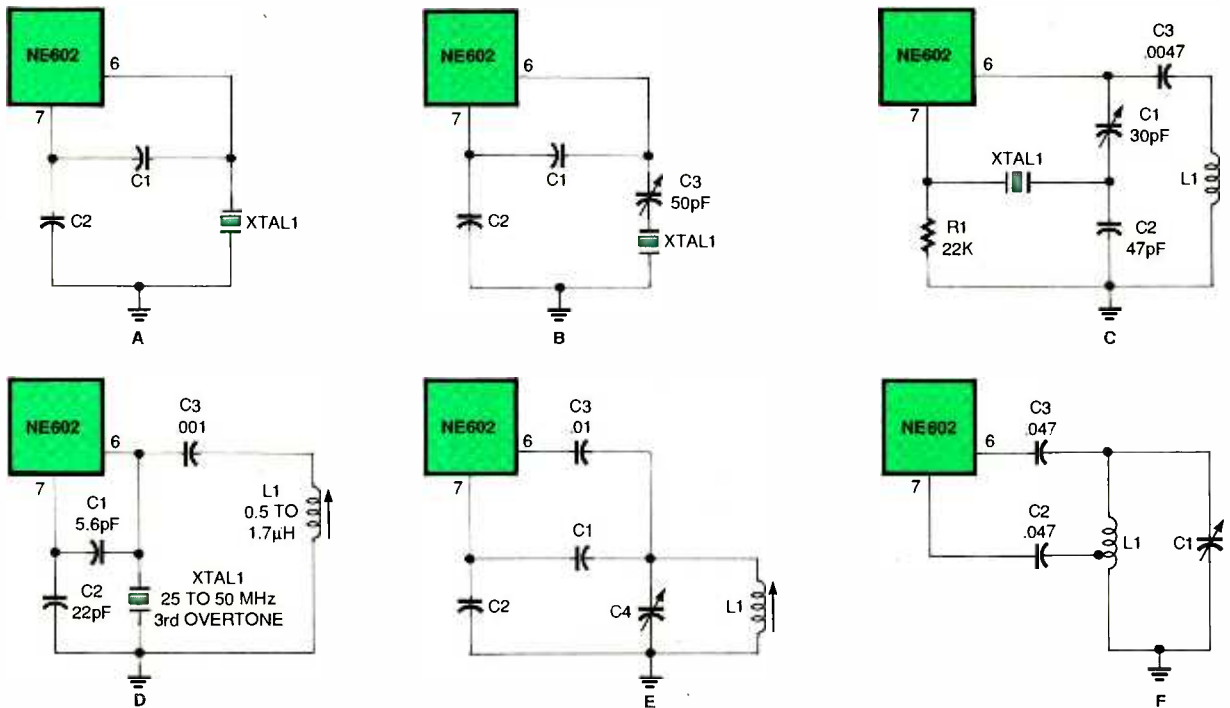

Fig. 7. The local oscillator for the NE602 can take the form of either a crystal-controlled (a through d) or a resonant-tank circuit (e and f).

has the correct output-voltage rating. The 78xx series and the LM-340-xx are essentially the same devices, with the "xx" replaced by the voltage rating. For example, the 7805 is a +5-volt DC voltage regulator. Because the NE602 device has such a low current requirement, it's possible to use the low-powered 78Lxx series. Good candidates are the 78L05, 78L06, 78L08 or 78L09 devices, with the first three preferred. The value of R1 in Fig. 4-d should follow the same rules as for Figs. 4-a and 4-b.

NE602 Input Circuits. The RF input side of the NE602 uses pins 1 and 2 (IN1 or IN2), which form a differential pair. The input impedance of the NE602 at lower frequencies is about 1,500 ohms shunted by 3 pF of capacitance, while at higher frequencies it drops to about 1,000 ohms. Both balanced and unbalanced input circuits can be used on the NE602. Unless a true differential configuration is used, the signal is usually applied to pin 1, and pin 2 is bypassed to ground.

Figure 5-a shows the simplest form of input circuit. A single capacitor (0.047- μ F typical) couples the signal from the outside world to pin 1 of the NE602. The other input pin (pin 2) is bypassed to ground with another

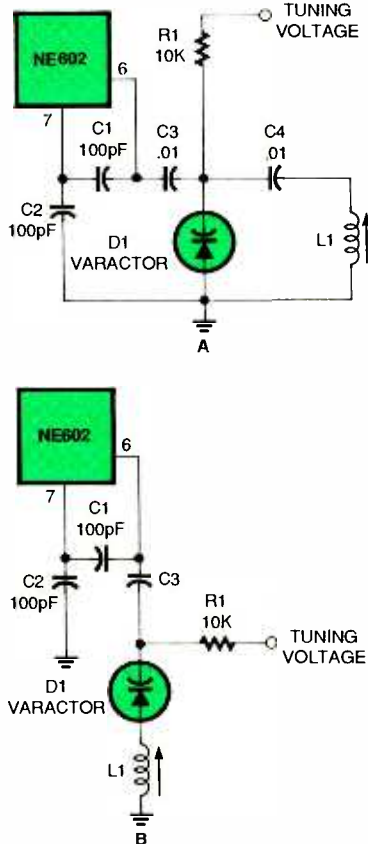

Fig. 8. The LO circuit for the NE602 can also be voltage-controlled. Here are two different methods of accomplishing that.

0.047- μ F capacitor. With that configuration, the input signal should be kept around -25 dBm, or 180-mV peak-to-peak.

The use of a wideband RF transformer is shown in Fig. 5-b. In that configuration, the secondary of a wideband transformer is connected across pins 1 and 2 of the NE602, while the primary is connected between the antenna and ground. The turns ratio of the transformer is set to transform the 1,000- to 1,500-ohm input impedance of the NE602 to the system impedance (usually 50 ohms). A general rule for the transformer is to set the inductance of the secondary winding to provide four times the NE602 input impedance at the operating frequency, or about 4,000 to 6,000 ohms. Either conventional- or toroid-wound transformers can be used for T1 in that application. As we've seen before, one input of the NE602 is decoupled to ground through a capacitor.

The circuits shown in Fig. 5-c and 5-d are tuned to a single frequency, but use different methods to provide impedance matching between the source and the input of the NE602. Of course, a capacitor could also be used to resonate the secondary of the transformer in Fig. 5-b. In Fig. 5-c, we do just that by resonating coil L1 with

variable capacitor C2. The input signal is coupled to coil L1 through an impedance-matching tap on L1 via capacitor C2. As with the other circuits, pin 2 is bypassed to ground.

The circuit in Fig. 5-d shows the use of a capacitor voltage divider (C3 and C4) to match the impedances. The resonant frequency is set by tuning L1 with variable capacitor C2, plus the series capacitance of C3 and C4. The tuning capacitance is:

$$C_{\text{tune}} = C2 + C3 \times C4 / C3 + C4$$

The circuits shown in Figs. 5-c and 5-d are used when the source impedance to be matched is less than the 1,500-ohm input impedance of the NE602 device. When a transformer input such as Figs. 5-b and 5-e are used, then the source impedance can be either higher or lower than 1,500 ohms, provided that we have the correct transformer turns ratio. One difficulty with the resonant circuits discussed earlier is the fact that the capacitor is connected across L1, which means that it must be ungrounded. That's fine as long as you can use trimmer capacitors, or somehow insulate a normally grounded variable capacitor. But it's not always practical to do that, so you can use the circuit of Fig. 5-e instead. Three tuning capacitors are used in that circuit: C2, C3 and C4. Capacitor C4 is effectively across the secondary winding of T1, provided that the value decoupling capacitor C1 is very large compared to the value of C4. In that instance, the value of the series combination of C1 and C4 is very nearly the value of C4. Capacitor C4 is used as the main tuning capacitor, while C2 is an optional trimmer capacitor for fine tuning. Also optional is C3, which is used to make up any extra capacitance required to meet a minimum value. If $C1 \gg C4$, the effective capacitance across the secondary of T1 is $C2 + C3 + C4 + 3 \text{ pF}$.

A voltage-tuned variant of the input

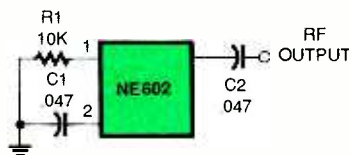

Fig. 9. If LO signal of the NE602 is sent directly to the output pins, the device can be used as a low-cost, high-frequency oscillator.

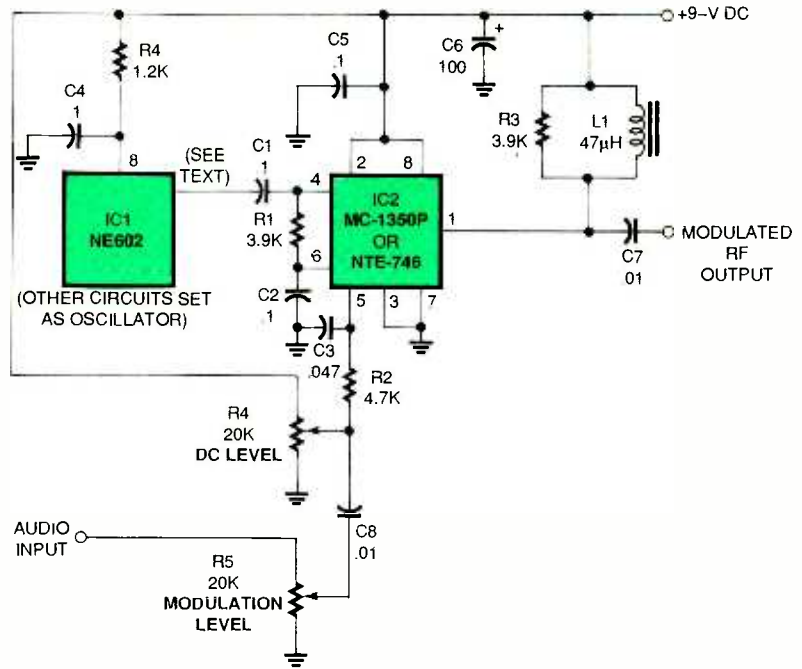

Fig. 10. By using an MC-1350P modulator IC, the output of the NE602 can easily be amplitude modulated.

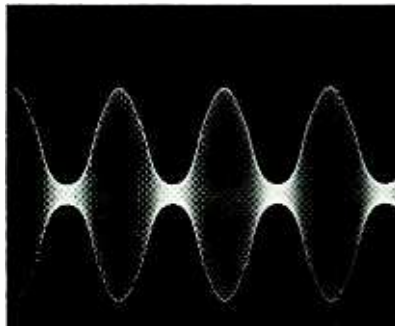

Fig. 11. This is the waveform of the circuit in Fig. 10, ready to be transmitted as an AM-radio signal.

circuit is shown in Fig. 5-f. That circuit is similar to Fig. 5-e, except that the variable "main tuning" capacitor (C4 in Fig. 5-e) is replaced with a voltage variable-capacitance (varactor) diode, D1. Those diodes provide a capacitance that drops as you increase the reverse voltage across the diode's terminals. As long as C4 is very much larger than the capacitance of D1 at any voltage, the tuning capacitance is that of D1. Resistor R1 is used to isolate the tuning voltage from the diode, so that it doesn't load the capacitance. Although a single "main tuning" potentiometer could be used, the circuit uses both coarse tune (R1) and fine tune (R2) potentiometers.

NE602 Output Circuits.

The NE602

has two outputs that can be used as a balanced pair, or alone as single-ended outputs. Either pin 4 or pin 5 can be used alone for single-ended circuits, or pins 4 and 5 are used together as a balanced, or differential, output. The simplest form of output circuit is shown in Fig. 6-a. Either pin 4 or pin 5 can be used. The output signal is coupled through a 0.01- to 0.1- μF capacitor to whatever circuit the NE602 is to drive. The circuit of Fig. 6-a is a wideband configuration and cannot tell which signals are the sum ($F1 + F2$) or difference ($F1 - F2$) signals.

A wideband balanced-output circuit is shown in Fig. 6-b. The transformer is used to change the 1,500-ohm output impedance of the NE602 to the impedance of whatever circuit is being driven. If both input and output system impedances are the same, then the same type of transformer can be used for both input and output, although reversed relative to each other. As in the case of the input circuit, either standard or toroidal transformers can be used for T1.

Tuned-output circuits are shown in Figs. 6-c through 6-e. The circuit of Fig. 6-c is balanced. The primary of the transformer is connected across pins 4 and 5, and is resonated by capacitor C1. A single-ended variation is shown in Fig. 6-d. In that case, the parallel-tuned circuit consists of C1

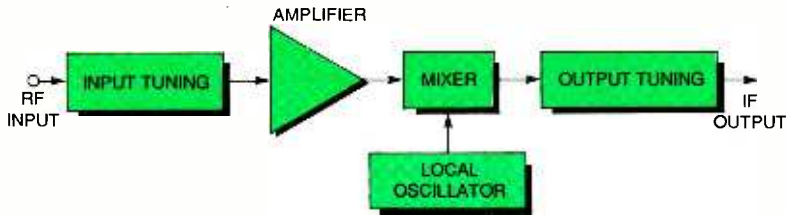

Fig. 12. If we add input and output tuning to the basic block diagram of Fig. 1-a, we can use the NE602 as a frequency translator.

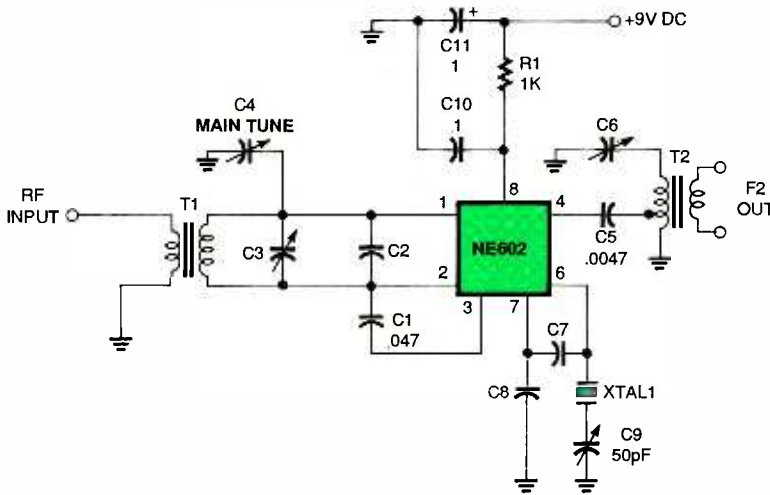

Fig. 13. This basic frequency translator/converter circuit is based on the block diagram of Fig. 12. It is useful as a demodulator in radio receivers.

and the primary of T1 as before, but the tank circuit is connected to either pin 4 or 5 and the DC-power-supply line. Another variation is shown in Fig. 6-e. There, impedance matching is provided between a higher impedance transformer primary and the output of the NE602 by using a tap on the transformer. Capacitor C1 (0.047- μ F) is used to provide DC isolation between the output and the coil. That capacitor is needed because the coil is grounded. Still another variation (not shown) connects the capacitor to the top of T1, rather than a tap. That would be a grounded version of Fig. 6-d.

Still another single-ended output configuration is shown in Fig. 6-f. The inductor (L1) is connected across the balanced outputs, pins 4 and 5, but the pin 5 end is bypassed to ground through capacitor C1. The inductor is resonated by the series combination C2/C3, which also serves as a capacitor voltage divider for impedance transformation.

The output network in Fig. 6-g is an L-C low-pass filter circuit. That configuration will select the difference IF frequency (F1 - F2) if the -3-dB point of

the filter is set correctly. If you want to select the sum IF frequency (F1 + F2), then use a high-pass L-C filter. That is done by replacing C2 and C3 with inductors, and L1 with a capacitor. The values of those components can be found using the normalized method in The ARRL Radio Amateur's Handbook (any recent edition), or by using the software FilterMaker for Windows (available from the author at P.O. Box 1099, Falls Church, VA, 22041 for \$20. VA residents should add appropriate sales tax).

The network in Fig. 6-h is for use with fixed-frequency filters such as a crystal, ceramic, or mechanical types. Such filters are used to provide the IF-bandpass characteristic in receivers, and are available with characteristics from "sorta decent" for a few bucks, to real good for \$100 and up. The center frequency of the filter is set to either the sum or difference IF, and its bandwidth is set according to application (e.g. 500 Hz for CW, 2.8 kHz for SSB, or 5 to 6 kHz for AM). An output circuit for a direct-conversion receiver is shown in Fig. 6-i. A direct-conversion receiver is similar to a superheterodyne, except that the LO and RF frequencies are

very close to each other, so that the difference is the recovered audio. For example, to receive SSB, set the LO 2.8-kHz from the RF, or to receive CW set it 400- to 1,000-Hz (depending on the tone you'd like to hear). To receive an AM signal, set the LO to exactly the same frequency as the RF. Transformer T1 in Fig. 6-i is an audio transformer. It can be a 1,000:1,000-ohm transformer if the next stage has a high impedance input, or it can be a 1,000:8-ohm audio-output transformer.

NE602 Local Oscillator Circuits.

There are two general methods for controlling the frequency of the LO in any oscillator circuit: inductor-capacitor (LC) resonant tank circuits, and piezoelectric-crystal resonators. We'll talk about both methods, starting with the crystal oscillator.

Figure 7-a shows a basic Colpitts crystal oscillator. It will operate with fundamental-mode crystals on frequencies up to about 20 MHz. The feedback network consists of a capacitor voltage divider (C1/C2). The values of those capacitors are critical, and should be approximately:

$$C1 = 100/\sqrt{F(\text{MHz})}$$

$$C2 = 1000/F(\text{MHz})$$

The values predicted by these formulas are approximate, but work well under circumstances where external stray capacitance does not dominate the total. However, the practical truth is that capacitors come in standard values and those may not be exactly the values calculated. When the capacitor values are correct, oscillation will be consistent. If you pull the crystal out, and then reinsert it, the oscillator will restart immediately. Alternatively, if the power is turned off and then back on again, the oscillator will always restart. If the capacitor values are incorrect, then the oscillator will either fail to run at all, or will operate intermittently. Generally, an increase in the capacitances will suffice to make operation consistent.

A problem with the circuit of Fig. 7-a is that the crystal frequency is not controllable except by replacing the crystal. The actual operating frequency of any crystal depends, in part, on the circuit capacitance seen by the crystal. Most crystals are designed for load capacitances of 20 or 32 pF, but

that can be specified if crystals are being ordered directly from a manufacturer. In Fig. 7-b, a variable, or "trimmer" capacitor is placed in series with the crystal in order to set the frequency. The trimmer capacitor can be adjusted to set the oscillator to the desired frequency.

The two previous crystal oscillators operate in the fundamental mode of crystal oscillation. The resonant frequency in the fundamental mode is set by the dimensions of the slab of quartz used for the crystal; the thinner the slab, the higher the frequency. Fundamental-mode crystals work reliably up to about 20 MHz, but at higher frequencies the slabs become too thin for safe operation; at that point, the thinness of the slabs of fundamental-mode crystal causes them to fracture easily. An alternative is to use overtone-mode crystals. The overtone frequency of a crystal is not necessarily an exact harmonic of the fundamental mode, but is close to it. The overtones tend to be close to odd

integer multiples of the fundamental (3rd, 5th, 7th, etc.). Overtone crystals are marked with the appropriate overtone frequency, rather than the fundamental.

Figures 7-c and 7-d are overtone-mode crystal-oscillator circuits. The circuit in Fig. 7-c is a Butler oscillator. The overtone crystal is connected between the oscillator emitter of the NE602 (pin 7) and a capacitive voltage divider that is connected between the oscillator base (pin 6) and ground. There is also an inductor in the circuit (L1) that must resonate with C1 to the overtone frequency of crystal XTAL1. Figure 7-c can use either 3rd- or 5th-overtone crystals up to about 80 MHz. The circuit in Fig. 7-d is a third-overtone crystal oscillator that works from 25 to about 50 MHz, and is simpler than Fig. 7-c.

A pair of variable-frequency oscillator (VFO) circuits are shown in Fig. 7-e and 7-f. The circuit in Fig. 7-e is a Colpitts-oscillator version, while Fig. 7-f is a Hartley-oscillator version. In both

oscillators, the resonating element is an inductor-capacitor (LC) tuned-resonant circuit. In Fig. 7-e, however, the feedback network is a tapped-capacitor voltage divider, while in Fig. 7-f it is a tap on the resonating inductor. In both cases, a DC-blocking capacitor to pin 6 is needed in order to prevent the oscillator from being DC grounded through the resistance of the inductor.

Voltage Tuned NE602 Oscillator Circuits. Figure 8-a and 8-b show a pair of VFO circuits in which the capacitor element of the tuned circuit is a voltage-variable capacitance diode, or varactor (D1 in Fig. 8-a and 8-b). Those diodes exhibit a junction capacitance that varies in direct response to the reverse-bias voltage applied across the diode. Thus, the oscillating frequency of those circuits is controlled by a tuning voltage. The version shown in Fig. 8-a is a parallel-resonant Colpitts oscillator, while Fig. 8-b is a series-tuned Clapp oscillator.

Using the NE602 as a Signal Generator. The NE602 is normally used as a receiver front-end or as a frequency converter. It can also be used as a signal generator. Figure 9 shows the basic configuration for providing the LO signal at output pins 4 and 5; place a 10,000-ohm resistor (R1) between pin 1 and ground, while bypassing pin 2 to ground through a 0.047- μ F capacitor. The output signal is taken from either pin 4 or 5 through another 0.047- μ F capacitor.

The output signal of Fig. 9 will be a sinewave at the frequency of oscillation for the oscillator circuit connected to pins 6 and 7. That signal can be swept or frequency modulated by using one of the varactor LO circuits shown in Fig. 8. To sweep the frequency, make the tuning voltage a sawtooth waveform, while to frequency-modulate it, use a sinewave. If you want to amplitude-modulate the signal, then use a circuit such as Fig. 10.

The signal source is any of the NE602 oscillators (IC1 in Fig. 10), while the modulator is IC2, an MC-1350P chip. That chip is also available from the service-repair industry replacement lines as the NTE-746 or ECG-746. It is an RF-gain block with a gain-control terminal (pin 5), and that gain-control terminal can be used for the

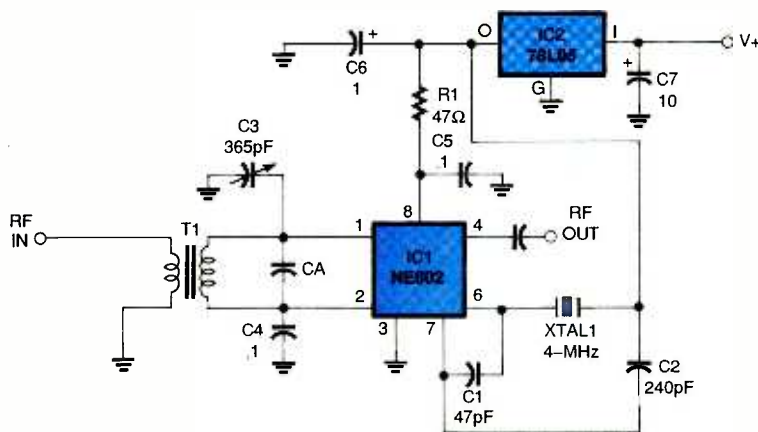

Fig. 14. Here is another simple frequency translator circuit; it does not select which frequency appears at the output.

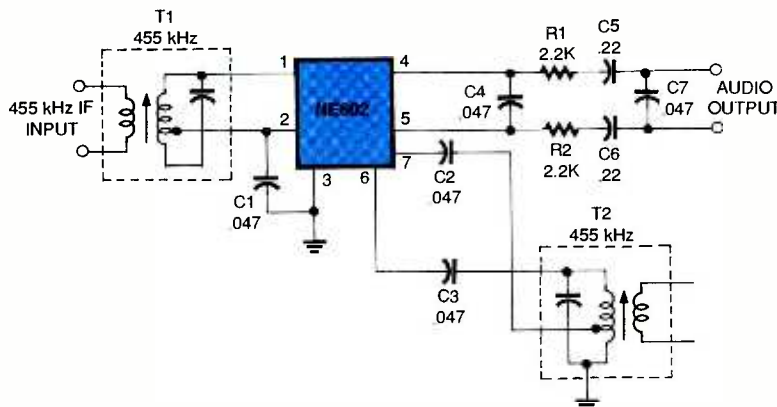

Fig. 15. After you've tuned in a particular radio frequency and demodulated it, this product-detector circuit can be used for Morse code (CW) or single-side band (SSB) reception.

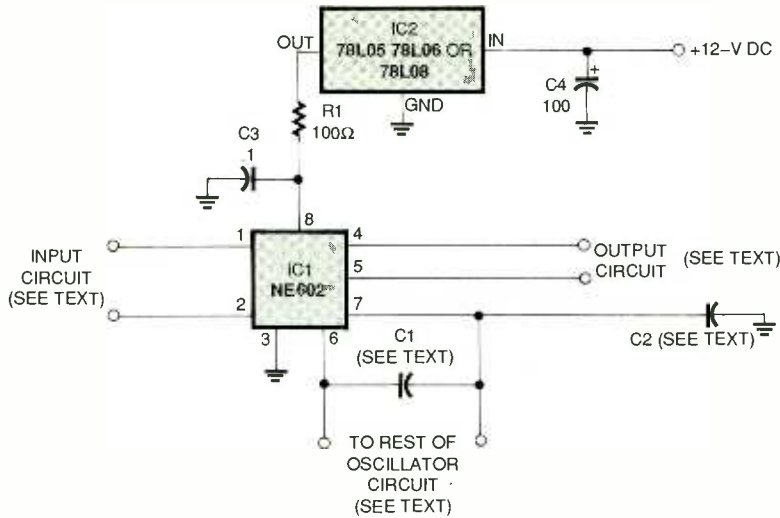

Fig. 16. There is just enough circuitry on the universal project board for NE602 to get you up and running with many different projects.

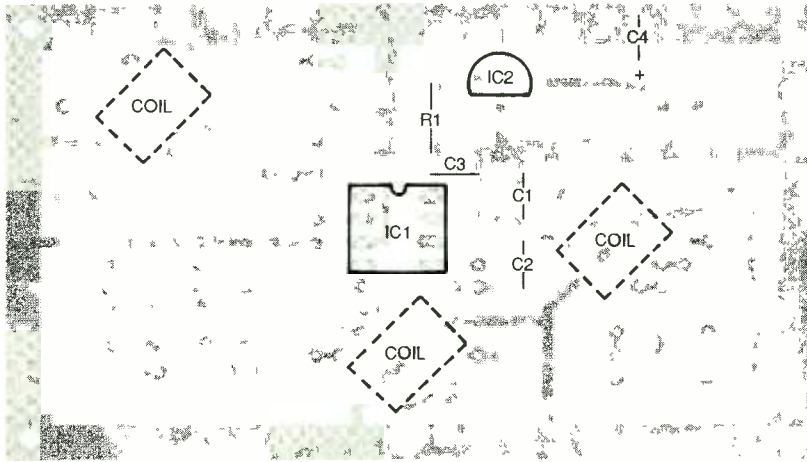
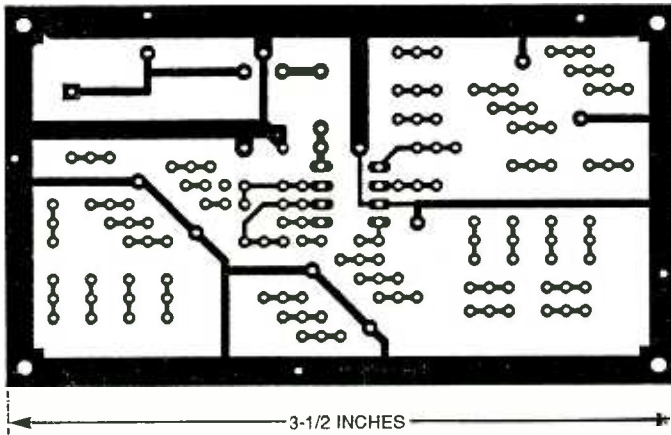

Fig. 17. Component placement on the universal project board leaves plenty of room for your own circuitry.



Here's the foil pattern for the NE602 universal project board. Many stand-alone pads are included to hold your circuitry.

amplitude-modulation function. Two signals are applied to the gain-control terminal as shown in Fig. 10; a DC level from potentiometer R4, and the

audio signal from the MODULATION LEVEL control (R5). Adjust both DC LEVEL and MODULATION LEVEL until the output signal, as viewed on an oscilloscope, looks

like Fig. 11. There should be good symmetry and no clipping of the peaks.

Using the NE602 in Converter Projects.

The basic frequency converter was shown in block form back in Fig. 1-a; now it is time to expand upon that as shown in Fig. 12. The NE602 and its supporting circuitry might be used as the mixer and local oscillator. The amplifier is optional, and should only be used when sensitivity is poor. Poor sensitivity might be caused when insertion loss of the input tuning network is high.

The input and output tuning networks are used to segregate the signals. The input tuning selects the desired RF-input frequency (F1), and rejects all other frequencies. The output tuning network selects either F1 - F2 (difference), or F1 + F2 (sum) signals. Those filters can be L-C resonant-tank circuits, low-pass filters, high-pass filters, or band-pass filters as needed for the specific application.

Figure 13 shows a basic NE602 frequency-converter circuit. The input circuit consists of a transformer with a secondary winding resonated by C2, C3, and C4. The LO circuit is a crystal Colpitts circuit that uses a trimmer capacitor (C9) for adjusting the oscillation frequency over a small range. The output circuit is a variant of the parallel-resonant tank circuit in which the primary of the transformer (T2) is tapped to match the impedance of the NE602 output to the coil.

Another variant is shown in Fig. 14. That circuit is similar, except that the output is not tuned. The reason for that approach is that the frequency converter is used to drive the antenna input of a radio receiver, which performs the frequency selection (sum vs. difference) function.

Using the NE602 as a Product Detector.

Figure 15 shows the circuit for a product detector based on the NE602. A product detector is a frequency converter that sets the LO frequency close enough to the RF or IF signal so a single-sideband (SSB) or CW signal is demodulated. For example, a 455-kHz IF signal from a receiver can be converted to an 800-Hz CW audio output ("beep-beep") by using an LO at 455.8 kHz or 454.2 kHz. The difference tone is found in the output.

(Continued on page 79)

BUILD THE FREEZER SENTRY— A FOOD FREEZER MONITOR

DAVE SWEENEY



Afraid that your freezer may not be as reliable as it used to be? Do you sometimes forget to close the door completely? Put your mind to rest—the Freezer Sentry will warn you of a problem before disaster strikes!

Having a separate food freezer in the home provides years of convenient, economical storage for perishable food. Stuffed with chicken, beef, fish and various specialty items, the home freezer offers a comforting feeling—until something goes wrong. Tucked away in a corner of the basement or garage, the freezer is conveniently forgotten. But with no warning or outward signs, a freezer malfunction might occur, easily costing you hundreds of dollars in thawed and spoiled food.

Imagine the horror of opening the freezer to select your dinner, and instead you're greeted by the odor of thawed and spoiling meat, poultry, and special desserts. The contents of your freezer could thaw overnight just because someone left the door open a crack or turned off a critical circuit breaker while servicing some other electrical device. With the freezer door closed, mechanical failures could also cause undetected prob-

lems. A Freon leak could weaken the ability of the freezer to maintain proper temperature. An overheated motor or compressor failure could leave you with soft or perhaps spoiled food if the freezer is down for a day or so.

For peace of mind, you can build the Freezer Sentry. An audio alert as well as a 5-volt remote-control output are activated if the freezer temperature rises or if there is a loss of AC power to the freezer. For a temperature problem, a special meltdown sensor inside the freezer detects a sustained temperature rise above 15° F. Regardless of the cause, a pulsating piezo-electric beeper sounds, and a 5-volt output for connection to a home-security system is activated. Because it latches in the on state once it is activated, the temperature alert will continue even if the temperature returns to normal. That feature will let you know that something went wrong, even if all appears OK when you examine the freezer.

Protecting A Freezer. To maintain the food for extended periods, a freezer is designed to keep the temperature of its storage area between -5° F and 0° F (well below 32° F, the freezing point of water). If a problem develops and you discover it in time, you might avoid a disaster. Even if the temperature in the freezer rises above freezing, the food will take a few hours to begin to thaw, and take even longer to spoil. If you detect a freezer meltdown in time, you might move your food to a neighbor's freezer, or, if there's room, to the freezer in the kitchen. A food loss might also be avoided by simply keeping the freezer door closed until the unit can be repaired.

The Freezer Sentry has to watch for two conditions: rising temperature in the freezer itself and a loss of AC power. The monitor itself is attached to the top or side of the freezer with a simple bar magnet glued to the Freezer Sentry's case. Inside the freezer, a special meltdown sensor is con-

nected to the Freezer Sentry. The sensor is designed to close a switch if the temperature sustains a rise above 15° F. The Freezer Sentry runs on a power supply that plugs into the same electrical outlet the freezer is plugged into. If AC power to the freezer fails, then the Freezer Sentry also loses AC power. In that event, a set of 8 AA batteries keeps the Freezer Sentry running, sounding the alarm.

The meltdown sensor contains a solution that stays frozen as long as the temperature is well below 15° F. The sensor is simple to build, easy to adjust, and is designed to keep the alarm circuit as simple as possible. When the temperature rises, the sensor solution melts (before the meat has a chance to thaw) and falls on two copper electrodes. For added reliability, a piece of aluminum foil is frozen to the solution to ensure the closing of the contacts when the weight of the solution pushes down on them.

Using a liquid switch provides significant advantages over the use of a thermistor for sensing a temperature rise in a freezer. Short air-temperature variations, due to opening the door during normal use, will not trigger a false alarm. Additionally, testing and calibrating a thermistor-based design would require warming and cooling the freezer or the use of a laboratory test chamber. Thermistor resistance in the temperature region where a food freezer operates does not change abruptly with temperature. To adjust the point where the alarm should trigger, the freezer would need to be defrosted and frozen for each adjustment, which is not practical. A liquid switch, however, allows a simple approach to setting the temperature at which the switch triggers. Instead of changing the freezer temperature, you adjust the mixture of the liquid in the switch to just freeze at the unit's normal operating temperature.

WARNING: The meltdown sensor uses a mixture of automotive antifreeze and tap water. The main ingredient in antifreeze, ethylene glycol, is **EXTREMELY POISONOUS**. There is a possibility that the antifreeze solution will completely melt if, for example, there is a freezer failure while you're not at home for an extended period of time. If the meltdown sensor leaks in any way, antifreeze might contaminate the food in the freezer. As an

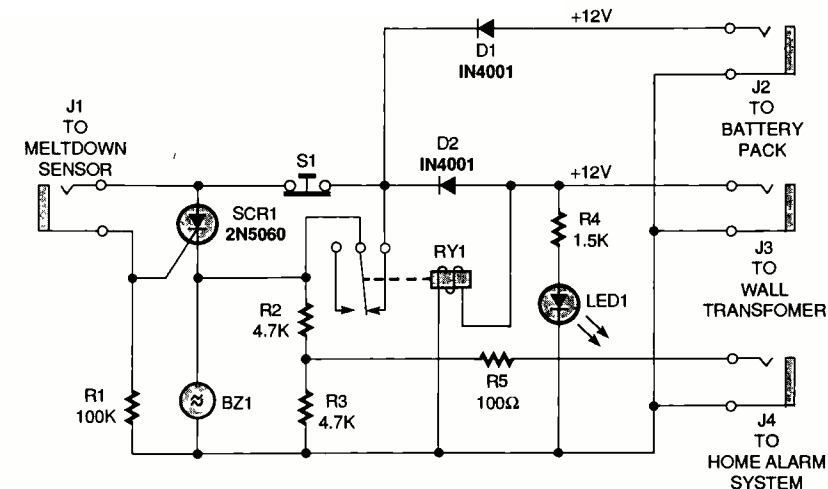

Fig. 1. The electronics for the Freezer Sentry is both simple and reliable. The meltdown sensor warns of a freezer malfunction and the relay together with the backup battery warns of AC power failure.

added safety precaution, the meltdown sensor could be placed in a plastic container, such as an empty margarine or cottage cheese tub. Any leaking fluid would then be captured by the container, preventing contamination.

The Monitor Circuit. The electronic circuit for the Freezer Sentry, shown in Fig. 1, is quite simple. The heart of the circuit is SCR1, a silicon-controlled rectifier. That type of semiconductor acts like a solid-state switch—it will only conduct in one direction (like a diode) when a trigger voltage is applied to the gate terminal. That trigger voltage is supplied through J1 by the meltdown sensor when its contacts close. Resistor R1 is included to prevent any false triggering of SCR1 due to voltage fluctuations or noise from the power supply. Once SCR1 is triggered it latches on, sounding the alarm buzzer until the reset switch (S1) is pressed. The reset switch interrupts current flow through the SCR, letting it turn off.

Power for the circuit is supplied by a 12-volt DC wall-mounted transformer, which is connected to J3. As long as the wall-mounted power supply is working, relay RY1 will be activated, opening its normally-closed contact. Normal power will also be indicated by LED1, with R4 limiting the current flow through the light-emitting diode. If the AC power fails, LED1 will go out and RY1 will de-energize, closing the relay's normally-closed contacts. The relay contacts bypass SCR1, sounding

PARTS LIST FOR THE FOOD FREEZER MONITOR

SEMICONDUCTORS

D1, D2—1N4001 silicon diode
LED1—Light-emitting diode
SCR1—2N5060 silicon-controlled rectifier

RESISTORS

(All resistors are 1/4-watt, 5% units.)
R1—100,000-ohm
R2, R3—4,700-ohm
R4—1,500-ohm
R5—100-ohm

ADDITIONAL PARTS AND MATERIALS

BZ1—Piezo beeper (Radio Shack 273-066 or similar)
J1, J3—Male coaxial power jack
J2—Audio jack, 3/8-inch
J4—Audio jack, 3/16-inch
RY1—Single-pole double-throw, 12-volt coil, PC-mount (Radio Shack 275-248 or similar)
S1—Single-pole, single-throw, normally-closed pushbutton switch, panel-mount
Printed-circuit board, case, bar magnets, 8 AA batteries, Battery holder (Radio Shack 270-387 or similar), wall-mount 12-volt DC 200-mA power adapter, wire, suitable plugs for J1-J4, aluminum foil, 35mm film canister and lid, automotive antifreeze, epoxy, hot-melt glue

the alarm. Backup power for that situation is supplied by a 12-volt battery pack, which is connected to the circuit through J2 and D1. Diode D1 prevents the AC-derived power supply

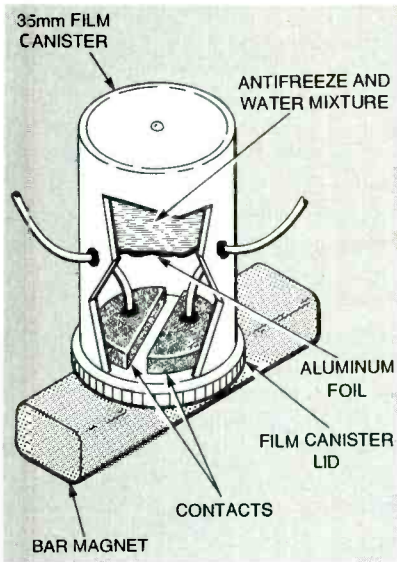
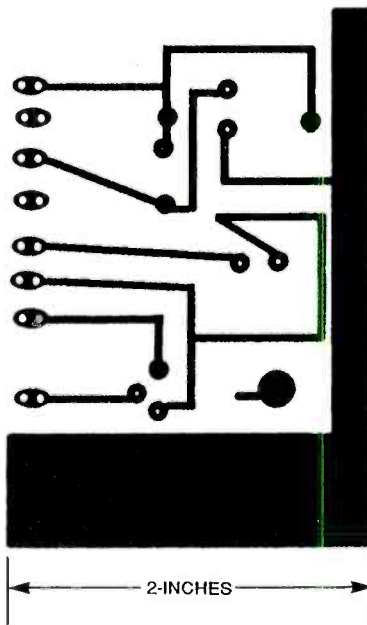

Fig. 2. The meltdown sensor contains a liquid that melts at about 15° F. When the liquid starts to melt, it falls down to the bottom of the canister, pushing an aluminum foil disc against the electrical contacts.



Here's the foil pattern for the Freezer Sentry. The circuit is simple enough to be built on a single-sided PC board.

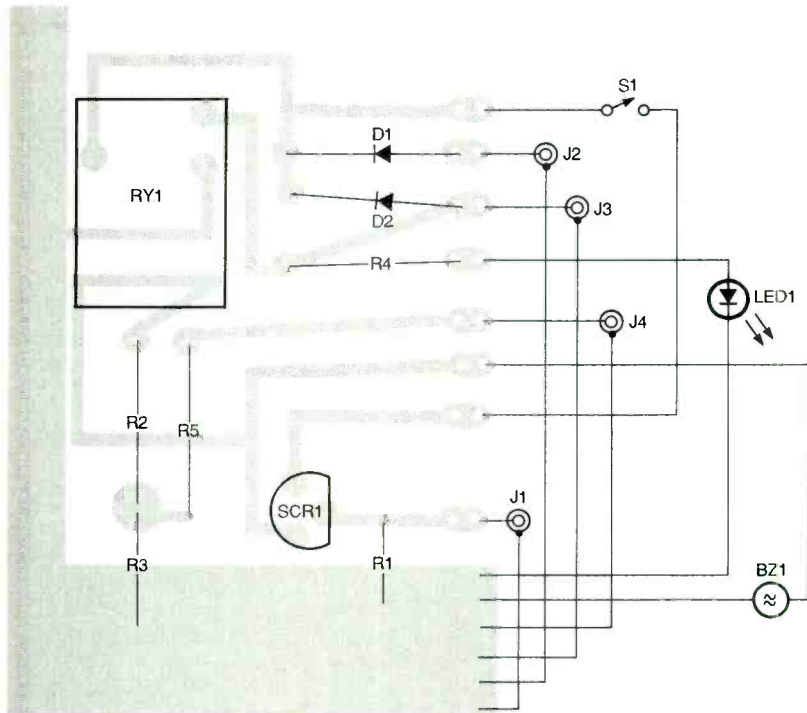

Fig. 3. If you want to etch a PC board from the foil pattern, use this placement diagram to locate the parts.

from attempting to charge the batteries, and D2 prevents the batteries from lighting the LED or energizing RY1 in the event of AC power failure. An additional feature of the circuit is that since the relay bypasses SCR1 during a loss of AC power, the reset button will not silence the alarm.

Regardless of which type of failure caused the alarm to sound, R2 and R3 form a voltage divider that provides a 5-volt signal to J4, with R5 limiting the current that can be drawn from J4. That signal could be connected to a home-alarm system or any other device you might wish to activate.

Assembling the Meltdown Sensor.

You can easily build the meltdown sensor with only a few simple parts. The overall design of the sensor is shown in Fig. 2. The sensor housing itself is made from a plastic 35mm film canister. Attach a bar magnet to the lid of the film canister. The magnet will hold the unit in place on a freezer shelf. One method of attaching the magnet is to first drill a small hole in the film-canister lid. Using a screw with nut, attach a piece of flat aluminum plate to the lid. Glue a magnet to the aluminum with epoxy.

Cut two "D" shaped pieces of copper-clad printed-circuit board such that they will easily fit side by side on the inside of the film canister's lid without touching each other. Solder two very thin wires to the PC boards. The wires should be long enough to reach from the location where the meltdown sensor will be in the freezer to where the alarm circuit will be without being stretched tight. Those PC boards are the switch contacts. Drill two holes near the top of the film canister and run the wires through them. Use hot glue to hold the PC board contacts on the film can lid. Hot glue will hold the PC board contacts sufficiently as long as the wires are not severely pulled.

In a disposable plastic container, mix a solution of 3 parts water to 1 part antifreeze. An easy way to measure the ingredients is by using two additional film canisters—one for antifreeze and one for water. Pour one film canister of antifreeze and three film canisters of water into the plastic container and mix well. The mixture is designed to freeze at 0° F. Because of the poisonous nature of antifreeze, do not use a plastic mixing container that will be saved and used elsewhere later—residual antifreeze on the bowl might possibly come in contact with food. After creating the proper mix, the plastic bowl and canisters should be thrown away.

The mixture can be carefully tested in the freezer. Fill the meltdown sensor half full of the mixture. Cut a circular disc of aluminum foil slightly smaller than the inside diameter of the film canister. Carefully "float" the aluminum disc on the antifreeze mixture and set the container upright in the freezer with a freezer thermometer next to it. After 24 hours, check the

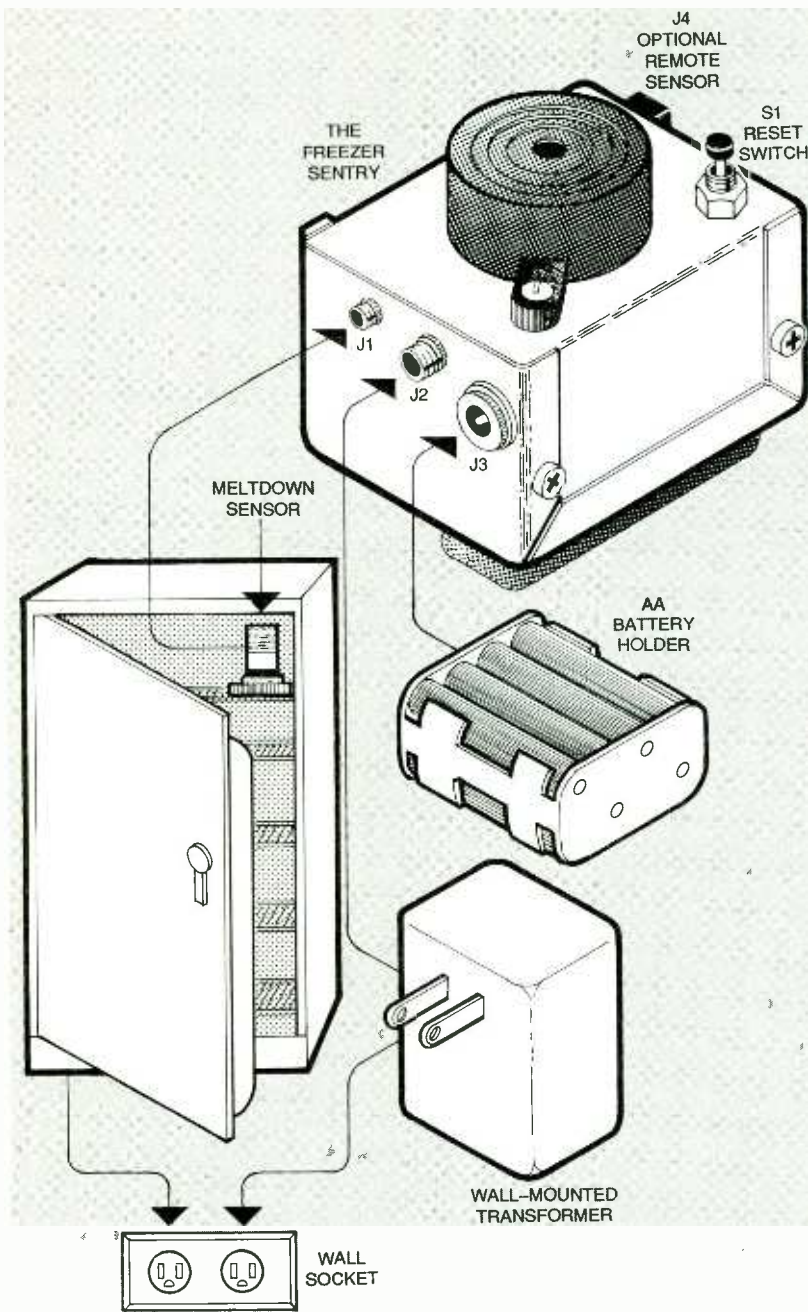

Fig. 4. A typical Freezer Sentry installation follows this general arrangement. The wall-mounted transformer should be connected to the same wall outlet that the freezer is plugged into.

temperature and the mixture. The temperature reading should be between 0° F and -5° F. The mixture should be frozen solid. If it is not, it will be "slushy". Add 3 teaspoons of water to the mixture to raise its freezing point and repeat the process for filling and freezing the switch. Once frozen, the switch must be kept frozen. After capping the sensor, turn it upside down so that the mixture will fall if it melts, and

place it where it will operate in the freezer.

If you are concerned about putting antifreeze in the freezer even if placed in a second container for improved safety, you can try substituting 200-proof grain alcohol for the antifreeze. The mixture ratio will be different, so you'll have to experiment to find the proper amounts of alcohol and water for the sensor. Grain alco-

hol, also called medical alcohol, is 100% pure natural alcohol. It is not "denatured" like wood alcohol, so it is non-poisonous—that is, it will not cause blindness or death. It will just get you intoxicated at about 2 times the rate of most vodkas (about 50% alcohol), or about 3 times the rate of most whiskeys (about 35% alcohol) due to the relative content of alcohol.

Electronics Assembly. The Freezer Sentry circuit can be built using either a printed-circuit board or hand-wired on a perfboard. A PC board is not absolutely necessary, as the component placement is not critical. If you wish to build your own PC board, you may use the foil pattern published here and follow the parts-placement diagram in Fig. 3. It is a good idea to use different connector hardware for each connection to the circuit in order to avoid errors when plugging in the sensor and other connections. The connector combinations in the Parts List are by no means definitive—they just represent the choices made for the prototype.

A small aluminum chassis box holds the PC board, alarm buzzer, and connectors. A large magnet can be epoxied onto the aluminum chassis box for easy mounting of the unit on the freezer itself.

Testing And Installation. The overall arrangement in Fig. 4 is a typical Freezer Sentry installation. To test the unit, connect both power and battery, but not the meltdown sensor. Momentarily connect the inputs at J1 together, which simulates a closure of the meltdown sensor. The beeper should sound, and the remote output should change from 0 to 5 volts. The beeper should continue to ring until the reset button is pressed. At that point, the sound should stop and the remote output should return to 0 volts. Remove the power pack from the wall. Again, the beeper should sound and the remote output change from 0 to 5 volts.

Replace the power pack and press the reset button. Plug in the meltdown sensor, and the Freezer Sentry is ready to go. The next time that the freezer is defrosted, monitor the temperature with a thermometer to verify that the sensor triggers the alarm when the temperature rises to about 15° F. Ω

BUILD A CONDUCTANCE ADAPTER FOR YOUR MULTIMETER

Extend your digital multimeter's range dramatically to include resistance in gigohms and current in picoamps with this simple adapter.



SKIP CAMPISI

Have you ever tried to make an accurate, stable measurement on a resistor with a value over 10 megohms? Are you in need of an instrument to measure very low leakage currents in insulators or semiconductors? Both of those tasks become trivial with the Conductance Adapter discussed in this article.

If you have access to a 4-1/2-digit multimeter, you can use the Conductance Adapter to measure a 1-gigohm resistor—that's right, 1 billion ohms—with a resolution of 1%, and to measure currents down to 10 picoamps. You can also use a 3-1/2-digit multimeter; however, the resolution obviously will be reduced. You can either use the built-in temperature-compensated 1,000-volt reference or use an external voltage reference of your choice. The circuit is extremely stable, and does not suffer from noise like a standard ohmmeter working at high impedances.

Measuring Conductance. Because working with a large conductance value is easier than working with a small resistance value, measuring conductance rather than resistance is much more convenient when the current flowing through a device being measured becomes very small. Conductance is measured in *mhos*. A mho is the reciprocal of the resistance unit

ohm, which is why a mho is called a mho: it is "ohm" spelled backwards.

The Conductance Adapter is so sensitive that precautions have to be taken to get an accurate measurement. Ordinary test probe leads just lying on the bench or across each other will show significant leakage currents due to their less than perfect insulation, which acts like a conductor at the extremely low currents needed to measure high resistances. The same can be said for printed-circuit board material, flux residue, and most plastics and other materials used as insulators. The only two insulators that can be trusted in the picoamp range are air and Teflon, which will both be used in the mechanical and electrical construction of the Adapter.

Incidentally, there is a new name for the mho, the *siemen*. Note that 1 mho equals 1 siemen. There is no change in definition of the unit—only its name. Since the abbreviation for siemen, "S", is easily confused with that for seconds, "s", we will use the older term in this article.

How It Works. The schematic diagram in Fig. 1 shows how simple the circuit actually is. A 1,000-volt reference is buffered by IC1, a TLC271, and is connected to J1 for use when measuring conductance. The voltage reference is derived from IC3, a 1.25-volt

temperature-compensated band-gap reference. The current drop developed by the component under test at J1 and J2 is converted by IC2 to an output voltage that can be displayed on a digital voltmeter. The output voltage is limited to a maximum of 2.0 volts and a minimum of 1.0 volt. With the inverting input of IC2 at "virtual ground", that means the maximum input current that can be measured is -2.0 microamps.

In reading the conductance of an unknown resistor (labeled "R_x" in Fig. 1), -1.0 volt is applied to J1, with J2 being at virtual ground. Based on the maximum input current that can be converted by IC2, the smallest resistance that can be measured is 500,000 ohms. The values chosen for the circuit generate a conductance reading of 1.0 micromho-per-volt, or 1.0 nanomho-per-millivolt output. A 1.0-million-ohm resistor will have a conductance of 1.0 micromho, or 1000 nanomhos. A 1.0-billion-ohm resistor would be equal to 1.0 nanomho.

The current-to-voltage conversion is set by R10, which gives an output of 1-volt-per-microamp, or 1-millivolt-per-nanoamp. The unit you select for R10 should have as high a tolerance as you can find. Standard 5% units will not do—the lowest tolerance you should use for R10 is 1%. That value is easily purchased from various mail-

PARTS LIST FOR THE CONDUCTANCE ADAPTER

SEMICONDUCTORS

- IC1, IC2—TLC271 CMOS operational-amplifier (Mouser 511-TS271CN)
 IC3—ICL8069 Band-Gap Reference integrated circuit (Mouser 570-ICL8069 DCZR)
 LED1—Red LED, super-bright, T1 case (Mouser 509-EBR3368S)

RESISTORS

- (All resistors are 1/4-watt, 5% units unless otherwise noted.)
 R1—12,000-ohm
 R2—49,900-ohm, 1/4-watt, 1%, metal film
 R3, R6—25,000-ohm, multi-turn trimpot, cermet
 R4—15,000-ohm
 R5, R7—680,000-ohm
 R8, R9—10-megohm
 R10—1.00-megohm, 1/4-watt, 1% or better, metal film (see text)

CAPACITORS

- C1, C2—0.1 μ F, ceramic disc
 C3—1.0 μ F, 16WVDC, solid tantalum

ADDITIONAL PARTS AND MATERIALS

- MATERIALS**
 S1—DPDT push-on/push-off or toggle switch
 TP1—Teflon-insulated stand-off (Johnson STD-1, STD-2, or similar)
 J1, J2—Teflon-insulated BNC jack (Pomona 4160)
 J3—Banana jack
 J4—RCA-style jack
 B1, B2—CR2032 3-volt lithium batteries
 Printed-circuit board (Radio Shack 276-150 or similar), 3/8- to 1/2-inch threaded spacers, screws, 22-gauge Teflon-insulated wire, enclosure, 14-gauge solid bus wire, alligator clips, 8-pin IC sockets, breakaway socket, battery holders, RCA-style plug

NOTE: All of the semiconductors, batteries, and battery holders are available through Mouser Electronics, Tel: 800-346-6873. Teflon-insulated BNC jacks and plugs are available from ITT Pomona, 1500 East 9th Street, Pomona, CA 91766-3835. Tel: 1-800-ITT-POMONA. Teflon-insulated wire, standoffs, and all passive components are available from: Johnson Shop Products, P.O. Box 2843, Cupertino, CA 95015, Tel: 408-257-8614.

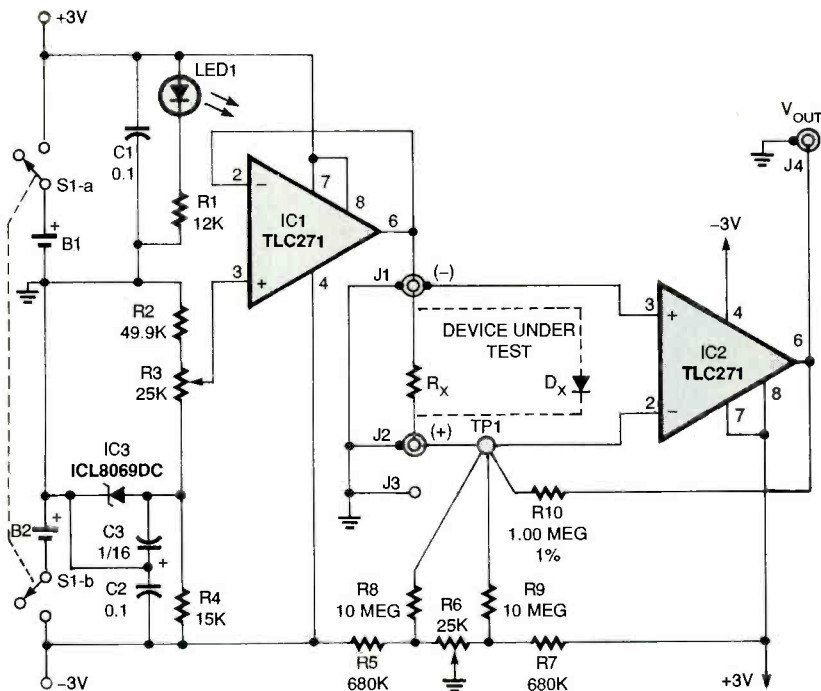

Fig. 1. The schematic diagram for the Conductance Adapter shows how simple a circuit is needed to accurately measure very high resistances and very low currents.

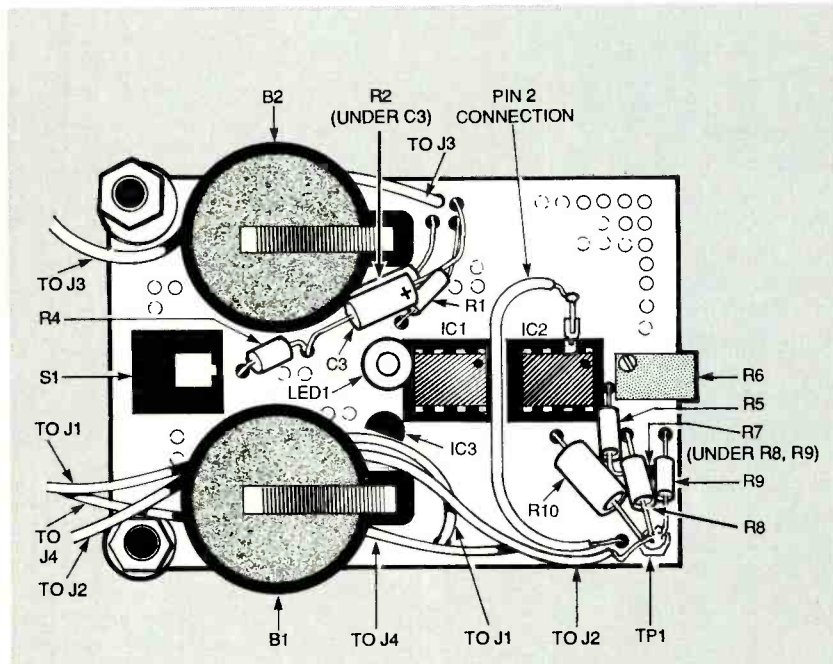

Fig. 2. Here is the top side of the Conductance Adapter. Because of the circuit's sensitivity to very high resistances, only Teflon-insulated wires should be used or the Adapter will not work properly.

order firms. For best accuracy, a 0.1% tolerance resistor is desirable. Unfortunately, a tolerance that tight is difficult to locate.

Power Supply. The ± 3 -volt power for the Conductance Adapter is supplied by two 3-volt lithium "coin"-type

batteries installed right on the board in suitable holders. Since the total current draw for the Conductance Adapter is less than 150 microamps, the batteries should last a very long time. A "super-bright" LED is used for LED1 limited by R1. In order to keep current

consumption to a minimum, LED1 is set to only put out a modest (but still discernible) glow.

Construction. The Conductance Adapter was built on standard perforated construction board. The actual placement of the parts is not critical, but if you want to follow the parts placement used in the prototype, that information is shown in the photographs of Fig. 2 (the component side) and Fig. 3 (the solder side). The balance of this article will assume that your board will resemble the author's prototype.

The board should be cut to fit the enclosure before starting construction. The board shown in Figs. 2 and 3 measures 1-7/8 inch x 2-3/4 inch.

Begin by installing the battery holders, the two 8-pin IC sockets, and potentiometer R6. You have the option of either mounting S1 on the board, or panel-mounting a slide or toggle switch on the case. Capacitors C1 and C2, along with resistor R3, are mounted on the underside of the board as shown in Fig. 3, but you may mount those components on top if you prefer.

Locate and install a Teflon-insulated standoff which has a solder terminal on its top near R6; that standoff will serve as TP1. Attach one end of resistors R8, R9, and R10 to TP1 with a mechanical crimp—**do not** solder them yet. Connect the other ends of those resistors to the appropriate locations as shown in Fig. 1, keeping the component bodies from touching the board. Attach two Teflon-insulated wires to TP1, then solder the joint. Make one wire long enough to reach J2, and the other long enough to reach pin 2 of IC2. Install one pin from a break-away type SIP socket on the wire for pin 2 of IC2. That socket pin will later be connected to pin 2 of IC2. Finish the board by installing the remaining components and make all of the interconnects on the board. Be sure to use Teflon-coated wires for insulated wires, and leave the lengths long enough to reach the panel-mounted components.

The case can be any convenient hand-held enclosure that will hold the entire circuit. Locate and install the four jacks and power switch. Drill clearance holes to mount the board and for LED1 and the adjustment

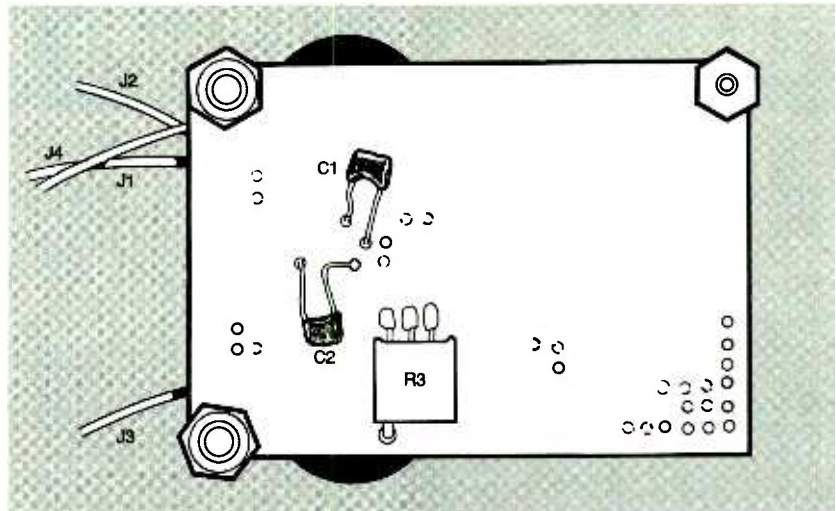

Fig. 3. Here is the bottom side of the Conductance Adapter. If you use a slightly larger board, these components can be placed on the top side along with the rest of the components.

screw of R6. If you have mounted S1 on the board instead, drill a hole for the push-button to protrude. Make sure that you use Teflon-insulated BNC jacks for J1 and J2.

Connect the board to the panel components and install IC1 in its socket. Install IC2 as follows: Carefully bend pin 2 out and away from its package so that it is at right angles to the rest of the pins. Install IC2 in its socket and slip the socket pin from the lead going to TP1 onto pin 2. That isolates pin 2 from all leakage paths. Inspect all of your connections and install the board in the enclosure with 3/8- to 1/2-inch spacers and screws.

Test Leads. Special attention must be given to both the input and output leads used on the adapter. Coaxial cable is NOT recommended for those leads, as the capacitance of the cable can cause oscillation at the outputs of IC1 and IC2. Prepare an output cable by twisting together a pair of foot-long Teflon-insulated wires. Attach one end of the twisted-wire pair to an RCA plug, and the other end to plugs that match your DMM's input sockets.

The input leads can be made similarly, using twisted pairs terminated in Teflon insulated BNC plugs. An easier method is to attach a single wire to a 1-inch length of 14-gauge bus wire. Pulling a conductor out of some 14-gauge Romex-type house wiring from a home-improvement center or hardware store will work fine for that. The 14-gauge wire will easily slide into

the center of the BNC jack. If you need to, you can plug a separate ground lead into J3, but be sure to use only Teflon-insulated wire for all of your cables, and don't allow the component under test (or the hooks or clips used to connect it) to touch any medium except air. A simple but effective test jig can be made from two pieces of 14-gauge bus wire, about 2- to 3-inches long, with a small alligator clip soldered to one end of each and inserted into the BNC jacks. That arrangement works well when testing components such as resistors or diodes individually.

Calibration. To calibrate the Adapter, connect a DVM between J1 & J2 (the input jacks), turn on the Adapter's power, and adjust R3 (CAL) for a reading of exactly -1.0000 volts. Now connect the output from J4 (the RCA-style jack) to the DVM and adjust R6 (NULL) for a reading of 0.00 millivolts. Check the "null" reading occasionally—temperature drift may cause it to shift 10 to 20 microvolts.

Operation. The advantage to using the Conductance Adapter in measuring high impedances rather than an ohmmeter is that the Adapter applies a constant voltage to the device under test and then reads the resulting current. That is opposite to how an ohmmeter does the same task. Because of that, the Conductance Adapter has much better noise suppression. When using the Adapter, (Continued on page 79)

Buyers' Budget Books Better Buys

BP294-A Concise Introduction to Microsoft Works \$6.95. In the shortest and most effective way, you can use the word processor to advantage to type, edit, print and save documents. It goes on to explain how Works can be used to build up simple spreadsheet examples, edit them, save them, print them and retrieve them. It informs you how to create simple macros, and enables you to simplify long repetitive tasks and to customize the program to your own needs.

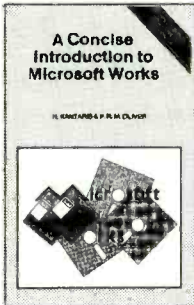

BP349-Practical Opto-Electronic Projects \$5.95. If you shun opto-electronic projects for lack of knowledge, this is the book for you. A bit of introductory theory comes first and then a number of practical projects which utilize a range of opto devices, from a filament bulb to modern infrared sensors and emitters.

BP350-Electronic Board Games \$6.00. Twenty novel electronic board games that you can build from the plans in this book. Whether you are interested in motor racing, searching for buried treasure on a barren island or for gold in Fort Knox, spinning the wheel of fortune, or doing a musical quiz—there is something for you to build and enjoy!

BP351-WordPerfect 6 Explained \$6.95. This is a practical, hands-on, book and the routines described will help you get the most out of WordPerfect 6. The book explains the hardware requirements for the package and steps you through a standard installation. It guides you through the WordPerfect program environment to enter, edit and enhance text and shows how to get the best from the three different operating modes, depending on the type of PC you are using. The formatting codes, button bars, ribbon, tabs, graphic manipulation and styles will no longer be a mystery.

BP388-Why Not Personalize Your PC? \$6.95. Find out how to: Set up and organize groups of programs and data files, and change the opening logo; use the Control Panel to personalize your working environment; use screen savers and wallpaper files; manage the DOS prompt; and transfer your customization files to a new Windows installation. In DOS, you discover how to: Write batch files and create specialist programs using the debug program, design professional looking menus, and more.

BP367-Electronic Projects for the Garden \$6.95. Electronics enters the Garden! New exciting book points out how gardeners can build simple gadgets to promote success where the elements work against you. Some of the projects are: over/under temperature monitoring, dusk/dawn switching, automatic plant watering, warming cables, etc.

BP368-Practical Electronics Musical Effect Units \$5.95. There is a constant hullabaloo for musical effects projects by the hobbyist community. This book provides practical circuits for several projects that range in complexity and are sure to work. All the circuits are easy to build and use readily-available parts.

BP363-Practical Electronic Music Projects \$5.95. The text contains a goodly number of practical music projects most often requested by musicians. All the projects are relatively low-in-cost to build, and all use standard, readily-available components. The project categories are guitar, general music and MIDI.

100% NEW TITLES LISTED EACH MONTH—CHECK US OUT!

BP385-Easy PC Interfacing \$6.95. The built-in ports in your PC provide an easy and hassle-free way of interfacing your circuits. This book provides useful PC add-on circuits including the following: Digital input/output ports; analog-to-digital and digital-to-analog converters; voltage and current measurement circuits; resistance and capacitance meters, temperature measurement interface, biofeedback monitor, and many other useful interfaces.

BP393-Practical Concise Introduction to UNIX \$5.95. If you are using or intend to use the UNIX multi-user operating system and want to get the most out of your computer system in terms of efficiency and productivity, then you must learn its operating system. The book explains how the UNIX operating system is structured so that you understand what happens when you first approach your computer.

BP396-Electronic Hobbyists Data Book \$5.95. This book provides a wide range of data. If, for example, you require details of a modern five-band resistor code or an old color code for a ceramic capacitor, the formula for parallel resistance, or basic data on an NE5534AN operational amplifier, it is contained within these pages. The subjects covered are numerous and widespread to cover all hobbyist interests.

BP343-A Concise Introduction to Microsoft Works for Windows \$7.95. The book explains and details: How the Works for Windows package fits into the general Microsoft Windows environment; how to use the word processor to advantage; how to use Microsoft Draw to create and edit graphics and place them in your documents; how to build up simple spreadsheet examples; and how single, and multiple charts, or graphs, of different types can be generated. And there's much more!

BP282-Understanding PC Specifications \$7.25. This book explains PC specifications in detail, and the subjects covered include the following: Differences between types of PC (XT, AT, 80386, 80486, Pentium etc.); math co-processors; input devices (keyboards, mice, and digitizers); memory, including both expanded (EMS) and extended RAM; RAM disks and disk caches; floppy disk drive formats and compatibility; hard disk drives; and display adapters (CGA, Hercules, super VGA, etc.).

BP298-Concise Intro to the Macintosh System and Finder \$6.25. Although the Mac's WIMP user interface is designed to be easy to use, much of it only becomes clear when it is explained in simple terms. The book explains: The System and Finder, what they are and what they do; how to use the System and Finder to manipulate disks, files and folders; configuring and printing files from the Finder; getting the most from the system utility programs; and running MultiFinder.

BP301-ANTENNAS FOR VHF AND UHF \$6.00. From installing a TV or FM antenna to setting up a multi-antenna array for shortwave listening or amateur radio, this book explains the essential basics of VHF and UHF antenna operation and installation. In easy-to-understand terms it helps you understand how antennas work, the advantages of different antenna types, and how to get the best performance out of an antenna.

BP316-Practical Electric Design Data \$7.95. A builder's bargain book—a comprehensive ready-reference manual for electronic enthusiasts with over 150 practical circuits. It covers the main kinds of components (from pig-tail leads to surface mount), pin-outs, specs and type selection. Basic units are defined and most used formulae explained. Five additional sections are devoted to circuit design, covering analog, digital, display, radio and power supply circuits.

BP319-Making MS-DOS Work For You \$6.50. This book could help you improve your system set-up and provide you with a simple-to-use, but professional looking, menu system. The routines described will help you understand more of the workings of MS-DOS and help you get the most out of your computer in terms of efficiency, productivity and enjoyment.

BP341-MS-DOS 6 Explained \$7.95. The book covers: How the DOS operating system of your computer is structured so that you can understand what happens when you first switch on your computer; How directories and subdirectories can be employed to structure your hard disk for maximum efficiency; how to use the DOS Shell program, and much, much more.

BP345-Getting Started In Practical Electronics \$5.95. If you are looking into launching an exciting hobby activity, this text provides basic essentials for the builder and 30 easy-to-build fun projects with which every experimenter should toy. Printed-circuit designs are included to give your project the professional touch.

ELECTRONIC TECHNOLOGY TODAY INC.
P.O. BOX 240, Massapequa, NY 11762-0240

Name _____
Address _____
City _____ State _____ Zip _____

SHIPPING CHARGES IN USA AND CANADA

\$0.01 to \$5.00.....	\$2.00
\$5.01 to \$10.00.....	\$3.00
\$10.01 to \$20.00.....	\$4.00
\$20.01 to \$30.00.....	\$5.00
\$30.01 to \$40.00.....	\$6.00
\$40.01 to \$50.00.....	\$7.00
\$50.01 and above.....	\$8.50

SORRY No orders accepted outside of USA & Canada

Total price of books.....	\$	No. of Books Ordered <input type="checkbox"/>
Shipping (see chart).....	\$	
Subtotal.....	\$	
Sales Tax (NYS only).....	\$	
Amount Enclosed	\$	

All payments must be in U.S. funds!

Miracle Energy Sources, New PICs, A History of Color Organs, and More

SUPPOSEDLY THERE IS THIS MAGIC, "SECRET" HINDU PLANT. MAKE A TEA OUT OF IT, SPRINKLE SOME LEMON JUICE ON IT, STEEP IT FOR A WHILE, AND PRESTO!—IT CHANGES INTO A CHEAP GASOLINE SUBSTITUTE. AT LEAST, THAT'S WHAT

the very latest pseudo-science techno-myth tries to tell us. If you want to check that out for yourself, try the *Keelynet* for ongoing details (use the link on my <http://www.tinaja.com> Web site to reach them).

Incidentally, this one obviously and totally fails my "looks like a duck, quacks like a duck, and is about to lay eggs" subjective pseudo-science test, but how can you tell for sure? After all, gasoline grows on trees—you just have to let them rot for a geological epoch or two. It turns out that any plant can be used to make gasoline—Kudzu, grass clippings, tumbleweeds—you name it. But scant few plants are even remotely worth all the time and trouble for you to do so.

The key questions you have to ask are these: (A) How many pounds of plant will you need for one pound of gasoline? (B) How much total energy has to go into the process compared to the energy you get back? (C) How expandable is the process to larger scale production? (D) What is the time to economic break-even for the labor and capital that has to go into the production system? (E) What are the hidden and off-the-books societal costs for new infrastructure? And, of course, (F) How badly will the government screw it up?

Yes, the so-called experts can sometimes be wrong. They typically overreact., but they'll usually end up back on target once all of these key questions get properly asked.

For instance, what appeared to be an outright scam in the 1920s sort of wasn't. Magic tablets were sold that instantly changed water into a motor fuel. The "experts" said it was impossible, but they were all dead wrong. There definitely are magic tablets that let you convert water into motor fuel. I use those tablets all the time. Of course, there are a few minor and tiny side effects—such as getting only 25 miles per engine instead of per gallon, but let's not quibble. The tablets work. And yes, you can still buy them today, and they are not even expensive.

Of course, those tablets are an "underground" product; only cavers use them. Ask any spelunker for more details.

PIC's New Babies

We have already seen that the new

PIC series of microcontrollers from Microchip Technology are easily the components of the decade. It has gotten to the point where it is, in my opinion, insane to ever again use a 555 timer or other bits-and-pieces solution to almost any electronic sensing or control application. The new PICs are incredibly fast, compact, and powerful microprocessors that literally blow the competition away. If you want to learn more, the Basic Stamp from Parallax and the Scott Edwards Tools can be your quickest and best ways to get yourself PIC-literate.

Well, there's now a brand new pair of baby PICs; see Fig. 1. The PIC12C508 and PIC12C509 both cost under a dollar in quantity and come in an eight-pin(!) mini-dip package. The '08 offers 512 bytes of EPROM and 25 bytes of RAM. The '09 doubles those values. Each offers several clock options: trimmable RC internal, external, or crystal. As with the other PICs, their powerful RISC instructions are mostly single cycle. Often executing three times faster in one-third the usual space.

There are up to six programmable

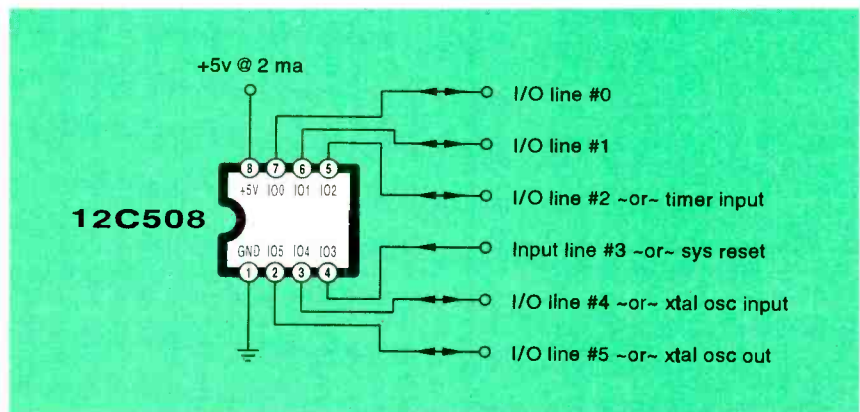

FIG. 1—MEMBERS OF THE "BABY PIC" family are among the smallest and the cheapest of microcontrollers, yet their capabilities are astounding.

new from
DON LANCASTER

ACTIVE FILTER COOKBOOK

The sixteenth (!) printing of Don's bible on analog op-amp lowpass, bandpass, and highpass active filters. De-mystified instant designs. **\$28.50**

CMOS AND TTL COOKBOOKS

Millions of copies in print worldwide. THE two books for digital integrated circuit fundamentals. About as hands-on as you can get. **\$28.50** each.

INCREDIBLE SECRET MONEY MACHINE II

Updated 2nd edition of Don's classic on setting up your own technical or craft venture. **\$18.50**

LANCASTER CLASSICS LIBRARY

Don's best early stuff at a bargain price. Includes the CMOS Cookbook, The TTL Cookbook, Active Filter Cookbook, PostScript video, Case Against Patents, Incredible Secret Money Machine II, and Hardware Hacker II reprints. **\$119.50**

LOTS OF OTHER GOODIES

Ask the Guru I or II or III	\$24.50
Hardware Hacker II, III or IV	\$24.50
Micro Cookbook I	\$19.50
PostScript Beginner Stuff	\$29.50
PostScript Show and Tell	\$29.50
Intro to PostScript Video	\$29.50
PostScript Reference II	\$34.50
PostScript Tutorial/Cookbook	\$22.50
PostScript by Example	\$32.50
Understanding PS Programming	\$29.50
PostScript: A Visual Approach	\$22.50
PostScript Program Design	\$24.50
Thinking in PostScript	\$22.50
LaserWriter Reference	\$19.50
Type 1 Font Format	\$16.50
Acrobat Reference	\$24.50
Whole works (all PostScript)	\$380.00
Synergetics Surplus Catalog	FREE
Technical Insider Secrets	FREE

POSTSCRIPT SECRETS

A Book/Disk combination crammed full of free fonts, insider resources, utilities, publications, workarounds, fontgrabbing, more. For most any PostScript printer. Mac or PC format. **\$29.50**

BOOK-ON-DEMAND PUB KIT

Ongoing details on Book-on-demand publishing, a new method of producing books only when and as ordered. Reprints, sources, samples. **\$39.50**

THE CASE AGAINST PATENTS

For most individuals, patents are virtually certain to result in a net loss of sanity, energy, time, and money. This reprint set shows you Don's tested and proven real-world alternatives. **\$28.50**

BLATANT OPPORTUNIST I

The reprints from all Don's Midnight Engineering columns. Includes a broad range of real world, proven coverage on small scale technical startup ventures. Stuff you can use right now. **\$24.50**

RESOURCE BIN I

A complete collection of all Don's Nuts & Volts columns to date, including a new index and his master names and numbers list. **\$24.50**

FREE SAMPLES

Check Don's Guru's Lair at <http://www.tinaja.com> for interactive catalogs and online samples of Don's unique products. Searchable reprints and reference resources, too. Tech help, hot links to cool sites, consultants. email: don@tinaja.com

FREE US VOICE HELPLINE VISA/MC

SYNERGETICS
Box 809-NV
Thatcher, AZ 85552
(520) 428-4073

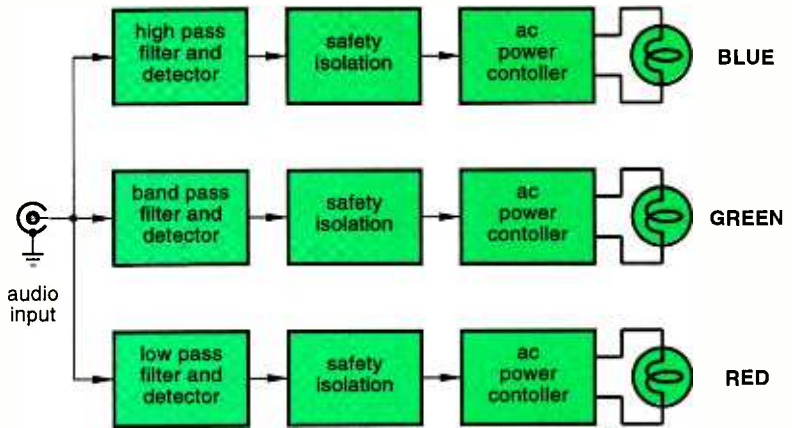

FIG. 2—HERE'S A BLOCK DIAGRAM of a classic color organ. The audio input gets filtered into three or more channels. Audio energy in each filter band sets the dynamic brightness of the chosen lamp color for that channel.

I/O pins. Pin 5 can be general I/O or a timer clock input. Pin 4 doubles as a master clear or an external wake-up call. You can hang a crystal on pins 2 and 3, or a system clock on pin 2. Analog input interface is easy. All you do is connect a capacitor and a resistor to any pin. Just briefly pull the capacitor low, and then loop recheck it until it charges to a logic one.

Although it may be a tad tricky to write a multitasking UNIX kernel for either chip (a free ISMM if you do), those baby PICs open up whole new worlds of low end applications. The free *PIC12C5XX Data Book* is published by Microchip Technology. Much more on PICs in general on my new Pick a Peck of Picks library shelf of www.tinaja.com.

Color Organs and Psychedelic Lighting

I guess it's way past time to update certain ancient history. People have long wanted to relate music to colors in one way or another. Back in the 16th century, a Jesuit monk by the name of James Bertrand Castell created his *Clavier au Lumier*. That was sort of a harp with flat colored strings. The strings were viewed edge on. As the string was plucked, you could see all the vibrating colors.

The first "classic" electronic color organ designs appeared in the 1950s. One used *thyatron* "vacuum" tubes in a half-wave design that only lit the lamps to partial brightness. Another used high-mu pentode audio-output vacuum tubes to drive scads of series-connected and

easily-burned-out #49 pilot-light strings.

Figure 2 shows the block diagram for a classic lamps-style color organ. The speaker-level input audio is somehow safety isolated and then lowpass, bandpass, or highpass filtered into (usually) three or more channels. Each channel's output is then converted into some DC control voltage. That DC control voltage then modulates a "power amplifier" of some sort. Which in turn relates the amount of audio energy in the band to the brightness of one or more colored lights. For instance, the lows might be red, the mid-ranges green, and the highs blue.

I designed and published my first three-channel solid state-color organ in April of 1963 in the now defunct magazine, *Electronics World*. That used brand-new (at the time) Silicon Controlled Rectifiers to control a few-hundred watts of lamps-per-channel. The SCRs were preceded by a full-wave rectifier. That design let the lamps go more or less smoothly from zero to full brightness. Input audio went through some LC ferrite-cup core filters, was converted to DC with germanium-diode rectifiers, and then was used to control the phase advance of the unijunction-transistor timing circuits. That design was followed a year later, in the January 1964 *Electronics World*, by a version that substituted neon lamp triggers for those costly unijunctions.

The next version appeared in the October 1965 issue of *Radio Electronics* (this magazine's predecessor). That was the first unit to use voltage-

AC PHASE CONTROL RESOURCES

P Claire 07 Audubon Road #8 Wakefield, MA 01880 (617) 246-4000	International Rectifier 233 Kansas St. El Segundo, CA 90245 (310) 322-3331	NTE Electronics 44 Farrand St. Bloomfield, NJ 07003 (201) 748-5089	Signetics/Philips PO Box 3409 Sunnyvale, CA 94088 (408) 991-2000
Crydom 411 N Central Avenue Glendale, CA 91203 (818) 956-3900	LSI/CSI 1235 Walt Whitman Rd. Melville, NY 11747 (516) 271-0400	PCIM 2472 Eastman Ave. #33-34 Ventura, CA 93003 (805) 658-0933	Teccor Electronics 1801 Hurd Dr. Irving, TX 75038 (214) 580-1515
Galco 26010 Pinehurst Dr. Madison Heights, MI 48071 (800) 521-1615	Motorola 5005 E McDowell Rd. Phoenix, AZ 85008 (800) 521-6274	SGS-Thomson 1000 E Bell Rd. Phoenix, AZ 85022 (602) 867-6259	Texas Instruments PO Box 809066 Dallas, TX 75380 (800) 336-5236
Grainger 2738 Fulton St. Chicago, IL 60612 (312) 638-0536	Mouser Electronics 11433 Woodside Avenue Santee, CA 92071 (800) 346-6873	Siemens Components 2191 Laurelwood Rd. Santa Clara, CA 95054 (408) 980-4500	Thomson CFS 40G Commerce Way Totowa, NJ 07511 (201) 812-9000

modulated, four-layer trigger diodes, and the first to provide a line filter to attack the bad AM radio interference common to color organs.

Skipping a few designs which are best left forgotten, next in line was my *Musette*, which appeared in the July 1965 issue of **Popular Electronics**. That was a five-channel unit that still featured SCRs and trigger-diode modulation. Filtering was done using resonant transformers. Color-coded background controls were added to improve the sensitivity and linearity. Brand new dichromic-filter spotlights were used to dramatically improve color purity.

What I first called *Stereo Lamps*, but some editor renamed *Hi Fi a Go Go* appeared in the July 1966 **Popular Electronics**. That was just a low-priced, compact and unfiltered single channel version. It was useful for psychedelic lighting applications.

I considered my "definitive" color organ to be the *Psychedelia I*, which appeared in the September 1969 issue of **Popular Electronics**. Innovations in that unit included the use of new low cost full-wave Triacs having built-in heat sinks, a brand new \$1 integrated-circuit phase-controller circuit, and steep-skirted two-pole active filters having broad between-channel guard bands. The use of prismatic lenses on the display gave hex "flower power" types of patterns. You had a choice of three or six channels.

Phase Control Fundamentals

The fundamentals of an AC-power phase control appear in Fig. 3. A Triac is a fast, efficient, and high voltage power AC switch that is turned on by a brief and low-level pulse on its gate. The Triac then stays on for the remainder of the

power-line half cycle. It automatically turns off when your main current drops to zero on the half-cycle zero. Triacs are fully bi-directional: either polarity of gate pulse can be applied on either polarity cycle.

If the Triac is pulsed very late in each half cycle, the duty cycle is very low; very little power reaches the load, say a lamp, and the lamp lights only dimly. When the Triac gets pulsed in mid cycle, around one half of the power reaches the lamp. When it gets pulsed very early, the lamp lights to nearly full brightness. Thus, you

might want your input control voltage to determine the time delay after a zero crossing when the Triac turns on. The higher the voltage the *less* your delay.

A modern Triac circuit appears in Fig. 4. For most applications, safety isolation is *essential* to prevent deadly "hot chassis" shock hazards. That is the purpose of the Motorola MOC3010 optoTriac isolator. While you can get Triacs from *Radio Shack*, *Texas Instruments* or *Motorola*, the definitive source is Teccor.

Usually, you will want to run your optoisolator "backwards" (as shown in

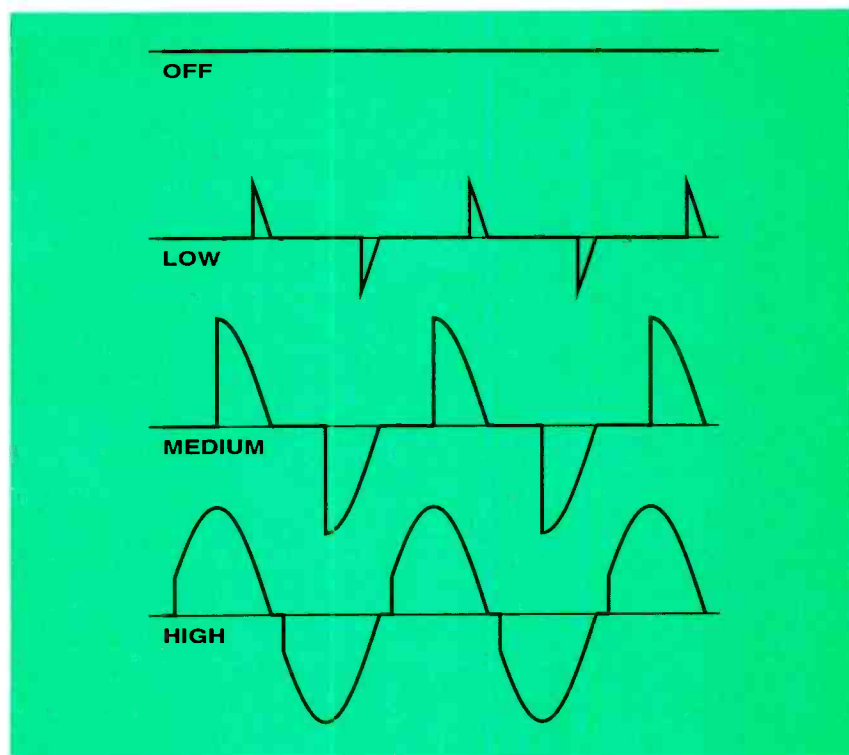

FIG. 3—THE FUNDAMENTALS BEHIND the phase control of AC power. The turn on of a Triac gets delayed after each AC half-power cycle. The longer the delay, the lower the load current. Simple phase control is useful for lamps, heaters, and AC/DC motors, But NOT for fluorescent lamps or induction motors.

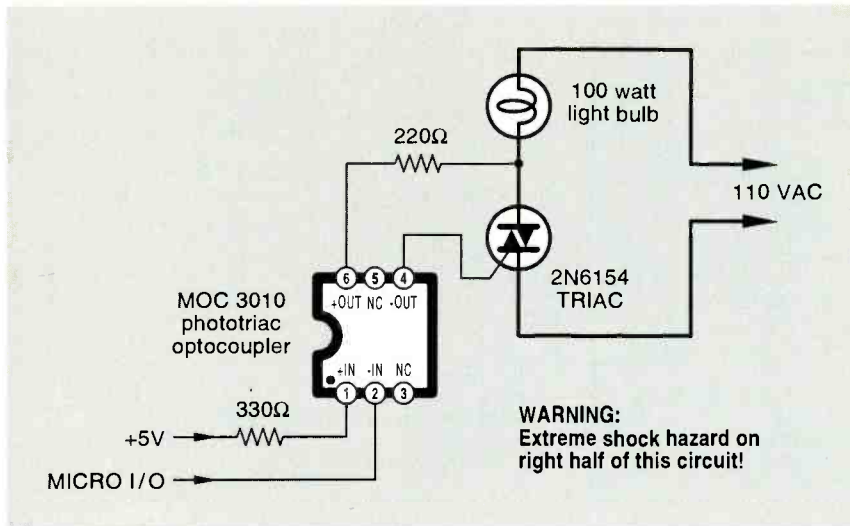

FIG. 4—A TYPICAL OUTPUT INTERFACE between a microcontroller and an AC power load. A one-piece solid state relay could be substituted. For a proportional phase control, a zero crossing reference must be provided.

the figure) so that a low or logic zero input turns the Triac on, and vice versa. That's simply because many microcontrollers and other digital ICs are better at sinking current to ground.

Two sources of specialized phase control integrated circuits are LSI/CSI and Signetics Philips. You can also get one-piece modules which include both Triac and optoisolation from CP Claire, International Rectifier, Crydom, or NTE. They are sometimes called *DC-in AC-out solid state relays*. A minimum rating of 200 volts is needed for AC-line operation, with 400 volts recommended. But at \$8 to \$12 each, the one-piece modules might not be cost effective against a pair of one dollar parts. The heat-sinking options are also limited using modules. The smaller module power limit is a few hundred watts. I have gathered several AC power-control suppliers together for you as this month's resource sidebar.

Back to the Present

What can we do to further improve color organ designs? Obviously, the new baby PIC is screaming to be used as a phase controller. With care, you might even get three channels out of a single low cost chip!

You would first have to question whether you'd prefer to use a classic design or something new. The crucial key to a classic color organ is some effective display. Even with the best designs, viewing can get boring.

At any rate, if I were doing a new "classic" color organ, two features I

would add are input compression and linearization. As Fig. 5 shows us, typical audio has ridiculously too much dynamic range for useful phase control of lights. Your lamps will be off or on most of the time, instead of smoothly tracking the music. Analog Devices has their low price SSM2165 speech-compression chip that should be ideal for this application.

The perceived brightness of a lamp is not at all linearly related to the phase angle. There are three reasons for that. First, the phase-angle versus power is an "S"-shaped curve rather than linear. Secondly, the eye is a nonlinear device that perceives light logarithmically. And thirdly, an incandescent lamp has a very nonlinear resistance at low brightness levels.

So, we take our new baby PIC and convert each input voltage into an 8-bit number between 0 and 255. Then we use table lookup to find a new number that sets up an acceptable phase delay for the desired apparent brightness level. The table lookup should be closely matched to the lamps in use. Since your eye perceives equal brightness light in the ratio of one part green, two parts of red and three parts blue, you might want to select a different lookup for each color.

The aim is to let music produce as many different brightness levels as possible. As before, you'd never let the lamps go completely off. A very low background level is a first step towards linearization. I guess I'd select digital band-pass filters these days. Both Maxim and Linear Technology have lots of fine selections for you.

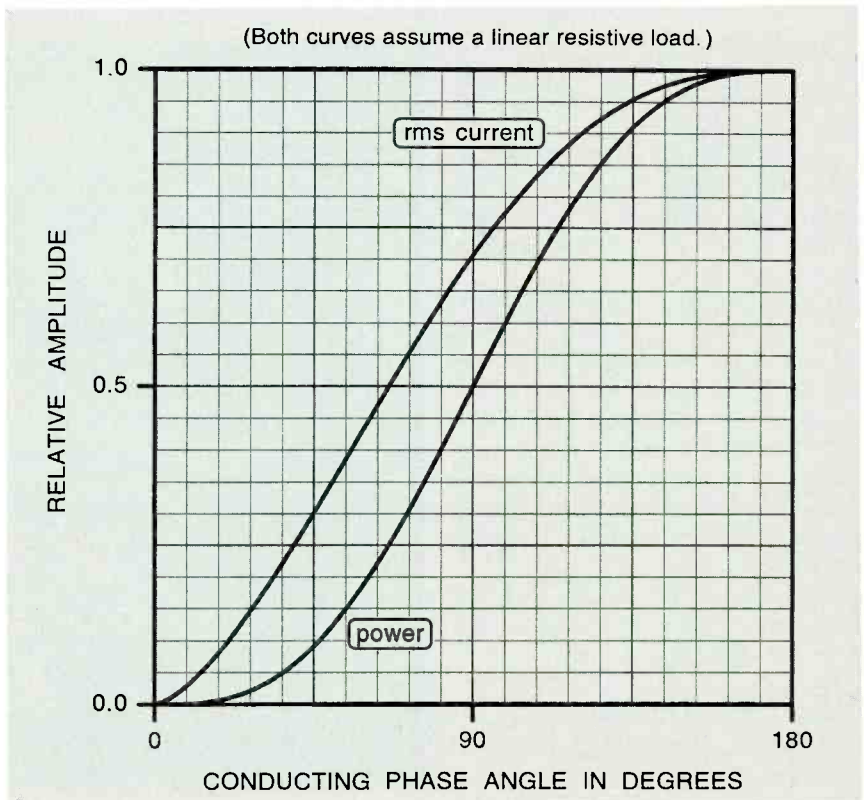

FIG. 5—THE "LINEAR" PORTION of an AC phase control has a sorely limited dynamic range of a mere ten to fifteen decibels. Linearity and dynamic range can both be greatly improved by using table lookup in a baby PIC.

NAMES AND NUMBERS

Ace Plastics

26 North Avenue
Garwood, NJ 07027
(800) 695-4223

Analog Devices

PO Box 9106
Norwood, MA 02062
(617) 329-4700

Brodhead Garrett

PO Box 8102
Mansfield, OH 44901
(800) 321-6730

Castcraft

Box 17000
Memphis, TN 38187
(901) 682-0961

Contract Professional

125 Walnut Street
Watertown, MA 02172
(617) 926-7077

Scott Edwards

964 Cactus Wren Lane
Sierra Vista, AZ 85635
(520) 459-4802

KeelyNet BBS

Box 1031
Mesquite, TX 75149
(214) 324-3501 BBS

Lindsay Publications

PO Box 538
Bradley, IL 60915
(815) 935-5353

Linear Technology

1630 McCarthy Blvd.
Milpitas CA 95035
(408) 432-1900

Maxim

120 San Gabriel Dr.
Sunnyvale, CA 94086
(800) 998-8800

Meredith Instruments

5035 N 55th Ave. #5
Glendale, AZ 85301
(602) 934-9387

Microchip Technology

2355 W Chandler Blvd.
Chandler AZ 85224
(602) 786-7200

MWK Industries

1440 S State College Blvd. 3B
Anaheim, CA 92806
(800) 356-7714

Parallax

3805 Atherton Rd. #102
Rocklin, CA 95765
(916) 624-8333

Rex Supply

3715 Harrisburg Blvd.
Houston, TX 77003
(800) 369-0669

Stemgas Publishing

PO Box 328
Lancaster, PA 17608
(717) 392-0733

Synergetics

Box 809
Thatcher, AZ 85552
(520) 428-4073

Tapestry

431 Griggs Street N
St Paul, MN 55104
(800) 876-3776

When you do your own design, do not forget to provide reliable safety isolation, always add some effective line noise filtering and shielding, and treat your input audio gently. Use the purest colors you can get. Avoid yellow because it typically overwhelms. Since an incandescent lamp is pretty much yellow to start with, filtering for other colors very much limits the light output. Go out of your way to prevent any and all white light from any pinholes, leaks, color recombination, or poor filters. There's a lot more on lamps and lighting resources in MUSE95.PDF. Available on www.tinaja.com or in the *Tech Musings* reprints. Grainger, of course, is your prime source for lighting options.

Going Non-Traditional

What about non-traditional color organ architectures? LEDs are one possibility, but power levels may be restrict-

ed, the blues will still be expensive, and you'd still be stuck with limited display options. Lasers are another possibility, but again the blues are a problem. (If you are still interested, you can find more on laser approaches from MWK Industries or Meredith Instruments.)

What if you instead combined a spectrum analyzer chip with a screen saver? The ultimate would be to use very sophisticated DSP techniques to attempt

to isolate music instruments. Let each instrument be a color blob on the screen. Some kind of tracking comb filter, maybe. The louder the instrument, the bigger and brighter the chosen blob.

Those blobs could wander around lava lamp style, continually showing new and interesting variations. Different algorithms could also be keyed to mood or music style. Texas Instruments has a new DSP demo board with a full real-time audio spectrum analyzer built in. It might make an interesting front end for audio-to-color displays.

New Tech Lit

The sudden demise of traditional data books might soon be upon us. That's because they have become outrageously expensive to produce and maintain. Instead they are being replaced by electronic versions. For example, new and free Acrobat-based CD-ROM versions of full-product data are freshly issued by Texas Instruments in a *Designer's Guide and Data Book*, and by Linear Technology in a similar publication.

A great source for the tech-education stuff is Brodhead-Garrett, who publish a free catalog. They stock everything from solar energy to injection molds.

Rex Supply prints a fat catalog chock full of machine-shop stuff. Stemgas Publishing has magazines and reprints of interest to collectors of antique gas or steam engines.

The Boy Mechanic III is the latest reissue from Lindsay Publications. It is a thick 1919 reprint full of wondrously essential projects such as full details on building your own cement kiln.

From Tapestry comes a complete line of fancier ink-jet media—glossies, clear, cling, golds, silvers, etc. Ace Plastics has a wide variety of unusual plastic shapes including tubing, rod, squares, rounds, balls, cubes, rings, diamonds, wedges, and more. From Castcraft comes a new flyer on casting and mold-making.

Contract Professional is a brand new magazine for independent tech consultants. If you are interested in that, you should also see the *Synergetics Consultant's Network* you'll find on www.tinaja.com.

I've still got some great surplus buys on Tektronics 1230 and Fluke 9010 logic analyzers. Most of the mentioned resources appear in our Names and Numbers or AC Phase-Control sidebars. Be sure to check there before calling our no charge U.S. help-line or visiting my www.tinaja.com Web site. **EN** 69

NEED HELP?

Phone or write all your US Tech Musings questions to:

Don Lancaster
Synergetics
Box 809-EN
Thatcher AZ, 85552
Tel: 520-428-4073

US email: don@tinaja.com
Web page: <http://www.tinaja.com>

Camcorder Zoom-Lens Systems

A ZOOM LENS IS ACTUALLY A SYSTEM OF SEVERAL LENSES THAT ARE COMBINED TO PROVIDE VARIABLE MAGNIFICATION OF THE PICTURE WHILE SIMULTANEOUSLY KEEPING THE IMAGE SHARPLY FOCUSED. WHEN THOSE SYSTEMS FAIL AND

require troubleshooting, you really need to know what you are doing. That requires a basic understanding of how each of the individual components that comprise the lens system operate, as well as how all those components interact.

There are four basic elements in every modern zoom-lens system. They are: the lens assembly, the zoom control, the focus control, and the iris control. We will look carefully at each of those elements; once we understand how and what they do, we will go on to troubleshooting techniques.

Basic Lens Assembly

The zoom-lens system is designed so that errors in magnification and focus are minimized whenever the system moves back and forth (zooms in or out). That is especially important at the beginning and ending positions of the zooming process. It is also important to keep those errors from becoming excessively large at any of the intermediate positions.

A lens system that is not very critical of the focus throughout the zoom range is called an optically compensated *varifocal* system. Figure 1 illustrates such a system. All three operating positions are shown in that figure. The focal length of the lens is determined by the camera operator who moves a zoom handle forward or backward on the camcorder. That can be either a manual or a powered

adjustment. Either way, the lens elements that produce the zoom action are stationary in the lens cylinder. They move as a group, not individually in relationship to each other.

Some of the early variable focal-length lenses contained as many as 15 or more separate groups of elements. Modern camcorders have as few as four. As the number of element groups has been reduced, the complexity of the electronics required to maintain proper zoom/focus characteristics has increased. The optical zoom ratio (the ratio of maximum to minimum power) is, in general, 6:1. But in some designs that range is as large as 15:1 or more.

The lens shown in Fig. 2 is typical of

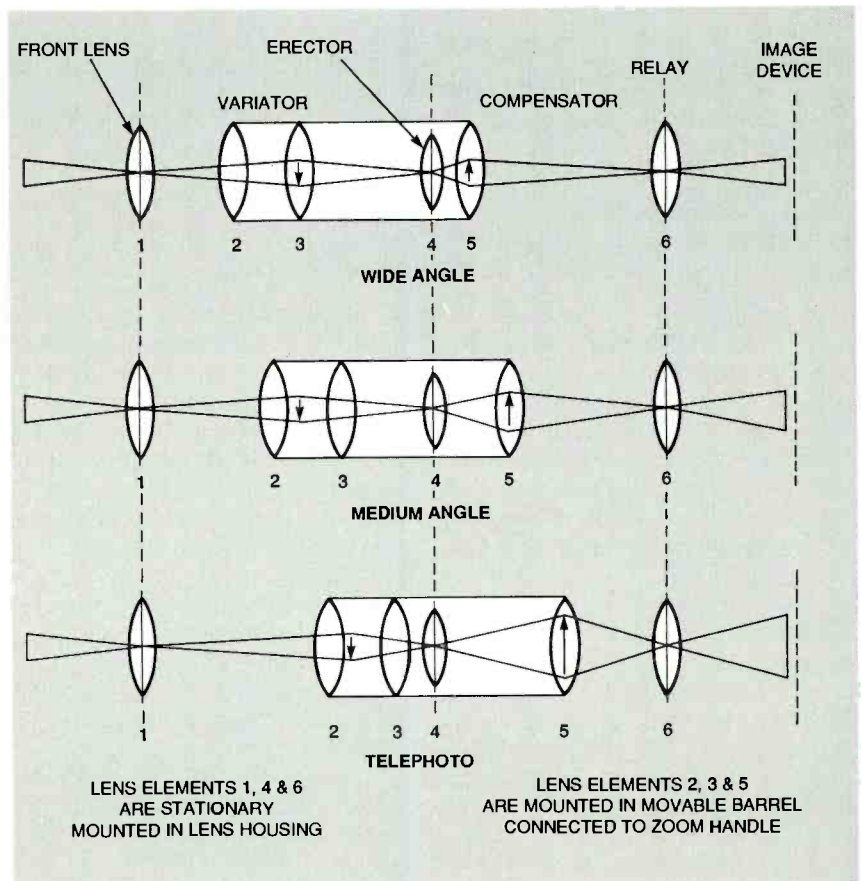

FIG. 1—A SIMPLE SLIDE ZOOM LENS SYSTEM that was used in early video camcorders. The lens elements are shown in all three common positions.

*Hitachi Hi-lite

Hitachi Home Electronics (America), Inc.
Suwanee, GA 30174

the lens system in many modern camcorders. It uses a device called a complicated cam to move the lens elements to produce the necessary zoom ratio. The complicated cam is a cylinder that has machined slots to position the lens elements in varying degrees of zoom or macro. (Macro is the opposite of zoom; it is used to focus on an object that is in close proximity to the lens.) The relationship of the two lens elements to each other changes according to the zoom and macro ranges. Also, the lens elements shift in direction depending on whether they are zooming in or zooming out.

The rear zoom element comes further forward during macro than it does during zoom. That is what moves the focal distance closer to the front lens. The precision of the lens group's movement is controlled by the complicated cam. To compensate for focus errors during the zoom process, an adjustable back-focus lens is located in the rear of the lens assembly. It is adjusted to eliminate errors throughout the full zooming range of the lens and to maintain image focus on the pickup device. No electronics are required to monitor movement of the lens-element groups.

In older camcorders, zoom controls were often simple electric motors that were fed a reversible voltage to change the rotational direction of the zoom barrel connected to the complicated cam. The zoom and focus functions were separate in those types of lenses.

How Focus Works

To produce sharp, high-resolution pictures, the camera lens must have good optical qualities. Equally important, the image that the lenses produce must be accurately focused on the sensor. The final element that determines picture resolution is the image sensor itself. It takes a high-quality lens coupled to a high-quality image sensor to produce a high-resolution picture.

Focusing is handled by moving the lens closer to or further away from the image sensor. The lens is closest to the sensor when it is focused on distant objects (such as landscapes), which are said to be at optical infinity. For most normal-focal-length camcorder lenses, infinity means anything further than 30 feet (10 meters) away. Focusing on subjects closer than infinity demands moving the lens away from the sensor. That is done with either a helical-thread lens (that can be operated manually or be dri-

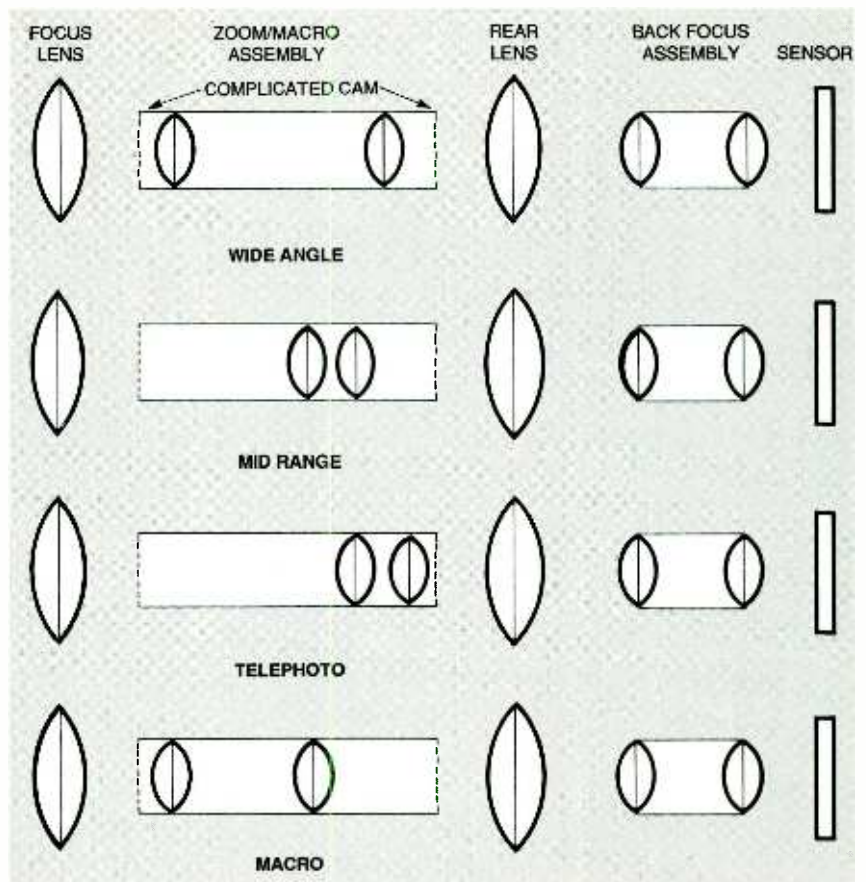

FIG. 2—MODERN CAMCORDER LENSES consist of fewer elements. Here's a look at how the elements appear in the four most commonly used positions.

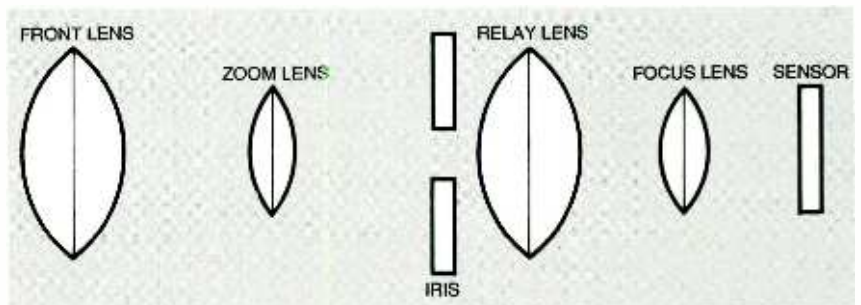

FIG. 3—THIS FOUR-ELEMENT INNER FOCUS LENS is used in many current Hitachi camcorders. Similar systems can be found in camcorders from other manufacturers.

ven by a gear-reduced miniature DC motor), or by an internal sliding lens assembly (that is driven by either a linear-drive or a stepping motor).

Focusing is very straightforward with manual-focus lenses. The helical-thread lens is rotated (manually or electronically) until the image in the viewfinder is sharp. That method leaves two variables: Is the viewfinder properly focused? Is the operator's eye properly focused to the viewfinder? An auto-focus system, on the other hand, removes the viewfinder from the focus system, leaving the

alignment of the auto-focus system as the only remaining variable.

Figure 3 is a block diagram of the lens system that is used in many current Hitachi camcorders, and similar systems are found in many other brands of camcorders. The lens consists of only four elements and has a stationary front-lens element. The focus-lens element is located at the rear of the lens assembly, and functions as a back-focus element. The zoom lens has been reduced to a single lens-element group, and the complicated cam has been eliminated. Many lens-con-

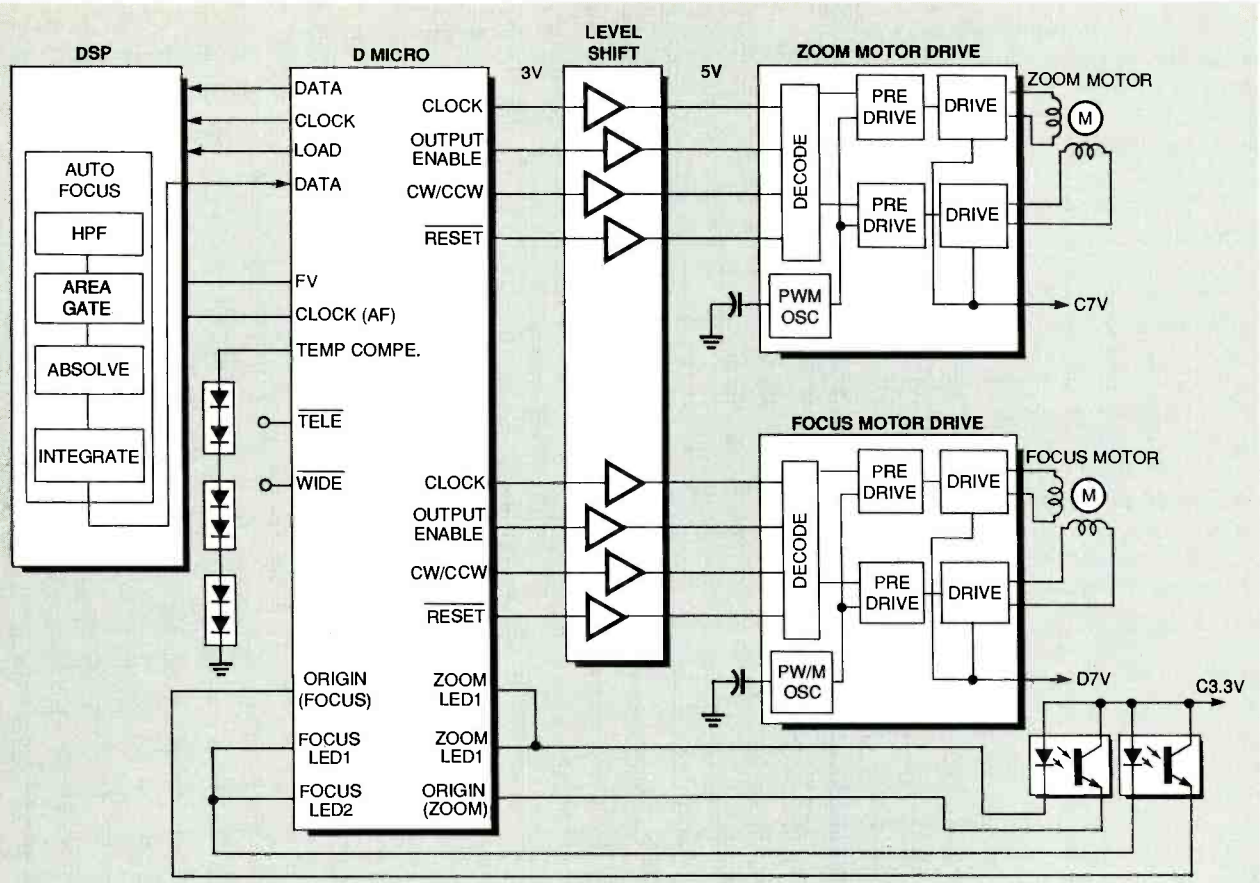

FIG. 4—A BLOCK DIAGRAM of the zoom/focus drive system. Note that zoom control circuitry is virtually identical to the focus control circuitry.

control functions are now provided entirely by electronics.

The system relies on the actual video signal processed by the camcorder for focusing. As shown in Fig. 4, the luminance portion of the video signal is sampled and fed to the auto-focus portion of the digital-signal-processing (DSP) IC as an evaluation signal. A high-pass filter converts the signal to a voltage. The frequency characteristics of the luminance signal increase in proportion to the sharpness of the focused image, and the developed voltage increases accordingly—the higher the voltage, the sharper the luminance signal and the better the focus.

That signal goes through its own signal processor to provide information to the digital microprocessor, which evaluates the data and determines whether or not the image is in focus. If it is not, it outputs motor-control data to the drive circuit to move the focus motor in the appropriate direction to bring the image into focus. The control data consists of four elements: the output-enable signal, the direction of rotation signal (C/CCW), the clock signal, and the reset signal.

The focus-drive motor is a small step-

ping motor driven by a 6-volt pulse from the focus-drive IC to rotate the motor in the right direction. The focus-drive IC is powered by the C7V power bus originating from the DC-DC converter.

The zoom-control circuitry is identical to the focus-control circuitry, with the exception of the evaluation signal that starts the process. The input for the zoom control is a simple switch that grounds an input to the microprocessor to tell the zoom the direction in which it should go (telephoto/wide). That information is compiled by the microprocessor and is output to the motor drive IC to rotate the zoom motor in the proper direction.

Since there is no back-focus assembly, the focus and zoom circuits must constantly interact to compensate for lens irregularities as well as normal focusing. That information is calibrated by the focus portion of the alignment procedure.

The first step in adjusting auto focus is the zoom/focus tracking. The lens is automatically run through the full zoom range, and focus tracks along with zoom to eliminate any lens errors. When this

process is finished, the information is stored and recalled to use as the zoom lens is moved. This means that the focus lens has become a back focus lens during the zooming process.

Now you know just about everything there is to tell about how the zoom-lens system works. Next time we will look at the troubleshooting procedures you will need to successfully service camcorder zoom-lens systems.

EN



Special Effects with a Galvanic Coil

WHEN LASER-LIGHT EFFECTS ARE WHAT YOU WANT TO PRODUCE, ANOTHER USEFUL COMPONENT TO HAVE IS A GALVANIC COIL OR GALVANOMETER. THE GALVANOMETER IS A DEVICE THAT IS USED TO MEASURE THE FLOW OF ELECTRIC CUR-

rent. You can make a simple one by winding 40 or 50 turns of magnet wire around a compass, in a north/south direction. When a voltage is applied to the coil, the compass pointer will swing from the north position to either east or west.

The same effect can be obtained by placing an external coil next to the compass at the east or west position. An applied voltage will then pull the compass pointer to the coil. You can use this principle to create an oscillation effect, which can be used effectively in light shows; in fact, it is the basis for many of the commercial light-show machines. The principle is simple: Feed a modulated voltage to the galvanometer coil, and the pointer movement will follow the signal or data being introduced in much the same way the laser flickers from electronic modulation.

Building a Galvanometer

For our purposes, a compass is far too delicate to be of much use. The alternative is to build a galvanometer that has a more rugged pointer—one that will support a mirror. There are a couple of ways to do that. But first, we must remember that the compass pointer reacts to the electromagnet, or coil, because it is also magnetized. So the first step is to rig a magnetic field on a vertical shaft that will pivot back and forth. That field can be permanent or electric, depending on the need; the merits of each will be discussed later.

Next, an electromagnet has to be positioned perpendicular to the vertical field, and at a distance that will allow the first magnet to clear the second in a full swing. With both components in place, a current sent through the electromagnet will attract the opposite pole of the vertical magnet and bring it around. I know that this is a rather simplistic explanation, yet it is the physical principle that makes the galvanometer function, and makes it a useful tool for visual productions.

WARNING!!!

This article deals with and involves subject matter and the use of materials and substances that may be hazardous to health and life. Do not attempt to implement or use the information contained herein unless you are experienced and skilled with respect to such subject matter, materials and substances. Neither the publisher nor the author make any representations as for the completeness or the accuracy of the information contained herein and disclaim any liability for damages or injuries, whether caused by or arising from the lack of completeness, inaccuracies of the information, misinterpretations of the directions, misapplication of the information or otherwise.

As mentioned before, the vertical field magnet could be either permanent or electric. A permanent magnet offers

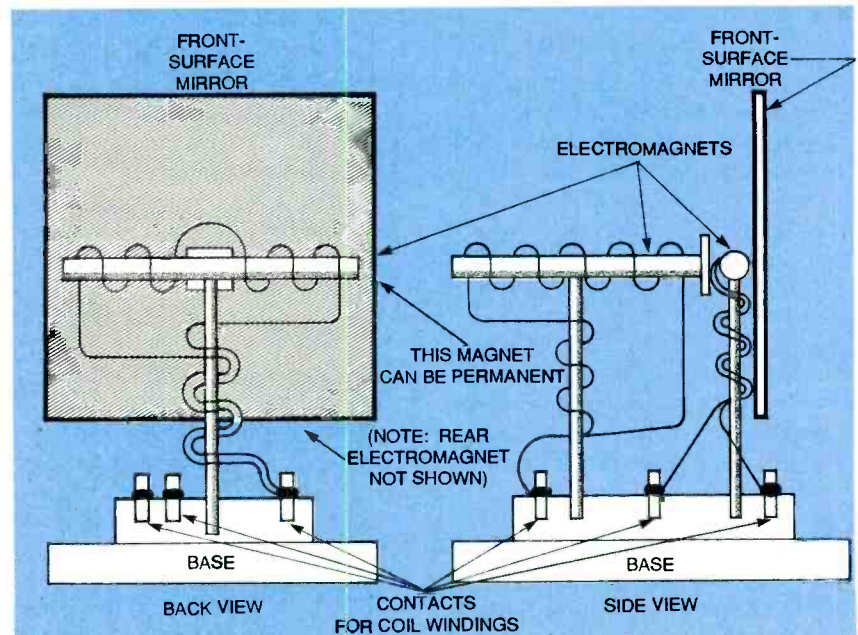

FIG. 1—A DETAILED LOOK AT A HOME-MADE galvanic-coil mirror assembly. It provides a great way to add a variety of movements to your light shows.

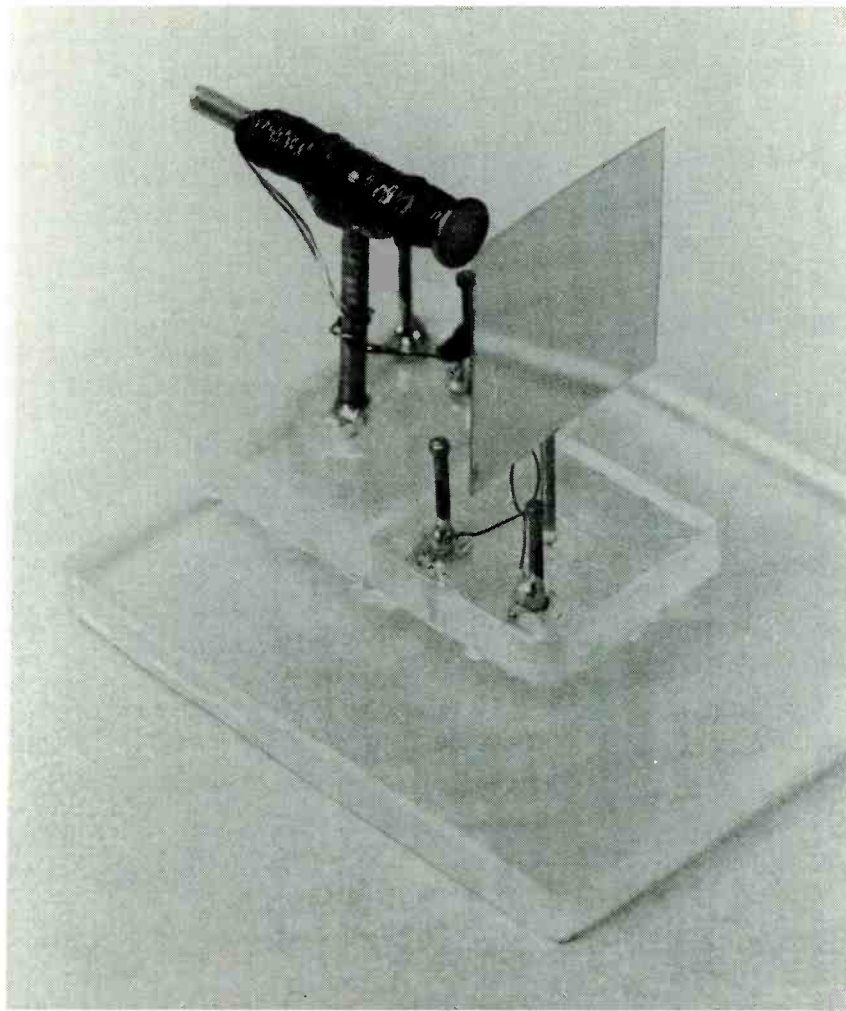

FIG. 2—THIS PHOTOGRAPH SHOWS the completed assembly. Note that the magnet-wire coils should be coated with glue or liquid rubber to hold them in place.

the advantage of not requiring a separate power source. The disadvantages are weight and mounting. If you use a permanent magnet, it will have to be a small bar magnet that is reasonably strong. Those tend to be a little on the heavy side. There are magnets that resemble rubberized strip material, with adhesive backing, that could also be used. However, while they are lighter in weight, they do not have as strong a magnetic field.

The next point to consider is mounting the magnet to the vertical shaft. In our unit, that will be a standard flat-head iron nail. Since permanent magnets can be damaged or destroyed by heat or shock, soldering, welding, or drilling a hole will not work. That leaves the use of some form of adhesive, such as epoxy, super glue, hot glue, or whatever else works for mounting.

The other alternative is an electro-magnet. The power requirement is the

primary disadvantage of using one. However, it can be turned to an advantage, since we could modulate the electromagnet's power source and further vary the patterns generated.

Figure 1 shows our galvanometer assembly. To build your own, start with a flat-top iron nail, and solder a second iron nail, with the top and point removed, to the head of the first to form a "T" shape. Using fine magnet wire, wind several hundred turns on the cross piece, and secure them with glue or liquid plastic. Bring the lead wires down to the base, leaving some slack for movement, and solder them to the connection posts. Again, small iron nails work well.

The second, or main, electromagnet is made in a similar fashion (though you can leave the head on the cross piece, if you wish) with 200 to 300 turns of wire on an iron nail. The coil is fixed in place with glue or plastic. The base that the magnets are attached to is made of wood

or Plexiglas. A front-surface mirror is then attached to the vertical, or moving magnet, and the galvanic coil is ready for use. The photo in Fig. 2 shows the completed assembly.

In this configuration, the mirror will move on the X axis. To get Y-axis movement, merely turn the assembly on its side. Most of the commercial units, called scanners, use two coils, one for each axis. When connected to control circuitry, they develop an expansive variety of visual images.

Using the Galvanometer

Despite its relative simplicity, you can create a wide variety of visual effects with the equipment you have just made. The control circuit could be any audio source, including a portable-amp/microphone arrangement, or a pulse source for an established pattern. Figure 3 shows a simple pulse-generator circuit that could be used for that purpose.

When the signal from the control circuit is applied to the main electromagnet, the vertical field will be activated proportionally. That moves the mirror and creates the oscillation effect.

You could also use the galvanometer with one of the optical-table assemblies we built in the previous months. For example, Fig. 4 shows one such modification—in this case from the December, 1996 column—with our galvanometer used in place of a speaker modulator. The reflected image that appears on the screen should be a combination of that produced by the revolving mirrors and the oscillating pattern generated by the coil. The dual revolving mirrors could also be replaced with additional galvanometers. If you incorporate beam splitters, a single laser can supply the light for various galvanic coils to produce a maze of intricate images. At the risk of sounding redundant, the only limit to a dramatic world of visual imagery is your imagination.

Once the combinations have been tested and a favorite light-table assembly has been selected, try introducing special effects to the presentation. Colloidal suspensions such as smoke, fog, dry ice in water, or fine powders puffed into the air all produce a reflective surface for the laser beam and make it visible when it passes through them. By introducing the suspensions at strategic locations, you can add another dimension to the show. Reflecting the beam off the surface of moving liquids provides an excellent

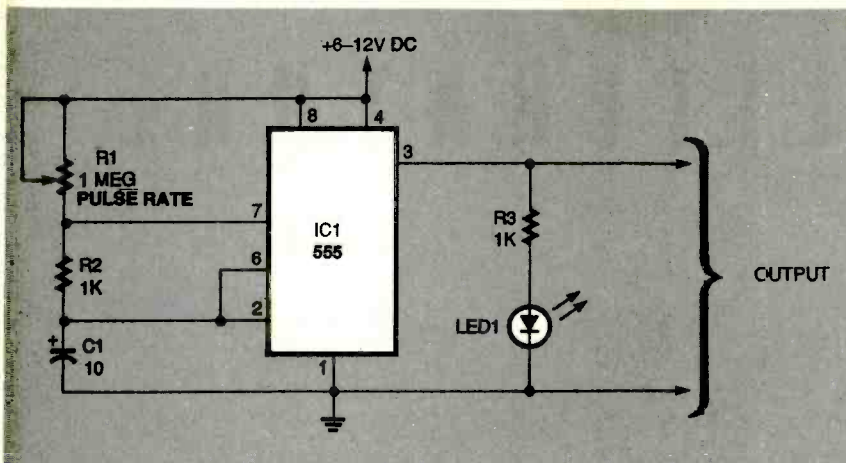

FIG. 3—THIS PULSE GENERATOR circuit could be used to drive the galvanic-coil/mirror assembly. Resistor R1 controls the pulse rate.

source of unexpected pattern variations. Try Mercury metal, if available, but be careful; it has a very high surface tension

and will get away quite easily. That's why they call it quicksilver! Warping the reflective surfaces is

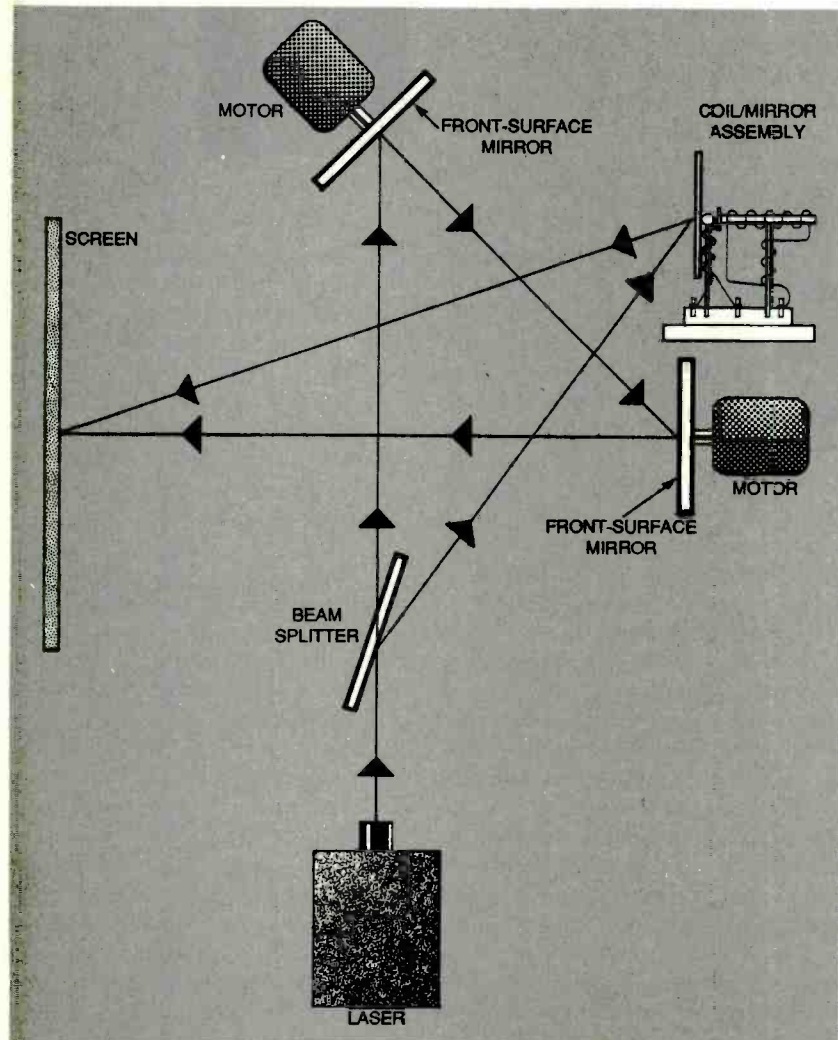

FIG. 4—HERE, THE GALVANIC-COIL ASSEMBLY has been combined with rotating mirrors and beam splitters to produce an intricate display. Note that the basic set-up was first presented in the December, 1996 issue; here a speaker modulator has been replaced with the galvanic assembly

another method of obtaining weird fun-house effects that add spice to the production. Aluminized Mylar materials are especially suited to that application. High sensitivity luminous paints or tape can hold a trace of the beam for a short period of time and give some outstanding results. These are just a few of the ideas that come to mind at the mention of special effects. With some thought and general observation, many more will present themselves.

If you have some ideas of your own that you would like to share with other readers, please put them down on paper and send them to Laser Editor, **Electronics Now Magazine**, 500 Bi-County Blvd., Farmingdale, NY 11735, or via e-mail to lartronics@aol.com.

That wraps things up for this issue. Next time we will take a look at how you might use your laser to conduct scientific experiments or as the basis of fascinating science-fair projects.

EN

ELECTRONIC GAMES

BP69—A number of interesting electronic game projects using IC's are presented. Includes 19 different projects ranging from a simple coin flipper, to a competitive reaction game, to electronic roulette, a combination lock game, a game timer and more. To order BP69 send **\$8.00 (includes s&h)** in the US and Canada to **Electronic Technology Today Inc., P.O. Box 240, Massapequa Park, NY 11762-0240**. US funds only. Use US bank check or International Money Order. Allow 6-8 weeks for delivery. MA07

Electronic Games



THE COLLECTED WORKS OF MOHAMMED ULLYES FIPS

#166—By Hugo Gernsback. Here is a collection of 21 April Fools Articles, reprinted from the pages of the magazines they appeared in, as a 74-page, 8½ × 11-inch book. The stories were written between 1933 and 1964. Some of the devices actually exist today. Others are just around the corner. All are fun and almost possible. Stories include the Cordless Radio Iron, The Visi-Talkie, Electronic Razor, 30-Day LP Record, Teleyeglasses and even Electronic Brain Servicing. Get your copy today. Ask for book **#166** and include **\$16.00 (includes shipping and handling)** in the US and Canada, and order from **CLAGGK Inc., P.O. Box 4099, Farmingdale, NY 11735-0793**. Payment in US funds by US bank check or International Money Order. Allow 6-8 weeks for delivery. MA05





NEW LITERATURE

USE THE FREE INFORMATION CARD FOR FAST RESPONSE

Dr. Bob's Painless Guide to the Internet & Amazing Things You Can Do With E-Mail

by *Bob Rankin*
No Starch Press
401 China Basin Street at Pier 50
Suite 108

San Francisco, CA 94107-2192

Tel: 1-800-420-7240

Fax: 415-284-9955

E-Mail: info@nostarch.com

\$12.95

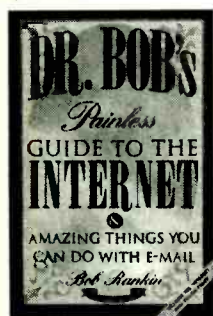

CIRCLE 337 ON FREE INFORMATION CARD

This relatively brief Internet guidebook stands out from the crowd for what it doesn't do: It never bogs down its readers in historical overviews, technical details, and complex jargon. Instead, it provides straight-

forward, plain-English advice on how to get connected to the Internet, quickly and easily.

The book is aimed at complete newcomers to online communications, as well as at folks who already use e-mail to send and receive messages. It gives readers a bit of background information on e-mail and the World Wide Web—what the basic rules of usage are, and how to find interesting and useful Web sites. It then explains how to use e-mail to access almost anything on the Internet, saving time and money in the process.

The book takes readers step-by-step through the Internet, starting with what is needed to get connected, and what type of account to get. It explains how to search the Internet for files (using Archie, Veronica, Gopher, and the World Wide Web) and then how to download them (using FTP) from computers worldwide. It shows readers how to use Telnet to log onto and use com-

puters around the world, and how to chat online with Internet Relay Chat. The book also includes a glossary of terms and the "Internet Yellow Pages," which lists a lot of useful Internet resources.

Troubleshooting & Repairing Computer Printers: Second Edition

by *Stephen J. Bigelow*
TAB Electronic Technician Library
McGraw-Hill, Inc.

11 West 19th Street
New York, NY 10011

Tel: 212-337-5951

Fax: 212-337-4092

\$24.95

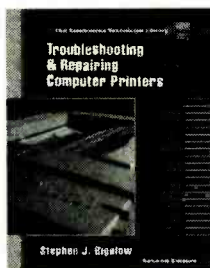

CIRCLE 338 ON FREE INFORMATION CARD

This popular guidebook has been completely overhauled and updated to reflect the latest in computer-printer technology and troubleshooting. It offers comprehensive coverage of the latest trends

and new technologies affecting printer servicing, including the problems associated with printing under Windows 95.

The book describes 150 symptoms of printer problems, and completely explains their solutions. Impact, thermal, ink jet, and electrophotographic printers are covered. The second edition features flowcharts and detailed schematics, block diagrams, and exploded-view illustrations throughout its pages. It describes specific, time-saving maintenance and repair techniques that help technicians get the job done right the first time. It offers complete details on how to use test equipment, along with troubleshooting tips and guidelines. A companion disk is available separately (priced at \$20 with the order form in the back of the book).

Master Catalog 1996-1997

Jensen Tools Inc.
7815 South 46th Street
Phoenix, AZ 85044-5399
Tel: 1-800-426-1194
Fax: 602-438-1690

Free

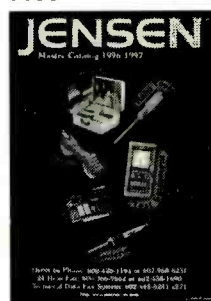

CIRCLE 339 ON FREE INFORMATION CARD

The 264 pages of this catalog are filled with tools and test instruments for the installation, service, and support of electronic products and systems. It includes inch and metric tools, ergonomic and

insulated tools, scopes, probes, meters, and analyzers. Other items featured in the catalog are LAN products including cable assemblies, scanners, and testers; soldering and desoldering equipment; static-control workbenches and accessories; cases; shipping containers; and technical manuals. Many major manufacturers' products are represented. Throughout the catalog, helpful selection charts are provided.

The New Internet Business Book

by *Jill H. Ellsworth and Matthew V. Ellsworth*
John Wiley & Sons, Inc.
605 Third Avenue
New York, NY 10158-0012
Tel: 1-800-225-5945
Web site: <http://www.wiley.com>

\$24.95

Aimed at small-business owners who are considering doing business on the Internet, this book answers all of the most commonly asked questions, including: Who is using the Internet? What are businesses and organizations doing on the Internet and the World Wide Web? Why are so many businesses of all sizes getting connected to the Internet?

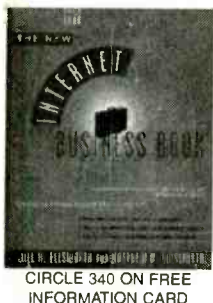

Where can you get Internet access? And, once you're connected, how do you actually use the Internet for business?

The book provides step-by-step guidelines for putting a company on

the Internet for the first time, including creating a Web site and integrating the Web and the Internet into a comprehensive marketing plan. It gives practical advice on such business basics as doing market research, obtaining competitive information, announcing products, and making sales—all on line. The book explains how to make on-line transactions secure, presents the rules and tools needed for creating an on-line business presence, and describes new "Netiquette" and Acceptable Use practices.

Test and Burn-In Sockets Brochure

3M Electronic Products Division
P. O. Box 3064

Cedar Rapids, IA 52406-8951
Tel: 1-800-328-0016, ext. 113

Web site: <http://www.mmm.com>

Free

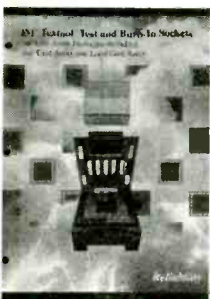

CIRCLE 341 ON FREE INFORMATION CARD

This 16-page booklet describes 3M's complete line of burn-in sockets for area array packages including ball grid array (BGA) and land grid array (LGA). The brochure contains color photos, technical

illustrations, and a listing of more than 65 available socket configurations. It also includes specifications, board-mounting instructions, performance data, and ordering information for BGA sockets.

Computers & Your Health: The Essential Manual for Every Computer User

by Joanna Bawa
Celestial Arts Publishing
P. O. Box 7123

Berkeley, CA 94707
Tel: 510-559-1600 or 1-800-841-2665
Fax: 510-524-4588
\$12.95

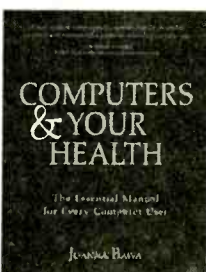

CIRCLE 342 ON FREE INFORMATION CARD

Computers are essential tools in the workplace, and are being used in more and more homes every day. Although they make our lives easier in many ways, computers can be hard on our bodies.

Many computer users have experienced eye strain, aching hands and wrists, and stiff backs; some have developed more serious health problems. This book examines how those problems can be prevented.

Drawing on the expertise of ergonomists, physical therapists, osteopaths, and optometrists, this holistic guide to safe home and office computer use explains how to prepare a healthier working environment before you begin computing. It also pinpoints a variety of computer-related hazards and offers ways to deal with them.

The book includes information on repetitive strain injury (RSI), electromagnetic radiation, and eye strain. It examines the effects of software design on our mental well-being, and offers pointers on how to manage your child's computing time and deal with video-game addiction. The book covers specific accessories, such as ergonomic keyboards, lighting, and furniture, that can help avoid computer-related health problems; provides tips for coping with stress; describes available medical treatments such as massage, physical therapy, and postural training; and touches on lesser-known topics including children's health and health legislation for computer users.

Test and Measurement Equipment Catalog 596A

Tucker Electronics
P. O. Box 551419
Dallas, TX 75355-1419
Tel: 1-800-527-4642
Fax: 214-348-0367
E-mail: sales@tucker.com
On-line catalog: <http://www.tucker.com>
Free



CIRCLE 343 ON FREE INFORMATION CARD

This 111-page catalog features both new and reconditioned test and measurement equipment. Represented in its pages are major manufacturers including Tektronix, Hitachi, Hewlett-Packard, Hameg, B+K Precision, Leader, and Goldstar. Highlighted in this issue are new digital real-time oscilloscopes, digital storage scopes, handheld scopes, and digital multimeters from Tektronix. With most reconditioned equipment, Tucker can provide instruction manuals and standard accessories.

1997 World Wide Web Yellow Pages

Luckman Interactive, Inc.
1055 West 7th Street
Los Angeles, CA 90017
Tel: 213-614-0966
Web site: <http://www.luckman.com>

\$24.95



CIRCLE 344 ON FREE INFORMATION CARD

This 1200-page directory offers current reviews and ratings of more than 10,000 Web sites, in all popular categories. Each site is rated by content, design, organization, and downloading time. The site is then assigned an overall rating of up to five stars. Only the best (three-, four-, and five-star) sites are included. The comprehensive guide to the Internet can save readers time and money by letting them know which sites are truly useful.

The book contains 18 general categories—art, business, children, computers, education, entertainment, government, health, humanities, Internet and the Web, life styles, music, news, regions, science, shopping, sports and recreation, and travel. Those topics are further divided into 400 secondary categories for quick reference.

A CD-ROM version of the 1997 World Wide Web Yellow Pages is available for Windows 3.1, Windows 95, and Macintosh. It costs \$59.95.

The Electronics Industry is looking for a lot of good people!

Here is your chance to get in on the ground floor as an Associate CET. Is your job title "Electronics Service Technician?" Would you like to have that title? You can prove you qualify for the title with a CET Associate Certificate. It can be your career door-opener and begin your rapid advancement!

A technician or student of electronics with less than a total of four years of basic experience may take the Associate Level Exam. The exam is the basic electronics portion of the full-credit CET exam. The 75-question, multiple-choice test covers basic electronics, math, DC and AC circuits, transistors and semiconductors, instruments, measurements and troubleshooting. A successful Associate CET will receive a wall certificate valid for four years and is eligible to join ISCET as an Associate Member. ISCET is the International Society of Certified Electronics Technicians.

The ISCET Computer-Aided Associate-Level Study Guide prepares you for the Associate CET Certificate by randomly selecting sample questions with appropriate diagrams, provides multiple-choice answers, grades the test and provides a summary of your strong and weak points.

Diskette requires IBM computer or compatible with VGA color monitor, 3.5-in. drive and a hard-disk drive.

CLAGGK INC. – CET Computer-Aided Study Guide Offer
PO Box 4099, Farmingdale, New York 11735

YES, I want to step up to a career in servicing. Here is my order for the CET Computer-Aided Study Guide on a 3.5 diskette. I am enclosing \$39.95 (price includes shipping and handling charges) in U.S. funds.

Bill my VISA MasterCard Expire Date / /
 USA Bank Check US or International Money Order

Card No. _____

Signature _____

Name (Please Print) _____

Address _____

City _____ State _____ Zip _____

New York residents add local sales taxes. Canadians add \$6.00 per order. No foreign orders. Do not send cash. Checks drawn on US Bank and International Money Orders in US funds only. Credit card users may telephone or FAX orders. Telephone 516-293-3751 or FAX 516-293-3115. Price subject to change. Allow 6 to 8 weeks for delivery.

CB06

Proof Positive that you are a Certified Electronics Technician



A New

Computer Software Program — ISCET Computer-Aided Associate-Level Study Guide

Prepare yourself for the 75-question CET Associate Examination. Model examinations provide the technician with a study program and introduction to the actual examinations. The model examinations are automatically graded in decimal numbers and bar graphs that can be outputted on your printer. The questions for each exam are selected randomly from a loaded data base—no two exams are exactly the same. When you answer a question, the correct answer is displayed and an explanation is given. From the print-outs you will determine whether you need more practice and in which topic areas, or if you are ready to take the real test and continue to promote your electronics career today!

BUILD THE PCDRILL

(Continued from page 46)

the compiled version. (Look for PCDRILL.ZIP on the Gernsback FTP site —ftp.gernsback.com/pub/EN).

Select each of the first four options in turn. The table and the drill should move in the selected direction. The test program moves the table and caddy in "slow motion," but real applications (like the one that will be presented next time) produce quicker and smoother movement. If either motor stalls and the table or drill does not move, the associated guide is probably jamming against the track. Adjust the guide and try again. Repeat the process until both table and caddy move smoothly throughout the entire range of travel.

Several tweaks can improve the performance of PCDrill. For instance, apply paste wax to all moving wooden surfaces, including the drill caddy sides and drill slides. All moving metal surfaces should get a thin coat of light oil. That includes the driver nuts, threaded rods, and aluminum angle tracks. Those lubrication efforts will decrease friction and make for smoother operation.

Next time we'll align PCDrill, and introduce the application program and all of its functions. We'll also look at the application's data file and explain each of its entries, including the Speed entry that maximizes speed of movement. We'll also provide details for building a 5.75-volt power supply from scratch, and use PCDrill to fabricate its own PC board. To round things out, we'll provide an AC wiring option that allows you to energize the drill only during actual drilling, as opposed to having the drill run continuously. See you then. Ω

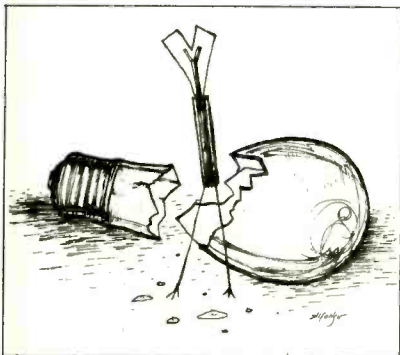

CONDUCTANCE ADAPTER

(Continued from page 63)

keep the input leads short to avoid 60-Hz line pickup. Although the ICs used in the Conductance Adapter are ESD protected, you should avoid letting any static discharges into J1 or J2.

Connect a 1-megohm resistor to J1 and J2 and the output on a DVM will be 1.000 volts, which is equal to 1.00 micromho or 1000 nanomhos. A 300-megohm resistor will read 3.33 millivolts, which is equal to 3.33 nanomhos. A diode (shown as D_x in Fig. 1) might show a reading of 2.55 millivolts when reverse biased. That is equal to a leakage current of 2.55 nanoamps. Leakages can be measured down to 10 picoamps. If you need a voltage greater than -1.00 volt for your tests, do not make any connection to J1. Apply an external voltage between the ground jack (J3) and the free lead of the device being tested. Do not let any voltages applied to J2 exceed 3 volts, or IC2 will be destroyed. Ω



This card can stop a bullet.

It's only a piece of paper, but that little card up there carries a lot of weight. Keeping millions of kids off drugs, out of gangs and in school. To learn how you can help the Boys & Girls Clubs, call: **1-800-854-Club.**

The Positive Place For Kids

USING THE NE602

(Continued from page 54)

If the signal is an SSB signal, then the LO is set at a frequency of 2.5- to 2.8-kHz higher or lower than the IF, depending on whether you want to demodulate an upper-sideband (USB) or lower-sideband (LSB) signal.

The input signal circuit in Fig. 15 uses a 455-kHz IF transformer of the sort used for transistor radios (see Digi-Key or Mouser catalogs for suitable types). The transformer that you want to use for T1 is the type that has a resonant secondary with a tapped inductance. The LO circuit uses the same type of transformer as the input, but configured as a Hartley oscillator.

The output signal is at audio frequencies, and is filtered by an R-C network. The audio output is balanced, so it should be fed to a differential audio amplifier such as an op-amp.

NE602 "Universal" Project Board.

We've included a printed circuit pattern for a "universal" project board based on the NE602. The on-board circuitry (Fig. 16) is limited to the DC power connection, which is regulated by a three-terminal IC voltage regulator. All other functions can be set by you to make any project that you want. There are a large number of multi-pad stand-alone connections for various components depending on the circuit that you want to make, as well as positions for three six-pin standard shielded coils of the sort manufactured by Toko and sold by Digi-Key. You can also use these same holes for mounting home-brew toroid inductors. Figure 17 shows the parts placement of the universal project board. The universal NE602 board can be bought from FAR Circuits, 18N640 Field Court, Dundee, IL, 60118 for \$4 plus \$1.50 shipping for every four boards ordered (i.e. 1 to 4 boards shipped for \$1.50). IL residents will have to add appropriate sales tax.

Now you've seen how well-behaved the NE602 is. Here is an RF chip that will function in a variety of applications from receivers, to converters, to oscillators, to signal generators. With the universal project board, the task of testing a new design based on the NE602 becomes "duck soup." Ω

USE ELECTRONICS NOW CLASSIFIEDS

READ BY ELECTRONIC BUYERS AND SELLERS AND TRADERS

INSTRUCTIONS FOR PLACING YOUR AD!

HOW TO WRITE YOUR AD

TYPE or **PRINT** your classified ad copy **CLEARLY** (not in all capitals) using the form below. If you wish to place more than one ad, use a separate sheet for each additional one (a photo copy of this form will work as well). Place a category number in the space at the top of the order form (special categories are available). If you do not specify a category, we will place your ad under miscellaneous or whatever section we deem most appropriate.

We cannot bill for classified ads. **PAYMENT IN FULL MUST ACCOMPANY YOUR ORDER.** We do permit repeat ads or multiple ads in the same issue, but in all cases, full payment must accompany your order.

WHAT WE DO

The first word and company name of each ad are set in bold caps at no extra charge. No special positioning, centering, dots, extra space, etc. can be accommodated.

RATES

Our classified ad rate is \$2.50 per word. Minimum charge is \$37.50 per ad per insertion (15 words). Any words that you want set in bold are each .40 extra. Indicate bold words by underlining. Words normally written in all caps and accepted abbreviations are not charged anything additional. State abbreviations must be post office 2-letter abbreviations. A phone number is one word.

If you use a **Box** number you must include your permanent address and phone number for our files. **ADS SUBMITTED WITHOUT THIS INFORMATION WILL NOT BE ACCEPTED.**

For firms or individuals offering Commercial products or Services. **Minimum 15 Words.** 5% discount for same ad in 6 issues within one year; 10% discount for same ad in 12 issues. **Boldface** (not available as all caps), add .40 per word additional. **Entire ad in boldface**, add 20%. **Tint screen behind entire ad**, add 25%. **Tint screen plus all boldface ad**, add 45%. **Expanded type ad**, add \$4.00 per word.

General Information: A copy of your ad must be in our hands by the 13th of the fourth month preceding the date of issue (i.e. Sept issue copy must be received by May 13th). When normal closing date falls on Saturday, Sunday or Holiday, issue closes on preceding work day. Send for the classified brochure.

DEADLINES

Ads not received by our closing date will run in the next issue. For example, ads received by November 13 will appear in the March issue that is on sale January 17. **ELECTRONICS NOW** is published monthly. No cancellations permitted after the closing date. No copy changes can be made after we have typeset your ad. **NO REFUNDS**, advertising credit only. No phone orders.

CONTENT

All classified advertising in **ELECTRONICS NOW** is limited to electronics items only. All ads are subject to the publishers' approval. **WE RESERVE THE RIGHT TO REJECT OR EDIT ALL ADS.**

AD RATES: \$2.50 per word, Minimum \$37.50

Send you ad payments to:

ELECTRONICS NOW 500 Bi-County Blvd, Farmingdale, NY 11735-3931

CATEGORIES

100 -- Antique Electronics	270 -- Computer Equipment Wanted	450 -- Ham Gear Wanted	630 -- Repairs-Services
130 -- Audio-Video Lasers	300 -- Computer Hardware	480 -- Miscellaneous Electronics For Sale	660 -- Satellite Equipment
160 -- Business Opportunities	330 -- Computer Software	510 -- Miscellaneous Electronics Wanted	690 -- Security
190 -- Cable TV	360 -- Education	540 -- Music & Accessories	710 -- Telephone
210 -- CB-Scanners	390 -- FAX	570 -- Plans-Kits-Schematics	720 -- Test Equipment
240 -- Components	420 -- Ham Gear For Sale	600 -- Publications	730 -- Wanted

CLASSIFIED AD COPY ORDER FORM

Place this ad in Category # _____ Special Category \$30.00 Additional _____

1 - \$37.50	2 - \$37.50	3 - \$37.50	4 - \$37.50	29 - \$72.50	30 - \$75.00	31 - \$77.50	32 - \$80.00
5 - \$37.50	6 - \$37.50	7 - \$37.50	8 - \$37.50	33 - \$82.50	34 - \$85.00	35 - \$87.50	36 - \$90.00
9 - \$37.50	10 - \$37.50	11 - \$37.50	12 - \$37.50	37 - \$92.50	38 - \$95.00	39 - \$97.50	40 - \$100.00
13 - \$37.50	14 - \$37.50	15 - \$37.50	16 - \$40.00	Total words _____ \$2.50 per word = \$ _____			
17 - \$42.50	18 - \$45.00	19 - \$47.50	20 - \$50.00	Bold Face _____ \$0.40 per word = \$ _____			
21 - \$52.50	22 - \$55.00	23 - \$57.50	24 - \$60.00	Special Heading _____ \$30.00 = \$ _____			
25 - \$62.50	26 - \$65.00	27 - \$67.50	28 - \$70.00	Other _____ = \$ _____			

Total classified ad payment \$ _____ enclosed **TOTAL COST OF AD \$ _____**

Check Mastercard Visa Discover Card # _____ Expiration Date ____/____

Signature _____

Name _____ Phone _____

Address _____ City State Zip _____

Electronic SHOPPER

Paperback Books

GREAT BOOKS AT BUDGET PRICES

100 RADIO HOOKUPS
—#7—\$3.00

First published in May, 1923 this popular booklet went into reprint editions nine times. It is packed with circuits, theory, antenna installation and tips on consumer radio receivers that were popular in the early 1920's. Antique radio buffs and those inquisitive about the early days of radio will find this booklet an exciting, invaluable and excellent reference into the minds of early-day radio listeners. Sorry, we cannot honor the original 25-cent cover price.

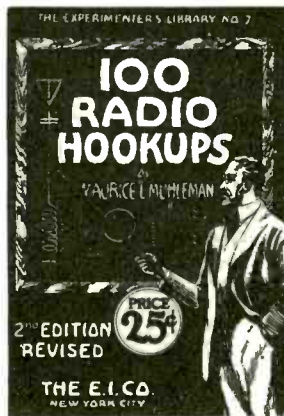

INTERNATIONAL RADIO STATIONS GUIDE—BP255
—\$9.95

Provides the casual listener, amateur radio DXer and the professional radio monitor with an essential reference work designed as a guide for listening to the complex radio bands. Includes coverage on Listening to Shortwave Radio, ITU Country Codes, Worldwide Radio Stations, European Long Wave and Medium Wave Stations, Broadcasts in English and more.

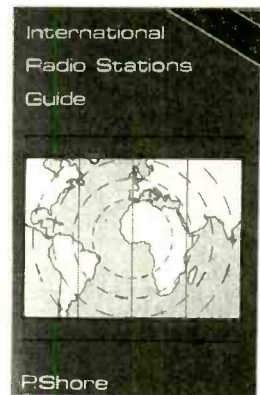

HOW TO USE OP AMPS
—BP88—\$5.95

The engineer's best friend is the op amp. This basic building block is found in many circuits, analog and digital alike. The op amp finds many useful purposes such as: oscillators, inverters, isolators, high- and low-filters, notch and band-pass filters, noise generator, power supplies, audio, MIDI, and much more. Prepared as a designer's guide, some limited math is used, however engineers and hobbyists alike find it a useful text for their design needs.

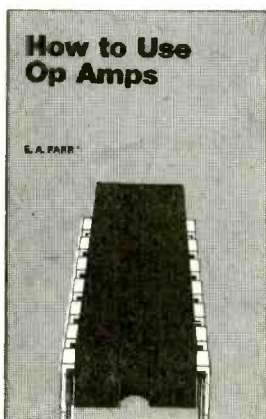

WIRELESS & ELECTRICAL CYCLOPEDIA
—ETT1—\$5.75

A slice of history. This early electronics catalog was issued in 1918. It consists of 176 pages that document the early history of electricity, radio and electronics. It was the "bible" of the electrical experimenter of the period. Take a look at history and see how far we have come. And by the way, don't try to order any of the radio parts and receivers shown, it's very unlikely that it will be available.

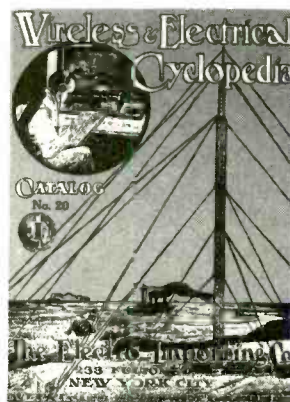

ELECTRONIC TECHNOLOGY TODAY INC.
P.O. BOX 240, Massapequa, NY 11762-0240

Name _____
Address _____
City _____ State _____ Zip _____

SHIPPING CHARGES IN USA AND CANADA

\$0.01 to \$5.00	\$2.00
\$5.01 to \$10.00	\$3.00
\$10.01 to \$20.00	\$4.00
\$20.01 to \$30.00	\$5.00
\$30.01 to \$40.00	\$6.00
\$40.01 to \$50.00	\$7.00
\$50.01 and above	\$8.50

SORRY No orders accepted outside of USA & Canada

Total price of merchandise \$ _____
Shipping (see chart) \$ _____
Subtotal \$ _____
Sales Tax (NYS only) \$ _____
Total Enclosed \$ _____

Number of books ordered

All payments must be in U.S. funds!

ET01

TUBES



SINO-CHINA

	1	10	25+
300B	\$49.00	\$42.00	\$38.00
807	6.90	5.90	4.90
811	7.90	6.20	5.30
812	12.00	10.75	9.70
813	25.00	23.00	21.50
845	27.00	25.50	22.00
2A3	12.90	11.90	10.90
211	21.90	19.50	17.80
5AR4/GZ34	7.90	6.90	5.90
6L6GC "Coke"	6.40	5.90	5.40
12A7	3.70	3.40	3.25
12AX7A	2.90	2.20	1.95
12AU7	3.90	3.50	2.90
KT88	14.90	13.50	11.90
KT100	21.00	19.50	17.75

LIMITED SUPER SPECIAL!

12AX7a CHINA In individually marked boxes.
100 pcs \$1.78 ea **1000 pcs \$1.49 ea**

STANDARD MATCHING available on most octal power tubes. **75¢ extra per tube. Pairs, Quads, Sextets FREE** on 26 (same type) tubes or more.

PLATINUM MATCHING available with 24 hour test and burn-in, ensuring premium match. **\$2.00 extra per tube.**



Visa/MasterCard.

Check out the *Sovtek World Wide* website, <http://www.turnstyle.com/sovtek>

SOVTEK

	1	10	25+	USED BY:
300B	\$69.00	\$59.00	\$49.00	
5881/6L6WGC	7.90	6.90	6.20	Fender, Marshall, Soldano, VTL
5881WXT	8.90	7.90	6.90	Full size base, Fender
5AR4/GZ34	6.90	5.90	4.90	Matchless, Holland
5U4G	4.90	4.50	3.90	Mesa Boogie Dual Rectifier
5Y3GT	3.90	3.50	2.90	
6922	7.50	6.60	6.10	Audio Res., Melos, Convergent
6CA7	9.90	8.90	8.20	
6CG7	7.50	6.60	6.10	
6EU7	8.90	8.50	7.80	
6L6GB	4.90	4.20	3.75	
6L6GC	3.40	2.90	2.65	
6LQ6+	18.90	17.50	16.40	
6SL7	4.90	4.20	3.75	
6SN7	4.90	4.20	3.70	
6V6GT	3.90	3.15	2.90	Crate, HIMU
7199	10.90	9.90	8.90	
12AX7WA/7025	3.40	2.90	2.50	Fender, Hartke, SLM, Orange
12AX7WB/7025	4.25	3.75	3.40	Bedrock, Carvin, Demeter
12AX7WXT	3.90	3.40	3.10	Conrad-Johnson
12AX7WXT+	4.90	3.95	3.50	Telefunken "diamond" sound
12AX7WXT+ SELECT	6.90	5.95	5.50	Selected for gain & symmetry
EL34G	7.50	6.80	6.30	Quicksilver, Marshall, Orange
EL34G+	7.95	7.25	6.75	Improved reliability
EL84/6BQ5	3.25	2.75	2.30	Peavey, Crate, Fender
EL84M/6BQ5WA	7.50	6.60	6.10	Matchless

TESLA-CZECHOSLOVAKIA

	1	10	25+
KT88	\$33.90	\$30.90	\$29.50
KT88BL sky blue glass	43.00	37.00	34.60
E34L	9.25	8.65	8.10
E34BL sky blue glass	15.90	14.80	13.70
E34RL light rose red glass	12.50	11.70	10.90
EL34	9.00	8.40	7.80
ECC83/12AX7	5.90	5.60	5.25
EL84/6BQ5	5.70	4.95	4.40

EI - YUGOSLAVIA

	1	10	25+
6CA7 "big bulb"	\$11.50	\$10.50	9.50
6CG7/6FQ7	6.50	5.80	5.20
12A7/ECC81	4.90	3.90	3.60
12AU7/ECC82	4.60	3.80	3.20
12AX7/ECC83	4.50	3.60	2.90
12BH7	6.90	5.90	5.50
12DW7/7247	7.90	6.90	5.90
EL34	7.50	6.50	5.90
EL519/6K66	11.90	10.90	9.90
KT90	28.50	25.80	23.90
PL519/40K66	11.90	10.90	9.90

SVETLANA

	1	10	25+
EL34	\$9.70	\$9.30	\$8.60
SV6550C	16.90	15.90	14.90

SOLID STATE RECTIFIER

BUILT INTO TUBE SOCKET.	1	10+
Direct Plug-in replacement for all 5Y3, 5U4 and 5AR4 types	\$5.90	\$5.50

NEW SENSOR CORPORATION

20 Cooper Square, New York City, NY 10003 • (212) 529-0466 • 1-800-633-5477 • Fax (212) 529-0486
 CIRCLE 258 ON FREE INFORMATION CARD



#72-2035 ...Reg.\$149
only
\$129

#72-2040 ...Reg.\$179
only
\$159

Quality you can afford.

TENMA® Test Equipment

Compact, rugged, and autoranging, this line of high-performance DMMs are perfect for troubleshooting electronic circuitry, adjusting and calibrating products and testing components. The "High Tech Series" offer performance and 5,000 count for greater resolution and repeatability. So whether you are solving problems in the field, at home, or at the workbench, Tenma digital multimeters give you all the measurement capability you need for today's technology.

Why should you buy Tenma DMMs?

- 30 day satisfaction guarantee
- Best price/performance
- One year warranty
- NIST calibration available
- 5000 count
- Feature packed

The complete Tenma line can be found at MCM Electronics. MCM stocks over 30,000 items...serving every need of the electronics repair industry. Test equipment, semiconductors, audio/video parts, tools, computer parts and more. Request your FREE catalog today!

Prices effective from January 2, 1997 through February 28, 1997

20th
Anniversary
1996



FREE Catalog

Authorized
Panasonic
Quasar/Technics
Original Parts Distributor

RCA/GE
Premier
Distributor

To order or receive a FREE catalog, Call...
1-800-543-4330

Hours: M-F 7 a.m.-9 p.m., Sat. 9 a.m.-6 p.m., EST.



MCM ELECTRONICS®
650 CONGRESS PARK DR.
CENTERVILLE, OH 45459
A PREMIER FARNELL Company

Fast delivery from distribution centers near Reno, NV and Dayton, OH.

CODE:ENS31

CIRCLE 331 ON FREE INFORMATION CARD

Discover DC Electronics

17-Module Course -- Only \$49.95

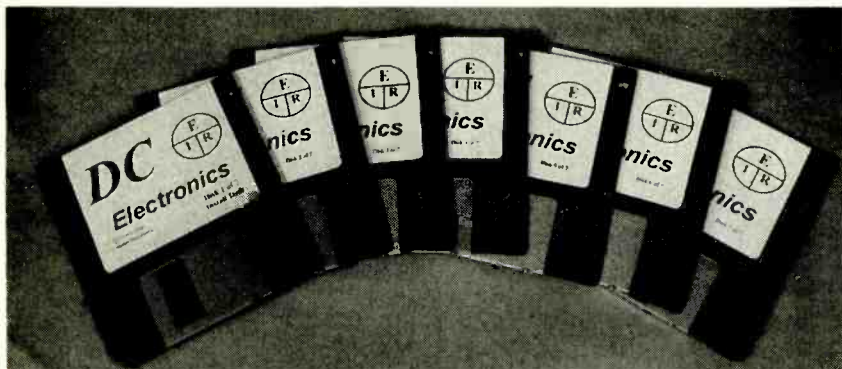

Contains everything you ever needed to know about DC electronics. Whether you are a professional working in electronics and you want a review of the basics, or a student or hobbyist new to this field and need a good self-paced course, this is the perfect way to get started.

The course starts with basics and assumes you know nothing about electronics. It teaches the required math, how to use a scientific calculator, and the metric notation system. Each module has been written by an electronics instructor, and will directly from a floppy or from a menu-driven system on your hard drive. Every module includes a review, summary, quiz, and a final exam that can be printed out. Important points are animated to make the explanation clear.

System requirements: IBM Compatible, 512K RAM, VGA Color, Hard Drive and DOS 3.2 or newer.



Here are the Modules

- | | |
|---|---|
| 1. Atoms and Electrons | 10. Series / Parallel Circuits |
| 2. Volts / Current / Resistance | 11. Voltage Dividers |
| 3. Numbers greater than one
Scientific - metric notation | 12. Kirchhoff's Law |
| 4. Numbers less than one
Scientific - metric notation | 13. Advanced DC Circuit
Analysis |
| 5. Resistor Color Codes | 14. Capacitors / RC Time
Constants |
| 6. Using Calculators | 15. Introduction to Magnetism |
| 7. Ohm's Law and Power | 16. Inductors and L/R Time
Constants |
| 8. Series Circuits | 17. Volt/Ohm/Current Meters |
| 9. Parallel Circuits | |

Clagg Inc. P.O. Box 4099, Farmingdale, NY 11735

Send me my course, today! Charge me the special introductory price!

Name _____ \$49.95 + \$4.95 shipping

Address _____

Address _____

City _____ State _____

Zip _____

Payment Enclosed \$ _____

Check Money Order Credit Card

New York residents add local sales taxes. Canadians add \$6

per order. Credit card orders by phone or fax. Automated

telephone orders 516-293-3751. Fax 516-293-3115.

Allow 4 to 6 weeks for delivery.

Credit Card Info

MC Visa

Card # _____

Exp Date _____

Signature _____

COMPUTER CONNECTIONS

continued from page 28

automation tool I'm developing in conjunction with another company, I've begun churning out Delphi components. One is a grid component. As the name suggests, it is a panel that displays a grid with user-selectable color, line style, and X and Y frequencies.

The grid is a descendant of Delphi's TCustomPanel. It's not a descendant of TPanel, because the latter has no paint events, so we have to move one level up the object hierarchy. As is often the case with Delphi components, TPanel exposes only some of the properties and methods of TCustomPanel. My grid component hooks into the Paint event, which is where it actually draws the lines. The component creates new properties for line color (GridColor), line style (GridStyle), and line frequency (GridX and GridY). Look for DEL_GRID.ZIP, which contains the source and a compiled DCU file.

Hardware Alert

The Seagate 43400N is a 5 $\frac{1}{4}$ -inch 3-GB SCSI hard drive that is widely available for \$300-\$400. I've been using one for months with nary a problem. (I discussed it here in the August issue.) But I know several people who have had problems with them.

These things cook; they are serious heat generators. If you use one, be sure to mount it in a case with good air circulation. The typical mini-tower won't cut it, as a friend found out the hard way. I happened to have mounted mine in a huge old tower with lots of space and air flow. If you start getting any sort of intermittent results, check temperature, and if necessary, increase air flow.

Until next time, you can stay in touch with me via e-mail at jkh@acm.org. **EN**

Get your copy of the CRYSTAL SET HANDBOOK

THE CRYSTAL SET HANDBOOK

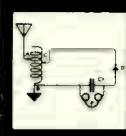

Go back to antiquity and build the radios that your grandfather built. Build the "Quaker Oats" type rig, wind coils that work and make it look like the 1920's! Only \$10.95 plus \$4.00 for shipping and handling. Clagg Inc., P.O. Box 4099, Farmingdale, NY 11735. USA Funds ONLY! USA and Canada—no foreign orders. Allow 6-8 weeks for delivery. MA01

Electronic CAD for Windows

Professional Windows EDA tools at an affordable price with powerful features to make designing faster. WinBoard PCB layout delivers sophisticated interactive routing for complex designs, plus it has the tools needed for high-speed circuits, analog, RF and SMT designs.

WinDraft® Schematics

- ◆ Use True-Type fonts. Quickly copy and paste into other applications.
- ◆ Supports hierarchical designs, electrical rules checking, Annotation & Bill of Materials.
- ◆ Thousands of library parts and symbol editor included.

WinBoard™ PCB layout

- ◆ Supports 16 layers, multiple copper pours, and advanced features for RF designs.
- ◆ SMD & through hole library with on-line graphical editor.
- ◆ CAM outputs include BOM, in-circuit test, NC Drill, Gerber, Pick & Place, & Advanced Design Rule Checking (DRC).

With our unique *pin capacity* versions you only pay for what you need. You choose the base configuration to suit your needs today, and expand that configuration to handle increased pin capacity as your design requirements change.

New Versions Available Now

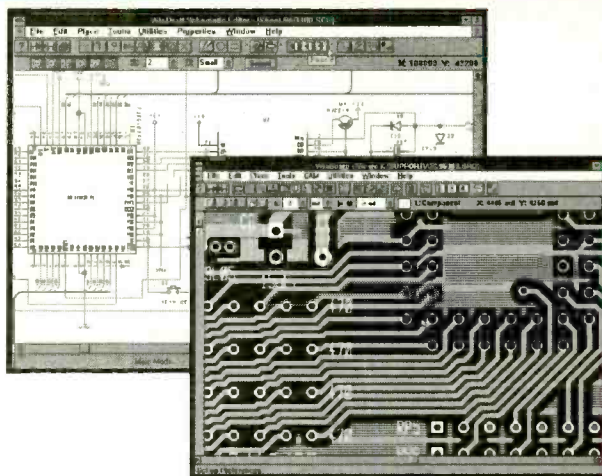

- \$ 250 WinDraft or WinBoard - P650
- \$ 495 WinDraft or WinBoard - unlimited
- \$ 895 WinBoard P650 with CCT Spectra® autorouter.

Thousands of satisfied customers are using this new generation of powerful and affordable Windows EDA tools from Ivex. Your satisfaction is guaranteed!

World Wide Web: <http://www.ivex.com>

Information and free evaluation version is available on the Ivex WW Web, FTP and BBS.

Tel: (503) 531-3555
 Fax: (503) 629-4907
 BBS: (503) 645-0576



Ivex Design International. 15232 NW Greenbrier Parkway. Beaverton, Oregon 97006. USA.

ADV2_1

CIRCLE 316 ON FREE INFORMATION CARD

SILICON-CONTROLLED RECTIFIER PROJECTS

1586T—From TAB Books. A treasure trove of exciting projects using SCR's and other low-cost thyristor devices for power-control applications. Includes a sophisticated burglar-alarm system, an SCR-based smoke-alarm system, a remote-control garage-door opener, and a high-tech light dimmer that uses the output from your stereo to modulate the intensity of your lights. And then there are 20 more. To order—ask for book 1586T, and include your check for \$12.95 (includes s&h) in US and Canada, and order from — Electronic Technology Today Inc., P.O. Box 240, Massapequa Park, NY 11762-0240. US funds only, use US bank check or International money order. Allow 6-8 weeks for delivery. MA09



PROGRAMMERS OVER 50 MODELS

ADVANTECH EETOOLS NEEDHAMS DATA VO ICE TECH-NOLOGY HILO SYSTEM GENERAL CHROMA MODULAR CIRCUIT TECH-NOLOGY XELTEK

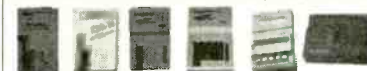

PROMAX EMP-20 MEGAMAX MEGAMAX4 SIMM/SIP-TESTER EMUPA

CALL ADVANTECH LABTOOL 629 ICE TECH MICROW 650 EETOOLS ALLMAX + 409 EETOOLS MEGAMAX 509 EETOOLS MEGAMAX4 369 XELTEK SUPERPRO II 409 XELTEK SUPERPRO II P 249 XELTEK SUPERPRO II 165 XELTEK ROMMASTER II 479 MOD-MCT-EMUPA 739 STAG ORBIT-32	599 EETOOLS SIMMAX 795 CHROMA SIMM/SIP 359 MOD-MCT-EMUPA/R 279 MOD-MCT-EMUP/R 49 EPROM 1G TO 512K 69 EPROM 1G TO 1MEG 99 EPROM 4G TO 1MEG 199 EPROM 16G TO 1 MEG 89 EPROM 1G TO 8MEG 129 EPROM 4G TO 8MEG 250 EPROM 8G TO 8MEG
---	--



LABTOOL48 MICROMASTER SUPERPRO ALLMAX PLUS ROMMASTER2

General Device Instruments

Sales 408-241-7376 Fax 241-6375 BBS 983-1234
 Web www.generaldevice.com E-Mail icdevice@best.com

Write your PIC programs in BASIC!

Still \$99⁹⁵

The PicBasic Compiler converts your BASIC programs and BASIC Stamp I programs into hex files that can be programmed directly into a PIC microcontroller. New Peek and Poke instructions let you access PORTA, A/D converter and other on-PIC features in BASIC.

- ◆ Expanded BASIC Stamp I compatible instructions
- ◆ True compiler provides faster program execution and longer programs than BASIC interpreters
- ◆ In-line assembler and Call support
- ◆ Supports PIC16C6x, 62x, 7x and 8x micros
- ◆ Pocket PIC Programmers from \$34.95
- ◆ PICProto prototyping boards \$9.95 - \$19.95

*BASIC Stamp is a trademark of Parallax, Inc.

microEngineering Labs

Box 7532 Colorado Springs CO 80933

(719) 520-5323 FAX 520-1867

<http://www.melabs.com>



PC PLACE

February 1997, Electronics Now

BAC552ES CONTROLLER

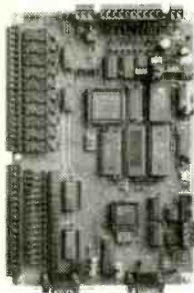

- Enhanced BASIC Language
- Philips 80C552 MCU
- 6"x9" circuit board
- 10 5A relay outputs
- 3 LED or logic outputs
- 16 opto-isolated inputs
- 8 ch. 10 bit analog inputs
- 2 ch. 8 bit analog outputs
- Real Time clock/calendar
- 128K Static RAM
- 128K FLASH memory
- 256 byte serial EEPROM
- 3 serial ports (RS232C/485)
- IIC bus expansion
- Plug-on I/O terminal blocks
- Single 12Vdc operation

APPLICATION READY ONLY \$334.90

Includes S14 P5 Connector Package!

APPLICATIONS: Industrial control • HVAC systems • security
• home automation • data logging • remote control & monitoring

SYLVA Control Systems a division of Sylva Energy Systems Inc.

519 Richard Street, Thunder Bay, Ontario, Canada P7A 1R2

Ph. 807-768-2487 Fax 807-683-6485 BBS 807-767-0587

WEB PAGE: <http://www.sylvacontrol.baynet.net>

Email: sylva@mail.baynet.net

16 Bit Control

& Data Acquisition System

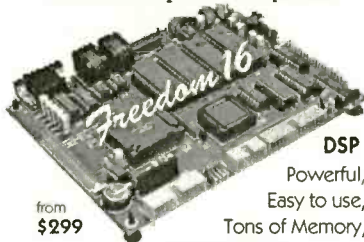

from \$299

16.8MHz 68HC16
RS-232 & RS-485
RT clock option

DSP
Powerful,
Easy to use,
Tons of Memory,
I/O & features:

34 digital I/Os (7 IRQ)
+ LCD/Keypad port
+ 8 ch 10b fast A/D

Affordable "C" compiler/library
Multi-tasking kernel
Up to 256K ea. SRAM, FLASH memory

INTEC INOVENTURES INC.

Ph: (604) 721-5150 FAX: 721-4191

<http://www.islandnet.com/~iii>

HIGH POWER AUDIO AMPLIFIER CONSTRUCTION

High Power Audio Amplifier Construction

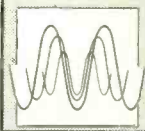

BP277—Here's background and practical design information on high power audio amplifiers capable of 300±400 watts r.m.s. You'll find MOSFET and bipolar output transistors in inverting and non-inverting circuits. To order your copy send \$6.25 plus \$3.00 for shipping in the U.S. and Canada to **Electronic Technology Today Inc., P.O. Box 240, Massapequa Park, NY 11762-0240.** U.S. and Canada only. Payment in U.S. funds by US bank check or International Money Order. Please allow 6-8 weeks for delivery.

MA03

CONTROL YOUR WORLD

32K ModCon HC11

Low Cost Microcontroller boards & kits + Applications

ZORIN

<http://ZORINco.com>
or call (206) 282-6061

Since 1965, we've worked to make sure all children have the opportunity to learn valuable lessons during the years when it's easiest for them to learn. To find out how you can help, call your local Head Start.



Nurture the future
BE A HEAD START VOLUNTEER



DATA ACQUISITION

Affordable Hardware and Software for PC's

ANA100 Analog I/O \$ 99



- 8 Channel 8-Bit
- 0 to 5 Volt Input
- 14 TTL I/O lines
- Analog Output
- 400KHz Sampling

DIG100 Digital I/O \$ 39



- 8255 PPI
- 24 or 48 TTL I/O Lines option
- Selectable Base Address

ANA150 Analog/Counter... \$ 89



- 8 Channel 8-Bit
- 0 to 5 Volt Input
- 3 16-Bit Counters
- 400KHz Sampling

DIG200 Counter I/O \$ 79



- 3 16-Bit Counters
- 8 TTL Input lines
- 8 TTL Output lines
- Selectable Clock Frequency Input

ANA200 Analog I/O \$ 79



- 1 Channel 12-Bit
- 0 to 5 Volt input optional bi-polar
- 100KHz / 300KHz Sampling rate
- 24 TTL I/O lines

ANA201 Analog \$ 129



- 8 Channel 12-Bit
- x1, x5, x10, x50 Programmable Channel gain
- 100KHz/300KHz Sampling rate

<NEW!> **PC-SCOPEII - PC Oscilloscope Software**
Use with our ANA100, ANA150, ANA151, ANA200, or ANA201 boards, for 1, 2, 4, or 8 channel capture and display of data on your PC. Oscilloscope, Storage, and X-Y modes of data display \$49.00



MasterCard/Visa orders accepted

More hardware and software items available. Call for information or See our catalog on the internet: <http://www.bsosf.com>

E-mail: sales@bsosf.com

BSOFT Software, Inc.

Phone 614-491-0832 * Fax 614-497-9971
444 Colton Road * Columbus, OH * 43207

Learn MICROCONTROLLERS EMBEDDED SYSTEMS and PROGRAMMING...

...with the AES learning system/ embedded control system. Extensive manuals guide you through your development project. All programming and hardware details explained. Complete schematics. Learn to program the LCD, keypad digital, analog, and serial I/O. for your applications.

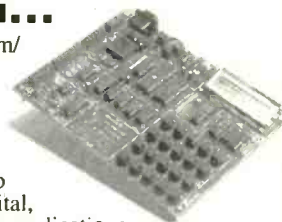

THREE MODELS AVAILABLE. Choose from an Intel 8051, Intel 8088, or Motorola 68HC11 based system. All models come with:

- 32K Byte ROM, 32K Byte RAM
- 2 by 16 Liquid Crystal Display
- 4 by 5 Keypad
- Digital, Analog, and Serial I/O
- Interrupts, timers, chip-selects
- 26 pin expansion connector
- Built-in Logic Probe
- Power Supply (can also be battery operated)
- Powerful ROM MONITOR to help you program
- Connects to your PC for programming or data logging (cable included)
- Assembly, BASIC, and C programming (varies with model)
- Program disks with Cross Assembler and many, well documented, program examples
- User's Manuals: cover all details (over 500 pages)
- Completely assembled and ready to use
- Source code for all drivers and MONITOR
- Optional Text Book

Everything you need. From \$279. Money Back Guarantee

Call for Free Info Pack, or see WEB at <http://www.aesmicro.com>
714-550-8094, FAX 714-550-9941

AES
Advanced Educational Systems

Call 1-800-730-3232

AES 970 W. 17TH STREET, SANTA ANA, CA 92706, USA

ROBOTIC MACHINING

ROUTE, MILL, DRILL, CARVE, ENGRAVE, PAINT
IN WOOD, PLASTIC, VINYL, PC BOARD, & LIGHT METALS!

STARTING AT
\$695.00

- 4 & 5 MOTOR GANTRY MILL CONFIGURATIONS
- PC COMPUTER CONTROLLED CNC/DNC
- IMPORT/ EXPORT FILES TO OTHER CADS
- AUTO-BACKLASH COMPENSATION
- PRE-MACHINED HEAVY CASTINGS
- SIMULTANEOUS 4 AXIS MOTION
- FREE 3D CAD/CAM SOFTWARE
- AVAILABLE IN KITS OR ASSEMBLED
- EXPEDITE SERVICE ALSO AVAILABLE
- OPTIONAL ALUMINUM WAY COVERS
- .0005" RESOLUTION / AMERICAN MADE



3 & 4 AXIS UNITS
FROM 12" X 12" TO
65" X 66" MACH. AREA

U.S. CYBERLAB, INC. 14786 SLATE GAP RD., WEST FORK, AR 72774

CALL NOW FOR INSTANT SPECS 501-839-8293 24 HR. FAX-BACK

PIC it μ P!

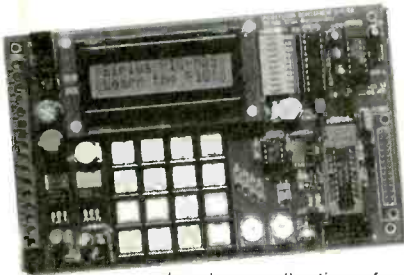

The PIC-MDS is a complete training and development environment for the mid-range PIC™ microcontrollers. Proven in classrooms, the PIC-MDS lets you learn to use and

develop applications for PIC microcontrollers quickly and easily. Our step-by-step examples guide you from simple programs through to keypad scanning, serial I/O, LCD display, A/D conversion, data logging, and interrupt routines.

The PIC-MDS Professional Pack includes:

- PIC16C71 & PIC16C84 microcontrollers
- EFIC Programmer & PM assembler
- detailed training manual with disk
- in-circuit programming cable & socket
- ZIF socket • buffered LED port indicators
- 2 X 16 LCD display • 2 analog pots • RS-232 port
- 256 byte serial EEPROM • crystal/resonator socket
- 5V & variable DC power supply • AC voltage adapter
- all I/O pins on screw terminals & PICBUS connector
- all code examples in Microchip and Parallax™ syntax

only
\$299!

Also Available:

- Professional Board (no programmer) **\$259**
- Hobbyist Pack **\$199** (kit, no ZIF, '84 only)
- Hobbyist Board **\$139** (kit, no ZIF, '84 only, no programmer)

Teachers manual Call

Prices exclude shipping. Parallax is a registered trademark of Parallax, Inc. PIC & Microchip are trademarks of Microchip Technology Inc.

Sirius
microSystems

Visit our Web page: <http://www.siriusmicro.com>

172 Harvard Road
Waterloo, ON N2J 3V3
CANADA
+1-519-886-4462 (ph.)
+1-519-886-4253 (fax)
support@siriusmicro.com

386 SBC \$83

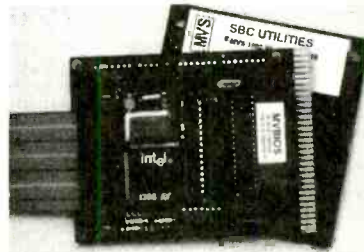

- OEM (1K) PRICE INCLUDES:
- 5 SER (8250 USART)
 - 3 PAR (32 BITS MAX)
 - 32K RAM, EXP 64M
 - STANDARD PCBUS
 - LCD, KBD PORT
 - BATT. BACK. RTC
 - IRQ0-15 (8259 X2)
 - 8237 DMA 8253 TMR
 - BUILT-IN LED DISP
 - UP TO 8 MEG ROM
 - CMOS NVRAM
- USE TURBO C, BASIC, MASM RUNS DOS AND WINDOWS EVAL KIT \$295

\$95 SINGLE PIECE PRICE UNIVERSAL PROGRAMMER

- DOES 8 MEG EPROMS
- CMOS, EE, FLASH, NVRAM
- EASIER TO USE THAN MOST
- POWERFUL SCRIPT ABILITY
- MICROCONT. ADAPTERS
- PLCC, MINI-DIP ADAPTERS
- SUPER FAST ALGORITHMS



OTHER PRODUCTS:

- 8088 SINGLE BOARD COMPUTER OEM \$27 ... *95
- PC FLASH/ROM DISKS (128K-16M)..... 21 75
- 16 BIT 15 CHAN ADC-DAC CARD 55 195
- WATCHDOG (REBOOTS PC ON HANGUP)..... 27 95

*EVAL KITS INCLUDE MANUAL BRACKET AND SOFTWARE. 5 YR LIMITED WARRANTY FREE SHIPPING HRS: MON-FRI 10AM-6PM EST



MVS BOX 850
MERRIMACK, NH
(508) 792 9507

PC PLACE

February 1997, Electronics Now

TRAVEL LIGHT.



EXERCISE.

American Heart Association



ALL ELECTRONICS

C O R P O R A T I O N

QUALITY PARTS

FAST SHIPPING

DISCOUNT PRICING

CALL, WRITE, FAX
or E-MAIL For A
Free 64 Page
CATALOG.
Outside the U.S.A.
send \$2.00 postage.



**PC MOUNT
POWER RELAY
24 Vdc**

Potter & Brumfield # T90N5D12-24
24 Vdc, 675 ohm coil. SPDT con-
tacts rated 20 amps (N.O.), 10 amps (N.C.) @
240 Vac. 1.15" X 0.09" X 0.65". PC terminals.
UL and CSA listed.

CAT# RLY-55 \$2.00 each

10 for \$18.50 • 100 for \$150.00

**SPECIAL PRICE!
TWIST ON
F-56 CONNECTOR**

We recently made a large
purchase of this twist-on co-ax
connector for RG-6 cable.



Special pricing while
the supply lasts.

**100 for \$15.00
500 for \$50.00
1000 for \$70.00**

CAT #FTO-56R

**SPECIAL PRICE
BI-COLOR LED**



RED/ GREEN diffused.
T 1 3/4 (5mm) Three Legs
Center cathode.

CAT# LED-63

35¢ each

100 for \$29.00 • 1000 for \$250.00

**(USED)
"HI-8" VIDEO CASSETTE**

SONY Hi-8

Top quality, metal
particle 120 minute video
cassettes. Used for a short
time, then bulk-erased.
Each cassette has its own
plastic storage box.

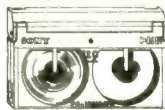

\$3.00 each

Satisfaction Guaranteed.

CAT # VCU-8

10 for \$28.00 • 100 for \$250.00

PADDED CARRYING CASE

Good-looking pro-
tective carrying
case for Zip dri-
ves, Walkman
players,
tools, guns,
photographic or
electronic equipment. This
well-made black canvas bag has
0.5" thick padding all around and a nylon
inner liner. 1.5" wide webbed handle and detach-
able shoulder strap. Heavy-duty zipper. Interior
pocket and adjustable velcro compartment.
Interior area: 16" X 6" X 2.5". These are new
bags with a company logo (Interactive Network)
on a patch on one side.



CAT # CSE-10

\$5.00 each

DRIVE CABINET W/ SUPPLY

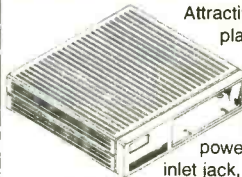

Attractive, heavy-gauge gray
plastic cabinet designed
to hold a 1/2 height
CD ROM drive.
Contains a 5 Vdc /
12 vdc switching
power supply, IEC power
inlet jack, on/off switch, cooling
fan, LED indicator, DB-15 connector and two RCA
jacks. 10.43" X 9.75" X 2.2" overall size. Drive
opening in front of case is 5.87" X 1.68". IEC
power cord not included.

CAT# MB-53

\$15.00 each

SPST, N.C. SWITCH

**SPECIAL
PURCHASE!**

Marquardt # 1050.0141A
Small, normally-closed switch rated 2 amps @
125/250 Vac. Prepped with 5" long wire leads
and 2 contact socket connector. Body
size: 0.78" X 0.4" X 0.25". UL and
CSA listed. Large quantity available.



4 FOR \$1.00

CAT# SMS-140

250 for \$50.00
1000 for \$150.00

12 Vdc, MINI BLOWER

Nidec, Gamma 28 # A34342-55APP
12 Vdc, 0.18 amp brushless
centrifugal blower designed for
applications with space limita-
tions. This small, lightweight
blower features permanently
lubricated ball bearings and a
quiet thermoplastic hous-
ing. 3" diameter X 1.18"
thick. Output port is 1.4" X 1".
5" leads.

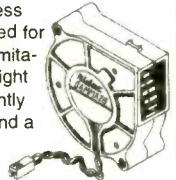

\$7.00 each

CAT# CF-39

**EDGEVIEW PANEL METER
FS=1 MICROAMP**

Mura

Beautifully constructed
edgeview meter move-
ment. 2.75" X 0.8" face.
Scale is labeled
"BEATS/MINUTE" and is cali-
brated from 50-150. It can be easily removed
or reversed to create a blank scale. The
black bezel is 3.53" X 1.33" and can be
adjusted or removed. 0.1" thick clear plexi-
glass case. Maximum case size behind
mounting plane: 2.75" X 1.18" X 2.18".
Solder lug terminals.



CAT # MET-47

\$5.50 each

S-VHS VIDEO CORD



4' cable with miniature 4 pin mini
DIN plugs on both ends.

CAT# CB-363

\$3.00 each

10 for \$25.00
100 for \$150.00

BILATERAL TRIGGER (DIAC)

CAT # DB-3 28-36 volt

CAT# HT-40 35-45 volt

3 FOR \$1.00

100 for \$27.00

ORDER TOLL FREE

1-800-826-5432

MAIL ORDERS TO:
ALL ELECTRONICS CORP.
P.O. BOX 567
VAN NUYS, CA 91408-0567

FAX (818) 781-2653 • INFO (818) 904-0524
INTERNET <http://www.allcorp.com/>
E-MAIL allcorp@allcorp.com



NO MINIMUM ORDER • All Orders Can Be Charged to Visa, Mastercard, American Express or Discover • Checks and Money Orders Accepted by Mail • Orders
Delivered in the State of California must include California State Sales Tax • NO C.O.D • Shipping and Handling \$5.00 for the 48 Continental United States - ALL
OTHERS including Alaska, Hawaii, P.R. and Canada Must Pay Full Shipping • Quantities Limited • Prices Subject to change without notice.

MANUFACTURERS - We Purchase EXCESS INVENTORIES... Call, Write, E-MAIL or Fax YOUR LIST.

**NEW !
PIC microcontroller &
Surveillance KITS.**

- Ultra small wireless FM mic.
- Phone transmitter SLeach™.
- PIC kits include: security, control, and hobby applications.
- Most kits use Surface Mount Technology (SMT).
- SMT kits include our exclusive surface mount soldering guide.
- Kits are designed and manufactured by IEC.

**Pager Decoder
Interface kit for PC**

Only \$19.⁹⁵ + S&H

PD shareware software included.

Order 1-800-417-6689

Mon. - Fri. 9AM-5PM ET.
Visa, MC, Money Orders

For a catalog send SASE to:
IEC, P O Box 52347
Knoxville, TN 37950-2347

Sorry, no refund for used kits.
Prices subject to change without notice.
Returns are subject to a restocking fee.

Shipping and Handling is non-refundable.

©1997 IEC

**PC-Based
Dual 100MHz Universal Counter
\$399**

- 2 internally synchronized, full-featured counters
- Built-in math functions
- 100 MHz frequency range
- 5 ppm accuracy
- Easy-to-read auto-adjustable display
- Designed and made in USA

Turn your PC into a test station with :

6 MHz Sweep/Function Generator	\$549
60 MHz Digital Storage Scope	\$749
100 MHz Digital Storage Scope	\$999

TC INSTRUMENTS INC.®

Tel: (909) 622-2006

Fax: (909) 622-7778

http://www.tcinst.com



**RF POWER
TRANSISTORS AND TUBES**

In depth stocking of popular and
hard-to-find Electronics Parts
for Transmitters & Linear Amplifiers

Popular Transistors

- 2SC1969
2SC2166 • 2SC2290
2SC2312C • 2SC2879
MRF454 • MRF455
MRF455A • MRF477
MRF492 • MRF497
SRF3749 • SRF7000-90

Popular Tubes

- 6JS6C • 6KD6 • 6LQ6
M2057 • 6146B • 6146W
3-500Z • 3-500ZG • 4-400C
811A • 572B • SV6550C
7558 • 8417 • 8873
8874 • 8875 • 8877 • 8975

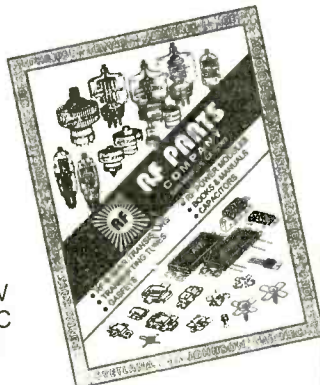

Order your FREE copy of our new Catalog by writing or calling us now.

Tel: (619) 744-0700 • Fax: (619) 744-1943

E-mail: rfp@rfparts.com



RF PARTS

435 SOUTH PACIFIC STREET
SAN MARCOS, CA 92069

AT LAST! DC-20 MHz SYNTHESIZED PERFORMANCE FOR ONLY \$795!



- DC-20 MHz, .1 Hz resolution, DC offset
- Linear/Log Sweep
- Internal/External AM
- Internal/External FM
- Internal/External PM
- Internal/External SSB
- Internal/External BPSK
- Dualtone Generation
- Internal/External FSK
- Burst
- DTMF Generation
- DTMF Detection
- Power Level Measmt

\$795
Quantity 1
Made in U.S.A.

The SG-100 gives you .1 Hz synthesized precision and a wide diversity of modulation functions all of which can be performed using an internally generated or externally applied signal. You also get signal analysis functions that are just not offered on any other signal source such as DTMF Detection and Power Level Measurement. And because you can download new instrument functions to Flash memory, you can ensure that your SG-100 will never become obsolete.

The SG-100 is available NOW and is ready to turn your engineering bench into a real powerhouse!



C.O.D. P.O.

Tetulex Inc.

2455 Old Middlefield Way S, Mountain View, Ca. 94043 (415) 938-0240
Fax: (415) 938-0241 http://www.tetulex.com email:sales@tetulex.com

BLOWOUT! TIMELINE INC. BLOWOUT!

Over 10 years and 27,000 customers and still growing

LIQUID CRYSTAL DISPLAYS

240x64 dot LCD with built-in controller.
AND 4021ST-EO. Unit is EL back-lit. \$79.⁰⁰ or 2 for \$149.⁰⁰ or
OPTREX. DMF5005 (non back-lit) \$69.⁰⁰ or 2 for \$129.⁰⁰

20 character x 8 line 7/8L x 2 1/2H

The built-in controller allows you to do text and graphics.

Alphanumeric—parallel interface

16x13 for \$25.00	20x2.....\$12.00	40x1.....\$8.00
16x1 (lg. char.)...\$12.00	20x4.....\$25.00	40x2.....2 for \$25.00
16x2.....\$8.00	20x4 (lg. char.)...\$25.00	40x4.....\$25.00
16x2 (lg. char.)...\$12.00	24x2.....\$12.00	4x2.....\$5.00
16x4.....\$15.00	32x4.....\$10.00	

5V power required • Built-in C-MOS LCD driver & controller • Easy "microprocessor" interface • 98 ASCII character generator • Certain models are backlit, call for more info.

Graphics and alphanumeric—serial interface

size	Mfr.	price	size	Mfr.	price
640x480 (backlit)	Epson	\$35.00	480x128	Hitachi	\$15.00
640x400 (backlit)	Panasonic	\$25.00	256x128	Epson	\$20.00
640x200	Toshiba	\$15.00	240x128 (backlit)	Optrex	\$20.00
480x128 (backlit)	ALPS	\$15.00	240x64	Epson	\$20.00
			160x128	Optrex	\$15.00

6" VGA LCD 640X480, Sanyo LMDK55-22 \$35.⁰⁰

LASER PRODUCTS

HeNe Laser Head (10mW max. output) TEMOO. 15.5" long MFG: NEC \$99.⁰⁰
Laser Power Supply (for HeNe tube) \$89.⁰⁰

LASER SCANNER ASSEMBLY \$29.⁰⁰

Assembly intended for a laser printer. Includes laser diode, polygon motor (6 sided) and misc. optics and lenses.

LASER DIODE (5mW) with collimator \$20.⁰⁰

VISIBLE LASER DIODE: 5mw at 670nm \$15.⁰⁰

Index guided. Threshold current 40 ma typical.

3 and 4mW, 1,300nm LASER DIODES, 5.6mm package, \$35.⁰⁰

Mitsubishi Electric part number ML701BIR-E21A, General specs are:

1. Vop=1.25, Beam Divergence 25.6° x 28.6°; 2. Tc=24°C, Iop=19 to 20mA, ITH=10.7mA; 3. Wavelength range between 1,280nm and 1,330 nm

POLYGON MOTOR UNIT & DRIVER \$79.⁰⁰

Ten-sided first surface mirror mounted on an armature that spins at 125 revolutions per second yielding a beam sweep rate of 1250 sweeps per second. The driver for the polygon unit requires 24 volts and plus and minus 12 volts to operate. There is also an f-theta lens in front of the polygon scanning mechanism with a three inch diameter. Great for optical experiments, etc. Very high quality units. (MFR: JAPAN ELECTRONICS)

NETWORK

Proteon ProNet-4 Model p1347 Token Ring Board \$49.⁰⁰

16 bit • 4 Mbps • IEEE 802.2 and 802.5 compatible • twisted pair • interoperable with IBM Token Ring network

POS & BAR CODE

MAGNETIC CARD READER \$25.⁰⁰

Includes: • 20 character dot matrix display with full alpha-numeric capability • keypad with full alpha-numeric entry • separate 7.5 VDC/0.5 Amp power supply • standard telephone interface extension cord • lithium battery and flat-cone speaker.

HP bar code wand (HBCS 2300).....\$25.00

POWER SUPPLIES

SWITCHING POWER SUPPLIES \$12.00 or 2 for \$20.00 115/230 Volts

73 WATT (2) 4 pin power connectors attached • Dim: 8.5" L x 4.5" W x 2" H

Output: +5V @ 2-9.75 A, +12V @ 0-1.5 A, -5V @ 0-0.4 A, -12V @ 0-0.5 A

68 WATT Dim: 5.5" L x 3.2" W x 1.7" H • Output: 5V @ 4 A, 12V @ 4 A

60 WATT Dim: 8 1/2 x 4 1/2 x 3 • Output: 5V @ 6A + 12V @ 1A - 5V @ 1A - 12V @ 1A

CHARGE COUPLED DEVICES



"The Spy In The Sky" \$79.⁰⁰ MATRIX TYPE

Thomson 576X550 pixel CCD

400-1,100nm resolution and responsivity. \$500.⁰⁰ Original cost device

Sony CCD Imager • designed for black and white composite video cameras. Picture elements: 384 (H) x 491 (V) \$29.⁰⁰
Chip size 10.7 (H) x 9.3 (V) mm² • Unit cell size 23.0 (H) x 13.4 (V) um².
Ceramic 24 pin DIP package • Mfr: Sony, Part# 016AL

4096 element CCD \$19.00

1024 element CCD \$15.00

2048 element CCD \$15.00 • 1728 element CCD \$15.00

LINEAR TYPE

2539 W. 237th Street, Bldg. F, Torrance, CA 90505

Order desk only: **USA: (800) 872-8878 CA: (800) 223-9977**

L.A. & Technical Info: **(310) 784-5488 Fax: (310) 784-7590**

OEM INQUIRIES WELCOME

MONITORS

Non-Enclosed TTL

Comes with pinout. 12V at 1.4 Amp input • Horizontal frequency 15KHz. • Ability to do 40 and 80 column.

5 inch Amber \$29.00 • 7 inch Amber \$39.00
9 inch Amber or Green \$29.95

5" COLOR MONITOR \$49.⁰⁰

• Flat Faceplate • 320 x 200 Dot Resolution • CGA & Hercules Compatible
• 12 VDC Operation • 15.75 KHz Horiz. Freq. • 60 Hz Vert. Sync. Freq.
• Open Frame Construction • Standard Interface Connector • Degaussing Coil included • Mfr. Samtron

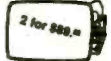

9" monochrome SVGA MONITOR \$99.⁰⁰

Tilt and swivel type. Mfr: WEN

MISCELLANEOUS

ADAPTEC 4070A (RLI) OR 4000A (MFM), SCSI Controller, your choice \$25.⁰⁰

IBM 370 option XT and AT emulation boards \$35.⁰⁰

HACKER CORNER

POINT OF SALE BANK TERMINAL \$49.⁰⁰ or 2 for \$89.⁰⁰

• LCD Display 20 Char. x 4 Line • Printer 16 Column Dot Matrix - Epson • 24 Key Domed Membrane Keypad • Intel 80C32 Processor • 2 PCMCIA Sockets (ICC Slots) • Dallas DS1287 Realtime Clock • 2 Solid State Buzzers (Piezo Electric) • 4 Crystals • Rockwell Modem Chip • Telephone Line Interface (4 Pin "RJ" Connector) • RS-232 Interface (8 Pin "RJ" Connector) • NI-CAD Battery Pack Inside
Note: We have not been able to bypass an access code in the software. Thus, while time of day and other introductory things are displayed on LCD, the full original capabilities of this unit cannot be guaranteed. Also, we do not have a source for the smart cards that were to go in the PCM CIA sockets. Requires 12 volt adapter for power. (Not included) Dimensions: 9-1/2L x 6-1/4W x 2-1/2 D • Original cost over \$450.00

CAMERA BLOCK \$149.⁰⁰ or 2 for \$199.⁰⁰

FOR ROBOTICS AND EVERYTHING ELSE

Unit is for Hi Band 8mm CamCorders, includes 8X zoom lenses, D/D converters, built-in CCD 2/3 in, 420 thousand picture elements, complementary mosaic filters. Excellent performance. High resolution, high sensitivity, low lag, low smear, good color reproduction, no distortion, 1/60-1/10000sec variable speed digital shutters, TTL auto focus, auto white balance, one-push auto white balance, auto/manual iris and gain up switch. Can be controlled by a 4bit micro computer. Remote controlling is possible for zoom and focusing. NOTE: We have Composite or PAL (European Standard) Units. MFR: SONY

CELL SITE TRANSCEIVER \$79.⁰⁰ 2 for \$149.⁰⁰

These transceivers were designed for operation in an AMPS (Advanced Mobile Phone Service) cell site. The 20 MHz bandwidth of the transceiver allows it to operate on all 666 channels allocated. The transmit channels are 870.030-889.980 MHz with the receive channels 45 MHz below those frequencies. A digital synthesizer is utilized to generate the selected frequency. Each unit contains two independent receivers to demodulate voice and data with a Receive Signal Strength Indicator (RSSI) circuit to select the one with the best signal strength. The transmitter provides a 1.5 watt modulated signal to drive an external power amplifier. Channel selection is accomplished with a 10 bit binary input via a connector on the back panel. Other interface requirements for operation are 26 VDC (unregulated) and an 18.990 MHz reference frequency for the digital synthesizer. The units contain independent boards for receivers, exciter, synthesizer, tunable front end, and interface assembly (which includes power supplies and voltage-controlled oscillator). Service manual, schematics and circuit descriptions included.

Encased Black & White Composite CCD Camera with Adapter

IR viewing to 1000 nm 7 1/2 L x 2 1/2 W x 1 1/2 H

Comes complete with CCD camera, mounting nut on bottom of casing,

12VDC power supply. Excellent low light capability, standard RCA NTSC video out.

\$89.00

Great for: entryway security/remote monitoring, video conferencing/desktop video conferencing 2 for \$159.00

This miniature camera is perfect for multimedia computer applications as well as security and surveillance. NTSC output allows use with all popular video digitizing boards for Apple Macintosh and Microsoft video for Windows. Connects directly to any composite monitor or VCR with "video" input. Its razor-sharp wide-angle lens focuses from two inches to infinity and its state-of-the-art CCD technology accurately captures 16 level grayscale images for Quick Time movies and still pictures. Records at 30 frames per second and 260 lines resolution with excellent low light capability. Uses 12VDC (adapter supplied) and standard RCA cable.

US made Micronics 486 VLB ALL in ONE \$99.⁰⁰

motherboard, supports 3.4 or 5V CPU, at either 25 or 33 mhz basic clock. Can use AMD or Intel from 4865X25 thru 486DX4-100 to HOT new AMD 5X86-133 cpu. On board 2 serial ports, 1 printer port, floppy and IDE hard drive controller. On board 256K cache. Uses 72 pin simm memory.

Board will not fit standard All in One case because of non standard location of riser board. VLB riser board is included with motherboard.

.6" COMPOSITE MINIATURE COLOR DISPLAY \$149.⁰⁰

Fully encased. Dim: 1.3" x 1.3" x 4". 12 Volts DC power. NTSC signal.

250 H x 300 V resolution. Focus adjustable eyepiece. Applications include camcorder viewfinder, helmet mounted display, etc... Original cost over \$600.00

Minimum Order: \$20.00. Minimum shipping and handling charge \$5.00. We accept cashiers checks, MC or VISA. No personal checks or COD's. CA residents add 8.25% sales tax. We are not responsible for typographical errors. All merchandise subject to prior sale. Phone orders welcome. Foreign orders require special handling. Prices subject to change without notice. 20% restocking fee for returned orders.

**FREE CATALOG
CALL TOLL FREE
1-800-338-0531**

E-Mail: xpress@parts-express.com



**Parts
Express™**

**30 DAY MONEY
BACK GUARANTEE!**

340 E. First St., Dayton, OH 45402-1257
Phone: 937-222-0173 • Fax: 937-222-4644

**Amplified Indoor
FM Antenna**

17" tall, amplified FM antenna. Improves reception with weak FM signals. 18 dB of gain. Includes AC adaptor, gain control, and 75 ohm coaxial cable terminated with an "F" connector.

**HOT
NEW
ITEM!**



#EN-219-055 **\$12⁹⁰**

Cable TV Stereo Decoder

When used in conjunction with a cable TV converter or cable ready VCR, this handy device allows you to feed the cable TV stereo signal into your home sound system for superb audio reproduction of your favorite shows, movies, and sporting events.



#EN-189-110 **\$19⁹⁰**

Digital Video Stabilizer

The digital video stabilizer will eliminate the constant picture distortion caused by the copyright protection on movie videotapes. This unit is fully automatic and operates on one 9V battery which is included.



#EN-180-320 **\$17⁹⁵**

Decoy Cameras

These 1/3" CCD cameras offer a clever means of disguise. Both feature a 3.6mm wide angle lens, built-in electronic shutter, and a 12 VDC power supply. Minimum illumination: 0.3 lux, 400 line resolution. Smoke detector decoy camera includes an audio output.

**AFFORDABLE
HIGH TECH
SURVEILLANCE!**

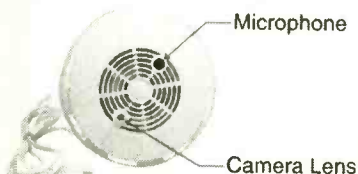

Part #	Description	Price
EN-335-535	Smoke detector decoy	\$249.50
EN-335-540	Decoy clock camera	299.95

**Portasol/Weller Butane
Soldering Tool**

**NO CORDS,
NO BATTERIES!**



This cordless, refillable, butane powered soldering tool is ideal for any on-site soldering job. Provides up to 35 watts with a temperature range up to 700 degrees F. Includes flint ignitor in plastic case, safety cut off switch, and C-2 chisel tip.

#EN-372-150 **\$25⁹⁵**

**150 MHz Oscilloscope Probe
Kit**

Deluxe probe kit features a modular design for longer life, switchable 10:1 probe with 150 MHz bandwidth, 2.8 ns rise time, and adjustable capacitance from 10-35 pF. 60" in length.



**GREAT
VALUE!** **\$29⁹⁵**

#EN-390-100 **\$29⁹⁵**

**Memorex CD Repair And
Maintenance Kit**

Don't throw away expensive CDs because of annoying mistracking and skipping errors! The Memorex CD Repair kit contains enough solution and materials to clean and repair 12 compact discs.

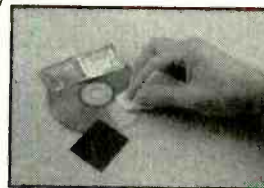

#EN-249-032 **\$1⁹⁵**

5" Sealed Back Midrange

5" heavy duty sealed back midrange with deluxe mesh grill. 1" aluminum voice coil. Popular midrange for auto sound installations. Power handling: 35 watts RMS/50 watts max. Voice coil diameter: 1 inch. Impedance: 8 ohms. Frequency response: 800-10,000 Hz.



#EN-280-030 **\$7⁵⁰**

1", Titanium Dome Tweeter

Features a ferro fluid cooled Kapton voice coil and a rubber surround. Very natural sounding high frequency reproduction with extended response to 30KHz. Power handling: 50 watts RMS/75 watts max. Voice coil diameter: 1". Impedance: 8 ohms. Frequency response: 2500-30,000 Hz.



#EN-275-050 **RESPONSE TO 30KHZ!** **\$16⁵⁰**



3 Channel Color Organ Kit

This sound to light unit features three separate outputs, which can be controlled independently. Each output reacts to three different bands of the musical spectrum: bass, midrange, and treble. Has built-in microphone, so no connection is required to music source, but a line input is provided.



**SUPER
QUALITY
KIT!**

#EN-320-210 **\$59⁹⁵**



6-1/2" Woofer

Polymer resin treated paper cone with poly foam surround. Long throw voice coil design helps to deliver powerful bass output. Perfect for bookshelf type speakers. Mfg. #C16LQ20-51F. Power handling: 60 watts RMS/120 watts max. Voice coil diameter: 1-1/4 inches. Impedance: 8 ohms. Frequency response: 57-7000 Hz.



#EN-290-023 **PIONEER** **\$19⁹⁵**



•30 day money back guarantee •\$20.00 minimum order •We accept Mastercard, Visa, Discover, and company C.O.D. orders •24 hour shipping •Shipping charge = UPS chart rate + \$1.90 (\$5.00 minimum charge) •Hours 8:00 am - 8:00 pm ET, Monday - Friday •9:00 am - 5:00 pm Saturday. Mail order customers, please call for shipping estimate on orders exceeding 5 lbs. •Foreign destination customers please send \$5.00 U.S. funds for catalog. •Quantity pricing available.

CIRCLE 262 ON FREE INFORMATION CARD

1-800-338-0531

Our Complete Catalog is now online

<http://www.cir.com>

CIRCUIT SPECIALISTS INC.

Check Out What We Have To Offer:

Fantastic DMM Offer!!!

Don't let the price fool you. This meter is a digital multimeter designed for engineers and hobbyists. Equipped with 5 functions and 19 ranges. Each test position is quickly and easily selected with a simple turn of the FUNCTION/RANGE selector rotary switch.

Rubber Boot Included

General

Display: 3-1/2 Digit LCD, 21mm Figure Height with Automatic Polarity
Overrange Indication: 3 Least Significant Digits Blank

Temperature for Guaranteed Accuracy: 23°C±5°C RH<75%

Temperature Ranges:

Operating: 0°C to 40°C (32°F to 104°F)
Storage: -10°C to 50°C (14°F to 122°F)

Power: 9V Alkaline or Carbon-Zinc Battery (NEDA1604)

Low Battery Indication: BAT on Left of LCD Display

Dimensions: 188mm long x 87mm wide x 33mm thick

Net Weight: 400g

DC Voltage (DCV)

Range: Resolution: Accuracy:

200mV 100µV
2000mV 1mV ±(1%rdg+2dgts)
20V 10mV
200V 100mV
1000V 1V

Maximum Allowable Input: 1000V DC or Peak AC.

DC Current (DCA)

Range: Resolution: Accuracy:

200µA 100nA
2000µA 1µA ±(1.2%rdg+2dgts)
20mA 10µA
200mA 100µA
10A 10mA ±(1.2%rdg+2dgts)

Overload Protection: mA Input, 2A/250V fuse.

AC Voltage (ACV)

Range: Resolution: Accuracy:

200V 100mV ±(1.2%rdg+10dgts)
750V 1V

Frequency Range: 45Hz-450Hz

Maximum Allowable Input: 750V rms

Response: Average Responding. Calibrated in rms of a Sine Wave.

CAT NO	DESCRIPTION	PRICE EACH
9300G	Rugged High Quality DMM with Rubber Boot	\$19.00



Our Best Offer Ever on a

High Quality Full Sized DMM

\$19.00 any qty

Resistance (Ω)

Range: Resolution: Accuracy:

200Ω 100mΩ
2000Ω 1Ω
20KΩ 10Ω ±(1.2%rdg+2dgts)
200KΩ 100Ω
2000KΩ 1KΩ
20MΩ 10KΩ ±(2%rdg+10dgts)

Maximum Open Circuit Voltage: 2.8V

Diode Test

Measures forward voltage drop of a semiconductor junction in mV test current of 1.5mA Max.

ohFE Test

Measures transistor hFE.



Positive Photo Resist Pre-Sensitized Printed Circuit Boards

These pre-sensitized printed circuit boards are ideal for small production runs. They provide high resolution and excellent line width control. High sensitive positive resist coated on 1oz. copper foil allows you to go direct from your computer plot or art work layout. No need to reverse art.

Single-Sided, 1oz. Copper Foil on Paper Phenolic Substrate

CAT NO	DESCRIPTION	PRICE EACH		
		1	10	50
PP101	100mm x 150mm/3.91" x 5.91"	\$2.55	\$1.90	\$1.70
PP114	114mm x 165mm/4.6" x 6.6"	2.98	2.45	1.98
PP152	150mm x 250mm/5.91" x 9.84"	5.40	3.98	3.60
PP153	150mm x 300mm/5.91" x 11.81"	6.15	4.48	4.10
PP1212	305mm x 305mm/12" x 12" NEW!	12.78	10.65	8.52

Single-Sided, 1oz. Copper Foil on Fiberglass Substrate

CAT NO	DESCRIPTION	PRICE EACH		
		1	10	50
GS101	100mm x 150mm/3.91" x 5.91"	\$ 3.90	\$2.98	\$2.60
GS114	114mm x 165mm/4.6" x 6.6"	4.80	3.49	3.20
GS152	150mm x 250mm/5.91" x 9.84"	8.69	5.98	5.78
GS153	150mm x 300mm/5.91" x 11.81"	10.20	7.20	6.80
GS1212	305mm x 305mm/12" x 12" NEW!	18.88	15.73	12.59

Double-Sided, 1oz. Copper Foil on Fiberglass Substrate

CAT NO	DESCRIPTION	PRICE EACH		
		1	10	50
GD101	100mm x 150mm/3.91" x 5.91"	\$ 5.07	\$3.68	\$3.38
GD114	114mm x 165mm/4.6" x 6.6"	5.95	4.29	3.99
GD152	150mm x 250mm/5.91" x 9.84"	10.47	7.39	6.98
GD153	150mm x 300mm/5.91" x 11.81"	11.95	8.69	8.30
GD1212	305mm x 305mm/12" x 12" NEW!	22.09	18.35	14.68



Developer This product is used as the developer on our positive photo-resist printed circuit boards. Includes instructions. 50 gram package, mixes with water, makes 1 quart.

CAT NO	DESCRIPTION	PRICE EACH		
		1	10	25
POSDEV	Positive Developer	\$.95	\$.80	\$.50



Etching Tank This handy etching system will handle PC boards up to 8" x 9", two at a time. Ideal for etching your PCB's! System includes an air pump for etchant agitation, a thermostatically controlled heater for keeping etchant at optimum temperature and a tank that holds 1.35 gallons of etchant. A tight fitting lid is also supplied to prevent evaporation when system is not being used. Typical etching time is reduced to 4 minutes on 1oz. copper board!

REDUCES ETCHING TIME!

CAT NO	DESCRIPTION	PRICE EACH
12-700	Etch Tank System	\$37.95

AC Power Cords

Our power supply cords are economical and practical for OEM and replacement applications. We stock 6' lengths, with the open end conveniently stripped and tinned (5mm).

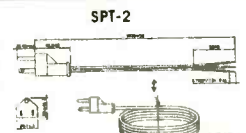

CAT NO	SIZE	TYPE	RATING @				LENGTH (ft)	COLOR	TEMP
			125V (A)	10	6	60°			
SPT-1BLACK	18/2	SPT-1	10	10	6	6	Black	60°	
SPT-1GRAY	18/2	SPT-1	10	10	6	6	Gray	60°	
SPT-2BLACK	18/3	SPT-2	10	10	6	6	Black	60°	

PRICE EACH

CAT NO	PRICE EACH			
	1	10	100	500
SPT-1BLACK	\$.88	\$.57	\$.51	\$.46
SPT-1GRAY	.92	.61	.55	.49
SPT-2BLACK	1.97	1.21	1.07	.97

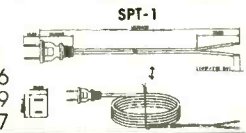

Switchable Scope Probe Sets

(Selectable X1/Ref/X10) These high quality scope probe sets are for oscilloscopes up to 60MHz (model HP 9060) or 150MHz (model HP9150). Both sets include a handy storage pouch and include an IC test-hook adapter for the probe. The BNC connector rotates to avoid cable tangle or kink. Cable length is 1.4 meters.

CAT NO	DESCRIPTION	PRICE EACH		
		1	10	100
HP-9060	Scope Probe Set DC~60MHz	\$16.49	\$14.49	\$11.58
HP-9150	Scope Probe Set DC~150MHz	24.95	21.95	18.62

Etching Chemicals/Ferric Chloride

A dry concentrate that mixes with water to make 1 pint of etchant, enough to etch 400 sq. inches of 1oz board.

CAT NO	DESCRIPTION	PRICE EACH	
		1	5
ER-3	Makes 1 pint	\$3.50	\$2.75



SEE OUR ON-LINE CATALOG AT
<http://www.cir.com>

Digital Panel Meters (LCD & LED)

Don't let the prices fool you. These digital panel meters are not surplus, so even if you design them into an ongoing manufactured product, you can be assured of continued availability. These high quality digital panel meters are decimal point selectable with guaranteed zero reading at zero volts input.



3-1/2 Digit LCD 3-1/2 Digit LED 4-1/2 Digit LCD
PM-328: 4-1/2 Digit LCD Digital Panel Meter

Features

- 200.00mV Full Scale Input Sensitivity
- Single 9V DC Operation
- Decimal Point Selectable
- 11mm LCD Figure Height
- Automatic Polarity Indication
- Low Battery Detection and Indication
- High Input Impedance (>100 Mohm)

Applications Include:

- Voltmeter
- Thermometer
- pH Meter
- dB Meter
- Watt Meter
- Current Meter
- Capacitance Meter
- LUX Meter
- LCR Meter
- Other Industrial & Domestic Uses

PM-128: 3-1/2 Digit LCD Digital Panel Meter

PM-129: 3-1/2 Digit LED Digital Panel Meter

Features

- 200mV Full Scale Input Sensitivity
- PM-128 - Single 9VDC Operation
- PM-129 - Single 9VDC Operation
- Decimal Point Selectable
- PM-128 - 13mm Figure Height
- Automatic Polarity Indication
- Guaranteed Zero Reading for 0 Volt Input
- High Input Impedance (>100Mohm)

Specifications - PM-128/PM-129

Maximum Input : 199.9mV DC
Maximum Display : 1999 counts (3-1/2 Digits)
w/Automatic Polarity Indication
Indication Method : PM-128 - LCD Display
PM-129 - LED Display
Measuring Method : Dual-Slope Integration
A/D Converter System
Overrange Indication : "1" Shown in the Display
Reading Rate Time : 2-3 Readings per sec.
Input Impedance : >100 Mohm
Accuracy : +/-0.5% (23+-5°C, <80% RH)
Power Dissipation : PM-128 - 1mA DC
PM-129 - 60mA DC
Decimal Point : Selectable w/Wire Jumper
Supply Voltage : PM-128 - 9V DC
PM-129 - 9V DC
Size : 67mm x 44mm

Specifications - PM-328

Maximum Input : 199.99mV DC
Maximum Display : 19999 counts (4-1/2 Digits)
w/Automatic Polarity Indication
Indication Method : LCD Display
Overrange Indication : "1" Shown in the Display
Input Impedance : >100 Mohm
Accuracy : +/-0.05% (23+-5°C, <80% RH)
Power Dissipation : 1mA DC
Decimal Point : Selectable w/Wire Jumper
Supply Voltage : 9V DC
Size : 67mm x 44mm

AS LOW AS \$5.25 ea.

CAT NO	DESCRIPTION	PRICE EACH				
		1	10	25	100	250
PM-128	3-1/2 Digit LCD Panel Meter	\$ 9.90	\$ 7.09	\$ 6.40	\$ 5.86	\$ 5.25
PM-129	3-1/2 Digit LED Panel Meter	11.49	9.54	8.67	7.95	6.95
PM-328	4-1/2 Digit LCD Panel Meter	19.88	16.40	14.90	13.66	11.93



Ball Bearing 12V DC Fans

These High Quality Fans feature Ball Bearings and Brushless DC Motors. All of them are designed to meet UL, CSA & VDE Standards. Design these fans into power supplies, computers or other equipment requiring additional air flows for heat removal. These fans are regular Circuit Specialists stock items — they are not surplus.

INDUSTRY BEST PRICING!

CAT NO	PRICE EACH			
	1	10	25	100
CSD 4010-12	\$ 9.88	\$ 6.38	\$ 5.48	\$ 4.87
CSD 6025-12	9.38	5.91	5.41	4.71
CSD 8025-12	8.88	5.85	5.19	4.49
CSD 9225-12	8.95	6.14	5.29	4.59
CSD 1225-12	11.45	8.96	7.82	6.85

Specifications

CAT NO	DIMENSIONS (MM)	RATED VOLTAGE (V)	START VOLTAGE (V)	INPUT CURRENT (A)	AIR FLOW (CFM)	STATIC PRESSURE (INCH-H ₂ O)	SPEED (RPM)	NOISE LEVEL (dB)	WEIGHT (g)
CSD 4010-12	40x40x10mm	12	7	0.06	5.1	0.19	5,500	26	20
CSD 6025-12	60x60x25mm	12	5	0.13	13.7	0.165	4,500	28	65
CSD 8025-12	80x80x25mm	12	5	0.16	37.8	0.177	3,000	31	80
CSD 9225-12	92x92x25mm	12	5	0.32	42	0.18	2,800	37	95
CSD 1225-12	120x120x25mm	12	5	0.35	62	0.180	2,500	42	135

- SOLDER
- SOLDER
- SOLDER
- SOLDER
- SOLDER
- SOLDER

We stock high quality 60/40(Sn%/Pb%), .031" and 63/37, .031" diameter. This is prime JIS certified solder that we maintain as a regular stock item (It is not "Left-overs, Rejects or Surplus") and you can buy it from us at a fraction of the price that you are used to.

Tired of Paying Inflated Prices for Solder?

CAT NO	DESCRIPTION	PRICE EACH		
		1	10	25
RH60-1	1-lb. Spool, .031", 60/40	\$ 6.90	\$ 5.96	\$ 5.30
RH63-1	1-lb. Spool, .031", 63/37	6.95	6.10	5.41
RH60-4	4.4-lb. Spool, .031", 60/40	24.00	21.90	17.92
RH60-TUBE	6-oz. Tube, .031", 60/40	.99	.89	.79

CAT NO	DESCRIPTION	PRICE EACH	
		1	5
CA-H34A	PCB Mounted IRCCD Camera	\$99.00	\$85.00
A34	Power Supply Regulating Kit	\$6.95	---

CCD Camera - IR Responsive

As Low As \$85!!

This black and white monochrome CCD Camera is totally contained on a PCB (70mm x 46mm). The lens is the tallest component on the board (27mm high from the back of the PCB) and it works with light as low as 0.1 lux. It is IR Responsive for use in total darkness. It comes with six IR LED's on board. It connects to any standard monitor, AUX or video input on a VCR or through a video modulator to a TV. Works with a REGULATED 12V power supply (11V-13V). Hooks up by connecting three wires: red to 12V, black to ground (power & video) and brown to video signal output.



Power Supply Regulating Kit for CA-H34 This simple kit is designed to fit onto the back of the CA-H34 CCD camera. It resolves the problem of hooking up the camera to an UNREGULATED supply (which damages the camera) by providing safe regulated power from any 12V-14V DC supply. It also provides regulated 12V DC from a 12V AC source.

SEE OUR ON-LINE CATALOG AT
<http://www.cir.com>

CIRCUIT SPECIALISTS, INC.

SINCE 1971
800-811-5203
602-464-2485
602-464-5824(FAX)

WE ACCEPT:



RECEIVE OUR LATEST 132 PAGE CATALOG!

It's chock full of all types of electronic equipment and supplies. We've got I.C.'s, capacitors, resistors, pots, inductors, test equipment, breadboarding supplies, PC supplies, industrial computers, data acquisition products, personal computers and computer parts, plus much, much more. FAX us your name and address or call 800-811-5203, ext. 5, to leave a message on our catalog request line.



CIRCLE 326 ON FREE INFORMATION CARD

TOP SECRET CONSUMERTRONICS

P.O. Drawer 537 Alamogordo, NM 88311

Orders: 505-439-1776

Fax Orders: 505-434-0234

users.aol.com/wizguru/hi-tech.html

Add \$5 S/H (US, Can.) 10% Off orders \$100+
Postal M.O. is best. VISA, MC OK. COD add \$6.
Since 1971! Sold for educational purposes only.

OFF-THE-SHELF HARDWARE

Van Eck Systems * Data Card Reader/Writers * Security/Surveillance * RF/EM/UV/Wave/Radar/Ultrasonic/IR/Light/Sound Detectors/Receivers/Xmitters/Jammers * Neurophone/Rife/Resonant Crystal Radionics * EM Weaponry/Countermeasures * ESS Infinity Devices * Voice Disguisers * Lineman's Hand-sets * Bug Detector/Blaster * Phone Color Boxes * DTMF Decoders * Carjack Foiler * Child Finder * Panic Button * Shriek Module * TENS * Subliminal Mixer/Amp (Ultrasonic & Infrasonic) * Electronic Dowzers * Ghost Busters * Hearing Assistor * Vortex Generator * 6th Sense Communicator * Buy Catalog Today!

SPECIAL PROJECTS

We design/build/repair/modify/consult on any device/system/project - electronic/computer/mechanical/optical (eg. phone/auto/security/radionic/lab/energy/HV/EM/RF/radar/ultrasonic/IR/UV/for business and personal invention needs. Describe & include nonrefundable \$30 pre-engineering fee. Time & cost estimates 7-10 days. Confidentiality guaranteed.

CELLPHONE MODS

See our Catalog for our infamous cellphone modification guide (\$59) - detailed, comprehensive, covers all makes - 10 times more info than competitor's "guide". Free Data Search: As a special service to our Cellphone Mods customers, we will perform one FREE search of our massive cellphone database. Request by mail (don't fax); include a #10 SASE.

PAGER (BEEPER) \$39 MANUAL

Describes in detail how Pagers work, different types and uses, frequencies, advantages over and uses with cellphones, and tips and tricks. And how Pagers are hacked and countermeasures. Includes the plans for your own Personal Pocket Paging System (transmitter and receiver).

HACKING FAX MACHINES \$39

Describes in detail how Faxes are hacked and countermeasures. Includes Fax protocols, commo parameters, compression, commands, spy switch. And insights into designing Fax interception devices and modifying existing Faxes into Stealth Faxes.

PBX HACKING

Exposes ALL issues relating to PBX hacking, including countermeasures! Can you afford a \$90,000 phone fraud loss (avg. loss of hacked PBXs)? Featured in Forbes. \$29.

VOICE MAIL HACKING

How VM Box systems are used and ways they are hacked. Includes ASPEN, MESSAGE CENTER, BIX, GENESIS, EZ, SYDNEY, PHONE MAIL, CENTAGRAM, CINDY, AUDIX, SPERRY, more! A must for security types! \$29.

CREDIT CARD SCAMS

Details every known means of credit card fraud and scams. Protect yourself! \$29.

INTERNET CONS & SCAMS \$29

Net fraud rakes in \$2+Billion annually! Most are done anonymously and with little fear of prosecution. Described in detail, includes countermeasures!

INTERNET TRACKING AND TRACING

The Net is infected with spammers, stalkers, scammers, infectors, and other wrongdoers who hide behind its anonymity. Learn how to trace them down in this comprehensive manual! \$39

AUTOMATIC TELLER MACHINES

Crimes, abuses, and vulnerabilities exposed! 100+ methods detailed, include: Physical, Reg. E, cipher, PIN compromise, card counterfeiting, magnetic stripe, false front, TEMPEST, Van Eck, tapping, spoofing, inside job, super-cool, Much more! Case histories, law, countermeasures, security checklist, labeled internal photos, figures. \$39

COMPUTER PHREAKING \$39

Describes in detail how computers penetrate each other, and how VIRUSES, TROJAN HORSES, WORMS, etc. are implemented. Dozens of computer crime and abuse methods and countermeasures. Includes IBM disk filled with hacker text files and utilities, and the legendary FLUSHOT+ protection system. BBS advice, password defeats, glossary - much more! Invaluable!

PHREAKING CALLER ID & ANI \$29

Details on how they work and dozens of ways of defeating Caller ID, ANI, *69, *57, and Call Blocking & *67. Describes Caller ID, Orange, Beige, Cheese and CF Boxes, ESS, SS7, E-911, various CLASS services, Diverters, Extenders, Centrex - much more!

HACKING ANSWERING MACHINES \$29

How answering machines are hacked to listen to - even erase - messages, and to convert them into mini-VMBs, and countermeasures!

HIGH VOLTAGE DEVICES \$29

Plans for: Stun Gun, Taser, Prod, Cane, Blaster, Flasher, Zapper, Audio/RF/Radar Jammer, Fence Charger, Plasma & Van de Graaff Gens., Jacob's Ladder, Geiger Counter, Fish Stunner, Plant Stim., Kirlian, Ozone Gen., much more!

BEYOND PHONE COLOR BOXES

Dozens described - many circuits. Plus Call Forwarding, Conferencing, Phreak History, Diverters, Extenders, Loops, REMOBS, Bridging Heads & Cans, Optocom, 3rd Party and other methods - more! \$29.

BEYOND VAN ECK PHREAKING

Eavesdropping on TV and computer video signals using an ordinary TV described in detail. Range up to 1 KM. Plans include our and original Top Secret Van Eck designs! \$29.

STOPPING POWER METERS \$29

As reported on CBS "60 Minutes"! How certain devices can slow down - even stop - watt-hour meters - while loads draw full power! Device simply plugs into one outlet and normal loads into other outlets. Also describes meter creep, overload droop, etc. Plans.

SHOCKING!

ALL-NEW TOP SECRET CATALOG. FEATURES 200+ SURVIVAL PRODUCTS! WILL BLOW YOUR MIND! MAIL \$3, OR \$1 WITH ORDER!

Motion Control System

\$299.95

INCLUDES NEW! (3) Slot Motherboard, Dual Stepper Controller Card, 12VCT 3 Amp Transformer, (2) Stepper Motors, Easy to use I.B.M Software!

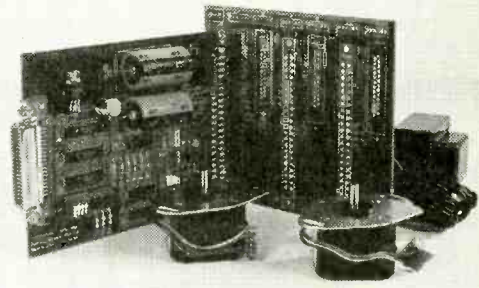

Complete System "Nothing more to Buy!"

Unit# SCK-2000

- * Design Robots, Plotters, Laser Systems, CNC Machines!
- * Drives (2), 100 step, 3.6 degree, 4 Phase Stepping Motors!
- * Unipolar 12v motors full step control. Torque is 8oz inches!
- * Bi-Directional 8 Bit Read and Write Port!
- * Board Addressable, 16 Possible Choices!
- * Fits in Standard 19" inch Card Rack!
- * Connects to any compatible I.B.M. LPT Port (1,2,3).
- * With Additional Cards Control 32 Motors on 1 LPT Printer Port!
- * Features Include: Variable Speed, Step, Range, Direction, and On/Off Control!
- * System is expandable, Add I/O cards, Slave cards, and Amplifier cards.
- * Free QBasic & Gwbasic Source Code \$ 59.95 value! *

Send Check or M.O. to:

CYBERMATION

"Intelligent Controllers"

1943 Sunny Crest Dr., Suite 288, Fullerton, CA 92635

Call Us Today!

Tel (714) 879-2000

Fax (714) 992-2082

Visa/Master/Amex Charge Accepted

Units are in stock and ready to be shipped!
* Add \$12.00 S&H: CA residents please add sales tax *

ELECTRONIX EXPRESS

FOR MORE Low-Priced Items Send For FREE 168-Page Catalog

WELLER SOLDERING STATION - MODEL WLC 100

- Variable power control (5 to 40 watts)
- Replaceable heating element
- Quality light-weight pencil iron



\$37⁹⁵

DUAL-TRACE OSCILLOSCOPE

Goldstar 9020

20MHZ \$339⁰⁰



SCOPE PROBE - 60 MHZ

SWITCHABLE X1, X10

Part No. E05SPAK220 \$12⁹⁵

DIGITAL MULTIMETER

WITH CAP/FREQUENCY/

TRANSISTOR TESTER \$34⁹⁵

Part No. E01DM645



SWITCHES

8 POS DIP 60¢ ea.

Toggle Mini SPDT ... 50¢ ea. ON-OFF



COMPONENTS

LM555 10 Min. 22¢ ea.

LM741 10 Min. 27¢ ea.

74LS00 10 Min. 18¢ ea.

7805 Regulator 10 Min. 30¢ ea.

2N3904 10 Min. 6¢ ea.

PN2222 10 Min. 6¢ ea.

Red LED T 1 3/4 10 Min. 6¢ ea.

Green LED T 1 3/4 10 Min. 7¢ ea.

ALLIGATOR LEADS

SET OF 10

Part No. E05ALS1 \$2¹⁰



TERMS: Min. \$20 + shipping. School Purchase Orders, VISA/MC, Money Order, Prepaid. NO PERSONAL CHECKS, NO COD. NJ Residents: Add 6% Sales Tax.

365 Blair Road • Avenel, NJ 07001-2293

http://www.elexp.com (Email: electron@elexp.com)

800-972-2225

In NJ: 908-381-8020

Fax: 908-381-1572

Synthesized FM Stereo Transmitter



Microprocessor controlled for easy frequency programming using DIP switches, no drift, your signal is rock solid all the time - just like the commercial stations. Audio quality is excellent, connect to the line output of any CD player, tape deck or mike mixer and you're on-the-air. Foreign buyers will appreciate the high power output capability of the FM-25; many Caribbean folks use a single FM-25 to cover the whole island! New, improved, clean and hum-free runs on either 12 VDC or 120 VAC. Kit comes complete with case set, whip antenna, 120 VAC power adapter - easy one evening assembly.

FM-25, Synthesized FM Stereo Transmitter Kit \$129.95

Tunable FM Stereo Transmitter



A lower cost alternative to our high performance transmitters. Offers great value, tunable over the 88-108 MHz FM broadcast band, plenty of power and our manual goes into great detail outlining aspects of antennas, transmitting range and the FCC rules and regulations. Connects to any cassette deck, CD player or mixer and you're on-the-air, you'll be amazed at the exceptional audio quality! Runs on internal 9V battery or external power from 5 to 15 VDC, or optional 120 VAC adapter. Add our matching case and whip antenna set for a nice finished look.

FM-10A, Tunable FM Stereo Transmitter Kit \$34.95
CFM, Matching Case and Antenna Set. \$14.95

RF Power Booster Amplifier



Add some serious muscle to your signal, boost power up to 1 watt over a frequency range of 100 KHz to over 1000 MHz! Use as a lab amp for signal generators, plus many foreign users employ the LPA-1 to boost the power of their FM Stereo transmitters, providing radio service through an entire town. Power required: 12 to 15 volts DC at 250mA, gain of 38dB at 10 MHz, 10 dB at 1000 MHz. For a neat, professionally finished look, add the optional matching case set.

LPA-1, Power Booster Amplifier Kit \$39.95
CLPA, Matching Case Set for LPA-1 Kit \$14.95
LPA-1WT, Fully Wired LPA-1 with Case \$99.95

Micro FM Wireless Mike



World's smallest FM transmitter. Size of a sugar cube! Uses SMT (Surface Mount Technology) devices and mini electret condenser microphone, even the battery is included. We give you two complete sets of SMT parts to allow for any errors or mishaps-build it carefully and you've got extra SMT parts to build another! Audio quality and pick-up is unbelievable, transmission range up to 300 feet, tunable to anywhere in standard FM band 88 to 108 MHz. 7/8" x 3/8" x 3/4".

FM-5 Micro FM Wireless Mike Kit \$19.95

Crystal Controlled Wireless Mike



Super stable, drift free, not affected by temperature, metal or your body! Frequency is set by a crystal in the 2 meter Ham band of 146.535 MHz, easily picked up on any scanner radio or 2 meter rig. Changing the crystal to put frequency anywhere in the 140 to 160 MHz range-crystals cost only five or six dollars. Sensitive electret condenser mike picks up whispers anywhere in a room and transmit up to 1/4 mile. Powered by 3 volt Lithium or pair of watch batteries which are included. Uses the latest in SMT surface mount parts and we even include a few extras in case you sneeze and loose a part!

FM-6, Crystal Controlled FM Wireless Mike Kit \$39.95
FM-6WT Fully Wired FM-6 \$69.95

Call for our Free Catalog !

RAMSEY

Super Pro FM Stereo Radio Transmitter



A truly professional frequency synthesized FM Stereo transmitter station in one easy to use, handsome cabinet. Most radio stations require a whole equipment rack to hold all the features

we've packed into the FM-100. Set frequency easily with the Up/Down freq buttons and the big LED digital display. Plus there's input low pass filtering that gives great sound no matter what the source (no more squeals or swishing sounds from cheap CD player inputs!) Peak limiters for maximum 'punch' in your audio - without over modulation, LED bargraph meters for easy setting of audio levels and a built-in mixer with mike and line level inputs. Churches, drive-ins, schools and colleges find the FM-100 to be the answer to their transmitting needs, you will too. No one offers all these features at this price! Kit includes sharp looking metal cabinet, whip antenna and 120 volt AC adapter. Also runs on 12 volts DC.

We also offer a high power export version of the FM-100 that's fully assembled with one watt of RF power, for miles of program coverage. The export version can only be shipped outside the USA, or within the US if accompanied by a signed statement that the unit will be exported.

FM-100, Professional FM Stereo Transmitter Kit \$299.95
FM-100WT, Fully Wired High Power FM-100 \$429.95

Speech Descrambler Scrambler



Decode all that gibberish! This is the popular descrambler / scrambler that you've read about in all the Scanner and Electronic magazines. The technology used is known as speech inversion which is compatible with most cordless phones and many police department systems, hook it up to scanner speaker terminals and you're in business. Easily configured for any use: mike, line level and speaker output/inputs are provided. Also communicate in total privacy over telephone or radio, full duplex operation - scramble and unscramble at the same time. Easy to build, all complex circuitry contained in new custom ASIC chip for clear, clean audio. Runs on 9 to 15VDC, RCA phono type jacks. Our matching case set adds a super nice professional look to your kit.

SS-70A, Speech Descrambler/Scrambler Kit \$39.95
CSS, Custom Matching Case and Knob Set \$14.95
SS-70AWT, Fully Wired SS-70A with Case \$79.95
AC12-5, 12 Volt DC Wall Plug Adapter \$9.95

Tone-Grabber Touch Tone Decoder / Reader



Dialed phone numbers, repeater codes, control codes, anywhere touch-

tones are used, your TG-1 will decode and store any number it hears. A simple hook-up to any radio speaker or phone line is all that is required, and since the TG-1 uses a central office quality decoder and microprocessor, it will decode digits at virtually any speed! A 256 digit non-volatile memory stores numbers for 100 years - even with the power turned off, and an 8 digit LED display allows you to scroll through anywhere in memory. To make it easy to pick out numbers and codes, a dash is inserted between any group or set of numbers that were decoded more than 2 seconds apart. The TG-1 runs from any 7 to 15 volt DC power source and is both voltage regulated and crystal controlled for the ultimate in stability. For stand-alone use add our matching case set for a clean, professionally finished project. We have a TG-1 connected up here at the Ramsey factory on the FM radio. It's fun to see the phone numbers that are dialed on the morning radio show! Although the TG-1 requires less than an evening to assemble (and is fun to build, too!), we offer the TG-1 fully wired and tested in matching case for a special price.

TG-1, Tone Grabber Kit \$99.95
CTG, Matching Case Set for TG-1 Kit \$14.95
TG-1WT, Fully Wired Tone Grabber with Case \$149.95
AC12-5, 12 Volt DC Wall Plug Adapter \$9.95



Mini-Peeper Micro Video Camera

Super small, high quality fully assembled B & W CCD TV camera the size of an ice cube! Provides excellent pictures in low light (2 lux), or use our IR-1 Infra-Red light source to invisibly illuminate an entire room on a pitch black night! Imagine the possibilities... build it into a smoke detector, wall clock, lamp, book, radio. Exact same camera that's in big buck detective catalogues and stores. Kit includes: fully assembled CCD camera module, connectors, interface PC board kit with proper voltage regulation and filtering, hook-up details, even a mini microphone for sensitive sound! Two models available: Wide Angle Lens 3.6mm/1/2, adjustable focus lens, 92 degree view; Pinhole Lens 5.5mm/1/4.5, 60 degree view. The Pinhole Lens is physically much flatter and provides even greater depth of focus. The camera itself is 1.2" square. The Wide Angle Lens is about 1" long, Pinhole Lens about 1/2", interface PC board is 1" x 2" and uses RCA jacks for easy hook-up to VCRs, TVs or cable runs. Power required is 9 to 14 VDC @ 150 mA. Resolution: 380 x 350 lines. Instruction manual contains ideas on mounting and disguising the Mini-Peeper along with info on adding one of our TV Transmitter kits (such as the MTV-7 unit below) for wireless transmission!

MP-1, Wide Angle Lens CCD TV Camera Outfit \$169.95
MP-1PH, Pin-Hole Lens CCD TV Camera Outfit \$189.95

MicroStation Synthesized UHF TV Transmitter



Now you can be in the same league as James Bond. This transmitter is so small that it can fit into a pack of cigarettes - even including a CCD TV camera and battery! Model airplane enthusiasts put the MTV-7A into airplanes for a dynamite view from the cockpit, and the MTV-7A is the transmitter of choice for balloon launches. Transmitter features synthesized, crystal controlled operation for drift-free transmission of both audio and video on your choice of frequencies: Standard UHF TV Channel 52 (which should only be used outside of the USA to avoid violating FCC rules), and 439.25 MHz or 911.25 MHz which are in the amateur ham bands. The 439.25 MHz unit has the nifty advantage of being able to be received on a regular 'cable-ready' TV set tuned to Cable channel 68, or use our ATV-74 converter and receive it on regular TV channel 3. The 911.25 MHz unit is suited for applications where reception on a regular TV is not desired, an ATV-79 must be used for operation. The MTV-7A's output power is almost 100 mW, so transmitting range is pretty much 'line-of-sight' which can mean many miles! The MTV-7A accepts standard black and white or color video and has its own, on-board, sensitive electret microphone. The MTV-7A is available in kit form or fully wired and tested. Since the latest in SMT (Surface Mount Technology) is used to provide for the smallest possible size, the kit version is recommended for experienced builders only. Runs on 12 VDC @ 150 mA and includes a regulated power source for a CCD camera.

MTV-7A, UHF TV Channel 52 Transmitter Kit \$159.95
MTV-7AWT, Fully Wired Channel 52 Transmitter \$249.95
MTV-7A4, 439.25 MHz TV Transmitter Kit \$159.95
MTV-7A4WT, Fully Wired 439.25 MHz Transmitter \$249.95
MTV-7A9, 911.25 MHz TV Transmitter Kit \$179.95
MTV-7A9WT, Fully Wired 911.25 MHz Transmitter \$269.95
ATV-74, 439.25 MHz Converter Kit \$159.95
ATV-74WT, Fully Wired 439.25 MHz Converter \$249.95
ATV-79, 911.25 MHz Converter Kit \$179.95
ATV-79WT, Fully Wired 911.25 MHz Converter \$269.95

RAMSEY ELECTRONICS, INC.
793 Canning Parkway
Victor, NY 14564

Order Toll-free: 1-800-446-2295
Sorry, no tech info or order status at this number

Technical Info, Order Status
Call Factory direct: (716) 924-4560



ORDERING INFO: Satisfaction Guaranteed. Examine for 10 days, if not pleased, return in original form for refund. Add \$4.95 for shipping, handling and insurance. Orders under \$20, add \$3.00. NY residents add 7% sales tax. Sorry, no CODs. Foreign orders, add 20% for surface mail or use credit card and specify shipping method.

CIRCLE 266 ON FREE INFORMATION CARD

DIGITAL STORAGE OSCILLOSCOPES

WITH
SPECTRUM
ANALYZER,
DVM, FREQ.
COUNTER,
AND DATA
LOGGER.

from
\$189.

PORTABLE
MODULES
CONVERT PC'S
INTO
MULTIPURPOSE
TEST AND
MEASURING
INSTRUMENTS.

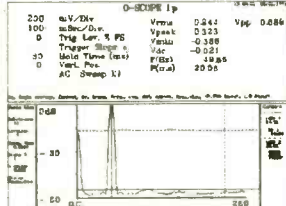
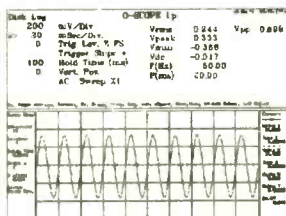

Why lug a scope around? Toss one of our modules into your laptop case or tool kit. For a multi-purpose test device, plug to a PC parallel port and use the PC screen. Continuous, delayed, or triggered sweeps can be frozen on the screen, printed out, or saved to disk. Frequency Spectrums DC to 25 MHz.

Allison now provides PICO TECHNOLOGY Ltd. portable test equipment, including high-speed scopes, and multi channel data loggers. Pico and O-Scope modules accept standard probes and work with 286 or faster PC's.

FEATURES:

- ♦ PORTABLE UNITS TO 25 MHz
- ♦ USES PRINTER PORT
- ♦ USES STD. PROBES

OPTIONS:

- ♦ PROBE SETS
- ♦ AUTOMOTIVE PROBES
- ♦ BATTERY PACKS
- ♦ SOFT & HARD CASES

O-Scopes Made in U.S.A. Picos Made in U.K.
Same Day Shipping
Includes Cable, Software & Manuals

- O-Scope Isp (DC-50KHz, single trace)\$189.
- O-Scope Ii (DC-500KHz, dual trace)\$349.
- PICO (ADC 200/20) (DC-10MHz, dual trace)\$699.
- PICO (ADC 200/50) (DC-25MHz, dual trace)\$925.
- PICO pc based data loggers from \$99.

Shipping within U.S. UPS Ground \$7.50(Second day \$11.50)

SEND CREDIT CARD INFO., M.O., or CHECK, OR CALL

1-800-980-9806

Allison Technology Corporation

8343 CARVEL, HOUSTON, TX. 77036 U.S.A.

PHONE: 713-777-0401 FAX: 713-777-4746 BBS: 713-777-4753

<http://www.atcweb.com>

WORLD'S SMALLEST UHF X-tal Locked Video Transmitters \$99.00

So small the transmitter, camera and battery will fit into a cigarette pack!!!

Used by hundreds in covert CCTV, R/C models, movie Special Effects, and Law Enforcement. "I've utilized your transmitters in covert video installations for about one year... previously, I used costly wireless units from Pelco, MVP, and Supercircuits. Nothing approaches the VidLinks in terms of power, picture quality, size, and value. Thank you." R. Leslie, CCTV Installer, NY. "Incredible color, resolution... easy to use, convenient. Very cool." P. Davis, Props, CA. "... like having a TV station in your pocket." J. Ramsay, Electronic Hobbyist, FL.



LIVE REMOTE VIDEO FROM: **\$99.00** ACTUAL SIZE !!!

- VidLink 100: 100mW Power- upto 1/4 Mile \$199.00 New! High-Power!
- VidLink 15: 15mW Power- upto 150 Feet \$99.00 New! Low Price- Same Size!
- Covert Camera: 1 1/4" sq. Pinhole Lens \$169.00 Pro Grade Japanese Quality!
- *** Audio Module Now Available. Call. ***

Check/MO, COD +\$5.00, S&H \$5.50

AEGIS RESEARCH

#671-1225 E. Sunset Dr.
Bellingham, WA
98226-3529 USA

1-604-224-0416

Visit our virtual catalog on the INTERNET at:
<http://www.lynx.bc.ca/virtualspy>

WHITE-STAR ELECTRONICS

TEL: 405-631-5153 FAX: 405-631-4788

CONVERTERS:	20	50	100+
Regal CR-83	45	39	35
* New, Panasonic TZPC 145	75	69	65
DON-5 (2 or 3) (unmodified)	45	39	35
DRZ-3 PJ (unmodified) 70 Channel Plain	35	32	29
DRX-3 PJ (unmodified) 60 Channel Plain	32	30	27

Call for FREE catalog.
405-631-5153



REMOTE CONTROL

HAND UNITS:	20	50	100+
Jerrold Replaces: 400/450/550	4.95	4.50	4.25
Scientific Atlanta: 075/175/475	4.95	4.50	4.25
8600: On screen display	7.50	7.00	6.50
Pioneer: BR 81, 82	4.95	4.50	4.25
Panasonic: Call for model #	7.50	7.00	6.50
Zenith: All	4.95	4.50	4.25
Tocom: 5503-VIP, 5503-A	7.00	6.50	6.25
Universal: 4 in 1 R/M	7.50	7.00	6.50

Call for Oak, Hamlin, Regal-83, Regency, Texscan, and all others.

Tamper-Bit tools: (10-lot)

- Jerrold compatible bits:
- 1/4" Stacom Bit\$8.00
- Oval Round D\$20.00
- Torx Bit:
- Tocom T-8\$8.00
- Zenith T-10, T-15\$8.00
- Pioneer T-20\$8.00
- Scientific Atlanta T-20\$8.00
- Pio 63XX Oval\$20.00
- Bit Driver Handle\$4.00

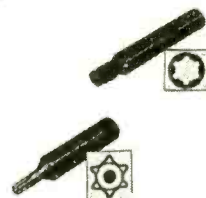

We carry most remote hand units. If you don't find the one you're looking for, we can locate for you.

Specializing in large quantities.

HOURS: Monday thru Friday 9 am to 5 pm Central Time.

Call for FREE catalog.

CIRCLE 323 ON FREE INFORMATION CARD

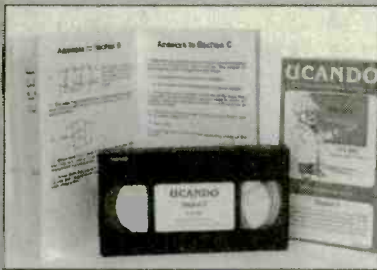

Electronic Training Videos From UCANDO

Now you can learn from the same training videos that are being used by technical schools, the Army, Navy, Air Force, Coast Guard, CET's and industries all across the United States and around the world. Advancing your troubleshooting skills has never been easier, thanks to UCANDO's extraordinary video training library. These unique training videos will teach you more in less time as you watch theory come to life. Each video is approximately one hour long and comes complete with a student workbook.



Basic Series

MODEL	DESCRIPTION	REGULAR	SALE
VT201	Direct Current: Series circuits, Parallel Circuits, Ohm's law, how to use the DMM. 55 Minutes	44.95	39.95
VT202	Alternating Current: The sine wave, coils, capacitors, transformers. 62 minutes	44.95	39.95
VT203	Semiconductors: Semiconductor theory, common diodes, transistors, switching devices. 57 Minutes	44.95	39.95
VT204	Power Supplies: Rectifier circuits, filter circuits, regular circuits, troubleshooting. 56 Minutes.	44.95	39.95
VT205	Amplifier: Amplifier basics, class A, class B, class C, operational amplifiers. 57 Minutes	44.95	39.95
VT206	Oscillators: LC and RC oscillators, crystal oscillators, crystal ovens. 56 Minutes	44.95	39.95

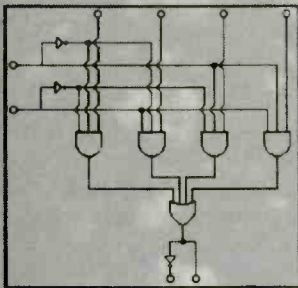
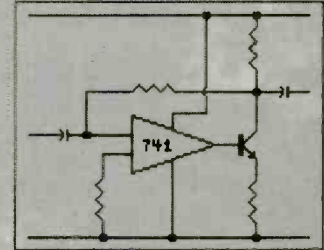

Digital Series

MODEL	DESCRIPTION	REGULAR	SALE
VT301	Digital 1: Digital basics, basic gates, binary notation, binary math, decimal notation. 54 Minutes	44.95	39.95
VT302	Digital 2: Octal notation, hexadecimal notation, flip-flops, counter circuits. 55 Minutes	44.95	39.95
VT303	Digital 3: Complement numbers, multiplexers, registers, decoder drivers, displays. 56 Minutes	44.95	39.95
VT304	Digital 4: R-2R DAC circuits, binary weighted no.s, slope circuits, S/A & flash circuits. 57 Minutes.	44.95	39.95
VT305	Digital 5: Memory devices, ROM, PROM, EPROM, EEPROM, SRAM, DRAM, MBM. 56 Minutes	44.95	39.95
VT306	Digital 6: The central processing unit, input devices, output devices. 56 Minutes	44.95	39.95

Other Popular Videos

MODEL	DESCRIPTION	REGULAR	SALE
VT401	AM Radio: Major stages of AM, signal conversion, signal detection, audio reproduction, AM stereo. 61 Minutes	44.95	39.95
VT402	FM Radio Part 1: Bandwidths, RF amplifier, mixer-oscillator, IF amplifier, limiter FM detector. 58 Minutes	44.95	39.95
VT403	FM Radio Part 2: Frequency doubler, stereo demultiplexer, audio amp stages, digital data encoding/decoding. 58 Minutes	44.95	39.95
VT404	TV Part 1, Intro to TV: Gain an overview of the television system and how the stages work together. 56 Minutes	44.95	39.95
VT405	TV Part 2, The Front End: UHF-VHF tuning stages, automatic fine tuning, remote control. 58 Minutes	44.95	39.95
VT406	TV Part 3, Audio: The sound strip, stereo TV, secondary audio programming, professional channels. 57 Minutes	44.95	39.95
VT501	Understanding Fiber Optics: Basic fundamentals, cable design, connectors, couplers, splicing. 58 Minutes	44.95	39.95
VT502	Laser Technology: Laser theory, types of lasers, applications, safety precautions. 57 Minutes	44.95	39.95
VT102	Intro to VCR Repair This video is designed for the serious technician. (workbook not available). 84 Minutes	44.95	39.95
VT103	Learn How To Clean Your Own VCR: This video is not technical, but will save you money. (workbook not available). 32 Minutes	29.95	25.95

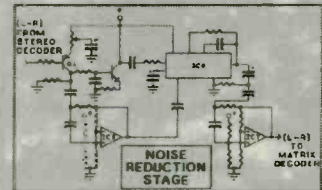

SAVE EVEN MORE!
Buy any six videos for only \$216.00. Order your UCANDO videos today!



Call for your free 84 page test instrument catalog today!!!
8931 Brookville Road * Silver Spring, Maryland * 20910

* Phone 800-638-2020 * Fax 800-545-0058 * email SMPRODINTL@AOL.com

CIRCLE 264 ON FREE INFORMATION CARD

EARN MORE MONEY!

Be an FCC LICENSED ELECTRONIC TECHNICIAN!



No costly school. No commuting to class. The Original Home-Study course prepares you for the "FCC Commercial Radio-telephone License." This valuable license is your professional "ticket" to thousands of exciting jobs in Communications, Radio-TV, Microwave, Maritime, Radar, Avionics and more...even start your own business! You don't need a college degree to qualify, but you do need an FCC License.

No Need to Quit Your Job or Go To School
This proven course is easy, fast and low cost! **GUARANTEED PASS**—You get your FCC License or money refunded. **Send for FREE facts now. MAIL COUPON TODAY!**

Or, Call 1-800-932-4268 Ext. 210

COMMAND PRODUCTIONS

FCC LICENSE TRAINING, Dept. 210
P.O. Box 2824, San Francisco, CA 94126
Please rush FREE details immediately!

NAME _____
ADDRESS _____
CITY _____ STATE _____ ZIP _____

Learn by Example!

The PRIMER 8085 Based Microprocessor Training and Control System shows you how to program by example. Program examples take you from writing simple programs to controlling motors. This trainer can be used stand alone via the keypad and display or connected to a PC with the optional upgrade (\$49.95). The Upgrade includes: an RS232 serial port, a serial cable, 32K of battery backed RAM and Assembler/Terminal software.

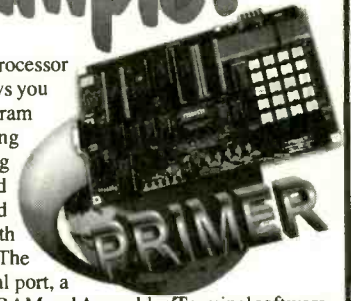

EXPERIMENTS USING THE PRIMER INCLUDE:

- Measuring Temperature
- Using a Photocell to Detect Light Levels
- Making a Waveform Generator
- Constructing a Capacitance Meter
- Motor Speed Control Using Back EMF
- Interfacing and Controlling Stepper Motors
- Scanning Keypads and Writing to LCD/LED Displays
- Using the Primer as an EPROM Programmer

The PRIMER is only \$119.95 in kit form. The PRIMER Assembled & Tested is \$169.95. Please add \$5.00 for shipping within the U.S. Picture shown with upgrade option and optional heavy-duty keypad (\$29.95) installed.

ENAC, inc.

P.O. BOX 2042, CARBONDALE, IL 62902
618-529-4525 Fax 457-0110 BBS 529-5708

1985 - 1996
OVER
10
YEARS
OF SERVICE

CONTROL MEASURE INPUT

RELAYS • LIGHTS • MOTORS
TEMPERATURE • PRESSURE • LIGHT LEVELS • HUMIDITY
SWITCH POSITIONS • THERMOSTATS • LIQUID LEVELS

MODEL 30 \$79

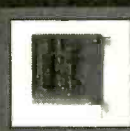

- PLUGS INTO PC BUS
- 24 LINES DIGITAL I/O
- 8 CHANNEL
- 8 BIT A/D IN
- 12 BIT COUNTER
- UP TO 14K BMP/SEC

MODEL 45 \$189

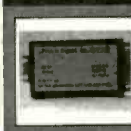

- RS-232 INTERFACE
- 8 DIGITAL I/O
- 8 ANALOG INPUTS
- 2 ANALOG OUTPUTS
- 2 COUNTERS-24 BIT

MODEL 100 \$279



- 12 BIT 100 KHZ A/D
- 4 ANALOG OUTPUTS
- 3 TIMER COUNTERS
- 24 DIGITAL I/O

MODEL 60 \$179

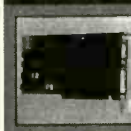

- 2-AMP RELAYS
- 16 DIGITAL I/O
- 1 1-BIT ANALOG INPUT

MODEL 40 \$99



- RS-232 INTERFACE
- 23 LINES DIGITAL I/O
- 8 ANALOG INPUTS
- PWM OUTPUT
- OPTIONAL 12 BIT A/D

MODEL 70 \$239



- RS-232 INTERFACE
- 18 BIT A/D
- 8.5 DIGIT
- UP TO 60 BMP/SEC

NEED A CUSTOM PCB? TRY US.

PRAIRIE DIGITAL, INC.

PHONE 608-643-8599 • FAX 608-643-6754
846 SEVENTEENTH STREET • PRAIRIE DU SAC, WISCONSIN 53578

CIRCLE 328 ON FREE INFORMATION CARD

COMPUTER-BASED TRAINING SOFTWARE

This new training software teaches, tests, and keeps track of your performance. It can even print a personalized certificate of completion when you have succeeded in the final test. This is the same high quality software used by schools throughout the country. Great for beginners, or just to enhance your knowledge of basic electronic concepts. All CBT's use 256 color, 3D animations, and digitized sound to make this a truly enjoyable multimedia experience.

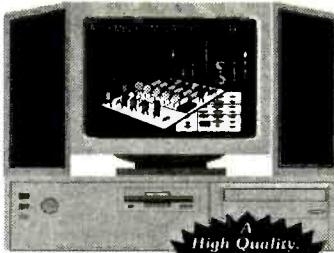

A High Quality, Interactive, Multimedia Experience!

CBT1: Current, Voltage And Resistance. This CBT introduces those without any previous knowledge of electronics to the concepts of atoms, electrons, circuits, current, voltage and resistance and the units used to measure these parameters. The ideal introduction to electricity and electronics. **C6640.....\$39.95**

CBT2: Ohm's Law. This CBT teaches Ohm's Law. It uses high impact animations to demonstrate the relationship between current, voltage and resistance in a circuit. **C6641.....\$39.95**

CBT3: Learning And Practicing The Resistor Color Code: This is the best tool to learn and memorize the resistor color code. It contains various drills and challenges. It also includes a resistor color code decoder, ideal for beginners. **C6642.....\$39.95**

CBT4: Component Identification And Schematic Symbols: This is the ideal tool for learning and memorizing the physical appearance, name, schematic symbol and basic function of basic electronic components (18 components are covered). It contains an introductory lesson and three drills. **C6643.....\$39.95**

CBT5: Learn To Solder. This CBT will teach all the necessary techniques to perform good soldering connections and shows the most common soldering mistakes beginners make. The soldering process is explained step by step using color animations, pictures and graphics. Created in connection with the popular Chaney C6445 Learn To Solder Kit (available below), however, you do not need to have the actual kit as this CBT simulates the assembly, troubleshooting and operation of this kit on the computer. A great introduction to electronic assembly. **C6644.....\$39.95**

Minimum System: 386/33MHz or 486/33MHz, 8 Megs RAM, 8 bit video card (256 colors), Windows 3.1 or higher or Windows 95. Presentation will run slower when played on a minimum system.
Recommended System: IBM compatible multimedia computer, 486/66 Mhz or higher (Pentium), 8 Megs RAM, 8 bit video card, sound card, Windows 3.1 or higher or Windows 95. Each CBT will need about 5 Megs of hard drive space.



Any Software Title

Only \$39.95 each!

Still not sure about our software?

Try our special introductory disk, "Electronic Assembly Tips". This is a handy reference tool for any electronic hobbyist containing useful information on the resistor color code, good soldering techniques, and more. Just a sampling of what our CBT's have to offer.

G8060.....Only \$5.00!

LEARN TO SOLDER KIT

Special kit designed for the person who has no soldering experience. The first 20 components are used to gain soldering experience. The remaining 10 components, when soldered properly, make a bright red and yellow alternating LED flasher! The LED flasher portion of the kit is built after you have learned by soldering the practice components which include capacitors, a transistor, resistors, and an IC socket. Requires one 9V battery (not included). Size of board: 4.75" x 3". Complete with all parts (including practice components), PC board, and instructions.

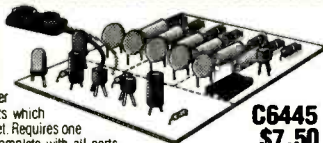

C6445 \$7.50

GIANT 100 PIECE LED ASSORTMENT

Assortment of all types, colors, sizes and shapes of prime quality LEDs. You'll receive LEDs in these colors: red, orange, yellow and green. Stock up now and save!

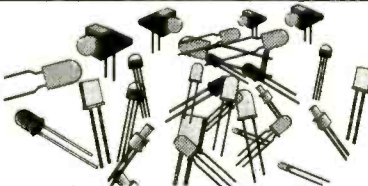

G8063 \$5.00

For Phone Orders Call 800-445-0697 or Fax Your Orders to (602) 451-9495



Minimum USA and Canada Order: \$10.00 (plus \$5.00 Shipping and Handling). We accept MasterCard, Visa and personal checks, however, we cannot accept personal checks on orders outside the United States.
Minimum Foreign Order Amount: \$50.00 (plus minimum \$10.00 shipping and handling).

ELECTRONIC GOLDMINE
PO Box 5408
Scottsdale, AZ 85261

PHONE ORDERS 800-445-0697

IF YOU CAN'T FIND WHAT YOU ARE LOOKING FOR, CALL FOR OUR LATEST CATALOG #229 CONTAINING OUR ENTIRE PRODUCT LINE OF OVER 4,000 ITEMS. MOST AT BELOW WHOLESALE PRICES!

HIGH QUALITY WIRELESS STEREO SPEAKER SYSTEM

This system provides the ultimate in portable music. Sends any audio signal from your stereo, TV, VCR, etc. up to 150 ft. away. The signal can go through walls, floors, patio doors, etc. Enjoy hearing your favorite CD music in stereo on your patio, near the pool or anywhere in your house without wires. Comes with a reliable performance stereo transmitter that has an AC adapter and an easy to use cable that plugs into your "line out" or "headphone jack" on your Stereo. The two speakers which come with it operate on four "C" batteries each (not included) and provide a nice sounding omnidirectional output. Each speaker is black, is 4.5" square x 8.5" tall, and has a power input jack (if you wish to provide an adapter). The output is 4 watts peak and the frequency response is 140Hz to 10kHz, and each speaker has a volume control. These are brand new units in beautiful retail boxes. Worth much more than our low price. Complete system includes two black speakers, one transmitter with an AC adapter and an audio hookup cable.



G8061 \$49.95

Additional pair of speakers (white only)

G8062 \$24.95

PERIMETER INTRUDER/BURGLAR ALARM UNIT



Sophisticated closed loop alarm with IC circuitry and built-in alarm horn. Provides a 3 zone alarm (has three 3.5mm jacks for sensor loops), with exit delay of 25 seconds, a pulsating horn, and operation from a 9V battery (not included). These are complete, ready-to-go units which only require you to provide hook-up wire, 3.5mm plugs and any sensors which you wish to use or make. Sensors can be reed switches, lever switches, window foil, 2 nails touching each other, etc. Very simple to use, just install a 9V battery and plug in your sensor wires. You can protect every window, room or door in your entire house with this one unit. Comes with complete instructions, schematic, and even a list of Radio Shack part numbers for different sensors you can use. We even show you how you can add one capacitor to provide an entry delay. Size of control box with horn is 3.58" x 6.18". Wood grain front panel. Brand new.

G8028 \$10.00

MYSTERIOUS RF OCEAN BEACON WITH STROBE/FLASHER

Consists of the "insides" of a very sophisticated ocean beacon. Perhaps these were designed to track and transmit at VLF ocean currents, track storms, show hazardous locations in the ocean, shipwreck locations, etc. - We don't know!

These are new, but to prevent them from transmitting to satellites, planes, Coast Guard, etc. a hole was drilled through the transmitter section disabling it, however, the brilliant strobe section still works perfectly. These beacons are about 14 1/2" Tall x 6 1/2" Dia. They have a round antenna device near the top, and a bright strobe tube that flashes at the very top. The circuit board operates from 12VDC and the strobe tube starts to flash about once a second when power is applied. We have no specs, schematics or other info on these. Circuitry consists of several hundred parts including an 80C31 CPU, a 27C256 RAM, 10 other ICs, various power transistors, a reed switch, various small signal transistors, a quantity of tantalum caps, trimmer caps, resistors, a crystal oscillator that operates at 5.0753125MHz, a 12MHz crystal, a copper/brass shielded circuit area. These were made by Westinghouse and have 3D60376 Rev E marked on the circuit board.

We will give \$500 worth of our catalog merchandise to the first person who can supply us with the schematics, frequency of operation and general operational data on this item - Please call us if you have it!

We don't have the outer plastic beacon case or any other data, however, these items have cost a fortune! Here's your chance to own a piece of very interesting technology at a tiny fraction of the original cost. "As is" only - Sorry, no returns on this item.

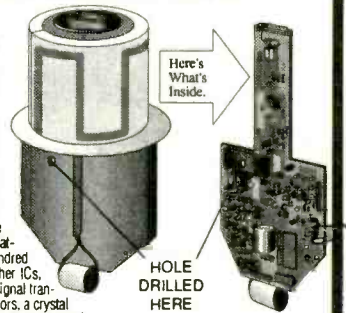

Here's What's Inside.

HOLE DRILLED HERE

G7859 \$12.95

SECURITY ALERT UNIQUE MONITOR FOR THE HEARING IMPAIRED

Unique monitor is designed to flash 4 brilliant laser like LEDs when activated by someone knocking on the door. It also has a switch position which causes a loud electronic beep to sound along with the LEDs if you wish. The device is great for everyone - not just the hearing impaired as it is a very high quality vibration sensing unit. We placed it on our phone and each time it rang, the unit set off its flashing alert. Precision made by Datawave, this unit is black in color and operates from three AA batteries (not included). Features adjustable sensitivity control, red/green LED battery tester and convenient hanging strap. Sophisticated 2-IC circuit. Brand new in retail blister card. Size of unit: 4 3/4" x 2 3/8".



G8041 \$8.95

SECURITY GUARD LAMP CONTROL

Turns any lamp off at dawn and on at dusk. Simply plug lamp into Security Guard and then plug Security Guard into wall outlet. Made by Gemini. Size: 3 1/2" x 1 1/2". White color.



G7940 \$4.95

MICROPHONE FOR COMPUTER SOUND

High quality microphone for use with your computer sound system features gray cord, handy peel-n-slick mounting holder and 3.5mm plug as shown. Prime unit - same as sold in many computer stores.



G7939 \$2.49

New and Pre-Owned Test Equipment

Goldstar

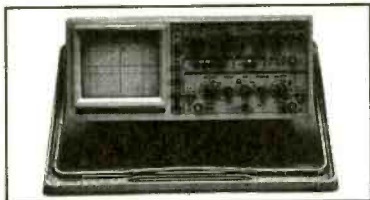

Model OS-9100P → **\$899.00**

Full 100 MHz Bandwidth!

- Dual-Channel, High Sensitivity
- TV Synchronization Trigger
- Calibrated Delayed Sweep
- Includes Two Probes, 2 Year Warranty

FREE SHIPPING!
ON GOLDSTAR EQUIPMENT
ANYWHERE IN THE U.S.
Excluding AK & HI



BK PRECISION
MAXTEC INTERNATIONAL CORP.

Model 4040 \$499.00

20 MHz Sweep/Function Generator

- 0.2 Hz to 20 MHz, 5 digit LED Display
- AM & FM Internal or External Modulation
- Sine, Square, Triangle, TTL, CMOS Outputs
- Burst Operation
- External 30 MHz Frequency Counter

NEW!



TOLL FREE 1-800-99-METER

CIRCLE 334 ON FREE INFORMATION CARD

Pre-Owned Oscilloscope Specials

B + K Precision 1476 10 MHz \$229.00
Great Starter Scope!

Tektronix 465	100 MHz	\$599.00
Tektronix 465B	100 MHz	\$699.00
Tektronix 475	200 MHz	\$799.00
Tektronix 475A	250 MHz	\$899.00

- The Industry Standard of Oscilloscopes
- Dual Channel, Calibrated Delayed Sweep
- Professionally Refurbished
- Aligned & Calibrated to Original Specifications
- 6 Month Warranty - The Longest Available!

LOWEST PRICES EVER!

NEW FLUKE MULTIMETERS & TEKTRONIX OSCILLOSCOPES

The Industry Standard in Multimeters

Fluke Model 87 ..\$285.00

**TEKTRONIX TDS SERIES
ON SALE!**

See us on the Web!
www.fotronic.com

1-800-996-3837

Test Equipment Depot

A FOTRONIC CORPORATION COMPANY

P.O. BOX 708 Medford, MA 02155

(617) 665-1400 • FAX (617) 665-0780

email: afoti@fotronic.com

Radiotelephone - Radiotelegraph

FCC Commercial License

Why Take Chances?

Discover how easy it is to pass the exams. Study with the most current materials available. Our **Homestudy Guides**, Audio, Video or PC "Q&A" disks make it so fast, easy and inexpensive. No college or experience needed. The new commercial FCC exams have been revised, covering updated Aviation, Marine, Radar, Microwave, New Rules & Regs, Digital Circuitry & more. We feature the Popular "Complete Electronic Career Guide". 1000's of satisfied customers **Guarantee** to pass or money back. Newest Q&A pools.

Send for **FREE DETAILS** or call

1-800-800-7588

WPT Publications
4701 N.E. 47th St.
Vancouver, WA 98661

Name _____

Address _____

City _____ St. _____ Zip _____

1-800-800-7588

WE SELL RED, BLUE-GREEN & IR

LASERS

HUNDREDS OF UNITS TO CHOOSE FROM!
PRICES AS LOW AS \$40.00!

- Experiments
- Laser Light Shows
- Cutting & Burning
- Communications

We also carry
books and plans
about LASERS.

CALL FOR FREE CATALOG!

TEL (909) 278-0563

FAX (909) 278-4887

MWK INDUSTRIES

1269 W. Pomona, Corona, California 91720

See our catalog on the internet.

HTTP://WWW.PWEB.COM/MWK/MAIN.HTM

EMAIL: MKENNY1989@AOL.COM

PROFESSIONAL DESOLDERING with the

Lane Norman - Normans Electronics Inc. Atlanta GA 404-451-5057
A cost effective solution to desoldering equipment at less than half the price of most equipment. Its performance is ASTOUNDING.

Keith Sahs - J & M Electronics - Omaha NE 402-291-7100 It's a must tool for my bench. I can

Mike Murphy - Service Center - Van Nuys CA 818-785-7805

The single best investment of repair equipment we've made. It outperforms all other desoldering tools we've used. Easier to use and least expensive.

Bob Monroe - M.A.R.C. Electronics - Virginia Beach VA 804-468-3932
Best investment we've made. Saves time, especially with multi-sided PCB's. Extremely pleased with warranty. Failed within 6 months and replaced by DEN-ON overnight.

Dick Manning - Dicks Electronics - Hartland WI 414-367-8339
The ease & speed of component removal greatly increases productive time. The SMD kit makes SMD removal a breeze, even for inexperienced Techs.

Bob Sorrels CET/CSM Polytronics Microcomputer - Shreveport LA
We've used our SC7000 almost every day for about three years with virtually no problems. Just clean it before you turn it off for the day.

George Hefner - Hefner Electronics - Coleridge NE 402-283-4333
Being a one-men service center, I hesitated to spend the money on a desoldering tool, however all that changed when I nearly ruined a \$400 computer logic board. It has cut my desoldering time by 50%.

Don Cressin - Certified Electronics Service - Ellicott City MD 301-461-8008
We have obtained excellent results with the SC7000 including repairing high density U/V tuners. It is one of the best purchases we have made.

Doug Pettit - LuRay Electronics - LuRay VA 703-743-5400
We found that the SC7000 not only saves money vs. wick, but saves valuable time in troubleshooting. It allows you to be more accurate in removing SMD's.

Randy Whitehead - Service West - Salt Lake City UT 801-262-4069
My techs thought it would be a waste. I bought one anyway after a demo. My techs then fought over it. Now we have three. It is the Best desoldering tool we have ever used.

Timothy Kraft - Monikraft, Inc. - Cherry Hill NJ 609-751-3252
We replaced all our existing desoldering stations with the SC7000. Our technicians are very pleased with the improved performance, portability, and reliability over our previous higher priced equipment.

Alan P. Dunasky - Al's TV, VCR, & Computer Service - Cleveland, OH 216-631-8132 One of my most valuable tools in the shop. I would be lost without it.

Bill Warren CET/CSM - Warrens Audio & Video - Knoxville TN - 423-546-1128
We have been extremely satisfied with the quality and durability of the DEN-ON SC7000 as well as with after the sale support.

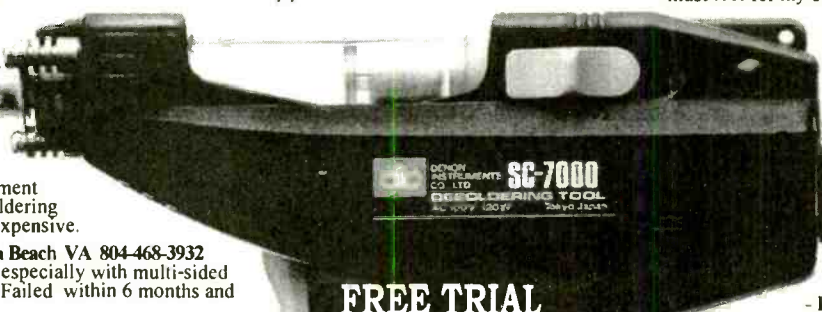

FREE TRIAL

Available on Request

Sale Price
\$395.00

Price includes
stand, two extra
filters, tip wrench
and tip cleaner

satisfied with this product.

Daryl Baker - Servus Electronics Wichita KS
The SC7000 is a better product than advertised. It has more than paid for the initial investment. We highly recommend the SC7000 Desoldering Tool.

Steve Hall - Telco Electronics, Inc. Boise ID 208-322-3304
My first mistake in purchasing the SC7000 was buying only one. My Techs. were so pleased with this tool and it's usefulness they begged for more. They raved about it and even fought over it. I intend to purchase one SC7000 for each workstation.

desolder multiple pin IC's quickly and clean. It will even take up large solder amounts on tuner and case grounds.

Ray Wurmnest - Ray's

Electronics, Inc. - Bloomington IL

309-829-3238 The SC7000 saves time when changing out parts in the home or in the Service Center - Worth every penny we spent.

James Dietrich - Dietrich Electronics - Monroe NY

Look mom, one hand, & I can go three times faster without breaking a sweat. I'll recommend anyone to DEN-ON Tools.

Don Scott - LAV Electronics Healeah-Miami Lakes FL

I am a constant user of the SC7000 Desoldering Tool and for quick component removal, this unit has no equal. It also comes with excellent company support. I am very satisfied and highly recommend it to anyone in the servicing field.

Gale TV, Inc. - Gale Holloway Virginia Beach VA 804-486-3562
Desoldering has never been easier with the SC7000. We use the desoldering tool daily and are fully

DEN-ON SC7000

Features

- ◆ Totally Self Contained diaphragm vacuum pump and AC motor for high vacuum suction or reversible hot air blow for SMD removal.
- ◆ 100Watt Ceramic heater with zero-crossover switching heater control circuit which prevents spikes and leakage currents.
- ◆ Unique patented long lasting filter cartridge design. Solder builds up on easily cleaned baffle, while air flows around the outside of baffle.
- ◆ Totally ESD Safe. The housing contains carbon and the tip is at ground potential for complete ESD Protection.
- ◆ Maximum vacuum of 600mmHg is attained in 200 milliseconds.
- ◆ Temperature adjustable from 300°C - 450°C (572°F - 842°F).

Specifications

- ◆ Voltage - AC100v, 120V, 230V, 50/60HZ
- ◆ Power Consumption - 120W
- ◆ Pump - Diaphragm Type
- ◆ Motor Output - 2W
- ◆ Vacuum Attained - 600mmHg
- ◆ Temperature Range - 300°C - 400°C (572°F - 842°F)
- ◆ Air Flow Rate - 15 Liter/Minute (Open)
- ◆ Heater - 100W (Ceramic)
- ◆ Control System - Feed Back Zero Cross-over Type
- ◆ Net Weight - 420Grams

Visa - M/C - Discover - American Express - Terms to Qualifying Companies
30 Day Money Back Total Satisfaction Guarantee - One Year Parts and Labor Warranty

HOWARD ELECTRONIC INSTRUMENTS INC
6222 N. Oliver Wichita, KS 67220

Toll Free U.S. and Canada
1-800-394-1984

Web Site www.heinc.com
E-Mail sales@heinc.com
International (316) 744-1993
or Fax (316) 744-1994

CIRCLE 330 ON FREE INFORMATION CARD

FM TRANSMITTER KITS! FUN PROJECTS AND MORE!

ELECTRONIC KITS!

WE ACCEPT VISA, MC, MO, COD
SHIPPING & HANDLING EXTRA
XANDI ELECTRONICS, INC.



YOUR MANUFACTURER OF HIGH QUALITY KITS

• TECH SUPPORT NUMBER (602-829-0755)

- Powerful 2 stage audio amplifier.
- Tunes 88-108 MHz.
- Up to 1 mile range.
- Requires 9V battery. (Not incl.)
- Sensitive, picks up sounds at the level of a whisper.

SUPER-MINIATURE FM TRANSMITTER
Super small FM transmitter. Use with any FM broadcast receiver. Easy to assemble, all chip (SMT) parts are pre-assembled to the circuit board.

XST500 E-Z Kit \$49.95

- Sensitive audio amplifier, picks up sounds at the level of a whisper.
- Tunes 88-108 MHz.
- Up to 1/2 mile range.
- Miniature photo battery mounts right on circuit board. (Included)

MICRO-MINIATURE FM TRANSMITTER
Including the battery, this is the Worlds smallest FM transmitter. Use with any FM broadcast receiver. Easy to assemble, uses pre-assembled circuit board.

XWB1000 E-Z KIT \$46.95

- Up to 1/2 mile range.
- Miniature photo battery mounts right on circuit board.
- Transmits at 143 MHz.
- Amazing audio sensitivity, picks up sounds at the level of a whisper.

CRYSTAL CONTROLLED FM TRANSMITTER
Including the battery, this is the Worlds smallest crystal controlled FM transmitter. Transmits to any scanner type receiver. Easy to assemble, uses pre-assembled circuit board.

XTL1000 E-Z KIT \$69.95

- Transmits a continuous beeping tone.
- Transmits at 143 MHz.
- Up to 1 mile range.
- Works with most any scanner type receiver.

TRACKING TRANSMITTER
Only 0.75 by 1.8 inches including the battery, the XTR300 is ideal for use in locating lost model rockets, bicycles, automobiles, games of hide and seek, and contests.

XTR300 E-Z Kit \$79.95

- Dial your phone from anywhere and listen to the sounds inside your home.
- Two digit Touch Tone code for secure operation.

TELEPHONE SNOOP

The latest in home or office security. Call home from anywhere, enter a two digit security code, and hear the sounds in your home. Automatically turns on without ringing the phone, verifies code, then activates for one and a half minutes.

XPS-CASE KIT \$14.95

XPS1000 C Kit \$55.95

- Smallest Phone transmitter anywhere!
- Tunes 88-108 MHz.
- Up to 1/4 mile range.
- Attach to phone line anywhere in house.
- No batteries required, powered by phone line.

SUPER-MINIATURE PHONE TRANSMITTER

Worlds smallest FM phone transmitter. Use with any FM broadcast receiver. Easy to assemble, all chip components are pre-assembled to the circuit board.

XSP250 E-Z Kit \$34.95

- Professional quality.
- Uses new Microwave Integrated Circuit amplifier.
- Assembly is a snap.
- Covers 1 to 2,000MHz.
- Adjustable sensitivity.
- Audio jack for privacy ear phone.

SUPER SENSITIVE BUG DETECTOR

Any intercepted signal causes an audio tone that increases from a low pitched growl to a high pitched squeal as you get closer to the source of the signal.

XBD500 E-Z Kit \$129.95

- Use with any FM broadcast receiver.
- Hear every sound in an entire house!
- Up to 1 mile range.
- Powerful 2 stage audio amplifier.

MINIATURE FM TRANSMITTER

The XFM100 has a super sensitive microphone and is capable of picking up sounds at the level of a whisper and transmitting them to any FM broadcast receiver.

XFM100 C Kit \$21.95

- Will analyze live voice best, but will work over the phone, and even from recordings.
- Has built in microphone.
- Easy to use LED output display.
- Voice-stress analysis instantaneous.

VOICE-STRESS ANALYZER
SEE THROUGH LIES AND DECEIT! This is the latest breakthrough in voice-stress analysis. Know if someone is under stress such as when telling a lie

XVA250 C Kit \$49.95

- Digital voice changing: male to female, female to male, adult to child, child to adult.
- Use with any modular phone.
- 16 levels of voice masking.
- Connects between handset and phone.

VOICE CHANGING ACCESSORY STOP THOSE ANNOYING TELEPHONE CALLS!

Sound older and tougher when you want to. Not a kit. Fully assembled. Use with single or multi-line phones.

TRANSITION, 2001 \$69.95

- Uninterrupted coverage of 800 to 950 MHz.
- Works with any scanner that can receive 400 to 550 MHz.

800-950 MHz SCANNER CONVERTER KIT

If your scanner can receive 400-550 MHz, just add the XLC900 for **uninterrupted 800-950 MHz** coverage. It converts all 800-950 MHz signals down to 400-550 MHz so your scanner can receive them! Add our custom case kit for that "Professional" look.

XLC-CASE KIT \$14.95

XLC900 C Kit \$49.95

- Transmit high quality stereo to any FM stereo receiver.
- Built-in output level monitor for quick and easy tuning.
- Ideal for use with personal CD player.

FM STEREO TRANSMITTER

Transmit full-bodied Hi Fi stereo to any FM stereo receiver. Separate left and right inputs and gain controls. Includes an output booster stage for greater range.

XFS-CASE KIT \$14.95

XFS108 C Kit \$39.95

XANDI Serving the public since 1981
ELECTRONICS, INC.
1270 E Broadway Rd. # 113, Tempe AZ 85282

TOLL FREE ORDER LINE: 1-800-336-7389
FAX LINE: 1-602-731-4748
CALL FOR YOUR FREE CATALOG

SEND MAIL XANDI ELECTRONICS
ORDERS TO: BOX 25647
TEMPE, AZ 85285-5647

CIRCLE 281 ON FREE INFORMATION CARD

ATTENTION CABLE VIEWERS

CABLE VIEWERS... get back to your **BASIC** Cable Needs

Call **800-577-8775**

For information regarding all of your **BASIC** cable needs.



5 GOOD REASONS TO BUY OUR FAR SUPERIOR PRODUCT

- ❖ PRICE
- ❖ EFFICIENT SALES AND SERVICE
- ❖ WE SPECIALIZE IN 5, 10 LOT PRICING
- ❖ ALL FUNCTIONS (COMPATIBLE WITH ALL MAJOR BRANDS)
- ❖ **ANY SIZE** ORDER FILLED WITH SAME DAY SHIPPING

We handle **NEW** equipment **ONLY** - Don't trust last year's **OBSOLETE** and **UNSOLD** stock!
COMPETITIVE PRICING—DEALERS WELCOME

HOURS: Monday-Saturday 9-5 C.S.T.

It is not the intent of B.E.S.W. to defraud any pay television operator, or we will not assist any company or individual in doing the same.
*Refer to sales personnel for specifications.

**BASIC
ELECTRICAL
SUPPLY &
WAREHOUSING
CORPORATION**

P.O. Box 8180 ■ Bartlett, IL 60103 ■ 800-577-8775

CIRCLE 324 ON FREE INFORMATION CARD

AMAZING ELECTRONIC & SCIENTIFIC DEVICES

Lasers, Tesla, Ions, Anti-Gravity, Magnetics & More!
Plans • Ready-to-Use • Easy-to-Build Kits

Laser Ray Gun
 Handheld, battery operated. Produces an intense burst of light capable of burning holes.
 LAGUN2 Plans \$20.00
 LAGUN2K KR / Plans Price on Req

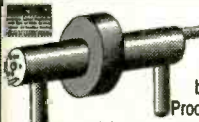

250KV Tesla Coil
 10-14" of Explosive Bolts of Lightning!
 • Transmit Wireless Energy
 • Ion Motors
 • Anti-Gravity
 • Strange and bizarre pyrotechnical effects
 • Many other experiments shown in detail
 • Award winning science project!



BTC3 Plans \$15.00
 BTC3K Kit/Plans with coil \$299.50
 BTC30 Assbl'd Ready to Use \$399.50
 BTC4 Plans, 500KV unit \$20.00

ATTENTION: Experimenters & Researchers!
 Anti-Gravity, Rail & Coil Guns, Mass Warping, Levitation Research, Exploding Water, Propulsion Drivers, Lattice Snapping, EMP etc. Loss-less Energy Charger with triggered spark switch. • Adjustable 500 to 3KV out
 • Charges up to 25KJ • Programmable Output
 HEP1 Plans \$15.00
 HEP1K Kit/Plans with 500J \$399.50
 HEP10 Lab Assembled - to your spec's.
 Write, call or fax for price & delivery



HEP10
 ...shown connected to potential rail gun system

Visible Beam Gas Lasers
 Millions degree temp equiv. Illuminates low level clouds
 • Light Shows
 • Window Listener
 • Optical Projects
 • 12/115V
 • Science Project



LAS1KM 1mw, low cost KR \$69.50
 LGU6K 2-3mw Kit \$119.50
 HNE70 5-7mw, ready to use \$299.50

Gravity Generator
 Levitate an object!
 Great science fair project!

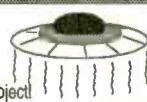

GRA1 Plans \$15.00
 GRA1K Power Supply Kit/Plans ... \$99.50
 GRA10 Assbl'd Kit/Plans \$149.50
 Includes text book on Anti-Gravity theory!

Solid State Tesla Coil
 • Generate fiery electrical plasma discharge
 • Powers light and objects without contact
 • Experiment with electrical and mechanical fields. TCL5 Plans \$8.00
 TCL5K Kit/Plans 12VDC \$49.50



Pioneer a Futuristic Weapon!
 Electric Gun - prototype designed in our lab - Join the research!
 • Ballistic Velocities
 • Handheld • Battery Operated
 • Labelled as DANGEROUS Product
 Experiment now before it is classified as a firearm! EGUN1 Plans \$20.00
 (Must be 21 for purchase of hardware)



Ion Ray Gun
 Project Energy!
 Star Wars technology demonstrates weapons potential. IOG7K Kit/Plans \$99.50



"Talking" Plasma Globe
 Spectacular color. Pulsates to music, sounds! 8-9", with intensity and sound controls. PLASMA1 Ready to Use . \$79.50



Electronic Hypnotizer **Caution Required**
 Control their minds! Programmable audible and visual stimuli induces hypnotic trances. HYP2K Kit with Book \$39.95
 EH2 Hypnosis Book & Plans \$14.95



We can design and build high voltage systems - to your spec's!
 Call or fax us with your requirements!

4000 Volts 10ma High Voltage Module - Ready to use - for many projects from hoverboards to pyrotechnics.
 MINMAX4 While they last! \$19.50

TACTICAL ELECTRONICS

Cybernetic Ear!
 Enhances normal hearing 3-4 times!
 Adjustable volume control, fits easily into either ear. Many, many uses.
 Ready to Use!
 CYBEREAR \$19.95



ALL NEW Telephone Line Grabber/Infinity Transmitter
 Use tone phone anywhere in the world to:
 • Monitor your premises - avoid break-ins
 • Access ongoing calls - longwinded kids
 • Control up to 8 appliances in your home!
 • Re-direct costly toll calls from pay phones!
 TELCON3 Plans (credit to purch) .. \$ 10.00
 TELCON3K Plans/Kit \$99.50
 TELCON30 Ready to Use \$149.50



Long Range "Ultra-Ear"
 Parabolic Mic can hear a distant whisper! BUG Mother Nature!
 20" dish uses satellite technology to capture distant sounds. PM5 Plans \$ 8.00
 PMSK Kit/Plans \$149.50
 • Optional Wireless Retrofit transmits captured sounds to an FM radio.
 WM5K Kit for Wireless Option \$29.50



Phasor Sonic Blast Pistol
 Rids areas of unwanted pests. Trains and conditions wild and domestic animals. Great for barns, attics, cellars, gardens.
 PPP1K Kit/Plans \$39.50



3 Mi Telephone Xmitter
 • Tune-able 80-130 Mhz • Undetectable
 • Only transmits when phone is used
 VWPM7K Kit/Plans \$39.50



3 Mi Voice Transmitter
 • Ultra-Sensitive Mike
 • Crystal Clear
 • Tunes 80-130 MHz.
 FMV1K Kit/Plans \$39.50



FireBall Gun
 Shoots flaming ball - two shot capacity. Great for special effects and remote fire starting. CAUTION REQUIRED!
 FIREBALL Plans (dangerous product) . \$10.00

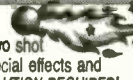

Shocker Force Field/Vehicle Electrifier
 Make hand and shock balls, shock wands and electrify objects. Great payback for those wiseguys!
 SHK1K Easy to Assemble Kit \$19.50



Extended Play Telephone Taping System
 • Tapes Phone Conversation • Extends Tape X4 • Check Local Laws before using!
 TAP30X Ready to Use \$84.50



"Drop-In" (1ml) Telephone Transmitter
 Easily tunable over FM radio. Never needs battery! #DROPIN Kit/Plans \$ 19.95



See in Total DARKNESS!
 • High Quality IR Night Vision Scope with IR illuminator.
 SD10 Ready to Use \$199.50



Electric Charge Gun
 Life is Precious - PROTECT IT!
 Stuns & immobilizes attackers 15 feet away! Check your state laws for legality. More knockdown power than most handguns. No permanent injury. ID coded.
 ECG1 Data (Creditable to purch) \$10.00
 ECG10 Charge Gun, Ready to Use, Includes FREE Stun Gun! \$249.50
STUN GUNS - sold separately:
 STUN100 100,000 Volts \$34.50
 STUN200 200,000 Volts \$49.50



Window Bounce Laser Listener
 Aim at window and listen to sounds from reflected light. CAUTION - Not for illegal use. LWB3 Plans \$10.00
 LWB3K Kit/Plans (req's vid tripod) \$149.50



MIND CONTROL!
 Places subjects under your control. Programmable audible & visual stimuli with biofeedback. Induces strange & bizarre hallucinations without drugs. Caution - not FDA approved.
 MIND2 Plans \$15.00
 MIND2K Kit and Plans \$49.50
 MIND20 Assembled Unit \$69.50



FANTASTIC BRIGHTNESS!
 High Quality Laser Pointer
 LAPN64 15mw equiv, 2000' \$39.50
 LAPN61 50mw equiv, 4000' \$84.50



1000' Potato Cannon
 Not a Toy! Uses electronic or piezo ignition. CAUTION REQUIRED!
 POT1 Plans (dangerous product) ... \$10.00



VISIT US ON THE WEB!
<http://www.amazing1.com>

INFORMATION UNLIMITED

Dept ENS-7, Box 716, Amherst, NH 03031
 Phone: 603-673-4730 FAX: 603-672-5406
 MC, VISA, COD, Checks accepted Please add \$5.00 S & H

CATALOG!
 FREE with Order or send \$1 P&H

24 Hour Phone
800-221-1705
 Orders Only Please!

February 1997, Electronics Now

CALL TOLL FREE
(800) 292-7711 orders only
Se Habla Español

C&S SALES
EXCELLENCE IN SERVICE

CALL OR WRITE FOR
A FREE 60 PAGE
CATALOG!
(800) 445-3201

XK-550 Digital / Analog Trainer

Elenco's advanced designed Digital / Analog Trainer is specially designed for school projects. It is built on a single PC board for maximum reliability. It includes 5 built-in power supplies, a function generator with continuously sine, triangular and square wave forms. **1560 tie point breadboard area.**

XK-550
Assembled and Tested
\$169.95

XK-550K - Kit
\$139.95

Tools and meter shown optional



TK-3000
\$89.95

Tools Included:

- SR-2 - Deluxe Soldering Iron
- SH-1 - Soldering Iron Stand
- ST-1 - Diagonal Pliers
- ST-2 - Long Nose Pliers
- ST-30 - Deluxe Wire Stripper
- SE-1 - Solder Ease Kit
- ND-3 - 3 pc. Nut Driver Set
- TL-8 - Precision Screw Drivers
- ST-5 - Screw Driver Slotted 3/16"
- ST-6 - Screw Driver #1 Phillips
- ET-10 - IC Puller
- SP-2 - Solder Pump
- ST-20 - Safety Goggles
- ST-9 - Pocket Screw Driver
- ST-4 - Solder Tube
- SW-3 - Solder Wick

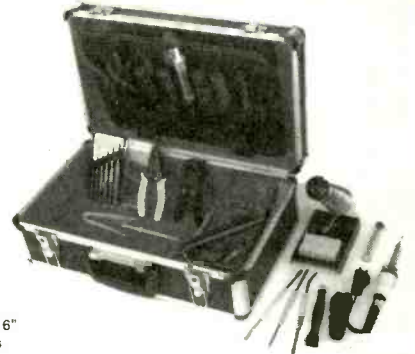

A professional technician service tool kit in a metal reinforced tool case with heavy-duty handle and locks. A removable pallet handles most of the tools listed with more room for tools and parts in the lower half.

GF-8026 w/ Frequency

- Linear and Log Sweep
- .02Hz to 2MHz
- Counter Range 1Hz to 10MHz
- 4 Digit Display

\$225



MX-9300 Four Functions in One

- One instrument with four test and measuring systems:
 1.3GHz Frequency Counter • 2MHz Sweep Function Generator
 Digital Multimeter • Digital Triple Power Supply
 (0-30V @ 3A, 15V @ 1A, 5V @ 2A)

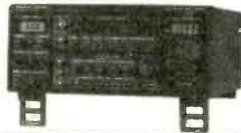

\$479.95

Model XP-581

4 Fully Regulated DC Power Supplies in One Unit
 4 DC voltages: 3 fixed - +5V @ 3A, +12V @ 1A, -12V @ 1A
 1 Variable - 2.5 - 20V @ 2A

\$85



Auto Ranging Hand-Held DMM w/ Bar Graph
Model EDM-163

\$99.95

7 Functions with data hold
 Compares to Fluke Model 77II

Digital Multimeter
Model M-1700

\$39.95

11 functions including freq to 20MHz, cap to 20µF. Meets UL-1244 safety specs.



Fluke Multimeters

70 Series

- Model 70II\$69.95
- Model 73II\$97.50
- Model 75II\$135.00
- Model 77II\$154.95
- Model 79II\$175.00

80 Series

- Model 83\$235.00
- Model 85\$269.00
- Model 87\$289.00

B&K Precision Multimeters

- Model 391\$159.00
- Model 390\$139.00
- Model 389\$109.00
- Model 388A\$99.00
- Model 2707\$79.00
- Model 2860A\$85.00

Kit Corner

over 100 kits available

PT-223K

\$15.95

Phone kit with training course.



Fiber Optics Technology

with training course
Model FO-30K

\$19.95



Model AM/FM-108K
Transistor Radio Kit

with training course

\$29.95

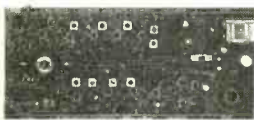

M-1005K
Compact Multimeter Kit

\$19.95
 6 Functions & Transistor Test



Model M-6100
Programmable DMM

Includes **FREE** Computer Interface and **FREE** Software

- Analog Bar Graph
- Large 3 3/4" LCD Display
- Menu Driven
- Triple Display
- RS-232 Interface
- True RMS
- 9 Basic Functions including cap. & freq.
- Auto Power Off
- Easy-to-use

\$125

WE WILL NOT BE UNDERSOLD

C&S SALES, INC.

UPS SHIPPING: 48 STATES 5%
 OTHERS CALL FOR DETAILS
 IL Residents add 8% Sales Tax

150 W. CARPENTER AVENUE
 WHEELING, IL 60090
 FAX: (847) 520-9904 (847) 541-0710
http://www.elenco.com/cs_sales/



15 DAY MONEY BACK GUARANTEE

FULL FACTORY WARRANTY

PRICES SUBJECT TO CHANGE WITHOUT NOTICE

CIRCLE 336 ON FREE INFORMATION CARD

**FREE PROBES
WITH ALL
SCOPES**

OSCILLOSCOPES

Lowest Prices of the Year!

**CALL OR WRITE FOR
A FREE 60 PAGE
CATALOG!
(800) 445-3201**

B&K Precision Scopes

60MHz ANALOG WITH DIGITAL STORAGE

Model 2560

- Cursors and readouts
- RS-232 port
- 20MS/s real time sampling
- 1GHz equivalent time sampling (at 0.1µs/div.)
- Prints via RS-232 port to any HP-GL plotter

\$1995

20MHz ANALOG WITH DIGITAL STORAGE

Model 2522A

- 20MHz analog bandwidth
- 20MS/s sampling rate
- 2K memory per channel
- 300MHz equivalent time sampling
- Pre-trigger capture

\$869.95

100MHz THREE-TRACE

Model 2190A

- 1mV/division sensitivity
- Sweeps to 5ns/division
- Dual time base
- Signal delay line
- 150V accelerating voltage

\$1379.95

60MHz DUAL-TRACE

Model 2160A

- 1mV/division sensitivity
- Sweeps to 5ns/division
- Dual time base
- Signal delay line
- V mode displays two signals unrelated in frequency
- Component tester

\$949.95

40MHz DUAL-TRACE

Model 1541C

- 1mV/division sensitivity
- Video sync separator
- 2-axis input
- Single Sweep
- V mode displays two signals unrelated in frequency
- Component tester

\$695

60MHz, CURSORS & READOUTS, DUAL TIME BASE

Model 2260

- Cursors and readouts
- 1mV/div sensitivity
- 23 calibrated ranges - main time base
- 18 calibrated ranges - delayed time base
- Signal delay time
- V mode - displays 2 signals unrelated in frequency
- Component tester
- 2-axis input
- Single sweep

\$1225

20MHz DUAL-TRACE

Model 2120 - 2 Year Warranty

Special \$389.95

Model 2125 with delayed sweep

\$539.95

- 1mV/division sensitivity
- AUTO-NORM triggered sweep operation
- AC, TVH, TVV and line coupling
- Calibrated 10 step time-base with x10 magnifier
- Compact low-profile design

Quality Scopes by Elenco



60MHz

DS-603 \$1350

- Analog / Digital Storage
- 20MS/s Sampling Rate

S-1360 \$749

- Analog with Delayed Sweep



40MHz

S-1345 \$569

- Analog with Delayed Sweep

S-1340 \$475

- Analog

25/30MHz

DS-303 \$1095

- Analog / Digital Storage

S-1330 \$439

- 25MHz Analog
- Delayed Sweep

S-1325 \$325

- 25MHz Analog

**2 Year
Warranty**

OSCILLOSCOPE SELECTION CHART

ANALOG		Sensitivity (max)	No. of Channels	Sweep Rate Max ns/div	Delayed Sweep	Video Sync	Component Tester	Beam Find	Time Base
Model	Bandwidth MHz								
S-1360	60	1mV/div	2	10ns/div	Yes	Yes	Yes	Yes	2
S-1345	40	1mV/div	2	10ns/div	Yes	Yes	Yes	Yes	2
S-1340	40	1mV/div	2	10ns/div	No	Yes	No	No	1
S-1330	25	1mV/div	2	10ns/div	Yes	Yes	Yes	Yes	2
S-1325	25	1mV/div	2	10ns/div	No	Yes	No	No	1

DIGITAL STORAGE		Analog Sen (max)	No. of Channels	Sampling Rate	Memory Channel	Internally Backed Up	Pretigger %	Output
Model	Bandwidth MHz							
DS-303	30	1mV/div	2	20MS/S	2K	Yes	0, 25, 50, 75	RS232
DS-603	60	1mV/div	2	20MS/S	2K	Yes	0, 25, 50, 75	RS232

Affordable Spectrum Analyzers by B&K

500MHz Series

Model 2615 - \$1595
Model 2620 w/ tracking generator - \$1895

1.05GHz Series

Model 2625 - \$2395
Model 2630 w/ tracking generator - \$2995

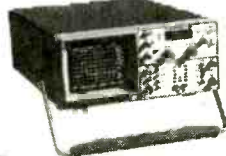

HITACHI SCOPES

HURRY... AT PRICES THIS LOW THEY'LL BE GONE FAST!

Inventory Reduction Sale

Lowest Prices of the Decade!

V-209 - 20MHz Battery Operated Was \$1505, NOW \$1095 Save \$410

V-422 - 40MHz Was \$965, NOW \$765 Save \$200

V-525 - 10MHz w/ Cursors Was \$1355, NOW \$955 Save \$400

V-552 - 50MHz Was \$1195, NOW \$850 Save \$345

V-555 - 50MHz w/ Cursors Was \$1375, NOW \$975 Save \$400

V-695 - 60MHz w/ Cursors Was \$1815, NOW \$1395 Save \$420

V-1065A - 100MHz w/ Cursors Was \$2139, NOW \$1565 Save \$574

V-1560 - 100MHz Was \$1790, NOW \$1490 Save \$300

V-1565 - 100MHz w/ Cursors Was \$1960, NOW \$1595 Save \$365

V-252 - 20MHz **\$419**

Fluke Scopemeters



91 \$1225
92B \$1445
96B \$1695
97 \$1795
97A \$2945
99B \$2095

Call or write for complete specs.

WE WILL NOT BE UNDERSOLD

UPS SHIPPING: 48 STATES 5%
OTHERS CALL FOR DETAILS
IL Residents Add 8% Tax

C&S SALES, INC.

150 W. CARPENTER AVENUE
WHEELING, IL 60090
FAX: (847) 520-9904 (847) 541-0710
http://www.elenco.com/cs_sales/



**15 DAY MONEY BACK
GUARANTEE**

FULL FACTORY WARRANTY
PRICES SUBJECT TO CHANGE WITHOUT NOTICE

CIRCLE 336 ON FREE INFORMATION CARD

**ABC ELECTRONICS 315 7TH AVE N. MPLS. MN. 55401
(612)332-2378 FAX (612)332-8481 30 DAY WARRANTY
WE BUY TEST EQUIPMENT AND COMPONENTS.**

TEK 7A13 DIFFERENTIAL COMPARATOR	\$150.00	TEK 7B15 1 GHZ DELAYING TIME BASE	\$250.00
TEK 7A16P PROG.200MHZ VERT.AMPLIFIER	\$75.00	TEK 7B50A 150 MHZ TIME BASE	\$75.00
TEK 7A17 150 MHZ SINGLE TRACE AMPLIFIER	\$50.00	TEK 7B52 DUAL TIME BASE	\$75.00
TEK 7A18 75 MHZ DUAL TRACE AMPLIFIER	\$50.00	TEK 7B53 100 MHZ DUAL TIME BASE	\$75.00
TEK 7A19 600 MHZ SINGLE TRACE AMPLIFIER	\$150.00	TEK 7B70 200 MHZ TIME BASE	\$75.00
TEK 7A22 DIFFERENTIAL AMPLIFIER	\$200.00	TEK 7B71 DELAYING TIME BASE	\$75.00
TEK 7A24 400 MHZ DUAL TRACE AMPLIFIER	\$200.00	TEK 7B80 400 MHZ DELAYED TIME BASE	\$100.00
TEK 7A26 200 MHZ DUAL TRACE AMPLIFIER	\$75.00	TEK 7B85 400 MHZ DELAYING TIME BASE	\$125.00
TEK 7D11 DIGITAL DELAY UNIT	\$50.00	TEK 7B90P PROGRAMMABLE TIME BASE	\$200.00
TEK 7D12 A/D CONVERTER MAINFRAME	\$50.00	TEK 7B92A 500 MHZ DELAYING TIME BASE	\$125.00
TEK 7D13 DIGITAL MULTIMETER	\$50.00	TEK AM502 DIFFERENTIAL AMPLIFIER	\$75.00
TEK 7M11 DUAL 50 OHM DELAY LINE	\$100.00	TEK MX5010 MULTIFUNC.INTERFACE EXTEN.	\$200.00
TEK 7M13	\$50.00	TEK 7834 400 MHZ STORAGE MAIN FRAME	\$400.00
TEK 7S11 SAMPLING PLUG IN	\$200.00	TEK 7844 400 MHZ MAIN FRAME	\$400.00
TEK 7S12 GENERAL PURPOSE SAMPLER	\$350.00	TEK 7854 400 MHZ DIGITAL STORAGE FRAME	\$500.00
TEK 7S14 1 GHZ SAMPLING PLUG IN	\$350.00	TEK 7904 500 MHZ MAIN FRAME	\$250.00
TEK PS5010 PROG.TRIPLE POWER SUPPLY	\$250.00	TEK 7104 1GHZ FRAME WITH-	\$2750.00
TEK 485 350 MHZ PORTABLE SCOPE	\$600.00	(7A29,7A29,7B10,7B15)	
KEITHLEY 480 PICOAMMETER	\$300.00	TEK 2235 100MHZ OSCILLOSCOPE	\$650.00
LEADER LBO516 100MHZ OSCILLOSCOPE	\$300.00	TEK 2246 100MHZ OSCILLOSCOPE	\$1200.00
GENRAD 1657 RLC BRIDGE	\$750.00	GENRAD 1658 RLC BRIDGE	\$900.00
SENCOR LC53 CAP-IND. METER	\$400.00	TEK 608 MONITOR	\$650.00
FLUKE 8505A 6.5 DIGIT DMM	\$250.00	TEK 577 D1/177 CURVE TRACER	\$1500.00
TEK DAS9100 WITH PROBES	\$750.00	HP 1651 LOGIC ANALYZER	\$1200.00
TEK 7D20 PROGRAMMABLE DIGITZER	\$500.00	TEK 2465 300MHZ OSCILLOSCOPE	\$2000.00

CELLULAR PROGRAMMERS!

COPYCAT MOTOROLA CELLULAR PROGRAMMER:
Program any phone up to EE3.
Ericsson Clip, OKI 900 Modified
Programming Cables Available.

TEL: 718-768-4963 718-575-1474

BROADCAST TRANSMITTER

The FMS2 studio quality transmitter is FULLY crystal controlled and programmable to any FM broadcast frequency.

Unit features: ALC, 2:1 compressor, audio buffer / amplifier, pre-emphasis, roll off filter, stereo generator, digital PLL tuning, 75 MHz-125MHz bandwidth, 500mW power output and a special introductory price of only \$295.00 US.

Schematics for unit \$27. CATALOG 800-504-1178
File #Q44 INFO 416-243-1067. TEK Line 416-243-2260

**WE HAVE IT ALL!
Surveillance**

- Infinity Transmitters
 - FM Wireless Transmitter Kits
 - Vehicle Tracking Systems
 - Bug Detectors
 - Caller I.D.
 - Wired Mikes
 - Telephone Register with Printer
 - Long-play Recorders
 - Shotgun Mikes
 - Telephone Recording Adapters
 - Alcohol Testers
 - Telephone Scramblers
 - Hidden Video Cameras
 - Telephone Tap Detectors
 - Drug Testers
- MUCH, MUCH, MUCH MORE.**

Our 27th Year!

Small catalog FREE.
Larger catalog send \$5.

Mail Order only. Visa, MasterCard and C.O.D. accepted for equipment only.

Inquire for dealers' prices.

A.M.C. SALES, INC.

193 Vaquero Dr. • Boulder, CO 80303
Mon.-Fri. 8 a.m.-5 p.m. Mtn. Time

800-926-2488

(303) 499-5405 • Fax (303) 494-4924

Internet: <http://www.siteleader.com/catalogdepot/AMCSC-home.html>

E-mail: amc-sales@siteleader.com

**BEST DEALER PRICING!
CABLE DIRECT
CONVERTERS • FILTERS
DESCRAMBLERS**

**IMPROVE YOUR IMAGE WITH
VIDEO STABILIZERS**



**30 DAY
FREE TRIAL!**

FREE Cable TV Catalog.



Now you can tune-in your favorite cable TV programming and **SAVE \$100'S - EVEN \$1000'S** on premium CABLE TV EQUIPMENT.

MODERN ELECTRONICS

1-800-906-6664

2125 S. 156TH CIRCLE • OMAHA, NE 68130

LASERS & ACCESSORIES

WE SPECIALIZE IN
Laser and Laser Related Surplus Inventory

HE NE LASERS

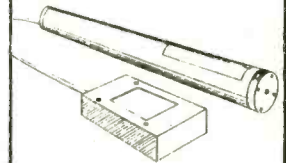

- Complete Systems
- Plasma Tubes
- Power Supplies

DIODE LASERS



- Visible I/R
- Complete Modules
- Collimating Optics
- Drive Circuits

ACCESSORIES

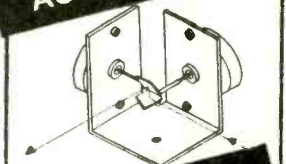

- Books
- Optics
- Electro-Optics

CALL FOR A FREE CATALOG!

We want your Laser related surplus items. Call or Fax us today for a quote!

MEREDITH INSTRUMENTS

P O Box 1724
5035 N. 55th Ave. #5
Glendale, AZ 85301

Phone: 602-934-9387
Fax: 602-934-9482

[HTTP://WWW.MI-LASERS.COM](http://www.MI-LASERS.COM)

DO-IT-YOURSELF AUDIO AMPLIFIER KITS

Mark V Electronics, Inc.
8019 E. Slauson Ave.,
Montebello, CA 90640

In business since 1985

Mention AD
& take 10% off
your 1st order!

Enclosures at Urbeatable prices!
New educational kits for learning and more fun!

Free Catalog 213/888-8988 Fax 213/888-6868

Order 1-800-521-MARK / 1-800-423-FIVE

Kit skill levels are specified as ▲ beginner ▲▲ intermediate or ▲▲▲ advanced!

Best Buy

Metal Cabinets with Aluminum Front Panel

LG-1273 3x12x7" \$ 26.50
LG-1684 4x16x8" 32.50
LG-1924 4x19x11 1/2" 38.25
LG-1925 5x19x11 1/2" 42.00
LG-1983 2 1/4x19x8" 35.25
LG-1923 3x19x11 1/2" 36.50
LG-1927 7x19x11 1/2" 50.50



LG- Black anodized rack cabinet

Modular Desktop Consoles

L x W x H
LE-453 4x4 3/4x3" \$ 7.50
LE-653 6x4 3/4x3" 9.75
LE-853 8x4 3/4x3" 11.75
LE- Black finished aluminum panel 1mm thick.

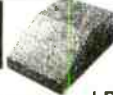

Alarm Box with Lock

LB-1085 8 1/2x10 1/4x5" \$ 18.75
LB-1395 9 1/2x13 1/4x5" 25.50
LB-1525 12 1/4x15 1/4x5" 35.25
*LB-1494 9 1/4x14 1/4x4 1/2" 21.50
LB-1383A 8 1/2x13 1/4x4" 23.25
*No lock & LB- Sheet Metal 0.8mm

Mejor Compra!

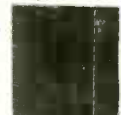

New

*LL-1923B 2 3/4x19x12" 69.50
*LL-1925A 5x19x12" 79.50

*LL- High quality full Aluminum Cabinet
*LL- Front panel .157" & other panels .078"
*LL- Gold plated cap screw for front panel

- Dimensions in inches ± .05
- Custom-made for other dimensions
if over 100 pcs for single model!

Camera Housing

*LD-1244 2 1/4x10 1/4x4" \$55.00
**LD-1516 3 3/4x13 3/4x4" 29.50
**LD-1565 4x13 3/4x5 1/4" 31.75
*LD- Stainless Steel 0.7mm
**LD- Sheet Metal 1mm



Power Transformers ***Toroidal Transformer

001 28/30V x 2 6A \$ 30.00
002 36v x 2 3A 25.00
003 40v x 2 6A 32.00
**008 2E/30V x 2 5A 40.00
**009 4E/53V x 2 3A 66.00
**012 3E/40/42Vx2 5A 48.00



TA-800MK2 ▲▲ 120+120W Pre & Main Stereo Amp. (4 lbs.)



Kit: \$ 67.92
Asmb. \$ 86.95

Power Output: 120W into 4 ohms RMS. 72W into 8 ohms RMS. Frequency Response: 10-20KHZ. THD: <0.01%. Tone Control: Bass ±12dB, Mid & Treble ±8dB. Sensitivity: Phono Input, 3mV into 47K. Line, 0.3V into 47K. Signal to Noise Ratio: 86dB. Power Requirement: 40VDC @ 6A. Suggested Mark V model 001 or 008 transformer. Recommended Metal Cabinet LG-1924.

AF-3 ▲▲▲ 300W MOSFET High Power Mono Amp. (7 lbs.)



Kit: \$ 165.00 Asmb. \$ 195.00

Power Output: 300W into 4 ohms RMS. 200W into 8 ohms RMS. Frequency Response: 10HZ-20KHZ. THD: <0.03%. Signal to noise ratio: 91dB. Input Sensitivity & Impedance at 1KHZ, 1V 47K. Load Impedance 4-16 ohms. Power Requirement: ±55 to ±65VDC 8A. Suggested Mark V model 009 Transformer. Capacitor 10,000uf 80-100V model 016 or 019. Recommended Metal Cabinet LG-1925 for each channel.

TA-388 ▲▲▲ Class A FET Dynamic Buffer Stereo Pre-Amp (1 lb.)

Best Pre-Amp



Kit: \$64.00 Asmb. \$ 80.00

Frequency Response (at rated output): Overall 10HZ-100KHZ +0.5dB-1dB. THD: Overall <0.007% at or below rated output level. Channel Separation (at rated output 1KHZ): Overall better than 70dB. Hum & Noise: Overall better than 90dB. Input Sensitivity (1KHZ for rated output): 300-600mV. Maximum Output Level: Pre-Amp output 1.8V (0.1% THD). Power Requirement: 30V X 2 AC 500mA

SM-100 ▲▲▲ 150 MHZ 8 Digit Frequency Counter (2 lbs.)

Best Buy



Kit: \$ 79.00
Asmb. \$ 99.00

Frequency Range: 10HZ-150MHZ. Gate Time: 0.01s, 0.1s, 1s, 10s. Input Sensitivity: KHZ range 10HZ-10MHZ 20mV(min.). MHZ range 1MHZ-120MHZ 20mV(min.) 120MHZ-150MHZ 35mV (min.), 150MHZ-200MHZ 40mV(typical). Time Base: 10MHZ crystal, ±10 ppm Input Impedance: 1M ohm. Response Time: 0.2s Resolution: 0.1 HZ: 10s gate time, 1HZ: 1s gate time 10HZ: 0.1s gate time, 100 HZ: 0.01s gate time. Hold the last input signal. Reset counter to 0. DC 9V power adapter not included.

School Educational Kits Source ...

KA-901 30-In-one electronic lab kit \$ 15.99

No soldering s required! Build a radio, alarm, timer... Earphone for private listening. Uses safe battery power. Requires 4 "AA" batteries*.

KA-902 130-In-one electronic lab kit \$ 29.99

Build your own AM broadcast station, electronic organ, timer.. No special tools or soldering required due to premounted parts, pre-cut wires and simple coil-spring connectors. Requires 6 "AA" batteries*.

KA-904 500-In-one electronic lab kit \$ 98.99

Contains its own computer with a simple explanation of the basic(Assembler) language required for operation. Compile programs to discover how computers operate while gaining an understanding of hardware & software. With easy-to-follow manual which explains by comprehensive diagrams. Requires 6 "AA" batteries*.

KA-905 75-In-one electronic lab kit \$ 24.99

Build strobe light, touch switch, metronome, sound-level meter... No special tools or soldering required. Requires 4 "AA" batteries*.

KA-906 300-In-one electronic lab kit \$ 59.99

Learn about transistors, capacitors & electronic circuits. Build electronic games, battery checker... It even includes a breadboard for adding your own components. Complete with easy-to-follow manual. Requires 6 "AA" batteries*.

*Batteries are not included!

KA-905



KA-906



See our catalog for more kits!

Minimum order \$ 20. We accept Visa, MasterCard & Money Orders. Checks allow 2 weeks for clearance. We ship by UPS ground inside US (2 lbs min \$ 5.00) and ship by US mail outside US. Please call for orders shipping & handling or fax (foreign) orders. PO Orders are welcome from schools. We are not responsible for typographical errors.

CIRCLE 332 ON FREE INFORMATION CARD

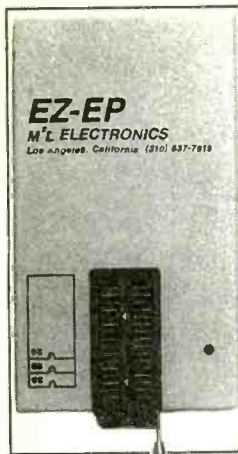

EZ-EP DEVICE PROGRAMMER - \$169.95

- Fast** - Programs 27C010 in 23 seconds.
- Portable** - Connects to PC Parallel Port.
- Versatile** - Programs 2716-080 plus EE and Flash (28F,29C) to 32 pins.
- Inexpensive** - Best for less than \$200

- Correct implementation of manufacturer algorithms for fast, reliable programming.
- Easy to use menu based software has binary editor, read, verify, copy, etc. Free updates via bbs or web page.
- Full over current detection on all device power supplies protects against bad chips and reverse insertion.
- Broad support for additional devices using adapters.

Adapters Available

EP-51 (8751,C51)	\$39.95
EP-11 (68HC11 E/A)	\$59.95
EP-PIC (16C5x,61,62x,71,84)	\$49.95
EP-PIC64 (16C62,63,64,65,73,74)	\$39.95
EP-PEEL (ICT 22V10, 20G10, 18V8)	\$59.95
EP-SEE (93x,24x,85x)	\$34.95
EP-16 (16bit 40 Pin EPROMs)	\$49.95
EP-49 (8742,48,49)	\$49.95
EP-750 (87C750,751,752)	\$59.95
EP-Z8 (Z86E03,04,05,06,07)	\$39.95
EP-55 (8755)	\$39.95
EP-51-PLCC (8751,C51)	\$59.95
EP-PIC-SOIC (16C5x,61,62x,71,84)	\$59.95
EP-PLCC (PLCC EPROMs)	\$49.95
EP-SOIC (SOIC EPROMs)	\$49.95
EP-LCC (LCC EPROMs)	\$49.95

M²L Electronics

3526 Jasmine #4; Los Angeles, CA 90034
 310/837-7818 Fax/BBS: 310/841-6050
<http://www.cit.ucla.edu/csd-grads-gs3/loving/www/m2l.html>
 CA orders add 9.25% sales tax. Ground shipping - \$5; 3 Day - \$7; 2 Day \$10; Overnight \$17; COD \$4.75.

You can Build Gadgets! Here are 3 reasons why!

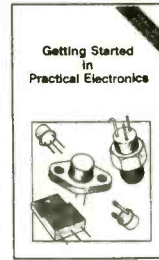

BP345—GETTING STARTED IN PRACTICAL ELECTRONICS \$5.95

If you are looking into launching an exciting hobby activity, this text provides minimum essentials for the builder and 30 easy-to-build fun projects every experimenter should toy with. Printed-circuit board designs are included to give your project a professional appearance.

BP349—PRACTICAL OPTO-ELECTRONIC PROJECTS \$5.95

If you shun opto-electronic projects for lack of knowledge, this is the book for you. A bit of introductory theory comes first and then a number of practical projects which utilize a range of opto devices, from a filament bulb to modern infrared sensors and emitters—all are easy to build.

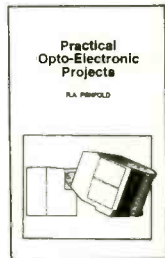

BP363—PRACTICAL ELECTRONIC MUSIC PROJECTS \$5.95

The text contains a goodly number of practical music projects most often requested by musicians. All the projects are relatively low-in-cost to build and all use standard, readily-available components that you can buy. The project categories are guitar, general music and MIDI.

Mail to:

Electronic Technology Today, Inc.
 P.O. Box 240
 Massapequa Park, NY 11762-0240

Shipping Charges in USA & Canada

\$0.01 to \$5.00	\$2.00	\$30.01 to \$40.00	\$6.00
\$5.01 to \$10.00	\$3.00	\$40.01 to \$50.00	\$7.00
\$10.01 to \$20.00	\$4.00	\$50.01 and above	\$8.50
\$20.01 to \$30.00	\$5.00		

Sorry, no orders accepted outside of USA and Canada. All payments must be in U.S. funds only.

Number of books ordered.

Total price of books	\$
Shipping (see chart)	\$
Subtotal	\$
Sales Tax (NYS only)	\$
Total enclosed	\$

Name _____

Address _____

City _____ State _____ ZIP _____

Please allow 6-8 weeks for delivery.

NEW DX SERIES DMMs

3 YEAR WARRANTY COVERS FULL PERFORMANCE

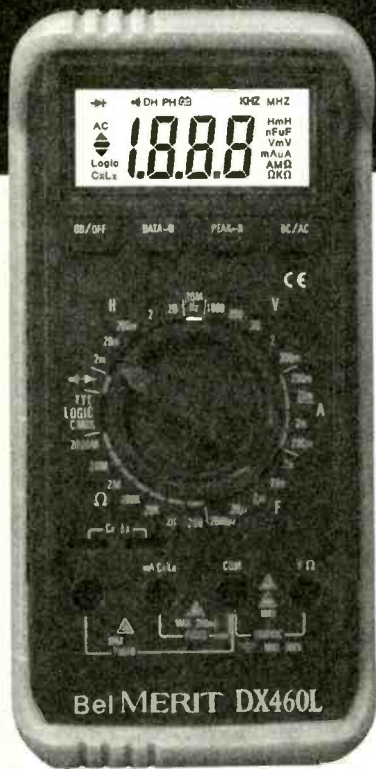

Bel MERIT DX Series DMMs have best values for performance, features and dependability with 3 year warranty.

Each DX model has standard DMM measurements with a set of additional capabilities; diode, continuity, TRhFE, capacitance, inductance, frequency, logic and temperature.

Additional features include auto power-off, data hold, annunciator, and input warning beeper & peak hold (DX451/DX460L only)

Deluxe holster, safety test leads and thermocouple probe (DX360T) supplied as standard accessories.

MODEL	DX350	DX360T	DX400	DX405	DX451	DX460L
AC/DC Voltage (750V/1000V)	*	*	*	*	*	*
AC/DC Current (10A)	20µA	*	*	*	*	*
Resistance (20MΩ)	20kΩ	2000M	*	*	2000M	2000M
Continuity Beeper/Diode	*	*	*	*	*	*
Temperature w/Probe, Type K	*	*	*	*	*	*
TRhFE	*	*	*	*	*	*
Capacitance (20µF)	*	*	*	*	*	2000µ
Frequency (20MHz)	*	*	*	*	*	*
Logic (TTL & CMOS)	*	*	*	*	*	*
Inductance (20H)	*	*	*	*	*	*
Auto Power-Off	*	*	*	*	*	*
Input Warning Beeper	*	*	*	*	*	*
Data Hold	*	*	*	*	*	*
Peak Hold	*	*	*	*	*	*
Protective Holster	*	*	*	*	*	*
Suggested Resale Price	49.95	64.95	64.95	69.95	89.95	109.95

• Lots of High Standard Test Instruments available

All in One Instrument, Oscilloscope, Power Supply, Function Generator, Frequency Counter, Multimeter, Capacitance, Engine Analyzer, Clamp-On, Electrical Tester and More.

• See your local distributors or Call for Catalog

Bel MERIT **1-800-532-3221**
 (714) 586-2310 • FAX (714) 586-3399
SOLUTIONS FOR THE TEST INSTRUMENT P.O. Box 744, Lake Forest, CA 92630

CIRCLE 325 ON FREE INFORMATION CARD

ARE YOU BEING "BUGGED?"

EVEN AS YOU READ THIS, countless individuals and firms are being enormously damaged by having their private conversations overheard, monitored, and/or recorded.

Almost without exception and AFTER the fact, the victims make a statement something along the lines of "But, I never thought it could happen to ME!"

OUR FINEST

Counter-Surveillance Device

THE ULTIMATE IN "BUG" DETECTION EQUIPMENT
"DEBUGS" ROOMS AND TELEPHONES!

If you require GUARANTEED PROTECTION against electronic telephone monitoring devices and COMPLETE CONFIDENTIAL PRIVACY in certain rooms and areas, we highly recommend the COUNTER-SURVEILLANCE DETECTOR CSD-18.



CONDUCT A PROFESSIONAL SEARCH...ANYTIME...ANYWHERE!

Every newspaper and magazine article and every radio and TV story discussing some new episode involving "bugging" devices, continues to increase the ever growing demand for electronic Counter-Surveillance "sweeps" and equipment. The very limited supply of competently trained and equipped Counter-Surveillance specialists has created a situation where "sweep" rates exceeding \$250 per hour are now considered reasonable and appropriate.

This is an exciting, immensely interesting and profitable field that you can enter with a minimum investment. Two hours actual practice with the CSD-18 will have you "reading" and "clearing" telephones and rooms with professional ease and competence. The average fee for "debugging" a single telephone is over \$200.00. It requires about 45 minutes to complete the job and once it gets around that YOU can provide this service, you'll quickly have more clients than you can handle. Even if you choose to provide "sweeps" for only a small number of friends and associates, your initial investment will quickly be returned many times over.

FREE WITH ORDER!

SUBMINIATURE "BODY WIRE" DETECTOR!

If you fear the possibility of being overheard and/or recorded during private conversations and require "silent" notification, we've also included our SBD-5 (regularly \$225) as a FREE GIFT! Only 3" x 2" x 1", this exciting new development in micro-miniaturization will instantly detect hidden body wires at ranges up to 10 ft and alert you via a silent vibration.

BIG MONEY OPPORTUNITIES!

Also, complete information describing the fantastic opportunities now open to trained Counter-Surveillance technicians and how a number of individuals are reaping a Bonanza in this booming business! You'll learn exactly how the ever increasing use of Electronic Listening Devices by investigative agencies, government agencies, jealous suitors and unscrupulous business competitors, etc. has created huge demand for this service.

FASCINATING HI-TECH INFORMATION PACKAGE!

A detailed analysis of a variety of extremely fascinating hi-tech devices and procedures used for ultra-sophisticated audio and video eavesdropping including micro-wave and laser device monitoring; new methods for listening thru walls; all about scramblers, voice changers and exactly how neighbors eavesdrop. How missing persons are found, confidential data banks are broken into, lie detectors deceived and much more!

A comprehensive information package JAM-PACKED FULL of some of the most exciting and fascinating reading imaginable. Reads like a James Bond novel, with one important exception...IT'S NOT FICTION!

THE ONE "BUG" TO FEAR MOST!

While most individuals are now somewhat guarded in their telephone conversations, they still rather naively feel secure in the "privacy" of their own home or office. However, the most common type of "tap" presently used by eavesdroppers now picks up ALL SOUNDS AND CONVERSATION WITHIN A ROOM... WITH THE TELEPHONE STILL ON THE HOOK!

Due to this devastating capability, this "Infinity" tap (variously referred to as Infinity Transmitter, Hookswitch Bypass, 3rd Wire, Harmonica Bug, etc.) has become the "bug of choice".

In flagrant violation of federal law prohibiting their use and sale, these devices in various forms are openly advertised in many technical publications for as little as \$30. Literally thousands of these devices are now in the hands of unscrupulous individuals all over the country!

In response to this ever-growing threat, a uniquely engineered feature of the CSD-18 now also detects Infinity type devices anywhere "down the line".

In other words, if ANYONE ... ANYWHERE ... is utilizing the telephone tap and/or ring wires to monitor your private room conversations while your telephone is on the hook, you'll immediately be made aware of it via a flashing LED!

100% POSITIVE INDICATION

The CSD-18 also flawlessly detects "Series" and "Parallel" telephone transmitters and "Telephone Recording Devices". And, a separate feature silently indicates when extension phones are picked up or being used. The CSD-18 completely eliminates all doubt and guesswork.

EXCLUSIVE "LISTEN-IN" FEATURE!

The CSD-18 will even allow you to "listen-in" to exactly what the eavesdropper is surreptitiously monitoring. And, without the eavesdropper ever becoming aware that he has been detected! We are unaware of ANY other detection equipment having this combined capability AT ANY PRICE!

EXTREME SENSITIVITY!

This is our finest piece of detection equipment! The CSD-18 quickly locates electronic eavesdropping devices in telephones, homes, offices, vehicles, boats, or concealed on the body. It will actually pick up many eavesdropping transmitters at ranges up to 25 ft! Extreme sensitivity is obtained via ultra-efficient amplification circuitry directly following the RF detection stages. Excellent quality dynamic headphones exclude all external sounds to further enhance detector output.

Encapsulating an extremely wide-band frequency coverage of under 1 Mhz to over 3 Ghz, the CSD-18 quickly "homes-in" on any eavesdropping transmitter and immediately pinpoints its location. The closer you get to the "bug", the further the needle moves to the right. It's as simple as that.



FULL RANGE DYNAMIC HEADPHONES

"FLASHING" LED Warns You Instantly!



And, for maximum telephone security, the CSD-18 automatically analyzes a pre-programmed series of electronic measurements along the telephone line and converts the analysis into an easy to follow, step by step, test procedure. No technical knowledge is required or necessary. A visual indication (via a flashing LED) immediately reveals the presence of the various types of telephone "taps" and the flashing sequence identifies the actual type of eavesdropping device.

DETECTS THE LATEST "SUPER-BUGS"

Exclusive GSS proprietary circuitry assures the utmost privacy protection possible today. The CSD-18 detects even the very latest ultra-sophisticated eavesdropping devices specifically designed to defeat detection, including sophisticated "Frequency Hoppers" and "Burst Bugs". Also includes multi-line option for testing business phones.

MAXIMUM PROTECTION

The CSD-18 detects and locates ALL major categories of surveillance equipment including:

- BUMPER BEEPERS,
 - "BODY" TRANSMITTERS
 - TELEPHONE RECORDING DEVICES
 - SERIES & PARALLEL PHONE TRANSMITTERS
 - "INFINITY", MICRO-WAVE AND "LASER" BUGS
 - & ALL TYPES OF CONCEALED TRANSMITTERS
- including Video, Computer and Fax Transmitters*

CSD-18 **\$495** Complete

Includes headphones, antenna/probe, all plugs and adapters, batteries, the Free SBD-5 & Info Packages.

HOW TO ORDER

Order NOW by Mail or Telephone. 10 DAY MONEY BACK GUARANTEE if you're not 100% pleased and completely satisfied. We pay shipping charges on all prepaid & credit card orders. Add \$15 for CODs.

© 1995 **Great Southern Security**

513 Bankhead Highway
Carrollton, GA 30117

FOR FASTEST SERVICE CALL TOLL FREE

ORDER BY PHONE **1 800 732-5000**



CIRCLE 315 ON FREE INFORMATION CARD

17" Sony Trinitron Monitor

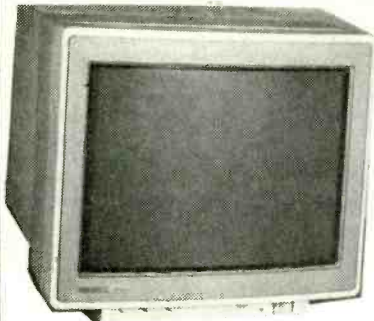

This is our most popular item. In good condition, they meet new unit specs. Not a multisync, works fine with Macintosh, or on IBM with Photon video card Tuned, with cables for Mac \$225.00. With Photon video \$375.00. Basic monitor \$175.00 52 Lbs Shipping.

Dear Readers,

Ordering from V&M Surplus is easy. No minimum order, no hidden charges, most items postpaid. Your satisfaction guaranteed, or your money back. I am an avid collector, and right now I am looking for the following items: Norden Bombsight, M209 Converter (crypto-machine), K9 Ball Turret Sight. Cash or trade. *Franklin D. Inn CEO, CC&RW*

Vision and Motion Surplus

222 Pleasant Street
Marlboro, MA 01752

1-800-471-0747, 1-508-881-4900

Welch Allyn Bar Code Reader



Dreaming about using bar code? Here is your big chance. This late model bar code reader is the Welch Allyn Scanteam 3600. Uses standard product barcode, easy to use, requires only 5 VDC. With full technical manual, works with standard bar code software. \$49.00 Postpaid. Unused.

Fascinating
Corner Cube
Prism

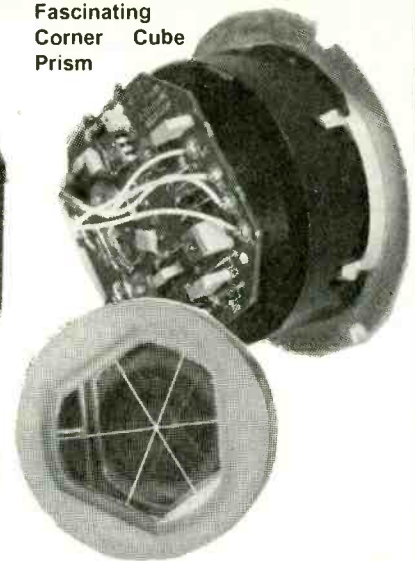

One of the most fascinating optical components, the corner cube directs light back to its source. Used by surveyors, planted on the moon by Apollo astronauts, these beautiful gem-like prisms are usually quite expensive. We have two types available:
1. 60 mm dia. 5 sec accuracy, surveyors type mounted 20mm offset.
2. Military assembly with corner truncated and electronic unit with IR filter, similar specs. If you know what these were used for, please tell me. Either type\$49.00 Postpaid. Unused.

CIRCLE 322 ON FREE INFORMATION CARD

M/C & VISA
ACCEPTED

TEST EQUIPMENT SALES

P.O. BOX 986
LONDONDERRY, NH 03053

HP 8012B...PULSE GENERATOR....\$595
 TEK FG504....FUNCTION GEN.....\$525
 FLUKE 752A....REF. DIVIDER.....\$2695
 DIO 2900.....PROGRAMMER.....\$1895
 AR 5014.....HIPOT TESTER.....\$295
 HP 8082A...PULSE GENERATOR....\$995
 TEK 7104.....1 GHz SCOPE M/F...\$1895
 TEK 2215A.....60 MHz SCOPE.....\$650
 TEK 11A72.....1 GHz PLUG-IN.....\$1495
 TEK 576.....CURVE TRACER.....\$2395
 TEK 7S14.....1 GHz SAMPLER.....\$595
 TEK 475.....200MHz SCOPE.....\$625
 FLUKE 5100B....CALIBRATOR.....\$5295
 TAS 112.NETWORK SIMULATOR.\$2995
 TEK PG502.....PULSE GEN.....\$550

HP 6205B....POWER SUPPLY.....\$250
 KEI 224....CURRENT SOURCE.....\$995
 TEK 465.....100MHz SCOPE.....\$475
 HP 6237B....POWER SUPPLY.....\$495
 TEK DM5010.....DMM P/I.....\$550
 TEK SG503...SINE WAVE GEN....\$695
 HP 6940B....MULTIPROGRAM....\$195
 TEK 11302A...500MHz SCOPE...\$2495
 TEK PS5010..POWER SUPPLY...\$795
 TEK 7L5...SPEC. ANALYZER....\$1295
 TEK TR503...TRACKING GEN....\$995
 TEK 2465....300MHz SCOPE.....\$2750
 HP 3325A...SYNTH/FUNC. GEN.\$1995
 MAR TF2091B.....NOISE GEN....\$495
 TEK DC509..COUNTER/TIMER...\$450

FLUKE 5200A....AC CALIBRATOR....\$1895
 TEK 2445.....150MHz 4 CH. SCOPE..\$1750
 KEI 619.....ELECTROMETER.....\$995
 WAV 801.....PULSE GENERATOR.....\$795
 TEK DC5010.....COUNTER P/I.....\$895
 HP 8444A/059....TRACKING GEN.....\$950
 HP 3312A.....FUNCTION GEN.....\$795
 TEK 11A52.....600MHz PLUG-IN....\$795
 ROD-L M100AVS4..HIPOT TESTER..\$695
 TEK 2252..100MHz PROG.SCOPE...\$2495
 HP 8754A..NETWORK ANALYZER.\$2495
 BMI 2400....POWER ANALYZER.....\$1095
 HP 3488A.....CONTROL UNIT.....\$995
 MAR TF2092C...NOISE RECEIVER...\$595
 ROD-L M35.....GROUND TESTER...\$1595

WE BUY
SURPLUS

PHONE (800) 684-4651
FAX (603) 425-2945

SATISFACTION
GUARANTEED



-SPY, INC.
 ELECTRONIC SURVEILLANCE &
 PRIVACY ASSURANCE DEVICES
 Cell & Home Phone Scramblers, Covert Video
 Cameras, State of the Art Electronic Devices
 "YOU NEVER KNOW WHO'S WATCHING OR LISTENING"
 For a Full Catalog Send \$5 Check or M.O. to:
 I-SPY, Inc., PO Box 1707EN Amherst, NY 14226
 or call (716) 874-1707

The Ultimate WWW Service Site

www.electronix.com

The One-Stop Service Site
for Electronic Technicians

Electronix Corp 313 W Main St Fairborn, OH 45324

CABLE TV CONVERTERS

Equipment & Accessories
Wholesalers Welcome

Call C&D ELECTRONICS
1-800-310-1153 M-F 10a-6p

Skyvision, Inc.
 1046 N. Frontier Dr. Fergus Falls MN 56537

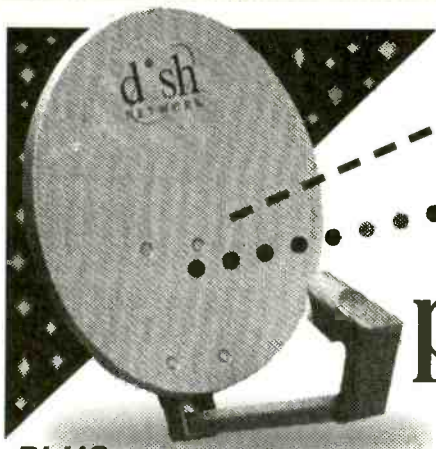

Small dish,
BIG
 programming!

PLUS:

- ▼ Multi-room TV viewing options & accessories
- ▼ Mobile systems for RV's & vacation homes

AND MORE!

800-500-9264

Skyvision®

www.skyvision.com

40 of America's Most Popular TV Channels includes DISNEY



- ▼ Makes cable & other 18" dish options obsolete.
- ▼ The HOTTEST digital programming available!



Nothing Else ComparesSM
DISH NETWORK is a registered Service Mark of EchoStar Comm. Corp.

FREE DISCOUNT BUYER'S GUIDE

**KEEP YOUR SYSTEM
 RUNNING STRONG!**

MOST COMPLETE SELECTION OF:

- ✓ System Upgrades
- ✓ Parts & Accessories
- ✓ Tune-up Tools & Kits
- ✓ Complete Systems
- ✓ Technical Support Hotline
- ✓ Discount SKYPAC™ Programming

GET YOUR FREE ISSUE NOW!

800-334-6455

NEED A REPAIR ITEM FAST? WE'LL GET IT OUT TODAY!

Skyvision®

www.skyvision.com



February 1997, Electronics Now

CIRCLE 270 ON FREE INFORMATION CARD

Move Up to the Ultimate in Robotic Kits.

OWIKIT™



OWI's "Next Generation" of affordable, rugged Robot Kits challenge the enthusiast to solder circuit boards and mechanically assemble.

Visit our homepage @ <http://www.owirobot.com>

Each OWIKIT also incorporates the basic principles of robotic experiments, sensing and locomotion, guaranteeing an exciting, hands-on adventure of knowledge and fun!

But remember! OWI is the recognized founder and leader in Educational Robot Kits. **ACCEPT NO IMITATIONS.**

ROBOT.TECH.CURR. MV-RTC	Teacher's Manual	158 Pg. Book	74.95
GEAR BOX OWI-GB25	Selectable Gear Box		10.00
ELECTRO-MAGNETIC TRAIN			10.00
S-CARGO OWI-936K	Sound Sensor	47 Pg. Book	36.95
WAO II OWI-961K	Programmable - Graphic	59 Pg. Book	69.95
SPIDER OWI-962K	Infrared Sensor	49 Pg. Book	49.95
LINE TRACKER OWI-963K	Infrared Sensor	48 Pg. Book	49.95
MANTA OWI-966K	Sound / Touch Sensor	44 Pg. Book	29.95
MOON WALKER OWI-989K	Solar Sensor	10 Pg. Book	34.95

CIRCLE 318 ON FREE INFORMATION CARD



EK ELEKIT

1160 Mahalo Place, Suite B
Rancho Dominguez, CA
90220-5443

(310) 638-7970
Fax: (310) 638-8347



Order M - Fr. 8am. - 4pm. PST

CABLE TV

CONVERTERS AND DESCRAMBLERS

WE CARRY A FULL LINE OF CONVERTERS AND DESCRAMBLERS COMPATIBLE WITH MOST MAJOR BRANDS INCLUDING:

- Scientific Atlanta™
- Jerrold™
- Tocom™
- Zenith™
- Pioneer™

30 DAY MONEY BACK GUARANTEE
BEST PRICES FREE CATALOG

ALLSTAR ELECTRONICS

800-782-7214

HOURS: 9-6 M-F 10-3 Sat EST

It is not the intent of Allstar Electronics to defraud any pay TV operator. Anyone implying theft of service will be denied assistance. All brand names are registered trademarks of their respective owners & are used for reference only. 110-84 Queen's Blvd., #488, Forest Hills, NY 11375. NO NYS SALES.

3 Axis Motion Control System Complete, ready to run

\$ 255.50 + 12.00 S/H

Build or adapt CNC mills, CNC routers, Robots, Etc. Includes: 3 Stepping motors (70 oz/in 200 steps/rev). External board (connects to parallel port of a PC). Power supply. Cables, Manual and the MAXNC drive software, with linear, circular and helical interpolation, acceleration deceleration, full contouring, 'G' code programming, screen plot, code generation from CAD (CAM), and more.

For more information, phone or write to:

MAXNC

6509 W. Frye Rd. Suite 3
Chandler AZ 85224
Ph (602) 940-9414
Fax (602) 940-2384

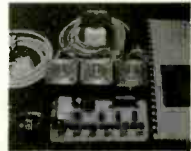

Robot Explorer Newsletter

Nano-ants, flying robots, Martian explorers. Explore an entire universe of exciting robots. 8 information-packed issues for only \$14.95. Call now! MasterCard/Visa Accepted.

1-(800) GO-ROBOT or 1-(800)467-6268

MICRO SIZE CCD VIDEO CAMERAS

MB-750U
Video Camera

\$99.95

MB-705UX
C-Mount Camera
with Lens Included;
8 or 12mm Lens



Micro Lipstick Cameras for Teleconferencing.

PANASONIC & SONY
Imaging Distributor

Polaris Industries

New Literature Available for All Models. Same Day Shipping from Stock!

1-800-752-3571

Visit Polaris Ind. Web Site at:
<http://www.polarisusa.com>



470 Armour Drive NE • Atlanta GA 30324 • Tech Info: 404-872-0722 • FAX 404-872-1038

NOW MAKE AN EXTRA \$600 PART TIME WEEKENDS -- UP TO \$2,000 A WEEK FULL TIME IN Explosive SATELLITE DISH TV/ELECTRONICS FIELD!

Hottest Career Opportunity Since Invention of the VCR!

See How Fast The Money Rolls In!

Part time: *Here's what you can earn
over a typical weekend:*

Install 2 Satellite dish systems at \$200 = \$400
Repair 4 TV's at \$50 each = \$200

Total Weekend Income = \$600

Full time: *Working just five days a week
you could easily earn:*

Install 5 Satellite dish systems at \$200 = \$1,000
Repair 10 TV's, average \$50 each = \$500
Clean and adjust 10 CD players, average \$35 each = \$350
Service 2 Home entertainment centers at \$75 = \$150

Total Weekly Income = \$2,000

**In addition you can make big extra profits
on other supplies you furnish!**



Get in **THE FAST LANE** on the NEW "INFORMATION SUPERHIGHWAY" Everyone's Talking About!

It's exciting! It's gigantic! The technology of tomorrow is here today! You've been reading and hearing about the amazing Information Superhighway. It's so new that few technicians are equipped to service

this fast emerging field! Foley-Belsaw gives you Satellite dish technology (including new mini-dish) along with the electronic expertise you need to make big money servicing TVs and other electronic equipment.

Be your own boss! It's quick and easy to become an expert at home in your spare time. Earn really BIG money adjusting, installing and repairing • **Satellite dish systems** • **TV's** • **Amplifiers** • **CD players** • **AM/FM tuners** • **Home entertainment centers**. Every home, every business, every office in your area desperately needs your expertise!

Your timing just couldn't be better! Never before and probably never again will you have a ground-floor opportunity like this to get into a booming business of your own, make really big money starting right away, be your own boss and enjoy financial freedom and security. The fact you're reading this message shows you're smart enough to realize this!

Satellite dish/TV/Electronics is easy

to learn in your spare time at home. This modern, practical hands-on course combines simple step-by-step lessons with easy-to-follow video cassette guidance. No special experience or electronics background is necessary. Just average mechanical aptitude and the ability to follow simple A-B-C repair procedures that are clearly outlined for you.

And when you complete the course you will receive Foley-Belsaw's official diploma attesting to your expertise.

**30-DAY
NO RISK TRIAL**
Send for details

Send coupon today for **FREE Fact Kit. No obligation.**

Don't miss out on this once-in-a-lifetime opportunity. Send in the coupon NOW. Get all the facts and study them in the privacy of your own home. There's absolutely no obligation and no salesman will call on you. So don't delay. Mail the coupon today!

MAIL TODAY FOR FREE INFORMATION PACKAGE

Foley-Belsaw Institute
6301 Equitable Road
Kansas City, MO 64120-1395



- YES! Without obligation send free Information kit so I can learn how to become a professional **Satellite Dish/TV/Electronics Specialist**, in order to earn high extra income. Dept. 31371
- VCR Repair**-Unlimited profits in this growing field. Dept. 62599
- Interested in an exciting, money making career in **Computer Repair, Maintenance and Upgrade?** Dept. 64496
- Personal Computer Programming**-Learn fast at low cost for big earnings. Dept. 35319

Name _____

Address _____

City _____ State _____ Zip _____

Call toll-free 1-800-487-2100

CIRCLE 321 ON FREE INFORMATION CARD

Fix It Yourself!



- Hands-on, detailed, troubleshooting instructions
- "How to" primer for test equipment: oscilloscopes, frequency counters, video analyzers, etc.
- Schematic diagrams
- Trouble analysis flowcharts
- Preventive maintenance techniques
- Safety precaution checklists
- Comprehensive replacement parts list
- Directory of manufacturers

It's easy, fast, and rewarding to repair it yourself with the Electronics Repair Manual!

Leading Manufacturers Represented...

- Emerson • Nintendo • RCA • Technics
- Hitachi • Panasonic • Sanyo • Toshiba
- IBM • Pioneer • Sharp • Zenith
- NEC • Quasar • Sony and others!

✓ Dozens of Fix-It-Yourself Projects for...

- | | |
|---|--|
| <input type="checkbox"/> CD Players | <input type="checkbox"/> Amplifiers |
| <input type="checkbox"/> VCRs | <input type="checkbox"/> Car Radios |
| <input type="checkbox"/> Televisions | <input type="checkbox"/> Home Appliances |
| <input type="checkbox"/> Camcorders | <input type="checkbox"/> AM/FM Tuners |
| <input type="checkbox"/> Computer Equipment | <input type="checkbox"/> Thermostats |
| <input type="checkbox"/> Fax Machines | ...and more! |
| <input type="checkbox"/> Telephones | |

30-Day Free Trial!



Keep Your Skills Up-to-Date!

The Electronics Repair Manual and the Modern Manual Electronics Manual will be a valuable reference for years to come. Supplements, each containing over 125 pages, add new repair projects, valuable insights into new technologies, diagnostic and repair techniques, electronics projects, and more schematic diagrams into your manual. Just \$35 each for Electronics Repair and \$49.50 each for Modern Electronics plus shipping and handling. Supplements are sent 4-5 times a year and are fully guaranteed. Return any supplements you don't want within 30-days and owe nothing. Cancel anytime.

ADAPT-11

68HC11 Module for Solderless Breadboards

- miniature 2.0" by 2.8" module
- plugs vertically into solderless breadboard
- reset circuit, button, & mode select switch
- RS-232 int., 5V reg. & ext. pwr. com.
- all I/O lines on dual row connector
- Programs 68HC11E2 & 711E9 chips



Starter Package comes with ADAPT-11 module, 49HC11E1 microcontroller with 2K EEPROM on-chip (re-programmable in circuit 1000s of times; no EPROM programmer or eraser required), PC serial cable for downloading code, Motorola Programming Reference Guide, ADAPT-11 User Manual, freely distributable 49HC11 software, and demo program. #AD11-SP \$74.95 + \$5 shipping & handling.

Use PLCCs in your Solderless Breadboard!

- Solderless breadboard socket adapters for all popular PLCC sizes.
- Vertical design saves space on breadboard.

Also available: Solderless breadboard adapters for DB9 & DB25, and IDC (ribbon cable) connectors, from \$5.

View, MasterCard, AmEx, Discover

TECHNOLOGICAL ARTS

309 Aragona Blvd., Suite 102, Box 418, Va. Beach, VA 23462
1644 Bayview Avenue, Box 1704, Toronto, ON M4G 3C2
voice/fax: (416) 963-8996 www.to.org/~techart

Printed Circuits in Minutes Direct From LaserPrint!

- 8 1/2" x 11"
- * Or Photocopy
- ** Use standard household iron or P-n-P Press.



Use Standard Copper Clad Board
20 Shts \$30/ 40 Shts \$50/ 100 Shts \$100
Visa/MC/PO/Ck/MO \$4 S&H

Techniks Inc.
P.O. Box 463
Ringoos NJ 08551
ph. 908.788.8249 fax 908.788.8837
http://chelsea.ios.com/~techniks
Retail Dealer Inquires Invited

WINDOWS 95

—One Step at a Time

Don't know what to do when confronted with Microsoft's Windows 95 screen? Then you need a copy of *Windows 95—One Step at a Time*. Develop your expertise with the straight-forward presentation of the frequently-used features that make Windows 95 so valuable to the PC user.



To order Book BP399 send \$6.95 plus \$3.00 for shipping in the U.S. and Canada only to Electronics Technology Today Inc., P.O. Box 240, Massapequa Park, NY 11762-0240. Payment in U.S. funds by U.S. bank check or International Money Order. Please allow 6-8 weeks for delivery.

UPGRADE YOUR COMPUTER!

TECHNOLOGY ASSOCIATES
959 W. 5th St. • Reno, NV 89503
(702) 322-8875 • Fax (702) 324-2900
www.techass.com • sales@hoopsware.com

Memory	Hard Drives	Modems
1Mb (128-70 ns) \$8	See 540Mb IDE \$129	14.4 Ext Fax/Modem \$38
4Mb (428-70 ns) \$21	WD 635Mb IDE \$136	28.8 Int Fax/Modem \$36
4Mb (1432-80 ns) \$19	WD 850Mb IDE \$157	vVoice \$71
8Mb (2032-80 ns) \$35	WD 1.2Gb IDE \$202	33.6 Int Fax/Modem v
16Mb (4432-80 ns) \$74	WD 1.8Gb IDE \$233	Voice \$88
32Mb (8432-80ns) \$154	WD 2.1Gb IDE \$277	33.6 Int USR Fax/Modem
	WD 2.5Gb IDE \$299	for Windows \$101
	WD 3.1Gb IDE \$343	33.6 Int USR Voice/Fax/Modem \$152
CPUs	Video Cards	Sound Cards
AMD 486DX4-100 \$33	256K ISA VGA \$20	16-bit Sound Blaster Pro compatible \$36
Cyrix 586-133 \$37	Prident 900 1Mb ISA SVGA \$37	16-bit SB Pro PnP \$79
Cyrix 586-110 \$90	Prident 9440 1Mb VLB SVGA \$32	Sound Blaster 32 PnP \$127
Cyrix 586-120 \$100	Prident 9680 1Mb PCI SVGA w/MPEG \$37	
Intel Pentium 100 \$129		
Cyrix 586-133 \$150		
Intel Pentium 133 \$204		
Intel Pentium 166 \$412		
Motherboards	Miscellaneous	Controller Cards
486Box VLB 256K \$70	1.44Mb FDD \$28	ISA Multi IO IDE, FDC, 2S/P/1G \$12
486Box PCI 256K \$87	1.2Mb FDD \$60	VLB Multi IO, EIDE, FDC, 2S/P/1G \$15
Pentium Intel Triton-2 Vx 256K pipeline \$110	8X CD-ROM IDE \$91	
Pentium Intel Triton2-HX 512K pipeline \$141	10X CD-ROM IDE \$110	
Pentium Pro \$276	Colorado Traven T1000 850Mb tape drive \$160	
	3-button serial mouse \$9	
	Split-resist 101-key \$17	

Prices and availability subject to change without notice.
CALL FOR DAILY LOW PRICES!

TELEPHONE TEST DEVICES

- 2 Line Simulator \$185.00
 - 7 Line Simulator \$399.00
 - Caller ID Simulator \$395.00
 - 20 HZ Ringing Module \$49.95
 - 9-1-1 Training System \$370.00
- *** And Much More ***

Check out our Web Site for detailed info about our unique line of test equipment. The CID-max Caller ID Simulator is a stand alone test unit that generates 10 different Caller ID messages per the Bellcore Specs!

http://www.infinet.com/~jectech

1-800-631-0349

Timid about getting on the . . . World Wide Web?

You've heard about the *Information Superhighway* and all the hype that goes with it! Sort of makes you feel timid about getting on the Web. Put your fears aside! A new book, *The Internet and World Wide Web Explained*, eliminates all the mystery and presents clear, concise information to build your confidence. The jargon used is explained in simple English. Once the tech-talk is understood, and with an hour or two of Web time under your belt, your friends will believe you are an Internet guru!

To order Book #403 send \$6.95 plus \$3.00 for shipping in the U.S. and Canada only to Electronics Technology Today Inc., P.O. Box 240, Massapequa Park, NY 11762-0240. Payment in U.S. funds by U.S. bank check or International Money Order. Please allow 6-8 weeks for delivery.

PROTOTYPES

Or large runs. PCBs, wave soldering, cabinets and other metal parts, silk screen printing, plastic injection, xformer/coil winding, etc. Assembly, wiring. Very low prices! Twin plant in Mexico. We ship to your door. V&V. PH. (713) 537-7518 Fax. 011 (525) 361-5996.

CABLE TV CONVERTERS

Equipment & Accessories
Wholesalers Welcome
Call C&D ELECTRONICS
1-800-310-1153 M-F 10a-6p

NEW MULTI FREQUENCY CUBES!

WIRELESS CABLE BOX TESTER
EXTERNAL AND INTERNAL MULTI-FREQUENCY WORKS ON ALL MODELS: J****, SA, PIONEER, ALSO FOR CFT 2200!
TEL: 718-768-4963 718-575-1474

Quality Microwave TV Systems
WIRELESS CABLE • ITFS • MMDS
ATV • INTERNATIONAL • S-BAND
Amplifiers • Antennas • Books • Components
Filters • Systems • Video Products
• RF Frequency 1990 - 2700 MHz
• Cable Ready - VHF - UHF Outputs
• SASE For "FREE" Catalog or Send \$1

PHILLIPS-TECH ELECTRONICS
PO Box 8533 • Scottsdale, AZ 85252
ORDER LINE 800-880-MMDS
CATALOG/INFO 602-947-7700
FAX LINE 602-947-7799
Visa • MC • Amx • Disc • COD's • Qty Pricing

CHALLENGER SYSTEM
33-Channel 52dB+ Gain
Complete Grid \$265
Five Year Warranty
FREE SHIPPING

CIRCLE 329 ON FREE INFORMATION CARD

The Electronic Experimenter's Journal
It's part catalog, part magazine and part data book with kits, parts, plans, articles, and application notes.
Call for your **FREE** copy today

Debco Electronics
4025 Edwards Rd.
Cincinnati, OH 45209 **1 800 423-4499**

BUGGED??

EAVESDROPPING is unbelievably widespread! Electronic Devices with amazing capabilities can be monitoring your telephone and room conversations RIGHT NOW! Are you sure you're safe? **FREE CATALOG tells you fast!** Includes Free Bonus details on fantastic opportunities now open in Counter-Surveillance field. Exciting, immensely interesting and EXTREMELY profitable (up to \$250/hr) full/part-time income. Call Now! **1-800-732-5000**

EASY TO USE CAD

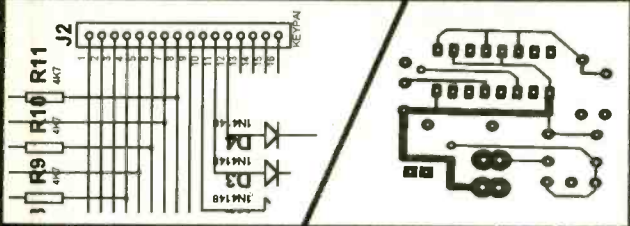

Now in
Both DOS and Windows

CADPAK DOS - \$159, **WINDOWS** - \$199

Ideal for New Users, Hobbyists, & Small Businesses! Provides everything for PCB Layout & Schematic Drawing.

PROTEUS Starts at \$425

Most Powerful on the market

- * Schematic Capture
- * Circuit Simulation
- * PCB Layout with Rip-Up & Retry Routing

R4 SYSTEMS INC.

1100 GORHAM ST. Suite 11B-332
Newmarket Ontario, Canada L3Y 7V1

905 898-0665 FAX 905 898-0683

FREE DEMO
WRITE OR CALL
TODAY

Download Demo - <http://www.r4systems.on.ca>

Internet email info@r4systems.on.ca

REMOTES Remote Control for Any Application

NEW NEW NEW NEW NEW

3.5" x 2.75"

\$69⁹⁵



- 3 Channel Receiver
- Channel 1 - 5 amp Relay, N/O, N/C
- Channel 2 and 3 Digital Outputs
- Compatible with 2 Button or 4 Button Remote
- Code Hopping Receiver at 434 Mhz
- Compatible with All Garage Doors and Some Car Alarms

2.75" x 2.75"

\$99⁹⁵



- 6 Channel Receiver with Digital Outputs
- All Channels are Programmable for Momentary, Latched, Latched with Condition, 30-60-90 Sec. Timed Outputs
- Code Hopping Receiver at 434 Mhz
- Compatible with 2 Button or 4 Button Remote
- Compatible with Some Car Alarms

1.25" x 1.75"

\$29⁹⁵



- 2 Button - 3 Channel Remote
- Extra Long Range 434 Mhz with S.A.W. Resonator
- Push Both Buttons together for Channel 3

1.25" x 1.75"

\$39⁹⁵



- 4 Button - 15 Channel
- Extra Long Range 434 Mhz S.A.W. Resonator
- Push Combination of Buttons together for Channel 5 through 15. i.e. Push Button 1 and 2 together for Channel 5

Street Smart Security ■ 800-908-4737

7147 University Avenue • La Mesa, CA 91941

Send, Fax or Call Order In - Use Credit Card or Check. Fax (619) 462-0652

SURVEILLANCE

The Latest High Tech Professional Electronic Devices

Our latest catalog offers a **HUGE** selection of surveillance, counter-surveillance/privacy devices: pinhole camera w/audio \$199⁰⁰, hidden video, electronic kits, telephone recording systems: 7-Hour \$125⁰⁰-16-Hour \$199⁰⁰ touch tone decoders, scanners, bug/phone tap detectors, voice disguisers, telephone scramblers, locksmithing tools, and more.

Catalog \$5.00

SPY OUTLET

PO Box 337, Buffalo NY 14226
(716) 691-3476/(716) 695-8660

EASY PIC'n MICROCONTROLLER BOOK

How to get started using PIC16CXX microcontrollers

- Programming techniques
- Instruction set
- Addressing modes
- Bit manipulation
- Subroutines
- Sequencing
- Lookup tables
- Interrupts
- Using a text editor - source code
- Using an assembler
- Timing and counting
- Interfacing - I/O conversion
- Lots of examples

PIC is a trademark of Microchip Technology Inc.
\$29.95 + \$3 mail in US VISA, MC, MO, Check
CA residents please add 7.25% CA sales tax

SQUARE **1** ELECTRONICS

P.O. Box 501, Kelseyville, CA 95451
Voice (707) 279-8881 FAX (707) 279-8843
<http://www.zapcom.net/~squareone>

TURN YOUR PC INTO A DIGITAL STORAGE OSCILLOSCOPE!

The PC-MultiScope by mission technology.

Featured in May '96 Electronics Now!

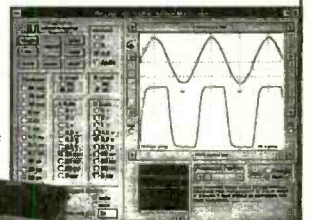

above: actual scope screen on PC
\$399+ S/H. Visa/MC/Check.

Dual channel; up to 20Ms/sec sampling; 2Mhz analog bandwidth; install thru PC parallel port; easy Windows interface; strip chart recdr/spectrum analyzer modes; ext. trig. +\$40; VB source code +\$99

AMAZE ELECTRONICS CO.

Tel: 800-996-2008 Fax: 408-996-0366
<http://www.hooked.net/users/amaze>
or email: amaze@hooked.net

!!! BROADCAST FARTHER !!!

The model 220 is a 80-110MHz RF amplifier that connects to mono or stereo FM transmitters and produces a powerful 2-15 watt signal which could broadcast up to 5 miles or more! Requires 50-150 mW drive.

Step by step plans complete with part source information and antenna designs... ONLY **\$14** PLUS \$2 S&H NO C.O.D.'S

Progressive Concepts
BOX 586 STREAMWOOD, IL 60107
(630) 736-9822 FAX: (630) 736-0353



Prototype It FAST!
with Protoboard #451 or 21
Fully assembled 8051 or 23 88C
4.5 x 8 inch board w/ large probe area
Supports up to 32K EPROM - 32K RAM
Chips in sockets - 8 volt operation
On-eye in EPROM w/ source and 8-conn.
Full size of schematic w/ the prototype
Ready to run... **\$99.00** ea.
Software Science
3750 Roundbottom Rd.
Cincinnati, Ohio 45244
1 888 561-2060

CABLE T.V.
Buy Direct From the Wholesaler
We will match or beat any advertising
Save \$\$\$
Dealers Welcome

- Tocom • Pioneer • Jerrold
- Zenith • Century • Panasonic and more

1 Year Warranty 30 days money back
Visual Concepts 1-888-838-4444

February 1997, Electronics Now

COUNTERSURVEILLANCE MANUFACTURER

AI-6600 PHONE TAP DETECTOR



DETECTS:

- Radio Frequency Taps
- Series and Parallel Taps
- Line Impedance Taps
- Extension Phone Listeners

\$149⁹⁵

AI-2100 VIBRATING TRANSMITTER DETECTOR

\$189⁹⁵



DETECTS:

- Body Wires
- FM Wireless Mics
- AM Transmitters
- UHF Transmitters

AI-5500 COMPLETE SAFETY SYSTEM

DETECTS:

- All Phone Taps and Extension Phone Listeners
- All Body Wires, Wireless Mics, AM/FM and UHF Transmitters

DEFEATS:

- All Body Wires, Transmitters and Distance Microphones with its built-in white noise generator

\$379⁹⁵



TRVD-900 TRANSMITTER / TAPE RECORDER & VIDEO DETECTION SYSTEM

DETECTS:

- Body Wires
- FM Wireless Mics • AM Transmitters • UHF Transmitters
- Tape Recorders • Video Equipment

Alerts User By Vibrating and/or Illuminated LEDs

\$495⁰⁰

WSS-100 WIRELESS SURVEILLANCE SYSTEM SEES & HEARS EVERYTHING!

FEATURES:

- 2.4 GHz Video / Audio Transmitter
- 4 Channel Receiver • 300' Transmission Range
- Black & White CCD w/ Auto-Iris Lens • 410(H) TV Line Resolution
- FCC Approved Frequency



\$649⁹⁵

Send \$6.00 for 32-Page Catalog (FREE w/ Purchase)

Items May Be Purchased by Certified Check, Money Order or C.O.D.

AMERICAN INNOVATIONS, INC.

119 ROCKLAND CENTER ~ SUITE 315 - NANUET, NY 10954

VOICE: (914) 735-6127 - FAX: (914) 735-3560

HTTP://WWW.SPYSITE.COM - E-MAIL: AMERICAN@SPYSITE.COM

Quantity Discounts Available



MEMBRANE SWITCH KITS!

FLAT PANEL KEYPADS ASSEMBLE IN MINUTES WITH YOUR LEGEND

AVAILABLE IN 4, 12, 16, 24 & 40 KEY TYPES



DSK-4 \$9.89



DSK-12 \$14.29

INDUSTRIAL TYPES AVAILABLE

MORE THAN 30 LAYOUTS TO FIT MOST APPLICATIONS

CALL FOR FREE BROCHURE

SIL-WALKER

880 CALLE PLANO, UNIT N
CAMARILLO, CA 93012

PHONE: (805) 389-8100

FAX: (805) 484-3311

VISA / MASTERCARD

CIRCLE 317 ON FREE INFORMATION CARD



Robotic Arm Kit \$195.00

Build your own Robotic Arm. The kit comes complete with all hardware, base enclosure, structural components, servos, servo controller kit, software and an illustrated assembly manual. Makes an excellent addition to a small mobile robot base. Great for teaching motion control.



S&H charges; \$7.50 USA and Canada, \$25.00 International Airmail, 10% off for 10 or more. IL residents add 6.25% to total.

Send check or money order to Technical Service & Solutions
104 Partridge Road
Pekin, IL 61554-1403 USA

We accept Mastercard and Visa

Tel: 309-382-1816
Fax: 309-382-1254
www.lynxmotion.com
jfrye@lynxmotion.com

Precious Life

This nurse was once a patient at St. Jude Children's Research Hospital. She fought a tough battle with childhood cancer. And won.

Until every child can be saved, our scientists and doctors must continue their research in a race against time. To find out more, write St. Jude Hospital, P.O. Box 3704, Memphis, TN 38103, or call 1-800-877-5833.



ST. JUDE CHILDREN'S RESEARCH HOSPITAL
Danny Thomas, Founder

OCEAN STATE ELECTRONICS

MAKE CIRCUIT BOARDS THE NEW, EASY WAY WITH TEC-200 FILM

JUST 3 EASY STEPS

- Copy Circuit pattern on TEC-200 film using any plain paper copier
- Iron film onto copper clad board
- Peel off film and etch



Convenient 8 1/2 x 11 size w/ complete instructions

5 SHEETS.....\$ 6.25
10 SHEETS.....\$10.75
20 SHEETS.....\$16.25
50 SHEETS.....\$33.50

DELUX CODE KEY

Adjustable, heavy duty brass base with ball bearing pivots. Designed for hard usage. 3/16" plated contacts.
\$14.95



CODE PRACTICE OSCILLATOR & MONITOR

3" Speaker, Headphone Terminal, Volume & Tone Controls. Uses 1 9V Battery.
Kit.....\$19.95
Wired.....\$24.95



TO ORDER CALL 1-800-866-6626

OR

401-596-3080 FAX 401-596-3590

OCEAN STATE ELECTRONICS

PC Box 1458

Westerly, RI 02891

Mail In orders please include \$5 S/H

CANADA \$12.00-OVERSEAS \$15.00

ALASKA & HAWAII \$12.00

Minimum Order \$10.00 (before shipping)

Visa and MasterCard Accepted

WRITE FOR FREE CATALOG

MAGNET WIRE

Enamel coated solid copper. For winding coils, transformers, toroids. 1/4lb spools.

#14.....\$4.00	#28.....\$4.85
#16.....4.00	#30.....4.85
#18.....4.00	#32.....4.85
#20.....4.00	#34.....6.25
#22.....4.25	#36.....6.85
#24.....4.25	#38.....6.95
#26.....4.85	#40.....7.85

VARIABLE CAPACITORS

BROADCAST TYPE - 1/4" SHAFT

1 GANG 14-365PF	\$12.95
2 GANG 10-400/10-400PF	\$19.95

VERNIER DIALS

1-1/2 Diameter 0-10 Marking	\$10.95
1-1/2 Diameter 0-100 Marking	\$14.95
2" Diameter 0-100 Marking	\$15.95

SIGNETICS NEG202AN	\$2.49
MINI-CIRCUITS SBL-1	\$7.95

REGULATED POWER SUPPLIES

13.8V DC OUTPUT. 120V AC INPUT.

3 AMP.....\$24.95
5 AMP.....\$29.95
6 AMP.....\$39.95
10 AMP.....\$49.95
20 AMP.....\$119.95
30 AMP.....\$139.95

SINGLE INJECTOR/TRACER KIT

Both a signal generator and receiver. Use it to check out an amplifier, stage by stage. Also tests AM radios IF and RF stages. You can pin point where a defective part exists. Will transmit and receive simultaneously. **\$19.95**



HOME AUTOMATION

World's Largest Selection!

Widest Selection of X-10 Devices Available

Hundreds of hard-to-find automation, X-10 and wireless control products. Computer interlaces, software, development tools, lighting control, telephone systems, security systems, surveillance cameras, infra-red audio/video control, HVAC, pet care automation, wiring supplies, books and videos and much more!



Packed with Pictures & Diagrams

Home Automation Systems, Inc.

Questions: 714-708-0610 Fax: 714-708-0614

e-mail: catalog@smarthome.com

http://www.smarthome.com/smarthome

Lowest Prices Guaranteed!

24 Hours Call 800-SMART-HOME 800-762-7845

ATTENTION DEALERS

BUY DIRECT FROM THE WHOLESALE

GET THE BEST PRICES AND SERVICE

ALL UNITS ARE IN STOCK FOR IMMEDIATE SHIPMENT

ADD-ONS

	QTY 5	QTY 10	QTY 20	QTY 50	QTY 100	QTY 500	QTY 1000
STEALTH-1000	\$48	\$42	\$38	\$30	\$28	\$25	\$23
STEALTH-80	\$50	\$44	\$40	\$31	\$29	\$26	\$24
M-80	\$55	\$48	\$45	\$40	\$38	\$36	\$34
TNT	\$55	\$48	\$45	\$40	\$38	\$36	\$34
PPG	\$57	\$50	\$47	\$42	\$40	\$38	\$36

NEW CONVERTERS

	QTY 5	QTY 10	QTY 20	QTY 50+
SA-8511	\$75	\$70	\$65	CALL
CENTURY CT-3000	\$68	\$64	\$60	CALL
PANASONIC-1003	\$59	\$55	\$50	CALL
ZENTEK	\$45	\$40	\$37	CALL

NOVAVISIONS

NV-5600	\$205	\$195	\$185	CALL
NV-5700	\$195	\$185	\$175	CALL
NV-5800	\$195	\$185	\$175	CALL
NV-5750	\$305	\$295	\$285	CALL

BOSS COMBOS

BOSS 1	\$210	\$195	\$185	\$160
BOSS 2	\$210	\$195	\$185	\$160
BOSS 3	\$210	\$195	\$185	\$160

ZENITHS

ST-1600	\$210	\$195	\$185	CALL
---------	-------	-------	-------	------

REFURBISHED CONVERTERS

REGAL • PANASONIC CALL FOR THIS MONTH'S SPECIALS

1-800-800-0766

KIMTRONICS INC

30 day money back guarantee. All shipping and handling at customers expense. Anyone implying theft of cable service will be denied sale. NO FLORIDA SALES. WE WILL MEET OR BEAT ALL COMPETITORS PRICES IN THIS MAGAZINE

The Hacker's Companion CD-ROM

Want a war-dialer program or something to crack a password? Do you want to learn how the phone company gets ripped off, or learn how to build a red box, or modify a cellular phone? Want to see what the security holes in a VAX are? Or how to compromise a Unix machine or a BBS? Want to learn how to use the system in ways you never imagined possible? This CD is the place to look! It contains all kinds of computer, telephone and general hacking information. Even a video of dutch hackers breaking into a classified US military computer! In all, 552 megabytes of fascinating information that's hard to get anywhere else!

PC-Compatible CD-ROM \$49.95

Shipping \$3

Call (800)719-4957 now!

to order (Visa/MC/COD) or call or write for FREE CATALOG of hard-to-get information about computer viruses, computer hacking, security and cryptography!!

American Eagle Publications, Inc.
P. O Box 1507
Show Low, AZ 85901

CIRCLE 282 ON FREE INFORMATION CARD

CONVERTERS & DESCRAMBLERS



TARGET ELECTRONICS

(800) 995-1749

We sell Test Chips!
MC, VISA, AF, C.O.D.

**DEALERS
WELCOME!**

Cable TV Descramblers

Converters * Filters * Accessories

30 day Free Trial - NO RISK!
Unbeatable wholesale prices!
Affordable extended warranty
1 Year Warranty on all products

Free
Catalog

Call the cable professionals!

Credit Cards Welcome!

1-800-379-3976

Prices starting
as low as \$99!

New Surveillance Devices!

Smoke Alarm and Table Clock Video Cameras

Ultra miniature video cameras hidden in smoke alarm or alarm clock - your choice. Wide field of view and super 1 lux low light sensitivity! Undetectable!

Best price on surveillance cameras anywhere!

Telephone Transmitter Kit hidden in dual modular adaptor. Transmits both sides of conversation to any FM radio up to 1/4 mile. "SnapKit" technology. Uses phone line for power and antenna. Goes completely unnoticed. MA-100 \$25.95

High quality cassette deck plugs directly into telephone jack. Records up to 12 hours of conversations on a single cassette. Recording starts and stops automatically when phone is used!

THR-12 12 Hour Telephone Recorder \$99.95 Free shipping! Check/MO Question line: (972) 255-7490

Seymour-Radix Inc. Box 166055-N Irving, TX 75016
Now you can visit us on the internet at <http://www.why.net/home/sr/>

American Heart Association
Fighting Heart Disease and Stroke

Research gave him a future

Support Research

CLASSIFIED

MISCELLANEOUS ELECTRONICS FOR SALE

TUBES: "oldest", "latest". Parts and schematics. SASE for lists. **STEINMETZ**, 7519 Maplewood Ave., EN, Hammond, IN 46324.

FIBER-Optic Projects — Swing into the new technology by assembling tried and true projects recently published. "Practical Fiber-Optic Projects" - BP374 is only \$9.95. (price includes shipping) **ELECTRONIC TECHNOLOGY TODAY INC.**, PO Box 240, Massapequa Park, NY 11762-0240.

GREEN Thumb Alert— Electronics enters the Garden! New exciting book points out how gardeners can build simple gadgets to promote success where the elements work against you. Some of the projects are: over/under temperature monitoring, dusk/dawn switching, automatic plant watering, warming cables, etc. "Electronic Projects for the Garden" only \$9.95 (price includes shipping) **ELECTRONIC TECHNOLOGY TODAY INC.**, PO Box 240 Massapequa Park, NY 11762-0240.

RESISTORS 20 for \$1.00. LEDs 4 for \$1.00. Catalog \$1.00. **ZIPFAST**, Box 12238, Lexington, KY 40581-2238.

POOR reception on your A.M. radio? Our Signal Booster will help. Guaranteed! Send \$2.00 for details (refundable with order). **FALA ELECTRONICS**, PO Box 1376, Dept. 4, Milwaukee, WI 53201.

TEST chips & Test Aids. All types, most models. **Best products, best prices.** E-mail for your price list (xlent@hi.net). Page your fax no# to 800-401-8641. Full tech support. 30 day trial. Wholesale pricing. Credit card/cod O.K.

GOVERNMENT auctions in your area. Electronic equipment available at surplus prices! Call now: 1 (800) 601-2212, ext SP6870.

PLANS-KITS-SCHEMATICS

CRYSTAL set Handbook — Visit antiquity by building the radios your grandfather built. Assemble a "Quaker Oats" rig, wind coils that work and make it look like the 1920's! Only \$10.95 plus \$4.00 for shipping and handling. **CLAGG INC.**, PO Box 4099, Farmingdale, NY 11735. US funds only! USA and Canada — no foreign orders.

FREE Catalog. 100 Leading-Edge kits. K1, PIC. Full instructions, source code. 1 (800) 875-3214. **SCIENCE FIRST**, 95 Botsford Place, Buffalo, NY 14216.

ELECTRONIC Project Kits. www.qkits.com 1-888-GO-4-KITS. 292 Queen St., Kingston, ON, K7K 1B8. **QUALITY KITS.**

HACKERS Catalog. **Hard-to-find** kits and assembled equipment (Red box, spy, cable, etc.) **Low prices.** \$1.00. **SMITH-04**, Box 371, Cedar Grove, NJ 07009.

CELLULAR Hackers Package. (3) Hacker Bibles, (2) Videos & Programming software. \$199.00 VISA/MC. **TELECODE** 1-520-726-2833. <http://www.hackerscatalog.com>

FM Micro Broadcasting: Transmit many miles. PLL mono/stereo. 88-108 MHz. Fully assembled. 1-100 W.R.F. amps. Call (718) 763-8302. **MICRO BROADCAST NETWORK.**

WE design, fabricate and assemble single or double layer PCBs. Fast turnaround. 30 years experience. State of the art equipment. Small runs O.K. Write or call for information. **SHORE PRINTED CIRCUITS**, 1658 Route 9, Toms River, NJ 08755. (908) 505-6363 Fax-505-6266.

<http://www.users.interport.net/~zebra/ts> is our Timex/Sinclair web site. **ZX81 Computer Kits** \$30.00 plus shipping. **ZEBRA SYSTEMS INC.**, 131 Joralemon St. #52, Brooklyn, NY 11201.

SECURITY

SURVEILLANCE Privacy security protection. Catalog \$5.00. **SPY EMPORIUM**, 6065 Hillcroft, Suite 413, Houston, TX 77081. (713) 774-1000.

TEST EQUIPMENT

TEST Equipment pre-owned now at affordable prices. Signal generators from \$50.00, oscilloscopes from \$50.00. Other equipment including manuals available. Send \$2.00 US for catalog. Refunded on first order. **J.B. Electronics**, 3446 Dempster, Skokie, IL 60076. (847) 982-1973.

LARGE assortment of used test equipment. Most instruments are priced at 10% of original cost or less. Request list. **JIM STEVENSON**, 3401 Sunny Slope Road, Bridgewater, NJ 08807. (908) 722-6157 Fax: (908) 722-6391.

BUSINESS OPPORTUNITIES

EASY work! Excellent pay! Assemble products at home. Call toll free. 1(800) 467-5566 EXT. 5192.

INVENTIONS, ideas, new products! Presentation to industry/exhibition at national innovation exposition. Patent services. 1 (800) 288-IDEA.

LOOKING for extra income? Assemble products at home. Guaranteed! Call: 1 (800) 377-6000 Ext. 6870. Open Sunday.

EDUCATION & INSTRUCTION

LEARN PC repair-troubleshooting, servicing. Home study. Free literature. **P.C.D.I.**, Atlanta, Georgia. (800) 362-7070 Dept. JJB342.

EDUCATIONAL and how-to videos. Huge selection for children and adults. Call now for free catalog. **TOTAL MARKETING SERVICES**. 1 (800) 469-7977 EXT. 85688.

CABLE TV TURN-ON CHIPS

SUPER Cable TV "Test Chips". Provides full service activation. Excellent! Instructions & illustrations. **Jerrold Starcom:** DP(V)5..DP(V)7..DPB87..CFT-2000..CFT-2200 Series. **Pioneer:** BA-5000 thru BA-6700. **Pioneer:** Custom Programmer (Clears E2 & rewrites new I.D. codes). **Scientific Atlanta:** 8500 thru 8600. **Tocom:** 5503-VIP. 5507. **Zenith:** ST-1000 thru ST-5612. **Call Now!! MASTER COMPONENTS**. 1 (800) 233-0570.

THE CABLE TV SUPER CUBE

THE Mobilizer!! External "Test Cube" activator. **Easy plug-n-play** operation. Excellent instructions & illustrations. Supports all DP(V)7..DPB87..CFT-2000..CFT-2200 series converters. **New enhanced performance features!** Locked box revitalizer! Restore command! Plus much more! **Dealers wanted! Call Now!! MASTER COMPONENTS** 1 (800) 233-0570.

CABLE TV

CABLE Descrambling New secret manual. Build your own descramblers for cable and subscription TV. Instructions, schematics for **SSAVI**, Gated Sync, Sinewave, (HBO, Cinemax, Showtime, UHF, Adult) \$12.95, \$2 postage. **CABLETRONICS**, Box 30502R, Bethesda, MD 20824.

CLASSIFIED

CABLE TV Equipment & Accessories Wholesale welcome! 30 day moneyback guarantee! Free catalog! **PROFORMANCE ELECTRONICS INC.**, 1 (800) 815-1512.

CABLE-safe. Guarantee cable privacy. The one-way valve for your cable TV signal. Cable signals come in, but they don't go out! \$29.95 + \$3.00 S&H. **VISA/MC/AMEX. ELECTROMAN**, Box 24474, New Orleans, LA 70184. (504) 482-3017.

"CABLE Unscrambled. Everything you want to know about cable, but are afraid to ask. \$10.00. **"Descrambler Schematics Revealed."** A powerful guide to descrambling schemes. \$10.00. **"Baseband Video Explained."** Discover what a Baseband Signal is and how it's constructed. \$10.00. Special offer. Get all three for only \$25.00! **VISA/MC/AMEX. ELECTROMAN**, Box 24474, New Orleans, LA 70184. (504) 482-3017.

UNIVERSAL Descrambler. Unscramble signals using your VCR as the tuner. Works with virtually any system, this is the only one you need. Declare cable box independence! Fully assembled. \$129.95 + \$5.00 S&H. **VISA/MC/AMEX. ELECTROMAN**, Box 24474, New Orleans, LA 70184. (504) 482-3017.

"BULLET Buster". Protect your cable box against the infamous cable "bullet". The "Bullet" Buster acts as an electronic shield. Installs in-line in seconds. Don't wait until it's too late! \$19.95 + \$3.00 S&H. **VISA/MC/AMEX. ELECTROMAN**, Box 24474, New Orleans, LA 70184. (504) 482-3017.

CABLE Descrambler! Anyone can build in seven steps with Radio Shack parts. Plans/Kit from \$5.00 plus free bonus!! 1 (800) 818-9103.

DESCRAMBLER Cable using simple circuit. E-Z to follow instructions and complete universal kit with free "Bullet Stopper". \$20.00. 1 (800) 522-8053.

CABLE Bullet "Terminator/I.D. Blocker." Electronically shields yourself and your box. Also new **Super Bullet/I.D. Eliminator!** Free Hackers Guide with purchase!! Lifetime Guarantee 1 (800) 820-9024.

GIANT Sale!!! Positive notch filter \$18.00. E-Z install cable test chips/boards from \$5.00. Original equipment descramblers from \$175.00. External activators \$125.00. Much more!! Dealers Wanted. 1(800) 449-9189 Anytime.

CABLE TV notch filters. Request our free brochure by calling our voicemail at 1 (800) 433-6319 or write to **STAR CIRCUITS** PO Box 94917, Las Vegas, NV 89193. Visit our web site at <http://our-world.compuserve.com/homepages/starcircuits>

CABLE TV, descramblers, converters. Quantity discounts. 30 day free trial. Competitive prices. Call now! 1 (800) 322-0921 **REGAL SALES, INC.**

25 + Master test chip files. Jerrold, Scientific-Atlanta, Tocom, Pioneer, Zenith. Software & book. \$79.95. **TELECODE** 1 (520) 726-2833. <http://www.hackerscatalog.com>

CABLE TV descramblers. Pioneer 6310's, Scientific Atlanta, Jerrold. Warranty. Lowest prices anywhere! Houston, TX (713) 691-4610.

CABLE TV "Power Cube". The Ultimate!! Provides full service activation for all Jerrold cable boxes. \$119.00 + \$10.50 s&h. 1 (800) 660-CUBE.

SATELLITE EQUIPMENT

VIDEOCYpher II descrambling manual. Schematics, video and audio. Explains DES EPROM, CloneMaster, Pay-per-view (HBO, Cinemax, Showtime, Adult, etc.) \$16.95, \$2.00 postage. Schematics for Videocypher II Plus. \$20.00. Schematics for Videocypher II 032, \$15.00. Software to copy and alter EPROM codes, \$25.00. VCII Plus EPROM, binary and source code, \$30.00. **CABLETRONICS**, Box 30502R, Bethesda, MD 20824.

OBTAINING sound for your VCII and VCII Plus is easy. No codes needed. Also **DSS Test Card** information. Details 1 (800) 211-5635.

DSS reverse engineering package. Software, schematics, chip programmer plans, reviews & more! \$49.95. **VISA/MC. TELECODE**, 1 (520) 726-2833. <http://www.hackerscatalog.com>

DSS Hacking: How to construct and program smart cards, w/pic16C84, software. Complete DSS system schematics. \$16.95. **CABLETRONICS**, Box 30502R, Bethesda, MD 20824.

SOUND for Videocypher-II and Plus without codes. Free details. **SAE. NASSIRIAN**, Box 382-E, Rio Linda, CA 95673.

DO-IT-YOURSELF VR Create Your Own Virtual Worlds and Share Them with 20 Million People!

- Learn How to Build Your Own Virtual Reality "Virtual Worlds" Quickly and Easily!
- Explore your Virtual Worlds on Your PC or put them on the Internet for Others to Explore!
- Explore your Worlds with your PC monitor and keyboard, or with Virtual Immersion using Low-cost Homebrew Virtual Reality Equipment!

Convert this \$69 Mattel Powerglove into a VR Glove! Save \$Thousands! We show you how, and where you can buy Powergloves!



VR Goggles with head tracking cost over \$4,000 only a few years ago. Now they're under \$500! And 3-D VR Shutter Glasses are under \$100! Now Immersive VR is affordable!

Six Publication Set!

Desktop VR contains a complete primer on using VR on your PC, plus: • Where to get low cost HMDs (head mounted displays) & other equip • The famous Mattel Powerglove hack (converting a \$69 Powerglove for use with VR) • Powerglove sources • Listings of virtual world building software • Comprehensive listings of HMD compatibility with popular games & software • Plus much more! • 36 pp.

VRML Primer explains VRML (Internet's VR Modeling Language), plus: • Building virtual worlds on the Internet • Virtual world authoring software & where to get it • Great VR worlds to visit on the Internet • Putting your virtual world on the Internet • More! • 32 pp.

Special Report: Virtual Reality an Exploding Technology Exclusive report on the explosion of VR in medical, amusement, consumer & other arenas • News blurbs on market entry by heavyweights & Fortune 500's • The VR marketplace • 28 pp.

VR InfoMania Time saving valuable resources including Listings of Internet websites devoted to VR • Listings of VR books • Listings of VR magazine articles & research papers • Listings of Internet FTP download sites & VR-related newsgroups • Article listings from back issues of VR magazines • Where to go to experience real VR • Reviews of popular VR books • Glossary of VR terms • Great VR applications • The future of virtual sex • Plus Much More! • 88 pp.

FREE DOUBLE BONUS!

FREE! **VR Resource Directory** is your guide to over 600 companies involved with VR products, software, R&D & consulting, plus professional trade organizations, clubs, more! 80 pp. Yours absolutely **FREE!**

FREE! **VR Cartoons** featuring dozens of funny cartoons about VR! Yours absolutely **FREE!** Limited printing, don't miss out! Order today!

"A Smorgasborg of info on VR!" -Sid Mirzad

"I love it! At under \$5 per book, don't miss out on this Incredible Value!" -Pam Eifert

UNDER \$5 PER PUBLICATION!

You Get All 6 Publications!
ONLY \$49! Calif. residents add sales tax
ONLY \$29! Plus \$3.95 S&H
Special Introductory Price! Includes All 6 Publications!
2-3 Day Delivery 17% FedEx Overnight Air 11.95

90-Day 100% Satisfaction Money-Back Guarantee!
24 HOUR TOLL FREE ORDER LINE 1-800-951-7100
FAX ORDERS 619-485-8968

Send Check or Money Order to: Virtual Reality Publishing 16436 Bernardo Center Drive, Suite 378, San Diego, CA 92128

*Some day shipping an order received before 4 pm EST. Personal check orders need 2 weeks to clear to cover the CCD process. All orders must be paid in US funds. Call for more S&H charges. We participate in the 25% Cash Program through the State Business Bureau of San Diego.

ORDER TODAY... HAVE IT TOMORROW!!

www.pueblo.gsa.gov

9 out of 10 mice prefer it.

Catch the free Consumer Information Catalog online and you'll get the latest info from the U.S. Government. Just point and click your way to www.pueblo.gsa.gov and you'll find more than 250 free publications ready to read or download.

Or, order the Catalog by mailing your name and address to **Free Catalog, Pueblo, CO 81009.** Scurry, this info's the cat's meow.

U.S. General Services Administration

ADVERTISING INDEX

Electronics Now does not assume any responsibility for errors that may appear in the index below.

Free Information Number	Page	Free Information Number	Page		
—	ABC Electronics	106	332	Mark V Electronics	107
—	Aegis Research, Canada	96	331	MCM Electronics	83
—	AES	86	—	Meredith Instruments	106
214	All Electronics	88	—	Merrimack Valley Systems	87
—	Allison Technology	96	128	MicroCode Engineering	CV3
—	Allstar Electronics	112	130	MicroCode Engineering	3
—	Amaze Electronics	117	—	Micro Engineering Labs	85
—	AMC Sales	106	—	Modern Electronics	106
282	American Eagle Publications	119	117	Mouser Electronics Inc.	22
—	American Innovations	118	—	MWK Industries	100
324	Basic Electrical Supply	102	258	New Sensor Corp.	82
325	Bel-Merit	108	—	NRI	57
—	Bsoft Software, Inc.	86	—	Ocean State Electronics	119
336	C&S Sales, Inc.	104	318	OWI	112
326	Circuit Specialists	92	262	Parts Express Inc.	91
—	CLAGGK Inc.	78	—	Polaris Industries	112
—	Cleveland Institute of Electronics	31	328	Prairie Digital	98
—	Command Productions	98	264	Print (Pace)	97
226	Consumertronics	94	129	Protek	17
—	Cybermation	94	—	R-4 Systems Inc.	117
—	DC Electronics	84	266	Ramsey Electronics	95
—	EDE - Spy Outlet	117	—	RF Parts	89
—	Electronic Goldmine	99	—	Sil Walker	118
—	Electronics Tech. Today	15, 64, 81	—	Sirius Micro Systems	87
320	Electronix Express	94	270	Skyvision Inc.	111
—	Emac Inc.	98	—	Square 1 Electronics	117
121	Fluke Corp.	CV2	—	Street Smart Security	117
321	Foley-Belsaw Co.	113	—	Tab Books	8, 23
334	Fotronic	100	—	TC Instruments	89
—	General Device Instruments	85	—	Technical Serv. & Solutions	118
122	Global Specialties	17	—	Tektronix, Inc.	7
—	Grantham Col. of Engineering	4	290	Telutex	89
315	Great Southern Security	109	—	Test Equipment Sales	110
—	Home Automation	119	275	Timeline	90
330	Howard Electronics	101	—	U.S. Cyberlab	87
—	ICS	39	—	Virtual Reality Publishing	121
—	IEC	89	322	Vision & Motion Surplus	110
—	Information Unlimited	103	—	Visual Communications	22
126	Interactive Image Technologies	CV4	319	Weka Publishing	114
316	IVEX Design International	85	323	White Star Electronics	96
—	Jameco	5	—	World College (Div. of C.I.E.)	21
—	Kimtronics	119	—	WPT Publications	100
—	Learn Inc.	34	281	Xandi Electronics	102
—	M ² L Electronics	108			

ADVERTISING SALES OFFICES

Gernsback Publications, Inc.
500 Bi-County Blvd.
Farmingdale, NY 11735-3931
1-(516) 293-3000
Fax 1-(516) 293-3115

Larry Steckler
 publisher (ext. 201)

Christina Estrada
 assistant to the publisher (ext. 209)

Arline Fishman
 advertising director (ext. 206)

Michele Torrillo
 advertising assistant (ext. 211)

Adria Coren
 credit manager (ext. 208)

For Advertising ONLY

EAST/SOUTHEAST

Stanley Levitan
 Eastern Advertising
 1 Overlook Ave.
 Great Neck, NY 11021-3750
 1-516-487-9357
 Fax 1-516-487-8402
 slevitan26@aol.com

MIDWEST/Texas/Arkansas/Okla.

Ralph Bergen
 Midwest Advertising
 One Northfield Plaza, Suite 300
 Northfield, IL 60093-1214
 1-847-559-0555
 Fax 1-847-559-0562
 bergenrj@aol.com

PACIFIC COAST

Janice Woods
 Pacific Advertising
 Hutch Looney & Associates, Inc.
 6310 San Vicente Blvd.
 Suite 360
 Los Angeles, CA 90048-5426
 1-213-931-3444 (ext. 228)
 Fax 1-213-931-7309

Electronic Shopper

Joe Shere
 National Representative
 P.O. Box 169
 Idyllwild, CA 92549-0169
 1-909-659-9743
 Fax 1-909-659-2469

Megan Mitchell

National Representative
 1201 N. Rainbow Blvd., #50
 Las Vegas, NV 89108-6819
 1-702-259-7043
 Fax 1-702-259-7043

Customer Service

1-800-999-7139
 7:00 AM - 6:00 PM M-F MST

CircuitMaker[®]

The Virtual Electronics Lab[™]

The screenshot displays the CircuitMaker software interface with several windows open. The main window shows a schematic diagram of a circuit with components like resistors (R1, R2, R3, R4, R5, R6), capacitors (C1, C2), and operational amplifiers (U1, U2). A 'DC Analysis' window shows a graph of voltage versus time, with a red line indicating a linear decrease. A 'Transient Analysis' window shows a graph of voltage versus time with a blue sine wave. An 'AC Analysis' window shows a graph of voltage versus frequency. A 'Count down to launch' window shows a rocket launch. A 'New For Windows 95/NT VERSION 4 Enhanced For Windows 3.1x' banner is overlaid on the bottom left of the screenshot.

Professional Schematic Layout

CircuitMaker's schematic capabilities are unmatched and include many advanced editing features not found in similar programs. These powerful features minimize the time and task associated with drawing a schematic and insure a professional looking final product. Printout and export options are numerous and results are of the highest quality. But that's what people have come to expect from CircuitMaker.

Unlimited, Indestructible Devices

CircuitMaker ships with over 1500 devices. That's more (at no additional cost) than any competing product. If you need a device that is not included, CircuitMaker provides industry standard SPICE import and a powerful macro capability. These indestructible devices accurately emulate actual devices and enable the user to try all those "what if" scenarios with no risk and at no additional cost.

Accurate Simulation & Advanced Analysis

CircuitMaker features analog, digital and mixed-mode simulation. Obviously, simulation is of no value if the results are not accurate. CircuitMaker's simulation engine is based on Berkeley SPICE3, which is renowned for its accuracy. That's why we can factually state that CircuitMaker provides its user with the most accurate simulation available. Furthermore, CircuitMaker provides a wealth of analysis capabilities not found in other products in its class. No other product offers this much simulation muscle at such a reasonable price.

Printed Circuit Board Output

CircuitMaker's PCB output capability helps you complete your design cycle, by generating a netlist that can be imported into any compatible PCB program. This is not a costly "add-on module", it comes standard with every copy of CircuitMaker. MicroCode Engineering also offers TraxMaker, a professional level, PCB layout and autorouting program for just \$299. Used in conjunction with CircuitMaker, TraxMaker completes a powerful end-to-end circuit design system.

Advanced Schematic Features
 Digital, Analog, and Mixed-Mode Simulation
 Full SPICE Compatibility
 SPICE Export/Import
 PCB Export
 Retail Price

	YES	YES	YES	YES	YES	YES	Retail Price
CircuitMaker	YES	YES	YES	YES	YES	YES	\$299
Electronics Workbench version 4	YES	NO	YES	NO	NO	NO	\$299
Electronics Workbench Engineer's Pack	YES	NO	YES	NO	YES	YES	\$599

"CircuitMaker Shocks The Competition, With An Unbeatable Bottom-line"

Total Customer Satisfaction

At MicroCode Engineering we are committed to total customer satisfaction. When you purchase CircuitMaker you have the confidence of knowing that a trained staff of professionals is available to serve you after the sale. Our free unlimited customer service is second to none! Whether you have general or technical questions they will be answered promptly by a knowledgeable representative.

FREE Functional Demo

A free functional demo is available on the Internet at <http://www.microcode.com>, on CompuServe (GO MICROCODE) and on America Online by doing a file search for CircuitMaker.

Call now to order or request additional information
800-419-4242



NEW VERSION!

Electronics Workbench Version 5 with analog, digital and mixed A/D SPICE simulation, a full suite of analyses and over 4,000 devices. Still the standard for power and ease of use. Now ten times faster. Still the same low price.

Join over 75,000 customers and find out why more engineers and hobbyists buy Electronics Workbench than any other SPICE simulator. You'll be working productively in 20 minutes, and creating better designs faster. We guarantee it!

\$299

SAME GREAT PRICE!

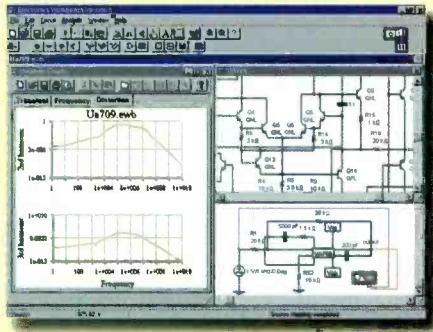

High-End Features

TRUE MIXED ANALOG/DIGITAL	YES
FULLY INTERACTIVE SIMULATION	YES
ANALOG ENGINE	SPICE 3F5, 32-BIT
DIGITAL ENGINE	NATIVE, 32-BIT
TEMPERATURE CONTROL	EACH DEVICE
PRO SCHEMATIC EDITOR	YES
HIERARCHICAL CIRCUITS	YES
VIRTUAL INSTRUMENTS	YES
ON-SCREEN GRAPHS	YES
ANALOG COMPONENTS	OVER 100
DIGITAL COMPONENTS	OVER 200
DEVICE MODELS	OVER 4,000
MONEY-BACK GUARANTEE	30-DAY
TECHNICAL SUPPORT	FREE

Powerful Analyses

DC OPERATING POINT	YES
AC FREQUENCY	YES
TRANSIENT	YES
FOURIER	YES
NOISE	YES
DISTORTION	YES

30-DAY MONEY-BACK GUARANTEE
VERSION 5.0 FOR WINDOWS 95/NT/3.1.
Upgrades from previous versions \$79.

FEATURES OF ELECTRONICS WORKBENCH VERSION 5

WHAT'S NEW

Now 10 times faster. Handles 3 times larger circuits. More and better device models. New thermal modeling. New on-screen graphs. New analyses (Fourier, Noise and Distortion). 25 new components including vacuum tubes, arbitrary sources. 50 new ICs. Improved accuracy. Improved schematic editor with zoom and growing pages. Improved printing. Improved fonts. Improved interface. Redesigned word generator and logic analyzer.

GENERAL

Integrated Tool: Fully integrated schematic editing, SPICE simulation and waveform generation and analysis. Supports modifications to the circuit during simulation. Circuit analysis through virtual test instruments or six analyzers listed below.
Simulation Engine: Interdive 32-bit SPICE 3F5, enhanced with native-mode digital and mixed analog/digital support. Automatic insertion of signal translation interface. Supports multiple reuse of hierarchical blocks. GMINI stepping for better convergence. No preset limits on circuit size or complexity.
Schematic Capture: Click-and-drag interface, hierarchical workspace, automatic wire routing with manual overrides, automatic reference designation (NAMES), schematic alias, copy/paste instruments for quick and simple circuit construction. Supports overlays for on-screen graphs and more flexible analysis (described below).
Design Information: Supports design information, including SPICE parameters, setup and simulation models. Supports a design file to capture design information and reuse.
Simulation: Supports standard SPICE simulation. Supports other simulators or to export simulation results. Imports manufacturers' models and netlists into reusable Electronics Workbench components. Exports to standard PCB layout packages such as OICAD, Protel and Tango.

ANALYSES

DC Operating Point: Calculates DC operating point and reports voltage at each node.
Transient: Circuit voltages and currents over time at any number of nodes. Specify start and stop times.
AC Frequency Sweep: Small-signal gain and phase over range of AC frequencies or any number of nodes. Specify range, type (decade, octave or linear) and resolution (number of steps) of frequency sweep.
Fourier: Magnitude and phase of DC and Fourier spectral components of transient response. Specify fundamental frequency and an unlimited number of harmonics.
Noise: Resistor and semiconductor noise contribution reported as RMS sum. Specify device of interest, output and reference nodes, and range, type and resolution of frequency sweep.
Distortion: Small-signal steady-state harmonic and intermodulation products over a range of frequencies. Specify any number of nodes and sweep range, type and resolution. Optionally exclude devices on an individual basis.

VIRTUAL TEST INSTRUMENTS

Digital: Models for AC, logic, and bus analysis. Adjustable duty cycle, amplitude and DC offset.
Word Generator: Acts as a digital stimulus editor to drive a circuit with up to 32K 1-bit words. Display and edit data as ASCII, binary or hex. Load, save, cut and paste words. Supports breakpoints and single step, burst and continuous modes. External trigger and data ready indicator for synchronization.
Logic Analyzer: Supports pre- and post-trigger, internal or external clock, negative or positive edge. Clock qualifier to synchronize data. User-defined trigger patterns and trigger qualifiers.
Logic Converter: Converts among gate, truth table and Boolean logic representations.

POWERFUL NEW VERSION!

COMPONENTS

Sources: DC Voltage, DC Current, AC Voltage, AC Current, Voltage-Controlled Voltage, Voltage-Controlled Current, Current-Controlled Voltage, Current-Controlled Current, AM, FM, Vcc, Clock, Pulse-Width Modulated, Frequency-Shift Keying, Polynomial, Piece-Wise Linear Controlled, Voltage-Controlled Oscillator and Nonlinear Dependent Base, Resistor, Capacitor, Inductor, Transformer, Relay, Switch, Time-Delay Switch, Voltage-Controlled Switch, Current-Controlled Switch, Pull-Up Resistor, Variable Resistor, Resistor Pack, Polarized Capacitor, Variable Capacitor, Variable Inductor, Coupled Inductor and Nonlinear Transformer.
Diodes: Diode, Zener Diode, LED, Shockley Diode, Diac, SCR, Triac and Full-Wave Bridge Rectifier.
Transistors: NPN and PNP BJTs, N- and P-Channel JFETs, 3- and 4-Terminal Enhancement and Depletion N- and P-Channel MOSFETs.
Analog ICs: 3- and 5-Terminal Opamps, Comparator and Voltage Regulator.
Mixed ICs: A-to-D Converter, D-to-A Voltage and Current Converters, 555 Timer and Monostable.
Logic Gates: AND, OR, NOT, NOR, NAND, XOR, INOR, Tri-state Buffer, Buffer and Schmitt Trigger.
Digital: RS, JK, J-K, D and D' Flip-Flops, Half and Full Adders, Multiplexer, Demultiplexer, Encoder and Decoder.
Indicators: Bulb, Voltmeter, Ammeter, Probe, Row and Decoded 7-Segment Display, Buzzer and Row and Decoded Bargraph.
Controls: Differentiator, Integrator, Gain Block, Transfer Function, Limiter, Divider and Summer.
Other: Fuse, Lossy and Lossless Transmission Lines, Crystal, DC motor, Vacuum Tube and Buck and Boost Converter.
74xxx ICs: 7400, 7402, 7404, 7405, 7406, 7407, 7408, 7409, 7410, 7411, 7412, 7415, 7420, 7421, 7422, 7425, 7426, 7427, 7428, 7430, 7432, 7433, 7437, 7439, 7440, 7442, 7445, 7447, 7451, 7454, 7455, 7469, 7472, 7473, 7474, 7475, 7476, 7477, 7478, 7486, 7490, 7491, 7492, 7493.
74xxx ICs: 74107, 74109, 74112, 74113, 74114, 74116, 74125, 74126, 74133, 74134, 74138, 74139, 74145, 74147, 74148, 74151, 74153, 74154, 74155, 74156, 74157, 74158, 74159, 74160, 74162, 74163, 74164, 74165, 74166, 74169, 4173, 74174, 74175, 74181, 74190, 74191, 74192, 74194, 74195, 74198, 74199, 74238, 74240, 74241, 74244, 74251, 74253, 74257, 74258, 74273, 74280, 74290, 74293, 74298, 74350, 74352, 74353, 74365, 74367, 74368, 74373, 74374, 74375, 74377, 74378, 74379, 74393, 74395, 74445, 74465, 74466, 74467, 74468, 74469, 74470, 74471, 74472, 74473, 74474, 74475, 74476, 74477, 74478, 74479, 74480, 74481, 74482, 74483, 74484, 74485, 74486, 74487, 74488, 74489, 74490, 74491, 74492, 74493, 74494, 74495, 74496, 74497, 74498, 74499, 74500, 74501, 74502, 74503, 74504, 74505, 74506, 74507, 74508, 74509, 74510, 74511, 74512, 74513, 74514, 74515, 74516, 74517, 74518, 74519, 74520, 74521, 74522, 74523, 74524, 74525, 74526, 74527, 74528, 74529, 74530, 74531, 74532, 74533, 74534, 74535, 74536, 74537, 74538, 74539, 74540, 74541, 74542, 74543, 74544, 74545, 74546, 74547, 74548, 74549, 74550, 74551, 74552, 74553, 74554, 74555, 74556, 74557, 74558, 74559, 74560, 74561, 74562, 74563, 74564, 74565, 74566, 74567, 74568, 74569, 74570, 74571, 74572, 74573, 74574, 74575, 74576, 74577, 74578, 74579, 74580, 74581, 74582, 74583, 74584, 74585, 74586, 74587, 74588, 74589, 74590, 74591, 74592, 74593, 74594, 74595, 74596, 74597, 74598, 74599, 74600, 74601, 74602, 74603, 74604, 74605, 74606, 74607, 74608, 74609, 74610, 74611, 74612, 74613, 74614, 74615, 74616, 74617, 74618, 74619, 74620, 74621, 74622, 74623, 74624, 74625, 74626, 74627, 74628, 74629, 74630, 74631, 74632, 74633, 74634, 74635, 74636, 74637, 74638, 74639, 74640, 74641, 74642, 74643, 74644, 74645, 74646, 74647, 74648, 74649, 74650, 74651, 74652, 74653, 74654, 74655, 74656, 74657, 74658, 74659, 74660, 74661, 74662, 74663, 74664, 74665, 74666, 74667, 74668, 74669, 74670, 74671, 74672, 74673, 74674, 74675, 74676, 74677, 74678, 74679, 74680, 74681, 74682, 74683, 74684, 74685, 74686, 74687, 74688, 74689, 74690, 74691, 74692, 74693, 74694, 74695, 74696, 74697, 74698, 74699, 74700, 74701, 74702, 74703, 74704, 74705, 74706, 74707, 74708, 74709, 74710, 74711, 74712, 74713, 74714, 74715, 74716, 74717, 74718, 74719, 74720, 74721, 74722, 74723, 74724, 74725, 74726, 74727, 74728, 74729, 74730, 74731, 74732, 74733, 74734, 74735, 74736, 74737, 74738, 74739, 74740, 74741, 74742, 74743, 74744, 74745, 74746, 74747, 74748, 74749, 74750, 74751, 74752, 74753, 74754, 74755, 74756, 74757, 74758, 74759, 74760, 74761, 74762, 74763, 74764, 74765, 74766, 74767, 74768, 74769, 74770, 74771, 74772, 74773, 74774, 74775, 74776, 74777, 74778, 74779, 74780, 74781, 74782, 74783, 74784, 74785, 74786, 74787, 74788, 74789, 74790, 74791, 74792, 74793, 74794, 74795, 74796, 74797, 74798, 74799, 74800, 74801, 74802, 74803, 74804, 74805, 74806, 74807, 74808, 74809, 74810, 74811, 74812, 74813, 74814, 74815, 74816, 74817, 74818, 74819, 74820, 74821, 74822, 74823, 74824, 74825, 74826, 74827, 74828, 74829, 74830, 74831, 74832, 74833, 74834, 74835, 74836, 74837, 74838, 74839, 74840, 74841, 74842, 74843, 74844, 74845, 74846, 74847, 74848, 74849, 74850, 74851, 74852, 74853, 74854, 74855, 74856, 74857, 74858, 74859, 74860, 74861, 74862, 74863, 74864, 74865, 74866, 74867, 74868, 74869, 74870, 74871, 74872, 74873, 74874, 74875, 74876, 74877, 74878, 74879, 74880, 74881, 74882, 74883, 74884, 74885, 74886, 74887, 74888, 74889, 74890, 74891, 74892, 74893, 74894, 74895, 74896, 74897, 74898, 74899, 74900, 74901, 74902, 74903, 74904, 74905, 74906, 74907, 74908, 74909, 74910, 74911, 74912, 74913, 74914, 74915, 74916, 74917, 74918, 74919, 74920, 74921, 74922, 74923, 74924, 74925, 74926, 74927, 74928, 74929, 74930, 74931, 74932, 74933, 74934, 74935, 74936, 74937, 74938, 74939, 74940, 74941, 74942, 74943, 74944, 74945, 74946, 74947, 74948, 74949, 74950, 74951, 74952, 74953, 74954, 74955, 74956, 74957, 74958, 74959, 74960, 74961, 74962, 74963, 74964, 74965, 74966, 74967, 74968, 74969, 74970, 74971, 74972, 74973, 74974, 74975, 74976, 74977, 74978, 74979, 74980, 74981, 74982, 74983, 74984, 74985, 74986, 74987, 74988, 74989, 74990, 74991, 74992, 74993, 74994, 74995, 74996, 74997, 74998, 74999, 75000.

MODELS

Digital: Models for ICs, Gates and FlipFlops in HC, L-series, HC buffer, HC operation, LS totem-pole, LS buffer, LS open-collector and LS open-collector buffer configurations.
Diodes: Over 1,300 models for Diodes, Zener Diodes, LEDs, Shockley Diodes and Diacs from Motorola, General Instruments, International Rectifier, Zetex and Philips.
Transistors: Over 1,400 models for NPN and PNP BJTs, JFETs, MOSFETs, SCRs, Triacs and IGBTs from Motorola, National Semiconductor, International Rectifier, Toshiba, Hitachi and Philips.
Analog ICs: Over 1,200 models for Opamps, Comparators and Voltage Regulators from Motorola, Texas Instruments, Maxim, Elantec, Analog Devices, Zetex, Burr-Brown and Linear Technology.
Other Models: a variety of Relays, Transformers, Vacuum Tubes, Transmission Lines and Crystals.

Electronics Workbench

VERSION 5

INTERACTIVE IMAGE TECHNOLOGIES LTD., 908 Niagara Falls Boulevard, #068, North Tonawanda, New York 14120-2060/ Telephone 416-977-5550
TRADEMARKS ARE PROPERTY OF THEIR RESPECTIVE HOLDERS. OFFER IS IN U.S. DOLLARS AND VALID ONLY IN THE UNITED STATES AND CANADA. ALL ORDERS SUBJECT TO \$15 SHIPPING AND HANDLING CHARGE

CALL 800-263-5552



Fax: 416-977-1818 Internet: <http://www.interactiv.com> CompuServe: 71333,3435/BBS: 416-977-3540/E-mail: ewb@interactiv.com
CIRCLE 126 ON FREE INFORMATION CARD