

# Radio - SUPERCONDUCTIVITY: THE LATEST NEWS

\$2.25 FEB. 1988  
IN CANADA \$2.75

# Electronics®

TECHNOLOGY - VIDEO - STEREO - COMPUTERS - SERVICE

## BUILD AN AUDIO/VIDEO SWITCHER

PUT YOUR A/V SIGNALS  
ON THE RIGHT TRACK

## MAKE YOUR OWN PC BOARDS

NEW STEP BY STEP GUIDE  
EXPLAINS HOW IT'S DONE

## THE FUTURE OF SHORTWAVE RADIO

NEWS FROM THE 1987 HIGH-FREQUENCY  
BROADCAST CONFERENCE

## PROGRAMMABLE LOGIC DEVICES

AN ATTRACTIVE ALTERNATIVE  
TO STANDARD TTL PARTS

## COMPUTERDIGEST

DESKTOP PUBLISHING SYSTEMS  
FROM SIMPLE TO SUPER

## BUILD THE ULTIMATE CONTROL SYSTEM

THE REACTS 7000 ADVANCED  
MODULAR CONTROL SYSTEM



A  
**GERNSBACK**  
PUBLICATION

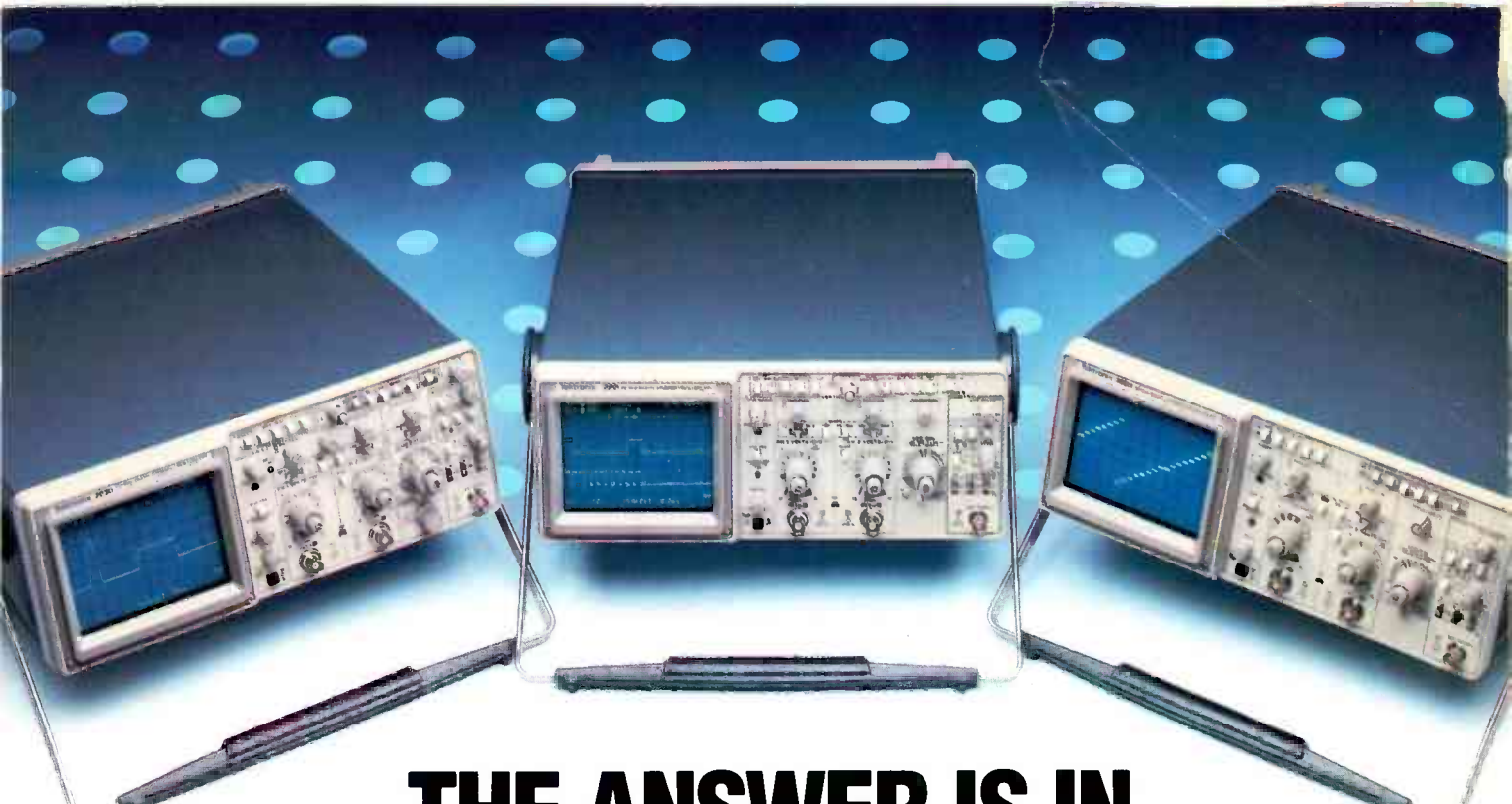

# THE ANSWER IS IN TEK DIGITAL STORAGE:

**Now! The new 60 MHz Tek 2221 joins the world's best-selling family of digital storage oscilloscopes.** All featuring 20 MS/s digitizing along with familiar, full-bandwidth analog operation. It's the best of both worlds in an easy-to-use portable.

**Discover the potential.** With digital storage you can freeze waveforms. Capture events invisible to nonstorage scopes. Find signals buried in noise. And build a library of reference waveforms.

Digital storage display accuracy enhances your confidence in measurements. And all you have to do is push a button for *real-time* display analysis.

**Compare the 2230, 2221 and 2220 to each other — and all others.** The new 2221 offers such advanced features as CRT readout and measurement cursors. For even more performance and flexibility, there's the 100 MHz, dual time base 2230 with optional battery-backed memory for saving up to 26 waveform sets. And if it's economy you want, choose the 60 MHz 2220 with many of the same features at an even lower cost.

**\$2995**  
**\$3995**  
**\$4995**

With each scope you can capture events as narrow as 100 ns at any sweep speed thanks to Tek's proprietary peak detect mode. View events prior to or following a trigger event with pre/post trigger. Store waveforms into 4K records. Automate measurements with optional GPIB and RS-232-C interfaces. And output direct to a printer or plotter.

Tek software is available to help you make the most of the 2230, 2221 and 2220 in system configurations.

**Call Tek for a free video brochure or to place an order.**

Ask about free digital storage application notes and educational materials. Orders include complete documentation, manuals and 3-year warranty on labor, parts and CRT.

**Call Tek direct:  
1-800-426-2200**  
for free video brochure for orders/assistance.

Features	2230	NEW! 2221	2220
Analog/Digital Storage BW	100 MHz	60 MHz	60 MHz
Maximum Sampling Speed	20 MS/s	20 MS/s	20 MS/s
Record Length	4K/1K (selectable)	4K	4K
Peak Detect	100 ns	100 ns	100 ns
Save Reference Memory	One, 4K Three, 1K	One, 4K	One, 4K
Vertical Resolution	8 bits 10 bits (AVG mode) 12 bits (AVG mode over the bus)	8 bits 10 bits (AVG mode)	8 bits
CRT Readout/Cursors	Yes	Yes	No
GPIB/RS-232-C Options	Yes (\$750)	Yes (\$500)	Yes (\$500)
Battery-Backed Memory (save 26 waveform sets)	Yes (inc with GPIB/ RS-232-C)	No	No
Price	\$4995	\$3995	\$2995



CIRCLE 92 ON FREE INFORMATION CARD

**Tektronix**  
COMMITTED TO EXCELLENCE

# February 1988 **Radio- Electronics**

Vol. 59 No. 2

## BUILD THIS

- 46 IN-CIRCUIT DIGITAL IC TESTER**  
Part 3. Three programs, some notes, and more.  
**Bill Green**
- 47 R-E ADVANCED CONTROL SYSTEM**  
A sophisticated control/robotics computer.  
**H. Edward Roberts, M.D.**
- 65 AUDIO/VIDEO SWITCH**  
Untangle that rat's nest of cables.  
**Tod T. Templin**
- 71 PC SERVICE**  
Direct-etch foil patterns for the Audio/Video Switcher.

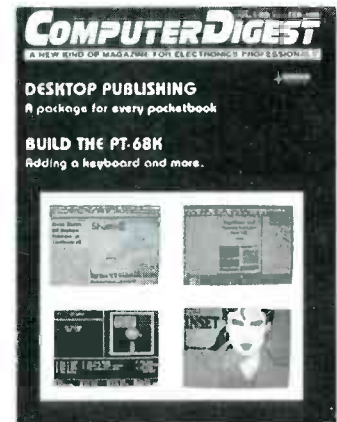

**PAGE 81**

## TECHNOLOGY

- 43 SUPERCONDUCTIVITY BREAKTHROUGHS**  
New discoveries that may change our lives forever.  
**Brian C. Fenton**
- 55 HFBC 87**  
Inside the last high-frequency broadcasting conference.  
**Stanley Leinwoll**
- 59 PROGRAMMABLE LOGIC DEVICES**  
These new IC's may revolutionize the way we design logic systems.  
**Ernest Meyer**



**PAGE 43**

## CIRCUITS AND COMPONENTS

- 51 MAKING YOUR OWN PC BOARDS**  
It's easier than you think!  
**Carl Laron**

## DEPARTMENTS

- |  |  |
|--|--|
| <ul style="list-style-type: none"> <li><b>6 VIDEO NEWS</b><br/>What's new in video.<br/><b>David Lachenbruch</b></li> <li><b>26 EQUIPMENT REPORTS</b><br/>Arkon Wire-Free Wireless Headphones.</li> <li><b>34 COMMUNICATIONS CORNER</b><br/>Pinning the blame.<br/><b>Herb Friedman</b></li> </ul> | <ul style="list-style-type: none"> <li><b>73 HARDWARE HACKER</b><br/>Superconductors for the hacker.<br/><b>Don Lancaster</b></li> <li><b>80 AUDIO UPDATE</b><br/>Documentation difficulties.<br/><b>Larry Klein</b></li> <li><b>98 NEW IDEA</b><br/>Parasitic signaller.</li> </ul> |
|--|--|

## AND MORE

- 120 Advertising and Sales Offices**
- 120 Advertising Index**
- 12 Ask R-E**
- 121 Free Information Card**
- 14 Letters**
- 100 Market Center**
- 32 New Products**
- 4 What's News**

FEBRUARY 1988

## ON THE COVER



In a typical home or office, there are literally dozens of instances where efficiency, convenience, or comfort would be greatly increased with the addition of computer control. However, although we live in an age of computational plenty, with computers literally all around us, the problem of getting computers to effectively and efficiently communicate with and control other devices for the most part remains. This month, we introduce a project that goes a long way toward solving that problem. Called the REACTS 7000, it is a sophisticated, modular computer designed specifically for control applications. For more information on the system, turn to page 47.

## COMING NEXT MONTH

### THE MARCH ISSUE IS ON SALE FEBRUARY 4

#### BUILD A PLASMA DISPLAY

Build our version of this attractive attention grabber.

#### **Radio Electronics** ADVANCED CONTROL SYSTEM

Build the first of the modules—the CPU.

#### **COMPUTERDIGEST**

#### BUILD A PRINTER MULTIPLEXER

Share your printer with 4 computers—automatically!

As a service to readers, RADIO-ELECTRONICS publishes available plans or information relating to newsworthy products, techniques and scientific and technological developments. Because of possible variances in the quality and condition of materials and workmanship used by readers, RADIO-ELECTRONICS disclaims any responsibility for the safe and proper functioning of reader-built projects based upon or from plans or information published in this magazine.

Since some of the equipment and circuitry described in RADIO-ELECTRONICS may relate to or be covered by U.S. patents, RADIO-ELECTRONICS disclaims any liability for the infringement of such patents by the making, using, or selling of any such equipment or circuitry, and suggests that anyone interested in such projects consult a patent attorney.

RADIO-ELECTRONICS, (ISSN 0033-7862) February 1988. Published monthly by Gernsback Publications, Inc., 500-B Br-County Boulevard, Farmingdale, NY 11735 Second-Class Postage paid at Farmingdale, NY and additional mailing offices. Second-Class mail registration No. 9242 authorized at Toronto, Canada. One-year subscription rate U.S.A. and possessions \$16.97, Canada \$22.97, all other countries \$25.97. All subscription orders payable in U.S.A. funds only, via international postal money order or check drawn on a U.S.A. bank. Single copies \$2.25 © 1987 by Gernsback Publications, Inc. All rights reserved. Printed in U.S.A.

**POSTMASTER:** Please send address changes to RADIO-ELECTRONICS, Subscription Dept., Box 55115, Boulder, CO 80321-5115.

A stamped self-addressed envelope must accompany all submitted manuscripts and/or artwork or photographs if their return is desired should they be rejected. We disclaim any responsibility for the loss or damage of manuscripts and/or artwork or photographs while in our possession or otherwise.

## Radio Electronics®

Hugo Gernsback (1884-1967) founder  
M. Harvey Gernsback,  
editor-in-chief, emeritus

Larry Steckler, EHF, CET,  
editor-in-chief and publisher

#### EDITORIAL DEPARTMENT

**Art Kleiman**, editorial director  
**Brian C. Fenton**, managing editor  
**Carl Laron**, WB2SLR, associate editor  
**Jeffrey K. Holtzman**,  
computer editor  
**Marc Spiwak**, associate editor  
**Robert A. Young**, assistant editor  
**Julian S. Martin**, editorial associate  
**Byron G. Wels**, editorial associate  
**M. Harvey Gernsback**,  
contributing editor  
**Jack Darr**, CET, service editor  
**Robert F. Scott**,  
semiconductor editor  
**Herb Friedman**,  
communications editor  
**Bob Cooper, Jr.**, satellite-TV editor  
**Robert Grossblatt**, circuits editor  
**Larry Klein**, audio editor  
**David Lachenbruch**,  
contributing editor  
**Don Lancaster**,  
contributing editor  
**Richard D. Fitch**,  
contributing editor  
**Teri Scaduto**, editorial assistant

#### PRODUCTION DEPARTMENT

**Ruby M. Yee**, production director  
**Robert A. W. Lowndes**,  
editorial production  
**Andre Duzant**, technical illustrator  
**Karen Tucker**, advertising production  
**Marcella Amoroso**, production traffic

#### CIRCULATION DEPARTMENT

**Jacqueline P. Cheeseboro**,  
circulation director  
**Wendy Alanko**,  
circulation analyst  
**Theresa Lombardo**,  
circulation assistant

Typography by Mates Graphics  
Cover photo by Nick Koudis

Radio-Electronics is indexed in  
*Applied Science & Technology Index*  
and *Readers Guide to Periodical Literature*.

Microfilm & microfiche editions are  
available. Contact circulation department  
for details.

Advertising Sales Offices listed  
on page 120.



# Information radio is on the air.



**B**efore you hear about it on your old radio, hear it live on your new Informant Information Radio. Whether its an all-points-bulletin from the State Police, the dispatcher for the city's Fire Department, an ambulance racing to the hospital or a National Weather Service report, the new Informant from Regency makes you a part of all the action... instantly.

## *Breakthrough Technology. Instant Information.*

Informant Information Radio uses a revolutionary new technology that allows you to constantly monitor your police, fire and



emergency frequencies, as well as NOAA weather information channels in all 50 states. All pre-programmed. This new Information Radio utilizes a principle similar to the seek and scan feature found on expensive AM/FM radios. Your information radio scans the public service channels in the area, locates the active signals, locks in and broadcasts all the information right to you. With revolutionary TURBO-SCAN speed!

## *Hear Your Hometown Like You've Never Heard it Before.*

Just turn it on. As easy to use as your AM/FM radio. Instantly, you're tuned into real life adventures. One touch control lets you select and hold police, fire and emergency broadcasts so you don't miss a single minute of the action.

Hear the amazing Information Radio today. Take it home and be a part of the action tonight!!



*Information Radio for Real Life Adventure*



CIRCLE 182 ON FREE INFORMATION CARD

# WHAT'S NEWS

## High-technology display doubles image resolution

The world's largest high-resolution liquid crystal display for aircraft cockpits has been designed and fabricated by scientists of the General Electric Research Center, in a joint effort with the company's Aircraft Instruments Department.

The new panel, measuring 6.25 × 6.25 inches, is a high-resolution, full-color liquid-crystal display designed to meet military specs. It can be programmed to display engine performance, logistic and ballistic data, and attitude references, as well as radar images and video.

The new displays produce a much higher resolution image not only because of the high number of pixels on the screen (more than 28,000 pixels-per-square-inch, or more than a million in total), but

because of GE's ability to position thin-film transistors at the corner of each pixel. That provides a switch that turns the liquid crystal material on or off at the point, enhancing contrast and improving the viewing angle. Sharpness is twice that of a home-TV screen.

The liquid crystals are sandwiched between two plates of glass. The inner sides of the plates are patterned with silicon structures that control the electrical charges that "paint" the images or alphanumeric characters on the LCD's screen. The unit includes a dimmable fluorescent backlight, which provides a high-contrast image over an ambient brightness range from full sunlight to complete darkness.

GE displayed a prototype panel at the Paris Air Show last year.

## Expert systems used in semiconductor fabrication

In semiconductor manufacture, a typical diagnosis includes testing of "test structures" with probes smaller than the diameter of a human hair. Those test structures are fabricated on the wafer and form test chips that replace the regular ones that would be in those spots. Test results from those structures are recorded in computer memory for evaluation.

The difficulty is that the numerical diagnostic data has to be analyzed by specialists with expert knowledge. But such experts often aren't available to translate pages and pages of numbers into usable solutions to problems.

The use of a computer *expert system* being developed jointly by the National Bureau of Standards and the Westinghouse Research and Development Center may greatly simplify the testing procedure. An expert system is a software program built up from the knowledge and experience on not one, but a number, of experts in a given field.

Using an expert system, data obtained from diagnostic test structures can be interpreted much easier than by older approaches. Process personnel armed with test data on a computer disk will be able to diagnose fabrication problems in a readily understood, English-language format on a computer screen.

Development of the expert system is still in the formative stage, and the National Bureau of Standards welcomes companies interested in working collaboratively with the Bureau to research expert systems further. For information, contact Loren W. Linholm, 8360 Technology Bldg., National Bureau of Standards, Gaithersburg, MD 20899 or Dr. Michael Cresswell, Westinghouse R & D Center, Pittsburgh, PA 15235. R-E

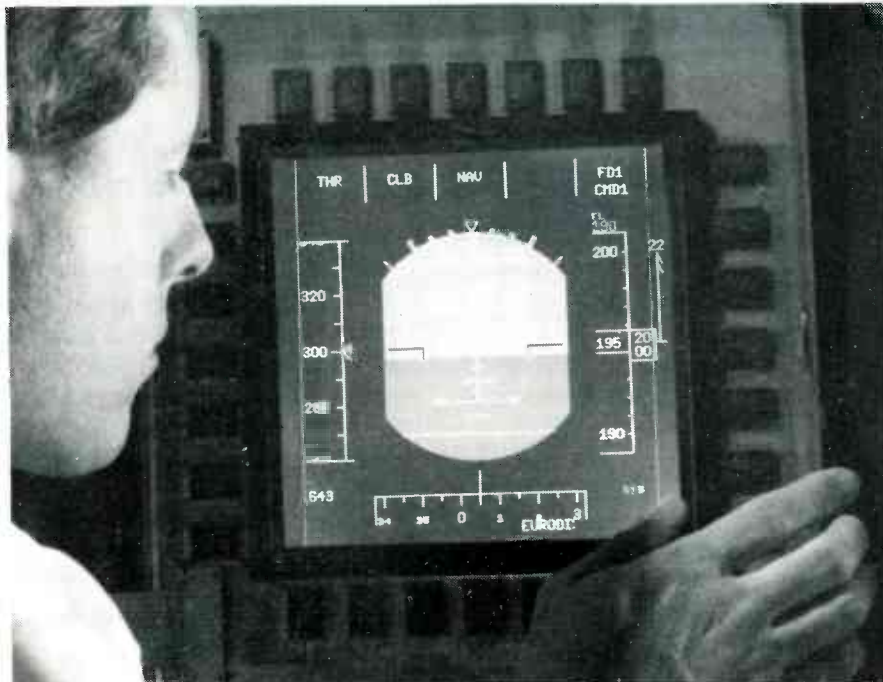

WORLD'S LARGEST LIQUID CRYSTAL DISPLAY panel for aircraft cockpits is programmable for display of engine performance, logistic and ballistic data, and attitude references, as well as radar images and video. The display's high resolution of 28,000 dots-per-square-inch give it twice the sharpness of a home-TV screen.

# EIA/CEG AUGMENTS DIGITAL AND MICROPROCESSOR COURSE HIGH TECH PARTS KITS NOW AVAILABLE

The members of the Electronic Industries Association Consumer Electronics Group (EIA/CEG) through the Product Services Committee, has marketed the illustrated parts kit for vocational schools, educators and technicians. This is the same material used in the Digital and Microprocessor Course during EIA's summer workshop programs. These workshops are organized by the Consumer Electronics Group and co-sponsored by national service organizations and state departments of vocational education.

Parts and components are contained in a lightweight tool box with individual compartments. It includes a breadboard, power supply, pre-dressed jumpers, resistors,

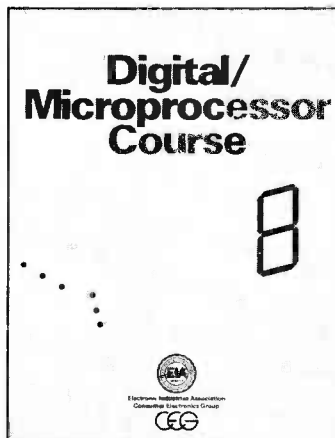

capacitors, and integrated circuits to perform all digital exercises 1 through 25 of the Digital/Microprocessor course book listed in the table of contents. Some parts have been included for the microprocessor section but other components will have to be acquired (as listed in the Introduction to Exercises 26-31).

Individual and classroom size quantities are available at the following cost: quantities 1-9, \$69.95 each, quantities 10-19, \$67.95 each, and for quantities 20 or more, \$64.95 each (cost includes shipping and handling). The kits will also include the Digital and Microprocessor Course book. Additional books are available at the cost of \$2.00 per copy.

## PLEASE COMPLETE ORDER FORM FOR PARTS KITS AND BOOKS

Send to: EIA/CEG, Department PS, P.O. Box 19100, Washington, D.C. 20036

ORDER FORM	Parts Kit	Quantity	Amount	Total
	1-9 .....	_____	\$69.95 each	_____
	10-19 .....	_____	\$67.95 each	_____
	20 or more .....	_____	\$64.95 each	_____
	<b>Additional Digital/Microprocessor Course Books</b> .....		\$2.00 per copy	_____
	<b>Total Amount Enclosed</b>			_____
	Name	[Grid]		
	Title	[Grid]		
	Firm	[Grid]		
	Address	[Grid]		
	City	State	Zip	[Grid]

---

---

# VIDEO NEWS



**DAVID LACHENBRUCH,**  
CONTRIBUTING EDITOR

• **Supercable.** The influence of Super-VHS continues to spread in ever-widening circles, vastly increasing the efforts devoted to developing *High-Definition TeleVision* (HDTV) and various improved TV systems. The mere idea that a home device can be capable of reproducing pictures superior to those coming in over the air (or by cable) has spurred the TV establishment to act immediately.

Now, there is a proposal to use the specs of Super-VHS (more than 400 lines of horizontal resolution, separate chrominance and luminance signals) as a form of deluxe cable.

The National Cable TV Association has named a subcommittee to look into the idea of "supercable." Since an increasing number of color-TV sets are capable of showing high-resolution pictures, and more and more will have Y/C connectors (for direct input of chrominance and luminance signals), why shouldn't cable feed its subscribers a picture of the same quality, either for viewing directly or taping on Super-VHS recorders? Under one scenario, a cable subscriber would pay extra for a super channel providing him or her with a Super-VHS picture. There is some question whether supercable would require more than the standard 6-MHz bandwidth. Some cable engineers suggest that the same channel could be used to provide a standard NTSC and a super picture. Subscribers with one type of set-top converter would receive a regular 330-line NTSC signal, while those with another type would receive the 400-plus line super channel—at extra charge, of course.

• **ACTV.** That acronym stands for Advanced Compatible TeleVision, and it's probably the last major project carried out by the old RCA using its in-house TV network (NBC) and research facilities (David Sarnoff Research Center). The results of six years' work, ACTV is a widescreen, 1,050-line TV system that can be transmitted within the same 6-MHz bandwidth as standard NTSC and is totally compatible with existing NTSC TV sets.

The ingenious system uses a series of subcarriers to multiplex the various elements of

the picture. The "ears" (the additional width at each side of the screen) are compressed for transmission, and expanded in ACTV receivers. In standard NTSC receivers, which will continue to provide a traditional 4- × -3 picture, they are in the overscanned portion of the picture hidden by the frame of the picture tube. The 1,050 scanning lines are double the number provided by a standard NTSC transmission, but an NTSC set would only "see" 525 of them.

ACTV was announced jointly by NBC, the David Sarnoff Research Center (now part of Stanford Research Institute), and GE/RCA Consumer Electronics, whose sale to Thomson of France was pending at the time of the announcement. A computer simulation of ACTV has been presented on tape, but no equipment has yet been built. Its developers hope to build and field test the equipment this year.

ACTV is not true high-definition TV, but its sponsors believe it is at least an interim step, ideally suited for standard terrestrial broadcasting because of its compatibility with the existing system and its use of a standard 6-MHz channel. All other systems demonstrated to date either require a wider bandwidth or are not compatible with NTSC. For example, two NTSC-compatible HDTV systems (by Philips and Charles Glenn) use one standard channel and a part of another. The Japanese 1,125-line system is incompatible with NTSC and is designed for direct satellite transmission. A system sponsored by Del Rey Group is aimed at a compatible 6-MHz picture but isn't yet HDTV and is still in an early development stage.

• **Sony joins the giants.** Sony celebrated the 20th anniversary of the *Trinitron* color-TV tube by introducing two giant sizes—34 and 45 inches in overall diagonal measurement—joining other manufacturers that are fielding giant versions of conventional color tubes. The 34-inch tube is built into a "Family Stereo TV" that will retail in Japan at about \$2,345. The 45-inch tube will be in a set selling for just under \$14,000, and that's designed for TV viewing in public places. **R-E**





**Now**  
**Hands-on**  
**Electronics®**  
**Every Month!**

■ IF YOU'RE THE KIND OF READER that doesn't want to wait, you can order your next copy of **Hands-on Electronics** now. **Hands-on Electronics** is crammed full of electronic projects that you won't be able to wait to build for yourself. You can expect top-notch digital projects, fun-to-play electronic games, valuable add-on computer projects, BCB and shortwave receivers, photographic/darkroom gadgets, devices to improve your car's performance, test equipment ideas, and more in every issue of **Hands-on Electronics**.

■ YOU CAN HAVE THE NEXT TWELVE ISSUES of **Hands-on Electronics** delivered to your home for only \$18.95 — saving \$11.05 off the single copy price.

■ EVERY ISSUE OF **Hands-on Electronics** will continue to contain a variety of construction articles to suit every taste. In addition, feature articles on electronics fundamentals, test equipment and tools will round out each issue. Of course, **Hands-on Electronics** will continue to provide new product and literature listings to keep you up to date on the latest developments in electronic technology.

■ GET IN ON THE ACTION! Order your next issue of **Hands-on Electronics** today. Use the convenient order coupon below. Be sure to send check or money order—no cash!

## Hands-on Electronics SUBSCRIPTION

I want to be sure I don't miss any issues. Send me ONE FULL YEAR — twelve issues — of **Hands-on Electronics** for \$18.95 (Canada \$23.95 U.S. Funds).

Payment Enclosed

Please charge my

Bill Me Later

Visa

Mastercard

Signature \_\_\_\_\_

Acct. # \_\_\_\_\_ Exp. Date \_\_\_\_\_

Allow 6-8 weeks for the first issue to arrive. Offer valid in U.S. Funds Only.

Please print

(Name) \_\_\_\_\_

(Street Address) \_\_\_\_\_

(City) \_\_\_\_\_

(State) \_\_\_\_\_

(Zip) \_\_\_\_\_

Detach and mail today to:  
**HANDS-ON**  
**ELECTRONICS**  
**SUBSCRIPTION DEPT.**  
**P.O. BOX 338**  
**MOUNT MORRIS, IL**  
**61054**

AREB8

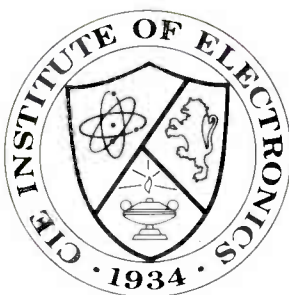

“If you’re going to learn electronics, you might as well learn it right!”

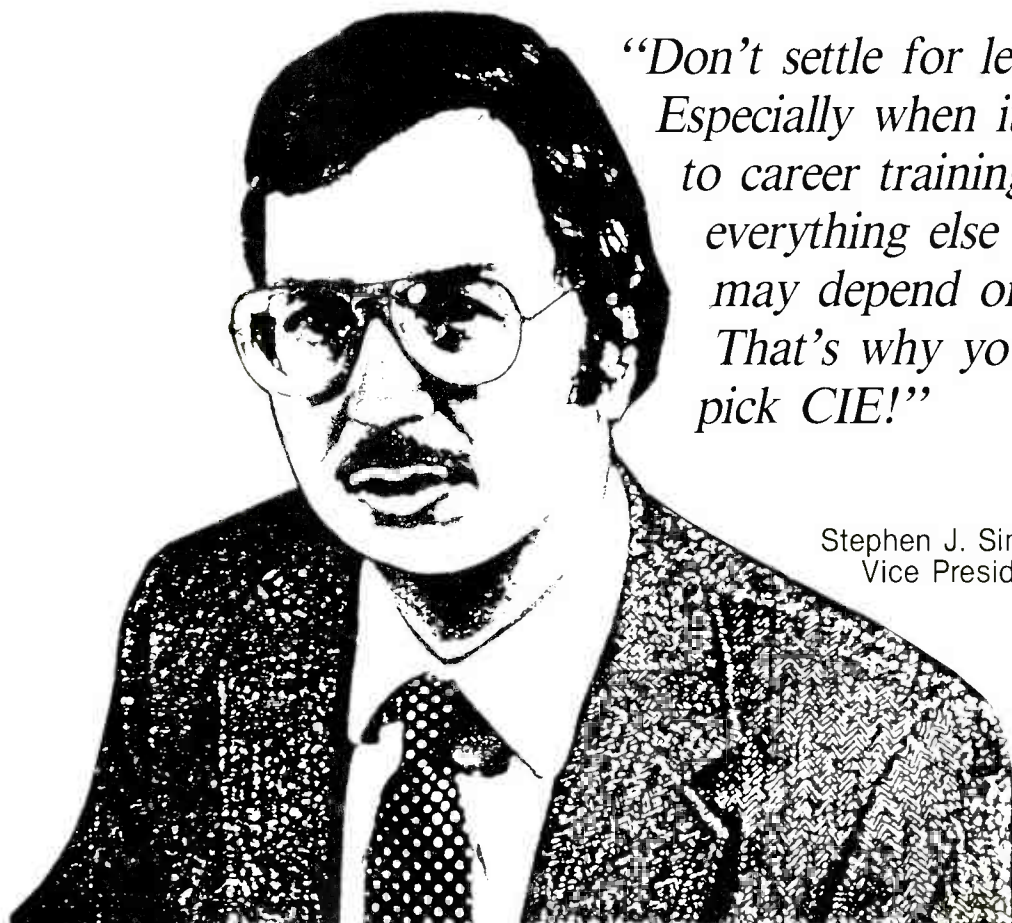

*“Don’t settle for less.  
Especially when it comes  
to career training...because  
everything else in your life  
may depend on it.  
That’s why you ought to  
pick CIE!”*

Stephen J. Simcic  
Vice President, Academic Affairs

**Y**ou've probably seen advertisements from other electronic schools. Maybe you think they're all the same. They're not!

CIE is the largest independent home study school in the world that specializes exclusively in electronics.

### Meet the Electronics Specialists.

When you pick an electronics school, you're getting ready to invest some time and money. And your whole future depends on the education you get in return.

That's why it makes so much sense to go with number one . . . with the specialists . . . with CIE!

### There's no such thing as bargain education.

If you talk with some of our graduates, chances are you'd find a lot of them shopped around for their training. Not for the lowest priced but for the best. They pretty much knew what was available when they picked CIE as number one.

We don't promise you the moon. We do promise you a proven way to build valuable career skills. The CIE faculty and staff are dedicated to that. When you graduate, your diploma shows employers you know what you're about. Today, it's pretty hard to put a price on that.

### Because we're specialists we have to stay ahead.

At CIE, we've got a position of leadership to maintain. Here are some of the ways we hang onto it . . .

### Programmed Learning

That's exactly what happens with CIE's Auto-Programmed Lessons. Each lesson uses famous "programmed learning" methods to teach you important principles. You explore them, master them completely, before you start to apply them. You thoroughly understand each step before you go on to the next. You learn at your own pace.

And, beyond theory, some courses come fully equipped with electronics gear (the things you see in technical magazines) to actually let you perform hundreds of "hands-on" experiments.

### Experienced specialists work closely with you.

Even though you study at home, you are not alone! Each time you return a completed lesson, you can be sure it will be reviewed, graded, and returned with appropriate instructional help. When you need additional individual help, you get it fast and in writing from the faculty technical specialist best qualified to answer your question in terms you can understand.

### Pick the pace that's right for you.

CIE understands people need to learn at their own pace. There's no pressure to keep up . . . no slow learners hold you back. If you're a beginner, you start with the basics. If you already know some electronics, you move ahead to your own level.

### Enjoy the promptness of CIE's "same day" grading cycle.

When we receive your lesson before noon Monday through Saturday, we grade it and mail it back the same day. You find out quickly how well you're doing!

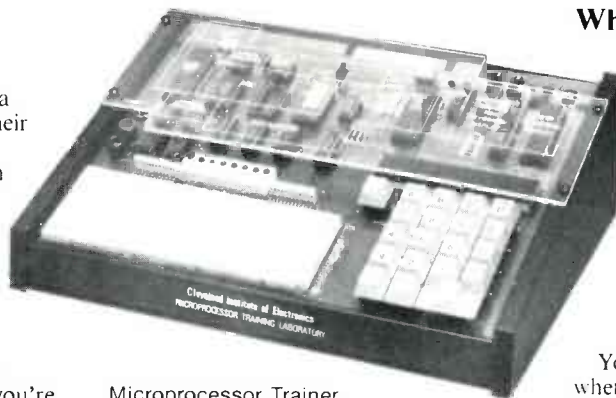

Microprocessor Trainer

### State-of-the-art Laboratory Equipment

Some courses feature the CIE Microprocessor Training Laboratory. An integral part of computers, microprocessor technology is used in many phases of business, including service and manufacturing industries.

The MTL gives you the opportunity to program it and interface it with LED displays, memory devices, and switches. You'll gain all the practical experience needed to work with state-of-the-art equipment of today and tomorrow.

### CIE offers you an Associate Degree.

One of the best credentials you can have in electronics — or any other career field — is a college degree. That's why CIE gives you the opportunity to earn an Associate in Applied Science in Electronics Engineering Technology. Any CIE career course can offer you credit toward the degree — more than half of the number needed in some cases.

*"Cleveland Institute of Electronics is the only accredited institution of higher learning offering an Associate Degree program with tuition based on actual study time used. The faster you complete your degree assignments, the less your overall tuition."*

Steve Simcic  
Vice-President Academic Affairs

### Which CIE Training fits you?

Beginner? Intermediate? Advanced? CIE home study courses are designed for ambitious people at all entry levels. People who may have:

1. No previous electronics knowledge, but do have an interest in it;
2. Some basic knowledge or experience in electronics;
3. In-depth working experience or prior training in electronics.

You can start where you fit and fit where you start, then go on from there to your Diploma, Associate Degree, and career.

### Today is the day. Send now.

Fill in and return the postage-free card attached. If some ambitious person has removed it, cut out and mail the coupon. You'll get a FREE school catalog plus complete information on independent home study. For your convenience, we'll try to have a CIE representative contact you to answer any questions you may have.

Mail in the coupon below or, if you prefer, call toll-free 1-800-321-2155 (in Ohio, 1-800-523-9109).

ARE-78

# CIE

## Cleveland Institute of Electronics, Inc.

1776 East 17th Street, Cleveland, Ohio 44114

Accredited Member National Home Study Council

YES...I want to learn from the specialists in electronics — CIE. Send me my FREE CIE school catalog...including details about the Associate Degree program... plus my FREE package of home study information.

Print Name \_\_\_\_\_

Address \_\_\_\_\_ Apt. \_\_\_\_\_

City \_\_\_\_\_ State \_\_\_\_\_ Zip \_\_\_\_\_

Age \_\_\_\_\_ Area Code/Phone No. \_\_\_\_\_/\_\_\_\_\_

Check box for G.I. Bill bulletin on Educational Benefits:  Veteran  Active Duty

**MAIL TODAY!**

**CIRCLE 60 ON FREE INFORMATION CARD**

# ASK R-E

## WRITE TO:

ASK R-E  
Radio-Electronics  
500-B Bi-County Blvd.  
Farmingdale, NY 11735

## SYNCHRONOUS INVERTER

My thanks to Mr. J. Dale E. Holt of Manchester, TN for pointing out that my reply to D.B. (December 1986) was inadequate. He points out that all-electronic synchronous inverters have been available for many years. He owns a 2-kW unit by Acheval Wind Electronics that he purchased for approximately \$1,000.00. He sent a diagram (Fig. 1) that the maker of the Gimini synchronous inverters uses to explain the theory of operation.

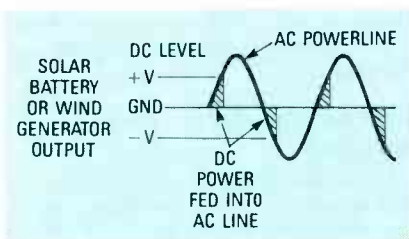

FIG. 1

The synchronous inverter takes the DC power from a bank of solar cells or a wind- or water-driven generator and switches it—through SCR's—at the zero-crossing point of the AC powerline voltage. Current flows into the power lines until the instantaneous AC voltage exceeds the DC voltage; at which time the SCR's turn off.

## MORE ON THE FISHER 400

I too, need a schematic for a Fisher model 400 FM stereo receiver. Since seeing your reply to J.T., of Thonotossa, FL (February 1987), here's what I've found out: 1) The model 400-C is a preamplifier, not a receiver. 2) The 400 is listed as a new item in the 1964 Allied Radio catalog. 3) The 400-T is a later transistorized version. 4) Sams photofacts does not have any information on the model 400.

Is there a reader who can supply a photocopy of the service manual or the schematic? I will greatly appreciate it, and I'm sure that the reader in Florida will too.—G.H.M., Kingsport, TN.

## AND STILL MORE

Here is a possible solution to J.T.'s problem with an intermittent channel in a Fisher AM-FM stereo receiver. Awhile back, I gutted and discarded a Fisher 400 because it had an intermittent right channel caused by a defective output transformer. It is a heavy monster with about ten separate windings. Rewinding the transformer wasn't practical. I kept the good left-channel output transformer along with all of the information on how it was hooked up.

I don't recall whether or not the set had a printed-circuit board, but I've seen many sets of that vintage that had dual-heater circuits where the center was grounded by soldering a certain point on the circuit board to the metal chassis. Intermittent heating and flexing of the circuit board over the years can crack the soldered connection. The soldered joint makes intermittent contact, effectively turning a tube's heater off and on, or simply not passing enough current to keep the tube hot. As the tube heats and cools, its output voltage or power varies.

If J.T. is interested in the transformer I'll sell it for \$5.00 and postage or will swap it for a standard center-tapped output transformer of the same or an earlier vintage. He can contact me through "Ask RE"—D.A.Y., Key West, FL.

## SPEAKER LEADS TOO SMALL?

I recently purchased a 100-watt-per-channel power booster intended

for use in an automobile. I built a 12-volt, 6-amp power supply, following the diagram on page 44 of the May 1987 issue of *Radio-Electronics*. The setup works nicely, but I'm bothered by the small size of the hookup wire that came with the speakers. It's only 26 or 24 gauge. Isn't that wire too small to carry the 100 watts that the booster can deliver? For example a 100-watt floodlamp usually requires No. 18 or larger wire.—J.M.B., Ballston Lake, NY

There is a considerable difference between delivering 100 watts of power to a floodlamp and the audio power that is fed to the speakers. Ordinary audio program material is very random in nature and a power amplifier operating at or near the 100-watt level will actually reach that level only on the random peaks of the program material. On the other hand, the sine-wave power fed to a lamp is constant, as are the losses in the power cord or transmission line.

One consideration in selecting speaker wires is their resistance. In general, the smaller the diameter (or the higher the gauge), the higher the resistance. Speakers are relatively inefficient devices, so you don't want to waste power in the connecting wires. In order to minimize power losses, be sure that the DC resistance of the speaker leads is much lower than the impedance of the speaker's voice coil.

No.-26 wire has a resistance of 4 ohms per 100 feet. If you have a 4-ohm speaker fed through 50-feet of two-conductor speaker wire, about half of the power will be dissipated in the leads.

The booster manufacturer probably used No.-24 or No.-26 wire because it is less expensive than



FIG. 2

**OLD CAPACITORS AND PCB's**  
 I collect and restore old TV sets and very often I have to replace the capacitors in the sweep circuits. I've heard that some old capacitors like the ones in Fig. 2 contain PCB's (Poly Chlorinated Biphenyl). What is the best method of disposing of them?—  
 B.T., Atlanta, GA

I can't confirm nor deny that the oil is a PCB material. My local environmental agency office seems to only think in terms of tens of

gallons of PCB material in transformers and capacitors used in power transmission. They can't understand that such material might be used in anything smaller and cannot offer any suggestions.

If the problem were mine, to avoid contaminating the environment I'd pack the leaky capacitors in a coffee can and, when I had a half can or so, would fill the can with cement or mortar mix, bury it, and forget it.

R-E

larger sizes. And, since power boosters for car stereos are usually installed within a few feet from the speakers, the power loss in the small-gauge wire is negligible.

You purchased a 100-watt booster amp and 120-watt speakers so you must want a high volume level. For the maximum available audio power while putting your mind at ease, use 18-gauge speaker wire. Its resistance is only 0.64 ohm per 100 feet. You can also use zip-type lamp cord, which uses 18-gauge wire.

You Can Be  
 One Of The  
 20,000 Technicians  
 Certified BY ISCET



The International Society Of Certified Electronics Technicians offers permanent certification by administering the CET exam with the FCC recognized communications option for \$20. A second exam on FCC regulations for a \$10 fee is required for a Radiotelephone License. Upon passing, technicians receive both a permanent Radiotelephone Operator Certificate and a CET Certificate issued by ISCET.

**ISCET Offers License Renewal**

ISCET has developed a program for registration of those who currently hold a valid Radiotelephone Operator License. By sending a completed application, a photocopy of your FCC License, and \$10 your license will be renewed with the assurance of a recognized national technicians association behind it.

For More Information Contact:  
 ISCET 2708 W. Berry, Ft. Worth, TX  
 76109. (817) 921 - 9101

# Get your hands on the standard: POMONA.

Since 1951 POMONA has grown to become the standard of the industry. And for good reason. Our test products assure honest test results because they are the best you can buy. Specify POMONA and get unsurpassed quality, the broadest product line, the greatest selection, the industry standard.



For your FREE 1988 General Catalog, circle reader service number printed below

**POMONA**  
 ITT Pomona Electronics

CIRCLE 101 ON FREE INFORMATION CARD

# LETTERS



## VIDEO PALETTE

In building the Video Palette video-effects generator (September–October 1987), I noticed several errors and discrepancies: No PC-board mounting locations are given for C11 or C14. In Fig. 12, the centers of J1, J2, and J3 are shown all tied together. You don't show where on the main board to connect the +5- and -5-volt leads from the effects board. The A lead from the effects board does not appear to connect to anything on the main board. Finally, the orientation of IC7 appears to be incorrect on the PC board.

RICHARD E. RICE  
Pickerington, OH

*The gremlins seemed to have done a thorough job this time: Jacks J1–J3 are incorrectly wired in Fig. 12; they should be wired as shown in Fig. 10, and only J3 should connect to S2-b. The +5-volt connection on the main board should be made at the junction of R14/R18; the -5-volt connection should be made at the junction of R19/C13. On the main board, install R33, a 10K unit, between the pad next to the A-lead pad and the hole adjacent to R34; that will tie the A lead to the rest of the circuit. And IC7 is indeed installed backwards. As to the missing capacitors, although they are shown in the schematic, C11 and C14 are not needed for proper operation and have been eliminated from the design.—Editor*

## CORRECTIONS

In the article "SMT Project: A Business-Card Tone Generator" (*Radio-Electronics*, November 1987) Forrest M. Mims III incorrectly states that sheet resistivity is

specified in units of ohms per square centimeter. The unit of sheet resistivity is ohms per square; all squares of the same material and thickness will have the same resistance. For example, if a material has a resistance for a given thickness of one ohm per square, a ¼-inch square will measure one ohm and a ½-inch will also measure one ohm.

Looking at Fig. 1 in the article, the ½-inch square can be seen to be equivalent to four ¼-inch squares. Looking at only the top two, you have one ohm in series with one ohm, equalling two ohms. That is paralleled by the identical bottom two. Two ohms in parallel with two ohms is one ohm. Following that line of reasoning, a square measuring one centimeter on a side will measure one ohm. However, a rectangle with the dimensions ¼-centimeter by four centimeters, which is equivalent to 16 quarter centimeter squares in series, will measure 16 ohms. Both cover an area of one square centimeter, but they have widely differing resistances.

Thus, it is obvious that sheet resistivity must be indicated in ohms per square, not ohms per area. Table 1 in the article also proves that, since the resistances of the 1" × 0.02" lines (equal to fifty squares of .02" on a side) is exactly fifty times the resistivities.

Mr. Mims also states that silver has several times the resistance of gold. That may or may not be true of gold and silver conductive paints, but it is definitely not true of the elements—short of superconductors, silver is the most conductive metal.

ALAN RAUCHWERGER  
Rochelle Park, NJ

*You're absolutely correct, and we apologize for some over-zealous editing regarding resistivity specifications.—Editor*

## ELECTRONIC COMBINATION LOCK

*It has come to our attention that the two IC's used in the "Electronic Combination Lock," which appeared in the November 1987 issue of *Radio-Electronics*, are difficult to obtain in single-unit quantities. However, they are available from Circuit Specialists, P.O. Box 3047, Scottsdale, AZ 85257. The MC145026 sells for \$3.60; the MC145028 sells for \$4.80. Add \$2.00 shipping and handling, and AZ residents must add appropriate sales tax.—Editor*

## COMPUTER GRAPHICS ON VCR

The latest copy of *Radio-Electronics* arrived today and I've been enjoying it. I've been reading the Gernsback "Radio-" publications all my life—I'm 82 now.

I have a simple project that other readers might enjoy. If you use a television set as a monitor, you can save the pictures on your color computer on a VCR. Connect the output of the computer to the input (antenna) connection of the VCR. Connect the output of the VCR to the TV monitor. Now you're ready to record.

I use channel 3, as it is not used here for TV, and a Tandy *Color Computer* to do that. An old Timex/Sinclair computer will do, but it won't give you color. I write notes about the program I record—the date, time, etc. The system also comes in handy for business presentations. Instead of drawing graphs on paper, photographing them, and having

# Eliminate Costly Guesswork And Interpretation Errors In LCR Testing!



- **Completely Analyze Capacitors**  
From 1pf to 20F for value, leakage, Dielectric absorption and ESR
- **Thoroughly Test Inductors**  
From .1uH to 20H for value, opens and shorts even to one shorted turn!
- **Dynamically Test for Resistance**  
Measure resistances up to 1,000 Megohms, and leakage down to 1 microamp with 1,000 volts applied potential
- **Good/Bad Tests Eliminate Guesswork**  
Exclusive good/bad readout gives you easy to read, reliable tests to informal EIA and industry standards.
- **100% Portable**  
Works all day on one charge for testing in the field or on the bench.

**LC77 AUTO-Z™**  
Capacitor-Inductor Analyzer  
\$1895 Patented

IEEE 488  
BUS-COMPATIBLE

THE **Z** STANDARD

100% American Made CIRCLE 180 ON FREE INFORMATION CARD

**SENCORE**

Call **1-800-843-3338** today.  
In Canada call **1-800-851-8866** today.

# HITACHI SCOPES AT DISCOUNT PRICES!

20MHZ



Model V212 \$475

100MHZ



Model V1060 \$1,375

Model V-212 20MHZ Dual Channel (1mV Sens.) \$475  
 Model V-422 40MHZ Dual Channel (1mV Sens.) \$699  
 Model V-425 40MHZ Dual Channel (with cursor) \$795  
 Model V-660 60MHZ Dual Channel (Delayed Sweep) \$990  
 Model V-1060 100MHZ Dual Channel (Delayed Sweep) \$1,375  
 All above scopes have a 3 year guaranty on parts and labor

**15-25%  
OFF LIST  
PRICE**

# ELENCO PRODUCTS AT DISCOUNT PRICES!

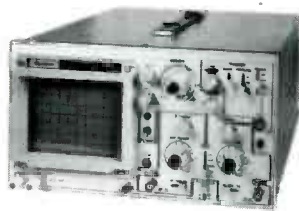

**MO-1253  
40MHz  
Dual Trace  
12KV HV  
Delayed Sweep  
\$550**

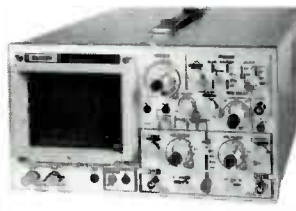

20MHz DUAL TRACE OSCILLOSCOPE

**\$349 MO-1251**

35MHz DUAL TRACE OSCILLOSCOPE

**\$498 MO-1252**

Top quality scopes at a very reasonable price. Contains all the desired features. Elenco's 2 year guarantee assures you of continuous service. Two 1x, 10x probes, diagrams and manual included. Write for specs.  
 100MHz test probes, switchable 1x, 10x, Ref. (Complete w/ 5 accessories) Fits most scopes \$22

MULTIMETER with CAPACITANCE AND TRANSISTOR TESTER  
 Model CM-1500A **\$58**  
 Reads Volts, Ohms, Current, Capacitors, Transistors & Diodes w/Case

TRUE RMS 4 1/2 DIGIT MULTIMETER  
 Model M-7000 **\$135**  
 .05% DC Accuracy  
 .1% Resistance with Freq. Counter & Deluxe Case

Auto Ranging plus Manual Ranging  
 3 1/2 Digit Meter  
 28 Functions  
 Fully protected  
 M-1180 .7% Acy \$36.95  
 M-1182 .25% Acy \$39.95  
 M-1181 .1% Acy \$42.95

GF-8016 FUNCTION GENERATOR with Freq. Counter  
**\$239**  
 • Sine, Square, Triangle  
 • Pulse, Ramp, 2 to 2MHz  
 • Frequency .1 thru 10MHz  
 GF-8015 without Freq. Meter \$179

10MHz OSCILLOSCOPE  
 Model S-3000 **\$239**  
 • 10MHz DC or AC  
 • Triggered Sweep  
 • Calibrated Vert & Hor  
 • Reads Volts & Freq

BREADBOARD  
 Model 9436 Shown  
 9430 1,100 pins \$15  
 9434 2,170 pins \$25  
 9436 2,860 pins \$35

DIGITAL TRIPLE POWER SUPPLY  
 Model XP-765 **\$239**  
 0-20V @ 1A  
 0-20V @ 1A  
 5V @ 5A  
 Fully Regulated, Short Circuit Protected with 2 Limit Cont. 3 Separate Supplies  
 XP-660 with Analog Meters \$169.50

DIGITAL LCR METER  
**\$138**  
 Model LC-1800  
 Measures: Inductors, Capacitors, Resistors

50MHz LOGIC PROBE  
 20 nsec with memory LP-700  
 Logic Pulsar LP-600 **\$23**

QUAD POWER SUPPLY  
 Model XP-580 **\$59.95**  
 Fully regulated and short circuit protected  
 Model XP-575 without meters \$49.95  
 2-20V @ 2A  
 12V @ 1A  
 +5V @ 3A  
 -5V @ 4A

MULTI-FUNCTION COUNTERS  
 F-1000 1.2GH **\$259**  
 F-100 120MH **\$179**  
 Frequency, Period, Totalize, Self Check with High-Stabilized Crystal Oven Oscillator, 8 Digit LED Display

C&S SALES INC., 1245 Rosewood Dr. Deerfield, IL 60015 **15 DAY MONEY BACK GUARANTEE**  
 800-292-7711 312-541-0710 **ASK FOR CATALOG**  
**2 Year Limited Guarantee! Add 5% for Postage (\$10 max), IL Res., 7% Tax**  
 CIRCLE 109 ON FREE INFORMATION CARD

slides made, I can have them ready to show on large-screen TV in a matter of minutes.  
 EDWIN WADSWORTH  
 North Miami, FL

**KEEP US INFORMED!**

Let's continue to see articles showing detailed plans for various descramblers, decoders, transmitters, and listening devices. Warn the readers of the consequences of illegal usage and include the proper disclaimers, but please don't feel it's necessary to protect society from itself.

Forrest Mims (Letters, January 1988) would have Radio-Electronics play the wise old grandfather who, in his infinite wisdom, withholds information that he deems unfit for the irresponsible youngsters' consumption.  
 WILLIAM RITZ  
 Cleveland, OH

**ACCURACY IN TEST EQUIPMENT**

Gregory D. Carey, in his article entitled "How to Analyze Waveforms" (Radio-Electronics, December 1987), did a disservice to all technicians by not stating that the accuracy of a digital scope is 2% only if it is calibrated at regular intervals. Being digital does not necessarily make it more accurate—especially if it isn't properly calibrated.

His coverage of the benefits of using newer, digital equipment when more precise measurements are required was very good. However, the technician must be aware that calibration is essential to ensure the continued accuracy of digital equipment.  
 RAYMOND E. TOWNSEND  
 U.S. Army Calibration Technician  
 Fort Carson, CO

**ELECTRON FLOW**

I was interested and pleased to see the two early examples of the use of positive current convention ("conventional current") reproduced in Figures 3 and 6 of Martin Clifford's "The Early Days of Radio" (Radio-Electronics, December 1987). However, I was more than a little disappointed in his misinformed comments about that current reference in his section entitled Electron Flow.  
 I realize that his comments rep-



# JDR INSTRUMENTS™

customer satisfaction... superior service... friendly, knowledgeable personnel... merchandise... providing the best values in leading edge technology.

**Our DMM-300**  
A remarkable value!  
**7995**

This full function 3.5 digit DMM offers highly accurate performance and a host of added features to help you do the job—fast. Capacitance, transistor, temperature, conductance and audible continuity in addition to the ranges you'd expect from a DMM of this quality. Temperature probe, test leads and battery included. Input impedance: 10M ohm. Basic DC accuracy: plus/minus 0.25% Approx. 7" x 3 1/2" x 1 3/4" Wt. 13 1/2 ozs.



DC VOLTAGE TO  
1000 VOLTS

AC/DC CURRENT  
200µA TO 10A

CAPACITANCE  
TESTER  
2000pF to 20µF

TEMPERATURE  
TESTER TO  
2000° F

**DPM-1000** **\$54.95**  
3.5 DIGIT PROBE TYPE DMM

Custom 80 pin LSI chip provides accuracy and reliability in such a compact size. Autoranging, audible continuity and data hold feature help you pinpoint the problem quickly. Case and batteries included.

- \* Basic DC accuracy: plus/minus 1%
- \* DC voltage: 2v-500v, autoranging
- \* AC voltage: 2v-500v, autoranging
- \* Resistance: 2k ohms-2M ohms, autoranging
- \* Fully over-load protected
- \* Input impedance: 11M ohm
- \* Approx. 6 1/2" x 1 1/4" Under 3 ozs.



- ★ **2 YEAR REPLACEMENT WARRANTY**
- ★ **30 DAY MONEY BACK GUARANTEE**
- ★ **TOLL FREE TECHNICAL SUPPORT**
- ★ **NEXT DAY AIR SHIP AVAILABLE**

**MODEL 2000** **\$349.95**  
20 MHz DUAL TRACE OSCILLOSCOPE

Model 2000 makes frequency calculation and phase measurement quick and easy. The component tester aids in fast troubleshooting. Service technicians appreciate the TV Sync circuits for viewing TV-V and TV-H and accurate synchronization of the video signal, Blanking, VITS, and V/H sync pulses.

- \* Exceptionally bright 5" CRT
- \* Built-in component tester
- \* TV Sync filter
- \* X-Y operation \* 110/220 volts



**MODEL 3500** **\$499.95**  
35 MHz DUAL TRACE OSCILLOSCOPE

Wide bandwidth and exceptional 1mV/DIV sensitivity make the Model 3500 a powerful diagnostic tool for engineers or technicians at a remarkable price. Delayed triggering allows any portion of a waveform to be isolated and expanded for closer inspection. Variable Holdoff allows stable viewing of complex waveforms.

- \* Exceptionally bright 5" CRT
- \* Delayed and single sweep modes
- \* Z axis intensity modulation
- \* X-Y operation \* TV sync filter
- \* Fast 10rs rise time



CIRCLE 59 ON FREE INFORMATION CARD

JDR INSTRUMENTS, 110 KNOWLES DRIVE, LOS GATOS, CA 95030  
RETAIL STORE: 1256 SOUTH BASCOM AVE, SAN JOSE, CA (408) 947-8881

**ORDER TOLL FREE 800-538-5000**

**DMM-200** **\$49.95**  
3.5 DIGIT FULL FUNCTION DMM

Get highly accurate performance at a very affordable price. Rugged construction, 20 amp current capability and 22 ranges make it a perfect choice for serious field or bench work. Low battery indicator and tilt-stand. Probes and 2000 hour battery included.

- \* Basic DC accuracy: plus or minus 0.25%
- \* DC voltage: 200mv-1000V, 5 ranges
- \* AC voltage: 200mv-750V, 5 ranges
- \* Resistance: 200 ohms-20M ohms, 6 ranges
- \* AC/DC current: 200µA-20A, 6 ranges
- \* Input impedance: 10M ohm
- \* Fully overload protected
- \* Approx. 7" x 3 1/2" x 1 1/2" Wt. 11 ozs.



**DMM-100** **\$29.95**  
3.5 DIGIT POCKET SIZE DMM

Perfect for the field service technician. Shirt pocket size without compromising features or accuracy. Large, easy to read 1/2" LCD display. Fully overload protected for safety. 2000 hour battery life with standard 9v cell. Probes and battery included.

- \* Basic DC accuracy: plus/minus 0.5%
- \* DC voltage: 2v-1000v, 4 ranges
- \* AC voltage: 200v-750v, 2 ranges
- \* Resistance: 2k ohms-2M ohms, 4 ranges
- \* DC current: 2mA-2A, 4 ranges
- \* Input impedance: 10M ohm
- \* Fully overload protected
- \* Approx. 5" x 3" x 1" Under 7 ozs.



COPYRIGHT 1987 JDR MICRODEVICES



*NRI Trains You At Home—As You  
Your Own IBM PC Compatible Could*

# GET THE KNOW-HOW TO SERVICE EVERY COMPUTER ON THIS PAGE... AND MORE!

## **Learn the Basics the NRI Way— and Earn Good Money Troubleshooting Any Brand of Computer**

The biggest growth in jobs between now and 1995, according to Department of Labor estimates, will occur in the computer service and repair business, where demand for trained technicians will actually *double*.

You can cash in on this opportunity—either as a full-time corporate technician or an independent service-person—once you've learned all the basics of computers the NRI way. NRI's practical combination of "reason-why" theory and "hands-on" building skills starts you with the fundamentals of electronics, then guides you through advanced electronic circuitry and on into computer electronics. You also learn to program in BASIC and machine language, the essential languages for troubleshooting and repair.

## **Total Computer Systems Training, Only From NRI**

No computer stands alone... it's part of a total system. To really service computers, you have to understand computer *systems*. And only NRI includes a powerful computer system as part of your training, centered around the new, fully IBM PC compatible Sanyo 880 Series computer.



IBM is a Registered Trademark of IBM Corporation.  
Epson is a Registered Trademark of Epson America, Inc.  
Apple and the Apple logo are Registered Trademarks of Apple  
Computer, Inc.  
Compaq is a Registered Trademark of COMPAQ Computer Corporation.  
© 1985 AT&T Technologies, Inc.

**NEW!**

Train with the newest Sanyo 880 Series Computer—it's fully IBM-compatible and runs almost twice as fast as the IBM PC!

You start with the step-by-step assembly of the new, highly-rated, Sanyo computer. You install and troubleshoot the "intelligent" keyboard. Then you assemble the power supply, install the disk drive, and add extra memory to give you a powerful 256K RAM system. The new 880 computer has two operating speeds: standard IBM speed of 4.77 MHz and a remarkable turbo speed of 8 MHz, making it almost twice as fast as the IBM PC. Next, you'll interface the high-resolution monitor and begin to use the valuable software also included with your complete computer system.

It all adds up to confidence-building, real-world experience that includes training in programming, circuit design, and peripheral maintenance. You'll be learning about, working with, servicing, and troubleshooting an entire computer system—monitor, keyboard, computer, disk drive, power



supply—to ensure that you have all the essential skills you need to succeed as a professional computer service technician.

### No Experience Needed, NRI Builds It In

This is the kind of practical, hands-on experience that makes you uniquely prepared, with the skills and confidence you need for success. You learn at your own convenience in your own home. No classroom pressures, no night school, no need to quit your present job until you're ready to make your move. Your training is backed by your personal NRI instructor and the NRI technical staff, ready to answer your questions and help you when you need it. You get it all with NRI at-home training.

### 100-Page Free Catalog Tells More

Send the postage-paid reply card today for NRI's big, 100-page, color catalog on NRI's electronics training, which gives you all the facts about NRI courses in Microcomputers, Robotics, Data Communications, TV/Audio/Video Servicing, and other growing, high-tech career fields. If the reply card is missing, write to the address below.

Your NRI total systems training includes:  
• NRI Discovery Lab™ to design and modify circuits  
• Your fourfunction, digital multimeter with walk-you-through instructions on audio tape  
• Digital logic probe for visual examination of keyboard circuits  
• The newest Sanyo 880 Series Computer with "intelligent" keyboard and 360K double density, double-sided disk drive  
• High resolution monochrome monitor  
• 8K ROM, 256K RAM  
• Bundled software including GW BASIC, MS-DOS, WordStar, CalcStar  
• Reference manuals, schematics, and bite-size lessons.



## SEND COUPON TODAY FOR FREE NRI CATALOG!

**NRI** SCHOOLS

McGraw-Hill Continuing Education Center  
3939 Wisconsin Avenue, NW, Washington, DC 20016



For Career courses approved under GI Bill  
 check for details

We'll give you tomorrow.

#### CHECK ONE FREE CATALOG ONLY

- |  |   |
|--|---|
| <input type="checkbox"/> Computer Electronics          | <input type="checkbox"/> Basic Electronics                  |
| <input type="checkbox"/> TV/Audio/Video Servicing      | <input type="checkbox"/> Electricians                       |
| <input type="checkbox"/> Satellite Electronics         | <input type="checkbox"/> Small Engine Repair                |
| <input type="checkbox"/> Robotics & Industrial Control | <input type="checkbox"/> Air Conditioning, Heating, & Ref   |
| <input type="checkbox"/> Industrial Electronics        | <input type="checkbox"/> Locksmithing & Electronic Security |
| <input type="checkbox"/> Telephone Servicing           | <input type="checkbox"/> Photography                        |
| <input type="checkbox"/> Digital Electronics Servicing | <input type="checkbox"/> Bookkeeping & Accounting           |

Name (Please print) \_\_\_\_\_

Age \_\_\_\_\_

Street \_\_\_\_\_

City/State/Zip \_\_\_\_\_

Accredited by the National Home Study Council

3-028

# Electronics Paperback Books

## GREAT ELECTRONICS PAPERBACKS FROM ETT

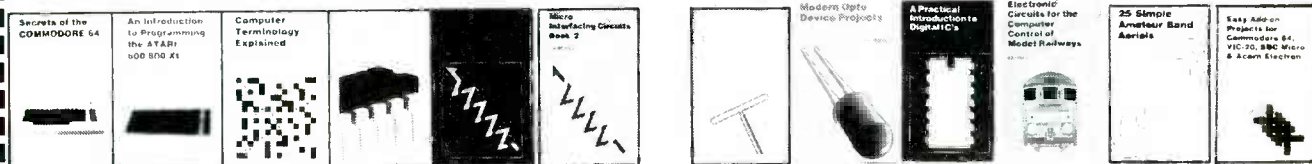

- BP125—25 SIMPLE AMATEUR BAND ANTENNAS.....\$5.00.** All are inexpensive to build, yet perform well. Diodes, beams, triangle and even a mini rhombic.
- BP128—20 PROGRAMS FOR THE ZX SPECTRUM AND 16K ZX82.....\$5.75.** Included with each program is a flow chart and a description of what happens. Notes for converting programs for use on other computers are also included.
- BP235—POWER SELECTOR GUIDE.....\$10.00.** Complete guide to semiconductor power devices. More than 1000 power handling devices are included. They are tabulated in alpha-numeric sequence, by technical specs. Includes power diodes, Thyristors, Triacs, Power Transistors and FET's.
- BP234—TRANSISTOR SELECTOR GUIDE.....\$10.00.** Companion volume to BP235. Book covers more than 1400 JEDEC, JIS, and brand-specific devices. Also contains listing by case type, and electronic parameters. Includes Darlington transistors, high-voltage devices, high-current devices, high power devices.
- BP99—MINI-MATRIX BOARD PROJECTS.....\$5.00.** Here are 20 useful circuits that can be built on a mini-matrix board that is just 24 holes by ten copper-foil strips.
- BP157—HOW TO WRITE ZX SPECTRUM AND SPECTRUM+ GAMES PROGRAMS.....\$5.95.** A crystal-clear step-by-step guide to writing your own graphics games programs.
- BP117—PRACTICAL ELECTRONIC BUILDING BLOCKS—Book 1.....\$5.75.** Oscillators, Timers, Noise Generators, Rectifiers, Comparators, Triggers and more.
- BP184—INTRO TO 68000 ASSEMBLY LANGUAGE.....\$6.50.** The 68000 is a great new breed of microprocessor. Programming in assembly language increases the running speed of your programs. Here's what you need to know.
- BP179—ELECTRONIC CIRCUITS FOR THE COMPUTER CONTROL OF ROBOTS ..... \$5.00.** Data and circuits for interfacing the computer to the robot's motors and sensors.
- BP126—BASIC & PASCAL IN PARALLEL.....\$4.95.** Takes these two programming languages and develops programs in both languages simultaneously.
- BP198—AN INTRODUCTION TO ANTENNA THEORY...\$6.95** Basic concepts relevant to receiving and transmitting antennas
- 225—A PRACTICAL INTRODUCTION TO DIGITAL IC'S.....\$4.95.** Mainly concerned with TTL devices. Includes several simple projects plus a logic circuit test set and a digital counter timer.
- BP170—INTRODUCTION TO COMPUTER PERIPHERALS.....\$5.95.** Shows how to use a variety of co computer add-ons in as non-technical a way as possible.
- 227—BEGINNERS GUIDE TO BUILDING ELECTRONIC PROJECTS.....\$5.00.** How to tackle the practical side of electronics so you can successfully build electronic projects.
- BP169—HOW TO GET YOUR COMPUTER PROGRAMS RUNNING.....\$5.95.** Shows how to identify error in program and what to do about them.
- BP194—MODERN OPTO DEVICE PROJECTS.....\$6.25.** Crammed with great projects for the experimenter. Includes sections on Fiber optics, passive Infra-Red detectors, plus an assortment of miscellaneous projects.
- BP180—ELECTRONIC CIRCUITS FOR THE COMPUTER CONTROL OF MODEL RAILROADS.....\$6.25.** It's easy to interface home computers to model railroad control. The main problem is in interfacing the computer to the system.
- BP110—HOW TO GET YOUR ELECTRONIC PROJECTS WORKING.....\$5.00.** How to find and solve the common problems that can occur when building projects.
- BP33—ELECTRONIC CALCULATOR USERS HANDBOOK.....\$5.75.** Invaluable book for all calculator owners. Tells how to get the most out of your calculator.
- BP36—50 CIRCUITS USING GERMANIUM, SILICON & ZENER DIODES.....\$5.00.** A collection of useful circuits you'll want in your library.
- BP37—50 PROJECTS USING RELAYS, SCR'S & TRIACS.....\$5.00.** Build priority indicators, light modulators, warning devices, light dimmers and more.
- BP39—50 FET TRANSISTOR PROJECTS.....\$5.50.** RF amplifiers, test equipment, tuners, receivers, tone controls, etc.
- BP42—SIMPLE LED CIRCUITS.....\$5.00.** A large selection of simple applications for this simple electronic component.
- BP127—HOW TO DESIGN ELECTRONIC PROJECTS.....\$5.75.** Helps the reader to put projects together from standard circuit blocks with a minimum of trial and error.
- BP122—AUDIO AMPLIFIER CONSTRUCTION.....\$5.75.** Construction details for preamps and power amplifiers up through a 100-watt DC-coupled FED amplifier.
- BP92—CRYSTAL SET CONSTRUCTION.....\$5.00.** Everything you need to know about building crystal radio receivers.
- BP45—PROJECTS IN OPTOELECTRONICS.....\$5.00.** Includes infra-red detectors, transmitters, modulated light transmission and photographic applications.
- BP48—ELECTRONIC PROJECTS FOR BEGINNERS.....\$5.00.** A wide range of easily completed projects for the beginner. Includes some no-soldering projects.
- BP49—POPULAR ELECTRONIC PROJECTS.....\$5.50.** Radio, audio, household and test equipment projects are all included.
- BP51—ELECTRONIC MUSIC AND CREATIVE TAPE RECORDING.....\$5.50.** Shows how you can make electronic music at home with the simplest and most inexpensive equipment.
- BP56—ELECTRONIC SECURITY DEVICES.....\$5.00.** Includes both simple and more sophisticated burglar alarm circuits using light, infra-red, and ultrasonics.
- BP59—SECOND BOOK OF CMOS IC PROJECTS.....\$5.00.** More circuits showing CMOS applications. Most are of a fairly simple design.
- BP72—A MICROPROCESSOR PRIMER.....\$5.00.** We start by designing a small computer and show how we can overcome its shortcomings.
- BP74—ELECTRONIC MUSIC PROJECTS.....\$5.95.** Provides the experimenter with a variety of practical circuits including a Fuzz Box, Sustain Unit, Reverberation Unit, Tremelo Generator and more.
- BP91—AN INTRODUCTION TO RADIO DXING.....\$5.00.** How you can tune in on those amateur and commercial broadcasts from around the world in the comfort of your home.
- BP94—ELECTRONIC PROJECTS FOR CARS AND BOATS.....\$5.00.** Fifteen simple projects that you can use with your car or boat. All are designed to operate from 12-volt DC supplies.

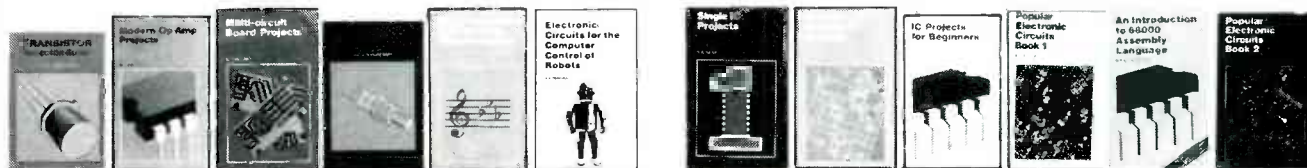

**ELECTRONIC TECHNOLOGY TODAY INC.**  
P.O. Box 240, Massapequa Park, NY 11762-0240

SHIPPING CHARGES IN USA & CANADA

\$0.01 to \$5.00	\$1.00
\$5.01 to \$10.00	\$1.75
\$10.01 to 20.00	\$2.75
\$20.01 to 30.00	\$3.75
\$30.01 to 40.00	\$4.75
\$40.01 to 50.00	\$5.75
\$50.01 and above	\$7.00

**SORRY** No orders accepted outside of USA & Canada

Number of books ordered

Name   
Address   
City  State  Zip

Total price of merchandise ..... \$   
Sales Tax (New York State Residents only) ..... \$   
Shipping (see chart) ..... \$

**All payments must be in U.S. funds** Total Enclosed ... \$

R2-88

resent a point of view that is widely held among technicians, but his summary dismissal of conventional current as an archaic and mistaken notion "that never really existed" is hardly consistent with the following facts of which he should have been aware, and could have very quickly verified.

The positive current convention is an implicit and integral part of the definition of electric current accepted by those international organizations responsible for determining scientific and engineering standards.

What Mr. Clifford calls "electron flow" and suggests is the only valid way to express current flow is utilized only in parts of the technician community. It is taught only in military schools, vocational technology curricula, and at some community colleges.

I realize that "electron flow" has a simplistic appeal and that the positive current convention may seem perverse and obscure at first glance. However, we need a common and universal definition of electric current and current direction—used by *all* writers, students, teachers, and practitioners—to ensure precise and unambiguous communication of ideas and information. That definition must be consistent with, and at the same time embrace all that is known about, the physics and chemistry of materials.

The most widely accepted definition for electric current is that it is the movement of electric charge. There are two kinds of charge: positive and negative. Thus it is not reasonable to limit the definition of current to the movement of electrons alone.

From what I can determine, the real source of confusion was a small number of writers and teachers who, in the mid-1930's, wanted to simplify electron-tube actions and their associated circuitry to the barest, zero-order, non-mathematical essentials. They wanted a simple conceptual model in which the electron stream inside the tube and the current outside the tube went the same way, and they didn't want any messy algebraic signs hanging around. In so doing, they discarded the algebraic sign properly associated with current in

the negative direction, and dismissed positive ion motion as being unimportant.

That sort of teaching and writing became the backbone of the technical training given to thousands of military technicians during World War II. When their use of "electron flow" was criticized, it was easier to rationalize by attacking "conventional current" with myth, misinformation, and innuendo than it was to deal with the facts of the situation.

I am extremely angry with the teachers and authors (and, yes, even editors) who continue to confuse good technical dialogue by using the "electron flow" atrocity. I am angry with those who endeavor to discredit the positive current convention by suggesting it is defective and that those who use it are less competent than those who use "electron flow." I'm also angry with those who say it really doesn't matter which convention you use.

I think it is time to identify "electron flow" as a simplistic, archaic,

# Free Famous hi-tech catalog



A very special guide to what the exciting world of computer and electronics kit-building can do for you.

The informative Heathkit Catalog shows you more than 450 exciting electronic products that will challenge, instruct, and entertain you. You'll find countless kits that you can build and enjoy, from computers and robots to color tv's and a variety of home products. And each is backed by our years of experience and our promise, "We won't let you fail."

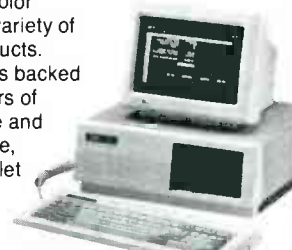

IBM-PC Compatible Expandable Computers

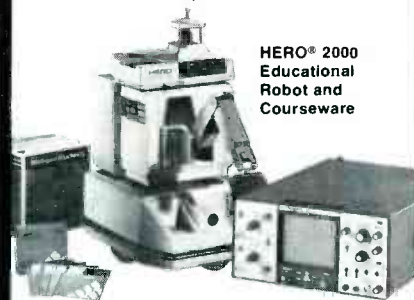

HERO® 2000 Educational Robot and Courseware



Precision Test Instruments



PackKit Multi-Mode TNC



Send NOW for your FREE Heathkit Catalog.

Send to: Heath Company, Dept. 020-612 Benton Harbor, Michigan 49022

Name \_\_\_\_\_  
 Address \_\_\_\_\_  
 City \_\_\_\_\_ State \_\_\_\_\_ Zip \_\_\_\_\_

A subsidiary of Zenith Electronics Corporation CL-784R3  
**Heathkit**  
 Heath Company

## 87" HI-TECH SALE

**Cobra Stun Gun** generates 45,000 volts of stopping power, the Cobra also delivers a burst of high intensity light directly into an attacker's eyes. Chances are that his optic nerves will be so overdosed with excess light energy that he will not be able to see you let alone continue the attack. If he does, the Cobra delivers its painful bite, leaving him dazed and confused. \$49.95. With NiCad battery & charging kit \$59.95 + \$3.74 shp.

**Centron Security Light**  
 The Centron security light puts unwelcome visitors in the spotlight... instantly! This smart lighting system's infrared sensors guard your yard or driveway when you're away or home alone. It senses the presence of people or cars by changes in temperature patterns and instantly floods the area with bright light. It guides your guest to your door and scares away would-be prowlers \$55.00 plus \$4.99 shipping.

**Remote Control Pen.**  
 Not only is it a hand-some high quality ball point writing pen, but a powerful remote-control device. Effective at distances up to 75 yds, the Remote Control Pen is perfect for turning on or off any 120 volt appliance or alarm system. Think of the possibilities. \$39.00 shipping \$3.74.

**The Private Eye Motion Detector.**  
 Alarm warns you to the presence of an intruder but the intruder doesn't know he has been detected. No wires just plug it in and it works. Information travels from the detector to the receiver via the electrical system. \$63.00 shipping \$5.40

World's smallest dialer \$49.95 Alcohol Breath Analyzer \$59.00  
 Levitator \$79.95 Telemonitor 2000..... \$175.00  
 Pistol Cross Bow \$59.95 Remote Car starter..... \$225.00

**\*\*All products ready to use and Guaranteed\*\***  
 ORDERS CALL TOLL FREE 1-800-624-1150 For information or free catalog call 402-554-0383 or write. Order by December 16th and we guarantee delivery

United Imports & U.S. Mfg. 6846 Pacific St. Omaha, Nebraska 68106 by the 24th M.C. VISA

CIRCLE 53 ON FREE INFORMATION CARD

FEBRUARY 1988

# DOES YOUR DIGITAL CAPACITANCE METER DO THIS?

FULL 4 DIGIT 0.5 INCH LCD DISPLAY COMPLETELY AUTORANGING WITH 10 RANGE MANUAL CAPABILITY

**AND THIS**  
RANGE OF 0.0 pF to 1 FARAD (999.9 mF)  
0.5% BASIC ACCURACY UP TO 100 uF

**AND THIS**  
READS DIELECTRIC ABSORPTION

**AND THIS**  
EXTENDED PSEUDO 5 DIGIT  
RESOLUTION ON SOME RANGES ONLY

**AND THIS**  
ABILITY TO ZERO LARGE CAPACITANCE  
VALUES UP TO 99.99 uF

**AND THIS**  
CALCULATES TRUE CAPACITANCE  
IF CAPACITOR IS LEAKY

**AND THIS**  
DIODE CLAMP AND FUSED  
PROTECTED INPUT.  
DISCHARGE RESISTOR IN OFF  
POSITION AT TERMINAL INPUTS.  
POWERED BY 9V BATTERY

**ONE YEAR PARTS &  
LABOUR WARRANTY**

**FOR ONLY THIS**

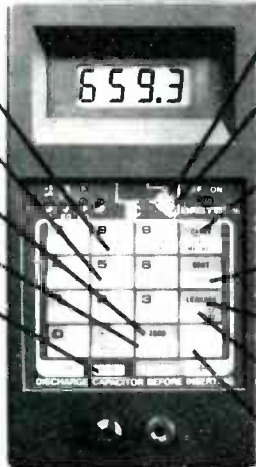

**AND THIS**  
IDENTIFIES TRANSISTORS (NPN, PNP)  
AND THEIR LEADS (E, B, C, ETC.)

**AND THIS**  
TESTS ZENER DIODES AND RECTIFIERS.  
UP TO 20V ZENER WITH AC ADAPTOR.  
ZENER VOLTAGE WITH 9V BATTERY  
DEPENDS ON ITS CONDITION

**AND THIS**  
AUTOMATICALLY CALCULATES LENGTHS  
OF CABLES IN FEET, METRES, MILES,  
KILOMETRES (THEORETICAL RANGE  
OF 9,999 MILES)

**AND THIS**  
ABILITY TO SORT CAPACITORS IN  
MANY DIFFERENT MODES

**AND THIS**  
ABILITY TO READ LEAKY CAPACITANCE  
(INSULATION RESISTANCE OR CURRENT)

**AND THIS**  
CALCULATES TIME CONSTANTS WITH  
USER DEFINED RESISTANCE VALUES

**AND THIS**  
HOLD FUNCTION FREEZES DISPLAY

**SHIPPING INSTRUCTIONS:**

All units shipped out F.O.B. Buffalo NY via United Parcel Service (except Hawaii & Alaska) unless otherwise indicated (in which case shipments will be F.O.B. Canada)

**\$169.95**

MODEL  
**MC300**  
**DAETRON**

Approx. Size  
7" x 4" x 1 1/2"

a division of Bergeron Technologies Inc.  
935 THE QUEENSWAY, BOX 641  
TORONTO, ONTARIO M8Z 5Y9  
CANADA (416)676-1600

PLEASE SEND ME		U.S. FUNDS
(QUANTITY) MC300(S) @	\$169.95	\$ _____
CARRYING CASE	\$ 16.95	\$ _____
AC ADAPTOR	\$ 9.95	\$ _____
SHIPPING AND HANDLING @ \$5.00 PER INSTRUMENT		\$ _____
<input type="checkbox"/> CHECK <input type="checkbox"/> MONEY ORDER		\$ _____
<input type="checkbox"/> VISA <input type="checkbox"/> MASTERCARD	TOTAL	\$ _____
<input type="checkbox"/> CARD NO. _____		
EXPIRY DATE _____	SIGNATURE _____	
NAME _____	TELEPHONE _____	
ADDRESS _____		
CITY _____ STATE _____	ZIP CODE _____	

**DEALER ENQUIRIES INVITED**  
CIRCLE 190 ON FREE INFORMATION CARD

and obsolescent idea whose time and usefulness has passed. It's time to identify those writers and teachers who cling to and defend "electron flow" as less than up-to-date and not well-informed. It is also time to stop teaching newcomers to the electronics community a lame-duck model for electricity that they must unlearn when and if they get serious about it. If you're going to learn electronics, why not just get it right the first time?  
**LUCIUS DAY**  
*Lakewood, CO*

**INVENTION PROTECTION**

As program manager of the Wisconsin Innovation Service Center (WISC), I have the opportunity to interact with a variety of people involved in new-product development. Our non-profit service, at the University of Wisconsin-Whitewater since 1980, assists individual inventors and entrepreneurs in assessing the market feasibility of their innovative ideas at early stages in the development process.

We've recently received many inquiries about certain "invention-development" firms that apparently prey on inventors' vulnerabilities. According to dissatisfied clients, extremely high fees were demanded up-front in exchange for promises of invention development. In many cases, inventors said they received only the "promise" for their investment.

As with most other endeavors, invention-development assistance is offered by both reputable and questionable sources. Before dealing with a company that promises commercial development of an idea, potential clients should consider these questions:

- Is there a substantial up-front fee involved (over \$400) for just an initial evaluation? Is there a subsequent fee involved?
- What is the company's success rate for placing inventions? Do they have data/references to support this? What percentage of their clients have received more money than they paid?
- Who are their references? Once supplied, check them out.
- Do organizations such as the Better Business Bureau, the

Buy five MOVIE TIME CONVERTERS at the advertised price and get one

**FREE**



V-7200 or V-7500

**MOVIE TIME**

**72 Channel Wireless Remote Cable Converter**

with \*VOLUME and \*MUTE controls — Fine Tuning — \*AUDIO and \*VIDEO outputs — 2/3 or 3/4 switch — 90-minute Sleep Timer

\*No. Vol. or A/V output  
EVERYTHING

V-7200 79.95  
V-7500 109.95

**V-7800**

78 Ch. Wireless Remote, Parental Control built-in, 10dB Amp. Favorite Channel Memory. Fine Tuning 89.95

**CALL**

Tel.: 1-305-652-1981  
1-800-843-9845

**COUPON**

NAME _____	ADDRESS _____
CITY _____	STATE _____ ZIP _____
TELEPHONE 1. _____	Exp. Dt. _____
COD <input type="checkbox"/> AMEX <input type="checkbox"/> CHECK <input type="checkbox"/> SIG _____	
Am. Ex. # _____	
QTY. _____	ITEM _____ PRICE _____ TOTAL _____
Send to: _____ Shipping _____ 5.50	
MOVIE TIME FL 5% Sales Tax _____	
20203 NE 15 Ct. TOTAL _____	
Miami, FL 33179	

CIRCLE 192 ON FREE INFORMATION CARD

Federal Trade Commission or Chamber of Commerce have any information on the company?

It is also recommended that an inventor consult with an attorney before a contract is signed.

We at the WISC are committed to encouraging the independent inventor. Fraudulent exploitation discourages individual creativity—a vital source of social and economic progress. Affordable invention evaluations are still available at the WISC and other non-profit organizations, but we urge inventors to proceed with caution when considering an invention-development firm.

DEBRA KNOX-MALEWICKI,  
PROGRAM MANAGER  
Wisconsin Innovation Service Center  
402 McCutchan  
University of Wisconsin-Whitewater  
Whitewater, WI 53190

### CERTIFICATION

As an electronics technician with the United States Marine Corps, I appreciated Clem Small's article on certification in the August issue of *Radio-Electronics*. It helped me realize that, although I have 22 years of electronics experience in the military, I will however need certification to start my second career.

I wrote to the organizations listed in the article, and most responded promptly with the information I requested. However, one—The National Association of Business and Educational Radio—has moved and left no forwarding address with the Post Office. I would appreciate hearing from any member of that organization who can provide me with the current address.

Your magazine is read and studied by a majority of those Marines who work in our division. It keeps us up to date on what is happening and what is new in electronics. Keep up the good work.

LAWRENCE E. FLICK  
MSgt., U.S.M.C.  
NCOIC Ground Electronics Maintenance Div., Communications-Electronics Department  
Marine Corps Air Station  
Iwakuni, Japan

R-E

### How to live with someone who's living with cancer.

When one person gets cancer, everyone in the family suffers.

Nobody knows better than we do how much help and understanding is needed. That's why our service and rehabilitation programs emphasize the whole family, not just the cancer patient.

Among our regular services we provide information and guidance to patients and families, transport patients to and from treatment, supply home care items and assist patients in their return to everyday life.

Life is what counts. The life of cancer patients. The lives of their families. So you can see we are even more than the research organization we are so well known to be.

No one faces cancer alone.  
AMERICAN CANCER SOCIETY

### CONSUMER REPAIR

New solid-state and digital TV sets, stereos and videocorders are tougher to repair than old-fashioned tube type sets, and require special training for the service technician who works on them.

Only a few states have laws requiring competency tests for licensing technicians who repair consumer electronics, but fifteen years ago the International Society of Certified Electronic Technicians (CSET) began its own certification program to qualify these technicians and those in the industry. To carry the CSET designation, technicians must have four years experience and pass a rigid examination on general electronics and a specific area of expertise such as audio or radio-TV.

Many consumers look for a Certified Electronic Technician in the shop when they need any electronic item repaired.

**Free Consumer Checklist**  
A consumer checklist for selecting a service shop is available free by sending a stamped, self-addressed envelope to: Checklist, ISCET, 2708 West Berry, Fort Worth, TX 76109. The list reminds consumers to check such items as "Does the business have the parts for your particular brand?" "Did you get an estimated price?" and "Did you check this company with the Better Business Bureau?"



Modern electronic equipment such as digital TVs or stereos should be repaired by specially trained people.

available free by sending a stamped, self-addressed envelope to: Checklist, ISCET, 2708 West Berry, Fort Worth, TX 76109. The list reminds consumers to check such items as "Does the business have the parts for your particular brand?" "Did you get an estimated price?" and "Did you check this company with the Better Business Bureau?"

## Nine Test Probes with only one difference between them and your scope's original equipment

Manufacturers Scope	Original Probe	Price	Coline/TPI Equivalent	Price
<b>TEKTRONIX</b>				
2300 Series	P6101A	\$53	M12X1	\$38
	P6108A	\$75	M12X10	\$62
	P6121	\$100	M12X10AP	\$68
2200 Series	P6122	\$58	P100	\$38
	P6131	\$140	M15X10HFAP	\$87
2400 Series	P6133	\$115	M12X10AP	\$68
	P6105A	\$93	M12X10AP	\$68
	P6106A	\$140	M15X10HFAP	\$87
	P6130	\$130	M12X10AP	\$68
<b>IWATSU</b>				
SS-5321	SS-0014	\$92	M12X10	\$62
SS-5711	SS-0012	\$77	M12X10	\$62
<b>LEADER</b>				
LBO-315	LP-060X	\$60	SP100	\$43
LBO-518	LP-100X	\$76	SP100	\$43
<b>PHILIPS</b>				
PM3267	PM8924	\$60	M12X1	\$38
& PM3256	PM8926	\$70	P100	\$38
PM3264	PM8928	\$95	M12X10	\$62
<b>HITACHI</b>				
V-1100A	AT-10AL1.5	\$64	SP100	\$43
V-670				
V-509				
<b>HEWLETT PACKARD</b>				
1715A	10018A	\$135	M20X10	\$68
1722B	10017A	\$130	M15X10HF	\$79
1725A	10017A	\$130	M15X10HF	\$79
1740 Series	10041A	\$135	P100	\$38
	10021A	\$85	IP20	\$29

Take up the TPI challenge and compare our prices with the probes you currently use. In many cases you can replace both probes on your dual trace scope at the cost of one probe from the scope manufacturer. Plus, bandwidth and overall performance of the TPI probe typically exceed that of the original equipment. Satisfaction is guaranteed with a ten day return privilege. TPI Specialists in probes for over 15 years.

Available from your local distributor.

TOLL FREE INFORMATION LINE

1-800-368-5719,

1-800-643-8382 in California

**TEST PROBES, INC. TPI**

9178 Brown Deer Road,  
San Diego CA, 92121  
Phone: (619) 535 9292

CIRCLE 133 ON FREE INFORMATION CARD

Sent to: 9178 Brown Deer Road, San Diego CA, 92121

Please send full line catalog

Name \_\_\_\_\_ Company \_\_\_\_\_ Address \_\_\_\_\_ Phone \_\_\_\_\_

Official 1934  
**SHORT WAVE  
 RADIO MANUAL**

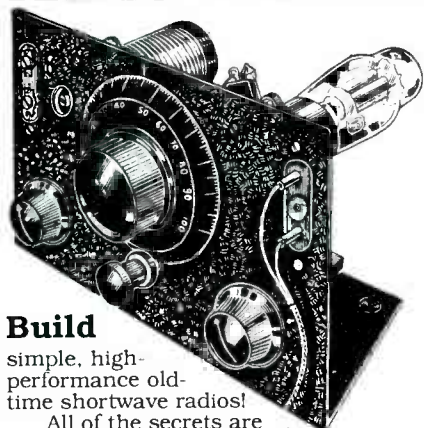

**Build**

simple, high-performance old-time shortwave radios!

All of the secrets are here: the circuit diagrams, parts layout, coil specifications, construction details, operation hints, and much more!

This is a compilation of shortwave construction articles from "Short Wave Craft" magazines published in the 20's & 30's. It's wall-to-wall "how-to."

Included are circuit diagrams, photographs, and design secrets of all shortwave receivers being manufactured in 1934 including some of the most famous: SW-3, the SW-5 "Thrill Box", the deForest KR-1, the Hammuriland "Comet Pro", and many more.

Also included is a new chapter showing how you can use transistors to replace hard-to-find vacuum tubes. You'll even see the circuit that was lashed together on a table top one night using junk box parts, a hair curler and alligator clips. Attached to an antenna strung across the basement ceiling and a 9 volt battery, signals started popping in like crazy. In a couple of minutes an urgent message from a ship's captain off Seattle over 1500 miles away was heard asking for a navigator to help him through shallow water!



These small regenerative receivers are extremely simple, but do they ever perform! This is a must book for the experimenter, the survivalist who is concerned about basic communication, shortwave listeners, ham radio operators who collect old receivers, and just about anyone interested in old-time radio.

Great book! Fun to read! One of the best old-time radio books to turn up in years. Heavily illustrated! Order a copy today! 8 1/2 x 11 paperback 260 pages only \$13.70 postpaid!

**Lindsay Publications**

Box 12-TK, Bradley IL 60915

Send a copy of *Short Wave Radio Manual*. Enclosed is \$13.70. Chk, MC, Visa. Send a free catalog of other books.

Name \_\_\_\_\_

Address \_\_\_\_\_

City \_\_\_\_\_ St \_\_\_\_\_ Zip \_\_\_\_\_

# EQUIPMENT REPORTS

**Arkon Wire-Free IR  
 Wireless Headphones**

*Low-cost, wireless system  
 for private listening*



CIRCLE 20 ON FREE INFORMATION CARD

OVER THE PAST TEN YEARS, OR SO, INFRARED signals have become the de-facto standard for remote-control applications. But, as many experimenters know, infrared can also be used for short-distance wireless communication, such as in cordless headphones for the convenience of private listening.

The first cordless infrared headphones were not successful as mass-consumer items because they were too costly for the average person, too bulky to wear comfortably, and had unsatisfactory performance. Over the past few years, however, the technology has improved to the point where low-cost, comfortable units with outstanding performance are now available. One of those is the Arkon *Wire-Free*, which sells for \$69.95. At that price, it is among the least expensive units of its type. Note, however, that the *Wire-Free* is a *mono* unit, though it does have a switch-selectable

*Spatial Sound Around* mode that provides an electronically enhanced, pseudo-stereo effect.

**Using Wire-Free**

The *Wire-Free* consists of the transmitter (4 1/2" wide, 3 1/2" deep and 3/4" high), the receiver (2 1/2" wide, 3 1/2" deep and 3/4" high), the AC adapter, and lightweight headphones. The receiver accepts a standard miniature mono or stereo phone plug, so you can use your favorite headphones instead of the ones supplied to you by the manufacturer.

The AC adapter is a wall-plug type. An on-off switch on the transmitter lets you turn the unit off without unplugging the supply. A red LED on the unit lets you know when power is on.

The transmitter has a hard-wired four-foot input cord that terminates in an RCA phono plug. That plugs into the audio-output jack of a TV, VCR, compact disk, hi-fi or



other audio source. Adapters to accommodate 1/4-inch and miniature phone jacks are included with the unit. For TV sets or other devices without an audio-output jack, Arkon sells a sensitive microphone for \$18.95, postpaid. That microphone is mounted in a small bracket that is held in front of a speaker grille with double-sided tape (supplied). With that microphone the speaker volume can be set at a nearly inaudible level and still supply enough signal to drive the transmitter.

A thumb-wheel volume control on the side of the transmitter lets you compensate for different audio-input source levels. To set the proper level, you adjust the volume control and watch two rectangular LED's on the front of the unit—a green one and a red one. If neither LED is lit, the volume is too low. Adjust either the source volume or the unit's volume control until the green light comes on with audio peaks. Advance the volume a bit more until the red LED goes on, and then back off until the red LED does not light. The red LED indicates overload, which could cause distortion. The adjustment technique is simple, but effective.

The receiver uses a standard 9-volt transistor-radio-type battery, (not included); an alkaline unit is recommended. A small cover is slid back and removed, the battery dropped in (oriented to the polarity shown), and the cover is then slipped back on.

The headphone jack is on one side of the receiver and an on/off/volume control is on the other side. You plug in the headphones, turn on the unit, and adjust the volume. When the unit is on, a small, red LED lights to let you know you have power. As the battery loses power, that LED gets dimmer and finally goes out.

The 900-nm infrared signal is FM. The frequency response is fairly wide; it is specified as 30 Hz to 18 kHz. That allows you to use better headphones to good advantage when listening to music or other material. For applications where wider bandwidth is not needed, such as speech, the lightweight headphones supplied with the unit work well. Distortion is specified as less than 1%. The sig-

# Crystek Crystals

FOR OPTIMUM STABILITY AND RELIABILITY IN FREQUENCY MANAGEMENT

## QUARTZ CRYSTALS

FOR

### Industrial Equipment/Instrumentation

- Micro-processor control
- Computers/Modems
- Test/Measurement
- Medical



### General Communications

- Channel element Service (VHF/UHF)
- Land Mobile 2-way
- Marine
- Aircraft
- Telemetry
- Monitors/Scanners/Pagers



### Amateurs/2-Meter/General Coverage CB/Hobbles/Experimenter



**NEW**

## The Pulse of Dependable Communications

Crystek Crystals offers their new 16 page **FREE** catalog of crystals and oscillators. Offering state of the art crystal components manufactured by the latest automated technology. Custom designed or "off the shelf," Crystek meets the need, worldwide. Write or call today!

## CRYSTEK CORPORATION

DIVISION OF WHITEHALL CORPORATION

2351/2371 Crystal Drive • Ft. Myers, FL 33907  
P.O. Box 06135 • Ft. Myers, FL 33906-6135

**TOLL FREE 1-800-237-3061**

PH 813-936-2109/TWX 510-951-7448/FAX 813-939-4226

**TOLL FREE IN THE U.S.A. EXCEPT FLORIDA, ALASKA, HAWAII**

CIRCLE 189 ON FREE INFORMATION CARD

## #1 IN CABLE BOXES

### JERROLD CORDLESS CABLE TV BOX

MODEL DRZ/450



- 66 channels
- On/off switch
- Automatic fine tuning
- A/B switch option
- Compatible with descramblers

**\$69<sup>95</sup>** / 10 Lot

\$79.95/1-9

### CORDLESS CABLE TV BOX

MODEL DRX3-105/400



- 72 channels
- Parental control
- Remote fine tuning
- On/off switch
- Compatible with descramblers

**\$59<sup>95</sup>** / 10 Lot

Write for **FREE CATALOG** 136 page

\$69.95/1-9

### JERROLD CORDLESS CABLE TV BOX

MODEL STARCOM-CVS



**\$99<sup>95</sup>** / 4 Lot

\$109.95/1-3

- Volume control
- 68 channels
- Automatic fine tuning
- On/off switch
- Compatible with descramblers

**SHIPPING CHARGES**  
For Orders ..... Add  
\$25-100 ..... \$6.50  
\$100-500 ..... \$8.50  
\$500-750 ..... \$10.50  
\$750 and up ..... \$20.00

Send Check, Money Order, or C.O.D. or Call Toll Free

**800-223-0826**  
in N.Y. State (212) 865-5580

# OMNITRON ELECTRONICS

770 Amsterdam Ave., New York, NY 10025



\* ADD 5% FOR CREDIT CARDS

CIRCLE 110 ON FREE INFORMATION CARD

## Save Over \$50 On Commercial Units

See Radio Electronics Mag. Constructors  
Project Feature May '86

### Bench Top Power Supply 0-30 Volt 1 Amp Kit

Looks so Good your Friends  
won't Believe you Built It!!

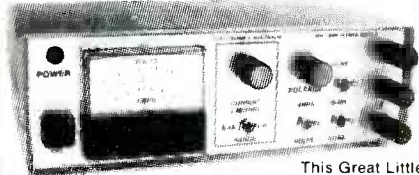

This Great Little power supply is a must for every Electronic Enthusiast and Electronic Student. Use it to power and test circuits and 1000 other uses. Very easy to build - even the beginner constructor should have no trouble - Just follow the plain English step by step instructions.

**FEATURES:** Output variable between 3 and 30 Volts  
• Short circuit Protection • Full 1 Amp output over entire voltage range • Load switching • Current limiting fully variable-twin selectable ranges • Dual Scale Meter  
• Separate earth terminal provided • Housed in Deluxe "ABS" instrument case.

**SPECIFICATIONS:** • Output Voltage - 3 to 30 Volts  
• Output Current - 0 to 1 Amp (fully variable) • Load Regulation - Better than 0.29% from 0 to full load  
• Output Ripple - Less than 2mV RMS.

Visa & Mastercard holders may  
Phone Order. After validating your  
purchase we guarantee same day despatch  
(Or Mail Check or Money Order)

MasterCard

VISA

Phone Your Order - We Guarantee  
Same Day Despatch

K 3210 Fantastic Value **\$59.95**  
Add \$5 Ship and Delivery Cont. USA  
**IMTRONICS INDUSTRIES LIMITED**  
11930 31st Court, St. Petersburg  
FLORIDA U.S.A. 33716  
Phone 813-577-9010

CIRCLE 186 ON FREE INFORMATION CARD

nal-to-noise ratio at 30 feet is specified as 40 dB.

You don't have to be particular about aiming the receiver directly at the transmitter. As a matter of fact, in most circumstances it works just as well pointed away from the transmitter since the receiver is very sensitive and the room is virtually flooded with the infrared signal from the transmitter as it bounces off the walls and ceiling. A belt clip is provided on the transmitter if you wish to use it while you walk around the room.

The receiver's high sensitivity helps eliminate noise/static problems, but it can work against the system in certain situations. More specifically, if the *Wire-Free* receiver is used in very bright light, such as near a large window with the sun shining, or under bright indoor lighting that has an unusually high infrared component, the unit may overload and shutdown. That won't harm the system, and can be compensated for by simply turning the receiver away from the light source, by

moving the receiver to a darker area, or by reducing the amount of ambient light in the listening area. If you cannot avoid using the unit under unusually bright lighting conditions, you can cut back the sensitivity by covering part of the sensor (red) area on the receiver with dark tape.

Other than that problem, we found that the unit worked well. The lack of true stereo is a shortcoming, but remember that this is a low-cost, low-end unit. The manufacturer does offer a stereo version (called *SoloSound*) for \$109.95; stereo units that are available from other manufacturers can run as high as \$481.

But for private TV listening, or for sound reproduction for the hard-of-hearing (without blasting speakers) the unit is hard to beat. For more information on the *Arkon Wire-Free*, the *SoloSound* stereo wireless head phones, or other *Arkon* wireless products, contact the *Art Sea Development* (U.S.A.) Corporation (11627 Clark St., Suite 101, Arcadia, CA 91006). R-E

## HITACHI COMPACT SERIES



V-1065 DC to 100MHz With Cursor Readout  
**\$1545<sup>95</sup> Save \$250!**

- 6" CRT with Internal Graticule
- Dual Channel X-Y Display
- Sweep Time Autoranging
- 400V High Input Voltage Protection
- TV Sync Trigger Circuit
- Bandwidth Limiter • Trigger Lock
- Delayed Sweep • Single Sweep
- CRT Readout • ±3% Accuracy

V-1060 DC to 100MHz  
**\$1295<sup>95</sup> Save \$200!**

V-665 DC to 60MHz  
With Cursor Readout.  
**\$1145. Save \$150!**

V-660 DC to 60MHz  
**\$945<sup>95</sup> Save \$150!**

Instant Hard Copy!!  
From Oscilloscopes

## POLAROID® DS-34 CAMERA



Save \$135! **\$290.**

- 5", 6" and 7" Hoods (Available separately @ \$51 ea. Please Specify size)
- Pistol Grip For Ease of Operation
- Works on Any Make of Oscilloscope
- Three Full Year Warranty

### Dual Channel 6" CRT Scopes

V-425 DC to 40MHz, CRT Readout  
**\$845. Save \$150!**

V-423 DC to 40MHz, Single Time Base Delayed Sweep  
**\$745. Save \$250!**

V-422 DC to 40MHz, DC Offset  
**\$795. Save \$130!**

V-225 DC to 20MHz, CRT Readout  
**\$720. Save \$75!**

V-223 DC to 20MHz, Delayed Sweep  
**\$695. Save \$100!**

V-222 DC to 20MHz, DC Offset  
**\$515. Save \$200!**

V-212 DC to 20MHz  
**\$440. Save \$175!**

### Dual Channel Mini-Portable Scopes

V-509 DC to 50MHz, Delayed Sweep  
**\$1195. Save \$250!**

V-209 DC to 20MHz  
**\$822. Save \$175!**

### Quad Channel Multi-Function Scopes

V-1150 DC to 150MHz, Delayed Sweep  
**\$2600. Save \$350!**

V-1100AU DC to 100MHz, Delayed Sweep  
**\$2175. Save \$315!**

### Digital Storage Scope

V-6020 1MHz Sampling, Dual Channels  
**\$1750. Save \$200!**

### NTSC Waveform Monitors

V-079 6" CRT  
**\$1625. Save \$125!**

V-099 3.5" CRT  
**\$950. Save \$300!**

### NTSC Vector Scopes

V-069 6" CRT  
**\$1825. Save \$125!**

V-089 3.5" CRT  
**\$1284. Save \$400!**

PROBES INCLUDED WITH ALL HITACHI  
SCOPES AT NO EXTRA CHARGE!



## WM. B. ALLEN SUPPLY COMPANY

ALLEN SQUARE  
300 Block North Rampart Street  
New Orleans  
Louisiana 70112

TOLL FREE 800 535-9593 • LA 800 462-9520  
NEW ORLEANS 504 525-8222 • FAX 504 525-6361  
• American Express • Visa • MasterCard •  
928 pg Catalog FREE with your order

Discover—Explore—Experience  
Today's Electronics With ...

# McGraw-Hill's Contemporary Electronics Series

Now you can meet the challenges of today's electronics quickly and easily. This professional level learning series is as innovative as the circuitry it explains and as fascinating as the experiments you build and explore! And it's for anyone who has an interest in electronics... from the hobbyist to the professional.

## Thousands Have Already Experienced the Excitement!

Today's high-tech world demands an entirely new and innovative approach to understanding electronics. That's why McGraw-Hill has developed this unique "hands-on" learning method that brings to life the dynamics of the new electronics. It's a unique combination of interactive materials that gets you involved as you build and experiment with today's latest electronic circuitry.

Just how well this innovative learning approach meets the challenge of the new electronics is confirmed by those who have already completed the Series... "You have put me right into the middle of an extraordinary learning experience. With each lab exercise I have gained a new understanding of the intricacies of today's electronics." Or... "For me, the Series was just the answer. I felt confident within my specialty, but my grasp of other areas of electronics was slipping away. Your Series helped me upgrade my knowledge of the latest electronics concepts." Or this from a company director of training... "We manufacture sophisticated electronic products, with a lot of people in sales, assembly and purchasing. McGraw-Hill has answered a real need in helping our employees see the total picture. They now communicate with customers and each other more effectively."

## Your Involvement in the New Electronics Begins Immediately.

You master one subject at a time with 15 McGraw-Hill *Concept Modules*, sent to you one

every 4 to 6 weeks. You waste no time on extraneous materials or outdated history. It's an entertaining, lively, nontraditional approach to the most modern of subject matter.

Your very first module takes you right to the heart of basic circuit concepts and gets you ready to use integrated circuits to build a digital oscillator. Then, you'll verify the operation of different electronic circuits using a light emitting diode (LED).

And each successive module brings you up to speed quickly, clarifying the latest advances in today's electronics... from digital logic and micro-processors to data communications, robotics, lasers, fiber optics, and more.

## Unique Combination of Interactive Instruction Materials Makes Learning Easy.

Laboratory experiments, vividly illustrated text and interactive cassette tapes all blend together to give you a clear, simplified understanding of contemporary electronics.

With each module, you receive a McGraw-Hill *Action-Audio Cassette* that brings to life the facts and makes you feel as if you're participating in a lively dialogue with experts.

Your ability to quickly make this knowledge your own is further aided by strikingly *illustrated* texts that use diagrams, explanations, illustrations, and schematics to drive home and rein-

force the meaning of each important point. Carefully indexed binders conveniently house all this material, as well as the instructions that will guide you through your "hands-on" lab experiments.

Throughout your Series, *laboratory experiments* reinforce every significant concept. With this essential "hands-on" experience using actual electronic components, you master principles that apply all the way up to tomorrow's VLSI (Very Large Scale Integrated) circuitry.

## Discover, Explore, Experience for Yourself—15-Day Trial.

In all ways, the Contemporary Electronics Series is an exciting learning experience that offers you the quickest and least expensive method available to master today's electronics... and the only one with "hands-on" experience.

To order your first module for a 15-day

trial examination, simply complete the card and send today! If the card is missing, write to us for ordering information.



McGraw-Hill  
Continuing  
Education Center

3939 Wisconsin Avenue, NW  
Washington, DC 20016

# NEW PRODUCTS



CIRCLE 10 ON FREE INFORMATION CARD

**BATTERY CHARGER.** General Electric offers a battery charger that can accommodate various combinations of household-sized rechargeable batteries—everything from AAA to 9-V.

GE nickel-cadmium batteries can be recharged up to 1000 times; the new battery charger is extremely versatile and is much easier to use than earlier models of battery chargers. A flip-up, see-through cover opens to sliding plastic fixtures that can accommodate all five common household-

battery sizes. The unit can recharge up to four AAA, AA, C, or D sizes, or two 9-volt batteries at a time.

The battery charger is housed in a durable high-impact plastic case; features include a six-foot UL-listed cord, rubber feet to prevent sliding or scratching on any surface, and an indicator light to show when the charging cycle is completed. The battery charger sells for under \$12.00.—**General Electric Company**, Nela Park, Cleveland, OH 44112.

**SPECIAL MIRRORS.** Metro Optics, Inc.'s 90° mirrors let the user see *under* electronics components such as surface-mount devices with "J" leads while looking down with a Metron 3-D scanner or a microscope.

Tilting a PC board to see the solder connections from an angle helps, but even tilting to 90° isn't

enough because components (except for the outer row) block off the view of the solder connections in the next row. The 90° mirrors require no tilting of the PC board, and components from one row cannot block the view of the next one. The mirrors go between the rows and permit both a top-down view and a 90° view. If the user needs to focus farther under the part, that can be done by focusing down, and the line of focus will move farther *under* the part—an inch, if desired.

The Metron 90° mirrors come in three sizes. The *Standard* 90° mirror is the largest and will fit component spacings of 0.225-inch or wider; it is priced at \$50.00. The *Thin* 90° mirror will fit in spaces down to .080-inch, and is priced at \$100.00. The *Extra Thin* 90° mirror can handle components spacings of as little as .035-inch, and is priced at \$250.00. All the 90° mirrors are canted to permit looking at all sides of a component.—**Metron Optics, Inc.**, 809-815 Academy Dr., P.O. Box 690, Solana Beach, CA 92075-0690.

**APPLIANCE TIMERS.** Intermatic's Time-All models *SB111B* and *TB111B* single on/off timers, and models *SB711B* and *TB711B* variable on/off timers, offer homeowners important safety and security features.

Plug-in timer *SB111B*, and tabletop version *TB111B*, can ensure that appliances are not left on all day. They are ideal for coffee pots, irons, and electric curlers—those appliances that are often left on in the morning rush to leave the house. They can also convert a standard coffee maker to one that starts brewing before you're out of bed. For crime prevention, they can create a "lived-in" look by timing lamps.

The 15-amp model *SB711B* plug-in timer adds a new dimension to

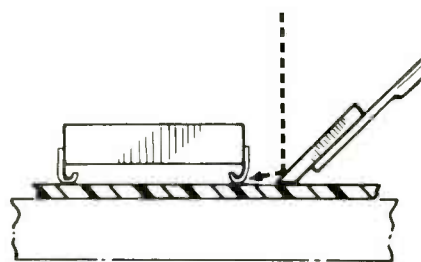

CIRCLE 11 ON FREE INFORMATION CARD



CIRCLE 12 ON FREE INFORMATION CARD

home security by switching lamps on or off at slightly different intervals each day, making the "lived-in" illusion more realistic. It can keep appliances on for as long as 23¼ hours, or as short a period as 45 minutes. A manual ON/OFF switch overrides the automatic setting so that appliances can be used whenever desired. The variable timer is also available in a tabletop version, model TB711B.

The suggested retail price for model SB111B is \$9.95; \$13.95 for model TB111B. Models SB711B and TB711B list for \$10.95 and \$14.95, respectively.—Intermatic Inc., Intermatic Plaza, Spring Grove, IL 60081.

**TOOLS.** Jensen Tools' Telvac Basic Service Kit is designed for field service, in-house maintenance, trade schools, and personal use. It contains over 40 high-quality hand tools in a solid wood/vinyl case



CIRCLE 13 ON FREE INFORMATION CARD

with removable pallets, document pouch, and key-lock latches.

The tool selection includes standard service tools, such as screwdrivers, pliers, nut and hex drivers, punches, wrenches, and soldering equipment, as well as a 5-inch hemostat, reverse-action tweezer, combination spring tool, wire crimper/stripper, and other specialty items. A choice of test meters is also offered as optional accessories.

The Telvac basic service kit is

priced at \$189.00.—Jensen Tools, Inc., 7815 S. 46th Street, Phoenix, AZ 85044.

### HEADPHONE STEREO SYSTEM.

The Aiwa model HS-PX700A incorporates Dolby B and Dolby C noise reduction and also features DSL-EX (Dynamic Super Loudness) that offers a wider, flatter frequency response for naturally balanced sound at all listening levels. Separate slide controls for high and low

*continued on page 37*

# BK

## INSTRUMENT SALE!

\$99.95  
 FOR ONLY  
**\$40.00**  
 COBRA  
 RADAR DETECTOR



Model 2120 Oscilloscope



Model 3011 Function Generator

## Joseph Electronics' 40th Anniversary Sale!

We are celebrating our 40th Anniversary by offering you huge savings on B&K Test Equipment. In addition to great prices, as an extra anniversary bonus you can get a \$99.95 Cobra Radar Detector for only \$40 when you purchase any B&K Instrument featured in this ad.

**Model 2120 Oscilloscope**  
DC to 20 MHz-Dual Trace-6" CRT-1mv Sensitivity  
Reg. \$479 **\$379.40**  
40TH ANNIVERSARY PRICE

**Model 2125 Oscilloscope**  
Some great features as 2120 except with delayed sweep  
Reg. \$570 **\$469.40**  
40TH ANNIVERSARY PRICE

**Model 1541A Oscilloscope**  
DC to 40 MHz-Dual Trace-6" CRT 1mv Sensitivity  
Reg. \$845 **\$739.40**  
40TH ANNIVERSARY PRICE

**Model 1803 Frequency Counter**  
100 MHz-8 digit display-zero blanking AC or Battery  
Reg. \$186 **\$159.40**  
40TH ANNIVERSARY PRICE

**Model 2005 RF Signal Generator**  
100 KHz to 150 MHz in 6 fundamental bands and 450 MHz in harmonics  
Reg. \$195 **\$169.40**  
40TH ANNIVERSARY PRICE

**Model 3011 Function Generator**  
-2 MHz-4 digit display-TTL & CMOS pulse outputs  
Reg. \$225 **\$189.40**  
40TH ANNIVERSARY PRICE

**Model 1630 DC Power Supply**  
-0-30V-0-3A-high-low current range. Low ripple  
Reg. \$233 **\$199.40**  
40TH ANNIVERSARY PRICE

**Model 1641 DC Power Supply**  
-Isolated 0-50V-0-2A in ranges fully automatic shutdown-Adj. current limit  
Reg. \$440 **\$369.40**  
40TH ANNIVERSARY PRICE

**Model 1650 Triple Output Power Supply**  
-two 0-25 VDC @ 5A and 5VDC @ 5A-fully automatic shutdown  
Reg. \$455 **\$379.40**  
40TH ANNIVERSARY PRICE

**Model 1653 AC Power Supply**  
-variable isolated 0-150 VAC @ 2A -built-in isolation transformer  
Reg. \$190 **\$169.40**  
40TH ANNIVERSARY PRICE

Send for FREE 480 page "Industrial Products Catalog". Understand it is FREE with any order or if requested on company letterhead. (Otherwise, \$4.95 to cover catalog and shipping costs.)

ORDER TOLL FREE  
**1-800-323-5925**  
IN ILLINOIS  
**312-297-4200**  
Our 40th Year

Joseph Electronics



**JOSEPH ELECTRONICS, INC.** Dept. R  
8830 N. Milwaukee Ave., Niles, IL 60648

Rush merchandise per attached order.  
I understand rated accounts are shipped open account; otherwise send per credit card.

Include \$5.00 per item for shipping and handling.

Visa  Master Card  Discover  
 Check  Money Order  Rush Catalog

Card No. \_\_\_\_\_ Exp. Date \_\_\_\_\_

Name \_\_\_\_\_  
Company \_\_\_\_\_  
Street Address \_\_\_\_\_  
City \_\_\_\_\_ State \_\_\_\_\_ Zip \_\_\_\_\_

IL Res. 7% Tax

# COMMUNICATIONS CORNER



HERB FRIEDMAN,  
COMMUNICATIONS EDITOR

## Pinning the blame

SEVERAL YEARS AGO, THE POLICE OF A major city, who were fed up to their blue hats by politicians who really didn't care two hoots about any of the civil servants, revolted in the only way they could short of striking: They simply broadcast nonsense on their radio network. It all started with a phantom voice asking, "Who dat?" Another voice asked, "Who dat who said who dat?" Then, "I know who said who dat?"; and so it went, hour after hour.

Now Hell hath no fury like a politician ridiculed, for that's what the "Who dat?" was, and the morning papers headlined the mayor's and the police commissioner's threats to hang the whole police force if necessary. The way the mayor and the commissioner told it, the time spent by the boys in blue asking "Who dat?" allowed criminals to run wild in the streets. In fact, however, the hundreds of man-hours the mayor ordered to be wasted trying to identify voices from air-check tape recordings probably resulted in more street crime and arson than a century of "Who dats?"

Today, the problem of identification would most likely not exist. Not because the politicians are any smarter—they most certainly are not—but because transmission identification has become so important a part of both cost accounting and legal defense that most communications systems are upgrading to automatic transmission identification. Where does "legal defense" come in? Simply because virtually any time a person dies before an ambulance or the EMS team arrives, some hot-

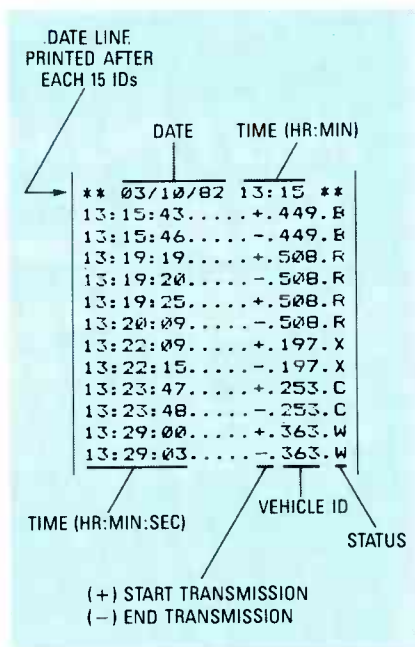

FIG. 1

shot *street lawyer* will claim the response was excessively late and agitate the bereaved family to institute a lawsuit.

### Accountability

In fact, our society has become so complex that it is essential that we have the capability to provide almost a second-by-second accounting of our communications. How else do we get accountability—which in plain English means "Who can we stick with the blame?"

Until recent times, the best system for communications accountability was the logging recorder, a special ultra-slow-speed tape recorder (so it could run unattended for up to a day) that recorded all communications traffic, as well the

date and time on a special time track. If you wanted to find out what was said or who was called at a specific time, you simply ran the logging recorder at a fast speed until a digital readout indicated the desired time (and date), and then listened to the channel traffic. It's the same kind of system the police use to record emergency calls.

But while the logging tape can tell you what was said and when it was said, it can't tell you who said it; particularly so since the modulation characteristics of modern transmitters are only a shade better than that of two paper cups connected by a string; so it's often difficult, if not impossible, to distinguish the difference between male and female, child and adult.

What was needed for true accountability was automatic transmitter identification, so that when the transmit switch was pressed the first thing that goes out is the mobile's or hand-held's ID number, which is indicated both on the dispatcher's console display and on a printout. The console display shows the time and the ID number; the printout can show the vehicle's ID number, the date, and time the transmission started, the time the transmission ended, and even the status of the vehicle. For example, if a taxi has its flag up or down, if the vehicle is moving or stopped, or if the vehicle is in trouble (keyed by a switch under the driver's seat). A sample printout from an ANI (Automatic Number Identification) system of the Control Signal Corp. (1985 S. Depew St., Denver, CO 80227) is shown in Fig. 1.

A really big feature with some units, such as the ANI, is an automatic time-out for stuck mobile-unit PTT (Push-To-Talk) switches, which would result in the channel being continuously jammed. If the mike's PTT switch jams closed, the dispatcher's console sounds an alarm and identifies the offending unit. After a preset time, the ANI encoder in the mobile automatically shuts off the transmitter. While that might take the transmitter out of service until the vehicle returns to the shop, at least it unjams the channel for other users.

More often than not, however, the primary purpose of automatic identification is to stop horseplay and eliminate mischief, such as "dead carriers," microphone clicks, belching, foul language, and "Who dat's."

### How it's done

Depending on the particular communications system, the identification data can be sent via sub-audible or audible tones. The disadvantages of subaudible tones are that they can't be used if the system already uses subaudible tones for CTCSS (tone squelch) or if the signal must be sent over conventional telephone lines, and every unit in the system must be able to handle subaudible tone.

Audible tones, on the other hand, will pass through any kind of communications equipment. In Control Signal's ANI system, a 3-digit ID code is a 100 millisecond ( $\frac{1}{10}$  second) two-frequency FSK burst after the transmitter is keyed. (The delay between keying the PTT switch and the tone burst is adjustable to accommodate the particular communications system.) Six half-cycles of the base (audio) frequency is a mark, and three half-cycles of one-half the base frequency is a space.

As you can see, since the ANI system uses conventional audio tones that fall within the passband of conventional communications gear, including telephone circuits, it can easily be added to just about any mobile-base system, providing 100% accountability. Ah, yes! Just when you think Big Brother has exhausted all his wiles and guiles, he can come up with yet another.

R-E

## Ten Things You Can Do With The VA62 Universal Video Analyzing System — That You Can't Do With The Others.

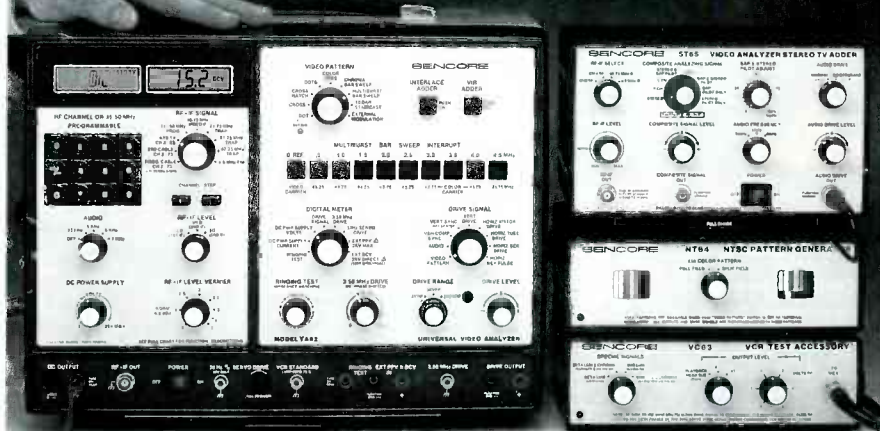

**\$3,495** Patented

1. Quickly locate defective circuits by injecting signals without disconnecting components.
2. Replace video heads with confidence; a simple good/bad head test removes all doubt.
3. Align IF traps simply by just the pattern on the CRT — have the picture "looking like it did when they bought it."
4. Quickly align VCRs with special video patterns, or NTSC color bars. Meets all manufacturers' warranty requirements.
5. Performance test and troubleshoot any MTS stereo TV or VCR system, so you can cash in on new technology.
6. Confidently test deflection yokes, IHVTs, and flyback transformers, in-or out-of-circuit, before you replace them.
7. Add on phase-locked accessories into your video analyzing system to increase service potential as technology changes.
8. Performance test and troubleshoot digital/analog RGB video monitors, so you can test all of today's video systems.
9. Conquer tricky servo circuits in VCRs by injecting a reference 30 Hz servo pulse.
10. Cut your video servicing time in half . . . or your money back.

**Discover what the Universal Video Analyzing System can do for you! Call Today 1-800-843-3338.**

**In Canada Call 1-800-851-8866.**

100% American Made

# SENCORE

3200 Sencore Drive, Sioux Falls, SD 57107 605-339-0100 In SD Only

CIRCLE 181 ON FREE INFORMATION CARD

# Direct Sale! Famous LogicBridge 136™ "Pocket Scope" only \$395.

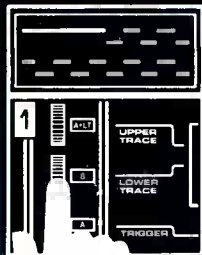

1 Compare a gate pulse (50% HI, 50% LO) on the A input with a microprocessor clock signal on the B input using the Boolean OR operator. The result is displayed in the upper trace.

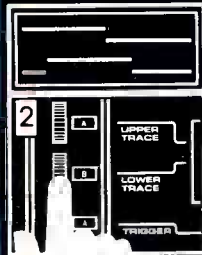

2 Determine the time delay between two input signals A and B directly from the upper and lower traces.

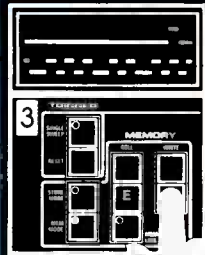

3 Extract an error bit (in upper trace) by an EXCLUSIVE OR comparison to a known good bit pattern (in lower trace). Results are stored in MEMORY MODE and recalled to the display.



4 Use SINGLE SWEEP and STORE MODE to display serial data input B (lower trace) after the occurrence of the single shot event A that is being displayed in the upper trace.

## LogicBridge 136™

Waveform analysis in the palm of your hand.

**Special Offer!** You read about it, maybe even ordered one; over 100,000 inquiries were received when this unique testing instrument was introduced, more orders than anyone could manufacture. No competitive tool ever came close to its versatility, even at twice the price.

LogicBridge 136 has sold recently for \$795. But we will soon replace it with an even more sophisticated, but costlier instrument. So now, for a brief time, you can get LogicBridge 136, as available, at the unheard of price of \$395—**or only \$365 if you hurry your order, direct to Inter-Venture.**

LogicBridge 136 is a digital storage instrument that combines the functions of logic analyzer and oscilloscope technology in a compact, hand-held, 1.25 pounds. It can be worn around your neck like a doctor's stethoscope—a kind of "badge of the engineer." Effective real time pulse bandwidth is 10MHz but the glitch catcher captures pulses down to 50 Ns. Patented LED array allows simultaneous display of two digital waveforms. Memory mode operation stores up to fifty 100-bit waveforms to be recalled and visually/logically compared to other waveforms. Exclusive "Audio-Trak" function produces audible logic analysis, along with "trig-tone."

At this special price, LogicBridge is a must for engineers, field technicians, educators, students and hobbyists. A great gift item for new graduate engineers. A complete brochure is available, but don't risk our running out. All new production will focus on the advanced units.

Order today, direct from Inter-Venture and save the additional \$30. Send coupon or phone now.

### SPECIFICATIONS

#### DISPLAY:

Dual LED Arrays  
2 x 100 Elements per Array  
16 LED Annunciators:  
Time Base Single Sweep  
Memory Battery Low  
Tone

#### Logic Compare Modes:

AND, OR, EXCLUSIVE OR

#### Display Options:

A, B, Trigger, Memory, Invert, Clock, SYNC, External, Logic Functions

#### INPUT:

Three Channels (A, B, Trigger)  
0.5 Volt: 1 Meg, 50 PF  
0.50 Volt: 1 Meg, 70 PF (10 x Probe)  
50 Volts Maximum  
Probes or Direct Via 10C Connector

#### TIME BASE:

10 MHz Real-Time Bandwidth  
50-100 NS Glitch Catcher  
1 μS-1 Sec/Div Ranges (6 steps)  
Auto-Seek Mode  
Single Sweep/Reset  
UNCAL Function

#### TRIGGER:

Threshold Adjust: 1.2-4.7 Volts  
Trigger Tone  
Dual Tone AUDIO TRAK (2.44 KHz, 4.88 KHz)  
100 NS Auto Restore

#### MEMORY:

50-100 Bit CMOS Display Waveform Memories  
Write/Recall Functions Memory Mode  
Store Mode Memory Link Mode

#### POWER:

AC Wall Transformer/Charger  
9 Volt Rechargeable Batter (Optional)

#### PHYSICAL:

8.0 (L) x 4.5 (D) x 1.75 (H) Inches  
1 Pound 4 Ounces  
50 NS 100 NS Glitch Catcher  
Neck Strap  
Operations Manual  
Modular Triple Probe Set  
25 Pin Input/Output/Control Port  
7 LED Keyboard Annunciators

#### WARRANTY:

One year parts and labor from date of purchase when returned to factory or local authorized service center.  
Custom HCMOS  
LSI Logic Chips used throughout.

### THE NEXT LOGICAL STEP IN TEST INSTRUMENTATION

- Please send me a LogicBridge 136 brochure.
- I want to save an additional \$30 per unit by ordering direct.  
( ) LogicScope 136 units at a cost of \$365 each.
- I have my own probes.
- I need \_\_\_\_\_ custom sets of 3-250 MHz, 1X-10X oscilloscope probes at cost of \$149 per set (\$225 value).  
Charge to my  Mastercard  Visa  
Credit Card No. \_\_\_\_\_ Expires \_\_\_\_\_

Offer expires March 31, 1988. Calif. residents add 6 1/2% sales tax.

### Inter-Venture

2114 Ringwood Avenue, San Jose, CA 95131

Name \_\_\_\_\_

Title \_\_\_\_\_

Company Name \_\_\_\_\_

Address \_\_\_\_\_

City \_\_\_\_\_ State \_\_\_\_\_ Zip \_\_\_\_\_

## Inter-Venture

Probing the limits of  
electronic excellence

Inter-Venture Corporation

2114 Ringwood Avenue, San Jose, CA 95131  
(408) 943-1688



## NEW PRODUCTS

continued from page 33

frequencies adjust the DSL-EX effect according to the user's listening preferences.

A three-way auto-reverse system allows the user to be free from manually switching tape sides. The system will play the tape through one complete cycle, play the tape continuously for non-interrupted music listening, or switch tape sides at any given point. With the music-sensor fea-



CIRCLE 14 ON FREE INFORMATION CARD

ture, the unit will automatically fast-forward to the next item or rewind to the previous one. There is an anti-rolling mechanism that provides stable playback, even when the unit is in motion.

The model *HS-PX700A* can be powered by either two AAA batteries, house current when used with the supplied AC adaptor, or by the supplied rechargeable battery pack. The quick-charge battery system takes one hour to recharge and provides two hours of playback enjoyment. The model *HS-PX700A* is priced at \$250.00.—*Aiwa America*, 35 Oxford Drive, Moonachie, NJ 07074.

**TELEPHONE OPTIONS DEVICE.** The *TELE-MATE* adds custom features to any standard, modular-type home phone. It allows the user to place a call on hold and transfer it to another extension, to ensure privacy by checking the line for unwanted listeners, to stop incoming calls by generating a busy signal, and to determine

continued on page 42

## Put Professional Knowledge and a COLLEGE DEGREE in your Technical Career through HOME STUDY

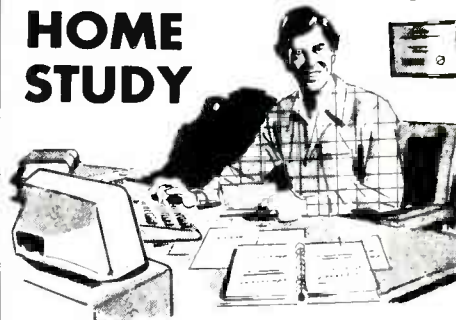

Add prestige and earning power to your technical career by earning your Associate or Bachelor degree through directed home study.

No commuting to class. Study at your own pace, while continuing on your present job. Learn from easy-to-understand lessons, with help from your Grantham instructors when you need it.

Grantham College of Engineering is a specialized institution catering to adults who are employed in electronics and allied fields such as computers. These fields are so enormous that opportunity to *move up* is always present. Promotions and natural turn-over make desirable positions available.

An important part of being prepared to *move up* is holding the proper college degree, but the essential part is *really knowing your field*. Grantham offers two B.S. degree programs — one with major emphasis in *electronics* and the other with major emphasis in *computers*. Both programs are offered by correspondence.

Write for our free catalog (see address below) or telephone us at (213) 493-4421 (no collect calls) and ask for our "degree catalog."

Accredited by  
the Accrediting Commission of the  
National Home Study Council

**GRANTHAM**  
College of Engineering  
10570 Humbolt Street  
Los Alamitos, CA 90720

## Test VCR Mechanics Fast and Easy!

Take the guesswork and hassles out of VCR mechanical problem diagnosis!  
Four Universal, Powerful Tools for VCR Service

**Tape Tension Gauge:** The Tentelometer® is the world's most universal method of measuring hold back tension. Calibration can easily be checked in the "field". Merely slide the probes over tape to measure tape tension directly in grams. Illustrated instruction manual included. This is the back tension gauge referenced by many of the VCR service manuals, and it will work on all VCRs.

T2-H7-UM \$295



**Video Head Protrusion Gauge:** Universal, fast, safe method of measuring the amount of video head tip wear. Measures in thousandths of an inch. Allows accurate predictions of remaining head life. Head wear provides useful information regarding VCR condition and wear on other components. Stop guessing about head wear. Accessory "S1" stand allows use on any VCR.

HPG-1 \$479 S1 \$95



**Spindle/Elevator Gauge:** The TSH gauge inserts into the VCR just like a cassette. The new TSH-V5 performs 6 critical measurements to eliminate tape binding and edge damage. This gauge quickly locates problems that can't even be detected by other methods. Fully illustrated instruction manual is included.

TSH-V5 for VHS: \$395

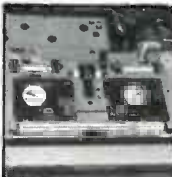

**Torque Gauge:** A universal, inexpensive, accurate torque gauge for VHS and Beta VCRs. Calibrated in Gram-Centimeters both clockwise and counterclockwise. Complete with easy-to-follow, detailed instruction manual for VHS recorders. Includes a modified VHS cassette for ease-of-use.

Complete System  
TQ-600 \$139



Tentel® provides the most powerful, easy-to-use, field calibratable, universal VCR test equipment available for various mechanical tests. Call our application engineers today for answers to your questions. Ask about the combination discount when ordering all 4 gauges.

**Tentel® Corp.**

1506 Dell Avenue  
Campbell, CA 95008

(800) 538-6894  
(408) 379-1881  
in California

CIRCLE 204 ON FREE INFORMATION CARD

# Join the Electronics and Control Engineers' Book Club®

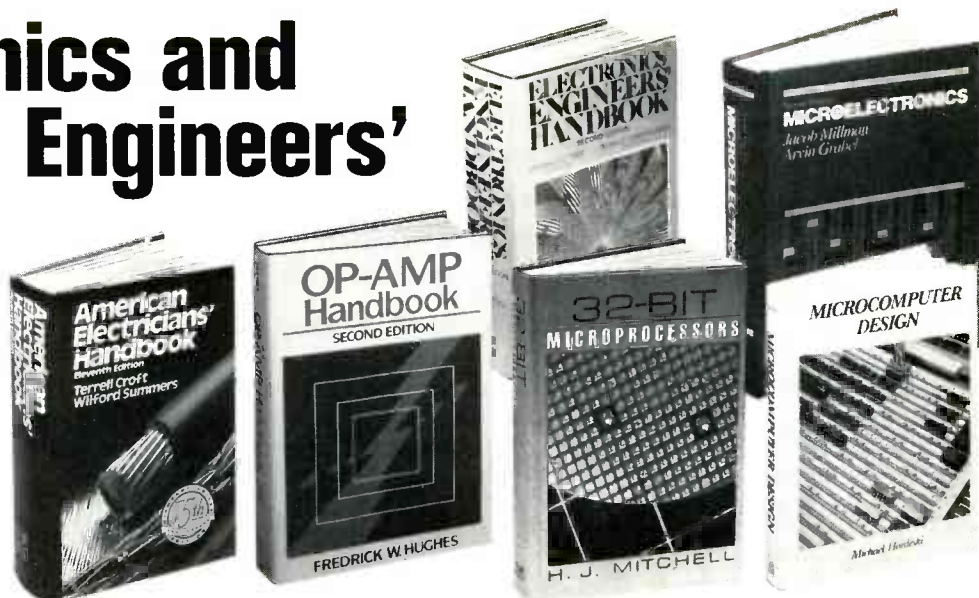

**ADVANCED DIGITAL COMMUNICATIONS: Systems and Signal Processing.** Edited by K. Feher. 768 pp., 436 illus. Emphasizes the newest advances and developments in telecommunications systems and networks. Chapters on subjects such as ISDN, speech coding algorithms, digital speech interpolation systems and interference are all written by international authorities to give you on-the-job expertise.  
583801-X Pub. Pr., \$59.95 Club Pr., \$42.50

**ELECTRONICS ENGINEERS' HANDBOOK, Second Ed.** Edited by D. G. Fink & D. Christiansen. 2,272 pp., 2,189 illus. This updated and enlarged edition covers all the latest knowledge in the field, including new advances in integrated circuits, pulsed and logic circuits, laser technology, telecommunications, and much more.  
209/812 Pub. Pr., \$89.00 Club Pr., \$61.50

**32-BIT MICROPROCESSORS.** Edited by H. J. Mitchell. 248 pp., 104 illus. and tables. A complete survey of the architecture, operation, and applications of today's most important new devices from AT&T, Immos, Intel, and Motorola.  
425/85X Pub. Pr., \$39.95 Club Pr., \$29.50

**MICROWAVE AMPLIFIERS AND OSCILLATORS.** By C. Gentili. 150 pp., 79 illus. A thorough, practical introduction to the theory and design of microwave amplifiers and oscillators, with coverage of the scattering matrix, the gallium arsenide field-effect transistor, and microstrip technology.  
229/953 Pub. Pr., \$31.95 Club Pr., \$24.95

**TROUBLESHOOTING ELECTRONIC EQUIPMENT WITHOUT SERVICE DATA** By R. G. Middleton. 303 pp., 162 illus. and tables. Packed with charts, diagrams, and case histories, this practical handbook shows you how to pinpoint defective electronic circuitry when no service data is available.  
583134-1 Pub. Pr., \$27.95 Club Pr., \$22.50

- your one source for engineering books from over 100 different publishers
- the latest and best information in your field
- discounts of up to 40% off publishers' list prices

New Members!  
Take any one of these great professional books for only **\$289** as a premium with your first selection!

Spectacular values up to **\$98.50**

**McGRAW-HILL CONCISE ENCYCLOPEDIA OF SCIENCE AND TECHNOLOGY** Editor-in-Chief S. P. Parker and the Staff of the McGraw-Hill Encyclopedia of Science and Technology. 2,065 pp., 1,600 illus. This volume serves every need for understanding today's science and technology. Written by over 3,000 of the world's topmost experts, including 19 Nobel Prize winners, it covers 75 disciplines from Acoustics to Zoology.  
454/825 Pub. Pr., \$98.50 Club Pr., \$63.99

**CIRCUIT DESIGN FOR ELECTRONIC INSTRUMENTATION: Analog and Digital Devices from Sensor to Display, Second Ed.** By D. Wobschall. 400 pp., 365 illus. Brings you the entire process of circuit design in a comprehensive, easy-to-follow format. This new edition reflects the latest in IC technology, including CMOS and ECL devices.  
712/31X Pub. Pr., \$49.50 Club Pr., \$36.95

**AMERICAN ELECTRICIANS' HANDBOOK, Eleventh Ed.** By T. Croft and W. Summers. 1,824 pp., 1,560 illus. This newly updated handbook shows you how to select, install, maintain, and operate all the latest electrical equipment and wiring. It includes the most recent code requirements, basic formulas, and a wealth of circuit diagrams and illustrations.  
139/326 Pub. Pr., \$64.50 Club Pr., \$49.50

**MICROELECTRONICS, Second Ed.** By J. Millman and A. Grabel. 1,001 pp., 646 illus. Takes you from the basics of semiconductor properties to an understanding of the operation of solid-state devices, and then to more advanced topics. Its up-to-date coverage, real-life examples, and practical data make this an ideal reference for the working engineer.  
423/30X Pub. Pr., \$49.95 Club Pr., \$36.50

**ENGINEERING MATHEMATICS HANDBOOK, Third Ed.** By J. J. Tuma. 512 pp., illus. This best-selling handbook gives you the essential mathematical tools-formulas, definitions, theorems, tables, and models for computer programming - that you need for your day-to-day engineering calculations.  
654/433 Pub. Pr., \$44.50 Club Pr., \$34.50

**ENGINEERING FUNDAMENTALS FOR THE PROFESSIONAL ENGINEERS' EXAM, Third Ed.** By L. M. Polentz. 432 pp., 170 illus. Features worked-out solutions and full explanations for all sample problems so you can learn how to solve them. It's a dependable way to prepare for the exam or a perfect on-the-job reference.  
503/931 Pub. Pr., \$36.50 Club Pr., \$27.95

**AUTOMATIC CONTROL SYSTEMS, Fifth Ed.** By B. C. Kuo. 736 pp., illus. Provides an overview of automatic control systems, including in-depth coverage of classical control techniques, optimal control theory, and analog and digital control system design. This updated edition discusses the latest ideas on the use of computers to design control systems and as components of such systems.  
583706-4 Pub. Pr., \$48.00 Club Pr., \$36.95

**OP-AMP HANDBOOK, Second Ed.** By F. W. Hughes. 320 pp., 231 illus. Organized for on-the-job reference, this handbook covers all facets of op-amps, from stability and protection to signal processing using op-amps. Includes a collection of over 60 practical circuits for a variety of applications, procedures, and experiments.  
583651-3 Pub. Pr., \$36.33 Club Pr., \$27.50

**THE LINEAR IC HANDBOOK.** By M. S. Morley. 614 pp., 163 illus. The one-stop sourcebook that helps you find - quickly and easily - the lowest-cost linear IC that will meet your needs. Includes specs, applications data, and prices of linear ICs from all major manufacturers, as well as design and fabrication techniques.  
583784-6 Pub. Pr., \$49.50 Club Pr., \$36.25

## HANDBOOK OF ELECTRONIC TABLES AND FORMULAS

### Sixth Edition

256 pages, illustrated. 583804-4

Up-to-date mathematical tables and electronic formulas in a convenient desk reference that you'll find indispensable. Included are basic formulas, constants, government/industry standards, symbols and codes, service data, and more. The handbook also has new sections describing how to do your calculations on a computer, and complete computer programs.

A \$19.95 Value — Yours ABSOLUTELY FREE when you join!

**PRINCIPLES OF PARALLEL AND MULTI-PROCESSING.** By G. R. Desrochers. 500 pp., illus. A highly practical guide to the best techniques in parallel problem-solving. Discusses parallel system design, architecture, implementation, software, and performance analysis.  
165/793 Pub. Pr., \$49.50 Club Pr., \$36.95

**ANALOG ELECTRONIC CIRCUITS.** By G. M. Glasford. 480 pp., 350 illus. Gives you the detailed information and equations you need to create and analyze top quality circuit designs or effectively utilize the designs of others.  
583768-4 Pub. Pr., \$52.33 Club Pr., \$37.95

**HANDBOOK OF ELECTRONIC NOISE MEASUREMENT AND TECHNOLOGY, Second Ed.** By C. A. Vergers. 440 pp., 213 illus. Provides answers to all your questions about noise origins, causes, effects. Also shows you how to predict and measure noise, and how to design low-noise circuits.  
583947-4 Pub. Pr., \$39.95 Club Pr., \$29.95

**SWITCHGEAR AND CONTROL HANDBOOK, Second Ed.** Edited by R. W. Smeaton. 1,056 pp., 789 illus. The only handbook that treats all aspects of switchgear control, including design, applications, safety, and maintenance. Updated to reflect the changes brought about by the use of computers, solid-state devices, and programmable controls.  
584/494 Pub. Pr., \$75.00 Club Pr., \$56.95

**ANTENNA APPLICATIONS REFERENCE GUIDE.** Edited by R. C. Johnson and H. Jasik. 496 pp., 368 illus. and tables. Covers the major applications of antenna technology in all areas of communications and their design methods. Emphasizes important new applications such as earth station, satellite, seeker, aircraft, and microwave-relay antennas.  
322/848 Pub. Pr., \$49.50 Club Pr., \$36.50

**MICROCOMPUTER DESIGN.** By M. Hordeski. 406 pp., illus. Emphasizes the most current, cost effective methods for developing, debugging and testing all types of microprocessor products, including software and hardware.  
583683-1 Pub. Pr., \$42.67 Club Pr., \$29.95

**DESIGNING ELECTRONIC CIRCUITS.** By R. G. Middleton. 351 pp., 192 illus. Covers virtually every category of circuits commonly used. This practical manual provides the basic design procedures, tables and formulas vital to effective electronic circuit design. Plus over 60 start-to-finish procedures are featured along with scores of computer programs to help you design and analyze electronic circuits.  
583673-4 Pub. Pr., \$36.95 Club Pr., \$27.50

**Be sure to consider these important titles as well!**

**INTRODUCTION TO RADAR SYSTEMS, Second Ed.** By M. I. Skolnik. 579/091 Pub. Pr., \$51.95 Club Pr., \$38.95

**MICROPROCESSORS IN INSTRUMENTATION AND CONTROL.** By S. A. Money. 427/070 Pub. Pr., \$39.50 Club Pr., \$29.50

**OPERATIONAL AMPLIFIERS AND LINEAR INTEGRATED CIRCUITS, Third Ed.** By R. F. Coughlin and F. F. Driscoll. 583754-4 Pub. Pr., \$34.95 Club Pr., \$25.95

**MCGRAW-HILL'S NATIONAL ELECTRICAL CODE HANDBOOK, 19th Ed.** By J. F. McPartland. 457/077 Pub. Pr., \$42.50 Club Pr., \$31.95

**ELEMENTS OF ENGINEERING ELECTROMAGNETICS, Second Ed.** By N. N. Rao. 583774-9 Pub. Pr., \$49.00 Club Pr., \$35.50

**PROBABILITY, SIGNALS, NOISE.** By J. Dupraz. 183/305 Pub. Pr., \$39.95 Club Pr., \$29.95

**POWER GENERATION CALCULATIONS REFERENCE GUIDE.** By T. G. Hicks. 288/003 Pub. Pr., \$36.50 Club Pr., \$27.50

**HUMAN FACTORS REFERENCE GUIDE FOR ELECTRONICS AND COMPUTER PROFESSIONALS.** By W. E. Woodson. 717/664 Pub. Pr., \$32.50 Club Pr., \$23.75

**THE FOURIER TRANSFORM AND ITS APPLICATIONS, Second Ed., Revised.** By R. N. Bracewell. 070/156 Pub. Pr., \$49.95 Club Pr., \$38.95

**THE LASER GUIDEBOOK.** By J. Hecht. 277/338 Pub. Pr., \$49.50 Club Pr., \$37.50



**68000 MICROPROCESSOR: ARCHITECTURE, SOFTWARE & INTERFACE TECHNIQUES.** By W. A. Triebel & A. Singh. 583613-0 Pub. Pr., \$42.67 Club Pr., \$29.95

**FOR FASTER SERVICE IN ENROLLING CALL TOLL-FREE 1-800-2-MCGRAW MAIL THIS COUPON TODAY**

## Why YOU should join now!

■ **BEST AND NEWEST BOOKS IN YOUR FIELD** — Books are selected from a wide range of publishers by expert editors and consultants to give you continuing access to the best and latest books in your field.

■ **BIG SAVINGS** — Build your library and save money too! Savings ranging up to 40% or more off publishers' list prices.

**BONUS BOOKS**—You will immediately begin to participate in our Bonus Book Plan that allows you savings up to 70% off the publishers' prices of many professional and general interest books!

■ **CONVENIENCE**—12-14 times a year (about once every 3-4 weeks) you receive the Club Bulletin FREE. It fully describes the Main Selection and Alternate Selections. A dated Reply Card is included. If you want the Main Selection, you simply do nothing — it will be shipped automatically. If you want an Alternate Selection — or no book at all — you simply indicate it on the Reply Card and return it by the date specified. You will have at least 10 days to decide. If, because of late delivery of the Bulletin you receive a Main Selection you do not want, you may return it for credit at the Club's expense.

As a Club member you agree only to the purchase of three books (including your first selection) during your first year of membership. Membership may be discontinued by either you or the Club at any time after you have purchased the first selection plus two additional books.

**Other McGraw-Hill Book Clubs:**  
Architects' Book Club • Byte Book Club • Chemical Engineers' Book Club  
• Civil Engineers' Book Club • Mechanical Engineers' Book Club

For more information, write to:  
McGraw-Hill Book Clubs, P.O. Box 582, Hightstown, New Jersey 08520-9959

### McGraw-Hill Book Clubs Electronics and Control Engineers' Book Club®

P.O. Box 582, Hightstown, NJ 08520-9959

Please enroll me as a member and send me the two books indicated, plus the HANDBOOK OF ELECTRONIC TABLES AND FORMULAS. I am to receive one book for just \$2.89, the other at the discounted member's price, plus local tax, shipping and handling charges. I agree to purchase a minimum of two additional books during my first year of membership as outlined under the Club plan described in this ad. I understand that a shipping and handling charge is added to all shipments.

Your FREE Handbook	
583804-4	
Write Code No. of the \$2.89 selection here	Write Code No. for the First selection here
<input type="text"/>	<input type="text"/>

Signature \_\_\_\_\_  
Name \_\_\_\_\_  
Address/Apt. # \_\_\_\_\_  
City \_\_\_\_\_  
State \_\_\_\_\_ Zip \_\_\_\_\_

This order subject to acceptance by McGraw-Hill. All prices subject to change without notice. Offer good only to new members. Foreign member acceptance subject to special conditions. E33921

Put a  
test lab in  
your tool pouch.



#### The Fluke 8060A 4½-digit handheld multimeter.

It's the best tool you could add to your tool pouch, because it lets you troubleshoot more ... with less.

This portable, powerful instrument has a unique combination of features not available in any other handheld DMM.

A simple push of a button on the Fluke 8060A lets you measure frequencies to 200 kHz, make relative offset measurements, convert voltages to direct reading decibels, or conduct audible continuity tests. Plus the 8060A offers wideband True RMS ac measurement capability to 100 kHz.

So say goodbye to your part-time counters, oscilloscopes, continuity testers, calculators and power supplies. And welcome a full-time professional that'll be there when you need it.

You'll find that for troubleshooting everything from motor controls to data communications equipment, the Fluke 8060A is the best multimeter value going.

Find out more by calling our toll-free hotline **1-800-227-3800, ext. 229**, day or night. Outside the U.S. call 1-402-496-1350, ext. 229.

FROM THE WORLD LEADER  
IN DIGITAL MULTIMETERS.



© 1986 Fluke

RADIO-ELECTRONICS

42 CIRCLE 121 ON FREE INFORMATION CARD

## NEW PRODUCTS

continued from page 37

whether the phone is in use without lifting the receiver. It also functions as a simple-phone circuit tester. You can trace problems, such as no dial tone or a dead line, to their source—modular jack, phone line, or the telephone unit.

Installation is simple. Using the 2-way T-adaptor and Velcro pads supplied with the *TELE-MATE*, it



CIRCLE 15 ON FREE INFORMATION CARD

can be connected to either the wall jack or to the phone itself.

The device itself is also simple—a small box with a push-button and red indicator light. Each of its functions is achieved by various combinations of pushing the button and observing the light, with the phone either on or off the hook.

*TELE-MATE* has a suggested price of \$14.95.—**B&M Engineering**, P. O. Box 823, 2551 Galena St., Simi Valley, CA 93062.

**ANTISTATIC WRISTWATCH.** The Spiring 35-Watch provides permanent on-hand availability of anti-static protection. The watch and wriststrap are both made of a durable special plastic. The electrical contact to the wearer's skin is made by a stainless-steel inlay within the wriststrap to guarantee 100%-reliable contact.



CIRCLE 16 ON FREE INFORMATION CARD

The watch can be entirely washed with a detergent to remove any traces of grease or other contaminants that could interfere with contact. The coiled cord is connected to the wriststrap by a detachable snap contact with a 1-megohm resistor incorporated within the mold.

The 35-Watch is available as a gent's and a lady's model; the price, which includes the coiled cord, is \$59.50.—**Solder Absorbing**

continued on page 96

Get A Complete Course In

## ELECTRONIC ENGINEERING

8 volumes, over 2000 pages, including all necessary math and physics. 29 examinations to help you gauge your personal progress. A truly great learning experience.

Prepare now to take advantage of the growing demand for people able to work at the engineering level.

Ask for our brochure giving complete details of content. Use your free information card number, or write us directly. **\$99.95**, Postage Included. Satisfaction guaranteed or money refunded.



**Banner  
Technical  
Books, Inc.**

1203 Grant Ave.  
Rockford, IL 61103

CIRCLE 183 ON FREE INFORMATION CARD

IMAGINE TRAVELING FASTER THAN 300 miles per hour in a train levitating above its tracks on a magnetic field. Imagine transistors operating more than 20 times faster than those of today, yet consuming only one twentieth the power. Imagine an energy-storage device so efficient that you could travel from coast to coast in an electric car—on a single charge.

the integrated circuit, or the laser. The interest and excitement it has generated in scientific circles is extraordinary. And the speed at which new discoveries are being made has fired the imagination of the general public as well.

Even high-school students have succeeded in producing superconducting materials and have demon-

Kamerlingh Onnes. He found that when mercury is cooled to a temperature of 4 Kelvin (that's 4 degrees above absolute zero, or  $-460^{\circ}\text{F}$ ), it loses all of its resistance to the flow of electricity and becomes a perfect electrical conductor.

For 75 years, research into the phenomenon of superconductivity yielded more than one thousand su-

## SUPERCONDUCTIVITY



## BREAKTHROUGHS

*A true revolution in physics has only just begun.*

BRIAN C. FENTON, MANAGING EDITOR\*

All those dreams won't be fulfilled this year, but thanks to the breakthroughs that have occurred in superconductivity research, they look a lot more probable than they did only a year ago.

The discovery of high-temperature superconductivity in a new class of materials is the most important scientific development in the last fifty years, perhaps even more important than the invention of the transistor,

strated the superconducting properties in magnetic levitation experiments such as that shown in Fig. 1. (You can experiment with superconducting materials too! See Don Lancaster's "Hardware Hacker" elsewhere in this issue for more details on the subject.)

### A change of pace

Superconductivity was first discovered in 1911 by Dutch physicist

perconductive substances. The maximum temperature at which a substance becomes superconductive—the *critical temperature* or  $T_C$ —did increase linearly with time as new superconductors were discovered. But, although the increase was steady, it was at a very slow pace. As late as April 1986, the record for the highest critical temperature belonged to Niobium-Germanium ( $\text{Nb}_3\text{Ge}$ ), a substance that was discovered to have a  $T_C$  of 23 Kelvin sometime in 1973.

\*We would like to thank Gerald Present, Ph.D., Senior Communications Specialist for IBM Corporation for his contributions to this article.



FIG. 1—A SUPERCONDUCTOR FLOATS IN air above a magnet. This experiment, which has come to symbolize the breakthroughs in superconductivity, demonstrates Meissner's effect, whereby magnetic flux does not enter a superconductive material. In effect, the superconductor looks like a "magnetic mirror."



FIG. 2—J. GEORG BEDNORZ AND K. ALEX MUELLER at IBM's Zurich Research Laboratory provided the spark that ignited the excitement of the world scientific community by their discovery of high-temperature superconductivity in a class of oxide materials.

rials exhibits superconductivity at temperatures much higher than anyone had ever seen.

The discovery, by K. Alex Mueller and J. Georg Bednorz, who are shown in Fig. 2, has kicked off a flurry of scientific activity around the world. The critical temperature has jumped sharply and, as shown in Fig. 3, dramatic increases in  $T_C$  have been coming at an astounding pace. Headlines in the popular press have proclaimed that superconductivity at room temperatures is not only possible, but around the corner!

Only time will tell whether we will ever reach that milestone. But at this time we have already passed an important point along the way: the liquid nitrogen barrier.

Finding a material that superconducts above the boiling point of liquid nitrogen (77 K) is so important because liquid nitrogen is so cheap—a fraction of the cost of the liquid helium that must be used when working with the lower-temperature superconducting materials. Superconductor applications will no longer be limited to such areas as high-energy physics research and oil exploration where the expense and inconvenience of cooling by liquid helium can be justified. Many common electrical applications could benefit, including electric-power generation, transmission, and storage; high-speed rail transport, computers; and electronic instruments as well.

### Superconducting materials

Before the recent discoveries, *intermetallic* compounds (such as niobium-tin, niobium-germanium, etc.) were the best superconductors. But Mueller and Bednorz had become convinced that no further progress would occur in raising the critical temperatures of such compounds. Their insight led them to metallic oxides. The Zurich researchers were very familiar with those oxides and believed they were candidates for higher-temperature superconductors.

For high superconducting-transition temperatures to occur in a material, either the number of electrons available to carry current must be high or the attractive or coupling forces between the electron pairs responsible for superconductivity must be strong. Even though oxides have fewer available electrons than metals (which generally make good super-

conductors), some metallic oxides were already known to be superconductors, although only at temperatures of up to 13 K. That could only imply, the researchers reasoned, that the materials had particularly strong electron-pairing forces. They thought they could find even stronger pairing forces in oxides of nickel and also copper.

After much work on a number of different systems, they become aware of a class of copper oxides that was reported to behave like a metal in conducting electricity. Those materials had not been studied previously for possible superconductivity, but Mueller and Bednorz believed they were perfect candidates.

In January 1986 they found a strong decrease in electrical resistance when they cooled the material, a ceramic copper oxide containing lanthanum and barium. By April, their best samples showed a transition occurring at 35 K—a very substantial increase over the 23 K reported for niobium-germanium in 1973. They immediately reported their results and the race was on—a new chapter in physics had begun.

The impact of the IBM discovery on the world physics community was astounding—by January 1987 several other research teams had prepared their own versions of the IBM compound and reported similar results and even higher transition temperatures.

Paul C.W. Chu, a leading superconductivity researcher from the University of Houston, found that by pressurizing a superconducting oxide, he could raise the critical temperature to 70 K. He theorized that the pressure helped increase the critical temperature by bringing the layers of copper and oxygen and lanthanum and barium closer together. He found another way to bring the layers closer: He replaced the barium with strontium, which is a similar element but has a "smaller atom." That raised the critical temperature even more. When Chu replaced lanthanum with the element yttrium, the composition of the substance was altered drastically—and the critical temperature shot up to 95 K. He announced his results on January 29, 1987, and started a revolution within a revolution. The liquid-nitrogen barrier had been broken.

By the time of the March, 1987 meeting of the American Physical So-

ciety in New York, thousands of scientists and engineers throughout the world were trying to understand more about the new class of oxide superconductors, to find variations that had still higher transition temperatures, and to explore possible applications.

Shortly after that, IBM researchers made the first thin films of the new higher-temperature superconducting material, which led to the development of the first superconducting devices to operate in the liquid-nitrogen range. The device, called a SQUID or Superconducting QUantum Interference Device, is an extremely sensitive magnetic-field detector.

### It's not easy

Despite all the truly fantastic discoveries and developments, there are still problems to overcome. But researchers seem intent on overcoming all of them.

For example, one of the major problems with the new superconductors was their low *critical current*—the current above which a material loses its superconductive properties. But researchers changed things in record time. IBM researchers reported that the materials were inherently capable of carrying 100,000 amperes-per-square-centimeter at liquid-nitrogen temperatures—more than 100 times more current than previously believed. Shortly after, Japan's NTT Ibaragi Telecommunication Laboratory reported producing a superconductor able to conduct 1.8 million amperes-per-square-centimeter!

Being able to *constantly* produce materials with such high critical currents is still a problem. The first isolated single crystals were grown by IBM scientists, who were able to show that the superconducting properties of the materials are stronger in certain special directions of the single-crystal specimens. The current can vary by as much as a factor of 30 depending on its direction in the crystal. That property, called *anisotropy*, might partially explain why typical samples of the new material, which are generally composed of a multitude of tiny crystals oriented in random directions, show low values of critical current.

Another problem with the new superconductive materials is that they are very brittle. It will take much more research to find a way to turn the materials into a type of flexible wire.

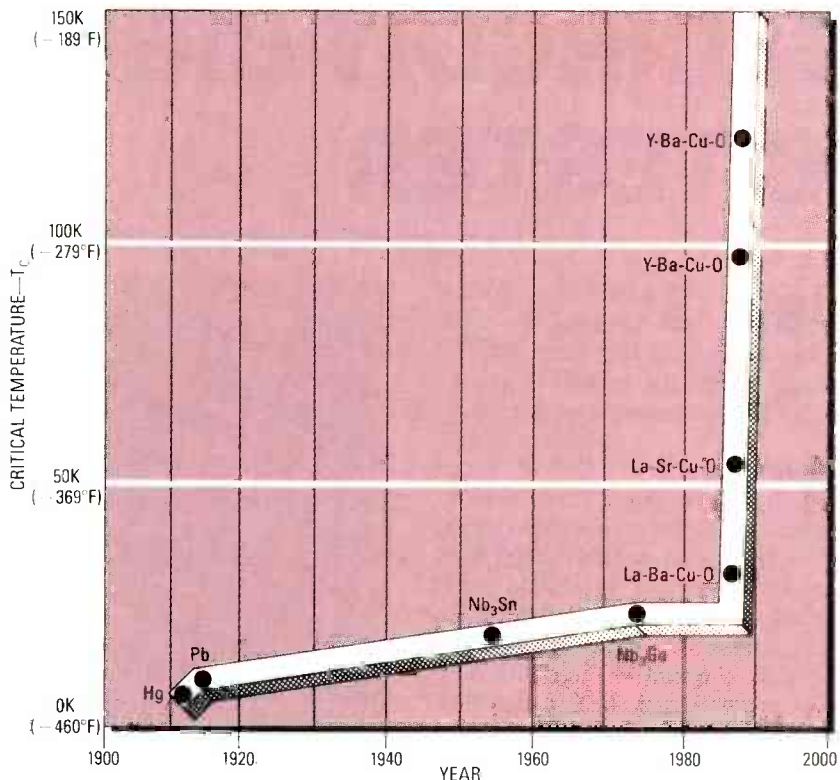

**FIG. 3—AFTER 75 YEARS OF SLOWLY INCREASING** as new superconducting materials were found, critical temperatures jumped dramatically with the discoveries of Mueller and Bednorz. While it's not certain that room-temperature superconductivity will ever be achieved, we're certainly heading in the right direction!

But researchers at AT&T Bell Laboratories are developing coils by filling copper tubing with powdered superconductors. And IBM scientists have shown how plasma spraying, a common industrial technique, can be used to coat even large and complex shapes with superconducting material.

### Applications

The potential applications for high-temperature superconductors are far-reaching. Even if critical temperatures do not increase over what they are today, the new superconductors will change our world.

For example, fusion power could become economically competitive years down the road because the superconducting electromagnets required to contain the fusion reaction will cost much less to produce and maintain than the magnets used in today's test reactors.

The tremendously expensive MRI (Magnetic Resonance Imaging) machines that are currently giving medical doctors detailed internal views of the human body will also become much more affordable because they will be cooled by liquid nitrogen. The images will also become many times

more detailed as the magnets became more powerful.

Supercomputers will become smaller, faster, and therefore will be more powerful.

But just imagine what would happen if room-temperature superconducting materials could be developed. In short, the world as we know it would change dramatically. Trains levitating on a magnetic cushion as they travelled quietly and pollution-free at speeds better than 300 miles per hour would become a reality. Power-generating plants could be located far from population centers, as lossless power transmission would become a reality. Power plants would even become good neighbors as they generated safe, pollution-free power using fusion or magneto-hydropagnetic technology.

Tremendous progress in superconductivity has been made in a very short time. And you can be sure that there are many other applications of superconductors yet to be discovered. Until 1986, it was generally believed that room-temperature superconductivity would never occur. Now we're asking not *if* that event will happen, but *when*.

R-E

# IN-CIRCUIT DIGITAL IC TESTER

BILL GREEN

Three BASIC listings, some corrections, and more!

**Part 3** DUE TO SPACE LIMITATIONS, we were unable to publish the three BASIC listings mentioned in Part 2 of this series. Those are shown on this page.

## Corrections

We have a couple of corrections to the first part of the article (November, 1987). First of all, the end of the third paragraph on page 48 should read, "When installing the test clip on the cable, orient the clip so that the connector on the end of the cable connects to the side of the test clip with pin 1 on it. When using a clip with less than twenty-four pins, align the connectors so that the pins on the right end of the clip—the end furthest from pin 1—are even with the right end of the connectors."

Second, on page 48 the next to last paragraph should read, "For example, ERROR PN01 GRP 1 EXP/RD 0100 would indicate a problem with pin 1 in test group 1: a "1" was expected where a "0" was read.

## New kit

Alpha Electronics (P.O. Box 1005, Merritt Island, FL 32952-1005, 305-453-3534) has decided to offer a minimum parts kit for the IC Tester. It includes the PC boards, the non-volatile RAM with code, and the three custom IC's—75498, 75499, and 75500. The cost is \$140.00, postpaid in the U.S.; FL residents must add appropriate sales tax. R-E

## LISTING 3

```

000 'THIS PROGRAM (ENTERTST.BAS)
015 'ALLOWS GENERATION OF TEST FILES
020 'ON AN EXTERNAL COMPUTER
025 'FOR TRANSFER TO THE IC TESTER.
030 'by ALPHA Electronics Corporation,
035 'PO Box 1005, Merritt Island, FL. 32952
100 CLS
105 PRINT"ENTER INFORMATION AS PROMPTED FOR GENERATING 'part number.FIL'"
110 DIM AS(256):DIM TFS(8):GRP=1
120 FOR X=1 TO 256:AS(X)="00":NEXT:PRINT 'initialize array to 0
130 PRINT"PART NUMBER MUST BE HEX (0-9, A-F), 8 DIGITS MAX."
140 INPUT"ENTER PART NUMBER ";TFS
150 IF TFS="" OR LEN(TFS)>8 THEN 140
160 IF LEN(TFS)<8 THEN TFS=TFS+"0":GOTO 160 'stretch to 8 digits
170 PRINT"NUMBER OF PINS MUST BE EVEN NUMBER(S) FROM 4 TO 24"
180 INPUT"ENTER NUMBER OF PINS ";NPS
190 IF NPS="" THEN 180:IF LEN(NPS)>2 THEN 180
200 IF LEN(NPS)<2 THEN NPS="0"+NPS 'stretch to 2 digits
210 NP=VAL(NPS):OFFSET=(24-NP)/2 'offset when less than 24 pins
220 IF NP<4 OR NP>24 THEN 180
230 NP=NP-2:IF NP=0 THEN 250
240 IF NP=-1 THEN 180 ELSE 230
250 NP=VAL(NPS):X=OFFSET+1
260 PRINT"ENTERING DATA FOR GROUP ";GRP:PN=1
270 PRINT"FUNCTION MUST BE I,O,D OR X"
280 PRINT"ENTER FUNCTION OF PIN ";PN;:INPUT:PFS:PRINT
290 IF PFS="I" THEN AS(X)="02":GOTO 340
300 IF PFS="O" THEN AS(X)="01":GOTO 340
310 IF PFS="D" THEN AS(X)="03":GOTO 340
320 IF PFS="X" THEN AS(X)="F0":PDS="00":GOTO 350
330 GOTO 270
340 PRINT"ENTER HEX DATA FOR PIN ";PN;:INPUT:PDS:PRINT
350 AS(X+24)=PDS
360 X=X+1:PN=PN+1:IF PN<NP+1 GOTO 280
370 GRP=GRP+1:IF GRP=6 THEN 420
380 INPUT"DO YOU WISH TO ENTER ANOTHER GROUP (Y/N) ";QS
390 IF QS="N" OR QS="n" THEN 420
400 IF QS="Y" OR QS="y" THEN 410 ELSE 380
410 X=(OFFSET+1)+((GRP-1)*48):CLS:GOTO 260
420 CLS:PRINT"TEST DATA FOR ";TFS;" HAS BEEN ENTERED. ";
425 PRINT"CREATING FILE ";TFS+".FIL"
430 FOR N=1 TO 8:TFS(N)=MID$(TFS,N,1):NEXT
440 FOR N=1 TO 8:PARTS=PARTS+"0"+TFS(N):NEXT 'stretch to 16 ASCII digits
450 PINS$="0"+LEFT$(NPS,1)+"0"+RIGHT$(NPS,1) 'stretch to 4 ASCII digits
460 OPEN TFS+".FIL" AS 1 LEN=512
470 FIELD 1, 480 AS BS,16 AS BPARTS,4 AS BPINS,12 AS BFILLS
480 CS=""
490 FOR X=1 TO 240
500 CS=CS+AS(X)
510 NEXT
520 LSET BS=CS
530 LSET BPARTS=PARTS
540 LSET BPINS=PINS$
550 LSET BFILLS="000000000000" 'stretch to 512 bytes
560 PUT 1
570 CLOSE

```

## LISTING 1

```

010 'THIS PROGRAM (SENDTEST.BAS)
015 'SENDS TEST FILES TO THE IC TESTER
020 'by ALPHA Electronics Corporation,
025 'PO Box 1005, Merritt Island, FL. 32952
100 INPUT"ENTER NAME OF TEST FILE TO SEND ";TFS
110 IF LEN(TFS)<8 THEN TFS=TFS+"0":GOTO 110
120 PRINT"SENDING ";TFS;" TO COM1"
130 OPEN TFS+".FIL" AS 1 LEN=1
140 FIELD 1, 1 AS BS
150 OPEN "COM1:1200,N,8,2,CS3000,BIN" AS 2 LEN=1
160 FIELD 2, 1 AS CS
170 FOR X=1 TO 512
180 GET 1,X
190 LSET CS=BS
200 PUT 2,1
210 NEXT X
220 CLOSE

```

## LISTING 2

```

010 'THIS PROGRAM (RECVTST.BAS) RECEIVES
015 'TEST FILES FROM THE IC TESTER
020 'by ALPHA Electronics Corporation,
025 'PO Box 1005, Merritt Island FL. 32952
100 INPUT"ENTER NAME OF TEST FILE TO RECEIVE ";TFS
110 IF LEN(TFS)<8 THEN TFS=TFS+"0":GOTO 110
120 PRINT"RECEIVING ";TFS;" FROM COM1"
130 OPEN TFS+".FIL" AS 1 LEN=1
140 FIELD 1, 1 AS BS
150 OPEN "COM1:1200,N,8,2,CS3000,BIN" AS 2 LEN=1
160 FIELD 2, 1 AS CS
170 FOR X=1 TO 512
180 GET 2,1
190 LSET BS=CS
200 PUT 1,X
210 NEXT X
220 CLOSE

```



# BUILD THIS

## Radio- Electronics

# ADVANCED CONTROL SYSTEM

THIS IS THE FIRST IN A SERIES OF ARTICLES IN WHICH WE WILL introduce REACTS, the *Radio-Electronics Advanced Control System*. Over the next few months, we will build a control/robotics computer called the REACTS 7000, which is based upon the DataBlocks, Inc. *Altair II* system, a complete line of modular control elements currently available for personal and industrial-control computers. We'll also build all the peripherals the computer will need in order to perform a wide variety of control functions. In addition, we will show you how to use your computer in *real* applications.

### Control computers

Control computers differ from conventional computers in several important ways. One of those differences, the ability to easily interface with a huge variety of external devices, gives the control computer the potential, over the next few years, to revolutionize our lives in more ways than anything yet produced by mankind.

In a typical home, there are applications for dozens of control computers. Some simple applications include controlling appliances; adjusting the heating, air conditioning, and/or humidity; minimizing power consumption; and ultimately running a robot lawnmower or vacuum cleaner so you won't have to.

REACTS 7000 is designed to be completely modular, with each module containing the circuitry to perform one or more complete functions. It also uses conventional programming languages (BASIC, C, assembly, etc.). Each subunit or module in the computer plugs into every other module. For example, the first module we will build is the central processor/computer module. That module is a complete stand alone system that includes its own memory, serial port, disk, vectored interrupt, real-time clock, system clock, memory-expansion hardware and all neces-

*A complete, sophisticated control computer that is capable of operating almost every appliance or system in your home, and more!*

H. EDWARD ROBERTS, M.D.



sary buffers. In other words, it is a complete personal computer. Following that, we will build modules that contain semiconductor disk systems along with integral PROM programmers, complete CRT terminals, A/D converter modules, stepping-motor modules, etc.

The goal of this series of articles is to make *you* the system designer. You do the designing by simply selecting what modules you need for your application. Those modules are then stacked together in any order to create a custom control computer for any application. You need only to pick a language and write the program. Surprisingly, most control applications require simple programs.

Central to REACTS is the soft-hardware concept. Soft-hardware is simply hardware that can be changed or altered as easily as software. The author first developed the concept at MITS while designing the Altair computer, but only recently has it been possible to exploit it in a practical way. Over the next few months you will see how we achieve soft-hardware using straightforward, well-established principles. Indeed, the main requirement for soft-hardware is to make sure that each module's operation doesn't interfere with the operation of any other module. Additionally, each module must be self-sufficient mechanically and electrically. Further, each module should provide shielding to meet FCC requirements, and each module must provide its own motherboard.

### CPU module

The REACTS CPU module consists of a microprocessor, 64K static RAM, 32K EPROM disk system, serial I/O port, vectored interrupt system, completely buffered bus drivers, crystal-controlled clock, 1-megabyte memory-expansion subsystem, and internal sense switches. If you aren't familiar with any of those terms, don't give up! Stick with us as we are going to discuss each item individually and will explore the engineering philosophy used in each decision.

Cost and reliability are important considerations with any computer system, but to a large extent they determine where and when it is practical to use a control computer. For instance, it is not practical to use a \$20,000 dedicated computer to provide security and environmental

### Sources

The following items are available from DataBlocks, Inc., 579 Snowhill Road, Glenwood, GA 30428. Or call (800) 652-1336; in Georgia call (912) 568-7101: DP-CPU—design package of schematics and instructions, \$10.00; PC-CPU—PC board for CPU module (includes DP-CPU design package, \$37.00; PC-CLK—PC Board for clock, \$18.00; SYS-PROM—the REACTS operating system (enhanced SB-80) installed on a 32K UV-erasable PROM (includes operating system documentation), \$44.00; REC-CPU—complete kit of parts, PC boards, IC's, connectors, for CPU module (does not include clock or system PROM), \$147.00; REC-CLK—complete clock subsystem including all parts, PC boards, NiCd battery, and connectors, \$43.00; and REC-SYS—All of the above, \$218.00. An Elpac power supply is also available for \$49.00. Please add \$10.00 postage and handling per order. GA residents must add appropriate sales tax.

control for your \$100,000 home. On the other hand, if the same job could be done by a computer system that sold for \$5, nobody could afford to be without one. Similarly, a system that would automatically drive your car to work but was only 99.5% reliable would not be very interesting.

Our goal is to design a machine that is affordably priced and as close as possible to being 100% reliable. That is accomplished by eliminating mechanical subsystems and using special connectors. Cost is controlled, to a large extent, by the soft-hardware concept; you only include what is required for the particular application.

There are some problems along the way with developing an "ultimate" control computer. First, most of us don't have a \$250,000 microprocessor-development lab. We have to be able to develop the hardware and software we need on the target system (a target system is the final product of a development project). But, that requires the development of both hardware and software that may only be needed for development and then scrapped when finished.

Fortunately, the soft-hardware approach allows us to use our target system as the development system. We do that by including the develop-

ment modules (CRT controllers, PROM burners, etc.) during the development stage and then removing the unneeded development modules when finally we install the target system. That approach is especially economical for those who will build multiple systems.

Most board-level computers are designed to work with custom software because that is the easiest to implement. The approach we will take is to use a disk operating system even on the most minimal system. That allows us to use a disk-operating system with all its inherent power. There are a number of disk operating systems from which to choose, but a CP/M-like system is familiar to both MS-DOS users as well as CP/M users. For that reason, we are using the DataBlocks disk-operating system which is a superset of CP/M; indeed, all standard CP/M software will be compatible with our system.

Included in the operating system are all the utilities needed for development, such as drivers for the PROM programmer, drivers for printers, debug routines, etc. Those special utilities can be left out of the final target system if desired, to minimize system size and cost.

### Design principles

The following discussion will give you an idea of the design concepts used in engineering REACTS. It will also give you a feel for the tradeoffs made in the design of the system.

The microprocessor used in the CPU module is a version of the Z-80. That is probably the most popular and widely used microprocessor ever made. It has become the standard in the control industry, and more personal computers have been built using it than any other microprocessor. It isn't the fastest of the microprocessors—indeed some of the newer high-performance microprocessor systems will out-perform it by a factor of 20 to 1. But of the modern microprocessors it is the easiest to understand, and it does not have any unpredictable or "funny" interfacing quirks. That is especially important to the non-expert designer. As we proceed, you will see how we get around the processor-speed problem by using the principle of distributed processing; that is the use of multiple processors in a single system. The multiprocessor concept is based on the assumption that com-

puters are free. It turns out that the principle is reasonably valid in practice, since the CMOS Z-80 is less expensive than a number of other IC's in REACTS. We will also use a number of other techniques that will greatly expand the power and capability of the system.

### REACTS CPU

To get an idea of how fast the REACTS CPU module is in terms of control functions, let's look at a simple example. Assume we needed to turn on or off 2000 switches in a pre-defined manner. The high-speed version of REACTS would be capable of doing that at a rate of 500 times a second, or approximately 1-million switch operations per second.

The microprocessor used is CMOS. Indeed, all components in the module are CMOS. That increases cost, but it makes battery power, either emergency or continuous, easy. In addition, the noise immunity is improved, and less heat is generated so no fans are needed. Further, less-expensive power supplies can be used and the system can be used in relatively confined quarters without the problem of overheating.

The minimum system memory is 64K of static CMOS RAM, but the system will address a total of 1 megabyte. Static RAM adds to the cost of the system, but it does allow for easy battery powering and makes the system more predictable in a multi-processor and/or control environment. The addressing scheme is straightforward with the exception of the expanded memory. The expanded memory is based on a paging scheme that allows the computer to switch pages of memory 32K bytes at a time. We will discuss some specific uses of that memory in future articles. It is interesting to note that the page-switching system allows the system to operate at effective direct-memory-access speeds of 10 gigabytes per second. As a comparison, if we could read a 40 megabyte disk that fast, it would only take 4 milliseconds to read the whole disk!

A conventional RS-232 port is included in the basic CPU module. That port can be used to connect to a terminal, modem, or any other standard RS-232 device. The baud rate and signal characteristics are under software control and can be modified from within the program.

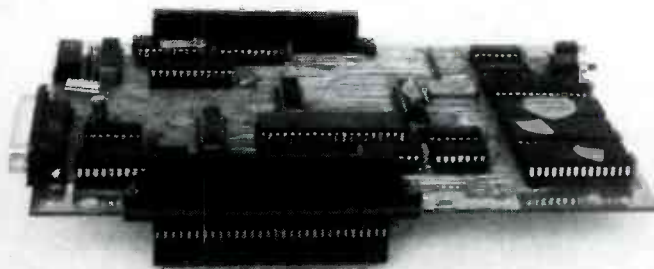

FIG. 1—EACH MODULE'S MOTHERBOARD interfaces to the REACTS system bus via feed-through Molex connectors.

The CPU module supports 9-levels of interrupts: one *Non-Maskable Interrupt*, or NMI, and 8 vectored levels. An interrupt-driven system is especially useful in process control.

There is somewhat of an aura of intimidation associated with interrupts. But actually, they make programming simpler and much faster in many applications. To use an interrupt, you simply pull the line low. That halts the program that is currently running and causes a jump to a special subprogram in memory; its much like a GOSUB command in BASIC. The computer executes the interrupt program and then returns to the original program. Interrupts provide two advantages to the system designer. The first is that the interrupting device can be serviced at random; that is, the program doesn't have to keep checking to see if a service is needed. Second, the interrupt can be serviced instantly; it doesn't have to wait for the main program. Vectoring simply means that the interrupts have levels of priority and that a high-priority interrupt can interrupt a lower priority one. Indeed, it is possible to have a number of interrupts waiting for service in a busy system. In later articles, we will see some detailed examples of practical uses of the interrupt system.

The basic CPU module includes sense switches. Those are simply switches that can be set and read by the program. They are actually a "poor man's" keyboard. An example of where they are useful is in the development vs. target system. In those systems, the computer checks to see the setting of the sense switch on power up, and from that determines

whether it should look for a terminal or start executing a program. In a real target system, the sense switches would be used to select which program is loaded at auto start-up.

### REACTS disk

In order to meet our design criteria, even the most minimum system will contain a disk. That is achieved in our system by using a UV-erasable PROM disk. That disk is seen as a disk by both the external hardware and software. It has all the attributes of a write-protected magnetic disk, save one: it operates at blinding speeds. In later articles, we will build larger semiconductor disk systems as well as a PROM programmer that allows you to burn your own PROM disk system for the computer.

REACTS makes extensive use of RAM and PROM disks. Semiconductor disks are significantly more reliable than conventional magnetic disk drives since there are no moving parts. They also consume much less power and are smaller. If large amounts of data need to be stored, then a magnetic disk becomes more attractive. In later articles, we will build a miniature floppy disk that's appropriate for mass storage and that will be compatible with our system. The overwhelming advantage of the semiconductor disk is speed.

The random-access time of a modern high-speed hard-disk system is approximately 25 milliseconds. The random-access time of our disk is approximately 10 microseconds, or approximately 2500 times faster. That is one of the reasons why our system is capable of outperforming some of the bigger and more expensive pro-

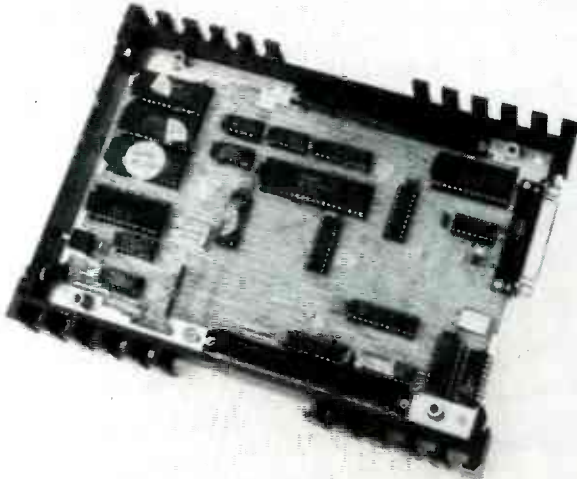
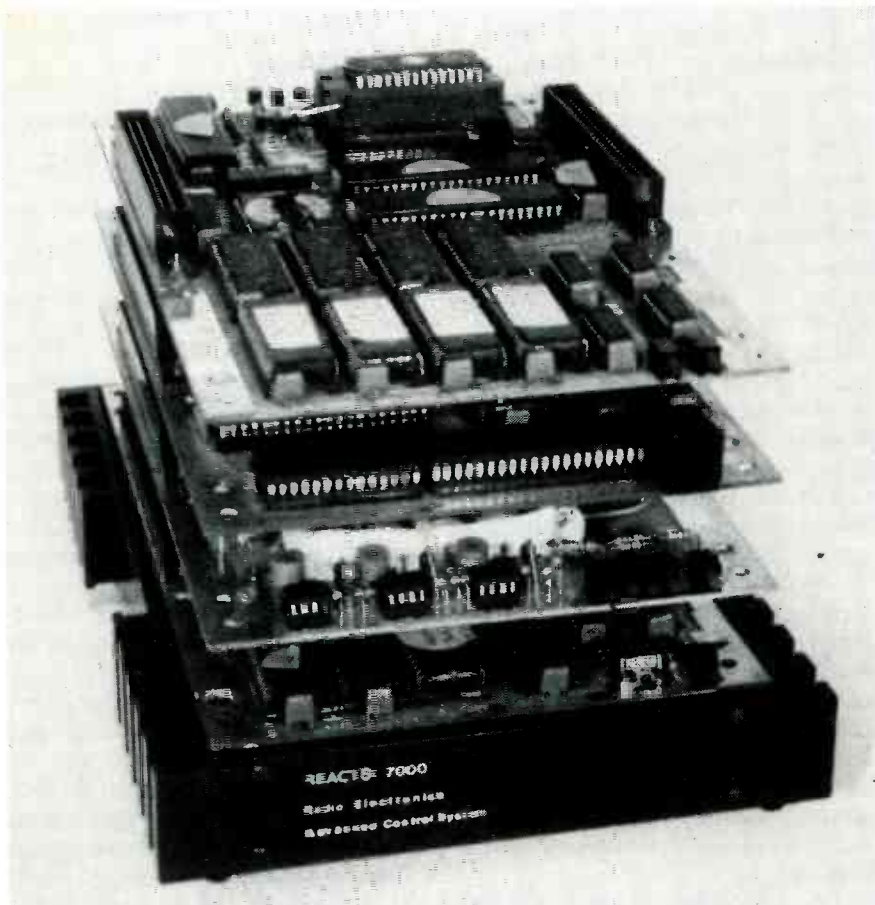

FIG. 2—THE EXTRUDED ALUMINUM CASE is designed to comply with FCC shielding requirements.



THE REACTS 7000 control/robotics computer system consists of series of stackable modules. Here, a four-module system consisting of the CPU, a power supply, a CRT/prINTER interface and a PROM programmer is shown. The modules are shown out of their shielded cases.

connecting the processor from the bus. That is a necessary condition in multiprocessor schemes. Buffers are not the most exciting topic, but their proper use is critical in a multi-processor, soft-hardware system so they will be addressed as we proceed.

The standard module card is 8 inches by 5.3 inches and connects to the 120-line system bus using special feed-through Molex connectors. See Fig. 1. Those two connectors allow the modules to be stacked together in any order. The bus that we are using is the Altair-II bus developed by DataBlocks. Our system is designed to be fully compatible with all the existing DataBlocks modules and software. At the present time, there are literally dozens of different modules available that use the DataBlocks Altair-II bus.

### REACTS case

Each module can be provided with its own shielded case that meets FCC standards. If you desire, you can mount the finished, unenclosed assembly inside a conductive case, which also meets FCC requirements. Figure 2 shows a module in its extruded aluminum case; note that the rear panel has been removed for clarity. While that case is unique to REACTS, it is compatible with the standard Altair-II system or equivalents.

A word about FCC standards is appropriate at this time. Each builder is responsible to make sure he meets the FCC requirements. All modules in this series of articles are tested to the most stringent FCC requirements using self-contained cases. Nevertheless, it is your responsibility to verify that your system doesn't interfere with any other service.

The real-time clock is plugged into the CPU-module board. That is done to keep cost at a minimum; the clock need only be installed if an application requires it. An on-board NiCd battery is used to provide backup power for the clock. The clock provides time, date, month, year, and can be used to generate interrupts to the main system. We will make extensive use of the clock in some of our future articles.

That's all we have room for this time. When we next meet we continue our look at REACTS and show you how to build the first of our modules, the CPU. R-E

processors. Finally, semiconductor disk systems are much easier to understand and much easier to use when designing custom software.

In order to maintain the soft-hard-

ware concept, the REACTS bus is driven by CMOS drivers. No more than 1 or 2 CMOS loads are ever placed on the bus by any one module. That buffer system also allows for dis-



**CARL LARON,**  
ASSOCIATE EDITOR

## Making your own PC Boards

*This month we debunk some of the myths about making PC boards and show you some shortcuts to success.*

HERE AT RADIO-ELECTRONICS WE GET hundreds if not thousands of questions a year on a variety of electronics topics. One of the most common questions, especially from beginning hobbyists, is about PC boards.

That's really not surprising. If you've never done it before, making a PC board can seem like an enormous job. That's why many builders will only undertake a project where a pre-etched PC board is available.

But if you do that you're missing out on a good deal of the fun of building! What's more, etching a PC board is really simple, once you've learned how and have mastered the techniques that are required.

In this article we are going to debunk some of the myths about etching boards. We'll show you that you don't need a darkroom or a camera to use

the photographic method. We'll explain the difference between the positive and negative etching systems, and how you can use either regardless of whether you start off with positive or negative art. We'll show you how to make simple PC boards by just drawing right on the copper blank. We'll show you how to make a PC board without etching at all. And we'll name suppliers of PC-board supplies for the hobbyist.

We'll even show you how to use our very own PC Service!

### Making PC boards

The final goal of making a PC board is creating a pattern in copper on a phenolic, glass-epoxy, or similar board. The various methods differ only in the technique used to get the pattern onto the board.

There are three basic steps in making a PC board. They are:

- Create the original artwork.
- Transfer the artwork to the PC board
- Etch the board.

For the purposes of this article, we have assumed that you already have a PC pattern (if you need help in creating a pattern from a schematic, see "Etch your own PC Boards, Part I" in the December 1982 issue of **Radio-Electronics**). Your next problem, then, is to transfer the artwork to the PC board.

The most popular way to do that is the *photographic method*. It's named that because it uses photographic techniques to transfer the pattern to the copper. That is, a photographic print is made on a photosensitized copper-clad board. The material used

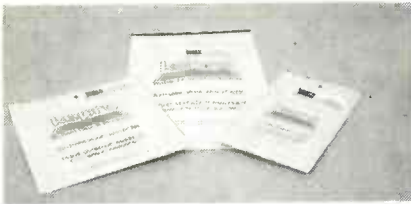

FIG. 1—PRESENSITIZED PC BOARDS conveniently take a step out of the board-making process.



FIG. 2—PHOTORESISTS are available in positive aerosols and negative aerosols and liquids. A negative liquid in a pump bottle from Datak is shown here.

to render the board photosensitive reacts in such a way when exposed to light that part of the copper is removed when placed in an etchant bath, and part is unaffected.

However, the photographic method does not require an elaborate darkroom, a camera, or any extensive photographic skills. Only a working area away from direct light, some trays, an inexpensive *contact frame* (or even just a piece of glass), a strong light source, a few chemicals, and access to running water. You also need the artwork in a form where it can be transferred to the board; that is called a *photomask*. We'll show you how to make a photomask shortly.

Copper blanks come in two varieties: presensitized and unsensitized. Both types have their advantages and disadvantages. Presensitized blanks (see Fig. 1) are easier to use since they take a step out of the PC-board making process. The photosensitizing material, called *photoresist*, has already been applied to the board for you. However, presensitized boards come in only a limited number of sizes and are relatively expensive.

If you use unsensitized blanks, you

must coat them with photoresist (see Fig. 2) prior to transferring the pattern. Applying photoresist to unsensitized blanks is cheaper and gives more flexibility than using presensitized blanks; but the process is tricky to master for beginners and takes time. Apply too much sensitizer and it will run, apply too little and it will disappear during the developing process. And after the sensitizer is applied, the board must be dried either overnight or carefully in an oven.

### Positive or negative

Photoresists come in two varieties—positive and negative. The type of photoresist you use determines whether you are using the *positive* photographic method or the *negative* one.

Photoresist is a plastic resin whose properties change when exposed to light. A negative photoresist toughens when exposed to light; when the exposed board is placed in etchant the copper under the now toughened photoresist is protected while the rest etches away. Therefore, *to create a positive image in copper, the negative method requires that you use a negative image of the foil-pattern artwork.* That's because we want light to reach the copper only at the traces and the pads, and nowhere else.

A positive photoresist breaks down when exposed to light; when placed in the etchant, the copper under the unexposed areas is protected, while the copper under the exposed areas is etched away. Therefore, *to create a positive image in the copper, the positive method requires that you use a positive image of the artwork.* We want to keep light away from the pads and traces.

So which method should you use? It depends on which you prefer, which manufacturers' products you are using, and what form your PC artwork is in. Note, however, that positive photoresist has a limited shelf life; GC Electronics manufactures both positive photoresist and positive presensitized blanks; Vector offers positive blanks only. Negative-method supplies are available from Datak, Kepro Circuit Systems, and GC Electronics.

If you have positive artwork and negative chemicals, all is not lost. *Lithographic reversing film* can be used to convert positive artwork to negative, or vice versa. An added

benefit of reversing film is it is relatively tolerant of "weak" artwork (artwork that is not perfectly opaque); that means it can be used to turn a low-contrast positive into a high contrast negative. Reversing film is available from Datak, GC Electronics, and Kepro.

### Exposing the board

Once the board is sensitized it is *light-sensitive*, so it must be handled away from strong light sources to avoid exposing it prematurely. But you don't need an absolutely light-tight darkroom. In fact, some manufacturers suggest that a 40-watt incandescent lamp, placed a few feet away, makes for an ideal work or *safe-light*. That may not hold true for all sensitizers, so follow the manufacturers' recommendations.

The next step is making a photographic exposure. To do that you need a strong light source. Note that different sensitizers react differently to different types of light. Some for instance, react most strongly to ultraviolet, and therefore you should use a sunlamp for best results. Follow the manufacturer's light instructions when selecting your light source.

**(Caution: Even a short exposure to UV radiation can cause permanent eye damage. Treat sunlamps with respect and never look directly at a lit sunlamp, or any other source of UV radiation.)**

Place the photomask on top of the sensitized copper blank and put the two under a piece of glass or into a



FIG. 3—TO EXPOSE THE BOARD, place the sensitized blank and the photomask in a contact frame and place under a strong light source.



**FIG. 4—AFTER EXPOSING THE BOARD, it must be placed in a tray filled with a developer like the one shown here. After developing, the board is no longer photosensitive and can be handled in normal light.**

contact frame. Place the assembly under your light source and expose them, making a *contact print*. See Fig. 3.

Exposure times will vary greatly depending on the nature of the sensitizer, the photomask, and the light source. Follow manufacturers suggestions, but be prepared to do some experimentation on your first attempts. Don't despair! After you've made your first few boards and have the hang of the materials you are using, you will be able to consistently produce an acceptable board on the first try without any trouble.

While the board is being exposed, prepare a developer bath. The type of tray you use may depend on the system you are following. Do not use plastic if you are using the negative system; do not use metal if you are using the positive system. Glass is fine for either. Be sure that the tray is large enough to accommodate your board and fill it to a depth of 1/2- to 1-inch with a PC-board developer like the one shown in Fig. 4.

When the board is exposed, turn off the light source and remove the blank. Place it copper side up in the developer bath and gently rock the tray back and forth. Follow the manufacturers instructions as to developing time; it will, as usual, vary with the materials you are using.

Once the board is developed, rinse it in cool tap water and stand it vertically to dry. Once the board is completely dry it is ready to etch.

The most common etchant is ferric

chloride. It is non-toxic, effective, economical, and quick. However, its etching speed slows down as more copper is dissolved. That is not usually a problem for hobbyist applications, but it is something you should be aware of if the board you are etching is very large, or the pattern requires that an abnormal amount of copper be removed. Also, ferric chloride stains clothing and material, so avoid spattering and work in old clothing. Another etchant is sodium persulphate. Available from Kepro, that etchant is a dry crystal that must be mixed with water to be used. It is supplied with a catalyst that provides for a constant etching speed.

Another necessity is an etching tray. Be sure that the tray is large enough to accommodate your board and is made of plastic, glass, or Pyrex, *not* metal (otherwise your tray will etch away as well).

For best results, the etchant should be slightly heated and agitated during etching. Different manufacturers have different temperature recommendations, but they generally range from 90°F to 125°F. Heating can be done with an aquarium type submersible heater or by placing the etchant on a stove burner or hot plate prior to etching. (Again, use a Pyrex tray or pot for that, *not* metal.) However you heat the etchant, be sure that the ventilation in your work area is adequate.

For small boards, simple hand agitation should be adequate; carefully rock the tray back and forth at regular intervals until etching is complete. But while agitating in that way greatly



**SEVERAL SUPPLIERS OFFER a full line of PC products. Shown here are one company's direct-etch products, presensitized blanks, reversing film, and board-processing chemicals.**

## SUPPLIERS

**Bishop Graphics**  
5388 Sterling Center Drive  
Westlake Village, CA 91359

**The Datak Corporation**  
65 71st Street  
Guttenberg, NJ 07093

**GC Electronics**  
Rockford, IL 61101

**Kepro Circuit Systems**  
630 Axminster Drive  
Fenton, MO 63026-2992

**Vector Electronic Company**  
12460 Gladstone Ave.  
P.O. Box 4336  
Sylmar, CA 91342-0336

speeds the process, a typical board will still take 20-60 minutes to etch. If you do a lot of etching, you may want to invest in an automatic agitator. Available from Datak, GC Electronics, and others, those range from elaborate systems to simple aquarium-type air pumps terminated with a bubbler to break up the air flow. One automatic agitator is shown in Fig. 5.

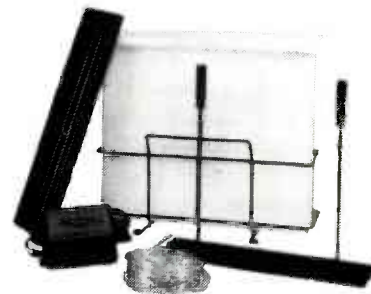

**FIG. 5—TO AVOID TEDIOUS HAND agitation, you may want to use an automatic agitator like the one shown here.**

Now, as to the etching itself: Use sufficient etchant to cover the board completely. Place the heated etchant in the tray (or heat the etchant in the tray with a heater) and then carefully immerse the board, pattern side up. Periodically, remove the board, rinse under tap water, and examine the progress of the etching. Once you are satisfied that all the unwanted copper is removed, rinse the board one last time and remove the resist using steel wool or a chemical solvent such as GC Electronic's *Stripping Solution*.

Finally, examine the board in good light and with a magnifier for shorted or open traces, or other defects. Shorted traces can be repaired by scraping the excess copper away with an *X-acto* or similar hobby knife.

Open or incomplete traces or pads can be fixed by touching up with conductive paints or inks, or even solder; conductive paints and inks are available from GC Electronics and others. Once you are sure you have corrected any problems your board is ready for drilling and then for mounting the components.

### Making the photomask

So far things have been straightforward. That's because we've assumed that you had a photomask in hand. Unfortunately, making a photomask can be the most difficult part in PC-board making.

But, as the old proverb says, there's more than one way to skin a cat and the same is true for making a photomask. Let's next look at some of those methods.

If the design is a very simple one, you might be best off using one of the non-photographic techniques that we'll describe shortly. Otherwise, you need to transfer the design to some type of clear film or translucent medium. One way to do that is to use a camera and photograph the artwork. An excellent description of the steps involved in that appeared in "Etch Your Own PC Boards, Part 2", which was presented in the January 1983 issue of **Radio-Electronics**.

Another method is to create a duplicate artwork master using translucent Mylar film and opaque PC drafting aids. That entails first laying out the pattern on 1/10-inch grid paper. Once the artwork is drawn, a Mylar sheet is taped over it, and the pattern is copied using opaque tape, rubylyth film (for large areas of copper such as ground planes), and other drafting aids. See Fig. 6. The result is a positive photomask. Granted, the technique can be tedious and time consuming, but it is certainly a viable

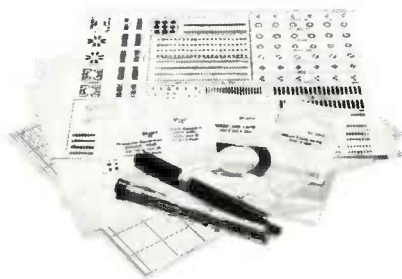

FIG. 6—YOUR ARTWORK can be transferred to a piece of Mylar film using drafting aids like these. The result is a positive photomask.

alternative for those not equipped with a camera or photographic skills. Suitable drafting supplies are available from Bishop Graphics, Datak, GC Electronics, Vector, and Kepro.

However, some of the products now on the market allow you even easier ways to get artwork onto film, even in cases where there is printing on the reverse side of the original. Datak offers a printed circuit kit that uses an interesting two-step *pos-neg* technique to create a photomask from a printed page. In the first step, specially processed high-contrast film is used to make a *reflex* (reflected) contact exposure. That is, the film is sandwiched between the artwork and a color filter, placed under glass or in a contact frame, and exposed to light. Enough light reflects from the printed artwork to create a low-contrast positive in the film. The low-contrast positive is not suitable for use as a photomask, but the Datak film can be processed by the user to make it act like the reversing films we've already discussed. Then, the low-contrast positive can be used to make a conventional contact print on the processed film. The result is a high-contrast *negative*, which can be used to etch a board using the negative method previously described.

Another approach is GC Electronic's *Lift-it* kit. With that system, which is intended for use with printed magazine art, a PC-board image is literally lifted from a page and turned into a photomask. Unfortunately, the magazine page is destroyed in the process. In the system, a sheet of transfer film is applied over the artwork to be copied, sticky side down, and burnished. The sheet is then allowed to soak in warm water for 20 minutes, after which the magazine page is hand-rubbed off and the film is allowed to dry. If everything has gone well, the ink should literally have been lifted off the page onto the film. The sticky side of the film is then covered with Mylar. The result is a positive image of the magazine art.

Another major drawback of the system is that a magazine print often does not contain enough ink to provide satisfactory results. That is, the image produced is not dense enough to use conventional etching techniques. If that is the case, the *Lift-It* image can be used as an intermediate stage and reversing film used to make a high-contrast negative as pre-



FIG. 7—PC ARTWORK CAN BE DRAWN directly on the copper blank using etch-resist pens. Lacquers and drafting aids can be used, too.

viously discussed. Those films, such as GC Electronic's *Reversing Film*, can tolerate a weak image very well and still produce a perfectly opaque negative. Making a contact exposure with the film will yield a usable negative photomask, which can be used to etch a board using the negative photoresist system.

### PC Service

Some publications, such as **Radio-Electronics** and the *ARRL Handbook* provide PC art on a page with no printing on the reverse side. That allows the printed page to be used as a photomask with little or no additional preparation. In **Radio-Electronics** that artwork is provided in the PC Service section; let's see how to use that art to make a PC board.

The first step is to carefully examine all traces, pads, etc. Printing is an inexact science and imperfections often creep in during the process, especially where thin, closely spaced traces are involved. Examine the art under a strong light or on a light table, and clean up any open or incomplete sections with an etch-resist pen or with PC drafting tape and aids. Shorts and bridges can be scraped away using a knife.

What you now have is a PC-board photomask that, although not as transparent as one on film, will serve nearly as well. You can make the page pass even more light by rubbing the blank side lightly with a small amount of mineral oil. Note, however, that mineral oil blocks ultraviolet light somewhat, so do not use it if your sensitizer is sensitive only to that type of light. Also be careful not to get any oil on the front (printing) side of the page; otherwise you will contaminate the board when you expose it and may get unsatisfactory results.

Once the page is dry, you are ready make the board. Place the mask *printing side down* on a sensitized board (PC-Service art is a mirror image of the actual pattern), place in a contact frame or under a piece of glass, and

*continued on page 70*





## HFBC 87: Planning the shortwave bands

*Although HFBC-87 did not achieve its primary objective, decisions taken at the Conference have set the stage for the planning of the shortwave bands.*

STANLEY LEINWOLL

THE SECOND SESSION OF THE WORLD administrative radio conference for the Planning of the High Frequency Broadcasting Service—officially designated HFBC-87—was held in Geneva, Switzerland from February 2 to March 8, 1987 under the auspices of the International Telecommunication Union (ITU), a specialized agency of the United Nations.

655 delegates from 116 countries participated in HFBC-87; its primary objective was to replace the coordination procedures currently being used by shortwave broadcasters with an automated, computer-based planning system under which all countries,

large and small alike, would have to share the available spectrum more-or-less equally.

HFBC-87 was a bitterly fought, highly contentious Conference, which on more than one occasion seemed on the verge of collapse. However, an eleventh-hour compromise postponed making a decision for four years (another major high frequency broadcasting Conference has been proposed for 1992), at which time another donnybrook is likely.

A band-allocation plan for shortwave broadcasting has eluded the world's broadcasters for forty years. Major conferences in 1948 (Mexico

City), 1949-50 (Florence Rapallo), and 1959 (Geneva) were unable to reach an agreement on how to plan shortwave frequency assignments.

### Planning problems

Rational planning of the shortwave spectrum is a formidable task because the tremendous demand for frequencies exceeds the capacity of the bands allocated to high-frequency (shortwave) broadcasting.

There are a number of reasons for that:

- Shortwave-radio signals are propagated via the ionosphere, an electrified region of the earth's upper at-

mosphere. The range of frequencies that will propagate through the ionosphere depends upon many factors, including time of day, season of the year, sunspot activity, and the relative geographical location of the transmitter and the reception zone, to name just a few.

The ionosphere is in a state of virtually constant flux, and it is extremely difficult to predict accurately which frequency band will provide a reliable service from a particular transmitter location to a given reception area. Because even the most sophisticated prediction methods available are not sufficiently accurate, most broadcasters frequently schedule more than one frequency for the same program going to the same target area.

- Jamming is the deliberate transmission of noise or other harmful interference on a frequency in order to hamper or destroy the programs of a broadcaster operating on that frequency. Since the end of World War II the USSR and its satellites have been responsible for most of the jamming observed in the shortwave spectrum.

Using multiple frequencies is one method broadcasters use to counteract the adverse effects of jamming. The rationale is that the more frequencies used to carry a program, the more difficult it will be to jam all the frequencies. During the height of the cold war in the early 1950's, the Voice of America used as many as 33 simultaneous frequencies to carry a single program. That kind of *saturation* technique has proved to be one of the most effective jamming counter-measures ever used.

Jamming, because of its broadband nature, also hampers broadcasts being carried on adjacent frequencies. Therefore, for each frequency being jammed, three are adversely affected—the one being jammed, and those on either side. It is clear under the circumstances that jamming and rational planning of the shortwave bands are not compatible.

- High-frequency broadcasting is used to serve the national interests of more than one hundred countries. It is the most economical method of reaching tens, even hundreds of millions of people throughout the world. The United States, the Soviet Union, and the United Kingdom alone transmit some 5,000 frequency-hours a

day to every continent on earth in virtually every major language.

In addition, many large countries, such as Brazil, Argentina, the People's Republic of China, Mexico, and the Soviet Union, to name only a few, use high-frequency broadcasting to transmit internal, national services.

Because of the versatility of shortwaves, the number of frequency-hours scheduled for shortwave broadcasting since World War II has tripled, and as competition for the limited amount of spectrum grew keener, the standard transmitter power has increased from 50 and 100 kW in the late 1940's to 500 kW used in the 1980's.

Rapidly growing demand for a limited number of frequencies, coupled with the power competition, has resulted in an increasingly chaotic situation in the shortwave broadcasting bands, prompting many countries, particularly the smaller developing countries, to seek remedial measures along several lines.

One is to expand the supply. That is done by re-allocating shortwave frequencies from other services to the broadcasting service. Since the shortwave spectrum is finite (3–30 MHz), such re-allocation is accomplished only after considerable haggling.

In 1979 a major World Administrative Radio Conference (WARC-79) was convened. At that Conference, the U.S. proposed to expand the shortwave broadcasting allocation by approximately 50%, all of which was to come from the fixed (point-to-point) services. The developing countries, on the other hand, wanted another planning conference; it was their position that the developed countries were in control of most of the shortwave broadcasting spectrum, and planning was the only way of distributing the spectrum equitably.

A compromise solution was found, and WARC-79 agreed to a 33% increase in the broadcasting allocation, on the condition that a two-session shortwave broadcasting conference be held.

The new channels allocated to broadcasting were to become officially available in two stages: the bands above 10 MHz in 1989, and the 9-MHz band in 1994. Although the U.S. and 21 other nations protested, there was no expansion of the vital 6- and 7-MHz bands.

Another method of alleviating congestion in the high-frequency bands is to plan them. Countries submit their requirements and frequencies are assigned in an orderly fashion in accordance with agreed-upon technical standards (protection ratio, minimum field strength, required signal-to-noise ratio, etc.). When a maximum number of assignments have been made, the unsatisfied requirements remaining are simply deleted.

It is clear that if you are trying to fit a size-11 foot into a size-7 shoe you aren't going to do it unless you use a very painful technique: you cut off the toes. That is essentially what planning is for a great many users. A scarce resource (frequencies) is rationed through a central planning system that distributes frequencies on an equitable basis.

During such an exercise, the requirements of the largest users are reduced. In 1977, the developing and non-aligned countries called for a "New World Information Order" which demanded that the largest users reduce their frequency usage to give the smaller ones access to the broadcasting spectrum.

### International politics

The First Session of the World Administrative Radio Conference for the Planning of the High Frequency (shortwave) Broadcasting Service, called the WARC-HFBC 84, was bitterly fought over the issue of planning. (For more information on that conference, see "WARC-84" in the November, 1984 issue of **Radio-Electronics**.) It finally reached a complex compromise agreement at the eleventh hour which called for the testing of an extremely involved automated computer planning method.

From 1984 to 1986 the International Frequency Registration Board (IFRB), an organ of the ITU, engaged a team of computer experts to develop a computer algorithm and appropriate software required for the shortwave planning system. The most controversial and complicated aspect of the system concerned cases involving incompatibilities—instances in which two or more broadcasters had a requirement for a program to the same target area at the same time in the same frequency band. Since there was not enough frequencies to satisfy all, the IFRB developed a series of "sus-

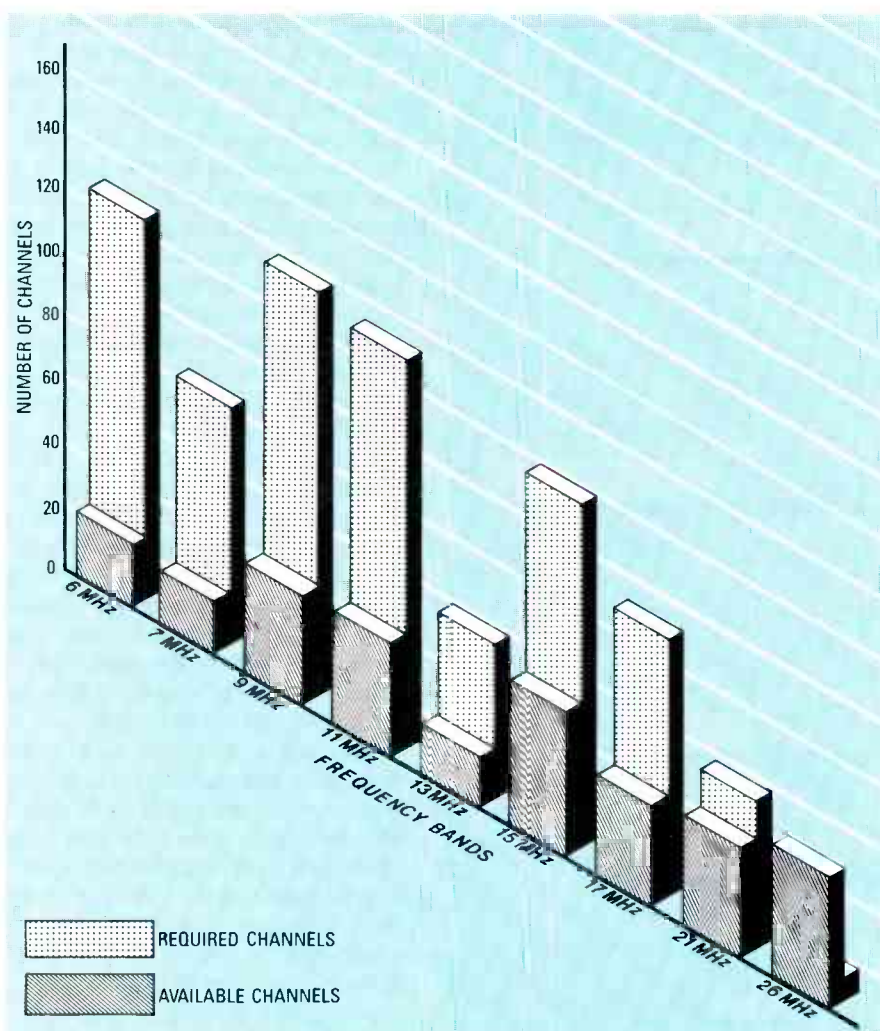

FIG. 1—AVAILABLE CHANNELS vs. channels needed for planning. In the case of 6 MHz, for instance, requirements exceed available channels by a factor of six.

pension” rules, in which certain requirements were deleted, and placed in limbo. It was clear that most of those requirements could never be fit back into the plan. Figure 1 is a comparison of the required number of channels with the number of channels available for planning during a one-hour period (1100-1200 UTC). It is clear that requirements far exceed available frequencies.

By the time HFBC-87 opened on February 2, 1987, it was clear that the planning system developed by the IFRB fell far short of most participants’ expectations. The first complete plans published by the IFRB showed that approximately 30 percent of all requirements were not satisfied (read “suspended”). Furthermore, a primary broadcasting need for frequency continuity was ignored. As an example, it was not unusual for a single continuous ten-hour requirement to be fragmented among seven or eight different frequencies, with fre-

quent half-hour gaps in which no frequency at all was assigned. The system also reduced many one-hour requirements to half an hour.

Clearly, the test plans were a great disappointment to many administrations. In 1984, at the first session, some 85 countries favored some form of automated planning. After seeing the test plans at HFBC-87, only India, Pakistan, and a dozen Arab nations strongly supported implementation of the new system.

Although it was clear that the system developed by the IFRB was not suitable, many Third-World and non-aligned countries remained solidly behind a commitment to planning, and during the first four weeks of the Conference debate centered around methods of improving the planning algorithm. A number of crucial issues emerged during that period:

- If the Conference was to succeed, the suspension rules would have to be eliminated.

- The lack of frequency continuity in the IFRB algorithm was unacceptable to most administrations.

- There was a serious problem involving national vs. international requirements (55 percent of all shortwave frequencies are used for international broadcasting). The users of shortwave frequencies for national broadcasting fought tenaciously for some form of specialized treatment to protect their services.

- The amount of spectrum available for planning the shortwave broadcasting bands was inadequate.

- The existence of harmful interference (jamming) was a detriment to any attempt to plan the shortwave bands.

- Spectrum conservation techniques, such as the use of Single Side Band (SSB), were essential to improve the effectiveness and the efficiency of the shortwave broadcasting bands.

- Another broadcasting conference would be required to again test the feasibility of planning the shortwave bands.

- The coordination procedures currently in effect would have to be greatly improved.

As the Conference entered its fifth week, working nights and on the weekend, it appeared that the Conference would fail. Debate was bitter and contentious, with some administrations putting forth different compromise proposals, none of which attracted much support. So fractious was the atmosphere that the Chairman of the working group charged with determining what, if any, parts of the spectrum would be planned, resigned angrily and its task turned back to the technical committee.

### Compromise

Finally, the Chairman of the Conference offered a compromise that was acceptable. He proposed that the WARC-79 expansion bands be set aside for testing an improved planning system; in addition, 400 kHz from the higher bands were also set aside for planning. That is shown in Fig. 2. The remainder of the spectrum would be coordinated, with an enhanced coordination procedure to be used.

An integral part of the compromise was that the suspension rules would be eliminated entirely, and that the planning algorithm would be rewritten to include frequency continuity.

On March 3, just five days before

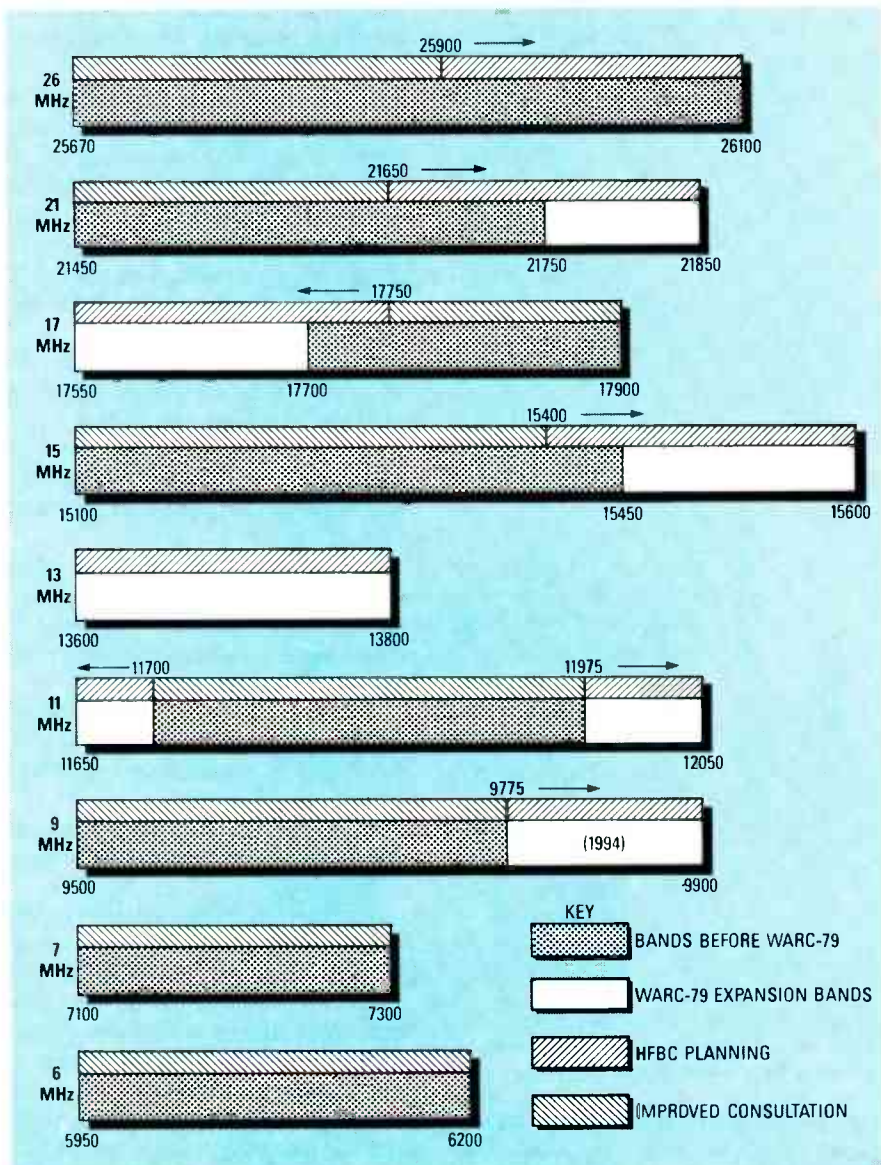

FIG. 2—UNDER THE COMPROMISE agreement adopted at HFBC-87, the WARC-84 expansion bands, plus a total of an additional 400 kHz from the 15-, 17-, 21-, and 26-MHz bands would be planned. The remainder of the spectrum will be coordinated under Article-17 procedures.

the end of the Conference, HFBC-87 moved into continuous session, and on the fourth day a broad action program was accepted.

Under that program, the current coordination procedures will remain in effect until the revised HFBC planning system has been tested and reviewed by a future conference.

Under the current coordination procedure (Article 17 of the Radio Regulations), all broadcasters submit their schedules to the IFRB six months in advance of implementation. The IFRB publishes that information in a book, called the *Tentative Schedule*. Where conflicts arise, it is up to the individual countries to solve them. In some instances, the IFRB

offers recommendations for resolving the conflicts, but acceptance of those recommendations is not mandatory. The new procedure, in contrast, will leave many of the crucial decisions up to the IFRB.

On March 5, the Conference approved the proposal of the Conference Chairman as a compromise. But one final threat developed:

Pakistan and India submitted a proposal to implement the original planning system in the WARC-79 expansion bands that became available in 1989. There was overwhelming opposition to the proposal and another solution was found. The official date of the WARC-79 expansion bands becoming available for broad-

casting was postponed to a date to be decided at a future conference.

That is the first time in history that a conference has agreed to take from itself available spectrum. Inasmuch as the fixed services are required to vacate those bands by 1989, it is apparent that broadcasting in those bands will be on a non-coordinated basis. Many broadcasters have already moved into the bands.

Although the planning controversy dominated the entire HFBC-87, a number of major issues were treated: The Conference:

- renewed the authority of the IFRB to conduct periodic monitoring programs to identify and locate sources of harmful interference (jamming);
- recommended that the ITU's 1989 Plenipotentiary Conference consider scheduling a conference whose agenda would include the possibility of extending the HF spectrum allocated exclusively to broadcasting;
- adopted a set of broad planning principles and technical standards;
- authorized the IFRB to modify its software and conduct another round of tests of a revised planning system;
- requested that the 1989 Plenipotentiary Conference authorize another shortwave broadcast planning conference "not later than 1992".

A major accomplishment of HFBC-87 was the adoption of single- and double-sideband system specifications, as well as a program for the gradual introduction of single-sideband by the year 2016. HFBC-87 approved SSB system specifications, and recommended that any transmitters installed after 1990 be capable of working either on SSB or in both the single- and double-sideband modes.

A number of developing countries expressed concern over the economic consequences of such a transition, particularly concerning the cost of SSB receivers.

Although SSB is an effective frequency conservation technique, its universal acceptance and implementation are far from assured. In addition, the 2016 target date defers for 28 years the benefits that transmission mode affords.

### Give me spectrum, or give me death!

Although HFBC-87 moved closer to the goal of planning the shortwave broadcasting spectrum, many of the

*continued on page 70*

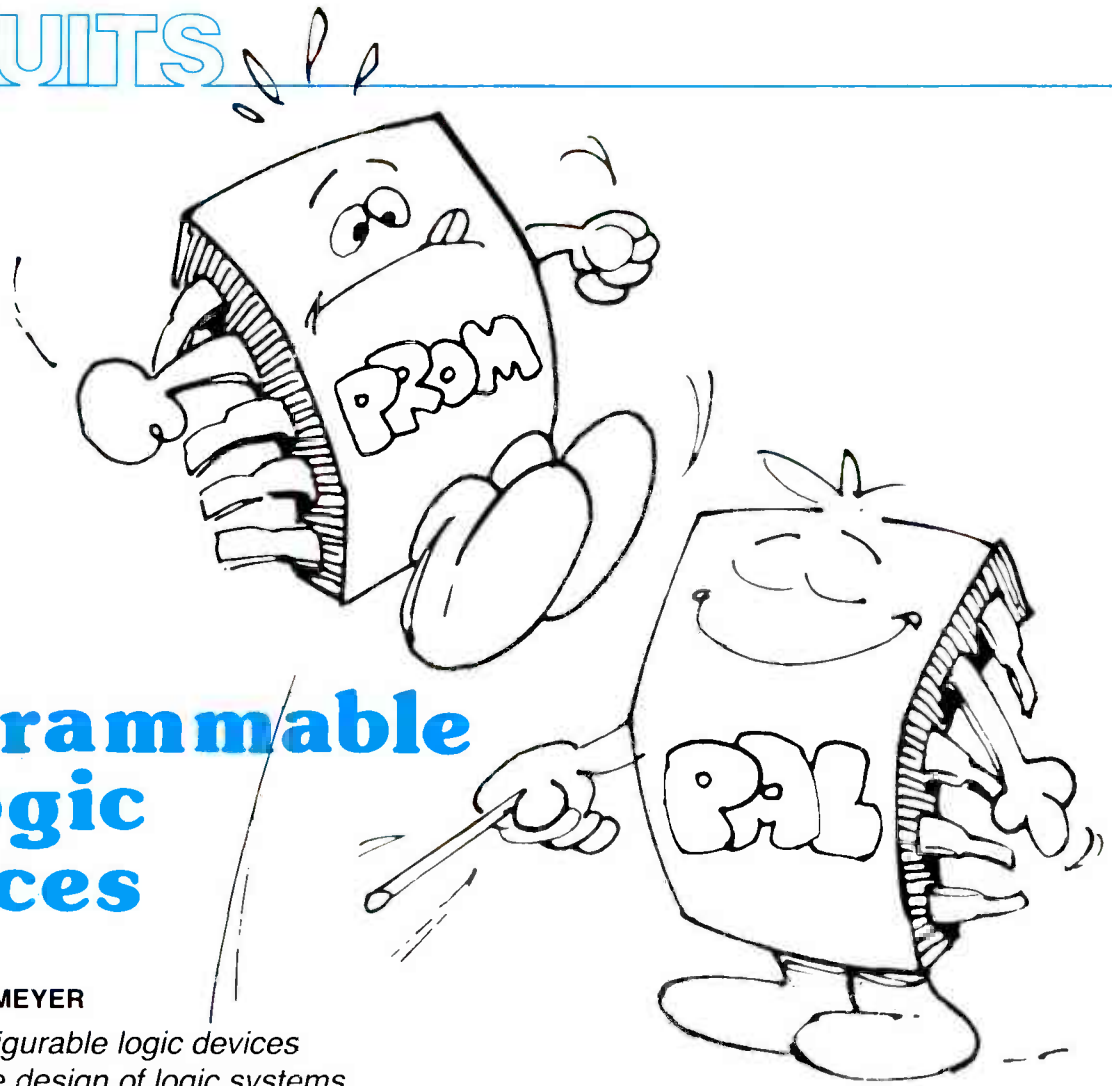

## Programmable Logic Devices

ERNEST MEYER

*The new reconfigurable logic devices revolutionize the design of logic systems*

IF YOUR PROJECT DESIGNS USE 7400-SERIES discrete components for random-logic or state-machine control, you'll probably find that you can simplify both the design and the assembly by merely substituting Programmable Logic Devices (PLD's) for the 7400-series hardware.

Programmable logic devices contain gates and flip-flops, just like regular 7400-series IC's. However, in the 7400 series, which is often considered to be standard parts, the gates and flip-flops are wired together in fixed configurations. On the other hand, PLD's aren't hard-wired; instead, they contain small fuses that are blown or left open to connect their internal gates and flip-flops in any needed configuration.

A PLD's fuses are similar to those used in PROM's (Programmable Read-Only Memories), EPROM's (Erasable PROM's), and EEPROM's (Electrically Erasable PROM's). Usually, the fuse is blown by addressing the location and applying a high-volt-

age pulse (12–30 volts, depending on the device) across the fuse while the IC is in its *programming mode*. Most standard PROM programmers can be used to configure PLD's.

Erasable PLD's (like EPROM's and EEPROM's) can be wiped clean and reprogrammed—although the wiping is actually a way of bypassing the blown fuses. In that way, hobbyists can reuse a single PLD for a variety of projects or applications.

Circuit designers have traditionally used PLD's for logic functions that are not generally available in standard off-the-shelf components. If not for PLD's, a large number of conventional IC's would otherwise be required to perform a relatively simple non-standard logic task.

### A lot for a little

Because they provide the circuit designer with an enormous array of user-programmable fuses, recent PLD designs can substitute for dozens of standard parts. Typically, a PLD can

replace about a half-dozen standard parts, although the exact number of required PLD's depends on the actual circuit. Without PLD's, the increased number of parts increases the size of the circuit board, which in turn lowers the system reliability while increasing the system's cost.

Because a single PLD replaces a variety of standard parts, manufacturers also prefer them to standard parts because inventory is minimized—the number of different IC's which must be stocked is sharply reduced. Also, the integration of discrete parts into a single device puts all the wiring inside an IC rather than on the circuit board, which means that the board's design is simpler and the logic can run faster.

Programmable logic is therefore an excellent choice in systems where board size, board complexity, system reliability, inventory considerations, or speed is important. Even if no single factor is crucial, their combined weight can easily swing the balance

toward a clean and simple PLD design rather than a large composite of standard parts.

Even so, as we will show, some standard parts are so complex they don't fit very well into a programmable logic architecture. To resolve the problem of complexity, there is now under development hybrid PLD's that contain many large standard-logic functions combined with a programmable logic array.

Since the proliferation of different logic architectures will inevitably bring PLD's into common use by both the hobbyist and the professional, we will look at the extraordinary development of complex reconfigurable PLD's, and examine their diverse capabilities.

### Programmable logic technology

To understand how fuse technology works, we must look at the techniques used for fabricating integrated circuits. *Silicon processing*, as it is called, is very complicated; but a quick-and-dirty description will make it a little easier to understand.

To make a silicon-based chip, wafers of silicon crystal are first processed to make transistors. The silicon crystal itself does not really conduct electricity at all. The transistors are created by doping selected regions of the silicon with phosphorus or arsenic, and metal lines deposited on the wafer connect the transistor sites. The transistors and metal lines are called features.

Simply speaking, each feature is formed on the crystal at the selected locations by spraying a light-sensitive protective chemical, called *photoresist*, in a thin, even coating on the wafer's surface. The wafer is then bombarded with light at selected locations through a precise slide projector. The slide projector (called an *optical aligner*) uses a very small slide, called a *mask*, to screen out the light where it isn't wanted. The chemical decays where the light strikes the photoresist-covered wafer, and is simply washed off, leaving bare silicon at selected locations.

The precision of the optical aligner determines how fine a feature can be made. In the early 1970's, it was difficult to make transistors smaller than 10 microns. Now, transistors can be less than a micron in size, meaning the same-size chip can hold more than 100 times as many transistors. More-

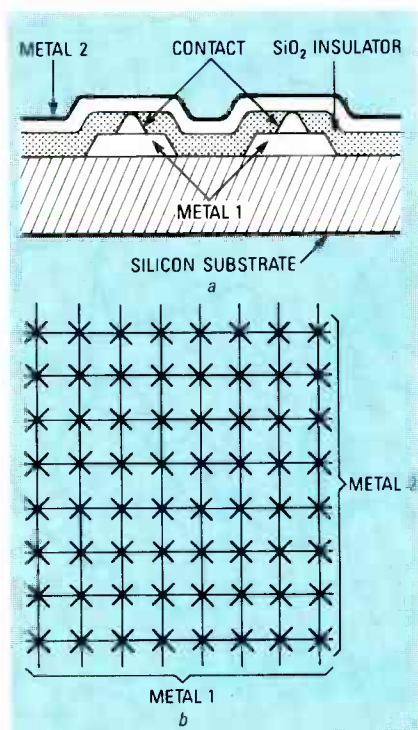

FIG. 1—THE METAL LAYERS on two-level chips are insulated by a layer of SiO<sub>2</sub> (a). The first programmable IC (b) provided 64 cross-points (fuses).

over, as features get smaller, the transistors are packed more densely; hence, the devices can work faster.

The bare silicon can be treated in various ways. For example, the silicon can also be treated to recast the crystalline structure into an amorphous form called *polysilicon*, which conducts electricity and therefore can be used to form wires. Single-level metal chips use polysilicon wires to cross under the metal wires at intersection points. However, polysilicon conducts electricity over a hundred times worse than metal, which substantially degrades performance.

The wafer is heated after the application of each wiring level, which causes the silicon on the surface to oxidize. Since the resultant SiO<sub>2</sub> is more bulky than crystalline silicon, the oxide *blooms* over any raised features (such as previously deposited metal lines) during oxidization. Since SiO<sub>2</sub> does not conduct electricity, it forms an insulating sheet a few microns thick over the entire wafer surface. The oxide can again be selectively etched: Photoresist is again applied to the wafer, selectively etched away again, and the wafer is exposed to chemicals that attack the SiO<sub>2</sub> (but not the pure Silicon) at the chosen feature locations. Further

layers can be grown on top of the resultant *planarized* wafer to form a sandwich-like structure, with SiO<sub>2</sub> as the "bread," and metal or doped silicon as the "meat."

### Several levels

The transistors on the chip are wired together with deposited strips or spots. The various layers are connected by holes (called *contacts*) through the SiO<sub>2</sub> layers. Although up to three levels of metal can be used, the metallization process is expensive, and so IC's are mostly made with two, or even only one, metal level. A cross section of a chip with two-level metal construction is shown in Fig. 1-a.

To make the first fuse-programmable chip, as shown in Fig. 1-b, eight 12-micron wide horizontal lines were deposited in first-level metal over the bare silicon substrate. The wafer was then heated up to cover the metal with the insulating SiO<sub>2</sub>. After applying photoresist, sixty four very small holes (five microns in diameter) were etched into the insulator in eight rows over the first-level metal. The contacts could be much smaller than the first-level metal because they just needed to touch the edge of the metal line to provide a conducting path. (Small contacts were necessary for programmable technology, but such contacts greatly reduced the reliability of the device.)

Next, photoresist was applied again to the wafer, and aluminum was deposited in the holes (or *contacts*). Another eight metal lines were deposited in second-level metal, but those were stacked in the vertical direction, crossing over first-level metal at each contact site. The final product was therefore an 8 × 8 grid having a very small aluminum contact between each metal-1/metal-2 crosspoint.

Although the contacts—called *fuses*—are made as wide as the wires in standard silicon chips, they are narrower than the wires in programmable logic chips. The interconnecting aluminum is burned away (blown) by applying a very large current across the fuse connection. At lower voltage levels, the fuses that have not been burnt away conduct normally. That is why the metal lines were made so wide and the contacts so small—they had to be made larger than the contacts so that the contacts and not the metal lines would burn away.

### Early PLD's

The earliest programmable chip is the one shown in Fig. 1-b; it contained nothing more than a fuse matrix and a wire grid. The crosses represent fuses that can be blown or left open.

The PLD pioneers were quick to stack transistors around the metal grid to make true *programmable devices*. Also, nichrome (nickel-chromium) fuses were used instead of contacts. In that kind of programmable technology, regular contacts are run from the lower metal to the upper metal layer; those contacts miss the actual wire intersection point by 3 microns. A 3-micron strip of nichrome compound is then deposited laterally to connect the contact site to the second-level metal strip. Because of its lower melting point, nichrome fuses out more cleanly than aluminum; in fact, the nichrome actually vaporizes during fuse programming. Therefore, a lower programming voltage is needed, which means that less power needs to be put into the chip. That simplifies programming while making the devices more reliable. Also, the metal lines are not much wider than the fuses themselves, which allows a greater density.

### The PROM

The earliest fuse-programmable device was the PROM. As shown in Fig. 2, PROM input logic (the AND plane) is fixed, while the output logic (the OR plane) is programmable. The upper non-fused fixed-wire matrix feeds a set of AND gates. In the fixed AND array, the output of any one column is high only if all the connected inputs to the column are high. In PROM's, the fixed AND array provides one and only one high output for each possible condition that can exist on the inputs. The non-fused matrix is called a *fixed AND plane*.

The lower matrix is fuse-programmable. Simply speaking, each of the wiring rows feeds into a single enormous OR gate. That description is a simplification, of course, but it is adequate for our purpose.

TABLE 1

IN <sub>1</sub>	IN <sub>0</sub>	OUT <sub>2</sub>	OUT <sub>1</sub>	OUT <sub>0</sub>
0	0	1	0	0
0	1	0	0	1
1	0	0	1	0
1	1	1	0	0

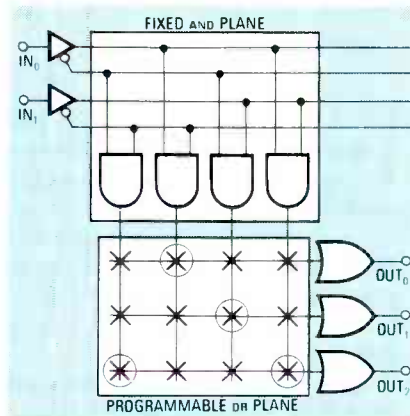

FIG. 2—IN THE EARLIEST FUSE-PROGRAMMABLE device, the AND plane was fixed; only the OR plane was programmed.

The OR gate is set so that the output is high if any connected input to the fuse row is high, a configuration that is called a *programmable or plane*. If the only fuses left connected in Fig. 2 are those indicated by a circled-X, the ones and zeros in Table 1 con-

stitute a truth table for a PROM programmed (blown) with the fuse pattern shown in Fig. 2

Conventionally, PROM's are regarded as programmable memories; however, the devices can obviously be used for logic as well. For example, logic equations can be written for the above device as follows:

$$\begin{aligned} \text{OUT}_0 &= \text{IN}_0 \text{ and NOT-}\text{IN}_1 \\ \text{OUT}_1 &= \text{NOT-}\text{IN}_0 \text{ and } \text{IN}_1 \\ \text{OUT}_2 &= (\text{NOT-}\text{IN}_0 \text{ and NOT-}\text{IN}_1) \text{ or } (\text{IN}_0 \text{ and } \text{IN}_1) \end{aligned}$$

Obviously, OUT<sub>2</sub> is a genuine XOR (exclusive-OR) of IN<sub>0</sub> and IN<sub>1</sub>. That may seem like a very clumsy way of making a simple gate, but by expanding the size of the array very complex logic terms can be created. In particular, that kind of architecture is very good for bus-decoding functions. For example, if an 8-bit-wide bus must be decoded in six different ways to provide six enable signals in a

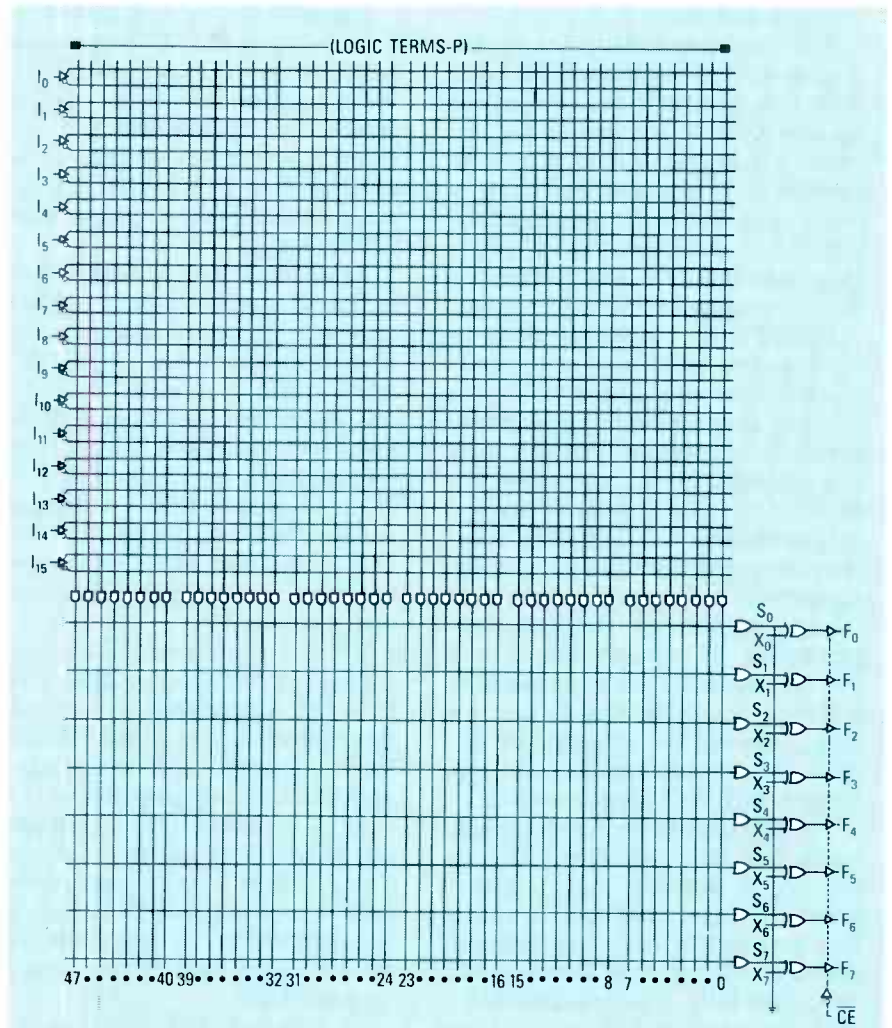
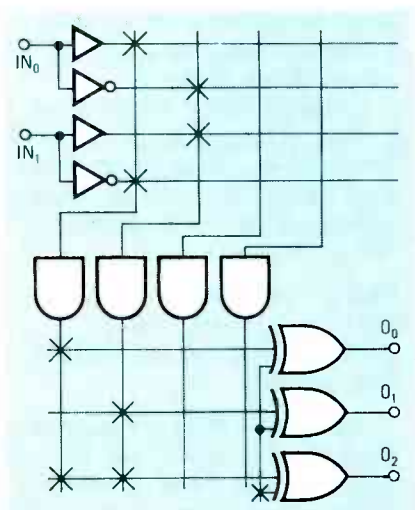

FIG. 3—THE FIRST COMMERCIALY AVAILABLE FPLA was a single-level device having approximately 2,000 fuses.



**FIG. 4—IT'S EASY TO IMPLEMENT COMPLEX logic functions in an FPLA. As shown, the functions previously described for a PROM can also be mapped directly into an FPLA's architecture.**

complex digital system (like a computer), one 16-pin device can replace at least a half-dozen IC's.

Since each possible input combination has a corresponding unique input to the fuse array, the fixed AND array in the above device is termed a *full decoder*. Of course, decoders can be constructed from simple logic gates in many ways, but we have depicted the logic structure in an array fashion to show how the AND gates themselves can be made part of an array structure.

PROM's are useful as memory components. When used as a memory, each input combination (on the left of Table 1) is considered an address. Similarly, the output resulting from any particular input combination (on the right of Table 1) is considered the data at that address. In that way, fuse-programmable ROM's provide the designer with a fast, static, long-term storage medium for fixed-data applications. However, even though PROM's are ideal for fixed memory, and even though they can be used for logic, they are not very efficient because they always contain a full decoder, which isn't always needed.

The full decoder increases the size of the fuse array, which restricts the number of possible input connections. To understand that, consider how two signals have four fully-decoded conditions, and three signals have eight fully-decoded conditions. Since every input is fully decoded in a PROM, each additional input doubles the number of fuses required. In a

PROM, the total fuse-array size is therefore:

$$2^I \times O$$

where  $I$  is the number of inputs and  $O$  is the number of outputs. However, for logic functions, not every input combination is crucial; therefore, a simpler and more compact approach is to make both the OR and the AND planes programmable.

### Exploring PLA's

IBM, using an architecture called PLA (for *Programmable Logic Array*), was the first company to use a device having both programmable OR and programmable AND planes. In the earliest PLA's, the array was metal-programmed rather than fuse-programmed. In other words, the device was customized during the actual chip fabrication rather than by the chip user, and was therefore used only by manufacturers needing a large quantity of chips.

Signetics was the first company to manufacture "Fuse-Programmable Logic Arrays" (FPLA's), which have fuses both in the OR and the AND planes. The first commercially available FPLA, the 82S100 (Fig. 3), was introduced in 1977; it is a single-level metal device having approximately 2,000 fuses.

At the same time, a similar fusing technique was also applied to PROM design, resulting in a rapid movement from 256-bit to 2K-bit PROM's. Also, single-level metal technology was used, with polysilicon for the lower interconnection level and metal for the upper interconnection level. As mentioned earlier, that technique reduces chip cost. In fact, to further reduce chip cost, some vendors now use fuses made of polysilicon rather than nichrome.

Because there is no full binary decoding, each additional input added to an FPLA structure does not double the required number of fuses. Instead, the fuse array is increased in size by an amount directly proportional to the number of vertical channels (which are called *logic terms* or *product terms*). Note, however, that because both non-inverted and inverted signals are provided for each input, there are two inputs into the fuse array for each pin input.

Each product term added to an array allows one additional set of AND products to affect an output con-

dition. Therefore, in the 82S100, there are 48 possible unique AND products that can affect the output. Since the AND-products can be combined together in the OR plane, more than 48 unique input combinations can affect the output. Therefore, three numbers are used when measuring the size of an FPLA: the number of inputs, the number of product terms, and the number of outputs. Those numbers are combined to form the *IPO number*. To calculate the total number of fuses, the number of inputs is doubled (to provide noninverted and inverted inputs to the array), added to the number of outputs, and multiplied by the number of product terms, or:

$$((2 \times I) + O) \times P$$

For the 82S100, the IPO is 16:48:8. The total number of fuses is therefore  $((16 \times 2) + 8) \times 48$ , or 1,920. By contrast, a PROM having 16 inputs and 8 outputs, like the 82S100, would require  $2^{16} \times 8$ , or 52,488 fuses—more than 25 more.

The smaller size of the FPLA architecture yields four advantages to the logic designer: 1) The array size is smaller, which makes the devices less expensive to manufacture and therefore less expensive to sell; 2) The smaller number of fuses makes programming faster; 3) The reduced array size makes the devices quicker to test; 4) The smaller size of the array makes it possible to make larger programmable devices, which increases their usefulness and power.

### Additional features

Architectural enhancements increase the flexibility of the device even farther. The Signetics 82S100 FPLA, for example, adds two additional programmable features to the basic AND/OR plane.

First, the FPLA can be permanently set to give inverted or non-inverted outputs. To achieve the complementary output, the outputs of the programmable OR plane feed into one input of an additional XOR gate. The other input to the XOR gate can be connected to ground. If the grounding fuse is left intact, the XOR gate inverts the output from the OR plane. If the fuse is blown, the input floats high, and the logic signal passes through the gate unaffected. Table 2 shows a truth table for the complementary-output feature.



TABLE 2

Output from array	inverting fuse	Output from IC
0	0	0
1	0	1
0	X	1
1	X	0

The second feature, three-stated output, is not programmable but greatly improves the IC's usability. If many fuses are left intact in the programmable array, the increased loading slows the device's switching speed. Conversely, if there is a product term with only one or two intact fuses, the output switches much more quickly. As array size increases, the difference in switching speed between the least- and most-loaded gates can produce glitches in the IC's output. Erroneous logic states can be avoided by disabling the outputs until all the signals have settled.

**Using an FPLA**

It is easy to implement complex logic functions in an FPLA. For example, the functions previously described for a PROM can also be mapped into an FPLA's architecture. The connections required to do that are shown in Fig. 4.

Four fuse columns were necessary for a PROM, but note from Fig. 4 that the FPLA architecture and complementary output permits only two product terms to be used for the three functions, freeing the other inputs, outputs, and product terms for other logic operations.

**Logic minimization**

In Fig. 4, it is relatively easy to work out the connections to use. However, as logic complexity increases, it becomes more difficult to work out which fuse combinations use the product terms most efficiently. When large numbers of logic signals interact, the product-term columns can be tied to different combinations of inputs, and or-ed together in respectively different ways to generate the same functions. Finding the optimal fuse map through *logic minimization* (the act of reducing logic equations to their most basic form) has two advantages: 1) The danger of running out of product terms is minimized; 2) The number of unblown fuses is minimized, which increases the speed and reliability of the device.

About the time when new software tools were developed to optimize fuse maps, a new development brought about a revolution in programmable-logic philosophy.

**The PAL**

The revolution in programmable logic was the 82S100 PAL (*Programmable Array Logic*). PAL's were marketed by Monolithic Memories as a simple alternative to standard parts—the emphasis being on *simple*. To that end, they supplied an easy-to-use programming language called PAL-ASM, a FORTRAN IV program that translates logic equations into a fuse map suitable for use with a standard PROM programmer. At about the time that PAL's were released into the marketplace, 512 × 4-bit (2048-bit) PROM programmers were also interfaced with IBM computers, making it possible for designers to design, document, and program a simple PAL within minutes.

PALASM accepts six distinct data entries as input. First, the PAL part number is entered so that the program knows what sort of fuse map to make. Second, the pattern number is entered, so that the generated file containing a fuse map can be named. Third, the name of the device and the author's name is entered for archiving (so when someone else looks at the file, they know who made it and what it's for). Fourth, a pin list is entered, which contains the symbolic names for the pins that are used in the equations. The symbolic names can be numbers, or signal names like INIT, RESET, NMI, etc. Fifth, the actual equations are entered. A field is left open for the designer to enter notes about the design.

PALASM removes the designer from the world of fuse maps and architectures. However, to use PAL's most efficiently, it is important to choose an architecture that maps on to the type of logic you want to have. Also, PALASM allows designers to generate fuse maps (now often called *JEDEC maps*) directly. But sometimes it is actually easier to type in a fuse map than the equations. Indeed, depending on the needed functions, sometimes it is easier to draw a truth table or a state diagram.

From the architectural point of view, PAL's are easier to use than PLA's because they don't have a programmable OR plane at all: in its place they have a programmable AND plane instead, making them the opposite of PROM's. However, as we'll see very shortly, additional architectural features make PAL's just as flexible to use as FPLD's. As shown in Fig. 5, a

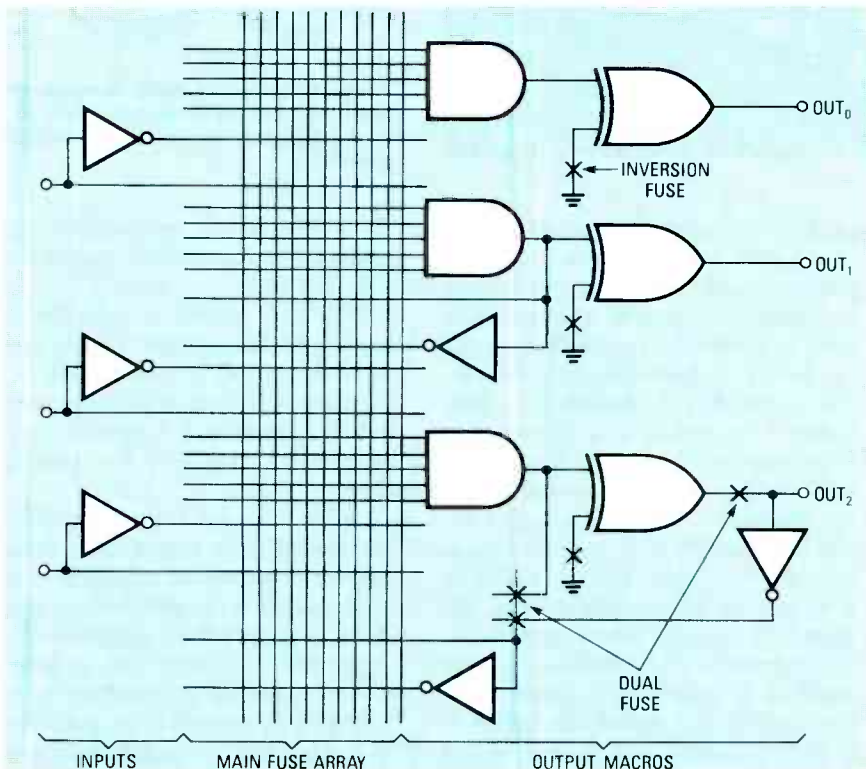

FIG. 5—PLA'S DON'T HAVE A PROGRAMMABLE OR plane at all; they have a programmable AND plane instead, making them the opposite of PROM's.

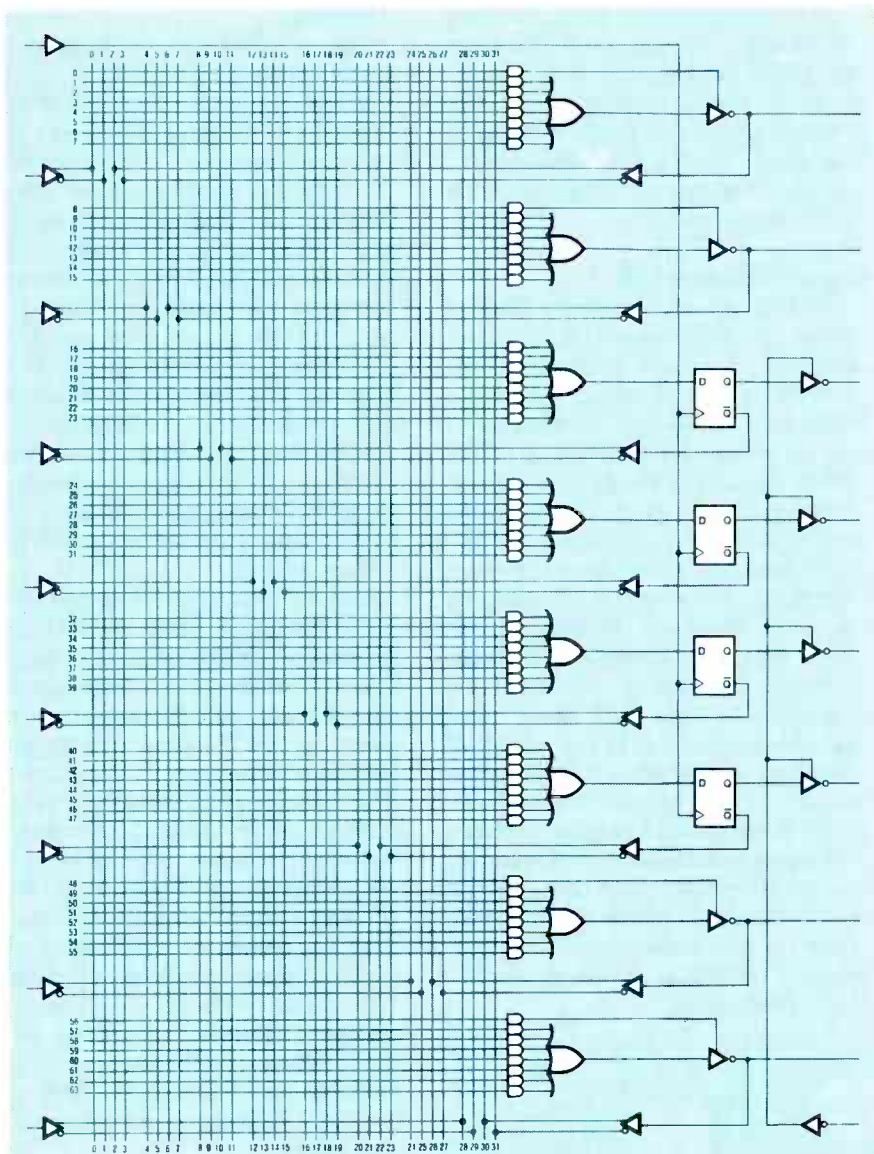

FIG. 6—THE COMMON PAL16R4 provides fuse-programmable three-stated outputs and four flip-flops.

PAL's inputs feed directly into the AND matrix.

Figure 5 also shows a new range of functions, called *macros*, at the output of the AND plane. In 1978, programmable logic components came to differ not only in their I/O ratios, but also in their macros, so that picking the best device for a particular application often hinged on choosing the one with the macros that incorporated the needed logic functions for that application.

In the top macro, the AND plane feeds a single AND gate with optional fuse-programmed inversion. That is a very simple macro; and because the inputs to the array are all inverted, we find that the output inversion is not needed at all.

The second macro down incorpo-

rates a very useful feature: the output of the AND gate is fed back into the programmable AND plane, permitting the output of the AND function to be used again in the array without feeding the output back around to the outside of the device into another input. Using a macro's outputs as inputs to other macros allows the chip to contain *multi-level* logic—which is to say, the signal can pass through a series of gates. By judicious manipulation of the logic equations, it is possible for an ingenious logic designer to put just about any digital function in a PAL architecture; we shall show you exactly how that's done in the next part of this series.

In the bottom macro, the output driver is replaced by a bidirectional driver consisting of dual fuses. De-

pending on how the fuses are blown, the macro can be configured as an output or as an input. If the output of the AND gate is broken, but the feedback path and the input driver are left intact, a signal can pass through the input driver and feedback path—however, the AND macro function then cannot be used at that location. On the other hand, if the output of the AND gate is broken and the input driver is taken out of the circuit, the AND macro functions normally, and the AND gate function is available for multi-level logic.

It should be obvious that there are a large number of possible macro constructions for combinational logic. However, that is just the beginning. Incorporating sequential logic elements in a PAL opens whole new dimensions of design. In Fig. 6 we see the architecture of the common



WHILE PAL's won't really relegate other technologies to the scrap heap, they do offer the designer another usable and useful alternative.

PAL16R4, which provides fuse-programmable three-stated outputs and four flip-flops.

That's all we have room for this month. In the next part of this series we will start off by seeing how *macrocells* containing flip-flops can be used for counters, for complex pattern generators, and even for state machines.

After that, we will also explore a number of more recent technologies, such as erasable and reprogrammable devices, universal programming systems, and advanced programmable-logic architectures; and to demonstrate the feasibility of the technology being used, we will show you how to actually program a programmable-logic device with commercially-available software.

R-E

# BUILD THIS

## AUDIO/VIDEO SWITCHER

*Eliminate the mess and confusion of wires that lurks behind your audio and video equipment with this easy to build switcher.*



TOD T. TEMPLIN

HAS YOUR VIDEO SYSTEM BECOME OVER-run with a tangle of patch cords, jumper cables, and wires? Do you have to grope around in the restricted space behind your VCR when you want to make a dub? Have you ever wanted to view one program while copying another? If the rat's nest of wires is keeping you from getting the most out of your equipment, then you need the same type of equipment-interconnection system used by professional video operations and television stations. You need an audio/video routing switcher.

We'll show you how to build a 4 × 1 electronic stereo-audio and video crosspoint switcher. It will enable you to select one out of four signal sources (consisting of a video signal and a stereo-audio signal), and connect it to an output bus which can supply an input signal for up to four additional devices. That, of course, can be done by merely pressing a button. You'll never have to touch another cable or jumper again. This device is not a simple mechanical RF-type switcher. This switcher was originally designed to expand the number of inputs on professional videotape recorders and monitors in a commercial television studio. Also, the technical specifications (shown in Table 1) are so good that the device is virtually transparent to any signal passing through it.

Consumer VCR's and monitors rarely have more than one set of inputs and outputs. But consumers often have several signal sources, including a second VCR, a video disc or CD-

video player, an image enhancer or noise reducer, or perhaps a special effects generator. If your system has several signal sources and you want to drive more than one monitor or VCR simultaneously, there is no simple way to connect them all together into an easy to use, versatile, and functional system. Just making a simple A to B dub may result in a maze of patch cables, Y-adapters, and double-terminated signals. And, since most VCR's and monitors have their input/output jacks located on the rear panel, getting to the connections can be a difficult and frustrating task.

The 4 × 1 switcher eliminates those problems by allowing all of your audio and video equipment to be connected together in one totally-integrated, "patchless" system. That

is accomplished by placing one 4 × 1 switcher at the input of each device that must receive a signal from more than one source, and then connecting each device's output to the inputs of each switcher. Each switcher has a four-output bus, so that any signal can be connected to four devices. Operation of the switcher is very simple. By pressing any one of the switches (S1-S4), the corresponding signal source is connected to the output bus. Because each switcher has a built-in distribution amplifier, up to four loads can be connected to the output bus. The block diagram for the device shown in Fig. 1 clearly shows how the four signal sources are multiplexed to one output bus.

Until recently, it would have been impossible to build a switcher of such

TABLE 1—SPECIFICATIONS

### Audio Section

Frequency Response	-1, +0dB 30Hz - 20KHz
S/N Ratio	75dB at 5V Input Level
Cross-Channel Isolation	62dB
Input Impedance	Greater than 50 Kilohms
Output Impedance	Kilohm
THD	.07% at 20Hz .04% at 1KHz .03% at 20KHz

### Video Section

Frequency Response	DC - 8MHz
Cross-Channel Isolation	70dB
Input Impedance	75 ohms
Output Impedance	75 ohms
Differential Phase	-0, +3 degrees
Differential Gain	Less than 3%

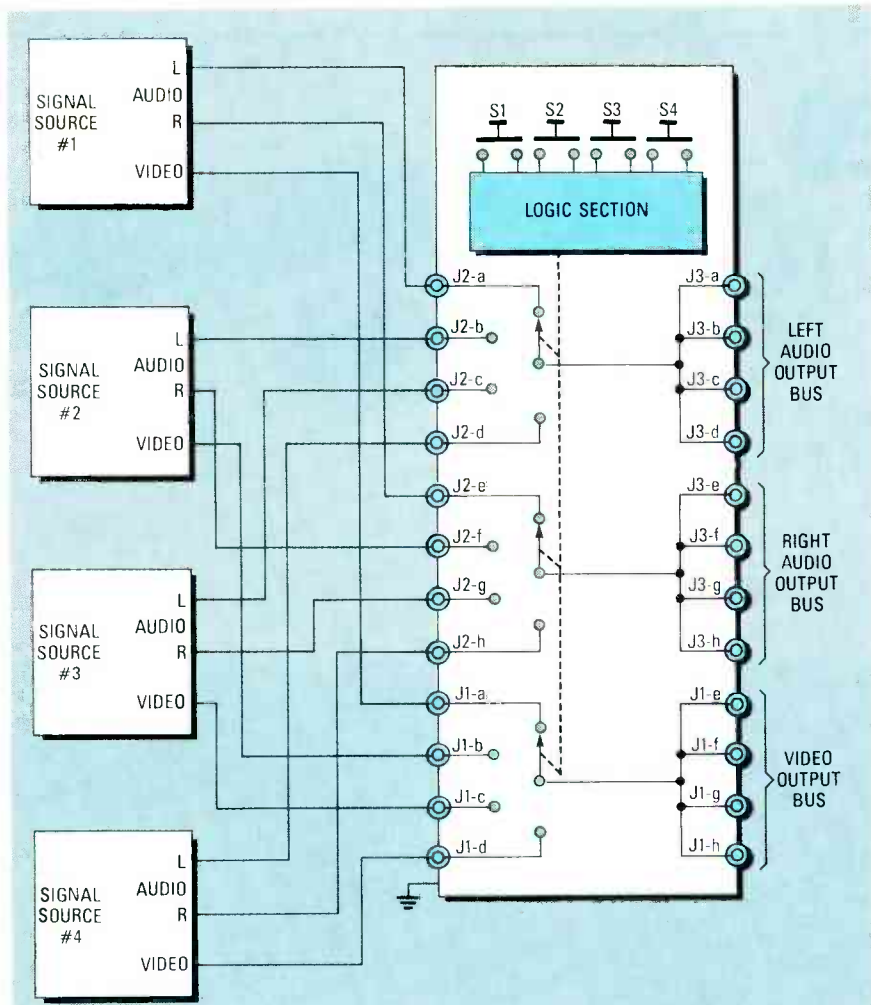

FIG. 1—THIS BLOCK DIAGRAM shows how one out of four signal sources can be switched to one output bus.

high quality using so few parts. However, new IC's are now available, which are specifically designed for audio and video switching. The MAX454 from Maxim Integrated Products (510 N. Pastoria Ave. Sunnyvale, CA 95054 408-737-7600) combines a CMOS 50-MHz video amplifier and 4-channel multiplexer in a single package. The TDA1029 from Signetics does the same for stereo-audio signals. It contains two 4-channel multiplexers plus input and output buffer amplifiers designed for audio frequencies.

### Logic circuit

The complete schematic for the 4 x 1 audio/video switcher is shown in Fig. 2; we'll begin our analysis with the logic section. Selector switches S1-S4 are connected via diodes D1-D8 to the four NAND gates in IC1. Those gates are configured as a cross-coupled SET/RESET flip flop (latch) and a 2-bit Binary Coded Decimal (BCD)

encoder. The outputs of IC1 are connected to the inputs of IC2 (another quad NAND gate), which decodes the latched information from IC1 back to decimal format, where it is used to light the LED of the selected channel and to drive the audio-channel-selector pins of IC5. The BCD information from IC1 is used to drive the video-channel-selector pins of IC3. Note that IC5 requires decimal information while IC3 requires BCD information.

To understand the operation of the logic circuit, suppose you have just pressed S4. A low (ground) signal is routed simultaneously through D7 and D8 to IC1-a and IC1-c. A low on either input of the gate will cause its output to go high, so we now have highs on the outputs of IC1-a and IC1-c. Those high levels are cross-connected to one set of inputs of IC1-b and IC1-d, and the other set of inputs are being pulled high by resistors R2 and R4. That action causes the outputs of IC1-b and IC1-d to go low.

Those low signals are again cross connected to the other set of inputs of IC1-a and IC1-c. We now have lows at both inputs of IC1-a and IC1-c, and highs at both inputs of IC1-b and IC1-d. That results in a steady state or "latched" condition in the circuit. The entire sequence, which happens almost instantaneously, also serves to de-bounce the switches. The two high outputs from IC1-a and IC1-b now also appear at both inputs of NAND gate IC1-b, causing its output to go low and light LED4 as well as select channel 4 of the audio switcher, IC5. The outputs of IC1-a and IC1-c also make up a 2 bit BCD "word" which defines the condition of the latch. Because both IC1-a and IC1-c outputs are now high, channel 4 is selected by the video switcher, IC3.

### Audio circuit

The audio section of the switcher is contained entirely in IC5, a complete stereo-audio, 4-channel switcher. Based on information fed to pins 11-13 from the logic section, it selects a pair of inputs and passes them through an on-chip op-amp buffer to the audio-output bus. DC decoupling for the inputs is provided by C11-C18, which also establish the low-frequency cut-off point of the circuit. The outputs are decoupled by C19 and C20. Technical specifications for the audio section include a frequency response from 30 Hz to 20 kHz, a S/N ratio of 75 dB with an input level of 0.5 volts, and a cross-channel isolation of 62 dB. The input impedance is greater than 50K, and the output impedance is about 1K. The total harmonic distortion for the audio section is 0.07% at 20 Hz, 0.04% at 1 kHz, and 0.03% at 20 kHz.

### Video circuit

The video section of the switcher is made up of two IC's connected in a unity-gain feedback loop. IC3 is a 4-channel CMOS video switch which also has an on-chip buffer amplifier. Because IC3 can drive only one 75-ohm load, a wideband power op-amp (IC4) was added to the circuit to increase the number of video outputs. BCD information from the logic section determines which of the 4 inputs is passed via IC3 to IC4. The buffer amp in IC3 is loaded by R11, while R10 and R12 set the entire circuit to unity gain. The output impedance of

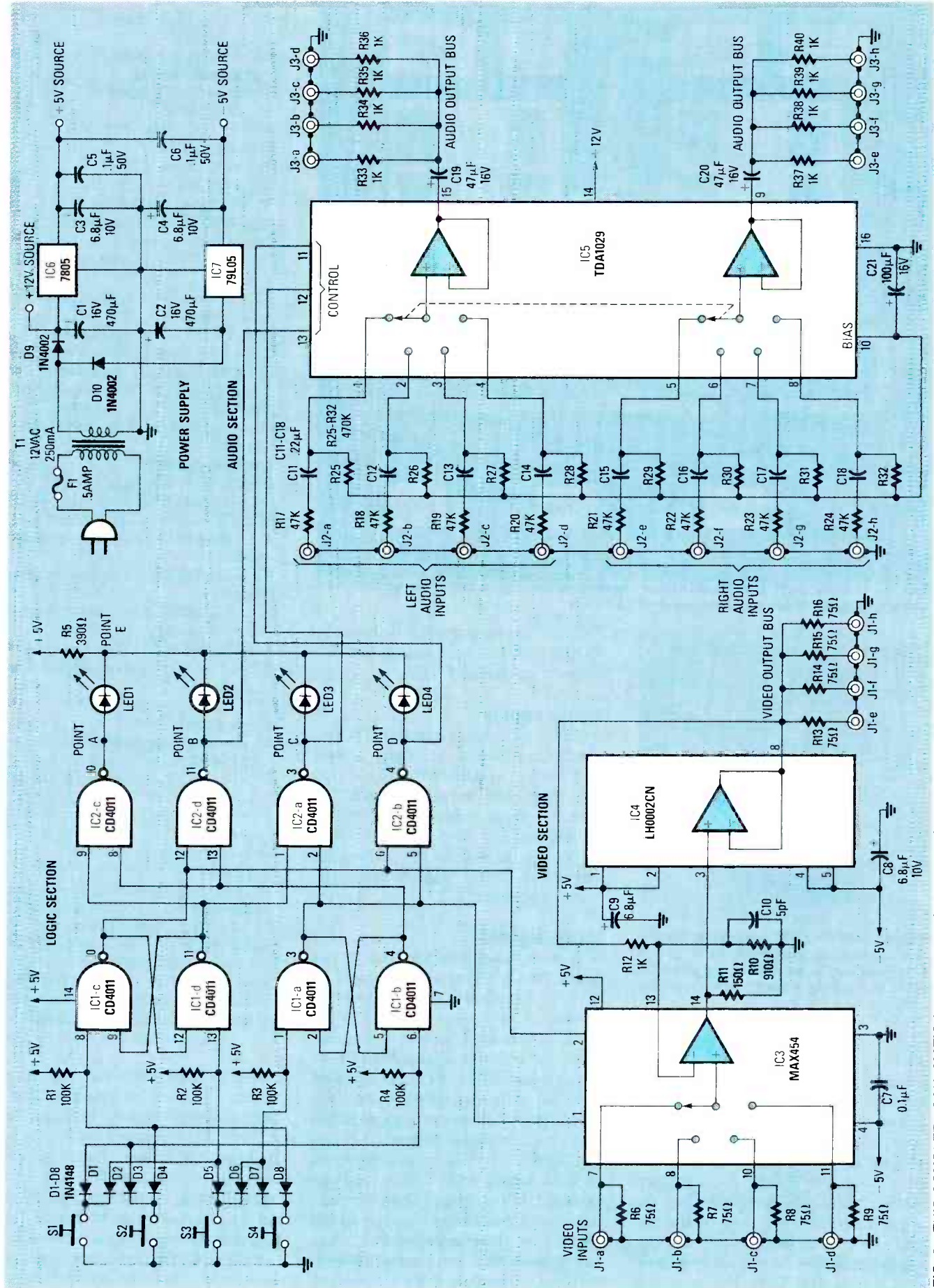

FIG. 2—THIS COMPLETE SCHEMATIC for the 4 x 1 switcher contains the three different sections, and the power supply.

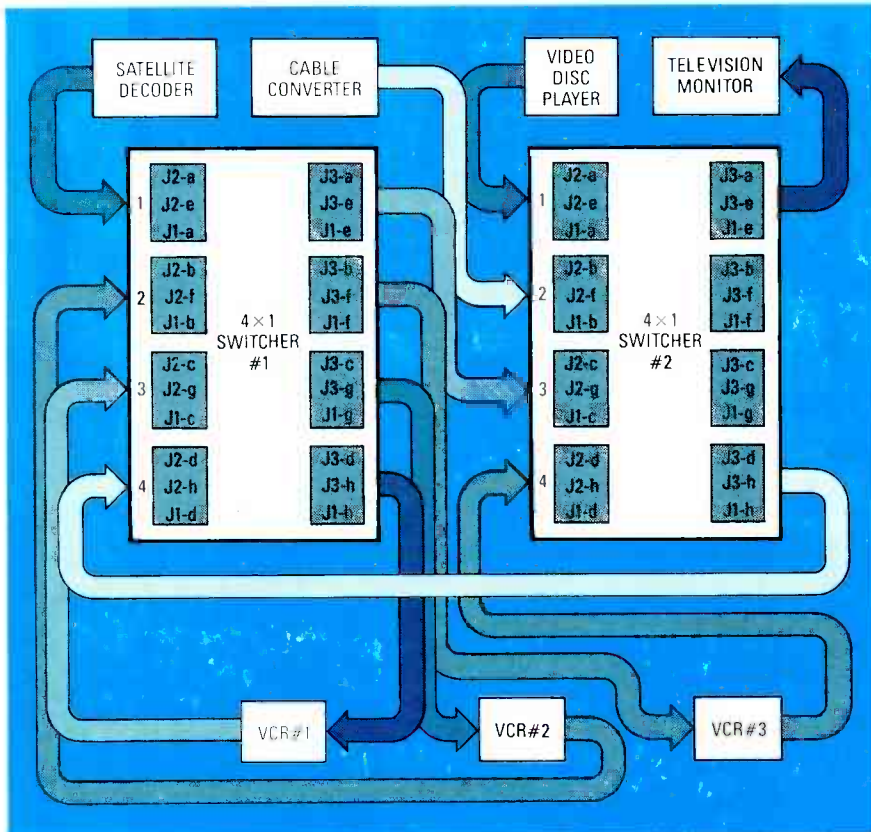

FIG. 3—ALMOST ANY COMBINATION of viewing, recording, or both, can be achieved using this setup which contains two 4 × 1 switchers.

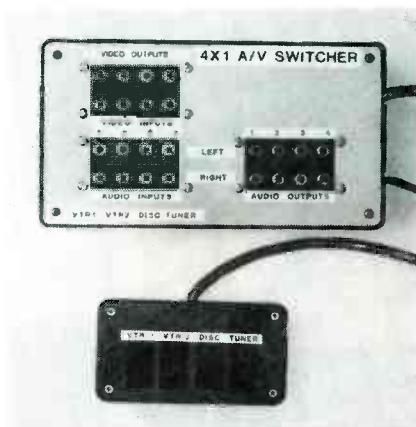

FIG. 4—THIS 4 × 1 SWITCHER has a separate control box which allows all of the messy wiring to be hidden out of sight, while controlling it from a convenient location.

IC4 is so low that its output approximates a zero-impedance voltage source. Consequently, loads connected to the output resistors have no effect on one another. The 75-ohm resistors, R13–R16, establish the correct drive-source impedance for 75-ohm cable as well as short-circuit protection for IC4. C10 establishes the upper-frequency response of the circuit. With C10 being 5 pF, the frequency response for the video section is virtually flat from DC to about

8MHz. The cross-channel isolation is 70 dB, and the input and output impedance are both 75 ohms.

### Power supply

The power supply is not at all complicated. 12 volts AC from a wall transformer is rectified by D9 and D10 into plus and minus 12-volt DC sources. Ripple filtering is provided by C1 and C2, and +12V is then tapped off to supply IC5. The plus and minus 5-volt sources are regulated by IC6 and IC7.

### Video signals

It is important that you understand a few basics about video signals in general. Standard composite video is defined as 1 volt from sync tip to maximum white level, across a 75-ohm load, and contains signals from DC to as high as 5 MHz. Because of those high frequencies, video signals require special attention; they must always be connected between devices by 75-ohm shielded cable, and must be terminated into a 75-ohm load impedance. If a constant 75-ohm impedance is not maintained throughout the system, an impedance mismatch between the source and load will occur, causing some of the video signal to be

### PARTS LIST

All resistors ¼-watt, 5% unless otherwise noted

- R1–R4—100,000 ohms
- R5—390 ohms
- R6–R9, R13–R16—75 ohms
- R10—910 ohms
- R11—150 ohms
- R12, R33–R40—1,000 ohms
- R17–R24—47,000 ohms
- R25–R32—470,000 ohms

### Capacitors

- C1, C2—470 µF, 16 volts, radial electrolytic
- C3, C4, C8, C9—6.8 µF, 10 volts, radial tantalum
- C5–C7—0.1 µF, metal film
- C10—5 pF, mica or disc (see text)
- C11–C18—0.22 µF, metal film
- C19, C20—47 µF, 16 volts axial electrolytic
- C21—100 µF, 16 volts, radial electrolytic

### Semiconductors

- D1–D8—1N4148 diode
- D9, D10—1N4002 diode
- IC1, IC2—CD4011 CMOS quad NAND
- IC3—MAX454 video switch/amplifier (Maxim)
- IC4—LH0002CN power op-amp (National)
- IC5—TDA1029 audio switch/amplifier (Signetics)
- IC6—7805 positive voltage regulator
- IC7—79L05 negative voltage regulator

LED 1—LED 4—red LED's

### Other components

- J1–J3—octal-type RCA jacks, or select jacks to suit needs
- S1–S4—SPST momentary push button switch
- T1—12VAC, 250 mA, plug-in wall transformer

### Miscellaneous

1 chassis of your choice

**NOTE: The following items are available from T3 Research, 5329 N. Navajo Ave., Glendale WI 53217-5036: 4 × 1 PC board, \$10.00 postpaid; MAX454, LH0002CN, and TDA1029N (1 of each type), \$18.50 postpaid; Wisconsin residents must add 5% sales tax.**

reflected back from the load to the source. The visible result of that is reflections or "ghosts" in the picture.

Each 4 × 1 switcher has four inputs and one output bus. Therefore, only one out of four inputs may be connected to the output bus, and supply an input signal for up to four devices. Chances are that one switcher will be sufficient for the average person's video system. However, by building two

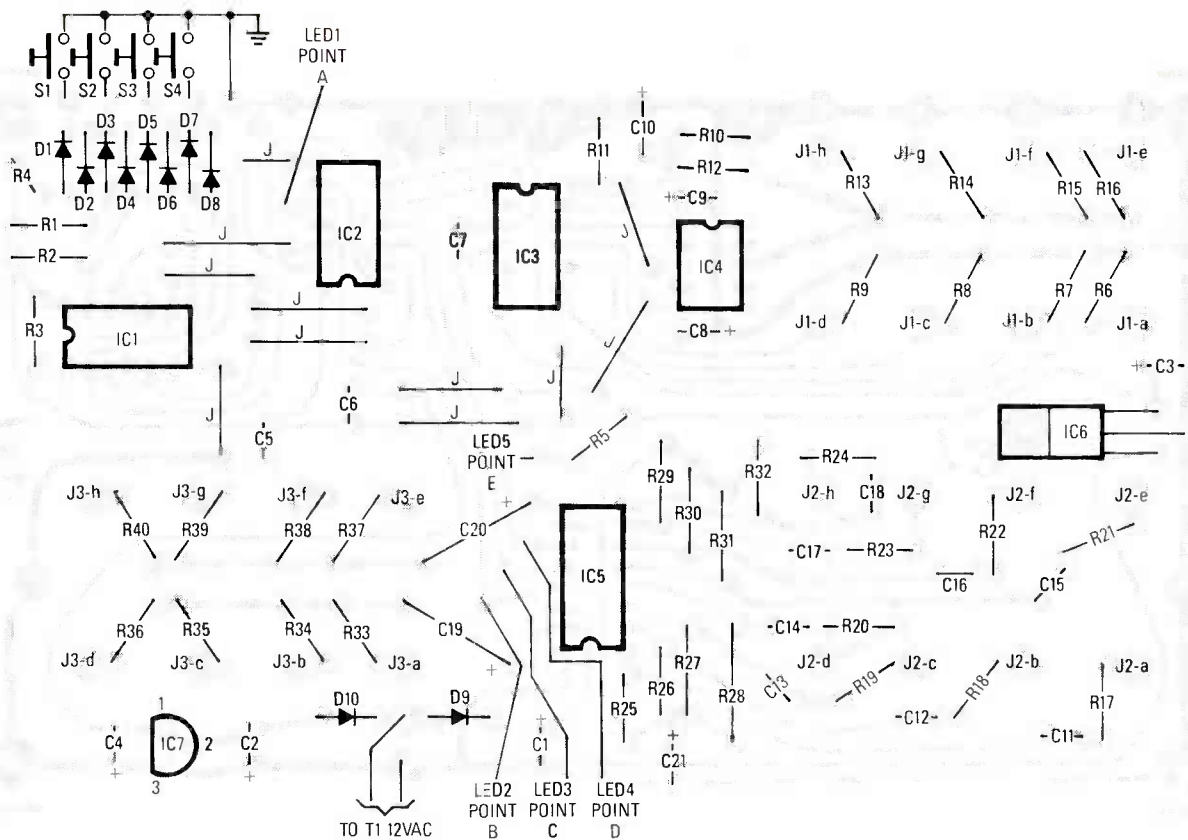

FIG. 5—REFER TO THIS parts-placement diagram when assembling the PC board.

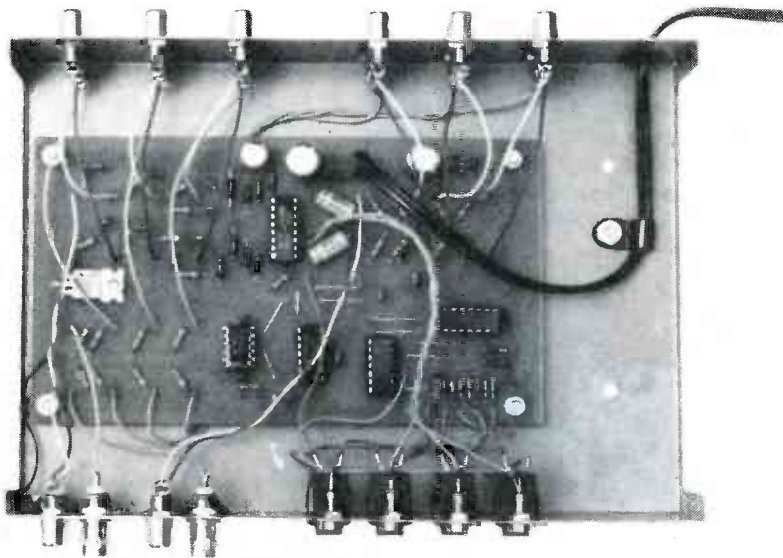

FIG. 6—YOU CAN MOUNT the completed PC board on the bottom of the chassis, and wire the jacks on the sides as shown.

or more 4×1 switchers, you can put together a system similar to that in Fig. 3. That system provides for just about any possible combination of viewing, recording, or both. Of course, the number of switchers you'll need and how you wire them together depends on your particular system's requirements.

### Construction

Before assembling your switcher, it's a good idea to sketch out how you want to connect your equipment together. You probably require only one 4×1 switcher. But, if you have a more complex system, make a diagram like that of Fig. 3, to see how many switchers you'll need. During actual

construction, you can then install as many switchers as you need in one chassis of an appropriate size. Note that a PC board can be purchased from the source mentioned in the parts list, or one can be made using the foil pattern shown in the PC Service. Remember, you'll need one 4×1 circuit board, and complete set of components for each switcher that you build.

There are two ways that the 4×1 switcher can be assembled. Although they perform identically, they are quite different in concept. In one model, shown in the opening of this article, the circuit board, input/output jacks, and selector switches are all mounted in a conventional chassis. That arrangement brings all of your system's interconnecting cables to wherever your switcher is located. That is certainly fine if you only need one switcher. In the other model, the selector switches and LED's are located in a separate control box and connected to the switcher by a 10-conductor cable, as shown in Fig. 4. In the cable, four conductors and one common are used for the switches, and the same goes for the LED's. That allows the main chassis to be located behind your equipment.

After you decide what configura-

tion your switcher will take on, you must come up with a suitable chassis to mount everything in. If you decide to go with the model that has a separate control box, you'll need a separate case to mount the four switches and LED's in. You'll also need an appropriate length of 10-conductor cable to reach the control box.

Start the construction by mounting all of the components flush against the circuit board. Refer to the parts-placement diagram in Fig. 5 for correct positioning of the components. Save some of the excess leads clipped from those components for the 11 required jumpers. Be certain to observe polarity on capacitors, diodes and IC's, and use standard precautions when handling the static-sensitive IC's. Note that you can use 8-pin (octal) RCA-jack panels, which cost less than separate RCA jacks. Also, they can be soldered directly to the circuit board, eliminating a good deal of wiring. If you choose octal jacks, make sure that the jacks are the *last* items you install on the board. Also, be certain you wire together all the ground tabs on each jack before you solder it down to the board. Leave enough wire on the end tab so that it can reach down to the ground hole on the circuit board.

Once the board is complete, all that is left to do is to mount it in the chosen chassis, and add the appropriate wiring. When finished, it should look similar to the one shown in Fig. 6. (Note that Fig. 6 shows the unit in which everything is contained in one chassis.) It is then ready to be hooked up to your video system and tested. Should any problems arise, go back and check your work.

Normally, if the 4×1 switcher is built totally from fixed-value components, it will perform as indicated in the specification chart, with no adjustments required. However, increasing the value of C10 (in the video section) will cause the video frequency response to tilt upwards. It is possible to compensate for high-frequency roll-off, caused by extremely long cable runs, by replacing C10 with a 5–20pf trimmer capacitor. That creates what is known as an equalizing DA (Distribution Amplifier). While observing a multiburst test signal, C10 is adjusted for a flat response. Don't be concerned about the problem of roll-off if your cables are less than 250 feet long. R-E

## PC BOARDS

*continued from page 54*

expose. Note that because of the nature of the paper, exposure time is likely to be longer than with clear film. Do some experimentation to determine the correct exposure time for your light source, chemicals, etc.

You can also use PC Service with the reversing films previously mentioned and then use the negative system to create the PC board.

### Non-photographic techniques

We alluded to the fact that there are alternatives to the photographic method for simple designs. One is to place the pattern directly on the copper blank using etch-resist ink (see Fig. 7), lacquers, tapes, and patterns. The board is then etched in ferric chloride. While the technique works well for small patterns, it is tedious to use for anything larger than a one-IC or two-transistor circuit. Etch-resist inks and patterns are available from Datak, Kepro, and GC Electronics.

Finally, there is a technique that requires no etching at all. Manufactured by Bishop Graphics and called *E-Z Circuit* (see Fig. 8), it involves placing copper strips, donuts, etc. directly onto a pre-drilled, non-copper-clad prototyping board. The copper is supplied on a super-thin, epoxy-glass substrate that has a special adhesive on one side. The copper is positioned onto the prototyping board and burished in place.



**FIG. 8—A NO-ETCH SYSTEM, *E-Z Circuit* from Bishop Graphics places adhesive copper strips, pads, and patterns on a pre-drilled prototype board.**

The drawback to the system is that it can't be used to mass produce boards, and that the pattern must be transferred to the board by hand. The system works well, however, especially for smaller layouts and for repairing existing boards, and it is possible to use it to do even the most complicated circuits R-E

## HFBC

*continued from page 58*

problems that have hounded broadcasting for forty years persist:

- conflicts between large, developed broadcasters and the smaller less-developed newcomers are at the forefront;
- conflicts between the interests of the national broadcasters and the international broadcasters remain largely unresolved;
- the planning system will still have to address the difficult problem of frequency continuity;
- during the intersessional period between now and 1992 a way will have to be found to fit enough requirements into the planned portion of the spectrum to satisfy the world's broadcasters. That is a formidable task, because it entails fitting that size-11 foot into a size-7 shoe.

A clue to the cantankerous nature of HFBC-87 may be found in the number of *reservations* taken at the conclusion of HFBC-87. A reservation is a statement a country enters at the conclusion of a Conference expressing its dissatisfaction over a particular event or events.

Of 116 participating administrations, 70 entered reservations. Some entered more than one reservation. That largely reflected, on the one hand, the continued wariness of major broadcasters toward even possible partial implementation of the modified HFBC Planning System and, on the other hand, it reflected the disappointment of its principal advocates at the uncertain prospects for even such limited application.

Of all the reservations taken at HFBC-87, perhaps the most expressive of the tone of the Conference, and possibly the outlook for the future, was one entered by Burkina Faso:

“Upon signing the Final Acts of the WARC-HFBC(2), Geneva, 1987, the Delegation of Burkino Faso reserves the right for its Government to take whatever measures it may consider necessary to safeguard its interests in the event that the provisions of this Conference are not respected or that any reservations entered by other Members should jeopardize its broadcasting services.

“Our country or death—we shall prevail!” R-E



# PC SERVICE

One of the most difficult tasks in building any construction project featured in **Radio-Electronics** is making the PC board using just the foil pattern provided with the article. Well, we're doing something about it.

We've moved all the foil patterns to this new section where they're printed by themselves, full sized, with nothing on the back side of the page. What that means for you is that the printed page can be used directly to produce PC boards!

**Note:** The patterns provided can be used directly only for *direct positive photoresist methods*.

In order to produce a board directly from the magazine page, remove the page and carefully inspect it under a strong light and/or on a light table. Look for breaks in the traces, bridges between traces, and in

general, all the kinds of things you look for in the final etched board. You can clean up the published artwork the same way you clean up your own artwork. Drafting tape and graphic aids can fix incomplete traces and doughnuts, and you can use a hobby knife to get rid of bridges and dirt.

An optional step, once you're satisfied that the artwork is clean, is to take a little bit of mineral oil and carefully wipe it across the back of the artwork. That helps make the paper translucent. Don't get any on the front side of the paper (the side with the pattern) because you'll contaminate the sensitized surface of the copper blank. After the oil has "dried" a bit—patting with a paper towel will help speed up the process—place the pattern front side down on the sensitized copper blank, and make the exposure. You'll

probably have to use a longer exposure time than you are used to.

We can't tell you exactly how long an exposure time you will need as it depends on many factors but, as a starting point, figure that there's a 50 percent increase in exposure time over lithographic film. But you'll have to experiment to find the best method for you. And once you find it, stick with it.

Finally, we would like to hear how you make out using our method. Write and tell us of your successes, and failures, and what techniques work best for you. Address your letters to:

**Radio-Electronics**  
Department PCB  
500-B Bi-County Blvd.  
Farmingdale, NY 11735

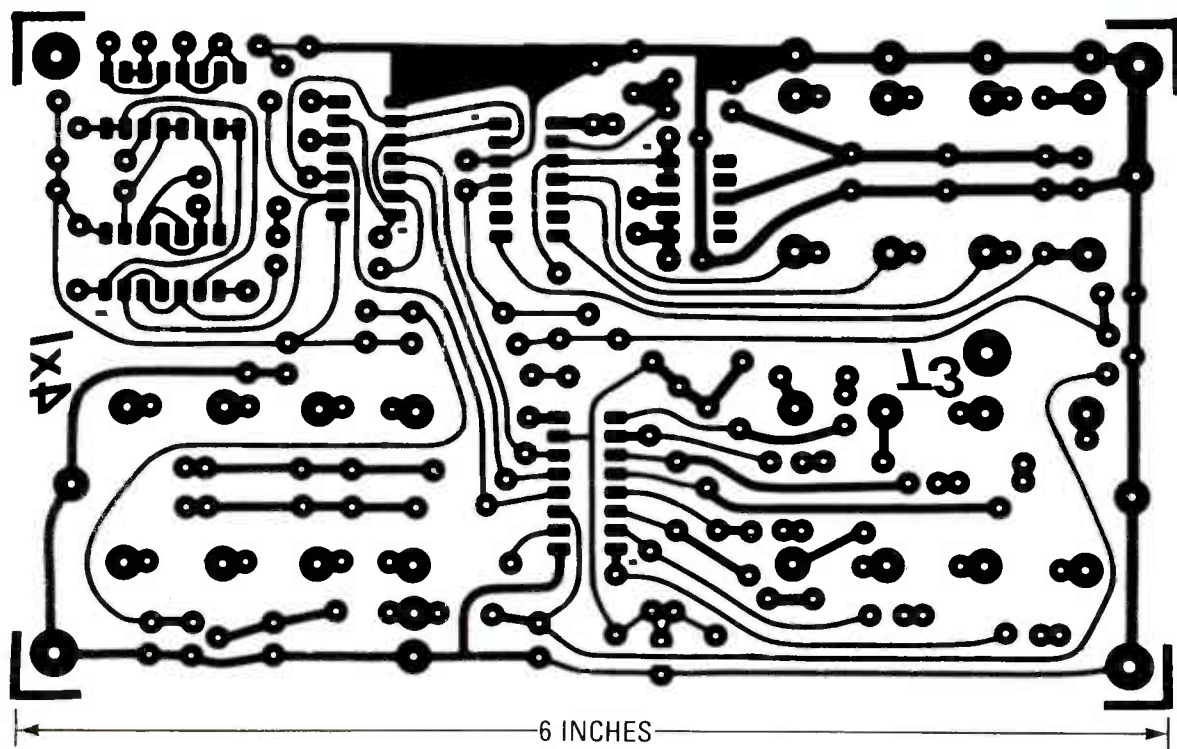

BUILD THE AUDIO/VIDEO switcher using this PC board.

---

---

# PC SERVICE

# HARDWARE HACKER

Superconductors for the hacker, and more!

HELLO AGAIN. WELCOME TO RELEASE number two of my brand new **Radio-Electronics** column. As we found out last month, we will be exploring all sorts of "neat stuff" hacker opportunities here, electronic and otherwise. We will start off with a reminder that you can get no-charge technical help at the number in the *Need Help?* box that accompanies this article.

I've found out a little more on suitable UV curing resins for that Santa-Claus machine that we looked at in the last installment of this column. It turns out that a leading manufacturer of photopolymerization resins is Hercules.

One fairly cheap and easy to get UV curing resin of theirs is used for making rubber stamps. That UV liquid resin is rebranded by the Merigraph Systems people as their product *MD-035*, and is distributed by R.A. Stewart.

The really big news this month is that hardware hackers can now buy superconductors off-the-shelf to play with!

## Superconductors for the hacker

When you cool certain metals or "magic" ceramic-oxide mixtures to extremely low temperatures, a very remarkable thing happens. Some of those materials will go into a *superconducting* state where they lose all of their internal electrical resistance. At the same time, any internal magnetic fields also will drop to zero.

The many potential uses for superconductors boggle the mind. Utility electrical power could be distributed long distances without

transmission loss. Much stronger and cheaper magnets for electric automobiles, transportation, atomic-particle research, and biomedicine would revolutionize each of those fields. Computers could be made much faster and much smaller. So, too, could new test instruments.

Until recently, the temperatures needed for superconductivity were so cold that only very expensive and cumbersome liquid helium could be used. But, within the last year, a new class of ceramic oxides consisting of copper, oxygen, and some rare-earth elements were discovered that superconducted at much higher, more economical temperatures.

Those new ceramic materials will superconduct in the 80°K to 100°K range (-173°C to -193°C). Now, that is still extremely cold, but you can easily hit those temperatures with cheap old liquid nitrogen in a styrofoam cup. Liquid nitrogen is available at less than draft-beer prices from almost any industrial gas supply house.

Better yet, there are hints of superconductivity at much higher temperatures, some of which even approach room temperature. But those new developments are not

More on uv curing resins  
Using liquid level detectors  
Circuits for electronic music  
Microprocessor fundamentals  
Off-the-shelf superconductors!

DON LANCASTER

yet confirmed or proven, and the whole field is up for grabs.

In fact, the entire future of electronics hinges on all of the new superconductor research being done worldwide today.

Believe it or not, you can run out right now and buy your own superconductor to play with for only \$8. One source of them is Laboratory Specialists.

What you get is not all that great looking. Your superconductor is the size, color, and shape of a pool cue tip. It is also very sensitive to moisture or to any oxygen when at low temperatures, so it can easily be degraded or destroyed. About all you can really do with it is demonstrate the fundamental superconductor properties—a zero internal-magnetic field and a zero resistance. On the other hand, it is a guaranteed instant winner for a school paper or a science fair.

Before we go on, though, let's talk some safety. You should treat liquid nitrogen like it was molten steel. It will instantly frostbite any tissue it comes in contact with. Safety glasses are an absolute must. You should also wear two layers of heavy clothes that cover as much of your body as possible. Be sure to review your frostbite first aid before beginning.

You must work in a very well ventilated area. While the liquid nitrogen is not itself toxic, it will displace oxygen in any confined area and can cause suffocation. Just confining the liquid nitrogen can cause a pressure explosion, so a loose fitting lid must be used on any non-approved container.

Some materials will instantly

## NEED HELP?

Phone or write your **Hardware Hacker** questions directly to:  
Don Lancaster  
**Synergetics**  
Box 809  
Thatcher, AZ 85552  
(602) 428-4073

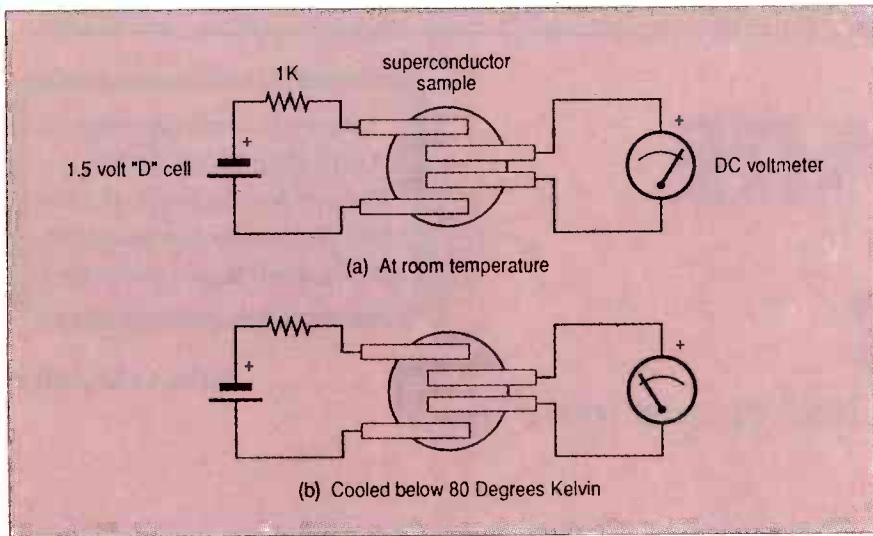

FIG. 1—A TEST CIRCUIT to demonstrate the zero internal resistance of a cooled superconductor. The meter will show a zero voltage drop when the super conductor is below its critical temperature. A "four-point" measuring scheme is used to minimize the effects of contact and lead resistance.

shatter at liquid nitrogen temperatures, so the safest container is a plain old styrofoam coffee cup. Meanwhile, any liquid oxygen that condenses out can become a very serious fire hazard.

Are you still there? Hello....Hello...

Actually, when treated with both common sense and respect, the dangers of liquid-nitrogen handling are no worse than, say, using a power lawnmower.

Figure 1 shows us how to demonstrate superconductive properties. Basically, you set up the superconductor as a voltage divider and measure the output voltage. As you slowly lower the material into the liquid nitrogen, the output voltage will drop to zero, proving that the material is superconducting.

Figure 2 shows you how to demonstrate a second measure of superconductivity. That is called the *Meissner effect*. The Meissner effect says you will get a zero internal magnetic field when the material you are working with is actually superconducting.

That effect does take a special, extra strength neodymium-iron-boron magnet. Physically levitating the magnet is not usually possible with these samples.

For more information, and for more cautions, be sure to thoroughly read the instructions that come with your sample of superconductor material.

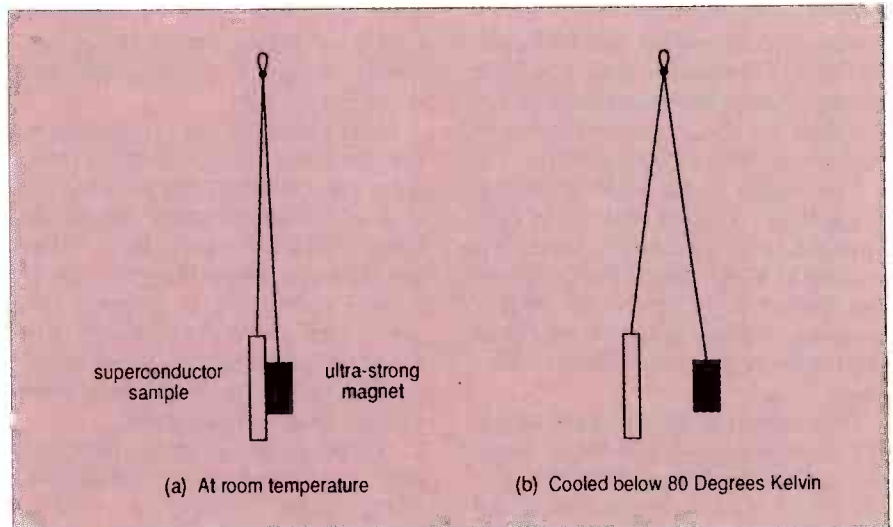

FIG. 2—THE MEISSNER EFFECT calls for a zero internal magnetic field in a superconductor. The resulting field distortion will deflect, or even levitate, an extremely strong magnet as shown.

### Making your own

Doing all your own personal superconductor research is rather tricky for the average hardware hacker, but it is certainly not out of the question. The basic technology is just about as complicated for you as microwaving a pan of brownies.

And a Nobel Prize is up for grabs for the first confirmed and verifiable stable room-temperature superconductor. Not to mention a very big bag of nickels.

Dimes, even.

First and foremost, you would have to be a lab-type person, and have access to either a school chemistry lab or else have your own very sophisticated home lab.

Second, of course, would be a very healthy respect for the dangers of working with those very low temperatures. Once again, safety glasses, heavy, double-layered clothing, good ventilation, and everyday common sense are always essential.

Third, you would need reprints of many of the current papers in superconductivity. While there are some expensive new journals out, check into Physics Abstracts, Science, or, best of all, the Dialog online technical and scientific information utility. All of those should be readily available at better schools and libraries.

Two rather good technical resources to get you started are the special superconductor issue of *Physics Today* (volume 39, #3,

1986) and Bednorz and Muller's classic paper in *Science* (volume 237, pages 1133-1139).

And, finally, you would need a source of raw materials. The AESAR people have long been a good source of small quantities of high purity metals, compounds, and elements. They have released a new superconductor-materials flyer that includes barium, strontium, scandium, copper, lanthanum, and yttrium in just the right combinations for the new superconductors. Cost ranges from \$1 to \$87 a gram in small quantities, depending on the material.

Be sure to let us know what results you come up with in this exciting new field.

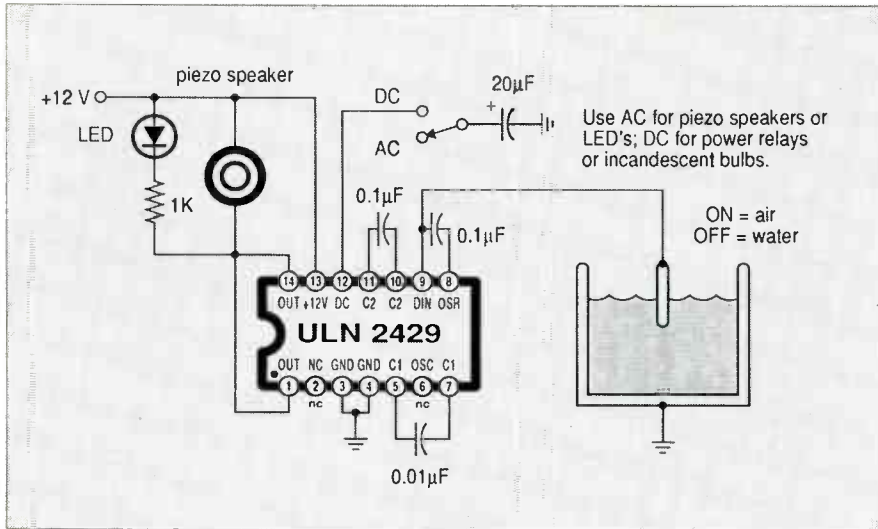

FIG. 3—THE SPRAGUE ULN-2429 is an automotive liquid-level detector that has plenty of hacker potential. Here is the basic test circuit using a pop can full of tap water.

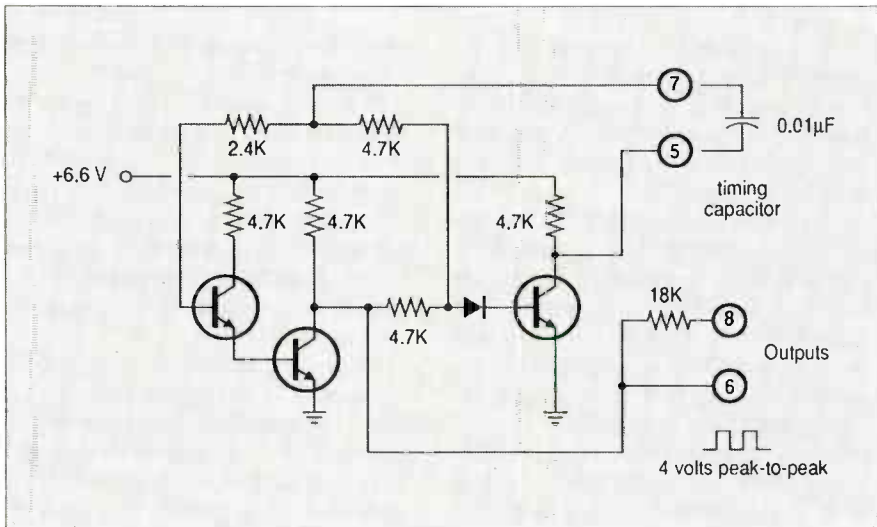

FIG. 4—A SIMPLIFIED SCHEMATIC of the internal audio oscillator found in the ULN-2429. The usual operating frequency is 2.5 kHz, and is set by the external timing capacitor.

### Liquid-level detectors

THE AUTOMOTIVE PEOPLE HAVE SHOWN a lot of interest lately in liquid-level detectors, particularly for low-radiator-water warning systems. There are quite a few circuit manufacturers that offer specialized IC's for liquid-level detection.

One interesting and low cost liquid-level detector is the Sprague ULN-2429A. That beastie is shown in Fig. 3.

There are three basic areas to the circuit. Those areas of the circuit include a regulator, an oscillator, and a detector.

The first circuit area is a 6.4-volt regulator that isolates the rest of the internal electronics from any battery and vehicle noise. Because of that regulator, the intended supply is from 10 to 16 volts.

For hacker uses, you can run on a 9-volt battery, but with less stability and accuracy than when running at the intended 12 volts. The current drain is under 10 mA, exclusive of the load.

The second area consists of a simple audio oscillator. You can change the frequency of that oscillator by changing the timing capacitor by changing the timing capacitor between pins 5 and 7. The intended operating frequency is 2.5 kHz, which can be used to directly drive a ceramic piezo squawker device.

A simplified circuit of the audio oscillator is shown in Fig. 4. It is a fairly low-power circuit, intended to work into a 10K or higher load. The output is a rather sloppy square wave of about four volts peak-to-peak.

# ATTENTION! ELECTRONICS TECHNICIANS

EARN YOUR  
**B.S.E.E.  
DEGREE**  
THROUGH HOME STUDY

Our New and Highly Effective Advanced-Placement Program for experienced Electronic Technicians grants credit for previous Schooling and Professional Experience, and can greatly reduce the time required to complete Program and reach graduation. No residence schooling required for qualified Electronic Technicians. Through this Special Program you can pull all of the loose ends of your electronics background together and earn your B.S.E.E. Degree. Upgrade your status and pay to the Engineering Level. Advance Rapidly! Many finish in 12 months or less. Students and graduates in all 50 States and throughout the World. Established Over 40 Years! Write for free Descriptive Literature.

## COOK'S INSTITUTE OF ELECTRONICS ENGINEERING

347 RAYMOND ROAD  
P.O. BOX 20345  
JACKSON, MISSISSIPPI 39209

CIRCLE 58 ON FREE INFORMATION CARD

## CABLE-TV



### signal remover

50dB NOTCH FILTER

Any signal coming in on your cable can be completely "removed" with this powerful filter. Particularly useful on "pay" channels. Also can be used to eliminate any over-the-air signal which prevents normal reception. The filter's external adjustments allow precise tuning to any frequency required.

\*AVAILABLE FOR THE FOLLOWING CHANNELS:  
MODEL 26 - For any channel between 2 and 6 (Tuning range 54 - 108 Mhz)  
MODEL 713 - For any channel between 7 and 13 (Tuning range 174 - 216 Mhz)  
MODEL 1422 - For any channel between 14(A) and 22(I) (Tuning range 120 - 174 Mhz)

★★ ONLY \$30 EACH ★★ 30 DAY FREE TRIAL ★★  
To order, send \$30 check or money order. Specify Model. If not completely satisfied, simply return within 30 days for a full and speedy refund.

★ All models in stock ★ One year warranty  
★ Fast, free delivery ★ Quantity discounts to 50%

STAR CIRCUITS/DEPT. R  
P.O. BOX 8332, PEMBROKE PINES, FL 33084

## Rely on JAN for 3-WAY Help

1. **TECHNICALLY CORRECT**  
Crystals to Your Specs
2. **QUICK TURNAROUND**  
with huge inventory, prompt  
service and Emergency Order  
Plan
3. **LOW PRICES**

**QUARTZ CRYSTALS FOR**  
Two-Way — Industry — Marine  
Amateurs — CB — Microprocessor  
Scanners

For Free Catalog  
Call or Write

**JAN CRYSTALS**  
P.O. Box 06017  
Ft. Myers, FL 33906  
(813) 936-2397

Since  
1965



CALL 1-800-237-3063  
FREE (Except Florida)

CIRCLE 104 ON FREE INFORMATION CARD

## Be an FCC LICENSED ELECTRONIC TECHNICIAN!



Earn up to  
\$30 an hour  
and more!

Learn at home in spare time.  
No previous experience needed.

No costly school. No commuting to class. The Original Home-Study course prepares you for the "FCC Commercial Radiotelephone License". This valuable license is your "ticket" to thousands of exciting jobs in Communications, Radio-TV, Microwave, Computers, Radar, Avionics and more! You don't need a college degree to qualify, but you do need an FCC License.

**No Need to Quit Your Job or Go To School**  
This proven course is easy, fast and low cost! **GUARANTEED PASS** — You get your FCC License or money refunded. **Send for FREE facts now. MAIL COUPON TODAY!**

### COMMAND PRODUCTIONS

FCC LICENSE TRAINING, Dept. 90  
P.O. Box 2223, San Francisco, CA 94126

Please rush **FREE** details immediately!

NAME \_\_\_\_\_

ADDRESS \_\_\_\_\_

CITY \_\_\_\_\_

STATE \_\_\_\_\_

ZIP \_\_\_\_\_

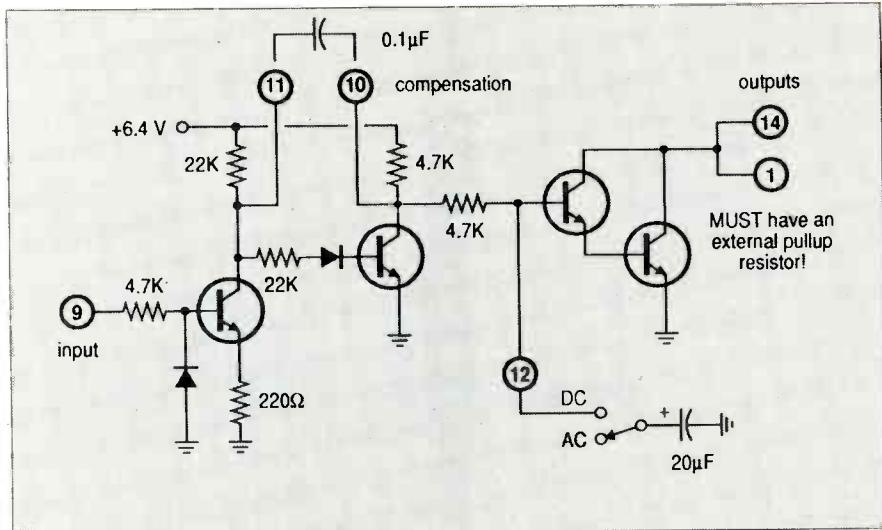

FIG. 5—THE ULN-2429 DETECTOR turns on with a square-wave input greater than 1.2 volts peak-to-peak, and stays off otherwise. The filter capacitor selects either an AC or DC output.

A series output resistor is normally used with the oscillator. You have your choice of using an internal 18K resistor at pin 8, or else adding your own external resistor on pin 6 if you like.

The third area is the detector circuit shown in Fig. 5. It's basically a three-stage amplifier that can work in two different modes. The detector will strongly amplify any audio signal that exceeds 1.2 volts peak-to-peak, but completely ignores anything weaker.

In the first mode, you amplify the 2.5-kHz or other audio signal and then directly drive a piezo transducer at the output. You can also drive an LED with that square wave if necessary.

There is one gotcha to driving an LED. You have to use a series resistor to make the peak LED current *twice* normal, since the output square wave will only be on *half* the time.

Should you close the AC-DC switch in Fig. 3, the output stage becomes a high-power DC driver that is capable of driving a relay or an incandescent lamp. You can output as much as one ampere from that tough driver circuit, if you use a heatsink clip and are certain to connect both output pins 1 and 14 to a large printed circuit foil area, as well as connecting both of ground pins 3 and 4 to a similar large foil area.

The capacitor on pins 10 and 11 reduces the frequency response of the detector to what is needed,

and eliminates any possible high-frequency noise.

If you input 1.2 volts peak-to-peak, or less, the output stays off. If you input more than 1.2 volts peak-to-peak, the output turns on. While you can drive the detector input from the oscillator with up to a 1-megohm resistor, the internal 18K resistor is far more stable and preferred.

How does the liquid-level detector work? Looking back at Fig. 3, if the probe does contact the liquid, enough of the square wave gets shunted to ground to turn off the detector. Thus, when you are contacting liquid, the output is off. When your coolant drops below the probe, the output turns on.

The Sprague data sheet also shows a series double-probe setup that turns the output on only when in contact with the liquid. But note that the alternate circuit will only work with isolated liquids that are not grounded. A liquid without a conductive or capacitive path to ground is highly unlikely in the real world.

Suitable liquids are tap water, sea water, weak acids and bases, wet soil, wine, beer, or coffee. Most oils, distilled water, dry soil, or vodka will not work.

One of the reasons for using an audio signal rather than a DC voltage for a level sensor is to prevent any plating or electrolysis effects that might alter the sensor probe over time.

When you are working with tap

## NAMES AND NUMBERS

### AESAR

P O BOX 1087  
Seabrook, NH 03874  
(800) 343-1990

### Ensoniq

263 Great Valley Pkwy  
Malvern, PA 19355  
(215) 647-3930

### Exar Corp

750 Palomar Ave  
Sunnyvale, CA 94086  
(408) 732-7970

### Gatorfoam/Intl. Paper

Highway 90  
Statesville, NC 28677  
(704) 872-8974

### Hercules

Hercules Plaza  
Wilmington, DE 19894  
(302) 594-6500

### Laboratory Specialists

2085 Dahlia  
Denver, CO 80207  
(303) 322-2120

### Lindsay Publications

P O Box 12  
Bradley, IL 60915  
(815) 468-3668

### Motorola

PO Box 6000 M/S F-8  
Austin, TX 78721  
(512) 928-6011

### SenSym

1255 Reamwood Ave  
Sunnyvale, CA 94089  
(408) 744-1500

### Signetics

811 E Arques Ave  
Sunnyvale, CA 94088  
(408) 991-2000

### Solid State Micro Technology

2076B Walsh Ave  
Santa Clara, CA 95050  
(408) 727-0917

### Sprague

15 Northeast Cutoff  
Worcester, MA 01247  
(612) 853-5000

### R. A. Stewart

641 S. Palm Unit H  
La Habra, CA 90631  
(213) 690-4445

### Synergetics

Box 809  
Thatcher, AZ 85552  
(602) 428-4073

water, there are three different forces at play. If you just shove an ohmmeter into a pop can full of tap water, you most likely will measure something in the 5- to 20-megohm range. That, obviously, is far too high to be able to shunt the 18K resistor.

But water has a dielectric constant of 84. Thus, what might have been a 10-pF capacitor when the probe is in air becomes an 840-pF capacitor when wet.

Finally, most any material has its loss tangent, which tends to attenuate high frequencies more than low ones. Therefore, any ions floating around in the tap water will further lower the impedance.

That sure had me fooled for a while. Intuitively, you would expect probed tap water in a pop can to look like something much higher than an 18K resistor at audio frequencies. But the triple combo of conduction, an exceptionally high dielectric constant, and an increasing loss tangent all gang up to

let the simple circuit work like a real champ.

Just because the IC is called a level detector does not mean that us sneaky hackers can't do wildly different things with it. For example, you can think of the device as a simple audio oscillator and a thresholding level detector with either AC or high-current DC outputs. Between the oscillator and detector, we have the options of making or breaking a series connection, or of shunting or not shunting some of the oscillator signal to ground.

So, for this month's contest, just dream up a new use for the ULN-2429A. Paper ideas are just fine; you do not have to actually test your circuit. There will be one of my books to the best twenty entries, and an all-expense-paid (FOB Thatcher, AZ) *tinaja* quest to the best of all.

I will eliminate the two most obvious new uses by showing them here as examples: You can make a

## BRIEF CASE RECORDERS



**NEW  
12 HOUR  
MODEL**

**USES  
D-120  
TAPE**

**\$359.00\*\***

Modified Panasonic recorder installed in top quality 3 inch Samsonite™ Attache Case. Has built in electret condenser mike. Recorder is activated by combination lock on brief case. Unit provides complete portable recording capability. Fold down work table conceals recorder. TDK DC 120 Cassette furnished.

### OTHER AMC ITEMS

12 hour modified Panasonic recorders, \$105.00\*\*. Also Telephone Recording Adaptors \$24.50\*, VOX SWITCHES \$24.95\*, Micro recorders with tie clip microphone, VOX activated micros, Wired mikes, Transmitter detectors, etc. Send for FREE data. \*\*Add \$4.00 each shipping and handling. \*Add \$1.50 shipping and handling. Calif. residents add sales tax. Mail Order.

**AMC Sales Inc., Dept. A (213) 869-8519**  
9335 Lubec St., Box 928, Downey, Calif. 90241

CIRCLE 108 ON FREE INFORMATION CARD

## LEARN TV/VCR REPAIR



**No Previous  
Experience  
Necessary**

**N**ow you can train at home in spare time for a money-making career as a TV/VCR Repair Specialist. No need to quit your job or school. We show you how to troubleshoot and repair videocassette recorders and TV sets, how to handle house calls and shop repairs for almost any make of television or VCR. You learn about TV receivers, tuners and antennas, x-ray emission, the characteristics of sound, how electrical impulses are converted into a TV picture, and much, much more. Tools are included with your course so you can get "hands-on" practice as you follow the lessons step by step. Send for free facts about opportunities in TV/VCR Repair and find out how you can start making money in this great career.

Experts show you what to do, how to do it...guide you every step of the way! Everything is explained in easy-to-understand language with plenty of drawings, photos and diagrams. But if there is ever anything in your lessons you don't understand, you can write or phone your instructor and you can count on getting an authoritative answer. Send for free facts and color brochure. No cost. No obligation. No salesman will visit you. **MAIL COUPON TODAY!**

**IGS SCHOOL OF TV/VCR REPAIR, Dept. DE018**  
SINCE 1981 Scranton, Pennsylvania 18515

Please send me free facts on how I can learn TV/VCR Repair at home in my spare time. No salesman will visit.

Name \_\_\_\_\_ Age \_\_\_\_\_

Address \_\_\_\_\_

City/State/Zip \_\_\_\_\_

Phone ( ) \_\_\_\_\_

# Radio-Electronics mini-ADS

continuity tester by using the oscillator and detector leads to do such things as ringing out cables. By replacing the water sensor with a long wire, you can create a burglar alarm that trips whenever the wire is cut.

Let's see what else new and exciting you can come up with using those new devices.

## Music IC's

AS WITH ANYTHING ELECTRONIC, there are two different types of high-performance electronic-music circuits: digital and analog.

The digital ones are used for such things as polyphonic and polytonic oscillators and envelope generators. One major source of those is Ensoniq, whose IC's are used in many popular high-end synthesizers. Their 5503 synthesizer IC is used in the Apple II's, and gives the II's far and away the finest sound available from any personal computer.

The analog IC's for electronic music are more traditional and include such things as voltage-controlled oscillators, amplifiers, and filters. The Solid State Micro Technology (formally SSM, or Solid State Music) people seem to be the leader in this area. They have a free *Product Guide* you may want to send for.

## New tech lit

Those new data books are continuing to pour in. Check out the *CMOS Data Manual* from Signetics, the new *CMOS/NMOS Special Functions* data book available from Motorola, a really great *Pressure Sensor Handbook* from SenSym, and the new *Modem Design Booklet* from Exar.

As with most data books, the price varies from free to optional to nominal, depending both on your supplier and how you go about asking for one.

For a most useful new hacker structural material, try *Gatorfoam* from International Paper. That flat, rigid, strong, and lightweight stuff is available in thickness from 3/16 to 1/2 inches and is much easier to handle and use than most of the woods, wood substitutes, and plastics. It is absolutely ideal both

*continued on page 96*



**SIMPLY SNAP THE WAT-50 MINIATURE FM TRANSMITTER** on top of a 9v battery and hear every sound in an entire house up to 1 mile away! Adjustable from 70-130 MHz. Use with any FM radio. Complete kit **\$29.95 + \$1.50 S + H**. Free shipping on 2 or more! COD add \$4. Call or send VISA, MC, MO. **DECO INDUSTRIES, Box 607, Bedford Hills, NY 10507. (914) 232-3878.**

CIRCLE 127 ON FREE INFORMATION CARD

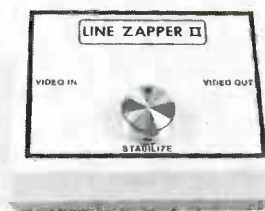

**DECODE THE NEW VIDEO TAPE COPY PROTECTION SCHEME.** Bothered by brightness changes, vertical jittering and video noise while watching rented tapes? Stop it with the LINE ZAPPER. New kit removes copy protection that often interferes with normal television operation. Complete KIT only **\$59.95**. Assembled with 1 year warranty **\$99.95**. Add **\$4.00** shipping per unit. **ELEPHANT ELECTRONICS, Box 41865-L, Phoenix AZ 85080. (602)581-1973.** Allow 6 weeks for delivery.

CIRCLE 120 ON FREE INFORMATION CARD



**DESIGNED SPECIFICALLY TO HOLD I.C.** board for fast, simple construction. Easy front to backside of board movement, multi position head, rubber lined jaws, solid oak construction, finish tolerates cleanup with alcohol, full refund if not completely satisfied. Send **\$21.50** each to: **ALLENS ELECTRONICS, P.O. Box 235, Ephrata, WA 98823**

CIRCLE 193 ON FREE INFORMATION CARD

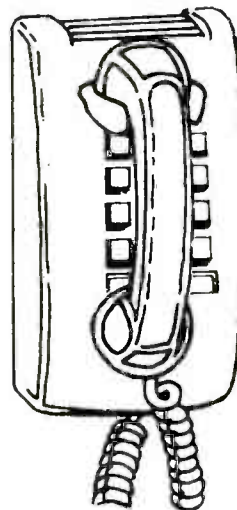

## CALL NOW AND RESERVE YOUR SPACE

- 6 x rate \$745.00 per each insertion.
- Fast reader service cycle.
- Short lead time for the placement of ads.
- We typeset and layout the ad at no additional charge.

Call **516-293-3000** to reserve space. Ask for Arline Fishman. Limited number of pages available. Mail materials to: mini-ADS, RADIO-ELECTRONICS, 500-B Bi-County Blvd., Farmingdale, NY 11735.



**CABLE TV CONVERTERS AND DE-SCRAMBLERS.** Large selection of top quality merchandise. Low prices. Quantity discounts. We ship COD. Most orders are shipped within 24 hrs. Send **\$2.00** for catalog. **CABLETRONICS UNLIMITED, P.O. Box 266 Dept. R, S. Weymouth, MA 02190 (617) 843-5191**

CIRCLE 191 ON FREE INFORMATION CARD



# Radio-Electronics mini-ADS



**ZENITH SSAV1** from \$169, UHF INPUT, re-conditioned. Level II modules available for SSAV1s. UHF SSAV1 project handbook \$6.50 ppd. Sylvania 4040 \$169. Z-TAC, N-12, MLD-1200s. Converters, amplifiers and accessories. Satellite components. Radar speed guns for car/boat racing, bowling, skiing; baseball, etc, from \$275 used. Professional police models. IBM-compatible computer systems from \$895. Catalog \$1. **AIS SATELLITE, INC.**, P.O. Box 126-E, Dublin, PA 18917. (215) 249-9411.

CIRCLE 81 ON FREE INFORMATION CARD

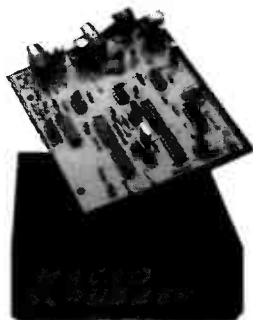

**DEC. R-E ARTICLE ON MACRO SCRUBBER**, the original parts as mentioned MAK-1. All components shown on parts list and much more. Silk screened and etched P.C. board, power supply, IC sockets, precut jumpers, power jack, plug and pre-drilled enclosure. \$562.95 & 3.00 S/H. Order today from: **THE HOBBY HELPER**, P.O. Box 308, Bridgewater, MA 02324, or call (617) 339-1026. Visa/MC accepted.

CIRCLE 203 ON FREE INFORMATION CARD

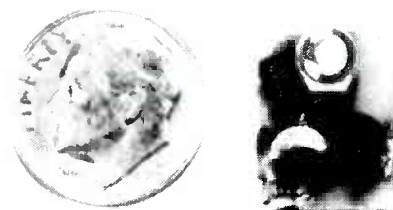

**THE MODEL WTT-20 IS ONLY THE SIZE OF A DIME**, yet transmits both sides of a telephone conversation to any FM radio with crystal clarity. Telephone line powered - never needs a battery! Up to 1/4 mile range. Adjustable from 70-130 MHz. Complete kit \$29.95 + \$1.50 S + H. Free Shipping on 2 or more! COD add \$4. Call or send VISA, MC, MO. **DECO INDUSTRIES**, Box 607, Bedford Hills, NY 10507. (914) 232-3878.

CIRCLE 127 ON FREE INFORMATION CARD

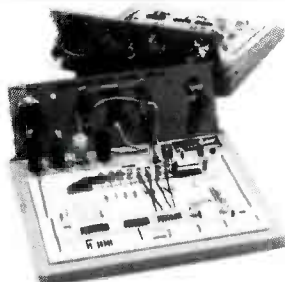

**X-TRA EDGE SOLDERLESS BREADBOARDS**. Four (4) models, each includes the Multi-use Edge Panel for mounting components which don't fit the 0.1" DIP size breadboard spacing. Transistors, SCRs, Triacs, Regulators, Heat Sinks, Switches, Lamps, Fuses, Pots, Buzzers, etc. Models include 810, 1620, 2230 and 2940 tie-points. Priced at \$16.95, \$34.95, \$49.95 and \$59.95. **CHENESKO PRODUCTS**, 21 Maple St., Centereach, NY 11720, 516-736-7977, Fax: 516-732-4650

CIRCLE 188 ON FREE INFORMATION CARD

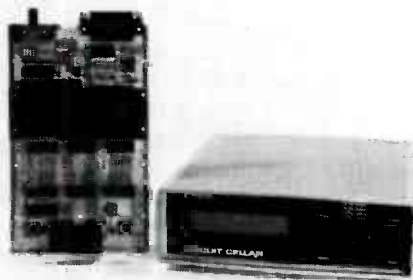

**BUILD STEVE CIARCIA'S NEW SUPER IC TESTER** Tests over six hundred 7400-series TTL, L, S, H, C, HC, HCT, F, AS, and ALS devices, 4000-series CMOS and PALs. Identifies unmarked chips and bad IC pins. User definable test sequence and user expandable ROM library. Tester operates standalone with LCD display, or with IBM PC or terminal. Partial kit—\$99. Full board kit—\$179. **CCI**, 4 Park St., Suite 12, Vernon, CT 06066. (203) 875-2751.

CIRCLE 52 ON FREE INFORMATION CARD



**DECODE NEARLY ANY SINGLE LEVEL GATED PULSE SIGNAL**. New circuit works with Hamlin, Jerrold, Sylvania, and Eagle systems. Decodes In-band, Out-band, AM or FM reference. Complete educational kit including P.C. board, parts, case, and 40 page gated pulse theory booklet is only \$47.00 plus \$3.00 shipping. Order no. 1PFD-1K. **ELEPHANT ELECTRONICS INC.** P.O. Box 41865-R, Phoenix, AZ 85080. (602) 581-1973

CIRCLE 185 ON FREE INFORMATION CARD



**AN INTRODUCTION TO BASIC PROGRAMMING TECHNIQUES**. This book is based on the author's own experience in learning BASIC and also in helping others, mostly beginners to programming, to understand the language. Included is a program library of programs that the author has actually written and run. Order your copy today. Send \$5.00 plus \$2.65 for shipping in the U.S. to **Electronic Technology Today Inc.**, P.O. Box 240, Massapequa Park, NY 11762-0240.



**PANASONIC CABLE CONVERTERS**, Wholesale and Retail. Scientific Atlanta and Pioneer Cable Converters in stock. Panasonic model 130N 68 channel converter \$79.95, Panasonic Amplified Video Control Switch Model VCS-1 \$59.95. Scientific Atlanta Brand new Model #8528 550MHZ 80 Channels Converter \$89.95. Video Corrector (MACRO, COPYGUARD, DIGITAL) ENHANCER \$89.95. We ship to Puerto Rico, Caribbean countries, & So. Amer. Write or call **BLUE STAR IND.**, 4712 AVE. N, Dept 105, Brooklyn, NY 11234. Phone (718) 258-9495.

CIRCLE 85 ON FREE INFORMATION CARD

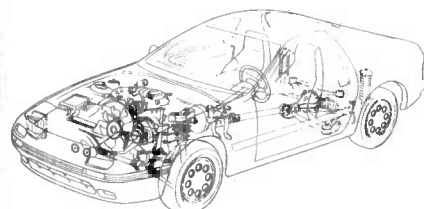

**LEARN AUTOMOTIVE ELECTRONICS**. 115 page manual and all necessary parts to conduct more than 100 experiments. Leads student through basic principles of automotive electronics thru to semi-conductors, logic circuit fundamentals and an introduction to robotics. Evolved from the 15 year teaching career of Frank Kurucz who believes in graphic and practical demonstrations to make theory interesting and understandable. Complete kit \$49.95. Manual only \$12.49 (add \$3 shipping) **OCTE ELECTRONICS**, PO Box 276, Alburg, VT 05440 (514) 739-9328

CIRCLE 80 ON FREE INFORMATION CARD

# AUDIO UPDATE

## Documentation difficulties

THE OTHER DAY I HEARD A STEREO-equipment dealer tell a customer that if he found the “documentation” for some of his just-bought audio components unclear, he, the dealer, stood ready to answer any questions that might arise. For me, that raises two matters worth discussing: When did audio instruction manuals become “documents?” And, more important, why did the dealer expect the documents/manuals to be unclear? The use of the term “documentation” is, of course, simply another minor example of the kind of jargon that puts roadblocks in the path of communication. Lord knows, stereo technology is difficult enough to explain without injecting computerese.

Because the technology is both difficult to understand and rapidly evolving, one might imagine that manufacturers would make special efforts to provide clearly written, well-illustrated instruction manuals. A clear, attractive, and interesting manual not only enhances the customer’s pride of ownership in his equipment, but could do much to eliminate those after-sale phone calls from customers confused about one or more of the operating features on their new components.

### The source of the problem

Of course, there are some manufacturers whose instructions are all that any one could ask. But why are so many manuals so incomplete, so strangely worded, and, in general, so inadequate? Almost all of the problem occurs because most of audio equipment sold in the U.S. is not only made,

but also written about in the Orient. (I say *almost* all, because for more than a year one U.S. manufacturer of a very sophisticated and complex preamplifier provided an “instruction manual” that consisted of a thick photo-offset copy of a typed transcript of someone’s free-association musings on the product.)

But even when the products come from overseas, aren’t their manuals written, or at least edited, by someone with at least some talent for communicating technical instructions in English to a non-technical audience? Sometimes, but certainly not always. I suspect that many U.S. importers are so pleased to get *any* printed material along with the product that they are not about to complain about such “trivial” matters as clarity, accuracy, or prose style! The following are two true, illustrative, personal anecdotes:

**Case 1.** I once received a frantic call from an audio sales manager surrounded by samples of his new line. They had arrived the day before completely devoid of any descriptive literature. His problem was that he needed to get some fast printed material out to his sales representatives, but he wasn’t sure that he fully understood the features and characteristics of the products that the Japanese had chosen to ship to him. My job, if I cared to accept it, was to go over each product and dictate into a recorder as much as I could deduce about its specifications, features, and functions.

Obviously, that was a worst-case situation, but it’s not at all uncommon for a U.S. subsidiary or im-

porter (or advertising agency) to be presented with a line of new products said to have “special design features” that, at best, are far from self-explanatory, and, at worse, make no sense at all. Which brings us to:

**Case 2.** I was asked by the U.S. sales manager of a respected high-end Japanese audio line to produce a technical “white paper” explaining a new “revolutionary” (aren’t they all?) amplifier circuit used in this year’s products. After studying the schematics and the quasi-English technical gobbledegook that purported to describe the new circuit—let’s call it Gamma-Plus—and its purpose, I generated about 1,500 words of what I hoped were plausible explanation and justification. I ran them by the company’s U.S. technical consultant who admitted to being no wiser than I about the absolute technical truth of the matter, but who thought my guesses about the operation and purpose of Gamma-Plus were as good as any he had yet heard.

I submitted my white paper, it was accepted and subsequently became part of the press kit to be given out at the press conference—which I was scheduled to attend—where the Japanese president and chief engineer would introduce the new Gamma-Plus line. During the question and answer part of the conference I tried to get an authoritative explanation of Gamma-Plus from the company’s chief engineer. In reply to my questions, he assured me that there was an “excellent explanation in the press kit”—thus

*continued on page 97*



LARRY KLEIN,  
AUDIO EDITOR

# COMPUTER DIGEST

VOL. 5 NO. 2 FEB. 1988

A NEW KIND OF MAGAZINE FOR ELECTRONICS PROFESSIONALS

A  
**GERNSBACK**  
PUBLICATION

## DESKTOP PUBLISHING

A package for every pocketbook

## BUILD THE PT-68K

Adding a keyboard and more.

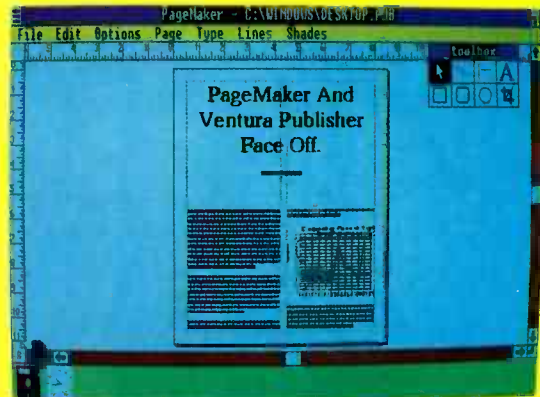
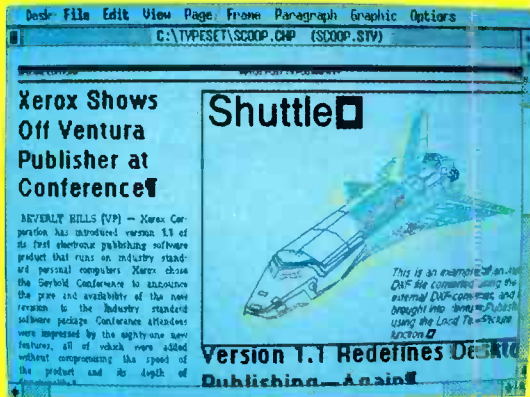

# CONTENTS

# FEBRUARY

# 1988

Vol. 5 No. 2

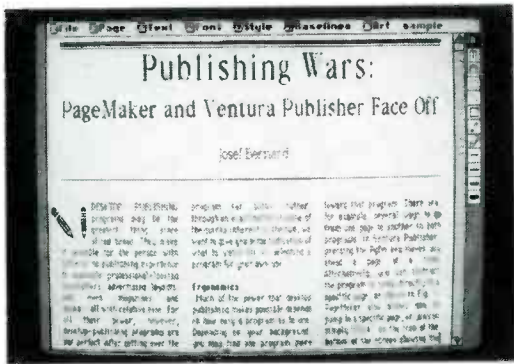

**85 DESKTOP PUBLISHING**  
Four popular products are profiled

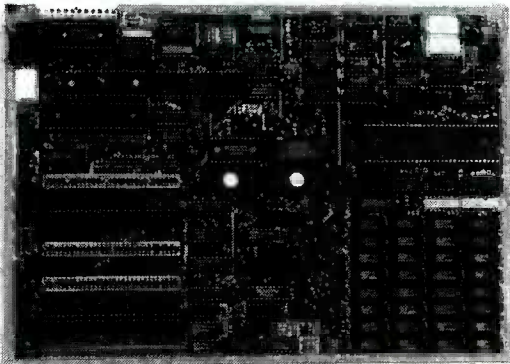

**91 CD CLASSROOM, PART 5**  
Expanding the PT-68K

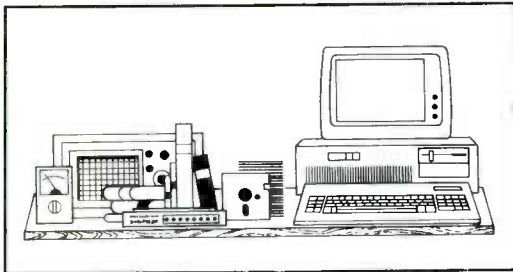

**83 EDITOR'S WORKBENCH**  
A no-slot clock for IBM and Apple II ZBASIC for MS-DOS, Z80, Apple II, and Macintosh

# COMPUTER

# DIGEST

**Larry Steckler,**  
EHF, CET: publisher & editor in chief

**Art Kleiman,**  
editorial director

**Brian C. Fenton,**  
managing editor

**Jeff Holtzman**  
technical editor

**Byron G. Wels,**  
associate editor

**Carl Laron,**  
associate editor

**Robert A. Young,**  
assistant editor

**Teri Scaduto**  
editorial assistant

**Ruby M. Yee,**  
production director

**Karen Tucker,**  
production advertising

**Robert A. W. Lowndes,**  
production associate

**Marcella Amoroso**  
production assistant

**Andre Duzant,**  
technical illustrator

**Jacqueline P. Cheeseboro**  
circulation director

**Arline R. Fishman,**  
advertising director

ComputerDigest  
Gernsback Publications, Inc.  
500-B Bi-County Blvd.  
Farmingdale, NY 11735

**ADVERTISING SALES 516-293-3000**

Larry Steckler  
Publisher

**NATIONAL SALES**

Joe Shere  
1507 Bonnie Doone Terrace  
Corona Del Mar, CA 92625  
714-760-8697

Cover Photography by Herb Friedman  
and Jeff Holtzman

# EDITOR'S WORK- BENCH

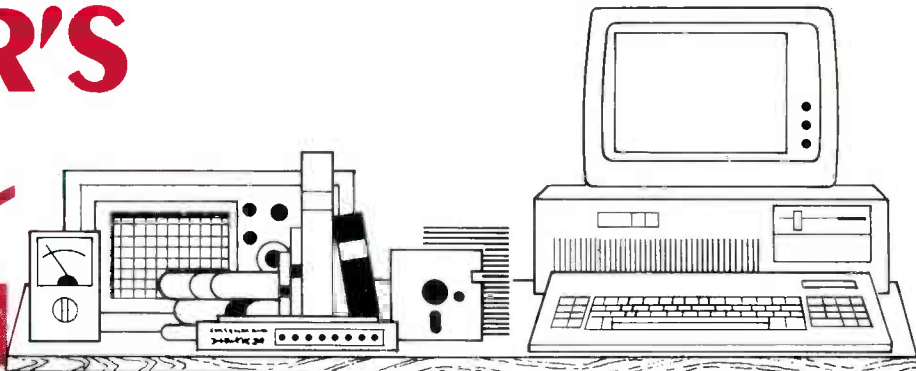

## No-Slot Clock for IBM and Apple II

Few things are more annoying than having to enter the time and date every time you boot your PC, XT, or clone. But if you don't enter the correct time and date, you lose a valuable source of information about when your files are modified and created. In addition, you lose flexibility in backing up your work if your files aren't correctly dated.

IBM corrected the deficiency in the AT, which includes its own battery-backed clock. PC and XT owners can correct the deficiency by adding an external clock, and there are several ways of doing so. A simple and inexpensive single-function—clock only—expansion card may be inserted in any available slot, as may a multi-function card. The problem is that you must give up a slot in either case, and because most clone motherboards now have 640K of built-in memory, the multi-function card's memory must go unused.

Systems Manufacturing Technology, Inc. has developed a simple, elegant, and low-cost solution to the problem; it's called the No-Slot Clock, and it's available from the distributors mentioned in the sidebar.

### What it is

The No-Slot Clock is a single-chip real-time clock/calendar that quickly and easi-

ly mounts in a PC, XT, PCjr, or clone to provide AT-like clock features. No expansion slot is required; normally you would install the clock in a ROM socket—used or unused.

The clock provides the following information: hundredths of a second, seconds, minutes, and hours, and it is accurate to within two minutes a year. In addition, date, day of week, month, and year are provided by the IC. Adjustments for leap years and months with fewer than 31 days are performed automatically.

The clock's design is unique in that

batteries are contained within the IC itself. Using techniques pioneered by Mostek in early 1983, the No-Slot Clock has two long-life lithium cells embedded in its sealed, 14-pin plastic DIP case. The batteries serve as backup power when the main power supply fails or when the machine is turned off. The batteries have a life expectancy of 10 to 20 years, and never need replacing. In fact, Systems Manufacturing Technology unconditionally guarantees the No-Slot Clock—including batteries—for a full 10 years!

The clock contains a circuit that

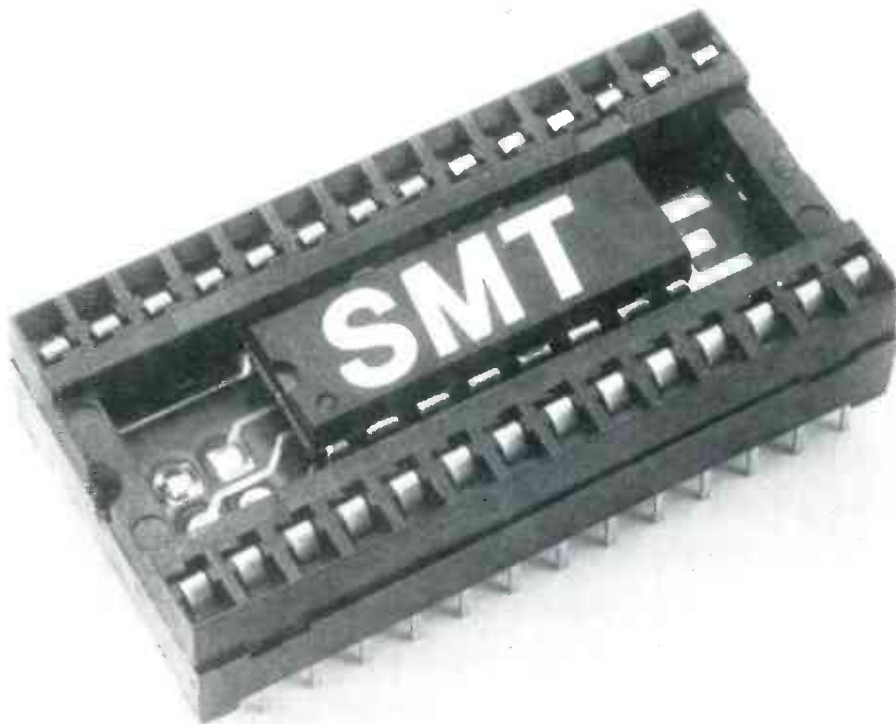

FIG. 1

monitors the state of the batteries, as well as the power-supply voltage. The circuit trips when the power supply drops to  $4.63 \pm 0.12$  volts. When the supply voltage falls below the trip voltage, control logic disables the clock's chip-enable input, thereby protecting internal registers from accidental data change.

As the power supply falls below 3.0 volts, the detector connects one of the three-volt lithium cells to the clock's power distribution bus and disconnects the external supply. The independent cell with the higher voltage is used for power.

During power-up, the switching circuit triggers when the power supply exceeds 3.0 volts, disconnects the lithium battery from the circuit, and reconnects the main power supply. As voltage passes the 4.63 volt threshold, the chip-enable input itself is enabled, thereby allowing the chip to become fully operational.

### Installation

The clock IC itself is a 14-pin DIP that is mounted inside a 28-pin DIP extender socket, as shown in Fig. 1. To install it in an IBM type machine, locate an empty 28-pin ROM socket on your motherboard, and plug in the assembly. If you have no empty socket, simply remove a socketed ROM IC, insert the No-Slot Clock in the socket, and then replace your ROM. True-blue PCs and some clones use 24-pin ROM's rather than the newer 28-pin ROM's. In that case, just install the No-Slot Clock on an adapter board (a CGA or EGA video adapter, a hard-disk controller, etc.) that contains a socketed BIOS EPROM or ROM.

Software supplied with the clock allows you to set the time and date from DOS and to recall the settings automatically on power up.

### Apple version

The No-Slot Clock can also be used in an Apple IIe. Even though the Apple doesn't require time and date entry on power up, many programs make use of a clock if it is available.

The No-Slot Clock is easily installed on

the IIe motherboard in the 28-pin ROM socket labeled CD. Simply remove the ROM IC that is mounted in that socket, insert the No-Slot Clock, and replace the ROM. Included software allows the clock to operate with ProDos, Dos 3.3, Pascal, and Appletworks.—TJ Byers 

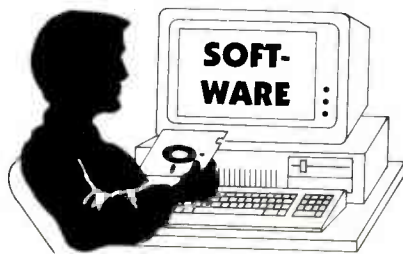

### ZBASIC, for MS-DOS, Z80, Apple II, and Macintosh

**B**asic is the language of choice for millions of people, ranging from rank beginners to dyed-in-the-wool hackers. In the past few years, the large system-language houses (Microsoft and Borland) have been battling by introducing new versions of the language that are light years beyond what was available only three or four years ago. Meanwhile, a small company named Zedcor has quietly been building a version of BASIC that has many of the features of Quick and Turbo BASIC, and that addresses one issue the big companies have ignored completely: portability.

Zedcor describes ZBASIC as an interactive BASIC compiler. That is, your normal working environment has the feel of interpreted BASIC, but programs are actually compiled to machine language before they're run. Unlike traditional BASIC compilers, however, compilation is fast—so fast, in fact, that for small programs you'll hardly notice compilation time at all.

ZBASIC is generally compatible with other versions of BASIC available for the target machine, but there are differences that prevent strict one-for-one translation. For example, in the MS-DOS version, ZBASIC will not accept standard BASICA (GW-BASIC) open file statements of the form:

```
OPEN "FILENAME" FOR INPUT AS #1
Rather, you must use the alternate syntax (which is also acceptable in BASICA):
```

```
OPEN "I", #1 "FILENAME"
```

All such syntactic differences are well documented, so translating an old program or writing a new one, if you're used to the old syntax, should not be difficult.

The biggest differences between ZBASIC and the native versions of the language are in the graphics statements,

```
00010 A$ = TIME$
00020 FOR I = 1 TO 500
00030 PRINT STRING$(62, "*" )
00040 NEXT
00050 B$ = TIME$
00060 PRINT "Start time: "; A$
00070 PRINT " Stop time: "; B$
00080 END
```

which have been standardized among all versions (MS-DOS, Z80 (including CP/M and TRS-80), Apple, and Macintosh) of the compiler. Graphics programs are written to conform to a device-independent coordinate system, so, theoretically, the source code of a graphics program written for one computer should compile and run on another.

There are numerous small goodies that BASIC aficionados will enjoy. In the MS-DOS version, for example, in addition to the standard CGA graphics of BASICA, both EGA and Hercules graphics are supported; arrays are not limited to 64K; a full-screen editor is instantly available; serial communications buffers can be maintained automatically; mice are supported; line numbers are not necessary; subroutines can be called by name; multi-line functions are supported; CASE, DO UNTIL, and multi-line IF statements are supported; the LIST command can highlight keywords; UNNUM removes unnecessary line numbers; and many more.

On the other hand, some statements have been left out inexplicably. For example, the INPUT\$ function (which is part of most Microsoft versions of BASIC is absent and is sorely missed.

### Using ZBASIC

After typing your program in, you can run it or compile it to produce a stand-alone executable (COM) file. The .COM file always contains the entire support library, so the following program compiles to a file that is about 20K in length:

```
00010 PRINT "HELLO"
```

However, ZBASIC programs run fast. For example, the program shown in Listing 1 runs in about 25 seconds in either the ZBASIC environment or as a stand-alone COM file; BASICA runs the program in about 92 seconds!

Zedcor includes a thick manual of more than 700 pages. Approximately half includes material that is applicable to all versions of the compiler, the rest are appendices with information specific to each implementation.

ZBASIC is available from Zedcor, Inc., 4500 East Speedway Blvd., Suite 22, Tucson, AZ 85712-5305, 800-482-4567, 602-795-3993. The current price of the IBM, Macintosh, and Z80 versions is \$89.95; the Apple DOS 3.3 and ProDOS versions cost \$49.95. 

The No-Slot Clock is manufactured by Systems Manufacturing Technology, Inc. (1145 Linda Vista Drive San Marcos, CA 92069, (800) 648-6262, (619) 744-3590).

#### CIRCLE 18 ON FREE INFORMATION CARD

The No-Slot Clock is distributed by:

- Jade Computer, 4901 W. Resecrans Ave., Box 5046, Hawthorne, CA 90251-5046, (800) 421-5500

#### CIRCLE 19 ON FREE INFORMATION CARD

- and by Micromint, Inc., 25 Terrace Drive Vernon, CT 06066 (302) 871-6170.

#### CIRCLE 20 ON FREE INFORMATION CARD

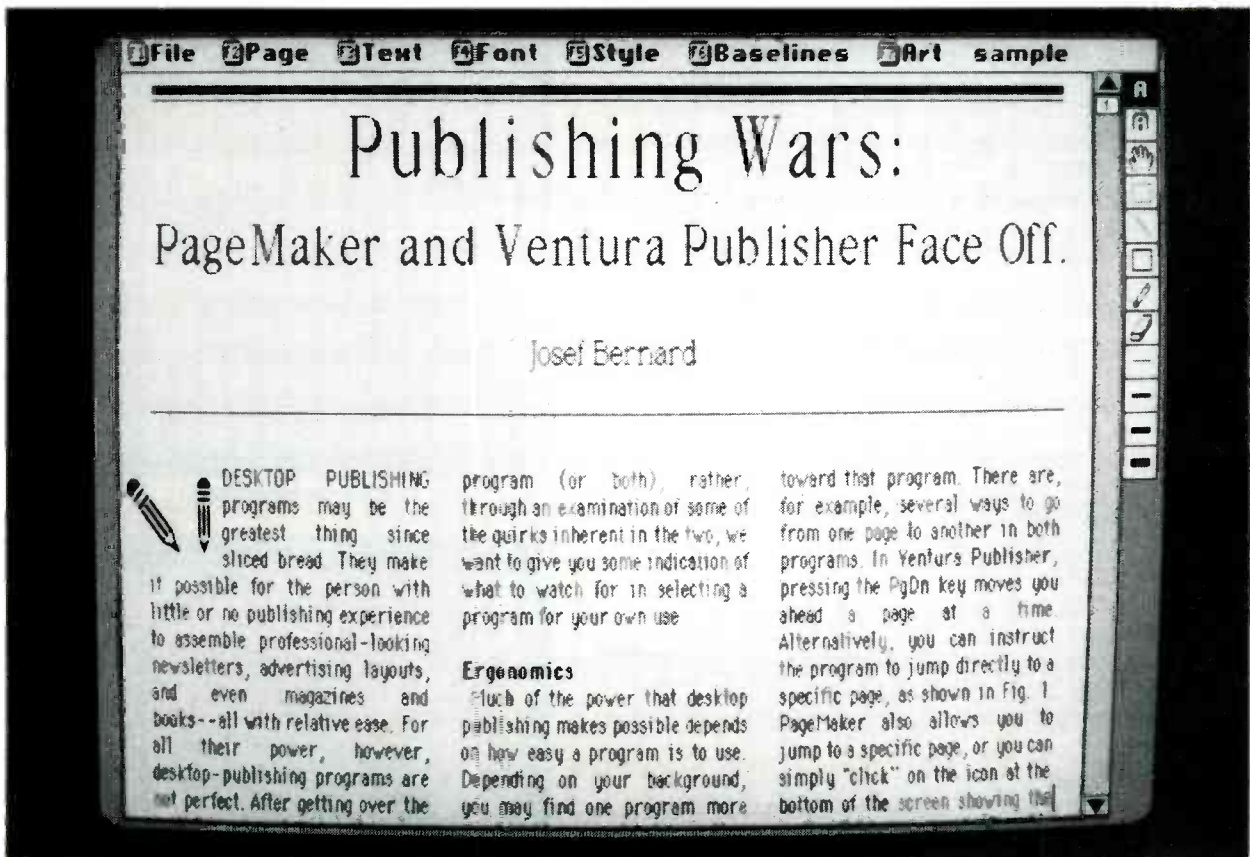

# DESKTOP PUBLISHING

*What is desktop publishing? What hardware and software are required? Must it be expensive? Read on . . .*

JEFF HOLTZMAN TECHNICAL EDITOR

**D**esktop Publishing—everybody's talking about it, but nobody knows exactly what it is. To some people, a specific program defines the field: If a program can do what program X does, it does desktop publishing. But many programs claim to do desktop publishing, and can't really, whereas many other programs don't claim to, and actually can.

In an attempt to remedy the confusion, here's a simple definition: A program does desktop publishing if it can merge bit-mapped graphics with text, and if it can produce that text in a variety of fonts (specific sizes of specific typefaces).

That definition allows us to view desktop publishing not as a *this* or a *that*, but as an activity with a range of possibilities. A skateboard and a Mercedes Benz both provide transportation, but obviously, each has different capabilities that appeal to different users. Thus, a \$50 program running on a \$500 PC clone and printing on a \$200 printer differs in degree, not in kind, from a \$7000 program running on a \$10,000 80386-based machine and printing on a \$20,000 laser printer.

With that in mind, in this and the accompanying article, we'll examine half a dozen programs, each of which

occupies a separate niche in the desktop-publishing spectrum. The programs we'll discuss (PageMaker, Ventura Publisher, PFS: First Publisher, Inset, The Printing Press, and Lotus Manuscript) represent a non-comprehensive sample of what's available, but several products are unique (Manuscript and Inset).

As for hardware, Printing Press and Inset will run a floppy-only system; the others require a hard disk. All programs will run on a standard IBM PC, XT, or compatible; but unless you've got a great deal of patience, you'll want an AT-class machine (or a PC with an accelerator card). All but Manuscript and Printing Press work with an optional mouse. In fact, menu and graphic manipulation is much easier with one, but keyboard-only operation is also possible.

## Overview

PageMaker, Ventura, and PFS all function in a graphic environment, wherein menus for accomplishing various actions drop down from the top of the screen. All menus and other text are presented in bit-mapped graphics form, so speed is required for all but the most occasional (and patient!) use.

PageMaker runs under Microsoft Windows, Ventura runs under Digital Research's GEM (Graphics Environment Manager), and PFS runs in its own proprietary environment. Windows and GEM are similar in that they provide both a consistent user interface that simplifies using a broad range of programs, and a consistent programmer interface that simplifies (in some senses) writing those programs. See the accompanying article for more information on PageMaker and Ventura Publisher.

Inset is a ram-resident program that monitors keyboard input and printer output. When Inset's hot key is pressed, the program pops up and allows you to integrate graphics images (created from scratch in Inset, or captured from other programs) with text. You use your word processor's normal print function to print a document that contains such an image; Inset automatically merges the graphics image with your text.

The Printing Press is an inexpensive program that allows you to create signs, greeting cards, etc., quickly and easily.

Lotus Manuscript provides a complete environment for creating documents, from initial note-taking to final printing. It combines a word processor, an outliner, and a flexible page-printing system. Of course it accepts Lotus 1-2-3 graphs, other types of graphics images, and it allows you to create tables and formulas easily.

### PFS: First Publisher

From the makers of several entry-level products (word processors, database managers, etc.) comes PFS: First Publisher, an amazing and frustrating \$99 package. It's amazing in what it can do (considering the price), and frustrating in how it does—or doesn't—do what it's supposed to do.

First Publisher has a complete graphics interface with drop-down menus. A mouse is not required, but makes most operations much easier. First publisher can drive just about any PC graphics adapter (CGA, EGA, and Hercules), and many printers, both dot-matrix and laser (HP and Apple) as well.

You work with the program in two layers: graphics and text. The placement of text is determined by *baselines*, analogous to ruled lines on paper. Baseline length and position is adjustable singly and in groups (by column, and above or below a given baseline.) Figure 1 shows the baseline display for our sample.

After setting the baselines, allowing space for graphic images, you can flow the text. (See Fig. 2.) The text must be formatted with CR's (no LF's). PFS word processors apparently do so, but few other word processors do, so you may need a conversion utility to get your text into First Publisher. You can also type text directly into the program, but only limited editing is available. First Publisher does no hyphenation, so when you flow text into your publication, you'll either have to hyphenate it manually or live with large gaps between words on some lines. By contrast, both PageMaker and Ventura are able to hyphenate words automatically.

Then you switch to the graphics layer. Graphics handling is First Publisher's strong point; the program provides a miniature graphics editor (which neither PageMaker nor Ventura Publisher provide), in addition to the usual tools for creating ruled lines and boxes. Also, First Publisher comes with five "sheets" of clip art with various images that you may "clip" and edit using the graphics

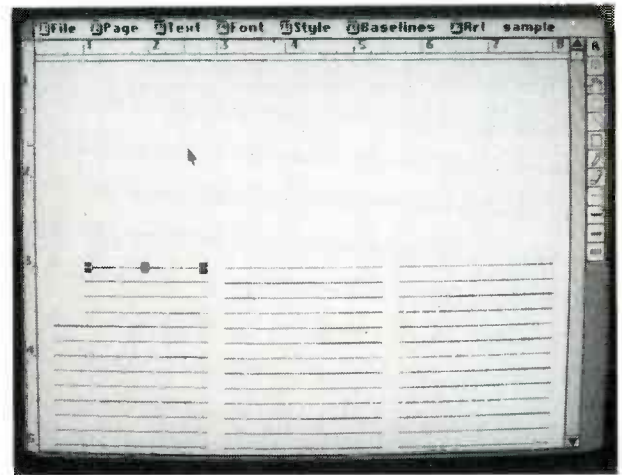

FIG. 1—PFS: First define baselines.

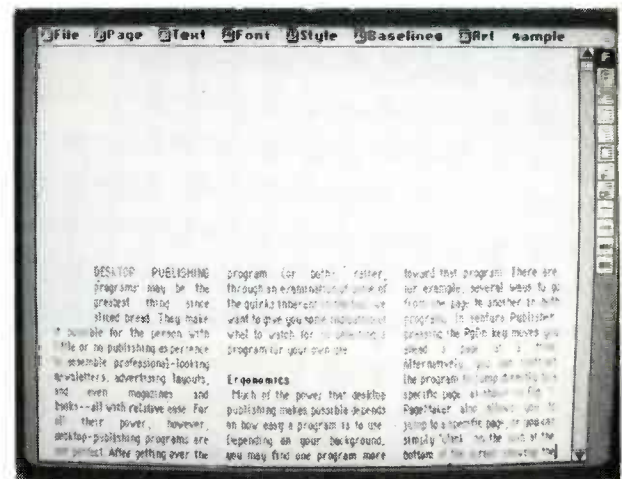

FIG. 2—PFS: Next add your text.

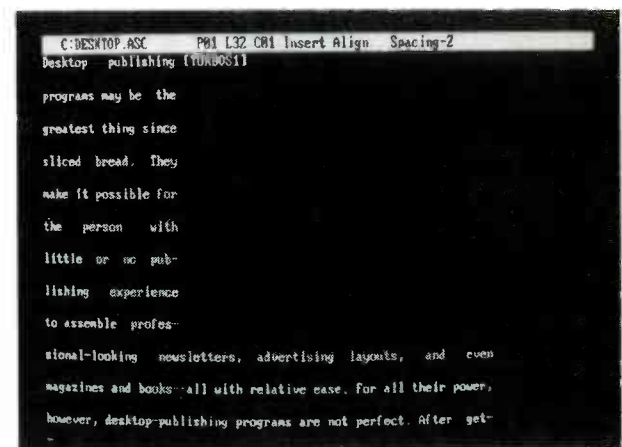

FIG. 3—INSET: Format text and add bracketed image name.

editor. The latter includes tools for flipping a selected image horizontally and vertically, resizing it, pixel-level editing, "inverting" (changing all black to white, and vice versa), and more.

You can also enter text (in any of the approximately 60 fonts provided) on the graphics layer; after pressing the Enter key, your text becomes a bit-mapped image that may be manipulated with all the tools mentioned above. Headlines are best created in that way. Creating certificates is possible by duplicating and flipping clip-art



images to create a border, and then adding your text. In addition, First Publisher includes templates for several types of publications, including a newsletter, business stationary, a greeting card, and more.

PFS: First Publisher has two problems: its documentation and its tendency not to do what you tell it to do. The user's manual is very poorly organized, with some highly necessary information buried in obscure places. The book is well-indexed, however. In addition, it neglects to delineate proper layout procedure. Is it best to flow text first and add graphics later? (No.) Or should the graphics be placed, then the baselines defined, and then the text flowed? (Probably.) Should the basic layout (baselines and graphics placement) of each page—not just the first—be defined before flowing any text? (Absolutely.) The manual is no help in answering those questions.

The second problem is more insidious. Even after defining your baselines, which itself takes quite a bit of simple trial-and-error experimentation, text often does not follow your guidelines. And adjusting baselines after text and graphics have been placed is next to impossible.

In spite of those problems, First Publisher provides many of the capabilities of the big-name packages, as well as a unique graphics editor, at five or ten percent of their cost. If nothing else, First Publisher might be a good way to get your feet wet in desktop publishing. Many of the skills you'll learn will be transferable should you decide to upgrade to one of the power packages.

### THANKS

Thanks to NEC Home Electronics for loan of a NEC Multi-Sync monitor, on which all photographs in this article and on this month's cover were taken.

### Inset

If you're interested in improving the quality of your presentations, but are unwilling or unable to invest the requisite time and money in a full-fledged desktop-publishing program, Inset may be for you. It's an ingenious package that allows you to integrate graphics and text, all within the confines of your regular word processor.

Inset runs on just about all IBM graphics adapters (CGA, EGA, and Hercules), and supports a variety of printers (IBM, Epson, Okidata, NEC, etc.), including several color printers and several laser printers. A mouse can be used, and is handy, but is not required.

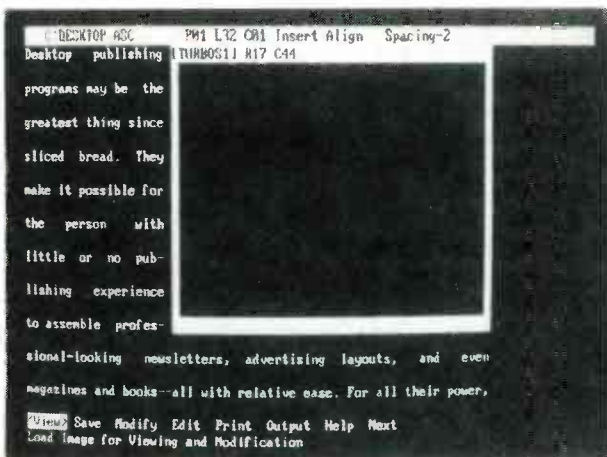

FIG. 4—INSET: Next bring up and size the image frame.

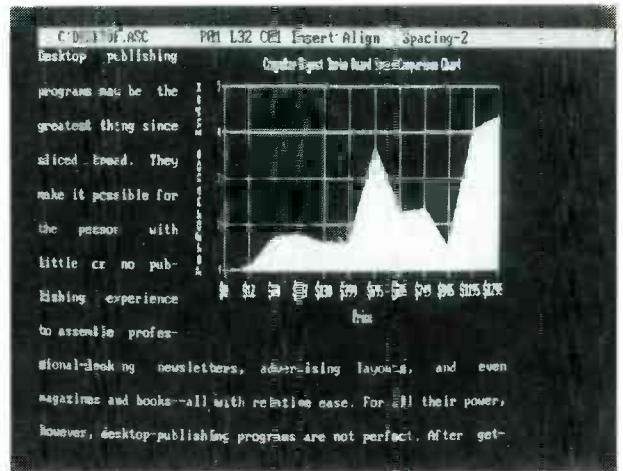

FIG. 5—INSET: Then preview the final page.

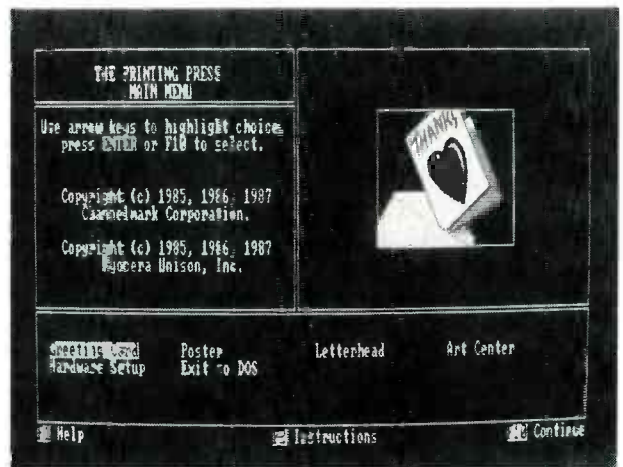

FIG. 6—THE PRINTING PRESS: Main menu.

You install Inset as a RAM-resident program that pops up when you press a hot key (normally PrtSc). The program requires from 35K to 115K of memory, depending on which options you enable. The smallest version only allows you to capture text or graphics screens from just about any program, including DOS, Lotus 1-2-3, dBASE, AutoCAD, etc. Those and other images may be edited later by the full version, which includes a fairly complete graphics editor.

You use your word processor to format your text, leaving a gap where the desired image will appear. Next you place the file name (surrounded by brackets) of the desired image in the upper-left corner of that area. (See Fig. 3.) Then, when you press the hot key, Inset will draw an outline on the screen showing where the image will appear, but not the image itself. (See Fig. 4.) At this point you can adjust the X and Y dimensions, independently or maintaining the original aspect (height to width) ratio. When the frame is the right size, you'll want to preview the actual image. (See Fig. 5.) If the size or the shape of the image is unacceptable, it's easy to modify either.

As for the image itself, you can create it from scratch within Inset, you can capture an image generated by another program—such as 1-2-3 graph, for example—and use it as is, or you can use Inset to modify a captured image from another package.

The text and graphics files are totally separate, but you print the text file using your word processor's usual print

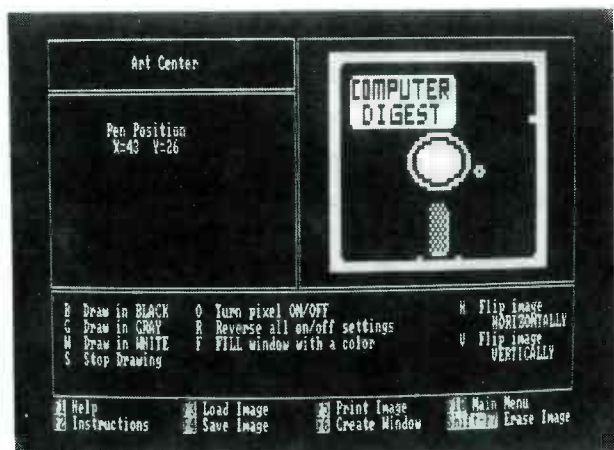

FIG. 7—THE PRINTING PRESS: Graphics editor.

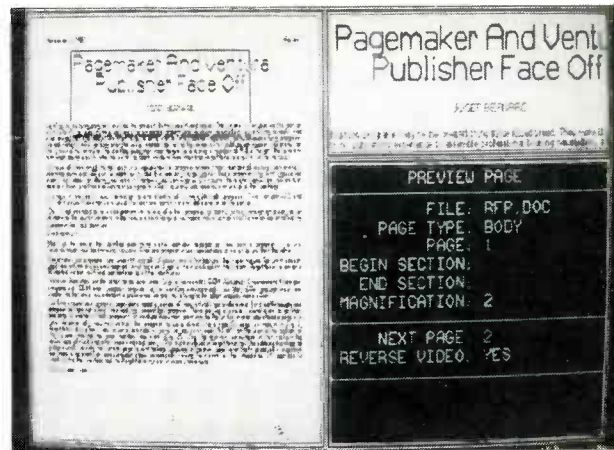

FIG. 8—LOTUS MANUSCRIPT: Print preview screen.

function. Meanwhile, Inset is lurking in the background monitoring all printer output, and when it sees the bracketed file name, it knows it's time to print the graphic image in the proper size, shape, and position. Color images are printed on a black and white printer by gray-scaling (simulating colors with various shades of gray).

Because of the way Inset works, it's best to use it with a word processor that displays text on-screen pretty much as it will appear on paper. WordStar 4.0 (which was used for our sample shots) works well; Inset systems also claims compatibility with DisplayWrite 2, DisplayWrite 3, MultiMate, Microsoft Word, Office Writer, Word Perfect, XyWrite II Plus, XyWrite III, and others.

The program and its drivers come on two floppy disks; a 150-page manual explains all operations. The manual includes a quick-start section for experienced users, and a brief tutorial for beginners.

### The Printing Press

By most people's definition, The Printing Press is not a desktop-publishing program, but because it allows you to integrate text and bit-mapped graphics, it fits ours. You use the program to create greeting cards, posters, and letterhead stationary. It runs on the Hercules monochrome graphics card, and on CGA compatibles (including EGA). Apparently the program was written for the CGA, and only crudely translated for the Hercules, because on the

latter graphics are "squashed." That's not a serious problem, though, because images still print correctly. Supported printers include: IBM, Epson, Okidata, Toshiba, NEC, C. Itoh, etc.

The program is supplied on a single floppy disk; it includes a 111-image graphics library (other libraries are available at reasonable prices), eleven border styles, and ten text styles. Installation amounts to copying all files to a working disk, and then telling the program which graphics card and printer you'll be using. The Printing Press comes with a context-sensitive on-line help system, and an on-disk documentation file you can print yourself. To keep costs down, printed documentation is not included.

When you run the program, you're presented with the opening menu (shown in Fig. 6), from which you choose the type of publication you want to create, set up the hardware, exit to DOS, or enter the "Art Center," a graphics editor. You navigate menus using the cursor keys, and make your selection by pressing the Enter key.

To make a poster, for example, you choose that item from the main menu, after which you're presented with the Poster Design Elements menu. There you choose a border style, one or two graphics images, their placement, and the text of your poster. Text can appear in ten different type styles, each of which may appear in one of two different sizes, and in one of five "textures" (standard, outline, checkered, etc.).

You can place graphic images in one of three sizes (regular, half-size, and double-size). Double-size images are centered on the design for you automatically; you have some control over how (and how many) images are placed in the other sizes, or the program will place them for you in one of several ways.

Last, you preview your design and then print it. Or you can return to the editing screens and further modify the images and text. When everything is as you want it, you can save the image to your working disk.

The Art Center (shown in Fig. 7) provides a rudimentary graphics editor that allows you to turn individual "dots" on and off, flip an image horizontally and vertically, reverse it (black to white and vice versa), and more. There is no provision for creating even simple shapes (lines, boxes, circles) or text other than dot by dot. You can create your own images from scratch or modify those in the supplied library. Each image is composed of an 88 x 52 array of dots.

### FOR FURTHER INFORMATION

The best single source of information we have seen that covers all aspects of publishing (not just the desktop variety thereof) is *The Illustrated Handbook of Desktop Publishing and Typesetting*, by Michael L. Kleper, c. 1987, Tab Professional Books, P.O. Box 40, Blue Ridge Summit, PA 17214.

The graphics department of your local college or university is another good source of information.

The explosion of the desktop-publishing industry has spawned a slew of magazines devoted to the field, many of which are not worth the paper they're printed on, and probably won't be in print very long. The best of the lot are *Personal Publishing* (Hitchcock Publishing Company, 25W550 Geneva Road, Wheaton, IL 60188-2292, 312-665-1000) and *Publish!* (PCW Communications, Inc., 501 Second St., San Francisco, CA 94107, 800-222-2990, 415-243-0600). PC World and Mac World magazines (also published by PCW) also carry desktop-publishing features occasionally.

It takes a fair amount of trial and error to get things right, because you don't see whether your image(s) will interfere with your text until you go to the preview screen. Your text, for example, could overlay an image and thereby be indecipherable. However, after creating a few designs, you get a feel for how much space images and the various text fonts occupy, so you can then plan your designs accordingly.

The only real problem with the program is the way you must select an image by scrolling through list after list after list of images in the currently selected set. It would be much more convenient to be able to select an image by name. In addition, you don't know what an image looks like until you select it. Another great convenience would be a way of printing an entire graphics library (with image names) at once.

### Manuscript

This product from Lotus Development Corporation attempts to combine three products in one: word processor, outliner, and graphics integrator. The latter capability is what qualifies Manuscript for inclusion here.

Unlike most desktop-publishing programs, Manuscript is intended for use at each step of the documentation process. You can take notes and subsequently rearrange them using the outliner, write and edit your text with the editor, and then print your document on a wide range of dot-matrix and laser printers.

Your documents can include several types of graphics elements: tables (with ruled lines); graphs imported from 1-2-3, Symphony, and other programs; equations, which you enter using a special equation-description language; and several others (including scanner and PostScript files). Describing an equation is straightforward. For example, the equation:

$$A^2 + B^2 = C^2$$

would be entered using a Manuscript "backslash" command as:

\equation A super 2 + B super 2 = C super 2\

### PRODUCTS DISCUSSED

- PageMaker (\$695), Aldus Corporation, 411 First Avenue South, Seattle, WA 98104, 206-622-5500.  
CIRCLE 21 ON FREE INFORMATION CARD
- Xerox Ventura Publisher (\$895), Xerox Corporation, P.O. Box 24, Rochester, NY 14692, 800-832-6979.  
CIRCLE 22 ON FREE INFORMATION CARD
- The Printing Press (\$49.95), Power Up!, 2929 Campus Drive, P.O. Box 7600, San Mateo, CA 94403, 800-851-2917, 800-223-1479 (CA).  
CIRCLE 23 ON FREE INFORMATION CARD
- Inset (\$99.95), Inset Systems, 12 Mill Plain Road, Danbury, CT 06811, 800-828-8088, 203-794-0396.  
CIRCLE 24 ON FREE INFORMATION CARD
- PFS: First Publisher, P.O. Box 7210, 1901 Landings Drive, Mountain View, CA 94039-7210, 415-962-8910.  
CIRCLE 25 ON FREE INFORMATION CARD
- Lotus Manuscript Lotus Development Corporation, 55 Cambridge Parkway, Cambridge, MA 02142, 800-345-1043, Lot No. QA-1450.  
CIRCLE 26 ON FREE INFORMATION CARD

Although a wide range of printers is supported, the bit-image capabilities of dot matrix printers are not used for text reproduction (as PageMaker, Ventura, and PFS can do), so only a printer's native text fonts are available. That means you won't be able to print half-inch headlines, italicized type, or Greek letters on a dot-matrix printer that doesn't have those capabilities built-in.

The editor is fast, but you don't get a WYSIWYG (What You See Is What You Get) display for either text or graphics, so you don't know where page breaks occur until you either print or preview the document.

The basic procedure for integrating a graphics image with a document is simple. To include a 1-2-3 graph, for example, you have to enter another backslash command of the form:

\picture filename\

The column where the command is located determines where the image will appear, and the command itself allows you to scale the image horizontally and vertically. But to see how the image appears on the page, you must do a print preview, as shown in Fig. 8. An overview of the page is shown on the left side of the screen; you can magnify a portion of the image by moving the box (shown in the upper left corner of the page image) around using the cursor keys. The current contents of the magnifying glass are shown in the upper right corner of the display.

Manuscript is supplied on eight floppy disks, whose contents occupy more than two megabytes of space. You can delete unnecessary printer and screen drivers to reduce that to about 1.5 megabytes. Two well-produced manuals (tutorial and reference) are included. The editing and outline functions work fairly quickly on a standard XT, but to preview pages on-screen, you'll want an AT-class machine, on which the preview process is by no means instantaneous.

### Conclusions

Each of the programs discussed in this article is a quality product, with its own strengths and weaknesses, and whose capabilities overlap the others in some areas. The Printing Press, for example, is by far the easiest to use, but has the lowest quality output. At the other end of the scale, it would be overkill to use Ventura Publisher to make a "Garage Sale" sign. A good compromise is PFS: First Publisher, which can provide fairly high quality output, but which requires a heavier investment in learning and usage time. For example, you'll have much better control over graphics and text placement with PFS than with Printing Press, but you'll have to spend time doing that placement—and it adds up quickly.

To produce a semi-formal report for school or business, Inset is hard to beat because of its ability to capture and edit images from a multitude of programs, and then include those images in your report.

Lotus Manuscript could be the ideal solution for the professional technical documentation specialist working with (and converting files to and from) several packages (outliner, word processor, and print formatter). The integrated environment, along with Manuscript's ability to work with really large documents, make it highly attractive to the user. Next time, we'll see how two of the heavyweights—PageMaker and Ventura Publisher—fare in a head-to-head competition. 

# R-E Computer Admart

Rates: Ads are 2 1/4" x 2 7/8". One insertion \$825. Six insertions \$800 each. Twelve insertions \$775. each. Closing date same as regular rate card. Send order with remittance to Computer Admart, Radio Electronics Magazine, 500-B Bi-County Blvd., Farmingdale, NY 11735. Direct telephone inquiries to Arline Fishman, area code-516-293-3000. Only 100% Computer ads are accepted for this Admart.

## Why waste your time formatting disks?

Preformatted disks save you time and money!

Memorex • Nashua • 3M  
5 1/4" (from 48c) • 5 1/4" HD • 3 1/2" • 3 1/2" HC  
Call toll-free TODAY!

**1-800-321-4668**

In Colorado (303) 234-0871.  
Open 8:00 to 5:30 Mountain Time,  
Monday—Friday.

**ALF**

ALF Products, 1315F Nelson St,  
Denver, CO 80215

CIRCLE 197 ON FREE INFORMATION CARD

## CALL NOW AND RESERVE YOUR SPACE

- 6 x rate \$800.00 per each insertion.
- Fast reader service cycle.
- Short lead time for the placement of ads.

Call 516-293-3000 to reserve space. Ask for Arline Fishman. Limited number of pages available. Mail materials to: Computer Admart, RADIO-ELECTRONICS, 500-B Bi-County Blvd., Farmingdale, NY 11735.

## PC Compatible CASH DRAWERS



**M-S CASH DRAWER**  
10711 Flower St., Stanton, CA 90680  
**(800) 544-1749**  
In California call:  
**(714) 821-1133**

CIRCLE 198 ON FREE INFORMATION CARD

## COMPUTER ASSEMBLY MANUALS



Eliminate Guesswork! Build with Confidence!

**BIG BLUE SEED for IBM™ BUILDERS!**  
Parts list, placement diagrams, instructions, mods, for assembling over 90 IBM-compatible bare cards. Latest version with guides for 640K, Turbo, AT & Baby AT MthBds. \$17.95

**APPLE™ BUILDERS NEED APPLE SEED!**  
Instructions for assembling over 90 Apple-compatible bare cards including II+ & IIe MthBds. For ALL Apple enthusiasts and hobbyists \$14.95

SAVE 10% - ORDER TWO OR MORE MANUALS OVER 40 BARE IBM & APPLE CARDS IN STOCK (MthBds - Disk - Video - Burner - MultiFm - I/O - Modern - Proto - etc)

Check/Money-order, VISA/MasterCard to:  
**NuScope Associates\*, Dept RE**  
In U.S.A. In CANADA  
P.O. Box 790 P.O. Box 742, Stn B  
Lewiston, NY 14092 Willowdale, Ont. M2K 2R1  
\*A Division of Kosmic MicroTech Inc.

CIRCLE 72 ON FREE INFORMATION CARD

## Motion Control & Data Acquisition

on your IBM PC or Apple II and all compatibles



**Smart 2 Axis Motion Controller:** For many types of motors & encoders. New I.C. (from HP) allows changes & monitoring on the fly. Optically isolated. W/SOFTWARE

**Four Axis Stepper Driver:** With SOFTWARE & motor for instant automation. \$95.

**Fast A/D Board:** With programmed gain, 650 KHz. 4 inputs. \$220. Complete Scope hardware & SOFTWARE \$500. Also: 12 Bit A/D. Relay Driver, Real Time Clock. Circuit developers Project Book \$25.

How do you do it? Use our Local Applications Bus, LAB 40. One host adapter (\$150) supports up to 8 boards, like those above, on a 50 ft. ribbon cable.

Please call (415) 755-1978 for free literature.

**Computer Continuum**

75 Southgate Ave., Suite 6  
Daly City, CA 94015 (415) 755-1978

## coldblue™

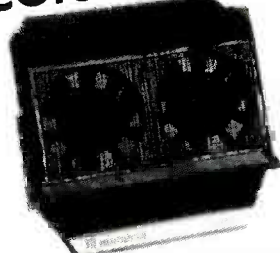

**A Ventilation System designed to extend the life of the IBM® PC, or PC/XT.**  
Coldblue™ fits inside the PC to reduce operating temperatures up to 27° by directing airflow onto the boards. The choice of users worldwide because it really works! Fits clones too. One year warranty. \$185.  
Mandrill Corp., P.O. Box 33848, San Antonio, TX 78265 (800) 531-5314, (512) 341-6155  
Dealers' inquiries welcome.

CIRCLE 196 ON FREE INFORMATION CARD

## ICs PROMPT DELIVERY!!!

SAME DAY SHIPPING (USUALLY)

QUANTITY ONE PRICES SHOWN for NOV. 22, 1987

OUTSIDE OKLAHOMA ADD SALES TAX

DYNAMIC RAM		PRICE
1Mbit	1048Kx1 100 ns	\$29.50
1Mbit	256Kx4 120 ns	34.00
51258	+ 256Kx1 100 ns	6.95
4464	64Kx4 150 ns	3.60
41256	256Kx1 80 ns	5.75
41256	256Kx1 100 ns	5.15
41256	256Kx1 120 ns	3.95
41256	256Kx1 150 ns	3.55
41264	+ 64Kx4 120 ns	5.25
EPROM		
27C1000	128Kx8 150 ns	\$37.95
27C512	64Kx8 200 ns	15.50
27256	32Kx8 250 ns	5.95
27128	16Kx8 250 ns	5.75
STATIC RAM		
43256L-12	32Kx8 120 ns	\$11.50
5565PL-15	8Kx8 150 ns	3.30

640K MOTHERBO UPGRD: Zenith 150.  
IBM PC/XT, Compat Portable & Plus; hp Vectra

\* 5% INSTL CHARGE  
\* 5% POINT OF PURCH RAM

8087-2 80397-6 80873-6  
\$160.00 \$249.00 \$510.00

OPEN 6 1/2 DAYS, 7:30 AM-10 PM: SHIP VIA FED-EX ON SAT.

SUNDAYS & HOLIDAYS: SHIPMENT OR DELIVERY, VIA U.S. EXPRESS MAIL.

SAT DELIVERY INCLUDED ON FED-EX ORDERS RECEIVED BY: Th: 2:30 PM; We: 4:15 PM; Fr: 1:15 PM (EST)

MasterCard/VISA or UPS CASH COD

Factory New, Prime Parts **μP** MICROPROCESSORS UNLIMITED, INC.

24 000 S. Peoria Ave., (918) 267-4961

NO. 3047, OK. 74421

No minimum order. Please note that prices are subject to change. Shipping & insurance extra & up to \$1 for packing materials. Orders received by 9 PM CST can usually be delivered the next morning, via Federal Express Standard Air @ \$4.00, or guaranteed next day Priority One @ \$10.00!

CIRCLE 61 ON FREE INFORMATION CARD

## THE RAM BACK CHAIR

For Stressless Sitting and Perfect Posture



- Features
- Adjustable Height 21"-27"
  - Adjustable knee and seat pad
  - Solid Wood - Oak Finish
  - Thick Velour Cushions
  - Folds for Storage

**\$54 EA**  
Credit 1-800-227-2001  
Cards 213-839-5974

Add \$9 ea. for UPS Delivery



**RAM**  
8306 Wilshire Blvd., #10  
Beverly Hills, CA 90211

Free Brochure • Money Back Guarantee

CIRCLE 69 ON FREE INFORMATION CARD

## EPROM PROGRAMMER FOR PC \$129.95



- 2716 to 1 MEG
- Programs 2764 A in 10 Seconds
- Menu Driven Software
- External 40 PIN ZIF (PC only)
- Adapter 8748, 49, 51, 52, 55, TMS 7742 \$50 PC only
- 1 Year Warranty
- 10 Day Money Back Guarantee
- Available for APPLE II \$92.50
- For More Information Call



**NEEDHAM'S ELECTRONICS**  
4535 Orange Grove, Sacramento, CA 95841  
**(916) 924-8037 (M-F) 8 AM to 5 PM PST**

CIRCLE 199 ON FREE INFORMATION CARD

RADIO-ELECTRONICS

# BUILD THE PT-68K

*Add keyboard and video this time.*

**PETER A. STARK,**  
STARK SOFTWARE SYSTEMS CORPORATION



Copyright 1987, Peter A. Stark

**Part 5** We quit last month just when HUMBUG (our monitor in ROM) signaled that it was working by sounding a “beep-boop” tone. Now let’s connect a keyboard and a video display to the computer so we can communicate with HUMBUG.

## One step backward

In order to get that beep-boop sound, we rushed the last few steps and mounted a few parts without explaining why, so let’s retrace our steps and see what we did.

In Step 13 last time, we installed four 10K resistors, an MC68681 DUART, and a 3.6864 MHz oscillator. The four resistors (R9, R10, R12, and R13) are needed because we want to use the computer before wiring is complete; they would not be needed if the entire system were completed. (They do no harm if used.)

As shown in Fig. 5 last time, the  $\overline{\text{DTACK}}$  generator contains an eight-input gate, IC36, that generates  $\overline{\text{DTACK}}$  when any input is brought low. Presently, four of those inputs (pins 1, 2, 3, and 12) are not connected to anything, because there is no DRAM, no hard disk, no serial port, and no XT expansion port. It’s not a good idea to leave those inputs floating, so the resistors hold the inputs high, and thereby prevent generation of a false  $\overline{\text{DTACK}}$ .

The MC68681 DUART (IC10), along with the 3.6864-MHz oscillator (IC3) are used mainly for serial communications. However, the DUART also has an internal counter/timer that is used to generate the tones for the speaker. The circuit is shown here in Fig. 1; only one wire (the connection to pin 13 of IC10) is used by the speaker circuit. We’ll discuss how the DUART works shortly.

## Communicating with the PT-68K

Now we’re ready to install the I/O (input/output) circuitry that will allow us to communicate with the computer via a keyboard and some sort of video display. There are several possible ways of doing so.

1. A “dumb” computer terminal with a serial (RS-232) interface (such as a Televideo, a Soroq, etc.). Often you can buy a serial terminal for a good price at a computer flea market or from a surplus dealer.

2. A personal computer (IBM PC, Apple II, Commodore, etc.) that can emulate a dumb terminal. Many telecommunications programs for PC’s have terminal-emulation modes that will allow the computer to emulate one of several different terminals.

3. Last, because the PT-68K has IBM PC-compatible expansion connectors, and an IBM-compatible keyboard port, you can use inexpensive IBM clone components (video adapter, monitor, and keyboard).

Using a terminal or a computer emulating a terminal is easy: just install a serial port on the PT-68K by adding two IC’s and a connector. The procedure is discussed in Step 14 later on in this article.

The keyboard and PC interface circuitry, however, is more complex and requires an additional hardware kit (PT-5a, available from Peripheral Technology, 404-984-0742), so it is optional. If you do not wish to install it now, you can do so later at any time. Adding the IBM-compatible slots and components is discussed in Steps 15 and 16.

The components for the serial interface are part of the basic kit, so you might as well install them even if you do not use a serial terminal, because you may in any event use a serial printer or a modem.

## Step 14: The serial ports

Figure 1 shows the circuitry for the PT-68K’s four serial ports. DUART IC10 drives the two primary ports, and IC4 drives the two optional ports. Resistor R9, 3.6864-MHz oscillator IC3, and MC68681 DUART IC10 have already been installed, so at this point we need only add IC29, IC30, J21, and J22 to finish installing the circuitry for the two primary ports.

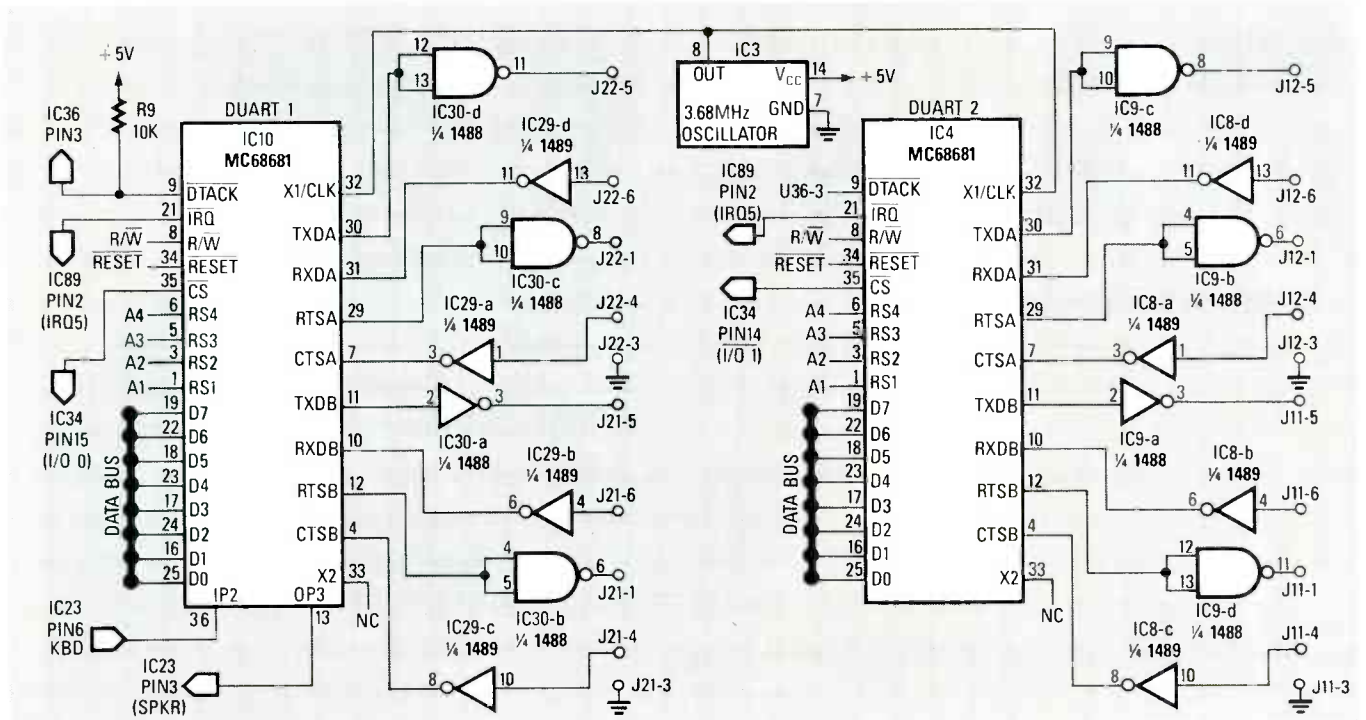

FIG. 1—THE PT-68K'S SERIAL INTERFACE is shown here. DUART IC4 and associated components are optional.

### MC68681 operation

DUART is an acronym for Dual Universal Asynchronous Receiver-Transmitter; the IC converts data between parallel form (as the microprocessor uses it and as it travels along the data bus) and serial form (used to link printers, plotters, modems, and other peripheral devices).

Although the DUART performs many of the same functions as a traditional UART (serial-to-parallel and parallel-to-serial conversion), it also does much more. Not only does it contain two internal receiver/transmitter ports and a baud-rate generator, but it also contains a multi-function six-bit parallel input port, an eight-bit output port, and a 16-bit programmable timer/counter. The PT-68K system software ignores most of the extra functions, but it does use bit 3 of the output port (pin 13, called OP3) and the programmable counter/timer to drive the speaker, and bit 2 of the input port (pin 36, called IP2) to monitor the PC-compatible keyboard interface.

As shown in Fig. 1, the connections to the computer (on the left of IC10) are straightforward. The clock signal comes from IC3, the 3.6864-MHz oscillator module that we installed last time. The  $\overline{\text{DTACK}}$  output connects directly to IC36 (shown in Fig. 5 in the January 1988 installment); the  $\overline{\text{IRQ}}$  output connects to  $\overline{\text{IRQ5}}$ , the level-five IRQ input (shown in Fig. 2 in the December 1987 issue);  $\overline{\text{R/W}}$  and  $\overline{\text{RESET}}$  connect to corresponding signals elsewhere; and  $\overline{\text{CS}}$ , the chip-select input, connects to  $\overline{\text{I/O0}}$  (pin 15 of IC34, shown in Fig. 3 in the January 1988 issue). As discussed in that installment,  $\overline{\text{I/O0}}$  goes low any time the microprocessor tries to access an address between \$FE0000 and \$FE003F.

The DUART's data pins connect to the lower eight bits of the data bus, and the four register-select lines (RS1–RS4) connect to the low-order address lines (A1–A4), respectively. The four register-select lines allow access to sixteen ( $2^4$ ) addresses. However, because only the lower eight bits of the data bus are used, those sixteen addresses are

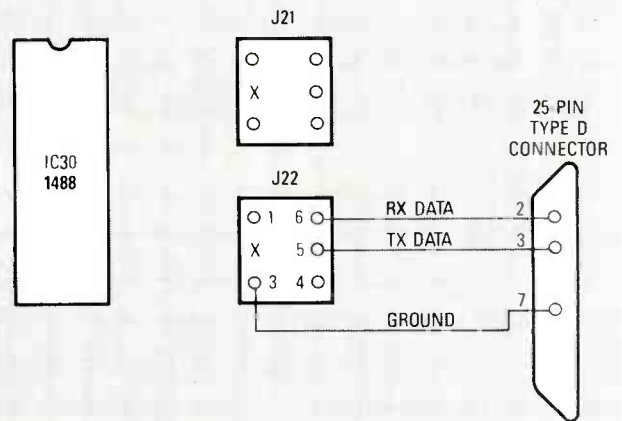

FIG. 2—TO CONNECT THE PT-68K TO A SERIAL TERMINAL, wire a 25-pin D connector to J22 as shown here.

all odd, so the DUART is addressed at \$FE0001, \$FE0003, \$FE0005, and so on, through \$FE001F. (The second DUART, IC4, is addressed at \$FE0041 and above.)

Internally, the DUART contains almost two dozen registers, some of which can be read from and some of which can be written to by the 68000. It takes Motorola about 70 pages to explain the DUART in the MC68681 data sheet (Motorola publication ADI-988, available from Motorola distributors or from Motorola Semiconductor Products, 3501 Ed Bluestein Blvd., Austin TX 78721), so there is no way to do it justice here. Instead, let us just list a few of the important addresses. The DUART contains two serial ports, called port A and port B. The following addresses are for port A, the port used for a terminal.

\$FE0007 is the data register. Sending a byte to that address outputs it to the first serial port (J22); a character input from the port can be read at the same address.

\$FE0003 is used to determine whether the DUART is

ready to send or receive a character. The bits at this address are numbered from 0 to 7, with bit 7 on the left and bit 0 on the right. Bits 0 and 2 are most important. If bit 0 is a 1, then the DUART has received a character from the serial port, and the character can be read from \$FE0007. If bit 2 is a 1, then it is ready to output a character to the serial port, so you can store that character in \$FE0007.

Port A's baud rate is determined by the value stored at \$FE0003. HUMBUG automatically recognizes the baud rate of your keyboard and sets the DUART's baud rate to match. (HUMBUG supports baud rates of 300, 600, 1200, 2400, 9600, and 19,200 baud.) Allowable DUART baud rates and also their corresponding register values are shown in Table 1.

Baud rate	Register value
110	11
300	44
600	55
1200	66
2400	88
4800	99
9600	BB
19200	CC

Addresses \$FE0005 and \$FE0015 can cause problems. The Motorola DUART data sheet states, "Do not access—this address location is used for factory testing of the DUART and should not be read. Reading this location will result in undesired effects and possible incorrect transmission or reception of characters. Register contents may also be changed." Accidentally reading this location may cause your PT-68K system to crash, so be careful!

Referring to Fig. 1, there are four active signals and one ground for each port. Port A (the terminal port) has a signal labeled TXDA (pin 30), which stands for Transmitted Data. As you might guess, RXDA (pin 31) stands for Received Data. The corresponding signals in Port B are called TXDB and RXDB, respectively.

RTSA (pin 29) is the Request To Send line, which is used to tell an external device that it's OK to send data. CTSA (pin 7), on the other hand, is the Clear To Send line; the external device can use it to tell the computer that it's OK to send data. Normally, PT-68K software ignores both RTS and CTS lines.

Now mount the following parts: socket for IC30 (1488 TTL-to-RS-232C converter) at IC30; socket for IC29 (1489 RS-232C-to-TTL converter); and two six-pin dual-row header strips at J21 and J22. As shown in Fig. 2, cut off one pin and position the header so that the side missing the pin is closest to IC30. Install IC29 and IC30.

Figure 2 also shows how to connect a terminal to the six-pin header. On the terminal end, you will need a DB-25S connector with wiring to pins 2, 3, and 7 as shown. On the computer end, you will need a special connector made by Berg and others (and supplied as part of the PT-68K basic kit). First, crimp (or lightly solder) a Berg 47747 pin on the end of each wire, then insert the three pins into the top end of a Berg plastic shell number 65043-034. Then insert a 65307-001 key (a plastic insulating pin) into the hole corresponding to the cutoff pin (labeled "X" in Fig. 2) to ensure that the connector can't be inserted backward. Don't insert extra pins in the re-

maining holes, because they cannot be connected to or removed after they have been installed.

### First test

If you do not have a serial terminal (or a computer emulating a terminal), then skip ahead to Step 15; otherwise keep going.

Now connect the DB-25S to the terminal, the Berg connector to J22 (not J21!), and turn on the power. Wait until the beep-boop tone is finished, and then press the Return (or Enter) key on your terminal once or twice. If all goes well, the terminal should display HUMBUG's sign-on message and prompt.

If the sign-on message does not appear, it's likely that there is a minor problem with the terminal wiring. First, set the terminal to either 300 or 1200 baud. Then, with a scope or meter (don't use the LED probe from J14-1 or you may damage IC32) check the voltage on the RXDATA and TXDATA lines at J22; they should both be negative, between -3 and -15 volts. If the TXDATA line is negative but RXDATA is not, then try swapping the two connections at pins 2 and 3 of the DB-25S connector—both the computer and the terminal may be sending data to the same line. If both lines are negative, check that pressing a key on the terminal makes the voltage on the RXDATA line swing from negative to positive and back; a scope will show this quite clearly, whereas a meter may just show a slight amount of wavering. A steady low on TXDATA probably means that some control lines (usually pins 5, 6, 8, and 20) should be connected together.

Apart from possible problems with IC29 and IC30 (which may not be passing either the received or transmitted signal), there are few other things that could be wrong, because at this point the remainder of the circuit (including IC3 and IC10) must be working, otherwise the speaker wouldn't have beeped. However, if you're still having problems, check IC3 anyway—if it is defective, IC10 might be picking up just enough noise that the speaker works, yet the serial port does not.

If you intend to install the PC-compatible keyboard and expansion connectors, continue on with Step 15; otherwise, skip ahead to Step 17.

### Step 15: The PC-compatible keyboard

PC-compatible keyboards are very different from the average computer keyboard in that they contain quite a bit of internal intelligence (including a buffer that stores keystrokes the computer hasn't yet accepted). Yet they do not generate an ASCII code for each key. Such keyboards require a fairly complex interface circuit, which is shown in Fig. 3, as well as a fairly complex program to decode key codes.

The keyboard connects to J9 via a five-pin DIN connector that carries ground, +5 volts, and  $\overline{\text{RESET}}$  signals to the keyboard, and carries the  $\overline{\text{CLOCK}}$  and DATA signals to the computer. Note, however, that both  $\overline{\text{CLOCK}}$  and DATA are bi-directional, so the PT-68K can send signals to the keyboard via those same lines.

When the computer is turned on or reset, pin 11 of IC32-e (BRESET) goes high. That signal is inverted and sent to the keyboard via the  $\overline{\text{CLOCK}}$  line, and that resets the keyboard. If your keyboard has CapsLock and NumLock lights, you'll see them flash when the keyboard is reset.

The system  $\overline{\text{RESET}}$  signal is also sent to the keyboard; that

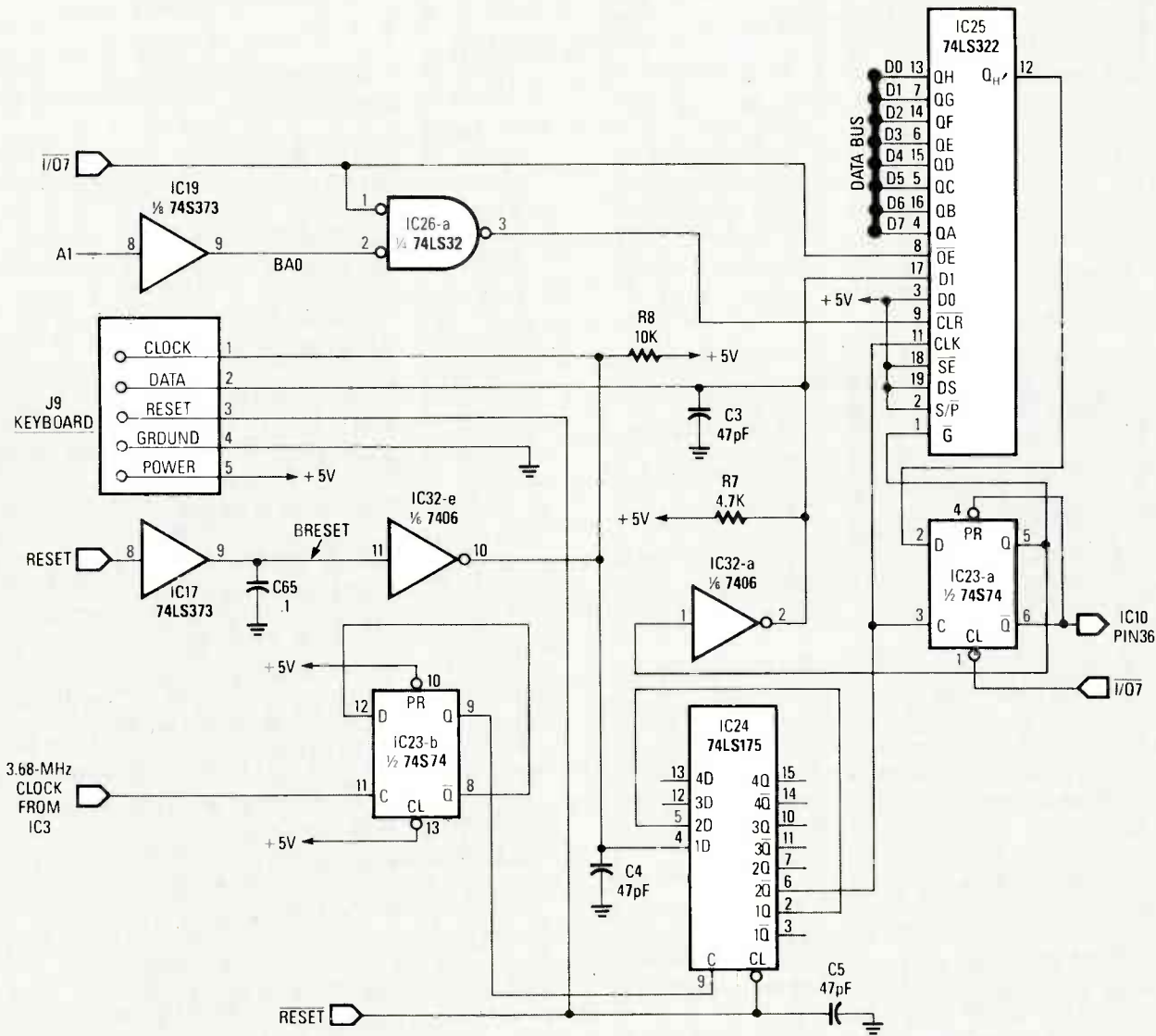

FIG. 3—THE PC-COMPATIBLE KEYBOARD INTERFACE is shown here.

signal simultaneously clears IC24, a quad D flip-flop. Meanwhile, HUMBUG reads the keyboard by asserting  $\overline{I/O7}$  (shown in the address decoder circuit, Fig. 3 in the January 1988 installment), and that read clears IC23a, which drops its  $Q$  output low. That signal then enables IC25 via pin 1,  $\overline{Q}$ , and it also goes to pin 1 of IC32a, which open-circuits its output and lets the keyboard's DATA line swing high or low, as needed. At the same time, the  $\overline{Q}$  output of IC23-a, which is high, goes to the IP2 input of the DUART (IC10).

Meanwhile, the 3.6864-MHz output of IC3 (the DUART's clock generator) also goes to IC23-b, where it is divided by 2 to produce a 1.8432 MHz signal, which in turn clocks IC24, which is wired as a shift register.

To understand the significance of all that, suppose you press (or release, as we'll see) one of the keyboard keys. The keyboard sends out a key number (not an ASCII code) on the DATA line in serial form, and simultaneously pulses the  $\overline{CLOCK}$  line, once for each bit. The data is sent to the  $D_1$  input of IC25, a 74LS322 shift register. At the same time, the  $\overline{CLOCK}$  signal sends a low pulse to the  $1D$  input of

IC24, whose first two flip-flops are also wired as a shift register.

After two pulses of the 1.8432-MHz clock (a delay of about 1 microsecond), a high comes out the  $\overline{Q}$  output and clocks both IC23-a (flip-flop) and IC25 (shift register). The data bit then enters the first stage of the shift register, and a moment later the  $\overline{CLOCK}$  signal goes high again.

This process is repeated once for each keyboard data bit, with the data bits proceeding through IC25, from  $Q_A$  to  $Q_B$ ,  $Q_C$ , and so on, until the first bit gets to the last flip-flop, at which time a high comes out  $Q_H$  (pin 12) and is sent to the  $D$  input of IC23-a. That bit is always a 1, but it is immediately discarded because the next clock pulse shifts it out of IC25. It is there long enough, however, to make IC23-a set at the next clock pulse.

When that occurs, the flip-flop does four things: (a) its  $\overline{Q}$  output goes low and sends an interrupt request to DUART 1, which relays it to the 68000; (b) the same low forces IC23-a to stay set in case there are more clock pulses; (c) the  $Q$  output sends a high to the  $\overline{Q}$  input of IC25, which prevents it from shifting further; and (d) the same



high is inverted by IC32-a into a low, which grounds the keyboard's DATA line and prevents the keyboard from sending further data.

Assuming that DUART 1 is properly programmed, the interrupt request goes to the 68000, which then stops its normal processing and goes into a special routine, called an Interrupt Service Routine (ISR), to accept the input from the keyboard. That routine is part of HUMBUG; when invoked it reads a byte from location \$FE01C3, which pulses the  $\overline{IO\bar{7}}$  line. That clears IC23-a and pulses the output enable ( $\overline{OE}$ ) pin of IC25, which then sends the received data byte to the data bus to be read by the 68000. The 68000 thus gets the data byte output by the keyboard.

A few microseconds later, the ISR reads location \$FE01C1, which pulses the  $\overline{IO\bar{7}}$  line a second time, but with a difference. On the first read (from \$FE01C3), A1 (and BA0, which is the same as A1 but buffered by IC19) was a 1, but on the second read (from \$FE01C1) that signal is a 0. The reason is that C3 ends with 0011 whereas C1 ends with 0001; the second bit from the right is A1, which now is a zero. Hence, on the second read, IC26-a receives two low inputs at the same time, so it outputs a low to IC25's  $\overline{CLR}$  input, which resets IC25, and prepares it ready for the next keystroke.

Rather than providing a specific ASCII character for each key, PC-compatible keyboards send a scan code when a key is pressed, and a different code when it is released. Since the circuit generates an interrupt request for each such code, the ISR in HUMBUG is called each time a key is pressed or released; that routine must convert those codes into ASCII depending on the state of the shift, Ctrl, NumLock, and other keys. (For more information on PC keyboards, see *A Programmer's Guide to the IBM PC*, by Peter Norton, published by Microsoft.)

Now install the following components: R7 (4.7K), R8 (10K), IC23 (74S74) and socket, IC24 (74LS175) and socket, IC25 (74LS322) and socket, IC17 (74LS373) and socket, IC19 (74S373) and socket, three 0.1  $\mu$ F disk capacitors at C8, C9, and C10; and J9, the keyboard connector. (IC26, IC32, and the three 47-pf capacitors were installed previously.) Check your work and then turn on the power to the system.

If you have a serial terminal connected, then testing the PC keyboard circuit is easy. Set the terminal to 2400 baud (HUMBUG's default rate), turn on the power, wait for the beep-boop, and press the Return key on the PC keyboard. You can now use that keyboard for input, but will see all output on the serial terminal.

If your terminal does not run at 2400 baud, you can change the baud rate from the PC-compatible keyboard as follows. (You must have heard the beep first.)

1. Type the following exactly as shown: MSFE0003
2. Press the space bar once.
3. Type in the baud rate code listed Table 1.

For example, to change the baud rate to 9600 baud, type in MSFE0003spaceBB (press the space key—don't type the word *space*.) That enters the value BB in the baud-rate register of the DUART at location \$FE0003.

Without a serial terminal, you have two choices: either use an oscilloscope or a logic probe to check various signals in the circuit, or else go on to Step 16, and test the keyboard after a video board is installed. The latter is probably easier.

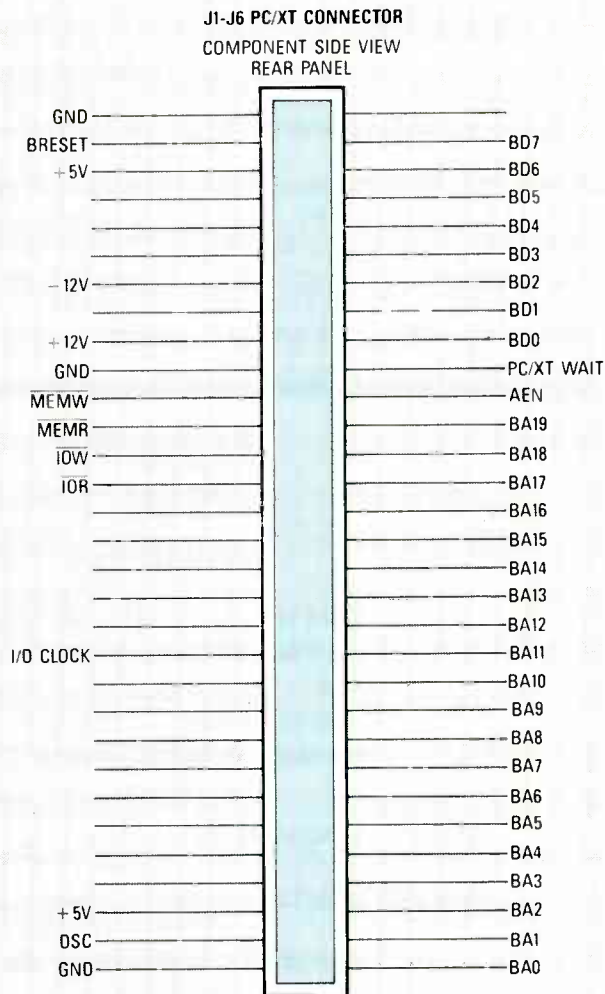

FIG. 4—THE PC-COMPATIBLE EXPANSION CONNECTOR is shown here. Unmarked pins are used by a PC, not the PT-68K.

### Step 16: The PC-compatible bus connectors

You can mount as many as six 62-pin PC-compatible card-edge connectors at the left rear corner of the PT-68K motherboard. You can install almost any PC- or XT-compatible plug-in I/O card, but cards intended for AT-type slots will not work.

At this time, the PT-68K software supports only the monochrome and CGA color video boards, and the WD1002A-WX1 hard disk controller, but it is fairly straightforward to write software for other cards as well. Also, our software does not support other popular expansion cards, including floppy-disk controllers, serial and parallel I/O cards, clock/calendar boards, or multi-function boards that combine several of the above; those I/O options are available on the PT-68K motherboard itself.

Although there are many hard-disk controllers available for PC's and clones, SK\*DOS (the PT-68K disk operating system) currently supports only the Western Digital WD1002A-WX1 controller. Figure 4 shows the pinout of the PC-compatible expansion connector. All of the labeled pins are used; the unlabeled pins are not needed in a 68000 system. Some of the pins, such as ground or power, are obvious; the other connections will be discussed when we continue next time.  $\blacklozenge\blacklozenge$



## AUDIO UPDATE

*continued from page 80*

bringing the matter full circle. Needless to say, I'm still not absolutely sure what Gamma-Plus was supposed to accomplish.

### Skewed priorities

I could provide other examples of the very low priority that many audio companies place on clear, accurate, and timely communications. Their *high* priority is usually on promoting their annual special technical gimmick—such as Gamma-Plus. Next year, Gamma-Plus is likely to be forgotten in favor of, say, a revolutionary "Lateral-Feedback circuit that prevents signal side-slip, a newly discovered source of semi-audible distortion." And it isn't just instruction manuals that suffer from the original manufacturers' skewed priorities. Many of the illiteracies and silliness seen in the ads and promotional literature arise from the same problem. The equipment is

obviously designed by talented professionals—so why do the manuals so often appear to be the work of incompetent amateurs?

There's no single answer to that question. Incompetent engineers don't last long, but incompetent technical copywriters apparently go on forever. Too many Far-Eastern manufacturers have on-staff technical writers who, on one hand, are overly dependent on "The Concise Japanese-English Dictionary", and on the other, are too prose-proud to accept criticism. The U.S. subsidiaries are then stuck with whatever their parent companies supply.

If anyone thinks I'm exaggerating the instruction manual problem, all they need do is interview a batch of customers who have recently bought new and/or more-complex components. Or read the mail that comes in to any of the major hi-fi magazines. Much of the mail is from readers seeking information on matters that should have been explained in the instructions that accompanied their

new equipment. It's obvious that overseas manufacturers (and some from right here at home) should pay closer attention to their manuals. Perhaps the only way that will come about is if they are deluged by complaints. If a newly bought component seems impossible to hook up with the instructions provided, don't assume that *you* are to blame. R-E



*But you didn't follow the testing equipment's operating manual. It states step 3 comes after step 4!*



**UNGAR UTC 100**  
Electronic Soldering System

**SPECIAL**  
**\$55.95**

- One Year Warranty
- U.L. Listed

The UTC combines accurate closed loop temperature control with economy. Easily calibrated at the station without disassembly, the CMOS-safe unit is fully grounded from tip to plug and meets military specs. System comes equipped with a macro iron, burn resistant cord and replaceable ceramic heater.

List  
**\$74.25**

---



**W.S. JENKS & Son**

1933 Montana Ave. NE  
Washington DC 20002  
(202) 529-6020

TOLL-FREE  
**1-800-638-6405**

CIRCLE 66 ON FREE INFORMATION CARD



**PAGE MAGIC!**

An **ETCHED** circuit board from a **Printed PAGE** in just **3 Hours**

The ER-4 PHOTO ETCH KIT gives you the tools, materials and chemicals to make your own printed circuit boards. The patented Pos-Neg™ process copies artwork from magazines like this one without damaging the page. Use the circuit patterns, tapes and drafting film to make your own 1X artwork. Or try the Direct Etch™ system (also included), to make single circuit boards without artwork. The ER-4 is stocked by many electronic parts distributors, or order direct, postpaid.

**ER-4 PHOTO ETCH KIT** (NJ and CA residents add sales tax) . . . \$38.00

**DATAK'S COMPLETE CATALOG** lists hundreds of printed circuit products and art patterns. Also contains dry transfer letter sheets and electronic title sets for professional looking control panels. **WRITE FOR IT NOW!**

**The DATAK Corporation • 3117 Paterson Plank Road • North Bergen, NJ 07047**

CIRCLE 187 ON FREE INFORMATION CARD

# NEW IDEAS

## Parasitic signaller

I WAS OFTEN CUT OFF FROM THE OUTSIDE world when working in my basement shop. I couldn't hear when I was being called for dinner, didn't know if a telephone call was for me, or if the doorbell had just rung and no one else was home to answer it. To solve this problem in communications with the rest of the family, I built a "parasitic signaller" that made the doorbell circuit do double-duty as both an annunciator and as a communications system.

The device is a simple assembly of junk-box parts that produces a warbling tone in my basement workroom, where the doorbell transformer is located, when it senses a current surge in the upstairs doorbell wiring. By using a surge in current on the already existing doorbell wiring as the "signal trigger," it saved me from having to run additional signal wires through the walls and ceilings of the house.

### How it works

The complete system schematic is shown in Fig. 1. T1 is the output transformer from an old tube radio. If you don't have an old transformer lying about, you can use anything you can get as long its windings have approximately the DC resistance values shown. (Note. The values are DC resistance, not AC impedance. A transformer having a 2500–5000-ohm primary impedance and a 4–8-ohm secondary impedance will probably provide close to the desired DC resistance values.)

Current flows through T1's low-resistance winding when doorbell BZ1 draws current from bell transformer T2. The current flow through T1 induces a current in T1's high-resistance winding, which forward-biases power-switching transistor Q1 through capacitor C1. That causes collector current flow in Q1, which actuates piezo-electric buzzer BZ2.

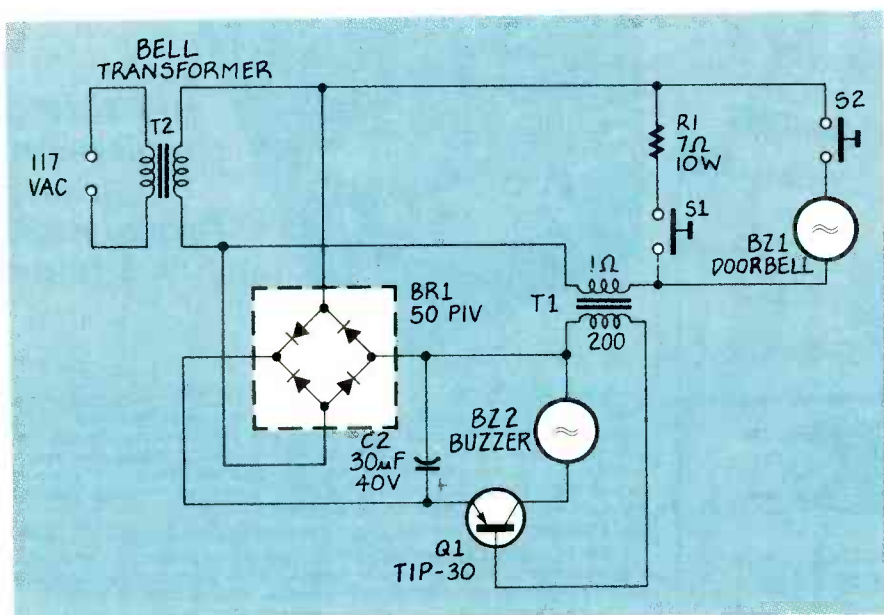

FIG. 1

### NEW IDEAS

This column is devoted to new ideas, circuits, device applications, construction techniques, helpful hints, etc.

All published entries, upon publication, will earn \$25. In addition, for U.S. residents only, Panavise will donate their model 333—The Rapid Assembly Circuit Board Holder, having a retail price of \$39.95. It features an eight-position rotating adjustment, indexing at 45-degree increments, and six positive lock positions in the vertical plane, giving you a full ten-inch height adjustment for comfortable working.



I agree to the above terms, and grant **Radio-Electronics Magazine** the right to publish my idea and to subsequently republish my idea in collections or compilations of reprints of similar articles. I declare that the attached idea is my own original material and that its publication does not violate any other copyright. I also declare that this material has not been previously published.

Title of Idea \_\_\_\_\_

Signature \_\_\_\_\_

Print Name \_\_\_\_\_

Date \_\_\_\_\_

Street \_\_\_\_\_

City \_\_\_\_\_

State \_\_\_\_\_

Zip \_\_\_\_\_

Mail your idea along with this coupon to: **New Ideas Radio-Electronics**,  
500-B Bi-County Blvd.,  
Farmingdale, NY 11735

# R-E Engineering Admart

Rates: Ads are 2 1/4" x 2 7/8". One insertion \$825. Six insertions \$800 each. Twelve insertions \$775 each. Closing date same as regular rate card. Send order with remittance to **Engineering Admart**, Radio Electronics Magazine, 500-B Bi-County Blvd., Farmingdale, NY 11735. Direct telephone inquiries to Arline Fishman, area code-516-293-3000. *Only 100% Engineering ads are accepted for this Admart.*

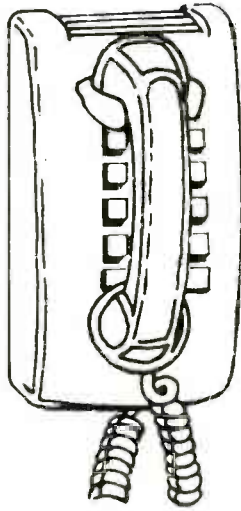

## CALL NOW AND RESERVE YOUR SPACE

- 6 x rate \$800.00 per each insertion.
- Fast reader service cycle.
- Short lead time for the placement of ads.

Call 516-293-3000 to reserve space. Ask for Arline Fishman. Limited number of pages available. Mail materials to: Engineering Admart, RADIO-ELECTRONICS, 500-B Bi-County Blvd., Farmingdale, NY 11735.

## MIDI PROJECTS

MIDI Projects

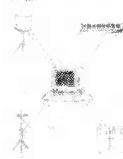

**BP182**—MIDI interfacing enables any so equipped instruments, regardless of the manufacturer, to be easily connected together and used as a system with easy computer control of these music systems. Combine a computer and some MIDI instruments and you can have what is virtually a programmable orchestra. To get your copy send \$6.95 plus \$1.00 for shipping in the U.S. to **Electronic Technology Today Inc.**, P.O. Box 240, Massapequa Park, NY 11762-0240.

## 117 PRACTICAL IC PROJECTS BUILD YOU CAN

**2645T**—117 PRACTICAL IC PROJECTS YOU CAN BUILD.....

**\$10.95.** Dozens of fully-tested, ready-to-build circuits you can put together from readily-available, low cost IC's! There are a total of 117 IC circuits ranging from an audio mixer and a signal splitter to a tape-deck amplifier and a top-octave generator organ! From TAB Books. To order your copy send **\$10.95 plus \$2.75 shipping to Electronic Technology Today Inc.**, P.O. Box 240, Massapequa Park, NY 11762-0240

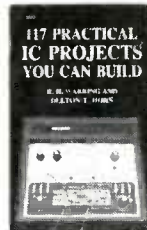

## FCC LICENSE PREPARATION

The FCC has revised and updated the commercial license exam. The **NEW EXAM** covers updated marine and aviation rules and regulations, transistor and digital circuitry. **THE GENERAL RADIOTELEPHONE OPERATOR LICENSE - STUDY GUIDE** contains the necessary preparation for **ONLY \$25.00.**

WPT PUBLICATIONS  
979 Young Street, Suite E  
Woodburn, Oregon 97071  
Phone (503) 981-6122

CIRCLE 179 ON FREE INFORMATION CARD

## LINEAR IC EQUIVALENTS & PIN CONNECTIONS

Linear IC  
Equivalents  
and Pin  
Connections

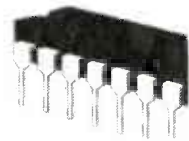

**BP141**—Shows equivalents & pin connections of a popular user-oriented selection of European, American and Japanese linear IC's 320 pages, 8 x 10 inches. **\$12.50 Plus \$2.75 shipping.** **ELECTRONIC TECHNOLOGY TODAY INC.**, PO Box 240, Massapequa Park, New York 11762-0240.

Power for Q1 and BZ2 is supplied by BR1, a full-wave bridge rectifier that is connected across bell transformer T2. Capacitor C2 functions as a simple filter for the rectifier's output voltage.

If you're not fussy about how the device looks—mine is screwed to a piece of wood nailed with masonry spikes to the wall below my home's bell transformer—you can assemble the signaller on an 8-lug terminal strip. Just be certain to solder all the connections; don't just twist them around the lugs.

### Testing

There should be no sound from buzzer BZ2 when the signaller is connected to the doorbell circuit. If it does make noise, try decreasing the value of C1. My bell transformer puts out 24 volts, others put out between 12 and 30 volts. Capacitor C1 is the variable that's used to compensate for different doorbell voltages. Experimentally increase C1's value for lower voltages, and decrease its value for higher voltages until the circuit works properly. (A false buzzing

could also be due to Q1 having excessive leakage.)

To improve the usefulness of the device, I installed a momentary switch (S1) in series with a wire-wound resistor (R1) having about the same resistance as the coil of doorbell BZ1 (around 7 ohms), which was located upstairs in the kitchen. When S1 is pressed, a current surge is generated without ringing the doorbell, so the family can easily signal me to pull the "big switch" and close down.  
—John F. Crooks.

# MARKET CENTER

## FOR SALE

**RESTRICTED technical information:** Electronic surveillance, schematics, locksmithing, covert sciences, hacking, etc. **Huge selection. Free brochure MENTOR-Z**, Drawer 1549, Asbury Park, NJ 07712.

**DESCRAMBLERS** All brands. Special combo Jerrold 400 and SB3 \$165. Complete cable descrambler kit \$39.00 Complete satellite descrambler kit \$45. Free catalog. **MJ INDUSTRY**, Box 531, Bronx, NY 10461.

IS it true...Jeeps for \$44 through the government? Call for facts! 1 (312) 742-1142, ext. 4673.

**TEST** equipment, reconditioned. For sale. \$1.25 for catalog. **WALTER'S**, 2697 Nickel, San Pablo, CA 94806. (415) 724-0587.

**TUBES**, new, unused. Send self-addressed, stamped envelope for list. **FALA ELECTRONICS**, Box 1376-2, Milwaukee, WI 53201.

**PHOTOFAC** folders, under #1400 \$3.00. Others \$5.00. Postpaid. **LOEB**, 414 Chestnut Lane, East Meadow, NY 11554.

## FREE CATALOG

**FAMOUS "FIRESTIK" BRAND CB ANTENNAS AND ACCESSORIES. QUALITY PRODUCTS FOR THE SERIOUS CB'er. SINCE 1962**  
**FIRESTIK ANTENNA COMPANY**  
 2614 EAST ADAMS  
 PHOENIX, ARIZONA 85034

**TI-99/4A** software/hardware bargains. Hard to find items. Huge selection. Fast service. Free catalog. **DYNA**, Box 690, Hicksville, NY 11801.

**FLASHLIGHT** that needs no batteries measures 5' x 3' ideal for every situation money back guarantee \$10.—**SAMUELS ENTERPRIZES**, 724 East 231 Street, Bronx, NY 10466.

**CABLE TV equipment S.A., Jerrold, Zenith, Hamlin, Oak, Eagle filters remotes and more. Best prices C.O.D.'s accepted dealers needed. Ours work where others failed and we guarantee it!** **TRANS-WORLD CABLE, Co.** (218) 543-6671

**TUBES** 59¢. Year Guarantee. Free catalog. Tube tester \$8.95. **CORNELL**, 4215 University, San Diego, CA 92105.

## CB RADIO OWNERS!

We specialize in a wide variety of technical information, parts and services for CB radios. 10M-FM conversions, repairs, books, plans, kits, high-performance accessories. Our 11th year! Catalog \$2.

**CBC INTERNATIONAL, P.O. BOX 31500RE.. PHOENIX, AZ 85046**

**VIDEOCIPHER II** manual 120+ pages/Oak "Orion" 120+ pages, either—\$27.45—both \$49.95. Plans, kits, descrambling books. Catalog—\$2.00. **MICRO-TRONICS**, P.O. Box 6426, Yuma, AZ 85364-0840.

**PICTURE** flyer lists quality surplus electronics at low prices. Since 1970. Send for the last 3 issues. **STAR-TRONICS**, Box 683, McMinnville, OR 97128.

**MINI** zip lock plastic bags keep small electronic parts clean and dry. Send LSASE for details. **DOMIN CO.**, 253 Fitzwatertown Road, Willow Grove, PA 19090.

**REPAIR your own TV...it's easy.** Write **RESEARCH**, Rt. 3, Box 601BR, Colville, WA 99114.

**PHOTOVOLTAIC** battery chargers by Arco solar. Cars, RVs, marine, etc. From \$49.50. Brochure. **SUN POWER-TEXAS**, P.O. Box 2788A, Freeport, TX 77541.

**LASER** light show projectors, complete systems start at \$350.00. **RED LINE**, 9737 Balboa Dr., St. Louis, MO 63136.

**TUBES** "Oldest", "latest". Parts and schematics. SASE for list: **STEINMETZ**, 7519 Maplewood Ave., R.E. Hammond, IN 46324.

## CLASSIFIED AD ORDER FORM

To run your own classified ad, put one word on each of the lines below and send this form along with your check to:

**Radio-Electronics Classified Ads**, 500-B Bi-County Boulevard, Farmingdale, NY 11735

**PLEASE INDICATE** in which category of classified advertising you wish your ad to appear. For special headings, there is a surcharge of **\$23.00**.

( ) Plans/Kits ( ) Business Opportunities ( ) For Sale  
 ( ) Education/Instruction ( ) Wanted ( ) Satellite Television  
 ( ) \_\_\_\_\_

Special Category: \$23.00

### PLEASE PRINT EACH WORD SEPARATELY, IN BLOCK LETTERS.

(No refunds or credits for typesetting errors can be made unless you clearly print or type your copy.) Rates indicated are for standard style classified ads only. See below for additional charges for special ads. **Minimum: 15 words.**

1	2	3	4	5
6	7	8	9	10
11	12	13	14	15 (\$42.75)
16 (\$45.60)	17 (\$48.45)	18 (\$51.30)	19 (\$54.15)	20 (\$57.00)
21 (\$59.85)	22 (\$62.70)	23 (\$65.55)	24 (\$68.40)	25 (\$71.25)
26 (\$74.10)	27 (\$76.95)	28 (\$79.80)	29 (\$82.65)	30 (\$85.50)
31 (\$88.35)	32 (\$91.10)	33 (\$94.05)	34 (\$96.90)	35 (\$99.75)

We accept MasterCard and Visa for payment of orders. If you wish to use your credit card to pay for your ad fill in the following additional information (Sorry, no telephone orders can be accepted.):

Card Number \_\_\_\_\_

Expiration Date \_\_\_\_\_

Please Print Name \_\_\_\_\_

Signature \_\_\_\_\_

**IF YOU USE A BOX NUMBER YOU MUST INCLUDE YOUR PERMANENT ADDRESS AND PHONE NUMBER FOR OUR FILES. ADS SUBMITTED WITHOUT THIS INFORMATION WILL NOT BE ACCEPTED.**

**CLASSIFIED COMMERCIAL RATE:** (for firms or individuals offering commercial products or services) \$2.85 per word prepaid (no charge for zip code)...**MINIMUM 15 WORDS.** 5% discount for same ad in 6 issues; 10% discount for same ad in 12 issues within one year; if prepaid. **NON-COMMERCIAL RATE:** (for individuals who want to buy or sell a personal item) \$2.30 per word, prepaid...no minimum. **ONLY FIRST WORD AND NAME** set in bold caps at no extra charge. Additional bold face (not available as all caps) 50¢ per word additional. Entire ad in boldface, \$3.40 per word. **TINT SCREEN BEHIND ENTIRE AD: \$3.55 per word. TINT SCREEN BEHIND ENTIRE AD PLUS ALL BOLD FACE AD: \$4.15 per word. EXPANDED TYPE AD: \$4.30 per word prepaid.** Entire ad in boldface, \$5.15 per word. **TINT SCREEN BEHIND ENTIRE EXPANDED TYPE AD: \$5.40 per word. TINT SCREEN BEHIND ENTIRE EXPANDED TYPE AD PLUS ALL BOLD FACE AD: \$6.25 per word. DISPLAY ADS:** 1" x 2 1/4"—\$320.00; 2" x 2 1/4"—\$640.00; 3" x 2 1/4"—\$960.00. **General Information:** Frequency rates and prepayment discounts are available. **ALL COPY SUBJECT TO PUBLISHERS APPROVAL. ADVERTISEMENTS USING P.O. BOX ADDRESS WILL NOT BE ACCEPTED UNTIL ADVERTISER SUPPLIES PUBLISHER WITH PERMANENT ADDRESS AND PHONE NUMBER.** Copy to be in our hands on the 12th of the third month preceding the date of the issue. (i.e., Aug. issue copy must be received by May 12th). When normal closing date falls on Saturday, Sunday or Holiday, issue closes on preceding working day. Send for the classified brochure. Circle Number 49 on the Free Information Card.

# CABLE EQUIPMENT PRICES SLASHED WHILE YOU WAIT!



**C**all Aunt Matilda at **Pacific Cable Co., Inc.**, and get a pleasant surprise: Instant price cuts even on our own cut-to-the-bone prices!

Here's how: Just supply her (or one of our other operators) with anybody else's published prices (even wholesale, if you're a dealer) for the unit you want; and if their price beats our published price, we'll match it—or even beat it! Simple as that.

Of course, you'll have to look far and wide to beat our prices (see below) and we're betting that Aunt Matilda will seldom need her "little hatchet" and can partake of her cherished afternoon nap. Which is fine with us—she makes us nervous with that thing!

(Not to mention our competition!)

## Check our prices on Scientific Atlanta Units!

ITEM	1 UNIT	10 OR MORE	ITEM	1 UNIT	10 OR MORE
RCA 36 Channel Converter (Ch.3 output only) .....	29.00	18.00	*Minicode (N-12) .....	89.00	58.00
Panasonic Wireless Converter (our best buy) .....	88.00	69.00	*Minicode (N-12) with Vari Sync .....	99.00	62.00
400 or 450 Converter (manual fine tune) .....	88.00	69.00	*Minicode VariSync with Auto On-Off .....	145.00	105.00
*Jerrold 400 Combo .....	169.00	119.00	Econocode (minicode substitute) .....	69.00	42.00
Jerrold 400 Hand Remote Control .....	29.00	18.00	Econocode with VariSync .....	79.00	46.00
*Jerrold 450 Combo .....	199.00	139.00	*MLD-1200-3 (Ch.3 output) .....	99.00	58.00
*Jerrold 450 Hand Remote Control .....	29.00	18.00	*MLD-1200-2 (Ch.2 output) .....	99.00	58.00
Jerrold SB-Add-On .....	89.00	58.00	*Zenith SSAVI Cable Ready .....	175.00	125.00
*Jerrold SB-Add-On with Trimode .....	99.00	70.00	Interference Filters (Ch.3 only) .....	24.00	14.00
*M-35 B Combo unit (Ch.3 output only) .....	99.00	70.00	*Eagle PD-3 Descrambler (Ch.3 output only) .....	119.00	65.00
*M-35 B Combo unit with VariSync .....	109.00	75.00	*Scientific Atlanta Add-on Replacement Descrambler .....	119.00	75.00

CHECK US OUT—WE'LL MEET OR BEAT THE OTHER'S ADVERTISED WHOLESALE OR RETAIL PRICES!



## Pacific Cable Co., Inc.

7325½ Reseda Blvd., Dept. R-2  
Reseda, CA 91335  
(818) 716-5914 • (818) 716-5140

• NO COLLECT CALLS! •

**IMPORTANT** • When ordering, please have the make and model number of the equipment used in your area—Thank you!

\*Call for availability

Prices subject to change without notice

Jerrold is a registered trademark of General Instruments Corp.

Quantity	Item	Output Channel	Price Each	TOTAL PRICE
SUBTOTAL				
Shipping Add \$3.00 per unit				
COD & Credit Cards—Add 5%				
TOTAL				

California Penal Code #593-D forbids us from shipping any cable descrambling unit to anyone residing in the state of California.

Prices subject to change without notice

PLEASE PRINT

Name \_\_\_\_\_

Address \_\_\_\_\_

City \_\_\_\_\_

State \_\_\_\_\_

Zip \_\_\_\_\_

Phone Number ( \_\_\_\_\_ ) \_\_\_\_\_

Cashier's Check

Money Order

C.O.D.

Visa

Mastercard

Acct. # \_\_\_\_\_

Exp. Date \_\_\_\_\_

Signature \_\_\_\_\_

YOU MUST SIGN AND RETURN FOR OUR RECORDS:

**DECLARATION OF AUTHORIZED USE** — I, the undersigned, do hereby declare under penalty of perjury that all products purchased, now and in the future, will only be used on cable TV systems with proper authorization from local officials or cable company officials in accordance with all applicable federal and state laws. **FEDERAL AND VARIOUS STATE LAWS PROVIDE FOR SUBSTANTIAL CRIMINAL AND CIVIL PENALTIES FOR UNAUTHORIZED USE.**

Dated: \_\_\_\_\_

Signed: \_\_\_\_\_

© Copyright 1987 PACIFIC CABLE CO., INC.

**AIDS?** Yes we have! Cable aids to help you. Zenith, Jerrold, Scientific Atlanta, Oak, Hamlins, much more. No Michigan sales! **HOTRONICS**, (313) 283-4299.

**AMAZING** space age metal. Hundreds of exciting uses. Send SASE and \$5.00 for sample and instructions. **BY DESIGN LABORATORIES**, 2754 Lexington Ave., Mansfield, OH 44904.

**CABLE descrambler liquidation.** Major makes and models available. Industry pricing! (Example: Hamlin Combo's, \$44 each...minimum 10 orders), **dealers only!** Call **WEST COAST ELEC TRONICS**, (818) 989-0890.

**TUBES**, name brands, new, 80% off list, **KIRBY**, 298 West Carmel Drive, Carmel, IN 46032.

**CATV wholesaler** and service center of new digital set top cable converters S.A., Jerrold, Panasonic, Pioneer, Sprucer, Hamlin and coax cable line-amps connectors tools. **REDCOAT ELECTRONICS**, (718) 459-5088.

**SINGERS!  
REMOVE VOCALS  
FROM RECORDS AND CDs!**

**SING WITH THE WORLD'S BEST BANDS!**  
An Unlimited supply of Backgrounds from standard stereo records! Record with your voice or perform live with the backgrounds. Used in Professional Performance yet connects easily to a home component stereo. This unique product is manufactured and sold Exclusively by LT Sound - Not sold through dealers. Call or write for a Free Brochure and Demo Record.

**LT Sound, Dept. R.L.-3, 7980 LT Parkway  
Lithonia, GA 30058 (404) 482-4724**  
Manufactured and Sold Exclusively by **LT Sound**  
**24 HOUR PHONE DEMO LINE: (404) 482-2485**

**SEND** fifty dollars to **EVOLA-ELECTRONICS**, P.O. Box 1268, Sterling Height, MI 48311. Phone numbers or addresses of over fifty dealers. Decoding cable and satellite and related items.

**CAD-CAM** controller sends computer screen drawings to XY table for cutting or etching. **KERN ELECTRONICS**, 812 King, Wadena, MN 56482.

**VCR'S** vhs minor repairs manual, parts replacement, maintenance, good for consumers too, parts number, suppliers, no technical, simple, practical, useful \$14.95. **USA ASSOCIATES**, Box 2168, Van Nuys, CA 91404.

**TRANSISTORS-tubes:** MRF421 \$24.00, MRF454 \$15.00, MRF455-MRF477 \$12.00, MRF492 \$16.95, SRF2072 \$13.50, 3800 \$18.95, 2SC2879 \$25.00, 6LF6-6LQ6-6JS6 \$10.95, 8950 \$15.95. New **Ranger AR3500** all mode 10 meter transceiver \$319. Quantity discounts! Best prices on hard-to-find parts, antennas, mics, power supplies, & equipment! Catalog \$1.00 (refundable), or free with order. **RFPC**, Box 700, San Marcos, CA 92069. For information or same day shipment—call (619) 744-0728. Visa/MC/C.O.D.

**LASERS**, components and accessories. Free catalog, **M.J. NEAL COMPANY**, 6672 Mallard Court, Orient, OH 43146.

**COPYGUARD** corrector restores rental movies. Connects between VCRs. 30 day unconditional money back guarantee. \$59.95. **1-800-338-8751**.

**SUPERCONDUCTORS** National Bureau of Standards research publication shows how to process Barium, Yttrium, Copper Oxides into high temperature superconducting ceramics. \$14.95. **CABLETRONICS**, Box 30502R, Bethesda, MD 20814.

**HACKER'S Handbook**, \$12.95, \$1 postage. **Computer underground**, \$14.95, \$1 postage. **CABLETRONICS**, Box 30502R, Bethesda, MD 20814.

**COMMODORE** chips or repairs. C-64 repair \$39.95 includes parts/labor. We sell chips at low cost (eg. 6526/6510-\$9.95 and many others). C-64 P.S. \$27.95. "Commodore Diagnostician," a complete chart for diagnosing faulty IC's \$6.95 + pp Send for catalog. **VISA/MC. KASARA INC.**, 31 Murray Hill Drive, Spring Valley, NY 10977, (800) 248-2983 (outside NY) or (914) 356-3131.

**SURVEILLANCE-counter, security.** 202 products: alarms, bulletproof, detectors, to underwater, voice scramblers, wireless! Catalog \$2.00. **SPYPRO**, Dept. 051ER, POB 45521, Seattle, WA 98145-0521.

**CHICAGO CRT** equipment rebuilds Sony/color tubes/other. **CRT SYSTEMS**, 633 North Semoran, Orlando, FL 32807. Call (305) 275-9543.

**NUTS & VOLTS** MAGAZINE

P.O. Box 1111-E  
Piscataway, NJ 08870  
714-932-7721

Subscription Rates  
3rd Class Mail-USA  
One Year \$10.00  
Two Years \$18.00  
Lifetime \$50.00

1st Class Mail  
One Year USA \$18.00  
Canada/Mexico \$20.00  
Air Mail  
Foreign 1 Yr. \$50.00

**GIVE YOURSELF A BREAK—A PRICE BREAK!**  
**NUTS & VOLTS** will **SAVE** YOU MONEY ON ELECTRONIC PARTS & EQUIPMENT. Plus show you where to find unique, unusual and hard-to-find items.

**SUBSCRIBE TODAY!**

A National Publication For The Buying And Selling Of Electronic Equipment

**PHOTOFACT** sets, tubes, test equipment, radio manuals for list send stamped envelope + .75¢. **ROBERT LESTER**, 5410 Tellier Road, Newark, NY 14513.

**TAKE** the beep out and get a clear picture. Any channel, cable converters Panasonic, Pioneer, Jerrold, Hamlin, Scientific Atlanta. Hand remotes. (313) 979-5794.

CALL FOR FREE CATALOG

**TEXT TO SPEECH BOARD!**

**PC/XT COMPATIBLE. MAKE YOUR COMPUTER TALK!**  
A VERY POWERFUL AND AMAZING SPEECH CARD. USES THE NEW GENERAL INSTRUMENT'S SPO256-AL2 SPEECH CHIP AND THE CTS256A-AL2 TEXT TO SPEECH CONVERTER.

THIS BOARD USES ONE SLOT ON THE MOTHER BOARD AND REQUIRES A COM SERIAL PORT. BOARD MAY ALSO BE USED IN A STAND ALONE ENVIRONMENT WITH ALMOST ANY COMPUTER THAT HAS A RS232 SERIAL PORT. FEATURES ON BOARD AUDIO AMP OR MAY BE USED WITH EXTERNAL AMPS. DEMONSTRATION SOFTWARE AND A LIBRARY BUILDING PROGRAM ARE INCLUDED ON A 5 1/4 INCH PC/XT DISKETTE. FULL DOCUMENTATION AND SCHEMATICS ARE ALSO INCLUDED.

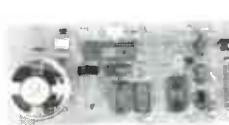

**NEW! PRICE CUT!**  
**\$69.95**  
ASSEMBLED & TESTED

**NEW! IC TESTER! \$149.00**

SIMILAR TO BELOW EPROM PROGRAMMER. PLUGS IN TO YOUR PC OR XT. TESTS ALMOST ALL 14, 16, AND 20 PIN 74XX SERIES. INCLUDES STANDARD POWER, "S" AND "LS" DEVICES. ALSO TESTS CD4000 SERIES CMOS. SOFTWARE INCLUDED CAN EVEN DETERMINE PART NUMBERS OF MOST UNMARKED AND HOUSE NUMBERED DEVICES WITH SIMPLE MOD. THIS UNIT CAN ALSO TEST 6.4K AND 256K DRAMS! WITH MANUAL AND SOFTWARE: \$149. PERFECT FOR SCHOOLS.

**PC/XT EPROM PROGRAMMER \$169**

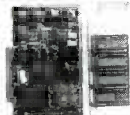

ASK ABOUT OUR NEW PAL PROGRAMMER!

\* LATEST DESIGN \* PROGRAMS UP TO 4 DEVICES AT ONE TIME \* FEATURES EASY TO USE MENU DRIVEN SOFTWARE THAT RUNS UNDER PC OR MS-DOS. \* USES AN INTELLIGENT PROGRAMMING ALGORITHM FOR SUPER FAST (8X) EPROM BURNING. \* THIS PLUG-IN BOARD ATTACHES TO AN EXTERNAL MINI CHASSIS CONTAINING 4 TEXTOL Z.I.F. SOCKETS. \* NO PERSONALITY MODULES REQUIRED \* AUTOMATIC VPP SELECTION: 12.5V, 21V, OR 25V. \* EPROM DATA CAN ALSO BE LOADED FROM OR SAVED TO A DISKETTE. \* PROGRAMMING SOFTWARE SUPPORTS: 2716, 2732, 2732A, 2764, 2764A, 27128, 27128A, 27256, 27256A, 27512, AND 27512A. \* ASSEMBLED AND TESTED, BURNED. IN WITH MANUAL. \$169 WITH SOFTWARE.

JUST RECEIVED. SAME AS ABOVE PROGRAMMER, BUT PROGRAMS 8 UNITS AT ONE TIME - \$299.

**Digital Research Computers**

P.O. BOX 381450 • DUNCANVILLE, TX 75138 • (214) 225-2309

TERMS: Add \$3.00 postage. We pay balance. Orders under \$15 add 75¢ handling. No C.O.D. We accept Visa and MasterCard. Texas Res. add 6-1/4% Tax. Foreign orders (except Canada) add 20% P & H. Orders over \$50 add 85¢ for insurance.

**EParts Express**  
International Inc.

**PIONEER**



**10" WOOFER**

Heavy duty paper cone with 20 oz magnet. 60 watts RMS, 90 watts max. Response: 35-3,500 Hz.  
#290-083 \$18.80 (1-3) \$16.90 (4-UP)

**FREE CATALOG**

Call or write today for your free catalog containing speakers, semi-conductors, CATV products, tools, hardware, TV-VCR parts, and more.

**PIONEER**



**8" POLY WOOFER**

Clear ribbed polypropylene cone. 60 watts RMS, 90 watts max power. 20 oz. magnet. 35-2000 Hz. 4-8 ohm compatible.  
#290-055 \$20.50 (1-3) \$18.95 (4-UP)

**PIONEER**



**HORN TWEETER**

3" wide dispersion horn tweeter. 1800-15,000 Hz response. 35 watts RMS, 50 watts max. 8 ohm impedance.  
#270-050 \$6.50 (1-9) \$5.90 (10-UP)

**PIONEER**



**15" WOOFER**

20 oz magnet, 60 watts RMS, 90 watts max. 8 ohm impedance. 1 1/2" voice coil. 25-2000 Hz.  
#290-160 \$30.95 (1-3) \$28.40 (4-UP)

**MOTOROLA**



**PIEZO TWEETER**

Mfg #KSN1005A. 3/4" x 3/8". No crossover required. 50 watts max. input power.  
#270-010 \$4.95 (1-79) \$3.95 (80-UP)

**CROSSOVERS**

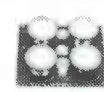

2-Way, 30 watt #260-190 \$3.95  
3-Way, 60 watt #260-200 \$7.50  
3-Way, 100 watt #260-210 \$12.50

**PIONEER**



**5" CUP MIDRANGE**

Tuned cup. Paper cone. 1" voice coil. 9.3 oz. magnet. 50 watts RMS, 70 watts max. Response: 320-6000 Hz. 8 ohm impedance.  
#280-020 \$11.50 (1-9) \$9.95 (10-UP)

• 15 day money back guarantee. • \$10.00 minimum order. • COD orders accepted. • 24 hour shipping. • Shipping charge - UPS chart rate (\$2.50 minimum charge). Hours 8:30 a.m. - 6 p.m. EST M-F.

**CALL TOLL FREE 1-800-338-0531**

Local: (513) 222-0173

**PARTS EXPRESS INTL. INC.**  
340 East First St  
Dayton, Ohio 45402



CIRCLE 56 ON FREE INFORMATION CARD

RADIO-ELECTRONICS  
ALL SALES SUBJECT TO THE TERMS OF OUR 90 DAY LIMITED WARRANTY. FREE COPY UPON REQUEST.



# TENMA

# TEST EQUIPMENT



## Tenma Compact DMM

Features: ■ 3½ digit LCD display ■ Shock mounted PC boards ■ Fuse and diode protection ■ Limited quantities

#72-057



## Tenma Clamp-On DMM

Features: ■ 3½ digit LCD display ■ Data hold: Holds display reading after meter is removed from circuit ■ Peak hold: Holds display for highest value measured ■ Audible continuity tester ■ Diode test

#72-395

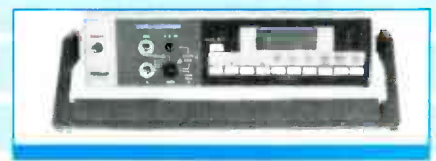

## Tenma Bench Top DMM/Capacitance Meter

Features: ■ 3½ digit LCD display ■ Measures capacitance up to 20µF ■ AC and DC current up to 20A ■ Diode test ■ Resistance up to 20Mohm ■ Comes complete with test leads and owners manual

#72-410

## Tenma Audio Generator

Features: ■ Generates sine and square waveforms ■ Six step and continuously variable attenuators ■ External sync input ■ Comes complete with test leads and owners manual

#72-455



## Tenma Hand-Held Audio Generator

Features: ■ Wide frequency range ■ Sine wave or square wave output ■ Sync output ■ Continuously variable and 20dB fixed output attenuators ■ Low battery indicator ■ Comes complete with test leads and owners manual

#72-505

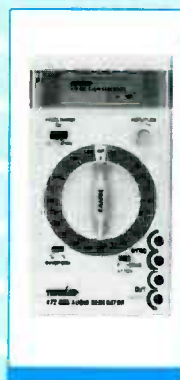

## Tenma AC Millivoltmeter

Features: ■ 3½" mirrored scale ■ Calibrated in mV RMS and dB ■ Amplified output for observing microvolt signals on oscilloscope ■ Comes complete with test leads and owners manual

#72-450

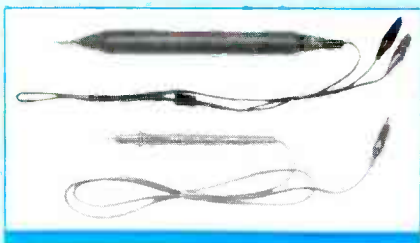
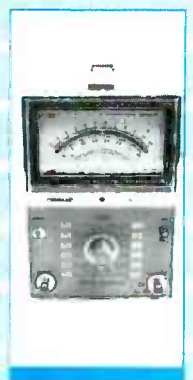

## Tenma 50MHz Logic Probe and Pulsar

Features: ■ Probe and pulser in one convenient package ■ 50MHz maximum input signal frequency ■ 120Kohm input impedance ■ 10nsec minimum pulse width

#72-500

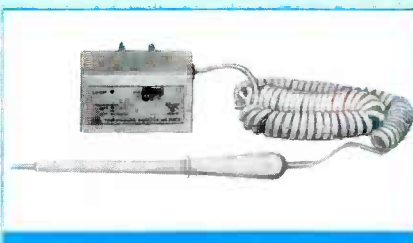

## Temperature Adaptor

Features: ■ Reads temperature in celsius or fahrenheit ■ Semiconductor sensor for fast temperature response ■ Rugged probe design ■ Low battery indicator

#72-520

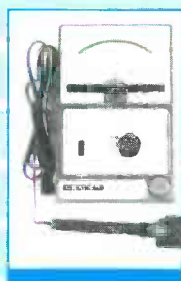

## Laser Power Meter

Features: ■ Measures output of laser devices on audio and video disc players ■ Two wavelengths and three power ranges

#70-420

For A Wide Variety Of Electronic Parts  
Call Toll Free 1-800-543-4330

In Ohio, 1-800-762-4315 — In Alaska and Hawaii, 1-800-858-1849



MCM ELECTRONICS

858 E. CONGRESS PARK DR.  
CENTERVILLE, OH 45459

A PREMIER Company



©1988, MCM ELECTRONICS

SOURCE NO. RE-41

CIRCLE 87 ON FREE INFORMATION CARD





## Test Electrical Equipment With Our Pocket-Size Digital Multimeter

- Full autoranging
- Easy-to-read LCD display
- Measures to 500V AC/DC
- Measures to 20 megohms
- 0.7% basic accuracy
- Audible continuity and diode tester

ONLY \$35 Add \$3.50 shipping



Carry this simple-to-operate multimeter in your shirt pocket for on-the-spot troubleshooting and wiring checks. A continuous audible tone indicates continuity, eliminating the need of watching the display. Quality construction with high tech features. Self contained in a protective vinyl case, complete with probes attached. Folds to 4 1/2 x 3 1/2" and weighs a mere 3 oz.



**Battery Tester**  
PAY ONLY \$1  
**SPECIAL OFFER!**

Test all sizes: AA, AAA, C, D, 9V, N, even 1.5 button cells. When purchased with above item Reg. \$7.95

**FOR FAST SERVICE CALL TOLL FREE**

**1-(800) 221-5749**

In CT: (203) 877-4417 Monday-Friday, 9-5:30 EST

To order by mail: enclose check or M.O., VISA or MasterCard incl. account number and exp. date. Please give your daytime phone number. CT residents, add 7 1/2% sales tax.

Satisfaction guaranteed! 30 day money-back return.

**eaglestone**

Dept. REME, 84 Research Drive, Milford, CT 06460

CIRCLE 202 ON FREE INFORMATION CARD

## MOTION CONTROL SYSTEM

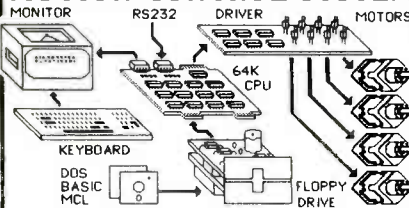

**COMPUTER-MONITOR-KEYBOARD-FLOPPY DISK DRIVE - MOTOR CONTROLLER - FOUR MOTORS - SOFTWARE - A. C. POWER SUPPLY**

**\$199.00**

■ GENERAL PURPOSE 64K SINGLE BOARD COMPUTER HAS 2 SERIAL PORTS & 1 CENTRONICS PORT ■ 800K OF DISK STORAGE-EXPANDABLE TO 3.2 MEG ■ AMBER MONITOR WITH 80 BY 24 LINES OF TEXT DISPLAY ■ HIGH-QUALITY KEYBOARD THAT HAS ■ A SEPARATE NUMERICAL KEYPAD ■ LIGHTED CAPS LOCK AND ENTER KEYS ■ 10 FUNCTION KEYS ■ STEPPER MOTOR DRIVER KIT WITH 4 OF OUR "EASY STEPPER" MOTORS ■ CPM ■ DOS ■ MICROSOFT BASIC ■ PILOT LANGUAGE ■ MOTOR CONTROL PROGRAM WITH SOURCE LISTING ON DISK ■ ALL NECESSARY CABLES. ■ JUST ABOUT EVERY THING YOUR ROBOT WILL NEED FOR "BUILT IN" SMARTS! ■ WE PROVIDE AN A.C. SUPPLY FOR BENCH TESTING. OUTPUT VOLTAGES ARE +12VDC @ 2.5 AMPS, -12VDC @ 5 AMPS, +5VDC @ 5 AMPS, +24VDC @ 1.5 AMPS ■ EXCEPT FOR THE STEPPER DRIVER KIT ALL BOARDS ARE ASSEMBLED AND TESTED JUST WIRE THEM TO THE POWER SUPPLY PLUG IN THE CABLES AND GO.

**HAVE A COMPUTER? THEN ORDER JUST THE MOTORS AND CONTROLLER**  
■ CENTRONICS INTERFACE ■ INCLUDES A.C. POWER SUPPLY AND SOFTWARE ■ SPECIFY MORROW = CPM/ENGINE OR IBM BASIC

**\$39.00**

Call for copy of 15 day trial agreement. Tax & freight extra. C.O.D. accepted just add \$1.90 Price may change. Store price may differ. While supplies last. No P.O.s, terms, or credit cards

**Silicon Valley Surplus**  
415-261-4506  
4401 OAKPORT OAKLAND CA. 94601  
CALL OUR BBS 415-261-4513

OPEN 10am-6pm  
CLOSED SUN & MON

CIRCLE 51 ON FREE INFORMATION CARD

## CABLE T.V. DESCRAMBLERS

**We Will Not Be Undersold BY ANYONE!!!**

**WARNING**—Be leary of prices that seem too low. Such companies offering this, have no responsibility to you, the customer and will often leave you holding the bag. This is why people go out of their way to do business with us.

**FULL WARRANTY**

FOR CATALOG CALL OR WRITE:  
402-330-7673  
ORDERS ONLY: 1-800-435-7075  
**DISTRIBUTORS**  
5078 So. 108th Suite #333 Dept RE  
Omaha, NE. 68137

**DESCRAMBLER.** Build our low cost satellite TV video-only descrambler for all major movies and sports. Uses all Radio Shack parts. Order P.C. board and instructions by sending check, money order, or Visa for \$35.00 U.S. funds to: **VALLEY MICROWAVE ELECTRONICS**, Bear River, Nova Scotia, Canada. BOS-1BO. (902) 467-3577.

**DESCRAMBLERS** for movies, network, \$149, video only, \$399 complete. Catalog \$4.00. **SKY-WATCH**, 238 Davenport Road, Toronto, Canada M5R-1J6.

**VIDEOCYPHERII descrambling manual.** Schematics, video and audio, DES, Cloning, Muskatereing, Eprom codes. (HBO, Cinemax, Showtime, adult channels) \$12.95, \$1 postage. **CABLETRONICS**, Box 30502R, Bethesda, MD 20814.

**VIDEO TAPE COPYGUARD**

Eliminate the latest copyguard problems  
units from \$59<sup>95</sup> to \$169<sup>95</sup>

*Deluxe Electronics* ..... (714) 998-6866  
1432 Heim Wy., Orange, Ca. 92665

## BUSINESS OPPORTUNITIES

**EARN** thousands with your own part time electronics business. I do. Free proof, information. **INDUSTRY**, Box 531, Bronx, NY 10461.

**PROJECTION TV**...Make \$\$\$'s assembling projectors...easy...results comparable to \$2,500 projectors...Total cost less than \$30.00...Plans, 8" lens and dealers information \$20.50...Illustrated information free...**MACROCOMA-GFX**, Washington Crossing, PA 18977. Creditcard orders 24hrs. (215) 736-2880.

**MICRO**-Electronic engineer to design and manufacture receiver. **JPH**, 4218 Bunker Hill, Bettendorf, IA 52722. (319) 355-2927.

**BIG PROFITS** **ELECTRONIC ASSEMBLY BUSINESS**

Start home spare time. Investment knowledge or experience unnecessary. **BIG DEMAND** assembling electronic devices. Sales handled by professionals. Unusual business opportunity.

**FREE: Complete illustrated literature**  
BARTA, RE-O Box 248  
Walnut Creek, Calif 94597

**EASY, lucrative.** One man CRT rebuilding machinery. Free info: (815) 459-0666 **CRT**, 1909 Louise, Crystalake, IL 60014.

**MECHANICALLY** inclined individuals desiring ownership of small electronics manufacturing business—without investment. Write: **BUSINESS**, 92-R, Brighton 11th, Brooklyn, NY 11235.

**EARN** big bucks designing custom cable television distribution systems for homes. This report also tells how to avoid the ten costly mistakes that professionals often make. \$10. postpaid. **W. TANNER**, Box 82582, Fairbanks, AK 99708.

## EDUCATION & INSTRUCTION

**F.C.C. Commercial General Radiotelephone license.** Electronics home study. Fast, inexpensive! "Free" details. **COMMAND**, D-176, Box 2223, San Francisco, CA 94126.

**SUPERFAST Morse Code** supereasy. Subliminal cassette. \$10. Learn Morse Code in 1 hour. Amazing new supereasy technique. \$10. Both \$17. Moneyback guarantee. Free catalog: **SASE BAH**, 2549-E9 Temple, Palmbay, FL 32905.

**100 FCC** sample questions. General radiotelephone operator license, \$10 **SASE. PEI**, Box 12056-RE, Omaha, NE 68152.

**MICROPROFESSOR** 16 bit trainer, 8088 C.P.U., 8 bit data bus, 4.77MHz, 59-key, full-size keyboard, Centronics parallel interface. Design, write, debug, and execute assembly language programs. **ETRONIX**, 5326—9th Ave. N.E., Seattle, WA 98105 1 (800) 426-1044.

**MICROPROFESSOR** 8 bit trainer, Z-80 C.P.U. 158-instruction set, 8K monitor ROM, enter programs in assembly, machine, basic, or forth. **ETRONIX**, 5326—9th Ave. N.E., Seattle, WA 98105. 1 (800) 426-1044.

## SCRAMBLE FACTS 718-343-0130

**PHONE TODAY** for 3 minutes of satellite TV industry news, technical tips, and new product information.

## DESCRAMBLER MODULE

**COMPLETE** cable-TV decoder in a mini-module. Latest technology upgrade for Jerrold SB-3 or Radio-Electronics Feb. 1984 project. Versatile, sophisticated, and low cost. For literature, **SOUTHTECH DISTRIBUTING**, (813) 222-3293.

**Pay TV and Satellite Descrambling NEW... VOL. 2 ... NEW**

Picks up where VOL 1 ended. Introductory price \$12.95. VOL 1 \$14.95 MDS Hackers Handbook \$9.95. Experiments with Videocipher Cloning, muskatereing. \$14.95. Cable TV Security, design. \$12.95 Build Satellite Systems Under \$600. \$12.95 Any 3 of preceding \$27. All \$40. Zenith manuals. 2-Trap \$14.95. 2-Bag \$19.95. Both \$29.95. Scrambling News. \$24.95; Free sample with order. Catalog \$1.

**Shojiki Electronics Corp.** 1327A Niagara St., Niagara Falls, NY 14303. COD's 716-284-2163

## CABLE TV DESCRAMBLERS

**CABLE TV converters.** Scientific Atlanta, Jerrold, Oak, Zenith, Hamlin. Many others. "New" Video Hopper "The Copy Killer." Visa, M/C & Amex 1-800-826-7623. **B&B INC.**, 10517 Upton Circle, Bloomington, MN 55431.

## SCIENTIFIC ATLANTA & SB-3

**SCIENTIFIC Atlanta** Models 8500—8550, remote included...\$240.00 **SB-3's**...\$74.00. **TRI-BI's**...\$95.00. **SBSA-3's**...\$99.00. **Zenith (Z-Tac)** Descramblers...\$169.00. **N-12 (Vari-sync)**...\$89.00. **M-35 B (Vari-sync)**...\$99.00. **Panasonic** converters...\$95.00—\$99.00. **Dealer discount** on (5) units. **Brochure** available. Call...**N.A.S. INTERNATIONAL**, (213) 631-3552.

## CABLE T.V. "BOXES"

Converters—Descramblers  
Remote Controls—Accessories

- ★ Guaranteed Best Prices ★
- ★ 1 Year Warranty—C.O.D.'s ★
- ★ Immediate Shipping ★
- ★ FREE CATALOG ★

Call or Write:  
**TRANS-WORLD CABLE CO.**  
HC 83, Box 531  
Pequot Lakes, MN 56472  
(218) 543-6871

### WANTED

**INVENTORS!** AIM wants—ideas, inventions, new products, improvements on existing products. We present ideas to manufacturers. Confidentiality guaranteed. Call toll free 1-(800) 225-5800 for information kit.

**INVENTIONS,** ideas, new products wanted! Industry presentation/national exposition. Call free 1-(800) 288-IDEA. Canada, 1-(800) 528-6060. X831.

**WANTED** Excess inventories of I.C.S., disk drives, circuit boards, computers, etc. **WESTERN TECH.** (818) 882-1355 (CAL.)

### INVENTORS

**INVENTORS!** Can you patent and profit from your idea? Call **AMERICAN INVENTORS CORPORATION** for free information. Over a decade of service. 1-(800) 338-5656. In Massachusetts or Canada call (413) 568-3753.

### PRINTED CIRCUIT BOARD LAYOUTS

**GUARANTEED** low pricing for single, double sided artwork layouts. (704) 464-1164; **PCBAL.** RT-3, Box 662-H, Conover, NC 28613.

**MASTERCARD AND VISA** are now accepted for payment of your advertising. Simply complete the form on the first page of the Market Center and we will bill.

### Cable Converters & Decoders

* Jerrold S.B. Add On.....	\$89.00	\$58.00
* Jerrold Tri-Bi Add On.....	\$98.00	\$78.00
Jerrold Starcom CSV.....	\$139.95	Call
MTS Converter + Remote.....	\$85.00	\$69.00
Jerrold 450 DRZ-3A.....	\$95.00	\$79.00
Parental Control MTS Plus.....	\$100.00	\$85.00
Hamlin MLD 1200-3.....	\$98.00	\$58.00
Scientific Atlanta Add On.....	\$140.00	\$99.00
M-35 B Combo With VariSync.....	\$99.00	\$69.00
Mini Code N-12 VariSync.....	\$99.00	\$58.00
442 VariSync (N-12 Substitute).....	\$89.00	\$58.00
Wireless Video Sender.....	\$45.00	Call

\*S.B. TRI-BI Flashing Got You Down? Try original Jerrold Equipment it might just solve your problems. Call or write for Free Catalog. All products Guaranteed 90 days plus. M.D. Electronics 5078 So. 108th Suite 115 Omaha NE. 68137 Phone (402) 554-0417

## AMAZING SCIENTIFIC & ELECTRONIC PRODUCTS

**PLANS**—Build Yourself—All Parts Available in Stock

- G7—BURNING CUTTING CO<sub>2</sub> LASER..... \$ 20.00
- 3UB—PORTABLE LASER RAY PISTOL..... 20.00
- TC1—3 SEPARATE TESLA COIL PLANS TO 1.5 MEV..... 20.00
- J0G1—ION RAY GUN..... 10.00
- BRA1—GRAVITY GENERATOR..... 10.00
- EML—ELECTRO MAGNET COIL GUN/LAUNCHER..... 6.00

**KITS**

- LFT1—FM VOICE TRANSMITTER 3 MI RANGE..... 49.50
- \*WPM5K—TELEPHONE TRANSMITTER 3 MI RANGE..... 39.50
- BTC3—250.00 VOLT 10-14" SPARK TESLA COIL..... 199.50
- LHC2—SIMULATED MULTICOLOR LASER..... 39.50
- BLS1—100,000 WATT BLASTER DEFENSE DEVICE..... 69.50
- TM1K—100,000 VOLT 20" AFFECTIVE RANGE INTIMIDATOR..... 69.50
- \*SP4—TIME VARIANT SHOCK WAVE PISTOL..... 59.50
- \*TC1—SPECTACULAR PLASMA TORNADO GENERATOR..... 149.50
- \*VPIK SEE IN DARK KIT..... 199.50

**ASSEMBLED**

- \*G70H—MULTICOLORED VARIABLE MODE PLASMA GLOBE "7"..... 199.50
- 3TC10—50,000 VOLT—WORLD'S SMALLEST TESLA COIL..... 44.50
- \*G040—1MW HeNe VISIBLE RED LASER GUN..... 199.50
- TAT20 AUTO TELEPHONE RECORDING DEVICE..... 24.50
- GPV1C—SEE IN TOTAL DARKNESS IR VIEWER..... 349.50
- LIST1—SNOOPER PHONE INFINITY TRANSMITTER..... 169.50
- IPG70—INVISIBLE PAIN FIELD GENERATOR—MULTI MODE..... 74.50

• **CATALOG** CONTAINING DESCRIPTIONS OF ABOVE PLUS HUNDREDS MORE AVAILABLE FOR \$1.00 OR INCLUDED FREE WITH ALL ABOVE ORDERS.

PLEASE INCLUDE \$3.00 PH ON ALL KITS AND PRODUCTS PLANS ARE POSTAGE PAID. SEND CHECK, MO, VISA, MC IN US FUNDS.

**INFORMATION UNLIMITED**  
P.O. BOX 716 DEPT. RE, AMHERST, NH 03031

## ELECTRONIC COMPONENTS CATALOG

... yours FREE by dialing

1-800-992-9943

In Texas: 1-800-346-6687

Call Today for your FREE subscription to the 1988 Mouser Electronics Catalog. Contains 176 pages featuring over 16,000 in-stock, quality electronic components.

..PLUS..Mouser's proven service and prompt delivery.

(Outside U.S.A., Send \$2.)



**MOUSER ELECTRONICS**

2401 Hwy 287 North  
Mansfield, Texas 76063

**DISTRIBUTION CENTERS NATIONWIDE**

CIRCLE 117 ON FREE INFORMATION CARD

**At KELVIN...  
Price, Service  
& Quality for  
over 42 years.**

**B & K · FLUKE · UNGAR  
HITACHI · WELLER  
BECKMAN · DREMEL  
STANLEY · MAKITA  
X-ACTO · KEPRO · XCELITE**



LISA HADAR  
EXECUTIVE VP, CPA

When someone in your family gets cancer, everyone in your family needs help.

Nobody knows better than we do how much help and understanding is needed. That's why our service and rehabilitation programs emphasize the whole family, not just the cancer patient.

Among our regular services we provide information and guidance to patients and families, transport patients to and from treatment, supply home care items and assist patients in their return to everyday life.

Life is what concerns us. So you can see we are even more than the research organization we are so well known to be. No one faces cancer alone.

AMERICAN CANCER SOCIETY

### METERS/OSCILLOSCOPES

B & K	2120	20Mhz Dual Trace	\$ 395*
Beckman	9020	20Mhz Dual Trace	425
Hitachi	V212	20Mhz	\$365
Fluke	73	3 1/2" Digit DMM	SPECIAL
Fluke	75	3 1/2" Digit DMM	
Fluke	77	3 1/2" Digit DMM	

\*PLUS Shipping & Insurance. Prices subject to change without notice.

WE HAVE IT ALL...

• COMPONENTS • TOOLS • KITS • SECURITY • SEMI-CONDUCTORS • ELECTRICAL SUPPLIES • SOLDER EQUIPMENT • KELVIN KITS • TSM KITS • DRAFTING SUPPLIES

Volume Quotes, Industrial & School Bids Welcome.

ORDER TOLL FREE FOR INQUIRES & N.Y.S.  
1-800-645-9212 516-349-7620

**KELVIN ELECTRONICS**

NEW ADDRESS:

7 Fairchild Avenue • Plainview, NY 11803 • FAX: 516-349-7830

VISA/MASTER CARD ACCEPTED

CIRCLE 195 ON FREE INFORMATION CARD

# 256K STATIC 32K x 8 \$12.95 150ns

# 256K DRAM 41256 \$2.95 150ns

## STATIC RAMS

2112	256x4	(45ns)	2.99
2114	1024x4	(70ns)	.99
2114L-2	1024x4	(200ns)(LOW POWER)	1.49
TMM2016-100	2048x8	(100ns)	1.95
HM6116-4	2048x8	(200ns)(CMOS)	1.79
HM6116-3	2048x8	(150ns)(CMOS)	1.85
HM6116LP-4	2048x8	(200ns)(CMOS)(LP)	1.85
HM6116LP-3	2048x8	(150ns)(CMOS)(LP)	1.90
HM6116LP-2	2048x8	(120ns)(CMOS)(LP)	2.45
HM6264P-15	8192x8	(120ns)(CMOS)(LTP)	3.95
HM6264LP-12	8192x8	(120ns)(CMOS)(LP)	4.49
HM43256LP-15	32768x8	(150ns)(CMOS)(LP)	12.95
HM43256LP-12	32768x8	(120ns)(CMOS)(LP)	14.95
HM43256LP-10	32768x8	(100ns)(CMOS)(LP)	19.95

## DYNAMIC RAMS

4116-250	16384x1	(250ns)	.49
4116-200	16384x1	(200ns)	.89
4116-150	16384x1	(150ns)	.99
4116-120	16384x1	(120ns)	1.49
MK4332	32768x1	(200ns)	6.95
4164-150	65536x1	(150ns)	1.25
4164-120	65536x1	(120ns)	1.55
MCM6665	65536x1	(200ns)	1.95
TMS4164	65536x1	(150ns)	1.95
4164-REFRESH	65536x1	(150ns)(PIN 1 REFRESH)	2.95
TMS4416	16384x4	(150ns)	3.75
41128-150	131072x1	(150ns)	5.95
TMS4464-15	65536x4	(150ns)	4.95
41256-150	262144x1	(150ns)	2.95
41256-120	262144x1	(120ns)	3.95
41256-100	262144x1	(100ns)	4.95
HM51258-100	262144x1	(100ns)(CMOS)	6.95
1 MB-120	1048576x1	(120ns)	19.95
1 MB-100	1048576x1	(100ns)	24.95

## EPROMS

2708	1024x8	(45ns)(25V)	4.95
2716	2048x8	(45ns)(25V)	3.49
2716-1	2048x8	(35ns)(25V)	3.95
TMS2532	4096x8	(45ns)(25V)	5.95
2732	4096x8	(45ns)(25V)	3.95
2732A	4096x8	(25ns)(21V)	3.95
2732A-2	4096x8	(20ns)(21V)	4.25
27C64	8192x8	(25ns)(12.5V CMOS)	4.95
2764	8192x8	(45ns)(12.5V)	3.49
2764-250	8192x8	(25ns)(12.5V)	3.69
2764-200	8192x8	(200ns)(12.5V)	4.25
MCM68766	8192x8	(35ns)(21V)(24 PIN)	15.95
27128	16384x8	(25ns)(12.5V)	4.25
27256	16384x8	(25ns)(12.5V CMOS)	5.95
27256B	32768x8	(25ns)(12.5V)	5.95
27512	65536x8	(25ns)(12.5V)	11.95
27C512	65536x8	(25ns)(12.5V CMOS)	12.95

xxV-Program Voltage

## 6500 1.0 MHz

6502	2.25
65C02 (CMOS)	7.95
6520	1.65
6522	2.95
6526	13.95
6532	6.95
6545	2.95
6551	2.95

## 2.0 MHz

6502A	2.69
6520A	2.95
6522A	5.95
6532A	11.95
6545A	3.95
6551A	6.95

## 3.0 MHz

6502B	4.25
-------	------

## 6800 1.0 MHz

6800	1.95
6802	2.95
6803	3.95
6809	2.95
6809E	2.95
6810	1.95
6820	2.95
6821	1.95
6840	3.95
6843	4.95
6844	6.95
6845	2.75
6847	4.75
6850	1.95
6883	22.95

## 2.0 MHz

6880	2.95
68802	3.95
68809E	5.49
68809	5.99
68821	1.85
68845	4.95
68850	1.75
68850	9.95

## Z-80 2.5 MHz

Z80-CPU	1.25
<b>4.0 MHz</b>	
Z80A-CPU	1.29
Z80A-CTC	1.69
Z80A-DART	5.95
Z80A-DMA	5.95
Z80A-PIO	1.89
Z80A-SIO /0	5.95
Z80A-SIO /1	5.95
Z80A-SIO /2	5.95
<b>6.0 MHz</b>	
Z80B-CPU	2.75
Z80B-CTC	4.25
Z80B-PIO	4.25
Z80B-DART	6.95
Z80B-SIO /0	12.95
Z80B-SIO /2	12.95
Z8671 ZILOG	9.95

## CLOCK CIRCUITS

MM58167	9.95
MM58174	9.95
MSM5832	2.95

## BIT RATE GENERATORS

MC14411	9.95
BR1941	4.95
4702	9.95
COM8116	8.95

## INTERSIL

ICL7106	9.95
ICL7107	10.95
ICL7660	1.99
ICL8038	3.85
ICM7207A	5.95
ICM7208	15.95

# ★ ★ ★ ★ HIGH-TECH ★ ★ ★ ★

## HM43256LP-15 \$12.95

- ★ 32K x 8 STATIC RAM
- ★ LOW POWER CONSUMPTION
- ★ HIGH SPEED — 100ns AVAILABLE
- ★ LOW STAND-BY CURRENT (2ma MAX.)
- ★ TTL COMPATIBLE INPUT AND OUTPUTS

# ★ ★ ★ ★ SPOTLIGHT ★ ★ ★ ★

## 8000

8031	3.95
8035	1.49
8039	1.95
8052AH BASIC	34.95
8080	2.49
8085	1.95
8086	6.49
8088	5.99
8088-2	7.95
8155	2.95
8155-2	3.95
8741	9.95
8748	7.95
8749	9.95
8755	14.95

## 8200

8203	14.95
8205	3.29
8212	1.49
8216	1.49
8224	2.25
8228	2.25
8237	3.95
8243	1.95
8250	6.95
8251	1.29
8251A	1.69
8253	1.59
8253-5	1.95
8255	1.49
8255-5	1.59
8259	1.95
8259-5	2.29
8257	2.25
8272	4.39
8274	4.95
8275	16.95
8279	2.49
8279-5	2.95
8282	3.95
8283	3.95
8284	2.25
8286	3.95
8287	3.95
8288	4.95

## intel MATH COPROCESSORS

8087	\$99.95	80287-8	\$249.95
8087-2	159.95	80287-10	\$309.95
80287	\$179.95	80387-16	\$499.95

TOLL FREE  
**800-538-5000**  
U.S. AND CANADA

## DISK CONTROLLERS

1771	4.95
1791	9.95
1793	9.95
1795	12.95
1797	12.95
2791	19.95
2793	19.95
2797	29.95
8272	4.39
UPD765	4.39
MB8876	12.95
MB8877	12.95
1691	6.95
2143	6.95
9216	6.29

## UARTS

AV5-1013	3.95
AV3-1015	4.95
TR1602	3.95
2651	4.95
IM6402	3.95
IM6403	9.95
INS8250	6.95
NS16450	10.95

## MISC.

ADC0804	2.99
AIC0809	3.85
DAC0800	3.29
DAC0808	1.95
DAC1022	5.95
MC1408L8	1.95
8T28	1.29
8T97	.59
9334	1.75
9368	2.85
9602	.69
ULN2003	.79
MAX232	.79
MC3470	1.95
MC3487	2.95
AV5-3600 PRO	11.95

## V 20 SERIES

V20* 5 MHz	8.95
V20* 8 MHz	10.95
V30 8 MHz	13.95

\*Replaces 8088 to speed up your PC by 10 to 40%

## CRYSTALS

32.768 KHz	.95
1.0 MHz	2.95
1.8432	2.95
2.0	1.95
2.4576	1.95
3.579545	1.95
4.0	1.95
5.0	1.95
6.0	1.95
6.144	1.95
8.0	1.95
10.0	1.95
10.738635	1.95
12.0	1.95
14.31818	1.95
16.0	1.95
18.0	1.95
18.432	1.95
20.0	1.95
22.1184	1.95
24.0	1.95
32.0	1.95

## OSCILLATORS

1.0MHz	5.95
1.8432	5.95
2.0	5.95
2.4576	5.95
2.5	5.95
4.0	4.95
5.0	4.95
6.0	4.95
6.144	4.95
8.0	4.95
10.0	4.95
12.0	4.95
16.0	4.95
18.432	4.95
20.0	4.95
24.0	4.95

## PALS

16L8	\$2.95
16R8	\$2.95
16R6	\$2.95
16R4	\$2.95

## 74F/74S

74F00	.35
74F02	.35
74F04	.35
74F08	.35
74F10	.35
74125	.45
74150	1.35
74151	.55
74153	.55
74154	1.49
74157	.39
74159	.65
74161	.69
74164	.85
74166	1.00
74175	.89
74367	.65
74S00	.29
74S01	.45
74S02	.49
74S03	.49
74S04	.39
74S05	.39
74S08	.39
74S09	.49
74S12	.39
74S11	.22
74S12	.22
74S13	.26
74S14	.39
74S15	.26
74S20	.17
74S21	.22
74S22	.22
74S27	.23
74S28	.26
74S30	.17
74S32	.18
74S33	.28
74S37	.26
74S38	.26
74S42	.39
74S47	.75
74S48	.85
74S51	.17
74S73	.29
74S74	.24
74S75	.29
74S76	.29
74S83	.29
74S85	.49
74S86	.22
74S90	.39
74S92	.49
74S93	.39
74S95	.49
74S107	.34
74S109	.36
74S112	.29
74S122	.45
74S123	.49
74S124	2.75
74S125	.39
74S126	.39
74S132	.39
74S133	.49
74S136	.39
74S138	.39
74S139	.39
74S145	.99
74S147	.99
74S148	.99
74S151	.39
74S153	.39
74S155	.59
74S156	.49
74S158	.39
74S160	.29
74S161	.39
74S162	.39
74S163	.49
74S164	.65
74S165	.65
74S166	.95
74S169	.95
74S173	.49
74S174	.39
74S175	.39
74S176	.39
74S192	.69
74S193	.69
74S194	.69
74S195	.69
74S196	.69
74S197	.59
74S221	.59
74S240	.69
74LS241	.69
74LS242	.69
74LS243	.69
74LS244	.69
74LS245	.79
74LS251	.49
74LS253	.49
74LS257	.39
74LS258	.49
74LS259	1.29
74LS260	.49
74LS266	.39
74LS273	.79
74LS279	.39
74LS280	1.98
74LS283	.59
74LS290	.89
74LS293	.89
74LS299	1.49
74LS322	3.95

# 20 MEG HARD DISK DRIVE ON A CARD \$349!

## BARGAIN HUNTERS CORNER

# 10 MEG HARD DISK SYSTEM

INCLUDES DRIVE, DRIVE CONTROLLER, CABLES AND INSTRUCTIONS  
PRE-TESTED WITH A ONE YEAR WARRANTY

# \$189

SPECIAL ENDS 1/31/88

### CAPACITORS

**TANTALUM**

1.0 $\mu$ f	15V .12	1.0 $\mu$ f	35V .45
6.8	15V .42	2.2	35V .19
10	15V .45	4.7	35V .39
22	15V .99	10	35V .69

**DISC**

10 $\mu$ f	50V .05	.001 $\mu$ f	50V .05
22	50V .05	.005	50V .05
33	50V .05	.01	50V .07
47	50V .05	.05	50V .07
100	50V .05	.1	12V .10
220	50V .05	1	50V .12

**MONOLITHIC**

.01 $\mu$ f	50V .14	1 $\mu$ f	50V .18
.047 $\mu$ f	50V .15	47 $\mu$ f	50V .25

**ELECTROLYTIC**

<b>RADIAL</b>		<b>AXIAL</b>	
1 $\mu$ f	25V .14	1 $\mu$ f	50V .14
4.7	50V .11	10	50V .16
10	50V .11	22	16V .14
47	35V .13	50	16V .19
100	16V .15	100	35V .19
220	35V .20	470	50V .29
47C	25V .30	1000	16V .29
220C	16V .70	2200	16V .70
47CC	25V 1.45	4700	16V 1.25

### SOLDER STATION

- UL APPROVED
- ADJUSTABLE HEAT SETTING W/TIP TEMP READOUT
  - QUICK HEATING & RECOVERY
  - RANGE 200°-900°F

## \$49.95

### EXTENDER CARDS FOR IBM

EXT-8088 \$29.95  
EXT-80286 \$39.95

### WIREWRAP PROTOTYPE CARDS

FR-4 EPOXY GLASS LAMINATE  
GOLD-PLATED EDGE CARD FINGERS

### XT

BOTH CARDS HAVE SILK SCREENED LEGENDS & MOUNTING BRACKET

IBM-PR1 \$27.95  
WITH -5V AND GROUND PLANE

IBM-PR2 \$29.95  
AS ABOVE WITH DECODING LAYOUT

### AT

IBM-PRAT \$29.95  
LARGE -5V & GROUND PLANES

### SOLDERLESS BREADBOARDS

WBU-D	100 TIE POINTS	2.95
WBU-T	630 TIE POINTS	6.95
WBU-204-3	1360 TIE POINTS	17.95
WBU-201	1660 TIE POINTS	24.95
WBU-206	4390 TIE POINTS	29.95
WBU-208	3220 TIE POINTS	39.95

### PAGE WIRE WRAP WIRE

PRECUT ASSORTMENT IN ASSORTED COLORS \$27.50

100ea: 5.5", 6.0", 6.5", 7.0"  
250ea: 2.5", 4.5", 5.0"  
500ea: 3.0", 3.5", 4.0"

### SPOOLS

100 feet	\$4.30	250 feet	\$7.25
500 feet	\$13.25	1000 feet	\$21.95

Please specify color: Blue, Black, Yellow or Red

### SOCKET-WRAP I.D.™

- SLIPS OVER WIRE WRAP PINS
- IDENTIFIES PIN NUMBERS ON WRAP SIDE OF BOARD
- CAN WRITE ON THE PLASTIC, SUCH AS AN IC #

PINS	PART #	PCK. OF	PRICE
8	IDWRAP 08	10	1.95
14	IDWRAP 14	10	1.95
16	IDWRAP 16	10	1.95
18	IDWRAP 18	5	1.95
20	IDWRAP 20	5	1.95
22	IDWRAP 22	5	1.95
24	IDWRAP 24	5	1.95
28	IDWRAP 28	5	1.95
40	IDWRAP 40	5	1.95

PLEASE ORDER BY NUMBER OF PACKAGES (PCK. OF)

### SWITCHES

SPDT	MINI-TOGGLE ON/OFF	1.25
DPDT	MINI-TOGGLE ON/OFF	1.50
DPDT	MINI-TOGGLE ON/OFF-OFF	1.75
SPST	MINI-PUSHBUTTON N.O.	.39

### DIP SWITCHES

4 position	.85	7 position	.95
5 position	.90	8 position	.95
6 position	.90	10 position	1.29

### "SNAPABLE" HEADERS

CAN BE SNAPPED APART TO MAKE ANY SIZE HEADER, ALL WITH .1" CENTERS

1x40	STRAIGHT LEAD	.99
1x40	RIGHT ANGLE LEAD	1.49
2x40	2 STRAIGHT LEADS	2.49
2x40	2 RIGHT ANGLE LEADS	2.99

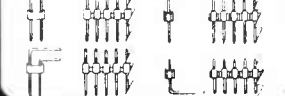

### 25 PIN D-SUB GENDER CHANGERS \$7.95



### EMI FILTER \$4.95 LINE CORDS

2 conductor 39c	3 conductor 99c
3 conductor w/female socket	\$1.49

### RESISTOR NETWORKS

SIP 10 PIN	9 RESISTOR	.69
SIP 8 PIN	7 RESISTOR	.59
DIP 16 PIN	8 RESISTOR	1.09
DIP 16 PIN	15 RESISTOR	1.09
DIP 14 PIN	7 RESISTOR	.99
DIP 14 PIN	13 RESISTOR	.99

### VOLTAGE REGULATORS

7805T	.49	7812K	1.39
7808T	.49	7905K	1.69
7812T	.49	7912K	1.49
7815T	.49	78L05	.49
7905T	.59	78L12	.49
7908T	.59	79L05	.69
7912T	.59	79L12	1.49
7915T	.59	LM323K	4.79
7805K	1.59	LM338K	6.95

### 36 PIN CENTRONICS

ICDCE36	RIBBON CABLE	3.95
CEN36	SOLDER CUP	1.85
ICDCE36/F	RIBBON CABLE	4.95
CEN36PC Rt Angle	PC Mount	1.85

### DISCRETE

1N751	.15	4N28	.69
1N4148 25.1 $\mu$		4N33	.89
1N4004 10.1 $\mu$		4N37	1.19
1N5402	.25	MCT-2	.59
KBPO2	.55	MCT-6	1.29
N2222	.25	TIL-111	.99
PN2222	.10	2N3906	.10
2N2907	.25	2N4401	.25
2N3055	.79	2N4402	.25
2N3904	.10	2N4403	.25
4N26	.69	2N6045	1.75
4N27	.69	TIP31	.49

### VERY THOUSANDS CHOOSE JDR

- QUALITY MERCHANDISE COMPETITIVE PRICES
- MOST ORDERS SHIPPED IN 24 HOURS
- FRIENDLY, KNOWLEDGEABLE STAFF
- MONEY BACK GUARANTEE (ASK FOR DETAILS)
- TOLL FREE TECHNICAL SUPPORT
- EXCELLENT CUSTOMER SERVICE



### DATARASE

- ERASES 2 EPROMS IN 10 MINUTES
- VERY COMPACT, NO DRAWER
- THIN METAL SHUTTER PREVENTS UV LIGHT FROM ESCAPING

\$34.95



### IDC CONNECTORS/RIBBON CABLE

DESCRIPTION	ORDER BY	CONTACTS					
		10	20	26	34	40	50
SOLDER HEADER	IDHxxS	.82	1.29	1.68	2.20	2.53	3.24
RIGHT ANGLE SOLDER HEADER	IDHxxSR	.85	1.35	1.76	2.31	2.72	3.39
WIREWRAP HEADER	IDHxxW	1.86	2.98	3.84	4.50	5.23	6.63
RIGHT ANGLE WIREWRAP HEADER	IDHxxWR	2.05	3.28	4.22	4.45	4.80	7.30
RIBBON HEADER SOCKET	IDSxx	.63	.89	.95	1.29	1.49	1.69
RIBBON HEADER	IDMxx	---	5.50	6.25	7.00	7.50	8.50
RIBBON EDGE CARD	IDExx	.85	1.25	1.35	1.75	2.05	2.45
10' GREY RIBBON CABLE	RCxx	1.60	3.20	4.10	5.40	6.40	7.50

FOR ORDERING INSTRUCTIONS, SEE D-SUBMINIATURE CONNECTORS, BELOW

### SPECTRONICS CORPORATION EPROM ERASERS

Model	Timer	Chip Capacity	Intensity (uW/cm <sup>2</sup> )	Unit Cost
PE-140	NO	9	8,000	\$89
PE-140T	YES	9	8,000	\$139
PE-240T	YES	12	9,600	\$189

### LIGHT EMITTING DIODES

#### LED DISPLAYS

FND-357(359)	COM CATHODE	.362"	1.25
FND-500(503)	COM CATHODE	5"	1.49
FND-507(510)	COM ANODE	5"	1.49
MAN-72	COM ANODE	3"	.99
MAN-74	COM CATHODE	3"	.99
TIL-313	COM CATHODE	3"	.45
TIL-311	4x7 HEX W/LOGIC	270"	10.95

#### DIFFUSED LEDS

JUMBO RED	T1 $\frac{1}{2}$	1.99	100-UP
JUMBO GREEN	T1 $\frac{1}{2}$	.10	.09
JUMBO YELLOW	T1 $\frac{1}{2}$	.14	.12
MOUNTING HDW	T1 $\frac{1}{2}$	.14	.12
MINI RED	T1	.10	.09

### 3 VOLT LITHIUM BATTERY \$1.95 HOLDER \$1.49

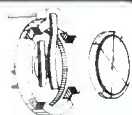

I would like you to know that I think you have a special employee in Helen M... giving the usual courteous and competent service that I have come to expect from JDR. Keep up the good work.

John Medcalf

### IC SOCKETS/DIP CONNECTORS

DESCRIPTION	ORDER BY	CONTACTS								
		8	14	16	18	20	22	24	28	40
SOLDERTAIL SOCKETS	xxST	11	11	.12	.15	.18	.15	.20	.22	.30
WIREWRAP SOCKETS	xxWW	.59	.69	.69	.99	1.09	1.39	1.49	.69	1.99
ZIF SOCKETS	ZIFxx	---	4.95	4.95	---	5.95	---	5.95	6.95	9.95
TOOLED SOCKETS	AUGATxxST	.62	.79	.89	1.09	1.29	1.39	1.49	.69	2.49
TOOLED WW SOCKETS	AUGATxxWW	1.30	1.80	2.10	2.40	2.50	2.90	3.15	3.70	5.40
COMPONENT CARRIERS	ICCxx	.49	.59	.69	.99	.99	.99	.99	.99	1.49
DIP PLUGS (IDC)	IDPxx	.95	.49	.59	1.29	1.49	---	.85	---	1.59

FOR ORDERING INSTRUCTIONS, SEE D-SUBMINIATURE CONNECTORS, ABOVE

CALL FOR VOLUME QUOTES COPYRIGHT 1987 JDR MICRODEVICES

**64K DRAM** 4164 150ns **\$129**

**256K DRAM** 41256 150ns **\$295**

**MONITOR STANDS**

**MODEL MS-100** **\$12.95**  
 • TILTS & SWIVELS • STURDY PLASTIC CONSTRUCTION  
**MODEL MS-200** **\$39.95**  
 • TILTS AND SWIVELS • BUILT-IN SURGE SUPPRESSOR  
 • BUILT-IN POWER STATION INDEPENDENTLY CONTROLS UP TO 5 120 VOLT AC OUTLETS • UL APPROVED



**NASHUA DISKETTES**

**BOXES OF 10**  
 5 1/4" DS/DD 360K **\$9.95**  
 5 1/4" DS/HD 1.2M **\$24.95**  
 3 1/2" DS/QD 720K **\$16.95**  
 5 1/4" DS/DD SOFT SECTOR  
**49¢ ea** **39¢ ea**  
 BULK QTY 50 BULK QTY 250

**5 1/4" DISKETTE STORAGE FILE** **\$8.95**

• HOLDS 70 5 1/4" FLOPPIES  
 • STURDY, ATTRACTIVE SMOKED ACRYLIC CASE  
 • COMPLETE WITH HINGED DIVIDERS



**VERSION FOR 3 1/2" FLOPPIES AVAILABLE**  
**\$9.95**

**2 WAY SWITCH BOXES** **\$39.95**

• CONNECT 2 PRINTERS TO 1 COMPUTER OR VICE VERSA  
 • SERIAL & PARALLEL MODELS AVAILABLE  
 • ALL LINES SWITCHED  
 • GOLD PLATED CONNECTORS & QUALITY SWITCHES

**6' INTERFACE CABLES**

MEETS FCC REQUIREMENTS 100% SHIELDED  
 IBM COMPATIBLE PARALLEL PRINTER **\$9.95**  
 CENTRONICS (MALE TO FEMALE) **\$15.95**  
 CENTRONICS (MALE TO MALE) **\$14.95**  
 IBM COMPATIBLE MODEM CABLE **\$7.95**  
 RS232 SERIAL (MALE TO FEMALE) **\$9.95**  
 RS232 SERIAL (MALE TO MALE) **\$9.95**  
 COILED KEYBOARD EXTENDER **\$7.95**

**JOYSTICK** **\$19.95**

• SET X-Y AXIS FOR AUTO CENTER OR FREE MOVEMENT  
 • FIRE BUTTON FOR USE WITH GAME SOFTWARE  
 • INCLUDES ADAPTOR CABLE FOR IBM



**SWITCHING POWER SUPPLIES**

**PS-135** **\$59.95**  
 • FOR IBM XT COMPATIBLE  
 • UL APP. 135 WATTS  
 • 5V 1A, 12V 4 2A  
 • 5V 5A, 12V 5A  
 • ONE YEAR WARRANTY  
**PS-150** 150W MODEL **\$69.95**  
**PS-200** **\$89.95**  
 • FOR IBM AT COMPATIBLE  
 • 200 WATTS  
 • 5V 22A, 12V 8A  
 • 5V 5A, 12V 5A  
 • ONE YEAR WARRANTY  
**PS-A** **\$49.95**  
 • FOR APPLE TYPE SYSTEM  
 • 5V 6A, 12V 3A  
 • 5V 1A, 12V 1A  
 • APPLE CONNECTOR  
**PS-1558** **\$34.95**  
 • 75 WATTS, UL APPROVED  
 • BY POWER SYSTEMS  
 • 5V 7A, 12V 3A  
 • 12V 250mA, 5 300mA



PS-135/150



PS-200



PS-1558

**MONITORS**

**SAMSUNG MONOCHROME**

• IBM COMPATIBLE TTL INPUT  
 • 12" NON-GLARE, LOW DISTORTION, AMBER SCREEN  
 • RES: 720 x 350  
 • SWIVEL BASE  
 • 1 YEAR WARRANTY



**\$129.95**

**MULTISYNC** BY NEC **\$549.95**

• ORIGINAL CGA/EGA/PGA COMPATIBLE MONITOR  
 • AUTO FREQUENCY ADJUSTMENT  
 • RESOLUTION AS HIGH AS 800 x 560

**EGA** BY CASPER **\$399.95**

• 15.75/21.85 KHz SCANNING FREQUENCIES  
 • RES: 640 x 200/350 • 31mm DOT PITCH  
 • 14" BLACK MATRIX SCREEN • 16 COLORS FROM 64

**RGB** BY CASPER **\$279.95**

• COLOR/GREEN/AMBER SWITCH • RES: 640 x 240  
 • RGB/IBM COMPATIBLE • 14" NON-GLARE SCREEN  
 • .39mm DOT PITCH • CABLE FOR IBM PC INCLUDED

**MONOCHROME** BY HYUNDAI **\$69.95**

• IBM COMPATIBLE TTL INPUT  
 • 12" NON-GLARE AMBER SCREEN  
 • ATTRACTIVE CASING WITH A TILT/SWIVEL BASE

**TOLL FREE**

**800-538-5000**  
**U.S. AND CANADA**

**20MB HARD DISK ON A CARD**



• SAVES SPACE AND REDUCES POWER CONSUMPTION  
 • IDEAL FOR PCs WITH FULL HEIGHT FLOPPIES  
 • LEAVES ROOM FOR A HALF LENGTH CARD IN ADJACENT SLOT

**\$349**

**RITEMAN II PRINTER**

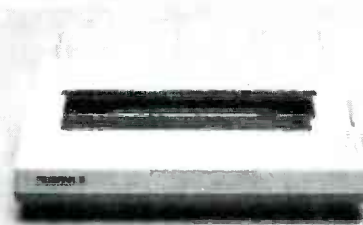

• 160 CPS DRAFT, 32 CPS NLQ MODE  
 • SUPPORTS EPSON/IBM GRAPHICS  
 • 9 x 9 DOT MATRIX  
 • FRICTION AND PIN FEEDS  
 • VARIABLE LINE SPACING & PITCH

**\$219.95**

IBM COMPATIBLE PRINTER CABLE **\$9.95**  
 REPLACEMENT RIBBON CARTRIDGE **\$7.95**

**DISK DRIVES**

**5 1/4" SEAGATE HARD DISK DRIVES**

ST-225 HALF HEIGHT 20MB 65ms **\$259**  
 ST-238 HALF HEIGHT 30MB 65ms (RLL) **\$299**  
 ST-251 HALF HEIGHT 40MB 40ms **\$469**  
 ST-277 HALF HEIGHT 60MB 40ms (RLL) **\$649**  
 ST-4038 FULL HEIGHT 30MB 40ms **\$559**  
 ST-4096 FULL HEIGHT 80MB 28ms **\$895**

**1/2 HEIGHT FLOPPY DISK DRIVES**

5 1/4" TEAC FD-55B DS/DD 360K **\$99.95**  
 5 1/4" TEAC FD-55F DS QUAD 720K **\$119.95**  
 5 1/4" TEAC FD-55G DS HD 1.2M **\$129.95**  
 5 1/4" FUJITSU M2551A DS DD 360K **\$89.95**  
 5 1/4" FUJITSU M2553K DS HD 1.2M **\$119.95**  
 5 1/4" DS/DD 360K **\$69.95**  
 5 1/4" DS/HD 1.2M **\$109.95**  
 3 1/2" MITSUBISHI DS/DD (AT OR XT) **\$129.95**

**DISK DRIVE ACCESSORIES**

1/2 HT MOUNTING HARDWARE FOR IBM **\$2.95**  
 MOUNTING RAILS FOR IBM AT **\$4.95**  
 "Y" POWER CABLE FOR 5 1/4" FDDs **\$2.95**  
 5 1/4" FDD POWER CONNECTORS **\$1.19**

**DRIVE ENCLOSURES WITH POWER SUPPLIES**

CAB-2SV5 DUAL SLIMLINE FOR 5 1/4" **\$49.95**  
 CAB-1FH5 FULL HEIGHT FOR 5 1/4" **\$69.95**  
 CAB-2SV8 DUAL SLIMLINE FOR 8" **\$209.95**  
 CAB-2FH8 DUAL FULL HEIGHT FOR 8" **\$219.95**

**EASYDATA MODEMS**

All models feature auto-dial/answer/redial on busy, power up self test, touchtone or pulse dialing, built-in speaker. Hayes & Bell Systems 103 & 212A compatible, full or half duplex, PC Talk III Communications software with internal models and more.



**INTERNAL**

12H 1200 BAUD 1/2 CARD **\$69.95**  
 24B 2400 BAUD FULL CARD **\$179.95**

**EXTERNAL**

(NO SOFTWARE INCLUDED)  
 12D 1200 BAUD **\$119.95**  
 24D 2400 BAUD **\$219.95**

**COMPUTER CASES**

Attractive, sturdy steel cases fit the popular sized motherboards and include speakers, faceplates, expansion slots and all necessary hardware.

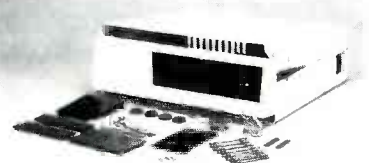

XT STYLE FLIP-TOP **\$34.95**  
 XT STYLE SLIDE-TOP **\$39.95**  
 AT STYLE SLIDE-TOP **\$89.95**  
 • FRONT PANEL KEYLOCK AND LED INDICATORS  
 JR. AT STYLE FLIP-TOP **\$149.95**  
 • INCLUDES 180 WATT POWER SUPPLY  
 • FRONT PANEL KEYLOCK AND LED INDICATORS

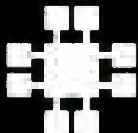

Visit our retail store located at 1256 S. Bascom Ave. in San Jose, (408) 947-8881

**JDR Microdevices**  
 110 Knowles Drive, Los Gatos, CA 95030  
 Toll Free 800-538-5000 • (408) 866-6200  
 FAX (408) 378-8927 • Telex 171-110

PLEASE USE YOUR CUSTOMER NUMBER WHEN ORDERING

TERMS: Minimum order \$10.00. For shipping and handling include \$2.50 for UPS Ground and \$3.50 for UPS Air. Orders over 1 lb. and foreign orders may require additional shipping charges—please contact our sales department for the amount. CA. residents must include applicable sales tax. All merchandise is warranted for 90 days unless otherwise stated. Prices are subject to change without notice. We are not responsible for typographical errors. We reserve the right to limit quantities and to substitute manufacturer. All merchandise subject to prior sale. A full copy of our terms is available upon request. Items pictured may only be representative.

COPYRIGHT 1987 JDR MICRODEVICES

THE JDR MICRODEVICES LOGO IS A REGISTERED TRADEMARK OF JDR MICRODEVICES. JDR INSTRUMENTS AND JDR MICRODEVICES ARE TRADEMARKS OF JDR MICRODEVICES. IBM IS A TRADEMARK OF INTERNATIONAL BUSINESS MACHINES CORPORATION. APPLE IS A TRADEMARK OF APPLE COMPUTER.

CIRCLE 177 ON FREE INFORMATION CARD  
[www.americanradiohistory.com](http://www.americanradiohistory.com)



# ALL MCT PRODUCTS CARRY A 1 YEAR WARRANTY

## INTERFACE CARDS

FROM MODULAR CIRCUIT TECHNOLOGY



MCT-MGP



## DISPLAY CARDS

**MCT-MGP MONOCHROME GRAPHICS \$5995**

TRUE HERCULES COMPATIBILITY. SUPPORTS LOTUS 123

- SOFTWARE DRIVER ALLOWS COLOR GRAPHICS PROGRAMS TO RUN ON A MONOCHROME MONITOR
- PARALLEL PRINTER PORT

**MCT-EGA ENHANCED GRAPHICS ADAPTOR \$14995**

100% IBM COMPATIBLE. PASSES IBM EGA DIAGNOSTICS

- 256K OF VIDEO RAM ALLOWS 640 x 350 IN 16 OF 64 COLORS
- COMPATIBLE WITH COLOR AND MONOCHROME ADAPTORS

**MCT-CG COLOR GRAPHICS ADAPTOR \$4995**

COMPATIBLE WITH IBM COLOR GRAPHICS STANDARDS

- SHORT SLOT SUPPORTS RGB, COLOR & COMPOSITE MONOCHROME
- 640/320 x 200 RESOLUTION. LIGHT PEN INTERFACE

## MULTIFUNCTION CARDS

**MCT-MF MULTIFUNCTION \$7995**

ALL THE FEATURES OF 6 PACK AT HALF THE PRICE

- 0-384K DYNAMIC RAM USING 4164s
- SERIAL, PARALLEL, GAME PORTS, CLOCK/CALENDAR

**MCT-MGMIO MONOGRAPHICS I/O \$11995**

TOTAL SYSTEM CONTROL FROM A SINGLE SLOT

- 2 FLOPPY CONT, SERIAL, PARALLEL, GAME PORT, CLOCK, CAL
- RUN COLOR GRAPHICS SOFTWARE ON A MONOCHROME MONITOR

**MCT-MIO MULTI I/O FLOPPY \$7995**

A PERFECT COMPANION FOR OUR MOTHERBOARDS

- SERIAL, PARALLEL, GAME PORT, CLOCK, CALENDAR
- SUPPORTS UP TO 2 360K FLOPPIES, 720K WITH DOS 3.2

**MCT-IO SERIAL 2nd SERIAL PORT \$1595**

USE WITH MCT-FH FOR A MINIMUM OF SLOTS USED

- SERIAL PORT, CLOCK, CALENDAR WITH A BATTERY BACK-UP
- PARALLEL PRINTER PORT ADDRESSABLE AS LPT1 OR LPT2

**MCT-ATMF AT MULTIFUNCTION \$13995**

ADDS UP TO 3 MEGABYTES OF RAM TO THE AT

- USER EXPANDABLE TO 1.5 MB OF MEMORY (ZERO K INSTALLED)
- INCLUDES SERIAL PORT AND PARALLEL PORT

**MCT-ATMIO AT SERIAL 2nd SERIAL PORT \$2495**

USE WITH MCT-ATMF FOR A MINIMUM OF SLOTS USED

- SERIAL, PARALLEL AND GAME PORTS
- USES 16450 SERIAL SUPPORT CHIPS FOR HIGH SPEED OPERATION

**MCT-ATMIO AT SERIAL 2nd SERIAL PORT \$2495**

## MEMORY CARDS

**MCT-RAM 576K RAM CARD \$5995**

A CONTIGUOUS MEMORY SOLUTION IN A SHORT SLOT

- USER SELECTABLE CONFIGURATION AMOUNTS UP TO 576K USING 64K & 256K RAM CHIPS (ZERO K INSTALLED)

**MCT-EMS EXPANDED MEMORY CARD \$12995**

2 MB OF LOTUS INTEL MICROSOFT COMPATIBLE MEMORY FOR XT

- CONFORMS TO LOTUS INTEL EMS - USER EXPANDABLE TO 2 MB
- EXPANDED CONVENTIONAL MEMORY, RAMDISK AND SPOOLER

**MCT-ATEMS AT VERSION \$13995**

## DRIVE CONTROLLERS

**MCT-FDC FLOPPY DISK CONTROLLER \$2995**

QUALITY DESIGN OFFERS 1 FLOPPY CONTROL IN A SINGLE SLOT

- INTERFACES UP TO 4 FDDs TO AN IBM PC OR COMPATIBLE
- SUPPORTS BOTH DS DD AND DS QD WITH DOS 3.2

**MCT-HDC HARD DISK CONTROLLER \$7995**

HDD CONTROL FOR WHAT OTHERS CHARGE FOR FLOPPY CONTROL

- SUPPORTS 16 DRIVE SIZES INCLUDING 5, 10, 20, 30 & 40 MB
- DIVIDE 1 LARGE DRIVE INTO 2 SMALLER, LOGICAL DRIVES

**MCT-FDC-1.2 1.2MB FLOPPY CONTROLLER \$6995**

ADD VERSATILITY & CAPACITY TO YOUR XT

- SUPPORTS 2 DRIVES, BOTH MAY BE 360K OR 1.2 MEG
- ALLOWS DATA TO FLOW FREELY FROM XTs TO ATs

**MCT-FH FLOPPY/HARD CONTROLLER \$13995**

SYSTEM STARVED FOR SLOTS? SATISFY IT WITH THIS TIMELY DESIGN

- INTERFACES UP TO 2 FDDs & 2 HDDs, CABLING FOR 2 FDDs & 1 HDD
- SUPPORTS BOTH DS DD & DS QD WITH DOS 3.2

**MCT-ATFH AT FLOPPY/HARD CONTROLLER \$14995**

FLOPPY HARD DISK CONTROL IN A TRUE AT DESIGN

- SUPPORTS UP TO 2 360K 720K 1.2MB FDDs
- AS WELL AS 2 HDDs USING STANDARD CONTROL TABLES



## 1/2 HEIGHT HARD DISK DRIVES

**40 MB \$469**

**60 MB \$649**

Drives are Seagate models ST-251 (40 MB) & ST-277 (60 MB RLL) 5 1/4" half heights  
FAST 40ms access time!

## 1/2 HT HARD DISK SYSTEMS

**20 MB \$289**

**30 MB \$329**

Systems include Seagate 1/2 height hard drive, drive controller, cables & instructions. All drives are pre-tested & warranted for 1 year.

## IBM COMPATIBLE MOTHERBOARDS

FROM MODULAR CIRCUIT TECHNOLOGY

**MCT-TURBO TURBO 4.77/8 Mhz \$9995**

- 4.77 OR 8 Mhz OPERATION WITH 8088-2 & OPTIONAL 8087-2 CO-PROCESSOR
- FRONT PANEL LED SPEED INDICATOR AND RESET SWITCH SET SUPPORTED
- CHOICE OF NORMAL/TURBO MODE OR SOFTWARE SELECT PROCESSOR SPEED

**MCT-XTMB STANDARD MOTHERBOARD \$8795**

**MCT-ATMB 80286 6/8 Mhz \$37995**

- E SLOT (2 EIGHT BIT, 6 SIXTEEN BIT) AT MOTHERBOARD
- HARDWARE SELECTION OF 6 OR 8 Mhz
- 1 WAIT STATE
- EYLOCK SUPPORTED, RESET SWITCH, FRONT PANEL LED INDICATOR
- SOCKETS FOR 1 MB OF RAM AND 80287
- BATTERY BACKED CLOCK

**MCT-BATMB MINI 80286 \$38995**

- REPLACEMENT BOARD FOR XT STYLE CHASSIS
- OPERATE AT 6/10 Mhz WITH UP TO 1MB ON-BOARD MEMORY (ZERO K INSTALLED)
- SOCKET FOR 80287 MATH CO-PROCESSOR
- BATTERY BACKED CLOCK
- E SLOTS, 2 EIGHT BIT, 6 SIXTEEN BIT
- USES CHIPS & TECHNOLOGY CHIP SET FOR RELIABILITY AND SMALL SIZE

## IBM COMPATIBLE KEYBOARDS

FULL ONE YEAR WARRANTY



**MCT-5339 \$7995**

- IBM ENHANCED STYLE LAYOUT
- SOFTWARE AUTOTENSE FOR XT OR AT COMPATIBLES
- LED INDICATORS
- AUTO REPEAT FEATURE
- SEPARATE CURSOR PAD

**MCT-5060 \$5995**

- IBM AT STYLE LAYOUT
- SOFTWARE AUTOTENSE FOR XT OR AT COMPATIBLES
- LED INDICATORS
- AUTO REPEAT FEATURE

**MCT-5150 XT STYLE LAYOUT \$4995**

**MCT-5151 KB5151™ EQUIV. \$6995**

## WHY BUY A SYSTEM FROM JDR?

- BUILD IT YOURSELF AND SAVE!
- MONEY BACK GUARANTEE (ASK FOR DETAILS)
- LEARN ABOUT THE INNER WORKINGS OF A COMPUTER
- YOU CAN ASSEMBLE A SYSTEM IN ABOUT 2 HOURS WITH A SCREWDRIVER & OUR EASY-TO-FOLLOW INSTRUCTIONS
- MOST ORDERS SHIPPED IN 24 HOURS
- QUALITY COMPONENTS AND COMPETITIVE PRICES
- TOLL FREE TECH SUPPORT IN THE U.S. AND CANADA

## BUILD YOUR OWN 256K XT COMPATIBLE

- \* MOTHERBOARD
- \* 256K OF MEMORY
- \* 135 WATT POWER SUPPLY
- \* FLIP-TOP CASE
- \* XT STYLE KEYBOARD
- \* 360K FLOPPY DRIVE
- \* DRIVE CONTROLLER
- \* MONOCHROME MONITOR
- \* GRAPHICS ADAPTOR

**FOR ONLY \$489<sup>15</sup>**

ANYONE CAN BUILD A SYSTEM IN ABOUT 2 HOURS USING A SCREWDRIVER AND OUR EASY-TO-FOLLOW INSTRUCTIONS!

OVER 10,000 SOLD!



## DEVELOPMENT TOOLS

FROM MODULAR CIRCUIT TECHNOLOGY

**MCT-EPROM PROGRAMMER \$12995**

PROGRAMS 27xx & 27xxx EPROMS UP TO 27512

- SUPPORTS VARIOUS PROGRAMMING FORMATS AND VOLTAGES
- SPLIT OR COMBINE CONTENTS OF SEVERAL EPROMS OF DIFFERENT SIZES
- READ, WRITE, COPY, ERASE CHECK AND VERIFY
- SOFTWARE FOR HEX AND INTEL HEX FORMATS

**MCT-EPROM-4 4 GANG PROGRAMMER \$18995**

**MCT-EPROM-10 10 GANG PROGRAMMER \$29995**

**MCT-PAL PAL PROGRAMMER \$26995**

**MCT-MP PROCESSOR PROG. \$19995**



PARTIAL LISTING ONLY-CALL FOR A FREE CATALOG!

COPYRIGHT 1987 JDR MICRODEVICES



# Radio Shack Parts Place™

## PARTS FOR PROJECTS IN YOUR NEIGHBORHOOD

### RS-232 Tester and Transient Suppressor

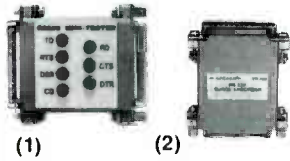

(1) RS-232 Inline Tester. Dual-color LEDs indicate status of TD, RTS, DSR, CD, RD, CTS and DTR lines. #276-1401 . . . . . 14.95  
 (2) RS-232 Spike Protector. Stops transients from reaching CPU/peripherals. #276-1402 . . . . . 16.95

### "Black-Box" Bargains

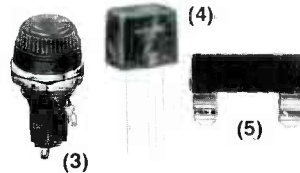

(3) Panel-Mount Fuse Holder. For 5x20 mm fuses. UL recognized. #270-362 . . . . . 1.29  
 (4) Mini SPDT Relay. 1 amp at 125 VAC. Coil: 6-9 VDC, 500 ohm. #275-004 . . . . . 2.99  
 (5) Fuse Adapt. #270-1219 . . . . . 99¢

### Precision Benchtop Digital Multimeter

**99<sup>95</sup>**

Low As \$15 Per Month\*

- Memory With Min/Max Hold
- Diode Checker



Our best! The 31-segment analog bar graph display makes input peaks and trends much easier to follow. Transistor checker measures transistor  $h_{FE}$  (gain). Autoranging with manual override. Full autopolarity, pushbut-

ton function selector, buzzer continuity checker. Measures AC/DC voltage/current and resistance. Input impedance: 10 megohms on DCV/ACV voltages. Fused and overload protected. Batteries extra. #22-195

### Builders' Treasure

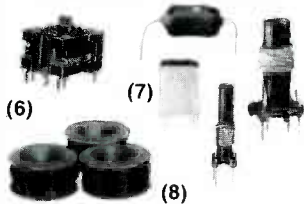

(6) Two-Section Variable Cap. 335 pF. PC-mount. #272-1337 . . . . . 4.95  
 (7) Inductor Assortment. 30-piece set. Includes small coils, chokes and transformers. #273-1601 . . . . . 1.98  
 (8) Magnet Wire. 22, 26 and 30-gauge spools. #278-1345 . . . . . 4.49

### Experimenters' ICs

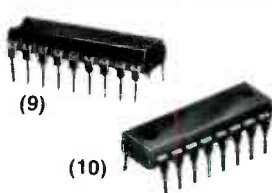

(9) TDA7000, FM Receiver on a Chip. 70 KHz IF means easy-to-build receiver projects. With data. #276-1304 . . . . . 5.95  
 (10) UMC 3482, Melody Synthesizer IC. With 12 tunes. For 1.5 VDC, 16-pin DIP. #276-1797 . . . . . 2.99

### Hookups for Computers and Peripherals

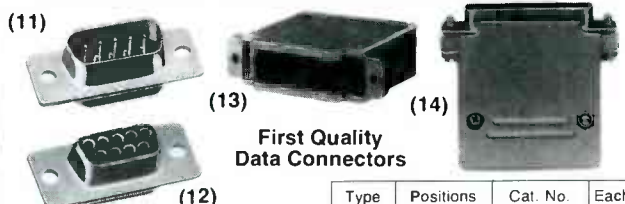

Solder-Type "D" Submini Connectors.

Fig	Type	Positions	Cat. No.	Each
11	Male	9	276-1537	1.49
12	Female	9	276-1538	2.49
13	Hood	9	276-1539	1.99

Type	Positions	Cat. No.	Each
Male	25	276-1547	1.99
Female	25	276-1548	2.99
Hood	25	276-1549	1.99

(14) RS-232 Modular Jack Adapter Kit. Lets you use phone cable and plugs to connect computers and peripherals. #276-1405 . . . . . 2.99

### Instrument Cases

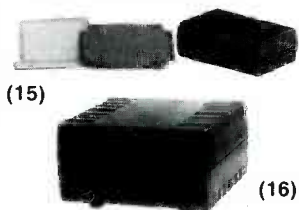

(15) Black Plastic With PC Board. Board is 2x3 1/8" accepts DIP ICs. Box is 3 7/16 x 2 5/16 x 1 3/16". With feet, labels, hardware. #270-291 . . . . . 3.99  
 (16) Deluxe Black Plastic Case. With slots for PC boards. 2 7/8 x 5 5/8 x 5 1/8" #270-250 . . . . . 4.99

### PC and Perfboards

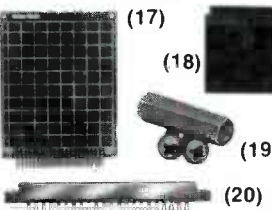

(17) Plug-In Board With Ground Plane. #276-188 . . . . . 4.99  
 (18) Multipurpose Plug-In Board. 4 1/2 x 4" 1/16" grids. #276-154 . . . . . 2.99  
 (19) PCB Standoffs With Screws. #276-195 . . . . . Set of 4/99¢  
 (20) 44-Position Card-Edge Socket. #276-1551 . . . . . 2.99

### Basic Electronics Book

**2.49**

Used in Classrooms Across the Nation



Getting Started in Electronics. By Forrest Mims III. An exciting and practical "hands-on" introduction to the world of electronics. Features 128 pages of large schematic diagrams and easy-to-understand text. Learn as you build! #276-5003

### Novice Exam Package

**NEW!**



Prepares You for the New Voice Class FCC Exam  
 Learn how to become a Ham with the new Novice voice privileges on Amateur radio. You get two cassette recordings for self-paced Morse code learning plus practice exam questions and answers to help you prepare for the test. #62-2402 . . . . . 19.95

### Jazzy Sight 'n Sound

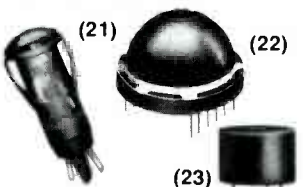

(21) Super-Bright Panel-Mount LED. Brilliant 500 mcd ruby light. Draws only 20 mA. #276-088 . . . . . 1.79  
 (22) Jumbo 20-mm Red LED. Six elements. #276-064 . . . . . 3.49  
 (23) Loud PC-Mount Buzzer. 2800 Hz. 78 dB. Requires 3-20 VDC. #273-065 . . . . . 2.49

### Resistor Assortments

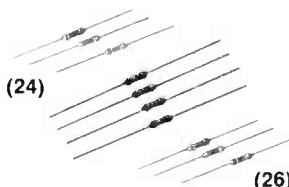

(24) 1/4-Watt Carbon Film. 500 pieces in 54 popular values. From 10 ohms to 10 megohms. #271-312 . . . . . 7.95  
 (25) 1/4-Watt Precision Metal Film. 1% tolerance. 50 pieces in 12 values from 10 ohms—1 meg ohm. #271-309 . . . . . 2.79  
 (26) 1/8-Watt Carbon Film. 100 pieces in 13 values, 10 ohms—1 megohm. #271-311 . . . . . 1.98

### Hi-Q Ceramic Caps



Low As **39¢** Pkg. Of 2

Rated at 50 WVDC except 272-126/130 rated 500 WVDC.

pF	Cat. No.	2-Pk.	µF	Cat. No.	2-Pk.
4.7	272-120	39	.001	272-126	49
47	272-121	39	.0047	272-130	49
100	272-123	39	.01	272-131	49
220	272-124	39	.047	272-134	49
470	272-125	39	1	272-135	59

### Special Order Hotline



Over 200,000 Substitutions  
 Your Radio Shack store manager can special-order a wide variety of parts and accessories not in our regular catalog—tubes, ICs, transistors, crystals and more. No minimum order, no postage. We'll call you when it comes in, in about a week.

Over 1000 items in stock: Binding Posts, Books, Breadboards, Buzzers, Capacitors, Chokes, Clips, Coax, Connectors, Fuses, Hardware, ICs, Jacks, Knobs, Lamps, Multitesters, PC Boards, Plugs, Rectifiers, Resistors, Switches, Tools, Transformers, Wire, Zeners, More!

\*Revolving credit from Radio Shack. Actual payment may vary depending on purchases.

Prices apply at participating Radio Shack stores and dealers

**Radio Shack®**  
 A DIVISION OF TANDY CORPORATION

CIRCLE 78 ON FREE INFORMATION CARD



# Worldwide • Since 1974

• QUALITY COMPONENTS • COMPETITIVE PRICING  
• PROMPT DELIVERY

Mail Order Electronics • Worldwide  
**Jameco**  
ELECTRONICS

## PROTOTYPING PRODUCTS

### Jameco Solderless Breadboard Sockets

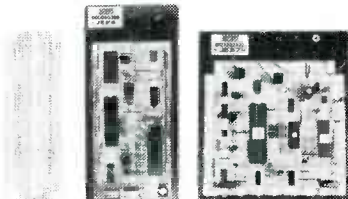

Part No.	Dim. L' x W'	Contact Points	Binding Posts	Price
JE23	6 1/2 x 3 1/4	200	0	\$ 2.29
JE21	3 1/4 x 2 1/8	400	0	\$ 4.49
JE22	6 1/2 x 1 3/8	630	0	\$ 5.95
JE23	6 1/2 x 2 1/8	830	0	\$ 7.49
JE24	6 1/2 x 3 1/8	1,360	2	\$14.95
JE25	6 1/2 x 4 1/8	1,660	3	\$22.95
JE26	6 7/8 x 5 3/4	2,390	4	\$27.95
JE27	7 1/4 x 7 1/2	3,220	4	\$37.95

### Jameco General Purpose Prototype PC Boards



- Wire Wrap
- Component Testing
- Point-to-Point Wiring
- 31/62 Connection

JE415 (6 1/2" No Pads, PC/XT) . . . . . \$14.95  
JE417 (6 1/2" Plated w/Pads, PC/XT) . . . . . \$19.95

### Extender Board

JE421 (4 1/2" Extender, 31/62 Connector) . . . \$19.95

### DATA BOOKS

30003	National Linear Data Book (82)	\$19.95
30005	Logic Data Book - Vol. II (84)	\$19.95
30009	Intersil Data Book (87)	\$14.95
21398	CMOS Cookbook (86)	\$14.95
210830	Intel Memory Handbook (87)	\$17.95
230843	Intel Microsystem Hndbk. Set (87)	\$24.95

### MUFFIN/SPRITE-STYLE FANS



TA450S	\$11.95
4.0" Torin Industries (4.68" sq, 50 cfm)	
SU2A1	\$11.95
EG&G Rotron (3.125" square, 34 cfm)	

### NEW! Switching Power Supply

+5V @ 5A, +12V @ 1A x 2

Switchable to +40 watt • Size 8 1/2" L x 3 3/4" W x 2 1/4" H • Weight: 1.1 lbs • Data included

PSSC07 . . . . . \$14.95

### Jameco Computer Power Protection

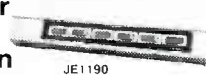

JE1190	Power Base . . . . .	\$29.95
JE1191	6-Outlet Power Strip . . . . .	\$11.95
JE1192	300 Watt Back-Up . . . . .	\$299.95
JE1193	500 Watt Back-Up . . . . .	\$399.95

## IBM AND APPLE COMPATIBLE DISPLAY MONITORS

### Franklin 12" Green Monochrome

Apple II, II+, IIe, IIc Compatible  
• Composite video output • 18MHz  
• Resolution: 800 lines at center

SMON. . . . . \$59.95



### 12" Amber Monochrome —

TTL Input, High Resolution (PC/XT/AT)

AMBER. . . . . \$109.95

### 14" RGB Color — CGA Compatible Amber/Green/Color Switchable.

640 x 200 Resolution (PC/XT/AT)

TTX1410. . . . . \$279.95

### 14" EGA Color - EGA/CGA Compat., 720 x 350 (max.) resolution (PC/XT/AT)

TE5154. . . . . \$399.95

### 14" Ultrascan Color — CGA/EGA/PGC/VGA Compatible, 800 x 560 (max.) Resolution (PC/XT/AT)

4375M. . . . . \$579.95



### IBM PC/XT/AT Compatible Cards

JE1050	Mono Graphics Card . . . . .	\$ 59.95
JE1052	Color Graphics Card . . . . .	\$ 49.95
JE1055	EGA Card . . . . .	\$149.95

## JAMECO COMPUTER KITS

FREE! PC Write Word Processing Software Included!

### Jameco's IBM™ AT Compatible Mini-286 6/8/10/12 MHz Kit!

Part No.	Description	Price
JE1043	1.2M/360K Floppy Control . . .	\$ 49.95
JE1015	XT/AT Style Keyboard . . . . .	\$ 59.95
41256-120	512K RAM (18 Chips) . . . . .	\$ 71.10
JE1012	Baby AT Flip-Top Case . . . . .	\$ 69.95
JE1032	200W Power Supply . . . . .	\$ 89.95
JE1022	5 1/4" High Density Disk Drive .	\$109.95
JE1003	Baby AT Motherboard (Zero-K RAM-incl. Award BIOS ROM) .	\$399.95

EGA Monitor  
TE5154 \$399.95  
EGA Card  
JE1055 \$149.95  
(not included)

JE1008 IBM™ AT Compatible Kit. . . . . \$799.95



### Jameco's 4.77/8MHz Turbo IBM PC/XT Compatible Kit

4164-150	128K RAM (18 Chips) . . . . .	\$ 22.50
41256-150	512K RAM (18 Chips) . . . . .	\$ 58.50
JE1010	Flip-Top Case . . . . .	\$ 34.95
JE1015	XT/AT Style Keyboard . . . . .	\$ 59.95
JE1030	150 Watt Power Supply . . . . .	\$ 69.95
JE1020	5 1/4" DSD Disk Drive . . . . .	\$ 89.95
AMBER	12" Amber Monitor . . . . .	\$109.95
JE1001	4.77/8MHz Turbo Motherboard (Zero-K RAM - Includes Award BIOS ROM) . . . . .	\$104.95

JE1071 Multi I/O with Controller and Graphics . . . . . \$119.95

Regular List \$670.65

SAVE \$70.70!

JE1005 (IBM™ PC/XT Turbo Compatible Kit) . . \$599.95



### Jameco's IBM PC/XT/AT Compatible Motherboards

• Award BIOS ROM included

JE1000	4.77MHz (PC/XT) . . . . .	\$ 89.95
JE1001	4.77/8MHz (PC/XT) . . . . .	\$104.95
JE1003	6/8/10/12MHz (AT) . . . . .	\$399.95

Additional Add-Ons Available!

## COMPUTER PERIPHERALS



Seagate 20, 30 & 40MB Half Height Hard Disk Drives

ST225	20MB Drive only (PC/XT/AT) . . .	\$269.95
ST225K	20MB w/Controller (PC/XT) . . .	\$319.95
ST238	30MB Drive only (PC/XT/AT) . . .	\$299.95
ST238K	30MB w/Cont. (PC/XT/AT) . . . . .	\$339.95
ST251	40MB Drive only (PC/XT/AT) . . .	\$469.95
ST251XT	40MB w/Cont. Card (PC/XT) . . .	\$549.95
ST251AT	40MB w/Cont. Card (AT) . . . . .	\$589.95

### Jameco PC/XT & AT Compatible Disk Drives

JE1020	360K Black Bzl. (PC/XT/AT) . . .	\$ 89.95
JE1021	360K Beige Bzl. (PC/XT/AT) . . .	\$ 89.95
JE1022	1.2MB Beige Bzl. (AT) . . . . .	\$109.95

## DATATRONICS

### 2400/1200/300 Modems

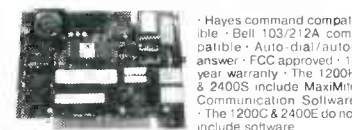

• Hayes command compatible • Bell 103/212A compatible • Auto-dial/auto-answer • FCC approved • 1-year warranty • The 1200H & 2400S include MaxiMe Communication Software • The 1200C & 2400E do not include software

1200H	1200/300 Baud Internal Modem . . .	\$ 79.95
2400S	2400/1200/300 Internal Modem . . .	\$174.95
1200C	1200/300 Baud External Modem . . .	\$119.95
2400E	2400/1200/300 External Modem . . .	\$219.95

### Jameco Extended 80-Column Card for Apple IIe



• 80 Col /64K RAM • Doubles amount of data your Apple IIe can display as well as its memory capacity • Ideal for word processing • Complete with instructions

JE864 \$49.95

ADD12 (Disk Drive II, II+, IIe) \$99.95

### Additional Apple Compatible Products Available

## ZUCKERBOARD



TANDY 1000 Expansion Memory Half Card

Expand the memory of your Tandy 1000 (128K Version) to as much as 640K. Also includes DMA controller chip

TE512	Includes 512K RAM . . . . .	\$119.95
TANC	Plug-in Clock option chip (only) . . .	\$39.95

### 20Meg Hard Disk for Tandy 1000/SX

T20MB	20MB Hard Disk Drive Board for Tandy 1000 . . . . .	\$494.95
SX20MB	20MB Hard Disk Drive Board for Tandy 1000SX . . . . .	\$499.95

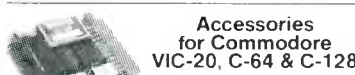

Accessories for Commodore VIC-20, C-64 & C-128

JE232CM	(Picture)	
JE232CM	(RS232 Inter. VIC-20, C-64 and C-128 in 64 mode) . . . . .	\$39.95
CPS10	(C-64 Power Supply) . . . . .	\$39.95
CPS128	(C-128 Power Supply) . . . . .	\$59.95

U.S. Funds Only  
Shipping: Add 5% plus \$1.50 Insurance  
(May vary according to weight)

California Residents:  
Add 6%, 6 1/2% or 7%  
Sales Tax  
FAX 415-592-2503  
2/88



1355 SHOREWAY RD., BELMONT, CA 94002 • FOR ORDERS ONLY 415-592-8097 • ALL OTHER INQUIRIES 415-592-8121

# What's New at AMERICAN DESIGN COMPONENTS?

We warehouse 60,000 items at American Design Components - expensive, often hard-to-find components for sale at a fraction of their original cost!

You'll find every part you need - either brand new, or removed from equipment (RFE) in excellent condition. But quantities are limited. Order from this ad, or visit our retail show-room and find exactly what you need from the thousands of items on display.

OPEN MON. - SAT., 9-5

## THERE'S NO RISK.

With our full 90-day warranty, any purchase can be returned for any reason for full credit or refund.

### ADAM COMPUTER



(Less printer)

No wiring necessary (just plugs together). Hook-up diagram included. Includes: Keyboard, 1 cassette digital data drive, 2 game controllers, power supply, & one cassette. Capable of running CP/M, has built-in word processor.

Item #7410 Complete - \$99.00

### ADAM

#### 5 1/4" DISK DRIVE

Gives your Adam fast, reliable data storage and retrieval. Can hold up to 160K bytes of information. Uses industry-standard SS/DD disks. Connects directly to your Adam memory console. Comes with disk drive power supply, Disk Manager disk and owner's manual.

Mfr - Coleco, model 7817. Item #12830  
Like New - \$199.00

#### 15 Mb 5 1/4" FULL HT. DISK DRIVE



(IBM® PC/XT Compatible)

Removed from working equipment. Tested & formatted. Mfr - CMI model CM5619  
Item #14511 \$199.00

#### 10 Mb 5 1/4" HALF HT. DISK DRIVE



(IBM® Compatible)

Shock mounted, high speed, low power. Mfr - Tandon TM252  
Item #13250 \$159.00  
Controller Card for above  
Item #10150 \$89.00

#### 5 1/4" FULL HEIGHT DISK DRIVES -

48 TPI (IBM® Compatible) DS/DD, 80 Track  
Tandon #TM100-2 or equiv.  
Item #7928 \$79.00 New  
2 for \$150.00 New  
48 TPI (TRS80/Zenith/Xerox 800 Compat.) DS/DD, 40Track  
Shugart #450. Item #1892.  
\$79.00; 2 for \$150.00  
48 TPI, SS/DD, 40 Track  
Shugart #SA400. Item #1895.  
\$39.50; 2 for \$75.00  
96 TPI, DS/Quad Density  
CDC #9409T  
Item #1893 \$89.00

#### 5 1/4" 1/2 HT. DISK DRIVES

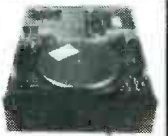

IBM® AT Compatible)  
48/96 TPI, 1.2 Mb  
Double side, high density; 160 tracks. Mfr - Panasonic #JU-475  
Item #10005 \$109.95 New  
96 TPI, (DOS 3.2 Compat. Double side, quad density.  
Mfr - Tandon TM55-4  
Item #1904 \$79.00  
2 for \$150.00

#### MAGNIFYING LAMP

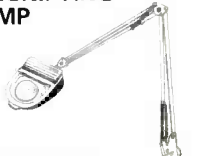

Multi position, 30", completely adjustable swing arm w/3-way metal C-clamp. Has 4" diopter magnifying lens, w/ruler. Porcelain lamp socket, & on/off switch; uses up to a 60W bulb. Color: Beige. UL listed.  
Item #13136 \$24.95 New

#### Protect your Printer/ Typewriter with our DIABLO CLEANING KIT



For printers & typewriters w/print wheel, spindle, & metal ball type print elements. Good for 5 cleanings. Incl.: platen cleaner, type/print element cleaner, sound shield cleaner, plus buffers & cloths.  
Mfr - Diablo Supplies #9R87106  
Item #15419  
3 sets/\$14.95 New

#### 5 1/4" FLOPPY DISKETTES



Single side/single density; 16 hard sectors. Mfr - Xerox #11R61630  
Item #14537  
Pack of 10 \$9.95 New

#### MICROCOMPUTERS with EPROM

##### MC68701



The MC68701 is an 8-bit single chip microcomputer unit that enhances the capabilities of the M6800 family. TTL compatible, requires one +5V power supply for nonprog. operation. Includes 2048 bytes of eeprom, 128 bytes of RAM, serial comm. interface (SCI), parallel I/O, and a 3-function programmable timer. Item #9496  
\$9.95 (house numbered)

##### MC68705



MC68705 - HMOS, 8-bit, medium performance microcomputer. On-chip resources: 3776 bytes Eprom, 112 bytes RAM, 8 inputs & 24 programmable bidirectional outputs. Self programming boot strap.  
Item #13608 \$9.95

#### 115 VAC 27 CFM MINI FANS



50/60Hz.; 12W. Low noise level fans, can be mounted for blowing or exhaust.  
1" Thin; contains 9 plastic blades  
Dim.: 3 1/4" sq. x 1" deep  
Mfr - Toshiba #U9201B  
Item #10960 \$7.95 RFE  
1 1/2" Standard; contains 7 metal blades.  
Mfr - Rotron #SU2A1  
Item #5970 \$7.95 New

#### 150 CFM SUPER VENTURI FAN



Ball bearing; 115 VAC, 60 Hz.; .195/.178 amps. Has 2 sets of mtg. holes (fits standard rack or larger). Can be mtd. for blowing or exhaust. Dim.: 5" sq. x 1 1/2" deep.  
Mfr - Rotron  
Item #1866 \$19.95 New

#### TIMEX-SINCLAIR 1000 & ZX-81 CASSETTES

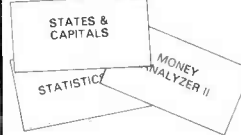

Consists of 13 assorted cassettes. May include: Money Analyzer II, States & Capitals, Casino Craps, Statistics, The Carpooler & others.  
Item #14651  
Set of 13 \$19.95 New

### Complete line of Computer & Game Equipment! Please call or write with your requirements.

#### ADAM Accessories . . .

- Adam Printer - Item #8839 \$69.50
- Data Drive - Item #6641 \$19.95
- Printer Power Supply - Item #6642 \$14.95
- ASCII Keyboard - Item #6643 \$19.95
- Controllers - (Set of 4) Item #7013 \$9.95 Used
- Adam Cassettes - (Consisting of Smart Basic, Buck Rogers & blank cassette.) Item #7786 BAKER'S DOZEN - \$19.95
- Adam Link Modem - (Software included.) Item #12358 \$29.95
- Auto-Dialer Address Book - Item #12365 \$19.95
- Adam Daisy Print Wheel - Item #13305 \$3.95
- Adam Ribbon Cartridge - Item #13306 \$3.95
- Disk Drive Power Supply - Item #14603 \$14.95
- ColecoVision to Adam Expansion Kit - Item #9918 \$59.50
- Expansion Module #2 - (w/Turbo cartridge.) Item #73146 \$39.95 New
- Roller Controller (w/Slither cartridge) - Item #13147 \$39.95 New
- Super Action Controller Set - (w/Baseball cartridge.) Item #13148 \$39.95 New

#### 115 CFM MUFFIN® FANS



115VAC/60Hz.; 21W.; 28A.; 3100 RPM; 5-blade model; aluminum housing. Can be mtd. for blowing or exhaust.  
Dim.: 4 1/4" sq. x 1 1/2" deep  
NEW - Mfr: IMC  
Item #1864 \$12.95  
USED - Mfr: Centaur/Howard  
Item #5345 \$5.95

#### MINI MICRO-COMPUTER REGULATOR



140 VA  
Provides voltage regulation & ultra-isolation for microprocessor-based equipment. Contains less than 3% harmonic distortion, better than 60 dB traverse noise rejection. Contains dual outlet for CPU & monitor, & 6 ft. line cord.  
Input: 95 - 130V, 60Hz.  
Output: 120V @ 1.17A  
Dimen.: 11 1/2" L x 4 3/4" H x 5 5/8" W  
Mtd on metal base w/rubber ft.  
Mfr - Sola #63-13-114  
Item #9999 \$99.00 New

#### STEPPING MOTORS for ROBOTICS

Precision steppers with increments from 1 to 7.5 degrees. Speeds up to 5,000 steps.

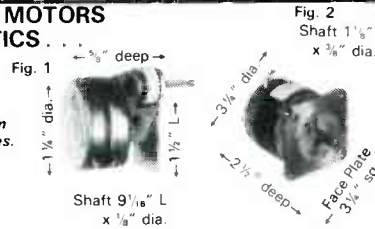

Item No.	Step Angle	Volts DC	Stall Torque oz/in	Type	Mfr. & Part No.	Fig	Price
5431	1	5	17	PM	N.A. Phillips A82310-M2	1	\$9.95 ea. 2/ \$14.95
5275	1.8	1.8	72	PM	Superior Electric 2 0 MO61-FF-6201B	2	\$19.95 ea. 2/ \$37.50
7630	1.8	3.0	200	PM	Superior Electric M092-FT-402	2	\$34.50 ea. 2/ \$59.50

#### COPPER-CLAD PRINTED CIRCUIT BOARD (Double-sided)

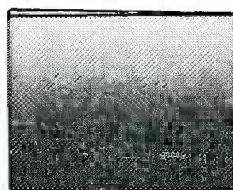

Glass coated, epoxy laminated. 1 oz. Double sided, .022" thick. Dimensions: 24" L x 18.5" H  
Item #13606  
3 sheets/ \$9.95

#### RECORDING TAPE 7 1/2" Reel, 2400 ft.



Bulk erased. Major mfrs.: Ampex, Scotch, etc.  
Item #6711 - 1/2 Mil.  
15 reels for \$9.95

#### BATTERIES - CASSETTES -

#### NEON TRANSFORMER (Hi-Voltage)



7300 VAC @ 5 Ma.  
May be used for powering neon lights, replacing oil burner ignition transformer, building Jacob's ladder (spark gap). A high-volt. output. 1/4 quick connect terminal & case ground input fully enclosed metal case. Weight: 12 lbs. Base mount: 4 1/2" H x 5 1/2" W x 6 1/2" D  
Item #151 \$9.95 RFE

#### JOYSTICK CONTROLLERS



Fits Atari, Apple, Commodore, and our Item #10336 PC8300 Computer. Has 4-ft. cord w/plug. Dimen.: 3 1/2" sq. x 1 1/2" H  
Item #12143 \$5.95 New



**SEND FOR  
FREE  
1987 CATALOG**  
OUR NEW MAILING  
ADDRESS IS:  
P.O. BOX 567  
VAN NUYS, CA 91408  
800-826-5432

**QUALITY PARTS \* DISCOUNT PRICES \* FAST SHIPPING!**

# ALL ELECTRONICS CORP.

# ALL ELECTRONICS CORP.

## BLACKLIGHT ASSEMBLY

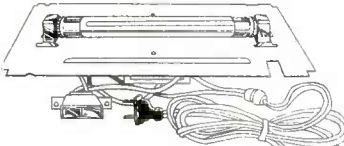

Complete, functioning assembly includes ballast, on-off switch, power cord, sockets and F4T5-BL blacklight. Mounted on a 7 1/8" X 3 1/8" metal plate. Use for special effects lighting or erasing EPRMS.

CAT# BLTA \$10.00 EACH

## 1mA METER

Modutec 0-1 mA signal strength meter with KLM logo. 1 1/4" X 1 3/4" X 7/8" deep.



CAT# MET-2 \$2.00 each

## NI-CAD CHARGER/TESTER

DELUXE universal charger and tester for almost every size Ni-cad battery available.



CAT# UNCC-N \$15.00 each

## RECHARGEABLE NI-CAD BATTERIES

- AAA SIZE 1.25V 180mAh \$2.25
- AA SIZE 1.25V 500mAh \$2.00
- AA with solder tabs \$2.20
- C SIZE 1.2V 1200mAh \$4.25
- SUB-C SIZE solder tab \$4.25
- D SIZE 1.2V 1200mAh \$4.25

## COMPUTER GRADE CAPACITORS

- 1,400 MFD 200 VDC  
2" dia. X 3" high  
CAT# CG-1420 \$2.00
- 7,500 MFD 200 VDC  
3" dia. X 4 3/4" h.  
CAT# CG-75 \$4.00
- 22,000 MFD 25 VDC  
2" dia. X 4 3/4" h.  
CAT# CG-22 \$2.50
- 72,000 MFD 15 VDC  
2" dia. X 4 3/8" h.  
CAT# CG-130 \$3.50

## TRANSISTORS

- 2N2222A  
3 for \$1.00
- PN2222A  
4 for \$1.00
- 2N2904  
3 for \$1.00
- 2N2905  
3 for \$1.00
- 2N3055  
\$1.00 each
- PN3569  
10 for \$1.00

## WALL TRANSFORMER

11.5 Vdc  
1.95 AMP.  
Input:  
120 Vac



SIZE: 3 3/4" X  
2 7/8" X 2 5/8"  
CAT# DCTX-11519  
\$6.50 each

## A/B SWITCH

JVC# PUS3593-2  
High quality  
A/B  
switch.

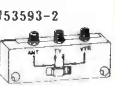

Measures:  
3 3/4" X 1 7/16" X 1".  
75 OHMS IN/OUT  
CAT# ABS-2 \$3.50 each

## 13.8 VDC REGULATED POWER SUPPLY

Solid state, fully regulated 13.8 Vdc power supplies. Both feature 100% solid state construction, fuse protection and LED power indicator. UL listed.

2 AMP CONSTANT, 4 AMP SURGE  
CAT# DVP-412 \$22.50 each

3 AMP CONSTANT, 5 AMP SURGE  
CAT# DVP-512 \$30.00 each



## ELECTRET CONDENSER MIKE

Mouser# 25LMO44 Highly sensitive mini microphone. 6" wire leads. 0.39" dia. X 0.27" high. Omni directional. Operates on 2-10 Vdc @ less than 1 mA. 1K impedance. 50 to 8 K Hz range.  
CAT# MKE-1 \$1.00 EACH

## SLIM LINE FAN

TOYO# TF92115A New 115 Vac cooling fan. 3 5/8" square X 1" deep. Metal housing. 5 blade impeller.  
CAT# SCPE-115 \$8.50 each  
10 for \$75.00



## 2K 10 TURN

Multi-turn pot Spectrol# MOD 534-7161  
CAT# MTP-10-2 \$5.00 each



## VENTED PROJECT CASE

Popla #BO 718L Vented top and bottom. Black plastic with removable end panels. 9" X 8 1/2" X 3"  
CAT# MB-718L \$12.50 each



## 6-12 VDC MOTOR

Mabuchi # RS-550S Permanent magnet motor. 1 7/16" dia X 2 1/4" long. 2,600 RPM @ 6 Vdc-200 mA. 5,300 RPM @ 12 Vdc  
CAT# DCM-7 \$3.00 each



## LED'S

Standard Jumbo Diffused T 1-3/4 Size  
RED 10 for \$1.50  
100 for \$13.00  
CAT# LED-1 1000 for \$110.00  
GREEN 10 for \$2.00  
100 for \$17.00  
CAT# LED-2 1000 for \$150.00  
YELLOW 10 for \$2.00  
100 for \$17.00  
CAT# LED-3 1000 for \$150.00  
FLASHING LED  
w/ built in flashing circuit operates on 5 Volts...

RED \$1.00 each  
CAT# LED-4 10 for \$9.50  
GREEN \$1.00 each  
CAT# LED-4G 10 for \$9.50  
BI-POLAR LED  
Lights RED one direction, GREEN the other. two leads.  
CAT# LED-6 2 for \$1.70

## LED HOLDERS

Two piece holder.  
CAT# HLED 10 for 65c  
CLIPLITE LED HOLDER  
Looks like a fancy indicator  
CLEAR CAT# HLDCL-C  
RED CAT# HLDCL-R  
GREEN CAT# HLDCL-G  
YELLOW CAT# HLDCL-Y  
4 of one color \$1.00

## 48 KEY ASSEMBLY



NEW T.I. KEYBOARDS. Originally used on computers, these keyboards contain 48 S.P.S.T. mechanical switches. Terminates to 15 pin connector. Frame 4" X 9"  
CAT# KP-48 \$3.50 each

## PUSHBUTTON PHONE

Spectra-phone Model# OP-1 1 piece telephone with rotary (pulse) output. Operates on most rotary or touch tone systems. Features fast minute redial and mute button. Includes coil cord with standard modular plug. IVORY.  
CAT# PHN-1 \$8.50 EACH  
2 FOR \$15.00



## RELAYS

### 12 VDC-4PDT

P.C. mount  
5 amp contacts  
150 ohm coil  
Size: 1 1/4" X  
1 3/4" X 7/8"  
CAT# 4PRLY-12PC \$3.50  
10 for \$30.00



### 10AMP SOLID STATE

Control: 3-32 Vdc  
Load: 10 AMPS, 120 Vac  
Size: 2 1/2" X  
3/4" X 7/8"  
CAT# SSRLY-10A \$9.50  
10 for \$85.00



### 25 AMP SOLID STATE

OPTO 22# 240D25 TTL compatible.  
INPUT: 3-32 VDC  
OUTPUT: 25 AMPS @ 240 VAC  
SIZE: 2 1/2" X 3/4" X 7/8"  
CAT# SSRLY-2524 \$15.00 each



## THIRD TAIL LIGHT

Sleek high-tech lamp assembly. Red lens is 2 3/4" X 5 1/2" mounted on a 4" high pedestal with up-down swivel adjustment. Has 12V replaceable bulb.  
CAT# TLB \$3.95 each

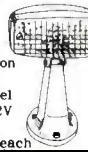

## SOUND EFFECTS BOARD

P.C board with 2 1/4" speaker, 2 LEDs, IC, battery snap, other components 2 3/8" X 3". When switch is pushed board beeps and leds light. Operates on a 9V battery (not included)  
CAT# ST-3 \$1.25 each



## XENON FLASH TUBE

3/4" long X 1/8" dia.  
CAT# FLT-1 2 for \$1.00

## VIC 20 MOTHERBOARD

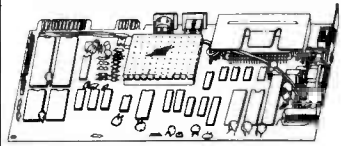

26 IC's including 6502A and 6560. 2 ea. 6522, 2 ea. 8128, 2 ea. 901486, 3 ea. 2114. Not guaranteed but great for replacement parts or experimentation.  
CAT# VIC-20 \$15.00 each

## SWITCHING POWER SUPPLY

Compact, well regulated switching power supply designed to power Texas Instruments computer equipment.  
INPUT: 14-25 vac @ 1 amp  
OUTPUT: +12 vdc @ 350 ma.  
+5 vdc @ 1.2 amp  
-5 vdc @ 200 ma.  
SIZE: 4 3/4" square.  
Includes 18 Vac @ 1 amp wall transformer designed to power this supply.  
CAT# PS-TX \$5.00 / set  
10 for \$45.00



## LIGHT ACTIVATED MOTION SENSOR

This device contains a photocell which senses sudden change in ambient light. Could be used as a door annunciator or modified to trigger other devices. 5 1/2" X 4" X 1". Operates on 6 Vdc. Requires 4 AA batteries (not included).  
CAT# LSMD \$5.75 per unit

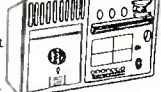

## TRANSFORMERS

- 5.6 VOLT- 750ma  
CAT# TX-56 \$3.00
- 12 V.c.t.-1amp  
CAT# TX-121 \$4.00
- 12 V.c.t.-2amp  
CAT# TX-122 \$4.85
- 12 V.c.t.-4amp  
CAT# TX-124 \$7.00
- 18 VOLT-650ma  
CAT# TX-186 \$2.00  
10 for \$18.00
- 24 V.c.t.-1amp  
CAT# TX-241 \$4.85
- 24 V.c.t.-2amp  
CAT# TX-242 \$6.75
- 24 V.c.t.-3amp  
CAT# TX-243 \$9.50
- 24 V.c.t.-4amp  
CAT# TX-244 \$11.00

## SWITCHES

- MINIATURE TOGGLE SWITCHES rated 5 AMPS  
S.P.D.T. (ON-ON)  
Non threaded brushing  
P.C. mount.  
CAT# MTS-40PC 75c each  
10 for \$7.00  
S.P.D.T. (ON-ON)  
Solder lug terminals.  
CAT# MTS-4 \$1.00 each  
10 for \$9.00  
D.P.D.T. (ON-ON)  
Solder lug terminals.  
CAT# MTS-8 \$2.00 each  
10 for \$19.00  
MINI PUSH BUTTON  
S.P.S.T. momentary.  
Push to make 1/4" brushing.  
Red button.  
CAT# MPB-1 35c each  
10 for \$3.00



## STORES:

LOS ANGELES  
905 S. VERMONT AVE.  
LOS ANGELES, CA 90006  
(213)380-8000  
VAN NUYS  
6228 SEPULVEDA BLVD.  
VAN NUYS, CA 91411  
(818)997-1806

## MAIL ORDERS TO:

ALL ELECTRONICS  
P.O. BOX 567  
VAN NUYS, CA 91408  
TELEX  
TWX-5101010163  
ALL ELECTRONICS  
Foreign Customers  
Send \$1.50 postage  
for FREE Catalog!!

## TOLL FREE

800-826-5432  
INFO: (818)904-0524  
FAX: (818)781-2653  
QUANTITIES LIMITED  
MINIMUM ORDERS \$10.00  
CALIF. ADD SALES TAX  
USA: \$3.00 SHIPPING  
NO C.O.D.I.  
FOREIGN ORDERS:  
INCLUDE SUFFICIENT SHIPPING



## SOUND AND VIDEO MODULATOR

TI# UM1381-1. Designed for use with T.I. computers. Can be used with video cameras, games or other audio/video sources. Built in A/B switch enables user to switch from T.V. antenna without disconnection. Operates on channel 3 or 4. Requires 12 Vdc. Hook up diagram included.  
CAT# AVMOD \$5.00 each



## TELEPHONE COUPLING TRANSFORMER

STANCOR # TTCP-8  
600 ohms c.t.  
to 600 ohms c.t.  
P.C. board mount.  
3/4" X 5/8" X 3/4"  
CAT# TCTXS \$2.50 each





# MARK V ELECTRONICS INC.,

8019, E. SLAUSON AVE.  
MONTEBELLO CA90640  
TELEX: 3716914 MARK 5

1-800-423-3483  
TOLL FREE

Only for orders paid by Master or VisaCard  
IN CAL.: 1-800-521-MARK

INFORMATION: (213) 888-8988

## DIGITAL MEMO TA-28



NEW FOR 1988

SPECIFICATIONS:  
16 SEC RECORD TIME \* LED FUNCTION INDICATOR \*  
AUTO RECORD CIRCUIT \* INTERNAL 256K DRAM MEMORY \*  
INTERNAL MIC AMPLIFIER \* ONE PUSH ON/OFF POWER \*  
TWO RECORD FUNCTION TALK-BACK MODE & MESSAGE  
MODE \* LOW POWER CONSUMPTION \* SUPPLY VOLTAGE:  
9V 20MA D.C.  
KIT \$20.00

## STATE OF ARTS HQ FET ST. PRE-AMP

TA-377A  
0.007% T.H.D.  
\* This Pre-amplifier employs 18 pairs of HIGH QUALITY N channel and P channel FET and 1% metal film resistor to form a state of arts full complementary asymmetric mirror circuit.  
\* It uses "OR" RIAA EQ pre-amplifier to minimize TIM distortion and to obtain high-fidelity.  
\* The power supply is based on pass coupling DC stabilizer which uses class A design to obtain low internal impedance at high frequency and to greatly reduce transient distortion.  
\* Professional relay delay circuit prevents noise which may occur during power on and off.  
\* All FETs were tested and paired in the factory so no problem is likely to occur during building.  
\* It can be directly connected to any power amp. The best partner is TA-477 120W MOS FET power amplifier.  
KIT/ASS. WITH TESTED METAL CABINET \$55/65 \$18



## NU-CR BI-FET PRE-AMP

TA-2800

WITH TREBLE MID-RANGE AND BASS 3 WAY TONE CONTROL



Match with TA-477 or other main power

KIT \$44.50

## 100W DYNAMIC CLASS "A" MAIN POWER AMPLIFIER

TA-1000A



OVER 5000'S SOLD!

KIT \$51.95  
METAL CABINET/X'FORMER \$26/\$16.80

We've rated our goods with a  $\Delta$  indicating the level of difficulty for kit assembly:

$\Delta$  beginner  $\Delta\Delta$  intermediate level; level;

$\Delta\Delta\Delta$  advanced level;

A indicates the product has already been assembled.

FREE CATALOG

## OFFICE HOURS: (PACIFIC TIME)

MON.-FRI. 9:30 to 5:00 SAT. 10:00 to 5:00

## 300W HQ HI-FI POWER AMPLIFIER (MONO)

TA-3600

QUASI-COMPLEMENTARY-SYMMETRY WITH PARALLEL HIGH OUTPUT TRANSISTORS' SPECIFICATIONS:

\*POWER OUTPUT: 300W (RMS) INTO 8 OHMS 250W (P.M.P.O.) INTO 8 OHMS 540W (MUSIC POWER) INTO 8 OHMS  
\*LOAD IMPEDANCE: 4 OHMS OR 8 OHMS  
\*FREQUENCY RESPONSE: 10Hz-200,000Hz  
\*TOTAL HARMONIC DISTORTION LESS THAN 0.05%  
\*INPUT SENSITIVITY AND IMPEDANCE AT 1KHz: 1V-1.4V 47K OHMS  
\*SUPPLY VOLTAGE: DC  $\pm$  75V OR AC 53V  $\times$  2.8A  
KIT/ASS. WITH TESTED X'FORMER \$80/92 \$30.00

## ELECTRONIC ECHO AND REVERBERATION AMPLIFIER



Asa with tested

\$99.85

## 4 1/2 HI-PRECISION D.P.M.

(WITH DIN STANDARD ABS CASE)

SM-48A

SM-48A Digital Panel Meter employs a high-quality analog-digital converter (ADC) as its main device and employs 0.55" high LED display as 4 1/2 digit display. The required external components of SM-48A are very little.

### SPECIFICATIONS:

\*4 1/2 digit 14mm red large display with overload flash.  
\*Multi-functions: including BCD, BUSHY, STROBE output, very suitable for micro computer.  
\*MEMORY SYSTEM CAN HOLD the input reading for comparison and monitor.  
\*Range: DC voltage DC  $\pm$  1mV- $\pm$ 2000A  
DC current DC  $\pm$  1uA- $\pm$ 20A  
\*Accuracy: DC  $\pm$  0.025%  $\pm$  2 digit  
\*Power: DC  $\pm$  6V at 200mA  
DIMENSIONS: 3 3/4" (W)  $\times$  1 7/8" (H)  $\times$  4 1/16" (D).  
(MEET WITH DIN STANDARD OF W. GERMANY.)  
KIT/ASS. WITH TESTED \$47/51

## 60W + 80W DC LOW TIM

PRE-MAIN POWER AMPLIFIER

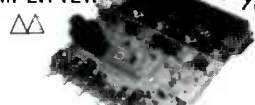

KIT \$55.38  
METAL CABINET/X'FORMER \$26/\$16.80

BUILD A 160W HI-FI STEREO AMP YOURSELF

Model No.	Description	Kit/Assemble	Unit Price
TA-006	6W MINI AMPLIFIER	Kit	\$ 4.92
TA-007	12W STEREO POWER BOOSTER	Kit	\$ 9.00
TA-008	AC/DC SHOULDER AMPLIFIER	Assm	\$ 48.00
TA-50A/B	MULTI-PURPOSE MELODY GENERATOR	Kit	\$ 19.78
TA-50C	MULTI-PURPOSE MELODY GENERATOR	Kit	\$ 11.50
TA-10	STEREO PRE-AMP WITH MAGNETIC MIC AMP	Kit	\$ 5.00
TA-28	DIGITAL MEMO	Kit	\$ 20.00
TA-120 MK2	PURE CLASS "A" MAIN POWER AMP (MONO)	Kit	\$ 25.00
TA-300	30W MULTI-PURPOSE SINGLE CHANNEL AMP	Kit	\$ 11.07
TA-302	60W VERSATILE STEREO POWER BOOSTER	Kit/Assm	\$ 50.00/60.00
TA-323A	HIGH QUALITY 30W + 30W STEREO AMP	Kit	\$ 24.60
TA-322	50W + 50W IC STEREO AMP WITH LED LEVEL DISPLAY	Kit	\$ 29.50
TA-377A	FULLY COMPLEMENTARY & SYMMETRICAL FET STEREO PRE-AMP	Kit/Assm	\$ 55.00/65.00
TA-400	40W SLDI STATE MONO AMP	Kit	\$ 13.84
TA-477	120W MOSFET POWER AMP (MONO)	Kit	\$ 61.28
TA-720	72W + 72W AC/DC STEREO HI-FI & PA AMP	Kit	\$ 63.00
TA-800	80W + 80W DC LOW TIM PRE-MAIN POWER AMP	Kit	\$ 55.38
TA-802	80W + 80W PURE OC STEREO MAIN POWER AMP	Kit	\$ 39.95
TA-820A	60W + 60W OCL DC PRE-MAIN STEREO AMP	Kit	\$ 43.00
TA-1000A	100W DYNAMIC CLASS "A" MAIN POWER AMP (MONO)	Kit	\$ 51.95
TA-1500	100W + 100W NEW CLASS "A" DC STEREO PRE-MAIN AMP	Kit	\$ 67.00
TA-2400A	ELECTRONIC ECHO AND REVERBERATION AMP	Kit/Assm	\$ 89.00/99.85
TA-2500	HO MULTI-PURPOSE PRE-AMP WITH 10 BAND GRAPHIC EQ	Assm	\$ 90.00
TA-2800	HI-FI BI-FET PRE-AMP (WITH 3 WAY TONE CONTROL)	Kit	\$ 44.50
TA-3000	STEREO SIMULATOR	Kit/Assm	\$ 25.00/30.00
TA-3600	300W HQ HI-FI POWER AMPLIFIER (MONO)	Kit/Assm	\$ 90.00/92.00
SM 43	3 1/2" MULTI-FUNCTIONAL LED D.P.M	Kit/Assm	\$ 30.00/36.00
SM 48	4 1/2" HI-PRECISION D.P.M.	Kit/Assm	\$ 38.00/48.00
SM 48A	4 1/2" HI-PRECISION O.P.M. (WITH DIN. STANDARD ABS CASE)	Kit/Assm	\$ 41.00/51.00

WE ALSO SUPPLY HIGH POWER TRANSFORMERS AND PROFESSIONAL LOOKING METAL CABINETS FOR OUR KITS, PLEASE REFER TO OUR CATALOG!

MOVING CELEBRATION

Our NEW Location has 10,000 SQ FEET!



FREE GIFTS

## FREE BALL POINT-PEN

WITH ANY PURCHASE  
FREE T-SHIRT  
(ONE SIZE FITS ALL) WITH EVERY PURCHASE OF \$ 100 OR MORE  
(AVAILABLE UNTIL STOCKS LAST)

## PROFESSIONAL COLOR LIGHT CONTROLLER



SM-328  
FEATURES:  
1 FOUR GROUPS OF INDEPENDENT OUTPUT SYSTEM 1000W CH MAX 4680W (110V 117V) 2 PROFESSIONAL COLOR CONTROL SYSTEM (KEY BOARD TYPE) 3 INDEPENDENT INPUT SIGNAL ADJUSTMENT 4 FOUR GROUPS OF INDEPENDENT DIMMER CONTROL 5 SPEED CONTROL CHASER 6 AUTOMATIC CHASING CONTROL SYSTEM 7 FOUR KINDS OF SPECIAL CHASING PROGRAM 8 COMBINATION OF PROGRAM AND MUSIC CHASING EFFECT 9 FORWARD BACKWARD CHASING CONTROL. SM 328 color light controller is specialized for ballroom night club disco and advertisement lighting. It consists with several color control characteristics which employ professional color control system and keyboard program selection. Therefore, it is capable of producing lighting effects by using chasing program and fluctuating music signal. There are two kinds of lighting effects. The first type is controlled by music signal. In order to adjust the brightness of four groups of lightings, each music signal will be separated into high, medium, low A and low B frequency range. Furthermore, each group of lightings is incorporated with an independent signal adjustment. The second kind is composed of electrical circuits and this is the main part for creating a special lighting effect. It has four chasing programs.  
Dimensions 14 5/16" x 8 15/16" x 3 3/16"  
Ass. with tested \$150.00 ONLY

## HIGH QUALITY PRE-AMPLIFIER WITH 10 BAND EQUALIZER

TA-2500  
NEW with CD input stage



Asa with tested \$90.00

## TA-120 MK2 36W PURE CLASS "A" MAIN POWER AMP. (MONO)

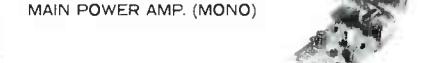

If you are a hi-fi fans, this high quality amplifier is especially designed for you. You will not believe why this amplifier, with only 36W RMS, sounds as good as Class AB amplifier of higher watts rating. Here's why: Composing this push-pull Class A amplifier is a fully direct-couple symmetrical DC preamplifier circuitries and is connected by Darlington amplifier circuits, thus reducing the heat generated. That is why the system can fill your ears with high-fidelity beautiful music than the ordinary Class AB amplifiers can provide. Whether you are listening to bold rock and roll music, or soft easy-listening tunes, this system will melt you in!  
Kit \$25.00

TERMS: \$10 min. order + \$20 min. charge card order + Check, money order or phone order accepted + We ship UPS Ground + Add 10% of total order (min. \$2.50) for shipping, outside USA add 20% (min. \$5.00) + Transit Insurance add 5% of total (outside USA only) + CA residents add sales tax + All merchandise subject to prior sale + Prices are subject to change without notice + Any goods proved to be defective, MUST BE RETURNED IN ORIGINAL FORM WITH A COPY OF YOUR INVOICE WITHIN 30 DAYS FOR REPLACEMENT.



# ADVERTISING INDEX

RADIO-ELECTRONICS does not assume any responsibility for errors that may appear in the index below.

Free Information Number	Page		Page		Page
81	A.I.S. Satellite	79	—	Electronic Technology Today	22
197	AIF Products	91	120, 185	Elephant Electronics	78, 79
108	AMC Sales	77	121	Fluke Mfg.	42
107	All Electronics	118	—	Fordham Radio	CV4
193	Allen Electronics	78	—	Grantham College of Engineering	37
103	Allen, W.B.	28	—	Heath	23
—	Amazing Devices	106	203	Hobby Helper	79
106	American Design Components	116	—	ICS Computer Training	77
183	Banner Technical Books	42	186	Imtronics	28
85	Blue Star Industries	79	—	Interventure	36
109	C & S Sales	16	—	ISCET	13
60	CIE	8	59	JDR Instruments	17
191	Cabletronics	78	113, 176	JDR Microdevices	108, 109
188	Chenesko Products	79	177, 178	JDR Microdevices	110, 111
52	Circuit Cellar	79	114	Jameco	114, 115
—	Command Productions	76	104	Jan Crystals	76
—	Computer Continuum	91	—	Joseph Electronics	33
58	Cook's Institute	75	193	Kelvin	107
189	Crystek	27	—	Lindsay Publishing	26
190	Daetron	24	87	MCM Electronics	103
187	Datak	97	198	MS Cash Drawer	91
127	Deco Industries	78, 79	196	Mandrill Corp.	91
82	Digi-Key	112	93	Mark V. Electronics	119
—	Digital Research Computer	102	—	McGraw Hill Book Club	38
202	Eaglestone	106	—	McGraw Hill (CED)	31
—	Elec. Industry Association	5	61	Microprocessors Unltd.	91
63	Micromart	105	63	Micromart	105
117	Mouser	107	117	Mouser	107
—	NRI	18, CV3	—	NRI	18, CV3
199	Needham's Electronics	91	199	Needham's Electronics	91
79	NuScope Associates	91	79	NuScope Associates	91
80	OCTE Electronics	79	80	OCTE Electronics	79
110	Omnitron Electronics	27	110	Omnitron Electronics	27
—	Pacific Cable	101	—	Pacific Cable	101
56	Parts Express	102	56	Parts Express	102
101	Pomona	13	101	Pomona	13
69	RAM	91	69	RAM	91
184	RD Electronic Surplus	120	184	RD Electronic Surplus	120
78	Radio Shack	113	78	Radio Shack	113
182	Regency	3	182	Regency	3
180, 181	Sencore	15, 35	180, 181	Sencore	15, 35
51	Silicon Valley Surplus	107	51	Silicon Valley Surplus	107
74	Solid State Sales	104	74	Solid State Sales	104
—	Star Circuits	75	—	Star Circuits	75
92	Tektronix	CV2	92	Tektronix	CV2
204	Tentel	37	204	Tentel	37
123	Test Probes	25	123	Test Probes	25
192	U.S. Cable/Movie Time	24	192	U.S. Cable/Movie Time	24
201	United Electronic Supply	96	201	United Electronic Supply	96
53	United Imports	23	53	United Imports	23
179	WPT Publications	99	179	WPT Publications	99
66	WS Jenks	97	66	WS Jenks	97



## DIGITAL CLOCK & APPLIANCE TIMER

# \$4.95

URNS ON HOUSEHOLD LIGHTS, COFFEE POTS, RADIOS, ETC.

Capable of switching up to 10 amps! Operates from 120 vac, 60 Hz. Automatically turns off after two hours or schematic available for bypassing automatic turn-off. Includes plastic mounting bezel, as pictured. MODEL #591F17 \$4.95. Bare bones models available in catalog.

SEND FOR FREE CATALOG

**R&DELECTRONICS CATALOG INCLUDES:** rechargeable batteries, cable, capacitors, connectors, converters, diodes, displays, fans, filters, hardware, heatsinks, integrated circuits, LEDs, lights, motors (all kinds), MOVs, PMTs, pots, power supplies, rectifiers, recorders, relays, resistors, SCR & TRIACS, switches, toroids, transformers, transistors, and wire.

**ALL AT DISCOUNT SURPLUS PRICES! SATISFACTION GUARANTEED.**

Brand new 38 page 1988 catalogs  
AVAILABLE NOW!  
**(813) 772-1441**

R&D Electronics is the mail order branch of ELECTRONIC SURPLUS of Cleveland, Ohio

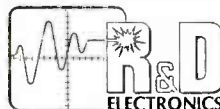

1202H Pine Island Road  
Cape Coral, Florida 33909

**Gernsback Publications, Inc.**  
500-B Bi-County Blvd.  
Farmingdale, NY 11735  
(516) 293-3000  
President: **Larry Steckler**  
Vice President: **Cathy Steckler**

**For Advertising ONLY**  
516-293-3000

**Larry Steckler**  
publisher

**Arline Fishman**  
advertising director

**Shelli Weinman**  
advertising associate

**Lisa Strassman**  
credit manager

**Christina Estrada**  
advertising assistant.

### SALES OFFICES

#### EAST/SOUTHEAST

**Stanley Levitan**  
Eastern Sales Manager  
Radio-Electronics  
259-23 57th Avenue  
Little Neck, NY 11362  
718-428-6037, 516-293-3000

#### MIDWEST/Texas/Arkansas/Okla.

**Ralph Bergen**  
Midwest Sales Manager  
Radio-Electronics  
540 Frontage Road—Suite 339  
Northfield, IL 60093  
312-446-1444

#### PACIFIC COAST/ Mountain States

**Marvin Green**  
Pacific Sales Manager  
Radio-Electronics  
5430 Van Nuys Blvd. Suite 316  
Van Nuys, CA 91401  
1-818-986-2001

Now electronics technicians can get into VCR Servicing quickly and easily

# Learn professional VCR servicing at home or in your shop with exclusive videotaped demonstrations

Today, there are more than 10 million VCRs in use, with people standing in line to have them serviced. You can bring this profitable business into your shop with NRI professional training in VCR servicing. This top-level training supports the industry's claim that the best technicians today are those who service VCRs.

## Integrated Three-Way Self-Teaching Program

In one integrated program, NRI gives you a study guide, 9 instructional units, 2 hours of video training tapes accompanied by a 32-page workbook that pulls it all together. At home or in your shop, you'll cover all the basic concepts of video recording, mechanical and electronic systems analyses, and the latest troubleshooting techniques. Your workbook and instructional units also contain an abundance of diagrams, data, and supplementary material that makes them valuable additions to your servicing library.

## The "How-To" Videotape

Your NRI Action Videocassette uses every modern communications technique to make learning fast and easy. You'll enjoy expert lectures and see animation and video graphics that make every point crystal-clear. You'll follow the camera eye into the heart of the VCR as step-by-step servicing techniques are shown. Both electronic and mechanical troubleshooting are covered . . . including everything from complete replacement and adjustment of the recording heads to diagnosing micro-processor control faults.

## Plus Training On All The New Video Systems

Although your course concentrates on VCRs covering Beta, VHS, and 3/4" U-Matic commercial VCRs, NRI also brings you up to speed in other key areas. You'll get training in capacitance and optical video disc players, projection TV, and video cameras. All are included to make you the complete video technician. There's even an optional final examination for NRI's VCR Professional Certificate.

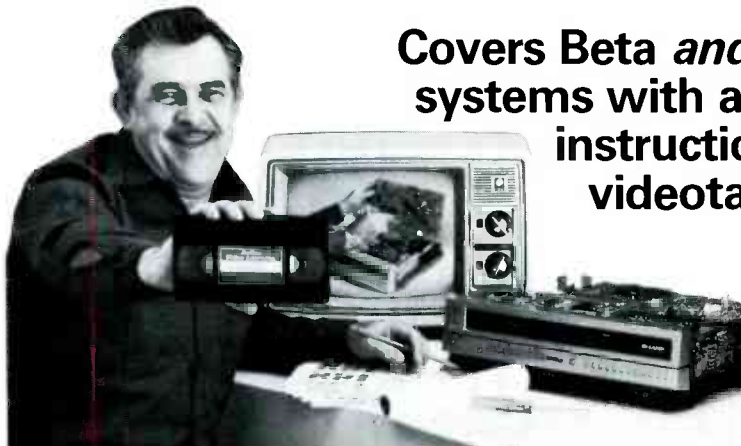

Covers Beta *and* VHS  
systems with actual  
instruction on  
videotape.

## The Best Professional Training

This exclusive self-study course has been developed by the professionals at NRI. NRI has trained more television technicians than any other electronics school! In fact, NRI has consistently led the way in developing troubleshooting techniques for servicing virtually every piece of home entertainment equipment as it appears in the marketplace.

## Satisfaction Guaranteed . . . 15-Day No-Risk Examination

Send today for the new NRI Self-Study Course in VCR Servicing for

Professionals. Examine it for 15 full days, look over the lessons, sample the videotape. If you're not fully satisfied that this is the kind of training you and your people need to get into the profitable VCR servicing business, return it for a prompt and full refund, including postage. Act now, and start adding new business to your business.

## Special Introductory Offer

This complete VCR training course with two hour videotape is being offered for a limited time only, on orders received from this ad, at our low introductory price of \$179.95. Save \$20 by acting now!

NRI Training For Professionals  
McGraw-Hill Continuing Education Center  
3939 Wisconsin Avenue Washington, DC 20016

**YES!** Get me started in profitable VCR servicing. Rush me my NRI self-study course in VCR Servicing for Professionals. I understand I may return it for a full refund within 15 days if not completely satisfied.

PLEASE SPECIFY TAPE FORMAT DESIRED  VHS  BETA

Name (please print) \_\_\_\_\_

Company \_\_\_\_\_

Street \_\_\_\_\_

City/State/Zip \_\_\_\_\_

Enclosed is my  check  money order for \$179.95 (D.C. residents add 6% tax) Make check payable to NRI

Charge to  VISA  MasterCard \_\_\_\_\_

Interbank Number

Card Number \_\_\_\_\_ Expiration Date \_\_\_\_\_

Signature \_\_\_\_\_

(required for credit card sales)



NRI Training For Professionals  
McGraw-Hill Continuing  
Education Center  
3939 Wisconsin Avenue  
Washington, DC 20016

2600-028

**SCOPE 3 1/2 Digital Multimeters**



**Model DVM-638**  
**\$8750**

- Test leads included
- 11 function, 38 ranges
  - Logic level detector
  - Audible visual continuity
  - Capacitance and conductance measurement

**Model DVM-636**  
**\$6750**

- 8 function, 37 ranges
- Capacitance measurement

**SCOPE 3 1/2 Digit Capacitance Meter**



**Model DCM-602**  
**\$5995**

- Test leads included
- 8 ranges with full scale values to 2000 uF
  - LSI circuit
  - Crystal time base
  - Frequency range 800 Hz to 8Hz

**SCOPE Pocket Sized Audio Signal Generator**



**Model RC-555**  
**\$5995**

- Test leads & 9V battery included
- Low distortion sine-wave signal
  - 46 step selected frequency
  - x1 range 20 Hz to 1.5 KHz
  - x100 range 2 KHz to 150 KHz

**SCOPE 4 1/2 Digit LCD Bench Digital Multimeter**



**Model DVM-6005**  
**\$21995**

- Test lead set 6, "D" size batteries included
- 0.4" high characters
  - Conversion period: 500 milliseconds
  - Automatic, negative polarity

# Mini-Meters with Maxi-Specs

**SCOPE 3 1/2 Digit LCD with 8 Full Functions**

**Model DVM-632**

**\$4495**  
OUR PRICE

Measures only 5 3/8" x 2 3/16" x 1 1/4"

- Deluxe test leads included
- 0.5% accuracy
  - Transistor gain test
  - Audible continuity checking & diode test
  - 10 Amp measurement

Zipped Carrying Case CC-30 **\$450**



**SCOPE 3 1/2 Digit LCD**

Measures only 5" x 2 3/4" x 7/8"

**Model DVM-630**

**\$2995**

- OUR PRICE
- Test leads included
- 0.5% accuracy
  - 6 functions, 19 ranges
  - Automatic zero adjust
  - Low battery indication

Zipped Carrying Case CC-30 **\$450**

ASK FOR FREE CATALOG.

Money orders, checks accepted. C.O.D.'s require 25% deposit.



# Fordham

260 Motor Parkway, Hauppauge, NY 11788

Toll Free  
**800-645-9518**  
In NY State 800-832-1446

**Service & Shipping Charge Schedule Continental U.S.A.**

FOR ORDERS	ADD
\$25-\$100	\$4.50
\$101-\$250	\$6.00
\$251-\$500	\$8.00
\$501-\$750	\$10.50
\$751-\$1,000	\$12.50
\$1,001-\$1,500	\$16.50
\$1,501-\$2,000	\$20.00
\$2,001 and Up	\$25.00