

JUNE 1955

RADIO - ELECTRONICS

TELEVISION • SERVICING • HIGH FIDELITY

In this issue:

Simple Antenna
for TV or FM

•

Bar Generator-
Sweep Adapter
for U.H.F.

•

An Unusual
Speaker Enclosure

•

What Is a Load Line?

•

Transistorized
Signal Injector

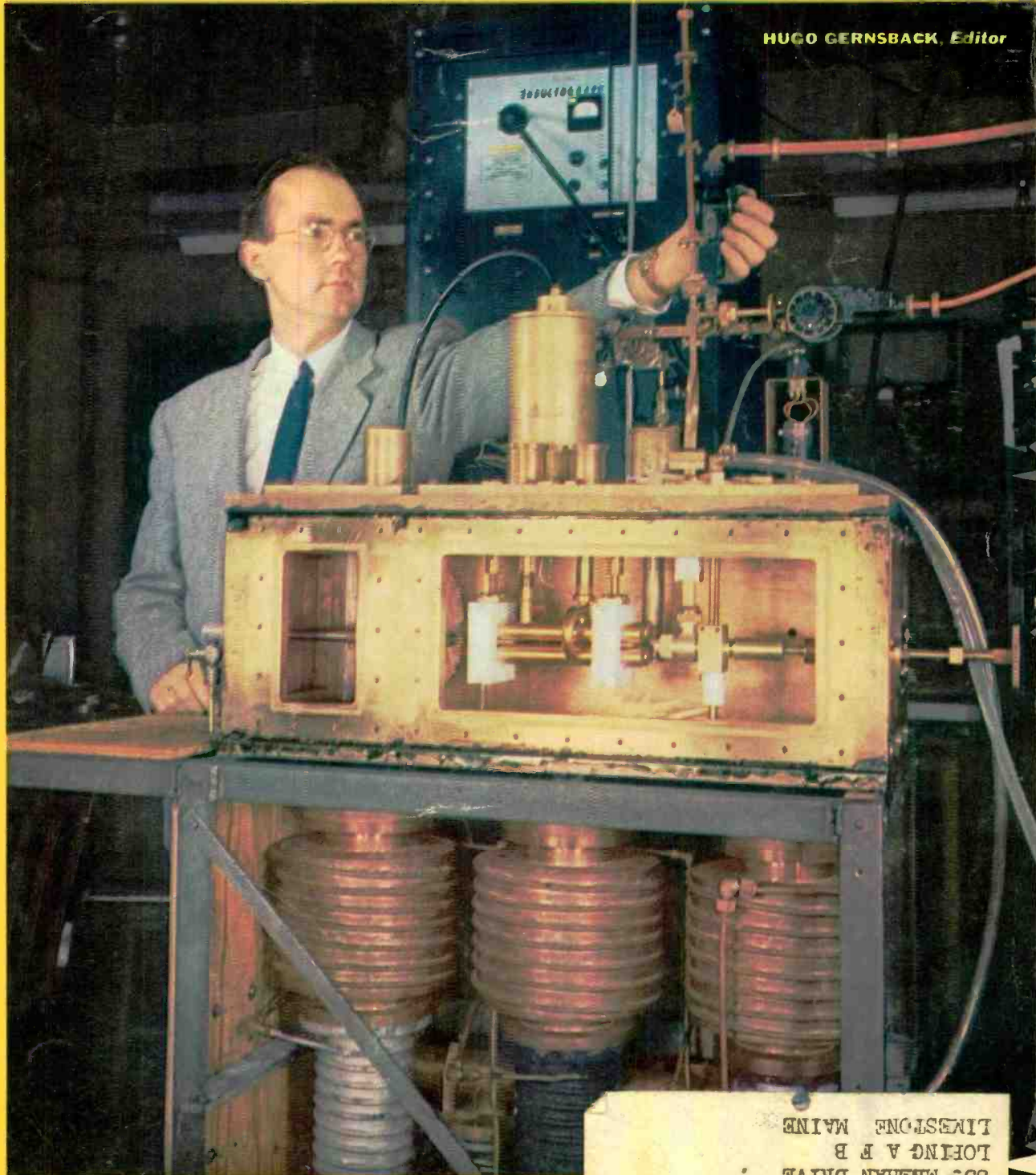

HUGO GERNSBACK, Editor

35¢

U. S. and
CANADA

New Electronic Ampli

(See page

WILDON A MARTELL 3-58
359 WASHMAN DRIVE
LOHNG A F B
LIVESTONE MAINE

this **RAYTHEON** "Bond"

pays a 10% "Dividend"*

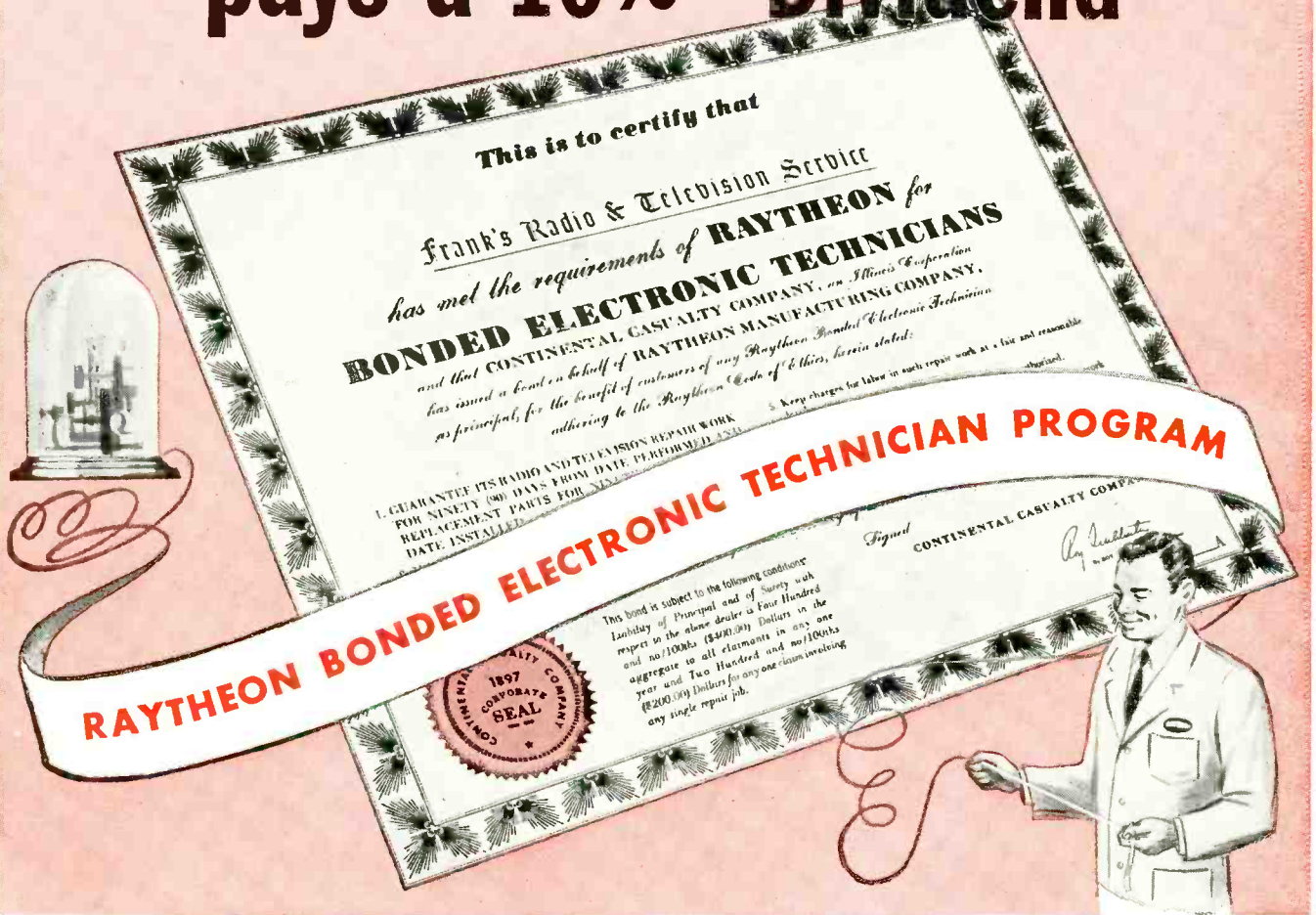

If you are interested in increasing your Radio & TV Service business and profits 10% or more call the Raytheon Tube Distributor in your area right now.

Ask him to tell you how the Raytheon Bond gives you a national backing of your 90 day guarantee, increases customer confidence in you and your shop.

Ask him to show you the many free business builders — Creed Displays, Decals, Certificate, Identification Cards, ad mats, etc. — that Raytheon makes available to you to help you tell your customers and prospects you're "Bonded".

Ask him about the Raytheon national advertising that makes it easy for you to get more business and then ask him if you can qualify for this exclusive Raytheon business builder. If you can, it costs you nothing — it's Raytheon's investment in your future.

*Recent surveys prove the Raytheon Bonded Program improves business by at least 10 per cent.



RAYTHEON MANUFACTURING COMPANY
 Receiving and Cathode Ray Tube Operations
 Newton, Mass. • Chicago • Atlanta, Ga. • Los Angeles, Calif.

Raytheon makes all these: Receiving and Picture Tubes • Reliable Subminiature and Miniature Tubes • Semiconductor Diodes and Transistors • Nucleonic Tubes • Microwave Tubes





J. E. SMITH
President, National
Radio Institute
40 years' experience
training men at home
for Radio-TV

I Will Send You A **SAMPLE LESSON FREE** to show you how easy, practical it is to **Train at Home for Good Radio-Television Jobs**



**START SOON TO MAKE \$10, \$15
A WEEK EXTRA FIXING SETS**

You can start to cash in fast. Many men I train fix neighbors' Radios, make extra money, starting soon after they enroll. Read below how actual equipment you build gives you practical experience.

America's Fast Growing Industry Offers You Good Pay Plus a Bright Future

TRAINING plus OPPORTUNITY is the PERFECT combination for ambitious men. Let me send you a sample lesson from my course to prove you can keep your job while TRAINING at home in your spare time for better pay and a brighter future. I will also send my 64-page book to show you that Radio-Television is today's field of OPPORTUNITY for properly trained men.

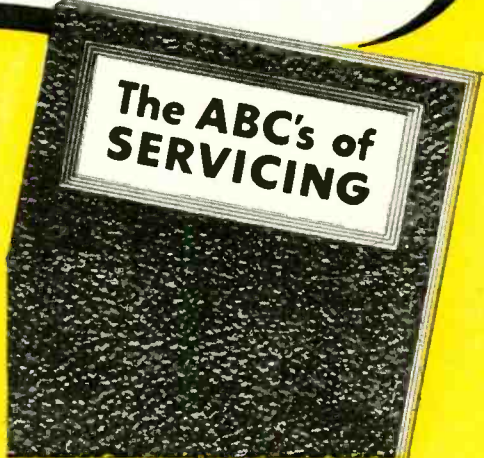

Television's Growth is Making More Jobs, Prosperity

Radio is bigger than ever and television is growing fast. Government, Aviation, Police, Ship, Micro-wave Relay, Two Way Communications for buses, taxis, railroads are other growing fields for Radio-Television trained men.

Mail Coupon—Find Out About This Tested Way to Better Pay

Take NRI training for as little as \$5 a month. Many NRI graduates make more in two weeks than the total cost of my training. Mail coupon today for Actual Lesson and 64-page Book—Both FREE. J. E. SMITH, National Radio Institute, Dept. 5FF, Washington 9, D. C. Our 40th Year.



I Trained These Men



"I am a police captain and also have a good spare time Radio and Television service business. Just opened my new showrooms and shop." C. W. LEWIS, Pensacola, Florida.

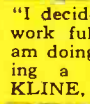

"I decided to quit my job and do TV work full time. I love my work and am doing all right. I'm not just punching a time clock." WILLIAM F. KLINE, Cincinnati, Ohio.



"Thanks to NRI, I operated a successful Radio repair shop. Then I got a job with WPAQ, later WBOB and now am an engineer for WHPE." VAN W. WORKMAN, High Point, N. Carolina.

You Learn by Practicing with Equipment I Send

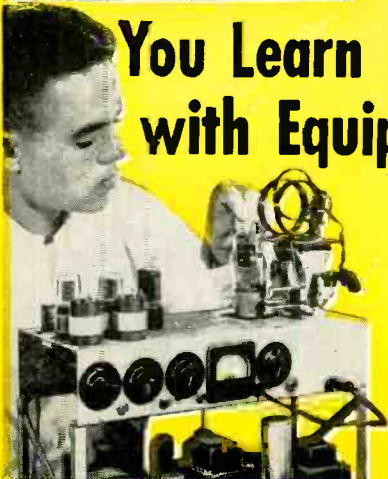

Nothing takes the place of practical experience. That's why NRI training is based on LEARNING BY DOING. My training includes kits of parts which you use to build equipment and get practical experience on circuits common to both Radio and Television. Shown at left is the low-power Broadcasting Transmitter you build as part of my Communications Course.



AVAILABLE TO **VETERANS** UNDER G.I. BILLS

Good for Both—FREE

Mr. J. E. Smith, President, Dept. 5FF
National Radio Institute,
Washington 9, D.C.

Mail me Sample Lesson and 64-page Book, FREE.
(No salesman will call. Please write plainly.)

Name Age

Address

City Zone State

VETS write in date of discharge
Approved Member, National Home Study Council

RADIO - ELECTRONICS

Formerly RADIO CRAFT • Incorporating SHORT WAVE CRAFT • TELEVISION NEWS • RADIO & TELEVISION*

Hugo Gernsback
Editor and Publisher
M. Harvey Gernsback
Editorial Director
Fred Shunaman
Managing Editor
Robert F. Scott
W2PWG, Technical Editor
Jerome Kass
Associate Editor
I. Queen
Editorial Associate
Matthew Mandl
Television Consultant
Angie Pascale
Editorial Production
Wm. Lyon McLaughlin
Tech. Illustration Director
Sol Ehrlich
Art Director

Lee Robinson
General Manager
John J. Lamson
Sales Manager
G. Aliquo
Circulation Manager
Adam J. Smith
Director, Newsstand Sales
Robert Fallath
Promotion Manager
Seymour Schwartz
Advertising Production

GERNSBACK PUBLICATIONS, INC.

Executive, Editorial and Advertising Offices, 25 West Broadway, New York 7, N. Y. Telephone REctor 2-8630.

Hugo Gernsback
Chairman of the Board
M. Harvey Gernsback
President
G. Aliquo
Secretary

ON THE COVER:

(Story on page 56) Professor Townes and one of the two existing models of the maser. The large cylindrical objects below are pumps.

Color original by Dan Rubin



JUNE 1955

Vol. XXVI, No. 6

Editorial (Page 29)			
Check Your TV Set Annually!	by Hugo Gernsback 29		
Audio—High Fidelity (Pages 30-42)			
A New Loudspeaker Enclosure	by George A. Coates 30		
What Is a Load Line?	by Norman H. Crowhurst 33		
New Developments in Tape Recorders	by Sol Heller 36		
High-Fidelity Dictionary, Part V	by Ed Bukstein 38		
For Golden Ears Only: The Regency HF-80 amplifier; Pickering cartridge; New Records Review	by Monitor 39		
Television (Pages 43-53)			
Simple TV/FM Antenna	by Paul F. Loveless 43		
Television Station List—to April 18, 1955	44		
TV Signal Circuit Feedback	by Robert G. Middleton 46		
Television—it's a Cinch: (Sixteenth Conversation, second half: Radio-frequency high-voltage supplies; when vice finally becomes a virtue! the bootstrap circuit	by E. Aisberg 48		
TV Service Clinic	Conducted by Jerry Kass 50		
Low-Frequency Compensation in Video Amplifiers	by Joseph F. Sodaro 52		
Electronics (Pages 54-62)			
IRE Attains New Heights	54		
Revolutionary New Oscillator—Amplifier (Cover Feature) by Fred Shunaman	56		
Electronic Vacuum Gauges	by A. A. Schulke 58		
Magnetic Tape Recorder Aids Industry	by James R. Cornelius 62		
Test Instruments (Pages 63-76)			
Midget Transistorized Signal Injector	by Elliott A. McCready 63		
U.H.F. Bar Generator and Sweep Adapter	by Bruce Morrisette 65		
Capacitor—Resistor Analyzer	72		
A Dependable Gas Test	by H. B. Conant 76		
Radio (Pages 77-85)			
Perk Up the Little Set	by Wayne E. Lemons 77		
460-Mc Radio	by Leo G. Sands 80		
Electronic Load	by Don M. Wherry 84		
DEPARTMENTS			
Books	124	People	121
Business	118	Question Box	107
Correction	126	The Radio Month	6
Correspondence	14	Radio-Electronic Circuits	98
Miscellany	96	Technical Literature	123
New Devices	86	Technicians' News	105
New Tubes and Transistors	92	Technotes	103
Patents	110	Try This One	114

Average Paid Circulation over 175,000

RADIO-ELECTRONICS, June, 1955, Vol. XXVI, No. 6. Published monthly at Mt. Morris, Ill., by Gernsback Publications, Inc. Second-class mail privileges authorized at Mt. Morris, Ill. Copyright 1955 by Gernsback Publications, Inc. Text and illustrations must not be reproduced without permission of copyright owners.

SUBSCRIPTIONS: Address correspondence to Radio-Electronics, Subscription Dept., 404 N. Wesley Ave., Mt. Morris, Ill., or 25 West Broadway, New York 7, N. Y. When ordering a change please furnish an address stencil impression from a recent wrapper. Allow one month for change of address.

SUBSCRIPTION RATES: U. S., U. S. possessions and Canada, \$3.50 for one year; \$6.00 for two years; \$8.00 for three years; single copies 35c. All other countries \$4.50 a year; \$8.00 for two years; \$11.00 for three years.

BRANCH ADVERTISING OFFICES: Chicago: 7522 North Sheridan Road, Tel. ROGers Park 4-8000. Los Angeles: Ralph W. Harker and Associates, 600 South New Hampshire, Tel. DUNkirk 7-2328. San Francisco: Ralph W. Harker and Associates, 582 Market St., Tel. GARfield 1-2481. **FOREIGN AGENTS:** Great Britain: Atlas Publishing and Distributing Co., Ltd., London E.C. 4. Australia: McGill's Agency, Melbourne. France: Brentano's, Paris 2e. Belgium: Agence et Messageries de la Presse, Brussels. Holland: Trilacton, Heemstede. Greece: International Book & News Agency, Athens. So. Africa: Central News Agency Ltd., Johannesburg; Capetown, Durban, Natal. Universal Book Agency, Johannesburg. Middle East: Stematzyk, Middle East Agency, Jerusalem. India: Broadway News Centre, Dadar, Bombay #14. Pakistan: Paradise Book Stall, Karachi 3. **POSTMASTER:** If undeliverable send form 3573 to: RADIO-ELECTRONICS, 25 West Broadway, New York 7, N. Y. *Trademark registered U.S. Patent Office.



National Schools brings you a new dimension in training for TELEVISION-RADIO-ELECTRONICS

YOU CAN LEARN BY HOME STUDY, IF—

- you are ambitious to increase your earning power.
- you want to broaden your knowledge and skill.
- you choose the school with the most complete training and service.

50 Years of Successful Training

National Schools has been training men for success since 1905. Our graduates are located around the globe, in good-paying jobs in servicing, installation and manufacturing... in public and private industry, or in their own businesses. All this experience and background are your assurance of success.

What This New Dimension in Home Study Means to You

As a National Schools student, with Shop Method Home Training, you master *all phases* of the industry—TV, Radio, Electronics—theory and practice. You learn **HOW** and **WHY**, in one complete course at one low tuition.

Because National Schools' world headquarters are in Los Angeles—"capital city" of TV-Radio-Electronics—our staff is in close touch with industry. Our lessons and manuals are constantly revised to keep you up-to-the-minute on latest developments. We show you how to make spare time earnings as you learn, and we give you free placement assistance upon graduation. National Schools is approved for G. I. Training. Both Resident and Home Study courses are offered. If you are of draft age, our training helps you achieve specialized ratings and higher pay grades.

This *new dimension* enables us to train you as you should be trained at home, regardless of your age or previous education.

Your Course Includes Valuable Units

We send you important equipment, including a commercial, pro-

fessional Multitester... plus parts to build Receivers, Oscillators, Signal Generator, Continuity Checker, other units, and Short Wave and Standard Broadcast Superhet Receiver.

Mail Coupon for Complete Information

Get these two free books about this new dimension in Home Training. A comprehensive, illustrated fact-book and a sample National Schools lesson. No obligation, so mail coupon today.

NATIONAL SCHOOLS
TECHNICAL TRADE TRAINING SINCE 1905
Los Angeles 37, Calif. • Chicago: 323 W. Polk St.
In Canada: 811 W. Hastings St., Vancouver, B.C.



MAIL NOW TO OFFICE NEAREST YOU!

(mail in envelope or paste on postal card)

NATIONAL SCHOOLS, Dept. RG-65

4000 S. FIGUEROA STREET OR 323 W. POLK STREET
LOS ANGELES 37, CALIF., CHICAGO 7, ILL.

Rush FREE BOOK, "Your Future in Radio-TV-Electronics," and FREE LESSON. No obligation, no salesman will call.

NAME _____ BIRTHDAY _____ 19 _____

ADDRESS _____

CITY _____ ZONE _____ STATE _____

Check if interested ONLY in Resident Training at Los Angeles.

VETERANS: Give date of discharge _____

the Radio month



MINIATURE ELECTRONIC BRAIN promises to open a new era in computers; it operates flawlessly in planes flying at supersonic speed. The new computer, known as *Tradic* (Transistor-digital-computer), was developed for the U. S. Air Force by Bell Telephone Labs.

The digital computer eliminates vacuum tube failure and heat, jet aircraft's greatest electronic problems, by the use of transistors. Nearly 800 of these are used in what is believed to be the first all-transistor computer designed for aircraft. The entire unit will probably occupy less than 3 cubic feet and require less than 100 watts to operate. In



addition to the transistors, the computer contains nearly 11,000 germanium diodes.

Tradic can do 60,000 additions or subtractions, or 3,000 multiplications or divisions per second; it can handle simultaneously as many as thirteen 16-digit numbers. Mathematical instructions are placed into Tradic by a plug-in unit, set up beforehand with interconnecting wires to represent problems at hand.

The laboratory model of Tradic provides answers to trigonometric problems with a series of dots on an oscilloscope (see photo). The dots of light appear as geometric diagrams on the face of the scope.

FM ECONOMIES were the subject of a speech by FCC Commissioner Robert E. Lee at the High-Fidelity Fair in Washington. He urged that established AM broadcasters, especially the larger ones, consider the economic advantages of FM.

Lee said, "It is no secret that radio network revenues have been declining while television network revenues have been gaining. Inevitably, radio network affiliates will look favorably on means of reducing operating expenses. In that light, FM, which can be broadcast from a single tower occupying a building roof or lot and even share space with TV, might look more attractive than a multiple-tower AM array tying up many acres of expensive, heavily taxed suburban real estate.

"I don't suggest that this is an immediate problem, or even one for the near future. But I do think it adds a further practical reason for approaching with extreme caution any proposals for reducing or eliminating the FM band."

TV INTERFERENCE was responsible for a bill proposed by the Vermont House of Representatives. The legislation would prohibit any person or firm in that state from causing unnecessary interference with television reception.

Offenders would be compelled to pay up to \$50 to correct the trouble. In cases where corrective measures do not eliminate the interference, the complainant would have to bear the expense of corrections.

GLOBAL NAVIGATION AID is planned as a result of experiments with a new system called Navarho, according to reports from the Air Research and Development Command Headquarters.

First station in the new experimental setup is to be erected at Camden, N.Y., near the Rome Air Development Center. It will supply position information to pilots of jet and other aircraft at all points within about 2,500 to 3,000 miles from the station.

The station is composed of three 15-kilowatt transmitters using three 625-foot towers, plus a master timing unit with a stability of one part in one billion. Exact method of operation is not revealed, but it was stated that a plane 1,000 miles from the station would receive information accurate to within 10 miles in any direction. It would direct planes to within 100 miles of their destination, at which point local navigation aids would take over for a more precise fix.

If the experiment is a success, a world-wide chain of installations completely covering the globe will be established.

Get New FREE PUBLIC ADDRESS HANDBOOK

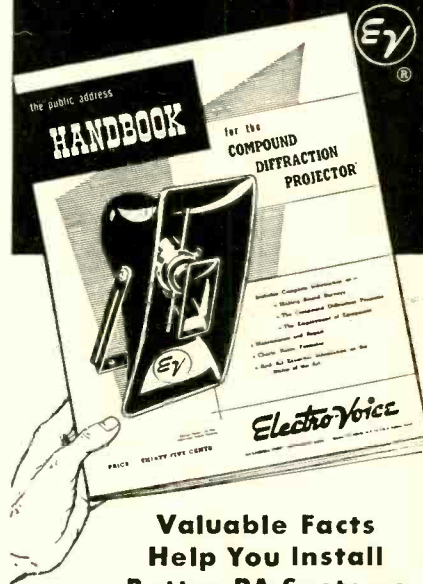

Valuable Facts Help You Install Better PA Systems

For the first time, such helpful information in a compact Handbook!

- Shows how to make sound surveys and recommendations—with factory and arena examples.
- Discusses public address requirements in auditoriums, stadiums, large rooms, etc.
- Explains operational factors of importance in public address loudspeaker systems for all types of applications, indoors and outdoors.
- Explains three major points to consider in public address loudspeaker projectors.
- Tells what the CDP Compound Diffraction Projector* is—what it does—and how it provides a PA speaker system of much greater range, efficiency and dispersion.
- Includes illustrations, diagrams, charts, formulas, engineering data, technical & architectural specifications.

*Design Patent 169,904
Additional Patent Pend.

Send for your FREE copy now
or see your E-V Distributor

Electro-Voice®

ELECTRO-VOICE, INC. • BUCHANAN, MICH.

Without obligation, send me FREE copy of the CDP Public Address Handbook.

NAME _____

ADDRESS _____

CITY _____ ZONE _____ STATE _____

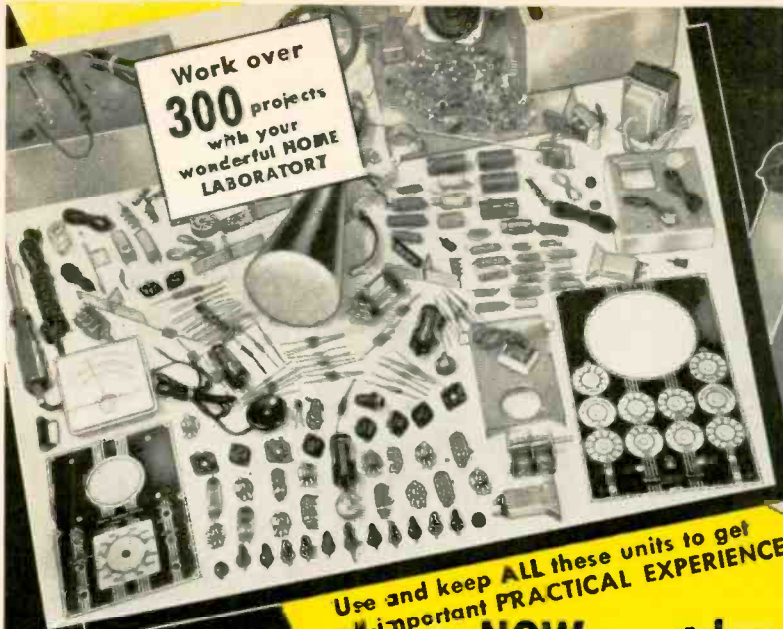

Work over
300 projects
with your
wonderful **HOME
LABORATORY**



21 INCH
Build and keep D.T.I.'s NEW
2 Unit TV Set—ideal for cus-
tom installation. (D.T.I. also
offers home training with-
out the TV set.)

Use and keep **ALL** these units to get
all-important **PRACTICAL EXPERIENCE**

**NOW... at home... get D.T.I.'s
amazingly effective NEW training in**

TELEVISION

RADIO-ELECTRONICS! Nothing else like it for providing real **LABORATORY-TYPE** training at home. Get the kind of thorough, practical experience **YOU NEED** for the kind of progress **YOU WANT** in today's tremendous field of Television, Radio and Electronics. Qualify yourself for real money... interesting work... a wonderfully promising future. And when you finish, D.T.I.'s active Employment Service **HELPS YOU GET STARTED!** Or open your own profitable Television-Radio Service Business.

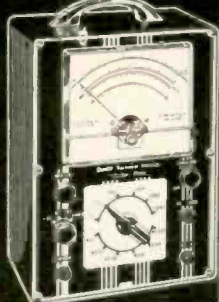

NEW!
Build and keep
D. T. I.'s new
**VACUUM TUBE
VOLTMETER**...
one of the most
useful of all test
instruments.



**5 INCH
"SCOPE"**
ABCVE: Also build
and keep this quality
Oscilloscope—almost
a "must" for Televi-
sion servicing.



**Exclusive
HOME
MOVIES**
help you grasp
important points
**FASTER...
EASIER...
BETTER.**
A tremendous
advantage!

Remarkable NEW Styrene ELECTRO-LAB*

Insert pictorial diagram on transparent styrene base. (See insert.) Mount parts to follow patterns—using fancy "snap in" fasteners. Eliminates wiring errors. Tops for speedy circuit changes... for providing maximum circuit experience in minimum time. Build and operate scores of interesting projects—such as the electronic circuit shown below.

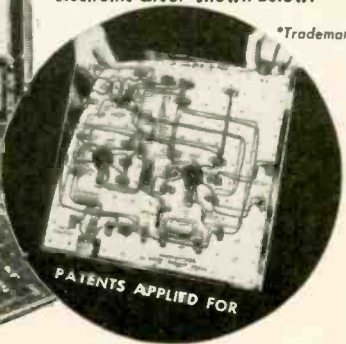

*Trademark

PATENTS APPLIED FOR

THOUSANDS OF SUCCESSFUL GRADUATES

WHY has D.T.I. become one of the largest training organizations of its kind? Because it provides **EVERY MAJOR HOME TRAINING AID** to help make the subject **EASIER** to learn... **EASIER** to remember—the kind of training so helpful for **REAL PROGRESS**. Students get thorough, up-to-date, practical training that **TAKES ADVANTAGE** of new and improved training developments. Study the **ADVANTAGES** shown on this page. Think what they can mean to **YOU... to YOUR FUTURE!** Or come to D.T.I.'s big Training Laboratories in Chicago. **MAIL COUPON TODAY** for complete facts—including valuable publication, "89 Ways to Earn Money in Television-Radio-Electronics." Also, valuable information for men subject to **MILITARY SERVICE**.

"One of America's Foremost Television Training Centers"

DeVRY
Technical Institute
CHICAGO 41, ILLINOIS
Formerly DeFCREST'S TRAINING, INC.

MAIL COUPON TODAY

DeVRY TECHNICAL INSTITUTE
4141 Belmont Ave., Chicago 41, Ill. Dept. RE-6-L

I would like complete facts including "89 Ways to Earn Money in Television-Radio-Electronics."

Name _____ Age _____
Street _____ Apt. _____
City _____ Zone _____ State _____
1 D.T.I.'s training is available in Canada.



Audio Powerhouse

MEETS THE HIGH POWER DESIGN REQUIREMENTS OF HIGH FIDELITY AUDIO AMPLIFIERS



For outputs up to 100 watts, two 6550's in push-pull will provide the same power now attained in most existing designs by the use of four or more tubes. Reduction in the number of tubes means simplified electrical balance, reduced maintenance and over-all lower cost. With proper circuitry, the 6550 will provide full power output with approximately the same grid voltage drive as the 6L6, 5881 or KT66 types. The 6550 is produced under laboratory conditions with exhaustive quality control to assure premium performance and long life. Ask your tube supplier for it.

TUNG-SOL ELECTRIC Inc., Newark 4, N.J.
Sales Offices: Atlanta, Chicago, Columbus, Culver City (Los Angeles), Dallas, Denver, Detroit, Montreal (Canada), Newark, Seattle.

TUNG-SOL
6550
BEAM POWER AMPLIFIER

THE RADIO MONTH

ALBERT EINSTEIN, greatest theoretical physicist of our age, died on April 18, at the age of 76. Famous as the discoverer and exponent of

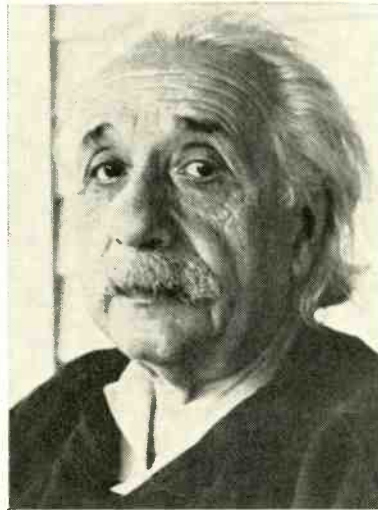

the theory of relativity, he postulated his field theory in 1905. Since that date Einstein developed his basic formulas, culminating in his unified field theory announced a few years back. In 1921 Einstein was awarded the Nobel Prize for physics (discovery of the law of the photoelectric effect).

Much of Einstein's life was devoted to the contemplation of the relationship of energy to mass. His theories based on the conversion of matter into energy ($E=mc^2$, the Einstein theorem), formed most of the groundwork in the development of the atomic bomb.

Einstein arrived in the United States in 1933 from Germany. At the time of his death Einstein was a life member of the Institute for Advanced Study, at Princeton, N. J.

ROBOT RADAR ANTENNAS monitored at a central station could be set up to detect an enemy attack, using a new system revealed at a meeting of the Institute of Radio Engineers. The system involves squashing the radar screen signal so it can be transmitted on ordinary telephone lines. At present, coaxial cables or expensive microwave relay systems are needed to carry radarscope pictures.

Taking advantage of the inherent repetition of radar signals from rotating antennas, the system can code the picture to fit in the limited bandwidth of a telephone circuit. Suspicious blips could be transmitted for analysis from the central station to higher authorities anywhere in the world where there are telephone lines.

RADIATION DETECTOR can be made from an ordinary camera, as the result of a recent patent. The invention converts conventional cameras into detectors without interfering with their use for normal photographic purposes.

The detector uses a photosensitive sheet which records a light spot on a black background when subjected to

(Continued)

X-ray or gamma radiations. The inventor, W. A. Shurecliff, of Cambridge, Mass., uses a Polaroid type camera, permitting rapid determination of the intensity of the radiation.

In operation, the shortwave radiations pass through an intensifier which emits a fluorescent light that causes the light spot. This spot can be easily distinguished from normal film fogging or light leaks.

STANFORD C. HOOPER, Rear Admiral USN, retired, a pioneer in developing radio for the Navy, died on April 7 at the age of 70. Admiral Hooper (see photo) became the first radio officer of the United States Fleet in 1912. He later became Director of Naval Communications.

Admiral Hooper was known as the Navy's top engineering specialist on radio communications from the days before World War I until World War II. Among the many honors bestowed on Admiral Hooper are the Franklin Institute's Elliott Cresson Gold Medal



for "pioneering leadership and practical utilization of discovery in the field of radio . . ." and the Veteran Wireless Operators Association's Marconi Memorial Medal of Merit for improving the Navy's radio system.

NEW SOUNDTAPE which plays up to 8 hours of uninterrupted music is now available in a 6 x 5½-inch cartridge about 2 inches thick. Developed by the Teflon company in Germany, the unit does not use a conventional tape. The sound is recorded by an engraved process on pure vinylite, with an average of 82 grooves on a ½-inch band. Sound is reproduced on a special playback machine using a stylus that is set against the soundband.

FINANCIAL EGG was laid in Broadway's first presentation of live, closed-circuit television. The telecast of the ANTA (American National Theater and Academy) Album was viewed by theater audiences in New York and 30 other cities.

Although featuring top-flight entertainers, the box-office results showed receipts of \$195,000 and expenses of \$200,000. A sellout crowd would have brought in \$400,000. ANTA produced the 2-hour show, and CARE underwrote the network costs. **END**

Let me send you FREE
the entire story

Just fill out the coupon and mail it. I will send you, free of charge, a copy of "How to Pass FCC License Exams," plus a sample FCC-type Lesson, and the amazing new booklet, "Money-Making FCC License Information."



CARL E. SMITH, E.E.
President

I can train you to pass your FCC License Exams in a minimum of time if you've had any practical radio experience — amateur, Army, Navy, radio servicing, or other. My time-proved plan can help put you, too, on the road to success.

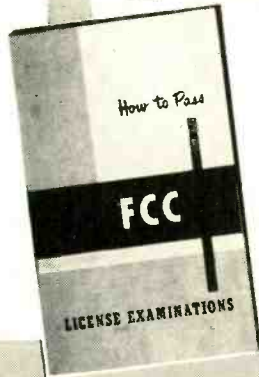

How to Pass FCC COMMERCIAL Radio Operator License Exams

FREE

Tells where to apply and take FCC examinations, location of examining office, scope of knowledge required, approved way to prepare for FCC examinations, positive method of checking your knowledge before taking the examination.

GET YOUR FCC TICKET IN A MINIMUM OF TIME

Get this Amazing Booklet FREE



TELLS HOW

HERE IS YOUR GUARANTEE

If you fail to pass your Commercial License exam after completing our course, we guarantee to continue your training without additional cost of any kind, until you successfully obtain your Commercial license.

WE GUARANTEE

TO TRAIN AND COACH YOU AT HOME IN SPARE TIME UNTIL YOU GET

YOUR FCC LICENSE

If you have had any practical experience—Amateur, Army, Navy, radio repair, or experimenting

TELLS HOW

TV ENGINEERING INCLUDED IN OUR TRAINING & COACHING

Our Amazingly Effective JOB-FINDING SERVICE

Helps CIRE Students Get Better Jobs

Here are a few recent examples of Job-Finding results

BROADCASTING

"Your 'Chief Engineer's Bulletin' is a grand way of obtaining employment for our graduates who have obtained their 1st class license. Since my name has been on the list I have received calls or letters from five stations in the southern states, and am now employed as Transmitting Engineer at WMMT."

Elmer Powell, Box 274, Sparta, Tenn.

CIVIL SERVICE

"I have obtained a position at Wright-Patterson Air Force Base, Dayton, Ohio, as Junior Electronic Equipment Repairman. The Employment Application you prepared for me had a lot to do with my landing this desirable position."

Charles E. Loomis, 4516 Genessee Ave., Dayton 6, Ohio.

AIRLINES

"Due to your Job-Finding Service, I have been getting many offers from all over the country, and have taken a job with Capital Airlines in Chicago, as Radio Mechanic."

Harry Clare, 4537 S. Drexel Blvd., Chicago, Ill.

Your FCC ticket is recognized by employers as proof of your technical ability.

TELLS HOW

Employers make

An Approved Member



JOB OFFERS Like These to Our Graduates Every Month

Letter from nationally-known Airlines:

"Radio Operators and Radio Mechanics are needed for our company. Periodic wage increase with opportunity for advancement. Both positions include many company benefits such as paid vacations, free flight mileage allowance and group insurance."

These are just a few examples of the job offers that come to our office periodically. Some licensed radioman filled each of these jobs . . . it might have been you!

Letter from nationally-known manufacturer:

"We have a very great need at the present time for radio-electronics technicians and would appreciate any helpful suggestions that you may be able to offer."

HERE'S PROOF FCC LICENSES ARE OFTEN SECURED IN A FEW HOURS OF STUDY WITH OUR COACHING AT HOME IN SPARE TIME

Name and Address	License	Time
Harry G. Frame, Box 429, Charleston, W. Va.	2nd Class	13 Weeks
Charles Ellis, Box 449, Charles City, Iowa	1st Class	28 Weeks
Omar Bibbs, 1320 E. 27th St., Kansas City, Mo.	1st Class	34 Weeks
Kenneth Rue, Dresser, Wisconsin	2nd Class	20 Weeks
B. L. Jordan, Seattle, Washington	1st Class	20 Weeks

CLEVELAND INSTITUTE OF RADIO ELECTRONICS
CARL E. SMITH, E. E., Consulting Engineer, President
Desk RE-77, 4900 Euclid Bldg., Cleveland 3, Ohio



Get All 3 FREE

MAIL COUPON NOW

CLEVELAND INSTITUTE OF RADIO ELECTRONICS

Desk RE-77, 4900 Euclid Bldg., Cleveland 3, Ohio
(Address to Desk No. to avoid delay)

I want to know how I can get my FCC ticket in a minimum of time. Send me your FREE booklet, "How to Pass FCC License Examinations" (does not cover exams for Amateur License), as well as a Sample FCC-type lesson and the amazing new booklet, "Money-Making FCC License Information." Be sure to tell me about your Television Engineering Course.

NAME.....

ADDRESS.....

CITY..... ZONE..... STATE.....

FOR PROMPT RESULTS SEND AIR MAIL
Special tuition rates to members of the U. S. Armed Forces

WIRE AND CABLE FOR EVERY ELECTRONIC PRODUCT

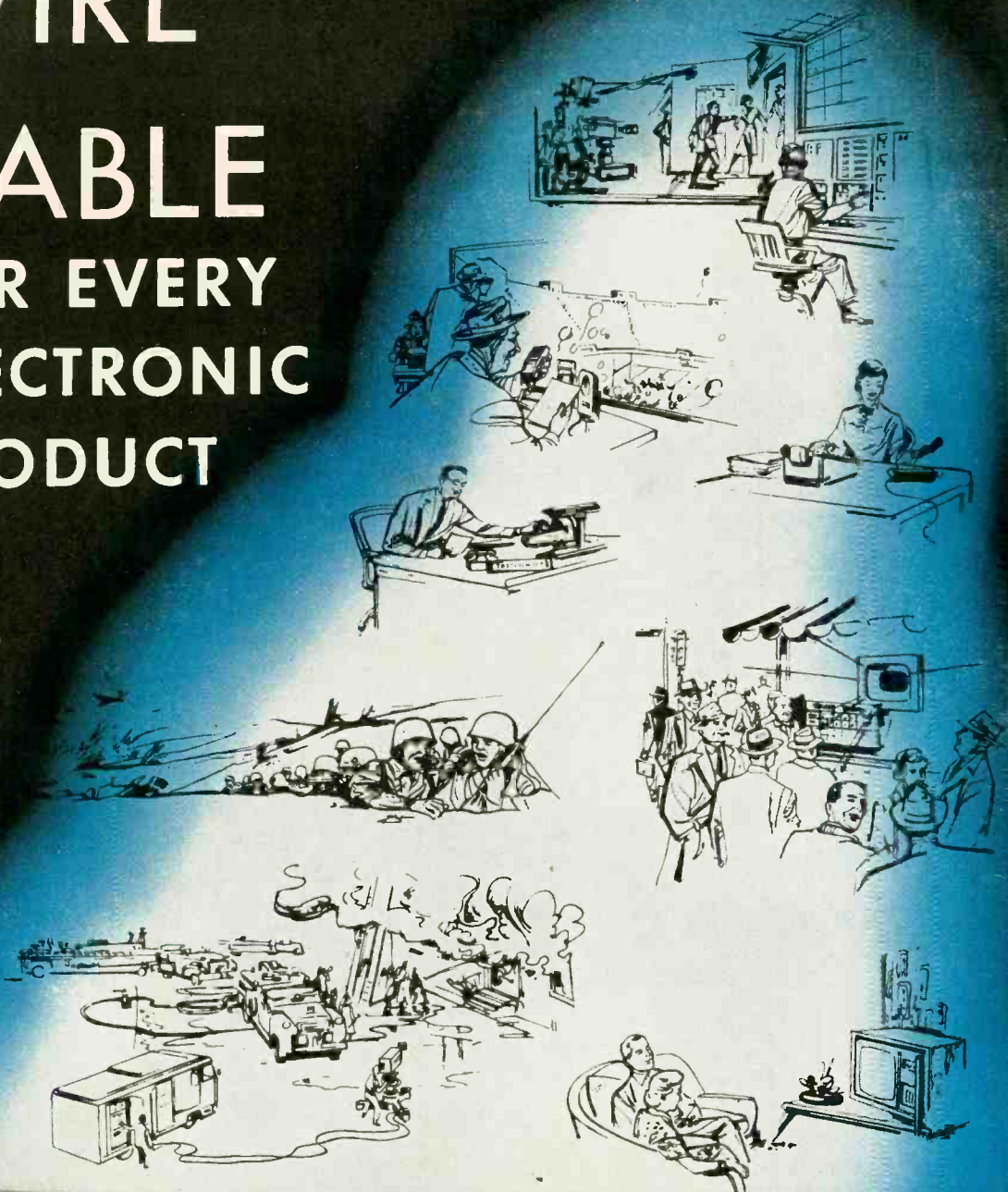

Belden

WIREMAKER FOR INDUSTRY
SINCE 1902

BELDEN MANUFACTURING CO. · CHICAGO

2-8



**Train for a secure career
—not just another job!
Success ahead for trained men
only in**



Radio-TV-Electronics

Stop Dreaming! Start Planning!

**START YOUR CREI CAREER TRAINING
AT HOME TO INSURE MORE INCOME!**

What would a \$10 or \$20 a week raise mean to you? Only one \$10-a-week raise will repay your investment in CREI training, and leave you a profit of \$200 or more the very first year! Your increases in pay thereafter are all pure profit, and you'll be prepared for many more promotions and pay raises in the future years of your life!

WHAT YOU DO NOW—today, tomorrow, next week—will decide your success in the electronics field. Every day counts because the trained technicians are the ones who get the "plums" when promotions are handed out. How can you be sure to step ahead of competition, to earn more money, to get the position that carries more responsibility—and the pay that goes with it? The answer is contained in a CREI booklet called "Your Future in the New World of Electronics."

ERA OF COMMUNICATION

This is the era of Communication: aeronautical, marine, police and fire, industrial, land transportation. This is the era of defense orders and a manufacturing industry which last year alone sold billions of dollars worth of electronic equipment, which will top ten billion dollars (without military) this year. This is the era of electronic development, research, design, production, testing, inspection, manufacture, broadcasting, telecasting and servicing. This is the era of electronic careers—well-paid, interesting, and secure.

PRACTICAL COURSES

Your work is under the supervision of a regular staff instructor who knows and teaches what industry needs. Training is accomplished on your own time, during hours chosen by you.

KEY TO SUCCESS — As a graduate you'll find your CREI diploma the key to success in the entire field of electronics. At your service is the Placement Bureau which finds positions for advanced students and graduates. No short cuts are promised; no jobs are guaranteed—but requests for CREI-trained personnel far exceed current supply.



COLLEGE DEGREE NOT ESSENTIAL—You don't have to be a college graduate to benefit from CREI's famed courses. You *do* have to be willing to study at home. You can do it while holding down a full time job. Thousands have. No matter what your level of electronics experience, CREI has a course for you.

CREI's professional guidance is recognized all over the world. Since 1927 CREI has trained technicians; you find them in radio and television stations; you find them in electronics planning and manufacture; you find them everywhere and, generally, near the top. During World War II CREI trained men for the Armed Services. Leading firms choose CREI courses for group training in electronics (among them are United Air Lines, Canadian Broadcasting Corp., Trans-Canada Airlines, Bendix Products Division, Radio Corporation of America RCA Victor Division and Canadian Marconi).

THIS CAN BE YOUR BIG YEAR!



Write today for this **FREE BOOKLET**. Tuition is reasonable, terms are easy, information is free. Fill out the coupon and mail it at once.

AVAILABLE TO VETERANS UNDER GI BILL!

FILL OUT AND MAIL TODAY—BEFORE YOU FORGET IT!

CAPITOL RADIO ENGINEERING INSTITUTE

Accredited Technical Institute Curricula

Dept. 146-B, 3224 16th St., N.W., Washington 10, D. C.

Please send me your course outline and FREE Illustrated Booklet "Your Future in the New World of Electronics" . . . describing opportunities and CREI home study courses in Practical Electronics Engineering.

- CHECK FIELD OF GREATEST INTEREST
- Practical Radio Engineering
 - Broadcast Radio Engineering (AM, FM, TV)
 - Practical Television Engineering
 - Aeronautical Electronics Engineering
 - TV, FM & Advanced AM Servicing

Name
Street
City..... Zone..... State.....

CHECK: Home Study Residence School Veteran

To help us answer your request intelligently, please give the following information:

EMPLOYED BY.....
TYPE OF PRESENT WORK.....
SCHOOL BACKGROUND.....
ELECTRONICS EXPERIENCE.....
IN WHAT BRANCH OF ELECTRONICS ARE YOU MOST INTERESTED?

a complete NEW line!

RADIART SEAL·VENT Communication Vibrators

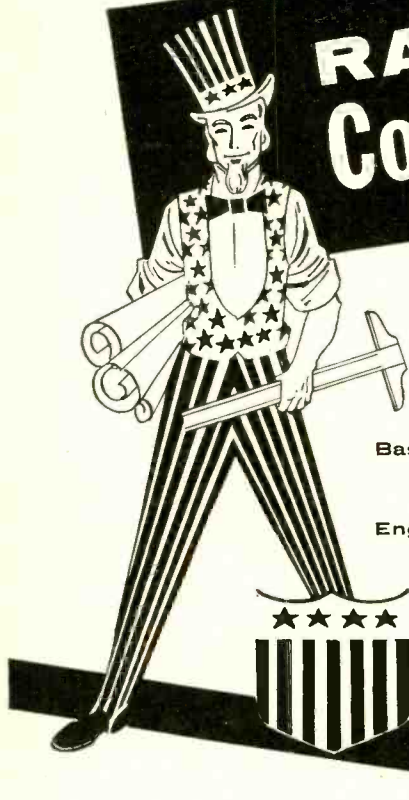

Based On Rigid
U. S. Government
Engineering Specifications

NOW... RADIART makes available to commercial users of communications equipment, a new line of vibrators based upon experience of producing over 2 million similar units to the exacting requirements of U. S. Signal Corps Specifications.

These Eight Types Offer Complete Replacement for ORIGINAL Communication Equipment:

Old No.	New No.
5515	5715
5518	5718
★	5721
★	5722
5605	5805
5620	5820
5621	5821
5622	5822

It's ready now!

The new 1955

Radiart Vibrator

Replacement Guide



THE **RADIART** CORPORATION
CLEVELAND 13, OHIO

TV ANTENNAS • AUTO AERIALS • VIBRATORS • ROTORS • POWER SUPPLIES

Here's a NEW Way to Reach the Top in TV SERVICING

**All-practice method—
professional techniques,
skills, knowledge of
circuits, etc.**



**Includes 17" picture tube, all other
tubes, components for a TV Receiver,
Scope, Signal Generator, HF Probe.
Low Introductory price under \$200,
on easy terms. Mail Coupon today.**

IF YOU HAVE some Radio or Television experience, or if you know basic Radio-Television principles but lack experience—NRI's new Professional Television Servicing course can train you to go places in TV servicing. This advertisement is your personal invitation to get a free copy of our booklet which describes this training in detail.

LEARN-BY-DOING "ALL THE WAY"

This is 100% learn-by-doing, practical training. We supply all the components, all tubes, including a 17-inch picture tube, and comprehensive manuals covering a thoroughly planned program of practice. You learn how experts diagnose TV receiver defects quickly. You see how various defects affect the performance of a TV receiver—picture and sound: learn to know the causes of defects, accurately, easily, and how to fix them. You do more than just build circuits. You get practice recognizing, isolating, and fixing innumerable TV receiver troubles.

You get actual experience aligning TV receivers, diagnosing the causes of complaints from scope patterns, eliminating interference, using germanium crystals to rectify the TV picture signal, obtaining maximum brightness and definition by properly adjusting the ion trap and centering magnets, etc. There isn't room on this or even several pages of this magazine to list all the servicing experience you get.

UHF AND COLOR TV MAKING NEW BOOM

Installing front-end channel selector strips in modern UHF-VHF Television receivers and learning UHF servicing problems and their solution is part of the practice you get if you live in a UHF area. To cash in on the coming color TV boom you'll need the kind of knowledge and experience which this training gives.

GET DETAILS OF NEW COURSE FREE

Once again—if you want to go places in TV servicing, we invite you to find out what you get, what you practice, what you learn from NRI's new course in Professional Television Servicing. See pictures of equipment supplied, read what you practice. Judge for yourself whether this training will further your ambition to reach the top in TV servicing. We believe it will. We believe many of tomorrow's top TV servicemen will be graduates of this training. Mailing the coupon involves no obligation.



**National Radio Institute, Dept. 5FFT
16th and U Sts., N.W., Washington 9, D. C.**

Please send my FREE copy of "How to Reach the Top in TV Servicing." I understand no salesman will call.

Name _____ Age _____

Address _____

City _____ Zone _____ State _____



Engineering Writing for Advancement in Electronics

If you are an Electrical Engineer or Physicist with aptitude for writing, here is a way to broaden your experience and enter a fascinating area of advanced electronics in one of the nation's leading organizations in its field...

Hughes Engineering Writers

work directly with design, development, test and maintenance engineers—performing the vital work of transforming complex theory and procedure into clear, concise technical information contained in manuals, handbooks and other publications for use by military and civilian technical people.

Here are some of the advantages of being an Engineering Writer at Hughes:

- Training at full pay to become familiar with Hughes-developed and manufactured radar, computer systems and guided missiles.
- Full status as a member of the Hughes Technical Staff, with same Company benefits.
- A salary commensurate with other Engineering categories.
- Close personal liaison with project engineers.
- Career permanence, with assured advancement opportunities.
- Reasonable traveling and moving expenses. Live and work in Southern California.

Write, giving education, experience and other qualifications, to:

HUGHES

RESEARCH & DEVELOPMENT LABORATORIES

SCIENTIFIC AND ENGINEERING STAFF

Culver City, Los Angeles County, Calif.

Correspondence

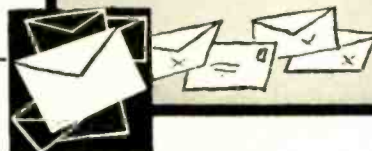

TRANSISTOR SYMBOLS

Dear Editor:

You have certainly noted—as have we—that transistors are represented by a varied group of symbols (Fig. 1). This causes confusion. I believe it possible to have some agreement on the subject. Please note the following:

Fig. 2—The present symbol widely adopted for the point-contact transistor.

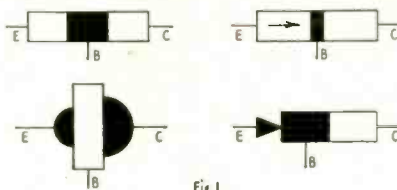

Fig. 1



Fig. 2

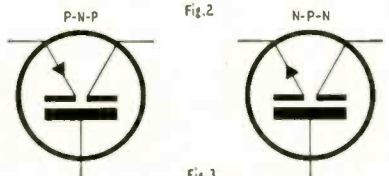

Fig. 3

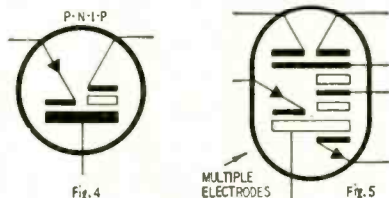

Fig. 4

Fig. 5

Fig. 3—Proposed symbols for junction transistors.

Fig. 4—The same as Fig. 3, with an intrinsic layer (p-n-i-p transistors).

Fig. 5—Multiple-electrode junction transistors (1960 types...).

We are sure you will see the value of adopting uniform symbols.

E. AISBERG

Director, Toute la Radio
Paris, France

(We are reasonably happy with our present transistor symbols and would certainly not like to use a circle—representing the glass envelope of a vacuum tube—around them. But what do our readers think?—Editor)

ROSIN FLUX

Dear Editor:

Like most readers I wait until I take exception to some statement before I make any comment on your excellent publication RADIO-ELECTRONICS.

In the article "Techniques for Servicing Printed Wiring" (October, 1954) the statement is made on page 90, "An activated rosin liquid flux may be used."

Printed circuitry is used extensively at the research and development lab where I work, and we have proved that activated rosin flux leaves metallic salt deposits on most materials that are used as bases for printed circuits.

This deposit can sometimes be removed by chemical flux removers or by rinsing thoroughly in cold water and then baking. The leakage resistance produced with the activated flux is in the same order as a pencil mark.

W. C. NEUENDORFF, JR.

North Hollywood, Calif.

S.S. MODIFICATION

Dear Editor:

I read the article "Silent Sound" in your April issue and was very much interested. I could not obtain the EHF-4155 tube (Transitime) locally, so I used the EHF-4169 which is electrically interchangeable but has a standard 11-pin loktal base.

I am using a Craftsmen C-800A FM-AM tuner. I invented an adapter so the system can be used on AM. It demodulates the signal and uses a type 6L7 reactance modulator. I measured the IM (taken off my temples with an electroencephalograph and fed into a Heath IM analyzer) and found it to be .00159%. Could you explain this distortion? (Dandruff?—Editor)

I am using an r.f.-operated power supply to develop the 900 volts for the Transitime tube. I figured out my own resistor values (see diagram) and waveguide dimensions. I can't hear anything with my system, but I attracted

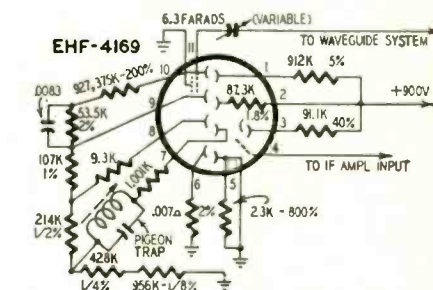

a hell of a lot of carrier pigeons. Could my resistor values be wrong? I would appreciate any suggestions from RADIO-ELECTRONICS readers.

HUGO SNARK

University of Miami, Miami, Fla.

(Try salt on the pigeons' tails.—Editor)

(Continued on page 18)

big values

from **ALLIED'S**
latest Free Supplement



**Super-Value
Knight**

Push-Button Tape Recorder

A best buy in recorders! Five push-buttons select all operating functions: fast forward, play-back, stop, record and fast reverse. Takes up to 7" reels. Two-speed dual-track for wide range of recording times. At 3.75" per second, 7" reel records for 1 hour—and additional hour on second half of tape; at 7.5" per second, records 1/2 hour continuously, 1 hour overall. 7" reel rewinds in 3 minutes. Response: ± 3 db from 75-8500 cps at 7.5" speed; 80-6000 cps at 3.75" speed. Efficient erase system; "lock" prevents accidental erase. Features: two neon recording level indicators, 2-watt built-in amplifier; 5 x 7" oval speaker. Records from mike, radio, tuner or phono. Handsome 2-tone portable case, 14 x 12 x 9". Complete with mike, take-up reel and 600-ft. roll of tape. For 110-120 v., 60 cycles AC. U.L. Approved. Shpg. wt., 29 lbs. 96 RX 675. *Only* **\$89.95**

WAS \$97.45
NOW ONLY **\$89.95**

continuously, 1 hour overall. 7" reel rewinds in 3 minutes. Response: ± 3 db from 75-8500 cps at 7.5" speed; 80-6000 cps at 3.75" speed. Efficient erase system; "lock" prevents accidental erase. Features: two neon recording level indicators, 2-watt built-in amplifier; 5 x 7" oval speaker. Records from mike, radio, tuner or phono. Handsome 2-tone portable case, 14 x 12 x 9". Complete with mike, take-up reel and 600-ft. roll of tape. For 110-120 v., 60 cycles AC. U.L. Approved. Shpg. wt., 29 lbs. 96 RX 675. *Only* **\$89.95**

FREE! Tape Carrying Case Worth \$5.95 with Purchase of 10 Reels of Quality Knight Tape



\$24.85 Buy ten 1200-ft. reels of this top quality recording tape and get the carrying case FREE! Knight tape meets the most critical professional requirements, yet costs far less. Noted for noise-free reproduction and uniform response. 1/4" wide, acetate plastic base with red oxide coating mirror-polished for high frequency response and minimum wear on recording heads. Splice-free type "A" (inside coated) tape on 7" plastic reel. Ten reels with carrying case. 13 1/4 lbs. 96 RX 836. *Only* **\$18.90**



Super-Thin Portable Radio

ONLY Reduced from regular \$14.95 price. Top value in a fine battery-operated personal portable, hardly thicker than a book. Advanced superhet circuit features low-drain tubes for 100 hours of battery life. Includes built-in loopstick antenna, PM speaker, easy-tuning thumbwheel controls, AVC. Red plastic case, 6 x 9 x 2 1/4". With tubes (less batteries). 4 lbs. 94 S 430. *Only* **\$12.95**
80 J 651. Battery Kit. *Only* **\$2.40**



**Knight
Preamp-Equalizer**

ONLY Reduced from \$36.95. Control unit for any basic Hi-Fi amplifier. Response, ± 1 db, 30-30,000 cps; 3-position record compensator; 4 inputs: magnetic phono, tuner or crystal phono, tape, microphone; output, 2.5 volts, hum, -65 db. 3 1/2 x 11 1/2 x 5 1/2". 7 lbs. 93 SX 315. *Only* **\$32.95**

807 Tube Value!

ONLY 99c Brand-new, famous name JAN—surplus transmitting tube. 5 prong base; 6.3 v. fil.; max. plate v. (CW) 750; max. plate curr. (CW) 100 mc. 58 E 403. *Only* **99c**

Bargain 8-Blade Solingen Steel Knife

ONLY \$5.95 Famous Swiss-style knife with 8 blades of finest Solingen Steel. Includes: 2 3/4" blade; 2" blade; screwdriver-bottle opener-wire scraper; Phillips screwdriver; reamer; can opener; 3" saw; scissors with spring-return handles. Highly polished blades; with belt loop; army-type red molded sides. A great value. 46 N 381. *Only* **\$5.95**



New Low-Cost Knight Geiger Counter Kit

ONLY \$19.95 Get started in uranium prospecting now with this extremely sensitive instrument—comparable to costly equipment, yet easy to build at only a fraction of the price. Just turn it on, flip the high-voltage switch and listen to the clicks in the headphone when you hit a radioactive source. Uses low-cost long-life batteries. Kit includes all parts, tube, carrying case with handle, 22 1/2 and 1 1/2 volt batteries, radioactive sample and headphone. Complete instructions for quick assembly. 1 1/2 lbs. 83 S 242. *Only* **\$19.95**

Bargain Knight VFO Kit



ONLY \$29.50

Easy to construct. Complete with built-in voltage regulated power supply. Calibrated for 80, 40, 20, 15, 11 and 10 meters; output on 80 and 40 meters. Features: very high stability; good oscillator keying characteristic for fast break-in; TVI suppression; plenty of bandspread; vernier drive; only 8 1/2 x 6 x 5". Includes all parts, tubes, case and full instructions. Shpg. wt., 8 lbs. 83 S 725. *Only* **\$29.50**

Knight In-Line Antenna Kit

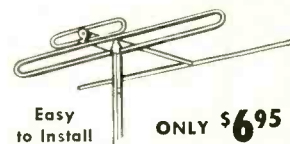

Easy to Install ONLY \$6.95

Complete quality VHF kit includes: efficient in-line antenna; 5-ft. mast; base mount; 75 feet of 300-ohm train line; five 3 1/2" standoff insulators. Antenna has separate folded dipole for low and high bands, reflectors for high gain on all channels. Elements are 1/2" seamless aluminum tubing. 10 lbs. 92 CX 041. *Only* **\$6.95**

Famous Multitester Value



ONLY \$14.95

Reduced from \$17.95. Famous name 22-range volt-ohm-milliammeter. Tops for radio servicing. DC ranges: 0-5, 50, 250, 500 and 2500 volts. AC and output voltage: 0-10, 100, 500 and 1000 volts. DC current: 0-1, 10, 100 ma; 0-1 and 10 amps. Resistance: 0-500, 100,000 ohms; 0-1 meg. Decibels, -8 to +55. Large 3" D'Arsonval meter, 2% accuracy. 4 1/2" x 8" x 3". With battery and instructions. Shpg. wt., 3 1/2 lbs. 84 F 393. *Only* **\$14.95**

Pet Drill Kit Buy!

Regularly \$16.82
NOW ONLY \$14.95



Terrific value 34 piece kit for shop or home use. Polishes, grinds, drills, sands. Includes: 1/4" drill with 3-jaw hand chuck (full load speed, 900 rpm), rubber backing pad, paint mixer, 7 carbon steel bits, lamb's wool polishing bonnet, buffing disc, bench stand, 12 abrasive discs, side handle, 6-piece adapter set, 3" grinding wheel; all in heavy steel kit box; with rack for drills. For 110-120 v. AC or DC. Wt., 6 lbs. 46 N 289. *Only* **\$14.95**

See Our 308-Page Catalog for Everything in Electronics

Always refer to your ALLIED Catalog for the world's largest stocks of parts, tubes, tools, test instruments. Hi-Fi equipment, recorders, Amateur gear, builders' kits, industrial apparatus, etc. If you haven't it, ask for FREE copy.



ALLIED RADIO CORP., Dept. 2-F-5
100 N. Western Ave., Chicago 80, Ill.

- Send FREE ALLIED Supplement No. 148
- Send FREE 308-Page 1955 Catalog

Enter order for.....\$.....enclosed.

Name.....

Address.....

City.....Zone.....State.....

order from **ALLIED RADIO**

WINEGARD *started the*

... still the undisputed leader

Since the advent of TV it has been a recognized fact that the yagi antenna was the most desirable basic antenna design for distant fringe area reception. Mechanical simplicity, neat appearance, sensational sensitivity and almost perfect horizontal polar pattern are the reasons. The only objection to the yagi type antenna has been its limitation to one or two channels because of inherent frequency sensitivity of this design. Almost every manufacturer at one time or another attempted to remove this one limiting factor for all channel use, but each time they met with failure. So they turned their engineering efforts to large, bulky antennas, figuring this was the only way to get acceptable all channel performance. Early in 1954, Winegard startled the industry by announcing they had overcome the difficulties of using a yagi for an all channel antenna, and had at last developed a yagi antenna covering all channels from 2-13 that really worked.

The impact of this triumph became more and more self evident as manufacturer after manufacturer joined THE ALL CHANNEL YAGI PARADE started by Winegard and their Interceptor with exclusive Electro-Lens Focusing. Today Winegard still leads the Parade with a complete line of yagi antennas for TV set owners no matter where they live—even in the most extreme fringe areas.

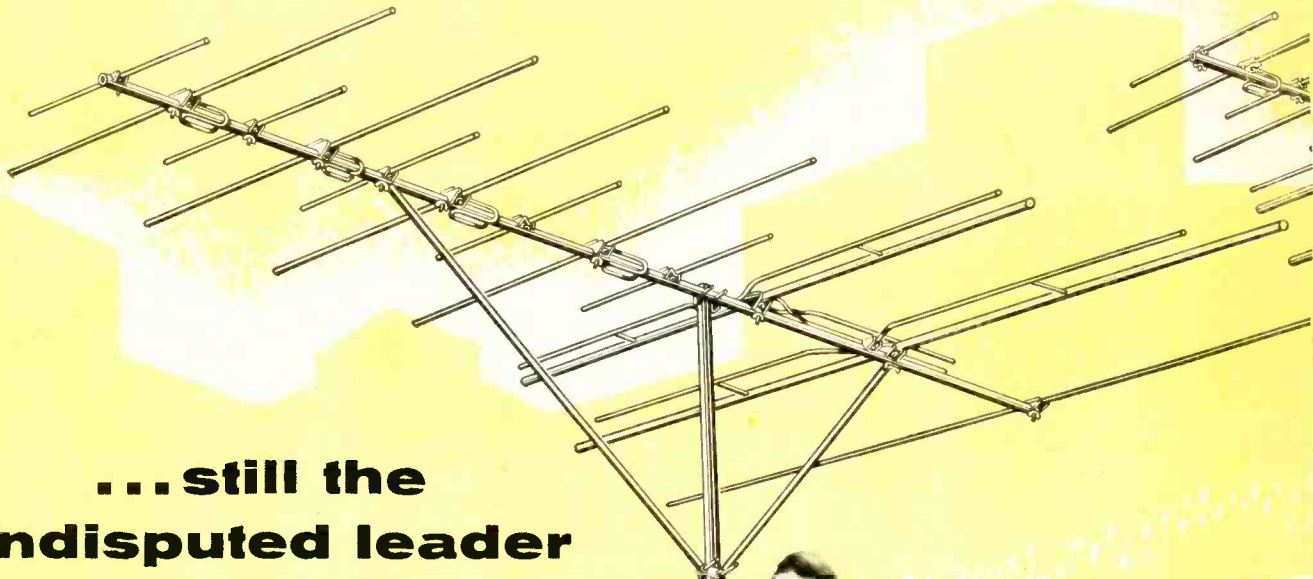

Miss Super 'Ceptor* 1955

Here's Why Winegard Leads in Sales Gains

Calendar of all channel yagi events (shown below)
 NOTE: Winegard months ahead of nearest competition with real all channel yagi antenna.

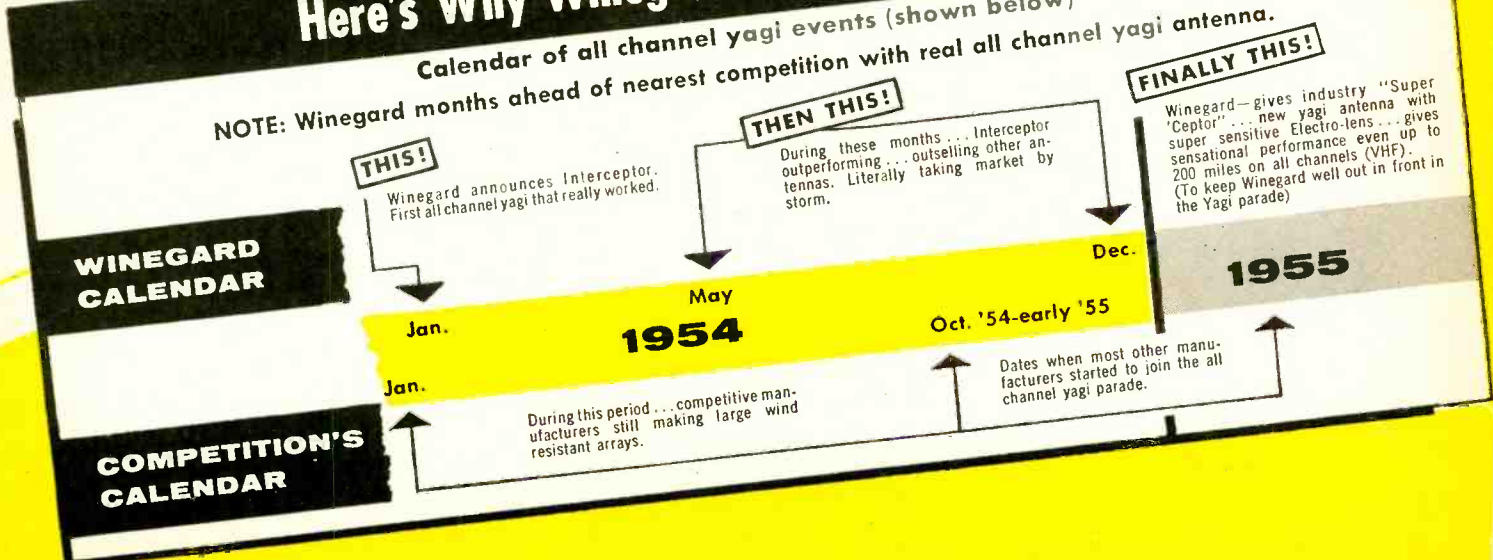

ALL CHANNEL YAGI parade in 1954!



Look! Here's Proof that Winegard leads in **1 ENGINEERING** **2 PERFORMANCE**

- ... The "Super 'Ceptor'" has more working elements on all channels
- ... The "Electro-Lens"*, the patented director system that works efficiently on both bands with NO interaction and without needless bulk. (Exclusive with Winegard.)
- ... The full length of Winegard antennas works on all channels—(many competitive antennas use only the back half for low band—only the front half on the high band.)
- ... Multi Resonant Driven Elements—a modified Tee matched dipole that works on the low channels as a 1/2 wave dipole ... on the high band as "full wave" dipoles. (Another Winegard engineering first.)

"Super 'Ceptor'"
DIAGRAM A

3 passive reflector elements **3**

Shows active elements on high channels (7-13)



4 MODEL SL4 4-1/2 wave Driven elements

13 ELECTRO-LENS* Gives action of 13 1/2 wave—resonant director elements on high band—

TOTAL 20 active elements working together in perfect phase on channels 7-13.
NOTE: dotted line on driven element to show current formation on channels 7-13.

"Super 'Ceptor'"
DIAGRAM B

Full dimension reflector **1**

Shows active yagi elements on channels 2-6

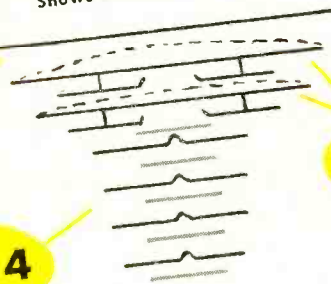

2 multi-resonant T matched Driven elements

4 ELECTRO-LENS* Gives action of 4 1/2 wave directors of low band

TOTAL 7 active genuine yagi elements on low band 2-6.

NOTE: dotted line on driven elements show current formation on channels 2-6.



WINEGARD COMPANY

3000 Scotten Boulevard, Burlington, Iowa

For Further Information Regarding
Winegard Antennas

See Your Jobber
or
Write Us.

your KEY
TO EXCELLENCE
phastron

"555"

metal-cased
MULTIMETER

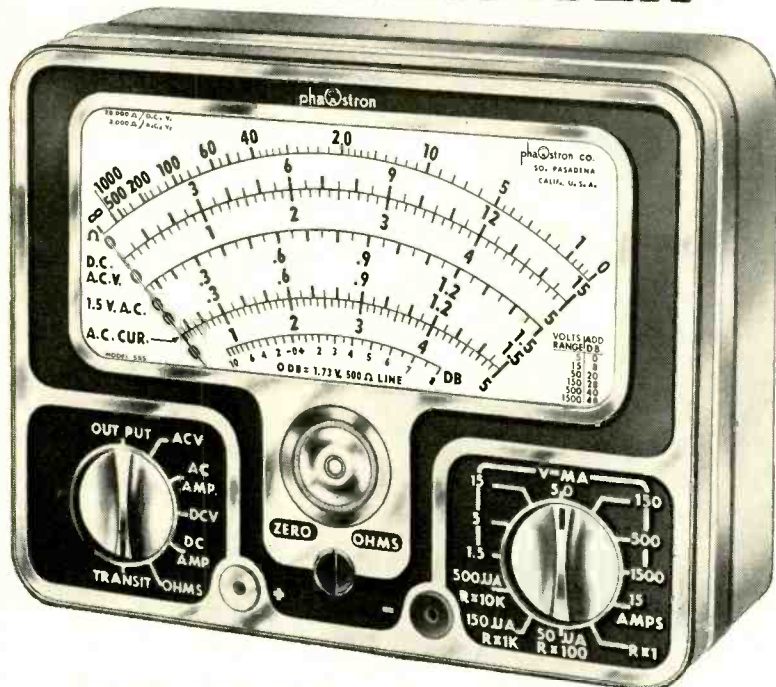

POCKET SIZE WITH A 4 7/8" LENGTH SCALE
an instrument of **PERMANENT ACCURACY**

in a case that **WON'T BREAK**

- ✓ AC CURRENT RANGES
- ✓ SEPARATE RANGE & FUNCTION SWITCHES
- ✓ SIMPLICITY . . . ONLY 2 JACKS
- ✓ EASY-TO-READ, LARGE 4 COLOR SCALES
- ✓ 43 UNDUPLICATED RANGES
- ✓ MAGNETIC SHIELDING
- ✓ 3% DC, 4% AC PERMANENT ACCURACY

Accessories Available

GENUINE LEATHER CARRYING CASE \$5.95



PANEL MOUNTING ADAPTER \$1.50

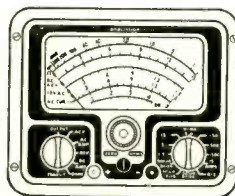

"555" MULTIMETER

\$39.95

complete with probes and batteries
at your **PARTS DISTRIBUTOR**

PHASTRON COMPANY 151 PASADENA AVE., SOUTH PASADENA, CALIF. U.S.A.

CORRESPONDENCE

(Continued)

LIKES GOLDEN EARS

Dear Editor:

As a long-time audio fan and experimenter I would like to give three rousing electronic cheers for Monitor and his "For Golden Ears Only" series.

These articles seem the only honest evaluation of audio equipment based on actual tests, in which the test data is openly presented, to be found in any radio magazine commonly available. In most audio equipment reviews each piece of equipment is presented as being simply wonderful and out of this world in construction and performance.

The wise reader merely deplores the waste of good space given to such equipment reviews, which might better be used much more productively. Many are a little tired of seeing an amplifier of the bargain-counter variety written up in glowing terms by equipment reviewers when they know it shouldn't be fed into a good-quality loudspeaker system if one wants to hear good lows, not hum.

All things considered, "For Golden Ears Only" calls an audio spade a spade, a refreshing innovation, especially when it is based on actual testing and experience. It gives confidence to the reader and stature to your magazine.

FRED H. SCHELLMAT

Detroit, Mich.

DUE CREDIT GIVEN

Dear Editor:

Looking over George Augspurger's article "Horn-Type Speaker Systems" (April, 1955), I find that I am being "quoted" as being in the "opposing" camp from Maximilian Weil.

My first paper on corner horns cites "Weil, U. S. Patent 1,820,996 (1931)," and I might add this patent was applied for in 1925. As far as I know, this is the first material on corner horns ever written to be eventually published.

A perusal of the patent in the light of present knowledge is not too revealing, but its non-use notwithstanding, Weil must be granted priority in the absence of further historical findings.

PAUL W. KLIPSCH

Hope, Ark.

FILING SYSTEM

Dear Editor:

In my possession are many, many volumes of RADIO-ELECTRONICS. For years there was always a jumbled mess when I tried to find an article I was hunting. I finally devised a very simple, effective method of clearing this confusion—clipping the contents (index) page and filing it with an index card. On the card I write special notes concerning articles of interest to me.

I especially enjoy reading your magazine because it is divided into sections according to main subjects. In keeping with this setup may I suggest that you insert a new heading Color TV, since each succeeding issue contains more and more articles on that subject.

L. B. KLINGLER

Miami, Fla.

END

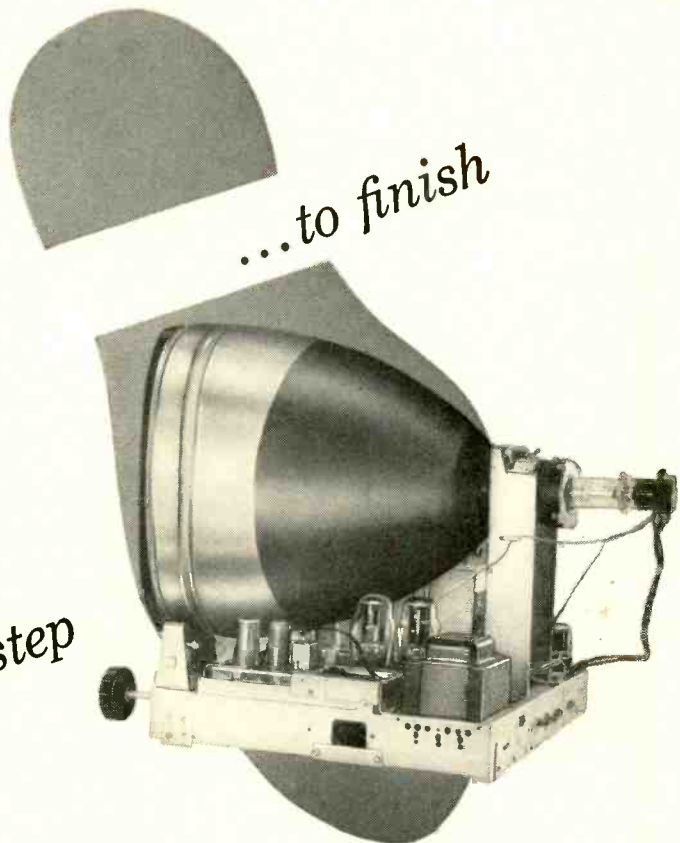

...and step by step

Become a top-notch television service technician

Now . . . RCA INSTITUTES offers modern TV KIT with Comprehensive Television Servicing Course

START to build with a TV Kit developed by one of America's foremost radio-tv schools—RCA Institutes. LEARN with simple step-by-step instruction how to build a modern, large-screen receiver. TEST each stage, as you build, and see how it works. Learn how "trouble-shooting" is applied. FINISH your Home Study Course ready and able to service all make and model sets!

Easy-to-follow instructions are planned and prepared for you through the efforts of RCA Institutes' instructors, engineers at RCA Laboratories, and training specialists of the RCA Service Company.

The RCA Institutes' TV Kit utilizes up-to-date circuits including:

- Synchro-Guide horizontal automatic frequency control circuit.
- Horizontal magnetic reaction scanning.
- Latest deflection circuits.
- FM sound discriminator.
- High-gain, low-noise cascade tuner.

Join the many thousands who have been successfully trained by RCA Institutes for a good job (or business of their own) in television servicing.

BASIC KNOWLEDGE OF RADIO NECESSARY
NO NEED FOR PREVIOUS TV TRAINING



RCA INSTITUTES, INC.
A SERVICE OF RADIO CORPORATION of AMERICA
350 WEST FOURTH STREET, NEW YORK 14, N.Y.

FREE BOOKLET! MAIL COUPON NOW.

RCA INSTITUTES, INC., Home Study Dept. EK-6-55
350 West Fourth Street, New York 14, N.Y.

With no obligation on my part, please send me a copy of your booklet on the TV Servicing Home Study Course and Kit. I understand no salesman will call.

Name: _____ (Please print)
Address: _____
City: _____ Zone: _____ State: _____

"The World's Most Promising Technological Revolution"

The Electronics industry is truly "the world's most promising technological revolution."

Even though it grew phenomenally during World War II, Electronics really came into its own following the war. By 1948, it had become a \$3,000,000,000 business, and was rapidly becoming a major industry.

Today, Electronics is a \$9,000,000,000 industry—counting television, radio, military electronics, commercial electronics, broadcasting, and related areas. There is every indication that by 1960 it will be a \$15 billion dollar industry and \$20 billion by 1964. And it will keep right on climbing.

No other major industry will grow that fast in the next decade.

The Armed Services, by far the largest customers of electronic products, spent an estimated \$145,000,000 in 1948 for electronic equipment for communications, navigation, gunnery systems, etc. Today, government electronic purchases amount to \$2,300,000,000 (or 6.3 per cent) of its total defense expenditures. Within the decade, this

may increase to 10 per cent of total government buying as the Armed Services become increasingly electrified. It is estimated that government electronic purchases will amount to over \$4,000,000,000 by 1964.

The potential volume in commercial and industrial electronics is unprecedented, especially in the field of computers, the heart of data processing, and "automation." Sales of electronic equipment to commerce and industry amounted to \$1,000,000,000 in 1954, and the surface was barely scratched. This figure will more than double within the next ten years, for this area of electronics has a future limited only by one's imagination.

The future of Electronics has no horizon. Many of the nearly 2,000 scientists and engineers throughout Sylvania are working on Electronics, constantly finding new and better ways to put Electronics to work. *They are keeping an eye to the future—assuring constant progress in the years ahead . . . "the world's most promising technological revolution."*

(Engineers: Sylvania has many opportunities in a wide range of defense projects. If you are not now engaged in defense work, you are invited to contact David W. Currier, Supervisor of Professional Placement, Sylvania Electric Products Inc., 1740 Broadway, New York 19, N. Y.)



SYLVANIA



Sylvania Electric Products Inc. • 1740 Broadway, New York 19, N. Y.

In Canada: Sylvania Electric (Canada) Ltd., University Tower Building, St. Catherine Street, Montreal, P. Q.

LIGHTING • RADIO • ELECTRONICS • TELEVISION • ATOMIC ENERGY

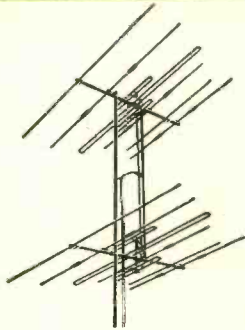
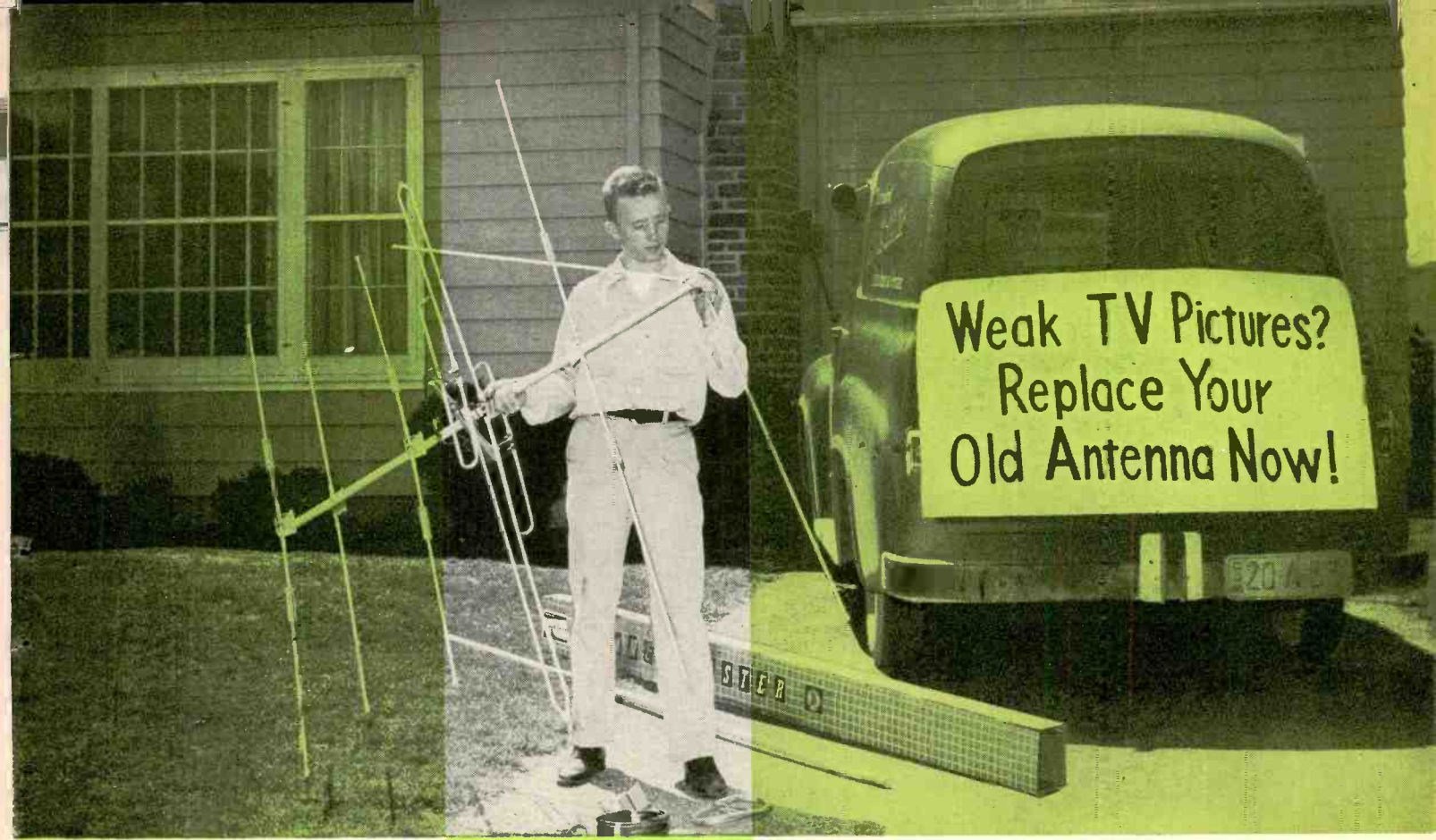

NEW!
Narrow-space
stacking!

Channel Master's RAINBOW and SUPER RAINBOW can now be stacked only 60" apart. These new, extremely efficient, 2-stage, impedance-matching stacking rods permit easier installations with an absolute minimum sacrifice of gain.

model no. 331-7

Champion Rainbow
330 series
Super Rainbow
331 series
Challenger Rainbow
332 series

**Warm
weather
is
profit
weather!**

Patent No. 2,491,730
Other Patents Pending

Copyright 1955, Channel Master Corp.

The weather's warmer! Days are longer! *This* is the time of year to go after that gold mine in your own backyard: the replacement of the antennas in your area that are damaged, worn, and obsolete.

Channel Master's RAINBOW is the favorite replacement antenna of America's TV installation men — and here's why:

- There's a RAINBOW model for every installation ... for every signal area ... for every budget.
- Regardless of competitive claims—Channel Master's RAINBOW antennas are *still* the most powerful antenna series available today! Advanced engineering and the exclusive Tri-Pole make the difference!
- Featuring the fastest and strongest of all preassemblies: trigger-fast "Snap-Lock" action, Channel Master's fabulous preassembly that *snaps* open, *locks* open, without hardware or tightening.
- All-aluminum construction. Rugged, durable, reinforced at all stress points.

Today's greatest all-channel antenna value — bar none!

**CHANNEL MASTER'S
RAINBOW***

the ideal replacement antenna



CHANNEL MASTER CORP.

ELLENVILLE, N. Y.

The World's Largest Manufacturer of Television Antennas

Pipes of Progress

Hundreds of thousands of telephone conversations or hundreds of television programs may one day travel together from city to city through round waveguides—hollow pipes—pioneered at Bell Telephone Laboratories.

Round waveguides offer tremendous possibilities in the endless search for new ways to send many voices great distances, simultaneously, and at low cost. Today, Bell Laboratories developments such as radio relay, coaxial cable and multivoice wire circuits are ample for America's needs. But tomorrow's demands may well call for the even greater capacity of round waveguides.

Unlike wires or coaxial, these pipes have the unique property of *diminishing* power losses as frequencies rise. This means that higher frequencies can be used. As the frequency band widens, it makes room for many more voices and television programs. And the voices will be true, the pictures faithfully transmitted.

These studies illustrate once more how Bell Telephone Laboratories scientists look ahead. They make sure that America's telephone service will *always* meet America's needs, at the lowest possible cost.

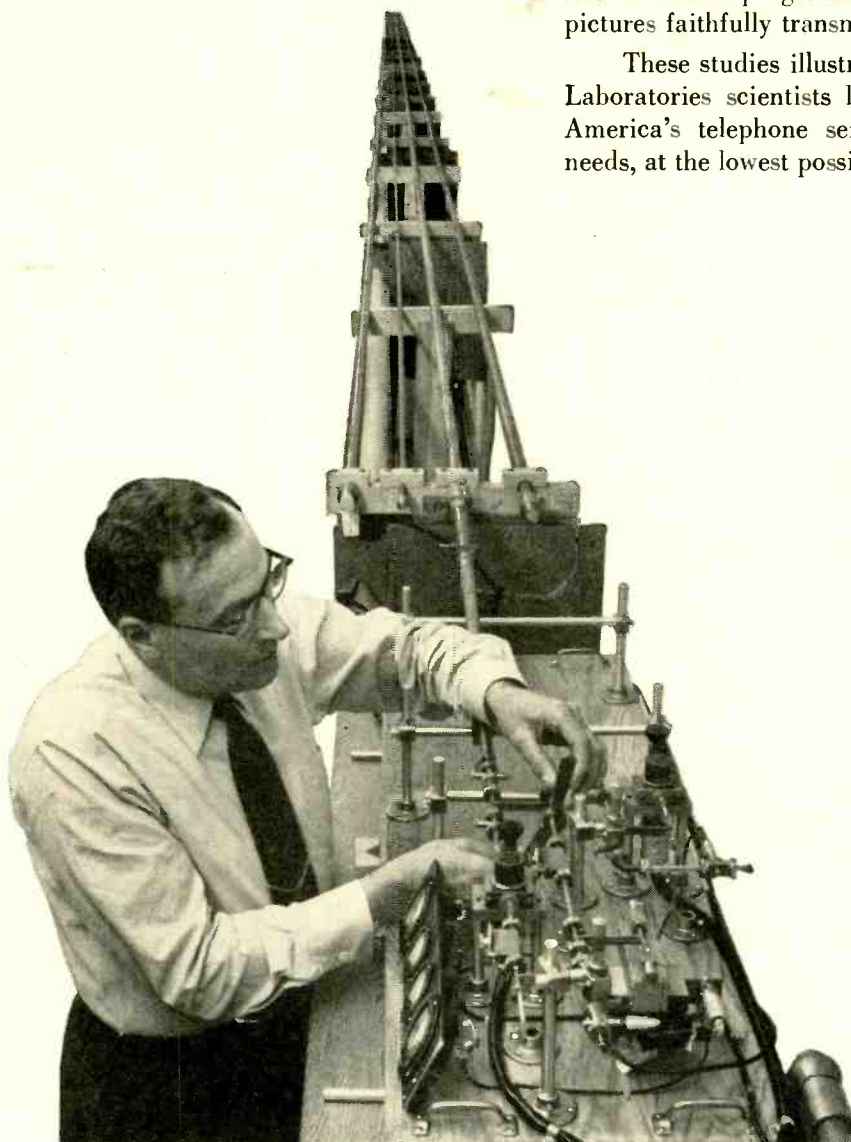

Testing round waveguides at Bell Telephone Laboratories, Holmdel, New Jersey. Unlike coaxial cable, waveguides have no central conductor. Theoretically, voice-capacity is much greater than in coaxial cable.

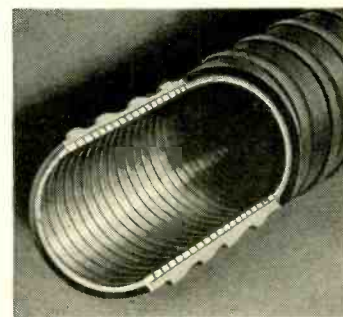

New type of waveguide pipe formed of tightly wound insulated wire transmits better around corners than solid-wall pipes.



New type waveguide is bent on wooden forms for study of effect of curvature on transmission. The waveguide itself is here covered with a protective coating.



Bell Telephone Laboratories

Improving America's telephone service provides careers for creative men in scientific and technical fields.

Let Satisfied Customers . . .

Build Repeat Sales

Use Genuine

PHILCO®

**RECEIVING
TUBES**



Unexcelled research plus better materials and advanced production methods make Philco receiving tubes leaders in the field . . . assure top performance . . . build complete customer satisfaction and repeat sales for you!

Advanced Philco engineering and production methods insure mechanical and electrical superiority, uniform operation and trouble-free performance. Rigid quality control, exhaustive tests and extensive performance checks guarantee that every Philco tube you install is right and ready for sale.

Philco Receiving Tubes Improve the Performance of any Radio or TV Receiver

Built-in Philco quality is the reason why. Now you can eliminate costly call backs and build solid future business that means greater profit.

Millions of Philco set owners and millions of owners of other make receivers demand the full measure of performance that Philco tubes provide. Stock the Philco line of conveniently packaged tubes that assure you this ready-made market. Call your Philco Distributor today.

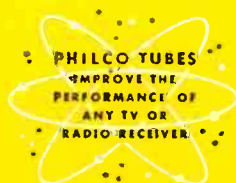

PHILCO CORPORATION

Accessory Division

Philadelphia 34, Pa.





When Godfrey
tells the ladies
... **There are
no finer tubes
than CBS tubes...**

**More women
than ever
are going to ask for
the tubes with the
Good Housekeeping
Guaranty Seal.**



Be sure YOU have
CBS tubes in your tube caddy.

**Arthur Godfrey's Talent Scouts
to sell CBS Tubes
on both TV and Radio
every other week starting in June**

*Quality products through **ADVANCED-ENGINEERING***

CBS-HYTRON, Danvers, Massachusetts . . . A DIVISION OF COLUMBIA BROADCASTING SYSTEM, INC.

PUT YOURSELF IN THE *High-Paying* TELEVISION PICTURE

R
Radio
T
Television
T
Training
A
Association

Today, when demand for trained men is higher than ever before, pay is higher than ever before, you can train AT HOME in your SPARE TIME to become a Television Technician.



L. C. Lane, B.S., M.A.
President, Radio-Television Training Association. Executive Director, Pierce School of Radio & Television.

PREPARE FOR A BRIGHTER FUTURE AS A TV TECHNICIAN

You can hold down a full-time job and still train AT HOME by the same successful methods I used to help hundreds of men—many with no more than grammar school training—master television!

NO EXPERIENCE NEEDED . . . I'LL TRAIN YOU AT HOME IN YOUR SPARE TIME

VETERANS!

My School fully approved to train veterans under new Korean G.I. Bill. Write discharge date on coupon.

GOOD SPARE TIME EARNINGS

Almost from the very start you can earn extra money while learning by repairing radio-TV sets for friends and neighbors. Many of my students earn up to \$25 a week . . . pay for their entire training from spare time earnings . . . start their own profitable service business.

EXPERT FM-TV TECHNICIAN TRAINING

My FM-TV Technician Course can save you months of training if you have previous Armed Forces or civilian radio experience! Train at home with kits of parts, plus equipment to build BIG SCREEN TV RECEIVER. ALL FURNISHED AT NO EXTRA COST!

NEW! PRACTICAL TV CAMERAMAN & STUDIO COURSE

(For men with previous radio & TV training) I train you at home for an exciting big pay job as the man behind the TV camera. Work with TV stars in the TV studios or "on location" at remote pick-ups! Available if you want it . . . one-week course of practical work on TV studio equipment at Pierce School of Radio & TV, our associate resident school in New York City.

OPTIDNAL: 2 WEEKS TRAINING IN NEW YORK CITY AT NO EXTRA COST

You get two weeks, 50 hours, of intensive laboratory work on modern electronic equipment at our associate school in New York City — Pierce School of Radio and Television. And I give you this AT NO EXTRA COST whatsoever, after you finish your home study training in the Radio-FM-TV Technician Course and FM-TV Technician Course. However, your home study course is complete even without this two-week laboratory session. It is only one of the many Extras available to you from RTTA if you want it.



C-W Telephone Transmitter



RF Signal Generator



Super-Het Radio Receiver



Public Address System



Combination Voltmeter-Ammeter-Ohmmeter



21"

ENOUGH EQUIPMENT TO SET UP YOUR OWN HOME LABORATORY

As part of your training, I give you all the equipment you need to prepare for BETTER PAY TV job. You build and keep a professional GIANT SCREEN TV RECEIVER complete with big picture tube (designed and engineered to take any size up to 21-inch) . . . also a Super-Het Radio Receiver, RF Signal Generator, Combination Voltmeter-Ammeter-Ohmmeter, C-W Telephone Transmitter, Public Address System, AC-DC Power Supply. Everything supplied, including all tubes.

FREE FCC COACHING COURSE

Qualifies you for Higher Pay! Given to all my students AT NO EXTRA COST after TV Theory and Practice is completed. Helps you qualify for the TOP JOBS in Radio-TV that demand an FCC License! Full training and preparation at home for your FCC License.

MY 4 FREE AIDS SHOW YOU HOW AND WHERE TO GET A BETTER PAY JOB IN TELEVISION.

See for yourself how my simple, practical methods can make success as easy for you as they have for my hundreds of graduates.

MAIL THIS COUPON TODAY! no salesman will call!

Mr. Leonard C. Lane, President
RADIO-TELEVISION TRAINING ASSOCIATION Dept. R-6
52 East 19th Street, New York 3, N. Y.

Dear Mr. Lane: Mail me your NEW FREE BOOK, FREE SAMPLE LESSON, and FREE aids that will show me how I can make BIG MONEY IN TELEVISION. I understand I am under no obligation and no salesman will call.

(PLEASE PRINT PLAINLY)

Name _____ Age _____

Address _____

City _____ Zone _____ State _____

I AM INTERESTED IN:

- Radio-FM-TV Technician Course
 FM-TV Technician Course
 TV Cameraman & Studio Technician Course

VETERANS!
Write discharge date

Radio Television Training Association

52 EAST 19th STREET • NEW YORK 3, N. Y.

Licensed by the State of New York • Approved for Veteran Training



G-C VINYLITE CEMENT

Great adhesion; many uses.
No. 58-2 NET \$0.39



G-C LACQUER THINNER

Thins all types.
No. 29-2 NET \$0.33



G-C LOW-LOSS TEST PRODS

Excellent for high voltage.
No. 5045 NET \$0.30



G-C PLI-O-BOND CEMENT

Sticks "anything to anything".
No. 43-2 NET \$0.39

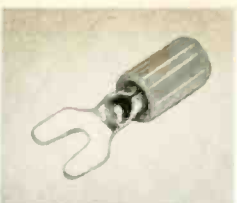

G-C INSULATED SPADE LUG

Red; fits all banana plugs.
No. 7712 NET \$0.11

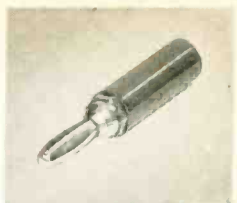

G-C INSULATED BANANA PLUG

Spring type, solderless.
No. 8994 NET \$0.21



G-C SCREW TYPE TERMINAL STRIPS

Has 6 contacts; others with 2-10.
No. 1776 NET \$0.21



G-C GRAFOLINE

Lubricant for metallic contacts.
No. 120-2 NET \$0.39



G-C SOLDERING PASTE

High-quality, non-corrosive.
No. 1207 NET \$0.27



G-C SPEAKER CONE RECONDITIONER

Rejuvenates dried-out cones.
No. 25-8 NET \$0.60



G-C KRYSTAL KOAT LACQUER

Dries in beautiful patterns.
No. 63-2 NET \$0.39



G-C RATIO FRICTION TAPE

Narrow 3/4" Tape, 60-ft. roll.
No. 870 NET \$0.39

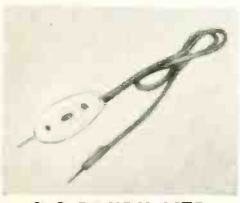

G-C DANDY LITE TESTER

Heavy duty; 60 V AC, 90-550 V AC-DC.
No. 8585 NET \$0.75

GENERAL

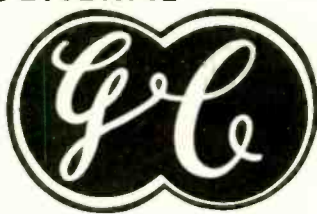

CEMENT

Ask For These
RADIO-TV SERVICE AIDS

... at Your Jobber

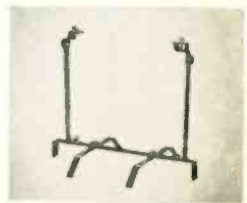

G-C PHONO TURNTABLE STAND
Ideal for all turntable repairs.
No. 5205 NET \$4.95



G-C "TUX" TOOL KIT

Carry all needed tools.
No. 8943 NET \$2.37



G-C "HI-VOLT" SAFETY PROBE

Neon glow for all high volt tests.
No. 8836 NET \$1.65



G-C 300-OHM LINE TUBING

Protects, waterproofs lead-in line.
No. 625 NET \$0.66



G-C RADIO-TV HARDWARE LAB

Contains 20 assorted jars.
No. 6601 NET \$10.20

Contains complete assortment of knob set, cabinet, wood and sheet metal screws; nuts; lock washers; lugs; clamps; cutters; etc.



G-C UTILITY BOX
Spacious, handy, all-steel box.
No. 4003 NET \$1.47



G-C SPEEDX FUSE PULLERS

Handy, safe for 1/4" - 1/2" dia. fuses.
No. 5525 NET \$0.42



G-C RADIO-TV SERVICE CEMENT

Famed high grade adhesive.
No. 30-2 NET \$0.39



G-C SPEEDX WIRE STRIPPER

Automatic, delayed action return.
No. 766 NET \$4.95



G-C SPRA-KLEEN

Power spray contact cleaner.
No. 8666 NET \$1.00



G-C KOLOID ACRYLIC SPRAY

Protects, insulates, prevents rust.
No. 8665 NET \$1.19



FREE! Postcard brings your big G-C Catalog.

Ask your jobber for these



SPECIALS OF THE MONTH

TELCO DELUXE CHIMNEY MOUNT



No. 8005-U NET \$1.11

TELCO 10-PACK ANTENNA KLIPS



No. 9015-X
Bag of 10
NET \$1.17

TELCO 6-PACK LIGHTNING ARRESTORS



No. 8642-6P
Pack of 6
NET \$2.25

G-C REAR SPEAKER KIT



No. 9180 NET \$2.70



GENERAL CEMENT MFG. CO.

910 TAYLOR AVENUE • ROCKFORD, ILLINOIS



THE BEST GENERATOR BUY IN THE WORLD

EICO

NEW! SIGNAL GENERATOR #324 KIT \$26.95 WIRED \$39.95



- ★ Expanded frequency range: 6 fundamental bands: 150—400 kc, 400—1200 kc, 1.2—3.5 mc, 3.5—11 mc, 11—37 mc, 37—145 mc, 1 harmonic band 111 mc—435 mc.
- ★ ± 1.5% frequency accuracy; 6:1 vernier tuning knob & excellent spread at most important alignment frequencies.
- ★ Etched tuning dial, plexiglass windows, edge-lit hairlines.
- ★ Variable depth of int. mod. 0 to 50% by 400 cps Colpitts osc.

You could pay scores of dollars more and not get all the advances EICO gives you in the new Model 324—today! Compare . . . and you'll buy EICO!

- ★ Variable gain ext. mod. ampl.; only 0.8 v for 30% mod.
- ★ Colpitts RF osc., directly plate-modulated by cathode follower for improved modulation.
- ★ Turret-mounted, slug-tuned coils.
- ★ Fine & Coarse (3-step) RF attenuators; 50-ohm output Z.
- ★ RF output 100,000 uv; AF output to 10 v.
- ★ Uses 12AU7, 12AV7, sel. rect.; xfmr-operated.
- ★ Supplied with shielded output cable.
- ★ Satin aluminum panel and grey wrinkle steel case.



You could spend 2 and 3 times more and not get all the advanced engineering features of these VTVMs. Compare . . . and you'll buy EICO!

THE BEST VTVM BUYS IN THE WORLD

EICO

NEW! PEAK-TO-PEAK VTVM #232, complete with *Uni-Probe* (Pat. Pend.) KIT \$29.95 Wired \$49.95

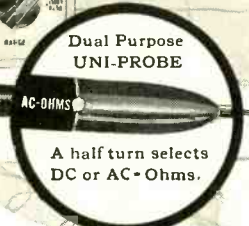

- ★ Measures directly p-p voltage of complex and sine waves: 0-4, 14, 42, 140, 420, 1400, 4200 volts p-p.
- ★ DC/RMS sine voltage ranges: 0-1.5, 5, 15, 50, 150, 500, 1500 volts. Reads up to 30,000 V. with HVP probe.
- ★ Resistance ranges: 0.2 ohms to 1000 megs in 7 ranges.
- ★ 7 non-skip ranges on every function.
- ★ 4 functions: +DC Volts, -DC Volts, AC volts, Ohms.
- ★ Uniform 3 to 1 scale ratio for extreme wide-range accuracy.
- ★ Large 4½" meter in can't-burn-out circuit.
- † Calibration without removing from cabinet.

- ★ Zero-center for TV-FM discriminator alignment.
- ★ One zero-adjustment for all functions and ranges.
- ★ Frequency response: 30 cps-3mc (up to 250mc with PRF probe).
- ★ 1% precision ceramic multiplier resistors.
- ★ Exceptional circuit stability and accuracy.
- ★ New compact size for extra-easy portability (8½ x 5 x 5")
- ★ Smart professional styling—new satin finish etched panel with contrasting knobs and meter and grey wrinkle steel case.
- ★ Leather handle.



NEW! DELUXE PEAK-TO-PEAK VTVM #249 with 7½" Meter and exclusive UNI-PROBE® (pat. pend.) KIT \$39.95 WIRED \$59.95

All the outstanding & exclusive features of Model 232—plus the extra convenience and readability of its big 7½" meter. An ideal bench instrument.



84 Withers Street • Brooklyn 11, N. Y.

Write for FREE Catalog CG-6

©55 Prices 5% higher on West Coast

TURN PAGE FOR OTHER EICO INSTRUMENTS

FREE 1955 EICO CATALOG!

Tells you how to SAVE 50% on
your test equipment costs!

EICO®

THE LARGEST MANUFACTURER OF ITS KIND IN THE WORLD

KITS INSTRUMENTS

THE INDUSTRY'S MOST COMPLETE LINE OF KITS & INSTRUMENTS
1/3 MILLION EICO INSTRUMENTS IN USE THE WORLD OVER —
SAVE 50% — BUILD 'EM IN ONE EVENING... THEY LAST A LIFETIME

the Exclusive **EICO** Make-Good
GUARANTEE

Each EICO Kit and Instrument is doubly guaranteed by EICO and priced to insure an outstanding value. EICO guarantees to replace any component which might become defective in normal use if returned to the factory within 90 days of purchase. EICO also services all kits assembled according to EICO's simplified instructions and calibrations of every EICO Kit and Instrument at the nominal charge as stated on the instructions.

ELECTRONIC INSTRUMENT CO., INC.
Test Equipment Manufacturers
84 WITHERS STREET, BROOKLYN 11, N. Y.

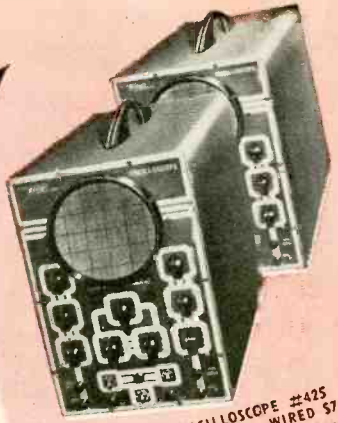

5" PUSH-PULL OSCILLOSCOPE #425
KIT \$44.95 WIRED \$79.95
NEW! #470 7" PUSH-PULL OSCILLOSCOPE
KIT \$79.95 WIRED \$129.50



CRA... \$4.50
TUBE TESTER #625
KIT \$34.95 WIRED \$49.95



20,000 Ohms/Volt
MULTIMETER #565
KIT \$24.95
WIRED \$29.95



1,000 Ohms/Volt
MULTIMETER #536
KIT \$12.90
WIRED \$14.90



NEW! #232 PEAK-TO-PEAK
VTVM with DUAL-PURPOSE
AC/DC UNI-PROBE (pat. pend.)
KIT \$29.95 WIRED \$49.95

NEW! #249 DELUXE
PEAK-TO-PEAK VTVM with 7 1/2" METER & UNI-PROBE (pat. pend.)
KIT \$39.95 WIRED \$59.95



VACUUM TUBE VOLTMETER #221
KIT \$25.95 WIRED \$39.95
DELUXE VTVM (with 7 1/2" METER) #214
KIT \$34.95 WIRED \$54.95



R-C BRIDGE & R-C-L
COMPARATOR #950B
KIT \$19.95 WIRED \$29.95

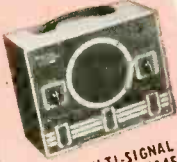

MULTI-SIGNAL
TRACER #145
KIT \$19.95
WIRED \$28.95

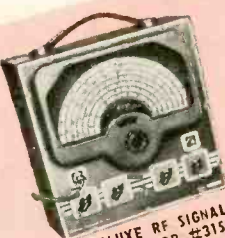

DELUXE RF SIGNAL
GENERATOR #315
KIT \$39.95 WIRED \$59.95

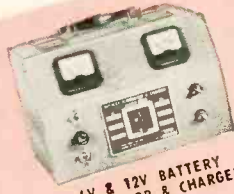

6V & 12V BATTERY
ELIMINATOR & CHARGER
#1050
KIT \$29.95 WIRED \$38.95



NEW! #944 FLYBACK
TRANSFORMER & YOKE
TESTER
KIT \$23.95
WIRED \$34.95



RF SIGNAL GENERATOR #320
KIT \$19.95 WIRED \$29.95



TV/FM SWEEP GENERATOR #360
KIT \$34.95 WIRED \$49.95

5MC-4.5MC CRYSTAL
\$3.95 ea.

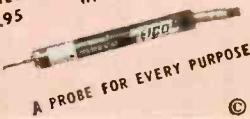

EICO®

See the famous EICO Line at your jobber today
SEND FOR FREE CATALOG C-6
ELECTRONIC INSTRUMENT CO., Inc.
84 Withers Street • Brooklyn 11, N. Y.
Prices 5% higher on West Coast

CHECK YOUR TV SET ANNUALLY!

Preventive Maintenance Operates Your TV set at top efficiency

MODERN man is healthier and lives longer because he has learned to have an annual medical check-up. The human machine is exceedingly complex—that is why a checkup on it pays ever increasing dividends.

Your car, too, is a complex machine. The smart car owner knows from sad experience that a yearly, or better, a half-yearly check and tuneup is cheap insurance in the long run.

A modern television receiver has anywhere from 1,500 to 2,000 parts, but the average owner apparently never gives this a thought. He uses his set constantly, never realizing its great complexity. Then one day when he least expects it—usually when he wants to enjoy a special program, or when he has company—one of the set's thousands of parts fails and the receiver goes dead. Worse yet, this usually happens late at night when a service technician is unavailable. When the owner really has a streak of bad luck, the breakdown occurs on a Friday evening and he is without television for three nights in a row—particularly in the summer when many service establishments close over the weekend.

When a TV set fails, the result is so obvious that the technician is called at once. Not so obvious is the gradual decline in performance which occurs in all TV sets over a period of time. Picture brightness drops, pictures become fuzzy, controls become critical to adjust, sets take minutes to come up to normal brightness and picture size. This is where the tuneup can do wonders.

For this reason, common sense dictates that TV set owners should have their sets tuned up and checked periodically—at the very least, once a year. In the end, it is cheap insurance.

If the set owner will only remember that literally hundreds of things can go wrong in the best TV set, he will understand that it does not pay to expect that his receiver will go on forever without the inevitable breakdown.

The periodic radioelectronic checkup is not a new thing to the servicing industry. It has been going on at least since the early 30's, long before the establishment of modern television—which is only nine years old. In those days the checkup usually concerned itself with the vacuum tubes of the radio set, and also that most important feature, "a check of your antenna." For the past few years, a "Preventive Maintenance Month" for TV sets has been current in the Harrisburg area of Pennsylvania by progressive service technicians. This movement has since spread to other parts of the state and country.

Usually the up-to-date servicing establishments cir-

cularize their customers with letters or circulars calling their attention to the necessity of periodic TV checkups.

Some of the larger TV set manufacturers also routinely advise "TV tuneups" and checkups through their servicing outlets and affiliates.

Thus, for instance, the RCA Tube Division instituted a nation-wide campaign among independent service technicians to alert TV receiver owners to the value of TV tuneups.

Their recommended tuneup is a quick and simple seven-point adjustment and examination of the set by the service technician to restore it to peak performance or discover needed servicing. The TV Tuneup Special charge, which varies somewhat in different localities, includes TV tube focus adjustment, adjustment of automatic gain control, frequency, and horizontal and vertical linearity controls, inspection and adjustment of tuner oscillators; also a performance check of the low-voltage rectifier and power-output tubes. Such a seven-point check can be made in approximately 30 minutes in the home of the set owner, without removal of the chassis.

Other servicing establishments have their own check-up and tuneup routines, some including a complete test of all tubes.

Outdoor antennas, too, should not be neglected by the set owner. Storms, sleet, ice, rust—all endanger the average antenna structurally, decrease its efficiency and consequently the quality of the sound and the clarity of the picture. The antenna lead-in is particularly vulnerable and should be replaced every 18-24 months. Storms also play havoc with exposed antennas. Not only have falling antennas frequently damaged property, but have also maimed or seriously hurt passers-by. *This, in turn, has often caused embarrassing and expensive lawsuits to TV owners, particularly in crowded centers.*

Moral: Have your TV antenna inspected regularly.

Remember also that the hot season is upon us now. Note that every television set generates a good deal of heat—equivalent to burning three 100-watt incandescent bulbs. But—unless you have airconditioning—80-90° summer heat in the room will make it practically impossible to dissipate the heat normally generated by your TV set. Consequently, it often heats up excessively during hot summer nights. The heat usually is accompanied by high humidity, too. *Hence summer failures of TV sets are common.*

One more reason to have your set checked *before* the hottest weather sets in.

To sum up: *Your TV set is no better than the intelligent servicing it gets!*

—H. G.

NOTE: Copies of this editorial for distribution to TV set owners by the service industry are sold at cost by RADIO-ELECTRONICS. 100 copies — \$.75; 500 copies — \$2.75; 1,000 copies — \$5.25 prepaid.

An original design that gives excellent transient response and produces unusual feeling of presence

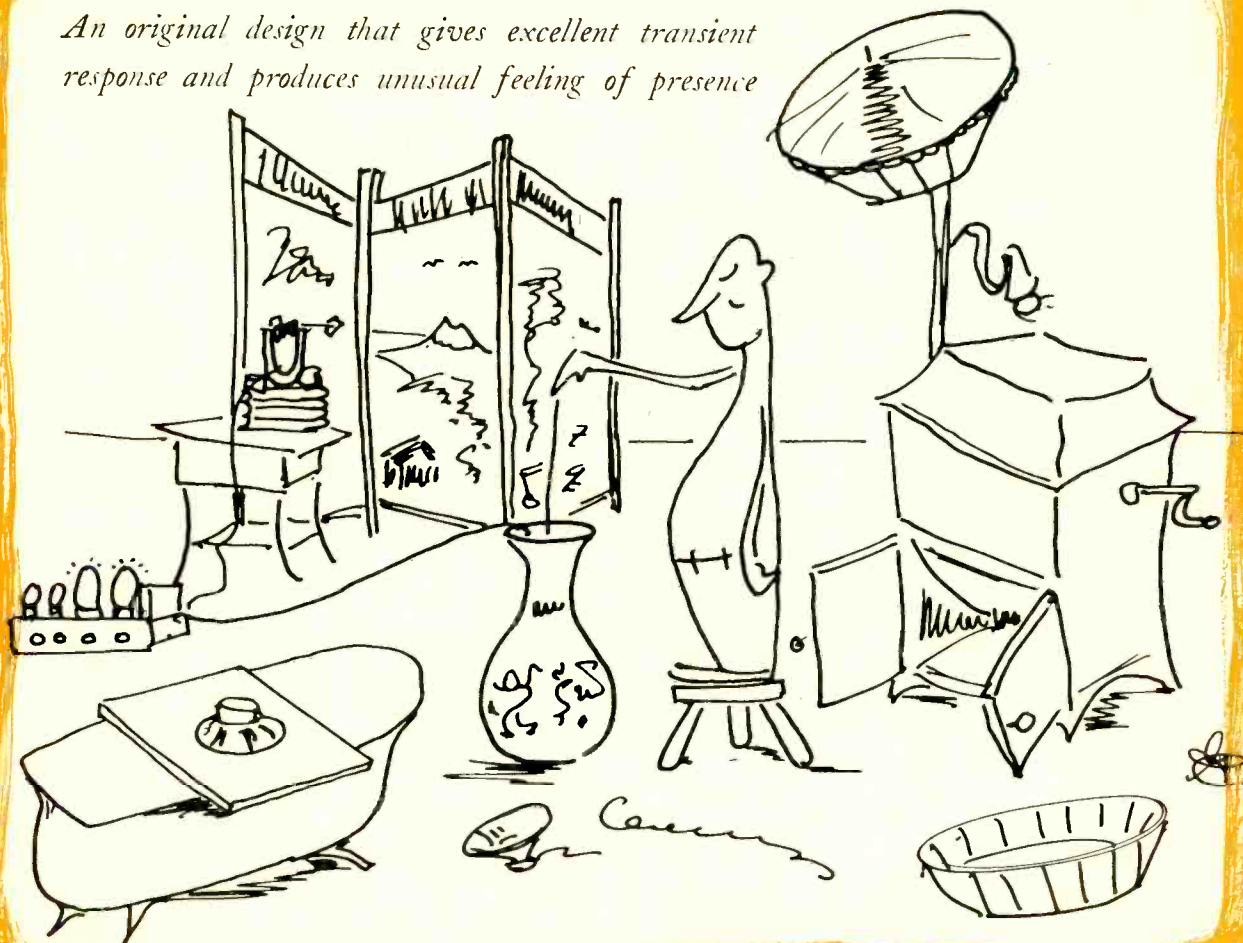

A
NEW
LOUDSPEAKER
ENCLOSURE

By GEORGE A. COATES*

SINCE the start of radio broadcasting and phonograph recording, designers have worked to reproduce the received signal with the same fidelity as at the point of origin. The earlier loudspeakers were nothing more than the adaptation of an ear-phone or headphone to a hearing aid trumpet. From this humble beginning a long line of horn, cone and baffled speakers have evolved.

Today's deluxe corner horns, bass-reflex and infinite-baffle speakers are all due to the work of engineers and designers striving for a loudspeaker system that will produce a "reasonable facsimile" of the source material. Amazing performance has been achieved, that from the listeners' and consumers' point of view, is very acceptable. With every high-fidelity installation (I use the term loosely) some type of loudspeaker system is used.

Let us analyze the listening public for a moment. Are they all critical listeners? Are they all engineers satisfied with only tone-for-tone and note-for-note perfection? Are they all mu-

* U. S. Navy Electronics Laboratory, San Diego, Calif.

coming from a hole in the wall nor from a well-padded box.

Enclosure construction

My enclosure approaches a state of presence that has amazed me and my friends. The construction is simple, inexpensive and so functional in design that the basic unit can be used without hiding it behind grille cloth and period furniture design. It consists of an open box with a small mounting ring or platform for the loudspeaker (see drawings and photographs).

From the inside edge of the speaker opening in this platform, bleached or unbleached muslin is stretched to the four front edges of the box to form a shallow horn-shaped diaphragm. Unbleached muslin of 80 to 100 count is preferred, the count being the number of threads per square inch. Bleached muslin is satisfactory but I am afraid the fibers are weakened in bleaching and may tear out if excessive dope is applied. However, I have successfully stretched some 15 diaphragms using both bleached and unbleached muslin.

This diaphragm is coated with two coats of airplane dope and then finished with any color lacquer desired. Clear lacquer is also good, and if an all-over patterned cotton material is used, an interesting appearance results. I have found that two coats of dope and one or two coats of lacquer are sufficient to give a strong resonant diaphragm. If applied with a spray gun, the coating will not load the diaphragm too heavily. In fact, in one experimental model approximately 3/64 inch of lacquer was built up without seriously impeding diaphragm operation.

The loudspeaker is mounted through the larger opening in the rear of the box. If a small piece of grille cloth is placed over the face of the speaker as in the photo, an additional cardboard shim should be added so that the excursion of the cone does not strike the grille cloth. Some loudspeakers have

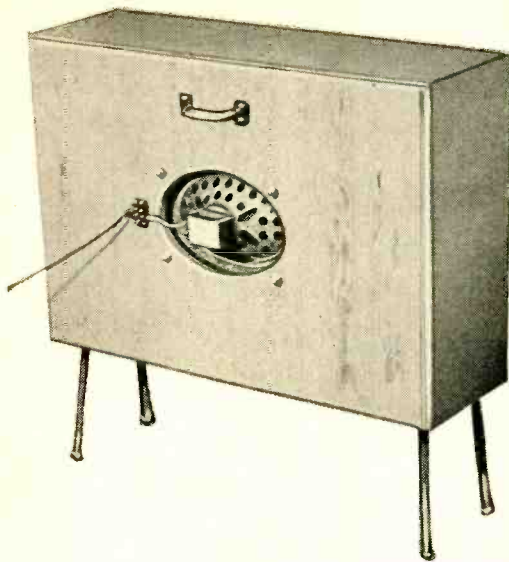

Rear view shows loudspeaker mounting.

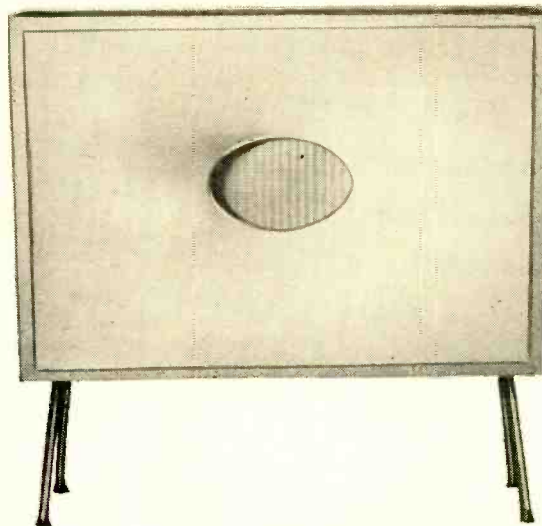

Front view of the loudspeaker enclosure.

sicians with ears sensitive to the slightest fault in a reproducing system? No. The buying public is made up of all kinds of people with varied hearing tastes. They are people who enjoy good music and are purchasing sound systems for their homes so they can satisfy their tastes, whether with jazz or symphonic music, hillbilly songs or opera.

Just as their choice of amplifier and preamplifiers, tuners and turntables varies, so does their choice of speakers and speaker enclosures. They buy what is acceptable to their own ears and pocketbooks. I am no exception, and through the years I have had a motley assembly of transducers from Western Electric 3-foot cone speakers to bass-reflex, infinite-baffle, corner-horn and multiple-speaker installations. I have experimented with speakers in tubes and tubs, both wooden tubs and bath-tubs. I have constructed parchment cones mounted on lamp-shade frames and dropped speaker units into expensive vases, ruined our old Victrola, screwed driving units to piano sounding boards, excited Japanese rice paper screens and bass drum heads. Why? Just because I have never been satisfied with the reproducers available. Much

of my experimentation was prior to the present hi-fi era and I still find myself trying odd combinations in the search for one thing, *presence*.

Even with the present array of enclosures, woofers and tweeters I am too conscious of the source and the music-in-a-box quality of the sound. Amazing strides have been made and with an unlimited pocketbook it is possible to re-create the sound of an orchestra in one's own home with nearly perfect fidelity. To some, even this is far from perfection. The critical listener pays the price and is happy for a while. Then he palms his equipment off on his friends, at a price, saying it is more than he can afford and all the time planning on that new and better system he just heard.

I want to present an unorthodox approach to this thing referred to as *presence*.

Presence as used by the followers of Williamson and Klipsch, Armstrong and Pickering is not defined in Webster. Future issues may include *presence* as "that quality in music reproduction that gives the listener the illusion that the musician or orchestra is in the room with him." This means that it is not

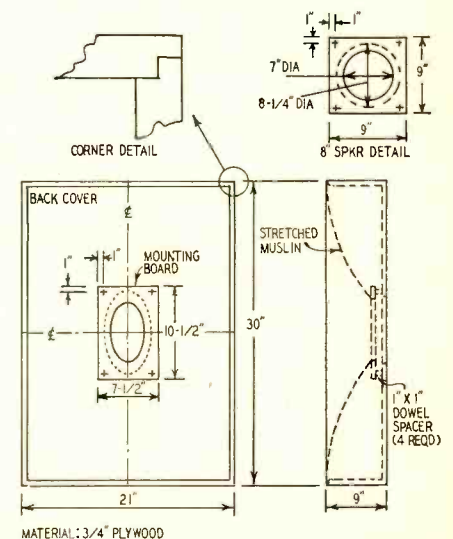

Front and side layouts of enclosure using a 6 x 9-inch oval speaker.

AUDIO—HIGH FIDELITY

sufficient space between the cone edge and the mounting ring, in which case the additional shim will not be needed. A cardboard shim can be purchased from any shop that recones loudspeakers.

The box is assembled with a few finishing nails and Wel-Hold or similar glue; all joints must be well fitted and glued. In laying out the speaker admittance hole in the back, find the exact center of the backboard and then fasten the speaker platform center to this point with a nail. With the speaker platform square with the sides of the back, drill the four $\frac{1}{4}$ -inch platform mounting holes, using a drill press if possible. Before removing, make a pencil mark so that you can assemble the platform with the correct hole lineup.

Now, lay out the circle or oval for the loudspeaker and admittance holes and cut out with a jig or keyhole saw. Smooth with a file and sandpaper, sanding a slight radius on the edge of the speaker opening over which the muslin is stretched. The inside edges of the four sides of the box should also be rounded slightly.

The 1-inch spacers are made from dowling or broom handle and drilled for $\frac{1}{4}$ -inch bolt clearance. Do this on a lathe if possible as the spacer should be square with the speaker platform and the backboard. Assemble platform and backboard. Assemble the platform using $\frac{1}{4}$ -inch steel machine bolts 3 inches long with large $\frac{1}{4}$ -inch brass washers under the heads and nuts. Draw up tightly until the washers have bitten into the plywood on both the speaker platform and the back. Carriage bolts can be used in place of machine bolts. Secure the nut on the outside with a lockwasher or a locknut. Now you are ready to stretch the diaphragm.

While preparing the muslin, paint the

edges of the box and the edge of the speaker opening with airplane dope and let dry. Two coats should be sufficient. This is so the muslin will adhere to the edges and give you a smoother edge to paint or cover when the speaker is finished. Now, take $1\frac{1}{2}$ yards of muslin 36 inches wide and fold it two ways to find the exact center. Using the template, draw a pencil line and—without disturbing the folds—cut out the center with scissors. This should give you an opening $\frac{3}{4}$ inch smaller all around than the opening in the speaker platform.

If this is done carefully, you can now staple or tack the material to the inside of the speaker opening with the opposite edge as a guide and using all the material without any surplus. It is better to stay on the small side as the material can be stretched to conform with the inside of the hole. Care at this point will result in a diaphragm free of wrinkles or surplus material. A Bostick staple gun and $\frac{1}{4}$ -inch staples are ideal for fastening the cloth to the box. If tacks are used, use copper-coated ones if possible.

Now you are ready to stretch the diaphragm. Starting at the center of one side, pull the material over the edge of the box and secure with at least three staples side by side. Do the same at the center of the adjacent side. Pulling on first one side and then the other, staple the muslin to the box, working toward the corner. Pull the muslin taut and watch for wrinkles. You will end up pulling the muslin on the bias where the greatest amount of stretch is available. As you stretch the material, it will begin to take the shallow horn appearance of the finished diaphragm. Be sure it is uniformly taut, feeling the surface with the tips of your fingers. Restretch and staple as needed to remove any soft spots.

When one corner is finished, repeat the directions until the diaphragm is complete. It should be free of soft spots or wrinkles over the entire surface. Don't be concerned too much with the lines of the thread. It is not necessary that the muslin be extremely tight, just free of wrinkles and of uniform tension over the entire surface. Let the diaphragm stand for about 12 hours before proceeding, to allow the muslin to adjust itself.

Before doping, pull all excess material over the outer edge of the box and secure with a few staples to the sides. This will insure a smooth outer edge to the diaphragm after doping. You will find that the rear edge of the material fastened to the speaker platform will tend to curl. With scissors, notch the curled edge and cement to the sides of the opening with Duco cement. Allow it to dry before continuing.

Apply one coat of dope and let it dry thoroughly. The diaphragm may appear to loosen, but if stretched carefully, it will shrink out free of wrinkles. Apply a second coat of dope and allow it to dry. After the second coat, the dia-

phragm will be as tight as a drum and fairly high pitched when thumped. If any wrinkles appear, they can usually be shrunk out with additional dope applied to that area or one more overall coat.

The dope used is nitrate dope and was brushed on without thinning. One coat was put on and a second coat was applied immediately, brushing at right angles to the first. This was allowed to dry thoroughly, then a second such treatment was applied, using the same procedure.

Before the final lacquer coat is applied, go over the surface with fine sandpaper (No. 320) to remove the small fibers that will raise up. Now apply one or two coats of lacquer, sanding lightly between each coat. When the last coat of lacquer is thoroughly dry, trim the surplus material with a sharp knife or razor blade. If the material pulls away along the outer edges, cement again with Duco cement. However, if the wood was painted with dope, the two coats of dope should soak through the material or the edge and give a good bond.

Sheet cork, available at auto supply stores, $1/16$ inch thick and usually 12 inches wide by 36 inches long, makes an easy method of covering the speaker. Cut to size to fit the top and sides, and use $\frac{3}{4}$ -inch strips to cover the stapled edges. A substitute for the cork strip for covering the stapled edges is a belting material available at most dry goods stores called E-Z belting. This is the material I used on the painted enclosures. It is applied with Wel-Hold cement, the same as the cork. Wel-Hold cement is also used to apply the sheets. After it is thoroughly dried the cork can be sanded like wood, using fine sandpaper. It is best to use butt joints in the corners rather than a mitered joint when covering the stapled edges. I have found that the cork will break away when cut to a fine point.

Finish the cork with either clear lacquer or shellac and mount the enclosure on wrought-iron legs or wood blocks.

With the speaker mounted and operating, you will find that the diaphragm will be parasitically driven and vibrating. Due to its shape, it will respond to a wider band of frequencies than would be possible with a flat diaphragm and standing waves do not form within the enclosure. Just what action is taking place is still under study. Free-field tests using the same speaker in both bass-reflex cabinets and my enclosure show from 3 to 6 db more energy radiated with my enclosure.

Used with a good audio amplifier and source, you will note a terrific transient response and a remarkable feeling of presence. The bass response will surprise you. With a tweeter to extend the range of the oval speaker or by using a Dia-cone or coaxial 8-inch speaker, you will have a system which stands up against others costing a great deal more. END

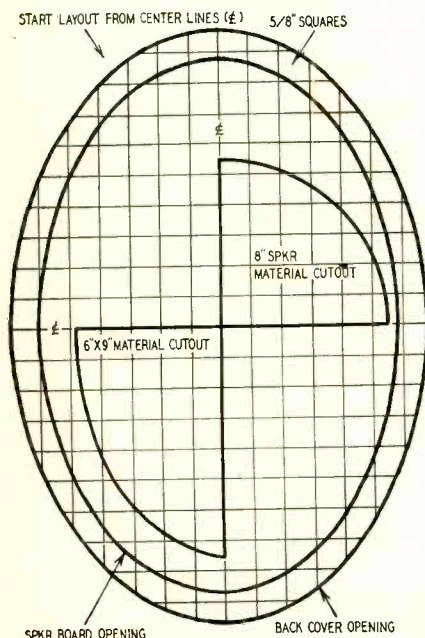

Layout of templates for cutting openings in muslin and cabinet.

What is a Load Line

An explanation of the static and dynamic characteristics of triodes and pentodes



sinusoidal grid voltage can be plotted using one of these curves by the method illustrated in Fig. 3.

A sine wave is drawn edgewise, underneath one of the curves, and the graph lines extended to provide reference points on the sine-wave input voltage. For clarity, only a few points are shown. To get a nice accurate curve a greater number of points should be used. At the right side of the diagram, corresponding reference points are projected out and the same baseline points along the curves are identified. In this way, if the plate-voltage curve were a straight line, as represented by the dotted line, a sine wave would be repeated, due to the proportional spacings. However, because of the curvature of the tube characteristic, the plate-current variation is distorted from sinusoidal as shown by comparing the solid plate-current curve with the dotted curve.

By NORMAN H. CROWHURST

RECENT correspondence from readers shows that many are hazy about the significance of a load line. I still remember when I first saw a senior engineer take a set of tube characteristics, lay a ruler across them and draw a line with a pencil on the curves. From this he produced some mystifying data about the gain of the tube, its distortion, etc. At that time it all seemed rather wonderful but mystifying. Since then I have met many who have studied the subject in their technical courses but who remain rather vague on the true significance of a load line.

The first thing to understand is the different ways in which tube characteristics can be presented. Taking first the simple triode, there are three quantities that can vary: grid-cathode potential, plate-cathode potential and plate current. The tube characteristics are usually shown in one of two ways: by taking fixed plate-cathode potentials, curves are plotted showing the way plate current varies with grid voltage (Fig. 1-a); by fixing the grid-cathode voltage at various values and plotting curves of plate current against plate voltage (Fig. 1-b). In the triode the curves produced by both methods are similar, probably one reason for the confusion that often exists about them.

The best method of proving to yourself the difference between the two kinds of curves is to use one set of curves to produce the other (Fig. 2). Here the curves of Fig. 1 are repeated but corresponding points on the two sets of curves are indicated by corresponding numbers. In Fig. 2-a a particular grid voltage is represented by a vertical line while in Fig. 2-b it is represented by a curve. Thus the points numbered 1, 2, 3 are all at a grid voltage of zero on both diagrams; the points numbered 8, 9, 10, 11, 12 are all at a grid voltage of -2. In Fig. 2-b a plate voltage is represented by a vertical line, while in Fig. 2-a it is represented by a curve. Thus the points

numbered 7, 11, 15, 18, 20 are all at a plate voltage of 200 on both diagrams. You can trace out the correspondence of other points on both graphs for yourself.

The grid-voltage plate-current curves are not very helpful in showing the characteristics of a tube when operated with a plate load, because each curve represents the change in plate current for constant plate voltage as the grid voltage is changed. If the tube is operated without any resistance in the plate circuit, so that only the current fluctuates and not the plate voltage, these curves can be very useful. The waveform of the plate current for a

The load line

Now we are introduced to the load line. A practical amplifier circuit in its simplest form is shown at Fig. 4. The addition of a plate coupling resistor means that when grid voltage is changed, plate voltage and plate current also *both* change. This is when the load line comes into use to plot the exact nature of plate-voltage and plate-current change with applied grid voltage.

At the top end of the plate resistor a fixed B plus voltage is applied. If the tube does not pass any current, there will be no current flow through this

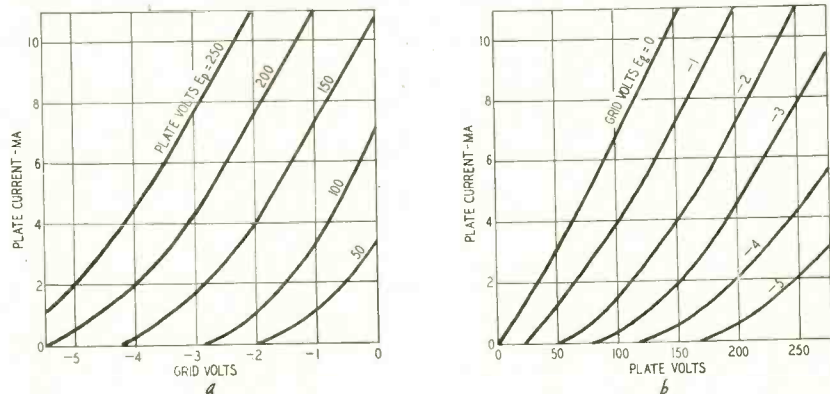

Fig. 1—Two ways of representing the characteristics of an electron tube.

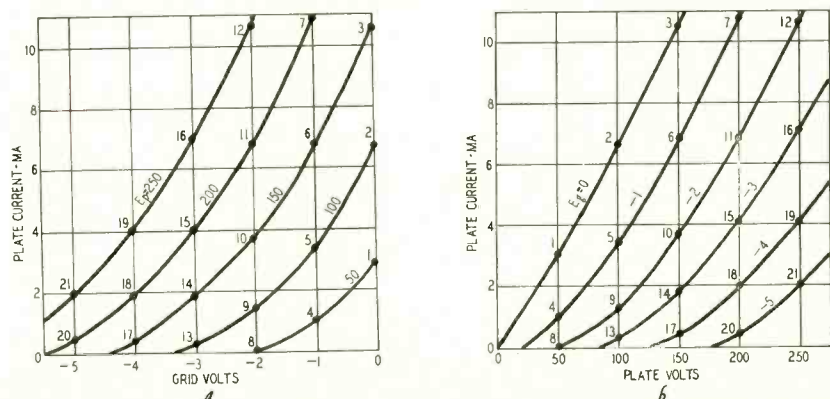

Fig. 2—Points on curves show correspondence between the sets of curves.

AUDIO—HIGH FIDELITY

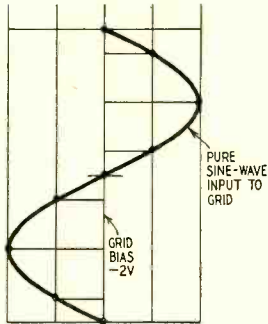
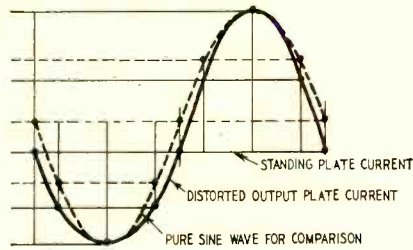
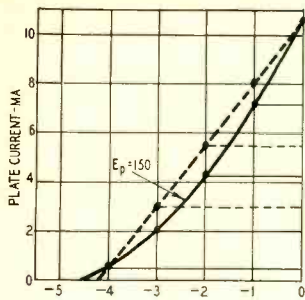

Fig. 3— E_g-I_p curve shows distortion in stage with constant plate voltage.

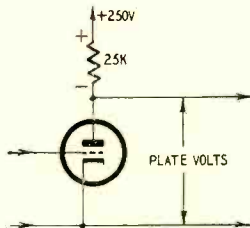

Fig. 4—A basic amplifier circuit.

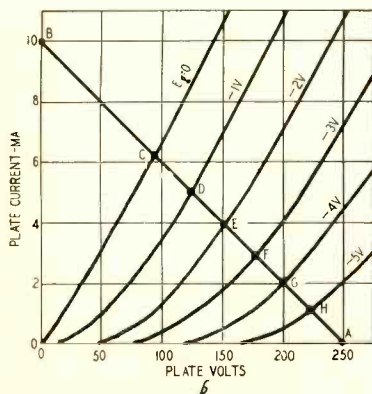

Fig. 5—Showing load line principle.

resistor, and the plate voltage will be the same as B plus, 250 volts in this case. But if the tube draws 10 ma, there will be a drop of 250 volts across the 25,000-ohm resistor—which means that the plate voltage will have dropped to zero. If the tube draws say 6 ma, there will be a drop of 150 volts across the resistor, leaving the plate at $250 - 150 = 100$ volts positive. A lot more points could be taken, representing different plate voltages according to the current drawn by the tube, but they will all be found to fall in the straight line AB of Fig. 5-a.

Whatever happens in the grid circuit the plate current and voltage must be given at some point along this line because of the voltage drop across the 25,000-ohm resistor. For this reason such a line is called a "25,000-ohm load line." In Fig. 5-b the curves of Figs. 1-b, 2-b are redrawn and the 25,000-ohm load line drawn through them.

Suppose that the grid voltage is -1 : The combination of plate current and plate voltage must be somewhere along the curve marked "grid volts -1 ." It must also be somewhere along the load line AB which represents the only possible plate voltage and current combinations in the circuit of Fig. 4.

The values when the grid voltage (E_g) is -1 are given by point D in Fig. 5-b—about 120 volts and 5 ma. Similarly other points C, E, F, G, H, along the load line, where the grid voltage curves cross it, give the plate

voltage and current for the value of grid voltage represented by each curve.

Load line shows distortion

Using a method similar to that used to show distortion of the plate current without any plate load in Fig. 3, a curve is plotted using the plate-volts-grid-volts points of Fig. 5-b. This is shown in Fig. 6. The dotted line represents a truly linear result while the slightly curved line is obtained by plotting the values obtained from the actual points C, D, E, F, G, H.

From Fig. 6 the reference lines are again extended downward and to the right so that a sine wave can be drawn as the input to the grid and a corresponding output waveform can be drawn by reference to the curve. The dotted and solid curves on the right side of Fig. 6 show the plate-voltage output waveform as compared with a pure sine wave. The difference between the dotted and solid curves here is much less than in Fig. 3, which indicates much less distortion from true sinusoidal.

The simple circuit of Fig. 4 can represent part of a direct-coupled amplifier. The method just described may be used to find the best value of coupling resistor to use. To do this, a number of different load lines can be drawn across the same set of plate-current-plate-voltage curves for the particular tube being used.

Fig. 7 shows how the slope of the load line depends upon the resistance value it represents. Three values of resistance are shown drawn through the same B plus voltage of 250. A simple way of drawing each load line consists of determining what current will flow if the plate is short-circuited to ground and then marking off this current value on the current scale at the left, where voltage is zero. This point is then joined to the B plus voltage point along the voltage scale, which

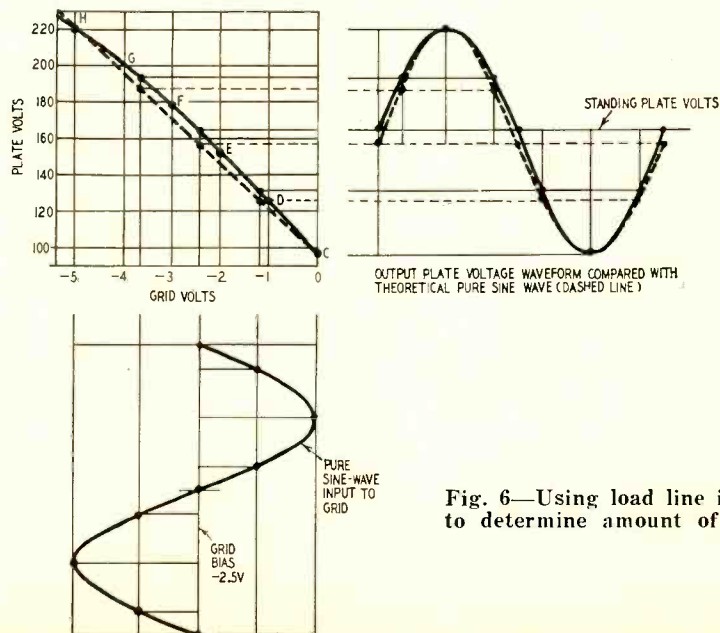

Fig. 6—Using load line information to determine amount of distortion.

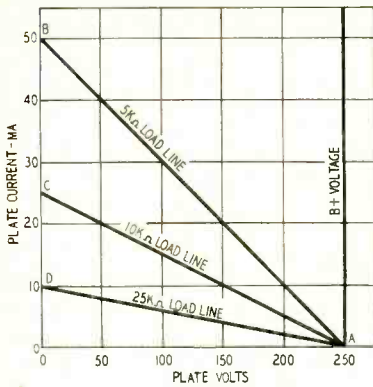

Fig. 7—Comparing load line slopes.

corresponds with the plate current being zero, as was explained in reference to Fig. 4. When no current is flowing, the plate voltage is equal to B plus. When the plate voltage is at zero, the whole B plus voltage is dropped across the load resistor.

An examination of Fig. 7 shows that lower resistance values are represented by steeper sloped lines, while higher resistance values correspond with lines nearer the horizontal.

This principle enables us to visualize the effect of other kinds of circuit in producing a *working* load line, including the effect of other circuit components. Actual values can be calculated quite simply and a load line drawn in to represent any particular kind of circuit. Fig. 8 shows practical load lines for (a) resistance-capacitance coupling and (b) choke or transformer coupling. In each case the line AB represents the d.c. drop from B plus to the plate under the condition of normal static bias, while the load line CD passing through the point B represents the dynamic load line when an alternating signal is applied to the grid.

In the case of Fig. 8-a—due to a further resistor (R_g of Fig. 9-a) coupled a.c.-wise in parallel with the plate load resistor by the coupling capacitor—the effective resistance in the plate circuit is reduced. Its value can be calculated by the simple parallel-resistance formula. Hence the load line AB, as determined by the value of load resistor R_L in Fig. 9-a, determines the operating position B, according to the grid bias applied to the tube.

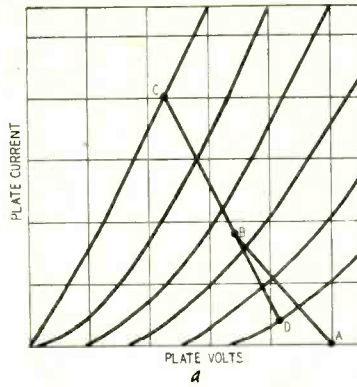

Fig. 8—Practical dynamic load lines for various type coupling circuits.

If the scales for current and voltage are the same as in Fig. 5, AB would represent 22,000 ohms. When alternating signal is applied, the load line CD (a resistance equal to R_L and R_g of Fig. 9-a in parallel) represents the "dynamic" behavior of the tube as signal voltages are applied. The slope of CD, according to scale, is 12,000 ohms, which means R_g must be 27,000 ohms. Points along load line CD can be used after the manner of Fig. 6 to determine the degree of distortion and also to determine the effective amplification of the tube.

When choke or transformer coupling is used, the resistance from B plus to the plate is small, being merely the winding resistance of the choke or transformer primary. This is represented by the section AB in Fig. 8-b. The position B is determined again by the static value of bias applied to the grid of the tube. In this case however, the effective a.c. resistance of Fig. 9-b is considerably higher than the d.c. resistance of the choke winding. Thus it is represented by a load line less steep, such as CD in Fig. 8-b.

Using the same scales AB represents a resistance of about 3,500 ohms, while that of CD represents about 32,000 ohms.

A similar construction applies for the direct-coupled transformer coupling of Fig. 9-c. In the case of transformer coupling the actual value of resistance applied across the secondary of the transformer must be "referred" by multiplying it by the square of the turns ratio to get the effective a.c.

resistance presented by the primary of the transformer in the plate circuit of the tube.

Figs. 10 and 11 show a whole family of characteristics for typical triode and pentode tubes. In each, a series of load lines has been drawn through the same static bias operating point. In the case of triodes (Fig. 10) the spacing of points where the grid-voltage curves intersect the individual load lines, lines nearer the horizontal, representing higher resistance values, produce the more even spacing, representing lower distortion. Load lines approaching the vertical and representing lower values of load resistance result in unevenness of spacing, stretching out toward the top end and second-harmonic distortion similar to that present in the plate-current curve shown in Fig. 3.

For pentodes (Fig. 11), the effect of variation of load resistance is reverse. A low value of resistance, represented by a load line that crosses the curves almost vertically, results in comparatively low distortion, while a high value of resistance, represented by a line that crosses the curves almost horizontally, produces a high degree of distortion. This is because all the grid-voltage curves converge together to the left of the "knee" of these curves and the spacing to the right spreads out.

Another useful feature of load lines, as shown in the article "What Is Optimum Load?" (March, 1954), enables the correct operating conditions to be chosen from the viewpoint of staying within various boundaries of tube operating characteristics. END

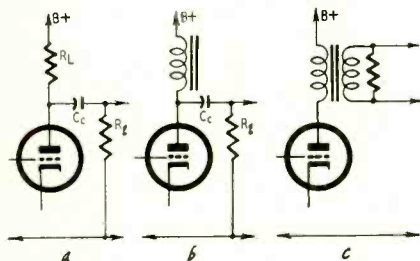

Fig. 9—Typical coupling circuits.

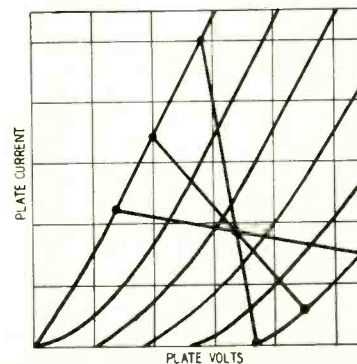

Fig. 10—Typical triode characteristics.

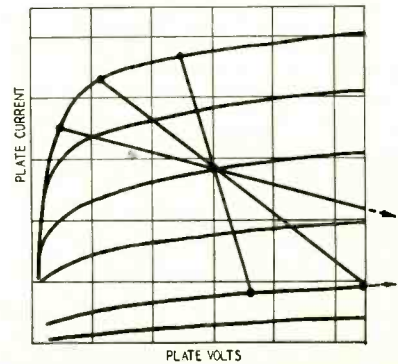

Fig. 11—Pentode characteristic curves.



*A new tape transport system;
a pocket tape recorder*

New Developments in Tape Recorders

By SOL HELLER

MECHANICAL problems in magnetic tape reproduction have proved harder to solve than electronic ones. These problems have centered about the tape transport mechanism. The most critical function of this assembly is to maintain

constant tape speed. Speed stability is essential in avoiding distortion.

Tape cannot be made to travel at a constant speed by simply rotating the takeup reel at a constant rate. The amount of tape rolled up per revolution—and therefore the tape speed—varies with the reel diameter. This diameter is not constant; its value depends on the amount of tape on the reel. When a reel has only a few windings, it must make several revolutions to gather the same amount of tape as a full reel does in one revolution (Fig. 1). The speed with which the tape moves will thus not be constant unless some compensation is made for the effect of the reel's changing diameter.

The conventional solution has been the use of a constant-speed shaft called a *capstan*, acting in conjunction with a mechanical *slipping clutch*. The clutch corrects for the nonuniform speed caused by the varying reel diameter. The clutch, however, prevents an optimum torque (rotational force) from being simultaneously applied to the two reels. In other words, if the rotational force applied to the full reel is proper, it will not be as good for the empty reel, and vice versa. This usually necessitates compromise adjustments that at best provide fair rather than perfect uniformity of tape speed.

A separate torque motor is used in more expensive machines to get around the difficulty, but here again a problem is present: the speed-torque charac-

teristic of the takeup motor must vary in accordance with the quantity of tape on the reel.

A solution offered by International Scientific Industries is the *Isimetric Drive*. The central component of this system is a single, gear-shaped, motor-driven magnet (Fig. 2) that whirls freely within two copper-lined steel cups. Each cup is coupled to one of the reels. The rotating magnetic field produced by the magnet causes the two cups to revolve in the same direction. The connection of the drive cups to the reels is such that the rotational force applied to one reel opposes the force applied to the other. The tape, as a result, is held taut between the reels.

When the magnet is centered with respect to the drive cups (Fig. 2), equal forces are applied to the cups and the reels they drive. When the magnet moves farther *into* one drive cup and correspondingly *out of* the other, the torque applied to one reel increases, while the torque for the other reel is proportionately decreased (Figs. 3, 4). The reel with the higher torque takes up tape; the reel with the decreased torque releases tape and acts as a brake.

Due to the symmetry of the system—the drive to one reel is a mirror-image of the drive to the other—a smooth transport system results. The tape reverses smoothly and easily and is capable of going from extremely slow to very high speeds with no tendency

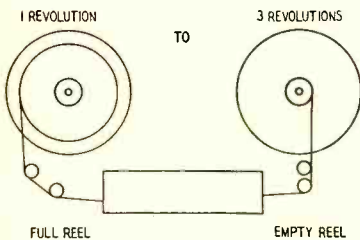

Fig. 1—Reels must travel at different speeds to maintain constant tape speed.

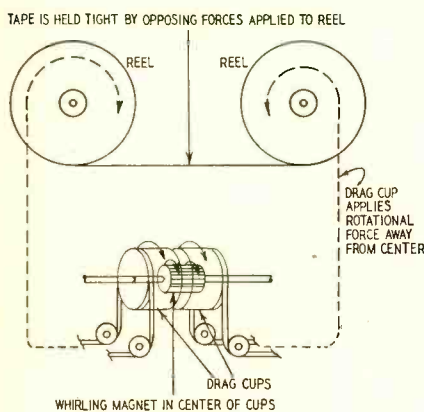

Fig. 2—The Isimetric Drive system.

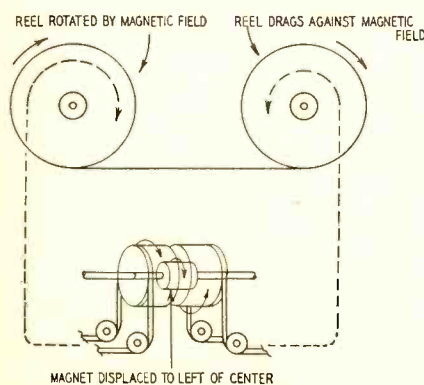

Fig. 3—Forces acting on the two reels when magnet is displaced *left* of center.

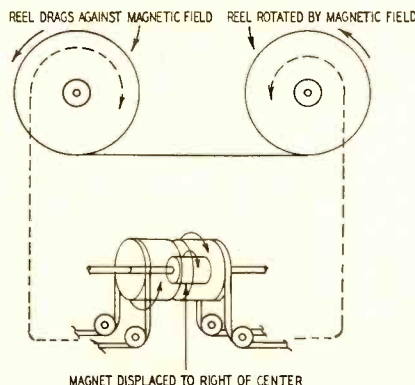

Fig. 4—Forces acting on the reels when magnet is displaced *right* of center.

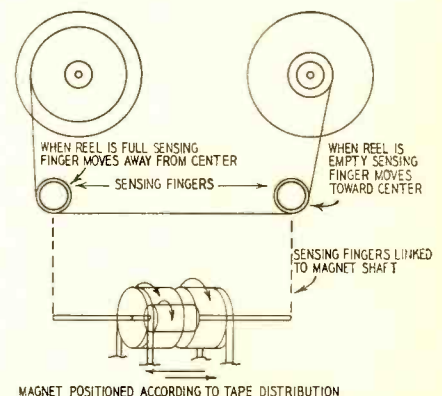
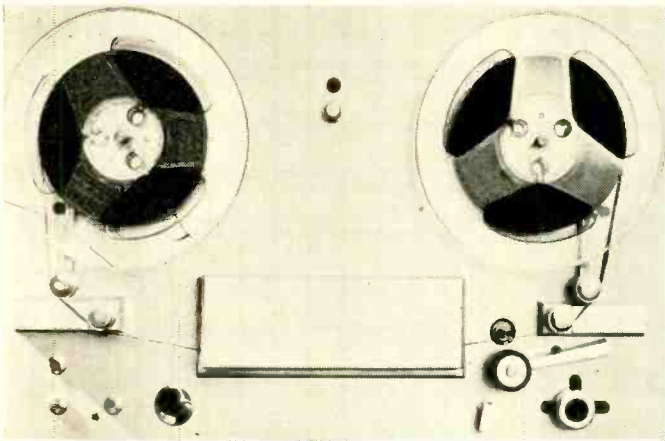
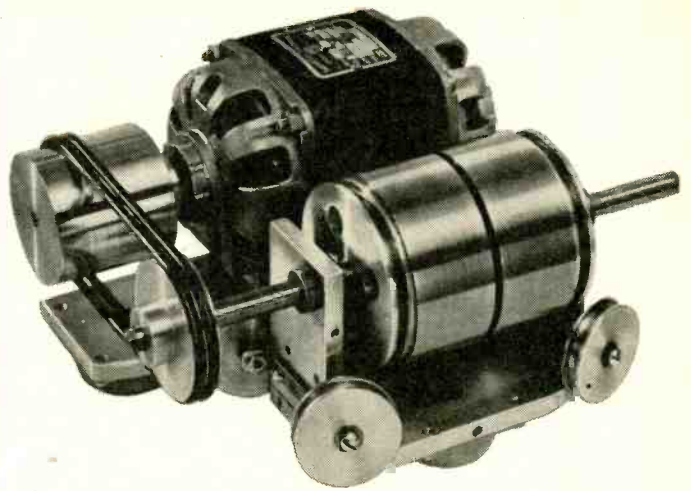

Fig. 5—Diagram indicates the position and operation of the sensing fingers.



Above, surface view of the tape transport mechanism in the Isimetric Drive system.



Above right, the mechanism used in Isimetric Drive system.

Right, the Midgetape model BR-1 pocket tape recorder, showing microphone attached.



to develop slack, snap off or spill.

As previously stated, the reel which is accumulating tape should rotate slower as its effective diameter increases, to maintain a constant tape speed. This is achieved in the Isimetric Drive system by *sensing fingers*. These fingers, due to their placement (Fig. 5), automatically move in the direction of the tape-accumulating reel. The distance they move is proportional to the amount of tape on the reel. Since these fingers are mechanically linked to the magnet shaft, they cause the magnet

to move farther and farther into the drive cup of the tape-gathering reel as its effective diameter increases. At the same time the magnet moves proportionately out of the cup linked with the tape-losing reel. The result is that the torque remains proper and correctly balanced at all times. The tape thus moves at a highly constant speed and remains under uniform tension.

A specially designed synchronous motor is used to "meter" the tape. This capstan motor, as it is called, is used only as a speed regulator—the

Isimetric Drive system supplies most of the energy needed to pull the tape.

Isimetric Drive eliminates problems associated with the braking used in conventional tape recorders. Braking is necessary in all tape transport mechanisms to prevent the free-wheeling reel from spilling tape. In conventional machines a frictional brake of some kind is commonly used, often requiring adjustments for satisfactory operation. In better-grade machines using a separate torque motor for drag braking, braking may still be imperfect unless

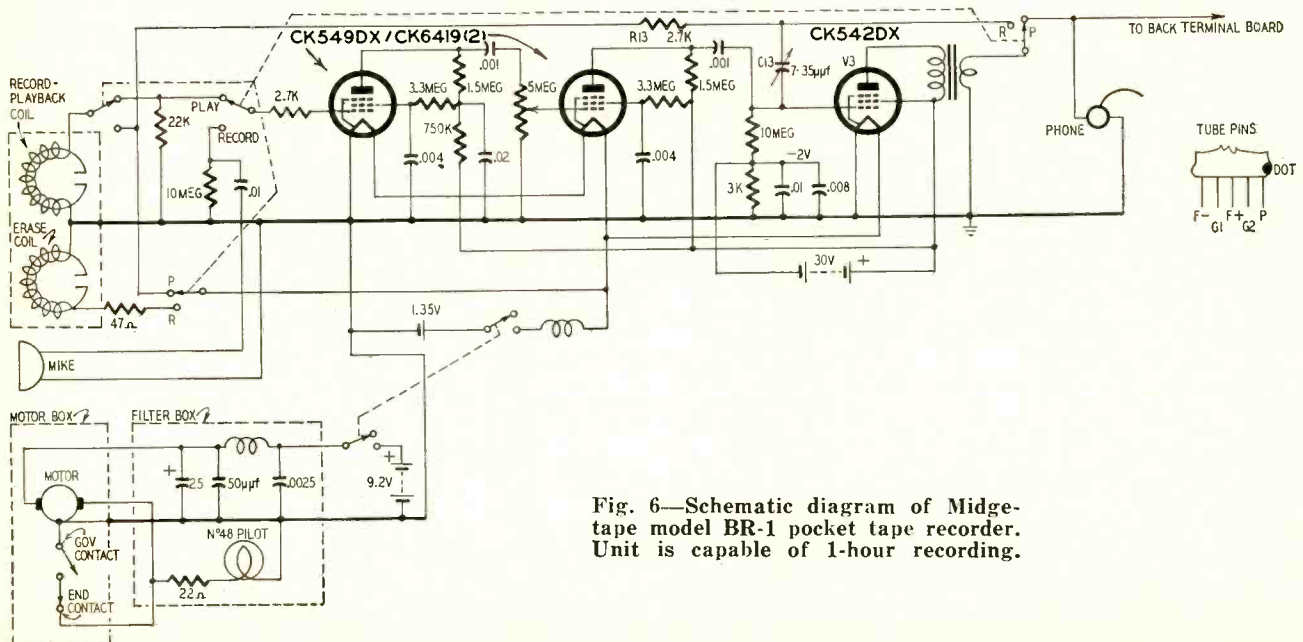

Fig. 6—Schematic diagram of Midgetape model BR-1 pocket tape recorder. Unit is capable of 1-hour recording.

AUDIO—HIGH FIDELITY

the speed-torque characteristic of the motor varies in step with the amount of tape on the reel. Isimetric Drive provides a frictionless magnetic type of slipping clutch, eliminating adjustment problems. No adjustments are ever required for this system throughout the life of the mechanism, according to the manufacturer. Another important problem eliminated by Isimetric Drive is the deforming of tape due to the setting up of nonuniform tensions in the tape by the tape transport mechanism. When wide variations in wind tightness occur—a common happening with conventional machines—the tape is often stretched or temporarily deformed. This deformation is generally due to the fact that the torque affecting the takeup and supply reels (in conventional tape recorders) is different for each reel at every speed of operation. This causes different degrees of tension on the tape. The deformation introduced becomes permanent if the tape is subsequently stored on a reel where the winding is uneven, egg-shaped or curled, since the tendency of the plastic to return to its original shape is sabotaged.

In most reels of tape, there is some uneven overlapping of successive layers of tape. Edges of the tape may overhang at certain points. If the recorder used introduces an uneven wind tightness, these edges curl, causing flap and flutter of the tape when it is going through the head units. Much hard-to-trace flutter, wow and other distortions are due to this. In the Isimetric Drive system, the very uniform tension under which the tape is held at all times tends to prevent temporary defects from developing in the tape and keeps them from becoming permanent if they do occur.

No pressure pads are needed when Isimetric Drive is used. Because the tape pressure is perfectly constant, tape pressure against the head remains constant without any pad. Pressure pads are undesirable because they require relatively frequent adjustment and tend to introduce frictional variations that produce undesired pitch and loudness changes.

Pocket tape recorder

A battery-operated pocket tape recorder—the first such machine on the market, according to the manufacturer—is being produced by Mohawk Business Machines Corp., Brooklyn, N. Y. The unit makes it possible to make inconspicuous recordings anywhere—in cars, trains, planes, etc.—up to a distance of 30 feet from the source of the sound. There are smaller recording machines on the market, but these use wire as the recording material. Wire is inferior to tape in that it is weaker, as well as very much harder to handle.

Midgetape, as Mohawk calls its unit is $8\frac{1}{2}$ inches long, $1\frac{1}{8}$ inches deep and $3\frac{1}{8}$ inches wide. It weighs $3\frac{1}{4}$ pounds. The selling price of \$229.50 includes the recording cartridge, bat-

teries, crystal mike and earphones. Accessories include wristwatch mikes, throat mikes, shoulder holster carrying case and a two-way telephone recording adapter. The speed is $1\frac{1}{8}$ inches per second.

The recorder is cartridge-loaded—a system of loading provided in no other recorder. Only a single reel is used for the tape, with the tape wound over the reel and both its ends joined together. The tape is enclosed in a cartridge the size of a pack of cigarettes. The cartridge is simply inserted into the machine; no threading is necessary.

Midgetape is capable of recording for one hour on a dual-track tape. It erases old material at the same time it makes a new recording.

Snap-in hearing-aid type batteries are used. The motor battery life is 45 hours, according to the manufacturer; the amplifier battery is rated at 100 hours. When battery aging has reached the point where it will permit only 2 hours more of recording, a small red light goes out, warning the operator.

Midgetape has a recording time indicator that tells how much of the 1-hour recording time has been used up and how much time remains. The indicator permits the easy location of any portion of a recording for playback.

The machine is geared for swift, unobtrusive operation. Flick a switch and it starts; push the switch again, and the unit plays back. The unit has only three controls.

A manual rewind is provided to conserve battery life. Rewinding takes less than 1 minute.

An a.v.c. circuit (Fig. 6) is used to insure a proper recording level at all times.

At the PLAYBACK setting of the selector switch a conventional three-stage amplifier is in operation. In the RECORD position of the switch, V3 acts as an oscillator and modulator, as well as an amplifier.

In conventional tape recorder systems either a separate oscillator and amplifier are used, or else a tube is used as an amplifier on PLAYBACK and as an oscillator on RECORD. In this circuit, V3 is used as an amplifier on PLAYBACK and as an amplifier and oscillator on RECORD, permitting a saving of one tube. The output transformer serves a dual purpose: it functions as a tank coil and controls the frequency of V3 as an oscillator; it acts as a conventional output transformer for the audio signal.

Variable capacitor C13 provides in-phase feedback between the output transformer secondary and the grid of V3. Oscillator V3 operates at a frequency of 11,000 cycles. The oscillator output is used for bias purposes.

At the plate of V3, the audio signal amplified in this tube is superimposed on the bias signal developed by oscillator action. The combined voltages are fed through current-limiting resistor R13 to the PLAY-RECORD coil. END

HIGH-FIDELITY DICTIONARY

PART V

By ED BUKSTEIN

Tweeter

A loudspeaker designed specifically for the higher audio frequencies and used where one or more additional speakers are available to reproduce the other portions of the audio spectrum.

Two-way loudspeaker system

A sound-reproducing system using two separate loudspeakers, one for the high frequencies and one for the lows. A filter circuit, known as a crossover or dividing network, channels the signal frequencies to the proper loudspeakers.

Ultra-linear

A push-pull output circuit in which the screen grids are connected to taps on the primary winding of the output transformer. This circuit is characterized by increased power and linearity.

Variable-reluctance pickup

A type of cartridge whose magnetic reluctance varies with movements of the stylus. The lateral movements of the stylus are imparted to a strip of magnetic material known as the armature. As the armature moves back and forth between two pole pieces, it varies the air gap and consequently the reluctance of the magnetic path.

Since reluctance in a magnetic circuit corresponds to resistance in an electrical circuit, an increase of reluctance results in a decrease of magnetic flux, and a decrease of reluctance permits an increase of flux. The changing magnetic field cuts through a coil, inducing a voltage—the cartridge output. Although the variable-reluctance cartridge has a relatively low output, its frequency response is excellent.

Volume expansion

In a sound-reproducing system, the process of making the loud sounds still louder and the quiet sounds still quieter. (See Compression.)

Volume unit

A unit of measurement of power level. The volume unit is equal to the decibel, but is based on a reference level of 1 milliwatt across 600 ohms.

Editor's Note: This dictionary will be concluded in our next issue. It will be followed by a glossary of purely tape terms, selected from a list put out by the makers of *Scotch* brand magnetic recording tape. It will cover a number of audio terms not previously given, and may redefine in purely tape terms some of those already covered.

FOR GOLDEN EARS ONLY

• *The Regency HF-80 amplifier;
Pickering cartridge and tone arm;
new records review*

By MONITOR

RAPID expansion of the high-fidelity market into the mass consumer field has accelerated the design and production of simple, small, inexpensive units combining equalization, tone control and amplifier functions. They require only speakers, tuner and record player to make a complete system. Some of this equipment meets the standards of genuine high fidelity for home use surprisingly well. An excellent example is the Regency HF-80 (Fig. 1), the lowest-priced unit in Regency's new line of hi-fi components.

The essential performance factors are shown in Fig. 2. Curve A is obtained by positioning the controls as follows: volume, full on; bass, a third on; treble, a quarter on. This "flat" position was determined by feeding 200- and 2,000-cycle square waves into the amplifier and adjusting the controls for flattest tops. Curve B was obtained with the bass and treble controls in the center position. Curve C is for maximum boost of bass and treble and curve D for maximum cut of bass and treble. The range of the tone control is clearly very wide.

Four square-wave responses (Fig. 3), taken in the flat position with 500-mw output, are shown and indicate a very acceptable transient response within the audio range. There was no sign of ringing or any other type of instability.

The power output curve (Fig. 4) was obtained by feeding an input signal at 15 different points in the frequency range from 20 to 30,000 cycles, increasing input until the scope trace showed clipping or distortion. The curve is flat from 50 to 30,000 cycles. Below 50 cycles the power output falls off to 8 watts at 30 cycles and just under 4 watts at 20 cycles before distortion shows up. This might limit the usefulness of the amplifier in applications—such as schools or small cafes—requiring high average power levels. But it is fully adequate for average home use and will take care even of the occasional demonstration at "full

concert-hall level," particularly since almost no records or broadcasts produce anything below 30 cycles.

Fig. 5 shows the distortion curve from 100 mw to 10 watts. In comparing these figures with those of quality amplifiers *without* control units, keep in mind that these curves give the overall distortion, including that contributed by the tone-control stages—everything but the phono preamp, in fact. This is the lowest distortion I have registered on any commercial 6V6 amplifier.

These are excellent curves; indeed as good or better than those obtainable with top components and designs a brief two or three years ago. They are improved upon in higher-priced equipment, principally in a flatter power curve below 50 cycles and a better square-wave response. The practical utility of both improvements for average home use is debatable and is obtainable only at a much higher price and larger size.

The amplifier listens as well as it tests. It is very clean in the high end and the definition and transient response are very good throughout the range. A slight deficiency in the very low bass end, at very high outputs, is evident when highest-quality speakers are used. With run-of-the-mill systems which are "flat to 50 cycles" and cut off below 40 cycles, the sound is excellent all the way and I would judge that it is completely acceptable to all but the crankiest of listeners.

The HF-80 provides three high-level input channels for tuners, tape recorders or TV, and a single input with a two-position equalizer for magnetic pickups loaded with a 47,000-ohm resistor. The curves of Fig. 6, obtained with a Pickering turnover cartridge and the Dubbings 101 test record, give the response of the phono channel. Position 1 yields excellent results with all four standard American curves. The bass-boost curve apparently is on the AES slope, which accounts for the small boost at the low end and the

slight dip around 250 cycles. Most G-E cartridges will show a little more slope at the high end, just about flattening the LP and NARTB curves and producing slight rolloffs with the RIAA and AES. A rumble filter can be actuated by a switch on the chassis and is very effective without much effect on the musical range.

Some readers may be at a loss to account for this excellent performance since there is nothing remarkable about the circuit. The answer is very simple: although the resistors are standard 10% and 20% units, the pairs in push-pull stages are matched on comparison bridges to 1% or better, and the output tubes are also matched closely.

The unit is very compact, light and dissipates little heat; can be put in a restricted space easily. The craftsmanship is excellent for a production unit. Despite the shallow and small chassis, individual components are easily accessible for replacement. All in all, the HF-80 is an excellent example of how much real high-fidelity quality can be provided at low cost by good design and care in manufacture.

Pickering turnover cartridge and new tone arm

The critical problem in the design and production of highest-fidelity pickup cartridges is providing a flat, smooth and clean response above 10,000 cycles. One of the earliest cartridges to offer a response extending to 20,000 cycles was the Pickering, and its success is well attested by its wide acceptance. Not long ago Pickering issued a model 260 turnover version (see photos) which provides facilities for playing both 78-r.p.m. and microgroove recordings at the turn of a lever. This is actually a combination of two cartridges mounted back to back. The cartridges can be disassembled in a few seconds for use independently if desired. Their performance is exceptional both by measurement and listening.

Fig. 7 is the response, without an equalizer, directly off the pickup ter-

AUDIO—HIGH FIDELITY

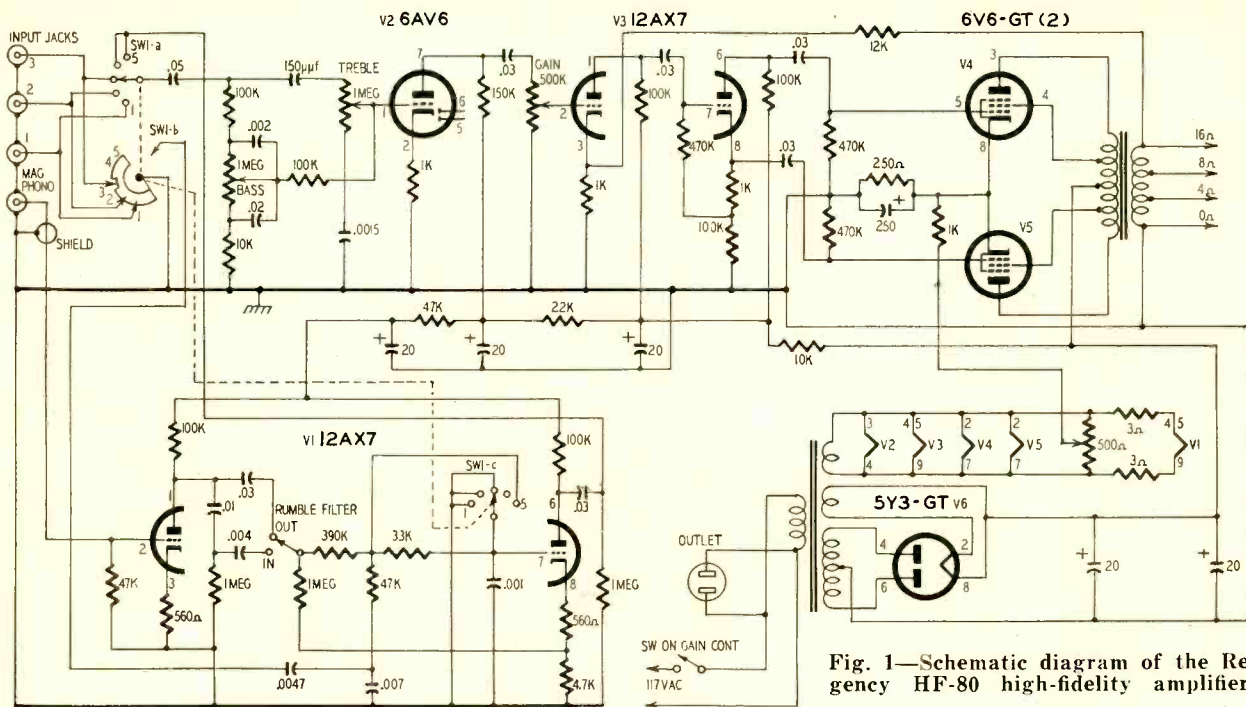

Fig. 1—Schematic diagram of the Regency HF-80 high-fidelity amplifier.

minals on a Cook 10-LP test record into a Heathkit a.c. v.t.v.m. The notable thing about the curve is the extreme linearity. The variations on the curve are largely variations on the test record which varies ± 1 db at various points. You will note that response is down only 1.5 db at 15,000 cycles, 6 db at 17,000 and 8 db at 20,000. Measurements in the range above 10,000 cycles with test records are difficult since various effects due to groove loading may occur. However, it is an entirely safe assumption that the Pickering is at least as good as indicated on the curves and possibly a few db flatter beyond 15,000 cycles.

The linearity is borne out by the curves (Fig. 8) taken with a 27,000-ohm load on the pickup, at the output of a preamplifier. To be sure, such curves are measures of the equalizer as well as the pickup. Nevertheless, they indicate the results which proper equalization can deliver. Again the linearity is very notable. The rise between 10 and 12 kc is not significant and probably represents the result of needle coupling to the grooves on this specific record. This coupling can vary with different record materials and even from day to day on the same record.

The curves speak for themselves. The only thing I need add is this: The sound of the Pickering in the high-high end—beyond 10,000 cycles especially—is exceptionally clean, smooth and sweet. Thoroughly pleasant to listen to, it is free of shrillness when used with tweeters which are themselves clean and sweet. I have used the pickup with several amplifiers and a number of speakers and, as near as I can determine, the pickup has no influence on the character of the high-highs, which will be determined by the characteristics

of the tweeter. On clean records, even those which have been played scores of times with diamond points at low pressures, I found no need for rolloffs. Indeed, it is possible to boost the high end severely and still maintain a clean, sweet sound. This is by no means true of all wide-range cartridges.

I made no measurements at 78 r.p.m. (my available test records stop at 10,000 cycles and up to that point the response was almost an exact duplicate of the microgroove cartridge). But listening tests reveal an exceptionally fine quality and a gratifyingly low scratch level, excellent evidence of a smooth, flat response free from peaks. Clearly the Pickering belongs in the top category of pickups and I can't imagine anyone, even the goldenest ear, being unhappy with it. Models 220 and 240 are available separately for 78- and 45-33 $\frac{1}{3}$ -r.p.m. records, respectively.

I was able to test the cartridges not only in my tone arms but also in the new Pickering arm (see photo). It is a worthy complement to the cartridges, makes no difference in the quality of reproduction, and is very convenient to mount and to use.

It provides an adjustment for the height over the record. With most cartridges this adjustment can be made so that the needle will just miss the turntable when no record is on it and yet provide good tracking with a record. Pressure is adjustable with a knurled knob underneath the arm (but above the turntable), and the adjustment can be easily made. Incidentally the cartridges tracked with as little as 3 grams, though 5 or 6 grams seem optimum and produce least distortion.

The arm is made in two sections, rather like the G-E in principle. The cartridge mounts on a light small front

section with very low vertical friction. In lifting the pickup off the record, only the cartridge and its mount are raised; the arm remains fixed. The vertical loading is therefore very slight and the arm will track extremely warped records with no difficulty whatever and practically no risk of damaging either record or needle.

The whole arm moves horizontally on fine bearings and has a large counterweight at the rear which tends to damp out resonances, maintains a uniform

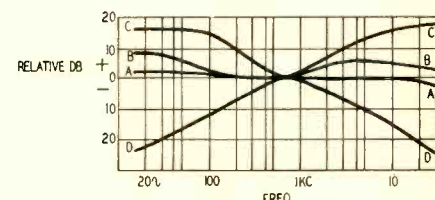

A—FLAT TEST POSITION; B—CENTER POSITION; C—MAX BOOST; D—MAX CUT
Fig. 2—Range of bass-treble controls.

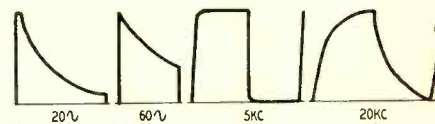

Fig. 3—HF-80 square-wave responses.

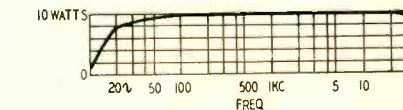

Fig. 4—Power output curve of HF-80.

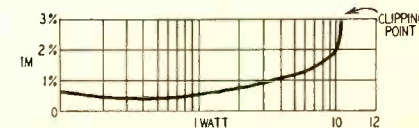

Fig. 5—Distortion curve of the HF-80.

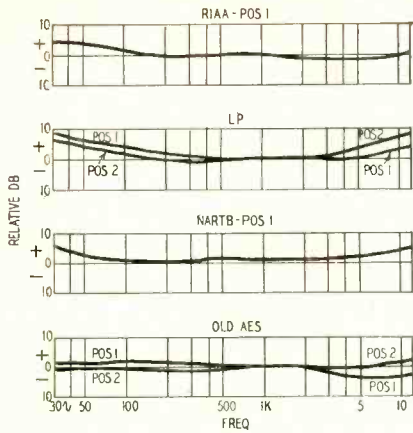

Fig. 6—Response of the phono channel.

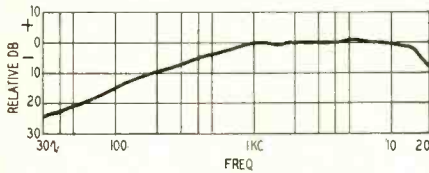

Fig. 7—Response of Pickering cartridge.

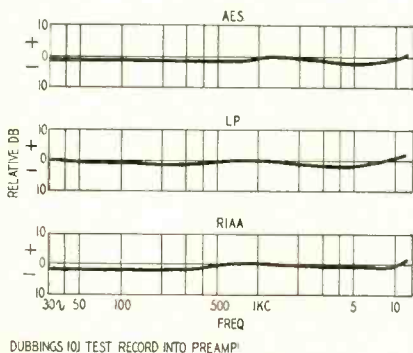
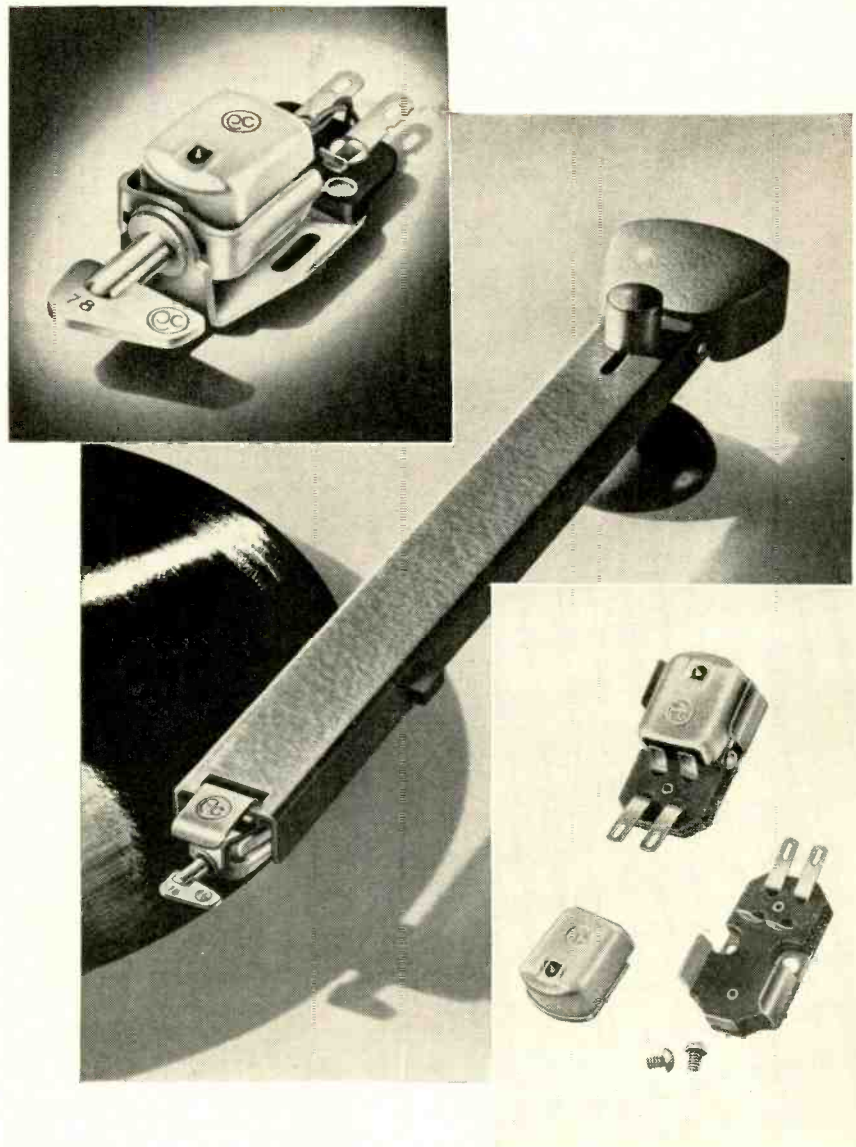

Fig. 8—Curves of the Pickering cartridge at the preamplifier output.

rhythm of movement as the arm travels toward the inside, offers considerable resistance to violent movement imparted by shock vibration, etc. The arm mounts with three screws which can be adjusted to level the arm. The method of holding the arm in the rest position is very clever and convenient. A small bar magnet mounted on the arm attracts it to the "holder" post and keeps it there firmly enough to resist any but the most violent accidental shock. The arm can be used with various other cartridges in permanent or slide mounting.

New records

NOTE: Practically all American records pressed since Sept. 1, 1954, use the standard RIAA curve or some modification of it which will be equalized to within 1 db by an RIAA equalizer. They can be equalized on the bass end exactly by the new RIAA equalizer and very closely with either the LP, NARTB or AES equalizer. Treble equalization is identical with the RCA ORTHO and calls for a slope of 13.7 db at 10,000 cycles. An LP treble equalizer will be -2 db at 10,000 cycles and an AES



The Pickering turnover cartridge (top left) installed in its arm (center). At right below, single-unit cartridges are also available, with 1- or 3-mil styli.

will be +2 db at the same point. The departures at intermediate points will be smaller. Therefore, in a pinch the new records can be equalized within 1 or 2 db by almost any of the four American playback curves: LP, NARTB, AES or ORTHO. Henceforth in my reviews I will not mention the recording curves unless the specific recording departs from the RIAA.

**An Adventure in High Fidelity
RCA Victor LM-1802**

RCA Victor left the pioneering in high-fidelity test records to others. But having at last risen to the challenge, it gives us a really remarkable test recording. Here in one disc is just about everything one needs to test, demonstrate or show off any high-fidelity system.

It starts with *An Adventure in High Fidelity*, a special composition by Robert Russell Bennett. Whatever one may think of it as music, it is

certainly deliberately composed to bring out almost every possible hi-fi effect. The second band, *The Orchestra in a Nutshell*, is a unique test of realism and naturalness, presenting most of the instruments of the orchestra in solo passages from the *Nutcracker Suite*, ending with a short but very fine demonstration of the percussives. The recording of the instruments is extremely faithful to the natural sound and, given a low enough noise level, one can hear not only the characteristic tone of each instrument but often many of the noises which accompany its production. Listen especially for the valving and breathing of the tuba player.

The first band on side B presents an excellent test for frequency range. It gives three switch bands, each succeeding one having a narrower bandwidth. Each test starts with a fast sweep of sine waves over the range covered. This is followed by a portion of *Adventure in High Fidelity* reproduced in the same bandwidth. A comparison of the effect of the three bands will quickly reveal the real range of any system and also demonstrate the difference between hi-fi and ordinary reproduction. However, the comparison is somewhat unfair to hi-fi since the 200-5,000-

AUDIO—HIGH FIDELITY

cycle band still maintains the excellent definition and low distortion of the previous higher-fidelity bands. No table radio sounds like that.

The second band is of solo voices, also extremely natural. Finally there are some selections of popular music concluding with *Eddie and the Witch Doctor* by the Sauter-Finnegan group, unquestionably the most terrific recording of percussion instruments so far put on discs and a severe test of transient response. Here we have not only the drums and other percussives individually and en masse, but we have them in counterpoint four or five layers deep. If on your system you can discern the separate drums throughout, even when they are layered, you can be sure that your system has a fine transient response and is free from hangover.

The record's only marring note is a rumble, apparently from the cutting lathe; but the result would be cheap at the price of several times the rumble. For an extra premium RCA includes a foam-rubber turntable pad and a well written and illustrated brochure.

BACH: *Concerto for Three Harpsichords, Nos. 1 and 2* *Concerto for Four Harpsichords in A Minor* Pro Musica String Orchestra of Stuttgart Vox PL 8670

The harpsichord is a fine instrument for testing both the dynamic range and frequency response of a system. The low amplitude of the tone and the high proportion of various noises require a very low hum and noise level for really faithful and natural reproduction. Furthermore, to bring out the wonderful color of the harpsichord's tone, the frequency response must be flat and the equipment free of distortion so that the harmonic structure is not altered. Finally, the semiperceptive quality requires a good transient response, while the slight overhang requires great freedom from wow. It is difficult, therefore, to reproduce one harpsichord perfectly.

Put three or four harpsichords together and you will severely try the mettle of any system. Harpsichords differ from one another much less than pianos, at least to the listener, and recognizing any specific harpsichord calls for a very discriminating ear. When you get three or four of them playing together and in the counterpoint of Bach, you need a very, very fine ear. Needless to say, you need as a prerequisite first a recording good enough to define the difference and, second, a reproducing system which maintains the definition. This recording meets the first condition. The rest is up to your system and your ears. If, after listening several times, you can hear the separate harpsichords in this record and, better yet, more or less count them and tell them apart, you can stop haunting the hi-fi shops and start haunting stamp dealers because they just don't make no better systems no more.

Oedipus

Music by Harry Partch
The Gate 5 Ensemble and Solo Voices

Available from Gate 5 Ensemble,
Box 387, Marin City, Calif.

Two 12-inch LP records. \$13, including packing. AES curve.

In one of the first of these columns, I reviewed *Plectra and Percussion Dances* by the same composer and ensemble, one of the most remarkable and astonishing records I have ever heard. Now the same outfit has recorded Mr. Partch's masterpiece, the musical background to a version of *Oedipus* performed some years ago at Mills College in Oregon. A large portion of this record consists of voices reciting or singing, as you prefer to name it, the text of the play. In the background—along with the Greek Chorus—the Gate 5 Ensemble plays the unusual music on the equally remarkable and unique instruments including cloud chamber bowls, kitharas, adapted cellos, chromelodeons and marimba eroica. The music illustrates and paints up the play with wonderful appropriateness since its 42-tone-to-the-octave scale is similar to, though more complicated than, the Greek scale used in the time

of Oedipus. It is impossible to describe the effect.

But the fact most likely to make this album worth its price to anyone owning a system capable of reproducing to 30 cycles or lower is that it has the finest genuine 31-cycle note on records, played by something called a marimba eroica. Given some bass boost or loudness control, the note will not only jar the china but any loose joints in the house. It is found best on the last of the four sides in the climax and finale. Nothing—not even the best organ records I have been able to lay my hands on—can compare with this 31-cycle note.

MOUSSORGSKY-RAVEL: *Pictures at an Exhibition*

Arturo Toscanini and the NBC Orchestra
RCA Victor LM-1383

This record demonstrates as no other recording the mastery of music and instruments of that incomparable and now, alas, defunct combination, Toscanini and the NBC Orchestra. This is not only, in my opinion, the finest and most spectacular version of this music, but all things considered (music, artists and recording) one of the finest recordings ever made. Moreover, it is one of the best demonstration and showoff records you can buy, if not the very best. It is so good, from its awe-inspiring bass to its clean and sharp highs, its very notable freedom from hangover and very fine inherent transient quality, that every time I hear it again I want to bow eastward in the direction of Camden, N. J. This is an absolute must for everybody from plain music lover to hi-fi addict. And if you have to go without lunch for a week to buy it, I can't think of anything better worth the sacrifice.

OFFENBACH: *Gaité Parisienne*

Boston Pops Orchestra with Arthur Fiedler
RCA Victor LM-1817

The quest for high-fidelity effects can produce some weird ones and this is one of the most conspicuous examples. If it is high-highs—the shimmer of struck and brushed cymbals, violently shaken tambourines, tinkling triangles, etc.—you want, here is a good half-hour and more in which not over 60 to 90 seconds lacks some example of high-high jinks! What's more it is a notably clean job of presenting them. Those whose systems have that "nice clean silky high end" will welcome this disc. As a demonstration piece of high-highs it is almost incomparable.

Unfortunately for those who like some music with their hi-fi, somebody overlooked the other end with a very sad effect. There is a modicum of bass. But those who know the music will recall the fine bass beat which accompanies the kicks of the can-cans and they will scarcely believe their ears when hearing this. Indeed, they may conclude that something has happened to the bass end of their system or the equalizers or the speakers. I hasten to reassure therefore: such fears are groundless. Apparently the boys behind the glass window were so intent on getting those high-highs in the groove they forgot the bass or were too busy to bother with it. In one spot they do show for a moment what they could have done if they'd happened to think of it. Otherwise this is one of the most lopsided pieces of music you're likely to hear. Recommended only for hi-fi shops; those who want the music are referred to several better balanced versions on other labels.

ORFF: *Cantata Carmina*

Vienna Kammerchor
Vox PL 8640

STRAVINSKY: *Les Noces, Mass, etc.*
N. Y. Concert Choir and N. Y. Concert Orchestra
Conducted by Margaret Hillis
Vox PL 8630

Because we hear voices every day and live music infrequently, well recorded choir works make excellent show-off records. These two are on the spectacular side and offer, beside the voices, some brilliant percussive effects in the orchestral background to delight the high-high addicts. Though one was recorded in Europe and the other in New York, the effects are similar and a casual listener might well suppose both were recorded by the same combination.

Both are excellent from the choral point of view, with fine definition and naturalness of voices. Played at moderately loud levels either one will bring the choir right into the house. And with the help of the texts which come with the records it is easy to follow and understand the voices even when they are massed. The Stravinsky has an excellent, sharply percussive piano and some chain-rattling effects. The Orff has brilliant triangles, etc. Both have the typically excellent Vox bass. The Stravinsky works are important in the history of modern music; the Orff is one of the recordings of a unique modern composer. Therefore, both should be of interest to musical students.

Caution: Very proficient students of college Latin will get the shock of their lives if they follow the Latin words of the Orff piece. Parents of brilliant high-school Latin scholars are urged to play this only when their offspring are in bed or out of the house and not to play it when the parish priest is around either. There are words here not fit for either young or pious ears. The text is based on the famous love poems of the Roman poet, Catullus.

STRAVINSKY: *The Rite of Spring* Steinberg and the Pittsburgh Symphony Capitol P-8254

Capitol has been improving its techniques, getting away from that dead, soundstage sound (sometimes called West Coast sound). This one is one of the very best of the new line labeled Incomparable High Fidelity. Most hi-fi addicts will quarrel with the claim because there are many other recordings with more spectacular hi-fi effects. In any case this is one of the most unusual modern pieces of music, recorded with great justice. However, these latest Capitol releases, for some reason I ken not, have a higher noise level than they used to.

PROKOFIEFF: *Chout* DE FALLA: *Dances from the Three Cornered Hat* Golschmann and the St. Louis Symphony Capitol P-8257

I liked these very much. The Prokofieff work, very seldom heard, presents the composer at his humorous best in spots. The De Falla *Dances* have been recorded many times, in several instances more spectacularly. However, both sides provide good listening and sound good on good systems.

STARLIGHT CONCERT Carmen Dragon and the Hollywood Symphony Capitol P-8276

AN ENCHANTED EVENING Mantovani and His Orchestra London LL 766

MANTOVANI PLAYS ROMBERG Mantovani and His Orchestra London LL 1031

Most good hi-fi demonstration and show-off records are either loud, strident or very modern, and often all three. Many people just plain don't like the sound, even on the finest system. On the other hand, pleasant, soft and harmonic classical music usually has little material with which to test the capabilities of a system or to demonstrate its superior qualities. Hence easy-listening demonstration records are very scarce and whenever I come upon one I make sure to mention it. The above three are all recommended. None has especially spectacular demonstration or show-off material, but any will show off both ends of the range, as well as definition and naturalness.

The Carmen Dragon record is a potpourri of various classical favorites ranging from the *Flight of the Bumblebee* to *Pomp and Circumstance*. Since the music is varied, the various section of the orchestra, including the percussives, get a workout. Mantovani's sharp high strings are a trademark and provide an excellent measure of clean high-end response. Both the above examples are clean enough not to require any rollofs, even when played with pickups absolutely flat to 20,000. They show the master at his best and with the kind of music most people like most.

END

Simple TV FM Antenna

Folded dipoles give broad-band wide-range pickup

By PAUL F. LOVELESS

MOST TV and FM antenna systems installed in primary and secondary areas are more complicated than necessary. This article describes a simple unit that has been used for some time. It is mechanically stable with no loose ends to cause vibration.

At first glance (see diagram and photo) it appears to be a rhombic, but a closer inspection will show two expanded folded dipoles. Elements AB, BC, CD and DA are each three-quarter wavelength for channel 12, and together equal approximately one wavelength for channel 4. Elements EB, BF, FL and LE are each one-quarter wavelength for channel 8 and one full wavelength on channel 4, thus giving good coverage throughout the v.h.f. band.

The dimensions are: AB, BC, CD and DA: 42.75 inches each; EB, BF, FL and LE: 16.1 inches each. The diagonal or boom BD is 35.3 inches, and diagonal BL is approximately 13.3 inches. This will vary with the insulator spacing between points L-L, approximately 3 inches. These diagonal lengths are very critical for best results.

As shown in the photo the array is mounted in a horizontal plane and provides a usable 360° pickup pattern with

maximum signal at 90° from each of the four straight sides.

Original models were made using crossed wood frames and copper wire (No. 18 B & S gauge or larger). This construction may be followed for indoor use with ½- or ¾-inch braided copper shielding used as the conductor.

For outdoor use ½-¾ inch O.D. type 52 ST or 61 ST aluminum tubing should be used, and the elements DA and AB as well as BC and CD may be made in

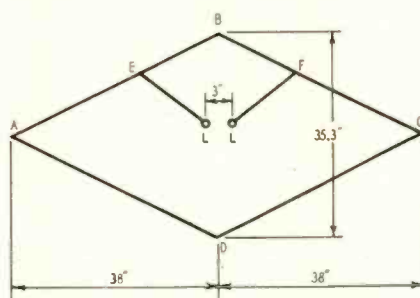

Layout of the broadband antenna.

one piece and bent at points A and C, respectively.

As shown in the photo, points B and D are bolted directly to supporting boom BD, to which is also attached the terminating insulator for points L-L. A strip of electrical grade linen-base Bakelite was used for the insulator, but Lucite or "Poly" will serve.

The elements were flattened in a vise for a distance of 2 inches from either end, drilled and bolted to the boom which was also flattened and drilled at points B and D. Aluminum clamps or straps should be used at points E and F

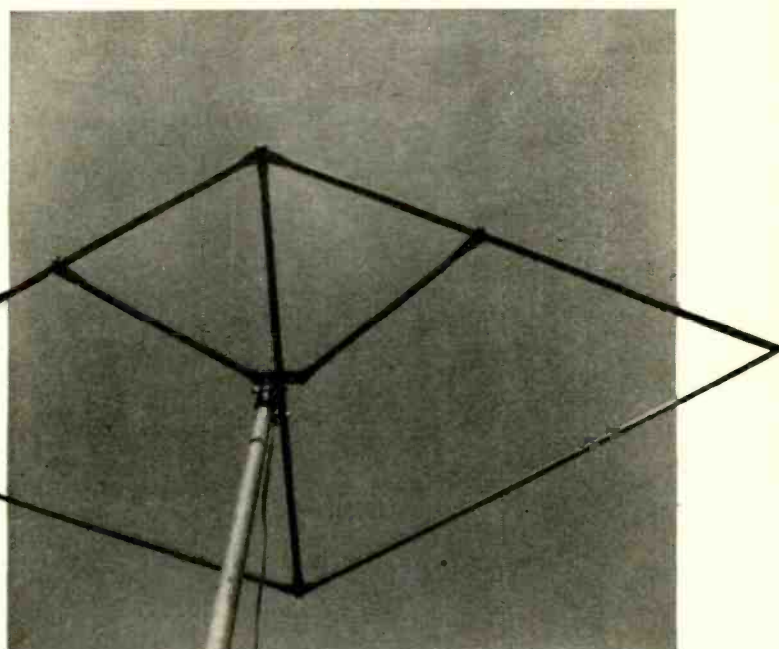

Closeup shows construction of antenna.

because drilling the longer elements would tend to weaken them.

This antenna, located at Ithaca, N. Y., in the hilly Finger Lakes region, gives excellent results on channels 3 and 8 from Syracuse, 45 miles, and channel 12 from Binghamton, 40 miles, without a booster.

These transmitters are located at points approximately 90° apart from our receiver location, thus proving the wide-angle pickup of this array.

For a single channel use the layout ABCD and insert the insulator at point B or D. In this case the 300-ohm lead-in should be attached to the two insulated or open ends, and elements EL and LF are omitted.

Excellent FM reception may be obtained using the figure ABCD with element lengths of 28.25 inches and a diagonal or boom (BD) length of 23.3 inches.

For any given frequency the element lengths may be calculated as follows: One-quarter wavelength (in inches) = $\frac{2.770}{f}$. The length of the diagonal

f in mc equals 0.825 times the element length. In installing the finished array it is important to select location and orientation to give best results on the weaker high-frequency channels 8 and 13, as even a few inches change in position at the higher frequencies may result in either maximum or minimum signal levels.

For a broad-banded system this unit is ideal and requires no rotor. A short time spent in constructing it should convince even the most skeptical. END

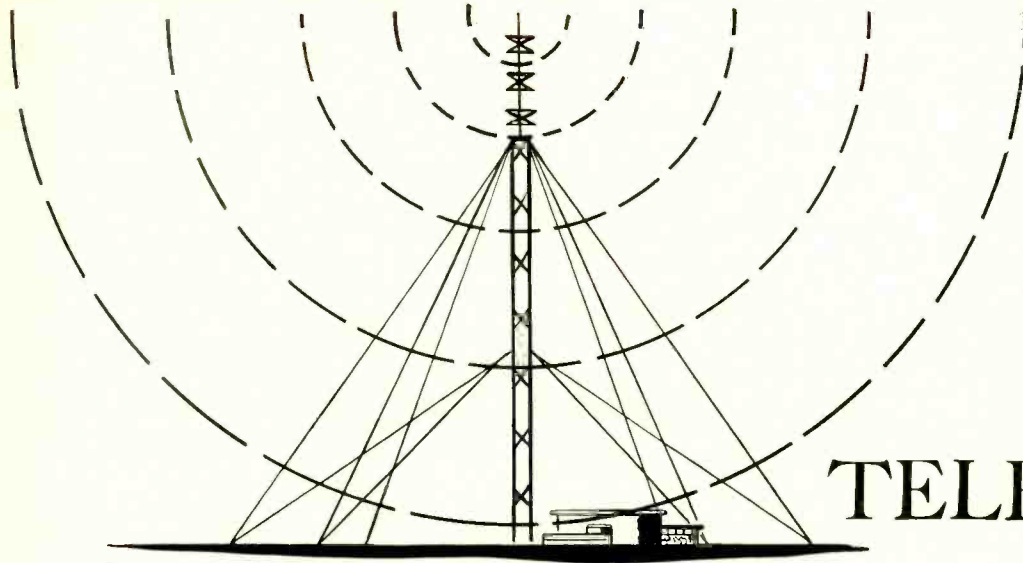

TELEVISION

Alabama

WBAT	Birmingham	13
WBRC-TV	Birmingham	6
WWSL-TV	Decatur	23
WTVY	Dothan	9
WALA-TV	Mobile	10
WCOV-TV	Montgomery	20
WSFA-TV	Montgomery	12
WEDM	Munford	7

Alaska

KENI-TV	Anchorage	2
KTVA	Anchorage	11
KFAR-TV	Fairbanks	2
KTVF	Fairbanks	11

Arizona

KVAR	Mesa (Phoenix)	12
KOOL-TV	Phoenix	10
KPHO-TV	Phoenix	5
KTVK	Phoenix	3
KDPD-TV	Tucson	13
KVOA-TV	Tucson	4
KIVA	Yuma	11

Arkansas

KFSA-TV	Fort Smith	22
KARK-TV	Little Rock	4
KATV	Pine Bluff	7

California

KBAK-TV	Bakersfield	29
KERO-TV	Bakersfield	10
KHSL-TV	Chico	12
KIEM-TV	Eureka	3
KJEO	Fresno	47
KMJ-TV	Fresno	24
KABC-TV	Los Angeles	7
KHUJ-TV	Los Angeles	9
KCOP	Los Angeles	13
KNXT	Los Angeles	2
KRCA	Los Angeles	4
KTLA	Los Angeles	5
KTTV	Los Angeles	11
KMBY-TV	Monterey	8
KBET-TV	Sacramento	10
KCCC-TV	Sacramento	40
KSBW-TV	Salinas	8
KFMB-TV	San Diego	8
KFSD-TV	San Diego	10
KGO-TV	San Francisco	7
KPIX	San Francisco	5
KQED	San Francisco	9
KRON-TV	San Francisco	4
KSAN-TV	San Francisco	32
KVEC-TV	San Luis Obispo	6
KEYT	Santa Barbara	3
KOVR	Stockton	13
KTVU	Stockton	36
KVVG	Tulare	27

Colorado

KKTU	Colorado Springs	11
KRDO-TV	Colorado Springs	13
KBTU	Denver	9
KFEL-TV	Denver	2
KLZ-TV	Denver	7
KOA-TV	Denver	4
KFXI-TV	Grand Junction	5
KCSJ-TV	Pueblo	5

Connecticut

WICC-TV	Bridgeport	43
WGTH-TV	Hartford	18
WKNB-TV	New Britain	30
WNHC-TV	New Haven	8
WATR-TV	Waterbury	53

Delaware

DWLE-TV	Wilmington	12
---------	------------	----

District of Columbia

WNAI-TV	Washington	7
WRC-TV	Washington	4
WTOP-TV	Washington	9
WTTG	Washington	5

Florida

WITV	Fort Lauderdale	17
WINK-TV	Fort Myers	11
WJHP-TV	Jacksonville	36
WMBR-TV	Jacksonville	4
WGBS-TV	Miami	23
WTVJ	Miami	4
WDBO-TV	Orlando	6
WJNO-TV	Palm Beach	5
WJDM	Panama City	7
WPFA-TV	Pensacola	15
WEAR-TV	Pensacola	3
WSUN	St. Petersburg	38
WFLA-TV	Tampa	8
WTVT	Tampa	13
WEAT-TV	W. Palm Beach	12
WIRK-TV	W. Palm Beach	21

Georgia

WALB-TV	Albany	10
WAGA-TV	Atlanta	5
WLWA	Atlanta	11
WQXI-TV	Atlanta	36
WSB-TV	Atlanta	2
WJBF	Augusta	6
WRDW-TV	Augusta	12
WDAK-TV	Columbus	28
WRBL-TV	Columbus	4
WMAZ-TV	Macon	13
WNEX-TV	Macon	47
WROM-TV	Rome	9
WTQC-TV	Savannah	11

Hawaii

KHBC-TV	Hilo	9
KGMB-TV	Honolulu	9
KONA	Honolulu	11
KULA-TV	Honolulu	4
KMAU	Wailuku	3

Idaho

KIDO-TV	Boise	7
KID-TV	Idaho Falls	3
KBOI-TV	Meridian	2

Illinois

WBLN	Bloomington	15
WCIA	Champaign	3
WBBM-TV	Chicago	2
WBKB	Chicago	7
WGN-TV	Chicago	9
WNBQ	Chicago	5
WDAN-TV	Danville	24
WTVP	Decatur	17

WSIL-TV	Harrisburg	22
WEEK-TV	Peoria	33
WTVH-TV	Peoria	19
WGEM-TV	Quincy	10
WREX-TV	Rockford	13
WTVQ	Rockford	39
WHBF-TV	Rock Island	4
WICS	Springfield	20

Indiana

WTTV	Bloomington	4
WSJV	Elkhart	52
WFIE	Evansville	62
WKJG-TV	Fort Wayne	33
WFBM-TV	Indianapolis	6
WISH-TV	Indianapolis	8
WFAM-TV	Lafayette	59
WLBC-TV	Muncie	49
WSBT-TV	South Bend	34
WTHI-TV	Terre Haute	10
WINT	Waterloo-Ft. Wayne	15

Iowa

WOI-TV	Ames	5
KCRG-TV	Cedar Rapids	9
WMT-TV	Cedar Rapids	2
WOC-TV	Davenport	6
WHO-TV	Des Moines	13
KQTU	Fort Dodge	21
KGLO-TV	Mason City	3
KTVI	Sioux City	4
KVTV	Sioux City	9
KWWL-TV	Waterloo	7

Kansas

KCKT	Great Bend	2
KTVH	Hutchinson	12
KOAM-TV	Pittsburg	7
WIBW-TV	Topeka	13
KAKE-TV	Wichita	10
KEDD	Wichita	16

Kentucky

WEHT	Henderson	50
WLEX-TV	Lexington	18
WHAS-TV	Louisville	3
WAVE-TV	Louisville	11

Louisiana

KALB-TV	Alexandria	5
WAFB-TV	Baton Rouge	28
WBRL	Baton Rouge	2
KPLG-TV	Lake Charles	7
KTAG-TV	Lake Charles	25
KNOE-TV	Monroe	8
WDSU-TV	New Orleans	61
WJMR-TV	New Orleans	6
KSLA	Shreveport	12

Maine

WABI-TV	Bangor	5
WTWO	Bangor	2
WMTW	Poland Spring	8
WCSH-TV	Portland	6
WGAN-TV	Portland	13

Maryland

WMAR-TV	Baltimore	2
WTAW	Baltimore	13
WBAL-TV	Baltimore	11
WBOC-TV	Salisbury	16

Massachusetts

WAGT	Adams-Pittsfield	19
WBZ-TV	Boston	4
WGBH-TV	Boston	2
WNAC-TV	Boston	7
WTAO-TV	Cambridge	51
WHYN-TV	Holyoke	55
WWLP	Springfield	61
WWOR-TV	Worcester	14

Michigan

WPAG-TV	Ann Arbor	20
WNEM-TV	Bay City-Saginaw	5
WTVT	Cadillac	13
WJBK-TV	Detroit	2
WWJ-TV	Detroit	4
WXYZ-TV	Detroit	7
WKAR-TV	East Lansing	60
WOOD-TV	Grand Rapids	8
WKZO-TV	Kalamazoo	3
WILS-TV	Lansing	54
WJIM-TV	Lansing	6
WKNX-TV	Saginaw	57
WPOR-TV	Traverse City	7

Minnesota

KMMT	Austin	6
KOAL-TV	Duluth-Superior	3
WDSM-TV	Duluth-Superior	6
KEYD-TV	Minneapolis-St. Paul	9
KSTP-TV	Minneapolis-St. Paul	5
WCCO-TV	Minneapolis	4
WTCN-TV	Minneapolis	11
KROC	Rochester	10

Mississippi

JACKSON	Jackson	25
WLBT	Jackson	3
WLSL-TV	Jackson	12
WTOK-TV	Meridian	11

Missouri

KFVS-TV	Cape Girardeau	12
KOMU-TV	Columbia	8
KHQA-TV	Hannibal	7
KRCG	Jefferson City	13
KSWM-TV	Joplin	12
KCMO-TV	Kansas City	5
KMBC-TV	Kansas City	9
WDAF-TV	Kansas City	4
KDRO-TV	Sedalia	6
KTTS-TV	Springfield	10
KYTV	Springfield	3
KFEQ-TV	St. Joseph	2
KETC	St. Louis	9
KSD-TV	St. Louis	5
KWK	St. Louis	4
KTVI	St. Louis	36

Montana

K00K-TV	Billings	2
KXLF-TV	Butte	6
KFBB-TV	Great Falls	5
KGVO-TV	Missoula	13

Nebraska

KHOL-TV	Kearney	13
KOLN-TV	Lincoln	10
KUON-TV	Lincoln	12
KMTV	Omaha	3
WOW-TV	Omaha	6

This list of United States and Canadian stations has been checked and verified with all possible sources, but may still not be perfect. We will be grateful for any corrections or additions from authoritative sources.

STATION LIST*

*To April 18, 1955

Nevada		WXEL Cleveland 8		WCSC-TV Charleston 5		WLVA-TV Lynchburg 13	
KLRJ-TV Henderson 2		WBNS-TV Columbus 10		WUSN-TV Charleston 2		WACH-TV Newport News-Norfolk 33	
KLAS-TV Las Vegas 8		WLWC Columbus 4		WCOS-TV Columbia 25		WTAR-TV Norfolk 3	
KZTV Reno 8		WTNH-TV Columbus 6		WIS-TV Columbia 10		WTVR Richmond 6	
New Hampshire		WHIO-TV Dayton 7		WNOK-TV Columbia 67		WSLS-TV Roanoke 10	
WMUR-TV Manchester 9		WLWD Dayton 2		WBTW Florence 8			
New Jersey		WLOK-TV Lima 73		WFBC-TV Greenville 4			
WATV Newark 13		WSTV-TV Steubenville 9		WGLV Greenville 23			
New Mexico		WSPD-TV Toledo 13		Washington			
KGGM-TV Albuquerque 13		WFMJ-TV Youngstown 21		KVOS-TV Bellingham 12			
KOAT-TV Albuquerque 7		WKBN-TV Zanesville 18		KEPR-TV Pasco 19			
KOB-TV Albuquerque 4		Oklahoma		KCTS Seattle 9			
KSBS-TV Roswell 8		KTEN Afta 10		KING-TV Seattle 5			
New York		Enid 7		KOMO-TV Seattle 4			
WROW-TV Albany 41		Lawton 8		KHQ-TV Spokane 6			
WNBF-TV Binghamton 12		Oklahoma City 25		KREM-TV Spokane 2			
WBF-TV Buffalo 4		Oklahoma City 9		KXLY-TV Spokane 4			
WBUF-TV Buffalo 17		Oklahoma City 4		KTVW Tacoma 13			
WGR-TV Buffalo 2		Tulsa 6		KTNT-TV Tacoma 11			
WCNY-TV Carthage-Watertown 7		KV00-TV Tulsa 2		KIMA-TV Yakima 29			
WTV-TV Elmira 24		Oregon		West Virginia			
WABC-TV New York 7		Eugene 13		WCBS-TV Charleston 8			
WABD-TV New York 5		Medford 5		WSAZ-TV Huntington 3			
WCBS-TV New York 2		Portland 12		WOAY-TV Oak Hill 4			
WOR-TV New York 9		Portland 6		WTAP Parkersburg 15			
WPIX-TV New York 11		Portland 27		WTRF-TV Wheeling 7			
WRCN-TV New York 4		Pennsylvania		Wisconsin			
WKYC-TV Kingston 66		Alltoona 10		WEAU-TV Eau Claire 13			
WIRI-TV Plattsburg 5		Bethlehem 51		WBAY-TV Green Bay 2			
WHAM-TV Rochester 5		Easton 57		WKBT La Crosse 8			
WHET-TV Rochester 10		Erie 12		WHA-TV Madison 21			
WRGB-TV Schenectady 6		Harrisburg 27		WKOW-TV Madison 27			
WHEN-TV Syracuse 8		Harrisburg 55		WMTV Madison 33			
WSYR-TV Syracuse 3		Harrisburg 71		WMBV-TV Marinette 11			
WKTV-TV Utica 13		Johnstown 56		WXIX Milwaukee 19			
North Carolina		Johnstown 6		WTMJ-TV Milwaukee 4			
WISE-TV Asheville 62		Lancaster 8		WTWV Milwaukee 12			
WLOS-TV Asheville 13		Philadelphia 10		WSAU-TV Wausau 7			
WUNC-TV Chapel Hill 4		Philadelphia 6		Wyoming			
WBTV-TV Charlotte 3		Philadelphia 3		KFBC-TV Cheyenne 5			
WTVD-TV Durham 11		Pittsburgh 2		Canadian			
WFMY-TV Greensboro 2		Pittsburgh 16		CHCT-TV Calgary, Alta. 2			
WNCT-TV Greenville 9		Pittsburgh 13		CFRN-TV Edmonton, Alta. 3			
WNAO-TV Raleigh 28		Reading 33		CBUT Vancouver, B.C. 2			
WFMY-TV Winston-Salem 6		Reading 16		CKX-TV Brandon, Man. 5			
WSJS-TV Winston-Salem 12		Scranton 16		CBWT Winnipeg, Man. 4			
WTOB-TV Winston-Salem 26		Scranton 22		CKCW-TV Moncton, N.B. 2			
North Dakota		Scranton 73		CHSJ-TV St. John, N.B. 4			
KFYR-TV Bismarck 5		Wilkes-Barre 28		CBHT Halifax, N.S. 3			
WDAY-TV Fargo 6		Wilkes-Barre 34		CJCB-TV Sydney, N.S. 4			
KCJB-TV Minot 13		York 49		CHCH-TV Hamilton, Ont. 11			
KXJB-TV Valley City 4		WSBA-TV York 43		CKWS-TV Kingston, Ont. 11			
Ohio		Puerto Rico		CKCO-TV Kitchener, Ont. 13			
WAKR-TV Akron 49		San Juan 4		CFPL-TV London, Ont. 10			
WICA-TV Ashtabula 15		San Juan 2		CFOT Ottawa, Ont. 4			
WCIN-TV Cincinnati 48		Rhode Island		CHEX-TV Peterborough, Ont. 12			
WCPO-TV Cincinnati 9		WJAR-TV Providence 10		CFPA-TV Port Arthur, Ont. 2			
WKRC-TV Cincinnati 12		WNET Providence 16		CJJC-TV Sault Ste. Marie, Ont. 2			
WLWT-TV Cincinnati 5		WPRO-TV Providence 12		CKSO-TV Sudbury, Ont. 5			
WEWS-TV Cleveland 5		South Carolina		CKLT-TV Toronto, Ont. 5			
WNBK-TV Cleveland 3		WAIM-TV Anderson 40		CKLW-TV Windsor, Ont. 9			
Utah		Rhode Island		CBFT Montreal, Que. 6			
KTV Salt Lake City 4		WJAR-TV Providence 10		CBMT Montreal, Que. 4			
KSL-TV Salt Lake City 5		WNET Providence 16		CFCM-TV Quebec City, Que. 3			
KUTV Salt Lake City 2		WPRO-TV Providence 12		CJBR-TV Rimouski, Que. 3			
Vermont		South Carolina		CKCK-TV Regina, Sask. 3			
WMVT Montpelier 3		WAIM-TV Anderson 40		CFQC-TV Saskatoon, Sask. 8			
Virginia							
WVEC-TV Hampton-Norfolk 15							
WSVA-TV Harrisonburg 3							

TV SIGNAL CIRCUIT

FEEDBACK

Regeneration symptoms in i.f. and front-end circuits

By ROBERT G. MIDDLETON*

WHEN picture quality is impaired by feedback in the signal circuits, time is often wasted hunting for other possible sources of trouble. Feedback appears in various guises, ranging from symptoms of interference in the picture to fuzzy, blurred or smeary reproduction.

Misalignment is a common, but elusive, cause of feedback. A receiver was brought in with a complaint of poor picture quality and high-frequency interference. The stagger-tuned stages had been peaked to the specified frequencies indicated in the service data, hence it was supposed that the receiver was aligned.

Investigation of the complete signal-circuit response disclosed that the cathode trap (Fig. 1) had been tuned as an accompanying sound trap, instead of an adjacent-channel trap. This mistuning disturbed the circuit so that when L_g and L_p were peaked to their specified frequencies, the stage would oscillate weakly, causing picture disturbance.

In an arrangement like that in Fig. 1, the specified peaking frequencies may call for peaking L_g and L_p only 1 mc apart. Under usual circumstances the arrangement would oscillate because of tuned-plate-tuned-grid feedback. But trap L_k , when tuned within a suitable range, will effectively make L_p appear slightly capacitive, instead of inductive, thus converting positive feedback to negative, and effectively broadening the

stage response. But if L_k should be mistakenly tuned to the other side of the channel, L_p will appear inductive and the stage will feed back positively.

Feedback symptoms

Although feedback usually shows up in the reproduction of picture and sound, the symptoms which appear during tests of the signal circuits with generator and scope are much more definite and provide more information concerning the source of the trouble. One of the most useful tests for feedback in the i.f. circuits can be made during i.f. alignment. After stagger-tuned coils and traps have been adjusted to their specified frequencies, reduce the grid bias to a very low value, using an override bias source (Fig. 2). As the bias approaches zero, the gain of the i.f. amplifier increases and the output from the sweep generator must be reduced to avoid overload. If feedback is present, it will then show up at low bias levels as a change in the shape and bandwidth of the response curve. If the feedback is substantial, the curve may collapse, indicating oscillation.

For this reason preliminary alignment of a receiver troubled by feedback should be made with a relatively high value of override bias, such as -6 volts. If a variable source of override bias is used, it is not necessary to open the a.g.c. line because the bias source has a low internal resistance, while that of a.g.c. bias line is relatively high. Hence the bias is determined by the voltage from the low-resistance source.

This test discloses the presence of

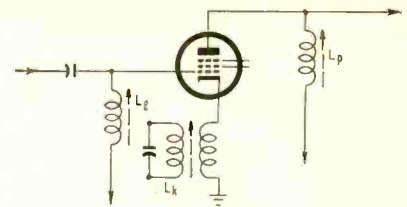

Fig. 1—Circuits containing cathode trap.

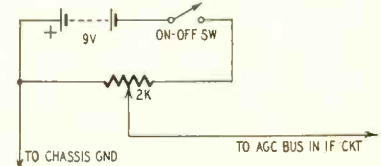

Fig. 2—Diagram of override bias box.

feedback only in the a.g.c.-controlled stages. It frequently happens that feedback occurs in later i.f. stages which may operate at fixed bias. In such cases, other types of feedback tests must be made. One effective method consists of sliding a tube shield up and down over the i.f. tube in the suspected stage. If the stage is feeding back substantially, the shape of the i.f. response curve will change markedly as the shield is moved.

Regeneration can also be traced where the feedback is taking place from the last i.f. stage, or from the video detector, back to some earlier stage. The test setup shown in Fig. 3 permits the technician to determine the feedback loop. In this test, the scope is connected across the load resistor in the video-detector circuit, and the sweep output voltage from a sweep generator is applied through an isolating resistor R to the grid of the last i.f. tube. Resistor R is made as large as possible, the value being determined by the point at which the curve height on the scope screen begins to approach less than a satisfactory deflection. The result of this test setup is to develop the single-stage response of the last i.f. stage. But, because the sweep generator is driving the last i.f. tube through a high resistance, any feedback voltage present is able to proceed through the video detector. This is the essential feature of the arrangement.

To trace the feedback voltage, .01- μ f capacitor C is shunted progressively from the grid of the second i.f. tube to chassis, from the grid of the first i.f. tube to chassis, from the grid of the mixer tube to chassis, etc. As each grid is bypassed successively in this manner, the technician watches for a change in height and shape of the response curve on the scope screen. Any change discloses the presence of regeneration and indicates that the test is being made within a feedback loop. When the bypassing moves out of the feedback loop, there will be no further changes in height or shape of the response curve.

It is thus easy to trace the feedback

*Field engineer, Simpson Electric Co.

loop in the receiver circuits, and the work of locating the faulty component is greatly eased. Without a feedback test, the job becomes hit or miss, and much more time is required to locate the faulty component.

The trouble may not be in the video i.f. amplifier; feedback trouble occurs occasionally in the sound i.f. amplifier. Here again, the type of test shown in Fig. 3 can be used to run down the feedback loop. In the sound i.f. amplifier, the scope is connected at the input of the de-emphasis network and the sweep signal applied through an isolating resistor to the grid of the sound i.f. limiter or driver tube. The bypass capacitor is then applied successively between grid and chassis of each preceding tube which carries the sound signal. It is surprising how at times the sound i.f. output voltage finds its way back to the front end of the receiver. Harmonics of the ratio-detector voltage may be picked up by front-end

picture, with the picture appearing at one setting of the fine-tuning control and the sound making its appearance at another setting. This situation results from the fact that unless either the picture carrier or the sound carrier is run up on the curve, it will be greatly attenuated by the very low gain along the base line away from the narrow response curve.

Feedback in the ratio-detector circuit causes corresponding difficulties in obtaining a properly shaped S curve. Even if the circuits can be brought into satisfactory alignment at one signal level, the shape of the S curve will go to pieces as the output level from the sweep generator is varied. Instability of this sort is one of the outstanding symptoms of feedback in sound i.f. circuits.

Tracing regeneration

Since only one stage is usually being swept in a feedback test, and because

generation-tracing applications should have high vertical sensitivity, a low-frequency response down to 20 cycles, and provision for 60-cycle sine-wave horizontal sweep.

Low-frequency response down to 20 cycles is required so that the scope will have good 60-cycle square-wave response. This may seem an odd requirement. However, a visual-response curve belongs to the same general family of waveforms as a 60-cycle square wave. In fact, when a four-stage i.f. amplifier is in good alignment, the resemblance of the response curve to a 60-cycle square wave is quite apparent. It is not true that a scope will have good 60-cycle square-wave response if the sine-wave response of the vertical amplifier extends down to 50 cycles. This is because the phase characteristic of the amplifier begins to become nonlinear before the frequency response drops off.

To maintain a linear phase characteristic through 60 cycles, it is necessary to extend the low-frequency response of the vertical amplifier down to approximately 20 cycles. Unless this is done, a 60-cycle square wave will tilt in reproduction and visual-response curves acquire the characteristics of reactive distortion—loops appear at the ends of the base line and the tops of trace and retrace are differently shaped.

It is desirable to provide for 60-cycle sine-wave horizontal sweep in the scope because synchronizing problems are avoided. The sweep motor in a service sweep generator is almost always energized from a 60-cycle sine-wave voltage. If the horizontal sweep of the scope is also driven by a 60-cycle sine-wave voltage, the pattern will always lock in tightly on the screen, whether the output from the generator is reduced to zero or the output from the receiver falls to a very low value during circuit adjustments. END

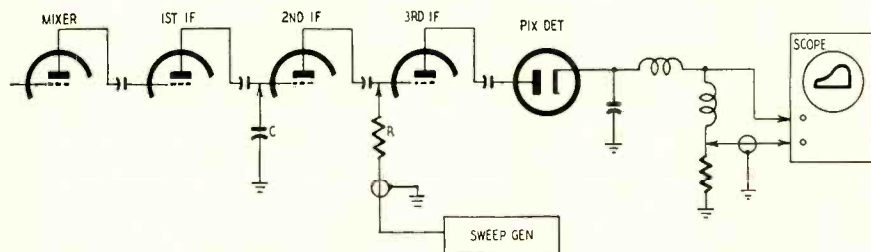

Fig. 3—Diagram of feedback test setup. Scope is connected across load resistor.

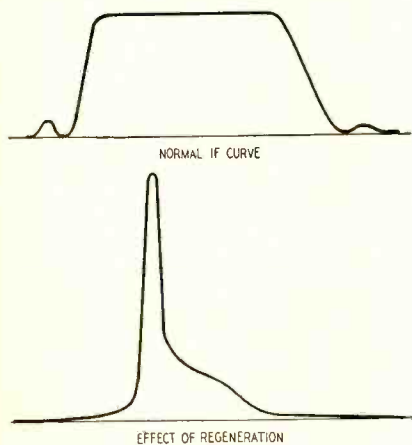

Fig. 4—Curves show effect of feedback.

an isolating resistor or equivalent decoupling means must be used (Fig. 3), fairly high output from the sweep generator is desirable to obtain sufficient deflection on the scope screen. Even if the sweep generator output is relatively low, the instrument can often be used satisfactorily in regeneration tests if the scope has high vertical gain.

A scope for visual-alignment and re-

circuits if shielding is not provided between the ratio detector and the front-end coils. In other cases a bias-clamp circuit is contained in the ratio detector, which may form harmonics of the sound signal that find their way back into the front end through the a.g.c. line. Better bypassing of the a.g.c. line will help clear this up.

Feedback affects i.f. response

Among other difficulties caused by feedback in the signal circuits is the inability to obtain the specified i.f. response curve. When feedback is severe, the response curve may show a very high peak (Fig. 4). Response curves of this type often separate sound and

NEW TV SERVICE BENCH

Virtually eliminating all chassis handling, a new television service bench has been designed having a movable center table (see photo). The bench, of wood and steel, is 72 inches long, 36 inches deep and 36 inches high. It has two deep drawers for tools.

The back panel is equipped with five double outlets, a master switch and a safety indicator light that glows when the power is on. The upper shelf is intended for holding the necessary test equipment.

The feature of this bench, the service table, is 2 feet square and is mounted on 3-inch casters. Being square, the table can be fitted into the slot on any of its four sides, to suit the servicing technician. If a set has to be run for a long time, as in an intermittent, the table could be moved out and another receiver set in. The bench is made by the Baumker Manufacturing Co., Toledo, Ohio.

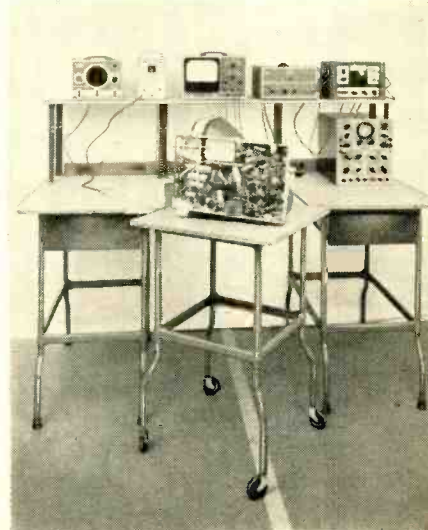

TELEVISION . . . it's a cinch

By E. AISBERG

*Sixteenth conversation, second half:
Radio-frequency high-voltage supplies;
when vice finally becomes a virtue!
the bootstrap circuit*

From the original "La Télévision? . . . Mais c'est très simple!" Translated from the French by Fred Shunaman. All North American rights reserved. No extract may be printed without the permission of RADIO-ELECTRONICS and the author.

Roll your own a.c.

KEN—Well, I think we can abandon the 60-cycle transformer as a television high-voltage supply. They pretty well all went out with the 7-inch tube.

WILL—Then what's wrong with finding out how high-voltage supplies really do work? If we don't step up the 60 cycles, what do we do? Use some other frequency, maybe?

KEN—You've said it—probably without intending to. One of the worst features of the old-fashioned system is the low frequency. Among other things, it needs big filter capacitors. A charge on even a 0.25- μ f capacitor by a 16,000-volt, 60-cycle power supply can be fatal, as I've told you already. But if we had a 10,000-cycle current, for instance, we could use a proportionally smaller filter capacitor. And the capacitor discharge, while it wouldn't be exactly pleasant, wouldn't be dangerous to life.

WILL—Fine! Do you think we could call up the power station and ask them to speed up the generators to give you 10 kc?

KEN—Why bother? I can make it myself, from the low-voltage d.c. supply!

WILL—Sounds like witchcraft. But go ahead.

KEN—It's easy enough. Simply use a good big tube, supplied with voltage from the televiser's own power supply. Hook it up as an oscillator at any frequency you want. It doesn't matter much what kind of circuit—t.p.t.g., Hartley or what have you. Once you get your a.c., you treat it like any other a.c. supply.

WILL—You mean . . . ?

KEN— . . . step it up with a secondary, then rectify it with a simple half-wave high-voltage rectifier tube.

WILL—In your schematic you show the heater winding on the r.f. transformer too. Are you heating the filament with radio frequency?

KEN—Why not? The tube is specially designed to use low filament power. And you can keep your high voltage well away from ground that way.

WILL—About what frequency would you use?

KEN—You could use anything from about 600 cycles up; but with lower frequencies you'd have to use iron-cored coils, and you'd have insulation problems again. It's much better to use air-cored coils and frequencies up in the radio range. Power supplies have been designed to work at various frequencies between 50 to about 300 kc.

WILL—And a radio-frequency power supply solves all the high-voltage insulation problems?

KEN—It makes them simpler. Remember, you still have big voltage differences between successive layers, even in air-cored coils. That's why they are usually wound in a number of well spaced pies, with not too many turns on each. Thus the voltage drop is distributed along the form, and no turns with large voltage differences are near each other.

WILL—I've seen those coils.

KEN—What you've seen was probably something quite a bit different—something that is used in all modern TV receivers. You see, we don't need to install an a.c. generator in our set—there's an efficient one there already.

Virtues out of faults

WILL—Surely you're not talking about the oscillator in the mixer circuit?

KEN—Not at all, though in some portable radios it has been used to supply cathode bias for the output tube. I'm thinking of something entirely different. Don't you

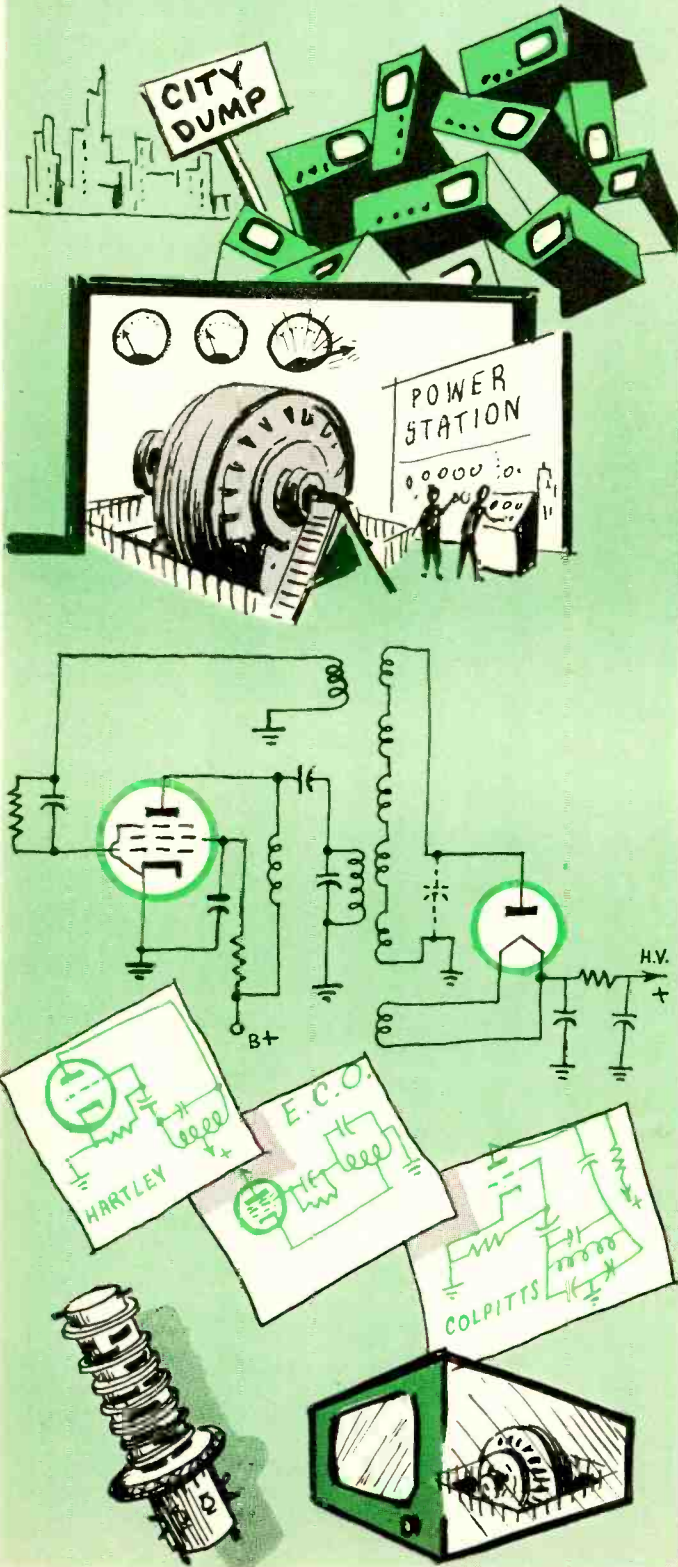

remember when we were talking about horizontal scanning circuits—back about our eighth conversation—we found we'd get surges of several thousand volts on the retrace?

WILL—I remember now. The sharp drop in current that produces the steep side of the sawtooth sets up dangerous voltages across the primary of the transformer connected to the anode of the pentode horizontal output amplifier. And—if I remember right—even then you said we could turn a vice into a virtue by using the surges as a source of high voltage for the picture tube.

KEN—With a memory like yours, you may still go far, Will! You see then that we can use the high-voltage pulses produced by the horizontal sweep circuits during the retrace period. And we can increase those voltages by adding another winding to our horizontal deflection transformer primary, making an autotransformer out of it.

WILL—And then all you have to do is rectify the high voltage and filter it in the ordinary way. I notice again that you heat the rectifier filament with a little winding on the same transformer.

KEN—Yes, we have that advantage of the r.f. system, plus one that no other system has. If by accident the sweep circuits fail, the bright spot resting on one point of the tube face would soon destroy the screen around that point—make an electron burn rather than an ion burn. But with this high-voltage supply system, the high voltage goes off as soon as the sweep fails, and there is no bright spot to damage the tube.

WILL—So this is efficient, economical and, on top of that, makes things safe for the picture tube. Practically a perfect system. But there's one thing that's been puzzling me. On some schematics I've seen B+, B++ and B+++ . I can understand two B+ voltages, but what do you do with the middle one?

KEN—That's still another advantage of this so-called flyback system of getting high voltage. High-voltage transformers get less efficient as you wind more wire on them and stretch them out over more space. So, to get high voltage on the big tubes, you have to use good sturdy horizontal output tubes and put more voltage on them. And believe it or not—the horizontal output tube itself supplies that extra voltage.

WILL—Sounds impossible. But I do remember hearing of a bootstrap voltage boost. This must be it!

KEN—You're so right, Will! Here it is. This is a simplified drawing—I've left out everything not needed for the voltage boost. Most transformers are harder to figure out because the primary, deflection and high-voltage windings all form part of one autotransformer on most modern sets. I have shown a separate winding here. (The principle is the same, of course, but the diagram is less confusing and you'll find plenty of older sets with such transformers.) And in a schematic of a complete receiver you'd find a width and linearity coil mixed up in the circuit.

WILL—I can't figure this out. Looks almost as if the damper was being used as a high-voltage rectifier.

KEN—Well, what is the purpose of a damper tube?

WILL—That's right! It does rectify, doesn't it? But it never occurred to me you could use the current that it rectifies.

KEN—And what is the source of this voltage that it rectifies?

WILL—That's simple enough, once you get the idea. The deflection winding is a half-wave secondary. And since its lower end is connected to the B+ supply, its voltage is added to the ordinary B+, so whenever the damper conducts, the voltage at its cathode is the rectified voltage across the deflection winding, plus the B+ voltage of the rest of the receiver.

KEN—Exactly. B++. And one more point will make your story complete. The rectified current is filtered by the .05- μ f capacitor you see in the diagram.

WILL—So now we have our B+++ voltage. And the B+++ is, of course, the supply for the picture tube. Anything more to learn about the power supply?

KEN—Nothing at all that we will have to bother about today, Will.

TO BE CONTINUED

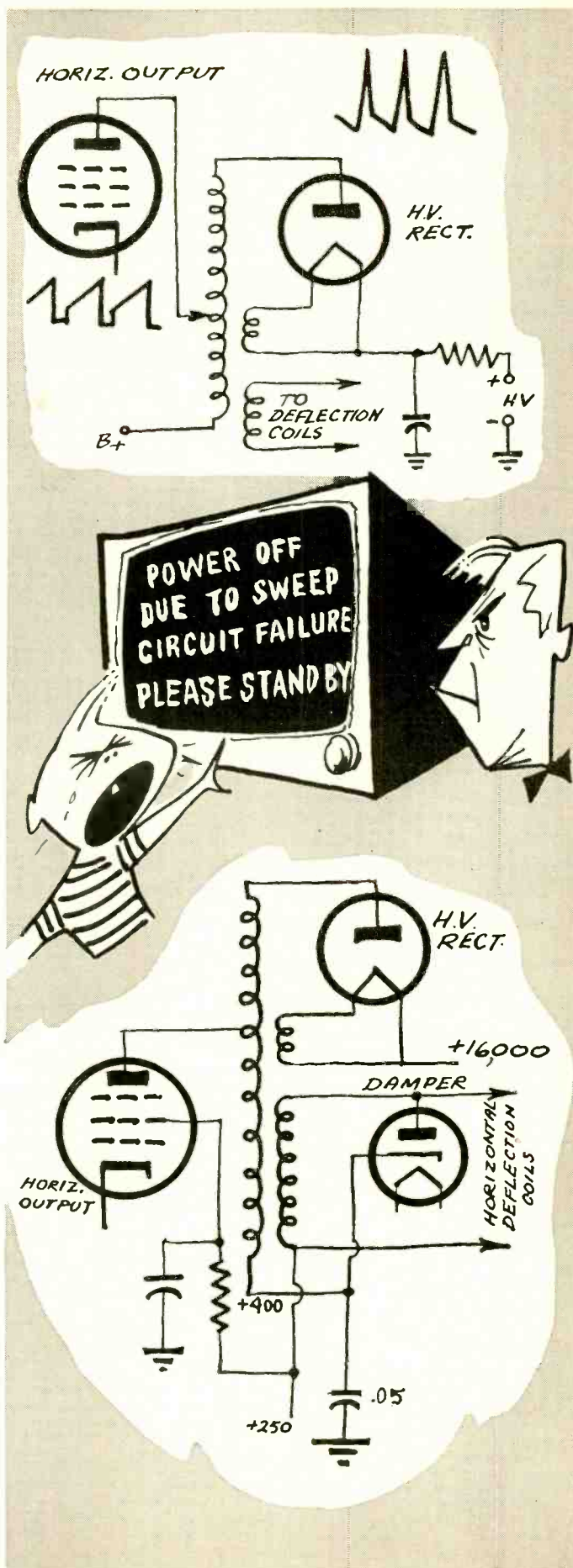

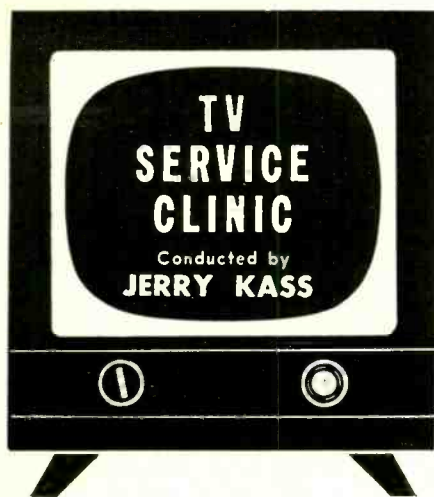

THAT flickering salt-and-pepper effect (see photo) known as "snow" is almost invariably due to trouble in or around the front end of a TV receiver when the set is connected to a good antenna in a reasonably strong-signal area. Snow is the video equivalent of noise and its effect on the picture depends largely on the amplitude of the noise voltages at the input of the receiver as compared to the amplitude of the incoming signal.

Noise comes principally from two sources—shot effect and thermal agitation. Shot noise occurs in all vacuum tubes and is caused by the uneven flow of electrons from cathode to plate. The variations in tube current flow cause slight modulation of the plate current, producing the noise or snow effect. Shot noise increases as the number of elements in a tube increases. Thus, a triode offers the greatest protection against shot effect.

Thermal agitation is caused by the random movement of electrons in any conductor or resistor. Noise caused by thermal agitation varies in proportion to the bandwidth of an amplifier, and so becomes a major problem in the 6 mc wide r.f. amplifier. In producing this noise the antenna must be considered just as important a source as the front-end components. In fact, an antenna with a characteristic impedance of 300 ohms will produce just as much noise as a 300-ohm resistor connected across the set's input terminals.

Since noise voltages are amplified by a receiver along with signal voltages, to obtain a snow-free picture it is necessary that the signal be much greater in amplitude than the noise. This is referred to as a high signal-to-noise ratio. Signals approximately equal in amplitude to the antenna-receiver noise are masked by the noise. Thus, improving fringe-area performance consists of reducing antenna and receiver noise and increasing antenna and receiver gain.

Unfortunately the minimum usable signal is not determined by the gain or sensitivity of a receiver, but by the noise of the r.f. stages of the tuner. The noise in the r.f. amplifier is so important because it is at this point

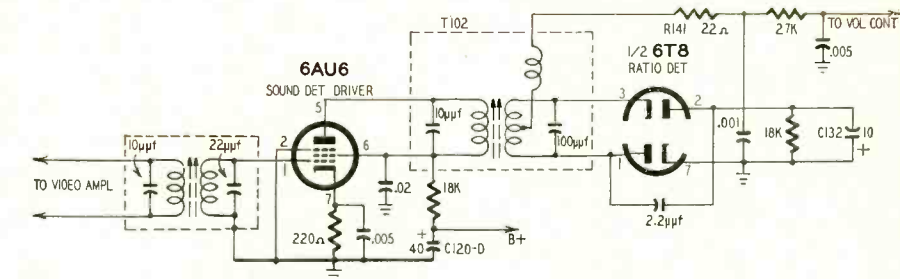

Ratio detector and driver circuit.

that the TV signal is weakest. Any noise voltages at the grid of the r.f. amplifier are amplified along with the signal. Any noise developed in later stages is generally much less than the noise from the r.f. amplifier.

The technician has virtually no control over shot-effect noise. About the best he can do is to substitute several tubes of the same type and check for minimum noise. This can be measured at the output of the video detector. But sometimes the difference between tubes is so slight that observing the snow condition may give a better indication. The development of low-noise front ends using tubes such as the 6BK7-A, 6BQ7-A and 6BZ7 in cascode amplifiers has done much to reduce noise effects.

With regard to antenna noise, the technician is limited to the installation of a high-gain antenna system. This includes selecting an appropriate antenna for the signal area involved; proper antenna orientation; proper impedance match between antenna, transmission line and receiver input; location of antenna in low-noise area and inspection of all electrical and mechanical connections.

In many areas of low signal strength, boosters are used to overcome snow. However, a booster—being nothing more than an r.f. amplifier—faces the same problem as the r.f. amplifier in the TV receiver—it must provide a high signal-to-noise ratio (perhaps 50:1 for a usable picture). If the r.f. amplifier of the booster does not operate at a noise level lower than that of the receiver, all the gain in the world will not eliminate snow. The best it can do is provide high contrast, but with annoying noise spots. Thus unless a booster can improve the signal-to-noise ratio it is of very little use.

Snow removal

The mixer or converter stage introduces a large amount of shot-effect noise (triodes to a lesser extent than pentodes). Thus, the snow can be used to isolate trouble as occurring before or after the mixer stage. A condition of no picture and no sound or weak

picture and sound occurring only on some channels indicates a front-end defect. This trouble on all channels spreads the possible trouble area to include the i.f. amplifier.

To isolate r.f. from i.f. trouble, advance the contrast and volume controls to maximum. If there is an increase in video snow and audio hiss while advancing the controls, indications are that the mixer and all the following stages are amplifying the noise. It thus locates the trouble in the antenna, r.f. amplifier or oscillator circuit. If there is no increase in receiver noise, the trouble is in the mixer stage or the following i.f. amplifiers. In general, a weak washed-out picture with lots of snow indicates loss of gain in the r.f. section.

Gain decreases and noise increases as bandwidth increases. Since the signal-to-noise ratio is so important in fringe areas it is a good idea to align the front end while observing the response curve at the output of the mixer. Aligning the front end while observing the response of the i.f. amplifiers will often result in an unwanted broadening of the front-end response, because, as the r.f. bandwidth is increased beyond about 4 mc, the overall i.f. curve looks good but the front-end curve may be too broad.

Thus, when running into a snow problem, carefully check the antenna and transmission line. Replace the r.f. and mixer tubes. Check the oscillator grid voltage. Check the a.g.c. circuit—excessive r.f. bias reduces the gain of the r.f. amplifier and increases snow. Measure the plate voltage on the r.f. amplifier. Excessive plate voltage results in an increase in shot-effect noise. Also, look for overheated resistors—they could produce noise through thermal agitation. Of less frequent occurrence is snow caused by a tuner that is not tracking properly or a poorly aligned i.f. amplifier.

Overheated output tube

In a model 9124 Silvertone receiver the 6BG6-G cathode and screen resistor become charred after operating for a very short time. When this occurs the

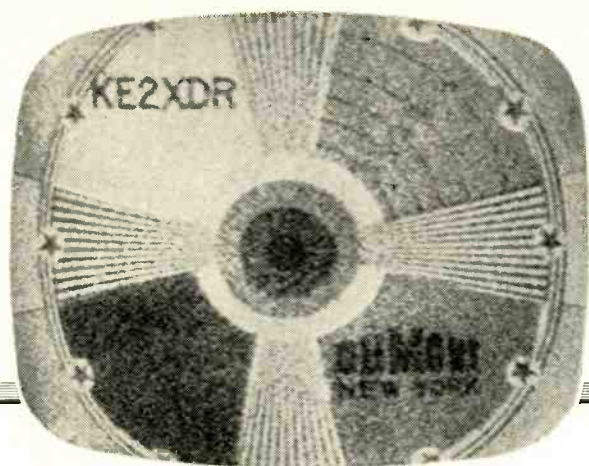

Excessive snow on a weak picture.

emission of the 6BG6-G is almost zero. I have replaced the horizontal output transformer and the deflection yoke as well as the high-voltage rectifier, damper and output tube.

When the trouble occurs, the picture and raster are normal and then suddenly disappear. At this time the screen and cathode resistors become overheated, the tube gets very hot and the screen voltage drops to 50. Could you tell me what causes this trouble?—G. F. G., Brooklyn, N. Y.

The symptoms indicate a defect in the horizontal oscillator. The 6BG6 operates as a class-C amplifier, developing a large bias voltage through grid-leak action. Should the oscillator fail, the bias voltage would be decreased greatly, increasing the plate and screen current through the output tube.

The heavy current flow through the screen-grid resistor and the cathode resistor is causing these resistors to overheat and char. In so doing, the screen-grid resistor greatly increases in value, lowering the screen voltage. The fact that the raster goes off is further indication of failure of the horizontal oscillator. Of course, the opening of the cathode resistor would also remove the raster.

Carefully check all components in the horizontal oscillator. Replace the oscillator tube. Check all components in the grid circuit of the output tube. Measure the grid bias on the 6BG6. If all components check good and operation is normal until the trouble occurs, it will be necessary for you to replace all components in the horizontal oscillation and output grid circuits whose failure would prevent the oscillator from functioning.

Dead oscillator

A Crosley u.h.f. Ultratuner used with a model EU-17TOB receiver has a completely inoperative oscillator. All B plus and heater voltages check perfectly and I can feed a single-frequency v.h.f. signal through the unit. However, the oscillator shows absolutely no sign of life. A v.t.v.m. check across the 10,000-ohm grid resistor of the 6AF4 oscillator shows no voltage.

I have replaced the oscillator tube and redressed the oscillator leads, but the circuit refuses to work. I have checked most of the components in this circuit and, outside of not operating, the circuit tests perfectly.—W. C., Waco, Tex.

Proper oscillation action at u.h.f. is often a touch-and-go affair and many checks have to be made that would ordinarily not be considered at lower frequencies. Before any detailed checks are made, replace the oscillator tube with a few you know to be good. Sometimes the slightest change in inter-electrode capacitance can make the difference.

If the circuit remains dead, check the connecting straps on the plate and grid capacitors for proper soldering—a loose or cold soldered joint could very easily be causing the trouble. Check the oscillator trimmer capacitor for loose plates. Check the contacts and mechanical alignment of the shorting bars in the Inductuner unit.

Check all capacitors for open circuits by shunting them with good units of the same value and temperature coefficient, keeping all leads as short as possible. Go over all wiring carefully, checking for broken leads and shorts, and apply the soldering iron to any suspected cold solder or rosin joints.

Be very careful about redressing wires. Try at all times to keep the wiring the same as when it left the factory.

21MP4 to a 21YP4

I have a 21MP4 badly in need of replacement. It is a metal tube and I would like to replace it with a 21-inch glass tube. I understand that generally it is not a good idea to replace a metal picture tube with a glass one. However, if it can be done, I would like to know what tube to use for a replacement.—R. L. M., Youngstown, Ohio

A 21MP4 metal tube can be replaced very nicely with a 21YP4 glass tube. The two are of approximately the same dimensions and have the same deflection angle and high-voltage requirements.

You will have to install an Aquadag grounding spring to each side of the yoke mounting bracket, and be sure that

the springs make good contact against the picture tube. Most brackets have holes into which self-threading screws can hold the springs. Since the conductive coating on the 21YP4 provides a high-voltage capacitor, the original unit in the set can remain or be removed. Because of the different second-anode connections, the high-voltage lead to the 21YP4 will have to be replaced.

Many technicians omit grounding the outer coating on the picture tube because the set already contains a high-voltage filter capacitor. This is dangerous and can produce a serious shock if the technician contacts the coating.

Audio buzz

A Crosley chassis 331-1 in the shop has a persistent buzz. I have checked every component in the sound circuits, including tubes. The voltages check out pretty close to the manufacturer's schematic. I have tried adjusting the ratio detector transformer, but the best I could do was to bring the buzz to a comparatively low value. Any hints toward repairing this trouble would be appreciated.—J. M., Trenton, N. J.

Since you have checked all components in the audio circuit (see diagram), try the following checks: Make sure that the 40- μ f electrolytic capacitor (C120-D) is properly grounded. To be sure, solder a wire from the chassis to one of the ground lugs of the capacitor. Check the connections of the various sections of C120 against the schematic. Proper filtering action is important in reducing this buzz.

Try shorting out R141; this often eliminates the trouble. Check capacitor C132 to see if it has dried out. If it has, chances are that it has greatly reduced in capacitance.

Adjust the ratio-detector transformer (T102) secondary for minimum hum or buzz while the set is tuned to a station. Make only a slight adjustment. If the screw is turned too far, it could result in weak or badly distorted audio output. If everything else fails, check the overall alignment as per manufacturer's instructions.

Other possibilities include a poorly grounded shield in back of the contrast control and improper a.g.c. adjustment—the a.g.c. level may be excessively high. END

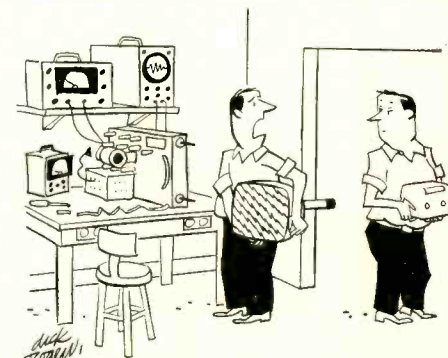

"Darn it, nothing seems to clear up the trouble."

Low-Frequency Compensation in VIDEO AMPLIFIERS

By JOSEPH F. SODARO

LOW-FREQUENCY phase shift in video amplifiers may result from the grid coupling, screen bypass or cathode bias networks. Phase shift can be compensated by the plate $R_p C_p$ network shown in the diagram. This is also a decoupling network which prevents feedback from developing across the power supply impedance. Plate circuit compensation can neutralize the phase shift produced by the grid, screen or cathode network.^{1, 2, 3} Complete compensation is obtained for the grid circuit if

$$R_o C_p = R_g C_c \quad (1)$$

where R_o is the output resistance, R_g the grid resistance and C_c the coupling capacitance. Equation 1 applies only if R_p is equal to or greater than 10 times the reactance of C_p at the lowest frequency to be compensated. Also, the shunt resistance of any following circuits, such as the grid resistor of the next amplifier, must be very large compared to R_o .

Phase shift produced by the screen network is neutralized if

$$R_p C_p = R_s C_s \quad (2)$$

in which C_s is the screen bypass capacitance and R_s the screen dropping resistance. In the case of a voltage divider network, the a.c. resistance from screen to ground is the parallel combination of the two resistance branches.

The cathode bias network is compensated if

$$C_k R_k = C_p R_p \quad (3)$$

$$g_m R_k = \frac{R_p}{R_o}$$

or $g_m R_k C_p = C_k \quad (4)$

in which C_k is the cathode bypass, R_k is the cathode resistance, and g_m the tube transconductance.

To determine circuit values for Equations 1, 2 and 3, use the nomograph shown in Chart 1. To solve Equation 1, select the value of R_g on the R scale and of C_c on the C scale. Connect these points with a straight line to determine a turning point (where this line intersects the T scale). Assume a convenient value for C_p and locate this point on the

C scale. Draw another straight line from this point through the turning point, to the R scale. At this intersection read the required R_o value. Conversely, R_o can be assumed and C_p determined. Also, R_g and C_c can be determined for given values of R_o and C_p by reversing the procedure. The nomograph is particularly convenient for determining equivalent R-C combinations. Thus, after establishing the turning point, pivot a straightedge about this point and you will obtain combinations of R and C which yield the same product as the first R-C combination.

As an example, determine the decoupling network required to compensate a 0.1- μ f coupling capacitor and a 390,000-ohm grid resistor. Locate 0.1 on the C scale and 390,000 on the R scale. Connect these points with a straight line, intersecting scale T. Assume a decoupling capacitance value for C_p of 20 μ f. Locate this point on the

C scale and draw a line from this point, through the turning point, to the R scale. At this intersection read 1,800 ohms, the value of R_o . If compensation is to extend to 30 cycles per second where the reactance of C_p is 265 ohms, R_p must equal or exceed 2,650 ohms.

To solve Equation 2 follow the same procedure on Chart 1 as that used for Equation 1. In this case use R_s and C_s values to establish the turning point. Assume either R_p or C_p and solve for the other, or simultaneously observe R_p and C_p values which give the required R-C product. As an example, assume that screen dropping resistor R_s is 1 megohm and screen bypass capacitor C_s is .05 μ f. Locate 1,000,000 on the R scale and .05 on the C scale. Connect these points by a straight line and determine the turning point. Pivot a straightedge about this point to find combinations of R_p and C_p that will cancel the phase distortion due to the screen-grid net-

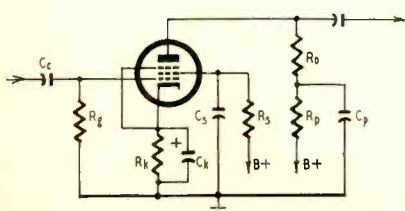

Low-frequency-compensated amplifier.

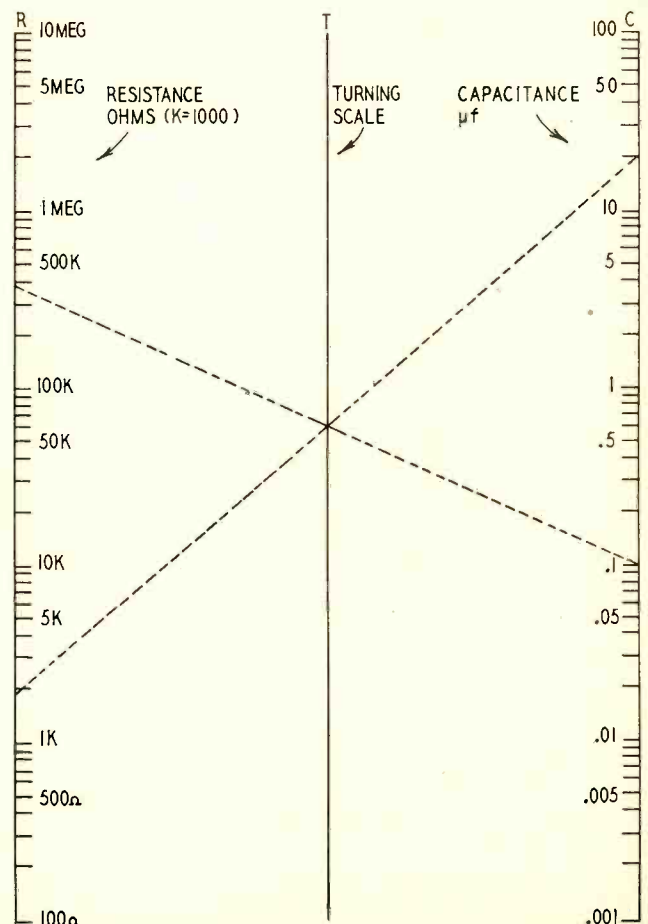

Chart 1 — Nomograph for determining video amplifier low-frequency-compensation circuit values for Equations 1, 2, 3.

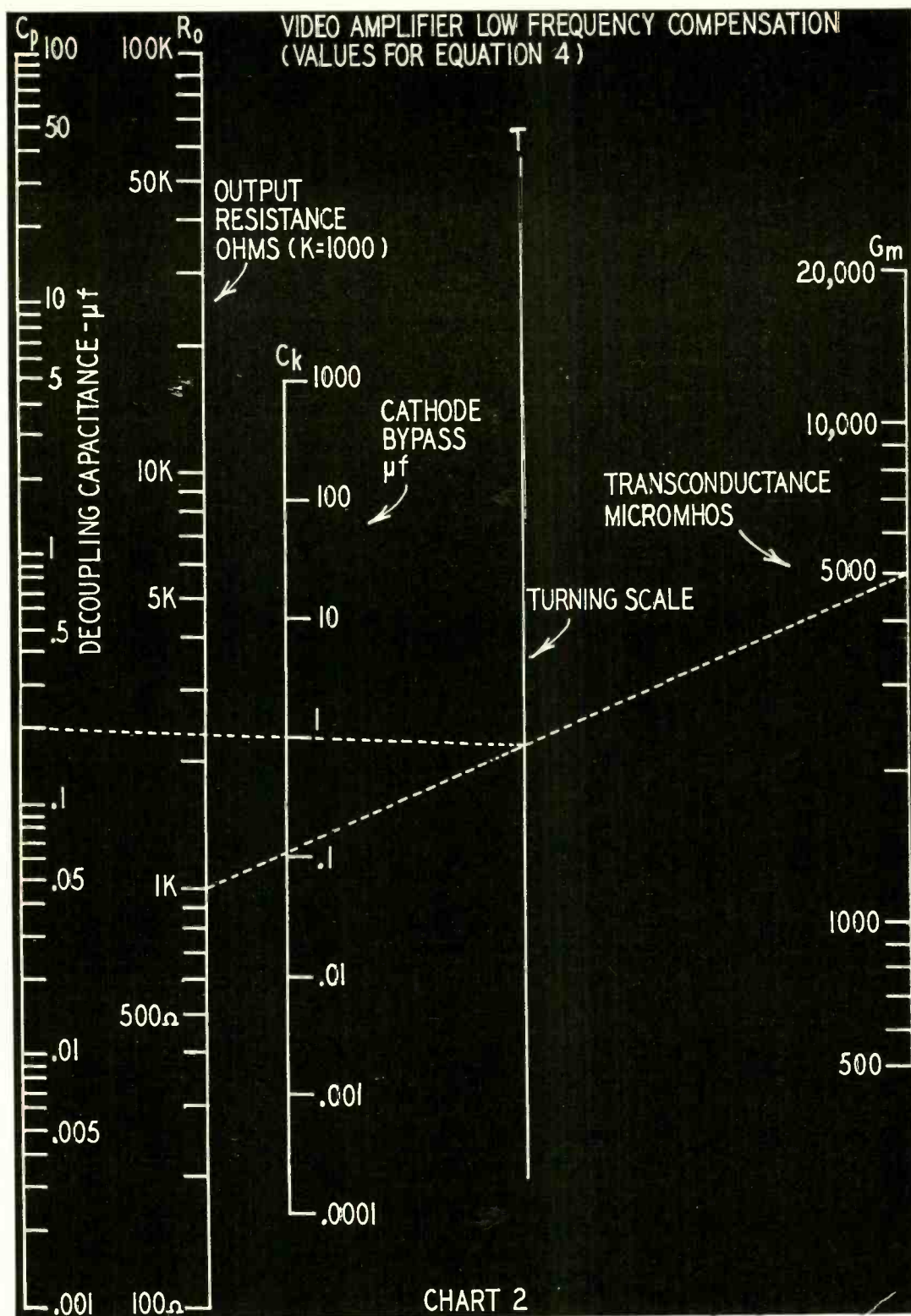

CHART 2

work. One combination is: R_p , 5,000 ohms; C_p , 10 μf .

Equation 4 can be solved by the nomograph shown in Chart 2. Select the mutual conductance on the g_m scale and the plate resistor on the R_o scale. Construct a straight line between these points. Locate a turning point where this line crosses the T scale. From the turning point to the decoupling capacitance value on the C_p scale draw another straight line. Read the required cathode bypass value where this line

crosses the C_k scale. An alternate procedure would be to determine C_p by extending a line from the turning point through the C_k value to the C_p scale. Here again, a straightedge can be pivoted about the turning point to determine suitable combinations of C_k and C_p to cancel low-frequency distortion.

As an example determine the decoupling capacitance required for a tube having a g_m of 5,000 micromhos if the cathode bypass is 1 μf and the output resistor is 1,000 ohms. From 5,000

on g_m to 1,000 on R_o draw a straight line. The turning point is the intersection of this line with the T scale. Extend a second straight line from the turning point, through 1 on C_k , until it intersects the C_p scale. Read 0.2 μf at this intersection. END

References

- ¹F. E. Terman, *Radio Engineers Handbook*, pages 414-417, McGraw-Hill, 1943.
- ²D. G. Fink, *Principles of Television Engineering*, pages 228-238, McGraw-Hill, 1940.
- ³K. R. Sturley, *Radio Receiver Design*, Part 2, pages 431-436, Chapman & Hall, 1945.

IRE Attains New Heights

Highlights of 1955 session include space satellites, ultrasonic dental drills, a transistorized scope, and new types of C-R tubes



Courtesy Cavitron Equipment Corporation
The ultrasonic dental drill differs from other types chiefly in being painless.



The transistorized oscillograph. The box at right holds the battery power supply.

LITERALLY and metaphorically, discussions soared to new heights at the 1955 convention of the Institute of Radio Engineers, held in New York. As one periodical put it, "Not even the sky is the limit." For one of the most important symposiums—that on remote control and telemetering—dealt entirely with electronically controlled space stations.

This subject was pretty much monopolized by the military, though the physical researchers were also interested, and one of the most interesting suggested applications of a satellite was as a trans-Atlantic television relay. This was proposed by Dr. John R. Pierce, director of research of the Bell Laboratories. He suggested that a satellite 100 feet in diameter, in an orbit 22,000 miles above the earth, would be large enough to reflect signals from one continent to the other.

Sending and receiving antennas 250 feet in diameter would be necessary, plus 50,000 watts of power for each transmitter. Noting that a cable to carry 30 TV channels is being laid across the Atlantic at a cost of \$35 millions and that a satellite could carry 900 channels, Dr. Pierce pointed out: "That would give us about a billion dollars to play with."

Automation was the second most

important feature of the convention. Most interesting to the radio-TV field were the discussions on automatic construction and assembly of electronic equipment. Included were papers on the Signal Corps' Auto-Semby system and Admiral's automatic TV receiver chassis construction (RADIO-ELECTRONICS, January, 1955, page 71). A complete session discussed the technical, managerial, social and economic implications of the trends toward automatization of procedures and processes in business and industry.

Ultrasonics was another important subject of the year. John M. Reid and John J. Wild of a Minneapolis hospital described equipment which can discriminate between the ultrasonic echoes returned from nonmalignant tumors, liquid-filled cysts and cancers. The experimental equipment shows a high percentage of correctness in diagnosing incipient cancers and an even better score (98% correctness) when deciding that a growth was *not* cancerous. Dr. Douglas Howry of the University of Colorado—a veteran worker in the field—described equipment and work in studying and describing the form of structures deep in the human body.

Closer home to the average man was the ultrasonic dental drill, subject of papers by Drs. Lewis Balamuth of

Cavitron and Alvin E. Strock, a Boston dentist. According to Dr. Balamuth, 150 of the machines have been placed throughout the country and about 4,000 patients treated. More than 97% of them report no pain from the new drill. The ultrasonic drill is not only painless, it can make sharp-cornered cuts that hold dentures much better than excavations made by the old-fashioned drill.

Frozen television

It may seem a backward step to try to stop motion in television, but that is just what Raytheon did in an elaborate display that looked like a TV set in a large rack. A camera beside the device was focused on the crowds ahead of it, and at intervals the picture on the screen was "frozen"—the images of spectators remaining fixed while they themselves walked away.

The secret of the device was a memory tube, scanned to produce the TV picture that appeared on the monitor screen. If the TV input signals were cut off after any one frame, the picture remained in the tube's memory and could be scanned or "read" up to 30,000 times. The picture could be held a week before playing back, if desired.

Service technicians were especially interested in an all-transistor oscillograph (the Du Mont term for what

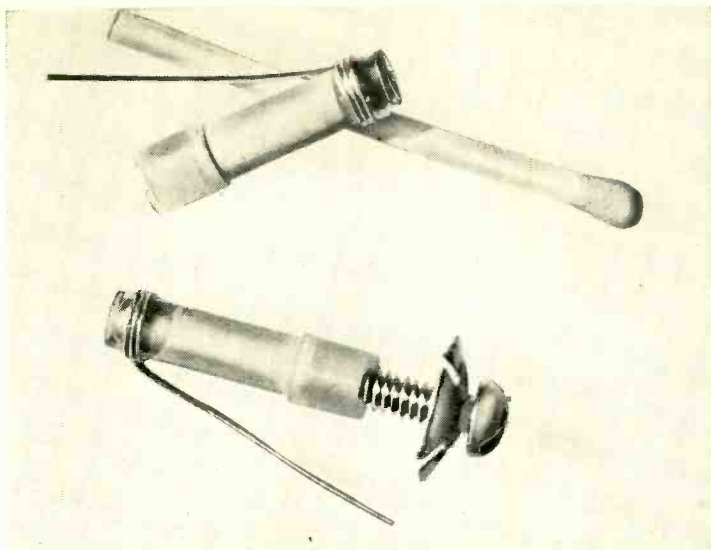

Two of the new glass trimmer capacitors.



New RCA tricolor Vidicon camera tube.

many call a scope). Weighing 16 pounds—and most of that battery—it occupies only $\frac{1}{4}$ cubic foot and consumes less than 5 watts, most of which is used by the C-R tube. Du Mont engineers described it as “real cool.”

From a spectacular standpoint, the various computer exhibits were particularly outstanding. With vast numbers of varied-colored lights flashing at fantastic rates and relays chattering madly, the computing devices were probably the most dramatic demonstrations of the show.

Other items of particular interest to the technician were a voltmeter which chose its own range, automatically stepping a switch around so that the indicated voltage would not only be on a range which would not overload the meter, but also on the lowest of such ranges, thus giving readings on the best half of the meter scale. Another, a “digital voltmeter” intended for factory use, used counter circuits giving a direct reading of the voltage measured.

Capacitors with a glass dielectric may also soon make their appearance in the service shop. Two types shown by Corning Glass will be distributed through Erie Resistor Corp. One was a small cylindrical trimmer. The other type was a series of subpostage-stamp fixed capacitors with a dielectric of

thin glass film. Capacitors made this way are smaller than silver-mica units for any given voltage and capacitance rating. The capacitances are in the same range as those of small micas or silver-micas and the units are intended for the same type of application.

Another intriguing device exhibited by Du Mont was the *Iconumerator*, a device which counts objects placed in its field of view. The remarkable feature of the instrument is that it can count objects of different sizes and shapes. In the tests, matches and small ball bearings were among the items mixed and counted correctly.

The unit demonstrated had a field of vision adapted to counting objects in 3-inch plastic trays, strongly reminiscent of those in which bacteria cultures are grown. Its importance in counting germ colonies and blood cells and in similar therapeutic applications was stressed by its exhibitors. It uses a flying-spot scanner and special circuitry which prevents it from recounting an object counted on the previous line.

Other C-R tubes included one containing storage elements behind the screen, so that a trace on its screen might be considered permanent. Exhibited by Hughes Aircraft, the *Memotron* was described as a direct-display stor-

age tube. Another version of the same tube used the long-term phosphor with the gun arrangement of the McNaney *Charactron* (RADIO-ELECTRONICS, December, 1949; October, 1953) together with the storage elements of the *Memotron*. Called the *Typotron*, it can display any one or any combination of 63 characters continuously till erased.

Two important television tubes were announced. One of these, the Rauland color kinescope, uses a sort of post-deflection focusing in connection with a shadow mask to get brightness three to four times as great as with former tubes. Due to the directing field, more than 80% of the electrons get through the mask to the screen.

The other tube was the new RCA Tricolor Vidicon, a TV camera tube which picks up all three color signals instead of only one. It has a large number of vertical color filter strips, together with horizontal color-sensitive elements. When traversed by the scanning beam, it supplies the complete composite color signal now produced as the joint effort of three camera tubes. Adapted to work at present, under conditions of high illumination, it is possible that it may—through development of more sensitive photoconductive materials—become usable under conditions of average lighting. END



Du Mont's *Iconumerator*, a device which can count objects of any size and shape in its field of vision. Here its subjects are similar to colonies of bacteria counted in medical laboratories, etc. The most startling feature of the instrument is that the size of the object (as long as it can be contained in the field) or its shape make no difference in the accuracy of the numeration.

Revolutionary new

OSCILLATOR-AMPLIFIER

The maser works on a new principle to produce microwave oscillations and amplify with a practically infinite signal-noise ratio

By FRED SHUNAMAN

MANAGING EDITOR

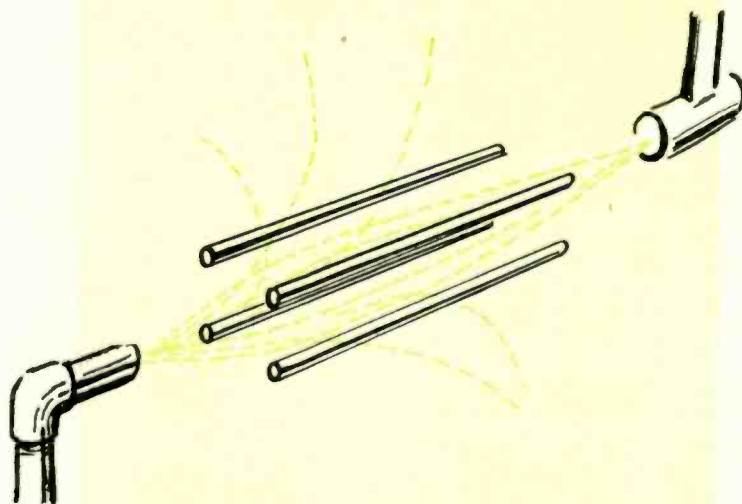

Path of molecules, through maser, showing separation of active and inactive ones.

THE instrument shown on our cover represents a completely new method of producing electronic oscillations or amplifying radio signals. Called "Microwave Amplification by Stimulated Emission of Radiation" (*maser*) it uses ammonia molecules as a source of energy and as an oscillating medium.

The maser was developed at the Columbia Radiation Laboratory, which is jointly sponsored by the Armed Services and Columbia University. It was conceived by Prof. Charles H. Townes, executive officer of the Physics Department of the university. The work on it was carried out by him and his assistants: Dr. H. J. Zeiger, Carbide and Chemicals Co., post-doctoral fellow in physics at Columbia, and J. P. Gordon, a graduate student. The device was conceived as an aid to microwave spectroscopy, but its applications will cover a far wider field.

Oscillations produced by the maser are so steady in frequency that they can be used in an "atomic clock" 20 to 50 times more accurate than any now in use or in a simplified navigation aid similar to Loran but dispensing with some of the stations necessary for that system. As an amplifier, it has a fantastic signal-noise ratio. The noise level is practically at the theoretical minimum level of zero. Thus, while the output of the amplifier is very low (about 10^{-9} watt), it can be used to

amplify signals far below the noise threshold of the best vacuum tubes, bringing them up to a level where they can be amplified by more conventional methods. In spite of its large size, the maser is a microwave oscillator, operating at 23,870 mc, the resonant frequency of the ammonia molecule. The brass box is simply a container into which ammonia gas at low pressure (10^{-6} atmosphere) may be injected. It contains the active part of the equipment—four cylindrical electrodes which form an electrostatic field, and a resonant cavity about 1 centimeter in diameter and 3 inches long. It is also fitted with airtight seals through which pass waveguides, control adjustments and pipes for admitting and removing gas, pumping the chamber to a low pressure and circulating coolants.

How it works

Operation of the maser is remarkably simple, though different from anything in the history of electronics. A stream of ammonia molecules is injected into the brass chamber and directed down the center of the field formed by the four copper cylinders. These molecules may be in one of two states—a low-energy state that may absorb energy and a high-energy one that can radiate energy. As they drift through the electrostatic field—formed by keeping two of the copper cylinders at a potential of 6 to 20 kilovolts and the two diagonally opposite grounded—the low-

energy "dead" molecules are diverted and scattered while the high-energy ones are focused into a sort of beam which enters the resonant cavity just beyond the field. The process may be compared with the refining of uranium, in which the inert U-237 is removed and only the active U-235 left in a more or less pure state.

Once inside the cavity, which is dimensioned to resonate at the frequency of the ammonia molecule, some of the molecules radiate—give up some of their energy. These tiny quanta of energy trigger other molecules, building up a chain reaction which may again be compared to that of purified uranium. In a short time the molecules have produced a vigorous oscillation in the cavity. The microwave energy is piped out of the cavity in an ordinary waveguide.

This type of oscillation is unique—it is like nothing previously experienced in controlled electronic reactions. There is a local electric source—to maintain the high-voltage electrostatic field—but the energy which produces the oscillations does not come from that supply. It comes from the ammonia gas itself. Approximately 10^{14} molecules per second must be admitted into the chamber to maintain oscillation.

The maser as amplifier

If the number of ammonia molecules admitted is not great enough to sustain oscillation, the maser can act as an

amplifier. An external signal may be introduced and increased in amplitude by energy picked up from the radiating molecules. The output of approximately one-billionth watt is high enough to apply to the grids of standard vacuum tubes, making the maser a preamplifier with a signal-to-noise ratio essentially equal to the limit set by fundamental thermal noise. The maser amplifier may in addition be cooled so that the fundamental thermal noise is further reduced.

Coupling the signal to be amplified to the maser is simple. Signals have been transmitted down the waveguide which enters the resonant cavity at the top and the amplified signals reflected back through the same guide. Should it prove more convenient, the signals could be admitted from a guide on one side of the cavity, passed straight through and removed by a guide on the other side. The amount of amplification is linked with the stability of the device. Operated to give very high gain, the system may break into oscillation. An amplification factor of 100 can probably be obtained without serious instability.

Two masers were in existence when this was written. It was necessary to build the second one so that it could check the first. No other instrument is accurate enough to test a maser.

During the tests the oscillation frequencies were compared with an accuracy of one part in 100 billion. Professor Townes states that this is probably the most accurate comparison or measurement of any two physical quantities that has ever yet been made.

While Professor Townes and his associates were chiefly interested in microwave spectroscopy, one of the most important immediate applications of the maser is as a frequency standard. It is at least 30 times as stable as the best systems using crystal oscillators. Thus it would make an excellent atomic clock. Incidentally, it operates on exactly the opposite principle from that of the atomic clock described in this magazine in the March, 1949, issue. In that clock, ammonia gas acted as a wave-trap at the resonant frequency, absorbing energy produced by a crystal oscillator. The maser produces its own power and does not have to depend on auxiliary equipment for its oscillations.

It is expected to increase the resolution or detail which can be seen by microwave spectroscopy about 10 times, improving and extending our knowledge of the structure of molecules, atoms and nuclei.

Many other applications—such as the navigation aid mentioned before—become apparent. The maser will find applications in radio astronomy and in many uses where a radio frequency must be measured with greater accuracy than is possible with present apparatus.

But it is in directions unknown at present that the maser may find its greatest usefulness. Simply because it

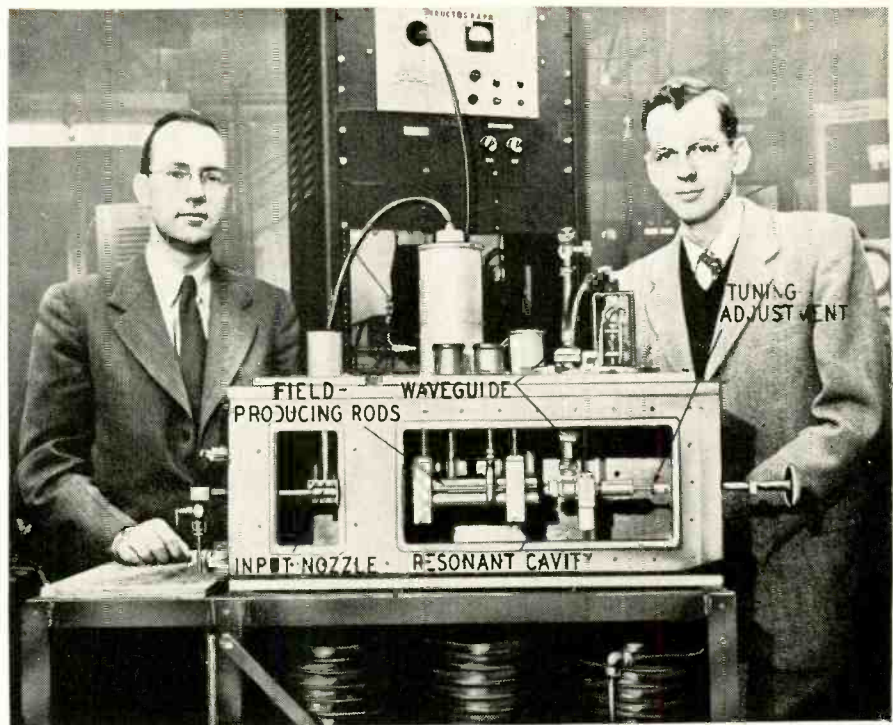

The first experimental maser, with Professor Townes (left) and J. P. Gordon.

can act beyond our known horizons, it is difficult to assign its fields of future application. Who can say, for example, what uses there may not be for an

amplifier which can amplify signals in a whole region which is now unexplored territory and whose very existence we may not suspect at present? END

AN ULTRA-SUPER-FRINGE TV ANTENNA

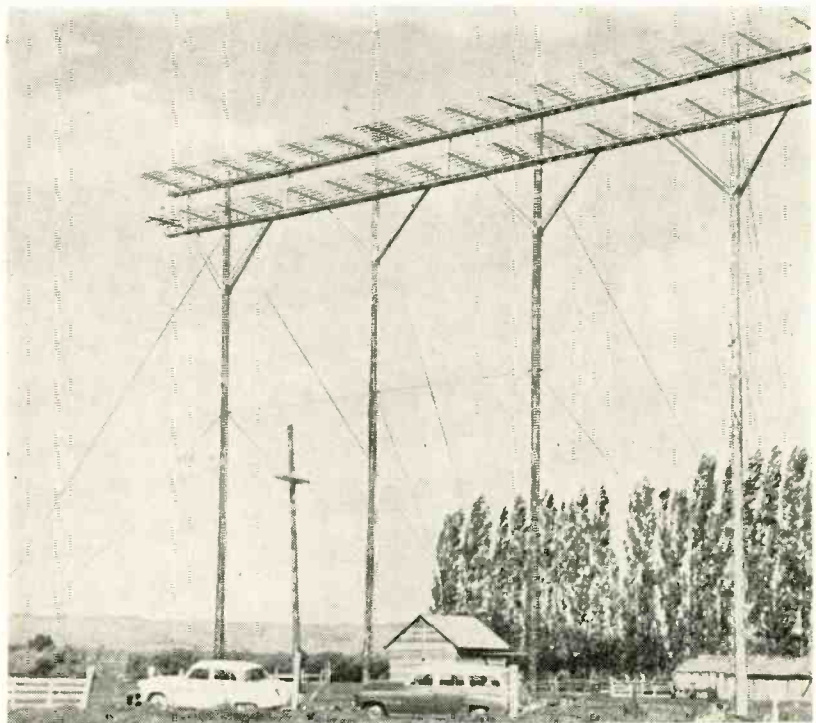

Ellensburg, Wash., a town of about 9,000, is located 100 air miles and a range of mountains east of Seattle. Every attempt to receive a picture from Seattle met with failure. In a final attempt, the Jerrold-Northwest Community Co. hit upon a plan for the installation of 16 stacked Yagis (see photo). Half of the antennas are designed for channel 4, the other half for channel 5. The project was successful, and the people of Ellensburg are now receiving nearly perfect pictures. The antennas used are eight-element *Balune* Yagis, made by JFD.

ELECTRONICS

JUST a few years ago, the production of low pressures was an art known to only a relatively few physicists and engineers. Today, vacuum has become one of industry's most important tools. Radio and television would be impossible without it, and its uses range from the production of jet engines and atomic bombs to the manufacture of phonograph records and thermos bottles. Fig. 1 illustrates a few of these processes. It may be seen that the range of pressure used in these applications is well over 100,000,000 to 1!

The use of such a wide range of pressures has made it necessary to develop a large variety of gauges for their measurement. The most popular of these instruments are essentially electronic and because of their increasingly widespread use it is inevitable that the electronic technician or plant electrician will be called upon to service them. This article will lay the foundation for this future service work by outlining the principles of some of the most popular of these gauges.

For many years, atmospheric pressure was used as the base for vacuum measurement. Since this pressure varies with geographical location, time of day and barometric changes, it proved a poor reference line. In recent years it has become customary to make vacuum measurements on an absolute scale. A theoretically perfect vacuum is taken as the reference level. With this as our zero, any vacuum less perfect than this exists at some definite pressure above this zero level.

If we should take a long glass tube, sealed at one end, completely fill it with mercury and then, by holding a finger over the open end so that no air is admitted, carefully place it in a small cup of mercury (Fig. 2), the mercury will settle down and stand at some definite height (H). A vacuum will be created in the space above the mercury column. The height of this column will be determined entirely by the pressure of the air on the open surface of the mercury in the cup. At sea level this

*Engineer in Charge, Cyclotron Laboratory, Washington University, St. Louis, Mo.

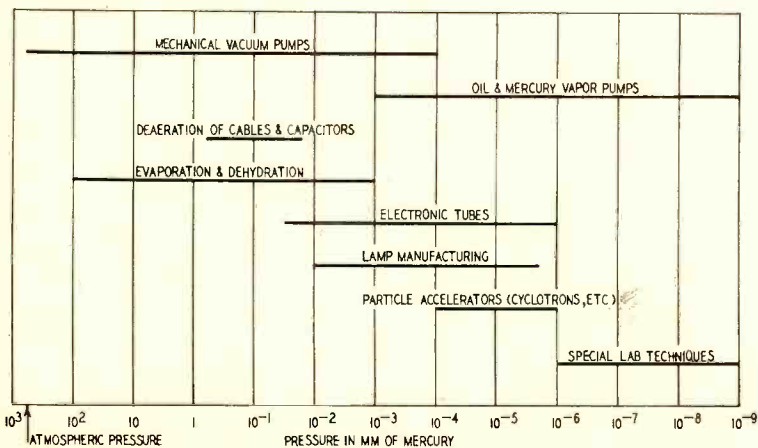

Fig. 1—Typical pressure ranges of some common pumps and processes.

Theory and circuitry of instruments for measuring extremely low pressures

ELECTRONIC VACUUM GAUGES

By A. A. SCHULKE*

will be about 760 mm. If the air pressure is reduced by taking this device to some great altitude, as for example, to the top of Mount Everest, the air pressure will be able to support the mercury column to a height of only about 235 mm. If we enclose this mercury tube inside a tight box (dotted lines in Fig. 2) and attach a vacuum pump to the box to reduce the pressure further, the mercury column would fall still lower.

The height of the column is therefore a function of the pressure which may be expressed in terms of the column

height as so many millimeters of mercury. This is usually abbreviated to "mm Hg." The mercury manometer (Fig. 2) is not useful for measuring pressures below 1 mm or so, other gauges being used for this purpose. Yet the unit (mm Hg) is still used to indicate the degree of partial vacuum obtained.

By using a classification system somewhat similar to that adopted for radio and television channels, we can loosely classify vacuum systems capable of producing pressures as low as 10⁻³ to 10⁻⁴ as "high"; those operating

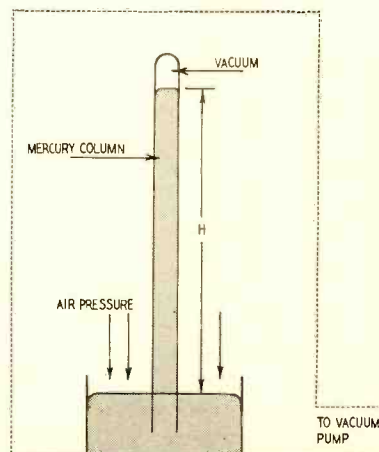

Fig. 2—Mercury-column pressure gauge.

still lower, say to 10^{-6} mm Hg, as "very high" and those few systems capable of going beyond this point, "ultra high."

To produce high vacua, it is necessary to work harder and harder to obtain less and less. The greatest effort must be applied to obtain practically nothing! Well, not quite nothing. Inside the average television tube, which is at a pressure of about 3×10^{-7} mm Hg, there are approximately 10^{14} (100 million million) air molecules per cubic centimeter. At the lowest pressure yet obtained in the laboratory, each cubic centimeter still contains more than 200 millions of these molecules.

Most vacuum gauges, certainly all those which may be classified as electronic, operate by ionizing these molecules in some way and then measuring the resultant current. Some of these gauges are listed in Fig. 3, together with the regions of pressure in which they usually operate.

McLeod and Knudsen gauges

Two nonelectronic gauges, the McLeod and Knudsen, which do not use this principle, are worth mentioning because they are the basic gauges used for calibrating all others.

The McLeod operates on the principle of taking a sample of gas of known volume V_1 from the vacuum system at a pressure P_1 , which is too low to measure. This sample is then compressed into a smaller volume V_2 at a higher pressure P_2 , which can be measured by a mercury column. The unknown pressure P_1 may then be easily calculated by Boyle's law, $P_1 V_1 = P_2 V_2$.

This gauge, though simple and easily calibrated, is not in general use as a vacuum gauge primarily because it is slow to read (it requires 10–15 minutes for one pressure measurement), is not continuously reading and cannot be read remotely. It is also very difficult to use at pressures below 10^{-4} mm Hg.

The Knudsen gauge consists of a thin sheet of metal suspended between two heated plates located on opposite sides and at each end of the sheet. Gas molecules entering the region between the sheet and the plates gain momentum

from the heated plates and bombard the sheet with greater force than those molecules which happen to strike other areas of it. The sheet will therefore be deflected away from the heated plates and the amount of the deflection, proportional to the number of gas molecules present, will be a direct measure of the pressure in the system.

The Knudsen gauge is unique in that its action is independent of the kind of gas or vapor pressure of the gas in the vacuum system. No other gauge has this property and the Knudsen gauge is thus the only absolute gauge we have. It is also a continuous-reading device, although somewhat slow in responding to pressure changes in the vacuum system.

Unfortunately, it has several serious disadvantages which preclude its more general use. The principal ones are that it is delicate and must be rigidly mounted on a vibration-free support, it cannot be read remotely and the pressure range of any given gauge is relatively narrow. Although the Knudsen gauge principle can be used to measure pressure from about 10^{-2} to 10^{-5} mm Hg, this can be done only by using instruments with different suspensions and heater temperatures.

The Alphatron

This is the newest of the vacuum gauges and since it was placed on the market comparatively recently it is not in very general use.

The heart of the device is a sealed radium source of about 200 milligrams, placed inside an ion chamber. Alpha particles emitted from this source at a constant rate cause ionization of some of the gas molecules from the sample taken of the vacuum system. Since these ions are collected in the chamber at a rate proportional to the number of gas molecules present, the response of the gauge should be linear. This has been found to be so for a range of pressure extending from about 10 to 10^{-3} mm Hg.

The output current from is gauge is very low, about 2×10^{-7} microamperes at 10^{-3} mm Hg. A very-high-gain d.c. amplifier must be used to measure this

minute current. The lower limit of pressure will measure about 10^{-4} mm Hg since, at this pressure, the ion current produced by the gauge has about the same magnitude as the grid current of the amplifier tube in the first stage. Input resistors for this amplifier range from 100 to 10,000 megohms—far beyond the range of most service shops to check.

The gauge appears to have few disadvantages and much to recommend it. The probe head containing the fairly husky radium source, although safe as constructed, should be taken apart only by someone trained in the handling of radioactive materials. Thus, it is likely that any field service done on this gauge will be limited to the d.c. amplifier. Other possible disadvantages are its comparatively high cost and the fact that it operates in a pressure region now occupied by well-established and substantially cheaper gauges.

Among its advantages are these: The source of ions requires no power supply and is self-regulating, it is very rugged and not easily broken, there is no filament to burn out and the gauge cannot be harmed by exposure to full atmospheric pressure.

In common with many other gauges, the response of the Alphatron varies with different gases. When measuring the pressure of a vessel containing helium, for example, the output current from the gauge will be only one-tenth as much as for air at the same pressure. Fortunately, however, the gauge response is almost the same for air as for water vapor. For this reason it should become a great favorite with the dehydration industry.

Thermocouple gauge

Of all the gauges available for the measurement of low pressure, the thermocouple type will probably be of greatest interest to the readers of RADIO-ELECTRONICS. Extremely rugged, simple and foolproof in operation, it cannot be damaged by operation at full atmospheric pressure. The control circuit requires only a few relatively inexpensive parts and the range of pressure measured is almost ideal for the vacuum systems used in the average shop or basement laboratory.

Its essential elements (Fig. 4) are a heated wire and a thermocouple. The operation of the gauge depends on the fact that over a certain range of pressure, the heat conductivity of a gas depends on the number of gas molecules (gas pressure) present. This means that with a constant current to the heated wire, the wire will be relatively cool when the pressure is high (poor vacuum and low output from the thermocouple) and will get progressively hotter as the pressure is reduced (better vacuum and higher output from the thermocouple).

The extreme simplicity of this gauge and of the electrical circuit used with it may be seen from Fig. 4. To operate the gauge it is only necessary to set

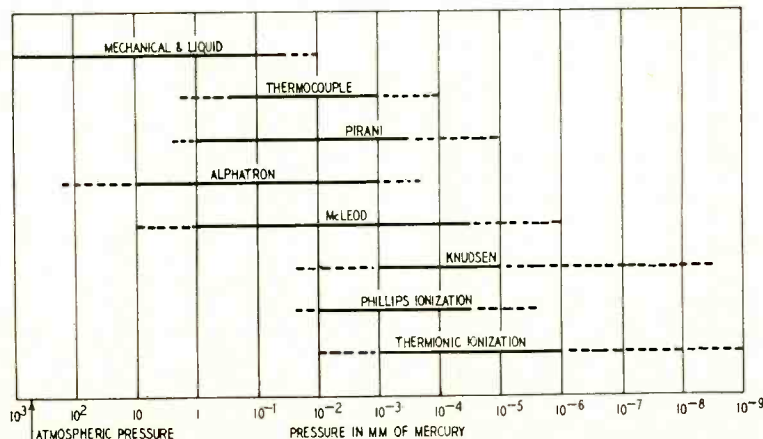

Fig. 3—Some of the various vacuum gauges and the ranges achieved by them.

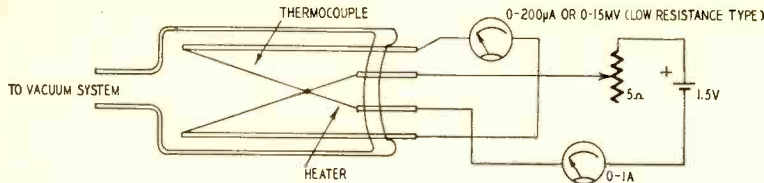

Fig. 4—The schematic and control circuit of a thermocouple vacuum gauge.

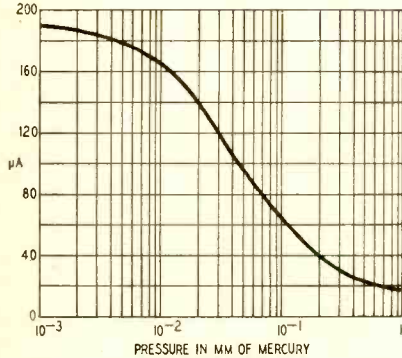

Fig. 5—The calibration curve for the model 501 thermocouple gauge.

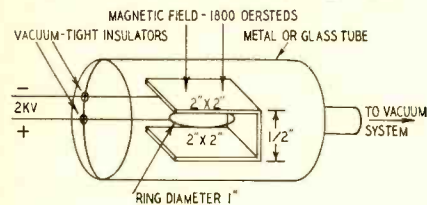

Fig. 6—Diagram of the Phillips gauge.

the heater current to the value marked on the tube (usually about 0.62 ampere) and read the output current on a microammeter or millivoltmeter.

The output current from the thermocouple is relatively high and may be read directly on a meter without intermediate amplification. The meter must be of the low resistance type, however.

One of the most popular thermocouple vacuum gauges is the model 501 all-metal tube manufactured by the National Research Corporation, Cambridge, Mass. It has a standard eight-prong octal base for the electrical connection, a threaded pipe for attaching the tube to the vacuum system and may be purchased for about \$12.

The calibration curve for this gauge for dry air, and for 70-ohm impedance in the thermocouple output circuit, is in Fig. 5. This curve will not be valid for gases other than dry air, however, because the heat conductivities of these gases are not the same for the same pressure. Each gas will require its own calibration curve, but this is usually not a serious disadvantage.

The Pirani gauge, which will not be described here, is a variation of the

thermal conductivity principle. In this gauge, the heated wire is part of a Wheatstone bridge circuit and the change of resistance, measured by the bridge, indicates the pressure.

Phillips ionization gauge

This extremely popular gauge overlaps the upper range of the thermocouple gauge and the lower range of the thermionic gauge, and frequently will take the place of both. It operates by maintaining a glow discharge between two electrodes in a magnetic field.

As pressures become lower and lower, the distance an electron must travel before it makes an ionizing collision with a gas molecule becomes greater and a glow discharge cannot be maintained for any reasonably low voltage between the electrodes. At a pressure of 10^{-3} mm Hg, for example, the average electron will travel about $2\frac{1}{2}$ inches before making an ionizing collision. But at 10^{-4} mm Hg this distance increases to 25 inches—over 2 feet!

In the Phillips gauge the glow discharge is maintained between a circular anode and double cathode arranged in a magnetic field as shown in Fig. 6. Because of the potential difference between the ring and the cathode, an electron which finds itself near the lower plate will be accelerated upward. It misses the ring, however, and continues through the ring, traveling in a tight spiral about one of the magnetic lines. As it approaches the upper plate it is repelled and travels downward through the ring to repeat the process. This oscillation up and down may be repeated many times. This makes the path length of the electron much longer than it would normally be and the chance of an ionizing collision is greatly increased.

There is nothing particularly critical about the geometry of the electrodes, the magnetic field intensity or the voltage used with the gauge; but the calibration does depend on these factors. In general, large electrodes and high voltage seem better for low-pressure work. For pressures above 10^{-3} , lower voltage (1 kv) and smaller electrode spacing are necessary.

The purpose of the magnetic field is to cause the electrons to move in a tight spiral; the weaker the field the wider this spiral will be. As the electron spirals about one of the magnetic lines the path length is increased in the horizontal plane, just as it was increased in the vertical direction by oscillating up and down. Values of field intensity used have been reported as low as 300 oersteds and greater than 5,000. It is apparently not at all critical but it should not be so low that the diameter of the spiral path of the electron becomes large in comparison with the diameter of the ring anode. For any particular gauge there will probably be a particular field strength where the gauge reaches maximum sensitivity. But it may work well with a variation of 50 to 100% of this value.

Given a small lathe and a little shop experience, a Phillips gauge can be easily constructed. One such gauge was made of a $1\frac{1}{2}$ -inch diameter brass pipe. The magnet was housed inside the pipe with the $\frac{1}{8} \times \frac{5}{8}$ -inch pole shoes, spaced $11/32$ inch apart, also serving as cathodes. The 2-kv supply for the $\frac{7}{8} \times \frac{5}{8}$ -inch anode was brought through the end of the pipe by a Kovar seal. This is a small glass-to-metal vacuum-tight insulator which can be obtained in a variety of sizes and styles from the Stupakoff Ceramic Co., Latrobe, Pa. With a field strength of 1,400 oersteds, the unit has been working very well for many months.

The electrical circuit for this gauge (Fig. 7) is also very simple. The 1-megohm resistor in series with the high voltage is a protective device used to limit the current in case of a short in the external circuit.

A typical dry-air calibration curve for a Phillips gauge is shown in Fig. 8. Since the response of the gauge will vary with different gases, the gauge must be calibrated for whatever gas is being used. The output of the gauge is high and—as for the thermocouple type—the output current may be metered directly.

This gauge is also very rugged and dependable and may be exposed to atmospheric pressure without harm. Because of its simplicity, the chances of trouble are greatly reduced and what difficulties do arise are usually due to the high voltage used.

Although the output of this gauge

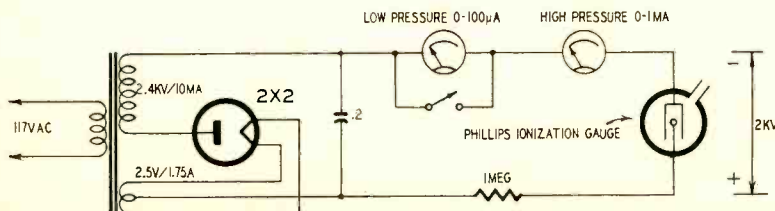

Fig. 7—Schematic shows the circuit for a Phillips ionization gauge.

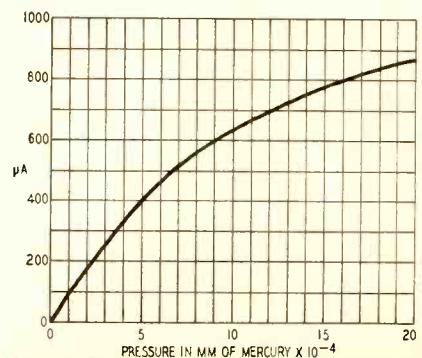

Fig. 8—Phillips ionization gauge curve.

is relatively high, in the higher pressure region of its range the output current will be reduced to only $10 \mu\text{a}$ or so when it is operating at pressures around 10^{-5} mm Hg. Because of the high voltage used, about 2,000, the insulation resistance must be greater than 1,000 megohms to avoid reading leakage currents comparable to the low output current. Another source of trouble is electrical breakdown of the insulators in the cable connectors at the gauge or power supply. Usually due to faulty design or damp locations, it can usually be corrected without difficulty.

Thermionic ionization gauge

The triode tube is the only device that can measure extremely low pressures, respond quickly to any change in pressure (useful for leak hunting) and still be read and operated at a considerable distance from the vacuum system.

The basic circuit for this gauge is shown in Fig. 9. Although it may seem simple, the actual device, as used industrially, may be somewhat bulky and complex. The reason for this is that the sources of voltage and current, shown on the diagrams as batteries, are replaced in the commercial form with voltage- and current-regulated power supplies. And a d.c. amplifier is almost always used to increase the output current to a more measurable value and to provide for a selection of scales so that a pressure range of more than 10,000:1 may be observed with the same gauge. Also included in the industrial version are a circuit for degassing the tube elements and a protective device for removing power from the filament in case the pressure should rise too high.

The gauge will work well with batteries, however, and a tube is frequently connected in this way to check the tube. It may also be used to calibrate other gauges.

In its original form, the thermionic ionization gauge was an ordinary triode tube, using a conventional positive plate and negative grid. When gas is collected in the tube, the positive ions, resulting from collisions between the gas molecules and the electron stream, are collected on the negative grid and the grid current used as a measure of the pressure.

It was discovered, however, that the gauge became much more sensitive when the grid was made positive and

the plate negative. Under these conditions, electrons emitted by the filament are accelerated toward the positive grid. Some will be trapped there but many will pass through into the region between the grid and the plate. As they approach the plate, they are repelled back toward the grid and, when the pressure is low, this action may be repeated many times. The net result is an appreciable increase in the path length, a greater chance of collision with stray gas molecules and increased output current (greater sensitivity) from the tube.

The positive ions produced as a result of these collision are collected at the negatively charged plate and the ion current measured with a sensitive microammeter or galvanometer.

If the emission current is kept constant and the electrode potentials remain fixed, the positive-ion current (Is this an *electronic* device?) will be directly proportional to the pressure and the gauge will be linear from 10^{-3} to beyond 10^{-7} mm Hg.

Although any triode will show this effect, special tubes have been developed for use as vacuum gauges. Two of the most popular are the D79510 made by Western Electric and the VG1A made by Distillation Products Inc.

To reduce leakage currents, these tubes are made with glass bulbs and do not have tube bases for the leads. Instead the leads are brought out through glass seals at the bottom of the bulb and, for the VG1A, the leakage current is reduced still further by bringing the plate lead out at the side. Other differences are that the grid wires are farther apart than in the conventional triode, the grid-to-plate spacing is greater and the bulbs have glass tubulations for convenience in attaching the tube to the vacuum system. The price of either of these tubes is about \$25 and the control circuits for these will cost approximately between \$250 and \$425.

The output of a thermionic ionization gauge is relatively low. The VG1A, for example, when connected as shown in Fig. 9, will produce an ion current of about $100 \mu\text{a}$ for each micron (10^{-3} mm) of mercury, when used with dry air. Thus, for 10^{-4} mm the current would be only $10 \mu\text{a}$, and this would be reduced to only $1 \mu\text{a}$ at 10^{-5} . A sensitive galvanometer is required to measure the ion current when operating in this region and a d.c. amplifier would be necessary to measure pressures below this.

Although the response of the gauge is linear, it is not the same for all gases and the data given are correct only for dry air. For other gases a correction must be made for the molecular weight of the gas or a calibration made against a McLeod or Knudsen gauge. When used with air, however, the operation of the triode ionization gauge has been found to be so predictable that it is being used more and more for the calibration of other gauges and it

is a growing practice to measure a vacuum system in terms of the micro-ampere output from the gauge. This is particularly true for the VG1A.

The life of a triode ionization gauge is difficult to predict but with the best of care and under conditions of constant low pressure it may last for 500 hours or more. As pressures increase to 10^{-3} the filament life will be somewhat shortened and the gauge should not be operated at all at higher pressures.

Oil or water vapor in the system will shorten its life to only a few hours and the admission of air to the tube at atmospheric pressure—or even at pressures very much lower than atmospheric—results in immediate destruction of the filament.

In conclusion, in addition to such considerations as pressure range, price and durability, the selection of a vacuum gauge will also depend on a variety of other factors. For example, the presence of oil vapor, which sometimes enters the vacuum system from the diffusion pumps, may cause hydrocarbon "poisoning" of the triode ionization gauge filament. The choice may, therefore, be made to use the VG1A tube in preference to the D79510, since the pure tungsten filament of the VG1A is more resistant to this effect than the thoriated tungsten filament of the Western Electric tube. However, the D79510 is more economical to operate because its thoriated tungsten filament requires less heating current.

The type and quantity of all contaminating vapors that may enter the vacuum system should also be carefully considered since these vapor will seriously affect the calibration of the gauge. This is a common difficulty in cyclotrons and other particle accelerators because gases such as hydrogen and helium are frequently admitted to the vacuum system for acceleration. When this occurs, it is necessary to choose between an absolute or relative measurement of the system pressure.

Other factors which may influence the selection of a vacuum gauge include the possibility of heated parts in the gauge causing decomposition of some of the gas in the system and (in the case of corrosive vapors), the likelihood of these gases attacking the gauge elements. The gauge itself may even influence the pressure in the system: the Phillips ionization gauge, for example, may act as a tiny vacuum pump and actually improve the vacuum because of the "getter" action of the glow discharge. This effect is very strikingly shown when the Phillips gauge is used on a small, closed, vacuum system at a pressure of about 10^{-4} mm Hg. As the gauge is operated, the pressures becomes lower and lower.

When all factors are considered, one "best" gauge will usually be found to satisfy specific requirements. With intelligent use and recognition of its limitations it can be relied upon to do a very dependable job. END

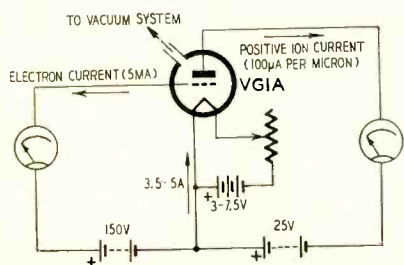
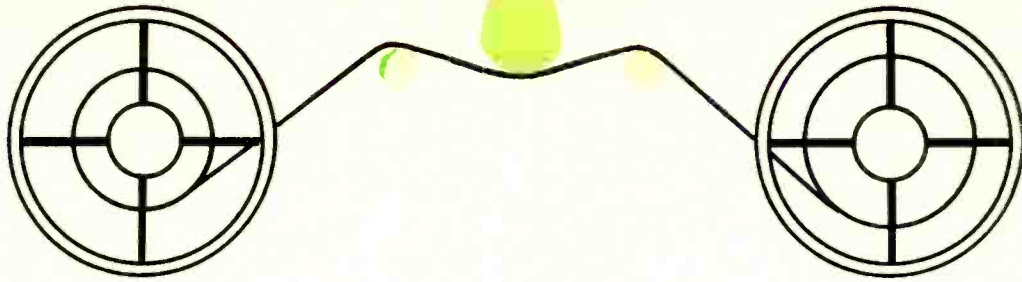

Fig. 9—The thermionic ionization gauge.



Magnetic Tape Recorder Aids Industry

By JAMES R. CORNELIUS*

IN many industrial manufacturing processes there is a time lag between the application of raw material to a machine and its arrival at an operating position. For instance, in the manufacture of self-tapping screws, the wire from which they are rolled arrives at the entrance to the machine at zero hour. But the screw cannot be made for some 10, 20 or 40 seconds due to the length of wire between the entrance to the machine and the production rollers. Or where cans of meat are being processed, each can passes an investigation point on the inspection table where rays such as the alpha or beta type examine the contents through the can walls for imperfections or loss of ingredients in processing. Any can not up to standard must be rejected. The rejection cannot take place at the position of inspection but must be performed physically some time later.

In these cases it is simple to mark the can or the wire and allow either an operator or a light cell to reject any can or length of wire so marked at the operating position of the machine.

A much more simple method, one that is practically foolproof, is to use a magnetic tape recorder as a memory system on a continuous basis.

Self-tapping screws are made from steel wire fed into a processing machine where it advances more or less rapidly, according to the size and length of the screws to be made. The wire, just prior to entering the machine, is passed through a materials flaw-detection apparatus (see diagram) which causes a relay to close every time a defective length of wire passes through the detector coil. This relay, in closing operates a circuit, permitting a 60-cycle signal to operate a recording head fitted into a memory box attached to the detector unit.

The type of screw being made requires a time lag of, say, 12 seconds before the defective portion of wire reaches the processing rollers. The machines are usually arranged so that it is not possible to remove the faulty wire without losing more in time than the material is worth. Thus the wire

is allowed to be processed and the screws fed to the scrap bin instead of being passed on to the next operation.

The signal to operate the deflector gate from pass to scrap is provided by the combination of: the defect signal given to the material detector by the wire; the signal passed by the instrument relay to the recording head of the memory box; the delay arranged between the recording head and a second pickup head fitted to a rotating disc around the periphery of which is a layer of magnetic film (the second head is adjustable around the disc to permit the correct time delay before the signal is used) and a second relay operated by the signal from the second pickup head that deflects the screws from good to scrap.

The time delay normally required in any manufacturing process rarely exceeds a minute and usually extends from a few seconds to about 35 seconds. The length of the signal may be many minutes, depending upon the quality of the material being processed. These conditions require a disc of about 10 inches in diameter with the edge containing a film of protected ferrous oxide or other paramagnetic coating.

The disc is mounted on a synchronous clock motor shaft to obtain continuous rotation with a speed of one revolution per minute. The combined recording and erasing head is fitted permanently so that the disc, in rotating, will always

meet the erasing-head before the recording-head position. This will allow any signal impressed on the film to be removed before the recording head imprints another on the film.

Owing to the slow speed of the disc, a signal frequency of 60 cycles will be very different from the same signal impressed on a tape moving at 8 feet per second. This must be borne in mind when deciding the frequency of the erasing oscillator. Since the purity of any signal is of minor importance, the main conditions to be considered are signal power and freedom from unwanted signal noises.

The pickup head must be mounted on an arm that permits the head to be swiveled around the disc from the vicinity of the recorder head to the eraser head, thus obtaining some 50-second variation in delay between impression and relaying of the signal.

The action is simple. The disc in rotating causes the film to pass first the erasing head which impresses the constant high-frequency unmodulated signal base. The film then passes the recording head which modulates the high frequency with the 60-cycle signal that will be impressed for as long as it exists. The distance between recorder and repeater determines the time delay and the repeater will repeat the signal for as long as it has been recorded. This signal can be used for any necessary service. END

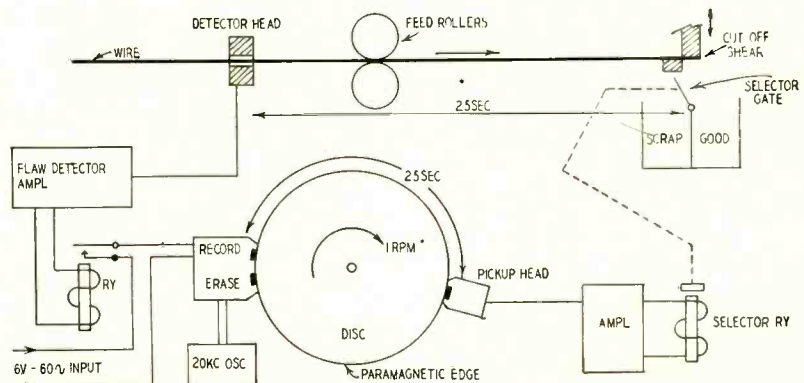

Applying the tape recorder to an industrial process for flaw detection

*Cornelius Electronic Instruments Ltd. Coventry, England

MIDGET TRANSISTORIZED SIGNAL INJECTOR

By ELLIOTT A. McCREADY

*Tiny instrument produces
a.f. and r.f. signals*



The completed signal injector.

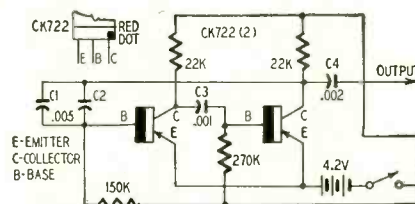

Schematic diagram of the midget transistorized signal generator.

TROUBLESHOOTING by signal injection is a speedy method of spotting a defective stage in a radio receiver or audio amplifier. Sometimes an r.f. or audio generator is used to provide the test signal. However, a slightly modified square-wave generator will, not only emit an audio tone, but also provide numerous harmonics usable as an r.f. source. Such an instrument was manufactured and widely advertised some years ago, and a home-constructed version appeared in *RADIO-ELECTRONICS* ("The Signal Launcher," Robert E. Altomare, October, 1951).

The wide availability and constantly decreasing price of the transistor now make it practical to construct a generator of this type as a very small, compact and self-powered unit.

The instrument was built around two Raytheon CK722 junction transistors and is contained in a plastic inhaler case (see photos). The completed unit measures only $\frac{3}{4}$ x 3 inches and draws so little current—approximately 300 microamperes—that the self-contained power supply will last indefinitely.

The two transistors are connected in a conventional multivibrator circuit and component sizes are chosen to produce a pulselike wave of approximately 2,000 cycles. The output wave has an extremely high harmonic content, and a usable signal extends from the fundamental frequency through the entire broadcast band. Three cells of an RCA type VS087 transistor battery provide a 4.2-volt power supply which measures only $\frac{1}{2}$ x $\frac{5}{8}$ inch. The output waveform (see photo) is approximately 3 volts peak to peak. A square wave of twice this amplitude can be obtained at the collector of V1, but the harmonic content is much lower and the usable range of the instrument is considerably decreased.

Construction

The two transistor sockets, with all unnecessary contacts removed, are clamped side by side and the emitter terminals joined. Base connections for the CK722 are shown in the diagram. Solder a length of tinned hookup wire to the emitter terminals for future connection to the battery. Then wire in all resistors and stack the disc type ceramic capacitors C1, C2 and C3 as shown.

Two .005- μ f capacitors, C1 and C2, are used instead of a single .01- μ f unit, due to the larger diameter of the .01- μ f capacitor. An Ungar soldering iron with a No. 535 tip is very handy for applying solder to the more inaccessible places. Insert the two transistors in their sockets and mount C4 on top of them as shown in the photo. Arrangement of parts will, of course, vary with the case used. An even smaller case could be used if the transistors are soldered directly into the circuit. The sockets, however, provide a convenient terminal strip and prevent the heat of

TEST INSTRUMENTS

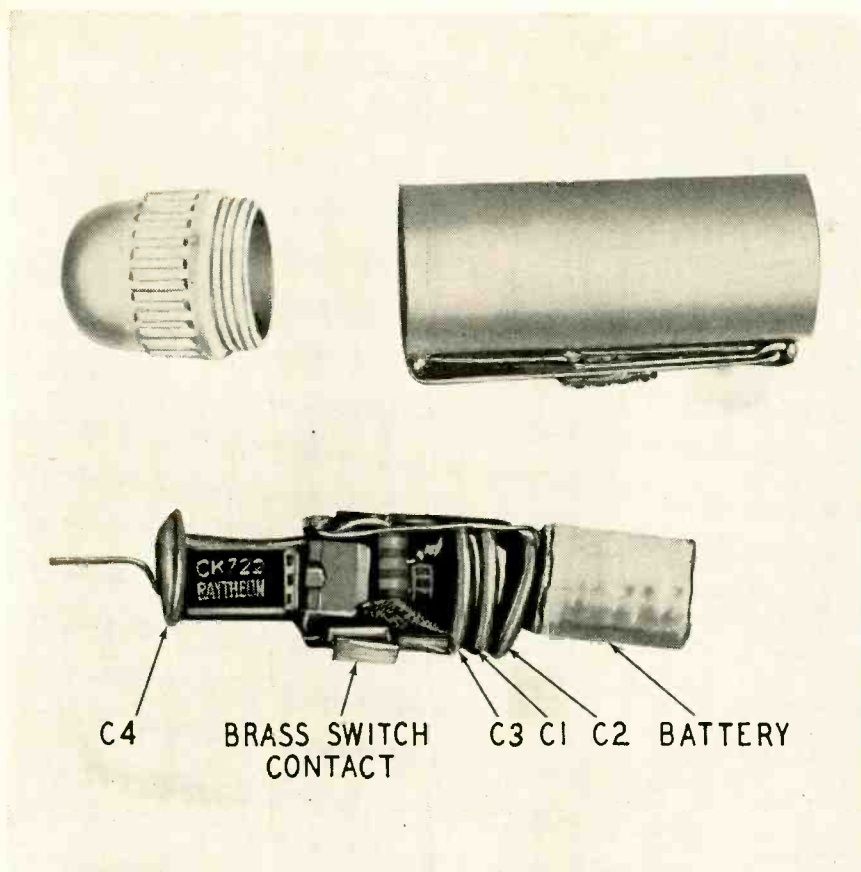

Disc type capacitors (right of center) permit compact assembly of the unit.

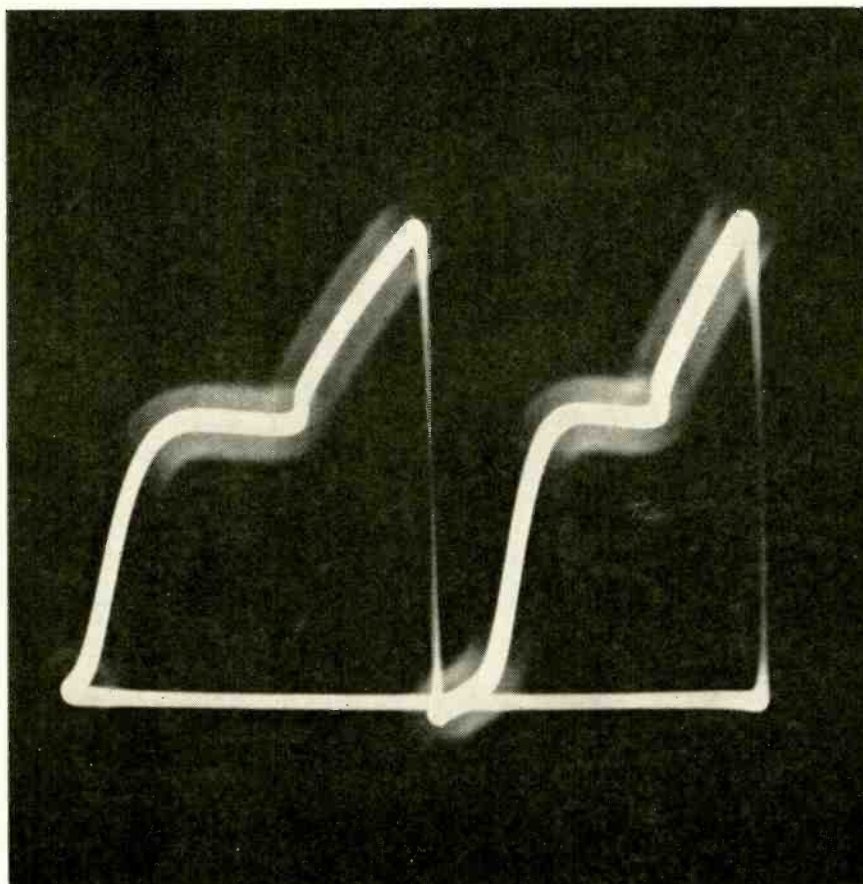

Highly distorted output waveform of the instrument has high harmonic content.

the soldering iron from damaging the transistors.

The big problem that I ran into was that of finding a suitable switch for the instrument. Switches seem to be one thing that manufacturers have neglected to miniaturize. There was no room left in the case for a switch so it had to be mounted externally. The problem was solved by removing the pocket clip and slide switch from a Burgess two-cell penlight, drilling a hole in the plastic case of the signal generator to accommodate the switch contact and gluing the entire assembly to the side of the case. A strip of thin spring brass, soldered to the negative terminal of the generator and folded several times to fit flush against the inside of the plastic case directly under the hole in the case, provides the other switch contact.

Another small piece of spring brass is placed in the bottom of the case to make contact with the negative terminal of the battery and is connected through a hole in the case to the end of the pocket clip. The positive terminal of the battery is then soldered to the lead from the emitters, a hole drilled in the screw cap of the plastic case to accommodate the output lead and the unit is ready to assemble.

Parts for transistorized signal injector

Resistors: 2—22,000, 1—150,000, 1—270,000 ohms, 1/2 watt.

Capacitors: 1—.001 μ f, 1—.002 μ f, 2—.005 μ f, ceramic disc.

Miscellaneous: 2—CK722 transistors; 2—Cinch-Jones subminiature hearing-aid sockets, type 2H5; 1—transistor battery (RCA type VS087 or equivalent); 1—switch assembly from Burgess two-cell penlight; 1—plastic case; 1—length of thin brass foil.

After carefully checking for shorts, insert the unit in its case and clip the excess lead from C4 to within about 1/4 inch of the cap. This protruding wire forms the generator probe.

Checking the unit

With the generator switched on, connect an oscilloscope between the metal switch assembly and the probe. A signal like that shown in the photo should appear. Interchanging V1 and V2 may change the waveshape somewhat, as each transistor will operate in a slightly different manner. Choose the most pulseline or differentiated waveshape since its harmonic content, and hence the r.f. output of the unit, will be higher.

Output frequency will vary from unit to unit as the ceramic capacitors have only a 20% tolerance, but anything around 1,000 to 2,000 cycles will be satisfactory.

With the signal injector switched on, touch the probe to the plate and grid of each stage of the unit to be tested, starting with the output stage and working back. With some receivers, the output of the signal injector can be increased by touching the metal switch with the finger while the unit is in use. The point at which the signal is no longer heard indicates the stage where the trouble lies. END

U.H.F.

Right, u.h.f. bar generator and sweep adapter, showing mixer assembly board. Below, under-chassis view shows arrangement of parts in oscillator and modulator.

BAR GENERATOR and SWEEP ADAPTER

Easily assembled, inexpensive unit built around a Mallory u.h.f. Inductuner

By BRUCE MORRISSETTE

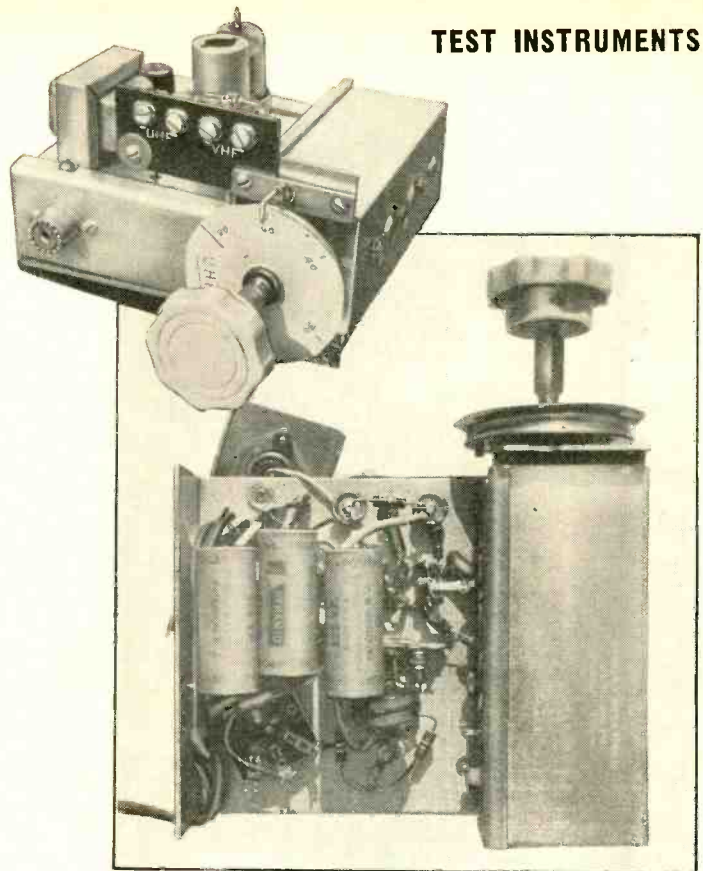

SERVICE technicians and u.h.f. experimenters still widely lack such expensive instruments as u.h.f. sweep, bar and marker generators. This simple, easily constructed unit (see photos), intelligently handled, will provide a variety of u.h.f. test and service functions with excellent results and at a substantial saving.

Used without auxiliary equipment, the u.h.f. unit is a compact, portable bar generator providing a stable, clean-cut pattern of black-and-white horizontal bars on the screen of any TV receiver using either a u.h.f. converter or tuner. This checks the performance of a set at u.h.f. from antenna to picture tube in the absence of a test pattern or signal from a local u.h.f. station.

With the bar modulation turned off, the unit becomes a u.h.f. marker generator whose accuracy is a matter of calibration. Low-impedance coaxial output permits the marker-output r.f. to be coupled into a mixer or other device.

Since the signal passing through the u.h.f. unit does not encounter any unidirectional vacuum tubes, it may go in either direction, from v.h.f. to u.h.f. or from u.h.f. to v.h.f. The instrument may thus be used as a regular converter to view u.h.f. station programs on a v.h.f. receiver.

In connection with equipment already on the v.h.f. service bench, the u.h.f. adapter converts v.h.f. sweep generators to u.h.f. and may be used for aligning and testing u.h.f. converters and tuners. The v.h.f. sweep generator may be set at any convenient frequency from around 20 to 200 mc, with the adapter then tuned to provide a sum frequency at the u.h.f. output terminals ranging

from television channel 14 to 83.

Harmonics of a v.h.f. signal generator may be used to supply calibrations along the alignment curve. This setup is shown in Fig. 1. Attenuation is controlled at the v.h.f. sweep generator output. The converter or tuner output is detected either by a crystal detector probe or by feeding the converted output to the regular v.h.f. input of a TV set and taking the scope output from the r.f. mixer grid test point. In the latter case the input to the v.h.f. tuner must match the frequency of the particular channel to which the v.h.f. tuner is set.

If two of the adapter units are constructed, one of them (which need not have the mixer assembly nor bar modulation feature) may be calibrated and used as a u.h.f. marker generator. The output of this oscillator may then be fed through a device such as the Sideband Modulator for Marker Generator, described by the author in the April, 1955, issue of RADIO-ELECTRONICS and, with a 4.5-mc crystal, provide both sound and video carrier markers for u.h.f. sweep curve adjustment to secure proper bandwidth, tilt and symmetry of response. This more complete alignment setup is shown in Fig. 2.

Circuitry and construction

The basic u.h.f. adapter design is a stable 6AF4 oscillator coupled in an ultradion circuit to the front section of a Mallory u.h.f. Inductuner, providing u.h.f. output through a range of approximately 450 to 900 mc. These u.h.f. Inductuners have been used in u.h.f. converters of many different makes. If a discarded u.h.f. converter

of the same or nearly any other design is available, its oscillator section may be used. It would be best not to build the unit around a converter that uses harmonic mixing, though it will work if the results are properly evaluated.

As is evident from the schematic Fig. 3, the pure r.f. from the 6AF4 u.h.f. oscillator may be plate-modulated to provide a horizontal bar pattern. When its heater is activated by modulation switch S1, a 12AT7 symmetrical multivibrator supplies square-wave modulation through a large (16- μ f) electrolytic capacitor to the plate of the 6AF4. Switch S1 is placed in the heater circuit so that when it is open it will remove, not only the plate current drain of the 12AT7, but the 0.3-ampere heater load as well, permitting the midget power transformer to run cool when the unit is used for extended periods of time as a receiver converter.

The untuned u.h.f.-v.h.f. mixer assembly is mounted on a phenolic terminal board. The 1N82 mixer is mounted point-to-point between one u.h.f. and one v.h.f. terminal. The r.f. chokes are in back, connected from the terminals to an aluminum grounding strip which supports the phenolic board. The oscillator output from the 6AF4 is coupled to one side of the crystal through a gimmick capacitor consisting of two insulated wires twisted together for about 1 inch to give about 2 μ mf of capacitance. Since the mixer is entirely untuned, it is a broad-band device that may be used at any frequency from about 20 mc up and may operate in either direction, from u.h.f. to v.h.f. or from v.h.f. to u.h.f.

The underchassis photo shows the



Heathkit PRINTED CIRCUIT 5" COLOR TV Oscilloscope Kit

MODEL
0-10
\$69⁵⁰
Shpg. Wt. 27 lbs.

The technical specifications for this fine instrument speak for themselves. Vertical channel sensitivity is 0.025 volts RMS/inch at 1 Kc. Vertical frequency response is essentially flat to 5 Mc, and down only 1.5 db at 3.58 Mc. Ideal for Color TV work!

Extended sweep generator range is from 20 cps to 500 Kc in five steps, far beyond the range normally encountered at this price level.

Other features are: plastic-molded capacitors for coupling and by-pass—preformed and cabled wiring harness—Z axis input for intensity modulation—peak-to-peak voltage calibrating source built-in—retrace blanking amplifier—regulated power supply—high insulation printed circuit boards—step attenuated and frequency compensated vertical input circuit—push-pull horizontal and vertical amplifiers—excellent sync. characteristics—sharp, hairline focusing—uses 5UP1 CRT—extremely attractive physical appearance.

An essential instrument for professional Laboratory, or for servicing mono-chrome or color TV.

Heathkit PRINTED CIRCUIT 3" OSCILLOSCOPE KIT



This light, portable 3" oscilloscope is just the ticket for the ham, for service calls, or as an "extra" scope in the shop, or lab. Measures only 9 1/2" H x 6 1/2" W x 1 1/4" D, and weighs only 11 lbs.
Employs printed circuit board for improved circuit performance. Vertical amplifiers flat within +3 db from 2 cps to 200 Kc. Vertical sensitivity 0.25 volts RMS/inch peak-to-peak, and sweep generator operates from 20 cps to 100,000 cps. R.F. connection to deflection plates.

MODEL OL-1
\$29⁵⁰

Shpg. Wt. 14 lbs.

Heathkit PRINTED CIRCUIT 5" OSCILLOSCOPE KIT



This full-size 5" Oscilloscope incorporates many outstanding features.
Vertical channel flat within +3 db, 2 cps to 200 Kc, with 0.09 volts RMS/ inch peak-to-peak sensitivity at 1 Kc. Sweep operation from 20 cps to 100,000 cps. Built-in peak-to-peak voltage calibration—3 step frequency compensated input attenuator—phasing control—push-pull deflection amplifiers. Printed circuits for reliable performance and reduced construction time.

MODEL OM-1
\$49⁵⁰

Shpg. Wt. 26 lbs.

Heathkit PRINTED CIRCUIT VACUUM TUBE VOLTMETER KIT



Shpg. Wt. 7 lbs.

MODEL V-7
\$24⁵⁰

This VTVM has set a new standard for accuracy and reliability in kit-form electronic instruments. Features modern, time-saving printed circuits, and functional arrangement of controls and scales. Includes new peak-to-peak scale for FM and TV work.

Measures AC (RMS) and DC voltage at 0-1.5, 5, 15, 50, 150, 500, and 1500; peak-to-peak AC voltage at 0-4, 14, 40, 140, 400, 1400, and 4000; center-scale resistance readings of 10, 100, 1000, 10,000, 100 K, 1 meg., and 10 meg. DB scale provided also. Zero-center operation within range of front panel controls. Polarify reversal switch—200 μ a 4 1/2 meter-transformer power supply—11 megohm input impedance—1% precision resistors—high quality components used throughout.

Heathkit VOLTAGE CALIBRATOR KIT

Once calibrated, this instrument provides a known peak-to-peak voltage standard for comparison with unknown voltage values on an oscilloscope. Panel calibrated directly—no involved calculations required. Operates within a voltage range of .01 to 100 volts peak-to-peak.



MODEL VC-2
\$11⁵⁰

Shpg. Wt. 4 lbs



MODEL MM-1

\$29⁵⁰

Shpg. Wt. 6 lbs.

Heathkit 20,000 ohms/volt MULTIMETER KIT

Features comprehensive range coverage, 20,000 Ω /V D.C. and 5000 Ω /V A.C. Ranges: 0-1.5, 5, 50, 150, 500, 1500, and 5000 V. direct current from 0 to 150 μ a, 15 a. in 5 steps. Center-scale resistance of 15, 1500 and 150,000 ohms, and db from -10 to +65.

Uses 1% precision resistors—50 μ a. meter—molded bakelite case.



MODEL AV-2

\$29⁵⁰

Shpg. Wt. 5 lbs.

Heathkit A. C. VACUUM TUBE VOLTMETER KIT

Measures AC voltage only, from 10 cps to 50 Kc. Covers the range from 1 millivolt to 300 volts in 10 steps at high impedance input. Incorporates full 10 ranges of db scale from -52 db to +52 db. Essential in the audio laboratory or for audio enthusiasts and experimenters. Provides sensitivity essential for low level audio measurements.

Heathkit DIRECT-READING CAPACITY METER KIT

Extremely valuable where speed and convenience are essential. Quality control work, production line checking, etc. Reads capacity directly on meter scale, from 0-100 mmfd, 1000 mmfd, .01 mfd, and 1 mfd. Residual capacity less than 1 mmfd. Not susceptible to hand capacity.



MODEL CM-1

\$29⁵⁰

Shpg. Wt. 7 lbs.

Heathkit ELECTRONIC SWITCH KIT

This device will electronically switch between 2 input signals to produce both signals alternately at the output. Used in conjunction with an oscilloscope, it will permit the observation of 2 signals simultaneously. Provides switching rates from 10 cps to 200 cps.



MODEL S-2

\$23⁵⁰

Shpg. Wt. 11 lbs.

HEATH Company

A SUBSIDIARY OF DAYSTROM INC.

BENTON HARBOR 20, MICHIGAN

SELECT YOUR NEXT HEATHKIT FROM

Heathkit TUBE CHECKER KIT



MODEL TC-2
\$29⁵⁰
Shpg. Wt.
12 lbs.

Because of its low price this fine tube tester is available, not only to the service shop and laboratory, but to part-time servicemen, experimenters, and radio amateurs, as well. Will test all tubes commonly encountered in radio and TV service work. Simple "GOOD-BAD" scale on the 4 1/2" meter. Tests for open, short, and quality on the basis of total emission. Includes illuminated roll chart. Fourteen different filament voltage values available. Separate lever switch for each tube element.

Model TC-2P is the same electrically as TC-2, except that it is housed in a beautiful two-toned portable carrying case. Only \$34.50. Shpg. Wt. 15 lbs.

Portable carrying case available separately for Model TC-2, or older model TC-1. Cab. No. 91-8, \$7.50. Shpg. Wt. 7 lbs.
CRT Test Adapter, Model 355 for use with TC-2, \$4.50. Shpg. Wt. 1 lb.

Heathkit TV ALIGNMENT GENERATOR KIT

Here is the complete R.F. signal source for FM and TV alignment, (both monochrome and color). Provides output on fundamentals from 3.6 Mc to 220 Mc in four bands, with harmonic output usable up through the UHF channels. Electronic sweep circuit eliminates mechanical gadgets and accompanying noise, hum, and vibration. Continuously variable sweep up to 0-42 Mc, depending on base frequency.

Variable marker (19-60 Mc on fundamentals) and crystal marker (4.5 Mc and multiples thereof) generators built-in. Crystal included with kit. Provision for external marker if desired.

Packed with outstanding features. 50 ohm output impedance — exceptionally good linearity — effective AGC action — plenty of R.F. output. An essential instrument for the up-to-date service shop.



\$49⁵⁰

MODEL TS-4
Shpg. Wt. 16 lbs.



Shpg. Wt.
8 lbs.

MODEL SG-8
\$19⁵⁰

Heathkit SIGNAL GENERATOR KIT

This is one of our most popular kits, and is "serviceman engineered" to fulfill the signal source requirements of the radio serviceman and experimenter.

Covers 160 Kc to 110 Mc on fundamentals (5 bands), with output in excess of 100,000 microvolts. Calibrated harmonics extend usefulness up to 220 Mc. Choice of unmodulated R.F. output, 400 cps modulated R.F. output, or 400 cps audio output. Step-type and continuously variable output attenuation controls.

Coils are prewound, and construction manual is complete. Calibration unnecessary for service applications.

Model RS-1

Heathkit RESISTANCE SUBSTITUTION BOX KIT



Provides switch selection of 36 RTMA 1 watt standard 10% resistors, ranging from 15 ohms to 10 megohms. Numerous applications in radio and TV work.

\$5⁵⁰
Shpg. Wt.
2 lbs.

Heathkit CONDENSER SUBSTITUTION BOX KIT

Very popular companion to Heathkit RS-1. Individual selection of 18 RTMA standard condenser values from .0001 mfd to .22 mfd. Aluminum panel, bakelite case, and includes 18" flexible leads with alligator clips.

Model CS-1
\$5⁵⁰
Shpg. Wt.
2 lbs.



Model DR-1

Heathkit DECADE RESISTANCE KIT



Twenty 1% precision resistors provide resistance from 1-99,999 ohms in 1 ohm steps. Indispensable around service shop, laboratory, ham shack, or home workshop.

\$19⁵⁰
Shpg. Wt.
4 lbs.

Heathkit DECADE CONDENSER KIT

Provides capacity values from 100 mmf to 0.111 mfd in steps of 100 mmfs. +1% precision silver-mica condensers used. High quality ceramic wafer switches for reduced leakage.

Shpg.
Wt. 3 lbs.

\$16⁵⁰

Model DC-1



Heathkit CONDENSER CHECKER KIT

Measures capacity in four ranges from .0001 to 1000 mfd. Power factor control is provided for indication of electrolytic condenser efficiency. Tests capacitors under actual load conditions. Checks resistance from 100 ohms to 5 megohms. Direct reading scales for all tests. No calculation necessary.



Model C-3
\$19⁵⁰
Shpg. Wt. 7 lbs.



Model T-3

Heathkit VISUAL-AURAL SIGNAL TRACER KIT

\$23⁵⁰

Shpg. Wt. 9 lbs.

This signal tracer features a high-gain R.F. channel and probe to permit signal tracing from the receiver antenna input through the R.F. and I.F. stages. Separate low gain channel for audio circuits. Both visual and aural indication by means of speaker and electron beam "eye" tube.

Also noise locator circuit, wattmeter, and terminals for "patching" output transformer or speaker into external circuit.

Heathkit LABORATORY GENERATOR KIT

Here is a signal generator for use where high accuracy and metered performance are essential. Covers 150 Kc to 30 Mc on fundamentals in 5 bands. 400 cps modulation variable from 0 to 50%. R.F. output at 50 Ω from 100,000 to 1 μ v. Meter reads R.F. output in μ v. or modulation percentage. Fixed-step and variable output.



Model LG-1

\$39⁵⁰
Shpg. Wt.
16 lbs.



Model M-1

Heathkit HANDITESTER KIT

\$14⁵⁰

Shpg. Wt.
3 lbs.

3 lbs.

3 lbs.

3 lbs.

3 lbs.

3 lbs.

3 lbs.

3 lbs.

3 lbs.

3 lbs.

3 lbs.

3 lbs.

3 lbs.

3 lbs.

3 lbs.

3 lbs.

3 lbs.

3 lbs.

3 lbs.

3 lbs.

3 lbs.

3 lbs.

3 lbs.

3 lbs.

The M-1 is literally pocket size to fit in your coat pocket, tool-box, glove compartment, or desk drawer. Measures A.C. or D.C. v. in 5 steps from a full scale minimum of 0-10 v. to a maximum of 0-5000 v. Measures direct current at 0-10 Ma and 0-100 Ma, and provides ohmmeter ranges of 0-3000 and 0-300,000 ohms. Sensitivity of 1,000 ohms/v. 1% precision divider resistors employed.

HEATH *Company*
A SUBSIDIARY OF DAYSTROM INC.
BENTON HARBOR 20, MICHIGAN

THESE HIGH QUALITY INSTRUMENTS

Heathkit HARMONIC DISTORTION METER KIT



MODEL HD-1
\$49.50
Shpg. Wt. 13 lbs.

Performs the functions of more elaborate and much more expensive audio distortion testing devices and yet is simple to operate and inexpensive to own. Used with a sine wave generator, it will check the harmonic distortion output of audio amplifiers under a variety of conditions. Essential in audio design work.

The HD-1 reads harmonic distortion directly on the meter as a percentage of the original signal input. It operates from 20 to 20,000 cps in 3 ranges, and incorporates a VTVM circuit for initial reference settings and final harmonic distortion readings. VTVM ranges are 0-1, 3, 10, and 30 volts full scale. 1% precision voltage divider resistors used. Distortion meter scales are 0-1, 3, 10, 30 and 100% full scale. Having a high input impedance the HD-1 requires only .3 volt input for distortion tests.

Heathkit AUDIO GENERATOR KIT

This basic audio reference generator deserves a place in your Laboratory. Complete frequency coverage is afforded from 20 cps to 1 Mc in 5 ranges, and output is constant within ± 1 db from 20 cps to 400 Kc, down only 3 db at 600 Kc., and 8 db at 1 Mc. An extremely good sine wave is produced, with a distortion percentage below 0.4% from 100 cps through the audible range.

Plenty of audio output for all applications; up to 10 v. under no load conditions. Output controllable with a continuously variable or step-type attenuator with settings of 1 μ v, 100 μ v, 1 v, and 10 v. Cathode follower output.



MODEL AG-8
\$29.50
Shpg. Wt. 11 lbs.

Heathkit AUDIO ANALYZER KIT



MODEL AA-1
\$59.50
Shpg. Wt. 13 lbs.

The AA-1 consists of an audio wattmeter, an AC VTVM, and a complete IM analyzer, all in one compact unit. It offers a tremendous saving over the price of these instruments purchased separately.

Use the VTVM to measure noise, frequency response, output gain, power supply ripple, etc. Use the wattmeter for measurement of power output. Internal loads provided for 4, 8, 16, or 600 ohms. VTVM also calibrated for DBM units so db gain or loss can be noted quickly.

High or low impedance IM measurements can be made. High (6 Kc) and low (60 cps) frequency generators built-in. Only 4 meter scales are employed, and one of these is in color so that results are easily read on the scale. Full scale VTVM ranges are .01 to 300 volts in 10 steps, full scale wattmeter ranges are .15 mw to 150 w in 7 steps. IM analyzer scales are 1%, 3%, 10%, 30% and 100%.



Heathkit VARIABLE VOLTAGE POWER SUPPLY KIT

Model PS-3
\$35.50
Shpg. Wt. 17 lbs.

Provides regulated DC output for B+, and 6.3 v. AC at 4 amps. for filaments. Output variable from 0 to 500 v. DC at no load, linear from 0-10 ma at 450 vdc and 0-130 ma at 200 vdc! Essential for circuit design and development. Voltage or current read on $4\frac{1}{2}$ " meter.



Heathkit "Q" METER KIT

Model QM-1
\$44.50
Shpg. Wt. 14 lbs.

Will measure Q of condensers, RF resistance and distributed capacity of coils, etc. Uses $4\frac{1}{2}$ " 50 μ a meter for direct indication. Will test at 150 Kc to 18 Mc in 4 ranges. Measures capacity from 40 mmf to 450 mmf within ± 3 mmf. Useful for checking wave traps, chokes, peaking coils. Indispensable for coil winding and determining unknown condenser values.

Heathkit AUDIO OSCILLATOR KIT



MODEL AO-1
\$24.50
Shpg. Wt. 10 lbs.

(SINE WAVE - SQUARE WAVE)

Features sine or square wave coverage from 20 to 20,000 cps in 3 ranges. An instrument specifically designed to completely fulfill the needs of the serviceman and high fidelity enthusiast. Offers high-level output across the entire frequency range, low distortion and low impedance output. Uses a thermistor in the second amplifier stage to maintain essentially flat output through the entire frequency range. Produces good, clean square waves with a rise time of only 2 microseconds.

Heathkit IMPEDANCE BRIDGE KIT



Model IB-2
\$59.50
Shpg. Wt. 12 lbs.

Measures resistance, capacitance, inductance, dissipation factors of condensers, and the storage factor of inductance. Employs 2-section CRL dial. D, Q and DQ functions are combined in one control. $\frac{1}{2}$ % resistors and capacitors used in critical circuits. 100-0-100 microammeter for null indications. 1000 cycle oscillator, 4 tube detector-amplifier, and power supply built-in.

Heathkit 6-12 VOLT BATTERY ELIMINATOR KIT



Model BE-4
\$31.50
Shpg. Wt. 17 lbs.

Furnishes 6 or 12 volt output for the new 12 v. car radios in addition to 6 v. models. Two continuously variable output voltage ranges; 0-8 v. DC at 10 A. continuously or 15 A. intermittent, 0-16 v. DC at 5 A. continuously or 7.5 A. intermittent. Output voltage is clean and well filtered by two 10,000 mfd condensers. Panel meters read voltage and current output.

Heathkit BROADCAST BAND RECEIVER KIT



MODEL BR-2
\$17.50
(Less Cabinet)
Shpg. Wt. 10 lbs.

Build your own receiver with confidence. Complete instruction book anticipates your every question.

Features transformer-type power supply, high-gain miniature tubes, built-in antenna, planetary tuning from 550 Kc to 1600 Kc, $5\frac{1}{2}$ " speaker. Also adaptable for use as AM tuner or phono amplifier. CABINET: Fabric covered plywood cabinet available, complete with aluminum panel and re-inforced speaker grille. Part No. 91-9, Shpg. Wt. 5 lbs., \$4.50

HEATH Company

A SUBSIDIARY OF DAYSTROM INC.

BENTON HARBOR 20, MICHIGAN

New

Heathkit DX-100 PHONE AND CW TRANSMITTER KIT



MODEL DX-100

\$189⁵⁰

Shpg. Wt. 120 lbs.

Shipped motor freight unless otherwise requested. \$50.00 deposit required for C.O.D. orders.

This one compact package contains complete transmitter, with built-in VFO, modulator, and power supplies. Provides phone or CW operation—VFO or crystal excitation—and band-switching from 160 meters through 10 meters. R.F. power output 100—125 watts phone, 120—140 CW. Parallel 6146's modulated by push-pull 1625's. Pi network interstage and output coupling for reduced harmonic output. Will match non-reactive antennas between 50 ohms and 600 ohms. TVI suppressed with extensive shielding and filtering. Rugged metal cabinet has inter-locking seams.

The high-quality transmitter is packed with desirable features not expected at this price level. Copper plated chassis—potted trans-

formers—wide spaced tuning capacitors—ceramic insulation—illuminated VFO dial and meter face—remote control socket—preformed wiring harness—concentric control shafts—high quality, well rated components used throughout. Overall dimensions 20 $\frac{3}{4}$ " wide x 13 $\frac{3}{4}$ " high x 16" deep.

Supplied complete with all components, tubes, cabinet and detailed construction Manual. (Less crystals.) Don't be deceived by the low price! This is a top-quality transmitter designed to give you years of reliable service and dependable performance.

Heathkit AMATEUR TRANSMITTER KIT

Enjoy the trouble-free operation of commercially designed equipment while still benefiting from the economies and personal satisfaction of "building it yourself."

This CW Transmitter is complete with its own power supply, and covers 80, 40, 20, 15, 11 and 10 meters. Single knob bandswitching eliminates coil changing. Panel meter indicates grid or plate current for the final. Crystal operation, or can be excited by external VFO. Crystal not included in kit. Incorporates features one would not expect in this price range, such as key-click filter, line-quality components throughout, prewound coils, 52 ohm coaxial output, and high quality components throughout. Instruction Book simplifies assembly. Uses 6AG7 oscillator, 6L6 final and 5U4G rectifier. Up to 35 watts plate power input.



MODEL AT-1

\$29⁵⁰

Shpg. Wt. 15 lbs.



Model GD-18

\$19⁵⁰

Shpg. Wt. 4 lbs.

Heathkit GRID DIP METER KIT

This is an extremely valuable tool for Hams, Engineers or Servicemen. Covering from 2 Mc to 250 Mc, it uses 500 μ a meter for indication. Kit includes prewound coils and rack. Will accomplish literally hundreds of jobs on all types of equipment.

Heathkit ANTENNA IMPEDANCE METER KIT

Use in conjunction with a signal source for measuring antenna impedance, line matching purposes, etc. Will double, also, as a phone monitor or relative field strength indicator.

100 μ a meter employed. Covers the range from 0 to 600 ohms. An instrument of many uses for the amateur.



Model AM-1

\$14⁵⁰

Shpg. Wt. 2 lbs.

Heathkit VFO KIT



MODEL VF-1

\$19⁵⁰

Shpg. Wt. 7 lbs.

Weigh the cost of this kit against the cost of crystals—and consider the convenience and flexibility of VFO operation. This is one of the most outstanding kits we have ever offered for the radio amateur.

Covers 160—80—40—20—15—11 and 10 meters with three basic oscillator frequencies. Illuminated and precalibrated dial scale clearly indicates frequency on all bands and provides more than two feet of dial calibration. Reflects quality design in the use of ceramic coil forms and tuning capacitor insulation, and copper plated chassis. Simply plugs into crystal socket of any modern transmitter to provide coverage of the bands from 160 meters through 10 meters. Uses 6AU6 Clapp oscillator, and OA2 voltage regulator for stability. May be powered from plug on Heathkit Model AT-1 Transmitter, or supplied with power from most transmitters.

Heathkit ANTENNA COUPLER KIT



Model AC-1

\$14⁵⁰

Shpg. Wt. 4 lbs.

Poor matching allows valuable communications energy to be lost. The Model AC-1 will match your low power transmitter to an end-fed long wire antenna. Also attenuates signals above 36 Mc, reducing TVI. 52 ohm coaxial input—power up to 75 watts—10 through 80 meters.

Heathkit COMMUNICATIONS RECEIVER KIT



Model AR-2

\$25⁵⁰

Shpg. Wt. 12 lbs. (Less Cabinet)

Covers 550 Kc to 35 Mc in 4 bands. Features electrical bandspread—separate R.F. and A.F. gain controls—noise limiter—AGC—BFO—phone jack—5 $\frac{1}{2}$ " PM speaker. CABINET: Fabric covered plywood cabinet. Part No. 91-10. Shpg. Wt. 5 lbs. \$4.50

HEATH Company

A SUBSIDIARY OF DAYSTROM INC.
BENTON HARBOR 20, MICHIGAN

Capacitor-Resistor Analyzer

Circuit analysis of the Pyramid CRA-1 tester

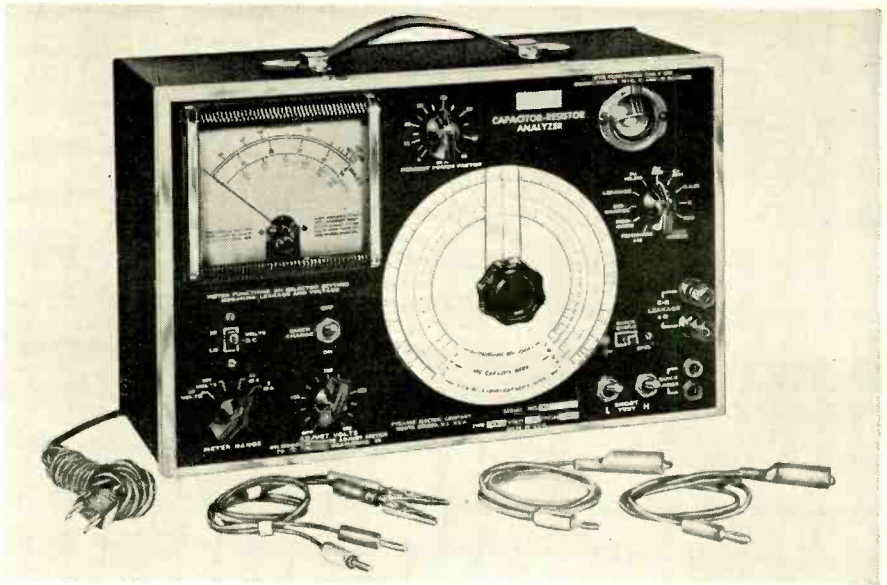

The Pyramid model CRA-1 capacitor-resistor analyzer.

CAPACITORS—more than almost any other component—deteriorate slowly, a condition which can be detected some time before complete breakdown. Running a test on electrolytics is one way of avoiding further service calls in the too-near future. The capacitor analyzer can be one of the most important instruments in the service shop.

Capacitors are also responsible—by opening or shorting—for a fair percentage of breakdowns in electronic equipment. An instrument which can detect capacitor opens, intermittents and shorts quickly is a time- and money-saver to the technician.

The capacitor-resistor checker described in this article is a complete instrument for checking capacitors, quantitatively with a bridge and qualitatively with a quick-check circuit, and has a few additional features. It measures capacitance from about 10 μf to 2,000 μf , and resistors from 100 ohms to 25 megohms, on accurate bridge circuits. An insulation tester extends the resistance range to about 20,000 megohms, and a capacitor leakage meter shows leakage under all desired test voltages. The capacitance bridge provides a power-factor measurement for electrolytics (or other capacitors, if they show appreciable losses).

Though not an essential part of an analytical instrument, a device that tells, without disconnecting them from the circuit, if capacitors are open or shorted is very useful to the technician. The quick-check circuit of the CRA-1 checks capacitors between 100 μf and 50 μf , virtually the entire range commonly encountered.

The circuit of this checker (Fig. 1) is a Hartley oscillator with its two sections so coupled by an additional coil L1 that—when properly adjusted—it will *not* oscillate. If a *capacitive* reactance is placed across L1 (by connecting it to the QUICK CHECK leads), the circuit is unbalanced and goes into oscillation. This signal voltage is applied to the grid of the 6E5 through a 100,000-ohm resistor and .02- μf capacitor, causing the shadow wedge ("eye") to close.

Resistance or inductance in the L1 circuit has no effect until the impedance drops to a few ohms. A capacitor can be checked with a 25-ohm resistor shunted across it.

Once a capacitor has been found to be not open, only half the job is done. It may be shorted (infinitely large to the checker). Two circuits (L and H) check for shorted capacitors. The L (low-capacitance) circuit of Fig. 2-a is

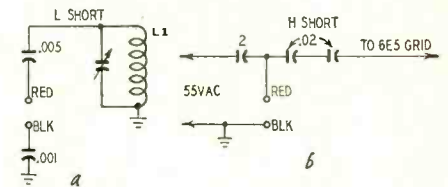

Fig. 2—Circuits for checking shorted capacitors—a, low, b, high capacitance.

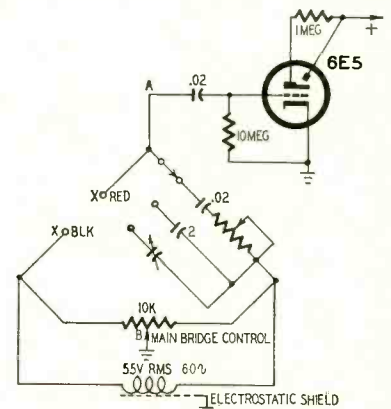

Fig. 3—Schematic diagram of bridge circuit for low-capacitance ranges.

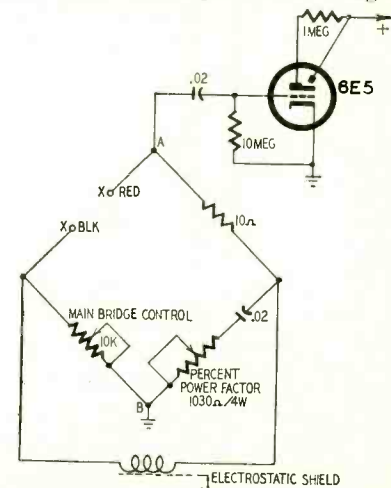

Fig. 4—Schematic diagram of bridge circuit for high-capacitance range.

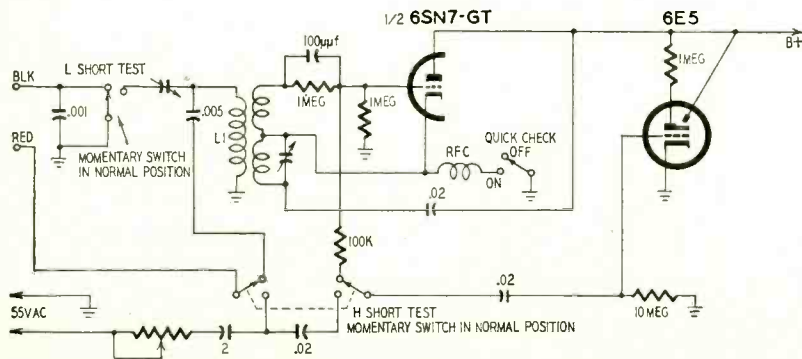

Fig. 1—Schematic diagram of the quick-check circuit in the analyzer.

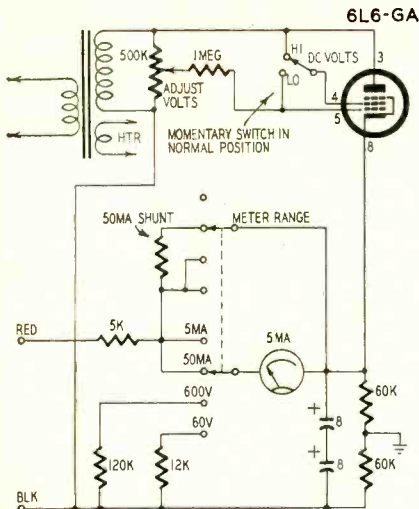

Fig. 5—Leakage-current test circuit.

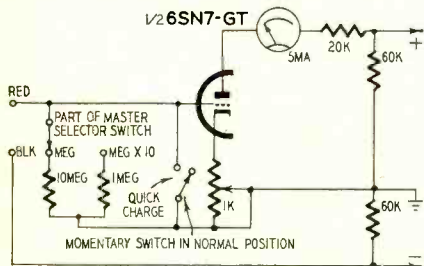

Fig. 6—Schematic diagram shows circuit for insulation resistance tests.

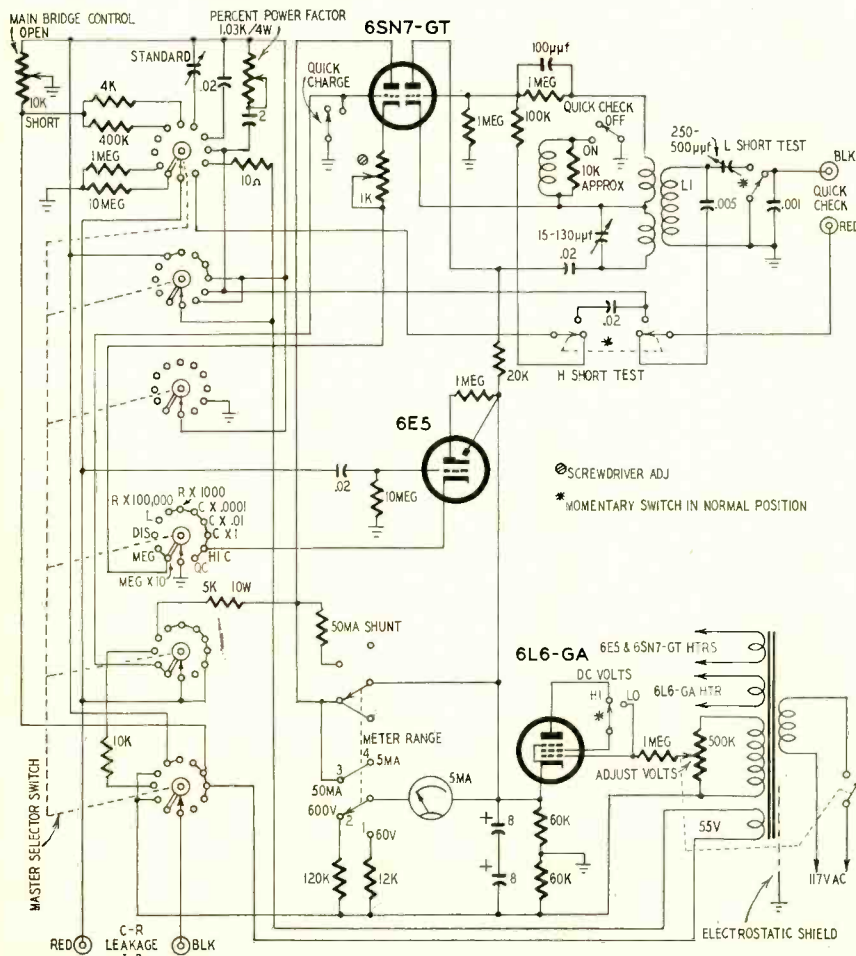
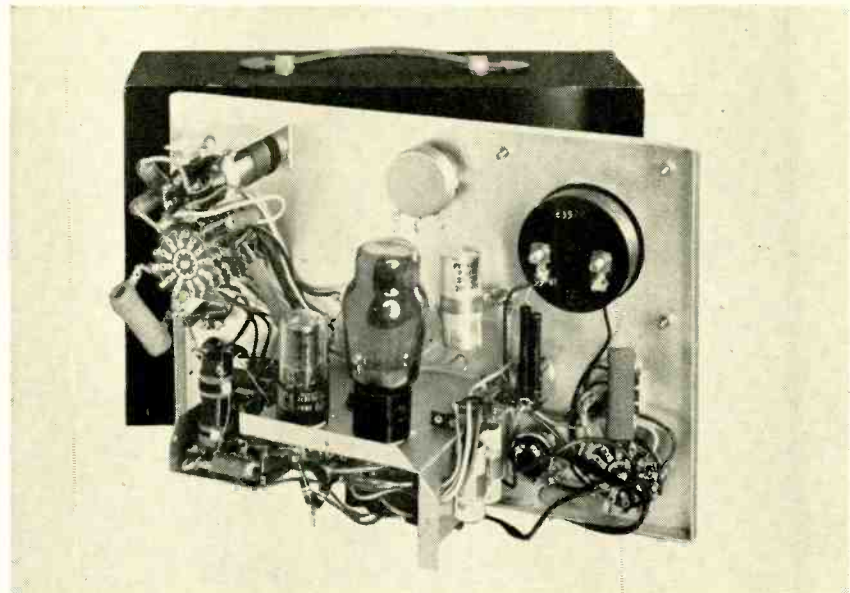

Fig. 7—Diagram of the Pyramid capacitor-resistor model CRA-1 analyzer.



Rear, internal view of analyzer shows layout of all major components.

connects an adjustable capacitor across L1 and makes the capacitor being checked the center unit of a series of three, also shunted across L1. The circuit is so adjusted that it is swamped out of oscillation if the tested capacitor has a reactance less than that of a good .002- μ f unit.

If the capacitor shows "short" on the L check, it is either defective or larger than .002 μ f. It is then tried on the H (high-capacitance) circuit (Fig. 2-b) which puts it across a 55-volt a.c. supply through a 2- μ f capacitor. The hot side of the 55-volt generator is connected to the 6E5 grid through two .02- μ f capacitors in series.

If the capacitor being checked is shorted, none of the generator output gets through to the 6E5, and the eye remains open. If the capacitor is good, some voltage reaches the 6E5 grid through the .02- μ f capacitors, closing the shadow wedge. This test works to about 50 μ f, after which point there is not enough voltage drop across the capacitor to "wink the eye."

Capacitance bridge

The bridge circuit for measuring capacitors is familiar to all technicians who remember the old Solar or similar analyzers. It consists of two resistive and two capacitive arms (Fig. 3). One of the capacitive arms is the capacitor being measured. The two resistive arms are formed by a single potentiometer, the ratio between the arms being changed by the potentiometer setting. When the resistance ratio of the two resistive arms is the same as the reactance ratio of the two capacitive arms, there is no voltage difference between points A and B, and therefore none between grid and cathode of the 6E5. The wedge opens and the capacitance of the unit being measured is indicated by the pointer attached to the potentiometer arm.

There are four capacitance ranges. Three ($C \times .001$, $C \times .01$, C) are obtained by switching the fixed capacitance arm. The three "standard" capacitors are .0002 (adjustable for calibration), .02 and 2 μ f. A variable resistor in series with the 2- μ f capacitor measures the power factor of electrolytics and makes it possible to bal-

**The World's Largest
Field Engineering Service Organization
With World-Wide Demands for BOTH
Its Engineering & Service "Know-How"
Offers...**



**A WORLD OF
OPPORTUNITIES**

**To Qualified
Communications and Radar Personnel!**

With a wide range of commercial and government operations to service on a long range basis . . . and with an ever-increasing volume of new orders resulting from our outstanding achievements in these fields, PHILCO requires the immediate service of men who are qualified by experience or training in the design, maintenance and instruction of Communications, Radar and Sonar Equipment. As the world-wide pioneer in

servicing electronic equipment, UNLIMITED OPPORTUNITY and JOB SECURITY are more than just "sales talk" at PHILCO. In addition to TOP COMPENSATION more than commensurate with your ability and education, our many valued benefits include hospitalization, group insurance, profit sharing, retirement benefits, merit and faithful service salary increases, paid vacation and educational assistance.

Join The Pioneer In The Servicing of Electronic Equipment

**IMMEDIATE OPENINGS AT ALL LEVELS
AND IN ALL FIELDS OF ELECTRONICS**

**For Detailed Information on These Challenging Positions
Write Now . . . In Confidence . . . For A Local Interview**

**PHILCO TECHREP
DIVISION**

22nd & Lehigh Avenue, Philadelphia 32, Pa.

TEST INSTRUMENTS

ance the bridge when capacitors with a high power factor are measured.

For the fourth (HIC) range, the bridge circuit is set up as in Fig. 4. The reason is that in a bridge of the type of Fig. 3 the ratio between arms changes very rapidly near the ends of the scale, crowding the readings for high capacitances. In the HIC range, therefore, the potentiometer becomes one resistive arm of the bridge and a 10-ohm resistor the other one.

Capacitor leakage

Leakage in electrolytic capacitors is measured with d.c. from a 6L6 rectifier, the output voltage of which can be varied continuously by adjusting its control grid voltage. The METER RANGE switch (see Fig. 5) is used first to measure the voltage applied to the capacitor, then to put a low-resistance shunt around the meter for the 50-ma range or to remove the shunt for the 5-ma range. There are two voltage ranges. The LO VOLTS range—set by a separate switch which disconnects the screen of the 6L6 from the plate and connects it to the control grid—is used for capacitors with a 60-volt or lower rating.

Other circuits

The circuit of Fig. 3 becomes a resistance bridge simply by substituting fixed resistors for fixed capacitors in one arm of the bridge and connecting the resistor to be measured across the X terminals. Thus all four arms of the bridge become resistors.

Much higher resistances—such as the leakage of coupling capacitors—can be measured by the insulation resistance test circuit of Fig. 6. The triode is so hooked up that its cathode is at the center point of a bleeder across the B supply. The unknown "resistor" is connected between the negative end of the B supply and the grid. Any leakage puts a negative voltage on the grid, driving it toward cutoff. In operation, the meter is set on the 5-ma range and tube plate voltage adjusted to give a full-scale reading (infinite resistance). Two resistors between grid and ground permit some of the negative charge to leak off the grid, and therefore permit calibration in two ranges which run roughly from 5 to 20,000 megohms. The QUICK CHARGE switch speeds up insulation tests on capacitors.

The DISCHARGE position of the selector switch connects a 10,000-ohm resistor across the test leads and discharges any capacitor connected across them.

The LEAKAGE circuit can be used as a continuity tester. The meter is set to the 50-ma range, the test leads shorted and the voltage adjusted to give a reading of about 15 ma. There is then about 120 volts at the probes. Continuity in any circuit between the probes will be indicated by some motion of the meter indicator.

A complete schematic diagram of the CRA-1 appears in Fig. 7. **END**

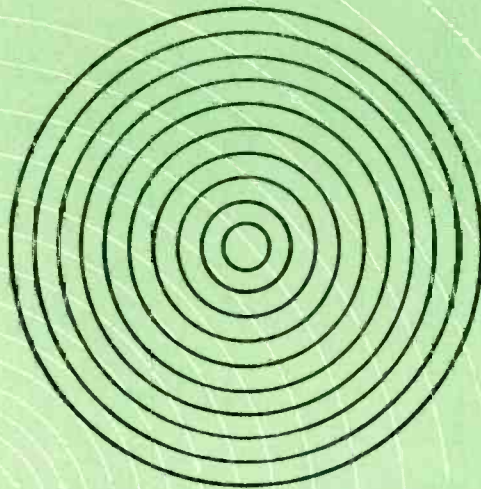

STANDARDIZE WITH CANNON



NEW XLR

*...an important addition
to the XL Series*

Standardize with Cannon Audio Connectors . . . designed to meet all audio equipment disconnect needs. Simplify circuitry and cabling. Get quiet, continuous operation with the standard connectors of the industry—*Cannon Plugs*.

You'll find exactly the type you need in 14 extensive series expressly designed for radio, sound, TV and related fields . . . in cord, rack or panel chassis, audio and low-level, portable, hermetic sealed, miniature and subminiature, and power-supply types. Standard equipment with leading manufacturers of electronic equipment. The old reliable "Latchlock" feature on Cannon microphone connectors . . . standard on top-ranking microphones.

Complete Audio Connector Bulletin is yours for the asking . . . D Series in separate bulletin coded D-4.



P series



X series

*for
simplified
AUDIO
circuitry!*



BRS series



UA series



D series



U series



K series

CANNON PLUGS



Please refer to Dept. 144

CANNON ELECTRIC COMPANY

3209 Humboldt St.
Los Angeles 31, California

Factories in Los Angeles; East Haven; Toronto, Canada;
London, England. Licensees in Paris, Tokyo, Melbourne.
Representatives in all principal cities.
Distributors everywhere.

A DEPENDABLE

GAS TEST

By H. B. CONANT

*An important addition
to tube testing*

THE presence of gas in a tube is usually unsuspected until it shows itself as a visible blue glow. However, long before that, gas ions are at work on the control grid, reducing its effectiveness as a control element. This is especially true when the grid is fed from a high-resistance circuit as in a resistance-coupled stage. And when the grid follows a tuned circuit, grid current due to gas ions loads the circuit.

Modern tube testers are a miracle of engineering but none of the commercial models provide for a gas test. The tube manuals make no mention of such tests in the sections on tube testing and the matter of gas seems to have received little attention.

In designing this gas test, I have borrowed from the technique of measuring high vacuum with a hot-cathode ionization gauge (Fig. 1). The circuit uses a triode but it is not connected in the customary manner. There is a relatively high positive potential on the grid and a relatively low negative potential on the plate.

The *modus operandi* of the vacuum gauge is simple: electrons are accelerated from cathode to grid because of the positive grid potential. Because of their velocity, some of them pass through the grid wires. If enough gas molecules are present, there will be

collisions with the high-velocity electrons, resulting in ionization of the gas molecules. Such positively charged gas ions will be repelled by the grid and attracted to the plate or "ion collector" where they can pick up the needed electrons to become normal gas molecules again. This causes a current to flow in the plate circuit, which is read on the plate microammeter in terms of gas pressure.

A well designed vacuum gauge will read to a pressure of 1×10^{-8} millimeter of mercury or enough gas pressure to support a column of mercury .0000001 mm or .000000003937 inch high. This would be considered high vacuum though it is far from perfect. However, at pressures greater than 1×10^{-8} mm, ionizable gas molecules are present; the vacuum gauge will not operate unless they are, and in sufficient numbers to insure a substantial number of collisions and thereby generate a readable value of plate or ion-collector current.

The blue glow in a tube is very unlikely if the pressure is less than 1×10^{-2} millimeter or 1,000,000 times the pressure at which the ionization gauge will no longer operate. In between these two pressures, no blue glow will show to warn of gas. Yet the ionization gauge proves beyond doubt that ionizable and therefore harmful gas molecules are present.

So why can we not make a modified ionization-gauge circuit into which we can connect the tube to be tested? It is true that triodes made for ionization gauges have a rather special geometry of the elements to achieve the greatest sensitivity and to provide a reproducible calibration or response curve. But this is no reason why a triode of different configuration will not behave in the same manner. Although we may find no indication of gas when the pressure may be 1×10^{-6} mm, for example, such a tube would contain so little gas that it could not be considered gassy.

Although the variations in element geometry among the many tube types prevent accurate measurement of the gas pressure within a given tube, if we can obtain no ionization in this test harmful ionization is very unlikely to occur in normal service.

The circuit of the gas test is shown in Fig. 2. The tube to be tested is connected as a triode, using the control grid or grid 1 as the electron accelerator. The ion collector will necessarily be the plate if the tube is a triode, but grid 2

will serve as the ion collector in tetrodes, pentodes, etc. It is not necessary or even helpful to tie the remaining elements together as a plate.

The potentiometer provides a variable source of voltage for the electron-accelerator grid and should always be started from zero voltage. This procedure is recommended to avoid damage to the ion-collector microammeter. A really gassy tube will slam the meter pointer hard if the whole accelerator potential is applied suddenly.

After the tube has heated thoroughly, advance the potentiometer, starting at zero, while watching both meters. With an ionization-gauge tube, the plate microammeter would read full scale by the time the grid potential has been increased to produce a grid current of 5 ma if the gas pressure is 1 micron (1×10^{-3} mm). These values may be used for approximating the gas or absence of gas in the tube under test. In other words, if the plate meter reaches full scale before the grid meter has done so, the tube is probably gassy enough to glow in service. When both meters reach full scale together, the tube probably won't glow in service but still contains a harmful gas pressure. Whenever the grid meter can be run to full scale without producing a readable indication on the plate meter, the tube may be considered strictly non-gassy.

Whenever enough gas has accumulated inside a tube to be detectable on this gas test, it must be assumed that the envelope or seal is leaking because the getter, normally used in the manufacture of the tube, is sufficient to take care of any outgassing of the elements for many years. A leak therefore is likely to get worse instead of better so any indication on the ionization-collector meter should be taken as a sure sign that the tube should be discarded.

When testing dual triodes such as, for example, the 6SN7, it is necessary to connect only one of the triodes. Unfortunately diodes cannot be tested for gas by this method.

In constructing this gas tester, it may be possible to build it into an existing tube tester, or an obsolete tube tester could be worked over as a gas tester. In any event, the heater voltages for the gas tester can be taken off the existing tube-tester heater switch. All the constructional details I will leave to the ingenuity of the individual technician. **END**

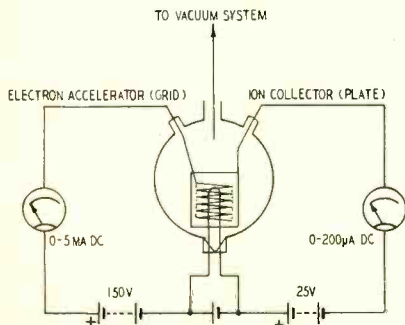

Fig. 1—Diagram of ionization gauge.

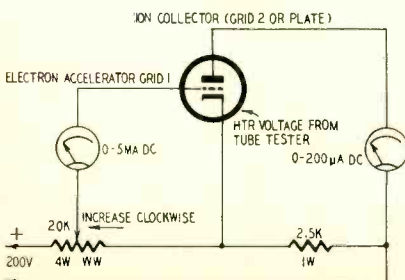

Fig. 2—Diagram of gas test circuit.

By WAYNE E. LEMONS

Perk up the LITTLE SET

*Improving the performance
of the popular a.c.-d.c. sets*

ONE of the greatest service headaches for the radio technician is the little set that sells for less than \$15 and usually contains three tubes and a rectifier. This may not be as much of a problem in a large city where there are several powerful local stations but it can be a genuine nuisance in fringe areas. Many manufacturers do not recommend these small sets except for strong local reception, but that doesn't prevent the public in outlying areas from buying. To make matters worse, these sets often receive even distant stations well when they are new.

When the set is brought to the service technician for repairs, he generally has the problem of bringing it back to normal and still keeping the bill low.

Although the following techniques may be used on more expensive radios, where applicable, they are primarily intended to help the service technician make a profit on the repair of the little set.

To start, check the tubes—but not with a tube checker. There is no better way to check tubes than by substitution. Do not attempt to use your ear to check the difference. Because of peculiar qualities of the ear it is sometimes impossible to distinguish between two tubes although one may have 25% to 100% more gain. This situation is aggravated by the warmup time between changing tubes. By far the best method is to use a v.t.v.m. on the a.v.c. line to check the converter tube and i.f. amplifier if there is one. A good tube will show a definite increase in voltage over a weak one.

The first a.f. tube should be checked with a signal tracer which has an a.f. indicator, while feeding in a steady tone from a signal generator. The output tube may be checked the same way, but usually a weak output tube will be accompanied by some distortion. The bias voltage may be measured across the cathode resistor and should be about 4.5 to 5 for a typical output tube (50L6). Unfortunately, this test cannot always be made because, for economy's sake, the output tube is often

biased by the negative voltage at the oscillator grid. Check the rectifier by measuring the B plus voltage. After checking the tubes and replacing any that are defective, the set should be aligned.

Other than tubes, the greatest reason for low sensitivity is one or more tuned circuits not properly peaked or not tracking. The gain of a small set depends almost entirely on the proper functioning of every tuned circuit. A typical small radio has only three tuned circuits contributing to gain and selectivity.

A station signal can be used to better advantage than a signal generator when adjusting these radios, except for aligning i.f. transformers.

This type of radio almost invariably uses a cut-stator capacitor and an i.f. of 455 kc. Peak the i.f. at the correct frequency, using the v.t.v.m. on the a.v.c. line as a peak indicator.

These radios usually have an antenna coil and a hank of antenna wire. It is very important that the original length of wire be used with the set and that it be extended to full length. Close coupling is used in the antenna coil and any large change in antenna capacitance will be reflected in the grid circuit tuning.

Peaking an oscillator trimmer at the low end is unheard of in manufacturers'

instructions; but if the radio has not been tampered with (bent capacitor plates, etc.), this is the quickest and surest adjustment. Improper tuning causes a marked reduction in sensitivity at the low end.

Keep the v.t.v.m. on the a.v.c. line and peak the oscillator trimmer while rocking the tuning capacitor for maximum response of a weak station near 600 kc. After the peak is found, turn to a weak station in the vicinity of 1400 kc and peak the r.f. trimmer. If a definite peak is found and the dial calibration is not too far off, the job is finished. However, if the r.f. trimmer cannot be peaked, turn the oscillator trimmer in the direction required to find a peak with the r.f. trimmer.

When it is necessary to move the oscillator trimmer at the high end more than a small amount, you can expect either an incorrect length of antenna hank or a change in inductance of the antenna coil.

If you are reasonably sure that the antenna wire is all right, use a tuning wand in the antenna coil to determine whether it needs an increase or decrease in inductance. If an increase is needed and the antenna coil has a hollow core, a tuning slug of the type used in auto radios may be slipped inside the coil and wedged into position.

Retune according to the preceding

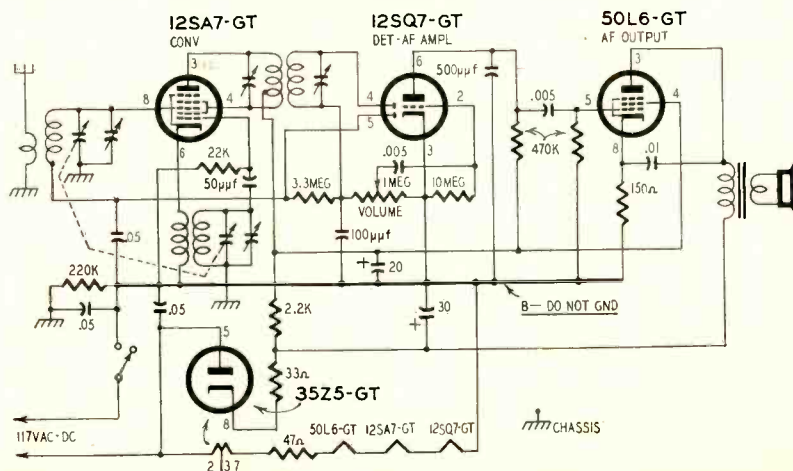

Typical of present-day small sets—diagram shows the a.c.-d.c. Trav-Ler 5054.

RADIO

instructions. After finding the correct placement of the slug, cement it into place and you have saved 75% of the cost of a new antenna coil. Occasionally the coil may have too much inductance—the tuning capacitor must be opened too much to arrive at a peak when adjusting the oscillator trimmer for low-frequency stations. This time use a slug of brass in the same manner as described for the tuning slug. An old brass volume-control shaft is ideal. The brass slug will lower the inductance and make the tuneup procedure possible.

If neither of these methods gives the desired results, it usually indicates that the antenna coil is not faulty and that the oscillator coil should be examined.

The same methods of increasing and decreasing inductance may be used with an oscillator coil. However, an oscillator coil may not have an open core. A metal washer with a hole slightly larger than the oscillator coil core can be slipped on to lower the inductance. If the inductance must be increased and a slug cannot be used, a few turns of wire between the coil and tuning capacitor may do the trick.

Occasionally a loop is found on a little set. If an increase in inductance is needed, you may be able to get just the right amount by using an old auto radio A choke in series with the loop and tuning capacitor. By cutting or spreading the turns of the choke the proper inductance can be found. To lower inductance use the capacitor-in-series method for a check. Don't remove turns until you find out whether the loop or oscillator coil is the offender. All this may sound as if it takes more time than the replacement of parts would cost, but after a little experience the whole procedure should take not more than 15 or 20 minutes.

Often the correct replacement part is not available and you may not always be sure which part is defective unless the above tests are made.

Many other things may cause a loss of volume. Some of them are difficult to troubleshoot.

The resistance of the volume control is normally higher than in more expensive sets, frequently being around 2 megohms. The volume control may change to a low value on rare occasions and still control the volume without introducing noise. Check with a good ohmmeter. Frequent offenders are mica capacitors used across the volume control and from the plate of the first audio amplifier to ground. They may become slightly leaky, permitting the set to play but reducing volume. A practical way to check these is by removing one lead from the circuit and noting any increase in volume. Do not confuse an apparent increase in volume due to the introduction of "highs." If in doubt, use a v.t.v.m. and see if the voltage increases when a lead is removed.

The first a.f. amplifier plate load resistor is often made purposely high to increase the stage gain. Check this

for any change in value. The coupling capacitor between the a.f. and output stage should always be checked in these sets. Many service technicians believe that a leaky coupling capacitor will show up as distortion in the output. This is not always the case, especially in "not-too-high-fidelity" sets. A slightly leaky capacitor will not show a positive voltage at the grid of the output stage even with a v.t.v.m. because of grid rectification. It can be easily checked by placing a v.t.v.m. on the grid pin and removing the output tube. If the capacitor is leaky, the voltmeter will go more positive. Sometimes a positive voltage on the output grid with the tube in place is caused by a defective output tube.

One trouble that can throw the novice for a loop is a leaky bypass capacitor across the primary of the output transformer. Unfortunately, there is practically no way of checking this component without removing it from the circuit. This trouble usually causes distortion, but it is of the type that can easily be attributed to poor design. Those who have had experience with universal replacement output transformers should have no trouble recognizing this improper-impedance distortion.

A fairly uncommon, although very possible trouble is loss of sensitivity of a PM speaker. As a matter of fact, any part used in these sets should be open to suspicion because of the inexpensive materials used.

Service technicians have increased the power output of these sets by bypassing the output tube's cathode bias resistor with an electrolytic filter capacitor. This is not recommended unless adequate B plus filtering is used. Bypassing the resistor increases the low-frequency response of the stage, introducing hum from a poorly filtered power supply.

Some technicians do not believe these small sets can be serviced profitably and therefore make no attempt at repair. In the long run I believe that a job well done for a reasonable amount of money will be profitable even if not on the individual set. These small sets are often the "extra" around the house. If you make that little radio perform, it means you are in line to repair the "other" radio or TV set when it becomes defective. All this points up the fact that doing a small job well today probably means a better job tomorrow, charge the time spent to advertising!

Check the tuning of these sets each time they are repaired. It might be a good idea to do what a customer of mine, who owned a t.r.f. Atwater Kent, asked me to do. He brought the set into the shop "for tuning up" every month or so. I finally asked him why he brought it in so often. "Well," he said, "it says on the back of the set to TUNE RADIO FREQUENTLY." As I seldom charged him anyway I didn't have the heart to tell him that it actually said TUNED RADIO FREQUENCY. END

POT AIDS PRINTED CIRCUIT SERVICE

To aid in the servicing of printed-circuit chassis, Motorola has developed a controlled-temperature heating pot. This soldering pot is used in a five-step plan for removing and replacing defective components in printed circuits:

3. After removing the defective part, heat each chassis terminal for the new component and then remove the excess solder from the chassis base and terminal holes with a low-wattage soldering iron.

4. Clean the chassis base around the

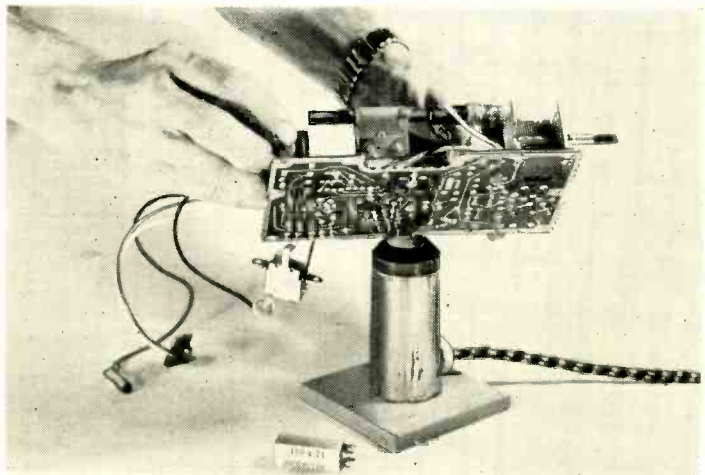

1. Simultaneously heat all terminals of the component. Check the bottom of the chassis to see that all terminals are straight and the soldered points free to make contact with the heat.

2. Dip the terminals into the soldering pot (see photo). With a gentle lift, the component will become unsoldered.

repair area with a suitable cleaner such as carbon tetrachloride before installing the replacement part.

5. Install the new component and resolder. If in removing the component a conductor is damaged, bridge the break with a short piece of tinned wire.

WHAT'S YOUR SERVICE PROBLEM?

FM Radios • Amplifiers and Tuners • Auto Radios • Record Changers

PHOTOFACT HELPS YOU SOLVE IT FASTER, EASIER, BETTER, MORE PROFITABLY!

THE WORLD'S FINEST SERVICE DATA

PHOTOFACT Service Data is the *only* service information based upon first-hand examination of the actual production-run receivers and equipment. It is authentic, uniform data developed through actual study and analysis by service engineers in the Howard W. Sams Laboratories. PHOTOFACT is the *only data* prepared from the practical point of view of the Service Technician.

Thousands of Service Technicians use PHOTOFACT daily for time-saving, profit-boosting service operations. If you've never used PHOTOFACT, you've never realized your full earning power—you've never given such complete customer satisfaction. So get the proof for yourself. Try PHOTOFACT—use it on any job. Your Parts Distributor has the Folder Sets you need for any of the 17,000 TV and radio receivers, changers, recorders, etc., covered in PHOTOFACT. Once you use this great service, we know you'll want the complete PHOTOFACT Library.



THESE GREAT FEATURES ARE EXCLUSIVE IN PHOTOFACT—THEY HELP YOU EARN MORE DAILY, HELP INSURE CUSTOMER SATISFACTION

FULL SCHEMATIC COVERAGE

1. Famous "Standard Notation" uniform symbols are used in every schematic.
2. The same standard, uniform layout is used for each schematic.
3. Diagrams are clear, large, easy to read, easy to handle.
4. Wave forms are shown right on the TV schematics for quick analysis by 'scope.
5. Voltages appear on the schematics for speedy voltage analysis.
6. Transformer lead color-coding is indicated on the schematic.
7. Transformer winding resistances appear on the schematic.
8. Schematics are keyed to photos and parts lists.

FULL PHOTOGRAPHIC COVERAGE

9. Exclusive photo coverage of all chassis views is provided for each receiver.
10. All parts are numbered and keyed to the schematic and parts lists.
11. Photo coverage provides quicker parts identifications and location.

ALIGNMENT INSTRUCTIONS

12. Complete, detailed alignment data is standard and uniformly presented in all Folders.
13. Alignment frequencies are shown on radio photos adjacent to adjustment number—adjustments are keyed to schematic and photos.

TUBE PLACEMENT CHARTS

14. Top and bottom views are shown. Top view is positioned as chassis would be viewed from back of cabinet.
15. Blank pin or locating key on each tube is shown on placement chart.
16. Tube charts include fuse location for quick service reference.

TUBE FAILURE CHECK CHARTS

17. Shows common trouble symptoms and indicates tubes generally responsible for such troubles.
18. Series filament strings are schematically presented for quick reference.

COMPLETE PARTS LISTS

19. A complete and detailed parts list is given for each receiver.
20. Proper replacement parts are listed, together with installation notes where required.
21. All parts are keyed to the photos and schematics for quick reference.

FIELD SERVICE NOTES

22. Each Folder includes time-saving tips for servicing in the customer's home.
23. Valuable hints are given for quick access to pertinent adjustments.
24. Tips on safety glass removal and cleaning.

TROUBLE-SHOOTING AIDS

25. Includes advice for localizing commonly recurring troubles.
26. Gives useful description of any new or unusual circuits employed in the receiver.
27. Includes hints and advice for each specific chassis.

OUTSTANDING GENERAL FEATURES

28. Each and every PHOTOFACT Folder, regardless of receiver manufacturer, is presented in a standard, uniform layout.
29. PHOTOFACT is a current service—you don't have to wait a year or longer for the data you need. PHOTOFACT keeps right up with receiver production.
30. PHOTOFACT gives you complete coverage on TV, Radio, Amplifiers, Tuners, Phonos, Changers.
31. PHOTOFACT maintains an inquiry service bureau for the benefit of its customers.

ONLY \$25 DOWN

Puts a Photofact Service Data Library in Your Shop. Ask Your Photofact Distributor—He Has the Full Easy-Pay Details.

FREE PHOTOFACT CUMULATIVE INDEX



Send for it! Your guide to virtually any model ever to come into your shop; helps you locate the proper PHOTOFACT Folder you need to solve any service problem on any model. Once you have the make and chassis number, it

takes just 60 seconds to find the applicable PHOTOFACT Folder. Send coupon now for your FREE copy of the valuable Cumulative Index to all PHOTOFACT Folders.

HOWARD W. SAMs & CO., INC.

Howard W. Sams & Co., Inc., Dept. 2-F-5
2205 E. 46th St., Indianapolis 5, Ind.

Send FREE Photofact Cumulative Index.

Name.....

Address.....

City.....Zone...State.....

HELPS YOU EARN MORE DAILY

460-mc RADIO

The spectrum between 450 and 470 mc—its characteristics, regulations, equipment

By LEO G. SANDS

THE rapidly expanding use of two-way mobile radio systems has caused concern to equipment manufacturers and potential users because it seemed that soon there would be no more room for new systems. All available channels in the 25-50 and 152-162-mc bands have been allocated to specific services and in several areas all channels for a specific service are being fully used. However, a 20-mc-wide band of premium radio spectrum

space has been available for almost 5 years and it has been only in the past 2 years that any serious attention has been given to it—the u.h.f. band between 450 and 470 mc.

This portion of the radio spectrum was long shunned because many felt that the communications range in mobile applications would be too short to be practical. However, the propagation characteristics of u.h.f. radio from 450 to 470 mc are fairly comparable

Left—460-mc antenna, made by Connecticut Telephone & Electric, has high gain, strong ground wave. Below—Ambulance in RCA's Camden plant uses 460-mc unit.

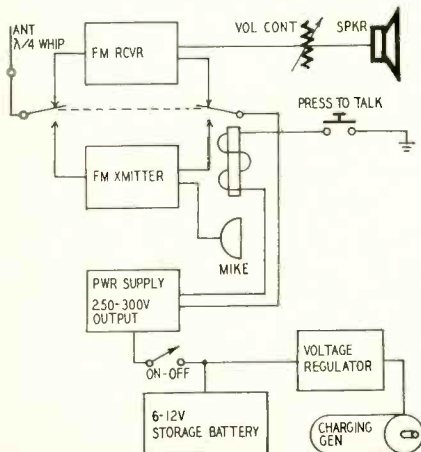
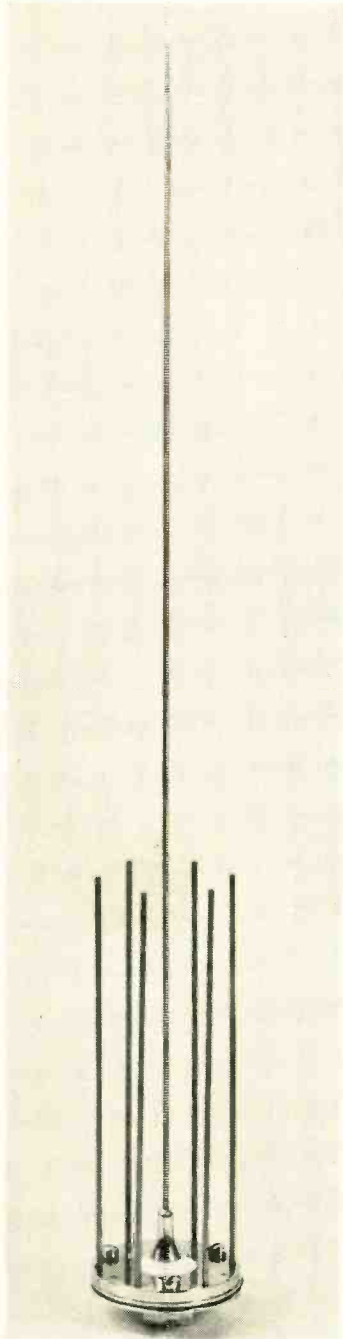

Diagram shows basic layout of mobile radio system for 460-mc operation.

to v.h.f. radio in the 152-162-mc band. The communications range is approximately the same but noise levels are much lower in the u.h.f. band. And because of the superior multiple-reflection characteristics of u.h.f. radio, better coverage is often obtained in electrically shaded areas such as narrow city streets lined with tall buildings. Tests have demonstrated that 460-mc radio talks well even inside tunnels.

The communications range at 460 mc depends upon effective antenna height to a greater degree than at 160 mc. Effective antenna height does not necessarily mean the distance of the antenna above ground, but does mean the distance of the antenna above the highest areas within the desired communicating range. For example, an antenna atop a 200-foot building will have an effective elevation of only 100 feet if the community is within a bowl with ridges 100 feet high.

As at 160 mc, the range is somewhat greater than line of sight. The calculated range for point-to-mobile communications is 7 miles when the base station antenna effective height is 50 feet and almost 19 miles with a 350-foot effective antenna height. In both cases it is assumed that the mobile unit antenna is on a car top. In heavily wooded areas or in hilly country covered with foliage, the range may be less. U.h.f. signals are easily reflected by hard surfaces whereas foliage tends to absorb the signals.

Since suitable equipment is now available for use in the 450- to 470-mc

bands and many have discovered the desirable characteristics of u.h.f. radio for mobile communications, there is considerable activity. FCC figures show the number of stations authorized to operate in these two bands (see table) but the figures do not mean that that many stations are actually operating since applicants apply for authority for the maximum number of stations they desire to operate and not the number of stations they plan to install immediately.

Some manufacturers are unwilling to give information on the number of mobile radio units and base stations they have sold, so it is not practical to guess closely how many stations are currently on the air. However, it is safe to assume that a goodly number are in service. The Yellow and Checker cab companies of Chicago, for example, have been authorized to install upward of 1,000 u.h.f. mobile units. The Burlington Trucking Co., a subsidiary of the Burlington Railroad, is equipping a fleet of 40 trucks with 460-mc radio. Griffith Consumers, a fuel-oil distributor in Washington, D. C., has been using 460-mc radio for over a year. Coca-Cola distributors in some cities have equipped their beverage-cooler service trucks with 460-mc radio. It is a big business but is uncalibrated in dollars or volume.

Frequency availability

Radio communications channels are available for occupancy in the still uncrowded 450-470-mc bands. Under

present operating standards with 100-ke separation, these two adjacent 10-mc-wide u.h.f. bands can be divided into 200 channels. And if standards are tightened to allow only 50-ke frequency separation, 400 radiotelephone channels can be made available.

The spectrum between 450 and 460 mc has been divided by the FCC into 100 radio communications channels allocated to various types of organizations and industry groups. The adjoining 460- to 470-mc band has been allocated to the Citizens Radio Service, a much misunderstood and as yet little used but extremely valuable band of radio frequencies.

In the 460-470-mc Citizens band, no specific frequency assignments are being made except for class-B stations which can be operated on only one specific frequency, 465 mc. Class-A stations may be operated on any frequency within the band if power input to the final r.f. stage of the transmitter is less than 10 watts. Power input up to 50 watts is permissible on any frequency between 460-462 and 468-470 mc.

The 450- to 470-mc section of the radio spectrum has been allocated as listed below:

Application	Band limits	No. channels
Remote pickup broadcast	450.05-450.95 mc	10
	455.05-455.95 mc	10
Industrial	451.05-451.95 mc	10
	456.05-456.95 mc	10
	452.05-452.95 mc	10
Land Transportation	457.05-457.95 mc	10
	453.05-453.95 mc	10
Public Safety	458.05-458.95 mc	10
	454.05-454.95 mc	10
Domestic Public	459.05-459.95 mc	10
Citizens Radio Service Class-A	460-470 mc	
Citizens Radio Service Class-B	465 mc	

Licensing regulations

All radio station authorizations in the 450-460-mc band are presently being granted on a developmental basis. This does not imply that licensees are apt to lose their authorizations without cause nor that the art is still in the experimental stage. It does mean, however, that sufficient experience has not been had as yet in this band upon which to formulate hard and fixed rules governing equipment and operating requirements. When the "developmental" tag is removed from authorizations for operation in the 450-460-mc band, licensees will be required to conform with possibly more rigid standards than now. Most equipment now available for use in the 450- to 470-mc bands far exceeds the current requirements of the FCC.

Any company or individual operating a business or commercial enterprise for which a radio service has been established by the FCC in the Land Transportation or Industrial Radio Services (for which frequencies have been allocated in the 450- to 460-mc band) may

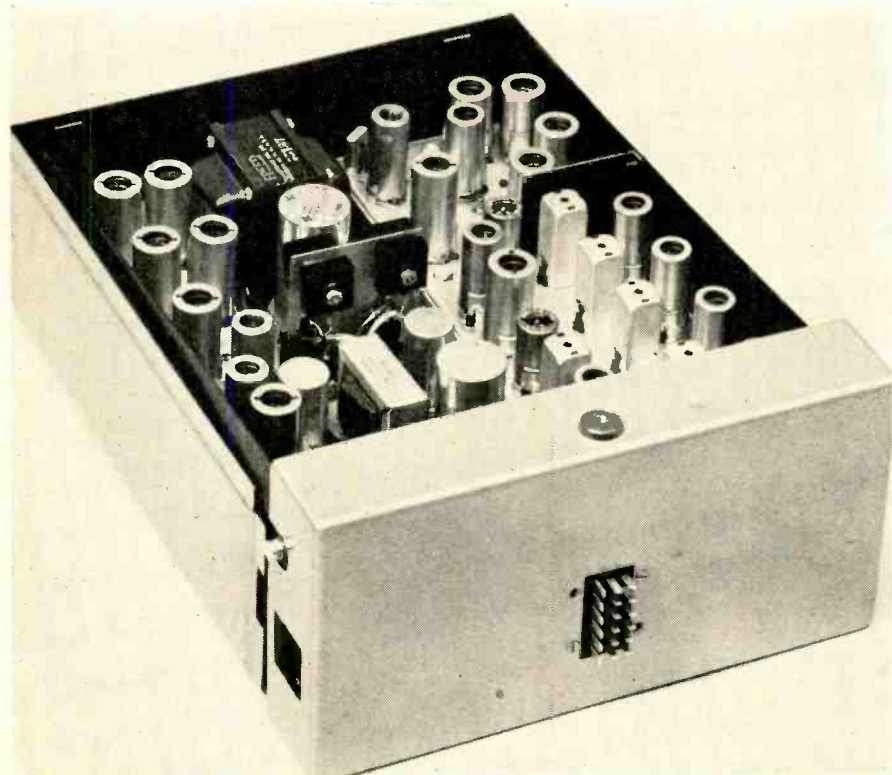

Two way 460-mc mobile radio—contains transmitter, receiver and power supply.

Connecticut Telephone and Electric Corp.

RADIO

apply for radio station licenses for operation in this u.h.f. band. Likewise, safety services such as police and fire departments are eligible. All applicants must qualify as outlined in Parts 10, 11 and 16 of the FCC rules and regulations and must be citizens of the U.S.A.

At the present time there is no charge for station licenses. Operator's licenses are not required by persons using mobile radio units but a third-class or restricted radiotelephone operator's license is required by the operator of the base station. No technical knowledge is required for this grade of operator's license. Application forms may be obtained from the FCC, Washington 25, D. C., and copies of Parts 10, 11 and 16 of the FCC rules may be obtained for 10 cents per part from the Government Printing Office.

Citizens radio

It is popularly believed that the Citizens Radio Service is primarily for the housewife, hobbyist and sportsman. This is not true. The Citizens band is being used and is intended for use by business for commercial purposes. Many types of industries and business organizations ineligible for radio station licenses in other radio services may be eligible in the Citizens Radio Service. Fuel-oil distributors, soft-drink bottlers, radio and TV service technicians, delivery organizations and farmers are typical of commercial enterprises making use of two-way radio in the Citizens band.

Two classes of Citizens radio stations may be operated in the 460-470-mc band. Class-B stations are limited to 10-watt input, must operate only on 465 mc and are intended for short-range personal communications or for radio control of objects like model airplanes.

A transmitter-receiver for class-B Citizens Radio Service generally consists of a superregenerative receiver that converts into an AM self-excited transmitter. It is an engineering feat to design and build such a unit to meet the frequency-stability requirements of the FCC. Equipment for class-B service is now on the market which will meet FCC requirements.

Two-way radio equipment designed for use in the 450- to 460-mc band is generally tunable to frequencies in the 460- to 470-mc Citizens band. This equipment exceeds FCC requirements for class-A Citizens radio service by a wide margin. For example, the rules specify transmitter frequency stability of $\pm 0.02\%$ whereas most available equipment is rated at $\pm 0.0005\%$. The allowable transmission band is 200 kc whereas 460-mc commercial mobile radiotelephone transmitters have a transmission band of only ± 15 kc of center frequency.

Commercial equipment

Commercial 460-mc mobile and base station radio units for other than class-B Citizens service use FM exclusively.

The transmitters and receivers are fixed-tuned to a specific frequency and are crystal-controlled. Double superheterodyne receivers are standard. Mobile units are available for direct operation from a 6- or 12-volt storage battery and some can be operated from either voltage by simple modification of the equipment. Base station units are normally designed for operation from 117-volt a.c. lines. Base stations may be operated locally or by remote control over wire lines or a radio link.

Transmitter power input is generally from 4 to 20 watts. Greater power is seldom necessary. A cheaper way to obtain greater range is to raise the antenna or use a high-gain antenna. Several types of medium- and high-gain antennas for 460-mc operation are available commercially.

Tubes used in 460-mc mobile radio equipment are generally standard, well known types. The power amplifier and driver tubes (5894-A) used in some RCA equipment are of a fairly new type manufactured to JAN specifications in the United States around a Dutch design. Some Motorola sets use the type 2C39 lighthouse tube which has found wide popularity in microwave systems.

FCC AUTHORIZATIONS

Band (mc)	Service	Stations*
450-460	Special and Safety	700
460-470 and 27.255	Citizens Radio Service**	7,054

* A station is defined as a separate license or construction permit authorization. For example, 65 mobile units operating on one license are counted as one station.

** No record is maintained by the FCC of the number of stations authorized in a specific band, so the 7,054 stations in the Citizens Radio Service include both those operating on 27.255 mc and the 460-470-mc band.

Information on mobile radio equipment for operation in the 450-460 and 460-470-mc bands should be readily obtainable from the manufacturers listed below:

Radio Corporation of America, Communications Marketing Dept., Camden, N. J.

Motorola, Inc., 4545 Augusta Blvd., Chicago 51, Ill.

General Electric Co., Communications Equipment, Syracuse, N. Y.

Connecticut Telephone & Electric Co., Meriden, Conn.

Allen B. Du Mont Laboratories, Inc., Clifton, N. J.

Platt Manufacturing Co., 125 W. 17th St., New York, N. Y.

Stewart-Warner Electric Div., 1826 Diversey Parkway, Chicago 14, Ill.

Servicing 460-mc equipment

Servicing u.h.f. mobile radio systems is very similar to that of v.h.f. mobile

radio. The same basic tools and test equipment are required. In addition, a suitable high-grade u.h.f. signal generator, a frequency and deviation meter for the 450- to 470-mc range and an electronic r.f. power output meter and dummy load are recommended shop equipment.

Information on alignment is generally available from u.h.f. mobile equipment manufacturers. Circuitry is usually standard so no unusual problems should be encountered. Be sure however, not to alter r.f. circuitry because at these frequencies physical misalignment could ruin performance.

In addition to tools, test equipment and familiarity with transmitters and superheterodyne receivers, the technician who is to service 460-mc mobile radio equipment (see diagram and photos) must possess a first- or second-class radiotelephone or radiotelegraph operator's license. Such a license is issued by the FCC without cost upon passing a test on radio and electrical principles and FCC rules and regulations.

Where a large volume of mobile radio service is anticipated, the shop should be provided with jigs to permit rapid setup of equipment for testing and alignment. A heavy-duty rectifier power supply may be used as a power source for operating 6- or 12-volt mobile sets on the bench. Since the current drain with the transmitter on is often two to three times the standby drain, it is wise to select a rectifier power supply with adequate voltage regulation. Of course, a storage battery and charger may be used as a bench power source. (Such a supply is unusually useful and flexible. The battery floating across the charger output acts like a very large filter capacitor and voltage regulator. Since current is supplied by the charger, an older battery can be used. — *Editor*)

Installation of 460-mc u.h.f. mobile equipment is much the same as installation of v.h.f. mobile equipment. The equipment is mounted in the same manner and looks the same. The antenna, however, is generally a vertical car-top whip only 6 inches long and easy to install.

Base station installations, too, are similar to v.h.f. base station installations. The length of the antenna transmission line, however, should be kept as short as possible because transmission-line losses at 460 mc are far greater than at 30 or 160 mc. Low-loss transmission line like *Styroflex*, RG-17/U or a good hollow line should be used.

Now that good equipment is available from a number of sources it is expected that the u.h.f. mobile radio will continue to expand at an even more phenomenal rate. The quality of communications, especially the freedom from noise, and solid coverage in either the 450-460 or 460-470-mc Citizens band makes u.h.f. mobile radio particularly attractive. END



SYLVANIA SILVER SCREEN 85

The picture tube with Selling Power!

That's right! Sylvania's "Silver Screen 85" puts powerful, profitable salesmanship behind your personal TV service. That's because "Silver Screen 85" is the picture tube TV America knows and asks for by name.

Every week Sylvania's "Beat the Clock" show builds greater consumer recognition and demand for the "Silver Screen 85." Every week dealers benefit at the payoff point.

Put the "Silver Screen 85's" selling power to

work for you. This booklet tells your customers the benefits of Sylvania's "Silver Screen 85." Leave a copy on every service call. Order a free supply now from your Sylvania Distributor.



SYLVANIA ELECTRIC PRODUCTS INC.
1740 Broadway, New York 19, N. Y.
In Canada: Sylvania Electric (Canada) Ltd.,
University Tower Building, Montreal
LIGHTING • RADIO • ELECTRONICS
TELEVISION • ATOMIC ENERGY



"Installing a 'Silver Screen 85' sure increases the value of a trade-in set and speeds turnover."



"'Silver Screen 85' sales are up over all other brands."

"TV service volume[#] increased by 'Silver Screen 85' tie-in advertising."



SYLVANIA[®]



... fastest growing name in sight

ELECTRONIC LOAD

*Forms a variable resistor
for checking power supplies*

By DON M. WHERRY

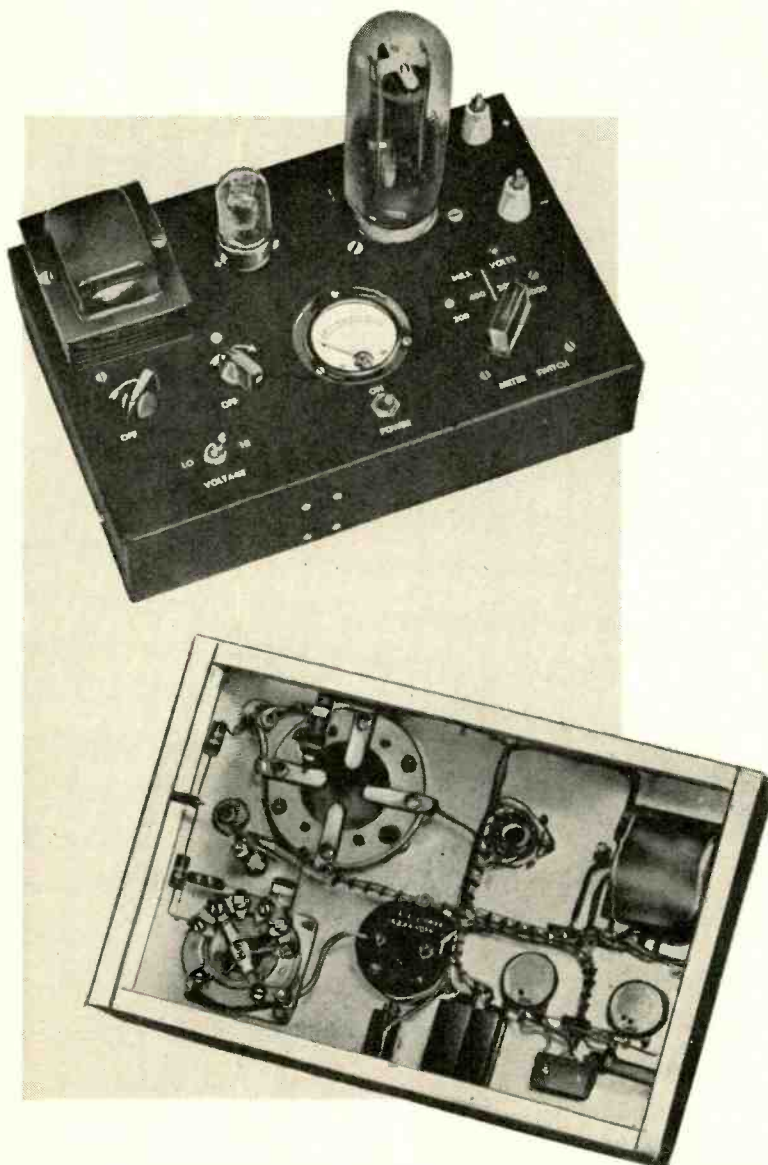

Above—the electronic load. Decals add attractiveness to the neatly arranged unit. Below—under-chassis view of electronic load.

WHILE the idea of an electronic load is not new you seldom see one rugged enough to test all sizes of power supplies used in audio amplifiers, small- to medium-sized “ham” transmitters and electronic equipment in general. When designing equipment of this type you have no idea what your power supply will put out under load, and as a result a blind guess is the best you can do. Feeling that that situation should be remedied at once, and with the least possible strain on the budget, the electronic load described in this article was conceived.

Since the tube used in the load must dissipate considerable power in the form of heat, the use of a receiving type tube was out of the question for higher values of current and voltage. Not wishing to purchase, or use, an expensive transmitting tube I cast about for the nearest acceptable substitute. The final choice was a surplus 211 or VT4C. This tube is very cheap on the surplus market (29 cents at one time) and a type many of us have on hand but never intend using. They will take 2,000 volts with little strain, and up to 300 or so milliamperes will not shorten their life appreciably. In any event a greatly shortened tube life means little when a tube is used only a few hours a year. Of course the maximum current at the maximum voltage will exceed the plate dissipation badly but even that can be handled if the meter readings are taken in a few seconds.

The unit (see diagram) uses a 6SN7-GT as a rectifier for the grid bias of the load tube. This is somewhat unusual but necessary because the 211 is a relatively high-gain tube. Thus, the grid must be at a positive potential to get a heavy load current at low voltages. As the grid draws considerable current when operated at a positive potential, some method other than a potentiometer for bias voltage control was desirable.

One half of the 6SN7 was connected so as to furnish that positive voltage, the value of which is controlled by its own grid bias adjusted by R1. This performs very well, the bias of the 211 being adjustable between zero and approximately 50 volts positive smoothly and easily. The remaining section of the 6SN7 is diode-connected to furnish a negative voltage for the 211 and also for the control of the positive section. The negative voltage to the 211 is controlled by potentiometer R2 as the grid takes no power while negative. A switch is used to go from positive to negative bias.

The transformer used is a standard broadcast type furnishing approximately 350 volts each side of center. The two filament windings are connected in series to furnish 10 volts for the 211. This voltage, being slightly high, is dropped by adjustable 1-ohm 10-watt resistor R3.

The current and voltage of the power supply under test are measured by a 1-ma meter with its various shunt and series resistors. To design meter shunts it is necessary to know the resistance of the meter. This is done with a small flashlight cell, two potentiometers and an ohmmeter.

Connect one potentiometer, the cell and the meter to be used in series and adjust the potentiometer for full-scale deflection. Without touching that adjustment connect the second potentiometer across the meter and adjust for half-scale deflection. Remove the second potentiometer and measure its resistance—this will be the resistance of the meter. With most 1-ma meters it will be low—my unit is 25 ohms. Knowing the resistance of the meter, the shunts and multipliers can be computed by the following formulas: milliammeter shunt $R = \frac{R_m}{n - 1}$ where R_m is the resistance of the meter and n is the scale multiplication factor; voltmeter multiplier $R = R_m (n - 1)$.

However, a slightly different approach was used. A 1-ohm resistor was permanently connected in series with the negative load line. Then, as the two current readings desired are 200 and 400 ma, respectively, it was calculated that the drop across the 1-ohm resistor would be 0.2 volt for the 200-ma range and 0.4 volt for the 400-ma. Since 0.2 volt will draw 1 ma through 200 ohms, it was necessary only to add a resistor of 175 ohms in series with the meter and place the two across the 1-ohm dropping resistor for the 200 scale. For the 400-ma scale it was necessary to add an additional 200-ohm resistor in series with the meter. You will find this method much easier than trying to wind two shunts to put directly across the meter. It's no cinch to wind a shunt for a multiplication of 400 and get it right.

The voltmeter was easy. As 1,000- and 2,000-volt ranges were desired, it was calculated that 1 megohm would pass 1 ma at 1,000 volts, so two 1-megohm resistors were used in series for the 2,000 range and the meter tapped off the center point for the 1,000 range. The meter resistance was neglected, being insignificant in this case.

Be careful how you wire the meter switch. Have the lowest voltage at the opposite side of the four positions from the lowest current. In this way you can go from any current range to the desired voltage range without harming the meter.

The meter switch used was a surplus affair, removed from a BC-375 tuning unit. Many of us have these laying around unused because of their rather violent indexing system. The remedy is, not to weaken the spring, but to file new indexing marks. It is easy. Remove the contact ring and the smaller wiper ring. Then revolve the shaft 180° and file small indexing notches on the smooth edge of the indexing disc. A

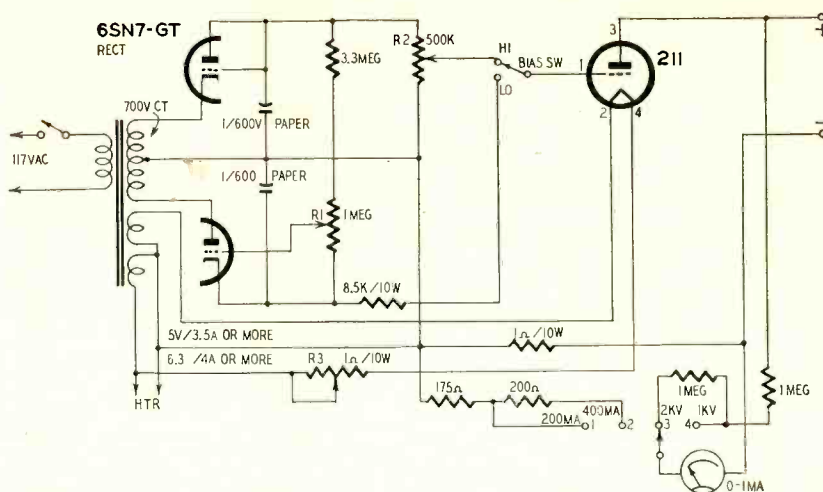

Schematic diagram of the electronic load. Extremely rugged 211 is used.

small rat-tail file will do the job nicely with no further disassembly. Reassemble and use with the shaft 180° rotated from normal.

When wiring the unit, wire the two load tube bias potentiometers so that, when both are in the "off" position, the tube has either high negative or zero bias on the grid, depending on the position of the bias switch. This switch is decaled LO—HI, which refers to the voltage being tested. When operating the unit, always start with the meter on the 2,000-volt scale, the bias potentiometers in the "off" position and the LO—HI switch in the HI position—this is important. Next, switch to the current range desired and advance R2 until the desired load current is drawn. If the voltage being measured is too low to obtain the desired current with R2 entirely advanced, turn it back to the "off" position and switch to LO and repeat with R1. The important thing is always to start with both potentiometers in the "off" position and the LO—HI switch in the HI position.

This unit can also be used as a variable resistance, when placed in the positive high-voltage lead, for first tuning up a new transmitter. The voltage on your pet transmitting tube can be kept to a safe value in case something goes

wrong. Take care, however, when it is being used in this manner because a very high voltage to ground may appear across the filament to the primary winding of the bias transformer in the load box. The chassis is left floating to lessen the danger to the technician when testing high voltage. High voltage is not dangerous—it's deadly.

Parts for electronic load

Resistors: 1—175, 1—200, 2—1 megohm, 1—3.3 megohms, 1/2 watt; 1—1, 1—8,500 ohms, 10 watts; 1—1 ohm, adjustable; 1—500,000, 1—1 megohm, potentiometers.
Miscellaneous: 2—1-μf 600-volt paper capacitors, 1—6SN7-GT and socket; 1—211 (VT4C) and socket; 1—s.p.s.t. switch; 1—s.p.d.t. switch; 1—single-pole 4-position rotary switch (see text); 1—transformer, 700 volts c.t. @ 50 ma, 6.3 volts @ 4 amperes, 6.3 volts @ 3.5 amperes; 1—meter, 0-1 ma; 1—chassis; 1—line cord; 2—output terminals.

As can be seen from the photo the electronic load is decaled. Decals are highly recommended. They are easy to apply and make the difference between a fine commercial-appearing unit and a "thing."

The unit shown was made completely from junkbox parts but its usefulness to most experimenters would well justify the purchase of new components. It is a valuable addition to the shop or ham shack equipment. END

CHASSIS HANDLING MADE EASY

Two simple and useful items to the TV service technician are these pieces of chassis-handling equipment, made by Barb City Industries (De Kalb, Ill.). They make it easier to get the set into the shop and to keep it on the bench once it gets there.

The pair of handles at the left form a chassis carrier. The slotted hooks seen on the one lying down are hinged to the handle with a rivet. The slot is wide enough to accommodate the edge of a chassis. When the handle is picked up, the weight of the chassis forces it against the outside of the chassis skirt, while the inner side of the hook is held firmly against the inside.

The two strips make up what is

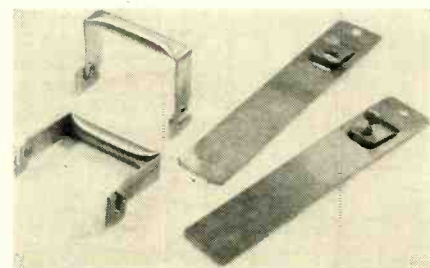

possibly the simplest chassis support ever manufactured. They are fastened to the bench—a suitable distance apart—with a screw through the hole in each one. Then, with the chassis held in a vertical position, one edge is slipped under the tab on each strip.

new Devices



AUTO ANTENNA, Antenna Specialists' Baseball, has rocker support for positive grounding. New mounting support design eliminates wet-weather shorts. Universal swivel base permits mounting on any curved sur-

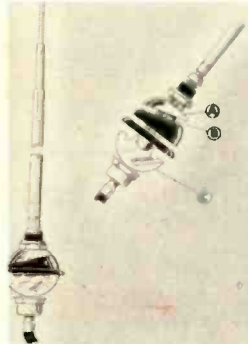

face with a slant of up to 35° from horizontal. Only one hole required for installation; entire job can be done from outside of car. Completely assembled with a 56-inch replaceable telescopic whip and either a 36- or 54-inch lead.—**Antenna Specialists Co.**, 13435 Euclid Ave., Cleveland 6, Ohio.

TV ANTENNA, JFD Super-Star-Helix (model SX13, single bay; model SX13S, stacked) incorporates *Star-Helix* layout with special front-end modification for peaking channel-13 performance. Modifications are added director and delta-

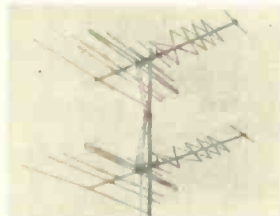

matched helical section, a shortened stub at center of helix. Flat helical section composed of individual nonlinear additive collectors, each tuned for high gain and sharp sensitivity on one high-band channel. Matching booster transformer for close stacking with maximum high-band response and electrical wide stacking with optimum low-band response.—**JFD Manufacturing Co., Inc.**, 6101 16th Ave., Brooklyn 4, N. Y.

TARGET TV ANTENNA, S & A Target Space Master, covers entire v.h.f. band; uniform cover-

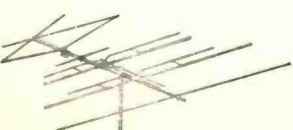

age over channels 2-6, higher gain on channels 7-13. Co-channel interference eliminated by high front-to-back ratio. Maximum transfer of signal by matching terminal impedance and 300-ohm transmission line. Good gain and directivity from Target V-X director system.—**S & A Electronics**, 1039 Nevada St., Toledo 5, Ohio.

U.H.F.-V.H.F. ANTENNA SWITCH, Superex model UV-1, features silver-plated switch contacts, positive indexing, no measurable signal loss and an



attractive case with easy out-of-sight mounting brackets, as well as a means of coupling two antennas to a TV set.—**Superex Electronics Corp.**, 4-6 Radford Pl., Yonkers, N. Y.

ANTENNAS, Telrex Thunderbird, loop-phased multielement arrays for fringe and subfringe area TV reception. Element function duplexed by variable impedance phasing loops to produce effective high-gain

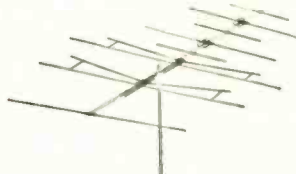

Yagis for high- and low-channel v.h.f. bands in all-in-line array. Compensated-T match for high- and low-band operation, for use with single transmission line through special decoupling system which isolates high- and low-channel signals to preserve symmetrical single-lobe response.—**Telrex, Inc.**, Asbury Park, N. J.

TV ANTENNA, Trio 99, for channels 2 to 13, uses two dual-purpose active elements, each consisting of three half-waves in phase on high channels and single half-wave on low channels. Three parasitic elements



on low channels and five on highs.—**Trio Manufacturing Co.**, Griggsville, Ill.

ZEE-BEAM ANTENNAS, Welco model 110, model 220 and Super ZEE-Beam, all featuring ex-

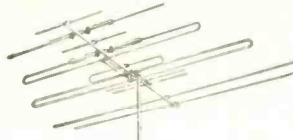

clusive ZEE-X elements.—**Welco Mfg. Co.**, Burlington, Iowa.

HI-FI EQUIPMENT, Allied model 728 FM-AM tuner (illustrated) has a.f.c. circuit, two controls, tuning and function selector, r.f. amplifier stage for FM and AM. Sensitivity on FM 5 μ v for 20-db quieting; AM sen-



sitivity 5 μ v for 1-volt output; response from 15 to 15,000 cycles, \pm 1db.

Knight Bantam 12-watt amplifier measures 3½ x 13 x 10½ inches. Frequency response at 12 watts output \pm 0.5 db from 20 to 20,000 cycles. Harmonic distortion less than 1% at rated output; intermodulation distortion less than 2% at rated output. Speaker output impedance 8 and 16 ohms.

Self-powered **Knight preamplifier**. Has bass and treble controls, five input jacks, 6 position input selector switch. Rated output 2.5 volts; frequency response at rated output 20 to 20,000 cycles, \pm 1 db; harmonic distortion at rated output 0.8%.—**Allied Radio Corp.**, 100 N. Western Ave., Chicago 80, Ill.

VOLTAGE AMPLIFIER, Electro Products model 3400-A, for use as preamp ahead of electronic instruments when actuating signals have insufficient amplitude. Also usable as all-purpose laboratory type voltage



amplifier. Boosts voltage of low-output transducers. Distortion less than 2½% up to 10 volts, 6% to 30 volts—saturation over 50 volts; gain of 200 or more between 1 and 30,000 cycles. Gain about 100 at 100,000 cycles; 50 at 200,000 cycles.—**Electro Products Laboratories**, 4503 N. Ravenswood Ave., Chicago 40, Ill.

THREE-WAY SPEAKER SYSTEM, Electro-Voice Skylark, 14 x 33 x 10½ inches, contains two tapered-horn ports which

load properly SP8C low-frequency and mid-range reproducer from 70 to 3,500 cycles. **Super T35B** high-frequency tweeter takes over at 3,500 cycles to beyond audibility. Reproduces



complete frequency range from about 70 to 15,000 cycles, \pm 6 db.—**Electro-Voice, Inc.**, Buchanan, Mich.

12-INCH WIDE-RANGE SPEAKER, Lansing model 123, is only 3½ inches in depth. This new *Signature* speaker mountable between studding, flush with surface of standard wall or partition; also enclosable in



reflex cabinet or can be loaded with a horn. Usable frequency response range, as direct radiator and enclosed with adequate baffle, from 20 to 15,000 cycles. Power input 20 watts; impedance, 16 ohms.—**James B. Lansing Sound, Inc.**, 2439 Fletcher Dr., Los Angeles 26, Calif.

SPEAKER SYSTEM, Permoflux Largo 12 inch (Big Brother to the famous Largo 8 inch), features *Super Royal* 12-inch speaker and 32KTR super tweeter. Utilizes enclosure similar to Largo 8, but larger. Peak-free reproduction over full range of 30 to 16,000 cycles. Power-handling capacity,

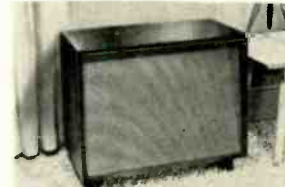

20 watts; impedance system, 8 ohms; overall size, 23½ x 27½ x 15½ inches. This speaker was described in this column in the May, 1955, issue and incorrectly illustrated with a photo of the *Maestro* speaker-headset control box. Correct photo appears here.—**Permoflux Corp.**, 4900 West Grand Ave., Chicago 39, Ill.

CRYSTAL TWEETER, Ronette, requires no output transformer. Connects into plate circuit of output tube, permitting wide-range response even with low-cost output transformers

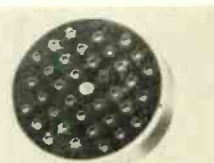

handling the lower frequencies. Blocking capacitor attenuates lower frequencies and eliminates expensive crossover networks.—**Ronette Acoustical Corp.**, 135 Front St., New York 5, N. Y.

NEW CONE, for the *Stephens 120LX* *Tru-Sonic* low-frequency driver, is straight-sided, ribbed cone of low resonance; cuts free-air resonance of 120LX to 45 cycles. This results in improved bass response, with lows



of 20 cycles with properly housed speaker. Voice coil in the 120LX woofer is 2 inches in diameter; power supplied by a 1½-pound Alnico-V magnet.—**Stephens Manufacturing Corp.**, 8538 Warner Dr., Culver City, Calif.

DESK MIKE, *Turner Chief*, usable as original or replacement equipment for tape recorders. Has ¾-inch adapter for stand mounting. *Model 808* (crystal interior): response, 70 to 7,000



cycles; level, -46 db. *Model 807* (ceramic interior): response, 780 to 7,000 cycles; level, -55 db. *Models S-807, S-808* have on-off slide switch. *Model 809* (magnetic interior for ruggedness): response, 100 to 8,000 cycles; level, -52 db.—**Turner Co.**, 933 17th St., N. E. Cedar Rapids, Iowa.

ELECTRONIC ORGAN KIT, *Schober*, a full concert instrument with 2 manuals, 32 pedals, 19 stops, 6 couplers. No moving



parts except keys and controls; 130 printed circuits. Kits for separate components, such as each of the 12 tone generators, or preamplifiers, stop filters, also available.—**Schober Organ Corp.**, 35 Dail St., New Hyde Park, N. Y.

PRINTED CIRCUIT KIT, *Tele-Diagnosis model 1955*, contains materials and equipment, such

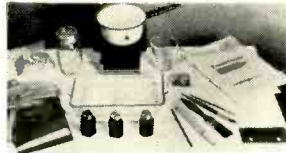

as heating apparatus, thermometer, etching trays, etc., for fabricating experimental printed circuits. Also step-by-step instructions and suggestions concerning design. Instructions supplemented by description of each process as accomplished in automatic mass production.—**Tele-Diagnosis Co.**, 155 W. 72nd St., New York 23, N. Y.

TELEVISION KIT, *Transvision model E1*, designed so that color TV may be added. Each part individually packaged and marked with an identification number. Eight types of kits

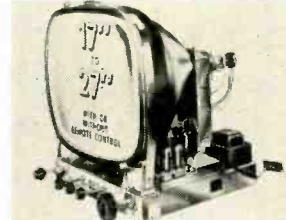

available in 17-, 21-, 24-, 27-inch sizes. Remote control optional. Photos and diagrams of each stage of assembly, a service section, and a book on TV and hi-fi.—**Transvision, Inc.**, New Rochelle, N. Y.

METALLIZED PAPER CAPACITOR, *Astron Comet*, small and lightweight with low r.f. impedance. New solid thermo-



setting impregnant provides high dielectric strength and improved insulation resistance. Operates dependably to 125° C. Bonded shell and protected seal immersion-proof and impervious to extremes of heat, cold and moisture.—**Astron Corp.**, 255 Grant Ave., East Newark, N. J.

6 FLYBACK TRANSFORMERS, *Stancor*, exact replacements for 11 G-E flybacks. Can be installed without circuit or chassis alteration by disconnecting old unit and replacing with proper *Stancor* flyback and re-connecting to exact same

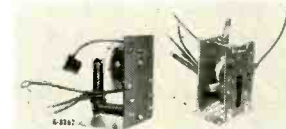

terminals.—**Chicago Standard Transformer Corp.**, Addison & Elston, Chicago 18, Ill.

ELECTROLYTIC CAPACITORS, *Cornell-Dubilier TH Tantalums*, rated from -55° to +125° C. (Units rated to +175° C. can be supplied). Standard case size ½ x ¾ inch to

RCA INSTITUTES

COLOR TV

HOME STUDY COURSE

trains you in the "why" and "how" of Color TV Servicing

Study Color Television Servicing from the very source of the latest, up-to-the-minute Color TV developments. Train under the direction of men who are experts in this field. Take advantage of the big future in Color TV through RCA Institutes' Home Study Course, which covers all phases of Color Servicing. It is a practical down-to-earth course in basic color theory as well as how-to-do-it TV servicing techniques.

This color television course was planned and developed through the efforts of instructors of RCA Institutes, engineers of RCA Laboratories and training specialists of RCA Service Company. You get the benefit of years of RCA research and development in color television.

Because of its highly specialized nature, this course is offered only to those already experienced in radio-television servicing. Color TV Servicing will open the door to the big opportunity you've always hoped for. Find out how easy it is to cash in on Color TV.



**SEND FOR FREE BOOKLET
NO SALESMEN WILL CALL**

RCA INSTITUTES, INC.
A SERVICE OF RADIO CORPORATION OF AMERICA
350 WEST FOURTH STREET, NEW YORK 14, N. Y.



DEPT. RE-6-55

Without obligation on my part, please send me a copy of your booklet on the Home Study Course in Color TV Servicing.

NAME _____

ADDRESS _____

CITY _____ ZONE _____ STATE _____

professional tube testers by EMC

featuring ...

**Lowest Prices
Precision Construction
Widest Instrument Choice
Advance-designs**

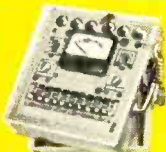

EMC MODEL 204

Tube - Battery - Ohm Capacity Tester

Easy, direct readings for all tubes from .75 to 117 filament volts • Flexible four-position lever-type switches positively protect against obsolescence • Large, 4½" three-color, "reject-good" scale meter • Checks batteries under rated load • Uses emission test • Checks continuity, shorts, opens and leakages • Line voltage control for variations from 105 to 135V • Checks resistance to 4 meg. ohms, capacity to 1 mfd., leakage to 1 meg. ohm • Easy-to-use roll chart • Handsome, hand-rubbed oak carrying case with removable cover

MODEL 204P
(fill.) \$55.90
MODEL 204C
(counter case) \$54.90
MODEL 207,
204 Tester with
extra large
7½" meter
for counter use.
\$65.90



EMC MODEL 205 Emission Tube Tester

Standard emission method accurately checks all tubes (with filament volts between 75 to 117V) • Individual sockets • Compensates for line variations between 105-135V • Flexible four-position lever-type switches positively protect against obsolescence • Checks continuity, shorts, opens and leakages • Large, clear, 4½" three-color, "reject-good" scale meter • Handsome, hand-rubbed oak carrying case with removable cover • Easy-to-use roll chart

MODEL 205P
(fill.) \$47.50
MODEL 205C
(counter case) \$46.50



EMC MODEL 206 Mutual Conductance Tube Tester

4½" three-color meter with calibrated micromho and "reject-good" scale checks mutual conductance and gas content • Plate current sufficient to check emission and mutual conductance • Flexible four-position lever-type switches positively protect against obsolescence • Easy, direct, readings for all tube types • Individual sockets • Instrument fuse replaced from panel front • Easy-to-use roll chart • Handsome, hand-rubbed oak carrying case with removable cover

MODEL 206P
(fill.) \$83.50
MODEL 206C
(counter case) \$79.50



New EMC MODEL 208 Portable Tube Tester

Requires no supplementary equipment • Completely tests all tube types for quality, shorts, leakages, filament continuity and opens between any two tube elements • Adjustable line voltage visually assures accurate quality testing • Space saving, portable case, 5½" x 6¾" x 2¾", fits serviceman's "caddy case" • Individual sockets • Matches Hi-Fi tubes • Comes with detailed instruction book and tube listings.

MODEL 208
(fill.) \$24.90
MODEL 208P
(Oak carrying
case) \$27.90
MODEL CRA (pic
-ture tube adap-
-ter for 204, 205
208) \$4.50
(CTA for 206) \$6.50

Free...
write Dept.
RE-6 for your
copy of complete
catalog TODAY!

EMC
ELECTRONIC MEASUREMENTS CORP.
280 LAFAYETTE STREET NEW YORK 12, N. Y.
EXPORT DEPT.—136 LIBERTY ST. N. Y.

NEW DEVICES

120 µf; only slightly larger to 240 µf. Series combinations supplied at higher capacitances and voltage ratings. Standard units from 25 to 120 µf with a

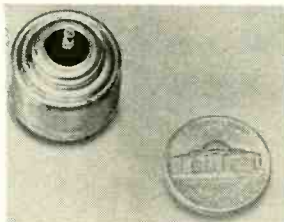

working range of 18 to 100 volts d.c. Higher capacitances and voltages to 630 volts d.c.

Series NT capacitors are ¼ inch in diameter, ⅝ inch in length. Retain characteristics of larger prototypes; are well suited for transistor, printed-circuit and other applications where space is at a premium. Capacitance range from 1.0 µf at 16 volts d.c. to 8.0 µf at 4 volts d.c.—Cornell-Dubilier Electric Corp., S. Plainfield, N. J.

FM TUNER, *Granco model T-160*, has built-in antenna, 5 tubes plus selenium rectifier, sensitivity of 5 µv for 20-db quieting. Selectivity of 200 kc at 6-db points, with ratio detector peak-to-peak separation of 300 kc and linear detector



response for 180 kc, minimizes interference. Hum level, 70 db below 1 volt; maximum audio output ±0.5 db, 20 to 20,000 cycles; audio distortion, 0.2% at 1-volt output; input, 300 ohms or built-in line-cord antenna; a.c. operation, 105-125 volts, 30 watts.—Granco Products Inc., 36-17 20th Ave., Long Island City 5, N. Y.

GERMANIUM POWER RECTIFIER, *International Rectifier type 53-0075-0* (35 kw liquid-cooled). A 3-phase bridge unit, rated for maximum of 450 amp, d.c. continuous output. For input voltages of 26, 36, 52, 66 r.m.s. maximum. Volume ap-



proximately 220 cubic inches as compared to 1,650 cubic inches for comparable selenium unit (fan-cooled) and 14,000 cubic inches for copper oxide unit (fan-cooled). Liquid coolant (water, oil, etc.) at maximum inlet temperature of 25° C, ½ gallon per minute minimum. Efficiency up to 97% attainable; power factor essentially 100%. Applicable for all types of

(Continued)

d.c. load requirements except those requiring heavy surge currents or subject to heavy intermittent overloads or occasional short circuits.—International Rectifier Corp., El Segundo, Calif.

12-V TRANSFORMERS, *Merit models P-2860 and P-2861*, are replacement vibrator units for auto radios.—Merit Coil & Transformer Corp., 4427 N. Clark St., Chicago 40.

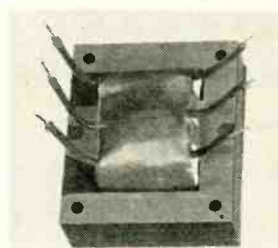
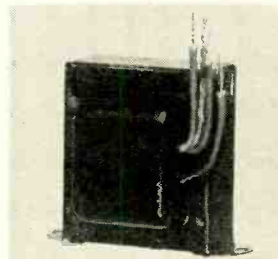

CAPACITEST, *Barjay*, shows open, shorted or intermittent capacitors and leaky electrolytics, as well as circuit con-



tinuity and a.c. and d.c. voltages. Indicates leakage of over 300 megohms. Checks capacitors at 150 volts. Measures 4 x 4 x 2 inches; compact and light.—Barjay Co., 145 W. 40th St., New York 18, N. Y.

TUNING SLUG RETRIEVERS, *General Cement*, 12- and 15-inch sizes work on all Standard Coil tuners to retrieve tuning slugs on oscillator coils of channel strips. Easily fit new wide-slotted slugs and deep-seated tuning units. Also useful for reclaiming screws and starting set screws in previously inaccessible spots.—General Cement Mfg. Co., 919 Taylor Ave., Rockford, Ill.

A. C. OSCILLOSCOPE, *Brown-*



RADIO-ELECTRONICS

JUST OUT! 90° CONVERSION SUPPLEMENT *with Brooks* LIFE-SIZE Edition

#630 TV Kit Builder-Set of Instructions . . . This enables you to build any #630 TV SET for any size CRT 10" to 27". COMPLETE PACKAGE only \$1.25



Build your own
Super De Luxe 31-TUBE #630 TV CHASSIS

#630 SUPER DE LUXE 31-TUBE TV KIT
Engineered in strict adherence to the genuine RCA #630 plus added features . . . OPERATES 16" to 21" PICTURE TUBES . . . CASCODE TUNER . . . COSINE YOKE . . . LARGER POWER TRANSFORMER . . . KEYS AGC . . . 12" SPEAKER . . . CONDENSERS and RESISTORS at rated capacities and tolerances. You receive a COMPLETE SET OF PARTS AND TUBES. Everything needed is included, (less CRT and wire.) You will enjoy building it with "LIFE-SIZE" easy to follow step-by-step ASSEMBLING INSTRUCTIONS" included with each KIT.

slashed to **\$99.99**
Same KIT for 27" and ALL 90° CRT's **\$110.39**

CUSTOM-BUILT CABINETS FROM THE FACTORY TO YOU

3 LEADING STYLES in genuine mahogany or walnut (blond 10% extra) • Ready drilled for any #630 TV chassis and cutout for any 16", 17", 19", 20" or 21" picture tube at no extras in price • Also supplied with undrilled knob panel for any other TV set • EVERYTHING NECESSARY for an easy perfect chassis and CRT assembly is included • Each cabinet is delivered complete as pictured with mask, safety glass, mounting brackets, backboard, backup, hardware and assembling instructions • Each cabinet is shipped in an air cushioned carton from FACTORY to YOU!

The VOGUE
Most Popular Table Model



H-25", W-26", D-22"
\$35.91

VOGUE also available for 24" or 27" picture tube
H-31", W-27" D-23"
\$59.54

The MANHATTAN
Style, Quality, Price



H-41", W-25", D-23"
\$53.43

MANHATTAN for 24" or 27" CRT \$79.22
H-46", W-30", D-24"
\$88.70

The MAYFAIR
Exclusively modern, with an elegance of simplicity in styling.



H-41", W-26", D-25"
\$88.70

#630 SUPER TV CHASSIS

LICENSED UNDER RCA PATENTS
COMPLETE READY TO PLUG IN AND PLAY—
Similar in characteristics and features to the 70° TV KIT above • Manufactured especially for us by nationally known manufacturers • No efforts or expense have been spared in workmanship or materials, to make this #630 SUPER DE LUXE TV CHASSIS the best obtainable for fringe areas, clarity and all-around performance. Customers report reception better than 200 miles. Each set is factory aligned and air-tested • All parts carry the RCA three month guarantee • Our mass volume of business on this CHASSIS (numbering thousands of pleased customers) now makes it possible for us to reduce the price. (less CRT.)

slashed to **\$142.27**

NATIONALLY KNOWN BRAND PICTURE TUBES

BRAND NEW in Factory Sealed Cartons—With a Full Year Guarantee

17" #17BP4A \$22.66 | 21" #21EP4B Aluminized \$32.21 | 24" #24CP4A Aluminized \$52.99 | 27" #27EP4A Aluminized \$74.31

We Also Sell the **TECH-MASTER** Complete Line of #630 TV CHASSIS. Catalog mailed on request.

Modernize a #630 or any TV Set with a **STANDARD CASCODE TUNER** For better all around performance Complete with tubes and Brooks CASCODE MANUAL with step-by-step instructions and all extra parts needed. **\$17.97**

Brooks CASCODE MANUAL, how to install Cascode Tuner in any make TV set. **25¢** Postpaid

UNIVERSAL Picture Tube MOUNTING BRACKETS

Fits All 12 1/2" to 21" picture tubes Complete including band that holds picture tube **\$4.97**

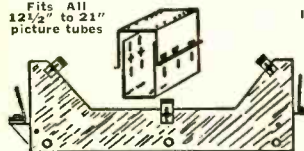

PULSE KEYED AGC KIT

Finest, most accurate and the easiest kit to install in a #630 or in any other make TV receiver. Improves performance, and insures a steady picture on all channels. **COMPLETE SET OF PARTS \$2.99** Including 6AU6 tube & Instructions

NEW 90° CONVERSION KIT

Any TV SET can now be converted for the 27" or any 90° PICTURE TUBE

TODD—90° DEFLECTION YOKE
TODD—SPECIAL FLYBACK TRANS.
30KV—500V HI-VOLTAGE CONDENSER CONDENSERS, RESISTORS, SOCKET

All for **15.98** including Instructions & Schematics for #630 and basic information for all other TV Receivers.

#630 Parts in COMPLETE SETS

TV WIRE & SOLDER KIT, for any Set. \$ 1.98
630-KIT, screws, nuts, rivets, washers, etc. 1.69
TERMINAL STRIP KIT, set of 30.69
VIDEO AND I.F. KIT, 19 items. 4.99
VARIABLE CONTROL KIT, 9 controls. 3.97
CARBON RESISTOR KIT, 107 resistors. 4.98
WIREWOUND RESISTOR KIT, 4 resistors. 1.76
BRACKET AND SHIELD KIT, 18 items. 6.44
ELECTROLYTIC CONDENSER KIT, 6 cond. 4.96
TUBULAR CONDENSER KIT, 38 condensers. 3.63
CERAMIC CONDENSER KIT, 28 condensers. 1.98
MICA CONDENSER KIT, 11 condensers.97
COMPLETE SOCKET KIT, 25 sockets. 1.57
COMPLETE SET OF TUBES, 29 tubes. 24.64

PARTS For #630 TV SETS

POWER TRANSFORMER, 295ma. 201T6. 9.16
COMPLETE SET OF KNOBS, incl. decals.99
VERTICAL OUTPUT TRANS. 204T2. 2.24
VERTICAL BLOCKING TRANS. 208T2.98
TV FLYBACK TRANS. 211T5. 2.97
TV FLYBACK TRANS. with AGC, 211T5. 4.94
FOCUS COIL, 470 ohms, 202D2. 2.93
DEFLECTION YOKE, Cosine 70° 3.45
SYNCHROLOC TRANSFORMER 208T8.98
FILTER CHOKE, 62 ohms. 1.15
WIDTH CONTROL COIL, keyed AGC.52

HINTS FOR BETTER PERFORMANCE 50¢ Postpaid on your #630 TV receiver.

FREE WITH THESE PACKAGE DEALS

CONDENSER & RESISTOR CODE CHARTS . . . with all orders
New 10-SIZE HEX. WRENCH with every \$5 order
STEEL CABINET, 12 x 8", 16, lucite see-thru Drawers. 48 Sections . . . with every \$25 order.

Every Assortment contains the most desirable types and sizes to enable you to get most repairs done with the least investment. All items are STANDARD, BRAND NEW and AMERICAN MADE.

100	ASSORTED TUBULAR CONDENSERS	\$3.69
All Are Standard Brands & Desirable Sizes		
	\$15.00 Value Only	
100	ASSORTED 1/2 WATT RESISTORS	\$2.88
15	Asst. Radio Electrolytic CONDENSERS	\$3.49
15	Assorted TV Electrolytic CONDENSERS	\$4.97
100	ASSORTED MICA CONDENSERS	\$3.72
100	ASSORTED CERAMIC CONDENSERS	\$3.72
100	ASSORTED 1 WATT RESISTORS	\$4.62
100	ASSORTED SOCKETS Octal, Loctal & Miniature	\$2.79
100	ASSORTED KNOBS SCREW & PUSH-ON	\$2.84
10	VOLUME CONTROLS ASSORTED, WITH SWITCH 1/4, 1/2, 1, 2 meg. and others	\$2.63

BROOKS RADIO & TV CORP., 84 Vesey St., Dept. A, New York 7, N. Y. TELEPHONE Cortland 7-2359

MAIL TODAY. LEARN RADIO AT HOME WITH THE PROGRESSIVE RADIO "EDU-KIT".

BUILD 15 RADIO CIRCUITS AT HOME ONLY

With the New Improved 1955 Progressive Radio "EDU-KIT" **\$19.95** Complete

"EDU-KIT"
NOW INCLUDES
RECEIVER,
TRANSMITTER,
CODE OSCILLATOR,
SIGNAL TRACER
CIRCUITS



- ATTRACTIVELY GIFT PACKED
- FREE SOLDERING IRON
- NO ADDITIONAL PARTS NEEDED
- EXCELLENT BACKGROUND FOR TV
- 30 DAY MONEY-BACK GUARANTEE
- SCHOOL INQUIRIES INVITED
- ABSOLUTELY NO KNOWLEDGE OF RADIO NECESSARY

WHAT THE PROGRESSIVE RADIO "EDU-KIT" OFFERS YOU

Our Kit is designed to provide a fundamental background in radio, with the basic facts of Radio Theory and Construction Practice expressed simply and clearly. You will gain a knowledge of basic Radio Principles involved in Radio Reception, Radio Transmission and Audio Amplification. You will learn how to identify Radio Symbols and Diagrams; how to build radios, using regular radio circuit schematics; how to mount various radio parts; how to wire and solder in a professional manner. You will learn proper chassis layout. You will learn how to service and trouble-shoot radios. You will learn code. You will receive training for F.C.C. Novice License. You will learn High Fidelity. In brief, you will receive a practical basic education in Radio, worth many times the small price you pay.

THE KIT FOR EVERYONE

The Progressive Radio "Edu-Kit" was specifically prepared for any person who has a desire to learn Radio. The Kit has been used successfully by young and old in all parts of the world. It is not necessary that you have even the slightest background in science or radio. The Progressive Radio "Edu-Kit" is used by many Radio Schools and Clubs in this country and abroad. It is used by Armed Forces Personnel and Veterans throughout the world. The Progressive Radio "Edu-Kit" requires no instructor. All instructions are included. All parts are individually boxed, and identified by name, illustration and diagram. Every step involved in building these sets is carefully explained.

PROGRESSIVE TEACHING METHOD

The Progressive Radio "Edu-Kit" comes complete with instructions. These instructions are arranged in a clear, simple and progressive manner. The theory of Radio Reception, Radio Transmission, Audio Amplification and servicing by Signal Tracing is clearly explained. Every part is identified by illustration and diagram. You will learn the function and theory of every part used. The Progressive Radio "Edu-Kit" uses the principle of "Learn by Doing". Therefore you will build radio circuits, perform jobs, and conduct experiments to illustrate the principles which you learn. These circuits are designed in a modern manner, according to the best principles of present-day educational practice. You begin by building a simple radio. The next set that you build is slightly more advanced. Gradually, in a progressive manner, you will find yourself constructing still more advanced multi-tube radio sets, and doing work like a professional Radio Technician. Altogether you will build Receiver, Transmitter, Code Oscillator and Signal Tracer Circuits—15 in all. These sets operate on 105-125 V. AC-DC. For use in Foreign Countries having 210-250 Volt Source, an Adaptor for 210-250 V. AC-DC operation is available.

THE PROGRESSIVE RADIO "EDU-KIT" IS COMPLETE

You will receive every part necessary to build 15 different radio circuits. Our "Edu-Kit" contains tubes, tube sockets, variable, electrolytic, and paper condensers, resistors, tie strips, coils, hardware, tubing, etc. No solder or wire included. Every part that you need is included. These parts are individually packaged, so that you can easily identify every item. A soldering iron is included, as well as an Electrical and Radio Tester. Complete, easy-to-follow instructions are provided. All parts are guaranteed, brand new, carefully selected and matched. In addition, the "Edu-Kit" now contains lessons for servicing with the Progressive Signal Tracer. F.C.C. instructions, quizzes, high fidelity instructions.

TROUBLE-SHOOTING LESSONS

Trouble-shooting and servicing are included. You will be taught to recognize and repair troubles. You will build and learn to operate a professional Signal Tracer. You receive an Electrical and Radio Tester, and learn to use it for radio repairs. While you are learning in this practical way, you will be able to do many a repair job for your neighbors and friends, and charge fees which will far exceed the cost of the "Edu-Kit". Here is your opportunity to learn radio quickly and easily, and have others pay for it.

FREE EXTRAS

ELECTRICAL & RADIO TESTER • ELECTRIC SOLDERING IRON
TV BOOK • QUIZZES • FREE CONSULTATION SERVICE • HIFI GUIDE

Progressive "Edu-Kits" Inc., 497 Union Ave., Brooklyn 11, N.Y.

MAIL TODAY—Order shipped same day received.
30-Day Money-Back Guarantee. Include ALL FREE EXTRAS

- Send "Edu-Kit" Postpaid. I enclose full payment of \$19.95 (U.S.A. only).
- Send "Edu-Kit" Postpaid. I enclose full payment of \$20.95 (Outside U.S.A.).
- 210-250 V. Foreign Line Voltage Adapter for "Edu-Kit"—\$2.50.
- Send "Edu-Kit" C.O.D. I will pay \$19.95 plus postage (U.S.A. only).
- I wish additional information describing "Edu-Kit". No Obligation.
- Send me FREE Radio-TV Servicing Literature. No Obligation.

Name _____
Address _____

PROGRESSIVE "EDU-KITS" INC.

497 UNION AVE., RM 105 G, PROGRESSIVE BLDG., BROOKLYN 11, N.Y.

BUILD 15 RADIO CIRCUITS AT HOME WITH THE PROGRESSIVE RADIO "EDU-KIT". MAIL TODAY

NEW DEVICES

(Continued)

ing models 701 and 701-D (with delay line), cover 5 cycles to 10 mc; useful to 20 mc. Sensitivity of 16 mv peak to peak per centimeter; rise time, .035 μ sec. Sweep circuits provide triggered or recurrent sweeps from 0.1 to 10,000-sec per centimeter. Input impedance of 2 megohms paralleled by 25 μ f permits more accurate measurements through low loading of tested circuit. Power supply permits operation at any frequency between 50 and 500 cycles and at voltages of either 115 or 230.—**Browning Laboratories, Inc.**, 750 Main St., Winchester, Mass.

voltage sapper check, gas check, simplified short check and latest roll chart. Measures 14 x 16 x 6 inches; weighs 30 pounds.—**Precise Development Corp.**, Oceanside, L. I., N. Y.

D.C. MIDGETSCOPE, RCP model 534, combines linear sweep with d.c. amplifier for color TV



PICTURE TUBE TESTER, Century model 102, self-contained, tests for quality by emission method. Also tests for inter-element leakage, shorts and open elements. Supplies own C-R tube power through cir-



cuit which allows efficient testing with tube in or out of set. Single master control eliminates complicated switching and shows condition of C-R tube under test.—**Century Electronics Co.**, Mineola, N. Y.

restorer circuits and for complex waveforms. Has provisions for a.c. coupling, full vertical and horizontal expansion of trace, automatic astigmatism control circuit, linear time base and sweep, automatic blanking of return trace, vertical or horizontal operation. Frequency range, d.c. to 500 kc; sensitivity better than 50 mv; push-pull deflection throughout.—**Radio City Products Co., Inc.**, Easton, Pa.

TUBE TESTER, Seco model GCT-5, tests over 40 tubes in a.g.c., r.f., i.f., sync circuits. Filament voltage selector for 3-, 4-, 5-, 6-, 7-, 12-volt tubes.



THREE NEW PRODUCTS, Triplet: new color bar generator model 3439; AM generator, model 3442-A, with frequency range from 160 kc to 110 mc; volt-ohm-milliammeter (illustrated here), model 630-NA.—**Triplet Electrical Instrument Co.**, Bluffton, Ohio.



Determines grid-to-cathode and cathode-to-heater shorts, gas, and control-grid emission.—**Seco Manufacturing Co.**, 5015 Penn Ave. South, Minneapolis, Minn.

RADIO-FREQUENCY BRIDGE, Sylvania, measures resistance in junction type transistors, making it possible to determine whether a transistor meets certain necessary performance standards which could not otherwise be measured and could not be determined until the transistor had

TUBE TESTER, Precise Model 111, available in wired and kit form. Checks emission and mutual conductance; all tubes, including hearing aid, miniatures and C-R. Has new type switches,



been applied directly to a circuit.—**Sylvania Electric Products Inc.**, Ipswich Electronics Laboratory, Estes St., Ipswich, Mass. END

All specifications given on these pages are from manufacturers' data.

RCA WO-78A

'Scope

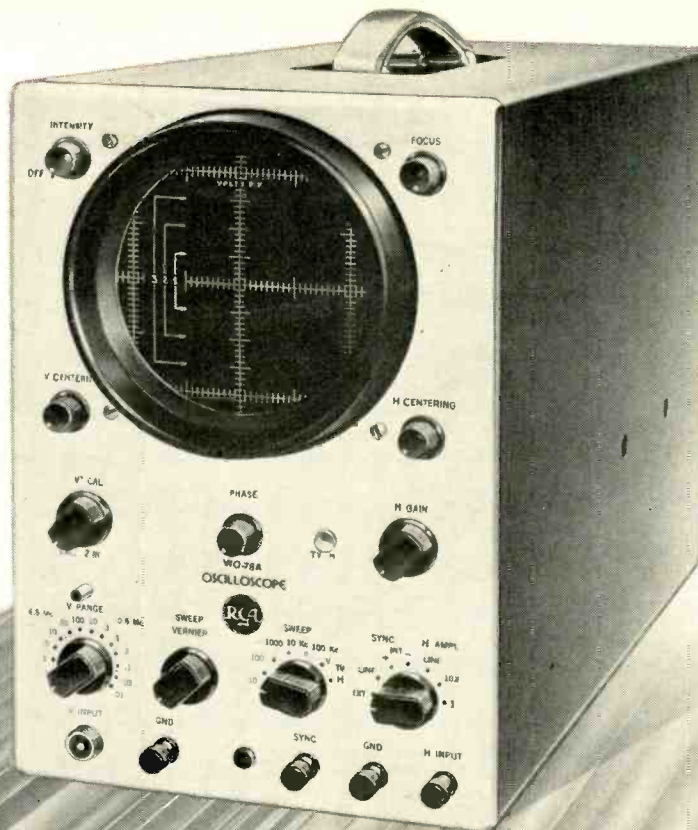

RCA-WO-78A — 5" Oscilloscope \$425.00 (suggested user price) complete with WG-294 direct probe and cable, WG-293 low-capacitance probe, alligator clip, ground cable, insulator, green graph screen, instruction book.

for BLACK and WHITE, COLOR TV

An investment in quality that can pay its own way

Expert technicians have learned that the fastest way to isolate trouble in "tough" sets is by using a good 'scope. A quality 'scope like the WO-78A is a sound investment which can pay its own way if it saves you only a few hours of trouble-shooting a week.

Advanced design and expert engineering make the WO-78A a superior instrument which helps you deliver top-grade TV service work in less time. And, with the wideband WO-78A, you have an instrument especially suited for the complex circuitry of color TV—to observe color burst signals and to aid in the analysis of complicated circuit waveforms. Your safest investment for both color and black-and-white TV is to choose the finest TV service 'scope available. Here are some of the outstanding features of the WO-78A:

- **Maximum utility** . . . dual-band response; wide-band position (3 cps to 4.5

Mc, -1 db with gradual roll-off to 6 Mc) for color TV; high-sensitivity position (3 cps to .5 Mc, -3 db) for general service, black-and-white TV.

- **High sensitivity** . . . direct sensitivity of 0.01 volt peak-to-peak per in. (0.0035 rms volt per in.) in high-sensitivity position; 0.1 volt peak-to-peak per in. (0.035 rms volt per in.) in wide-band position.

- **Excellent phase and frequency response** . . . minimum ringing, negligible tilt, and overshoot.

- **Full-screen vertical deflection** . . . without distortion up to 4.5 Mc (many lab 'scopes provide only half-screen deflection).

- **Voltage calibrated "V" input attenuator** . . . frequency compensated 14-position (steps of 3 to 1) vertical-input attenuator.

- **Low circuit loading** . . . WG-293 Low-Capacitance probe, supplied with RCA

WO-78A has impedance of 10 megohms shunted by 14 μ f.d.

- **Bright sharply focused trace** . . . provided by the use of the RCA 5ABP1 flat-face cathode-ray tube which utilizes post-deflection acceleration and an ultor potential of 3000 volts.

- **Extremely simplified operation** . . . No need to disconnect the input or to apply external calibrating voltages. Push-button applies fixed input voltage to vertical amplifier for calibration. Limiter in sync circuit eliminates horizontal sync adjustments; gives positive lock. Removable graph screen calibrated in inches and tenths of an inch permits easy measurement and comparison of signal amplitudes. As speedy to read as a VTVM.

See the RCA WO-78A with the "features plus" . . . at your RCA Distributor. For technical data write RCA, Commercial Engineering, Sec. F-39-W, Harrison, N.J.



RADIO CORPORATION of AMERICA
TEST EQUIPMENT
HARRISON, N.J.

a HIT in
High Fidelity
with
COLLINS
AUDIO PRODUCTS CO.
'PRE-FAB' TUNERS

Collins Audio Products Co. is in no way affiliated with Collins Radio Co. Each Collins Tuner Kit is complete with punched chassis, tubes, power transformer, power supply, components, hardware, dial assembly, tuning eye, knobs, wire, etc., as well as the completed sub-assemblies: FM tuning units, AM tuning units, IF amplifiers, etc. All sub-assemblies wired, tested and aligned at the factory make Collins Pre-Fab Kits easy to assemble even without technical knowledge. The end result is a fine, high quality, high fidelity instrument at often less than half the cost—because you helped make it AND BOUGHT IT DIRECT FROM THE FACTORY.

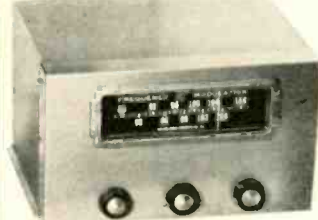

NEW FM TUNER KIT

New decorative gold front. New cascade front end—3 mv sensitivity. IF amplifier mounted, wired and tested in the chassis. You mount completed RF tuning unit and power supply, 11 tubes, 20 to 20,000 cycle response, A.F.C. and switch. Size: 12½" x 9½" x 7" high. Shipping weight: 15 pounds. Manual supplied. Gold screen cover available at \$3.50 extra. **PRICE: \$59.50**

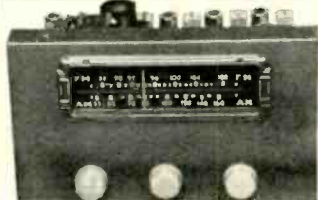

NEW FM-AM TUNER KIT

New, decorative gold front like FM tuner above. New cascade front end on FM—3 mv sensitivity. 15 tubes. Comprises chassis, power supply parts, AM unit, FM unit, IF amplifier, all wired and tested, ready for mounting in chassis. A.F.C. with switch. Kits include all parts and hardware. Size: 14" x 12" x 7½" high. Shipping weight: 19 pounds. Manual supplied. Gold screen cover available at \$3.75 extra. **PRICE: \$82.50**

FMF-3B Tuning Unit with Cascade

Permeability tuned, 3 tubes, A.F.C. 3 microvolts sensitivity. May be used with any 10.7 MC IF amplifier such as our IF-6. **2 pounds \$19.50**

AM-4 Tuning Unit

3-gang tuning condenser. Unit covers 530 to 1600 KC. Completely wired and tested with tubes. 4 tubes. Chassis plate measures: 4" x 7¾", 2½ pounds. **\$24.50**

IF-6 Amplifier

6 tubes, 10.7 MC, Low distortion, high gain. 3 pounds. **\$21.50**

--- MAIL COUPON TODAY! ---

To: Collins Audio Products Co., Inc.
 P. O. Box 368, RE-6
 Westfield, N. J.
 Tel. Westfield 2-4390

- FM Tuner Kit
- FM-AM Tuner Kit
- FMF-3B Tuning Unit
- IF-6 Amplifier
- AM-4 Tuning Unit
- COVER

Name _____
 Address _____
 City _____ State _____
 Amount for Kit \$ _____
 See weights, add shipping cost \$ _____
 Total amount enclosed \$ _____
 Check Money Order

**WHEN YOU THINK OF TUNERS,
 THINK OF
 COLLINS AUDIO PRODUCTS**

new
Tubes &
Transistors



5AM8, 6AM8, 6AW8, 6BZ6, 12CA5

RCA has announced five new miniature tubes for use in television receivers.

The 5AM8 and 6AM8 are general-purpose multiunit tubes of the nine-pin miniature type, each containing a high-perveance diode and a sharp-cutoff pentode in one envelope.

The high-transconductance pentode may be used as an i.f., video and a.g.c. amplifier. It has separate base pins for the suppressor grid and the cathode. This permits the use of an unbypassed cathode resistor to minimize changes in input loading and input capacitances with bias, without causing oscillation that might otherwise occur if the suppressor grid were internally connected to the cathode. The tube also contains an internal shield to minimize coupling between the diode plate and the pentode unit.

The high-perveance diode, which has its own cathode terminal, may be used as a video detector, d.c. restorer or a.g.c. delay diode.

The 5AM8 is like the 6AM8 except for its heater characteristics—the 5AM8 draws 600 ma at 4.7 volts, the 6AM8 450 ma at 6.3 volts.

The 6AW8 is a general-purpose, multiunit tube of the nine-pin miniature type containing a high-mu triode and a sharp-cutoff pentode in one envelope. The tube has a 600-ma heater for series-string operation.

Featuring high transconductance (9,000 micromhos), the pentode section of the 6AW8 may be used as a video amplifier, a.g.c. amplifier and reactance tube. The triode section may be used in sync-separator, sync-clipper and phase-splitter circuits.

The 6BZ6 is a semiremote-cutoff pentode of the seven-pin miniature type, intended for use in gain-controlled video i.f. stages.

The semiremote-cutoff characteristic minimizes cross-modulation effects in the video i.f. stages and distortion resulting from high signal levels and a.g.c. time delay. In addition, the tube has a high transconductance permitting high gain per stage. The 6BZ6 has separate base pins for the suppressor grid and the cathode.

The 12CA5 is seven-pin miniature beam power tube intended for use in the audio output stage of TV receivers. The tube has a 600-ma heater for series-string operation.

The 12CA5 has a high power sensitivity, high efficiency and is capable of providing high power output at relatively low supply voltages.

6BA8

Still another tube designed for series-string operation is the 6BA8. The miniature nine-pin, medium-mu triode and sharp-cutoff pentode has a 600-ma heater. Designed to operate as a video amplifier, the pentode section of the 6BA8 has a plate dissipation rating of 3.25 watts. The triode section has a mu of 18 and is suitable where low-mu triode operation is desirable, such as in sync amplifiers. The 6BA8 was announced by Sylvania.

The 24YP4 is identical in all respects to the 24DP4-A except that it has a higher value of capacitance between external conductive bulb coating and the second anode.

24YP4

The tube uses low-voltage electrostatic focus, 90° magnetic deflection. Maximum overall length is 21½ inches. The external conductive bulb coating, together with the internal conductive coating, forms a supplementary filter capacitor having a value within the range of 1,200 to 1,500 µmf. The ion-trap gun requires an external single-field magnet. The 24YP4 was announced by RCA.

A new directly viewed 5-inch cathode-ray tube, the 5AYP4, has been announced by RCA. Designed for viewfinder service in connection with portable TV cameras, it provides a 3¾ x 2½-inch view of the televised scene.

5AYP4 view-finder

Electrostatically focused and magnetically deflected, the 5AYP4 uses an electron gun designed to provide high resolution and good uniformity of focus over the entire picture area.

The 5AYP4 has a practically flat face; a high-efficiency, aluminized, white fluorescent screen which not only improves picture contrast and brightness, but also eliminates the need for an ion-trap magnet, and an external conductive coating which with the internal conductive coating forms a supplementary filter capacitor. The maximum design-center rating for the second anode is 10,000 volts; for the focusing electrode, 1,500 volts.

Bogue Electric has announced quantity production of high-current high-voltage silicon power rectifiers. Outstanding among the characteristics of this type rectifier are its efficiency of

Silicon power rectifiers

Still another tube designed for series-string operation is the 6BA8. The miniature nine-pin, medium-mu triode and sharp-cutoff pentode has a 600-ma heater. Designed to operate as a video amplifier, the pentode section of the 6BA8 has a plate dissipation rating of 3.25 watts. The triode section has a mu of 18 and is suitable where low-mu triode operation is desirable, such as in sync amplifiers. The 6BA8 was announced by Sylvania.

NEW TUBES AND TRANSISTORS (Continued)
 approximately 99% and its ability to operate in extremely high ambient temperatures. The rectifiers (see photo) are small, occupying about $\frac{1}{8}$ cubic inch and weighing about 0.1 ounce. They are hermetically sealed:

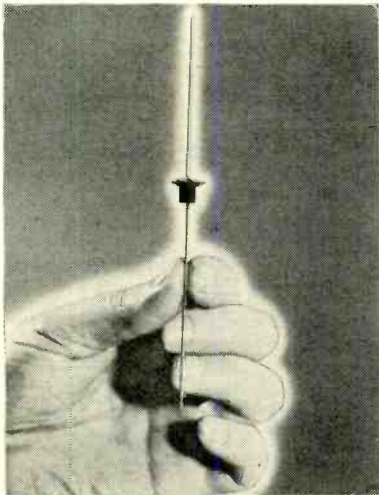

The high efficiency is due to the low voltage drop and extremely small reverse leakage current (100 μma). The silicon power rectifier's efficiency is approached only by germanium rectifiers but, unlike the germanium, the silicon type may be used in ambient temperatures of 100° C and higher.

6655

RCA has announced a new flat-face head-on multiplier phototube for use in scintillation counters and other applications involving the measurement of low-level large-area light sources.

The 6655, having the 5819 as its prototype, retains the high sensitivity and other electrical characteristics of the older type but contains new design features. These include a flat face with a minimum diameter of 1 $\frac{11}{16}$ inches to simplify the mounting of flat phosphor crystals in direct contact with the surface.

The spectral response of the 6655 covers the range from about 3,000 to 6,500 angstroms, with maximum response at approximately 4,400 angstroms.

1N286

A new silicon crystal diode, the 1N286, a broadband, coaxial point-contact type (see photo), has been announced by Sylvania. It is designed

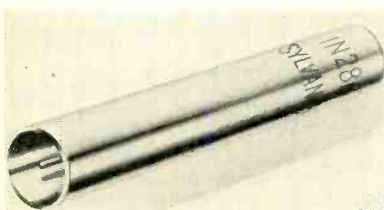

for use as a crystal mixer and covers a range from 10,000 to 20,000 mc. Its broadband characteristics make it particularly useful in tunable-frequency radar systems and counter-measuring devices. END

Announcing...

Retract-O-Matic

—the new, foolproof replacement

Pickup



Even if you drop it...or slide it...

Retract-O-Matic protects records and needles from damage!

WEBSTER ELECTRIC proudly offers the new, exclusive RETRACT-O-MATIC—the sensational crystal pickup that provides positive protection to record and needle, even when it is dropped or slid across the record surface.

Retract-O-Matic is priced to make it a practical replacement for installation on any manual record player.

THE DOME ABSORBS THE SHOCK

The unique spring-mounted construction gives absolute insurance against damage to cartridge, needle, or record. The slightest pressure on the arm automatically lifts the needle from the record's surface, and lets Retract-O-Matic's rounded "dome" absorb the shock.

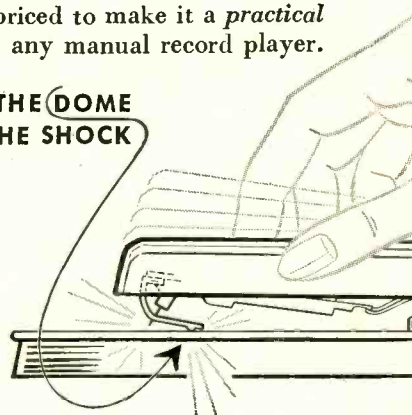

A BIG PROFITABLE MARKET

Retract-O-Matic is a "natural" as a pickup replacement for record players, children's and portable phonographs. List price of complete assembly (tone arm, cartridge, arm rest and all parts needed for installation) is only \$6.95—little more than the price of the cartridge alone. Order a stock today. Step up your sales with Retract-O-Matic!

WEBSTER  ELECTRIC
 RACINE WISCONSIN

Superior's new
Model 670-A

SUPER METER

A COMBINATION VOLT-OHM MILLIAMMETER PLUS
CAPACITY REACTANCE INDUCTANCE AND DECIBEL
MEASUREMENTS

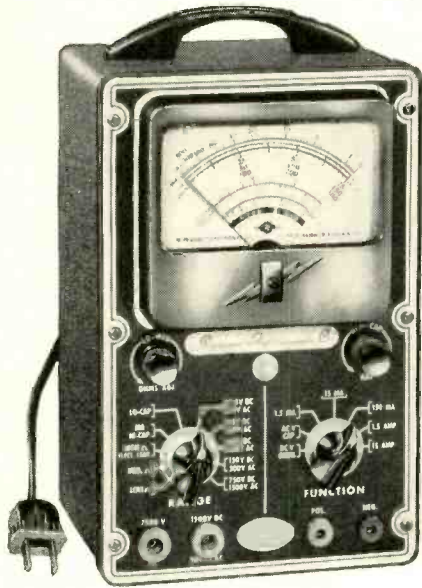

SPECIFICATIONS:

- D.C. VOLTS: 0 to 7.5/15/75/150/750/1,500/7,500 Volts
- A.C. VOLTS: 0 to 15/30/150/300/1,500/3,000 Volts
- OUTPUT VOLTS: 0 to 15/30/150/300/1,500/3,000 Volts
- D.C. CURRENT: 0 to 1.5/15/150 Ma. 0 to 1.5/15 Amperes
- RESISTANCE: 0 to 1,000/100,000 Ohms 0 to 10 Megohms
- CAPACITY: .001 to 1 Mfd. 1 to 50 Mfd. (Good-Bad scale for checking quality of electrolytic condensers)
- REACTANCE: 50 to 2,500 Ohms, 2,500 Ohms to 2.5 Megohms
- INDUCTANCE: .15 to 7 Henries 7 to 7,000 Henries
- DECIBELS: -6 to +18, +14 to +38, +34 to +58

ADDED FEATURE:

Built-in ISOLATION TRANSFORMER
reduces possibility of burning out
meter through misuse.

The Model 670-A comes housed in a rugged crackle-finished steel cabinet complete with test leads and operating instructions.

\$28⁴⁰
NET

Superior's New
Model
TV-50

GENOMETER

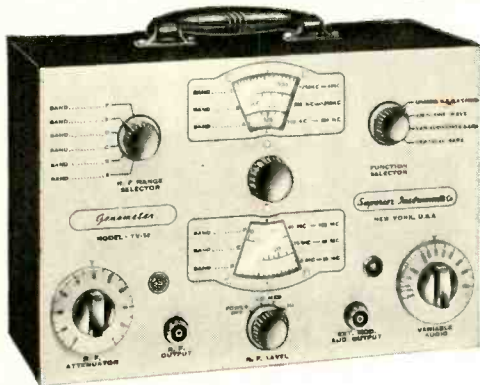

A versatile all-inclusive GENERATOR which provides ALL the outputs for servicing:
A.M. Radio • F.M. Radio • Amplifiers • Black and White TV • Color TV
7 Signal Generators in One!

- ✓ R. F. Signal Generator for A.M.
- ✓ R. F. Signal Generator for F.M.
- ✓ Audio Frequency Generator
- ✓ Bar Generator
- ✓ Cross Hatch Generator
- ✓ Color Dot Pattern Generator
- ✓ Marker Generator

R. F. SIGNAL GENERATOR: The Model TV-50 Genometer provides complete coverage for A.M. and F.M. alignment. Generates Radio Frequencies from 100 Kilocycles to 60 Megacycles on fundamentals and from 60 Megacycles to 180 Megacycles on powerful harmonics.

VARIABLE AUDIO FREQUENCY GENERATOR: In addition to a fixed 300 cycle sine-wave audio, the Model TV-50 Genometer provides a variable 300 cycle to 20,000 cycle peaked wave audio signal.

BAR GENERATOR: The Model TV-50 projects an actual Bar Pattern on any TV Receiver Screen. Pattern will consist of 4 to 16 horizontal bars or 7 to 20 vertical bars.

CROSS HATCH GENERATOR: The Model TV-50 Genometer will project a cross-hatch pattern on any TV picture tube. The pattern will consist of non-sliding horizontal and vertical lines interlaced to provide a stable cross-hatch effect.

DOT PATTERN GENERATOR (FOR COLOR TV) Although you will be able to use most of your regular standard equipment for servicing color TV, the one addition which is a "must" is a Dot Pattern Generator. The Dot Pattern projected on any color TV Receiver tube by the Model TV-50 will enable you to adjust for proper color convergence.

MARKER GENERATOR: The Model TV-50 includes all the most frequently needed marker points. The following markers are provided: 189 Kc., 262.5 Kc., 456 Kc., 600 Kc., 1000 Kc., 1400 Kc., 1600 Kc., 2000 Kc., 2500 Kc., 3579 Kc., 4.5 Mc., 5 Mc., 10.7 Mc., (3579 Kc. is the color burst frequency.)

THE MODEL TV-50 comes absolutely complete with shielded leads and operating instructions. Only _____

\$47⁵⁰
NET

**SHIPPED ON APPROVAL
NO MONEY WITH ORDER — NO C.O.D.**

Try any of the above instruments for 10 days before you buy. If completely satisfied then send down payment and pay balance as indicated on coupon. **No Interest or Finance Charges Added!** If not completely satisfied return unit to us, no explanation necessary.

MOSS ELECTRONIC DISTRIBUTING CO., INC.
Dept. D-136, 3849 Tenth Ave., New York 34, N.Y.

Please send me the units checked. I agree to pay down payment within 10 days and to pay the monthly balance as shown. It is understood there will be no finance, interest or any other charges, provided I send my monthly payments when due. It is further understood that should I fail to make payment when due, the full unpaid balance shall become immediately due and payable.

Model 670-A..... Total Price \$28.40
\$7.40 within 10 days. Balance \$3.50 monthly for 6 months.

Name

Address

City..... Zone..... State.....

Model TV-50..... Total Price \$47.50
\$11.50 within 10 days. Balance \$6.00 monthly for 6 months.

Superior's
New
Model TV-11

TUBE TESTER



SPECIFICATIONS

- ★ Tests all tubes, including 4, 5, 6, 7, Octal, Lockin, Peanut, Bantam, Hearing Aid, Thyatron Miniatures, Sub-miniatures, Novals, Sub-minars, Proximity fuse types, etc.
- ★ Uses the new self-cleaning Lever Action Switches for individual element testing. Because *all elements are numbered according to pin-number in the RMA base numbering system*, the user can instantly identify which element is under test. Tubes having tapped filaments and tubes with filaments terminating in more than one pin are truly tested with the Model TV-11 as any of the pins may be placed in the neutral position when necessary.
- ★ The Model TV-11 does not use any combination type sockets. Instead individual sockets are used for each type of tube.

Thus it is impossible to damage a tube by inserting it in the wrong socket.

- ★ Free-moving built-in roll chart provides complete data for all tubes.
- ★ Newly designed Line Voltage Control compensates for variation of any Line Voltage between 105 Volts and 130 Volts.
- ★ **NOISE TEST:** Phono-jack on front panel for plugging in either phones or external amplifier will detect microphonic tubes or noise due to faulty elements and loose internal connections.

The model TV-11 operates on 105-130 Volt 60 Cycles A.C. Comes housed in a beautiful handrubbed oak cabinet, complete with portable cover

\$47⁵⁰
NET

EXTRA SERVICE—The Model TV-11 may be used as an extremely sensitive Condenser Leakage Checker. A relaxation type oscillator incorpor-

ated in this model will detect leakages even when the frequency is one per minute.

Superior's new Model TV-40

C. R. T. TUBE TESTER



★ **A complete picture tube tester for little more than the price of a "make-shift" adapter!!**

The Model TV-40 is absolutely complete! Self-contained, including built-in power supply, it tests picture tubes in the only practical way to efficiently test such tubes; that is, by the use of a separate instrument which is designed exclusively to test the ever increasing number of picture tubes!

EASY TO USE:

Simply insert line cord into any 110 volt A.C. outlet, then attach tester socket to tube base (*ion trap need not be on tube*). Throw switch up for quality test . . . read direct on Good-Bad scale. Throw switch down for all leakage tests.

★ **Tests all magnetically deflected tubes . . . in the set . . . out of the set . . . in the carton!!**

SPECIFICATIONS

- Tests *all* magnetically deflected picture tubes from 7 inch to 30 inch types.
- Tests for quality by the well established emission method. All readings on "Good-Bad" scale.
- Tests for inter-element shorts and leakages up to 5 megohms.
- Tests for open elements.

Model TV-40 C.R.T. Tube Tester comes absolutely complete—nothing else to buy. Housed in round cornered, molded bakelite case. Only . . .

\$15⁸⁵
NET

**SHIPPED ON APPROVAL
NO MONEY WITH ORDER — NO C.O.D.**

Try any of the above instruments for 10 days before you buy. If completely satisfied then send down payment and pay balance as indicated on coupon. **No Interest or Finance Charges Added!** If not completely satisfied return unit to us, no explanation necessary.

MOSS ELECTRONIC DISTRIBUTING CO., INC.
Dept. D-136, 3849 Tenth Ave., New York 34, N.Y.

Please send me the units checked. I agree to pay down payment within 10 days and to pay the monthly balance as shown. It is understood there will be no finance, interest or any other charges, provided I send my monthly payments when due. It is further understood that should I fail to make payment when due, the full unpaid balance shall become immediately due and payable.

Model TV-11 Total Price \$47.50
\$11.50 within 10 days. Balance \$6.00 monthly for 6 months.

Name
Address
City Zone State

Model TV-40 Total Price \$15.85
\$3.85 within 10 days. Balance \$4.00 monthly for 3 months.

double PROTECTION PROTECTION

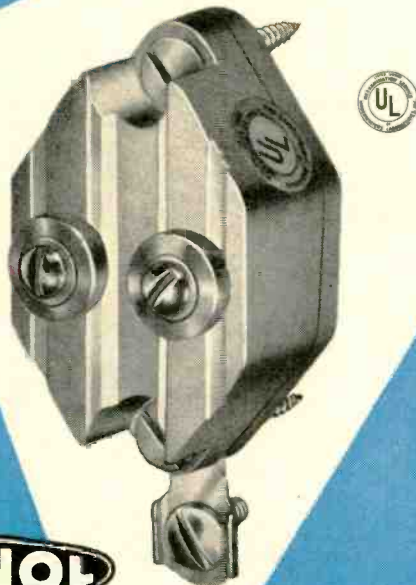

AMPHENOL

effectively bleeds
off static charges

Protection against
lightning

LIGHTNING ARRESTOR

Only one lightning arrester offers this double protection—AMPHENOL'S. Only the AMPHENOL VHF/UHF Lightning Arrester helps guard the tv set from lightning entering the antenna system and guards the signal strength as well. Only the AMPHENOL Lightning Arrester effectively bleeds off static charges for added set protection.

Available in wall-mounting or pipe-mounting design. Packed in an attractive counter display carton to help dealers in their merchandising. Explanatory folder available.

Other Distinctive Features:

- Universal design for all types of lead-in.
- Special cup contacts and improved sealing compound for assured operating efficiency.



- 114-328 Lightning Arrester, wall-mounting List \$1.50
- 114-329 Same, pipe-mounting, List 1.60

At Your Distributor

AMPHENOL

AMERICAN PHENOLIC CORPORATION
chicago 50, illinois

In Canada: AMPHENOL CANADA LIMITED, Toronto

www.americanradiohistory.com

MISCELLANY

THE FUND REACHES
\$11,573.86



**HELP -
FREDDIE-WALK
FUND**

WHEN the Help-Freddie-Walk Fund was inaugurated in April, 1950, no one at RADIO-ELECTRONICS was willing even to guess how far it would go, for we knew only too well that its success or failure depended upon the interest and generosity of our readers. However, our contacts with Herschel Thomason, radio technician of Magnolia, Ark., had convinced us that the plight of his son Freddie—born without arms or legs—was a cause worthy of our time and effort, and we were certain that readers all over the world would respond with characteristic sincerity.

The Fund is now in its fifth year. During that time Freddie's friends have contributed a total of \$11,605.11, far more than our most optimistic hopes. Thanks to their generosity, Freddie's family has been able to provide for him many of the necessary mechanical appliances that help make his life as nearly normal as is possible under the circumstances.

At 7 years of age, Freddie is able to walk about very competently on his artificial legs, and he is eagerly awaiting the day when he will be fitted with mechanical arms. In the meanwhile, he exercises in his specially built playroom, plays with his younger brother and his friends and attends school regularly, a happy and healthy youngster.

Lack of space precludes running the story of Freddie every month, but we sincerely hope that our readers will not construe this as a lack of interest. We are still receiving contributions, which are forwarded to the Thomasons promptly, and we know that their appreciation of any donation, no matter how small, is heartfelt. We ask each of our readers to make a special effort to send Freddie a word of encouragement, for, as Freddie grows, so must the Fund grow if he is to develop into the responsible member of society we all know he can be.

Please send your contributions as often as you can. No amount is too small to receive our sincerest thanks and appreciation, and every donation is acknowledged by letter. Make all money orders, checks, etc., payable to Herschel Thomason. Address all letters to:

Help-Freddie-Walk Fund
c/o RADIO-ELECTRONICS Magazine
25 West Broadway
New York 7, N. Y.

FAMILY CIRCLE Contributions.....\$ 602.50
RADIO-ELECTRONICS

Contributions as of Jan. 17, 1955 10,971.36
Louis J. Buttell, Jamaica, N. Y..... 2.00
Capt. Romeo L. Buttolo,
Cape Town, South Africa..... 2.00
A. H. Danter, St. Louis, Mo..... 5.00

RADIO-ELECTRONICS

MISCELLANY

Lillian Everts, N. Y., N. Y.....	5.00
Mr. and Mrs. Clayton Loyd, Chicago, Ill.....	1.00
J. L. McClurg, Baltimore, Md.....	1.00
Alexander Rys, Minneapolis, Minn.....	.25
R. Six, Inglewood, Calif.....	5.00
Gray C. Trembly, Arlington, Mass.....	10.00

TOTAL CONTRIBUTIONS
as of April 15, 1955..... \$11,605.11

L'ANTENNE GERNSBACK

A highly improved indoor antenna, a form of the Gernsback *Variotenna* (see photo) is now being manufactured in France. The unit was introduced in 1949 by Hugo Gernsback, appearing

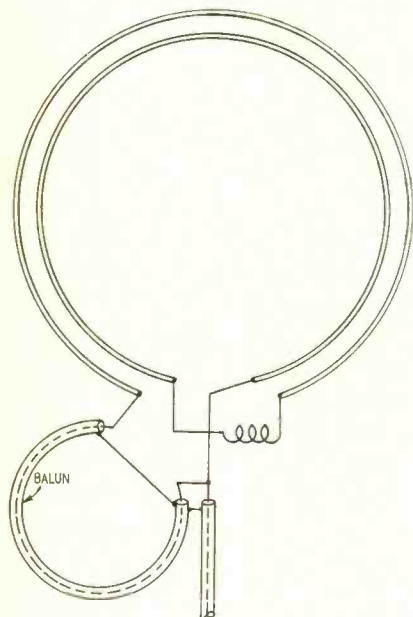

in the August and September issues of **RADIO-ELECTRONICS** that year. The improved model (see schematic) contains



a small coil in series with the antenna for operation in the 185-mc range. The balun, mounted in the base, permits connecting the antenna to an unbalanced transmission line.

The appearance of the Europeanized Gernsback antenna is highly attractive. Approximately 18 inches in height, the two loops are made of 1/2-inch tubing finished in gold. The entire unit rests on a heavy ceramic base. The antenna comes with several feet of 72-ohm lead-in. **END**

Apply Your Electronics Experience

ENGINEERS AND
PHYSICISTS WITH
ELECTRONICS TRAINING
ARE NEEDED TO
CONDUCT CLASSROOM
AND LABORATORY
PROGRAMS ON ADVANCED
SYSTEMS WORK IN THE
FIELDS OF RADAR FIRE
CONTROL, ELECTRONIC
COMPUTERS, GUIDED
MISSILES.

The proper functioning of the complex airborne radar and computer equipment produced by Hughes requires well-trained maintenance crews in the field.

At Hughes Research and Development Laboratories in Southern California engineers assigned to this program are members of the Technical Staff. As training engineers they instruct in equipment maintenance and operation for both military personnel and field engineers.

Prior to assignment, engineers participate in a technical training program to become familiar with latest Hughes equipment. After-hours graduate courses under Company sponsorship are available at nearby universities.

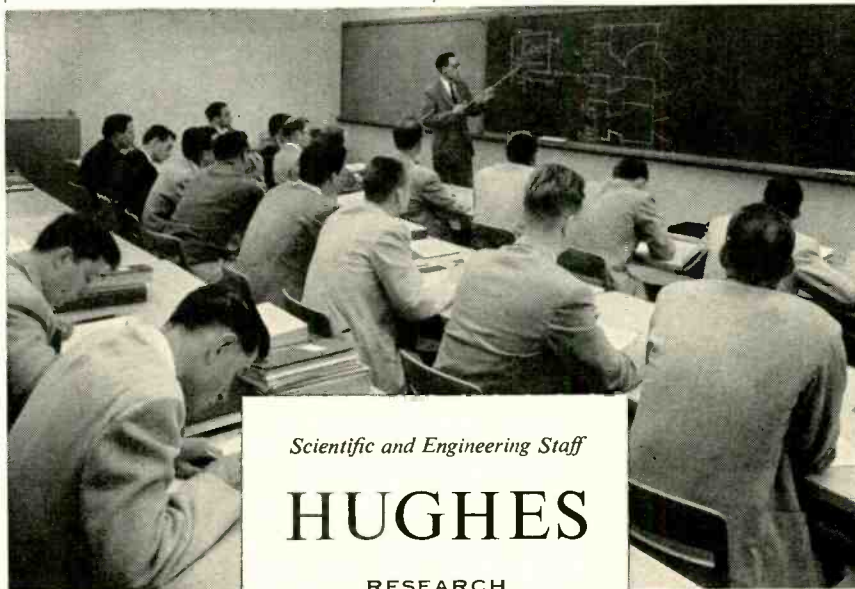

Scientific and Engineering Staff

HUGHES

RESEARCH
AND DEVELOPMENT
LABORATORIES

Culver City, Los Angeles County, California

Your High Fidelity System Will Sound Better with a

GOODMANS Loudspeaker

made in england

ROCKBAR CORPORATION Dept. HF-9
215 East 37th Street, New York 16, N. Y.

Please send complete description of
Goodmans High Fidelity loudspeakers.

Name.....

Address.....

City.....Zone.....State.....

My Dealer is.....

radio-electronic Circuits

STARVED-CURRENT INTERCOM

Needing an intercom between my basement and kitchen I decided to try the small amplifier that I had con- operate two switches simultaneously but this is of no consequence. —Paul S. Lederer

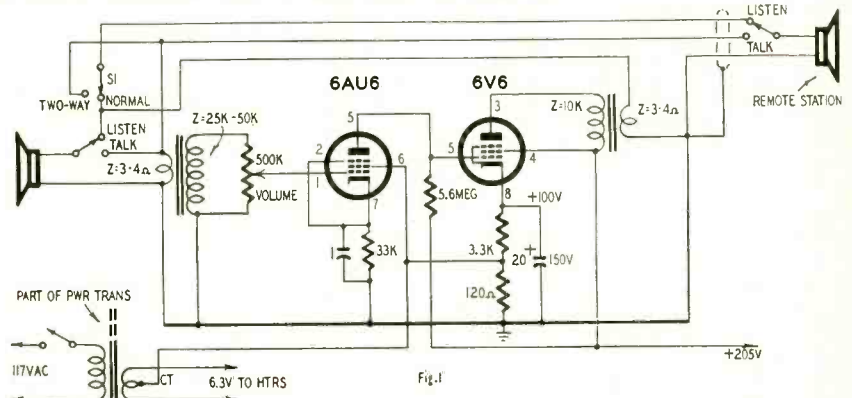

structed when experimenting with starved-current circuits. (See "Ultra-High-Gain Starved-Current Amplifier" in the March, 1954, issue.)

This amplifier has a number of advantages for this application. It has very high gain, uses few components and is small. Its limited frequency response is an asset in reducing hum and noise. It draws about 20 ma at 205 volts. The circuit is wired as in Fig. 1. Spring-return s.p.d.t. TALK-LISTEN switches in the master and remote stations switch the 4-inch PM speakers to the amplifier input for use as microphones.

The circuit is wired so both speakers are across the amplifier output circuit when the intercom is not in use. When S1 is in the NORMAL position, each station has to operate its TALK-LISTEN switch in turn. Throwing S1 to TWO-WAY enables the master station to hold two-way conversations without the need for operating the switch on the remote station. The master station must now

(By using a double-pole three-position switch as the master as in Fig. 2, all switching is handled at the master station except when the remote station initiates the call. The master switch

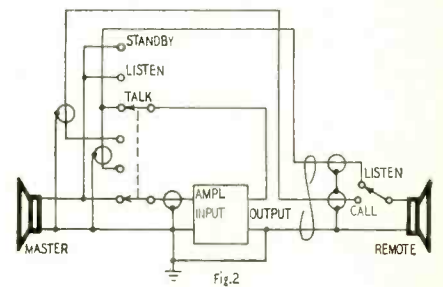

may be a rotary or lever type with spring return to center from one side and positive action on the opposite side. Use the positive position for STANDBY, the center for LISTEN and the other side for TALK. Wire the switch on the remote so it automatically returns to LISTEN.—Editor)

LIQUID-LEVEL CONTROL

This simple liquid-level control is automatic, inexpensive and remarkably troublefree.

There are no floats or moving parts inside the tank to jam or fail. It is designed around the TT-1 cold-cathode control tube (manufactured by Haledy Electronics Co., New York) which differs from the 0A4-G and similar types in several respects. It has a sprayed-on external electrode that connects to a high-resistance voltage divider between plate and cathode. Its starter anode must be at least 20 volts negative with respect to the cathode to initiate the glow discharge that fires the tube. It has an amplification factor

of 2.5 million. In this circuit, the trigger current is less than 2 μ a.

The starter anode is the control electrode when connected as shown in the diagram. Capacitor C is charged with its upper plate negative with respect to ground and the cathode of the TT-1. This charge appears across a voltage divider consisting of R1, R2 and the resistivity of the liquid between the probes and ground. When the resistance of the liquid is less than 10 megohms, the voltage on the starter anode is not sufficiently negative to fire the tube.

When the liquid level drops below the long probe, its effective resistivity

P. R. MALLORY & CO. INC.
MALLORY
 APPROVED PRECISION PRODUCTS

P. R. MALLORY & CO. INC.
MALLORY
 APPROVED PRECISION PRODUCTS

P. R. MALLORY & CO. INC.
MALLORY
 APPROVED PRECISION PRODUCTS

THE
MALLORY
 25th
Anniversary
VIBRATOR

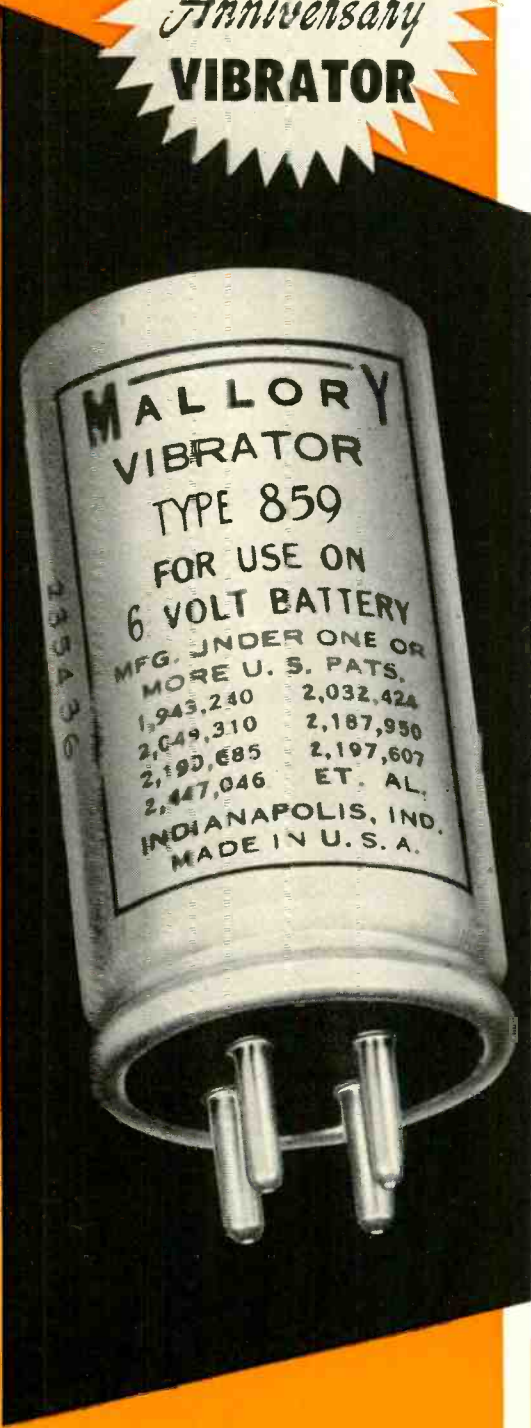

Now hear this! (if you can)

The Mallory 25th Anniversary
 Vibrator is the quietest ever...

You've never heard a vibrator as silent as the new Mallory 25th Anniversary model. Mechanical hum and shake are reduced practically to zero... by a unique "floating" design* that isolates the vibration of the reed element from the case. Hum is squelched to a level never before possible.

The experience of 25 years of pioneering development... and the manufacturing know-how gained by making more than 60 million vibrators... went into this latest Mallory model. Always the leader in performance, and in usage by service men and manufacturers alike, Mallory vibrators are now better than ever!

NO EXTRA COST. The new, ultra-quiet vibrators cost no more than previous models. They're a real bargain in performance.

NO CHANGE IN PART NUMBERS. Order by the same catalog numbers—and you'll automatically get the improved model.

Get ready to give your customers the best, by ordering your supply today from your nearby Mallory distributor.

*Patent applied for

**ON AUTO RADIO JOBS
 BE SURE TO USE... MALLORY MIDGETROLS**

The fast, sure way to get tailor-made replacements for carbon volume controls. High stability resistance elements, with accurate tapers. A small stock equips you to replace practically any control. In single and dual concentric types.

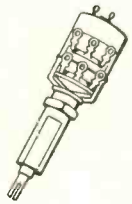

MALLORY

CAPACITORS • CONTROLS • VIBRATORS • SWITCHES • RESISTORS
 RECTIFIERS • POWER SUPPLIES • FILTERS • MERCURY BATTERIES
APPROVED PRECISION PRODUCTS

P. R. MALLORY & CO. Inc., INDIANAPOLIS 6, INDIANA

P. R. MALLORY & CO. INC.
MALLORY
 APPROVED PRECISION PRODUCTS

P. R. MALLORY & CO. INC.
MALLORY
 APPROVED PRECISION PRODUCTS

P. R. MALLORY & CO. INC.
MALLORY
 APPROVED PRECISION PRODUCTS

LAFAYETTE'S SPECTACULAR MONEY SAVERS

A BUY OF A LIFETIME PORTABLE ELECTRONIC MEGAPHONE and AMPLIFIER SYSTEM



COST U.S. NAVY \$1850⁰⁰ YOURS FOR ONLY \$89.⁵⁰

- Powerful 20 watt amplifier!
- Pistol grip dynamic megaphone!

All Units BRAND NEW and GUARANTEED

A complete portable 20 watt amplifier system at a fraction of its original cost! Quality is unquestionable—designed and built for the U. S. Navy! Use on fishing boats—pleasure craft—traffic control—parking lots—day camps—carnivals—sports events—life saving stations—any place where handling large crowds; or reaching large audiences is necessary. Operates from self contained rechargeable batteries—no power line connections necessary. May be set up permanently when used with charging rack. System consists of a 20 watt 6 tube amplifier—In a waterproof portable metal case, an electronic megaphone, a battery charger power unit that operates on 110 volts AC/DC and on 12, 24, 48, or 96 Volts DC, 3 cell 6 volts storage battery, tubes, cables, plugs and 30 page instruction and diagram book. Overall size complete 15 1/2" x 13" x 12". Shpg. wt. 88 lbs.

ELECTRONIC MEGAPHONE SYSTEM.....Net 89.50

Lafayette Greatest Tape Buy Ever!



**1200 FT. REEL
Genuine Plastic Base
RECORDING TAPE**
Shpg. Wt. 14 oz.

\$1.89 per roll plus postage
LAFAYETTE made a terrific deal with one of the leading manufacturers of recording tape to supply us with their regular tape which sells for almost twice our price. **WE GUARANTEE ABSOLUTE SATISFACTION OR YOUR MONEY BACK.** The finest, professional-quality recording tape obtainable. Highest performance for thousands of playings. Red Oxide Base in a smooth, uniform coating; greater signal strength; with maximum fidelity; uniform frequency response from 40-15,000 cps.

In lots of 10 rolls - 1.75 ea

LAFAYETTE EXCLUSIVE! DYNAMIC EAR PHONE

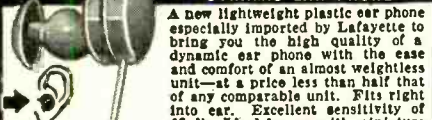

A new lightweight plastic ear phone especially imported by Lafayette to bring you the high quality of a dynamic ear phone with the ease and comfort of an almost weightless unit—at a price less than half that of any comparable unit. Fits right into ear. Excellent sensitivity of 65 db. Ideal for use with miniature sets, hearing aids, transcribing, etc. DC resistance 2000 ohms, impedance 5000 ohms at 1000 cycles. Complete with 3 ft. plastic covered cord.

MS-72.....Net 1.95

LOW IMPEDANCE MODEL FOR SILENT LISTENING OR VIEWING

Will replace speaker on any radio set or TV for silent listening, by direct connection to secondary of output transformer. Impedance 8 ohms.

MS-100.....Net 1.95



SALE ASTATIC UHF CONVERTER

channels 14 thru 83
In Lots of 3..... **13.95**

Singly, each..... **14.45**

Below manufacturer's cost! Continuous vernier tuning—14 thru 83. Operates into TV receiver channels 2-3-4-5 and 61. Two-stage preselector. Fully shielded spiral inductance tuner reduces oscillator radiation. Uses 6AF4 or 6T4 and IN82 crystal diode. High sensitivity—low noise performance!

ASTATIC UHF—Singly, each..... 14.45
In lots of 3, each..... 13.95



QUALITY HEARING AID at an UNBELIEVABLE PRICE

- QUALITY BUILT FOR YEARS OF OUTSTANDING PERFORMANCE
- Completely self contained unit—including batteries slips into breast pocket.
 - Extra sensitive microphone.
 - Tiny sensitive dynamic ear piece.
 - Continuously variable volume control.
 - 3 position tone Control.

Modern! Powerful! Tiny! As small as a pack of cigarettes! Only 3 1/2" x 2 3/4" x 7/8". And only 1/2 the usual price for an instrument of this quality. Weighs only 5 ozs.—including the batteries! No extra bag or pouch to carry—batteries are inside the unit. Guaranteed to suit your particular hearing problem. Only Lafayette's purchasing power makes this price possible—backed by their amazing Warranty. No charge replacement on any defective part (except cords and batteries) due to normal usage for 1 year from date of purchase. Complete with batteries and carrying case.

HA-100.....Net 39.50

INDUCTION MODEL
Identical to HA-100, but has built in induction coil for use with telephone.
HA-101.....Net 49.50

MINIATURE CRYSTAL MICROPHONE

Here's a typical Lafayette special for the experimenter, student or dealer. An extremely sensitive and small crystal microphone used in hearing aids and other small apparatus. Can be used as lapel mike—miniature transmitter mike for concealed locations, etc. Its size and performance gives it joint versatility. Brand new. Size only 1 3/8" Diam. x 5/16" deep. Imported to save you money.

MS-108.....Net 1.95

REAR SEAT AUTO SPEAKER KIT



HEAVY DUTY 6" x 9" PM KIT
A complete kit for adding another speaker in the rear of your car. You get a 6"x9" PM speaker with a 2.15 oz. Alnico V magnet; a CRL PK300 three position switch so you can select either speaker alone or both together, dial plate with mounting bracket, knob and hardware; a plastic grille (illustration A) (your choice of brown, grey or silver), wire and wiring instructions. Simple to install. Shpg. Wt. 4 lbs.

SK-36.....Net 4.50

DELUXE 6" x 9" KIT
SK-37, with chrome plated metal grill (Fig. B). Shpg. Wt. 5 lbs.....Net 5.75



5" Tweeter AND Crossover Network

A specially designed 5" Tweeter and Crossover Network that will raise high frequency speaker to new heights. You can now make your present speaker into a 2-way speaker system increasing the high frequency range up to 15,000 cycles. Diagram included. Shpg. Wt. 5 lbs.

STOCK NO. SY-14.....Net 7.95

DUAL STYLUS — TRIPLE PLAY

DIAMOND and SAPPHIRE
LIST \$34.00
Replacement for All G.E. RPX-050 Triple-Play Cartridge!
Stock No. PK-29 Net 11.95

Masco CASCADIAN TV BOOSTER



Reg. Price **\$42.50**
SALE 9.95

Biggest Booster Buy Ever! Famous Masco Cascade Booster!!

- Three tuned circuits—cascode!
- Golden Grid 6BZ7 Plus 616 Plus rectifier!
- 35 db gain (56 times!) average on all channels!

A sensational new tunable VHF booster utilizing a special low-noise circuit. Employs the new Golden Grid 6BZ7 tube so well known for its use in cascode circuits. Field pioneer and specifically designed for new low noise-high gain front ends. Brings superior reception to older type receivers. Single knob control for utmost simplicity of operation. Signal strength is increased at least 56 times—35 db—average on all channels. Rack and pinion permeability for precision stability. Automatically switched on and off by TV set. Uses cross-neutralized 6BZ7 and 6BZ7 tubes for maximum gain and bandwidth. U/L approved. For 110 volts AC. Wt. 5 lbs.

Masco TVB-53. In lots of 3, Net 9.45 Singly, ea. 9.95

SALE! RADIO RECEPTOR UHF CAVITUNER



Complete with 6 AF4, 6BZ7 and IN82
4.95

Tunes all UHF channels 14-82. Most advanced engineering, three cavities, two used as bandpass pre-selector, one controlling local oscillator. Features frequency stability, uniformly broad bandwidth, high selectivity, low noise, high gain. Completely shielded. Ideal for building converters, etc. Size 3 1/2" H x 4 1/2" W x 1 1/2" D. Shpg. Wt. 4 1/2 lbs.

TL-26.....Lots of 3, ea. 4.45 Singly, ea. 4.95

BINOCULARS NEVER BEFORE AT THIS PRICE

- IMPORTED DIRECT**
Prism-Coated Lenses
- All-Metal Construction
 - Individual Focus
 - Leather Case & Straps

F-86 — 8X, 25 I.F.Net 17.45
F-105 — 8X, 30 I.F.Net 18.25
F-15 — 7X, 35 I.F.Net 19.95
F-103 — 7X, 50 I.F.Net 21.95
F-117 — 10X, 35 C.F.Net 23.95
F-104 — 12X, 50 I.F.Net 32.50
F-118 — 16X, 50 C.F.Net 34.95

FREE send for it

RADIO CATALOG
GET LAFAYETTE'S NEW CATALOG PACKED WITH THE LARGEST SELECTION OF QUALITY ELECTRONICS EQUIPMENT AT BARGAIN PRICES.

Lafayette Radio

NEW YORK, N.Y. 100 Sixth Ave.
BRONX, N.Y. 542 E. Fordham Rd
NEWARK, N.J. 24 Central Ave.
PLAINFIELD, N.J. 139 West 2nd St.
BOSTON, MASS. 110 Federal St.

DEPT. JF
Include postage with order.



TESTED AND PROVEN E-Z WAY TILT OVER TOWERS

E-Z Way TV Towers crank up and down. Can be easily lowered and the antenna tilted over to a height of only six feet above the ground and made absolutely hurricane proof!



- CRANKS UP AND DOWN • TILTS OVER
- NO GUY WIRES—NO CONCRETE
- NO ROOF DAMAGE
- NO LIGHTNING RISK • HURRICANE PROOF
- GREATER DISTANCES—CLEARER PICTURES

The only practical free-standing tower is one that can be lowered in case of strong winds. E-Z Way Tower is the sturdiest, most unique and versatile tower in the industry. High-test steel construction. Electric Arc welded. Each section completely immersed in Pliotite S-5 (rubber base) aluminum enamel for long-lasting weather resistance. Most economical. Easiest to install. Easiest to service and add antennas. Twelve tilt-over types from 30' to 85' VHF heights. Fifteen building-attached crank-up types of towers. Each tower specifically designed for a particular use.

DISTRIBUTOR INQUIRIES INVITED
FOR FREE CATALOGUE AND INFORMATION WRITE:

E-Z WAY TOWERS, Inc.
5901 E. BROADWAY • P. O. BOX 5491 • TAMPA, FLORIDA

RADIO-ELECTRONIC CIRCUITS (Continued)

The audio transformer is a surplus unit to match push-pull plates to headphones. Its turns ratio is 41 to 1. You can use almost any conventional push-pull output transformer with a 250- or 500-ohm secondary.

The r.f. coil and capacitor may be any combination that tunes to the desired frequency range. You can use superhet oscillator coils with an r.f. takeoff coil of about 10 turns of No. 28 wire wound around the ground end.
—Arthur L. Manning

SYNC FOR TV SCOPE

A scope is a useful tool for TV sync and deflection circuits. However, if a defective sync circuit does not produce enough sync to operate the set properly, it may also not produce enough to sync the scope. In such cases the scope can be synchronized from a reliable external source such as an old TV set.

The diagram shows the modification of the auxiliary receiver. The cathode follower couples the outside set's sync sweep circuits to a length of shielded cable or coax going to the scope's

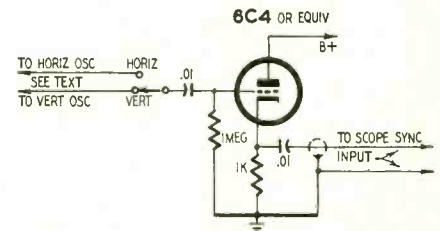

external sync terminals. Either an extra triode can be added to the chassis or its present a.f. amplifier tube can be replaced by a dual triode with one section used as the cathode follower.

You can take the sync signals from the set's sync separator, but I prefer using scanning-generator voltages, since the larger signals make for more reliable synchronization. The actual connections to be made depend both on the type of scanning generators used in the TV set and the type of sweep generator in the scope. A scope with a multivibrator sweep requires negative sync pulses. In that case, if the scanning generator (vertical or horizontal) in the TV set is a blocking oscillator (or a Synchronguide) connect to the blocking oscillator plate. If it is a multivibrator or a Synchronlock, connect to the plate of the discharge tube or second triode in the multivibrator.

If your scope has a gas-tube sweep, it requires positive pulses for sync. Then connect to the grid of a blocking oscillator or Synchronguide blocking-oscillator section, the grid of the discharge tube in a Synchronlock or the plate of the first triode in a multivibrator.

Connect the shielded output cable to the scope's sync input terminals and set the scope for external sync operation. Tune the auxiliary set for a clear steady picture on the same channel tuned in on the set under test —Charles Erwin Cohn
END

NEW! EICO FLYBACK & YOKE TESTER KIT

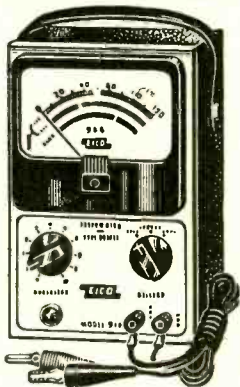

MODEL 944

LOWEST PRICED KIT \$23.95

Wired \$34.95

Checks all flybacks & yokes instantly—in or out of set!

- Detects even 1 shorted turn!
- Exclusive separate calibration for air & iron-core flybacks for accurate testing of all types.
- Tests continuity of coils, speakers, switches, etc.
- Large 4½" meter, 3 colored scales.
- Complete with easy instructions.
- Compact, rugged, smartly styled.

See it at your jobber today. Write for FREE Catalog CF-6 describing EICO's 36 Kits and 42 Wired Instruments. Prices 5% higher on West Coast.

EICO ELECTRONIC INSTRUMENT CO., Inc.
84 Withers Street, Brooklyn, N. Y.



DON'T THROW OLD RADIOS AWAY!

Here's the data you need to fix them FAST and r-i-g-h-t!

Just look up the how-to-do-it data on that old radio you want to fix!

Four times out of 5, this giant, 3½-pound, 711-page Chiaradi RADIO TROUBLESHOOTER'S HANDBOOK gives exactly the information you need to fix it in a jiffy. Tells what is likely to be causing the trouble . . . shows how to fix it. No useless testing. No wasted time. Handbook covers practically every radio receiver model made by 202 manufacturers between 1925 and 1912. Using it, even beginners can easily fix old sets which might otherwise be thrown away because service information is lacking. With a few simple repairs, most of these old sets can be made to operate perfectly for years to come.

THE ONLY GUIDE OF ITS KIND!
Cuts service time in half!

Included are common trouble symptoms and their remedies for over 4,800 models of old home, auto radios and record changers. Alltime, Apex, Arvin, Atwater Kent, Belmont, Bosch, Brunswick, Clarion, Crosley, Emerson, Eddo, G-E, Kolser, Maestri, Motorola, Philco, Pilot, RCA, Silvertone, Spartan, Stromberg and dozens more. Gives how-to-do-it data on SPECIFIC jobs—NOT general theory. Includes hundreds of pages of invaluable tube and component data, service short cuts, etc.

TRY IT 10 DAYS . . . at our risk!

Dept. RE-65, RINEHART & CO., Inc.

232 Madison Ave., New York 16, N. Y.

Send Chiaradi's RADIO TROUBLESHOOTER'S HANDBOOK for 10-day free examination. If I decide to keep book, I will then remit the full price of only \$4.50 plus a few cents postage. Otherwise, I will return book postpaid and owe you nothing.

NAME.....

ADDRESS.....

CITY, ZONE, STATE.....

Outside U. S. A.—Price \$7.00 rush only. Same return privilege.

Technotes



MITCHELL 1250, 1251

Low volume on these models can be corrected by taking out the 220-ohm cathode resistor of the 50L6-GT output tube and replacing it with a 120-ohm resistor.—*John Flint*

RCA MODEL 6T72A

A 16-inch picture pulled in to the size of a 14-inch rectangular and remained that way, with slight distortion in sound. By substituting a low-voltage 5U4-G rectifier known to be good from a radio and replacing a 6SN7 the picture returned to normal size and the sound returned to full brilliance.—*James H. Bell*

SQUEAKING RECORD PLAYER

When a Philco 47-1201 comes in with the record player making a squeaking noise, open the cabinet and inspect the two locating rollers. Make sure they do not touch when the record is playing. If they are touching, an adjustment can be made with the 1/4-inch nut under the pickup arm that locks an eccentric bushing.—*G. Anglado*

RCA 56-X

When replacing the 50- μ f filter capacitor in these sets, oscillations usually take place. These can be corrected by connecting a 0.1- μ f capacitor in parallel with the new filter capacitor.—*George Taylor*

17-INCH PHILCO

Trouble: no high voltage on a brand-new 17-inch Philco television receiver. Sound was O.K. and all tubes tested good; even the voltages appeared normal. Examining the rear of the set in the darkened room, I noticed arcing in the multiprong connecting plug. The horizontal sweep leads feeding the deflection yoke were shorting to the vertical sweep wires by way of a small hole burned through the plug. The horizontal wires were removed from the plug and a new wide-gap connecting plug was used to join the two horizontal leads, restoring the high voltage.

This is a common defect in these sets and should be checked for in every case where the picture tube is mounted to the cabinet and the deflection yoke and focus coil leads are disconnected from the chassis by a coupling plug. In this set, the socket is fastened to a bracket on the high-voltage cage.—*J. Dubinsky*

STROMBERG-CARLSON TV-12

Complaint: hum; found especially in the 1220-T AM chassis used in the TV-12 combinations.

Connect a 25- μ f 25-volt capacitor between the cathode terminal of the 6SC7 and ground. This reduces the hum to a point where in most cases it will no longer be objectionable.—*George R. Anglado*

OSCILLATOR REPLACEMENTS

Instruction sheets accompanying commercial oscillator coils specify the correct points for connection to grid, ground, B plus and plate. I have received sets in which the terminals for both windings were transposed, either by accident or heedlessness. Since both were transposed, the circuit still produced oscillations but tuning was wrong because of the additional coil capacitance due to the incorrect connections. In some cases the full tuning range could not be covered. The remedy is obvious. This presumably applies—to a lesser extent—with r.f. and antenna coils.—*Charles Erwin Cohn*

RCA 1953 21-INCH SETS

Four of these have come in with a complaint of loud hiss. The trouble is arcing inside the high-voltage capacitor. The noise is loud but nothing can be seen. Disconnect the high-voltage leads from the capacitor. If the trouble stops, the capacitor was defective. Replace with a 20,000-volt .0005- μ f unit.

The capacitor is threaded on both ends and is mounted on the outside wall of the high-voltage compartment, facing front, and fastened to the wall with a nut. It can be installed with a pair of pliers in about 15 minutes. When I service one of these sets, I always replace the capacitor as callback insurance.—*Jacob Dubinsky*

G-E MODEL 20C105

A very elusive intermittent condition occurred on this receiver. It would work O.K. for a few days, then sound and picture would vanish while the raster remained. Advancing the contrast control all the way restored sound and picture.

Finally tracked down, the trouble proved to be that the 6SL7-GT sync separator was oscillating. This caused the a.g.c. voltage on the grid (pin 1) to be from 30 to 50 volts negative. The 10- μ f 450-volt capacitor in the plate circuit was opening intermittently.—*Henry Josephs*

TERADO



Trav-Electric CONVERTERS

provide
House Current

Anywhere

—from battery in car, truck, boat. At the beach—picnic grounds—at cabin—on trips—anywhere! Easy! No installation! Just plug Trav-Electric into cigar lighter on dash.

Trav-Electric Operates:

- Tape Recorders
- Dictating Machines
- Electric Shavers
- Small Electric Drills
- Radios
- Portable Phonographs
- Soldering Irons
- Etc. etc. etc.

6 Models 10 to 100 Watts

—a size for every need.

"Midget"

Model 6-11160
10-15 Watts

As small as a pack of cigarettes.

\$11.95 LIST



PORTABLE PHONOGRAPH



DICTATING MACHINE



ELECTRIC SHAVER

"JUNIOR"

Model 6-1110
115 Cycle
30-40 Watts
\$12.95 LIST

"SENIOR"

Model 6-1160
Size 2 1/2" x 2 1/2" x 4 1/2"
35-40 Watts
\$15.95 LIST

"MASTER"

Model 6-51160
40-50 Watts
Size 4" x 5" x 6"
\$27.50 LIST

"SUPER"

Model 6-71160
(Shown at top of ad)
60-75 Watts
Size 4" x 5" x 6"
\$37.95 LIST

—and now, the "CHIEF"
NEW—JUST OUT—Model 6-81160—75-100 Watts—automatic on-off switch—**\$49.95 LIST**

See your *Electronic, Hardware, or Automobile Jobber or Dealer*

Terado Company

Designers and Mfrs. of Electronic Equipment
1057 Raymond Ave., ST. PAUL 14, MINN.
In Canada Write: Atlas Radio Corp., Ltd.
560 King St. West, Toronto 28, Ont.
Export Sales Division: Scheel International, Inc.
4237 N. Lincoln Ave., Chicago 18, Ill. U.S.A.
Cable Address—Harcheel

GENERAL ELECTRIC

Early production models came in with a complaint of buzz in the audio when tuned for the best picture on weak signals. This was due to a 41.25-mc trap coupled to the second video i.f. coil (removed in later models). The trouble can be cleared up by shunting the trap with a 5,000-ohm resistor. Connect it across the trap trimmer. —Wayne Miller

SENTINEL 309-W

This set was very noisy at times—especially when moved around for directional reception. The copper loop—pressed on a Masonite section on the back of the receiver—was found loose in a few places. Putting a little speaker cement on the loose loops, pressing them down and letting the cement dry stopped the noise.—Manuel E. Silva

DAMPING BARS

When a vertical damping bar appears on the left side of the screen on an Olympic 950, and the 6BG6 and 6W4 tubes are not at fault, replace the balancing capacitor across the high side of the horizontal deflection coil. Its original value is 47 μf —change it to 110 μf .—John Flint

ELIMINATING B.O.

No single remedy will correct Barkhausen oscillation on all sets. Things that correct it on one set or model group may have very little effect on others. Likewise, one particular remedy may eliminate it, or it may require a combination of several.

The following suggested remedies have been found very effective:

1. Keep the antenna lead-in dressed as far as possible from the horizontal output circuits.
2. Check the setting of the horizontal drive control.
3. Connect a capacitor (.005 to 0.1 μf) between the damper tube filament (pin 7 on Super V's) and chassis. (Keep leads short as possible.) This is usually very effective. However, in some cases it may shift the oscillation to another channel. In such cases use the particular value which shifts it to an unused channel.
4. Check the horizontal output tube's screen resistor.
5. Check the B boost filter capacitor (C138 on the Super V's) and try bypassing it with a .05- μf capacitor.
6. Try several horizontal output and damper tubes.

NOTE: It has been found that tubes which cause Barkhausen oscillation in some sets will work satisfactorily and not show any trace of it in another.

7. Install a magnet (ion trap) on the horizontal output tube. Adjust it to the position which eliminates or shifts the oscillations to an unused channel.
8. Check bypass capacitors in the r.f. tuner and i.f. section of the receiver.

—Crosley Service Department **END**



CAP-CHECK
the only precision instrument that checks condensers **WHILE IN THE CIRCUIT!**
\$44.95

YOUR BEST BUY!

3

New IFS Exclusives!



FIL-CHECK
The Only Complete Instantaneous Series Heater or Filament Checker.
\$3.25



ALL-CHECK
Compact Multi-Purpose Checker
\$14.95

SOLD BY LEADING JOBBERS OR WRITE FOR INFORMATION.

IFS Instruments for Service Inc.
96 SOUTH GRAND AVENUE, BALDWIN, LONG ISLAND, N. Y.

LEARN

Television-Radio Electricity

REFRIGERATION-ELECTRONICS

IN THE GREAT SHOPS OF COYNE

TRAIN QUICKLY! OLDEST, BEST EQUIPPED SCHOOL of ITS KIND in U.S.

Come to the Great Shops of Coyne in Chicago. Get practical training in opportunity fields—TELEVISION—RADIO—ELECTRICITY—ELECTRONICS. Prepare now for a better job and a real future.

Approved for Veterans
Finance Plan—Enroll now, pay most of tuition later. If you need part-time work to help out with living expenses we'll help you get it. Advanced education or previous experience not needed.

FREE BOOK Clip coupon for Big Free Illustrated Book. No obligation and No Salesman Will Call. Act NOW.

B. W. Cooke, President

COYNE ELECTRICAL SCHOOL

A TECHNICAL TRADE INSTITUTE OPERATED NOT FOR PROFIT
Established 1899
500 S. Paulina, Chicago

**ELECTRICITY ★ TELEVISION
RADIO ★ REFRIGERATION ★ ELECTRONICS**

B. W. COOKE, Pres.
COYNE Electrical School
500 S. Paulina St., Chicago 12, Ill. Dept. A5-81H

Send FREE BOOK and full details on:

TELEVISION-RADIO ELECTRICITY

NAME.....
ADDRESS.....
CITY..... STATE.....

New Secret Recorder



with Built-In Microphone and Playback Facilities

Now you can easily and inconspicuously record natural customer reactions, legal evidence, personnel interviews, verbal contracts, criminal confessions, personal data and other highly confidential matter in utmost secrecy with maximum intelligibility.

This new reliable seven pound tape recorder, perfectly camouflaged in a genuine leather briefcase operates noiselessly on long-life batteries and is instantly activated by a clever combination slide-lock and switch. A recently developed, highly effective automatic volume control circuit eliminates level adjustments. Clear pick-up with sensitive built-in microphone at a distance up to 100 ft.

Provides uninterrupted recording for 1½ hours at a tape speed of 1½ ips. A 5" reel records for three hours. Tapes play back faultlessly on all professional and home recorders. All models guaranteed for One Full Year.

for complete technical information and direct factory prices write to Dept. RE:

AMPLIFIER CORP. of AMERICA
398 Broadway, N. Y. 13, N. Y.

Technicians' News



TECHNICIANS IDENTIFIED

The Lancaster County (Pa.) Electronics Servicemen's Association has issued cards (see illustration) to bona-fide service companies and technicians

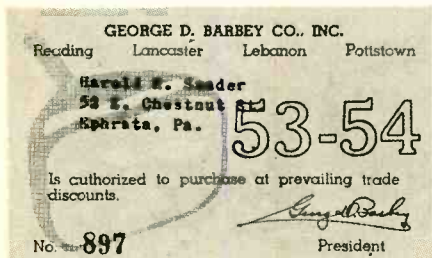

in the Reading, Lancaster, Lebanon and Pottstown areas, to indicate to distributors that they are not retail customers and are entitled to purchase goods at regular trade discounts.

The secretary of the association, Harold R. Snader, reports encouraging cooperation from distributors. "Not all the distributors in the area have as yet set up a card system," he says, "but they have all promised to do so shortly."

MICHIGAN REVIEWS ACTS

New officers of the Television Association of Michigan (Detroit) were elected at the annual meeting in March. Alexander Weiss was re-elected president. Charles Judd was elected first vice president; Karl Heinzman, second vice president; Ray Cobbledick, secretary, and Malcolm Wright, treasurer.

Six directors—Edward Brown, Wm. Mattingly, Clayton Hibbert, Vernon Ederhardt, Harold Chase and Jack Barton—were elected.

Among the activities of the past year reviewed at the meeting were the writing of the proposed licensing law for service shops in Detroit, pretesting on the new educational u.h.f. TV channel and fulfilling the organization's consumer education program on television servicing. This program was carried to more than 500,000 consumers and school children during the year, the educational committee reported.

FRSAP DEMANDS PROOF

The following resolution was passed at the March meeting of the Pennsylvania Federation of Radio Servicemen's Associations:

"Resolved: That Glenn McDaniels, president of the Radio-Electronics-Tele-

vision Manufacturers Association, and Wm. H. Parkinson, chairman of the RETMA committee on technical education, furnish satisfactory proof to the federation that licensing of technicians would increase cost of service to the consumer, as stated before various legislative bodies."

The federation also formulated plans for the annual award to the individual or company who had contributed most to the welfare of the television servicing industry. This year's recipient will be Lewis E. Winner, editor of *Service* magazine.

TUBE FIRM CONVICTED

Barrack Electronics, Inc., of Brooklyn, N. Y., and two of its officials were found guilty of fraudulent practice in the sale of radio and television tubes. They had been charged with reconditioning used tubes and selling them as new, affixing to them counterfeit or imitation trade marks of legitimate manufacturers.

The president of the firm, Isidore Barrack, and its secretary were found guilty and continued in \$5,000 bail each for later sentencing. Maximum penalty is a year in jail, a fine or both.

A Q & A REPORT

Licensing was the subject of discussion at a meeting of independent television service technicians and service shop organizations held under the auspices of the Western New York Electronics Guild (Buffalo). The conclusion, as given below, was that licensing would not be beneficial to the industry or the public:

Question: Do you believe a licensing law would stop malfeasance practices by some within the industry?

Answer: No, present laws already govern this as to petty larceny and fraud. Some believe or would like you to believe that this is practiced only by new and part-time members of the trade, but unfortunately this is not altogether so. Cooperation with local law enforcement agencies could do as much under existing laws.

Remedy we propose to take: Set up a local investigating committee to study charges of malfeasance practices and misleading "bait" advertising and induce cooperation with the District Attorney's office to bring those guilty into the courts.

Question: Do you believe a licensing

Hand size... Voice size...

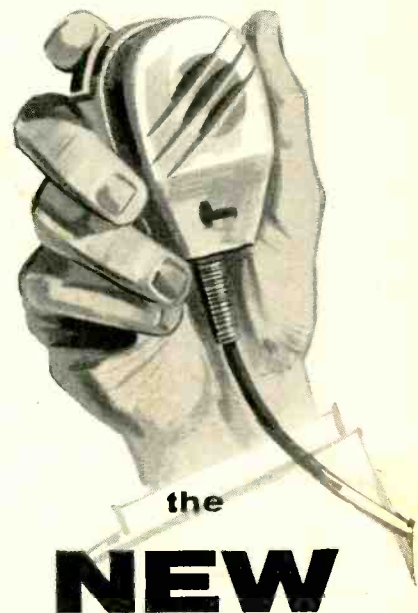

the
NEW

American "501" Series Microphones

Lightweight, rugged, easy to handle... true-to-life in fidelity of voice pickup. The new American "501" Series presents a complete line of dynamic or carbon hand microphones to improve all types of voice communications.

The attractive styling is completely functional... the gently curved case fits easily into the hand. Positive operation under all conditions is provided by a specially designed cantilever switch. The case is made of die cast aluminum to assure durability and minimum weight.

There's a model for every need:

- Mobile Communications
- Police
- Ship-to-Shore
- Aircraft
- Amateur

To be heard and understood... start with an American Microphone. Write for complete details and specifications today. Ask for Bulletin 501.



AMERICAN
microphone
company

370 South Fair Oaks Ave., Pasadena 1, Cal.

AN ELGIN NATIONAL WATCH COMPANY AFFILIATE

Sensational! The NEW...

VACO[®]

Hollow Shaft NUT DRIVERS in Color

Nothing else like them anywhere! Choice of 28 types and sizes! New plastic kit at right contains 7 most popular drivers in self-standing bag for service work or bench use.

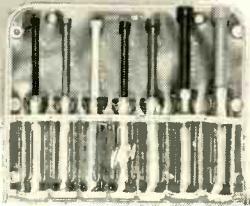
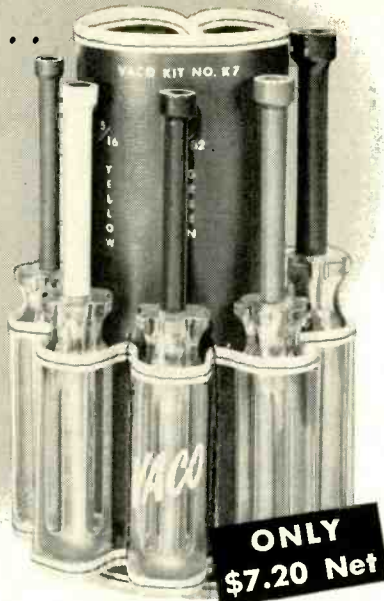

**No. K7 Self-Standing Service Kit
Stands Up! Hangs Up! Folds Up!**

Stands upright for easy accessibility. May be hung flat on wall or may be folded. Each driver fits in individual holder marked for size, color.

Check These 6 Important VACO Features

NEW! Each size color-keyed!

NEW! All-hollow shafts

NEW! Extra large VACO Comfordome Handles!



NEW! Extra hard long wearing sockets!

NEW! Shafts insulated from handle to tip!

NEW! Available in 4 shaft lengths and 7 Hex sizes!

THIS COUPON WORTH \$1.20

Coupon only valid for use as stated below. Not valid in states where prohibited.

Name..... RE
Street.....
City..... Zone..... State.....

VACO PRODUCTS COMPANY
317 E. Ontario St., Chicago 11, Ill.
In Canada: Vaco-Lynn Products Co., Ltd., Montreal 1, Que.

Take this coupon to your jobber. It is worth \$1.20 when filled in and used to purchase one VACO K7 Kit. If your jobber cannot supply you, write direct.

Important Notice to SUBSCRIBERS

If you're moving, please don't forget to send us your address as it appears on the copy of the magazine, including the numbers shown beside your name, as well as your new address. If possible, send us your address label which is pasted on the upper left hand corner of the back cover.

If we receive this information before the 20th of the month, you will continue getting the magazine without interruption.

Your cooperation will be most helpful and greatly appreciated.

Please send your new address to:

Subscription Department
RADIO-ELECTRONICS
25 W. Broadway, New York 7, N. Y.

law would retard the growth of the service industry?

Answer: Yes, as these laws would possibly put an undue burden on part-time technicians and one-man shops with possible loss of their experienced services to the public, thereby increasing service cost through a non-competitive field. . . .

Other opinions:

Many proponents of these laws attempt to compare the radio and television service industry with that of plumbers, electricians and liquor stores, falsely. It is incredible as to how the pure foods and hygiene laws could apply to television service with the only possible encroachment in the electricians' field being antenna installations. . . .

Open service field to unionization, forcing in many cases an increase of service cost beyond the reach of most of the public. Increase "do-it-yourself" era and the neighbor "tinkerer" and "tube-change artist"—with no fanfare, no bill, no overhead or tax.

WILL POLICE TRADE

TV repairmen of Toronto, Canada, at a meeting attended by more than 400 technicians and service dealers pledged themselves to a public relations plan aimed at driving racketeers out of TV repair. The meeting was sponsored by the Radio Electronic Technicians Association (RETA).

The plan is to open a complaint bureau under the auspices of the association to handle customer complaints and to recommend reliable repairmen to set owners, on request.

According to Richard Cartwright, president of RETA, "Complaints (on TV service) have gone up 300% since firms have been offering cut-rate service calls." Thomas Rimmer, of the Better Business Bureau, corroborated, stating that one complainant had repairs to his set appraised at \$80, including a new picture tube. An honest repairman then appraised the repair at \$3.50 for one tube and \$5.50 for the service call.

GUILD SHOPS AROUND

The Radio Television Guild of Long Island has initiated a "shopping service" to check on the amount of retail selling going on among the distributors in the area. In recent issues of the *Guild News* (which circulates among 2,000 Long Island technicians) full-page reports list distributors who either sold or did not sell to a customer who had "nothing about his appearance or manner to lead the distributor to believe he was in any way connected with the service industry." It is interesting to note that in the guild area—where an intensive educational campaign has been carried on both for the distributor and customer—a majority of the distributors do not sell retail. Of 30 concerns listed in a recent issue of the *Guild News*, 17 would not sell to the "shopper." END

Question Box

RECORDER AMPLIFIER USES DRY BATTERIES

I want to construct a battery-powered portable tape recorder but have not been able to find a suitable circuit. Please print a diagram or tell me where I can find one.—H. C. C., Long Island City, N. Y.

This battery-powered tape recorder amplifier was described originally in

Revue du Son (Paris, France). Its audio circuit for record and playback consists of a 1L4 input stage, a 1L4 driver and a 3Q4 power amplifier.

The plate circuit of the power amplifier is capacitance-coupled to a jack for external amplifier on playback and to the head when recording. The plate

load is an output transformer with a 10,000-ohm primary and 3-ohm secondary. The latter is loaded with a 3-ohm resistor but a small speaker may be substituted and used for playback and as a recording monitor. An auxiliary volume control may be inserted in the voice-coil circuit so the speaker output can be held below the feedback level when recording from a microphone. The input and output circuits are designed for high-impedance heads.

The 35-kc bias oscillator—a triode-connected Colpitts—operates only on recording. The oscillator coil has an inductance of approximately 14 mh. It may be a high-Q r.f. choke or a TV linearity or width coil that can be adjusted to the required inductance.

The record-play switch is a four-circuit double-throw type with low-capacitance contacts designed for audio switching. Shield all leads to the input

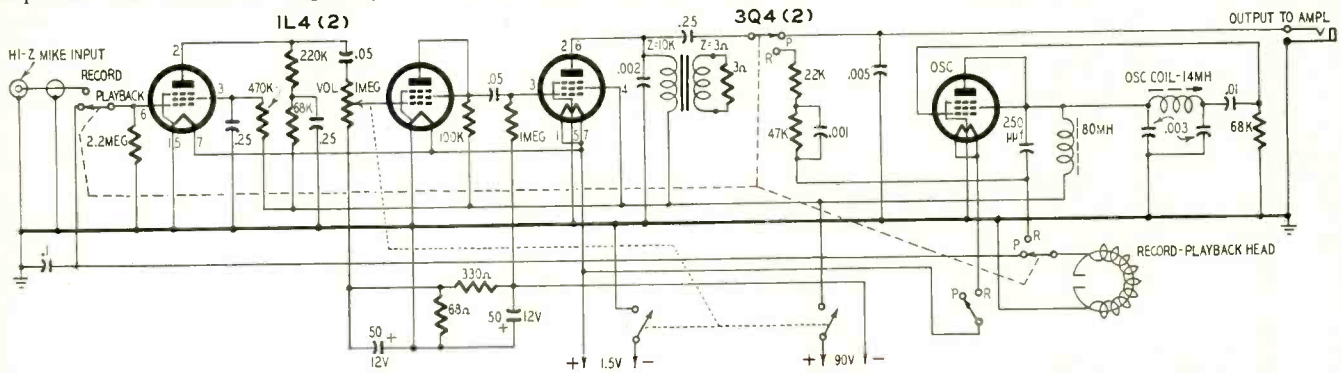

Get This Valuable Book

Just for Examining COYNE'S New 6-Volume Set

FREE



"Applied Practical Radio-Television"

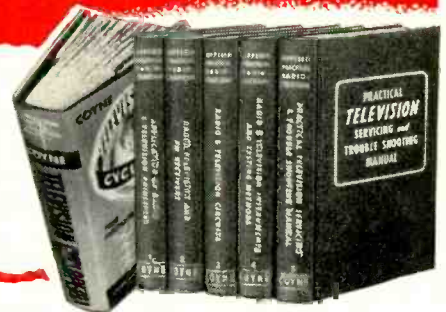

Yes, you get this big, brand new book, "150 Radio-Television Picture Patterns and Diagrams Explained", absolutely FREE! Just off the press! Gives complete 11x22" Schematic Diagrams on leading models Radio and Television Sets. Easy-to-read, large 8½x11" pages, with full instructions on how to read and use the diagrams. A "must" in every Radio and Television service-man's repair kit. You get this valuable book as a FREE Gift for asking to see Coyne's great new 6-book set, "Applied Practical Radio-Television"!

ON 7 DAY FREE TRIAL!

At Last! Money-Making "Know-How" on Transistors, Color TV and Servicing

Coyne's great new 6-volume set gives you all the answers to servicing problems—quickly! For basic "know-how" that is easy to understand, you'll find everything you want in volumes 1 to 5 which contain over 5000 practical facts and data. They cover every step from principles to installing, servicing, trouble-shooting and aligning all types of radio and TV sets. So up-to-date it includes COLOR TV and UHF, adapters, converters. Also covers latest data on TRANSISTORS.

Extra! 900-Page Television Cyclopeda Included

And then, for speedy on-the-job use, you get volume 6—the famous Coyne TELEVISION CYCLOPEDIA. It answers today's television problems on servicing, alignment, installation and others. In easy-to-find ABC order, cross indexed. Use this 6 volume TV-RADIO LIBRARY free for 7 days; get the valuable Servicing Book ABSOLUTELY FREE!

SEND NO MONEY! Just mail coupon for 6-volume set on 7 days free trial. We'll include book of 150 TV-Radio Patterns & Diagrams. If you keep the set, pay \$2 in 7 days and \$2 per month until \$22.50 plus postage is paid. (Cash price \$20.95). Or you can return the library at our expense in 7 days and owe nothing. **YOU BE THE JUDGE.** Either way, the book of TV-Radio Patterns is yours FREE to keep! Offer is limited. Act NOW!

FREE BOOK—FREE TRIAL COUPON!

Educational Book Publishing Division

COYNE ELECTRICAL SCHOOL, Dept. 65-T1
500 S. Paulina St., Chicago 12, Ill.

YES! Send 6-volume "Applied Practical Radio-Television" for 7 days FREE TRIAL per your offer. Include TV-Radio Patterns & Diagram Book FREE.

Name _____ Age _____

Address _____

City _____ Zone _____ State _____

Where Employed _____

() Check here if you want library sent COD. You pay postman \$20.95 plus COD postage on delivery. 7-day money-back guarantee.

Educational Book Publishing Division
COYNE ELECTRICAL SCHOOL
500 S. Paulina St., Dept. 65-T1, Chicago 12, Ill.

These new books can help you get ahead in electronics

RADIO-CONTROL HANDBOOK—

No. 53

R/C expert Howard G. McEntee, W2SI, gives you all the necessary practice details on how to build R/C systems and mechanical components to control model planes, boats, etc. 192 Pages. 175 Illustrations.

\$2.25



THE OSCILLOSCOPE—No. 52



A practical book that tells you how to use the scope to best advantage in all types of servicing. Gives you tips on use and warns about pitfalls to avoid. 192 Pages. Over 100 illustrations.

\$2.25

TRANSISTORS—THEORY AND PRACTICE—No. 51

Rufus P. Turner explains transistors for the practical man. Gives applications in well-known circuits. Contains guide to characteristics of commercial transistors. 144 Pages.

\$2.00

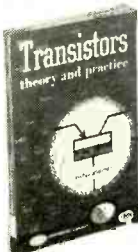

TV REPAIR TECHNIQUES—No. 50



Top technician-writers tell you how to recognize and correct quickly the tough servicing problems which stump even the experts. Will help you do a better job faster. 128 Pages.

\$1.50

RADIO & TV TEST INSTRUMENTS—No. 49

How to build just about every modern TV-radio-audio servicing instrument, plus unique chapters on service bench and carrying case construction. 128 Pages. Over 100 illustrations.

\$1.50



See Coupon on pg. 118

Gernsback Publications, Inc.
Publishers of RADIO-ELECTRONICS
25 West Broadway New York, N.Y.

QUESTION BOX

(Continued)

anode (pin 7) of the 0A4-C connects to a metal screen or "feeler" plate on the wall through a 200- μ f trimmer capacitor. When the capacitor is set properly, the tube fires and operates RY2 when the hand is brought close to the "feeler" plate. When RY2 (a plate-circuit relay) operates, it closes the circuit to the coil of RY1, a 117-volt a.c. locking type ratchet or impulse relay. A momentary application of voltage to its coil locks the contacts closed. The next application of voltage locks the contacts open. The contacts of RY1 control the light circuit.

If the control is mounted in the wall, be sure that it is enclosed in an approved type box with cover. Mount it so the cover will be flush with the outer surface of the wall. The cover may then be painted or papered to match the surrounding surface.

RCA 65BR9 PORTABLE

I have an RCA 65BR9 a.c.-battery 2-volt storage battery with a vibrator to supply B voltage. On a.c. it uses a stepdown transformer and rectifier to supply the vibrator and filaments. Please show how I can convert this set to eliminate the vibrator supply and operate it from a.c. lines.—H. J. V., Kittanning, Pa.

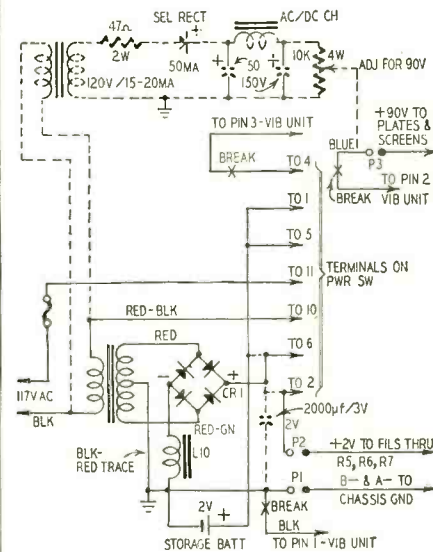

Here is a partial schematic of the power supply with modifications shown by dashed lines. The charger unit (line transformer, rectifier and power switch) is retained intact. The vibrator unit is removed to make room for the new a.c.-operated plate supply. The line (step-down) transformer and rectifier are used to supply 2 volts d.c. to the filaments. If the storage battery is not shorted, leave it in place as a low-voltage filter. If it is damaged, replace it with a 2,000- μ f electrolytic capacitor as shown. Codes on the diagram are those used in the original RCA schematic.

The added power supply is a simple half-wave unit using a 50-ma selenium rectifier. The transformer can be small, a 20-ma unit being sufficient. END

NEW!



a Volt-Ohmmeter you can carry in your shirt pocket!

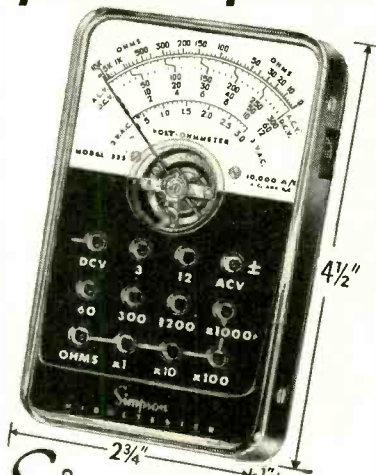

Simpson MIDGETESTER

SELF SHIELDED! MODEL 355

\$29.95
including probe leads

The world's first practical shirt-pocket volt-ohmmeter. Rugged and accurate. Not affected by any outside magnetic influences. 10,000 Ohms per volt AC and DC! Fourteen ranges: 5 for AC voltages, 5 for DC voltages, and 4 for DC resistances.

See your Parts Distributor

Simpson ELECTRIC COMPANY
WORLD'S LARGEST MANUFACTURER OF ELECTRONIC TEST EQUIPMENT

5203 W. Kinzie St., Chicago 44, Ill.
ESTebrook 9-1121

IN CANADA: Bach-Simpson, Ltd., London, Ontario

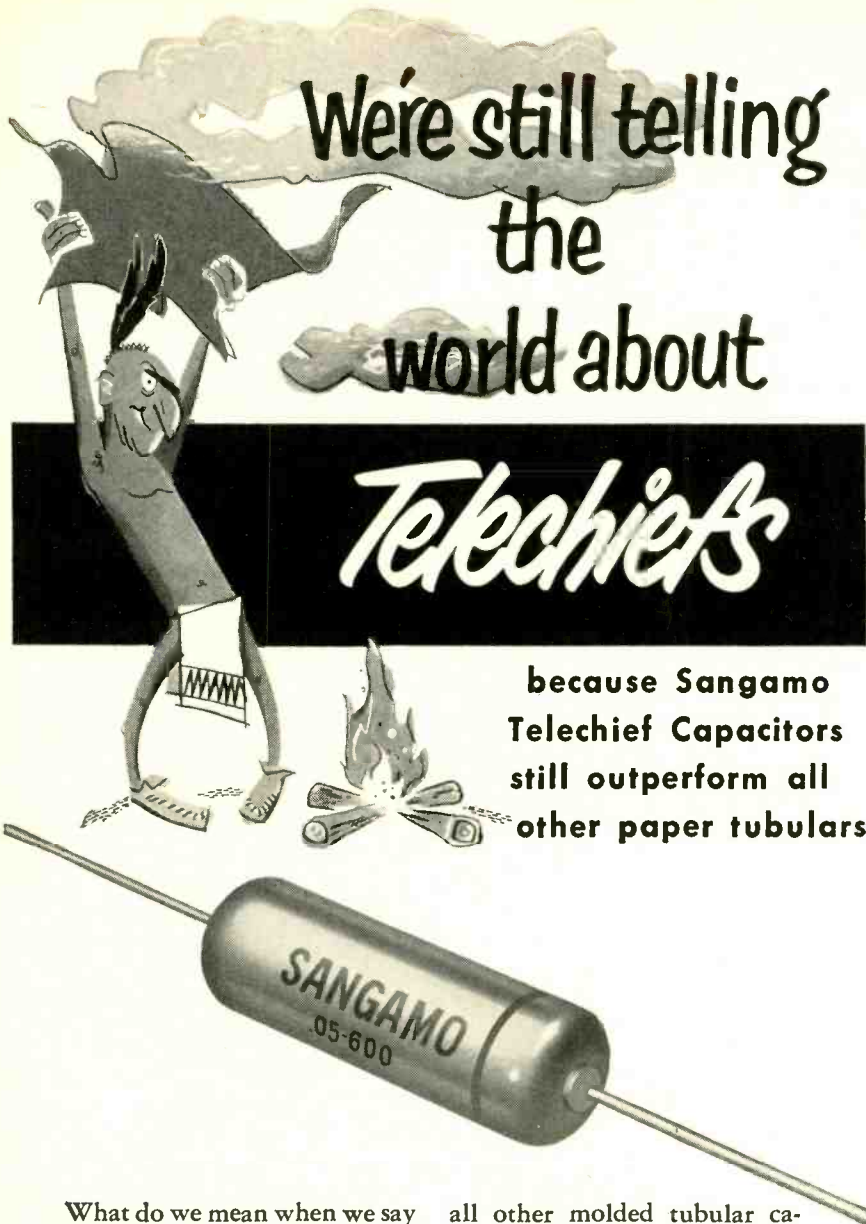

We're still telling
the
world about

Telechiefs

because Sangamo
Telechief Capacitors
still outperform all
other paper tubulars

What do we mean when we say Sangamo Telechief Capacitors outperform all other molded paper tubulars?

Simply this: When it comes to moisture resistance... optimum operation in high temperatures... when it comes to holding rated capacity under all conditions, the Sangamo Telechief wins hands down.

Tests by major manufacturers and branches of the Armed Services—not our tests—have proven that Telechiefs outlive

all other molded tubular capacitors... that they have a final insulation resistance 10 to 15 times greater than any other paper tubular because they're molded in HUMIDITITE... the remarkable plastic molding compound developed by Sangamo.

HERE IS TRULY EXTRA VALUE AT NO EXTRA COST! Best of all, Telechief, the biggest value in molded paper tubulars, is available to you at the price of an ordinary capacitor.

SC55-9



SANGAMO ELECTRIC COMPANY
MARION, ILLINOIS

Patents

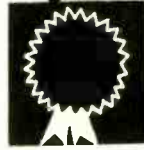

RADIATION METER

Patent No. 2,696,563

John H. Coleman, Palm Beach, Fla.
(Assigned to Radiation Research Corp.,
W. Palm Beach, Fla.)

An electron-ray indicator (see diagram) is used here to measure radiation. It can be used with ionization chambers, Geiger counters, or

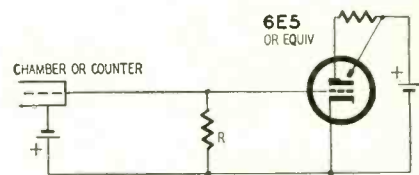

any device in which a variation in ionization or radiation may be caused to produce a voltage change across a load.

The chamber or counter shown in the figure is exposed to radiation and the indicator tube measures the voltage across R, which acts as the load resistor for the counter tube and grid leak for the electron-ray indicator, which measures the voltage across R. The shadow angle of the "eye" may be calibrated in terms of radiation rate (Roentgens per hour). If a capacitor is substituted for R, the eye measures the total dosage, since the charge on a capacitor is the integral (sum) of all current over a period of time.

SINGLE-GUN COLOR TUBE

Patent No. 2,692,532

Ernest O. Lawrence, Berkeley, Calif.
(Assigned to Chromatic TV Laboratories, Inc.)

Designed especially for any sequential method of color transmission, including dot, line or frame, this single-gun tube differs from a conventional tube—either black-and-white or color—in that it includes a secondary deflection assembly composed of grids G1, G2. See Fig. 1. Anodes A1, A2 accelerate and focus the electron beam. T is the target.

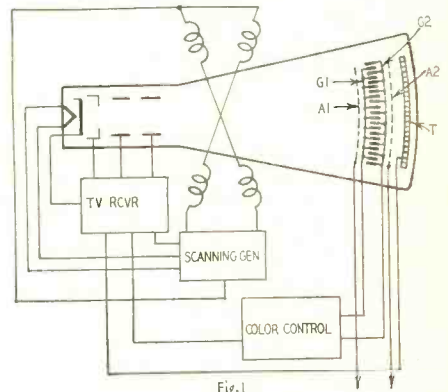

G1 and G2 form a structure in which a large number of alternate grids are connected together and fed from a color control circuit. Fig. 2 shows the grids in greater detail. Electrons passing between the grids are deflected by them. When G1, G2 are at the same potential, the particles move straight on and fall on areas G which are coated with green phosphor. If G1 is more positive than G2, the electrons are

deflected toward B, which is coated with blue phosphor. In the same way, a higher potential on G2 than on G1 deflects the beam toward R, containing red phosphor. Thus the signal at G1, G2 determines the color at the moment.

If a frame-sequential system were used, a square-wave signal would be fed to the grids. The voltage would be positive during one frame, zero during the next and negative for the third. Thus successive frames would be seen as blue, green and red images, in synchronization with color pickup at the transmitting end.

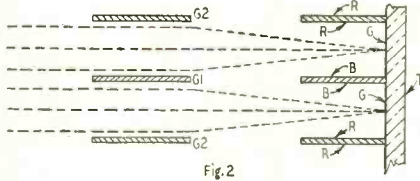

Fig.2

The tube may be used with present-day simultaneous color TV, but a special control signal is needed to energize G1 and G2 in proper sequence. One method is to spin the electron beam during deflection so that the three colors alternate rapidly and continuously.

ORGAN SWELL CONTROL

Patent No. 2,695,386

Francis M. Schmidt, N. Tonawanda, N. Y.
(Assigned to Rudolph Wurlitzer Co.)

Musicians know (and Fletcher-Munson curves show) that hearing sensitivity depends upon sound level. For example, when good music is reproduced at low levels, it seems lacking in bass. Therefore, when a radio, organ, or other instrument is played with volume down, its bass must be boosted. This patent deals with an organ swell control which compensates for deficiency of bass when the volume is turned down. It does not introduce noise typical of other volume controls.

Some convenient point in the organ's audio system (between two successive stages, for ex-

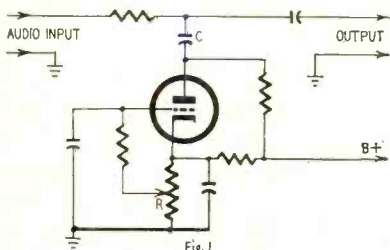

Fig.1

ample) is shunted by a tube network through C in Fig. 1. At low frequencies this capacitor has considerable reactance, so the tube resistance has less effect on the signal. For treble tones, the tube may be considered directly across the signal.

R is a volume control operated by the pedal clavier of the organ. It varies the bias of the tube and, therefore, its resistance. For loud volume, R's arm is moved to the grounded end and the tube is blocked or nearly so. There is no shunting of the audio. See curve B (Fig. 2).

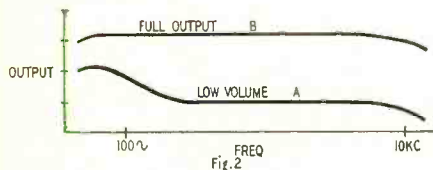
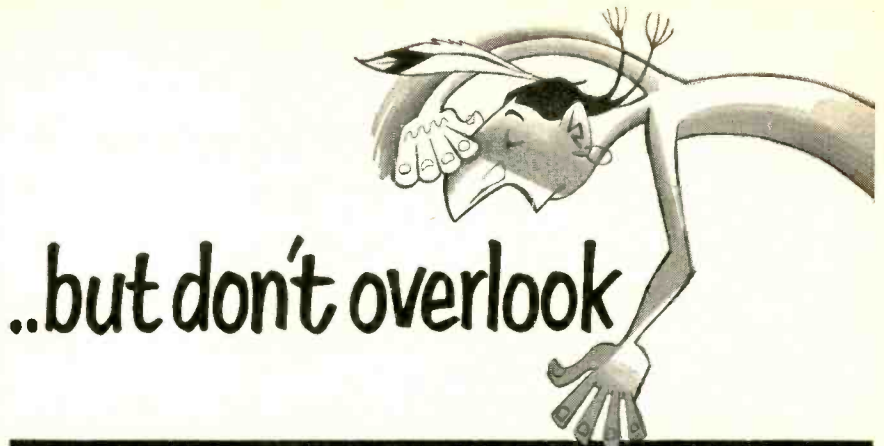

Fig.2

When volume is cut down, the arm approaches the cathode and bias decreases toward zero. Now the tube resistance is relatively low. Higher frequencies pass easily through C and are shunted to ground through the tube network to a great extent. Of course the bass is affected, but to a considerably lesser degree. See curve A.

A grid capacitor and resistor form a network to filter out noise originating in volume control R.



..but don't overlook

SANGAMO REPLACEMENT ELECTROLYTIC CAPACITORS



SANGAMO Type MT "Chieftains." Specially designed for television and other electronic applications where operation at 85° C is required... hermetically sealed in round aluminum containers... small size makes them good for mounting in limited space... they fit anywhere and can be mounted in almost any position.



SANGAMO Type PL "Warrior." These twist-tab electrolytics are used as original equipment by all major manufacturers... they are exact replacements... assure long life and dependable performance at 85° C and under conditions of high surge voltages and extreme ripple currents.



SANGAMO Type CS "Tomahawk." These electrolytic capacitors are contained in wax-filled cardboard tubes with insulated flexible leads approximately 8 inches in length extending from both ends of the unit. Each unit is supplied with a mounting strap to facilitate mounting to the chassis.

SC55-10

SANGAMO ELECTRIC COMPANY
MARION, ILLINOIS



No Motors! No Electricity!
ROTATES ELECTRONICALLY

360° Reception VHF-UHF Channels 2-83

Snyder Super-Directronic

Exclusive AX-524 design cuts costs to **\$24.95**

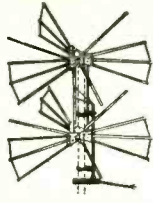

Powerful, 24 element 2 bay Directronic antenna is electronically beamed to any transmitter in fringe area by 6-position selector sw. No motors or electricity. Extremely high gain. COMPLETE WITH 6-POSITION DIRECTRONIC BEAM SELECTOR, 100' TUBULAR TRI-X CABLE, UNIVERSAL U CLAMPS. Order Model AX-524.

MORE Special Values on Antennas and Accessories

SNYDER Broad Band Vagis, for fringe or ultra fringe. Complete with U-clamps. RB-2-6 for Chls 2 thru 6. **\$9.95**
RB-7-13 for Chls. 7 thru 13. **\$4.95**
LEAD in, 300 ohm flat twin lead #20-55 mil. poly 2 1/2¢ per ft. \$1.95 per 100 ft. \$14.50 per 1,000 ft.
UNIVERSAL 3/16" Wood Screw-in, Stand Off Insulators only 3¢ each.
LIGHTNING Arrestor Bust UL approved. #1-A139¢ ea.

SWIVEL Mount base for 1 1/2" OD Mast 39¢ ea.
STRAP type 3/16" Stand Off Insulators for masts up to 2 1/2 inches9¢ each
SNAP-ON type 3/16" Stand Off Insulators for 1 1/2" OD Masts6¢ each
CHIMNEY Mount Brackets CM-100 . . . \$1.59
GUY Wire, 50 ft. coil, 6 stranded #20-.39¢
WALL MOUNTS
6", for masts 1-1 1/2 inches. #8306 \$1.55
12", for masts 1-1 3/4 inches. #8312 \$1.89
Special! 18", for masts up to 1 3/2". WB-2 \$2.95

DUD REJUVENATOR!

Save on TV reconditioning, increase service profits by rejuvenating 80% of all duds. The portable "C.R.T." removes shorts, repairs open circuits, reactivates cathode, etc. Restores emission. Performance guaranteed. **\$54.95** Complete

SYLVANIA 5XPA4 5" Universal Test Pic Tube
Handiest, safest, fastest all purpose test tube. Checks performance of ANY TV set, any size, make or model. 5" dia. **\$22.00**

Write for FREE FYI Bulletin 225

WHOLESALE RADIO PARTS CO., Inc.

311 W. Baltimore St. Baltimore 1, Md.

TELEVISION

Big demand for graduates

B.S. DEGREE IN 27 MONTHS in radio including TV engineering—VHF, UHF, AM and FM. Students use over \$100,000 worth of equipment including 2 large commercial type transmitters in new TV lab. Intense specialized course includes strong basis in mathematics, science and advanced design in radio and TV. Hundreds of young men each year are earning engineering degrees in this recognized institution. Start any quarter. Many earn a major part of expense in this industrial center. Low tuition. Competent instruction. Thorough, intense, practical program. Also **B.S. DEGREE IN 27 MO.** in Aeronautical, Chemical, Civil, Electrical and Mechanical Engineering. G.I. Gov't approved. Enter June, Sept., Dec., March. Free catalog. **ENROLL NOW.**

INDIANA TECHNICAL COLLEGE
1765 E. Washington Blvd., Fort Wayne 2, Indiana

TV SERVICING WITH PICTURE TUBE PATTERNS

A complete library of valuable troubleshooting methods and servicing information in one handy 50 page book. Fully illustrated!

- Troubleshooting
- Locating and Orienting the Antenna
- Television Alignment
- Waveform Analysis
- Troubleshooting Procedures
- And Other Subjects

Enclose 25¢ in coin (scotch taped to paper) together with your name and address and mail to:

CENTURY BOOKS
111 Roosevelt Avenue Mineola, N. Y.
LIMITED SUPPLY . . . 50 ORDER TODAY!



Watch For The July Issue Of Radio-Electronics ON SALE—JUNE 23rd

PATENTS (Continued)

IMPROVED 3-GUN KINESCOPE

Patent No. 2,690,518

Norman F. Fyler and William E. Rowe, Newburyport, Mass. (Assigned to Columbia Broadcasting System, Inc.)

The planar mask 3-gun kinescope is very difficult and expensive to manufacture. The shadow mask and phosphor-dot plate present many problems. These cannot be aligned after they are inside the tube, so they must be assembled as one unit beforehand. To assure correct alignment in any tube in which it might be placed, the assembly requires flat and parallel elements. Special construction is necessary, since the slightest warping or bending can produce serious color distortion. Also, as most color TV technicians know, the flat mask and plate present difficult problems of focusing and convergence.

This is the basic patent for the now familiar curved-mask type of color tube. The new kinescope described in it has many advantages over previous models. In constructing it, the glass tube is cut apart, leaving a screen portion and a conical section. Each of these is sealed to a protruding flange. The phosphor-dot trios are coated photographically directly on the faceplate, providing maximum light for viewing. Then the shadow mask (curved like the faceplate) is placed against the upper flange along its rim. There is provision for proper alignment of mask and dot plate. Finally, the two flanges are welded together to finish the tube.

With a curved mask and dot plate, there is no need for special or "dynamic" focusing and convergence. Adjustment made at any point of the screen holds over the entire face of the kinescope. There is no longer the problem of convergence as the electron beam sweeps over a varying radius.

MECHANICAL CONVERTER

Patent No. 2,695,357

Hugh L. Donley, Princeton, N. J. (Assigned to Radio Corp. of America)

This superhet converter operates on the piezoelectric principle. A piezoelectric element is driven to vibration by a signal voltage. A similar element is energized by a local electronic oscillator. The resulting beat gives a mechanical vibration at an i.f. rate. Another piezoelectric element converts the vibration back to an electric voltage at the intermediate frequency. In this mechanical system, the Q is very high so excellent selectivity can be obtained. Another advantage, of course, is that no tubes are required.

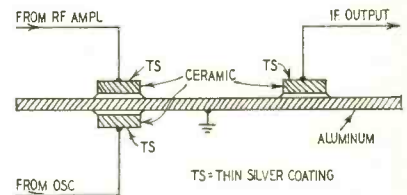

An elementary converter is shown in the diagram. Signal and oscillator voltages are fed into separate piezoelectric capacitors at the left. The ceramic piezoelectric may be barium titanate or similar material which has a high dielectric constant and a nonlinear response. A beat vibration is set up in an aluminum bar, 1 wavelength long. For an i.f. of 50 kc, this is only 4 inches, and for higher frequencies would be less.

Vibrations transmitted along the bar are picked up by the ceramic capacitor on the right. Here the vibrations are converted back to an i.f. voltage which feeds the intermediate frequency amplifier.

The inventor states that higher efficiency is obtained when a harmonic of the oscillator is used rather than its fundamental. Output can also be increased by connecting a bias battery across each ceramic capacitor.

In a typical converter, the oscillator frequency was 101.5 kc. Its second harmonic (203 kc) was heterodyned against a 153-kc signal to produce the desired 50-kc intermediate frequency. Making use of a mechanical beat frequency, this converter is an extremely rugged device.

TUBE LOCATIONS PLUS ALL THESE FEATURES:

TV FIELD SERVICE MANUAL WITH TUBE LOCATIONS, VOLUME 4

A complete TV tube location handbook . . . plus all these other valuable features: for each model, a table of more than 30 trouble symptoms, showing tubes to check, parts to check, adjustments to make (field and shop) on horizontal oscillators, tuner oscillators, AGC controls, picture tubes! Explanations of 40 most-commonly-found troubles, with picture tube patterns to illustrate each one! Drawings of front and rear preset controls and tuner dial stringing, tube complement, key voltages, series filament wiring, 7 years (starting with 1947) of TV receiver production in each volume! Special bonus: each volume is spiral bound—open the book and it stays open for easier use.

VOLUME 4 (just published) covers: GE, Hallicrafters, Hoffman; cat. #155-4; only \$2.40

VOLUME 3 covers: Emerson, Fada; cat. #155-3; only \$2.10

VOLUME 2 covers: Bendix, Capehart, CBS-Columbia, Crosley, DuMont; cat. #155-2; only \$2.40

VOLUME 1 covers: Admiral, Affiliated Retailers (Artone), Airmec (AMC), Air King, Air Marshall, Allied Purchasing, Andrea, Arvin, Automatic; cat. #155; only \$2.10

DOES YOUR TROUBLE-SHOOTING FOR YOU!

PICTURE BOOK OF TV TROUBLES, VOL. 3 (Video I-F & Video Amplifier Circuits)

Here's the only book ever devoted exclusively to Video I-F and Video Amplifier circuits! Rider's expert lab staff tells you about sixty different troubles found in these circuits—all based on actual troubleshooting done right in the Rider lab! To describe these troubles, they show you 72 "faulty" picture tube pattern illustrations—and right next to each one, you see the "abnormal" waveforms they got while checking key points . . . the same waveforms you'd see on your scope screen if you'd done the checking! And here's a very special feature: the last 5 pages of the book form a handy pull-out section that shows you exactly what the RIGHT waveform should look like! It takes just seconds to compare any "abnormal" waveform in the book with its "normal" version shown on this pull-out. There's no theory—no "maybes" . . . this series tells and shows you how to diagnose TV receiver troubles by picture and waveform observation—how to do that servicing job faster, better, easier! Order today!

VOLUME 3 (just published) Video I-F & Video Amplifier Circuits; cat. #168-3; paper bound; only \$1.80

VOLUME 2 (Vertical Sweep-Deflection Circuits) cat. #168-2; paper bound; only \$1.80

VOLUME 1 (Horizontal AFC-Oscillator Circuits) cat. #168; paper bound; only \$1.35

ORDER TODAY! Rider books are sold by parts jobbers and book stores throughout the country. If YOUR dealer doesn't have these books, mail this coupon to us!

JOHN F. RIDER PUBLISHER, INC., 480 CANAL STREET, N. Y. C.

Enclosed is \$..... Send books checked:

TV FIELD SERVICE MANUALS
 VOL. 1 VOL. 2 VOL. 3 VOL. 4

PICTURE BOOKS VOL. 1 VOL. 2 VOL. 3

Name

Address

City & State

HIGH-FREQUENCY TRANSISTOR

Patent No. 2,695,930

Robert L. Wallace, Jr., Plainfield, N.J.
(Assigned to Bell Telephone Labs., Inc.)

The frequency response of present-day junction transistors is limited generally to the broadcast band or slightly above. This patent indicates methods for increasing the range as much as 15 to 1. For example, junction oscillators have been designed for reliable operation above 50 mc, and experimental ones have operated at far higher frequencies.

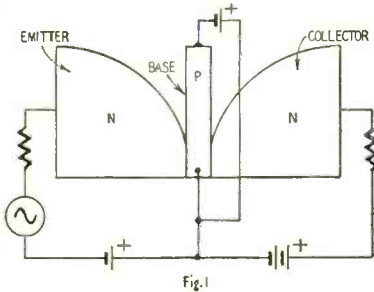

The frequency-limiting factors of a junction are capacitance between elements, transit-time effects and base resistance. All can be greatly reduced by a chemical process which etches or dissolves active material at the junctions. Fig. 1 shows a treated n-p-n crystal. Note how little junction area remains. In many cases each area is decreased to 0.1 sq mm or less.

Effective junction area can also be lowered by adding a second base connection as shown. A current is passed from base to base, biasing the upper end negative. Electrons from the emitter (at left) tend to drift into more positive regions. This limits the flow to the very lowest portion of each junction. In effect, this means a still further reduction of each of the junction areas. This is the famous "tetrode transistor" also an invention of Dr. Wallace, the holder of this patent.

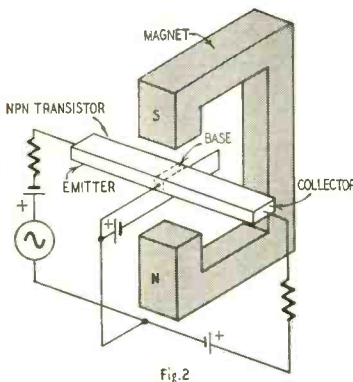

Fig. 2 shows a third method of increasing high-frequency response. A magnet (N-S) is positioned near the base of the transistor. By the "motor law," electrons moving at right angles to the field are deflected perpendicularly both to the field and the direction of their motion. Thus, the charges moving in the base are deflected in the direction of the collector.

Ordinarily, electrons coming from the emitter are diffused into the base from different directions. If they can be made to travel directly from emitter to collector (rather than through some roundabout path), transit time is shortened and the frequency range extended. This is accomplished by the magnet.

Any tendency to move in an undesired direction is eliminated by the "motor law" described above.

This invention provides a transistor which is a structural compromise between the junction and point-contact units. It retains the desirable characteristics of the junction transistors while substituting the lower base resistance and shorter transit time of the point-contact transistor. This is attained by a great decrease in the cross-sectional area of the emitter or collector junctions. END

RAVE NOTICES!

It's the talk of the television industry—the way the new Teletest Flyback Tester rates the immediate and unanimous endorsement of the experts! For example, Teletest Flyback Tester is a top news story in the March 1955 issue of RADIO-ELECTRONICS magazine!

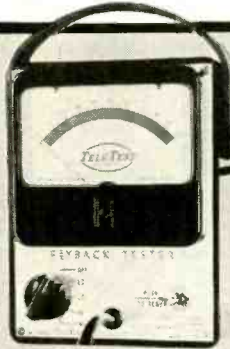

FLYBACK TESTER!

the only flyback tester that's 100% accurate

- the tester that needs no reference flyback!
- tests flyback under full operating voltage!
- tests for even a single shorted turn!
- does not require calibration!

\$44.95

See your jobber or write Teletest for reprints of article and information.

**31-01 Linden Place
Flushing, New York**

TELETEST
INSTRUMENT CORP.

WANT POWER & VERSATILITY?

FOLLOW THE LEADER...



KIT \$29.95

Wired \$38.95

6V & 12V BATTERY ELIMINATOR & CHARGER #1050

- operates 6V and 12V auto radios for servicing and sales demonstration.
- charges 6V and 12V storage and Edison Batteries.
- operates mobile and marine receivers, transmitters, boat lights, electric trains, projection and other equipment.

SPECIFICATIONS

- 6-Volt range: 0-8V (up to 20 Amp.)
- 12-Volt range: 0-16V (up to 10 Amp.)
- variac-type transformer for continuously variable voltage adjustment.
- reads volts and amperes at same time on 2 separate meters.
- Transformer primary and secondary fully protected.

In stock at local jobbers throughout the world. Write for free Catalog CB-6
Prices 5% higher on West Coast



84 Withers Street
Brooklyn 11, N. Y.



It's got the Rotor Industry in a spin!

RMS ROTOR QUEEN

only **19.95** list

(all the quality features of high priced rotors... and more).

Radio Mds Sls, Inc. N. Y. 62

Liberal trade Discounts!

ARKAY KITS

WORLD'S FINEST

RADIOS PHONOGRAPHS TV TEST EQUIPMENT HI-FI

Write for FREE Brochure

RADIO KITS, INC. • 120 Cedar St., N. Y. 6

RADAR

Our school is now introducing a correspondence course in Radar, Microwaves, and Loran. Get your FCC endorsement, high paying job in industry as a radar technician. Special introductory offer. Write

PROGRESSIVE ELECTRONICS INSTITUTE
P.O. Box 543 Akron 9, Ohio

NOT 40% . . . NOT 50% . . . NOT 60% but . . .
SAVE 70%, 80% and 90% OFF LIST PRICES!

**STANDARD BRANDS
 and NATIONAL BRANDS**

All tubes individually boxed. We also carry a full line of all special purpose tubes. Send us your requirements.

FREE

with each S 2 S or more order. 5-Pc. Sylvania



Repair Kit. Value \$4.95. Includes: flashlight head, Philips screwdriver, flat head screwdriver, alignment tool and polystyrene case.

19¢ SPECIALS!
 For Limited Time Only

1A4P	1H4	2A4	1619
1E7GT	7E5	26	39 44
1F4	10V	27	9004
1G6	12Z3	954	9006

FREE with every order . . . regardless of size! Here it is—free to everyone—a combination kit of resistors, condensers, volume control and line cords—retail value \$2.95. (May be purchased separately, if desired.)

Send for our parts and tube catalogue. Terms to rated firms.

SEND FOR COMPLETE TUBE LISTING

TERMS: 25% deposit required on all orders, balance COD. Orders under \$5.00, 50c service charge. Postage paid in USA on all orders accompanied by full remittance. All unused money refunded with order.

Our tubes come from such surplus sources as gov't agencies, receiver mfgs., etc. Most are new, balance from gov't and other equipment. ALL TUBES RTMA GUARANTEED FOR ONE YEAR!

OA2	.70	3B7	.57	6B16	.49	6W4GT	.40	14Q7	.52
OA4G	.60	3D6	.45	6B15	.70	6W6GT	.56	19B6G6.1	1.18
OB2	.70	3LF4	.66	6B17A	.78	6X4	.35	19J6	.66
OC3	.90	3Q4	.48	6B18	.59	6X5GT	.35	19T8	.70
OD3	.90	3Q5GT	.59	6B17GT	.77	6Y6G	.57	25A7GT.1.50	
OZ4	.45	354	.48	6B07A	.80	6X8	.75	25AV5GT.80	
1A7GT	.45	3V4	.58	6B27	.90	7A4-XXL	.47	25B0GT.80	
1B3GT	.68	5R4GY	.75	6BY5G	.60	7A5	.55	25L6GT.48	
1C5GT	.43	5T4	.70	6C4	.39	7A6	.47	25Y5	.45
1D5GP	.45	5U4G	.44	6C5	.36	7A7	.45	25Z5	.38
1H5GT	.49	5V4	.60	6C8E	.51	7A8	.46	25Z6GT.38	
1J6GT	.49	5X4G	.44	6C06G	1.18	7B5	.41	32L7GT.60	
1L4	.43	5Y3GT	.32	6E5	.46	7B7	.43	35A5	.48
1L6	.59	5Y4G	.37	6F5GT	.39	7B8	.47	35B5	.52
1LA4	.59	5Z3	.42	6F6	.40	7C4	.40	35C5	.51
1LA6	.49	5Z4	.54	6G6G	.42	7C5	.44	35L6GT.48	
1LB4	.59	6A7	.59	6H6GT	.40	7C6	.45	35W4	.35
1LC6	.49	6A8	.59	6J4	2.00	7F8	.70	35Y4	.35
1LD5	.59	6AB4	.44	6J5GT	.40	7Y4	.35	35Z3	.41
1LE3	.59	6AF4	.80	6J6	.49	12A6	.40	50L6GT.45	
1LG5	.59	6AG5	.51	6J7	.45	12AT6	.42	45Z5GT.40	
1LH4	.66	6AH6	.70	6J8G	.90	12AT7	.68	50A5	.48
1LN5	.49	6AJ5	.70	6K6GT	.39	12AU6	.43	50B5	.52
1NSGT	.51	6AK5	.55	6K7	.40	12AV7	.68	50C5	.51
1PSGT	.50	6AL5	.40	6K8	.67	12AV6	.37	50L6GT.45	
1R4	.66	6AL7GT	.70	6L7	.44	12AX7	.60	70L7GT.60	
1R5	.57	6AQ5	.48	6N7	.61	12AY7	.90	75	.44
1S4	.53	6AS5	.50	6O7	.45	12BA6	.48	77	.39
1S5	.52	6AS6	1.75	6R7	.49	12B4	.70	78	.39
1T4	.58	6AS7G	2.25	6S4	.41	12BE6	.50	80	.35
1T5GT	.58	6AT6	.40	6S7G	.47	12BH7	.61	83V	.60
1U4	.49	6AU5GT	.60	6S7GT	.48	12BV7	.68	117L7GT	1.10
1U5	.50	6AU6	.43	6SC7	.50	12J5GT.40		117N7GT	1.10
1V	.43	6AV5GT	.75	6S7	.43	12K8	.49	117P7GT	1.10
1X2A	.63	6AV6	.40	6SH7	.45	12SA7	.48	117Z3	.37
2A5	.59	6AX5GT	.59	6SJ7GT	.45	12SH7	.47	117Z6GT.65	
2A7	.23	6B4G	.54	6SK7	.48	12S1GT.45		2050	1.25
2B7	.89	6B8	.70	6SL7GT	.57	12SK7	.48	2051	1.25
2D21	1.00	6B8C	.49	6SN7GT	.57	12SL7GT	.59	9001	1.50
2V3G	.80	6BC5	.49	6SQ7GT	.43	12SN7GT	.57		
2X2A	1.00	6BE6	.50	6SR7GT	.43	12SQ7GT.40			
3A4	.53	6BF5	.41	6S7	.43	14A5	.59		
		6BG6G	1.18	6T7G	.63	14A7	.45		
		6BH6	.51	6V6GT	.48	14B6	.40		

Same day service. All tubes RTMA guaranteed for one full year

Stanley ELECTRONICS CORP.

935 MAIN AVENUE - PASSAIC, N. J.

Dept. RE-6

GRegory 1-2498



A.C.-D.C. PHONO MOTOR

My phonograph turntable is a military surplus type with a 115-volt a.c.-d.c. Green Flyer motor. When I substituted a Pickering cartridge for a crystal type, the hum level increased considerably because the a.c. field around the motor was inducing hum voltages in the coils in the pickup.

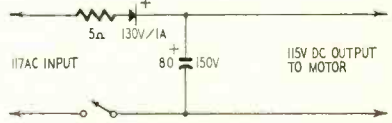

The trouble could not be eliminated with magnetic shielding. I finally solved the problem by using a small d.c. supply for the motor. The circuit of the supply is shown. When this supply is in use, the motor's voltage selector switch must be set for d.c.—*J. V. Cavaseno*

MUTING CHANGER SWITCH

I found that my RC-80 Garrard and several other record changers produce a loud and annoying thump in the speaker when the automatic stop switch opens after the last record has played. This can be eliminated by shunting a .05-μf capacitor across the switch terminals.—*Eduardo Maass*

BRIGHTER PILOT LIGHTS

It is well known that a well-finished cabinet and a bright pilot light have sold many sets. A bright pilot light can also help to sell a repair job. Many of the older sets have either a ballast tube or a series-dropping resistor with

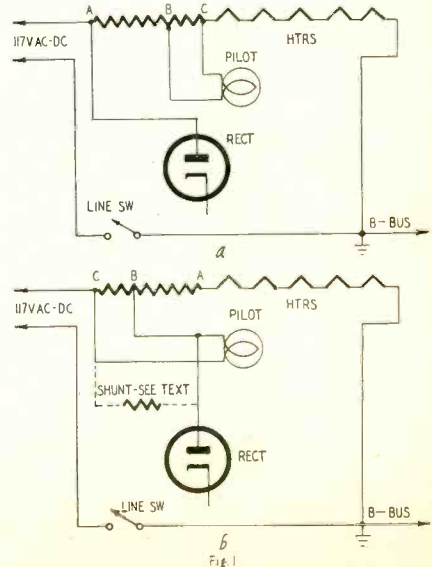

AUDELS TV-RADIO SERVICE LIBRARY

HERE IS LATE INFORMATION IN A HANDY FORM FOR RADIO AND TELEVISION REPAIRMEN, SERVICEMEN AND STUDENTS

2 VOLS. \$6 COMPLETE \$1 MO. PAY ONLY

AUDELS T.V.-RADIO SERVICE LIBRARY—Highly Endorsed—1001 Facts—Over 1552 Pages—625 Illustrations, Diagrams of Parts. Presents Important Subjects of Modern Radio, Television, Industrial Electronics, F.M., Public Address Systems, Auto, Marine & Aircraft Radio, Phonograph Pick-Ups, etc.

IT PAYS TO KNOW!
 The Basic Principles—Construction—Installation—Operation—Repairs—Trouble Shooting. Shows How to get Sharp, Clear T.V. Pictures. Install Aerials—How to Test. Explains Color Systems, Methods of Conversion, Terms, etc. Includes Ultra High Frequency (U.H.F.)—Valuable for Quick Ready Reference & Home Study. Tells How to Solve T.V. & Radio Troubles—Answers Your Questions.

Get this Information for Yourself. 7 DAY TEST—ASK TO SEE IT!

MAIL ORDER

AUDELS Publishers, 49 W. 23 St., N.Y. 10, N.Y. Mail AUDELS T.V. RADIO SERVICE LIBRARY 2 Vols. \$6 on 7 days free trial. If O. K. I will remit \$1 in 7 days and \$1 monthly until \$6 is paid. Otherwise I will return them.

Name _____
 Address _____
 Occupation _____
 Employed by _____ RE

Build your own PRE-AMPLIFIER!



Mail coupon below for free article "Pre-Amp with Presence" by C. G. McProud, Audio Magazine—together with other pre-amplifier circuits featuring the outstanding

Genalex Z729

lowest hum, lowest noise, high-gain input Pentode on the market.

About the Z729...

- Total hum voltage infinitesimal... actually less than 1.5 microvolts.
- Expressly designed for use as first stage of high gain amplifier or tape recorder.
- Internal shield completely surrounds tube elements.
- Fits standard 9 pin miniature socket.



Quality Endorsed Product of the British Industries Group.

British Industries Corp., Dept. RT-6 164 Duane St., New York 13, N. Y.

Please send Circuit Design and literature on the Z729

Name _____
 Address _____
 City _____ Zone _____ State _____

TRY THIS ONE

(Continued)

a tap for the pilot light. When first turned on the light is very bright, but after warming up the light output is low. This can be changed with a few minutes' work on the service bench.

Fig. 1-a shows the general type of series-dropping network, with 4.5 to 5.5 volts across the light bulb after the tubes are warmed up. By simply reversing the resistor connections as in Fig. 1-b and then connecting the plate of the rectifier tube to the tap for the pilot light, the circuit operation becomes essentially the same as if a 35Z5 or similar tube were used. The parallel section of resistor for the pilot light may have to be shunted in some sets.

To determine the shunt resistor value make all connections and measure the voltage across the pilot lamp after operating the set for a few minutes. The voltage across the bulb should be 5.9 to 6.1 (115-volt line) when the set is fully warmed up. If the voltage is higher, shunt the lamp with a 150-ohm resistor and measure the voltage. The exact value of resistance will be determined by the rectifier plate current and the parallel resistance of the series voltage-dropping resistor; 100 to 150 ohms is the average resistance needed.

If the set has a surge resistor in series with the rectifier plate, remove it. The pilot light and dropping resistor now perform the same function.—*L. H. Trent*

AN TYPE CONNECTORS

When soldering leads to AN type or similar connectors with solder-cup connections, it is best to connect first to terminals at the bottom of the connector when the index groove or land is toward the top and the solder cup curved upward. This is because solder and heat

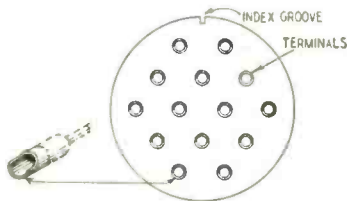

from the iron must be applied to these terminals from the top and this is difficult when there are already wires above the terminal. Also, these wires may be damaged. The diagram shows layout of a typical connector.—*Charles Erwin Cohn*

CHEMICAL DISPENSER

Empty lighter fluid cans with the new switch spout nozzle (Ronson) make handy dispensers for carbon tet, oils and other radio chemicals that may be purchased in bulk.

Simply drill a small hole in the center bottom of the can. Place the can in a shallow pan of the liquid and alternately squeeze and release the sides of the can. When it is full, seal the hole with 40/60 solder. Use as little heat as possible to prevent evaporation.—*G. P. Oberto*



free!

New STANCOR Auto Radio Transformer Replacement Guide, the most complete ever published. This valuable book lists accurate replacement data for over 540 car radios, built or used by over 40 manufacturers. Both vibrator powers and audio outputs are included. It's available FREE from your CHICAGO STANDARD distributor.

REPAIR AUTO RADIOS quickly, easily with STANCOR EXACT REPLACEMENT AUTO VIBRATOR TRANSFORMERS

You can increase your auto radio repair profits by reducing installation time with STANCOR exact replacement vibrator transformers. Like STANCOR flybacks, STANCOR auto vibrator transformers are faithful duplicates of the originals they are designed to replace.

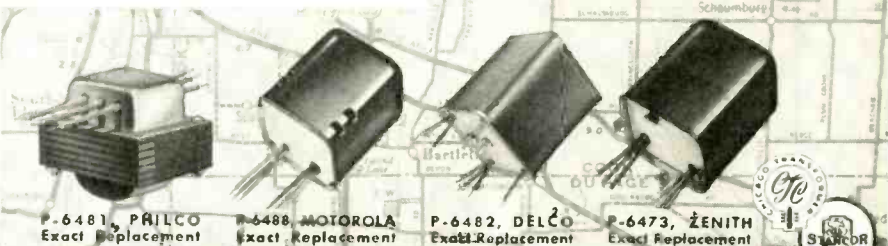

CHICAGO STANDARD TRANSFORMER CORPORATION

3592 ELSTON AVENUE

CHICAGO 18, ILLINOIS

Export Sales: Roburn Agencies, Inc., 431 Greenwich St., New York 33, N.Y.

NEW! For the First Time!

CHECK CAPACITORS UNDER WORKING CONDITIONS!

CAPACITEST

Quickly, Accurately checks:

- PAPER, MICA, CERAMIC CAPACITORS
- ELECTROLYTICS
- CONTINUITY
- AC/DC VOLTAGES
- FLASHBULBS



SATISFACTION GUARANTEED OR RETURN WITHIN TEN DAYS FOR REFUND

\$9.95 postpaid. Dir. Net complete, ready for operation.

NOT A KIT

FREE Special Introductory Offer for limited time only: Set of test leads Free with each CAPACITEST. Order direct from manufacturer — include \$3 deposit with C.O.D.'s. Save PP & COD fees, send \$9.95 & we'll pay postage.

CAPACITEST, the result of months of development, is a new, compact checker that does a giant job to save you time and money. It will check condensers at 150 Volts, which is approximately the working voltage in a radio or TV set. Meters will not give this type of check since the applied voltage is 20 Volts or less. Avoid call-backs by using CAPACITEST. Accurately, quickly, it shows open, shorted, or intermittent capacitors and leaky electrolytics. Compact: 4"x4"x2"—lightweight, for bench or tool kit.

BAR JAY The Barjay Co. 145 West 40 Street New York 18, N.Y.

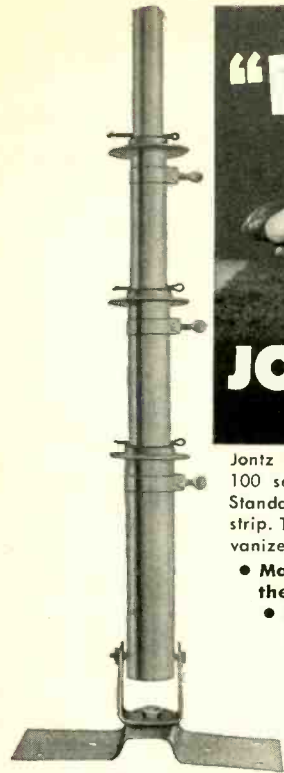

JONTZ Kwick-Up Telescoping Masts

Jontz Kwick-up telescoping masts are available in 3 lines: The De Luxe 100 series, made from hot-dipped galvanized 16 gauge tubing. The Standard 200 series, made of 16 gauge tubing rolled from galvanized strip. The Standard 300 series made of 18 gauge tubing rolled from galvanized strip with 1 1/4", 16 gauge top.

- Mast sections will not pull apart with the exception of the top section which enables easier antenna mounting.
- New type locking device for faster erection and locking without tools.
- Revolutionary new guy ring eliminates all strain, tension, and friction on the next section to be erected.
- Newly designed companion base assures definite locking, will not turn in the wind.

Sell the Line that is "Really Built" to do the job Available at better jobbers everywhere



JONTZ MANUFACTURING CO.

1101 East McKinley, Mishawaka, Indiana

IN CANADA: Active Radio & TV Distributors
60 Spadina Ave • Toronto, Canada

TRY THIS ONE

(Continued)

CONVERTER PROTECTOR

The average self-contained u.h.f. TV converter has five leads attached to its back: u.h.f. lead-in, v.h.f. lead-in, signal-output lead, TV power cord and power cord to the converter. All these, tied onto the back of a small converter, leave it perched in a hazardous position near the edge of a TV top. It is easy for the housewife or a technician to dislodge and drop the converter when moving the set away from the wall for cleaning or servicing.

When installing a converter, protect it against damaging falls simply by running its power cord around one of the back-panel screws as shown in the

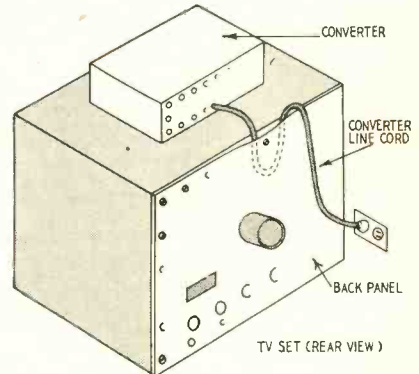

drawing. The cord is thus held tightly between the TV cabinet and back panel so that the converter cannot fall to the floor if it is knocked or dragged off the TV cabinet. Boosters, lamps, clocks, phono preamps and similar accessories can be protected in the same manner.

Doing this may not only save you some grief on future service calls on that particular set, but your thoughtfulness will be appreciated by the housewife if you point out to her how you have tried to prevent an accident and protect her investment.

In doing this it will be necessary to observe the usual precautions with regard to bending and pinching the power-line cord. On most television receivers there is sufficient play in the back panel so as not to create excessive pressure against the power cord, and still keep the panel fairly tight.—L. H. Wilson

SAVING BANDSWITCHES

Bandswitches in communications, shortwave and AM-FM receivers and test oscillators may fail prematurely or become erratic or noisy due to arcing when a B plus circuit is broken momentarily while changing bands. Communications receivers have a standby switch that breaks the plate supply circuit. Open it before changing bands and you will increase the life of the bandswitch.

A simple toggle switch can be added to sets and test oscillators that do not have one for standby operation. It is far less expensive and much easier to replace than the bandswitch, and will pay for itself by insuring troublefree operation and long life.—Samuel H. Beverage

END

"This bulb indicates gold.
This one lights up for Uranium
— and this one spots
JENSEN NEEDLES."

NEW! ATLAS CJ-30 COBRA-JECTOR INDESTRUCTIBLE FIBER-GLASS ALL WEATHER WIDE ANGLE DISPERSION

List \$40.00
NET \$24.00
Complete with Driver.

Weatherproof
Line Matching
Transformer
as shown,
Net \$5.10.

New versatile all-purpose projector—excellent for paging & talk-back, intercom, marine, and industrial voice & music systems. Penetrating articulation assures wide angle intelligible coverage even under adverse sound conditions. "ALNICO-V-PLUS" magnetic assembly. Double-sealed against all weather. Omni-directional mounting bracket. Quick, easy installation. An amazing "power package"—Specify the CJ-30 for the "tough" jobs!

Input Power (continuous).....15 watts
Input Impedance.....8 ohms
Response250-9000 cps
Dispersion120° x 60°
Dimensions:Opening, 14" x 6"
Overall Length, 14"



WRITE FOR COMPLETE CATALOG
ATLAS SOUND CORP.
1443—39 St., Bklyn. 18, N.
In Canada:
Atlas Radio Corp., Ltd., Toronto, Ont.

OPPORTUNITY ADLETS

Rates—45c per word (including name, address and initials). Minimum ad 10 words. Cash must accompany all ads except those placed by accredited agencies. Discount, 10% for 12 consecutive issues. Misleading or objectionable ads not accepted. Copy for Aug. issue must reach us before June 15, 1955.

Radio-Electronics

25 W. Broadway, New York 7, N. Y.

HIGH-FIDELITY SPEAKERS REPAIRED. Amprite Speaker Service, 70 Vesey St., New York 7, N.Y.

WANTED: Used Hallcraft S47. All wave receiver. J. W. Bailey, 3528 Campbell Ave., Lynchburg, Va.

"Buy Surplus Radio. Electronic Equipment direct from Government. List \$1.00. Box 169AK, East Htrd 8, Conn."

SPEAKER RECONING: Guaranteed workmanship. C&M Recone Co., 255 Tioga St., Trenton 9, N.J.

TUBES—70% to 90% DISCOUNT. Government, manufacturers, jobbers, etc. surplus. Guaranteed 1 year. Free catalog on request. Cadillac Trading, Dept. AA, 231-07 Linden Blvd., Jamaica 11, N.Y.

GEIGER COUNTER KITS \$34.50. Geiger Counter & Scintillator Diagrams Catalog Free. R. F. Chambers, 13833 San Antonio Dr., Norwalk, Calif.

DIAGRAMS FOR REPAIRING RADIOS \$1.00. Television \$2.00. Give Make, Model, Diagram Service, Box 672-RE, Hartford 1, Conn.

TAPE RECORDERS, Tapes, Accessories. Unusual values. Dressner, Box 66S, Peter Stuyvesant Station, New York 9.

USED CORRESPONDENCE COURSES. Books, Bought, Sold. Catalog Free. Educational Exchange, Summerville, Ga.

TUBES—TV, RADIO, TRANSMITTING, AND SPECIAL PURPOSE TYPES BOUGHT, SOLD AND EXCHANGED. Send details to B. N. Geisler W2LNI, 512 Broadway, N.Y. 12, N.Y.

ALL MAKES OF ELECTRICAL INSTRUMENTS AND TESTING equipment repaired. Write for free catalogue on new and used instruments at a savings. Hazelen Instrument Co., 128 Liberty Street, New York, N. Y.

TV SETS \$15.95. Tubes 20c. Jones, 1115 Rambler, Pottstown, Pa.

WANTED: AN/APR-4, other "APR.", "TS.", "TE.", "ARC-1, ARC-3, ART-13, BC-348, etc. Microwave Equipment. Everything Surplus, Special tubes. Tee Manuals, Lab Quality Equipment, Meters, Fast Action, Fair Treatment. Top Dollar! Littell, Fairhills Box 26, Dayton 9, Ohio.

MATHEMATICS SERVICE, problems, calculations. Electronics, mathematics. Reasonable rates. Mathematics Service, Box 6671, Orlando, Florida.

SPEAKER RECONING, low prices. Michigan Speaker Reconing Service, 930 Metropolis, Marine City, Michigan.

DIAGRAMS: Professional Model Timers, Counters, Intercom Organs, etc. \$1.00 each. List free. Parks, 101 S.E. 57th, Portland 15, Oregon.

PHONOGRAPH RECORDS 20c. Catalogue. Paramount, R-313 East Market, Wilkes-Barre, Penna.

USED BOOSTERS: 20-odd used boosters of various makes for sale to one buyer at \$10 apiece; all in working order, some only slightly used. Pocono TV Relay, Inc., 155 Broad St., Stroudsburg, Pa.

ALUMINUM TUBING, Angle and Channel. Plain and Perforated Sheet. Willard Radcliff, Fostoria, Ohio.

POWER TRANSFORMERS REBUILT—all makes. TV-Radio or Special. Red Arrow Radio, 924 Metropolis, Marine City, Michigan.

25-50% DISCOUNT, guaranteed. Factory Fresh LP records; 69c and up; pre-recorded tapes. Send 20c for catalogue. SOUTHWEST RECORDS, 4710 Caroline, Houston 4, Texas.

FOR SALE: TELEVISIONS, repairable from \$10, also working. W4APL, 1420 South Randolph, Arlington 4, Virginia.

16" HI FI ELECTRICAL Transcriptions Catalog 10c. Transcriptions, 166 Barkley, Clifton, N.J.

TV FM ANTENNAS, ALL TYPES INCLUDING UHF. Mounts, accessories. Lowest prices. Wholesale Supply Co., Lunenburg 2, Mass.

\$3.00

FOR CARTOON IDEAS

RADIO-ELECTRONICS prints several radio cartoons every month. Readers are invited to contribute humorous radio ideas which can be used in cartoon form. It is not necessary that you draw a sketch, unless you wish.

Address

**RADIO-CARTOONS,
RADIO-ELECTRONICS**

25 West Broadway, New York 7, N.Y.

NEW KITS BY precise

NOW YOU CAN CHECK TUBES THE WAY THE TUBE MANUFACTURER DOES!



The Model 111 is the only single commercial tube tester that checks all tubes for both EMISSION and MUTUAL CONDUCTANCE separately. Filament current is measured directly on large meter when checking a VOLTAGE SAPPER tube. NEW, MODERN DESIGNED ROTARY SWITCHES allow you to check each tube element individually. NEW TYPE Single Rotary switch for complete short checks. The 111 makes all BIAS, FILAMENT VOLTAGE, GAS, LIFE checks visually on large meter . . . 5 individually calibrated ranges and scales for mutual conductance tests. NEWLY DESIGNED "NO BACKLASH" ROLL CHART lists all tubes including the new type 500 mil series tubes. Provisions are made for testing many color tubes. All CRT's can be checked with accessory adaptor, Model PTA.

111K (kit form) **NOW ONLY \$69⁹⁵**
111W (factory wired) \$139.95

PRECISE COLOR or BLACK & WHITE OSCILLOSCOPES ARE NOW USED BY AMERICA'S LEADING MANUFACTURER OF COLOR TV SETS!

SPECIFICATIONS: PRECISE MODEL 300 OSCILLOSCOPE
VERTICAL — Vertical-flat (3db) DC through 5 megacycles with sensitivity of greater than 10 millivolts push-pull (3.94 Millivolts/cm). Constant Resistance. Push-pull input immediately converted to single-ended normal or reverse phase by shorting bar at inputs 1 and 2. Frequency compensated vertical stepping attenuator selects AC or DC inputs. Push-pull DC amplifiers from input through output. Internal electronic mixing through inputs 1 and 2. five-way binding posts.
POSITIONING — Bridge type positioning on vertical and horizontal does not vary tube characteristics.
HORIZONTAL — Frequency compensated stepping attenuator in horizontal amplifier. Push-pull Horizontal out.
BLANKING — Internal (return trace blanked), external (return trace not blanked). 60 cycle or 120 cycle Blanking through Blanking amplifier circuit.
SYNCHRONIZATION — External, Internal Positive, Internal Negative, Internal 60 cycle or Internal 120 cycle synchronization.
SWEEP RATE — Driven or non driven linear sweeps from 1 cycle to 80KC in five ranges (1-10 cycles uses external C circuit). Trigger potentiometer.
MAGNIFIER — Electronic magnifier and magnifier positioner allows any part of a signal to be magnified up to ten times (equivalent to 70 inches of horizontal deflection).
CALIBRATION — Internal square wave calibrator and potentiometer for using oscilloscope at a VTVM on Peak to Peak measurements.
CALIBRATION SCREEN — Edge-illuminated scale and graticule may be turned on or off; filtered screen.
OUTPUTS ON FRONT PANEL — Plus Gate output; Sawtooth output; 60 cycle phasing output; 60 cycle unphased output; Calibration output.
FOCUSING — Astigmatism, focus and intensity control.
CRT — NEW 7" Tube, normally supplied is medium persistence type 7JF1 (oscilloscope green trace) — high persistence types available at additional cost.
DIRECT — Deflection plates available from rear of cabinet.
INTENSITY MODULATION — Z modulation through modulation amplifier.
GENERAL — Low loss components; Over-designed fused power supply for additional circuitry. Deeply etched aluminum panel; New parts from original manufacturers — (NO SURPLUS). Steel cabinet; 11" x 14" x 17"; complete with instruction book and all components; Accessories: Model 912(VMM) Demodulator Probe and Model 950 Capacity Attenuator Probe available at extra cost — please see specifications on following pages.
There are many additional features and circuits in kit form, which may be added to the Model 300. Please write us for descriptive literature.

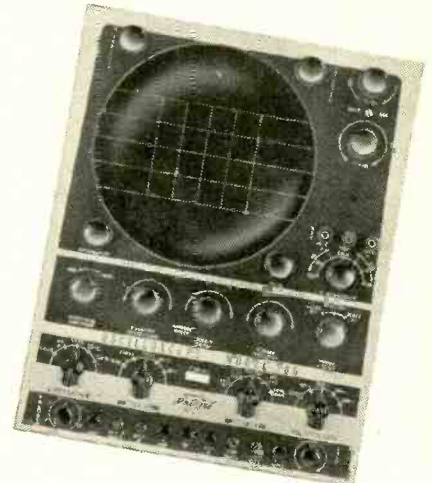

7" COLOR SCOPE
300K (kit form) **NOW ONLY \$94⁹⁵**
300W (factory wired) \$199.50

SEE COMPLETE LINE OF PRECISE TEST INSTRUMENTS AT YOUR JOBBER —
SEND FOR CATALOG RE-6

precise DEVELOPMENT CORP., OCEANSIDE, NEW YORK

8 1/2" COLOR SCOPE MODEL #308
Kit \$129.50
Wired \$229.50

NEW RCA SURPLUS

TV CAMERA only \$197.50



Labs, technicians, industries, hobbyists, medical—set up your own telecast system! It's a "mechanical eye" for factories, swim pools, dental and mental institutions, closed circuit TV—hundreds of other uses! Send for full details today!

Ask For New Free Catalogue!

SURPLUS EMPORIUM, Dept. RE

503 N. Victory Blvd. Burbank, Calif.

ENJOY 3 COLOR TELEVISION FILTER SCREEN NOW

Changes dull eye-straining black and white pictures into beautiful color tones. Seconds to attach. No tools used. Helps eliminate glare and snow in fringe areas. Order direct. Send \$1 for screen size up to 16" . \$1.25 size 17" . \$1.50 size 20" . \$2 size 21" . \$2.50 size 24" . \$3 size 27" . We pay postage except on C.O.D. orders. Satisfaction guaranteed. Inquiries from dealers also welcomed.

Zingo Products, Johnstown 13, New York

For latest tube test data

JACKSON

tube testers

see the current issue of

REPORTER

The Gernsback Library

An up-to-the minute library of low-cost technical books which gives you complete and valuable information on every phase of practical electronics in a readable and understandable way.

BOOKS ON TV-RADIO-AUDIO SERVICING



The Oscilloscope—
No. 52. 192 Pages.
\$2.25

Gives details on how to use the scope for more efficient TV, radio, or audio servicing. Will open many new scope applications to the practicing service technician.

TV Repair Techniques—No. 50.
\$1.50

Top technician-writers give you the benefit of their experience in finding and correcting tricky TV servicing problems. Will save you hours of servicing time.

Radio & TV Test Instruments—No. 49. **\$1.50**

How to build the instruments required for modern TV-radio-audio servicing, plus chapters on constructing a bench and carrying case. Each instrument tested by the authors.

Television Techniques—No. 46.
\$1.50

Symptoms, causes, and cures of over 600 TV troubles which occur in scores of sets made by leading manufacturers. Will help cut trouble-shooting time to the bone in TV servicing.

HIGH FIDELITY

High-Fidelity — Design, Construction, Measurements—No. 48. **\$1.50**

New 3-way approach to top hi-fi performance.

High-Fidelity Techniques—No. 42. **\$1.00**
James R. Langham's humorous, common-sense guide to high fidelity.



FUNDAMENTALS

Basic Radio Course—
No. 44 Cloth cover **\$2.25**

John T. Frye teaches you theory from Ohm's Law to advanced techniques, in an entertaining way.

Radio Tube Fundamentals—No. 45. **\$1.00**

Theory of tubes from the technician's viewpoint.



RADIO CONTROL

Radio-Control Handbook—No. 53. **\$2.25**

R/C expert, Howard G. McEntee, W2SI, tells you how to build R/C systems and the mechanical components to control model planes, boats, etc.

Model Control By Radio
No. 43. 112 Pages. **\$1.00**

A wonderful companion volume for book 53. For both beginner and expert. Covers theory and practical construction.



TRANSISTORS

Transistors — Theory and Practice—No. 51.
\$2.00

Rufus P. Turner writes about transistors for the practical man, in a down-to-earth way. Transistor applications in well known circuits. First complete guide to commercial transistors.



See your distributor—or mail this coupon

GERNSBACK PUBLICATIONS, INC., Dept. 65
25 West Broadway
New York 7, N.Y.

Enclosed is my remittance of \$.....
Please send me the following books postpaid.

39 41 42 43 44 45 46
 47 48 49 50 51 52 53

Name
(Please print clearly)

Street

City Zone State

MISCELLANEOUS

Radio & TV Hints—No. 47. **\$1.00**

300 hints, gimmicks and short cuts on TV, radio, audio.

Public-Address Guide—No. 41. **75c**

How to make extra money in PA work.

Practical Disc Recording—No. 39. **75c**
Theory and techniques.



Merchandising and Promotion

Electro-Voice Inc., Buchanan, Mich., developed a series of sales aids for its phonograph cartridges including a disc



type interchangeability guide, a new metal merchandiser for stocking and displaying and a new sealed-in-plastic "Blister Pak" package.

CBS-Hytron, Danvers, Mass., a division of Columbia Broadcasting System, changed the brand name of its tubes and semiconductor products to CBS to capitalize on public recognition and acceptability of these letters. The company redesigned its packaging to feature the new trademark.

Astron Corp., East Newark, N. J., launched a promotion offering a selec-

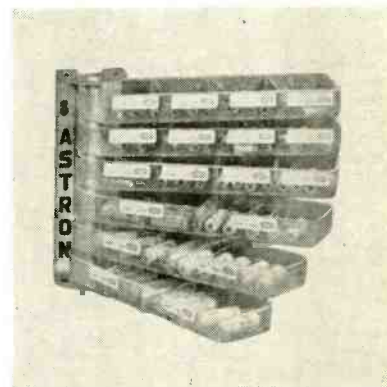

tion of its Blue Point capacitors and a plastic display, "Swing Bin Jr.," at a special low price. The offer is good for a limited time only.

Centralab, division of Globe-Union, Milwaukee, was chosen by the National

Association of Manufacturers to represent a segment of the electronics industry in the association's TV movie series "Industry on Parade."

Channel Master Corp., Ellenville, N. Y., embarked on a new packaging program for its line of TV accessories.

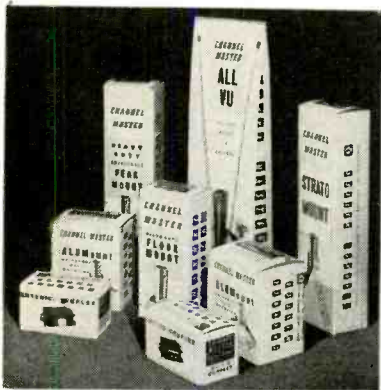

The new program provides uniformly designed cartons for the entire line. The company is also engaged in a promotion around the theme "1955 Is Channel Master's Banner Year." Satin banners dramatizing this slogan are being made available to dealers.

Kuehne Manufacturing Co., Mattoon, Ill., is backing its new weatherproof coated TV towers with a promotion campaign including TV films, envelope stuffers, catalogs, radio spot discs, window streamers and ad mats.

JFD Manufacturing Co., Brooklyn, N. Y., recently conducted a series of dealer forums in Buffalo, N. Y., in cooperation with Radio Equipment Co., its distributor in that area. At the meeting, the company introduced its Silver Bonanza Program which is being developed nationally as a tie-in with the company's 25th anniversary.

Admiral Corp., Chicago, recently held a series of 12 dealer service schools on printed circuits and automation production techniques in the Atlanta, St. Louis and Columbia, S. C., territories.

Walsco Electronics Corp., Los Angeles, produced a new color motion picture "Something to Talk About" for jobber and dealer salesmen who handle its TV antenna line. The picture tells the sales story of Walsco antenna production and testing techniques.

Ram Electronics Sales Co., Irvington, N. Y., is sponsoring a series of TV service technician forums to be held in major TV areas throughout the U. S.

Supreme Publications, Highland Park, Ill., has designed a display stand for its manuals.

Clarostat Manufacturing Co., Dover, N. H., is merchandising its *Fuzohm* protective resistors on an attractive display card kit GL-1 which holds 12 individually packed resistors.

Production and Sales

RETMA reported the production of

1,357,096 TV sets and 2,157,870 radios for the first two months of 1955, compared with 847,504 TV sets and 1,641,213 radios during the same period in 1954.

RETMA announced the retail sale of 647,585 TV sets and 474,947 radios exclusive of automobile sets for January, 1955, as compared to 731,917 TV sets and 310,623 radios in January, 1954.

Mergers

Daystrom Inc., Elizabeth, N. J., announced plans for a merger with Weston Electrical Instrument Corp., Newark, N. J., subject to formal approval by directors and stockholders of both companies.

Fairchild Camera and Instrument Corp., Syosset, N. Y., acquired all the voting stock of Freed Electronics Controls Corp., New York.

Reon Resistor Corp., Yonkers, N. Y., bought Columbia Resistors, Pearl River, N. Y., and moved all the latter's equipment to the home plant in Yonkers.

Brush Electronics Co., a division of Clevite Corp., Cleveland, merged with Technical Instrument Co., Houston, Tex.

Textron American Inc., New York, purchased Ryan Industries, Detroit manufacturer of electronic products for the Air Force, as another step in its nontextile diversification program.

Aerovox Corp., New Bedford, Mass., acquired Luther Manufacturing Co., Olean, N. Y., manufacturer of automatic production equipment.

New Plants and Expansions

Sylvania Electric Products, New York, purchased a 30-acre site in Camillus, N. Y., where it plans to build a new 50,000-square-foot plant as a data processing center.

Phaostron Co., South Pasadena, Calif., manufacturer of 555 multimeter, panel instruments and electronic measuring devices, purchased 13,000 square feet of additional factory space adjacent to its present plant.

Erie Resistor Corp., Erie, Pa., established a new division for the engineering and production of special electrical, electronic and mechanical assemblies.

Espey Manufacturing Co., New York City, consolidated its engineering and production facilities at its plant in Saratoga, N. Y.

Westinghouse Electronics Division announced plans for the construction of a new 350,000-square-ft. plant near Friendship Airport, Baltimore, Md.

Pace Electrical Instrument Co., meter manufacturing division of Precision

BUILD *the New* TRANSVISION TV KIT

ONLY \$15⁰⁰ gets you started*



* THIS MODEST INVESTMENT gets you started on a most fascinating project — assembling the new "E" type Transvision TV Kit in easy stages. For \$15 you get PACKAGE #1 (standard first package for all new "E" kits). This package gives you the BASIC CHASSIS and required first-stage TV COMPONENTS, with complete instructions. When ready, you order the next stage (pkg. #2), etc. All stages (or packages) are low priced, making your complete kit the best buy in TV.

YOU PROFIT 3 WAYS:

1 Learn TV

You learn TV the practical way — by doing. No previous technical knowledge is required. With Package #1 you get a complete Instruction Book; a 95-page Book of interesting, educational facts and explanation about TV, servicing, etc.; over 200 drawings and diagrams; and a 16-page booklet on Hi-Fidelity.

2 Save up to 50%

You build a TV set worth up to double your cost of the parts; and you learn how to save on servicing, too.

3 Prepare for COLOR TV

By assembling your own TV Kit, you will learn enough about TV to be able to make the necessary modification to add color. Transvision will supply the required components to make change over to COLOR practical and inexpensive.



FREE CATALOG Shows 8 Great TV Kits: EXCLUSIVE: Only Transvision TV Kits are adaptable to UHF. Ideal for FRINGE AREAS. No Previous Technical Knowledge required. Write now!

TRANSVISION
THE OLDEST NAME IN TV KITS
NEW ROCHELLE, N. Y.

MAIL THIS COUPON TODAY

Educational Director
TRANSVISION, INC., NEW ROCHELLE, N. Y. Dept. E-6
 I'm enclosing \$ _____ deposit. Send standard kit PACKAGE #1, with all Instruction Material. Balance C.O.D.
 Send FREE copy of your new TV Kit Catalog.
Name _____
Address _____
City _____ State _____



Need a Tube Tester?

FOLLOW THE LEADER...

Buy **EICO**

© 1955

TUBE TESTER #625
KIT \$34.95 Wired \$49.95



More Servicemen buy EICO TUBE TESTERS — in KIT and wired form — than any others sold through distributors. Why? Because EICO gives you the MOST value at LOW-EST cost.

- Test all conventional & TV tubes and pilot lights.
- 10 individual lever-type element switches.
- Illuminated anti-backlash rollchart kept up-to-date by EICO's Engineering Dept.
- 4½" meter, 3-color "Good-Bad" scale.
- Line-adjust control. Blank socket for new tubes. Protective overload bulb.

In stock at your local jobber. Write for free Catalog CT-6 Prices 5% higher on West Coast.

ELECTRONIC INSTRUMENT CO., INC.
84 Withers Street • Brooklyn 11, N. Y.

You Save... when you select Hi-Fi's Best **craftsmen**

The NEW *Solitaire*



20 watt power amplifier, a preamplifier and an exclusive noise filter all in one attractive cabinet. Simply add retard changer and speaker for a professional home music system.

Price was \$113.50. NOW ONLY **8650**

F.O.B. Chicago. Send check or M.O.

Send for New Brochure

See the new low prices on Tuners, Amplifiers, Preamplifiers.

- One year factory warranty.
- 15 Day Home Trial—you must be satisfied — if not, return equipment for refund of purchase price.

The Radio Craftsmen Inc.

Dept. G-6, 4403 N. Ravenswood Ave. Chicago 40, Illinois

BUSINESS

(Continued)

Apparatus Co., moved to its new plant in Glendale, L. I., N. Y.

Magnavox Co., Fort Wayne, Ind., is expanding its research laboratories in West Los Angeles, Calif. Dr. Ragnar Thorensen was named director of research for the new laboratories. He formerly directed work on digital computers at U. C. L. A.

Sunshine Scientific Instrument, Philadelphia, purchased all the stock, parts, drawings, jigs, patent rights, etc. to 18 instruments recently designed and developed by the Special Products Division of General Electric. These instruments will now be manufactured, sold and serviced exclusively by the Sunshine company.

Business Briefs

... Raytheon Manufacturing Co., Receiving and Cathode-Ray Tube Operations, Newton, Mass., recently held a symposium for its sales representatives, sales engineers and company officials. Norman B. Krim, vice president and general manager of the operations, predicted a two-fold or greater increase in sales of receiving tubes for replacement use by 1965.

... Arvin Industries, Columbus, Ind., announced plans to discontinue the manufacture of TV sets about June 1. The company will continue in the radio field and plans to expand production of other electrical items.

... The FTC charged Admiral Corp., Chicago, with falsely advertising its 21-inch picture tube set as providing 20% more screen area than other 21-inch TV sets.

... Stanford Research Institute and the National Industrial Conference Board will sponsor a symposium on "Electronics and Automatic Production" in San Francisco, Aug. 22-23, immediately preceding the annual Western Electronic Show and Convention.

... Electro-Voice Inc., Buchanan, Mich., held a two-day Open House and product exhibition for its Midwest distributors. The exhibit was presented for three additional days for the press, local civic and business leaders and the families and friends of Electro-Voice employees.

... Kay-Townes Antenna Co., Rome, Ga., was granted a patent for its Big Jack TV antenna.

... RCA Service Co. and RCA Consumer Products Division, Camden, N. J., sponsored a survey conducted by Elmo Roper which indicated that a great majority of the nation's 34,500,000 TV set owners are pleased with the nature, quality and prices of the TV service they receive.

END

6-VOLT BATTERY SOLDERING IRON AND WELDER

U.S. Army release. Brand New—Never Used. Fully Guaranteed. This soldering iron can be used to solder or weld when connected to any six-volt storage battery. Uses approximately 200 to 300 watts. The high intensity arc created between the metal to be soldered and the carbon electrode (carbons supplied free with iron) can be used to heat tin or aluminum solder. Suitable also for light brazing and spot welding. Arc can be used

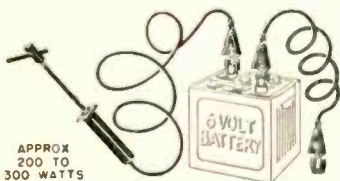

APPROX 200 TO 300 WATTS

for melting metals, cutting holes and soldering seams in chassis. Also useful for analyzing metals and minerals. Battery soldering iron outfit includes 2 carbons, 3 heavy duty spring clips, 2 pieces 5 ft. heavy duty wire cable. (Battery not included.) Ideal for use where current is not available. Ship wt. 4 lbs.

ITEM NO. 126 UNUSUAL BUY(P.P. & Hdg. Chgs. 50c) **\$1.95**

VARIABLE SPEED UNIVERSAL MOTOR

FOR 110 VOLTS, A.C. OR D.C. Used, but in excellent condition. Special lever control permits variable speeds up to 3000 r.p.m. ¼" shaft extends from both sides of motor. Measures 7½ x 3¼" diam. overall Shp. Wt. 6¾ lbs.

ITEM NO. 127 Your Price..... **\$2.45**

(P.P. & Hdg. Chgs. 60c)

WATTHOUR METER



Leading makes — reconditioned. Ideal for trailer parks. 100-110 volts, 60 cycles, 2-wire A.C. 5 amp. Heavy metal case 8½" x 6¼" x 5". Easy to install. Ship. wt. 14 lbs.

(P.P. & Hdg. Chgs. \$1.25) ITEM NO. 33 **\$4.50**

AMAZING BLACK LIGHT

250-watt ultra-violet light source. Makes fluorescent articles glow in the dark. Fits any lamp socket. For experimenting, entertaining, unusual lighting effects. Ship. wt. 2 lbs.

ITEM NO. 87 **\$2.45**

(P.P. & Hdg. Chgs. 35c)



BLAK-RAY SELF-FILTERING ULTRA-VIOLET LAMP



BLAK-RAY 4-watt lamp, model X-4, with U-V tube. Lamp has a wave-length of 3654 to 4000 angstrom units. Some of the substances made to fluoresce are certain woods, oils, minerals, milkstone, cloth, paints, plastics, yarn, drugs, crayons, etc. Self-filtering and harmless.

Equipped with aluminum reflector. 110 volt 50-60 cycle A.C. 2000 to 3000 hours of service. Approved by Underwriters has a built-in transformer. ITEM NO. 125 (Shp. Chgs. 70c) **\$16.75**

POWERFUL ALL PURPOSE MOTOR

Sturdy shaded pole A.C. induction motor. 15 watts, 3000 rpm. 3"x2"x1¼"; 4 mounting studs; 7/8" shaft, 3/16" diameter; 110-120 volts, 50-60 cycles. A.C. only. ITEM NO. 147 UNUSUAL BUY **\$2.45**

250 POWER TELESCOPE LENS KIT

Make your own high powered 6 ft. telescope! Kit contains 2" diam., 75" focal length, ground and polished objective lens and necessary eye pieces. Magnifies 50x to 250x. Full instructions.

ITEM NO. 123 (Shp. Chgs. 10c) **\$2.95**



HUDSON SPECIALTIES CO.

25 West Broadway, Dept. RE-65 New York 7, N. Y.

I am enclosing full remittance for items circled below. (Be sure to include shipping charges.) OR, my deposit of \$..... Shp. balance C.O.D. MINIMUM C.O.D. ORDER \$5.00. C.O.D. ORDERS ACCEPTED ONLY WITH 20% DEPOSIT INCLUDE SHIPPING CHARGES.

Circle Items Wanted
97 147 33 126 123 125 127
Name.....
Please Print Clearly
Address.....
City.....Zone.....State.....

XCELITE Hand Tools
PREFERRED BY THE EXPERTS

Now...

IN BEAUTIFUL
RUST-RESISTANT
**CHROME
FINISH!**

No. 51C
LONG
NOSE
SIDE
CUTTER

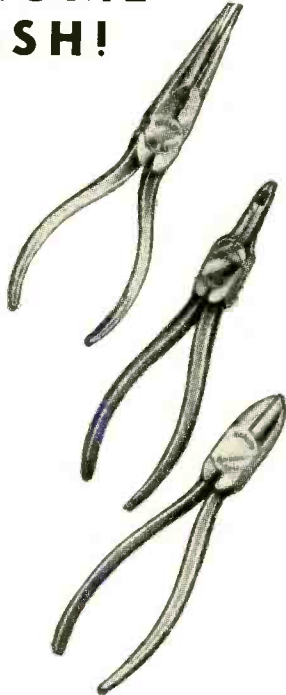

No. 56C
RADIO-
TV
PLIER

No. 66C
6-IN.
DIAGONAL
PLIER

You know XCELITE PLIERS stand up well and make your work easier—but did you know they're available chrome-plated at slight extra cost? It's well worth the added years of protection to their good looks! The three shown are just part of the wide selection to choose from—ask your dealer!

XCELITE, INCORPORATED
(formerly Park
Metalware Co., Inc.)
Dept. J
Orchard Park, New York

For Originality
LOOK TO XCELITE

RADIO-ELECTRONICS is paying good rates on acceptance for original and unusual articles on audio, television, FM and AM servicing, as well as articles on industrial electronic equipment and applications. Send for a copy of our Austors' Guide. Address:

**THE EDITOR
RADIO-ELECTRONICS**
25 West Broadway
New York 7, N. Y.



Matthew D. Burns, recently appointed general manager in charge of electronic-tube operations of Sylvania Electric Products, New York City, was elected a vice-president.



M. D. Burns

Roland S. Withers was appointed general manager of United Motors Service Division of General Motors, Detroit, Mich. He was formerly general merchandising manager of the AC Spark Plug Division.



R. S. Withers

Grady L. Roark, marketing manager of the General Electric Tube Department, Schenectady, N. Y., was named manager of tube sales, a newly established central sales service organization for electronic tubes and radio and TV components. This move is in line with the company's reorganization plans for the Tube Department.



G. L. Roark

Earl Olson was named vice president in charge of operations for Jensen Industries, Forest Park, Ill. Mr. Olson was formerly the chief engineer for the company.



E. Olson

Al Polak was appointed assistant distributor sales manager of Permoflux Corp., Chicago. He was formerly in charge of plant operation.

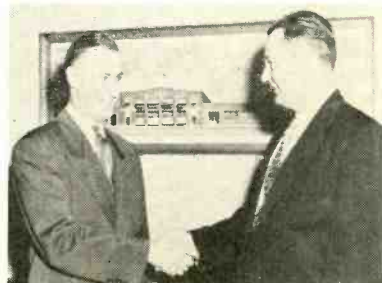

Mr. Polak, left, being welcomed by Floyd J. Van Alstyne of Permoflux.

Color Servicing

IS NOW IN THE FAMOUS
Mandl's TV Servicing

**A MASTER HANDBOOK
FOR ANY SERVICE JOB
A COMPLETE COURSE
IN TV SERVICING**



The new section on color servicing and color circuits gives you the same clear how-to-do-it instruction that has made this book a favorite with servicemen everywhere. You'll be FULLY prepared to service any set, do the best job of installation or trouble shooting in minimum time, either for color or for black and white.

Make your Math EASY!

You'll find those time-saving equations easy to use, easy to solve with the aid of

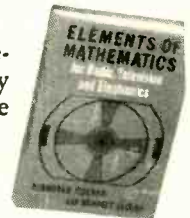

Elements of Mathematics for Radio, TV & Electronics

By Bernhard Fischer & Herbert Jacobs

If you've ever hesitated to use a time-saving equation because you were not quite sure how to set it up, or had moments of doubt about decimals or percentages, or wanted a quick check on your figuring—THIS IS THE BOOK FOR YOU. It makes crystal clear each step in the reasoning and each procedure in the arithmetic, geometry, and algebra needed by radio and TV technicians. You'll find it EASY to work out frequency resolutions, voltage drops, inductive reactances, decibels and the many other radio and TV problems in which accurate use of math is essential. Hundreds of sample problems, with answers, give you thorough practice.

10-day FREE TRIAL

The Macmillan Co., 60 Fifth Ave., New York 11
Please send me the books checked below. I will remit full price plus small delivery charge, or return books in 10 days. (Save: Send check or money order and we pay delivery charge)

Mandl's TV Servicing \$5.75 Elements of Mathematics for Radio & TV \$7.20

Signed _____

Address _____

RE-7

This offer good only within continental limits of U.S.A.

For Function and Beauty

TO THE EYE - TO THE EAR

**SHERWOOD
HIGH FIDELITY
S-1000 AMPLIFIER**

outstanding engineering provides: 20 watt ultra-linear output • push-button record equalization • 7729 low noise phono preamplifier • new "center-set" loudness control • rumble and scratch filters • speaker damping selector • tape recording provisions • 5 inputs



with cabinets to fit any decorating scheme. \$99.50 to \$109.50 complete.

Sherwood
ELECTRONIC LABORATORIES

Dept. 6E, 2802 W. CULLOM AVE. • CHICAGO 18, ILL.

STEEL ANTENNA TOWERS

need no GUY WIRES



Improve radio and TV reception. Easy to erect . . . self-supporting 3 post towers . . . last a lifetime. Built of galvanized steel sections—no guy wires necessary—safe and resistant to high wind.

Available in heights of 33, 47, 60, 73, 87, and 100 feet.

TERRITORIES OPEN FOR JOBBER-DEALER FRANCHISE

Write for dimensions, structural details, prices, discounts, and available territorial assignments.

AERMOTOR COMPANY

Dept. 7006, 2500 Roosevelt Rd., Chicago 8, Ill.

BUILDERS OF STEEL TOWERS SINCE 1888

PEOPLE

William O. Hamlin was appointed supervisor of Technical Information Service for CBS-Hytron, Danvers, Mass. He comes to the company from Sylvania where he was technical editor of *Sylvania News*.



W. O. Hamlin

William H. Miller was named manager of the newly formed Community Operations Division of Jerrold Electronics Corp., Philadelphia. Other key executives in the new division include: Robert J. Tarlton, manager, Community Constructions; Barbara Loomis, planning supervisor; Claire Ostroff, field management representative, and Earl Fletcher, engineering supervisor, among others.



W. H. Miller

Carl J. Harshbarger joined Kay Townes Antenna Co., Rome, Ga., as general sales manager. He was formerly with Westinghouse. In his new position, he will direct advertising, sales and promotion.



C. J. Harshbarger

Obituary

Walter N. Potter, former general manager of the United Motors Service Division of General Motors, died suddenly while on a trip to San Francisco.

Personnel Notes

. . . William R. Crotty was promoted to manager of radio and TV sales for the Electronic Division of Erie Resistor Corp., Erie, Pa. He was formerly manager of the Chicago district sales office. Robert W. Orr, formerly an electrical engineer with the company, was named to head Government liaison activities for the division. These promotions complete the company's plan for dividing Electronic Division sales into four sections: radio and TV, industrial electronic sales, Government liaison and distributor sales.

. . . O. I. Thompson, educational director of De Vry Technical Institute, Chicago, was elected president of the 1955 National Electronics Conference, Inc., which will hold its 11th Annual Conference, Oct. 3-5, in Chicago.

. . . Alfred Y. Bentley was promoted to assistant manager of the Allen B. Du Mont Laboratories, Cathode-Ray Tube Division, Clifton, N. J. He was formerly technical assistant to the president.

. . . Joseph H. Gillies was appointed vice president in charge of manufacturing for Philco Corp., Philadelphia, in addition to his present duties as vice president and general manager of the Government and Industrial Division.

. . . Dr. Percy L. Spencer, a vice president of Raytheon Manufacturing Co., Waltham, Mass., and J. E. Smith, assistant vice president and director of engineering for the company's equipment operations, were named Fellows of the IRE.

. . . Walter A. Weiss was named general manager of the Radio Tube Division of Sylvania Electric Products, Emporium, Pa. Herbert A. Ehlers succeeds Weiss as general manufacturing manager of the division.

. . . Kendrick K. Lippitt, vice president in charge of engineering for Technical Appliance Corp., Sherburne, N.Y., and Robert T. Leitner, Taco project engineer, spoke at meetings of the IRE and AIEE, respectively.

. . . E. R. Rutledge joined Hallicrafters, Chicago, as Eastern regional manager. He was formerly with Stewart-Warner.

. . . Herbert J. Allemang was elected a director of National Union Electric Corp., Hatboro, Pa. He is an executive vice president of Eureka Williams Co.

. . . Franklin F. West joined Clarostat Manufacturing Co., Dover, N. H., as manager of the new Quality Control Department. He was formerly with Sonotone Corp. END

Radio Thirty-Five Years Ago
In Gernsback Publications

HUGO GERNSBACK Founder	
Modern Electrics	1908
Wireless Association of America	1908
Electrical Experimenter	1913
Radio News	1919
Science & Invention	1920
Television	1927
Radio-Craft	1929
Short-Wave Craft	1930
Television News	1931

Some of the larger libraries still have copies of **ELECTRICAL EXPERIMENTER** on file for interested readers.

In June, 1921, Science and Invention
(formerly *Electrical Experimenter*)

- 3,013 Miles with 2 K.W. Arc Set, by Arthur H. Lynch
- The "Loop Aerial" and Its Applications, by Robert E. Lacault
- Measuring the Motion of a Telephone Receiver Diafram, by Prof. Lindley Pyle
- "Funny-Tone" Radio Receiver, by E. W. Start
- Telegraph Tape Recorder, by F. William Jung
- A Motor-Driven "Bug" Key, by Norman H. Allen
- Utilizing Morse Relay as Coil Interrupter, by Penuel E. Ballard

technical Literature

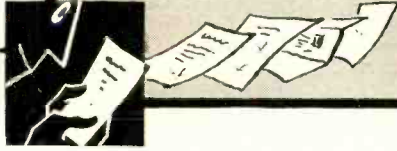

THE ELECTRON

What's New with the Electron covers new and improved Eimac tubes including the revolutionary 4X5000A, the first Eimac ceramic radial-beam power tetrode.

Eitel-McCullough, Inc., San Bruno, Calif.

THREE BULLETINS

Bulletin SR-3 on varistors (asymmetric nonlinear resistors) contains comprehensive data on applications, characteristics, current ratings, enclosures, terminations and detailed charts and graphs.

Bulletin D-2 on sealed precision voltmeter multipliers offers information on moistureproof construction, temperature coefficient, terminations, wiring, voltage rating, dielectric strength, charts and graphs.

Bulletin B-9 on 1/2-watt molded deposited-carbon resistors presents data on characteristics, applications, tolerance, wattage rating, terminations, dimensions, insulation, charts and graphs.

International Resistance Co., 401 N. Broad St., Philadelphia 8, Pa.

SUBSTITUTION CHART

CBS-Hytron's *Substitution Chart for Television Picture Tubes* (Second Edition) contains substitution information for all electromagnetically reflected types, regardless of make, including mirror-back (aluminized) types. An eight-page chart indicates interchangeable types as well as substitutes requiring a minimum of service changes. An index lists all picture-tube types and places each in its correct substitution group. Then, by a tabulation of characteristics within each group, the best choice of an individual substitute type is made easy to find.

CBS-Hytron distributors.

TV BOOKLET

A Fleeting Glance at Fleetwood Custom Television suggests ways to custom-install television receivers. Photos of installations feature TV sets controlled by remote tuning units and conventionally controlled sets.

Conrac, Inc., Glendora, Calif.

GERMANIUM DIODES

Bulletin GD-2 lists ratings and specifications on germanium, high-temperature, computer, u.h.f. mixer, meter-protection and general-purpose diodes. Also included is an interchangeability and replacement chart.

International Rectifier Corp., Semi-

Conductor Div., 1521 E. Grand Ave., El Segundo, Calif.

AUDIO CATALOGS

Altec Lansing's *Engineered Sound Products* offers information and photos on microphones, preamplifiers, power amplifiers, loudspeakers, microphone accessories, AM-FM tuners, reproducers, mounting assemblies, matching transformers, etc.

High Fidelity Home Music Systems illustrates and describes a power amplifier, AM-FM tuner and phonograph control unit, preamplifiers, speakers, speaker system, speaker enclosures, etc.

Altec Lansing Corp., 9356 Santa Monica Blvd., Beverly Hills, Calif., or 161 6th Ave., New York 13, N. Y.

Any or all of these catalogs, bulletins, or periodicals are available to you on request direct to the manufacturers, whose addresses are listed at the end of each item. Use your letterhead—do not use postcards. To facilitate identification, mention the issue and page of RADIO-ELECTRONICS on which the item appears.

UNLESS OTHERWISE STATED, ALL ITEMS ARE GRATIS. ALL LITERATURE OFFERS ARE VOID AFTER SIX MONTHS.

C-R OSCILLOGRAPHS

A Quick Reference Instrument Catalog lists the salient points of Du Mont C-R oscillographs and accessory instruments. The eight-page catalog is divided into three sections devoted to low-frequency, high-frequency and accessory instruments, respectively. A picture of each instrument is shown together with a brief description of its features and applications. Additional technical information is provided in tabular form in each of the catalog's three sections.

Technical Sales Department, Allen B. Du Mont Laboratories, Inc., 760 Bloomfield Ave., Clifton, N. J.

MINIATURE TERMINALS

A four-page catalog describes miniature tubular terminals and contacts for printed-circuit applications.

Malco Tool & Mfg. Co., Dept. RLN, 4025 W. Lake St., Chicago 24, Ill.

BATTERY ELIMINATOR

A two-page catalog sheet No. 100 describes and illustrates the model KM88 aircraft battery eliminator. Detailed electrical and physical specifications in addition to an outline drawing of the rack mounting type enclosure are included.

Opad Electric Co., 69 Murray St., New York 7, N.Y.

EDLIE for TOP VALUES

Newest & Best "Fix-It-Yourself" Aid

Larrel's E-Z TV REPAIR GUIDE

The Only FIX-IT-YOURSELF Guide Made expressly for YOUR TV Set!

Now you can save costly TV repairs with this new, simplified method which includes all necessary data for just YOUR set. No confusing, unimportant information applicable to hundreds of other makes. Simplifies detection of faulty tubes in your TV receiver quickly, accurately.

It's a terrific idea—it's a terrific guide! Order today and have your set back in perfect condition at once. Be sure to send us make and model of your TV when ordering.

For Most TV Sets—Old & New

only 50¢

SAVINGS ON KITS

TUBULAR PAPER By-Pass CONDENSER KIT

Contains 50 capacitors ranging in values from .0001 to .5 mfd working voltages from 200 to 1800 also some metal clad black molded as well as cathode electrolytic condensers.

Special! 50 for \$245

ELECTROLYTIC CONDENSER KIT

Contains 20 assorted electrolytic capacitors—mostly metal, many suitable as TV replacements; single, dual & triple section; working voltages: 150, 250, 350, 450.

Giant Savings! 20 for \$225

INSULATED RESISTOR KIT

100 INSULATED RESISTORS. RMA code marked all 1/2 watt varying in ohmages from 1 ohm to 10 megohms and tolerance of 5%, 10% & 20% of standard makes. RMA color code chart included. FREE Special.

95c

DeLuxe Insulated Resistor Kit

Includes: 15-2 watt, 35-1 watt and 50-1/2 watt values up to 20 megohms. Bloused in a transparent plastic box, 4 3/8" x 2 3/4" x 1 1/4" 4-compartment. Reduced to

\$225

FLEXIBLE W. W.

PIGTAIL RESISTOR KIT

100 Resistors of ass't. ohmages and wattage... \$165

PRECISION CARBOFILM RESISTOR KIT

1% tolerance in ohmages from 5 to 2.2 megohm. \$25 value... \$245

WIRE WOUND RESISTOR KIT

25 Wire Wound Resistors up to 50-1/2 ohms 5, 10, 20, 30, 50, and 100 watt resistors

\$195

Terrific Buy

PRECISION WIRE WOUND RESISTOR KIT

20 Precision W.W. resistors. 1% tolerance. 20 different ohmages ranging up to 1/2 megohm, 1/2 & 1 watt. \$25 value

\$245

Disc Condenser Kit

50 Disc condensers—.001, .0015, 2X0015, 2X0004, .007, .005, .01, 2X01, & 0000 10/2KV mfd. of equal amounts. Now!

\$195

CERAMIC CONDENSER KIT

50 Tubular ceramic (solid and hollow) ranging in capacity from 1 to 4700 mfd. Special!

\$175

Save! HIGH PASS FILTER

Input impedance: 600 ohms; output impedance 5,000 ohms. 300 cycles cut off frequency at 3,500 cycles attenuates at 2 db.; at 120 cycles attenuates at 20 db.; at 60 cycles attenuates at 45 db. 2" x 3 1/2" x 2". Original cost: \$20.

\$135

Save! LOW PASS FILTER

At 3,500 cy. attenuates at less than 0.2 db.; at 8,000 cy. attenuates at greater than 60.0 db.; at 6,000 cy. attenuates at greater than 50.0 db. Input impedance: 5,000 ohms. Original cost: \$15.

\$145

Write today for FREE Catalog. All misc. shipped F.O.B. New York City, prices subject to change without notice. Include 20% deposit with C.O.D.'s.

EDLIE ELECTRONICS

154 Greenwich St. New York 6, N.Y. DI. 9-3143

New PORTABLE DOUBLE-DUTY Money-Maker



B&K



**TESTS and
REPAIRS
TV PICTURE
TUBES**

**SPOTS THE TROUBLE AND QUICKLY
CORRECTS IT—WITHOUT REMOVING TUBE FROM SET**

AMAZING
LOW PRICE

SIZE 11" x
7 1/2" x 5"

\$54⁹⁵

No Extra Accessories Necessary

Now it's easy to save thousands of weak and inoperative TV picture tubes. As much as 80% of the troubles which arise in picture tubes may easily be repaired with the CRT. This portable instrument creates new profitable picture tube repair business. Saves servicing time, speeds work. Eliminates tube transportation. Saves money on trade-in reconditioning. The CRT quickly pays for itself—and continues to make profits for TV service dealers.

DOES ALL THIS

Tests for Emission, Inter-Element Shorts, Leakage, Open Circuits, Grid Cut-Off, Gas Content, Probable Useful Life.

RESTORES—Emission and Brightness

REMOVES—Shorts

REPAIRS—Open Circuits

10% REQUIRED
WHEN ORDERING

Almo RADIO CO.

MAIN STORE: 509 ARCH ST., PHILA., PENNA.

BRANCHES: NORRISTOWN, PA. CAMDEN, N. J. ATLANTIC CITY, N. J. WILMINGTON, DEL. SALISBURY, MD.

**REPEAT SALE BY
POPULAR DEMAND**

**WORLD-FAMOUS HI-FI AM-
PLIFIER WITH LATEST MODEL
VM 3-SPEED CHANGER**

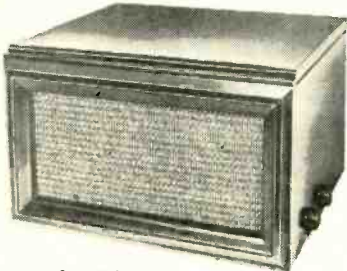

Deluxe 3-speed automatic record player with speaker cross over network for true high-fidelity. 4 tube amplifier scientifically designed to reproduce from 20 to 20,000 cycles. Automatic shut-off for amplifier when last record has played. Beautiful mahogany cabinet with luxurious woven grill. Dimensions: 17 7/8" x 15 7/8" x 11" Weight 30 lbs.

Nationally
Advertised
for \$139.95

CLOSE OUT
PRICE!

\$72⁵⁰

Write Dept. RE-6 for FREE catalog.

STEVE-EL Electronics Corp.

61 Reade St.

New York 7, N. Y.

**DOUBLE DUTY
AC/DC RADIO KIT**
with Baby Sitter Attachment

Radio kit includes 5-tube superhet receiver and amplifier in smartly finished custom WOOD CABINET. Baby sitter attachment includes switches, complete wiring, 4" speaker. Comes with full assembly instructions.

Radio kit.. \$13.95 Attachments.. \$6.95
FUN TO ASSEMBLE—A PLEASURE TO HAVE

CIRCLE ELECTRONICS PRODUCTS COMPANY
39 East 19th Street, New York 3, N. Y.

EASY TO LEARN CODE

It is easy to learn or increase speed with an Instructograph Code Teacher. Affords the quickest and most practical method yet developed. For beginners or advanced students. Available tapes from beginner's alphabet to typical messages on all subjects. Speed range 5 to 40 WPM. Always ready—no QRM.



ENDORSED BY THOUSANDS!

The Instructograph Code Teacher literally takes the place of an operator-instructor and enables anyone to learn and master code without further assistance. Thousands of successful operators have "acquired the code" with the Instructograph System. Write today for convenient rental and purchase plans.

INSTRUCTOGRAPH COMPANY

4701 Sheridan Rd., Dept. RC, Chicago 40, Ill.

**RADIO CONTROLLED
Garage Door
Operating Mechanism \$24.⁵⁰**
Write for Information

P. E. HAWKINS CO.
631 Prospect Kansas City 24, Mo.

Books



ESSENTIAL CHARACTERISTICS (of Receiving, TV Picture and Special-Purpose Tubes and Germanium Diodes). Compiled and published by General Electric Co. (obtainable only from General Electric tube distributors). Loose-leaf spiral binding, 5 1/2 x 8 1/2 inches, 192 pages. 50 cents.

This book has come into ever greater use because of the large number of tubes described in small space. The most recent edition (ETR-15F) is a 192-page book giving the characteristics of some 2,000 tubes, of which 150 are new. Other new features include a classification chart which permits selecting a receiving tube by the type of application; characteristic curves of representative types; a thumb index and a table of contents. The basing diagrams at the bottom of each page are an important and valuable feature.

RIDER'S SPECIALIZED TAPE RECORDER MANUAL (Volume 1), by Rider Laboratory Staff. John F. Rider Publisher, Inc., 480 Canal St., New York, N. Y. 8 1/2 x 11 inches, 311 pages. \$4.50.

Prepared especially for the service technician, this book is devoted entirely to general information, operating instructions and servicing data on nearly 100 tape recorder models made by 14 manufacturers. Electronic circuits are shown with all values and (in most cases) resistance and voltage check tables. The mechanics of the tape deck is shown in photographs and drawings and is accompanied by troubleshooting tables and detailed instructions for clearing up most defects and complaints.

LICENSE MANUAL FOR RADIO OPERATORS, by J. Richard Johnson. Rinehart & Co., 232 Madison Ave., New York, N. Y. 6 1/2 x 9 inches, 430 pages. \$5.

This book is designed to assist the reader in passing FCC commercial radio operator's license examinations. The questions include all those in the "Study Guide" issued by the FCC through the Government Printing Office, along with clear concise answers. The eight elements covered include the six relating to radiotelephone and radiotelegraph licenses plus elements 7 and 8 required for aircraft-radiotelegraph and ship-radar endorsements.

An added feature is an appendix in which all questions on a given phase of radio are keyed to the various elements in which they are found so the reader can concentrate on any particular phase (amplifiers, detectors, laws, transmitters, etc.).

When answering advertisements please mention

RADIO-ELECTRONICS

MOST-OFTEN-NEEDED 1955 RADIO DIAGRAMS AND SERVICING INFORMATION (Volume 15), compiled by M. N. Beitman. Supreme Publications, Highland Park, Ill. 8 1/2 x 10 1/2 inches, 128 pages. \$2.

A compilation of reprints of radio diagrams and servicing information on several hundred models of portables, combinations, clock radios and amplifiers by leading manufacturers.

COMPUTER DEVELOPMENT (SEAC AND DYSEAC) AT THE NATIONAL BUREAU OF STANDARDS (National Bureau of Standards Circular 551). Government Printing Office, Washington 25, D. C. 7 1/2 x 10 1/2 inches, 146 pages. \$2.

A report on the bureau's computer program based largely on the experiences with the SEAC (National Bureau of Standards Eastern Automatic Computer) and DYSEAC (Second SEAC). Topics include dynamic circuit techniques, systems design, high-speed memories and input and output devices.

STORAGE BATTERIES (Fourth Edition), by George Wood Vinal. John Wiley & Sons, 440 Fourth Ave., New York, N. Y. 6 x 9 inches, 446 pages. \$10.

Latest edition of the standard work, originally published in 1924, on the physics, chemistry, applications and operation of secondary batteries, this book stresses scientific principles without becoming too highly technical. Selection and care of batteries for automotive, railway, telephone, marine, aircraft, mining and lighting applications are covered in detail. Interesting and instructive reading for all persons who use or maintain storage batteries and battery-operated equipment.

INDUCTION AND DIELECTRIC HEATING, by J. Wesley Cable. Reinhold Publishing Corp., New York, N. Y. 6 x 9 inches, 576 pages. \$12.50.

This book is a carefully organized treatment of the latest applications of industrial induction and dielectric heating. Divided into two sections, dealing with induction and dielectric heating, respectively, it contains sufficient theory to enable the reader to understand fully the basic operation of both types. Coil and electrode design, jig construction and work-handling methods are covered in detail. Equal coverage is given to such specific metal-working applications as forging, melting, brazing and hardening by induction heating and to plastic fabrication, woodworking, and other applications of dielectric heating.

MICROWAVE LENSES, by J. Brown. John Wiley & Sons, 440 Fourth Ave., New York, N. Y. 4 x 6 1/2 inches, 126 pages. \$2.

A highly mathematical treatise reviewing much of the material on micro-

STAN-BURN E-D-A-R-K-E

CATHODE RAY TUBE SPECIALS

ONE YEAR GUARANTEE

G. E.		STAN-BURN	
10BP4A	\$14.95	10BP4	\$10.20
10FP4A	21.10	12LP4	11.90
12KP4A	24.45	12LP4A	13.95
12LP4A	18.75	12QP4	11.90
12QP4A/B1014		12JP4	11.90
Dumont	25.10	12UP4A	14.50
14CP4	34.25	14CP4	15.60
15DP4	22.50	15DP4	17.50
15DP4/B1014		16KP4	17.50
Dumont	26.75	16DP4 or A	17.50
16AP4A	34.25	16JP4 or A	17.50
16DP4A (N.U.)	25.25	16CP4 or A	17.50
16GP4 A or B	33.25	16FP4	17.50
16KP4/16RP4	24.20	16WP4	17.50
16KP4A	28.35	16AP4A	23.00
(Aluminum)	28.35	16EP4	19.00
16JP4A (N.U.)	27.95	16EP4A	23.50
16LP4A	28.50	16GP4 or A	21.00
16WP4A	27.50	17BP4	18.50
16GP4B	33.95	17CP4A	18.50
17BP4A	27.50	17GP4B	22.60
17BP4	29.75	17CP4B	22.60
17CP4	29.95	19FP4	23.00
17CP4B		19FP4A	24.00
(Aluminum)	38.50	19AP4	23.90
19AP4A	39.75	19AP4A	24.90
20CP4	30.00	20CP4	23.95
20LP4	37.50	21EP4	25.50
21AP4	39.75	21EP4	25.50
21EP4	31.80	24AP4	26.50
21EP4A	36.35		
24AP4	89.75		

Prices Subject to Change Without Notice

AUTHORIZED DISTRIBUTORS for: General Electric, Kenrad, Tung-Sol, National Union, De Wald, Regal, Automatic and General Motors.

URANIUM PROSPECTORS 5 TUBE EQUIPMENT

Geiger Kits \$39.50—Books—Maps—Scintillators—Parfs. Buy Direct from factory & save. Send \$1.00 for Geiger & Scintillator diagram plus other free information.

URANIUM PROSPECTORS EQUIP.

13833 San Antonio Dr. Dept. RE Norwalk, Calif.

Repeated by Popular Demand

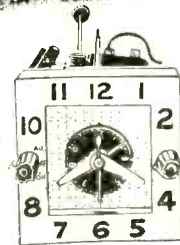

Genuine TELECHRON Switch Timer Clocks
Now \$3.95 ea.
\$3.85 Lots of 3

Below WHOLESALE Cost!

Brand New, individually boxed TELECHRON (GE) Switch Timers at a fraction of their original price. Will turn appliances on at any pre-set time up to 12 hours. Operates on 115 Volts. Appliance switch rated at 115 V 15 Amps. Has 3 control knobs, on-off auto knob for controlling appliances, Auto Set knob for pre-setting turn-on time, and Time-set knob. Clock mounts in a 3 1/2" diameter hole. Comes complete with handsome easy-to-read bezel.

Remember, this is the very same clock movement that is used by many of the nations leading radio manufacturers in the more expensive clock radios. While our supply is large, we really do not know how long they will last at this sensational price. Order early and avoid disappointment. Stimp. Wt. 1 1/2 lbs Stock No. 99-G-C40B-G7 \$3.95 ea.

Send For Big Free Catalog!

CONCORD RADIO 54 Vesey St., N. Y. 7, Dept C6
20% deposit with C.O.D. MINIMUM ORDER \$5.00

NAME _____
ADDRESS _____
CITY _____ ZONE _____ STATE _____

CONCORD RADIO • 54 VESEY ST.
NEW YORK 7, N. Y. • Digby 9-1132

CASCADE TUNERS—Long shaft BRAND NEW, While they last. \$15.95 ea.
WEBSTER CHANGER Model 113, Flip-over cartridge \$25.49 ea.
VM CHANGER—Model 950 Special \$23.49 ea.
HALLICRAFTER 5 Tube AC-DC Battery (3 way) British Tan, Cordovan, champagne. \$27.93 net List \$39.95

6 x 9 REAR SEAT SPEAKER KIT Includes: 6 x 9 speaker, grille, mtg. screws, switch, bracket and wire. List... \$9.95 SPECIAL... \$4.82

ANTENNA SPECIALS
JFD—P800—Double V roof antenna \$1.29 ea.
Indoor Antenna—CORONET .89 ea.
SPICO-S9—Indoor Antenna 2.19 ea.
10 foot Alumicote MAST 1.09 ea.
5 foot Alumicote MAST .69 ea.

STAINLESS STEEL MOUNTS
Z Type... \$1.29 ea. Y Type... \$1.49 ea.
4" WALL MOUNTS .29 ea.
CRT REJUVENATOR .65 ea.
72 OHM CO-AXIAL CABLE 500' spool \$14.75
CHEATER CORDS .19 ea.
TUNER BELT for RCA .19 ea.

AUTOMATIC CUSTOM-BUILT RADIOS for Plymouth, Ford, Chevrolet and many others, always in stock. We carry a complete stock of HI-FIDELITY and SOUND EQUIPMENT. Send us your requests. We also carry a complete line of popular makes of Radio tubes at 50/10% discount. Also many other special purpose and transmitting types, and all electronic parts and equipment at lowest prices. Send us a list of your requirements for prompt quotations. Terms: 20% with order. Balance COD. All prices FOB: NEW YORK Warehouse. Minimum order \$5.00. Write for our latest price list and Hi-Fi Catalog to Dept. RE-6.

STAN-BURN RADIO and ELECTRONICS CO.
1697 BROADWAY • NEW YORK 19, N. Y.

COLOR TV

COLORDAPTOR—Simple 9 tube circuit and rotating color wheel converts any black and white TV, direct view or projection, to receive color TV. Specifications, including theory of operation, complete simplified construction plans, schematic, and sample color filters. \$2.95

COLORDAPTOR Palo Alto, Calif.
3471 Ramona



Only from famous COYNE do you get this modern up-to-the minute TV Home Training. Easy to follow instructions—fully illustrated with 2150 photos and diagrams. Not an old Radio Course with Television tacked on. Includes UHF and COLOR TV. Personal guidance by Coyne Staff. Practical Job Guides to help you EARN MONEY QUICKLY IN A TV-RADIO SALES AND SERVICE BUSINESS—part time or full time. COSTS MUCH LESS—pay only for training—no costly "put together kits".

SEND COUPON FOR FREE BOOK
SEND COUPON BELOW for Free Book and full details including EASY PAYMENT PLAN. NO COST OR OBLIGATION—NO SALESMAN WILL CALL.

B. W. COOKE, Pres. **COYNE ELECTRICAL SCHOOL** FOUNDED 1899

A TECHNICAL TRADE INSTITUTE CHARTERED NOT FOR PROFIT
500 S. Paulina Dept. A5-HT4 Chicago 12, Illinois

COYNE ELECTRICAL SCHOOL
Television Home Training Div.
500 S. Paulina St., Chicago 12, Ill., Dept. A5-HT4
Send FREE BOOK and details of your Television Home Training offer.

Name _____
Address _____
City _____ State _____

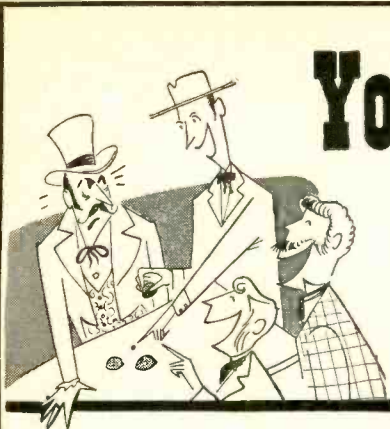

You can't lose—

when you
subscribe to

RADIO — ELECTRONICS

First of all, you're sure of getting the best articles in the field of practical electronics written in a crisp, fresh, informative style. Next you're certain of getting your copy every month—no danger of forgetting, or finding your dealer sold out. When you subscribe, you know you'll get every issue promptly (including the big 50c January TV issue—at no extra cost).

A subscription to RADIO-ELECTRONICS SAVES YOU MONEY TOO. You can save up to \$5.05 over the newsstand price by taking a three year subscription. Look over this list of a few of the features scheduled for the months ahead—then make up your mind to subscribe now—send in the attached coupon today.

Don't miss these features in the months ahead

- ✎ Multiple Speakers for Higher Fidelity
- ✎ Electronics Searches for Oil
- ✎ Trouble Shooting the Video Detector
- ✎ Servicing Light Plane Radios
- ✎ How Much Will a Resistor Take
- ✎ Employment in Electronics

SEND ME RADIO-ELECTRONICS

Please check:

- 3 YEARS—36 Big Issues—ONLY \$8.00
SAVES YOU \$5.05 over the single copy price!
- 2 YEARS—24 Big Issues—ONLY \$6.00
SAVES YOU \$2.70 over the single copy price!
- 1 YEAR—12 Big Issues—ONLY \$3.50
SAVES YOU 85c over the single copy price!

- I enclose \$.....
- Bill Me

NAME _____ (Please Print Clearly)

STREET ADDRESS _____

CITY _____ ZONE _____ STATE _____

MAIL TO:
RADIO-ELECTRONICS
25 West Broadway
New York 7, N. Y.



wave lenses heretofore available only in a few scattered technical reports and magazine articles. Chapter headings are: Introduction, Radiation Patterns, Solid Dielectric Lenses, Metallic Delay Dielectrics, Metal-Plate and Rodded Dielectrics, Wide-Angle Scanning, Non-homogeneous Lenses, Path Length Lenses and Lens Aerials.

TABLE OF THE GAMMA FUNCTION FOR COMPLEX ARGUMENTS (National Bureau of Standards Applied Mathematics Series 34). U. S. Government Printing Office, Washington 25, D.C., 105 pages. \$2.

This table is of fundamental importance in pure and applied mathematics and exceptionally useful in atomic and nuclear research. It makes the complex gamma function as easily accessible to interested workers as the more familiar exponential and trigonometric functions.

YOUR TELEVISION ANTENNA SYSTEM, compiled by Radio-Electronics-Television Manufacturers Association and Association of Better Business Bureaus. 5½ x 8½ inches, 12 pages. Distributed through BBB offices, single copies free to interested parties.

In spite of its small size, this may be one of the year's most valuable books to the TV service technician and installation man. Beginning with a highly simplified discussion of what an antenna is and does, it nevertheless leaves the idea with the reader that satisfactory selection and installation are a function of the "installation man or dealer serviceman."

The questions of why and where are given a heading each, and a couple of pages are devoted to the question of "How to care for your TV antenna system." The owner is informed that age, weather, heat, cold, soot or salt, and deterioration of the transmission line may reduce picture quality. Antennas should be inspected regularly (for which job "your service technician" is qualified) to maintain peak performance and make necessary repairs and replacements. END

CORRECTION

The diameter of the coils was not specified for the set in Fig. 2 of "Emergency Receiver" in the April issue. The forms are approximately ⅜ inch in diameter. Slight variations can be made in the diameter without adversely affecting the tuning range. The band-switch should be a three-pole rather than a double-pole type as specified in the parts list. A legend on the under-chassis view points out an output transformer. This is actually an interstage type as indicated on the diagram.

Our thanks to Fred Butterfield of Brooklawn, N. J., for this correction.

OVER 97,000 TECHNICIANS HAVE LEARNED HOW TO GET THE MOST OUT OF BASIC TEST EQUIPMENT for AM FM-TV

'Servicing by Signal Substitution'

A BEST SELLER FOR OVER 13 YEARS!
(NEW, UP-TO-DATE, 14th EDITION)

The Modern, Simplified, Dynamic Approach to all Receiver Adjustment & Alignment Problems

- ★ Nothing complicated to learn
- ★ No extra equipment to purchase
- ★ Universal... non-obsolete
- ★ Employs only Basic Test Instruments

Ask for "S.S.S." at your local Radio Parts jobber or remit 40¢ in small stamps or coin directly to factory.

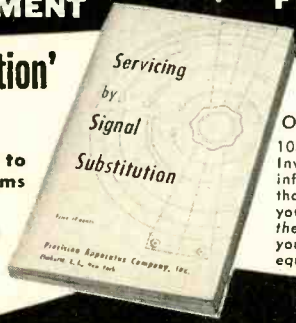

ONLY 40¢
103 pages. Invaluable information that will help you redouble the value of your basic test equipment.

PRECISION APPARATUS COMPANY, INC.
70-31 84th STREET, GLENDALE 27, L. I., N. Y.

RADIO SCHOOL DIRECTORY

Get Your F.C.C. LICENSE Quickly!

Correspondence or residence preparation for F.C.C. examinations. Results guaranteed.

Resident classes held in WASHINGTON, D.C. and HOLLYWOOD, CALIF.

An FCC commercial operator license means greater opportunities and higher pay. We are specialists in preparing you, in a MINIMUM OF TIME, to pass FCC examinations for all classes of licenses. Beginners get 2nd class license in 5 weeks and 1st class in 3 additional weeks. Write for our FREE booklet with complete details.

GRANTHAM School of Electronics

Dept. 102-K, 6064 Hollywood Blvd., Hollywood 28, Calif.
Dept. 201-K, 737 11th Street NW, Washington 1, D.C.

GET INTO ELECTRONICS

You can enter this uncrowded, interesting field. Defense expansion, new developments demand trained specialists. Study all phases radio & electronics theory and practice: TV; FM; broadcasting; servicing; aviation, marine, police radio, 18-month course. Graduates in demand by major companies. U.S. or equivalent required. Begin Jan., March, June, Sept. Campus life. Write for catalog.

VALPARAISO TECHNICAL INSTITUTE
Dept. C Valparaiso, Ind.

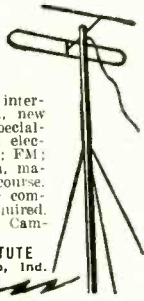

TELEVISION

PREPARE FOR A GOOD JOB!

BROADCAST ENGINEER
ELECTRONICS
RADIO SERVICING

Television Servicing

(Approved for Veterans)

SEND FOR FREE LITERATURE

BALTIMORE TECHNICAL INSTITUTE
1425 EUTAW PLACE, BALTIMORE 17, MD.



TV REPAIRMEN EARN TOP MONEY!

IN JUST 12 MONTHS, COMPLETE TV SERVICE TRAINING, INCLUDING COLOR TV. Streamlined course gives you all essentials for a good job as service technician. Graduates in great demand; jobs are plentiful in this growing field. Other electronic courses in radio operation and maintenance. Day or evening classes. Opportunity for employment in local industry. Approved for Korean veterans.

Write for Catalog 111 Today

INDIANAPOLIS ELECTRONIC SCHOOL
312 E. Washington, Indianapolis 4, Ind.



RCA INSTITUTES, INC.

A service of Radio Corporation of America
350 West 4th St., New York 14, N. Y.

OFFERS COURSES IN ALL TECHNICAL PHASES OF RADIO, TELEVISION, ELECTRONICS

Approved for Veterans
Write Dept. RE-55 for Catalog

Please Mention
RADIO-ELECTRONICS
WHEN ANSWERING
ADVERTISEMENTS

MORE JOBS

than graduates

Demand for our engineering graduates exceeds supply. Effective placement service. Study in this world-famed college established 1884. Quarters start June, September, January, March. Approved for Veterans.

Bach. Sc. degree in 27 months

Complete Radio Eng. course includes TV, UHF and FM. Also Mech., Civil, Elec., Chem., Aero. and Adm. Eng.; Bus. Adm., Aect. Small classes. Well-equipped labs. Modest costs. Prep. courses. Write Jean McCarthy, Director of Admissions, for Catalog, View Book and "Your Career" Book.



TRI-STATE COLLEGE

2465 College Avenue, Angola, Indiana

CODE SENDING SPEED

Be a "key" man. Learn how to send and receive messages in code by telegraph and radio. Commerce needs thousands of men for jobs. Good pay, adventure, interesting work. Learn at home quickly through famous Gandler System. Qualify for Amateur or Commercial License. Write for FREE BOOK, GANDLER SYSTEM CO., Dept. 3-G, Box 928, Denver 1, Colo., U.S.A.

RADIO ENGINEERING DEGREE IN 27 MONTHS

Intensive, specialized course including strong basis in mathematics and electrical engineering, advanced radio theory and design, television. Modern lab. Low tuition. Self-help opportunities. Also B.S. degree in 27 months in Aeronautical, Chemical, Civil, Electrical, and Mechanical Engineering. G.I. Gov't approved. Enter June, September, December, March. Catalog.

INDIANA TECHNICAL COLLEGE

1565 E. Washington Blvd., Fort Wayne 2, Indiana

EARN MORE MONEY— BE A PROFESSIONAL TELEVISION SERVICE TECHNICIAN

HOW TO BE A SUCCESSFUL TELEVISION TECHNICIAN

GET DOWN-TO-EARTH PRACTICAL TV TRAINING WITH WTI EXPERTS FOR THE TOP PAYING \$5,000-\$10,000 PER YEAR JOBS.

UHF—COLOR—VHF

Master the latest, up-to-the-minute TV and Color TV developments QUICKLY.

SEND FOR FREE BOOK TODAY!

WESTERN TV offers real experience on live equipment in our BIG SHOPS AND LABORATORIES in the shortest practical time under expert instructors. Graduates are in big demand because they have the "field experience" necessary for immediate "bench" or supervisory positions. You learn every phase of Radio and TV servicing (AM, FM, VHF, UHF). WTI men win fast promotion... can demand better pay... develop highly profitable businesses of their own with the latest and most PRACTICAL PERSONALIZED TRAINING BEHIND THEM. You concentrate all your time on being a PROFESSIONAL TV SERVICE TECHNICIAN — non-essential math and engineering theory omitted. YOU CAN EARN WHILE YOU LEARN. Special Finance Plan.

APPROVED FOR VETERANS. Find out how you can get into the TOP PAY GROUP — Send for this fact-packed book NOW!

WESTERN TELEVISION INSTITUTE

America's Leading Television Servicing School

Western Television Institute Dept. E-6-55
341 W. 18th St., Los Angeles 15, Calif.
Without obligation, please send FREE fully illustrated booklet. (No salesman will call.)

NAME _____ AGE _____
ADDRESS _____
CITY _____ ZONE _____ STATE _____

Become an

ELECTRICAL ENGINEER



Major in Electronics or Power BS Degree in 36 months

Prepare now for a career as an electrical engineer or engineering technician — and take advantage of the many opportunities in these expanding fields.

You can save a year by optional year 'round study. Previous military, academic, or practical training may be evaluated for advanced credit.

Enter Radio and Television — courses 12 to 18 months

You can be a radio technician in 12 months. In an additional 6-months you can become a radio-television technician with Associate in Applied Science degree. Color television instruction is included in this program.

These technician courses may form the first third of the program leading to a degree in Electrical Engineering. Twenty-one subjects in electronics, electronic engineering and electronic design are included in these courses.

Courses also offered: radio-television service (12 mos.); electrical service (6 mos.); general preparatory (3 mos.).

Terms — July, September, January, April

Faculty of specialists. 50,000 former students—annual enrolment from 48 states, 23 foreign countries. Non-profit institution. 52nd year. Courses approved for veterans. Residence courses only.

MS-6A

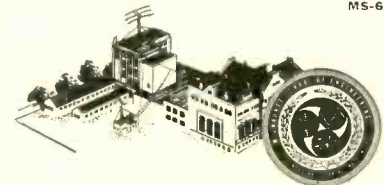

MILWAUKEE SCHOOL OF ENGINEERING

MILWAUKEE SCHOOL OF ENGINEERING
Dept. RE-655, 1925 N. Milwaukee Street
Milwaukee 1, Wisconsin

Send FREE illustrated booklets
 Career in Electrical Engineering,
 Career in Radio-Television.

I am interested in _____ (name of course)

Name _____ Age _____

Address _____

City _____ Zone _____ State _____

If veteran, indicate date of discharge _____

TRIO

America's Top Quality Line...

is the Best Buy for the Money!



Behind every TRIO antenna is the RESEARCH—ENGINEERING—EXPERIENCE and CRAFTSMANSHIP that has made TRIO the leader in antenna development.

TRIO — THE COMPLETE LINE
 "VARI-CONS"
 CONICALS
 COLINEAR ARRAYS
 YAGIS
 RADAR SCREEN TYPES
 UHF & REFLECTOR TYPES
 CONICAL — YAGIS

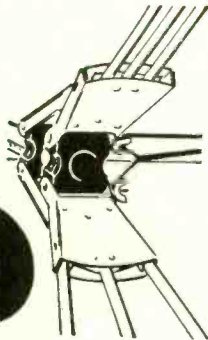

New "Vari-Con" Head

Four hi-strength aluminum adjusting arms. Interlocking butterfly sections. Heavier snap-action spring assembly. Spring dampeners lessen vibration and breakage. Mycastyrene insulators. Used on the popular TRIO "88" and "Vari-Con" antennas.



Sensational "INSTA-LOK" CLAMP

(Good-Bye Nuts)
 Revolutionary TRIO clamp employed on all TRIO antennas with parasitic elements. Permits instant flip-out assembly — permanent alignment and ultra-strength. Nothing stronger! Nothing faster!

COMPARE THESE FEATURES!

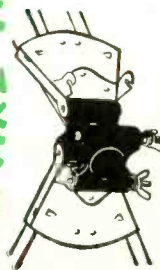

New Minit-Up Conical Head

Superior strength — with the new modern riveted construction. No shedding of elements as with doweled, friction held elements.



Heaviest Booms!

Thick-wall, extra sturdy 1 1/4" diameter booms used on ALL low band Yagis. Highest grade Alcoa aluminum for added strength.



THE TRIO "ARISTOCRAT"

America's Most Dependable Rotator Is Also America's Most Beautiful

Control unit available in four glorious colors.

America's No. 1 Choice

The TRIO "88"

More DB gain per dollar cost. Completely pre-assembled, ready to unfold and install. New Mycastyrene insulators for greater strength and insulating qualities. Highest quality Alcoa aluminum elements and extra sturdy boom. Exclusive, sensational TRIO Jr. & Sr. "Insta-Lok" clamps combined with famous "Vari-Con" head gives the "88" all the plus features everyone wants. Rugged construction, completely pre-assembled, superior performance and low unit cost. The best buy on the market today! Available in single or two bay models.



NEWEST ADDITIONS TO THE TRIO LINE

The TRIO "99" CHANNELS 3-13

A well-known broad band Yagi type featuring sturdier construction, higher quality materials and faster assembly. Improved forward gain with reduced side and rear pick-up as a result of TRIO engineering and research. Uses famous "Insta-Lok" clamps and all riveted construction as originally introduced by TRIO.



The TRIO "77" CHANNELS 3-13

High gain, broad band type now greatly improved as a result of TRIO engineering. Highest quality Alcoa elements and boom. Exclusive "Insta-Lok" clamps for easy, fast assembly. Designed for low wind resistance and balanced for rotator operation.

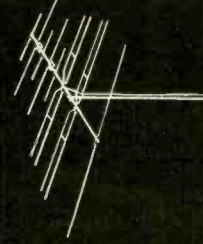

TRIO MANUFACTURING COMPANY · GRIGGSVILLE, ILLINOIS

Leader in Antenna Development

Copyright 1955 by TRIO MANUFACTURING CO.

EXPORT SALES DIV., SCHEEL INTERNATIONAL, INC., 4237 N. Lincoln Ave., Chicago, U.S.A.

ADVERTISING INDEX

Radio-Electronics does not assume responsibility for any errors appearing in the index below.

Aermotor Company	122
Allied Radio Corp.	15
Almo Radio Co.	100, 124
American Microphone Co.	105
American Phonic Corp.	96
Amplifier Corporation of America	104
Arky Radio Kits, Inc.	113
Atlas Sound Corp.	116
Audel Publishers	114

Barjay Co., The	115
Barry Electronics Corp.	129
Belden Mfg. Co.	10
Bell Telephone Labs.	22
British Industries Corp.	114
Brooks Radio & TV Corp.	89

CBS Hytron (Div. of Columbia Broadcasting System)	24
Cannon Electric Co.	75
Capitol Radio Engineering Institute	11
Century Books	112
Channel Master Corp.	21
Chicago Standard Transformer Corp.	115
Circle Electronics Products Co.	124
Cleveland Institute of Radio Electronics	88
Collins Audio Products Co.	92
Colordaptor	125
Concord Radio	125
Coyne Electrical School	104, 107, 125

DeVry Technical Institute	7
---------------------------	---

Edlie Electronics	123
Electro-Voice, Inc.	6
Electronic Instrument Co. (EICO)	27, 28, 102, 113, 120
Electronic Measurements Corp.	102
E-Z Way Towers, Inc.	102

General Cement Mfg. Co.	26
Goodmans Loudspeaker	98

Hawkins, P. E. Co.	124
Health Co.	67, 71
Hudson Specialties Co.	109
Hughes Research & Development Labs.	14, 97

Indiana Technical College	112
Instructograph Co.	124
Instruments For Service, Inc.	104

Jackson Electrical Instrument Co.	117
Jensen Industries	116
Jontz Manufacturing Co.	116

Lafayette Radio Corp.	101
Leotone Radio Corp.	100

Macmillan Co., The	121
Mallory, P. R. & Co., Inc.	99
McGraw-Hill Book Co., Inc.	100
Moss Electronic Distributing Co.	94, 95

National Radio Institute	3, 13
National Schools	5

Opportunity Adlets	117
--------------------	-----

Phaestron Co.	18
Philco Corporation	23, 74
Precision Apparatus Co., Inc.	126
Precise Development Corp.	117
Progressive Electronics Institute	113
Progressive "Edu-Kits", Inc.	90

RCA Institutes, Inc.	19, 87
RCA Tube Div. (Radio Corp. of America)	91, Back Cover
Rad-Tel Tube Co.	108
Radiart Corp.	12
Radio City Products	129
Radio Craftsmen, Inc. The	120
Radio Merchandise Sales	113
Radio Products Co.	100

RADIO SCHOOL DIRECTORY PAGE 127

Baltimore Technical Institute	
Candler System Co.	
Grantham School of Electronics	
Indiana Technical College	
Indianapolis Electronic School	
Milwaukee School of Engineering	
RCA Institutes, Inc.	
Tri-State College	
Valparaiso Technical Institute	
Western Television Institute	

Radio & Television Training Association	25
Raytheon Mfg. Co.	Inside Front Cover
Rider, John F., Inc.	112
Rinehart & Co., Inc.	102, 129
Rockbar Corporation	98

Sams, Howard W. & Co., Inc.	79
Sangamo Electric Co.	110, 111
Sherwood Electronic Laboratories	122
Simpson Electric Co.	109
Stan-Burn Radio & Electronics	125
Stanley Electronics Corp.	114
Steve-EI Electronics Corp.	124
Surplus Emporium	117
Sylvania Electric Products, Inc.	20, 83

Tab	130
Teletest	113
Terado Co.	103
Transvision, Inc.	119
Trio Mfg. Co.	128
Triplet Electrical Instrument Co.	Inside Back Cover
Tung-Sol Electric Co.	8

Uranium Projectors' Equip.	125
----------------------------	-----

Vaco Products Co.	106
-------------------	-----

Wehster Electric Corp.	93
Wholesale Radio Parts Co.	12
Winegard Co.	16, 17

Xcelite, Inc.	121
---------------	-----

Zingo Products	117
----------------	-----

NEW RCP AC-DC MULTITESTER

IMPROVED... ALL MOLDED

Unequaled
in Appearance
and Performance
by any other
in its class

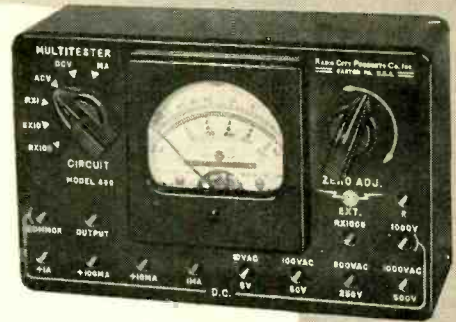

Now within an all molded panel and case RCP has built a multitester based upon the successful tradition of its famous Model 447, whose acceptance has been proven through the sale of 100,000 prototypes. The Model 480 provides greater multitester value than ever before at a far lower price. Here is a must for every laboratory, shop and serviceman's kit... truly universal in design. Its smart looking appearance is only equalled by its quality of performance.

Model 480
An Exceptional Value at... **\$14.85** Complete with battery, ready to operate

3" square meter with 800 microampere D'Arsonval movement gives 1000 ohms per volt sensitivity on DC. Battery for ohmmeter circuit is readily removable and replaceable without soldering or unsoldering. Special spring contact clips make replacement immediately and easily. Excellent rectifier characteristics and quality control of components in a very large production result in an unusually low price.

- RANGES**
- DC Voltmeter... 0-5-50-250-500-1000 volts.
 - AC Voltmeter... 0-10-100-500-1000 volts.
 - Output Voltmeter... 0-10-100-500-1000 volts.
 - DC Milliammeter... 1-10-100-1000 milliamperes.
 - Ohmmeter... 0-10,000 ohms—100,000 ohms—1 megohm and 10 megohms external.
 - Decibel Meter... —8 to 55 Decibels.

RADIO CITY PRODUCTS CO.
EASTON PENNSYLVANIA

See your local parts distributor, or write Dept. RE-6 for RCP catalog.

STANDARD BRAND TUBES AT SENSIBLE PRICES

- Only the 5 Top-Quality Brands Shipped
- Individually boxed. • Only 1st quality.
- Latest Dating • Standard RTMA Guarantee
- No private label, electrical or mechanical rejects.
- No rebrands or reworked "bargains."

Write for Free 1955 New Air-Mail Handy-Order Blank.

- Lists ALL Popular TV & Radio Types.
- Makes Mail-Order a Pleasure.
- All Tube Orders Over \$25.00 (with Remittance) Postpaid, Overnight Shipment.



- Immediate shipments on all types of CBS C.R. Tubes direct from factory-to-you! Only 1st quality new pix tubes shipped. Write for complete price list. New low prices.

SPECIAL-PURPOSE TUBES

Write for our complete listing on XMTG, Industrial, Special-Purpose and Crystal Diodes. We stock over 2,000 types at excellent prices.

1835	5.50	417A KLY.	4.00
2C43	10.00	803	1.90
2C46	8.00	838	1.00
2E30	1.95	829	6.75
3B24	2.00	829-B	8.75
3C45	6.95	65N7 JAN	.55
6J4	3.95	3A5 JAN	.50
26A76T	3.95	7GP4	12.00
211	.50	7EP4	12.00
		AND OTHERS!	

TWO-COLORED TUBE CARTONS, with new Safety Partitions. Prevents Tube Breakage. This Super-Gloss Red and Black Carton is the Most Distinctive Box available Today! Minimum: 100 any one size. Quantity prices on request. Boxes F.O.B., N.Y., N.Y.

SIZE	EACH
Miniature (6AU6, 6AL5, etc.)	\$.01
GT (6SN7, 6W4, etc.)	.0125
LARGE GT (183, 6B06GT, etc.)	.015
LARGE G (5U4G, 6B06G, etc.)	.02

NEW! Same tube cartons as above, but in glossy white. Same prices apply. Specify white.

Terms: 25% with order, balance C.O.D. All merchandise guaranteed. F.O.B., N.Y.C.
New phone and address. Phone: Walker 5-7000.

BARRY ELECTRONICS CORP.
512 Broadway N.Y. 12, N.Y.

PUT YOUR OSCILLOSCOPE TO WORK!

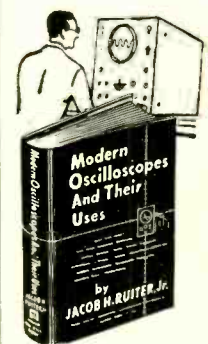

Dust off that oscilloscope of yours! Put it to work fully on the dozens of jobs it can do better than any other instrument. Handle jobs TWICE AS FAST, better and lots more profitably!

This big book, MODERN OSCILLOSCOPES AND THEIR USES shows you how... in a way you can really understand. Clearly and simply, it explains exactly where and how to use your 'scope on all types of AM, FM and TV service... from trouble-shooting to set realigning and everything in between. No fancy theory. You quickly learn how to make connections; how to adjust circuit components; how to set the controls; and how to analyze patterns fast and right! Practice from it 10 days... at our risk! See for yourself how much this clear, easy instruction can mean!

Modern Oscilloscopes and Their Uses
The book that really teaches you to use 'scopes!
326 pages
370 pictures

RINEHART & Co., Inc., Dept. RE-65
232 Madison Ave., New York 16, N. Y.

Send MODERN OSCILLOSCOPES AND THEIR USES for 10-day FREE EXAMINATION. If I decide to keep book, I will then send you \$6.00 plus a few cents postage in full payment. If not, I will return book postpaid and owe you nothing.

Name _____
Address _____
City, Zone, State _____
OUTSIDE U.S.A.—Cash with order only. Price \$6.50. Money back if book is returned in 10 days.

FIRST V-O-M with ALL in ONE!

TRIPLETT

MODEL 630-NA
 Volt-Ohm-Mil-Ammeter
 DEALER Net Price . . . \$69.50

MODEL 630 Famous
 Volt-Ohm-Mil-Ammeter \$39.50
 33 ranges and many other
 features making this the
 favorite in a popular V-O-M line

MODEL 630-A Laboratory Type
 Volt-Ohm-Mil-Ammeter with
 mirror scales, 1-1/2% DC
 accuracy and special 1/2%
 resistors for greater accuracy.
 Found in the best laboratories
 and production lines. \$49.50

MODEL 631 Combination
 V-O-M and VTVM \$59.50
 This sensational 2-in-1 battery
 operated combination saves
 you money — will do all your
 work easier at half the price.

MODEL 666-R Pocket size
 V-O-M. Practically a portable
 laboratory with self contained
 snap-in type batteries. \$26.50

The above are examples of
 the complete Triplett V-O-M
 line in which 10,000 ohms per
 volt AC sensitivity has been
 featured for 10 years.

TRIPLETT HAS THE MOST COMPLETE V-O-M LINE

BURTON BROWNE ADVERTISING

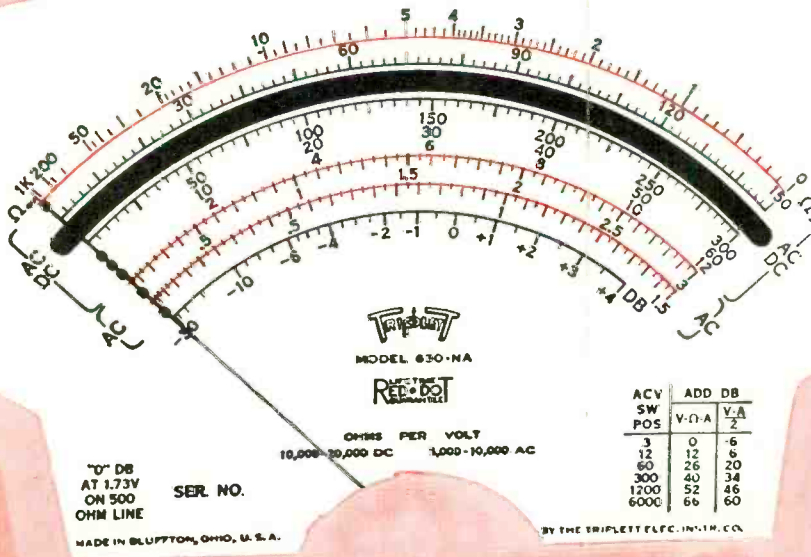

- 70 RANGES . . . nearly double those of conventional testers
- FREQUENCY COMPENSATED . . . for accurate readings over entire audio range
- HIGH AC-DC ACCURACY ON SAME SCALE
- ACCURACY: 1-1/2% DC to 1200 Volts, 3% AC to 1200 Volts
- METER PROTECTION AGAINST OVERLOADS
- TEMPERATURE COMPENSATED . . . Accurate within a wide range of ambient temperatures
- SIX RESISTANCE RANGES Including 100 Megohms
- COMPLETELY INSULATED Black Molded Case
- MIRROR SCALE And Knife-Edge Pointer

actual size

**ALL TRIPLETT
 TESTERS APPROVED FOR COLOR
 see them at your distributors**

TRIPLETT
 TRIPLETT ELECTRICAL
 INSTRUMENT CO.
 Bluffton, Ohio

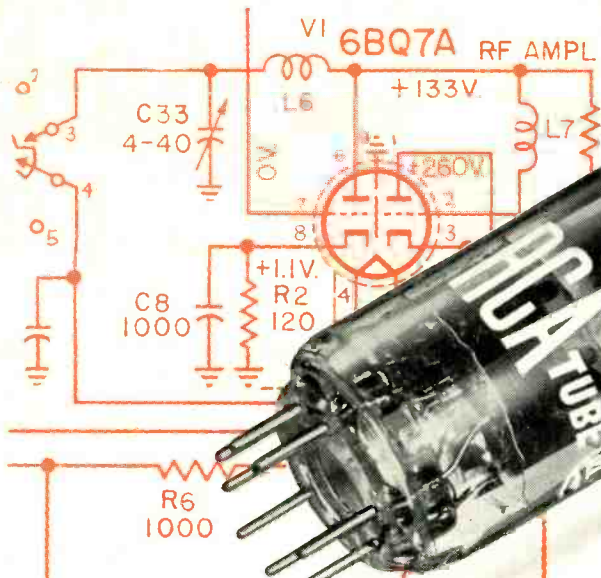

RESTORE
THE "HOP" IN
TV TUNERS...

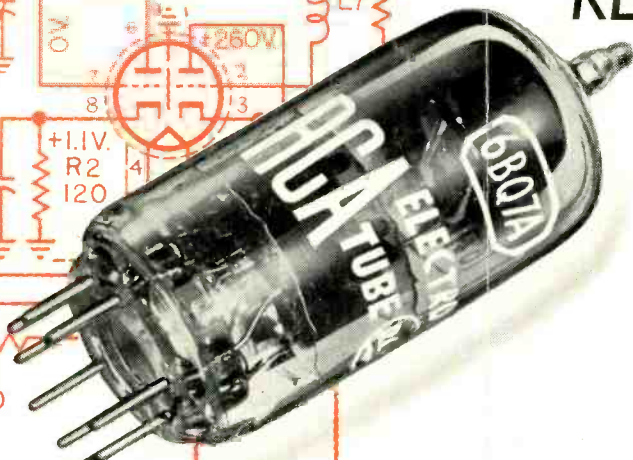

Use RCA Tubes with Built-In Quality!

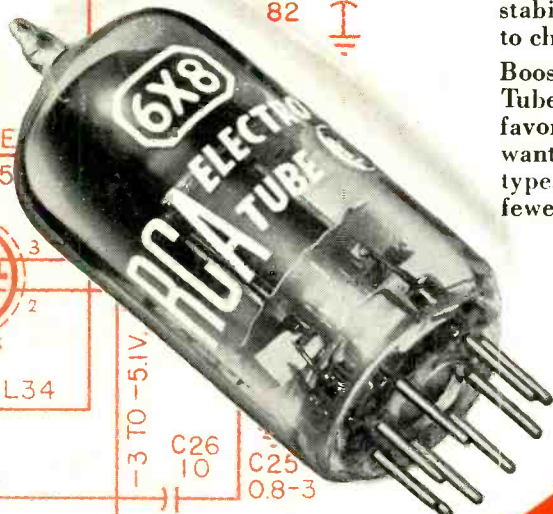
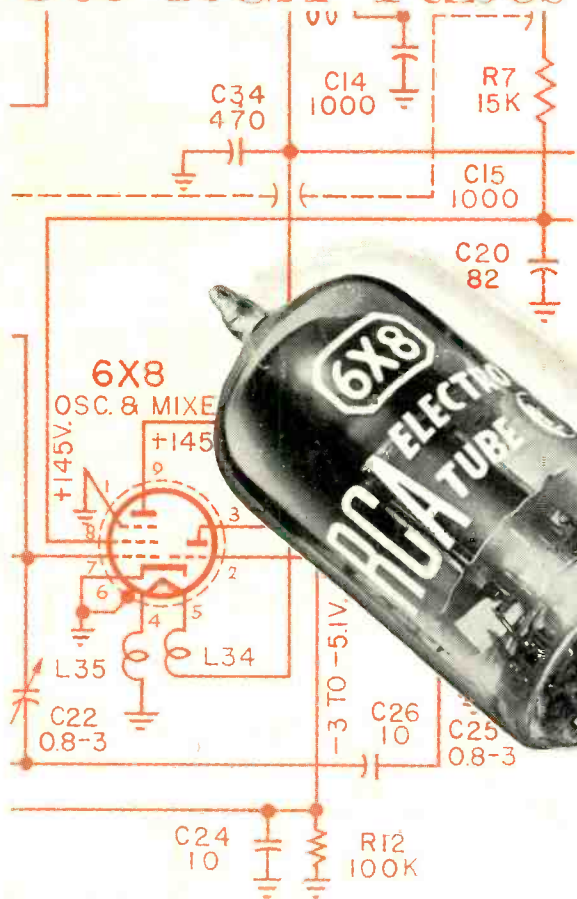

Known for their stability and background "quietness," RCA Tubes help boost the sensitivity of your tuner and reduce tuner noise.

Take the RCA-6BQ7A. Here is a tube having high transconductance, low input capacitance, low plate-to-cathode capacitance, and remarkable uniformity of characteristics—made possible by exacting control procedures during manufacture. Benefits: Greater stability, less receiver noise, higher gain—all the way to channel 13.

Boost the performance of that TV tuner—with RCA Tubes. Next time . . . and every time . . . tell your favorite distributor's counterman or salesman you want genuine RCA Receiving Tubes *only*—type for type. You'll see the difference in better performance, fewer call-backs, and happier customers!



**RADIO CORPORATION
of AMERICA**
ELECTRON TUBES HARRISON, N.J.

Your First Choice for TV circuits . . . dependable RCA Tubes.