

FEBRUARY 1954

RADIO - ELECTRONICS

TELEVISION • SERVICING • HIGH FIDELITY

HUGO GERNSBACH, Editor



In this issue:

Home-Built U. H. F.
Converter

Servicing
High-Fidelity
Amplifiers

Build a
Transistorized
Ukelele

Dielectric
Amplifier

35¢

U. S. and
CANADA

Tetrode Transistor in World's Smallest Amplifier

(See page 4)

MEASURABLE

LIST PRICE ONLY \$22.95

STACKING OF TWO BAYS

Recommended only for the most remote and difficult fringe area reception. Single lead-in; stacking bars available.



Available In "Blonde" Or Mahogany



higher gain **than any other**
All-Channel VHF Antenna!

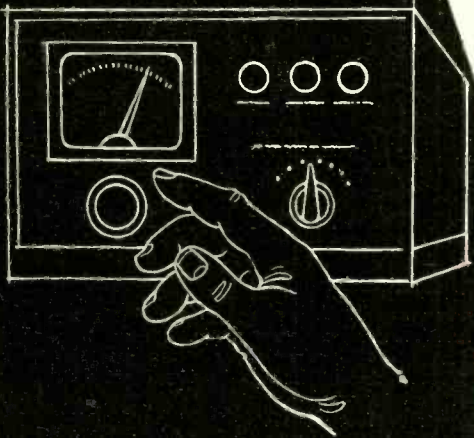

New TRIO "TWIN-SIX"

(channels 2-83)

ONE BAY DOES IT ALL

- No stacking necessary for most fringe areas.
- Exclusive Zig-Zag principle provides that additional gain.
- Single lead-in operation.
- Excellent UHF reception in primary and near fringe areas.
- Rugged "bridge-type" construction, low wind resistance, attractive appearance.
- Performance proved in thousands of actual installations.

America's Most Dependable

TV ROTATOR

- ✓ Only rotator that provides a 2 year guarantee.
- ✓ Only rotator with 2 motors.
- ✓ Only rotator that passes the 200 lb. weight test.

TRIO

TRIO MANUFACTURING COMPANY, GRIGGSVILLE, ILLINOIS



RADIO - ELECTRONICS

Formerly RADIO-CRAFT • Incorporating SHORT WAVE CRAFT • TELEVISION NEWS • RADIO & TELEVISION*

Hugo Gernsback Editor and Publisher

M. Harvey Gernsback
Editorial Director

Fred Shunaman
Managing Editor

Robert F. Scott
W2PWG, Technical Editor

Jerome Kass
Associate Editor

I. Queen
Editorial Associate

Matthew Mandl
Television Consultant

Charles A. Phelps
Copy Editor

Angie Pascale
Production Manager

Wm. Lyon McLaughlin
Tech. Illustration Director

Sol Ehrlich
Art Director

Lee Robinson
General Manager

John J. Lamson
Sales Manager

G. Aliquo
Circulation Manager

Adam J. Smith
Director, Newsstand Sales

Robert Fallath
Promotion Manager



Member
Magazine Publishers
Association

ON THE COVER (More details
on page 95)

The gold-colored piece in the cable is Bell Telephone's experimental transistor amplifier, no larger than a single coaxial conductor. Model Mona McHenry is holding one of the transformers and the transistor used in the amplifier.

Color original by Habershaw Studios, N.Y.C.

CONTENTS

FEBRUARY, 1954

Editorial (Page 29)			
Wanted: Technicians	by Hugo Gernsback	29	
Audio—High Fidelity (Pages 30-42)			
Transistorized Ukulele	by G. B. Herzog	30	
Amplifier Without Frills	by Don V. R. Drenner	33	
An Economical Transmission Set	by Ken Maxwell	34	
One Audio Amplifier—Two Tough Problems	by Henry O. Maxwell	35	
Push-Pull Volume Controls	by Albert H. Taylor	36	
Servicing High-Fidelity Audio Equipment, Part I—High-quality equipment demands high-quality servicing	by Joseph Marshall	38	
High-Quality Audio, Part VI—Pickups, preamps and recording and playback characteristics	by Richard H. Dorf	40	
Television (Pages 43-59)			
Basic Color TV, Part II—Mixing and transmitting colors; reduction of bandwidth	by D. Newman and J. J. Roche	43	
Pay as You Go	by Ira Kamen	46	
Television—It's a Cinch (Eighth Conversation, second half) Horizontal retrace surges and damped oscillations	by E. Aisberg	49	
Home-Built U.H.F. Converter	by Paul S. Lederer	52	
TV DX in February		53	
TV Service Clinic	Conducted by Matthew Mandl	54	
Modern 630 Circuitry, Part II—Circuit Changes for Conversion to Larger Picture Tubes	by Robert F. Scott	56	
Melting U.H.F. Snow	by R. Frier	58	
Test Instruments (Pages 60-65)			
Modifying the Eico 425	by Herman Burstein	60	
Service Technician's Frequency Standard	by John T. Frye	63	
Plug-in TV Bar Generator		65	
Radio (Pages 66-88)			
Parallel Resistors and Series Capacitors	by Norman H. Crowhurst	66	
Electrolytic Capacitors	by Emery Deutsch	69	
Improved Tracking	by Harvey R. Erb	84	
Reconcile that Speaker	by Alan G. Sorensen	86	
Electronics (Pages 92-115)			
Introducing the Dielectric Amplifier	by James S. Fink	92	
Smallest Amplifier (Cover Feature)	by R. L. Wallace	95	
Radio Thirty-Five Years Ago		95	
Electropilot	by Fred Shunaman	96	
Microwave Radiometers	by Donald B. Harris	104	
New Design (Page 117)			
New Tubes		117	
Departments			
The Radio Month	6	New Patents ..	118
Correspondence	12	New Devices ..	122
Business	17	Radio-Electronic Circuits	124
With the Technician ..	116	Try This One ..	132
		Question Box ..	134
		Technotes	137
		People	139
		Electronic Literature ..	142
		Book Reviews ..	143



MEMBER Audit Bureau of Circulations

Vol. XXV, No. 2

Average Paid Circulation over 173,000

RADIO-ELECTRONICS, February, 1954, Vol. XXV, No. 2. Published monthly at Erie Ave., F to G Sts., Philadelphia 32, Pa., Gernsback Publications, Inc., Entered as Second Class matter September 27, 1948, at the Post Office at Philadelphia, Pa., under the Act of March 3, 1879.
SUBSCRIPTION RATES: In U. S. and Canada, and in U. S. possessions, \$3.50 for one year; \$6.00 for two years; \$8.00 for three years; single copies 35¢. All other foreign countries \$4.50 a year, \$8.00 for two years; \$11.00 for three years.
EXECUTIVE, EDITORIAL AND ADVERTISING OFFICES: 25 West Broadway, New York 7, N. Y. Telephone REctor 2-8630. Gernsback Publications, Inc. Hugo Gernsback, President; M. Harvey Gernsback, Vice-President; G. Aliquo, Secretary.
SUBSCRIPTIONS: Address correspondence to Radio-Electronics, Subscription Dept., Erie Avenue, F to G Sts., Philadelphia 32, Pa., or 25 West Broadway, New York 7, N. Y. When ordering a change please furnish an address stencil impression from a recent wrapper. Allow one month for change of address.
BRANCH ADVERTISING OFFICES: Chicago: 7522 North Sheridan Road, Tel. Rogers Park 4-8000. Los Angeles: Ralph W. Harker and Associates, 1127 Wilshire Blvd., Tel. MAdison 6-1271. San Francisco: Ralph W. Harker and Associates, 582 Market St., Tel. G ARfield 1-2481. FOREIGN AGENTS: Great Britain: Atlas Publishing and Distributing Co., Ltd., London E.C.4. Australia: McGill's Agency, Melbourne. France: Brentano's, Paris 2e. Belgium: Agence et Messageries de la Presse, Brussels. Holland: Trillectron, Heemstede. Greece: International Book & News Agency, Athens. So. Africa: Central News Agency Ltd., Johannesburg. Capetown Durban, Natal: Universal Book Agency, Johannesburg. Middle East: Steimatzy Middle East Agency, Jerusalem. India: Broadway News Centre, Dadar, Bombay #14. Pakistan: Paradise Book Stall, Karachi 3. Copyright 1954 by Gernsback Publications, Inc. Text and illustrations must not be reproduced without permission of copyright owners. POSTMASTER: If undeliverable send form 3578 to: RADIO-ELECTRONICS, 25 West Broadway, New York 7, N. Y. *Trademark registered U.S. Patent Office.

RADIO-ELECTRONICS

ADVANCE! Raise your earning power—learn RADIO-TELEVISION-ELECTRONICS by SHOP-METHOD HOME TRAINING

GOOD JOBS AWAIT THE TRAINED RADIO-TV TECHNICIAN

There is a place for *you* in the great Radio-Television-Electronics industry when you are trained as National Schools will train you at home!

Trained technicians are in growing demand at good pay—in manufacturing, broadcasting, television, communications, radar, research laboratories, home Radio-TV service, and other branches of the field. National Schools Master Shop-Method Home Training, with newly added lessons and equipment, trains you in your spare time, right in your own home, for these fascinating opportunities. **OUR METHOD IS PROVED BY THE SUCCESS OF NATIONAL SCHOOLS TRAINED MEN, ALL OVER THE WORLD, SINCE 1905.**

EARN WHILE YOU LEARN

Many National students pay for all or part of their training with spare time earnings. We'll show you how you can do the same! Early in your training, you receive "Spare-time Work" Lessons which will enable you to earn extra money servicing neighbors' and friends' Radio and Television receivers, appliances, etc.

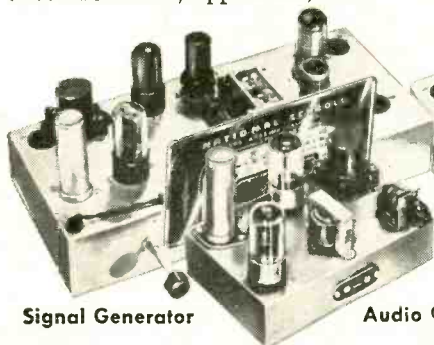

Signal Generator



T. R. F. Receiver

Audio Oscillator

National Schools Training is All-Embracing

National Schools prepares you for your choice of many job opportunities. Thousands of home, portable, and auto radios are being sold daily—more than ever before. Television is sweeping the country, too. Co-axial cables are now bringing Television to more cities, towns, and farms every day! National Schools' *complete* training program qualifies you in all fields. Read this partial list of opportunities for trained technicians:

- Business of Your Own • Broadcasting
- Radio Manufacturing, Sales, Service • Telecasting
- Television Manufacturing, Sales, Service
- Laboratories: Installation, Maintenance of Electronic Equipment
- Electrolysis, Call Systems
- Garages: Auto Radio Sales, Service
- Sound Systems and Telephone Companies, Engineering Firms
- Theatre Sound Systems, Police Radio
- And scores of other good jobs in many related fields.

TELEVISION TRAINING

You get a complete series of up-to-the-minute lessons covering all phases of repairing, servicing and construction. The same lesson texts used by resident students in our modern and complete Television broadcast studios, laboratories and classrooms!



MASTER ALL PHASES!

Get Master Shop-Method Home Training from an Established Practical Resident School with its own Training Studios—almost 50 Years of Successful Experience in Training Ambitious Men.



We Bring National Schools To You!



Superheterodyne Receiver

You also receive this Multitester

LEARN BY DOING

You receive and keep all the modern equipment shown above, including tubes and valuable, professional quality Multitester. *No extra charges.*

FREE! RADIO-TV BOOK AND SAMPLE LESSON!

Send today for National Schools' new, illustrated Book of Opportunity in Radio-Television-Electronics, and an actual Sample Lesson. **No cost—no obligation.** Use the coupon now—we'll answer by return airmail.

APPROVED FOR VETERANS AND NON-VETERANS
Check coupon below

Both Resident and Home Study Courses Offered!



NATIONAL SCHOOLS

LOS ANGELES 37, CALIFORNIA • ESTABLISHED 1905
IN CANADA: 811W. HASTINGS STREET, VANCOUVER, B.C.

GET FACTS FASTEST! MAIL TO OFFICE NEAREST YOU!

(mail in envelope or paste on postal card)

NATIONAL SCHOOLS, Dept. RG-24
 4000 S. Figueroa Street or 323 West Polk Street
 Los Angeles 37, Calif. or Chicago 7, Ill.

Send FREE Radio-TV Electronics book and FREE sample lesson. No obligation, no salesman will call.

NAME _____ BIRTHDAY _____ 19 _____

ADDRESS _____

CITY _____ ZONE _____ STATE _____

Check here if interested in Resident School Training at Los Angeles.

VETERANS: Give Date of Discharge _____

CALL BACKS COST MONEY...

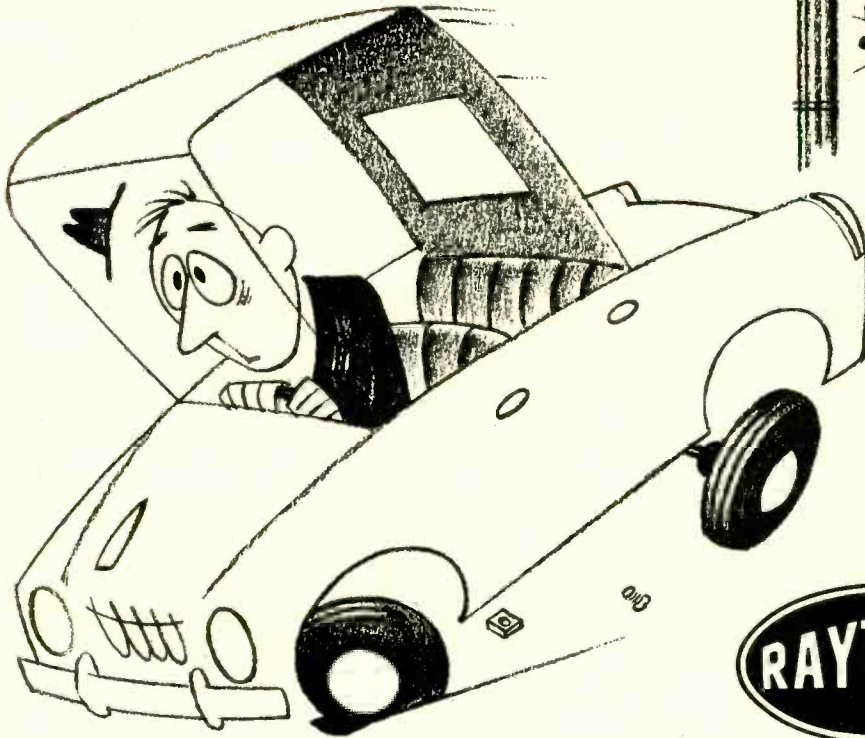

**AVOID
THEM
WITH
THE**



SERVICE SAVER PLAN

available through your **RAYTHEON TUBE DISTRIBUTOR**

The Raytheon Service Saver Plan, which permits customers to identify about 85% of all the troubles that may occur on the screen of a defective TV receiver — and accurately transmit this information to the Service Dealer via telephone — is helping to minimize costly call-backs two ways.

First, when a Service Dealer goes on a call knowing in advance what ails a TV receiver (thanks to Raytheon's Service Saver Plan), he goes completely equipped to do

the job — no more running back to the shop for tubes or parts.

Second, customers frequently call about TV receiver trouble when a minor control adjustment is all that is needed to correct the fault. The Raytheon Service Saver Plan helps Service Dealers avoid these needless, unprofitable calls.

Ask your Raytheon Tube Distributor to tell you how to put the Raytheon Service Saver Plan to work for you.

RAYTHEON RADIO AND TELEVISION TUBES cut call-backs, too! Their outstanding quality reduces early tube failures to a minimum. Use them. You'll find them Right ... for Sound and Sight ... and you!



RAYTHEON MANUFACTURING COMPANY

Receiving Tube Division

Newton, Mass., Chicago, Ill., Atlanta, Ga., Los Angeles, Cal.

RAYTHEON MAKES ALL THESE:

RECEIVING AND PICTURE TUBES • RELIABLE SUBMINIATURE AND MINIATURE TUBES • SEMICONDUCTOR DIODES AND TRANSISTORS • NUCLEONIC TUBES • MICROWAVE TUBES



Excellence in Electronics

RADIO-ELECTRONICS

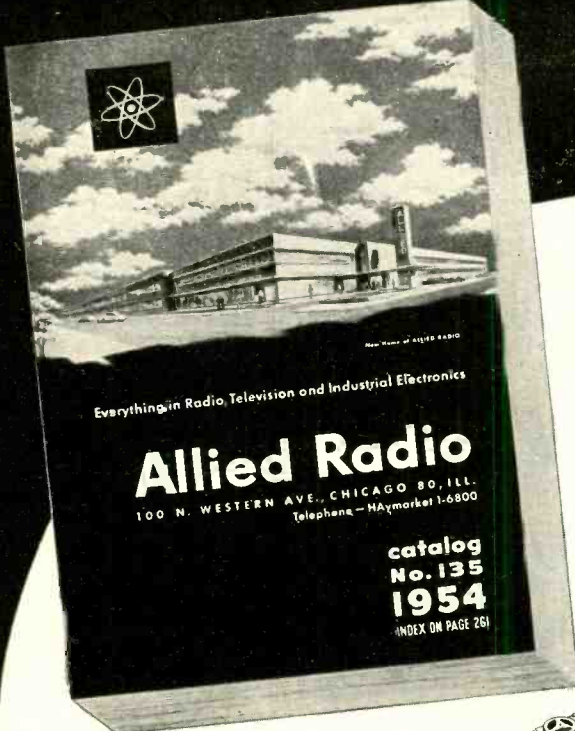

the only **COMPLETE** catalog
for Everything in TV, Radio
and Industrial Electronics

FREE value-packed

1954 ALLIED 268-PAGE CATALOG

The World's Largest Stocks

- TV and Radio Parts
- Test Instruments
- High-Fidelity Equipment
- Custom TV Chassis
- AM, FM Tuners and Radios
- Recorders and Supplies
- P.A. Systems, Accessories
- Amateur Station Gear
- Builders' Kits, Supplies
- Equipment for Industry



Fastest Service in Electronic Supply

SEND FOR THE LEADING
ELECTRONIC
BUYING GUIDE
FREE!



SEND FOR IT TODAY

Get ALLIED'S latest catalog—268 pages packed with the world's largest selection of quality equipment at lowest, money-saving prices. See all the latest releases in custom TV chassis, TV antennas and accessories; AM and FM tuners and radios; everything in High-Fidelity custom components; latest P. A. Systems and accessories; recorders and supplies; Amateur receivers, transmitters and station gear; specialized industrial electronic equipment; test instruments; builders' kits; huge listings of parts, tubes, tools, books—your choice of the world's most complete stocks of quality equipment. ALLIED gives you every buying advantage: speedy shipment, expert personal help, lowest prices, assured satisfaction. Get the big 1954 ALLIED Catalog. Keep it handy—and save time and money. Send for your FREE copy today.

**SAVE ON EVERYTHING
IN ELECTRONICS**

NEW HOME OF
ALLIED RADIO
ultra-modern facilities
TO SERVE YOU BEST



ALLIED RADIO
World's Largest Electronic Supply House

EASY PAY TERMS
Use ALLIED'S liberal Easy Payment Plan—only 10% down, 12 months to pay—no carrying charge if you pay in 60 days. Available on Hi-Fi and P.A. units, recorders, TV chassis, test instruments, Amateur gear.

TV and HI-FI SPECIALISTS
To keep up with developments in High-Fidelity and TV, look to ALLIED. Count on us for all the latest releases and largest stocks of equipment in these important fields. If it's anything in High-Fidelity or Television—we have it in stock!

ALLIED RADIO CORP., Dept. 2-B-4
100 N. Western Ave., Chicago 80, Illinois

Send FREE 268-Page 1954 ALLIED Catalog

Name _____

Address _____

City _____ Zone _____ State _____

Choice of Hi-Fi Enthusiasts!

E-V RADAX

SUPER-EFFICIENT COAXIAL SPEAKERS



Model SP8-B Radax Super-Eight. Unusual bass balance in 8-inch coaxial speaker. Response 35-13,000 cps ± 6 db. 15-20 watts. Imp: 8 ohms. 1 lb. Alnico V magnet. $5\frac{1}{2}$ " depth behind mtg. panel. List Price... \$47.50 Audiophile Net... \$28.50

Model SP12-B Radax Twelve. Full range 12-inch coaxial speaker. Response 35-13,000 cps ± 6 db. 15-20 watts. Imp: 8 ohms. 1 lb. Alnico V magnet. $6\frac{1}{2}$ " depth behind mtg. panel. List Price... \$49.50 Audiophile Net... \$29.70

Model SP12 Radax Super-Twelve. Amazing lows and highs in 12-inch coaxial speaker. Response 30-13,000 cps ± 5 db. 25 watts. Imp: 16 ohms. 3 lb. Alnico V magnet. $7\frac{1}{2}$ " depth behind mtg. panel. List Price... \$95.00 Audiophile Net... \$57.00

Model SP15 Radax Super-Fifteen. Full range and balance in 15-inch coaxial speaker. Response 30-13,000 cps. ± 5 db. 30 watts. Imp: 16 ohms. $5\frac{1}{4}$ lb. Alnico V magnet. $8\frac{7}{8}$ " depth behind mtg. panel. List Price... \$130.00 Audiophile Net... \$78.00

Enjoy the Range and the Realism

New concepts by E-V create new values for you in the enjoyment of sound reproduction. Unique Radax principle and built-in mechanical crossover permit design of the low-frequency cone and high-frequency axial radiator for extended optimum bass and treble response. Heavier "pound-rated" magnets provide more driving power and generous distortion damping factors. These and other E-V quality features assure more listening pleasure.

Hear them at your E-V Distributor
or Write for FREE Hi-Fi Bulletins

Electro-Voice

421 CARROLL ST. • BUCHANAN, MICH.
Export: 13 E. 40th St., N.Y. 16, U.S.A. Cables: Arlab

SURFACE-BARRIER TRANSISTOR

capable of operating at higher frequencies and lower power consumption than point contact or junction transistors has been announced by Philco.

The surface-barrier transistor is made from a small slab of N-type ger-

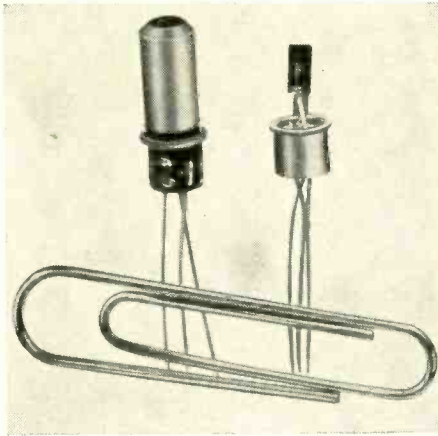

manium which is first etched with tiny jets of indium salt to a thickness of two ten-thousandths of an inch, and then electroplated with indium to form electrodes. Thickness is controlled to within 1 wavelength of light.

The transistor operates reliably up to 70 mc. Its low power consumption permits a 2 cubic-inch battery to operate 5 to 10 hours-per-day over a 6-month period, making it highly applicable to military use.

Having a power gain of 1,000 and a controllable base resistance of between 50 and 1,000 ohms, this transistor and the surface-barrier technique opens the door to whole new families of transistors.

SUBSCRIPTION TV

took the role of villain at a meeting held by the Theater Owners of America in Chicago.

With the theme that subscription TV is the greatest threat to theater TV, the Theater Owners of America declared that they will fight to keep boxoffice TV for use by theaters instead of through home subscription.

S. H. Fabian, head of the Warner-Fabian chain, chairman of the meeting, and M. Wolfson, head of the Wometco circuit, Florida, who acted as co-chairman, stated that theater TV will have a definite place in motion picture theater programming in the future. Wolfson went so far as to say that he doubted the legality of subscription TV for homes.

PRINTED CIRCUIT TV

receivers are being mass produced by the Kaye-Halbert Television Corp. The chassis has been divided into nine major sections, rather than one complete printed circuit, and is mounted vertically behind the picture tube. The backs of the TV cabinets will be so hinged that service technicians may merely drop the back of the cabinet to look directly at the vertical chassis.

By breaking down the chassis into nine major sections and designing a snap-in arrangement for these sections,

it is estimated that about 95% of all servicing on the K-H sets will be made in the home.

TELEVISION RECEIVERS

totaled 25,690,000 in operation throughout the U.S. as of October 1, 1953. The estimate was made by H. M. Beville, Jr., NBC director of research and planning.

The figure represents an increase of 457,000 sets during September. Based on the 25,690,000 figure, about 56% of all U.S. homes now have television, of which 4,456,000 sets have been installed since January 1, 1953.

COLOR TV POWER

consumption may pose new problems of installation and servicing. Many of the nations homes, the newspaper *Retailing Daily* pointed out recently, are already straining their electrical wiring circuits to the limit with numerous electric appliances including such high-wattage apparatus as home freezers, air conditioners, and clothes dryers.

Some cities already are having trouble with fire hazards arising from inadequate home electrical wiring.

The average monochrome TV receiver consumes about 250 watts. Estimates from officials of RCA, CBS, and DuMont on the power required by the first color TV receivers ranged from 350 to 500 watts. This is not large in comparison with many appliances, but in many instances may become the "last straw."

It is believed that by the time commercial color receivers are in mass production, the power requirements will be reduced drastically through a reduction in tubes and the use of transistors.

TWENTY-ONE NEW STATIONS

may be added to the complete list of TV stations on the air which we ran on page 80 last month. These are:

KTVA	Anchorage, Alaska	11
KATV	Pine Bluff, Ark.	7
WITV	Fort Lauderdale, Fla.	17
WJHP-TV	Jacksonville, Fla.	36
WJDM	Panama City, Fla.	7
KID-TV	Idaho Falls, Ida.	3
WBLN	Bloomington, Ill.	15
WDAN-TV	Danville, Ill.	24
WSIL-TV	Harrisburg, Ill.	22
WLAM-TV	Lewiston, Me.	17
WCSH-TV	Portland, Me.	6
WWTV	Cadillac, Mich.	13
KOMU-TV	Columbia, Mo.	8
WRTV	Asbury Park, N. J.	58
WAYS-TV	Charlotte, N. C.	36
KFYR-TV	Bismarck, N. D.	5
WSTV-TV	Steubenville, O.	9
KWTV	Oklahoma City, Okla.	9
WAIM-TV	Anderson, S. C.	40
WEAU-TV	Eau Claire, Wisc.	13
WNAM-TV	Neenah, Wisc.	42

WBES-TV, Buffalo, N. Y. (Channel 59) has gone off the air. It is the third station to do so.

These bring the total up to 349 on the air as of December 19, 1953.

KEYL, San Antonio, Texas (Channel 5), has changed its call letters to KGBS-TV. KGBS-TV, Harlingen, Tex. (Channel 4), has changed its call letters to KGBT-TV.

WOOD-TV, Grand Rapids, Mich. has switched from Channel 7 to 8.

WTAP, Parkersburg, W. Va., (Channel 15) was erroneously listed with the Virginia stations—as well as in its proper place—last month.

NOW... get laboratory-type training **AT HOME!**

in TELEVISION RADIO-ELECTRONICS

... thanks to D.T.I.'s practical

HOME LABORATORY

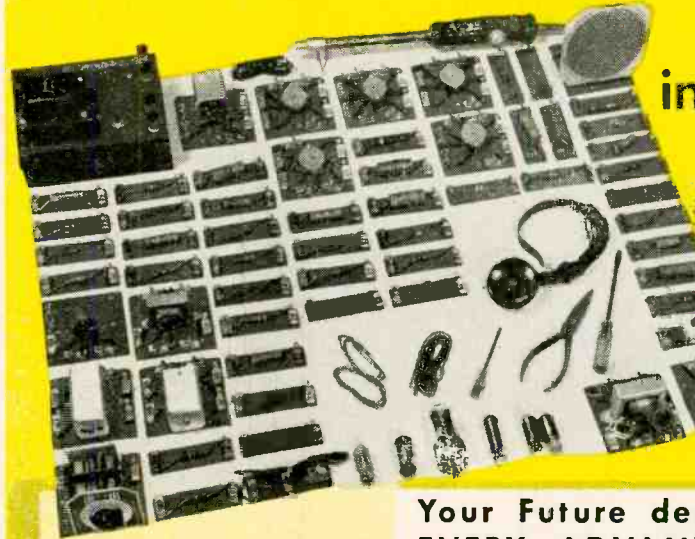

THE D.T.I. HOME LABORATORY is a remarkable development that enables you to get PRACTICAL experience in Television-Radio-Electronics right in your own home—much the same type of practical, basic training that might be expected from attending a well equipped training laboratory.

300 Over a period of time you get and KEEP 16 shipments of Radio-Electronic parts for working over 300 "Learn By Doing" projects and experiments. First you mount your parts on individual fiber bases with spring clip connectors. Simply push down connector... insert wire... release... and you have a good connection. By means of this flexible system, you speedily rearrange your parts into many different circuits—saving hours of time. Wonderful for experimenting.



You build and operate six different types of Radio circuits... Television circuits... a wireless microphone... continuity testers... and many other major projects. We have found nothing else like it for getting practical circuit knowledge at home.



LEFT: Student arranging his D. T. I. parts into 6 tube "Super" Radio Circuit. This is but one of the many major circuits you build... and operate. You will find D. T. I.'s system unsurpassed for speedy circuit construction and experimenting.

MODERN LABORATORY

If preferred, you can get all of your preparation in our modern Chicago Training Laboratory—one of the finest of its kind. Ample instructors, modern equipment. Write for details!

MILITARY SERVICE

If subject to military service, the training information we have for you should prove very helpful.

Your Future deserves EVERY ADVANTAGE!

What will mailing the coupon below do for YOU? Just this! You'll find out about one of today's most practical ways to prepare to get into America's great billion dollar opportunity field of TELEVISION-RADIO-ELECTRONICS—a way that has already enabled thousands of men to get started toward a bright future in Television. You'll see how you may get into interesting work that pays well... that offers one of today's most promising futures... that enables you to start your own TV-Radio service business on little capital, if you prefer this to a job opportunity.

And above all, you'll see that it's no longer necessary to leave home to get the kind of practical, laboratory type training so desirable for making real progress in this fast-growing opportunity field. You get home training that has the full benefit of the knowledge and experience gained from training thousands of students first hand in Chicago. You get (1) well-illustrated lessons, (2) D.T.I.'s wonderfully effective Home Laboratory as described to the left—which also includes building and keeping a commercial-type 5-inch Oscilloscope and jewel-bearing Multi-Meter, and (3) D.T.I.'s amazingly effective and exclusive home training aid—INSTRUCTIVE MOVIES. But why not get the complete story? Mail the coupon today.



21 INCH

Build and keep this BIG DTI Engineered TV set—easily converted to U.H.F. (DTI offers another home training, but without the TV set.)

"ONE OF AMERICA'S FOREMOST TELEVISION TRAINING CENTERS" — Established 1931 —



RIGHT: As part of many interesting home laboratory projects, you build and keep this high quality, commercial-type 5-INCH OSCILLOSCOPE. This valuable test instrument—almost a "must" for efficient Television Servicing—is an important reason why so many D.T.I. men are able to EARN WHILE THEY LEARN.



LEFT: You also build and keep this valuable jewel-bearing self-powered MULTI-METER—one of the handiest ALL-PURPOSE meters you can own. It will also prove a valuable aid to helping you earn while a student, and later when working full time in the field.

16-mm. MOVIES

You use this 16-mm. motion picture projector and many reels of educational film—a wonderful, exclusive, D.T.I. home aid to help you understand important fundamentals faster... easier... better. It's almost like having a teacher in your home.

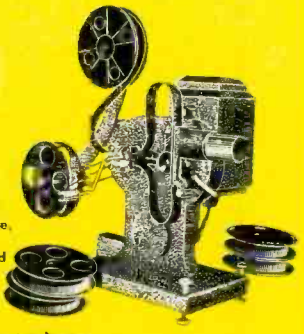

ACT NOW! Mail coupon today for complete facts—including valuable publication that shows 89 Ways Money To Earn in Television-Radio-Electronics.

89 WAYS TO EARN MONEY IN TELEVISION RADIO-ELECTRONICS

DEVRY TECHNICAL INSTITUTE
2533 N. ASHLAND AVE., CHICAGO 14, ILL. DEPT. RE-2-K

I would like your Opportunity News Bulletin showing "89 Ways to Earn Money in Television-Radio-Electronics"; also, complete facts about the training opportunity made possible by your organization.

Name _____ Age _____
Address _____ Apt. _____
City _____ Zone _____ State _____

DEVRY TECHNICAL INSTITUTE
AFFILIATED WITH
DEFOREST'S TRAINING, INC.
CHICAGO 14, ILLINOIS

You can build a reputation on Tung-Sol® Quality

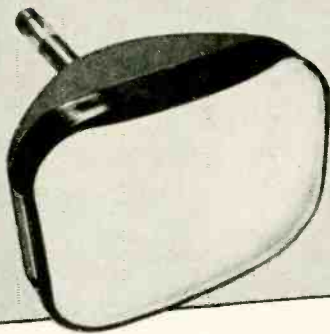

TUNG-SOL makes
All-Glass Sealed Beam Lamps,
Miniature Lamps,
Signal Flashers,
Picture Tubes, Radio, TV,
Special Purpose Electron Tubes,
Semiconductor Products.

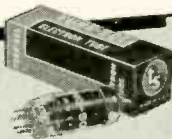

TUNG-SOL ELECTRIC INC.
Newark 4, New Jersey

Sales Offices: Atlanta, Chicago, Columbus, Culver City (Los Angeles), Dallas, Denver, Detroit, Newark, Seattle

CITIZENS BAND RADIO took a long step forward with Stewart-Warner's announcement that their transceiver, the Portafone, is now on the market,



The Portafone—Citizens band transceiver.

after a number of years' work by the Citizens Radio Corporation and, later, by Stewart-Warner.

Carrying FCC class-B radio telephone approval, the Portafone operates in the citizens radio band at a fixed frequency of 465 mc. It may be operated as a portable radio station when used with a battery pack, or as a fixed central radio station when used with a special power pack. It can be operated in an automobile by plugging a special adapter into the cigaret lighter socket.

The Portafone requires an FCC station license, but not an operator's license.

HYDROGEN GAS atoms, in cold areas of interstellar space far from "radio stars" are sending signals to earth. Writing in *Scientific American*, H. I. Ewen states that a high-pitched "noise" at 1420 mc is being picked up from outer space.

The prediction of a Dutch astronomer that hydrogen atoms, when excited to glow in the far reaches of space, emit a detectable amount of energy, was verified by Harvard University scientists. Using a radio-telescope (parabolic-type receiving antenna, wave guide, and supersensitive receiver), the 1420-mc (21-centimeter) radiation was detected.

The total radiation energy of hydrogen from space falling on the entire earth is no more than 2 watts. Radio-telescopes have been made so sensitive, however, that they can amplify a signal one six-thousandth as strong as the receiver circuit noise.

RADIO SATURATION has been reached in farm areas. W. B. Ryan, president of Broadcast Advertising Bureau told the annual meeting of the

National Association of Radio Farm Directors in Chicago.

Stating that radio was the only advertising medium with virtually complete saturation of the farm market, Ryan indicated that several national advertisers planned to enter radio for the first time this year to reach the farm market.

Ryan said that more farm homes have radio than electricity, running water, telephones, or even cows.

RADIO DISTURBANCE warnings are now being broadcast by station WWVH, the Hawaiian counterpart of the National Bureau of Standards' Washington station, WWV.

WWVH broadcasts short-term radio propagation forecasts for the North Pacific area. The disturbance notices tell the condition of the ionosphere at the time of the announcement, and communication conditions expected for the next 12 hours.

A RADIO OF THE FUTURE, though still in an experimental stage, was demonstrated recently by RCA. The smaller all-transistor radio receiver shown in the photo uses junction transistors that amplify signals as high as 10 mc. It weighs only a pound, and has an audio output comparable to small portable receivers.

The larger receiver is an older all-transistor set, also designed by RCA. Its sensitivity and fidelity are comparable to table model receivers several times its size.

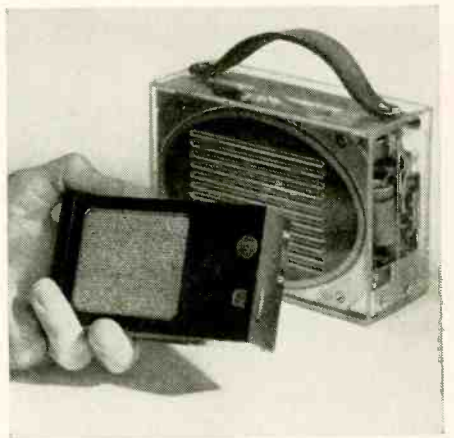

DR. ROBERT A. MILLIKAN, who contributed to electronics one of its fundamental measurements by isolating a single electron and determining its charge, died December 19, 1953, at the age of 85.

Dr. Millikan received the Nobel Prize in 1923 for his achievements in measuring the charge on the electron and for research in photoelectricity. His later studies in cosmic rays attracted even greater attention in recent years than this important early work.

Head of the California Institute of Technology till 1946, Dr. Millikan continued to make contributions to cosmic ray research. He was the author of numerous books, including a number of high-school and college physics texts of extremely wide distribution. **END**

RADIO-ELECTRONICS

Brand New- Just Off The Press!

FREE



TO ANY RADIOMAN WHO WANTS A

BIGGER INCOME

SERVICING 2-WAY MOBILE RADIO SYSTEMS

PAYS BIG MONEY

Get Your FCC COMMERCIAL RADIO OPERATOR LICENSE IN A MINIMUM OF TIME!

Get These Amazing Booklets FREE

Money-Making FCC Commercial Radio Operator LICENSE Information

How to Pass FCC LICENSE EXAMINATIONS

TV ENGINEERING INCLUDED IN OUR TRAINING AND COACHING

TELLS HOW

WE GUARANTEE TO TRAIN AND COACH YOU AT HOME IN SPARE TIME UNTIL YOU GET YOUR FCC LICENSE

TELLS HOW

Employers Make Job Offers To Our Graduates Every Month In Practically Every Field Of Radio!

NATIONAL MANUFACTURER of Mobile Communications Equipment has several openings in the Southwest for FCC licensed, experienced technicians in the field of 2-way Radio Mobile Communications. Salary commensurate with experience and ability.

TECHNICIANS: Wanted by nationally known Airlines at Washington, D. C. office, in all phases of aircraft and ground radio maintenance and troubleshooting. Starting salary \$340 per month with automatic advancement under present wage scale. 1st or 2nd class license required.

TELLS HOW

Our Amazingly Effective JOB FINDING SERVICE Helps CIRE Students Get Better Jobs.

GETS 2-WAY MOBILE RADIO JOB

"After receiving my 1st class phone license and looking over several jobs on your Job-Opportunities Bulletin, have decided on one with Transcontinental Gas Pipe Line Corp." James Driver, 6419 Fitzhugh Avenue, Richmond, Virginia.

GETS AIRLINE JOB

"Many thanks for your assistance in obtaining employment. I am now working for United Airlines." Charles P. Krause, 4026 W. 57th Place, Chicago 29, Illinois.

GETS LABORATORY JOB

"I am happy to tell you that I have obtained a job at Collins Radio Company as a senior laboratory assistant, and I wish to thank you for the assistance you gave me in obtaining this job." James M. Schoening, 1300 Oakland Road, N. E., Apt. 1308, Cedar Rapids, Iowa.

Get All 3 Booklets Free MAIL COUPON NOW



Cleveland Institute of Radio Electronics, 4900 Euclid Avenue, Desk R0-61, Cleveland 3, Ohio (Address to Desk No. to Avoid Delay)

Without obligation, I want to know how I can get my FCC commercial ticket in a minimum of time, and all about the profit opportunities in all types of radio jobs, including 2-WAY MOBILE RADIO SERVICING. Rush me your FREE BOOKLETS: HOW TO PASS FCC LICENSE EXAMINATIONS, MONEY-MAKING FCC COMMERCIAL RADIO OPERATOR LICENSE INFORMATION and THERE'S MONEY FOR YOU IN 2-WAY MOBILE RADIO SERVICING, and give me the details about all radio fields that offer employment opportunities at good pay. Also send me your free sample FCC-type license examination. (PLEASE PRINT BELOW)

NAME _____ ADDRESS _____ CITY _____ ZONE _____ STATE _____

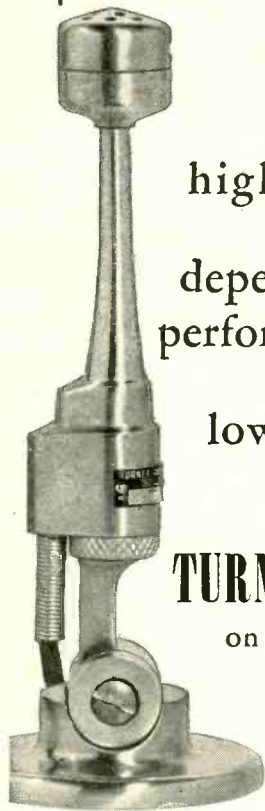

high style
dependable
performance

low price

TURNER 80
on C-4 stand

In design, there is no comparable microphone that equals Turner 80 styling and compactness. Styling that pleases the eye and fits in with modern surroundings. Compactness that makes this microphone convenient and easy to use. You can cradle it in the palm of your hand. Actual size (not including C-4 stand) only 4½" in length.

For PA, home recorder, dictating machine, office and factory call systems and amateur uses, the Turner 80 performance is always dependable.

Sensitivity: Approx. 58 db below 1 volt/dyne/sq. cm.
Response: 80 to 7000 cps.
Weight: 5 oz. less cable.
Cable: 7 foot attached single conductor shielded.

C-4 stand gracefully matches the Turner 80. Both are satin-chrome plated. Stand won't tip or slide with weight of cord.

Turner 80 list price.....\$15.95

C-4 stand list price.....\$ 5.75

THE TURNER COMPANY
933 17th St., N.E.
Cedar Rapids, Iowa

EXPORT: Ad Auriema, Inc.,
89 Broad St., New York 4

CANADA: Canadian Marconi Co.,
Toronto, Ont., and Branches

CORRESPONDENCE

WHAT PRICE "GOLDEN EAR?"

We have received a number of letters pointing out that the Junior Golden Ear amplifier described in our November issue could not possibly be built for \$25, but would cost nearer \$40. These were forwarded to Mr. Marshall, who returned to us a carbon copy of his reply to one of them. We print it below for the benefit of our readership:

Dear Sir:

I'm sorry to have been found guilty of a practice I have deplored in my time as severely as you do. I can assure you it was not deliberate. Like many other experimenters I have a workshop full of parts and junk and usually raid it to assemble an experimental unit, thus bringing my costs down considerably. Then, when I have written it up, I check the catalog for the cost of duplicating it with standard components. I messed that up.

Actually, the situation is not quite as bad as your figures present it. I don't have my original cost figures which were made last February or thereabout; but a check of Allied Radio Corporation's catalog gives me the figures enclosed which amount to \$32.95 with ordinary paper coupling capacitors and \$38.95 with the bathtubs. I concede this is too high to dismiss with a \$25 price tag. I suspect that my original figures were made without the cost of the Compentrol and the chassis, which would bring it to around \$29.00. The Compentrol was an after-thought, added at the last moment, and I probably did not figure its cost. Actually the cost could be brought down to about \$25 by using bargain tubes, filter capacitors, and surplus bathtub capacitors—some of which, incidentally, I have found to be very good. I should have said so in my article. I present this not as an alibi but to explain how authors perpetrate such blunders.

I'm sorry you were let down by your findings. Might I suggest a practical way to reduce the cost, if you are interested in duplicating the Golden Ear Junior? You will note that the power supply accounts for a very large portion of the total cost. If you look around your own or your friends' basements, attics, and storerooms, you can probably find a 10- or 15-year-old radio with a transformer and chokes suitable for the amplifier—one of those 8- or 10-tube consoles would provide a suitable set. You can probably get one of these for free or for a buck or two. I know this is poor retribution but it might make possible an amplifier which does fit your purse.

In any case I appreciate the left-handed compliment implied by the fact that you were sufficiently interested in my piece to go to the trouble involved in figuring out the cost and writing your letter. I won't be guilty of a blunder like this again.

JOSEPH MARSHALL

(The letter was accompanied by a bill of materials, showing prices varying from \$32.95 to \$52.28, according to components used.)

In view of the great interest in this amplifier, we are sure the above letter will answer the questions of many of our readers who have not written. Incidentally, we hope very soon to present a preamplifier for the Junior Golden Ear.—*Editor*)

CAPACITORS AND TESTS

Dear Editor:

"Why buy or make a capacitor tester when you have an ohmmeter on hand?", I used to tell myself. Anyway, I decided to make George Kelley's "Quick Capacitor Checker" described in RADIO-ELECTRONICS on Page 114 of the January 1953, issue. It proved to be quite a revelation. It showed me some things good—some bad. Up to the time I built the capacitor checker, I had more or less relied on my ohmmeter.

One of the good things it told me is that a capacitor can test good on an ohmmeter and be proved absolutely "kaput" on a checker: no good, that is. One of the bad things the tester revealed to me is that many supposedly reputable radio parts dealers sell defective capacitors without giving the buyer

Build Your Own Interior - Styled Cabinets

KITS

by **Cabinart**

presenting the

Paul Klipsch-designed REBEL IV . . .

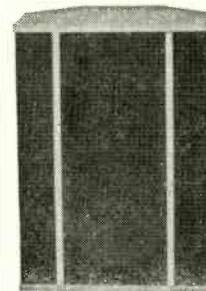

Now you can build your own Klipsch Corner Horn Enclosure and save money—identical in acoustic design to assembled units and easily put together with a minimum of tools. Priced for the home-builder in unfinished birch.

\$36.00* Net for 12" model

\$42.00* Net for 15" model

BASS REFLEX and EQUIPMENT CABINETS

Ideal housing for hi-fi components. Removable panels make future changes easier. Loudspeaker cabinet acoustically designed for either 12" or 15" speaker.



Overall dimensions:
33½" H. 23"
16" W. Tuner
Compartment:
20" H. 21¾"
W. (inside dimensions).
15¼" Deep.
Baffle volume:
6 cubic feet.

No. 80 . . \$27.00*
(Equipment Kit)

No. 8112 . \$18.00*
(12" speaker)

No. 8115 . \$18.00*
(15" speaker)

All kits include 5/8" white pine plywood cut to size, baffle pre-cut for 12" or 15" speaker, Saran Plastic AcoustiCloth, Kim-sul Acoustic Insulation, Assembly and finishing instructions, hardware, plastic wood, sandpaper and glue.

CORNER FOLDED HORN ENCLOSURES

Reproduces a quality of bass heretofore only possible through the use of far more expensive designs.

No. 61 (12" speaker) . . \$19.95*

No. 63 (15" speaker) . . \$23.95*



* Prices higher West and South.
Write for free catalog and nearest distributor
Pioneers in radio furniture for high fidelity equipment

G & H WOOD PRODUCTS COMPANY
75 NORTH 11th STREET
BROOKLYN 11, N. Y.

RADIO-ELECTRONICS

Get in on the TV boom...

starting today!

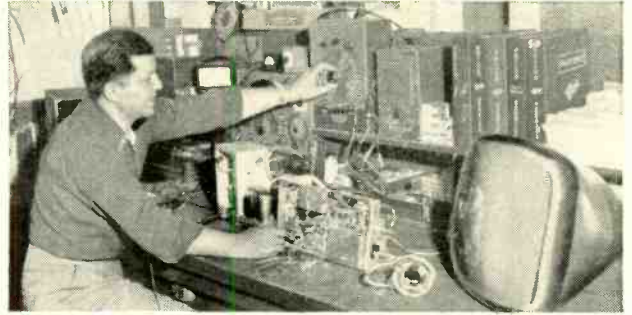
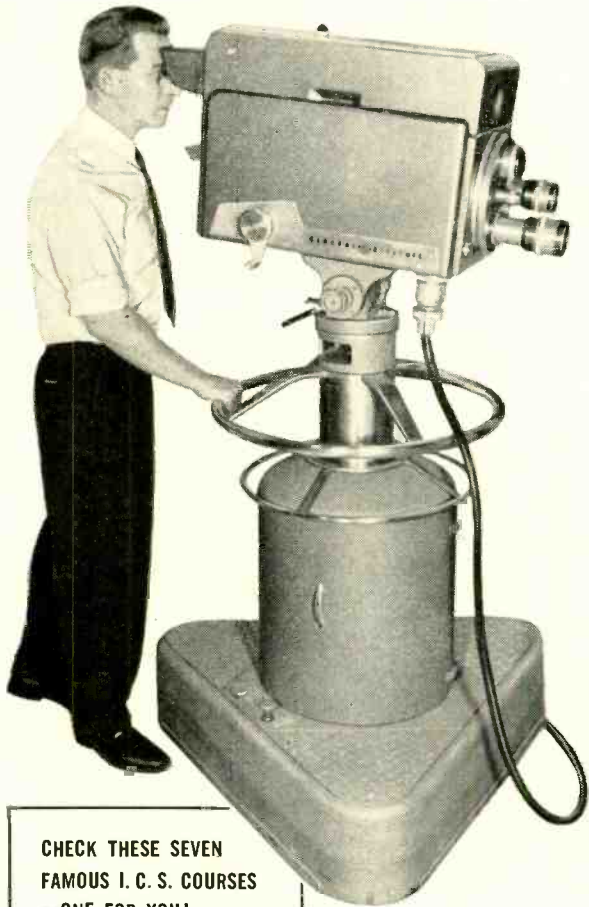

- Prepare now for the new Radio-TV-Electronics boom. Get in on VHF and UHF . . . aviation and mobile radio . . . color TV . . . binaural sound! The International Correspondence Schools can help you!

If you've ever thought about Radio or Television as a career . . . if you have the interest, but not the training . . . if you're waiting for a good time to start . . . NOW'S THE TIME!

No matter what your previous background, I. C. S. can help you. If Radio-TV servicing is your hobby, I. C. S. can make it your own profitable business. If you're interested in the new developments in Electronics, I. C. S. can give you the basic courses of training you need. If you have the job but want faster progress, I. C. S. can qualify you for promotions and pay raises.

I. C. S. training is *success-proved* training. Hundreds of I. C. S. graduates hold top jobs with top firms like R.C.A., G.E., DUMONT, I.T.&T. Hundreds of others have high ratings in military and civil service. Still others have successful businesses of their own.

With I. C. S., you get the rock-bottom basics and theory as well as the all-important bench practice and experimentation. You learn in your spare time—no interference with business or social life. You set your own pace—progress as rapidly as you wish.

Free career guidance: Send today for the two free success books, the 36-page "How to Succeed" and the informative catalog on the course you check below. No obligation. Just mark and mail the coupon. With so much at stake, you owe it to yourself to act—and act fast!

I.C.S., Scranton 9, Penna.

CHECK THESE SEVEN FAMOUS I. C. S. COURSES —ONE FOR YOU!

- PRACTICAL RADIO-TELEVISION ENGINEERING**—Foundation course for radio-television career. Basic principles plus advanced training. Radio, Sound, TV.
- TELEVISION TECHNICIAN**—To qualify you for high-level technical positions in television. Camera, studio, transmitter techniques. Manufacture, sale and installation of TV equipment.
- TELEVISION RECEIVER SERVICING**—Installation, servicing, conversion. Dealership. For the man who knows about radio and wants TV training.
- RADIO & TELEVISION SERVICING**—Designed to start you repairing, installing and servicing radio and television receivers soon after starting the course.
- RADIO & TELEVISION SERVICING WITH TRAINING EQUIPMENT**—Same as above but with addition of high-grade radio servicing equipment and tools.
- RADIO OPERATING COURSE**—Special course to help you pass the Government examination for operator's licenses. Code, TV, FM, Radio regulations.
- INDUSTRIAL ELECTRONICS**—Broad, solid background course devoted to the electron tube and to its many applications.

INTERNATIONAL CORRESPONDENCE SCHOOLS



BOX 2878-K SCRANTON 9, PENNA.

Without cost or obligation, send me "HOW TO SUCCEED" and the booklet about the course BEFORE which I have marked X:

- | | | | | |
|--|--|---|--|---|
| <p>ART</p> <ul style="list-style-type: none"> <input type="checkbox"/> Commercial Art <input type="checkbox"/> Magazine Illustrating <input type="checkbox"/> Fashion Illustrating <input type="checkbox"/> Cartooning <input type="checkbox"/> Sketching and Painting <input type="checkbox"/> Show Card and Sign Lettering <p>AUTOMOTIVE</p> <ul style="list-style-type: none"> <input type="checkbox"/> Automobile, Mechanic <input type="checkbox"/> Auto Elec. Technician <input type="checkbox"/> Auto Body Rebuilding and Refinishing <input type="checkbox"/> Diesel—Gas Engines <p>AVIATION</p> <ul style="list-style-type: none"> <input type="checkbox"/> Aeronautical Engineering Jr. <input type="checkbox"/> Aircraft Engine Mechanic <input type="checkbox"/> Airplane Drafting <p>BUILDING</p> <ul style="list-style-type: none"> <input type="checkbox"/> Architecture <input type="checkbox"/> Arch. Drafting <input type="checkbox"/> Building Contractor <input type="checkbox"/> Estimating <input type="checkbox"/> Carpenter and Mill Work <input type="checkbox"/> Carpenter Foreman <input type="checkbox"/> Reading Blueprints <input type="checkbox"/> House Planning <input type="checkbox"/> Plumbing | <p><input type="checkbox"/> Heating</p> <p><input type="checkbox"/> Painting Contractor</p> <p><input type="checkbox"/> Air Conditioning</p> <p><input type="checkbox"/> Electrician</p> <p>BUSINESS</p> <ul style="list-style-type: none"> <input type="checkbox"/> Business Administration <input type="checkbox"/> Certified Public Accountant <input type="checkbox"/> Bookkeeping and Accounting <input type="checkbox"/> Office Management <input type="checkbox"/> Stenography and Typing <input type="checkbox"/> Secretarial <input type="checkbox"/> Federal Tax <input type="checkbox"/> Business Correspondence <input type="checkbox"/> Letter-writing Improvement <input type="checkbox"/> Personnel and Labor Relations <input type="checkbox"/> Advertising <input type="checkbox"/> Retail Business Management <input type="checkbox"/> Managing Small Business <input type="checkbox"/> Ocean Navigation <input type="checkbox"/> Sales Management <input type="checkbox"/> Short Story Writing <input type="checkbox"/> Creative Salesmanship <input type="checkbox"/> Traffic Management <p>CHEMISTRY</p> <ul style="list-style-type: none"> <input type="checkbox"/> Chemical Engineering <input type="checkbox"/> Chemistry <input type="checkbox"/> Analytical Chemistry | <p><input type="checkbox"/> Petroleum—Nat'l Gas</p> <p><input type="checkbox"/> Pulp and Paper Making</p> <p><input type="checkbox"/> Plastics</p> <p>CIVIL, STRUCTURAL ENGINEERING</p> <ul style="list-style-type: none"> <input type="checkbox"/> Civil Engineering <input type="checkbox"/> Structural Engineering <input type="checkbox"/> Surveying and Mapping <input type="checkbox"/> Structural Drafting <input type="checkbox"/> Highway Engineering <input type="checkbox"/> Reading Blueprints <input type="checkbox"/> Construction Engineering <input type="checkbox"/> Sanitary Engineering <p>DRAFTING</p> <ul style="list-style-type: none"> <input type="checkbox"/> Aircraft Drafting <input type="checkbox"/> Architectural Drafting <input type="checkbox"/> Electrical Drafting <input type="checkbox"/> Mechanical Drafting <input type="checkbox"/> Structural Drafting <input type="checkbox"/> Sheet Metal Drafting <input type="checkbox"/> Ship Drafting <input type="checkbox"/> Mine Surveying and Drafting <p>ELECTRICAL</p> <ul style="list-style-type: none"> <input type="checkbox"/> Electrical Engineering <input type="checkbox"/> Electrician <input type="checkbox"/> Electrical Maintenance | <p><input type="checkbox"/> Electrical Drafting</p> <p><input type="checkbox"/> Electric Power and Light</p> <p><input type="checkbox"/> Lineman</p> <p>HIGH SCHOOL</p> <ul style="list-style-type: none"> <input type="checkbox"/> High School Subjects <input type="checkbox"/> Mathematics <input type="checkbox"/> Commercial <input type="checkbox"/> Good English <p>MECHANICAL AND SHOP</p> <ul style="list-style-type: none"> <input type="checkbox"/> Mechanical Engineering <input type="checkbox"/> Industrial Engineering <input type="checkbox"/> Industrial Supervision <input type="checkbox"/> Foremanship <input type="checkbox"/> Mechanical Drafting <input type="checkbox"/> Machine Design-Drafting <input type="checkbox"/> Machine Shop Practice <input type="checkbox"/> Tool Design <input type="checkbox"/> Industrial Instrumentation <input type="checkbox"/> Machine Shop Inspection <input type="checkbox"/> Reading Blueprints <input type="checkbox"/> Toolmaking <input type="checkbox"/> Gas—Electric Welding <input type="checkbox"/> Heat Treatment—Metallurgy <input type="checkbox"/> Sheet Metal Work <input type="checkbox"/> Sheet Metal Pattern Drafting <input type="checkbox"/> Refrigeration | <p>POWER</p> <ul style="list-style-type: none"> <input type="checkbox"/> Combustion Engineering <input type="checkbox"/> Diesel—Electric <input type="checkbox"/> Electric Light and Power <input type="checkbox"/> Stationary Steam Engineering <input type="checkbox"/> Stationary Fireman <p>RADIO, TELEVISION COMMUNICATIONS</p> <ul style="list-style-type: none"> <input type="checkbox"/> Practical Radio—TV Eng'ing <input type="checkbox"/> Radio Operating <input type="checkbox"/> Radio and TV Servicing <input type="checkbox"/> Television—Technician <input type="checkbox"/> Electronics <input type="checkbox"/> Telephone Work <p>RAILROAD</p> <ul style="list-style-type: none"> <input type="checkbox"/> Locomotive Engineer <input type="checkbox"/> Diesel Locomotive <input type="checkbox"/> Air Brakes <input type="checkbox"/> Car Inspector <input type="checkbox"/> Railroad Administration <p>TEXTILE</p> <ul style="list-style-type: none"> <input type="checkbox"/> Textile Engineering <input type="checkbox"/> Cotton, Rayon, Woolen Mfg. <input type="checkbox"/> Carding and Spinning <input type="checkbox"/> Warping and Weaving <input type="checkbox"/> Loom Fixing <input type="checkbox"/> Throwing <input type="checkbox"/> Finishing and Dyeing <input type="checkbox"/> Textile Designing |
|--|--|---|--|---|

Name _____ Age _____ Home Address _____

City _____ Zone _____ State _____ Working Hours _____ A.M. to P.M. _____

Occupation _____

Canadian residents send coupon to International Correspondence Schools Canadian, Ltd., Montreal, Canada. . . . Special tuition rates to members of the U. S. Armed Forces.

You can't do without...

SYLVANIA'S SEE-WELL TOOL KIT

A NEW, TIME-SAVING TOOL-SENSATION!

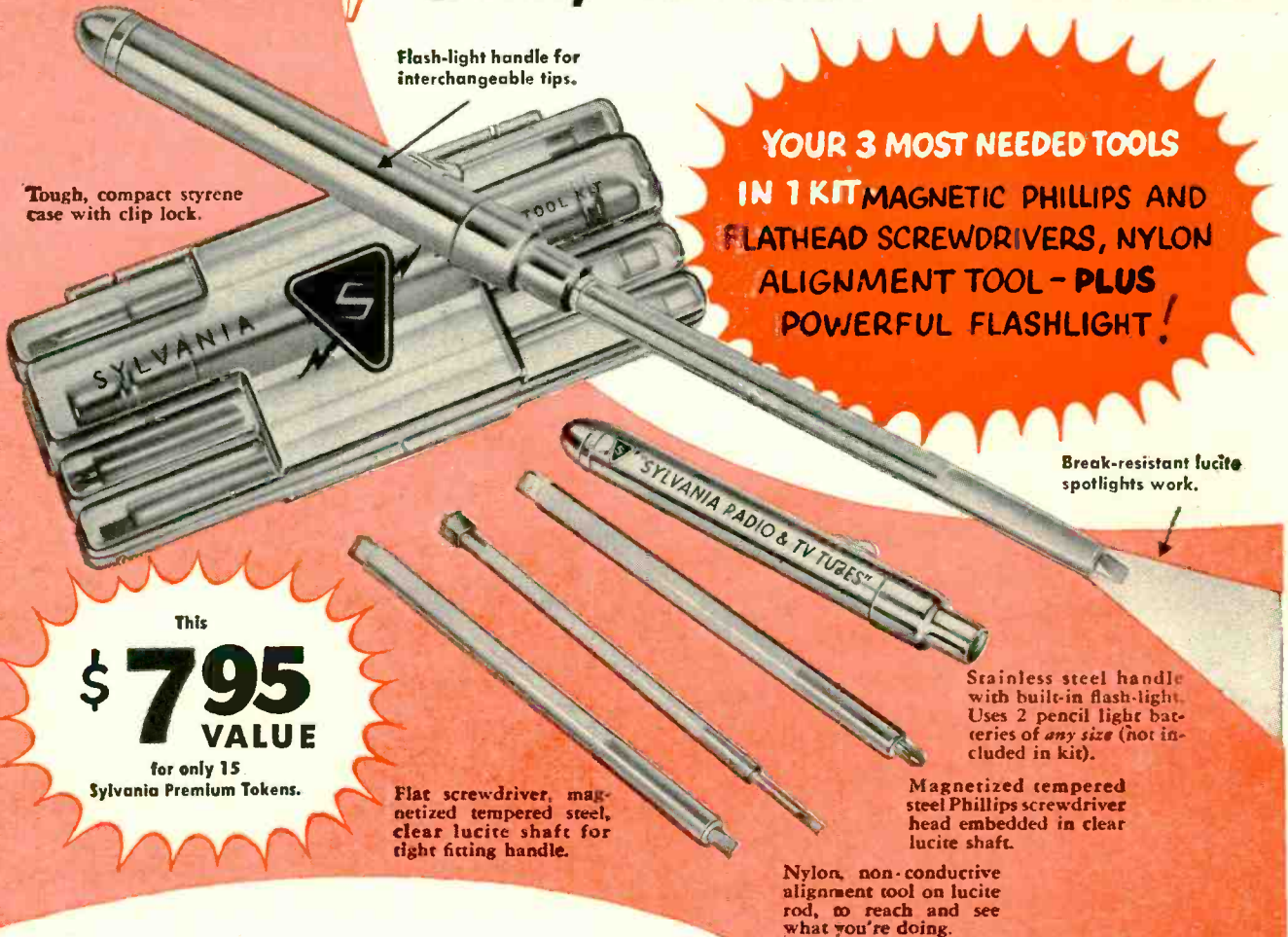

Tough, compact styrene case with clip lock.

Flash-light handle for interchangeable tips.

YOUR 3 MOST NEEDED TOOLS IN 1 KIT MAGNETIC PHILLIPS AND FLATHEAD SCREWDRIVERS, NYLON ALIGNMENT TOOL - PLUS POWERFUL FLASHLIGHT!

This **\$7.95** VALUE

for only 15 Sylvania Premium Tokens.

Break-resistant lucite spotlights work.

Stainless steel handle with built-in flash-light. Uses 2 pencil light batteries of any size (not included in kit).

Magnetized tempered steel Phillips screwdriver head embedded in clear lucite shaft.

Nylon, non-conductive alignment tool on lucite rod, to reach and see what you're doing.

NO MORE FUMBLING inside dark radio and TV cabinets. At the flick of a switch, a bright light automatically focuses right at the spot you're seeking. Saves your time . . . improves your work.

3 Handy Tools in 1. Magnetized Phillips and Flathead screwdrivers, nylon alignment tool - all 3 built into break-resistant lucite shafts perfectly fitted to flashlight handle.

Without doubt, this SEE-WELL Tool Kit is one of the slickest, quickest service tools ever built!

See your Sylvania Distributor Today! He has this remarkable tool kit for you now - you need only 15 Sylvania Premium Tokens. The time to get this valuable Sylvania See-Well Tool Kit is NOW - so don't delay, order high quality Sylvania tubes TODAY.

Remember, you get 1 token with every 25 Sylvania Receiving Tubes or every Sylvania TV Picture Tube you buy.

SYLVANIA

Sylvania Electric Products Inc. Dept. 4R-3802, 1740 Broadway, New York 19, N. Y.

In Canada: Sylvania Electric (Canada) Ltd. University Tower Bldg., St. Catherine Street, Montreal, P. Q.

LIGHTING • RADIO • ELECTRONICS • TELEVISION



RADIO-ELECTRONICS

CREI prepares you quickly for success in

The future is in your hands!

The signs are plain as to the future of the trained men in the electronics industry. It is a tremendous industry, and—at the *present time* there are more jobs than there are trained men to fill them. But—when there's a choice between a trained and untrained applicant, the trained man will get the job. Your biggest problem is to decide on—and begin the best possible training program.

CREI Home Study . . . The Quick Way to Get There.



Since 1927, CREI has given thousands of ambitious young men the technical knowledge that leads to more money and security. The time-tested CREI procedure can help *you*, too—if you really want to be helped. CREI lessons are prepared by experts in easy-to-understand form. There is a course of instruction geared to the field in which you want to specialize. You study at *your* convenience, at *your* rate of speed. Your CREI instructors guide you carefully through the material, and grade your written work personally (not by machine).

Industry Recognizes CREI Training.

CREI courses are prepared, and taught with an eye to the needs and demands of industry, so your CREI diploma can open many doors for you. Countless CREI graduates now enjoy important,

good-paying positions with America's most important companies. Many famous organizations have arranged CREI group training for their radio-electronics-television personnel. To name a few: All America Cables and Radio, Inc.; Canadian Aviation Electronics, Ltd.; Canadian Broadcasting Corporation; Columbia Broadcasting System; Canadian Marconi Company; Hoffman Radio Corporation; Machlett Laboratories; Glenn L. Martin Company; Magnavox Company; Pan American Airways, Atlantic Division; Radio Corporation of America, RCA Victor Division; Technical Appliance Corporation; Trans-Canada Air Lines; United Air Lines. Their choice for training of their own personnel is a good cue for *your* choice of a school.



Benefits Felt Right Away.

Almost immediately, you feel the benefits of CREI training. Your employer, when informed of your step toward advancement (only at your request), is certain to take new interest in you and in your future. What you learn in CREI Home Study can start helping you do a better job immediately.

- BROADCASTING
- TELEVISION
- MANUFACTURING
- COMMUNICATIONS
- SERVICING
- AERONAUTICAL ELECTRONICS



CREI also offers Resident Instruction

at the same high technical level—day or night, in Washington, D. C. New classes start once a month. If this instruction meets your requirements, check the coupon for Residence School catalog.

INFORMATION FOR VETERANS

If you were discharged after June 27, 1950—let the new G. I. Bill of Rights help you obtain resident instruction. Check the coupon for full information.

Get this fact-packed booklet today. It's free.

Called "Your Future in the New World of Electronics," this free illustrated booklet gives you the latest picture of the growth and future of the gigantic electronics world. It includes a complete outline of the courses CREI offers (except Television and FM Servicing) together with all the facts you need to judge and compare. Take 2 minutes to send for this booklet right now. We'll promptly send your copy. The rest—your future—is up to you.



CAPITOL RADIO ENGINEERING INSTITUTE

An Accredited Technical Institute • Founded in 1927

3224 16th Street, N.W.

Washington 10, D. C.

FEBRUARY, 1954

MAIL COUPON TODAY

CAPITOL RADIO ENGINEERING INSTITUTE

Dept. 142-A 3224 16th St., N.W., Washington 10, D.C.

Send booklet "Your Future in the New World of Electronics" and course outline.

CHECK FIELD OF GREATEST INTEREST { TV, FM & Advanced A/V Servicing Aeronautical Radio Engineering
 Practical Radio Engineering Broadcast Radio Engineering (AM, FM, TV)
 Practical Television Engineering

Name.....

Street.....

City..... Zone..... State.....

Check— Residence School Veteran

Why is the SHURE SLIM-X "777" all-purpose crystal microphone a "best buy?"

Professor Profit

CAN BE USED IN EVERY POSSIBLE WAY

BECAUSE IT'S VERSATILE LIKE THIS!

CAN BE REMOVED IN A FLASH—NO TOOLS NEEDED!

BECAUSE IT'S "HANDABLE" LIKE THIS!

SIMPLY PULL OUT LIKE THIS!

IDEAL FOR SO MANY APPLICATIONS

BECAUSE IT'S USEFUL ALMOST EVERYWHERE!

- HOME RECORDING
- HAMS
- OUTDOOR P.A.
- PAGING
- AUDIENCE PARTICIPATION
- NIGHT CLUBS
- AUDITORIUMS

IF you're looking for a low-cost, versatile, good-quality microphone, ask your Shure Distributor about the "777". After he has given you technical information and shown you its amazing versatility—you will see why the "Slim-X" is the answer to your requirements.



*with special Humi-Seal for protection against heat & humidity

SHURE BROTHERS, Inc.
225 West Huron St.—Chicago 10, Illinois
Cable Address: SHUREMICRO

any warning that the units are not top-notch. This is not good. I will explain:

After completing the checker, I tested a whole box of capacitors I bought from concerns who ran ads like this: "Big Bargain in Condensers—Made By One of Nation's Top Manufacturers—We Promised Not To Mention the Name. Stock Up: Buy a Hundred at Our Giveaway Price," etc. (Note: No mention is made of quality, but you are led to believe by the ad wording that the capacitors are of top performance.)

Well, to make a long story short—I tested all these capacitors. And—all but one showed leakage! To double-check, I then tested some capacitors bought from my regular jobber—they were made by the same manufacturers. All these tested good. Obviously something is rotten in Radio Row. There is need for a change in the present code of ethics. Substandard capacitors marketed by reputable manufacturers should carry some distinctive marking if these units are marketed (and they should not be) so the service technician could be sure of the quality he gets.

I wouldn't take a hundred dollars for the Kelly checker. It is good. I have an old Apex 8B receiver which played with fair volume. Not long ago, I tested all the bypasses with an ohmmeter. They checked O.K. Recently I rechecked them with the Kelly tester. Every one showed leakage. I replaced all bypasses and now the set sounds like a PA system. Tell George Kelly "Thanks."

Also tell Jerome Kass that his article "Electronic Kits" in the November, 1953, issue was really tops! I had often wondered just how good were some of these kits. And were they worth risking the amount asked for them; could one be assured of achieving the results claimed for the kit sets? His article answered those questions very well and it gave me renewed faith in attempting more electronic projects in kit form. Like Kass, I, too, have had sad experiences with kits projects that didn't pan out or live up to the claims made.

JOSEPH D. AMOROSE.

Richmond, Va.

(We cannot agree with friend Amorose that seconds should not be marketed at reduced prices. No one who buys parts at "giveaway price" with no brand advertised has a right to expect the performance of top-quality parts sold under the brand name at regular prices. On the other hand, if the manufacturer did not sell them, he would have to throw them away. That would make first-run capacitors more expensive. The second-run units are quite usable on many jobs. Who would worry about a 200,000-ohm leakage in a capacitor across a 10,000-ohm resistor, for example? So by getting back his costs on the second-rate components, the manufacturer is able to avoid loss and keep his list price down; and the service technician is able to get low-priced components of real usefulness within certain limits. Why shouldn't everyone be happy?—Editor) END

**SERVICE TECHNICIANS:
FOR YOUR SHOP!**

THE COMPLETE

**PHOTOFACT
SERVICE DATA LIBRARY**

(world's best TV-Radio service data)

**in this one handy
file cabinet**

YOURS FOR ONLY

\$25 DOWN
NO CARRYING CHARGES

1. If you now own some Sets of PHOTOFACT Folders, you can COMPLETE your present library this EASY-PAY-WAY
2. If you've never used PHOTOFACT, you've never realized your full earning power. Put this file cabinet with its 220 Sets of PHOTOFACT Folders to work... starting right NOW!

YES, ONLY \$25 DOWN PUTS THE COMPLETE PHOTOFACT LIBRARY IN YOUR SHOP...
COVERS OVER 17,000 TV, RADIO, RECORD CHANGER, RECORDER AND AMPLIFIER MODELS

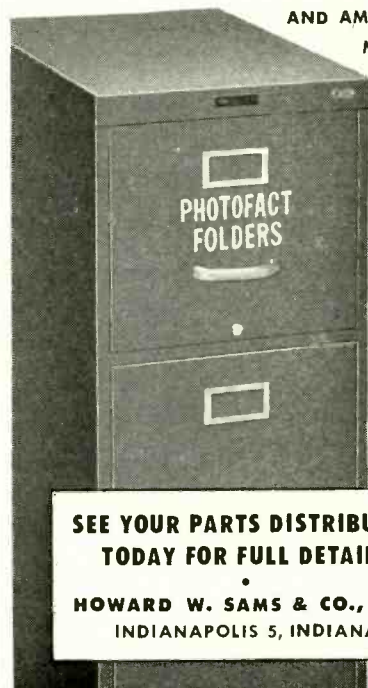

**SEE YOUR PARTS DISTRIBUTOR
TODAY FOR FULL DETAILS**
HOWARD W. SAMS & CO., INC.
INDIANAPOLIS 5, INDIANA

Merchandising and Promotion

CBS-Hytron, Danvers, Mass., will give away 10 of its new socket locators with the purchase of 20 miniature tubes

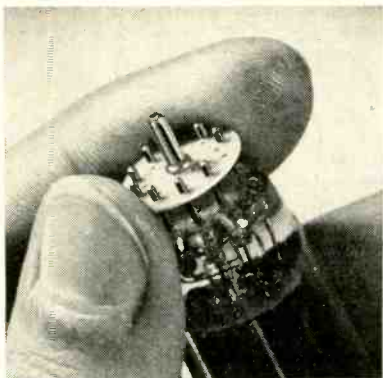

in a promotion during January and February. The device simplifies plugging miniature tubes into hard-to-locate sockets.

Sprague Products Co., North Adams, Mass., is now packaging its replacement line of ceramic capacitors in clear plastic boxes to permit easier storage



and recognition. Sprague Bulplate printed circuits will also be packed in the new reusable hinged containers.

La Pointe Electronics, Rockville, Conn., released a new mailing piece on its Vee-D-X line of antennas and accessories.

Jensen Manufacturing Co., Chicago,



developed a convenient proposal form for its distributors and dealers in recommending high-fidelity music systems to their customers.

Raytheon Manufacturing Co., Receiving Tube Division, Newton, Mass., held another meeting for service technicians (CONTINUED ON PAGE 24)

FEBRUARY, 1954

Don't Worry—I used
ASTRON[®]
BLUE-POINT

you're always sure with
BLUE-POINT*

MOLDED PLASTIC CAPACITORS *because...*

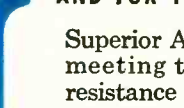
-  Bonded Blue Point Seal — locks out humidity
-  85° C Operation
-  No Soldering Damage
-  Highest Insulation Resistance

Patent Pending

*Trade Mark

AND FOR THE DRY ELECTROLYTICS YOU NEED... 

Superior Astron SM† will do the job better, meeting the most exacting demands for heat and moisture resistance and low leakage.

Ask your jobber for Astron — the best capacitor made. For the name of your nearest Astron jobber, write today to Dept. RE

ASTRON CORPORATION
255 Grant Avenue, East Newark, New Jersey
Manufacturers of a complete line of capacitors and filters for every television, radio, and electronic application.
In Canada, Charles W. Poinlon, 6 Alcina Avenue, Toronto 10, Ont.

† Safety Margin

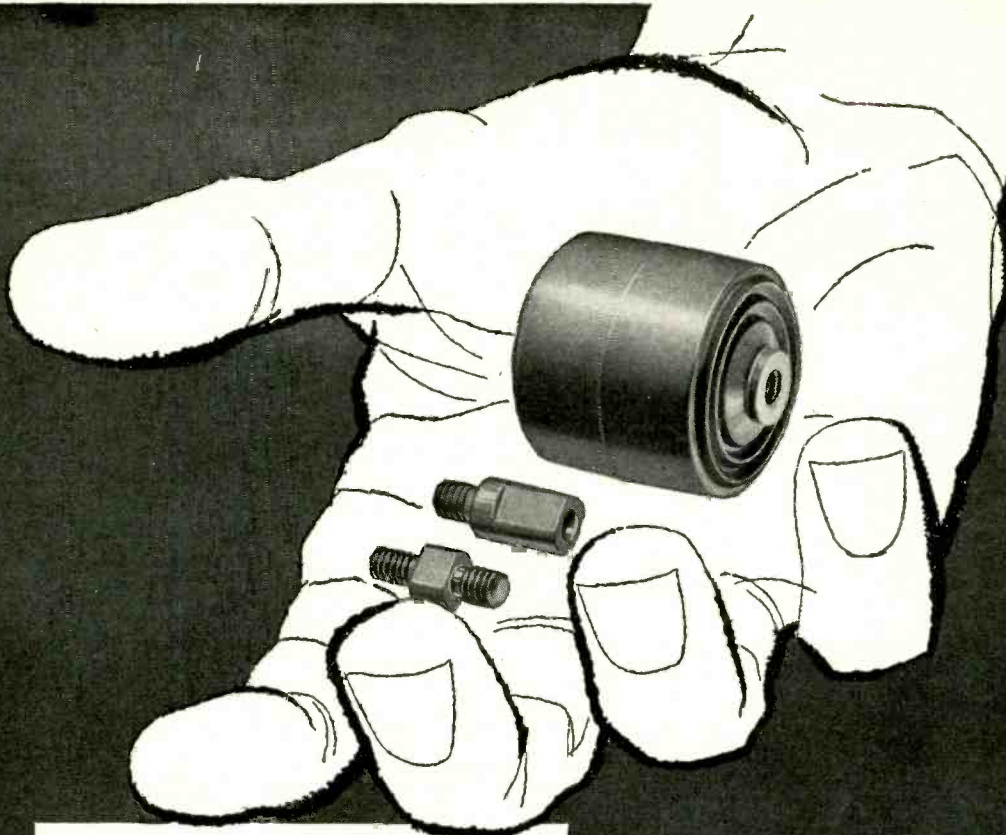

Centralab announces

Precision Attachable Terminal HI-VO-KAPS®

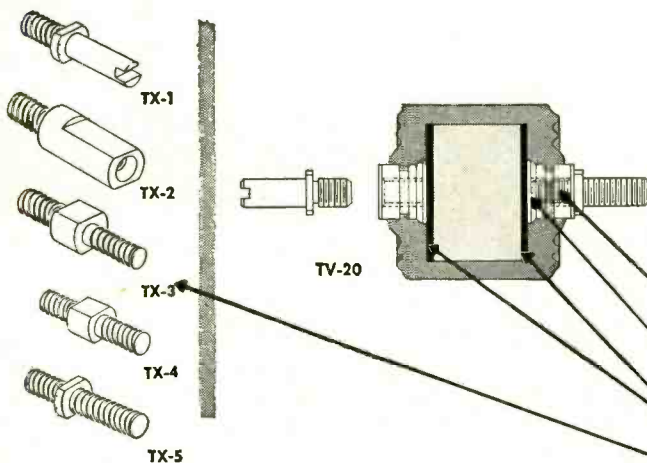

Again, Centralab research pays off for you. For, now, you get CRL high-voltage capacitors with *precision* attachable terminals that give you positive connections *every time*.

These CRL *Precision Attachable Terminal Hi-Vo-Kaps* withstand continuous overload up to 40,000 v.d.c. They are 100% factory-tested at twice rated working voltage — for maximum safety factor.

The diagrams at the left show other reasons why both you and your customers are money ahead, when you use CRL *Precision Attachable Terminal Hi-Vo-Kaps*:

1. Terminals and taps have heavy 8-32 thread and cannot strip or break off, when terminals are tightened. They lock in place — thus can't loosen and cause voltage breakdown.
2. Terminals seat flat at bottom of tap. There are no gaps between terminals and capacitor body to cause internal corona and "blow-up" of capacitor.
3. Positive mechanical bond between stub terminals and internal electrodes prevents loosening when terminals are attached.
4. Terminals and capacitor body are packaged separately. You don't have to buy five different terminals to get the one you need. You pay only for what you use—save money for yourself and your customers.

Keep a stock of CRL *Precision Attachable Terminal Hi-Vo-Kaps* on hand. See your Centralab distributor. Send coupon for his name and further information on this new CRL development.

CENTRALAB, A Division of Globe-Union Inc.
922B E. Keefe Avenue, Milwaukee 1, Wisconsin

- Send me further information on Centralab's new precision attachable terminal Hi-Vo-Kaps.
- Send me name of nearest Centralab distributor.

Name.....

Company.....

Address.....

City..... Zone..... State.....

Centralab

A DIVISION OF GLOBE-UNION INC.
Milwaukee 1, Wisconsin
804 Mt. Pleasant Rd., Toronto 12, Ontario

RADIO-ELECTRONICS



I Will Train You at Home

For Good Pay Jobs, Success in
RADIO-TELEVISION

J. E. SMITH
President
National Radio
Institute
Washington, D. C.
40 years of success
training men at
home in spare time.

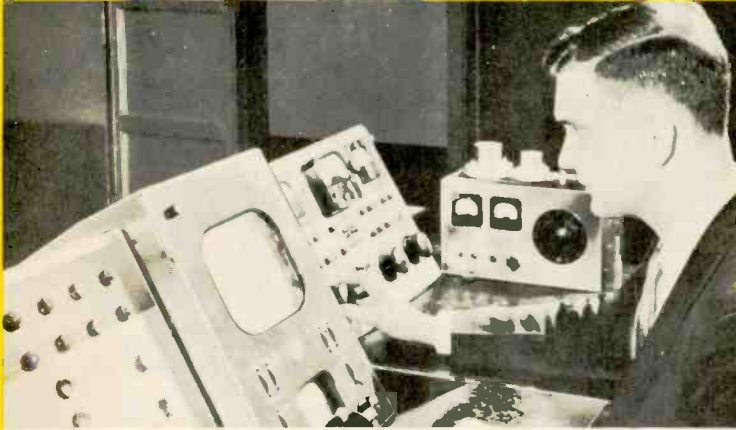

Practice Broadcasting with Equipment I Send

As part of my Communications Course I send you kits of parts to build the low-power Broadcasting Transmitter shown at the left. You use it to get practical experience putting a station "on the air," performing procedures demanded of Broadcasting Station Operators. An FCC Commercial Operator's License can be your ticket to a better job and a bright future; my Communications Course gives you the training you need to get your license. Mail card below and see in my book other valuable equipment you build.



Practice Servicing with Equipment I Send

Nothing takes the place of PRACTICAL EXPERIENCE. That's why NRI training is based on LEARNING BY DOING. You use parts I furnish to build many circuits common to Radio and Television. With my Servicing Course you build a modern Radio (shown at right). You build a Multitester which you use to help fix sets while training. Many students make \$10, \$15 a week extra fixing sets in spare time starting a few months after enrolling. All equipment is yours to keep. Card below will bring book showing other equipment you build.



Television is Growing Fast Making New Jobs, Prosperity

More than 25 million homes now have Television sets and thousands more are being sold every week. Well trained men are needed to make, install, service TV sets. About 200 television stations on the air with hundreds more being built. Think of the good job opportunities here for qualified technicians, operators, etc. If you're looking for opportunity get started now learning Radio-Television at home in spare time. Cut out and mail postage free card. J. E. Smith, President, National Radio Institute, Washington, D. C. OUR 40TH YEAR.

AVAILABLE TO
VETERANS
UNDER G. I. BILL

Good Jobs, Good Pay, Success
in Radio-TV! SEE OTHER SIDE

CUT OUT AND MAIL THIS CARD NOW

Sample Lesson & 64-Page Book

Both FREE

This card entitles you to Actual Lesson on Servicing, shows how you learn Radio-Television at home. You'll also receive my 64-Page Book, "How to Be a Success in Radio-Television." Mail card now!

NO STAMP NEEDED! WE PAY POSTAGE

Mr. J. E. SMITH, President,
National Radio Institute, Washington 9, D. C.

Mail me Lesson and Book, "How to Be a Success in Radio-Television." (No Salesman will call. Please write plainly.)

NAME AGE

ADDRESS

CITY ZONE STATE

VETS write in date
of discharge.

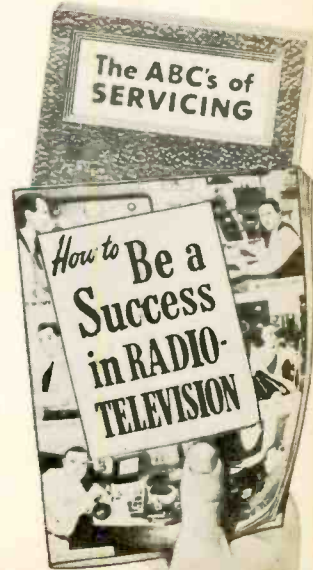

Train at Home to Jump Your Pay as a RADIO-TV Technician



**J. E. Smith, President
National Radio Institute**

The men whose messages are published below were not born successful. Not so long ago they were doing exactly as you are now . . . reading my ad! They decided they should **KNOW MORE** . . . so they could **EARN MORE** . . . so they acted! Mail card below now.

Get a Better Job—Be Ready for a Brighter Future in America's Fast Growing Industry

Training PLUS opportunity is the PERFECT COMBINATION for job security, good pay, advancement. When times are good, the trained man makes the BETTER PAY, GETS PROMOTED. When jobs are scarce, the trained man enjoys GREATER SECURITY. NRI training can help assure you and your family more of the better things of life.

Radio-Television is today's opportunity field. Even without Television, Radio is bigger than ever before. Over 3,000 Radio Broadcasting Stations on the air; more than 115 million home and Automobile Radios are in use. Then add Television. Television Broadcast Stations extend from coast to coast now with over 25 million Television sets already in use. There are channels for 1,800 more Television Stations. Use of

Aviation and Police Radio, Micro-Wave Relay, Two-way Radio communication for buses, taxis, trucks, etc. is expanding. New uses for Radio-Television principles coming in Industry, Government, Communications and Homes.

My Training is Up-to-Date You Learn by Practicing

Get the benefit of my 40 years experience training men. My well-illustrated lessons give you the basic principles you must have to assure continued success. Skillfully developed kits of parts I furnish "bring to life" the principles you learn from my lessons. Read more about equipment you get on other side of this page.

Naturally, my training includes Television. I have, over the years, added more and more Television information to my courses. The equipment I furnish students gives experience on circuits common to BOTH Radio and Television.

Find Out About the Tested Way to Better Pay

Read at the right how just a few of my students made out who acted to get the better things of life. Read how NRI students earn \$10, \$15 a week extra fixing Radios in spare time starting soon after enrolling. Read how my graduates start their own businesses. Then take the next step—mail card below.

You take absolutely no risk. I even pay postage. I want to put an Actual Lesson in your hands to prove NRI home training is practical, thorough. I want you to see my 64-page book, "How to Be a Success in Radio-Television" because it tells you about my 40 years of training men and important facts about present and future Radio-Television job opportunities. You can take NRI training for as little as \$5 a month. Many graduates make more than the total cost of my training in two weeks. Mailing postage free card can be an important step in making your future successful. J. E. Smith, President, National Radio Institute, Washington 9, D. C. OUR 40TH YEAR.

I TRAINED THESE MEN



Handicapped but Successful

"I am now Chief Engineer at WHAW. My left hand is off at the wrist. A man can do . . . If he wants to." R. J. Bulley, Weston, W. Va.



\$10 a Week in Spare Time

"Before finishing, I earned as much as \$10 a week in Radio servicing, in my spare time. I recommend NRI." S. J. Petruff, Miami, Fla.



Control Operator, Station WEAN

"I received my license and worked on ships. Now with WEAN as control operator, NRI course is complete." R. Arnold, Rumford, R. I.



Has Own Radio-Television Shop

"Doing Radio and Television servicing full time. Have my own shop. I owe my success to NRI." Curtis Stath, Fort Madison, Iowa.



Has Growing Business

"Am becoming expert Teletician as well as Radiotriician. Without your course this would be impossible." P. Brogan, Louisville, Ky.



Get First Job Thru NRI

"My first job was with KDLR. Now Chief Engr. of Radio Equipment for Police and Fire Dept." T. Norton, Hamilton, Ohio.

NRI Training Leads to Jobs Like These

BROADCASTING
Chief Technician
Chief Operator
Power Monitor
Recording Operator
Remote Control Operator

SERVICING
Home and Auto Radios
P. A. Systems
Television Receivers
Electronic Controls
FM Radios

IN RADIO PLANTS
Design Assistant
Transmitter Design Technician
Service Manager
Tester
Serviceman
Research Assistant

SHIP AND HARBOR RADIO
Chief Operator
Assistant Operator
Radiotelephone Operator

GOVERNMENT RADIO
Operator in Army, Navy, Marine Corps, Coast Guard
Forestry Service
Dispatcher
Airways Radio Operator

AVIATION RADIO
Plane Radio Operator
Transmitter Technician
Receiver Technician
Airport Transmitter Operator

TELEVISION
Pick-up Operator
Voice Transmitter Operator
Television Technician
Remote Control Operator
Service and Maintenance Technician

POLICE RADIO
Transmitter Operator
Receiver Serviceman

FIRST CLASS
Permit No. 20-R
(Sec. 34.9, P.L. & R.)
Washington, D.C.

BUSINESS REPLY CARD

No Postage Stamp Necessary If Mailed In The United States

POSTAGE WILL BE PAID BY

NATIONAL RADIO INSTITUTE

16th and U Sts., N.W.

Washington 9, D. C.

Find Out What RADIO-TV Offers You



**SAMPLE LESSON
and 64-PAGE BOOK
Both FREE**

**Cut out and mail
postage-free card today!**

Start Soon to Make \$10, \$15 a Week Extra Fixing Sets

Keep your job while training. Many NRI students make \$10, \$15 and more a week extra fixing neighbors' Radios in spare time starting a few months after enrolling. I start sending you special booklets that show you how to fix sets the day you enroll. The multitester you build with parts I furnish helps discover and correct troubles.



Do You Want Your Own Business?

Many NRI trained men start their own successful Radio-Television sales and service business with capital earned fixing Radios in spare time. My book tells how you can be your own boss. Joe Travers, a graduate of mine, in Asbury Park, N. J., writes: "I've come a long way in Radio and Television since graduating. Have my own business on Main Street."



SOLVED! Your TV tuner small parts problem!



THE STANDARD TUNER
(not included in kit)

Get the handy, all-new **STANDARD Tuner Replacement Parts Kit** No. 1011

IN TV IT'S STANDARD

Standard
COIL PRODUCTS CO., INC.

CHICAGO LOS ANGELES BANGOR, MICH.
NO. DIGHTON, MASS.

Export Agent:
Rocke International Corporation, 13 E. 40th St., New York City

Now... 104 small TV tuner parts are at your fingertips in one convenient, low-cost kit that's sturdy, compact, fully labeled for quick reference. You get the most-called-for parts servicing Standard tuners series TV-200, TV-1500, TV-2000 and TV-2200. Each item is individually boxed, except the very small.

More Profit—\$25.03 worth of tuner parts for only \$22.50.

Save Time—Hard-to-find tuner parts right at hand for quick, sure selection.

Build Customer Goodwill—Replace tuner parts direct from your Standard kit, so your customer will *know* each part is completely new.

Plan now to speed up your service work, bring new order and efficiency to every job. Get your Standard tuner replacement parts kits today! Call, write or wire your parts jobber, or address Standard Coil Products Co., Inc., 2085 N. Hawthorne Ave., Melrose Park, Ill.

THIS ANTENNA OUT-PERFORMS:

this ... this ... this ... or this

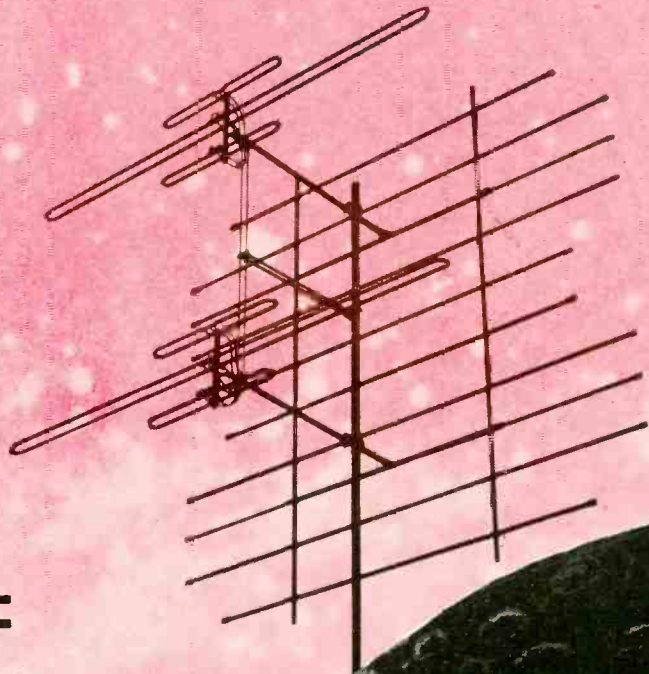
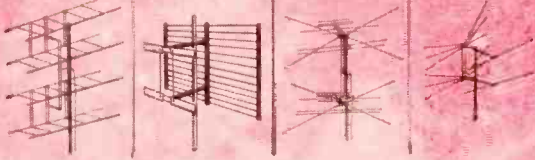

the AMAZING VHF CHAMPION*

a NEW KIND of Antenna
that out-performs every all-channel
VHF antenna ever made — —
and many Yagis, too!

America's servicemen have spoken! In only 3 months, they've made the CHAMPION the nation's top-selling VHF antenna! It's the highest gain all-channel VHF antenna ever developed, and its performance has now been proven by over 50,000 outstanding installations.

Only the CHAMPION has the unique new "Tri-Pole", a triple-powered dipole system in which the Low Band dipole also functions as three dipoles tied together, in phase, on the High Band.

Folded dipoles throughout give close to 300 ohms impedance across entire band. Lightweight, all-aluminum construction. Available in one, two, or four-bays.

CHANNEL MASTER CONQUERS SPACE!

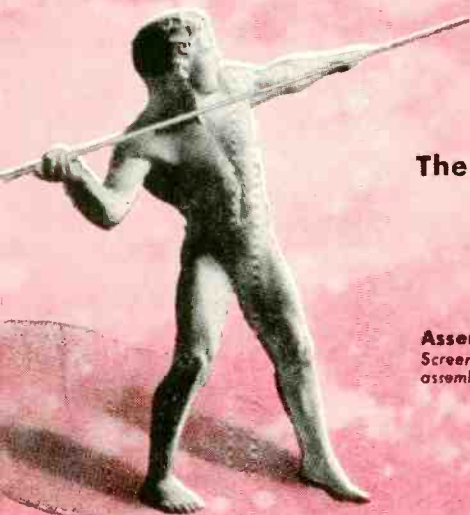

The stacked CHAMPION provides:

- 11-13 DB High Band gain
- 6½-7½ DB Low Band gain

Assembles faster than a five-element Yagi.
Screen "Pops-Up" instantly. "Tri-Pole" assembly just snaps into place.



horizontal polar pattern (relative voltage)

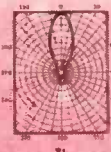

CHANNEL MASTER CORP.
GREENVILLE, N. C.



model no.		list price
325	single bay	\$20.00
325-2	two bay	42.50
325-4	four bay	68.00
Superior Striking Maroones		
325-3	2 Bay Maroones	\$7.00
325-5	4 Bay Maroones	4.15

*Pat. Pend.

3 great, new UHF antennas

by **CHANNEL MASTER**

STACKED TWIN CORNER REFLECTOR model no. 406-2

The most powerful UHF fringe area installation you can make today!

- Broad Band coverage — yet out-performs most stacked Yagis.
- Covers every UHF channel, not just segments of the band.
- New impedance-matching, two-stage stacking system.

Another original Channel Master development!

Model No.	Description	List Price
406	Twin Corner Reflector	\$18.06
406-2	2-Bay Twin Corner Reflector. Stacking harness furnished free.	36.10
406-3	Stacking harness only, furnished separately.	2.08

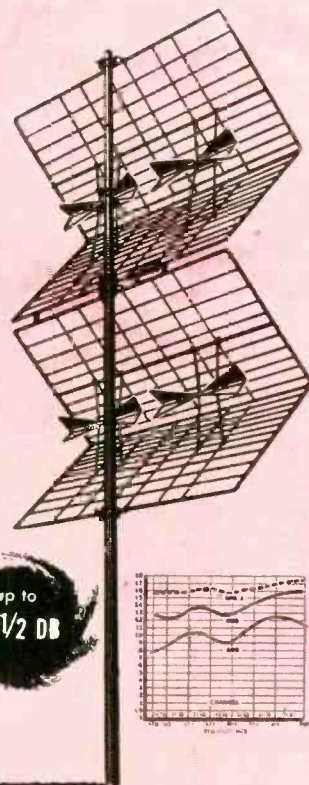

up to
17 1/2 DB

*powerful
new
antennas
span
vast
distances*

the first UHF CORNER REFLECTOR with optional "2-way" mounting!

model no. 409

Only CHANNEL MASTER'S CORNER REFLECTOR can be adapted to any kind of UHF installation — with or without VHF — at no extra cost. Every antenna contains all necessary hardware and braces for BOTH popular types of mounting. Sharp directivity and unusually high gain across entire UHF band.

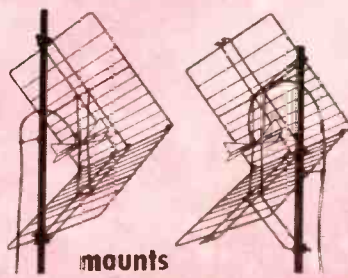

mounts

this way . . . or this way

only
\$9.03
list

Installs instantly! Original Channel Master assembly feature: Screen swings open like a book — dipole assembly snaps into place.

"SWEET 16" The World's First 16-Element UHF Yagi!

- Custom-designed for your particular area.
- Super-power! Sensational fringe area reception.
- Delta-Weld design. Elements WELDED to crossarm. Delta-matched dipole gives uniform impedance.
- Wide band coverage, up to 21 channels.
- Average gain: 13 DB single
16 DB stacked

model no. 420

\$8.20 list

CHANNEL MASTER CORP.
ILLICHOPE, N. C.

Send for complete technical literature.



THE *American* IDEA

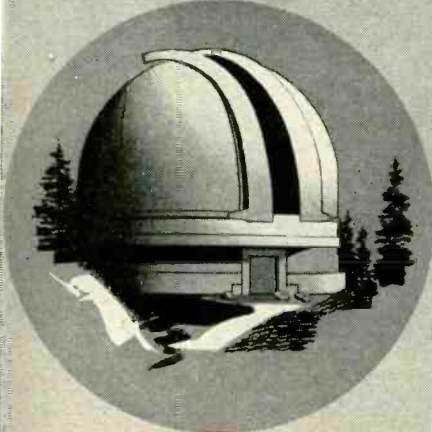

"To find and follow the better way" . . . Out of the vision of Dr. George Ellery Hale came the great "American Idea" that resulted in the creation of the "Glass Giant of Palomar"—worl'd's largest telescope—to gather new light from the farthest stars for the searching eye of science.

With us, the "American Idea" is, by directed effort and applied know-how, to continue to lead in bringing you electronic products of the highest quality.



INSIST ON
AMERICAN
MICROPHONES
D-33 Broadcast
D-22 Public Address

Send for FREE catalog 46



American microphone co.

370 South Fair Oaks Ave. • Pasadena, 1, Calif.

in the Buffalo, N. Y. area. The meeting was co-sponsored by Standard Electronics Distributing Co., Raytheon tube distributor, and the Buffalo Radio Television Service Association. The Raytheon Bonded Dealer Program was the main topic of the discussion. The company also reports enthusiastic response to its new film, "Electronics In Action," which is currently being shown under the sponsorship of Raytheon tube distributors, at dealer meetings throughout the country.

Blonder-Tongue Laboratories, Westfield, N. J., is offering service techni-

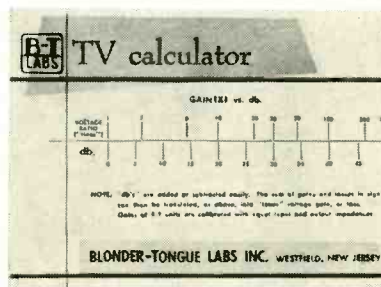

cians a free TV Calculator containing a scale for instant conversion of decibels to voltage gain, along with other convenient scales and tables.

Switchcraft, Inc., Chicago, developed



an attractive new counter display for its 2-input audio mixer, Mini-Mix.

Permo, Inc., Chicago, designed a new phonograph needle registration card to be attached to turntable spindles to aid dealers and customers in identifying phonograph-needle replacements.

New Plants and Expansions

RCA Victor dedicated a new plant in Moorestown, N. J., which will be used for engineering and development of radar techniques for defense.

Permo, Inc., Chicago, has let contracts for the construction of a new 17,000-square-foot addition to its plant, which will give the company a total of 54,000 square feet for its manufacturing, warehouse, and office facilities. 1954 marks the anniversary of Permo's 25th year in the business.

Radio Merchandise Sales, New York City, acquired the controlling interests in Ames Mfg. Corp., wire products

manufacturer, and Jeb Sales Corp., producer of the Jeb rotator.

Insuline Corp. of America, Long Island City, N. Y., acquired a four story plant in Manchester, N. H. The company will also retain its present plant in Long Island City.

Pentron Corp., Chicago, manufacturer of tape recorders and accessories, acquired additional manufacturing facilities by leasing space in two new buildings.

Electro Products Laboratories, Chicago, has expanded the production area in its present plant.

Elco Corp., Philadelphia electronic component manufacturer, added a new 15,000-square-foot plant to its present facilities.

Business Briefs

. . . Telrex, Inc., Asbury Park, N. J., manufacturer of conical-V-Beam TV antennas, has withdrawn its patent infringement suit against H. L. Dalis upon payment of a substantial sum by Snyder Manufacturing Co. The latter signed a nonexclusive licensing agreement providing for payment to Telrex of royalties on future sales of antennas covered by Telrex patents. Telrex is continuing to prosecute its infringement suits against other manufacturers.

. . . Hudson Industrial Electronics Co., New York City, a new firm in the electronic component and equipment field, was established by Irwin Hecht, who has had wide experience in the electronics industry.

. . . The Association of Electronic Parts and Equipment Manufacturers has embarked on two major projects involving the analysis of trade practices and merchandising of sound equipment. The task group making the study includes many of the leaders in the sound equipment field.

. . . The first New England Television Exposition will be held in Worcester, Mass., February 5-7.

. . . Sylvania Electric's chairman, Don G. Mitchell, told a national conference of Sylvania salesmen that present day trends in industry add up to "an extremely favorable picture for 1954."

. . . The 1954 Electronic Parts Show management announced a sellout of booth space for the Exhibition Hall in the Conrad Hilton Hotel for the annual show to be held in Chicago, May 17-20.

. . . Howard W. Sams, Indianapolis, announced four new participants in its Photofact service: Sylvania Electric Products, New York City, for its crystal diodes in addition to receiving and picture tubes; Westinghouse Electric, Elmira, N. Y., receiving and picture tubes; Halldorson Transformer Co., Chicago; and Thordarson-Meissner, Mount Carmel, Ill., transformers.

. . . Mark Simpson Manufacturing, Long Island City, N. Y., reports a profit on recent operations since it has filed under Chapter XI.

. . . Fidelity Tube Corp., Gem Radio & Television and Jewel Radio Corp. all of the same address at East Newark, N. J., filed under Chapter XI of the Bankruptcy Act.

END

No matter where you live
or what you are doing now . . .

I WILL TRAIN YOU FOR A BIG PAY JOB IN TELEVISION

L. C. Lane, B.S., M.A.
President: Radio-
Television Training
Association,
Executive Director:
Pierce School of
Radio-Television.

CIVILIANS! VETERANS!

Thousands of new jobs in TV are opening up in every state as new stations go on the air. You too can take your place in America's booming TELEVISION and Electronics industry. . . enjoy the success and happiness you always wanted out of life! Now . . . prepare for a life-time career as a trained TV TECHNICIAN, often within months . . . using the same successful "learn-by-doing" home study methods that have helped hundreds of men with NO PREVIOUS TRAINING!

NO EXPERIENCE NECESSARY
LEARN TELEVISION AT HOME
IN YOUR SPARE TIME!

GET MORE! LEARN MORE!
EARN MORE!

I give you ALL the equipment and training you need to prepare for the BETTER PAY jobs in TV. While training, many of my students make \$25.00 a week repairing Radio-TV sets in their spare time . . . start their own profitable service business.

MORE EQUIPMENT!

You build and keep this professional GIANT SCREEN TV RECEIVER complete with big picture tube (designed and engineered to take any size up to 21-inch). Also all units illustrated, plus additional equipment! Everything supplied complete with all tubes.

FREE FCC COACHING COURSE!

Prepares you at home for your FCC License. The best jobs in TV and radio require an FCC License. My FCC Coaching Course is given to you at NO EXTRA COST after TV Theory and Practice is completed.

NEW! PRACTICAL TV CAMERAMAN & STUDIO COURSE!

For Men With Previous Radio & TV Training

I train you at home for an exciting big pay job as the man behind the TV camera. Work with TV stars in TV studios or "on location" at remote pick-ups! A special one-week course of practical work on TV studio equipment at Pierce School of Radio & TV, our associate resident school in New York City, is offered upon your graduation.

FM-TV TECHNICIAN TRAINING!

My FM-TV Technician Course will save you months of training, if you have previous Armed Forces or civilian radio experience. Complete with kits, BIG SCREEN TV RECEIVER, and FREE FCC Coaching Course.

OPTIONAL: TWO WEEKS TRAINING IN NEW YORK CITY AT NO EXTRA COST

You get two weeks, 50 hours, of intensive Laboratory work on modern electronic equipment at our associated school in New York City—Pierce School of Radio and Television. And I give you all this AT NO EXTRA COST whatsoever, after you finish your home study training in the Radio-FM-TV Technician course and FM-TV Technician Course.

RADIO-TELEVISION TRAINING ASSOCIATION

52 EAST 19th STREET, NEW YORK 3, N. Y.

Licensed by the State of New York

Approved by the VA

VETERANS!

MY SCHOOLS FULLY APPROVED TO TRAIN VETERANS UNDER NEW G.I. BILL! If discharged after June 27, 1950 — CHECK COUPON BELOW! Also approved for RESIDENT TRAINING in New York City . . . qualifies you for full subsistence allowance up to \$160 per month. Write for details.



MAIL COUPON TODAY!

MY 4 FREE AIDS SHOW YOU HOW AND WHERE TO GET A BETTER PAY JOB IN TELEVISION!

See for yourself how my simple, practical methods make success easy.



NO SALESMAN WILL CALL!

Mr. Leonard C. Lane, President
RADIO-TELEVISION TRAINING ASSOCIATION
52 East 19th Street, New York 3, N. Y.

Dear Mr. Lane: Mail me your NEW FREE BOOK, FREE SAMPLE LESSON, and FREE aids that will show me how I can make BIG MONEY IN TELEVISION. I understand I am under no obligation and no salesman will call.
(PLEASE PRINT PLAINLY)

NAME _____ AGE _____

ADDRESS _____

CITY _____ ZONE _____ STATE _____

I AM INTERESTED IN:

- Radio-FM-TV Technician Course **VETERANS!** Check here
 FM-TV Technician Course for Training under NEW
 TV Cameraman & Studio Course G.I. Bill

THIS BOOK HELPS YOU

Make Increased Profits

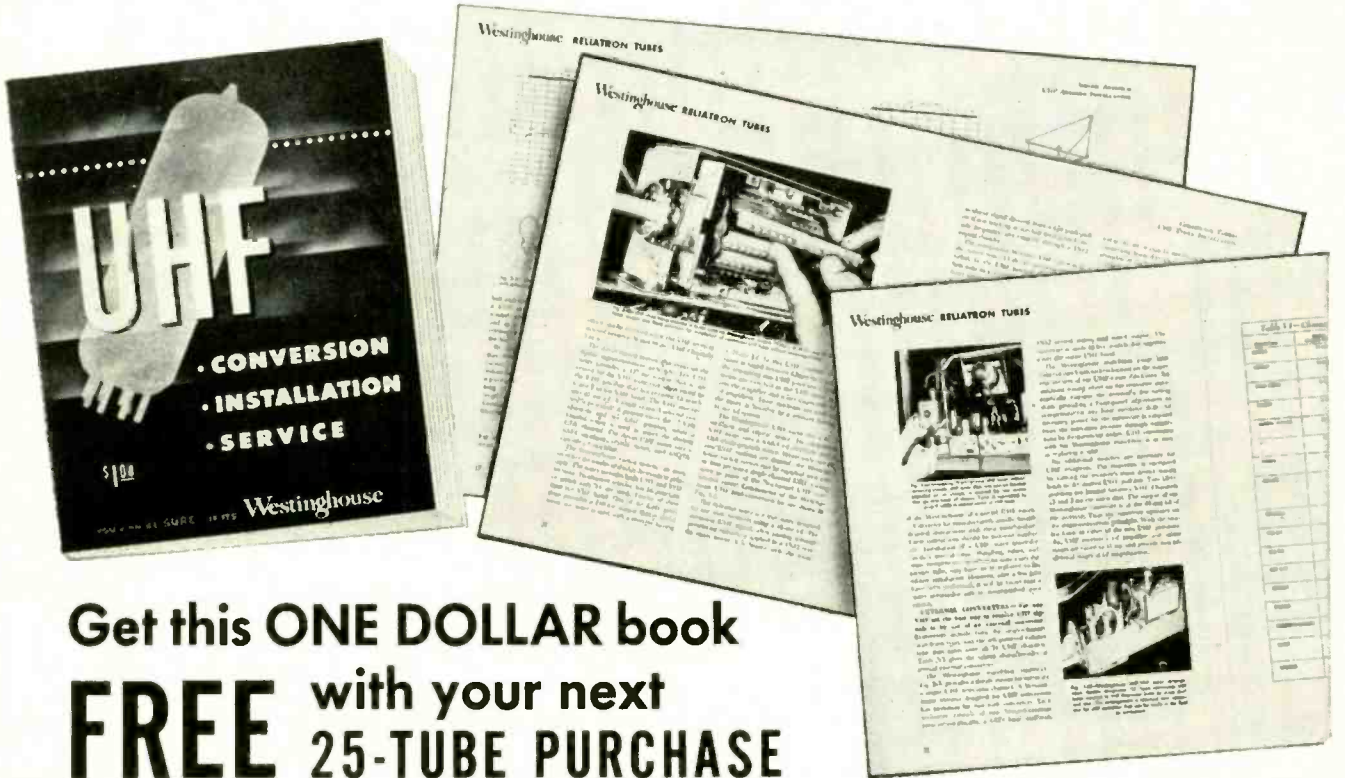

Get this ONE DOLLAR book
FREE with your next
 25-TUBE PURCHASE

This newest, most helpful book on UHF conversions is yours free when you buy 25 RELIATRON receiving tubes or one picture tube from your Westinghouse Distributor.

This vital handbook covers conversion data, tuners and converters, antenna installations, channel frequency charts, station coverage, and many other necessary, conveniently arranged facts you will need.

There's a gold mine in UHF conversions. And this book will help you make the most out of

the biggest profit opportunity since television came alive.

Get this dollar value for no extra charge with your next order of 25 tubes! See your nearest Westinghouse RELIATRON Tube Distributor for your copy of this new "how to do it" book that will build your profits.

Act Now for
UHF PROFITS

See Westinghouse Tube Listings in 1954 Photofact Folders.

ET-95046A

YOU CAN BE SURE...IF IT'S
Westinghouse

RELIATRON TUBES
 T M

WESTINGHOUSE ELECTRIC CORPORATION, ELECTRONIC TUBE DIVISION, ELMIRA, N. Y.

RADIO-ELECTRONICS

Here's your Opportunity

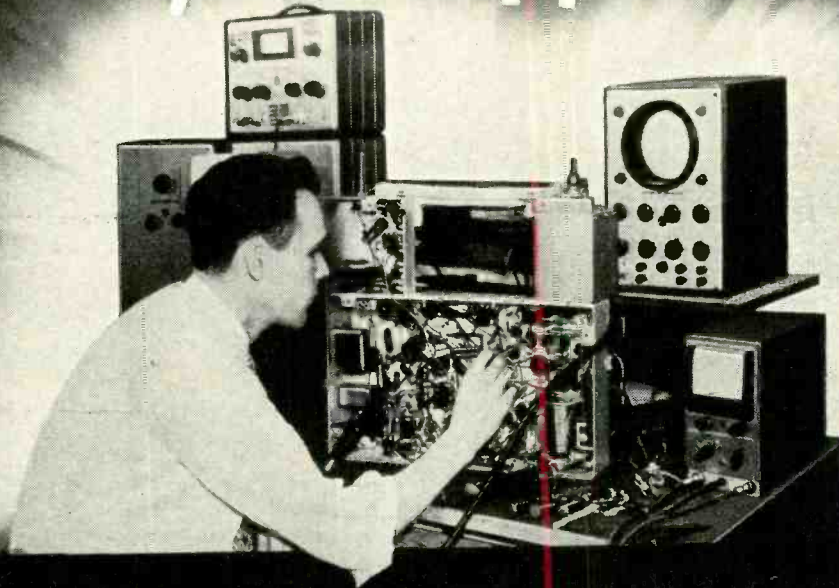

**to prepare for a good job or a business
of your own in TV SERVICING**

ARE YOU SATISFIED with the position you now hold? Do you feel you're worth more money? Are you pleased with yourself, your work, your associates . . . and your future? What does the next year hold for you . . . and the year after that?

Are you content merely to plod along through the best years of your life . . . or do you want to get into more pleasant work . . . hold a well-paid job . . . perhaps establish your own business?

If you are looking for a REAL opportunity . . . If you want to GROW with a GROWING INDUSTRY . . . If you want to grasp the success that should be yours, then we say to you, study TV Servicing.

Everyone knows that Television is the fastest growing industry today. Opportunities are going begging for men who have

the training and ability to grasp them. *Now is the time to start on the road to success in TV Servicing.*

Study at Home in your spare time

The RCA Institutes Home Study Course in TV Servicing is easy to learn. You progress rapidly, step by step, as you learn the procedure of servicing and trouble-shooting TV receivers and installing TV antennas. Hundreds of pictures and diagrams help you understand the how-it-works information and the how-to-do-it techniques.

A Service of Radio Corporation of America

The RCA Institutes TV Servicing course was written and planned by instructors with years of specialized experience in training men. You get up-to-the-minute information, too, because you study right at the source

of the latest developments in Television. Your lessons are carefully examined and accurately graded by competent teachers who are interested in helping YOU to succeed.

RCA Institutes is licensed by the University of the State of New York . . . an affiliate member of the American Society for Engineering Education . . . approved by leading Radio-Television Service Organizations.

It costs so little to gain so much

RCA Institutes makes it easy for you to take advantage of the big opportunities in TV Servicing. The cost of the TV Servicing Home Study Course has been cut to a minimum. You pay for the course on a pay-as-you-learn unit lesson basis. *No other home study course in TV Servicing offers so much for so little cost to you.*

RCA Institutes conducts a resident school in New York City offering day and evening courses in Radio and TV Servicing, Radio Code and Radio Operating, Radio Broadcasting, Advanced Technology. Write for free catalog on resident courses.



RCA INSTITUTES, INC.
A SERVICE OF RADIO CORPORATION OF AMERICA
350 WEST FOURTH STREET, NEW YORK 14, N.Y.

FEBRUARY, 1954

SEND FOR FREE BOOKLET—Mail the coupon—today. Get complete information on the RCA INSTITUTES Home Study Course in Television Servicing. Booklet gives you a general outline of the course by units. See how this practical home study course trains you quickly, easily. Mail coupon in envelope or paste on postal card.



MAIL COUPON NOW!

RCA INSTITUTES, INC., Home Study Dept. RE254
350 West Fourth Street, New York 14, N. Y.

Without obligation on my part, please send me copy of booklet "RCA INSTITUTES Home Study Course in TELEVISION SERVICING." (No salesman will call.)

Name _____ (please print)

Address _____

City _____ Zone _____ State _____

NOW... 2 SENSATIONAL EICO SCOPE VALUES!

NEW AMAZING FEATURE PACKED

7" PUSH-PULL OSCILLOSCOPE

Only **EICO** Has All These Features

- VERTICAL FREQ. RESPONSE: flat ± 2 db 10 cps - 1 mc
- VERTICAL SENS.: .01 volts rms/inch
- HOR. FREQ. RESP.: flat ± 0 db 10 cps - 200 kc, -4 db at 500 kc
- HOR. SENS.: .3 volts rms/inch
- SWEEP RANGE: 15 cps-100 kc
- 3-STEP FREQ. COMPENSATED ATTENUATOR eliminates freq. distortion, overloading.
- CATHODE FOLLOWER inputs to both amplifiers
- PUSH-PULL outputs in both amplifiers
- RETURN TRACE BLANKING
- INT. VOLTAGE CALIBRATOR
- V & H TRACE EXPANSION & CENTERING: 1.5X full screen without distortion.
- DIRECT CONNECTION to vert. CRT plates.
- PHASING CONTROL of internal 60 cps sine wave sweep.
- AT FRONT PANEL: intensity mod. input; 60 cps, sawtooth outputs

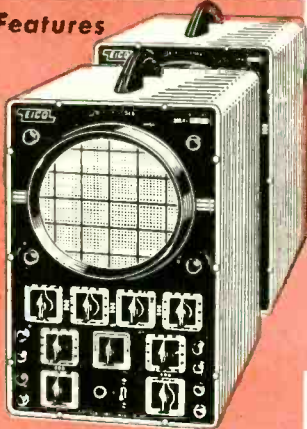

MODEL 470K
KIT \$79.95. WIRED \$129.50.

EICO EXCLUSIVE! 5" PUSH-PULL SCOPE, 425K, Amazing feature-packed economy-priced Wired, \$79.95.

- PUSH-PULL V & H amplifiers. Sens. 0.5-1 rms v/in. Useful to 2.5 mc.
- SWEEP: 15 cps-76 kc. Z-axis intensity modulation. Dual trace positioning controls.



SCOPE VOLTAGE CALIBRATOR KIT
495K KIT \$12.95. WIRED \$17.95.

- Sq. wave output at power-line freq. with full-scale readings of 1, 1, 10 or 100 V. peak-to-peak.
- Accuracy $\pm 5\%$ of full-scale on each range.

6V & 12V BATTERY ELIMINATOR KIT 1050K KIT \$29.95. WIRED \$38.95.

- DC output: 0-8 V or 0-16 V.
- Continuous current rating: 10 A at 6 V, 6 A at 12 V.
- Intermittent current rating: 20 A at 6 V, 12 A at 12 V.
- Separate Voltmeter & Ammeter.



New! EICO SCOOPS!

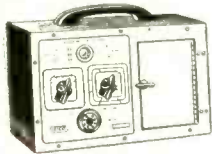

CATHODE RAY TUBE CHECKER 630K, WIRED \$24.95 KIT, \$17.95.

- Checks all types of TV picture and C.R. tubes in the set or carton. Bridge measurement of peak beam current (proportional to screen brightness).
- Detects shorted & open elements.

BAR GENERATOR 352K, WIRED \$19.95 KIT, \$14.95

- Enables rapid adjustment of TV picture V & H linearity without hard-to-find station-transmitted test pattern.
- Produces 16 V or 12 H bars. Operates on TV channels 3, 4, or 5

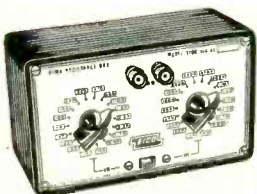

RTMA RESISTANCE SUBSTITUTION BOX 1100K WIRED \$9.95 KIT, \$5.50.

- Enables rapid substitution of resistances from 15 ohms to 10 megs in decade multiples of 15, 22, 33, 47, 68, 100 ohms.
- Uses 36 standard 1 watt, $\pm 10\%$ RTMA resistors.

221K VTVM KIT \$25.95. WIRED \$49.95.

- AC & DC volts: 0-5, 10, 100, 500, 1000 V (30 KV with HVP-1 probe).
- 5 ohm ranges from .2 ohm to 1000 megs.
- DC input Z 26 megs.
- $4\frac{1}{2}$ " meter movement in can't-burn-out circuit.
- 1% mult. resistors.



HIGH VOLTAGE PROBE \$6.95

- Extends range of VTVMs & voltmeters to 30 KV.



PIX TUBE ADAPTER for Tube Testers \$4.50. Checks TV picture tubes while in set.

625K TUBE TESTER KIT \$34.95. WIRED \$49.95.



- Illum. gear-driven "Speed Rolchart."
- New lever-action switches for individual testing of every element.
- Tests all conventional & TV tubes.

COUNTER CABINET for above: add \$10.00 to Kit or Wired Prices.

360K SWEEP GEN. KIT \$34.95. WIRED \$49.95.

- Continuous coverage of all TV & FM freqs. from 500 kc to 228 mc.
- Sweep width variable 0-30 mc.
- Crystal marker oscillator, variable amplitude.

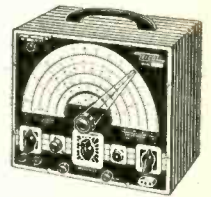

214K VTVM KIT \$34.95. WIRED \$54.95.

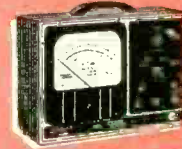

- Large $7\frac{1}{2}$ " meter, can't-burn-out circuit.
- AC/DC volts: 0-5, 10, 100, 500, 1000 (30 KV with HV Probe).
- 5 ohm ranges from .2 ohm to 1000 megs.
- DC input Z 26 megs.
- 1% mult. resistors.

950A-K R-C BRIDGE & R-C-L COMP. KIT \$19.95. WIRED \$29.95.



- Measures & tests all resistors; .5 ohm to 500 megohms.
- Every type condenser, 10 mmf to 5000 mfd.
- 0-500 DC voltage source for capacitor leakage testing.

NOW! ONLY EICO KITS & WIRED INSTRUMENTS Gives You LIFETIME SERVICE & CALIBRATION GUARANTEE*

*at less than our cost of handling (See EICO Guarantee Card enclosed with each Kit & Instrument).

1171K RES. DECADE BOX KIT \$19.95. WIRED \$24.95.

- Resistance values from 0 to 99,999 ohms with 0.5% precision.
- All resistors have 0.5% accuracy

DECADE CONDENSER BOX KIT 1180K KIT \$14.95. WIRED \$19.95.

- All capacitors precision silver mica, accuracy $\pm 1\%$.
- Range from 100 mmf - 0.111 mfd in steps of 100 mmf.
- Smooth-action positive detent ceramic switches.

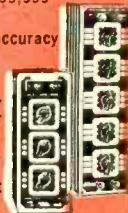

Prices 5% higher on West Coast. Specifications and prices subject to change without notice.

315K DELUXE SIG. GEN. KIT \$39.95. WIRED \$59.95.

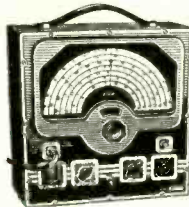

- Covers range of 75 kc to 150 mc.
- 7 calibrated scales: accuracy better than 1%.
- Bandsread vernier tuning.
- 4-step RF shielded output multiplier: constant output Z.

565K MULTIMETER KIT \$24.95 WIRED \$29.95.

555K MULTIMETER KIT \$29.95 WIRED \$34.95. (1% precision resistors)



- 20,000 Ω/V ; 31 ranges.
- DC/AC/Output volts: 0-2.5, 10, 50, 250, 1000, 5000.
- DC Current: 0-100 ua; 10, 100, 500 ma; 10 A.
- Ohms: 0-2K, 200K, 20 meg.

377K SINE & SQUARE WAVE AUDIO GEN. KIT \$31.95. WIRED \$49.95.



- Complete sine wave coverage, 20-200,000 cps in 4 direct-reading ranges.
- Complete square wave coverage, 60-50,000 cps.
- Cathode follower output circuit.

145K SIG. TRACER KIT \$19.95. WIRED \$28.95.

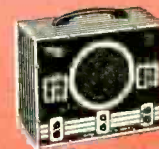

- Audibly signal traces all IF, RF, Video & Audio circuits from ANT to SPKR or CRT in all TV, FM, AM, etc. without switching.
- Germanium crystal diode probe responsive to over 200 mc.
- Integral test speaker

536K MULTIMETER KIT \$12.90. WIRED \$14.90.



- 1000 Ω/V ; 31 ranges
- DC/AC volts: Zero to 1, 5, 10, 50, 100, 500, 5000.
- DC/AC Current: 0-1, 10 ma; 0.1, 1 A.
- Ohms: 0-500, 100 K, 1 meg.

320K SIG. GEN. KIT \$19.95. WIRED \$29.95.



- Fundamentals 150 kc to 34 mc, harmonics to 102 mc.
- 5-step band switching.
- Colpitts audio oscillator generates 400 cps pure sine wave voltage.
- Permits pure RF, modulated RF, or pure AF.

Write NOW for FREE latest Catalog C-2

Ask your jobber for FREE EICO business building decals.

Separate Assembly & Operating Manuals supplied with each EICO KIT!

You build EICO Kits in one evening, but... they last a lifetime!

SAVE OVER 50%! See the famous EICO line TODAY, at your local jobber.

ELECTRONIC INSTRUMENT CO., Inc., 84 Withers Street, Brooklyn 11, N. Y.



WANTED: TECHNICIANS

... *The U.S. is still short of radio-electronic specialists* ...

By HUGO GERNSBACK

IT IS not news that the U.S. today leads the world in radio-electronics—in research, in development, and in volume. In 1951 (the November 1951 issue of this magazine) the writer predicted that the industry would reach a ten billion dollar output by 1960. It is now certain that this figure will be exceeded by a large margin.

What is news—disturbing news—is that—for a variety of reasons—we have already been surpassed by the U.S.S.R. in manpower in numbers of radio-electronic engineers and technicians. One of the main reasons for this state of affairs is that the Russians—according to the best available information—do not draft young men who show technical promise, for military service. The U.S. drafted young men between 18 and 26 indiscriminately during the Korean War. Add to this the smaller number of youngsters coming of age between 1950 and 1960 because of the low birthrate of the depression years. The result is that we now have an unprecedented shortage of many thousands of radio engineers, radio-electronic specialists, technicians, physicists and others.

Since 1951, the shortage of technical personnel—particularly in the higher brackets—has been acute. It is likely to become worse during the next few years, until we can make up the deficiency.

Nor are there any easy short-cuts when it comes to the complex knowledge required by the present-day radio-electronic specialist. This is a long evolutionary process in a field, which, with few exceptions, leads all other endeavors in advanced technical ingenuity. Such specialized knowledge is not easy to come by; it takes a high I.Q., long years of intense study and training, plus lengthy experience and practice. But in the end, it pays handsome dividends, so much so that nowadays a top man in the field can name his own salary.

Nor is the field likely to be overcrowded in the foreseeable future—at least as far as good men are concerned. Quite the contrary. The reason, of course, is that new branches of radio-electronics are being opened up so rapidly that even present experts are hard put to keep up with its progress. And every one of these new branches is chronically short of able personnel, as even a cursory inspection of help-wanted columns will demonstrate. Let us take just a few examples.

Automation. The automatic, manless, factory is no longer a dream—it is here now—today. At Cleveland, Ohio, the Ford Motor Co. has a new and huge automatic engine plant, where electronically-controlled robots are turning out automobile engines without benefit of human hands.

Many oil refineries are run by robots today—crude oil comes in at one end, and at the other, an amazing variety of cans, tins, and other packages of petroleum products leave the plant with hardly a human being in attendance.

Yet the heart of all automation—all robots—is radio-electronics in some form. And it is here that the technician-specialists are found, often in around-the-clock vigil. For the life and continuous operation of the plant depend upon the technicians in charge. Their duty is to guard against failure of the complex circuitry, instrumentation, or both.

However, long before the plant began operation, the highest caliber technicians, engineers, and other specialists had to design and plan the complicated electronic robots and think through every last complex detail of the plant-to-be. This task in all its ramifications often takes years, even with a good-sized elite force of technician specialists.

Electronic Computers. This branch of the radio-electronics industry is, next to atomics, possibly man's greatest present intellectual endeavor. There is no doubt whatever that these computers will revolutionize most of our industries and our lives to a far greater extent than any other agency up to now. Today, even in our best-run industries and businesses, we still depend upon human—hit or miss—decisions. In the very near future, electronic computers will make the decisions and—given the proper facts to work from—*they will always be right*. No more guesswork!

But these computers do not run themselves: they must be attended by a special breed of technicians, a combination of a higher mathematician, physicist, chemist, and electronics engineer. Depending upon the industry or business, such a super-technician may have to be versatile in a half dozen other fields besides.

How do we get such men? Says Richard W. Cotton, chairman of the Electronics Production Board: "Industry and the armed forces agree that it takes not less than five years of intensive training to make an across-the-board electronics man out of a high school graduate with a good I.Q."

This checks precisely with what this magazine has preached for years, namely: *To be a top-notch electronics man, he must start young, very young*. To help ameliorate the serious electronics manpower shortage during the coming years, we think it our duty to reprint here a few lines on the subject from our May 1952 editorial, "Go Electronic, Young Man":

"Grade schools and high schools can do a tremendous service by educating young boys in the intricacies of radio-electronics. This is not as difficult as it sounds, because there is always a large percentage of young boys who are mechanically inclined and radio-minded. By supplying them with tools and a few simple radio appliances a young boy can, in easy stages, be made into a technician.

"It is much more difficult to instill the radio-electronics spark into a boy once he has reached puberty. The sooner he begins the quicker he will become proficient in the greatest endeavor the world has ever seen. Moreover, as has been found out by past experience, boys who start young in this endeavor are not likely to land in poolrooms and become public charges later. There is, perhaps, nothing quite so intriguing to the young mind as radio-electronics today. If the boy is started young and kept interested, he will not have to be pushed on by others. He will push himself ahead and be the better for it in the future."

TRANSISTORIZED UKULELE



Good tonal effects coupled with small size, low power consumption, and elimination of microphonics gives ukulele quality of high-priced instrument

By G. B. HERZOG*

DURING November, 1952, the David Sarnoff Research Center of RCA Laboratories in Princeton announced important developments in transistors and transistor circuitry¹. Among the many items was a transistorized ukulele suggested by George Sziklai and constructed and aptly demonstrated by Dan Hunter. Though the device could theoretically have been built with tubes, considerations of size, power consumption, and, most important, microphonics, rule out such an approach.

A baritone ukulele equipped with a magnetic pickup and steel strings in place of the normal gut strings acquires tones like those of a Hawaiian electric guitar when an amplifier and loudspeaker are mounted in its body. The amplifier boosts the output of the magnetic pickup to a level high enough to operate the loudspeaker. If this loudspeaker is mounted correctly in the uke, its output will reinforce the oscillation of the strings and increase the decay time. This allows sustained chords to be played and many effects to be obtained which have until now been possible only with high-priced instruments.

The amplifier

The amplifier, though designed for this particular instrument, is of general interest because of the unusual

Foot movements vary potentiometer to provide convenient volume control.

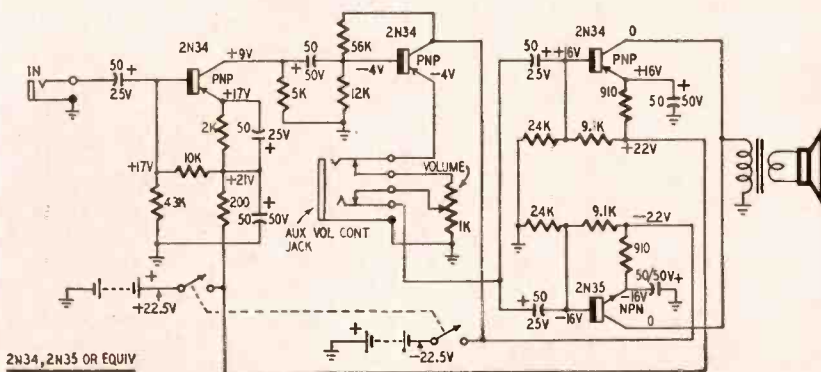

2N34, 2N35 OR EQUIV

Schematic shows unusual output circuit used in transistorized ukulele.

*RCA Laboratories Division, Princeton, N.J.

Right, photo shows internal layout of small transistorized ukulele.

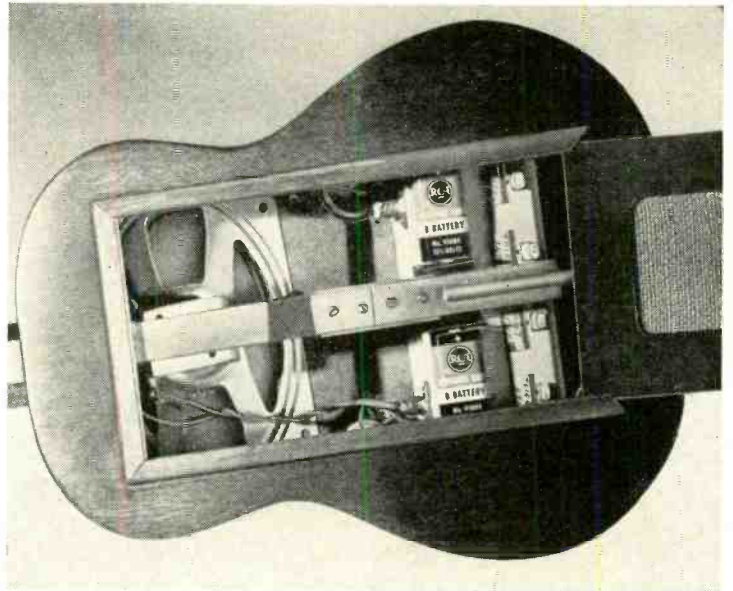

Center, amplifier removed from ukulele. Two small batteries supply power.

Below, underchassis view of amplifier. Strip mounting facilitates construction.

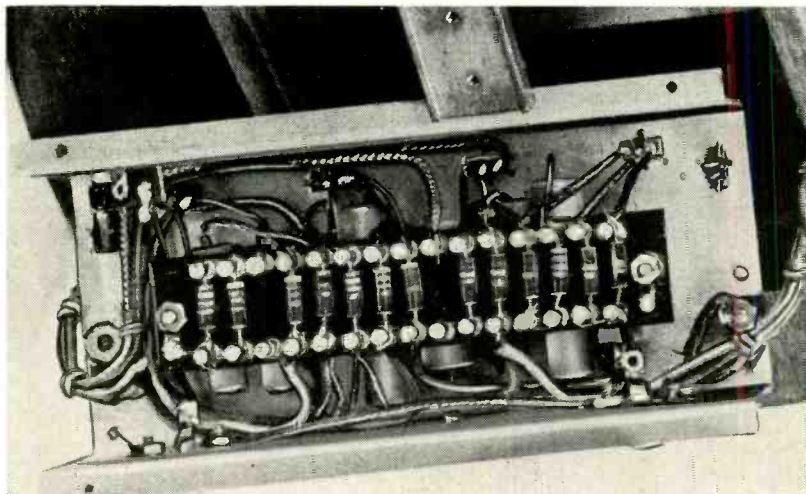
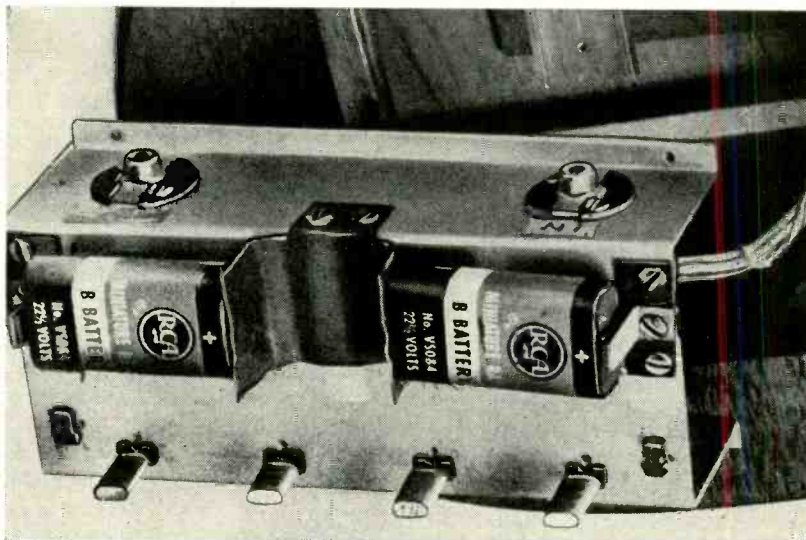

of junction transistors, push-pull amplifiers can be built that do not require a source of split driving voltage such as a transformer or a phase-inverter. Such operation will be explained briefly in describing the output stage.

Only one stage of voltage amplification in addition to the output stage is needed in the amplifier, one additional stage being used to provide a low-impedance driving source for the output stage. Power is supplied by two small 22.5-volt batteries, one connected to give a negative voltage with respect to ground, the other positive. This is necessary for the push-pull output stage, which puts an equal load on each battery.

To keep the loads on the batteries balanced for equal life, the current requirements of the first two stages are distributed between the two batteries by supplying one stage from the positive voltage and one from the negative. The fact that one stage happens to be a grounded-emitter amplifier and the other a grounded-collector stage is purely coincidental. Both stages could have been supplied from either of the batteries by appropriate biasing arrangements. As it is, the current drains of 9 ma and 10 ma on the positive and negative batteries respectively are nearly equal.

The first stage employs a p-n-p junction transistor in a base-input, stabilized grounded-emitter circuit². The base of the transistor is held at a fixed voltage by a voltage divider of 10,000 and 43,000. Since a junction transistor requires only a small bias voltage to cause substantial current to flow, it would be difficult to set the exact voltage required if the emitter were returned to a fixed potential. By inserting a resistor in the emitter lead, the correct operating conditions are automatically obtained. The action is much like that of a cathode resistor in tube operations. If the current increases for any reason, the bias on the transistor is reduced and the cur-

output circuit employed, and might be used in many other applications. The output circuit employs both a p-n-p and an n-p-n junction transistor in what is called a complementary-symmetry push-pull amplifier.^{2, 3, 4} The principles of this amplifier have been

described in engineering journals, and its operation has been analyzed in detail, by Mr. Sziklai and Mr. Lohman, but the finer points of its operation need not concern us at the moment. Suffice it to say that because of the inherent differences in the two types

rent drops to the desired value. The drop between the emitter and base connections is much less than a volt for low-power applications such as this. One can therefore set the desired operating conditions by so choosing the emitter resistor that, when the desired operating current is flowing, the drop across the resistor will cause the emitter voltage to approach the voltage at the tap on the voltage divider.

The voltage divider tap and the values of the two resistors are determined by what shunting impedance across the input can be tolerated and the desire to make the base current a negligible part of the bleeder current. As with cathode resistors in tubes, it is necessary to bypass these emitter resistors with a rather large electrolytic capacitor to avoid degeneration.

The collector load resistor is of such a value that the collector receives about 9 volts for operation. Increasing its resistance would increase the gain of the stage but little, as the output is shunted by the biasing network of the next stage. This network is similar to that described for the first stage except that the emitter resistor is not bypassed. Instead the collector is at a.c. ground and the output is taken from the emitter. The emitter resistor is a potentiometer and is used as a gain control.

A jack is provided for an auxiliary foot-pedal volume control, to be used for special harmonium effects or just for convenient volume control. The foot-pedal actually used is a modified commercial model, but an experimental one can be made by wrapping a piece of heavy string around an enlarged 1,000-ohm potentiometer shaft and connecting the ends to a suitably mounted pedal as shown in the foot-pedal sketch.

Both transistors in the output stage have stabilized bias, but since one is a p-n-p and the other an n-p-n, different voltage polarities are necessary. The bases of the two transistors are connected together as far as a.c. is concerned and the two collectors are connected together for both d.c. and a.c.

Output circuit operation

With no input signal, each transistor conducts the same amount of current, approximately 7 ma. Since these currents are opposite in direction, the two collector currents cancel and no current flows in the output transformer. (The current that flows out of the p-n-p transistor flows into the n-p-n transistor.) When a signal is applied to the bases tied in parallel, the conduction of the transistors is changed. If the signal is instantaneously negative, the p-n-p will increase its conduction and the n-p-n will decrease its conduction. This results in different collector currents for the two transistors. The difference current must flow through the output transformer. Therefore, a push-pull output has been achieved with a single-ended input.

If it should not be possible to get an n-p-n transistor for the output stage at the same time the p-n-p transistors are purchased, it is possible to operate the amplifier with just the p-n-p in the output, but the power output will be limited and there will be unbalanced current in the output transformer just as in any push-pull stage with one tube removed.

When the amplifier is finished, if the voltages check with those that are shown on the schematic to within 10 or 15%, one can stop right there and have a good general-purpose transistor amplifier, or one can get out some woodworking tools and start mutilating the nearest ukulele. The instrument used in the model shown is a standard baritone uke and retails for about \$15, but any reasonably priced ukulele should be satisfactory.

The ukulele end

Remove the gut strings and cut a rectangular opening approximately 5 x 9 inches in the back of the uke, saving the removed piece to replace after the amplifier is installed. In the instrument pictured, grooved edging was fastened around the sides of the opening so that the back would slide open for examination of the amplifier. Any other convenient fastening would be satisfactory provided it holds the back panel firmly to prevent vibration. In all cases, make an opening at least 2½ x 6 inches in the back panel for proper speaker operation. This opening may be covered with grill cloth for the sake of appearance. Unfortunately, in cutting the opening in the back, some reinforcing ribs put in the uke to keep it from curling up when the strings are tightened are removed. To make up for the loss of these ribs, a brass reinforcing bar is run the length of the body of the instrument. This bar is shown in the rear-view photograph. It is fastened permanently to the heavy neck support block at one end, and tightened at the other end by a cap nut. A separable connection in the middle of the bar makes it easy to remove the amplifier for servicing or alteration.

A commercial magnetic guitar pickup is mounted on a guide rod so that it may be moved up or down under the strings to vary the amount of output, thereby affecting the tonal quality. The rod is similar to the one that comes with the pickup, but the mounting is different because of the construction differences between a ukulele and a guitar. The rod is fastened to brass studs mounted on the face of the uke as shown in the front-view photograph. A brass plate on the other side holds the pickup flush as would the finger board on a guitar. The output lead is fed through the face of the uke via a small hole drilled at an angle to permit the lead to lie flat, and is connected to a phone plug on the amplifier chassis. Placement of the volume potentiometer and the jack for the foot-pedal control is not critical, but the placement shown in the photograph has

proved convenient.

The amplifier chassis is bolted directly to the front panel of the uke with four machine screws. No shock mounting is necessary, because of the nonmicrophonic nature of the transistor. The speaker, however, must be isolated from the body of the uke to prevent undesired mechanical feedback to the ends of the strings, since the desired feedback path is through the air. A piece of sponge rubber ½-inch thick is placed immediately behind the round opening in the face of the uke and a slightly larger corresponding hole is cut in the sponge rubber. The speaker is placed over this hole and the complete assembly is held in place by the pressure of the strengthened bar.

The output transformer—which is a 1,000 ohms to voice coil type—may be mounted on the speaker as in this case, but if the amplifier chassis is reduced in size, it may mount on the chassis proper. The chassis shown in the rear-view photo was made much larger than necessary for the amplifier. This was done to provide room for experimental work with auxiliary circuits such as an r.f. transmitter section. This would allow the ukulele signal to be picked up on a standard receiver should quite large amounts of output be desired. Such an r.f. section may be described in a future article.

Materials for transistorized ukulele

Resistors: 1—200, 2—910, 1—2,000, 1—5,000, 2—9,100, 1—10,000, 1—12,000, 2—24,000, 1—43,000, 1—56,000 ohms, ¼-watt; 1—1,000-ohm potentiometer.

Capacitors: (Electrolytic) 4—50-µf, 50 volts; 4—50-µf, 25 volts.

Transistors: 3—RCA 2N34 or equivalent; 1—RCA 2N35 or equivalent.

Miscellaneous: 1—ukulele; 1—output transformer, Jensen 2L-2021 or equivalent, primary impedance 500, 1,000, 1,500 and 2,000 ohms—secondary impedance 3-4 ohms; 4—Cinch 2H5 subminiature sockets; 1—d.p.s.t. switch; 1—3-conductor closed-circuit jack; 1—3-conductor plug; 1—3-inch speaker; 1—guitar pickup, Sears, Roebuck catalog No. 57G-1399; 2—22.5-volt miniature batteries, RCA VS084 or equivalent.

Note that the maximum power output of the self-contained amplifier is not limited by the transistors, but by the usable amount of (acoustic) feedback. The purpose of the amplifier is primarily to provide feedback and give the uke a sustained tonal quality, and too much output will cause self-oscillation. Nevertheless, the modified instrument does have considerable volume. Of course, there will be very little output unless the gut strings which were removed when starting work on the uke are replaced by steel ones. Standard steel strings are used, and the instrument is tuned to suit the desires of the particular musician. It has been tuned successfully as a uke, a banjo, a guitar, and a Hawaiian steel guitar. END

References

1. RADIO-ELECTRONICS, Vol. 24, No. 1, January, 1953, pp. 12.
2. G. C. Sziklai, "Symmetrical Properties of Transistors and Their Applications", *Proc. I.R.E.*, Vol. 41, No. 6, June, 1953, pp. 717-724.
3. R. D. Lohman, "Complementary Symmetry Transistor Circuits", *Electronics*, Vol. 26, No. 9, September, 1953, pp. 140-143.
4. Fred Shunaman, *RADIO-ELECTRONICS*, Vol. 24, No. 6, June, 1953, pp. 68.
5. Richard F. Shea, "Transistor Power Amplifiers," *Electronics*, Vol. 25, No. 9, September, 1952, pp. 106-107.

AMPLIFIER WITHOUT FRILLS

By DON V. R. DRENNER

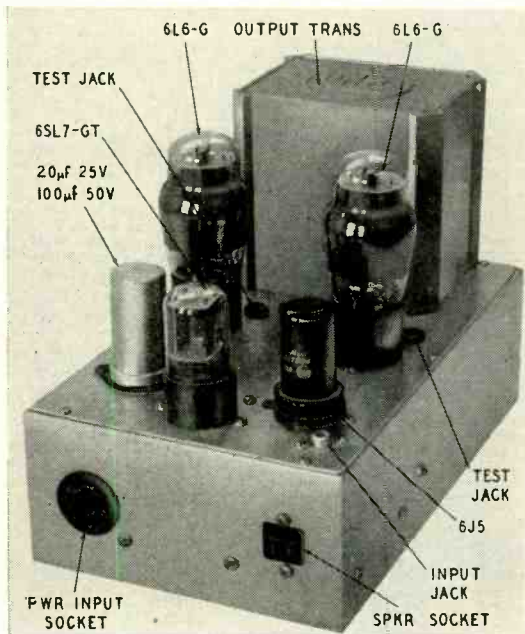

A top-chassis view of the amplifier.

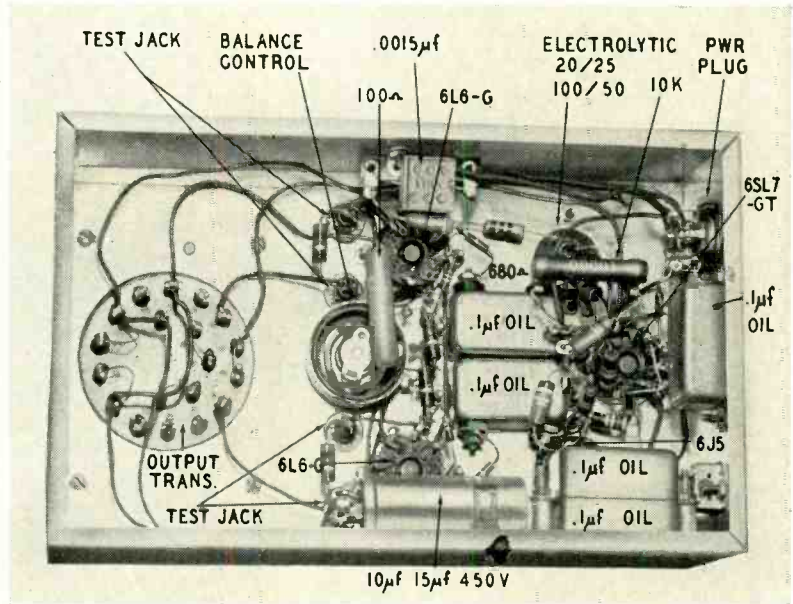

How the job looks beneath the chassis.

HERE are almost as many types of amplifiers as there are people who listen to them. The schematic of this one may appear so conventional you'll wonder "Why Write About It?" We tried everything from triodes to push-pull parallel tetrodes,—yes, even the Williamson and the Ultra-Linear!—and listened to most of the commercial units. Then we decided to simplify matters. This choice may also appear quite conventional, but something simple to give music is a thing hard to come by!

First, you have to rid yourself of the idea an amplifier has to be complex and

decorated with a multiplicity of controls. And that it really needs all that power; 5 watts doesn't sound like much in these days of beach-blasting 40-watters, we admit. But our observation is that 5 watts shakes the walls nicely.

The only thing you need to spend money on is the output transformer, and you can get a good one for around \$15 to \$20.

We believe our ears. This amplifier sounds wonderful to us; but the curves aren't bad, either. You'll see that it uses a pair of 6L6's—or 5881's if you have them—and they are run class A. The stuff ahead to drive them is the

same old thing we've all used. After fighting every known phase inverter, we'll settle for this one.

Only two gimmicks are used: the .0015-µf mica capacitor across the feedback resistor to smooth out the high-frequency response, and the fixed cathode bias on the input triode. A 100-µf electrolytic can be used here, but that adds about a dollar to the cost.

Construction can follow the photographs, or maybe you have your own ideas. In general, wire point-to-point and keep those filament leads against the chassis!

The feedback loop—and in our case the output impedance used—is 4 ohms. To achieve this value on the secondary of our transformer the primary is connected for 3,000 ohms, and the 2.5-ohm secondary tap is used to feed the 4-ohm



MEASURED ON HEWLETT-PACKARD 200AR OSC & G-E VU PANEL WITH DAVEN MEASURING SET

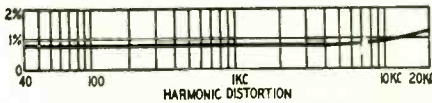

MEASURED WITH HEWLETT-PACKARD N/D METER 330-B (-65DB NOISE FIGURE. ALL MEASUREMENTS AT 5 WATTS)

Frequency response and harmonic distortion curves of the unfrilled amplifier.

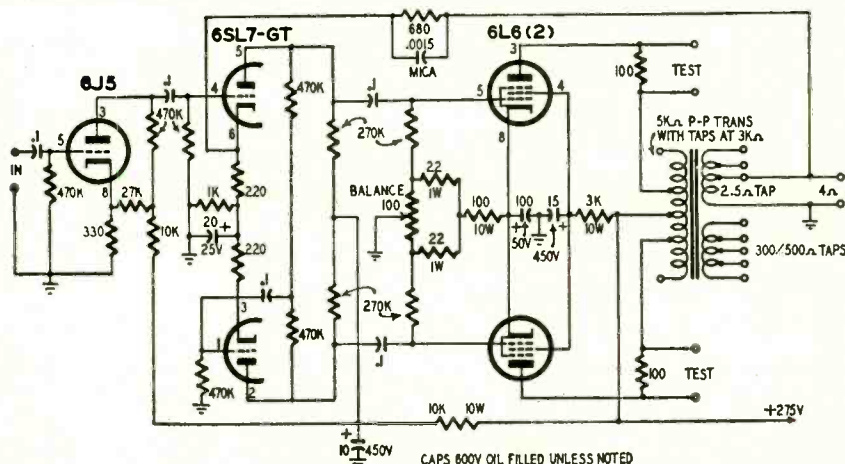

The schematic. Mr. Drenner used a UTC LS-55 output transformer. If the 500-ohm output winding is not needed, the cheaper LS-57 may well be substituted.

Materials for amplifier

- Resistors:** 2—100, 2—220, 1—680, 1—1,000, 1—10,000, 1—27,000, 4—270,000, 1—330,000, 6—470,000 ohms, 1/2 watt; 2—22 ohms, 1 watt; 1—100, 1—1,000, 1—10,000 ohms, 10 watts.
- Capacitors:** 1—.0015 µf mica; 5—0.1 µf, 600-volt oil-filled paper; 1—10, 1—15 µf, 450 volts, 1—20 µf, 25 volts, 1—100 µf, 50 volts, electrolytic.
- Tubes:** 1—6J5, 1—6SL7-GT, 2—6L6-G.
- Miscellaneous:** 1—output transformer primary 5,000 and 3,000 ohms plate-to-plate, secondary 30 to 1.2 ohms, UTC LS-57 or equivalent; 1—RCA phono jack; 4—banana jacks; tube sockets, chassis, wiring, hardware, etc.

voice coil of our Western Electric 728-B speaker. The reflected impedance, connected this way, gives 4,800 ohms plate-to-plate, which is plenty close to the required 5,000 ohms for 6L6's class A. If you use an output impedance other than 4 ohms, the feedback resistor is subject to change. The value used here gives around 15 db feedback.

A power supply? Why, anything that will deliver 275 volts at about 150 ma will do. END

AN ECONOMICAL

TRANSMISSION SET

By KEN MAXWELL

This gain set simplifies hook-up problems and increases accuracy of output and response measurements

ANYONE who has an audio oscillator probably has found the need for a convenient means of connecting it to the input of an audio amplifier. The difficulty involved depends upon the type of tests to be made on the amplifier. For the simplest test, that of measuring power output, an attenuator is required to reduce the output of the oscillator to the proper input level of the amplifier. A simple voltage divider of two resistors will suffice. However, if frequency-response and distortion measurements are to be made, this method may not be very satisfactory. For response measurements, the signal must be accurately metered and fed into the amplifier through an impedance equal to that of the microphone or pickup usually connected to the amplifier.

Commercial gain or transmission sets which have adequate facilities for these tests and include a metering circuit for measuring the output signal of the amplifier are available for several hundred dollars. Gain or transmission sets are calibrated attenuation circuits with a volume indicator or decibel meter to show the output of the audio oscillator. Most have three variable attenuators. One covers a range of 0-100 db in 10-db steps, another 0-10 db in 1-db steps, while the third has 0.1-db steps with a maximum attenuation of 1 db. A transformer with a multiimpedance output couples the signal to the amplifier. With this arrangement the oscillator voltage applied to the amplifier may be set to the nearest tenth of a decibel. All adjustments in level are made by varying the attenuators and the meter is made to read the same at all times by correcting any changes with the

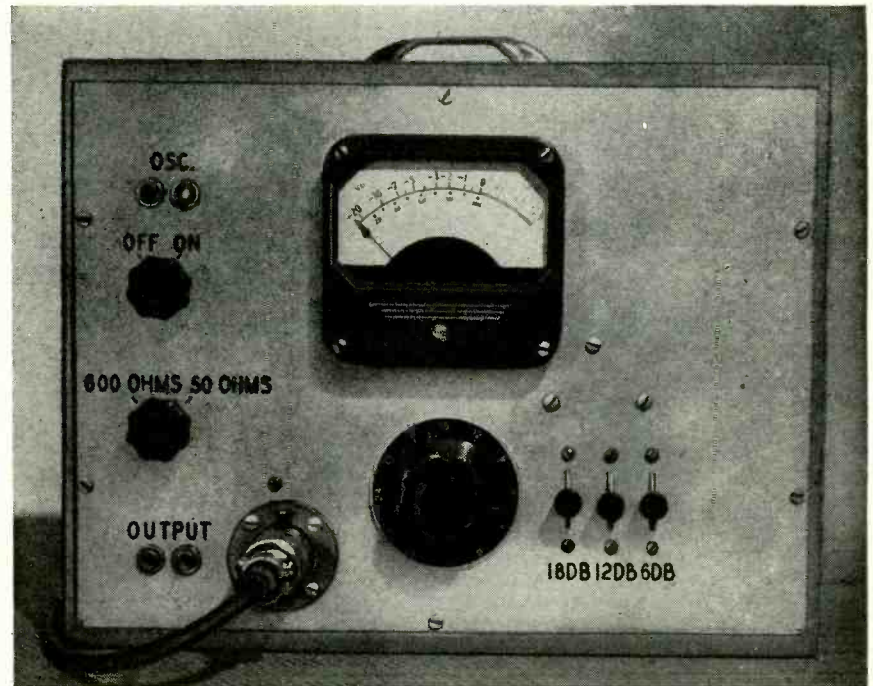

Photo shows front view of the transmission set. The cable connector parallels the output terminals to simplify feeding test signals to broadcast preamplifiers.

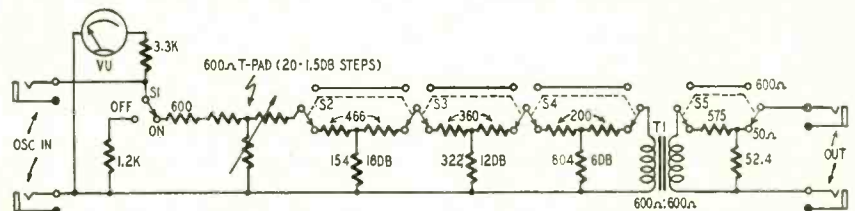

Diagram of the transmission set. Input and output impedances are 600 ohms. Stepped control gives 30 db attenuation; switched pads, 36 db additional loss.

audio-oscillator gain control.

The gain set shown in the schematic and photographs is a compromise design which results in adequate performance and serviceability at comparatively low cost. Its principal parts are a single rotary T-pad attenuator, three fixed pads which can be switched in or out, a meter for reading the oscillator output voltage, and a transformer for matching the input impedance of the amplifier under test. The rotary attenuator should have steps of approximately 2 db per step. The attenuator in this instrument is a Daven type T-323G which I happened to have on hand. It has 20 steps of 1.5 db each. The 1.5-db steps are useful when working on radio-telephone transmitters where measurements are usually made at 25, 50, 85, and 100% modulation. These values are

approximate multiples of 1.5 db. It is 1.5 db from 100 to 85%, and 4.5 db from 85 to 50%. Another 6 db brings the modulation down to 25%. Fixed 6-, 12-, and 18-db pads may be switched in to increase the available attenuation.

A Weston type 802 VU meter and a 3,300-ohm resistor are connected in series across the input terminals. If another type of meter is used, follow the manufacturer's recommendations in selecting the series resistor if needed. The single-pole double-throw switch, S1, was inserted in the signal circuit to cut off the signal to the amplifier and still allow the oscillator voltage to be read on the meter. A 1,200-ohm resistor is connected in parallel with the meter when S1 is in the off position. It replaces the 1,200-ohm resistance of the attenuator circuit.

ONE AUDIO AMPLIFIER, TWO TOUGH PROBLEMS

A few months ago, I moved into a new spacious apartment and resurrected my prewar high-fidelity audio system that had been stored since 1943. The amplifier uses push-pull class AB1 6L6's with lots of feedback from the secondary of the output transformer to the cathode of the phase inverter.

The amplifier was pulled down and all capacitors and tubes checked and replaced where necessary before being connected up. When records were played through the amplifier, the highs were shrill and unrealistic. Although its performance was far from satisfactory the amplifier got a good workout while I listened to my old—now priceless—collection of jazz records. But during the evening the big 30-watt output transformer came to the end of its trail, going up in smoke.

I borrowed a scope to check the amplifier and see if I could clean up the highs while replacing the transformer. The scope showed that the amplifier was feeding a husky but inaudible signal into the speaker. Pulling the tubes one by one, I found that the spurious signal was still present with all audio tubes except the 6L6's out of the circuit. Then it dawned on me. Oscillations in the output circuit!

The solution to this problem was to insert 1,000-ohm resistors in series with each 6L6 grid lead and 100-ohm resistors between each screen grid and the screen dropping resistor. A 20- μ f electrolytic was then connected between ground and the junction of the two 100-ohm resistors.

A very annoying hum developed when a wide-range speaker and R-J enclosure were substituted for the original bulky speaker system. A check showed that the hum originated in the output stage. Tubes were checked, substituted, and balanced without any effect on the hum that could be heard with both 6L6 grids grounded. I unbolted the mounting board for the filter and cathode-bypass capacitors so I could push it to one side and get at the base of one of the 6L6's. While the mounting board was moved slightly from its original position, I turned on the amplifier and found that the hum had gone. The hum returned to full intensity as the mounting board was pushed toward its original position.

Finally, I spotted a small half-shell type filter choke sticking through the chassis just under the mounting board. With clip leads shorting the choke, the large bypass capacitor could be placed in any position without producing hum in the circuit. Evidently the capacitor that I used acted as an inductance shunted by its own internal capacitance. This combination picked up hum from the strong magnetic field surrounding the choke. Replacing the choke with a wire-wound resistor of a few hundred ohms ended one annoying but enlightening and interesting job of debugging an amplifier.—Henry O. Maxwell

END

A 600-ohm resistor is used ahead of the variable attenuator to simulate the internal impedance which the transmission set represents as a signal source. This section may be considered as an equivalent circuit wherein the voltage measured by the meter is the zero impedance generator and the 600-ohm resistor is the internal resistance of the generator. The audio oscillator is effectively a zero-impedance generator because any deviation of voltage due to change in current is corrected with the level or output control of the oscillator.

Double-pole double-throw switches S2, S3, and S4 control the insertion of the fixed pads into the circuit. Transformer

unit are surplus units obtained from TAB. The 322-ohm resistor in the 12-db pad was made by connecting a high-ohmage carbon resistor in parallel with a 325-ohm precision unit.

Attenuator switches S2, S3, and S4 are double-pole double-throw locking-type lever switches. S1 and S5 are s.p.d.t. and d.p.d.t. rotary types, respectively. With this particular layout, you may run into trouble with stray coupling between the input and output circuits. You can prevent this by separating the hot leads and by inserting a shield between S1 and S5.

All components are mounted directly on the 9 $\frac{3}{4}$ x 13 $\frac{3}{4}$ -inch front panel. The

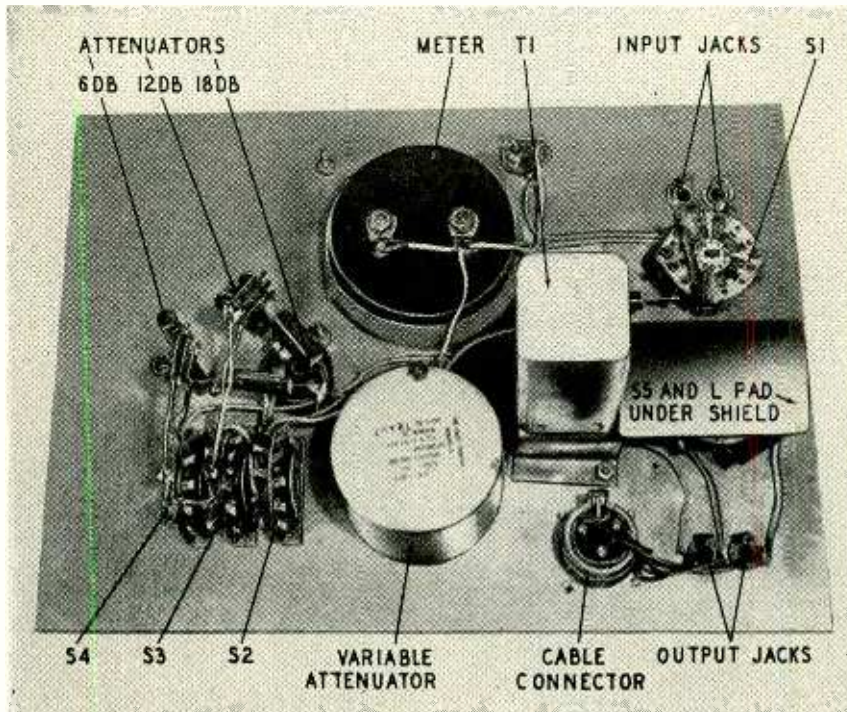

Behind-the-panel view shows the placement of components. The shield around S5 and the L pad prevents interaction between the input and output circuits.

T1 is a 600-to-600-ohm unit which is used to reduce electrostatic coupling to the amplifier. Good frequency response is necessary in this transformer, and taps at the impedances desired are very useful.

Construction hints

If only high-impedance inputs are likely to be encountered, T1 could be a high-quality input transformer which would operate directly into the grid circuit of an amplifier. Where both 600-ohm and high-impedance circuits are encountered, switch a load resistor of 600 ohms across the output circuit when operating into a low-impedance input.

The 18-db fixed attenuator was salvaged from a piece of surplus equipment. The other attenuators and the L-pad were assembled from 1% precision resistors. In the L-pad, I used 50- and 550-ohm resistors in place of the correct values specified without running into any difficulty. Most of the required values are nonstandard and are available only on special order from the manufacturer. The ones used in this

wooden case is 6 inches deep and $\frac{3}{4}$ inch larger than the front panel. The front edge of the case is recessed so the panel fits flush.

Material for transmission set

Resistors (Precision 1% tolerance or better) 1—52.4, 1—154, 2—200, 2—322, 2—360, 2—466, 1—575, 1—600, 1—804, 1—1,200, 1—3,300 ohms; 1—T-pad attenuator, 600 ohms impedance, 30-db attenuation in 20 or more steps.

Miscellaneous: 1—VU meter, minus 20 to plus 3 VU; 1—s.p.d.t., 1—d.p.d.t. rotary switch; 3—d.p.d.t. locking-type lever switches; 1—audio transformer, 600-ohm line-to-line or 600-ohm line line-to-grid, see text. Jacks, panel, wire, tie-points, hardware.

Before using, connect a vacuum-tube voltmeter or a good quality a.c. voltmeter across the output circuit and vary the audio oscillator throughout the range of frequencies to be used. Maintain the reading of the VU meter constant with each frequency and check to see if the meter across the output remains constant. Note any discrepancy and make a permanent record so that all future readings may be corrected. If a low-impedance output transformer is used, the circuit should be loaded with the proper resistance while making this check.

END

PUSH PULL VOLUME CONTROLS

ALBERT H. TAYLOR

RECENTLY an author stated that push-pull in low-level audio stages is pointless. Yes, as regards distortion; but an amplifier that is push-pull throughout, right back to the input, requires less filtering and less shielding. This can mean a lot to the novice, whose worst trouble is apt to be HUMMMM! About the only problem to vex the implacable push-puller is that of volume control. How does one vary the gain (control the volume) of an all-push-pull amplifier without unbalancing it? Let us begin by making balance tests.

Balance tests

We can compare the signal on the two sides of a push-pull stage with a v.t.v.m. or a C-R oscilloscope. The scope shows up any unsymmetrical phase rotation as well. Fig. 1 shows a simple indicator built into a typical pushpull amplifier. The diode can be in a separate tube, or in one of the amplifier tubes as shown. Refinements are possible, such as an indicator amplifier, or a 6AL7 to indicate balance without switching.

To use balance test in Fig. 1, switch the indicator to one side of the amplifier and set its control so that the eye tube just closes. Then without changing the setting, switch to the other side for comparison. Adjust any amplifier balancing controls, such as those shown in Figs. 2-b, 3, 6, 7, and 8, so that both sides indicate alike. This can be done at various signal levels.

A balance test which requires no special indicator can be performed as in Fig. 2-a by temporarily tying the two input grids of an all-push-pull amplifier together and applying the signal between them and ground. The test signal may come from a phonograph pickup, an oscillator, the heater circuit, or a wire "hum antenna." If the amplifier is balanced, there will be no output except for uncanceled distortion. When a wholly resistance-coupled amplifier is balanced like a bridge for zero output with parallel input, the over-all balance includes the output stage; but if there is an interstage transformer as in Fig. 2-b, the balance does not go beyond the transformer. Balance of a transformer-driven stage can be tested by applying the input signal normally except that each of the two grids of the stage under test is connected to one side of its driving transformer as in Fig. 2-b. However, balance by either of these tests may not always correspond to minimum hum (see section 1.32).

Volume-control circuits

1. Separate control for each side (Fig. 3)

- 1.1. Advantages:
 - 1.1.1. Grids are at ground potential at zero volume.
 - 1.1.2. Severe hum pickup can often be canceled by setting the controls carefully. I have seen it canceled from unshielded crystal pickup leads which went 20 feet through a cellar and crossed power lines.
 - 1.1.3. Perfect balance is theoretically possible despite manufacturing tolerances.
 - 1.1.4. In many amplifiers, balancing by Figs. 2-a,b works both output tubes equally.
 - 1.1.5. The circuit is easily converted to a phase inverter by linking D to B, applying input between A and G, and adjusting R2. R3 is several times R2, and C blocks DC.
 - 1.1.6. The circuit is simple and inexpensive.
- 1.2. Disadvantages:
 - 1.2.1. There are two controls to set when changing gain.
 - 1.2.2. Calibration is necessary for perfect balance.
 - 1.3. Calibration: It may be enough just to set two bar knobs parallel, varying them if necessary to cancel hum. For more accurate balance, fit a piece of white paper or thin cardboard under the two pointers. Calibrate the rotation of one control in any convenient steps, and mark the corresponding settings of the other for balance at various levels by either of the tests suggested.
 - 1.3.1. Recalibration: Aging and replacements can unbalance any push-pull amplifier, so recheck occasionally.
 - 1.3.2. Hum: Unsymmetrical hum pickup may make the settings for hum cancellation differ from those for signal balance. Out-of-phase hum components which cannot be canceled by resistance adjustments alone can sometimes be helped by small capacitors from A or B to ground, or elsewhere in the amplifier.

I prefer this circuit for my own use and I have built several amplifiers with twin controls for nontechnical users who found them no hardship.

2. Ganged controls (Fig. 3 but with R1 and R2 ganged)

- 2.1. Advantages:
 - 2.1.1. Single control knob.
 - 2.1.2. Grids at ground potential at zero volume.
- 2.2. Disadvantages:
 - 2.2.1. In the writer's experience there was never a pair of ganged composition controls that would track.
 - 2.2.2. If the controls should track perfectly, they would not correct for unbalance elsewhere in the amplifier as separate controls can do.

3. Ganged step attenuators (Fig. 4)

- 3.1. Advantages:
 - 3.1.1. Single control.
 - 3.1.2. Accurate tracking if resistors are selected and stay put.
 - 3.1.3. With trimmer capacitors for equal R-C on all steps, step attenuators of high impedance can be used up to video frequencies.
 - 3.1.4. Grids are at ground potential at zero volume.
- 3.2. Disadvantages:
 - 3.2.1. Expensiveness.
 - 3.2.2. Discontinuousness.
 - 3.2.3. There is no compensation for unbalance elsewhere in the amplifier without separate balance adjustment.

(The writer has used step attenuators only on wide-band oscilloscopes.)

4. Single control between grids (Fig. 5)

- 4.1. Advantages:
 - 4.1.1. Single Control.
 - 4.1.2. Cheapness and simpleness.
- 4.2. Disadvantages:

4.2.1. Grids are never at ground potential and will rectify a strong radio signal. The writer once picked up a nearby ham this way.

4.2.2. Asymmetry makes Fig. 5 inferior to Fig. 3 for hum cancellation and amplifier balance. At full volume, any difference in voltage from A to ground and B to ground by reason of different lead and source capacitances, etc., will unbalance the amplifier. At low or zero volume, any large voltage from B to ground will produce even harmonics as well as the fundamental, if the amplifier is not perfectly balanced.

4.2.3. This circuit can be used only with floating sources such as an ungrounded phonograph pickup. It cannot be used between stages.

You can get away with using Fig. 5 where the source has little capacitance to ground and low enough impedance so that R1 and R2 need not be high. It is risky with crystal pickups, but I am using a Pickering magnetic.

5. Bridge attenuator (Fig. 6)

- 5.1. Advantages:
 - 5.1.1. Single control.
 - 5.1.2. Accurate balance adjustment.
 - 5.1.3. It is usable at input or interstage, with floating or center-tap source.
- 5.2. Disadvantages:
 - 5.2.1. More components.
 - 5.2.2. More space.
 - 5.2.3. More care required in construction and shielding.
 - 5.2.4. Grids off ground at zero volume.

In Fig. 6, R1 and R2 are equal and R6 is a linear control which is adjusted for symmetry. $R6 + R1 + R2$ should be high compared to R3 and R4 but low enough to act as grid resistors for the tubes used. R3 and R4 are equal dropping resistors high enough to maintain the source impedance with R5 near zero, but low enough not to be themselves much affected by $R6 + R1 + R2$ or by the grid capacitances. R5 is the tapered volume control and its maximum value should be high compared to $R3 + R4$ unless there is gain to spare. C1 and C2 are trimmers to balance the source to ground and their size depends upon its capacitances. They are of most use with floating sources. Typical values for Fig. 6 with two types of pickup are given below:

Crystal	Pickering
R1 = R2 = 1 meg	470,000 ohms
R3 = R4 = 220,000 ohms	47,000 ohms
R5 = 5 meg	1 meg
R6 = 250,000 ohms	100,000 ohms
C1 = C2 = 10- to 50- μ f trimmers	

If you arrange Fig. 6 carefully, shield it well, and balance it correctly, it should be satisfactory even with high impedances.

6. Pentagrid compressor¹ (Fig. 7)

- 6.1. Advantages:
 - 6.1.1. Single control.
 - 6.1.2. If cross-coupled as shown, it will produce balanced output from single or push-pull input.
 - 6.1.3. Usable at video frequencies without

¹Taylor, A. H., "New Uses for Pentagrids," *Electronics*, December, 1946, pp-140.

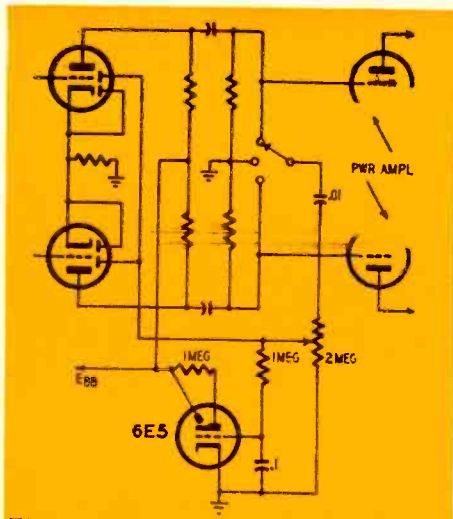

Fig. 1—Schematic shows simple indicator.

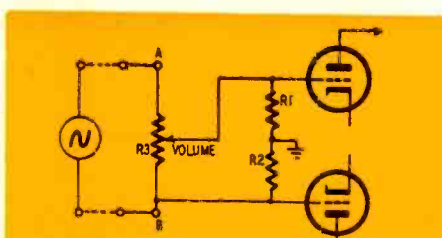

Fig. 5—Single control between grids.

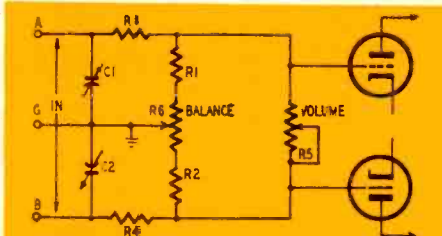

Fig. 6—Circuit using bridge attenuator.

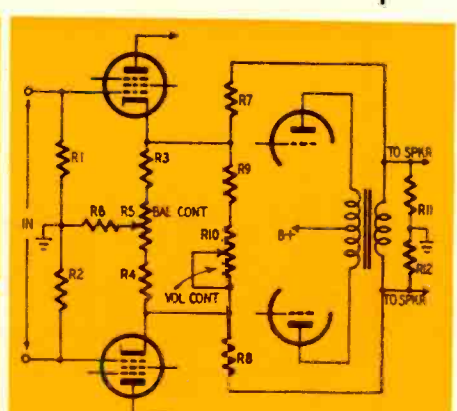

Fig. 8—Diagram of feedback bridge.

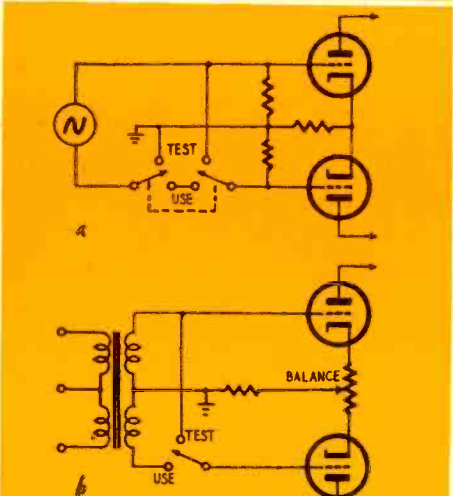

Fig. 2—Balancing push-pull amplifiers.

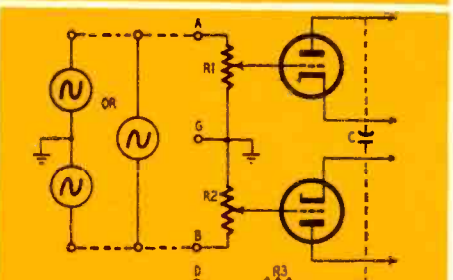

Fig. 3—Circuit shows separate controls.

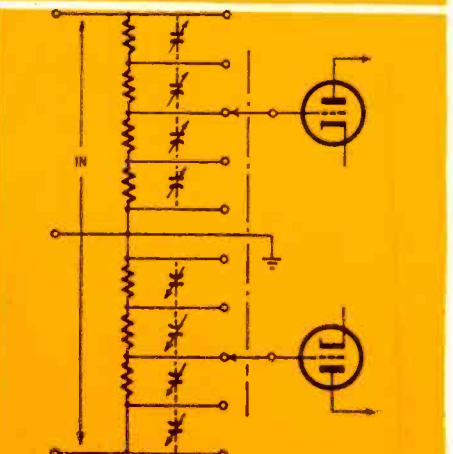

Fig. 4—Circuit uses step attenuators.

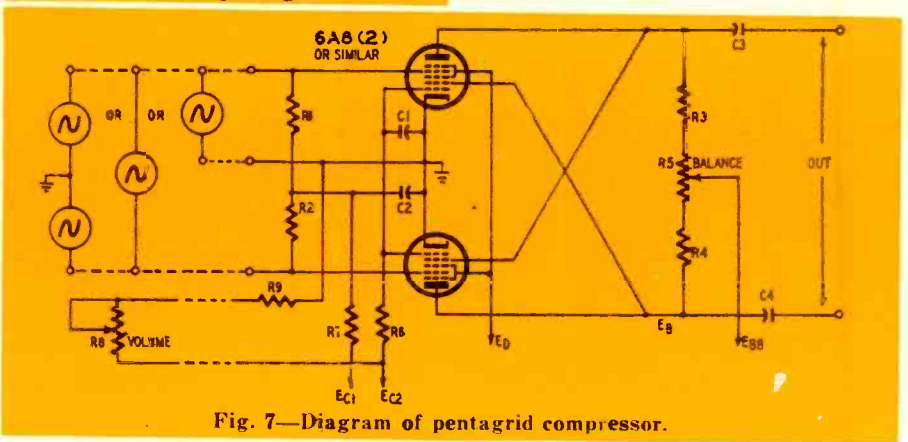

Fig. 7—Diagram of pentagrid compressor.

such laborious trimming as in 3.1.2.

6.1.4. Very high input grid resistance is tolerated. I found a 6A8-GT stable with 80 megohms.

6.1.5. The actual gain control R8 is bypassed, handles only d.c., and can be located remotely.

6.1.6. Automatic volume expansion or compression is possible by applying rectified and filtered output to grid No. 1 of both tubes.

6.2. Disadvantages:

6.2.1. Complexity and increased cost.

6.2.2. Tubes must be selected if compression characteristics are to track.

6.2.3. The 6A8 will not handle enough signal for driver stages and some tubes are too noisy for early stages. The writer has not tried other pentagrid converters.

6.2.4. Low stage gain.

In Fig. 7, R5 is a balancing adjustment. Controls carrying both d.c. and signal should be avoided as possible noise sources. Balancing might be done in next stage. Typical values of components for Fig. 7 are:

- R1 = R2 = up to 80 megs
- R3 = R4 = 15,000 ohms, 2 watts
- R5 = 10,000 ohms
- R6 = 100,000 ohms
- R7 = 100,000 ohms
- R8 = 100,000 ohms
- R9 = 68,000 ohms
- E_{BB} = 350 volts
- E_B = 200 volts (at plates)
- E_D = 100 volts
- E_{C1} = -4 volts
- E_{C2} = -15 volts

Under these conditions, the amplification of this stage is about 15.

I have used a single 6A8 as a video phase inverter to deliver synchronizing voltage in either phase to the sweep of a wideband oscilloscope.

7. Feedback bridge (Fig. 8)

7.1. Advantages:

7.1.1. One control only.

7.1.2. Feedback helps keep balance.

7.1.3. Inexpensive, since many amplifiers have feedback anyway, hence R₉ and R₁₀, R₁₁ and R₁₂, are the only extra parts.

7.2. Disadvantages:

7.2.1. Does not reduce to zero volume. This does no harm in a home record player where there is no advertising to shut out and the only need is to compensate different recording levels.

7.2.2. Feedback, hence speaker damping, varies with gain setting.

In Fig. 8, the push-pull feedback may come from the voice-coil winding as shown, or from another winding, or from the plates of any later stage than that which receives it, etc. The equal cathode resistors R3 and R4 should be as small as will give enough feedback with values of dropping resistors R7 and R8 which do not load the output. Typical values for a pair of 6SJ7's in the first stage of Fig. 8 with a 300-volt supply, 500,000-ohm loads, and 500,000-ohm gridleaks in following stage would be:

- R_k = 1,300 ohms per Resistance-Coupled Amplifier Chart No. 20 (RCA HB-3, Vol. 3-4).
- R1 = R2 = 1 megohm
- R3 = R4 = R5 = 220 ohms
- R6 = 470 ohms
- R7 and R8 depend on following stage(s) and can be determined by trial.
- R9 = 47 ohms
- R10 = 4,700 ohms
- R11 = R12 = 47 ohms for 15-ohm voice coil; 27 ohms for 8-ohm v.c.

These values should give about 220 db variation in gain. END

the speaker. In this way the faulty unit can be isolated without removing the various chassis from their cabinets.

Tracing distortion is more difficult than tracing inoperation. A hi-fi installation may include from 2 to 4 or even 5 volume controls in the chain from signal source to loudspeakers. Improper setting of these controls may result in overloading of a tube somewhere in the chain even at low output levels. For lowest distortion, all volume controls should be wide open except the very first one in the chain which should be used to set overall volume. It is surprising how many cases of distortion in complicated hi-fi systems can be cleared up simply by manipulating the volume controls.

Also check the setting of the treble boost control. Many hi-fi addicts are inclined to overboost the highs. This results in abnormal distortion, first, because the distortion present in the program is accentuated and possibly multiplied, and second, because succeeding stages are driven harder at the high frequencies and therefore generate considerably more distortion in this region.

Finally, before starting to chase small amounts of distortion, check to see whether or not the distortion is present in the program itself. All recordings and radio programs have some distortion which is made worse by the radio detector or the phono-pickup. This is fairly easy to determine. If the distortion is present in the signal, it will be constant at all volume levels. Therefore, vary the first volume control while listening to the distortion carefully; if it is audible at low as well as high volume, it is a fairly safe assumption that it is either in the program itself or caused by the tuner detector or phono-pickup.

If all these tests do not clear up the distortion, adjust the controls until the distortion is plainly audible and then, with the headphones, trace the signal from front to back as described above until you locate the unit in which the distortion first occurs. When the unit is spotted, the tubes should be checked, preferably by substitution. If substituting tubes does not clear the trouble, the unit can be removed from the cabinet for further testing.

The headphones are equally useful for stage by stage testing of amplifiers. With one terminal grounded, the other can be touched to the grid terminal of each tube until the inoperative or distorting stage is located. The specific fault can then be found by voltage and resistance measurements in the indicated stage.

In the case of complete non-operation, the trouble is usually no great problem to the service technician since the fault—shorted or open capacitors, burnt out or shorted resistors, bad tubes, etc.—is almost always similar to that existing in an inoperative radio, and can be repaired the same way. Finding and eliminating distortion, however, is another matter. A wiring

diagram, particularly one which indicates the voltages existing at tube terminals, can be extremely helpful here.

In general, distortion is produced by the following:

Overloading—or driving a tube into the non-linear portion of its operating curve. This is easily checked since reducing the input signal will reduce or eliminate the distortion. In a properly designed hi-fi system this type of distortion should only occur at or beyond the maximum rated output and should not be very serious even then. However, the distortion curves of hi-fi amplifiers rise very steeply beyond a certain output level; a Williamson designed to deliver 10 watts with only 1% distortion, may generate 5 or even 10% distortion if an attempt is made to drive it to 15 watts. The intermodulation distortion rises even more steeply. Some less-informed hi-fi listeners try to get more out of their amplifiers than they can deliver. If the overload distortion disappears or is scarcely audible at the maximum rated output of the amplifier—usually about 10 watts (equivalent to roughly 9 volts across an 8-ohm load or 13 volts across a 16-ohm load)—it is safe to assume the trouble lies with the customer rather than the equipment. But if the overload distortion is serious at rated output, or occurs at lower than maximum rated output, the fault may lie with weak tubes. The most likely offenders (aside from rectifiers) are the driver tubes—but any tube which fails to deliver rated amplification can result in overload distortion. Weak output tubes can also be guilty since they must be overdriven to produce rated output. If changing tubes does not clear up the distortion, it is pretty safe to assume (in the case of commercial gear) that the trouble lies in other causes.

Improper operating characteristics. For lowest distortion with maximum amplification a vacuum-tube circuit must be carefully designed to preserve certain relationships between plate and grid voltages. The tolerances permissible in this relationship are very much lower in the case of hi-fi circuits than in ordinary audio circuits. Therefore, if the relationship is disturbed by some change in one or more of the circuit components, or the voltages supplied to it, distortion may become too serious for hi-fi reproduction.

In effect, the tube is either over or under-biased by such changes. In either case, it will generate distortion with a lower-than-normal driving signal—in the over-biased case because the bend of the curve is advanced; in the under-biased case because the grid is driven positive on a lower signal; one results in negative peak clipping, the other in positive peak clipping.

An audio generator and an oscilloscope are extremely helpful in tracing this type of distortion. The signal generator can feed the amplifier input, while the oscilloscope input is moved from stage to stage and the trace

examined for evidence of clipping.

In the absence of this equipment, the trouble can usually be spotted by voltage measurement and a wiring diagram or a tube manual. Measure the grid and plate voltages and check them against the operating characteristics given in the tube manual. Some hi-fi amplifiers use direct coupling and the net grid voltage in such cases can only be determined by grid to cathode measurement. If the voltage departs by more than 10 or 20% from that specified on the diagram or in the tube

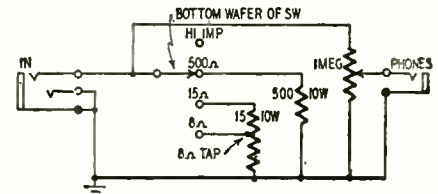

Fig. 2—Schematic of signal tracer.

manual, check the resistors in the circuit, plate and cathode, and if the resistance departs from that specified in the diagram or marked on the resistor by more than 10%, replace it. (Be sure, however, that your ohmmeter is accurate, by testing it with 1% precision resistors.)

Plate resistors are most likely to change value due to overheating, especially in amplifiers using resistors with a rating of less than 1 watt. Never use a resistor of lower wattage than the one replaced; and if the replaced resistor shows signs of overheating, it should be replaced with one of higher rating. Select a resistor as close to the specified value as possible. In any group of four or five stock resistors of a given nominal value one can usually be found which is within 1 to 5% of the desired value. If the replaced resistor is in a push-pull stage, match it to its opposite mate.

An unduly low or unduly high plate voltage may disturb operating voltages to produce under or over biasing. Therefore, check the power supply.

A possible cause of under-bias is a leaky interstage coupling capacitor. Measure the voltage between grid and ground with the tube removed, using a high-resistance v.t.v.m. on the 2.5 or 5-volt range. If the meter indicates a voltage in excess of one or two tenths of a volt, change the capacitor. Since the bias may be as little as 1 or 2 volts, any appreciable leakage through a capacitor may seriously upset operating characteristics.

A similar effect is produced by tubes which draw grid current. This is most likely to occur in power output tubes and can be checked with a high-resistance v.t.v.m. by measuring grid to ground voltage. The meter resistance should be at least 5 megohms. If any appreciable voltage exists, try substituting tubes; if that doesn't help, check the grid resistors. Most output tubes can tolerate a grid resistance of 500,000 ohms, but not higher.

(TO BE CONTINUED)

HIGH-QUALITY AUDIO

By RICHARD W. DORF*

Part VI—Pickups, preamps, and recording and playback characteristics

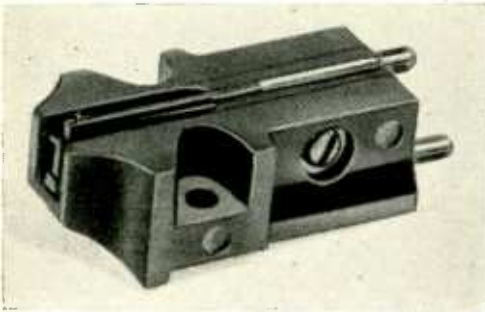
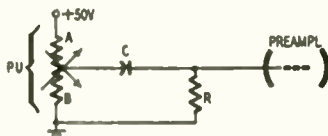

Fig. 1—The Pfanstiehl strain pickup.

TWO types of pickup, both fairly new, are of special interest in addition to the types we discussed last month. They differ from the usual kinds in that they do not generate voltage or current, but modulate it.

One of these is the Pfanstiehl strain-sensitive pickup illustrated in Fig. 1. This pickup contains as an element a thin section of plastic material on which is inscribed a strain-sensitive resistive material. When the plastic and the resistive material are slightly bent by movement of the attached stylus the resistance is varied in direct proportion to the amplitude of the bend.

The principle, though not the exact circuit, is illustrated in Fig. 2. PU is the pickup element, with a normal resistance of about 250,000 ohms. When the element bends, section A increases in resistance while section B decreases—or *vice versa*, depending on the direction of the bend. A steady d.c. of 50 volts is applied from the top of PU to ground. A and B constitute a voltage



divider, with output taken across B, the lower half. When the resistance of A increases and that of B goes down, the output voltage is reduced. During the second half of an audio cycle, the output goes up. Capacitor C blocks the d.c. from the preamplifier tube grid but allows the audio-frequency variations to pass. R is the audio load resistor.

Since the output of the voltage divider varies to exactly the same extent for either fast or slow movements of the stylus and strain on the element, the pickup is responsive right down to zero cycles—d.c.—and theoretically up to infinity. Practically speaking, the blocking capacitor and R pro-

vide a high-pass filter action so that the bass range below the lowest audio frequencies is not passed to the grid. High-frequency response, which extends to 25,000 cycles (exclusive of the preamplifier), is limited by the stray capacitance of the element and leads.

Special preamplifiers are provided by the maker to raise the a.c. output level of the pickup itself (50 to 10 millivolts) to about 2 volts, and to equalize response for the various records. Other pickup models include a turnover cartridge for quick change from standard to LP stylus.

Capacitance pickup

For many years amateurs have been building capacitance-operated pickups of one sort and another, and magazines have been publishing articles on them. The principle is a fascinating one, for theoretically a capacitance pickup can achieve the highest possible frequency range and least distortion of practically any type. The principal reason is that the moving stylus assembly needs to do no work whatever except to move its own mass. That mass can be kept down to negligible proportions.

The capacitance pickup is nothing more nor less than a small variable capacitor. Both the stylus assembly and the element consist of small metal plates. When one plate moves with relation to the other, as when the stylus is traversing a groove, the capacitance varies in proportion to the movement. The varying capacitance may then be used to vary the amplitude or frequency of an oscillator, with a detector following the oscillator to convert the AM or FM to audio, or it may be part of an electrostatic circuit. The electrostatic circuit requires high voltage which is inconvenient and may be dangerous, so almost all workers have employed the oscillator modulation approach.

Fig. 3 is a photograph of the Weathers FM pickup assembly, the only capacitance pickup on the market today, but one which easily equals the performance of the best magnetics in sound quality and has some interesting

mechanical features. A bottom view of the cartridge itself appears in Fig. 4; Fig. 5 shows the cartridge with the stylus assembly removed. The stylus assembly consists of a holder which slides onto flanges on the pickup housing, a shank fastened to the holder, and a jeweled stylus tip at the end of the shank. There is also a small piece of damping material cemented to the holder and shank.

The only part of the assembly that moves is the front part of the shank. When the assembly is on the pickup, a small metal plate is near this part of the shank to form one plate of a capacitor, the other plate being the shank itself. Connections are made to the pickup case and stylus holder and shank, which are grounded, and to the small stationary metal plate, which is above ground. A very soft brush is attached to one side of the cartridge. The total downward pressure of the pickup at a point $1\frac{1}{2}$ inches above the record surface is 4 to 5 grams. When the stylus is on the disc the brush absorbs about three-quarters of the total pressure and the stylus contacts the groove with a pressure of about 1 gram, a good deal less than is possible with other pickups. This pressure makes it feasible to play back instantaneous recordings which are intended for processing—pressing in quantity. Until this pickup appeared, such practice was strictly taboo, since even 3 or 4 grams of pressure and the usual stylus-assembly resistance will damage the grooves enough to prevent good processing.

Fig. 6 shows the power-supply and oscillator units which go with the pickup. The power supply is conventional. The oscillator assembly is diagrammed in Fig. 7. The single triode is both oscillator (at about 21 mc) and demodulator. The demodulated audio output is directly proportional to the amplitude of stylus motion; this is constant-amplitude response, which will be discussed in the section on equalizers. A simple filter is included to equalize this to the AES (Audio Engineering Society) curve. An additional output

*Audio Consultant, New York

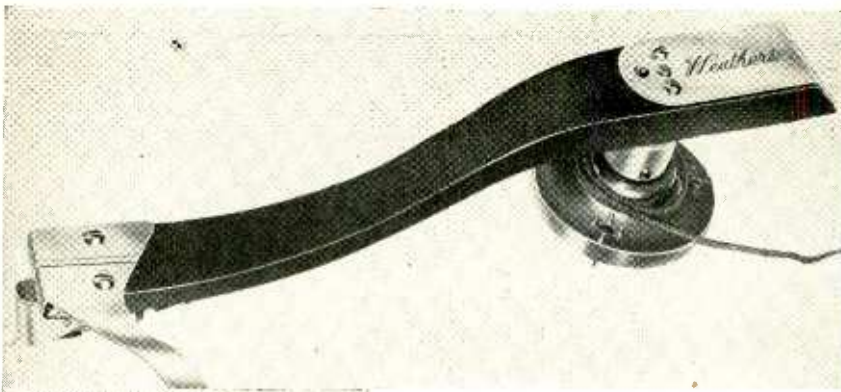

Fig. 3—Weather's capacitance pickup.

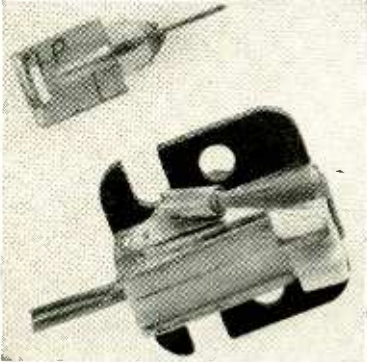

Fig. 4—Bottom of Weather's cartridge.

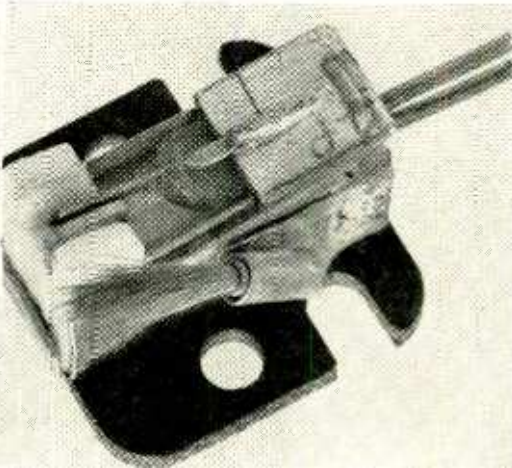

Fig. 5—Disassembled capacitance unit.



Fig. 6—Left, the oscillator; right, power unit for the capacitance pickup.

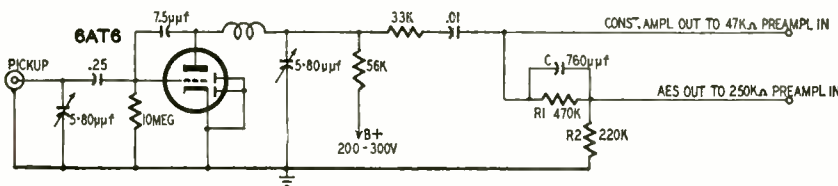

Fig. 7—Capacitance pickup oscillator.

jack is provided for this purpose. A specially built equalizer can be connected to the constant-amplitude jack if variable equalization is desired.

Preamplifiers and equalizers

A preamplifier is a small one- or two-stage amplifier used to raise the level of a signal to supply a "main" amplifier. Preamplifiers are required in home music systems for magnetic

(and most other) phonograph pickups because these pickups have much lower output level than tuners. The preamplifier raises the pickup output to about the same amplitude as that of the tuner (and possibly the tape recorder) so that the input of the main amplifier can be switched between preamplifier and tuner. If levels were not more or less equal, that would not be possible. Main amplifiers are almost al-

ways designed for input levels of about 0.5 to 1.5 volts minimum for full output. Magnetic pickup levels range generally from approximately .012 to 0.1 volt or so.

A preamplifier is merely an audio-frequency voltage amplifier with no special characteristics other than conservative design for low distortion. It may be a separate unit like the General Electric type UPX-003 shown in Fig. 8, with or without its own power supply (the UPX-003 has its own transformer and selenium rectifier), or it may be simply another stage on the main-amplifier chassis.

While preamplifiers are not peculiar in any way, almost all of them intended for home music system use include not only amplification but some equalization as well. Equalization is extremely important for good record reproduction. It can be understood quite well without a technical background; it is mainly a matter of understanding one facet of how records are made.

Record curves

A frequency curve is a very easy thing to understand. It is merely a line on a graph. The distance of any point above or below a zero reference line represents the amplitude (bigness) of something, while the distance horizontally from left to right across the chart is marked off in terms of frequency. We shall be using a few of these frequency curves.

Two months ago we showed what a record groove is—a picture of audio waves bent around into a spiral track. Let us assume for a moment that a natural conclusion is justified, that is, that the amplitude of any wave in the groove track is proportional to the amplitude of the sound wave that produced it. In Fig. 9, for instance, we have two waves lifted out of a record groove; the figure is a picture of two 1-cycle groove swings. We are assuming that no matter what the frequency of these waves, B is twice as great as A because the microphone in the studio produced twice the output at the time. We now have a situation where every groove waveform on the record indicates directly the volume of the sound that produced it. The maximum variation of the groove from a true spiral path at any point in the spiral may be called the *groove width* or groove amplitude at that point. While the term is not strictly accurate because the width or amplitude of the groove itself remains the same at all times, it is an easy-to-use pair of words, as long as we understand their meaning here.

Under our conditions as given we can make a frequency curve like curve A in Fig. 10. Notice that the vertical axis of the graph is marked off in relative groove width (though no specific measurements are given, such not being necessary for understanding the subject; actual width variations are in the very small fractions of inches). This curve says that if the microphone—or a signal generator—puts into the

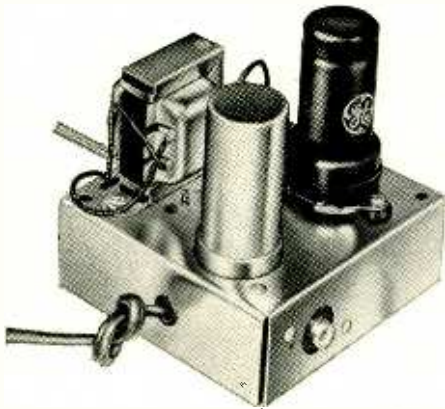

Fig. 8—A typical preamplifier unit.

recording system signals of any of the frequencies shown, with all signals having the same voltage, then the groove width or groove amplitude will not change from one frequency to another. Groove amplitude is *constant* for any one signal *voltage* regardless of frequency.

If we play back a record made in this manner with a pickup whose output level is dependent solely on amplitude and not at all on frequency, we will have perfect reproduction of what went into the original microphone. The system as a whole will have *flat* response. Pickups which will do this include crystals (ideally, that is, but not usually in practice, because of natural defects), capacitance pickups like the Weathers, and strain-gage pickups like the Pfanstiehl.

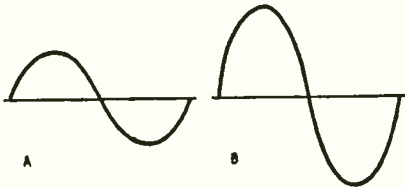

Fig. 9—Two waves "out of the groove."

There is one good reason, however, why this *constant-amplitude* method of recording is not commercially used. That reason is that the *cutters* used in making records are magnetic, and magnetic devices inherently are *not* constant-amplitude devices.

Any magnetic transducer such as a magnetic cutter or an electromagnetic motor is a *constant-velocity* device. That is, the voltage applied to it does not determine how far it moves, but rather how *fast* it moves. We all know that we can control the speed of a motor by controlling the voltage applied to its armature; but as long as any voltage is applied, we can control how far the shaft moves only by physically restraining it. Therefore, in the magnetic cutter, when a certain voltage is applied, the cutting stylus moves at a certain speed, no matter what the frequency of the voltage.

Suppose we apply 10 volts to the

cutter at 1,000 cycles. For half the duration of the cycle or 1/2,000 second the stylus moves in one direction. It moves at a speed imparted by the voltage and it keeps on going for 1/2,000 second, until it is stopped by the reversal of signal polarity at the end of the half-cycle. The maximum distance traveled can easily be calculated if we know the actual speed corresponding to 10 volts. During the second half of the cycle—the next 1/2,000 second—it does exactly the same thing in the other direction.

Now let us keep the voltage the same, but change the frequency to 2,000 cycles. During the first half of this cycle the stylus goes at the same speed as before, but it keeps going for only half the time—1/4,000 second instead of 1/2,000. Obviously, then, it can travel only half the distance it did at 1,000 cycles, and the groove will be only half as wide.

From this you can quickly see that with constant-velocity recording, groove width or amplitude is inversely proportional to frequency; as frequency rises, the groove width becomes smaller. This is shown by curve B in Fig. 10.

Equalization in a constant-velocity system is needed to overcome two problems—one at bass and the other at treble frequencies. The difference in groove width or amplitude between 50 and 10,000 cycles represented by the extremes of curve B in Fig. 10 is about 250 times—the groove width at 50 cycles is 250 times as much as at 10,000 cycles. The wiggles at the high frequencies are so small that they begin to compare with the natural small imperfections in the surface of the disc material which creates noise. That makes the signal-to-noise ratio very poor and, especially with low-volume music, we would never hear the treble.

To correct this condition, we deliberately pre-emphasize the treble frequencies somewhere between the microphone and the cutter. As a result of this artificial emphasis the high-frequency portion of the constant-velocity recording curve no longer droops as much as B in Fig. 10, but is lifted as in curve C: This means that the 10,000-cycle groove is now much less small with respect to the 50-cycle groove; and it is much larger than the noise irregularities.

The second problem is that the difference between highest- and lowest-frequency record groove widths is still too great to allow economical record content. Naturally, the wider the groove at its maximum (the lowest frequency) the fewer grooves we can have—the less tight the spiral—and the shorter the playing time. So the next step is to reduce the size of the bass grooves by the same kind of scheme we used to enlarge the treble grooves. We artificially make the recording system less sensitive to bass. By doing that we arrive at curve D for the lower part of the range. Combining curves C and D we can see that there is now very little difference in groove width between top and bottom

frequencies. In fact, it looks almost like the constant-amplitude record of curve A!

Curve C-D is the most common of the curves with which records are made, particularly LP's, but there are others. Those known to be used by the various companies are detailed and discussed on page 42 of the March, 1952, issue of RADIO-ELECTRONICS.

Playback

Now that we have a record with curve C-D of Fig. 10, suppose we play it back with a constant-amplitude pickup such as a crystal or the strain-gauge or capacitance cartridge. Since output voltage of these cartridges is (ideally) proportional to groove width, reproduction will be perfect from 500

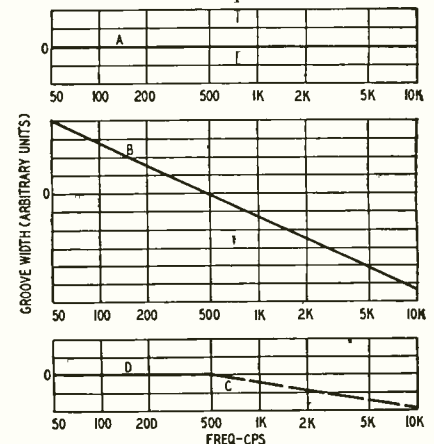

Fig. 10—Arriving at a recording curve.

cycles downward. From 500 cycles upward, it will be exactly as the curve shows—a rolloff of response, but not a very great one. The rolloff can be corrected by inserting, somewhere between the pickup and the loudspeaker, an equalizer which will tend to emphasize the upper frequencies by the same amount that the curve shows they drop off on the record. This equalization is provided in the Weathers oscillator unit of Fig. 7 by R1-R2-C. R1-R2 is a voltage divider equally effective at all frequencies. At higher frequencies R1 is bypassed to a greater and greater extent as frequency rises, making the series arm of the divider smaller and allowing the output voltage taken from across R2 to rise. These components are proportioned just right to give the desired offset of record rolloff for discs made with the AES (Audio Engineering Society) curve. With the AES curve the C portion of the Fig. 10 curve would drop somewhat lower; as it stands C is the NARTB (National Association of Radio and Television Broadcasters) curve.

The use of a magnetic pickup makes necessary a bit of reorientation in our thinking about these record curves; for instance, the C portion is considered a pre-emphasis (which it is, of course, during the recording process) rather than a rolloff. We will take this up, together with some actual equalizer arrangements, next month.

(TO BE CONTINUED)

BASIC COLOR TV

Part II—Mixing and transmitting colors; reduction of bandwidth

By D. NEWMAN* AND J. J. ROCHE*

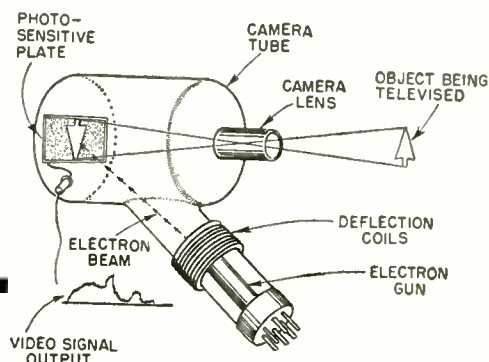

Fig. 1—Black-and-white TV camera.

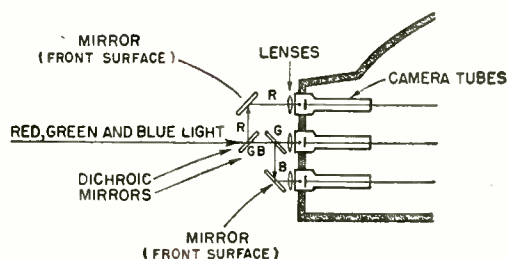

Fig. 2—Dichroic mirrors split light.

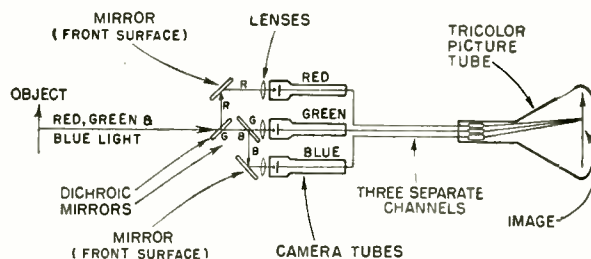

Fig. 3—Simple color television system.

IN THE previous article, we saw that it is possible to produce a wide variety of colors by mixing varying amounts of red, green and blue. This is the basis of many color reproduction processes and is the principle used in color television.

In television, color pictures are transmitted by using special methods to specify how much red, green and blue is present for every portion of the picture.

Let us review how a regular black-and-white television signal is obtained. Fig. 1 shows how the image of an object being televised is formed on the light-sensitive plate or face of a camera tube. An electron beam is swept across the picture and—depending on the variations in light—the voltage output of the camera varies.

Suppose we equip our camera lens with a red filter. Now, the image formed on the face of the camera tube will be related only to the light which is reflected from the "red portions" of the object being televised.

By "red portions" we do not mean that the camera tube will "see" only those objects which are colored "red." Most colored objects are composed of a mixture of the three primary colors. Therefore, the "red" camera will produce a signal which is proportional to the amount of red in the televised object, even though the object may not appear red.

For example, we can take three separate cameras, each with a color filter, and produce three video output signals. The "red" camera, whose lens is equipped with a red filter, will "see" the amount of red in the object, and produce a corresponding video signal.

Another camera, equipped with a green filter, scans the same object, and "sees" only the amount of green in the object.

Similarly, a camera with a blue filter "sees" only the blue portions in the object being televised.

It is easier to use a single camera lens, then split the light into its three

primary colors, by using special dichroic mirrors as shown in Fig. 2. A dichroic mirror reflects light of only one color, and permits all other colors to pass through it undisturbed.

Thus, a color television camera produces three separate video signals, each describing primary color information. One signal tells us how much red is present in any part of the picture, the other two signals describe the green and blue content.

If we feed the three color video signals directly to three picture tubes whose phosphor coatings have been chosen to glow in red, green and blue respectively (rather than the usual white), we will recreate the original color picture.

Fig. 3 shows the elements of a simple color television system. This is the basis for a practical color television system which is used in some industrial closed-circuit installations.

If this system were used in commercial color television broadcasting, three separate r.f. carriers would be required. If we wished to maintain the same definition and standards as are used in black-and-white telecasting, a

total bandwidth of 18 mc would apparently be needed, as shown in Fig. 4.

Obviously, if such a system were to be used, new channel allocations would be needed, and the black-and-white receivers in use would be unable to receive the new color programs, even in black-and-white. The increased bandwidth would make such a system unacceptable. Therefore, a way had to be found for transmitting the essential portions of a color picture within a 6-mc channel.

Reduction of bandwidth

How was the bandwidth reduced while still producing excellent color pictures? The first steps taken stemmed from the fact that the eye is unable to distinguish color in small areas.

By taking the blue-colored object and gradually reducing its size, a point is reached where its "blueness" disappears, and we see it as a shade of gray. In other words, we can still see the blue object and distinguish its brightness, but we can no longer recognize its color.

The same thing can be demonstrated with a red-colored object. In this case,

* Allen B. DuMont Laboratories, Inc.

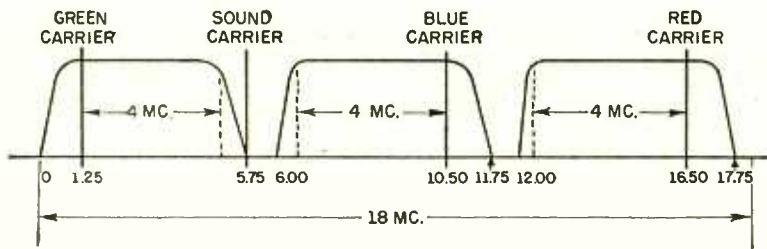

Fig. 4—An 18 mc channel for transmitting red, green, and blue r.f. carriers.

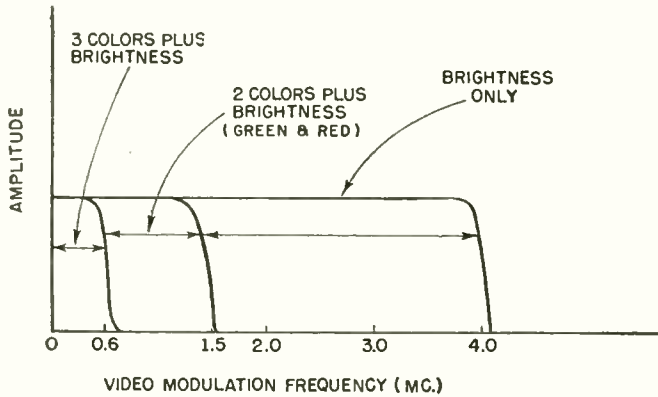

Fig. 5—Color and brightness information.

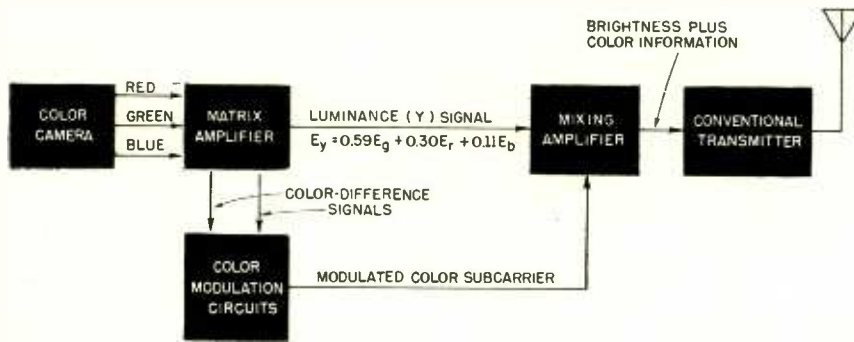

Fig. 6—Block diagram of the NTSC color transmitter.

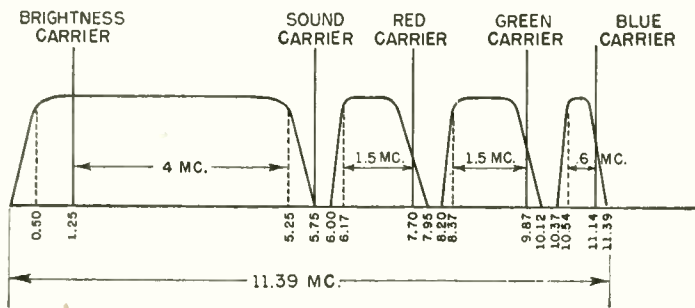

Fig. 7—Theoretical color TV system.

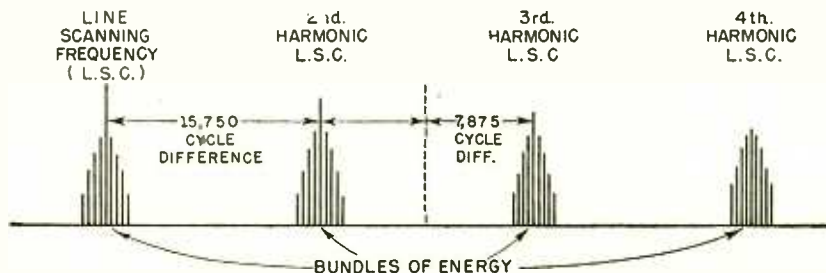

Fig. 8—Diagram of energy distribution.

it will have to be made somewhat smaller before it appears gray and we are unable to distinguish its color. A green-colored object must be still smaller before it appears gray.

People with normal vision see very small objects in much the same way that some color-blind people see all colored objects.

The small areas, or fine detail in a television picture represent the higher-frequency components of the video signal. Since color cannot be distinguished in these small areas, we can do without some of the higher-frequency components of the color signals, and thereby reduce the bandwidth.

In actual tests, it has been found that the eye of the average viewer will not detect the loss of color information which corresponds to video modulation frequencies of approximately 1.5 mc or higher. In the case of blue, any information above approximately 0.6 mc serves no useful purpose.

This knowledge of the color characteristics of the eye can be applied to the problem as follows:

1. In the relatively large areas of the picture, it is necessary to transmit complete three-color information to produce good results.

2. In the intermediate areas of the picture (those corresponding to video frequencies between approximately 0.6 mc and 1.5 mc), only green and red information need be transmitted, since blue color information no longer serves any useful purpose.

3. In the very small areas of the picture (details corresponding to video frequencies in excess of approximately 1.5 mc), no color information at all need be transmitted.

The above applies only to the color content of the picture—brightness information must be transmitted at all times. Fig. 5 illustrates the above principles.

We want to transmit the brightness (or black-and-white) information with the same definition provided by present black-and-white standards. Thus, our brightness signal must contain video frequencies out to approximately 4 megacycles.

We also have seen that we must transmit the red and green color information with modulation frequencies up to approximately 1.5 mc, and blue signals up to approximately 0.6 mc.

A convenient method of doing this is by separating the brightness from the color information and handling each separately.

Brightness-signal transmission

Fig. 6 shows how the brightness signal, called the "luminance" or "Y" signal, is obtained. The red, green and blue camera output signals are combined in a special amplifier, called the "matrix amplifier." The purpose of the matrix amplifier is to add together specified proportions of each of the three color signals.

The output of the matrix amplifier is the luminance or Y signal, made up

of 59% green, 30% red and 11% blue.

State d as a formula:

$$E_y = 0.59E_g + 0.30E_r + 0.11E_b$$

The above proportions of the three color signals produce a good white, and satisfy certain other requirements of the system which will become apparent in later discussions.

The Y or luminance signal contains video frequencies up to 4 mc, and in the NTSC system, is transmitted within a 6-mc channel using the existing FCC standards for black-and-white television.

The luminance signal can be received by any conventional black-and-white receiver, and actually produces better tonal gradations in black-and-white than do existing methods. This is due to the better color balance selected for the Y signal, as opposed to present black-and-white cameras which are more sensitive to the blue-green end of the color spectrum than they are to the red.

Color-difference signals

In the simple color TV system of Figs. 2 and 3 we saw how red, green and blue video signals which are proportional to the color and brightness of the televised object can be produced. We have just discussed how these signals are combined in fixed proportions to form the luminance or brightness signal.

Complete information regarding the *brightness* of any object is thus transmitted via the luminance signal. Obviously, it is unnecessary to retransmit this brightness information along with the desired color information, since it would serve no useful purpose.

Retransmission of the brightness information is avoided by the transmission of what are called "color difference" signals, rather than the original color signals which contain both color and brightness information.

These signals are obtained in the transmitter circuits by subtracting or removing the brightness component from each color signal, leaving as the remainder, a signal which contains only the *color* (hue and saturation) of the object. (In the receiver, the original color signal is reconstructed by adding the brightness component to the color-difference signal, before it is applied to the color C-R tube).

By this last device, we have further reduced the amount of information needed to transmit a color picture.

At this point, we could take the red, green and blue color-difference signals and transmit them on three separate r.f. carriers, adjacent to the 6-mc channel which is carrying the luminance signal. By using receivers of proper design, we could receive all of these signals (four in all), detect them individually, and reproduce a color picture.

However, if we were to use this system, our bandwidth requirements would still be approximately 11 mc, as shown in Fig. 7. This would not meet the FCC requirement for a 6-mc channel bandwidth.

A further reduction in bandwidth can be obtained by taking advantage of the fact that the luminance or Y signal is composed of specified amounts of all three primary colors.

We know that at the transmitter, the luminance signal is made up of proportions of red, green and blue. If, at the receiver, we know the total amplitude of the luminance signal, and if we are informed as to how much red and blue there is, what remains must be the green signal.

In other words, we can add the red and blue signals together and subtract their sum from the luminance (Y) signal, in appropriate receiver circuits, and obtain the green color information.

Thus we can see that another important reduction in bandwidth is obtained by eliminating the transmission of the green color-difference signal.

Frequency interlace

We are now left with the necessity of transmitting the luminance (Y) signal along two color-difference signals (red minus brightness and blue minus brightness) in order to produce good color television pictures.

We know that the Y signal plus its associated sound carrier is already occupying the whole allotted 6-mc channel. Where and how are we going to squeeze the two color-difference signals into what seems to be space already occupied?

In the NTSC system the color information is actually transmitted within the same channel as the brightness signal. You might expect this to produce a serious crosstalk problem.

The answer to the crosstalk problem has been found in a technique known as "frequency interleaving" or "frequency interlace." This enables us to transmit two signals in the same channel with a minimum of interference.

Some years ago, it was observed that video information in a black-and-white television channel was *not* distributed uniformly across the frequency spectrum. Instead, it was noted that the video modulation energy was concentrated in bundles, in the form of sideband clusters, grouped around harmonics of the line-scanning frequency.

Fig. 8 illustrates this phenomenon. Note that the energy distribution in the video-channel spectrum is such that fairly heavy concentrations of energy are present at multiples of 15,750 cycles, the line-scanning frequency. At points midway between multiples of the line frequency, there are relatively empty spaces.

The NTSC system takes advantage of this by

sandwiching the color signals into these empty spaces.

The empty spaces correspond to odd multiples of half the line frequency. By choosing a color carrier frequency (known as the color sub-carrier) which falls at some odd multiple of half the line frequency (any odd multiple of 7,875 c.p.s.), the color sub-carrier sidebands will fall into the relatively unused portion of the channel spectrum.

In other words, the sidebands of the luminance signal and the sidebands of the color or "chrominance" signal will be *interleaved* or *interlaced* in frequency with one another. In effect, the luminance and chrominance signals are made to *share* the same band of frequencies.

Remember that the sideband components of each signal fall into the relatively blank spaces between the sideband components of the other. This means that each signal will have a minimum of effect on the other.

A black-and-white receiver will not be affected by the *chrominance* signal which is interleaved with the brightness signal. Having no color detection circuits, it will simply produce a black-and-white picture.

On the other hand, the color-decoding circuits in a color receiver make use of the color information which has been inserted in the composite video signal to reproduce a color picture.

The color sub-carrier frequency selected by the NTSC is approximately 3.58 mc above the video r.f. carrier. This frequency was chosen as the best compromise between low visibility of the sub-carrier and the need to transmit essential color information.

The distribution of the brightness and color information in the 6-mc channel using one system is shown in Fig. 9. Modulation information for both the red and blue color-difference signals is imparted to the color sub-carrier by modulating *both* its *amplitude* and its *instantaneous phase*.

In the next article, the methods used to combine the NTSC color and brightness signals and transmit them within a 6-mc channel will be discussed in greater detail.

(TO BE CONTINUED)

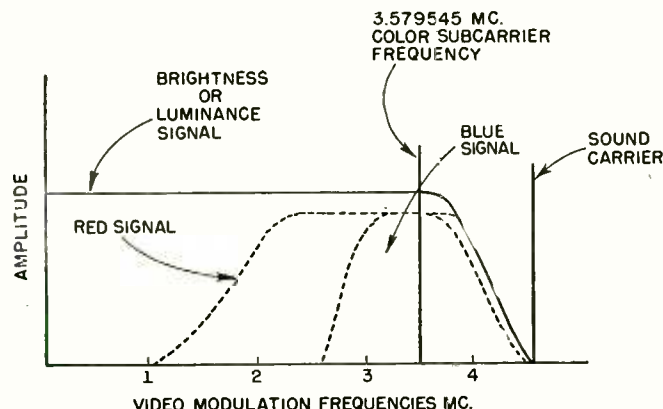

Fig. 9—Diagram shows the brightness and color information in 6-mc channel.

PAY **as you go**

A solution to the problem of presenting expensive, high-quality TV productions at a profit?

By **IRA KAMEN**

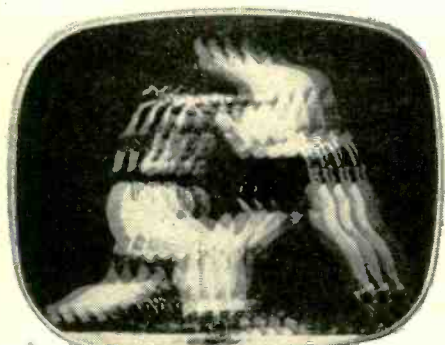

Fig. 1—Phonevision scrambled picture.

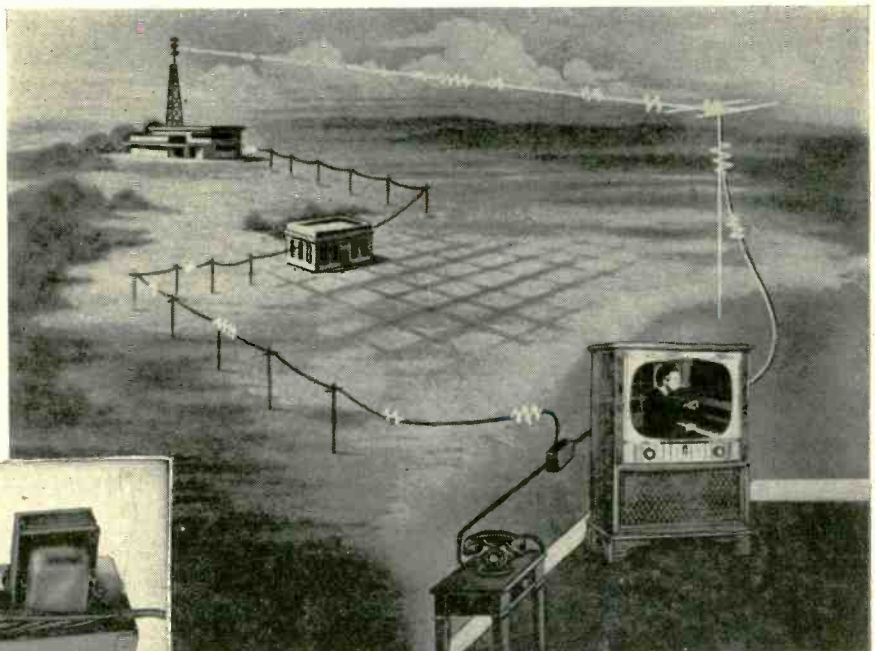

Fig. 2—Phonevision transmission system. Decoding signal is sent by telephone.

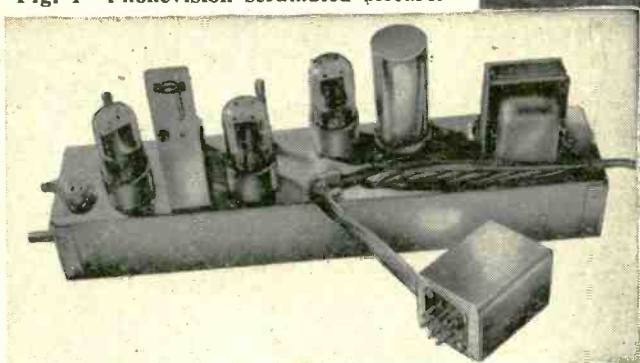

Fig. 3—Phonevision decoder for TV set. It is connected to the telephone line.

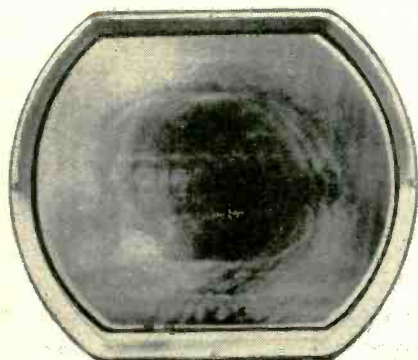

Fig. 4—Subscribervision scramble.

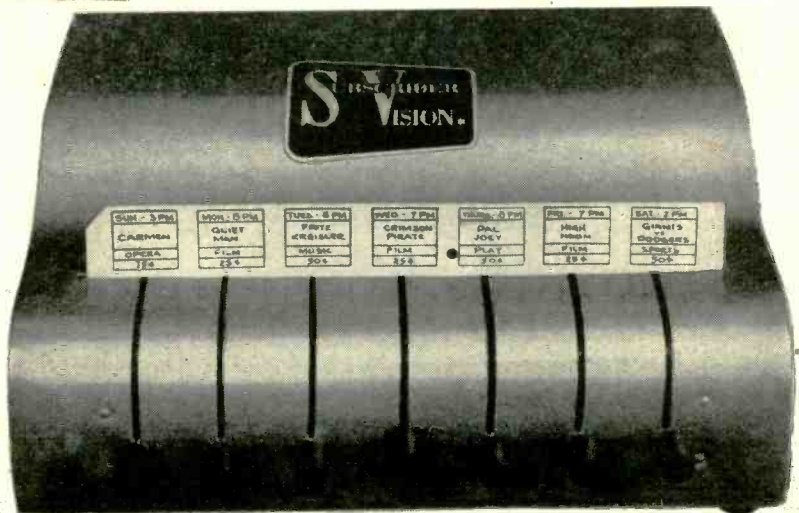

Fig. 5—Subscribervision decoder with weekly decoding card inserted in slot.

RADIO-ELECTRONICS

SINCE the advent of the TV boom, service technician readers of RADIO-ELECTRONICS have been expending all their energies keeping TV pictures clear. Now the efforts of industry leaders are directed toward making such a hash of them that they are unwatchable.

The apparent madness has method. By scrambling pictures and requiring viewers to pay for unscramblers (decoders), the engineers and businessmen involved will be able to give the viewing audience programs which broadcasters now find it impractical to present.

Such programs might include first-run motion pictures from Hollywood and abroad. With picture-making costs what they are, only pay-by-the-head audiences from coast to coast can presently give the producers a profit. Major fight promoters are using closed circuits without losing their shirts due to lack of attendance, but the viewers have to journey to theaters so that payment can be made. The same story applies to opera presentations. When Broadway legitimate stage productions appear on closed-circuit television, the screens will also be located in theaters equipped with projection TV.

How much nicer it would be, to sit at home in front of the family TV set and watch the same entertainment! No trips, no baby sitters! And what could be a better solution to the technical problem of collecting money from home viewers for the privilege of seeing these programs than scrambled TV? The idea is very simple: The program is transmitted in such a manner that the picture is defective (scrambled) in some way and can't be properly received. Then, the receiver is equipped with a device, which, when properly stimulated with a key, card, telephone connection or coin, will untwist (unscramble) the picture back to its original position.

Scrambled pictures may be the answer to a number of other hitherto unsolvable problems. Educational TV has been, up to now, a dismal flop, largely because very few people, institutions, or state governments are willing to pay the bill. But look at the tremendous number of home-study (mail-order) students there are. Standard mail

courses could be improved by putting them in the form of audio and video and piping them into the home. Scrambled television would allow educators to use highly competent personnel and superior methods of instruction.¹

To date, four different systems have been developed to scramble and unscramble pictures. They are (in the order in which they made their appearance) Phonevision, Subscribervision, Telemeter, and Boxoffice.

Phonevision

Phonevision was developed by Zenith. Pictures are transmitted in such a way that when they are received they jitter back and forth on the screen, producing an annoying effect which makes watching impossible. Fig. 1 shows the picture as it appears to the viewer whose receiver has no decoder or who has not paid to watch the program.

Fig. 2 illustrates how the picture is made to stand still. The main signal is shown being transmitted and received. This is the scrambled signal. A key signal is simultaneously sent out by the station over local telephone lines. To receive the unscrambling signal, the subscriber calls a certain number and the operator connects the key signal to his line. The transmission of the decoding signal does not interfere with the use of the phone.

The decoder unit pictured in Fig. 3 is installed in the TV receiver. The decoder is connected to the telephone line. When the key signals arrive, the decoder utilizes them to unscramble the picture.

Program payments with this system are made by monthly billing, or coin box installed in the home. Zenith has recently announced two additional systems. In one, the key signals are transmitted over the air rather than by phone. The subscriber purchases a card which when inserted into the decoder utilizes the keying signals to decode the picture. The second employs a coin-operated electronic mechanism to decode the program. In this method the subscriber drops the proper amount in coins into a box attached to his receiver.

¹ "Merchandising Education via TV," Ira Kamen, *Television Engineering*, April, 1952.

Subscribervision

This system was developed by Skiatron Electronics and Television Corp., New York. (An earlier version of Subscribervision was described on page 50 of the Feb., 1951, issue of RADIO-ELECTRONICS). The present Subscribervision technique calls for the transmission of a picture which when received without decoding, jumps back and forth horizontally. The picture is annoying and unwatchable. Fig. 4 shows how the scrambled picture looks to the camera; the eye also gets a blur effect due to persistence of vision.

To get normal pictures during the special transmissions, the receiver must have installed or attached to it, the decoder of Fig. 5. The subscriber must also purchase a special card for a specified period, which is inserted into a slot in the decoder. A printed electronic circuit on the card automatically makes the correct connections to set the decoder into action and produce a normal, steady picture.

The Subscribervision card, like Duz, does everything. A new card is issued for each time interval—a week, for example, and only the correct card for that week will decode programs. A number of pushbuttons are also provided—seven, if the system is set up for weekly card distribution. The button corresponding to the proper day and program must be pushed.

The card itself is of the business-machine type. It not only selects the right one of the possible 300,000 or more decoding combinations with the aid of the printed circuit, but it also automatically furnishes billing and addressing information by means of punched holes and acts as the bill itself. A sample card is shown in Fig. 6.

Telemeter

The pictures in the Telemeter system, developed by International Telemeter Corp., are received on the ordinary set in unwatchable form, as seen in Fig. 7. The audio is transmitted on a coded "barker channel."

Decoding depends on the installed decoder unit shown in Fig. 8 and a coin box attached to it. Whenever the coded program is received by a set so equipped, a dial shows the cost of the

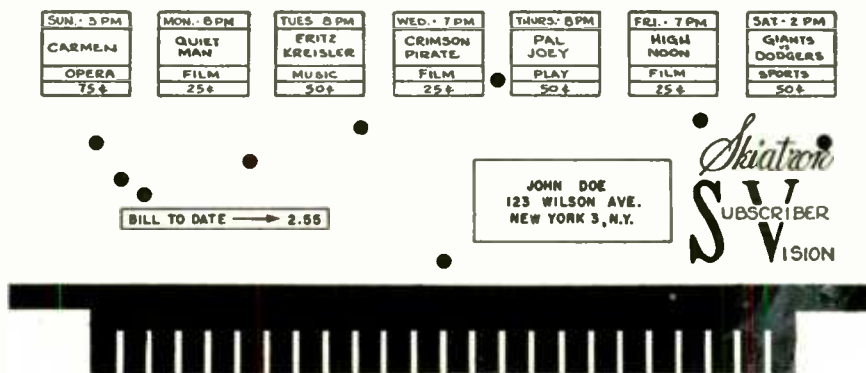

Fig. 6—Subscribervision decoding card.

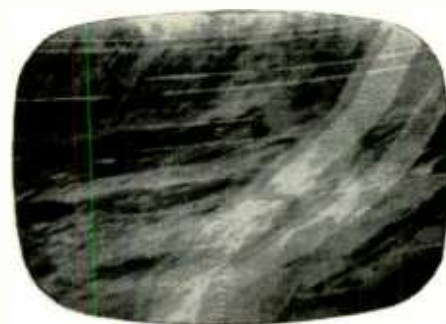

Fig. 7—Telemeter scrambled picture.

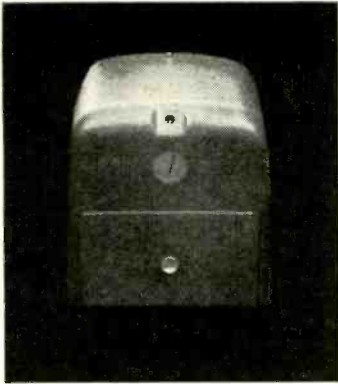

Fig. 8—Telemeter coin-box decoder.



Fig. 9—The Boxoffice Picturecaster is a closed-circuit TV transmitter.

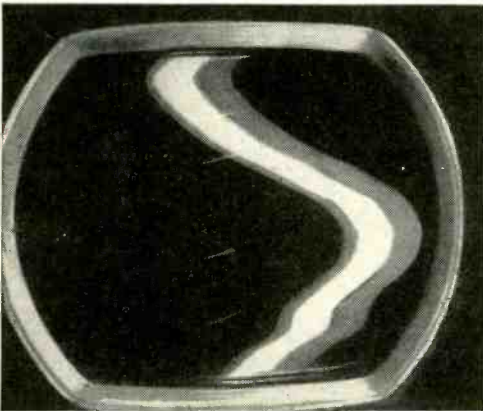

Fig. 10—Boxoffice scrambled picture.

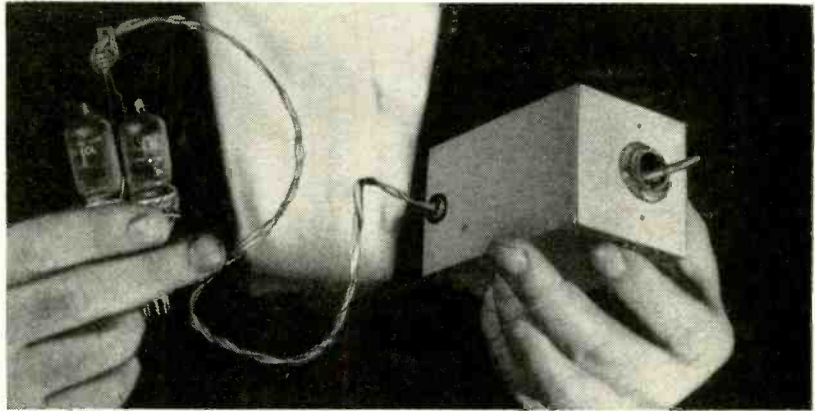

Fig. 11—Boxoffice decoder assembly.

program. When the correct amount is deposited in the box, the picture clears and the correct sound is heard. If the subscriber does not have the exact amount on hand, he may insert a larger amount; the coin mechanism will automatically credit the extra amount to his next program.

An interesting feature of Telemeter is a small magnetic tape recorder in the receiver unit which runs just long enough at the start of each program to record the fact that the program has been selected for viewing and has been paid for. The tapes are collected periodically and indicate how many subscribers paid for which programs, information necessary, in many cases, to allocate payments to performers and producers who work on a percentage of gross receipts. The tape also constitutes an accurate survey of listening and viewing habits.

It is planned to operate the Telemeter system through the agencies of subscription service organizations throughout the country. These companies will install the receiver units in subscribers' homes but will retain ownership of the units. They will periodically collect the coins and the tapes, and will handle all the accounting and distribution of the money to

producer, broadcaster, and other program furnishers.

Boxoffice

The Boxoffice system, developed by Boxoffice Television, New York, was specifically worked out for closed-circuit use in hotels, apartment houses, community systems, and other places where there are master television antenna systems. The purpose of this emphasis was to allow widespread operation of pay-as-you-see television immediately, without the necessity for FCC approval. Subsequent adaptations of the system described here will be suitable for general home use with on-the-air programs and will be submitted to the FCC for approval.

Using the Boxoffice system, any standard composite television signal may be coded, and no access to station or studio facilities is necessary. This makes it possible to utilize signals which are simultaneously being transmitted to theaters for projection with standard equipment.

The video and sound signals are sent by coaxial cable or microwave relay to each of the locations—hotels, apartment buildings, etc.—at which the system is to be used. Here they are fed into the TV Picturecaster shown in Fig. 9.

This is a small television transmitter and coder which uses the incoming video and audio to modulate a carrier tuned to any one of the 12 v.h.f. channels. The one selected is one not used in the area. The signal is standard except for being coded. It is fed to the input of the master antenna system in the same manner as a signal received from a transmitter.

Receivers will ordinarily tune to receive a picture such as that shown in Fig. 10. The character of the scrambled images varies somewhat from moment to moment from slight hints of actual picture content to complete distortion.

Each receiver is equipped with a small adapter like the one shown in Fig. 11. This may usually be inserted into one of the set's tube sockets. Part of the decoder unit is a small metal box containing a lock similar to that on an automobile ignition system. When normally installed only the lock will show through the back of the set.

To decode the picture, the viewer inserts a key and turns it. In hotels and similar establishments the key will be rented for the program from the hotel. In community systems the keys may be made available on a weekly or monthly basis. The key rental constitutes payment for the program. **END**

TELEVISION... it's a cinch!

By E. AISBERG

Eighth conversation, second half—Horizontal retrace surges and damped oscillations

Figures don't lie

Will—I don't always like formulas, but I think if we call the voltage induced at the ends of the winding e , then:

$$e = \frac{L \times I}{t}$$

Ken—Fine! Your formula is perfect! Now if L equals 0.15 h and I equals 0.12, can you figure out the voltage?

Will—But what is t equal to? There are two chances here. The current rises and falls like in this diagram. Is t the time of the long rise, or the quick drop?

Ken—Let's take the line deflection. For 30 frames a second and 525 lines, we have 15,750 sawteeth a second. Then each one lasts only 63 microseconds. The time it takes to get across the screen is 55 microseconds, and to get back only 8!

Will—The voltage e on the scan seems to be:

$$\frac{0.15 \times 0.12}{.000,055} = 345 \text{ volts;}$$

and on the return

$$\frac{0.15 \times 0.12}{.000,008} = 2,250 \text{ volts}$$

Two thousand, two hundred fifty volts! but this is unbelievable!

Ken—The most unbelievable thing about it is not the amount of voltage, but that you got the figures right!

Will—Now I know why you call them "surges!" I would never have believed that such small variations of current could build up voltages like that!

Ken—With bigger tubes, you have to use heavier currents, and the surges reach several thousand volts. And your figures are too low, for the sweep voltage does most of its dropping in less than the 8 microseconds we used, making the variation more rapid than we figured.

Will—But isn't that dangerous?

Ken—Surges are one of the greatest dangers in electricity. You can get hurt—or killed by them. But our coils are in even greater danger. We have to keep them small, so we can't put safe, thick insulation on those thousands of turns of fine wire. With the relatively thin insulation we have to use, we run the risk that it won't be able to stand up under a particularly heavy surge.

Will—M'mm. Bad! Can't we cut down the number of turns in the winding, then run the current up enough to keep the number of ampere-turns constant?

Ken—Sure we can. But what good will it do us?

Will—Well, if you cut down the number of turns to one-fifth, the inductance will be reduced 25 times. Then, even though you have to increase the current five times, the surges will only be one-fifth as high. And you can use heavier insulation on the wire, because there are only 200 turns to go into the space.

Ken—You're doing well, keep on!

Will—But there's one thing wrong. If we cut down the number of turns five times, and use five times the current, we'll have 0.12×5 , or 0.6 ampere. What kind of a tube is going to pass a plate current like that?

Ken—There's a very easy way of getting around that. With only one-fifth the turns and $1/25$ the self-inductance, you can get a current five times as strong with only one-fifth the voltage. Catch?

Will—Wait a minute. This has me going in circles.

Ken—Think a little. The inductance of your winding, and therefore the inductive reactance that opposes a varying

From the original "La Télévision? . . . Mais c'est très simple!" Translated from the French by Fred Shunomon. All North American rights reserved. No extract may be printed without the permission of RADIO-ELECTRONICS and the author.

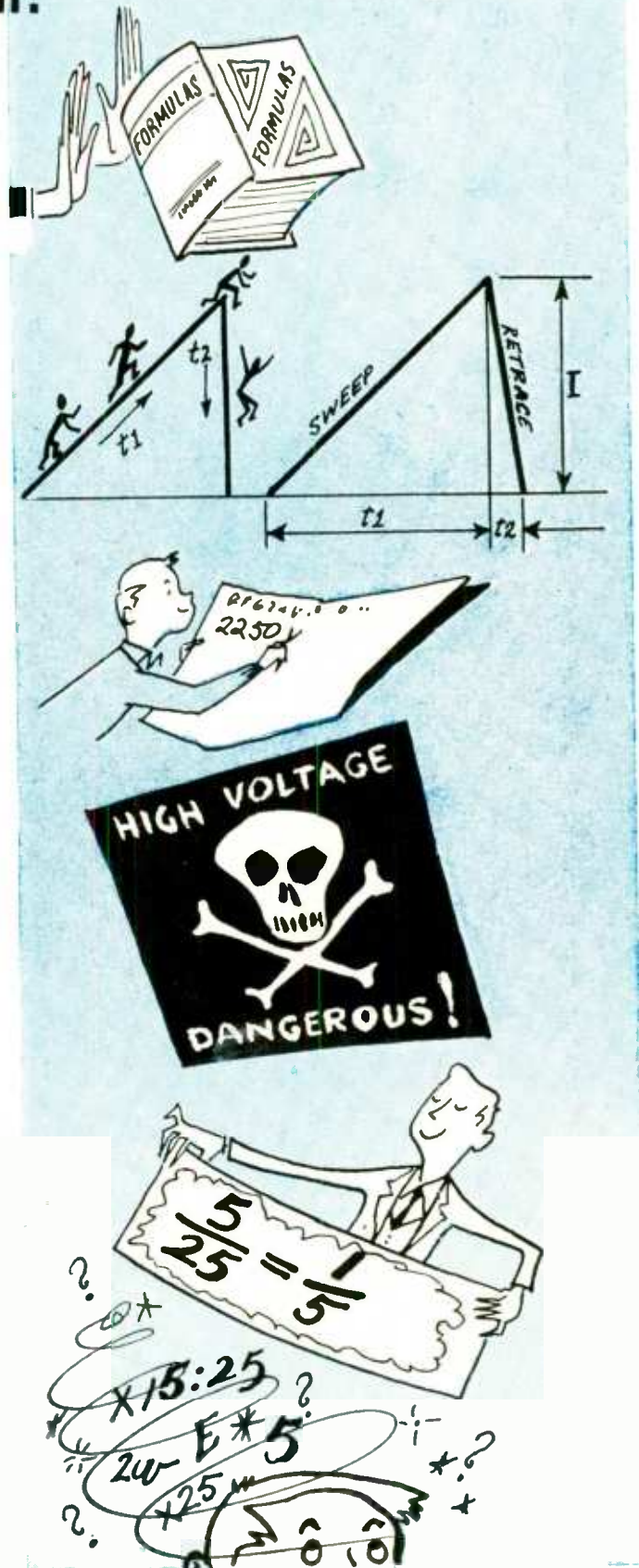

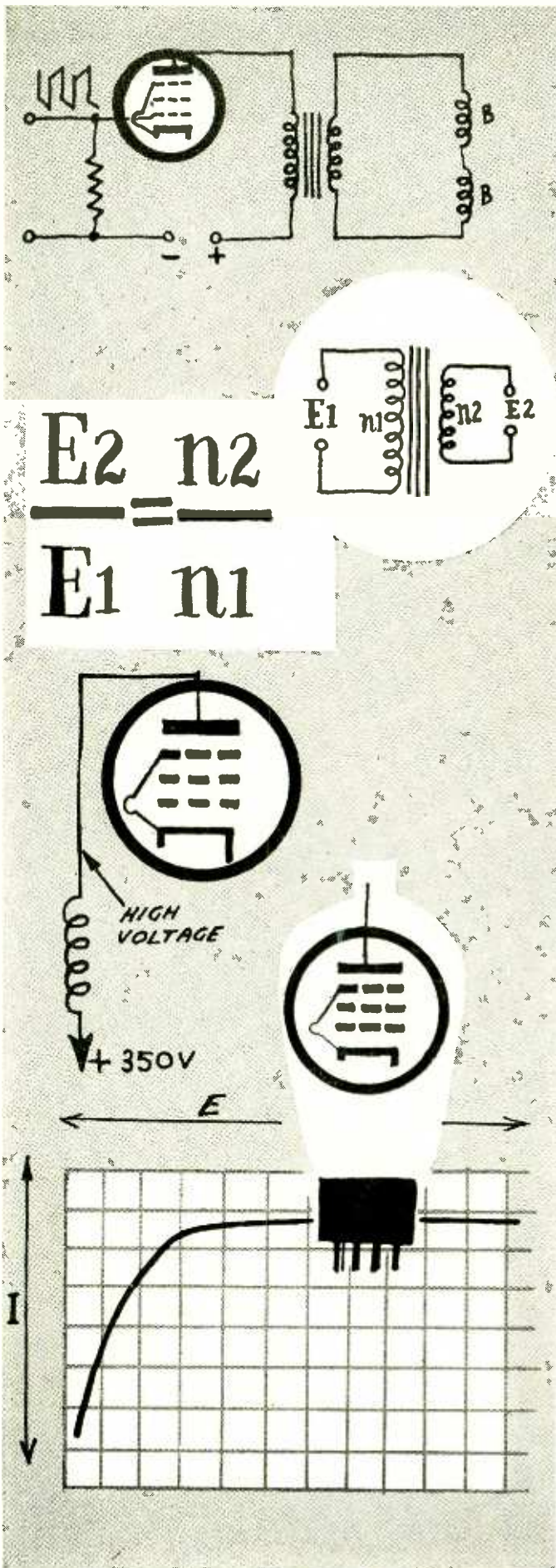

current—is 25 times less than before. So with the same voltage, you would get a current 25 times as strong. For one 5 times as strong you need only one-fifth the voltage.

Will—So how does that help me?

Ken—Haven't you heard of that queer thing called a transformer?

Will—Of course! How dopey! I just use the same tube, same voltage, and put a 5-1 stepdown transformer in the plate circuit, and get the current I need for my lower-impedance deflection coil!

Ken—Actually, transformer coupling—like this—is used very often in horizontal deflection circuits. For vertical deflection you could use resistance coupling, replacing the inductance A of your capacitor-coupled circuit (RADIO ELECTRONICS Jan. 1954, p. 57) with a resistor.

Other surge troubles

Will—But don't we have to worry about surges in vertical deflection circuits?

Ken—No, for two reasons. First, we don't need quite as much variation in the magnetic field as for the horizontal sweep, because the spot doesn't have to travel so far vertically.

Will—That shouldn't make much difference!

Ken—It doesn't! The main reason for the weaker surges is that the current varies at a slower rate. While the horizontal sweep is tracing out 525 lines, the vertical sweep makes only 2! So you can forget about the vertical sweep. But the surges in the horizontal deflection circuit complicate everything, even the functioning of the amplifier.

Will—I don't see why.

Ken—Don't you see that—no matter what type of output circuit we use—the deflection voltage is superimposed on the direct plate voltage, half the time in opposition to it and the other half adding to it? In an inductively coupled circuit—getting back to your hookup again—these surges pass through the capacitor C. In transformer-coupled hookups, they appear on the primary. Can you figure out the direction?

Will—While the current is pushing the spot across the screen, it's increasing. Then the induced current will be in the opposite direction to the plate current, to oppose the increase. So, plate current and voltage should decrease. In our example the deflection voltage was 250. So, if we're to have enough plate voltage left to work the tube—say 100 volts—we need a high-voltage supply of at least 350 volts.

Ken—And then?

Will—The spot flies back to its starting point. The plate current drops, but fast! So self-induction produces a strong current in the same direction, increasing the number of electrons moving toward the plate by making the voltage more positive. The 2,250-volt surge adds itself to the 350-volt plate supply, and puts about 2,600 volts on the plate!

Ken—That's why you need special tubes in the horizontal deflection circuit. Plate insulation has to be excellent, so many of the tubes have the plate connection at the top.

Will—One thing still bothers me. How does the tube manage to do its regular work while the plate voltage is shifting so much? There's enough variation to mess up the workings on any tube, no matter how rugged it is.

Ken—Not quite. The plate voltage variation won't produce very serious effects if we use tubes whose plate current varies very little with large changes of voltage. What kind of tubes would they be?

Will—Pentodes, of course! But to go on—if I get it right, we use a pentode amplifier for horizontal deflection, and connect it to the primary of a step-down transformer, insulating everything very carefully because of those surges?

Ken—You're not far out. But don't be too hard on the surges—you'll find out later that there's a very ingenious way of using them to obtain the high voltage for the cathode-ray tube!

Will—You mean we make a virtue out of a fault again?

Ken—Something like that! But now all we have to do to finish with this subject is to remember that, because the surges are a lot less serious in the vertical deflection circuits, a simple triode with inductance or resistance coupling is all we need in the vertical oscillator.

Damped oscillations

Will—Maybe this is stupid, but one thing I can't understand. With so much inductance in the circuit, how can the current vary fast enough to let the spot fly back in the short time it does?

Ken—A very sensible question. The surge we've just been talking about is the price we have to pay for that rapid flyback. We make the fast variation possible by designing our circuit so that we have a genuine oscillating circuit, complete with inductance, capacitance, and resistance.

Will—But I don't see any resistors or capacitors!

Ken—We don't have to draw them on the diagram—they're there, even if you can't see them. For instance, can you imagine transformer windings without resistance and distributed capacitance?

Will—Oh, I see! The deflection windings have resistance and distributed capacitance, just like transformer windings.

Ken—Exactly! Now, if the resistance isn't too high, we have a real oscillating circuit. And the rapid motion of the electrons as the spot returns is helped, because it's part of the circuit oscillation.

Will—H'mm—good! And these oscillations stop immediately?

Ken—Unfortunately, no! That's the other side of the story! Once these electrons get going in an oscillating circuit, they don't stop till after several oscillations, which grow smaller and smaller, like the motion of a pendulum that has been set swinging by a sharp push.

Will—But can we get along with these extra waves?

Ken—Not too well. The sawtooth finds itself with a little sinusoidal parasite which affects the spot as it starts at the left of the screen. Instead of starting from the left side and going across to the right in a single movement and with uniform speed, it starts out with a sort of hesitation-waltz—three steps to the right, two to the left, one-and-a-half to the right, one to the left—then at the end, one big leap to the right. These little to-and-fro motions show up as very disfiguring vertical fringes at the left side of the image.

Will—How do you get rid of these hangover oscillations?

Ken—Damp 'em out! Absorb enough energy so that the circuit will be able to oscillate, but won't be able to support parasites.

Will—Well, about the only way to absorb the energy would be to put a resistance across the deflection windings.

Ken—That is the easiest and cheapest way. We can keep cutting down the value of the resistance till we find a value just small enough to load the circuit so that it damps out parasitic oscillations.

Will—What a pity to absorb energy that could be used to pull the spot across the screen! It's a shame we couldn't have a very rapid switch that would connect our resistor only while it was needed to damp out the parasite, then disconnect it as the spot started to scan.

Ken—Nothing easier. Will! Just put a diode (hooked up in the right direction) in series with your resistor, so that it doesn't conduct during positive alternations of the current, but passes current during the negative alternations. Then it absorbs power just at the end of the return and the beginning of the scan, which is the danger point. This figure gives you the idea.

Will—Ingenious! But what is this capacitor C across resistor R?

Ken—It charges during each passage of current, and by discharging through the resistor keeps the diode's plate biased a little. Then no current passes till the voltage on the winding is high enough to overcome the slight bias. The bias keeps the circuit undamped over a larger part of the cycle. Then the oscillation can go a little further negative on its return—just the difference between the dashed and solid lines here—and give you a higher-amplitude sweep. That uses the expendable energy more efficiently.

Will—Right now the efficiency of my brain has dropped to a very low value! I think it's being damped by all the ideas it had to absorb today. Suppose we let the rest go till the next time.

(TO BE CONTINUED)

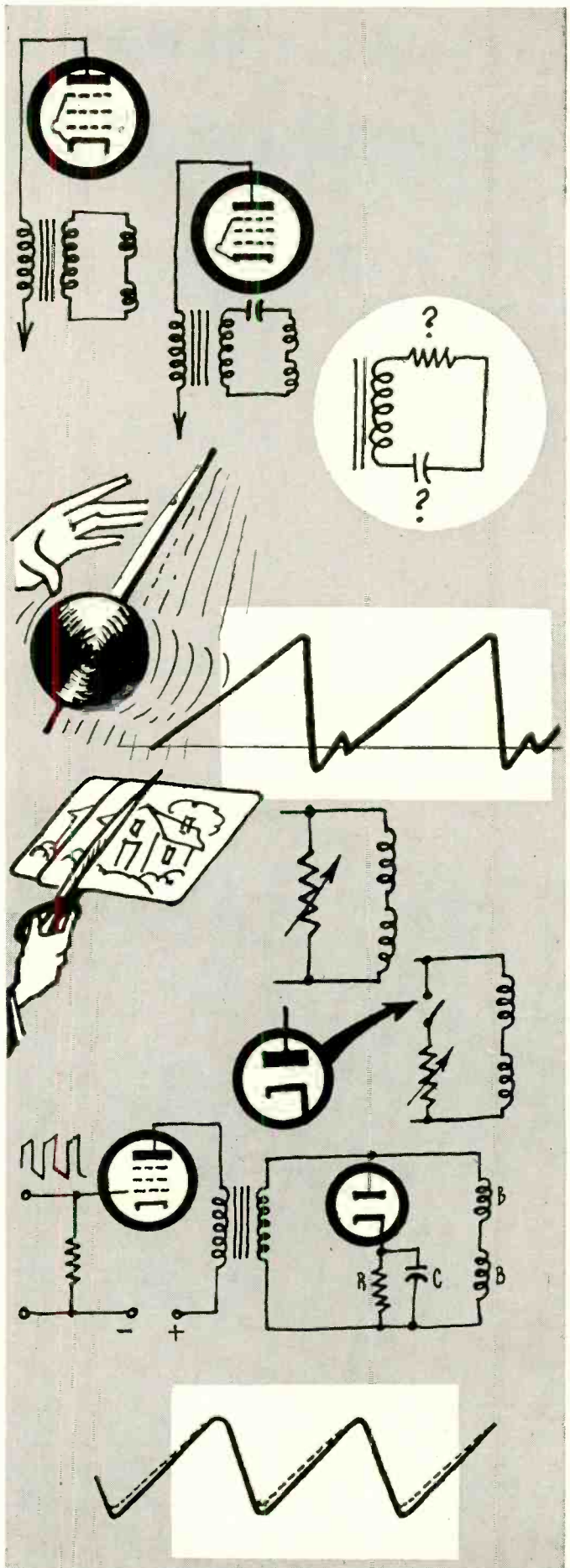

HOME BUILT

U.H.F. CONVERTER

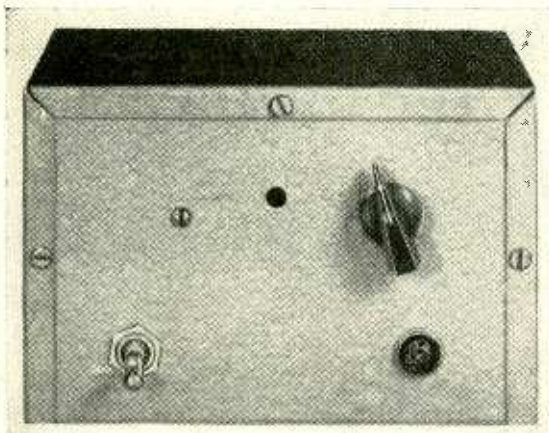

Photograph shows front view of the converter. The hole in upper center is for tuning the trimmer.

*Made for particular signal area,
converter is efficient and cheap*

By PAUL S. LEDERER

FOR three years the Tidewater area of Virginia, the author's home, had been served by a single television station. Recently the area was assigned u.h.f. channel 15 and it became very desirable to be able to receive that channel. This was the incentive for the building of this converter.

Any converter consists essentially of an oscillator whose signal—fed into a modulating device or mixer—is beat with the incoming signal to produce a frequency low enough to be received by the television set.

Commercial converters usually have a preselector—a resonant circuit tuned to the desired channel—and an intermediate—or beat frequency—(i.f.) amplifier.

The signal is fairly strong at the author's house, the transmitter being eight miles away. So to simplify construction, it was decided to dispense with the preselector and intermediate amplifier. It became necessary only to build an oscillator and mixer.

The u.h.f. band extends from 470 to 890 mc. To receive these signals on a standard television receiver, they must be mixed with an oscillator signal so that the resulting beat frequency is somewhere between 54 to 88 mc (channels 2 to 6) or between 174 to 216 mc (channels 7 to 13). Such a beat can be produced by having the oscillator frequency either above or below the u.h.f. frequency. Since the problems of oscillator construction increase rapidly as the frequency increases, the oscillator is generally designed to operate at a frequency below that of the desired u.h.f. station.

To keep the oscillator frequency low, the beat frequency was placed high, between channels 7 and 13. As channel

15 occupies a band from 476 to 482 mc, an oscillator frequency between 263 and 305 mc should produce the desired results.

After the converter was completed, channel 15 was seen on channels 8 or 9 depending on the oscillator trimmer setting; thus the oscillator frequency is about 290 mc.

Construction Features

Keeping the oscillator frequency low made it possible to use an easily available tube, a 9002. Otherwise it would have been necessary to procure a special high-frequency oscillator tube such as a 6AF4 (Not a bad idea, in any case.—*Editor*). The oscillator circuit is one well suited for high-frequency work, the Ultraodion. It is simple, requires few parts, and is quite stable.

The mixer can be a vacuum tube or a crystal. Although a vacuum-tube mixer would produce a stronger beat signal than a crystal diode, it would require a more elaborate circuit, would be subject to greater instability, and finally would produce more noise. There are silicon crystal diodes with excellent mixing characteristics on the market. The author chose a 1N82. Results fully justified the choice.

The rest of the converter consists of a built-in selenium-rectifier power supply and an antenna switch which permits switching from an external v.h.f. antenna to a u.h.f. bowtie and reflector type antenna.

In constructing the oscillator the leads were kept very short and all lead-ins were kept away from the aluminum box in which the converter was put. Other than that, no special precautions were necessary.

The tank circuit of the oscillator consists of a hairpin loop of $\frac{3}{16}$ -inch copper

wire about $1\frac{1}{2}$ inches long and $\frac{3}{4}$ -inch wide. The plate supply is connected to the center of the loop through a 2,200-ohm resistor. The loop is tuned by a 1.5–3.1- μ f Johnson butterfly capacitor. A grid leak consisting of an 18,000-ohm resistor and a 47- μ f ceramic capacitor completes the circuit. Since the cathode of the 9002 is grounded, no special chokes are needed. A similar loop placed $\frac{1}{8}$ inch away edgewise with the 1N82 across it acts as the mixer circuit.

The antenna switch is an ordinary d.p.d.t. wafer switch. The power supply is standard and delivers 150 volts at 7 ma to the oscillator. A 470- μ f silver mica capacitor across the output of the power supply presents a short-circuit to any high-frequency voltage.

An isolating transformer was used, since it costs very little more than the filament transformer necessary if the selenium rectifier were operated from the line.

When the oscillator operates properly, a bias voltage of -7 to -10 volts will appear from grid to ground across the 18,000-ohm resistor.

It is desirable to enclose the entire converter in a metal cabinet to reduce radiation. When tuning, the oscillator trimmer should be adjusted with a fiber tuning wand until both picture and sound are at their best. Using the fine-tuning knob of the receiver is also helpful.

The results obtained with this converter compare very favorably with those obtained with commercial converters.

By decreasing the size of the copper-wire loops, the oscillator frequency can be increased so that u.h.f. channels higher than 15 can be received. This will require a trial-and-error procedure

tv dx

IN FEBRUARY

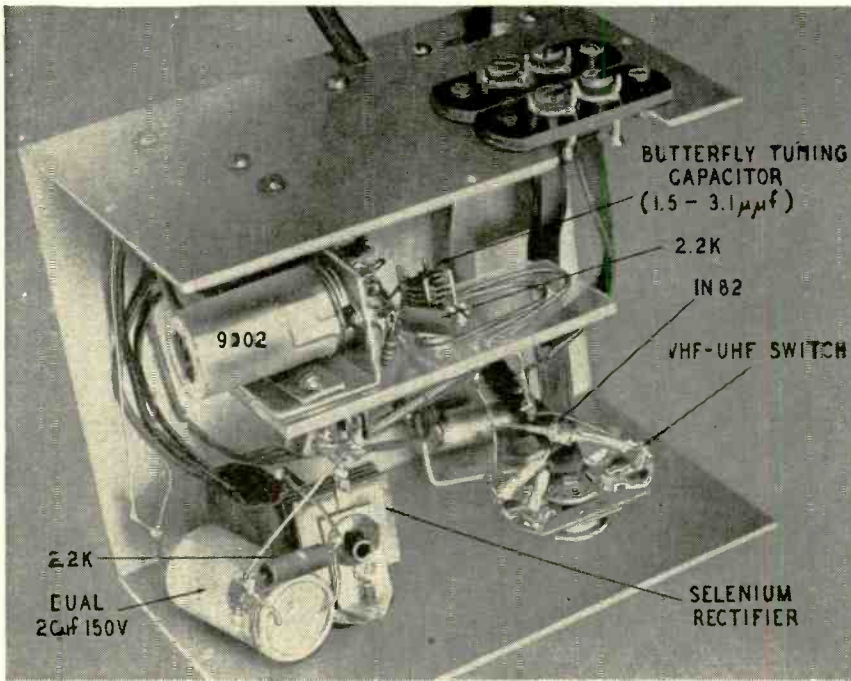

This view of the converter displays the tuned-line arrangement excellently.

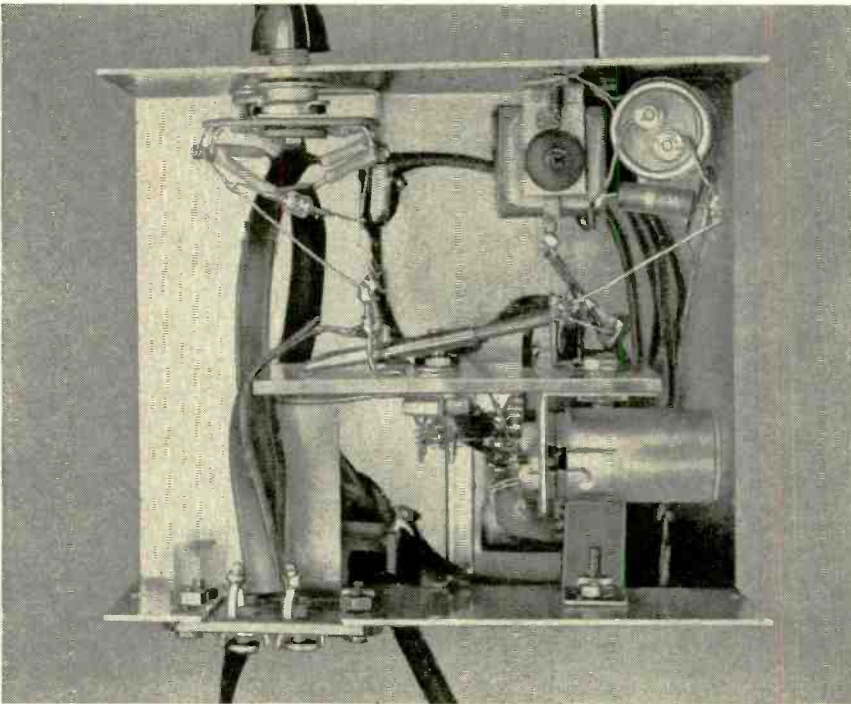

This "under-chassis" view shows some of the details better than the other photo.

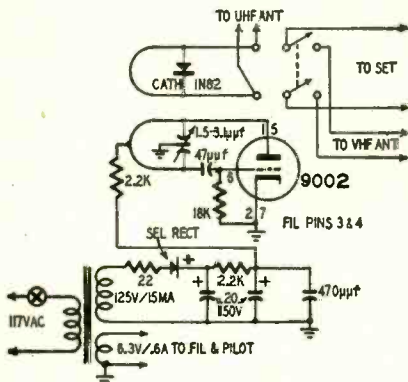

Schematic of the u.h.f. converter. An untuned type antenna circuit is used.

Materials for Converter

Resistors: 1—22, 1—2,220, 1—18,000 ohms, 1/2 watt; 1—2,200 ohms, 2 watts.
Capacitors: 1—47-μf ceramic, 1—470-μf silvermica, 1—20-20-μf, 150-volt electrolytic, 1—variable, 1.5—3.1-μf Johnson butterfly.
Miscellaneous: 1—9302, 1—IN82 crystal diode; 1—transformer, Stancor PS 8415 or equivalent; 1—d.p.d.t. wafer switch; 1—selenium rectifier, 65 ma (rating not critical); 1—pilot lamp and socket; 3/16-inch tubing or wire for tuned lines, chassis, cabinet, wiring, hardware, etc.

since it is rather hard to predict the exact frequency at which the oscillator will operate.

It is hoped that this article will inspire those who have hesitated so far to tackle the problem of u.h.f. conversion. **END**

THERE is probably no lower spot in all the year for the TV dx enthusiast than the month of February. Sporadic-E dx, though it can appear in any season, is rare at this time of year. And as one of the coldest months, February is at the bottom of the list for tropospheric propagation, too.

This is bad news for the TV dx-er, but just the opposite for the TV sales and service people, for interference from dx stations, often hard to explain to complaining customers, is not likely to give much trouble for the next few weeks, at least.

About the only dx phenomenon that can be counted on to show in February is aurora borealis. Relatively few dx-ers have ever logged anything exciting by this medium, but the possibility remains, and it reaches its peak usually in the late winter. Watch for shadowy streaks flitting across the screen, and when they appear swing the antenna north and try all the channels. There might be something coming through from distances up to 800 miles or so.

Tropospheric propagation will be good a few times during the month, too. Be on the watch for the thin high cloudiness that rings the moon or veils the sun.

U.h.f. dx in winter? Well, you tell us! How are you making out? **END**

TV STATIONS IN THE AMERICAS

(Excluding U.S.A. On air Dec. 30, 1953)

Argentina		
LR3-TV	Buenos Aires	7
Brazil		
PR-5-TV	Rio de Janeiro	2
PRE-8-TV	Rio de Janeiro	6
PRF-3-TV	São Paulo	3
Canada		
CBUT	Vancouver, B.C.	2
CFPL-TV	London, Ont.	10
CBOT	Ottawa, Ont.	4
CKSO-TV	Sudbury, Ont.	5
CBLT	Toronto, Ont.	9
CBFT	Montreal, Que.	2
Cuba		
CMA-TV	Havana	2
CMBF-TV	Havana	7
CMQ-TV	Havana	6
(CMJL-TV)	Camaguey	Relay Stations: 6
(CMGQ-TV)	Matanzas	(carry program) 9
(CMHQ-TV)	Santa Clara	5
(CMKN-TV)	Santiago de Cuba	of CMQ-TV) 2
CMTV	Havana	11
CMUR-TV	Havana	4
(CMNQ-TV)	Santa Clara	Relays CMUR-TV 4
Dominican Republic		
HIT-TV	Ciudad Trujillo	4
Mexico		
XELD-TV	Matamoros	7
XEQ-TV	Mexico City	9
XEW-TV	Mexico City	2
XHGC-TV	Mexico City	5
XHTV	Mexico City	4
XETV	Tijuana	6
Venezuela		
YVKA-TV	Caracas	5
YVKS-TV	Caracas	7
YVLV-TV	Caracas	4

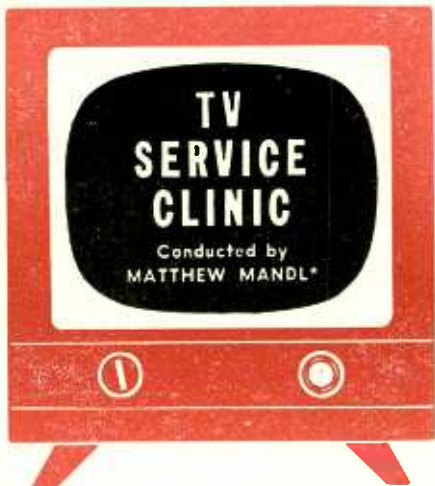

MANY letters are received each month regarding high-voltage loss. In many instances the technician has replaced the high-voltage rectifier, the damper, and the horizontal output tube without finding the trouble. On occasion, the flyback transformer is replaced when all other checks on the horizontal output amplifier fail to disclose the trouble.

Often overlooked, of course, is that the horizontal oscillator circuit could be the source of the trouble. If the horizontal oscillator fails, there will be no sweep waveform developed, and hence no collapsing field in the yoke and no flyback to generate the high voltage. For this reason a check of the horizontal oscillator tube is a virtual must in the absence of high voltage. In the Synchroguide circuits, a new 6SN7-GT will replace both the control tube and the oscillator. In receivers using the Synchrolock with its discriminator and reactance tube, these tubes should be checked or replaced, because if either circuit is defective it could load down the oscillator and kill its output. The same holds true with the phase-detector systems. Suppose, however, that you've replaced the horizontal oscillator and associated tubes, and still get no high voltage. What then? This would indicate that there is some defective component causing the trouble. But, the catch here is how can we localize the circuit involved, since it could be in the horizontal control, the oscillator, the discharge circuit, the horizontal output, or the high-voltage system? The simplest and easiest way is to use an oscilloscope to isolate the offending stage.

This procedure doesn't involve too much time, yet it is surprising how many technicians are reluctant to use the instrument. A number of service managers have complained that this is the most common fault with apprentice service technicians—their reluctance to use the scope. Even some experienced men do not use it as often as they should to save hours of fruitless hide-and-seek tactics with the offending component. The reason is probably that

*Author: Mandl's Television Servicing

Fig. 1—Waveform at grid of horizontal output tube as seen on oscilloscope.

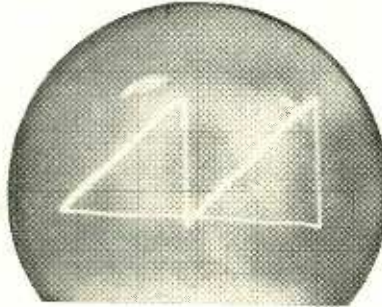

they haven't had time to become thoroughly acquainted with their instrument. The time spent in practicing with it, however, is well worth while in terms of future time saved.

Just placing the scope at the grid of the horizontal output tube can produce a wealth of information. Adjust the scope sweep to give one or two waveforms and you have a pattern similar to that shown in Fig. 1. Since the waveform is present at the grid, it indicates that the oscillator and all stages prior to the horizontal output must be all right. Thus, the trouble causing the lack of high voltage must now be confined to the stages which follow. Besides this information, the linearity of the waveform can be judged, as well as its peak-to-peak amplitude.

The waveform at Fig. 1 was taken from an RCA model 21T159 receiver. According to the service notes, the peak-to-peak voltage should be 140 (pin 5 of the 6CD6-G). Any appreciable difference (either higher or lower) would call for a check of the drive-control setting, as well as a test of the circuit parts for correct values. Since the voltage will vary for different tubes and receivers, the service notes should always be consulted for the voltages which should be present.

If the sawtooth waveform were not present at the grid of the output tube, the scope should be placed at the plate of the horizontal oscillator. For the Synchroguide system (6SN7-GT) the waveform will appear as shown in Fig. 2. If this is present, but does not appear at the grid of the output tube, the trouble will have been localized to the coupling capacitor, or coupling network.

Since the high voltage can also be affected if the oscillator output is low, the peak-to-peak voltage of the waveform shown at Fig. 2 will give this information also. For the RCA mentioned, the peak-to-peak voltage at the plate of the oscillator should read 290.

When checking the horizontal system with a scope, remember not to apply the scope to the plate of the horizontal output tube. High pulse amplitudes are present here which will damage ordinary equipment. If you are wondering whether the waveform gets across the

Fig. 2—Oscilloscope view of waveform on grid of Synchroguide output tube.

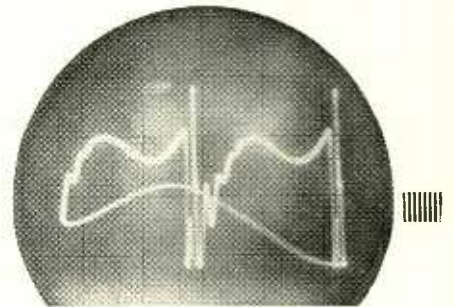

transformer and to the yoke, open one of the leads to the yoke (the horizontal deflection coils) and insert a 10- or 20-ohm resistor. This will provide a sufficient voltage waveform amplitude for pattern analysis without danger of high-voltage damage to the instrument.

The horizontal trouble localization hints mentioned are also applicable to the vertical sweep system. However, don't wait until you *have* to use the instrument. Get familiar with it now! You'll be surprised how you'll use it more and more to save you time once you become accustomed to it.

U.h.f. drift

I have a drift problem on u.h.f. with a Craftsman 202 receiver. I have changed the local oscillator tube, which is what the manufacturer recommends for drift. However, this has made little difference, and the sound drifts for about one hour or more before settling down. The receiver has been aligned but this still did not help. Would a voltage-regulator tube help if applied to the local oscillator circuit? M. L., Portland, Ore.

There is considerably more sound drift problem with split-carrier receivers than with intercarrier types. The problem is difficult to solve, but the following suggestions may help:

The sound i.f. stages can be realigned for a broader bandpass to minimize the drift. Besides changing the local oscillator tube such as you have done, negative-temperature coefficient components can be installed to minimize the drift during warmup. Adequate ventilation also helps, and the receiver can be operated with the back panel modified to give more ventilation by drilling extra holes, or cutting out several 3-inch diameter holes near the top. The voltage regulation which you mentioned wouldn't help much, since the trouble is caused by the influence of the heat on the oscillator components during warmup, and not so much by a d.c. voltage change.

H.v. regulation

In my repair work I have a Montgomery Ward 94BR-3024A receiver, which gives a good picture when tuned to a station. When the receiver is not tuned to a channel the high voltage in-

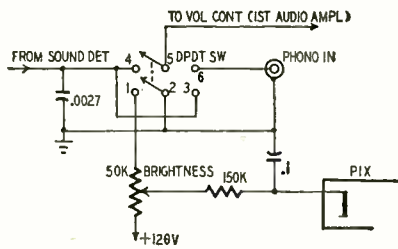

Fig. 3—Diagram of phono switch circuit.

creases from 9,000 to over 12,000. When this occurs, the high-voltage transformer sings, and eventually causes arcing from the high-voltage winding to the 1X2 filament winding. To stop this trouble, I changed the resistor to pin 5 of the 6SN7-GT oscillator from 6,500 to 4,700 ohms. This holds the high voltage steady—but now I can't center the picture and there is distortion on some stations along a horizontal plane. I would appreciate knowing what could cause this condition? E. G., Pomona, Calif.

When the station selector is turned off a station, the bias change between grid and cathode of the picture tube will change the load on the high-voltage system. With a decrease in bias during reception of a station, more beam current flows than when off a station. Thus, a high-voltage system with poor regulation will develop high peak voltages which are causing the annoying arcing and corona you mentioned.

A new horizontal output tube should be tried, as well as a new high-voltage rectifier and damper. If these do not help, adjust the drive control below the point where left-hand stretch occurs. Also check the components associated with the high-voltage compartment for defective or off-value resistors or capacitors which affect regulation.

You will have to replace the original 6,500-ohm resistor for proper linearity. The troubles you detailed are not due to faulty design and no attempt whatsoever should be made to correct the difficulties by changing the design of the receiver.

Neck glow

In an Admiral 30A14SA receiver there is good audio but no picture or raster. The neck of the picture tube has a purple glow. Please tell me what causes this and how to remedy it. K. Y., Hawthorne, Calif.

The presence of audio indicates the trouble is confined to the horizontal sweep system (with its high voltage) or the picture tube itself. The bluish glow at the neck of the picture tube could indicate internal corona or arcing, in which case the tube will have to be replaced. You did not state what

checks had been made, or just where in the tube neck the glow appears. With such information we might have been able to suggest other checks—because a slight blue envelope glow may not necessarily indicate a bad picture tube. In such a case, the trouble would be in the high-voltage failure. This could be caused by a defective tube or part in the horizontal oscillator, horizontal output, or high voltage system.

TV-phono switch

In an RCA model 6T54, I found a short between a resistor and capacitor. This short connected the high side of the horizontal drive control to the high side of the horizontal lock control. In checking the horizontal and sync circuits I found several resistors and capacitors defective and replaced them. Since then, however, the receiver has intermittent loss of brightness. It occurs immediately after the set is turned on, although it sometimes remains dim for 1 to 5 minutes, and corrects itself. The phonograph switch cuts out the picture and sound but the screen stays lighted when this control loss occurs. When I turn the brightness control up full, I get brightness equal to half its range when it is operating correctly. Since the screen should darken when the switch is turned to phonograph, it seems this would be a clue to the source of the trouble. Can you help me localize the fault? F. D., Philadelphia, Pa.

The initial short you corrected in the horizontal a.f.c. circuit would not cause the defect in the brightness according to the symptoms you detailed, nor would it have caused damage to any of the other components mentioned. It is likely that these units had begun to go bad before the shorting of the resistor and capacitors and that the intermittent brightness developed of its own accord without any assist whatsoever from the trouble in the horizontal a.f.c.

Fig. 3 shows a simplified drawing of the action of the phono switch with respect to the brightness. In the phono position, one side of the brightness control is removed from ground, thus placing a high positive voltage on the cathode (and a high negative bias on

A CORRECTION

(U.H.F. Transmission Line Lead-In, Jan., 1954)

In the article "Transmission Line Lead-In for U.H.F." (RADIO-ELECTRONICS, January 1954, page 37) there was a confusing reference to Fenton Airspaced cable, shown in Fig. 4 on page 38. It was stated that "The bottom cable in Fig. 4 illustrates the design used by Spiraline." While the statement was literally correct, the impression was left that this was Spiraline cable, rather than the idea that was intended—that Spiraline simply followed the design.

The figure definitely shows two types of Fenton cable, made by the Fenton Co., New York, N. Y., and covered by U. S. and British patent applications. The two are shown in a little closer detail below.



Fig. 1

Fig. 2

Fig. 1 shows the construction of the original Fentube-Airspaced. It has only one common covering tube in which the conductors are suspended in the air by helical polyethylene cords, which are fused to the inside of the common covering jacket. One conductor is plain 20-gauge copper conductor, the other Formvar coated. As both are completely surrounded by air, the electromagnetic fields and the concentrated energy field of the conductors remain chiefly inside the tube.

Fig. 2 shows the Fenton Twistube, a semi-airspaced transposed tubular wire. It is a transmission line specially created with the added feature and purpose of automatically reducing interference pick-up by equalizing the distance, and thus the capacitance, of both conductors in their relation to the earth. Twistube uses 20-gauge stranded conductors—again one plain and one Formvar coated. END

the grid), shutting off beam current. The fact that you still get some brightness when the trouble occurs could indicate a partial short to ground. This would also diminish the brilliancy during TV operation, because of shorting some of the components in the brilliancy control, or failing to establish a good ground at the phono switch. Thus, check both the brilliancy control and the phono switch components and lead wires for a short, or partial short. An ohmmeter check with the receiver shut off should localize the trouble. Also make sure there is no change in the plus 120 volts during the intermittent condition. END

MODERN

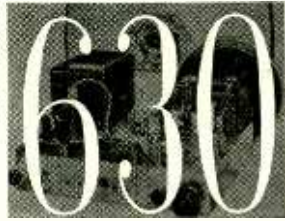

CIRCUITRY

By **ROBERT F. SCOTT**
TECHNICAL EDITOR

Part II—Circuit changes for conversion to larger picture tubes

IN THE first installment of this article we discussed circuit changes which were made to improve the sensitivity and sync stability of the original 630 circuit. Since the sensitivity of the original circuit is adequate for urban and suburban areas, there is little need to incorporate these changes in your old 630 if it is properly aligned and all tubes and components are in good condition.

This month, we cover deflection circuits in large-screen models and show various types of keyed a.g.c., retrace blanking, and push-pull audio-output stages which may be conveniently installed when converting the 630 to use a larger picture tube.

Sweep circuits

The horizontal and vertical deflection circuits in the 630 have withstood the test of time without undergoing any radical changes. In some sets, half of a 6SN7-GT or a 6SR7 has been substituted for the 6J5 vertical oscillator, and a 6S4 is used instead of the triode-connected 6K6 in the vertical output stage. Similarly, various types of output transformers are used and tubes have been substituted in the horizontal output and damper circuits to provide higher deflection and second-anode voltages for tubes up to 27 inches.

Fig. 9 is the output circuit in the Tech-Master 2430 and 2431P receivers. An auxiliary width-control switch is connected across a 600-ohm tapped resistor in series with the 280-volt B plus lead to the damper-tube plate. When the control is in one position,

the resistor is shorted out to provide adequate width for 70° tubes. In the other position, a 200-ohm section of the resistor is shorted out to reduce the sweep voltage to the level required for 60° tubes.

The horizontal output circuit in the Airex 630FA-2-A is similar to Fig. 9 but it does not have the auxiliary width control or the horizontal blanking circuit.

Note the position of the horizontal centering control in Fig. 9. Compare it with Fig. 10, and the conventional arrangement in Fig. 11. The circuits in Fig. 10 are used in Airex 630FA-2 and Tech-Master 1930R-C models, where the picture is centered horizontally by shifting the position of the focus coil (not shown in diagram). They do not use a horizontal centering control. The horizontal linearity control in Fig. 10 occupies the same position as the centering control in Fig. 9.

Mattison, Regal, Transvision, and Video Products use the horizontal output circuit in Fig. 11. These models use horizontal output transformers and horizontal centering controls similar to those in the 630TS. A special secondary winding has been added to supply horizontal output pulses to the keyed a.g.c. circuit.

The horizontal output circuit of the Philmore is designed to use 211T1, 211T3, 211T5, and 218T1 output transformers using voltage-doubler high-voltage supplies as shown in Fig. 12. When the 211T5 is used in this circuit, the flyback pulse for the keyed a.g.c.

tube is tapped off pin 8. When either of the other types is used, the a.g.c. keying pulses are taken from a secondary winding on a 208R1 width coil.

Retrace blanking and brightness controls

Vertical retrace blanking is used in all sets discussed in this series. Horizontal and vertical retrace blanking circuits are used in the Tech-Master 2430 and 2431P. These circuits are shown in Fig. 13-a. Vertical blanking pulses are produced by differentiating the vertical sweep sawtooth and applying it to the cathode of the picture tube. Horizontal blanking is obtained by applying the negative overshoot of the flyback pulse to the screen grid (pin 10) of the picture tube. Brightness is controlled by varying the negative bias on the kinescope grid.

Brightness in the Mattison, Regal, Transvision, and Video Products sets is controlled by a circuit similar to Fig. 13-a. The vertical retrace blanking and kinescope cathode circuits are shown in Fig. 13-b. The circuit used in the Regal models is shown in Fig. 13-c.

Airex 630FA-2, 630FA-2-A, and Tech-Master 1930R-C sets vary the brightness by controlling the positive bias applied to the kinescope cathode. Differentiated vertical sweep sawtooth waves are fed to the cathode of the picture tube as in Fig. 14.

Keyed a.g.c. circuits

The keyed a.g.c. circuits in modern 630 sets vary slightly depending on

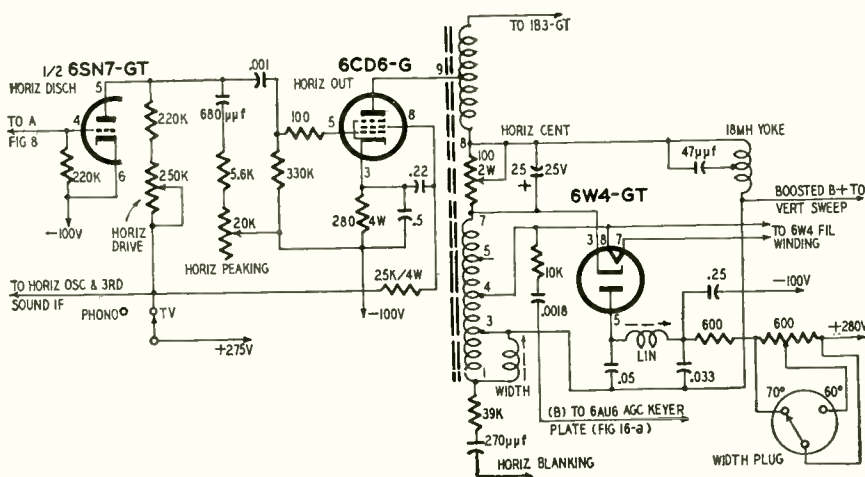

Fig. 9—Output circuit in the Tech-Master 2430 and 2431P television receivers.

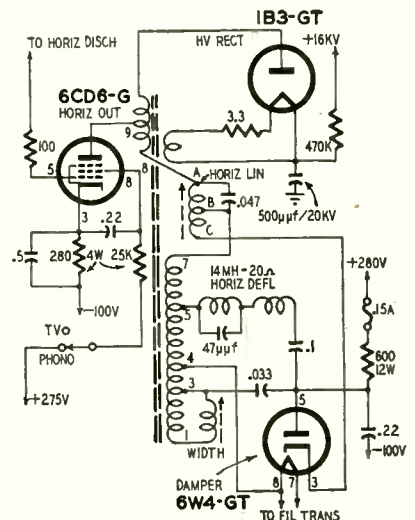

Fig. 10—Output circuit used in Airex 630FA-2 and Tech-Master 1930R-C.

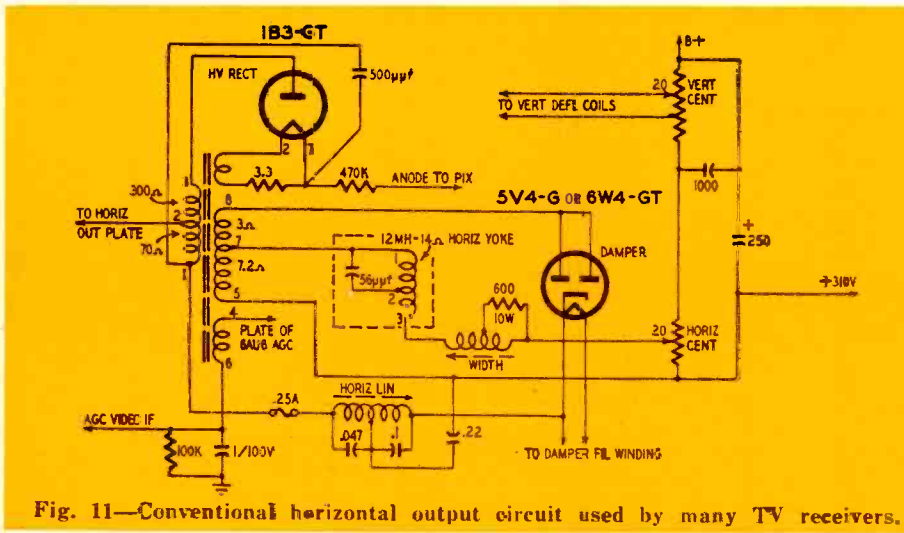

Fig. 11—Conventional horizontal output circuit used by many TV receivers.

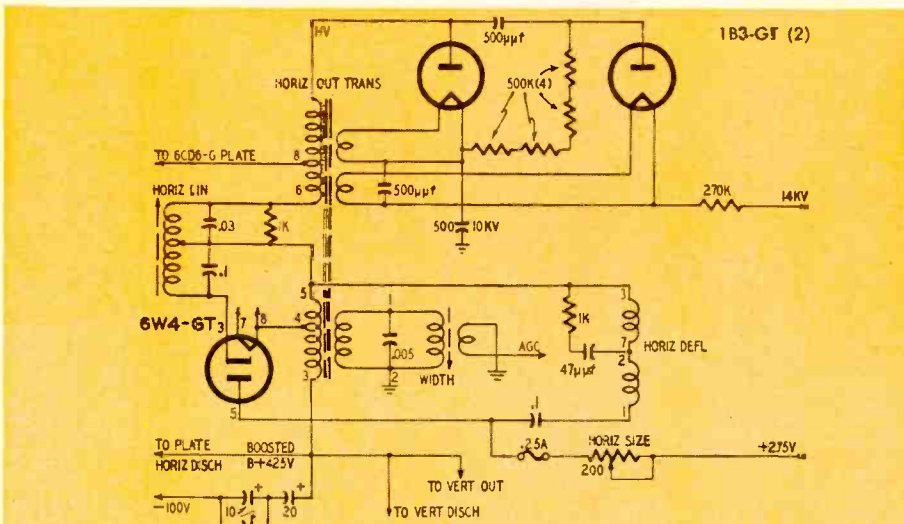

Fig. 12—Philmore horizontal output, showing doubler high-voltage supply.

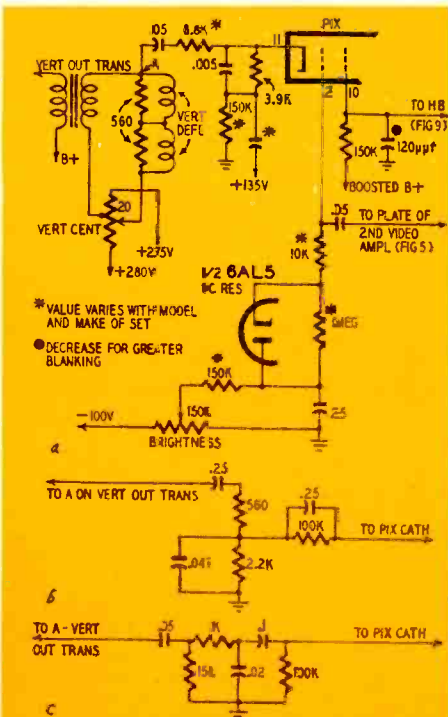

Fig. 13—Horizontal and vertical retrace blanking circuits used in some 630's.

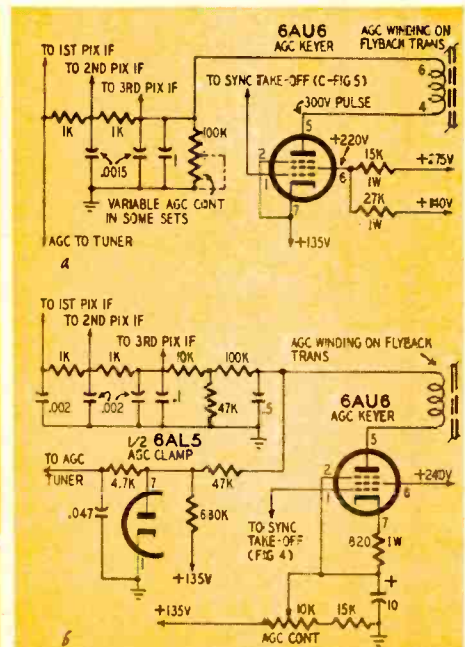
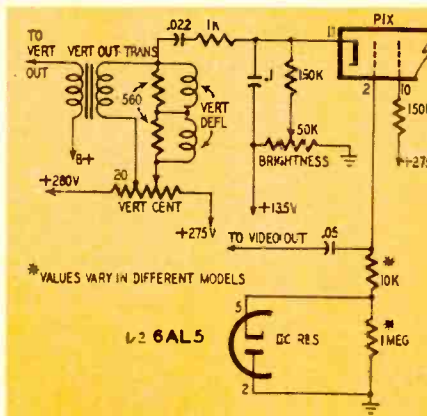

Fig. 15—Obtaining keying pulses from separate flyback transformer winding.

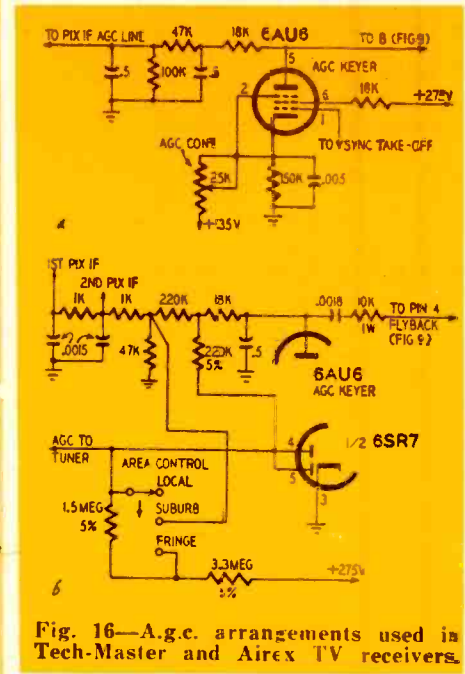

Fig. 16—A.g.c. arrangements used in Tech-Master and Airex TV receivers.

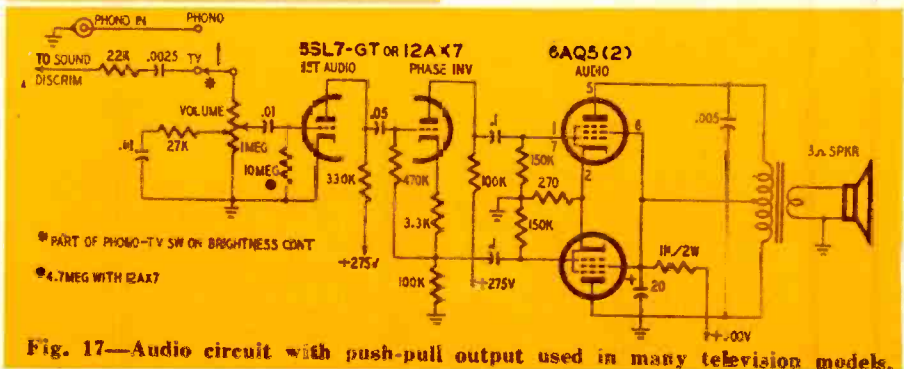

Fig. 17—Audio circuit with push-pull output used in many television models.

the method of tapping keying pulses from the horizontal sweep circuit. The diagrams in Fig. 15 show the basic circuits used when keying pulses are obtained from a separate winding on the flyback transformer. Fig. 15-a is the version used in Regal and Airex 630FA sets. In the latter, the 100,000-ohm 6AU6 plate-load resistor is replaced by a 100,000-ohm variable threshold control.

Fig. 1 (in last month's installment) is the video i.f. amplifier and a.g.c. circuit in Video Products and Mattison receivers. In these, a.g.c. voltage are not applied to the tuner until the incoming signal is strong enough to overload the i.f. amplifier with the tuner working at maximum gain. Fig. 15-b is the keyed a.g.c. circuit in the Transvision receiver. The threshold control is a part of a B plus voltage divider supplying bias to the cathode of the 6AU6 a.g.c. keyer. Tuner a.g.c. voltage is delayed and clamped by the 6AL5. Details on the operation of tuner a.g.c. delay circuits appears in the "Circuit Shorts" column of the July and December, 1953, issues.

Tech-Master and Airex 630FA-2 sets use the a.g.c. arrangement shown in Fig. 16-a. The a.g.c. keying pulse is tapped off pin 4 of the flyback transformer through an 18,000-ohm resistor and a .0018- μ f capacitor. The threshold control is in the cathode of the 6AU6. The arrangement is slightly different from that in Fig. 15-b.

Delayed and graded a.g.c. with manual area control is used on the tuner in the Airex 630FA-2-A (see Fig. 16-b). The diode plates of the 6SR7 vertical oscillator are used as the tuner a.g.c. clamp and delay diode. The area control switch varies the tuner a.g.c. delay bias and the amount of control voltage applied to the tuner.

Audio output circuits

The push-pull audio output circuit in Fig. 17 is used in a number of receivers. The first a.f. amplifier and phase inverter tube may be a 12AX7 or 6SL7. Many of the present-day 630's have phonograph input circuits. The PHONO-TV switch is usually a d.p.s.t. type with one section in the 135-volt B plus lead to the third sound i.f. amplifier and screen of the 6AU6 video amplifier. The other section may be used to open the heater circuit of the horizontal output stage, as in the Mattison receiver, or it may be used in the 275-volt B plus lead to the horizontal output screen grid and the plate and screen supply lines that go to the horizontal oscillator, control, and discharge tubes. Usually, this switch is ganged to the brightness control so it opens when the control is fully counterclockwise. In some sets, a separate switch section connects the hot side of the volume control to the phono input jack or to the audio detector output. In others, the phonograph input and detector output circuits are both paralleled across the volume control. END

Melting



By R. FRIER

IT HAS been the writer's experience that 8 out of 10 service calls in new u.h.f. areas are due to snowy pictures. This stands to reason, since the losses at u.h.f. are much greater than at v.h.f., any decrease in receiver sensitivity, converter losses, transmission-line losses, or badly oriented antennas will cause picture snow.

Confronted with this problem, some service technicians attempted to clear up snowy pictures in a new u.h.f. area (channel 38). The procedure went something like this: The converter strip was changed first—if another one was handy. If this did not help, the original strip was replaced. Then, the tubes were changed—one at a time, beginning with the r.f. amplifier and ending with the video detector. If this did not help, the service technician would assume that the receiver was normal and would go to work on the antenna. If there was still no improvement, the approach was to advise the customer that, "This is the best that can be done. You are located in a bad signal area".

Some of the better service technicians in this area realized that there were four unknowns associated with a receiving system of this type: the antenna, the transmission line, the u.h.f. converter, and the v.h.f. television set, all of which could be responsible for snow. They purchased field-strength meters to isolate the trouble to the receiver or antenna and transmission line. The difficulty with this is that some service-type field-strength meters are not calibrated in microvolts; they read noise as well as signal, and they may offer a different impedance match to the transmission line than the receiver. Also, if a tube or component in the field-strength meter becomes defective, there is no indication of this defectiveness, and the service technician uses it, thinking that the readings are low. Service type field-strength meters are excellent for orienting antennas but one must also realize their shortcomings.

To discover a better answer to the snow problem, an installation was se-

lected by the writer where three service technicians had informed the customer that the signal area was "just bad" and there was nothing that could be done about it. The installation consisted of stacked bowties mounted to a chimney on the roof, about 60 feet of tubular type transmission line, and an Admiral 19G1 chassis with strip conversion. The picture was extremely snowy and could barely be seen. The installation was located about 16 airline miles from the transmitter. To isolate one thing at a time, the receiver sensitivity was checked with a generator calibrated in microvolts (SensiMeter). This was done by placing the generator on top of the cabinet (See Fig. 1) and connecting the output cable to the antenna terminals. A vacuum-tube voltmeter was connected to the video detector by removing the 6AL5 detector tube and placing a wire loop around pin 2 (plate). (A 20,000 ohm-per-volt meter would have worked as well.) The sensitivity reading was 6 microvolts at the peak of the curve. This indicates a very sensitive receiver and it was not likely that the v.h.f. portion was the cause of the snow. To make doubly sure, the output leads of the SensiMeter were disconnected from the antenna terminals and the voltage was read at the video detector with no signal applied. The reading was 0.4 volt. Receivers using cascode front ends will not normally measure more than 0.5 volt, and pentode front ends 0.6 volt. The receiver was then known to be in good operating condition and not the cause of the great amount of noise mixed with the picture signal. While the generator and voltmeter were connected to the receiver, the generator frequency was varied to cover one channel (channel 2). The voltmeter rose to 1 volt, dipped to 0.8 volt, and then rose to 0.95 volt before dropping to 0.4 volt (noise level of the set). The frequency-response curve of the receiver was in effect plotted and found to be satisfactory. See Fig. 2. Naturally, this is not necessary to correct snow problems but takes only a minute and accurately determines

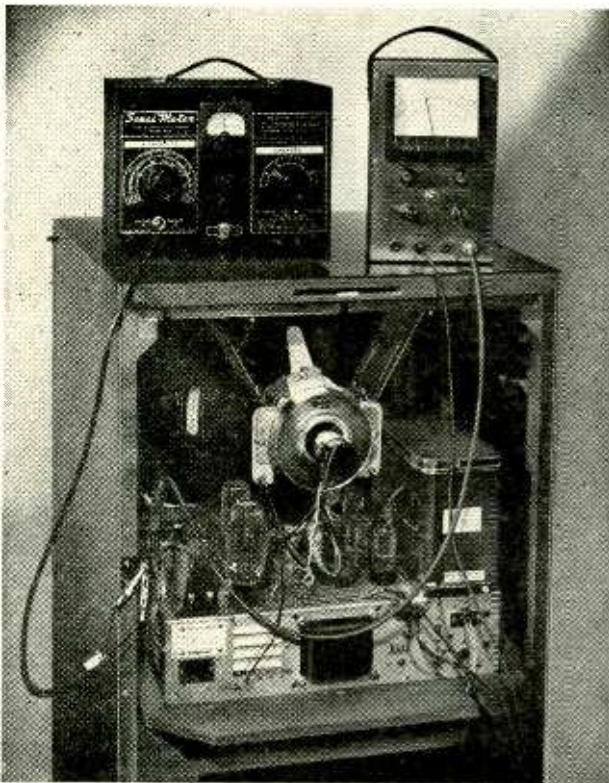

Fig. 1—Checking receiver sensitivity without removing chassis from cabinet.

four or five strips will not improve the picture. Adjustments can be made on all Standard Coil strips by removing two or three strips on the opposite side of the turret. The slugs are slotted on both ends and can be reached through the turret. Purchase a No. 1 or No. 2 plastic knitting needle. It will make about four tools and costs only 10¢. Adjust each slug for minimum snow while listening to the sound to be sure it hasn't disappeared.

5. A defective local oscillator tube. If the oscillator injection voltage is low, the u.h.f. receiver sensitivity also will be low. This is especially true where harmonics of the local oscillator are used to convert the v.h.f. signal to u.h.f.

6. Wet transmission line. Be sure that installation techniques set down by the line manufacturer are followed. Wet line will attenuate the signal as much as 25 db per hundred feet. Be sure tubular line is sealed at the antenna end or is bent in such a way that the rain cannot come in. Also, be sure a drainage hole is cut in the line at the point where the line enters the house.

7. v.h.f. receiver sensitivity. This is the portion most often overlooked. It will be found that many older model TV receivers with low sensitivity will always be troubled with snow on u.h.f. even though they work satisfactorily on v.h.f. It is strongly recommended that an instrument accurately calibrated in microvolts be used for checking sensitivity. See Fig. 3. Alignment generators with resistor attenuators and without output monitoring meters are not satisfactory. Sensitivity is the required r.f. input to develop 1 volt d.c. at the video detector. The table is

Receiver Sensitivity Ratings

Receiver Characteristics	Sensitivity In Microvolts
Pentode r.f. amplifier and conventional diode a.g.c. Two i.f. amplifiers Three i.f. amplifiers Four i.f. amplifiers	100 to 150 40 to 100 20 to 40
Cascode r.f. amplifier and conventional diode a.g.c. Three i.f. amplifiers Four i.f. amplifiers	30 to 40 15 to 25
Cascode r.f. amplifiers and gated a.g.c. Three i.f. amplifiers Four i.f. amplifiers	10 to 20 5 to 10

Table 1—Typical sensitivity readings.

a guide to what to expect in sensitivity readings. In 4 out of 10 cases, the cause of snow was traced to low sensitivity in the u.h.f. receiver, on calls made in a new u.h.f. area.

8. Defective converters: It is a good idea to carry a compact converter, known to be in good condition. If the converter or conversion strip is suspected, the good converter can be substituted. Do not sell the good converter but retain it as a piece of u.h.f. test equipment. END

the alignment of the TV receiver.

A set of channel 38 u.h.f. conversion strips (Q type) were substituted by removing the screen from the cabinet directly below the tuner. This reduced the snow level slightly but the picture was anything but saleable. At this point, the receiver and converter had been isolated and it was definite that the trouble was in either the transmission line or antenna.

The transmission line was inspected and found to be well installed, except for a few feet coiled behind the television set. This was removed and resulted in some reduction in snow level. The line appeared to be fairly free from standing waves and had been sealed at the antenna end.

The transmission line was reconnected to the television receiver antenna terminals and the voltmeter was left connected to the video detector. Channel 38 was tuned in. The voltmeter read 1.9 volts. The two-bay bowtie antenna was then removed from the chimney mounts on the roof. The roof was walked in both directions and readings were called off on the voltmeter. At one spot on the roof the voltage at the detector read 4.7 volts. This produced a clear, snow-free picture. The antenna was mounted on a

second chimney near this spot and carefully oriented to obtain the same 4.7 volts. Needless to say, the customer could hardly believe her eyes since she had had three previous service calls.

Other factors not mentioned that cause loss in u.h.f. signal strength are as follows:

1. Mismatched transmission line, especially on the receiver end. Merely run the hand up and down the line to see if the picture contrast changes about every quarter wavelength. If it does, use a piece of tin foil from a cigarette pack; wrap it around the line and adjust it for maximum contrast.

2. Kinks in the line, especially at the point where it is brought into the house or on top of the chassis. Some v.h.f. receivers have transmission line running from the antenna terminals to the tuner through a cardboard holder. The line is usually kinked at this point and makes a wonderful trap at u.h.f.

3. Line running near metal chassis. This is especially true on all-channel tuners where switching is necessary and a considerable amount of line is left on top of the chassis. Be sure to dress it away from the chassis.

4. Detuned channel strips on receivers using strip conversion. Occasionally, a receiver will be found where

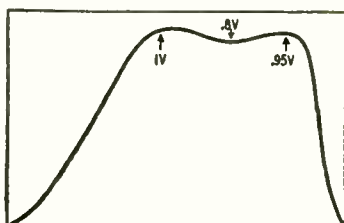

Fig. 2—Response curve of TV receiver.

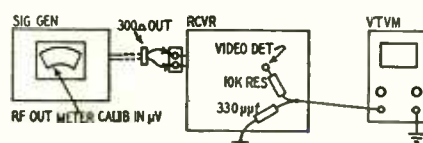

Fig. 3—Making sensitivity measurements using the SensiMeter generator.

MODIFYING THE

EICO 425

By HERMAN BURSTEIN

FACED with a growing need for an oscilloscope with high gain, broad bandwidth, and specific other features, I recently modified my Eico 425 oscilloscope in several ways that have greatly increased its usefulness. Cost of additional parts was about \$10. The following features, employing more or less conventional circuitry, were gained:

1. A high-gain, wide-band vertical amplifier section incorporating a cathode-follower input stage, a compensated input attenuator, and push-pull output.
2. Optional retrace blanking control.
3. Astigmatism (sharp trace) control.
4. A 60-cycle voltage phase shifter.
5. Internal sync phase inverter.
6. Sawtooth voltage on front panel terminal.

These features, together with those already present—push-pull horizontal output, intensity modulation input jack, wide sweep range, direct connections available to deflection plates, etc.—provide a truly useful instrument.

Vertical amplifier

The entire original circuit of the Eico 425 appears in Fig. 1. Fig. 2 shows the new vertical amplifier section, which accounts for the preponderance of labor and expense involved in the above changes. Sensitivity is very nearly .01 r.m.s. volts per inch, which is seldom exceeded by other than laboratory oscilloscopes. With care, waveforms of frequencies up to about 3 megacycles may be viewed on the screen by substantially increasing horizontal gain. Discernible vertical deflection can be obtained up to approximately 6.5 megacycles. The oscilloscope is essentially flat from less than 10 cycles to about 500 kc and is down about 3 db at 1 mc.

The 3-step attenuator switch, S101 in Fig. 2, is a 2-pole, 3-position rotary type, mounted in place of the original 1-megohm vertical gain control. A miniature wafer switch was not available at the time of construction, so a rotary type was used because it took less space than the standard wafer type. For the vertical fine gain control R107, a hole was drilled in the front panel 3/4 inch below a point midway between the coarse frequency control and the vertical positioning control. Fig. 3 shows the panel location of S101 and R107.

Trimmer capacitors C102 and C103 are miniature and should be soldered as nearly as possible directly across the attenuator switch lugs. These capacitors, together with C104 and C105, provide correct attenuation of high frequencies in the $\times 1$ and $\times 10$ settings of S101.

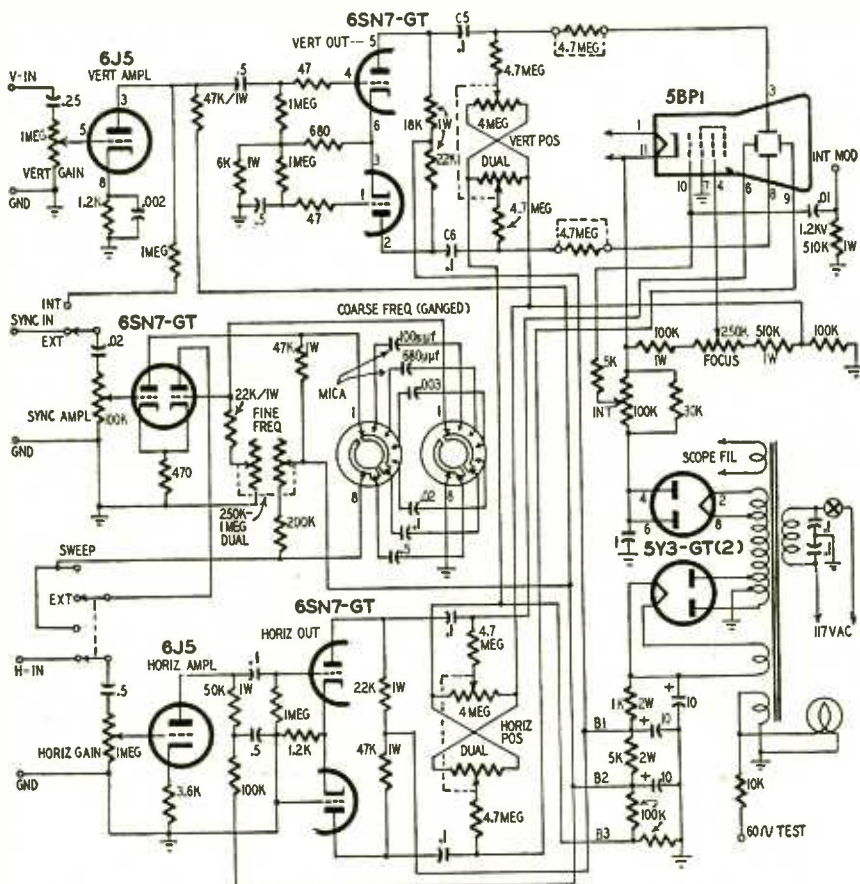

Fig. 1—Eico model 425 oscilloscope. Simple changes widen its usefulness.

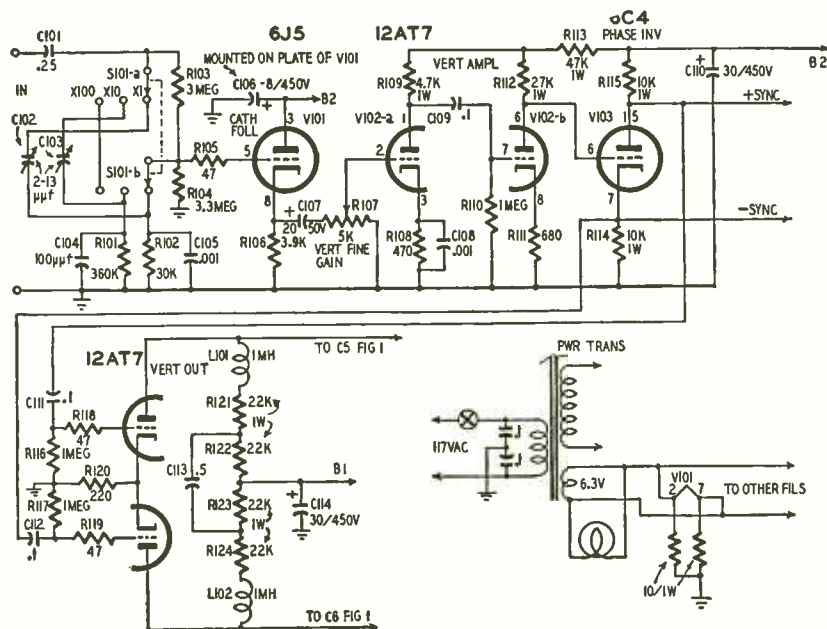

Fig. 2—Schematic diagram of the new wide-band, high-gain vertical amplifier.

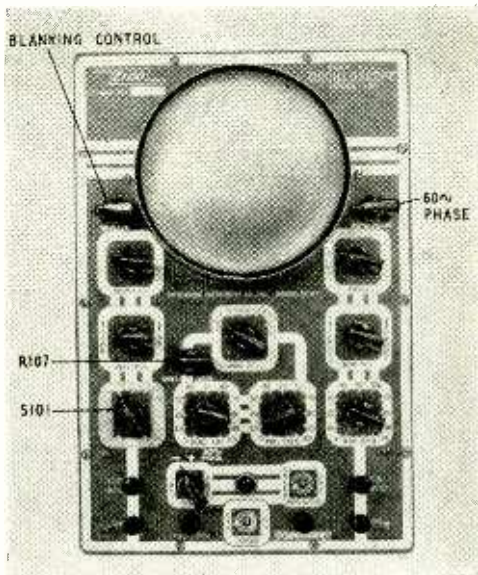

Fig. 3—The panel of the modified scope.

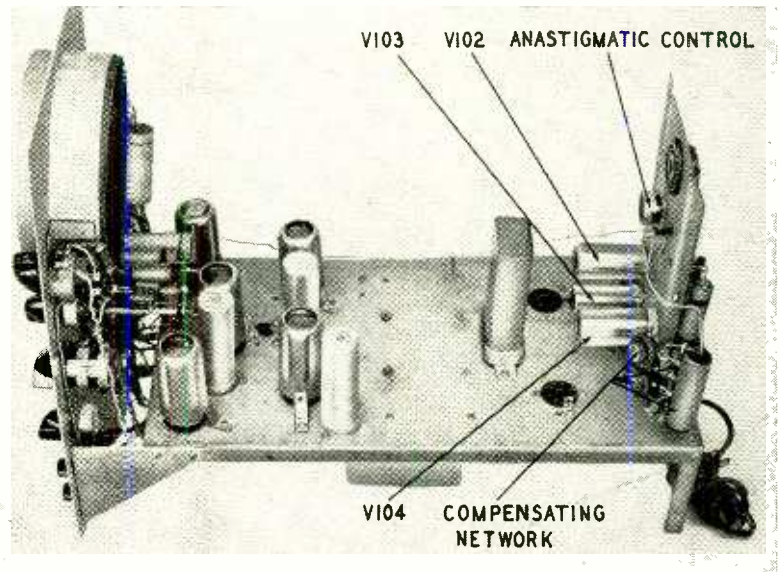

Fig. 5—Top view of the scope with the rectifiers and 5BP1 removed for clarity.

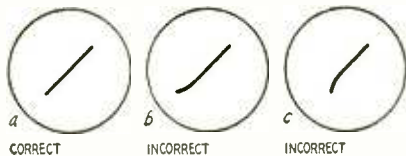

Fig. 4-a—Pattern obtained with correct adjustment of the compensated attenuator. Patterns b and c are the result of too much or too little compensation.

These capacitive voltage dividing networks after completion of the vertical amplifier are aligned as follows: Set the multivibrator controls to the 2-10- μ range. Feed the resulting sawtooth from pin 5 of the multivibrator to the vertical input terminal. Upon completion of modifications this sawtooth voltage is available at the front panel. Set the oscilloscope on internal sweep and the attenuator (VERT. COARSE GAIN) at $\times 10$. Adjust the vertical gain control and the horizontal gain control for a diagonal trace on the C-R tube screen. Adjust trimmer C102 for a diagonal trace without a curved hook at one end. Set the attenuator switch at $\times 1$ and adjust first the vertical gain and then C103 for correct trace in Fig. 4-a. Figs. 4-b and 4-c show traces that result from poor compensation.

The $\times 1$ attenuator position reduces the gain of the oscilloscope by a factor of 100 and is used for relatively high voltages not in excess of 500 volts. Ten times and 100 times as much gain, are provided, respectively, in the $\times 10$ and $\times 100$ positions. The oscilloscope must be operated with the attenuator at the lowest feasible setting to avoid overloading the input stage V101.

The cathode-follower input stage is a 6J5 and therefore can employ the same tube and socket of the original vertical input stage. Decoupling capacitor C106, a tubular electrolytic, is mounted right at the plate of V101.

To minimize hum level, filter capacitors C110 and C114 are added to the

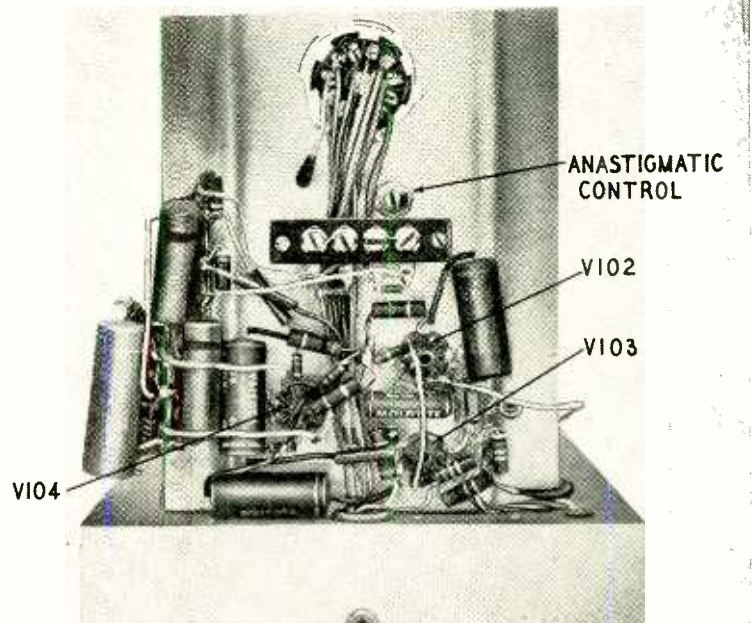

Fig. 6—The 5BP1 mounting bracket is flattened out and used as a chassis.

B1 and B2 supplies. There is sufficient room on the front half of the chassis for drilling mounting holes so that can type capacitors may be used. Their location is shown in Fig. 5.

The remainder of the vertical amplifier section is constructed on the C-R tube support at the rear of the chassis, as shown in Fig. 6. Room for the components is made by straightening out the right-angle sides of the support, thus increasing its width. There is not much room to spare, so a careful layout is necessary. All heaters should be wired first, using twisted pairs, and then wiring can proceed from stage to stage in accord with the schematic.

The lead from the arm of the gain control resistor R107 on the front panel to the grid of V102-a at the rear is placed above chassis to reduce the pos-

sibility of hum pickup from the power transformer, which lies below chassis.

The original circuit of the Eico 425 calls for supplying one side of the heaters through ground. However, it was found that less hum resulted from using twisted-pair heater leads to all sections of the oscilloscope and grounding each side through a 10-ohm, 1-watt resistor at V1. This procedure simultaneously permits installation of a simple 60-cycle voltage phase-shifting circuit.

The network of L101, R121, R122, R123, R124, and L102 maintains response at the low and high ends of the frequency range. This network is constructed separately on a tie lug, which is then mounted alongside the C-R tube support, as shown in Fig. 5.

To minimize attenuation of high fre-

quencies the grounding bus technique is avoided. All grounds are to the nearest ground lug on a tube socket or chassis point. The usual precautions of careful lead dress and short leads are called for. All tubes except the two 5Y3 rectifiers are shielded.

Adding 2 12AT7's and a 6C4, and replacing a 6SN7-GT with a 6J5 reduces filament voltage slightly, but not enough to affect operation.

Retrace blanking control

Fig. 7 shows the retrace blanking circuit. Short-duration positive pulses produced during the retrace portion of the sawtooth are tapped off pin 2 of the 6SN7-GT multivibrator and are amplified and inverted by V105. The negative pulse at the plate of V105 may be applied to the intensity modulation terminal and used to blank out the retrace line.

V105 is a 6J5 installed in the socket formerly used for the 6SN7-GT vertical output tube. Blanking is optional and

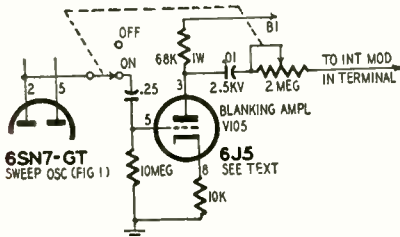

Fig. 7—The blanking amplifier circuit.

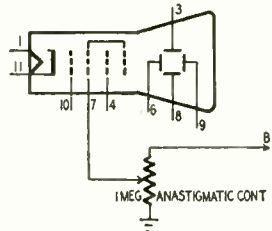

Fig. 8—The anastigmatic control is easy to add to the basic oscilloscope.

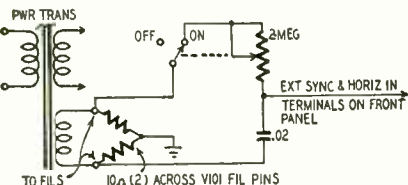

Fig. 9—Variable phase-shift circuit.

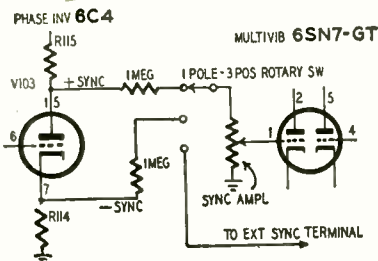

Fig. 10. Modification for synchronizing on positive- or negative-going signals.

can be eliminated by opening the switch ganged to the 2-megohm blanking control. The correct setting of the blanking control varies with the sweep frequency. At low frequencies, there is a tendency for a bright blur to appear at the left of the trace when the resistance in the control is too low. At high frequencies, very little resistance is needed for good results.

Anastigmatism control

The anastigmatism control, shown in Fig. 8, is quickly installed and requires no additional components. The 1-megohm potentiometer was previously used as the vertical gain control. Pin 7 of the 5BP1 was removed from ground and was connected to the arm of the control. The resistance of the control was connected between B1 and ground.

This control does not require frequent adjustment, so it need only have a slotted shaft and it is best located out of the way on the back of the chassis as in Fig. 6.

To adjust the control for a sharp trace, set the vertical and horizontal gain controls at zero and adjust the focus and astigmatism controls for the roundest dot possible with the intensity control in a normal position. Possibly, however, it may be easier and more satisfactory to make these adjustments while viewing a sine wave. Use a nonmetallic screw-driver to adjust the astigmatism control. This minimizes the shock hazard and reduces the chances of shorting the high voltages on the base of the 5BP1.

60-cycle phase shifter

Fig. 9 shows the circuit which provides nearly 180° phase shift of 60-cycle voltage. The two additional components required are a .02- μ f capacitor and a 2-megohm potentiometer with a switch. The control is mounted above the focus control, as shown in Fig. 3. The circuit also requires a 10-ohm, 1-watt resistor from each side of filament supply to ground, but these resistors are already mounted at V101 in order to reduce hum, as shown in Fig. 2.

When the phase-shifter switch is on, 60-cycle voltage is fed to both the horizontal input and sync input terminals on the front panel. Setting the oscilloscope on external sweep and adjusting

the phase shifter produces a properly phased 60-cycle sinewave sweep, such as might be desired in aligning a discriminator circuit. To obtain the phased 60-cycle sawtooth sweep required in sweep alignment, set multivibrator controls for a 60-cycle internal sweep, throw the sync switch to the external position, and adjust the phase shifter to bring in the desired pattern.

The phased 60-cycle voltage is available at the external sync terminal of the oscilloscope when the phase-shifter switch is on.

Other modifications

When using internal synchronization, it is sometimes difficult to sync the oscillator because of the nature and polarity of the signal applied to the vertical amplifier. To simplify this operation and to provide for syncing on negative- or positive-going signals, replace the original s.p.d.t. sync switch with a single-pole, 3-position rotary type. Positive and negative sync signals are tapped off the plate and cathode, respectively, of V103 and fed to the switch contacts through 1-megohm resistors as in Fig. 10.

If you want to make only this modification on your scope, then positive and negative sync signals can be obtained directly from the plates (pins 2 and 5) of the push-pull 6SN7-GT vertical output stage. Use 3.3-megohm resistors in place of the 1-megohm units in Fig. 10.

The oscilloscope's sawtooth voltage can be made available at the front panel by feeding it from pin 5 of the multivibrator to the terminal previously used for 6.3 volts, 60 cycles.

The final change concerns mechanical cabinet hum produced by the power transformer. This can be completely eliminated by gluing a strip of foam rubber 3 or 4 inches wide to each inside wall of the cabinet.

Materials for new vertical amplifier

- Resistors: 1—30,000, 1—360,000 ohms, 1/2 watt; 3—47, 1—220, 1—470, 1—680, 1—3,900 ohms, 1/2 watt; 3—1, 1—3, 1—3.3 megohms, 1/2 watt; 2—10, 1—4,700, 2—10,000, 4—22,000, 1—27,000, 1—47,000 ohms, 1 watt; 1—5,000 ohms, potentiometer.
- Capacitors: (Ceramic trimmer) 2—2-13 μ f, (Mica or ceramic) 1—100 μ f, 2—.001 μ f. (Paper) 3—0.1, 1—0.25, 1—0.5 μ f, 600 volts. (Electrolytic) 1—8, 2—30 μ f, 450 volts; 1—20 μ f, 50 volts.
- Miscellaneous: 2—r.f. chokes, 1 mh; 1—switch, 2 poles, 3 positions, rotary or miniature wafer; 1—6J5, 1—6C4, 2—12AT7 tubes, hookup wire, sockets, tube shields, knobs, hardware.

END

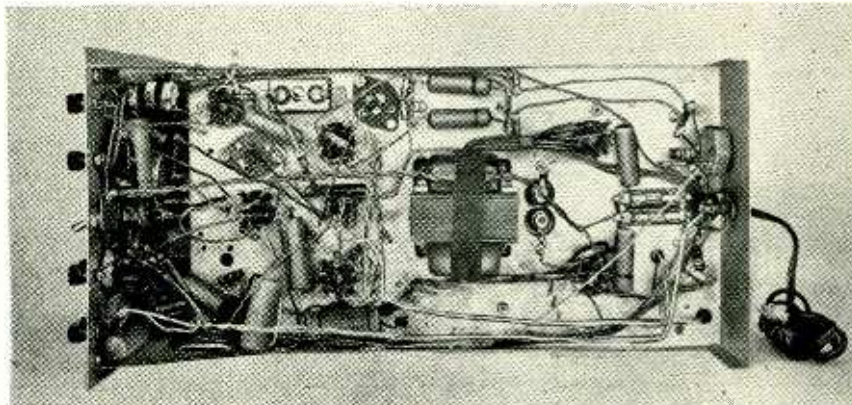

Photo shows an underchassis view of the Eico model 425 oscilloscope.

SERVICE TECHNICIAN'S FREQUENCY STANDARD

Extremely reliable crystal oscillator produces accurate signals for TV alignment and test equipment calibration

By JOHN T. FRYE

JUST because there is a clock on the courthouse steeple is scarcely a good reason for not carrying a watch. By the same token the accurate frequency broadcasts of the National Bureau of Standards Station, WWV, do not relieve the service technician of the need for a frequency standard of his own to which he can refer instantly and confidently. Such an instrument is indispensable for checking the accuracy of radio signal generators, TV sweep and marker generators, and audio-frequency generators; furthermore, the highly accurate signals the frequency standard produces can often be used in alignment operations.

A service technician's frequency standard has some special require-

ments: it should be rugged and dependable, for service instruments cannot be mollycoddled. It must be simple to operate, because the busy technician has no time for involved figuring. While a high degree of accuracy is required, it is not necessary to be able to check every kilocycle throughout the spectrum. Reasonably closely-spaced marker points that fall on critical frequencies will serve nicely. Finally, the instrument must be compact.

These requirements point directly at crystal type frequency meters. A properly constructed crystal oscillator will withstand a lot of rough handling. Even though a good crystal does cost a few dollars, in the long run the total cost of parts for a standard crystal oscillator is far less than the price of the several high-quality components that must go into a v.f.o. type of standard. Calibrating the crystal oscillator is child's play compared to calibrating a v.f.o.; moreover, once the crystal standard has been calibrated, the only control you have to manipulate is the on-off switch.

I do not want to leave the impression that you can throw a standard

crystal into just any old circuit and get the same satisfactory results; especially when you want strong, dependable output from the higher-order harmonics. A half-dozen low-frequency crystal oscillator circuits were tried before the one shown in Fig. 1. It was selected as being outstanding for ease of oscillation, frequency stability, and high harmonic output. The circuit is not original. It is similar to one used by National in some of their receivers, but several important construction features are incorporated in the unit.

Construction

The complete 100-kc crystal oscillator and transformer type power supply are built into a 4 x 5 x 6-inch metal utility cabinet. Fig. 2 shows all parts mounted on a 3 x 4 x 1/4-inch bakelite shelf fastened across the narrow dimension of a 5 x 6-inch panel, 2 1/2 inches down from the top edge, with a couple of reinforced angle brackets. The selenium rectifier, the transformer, the tube, the surge-protecting and filter resistors—in short, all the heat-producing parts—are mounted on top of this shelf, deliberately chosen for its

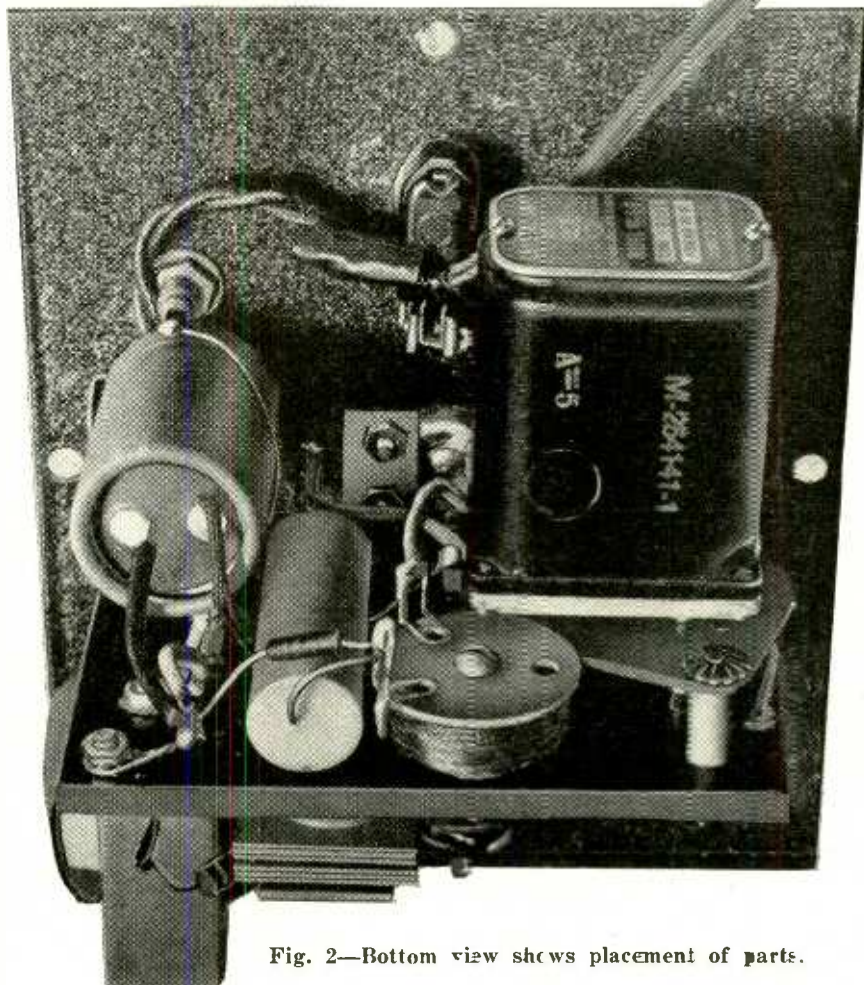

Fig. 2—Bottom view shows placement of parts.

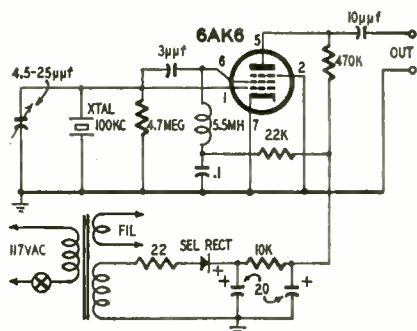

Fig. 1—Crystal oscillator circuit.

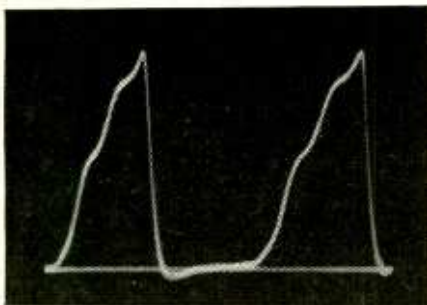

Fig. 3—Crystal oscillator waveform.

minimal heat-conducting properties. The remainder of the parts are mounted below. The ceramic trimmer capacitor is fastened to the shelf with a small angle bracket so that the adjusting screw is just behind the center of the panel. A $\frac{1}{4}$ -inch hole is drilled in the panel for access to this screw.

The 100-kc crystal shown in Fig. 2 is an RCA VC-5-M silver-plated crystal of a DT-cut, picked up on the surplus market. Three sturdy mounting prongs come out of the base. Two, close together, are an integral part of the base and constitute twin ground terminals. The other insulated prong is the hot lead and should go to the oscillator grid. No socket came with the crystal; so one had to be made. The two ground prongs fitted into the two large openings of a standard 4-prong wafer tube socket. It was no big job to remove the grid and plate pin receptacles from the socket, drill a new hole in the wafer for the single prong, and then remount one of the receptacles so that it would receive the prong thrust down through this hole. The socket used was selected to make this operation as easy as possible. The type of pin receptacles is the important thing: they should have a strong clamping action to support the heavy crystal in its inverted position, and they should be of a type that can be removed and remounted without too much difficulty. Half-inch lengths of tubing slipped over the 6-32 mounting bolts support this socket away from the shelf.

It is strongly suggested the general layout of parts shown in the photograph be closely followed. It has been carefully worked out to keep the temperature-rise of the crystal at a minimum. Even more important is the use of exact values of the following parts: the 3- μ f feedback capacitor, the 5.5 millihenry choke, the 4.5–25- μ f negative coefficient trimmer capacitor, the 10- μ f output coupling capacitor, the 4.7-megohm, 470,000-ohm, and 22,000-ohm resistors.

The red and the black insulated tip jacks are mounted 1 inch in from the sides and $1\frac{1}{4}$ inches up from the bottom of the panel. The line switch is in the center $1\frac{1}{4}$ inches up from the bottom. The line cord is brought in through a $\frac{3}{8}$ -inch grommet-lined hole near the bottom-center of the rear panel. Four rubber feet are fastened

to the bottom of the cabinet itself. The two panels are screwed into place, and the instrument is ready to test and calibrate.

Calibration

Run a lead from the red tip jack to the antenna post of an all-wave broadcast receiver. If the receiver uses a loop, the lead can simply be placed near the loop winding. Turn on both the receiver and the frequency standard and tune the set to 600 kc. If the oscillator is working, a loud unmodulated carrier will be heard. Similar carriers will be picked up at 700, 800, 900 kc, etc. Allow the standard oscillator to run a full 15 minutes before starting calibration.

The receiver should then be tuned to one of WWV's frequencies that can be received well in your locality. These signals are sent out on 2.5, 5, 10, 15, 20, 25, 30, and 35 mc. The 10 mc signal is most likely to be received on the average all-wave receiver during the daylight hours in most parts of the United States. At any rate, this frequency is a good one to use because it represents the 100th harmonic of our 100 kc crystal.

With WWV tuned in, wait until the tone modulation is cut off, as happens 1 minute before each hour and every 5 minutes thereafter. During this 1-minute no-modulation interval, place an insulated screwdriver in the slot of the trimmer capacitor and turn it carefully, listening for a low-frequency beat note between the oscillator and the WWV carrier. Varying the coupling between the oscillator and the receiver will often increase the volume of the beat. Connecting a lead from the black pin jack of the frequency standard to the receiver chassis may help, too.

Carefully adjust the trimmer so that the beat note becomes lower in frequency and finally no longer can be heard. *This point is not zero beat.* If you continue turning the capacitor in the same direction, you will pass through a dead space and then the beat note will be heard again. Somewhere in this dead space is the point of actual zero beat. If you turn up the receiver volume and carefully turn the trimmer back through this dead space, you will find a point at which a flutter can be heard. A slight movement of the trimmer will have a marked effect on the frequency of this flutter—which, incidentally, can be heard while WWV is being tone-modulated. When the modulation is on, the flutter becomes more of a “wow-wow-wow” variation in amplitude of the modulating tone. The trimmer should be adjusted so that the frequency of those “wow’s” is as low as possible. With a little patience you can reduce them to 1-per-second or less. When you accomplish that, calibration of the oscillator is complete. The difference between WWV's 10-mc frequency and the oscillator's 100th harmonic at that point is the difference

between 10,000,000 and 10,000,001 cycles per second, or one one-hundred-thousandth of 1%!

Performance

The frequency standard produces strong harmonics through 30 megacycles. High bias, generous feedback, and strong oscillation account for this. The oscillator is such an eager beaver that it continues to work until the supply voltage falls below 25. Fig. 3 is a picture of the output on an oscilloscope with a wide-band amplifier. The peak-to-peak value of the waveform is 10.5 volts. The great departure from a sine wave is an indication of very high harmonic output. A true sine wave has no harmonic output at all. The very irregular r.f. waveshape has no bad effect on the tone of a beat note produced with this oscillator. At all points checked the note was clear and musical—what hams term a “crystal pure direct current note.”

The total power consumed by the oscillator, including the filament power for the 6AK6, is less than 2.25 watts. When it is first turned on the frequency is about 30 cycles—not kilocycles—high. This frequency lowers rapidly during the first 2 or 3 minutes of operation and then the rate of change slows down. At the end of 15 minutes it is right on the nose. After several hours of operation it was found to be about 15 cycles low. Raising or lowering the line voltage 10 volts from a normal value of 115 volts will produce about a 10-cycle shift in frequency. Changes in the load placed on the output will also cause a few-cycle change in frequency.

To determine if ventilation of the case would be necessary, a small thermometer was attached to the side of the crystal and the panels were screwed into place. Then the oscillator was operated continuously for 5 hours in a room temperature maintained at 72° F. At the end of that period the thermometer read 80°, representing a rise of only 8°. Since the crystal was actually calibrated at 86° F by the manufacturer, obviously no ventilation was necessary.

Applications

The first use of the frequency standard is to check other frequency generating equipment in the shop. With r.f. generators operating between 100 kc and 10 mc, this is very easy to do. Simply place the output of the generator to be checked in parallel with the output of the frequency standard.

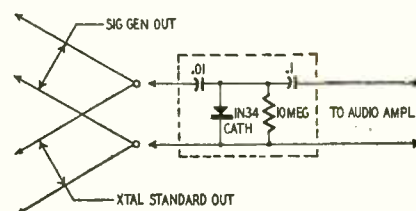

Fig. 4—Locating beat-frequency points.

Use a demodulator crystal probe, such as the one shown in Fig. 4, in conjunction with a signal tracer or other audio amplifier to indicate beat frequency points. When the variable generator is tuned across any one of the 100 harmonics in the range indicated, the beat will be clearly heard in the speaker. When zero beat is obtained, the variable generator is operating exactly on the frequency of that particular harmonic.

Between 10 and 30 megacycles a more sensitive beat-note detector is desirable, such as a receiver that will receive those frequencies. The receiver is tuned to a particular harmonic of the crystal oscillator, and then the signal generator is tuned to zero beat with this harmonic.

Since the 0.1-megacycle harmonics are crowded closer together on these upper frequencies, it is necessary to have some way of knowing which harmonic is which. This can be done by placing the signal generator on exactly 1000 kc. and turning on the audio modulation. Then at every 1 megacycle will be heard the tone-modulated harmonics of this oscillator, and on the same frequencies will be heard the 20th, 30th, 40th, 50th, etc., harmonics of the crystal oscillator. It is then a simple matter to identify any of the harmonics of the crystal falling between these check points.

Suppose, for example, you are aligning a TV set and want to set a trap precisely to 21.6 mc. Locate the 210th crystal harmonic on 21 mc and then count 6 harmonics higher and place your signal generator precisely on this frequency. Another case where accuracy is even more important occurs when you are aligning the sound detector of an intercarrier set. It is most essential that the zero-response point of the detector be set exactly at 4.5 mc. Here is one place where "close" does not count. If you set your generator to zero beat with the 45th harmonic of the crystal standard, this critical adjustment is as precisely correct as it could be made in the factory itself.

Even audio generators, that now go up to as high as 100,000 cycles, can be checked against the crystal standard. Using the tone modulation frequencies of 440 and 600 cycles on WWV, Lissajou figures can be used to calibrate the audio oscillator to about 6,000 cycles; but beyond that the figures become too complicated to read with a reference frequency as low as 600 cycles. By running the frequency standard into the vertical amplifier and the audio generator into the horizontal amplifier of a 'scope, you can check the audio oscillator up to its highest frequency.

Using only ratios that are easily recognized ($\frac{1}{2}$, $\frac{2}{3}$, $\frac{3}{4}$, etc.) you will have check points at 100,000, 50,000, 33,333, 25,000, 20,000, 16,666, 14,444, 12,500, 11,111, 10,000, 9,091, 8,333 cycles, etc. As you go lower in frequency, it will be increasingly difficult to make the figures stand still while

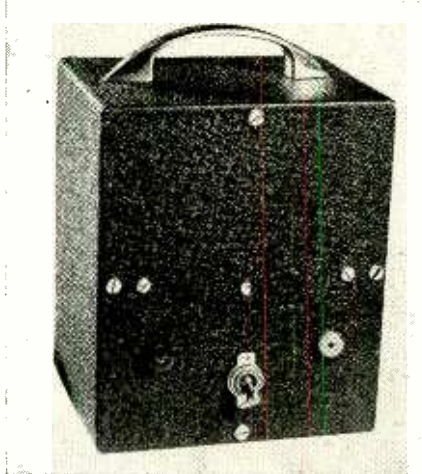

External view of frequency standard.

you count them; but if you have a little patience and a steady hand it can be done. If you will start at a high frequency and come down you will soon learn to note the way the pattern looks as it approaches a check point condition. Then you will be able to spot the lower frequencies producing these patterns without actually counting the loops. The irregular shape of the r.f. signal is no drawback in using Lissajou figures in this manner. In fact, it makes it easier to tell the back traces from the front ones. If you are a little rusty on your Lissajou figures, I recommend you read N. H. Crowhurst's article "Calibrating Audio Oscillators," in the November 1952, RADIO-ELECTRONICS.

In many operations the frequency standard output can be used directly. As an example, suppose you have just replaced the oscillator, r.f., or loop coil

Materials for Frequency Standard

Resistors: 1—22, 1—22,000, 1—470,000, 1—4.7 megohm, $\frac{1}{2}$ watt; 1—10,000 ohm, 1 watt.
Capacitors: 1—3 μ mf, ceramic; 1—10 μ mf, ceramic or mica; 1—0.1 μ f, 600 volts plastic (Mallory PT-601 or equivalent); 1—20-20 μ f, 250 volts, common negative electrolytic (Mallory TCD-55 or equivalent); 1—4.5-25 μ mf, negative coefficient steatite trimmer (Centralab 822CN or equivalent)
Miscellaneous: 1—power transformer, 125 volts, 15 ma; 6.3 volts, 6 amp (Stancor PS 8415 or equivalent); 1—5.5-mh choke (Meissner 19-4551 or equivalent); 1—6AK6 tube; 1—miniature tube socket; 1—100-kc standard crystal; 1—4-prong wafer socket; 1—selenium rectifier (Sarkes Tarjian 65 or equivalent); 1—s.p.s.t. switch with $\frac{1}{4}$ -inch shank; 2—phone tip jacks, insulated; 1—4 x 5 x 6-inch metal utility cabinet (Bud CU 729 or equivalent); 1—3 x 4 x $\frac{1}{4}$ -inch strip of bakelite; 3—angle brackets; 4—rubber feet; hardware, etc.

of a radio set and must re-establish proper dial tracking. Instead of constantly changing your signal generator from one end of the band to the other as you work with the trimmers, slugs, and turns, simply flip on the frequency standard. Then you will have a rock-steady signal every 100 kc, and the tracking of the dial can be worked out quickly.

Once you become accustomed to using and depending upon a frequency standard like the one described, you will be like a man who has just received a really dependable watch: you will not be able to imagine how you previously got along without it. END

PLUG-IN TV BAR GENERATOR

The main feature of the Crest bar generator below lies in its simplicity. The generator is inserted between the picture tube base and socket (see diagram). A VERTICAL-HORIZONTAL switch then selects the linearity the technician wants to adjust, and a GRID-CATHODE switch permits either black or white bars to be seen on the screen.



The Crest model MA-4 bar generator.

A FREQUENCY control enables the technician to use as many bars as he wishes, and a SYNC control locks the bars on the screen. With bars visible

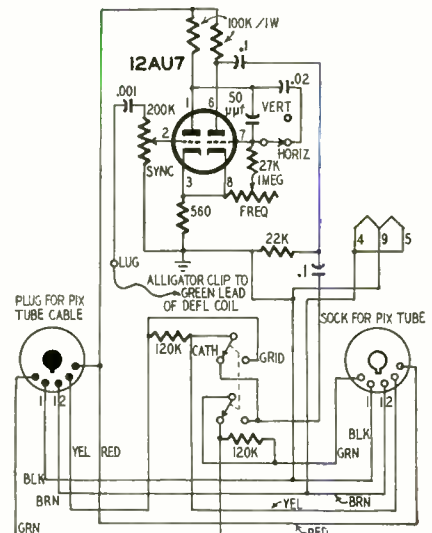

Schematic diagram of bar generator.

on the screen, the TV receiver controls (vertical linearity, height, etc.) can be adjusted until the bars appear equally spaced.

Being extremely compact, the Crest bar generator is a portable linearity marker that can easily be stored in a tool box. Connected directly to the back of a cathode ray tube, the bar generator is self powered. No tools are required in its installation. END

PARALLEL RESISTORS

..... and

SERIES CAPACITORS

By

NORMAN H. CROWHURST

IT IS often necessary to calculate the value of resistors in parallel or of capacitors in series. The formula for such calculations is well known but difficult to handle. Various charts and "slide-rules" have been designed as aids, but such methods lack the directness desirable for general use.

Compare the difference between calculating the values of resistors in parallel and values of resistors in series. For example: a 33,000-ohm resistor in series with a 47,000-ohm one will total 80,000 ohms. The result is found by simple addition. If we want to know the over-all tolerance, using standard 20% resistors: the 33,000-ohm unit can vary between 27,000 and 39,000 ohms, and the 47,000-ohm unit between 39,000 and 56,000. Adding together the highest and lowest pairs of figures, we find the resultant series combinations can be anywhere from 66,000 to 95,000 ohms. All this is calculated by simple arithmetic. But the arithmetic for working out the same information about parallel resistors—or series capacitors—becomes much more involved. The chart presented on page 67 has been designed to simplify this and similar calculations.

A case where such calculations can arise is the R-C coupling circuit of Fig. 1. The actual circuit is shown at 1-a. At 1-b is the equivalent circuit for calculating low-frequency response. It contains plate resistance R_p and coupling resistor R_c in parallel. At 1-c

is shown the equivalent circuit for high-frequency response. It contains R_p , R_L , and R_g (the grid resistor) in parallel. To discover whether the tube may cause distortion, the equivalent plate load, made up of R_p and R_c in parallel (Fig. 1-d) must be known. So, to work out these three details of an R-C coupling stage, we need to know three different parallel combinations of the circuit resistances.

When we apply these principles to the calculation of complete amplifier circuits as described in George Fletcher Cooper's series of articles, "Audio Feedback Design" (RADIO-ELECTRONICS, October, 1950, to November, 1951), a great many such calculations must be made, and a simple method of doing it proves very useful.

Another application is for attenuator circuits, where a resistor has to be held to a closer tolerance than usual. A simple method of getting the right resistance is by selecting one resistor that is slightly higher than the required value and shunting it with a much higher value to trim it to the correct resistance. Of course, the best way to do such jobs is to obtain close-tolerance resistors in the first place. If an attenuator is being built to a ready-made design, a kit of resistors with the correct close-tolerance values is probably available. Frequently, however, a simple fixed attenuation pad of some predetermined value is required for some purpose, for which the close-tolerance resistors are not available, so the simplest method is to make them up. You can search through a large batch of ordinary resistors with a resistance bridge—a very tedious process—or else use the trimming technique suggested above. For a variety of reasons the trimming technique is usually more practical.

When resistors are connected in parallel it is necessary to add their conductances to find the resultant value. For this reason the scale law used in the chart is a reciprocal one. The operation of the chart is graphically that of simple addition, and the scale calibration changes this graphical addition of conductances into terms of resistances, with which we are more familiar.

The chart automatically tells us the effect of different values of resistors connected in parallel, or of capacitors connected in series. For example, when

a high-value resistor is connected in shunt with one of lower ohmage, changing the value of the higher resistor makes a smaller movement on the scale than a similar change in the value of the lower resistor. This indicates that the total value is more dependent on the lower one than on the higher one.

If the resistors used are of the 20% tolerance type the first two colors of their color coding designate the numerals 10, 15, 22, 33, 47, or 68; the third color indicates the number of zeros that follow. The chart does not take into account the number of zeros, but its correct use is dependent upon choosing reference values so that the same number of zeros follow the scale reading for each resistance value in any one calculation. This is what is meant by the comment on the right-hand side, "Use All Scales for Same Units." For example, if the numerals on the chart can be taken to be in thousands they must be in thousands for every value in that particular calculation. If the numerals represent hundreds of ohms, they must do so for every value in the calculation.

The 20% nominal (color coded) values are indicated in the legend by the larger circle with a short horizontal line attached, to indicate the exact position on the reference scale to which each refers. The limits between which such nominal values may actually vary are indicated by the smaller circle with a horizontal line attached.

These smaller circles also represent the intermediate nominal values for 10% tolerance resistors of the preferred value range, designated by the numerals 12, 18, 27, 39, 56, and 82. The limits of 10% resistors are indicated by the smaller solid circle with line attached. This is true for all the 10% range, whether the numerical value is identical with one of the 20% range or is one of the intermediate values.

The solid circles also indicate the nominal values for the intermediate 5% ratings, the complete range of which is made up also by values identical with the 10% nominals. The limits between 5% ratings are indicated by the intermediate lines without any circles attached.

The numbers on the chart apply to the scales themselves, and only at the 10, 100, and 1,000 figures do they actually coincide with preferred value markings. All other preferred value

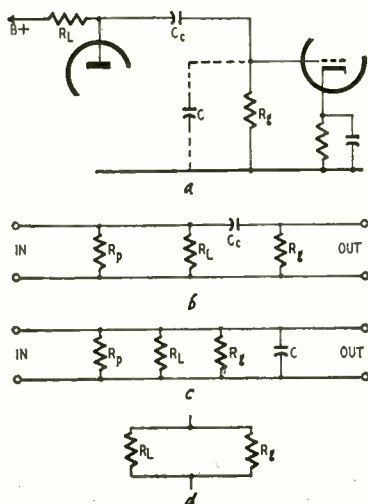
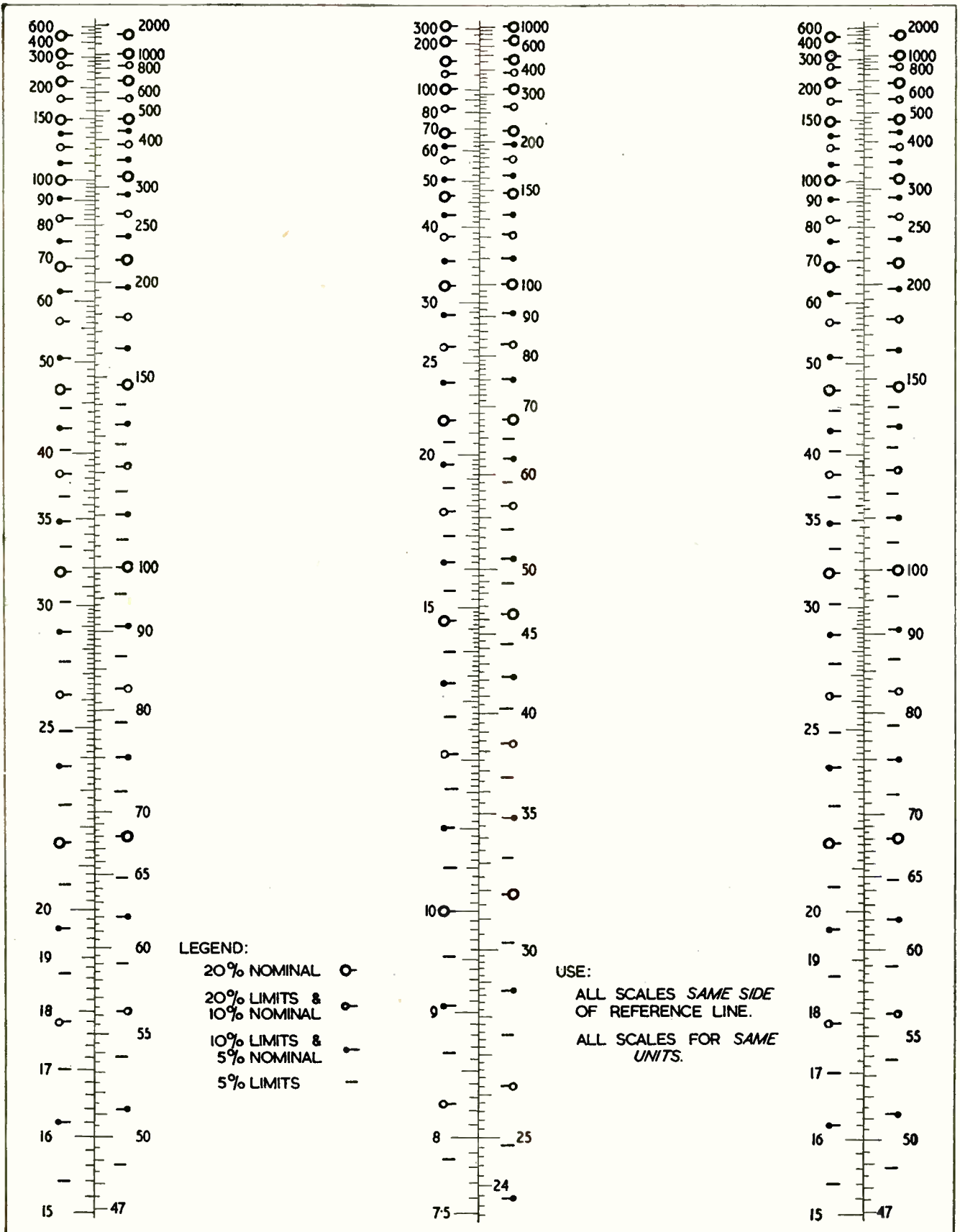

Fig. 1—Diagrams illustrate circuit and equivalent parallel resistances.



A new nomogram for finding resistances in parallel and capacitances in series; it contains two complete reference scales.

markings are spaced logarithmically along the scales, which allows correct percentage overlap. Thus, 39 appears as 38.5; 47 as 46.5, etc. (The precise values are rounded off by the manufacturers in actual production.) It is simple to identify a preferred value by comparison with the numerical scale.

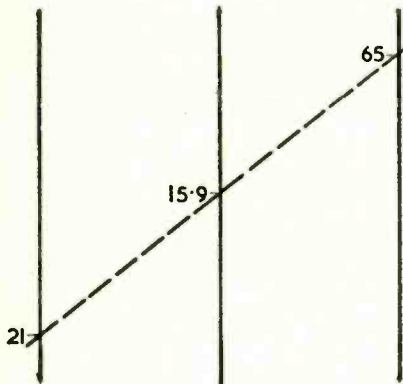

Fig. 2—Use of left-hand scales on chart.

Using the chart

The chart has been provided with two complete sets of reference scales—one using the left-hand side of all three reference lines, while the other uses the right-hand side. For this reason any individual calculation must use all scales on the same side of the reference lines.

Example 1: The total value of two resistors in parallel, 21,000 and 65,000, is to be found: the lower of these values is 21,000. On the outside pair of reference lines, the lowest position at which the number 21 can be used appears on the left-hand side. So the scale marking corresponding to 21, and that corresponding to 65, on the left-hand side of the outside reference lines, are aligned with a straightedge or ruler. The total resistance is read from the left-hand side of the center reference line, in this case 15.9, so the parallel resistance is 15,900 ohms. This is illustrated in Fig. 2.

The same position of the straight-edge could represent the parallel resistance of 210 ohms and 650 ohms, giving a total resistance of 159 ohms, by using the scale numerals to represent

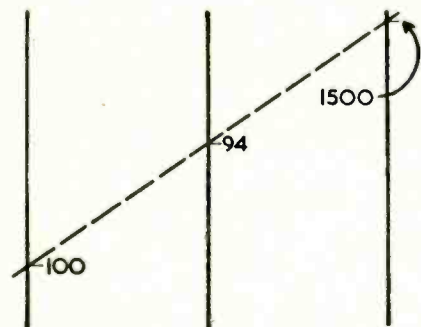

Fig. 3—Use of the right-hand scales.

ohms times 10. The scale numerals could represent any other desired units: ohms, hundreds of ohms, etc.

Example 2: Fig. 3 illustrates a case requiring use of the right-hand reference scales. The resistors to be connected in parallel have values of 1,000 and 15,000 ohms. For the lower of these values, 1,000, the lowest reference position on the outer reference lines is on the right-hand side, where it can be represented by the figure 100. This means the scale units will be ohms divided by 10, so that the numerals on the right-hand side of the reference lines that represent 1,000 and 15,000 will be 100 and 1,500. Aligning these, the right-hand side of the center reference line reads 94, indicating that the total resistance is 940 ohms.

Example 3: Fig. 4 shows the use of the chart for lowering the resistance of a known resistor to another value by connecting a resistor in parallel with it.

The known resistor measures 18,000 ohms and the required total resistance is 12,000. The points on the scale corresponding to 18 and 12, on the left-hand side of the left-hand and

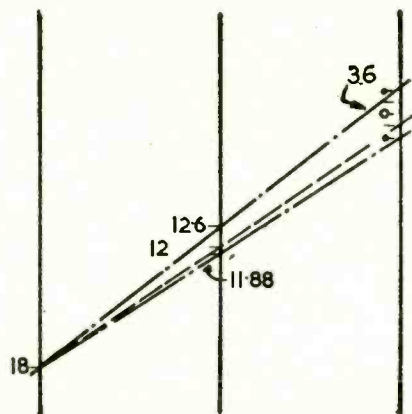

Fig. 4—Adding parallel resistors to reduce total resistance of combination.

center reference lines respectively, are aligned, reading 36 on the left-hand side of the right-hand reference line. A preferred value resistor should be used to obtain this result. Assuming that 10% resistors are the closest tolerance values available, the nearest nominal value will be a 39,000, whose limits are marked by the solid circles nearest to the small circle representing 39,000, as 34.8 and 42.2. Aligning the scale position on the left-hand side of the left-hand reference line at 18, with each of these points in turn, the readings on the center reference line show that a stock 39,000-ohm 10% resistor in parallel with the resistor already known to be 18,000 ohms can give a total value somewhere between 11,800 and 12,600 ohms. The chart indicates that a 39,000-ohm 10% resistor, a little more than 5% below the nominal value, is required to give the 12,000-ohm resultant exactly. The proper value can then be sorted out

comparatively easily with an ohmmeter. Similarly, a 33,000-ohm 20% resistor just under 15% up on its nominal value would do.

Example 4: Fig. 5 shows the chart used for a purpose similar to the example mentioned at the beginning of the article with series resistors. Suppose a circuit diagram specifies a 62,000-ohm 5% resistor connected in parallel with a 470,000-ohm 20% resistor, and we would like to determine the tolerance on the resultant combination as easily as it was calculated previously where there were two resistors in series.

This is found, as indicated in Fig. 5, by aligning the upper and lower limits for these two values, and reading off the resultant values, shown as 51 and 59, on the right-hand side of the center scale, since the right-hand side of the other scales is used. This means the combined parallel resistance can vary anywhere between 51,000 and 59,000 ohms.

The 51,000 point has a solid circle with line opposite it, while that for 59,000 has a plain line opposite it; in between are two other markings, making three spaces. At this part of the scale the spaces represent 5% tolerance intervals, so the total range is easily estimated as 15%, meaning that the 51,000 and 59,000 limits represent about $\pm 7\frac{1}{2}\%$ from the average value of 55,000.

Thus the chart has shown quite clearly that the accuracy of the total resistance depends more on the lower-value close-tolerance resistor than on the high-value wide-tolerance resistor, because the deviation of the parallel combination is only $7\frac{1}{2}\%$ as compared with 5% and 20% for the individual resistors.

These examples should enable the reader to practice using the chart. Ex-

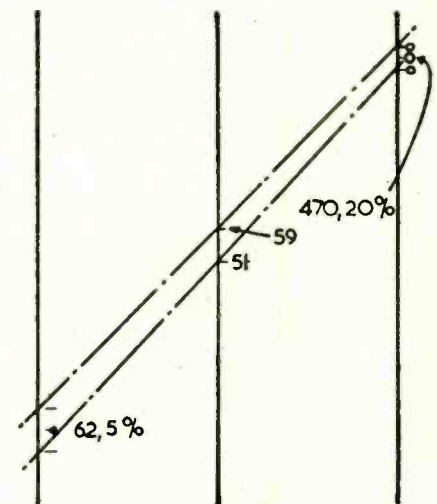

Fig. 5—Finding tolerance limitations.

amples have not been given dealing with series capacitors, because the method of calculation is identical with that for parallel resistors, and including examples would be just a repetition of the explanation that has already been given for resistors.

END

ELECTROLYTIC CAPACITORS

Changes in design due to new applications

By EMERY DEUTSCH*

VACUUM-TUBE, selenium, and germanium rectifiers are all common in electronic circuits. Each of these has its own characteristic effect on the electrolytic filter capacitors used with it. Capacitors therefore must be chosen to suit the rectifying device with which they are to be used.

The vacuum-tube rectifier is easiest on the electrolytic capacitor. Due to the gradual heating of its filament, the initial current applied to the first filter capacitor is gradual instead of abrupt as with the selenium rectifier. The vacuum tube rectifier also has a higher internal resistance than metallic rectifiers, and so subjects the filter capacitors to much less ripple.

Selenium and germanium rectifiers have a similar effect on the electrolytic filter capacitor, though the germanium type has a lower internal resistance and therefore operates cooler and with greater efficiency.

Because of their low forward resistance, selenium rectifiers subject the first filter capacitor to very high surges and ripple voltages that are highly detrimental to ordinary electrolytic capacitors, which could be used quite safely with vacuum-tube rectifiers. To limit this ripple to some acceptable value, much higher values of capacitance must be used than in vacuum-tube rectifier circuits. Where 300 to 400 milliamperes are supplied by selenium rectifiers, it is not uncommon to use capacitors of 200 to 300 μf as the first input filter.

Therefore, to handle the high-ripple conditions encountered by the first filter capacitor—or the charging capacitor in voltage multiplying circuits—the capacitors have to be specially constructed with etched cathode foil.

Selenium rectifier stacks consist of individual cells connected in series. Each cell is so constructed that it provides an easy path for the forward voltage and a barrier for the reverse voltage. This barrier is partially destroyed during the periods of idleness. However, it reforms in a few seconds after the rectifier is turned on. During this reforming period, the rectifier acts like a short, allowing high reverse current to reach the capacitor. To safeguard the capacitor from receiving a higher reverse current than the maximum allowable, a limiting resistor has

to be used.

The secondary purpose of the limiting resistor is to limit the surge current through the rectifier at the instant the circuit is turned on. A discharged capacitor connected across a rectifier acts practically as a short-circuit the instant current is applied and would draw excessive current through the rectifier.

In practice the value of this limiting resistor ranges from 40 ohms for a 25-milliamperer rectifier to 5 ohms for a 250-milliamperer rectifier.

To understand clearly the effects of ripple current on the electrolytic capacitor, one should be familiar with the theory and construction of these capacitors.

Briefly, capacitors of this type consist on an aluminum-ribbon anode foil, which is the positive electrode; an oxide film deposited on the anode serves as the dielectric; paper separators containing the electrolyte which serves as the negative electrode; and finally the cathode film which is the means of contact to the electrolyte.

The oxide film on the anode is formed by applying a voltage to the aluminum ribbon suspended in a suitable electrolyte. The capacitance for a given foil area is inversely proportional to the thickness of this film.

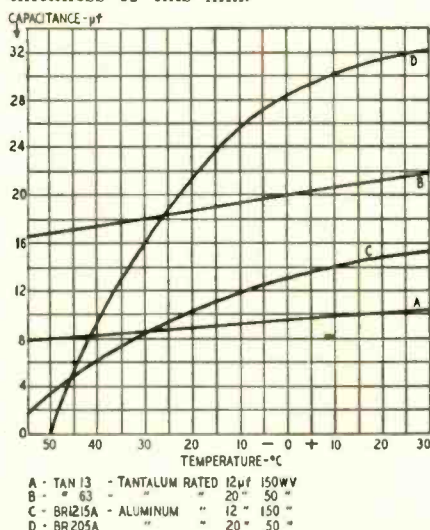

Fig. 1—Capacitance at low temperature, tantalum and aluminum capacitors.

Practically speaking, all electrolytic capacitors consist of two capacitors in series. One is formed by the anode foil and the electrolyte, the other by the

cathode foil and the electrolyte. The capacitance of a foil with no oxide film could be considered as approaching infinity.

Plain Cathode Foil Types

When high-ripple voltages are applied to plain cathode foil capacitors, the cathode foil receives an oxide deposit during the negative slope of the ripple voltage. This oxide film is similar to the anode film. The thickness of the oxide film is governed by the magnitude of the ripple voltage. This phenomenon is called cathode formation. Since the total capacitance of two capacitors connected in series is less than that of the lowest one, some of the original capacitance will be lost. This loss is proportional to the cathode formation and is most pronounced at the lower voltages.

In the case of the etched anode and plain cathode electrolytic capacitor, if an appreciable ripple voltage is applied, the capacitance drop is considerable. This is due to the relatively small surface area of the cathode foil in comparison to the area of the etched anode.

This undesirable capacitance drop will occur much before the capacitor heats noticeably.

The amount of ripple current capacitors of this type can stand is therefore small and reaches its maximum as the capacitance drop becomes appreciable.

Etched Cathode Foil

If it is desirable to apply higher ripple voltages to filter capacitors as is usually the case with selenium rectifiers, without capacitance drop because of the cathode effect, etched cathode foil can be used. Since the capacitance of the etched cathode will be much larger, if cathode formation sets in due to the ripple voltage, the effective capacitance drop of the whole capacitor will be negligible. In fact, instead of the capacitance drop the heating effect has to be considered. Therefore in power-supply design the ripple current through the capacitor should be held within the manufacturer's specified values to prevent overheating.

Also if a vacuum tube supplying in excess of a 75-ma d.c. load is replaced by a selenium rectifier, the first filter capacitor should also be replaced with an etched cathode type. In this case a limiting resistor has to be placed in the circuit. Its value is usually recommended by the manufacturer for the particular rectifier and load.

Tantalum Capacitors

Tantalum capacitors are similar to aluminum electrolytics except—as their name implies—the metal used for the electrodes is tantalum. They were developed to fill the need for compara-

*Assistant Chief Engineer, Electrolytic Division, Cornell-Dubilier Corp., South Plainfield, N.J.

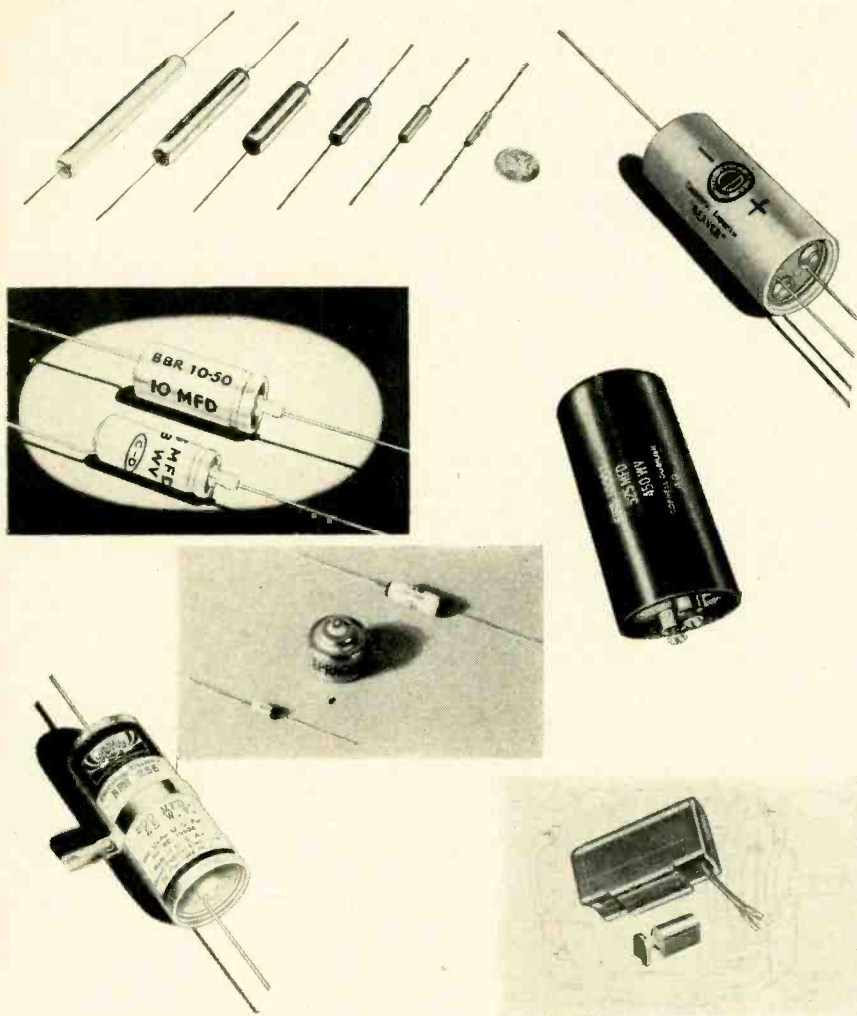

Some typical electrolytics. The six at the upper left are tantalum types.

Motor Starting Capacitors

The electrolytic motor-starting capacitors are used in series with the starter winding of split-phase motors. The starter winding is automatically disconnected when the motor has reached a predetermined speed. The purpose of the capacitor is to cause the auxiliary phase current to lead the main phase current, obtaining a large angle of displacement between the currents of the two windings. This produces the rotating field necessary to develop the torque required for starting the motor.

The a.c. motor-starting capacitors are similar in construction to the radio type except that both foils have an oxide coating. Therefore in an a.c. capacitor there are *two* anode foils, giving the effect of two polarized capacitors connected back-to-back (in series with the positive or negative terminals of both units connected together).

The capacitance limits are usually kept closer to the nominal value on these capacitors than on the radio types, for several reasons:

If the capacitance is too low for the motor, the motor may not have enough starting torque, causing it to run too long on the starter winding and burn out the capacitor. On the other hand, if the capacitance is too great it will adversely affect the pull-in torque of the motor. It may also burn out the starter winding, due to the heavy current flow.

These capacitors are for *intermittent duty only*, and should not be across the voltage for longer than one second at a time and not more often than 60 times per hour.

Motor starting capacitors are so constructed that their maximum power factor is 10%. Capacitors with a larger power factor would cause abnormal heating of the capacitor, and thus would shorten the life of the unit. High power factor also causes lower effective capacitance, which affects the pull-in torque of the motor.

The d.c. leakage of these types of units is usually slightly higher than of the radio types. It is not a detrimental factor in this application, for fairly high d.c. leakage would be required to increase the shunt resistance to the point where increased power factor could be noted.

Non-Polarized Capacitors

The difference between the nonpolarized and a.c. motor-starter capacitors is that the nonpolarized capacitor has lower d.c. leakage resistance than the a.c. type. These are used in circuits where intermittent high reversal voltages occur as across a relay coil (the inductive kick produces high voltages of opposite polarity) and it is desirable to prevent the capacitor from losing its capacitance through cathode formation.

END

tively small-size application where a temperature range of $+85^{\circ}\text{C}$ to -55°C is encountered.

The advantage of tantalum capacitors over aluminum ones are smallness, lower leaking current especially at high temperatures, longer shelf life, and better operating characteristics at low temperatures.

Advantages of Tantalum

The main advantage of the tantalum capacitor is its satisfactory operation at low temperature as far down as -55°C . Fig. 1 compares the capacitance drop of standard aluminum radio type capacitors versus tantalum capacitors. While the aluminum types lost almost all their capacitance at -55° , the tantalum one retained 80% of their original value.

The second major advantage of the tantalum capacitor is its longer shelf life. When ordinary types of electrolytic capacitors are stored idle for long periods of time their leakage is appreciable when voltage is first applied to them. This characteristic necessitates reforming these capacitors by applying their rated working voltage to them till the leakage returns to normal, before they are used. The tantalum capacitor has much better idling characteristics, as shown in Fig. 2. This chart was prepared by subjecting both types of capacitors to an ambient temperature of 85°C for 24 hours without any voltage application. After this period of time the capacitors were allowed to reach room temperature and their leakage *versus* time was plotted. This test is a good simulation of a long period of idleness for the capacitor.

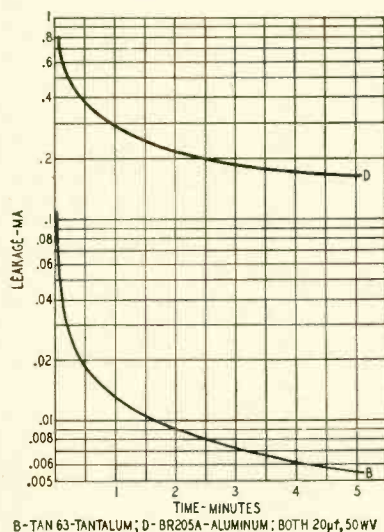

Fig. 2—Recovery time of tantalum and aluminum capacitors after idleness.



I'll Train **YOU** at Home in Your Spare Hours for Big Pay Job • Your Own Business • Exceptional Opportunity in

RADIO-TELEVISION

ON *New* NO-OBLIGATION PLAN!

I Send You 18 BIG KITS OF RADIO-TELEVISION EQUIPMENT

You Have NO MONTHLY PAYMENT CONTRACT to sign . . . you pay for your training as you learn and earn... ENROLL NOW! Be Ready in Little as 10 MONTHS!

Now you can get into Radio-Television, today's fastest growing big money opportunity field, in months instead of years! My completely new "package unit" training plan prepares you to qualify as a Radio-Television Technician in as short a time as 10 months, or even less! I offer you my training with no monthly payment contract to sign—thus **NO RISK** and **NO OBLIGATION** for you! This is America's finest, most modern and really practical training. Includes FM . . . UHF Television and all the most recent developments. My training gets you ready to handle any practical job in the booming Radio-Television industry. Start your own profitable Radio-Television Service Shop . . . or accept a fine paying job. I have trained hundreds of successful Radio-Television technicians—and I can train you regardless of lack of previous experience. Mail coupon and get all the facts—**FREE!**

VALUABLE EQUIPMENT INCLUDED WITH TRAINING

Much of your Sprayberry Training is actual construction, demonstration and experimentation. You get priceless practical experience this way. You build the 6 tube Sprayberry Short Wave and Broadcast Training Radio Receiver, the Sprayberry Television set, multi-range test meter, signal generator, signal tracer, cathode ray oscilloscope and many other projects. All this equipment is yours to keep. You have practically everything you need to set up your own profitable Radio-Television shop. All lessons and books I send you remain your own property.

OUR 21st YEAR TRAINING MEN FOR RADIO-TELEVISION

Earn Extra Money While You Learn

All your Sprayberry Training is given **IN YOUR OWN HOME** during your free time. Keep on with your present job and income while learning Radio-Television. With each Sprayberry "Package Training Unit" I include money-making plans and special "Business Builders" for spare time Radio-Television service obs. New Television stations opening everywhere open big money opportunity for men to install UHF antennas—I tell you how! If you expect to be in the Armed Forces later, there is no better preparation than Radio-Television. Mail coupon below . . . get facts **FREE**. *No salesman will call.*

FREE TO YOU 3 BIG RADIO-TELEVISION BOOKS

I invite you to get all the facts—

I want you to have ALL the facts—without cost! Rush coupon for my three big Radio-Television books! "How to Make Money in Radio-Television" PLUS my new illustrated "Television Bulletin" PLUS an actual sample Sprayberry Lesson—**ALL FREE**. No obligation and no salesman will call. Mail coupon **NOW!**

SPRAYBERRY ACADEMY OF RADIO

111 NORTH CANAL STREET, DEPT. 20-F
CHICAGO 6, ILLINOIS

Mail Coupon Today!

NO OBLIGATION ON No Salesman Will Call

SPRAYBERRY ACADEMY OF RADIO, Dept. 20-F
111 North Canal St., Chicago 6, Illinois

Please rush to me all information on your 10-MONTH Radio-Television Training Plan. I understand this does not obligate me and that no salesman will call upon me. Be sure to include 3 books FREE.

Name Age

Address

City Zone State

Are you Experienced? No Experience

Approved for Veterans Under the G. I. Bill

IF YOU ARE EXPERIENCED IN RADIO

Men already in Radio who seek a short intensive 100% TELEVISION Training with FULL EQUIPMENT INCLUDED are invited to check and mail the coupon at the right.

THE MOST *Outstanding* OSCILLOSCOPE IN HEATHKIT HISTORY

NEW MODEL O-9

OSCILLOSCOPE KIT



MODEL O-9

\$59⁵⁰

SHIPPING WT.
28 LBS.

Check THESE FEATURES

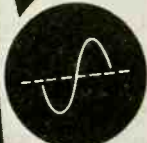

Voltage regulated for rock steady traces—complete freedom from bounce and jitter.

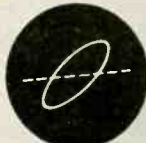

Built-in 60 cycle sweep and phasing control—a necessity for TV service work.

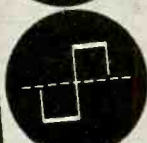

Wide band width down only 6 db at 3mc—reproduces 500 kc square wave and up to 10 mc sine wave.

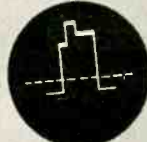

New production 5U1 CR tube by RCA gives finest trace available for complex, hard-to-see wave forms.

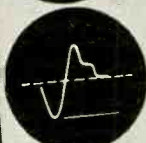

Acts as peak-to-peak vacuum tube voltmeter—measures directly on calibrated screen—built-in calibrator voltage.

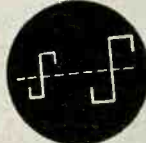

Properly compensated cathode follower vertical input controls trace reproduction at any input level.

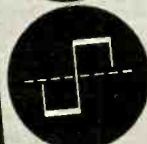

Retrace blanking amplifier eliminates confusion and gives clear concise picture of viewed wave form.



New ready formed and laced wiring harness eliminates unsightly and time consuming work of assembly.

Announcing the newest addition to a brilliant series of Heathkit Oscilloscopes, the outstanding new model O-9 instrument. This Oscilloscope features a brand new 5U1 cathode ray tube for really fine hairline focusing, good intensity and freedom from halation.

NEW FEATURES

Efficient voltage regulation system maintains rock steady trace stabilization. New retrace blanking amplifier circuit—amplifier band width further extended through efficient circuitry. Calibrated 1 volt peak-to-peak reference—wiring simplified by ready laced and formed wiring harness—new phasing control.

GOOD DESIGN

Terminal board for quick access to deflection plates—provisions for Z axis input—astigmatism control—balanced push-pull deflection amplifiers—internal sync on either positive or negative peaks.

VERTICAL AMPLIFIER

High impedance input with 6AB4 cathode follower, twin triode 12AT7 Cascade amplifier, 6C4 phase splitter and 12AT7 push-pull high gain deflection amplifier. Sensitivity .025 volts per inch.

HORIZONTAL AMPLIFIER

Five position input switch for choice of external input—line sweep—line sync—internal sync and external sync. Uses 12AU7 input stage, half as triode phase splitter driving 12AT7 push-pull high gain deflection amplifier. The remaining half of the 12AU7 used as retrace blanking amplifier.

POWER SUPPLY

New heavy duty internally shielded 100 milliampere power transformer. Efficient high voltage filtering system—voltage regulation completely eliminates trace bounce or jitter.

The Heathkit O-9 is the ideal general purpose oscilloscope for educational and industrial use. Radio and TV servicing and any other application requiring the instantaneous reproduction and observation of actual wave forms.

Heathkit LOW CAPACITY PROBE KIT



No. 342

\$3⁵⁰

SHIP. WT. 1 LB.

Oscilloscope investigation of high frequency, high impedance or broad band width circuits requires the use of a low capacity probe. The Heathkit Low Capacity Probe features a variable capacitor to provide the necessary degree of instrument impedance matching.

Heathkit SCOPE DEMODULATOR PROBE KIT



No. 337-B

\$3⁵⁰

SHIP. WT. 1 LB.

In applications such as trouble shooting TV, RF, IF and video stages, the frequency ranges encountered require the demodulation of signals before oscilloscope presentation. The Heathkit Demodulator Probe will fulfill this function and readily prove its value as a service accessory.



MODEL VC-2

\$11⁵⁰

SHIP. WT. 4 LBS.

Heathkit VOLTAGE CALIBRATOR KIT

The Heathkit Voltage Calibrator provides a convenient method of making peak-to-peak voltage measurements with an oscilloscope. Peak-to-peak voltages are read directly on the calibrated panel scales in the range of .01 to 100 volts peak-to-peak. A convenient "signal" position on the panel switch can be used to by-pass the calibrator and apply the signal directly to the scope input.

Heathkit ELECTRONIC SWITCH KIT

The basic function of the Heathkit S-2 Electronic Switch kit is to permit simultaneous oscilloscope observation of two separate traces which can be either separated or super-imposed for individual study. Continuously variable switching rates in three ranges from less than 10 cps to over 2000 cps. Individual gain controls for each input channel and a positioning control.



MODEL S-2

\$23⁵⁰

SHIP. WT. 11 LBS.

HEATH COMPANY • Benton Harbor 20, Mich.

RADIO-ELECTRONICS

Heathkit IMPEDANCE BRIDGE KIT

MODEL IB-2

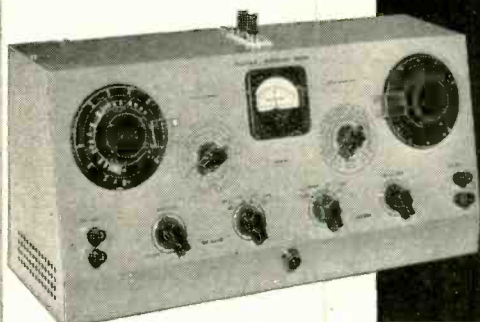
\$59⁵⁰SHIPPING WT.
15 LBS.

Another new, outstanding instrument design so typically characteristic of Heathkit operation in producing high quality instrument kits at the lowest possible price. A new, improved model Impedance Bridge kit featuring modern cabinet styling, with slanted panel for convenience of operation and interpretation of scales at a \$10.00 price reduction over the preceding model. Built-in adjustable phase shift oscillator and amplifier with all tubes of the battery operated type completely eliminates warm-up time. The instrument is entirely AC line operated. No bothersome battery replacements.

The Heathkit IB-2 Impedance Bridge Kit actually represents four instruments in one compact unit. The Wheatstone Bridge for resistance measurements, the Capacity Comparison Bridge for capacity measurements, Maxwell Bridge for low Q, and Hay Bridge for high Q inductance measurements. Read Q, D, DQ all on one dial thereby eliminating possible confusion due to the incorrect dial reference or adjustment. Only one set of instrument terminals nec-

essary for any measurement function. Panel provisions provided for external generator use.

A newly designed two section CRL dial provides ten separate "units" switch settings with an accuracy of .5%. Fractions of units are read on a continuously variable calibrated wire-wound control. A special minimum capacity, shielded, balanced impedance matching transformer between the generator and the bridge. The correct impedance match is automatically switch selected to provide constant load operation of the generator circuit. The instrument uses 1/2% precision resistors and condensers in all measurement circuits.

The new Heathkit IB-2 provides outstanding design features not found in any other kit instrument. The single low price includes the power supply, generator, and amplifier stages. No need to purchase separate instrument accessories in order to obtain the type of operation desired.

Features

- Simpson 100-0-100 microampere meter.
- Completely AC operated.
- Built-in phase shift generator and amplifier.
- Battery type tubes, no warm-up required.
- Newly designed two section CRL dial.
- Single knob D, Q, and DQ functions.
- Special impedance matching transformer.
- New modern cabinet styling.
- 1/2% precision resistors and silver mica condensers.

Heathkit AUDIO WATTMETER KIT

MODEL AW-1

\$29⁵⁰SHIPPING WT.
6 LBS.

A new Heathkit design for the audio engineer, serious hi fi enthusiast, recording studio, or broadcast station; the Heathkit Audio Wattmeter Kit. This specialized instrument instantly indicates the output level of the equipment under test without requiring the use of external load resistors. All readings are taken directly from the calibrated scales of a 4 1/2" 200 microampere Simpson meter.

The Heathkit Audio Wattmeter features five full scale power measurement ranges from 5 milliwatts up to 50 watts with db ranges of -15 db to +48 db. The instrument has a power measurement rating of 25 watts continuous and 50 watts maximum for intermittent operation. Non-inductive resistance load impedances of 4, 8, 16, and 600 ohms are provided through a panel impedance selector switch. Frequency effect is negligible from 10 cycles to 250 kc. A conventional VTVM circuit utilizes a 12AU7 twin triode tube. The meter bridge circuit uses four germanium diodes for good linearity.

With the Heathkit AW-1 desired information can be obtained instantly and conveniently without bothering with the irksome setups and calculations usually required. Useful for power curve measurements, frequency response checks, monitoring indicator, etc. Convenient calibration directly from 110 volt AC line source. This new instrument will help to supply the answers to your audio operating or power output problems.

Heathkit LABORATORY GENERATOR KIT

MODEL LG-1

\$39⁵⁰SHIP. WT.
16 LBS.

Another welcome new addition to the popular line of Heathkit instruments, the Heathkit Laboratory Generator. Specifically designed for flexibility of operation, accuracy and versatility beyond the performance level provided by the conventional service type generator. Frequency coverage of the Colpitts oscillator is 150kc to 30mc in five convenient ranges with provisions for internal or external modulation up to 50%, and .1 volt RF output throughout the frequency range. Panel mounted 200 microampere Simpson meter for RF "set reference level" to provide relative indication of RF output. Individually shielded oscillator and shielded variable and step attenuator provide flexible control of RF output.

The circuit features a 6AF4 high frequency oscillator, a 6AV5 amplifier with grid modulation, 12AU7 400 cycle oscillator and modulator, OB2 voltage regulator tube, and a selenium rectifier for the transformer operated power supply. The smart professional instrument appearance and over-all flexibility of operation will prove a decided asset to any industrial or educational laboratory. The Heathkit Laboratory Generator sets a new level of operation, far superior to any instrument in this price classification.

HEATH COMPANY • Benton Harbor 20, Mich.

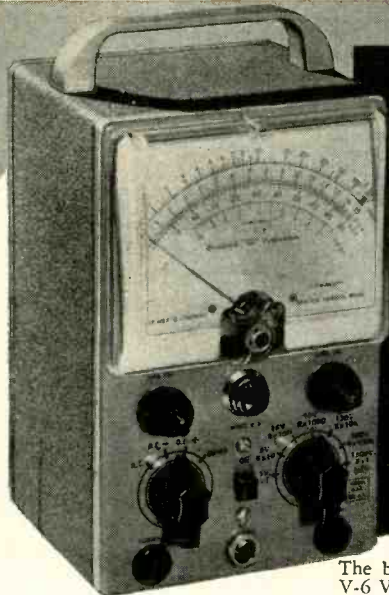

Heathkit VACUUM TUBE VOLTMETER KIT

MODEL V-6

\$24.50

SHIPPING WT. 6 LBS.

The beautiful Heathkit Model V-6 VTVM, the world's largest selling kit instrument, now offers many outstanding new features in addition to retaining all of the refinements developed and proven in the production of over 100,000 VTVM's. This is the basic measuring instrument for every branch of electronics. Easily meets all requirements for accuracy, stability, sensitivity, convenience of ranges, meter readability, and modern styling. It will accurately measure DC voltages, AC voltages, offers tremendous ohmmeter range coverage, and a complete db scale for a total of 35 meter ranges.

New 1½ volt full scale low range provides well over 2¼" of scale length per volt. Upper DC scale limit 1,500 volts. DC ranges 0-1.5, 5, 15, 50, 150, 500, 1,500 volts full scale. AC ranges 0-1.5, 5, 15, 50, 150, 500, 1,500 (1,000 volts maximum). Seven ohm-

meter ranges from .1 ohm to 1,000 megohms. For added convenience a DC polarity reversing switch and a center scale zero adjustment for FM alignment.

The smartly styled, compact, sturdy, formed aluminum cabinet is finished in an attractive gray crackle exterior. The beautiful two-color, durable, infra-red, baked enamel panel further adds to the over-all professional appearance.

Top quality components used throughout. 1% precision resistors — silver contact range and selector switches — selenium rectifier — transformer operated power supply. Individual calibration on both AC and DC for maximum accuracy. DB scale printed in red for easy identification, all other scales a sharp, crisp black for easy reading. A variety of accessory probes shown on this page still add further to over-all instrument usefulness.

Features

- ✓ New 1½ volt full scale low range
- ✓ 1,500 volt upper limit DC range
- ✓ Increased accuracy through 50% greater scale coverage
- ✓ High impedance 11 megohm input
- ✓ Center scale zero adjust
- ✓ Polarity reversal switch
- ✓ 1% precision resistors
- ✓ Clearly marked db scales

Heathkit 30,000 VOLT DC PROBE KIT

For TV service work or any similar application where the measurement of high DC voltage is required, the Heathkit Model 336 High Voltage Probe Kit will prove invaluable. A precision multiplier resistor mounted inside the two-color, sleek, plastic probe body provides a multiplication factor of 100 on the DC ranges of the Heathkit 11 megohm VTVM. The entire kit includes precision resistor, two-color plastic probe, tip connector spring, test lead, phone plug panel connector, and complete assembly instructions.



No. 336

\$4.50SHIP. WT.
2 LBS.

No. 338-B

Heathkit PEAK-TO-PEAK PROBE KIT

**\$5.50**

SHIP. WT. 2 LBS.

Now read peak-to-peak voltages on the DC scales of the Heathkit 11 megohm VTVM. Readings can be directly made from the VTVM scale without involved calculations. Measurements over the frequency range of 5 kc to 5 mc. Use this probe to extend the usefulness of your VTVM in radio and TV service work. The Peak-to-Peak Probe Kit features the new polished aluminum housing with two-color polystyrene probe ends. Detailed assembly sheet including instructions for probe operation.

Heathkit RF PROBE KIT

The Heathkit RF Probe used in conjunction with any 11 megohm VTVM will permit RF measurements up to 250 mc, ± 10%. A useful, convenient accessory for those occasions when RF measurements are desired. The RF probe body is housed in the new, smartly-styled polished aluminum probe body featuring two-color polystyrene probe ends and a low capacity flexible shielded test lead. The kit is complete with all necessary material and a detailed assembly sheet as well as instructions for probe operation.



No. 309-B

\$3.50

SHIP. WT. 2 LBS.

Heathkit AC VACUUM TUBE VOLTMETER KIT

MODEL AV-2

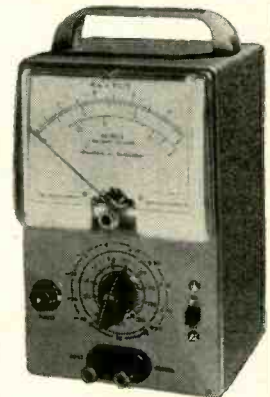
\$29.50SHIPPING WT.
5 LBS.

The new Heathkit AC VTVM that makes possible those sensitive AC measurements required by laboratories, audio enthusiasts, and experimenters. Especially useful for hum investigation, sensitive null detection, phono pick-up output measure-

ments, making frequency response runs, gain measurements, ripple voltage checks, etc. Low level measurements are easy to make because of the complete voltage coverage of the instrument and the one knob operation.

The large 200 microampere Simpson meter has clearly marked and easy to read meter scales. Ten voltage ranges covering from .01 rms full scale to 300 volts rms full scale, with frequency response ± 1 db from 20 cycles to 50,000 cycles. Instrument input impedance 1 megohm, ten db ranges from -52 db to +52 db. For stability and good linearity characteristics the meter bridge circuit features 4 germanium diodes. Attractive instrument styling, a companion piece for the popular Heathkit VTVM and the new AW-1 Audio Wattmeter.

HEATH COMPANY • Benton Harbor 20, Mich.

RADIO-ELECTRONICS

CHECK THESE *Features*

- ✓ 20,000 ohms per volt DC sensitivity, 5,000 ohms per volt on AC
- ✓ Polarity reversal switch
- ✓ 1% precision multiplier resistors
- ✓ 50 microampere 4½" Simpson meter
- ✓ Meter ranges for service convenience
- ✓ New resistor ring-switch assembly
- ✓ Total of 35 meter ranges
- ✓ New Modern cabinet styling

NEW *Heathkit* MULTIMETER KIT

MODEL MM-1

\$26⁵⁰

SHIPPING WT. 3 LBS.



The most important Heathkit announcement of the year, the new 20,000 ohms per volt Heathkit Multimeter, Model MM-1. The universal service measuring instrument, accurate, sensitive, portable, and completely independent of AC line supply. Particularly designed for service use incorporating many desirable features for the convenience of the service man. Full 20,000 ohms per volt sensitivity on DC ranges — 5,000 ohms per volt sensitivity on AC — polarity reversal switch, no bothersome transferring of test leads — 1% precision multiplier resistors — large 4½" recessed non-glare 50 microampere Simpson meter — conveniently slanted control panel — recessed safety type banana jacks — standard universally available batteries — rugged practical sized cabinet with plastic carrying handle, and a total of 35 calibrated meter ranges.

RANGES

Voltage ranges selected entirely for service convenience. For example 1½ volt full scale low range for measuring portable radio filament voltages, bias voltages, etc., 150 volt full scale range for AC-DC service work, 500 volt full scale range for conventional transformer operated power supply systems. Complete voltage ranges AC and DC, 0-1.5—5—50—150—500—1,500—5,000 volts. DC current ranges, 0-150 microamperes—15 milliamperes—150 milliamperes—500 milliamperes—15 amperes. Resistance measurements from .2 ohms to 20 meg-

ohms x 1 x 1,000 x 10,000.
DB coverage from -10 db
to +65 db.

CONSTRUCTION

Entirely new design permits assembly, mounting and wiring of precision resistors on a ring-switch assembly unit. The major portion of instrument wiring is completed before mounting the ring-switch assembly to the panel. No calibration procedure is required, all precision resistors readily accessible in event of replacement.

CABINET

Strikingly modern cabinet styling featuring two piece construction, durable black Bakelite cabinet, with easy to read panel designations. Cabinet size 5½" wide x 4" deep x 7½" high. Good cabinet physical stability when operated in vertical position.

The Heathkit MM-1 represents a terrific instrument value for a high quality 20,000 ohms per volt unit using all 1% deposited carbon type precision resistors. Here is quality, performance, functional design, and attractive appearance, all combined in one low priced package.

Heathkit BATTERY TESTER KIT



MODEL BT-1

\$8⁵⁰SHIP. WT.
2 LBS.

The Heathkit Battery Tester measures all types of dry batteries between 1½ volts and 150 volts under actual load conditions. Readings are made directly on a three color Good-Weak-Replace scale. Operation is extremely simple and merely requires that the test leads be connected to the battery under test. Only one control to adjust in addition to a panel switch for "A" or "B" battery types. The Heathkit Battery Tester features compact assembly, accurate meter movement, and a three deck wire-wound control, all mounted in a portable rugged plastic cabinet. Checks portable radio batteries, hearing aid batteries, lantern batteries, etc.

Heathkit HANDITESTER KIT



MODEL M-1

\$14⁵⁰SHIPPING WT.
3 LBS.

The Heathkit Model M-1 Handitester readily fulfills major requirements for a compact, portable volt ohm milliammeter. Despite its compact size, the Handitester is packed with every desirable feature required in an instrument of this type. AC or DC voltage ranges full scale, 0-10—30—300—1,000—5,000 volts. Two ohmmeter ranges, 0-3,000 and 0-300,000. Two DC current measurement ranges, 0-10 milliamperes and 0-100 milliamperes. The instrument uses a Simpson 400 microampere meter movement, which is shunted with resistors to provide a uniform 1 milliampere load on both AC and DC ranges. Special type, easily accessible, battery mounting bracket — 1% deposited carbon type precision resistors — hearing aid type ohms adjust control. The Handitester is easily assembled from complete instructions and pictorial diagrams. Necessary test leads are included in the price of this popular kit.

HEATH COMPANY • Benton Harbor 20, Mich.



New Heathkit 12 Volt BATTERY ELIMINATOR KIT

MODEL BE-4

\$31⁵⁰

SHIPPING WT.
18 LBS.

CHECK THESE *Features*

- ✓ Either 6 or 12 volt operation
- ✓ Continuously variable voltage output
- ✓ Constant ammeter and voltmeter monitoring
- ✓ Automatic overload relay — self-resetting
- ✓ Two 10,000 mf condensers
- ✓ New 18 disc split type heavy duty rectifier unit
- ✓ Fuse protection

Here is the new Heathkit Battery Eliminator necessary for modern, up-to-date operation of your service shop. The Heathkit Model BE-4 furnishes either 6 volts or 12 volts output which can be selected at the flick of a panel switch. Use the BE-4 to service the new 12 volt car radios in addition to the conventional 6 volt radios.

This new Battery Eliminator provides two continuously variable output ranges, 0-8 volts DC at 10 amperes continuously, or 15 amperes maximum intermittent; 0-16 volts DC at 5 amperes continuously or 7.5 amperes maximum intermittent. The output voltage is clean and well filtered as the circuit uses two 10,000 mf condensers. The continuously variable voltage output feature is a definite aid in determining the starting point of vibrators, the voltage operating range of oscillator circuits, etc. Panel mounted meters constantly monitor voltage and cur-

rent output and will quickly indicate the presence of a major circuit fault in the equipment under test. The power transformer primary winding is fuse protected and for additional safety an automatic relay of the self-resetting type is incorporated in the DC output circuit. The heavy duty rectifier is a split type 18 plate magnesium copper sulfide unit used either as a full wave rectifier or voltage doubler according to the position of the panel range switch.

Here is the ideal battery eliminator for all of your service problems and as an additional feature, it can also be used as a battery charger. Another new application for the Heathkit Battery Eliminator is a variable source of DC filament supply in audio development and research. More than adequate variable voltage and current range for normal applications.

Heathkit VIBRATOR TESTER KIT

Your repair time is valuable, and service use of the Heathkit Vibrator Tester will save you many hours of work. This tester will instantly tell you the condition of the vibrator being checked. Checks vibrators for proper starting and the easy to read meter indicates quality of output on a large Bad-?-Good scale. The Heathkit VT-1 checks both interrupter and self rectifier types of vibrators. Five different sockets for checking hundreds of vibrator types.

The Heathkit Vibrator Tester operates from any battery eliminator capable of delivering continuously variable voltage from 4 to 6 volts DC at 4 amperes. The new Heathkit Model BE-4 Battery Eliminator would be an ideal source of supply.

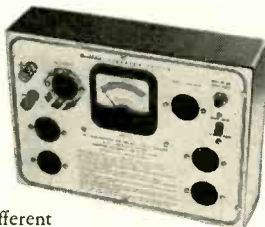

MODEL VT-1

\$14⁵⁰

SHIPPING WT.
6 LBS.

NEW Heathkit VARIABLE VOLTAGE ISOLATION TRANSFORMER KIT

The new Heathkit Isolation Transformer Kit provides line isolation for AC-DC radios (not an auto transformer), thereby eliminating shock hazard, hum problems, alignment difficulties, etc. The output voltage is variable from 90 to 130 volts AC and is constantly monitored by a panel mounted AC volt meter. Use it to increase AC supply voltage in order to induce breakdown of faulty components in circuits thereby saving service time. Use it also to simulate varying line voltage conditions and to determine the line voltage level at which oscillator circuits cease functioning, particularly in three-way portable radios. Rated at 100 watts continuous operation and up to 200 watts maximum intermittent operation. A useful radio and TV service tool.



MODEL IT-1

\$16⁵⁰

SHIP. WT. 9 LBS.

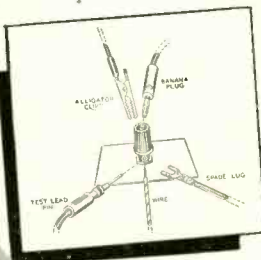

Heathkit BINDING POST

Binding post kit now available so that standardization of all instrument connectors is possible. This new, five-way binding post will accommodate an alligator clip, banana plug, test lead pin, spade lug, or hook-up wire. Sold in units of 20 binding post assemblies. Each assembly includes binding post, flat and shoulder fiber washers, solder lug, and nut. 120 pieces in all. Kit 362, \$4.00.



Heathkit TECHNICAL APPLICATION BULLETINS

APPLICATION BULLETINS

An exclusive Heathkit service. Technical application bulletins prepared by recognized instrument authorities outlining various combinations of instrument applications. Available now with 40 four-page illustrated bulletins and an attractive flexible loose-leaf binder. Only \$2.00. (No c.o.d. on this item, please.)

HEATH COMPANY • Benton Harbor 20, Mich.

RADIO-ELECTRONICS

CHECK THESE *Features*

- ✓ INCREDUCTOR controllable inductor sweep
- ✓ TV and IF sweep deviation 12-30 mc
- ✓ 4 mc- 220 mc continuous frequency coverage
- ✓ Oscillator operation entirely on fundamentals
- ✓ Output in excess of 100,000 microvolts
- ✓ Automatic amplitude circuit
- ✓ Voltage regulation
- ✓ Simplified operation

NEW *Heathkit*
**TV ALIGNMENT
 GENERATOR
 KIT**

MODEL TS-3

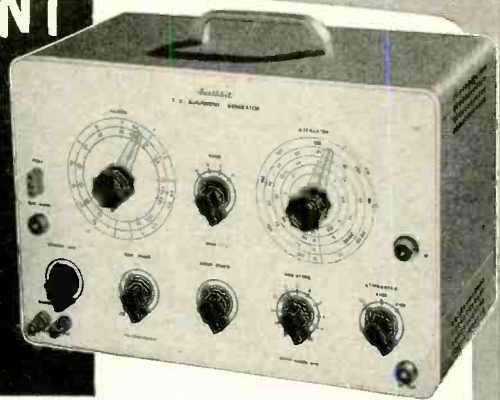
\$44.50SHIPPING WEIGHT
18 POUNDS

Proudly announcing an entirely new, advanced model TV and FM Sweep Generator, the Heathkit Model TS-3. This new design provides features and combinations of functions not found in any other service type instrument. Every design consideration has been given to the requirements of the TV service man to provide a flexible, variable sweep source with more than adequate RF output and complete frequency coverage throughout the TV and FM spectrum.

The frequency range of the TS-3 is from 4 mc to 220 mc in four switch selected ranges. All frequency ranges are overlapping for complete coverage. A particularly important feature of the instrument is that the oscillator operates entirely on fundamentals, thereby providing complete freedom from spurious oscillation and parasitics normally encountered in beat frequency type oscillators. This circuitry assures a much higher total RF output level and simplifies attenuation problems.

The new TS-3 features an entirely new principle of sweep operation. Sweep action is entirely electronic with no moving parts or electro-mechanical devices so commonly used. The heart of the sweep system is a newly-developed INCREDUCTOR controllable inductor. With this system, the value of inductance of each oscil-

lator coil is electrically varied with an AC control current, and the inductance variation is achieved by a change in the magnetic state of the core on which the oscillator coils are wound. This system provides a sweep deviation of not less than 12 mc on all TV frequencies, and up to a maximum of 30 mc on TV IF frequencies. The high RF output level throughout the instrument frequency range overcomes the most common complaint of the older type sweep generators. A new, automatic amplitude control circuit maintains the output level flat to ± 2 db throughout the instrument range. For convenience of operation a low impedance 50 ohm output is used.

Operation of the instrument has been simplified through the reduction of panel controls and separate panel terminals provide for external synchronization if desired. The circuit uses a voltage regulator tube to maintain stable instrument operation. A built-in variable oscillator marker further adds to flexibility of instrument operation. Provisions are also made for the use of an external marker, such as your service type signal generator, if desired. Use the Heathkit TS-3 for rapid, accurate TV alignment work, and let it help you solve those time consuming, irksome problems so frequently encountered.

NEW *Heathkit*
SIGNAL GENERATOR KIT

MODEL SG-8

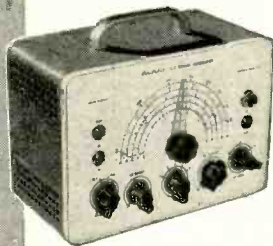
\$19.50SHIPPING WEIGHT
8 POUNDS

Announcing the new Heathkit Model SG-8 service type Signal Generator, incorporating many design features not usually found in an instrument in this price range. The RF

output is from 160 kc to 100 mc in five ranges, all on fundamentals, with useful harmonics up to 200 mc. The RF output level is in excess of 100,000 microvolts throughout the frequency range.

The oscillator circuit consists of a 12AT7 twin triode tube. One half is used as a Colpitts oscillator, and the other half as a cathode follower output which acts as a buffer between the oscillator and external load. This circuitry eliminates oscillator frequency shift usually caused by external circuit loading.

All coils are factory wound and adjusted, thereby completely eliminating the need for calibration and the use of additional calibrating equipment. The stable low impedance output features a step and variable attenuator for complete control of RF level. A 6C4 triode acts as a 400 cycle sine wave oscillator and a panel switching system permits a choice of either external or internal modulation.

The transformer operated circuit is easy to assemble, requires no calibration, and meets every service requirement for an adjustable level variable frequency signal source, either modulated or un-modulated.

NEW *Heathkit*
BAR GENERATOR KIT

MODEL BG-1

\$14.50SHIPPING WEIGHT
6 POUNDS

The Heathkit BG-1 Bar Generator represents another welcome addition to the fast growing line of popular Heathkits. The

station transmitted test pattern is rapidly disappearing, and the bar generator is the logical answer to the TV service man's problem in obtaining quick, accurate adjustment information without waiting for test patterns.

The Heathkit BG-1 produces a series of horizontal or vertical bars on a TV screen. Since these bars are equally spaced, they will quickly indicate picture linearity of the receiver under test. Panel switch provides "stand-by position" — "horizontal position" — "vertical position." The oscillator unit utilizes a 12AT7 twin triode for the RF oscillator and video carrier frequencies. A neon relaxation oscillator provides low frequency for vertical linearity tests. The instrument will not only produce bar patterns but will also provide an indication of horizontal and vertical sync circuit stability, as well as overall picture size.

Instrument operation is extremely simple, and merely requires connection to the TV receiver antenna terminal. The unit is transformer operated for safety when used in conjunction with universal or transformerless type TV circuits.

HEATH COMPANY • Benton Harbor 20, Mich.

NEW *Heathkit* TUBE CHECKER KIT

MODEL TC-2

\$29⁵⁰

SHIP. WT. 12 LBS.



The new Model TC-2 Heathkit Tube Checker features many circuit improvements, simplified wiring, new roll chart drive and illumination of roll chart. The instrument is primarily designed for the convenience of the radio and TV service man and will check the operating quality of tubes commonly encountered in this type of work. Test set-up procedure is simplified, rapid, and flexible. Panel sockets accommodate 4, 5, 6, and 7 pin tubes, octal and loctal, 7 and 9 pin miniatures, 5 pin Hytron and a blank socket for new tubes. Built-in neon short indicator, individual three-position lever switch for each tube element, spring return test switch, 14 filament voltage ranges, and line set control to compensate for supply voltage variations, all represent important design features of the TC-2. Results of tube tests are read directly from a large 4½" Simpson three-color meter, calibrated in terms of Bad?-Good. Information that your customer can readily understand. Checks emission, shorted elements, open elements, and continuity.

The use of closer tolerance resistors in critical circuits assures correct test information and eliminates the possibility of inaccurate test interpretation. Improvement has been made in the mechanical roll chart drive system, completely eliminating diagonal running, erratic operation, and backlash. The thumb wheel gear driven action is smooth, positive, and free running. As an additional feature, the roll chart is illuminated for easier reading, particularly when the tube checker is used on radio or TV home service calls.

Wiring procedure has been simplified through the extended use of multi-cable, color coded wires, providing a harness type installation between tube sockets and lever switches. This procedure insures standard assembly and imparts that "factory built" appearance to instrument construction. Completely detailed information is furnished in the new step-by-step construction manual, regarding the set-up procedure for testing of new or unlisted tube types. No delay necessary for release of factory data.

The new Heathkit Tube Checker will prove its value in building service prestige through usefulness—simplified operation—attractive professional appearance. Don't overlook the fact that the kit price represents a savings of \$40.00 to \$50.00 over the price of a comparable commercially built instrument. At this low price, no service man need be without the advantages offered by the Heathkit Tube Checker.

CHECK THESE NEW *Features*

- ✓ Simplified harness wiring
- ✓ Improved, smooth, anti-backlash roll chart action
- ✓ Optional roll chart illumination
- ✓ Individual element switches
- ✓ Portable or counter style cabinet
- ✓ Spare blank socket
- ✓ Contact type pilot light test socket
- ✓ Simplified test set-up procedure
- ✓ Line adjust control
- ✓ 4½" three-color meter

New

HEATHKIT PORTABLE TUBE CHECKER KIT

MODEL TC-2P

\$34⁵⁰

SHIP. WT. 14 LBS.



The portable model is supplied with a strikingly attractive two-tone cabinet finished in rich maroon, proxylin impregnated, fabric covering with a contrasting gray on the inside cover. Detachable cover, brass-plated hardware, sturdy plastic handle help to impart a truly professional appearance to the instrument.

PORTABLE TUBE CHECKER CABINET as described above will fit all earlier Heathkit TC-1 Tube Checkers. Shipping weight 7 lbs. Cabinet only, 91-8, \$7.50.



No. 355
Ship. Wt. **\$4⁵⁰**
1 Lb.

Heathkit TV PICTURE TUBE TEST ADAPTER

The Heathkit TV Picture Tube Test Adapter used with the Heathkit Tube Checker will quickly check for emission, shorts, etc., and determine picture tube quality. Consists of standard 12 pin TV tube socket, four feet of cable, octal socket connector, and data sheet.

Heathkit POWER SUPPLY KIT



MODEL PS-2

\$33⁵⁰SHIPPING WT.
17 LBS.

The Heathkit Laboratory Power Supply features continuously variable, regulated voltage output with good stability under wide load variations. A 4½" Simpson plastic enclosed panel mounted meter provides accurate meter output information of voltage or current. All panel terminals completely isolated from the cabinet. Separate 6.3 volt AC supply at 4 amperes for filament requirements. Ripple component exceptionally low, stand-by switch provided to eliminate warm-up time of the five tube circuit.



LABORATORY AND SERVICE SHOP BOOKLETS

"Planning Your Service Business" by John T. Frye, and "Establishing the Industrial Electronics Laboratory" by Louis B. Garner, Jr., are booklets available to Heathkit customers at no charge. These booklets, written by nationally recognized authorities, outline the various requirements and considerations for establishing your own service business or for setting up an industrial electronics laboratory. Full attention is given to various details that are frequently overlooked when projects of this nature are undertaken. Just write in to the Heath Company requesting your free copy, or attach a memo to your next order.

HEATH COMPANY • Benton Harbor 20, Mich.

RADIO-ELECTRONICS

CHECK THESE *Features*

- ✓ Visual and aural signal tracing
- ✓ Two channel input
- ✓ High RF sensitivity
- ✓ Unique noise locator circuit
- ✓ Calibrated wattmeter
- ✓ Substitution test speaker
- ✓ Utility amplifier
- ✓ RF, audio probes and test leads included

Heathkit VISUAL-AURAL SIGNAL TRACER KIT

MODEL T-3

\$23⁵⁰SHIPPING WEIGHT
10 POUNDS

An entirely new type of signal tracer incorporating a combination of features not found in any other instrument. Designed expressly for the radio and TV service man, particularly for the servicing of AM, FM, and TV circuits. Here in a five tube, transformer operated instrument are all of the useful functions so necessary for speedy, accurate isolation of service difficulty.

This new signal tracer features a special high gain RF input channel, used in conjunction with a newly-designed wide frequency range demodulator probe. High RF sensitivity permits signal tracing at the receiver antenna input. A separate low gain channel and probe available for audio circuit exploration. Both input channels are constantly monitored by an electron ray beam indicator, so that visual as well as aural signal indications may be observed. The instrument can also be used for comparative estimation of gain per stage.

A decidedly unusual feature is a noise localizer circuit in conjunction with the audio probe. With this system, a DC potential is applied to a suspected circuit component and the action of the

voltage in the component can be seen as well as heard. Invaluable for ferreting out noisy or intermittent condensers, noisy resistors, controls, coils, IF and power transformers, etc. A built-in calibrated wattmeter circuit is very useful for a quick preliminary check of the total wattage consumption of the equipment under test. Separate panel terminals provide external use of the speaker or output transformer for substitution purposes. Saves valuable service time by eliminating the necessity for speaker removal on every service job. The terminals also permit the utilization of other shop equipment, such as your oscilloscope or VTVM. The T-3 Signal Tracer can be used as a high gain amplifier for checking tuners, record changers, microphones, phono crystals, etc.

Don't overlook the interesting service possibilities provided through the use of this new instrument and let it work for you by saving time and money. The kit is supplied complete with all tubes, circuit components, demodulator probe, audio probe, and additional test leads.



Heathkit DECADE RESISTANCE KIT

MODEL DR-1 The Decade Resistance Kit provides individual switch selection of resistance values using twenty 1% resistors providing a choice of 1 to 99,999 ohms in 1 ohm steps. Ceramic wafer switches, silver-plated contacts, smooth, positive detent action, baked enamel panel, and handsome, polished birch cabinet.

\$19⁵⁰SHIP. WT.
4 LBS.

Heathkit DECADE CONDENSER KIT

The Heathkit Decade Condenser Kit features silver mica, precision condensers with a rated accuracy of $\pm 1\%$. Capacity values are arranged in three decades from 100 mmf to .111 mf in steps of 100 mmf. Ceramic wafer switches with silver-plated contacts and smooth detent action. Useful in laboratory work, for circuit development.

MODEL DC-1

\$16⁵⁰SHIP WT.
4 LBS.

Heathkit RESISTANCE SUBSTITUTION BOX KIT

MODEL RS-1

\$5⁵⁰SHIP. WT.
2 LBS.

The Heathkit Resistance Substitution Box provides individual switch selection of any one of 36 RTMA 1 watt 10% standard value resistors, ranging from 15 ohms to 10 megohms. Many applications in circuit development work, and also in radio and TV service work. Ideal for experimentally determining resistance values and for quickly altering circuit operating characteristics. Entire unit housed in attractive Bakelite cabinet, featuring the new universal type Heathkit binding posts to simplify circuit connections.

Heathkit CONDENSER CHECKER KIT

MODEL C-3

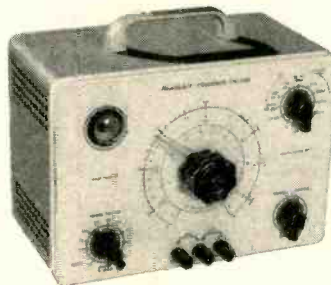
\$19⁵⁰SHIPPING WT.
8 POUNDS

Use the Heathkit C-3 Condenser Checker to quickly and accurately measure those unknown condenser and resistor values. All readings are taken directly from the calibrated panel scales without requiring any involved calculation. Capacity measurements in four ranges from .00001 mf to 1,000 mf. Checks paper, mica, ceramic, and electrolytic condensers. A power factor control is available for accurate indication of electrolytic condenser measurements. A leakage test switch with switch selection of five polarizing voltages, 25 volts to 450 volts DC, will indicate condenser operating quality under actual load condition. The spring return leakage test switch automatically discharges the condenser under test and eliminates shock hazard to the operator.

Resistance measurements can be made in the range from 100 ohms to 5 megohms. Here again all values are read directly on the calibrated scale. Increased circuit sensitivity coupled with an electron beam null indicator increases overall instrument usefulness.

For safety of operation the circuit is entirely transformer operated and the instrument is housed in the attractive, newly-styled Heathkit cabinet, featuring rounded corners, and drawn aluminum panel. The outstanding low kit price for this surprisingly accurate instrument includes necessary test leads. Good service shop operation requires the use of this specialized instrument, designed for the express purpose of determining unknown condenser values and operating characteristics.

HEATH COMPANY • Benton Harbor 20, Mich.



Heathkit AMATEUR TRANSMITTER KIT

MODEL AT-1

\$29.50

SHIPPING WEIGHT
16 POUNDS

CHECK THESE NEW Features

- ✓ Single knob band switching
- ✓ Pre-wound coils
- ✓ Metered operation
- ✓ 52 ohm coaxial output
- ✓ Crystal or VFO excitation
- ✓ Built-in power supply
- ✓ Rugged, clean construction

Here is the latest Heathkit addition to the ham radio field, the AT-1 Transmitter Kit, incorporating many desirable design features at the lowest possible dollar-per-watts price. Panel mounted crystal socket, stand-by switch, key click filter, AC line filtering, good shielding, etc. VFO or crystal excitation—up to 35 watts input. Built-in power supply provides 425 volts at 100 ma.

This kit features pre-wound coils, single knob band switching, 52 ohm coaxial output, plug in chassis provisions for VFO or modulator and rugged clean construction. Frequency range 80, 40, 20,

15, 11, and 10 meters. Tube line-up 6AG7 oscillator-multiplier, 6L6 amplifier-doubler, 5U4G rectifier. Physical dimensions $8\frac{1}{8}$ " high x $13\frac{1}{8}$ " wide x 7" deep.

This amazingly low kit price includes all circuit components, tubes, cabinet, punched chassis, and detailed construction manual. The ideal kit for the novice just breaking into ham radio. It can be used later on as a stand-by rig or an all band exciter for higher powered transmitter.

NEW Heathkit ANTENNA COUPLER KIT

New Heathkit Antenna Coupler, specially designed for the Heathkit AT-1 Transmitter. The Antenna Coupler can be used with any 52 ohm coaxial input—up to 75 watts power. Low pass filter with cut-off frequency of approximately 36 mc — L section tuning network — neon tuning indicator — rugged, compact construction — transmitter type variable condenser, and high Q coil are all outstanding features. The AC-1 has both inductance and capacity tuning for maximum operating versatility. Dimensions $8\frac{1}{8}$ " wide x $4\frac{3}{8}$ " high x $4\frac{7}{8}$ " deep.



MODEL AC-1

\$14.50 SHIP. WT.
3 LBS.

Heathkit ANTENNA IMPEDANCE METER

Use the Heathkit Antenna Impedance Meter for measuring antenna impedance for line matching purposes—adjustment of beam antennas—phone monitor, etc. It will determine antenna resistance at resonance, match transmission line for minimum SWR, determine receiver input impedance, and provide a rough indication of SWR. Precision resistors, germanium diode, 100 micro-ampere Simpson meter. Dial calibrated from 0-500 ohms. Shielded aluminum cabinet. 7" long x $2\frac{1}{2}$ " wide x $3\frac{1}{4}$ " deep.



MODEL AM-1

\$14.50

SHIP. WT. 3 LBS.

Heathkit COMMUNICATIONS RECEIVER KIT

MODEL AR-2

\$25.50 SHIP. WT.
12 LBS.



Here is the new receiver kit you have repeatedly asked for, the Heathkit Communications Receiver. The perfect companion piece for the AT-1 Transmitter kit. Many outstandingly desirable features have been incorporated in the design of the AR-2; such as, electrical bandspread

for logging and tuning convenience—high gain miniature tubes—IF transformers for high sensitivity and good signal to noise ratio—separate RF gain control with optional automatic volume control or manual volume control, in addition to the conventional audio gain control. Noise limiter—stand-by switch—stable BFO oscillator circuit—headphone jack—transformer operation, etc., all contribute to a high performance standard.

Frequency coverage is continuous from 535 kc to 35 mc in four ranges. For added convenience, various ham bands have been separately identified in respect to their relative placement on the slide rule tuning scale. A chassis mounted, $5\frac{1}{2}$ " PM speaker is included with this kit. Tube line up 12BE6 mixer oscillator, 12BA6 IF amplifier, 12AV6 detector AVC audio, 12BA6 BFO oscillator, 12A6 beam power output, 5Y3GT rectifier.

RECEIVER CABINET

Proxylin impregnated, fabric covered, plywood cabinet with aluminum panel designed expressly for the AR-2 Receiver. Part 91-10, shipping weight 5 lbs., \$4.50.



IMPROVED Heathkit GRID DIP METER KIT

\$19.50 SHIP. WT.
4 LBS.

MODEL GD-1B

The invaluable instrument for service men, hams, and experimenters. Useful in TV service work for alignment of traps, filters, IF stages,

peaking compensation networks, etc. Locates spurious oscillation, provides a relative indication of power in

transmitter stages, use it for neutralization, locating parasitics, correcting TVI, measuring C, L, and Q of components, and determining RF circuit resonant frequencies. With oscillator energized, useful for finding resonant frequency of tuned circuits. With the oscillator not energized, the instrument acts as an absorption wave meter. Variable meter sensitivity control, head phone jack, 500 microampere Simpson meter. Continuous frequency coverage from 2 mc. to 250 mc. Pre-wound coil kit and rack, new three prong coil mounting, 6AF4 high frequency triode.

Two additional plug-in coils are available and provide continuous extension of low frequency coverage down to 355 kc. Dial correlation curves included. Shipping weight 1 lb., kit 341, \$3.00.



HEATH COMPANY • Benton Harbor 20, Mich.

RADIO-ELECTRONICS

CHECK THESE *Features*

- ✓ First popular priced Q Meter
- ✓ Reads Q directly on calibrated scale
- ✓ Oscillator supplies RF frequencies of 150 kc to 18 mc
- ✓ Calibrate capacitor with range of 40 mmf to 450 mmf with vernier of ± 3 mmf
- ✓ Measures Q of condensers, RF resistance, and distributed capacity of coils
- ✓ Many applications in design and development work
- ✓ Useful in TV service work for checking deflection yokes, coils, chokes, etc.

Heathkit "Q" METER KIT

MODEL QM-1

\$44.50

SHIPPING WT. 14 POUNDS

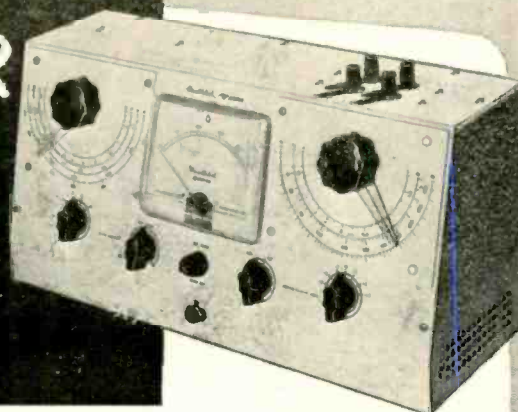

Another outstanding example of successful Heathkit engineering effort in producing a Q Meter Kit within the price range of TV service men, schools, laboratories, and experimenters. This Q Meter meets RF design requirements for rapid, accurate measurement of capacity, inductance, and Q at the operating frequency and all indications of value can be read directly on the meter calibrated scales. Oscillator section supplies RF fre-

quencies of 150 kc to 18 mc. Calibrate capacitor with range of 40 mmf to 450 mmf, with vernier of ± 3 mmf.

Particularly useful in TV service work for checking peaking coils, wave traps, chokes, deflection coils, width and linearity coils, etc. At this low kit price research laboratory facilities are within the range of service shops, schools, and experimenters.

Heathkit INTERMODULATION ANALYZER KIT



MODEL IM-1

\$39.50SHIPPING WT.
17 POUNDS

The Heathkit IM-1 is an extremely versatile instrument specifically designed for measuring the degree of inter-action between two signals in any portion of an audio chain. It is primarily intended for making tests of audio amplifiers, but may be used in other applications, such as checking microphones, records, recording equipment, phonograph pick-ups, and loud-speakers. High and low test frequency source, intermodulation unit, power supply, and AC vacuum tube volt meter all in one complete instrument. Per cent intermodulation is directly read on the calibrated scales, 30%, 10%, and 3% full scale. Both 4:1 and 1:1 ratios of low to high frequency easily set up. With this instrument the performance level of present equipment, or newly developed equipment can be easily and accurately checked. At this low price, you can now enjoy the benefits of intermodulation analysis for accurate audio interpretation.

Heathkit AUDIO GENERATOR KIT

A Heathkit Audio Generator with frequency coverage from 20 cycles to 1 mc. Response flat ± 1 db from 20 cycles to 400 kc, down 3 db at 600 kc, and down only 8 db at 1 mc. Calibrated, continuously variable, and step attenuator output controls provide convenient reference output level. Distortion is less than .4% from 100 cps through the audible range. The ideal controllable extended frequency sine wave source for audio circuit investigation and development.



MODEL AG-8

\$29.50

SHIP. WT. 11 LBS.

Heathkit AUDIO OSCILLATOR KIT

Sine or square wave coverage from 20 to 20,000 cycles in three ranges at a controllable output level up to 10 volts. Low distortion, 1% precision resistors in multiplier circuits, high level output across entire frequency range, etc., readily qualify this instrument for audio experimentation and development work. Special circuit design consideration features thermistor operation for good control of linearity.



MODEL AO-1

\$24.50

SHIP. WT. 11 LBS.

Heathkit AUDIO FREQUENCY METER KIT



MODEL AF-1

\$34.50

SHIP. WT. 12 LBS.

The Heathkit Audio Frequency Meter provides a simple and convenient means of checking unknown audio frequencies from 10 cycles to 100 kc at any voltage level between 3 and 300 volts rms with any non-critical wave shape.

Instrument operation is entirely electronic. Just set the range switch, feed an unknown frequency into the instrument, and read the frequency directly on the calibrated scale of the Simpson 4 $\frac{1}{2}$ " meter.

Heathkit SQUARE WAVE GENERATOR KIT



MODEL SQ-1

\$29.50

SHIP. WT. 12 LBS.

The Heathkit Square Wave Generator provides an excellent square wave frequency source with completely variable coverage from 10 cycles to 100 kc. This generator features low output impedance of 600 ohms and the output voltage is continuously variable between 0 and 20 volts, thereby providing the necessary degree of operating flexibility. An invaluable instrument for those specialized circuit investigations requiring a good, stable, variable square wave source.

HEATH COMPANY • Benton Harbor 20, Mich.

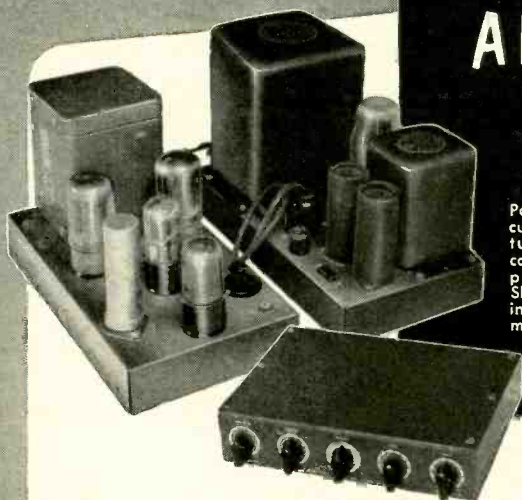

Heathkit WILLIAMSON TYPE AMPLIFIER KIT

MODEL W-2

Particularly designed for custom installations, featuring separate cable connected units for simplicity of installation. Sheet metal work finished in attractive gray hammer-tone for smart appearance. All control shafts of the adjustable length break-off type.

\$69.50

PRICES OF COMBINATIONS

W-2 Amplifier Kit including main amplifier, power supply, and WA-P1 Preamp Kit. Shipping Weight 37 lbs. Shipped Express only. **\$69.50**

W-2M Amplifier Kit includes main amplifier and power supply. Shipping Weight 29 lbs. Shipped Express only. **\$49.75**

WA-P1 Preamp Kit only. Shipping Weight 6 lbs. Shipped Express or Parcel Post. **\$19.75**

When selecting an amplifier for the heart of your high fidelity audio system, investigate the outstanding advantages offered by the Heathkit Williamson Type Amplifier. Meets every high fidelity audio requirement and makes listening to recorded music a thrilling new experience.

This outstanding amplifier is offered with optional output transformer

operation, providing either the conventional triode output circuit or the new extended power circuitry in which the screen supply voltage is obtained from separate transformer primary taps. Frequency response within ± 1 db from 10 cycles to 100 kc. Tube complement — 6SN7 cascade amplifier and phase splitter, 6SN7 push pull driver, two 5881 push pull power amplifiers, one 5V4G cathode type rectifier.

Matching preamplifier available providing three switch selected inputs, correct compensation, and individual bass and treble tone controls. Uses 12AX7 (or 12AX7) preamplifier — 12AU7 tone control amplifier.

Particularly designed for the novice kit builder and requires no specialized knowledge or equipment for successful assembly and operation.

NEW Heathkit 20 WATT High Fidelity AMPLIFIER KIT

MODEL A-9A



\$35.50

SHIP. WT. 18 LBS.

A new 20 watt high fidelity amplifier, designed especially for custom audio installations demanding clean reproduction, adequate power, and flexibility to meet individual requirements. Separate treble and bass tone controls provide up to 15 db boost or cut. Four switch selected inputs, each with the necessary compensation for the service desired. Output transformer impedances of 4, 8, and 16 ohms. Preamplifier, tone control, and phase splitter circuits utilize 9 pin twin triode miniature tubes for low hum and noise level. Two 6L6 push pull power output tubes provide full 20 watts power. Frequency response ± 1 db, 20-20,000 cycles. Total harmonic distortion 1% (at 3 db below rated output). Tube line-up: 12AX7 pre-amplifier, 12AU7 voltage amplifier and tone control, 12AU7 voltage amplifier and phase splitter, two 6L6 push pull pentode power output, 5U4G rectifier. Truly outstanding amplifier performance coupled with low cost.

Heathkit ECONOMY 6 WATT AMPLIFIER KIT



MODEL A-7B

\$15.50

SHIP. WT. 10 LBS.

The new Heathkit Model A-7B Amplifier offers many unusually fine features not normally expected in this low price range. Either of the two input circuits may be individually switch selected for phono or tuner operation. Separate bass and treble tone controls. Output impedances of 4, 8, and 15 ohms. Push pull beam power output stage for balanced reproduction. Excellent voltage gain characteristics, good frequency response, and full 6 watts power output. 12J5 amplifier, 12SL7 second amplifier and phase splitter, two 12A6 beam power output, one 5Y5 GT rectifier. A-7C incorporates preamplifier stage with special compensated network to provide necessary gain for operation with variable reluctance or low output level phono cartridge. Circuit is properly compensated for microphone operation. \$17.50.

NEW Heathkit BROADCAST BAND RECEIVER KIT

Another new Heathkit for the student, beginner, or hobbyist. If you have ever had the urge to build your own radio receiver, this kit warrants your attention.

New high gain miniature tubes and IF transformers provide excellent sensitivity and good signal to noise ratio. A built-in ferrite core rod type antenna has been provided. A chassis mounted $5\frac{1}{2}$ " PM speaker provides excellent tone and volume. Convenient phono input. Can be operated either as a receiver or tuner. Simplified construction manual outlines circuit theory. Ideal for students. Tube line-up: 12BE6 mixer oscillator, 12BA6 IF amplifier, 12AV6 detector-AVC-first audio, 12A6 beam power output, 5Y3GT rectifier.

CABINET — Proxylin impregnated fabric covered plywood cabinet. Shipping weight 5 lbs. Part number 91-9, \$4.50.



MODEL BR-2

\$17.50 SHIP. WT. 11 LBS.

Heathkit FM TUNER KIT

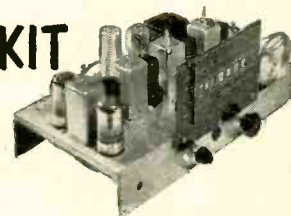

MODEL FM-2

\$22.50

SHIP. WT. 9 LBS.

The Heathkit FM-2 Tuner was specifically designed for simplified kit construction. Can be operated through the "phono" portion of your radio or with a separate amplifier. The kit features a pre-assembled and adjusted tuning unit, three double tuned IF transformers, and a discriminator transformer in an 8 tube AC operated circuit. Frequency coverage 88 to 108 mc. Experience the thrill of building your own FM tuner and at the same time enjoy all of the advantages of true FM reception.

Free CATALOG

Write for free catalog containing latest price information, schematics, specifications, and descriptions of all Heathkits.

HEATH COMPANY • Benton Harbor 20, Mich.

RADIO-ELECTRONICS

IMPROVED TRACKING

By HARVEY R. ERB

*Mechanical tracking—
a different approach
to an old problem*

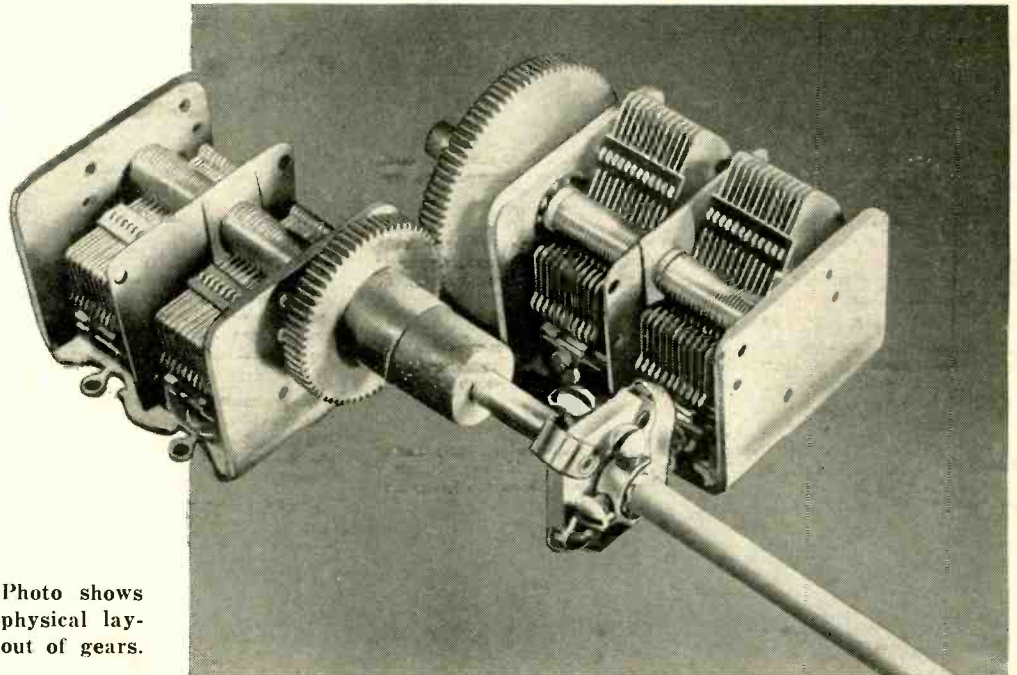

Photo shows physical layout of gears.

TRACKING a super-heterodyne with funny plates and padders and finally securing alignment at only three points just doesn't seem good enough.

We are told that the reason we cannot expect anything better is that the r.f. and oscillator circuits cover ranges having different ratios—they follow different frequency curves.

Single-dial tuning, with r.f. and oscillator rotors fixed to a common shaft, is certainly simple, but the results leave much to be desired. The mechanical simplicity is just enough to miss our requirements.

Suppose we dispense with some of this simplicity and use a little mechanics where it will do the most good, and see what happens?

Two identical tuning capacitors, geared together, and separated by any intermediate frequency we choose, can be made to follow the same frequency curve. That should just about take care of everything.

Theory is all right in its place, but has to be proven in practice. The queer contraption illustrated is the "guinea pig" that does it. We'll come back to that later.

Our first problem is to determine the proper gear ratio, Table I shows how easily it is done.

Don't let these decimals scare you. We're just curious to know how ac-

curate we have to be. We now divide the larger of these ratios by the smaller to get our final ratio: 1:1.43376. Now what gears will give us this ratio?

To make use of the gear tables in *Machinery's Handbook* (Industrial Press) we must know the logarithm of the ratio, which happens to be 0.156458. The logarithm nearest this in the table is 0.156469, opposite 119:83. If we divide 83 by 119 we find that the error is only .00002. Don't blame any final error on the gears.

The 83-tooth gear goes on the r.f. capacitor shaft, and the 119 on the oscillator. They are meshed together in the fully open position. The r.f.

of the dial. Just forget the usual 600-1400-1000-kc business and work at the ends of the range. Any mismatch at any point on the dial will never be more than the average of that at the ends.

Now for the "guinea pig".

The brass gears, cut at a local machine works, are 48-diametral pitch, 1/8-inch face, 5/8-inch hub, and drilled to fit the capacitor shafts. The capacitors could have been *singles* but only *twins* were available. The meshed gears must rotate in opposite directions to open the rotors at the same time. This accounts for their peculiar position. A third gear between the two would permit a parallel position. My gears were made to order. As a practical matter stock gears can be used. A gear ratio of 120 to 84 is easily obtainable and is accurate to .0051. Streamlining this gadget should be no great problem. See what you can do with it.

I don't expect this silly system to revolutionize the radio industry, but better tracking can be had, if you really want it.

Lacking suitable test equipment, my set was lined up on broadcast stations, so it is reasonable to suppose that the best settings were not obtained. Despite this, though, the results far exceeded my fondest expectations, and provided food for thought. END

Frequency Range	Ratio
r.f. 540 to 1620 kc	1:3
i.f. 455 kc	
osc. 995 to 2075 kc	1:2.085427

Table I—Frequency ranges and ratios.

rotor turns 180° while the oscillator section turns slightly more than 125°, and never fully closes. Both frequencies follow the same curve, exactly 455 kc apart.

The oscillator inductance must be variable, and a preliminary adjustment made at the low-frequency end

\$5000

IN PRIZES

... easy to win

503

PRIZES!

\$2000 - 1st prize

\$500 - 2nd prize, \$100 - 3rd prize

100 - \$10 prizes, 400 - \$5 prizes

HOW TO WIN

To win one of these 503 prizes all you have to do is complete in 25 words or less "I like Pyramid capacitors because_____." You fill in this statement on a Pyramid contest entry blank which can be obtained from any electronic parts jobber selling Pyramid capacitors. You have this entry blank countersigned by your jobber or one of his salesmen and forward it to us attached to a Pyramid Dry Electrolytic Capacitor box top—the top being the part which carries the description of the item. There is no limit to the number of entries which you may make in this contest but each entry must be accompanied by a box top. Full rules for the contest appear on the entry blank.

It's so easy. Here is the kind of statement that might win:

"I like Pyramid capacitors because they always check out perfectly and don't deteriorate and so I know I won't have to call back at my expense."

"I like Pyramid capacitors because the line is so complete that I can always get what I need and don't have to worry about an off-brand capacitor."

PYRAMID



PYRAMID FEATURES:

- 1 Only one quality—the best at no premium. All Pyramid capacitors are made of materials commanded by rigid military specifications.
- 2 All Pyramid capacitors are non-hygroscopic.
- 3 Highest quality insulator material used in all production results in low leakage factor.
- 4 Exclusive non-contamination technique guarantees close tolerances and no deterioration. Peak performances for life.
- 5 Pyramid capacitors operate unchanged at ambient temperature of 85° centigrade.
- 6 Designed by service technicians across the country for their requirements.
- 7 Individually packaged for protection.
- 8 Permanently legible, high visibility ratings on each item.
- 9 100% absolute electronic inspection before shipment.

Pyramid is in its 10th year as a leading manufacturer of high-quality capacitors.

PYRAMID ELECTRIC COMPANY
1445 HUDSON BOULEVARD
NORTH BERGEN, N. J.

RECONE THAT SPEAKER!

Fig. 1—To find the cone depth, measure from bench to the top of the voice coil.

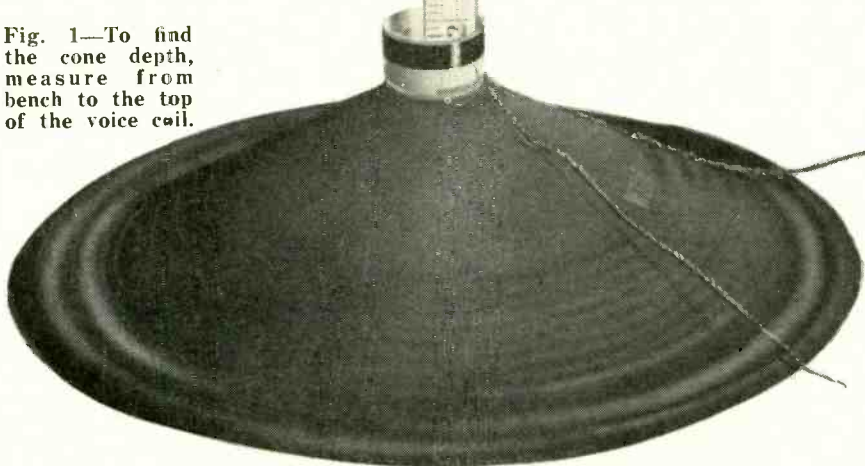

By ALAN G. SORENSEN

*Do your service work
more efficiently and
make a little more
at the same time*

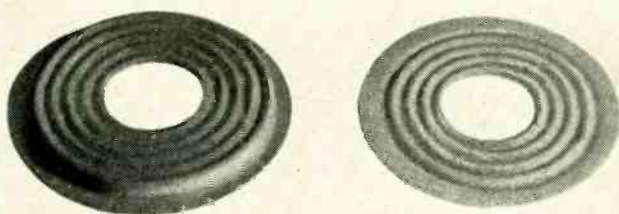

Fig. 2—Modern spiders look like this. Older ones may often be fastened by screws.

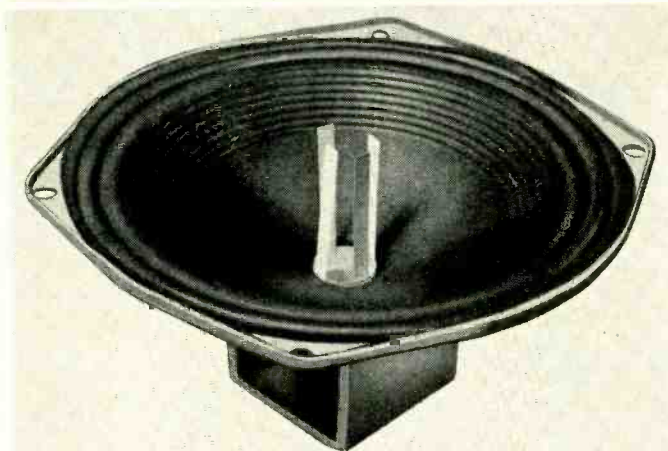

Fig. 3—The cone with spider attached, shimmed up and ready for edge cementing.



All the equipment needed to replace cones—plus two finished jobs—appears above.

HOW often have you been faced with the problem of having to ship a speaker away to have it reconed, often tying up your service job for as long as two weeks? Believe it or not, you can do your own reconing in a matter of minutes—and make a larger profit on the job too. It's easy. Replacement cones are available for virtually any speaker you will find in radio and TV sets. This article gives you step-by-step instructions on how to go about putting them on the speakers.

In this shop, speaker reconing has proved a very lucrative sideline. At the same time, customer satisfaction has been increased. The speakers in many table-model radios are cheap and just barely satisfactory to begin with. Their cones are tissue-paper thin. Older models have cones that have dried out and become brittle, or have holes or cracks. Some are out of shape, so the voice coil rubs on the pole piece.

You can safely bet that the customer is tired of trying to separate his favorite program from the distortion and rasping noises which accompany it. In many cases it is difficult or out-and-out impossible to install a new speaker, due to odd frame shape or mounting-hole considerations. When he hears that a few dollars will make his set sound as good as—or in most cases, better than—it did when it was new, you will have the job. Show him a new cone and explain the process briefly. You will usually make a sale.

Replacement cones are heavier and softer than most of the originals, giving a cleaner, smoother bass response as well as a wider frequency range. Consequently they often sound a great deal better than the old cone. Cones are carried in stock by various distributors; Allied Radio Corporation in Chicago is

RADIO-ELECTRONICS

one. A catalog listing the proper cone for the speaker you have may be obtained from Waldom Electronics, Inc., 911 North Larrabee Street, Chicago 10, Ill.

The procedure is a simple one. Very few items or tools are required that are not already available on the average service bench. When the cone is cemented in place, shims must be used between it and the pole piece to assure proper alignment. Two shim kits should be obtained. These consist of four or five various sizes. Cement in a tube is the easiest to use and apply. A bottle and brush is not satisfactory. Such items as a chisel, long-nose pliers, and ruler are probably available already. The ruler to be used must be narrow, say 3/8 inch. This problem was solved by cutting a 10-cent plastic ruler in half lengthwise.

As a first step, the old speaker should be examined. In some cases the proper cone type can be determined by checking the catalog under make and model of the radio or TV set. This is the exception rather than the rule. If you find your set listed, you're lucky! More often than not it will be necessary to (very carefully) remove the old cone so that it may be measured. A chisel, screwdriver, or knife should be used to try to separate the cone from the frame at the extreme edges. (The service technician no doubt already knows the tricks of loosening a cone. If not, it is well to know that the felt can be separated from the metal easier by heating it with a large soldering bit (or domestic electric flatiron) or by applying cement solvent lacquer thinner liberally around the edges. Be careful—the stuff is highly flammable!—*Editor*) It will later be necessary to measure the cone depth. So take care not to destroy the cone edges. Next cut the two flexible leads running to the voice coil and then loosen the spider. Spiders are made of cloth and are torn away from the frame easily. The old cone may then be lifted out and measured.

Fig. 1 shows the proper method of measuring cone depth with the narrow ruler put down through the center. Also to be measured are the cone outside diameter and the voice-coil inside diameter. Two main types of spiders are shown in Fig. 2. Cup and flat (respectively, left and right). The outside diameter of the spider is measured next. On very old speakers a type of spider retained by two or three screws may be found. These are ordered as "2-point" or "3-point". With all the dimensions pertinent to the speaker available it is necessary only to locate the proper replacement cone from the listings in the catalog. The whole process outlined in the last two paragraphs takes only a few minutes; not much longer than it took to read about it. In those few cases where there is no exact replacement listed, send the old cone to your distributor and the factory will make one to fit.

A clean-up job should be done on the speaker frame to remove all glue and bits of the old cone. Some speakers are

WEN

Electronic SOLDERING GUN

Way out front in LONG LIFE TESTS

It was startling — "No Contest" really. Three competitive soldering guns were to be plugged in each morning . . . kept connected, operative, HOT all day. But Soldering Gun "A" lasted only 1 1/4 hours, burned out its transformer and started smoking! Gun "B" burned out in 21 minutes! The WEN Soldering Gun with Feraloy tip scored 567 HOURS! Or compare this way — the WEN Gun with 50c Feraloy tip averages 25,000 soldering connections. Gun "A" (replacement tip 25c) 800 connections. Gun "B" (new tip \$5.00) 1,627 connections. That means your soldering connections need cost you but 1/500 of 1c — using the WEN Gun. Practically lasts forever under ordinary conditions.



Also Cuts Plastic Tile!

By simple change from standard soldering to WEN special Hot-Cutting Tip, anyone can cut plastic tile any shape, quickly, accurately, with no spoilage. This extra use means an extra market for dealers. Hot-Cutting Tip No. 25-C-1 sells for 50c.

WEN PRODUCTS, INC.

5808 NORTHWEST HIGHWAY, CHICAGO 31, ILLINOIS

(Export sales — Scheel International, Inc., Chicago)

HERE IT IS! The tool that takes the work out of dial-cord stringing!

DOC'S STRING-AID

Perfect for looping cord over pulleys—hooking end shaping springs—working in close places. Makes any dial job a breeze!

• All steel • Five-inch length • Insulated, easy-to-grip shank

ORDER FROM THIS AD! Money Back Guarantee

DOC'S RADIO TOOLS 509 FISK AVE. BROWNWOOD, TEXAS **75c**

OSCIL-O-PEN

Extremely convenient test oscillator for all radio servicing; alignment • Small as a pen • Self powered • Range from 700 cycles audio to over 600 megacycles u.h.f. • Output from zero to 125 v. • Low in cost • Used by Signal Corps

• Write for information.

GENERAL TEST EQUIPMENT
38 Argyle Ave. Buffalo 9, N. Y.

ASK YOUR JOBBER for

Carleo PARTS KITS

Amazing values! All new, standard brands, guaranteed perfect. Most popular items for every need. At your jobber's. Catalog sheets on request. Carl Cordever & Co., 100 Warren St., New York 7, N. Y.

FREE: Display Rack for Jobbers

MAKE MORE MONEY ON SERVICE!

TELEVISION • RADIO • ELECTRONIC



Learn to handle ANY job easier, better and lots FASTER this modern professional way!

ONLY \$12 FOR THE COMPLETE TRAINING You Save \$1.25

THESE two big, fact-packed Ghirardi training books make it easy for you to become expert on all types of home radio and television receiver service—at absolute minimum cost!

Ask the men who already have good-pay jobs! They'll tell you that Ghirardi training is the finest—AT ANY PRICE—because it is so outstandingly complete, and because it makes even the

toughest subjects so easy to understand.

Each of these two books is entirely new, completely modern in every respect—NOT a re-hash of old, outmoded material. Together, they form a complete service library written so you can easily understand every word—and designed to serve either as a complete training course or as a handy reference for experienced servicemen who want to look up puzzling jobs or develop new and faster methods.



Radio and Television Receiver
CIRCUITRY AND OPERATION

By Ghirardi and Johnson
669 pages, 417 helpful illustrations; Price \$6.50

Learn all about Circuits . . . AND WATCH SERVICE "HEADACHES" DISAPPEAR

Years of experience plus hundreds of talks with service technicians proved to Mr. Ghirardi the need for a book that got right down to earth in explaining the basic circuits and operation of modern radio and television receivers. Radio & Television Receiver: Circuitry and Operation is the result. Backed by what you can learn from it, you'll find that 9 out of 10 service jobs are tremendously simplified. You'll work faster with less testing—and make more money in the bargain! Guesswork is eliminated.

Starting with AM and FM processes and characteristics, the book

progresses to a complete understanding of basic circuits, how they operate, how to recognize them quickly and what is likely to go wrong with them. By making it easy for you to understand each circuit and its relation to other circuits, the book helps you go right to the seat of trouble in far less time. You'll know what different trouble symptoms mean—and you'll know how to repair troubles lots faster and more efficiently.

Sold separately for \$6.50. Try it for 10 days on our FREE examination offer.

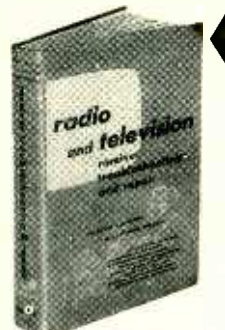

Radio and Television Receiver
TROUBLESHOOTING AND REPAIR

By Ghirardi and Johnson
822 pages, 417 clear illustrations; Price \$6.75

Complete Training in MODERN, PROFESSIONAL SERVICE METHODS

This big book makes the tough service jobs, easy, makes the easy ones a cinch!

Actually, Radio & Television Receiver TROUBLESHOOTING AND REPAIR is a complete guide to modern professional methods.

First you get a full analysis of components, their functions, their troubles and their remedies. Next you learn modern troubleshooting methods from "static" tests to dynamic signal tracing and injection techniques. You learn basic procedures and how to interpret performance data. Four big chapters show how to realign Television, FM and AM receivers in less time. You'll learn how a glance at a TV set may quickly tell you what is wrong. Special hard-to-fix service problems are explained. Puzzling "intermittent" troubles and their remedies are clearly outlined. Step-by-step service procedure charts

demonstrate many operations almost at a glance. In short, from the simplest troubles to the most difficult ones, nothing has been omitted—nothing has been condensed. Everything is carefully explained—and the entire book is fully indexed so you can find exactly what you want in a jiffy.

Read it 10 days FREE! See for yourself how this great book can pave your way for bigger pay. Sold separately for \$6.75. Save money by ordering special combination offer.



SPECIAL money-saving OFFER!

Save \$1.25 by ordering both of the above big books. Make your service library complete!

Dept. RE-24, Rinehart Books, Inc., Technical Division, 232 Madison Avenue, New York 16, N. Y.
Send books below for 10-day FREE EXAMINATION. In 10 days, I will either remit price as indicated (plus a few cents postage) or return books postpaid and owe you nothing.

Check here to order books singly:

- Radio & TV Receiver **CIRCUITRY & OPERATION** (Price \$6.50 separately)
- Radio & TV Receiver **TROUBLESHOOTING & REPAIR** (Price \$6.75 separately)

Check here for MONEY SAVING COMBINATION . . . SAVE \$1.25!

Both of the above big books at the special price of only \$12.00 for the two. (Regular price \$13.25—you save \$1.25.) Payable at the rate of \$3 after 10 days if you decide to keep books and \$3 a month thereafter until the total of \$12 plus postage has been paid.

Name
Address
City, Zone, State

OUTSIDE U.S.A.—\$7.25 for TROUBLESHOOTING & REPAIR book; \$7.00 for CIRCUITRY & OPERATION; \$13.00 for both books. Cash with order only. Money refunded if you return books in 10 days.

rusty. Remember that rust is usually attracted by a magnet and particles may be drawn into the space around the pole piece. Place Scotch tape over this opening and try to scrape off some of the rust. Then use some oil on the portion of the frame normally covered by the spider to help prevent further rusting. Several strips of Scotch tape may be used to clean around the pole piece by wrapping them around a speaker shim with the sticky side out and probing around to pick up dirt and metal filings.

These cones come partially assembled. That is, the cone and voice coil are already glued together. Some other types are shipped in separate pieces, in which case the general procedure still will be very similar to the method described here. The new cone will be installed and cemented into place at one time, with very little left to be done after the cement has dried. This writer has found no point in trying to use cement sparingly; put plenty on but don't have a sticky mess when you are through. Keep it where it belongs, have enough to do the job, and don't ever get any on the voice coil or paper tube except above the spider. It seems that speakers don't sound so hot with the voice coil stuck firmly to the speaker frame!

First apply a ring of cement around the junction of the voice-coil tube and the cone. Work the spider down over the tube as far as it will go and then give it one turn to be sure it is properly seated and that the adhesive is evenly distributed. Next apply cement to the frame at the points where the edges of the spider and cone will rest. With due respect to the location of the two flexible wire leads, put the cone in position and insert the shims. These are slid into place one at a time at four points as shown in Fig. 3. Use the largest size possible. They will fit quite snugly, but try not to employ less than four. Space them evenly. One more application of cement will take care of the heavy cardboard gasket ring. Don't remove the shims. Then lay the speaker upside down on a flat surface with a weight on top and allow between 2 to 4 hours to dry the cement. Later, when you return to it, remove the shims and check for any misalignment of the voice coil, glue the felt dust cap in place, and solder the leads to the terminals. The job is done.

There is nothing difficult or complicated about reconing speakers. Nor does it take a great deal of time. Take one of the old speakers that are to be found in most every shop and try it yourself. You will be surprised at how easy it is. Then, with only the smallest amount of salesmanship, you will again be surprised at the business you have been missing. Show the customer a new cone and explain briefly what is done to his old speaker. If his speaker is at all bad he will ask a couple of questions and then say, "Go ahead." A display on your counter showing "before" and "after" will also help a great deal. At a profit of almost two dollars per speaker you can't lose. Try it! END

TO THE
E. E.
OR
PHYSICS
GRADUATE
WITH EXPERIENCE IN
RADAR
OR
ELECTRONICS

HUGHES RESEARCH AND DEVELOPMENT LABORATORIES ARE ENGAGED IN A CONTINUING PROGRAM FOR DESIGN AND MANUFACTURE OF ADVANCED RADAR AND FIRE CONTROL SYSTEMS IN MILITARY ALL-WEATHER FIGHTERS AND INTERCEPTORS.

YOU WILL serve as technical advisor in the field to companies and government agencies using Hughes equipment.

TO BROADEN your field of experience in radar and electronics you will receive additional training at full pay in the Laboratories to become thoroughly familiar with Hughes radar and fire control equipment.

AFTER TRAINING you will be the Hughes representative at a company where our equipment is installed; or you will direct operation of Hughes equipment at a military base.

THE GREATEST advancements in electronics are being made in this sphere because of military emphasis. Men now under 35 years of age will find this activity can fit them for future application of highly advanced electronic equipment.

HUGHES

RESEARCH AND DEVELOPMENT LABORATORIES

SCIENTIFIC AND ENGINEERING STAFF

Culver City, Los Angeles County, Calif.

Assurance is required that relocation of the applicant will not cause disruption of an urgent military project.

NO ROTORMOTOR-YET

ALL DIRECTION UHF-VHF RECEPTION

53 CLAIMS GRANTED IN
5 U. S. PATENTS

#2,585,670

#2,609,503

#2,625,655

#2,644,091

#2,661,423

OTHERS PENDING

UP TO

10 TIMES MORE POWERFUL THAN ALL OTHER ANTENNAS

Solves Your Problem in Your Area

Yes, we said YOUR area. With the FCC allocating over 2,000 new TV Stations covering 12 VHF and 70 UHF channels, your area is due to change and you will require an antenna able to receive both UHF and VHF channels from all directions. All Channel Antenna Corp. has just the antenna to fill your needs and money back guaranteed to positively bring you at your location, clearer, sharper, pictures than any combination of present day antennas using expensive rotor motors, boosters, etc. With a flick of the 9 position electronic beam selector switch, any station in any area is instantly brought in on any TV set clearer and sharper.

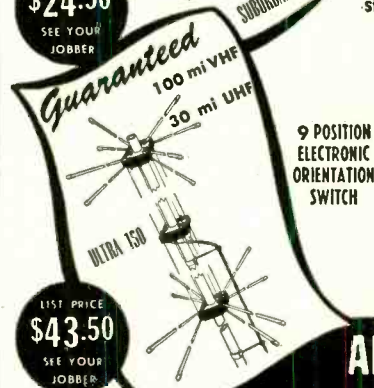

9 POSITION
ELECTRONIC
ORIENTATION
SWITCH



The 9 position selector switch electronically rotates the antenna in a stationary position.

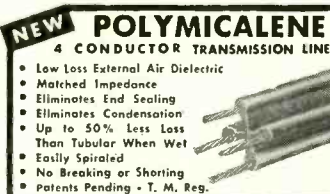

NEW POLYMICALENE
4 CONDUCTOR TRANSMISSION LINE

- Low Loss External Air Dielectric
- Matched Impedance
- Eliminates End Sealing
- Eliminates Condensation
- Up to 50% Less Loss Than Tubular When Wet
- Easily Spiraled
- No Breaking or Shorting
- Patents Pending - T. M. Reg.

While antenna reception is guaranteed as specified, perfect pictures have been consistently received from 2 to 3 times these distances.

ALL CHANNEL ANTENNA CORP.,

70-07 Queens Blvd., Woodside 77, N. Y. Hickory 6-2304

ENJOY 3 COLOR TELEVISION FILTER SCREEN NOW

Changes dull eye-straining black and white pictures into beautiful color tones. Seconds to attach. No tools used. Helps eliminate glare and snow in fringe areas. Order direct. Send \$3 for screen size up to 16". \$1.25 size 17", \$1.50 size 20", \$2 size 21", \$2.50 size 24", \$3 size 27". (Also available are single solid color screens in blue, green, or amber.) Prices on solid color screens are 10% less. We pay postage except on C.O.D. orders. Satisfaction guaranteed. Inquiries from dealers also welcomed.
Zingo Products, Johnstown 13, New York

YOUR TESTER DAMAGED?

Let Douglas Repair It

Contractors to U. S. Government

Repairs and calibration by skilled craftsmen on all makes of Meters, Sig. Gens., Testers, etc. Prompt service. All work guaranteed. For immediate estimate send instrument by P. P. Ins. to

DOUGLAS INSTRUMENT LABORATORY
Electrical Instrument Repairers
176a Norfolk Avenue Boston 19, Mass.

PRES-
PROBE

CONDENSER TESTER

Finds Intermittent
Condensers Instantly
NET

Pres-probe's sliding tip with variable resistance prevents condenser heating. Tests with power on. Requires no adjustment. Stops guesswork. Saves time. Convenient probe size (7/8" long). Satisfaction guaranteed.

See Your Dist. or Order Direct

PRES-PROBE CO.

4034 N. Sixth St., Milwaukee 12, Wis.



795
Postpaid
U. S. A.

Buy on our radically new

NO INTEREST!! **Time Payment Plan** **NO CARRYING CHARGES!!**



Superior's new **SUPER METER**
Model 670-A

A COMBINATION VOLT-OHM MILLIAMMETER PLUS CAPACITY REACTANCE INDUCTANCE AND DECIBEL MEASUREMENTS

SPECIFICATIONS:

D.C. VOLTS: 0 to 7.5/15/75/150/750/1,500/7,500 Volts
 A.C. VOLTS: 0 to 15/30/150/300/1,500/3,000 Volts
 OUTPUT VOLTS: 0 to 15/30/150/300/1,500/3,000 Volts
 D.C. CURRENT: 0 to 1.5/15/150 Ma. 0 to 1.5/15 Amperes
 RESISTANCE: 0 to 1,000/100,000 Ohms 0 to 10 Megohms
 CAPACITY: .001 to 1 Mfd. 1 to 50 Mfd. (Quality test for electrolytics)
 REACTANCE: 50 to 2,500 Ohms 2,500 Ohms to 2.5 Megohms
 INDUCTANCE: .15 to 7 Henrys 7 to 7,000 Henrys
 DECIBELS: -6 to +18 +14 to +38 +34 to +58

ADDED FEATURE:

The Model 670-A includes a special **GOOD-BAD** scale for checking the quality of electrolytic condensers at a test potential of 150 Volts.

The Model 670-A comes housed in a rugged, crackle-finished steel cabinet complete with test leads and operating instructions.

\$28⁴⁰
NET



Superior's new **TUBE TESTER**
Model TV-11

SPECIFICATIONS:

- ★ Tests all tubes including 4, 5, 6, 7, Octal, Lock-in, Peanut, Bantam, Hearing Aid, Thyatron, Miniatures, Sub-miniatures, Novals, Sub-minars, Proximity fuse types, etc.
- ★ Uses the new self-cleaning Lever Action Switches for individual element testing. Because all elements are numbered according to pin-number in the RMA base numbering system, the user can instantly identify which element is under test. Tubes having tapped filaments and tubes with filaments terminating in more than one pin are truly tested with the Model TV-11 as any of the pins may be placed in the neutral position when necessary.
- ★ The Model TV-11 does not use any combination type sockets. Instead individual sockets are used for each type of tube. Thus it is impossible

- to damage a tube by inserting it in the wrong socket.
- ★ Free-moving built-in roll chart provides complete data for all tubes.
- ★ Newly designed Line Voltage Control compensates for variation of any Line Voltage between 105 Volts and 130 Volts.
- ★ **NOISE TEST:** Phono-jack on front panel for plugging in either phones or external amplifier will detect microphonic tubes or noise due to faulty elements and loose internal connections.

The model TV-11 operates on 105-130 Volt 60 Cycles A.C. Comes housed in a beautiful hand-rubbed oak cabinet complete with portable cover

\$47⁵⁰
NET

EXTRA SERVICE—The Model TV-11 may be used as an extremely sensitive Condenser Leakage Checker. A relaxation type oscillator incorporated in this model will detect leakages even when the frequency is one per minute.



Superior's New Model 660-A AN AC OPERATED **SIGNAL GENERATOR**

PROVIDES COMPLETE COVERAGE for AM-FM & TV Alignment

SPECIFICATIONS:

● Generates Radio Frequencies from 100 Kilocycles to 60 Megacycles on fundamentals and from 60 Megacycles to 220 Megacycles on powerful harmonics. ● Accuracy and Stability are assured by the use of permeability trimmed Hi-Q coils. ● R.F. available separately or modulated by the Internal audio oscillator. — Built in 400 cycle sine wave audio oscillator used to modulate the R.F. signal also available separately for audio testing of receivers, amplifiers, hard of hearing aids, etc. ● R.F. Oscillator Circuit: A high transconductance hep-

tode is used as an R.F. oscillator, mixer and amplifier. Modulation is effected by electron coupling in the mixer section thus isolating the oscillator from load changes and affording high stability. ● A.F. Oscillator Circuit: A high transconductance heptode connected as a high- μ triode is used as an audio oscillator in a High-C Colpitts Circuit. The output (over 1 Volt) is nearly pure sine wave. ● Attenuator: A 5 step ladder type of attenuator is used.

TUBES USED:

- 1—68E6 as R.F. Oscillator, mixer and amplifier.
- 1—6BE6 as Audio Oscillator.
- 1—6H6 as Power Rectifier.

The Model 660-A comes complete with coaxial cable test lead and instructions.

\$42⁹⁵
NET

MOSS ELECTRONIC DISTRIBUTING CO., INC.
Dept. B-93, 3849 Tenth Ave., New York 34, N. Y.

Please send me the units checked. I am enclosing the down payment with order and agree to pay the monthly balance as shown. It is understood there will be no carrying interest or any other charges, provided I send my monthly payments when due. It is further understood that should I fail to make payment when due, the full unpaid balance shall become immediately due and payable.

Name.....
 Address.....
 City.....Zone.....State.....

- MODEL 670-A Total Price \$28.40
\$7.40 down payment. Balance \$3.50
monthly for 6 months.
- MODEL TV-11 Total Price \$47.50
\$11.50 down payment. Balance \$6.00
monthly for 6 months.
- MODEL 660-A Total Price \$42.95
\$12.95 down payment. Balance \$5.00
monthly for 6 months.
- I enclose \$..... as down payment.
- SHIP C.O.D. for the down payment.

RADIO-ELECTRONICS

Buy on our radically new
NO INTEREST!! **Time Payment Plan** **NO CARRYING CHARGES!!**



Superior's New Model 770-A *The FIRST Pocket-Sized*

VOLT-OHM MILLIAMMETER

USING THE NEW "FULL-VIEW" METER

71% MORE SCALE AREA!!

Yes, although our new FULL-VIEW D'Arsonval type meter occupies exactly the same space used by the older standard 2 1/2" Meters, it provides 71% more scale area. As a result, all calibrations are printed in large, easy-to-read type and for the first time it is now possible to obtain measurements instead of approximations on a popular priced pocket-sized V.O.M.

- Features**
- ★ Compact—measures 3 1/8" x 5 7/8" x 2 1/4"
 - ★ Uses "Full View" 2% accurate, 850 Microampere D'Arsonval type meter
 - ★ Housed in round-cornered, molded case
 - ★ Beautiful black etched panel. Depressed letters filled with permanent white, insures long-life even with constant use.

Specifications

6 A.C. VOLTAGE RANGES: 0-15/30-150/300/1500/3000 Volts. 6 D.C. VOLTAGE RANGES: 0-7.5/15/75/150-750/1500 Volts. 2 RESISTANCE RANGES: 0-10,000 Ohms, 0-1 Megohm. 3 D.C. CURRENT RANGES: 0-15/150 Ma., 0-1.5 Amps. 3 DECIBEL RANGES: -6 db to +18 db, +14 db to +38 db, +34 db to +58 db.

THE MODEL 770-A COMES COMPLETE WITH SELF-CONTAINED BATTERIES, TEST LEADS AND ALL OPERATING INSTRUCTIONS. ONLY

\$1585

NET

Superior's New TELEVISION BAR GENERATOR

THROWS AN ACTUAL BAR PATTERN ON ANY TV RECEIVER SCREEN



Two Simple Steps

1. Connect Bar Generator to Antenna Post of any TV Receiver.
2. Plug Line Cord into AC Outlet and Throw Switch.

Result: A stable never-shifting vertical or horizontal pattern projected on the screen of the TV receiver under test.

SPECIFICATIONS:

Power Supply: 105-125 Volt 60 Cycles
 Power Consumption: 20 Watts
 Channels: 2-5 on panel, 7-13 by harmonics
 Horizontal lines: 4 to 12 (Variable)
 Vertical lines: 12 (Fixed)
 Vertical sweep output: 60 Cycles
 Horizontal sweep output: 15,750 Cycles

FEATURES:

Provides linear pattern to adjust VERTICAL linearity, height, centering • Provides linear pattern to adjust HORIZONTAL drive, width, peaking, linearity, centering • Provides vertical sweep signal for adjusting and synchronizing vertical oscillator discharge and output tubes • Provides vertical signal to replace vertical oscillator to check vertical amplifier operation • Provides horizontal sweep signal for adjusting and synchronizing horizontal oscillator A.F.C. and output tubes • Provides horizontal sweep signal to check H.V. section of fly-back and pulse operating power supplies • Provides signal for testing video amplifiers • Can be used when no stations are on the air.

TV BAR GENERATOR COMES COMPLETE WITH SHIELDED LEADS AND DETAILED OPERATING INSTRUCTIONS. ONLY.....

\$3995

NET

SUPERIOR'S NEW MODEL TV-40

C.R.T. TUBE TESTER

★ A complete picture tube tester for little more than the price of a "make-shift" adapter!!

★ Tests all magnetically deflected tubes . . . in the set . . . out of the set . . . in the carton!!



The Model TV-40 is absolutely complete! Self-contained, including built-in power supply, it tests picture tubes in the only practical way to efficiently test such tubes; that is by the use of a separate instrument which is designed exclusively to test the ever increasing number of picture tubes!

EASY TO USE:

Simply insert line cord into any 110 volt A.C. outlet, then attach tester socket to tube base (Ion trap need not be on tube). Throw switch up for quality test . . . read direct on Good-Bad scale. Throw switch down for all leakage tests.

SPECIFICATIONS:

- Tests all magnetically deflected picture tubes from 7 inch to 30 inch types.
- Tests for quality by the well established emission method. All readings on "Good-Bad" scale.
- Tests for inter-element shorts and leakages up to 5 megohms.
- Test for open elements.

Model TV-40 C.R.T. Tube Tester comes absolutely complete—nothing else to buy. Housed in round-cornered, molded bakelite case. Only

\$1585

NET

MOSS ELECTRONIC DISTRIBUTING CO., INC.
 Dept. B-93, 3849 Tenth Ave., New York 34, N. Y.

Please send me the units checked. I am enclosing the down payment with order and agree to pay the monthly balance as shown. It is understood there will be no carrying, interest or any other charges, provided I send my monthly payments when due. It is further understood that should I fail to make payment when due, the full unpaid balance shall become immediately due and payable.

Name.....
 Address.....
 City.....Zone.....State.....

- Model 770-A Total Price \$15.85 \$3.85 down payment. Balance \$4.00 monthly for 3 months.
- Bar Generator Total Price \$39.95 \$9.95 down payment. Balance \$5.00 monthly for 6 months.
- Model TV-40 Total Price \$15.85 \$3.85 down payment. Balance \$4.00 monthly for 3 months.
- I enclose \$..... as down payment.
- Ship C.O.D. for the down payment.

A non-linear capacitor joins the electronic amplifiers; providing power gain by dielectric variation

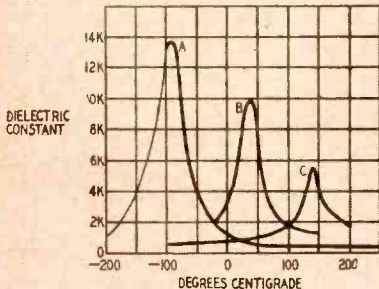

Fig. 1—Graph shows the variation of dielectric constant with temperature.

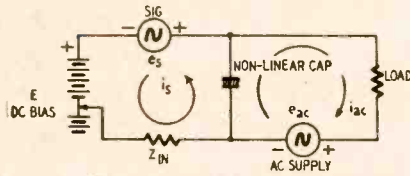

Fig. 2—Basic dielectric amplifier.

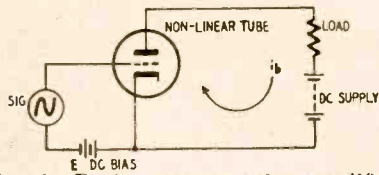

Fig. 3—Basic vacuum tube amplifier.

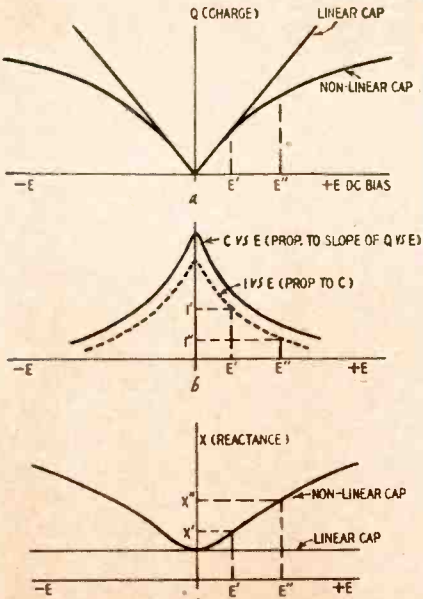

Fig. 4—Series of curves showing the characteristics of nonlinear capacitors.

Introducing the Dielectric Amplifier

By JAMES S. FINK

MANY circuits, according to recent literature, now use magnetic amplifiers and transistors instead of the formerly universally used vacuum tubes. Still another device—the dielectric amplifier—may become very important in replacing the vacuum tube.

The dielectric amplifier is a power device like the magnetic unit but uses a nonlinear capacitor instead of a nonlinear inductor. Like the transistor and magnetic amplifier, the dielectric amplifier came from a need for a unit more reliable than the ordinary vacuum tube.

The dielectric amplifier is an outgrowth of a study of dielectrics which began about 1902, when Schmidt measured the dielectric constant of a form of titanium dioxide.¹ Around 1912, Debye discovered that certain crystalline substances have electric dipoles similar to magnetic dipoles.² Alignment of these electric dipoles under the influence of a d.c. voltage causes the substance's dielectric constant to vary, depending on the voltage. This characteristic suggested the possible use of the dielectric as an amplifier. In 1942, Wainer and Solomon learned of the unusual electrical properties of various compounds of titanium.³ Since then, the U.S. Navy, some universities, technology institutes, and industrial companies have been applying nonlinear capacitors to some circuits that ordinarily would use vacuum tubes.

Materials for dielectric amplifiers

Compounds of titanium like barium, strontium, and calcium titanates have

variable dielectric constants (K). Temperature, voltage, and frequency all help in determining the value of K. Most present amplifiers use a mixture of barium titanate and strontium titanate. Records show values of K between 1,500 and 10,000 as the Curie point (the temperature at which the dielectric constant is maximum). Fig. 1 shows how the constant changes with temperature but does not show changes with voltage and frequency.

A comparison of these large values of K with more familiar materials will help tie down their significance. For instance, air has a K of 1, glass has values from about 5 to 10, and mica has K's from about 2.5 to 8. Obviously, the titanates are able to provide high capacitance in a relatively small space.

Methods of operation

As already mentioned, dielectric amplifiers are similar to the magnetic and vacuum-tube types. The dielectric amplifier uses a capacitor and has a fairly high impedance, as mentioned by A. M. Vincent.⁴ The magnetic amplifier uses an inductance and has a low impedance. The impedance of a vacuum-tube amplifier can be either high or low. Like the magnetic amplifier, an a.c. supply is necessary; an explanation of this comes later. The supply is usually a high-frequency vacuum-tube oscillator.

Figs. 2 and 3 show the basic circuits for dielectric and vacuum-tube amplifiers. The similarity is apparent except for the supply voltages. The charge curve for a nonlinear capacitor appears in Fig. 4-a. For d.c., this means that as one increases the voltage the electric

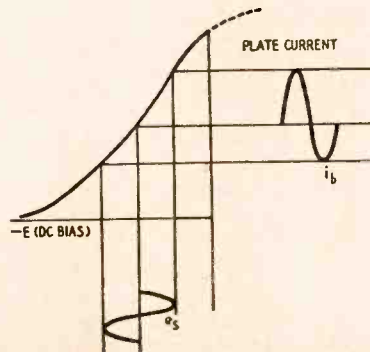

Fig. 5—Nonlinearity of tube curve.

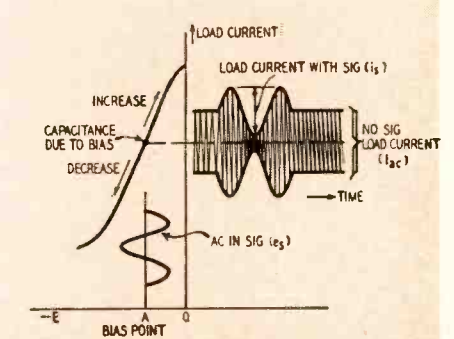

Fig. 6—Transfer characteristic curve.

dipoles (equivalent to charge) begin to line up. But, increasing the voltage an equal amount each time does not mean the same number of electric dipoles line up; consequently, the curve is not a straight line. The curve of charge *versus* d.c. voltage for a linear capacitor is included for comparison. A d.c. voltage on the capacitor represents a bias and is similar to the grid bias of a vacuum tube. The variation of the dielectric constant with d.c. voltage is similar to the curves of Fig. 1, with temperature and frequency constant. Figure 4-b is a composite curve which shows that the capacitance of the capacitor is proportional to the slope or steepness of the Q vs E curve. It also shows that the alternating current flowing into the capacitor is, by Ohm's law, directly related to the capacitance; therefore, the I vs E curve will have the same general shape as the C vs E curve. Since the slope of Q vs E is greatest at the origin, one would expect the capacitance and current to be maximum with no d.c. voltage applied. As the bias increases on the Q vs E curve, the slope decreases; thus, C and I become smaller. The reactance of the capacitor, by Ohm's law, depends on $1/C$, as seen in Fig. 4-c. Therefore, when C is large, X is small, and *vice versa*. The nonlinear nature of the vacuum tube is illustrated in Fig. 5.

Suppose one puts a bias voltage, E' , on the nonlinear capacitor (Fig. 4-c); this gives a reactance, X' , and some current, I' , flows in the load. Increasing the voltage to E'' , now gives a higher reactance, X'' . Apparently the alternating current to the load decreases to I'' . In practice, the change in voltage from E' to E'' is quite small, but changes in reactance are large, giving large current changes. This discussion gives an idea of how one controls current to the load. But, how about amplifying a signal?

Amplification

Referring to Fig. 2, amplification of e_s is the objective. E is the bias voltage, $e_{h.c.}$ is the high-frequency supply. The impedance, Z_{in} , should be large to the supply frequency so that very little current from the supply flows in the first branch. Setting the bias to E' establishes a value for the dielectric constant

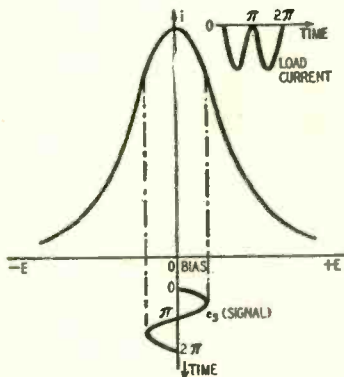

Fig. 7—Zero-bias for doubling.

BEST ALL-AROUND TESTER ON THE MARKET

USE IT FOR:

- TV SETS
- RADIOS
- TRANSMITTERS
- BROADCASTING EQUIPMENT
- HOME APPLIANCES
- TWO-WAY RADIO COMMUNICATIONS SYSTEMS
- PHONE LINES
- AIR CONDITIONING SYSTEMS
- STARTER CONTROLS
- AUTO IGNITIONS, GENERATORS, BATTERIES
- MOVIE EQUIPMENT
- PANEL INSTRUMENTS
- TV CAMERAS
- AUTO LIGHTING SYSTEMS
- GENERATORS
- VOLTAGE SOURCES
- "HAM" RADIO EQUIPMENT
- CABLES
- CONNECTORS
- AUDIO FREQUENCY SOUND CURRENTS

... and write for your complimentary copy of "19C1" Uses for the Simpson Model 260"

RANGES:

- 20,000 OHMS PER VOLT DC
- 1,000 OHMS PER VOLT AC
- VOLTS, AC AND DC: 2.5, 10, 50, 250, 1,000, 5,000
- OUTPUT: 2.5, 10, 50, 250, 1,000
- MILLIAMPERES, DC: 10, 100, 500
- MICROAMPERES, DC: 100
- AMPERES, DC: 10
- DECIBELS (5 RANGES): -12 TO +35 DB
- OHMS: 0-2000 (12 OHMS CENTER), 1-200,000 (1,200 OHMS CENTER), 0-20 MEGOHMS (20,000 OHMS CENTER)

SIMPSON ELECTRIC COMPANY

520 W. Kinzie St., Chicago 44 • ESTebrook 9-1121

In Canada: Each-Simpson, Ltd., London, Ont.,



Simpson
Model 260
VOLT-OHM-MILLIAMMETER

HEADSET SALE!

HS-33 \$4.50 each

HS-23 \$4.00 each

BRAND NEW

TALLEN CO., Inc., Dept. RE
139 Carlton Ave., Brooklyn 5, New York

arkay HI-FI AUDIO kit
AMPLIFIER

10 Watt high-fidelity amplifier. Separate tone controls for bass and treble through inverse feedback circuit; 10 watt output or 32 db. less than 3% distortion; frequency response ± 1 db. from 20 to 20,000 cps. Tone controls produce maximum bass boost ± 8 db. @ 100 cps. Treble controls produce maximum treble boost ± 10 db. @ 10,000 cps. Hum: 70 db. below rated output.



Model A10 21.95

Write for new catalog of the complete ARKAY line of radio, TV, phonograph and test equipment kits.

arkay
BE 3-6686

RADIO KITS, INC.
120 CEDAR STREET
NEW YORK 6, N. Y.

OUTSTANDING for HIGH FIDELITY!

BUY DIRECT AND SAVE

'PRE-FAB' COLLINS TUNERS and RECEIVERS
AUDIO PRODUCTS CO.

Two ALL NEW Complete Kits for Every High-Fidelity Need

Collins Audio Products Co. is in no way affiliated with Collins Radio Co.

Each Collins Tuner Kit is complete with punched chassis, tubes, power transformer, power supply components, hardware, dial assembly, tuning eye, knobs, wire, etc., as well as the completed sub-assemblies: FM tuning units, AM tuning units, IF amplifiers, etc., where applicable. All sub-assemblies wired, tested and aligned at the factory make Collins Pre-Fab Kits easy to assemble even without technical knowledge. The end result is a fine, high quality, high fidelity instrument at often less than half the cost—because you helped make it and bought it direct from the factory.

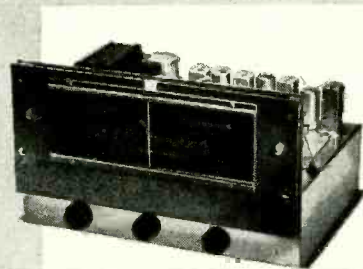

FM Tuner Kit

\$55

The FM-11 tuner is available in kit form with the IF Amplifier mounted in the chassis, wired and tested by us. You mount the completed RF Tuning Unit and power supply, then after some simple wiring, it's all set to operate. 11 tubes: 6J6 RF amp, 6AG5 converter, 6C4 oscillator, 6BA6 1st IF, (2) 6AU6 2nd and 3rd IF, (2) 6AU6 limiters, 6AL5 discriminator, 6AL7-GT double tuning eye, 5Y3-GT rectifier. Sensitivity 6 to 10 microvolts, less than 1/2 of 1% distortion, 20 to 20,000 cycle response with 2DB variation. Chassis dimensions: 12 1/2" wide, 8" deep, 7" high. Illustrated manual supplied. Shipping weight 14 lbs.

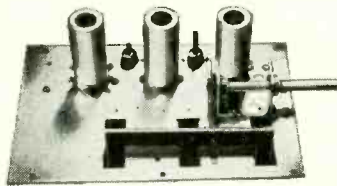

FMF-3 Tuning Unit

\$1525

The best for FM. The most sensitive and most selective type of "front end" on the market. 6 to 10 microvolts sensitivity. Image ratio 500 to 1. 6J6 tuned RF stage, 6AG5 converter, 6C4 oscillator. Permeability tuned, stable and drift-free. Chassis plate measures 6 1/2" x 4 1/2". In combination with the IF-6 amplifier, the highest order of sensitivity on FM can be attained. Tubes included as well as schematic and instructions. Draws 30 ma. Shipping weight FMF-3: 2 1/2 lbs. Dial available @ \$3.85.



IF-6 Amplifier

\$1975

A remarkable value! 6 tubes are used in the IF amplifier: 6BA6 1st IF, (2) 6AU6 2nd and 3rd IF's, (2) 6AU6 limiters and 6AL5 discriminator. High gain, wide-band response (200 KC) for highest fidelity. 20 to 20,000 cycles. Distortion less than 1/2 of 1%. Draws 40 ma @ 220 volts. Chassis plate dimensions: 11 3/8" x 2 1/2". Shipping weight: 3 lbs.

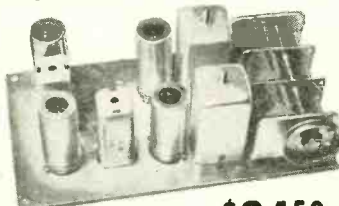

AM-4 Tuning Unit

\$2450

Top in AM superhet performance! A 3-gang tuning condenser gives 3 tuned stages with high sensitivity and selectivity. Assembly is completely wired, tested and aligned ready for immediate use. Frequency coverage 540 KC to 1650 KC at a sensitivity of 5 microvolts. Tubes 6BA6 RF amplifier; 6BE6 converter; 6BA6 IF amplifier and 6AT6 detector. Draws 30 ma @ 220 volts. Mounts on a chassis plate measuring 4" x 7 3/8". Shipping weight 2 1/2 lbs. Dial available at \$3.85.

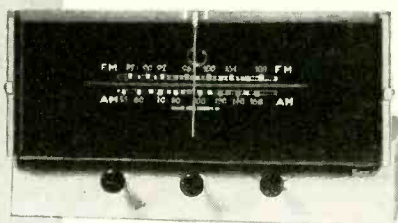

FM/AM Tuner Kit

\$7750

The original 15 tube deluxe FM/AM pre-fab kit redesigned on a smaller chassis. The tuner now measures 14" wide by 12" deep by 7 1/2" high. This attractive new front and dial assembly opens up new applications where space is at a premium. Kit includes everything necessary to put it into operation—punched chassis, tubes, wired and aligned components, power supply, hardware, etc. Kit comprises FMF-3 tuning unit, IF-6 amplifier, AM-4 AM tuning unit, magic eye assembly and complete instructions. All tubes included. Shipping weight 19 lbs.

MAIL COUPON TODAY!

To: Collins Audio Products Co. Inc. RE-2
P.O. Box 368, Westfield, N. J.
Tel. Westfield 2-4390

FM Tuner Kit FM/AM Tuner Kit Slide Rule Dial Assembly
 FMF-3 Tuning Unit IF-6 Amplifier AM-4 Tuning Unit

NAME _____
ADDRESS _____
CITY _____ STATE _____
Amount for Kit \$ _____ See weights, add shipping cost \$ _____
Total amount enclosed \$ _____ Check Money Order

and fixes the average or no-signal capacitance. The supply voltage now sets up an alternating current in the second loop. The current of course depends on the value of capacitance, the load and the magnitude of the supply voltage. It appears as i_{ac} in Fig. 6. With the signal voltage e_s , applied, another current, i_s , flows in the first loop. By superposition of the two currents, i_{ac} and i_s , we get a modulated wave of current in the second loop. The envelope, as seen in Fig. 6, is that of the signal but increased in amplitude. That is, a gain in signal occurs. A quick look at Fig. 5 shows almost the same situation for the vacuum tube. To get the desired signal again, some form of demodulation and filtering must be used, since the high frequency also appears in the load current. To get the largest gain, operation should be close to the Curie point. This discussion shows in a qualitative way how a signal is amplified using the basic circuit. In his article, Vincent shows a few circuits such as a bridge, a push-pull amplifier, and a radio receiver, all of which use the basic circuit. With some extension, the discussion above can be applied to these circuits.

By setting the bias to zero (Fig. 7) and applying a signal, the dielectric amplifier becomes a frequency doubler. Frequencies other than the fundamental and second harmonic occur because of the departure of the curve from a straight line. In other words, the output current will not be a sine wave for a sine wave input.

Vincent says the dielectric amplifier works in multivibrators, sweep generators, phonograph pickups, relays, and many other circuits where conventional amplifiers are used.

He also lists some advantages, such as it being dependable, rugged, compact, efficient, having high gain, and requiring no heater. The unit is cheaper than equivalent magnetic or vacuum-tube amplifiers.

Some of the disadvantages mentioned by Vincent are that it has a frequency limit of only about 10 mc, temperature-dependent capacitance, molecular noises, some phase shift, and a need for a high-frequency supply.

The present stage of development is similar to that of vacuum tubes before World War I. Research is continuing, even to the extent of transforming insulators to show both ferroelectric and magnetic effects. While no claim is made that the dielectric amplifier is a cure all for electronic ills, its extreme ruggedness and reliability will probably be put to use on a large scale.

References

"Rochelle Salt as a Dielectric," C. B. Sawyer, C. H. Tower. *Physical Review* (New York, N. Y.) Vol. 35, Feb., 1950, pp 269-73.
"Ferroelectric Storage Elements for Digital Computers and Switching Systems," J. R. Anderson. *Electrical Engineering*, Vol. 71, No. 10, Oct., 1952, pp 916-22.
1. W. Schmidt, *Ann. Physik* (14) 9, 919 (1902): 11, 114 (1903).
2. "Polare Molekeln," P. Debye, Hirtzel; Leipzig, 1929.
3. "High Titania Dielectrics," E. Wainey. *Transactions of The Electro-Chemical Society*, Vol. 89, 1946.
4. "Dielectric Amplifier Fundamentals," A. M. Vincent. *Electronics*, Dec., 1951. END

WHEN YOU THINK OF TUNERS, THINK OF COLLINS AUDIO PRODUCTS

SMALLEST AMPLIFIER

(Cover Feature)

By R. L. WALLACE

This miniature coaxial amplifier was designed and constructed by Bell Telephone Laboratories to study some of the problems involved in making a wide-band amplifier which could be inserted in very small coaxial cables. Such a combination of amplifiers and cables might conceivably be useful for transmission of broad-band signals such as television over short distances.

The most interesting feature of the amplifier is of course its small size. In spite of the fact that it contains two transformers, one inductor, four resistors, one capacitor, two voltage-regulating diodes, two coaxial jacks and a junction tetrode transistor, it measures only 0.15 inch in diameter by 1.5 inches in length. It amplifies a band of frequencies which extends from 0.4 megacycle to 11 megacycles, producing a gain of 22 decibels flat within 0.1 decibel in this range.

The photograph shows a short section of lead-covered cable which contains seven 0.1-inch diameter coaxials. The small amplifier is shown inserted in one of the coaxial cables. One of the small transformers, which measures 0.125 inch in diameter by 0.080 inch in length is shown resting on the girl's thumb. The other small item between the girl's fingers is a junction tetrode transistor. It is the excellent high-frequency performance of this experimental kind of transistor which makes possible the design of wide band amplifiers in this frequency range. END

Radio Thirty-Five Years Ago
In Gernsback Publications

HUGO GERNSBACK
Founder

Modern Electrics	1908
Wireless Association of America	1908
Electrical Experimenter	1913
Radio News	1919
Science & Invention	1920
Television	1927
Radio-Craft	1929
Short-Wave Craft	1930
Television News	1931

Some of the larger libraries still have copies of ELECTRICAL EXPERIMENTER on file for interested readers.

FEBRUARY 1920
ELECTRICAL EXPERIMENTER

- The Versatile Audion, by H. Winfield Secor
- The New Theory of Electrical Mass, by Rogers D. Rusk, M.A.
- The Fessenden Oscillator, by E. T. Jones
- Audions Stronger Than Sun!
- Vacuum Tube Circuits, by Pierre H. Boucheron, U.S.N.R.F.
- Radio Telepathy and the Airplane, by William C. Mundt
- Making a Wave Meter Direct Reading
- A Small Radio Frequency Alternator
- Why Not a Radio "Efficiency Meter"? by E. T. Jones
- An Improved Hy-Tone Radio Buzzer, by Robert W. Hart
- An Improved Loose Coupler, by Frank H. H. Broome, B.Sc.
- Getting Together on the Antenna, by E. T. Jones

FEBRUARY, 1954



STUDENTS AND EXPERIMENTERS

HOW TO TROUBLESHOOT

A TV RECEIVER

by J. R. Johnson

A step-by-step guide for newcomers to rapid systematic troubleshooting. Read this book and start out on the right foot!

Over 120 (5 1/4 x 8 1/4") pages..... \$1.80

HOW TO USE SIGNAL AND SWEEP GENERATORS

by J. R. Johnson

First book on all types of signal and sweep generators. Gives test uses and discusses problems and their solutions in using this equipment. Applications of all signal and sweep generators in AM, FM radio and TV servicing.

Over 140 (5 1/2 x 8 1/2") pages..... \$2.10



COMPLETE COLOR TV STORY

INTRODUCTION TO COLOR TV

by Kaufman & Thomas

Complete story on NTSC color TV system. Explains how color receiver differs from black and white; how single and triple gun color tubes differ from black and white picture tubes. Answers all questions on present day color TV.

Over 100 (5 1/4 x 8 1/4") pages, illus..... \$2.10

TV TROUBLESHOOTING AND REPAIR GUIDE BOOK VOL. 2

by R. G. Middleton

Companion book to best selling Vol. 1. Finest practical book to make TV servicing easy. Spot TV receiver troubles fast. All items in TV receivers not in Vol. 1. Ooes not duplicate!

Vol. 2, 160 (8 1/2 x 11") pages..... \$3.30

Vol. 1, 204 (8 1/2 x 11") pages..... \$3.90

GUIDE TO AUDIO REPRODUCTION

by David Fidelman

A to Z explanation of the reproduction of sound, design, construction, assembly and testing of sound systems and their components. Valuable for service technicians, engineers, amateurs.

Over 250 (5 1/2 x 8 1/2") pages..... \$3.50

OBTAINING AND INTERPRETING TEST SCOPE TRACES

by J. F. Rider

Over 500 actual photographs of test scope traces. Shows how to use scopes and what traces mean. Valuable for servicing TV receivers, FM and AM radio receivers, audio systems and test equipment. Specific test equipment set-ups shown with each application. No other book like it! Over 140 pages..... Only \$2.40

IN CANADA, ALL PRICES APPROXIMATELY 10% HIGHER.

CAREFULLY SELECTED
for EVERY NEED
of **RADIO, TV**
Service Technicians

POSITIVE CURES FOR TV TROUBLES JUST OUT-VOL. 5



TV MANUFACTURERS' RECEIVER TROUBLE CURES

VOL. 1, VOL. 2, VOL. 3, VOL. 4, VOL. 5.

Positive cures for TV troubles! Gives you exact directions for correcting TV receiver performance "bugs". Each cure is official, factory-authorized, direct from the receiver's manufacturer. Listings by manufacturer and model or chassis number. Helps correct the most difficult faults—picture jitter, hum, instability, buzz, tearing, etc.

Vol. 1, 115 (5 1/4 x 8 1/4") pages..... \$1.80

Covers 12 brands, Admiral through Dumont.

Vol. 2, 117 (5 1/4 x 8 1/4") pages..... \$1.80

Covers 11 brands, Emerson through Jackson.

Vol. 3, 119 (5 1/4 x 8 1/4") pages..... \$1.80

Covers 16 brands, Kaye-Halbert through Philco.

Vol. 4, Over 115 (5 1/4 x 8 1/4") pages..... \$1.80

Covers 10 brands, Philharmonic through Shaw TV.

Vol. 5, Over 120 (5 1/4 x 8 1/4") pages..... \$1.80

Covers 12 brands, Sparton through Zenith.

ONE SERVICE JOB WILL MORE THAN PAY THE COST OF THIS SERIES OF BOOKS!

TV SWEEP ALIGNMENT TECHNIQUES

by Art Liebscher, Test Equipment Specialist

Never before has there been a book such as this on TV sweep alignment! An expert gives you accurate time-saving methods—and tells you how they work. Introduces the new Supermark method. Chock-full of sweep curve pictures. Valuable for servicing in UHF signal areas.

123 (5 1/2 x 8 1/2") pages, illus..... \$2.10

ENCYCLOPEDIA ON CATHODE-RAY OSCILLOSCOPES AND THEIR USES

by Rider and Usland

Most complete "scope book! Cloth cover.

992 (8 1/2 x 11") pages, 3000 illus..... \$9.00

SECOND SUPPLEMENT, RECEIVING TUBE SUBSTITUTION GUIDE BOOK

Features picture tube substitutions and receiving tubes not covered in First Supplement and original book..... \$.99

RECEIVING-TUBE SUBSTITUTION GUIDE BOOK

by H. A. Middleton

Answers all tube problems by listing 2,500 radio-television tube substitutions in numerical sequence, with accompanying wiring instructions, original and substitute socket illustrations.

224 (8 1/2 x 11") pages..... \$3.00

FIRST SUPPLEMENT, RECEIVING TUBE SUBSTITUTION GUIDE BOOK

48 (8 1/2 x 11") pages..... \$.99

UHF TELEVISION ANTENNAS & CONVERTERS

by A. Lytel

Latest information on all types of converters, antennas, transmission lines. Valuable for UHF installation techniques Over 128 (5 1/4 x 8 1/4") pages..... \$1.80

WRITE FOR COMPLETE RIDER CATALOG

Buy these books now from your jobber, bookstore — if not available from these sources, write to:



JOHN F. RIDER

Export Agents:
Roburn Agencies, Inc.
39 Warren Street
New York 7, New York

PUBLISHER, INC.

480 Canal Street, New York 13, N. Y.

West Coast Office:
4216-20 W. Jefferson Blvd.
Los Angeles, California

Cable Address:
Roburnage N. Y.

ELECTROPILOT

By FRED SHUNAMAN

Electronics now guides planes with the skill of a human pilot, but without his weaknesses

THE purpose of the automatic plane pilot," says Bill Lear on the introductory page of his instruction manual, "is to hold the aircraft on any predetermined course that may be desired . . . change this course at will with an exact, co-ordinated turn, and . . . maintain the aircraft laterally level and in any desired angle of climb or dive."

That's just what the human pilot does. He watches his instrument board, notes deviations from course, altitude, or position, then applies forces which move rudder or elevator to bring the plane back where it is wanted.

The Lear Electropilot does the same thing, but does it better. Its sensing mechanisms, like the pilot's eyes, detect variations from the prescribed correct course. Its circuitry plays the part of the pilot's nerve system and transmits these indications to a unit which interprets and translates them into

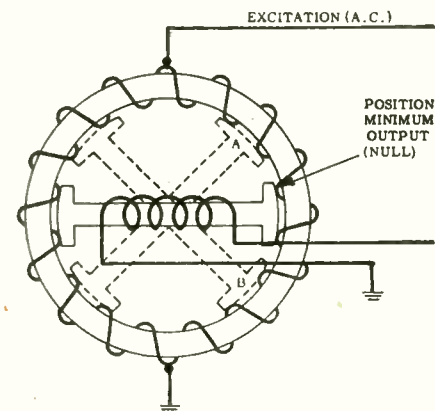

Fig. 1—The inductive pick-off circuit.

instructions to act, as does the pilot's brain. And its servomechanisms play the part of muscles, applying forces to the various controls to bring the plane back to the desired co-ordinates.

Unlike the human pilot, the electronic one never tires—never interprets the same indications in different ways. And it never lags—it responds *immediately*.

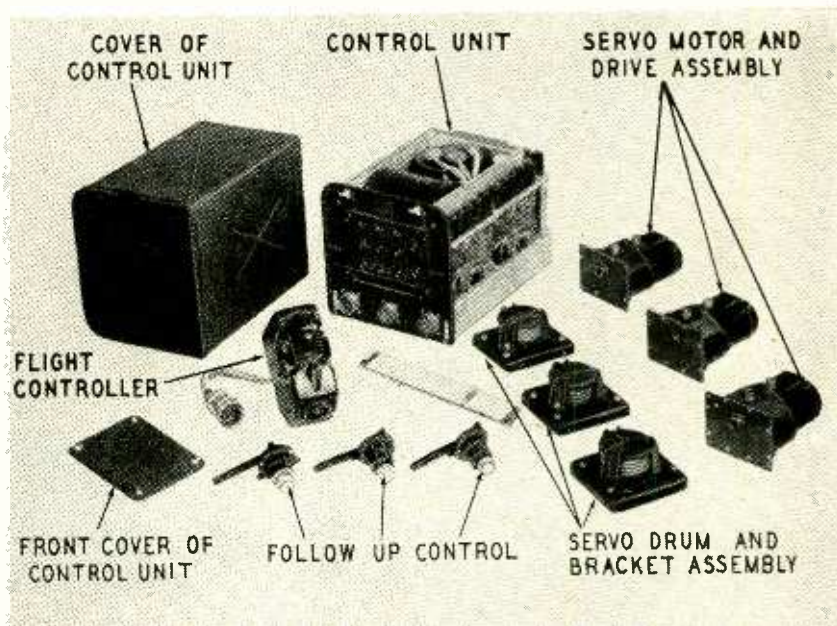

Photo shows the fundamental components of the Lear Electropilot (type L-5).

Each of its sensing mechanisms is always alert, and no one of them is distracted because another is receiving a signal.

The first of these important sensing mechanisms is the *inductive pick-off*. In the form used in the model F-5 pilot, its circuit looks like Fig. 1. The ring-shaped coil is a stator excited by 400-cycle a.c. This acts as the primary of a transformer. The secondary is a rotor mounted inside the ring-shaped coil. It is mounted so that there is one position where the stator induces no voltage into it. If it rotates from that position, a voltage is induced, either in phase or 180° out of phase with the excitation voltage depending on the direction of movement, and that voltage increases with the rotor's displacement from the null position.

The stator is fixed to some portion of the aircraft, while the rotor is kept in a fixed position relative to the earth with a gyroscope. It is adjusted so as to be in the null position when the plane is moving in the desired direction or altitude. Any deviation then creates a current in the rotor winding.

Three inductive pick-offs take care of the three possible deviations of the plane: *roll* (motion in which one wing becomes higher than the other), *pitch* (motion causing nose or tail to go up or down), and *yaw* (deviation from correct compass course). To avoid continually repeating a list, this article will speak of deviations from course, with the understanding that any statement applies to all deviations equally.

If the plane deviates in any of these

three ways, the rotor—still in the same position relative to earth—is no longer at the null point, and a current is induced in it. The amount of induced current is proportional to the displacement from null, and its phase is proportional to the *direction* of displacement. (A deviation of 10° to the right and one of 10° to the left would produce currents of the same amplitude, but in opposite directions.)

Discriminators and amplifiers

The signal from the inductive pick-off's rotor is fed to the grids of two tubes, a *displacement amplifier* and a *rate amplifier*. See Fig. 2, a simplified schematic based on the yaw correction circuitry. The signal from the rate amplifier is fed to a *rate discriminator*. The signal from the displacement amplifier is fed to a *mixer-discriminator*.

A *discriminator*, in this equipment, is a special type of push-pull amplifier. It is indeed a true phase discriminator and its job is to distinguish between signals calling for a *left* and those calling for a *right* correction. We will ignore the rate circuits for the moment, and follow the signal from the displacement amplifier.

The signal is fed to the grids of the mixer-discriminator. The plates of the discriminator are fed with a.c., so they conduct on only one half of each cycle. But, since the a.c. on the plates is from the same source as that which provides the signal from the pick-offs, the plate voltage must at all times be in phase with the signal on one of the grids. That means that as the signal



Arthur Godfrey, famous CBS-TV star

GET BETTER THAN NEW-SET PERFORMANCE

WITH CBS-HYTRON MIRROR-BACK SCREEN

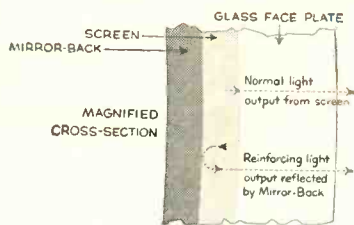

Mirror-Back (aluminized) screen mirrors all the light output to the viewer. Offers: Brighter pictures. Greater contrast. Better resolution. Reduced strain on other components. Full effective anode potential. Prevention of cross-burns. And longer life. For greater customer satisfaction . . . more profit, replace with original CBS-Hytron Mirror-Back tubes. Many types now available.

WITH CBS-HYTRON BLUE-WHITE SCREEN



Ever notice how a shirt laundered with bluing appears whiter? With the CBS-Hytron Blue-White screen, whites are whiter; blacks, blacker. Expanded gray scale gives noticeably sharper pictures in fringe areas. No wonder CBS-Hytron's original Blue-White screen has become the universally preferred standard. Your customers, too, will prefer Blue-White screens.

WITH CBS-HYTRON SMALL-SPOT GUN

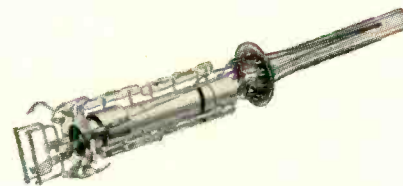

Smaller the spot produced by electron beam, sharper the picture. New lens focusing system of CBS-Hytron Small-Spot Gun reduces spot size 30 per cent. Prove it. Replace with a new CBS-Hytron Small-Spot tube. See, yourself, the superior resolution. Profit more. Combine all three: CBS-Hytron Mirror-Back . . . Blue-White Screen . . . Small-Spot Gun. Get and give that better-than-new-set thrill!

LOOK TO CBS-HYTRON FOR COLOR, TOO!

New CBS-Colortron stresses simplicity. Offers many advantages: Simpler construction. Fool-proof assembly. Lower cost. Lighter weight. Adaptability to mass production in large sizes. Improved contrast. Simplified focusing . . . circuitry . . . adjustment. Resistance to overload. Greater stability. All stemming from unique spherical mask and face plate. You'll appreciate these advantages when you start servicing color TV.



NEW . . . FREE CBS-COLORTRON DATA

For a look into the future, get complete advance data on the new, revolutionary CBS-Colortron: Construction . . . operation . . . application . . . installation and adjustment . . . electrical and mechanical data. FREE . . . from your CBS-Hytron distributor . . . or direct.



FREE CATALOG . . . CBS-HYTRON BUSINESS BUILDERS

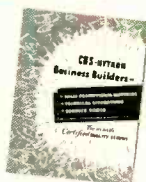

Describes all CBS-Hytron Business Builders to date: Certified Quality Service tags, streamers, decals, illuminated and flange signs, clocks, postal cards, and ad mats. The famous CBS-Hytron service tools. Technical literature. Price lists. Special offers. Get your Business Builders Catalog, PA-37, today . . . from your distributor, or direct.



Manufacturers of Receiving Tubes Since 1921

CBS-HYTRON Main Office: Danvers, Mass.

A Division of Columbo Broadcasting System, Inc.

A member of the CBS family: CBS Radio • CBS Television
Columbia Records, Inc. • CBS Laboratories • CBS-Columbia • and CBS-Hytron

RECEIVING • TRANSMITTING • SPECIAL-PURPOSE • TV PICTURE TUBES • GERMANIUM DIODES AND TRANSISTORS

FEBRUARY, 1954

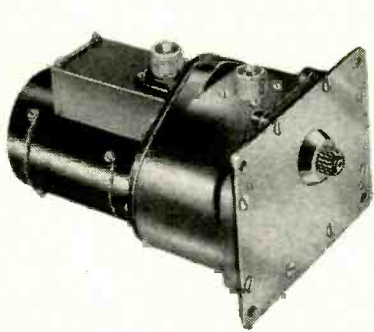

Servo actuator—a special type clutch.

drives one grid positive, the plate current of that tube increases while that of the other decreases. For example, if a positive signal were applied to the upper mixer-discriminator tube in the diagram while the plates were positive, the current in the upper tube would increase and that in the lower tube would decrease.

In the next alternation, the grid of the lower tube is positive and that of the upper one is negative, but since neither tube is drawing plate current, the voltage on the grids will have no effect.

With no signal, each tube's output is equal, so there is an equal voltage drop across each of the 100,000-ohm

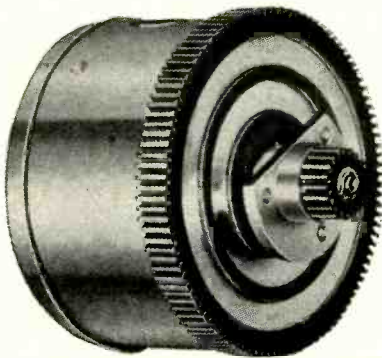
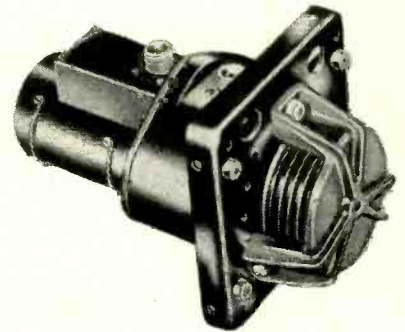

Photo of Lear magnetic powder clutch.

plate resistors. A signal causes one tube's output to increase and the other's to decrease, causing an unequal voltage drop across the plate resistors. For instance, with the positive signal applied to the grid of the upper tube during the conducting half of the cycle, the upper plate resistor would have a larger voltage across it and the lower resistor would have a smaller voltage across it than in the no-signal condition, and a signal is passed on to the final amplifier. Since the phase of the signal depends on which way the pick-off deviates from zero, a right deviation will always increase the signal from one tube and a left deviation will increase the signal from the other tube.



The Lear servo actuator with capstan.

The servo-actuator

The output of the final stage is applied to one of the most interesting units of the whole setup—the Lear servo-actuator. This is a special type of clutch through which power is actually applied to rudders, elevators and ailerons. The servo-actuators are amplifiers in their own right and put out a great deal more power than they receive from the signal circuits.

The complete actuator consists of a 28-volt motor, which supplies the power to be controlled by the signal, two magnetic clutches so geared to it as to move in opposite directions, and a power take-off shaft geared to the clutches. The mechanical circuit is shown in Fig. 3.

The magnetic clutches are made up of two discs separated by a fine, dry powder of magnetic material (finely divided iron particles, nickel-plated to prevent change in their magnetic characteristics with time). One of the discs is driven continuously by the 28-volt motor; the other is attached to the power take-off shaft. A coil in the plate circuit of the output tubes magnetizes the powder in one or the other clutch. As current through one or the other tube in the final amplifier increases, the powder in the corresponding clutch is magnetized and coheres, dragging the output disc around with the one attached to the motor. Transfer of power from the driving disc to the driven disc is proportional to the amount of current flowing in the clutch coils. A small signal produces a slight motion of the rudder, while maximum signal jerks the controls around as would a pilot in an emergency. A magnetizing current of 8 ma applies 200 pound-inches of power to the output circuit. This represents a power amplification of 130 in the servo-actuator.

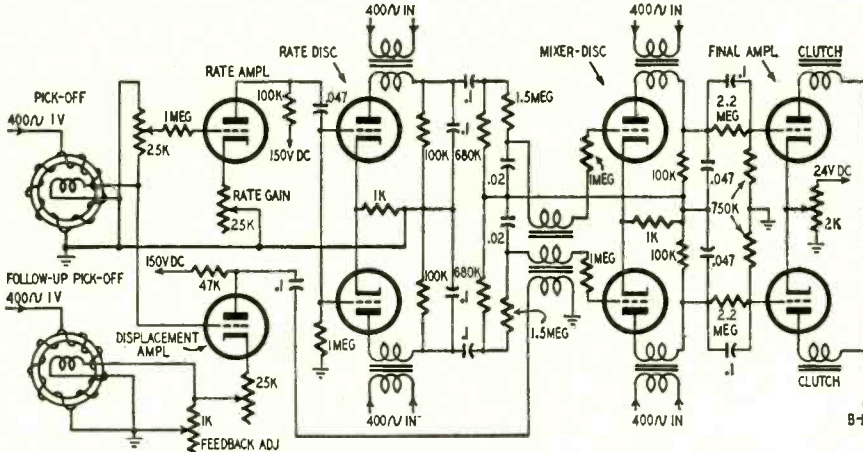

Fig. 2—A simplified basic circuit diagram based on the yaw correction circuitry.

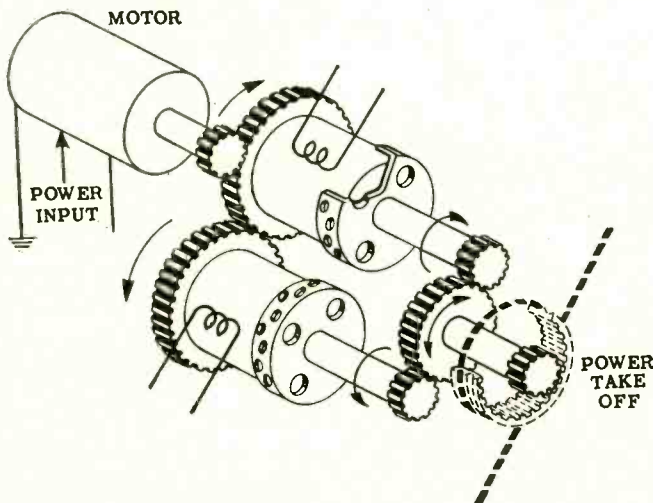

Fig. 3—Diagram shows mechanical circuit of the servo actuator. Motor supplies power that is controlled by signal.

Rates and feedback

As described so far in this article, the Electropilot is remarkably simple—altogether too simple. Such a pilot would have just one drawback—it simply wouldn't work! If signals in the displacement circuits caused the plane to be brought back on course, the plane's own weight and inertia would swing it to the other side of the correct line of flight. Then, of course, corrections would be applied in the opposite direction, with the same result. A plane

with such a pilot would spend most of its time seesawing back and forth across the course, not to mention oscillating around a correct level position, both fore-and-aft and laterally.

However, two things we ignored earlier in the story make the Electropilot as responsive and foresighted as an untiring human pilot. These are the *rate* and the *follow-up* (feedback) circuits.

The human pilot never applies just enough correction to bring the plane back to its line of flight, and then holds the controls till it gets there. If a sudden gust of wind swings his craft off course, he immediately applies a *great deal of correction* to stop the deviation and bring the plane back toward correct course. Then—as the craft responds—he eases off on the controls, bringing them back to center—or sometimes a little beyond it—long before the plane is on course. He anticipates!

With the Electropilot the signal from the pick-off is fed to a *rate amplifier* in parallel with the displacement amplifier. Its output goes to a *rate discriminator*. (See Fig. 2)

The rate discriminator detects the *rate* at which the signal from the inductive pick-off is changing, and puts out a signal proportional to that rate. It feeds the mixer-discriminator (so called because it mixes the rate and displacement signals) and supplies to it voltages which add to or subtract from the displacement signals. These are fed to the mixer-discriminator in push-pull, so the output of the rate amplifier is also push-pull, being supplied with 400-cycle alternating current 180° out of phase by the two transformers in its plate circuits. While one plate is conducting, the other is negative. The signals from the rate amplifier are applied to the grids in parallel.

The effect is the same as in the mixer-discriminator. If a positive signal is applied while the upper tube is conducting, the current in that tube is increased. There is no effect on the lower tube, since its plate current is zero. During the next half cycle, the lower tube conducts, but the signal on its grid is now negative, so its plate current is lower than it would be with no signal. Therefore a signal indicating the phase of the input signal is passed on to the mixer-discriminator.

The rate discriminator differs from the mixer-discriminator also by having a pair of coupling capacitors in its output. Without them, the circuit would be a d.c. amplifier, and any deviation from the straight-ahead (null) position would set up a voltage proportional to the *amount* of deviation. With them, the circuit is an a.c. amplifier, and no amount of displacement (voltage difference across the 100,000-ohm plate resistors) can send a signal into the next stage, *unless that voltage is changing*. If the signal supplied by the inductive pick-off changes suddenly, the voltage across the plate-load resistors varies rapidly and a strong signal, in phase with the signal from

You name the
speed . . .

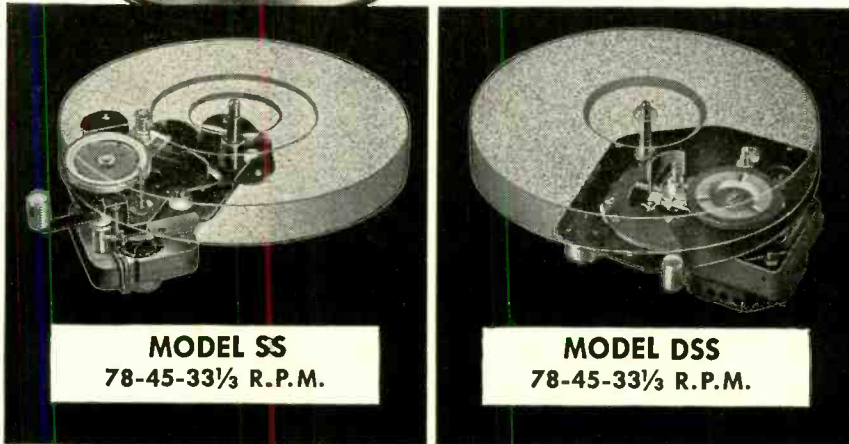

MODEL SS
78-45-33 $\frac{1}{3}$ R.P.M.

MODEL DSS
78-45-33 $\frac{1}{3}$ R.P.M.

G.I. has the phonomotor

Single speed . . . two speeds . . . or three speeds . . . there's no limitation on combination or type when you choose from General Industries' broad line of phonomotors.

For example, shown above are two of General Industries' newest three-speed developments: Model SS, an extremely compact design with 2-pole motor; and Model DSS, with 4-pole motor and heavy-duty construction features for high fidelity reproduction. Both models incorporate the General Industries' unique, stepped-shaft drive principle which assures accurate reproduction and trouble-free long life. Both contain an "OFF" position in which the idler wheel is released from contact with the turntable rim. "OFF" position on Model DSS also cuts off current to motor.

For complete information, specifications, dimensions, and quantity-price quotations on these, or other phonomotors in the famous Smooth Power line, write us *today*.

THE GENERAL INDUSTRIES CO.
DEPARTMENT ME • ELYRIA, OHIO



EASY TO LEARN CODE TELEVISION

Big demand for graduates

It is easy to learn or increase speed with an Instructograph Code Teacher. Affords the quickest and most practical method yet developed. For beginners or advanced students. Available tapes for beginner's alphabet to typical messages on all subjects. Speed ranges 5 to 40 WPM. Always ready—no GRM.

ENDORSED BY THOUSANDS!

The Instructograph Code Teacher literally takes the place of an operator-instructor and enables anyone to learn and master code without further assistance. Thousands of successful operators have "acquired the code" with the Instructograph System. Write today for convenient rental and purchase plans.



B.S. DEGREE IN 27 MONTHS in radio including TV engineering—VHF, UHF, AM and FM. Students use over \$100,000 worth of equipment including 2 large commercial type transmitters in new TV lab. Intense specialized course includes strong basis in mathematics, science and advanced design in radio and TV.

Hundreds of young men each year are earning engineering degrees in this recognized institution. Start any quarter. Many earn a major part of expense in this industrial center. Low tuition. Competent instruction. Thorough, intense, practical program.

Also B.S. DEGREE IN 27 MO. in Aeronautical, Chemical, Civil, Electrical and Mechanical Engineering. G.I. Gov't approved. Enter March, June, Sept., Dec. Free catalog. ENROLL NOW.

INSTRUCTOGRAPH COMPANY

4701 Sheridan Rd., Dept. RC, Chicago 40, Ill.

INDIANA TECHNICAL COLLEGE
1724 E. Washington Blvd., Fort Wayne 2, Indiana

the displacement amplifier, is applied through the coupling capacitors to the mixer-discriminator grids. This signal is proportional to the *rate of change* of the pick-off voltage, and adds to the displacement signal, producing a far greater correction for a sudden change than for a gradual one.

As soon as the plane has stopped its deviation from course, the signal from the pick-off ceases to increase, so the output of the rate discriminator drops to zero. The displacement amplifier still supplies a signal which continues to bring the ship back toward the correct line of flight.

Now, as the plane returns to course, the signal from the inductive pick-off starts to fall. The rate amplifier again marks this change, with an output *opposite in phase* from that of the displacement amplifier. This acts to *reduce the amount of correction* as the ship approaches its true course, and is exactly what a human pilot would do.

The rate discriminator is the circuit that permits the Electropilot to anticipate. Current in a capacitor leads the applied voltage by 90°. This means—in this particular application—that the heaviest current into the capacitor flows at the *beginning of a cycle*—just at the time the Electropilot discovers that the ship is swinging off course. It therefore applies the greatest correction at the very start—just as would a human pilot—and then allows the amount of correction to drop off as the ship starts to come back to course.

The follow-up circuits are equally important. Acting almost like an automatic gain control in radio or TV, they make it possible for the Electropilot to be extremely sensitive to small deviations from correct course, while not responding too strongly to large ones. The follow-up pick-offs are located on the rudders or other surfaces to be controlled, and they supply to the cathode of the displacement amplifier a signal *out of phase* with the correction signal. When a large correction is applied, the rudder surfaces swing widely, and the follow-up pick-offs send a signal almost strong enough to neutralize the correction signal. This has the same effect as returning the steering wheel of an automobile toward center after bringing it far around for an unusually sharp curve.

One more circuit helps the Electropilot anticipate and make large, quick corrections when sudden forces act on the craft. It acts to slow down and avoid overshoot as the plane comes back toward its proper course. It is the network consisting of a 0.1- μ f capacitor shunted by a 2.2-megohm resistor in each grid of the final amplifier. Without the capacitors, the grids would receive signals through the series resistors. With them, a stronger signal is received if the signal passing through is changing rapidly. There is then enough voltage drop across the resistors to set up a voltage across the capacitor, and a signal reaches the grid through both capacitor and resistor.

The signal the final amplifier receives is strongly modified by the rate discriminator. But the capacitor in the grid circuit of the final amplifier makes it also a type of rate discriminator. Therefore it becomes sensitive to the *rate at which the rate is changing*. In simpler words, it puts the strongest signal out when the rate at which the aircraft is being forced off its course is *increasing*—just when the strongest force on the controls is needed. And the anticipating abilities of the capacitors apply most of that force in the earlier portion of the cycle.

The combination of circuits above, when adjusted to the plane on which the Electropilot is installed, provide plenty of correction for any departure from correct course, angle of climb or descent, or from the horizontal (in straight flight) or correct bank (in turns). It provides also just the right amount of "easing off" on the controls once the immediate correction has been made, and assures the return of the plane to its correct attitude, with the minimum of overshoot.

Further features

Not only can the Electropilot keep the plane on a desired course and at a desired altitude and bring it back when some outside force has moved it from its correct co-ordinates, but it maintains desired angles of climb or dive, and can be set to pick up the landing beams of an airport and bring the ship in automatically. END

PARTS for #630 TV SETS

STANDARD CASCODE TUNER, incl. tubes	\$22.49
ESCUTCHEON PLATE, for tuner	.69
COMPLETE SET OF KNOBS, incl. decals	1.34
POWER TRANSFORMER, 295ma.	201T6... 9.97
VERTICAL OUTPUT TRANS.	204T2... 2.69
VERTICAL BLOCKING TRANS.	208T2... 1.32
HORIZONTAL OUTPUT TRANS.	211T1... 2.47
HORIZONTAL OUTPUT TRANS.	211T5... 3.98
FOCUS COIL, 247 ohms,	202D1... 2.29
FOCUS COIL, 470 ohms,	202D2... 3.42
DEFLECTION YOKE, 60"	201D1... 2.97
DEFLECTION YOKE, Cosine 70°	206D1... 3.98
SOUND DISCRIMINATOR TRANS.	203K1... 1.12
1st PIX I.F. TRANSFORMER,	202K2... 1.08
2nd PIX I.F. TRANSFORMER,	202K3... 1.08
1st & 2nd SOUND I.F. TRANS.	201K1... 1.02
HORIZONTAL DISCRIM. TRANS.	208T8... 1.49
FILTER CHOKE, 42 ohms	202K4... 1.08
CATHODE TRAP COIL,	203K1... 1.12
WIDTH CONTROL COIL, keyed AGC IR4AG	201R3... .39
HORIZONTAL LINEARITY COIL,	202L1... .39
3rd & 4th PIX COILS	204L1... .09
FILAMENT CHOKES	203L1... .18
VIDEO PEAKING COIL,	203L2... .18
VIDEO PEAKING COILS	203L3... .18
VIDEO PEAKING COILS	203L4... .18
ION TRAP BEAM BENDER, double	203D3... .98
ION TRAP BEAM BENDER, single	203D1... .79
PUNCHED CHASSIS PAN, cadmium plated	4.87
#30-KIT, screws, nuts, rivets, washers	1.69
HI VOLTAGE CAGE ASSEMBLY, complete	3.73
VOLTAGE DIVIDER SHIELD & COVER	1.79
ELECTROLYTIC COND. SUB-CHASSIS	.94
SOUND DISCRIMINATOR SHIELD	.19
DEFLECTION YOKE BRACKET	.29
DEFLECTION YOKE MOUNTING HOOD	.59

#630 PARTS & COMPLETE SETS

TV WIRE & SOLDER KIT, for any Set	\$1.49
VIDEO AND I.F. KIT, 19 items	7.84
VARIABLE CONTROL KIT, 9 controls	5.83
CARBON RESISTOR KIT, 107 resistors	6.98
WIREWOUND RESISTOR KIT, 4 resistors	2.31
BRACKET AND SHIELD KIT, 18 items	8.63
ELECTROLYTIC CONDENSER KIT, 6 cond	7.37
TUBULAR CONDENSER KIT, 38 condensers	4.28
CERAMIC CONDENSER KIT, 28 condensers	3.37
MICA CONDENSER KIT, 11 condensers	1.38
TERMINAL STRIP KIT, set of 30	.98
COMPLETE SET OF TUBES, 29 tubes	30.31

UNIVERSAL Picture Tube BRACKETS

Fits All 12 1/2" to 21" picture tubes

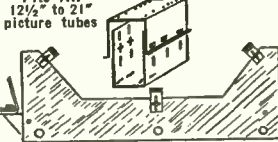

Complete—including band that holds picture tube.

\$6.97

100 ASSORTED TUBULAR CONDENSERS

All Are Standard Brands & Desirable Sizes

\$15.00 Value Only **\$4.69**

100 — ASSORTED 1/2 WATT RESISTORS	\$3.97
15 — Asst. Radio Electrolytic CONDENSERS	\$4.74
15 — Assorted TV Electrolytic CONDENSERS	\$6.88
100 — ASSORTED MICA CONDENSERS	\$4.99
100 — ASSORTED CERAMIC CONDENSERS	\$4.99
100 — ASSORTED 1 WATT RESISTORS	\$5.86
100 — ASSORTED SOCKETS Octal, Localt & Miniature	\$3.92
100 — ASSORTED KNOBS SCREW & PUSH-ON	\$3.97
10 — VOLUME CONTROLS ASSORTED, WITH SWITCH 1/4, 1/2, 1, 2 meg. and others	\$2.94
10 — VOLUME CONTROLS ASSORTED, LESS SWITCH 1/4, 1/2, 1, 2 meg. and others	\$1.94

Resistor & cond. code charts FREE with each order

BELIEVE IT OR NOT!

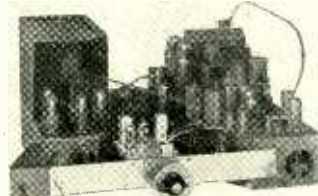

It's Yours for **\$7.89**

Lists for \$24.95

AM SUPER RADIO FOR #630 or other TV. Complete, ready to install w/tubes & instructions.

72 OHM COAXIAL CABLE

100' — hank	\$ 4.64
500' — spool	21.99
1000' — two 500' spools	39.86



300 OHM TWIN LEAD-IN

100' — hank	\$ 1.48
500' — spool	6.91
1000' — two 500' spools	12.82



INDOOR TV ANTENNA

- Newest, panorama high-gain type
- Brass 3-section chrome plated dipoles
- Absolutely tilt and tip-proof

list price \$5.95 special at **\$1.69**



BROOKS RADIO & TV CORP., 84 Vesey St., Dept. A, New York 7, N. Y.
RADIO-ELECTRONICS

THE #630 TV RECEIVER remains unmatched for quality and performance • • • RCA designed and developed this set quality-wise not price-wise • • • The original 10" set retailed at \$375.00 • • • Subsequent TV sets serve to prove the sacrifice of quality for price • • • what better proof can there be of its superiority than the fact that it is the choice of TV engineers and TV technicians! Herewith we offer you — **YOUR BEST BUYS IN TV!** — All you pay is the price shown • • • Excise taxes have already been paid by us.

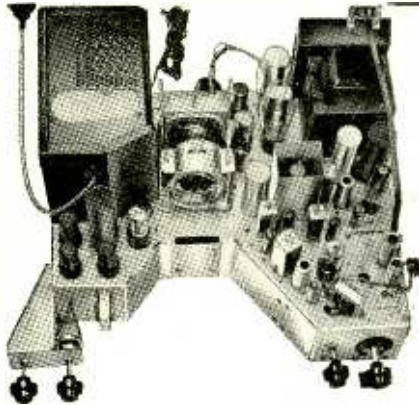

Build your own

#630 Super Deluxe TV CHASSIS

with . . . U. H. F.

With a **#630 SUPER DELUXE 31-TUBE TV KIT** including your favorite U.H.F. Station • OPERATES 16" to 24" PICTURE TUBES • Engineered in strict adherence to the genuine RCA #630 plus added features • FULL 4MC BANDWIDTH • CAS-CODE TUNER • COSINE DEFLECTION YOKE • LARGER POWER TRANSFORMER • KEYED AGC • 12" SPEAKER • UNIVERSAL MOUNTING BRACKETS • CONDENSERS and RESISTORS at rated capacities and tolerances. You receive a COMPLETE SET OF PARTS and TUBES, everything needed is included (less wire & solder). All I.F. Coils and Transformers are factory pre-aligned and tuned. You will enjoy building it with "LIFE-SIZE" easy to follow step-by-step ASSEMBLING INSTRUCTIONS" included with each KIT.

NOTHING BETTER AT ANY PRICE !
only . . . **\$119.44** (less CRT)

#630 SUPER DELUXE TV CHASSIS

with U.H.F.—Licensed under RCA patents

COMPLETE READY TO PLUG IN AND PLAY—Similar in characteristics and features to the TV KIT at left • Manufactured especially for us by Regal Electronics Corporation • No efforts or expense have been spared in workmanship or materials, to make this #630 SUPER DELUXE TV CHASSIS the Best obtainable for fringe areas, clarity and all-around-performance, regardless of price. Customers report reception better than 200 miles • Each Set is factory aligned and air-tested • All parts carry the RMA three month guarantee • Our mass volume of business on this CHASSIS (numbering thousands of pleased customers) now makes it possible for us to reduce the price to

\$157.97 (less CRT)
only

#630 TV SPECIALS BY TECH-MASTER

bath with U.H.F.

TECH-MASTER Model C-30 TV CHASSIS. This Model has retained the outstanding characteristics of the RCA-630 circuitry, namely the four-stage, full bandwidth picture IF strip and the three-stage FM sound section • In addition, the latest innovations in synchronization and sweep circuits have been incorporated to produce a custom-quality receiver assuring outstanding performance • 30 tubes, 12" speaker.

Complete Ready to Plug in and Play **\$149.50** (less CRT)
Special at

TECH-MASTER Gold Medal Model 2430-9 TV CHASSIS, 90° deflection, operates all 24" or 27" rectangular and 30" round picture tubes. The last word in TV achievement • Ideal for wall or custom-cabinet mounting • Detailed technical data mailed on request, however with the knowledge that this CHASSIS is a 30-tube #630 with both TECH-MASTER'S and OUR guarantee, you need not hesitate sending your order in now.

Complete Ready to Plug In and Play **\$262.50** (less CRT)
Special at

SHELDON FINEST GUARANTEED PICTURE TUBES

MOST desirable 5 sizes—ALL RECTANGULAR • • • BRAND NEW in Factory Sealed Cartons—With a Full Year Guarantee

17" #17BP4A **\$29.63** | **20"** #20CP4A Aluminized **\$39.74** | **21"** #21EP4A Aluminized **\$44.68** | **24"** #24CP4A Aluminized **\$58.26** | **27"** #27NP4A Aluminized **\$82.57**

CUSTOM-BUILT CABINETS FOR #630 AND ALL OTHER TV SETS — from FACTORY to YOU

5 LEADING STYLES in genuine mahogany or walnut (blond 10% extra) • Ready drilled for any #630 TV chassis and cutout for any 14", 17", 19", 20" or 21" picture tube at no extras in price • Also supplied with undrilled knob panel for any other TV set • EVERYTHING NECESSARY for an easy perfect assembly is included • Each cabinet is delivered complete as pictured with mask, safety glass, mounting brackets, backboard, backup, hardware and assembling instructions • Each cabinet is shipped in an air cushioned carton from FACTORY to YOU!

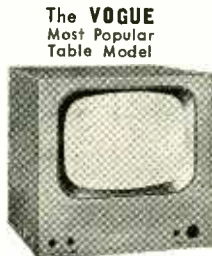

The **VOGUE**
Most Popular
Table Model

H-25", W-26", D-22"

\$39.89

VOGUE also available for 24" or 27" picture tube

H-31", W-27", D-23"

\$62.54

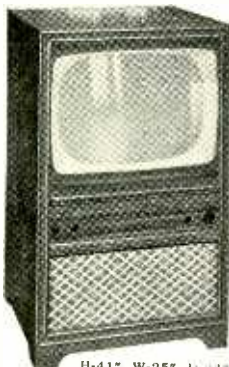

The **MANHATTAN**
Style, Quality, Price

H-41", W-25", D-23"

\$59.37

MANHATTAN for 24" or 27" CRT
H-46½", W-27¾", D-24" **\$86.22**



The **MAYFAIR**
Exquisitely modern, with an elegance of simplicity in styling.

H-40", W-26", D-25"

\$98.56

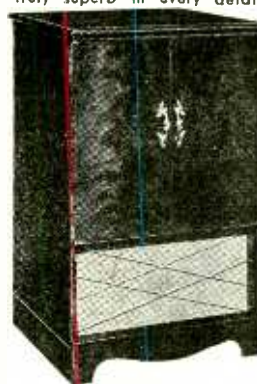

The **PLYMOUTH**
Choice of interior Decorators, truly superb in every detail.

H-40", W-27", D-23"

\$105.48

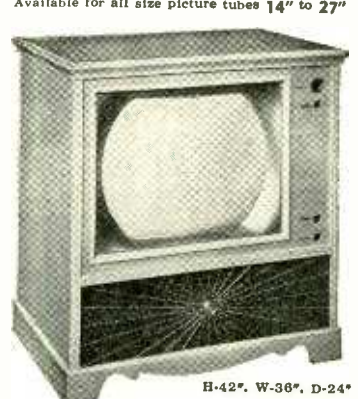

The **TOWN & COUNTRY**
Patterned after the popular credenza. Available for all size picture tubes 14" to 27"

H-42", W-36", D-24"

For 14", 16", 17", 19", 20", 21", 24" or 27" C.R.T.'s **\$109.62**

#630 TV BASIC PARTS KIT

PUNCHED & DRILLED CHASSIS PAN BRACKET & SHIELD KIT (18 items) All for Video & I.F. KIT (19 items) Only
POWER TRANSFORMER #20IT6
VERTICAL OUTPUT TRANSFORMER
VERTICAL BLOCKING TRANSFORMER #21IT5
FLYBACK TRANSFORMER #21IT5
FOCUS COIL, 470 ohms #202D2
COSINE DEFLECTION YOKE 70°
\$39.49
Including LIFE-SIZE TV BUILDER INSTRUCTIONS

Modernize a #630 or any TV Set with a

STANDARD CASCODE TUNER

For better all around performance

Complete with tubes, and Brooks CAS-CODE MANUAL with step-by-step instructions and all extra parts needed.

\$22.49

Brooks CASCODE MANUAL, how to install Cascode Tuner in any make TV Set. Postpaid . . . **50¢**

PULSE KEYED AGC KIT

Finest, most accurate and the easiest Kit to install in a #630 or in any other make TV receiver. Improves performance, and insures a steady picture on all channels.

COMPLETE SET OF PARTS \$4.59
Including GAUG tube & Instructions

Brooks LIFE-SIZE TV INSTRUCTIONS for building any #630 TV Receiver. Postpaid. **\$2.49**

HINTS FOR BETTER PERFORMANCE on your #630 TV receiver. Postpaid **\$1.00**

BROOKS RADIO & TV CORP., 84 Vesey St., Dept. A, New York 7, N. Y.

FEBRUARY, 1954

KAY-TOWNES

Announces

the new
Super

"KATYS"

(PATENTS PENDING)

Highest Gain

ALL-CHANNEL VHF ANTENNAS
EVER DESIGNED!

GUARANTEED

**TO OUT-PERFORM ANY OTHER
ALL-CHANNEL VHF ANTENNA
ON THE MARKET**

Practically every TV Antenna maker in America has made just such statements as these . . . *but there is a big difference in making these broad claims and then being able to back them up!*

WE CAN! We are prepared to run a PERFORMANCE TEST with *anyone . . . anywhere . . . anytime . . .* to prove the vast superiority of the new SUPER "KATYS" over all other all-channel VHF antennas . . . regardless of manufacture, design, type or number of bays!

IN FACT, WE WILL POSITIVELY AND ABSOLUTELY GUARANTEE THAT OUR SINGLE-BAY SUPER KATY WILL OUTPERFORM ANY VHF 4-BAY ANTENNA MADE TODAY!

Our 2-Bay SUPER KATY is designed for *extremely difficult* reception areas. It has been tested in many practically impossible locations . . . **AND HAS NEVER FAILED TO BRING IN A PICTURE RATED EITHER "VERY GOOD" OR "EXCELLENT"!**

4½ Years IN DEVELOPMENT...

**THE AMAZING SUPER KATY DESIGN MAKES OTHER VHF ALL-CHANNEL ANTENNA DESIGNS AS OBSOLETE AS THE HORSE AND BUGGY!
WE CHALLENGE YOU TO TEST IT . . . ANYWHERE!**

Super
KATY-2
2-BAY

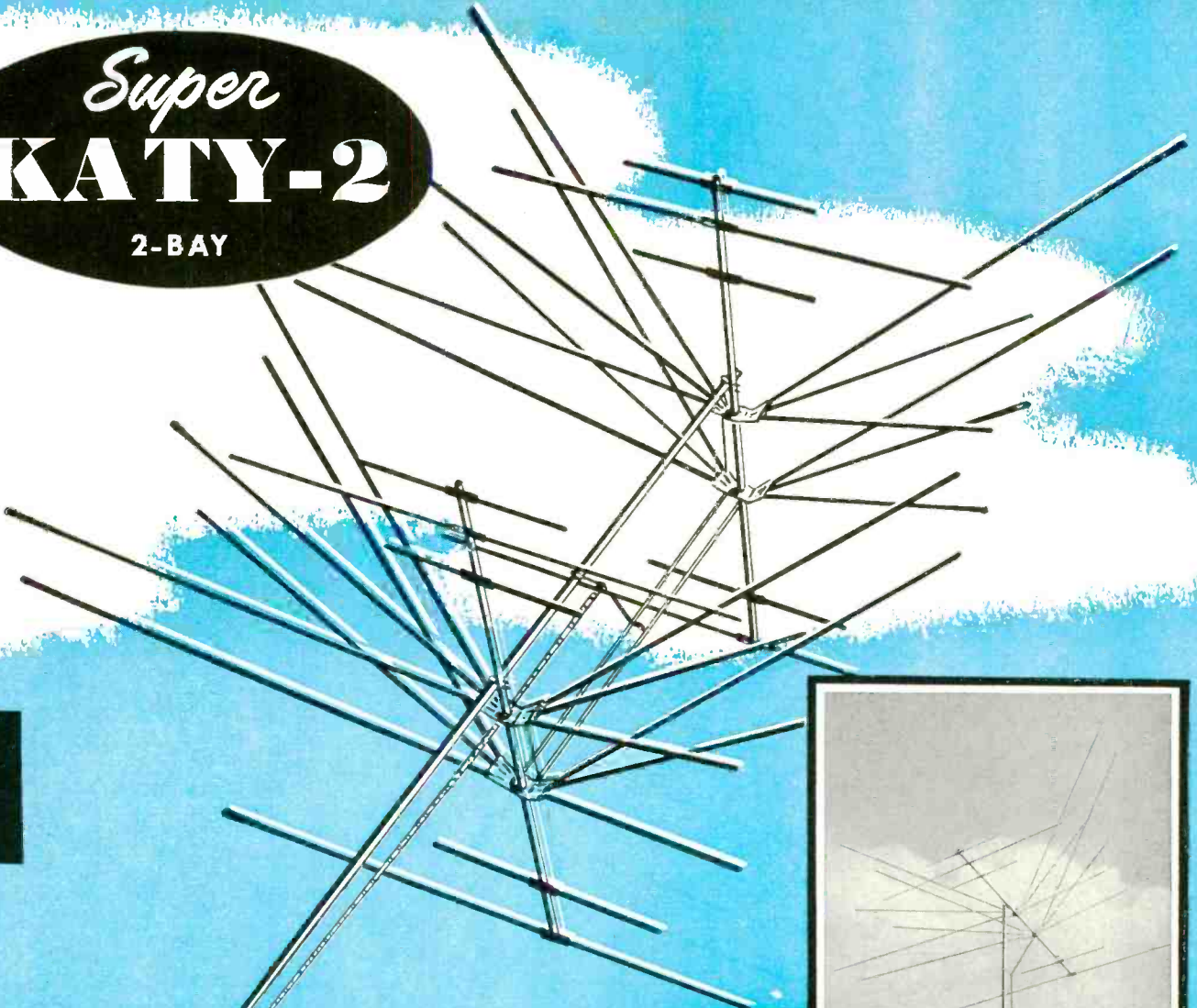

Super
KATY-1
SINGLE-BAY

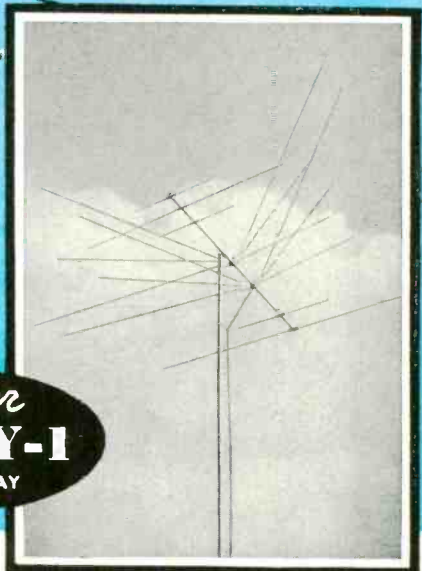

Now **THE WORLD'S FINEST ALL-CHANNEL VHF RECEPTION!**

The SUPER KATY all-channel VHF antennas feature a twin-driven array with a combination of special cut elements for a close 300 OHM impedance across the entire VHF Band. This feature in conjunction with the long, accumulative fan dipoles, with directors and reflectors properly cut and spaced, results in performance never before obtained by any antenna design . . . including our own "BIG JACK", whose design has been so widely "hijacked".

Actual tests show that the Single-Bay KATY-1 will outperform any 10-element Yagi on every channel, 7 through 13 . . . and will perform as well as any 10-element Yagi on every channel, 2 through 6.

	List Price
SUPER KATY-1	\$25.00
Single-Bay	
SUPER KATY-2	\$50.00
2-Bay	

K-T Antennas are sold through selected distributors only . . . write for name of your nearest jobber.

KAY-TOWNES
ANTENNA COMPANY
ROME, GEORGIA

Recognized leaders in the field of fringe area antenna design

MICROWAVE RADIOMETERS

A new instrument for exploring the universe

by measuring radiation from distant sources By DONALD B. HARRIS*

WHEN Sir William Herschel, the great pioneer astronomer, trained a large telescope for the first time on the Milky Way, he saw the nebulous glow of the galaxy resolved into millions of stars; but when he came to the Coal Sack, the dark patch in the vicinity of Sagittarius, he literally believed he had found a "hole in the heavens" ("Wahrlich hier ist ein Loch im Himmel!"). Later generations of astronomers came to doubt the validity of Herschel's conclusions because it did not seem likely to them that the stars were distributed in such a way as to create a tunnel

*Associate Director, Electronics Research Laboratory, Stanford University.

pointed directly at the Earth. But the true explanation—that the Coal Sack is actually a cloud of dust obscuring our view of the stars behind it—was not finally established until quite recently, when radiometry showed that this dark-spot radiates a measurable amount of heat.

Radiometry is the technique of measuring the rate at which energy in some particular frequency band is radiated from a distant source. According to well-established principles of physics, all absorbing bodies emit electromagnetic radiation (light, heat, or radio waves) at all frequencies and at rates which depend on their temperatures. Radiometry's usefulness to science arises from the fact that, once the rate of energy radiation is known, the

temperature of the source can be computed. The "black-body" radiation curves of Fig. 1 show the relationships involved. In this figure, the horizontal scale represents the wavelength (in angstrom' units) of the radiation emitted; the vertical scale is the rate of emission; and each curve shows the rate at which energy is radiated throughout the optical spectrum by a hypothetical "black" or perfectly absorbing body when heated to the Kelvin² temperature indicated. Thus the curve for a temperature of 5,000 degrees Kelvin shows that a black body heated to this temperature radiates about 0.1 calory³ per square centimeter per second (cm²/sec) at a wavelength of 5,000 angstroms; about 0.06 calories cm²/sec at a wavelength of 10,000 angstroms; about 0.02 calories cm²/sec at 15,000 angstroms; and so on. The curve for 6,000° K shows that a body heated to this temperature radiates more than double the amount of energy throughout most of the spectrum than is radiated by a body heated to 5,000°.

The curves in Fig. 1 also point up another highly important relationship between temperature and energy radiation. Not only does the amount of energy radiated increase enormously with a relatively small rise in temperature, but the frequency of the strongest radiations increases as the temperature rises. This can be demonstrated very simply with an ordinary 6-volt radio pilot lamp, and four dry cells connected in series. With only one or two cells in series across the lamp, the filament glows dull red—the lowest frequency in the visible portion of the optical spectrum. Add one more cell in series and the filament not only gives off more light but changes color to yellow—a higher frequency. With

¹ The angstrom (A) is a unit of wavelength preferred by physicists and astronomers for identifying radiations in the optical and superoptical range because it allows these incredibly high frequencies to be expressed in relatively small numbers. One A is equal to 1/100,000,000 centimeter (10⁻⁸ cm). Thus according to the familiar formula

$$\lambda = \frac{300,000,000}{f}$$

the wavelength decreases as the frequency increases and is much simpler to identify violet light, for example, by its wavelength (4,000 A), than by its frequency (7.5 × 10¹⁴ cycles).

² The Kelvin, or absolute scale of temperature, is identical to the more familiar centigrade (now known as Celsius) scale except that zero on the Kelvin scale (0° K) is the theoretical absolute zero (-273.13° C), while 0° C is the temperature of melting ice.

³ The calory is the basic unit of heat energy in the metric system. In general it represents the quantity of heat required to raise the temperature of 1 gram of water by 1° C.

RADIO-ELECTRONICS

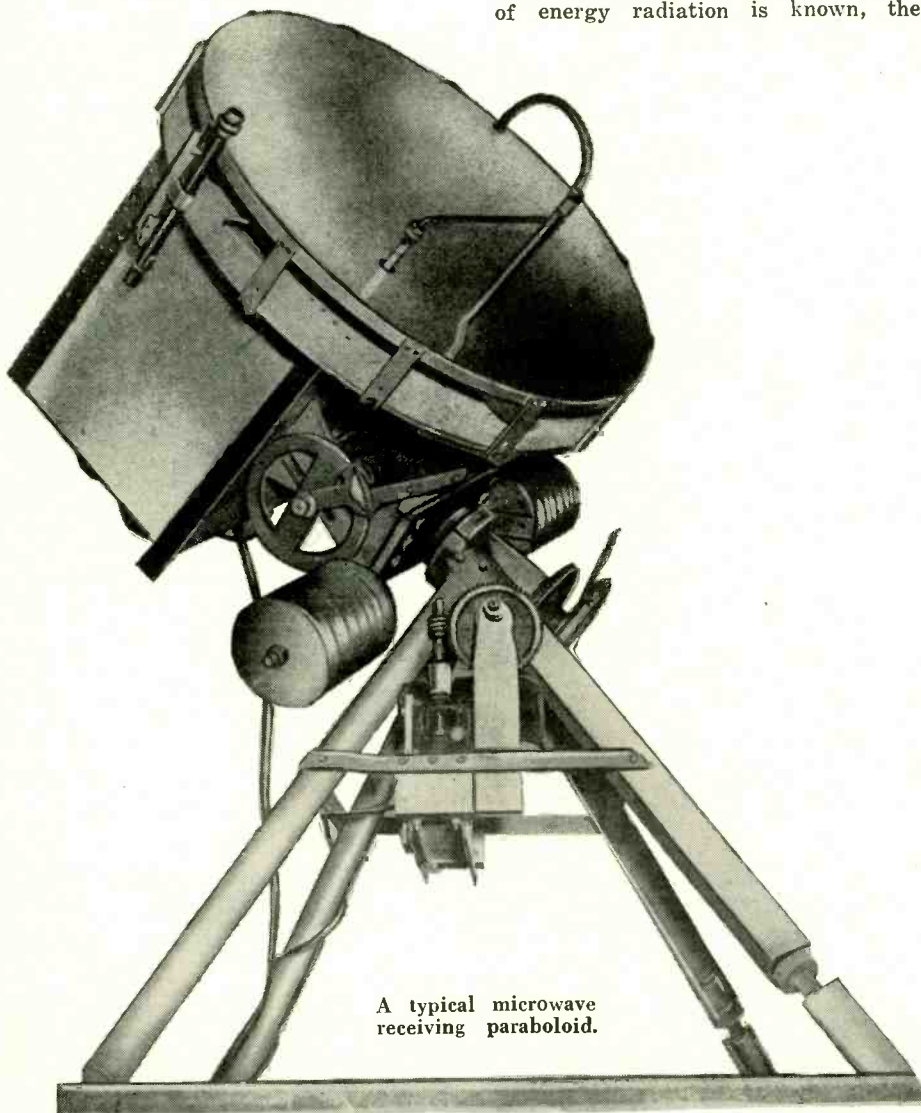

A typical microwave receiving paraboloid.

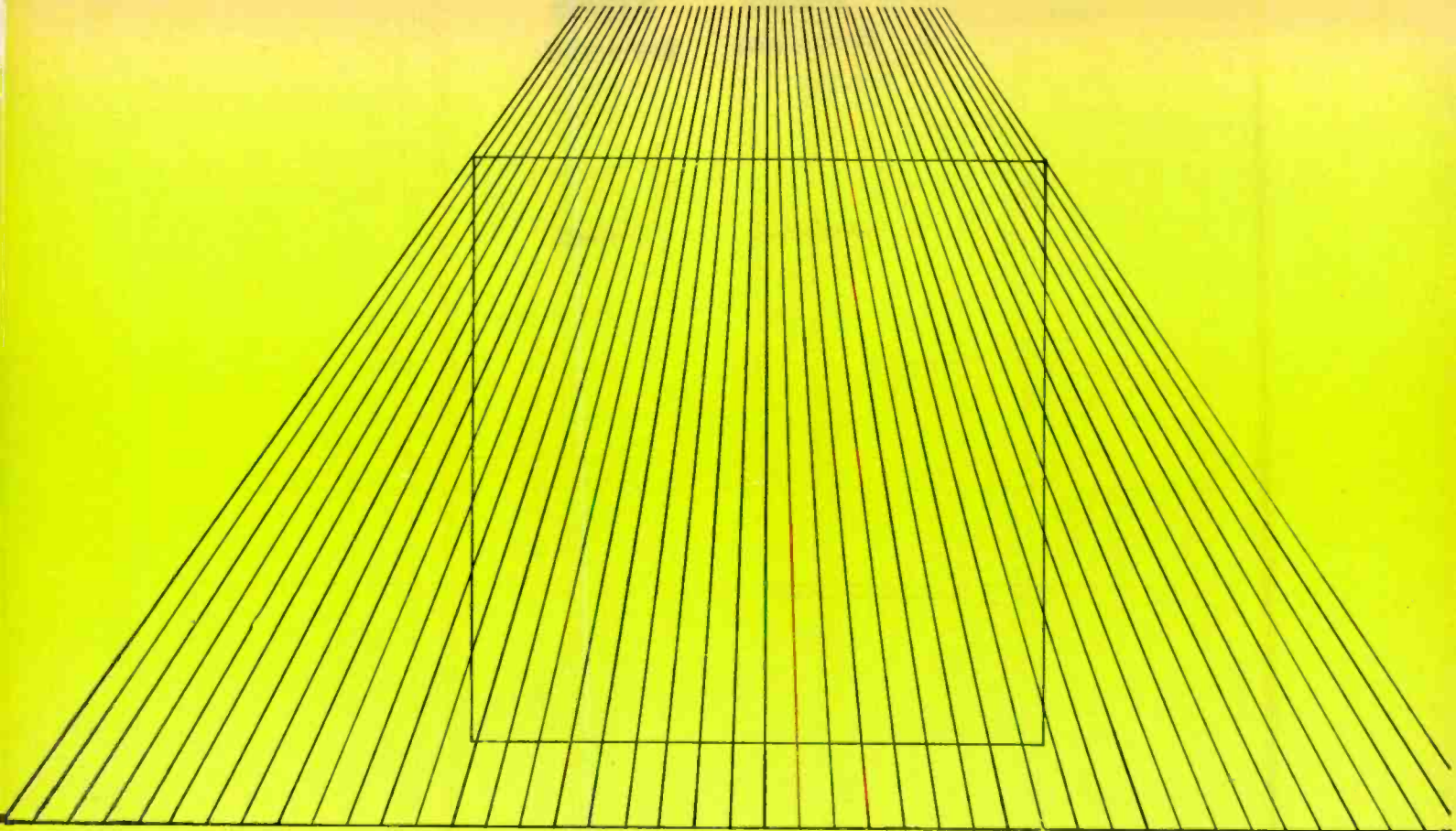

THINGS ARE **NOT** AS THEY SEEM...

This *is* a perfect square.
It is an optical illusion that the sides bend.

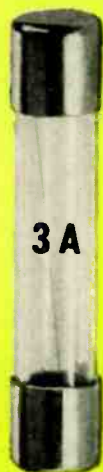

3 amps fuse will not blow at 3 amps.

Fuses are not rated by the current at which they blow. Fuses are rated by the maximum current they should carry indefinitely.

Each type of fuse blows according to the requirements of the equipment it was designed to protect.

Littelfuse has cooperated with NEC, Underwriters, Armed Forces MIL Specs Committees in establishing the characteristics of the various fuse types.

Littelfuse holds more design patents on fuses than all other manufacturers combined.



3 AG "SLO-BLO"



3 AB



8 AG U/L



1 AG



4 AG ANTI-VIBRATION

LITTELFUSE

DES PLAINES, ILLINOIS

Robert Plaines, 1948

now!

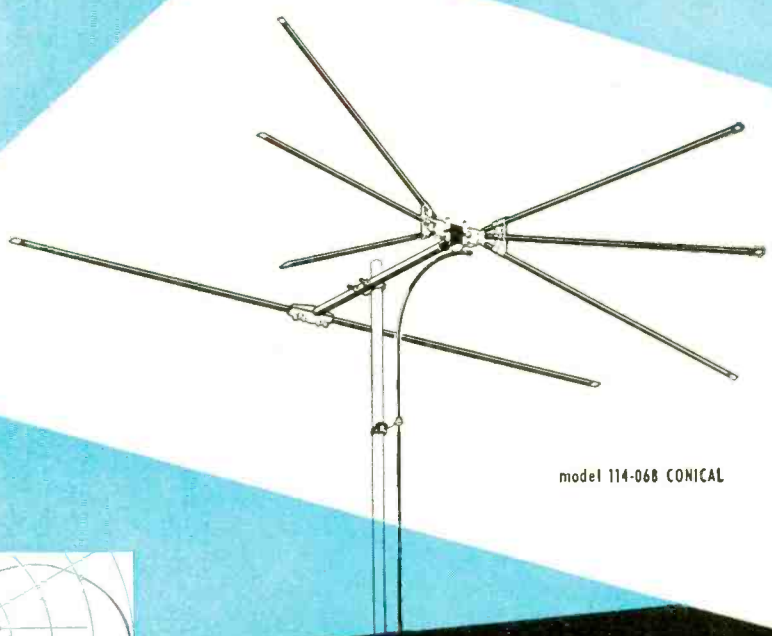

model 114-068 CONICAL

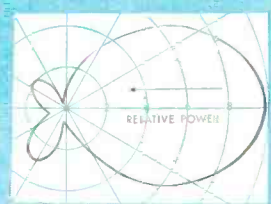

69 mc - channel 4

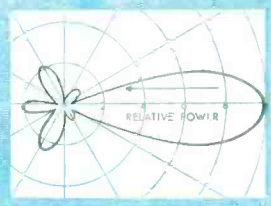

195 mc - channel 10

Directivity patterns of the CONICAL are exceptionally clean. The strong major lobe indicates fine directivity.

a VHF CONICAL antenna built to the Quality Standards of

Now ready to join the fastest-growing and fastest-selling antenna line in the United States is a new AMPHENOL VHF antenna. Designed to supplement the fabulous INLINE* for VHF reception, the new CONICAL antenna will give true-picture reception in every VHF signal area: major, fringe and long-distance. Gain and directivity have been engineered to the high AMPHENOL standards that have set the quality goal for the entire industry; craftsmanship attention to the small but important details make the CONICAL another example of AMPHENOL's fine antenna work.

AMPHENOL CONICALS are available in single, two and four bay models. The stacked models use unique phasing harnesses for extra gain. The CONICAL may be obtained in packaging that contains all the necessary stacking equipment or else the individual antenna may be purchased one or two to a carton. In addition, the single bay CONICAL is available in a complete antenna installation kit.

All elements of the CONICAL are constructed of sturdy, long-lasting seamless aluminum tubing - assuring rust-free years of top performance.

*Reissue U. S. Patent 23,273

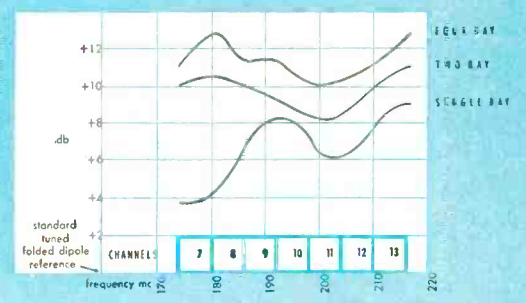
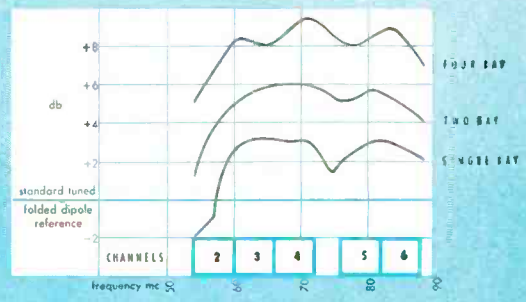

High gain of the CONICAL is illustrated in the gain charts for single, two bay and four bay models. Measured in accordance with proposed RETMA standards, the charts also show the desirable flatness of the gain.



AMERICAN PHENOLIC CORPORATION • chicago 50, illinois

all four cells (6 volts) across the lamp, the filament gives off almost pure white light—showing the addition of still higher frequencies (green-blue, and violet) to the radiation.

(This also explains the dangerous radiations associated with atomic-bomb explosions. The multimillion-degree heat of fission releases radiations that extend up into the incredibly high frequencies of *alpha*, *beta*, and *gamma* rays, and perhaps even to the highest frequency known—the *cosmic ray*. Of course, these frequencies are also radiated continually by the sun and other hot bodies in space, but all except super-powerful cosmic rays are filtered out by cosmic dust and the Earth's atmosphere.—*Editor*)

The energy emitted in the region A-A in Fig. 1 is visible to the naked eye in the form of light. Radiometers for wide-band operation in this region may be simply *bolometers*, strips of metal capable of absorbing all or most of the radiation falling on them.

The bolometer is placed at the focus of a large telescope, and the amount of energy absorbed is determined by measuring the change in the electrical resistance of the strip. The rate of emission at the source can be calculated from the amount of energy absorbed by taking into account the energy-gathering power of the telescope and the angular size of the emitting body. Reference to the black-body radiation curves then gives the temperature of the body.

A more specialized type of instrument for narrow-band measurements is the spectro-bolometer, in which a prism allows only light in a certain wavelength band to fall on the metal strip. For example, a spectro-bolometer might show that radiation over a band 1-A wide, at the wavelength λ marked on Fig. 1, is emanating from a certain body at a rate of about 0.25 calories per square centimeter per second. Reference to the radiation curves show that under these conditions, the temperature of the body must be about 6,000° Kelvin.

Radiometers for measurements at various *optical frequencies* have been in use for years, and have yielded important information regarding the characteristics of our neighbors in space which otherwise would have remained mysteries for some time to come. Now the latest addition to the radiometer family, the *microwave radiometer*, which will be discussed here, promises to open up still wider scientific vistas, by making available a new section of the spectrum three times as wide (in terms of octaves or decades) as the optical region.

Microwave radiometers—sometimes called "radio telescopes"—do not operate in the visible region of the spectrum, but rather at much lower frequencies (longer wavelengths) such as those of Fig. 2. These wavelengths are so far from the optical region that it was impossible to show the radiation curves for the radio-frequency region and for the optical region in the same

figure. The much greater width of the radio-frequency region also makes it necessary to use the logarithmic scale in Fig. 2 instead of the linear scale of Fig. 1.

History

The original observations which led to the development of radio-frequency radiometry were made by Karl G. Jansky of the Bell Telephone Laboratories in 1931. These observations were carried out on what would now be regarded as a very low frequency—20.5 mc. Operating at this frequency, Jansky discovered the existence of cosmic noise, originating in the plane of the Milky Way. Jansky's measurements were supplemented by a series of observations started by Grote Reber in 1936 on 160 mc. Reber was able to localize a definite maximum in the level of cosmic noise, in the direction of the center of the galaxy. Subsequent measurements made by Reber on 480 mc localized two maxima in the Cygnus region.

G. C. Southworth of Bell Telephone Laboratories made the first observations at centimeter wavelengths in 1942 and 1943. He found that the type of *cosmic noise* reported previously by Jansky and Reber was not detectable at this frequency, but he did succeed in making rather careful comparisons between calculated and observed *solar noise* levels.

Radiometric measurements of r.f. radiation have been made at frequencies ranging from less than 30 mc to as high as 30,000 mc, corresponding to wavelengths of about 10 meters to about 1 centimeter. The shortest of these wavelengths is more than 3,000 times as long as the longest wavelength in the optical region of the spectrum, which extends from about 3,000 Å to about 30,000 Å.

It is interesting to observe that the radiation laws still hold good in the r.f. region and that hot bodies like our sun, which we are used to thinking of only as an emitter of light and heat, are also radio transmitters. The reason why we do not ordinarily pick up the sun on our home radio receivers is that it is not a very good radio transmitter. The amount of r.f. energy radiated by the sun is only a very small fraction of the energy it radiates in

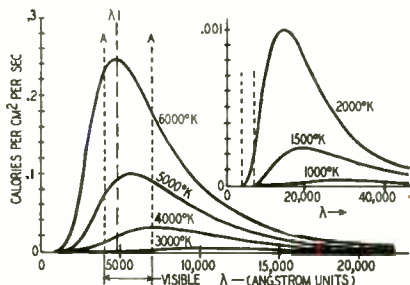

Fig. 1—"Black-body" radiation curves in the "optical" region of the electromagnetic spectrum. The insert shows the emission at lower frequencies (longer wavelengths) on an enlarged scale.

Here's how to GET MORE WORK OUT OF YOUR Oscilloscope!



A complete, easily understood guide to using the handiest, most profitable service instrument of all MODERN OSCILLOSCOPES AND THEIR USES

By Jacob H. Ruiter, Jr.

of Allen B. Du Mont Laboratories, Inc.
326 pages, 370 illustrations. Price \$6.

Oscilloscopes are gold mines for servicemen who learn to use them fast, fully and accurately on all types of work—and here at last is a book that really shows you how.

In clear, easily understood terms, it teaches you when, where and exactly how to use the oscilloscope... how to interpret patterns... how to use your 'scope to handle tough jobs easier, faster, and better.

It contains no involved mathematics—no complicated discussions. Instead, it gets right down to "brass tacks" in explaining how oscilloscopes operate. Then you learn exactly how to use them in lab work and on all types of AM, FM and television service—from locating troubles to handling tough realignment jobs.

Each operation is clearly explained step by step. You learn to determine just where and how to use the 'scope on a specific job; how to make connections and adjust the circuit components; how to set the controls; and HOW TO ANALYZE OSCILLOSCOPE PATTERNS fast and accurately. 370 illustrations including dozens of pattern photos make things doubly clear.



No other type of specific service training can mean so much to you in boosting your efficiency and earning power! Send coupon NOW for 10-day FREE examination!

'SCOPE PRACTICE EXPERTS get better jobs... bigger pay! 10-DAYS FREE!

Dept. RE-24
RINEHART BOOKS, Inc., Technical Div.
232 Madison Ave., New York 16, N. Y.

Send MODERN OSCILLOSCOPES AND THEIR USES for 10-Day FREE EXAMINATION. If book is satisfactory, I will then send you \$6.00 plus postage promptly in full payment. If not, I will return book postpaid in good condition and owe you nothing.

NAME

ADDRESS

CITY, ZONE, STATE

OUTSIDE U.S.A. \$6.50, cash only. Money back if you return book within 10 days.

CBS-COLUMBIA
GENERAL ELECTRIC
PHILHARMONIC
WESTINGHOUSE
MOTOROLA
SYLVANIA
HOFFMAN
EMERSON
PHILCO
ADMIRAL
MUNTZ
RCA

**STANCOR HAS EXACT
 REPLACEMENT FLYBACKS
 FOR ALL THESE TV
 MANUFACTURERS' SETS...and
 others will be available soon**

Designed for quick, simple installation, these Stancor flybacks save your time. There are no holes to drill, no leads to splice. Terminal board layouts duplicate the original units—even include choke coils, resistors, tube sockets and any other components that are on the original.



Stancor TV replacements are listed in Sams' Photofact Index, Counterfacts, Rider Manuals and Tek-Files

**CHICAGO STANDARD
 TRANSFORMER CORPORATION**
 3592 ELSTON AVE., CHICAGO 18, ILL.

EXPORT SALES: Roburn Agencies, Inc.
 39 Warren Street • New York 7, New York

ELECTRONICS

the visible region. We must have an extremely sensitive receiver to pick up the sun at all. If we *can* pick it up, we immediately notice, from Fig. 2, that we have at least one advantage in making measurements at radio frequencies: *the energy radiated is almost directly proportional to the temperature.* We therefore may calibrate our microwave radiometer directly in degrees Kelvin.

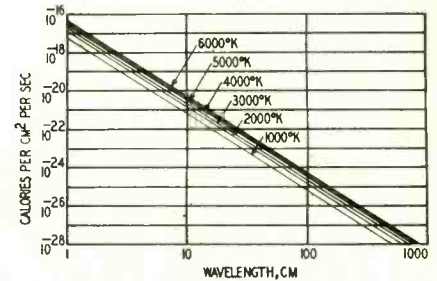

Fig. 2—"Black-body" radiation curves in the r.f. region plotted on logarithmic co-ordinates for compactness. Note the uniform relationship between amount of energy radiated and body temperature.

The radio signals emitted by the sun or by other celestial bodies are not nicely modulated r.f. waves or even fixed-frequency carriers. They are, in fact, just ordinary, everyday noise, of the same variety that can be heard on any communications receiver or on an FM receiver when it is not tuned to a carrier. It is therefore the amplitude of this noise which we measure when we want to determine the rate at which the sun or some other celestial body is emitting energy in the microwave region.

Radiometer receiver

Fig. 3 is a block diagram of a modern radiometer. This equipment, which was originally invented and used at the MIT Radiation Laboratory by Dicke, Kyhl, Vane, and Beringer, and later developed to its present form by the Research Division of the Collins Radio Company at Cedar Rapids, Iowa, is an extremely sensitive superheterodyne receiver provided with special means for canceling out the inherent receiver noise. This feature is necessary because under actual operating conditions the noise signal being measured may be much weaker than the inherent noise of the receiver. If the receiver noise were permitted to appear in the output, it would mask the signal to such an extent that it would be practically impossible to measure the signal amplitude.

In this radiometer the receiver noise is canceled by modulating the incoming r.f. signal at a 30-cycle rate with a "reference wheel." A segment of the wheel equal in area to the cross-section of the waveguide is painted with resistive material to form a *termination*. As the wheel revolves, the termination moves in and out of the waveguide 30 times a second. When inserted, the termination blocks the signal from the antenna, and provides a nearly perfect impedance match for the receiver input

TRAIN AT HOME FOR COLOR-TV and

**TELEVISION
 SERVICING**

Learn practical, professional type TV Servicing without leaving your present job. Included are money-making extras such as set conversion, master antenna installation, UHF-TV, NTSC Color System, field servicing short cuts. You can start earning Television money after first few lessons. You learn to test, trouble shoot and repair all types of TV sets.

HERE'S HOW YOU GET EXPERIENCE!

You train on a large screen, modern TV receiver, furnished with the course and yours to keep! As an optional feature you can get two weeks actual experience with Chicago's largest independent servicing organization. You learn by doing! Age is no barrier. Many students are over 40! ACT NOW! Send for FREE Catalog and SAMPLE LESSON today!

TV COMMUNICATIONS INST.
 605 W. Washington Blvd.
 Dept. RE-26 Chicago 6, Ill.

VETERANS!
 T.C.I. is approved for G.I. training Under Public Law 550. Check coupon.

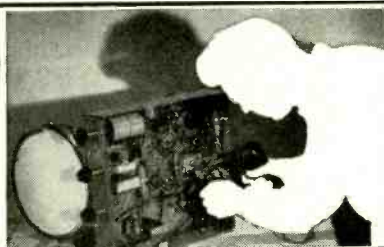

MAIL NOW FOR FREE BOOKLET

MILTON S. KIVER, President
 TELEVISION COMMUNICATIONS INST.
 605 W. Washington Blvd., Dept. RE-26, Chicago 6, Ill.
 Rush FREE Catalog and Sample Lesson. I am not obligated. Salesman will not call.

Name..... Veterans: Check here
 Address.....
 City..... Zone..... State.....
 BEGINNERS check here for Basic TV Course.

HICKOK

MODEL 605A



Large
5"
Meter

TECHNICAL DESCRIPTION

Enthusiastically accepted everywhere, this fine instrument is specifically designed to meet the technician's need for a smaller size, lower cost portable tube and set tester. The 605A is built with HICKOK Dynamic Mutual Conductance circuits with a 3-range micromho scale of 0-3000, 6000, 15,000. Tests all tubes normally encountered in all phases of communications and electronics. Provides the HICKOK Tube Gas Test. New bias fuse prevents accidental damage to bias potentiometer. Operating voltages, including DC grid bias, are applied to the control grid and large 5" meter shows AC component in plate current. This HICKOK test is the same test used by tube manufacturers in their own laboratories.

See your nearest parts jobber and ask for a demonstration of this lighter, smaller, handier Tube & Set Tester. (Also available as Model 600A without multimeter.)

THE HICKOK ELECTRICAL INSTRUMENT CO.

10531 DUPONT AVENUE • CLEVELAND 8, OHIO

Complete TUBE TESTER AND SET ANALYZER

INCLUDES:

High Sensitivity MULTIMETER

The Model 605A, in addition to being a complete and highly accurate tube tester, also contains a handy 20,000 ohm per volt DC multimeter to measure . . .

Volts: AC-DC; 0-10, 100, 500, 1000

Sensitivity: 20,000 ohms per volt DC; 1,000 ohms per volt AC

Resistance: 0.1 ohm to 100 megohms, (center scale 25, 2500, 500,000 ohms)

Inductance: to 70 henries through use of conversion chart furnished

Capacitance: Microfarads; 50, 5, as low as .0001

Current: DC; 10, 100, 500 M.A.

Built with minimum number of jacks. Ranges are selected with a rotary master switch.

Write today for new brochure outlining all methods of tube testing.

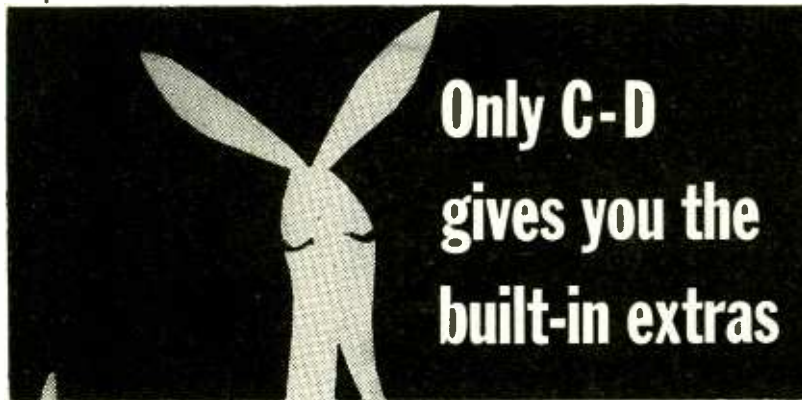

No other line puts so much engineering, so many heavy duty construction features, and so much experience into every capacitor.

Whether it's an electrolytic, a ceramic, a paper or a mica, you know you're getting field-proved performance when you ask for C-D. Why take less?

Don't accept substitutes on the basis that they even "look-alike". It's what's inside that counts. Insist on C-D's.

Order a supply today from your C-D jobber! His name is in the Yellow Pages of the Classified Telephone Directory. For catalog write to Dept. RC-224, Cornell-Dubilier Electric Corporation, South Plainfield, New Jersey.

CONSISTENTLY DEPENDABLE
CORNELL-DUBILIER
CAPACITORS



There are more
C-D capacitors in
use today than any
other make.

PLANTS IN SO. PLAINFIELD, N. J.; NEW BEDFORD, WORCESTER AND CAMBRIDGE, MASS.; PROVIDENCE AND HOPE VALLEY, R. I.; INDIANAPOLIS, IND.; DANFORD AND FOGUAT SPRINGS, N. C. SUBSIDIARY: RADIART CORP., CLEVELAND, OHIO



CUB



CERAMIC



MICA

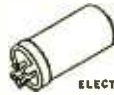

ELECTROLYTIC

RECORDING TAPE (Plastic Base)
40% OFF (NEW)

WHERE ELSE WOULD THERE
BE MORE RED TAPE?

- 1200 ft. plastic tape with plastic reel included. . .
- Each reel individually boxed.
- Choice of nationally famous top quality brands such as:
Weber (2806) 3.20; Reeves (SPN-12) 3.20; Audio (1251) 3.25; Scotch (111-A) 3.25; Panacoustic (711-A) 3.25; High Professional grade (211 RPA) 3.30.
- FREE—7.95 Penton tape carrying case included with purchase of 12 new tapes.

USED RECORDING TAPE (PLASTIC BASE)



1.99 for 7"—1200 foot
.99 for 5"—600 foot
.59 for 4"—300 foot
.29 for 3"—150 foot
Plastic reels included with
all above sizes

New empty plastic reels in
boxes for easy labeling. 3"
10c; 4" 24c; 5" 24c; 7"
30c; 7" Professional reel
(2 1/4" hub) 45c ea. EMPTY
BOXES: 3" 3c; 4" 5c; 5"
5c; 7" 10c ea.

We carry all brands of new tape, recording blanks, tape recorders, etc., at low prices. PLEASE INCLUDE SUFFICIENT POSTAGE.

COMMISSIONED ELECTRONICS CO.
2503 Champlain St. N.W., Washington 9, D. C.

SUBSCRIBERS

If you're moving, please don't forget to send us your address as it appears on the copy of the magazine, including the numbers shown beside your name, as well as your new address.

If we receive this information before the 20th of the month, you will continue getting the magazine without interruption.

Your cooperation will be most helpful and greatly appreciated.

Watch for the
March Issue
of
RADIO-ELECTRONICS
on the newsstands
FEBRUARY 24

CORRECTION

In the January advertisement of the Rad-Tel Tube Co., the price of the 70L7GT tube was inadvertently given as \$.09 instead of \$1.09.

circuit. Under these conditions the receiver picks up only thermal noise (called *reference noise*) from the termination itself in addition to the receiver's own input noise. When the termination is withdrawn from the waveguide, the path to the antenna is open, and the noise signal received by the antenna is superimposed on the receiver noise. The result is a signal with a 30-cycle square-wave modulation envelope. The positive modulation peaks represent receiver noise plus antenna signal, and the negative peaks represent receiver noise plus reference noise. As shown in Fig. 4, the modulation amplitude is one-half the difference between the positive and negative peaks. This amplitude is proportional to the *difference* between the power received by the antenna and the power emitted by the termination. The receiver noise is thus canceled out, provided it remains constant on successive half cycles.

The modulated noise signal is heterodyned with a local oscillator in a hybrid-T balanced mixer, amplified in a 30-mc i.f. amplifier and then rectified to extract the 30-cycle modulation. This in turn is amplified and demodulated a second time in a phase detector. The output of the phase detector feeds a balanced d.c. amplifier which controls the deflection of a meter. The meter shows the net difference between the power received by the antenna and the power emitted by the reference-wheel termination. Fig. 2 shows that this is directly proportional to the difference between the temperature of the radiating body and the temperature of the termination.

In practice, the output meter is calibrated directly in degrees Kelvin, and if the radiating body is a perfect black body and fills the antenna pattern (Fig. 5-a), the meter reads directly the difference in temperature between the body and the reference-wheel termination. Since the temperature of the termination is known, the temperature of the radiating body may be calculated directly. Appropriate corrections are made when, as is usually the case, all the power is not intercepted (Fig. 5-b) or the source is not a perfect black body.

Sensitivity

The expedients employed in this receiver to permit the measurement of antenna signals far below the inherent noise level give it much greater sensitivity than even the finest superheterodynes designed for communications and broadcast applications. The sensitivity depends primarily on the extent to which it is possible to cancel out the receiver noise by comparing the positive-modulation half cycles with the negative-modulation half cycles. If the receiver noise is not equal during the positive and negative intervals, the difference will appear as fluctuations of the meter. It will then be impossible to read the value of a signal having an amplitude smaller than these fluctuations. To improve the performance and reduce meter fluctuations due to varia-

The Complete Line

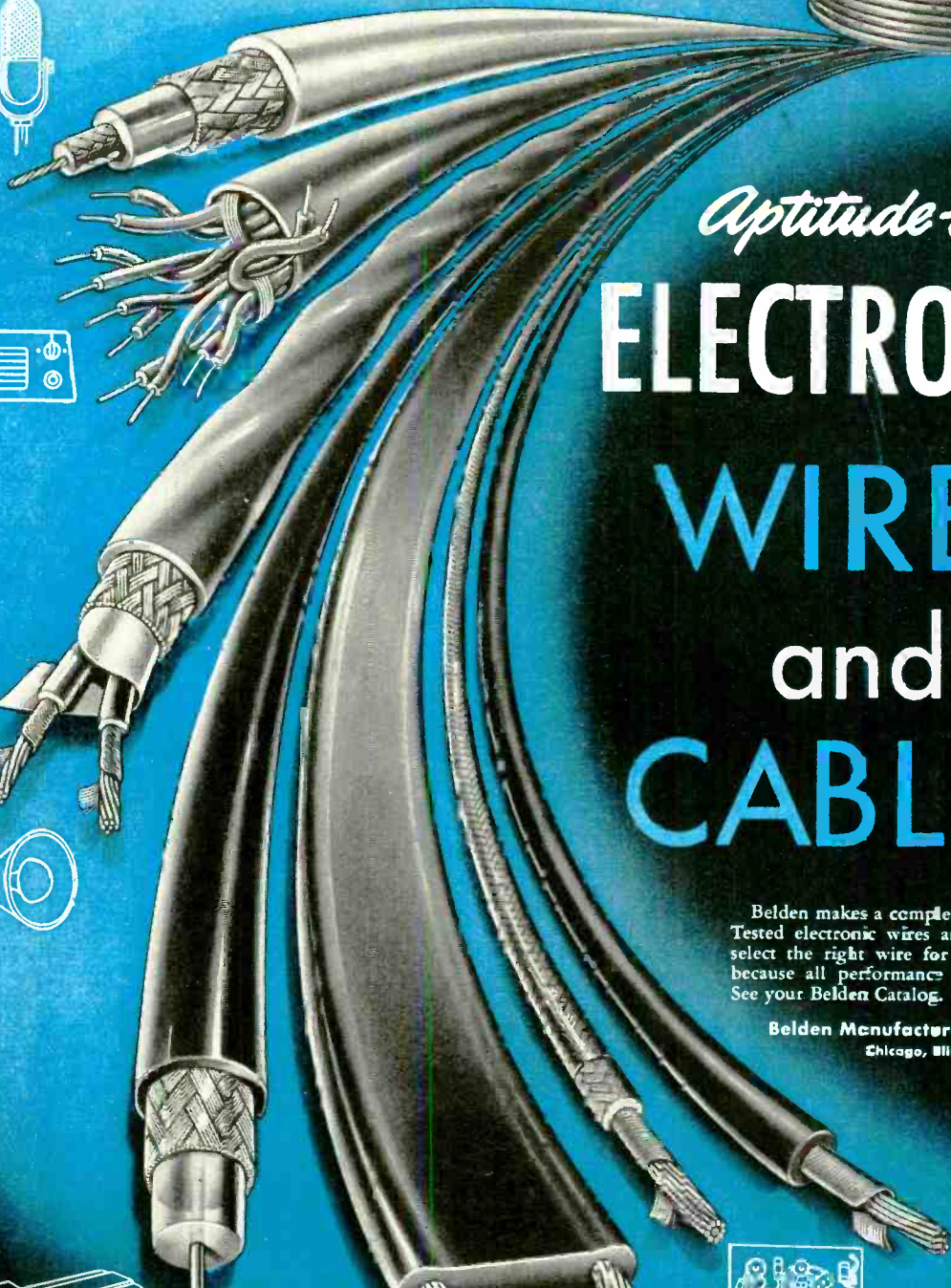

Aptitude-Tested
**ELECTRONIC
WIRES
and
CABLES**

Belden makes a complete line of Aptitude-Tested electronic wires and cables. You can select the right wire for every application, because all performance values are shown. See your Belden Catalog.

Belden Manufacturing Company
Chicago, Illinois

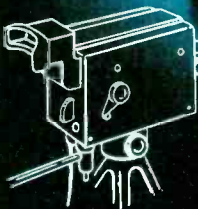

Belden

**WIREMAKER
FOR INDUSTRY**

Save TV
Alignment Time
 with the EAZY to use
Align-O-Pak
 TV alignment Bias
 Battery Eliminator



★ Quickly determines
 AGC troubles

Think of the time wasted
 connecting batteries in series...
 The *Align-O-Pak* provides all
 the voltages recommended by
 these leading TV manufacturers:
 • ADMIRAL 1½-4½v
 • MOTOROLA 3v • PHILCO 7½v
 • RCA 1v • ZENITH 2v Variable.

- ★ Forget messy Bias Batteries
- ★ Fix only TWO AGC troubles and your *Align-O-Pak* is paid for
- ★ Just Plug it in - - -
- ★ Provides from 0 to 10 Volts BIAS Instantly
- ★ Completely isolated from Power Line and Case

Only
7.85
 DEALER NET

INSTRUCTIONS

FOR ALIGNMENT: Plug *Align-O-Pak* in and turn unit on. Connect black lead to the Receiver AGC buss and red lead to B minus (usually chassis). Set *Align-O-Pak* knob to voltage recommended by TV manufacturer.

FOR AGC TROUBLE SHOOTING: With *Align-O-Pak* connected as described above, turn control knob slowly from 0 to 10. If normal picture appears, AGC is defective.

Carried by leading jobbers!

SI SERVICE INSTRUMENTS COMPANY
 422 South Dearborn Street, Chicago 5, Illinois

tions in internal noise, a low-pass filter is inserted between the output of the phase detector and the meter. This filter integrates the phase-detector output over a period of time, the length of which may be selected by a switch

which changes the width of the acceptance band of the filter. Due to the statistical nature of receiver noise, the longer the time-constant of the filter, the more the meter fluctuations are reduced. If the integration process is

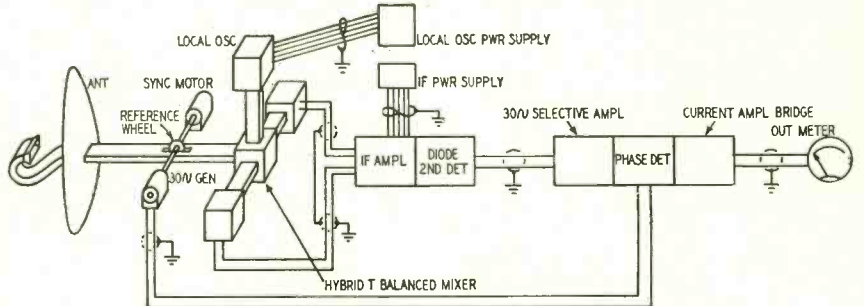

Fig. 3—Block diagram of a modern radiometer receiver. The functions of the various circuit elements shown in the diagram are described in detail in the text.

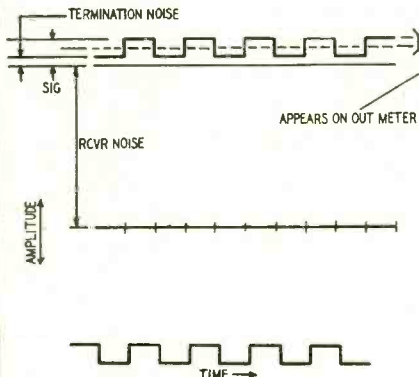

Fig. 4—Modulation envelope of the radiometer receiver input signal. Positive and negative peaks of the 30-cycle square wave represent "termination" noise and signal noise respectively. Circuits in the receiver remove the 30-cycle component and show the net signal voltage.

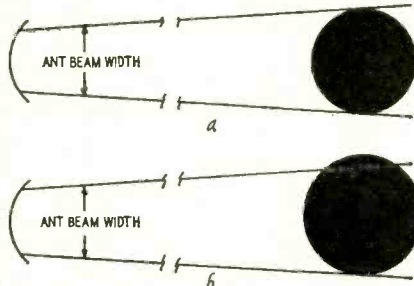

Fig. 5—How antenna beam width affects the accuracy of radiometric measurements. (a) Where the radiating body just fills the beam width all the energy emitted in the direction of the antenna is picked up. (b) With bodies wider than the antenna beam much of the energy radiated is lost.

carried out over a long period of time, there is a much greater probability that the total noise during *positive intervals* will equal the total noise during *negative intervals* and there will be more complete noise cancellation. Calculations confirmed by experiment show that if the acceptance band of the low-pass filter is approximately 10% of the cutoff frequency and if the receiver noise figure is 23:1, the r.m.s. temperature fluctuations of the output meter will have an amplitude of approximately 0.3° Kelvin. With existing receiver designs temperature variations in the order of 0.3° Kelvin can be detected. This temperature variation is equivalent to a power variation of 0.66×10^{-6} watts, and therefore to a sensitivity of -132 dbm. The sensitivity of a conventional microwave superheterodyne receiver may be of the order of -90 dbm. The radiometer receiver therefore has a sensitivity 42 dbm better than a conventional receiver; in other words, it can measure power levels only about 1/10,000th as great as the minimum level detectable by a conventional superheterodyne receiver in this frequency range. This is perhaps an extreme figure which can be attained only under optimum conditions. However, 3.0° accuracy, corresponding to a sensitivity of approximately -122 dbm, is commonly realized in practice.

Circuits

To a considerable extent, the block diagram of Fig. 3 is self-explanatory. Conventional microwave components are used in the r.f. sections of the circuit,

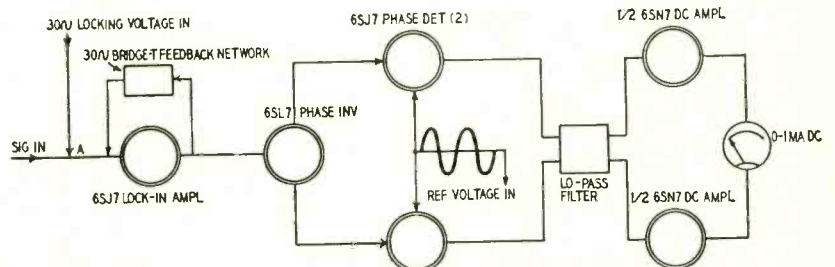

Fig. 6—Block diagram of the indicator circuits in the radiometer receiver. The bridged-T network feedback in the first tube filters out unwanted sideband noise.

including a paraboloidal antenna equipped with a horn feed. The size of this antenna depends of course on the beam width required, and the diameter of the paraboloid may vary from 30 inches to as much as 50 feet. The balanced-T mixer prevents the local-oscillator signal from traveling out on the wave guide to the antenna and to the reference wheel, where it might be reflected back to the mixer input. Such reflection of the oscillator signal of course would cause an error in reading.

The square of terminating material on the reference wheel has a resistance of 400 ohms. A small 30-cycle generator coupled to the reference-wheel shaft provides the 30-mc cycle demodulating voltage furnished to the phase detector.

Standard production-type 30-mc i.f. amplifiers with passbands from 6 to 8 mc wide may be used, equipped with a.g.c. to minimize fluctuations in receiver gain.

The output section of the radiometer, including the 30-cycle selective amplifier, the phase detector, and the current-amplifier bridge, deserves special mention. This part of the circuit is shown in Fig. 6. The first 6SJ7 tube is a 30-cycle lock-in amplifier, in which the locking voltage derived from the 30-cycle generator coupled to the reference-wheel shaft is applied to the input at A. This amplifier has a very narrow acceptance band, and helps eliminate interfering sideband components which may modulate the 30-cycle output of the second detector. This lock-in amplifier is followed by a 6SL7 phase inverter, which feeds a relatively pure 30-cycle sine wave to the pair of 6SJ7's operated in push-pull.

These 6SJ7's are the phase detector shown in Fig. 3. This part of the circuit demodulates the 30-cycle wave to produce a d.c. voltage, the value of which is exactly proportional to the amplitude of the 30-cycle wave. It operates, in effect, by multiplying the instantaneous value of the 30-cycle wave impressed push-pull on the control grids of the 6SJ7's by another 30-cycle wave impressed on the suppressor grids in parallel. Since the wave on the suppressor grids is identical in frequency and phase with the wave to be demodulated, both having been derived from the same 30-cycle generator, the d.c. output of the phase detector is directly proportional to the amplitude of the input signal.

The network across the output of the phase detector is the low-pass filter referred to above. This network eliminates all extraneous modulation products, and passes a practically pure d.c. signal. Its cutoff frequency is so low that any a.c. components higher than a fraction of a cycle per second are suppressed. The cutoff frequency may be varied with the switches shown in this part of the circuit, which change the values of the bridged capacitance in the network.

The output of the network feeds a 6SN7 balanced d.c. amplifier with a milliammeter calibrated in degrees Kelvin bridged across its output. This is



**Built to
sell!**

utone

THE NEW WALL BAFFLE BY UTAH

The new, luxurious looking UTONE wall baffles will complement the interior of any restaurant, church, school, home, club, tavern or factory wherever speaker housing is needed.

The quality and construction of Utone wall baffles is of the finest, the finest woods matched by the fine production skill of Utah—a pioneer and leader in the sound field for over 30 years.

Utone wall baffles are available in three beautiful finishes and four versatile sizes—Genuine Honduras Mahogany—in red or brown finish, handsome limed oak and natural unfinished wood. Models in 6, 8, 10 and 12 inch sizes.

Utone baffles are also available for delivery complete with mounted speakers.

NOTE THESE UTONE QUALITY FEATURES

- Styled By Master Woodworkers
- High Gloss Lacquer Finish
- Beautiful Matching Grill Cloth
- Free of Vibration and Rattles
- Moisture and Water Resistant
- All Joints Mortised and Secured With Water Proof Glue
- Made from the Finest 5 Ply— $\frac{3}{8}$ and $\frac{1}{2}$ Inch Veneer

THE NEW UTONE WALL BAFFLES ARE BUILT RIGHT
AND PRICED RIGHT TO SELL.



Write today for catalog and prices

RADIO PRODUCTS CO., INC.

OPPORTUNITY ADLETS

Rates—45¢ per word (including name, address and initials). Minimum ad 10 words. Cash must accompany all ads except those placed by accredited agencies. Discount, 10% for 12 issues. Misleading or objectionable ads not accepted. Copy for April issue must reach us before February 21, 1954.

Radio-Electronics, 25 W. Broadway, New York 7, N. Y.

SPEAKERS REPAIRED at wholesale prices. Guaranteed workmanship. Jobbers wanted. Amprite Speakers Service, 70 Vesey St., New York 7, N. Y.

REVOLUTIONARY NEW TYPE TELEVISION ANTENNA solves installation problems, guaranteed. Derr, 1018 Taylor, Vallejo, California.

"ELECTRIC EYE EQUIPMENT." KITS, photoelectric cells, relays, etc. Lowest prices! Write—Electronics, 709 Grove, Buckroe-Hampton, Virginia.

DIAGRAMS, RADIO \$1.00 TELEVISION \$2.00. Give make and model. Diagram Service, Box 672 RE, Hartford, Conn.

TUBES-TV, RADIO, TRANSMITTING, AND SPECIAL PURPOSE TYPES BOUGHT, SOLD AND EXCHANGED. Send details to B. N. Gensler W2LNI, 136 Liberty, N. Y. 6, N. Y.

ALL MAKES OF ELECTRICAL INSTRUMENTS AND TESTING equipment repaired. Write for free catalogue on new and used instruments at a savings. Hazelton Instrument Co., 128 Liberty Street, New York, N. Y.

"RADIOBUILDER" MAGAZINE FOR EXPERIMENTERS, beginners. 12 issues \$1.50; Copy 15¢. Unusual catalog free. Laboratories, 328-B Fuller, Redwood City, California.

WANTED: AN/APR-4, other "APR-", "TS-", "IE-", ARC-1 ARC-3, ART-13, RC-348, etc. Microwave Equipment, Everything Surplus, Special tubes, Tec Manuals, Lab Quality Equipment, Meters, Fast Action, Fair Treatment. Top Dollar! Littell, Fairhills Box 26, Dayton 9, Ohio.

BUY WHOLESALE—25,000 ITEMS—CATALOG 25¢. Matthews, 1472-1P5, Broadway, N. Y. C. 36.

ALUMINUM TUBING, ANGLE AND CHANNEL. Plain and perforated sheet. Willard Radcliff, Fostoria, Ohio.

AMATEUR RADIO IS FUN. FIFTY PAGES, EASY TO understand, code and theory for Novice Class license. \$1.00. Satisfaction guaranteed. Radiographic, 3246 North Orange, Chicago, Illinois.

SURPLUS BARGAINS. New coaxial cables 100 ft. RG 8/U, \$5.95; 100 ft. RG 59/U, \$6.25. Coaxial Connectors 83-1SP plug 5 for \$2.25; 83-1R Socket 5 for \$2.00. 200 Asst. $\frac{1}{2}$ watt resistors, all insulated, \$2.50. Postage Extra. Request Bargain Bulletin. RELIANCE MERCHANDISING CO., 2221 ARCH ST., PHILADELPHIA 3, PA.

WORKING TELEVISION SETS \$30 UP. W4API, 1420 South Randolph, Arlington 4, Virginia.

TV FM ANTENNAS, ALL TYPES INCLUDING UHF. Mounts, accessories. Lowest prices. Wholesale Supply Co., Luenburg 2, Mass.

Exciting New Performance . . . Superb Cabinet Craftsmanship

THE PERMOFLUX

Fortissimo

2-Way Speaker System with "DUAL DRIVING POINT" Horn Design
Now Brings You

FULL RANGE HIGH FIDELITY
At Either Low or High Volume Level

Perfection
in Cabinetry
by
*Contemporary
American
Furniture*
in
Mahogany or
Korina Blonde.

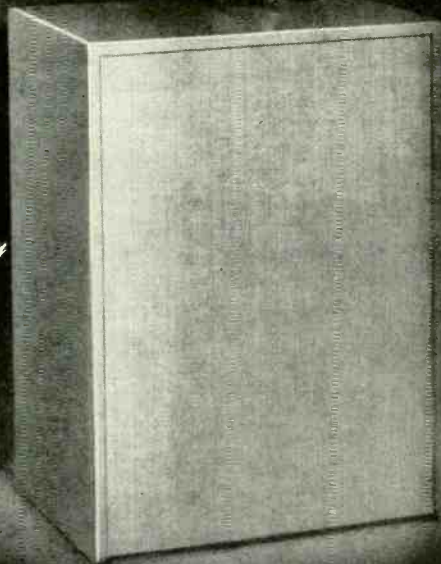

Unique "New Dual Driving Point" Enclosure Design, employing Dual Eight inch woofer system, surpasses bass and mid-range performance of finest conventional 12 and 15 inch systems. Satin smooth highs are added by specially designed Super Tweeter. Beautiful modern cabinet styling . . . precision constructed of carefully selected veneers . . . hand rubbed to a lustrous enduring finish . . .

New . . . Diminutive 2-Way Speaker System

THE PERMOFLUX

Diminutive

Exclusive New Design . . . combines full high fidelity performance with minimum cabinet size and low cost. Angled speaker mounting assures correct distribution of sound regardless of placement. Perfect for Binaural when used in pairs.

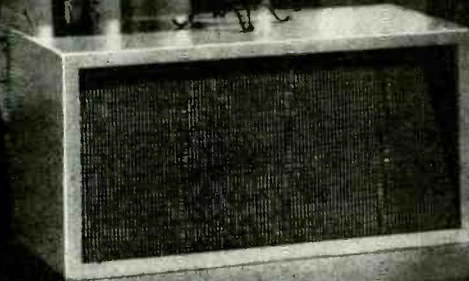

Two Royal 6 inch Speakers and Super Tweeter housed in choice of Mahogany or Blonde enclosure.

See your Hi-Fi dealer for demonstration; also hear the New Super Royal Speaker (8, 12 and 15 inch sizes).

For complete descriptive literature write to . . .

Permoflux CORPORATION

4912 West Grand Avenue • Chicago 39, Illinois

West Coast Plant

4101 San Fernando Road • Glendale 4, California

generally an Esterline-Angus recording milliammeter with a full-scale sensitivity of 1 milliamperere.

Other radiometers

The radiometer receiver described above is perhaps the latest development in this field, but even conventional superheterodynes have been used for radiometry and have been found satisfactory, particularly at lower frequencies.

A number of programs for measuring the energy emitted by various kinds of celestial bodies in the solar system and in the galaxy are now under way throughout the world. As time has progressed, techniques have been developed for making measurements at higher and higher frequencies, culminating in the microwave techniques described above. Observations continue, however, throughout the radio-frequency spectrum, and low frequencies have been found most suitable for some types of celestial objects, while high frequencies are best for observing other types. All in all, the observational program is now much too extensive to be reported in detail in a short article of this type. Some mention should be made of the discovery of "radio stars"—point sources located at stellar distances which emit radiation at r.f. wavelengths—though they cannot be seen even with the aid of a telescope. Observations of radiation emitted by the sun's corona, which indicate momentary coronal temperatures far in excess of those predicted by theory, are also being carried on.

Lunar Eclipses

Measurements of the temperature of the moon were made during the lunar eclipses of April and October, 1949, by W. W. Salisbury, D. O. McCoy, C. M. Hepperle, R. M. Ringoen, W. E. Gilberston, and the author, all of whom were at that time associated with the Collins Radio Company at Cedar Rapids, Iowa. During both these eclipses microwave measurements of the temperature of the moon were taken before, during, and after totality. Scientists had expected there would be a pronounced drop in temperature as the moon entered the Earth's shadow. (Previous radiometric measurements made at optical frequencies had shown such a drop.) They were surprised to find that the moon's temperature, as indicated by its microwave radiation, remained practically constant throughout the period of the eclipse. Subsequent calculations led to the conclusion that these results were in fact good confirmation of what had previously been suspected to be true: that the moon's surface is covered with a layer of some kind of dust (such as volcanic ash) which has good insulating properties and low dielectric losses. It appears that the radiation measured was actually transmitted through the low-loss dust blanket from strata about 10 centimeters below the visible surface of the moon, where temperatures remained practically constant during the eclipse due to the insulating effect of the ash.

Future Radio Astronomy

Thus a new type of instrument, the radio-frequency radiometer, has now been added to the list of tools—including the telescope, the spectroscope, and the optical radiometer—which are available to help astronomers in their work of exploring the universe. From now on it may be expected that increasing emphasis will be placed on the use of this new tool, while its development will also continue at a somewhat less rapid rate. On account of the effectively wider spectrum available, radio-frequency radiometers will be able to furnish much new information which should lead to the discovery of new facts regarding the constitution and evolution of celestial objects, and to the solution of problems which it has not been possible to solve in the past.

For example, it is conceivable that at some time in the future microwave radiometers might settle the question of the temperatures of the cloud-covered planets, Venus, Jupiter, Saturn, and Neptune. Although it was originally theorized (from its apparent age and size, and from the appearance of the "great red spot") that the planet Jupiter was very hot, radiometric measurements made some years ago at optical frequencies yielded a temperature many degrees below the freezing point. It is highly probable that these temperature measurements actually give the temperature of Jupiter's superficial visible cloud layer.

Microwave radiometers may also eventually make it possible to measure the temperature of individual spots on the moon's surface and to discover the fine structure of layers of the sun's interior lying below the photosphere. Before any of these things can be done, however, great improvements will have to be made in the definition of microwave radiometers. The smallest object which can be seen with a radiometer can be no smaller than the beam width of the radiometer antenna. Small radiometers of the type shown in the photograph have beam widths several degrees wide. Even large celestial bodies such as the sun and moon, which are approximately one-half degree in diameter, occupy only a fraction of the cross-sectional area of the radiometer antenna pattern, and the largest planets, even at opposition, are completely undetectable. Greater emphasis is now being placed on the development of larger antennas with much narrower beams. One example is the parabolic antenna built by the Collins Radio Company for the Naval Research Laboratory, which is now in place on top of Building O at NRL. This mammoth reflector is 50 feet in diameter and is theoretically capable of a beam width in the order of one minute of arc ($\frac{1}{60}$ of a degree). As the planet Jupiter, when in opposition, may subtend an angle as large as 50 seconds of arc, it is almost large enough to fill the beam of the NRL radiotelescope if observed under favorable conditions. It may therefore be possible, in the near future, to discover new information regarding planetary temperatures.

END

EICO

TEST EQUIPMENT
for AM, FM, and TV

New EICO Instruments BAR GENERATOR

Easy to use. Connects to antenna terminals of TV set. Tests picture linearity, picture size, and vertical and horizontal synch circuit stability.

Model 352-K
Complete Kit \$14.95
Model 352
Factory Wired 19.95

• Operates on channels 3, 4 or 5 • Provides 16 vertical and 12 horizontal bars • Switch permits selection of "vertical", "horizontal" or "stand-by" • Output Voltage: 100,000 microvolts • Dimensions: 7 1/2" x 5" x 4 1/2" • Weight: 6 lbs.

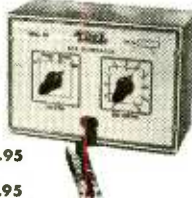

CATHODE RAY TUBE CHECKER



An easy, fast and fully reliable instrument for testing oscilloscope and TV picture tubes without removing from the scope or the set.

Model 630-K Complete Kit \$17.95
Model 630 Factory Wired 24.95

• Provides bridge measurement of peak beam current • Indicates shorts and open elements in electronic gun • Tests sockets and cables used with picture tubes • 2 1/2-foot cables permit testing of tube directly in set or in carton.

VACUUM TUBE VOLTMEETER

A rugged, accurate VTVM with 4 1/2" meter. Has 15 different ranges, plus zero-center adjustment for TV and FM alignment.

Model 221-K Kit \$25.95
Model 221 Wired 49.95

• 1% multiplier resistors for extreme accuracy • AC and DC ranges: 0-5, 10, 100, 500, and 1000 volts • Measures up to 25 Kilovolts with HVP-2 • Input DC impedance: 25 megohms • Measures up to 200 mc with P-75 Probe • .2 to 1000 megohms in 5 ranges



Prices Net, F.O.B. N. Y. C. Subject to change without notice. *PAT. APP. FOR

HARVEY RADIO CO., INC.

103 W. 43rd Street, New York 36, N. Y. • JUDSON 2-1500

HARVEY

ALWAYS HAS IT... IN STOCK
for IMMEDIATE DELIVERY

5-inch PUSH-PULL OSCILLOSCOPE

A laboratory precision instrument at lowest cost. Has extra sensitivity, range, and other plus features for fast accurate servicing. Steel chassis and cabinet minimize external interference.

Model 425-K
Complete Kit.....\$44.95

Model 425
Factory Wired... 79.95

• Push-pull vertical and horizontal amplifiers • Vertical sensitivity: .05 to .1 rms volts/inch • Useful response from 5 cps to 500 kc • TV-type multivibrator sweep generator • Stable, accurate sweep range: 15 cps to 75 kc • Direct connection terminals to CRT plates for measuring % modulation and voltage amplitude • Dual controls for positioning trace on screen • Dimensions: 8 1/2" x 17" x 13", Ship. Wgt. 29 lbs.



New EICO PROBES



SCOPE DEMODULATOR PROBE

Model PSD
Complete Kit \$3.75
Factory Wired 5.75

LOW CAPACITY PROBE

Model PLC
Complete Kit \$3.75
Factory Wired 5.75

DIRECT PROBE Model PD

Complete Kit \$2.75
Factory Wired 3.95

SPECIAL

ALL 3
SCOPE
PROBES
Kit ... \$9.95
Wired \$14.95

VTVM RF PROBES

Model PRF-11 or 25

For any 11 or 25 megohm VTVM

Complete Kit \$3.75
Factory Wired 4.95

PEAK-to-PEAK PROBES

Model PTP-11 or 25

For any 11 or 25 megohm VTVM

Complete Kit \$4.95
Factory Wired 6.95



SENSATIONAL HIGH VOLTAGE PROBE

Model HVP-2
Factory Wired Only \$4.95

TV GLO-TEST

The answer to the T.V. serviceman's prayer.

An extremely compact all purpose T.V. tester, that almost talks. TV GLO-TEST was designed by T.V. instructors; men who know what is needed for fast and accurate servicing. In actual servicing tests it was proven that TV GLO-TEST can find trouble much easier and faster than many other common methods. By the



liberal use of miniature components TV GLO-TEST is kept small in size with no loss in overall efficiency or accuracy. The price has been kept so low that all T.V. servicemen can afford TV GLO-TEST. Its cost is much lower than almost any of the many instruments it replaces. One or two service jobs can pay for TV GLO-TEST. The instrument is more rugged than an ordinary VTVM. TV GLO-TEST comes complete with instruction book, explaining 50 USES of the instrument plus a trouble shooting guide. A few of the 50 USES are: Pixtube tester, low and high range voltmeter up to 50kv, with accuracy comparable to VTVM, Condenser tester, Signal tracer, Signal generator, tests all circuits and components. See your dist. or order direct. New low price \$12.50.

VIDEO SPECIALTIES INC.

4508 Firestone Blvd. South Gate, Calif.

CORONA RADIO KITS

EASY TO BUILD • EDUCATIONAL
EXCELLENT RECEPTION

BROADCAST
SUPERHET
KIT

\$14.75

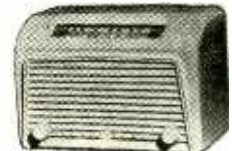

Rocket 115K—Latest Single Band superhet circuit for ultimate in sensitive reception and tonal quality. Kit includes all necessary parts, punched chassis, attractive bakelite mahogany cabinet, built-in loop antenna, iron core IFs, big 5" Alnico V spkr.; tubes: 12SK7, 12SA7, 12SQ7, 501L6, 35Z5. Automatic vol. control, beam power output. Tunes 510 to 1700 Kc. Simple step-by-step instructions included.

Plaza 812K 2-Band AC-DC Super Kit...net \$20.75
Globemaster 814K 3-Band Super Kit...net \$24.75
All kits supplied less wire and solder. Please include 25% deposit with C.O.D. Orders. Dept. E-2

CORONA RADIO & TV CO.

132 LIBERTY ST., NEW YORK 6, N. Y.

The world's most desirable oscilloscope for TV service.



JACKSON

MODEL CRO-2

Proved by the hundreds in use by TV manufacturers' and dealers' technicians

Judging by ratio of sales to market potential, this laboratory grade 5" oscilloscope is preferred by the great majority of television and electronic technicians. The specifications explain why such is the case.

Specifications

Vertical Amplifier—Push-pull amplifiers provide flat response within 1.5 db from 20 cycles thru 4.5 Mc.

Sensitivity Ranges—The sensitivity ranges are .018, .18, 1.8, .25, 2.5, 25 RMS volts-per-inch.

Horizontal Amplifier—Push-pull with sensitivity of .55 RMS volts-per-inch.

Input Impedances—Vertical 1.5 megohms shunted by 20 mmfd. Direct to plates, balanced 6 megohms shunted by 11 mmfd. Horizontal: 1.1 megohms.

Linear Sweep Oscillator—Saw tooth wave 20 cycles to 50 Kc in 5 steps. 60 cycle sine wave also available as well as provision for using external sweep.

Input Voltage Calibration—Provides a standard voltage against which to measure voltages of signal applied to vertical input.

Vertical Polarity Reversal—For reversing polarity of voltage being checked or for choosing either positive or negative sync. voltages.

Return Trace Blanking—Electronic blanking provides clear, sharp trace to prevent confusion in waveform analysis.

Synchronizing Input Control—to choose among INTERNAL, EXTERNAL, 60 CYCLE, or 120 CYCLE positions.

Intensity Modulation—60 cycle internal or external thru front panel binding posts.

Accessory—Model CR-P Probe for demodulating RF and IF voltages.

Prices: Model CRO-2, Users' Net \$197.50
Model CR-P Probe, Users' Net \$9.95

See your electronics distributor for more information, or write

JACKSON ELECTRICAL INSTRUMENT CO. • DAYTON 2, OHIO

"Service Engineered" Test Equipment

IN CANADA: THE CANADIAN MARCONI CO.

FRSAP RE-ELECTS SLATE

The Pennsylvania State Federation of Radio Servicemen's Associations re-elected all their present officers at the annual meeting held at Harrisburg, December 13.

The officers are Milan Krupa, Wilkes-Barre, president; Bert Bregenzer, Pittsburgh, vice-president; Leon Hlek, Carbondale, secretary; and Fred Schmidt, Steelton, treasurer.

The Federation has announced plans for the proposed Eastern Conference of radio and television service technicians. The scheduled dates are April 3, 4, and 5, and the conference will feature a three-day Color Symposium, to include lectures by eminent workers in the field. All independent service groups in the East, as well as affiliates of NATESA and NETSDA, will be invited.

WESTERN N. Y. REVIEWS WORK

The Radio and Television Service Association of Western New York (Buffalo) has drawn up a balance sheet showing what the organization has accomplished during the past year. Among the items listed are: acceptance of a code of Ethics and set of bylaws; participation in the Better Homes and Gardens show; adoption of a suggested price schedule, including minimums for service and bench labor charges; a joint advertising program; better cooperation with the Better Business Bureau, and better relationship with the parts jobbers; a group health and accident insurance program; affiliation with NATESA; and last but by no means least, the development of a spirit of harmony and confidence among the service shops in the area.

COLOR CLINICS PLANNED

With some color receivers expected to be manufactured from the beginning of the year (full-scale mass production of color TV sets may not come till 1956, according to Dr. W. R. G. Baker of General Electric), the manufacturers are readying training courses and TV clinics in various areas.

RCA has announced a proposed 65-city training course. With the approval of color TV, Westinghouse stated that a school for distributor service technicians was planned at their Metuchen, N. J. plant. CBS-Columbia was "starting clinics" early in the year. Hoffman planned service instruction, and Pacific Mercury is already holding bi-monthly meetings.

COLOR LECTURE ON L. I.

The Long Island Television and Radio Technicians Guild heard the first in a series of color lectures at their November 24th meeting, held in the American Legion Hotel, Williston Park, N. Y.

Officers for 1954 were elected at the meeting. They were: Henry Wawryck, president; Arthur Cyr, vice-president; Jack Wheaton, treasurer; Murray Barlowe, corresponding secretary; Al Weil, recording secretary; Earl Horton, sergeant-at-arms.

END

RADIO-ELECTRONICS

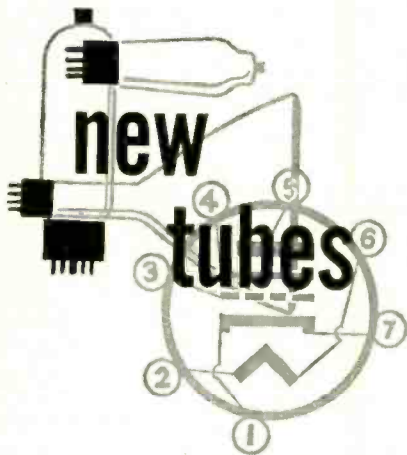

RA has announced a series of tubes covering a wide range of applications.

The 21ZP4-A is a rectangular glass picture tube using magnetic focus and magnetic deflection. It has a screen size of $19\frac{1}{8} \times 14\frac{3}{16}$ inches, and a spherical faceplate. Other design features include a 70° diagonal deflection angle, and an ion-trap gun requiring a single-field magnet. The maximum high-voltage rating is 18,000.

The 6263 and 6264, pencil-type triodes with external plate radiators, are small u.h.f.-type tubes designed for use in low-power mobile transmitters and high-altitude aircraft. They have a maximum plate-dissipation rating of 13 watts (ICAS) and can be operated

at full ratings at frequencies up to 500 mc. With reduced ratings they can be operated as high as 1,700 mc. The 6263 has a mu of 27; the 6264 a mu of 40. Both types are identical in size.

The 6263 is an r.f. power amplifier and c.w. oscillator. The 6264, while designed primarily as a frequency multiplier, may also be used as an r.f. power amplifier and c.w. oscillator. When operated as a frequency tripler up to 510 mc in a cathode-drive circuit under ICAS conditions, the 6264 can deliver approximately 3.4 watts.

The tubes have a 9-fin radiator for cooling the plate by convection or forced air.

The 6AU4-GT is a glass octal-type half-wave vacuum-tube rectifier for use as a damper diode in television receivers. It is particularly useful in receivers having picture tubes with 90° deflection.

Rated to withstand a maximum peak inverse plate voltage of 4,500, the 6AU4-GT can supply a maximum peak plate current of 1,050 ma and a maximum d.c. plate current of 175 ma. When the heater is operated negative with respect to cathode, negative peak pulses between heater and cathode of as much as 4,500 volts with a d.c. component of up to 900 volts may be used.

G-E has announced the GL-6299, a low-noise triode designed for use in the radio-frequency stages of receivers operating at frequencies as high as 3,000 mc. The tube has a noise figure

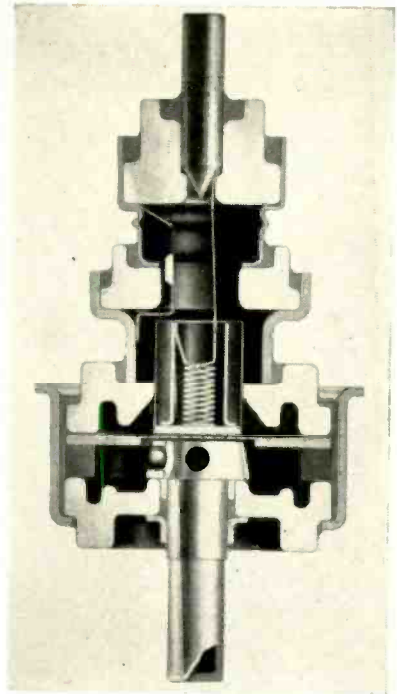

GL-6299; triode operates at 3,000 mc.

of less than 9 db at 1,200 mc when used in a grounded-grid coaxial type circuit.

Extremely small, the GL-6299 is 1-inch long and $\frac{1}{2}$ inch in diameter. Its planar electrode construction with very close spacings reduces transit-time effects.

END

Get This Valuable Book

Just for Examining COYNE'S New 6-Volume Set

FREE



Applied Practical Radio-Television

Yes, you get this big, brand new book, "150 Radio-Television Picture Patterns and Diagrams Explained", absolutely FREE! Just off the press! Gives complete wiring circuits and diagrams on the latest Radio and Television Sets. Easy-to-read, large $8\frac{1}{2} \times 11$ " pages, with full instructions on how to read and use the diagrams. A "must" in every Radio and Television service-man's repair kit. You get this valuable book as a FREE Gift for asking to see Coyne's great new 6-book set, "Applied Practical Radio-Television"!

Here's "Know-How" That Makes You Worth More!

Coyne's great new 6-volume set gives you all the answers to servicing problems—quickly! For basic "know-how" that is easy to understand, you'll find everything you want in volumes 1 to 5 which contain over 5000 practical facts and data. They cover every step from principles to installing, servicing, trouble-shooting and aligning all types of radio and TV sets. So up-to-date it includes COLOR TV and UHF, adapters and converters. Also covers very latest information on TRANSISTORS.

802-Page Television Cyclopedic Included

And then, for speedy on-the-job use, you get volume 6—the famous Coyne TELEVISION CYCLOPEDIA. It answers today's television problems on servicing, alignment, installation and others. In easy-to-find ABC order, cross indexed. Use this 6 volume TV-RADIO LIBRARY free for 7 days; get the valuable Servicing Book ABSOLUTELY FREE!

ON 7 DAY
FREE TRIAL!



SEND NO MONEY!

Just mail coupon for 6-volume set on 7 days free trial. We'll include book of 150 TV-Radio Patterns & Diagrams. If you keep the set, pay \$2 in 7 days and \$2 per month until \$22.50 plus postage is paid. (Cash price \$20.95). Or you can return the library at our expense in 7 days and owe nothing. **YOU BE THE JUDGE.** Either way, the book of TV-Radio Patterns is yours FREE to keep! Offer is limited. Act NOW!

FREE BOOK — FREE TRIAL COUPON!

COYNE ELECTRICAL & TELEVISION-RADIO SCHOOL, Dept. 24-T
500 S. Paulina St., Chicago 12, Ill.

YES! Send 6-volume "Applied Practical Radio-Television" for 7 days FREE TRIAL per your offer. Include TV-Radio Patterns & Diagram Book FREE.

Name..... Age.....

Address.....

City..... Zone..... State.....

Where Employed.....
() Check here if you want library sent COD. You pay postman \$20.95 plus COD postage on delivery. 7-day money-back guarantee.

COYNE ELECTRICAL & TELEVISION-RADIO SCHOOL
500 S. Paulina St., Dept. 24-T Chicago 12, Ill.

Windsor TUBES

RADIO & TV RECEIVING

TESTED and
GUARANTEED
for **PEAK**
PERFORMANCE

WHAT EVERY SERVICEMAN SHOULD KNOW. No tube checker reading of "Good" can positively insure that a specific tube will function perfectly in a TV set... only a substitution test in an actual set will do that! This is particularly true of tubes used in power and sweep circuits, deflection amplifiers, oscillators, reactance modulators, etc.

YOU PLAY IT SAFE when you buy Windsor tubes—because every tube we ship has been carefully pre-tested in a radio or TV set for **PEAK PERFORMANCE** under actual operating conditions. So we unconditionally guarantee every Windsor tube in accordance with the Standard Warranty: full replacement of any defective tube within 90 days of purchase, excepting only burnouts and breakages. Each tube is attractively packaged in individual carton.

BUY—AND SELL—WINDSOR TUBES, WITH CONFIDENCE

Type	Each	Type	Each	Type	Each	Type	Each
1A7GT	\$.67	1U5	.81	6AU6	.47	6J5GT	.44
1B3GT	.89	1X2A	.74	6AV5	.65	6J6	.68
1C8	1.06	2A7	.74	6AV8	.41	6J7	.70
1E7GT	1.09	2X2	1.43	6AX4	.72	6K6GT	.45
1H5GT	.51	3LF4	.76	6B8G	.93	6K7	.70
1H6	.93	3Q4	.66	6BA6	.50	6L6G	.88
1J6	.93	3Q5GT	.72	6BA7	.86	6L6GA	.88
1L4	.63	3S4	.61	6BC5	.58	6Q7GT	.55
1L6	.68	3V4	.82	6BD5GT	.98	6S4	.51
1L4A	.82	5H4GY	1.00	6BD6	.54	6S8GT	.75
1LA6	.80	5U4G	.44	6BE6	.51	6SA7GT	.57
1LB4	.82	5V4G	.83	6BF5	.66	6SC7	.63
1LC5	.80	5Y3G	.37	6BF6	.43	6SD7	.53
1LC6	.80	5Y3GT	.32	6BG6G	1.47	6SF5GT	.66
1LD5	.80	5Y4G	.43	6BH6	.63	6SH7GT	.52
1LE3	.80	6AR8GT	.61	6BJ6	.53	6SJ7GT	.52
1LH4	.80	6AB4	.88	6BK5	.76	6SK7GT	.58
1LN5	.80	6AC5GT	.82	6BK7	.97	6SL7GT	.66
1NS5GT	.63	6AG5	.59	6BL7GT	.94	6SN7GT	.59
IP5	.76	6AK5	1.05	6BN6	.98	6SQ7GT	.46
IQ5	.72	6AL5	.44	6BQ6GT	.98	6T8	.85
IR4	.85	6AQ5	.51	6BQ7	.92	6U8	.86
IR5	.62	6AQ6	.47	6BZ7	1.09	6V3	1.09
IS4	.67	6AQ7	.73	6C4	.41	6V6GT	.51
IS5	.52	6AR5	.42	6CB6	.58	6W4GT	.50
IT4	.82	6AS5	.55	6CD6G	2.04	6W6GT	.53
IT5GT	.78	6AU5GT	.85	6D6	.63	6X4	.37
IU4	.61			6E5	.72	6X5GT	.36
				6F5GT	.54	6Y6G	.64

Type	Each	Type	Each
7A4/XXL	.57	7A7	.57
7A5	.57	7A8	.56
7A6	.57	7A7	.57
7A7	.57	7A8	.56
7A8	.56	7A07	1.05
7A07	1.05	7A7	.63
7A7	.63	7A8	.65
7A8	.65	7A7	.65
7A7	.65	7A8	.65
7A8	.65	7A7	.70
7A7	.70	7B4	.54
7B4	.54	7B5	.51
7B5	.51	7B6	.52
7B6	.52	7B7	.58
7B7	.58	7C4	1.05
7C4	1.05	7C5	.56
7C5	.56	7C6	.58
7C6	.58	7C7	.58
7C7	.58	7E5	.85
7E5	.85	7E6	.65
7E6	.65	7E7	.85
7E7	.85	7F7	.69
7F7	.69	7F8	.87
7F8	.87	7G7	.85
7G7	.85	7H7	.61
7H7	.61	7J7	.85
7J7	.85	7K7	.85
7K7	.85	7L7	.85
7L7	.85	7N7	.62
7N7	.62	7Q7	.62
7Q7	.62	7R7	.70
7R7	.70	7S7	.90
7S7	.90	7V7	.92
7V7	.92	7X6	.62
7X6	.62	7Y4	.45
7Y4	.45	7Z4	.50
7Z4	.50	12A7	.53
12A7	.53	12A7	.75
12A7	.75	12A6	.47
12A6	.47	12A7	.58
12A7	.58	12A6	.41
12A6	.41	12A7	.33
12A7	.33	12A8	.72
12A8	.72	12A7	.67
12A7	.67	12A7	2.15
12A7	2.15	12A6	.50
12A6	.50	12A7	.66
12A7	.66	11723	.43

FREE!
WINDSOR
TUBE CADDY



The most practical Service-Aid ever designed for the radio and TV repairman. This ideal television carry-all now offered free with every purchase of \$160.00 or accumulated purchases totaling \$160.00 within 90 days. (You get caddy credit memo with each purchase). Windsor Tube Caddy may also be purchased outright for \$14.95.

- Carries approximately 125 tubes including meters and tools.
- 16 3/4 inches long x 8 1/4 inches wide x 13 3/4 inches high.
- Weighs only nine pounds.
- Ruggedly constructed with heavy leatherette covering, strong plastic handle, nickel plated hardware, and reinforced with metal clamps.

DON'T MISS THIS SENSATIONAL OFFER!

Windsor ELECTRONIC TUBE CO.
1515-C SHEEPSHEAD BAY ROAD, BROOKLYN 35, N. Y.

25% Deposit with Order. All merchandise F.O.B. NYC. For orders less than \$10. Add \$1 handling cost. Deduct 2% if full remittance accompanies order. All merchandise subject to prior sale and price changes without notice.

WRITE FOR ADDITIONAL TUBE TYPES AND PRICES. We also stock Special Purpose and Transmitting Tubes at similar savings! Dept. C-2

COMPARISON CIRCUIT

Patent No. 2,632,886
Kay H. Barney, Great Neck, N. Y.
(Assigned to Sperry Corporation)

This circuit compares the amplitudes of two signal voltages and shows which is the larger. It has exceptionally high sensitivity.

The two input signals are identified in the schematic by E_1 and E_2 . E_1 is a steady reference voltage and E_2 is a variable d.c. signal. A polarized vibrator coil L is energized from an a.c. source. When the a.c. voltage goes positive, the vibrator reed is drawn downward, feeding E_1 to the grid of amplifier V1. A negative half cycle repels the reed, so E_2 replaces E_1 . Thus the input to V1 is a square wave whose peak-to-peak amplitude is the difference between E_1 and E_2 .

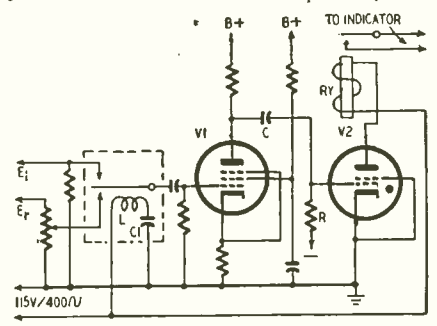

Fig. 1

Fig. 2 shows the relation between the a.c. line voltage (a) and the square-wave signal (b). In this case E_1 is greater than E_2 . Due to residual magnetism, mechanical inertia, and the inductance of the vibrator winding L, the a.c. voltage across the vibrator winding leads the motion of the reed. This lead is controlled to some extent by capacitor C1.

The a.c. component of the square wave is amplified and inverted by V1 and differentiated by R-C. Waveform c is the resulting peaked wave at the grid of V2, a thyatron. The plate voltage for this tube is taken directly from the a.c. line itself, so it looks exactly like the sine wave of a. Comparing the grid and plate voltages of V2, we find are almost 180° out of phase. Therefore the thyatron does not conduct when E_1 is larger than E_2 .

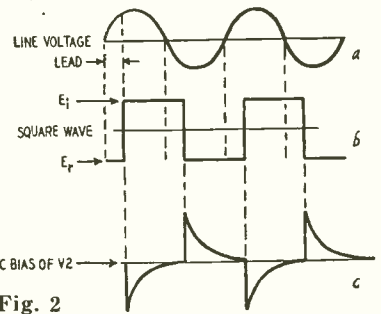

Fig. 2

When E_1 becomes smaller than the reference voltage, the square wave will have a reversed phase. That is, the top of the wave will have amplitude E_2 and the bottom will be E_1 . Obviously, the peaked wave c also will have reversed phase. Now the thyatron grid and plate will be in phase during part of the positive half cycles from the a.c. line, and relay RY will be energized. The relay can operate any desired indicator to show that E_1 is smaller than E_2 .

AUTOMATIC OVERLOAD RESET

Patent No. 2,654,052
Harry F. Mayer, Baldwinsville, N. Y.
(Assigned to the United States of America as represented by the Secretary of the Air Force)

Fuses are the lowest-cost protection against overload and short-circuits. Sometimes, however, this cost is less important than the time lost when replacing them. For example, a momentary short or sparkover may leave lights out and machines idle while someone locates and inserts new fuses. This invention discloses a circuit that resets itself automatically and quickly. Restoration time is ad-

HELP WANTED

This established radio & television manufacturing firm in Western New York has openings for:

- Test Engineers
- Trouble Shooters
- Technicians
- Aligners

Applications should contain details of past experience. Write to

Personnel Manager, H. E. Dudley

STROMBERG-CARLSON COMPANY, Rochester 3, N. Y.

justable, for example to 1/2 second after the short is removed.

When an overload occurs excessive current flows through the load coil of RY1. The armature of relay RY1 is attracted upward. Then d.c. (28 volts) flows through a limiting resistor into the holding coil of RY1 and the relay remains energized with its armature in the uppermost position. The 28-volt supply is disconnected from RY2, so the contacts of this relay open and the power line circuit is broken.

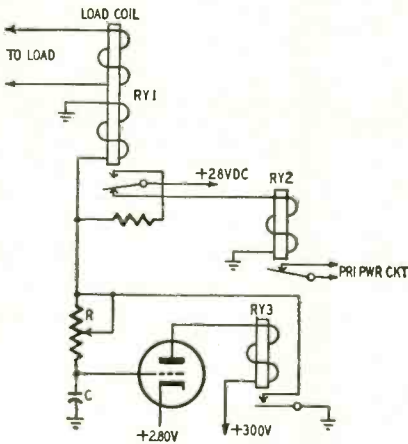

During this time the 28 volts d.c. flows into R to charge C. The control grid grows more positive until the tube conducts fully. RY3 is energized by plate current and both its contacts are grounded. This shorts out the holding coil of RY1. If the overload has disappeared by now, RY1 drops out and RY2 again becomes energized. The contacts of RY2 close and power is restored. If the short persists, RY1 remains energized and power is not restored.

There is no lag between the moment an overload appears and the instant the power line opens. Time is required, however, to charge C and begin tube conduction. Therefore the time-constant of R-C controls the interval before power may be restored.

Voltages, relays, and tube types in the diagram are typical values selected for the purpose of illustrating the patent. In practice, the various values may be altered as desired to fit a specific application as long as the basic operating conditions are followed closely.

Q METER

Patent No. 2,654,066

Jacob Rosenbaum, Spring Valley, N. Y.

This invention eliminates some of the difficulties encountered in a conventional Q meter. Any technician who uses such an instrument knows that the thermocouple is a very delicate and expensive unit. Even with special care, the couple may burn out due to momentary overload. To make matters worse, the couple is calibrated for its own Q meter and special resistor, so a new one must be ordered for the specific instrument into which it will be connected. This Q meter eliminates the thermocouple as well as the low resistance (usually .04 ohms) which injects r.f. into the tuned circuit.

An r.f. voltage from a variable oscillator is developed across a thin-walled tube as shown. A

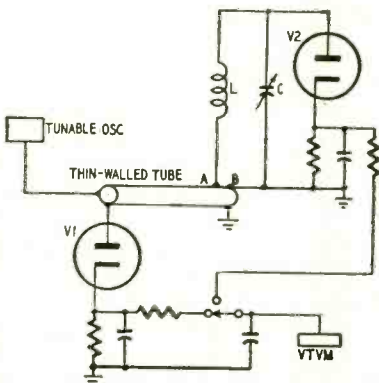

FEBRUARY, 1954

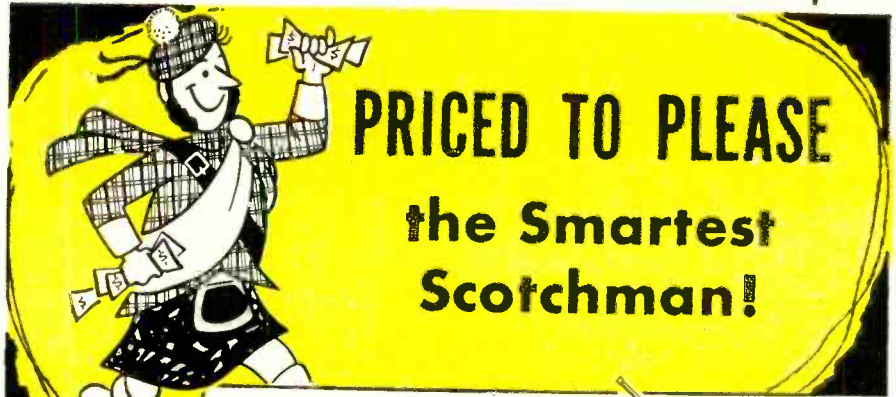

RADELCO BAR-X DIPOLE

with the original HIGH CHANNEL DIRECTOR BAR

Definitely improves performance on high channels. Heavy duty construction thru-out. All boom fittings are pre-assembled.

SINGLE STACK
Model RS-751
List Price \$7.45

DOUBLE STACK
Model RS-752
List Price \$15.75

QUAD STACK
Model RS-754
List Price \$35.00

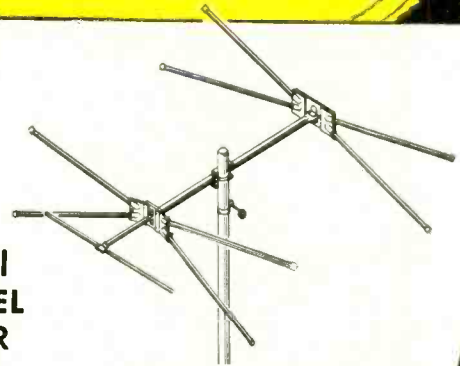

\$745
LIST PRICE
Model RS-751
Single Stack



RADELCO 5 ELEMENT YAGI

Ideal for Extreme Fringe Areas

• Aluminum elements pre-assembled on a 1" steel boom. U-bolt mounting assembly accommodates up to 1 1/2" mast. Exact 300-ohm impedance. Fittings and brackets of heavy gauge steel with thick zinc plating.

Model	Chan.	List	Model	Chan.	List
YS-502	2	\$12.00	YS-506	6	\$9.25
YS-503	3	11.35	YS-507		7.00
YS-504	4	10.65	thru		
YS-505	5	10.00	YS-513		7.00

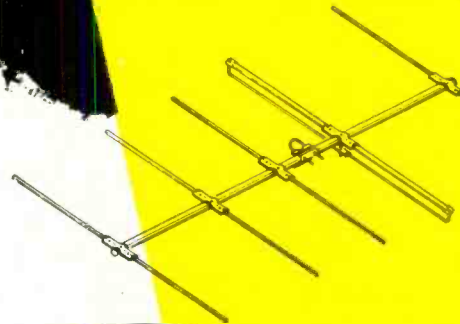

AS LOW AS
\$700
LIST PRICE
Models YS-507
thru YS-513



7580 GARFIELD BLVD.
CLEVELAND 25, OHIO

... you can believe what you read
on the **PRECISION** Series 40
COMPACT, WIDE-RANGE AC-DC CIRCUIT TESTER

A 100% factory-engineered, factory-wired, factory-tested and factory-calibrated professional instrument.

PRECISION-designed and constructed to provide long, trouble-free, accurate performance... to withstand the hard usage of Radio-TV Service, Radio Communications, and other phases of electronic equipment production and maintenance.

The compact Series 40 provides highest quality components and specifications as associated with PRECISION's larger and more costly instruments.



Sold by leading Electronic Parts and Equipment Distributors

Compare These Specifications:

- ★ 31 self-contained ranges to: 6000 volts, 600 ma., 5 megohms, +70 db.
- ★ 1% wirewound and film-type multipliers and shunts.
- ★ Easy-reading, full-sized, rugged 3" rectangular PACE meter. 400 microamperes, ±2% accuracy.
- ★ All standard ranges available from only 2 pin jacks, for utmost convenience and simplicity of operation.
- ★ Recessed 6000 volt safety jack.
- ★ Anodized, aluminum panel and markings that resist rubbing and moisture.
- ★ Compact, rugged molded phenolic case, 3 3/4"x6 1/4"x2 1/2".
- ★ Complete with ohmmeter batteries, test leads and full operating instructions..... **\$26.95**

LC-2: Leather carrying case, custom designed for Series 40\$5.75

PRECISION APPARATUS CO., INC.

92-27 Horace Harding Blvd., Elmhurst 7, N. Y.
Export: 458 Broadway, New York, U.S.A.
In Canada: Atlas Radio Corp., Ltd., Toronto, Ont.



small fraction of this voltage (between AB) is injected into the tuned circuit LC. As most readers know, the voltage across L (at resonance) is Q times as large as the injected voltage across LC. One voltmeter is used to measure the injected voltage and the voltage developed across L alone. First the meter is connected as shown to measure the rectified output of V1. This reading is proportional to the injected voltage. For example, it may be 10 times as large as the voltage between A and B. Then the meter is switched to measure the rectified output of V2. This gives the voltage across L (or C). The Q of the coil (or capacitor) is calculated from these readings.

The thin-walled tube may be of copper or silver. It eliminates errors due to skin effect at high frequencies. Of course its length should be small compared with a wavelength at the r.f. being used.

SLOTTED ANTENNA

Patent No. 2,633,532
William Sichak, Lyndhurst, N. J.
(Assigned to International Standard Electric Corp., New York, N. Y.)

This antenna makes an efficient microwave radiator and is easy to manufacture. The radiating slot may be cut in the outer conductor of a section of coaxial cable, or in a waveguide. The antenna may be mounted horizontally or vertically to meet directivity and polarization requirements. (Vertical mounting is shown here.)

A tubular conductor is provided with a helical slot, the pitch of which is determined by the wavelength to be radiated.

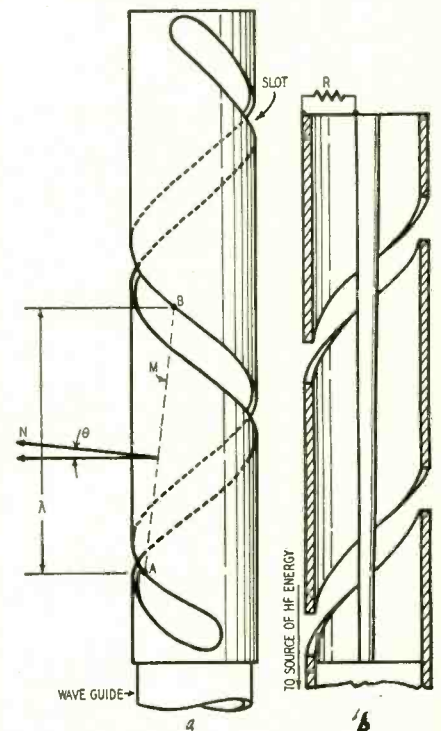

In the figure, a shows the antenna as an extension of a waveguide. The helical slot makes two complete turns. A and B are any two points a full wavelength apart. The signal voltages at these points have the same phase, and the line M connecting A and B shows the plane of the propagated wavefront. The direction of propagation (N) is at right angles to M. The angle of elevation theta (θ) between N and the surface of the antenna is determined by the ratio of the slot pitch to the wavelength of the signal. The plane of polarization is at right angles to the slot.

For highest efficiency the antenna should radiate uniformly throughout its length. In a coaxial-type antenna, however, the voltage and current drop off with distance from the h.f. source. To compensate for this, the inner conductor of the antenna is tapered as shown at b. This increases the coupling between the inner and outer conductors in proportion to the distance from the feed end. R is a terminating resistor.

BARGAINS · BARGAINS · BARGAINS

BARGAINS · BARGAINS · BARGAINS

Standard Brands

TUBES

All Brand New Individually Boxed Far Below Wholesale Cost

0Z4	.66	6AC7	1.29	6BG6	1.99	6SL7	.96	12AV7	1.14	35Z5	.53
1A7	.87	6AG5	.89	6RM6	.89	6SN7	.86	12AX7	1.06	50B5	.84
1B3	.99	6AG7	1.24	6BK7	1.26	6SQ7	.63	12AZ7	1.59	50C5	.84
1K5	.73	6AK5	1.39	6BL7	1.14	6T8	1.09	12BA6	.72	50L6	.71
1N5	.82	6AK6	1.44	6BQ6	1.35	6U8	1.14	12BE8	.98	50V6	.79
1R5	.79	6AK5	.93	6BQ7	1.49	6V6GT	.71	12BH7	.78	70L7	1.59
1S5	.79	6AL5	.71	6BN6	1.14	6W4	.72	12SA7	.83	80	.89
1T4	.77	6AQ5	.79	6BZ7	1.59	6W6	.91	12SK7	.79	117N7	1.59
1U4	.79	6AQ6	.89	6C4	.66	6X4	.62	12SL7	.99	117P7	1.59
1U5	.78	6AR5	.73	6CB6	.87	6X5	.62	12SN7	.91	117Z3	.64
1V2	.99	6AS5	.83	6CD8	2.59	6X8	1.09	12SQ7	.69	117Z6	.96
1X2A	1.02	6AT6	1.72	6G6	.71	7C5	.71	1978	1.29		
304	.89	6AU5	1.04	6K8	.63	7F7	.89	25BQ6	1.29		
305	.99	6AU6	.71	6J6	.99	7N7	.87	25L6	.73		
354	.77	6AV5	1.04	6K9	.71	7Y4	.69	25W4	.77		
3V4	.62	6AV6	.63	6L6GA	1.39	12AH7	1.18	25Z6	.67		
5U4	.65	6BA6	.82	6SA7	.73	12AL5	.71	35B5	.79		
5V4	.99	6BA7	.99	6SC7	.84	12AT6	.62	35C5	.62		
5Y3	.49	6BC5	.86	6SM7	.86	12AT7	1.07	35L6	.73		
6AB4	.79	6BC7	1.04	6SJ7	.66	12AU6	.77	35W4	.53		
6AB7	.99	6BE6	.74	6SK7	.72	12AU7	.94	35Y4	.74		

SPECIAL DISCOUNTS
50 Asst. | 5%
100 Asst. | 10%

Wen SANDER-POLISHER

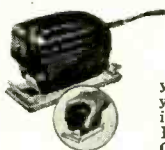

Here is the unit you have been waiting for. Does everything from sanding your car to polishing your shoes. Large sanding area a full 13 1/2" sq. Lightweight, easy to use. Complete with on-off switch, 6 sheets of sand paper and polishing cloth. Powerful high speed cool operating motor. Choice of 3 colors: Black, Fire-Engine Red, and Marbled Green. 110-120 volts, 60 cycles AC only.

List Price\$13.95
Net Price **\$10.46**

\$16.99 Lots of 3
\$17.95 each
Factory aligned ready to use. Complete with tubes and instructions.

CASCADE TUNER

SUPREME TESTERS



Model 600
—Tube & Set Tester.... **\$64.95**
Model 616
—Tube & Battery Tester.... **\$49.95**

Minimum Order \$5.00
SEND FOR OUR LATEST CATALOG

WEN ELECTRONIC SOLDERING GUN



250 Watts.
Choice of red, green, black.
Lots of 3 \$9.71 each

STEVE-EL ELECTRONICS CORP.

Dept. RE-2 61 Reade St., New York 7, N. Y. COrtland 7-0086

BARGAINS · BARGAINS · BARGAINS

NO TRICKS HERE!

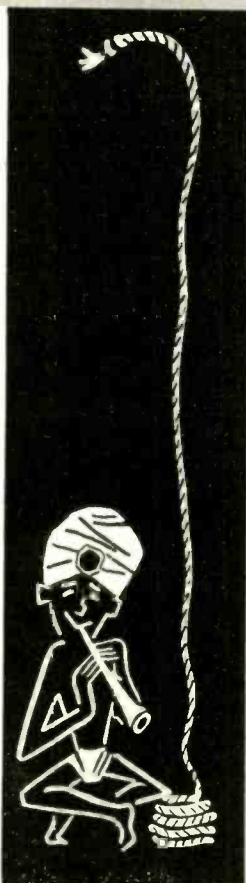

No Indian rope tricks for us—just clear thinking makes a Jontz Mast easier and quicker to install. Planned with the servicemen in mind, our Kwik-Up Masts have many built-in innovations, two of which are shown below. Jontz constantly works—to make your installations faster—your structures more permanent.

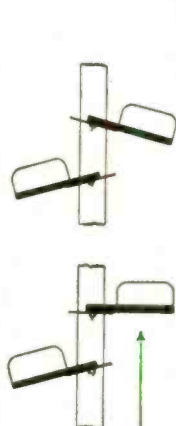

CLIMB ABOARD!

Climbers are furnished with mast. No ladders needed—stirrups fastened to mast, slide one foot at a time up the mast and descend in same manner.



THREE STRIPES—YOU'RE IN!

Naive idea—innermost section is withdrawn until paint stripe is exposed, then catter pin inserted in place as shown by paint stripe: The following section is then drawn out in same manner. No time consuming guess work.

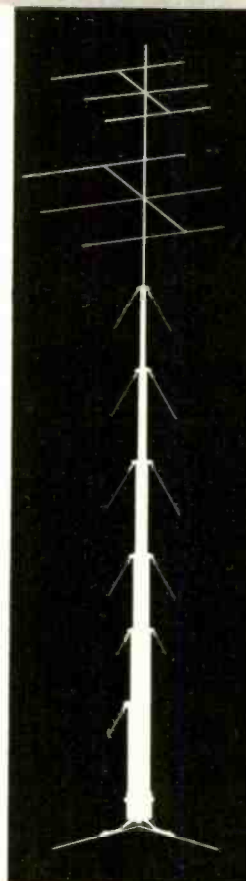

FOR QUALITY AND ECONOMY DEPEND UPON **JONTZ**



The Elements of Rust and Corrosion are sealed out!

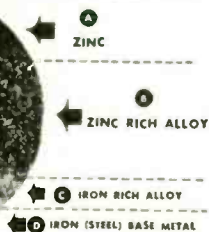

WHEATLAND

The search for quality and economy—for reliability under all weather conditions is answered with WHEATLAND HOT DIP GALVANIZED ELECTRIC WELD STEEL TUBING. Made by men who know tubing, who understand the problems that TV masts must withstand—Wheatland is used by more and more industry leaders. Hot Dip galvanized coating is perfect protection against rust and scratches—because it seals out destructive elements.

Next order specify—

HOT DIP GALVANIZED ELECTRIC WELD TUBING

by

WHEATLAND

WHEATLAND TUBE COMPANY • BANKERS SECURITY BLDG. • JUNIPER & WALNUT STS., PHILA. 7, PA.

CONICAL YAGI

Falcon Electronics Co., Quincy, Ill., has announced a v.h.f. conical-Yagi antenna, the 88. This antenna has five elements on the low channels and four on the highs.



The low-channel section consists of a conical driven element using the Vari-Con adjustable head, dual reflectors and a director.

The high-channel section uses two separate driven elements and a director for each. One driven element and director operates across Channels 7-9, and the other pair across channels 10-13. The entire array is fed with a single 300-ohm line.

U.H.F. GENERATOR

Triplett Electrical Instrument Co., Bluffton, Ohio, has announced a new u.h.f. marker generator and signal generator, model 3436, with the following features:

All fundamentals on channels 14-83 (470-900 mc). No confusing harmonics. Large dial with uniform frequency graduations. Scale 13 inches

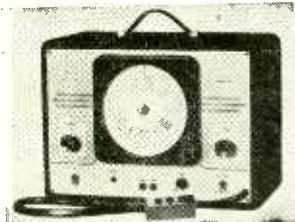

long. *Marked in both frequency and channels. Hand-drawn for extreme accuracy. R.f. output average 0.3 volt. Variations in output minimized. Output impedance 150 and 300 ohms. Piston type attenuator. Triple shielding. Excellent stability through special construction. Voltage-regulated power supply. Adjustable modulation of r.f. signal at approximately 1,000 cycles. 0-20 volt audio output at panel. Can be used as horizontal bar generator.

U.H.F. ANTENNA

Metal Products Corp., 807 N. W. 20th St., Miami 31, Fla., has announced the TW-30 Traveling Wave antenna, designed for fringe-area u.h.f. and medium-range v.h.f. reception. It is said to perform satisfactorily in winds up to 45 m.p.h. A smaller version, the TW-15 is also available. This model is intended for primary u.h.f. areas. Both are all-aluminum, with Plexiglass insulation.

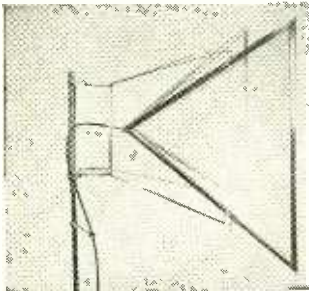

MARKER ADDER

Hickok Electrical Instrument Co., 10531 Dupont Ave., Cleveland 8, Ohio, has designed a heterodyned marker adder to provide the utmost in TV alignment technique when used with any sweep marker equipment.

Model 691 provides a marker visible at all times. The output of the sweep generator and marker generator are heterodyned and applied to an oscilloscope in such a manner that the marker

signal does not pass through the receiver itself and therefore cannot cause overloading.

The unit has an output marker voltage up to 3 volts, variable attenuation of markers from 0 to 60 db, variable attenuation of response curve from 0 to 20 db, and an input impedance of 90 ohms. The steel portable case measures 11 1/2 x 9 x 6 inches and weighs 14 pounds.



U.H.F. SELECTOR

Tech-Master Products Co., 443 Broadway, New York 13, N. Y., has announced a u.h.f. selector, model TV101-U, to bring in all u.h.f. stations. The unit fits into the front recess on all 630 style chassis.

Mounting is simple: only two internal connections and the antenna lead. One-knob, continuous-tuning covers the entire u.h.f. spectrum. Noisy electrical contacts have been eliminated. Three high-Q resonators give high-gain sensitivity, and the cascode i.f. stage is completely shielded for maximum selectivity.

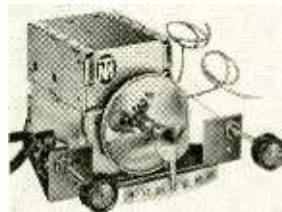

The unit features a tuning range of 465-900 mc. input and output impedances of 300 ohms, image rejection of 50 db minimum, i.f. output of 76-88 (channels 5 and 6), i.f. rejection of 85 db at 84 mc, over-all converter gain of 8 db, and i.f. gain of 18 db.

NEW YAGI

JFD Mfg. Co., Inc., 6101 16th Ave., Brooklyn 4, N. Y., is producing a new Yagi, the UHF312. Intended for deep-fringe reception of single u.h.f. channels, it also picks up adjacent channels due to mean-frequency pickup.

The gain ratio for various channels with this antenna is: a 2-bay array delivers a gain of 13.75 db on the channel that the antenna is measured for; and, on the most remote adjacent channel that the array can receive, a gain of 11.5 db. A single unit produces a high of 10.78 db on the channel it is specified for and a low of 8.5 db on the most remote channel it can receive.

For example, if a model cut for channel 43 receives channels 39 to 48, a model cut for channel 48 will receive channels 43 through 52. Therefore, a channel 43 area has provision to receive channel 48 if a 48 station opens. And a channel 48 area will get top channel 48 reception with the channel 48 model.

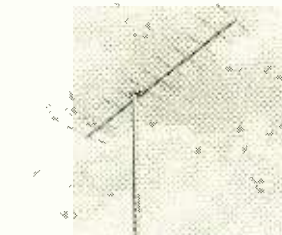

BAR GENERATOR

Electronic Instrument Co., Inc., 84 Withers St., Brooklyn 11, N. Y., has



released a portable bar generator, model 352. The instrument operates on channels 3, 4, or 5 and has 16 vertical and 12 horizontal bars. Output voltage is 100,000 microvolts and the power supply is a transformer operated half-wave selenium-rectifier circuit.

The unit measures 7 1/2 x 5 x 4 1/2 inches and weighs 8 pounds. It is available in kit or wired form.

U.H.F.-V.H.F. ANTENNA

Television Hardware Mfg. Co., Rockford, Ill., has announced a new u.h.f.-v.h.f. antenna, the Double-V. This stack-type antenna can be used for both

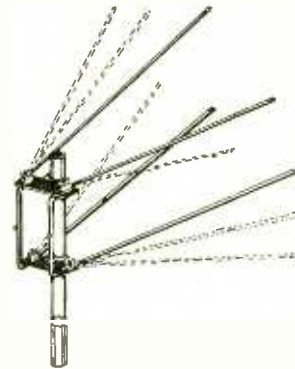

u.h.f. and v.h.f. in primary and secondary signal areas; it is highly directional and can be adjusted to 50°, 70°, and 90° for either band or for combined bands.

MOBILE RECEIVER

S & W Electronics, 3418 W. Pico Blvd., Los Angeles 19, Calif., is manufacturing a fixed-frequency mobile receiver for use with converters, the Mobil-Ceiver. The unit mounts under the dash-



board and supplies adequate power to run the converter. When used with any converter with 1400-1600 kc output, it becomes a double conversion superhet.

The receiver features variable selectivity, an input frequency range of 1400-1600 kc, four 175-kc i.f.'s image rejection of 60 db or better, and provision for transmitter relay. It measures 4 1/2 x 6 1/4 x 7 1/4 inches.

U.H.F. BOOSTER

David Bogen Co., Inc., 29 Ninth Ave.,



New York 14, N. Y., has announced a u.h.f. TV booster, model UHB. There is gain of 13 1/2 db at the lower frequencies and 8 db at the high end. Noise figure is 11 db at the low-frequency end and 15 db at the high end.

A coaxial-type tuning system is used with a u.h.f. type 6AN4 tube. The power supply is self-contained, and uses a selenium rectifier.

The unit can be used with u.h.f. sets using strip tuners as well as with new sets using an 82-channel tuner.

ANTENNA COILS

Master Mobile Mounts, Inc., 1306 Bond St., Los Angeles 36, Calif., has announced their Hy Q coils for 20-, 40-, and 75-meter operation.

These units require little or no tuning and are instantly interchangeable. They are weather-sealed and durably constructed.



Specifications are: 20-meter, 3 1/2 x 2 3/8 inches in diameter, weight 7 1/2 oz.; 40-meter, 6 1/2 x 2 3/8 inches, weight 11 oz.; and 75-meter, 7 1/2 x 2 3/8 inches in diameter, weight 12 oz.

SOUND SYSTEM

Rauland-Borg Corp., 3515 W. Addison St., Chicago 18, Ill., has announced a dual-channel central control sound system, model S214, designed to serve up to a total of 40 rooms in schools or institutions. The system feeds microphone, radio, and phono programs to



any or all rooms and provides 2-way intercommunication between any room and central control console. All facilities are housed in the studio-type all-steel console.

Facilities include a program panel, FM-AM radio, switch panel, intercom panel, all-call switch, and automatic record changer.

U.H.F.-V.H.F. SWITCH

Plymouth Electronics Corp., Worcester 10, Mass., has announced a u.h.f.-v.h.f. antenna transfer switch designed for low loss and low leakage. It can be installed without soldering.

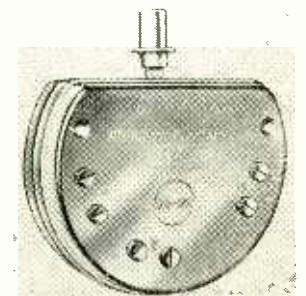

TUBE RESTORER

Miller Television Co., 2840 N. Naomi, Burbank, Calif., is producing an instrument designed to reactivate low-emission cathode-ray tubes, the *Re-Katho*.

The instrument is a tube checker as well as restorer. It checks magnetic and electrostatically deflected cathode-ray tubes, using the beam current



principle, and has a microammeter to give the current readings. It checks the electron gun for open or shorted elements, and gives a dynamic check. There is no need to remove the tube from the set (or the tube carton) when checking.

COLOR TV UNITS

Crest Laboratories, Inc., 84-11 Rockaway Beach Blvd., Rockaway Beach, N. Y., has announced a line of variable inductors suitable for use with the latest color television circuitry, as shown in the NTSC published schematics.

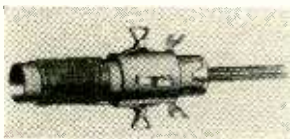

These variable inductors are designed for both laboratory and prototype use. Additional information will be furnished on request.

TWO ANTENNAS

Walsco Electronics Corp., 3225 Exposition Plaza, Los Angeles Calif., has announced a conical v.h.f. and a u.h.f. Yagi antenna.

The v.h.f. model uses an insulator containing barrier-discs and two inches of air space between terminals to prevent shorts. Its front-end hardware is stainless steel.

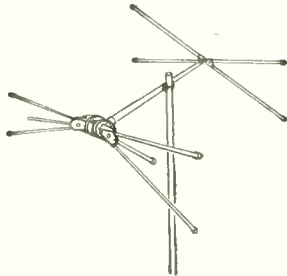

The 10-element u.h.f. Yagi has a gold-plated receiving dipole for high gain under all weather conditions. This antenna is designed for single-channel or broad-band (15 channels or more).

RECORD CLOTH

Jensen Industries, Inc., 329 S. Wood St., Chicago, Ill., has introduced an anisotropic record cloth, *Silcloth*. The red cloth deposits a microscopic film of silicones in the record grooves to lubricate and lessen friction between

needle and record. One treatment with the cloth is said to last for several months.



REEL-TAB

Orradio Industries, Inc., T-120 Marvyn Road, Opelika, Ala., has designed a tab for identifying sound-tape reels. This tab fits beneath the edges of any 7-inch plastic or metal reel. It may be obtained free direct from the company.



TEST INSTRUMENT

Century Electronics Co., 8509 21st Ave., Brooklyn, N. Y., is producing a new model of its *Dynatracer*. The portable, self-powered instrument traces TV signals through any sound, sync, a.f.c., or vertical or horizontal sweep circuit.

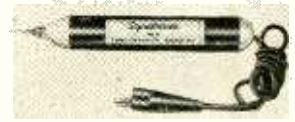

It also will trace voltages of 50-500 volts a.c.-d.c. and locate faulty capacitors, resistors, coils, and transformers.

HIGH-FIDELITY TUNER

Radio Craftsmen, Inc., 4401 N. Ravenswood, Chicago 40, Ill., has developed a new FM tuner model C930. This



high fidelity unit has a cascode double-triode r.f. amplifier which gives sensitivity of 1 μ v for 20 db quieting; photo-etched i.f. coils; 20.6 mc i.f. channel; amplified a.f.c. to reduce drift; and continuously variable a.f.c. for easy tuning of weak stations adjacent to strong locals.

Minimum distortion is assured by the almost complete absence of regeneration and adequately wide i.f. band-pass and discriminator linearity. Controls are provided for a.f.c., off-on volume and tuning. **END**

All specifications given on these pages are from manufacturers' data.

Just Out

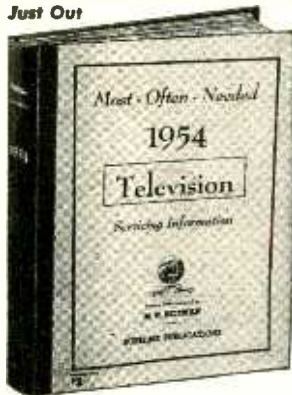

This newest giant volume of the *Supreme TV* manuals covers 1954 factory data on all popular television sets of all makes. There are explanations of new circuits, 192 pages of alignment procedure, test patterns, response curves, pages of waveforms, voltage charts, service hints, production changes, and dozens of double-spread circuit diagrams. Manual-style binding (opens flat). Special price, only \$3

New SUPREME 1954 TV Manual
FULL YEAR'S TV MATERIAL IN A GIANT VOLUME — \$3

COVERS ALL POPULAR SETS

This new *Supreme 1954 TV* manual has all the required service material on every popular television set of every important manufacturer. Here is helpful, practical, factory-prepared data that will really make TV servicing and adjustment easy for you. More pages, more diagrams, more service data per dollar of cost. This new giant TV manual and previous volumes for other years have complete circuits, alignment facts, test patterns, response curves, service hints, recommended changes, voltage charts, waveforms, and many double-page diagram blueprints. Here is your TV service material to help you do more expert work quicker; and priced at only \$3 and \$2 per manual covering a whole year of material. See coupon below for complete list of all eight TV volumes, from 1947 to 1954, and the 1953 UHF Converters manual. Order for a 10-day trial.

AMAZING BARGAIN OFFER

The new 1954 TV manual is the most remarkable value offered by *Supreme Publications* in their 20 years of business. This mammoth television servicing manual at only \$3, or the TV manuals for previous years for only \$3 and \$2 each, are amazing bargains and defy competition. There is nothing else like them. Each manual is a virtual treatise on practical television repairs. By normal standards, each such large manual packed as it is with practical facts, hundreds of illustrations, diagrams, charts, photographs, and expensive extra-large blueprints, should sell for \$10—but as *SUPREME* special values they are priced at \$3 and \$2 each. Only a publisher who sold over one million TV and radio manuals can offer such bargains based on tremendous volume-sales. Be ready to repair any TV set by having in your shop all eight *Television Manuals* listed in coupon. Or try the new 1954 TV manual to see what an amazing bargain you get for only \$3. Send trial coupon or ask your jobber.



The repair of any television set is really simple with *Supreme TV* service manuals. Every set is covered in a practical manner that will simplify troubleshooting and repair. This is the help you need to find toughest faults in a jiffy. Each \$3 volume covers a whole year of material. Be wise, buy *Supreme Manuals* only once each year instead of spending dollars every week for not needed data.

Newest

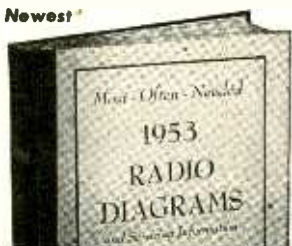

RADIO DIAGRAMS

Here is your complete source of all needed **RADIO** diagrams and service data. Covers everything from most recent radios to pre-war old-timers; home radios, auto sets, combinations, changers, and portables. Sensational values. Still sold at pre-Korean prices. Only \$2 for most volumes. Every Radio manual contains large schematics, all needed alignment facts, parts lists, voltage values, trimmers, dial strings, and helpful service hints. All volumes are large in size, 8 1/2 x 11 inches, about 192 pages. See coupon at right for a complete list of these low-priced manuals.

NO-RISK TRIAL ORDER COUPON

SUPREME PUBLICATIONS, 1760 Balsam Rd., Highland Park, ILL.

Radio Diagram Manuals

- New 1953 Manual, \$2.50
- 1952 Radio
- 1951 Diagrams
- 1950 Manual
- 1949 Radio
- 1948
- 1947
- 1946
- 1942
- 1941
- 1940
- 1939
- 1926-1938 Manual, \$2.50
- Master INDEX only 25¢

PRICED AT ONLY \$2 EACH

Send TV manuals checked below and Radio manuals at left. Satisfaction guaranteed or your money back.

- New 1954 Television Servicing Manual, only . . . \$3.
- 1953 TV Manual, \$3. 1953 UHF Units, \$1.50
- 1952 Television Manual, \$3. 1951 TV, \$3.
- 1950 Television Manual, \$3. 1949 TV, \$3.
- 1948 TV, \$3. 1947 TV & FM, only \$2.

I am enclosing \$ Send postpaid.

Send C.O.D. I am enclosing \$ deposit.

Name:

Address:

Supreme Publications
 Available from Leading Parts Jobbers



THE Case WITH A 1,000 APPLICATIONS

This all-purpose case is ideal for housing meters, controls and switches of all types.

Made of heavy molded black plastic. Available with matching phenolic panel.

Easy to drill and saw. Available in two sizes;

5-1/4" x 6-7/8" x 2-5/16"
3-3/4" x 6-1/4" x 2"

Ask your Distributor for Waldom's Plastic Case.



MIDGETS that do

a Giant Job

a Grayburne **FERRI-LOOPSTICK**
World's most sensitive, compact, efficient small radio antenna **75c**

b Grayburne **VARI-LOOPSTICK**
Same as Ferri-Loopstick with variable micrometer adjustment **1.00**

Over 50,000,000 small radios are prospects for Loopsticks. Replaces inefficient loop antennas... pulls in stations strong and clear. Customers rave over performance... you'll rave over profits.

CARRY several Loopsticks in your kit. Order today from your distributor.



SIMPLE INSULATED-WIRE TESTER FOR QUALITY CONTROL

This simple circuit was developed to test insulated wire under specifications set up by the American Society for Testing Materials. The tester is independent of line voltage and frequency fluctuations and can be modified readily to test other materials. It supplies a constant test voltage between the wire conductor and its insulation and immediately indicates when the insulation

resistance between the insulated conductor and ground.

A switch and 300,000-ohm standard resistor are provided for calibrating the instrument. With the switch set to CALIBRATE, adjust R2 so the voltage between the cathode and starter anode is about 75—just below the value required to fire the tube. When the switch is thrown to TEST, the voltage

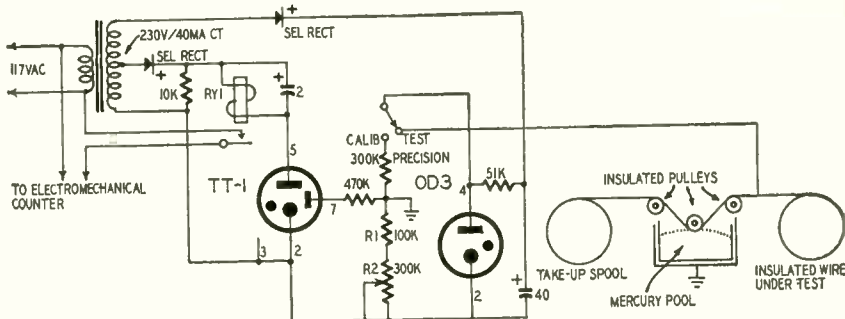

resistance at any point is below 300,000 ohms. One side of the test voltage is applied to the conductor and the other connects to a pool of mercury through which the wire is drawn.

The circuit is designed around a Haledy TT-1 cold-cathode triode. The plate of the tube is fed through a rectifier connected across one half of the transformer secondary. The starter anode is supplied from a rectifier connected across the full secondary winding. The starter anode voltage is tapped off a voltage divider across the output of the OD3 150-volt voltage regulator tube. One leg of the divider consists of R1 and R2 and the other consists of the

is taken off the standard resistor and applied between the conductor and its insulation. When the insulation resistance drops below 300,000 ohms, the starter anode voltage rises and fires the tube. Plate current operates the relay which may control an alarm, electromechanical counter, or any similar indicating device. The relay contacts can also be used to control an electronic timer-counter that sounds an alarm or automatically marks or rejects the material being tested only after the TT-1 tube has fired a given number of times during a previously determined time interval.—Harry Peach and E. Spierer

LOW-DISTORTION DETECTOR FOR HIGH-QUALITY AM SETS

Diode detectors are used universally in AM receivers and tuners. For minimum distortion, the detector load must be considerably higher than the internal resistance of the diode and the a.c. and d.c. load impedances should be equal. The ratio of a.c. load to d.c. load is usually far from unity in the average application where the detector feeds into an audio amplifier through a volume control or a R-C network.

While developing a low-distortion AM tuner, W. Winder designed the detector and a.f. amplifier circuit reprinted here from *Wireless World*

(London, England). This circuit uses direct coupling between the detector diode and the audio cathode follower, so the a.c. and d.c. load impedances are equal except for the cathode-follower input capacitance which is about 10 μf.

A positive voltage applied to a part of the diode load chain combines with the d.c. component of the detector output to bias the cathode-follower grid to the correct operating point with respect to the cathode.

V1 and V2 are conventional detector-type diodes. V3 may be any medium-μ triode or a triode-connected pentode.

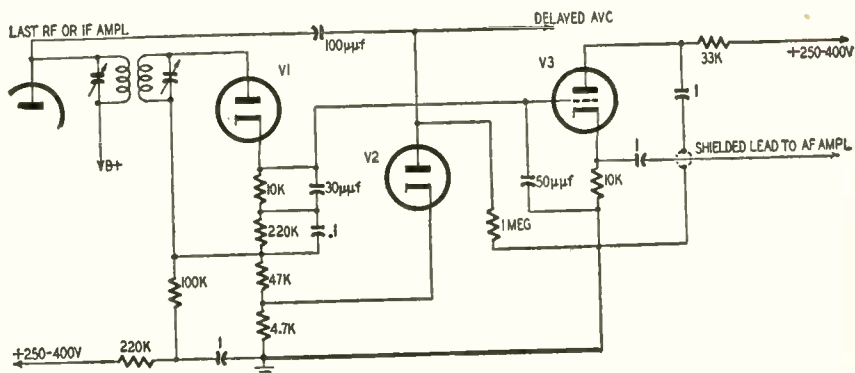



*Prepare now for
the great opportunity
field of...*

*You Can Quickly
be doing interesting
profitable work
like this!*

TELEVISION

RADIO-ELECTRONICS

*In spare time
at home!*

A fascinating field! A great future! A good job or independence in a business of your own! TV is growing by leaps and bounds—1227 new communities, 1845 new stations have been given the "go-ahead". Trained men are worth their weight in gold!

**MODERN TRAINING BY COYNE
RIGHT IN YOUR OWN HOME**

Here is modern, up-to-the-minute Home Training in Television and Radio designed to meet the standards that have made the Coyne School famous for many years. You get personal supervision by members of Coyne instruction staff—men who know TELEVISION AND RADIO AND KNOW HOW

B. W. COOKE, President

COYNE
SCHOOL

**A TECHNICAL TRADE INSTITUTE
CHARTERED NOT FOR PROFIT**
Established 1899

500 S. Paulina Dept. 24-HR4, Chicago 12,

TELEVISION ★ RADIO ★ ELECTRICITY ★ REFRIGERATION ★ ELECTRONICS

TO TEACH IT—men who have helped train thousands of men and young men, Service men and Veterans.

LEARN TO EARN IN SPARE TIME

COYNE offers a most practical, down-to-earth Home Television Training. Simple, easy to follow step-by-step instructions, fully illustrated. So practical, you can quickly be earning money in Television and Radio and keep your present job while training.

Let us show you that this is not only the newest, most up-to-the-minute Training in Television-Radio-Electronics—but also it costs you much less than you'd expect to pay. Send coupon today for details including Easy Payment Plan.

B. W. COOKE, President
COYNE SCHOOL
500 S. Paulina St., Chicago 12
Dept. 24-HR4

Send details of your offer on training checked below. This does not obligate me and no salesman will call. I am interested in:

- Television-Radio Home Training
- Electricity in Coyne Shops
- Television-Radio in Coyne Shops

Name

Address

City State

YOU CAN ALSO TRAIN FOR
TELEVISION-RADIO OF ELECTRICITY
IN THE GREAT SHOPS
OF COYNE AT CHICAGO



Coyne, of course, also offers practical resident training in the Coyne Training Shops here in Chicago in the fields of TELEVISION-RADIO and ELECTRICITY. If you prefer to get information about our resident courses in either or both of these fields, then check on the coupon accordingly and mail it to us. Our fully illustrated 48 page Guide To Careers in Television-Radio and Electricity and complete details about our resident training will be sent you by return mail. No cost or obligation to you, of course, and no salesman will call on you.

**MAIL COUPON FOR
INFORMATION**

Fill in and mail coupon TODAY. Paste it on a postcard if you wish. Complete details will come by return mail. No cost —no obligation and no salesman will call.



NEW PROBES!

FOR VTVM'S & SCOPES

- FULLY SHIELDED
- SHOCK-MOUNTED TERMINAL BOARD
- SWIVEL ACTION
- ALL PARTS ACCESSIBLE
- COLOR CODED

Only EICO Probes Have All These Features!

SCOPE DEMODULATOR PROBE MODEL PSD



KIT \$3.75 WIRED \$5.75

LOW CAPACITY PROBE MODEL PLC



KIT \$3.75 WIRED \$5.75

DIRECT PROBE MODEL PD



KIT \$2.75 WIRED \$3.95

VTVM RF PROBES MODEL PRF-11 OR 25
For any 11 or 25 megohm VTVM



KIT \$3.75 WIRED \$4.95

PEAK-TO-PEAK PROBES MODEL PTP-11 OR 25
For any 11 or 25 megohm VTVM



KIT \$4.95 WIRED \$6.95

SENSATIONAL HIGH VOLTAGE PROBE MODEL HVP-2



ONLY . . . \$4.95 FOR VTVM'S & VOM'S

See these amazing probe values at your jobber today. Write now for free catalog PC-2. Turn to our full-page ad on page 5 of this magazine.

EICO® All Above Probes Pat. App. For
ELECTRONIC INSTRUMENT CO., Inc.
84 WITHERS STREET, BROOKLYN, NEW YORK

USEFUL SIGNAL TRACER FOR AM, FM, AND INTERCARRIER TV

This is the circuit of a tuned signal tracer that I use for tracing signals through the i.f. circuits of FM, AM, and intercarrier type TV sets. The r.f. input terminal feeds into a pentode r.f. amplifier. S1 in the plate circuit of this stage selects the primaries of the 262-

circuit of the 6AT6 triode to the AM or FM detector outputs or to the audio input terminal. The 6AQ5 is a conventional power-amplifier stage.

The constructor has a choice of using octal or miniature tubes. The latter type is recommended for compactness

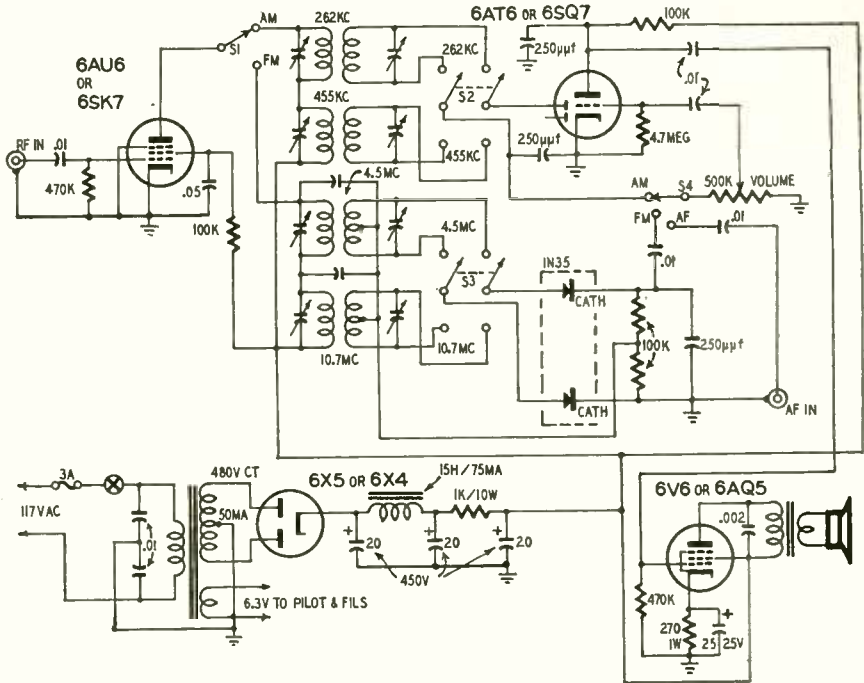

and 455-kc AM i.f. transformers or the series-connected primaries of the 4.5- and 10.7-mc. S2 selects either one of the AM i.f. transformers and connects the desired circuit to the AM detector using the diode section of the 6AT6. S3 selects the desired FM i.f. signal and feeds it to a discriminator using a 1N35 germanium duo-diode. S4 connects the volume control and the grid

so the leads can be kept short. Use an r.f. probe that will not load or detune the circuit to which it is connected. A probe head consisting of a pair of 2.2- μ f ceramic capacitors in series would do the job. A short, low-capacitance coaxial cable should be used between the probe and the signal tracer radio-frequency input circuit.—Francis R. Miles

LOW-FREQUENCY NARROW-BAND AMPLIFIER FOR SPECIAL JOBS

Many electronic and research applications require amplifiers which will handle signals of very low frequencies. Strain gages, radiation thermocouples, encephalographic recorders, and many other devices handle a.c. signals which may go down to a fraction of a cycle per second. Tuned and direct-coupled amplifiers are often used, with each type exhibiting its own particular disadvantage. An article in *Electronic Engineering* (London, England) describes a simple low-frequency amplifier with a gain of 1,000, a Q of 20, good linearity over a wide range of

input signal levels, and a range of 1 to 3 cycles.

The circuit shows two cascaded amplifiers coupled through a tunable twin R-C network. Positive feedback across the common cathode resistors causes the signal to peak at the frequency of the R-C network. Stability is assured by negative feedback produced by omitting bypass capacitors in the cathode circuits of the amplifiers. The frequency of the network is varied between 1 and 3 cycles by varying the settings of the ganged 1.5-megohm controls. Q values are determined by the resistance com-

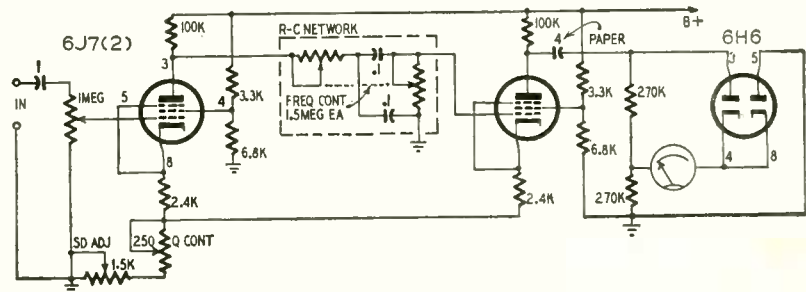

Now! RAD-TEL Tubes & Parts At Savings!

Wafer Rotary Switch Kit



A choice combination of single, double, etc. from 2 to 8 positions. Special kit of 10 . . .

\$1.39

Smashing Reductions on FP CONDENSERS



All famous makes. Save plenty on these top quality FP Condensers. Made by leading manufacturers. You can't miss—these values are hits you look at them!

\$1.99

CERAMIC KIT



1 kit of 50 assorted ceramic discs, biplates, tubular condensers. All condensers popular sizes, used in T.V. and M. sets. A MUST kit! List price \$10.00. . .

\$1.99

Hi-Watt RESISTOR KIT



Consisting of 5, 10, 15 and 20 Watt vitreous type resistors by Ward, etc. A top-flight buy! . . .

\$1.95

FILTER CONDENSER KIT* 150 V



Filter CONDENSER KIT* 150 V. \$10 to a pkg. min. Kit of 10 20-20. List price \$15. \$3.25. Kit of 10 40-40. List price \$15. \$3.25. Kit of 10 50-30. List price \$15. \$3.25.

49c

FILTER CONDENSER 20-20 Mid, 450 V



Color-coded leads. Ideal for use where impossible to use metal cans. For top performance at a giveaway price. List price \$2.40. . .

49c

BIAS CONDENSERS

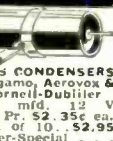

Sangamo, Aerovac & Cornell-Dubilier 300 mfd. 12 V List Pr. \$2.35 ea. Pkg. of 10. \$2.95 Super-Special. 450 mfd. 8-100 VDC. Kit of 7—\$1.29.

CAN ELECTROLYTICS

Made by Leading Mfrs.

Capacity	DC Working Voltage	Price
40-40-40	450-450-25	.99
250-1000	10-6	.49
40	450	.49
60-10-10-20	450-450-450-150	.89
80-40-10	450-450-450	.99
20-8-8-8	450-450-450-250	.59
80	500	.79
15-15-20	450-450-25	.59
40-10-100	450-450-200	.79
10-20	450-25 F.P.	.39
10-8-8-8	450-450-450-150	.49

Kit of 10 assorted Electrolytic Condensers

Consists of singles, doubles, triples and quadruples, all of popular voltages and capacities—all standard popular brands.

\$2.39

National Turret T.V. BOOSTER



Made by National, famed for quality and precision communications equipment. Turret selects each channel. Completely self-contained including tube and selector rectifier for A.C. operation. Housed in metal cabinet. In factory-sealed cartons with complete instructions. . .

\$9.95

25 Paper BY-PASS CONDENSERS



An assortment of 25 by-pass condensers, made by leading manufacturers. Top quality. Most popular sizes and voltages. Values .002 to .2 MFD. 200 to 1000 VDC. KIT OF 25 . . .

99c

Hi-Voltage POWER SUPPLY 4500 VOLTS 6 MA.



12AU7 oscillator 183 rectifier. Completely wired, enclosed in slided metal case, removable cover. Improve performance of your scope; use as R.F. high voltage supply. R.F. high voltage supply. . .

\$2.95

FLYBACK TESTER



A MUST For Every Serviceman! Fast, sure horizontal trouble-shooting. Responsive to as small a defect as a 1-turn short. Tested while in receiver! Tests continuity on yokes, coils, speakers, switches, etc.

\$39.95

Variable Condensers



Manufactured by Philco, Radio Condenser, etc. 2 Gang AM and FM contains 2 separate sections for AM and 2 for FM with padders and drum pulley drive. . .

99c

ALL BRAND NEW PARTS!

FILAMENT ISOLATION TRANSFORMER



6.3 V @ 1.2 A

For damper use with 6W4, etc. High voltage insulation between primary and secondary to withstand high voltage surge. Can be used for general replacement. . .

List price—\$1.75

RCA Type FLYBACK TRANSFORMER



Type 215T1

Lowest net Price elsewhere—\$4.70. At this giveaway price, order in quantity while they are available. Each. . .

.95c

Vertical OUTPUT TRANSFORMER



Very popular, used in most T.V. sets. Well-known manufacturer. Matches vertical output tube to the deflection yoke. 10 to 1 ratio. A terrific buy on a top performer. . .

List price—\$4.50

BIG SAVINGS YOU CAN'T PASS BY! 70" YOKE



Mfd. by Todd, Sickle, and other Leading Mfrs. Very good value, makes conversion profitable and simple. . .

List price—\$7.50

55" Yoke . . . 99c

70% to 90% OFF ON TUBES!

All Tubes Individually Boxed Some Day Service! Check this list for Fully 1-Year Guaranteed Tubes.

Type	Price	Type	Price	Type	Price
0A2	.74	6BN6	.59	12AY7	.99
0B2	.91	6BQ6	.79	12BA6	.38
0C3	.92	6BQ7	.90	12BA7	.45
0D3	.70	6BZ7	.90	12BD6	.45
0Z4	.55	6C4	.37	12BE6	.39
1A5	.30	6C5	.39	12BF6	.39
1A7	.47	6C6	.58	12BH7	.63
1AX2	.62	6C8B	.44	12BY7	.65
1B3	.60	6C8C	1.11	12BZ7	.65
1B7	.60	6D5	.38	12CA7	.42
1C5	.43	6F5	.19	12J5	.42
1E7	.29	6F6	.59	12K8	.59
1G6	.24	6G6	.52	12Q7	.59
1H4	.30	6H6	.41	12S8	.62
1H5	.49	6J5	.43	12SA7	.65
1L4	.50	6J6	.52	12SF5	.67
1LA4	.59	6J7	.47	12SK7	.63
1N5	.67	6K6	.37	12SL7	.47
1P5	.57	6K7	.44	12SN7	.62
1Q5	.58	6L6	.64	12SQ7	.56
1R5	.49	6Q7	.45	12SR7	.49
1S4	.49	6R5	.43	12T6	.44
1S5	.43	6S8	.63	12X4	.38
1T4	.49	6SA7	.43	14A5	.59
1U4	.49	6S7	.41	14AF7	.59
1U5	.43	6S75	.46	14H7	.59
1V4	.53	6S77	.49	14J7	.30
1X2A	.30	6S78	.40	14K7	.30
2A3	.30	6S79	.41	18B6	.70
2A4G	.24	6SK7	.41	19C8	.70
2W3	.38	6SL7	.48	19T8	.69
2X2	.59	6SN7	.52	19V8	.79
3A4	.46	6SQ7	.37	24A	.39
3E5	.48	6SR7	.37	25AV5	.79
3Q4	.48	6SS7	.42	25BQ6	.79
3Q5	.49	6T4	.99	25L6	.59
354	.49	6TR	.56	25W4	.59
3V4	.51	6U4	.60	25Z5	.66
5U4	.50	6U5	.44	26	.45
5W4	.50	6U6	.59	27	.35
5Y3	.57	6U8	.37	28	.38
5Z4	.59	6V6	.39	35B5	.40
6AB4	.44	6W4	.44	35C5	.39
6AC7	.86	6W6	.44	35L6	.41
6AF4	.90	6X4	.37	35W4	.37
6AG5	.48	6X5	.37	35Z3	.59
6AH4	.57	6X8	.37	35Z4	.47
6AH6	.73	6Y6G	.48	35Z5	.59
6AJ5	.65	7A4	.47	36	.39
6AK5	.55	7A5	.59	41	.42
6AL5	.38	7A6	.69	42	.59
6AQ5	.39	7A7	.53	43	.55
6AQ6	.37	7A7F	.53	45	.55
6AR5	.37	7B4	.44	45Z3	.44
6AS5	.50	7B6	.69	45Z5	.49
6AT6	.37	7C4	.69	50B5	.43
6AU4	.68	7C5	.69	50C5	.39
6AU5	.82	7E5	.59	50L6	.61
6AU6	.39	7F5	.59	50Y7	.50
6AV5	.83	7E7	.59	50Z3	.54
6AV6	.37	7H7	.59	57	.58
6AX4	.53	7L7	.59	58	.60
6B4	.64	7X7	.70	70L7	.97
6BA6	.39	7Y4	.69	76	.44
6B7	.57	7Z4	.67	77	.57
6BC5	.59	12A8	.31	78	.47
6BD5	.59	12A15	.67	80	.35
6BD6	.45	12A25	.52	83V	.68
6BE6	.39	12AT6	.36	85	.59
6BF6	.41	12AT7	.66	117L7	.99
6BF8	.37	12AU6	.66	17Z3	.37
6BG6	1.25	12AU7	.54	80T	.99
6BH6	.46	12AV6	.39	86A6	1.39
6BJ6	.43	12AV7	.63	1274	.30
6BK7	.80	12AX4	.56	2050	.89
6BL7	.83	12AX7	.56	1000F M	.59

Horizontal Output TRANSFORMER



Type 204T1

A horizontal Output Transformer designed for deflection circuits employing operated high-voltage supplies. Intended for 50" magnetron-deflection kinescope. Used with RCA Deflecting Yokes 201D1, 201D2, 201D3 or 201D12. . .

List price—\$13.95

HI-PO TV rectifier tube—replaces the 5U4 tube directly! Makes pictures bigger, brighter, larger and increases the gain in TV receivers. . .

HI-PO 567 . . . **\$1.39**

50 MICA CONDENSERS



All popular sizes of mica condensers. In regular and silver finishes. Suitable for FM and TV use. . .

List price—\$12.50

American Makes Kit of 100 Insulated RESISTORS 25-50 1/2 construction. 1 Watt, 25-2 Watt. All new, all clean. Good value. . .

List price—\$15.00

Hi-Voltage T.V. CONDENSERS



500 mmd 10KV. . . 39 ea.
500 mmd 15KV. . . 49 ea.
500 mmd 20KV. . . 49 ea.
500 mmd 30KV. . . 1.59 ea.

.. OLD FASHIONED SAVINGS!

Cathode Ray TUBE REJUVENATOR



Fits all makes of picture tubes. Completely automatic. Easy to install, no tools needed. For A.C. parallel circuits. (Available for sets.) . . .

List price—\$1.39

Everyone is a potential user—10 for \$12.90

Army-Navy HEADSETS

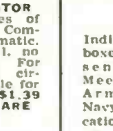

Individually boxed. Very sensitive. Meets both Army and Navy specifications. . .

Ea. per set. . . \$2.95

List price—\$16.00

Volume Control Kit



Kit of 10 includes 3 wire-wound 2 dual post, 5 carbon. The price of one (1) for the quantity of ten (10). Short and long shaft. . .

PKR KIT . . . \$1.79

SPEAKERS—All Standard Brands, Dynamic

Size	Ohms	Price	Size	Ohms	Price
3"	1000	79c	6.5"	38	1.49
4"	1800	79c	4"	Alnico V P.M. standard brand Speakers	
5"	(tapped at 300)	79c	4"	1.47 oz. with 50L6 output transformer	\$1.95
4"	(auto speaker)	99c	5"	1.47 oz. with 50L6 output transformer	\$2.19
10"	2500	1.49	6"	2.15 oz.	\$2.95
4 x 6	1800	99c	4"	2.15 oz. with 50L6 output transformer	\$1.89
4 x 8	2750	99c	4 x 6		\$1.95
5 x 7	1000	99c	5"	2.15 oz.	\$2.95
5 x 7	1800	99c	6"	2.15 oz. with 50L6 output transformer	\$2.95
5 x 7	2750	99c	10"	2.15 oz. with 50L6 output transformer	\$3.95
6"	90	1.49	12"	Magnavox	\$5.95
(with 6K6 output transformer)	680	1.95			
(with 6V6 output transformer)					

Knob Kit (Choice Groups!)



Assortment of home, auto, and T.V. knobs. All colors—plastic, wood and bakelite knobs. Bag of 50. . . \$1.29

Super Bag of 100 extra val. 1.95

Sells from 12c to 18c each.

Kit of BATTERY PLUGS



Polarized, 3, 4, 5, etc. 50 for . . .

\$1.69

T.V. RADIO, and F.M. COIL KITS



Kit for television servicemen and experimenter consisting of width coil, peaking coil, 4.5 m.c. ratio detector, and 21.0 m.c. IF coil. (10) . . . 99c

TV. Super value; not duplicated. . . \$1.85

Broadcast and short-wave, midget to multi-band replacement coils. BC Standard kit of ten (10) . . . 99c

BC Super value; not duplicated. . . \$1.85

Kit of 25. BC kits include RF, Osc., IF, and detector coils. . . \$1.85

SOLDER LUG STRIPS



Kit of 48—very usable assortment of solder lug terminal strips. Brand new. Unusually fine value! . . .

Comp. Kit of 48. . . **89c**

List price—\$4.00

TERMINAL STRIPS

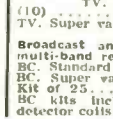

Assortment of 50 terminal strips (screw type). Kit contains wide selection to meet every design. . .

Kit of 25. . . **89c**

2, 3, 4 and 5 screw strips.

RAD-TEL TUBE CO.

"Integrity Is Our Chief Asset!"
Ph: Essex 5-2947, Dept. RE-2, 115 Coit St., Irvington 11, N. J.

BRAND NEW TELTRON TUBES

LOWEST PRICES EVER

All of our tubes are individually boxed and unconditionally guaranteed for one year.

To insure your complete satisfaction and to do away with costly "call backs" all Teltron tubes have been "set tested."

TYPE	PRICE	TYPE	PRICE	TYPE	PRICE	TYPE	PRICE	TYPE	PRICE
1A7GT	.53	6AB4	.43	6BQ6GT	.83	6U8	.76	125K7GT	.45
1B3GT	.62	6AG5	.52	6BQ7	.85	6V6GT	.48	125N7GT	.56
1H5GT	.51	6AJ5	.96	6BZ7	.95	6W4GT	.43	125Q7GT	.38
1L4	.51	6AK5	.96	6C4	.41	6W6GT	.53	198G6G	1.48
1L6	.51	6AL5	.43	6CB6	.51	6X4	.37	1978	.71
1N5GT	.51	6AQ5	.48	6CD6G	1.63	6X5GT	.38	258Q6GT	.82
1R5	.51	6AT6	.37	6F6	.42	12AL5	.43	25L6GT	.41
1S5	.43	6AU6	.43	6J6	.61	12AT6	.37	25W4GT	.43
1T4	.51	6AV6	.37	6K6GT	.38	12AT7	.71	25Z6GT	.36
1U4	.51	6AX4GT	.60	6L6C	.78	12AU6	.43	35B5	.48
1U5	.43	6BA6	.56	6L6GA	.78	12AU7	.58	35C5	.48
1X2A	.65	6BA7	.58	654	.41	12AV7	.73	35L6GT	.41
3Q4	.53	6BC5	.48	658GT	.65	12AX4GT	.60	35W4	.33
3Q5GT	.61	6BE6	.46	65A7GT	.45	12AX7	.61	35Z5GT	.33
354	.48	6BG6G	1.18	65K7GT	.45	12BA6	.46	50B5	.48
3V4	.48	6BH6	.51	65L7GT	.60	12BE6	.46	50C5	.48
5U4G	.43	6BJ6	.51	65N7GT	.60	12BH7	.61	50L6GT	.50
5Y3GT	.30	6BK7	.78	65Q7GT	.38	12SA7GT	.45	117Z3	.33
5Z3	.42	6BL7GT	.78	6T8	.71				

FREE

\$5.00 list value Bonus Box of Radio & TV components including resistors, condensers—push pull transformers and many other items with each order of \$25.00 or more.

Minimum order \$10.00. 25% deposit on C.O.D. orders—Save parcel post charges. Orders accompanied with full remittance will be shipped prepaid anywhere in continental U.S.A.—All orders subject to prior sale.

We have hundreds of tube types in stock—you may order any type at similar savings.

Send for Free complete tube listing

SPECIAL

while they last
39¢ Each
10 for \$3.50

TYPE	TYPE	TYPE	TYPE	TYPE
1A4P	1E7GT	19	34	39/44
106	1F4	1629	35	46
1C7G	1H4C	22	35/51	49
1D5GP	2A7	33	36	1F5G
1D7C				

These specials are brand new Sylvania's in their original cartons.
Order now.

TELTRON ELEC. CO.

P.O. Box 107, Harrison, New Jersey
Phone: Waverly 6-1339

**IT'S LIKE \$\$\$ IN YOUR POCKET
WHEN YOU HAVE OUR BIG 1954**

FREE CATALOG!

**156 VALUE-LOADED PAGES OF EVERYTHING
IN RADIO, TELEVISION AND ELECTRONICS**

**FOR 26 YEARS
THE OUTSTANDING
DOLLAR-SAVING
BUYING GUIDE
IN THE ENTIRE
ELECTRONICS
INDUSTRY!**

**1954
RADIO
TELEVISION
ELECTRONICS**

for DEALERS • SERVICEMEN • SCHOOLS • AMATEURS
BROADCASTERS • PUBLIC UTILITIES • ENGINEERS
EXPERIMENTERS • FACTORIES • LABORATORIES

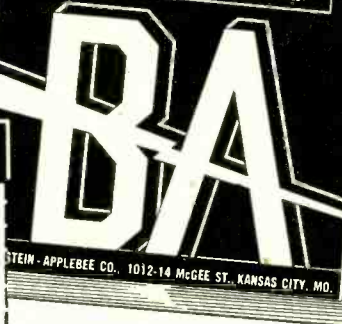

BURSTEIN-APPLEBEE CO.

BURSTEIN-APPLEBEE CO. Dept. 5,
1012-14 McGee St., Kansas City 6, Mo.

Send Free B-A Catalog No. 541.

Name.....
Address.....
City..... State.....

mon to the cathodes of the 6J7's. The Q range is determined by presetting the 1,500-ohm control. The 250-ohm control permits the Q to be varied up to 20. In the experimental amplifier shown in the diagram, the output is rectified by a full-wave rectifier and read on a micrometer. The frequency range and Q of the amplifier can be altered by changing the circuit parameters.

ELECTRONIC ANTENNA RELAY

If you need an antenna relay without moving parts, one that operates instantly and efficiently, build the *dioplex*. This device, described in the May-June, 1953, issue of G-E *Ham News*, isolates and protects your receiver while high power from the transmitter is on the antenna.

The dioplex (see schematic) uses a pair of 6X4 tubes and two 100-ma, 380-volt selenium rectifiers. Diodes D2, D3 are connected back-to-back across the π -section filter circuit. They are blocked by a few volts bias supplied by a power transformer and half-wave diode D1. The bias voltage appears across the two 50- μ f capacitors. The selenium rectifiers D5 and D6 shunt these capacitors and thus limit their potential. With the diodes blocked, the dioplex is simply a filter that transmits signals from antenna to receiver.

When the transmitter feeds the antenna, the high voltage overcomes the bias on the 6X4 tubes, and they conduct. L1 and the diodes form a voltage divider which passes only a small fraction of the antenna voltage. A second divider is formed by L2 and the receiver input which must have low impedance, for example 50 ohms.

A coil data table for various ham bands is given here. Follow the winding data closely and it won't be necessary to reset the trimmer capacitor when

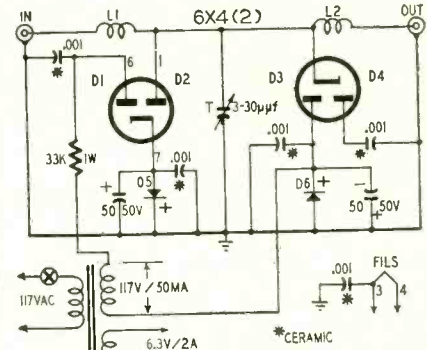

"IN" TO ANT. & XMITTER "OUT" TO RCVR ANT POSTS

Materials for dioplex

6—.001- μ f ceramic capacitors; 1—3-30- μ f compression trimmer; 2—50- μ f, 50-volt electrolytic capacitors; 1—33,000-ohm, 1-watt resistor; 2—100-ma, 380-volt selenium rectifiers (G-E-5GH1 or equivalent); 1—power transformer with 117-volt, 50-ma secondary and 6.3-volt, 2-amp heater winding; 2—Amphenol 24-5H forms and sockets, 2—6X4 tubes; chassis, hardware, hookup wire, and wire for coils; sockets for tubes.

changing bands. Cement the end turns of each coil all the way around with Duco or G-E Glyptal No. 1286 and then apply four strips of cement 90 degrees apart lengthwise of the form to hold the winding in place.

Proper performance of the dioplex



This rubber "tire" talks to you

Bell Laboratories engineers have developed a new and highly economical way to record sound magnetically.

Instead of tape or wire they use a mixture of rubber and iron oxides which is formed into a band and mounted on a wheel. This simple and very rugged "talking rubber" can play back messages clearly millions of times.

Talking rubber is already at work for the Bell System announcing weather and answering customers who call vacant or disconnected numbers. It promises

to have many other uses. In a new machine, it answers your telephone in your own voice when you are away—and takes a message for you in the voice of your caller.

Many businesses, too, other than telephone, are expected to find a variety of ways to use talking rubber—especially whenever a message must be given quickly to many people.

Talking rubber proves again the downright practicality of Bell Laboratories' research to improve telephone service.



One of a bank of recorder-reproducers operated by the New York Telephone Company for the New York Stock Exchange. They give instant stock quotations to brokers who dial a code number. Recording and pickup heads are shown above wheel.

BELL TELEPHONE LABORATORIES

Improving telephone service for America provides careers
for creative men in scientific and technical fields.



FEBRUARY, 1954

Now Available

MUNTZ

Flyback Replacements

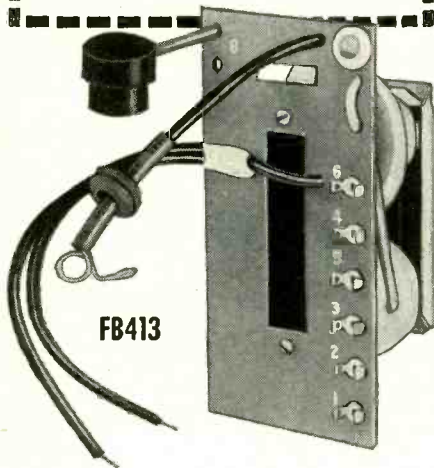

FB413

HALLDORSON FB413—A new exact replacement for Muntz TO-0031 Flyback used in hundreds of thousands of Muntz TV sets during 1951, 1952 and 1953.

DEALER'S NET, \$5.97

HALLDORSON FB403—An exact replacement for Muntz TO-0024 used in earlier Muntz TV sets.



DEALER'S NET, \$6.30

NOW, AT LOWEST PRICES, you get complete flyback coverage for all popular Muntz TV Sets. Write for descriptive Bulletin 115 showing models and chassis.

HALLDORSON REPLACEMENTS are now being listed in **PHOTOFACTS** and **COUNTER FACTS**

HALLDORSON TRANSFORMER CO.
4500 Ravenswood Avenue
Chicago 40, Illinois



depends on careful adherence to the following construction and operation pointers:

1. Scrape the paint from around punched socket holes to assure a good ground for the sockets.

2. Start the coil windings $\frac{3}{8}$ inch from the bottom end of the forms at pin 3 and terminate the windings at pin 1.

3. Maintain a d.c. path between the coils and the chassis of the dioplex. Ordinarily, the input circuit of the receiver or the output circuit of the transmitter provides this path through the outer conductor of the coaxial. If there is no d.c. path, shunt a 2.5-mh r.f. choke across one of the coaxial connectors.

4. The unit should work into a 50-ohm impedance. When uncertain as to the receiver's antenna input impedance, shunt the output connector with a 51-ohm, 1-watt resistor.

5. The dioplex operates from 50 ohms, so make sure that the standing wave ratio is close to unity on the 50-ohm coaxial line between the input terminal and the transmitter.

6. Do not let the r.f. voltage applied by the transmitter exceed 500 on 3.5 mc, 250 on 7 mc, 125 on 14 mc, 80 on 21 mc, or 56 volts on 28 mc.

7. The output stage of the transmitter must be biased beyond cutoff to avoid interference when receiving.

8. The polarities of the selenium diodes and 50- μ f capacitors are correct as shown in the diagram. D5 and D6 are connected backward to provide stiff bias for the vacuum-tube diodes. This bias should be 2-3 volts when the tubes warm up. Higher voltage indicates that the selenium rectifier is defective or is connected backward.

9. Strong receiving signals may cause cross-modulation. You can prevent this by using two selenium rectifiers in series where one is now called for on the diagram.

10. Never operate the transmitter without the correct coils and being sure that the 6X4's are lighted.

11. Maximum transmitter output on AM, c.w., and NBFM is 5 kw on 80, 1,150 watts on 40, 290 watts on 20, 130 watts on 15, and 64 watts on 10 meters. SSB peak power outputs are 10 kw for 80 and 40 meters and 4.5, 2, and 1 kw respectively for 20, 15, and 10 meters.

12. Set the trimmer capacitor for best received signal strength on the high end of one band. The adjustment should hold for all other bands involved if the coil winding data is followed closely.

COIL TABLE

Band (Mc)	Wire size	No. of turns	Winding length
3.5	32	110	1 in.
7.0	26	57	1 in.
14.0	19	29	1 in.
21.0	19	20	1 in.
28.0	19	13	$\frac{3}{4}$ in.

Note: Two coils are required for each band. Coils for 3.5, 7.0, and 14.0 mc are close-wound, all others are spaced. Coils are wound with enameled wire on Amphenol 24-5H $\frac{3}{4}$ " diameter forms. END



you're on easy street with **PHOTOFACT**

FIELD SERVICE HINTS & TROUBLE-SHOOTING AIDS

EXCLUSIVE Trouble-Shooting Aids—in each and every PHOTOFACT TV Folder—applicable to the particular receiver covered by the Folder. Describes trouble symptoms—tells where to look for them; explains new or unusual circuits used in the receiver. Specific, invaluable time-saving help!

NOW—included in each and every PHOTOFACT TV Folder! Invaluable time-saving guide and reference for adjustments and services you can perform on the specific receiver in the customer's home—right down to safety-glass cleaning tips. Helps eliminate costly chassis-hauling back to shop...

22 other exclusive features consistently in every PHOTOFACT Folder—the world's best data for faster, more profitable servicing...

NOW! GET THE PROOF FOR YOURSELF!

FREE

We'll send you a Free Photofact TV Folder—just ask us for it!

Learn for yourself how PHOTOFACT pays for itself by earning bigger profits for you! We'll send you the proof—a FREE specimen PHOTOFACT TV Folder that shows all the features found consistently and exclusively only in PHOTOFACT. Send for your FREE specimen TV Folder now. Examine it. Compare it. You'll see why PHOTOFACT belongs in your shop! And you'll want to ask your parts distributor about the pay-as-you-earn-plan. Only \$25 down brings you the entire PHOTOFACT Library. Write for FREE specimen TV Folder—learn now how to earn more!

HOWARD W. SAMS & CO., INC.
2205 E. 46th St., Indianapolis 5, Ind.

HOWARD W. SAMS & CO., INC.

FREE EXTRAS:

- ELECTRICAL AND RADIO TESTER • ELECTRIC SOLDERING IRON • BOOK ON TELEVISION • RADIO TROUBLE-SHOOTING GUIDE • MEMBERSHIP IN RADIO-TELEVISION CLUB • CONSULTATION SERVICE • QUIZZES • TRAINING FOR F.C.C. LICENSE.



Build 15 RADIOS AT HOME

WITH THE NEW
IMPROVED 1954
PROGRESSIVE RADIO "EDU-KIT"
ONLY \$19.95

NOW INCLUDES SIGNAL TRACER
AND CODE OSCILLATOR
• FREE TOOLS WITH KIT
• NO ADDITIONAL PARTS NEEDED
ABSOLUTELY NO KNOWLEDGE
OF RADIO NECESSARY

10-DAY MONEY BACK GUARANTEE

Excellent Background
For Television

BECOME A RADIO AMATEUR



GET A WELL-PAYING JOB



GO INTO A PROFITABLE BUSINESS



FEBRUARY, 1954

WHAT THE PROGRESSIVE RADIO "EDU-KIT" OFFERS YOU

The Progressive Radio "Edu-Kit" offers you a home study course at a rock bottom price. Our Kit is designed to train Radio Technicians, with the basic facts of Radio Theory and Construction Practice expressed simply and clearly. You will gain a knowledge of basic Radio Principles involved in Radio Reception, Radio Transmission and Audio Amplification.

You will learn how to identify Radio Symbols and Diagrams: how to build radios, using regular radio circuit schematics; how to mount various radio parts; how to wire and solder in a professional manner. You will learn how to operate Receivers, Transmitters, and Audio Amplifiers. You will learn how to service and trouble-shoot radios. You will learn code. You will receive training for F.C.C. license.

In brief, you will receive a basic education in Radio exactly like the kind you would expect to receive in a Radio Course costing several hundreds of dollars.

THE KIT FOR EVERYONE

The Progressive Radio "Edu-Kit" was specifically prepared for any person who has a desire to learn Radio. The Kit has been used successfully by young and old in all parts of the world. It is not necessary that you have even the slightest background in science or radio.

The Progressive Radio "Edu-Kit" is used by many Radio Schools and Clubs in this country and abroad. It is used for training and rehabilitation of Armed Forces Personnel and Veterans throughout the world.

The Progressive Radio "Edu-Kit" requires no instructor. All instructions are included. All parts are individually boxed, and identified by name, photograph and diagram. Every step involved in building these sets is carefully explained. You cannot make a mistake.

PROGRESSIVE TEACHING METHOD

The Progressive Radio "Edu-Kit" comes complete with instructions. These instructions are arranged in a clear, simple and progressive manner. The theory of Radio Transmission, Radio Reception, Audio Amplification and servicing by Signal Tracing is clearly explained. Every part is identified by photograph and diagram. You will

learn the function and theory of every part used.

The Progressive Radio "Edu-Kit" uses the principle of "Learn by Doing". Therefore you will build radios to illustrate the principles which you learn. These radios are designed in a modern manner, according to the best principles of present-day educational practice. You begin by building a simple radio. The next set that you build is slightly more advanced. Gradually, in a progressive manner, you will find yourself constructing still more advanced multi-tube radio sets, and doing work like a professional Radio Technician. Altogether you will build fifteen radios, including Receivers, Transmitters, Amplifiers, Code Oscillator and Signal Tracer. These sets operate on 105-125 V. AC/DC.

THE PROGRESSIVE RADIO "EDU-KIT" IS COMPLETE

You will receive every part necessary to build 15 different radio sets. Our kits contain tubes, tube sockets, chassis, variable condensers, electrolytic condensers, mica condensers, paper condensers, resistors, line cords, selenium rectifiers, tie strips, coils, hardware, tubing, etc.

Every part that you need is included. These parts are individually packaged, so that you can easily identify every item. Tools are included, as well as an Electrical and Radio Tester. Complete, easy-to-follow instructions are provided.

In addition, the "Edu-Kit" now contains lessons for servicing with the Progressive Signal Tracer, F.C.C. instructions, quizzes. The "Edu-Kit" is a complete radio course, down to the smallest detail.

TROUBLE-SHOOTING LESSONS

Trouble-shooting and servicing are included. You will be taught to recognize and repair troubles. You will build and learn to operate a professional Signal Tracer. You receive an Electrical and Radio Tester, and learn to use it for radio repairs. While you are learning in this practical way, you will be able to do many a repair job for your neighbors and friends, and charge fees which will far exceed the cost of the "Edu-Kit". Here is your opportunity to learn radio quickly and easily, and have others pay for it. Our Consultation Service will help you with any technical problems you may have.

Attractively Gift Packed

**MAIL
TODAY**
YOUR ORDER
SHIPPED SAME
DAY RECEIVED

Send me the "Edu-Kit" with 10 Day Money-Back Guarantee—include All FREE extras.

- Check or M.O. enclosed—postage prepaid
 C.O.D. (U. S. Only)—I will pay postage

Send further information.

NAME _____

ADDRESS _____

Outside U.S.A.—no C.O.D.'s; send check on U.S. bank or intern'l M.O. for \$19.95. Postage prepaid. "Edu-Kit" for 210-250 V. AC/DC \$22.45.

PROGRESSIVE "EDU-KITS" INC.

497 UNION AVE., Dept. RE-80, Brooklyn 11, N. Y.

AUDEL'S TV-RADIO SERVICE LIBRARY

HERE IS LATE INFORMATION IN A HANDY FORM FOR RADIO AND TELEVISION REPAIRMEN, SERVICEMEN AND STUDENTS



2 VOLS. \$6 COMPLETE \$1 A MONTH PAY ONLY

AUDEL'S T.V. RADIO SERVICE LIBRARY—Highly Endorsed—1001 Facts—Over 1552 Pages—625 Illustrations, Diagrams of Parts. Presents Important Subjects of Modern Radio, Television, Industrial Electronics, F.M., Public Address Systems, Auto, Marine & Aircraft Radio, Phonograph Pick-Ups, etc.

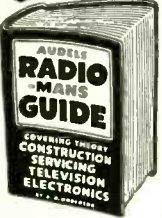

IT PAYS TO KNOW! The Basic Principles—Construction—Installation—Operation—Repairs—Trouble Shooting. Shows How to get Sharp, Clear T.V. Pictures. Install Aerials—How to Test, Explains Color Systems, Methods of Conversion, Terms, etc. Includes Ultra High Frequency (U.H.F.)—Valuable for Quick Ready Reference & Home Study. Tells How to Solve T.V. & Radio Troubles—Answers Your Questions.

Get this Information for Yourself. 7 DAY TEST—ASK TO SEE IT!

MAIL ORDER

AUDEL, Publishers, 49 W. 23 St., N.Y. 10, N.Y. Mail AUDEL'S T.V. RADIO SERVICE LIBRARY 2 Vols. \$6 on 7 days free trial. If O. K. I will remit \$4 in 7 days and \$1 monthly until \$6 is paid. Otherwise I will return them.

Name _____
 Address _____
 Occupation _____
 Employed by _____ RE

QUARTZ CRYSTALS

FT-243-.093" PIN DIA.—.486" PIN SPC FOR HAM OR GENERAL USE

4035 5500 8950 6708 7506 7825	1015 2605 3995 6573 7240 8173
4080 5675 5975 6725 7525 7840	1110 2738 6000 6575 7273 8175
4110 5677 5975 6740 7540 7850	1150 2785 6025 6600 7275 8200
4165 5700 5975 6750 7550 7875	1225 2895 6085 6608 7300 8340
4190 5706 6225 6773 7573 7875	1915 2940 6050 6623 7308 8350
4255 5725 6240 6775 7575 7890	1930 3005 6073 6640 7325 8375
4280 5740 6250 6800 7600 7906	1940 3010 6075 6650 7340 8380
4300 5750 6255 6806 7606 7925	1950 3202 6100 7000 7350 8400
4397 5760 6273 6825 7610 7940	2065 3215 6106 7006 7375 8425
4450 5775 6275 6840 7625 7950	2105 3237 6115 7015 7380 8440
4490 5775 6300 6850 7640 7973	2118 3245 6140 7040 7425 8450
4495 3800 6306 7641 7975	2125 3250 6150 7050 7440 8460
4760 5806 6324 6875 7650 8205	2140 3460 6173 7073 6000 8475
4645 5825 6335 6900 7673 8225	2145 3500 6175 7075 6000 8483
4930 5840 6340 6906 7676 8240	2305 3540 6200 7100 8023 8500
5030 5850 6350 6925 7700 8250	2350 3590 6240 7108 8040 8525
5205 5932 6373 6940 7708 8273	2390 3640 6250 7128 8050 8550
5235 5873 6375 6950 7720 8275	2415 3680 6273 7140 8073 8573
5250 5875 6400 6973 7725 8300	2430 3720 6275 7150 8075 8583
5300 5880 6406 6978 7740 8325	2442 3737 6280 7160 8100 8600
5305 5900 6425 7450 7750 8325	2460 3760 6306 7175 8106 8623
5333 5906 6473 7473 7773	2532 3800 6325 7200 8125 8650
5385 5925 6475 7475 7775	2545 3840 6340 7205 8140 8700
5485 5940 6700 7500 7800	2557 3885 6350 7225 8150 8733

49¢ each—10 for \$4.00

99¢ each—10 for \$8.00

Low Frequency—FT-241A for 889, Lattice Filter etc.—.093" Pins—.486" SPC, marked in Channel Nos. 1, 2, 3, 79, 54th Harmonic and 270 to 389, 72nd Harmonic. Listed below Fundamental Frequencies. Fractions omitted.	CR-1A SCR 522 3 Banana Plugs 1/2" P 1/2" S	FT-17-B BC-610 3 Banana Plugs 3/4" SPC
370 393 414 436 458 520	400 459 5910 2030 2300 3155	5910 2030 2300 3155
372 394 415 437 501 522	440 461 6370 2043 2303 3202	2043 2303 3202
374 394 416 438 502 523	441 462 6450 2052 2320 3215	2052 2320 3215
375 396 418 441 503 525	442 463 6470 2063 2360 3238	2063 2360 3238
376 397 419 463 504 526	444 464 6497 2082 2390 3237	2082 2390 3237
377 398 420 464 505 527	445 465 6522 2105 2415 3250	2105 2415 3250
379 401 422 485 506 529	446 466 6547 2125 2435 3252	2125 2435 3252
380 402 423 486 507 530	447 468 6610 2148 2442 3310	2148 2442 3310
381 403 424 487 508 531	448 469 7380 2148 2332 3520	2148 2332 3520
383 404 426 488 509 533	450 470 7380 2155 2545 3550	2155 2545 3550
384 405 426 490 511 534	451 472 7390 2200 2557 3570	2200 2557 3570
385 406 427 491 512 538	452 473 7480 2258 2560 3580	2258 2560 3580
386 407 429 492 513 538	453 474 7380 2260 2940 3945	2260 2940 3945
387 408 430 493 514 538	454 475 7810 2280 3033 3985	2280 3033 3985
388 409 431 494 515	455 476 7930 2282 3120 3970	2282 3120 3970
390 411 433 495 516	456 477 7930 2290 3150 3993	2290 3150 3993
391 412 434 496 518	457 479 7930 2290 3150 3993	2290 3150 3993
392 413 435 497 519	458 480 7930 2290 3150 3993	2290 3150 3993

49¢ each—10 for \$4.00

99¢ each—10 for \$8.00

BC 746 TUNING UNITS—foundation coils and condenser for 80 meter VFO or exciter—less extals...\$98
 Special—200 KC or 500 KC in FT241A Holder...\$1.95 ea.
 add 20¢ postage for every 10 crystals (or less).



520 Tenth St. N.W. — Wash. D.C., Dept. R

PROTECTING I.F. TRANSFORMERS

The photo shows how to put simple covers over the openings in the tops of i.f. transformer cans to keep out dust (and to prevent children or other inexperienced persons from turning the trimmer screws and throwing the stages out of alignment.) The pencil points to the removable protective discs.

The i.f. transformers shown in the photo are a common type found in many home radios. With these, it's handy to use those storm-door metal discs sold at hardware stores. You get a handful for a few cents, and they

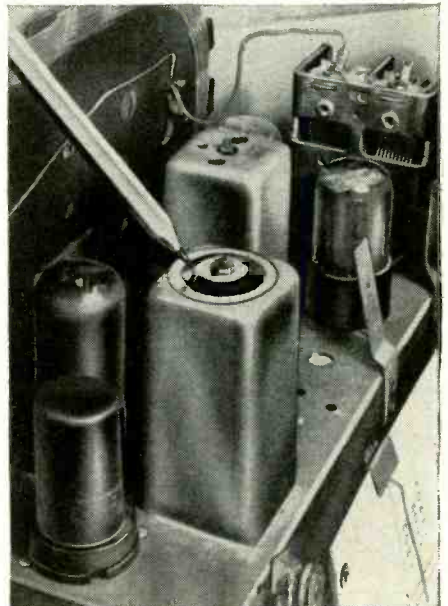

are made in two or three different diameters. Drill a hole in the center of the disc so it will fit over the screws at the tops of the transformers, and then use the nuts to hold the discs down, as shown. Any large-diameter washers with small holes in the centers will serve just as well. Where the transformers do not have screws and nuts projecting from the tops, simply cover the trimmer-screw holes with Scotch tape. The tape will keep dust out, but perhaps not the children.—Arthur Trauffer

INCREASING A.F. METER RANGE

The range of the direct-reading audio-frequency meter (in the February, 1952, issue) may be increased to 200 kc by eliminating the 60-cycle test position and making the following modifications:

1. Remove all connections to the No. 8 (60-CYCLE TEST) terminals of sections S1-a, S1-c, and S1-d of the range selector.
2. Connect terminals 7 and 8 on S1-a.
3. Connect a 100-µf capacitor from the plate of the 6V6-GT to terminal 8 on S1-c.
4. Connect a 500-ohm wirewound potentiometer between the ungrounded side of the meter and terminal 8 of S1-d.
5. Shunt the 220,000-ohm 6V6 series grid resistor with a 400-µf mica capacitor.

RADIO-ELECTRONICS

EDLIE says

3-TUBE PHONO AMPLIFIER



An assembled unit ready for installation using tone and volume control and 6 ft. rubber cord.

Save! **\$2.95** (less tubes)
 With complete set of tubes... **\$3.95**

PHONO OSCILLATOR

New Savings! Not a Kit!

Wireless phono oscillator transmits recording for crystal pickups or voice from carbon mike through radio without wires. Can also be used as an intercom by using PM speaker at mike.

\$2.95 (less tubes)
 Reduced to... **\$3.95** (less tubes)
 With complete set of tubes...

PRECISION RESISTOR KIT

Consists of 50—1% Wilkor carbon resistors of 50 different ohmages, housed in a transparent plastic box. May be combined in series or parallel to produce almost any desired ohmage. Each resistor retails for about 85¢.

Kit of 50 only... **\$2.45**

"Save with confidence" TERRIFIC BUYS—KITS AND WIRED UNITS

LOWEST PRICED SIGNAL GENERATOR BROADCAST BAND



Completely Wired—New, simplified circuit provides the following switch tuned, tone modulated frequencies:

1. 455 KC—Intermediate IF frequency
2. 1500 KC—HI freq. of b'cast band
3. 600 KC—Lo freq. of b'cast band
4. Audio tone for audio amplifier trouble shooting
5. Attenuator control is included for adjustment of the output signal strength.

Completely Wired—only... **\$7.95** Size: 6" x 6" x 3 1/2"

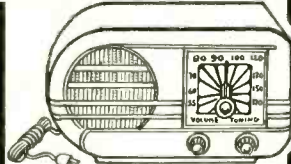

5-TUBE AC/DC SUPERHET KIT
 Kit #1: 5-tube superhet kit. AC/DC Includes all quality components required to construct this latest design, highly sensitive superhet, broadcast receiver, complete with black, glistening bakelite cabinet (excludes wire & solder). **\$7.95**
 Now!
 Kit of 5 tubes, 12AT6, 12BA6, 12BA8, 12BE6, 6X5W4, 50B5. Only **\$3.25**



NEW SUPERSENSITIVE 2 STATION INTERCOMMUNICATION SYSTEM
 This fine unit is suitable for use in home, office, factory, nursery, or sick room. So sensitive it will pick up baby's whimper. Operates from 115 V. AC/DC. Both stations housed in compact, handsome, plastic cabinets: 6" x 6" x 3 1/2". Requires only 2 wires to connect for quick installation. Complete with 50 ft. of twin conductor wire. Model D-1910 Special Price

TERMS: All mdsd. shipped FOB New York City. Prices subject to change without notice. Include 20% deposit for COD's. WRITE TODAY FOR NEW FREE CATALOG!

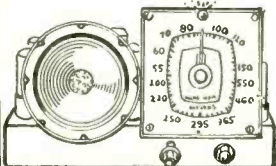

Great Savings! **6-TUBE RADIO KIT**
 Kit #2: Low priced 6-tube kit designed for extra high sensitivity, excellent selectivity and good, rich tone quality. Uses 25L6, 25Z6, 6SQ7, 6SA7, 6SK7, 6SK7 in an easily constructed circuit. Includes all parts: punched chassis, resistors, condensers, coils, sockets, PM speaker, hardware, etc. Special close-out price (Less tubes & cabinet)... **\$6.55**
 Matched set of 6 tubes for kit... **\$3.25**

154 Greenwich St. NY 9-3143 New York 6, N. Y.

EDLIE Electronics



Use this UHF CONVERTER check list

Because they all look alike, externally, it's wise to check any UHF converter internally—feature by feature:

COAXIAL TUNING . . .

Does it have this most efficient UHF tuning system known? No troublesome noise-producing wiper contacts? Highest stability? Provably better UHF reception?

FINE TUNING . . .

Does it have simple and positive tuning—high-ratio single tuning knob? Granco provides "on the button" tuning without need of a safecracker's touch!

PRESELECTION . . .

Does it have tuned circuits that reject unwanted signals and images—with only the desired channel tuned in? It's a "must" in areas having two or more channels, UHF or VHF.

AMPLIFICATION . . .

Does it have low-loss tuning and associated circuitry, plus true high-gain amplification of only the tuned-in channel?

GRANCO
HAS EVERYTHING!

No other converter offers all these essential functions to the degree that Granco does, at only \$29.95 list. Try a Granco! Ask your distributor about Granco converters—or write us for literature.

GRANCO
PRODUCTS, INC.,
36-17 20th Ave., Long Island City 5, N. Y.
AVAILABLE AT LEADING JOBBERS

itor to aid in overcoming the effects of the tube's input capacitance.

6. Calibrate the 200-kc position with a 100-kc secondary frequency standard or an r.f. signal generator set to exactly 100 kc.

The increased range of the instrument makes it useful in crystal manufacturing operations and other applications which require a stable cycle counter which covers a wide range.—*Walter T. Stevenson*

CHASSIS SUPPORT

Propping up a big TV chassis on the bench is sometimes quite a problem. However, there usually is one side of the chassis strong enough to support the weight, if only the thing would balance. Instead of putting my trust in precarious temporary supports, such as boxes, books, or blocks, I clamp the edge of chassis to the bench top. A heavy C-clamp would do as well but the hand-screw has broader surfaces and the wooden jaws are safer from the standpoint of electrical hazards. Turn the chassis on the most convenient side and pull it near the edge of the work surface so one jaw of the clamp goes under the bench top and the other locks the side of the chassis flat against the top.—*Nicholas B. Cook*

LOAD TESTING B BATTERIES

Although load testing is a fairly standard procedure with wet cells, we have been taught never to put anything but a high-resistance voltmeter across a B battery. This protects the battery from accidental discharge. If we want to predict how long the battery will serve in portable or emergency equipment, this is a poor test, since the battery may have nearly normal voltage and yet deliver very little current to a load. To avoid unexpected battery failures, some form of load testing seems desirable.

An unorthodox but satisfactory way of doing this is to connect a low-resistance light bulb across the battery for about one second. With a good battery, the bulb will light instantly. With a weak or failing one, the bulb will light, but will start to dim immediately. If the bulb does not light at all, discard the battery. This test is obviously unsuited to the smallest miniature batteries, but a 25-watt bulb held briefly across a battery such as the Eveready 467 will not shorten its life appreciably, even though the momentary overload is staggering.—*Wm. Bruce Cameron*

MEASURING SMALL CAPACITORS

When measuring small capacitors on a capacitance bridge or tester, readings are often highly inaccurate because of the capacitance between test leads. To increase the accuracy of such readings, mount two alligator clips on the binding posts of the tester and then clip between them the capacitor to be checked. This minimizes inaccuracies caused by stray capacitance outside the instrument.—*Hyman Herman* END

CONCORD PROUDLY FEATURES

precise

KIT AND WIRED
INSTRUMENTS

NOW
IN
STOCK

EXCLUSIVE...

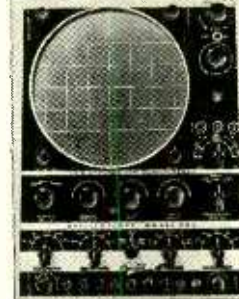

precise

MODEL #308

8 1/2" SCOPE

KIT **\$129.50**

#308W \$229.50

No other oscilloscope, at any price, can meet all the specifications of this electronic masterpiece

- VERTICAL FREQ. RESPONSE—Flat $\pm 1\frac{1}{2}$ db DC thru 5 MC.
- SENSITIVITY—Greater than 10 millivolts push-pull (3.9 Millivolts/CM)
- BLANKING—60 cycle or 120 cycle Blanking through Blanking amplifier circuit.
- SWEEP RATE—Linear sweeps from 1 cycle to 80 KC in 5 ranges. (1-10 uses Ext. C.) DRIVEN and RECURRENT sweeps.
- MAGNIFIER—Expands and magnifies signal up to 10 times.
- PUSH-PULL—Output in both amplifiers.
- CRT—The latest type 8 1/2" NEW tube a PRECISE EXCLUSIVE.
- VOLTAGE REGULATED.
- ANODE INTENSIFIER—a PRECISE FIRST
- INTERNAL CALIBRATOR

NEW 7" OSCILLOSCOPE

MODEL #300K \$94.95
MODEL #300W \$199.50

LOWEST PRICED IN ITS FIELD

NEW MODEL #909 VACUUM TUBE VOLTMETER

FACTORY
WIRED **\$37.50**

Model 909 Vacuum Tube Voltmeter. 1% Ceramic precision Resistors; Coax DC connector; FM zero alignment scale; burn-out proof circuit; DC input 25 Meg. Rugged oversize 4 1/2" meter.
MODEL #909 KIT.. \$25.98



FREE! A complete, comprehensive listing of all your electronic requirements. Bursting with these SPECIAL VALUES FROM CONCORD

- Send me at once your new 1954 catalog.
 Send complete information and technical data on NEW PRECISE Models
 #308 #300 #909
 Please send PRECISE Model
Enclosed find \$..... 20% deposit with C.O.D. required. Pre-paid if remittance in full.

Name
Street
City STATE.....

Concord Radio
54 Vesey Street, New York 7, N. Y.

STAN-BURN E-PARKS

CATHODE RAY TUBE SPECIALS

ONE YEAR GUARANTEE		STAN-BURN	
G.E.			
★ STP4	\$44.95	★ 10BP4	\$11.00
★ 7JP4	17.10	★ 12LP4A	14.20
★ 10BP4A	19.25	★ 14CP4	17.00
★ 10FP4A	24.00	★ 15DP4	19.50
★ 12KP4A	27.10	★ 16AP4	21.60
★ 12LP4A	21.70	★ 16FP4	19.60
★ 12UP4B	28.25	★ 16GP4	21.60
★ 14CP4	24.50	★ 16EP4A	22.60
★ 16AP4A	30.95	★ 16DP/HP4	19.60
★ 16DP4A (N.U.)	28.20	★ 16DP/MP4A	20.60
★ 16GP4	31.25	★ 16KP4	18.50
★ 16KP4/16RP4	28.20	★ 16LP4	20.60
★ 17BP4A	23.90	★ 18LP4A	21.60
★ 17CP4	25.90	★ 17CP4	21.60
★ 19AP4A	39.45	★ 17CP4	21.60
★ 20CP4	32.50	★ 19AP4	23.90
★ 20UP4	37.50	★ 19AP4A	25.90
★ 21EP4A	37.35	★ 20CP4	29.50
★ 24AP4 A	78.50	★ 21EP4	32.50

ANTENNAE SPECIALS

	1-5	6 or more
★ RED DOUBLE "V" Antenna	2.19	1.98
★ 10 ELEMENT CONICAL	2.98	2.79
★ Dowled Inserts	4.25	3.25
★ Folded Hi Straight Low Quick Rig	4.95	3.75
★ 1/2" elements	.79	.69
★ WINDOW CONICALS	1.39	1.29
★ MASTS	1.69	1.49
★ 5 FOOT SWAGED		
★ 10 FOOT PLAIN		
★ NEPCO MASTS	\$9.95 M Ft.	
★ TV WIRE		
★ 42 Mil.		11.95 M Ft.
★ 55 Mil. 300 OHM		35.00 M Ft.
★ 72 OHM COAXIAL		
★ 12" Heavy Slug Speaker	Special	\$3.98

CHASSIS 630 TECH-MASTER
Model C-30 with Cascade Tuner... **\$149.50**
OPEN FACE CABINET.....**\$42.00**

WIRE RECORDERS IN STOCK

PENTRON—Model 9T3C—2-speed Tape Recorder.....Write for Price.

RADIO CRAFTSMAN

Model C400—Hi Fi Amplifier.....Net \$42.90
Model C10—AM-FM Tuner.....Net \$31.50
Model C500—Williamson Amplifier.....Net \$9.50

We also carry MASCO—BOGEN—PILOT, etc. Amplifiers—Pre-Amps, FM Tuners and WEBSTER Tape Recorders.

★ 6"x9" PM SPEAKER.....\$3.98
★ 7" PM SPEAKER.....3.98
★ 77J1 G.E. Flyback.....1.98
★ 70" Yoke.....1.98
★ 630 Vert. Output Upright.....1.98
★ 630 Vert. Output Potted.....1.29
★ 630 Vert. BEPCO Osc. Xform......89
★ CASCADE TUNERS.....19.95
★ STANDARD TUNERS.....17.95
★ DUMONT 21.25mc.....14.95
★ FAMOUS INPUT TUNER.....10.90
★ TV Permanent Magnet Focus Assemblies.....1.98

CONVERSION SPECIAL
21EP4 American Standard Tube—21" Beveled Mask—Ram Conversion Kit.
(Mention set to be converted)
ALL FOR ONLY.....\$43.50

AUTHORIZED DISTRIBUTORS for: General Electric, Kenrad, Tung-Sol, National Union, De Wald, Regal, Automatic and General Motors.

AUTOMATIC CUSTOM-BUILT RADIOS for Plymouth, Ford, Chevrolet and many others, always in stock. We carry a complete stock of Hi-FIDELITY and SOUND EQUIPMENT. Send us your requests. We also carry a complete line of popular makes of Radio tubes at 50/10% discount. Also many other special parts and equipment at lowest prices. Send us a list of your requirements for prompt quotations. Terms: 20% with order. Balance C.O.D. All prices FOB. NEW YORK Warehouse. Minimum order \$5.00. Write for our latest price list and Hi-Fi Catalog to Dept. RE-2.

STAN-BURN RADIO and ELECTRONICS CO.
(C.B.S. THEATRE BLDG.)
1697 BROADWAY • NEW YORK 19, N.Y.

Supply your own **TEST PATTERN**

Use **MODEL CB-101 UTL PATTERN GENERATOR**

\$29.50 COMPLETE WITH SHIELDED LEADS

MODULATES YOUR T.V. SIGNAL GENERATOR FOR OVER-ALL TEST OF T.V. RECEIVER

No more waiting for TV test patterns to be transmitted! No more setting of controls by guess! No necessity of purchasing expensive equipment! Model CB 101 Pattern Generator is designed for the quick, accurate adjustment of the TV picture quality; provides steady pattern of vertical or horizontal bars; makes horizontal and vertical linearity, width and centering easy at ANY TIME, at ANY PLACE.

Also useful in general TV service work, and testing TV tubes. Ask your local distributor about it, or write us direct giving distributor's name and address. FREE 4-page folder on request.

UNITED TECHNICAL LABORATORIES
BOX 425 G • MORRISTOWN, N. J.

first turned on, reverse the connections to the secondary of the transformer.

CORNER-REFLECTOR ANTENNA

? I live near an airport and am having trouble with ghosts and airplane flutter. I've tried several types of antennas and sets with different types of a.g.c. but nothing seems to eliminate the trouble. As the last resort, I'd like to try a corner-reflector antenna. I have not been able to find complete construction details or design data in any texts or antenna handbooks. Can you supply construction details on a corner-reflector antenna? Why is it that corner-reflector and Yagi antennas are not covered as fully as other types of antennas in books on the subject?—H. O. M., Forest Hills, N. Y.

A. The gain, impedance, and directivity characteristics of a Yagi depends on the number of elements, the length of each parasitic element, and the spacing between elements. Each of these factors and characteristics are related to the other so it is very difficult to design an antenna having definite characteristics from a formula. Details on a 6-element u.h.f. Yagi appeared on page 98 in the June, 1953, issue.

In a corner reflector, the impedance, gain, and directivity depend on a number of interdependent factors which include the corner angle, the diameter of the dipole radiator, the distance be-

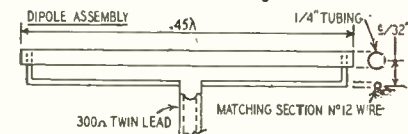
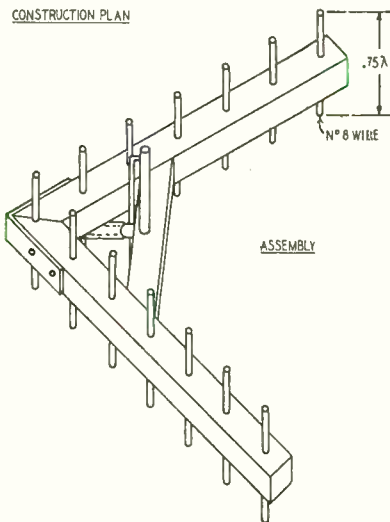
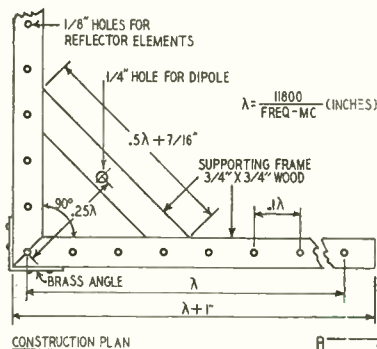

TRANSVISION

makes this greatest of TV offers—backed by

MONEY-BACK GUARANTEE:

\$88 TV SERVICE INSTRUMENT VALUE FOR— **\$39.95**

NEW TV Component Tester performs functions you've always wanted. Look what you get:

FLYBACK TESTER, value.....\$39.
SELENIUM RECTIFIER TESTER, value.....29.
CRT TESTER and REACTIVATOR, value.....20.
Total Instrumentation, value.....88.
ALL 4 in 1 great instrument, net.....39.95



NEVER BEFORE SUCH GREAT VALUE. For only \$39.95 you get 4 testing-and-repair instruments all in one! Compact, weighs only 3 lbs. Does things never been done before. Pays for itself quickly. Prove it yourself—

TRY IT for 10 DAYS
on Money-Back Guarantee:

10 DAY TRIAL: Try this Transvision TV COMPONENT TESTER for 10 days. Then, if you are not 100% satisfied, you may return it. Your purchase price, less 10% (our cost of handling and repacking) will be promptly refunded.

TRANSVISION, INC. • NEW ROCHELLE, N. Y.

RUSH THIS COUPON NOW

TRANSVISION, INC.

DEPT. RE-24 NEW ROCHELLE, N. Y.

() Send _____ TV COMPONENT TESTERS @ \$39.95

() Enclosed find \$_____ deposit. Balance C.O.D.

() Enclosed find \$_____ in full.

I accept your 10 Day Trial terms.

Name _____

Address _____

City _____ State _____

My Jobber is _____

JOBBER INQUIRIES INVITED

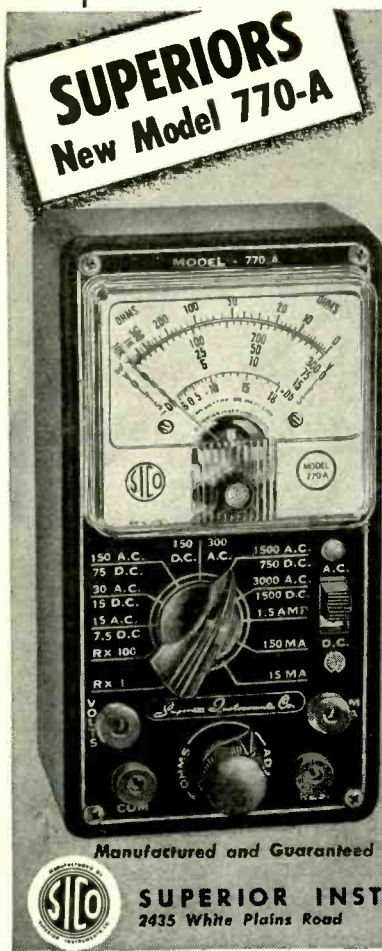

**The first Pocket-Sized
volt-ohm
milliammeter
using the new
"full-view" meter**

71% More Scale Area!

Yes, although our new FULL-VIEW D'Arsonval type meter occupies exactly the same space used by the older standard 2 1/2" Meters, it provides 71% more scale area. As a result, all calibrations are printed in large easy-to-read type and for the first time it is now possible to obtain measurements instead of approximations on a popular priced pocket-sized V.O.M.

Specifications

- 6 A.C. VOLTAGE RANGES:
0-15/30/150/300/1500/3000 Volts
- 6 D.C. VOLTAGE RANGES:
0-7.5/15/75/150/750/1500 Volts
- 2 RESISTANCE RANGES:
0-10,000 Ohms 0-1 Megohm
- 3 D.C. CURRENT RANGES:
0-15/150 Ma. 0-1.5 Amps.
- 3 DECIBEL RANGES:
-6 db to +18 db +34 db to +58 db
+14 db to +33 db

The Model 770-A comes complete with self-contained batteries, test leads and all operating instructions

\$15⁸⁵

Write Dept. RC-2 for catalog of complete line.

Manufactured and Guaranteed by



SUPERIOR INSTRUMENTS CO.
2435 White Plains Road New York 67, N. Y.



SAVE ON INSTRUMENTS!

- do better testing with your old instruments
- avoid buying new ones you don't really need

No sooner do you buy one expensive new test instrument than another new type comes along that is supposed to be better. But is it?

Almost any radio-TV man has paid good money for instruments he didn't really need. And lots of perfectly good old instruments are gathering dust on benches because their owners don't know how to use them to best advantage.

That's why Rufus Turner's book **BASIC ELECTRONIC TEST INSTRUMENTS** can save you money and help you work faster and more accurately in the bargain. It's a down-to-earth instrument guide that can help you in doz-

ens of ways—from showing new uses for old instruments—to helping you extend their ranges and modernize them, to explaining work-saving short cuts and avoiding unnecessary instrument purchases.

Over 60 types . . . from the latest TV pattern generators to special-purpose bridges, general-purpose instruments and all the old standbys . . . are clearly described and their uses as well as their limitations fully explained.

CHOCK FULL OF TIME-SAVING INSTRUMENT TIPS

You see exactly how to use VOM's, oscilloscopes, etc., in new time-saving ways. You learn to make an accurate bridge from old instruments; how to speed up and greatly simplify TV service by using power drain measurements; how to calibrate shunts and multipliers; how to measure r-f impedance with a simple T-network; how to get the most out of a grid-dip oscillator . . . and scores of other money-saving tips. Use coupon today for 10-day FREE TRIAL. You be the judge!



10-DAY FREE TRIAL

The instrument guide written expressly for **SERVICEMEN, AMATEURS, EXPERIMENTERS**

BASIC ELECTRONIC TEST INSTRUMENTS

by Rufus P. Turner
254 pages, 171 illus., Price only \$4

Just what instruments do you really need—and why? This great book answers your instrument questions . . . saves you money . . . helps you work better, faster and more accurately. Covers all standard types from simple meters to capacitance checkers, oscillators, scopes and dozens more. Also gives full details on the newer ones such as grid-dip oscillators; TV sweep and marker generators; TV linearity pattern and square-wave generators; distortion meters and many others.

Dept. RE-24, RINEHART BOOKS, Inc.
Technical Division, 232 Madison Ave.
New York 16, N. Y.

Send Turner's **BASIC ELECTRONIC TEST INSTRUMENTS** for 10-day FREE EXAMINATION. If I decide to keep book, I will then remit \$4.00 plus postage. Otherwise I will return book postpaid promptly and owe you nothing.

Name

Address

City, Zone, State

OUTSIDE U.S.A.—Price \$4.50, cash only. Money back if book is returned postpaid in 10 days.

tween the corner and radiator, and the dimensions of the reflector sheets. These factors all play major parts in determining gain and sharpness of the vertical and horizontal radiation patterns. Thus, any set of design or construction data would apply only to an antenna having a definite impedance and gain-directivity characteristics. For example, the impedance can be varied by changing the corner angle, by changing the distance between the corner and radiator and by changing the size or shape of the radiator.

The drawings show the construction of a corner reflector antenna as described in *Sylvania News*. This antenna was recommended for use on the u.h.f. TV channels but it can be used on v.h.f. channels. It has a gain of about 10 db over a half-wave dipole and matches a 300-ohm transmission line. This antenna will reduce ghosts caused by reflections and may greatly reduce air-plane flutter.

The array is shown vertically for ease of presentation, but it should be mounted with the dipole and reflector elements horizontal for all TV reception. Mount the antenna vertically as shown for reception of vertically polarized signals from fixed-station transmitters in the Citizens band, public service, and other communications allocations.

CITIZENS BAND INTERFERENCE

? My radio-controlled model plane has had several bad crashes because of interference from other radio-control transmitters operating on the same field. Most of the transmitters operate on the 27.255-mc Citizens band and the others in the 11-meter amateur band. Can you tell me how to eliminate the interference problem?—F. S., Great Neck, N. Y.

A. Class C (radio control) Citizens band transmitters must operate on a spot frequency (27.255 mc) with a frequency tolerance of .04%. Since the interference is mutual and you cannot shift frequency to avoid it, the radio-control modelers will have to get together and agree to share the available flying time. Each operator may then be allotted a certain amount of time for flying and making adjustments which require that the transmitter be put on the air.

Interference will be reduced greatly if each operator is careful to keep his transmitter turned off as long as another modeler has a ship in the air. If the transmitter must be turned on for adjustments while another is flying, feed its output into a dummy load and reduce input power to the lowest level that can be used for successful completion of the job.

Possibly the only other alternative is for you to qualify for a general class amateur license which permits you to operate in any of the amateur bands and to shift frequency to avoid interference.

END

MOTOROLA AUTO RADIOS

Take care that you do not short the ignition switch when installing SR3A6 or SR3M6 Motorola radios in 1953 Studebaker automobiles. The space between the control unit and one terminal of the switch is very limited and a short may develop. Later shipments of these models include an insulator to eliminate this possibility. Insulators (part 14A531128) for sets already in stock can be obtained free of charge from Motorola distributors.

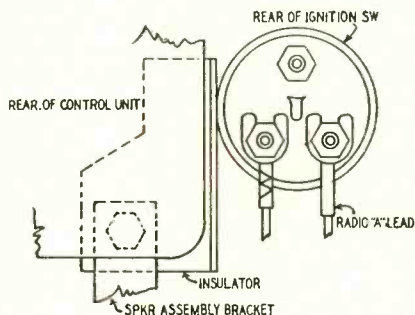

Place the insulator over the speaker mounting bracket as shown in the illustration and attach it to the tuner with a No. 8 sheet-metal screw. Make sure that the lead connected to the closest terminal of the switch has its lug pointing straight down.—*Motorola Service and Installation Bulletin*

NO SOUND OR PIX IN 630

A Mattison Silver Rocket 630-type TV set was dead. Most tubes did not light. Upon removing the cover from the voltage-divider compartment on the rear of the chassis, I found that the center tap of the 12.6-volt filament winding had come loose from its ground terminal. Soldering the lead to the ground lug restored normal operation.—*Fred Roser*

SALVAGED BATTERY TERMINALS

Before discarding used B batteries with snap terminals, remove the fiber terminal board. When trimmed, these make perfect replacements for sprung or broken terminals in radios using these batteries.—*Bruce A. Brown*

CROSLY 24- AND 27-INCH SETS

If the picture on 24- and 27-inch receivers has excessive pincushioning (a tendency to bow or curve at the top or bottom edge), the pincushion magnets mounted on the front side of the deflection yoke—one above and one below the tube flare—may be misadjusted. Bend the brass support straps and adjust the position of the magnets relative to the picture tube until the bowing is minimized or eliminated entirely.

If the receiver does not have the magnets (part number 157599) they may be added readily. The upper magnet may be mounted by using the center hole in the flange at the top front of the deflection yoke bracket. The lower magnet may be mounted by soldering the end of the support strap directly to the deflection yoke bracket. Position it so the hole in the end of

Dealers—Servicemen ATTENTION

Tremendous Bargains in Conicals
2-BAY 16-ELEMENT CONICAL ARRAY

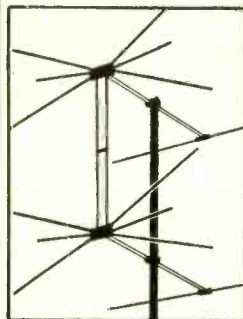

With Hi-Band Adapters
Sturdy 3/8" Element
\$4.99 Each
In Lots of Three Single Lots \$5.30

Never before has National Electronics had a Bargain like this. We made a special purchase in order to get these sensational prices. And this array has everything. This conical 2-bay 16-element array provides ultra-fine fringe reception. Includes sixteen 3/8 inch airplane type aluminum elements, including hi-band adapters for greater gain on the high channels and is complete with one pair of stacking bars to each array. These are packed in cartons of three 16-element arrays per carton. With tie rods at \$14.95 per carton.

When purchased in single 16-element arrays, separately boxed—your cost is \$5.30. Each
3 Two-Bay Arrays per carton without Tie Rods \$13.50 Carton
4 Bay Ultra-Fringe stacking Assembly for above—Model 4B \$1.95 Each



Hi-Gain Bow-Tie Reflector
For UHF—\$1.95 EACH

High gain at low cost. Completely pre-assembled. Easily stacked for fringe use.
2 bay with tie rods \$4.40
4 bays with stack harness \$9.95
Lots of 6—individually cartoned \$9.95

Save With Rocket 35 Foot Mast Kits

Economy mast kit contains 3 self-coupling 10' seamless TIT-COATED 1 1/2" O.D. masts, one 5' mast, 300 feet of 6/20 galvanized steel guy wire, and everything else needed including guy rings, insulators, cable clamps, guy hooks, and swivel mounting base.
35 foot Mast Kit \$15.95 25 foot Mast Kit \$11.95

ALL PRICES F.O.B. CLEVELAND, OHIO
Do not remit more than complete purchase price. Pay shipping charges on receipt of goods. 20% deposit on all C.O.D. orders, please. Money-back guarantee.
Prices Subject to Change Without Notice

NEW SUPER FRINGE MOTORLESS DIRECTRONIC

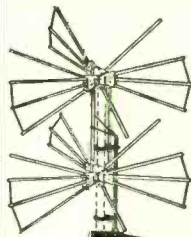

VHF—UHF CHANNEL 2—83
Reception From All Directions
No Motors Needed

New Super Directronic is electronically sealed in all directions by directronic selector switch at receiver. Hi-gain 24-element array eliminates need for motors. Kit complete with 75' tubular tri-x cable, Directronic Switch, Matched Stacking Bars and Universal U-Clamp.

ONLY \$23.50
You save 30% on average installation.

ROCKET BROAD BAND YAGIS

- SENSATIONAL GAIN
- SENSATIONAL PICTURES IN FRINGE AND ULTRA FRINGE AREAS



Switch to Yagi Broad Band Hi-Gain Antennas! These new Yagis give you Yagi reception on the 5 low-band and 7 hi-band channels—no restriction to one single channel. A two-bay array will outperform even a 10 or 12-element single channel Yagi. Price is sensationally low. Complete serviceman's array includes 1 double reflector, 2 folded dipoles, 3 directors. Universal mast clamp. Easy-to-assemble—quick rig construction.
26—Ch. 2 thru 6—7-element \$10.95 ea.
Model RB 713—Ch. 7 thru 13—9-element \$5.95 ea.
Matched Stacking Bars \$1.25 ea.

SAVE ON ANTENNA ACCESSORIES

- UHF tubular low-loss twin lead 100' coil \$4.95
- Rocket twin lead—7/28 straitened .02 ft.
- UHF-VHF Antenna Coupler, permits use of 1 lead for both UHF & VHF Antennas 2.75
- Lightning Arrestor—for tubular or flat lead .69
- UHF Mast Stand-off Insulators—7" .12
- UHF Screw Stand-off—7" .06

New Spring Catalog Available
Includes Sensational Profit Sharing Point Plan

National Electronics OF CLEVELAND

THE HOUSE OF TV VALUES
202 Delco Building Cleveland 3, Ohio

The skyline of tomorrow is the SKYLINE of today!

Install it today and enjoy the fabulous reception that makes it famous!

- Amazing reception at 150 miles and more!
- UHF reception to 50 miles
- Now 32 elements
- Extra-heavy... All-aluminum
- Pre-assembled... Quick rig

SKYLINE MANUFACTURING CO.
1652 ROCKWELL AVENUE
CLEVELAND 14, OHIO

RADIO-ELECTRONICS is paying good rates on acceptance for original and unusual articles on audio, television, FM and AM servicing, as well as articles on industrial electronic equipment and applications. Send for a copy of our Authors' Guide. Address:
THE EDITOR
RADIO-ELECTRONICS
25 West Broadway, New York 7, N. Y.

ALL RADIO AND TV TYPES

CLOSE OUT SET MFR'S SURPLUS TUBES

- STANDARD BRAND WARRANTY
- BRANDED
- BULK PACKED IN ORIGINAL MFR'S NESTED CARTONS OR INDIVIDUALLY BOXED
- EVERY TUBE METER AND CHASSIS TESTED FOR TOP QUALITY

OZ4	\$.49	6J6	\$.51	6BL7	\$.76	6T8	\$.61
1B3GT	.54	6K6GT	.36	6BN6	.72	6V6GT	.41
1L4	.47	6L6GA	.99	6B06	.76	6W4GT	.41
1R5	.46	6SA7GT	.61	6B07	.76	6W6GT	.41
1S4	.52	6SC7	.81	6C4	.31	6X4	.49
1S5	.38	6SF5	.58	6C5	.41	6X5GT	.43
1T4	.46	6SH7	.65	6CB6	.42	12AT6	.31
IU4	.46	6AQ5	.38	6CD6G	1.08	12AT7	.57
IU5	.38	6AQ6	.49	12AU7	.52	12AU6	.34
IX2A	.52	6SG7	.59	12AV7	.88	19BG6G	1.49
3Q4	.69	6AS5	.62	12BA6	.52	19T8	.61
3Q5GT	.55	6AT6	.36	12BE6	.42	25AV5GT	1.05
3S4	.46	6AU6	.36	12BH7	.53	25BQ6GT	.79
3V4	.46	6AV5GT	.79	12SA7GT	.59	25L6GT	.42
5U4G	.44	6AV6	.36	12SG7	.61	25Z6GT	.49
5Y3G	.36	6B4G	.79	12SH7	.49	35B5	.46
6AC7	.68	6BA6	.33	12SK7GT	.49	35C5	.46
6AG5	.46	6BA7	.76	12SN7GT	.46	35L6GT	.42
6AH6	.61	6BC5	.46	12SQ7GT	.49	35W4	.32
6AK5	.79	6BE6	.38	6SJ7	.54	35Z5GT	.33
6AL5	.34	6BF5	.69	6SL7GT	.59	50B5	.46
6E5	.76	6BG6G	1.16	6SN7GT	.46	50C5	.46
6F6GT	.54	6BH6	.46	6SQ7GT	.49	50L6GT	.42
6H6	.38	6BJ6	.46	6SR7	.49	I17Z3	.49
6J5GT	.34						

More than 400 Types in Stock—Include all your needs when ordering.

MINIMUM ORDER: \$10.00. Terms: 25% with order, balance C. O. D. Please include postage.
All prices subject to change without notice. F. O. B. New York City. Mail Order Division:

TRANSAMERICA ELECTRONICS CORP.
120 LIBERTY ST., NEW YORK 6, N. Y., COrtlandt 7-4307

the strap is located on the vertical center line of the bracket and approximately 1 3/4 inches below the bottom edge of the large hole provided for the tube neck.—Crosley Service Department

HALLICRAFTERS T-54

Intermittent or continuous hum in this set and the 505, 506, and 514, with or without a station being tuned in, is often caused by heater-to-cathode leakage in the 25L6 audio output tube. In the majority of cases, you can save time by replacing the 25L6 instead of removing the chassis and checking the filter capacitors and other sources of hum.

Poor horizontal sync stability on weak or strong signals with the contrast control wide open is usually caused by a poor or gassy 6AU6 first video amplifier tube. Try several tubes and choose one that doesn't show any signs of positive voltage on the control grid. Sometimes a leaky 0.1-µf coupling capacitor between the video detector and the grid of the 6AU6 will cause poor sync stability.

For fringe-area or dx use, change the 3,300-ohm (or two paralleled 6,800-ohm) 6C4 plate dropping resistors to a 2,320-ohm 10-watt resistor. This raises the conversion gain especially on the higher channels. For peak performance try several 6C4's and choose the one that gives the greatest grid-leak bias on channel 13. Clean the tuner well with carbon tetrachloride.—G. P. Oberto

FRYING NOISE IN TV SETS

A spitting, frying noise is a fairly frequent complaint in the newer receivers using 21-inch and larger glass picture tubes. This trouble is especially apt to occur during a period of damp and humid weather. Before looking elsewhere for the source of the disturbance, take a look at the glass shoulder between the cone and the neck of the tube. In the dark, you can often see tiny sparks leaping across the shoulder from the cone to deflection coil supports.

Dust collects on this shoulder, and when partially saturated with moisture, forms a low-leakage path for the high voltage.

Wiping thoroughly with a clean cloth saturated with carbon tetrachloride or some other volatile nonexplosive cleaner will eliminate the arcing quickly. If you want to do a real job, follow this with a window cleaner such as Windex. Wipe off with a paper towel.

I advise against spraying with an insulating substance because dust will still collect, and the sprayed finish is more difficult to clean.—H. L. Mattinger

AUTO RADIOS WITH 6X5'S

I've serviced several auto radios in which a 6X5 had been replaced by a 6AX5. Don't do it! The 6AX5 draws twice as much heater current as the 6X5. This increases battery drain and may burn out a choke or series resistor.—C. D. Lessig

Now! HANDLE TELEVISION SERVICE THIS NEW "SHORT CUT" WAY!

Spot TV troubles at a glance . . . Fix 'em twice as fast!



NEW! PIX-O-FIX No. 2 JUST OUT!

Users of PIX-O-FIX No. 1 were so enthusiastic about it that No. 2 has now been issued to include 23 TV receiver troubles not previously covered. Get both at bargain price of only \$2 . . . a saving of 50¢!

HANDLE 90% OF TV TROUBLES BY EASY PICTURE ANALYSIS!

Cut TV testing time to minutes! Make repairs fast and right! Just turn the dial of the Ghirardi PIX-O-FIX. When the TV screen image in the PIX-O-FIX "window" matches the image on the set you're repairing you've got your clue as to what is wrong! PIX-O-FIX then gives you all causes of this particular trouble plus the section of the receiver in which it has probably happened. Next you get step by step repair instructions.

Usually, the component likely to be faulty is specified. Quick tests to apply to it are explained—or parts substitution recommended where this is the best procedure.

The two PIX-O-FIX units cover 47 different kinds of TV trouble—just about anything you're ever likely to be called on to fix. Operation is simple and easy. Our money-back guarantee protects you fully.

PIX-O-FIX TV TROUBLE FINDING GUIDES
by Ghirardi & Middleton

The looks of the picture on a bad TV receiver can tell you at a glance what is wrong. PIX-O-FIX not only make this easy—but also show how and where to make repairs.

PIX-O-FIX No. 1—Identifies 24 common troubles by actual TV screen photos. Gives 192 causes and 253 remedies for these troubles. Price separately, \$1.25.

PIX-O-FIX No. 2 (New)—Covers 23 additional troubles not included in No. 1. Together, the 2 volumes are a comprehensive guide to easy "picture analysis" servicing of any TV set. Price separately, \$1.25.

SPECIAL! Get both PIX-O-FIX No. 1 and No. 2 for only \$2. Use coupon.

10-DAY MONEY-BACK GUARANTEE

Dept. RE-24, Rinehart Books, Inc., Technical Division, 232 Madison Ave., New York 16, N. Y.

Enclosed find \$..... for which please rush the following:

PIX-O-FIX No. 1 (\$1.25) PIX-O-FIX No. 2 (\$1.25)

BOTH PIX-O-FIX No. 1 and No. 2 at the special price of only \$2.00 for two plus postage

If not satisfactory, I will return PIX-O-FIX postpaid in 10 days and you guarantee to refund the purchase price.

Name.....
Street.....
City, Zone, State.....

OUTSIDE U.S.A. \$1.50 each. \$2.50 for both.
Same return privilege.

Lynn Eaton was appointed vice-president in charge of sales for the National Co., Malden, Mass., according to an announcement by Raymond C. Cosgrove, chairman of the Board at National. Eaton has had wide experience in executive sales positions with leading electronics and appliance firms including Bendix Home Appliance, Inc.



L. Eaton

including Bendix



Dr. P. S. Christaldi

Dr. P. S. Christaldi was promoted from assistant manager to manager of the Instrument Division of Allen B. Du Mont Laboratories, Clifton, N. J. Dr. Christaldi has been with Du Mont since 1938.

P. R. (Phil) Dawson, staff assistant to the general sales manager of Tung-Sol Electric, Inc., Newark, N. J., retired after 34 years of service with the company. He joined Tung-Sol in 1919.



P. R. Dawson



D. H. Rogers

has been with Blonder-Tongue for over a year. Prior to that, he was with Western Electric Co.

Donald H. Rogers was appointed chief engineer of Blonder-Tongue Laboratories, Westfield, N. J., in line with the expansion of the Engineering Department. Rogers

Obituaries

Henry C. Roemer, vice-president in charge of administration of Domestic Divisions of the International Telephone and Telegraph Corp., died suddenly of a heart attack.

John Otis Hoge, at one time vice-president of the United States Television Manufacturing Corp., succumbed in New York.

Irving Herriott, director and general counsel of Zenith Radio Corp. and one of the founders of the National Association of Broadcasters, passed away after an illness of seven weeks.

William B. Ziff, publisher of *Radio and Television News*, died December 20 last, aged 55. Besides being a radio magazine publisher, Mr. Ziff was chairman of the board of Ziff-Davis Co., publishers of several other magazines, the author of four books, and an aviator in World War I.

Personnel Notes

... John A. Curtis joined the Westinghouse Electronic Tube Division as gen-

NOW EICO® brings you
A LABORATORY SCOPE AT A PRICE YOU CAN AFFORD!

Now you can enjoy all the tremendous advantages of troubleshooting with the greater speed precision and visual meaning which only an oscilloscope gives you. With the EICO 5" Scope you can:

- Visually align TV, FM and AM sets
- Visually signal trace and trouble-shoot every stage of any electronic device
- Visually analyze complex waveforms

All without disturbing circuits

425K 5" Push-Pull Scope KIT \$44.95. Wired \$79.95.

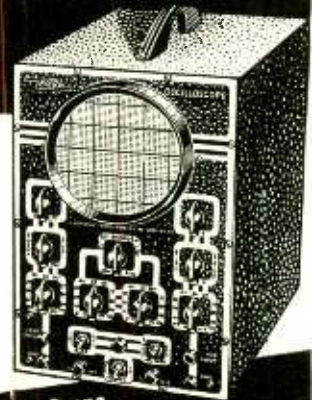

NEW 3 PROBES make 3 INSTRUMENTS of your EICO Scope

DEMODULATOR PROBE KIT \$3.75. Wired \$5.75 - For signal tracing every stage of TV, FM and AM sets.
 LOW CAPACITY PROBE KIT \$3.75. Wired \$5.75 - For broad bandwidth and high impedance circuits.
 DIRECT PROBE KIT \$2.75. Wired \$3.95 - For voltage and current measurements and general analysis.

Special introductory price, set of three PROBE KITS \$9.95. Wired \$14.95

Compare these specifications with scopes selling at many times the EICO economy price!

- Push-pull Vert. & Hor. amplifiers
- Full-screen V & H centering controls
- Intensity (Z-axis) mod.
- 6.3 volt AC, 60 cps test signal output

- Direct connections to deflection plates
- V & H Freq. Resp: 5 cps - 500 kc; usable to 2.5 mc.
- V Sens: .05 to .1 volts rms/inch
- V & H input imp: 1 megohm
- Multivibrator Sweep Generator Range: 15 cps - 75 kc
- Tubes: 2-5Y3, 2-6J5, 3-6SN7, 1-5" CRT.



See this amazing Scope value at your jobber today. Write NOW for FREE Catalog SC-2 describing the complete EICO line. Turn to our full-page ad on page 32 of this magazine.

ELECTRONIC INSTRUMENT CO., INC.
 84 Withers Street, Brooklyn 11, N. Y.

Check! these NJRT TUBE prices
70% to 90% off list ...

Type	Price	Type	Price	Type	Price	Type	Price
1A7GT	.45	6AB4	.42	6BQ7A	.92	6X5GT	.35
1B3GT	.67	6AF4	.92	6BZ7	.95	7E6	.35
1H5GT	.38	6AF6	.75	6C4	.39	7F8	.63
1L4	.50	6AG5	.47	6CB6	.45	12AL5	.40
1NSGT	.62	6AJ5	.73	6CD6G	1.15	12AT6	.35
1R5	.48	6AK5	.75	6F6	.45	12AT7	.65
1S5	.40	6AL5	.37	6J5	.40	12AU6	.38
1T4	.48	6AQ5	.37	6J6	.50	12AU7	.55
1U4	.48	6AQ6	.36	6K6GT	.37	12AV6	.50
1U5	.40	6AT6	.37	6L6	.62	12AV7	.60
1X2	.65	6AU4GT	.70	6R7	.49	12AX4GT	.55
3A4	.43	6AV6	.37	6S8GT	.51	12BA6	.40
3L4	.49	6AX4GT	.55	6SA7GT	.41	12BA7	.57
3Q4	.48	6BA6	.40	6SD7GT	.39	12BE6	.41
3Q5GT	.48	6BA7	.57	6SK7GT	.39	12BH7	.65
354	.48	6BC5	.49	6SL7GT	.49	12BY7	.65
3V4	.50	6BD6	.45	6SN7GT	.50	12BZ7	.65
5A24	.50	6BE6	.37	6SQ7GT	.37	12SA7	.58
5U4G	.45	6BG6G	1.20	6T8	.57	12SK7	.58
5Y3GT	.39	6BH6	.45	6U8	.59	12SL7GT	.49
5Z3	.45	6BJ6	.41	6V6GT	.38	12SN7GT	.50
5Y4G	.39	6BK7	.89	6W4GT	.42	12SQ7	.55
6A3	.57	6BL7GT	.65	6W6GT	.45	12SR7met	.55
6A6	.49	6BQ6GT	.70	6X4	.35	12V6GT	.50

Guarantee
 ALL NJRT TUBES ARE
 BRAND NEW AND
 FULLY GUARANTEED
 FOR A YEAR.

Type	Price	Type	Price
19B6GG	1.15	35Z5GT	.45
19T8	.75	42	.40
25B06GT	.75	43	.53
25L6GT	.40	45	.53
25W4GT	.45	50B5	.41
25Z6	.37	50C5	.41
35A5	.49	50L6GT	.59
35B5	.38	70L7GT	1.07
35C5	.38	76	.42
35L6GT	.45	117Z3	.39
35W4	.37	117L7GT	1.19
35Z3	.43	807	1.25

T.V. PIX TUBE BRIGHTENER..\$1.39

For T.V. sets where voltage supply is low AC LINE BOOSTER with safety fuse and switch\$5.95

Free

Five 1L4 tubes individually cartoned list value \$11.25 with every order of \$25.00 or more. Many 7 volt types not listed. All tubes individually boxed. Orders under \$10 subject to \$1 handling charge. Tubes offered subject to prior sale. Prices subject to change. All orders shipped F.O.B. 2% discount if full remittance accompanies order. 25% deposit required on c.o.d. shipments.

SEND FOR FREE TUBE LISTING



NEW JERSEY TELEVISION SUPPLY CO.

Sole Distributor of NJRT Tubes

906A WESTFIELD AVE., ELIZABETH, N. J. EL. 3-6166

PRECISE — THE FASTEST-GROWING
KIT MANUFACTURER IN THE WORLD

precise

KIT AND WIRED
INSTRUMENTS

IN STOCK
AT YOUR
JOBBER

EXCLUSIVE...

precise

MODEL #308

8 1/2"

SCOPE

\$129.50

KIT #308W \$229.50

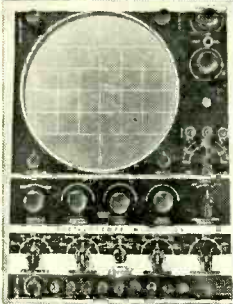

No other oscilloscope, at any price, can meet all the specifications of this electronic masterpiece.

- VERTICAL FREQ. RESPONSE—Flat $\pm 1\frac{1}{2}$ db DC thru 5 MC.
- SENSITIVITY—Greater than 10 millivolts push-pull (3.9 Millivolts/CM)
- BLANKING—60 cycle or 120 cycle Blanking through Blanking amplifier circuit.
- SWEEP RATE—Linear sweeps from 1 cycle to 80 KC in 5 ranges. (1-10 uses Ext. C.) DRIVEN and RECURRENT sweeps.
- MAGNIFIER—Expands and magnifies signal up to 10 times.
- PUSH-PULL—Output in both amplifiers.
- CRT—The latest type 8 1/2" NEW tube a PRECISE EXCLUSIVE.
- VOLTAGE REGULATED.
- ANODE INTENSIFIER—a PRECISE FIRST.
- INTERNAL CALIBRATOR

NEW 7" OSCILLOSCOPE

MODEL #300K \$94.95

MODEL #300W \$199.50

LOWEST PRICED IN ITS FIELD

NEW MODEL #909

VACUUM TUBE VOLTMETER

FACTORY
WIRED \$375.00

Model 909 Vacuum Tube Voltmeter. 1% Ceramic precision Resistors; Coax DC connector; FM zero alignment scale; burn-out proof circuit; DC input 25 Meg. Rugged oversize 4 1/2" meter.

MODEL #909 KIT... \$25.98

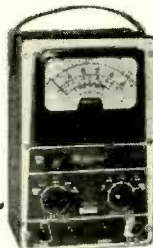

OTHER PRECISE TEST INSTRUMENTS AVAILABLE

- 907 — 7 1/2" VTVM — Kit \$38.98 • Wired \$58.98
- 610 — RF SIG. GEN. — Kit \$23.95 • Wired \$39.95
- 630 — RF-AF TV MARKER — Kit \$33.95 • Wired \$53.95
- 635 — AF SINE, SQ., PULSE GEN. — Kit \$33.50 • Wired \$52.50
- 468 — RESISTANCE DECADE BOX — Kit \$18.95 • Wired \$24.95
- 478 — CAPACITY DECADE BOX — Kit \$18.95 • Wired \$24.95
- 912 — RF PROBE — Wired and Calib. \$4.25
- 960 — 10-1 CA. PROBE — Wired \$5.95
- 999 — HIGH VOLTAGE PROBE — Wired \$6.95

SEND FOR YOUR FREE 1954 DESCRIPTIVE CATALOG
Prices slightly higher in West

precise

DEVELOPMENT CORP.
OCEANSIDE, NEW YORK

the new GERNSBACK LIBRARY

top technical information at low cost

TV Repair Techniques—
No. 50.

Top technician-writers tell how to recognize, find and correct quickly, the tricky TV servicing problems which stump even the experts. A few minutes reading this hook can save you hours of servicing time. 128 Pages. Over 100 Illustrations. **\$1.50**



Radio & TV Test Instruments—No. 49.

How to build just about every instrument required for modern TV-radio servicing. Plus chapters on constructing a practical servicing bench and carrying case. 128 Pages. Over 100 Illustrations. **\$1.50**



High-Fidelity — Design,
Construction, Measure-
ments—No. 48.

An audio man's audio book. How to get top performance from a high-fidelity system. New 3-way approach. 21 top audio men wrote this book. 128 Pages. Over 100 Illustrations. **\$1.50**



Radio & TV Hints—No. 47.

Offers over 300 sure-fire hints, gimmicks, and short cuts on radio, TV and audio. Gathered from the hard-earned experience of experts. Grouped in seven sections. 112 Pages. 132 Illustrations. **\$1.00**



Television Technotes—
No. 46.

Cut routine trouble shooting to the bone in TV servicing. Here are the symptoms, causes and cures of over 600 troubles which occur in scores of sets made by leading manufacturers. 128 Pages. **\$1.50**



Basic Radio Course—
No. 44.

John T. Frye's classic on fundamentals! For the practical man who wants to learn theory. Covers everything from Ohm's Law to advanced servicing in a style which makes learning fun. 176 Pages. Cloth cover. **\$2.25**



Best sellers on Radio and Audio

Radio Tube Fundamentals—No. 45

How and why tubes behave as they do in modern radio circuits. Written for the technician. 96 Pages. **\$1.00**

Model Control By Radio—No. 43

Remote control of model planes, boats and trains. Theory and construction details. 112 Pages. 114 Illustrations. **\$1.00**

High-Fidelity Techniques—No. 42

One of the best written and most informative high-fidelity books published—at any price. By James R. Langham. 112 Pages. **\$1.00**

Public-Address Guide—No. 41

Covers every phase of PA installation and maintenance plus construction details. 80 Pages. Illustrated. **75¢**

Practical Disc Recording—No. 39

Covers theory and practical techniques. A full chapter for each important recording component. 96 Pages. **75¢**

The quality of the technical writing, the scope of the contents and the low price, make the Gernsback Library books on TV, radio and high-fidelity a unique value in the field.

From the publishers of
RADIO-ELECTRONICS

See your distributor—or mail this coupon

GERNSBACK PUBLICATIONS, INC., Dept. 24
25 West Broadway
New York 7, N.Y.

Enclosed is my remittance of \$ _____
Please send me the following books postpaid.

39 41 42 43 44
 45 46 47 48 49 50

Name _____
(Please print clearly)

Street _____

City _____ Zone _____ State _____

RADIO-ELECTRONICS

eral manager. A pioneer in the field of railway radio-telephone communications, he was formerly with the Pullman-Standard Car Manufacturing Co. In his new position, he succeeds Harold G. Cheney, who becomes assistant to the vice-president of the Electronic Tube Division.

. . . Verne Roberts joined I.D.E.A., Inc., Indianapolis, manufacturer of Regency TV accessories, as distributor sales manager. He was formerly sales manager of Radio Apparatus Corp. In his new position he succeeds Earl H. Kirk, who was promoted to sales co-ordinator.

. . . Howard J. Greenley was appointed Advertising Manager of the Hickok Electrical Instrument Co., Cleveland. Greenley had been with the Hickok Sales Department for the past fourteen years.

. . . Thomas T. Goldsmith, Jr., Irving G. Rosenberg, and C. Edwin Williams were elected vice-presidents in charge of Research, Tubes and Government Requirements, and Instruments and Transmitters respectively for Allen B. Du Mont Laboratories, Clifton, N. J. All have been with the company for some time.

. . . Robert C. Foster, sales engineer with Ohmite Manufacturing Co., Skokie, Ill., was promoted to sales engineer in charge of the Ohmite branch sales office in Rochester, N. Y.

. . . Robert O. Monk was promoted to assistant general manager in charge of over-all operation of Quietrol Co., Spartanburg, S. C. In the past he has served as treasurer, and office and plant manager.

. . . Evelyn J. Horne joined the Advertising Department of Brook Electronics, Elizabeth, N. J. She was formerly connected with a subsidiary of Olin Indus.

. . . Marvin L. Bruckner joined Oxford Electric Corp., Chicago, as sales co-ordinator. He has had wide experience in the electronic field. In his new position Bruckner succeeds Jack Harvey, who will assist Hugo Sundberg, Oxford vice-president in servicing manufacturing accounts in the Chicago area.

. . . Grant Graham was promoted to the newly created position of product applications engineer of Triad Transformer Corp., Venice, Calif. He was previously in the Jobber Sales Division.

. . . Murray Platt, president of Platt Manufacturing Corp., New York City, was elected president of Link Radio Corp., also of New York City in a transfer of stockholding interests. Engineering and production facilities of both organizations will now be combined.

. . . Leslie Hill, Ph.D., was appointed director of research of the Pentron Corp., Chicago. Dr. Hill has worked on the design of electronic equipment both here and abroad.

. . . Robert E. Ricketts joined Radio City Products, New York City, as chief engineer. He was formerly with Allen B. Du Mont Laboratories.

. . . Simon Holzman joined JFD Manufacturing Co., Brooklyn, N. Y., as chief engineer. He was formerly with Federal Radio and Engineering Corp.

THAT'S A BUY "TAB" A BUY

FACTORY DISTRIBUTORS FOR PRECISE TEST EQUIPMENT

PRECISE 8 1/2" LAB SCOPE



- 8 1/2" INCH TUBE 8CPI
- WIDE RANCH
- PUSH-FULL INPUT THRU OUTPUT
- VOLTAGE REGULATED
- HI-LOW-NORMAL SYNCH
- INTENSIFIER ANODE
- EXTRA FAST RETRACE
- TV PICTURE CLARITY (8 1/2" x 7 ft.)
- LAB TESTED ACCURACY
- LOW IN PRICE
- MODEL 308K (Kitform) **\$129.50**
- MODEL 308W LAB WIRED TESTED AND CALIBRATED **\$229.50**

VERTICAL—Vertical-flat (3rd) DC through 5 megacycles with sensitivity of greater than 10 millivolts push-pull (3.94 Millivolts/cm); Con stan Resistance; Push-pull input immediately converted to sine-ended normal or reverse phase by shorting bar at inputs 1 and 2; Frequency compensated vertical stepping attenuator selects AC or DC inputs; Push-pull DC amplifiers from input through output; Internal electronic mixing through inputs 1 and 2; five-way binding posts.

POSITIONING—Bridge type positioning on vertical and horizontal does not vary tube characteristics.

HORIZONTAL—Frequency compensated stepping attenuator in horizontal amplifier; push-pull Horizontal out.

BLANKING—Internal (return trace blanked), external (return trace not blanked), 60 cycle or 120 cycle Blanking through Blanking amplifier circuit.

SYNCHRONIZATION—External, Internal Positive, Internal Negative, Internal 60 cycle or Internal 120 cycle synchronization.

SWEEP RATE—Driven or non-driven linear sweeps from 1 cycle to 80KC in five ranges (1-10 cycles uses external C circuit); Trigger potentiometer.

MAGNIFIER—Electronic magnifier and magnifier position allow any part of a trace to be magnified up to ten times (equivalent to 70 inches of horizontal deflection).

CALIBRATION—Internal square wave calibrator and potentiometer for using oscilloscope at a VTVM on Peak to Peak measurements.

CALIBRATION SCREEN—Edge-illuminated scale and graticule may be turned on or off; if fered screen.

OUTPUTS ON FRONT PANEL—Plus Gate output; Sawtooth output; 60 cycle phasing output; 60 cycle unphased output; Calibration output.

FOCUSING—Astigmatism, focus and intensity control.

CRT—NEW 7" Tube, normally supplied is medium persistence type 7VP1, or 7JP1 may also be used (oscilloscope green trace)—high persistence types available at additional cost.

DIRECT—Deflection plates available from rear of cabinet.

INTENSITY MODULATION—Z modulation through modulation amplifier.

GENERAL—Low loss components; Over-designed fused power supply for additional circuitry; Deeply etched aluminum panel; New parts from original manufacturers—**NO SURPLUS**; Steel cabinet: 11" x 14" x 19"; complete with instruction book and all components.

MODEL 300K/7" OSCILLOSCOPE KIT \$94.95
MODEL 300W/7" FACTORY WIRED \$199.50



MODEL 909
VACUUM TUBE VOLTMETER. % Ceramic precision Resistors; Coax DC connector; FM zero alignment scale; burnout proof circuit. Rugged oversize 4 1/2" meter. Specially prepared 3 color space instruction books with exploded views that explain each step and define the purpose.

RANGE—DC: 0-5-25-250-500-1000 Volts
RANGE—DC: 0-5-25-250-500-1000 Volts
RANGE—AC: 0-5-25-250-500-1000 Volts
RANGE—AC: 0-5-25-250-500-1000 Volts
RANGE—R_x100,000 Ohms
RANGE—R_x10,000 Ohms
RANGE—R_x1,000 Ohms
RANGE—R_x100 Ohms
RANGE—R_x10 Ohms
RANGE—R_x1 Ohm

RANGE—DB: From -20 to +35 DB

"TAB" SPECIAL #909K (KIT) **\$25.98**
#909W (FACTORY WIRED) **\$75.80**



MODEL 610 AM-FM AND TV
The first low-priced RF Signal Generator to reach 110 MC on fundamentals, 330 MC on harmonics, with the accuracy and stability of high-priced equipment. PRECISE achieves this by slug and capacity tuning of the coils, along with complete isolation of the Colpitts Oscillator by a Cathode Follower Buffer Output, External Modulation; Speech Amplifier; Bridge Type AF Oscillator; Colpitts RF Oscillator; Coaxial Fittings; Individually Tuned Coils; Vernier Tuning; Separate RF Section; Complete Shielding, 400 Cycle and 60 Cycle Internal Modulation. Wrinkle steel cabinet; deeply etched aluminum panel; wt.: 10 lbs.

RF FREQUENCIES:
Band 1 — 300KC to 1MC FUNDAMENTALS
Band 2 — 1MC to 3MC FUNDAMENTALS
Band 3 — 3MC to 10MC FUNDAMENTALS
Band 4 — 10MC to 30MC FUNDAMENTALS
Band 5 — 30MC to 110MC FUNDAMENTALS
Band 5A — 60MC to 220MC 2nd Harmonic
Band 5B — 90MC to 330MC 3rd Harmonic

"TAB" SPECIAL #610K (KIT) **\$23.95**
#610KA (PRE-ASSEMBLED RF HEAD) **\$28.95**
#610W (FACTORY WIRED) **\$39.95**

EICO TUBE TESTER
Model 625 tube tester. Features include 4 1/2" easy to read meter speedroll chart; lever switches for testing individual elements—checks all the latest Radio-TV—and VR tubes; protective over load indicator; etched panel; rugged heavy gauge steel.

"TAB" SPECIAL #625K (KIT) **\$34.95**
#625 (FACTORY WIRED) **49.95**

precise



MODEL 635 UNIVERSAL AF SINE—SQUARE & PULSE GENERATOR
Efficiently & effectively tests all audio & video circuits. 1% ceramic precision resistors. Wein Bridge osc, verily constant output, cathode follower output, voltage regulated.

Band 1—20-40 cycles
Band 2—40-200 cycles
Band 3—200-2000 cycles
Band 4—2000-20,000 cycles
Band 5—20,000-200,000 cycles

"TAB" SPECIAL #635K (KIT) **\$33.50**
#635W (FACTORY WIRED) **\$52.50**



PRECISE MODEL 468 RESISTANCE DECADE BOX
PRECISE AGAIN LEADS THE FIELD with its New Low-Priced Resistance Decade Box. Ideal for specialized service work. Compact in size for Bench Drawers and Tool Boxes. Engineered with the customary Precise Accuracy and Dependability.

5 Separate Switches, 11 Positions on Each; plus or minus better than 1% for Extreme Accuracy; Readings from 10 OHM to 1,111,110 OHM in 5 Decades. Deeply etched Aluminum Panel; Rugged Construction; Complete with Simplified Construction Manual. 3 1/2" x 6 1/4" x 2"

468K kit form **\$18.95**
468W factory wired **\$24.95**
478K—CAPACITY DECADE BOX (Not illus.) **\$18.95**
kit only "TAB" SPECIAL **\$18.95**
478W—CAPACITY DECADE BOX (Not illus.) **\$24.95**
factory wired. "TAB" SPECIAL

TEST EQUIPMENT ACCESSORIES

Model 999 Hi-Voltage Probe, for use with VTVM #909 or 907, Essential for every TV serviceman, engineer and ham. Rugged construction features include: 3 individual media protection against voltage breakdown, shockproof tips & resistors, swivel mount, mechanical checkproof construction. "TAB" SPECIAL #960 **\$6.98**

Model 912 RF Probe, Input capacity less than 3mf frequency range up to 250mc. Input resistance; 200K ohm 1mc, 150K ohm 10mc, 25K ohm 100mc. Calibrated at 75mc for accuracy, impedance & shunt capacity. The finest low price RF probe made.

#912AS PROBE (FOR VTVM 909 & 907) **\$4.25**
912T-MM PROBE (FOR OSCILLOSCOPE) **\$4.25**
Model 960 10 to 1 capacity attenuator probe, permits scope measurements with 1/10 capacity loading effect. Frequency range through 100mc. Less than 7mf input capacity. "TAB" SPECIAL #960 **\$5.95**

PRECISE MODEL 630 RF—AF & TV MARKER GENERATOR
Check these features: Advanced circuitry *Variable modulation, cathode follower output *Crystal marker *Wein bridge AF Osc *Colpitts RF Osc *Constant output impedance *Vernier tuning *Complete shielding *Fundamentals through 110 Mc *Rugged design, quality components *7 RF bands 300 Kc to 330 Mc. *4 audio bands, 20 cy to 20 Kc.

"TAB" SPECIAL #630K (KIT) **\$33.95**
#630KA (KIT) Pre-Assembled RF Head **\$38.95**
#630W (FACTORY WIRED) **\$53.95**

"TAB" SPECIAL
Order Precise or Elco Kits and you will receive.
* Soldering Iron
* Long Nose Pliers
* Diagonal Cutters
* Screw and Socket Driver Set
* Roll of Solder
Reg. Value \$4.98.
With Any Kit Order **\$1.98**

FAST TESTING FOR FLYBACK TRANSFORMERS AND YOKES
"Radio City Products"
Cut time in half. Quickly & efficiently test Horiz. circuits. Eliminates troublesome hit or miss replacements. Extremely sensitive, indicates single shorted. Turn or opens. 3 good-band scales & Special Yoke scale. Checks components while in TV set. with test leads & instructions. 115V 60 cy. ready to use. shpg wt 8 lbs.

Model 123. SPECIAL **\$38.95**

Write For Test Equipment Catalog and "TAB" Prepaid Equipment Prices WE BUY & SELL & SWAP AS WELL

THAT'S A BUY "TAB" A BUY

Money Back Guarantee (Cost of Mds. Only) Order F. O. B. N.Y.C. Add Shpg. Charges or 25% Dep. Phone Rector 2-6245 CABLE: "TABPARTS"

Dept. 2RE 111 LIBERTY STREET, NEW YORK 6, N. Y., U.S.A.

LEARN MORE! EARN MORE!

WITH H. G. CISIN'S

SERVICE BOOKS

**NEW! 1954 TV Consultant
TV Serviceman's Silent Partner**



New, easy-to-use way to solve toughest TV troubles. UHF sect. includes conversions, installations and servicing. Modern alignment methods shown by pictures, diagrams and simple directions, tell exactly what to do and how to do it. Practical pointers on use of all TV Test Instruments. Over 300 pix, raster and sound symptoms. Detailed directions tell where and how to find faulty parts. Over 135 RAPID CHECKS, many using pix tube as trouble locator. 25 illustr. of scope wave forms, diagrams, station patterns, show various defects—take mystery out of TV servicing. **NO THEORY—NO MATH—NO FORMULAS—** just practical service info. covering all types of TV sets.

Only.....\$2

**NEW! 1954 TV Tube Locator
All Pix Tubes Listed!**

Money-making Time Saver tells which tubes to replace to cure every type of tube trouble. Over 135 such TV troubles listed with clear charts for quickly locating the faulty tubes. Copyrighted TROUBLE INDICATING TUBE LOCATION GUIDES for over 3000 most popular models from Admiral to Zenith plus PIX TUBES used in each model! 1947 to 1953 models. A storehouse of valuable TV servicing info. Priced very low for large volume sales.

Only.....\$1



**NEW! Trouble Shooting PIX
GUIDE incl. TV TERMS Explained**



Sec. 1 is a fully illustrated GUIDE to oft-recurring pix faults. Causes and cures explained. Copyrighted Trouble Indicating illustrated chart tells where troubles start in typical TV set—illustrations show resulting faulty TV pictures. Sec. 2 explains hundreds of TV terms in non-technical language. SPEEDS UP TV SERVICING—HELPS YOU DO A BETTER JOB FASTER!

Only.....\$1

**NEW! TV Trouble Tracer
Vol's 1 & 2 Now Ready!**

70 Common TV troubles traced to source and cured. Copyrighted trouble indicating tube location guides covering over 1200 most popular TV models. Many models different from those shown in TV TUBE LOCATOR. Each contains over 70 illustrations and tube location guides. Forty most common picture troubles illustrated, with symptoms described, causes given and remedies prescribed.

Vol. 1 Only 50¢
Vol. 2 Only 50¢



H. G. CISIN, PUBLISHER

Order from your Jobber today, or if not stocked, write to
Harry G. Cisin, Dept. E-25
Amagansett, New York

Enclosed find \$.....Send

- TV Consultant TV Locator
- TV Pix Guide TV Tracer Vol. 1
- TV Tracer Vol. 2

Name

Address

CityZone.....State.....

Any or all of these catalogs, bulletins, or periodicals are available to you on request direct to the manufacturers, whose addresses are listed at the end of each item. Use your letterhead—do not use postcards. To facilitate identification, mention the issue and page of RADIO-ELECTRONICS on which the item appears. All literature offers void after six months.

SELENIUM RECTIFIERS

Sarkes Tarzian has issued a 25-page selenium rectifier replacement guide for television and radio receivers.

Obtainable from Sarkes Tarzian distributors or direct from the factory at 415 N. College Ave., Bloomington, Ind., for 25¢.

SOUND TALK

Sound Talk Bulletin No. 26, "Splicing Techniques for Magnetic Tape" is a 3-page technical bulletin which discusses general considerations in magnetic tape splicing including the solutions to such problems as splice weakness, loss of recorded signal due to poor head contact and adhesive transfer causing sticky layers.

Detailed instructions for properly splicing magnetic tape for audio recording are given, as well as information on splicing critical recordings such as those used in computer work and instrumentation.

Available free on request from Minnesota Mining and Manufacturing Co., St. Paul, Minn.

AUDIO CATALOG

Terminal's 1954 Audio Guide has more than 130 pages listing high fidelity, audio, communications, and public address sound equipment. The well-illustrated catalog contains everything for professional and custom installations.

Free on request to Terminal Radio Corp., 85 Cortlandt St., New York 7, N. Y.

PICTURE TUBE CHART

Sylvania's newly-revised "TV Picture Tube Comparison Chart" lists over 160 different picture tube types. Additional features include ion trap listings and base diagrams. Face, body, focus, deflection angles, basings, and length in inches on all tubes are also given on the chart.

Can be obtained free from the Sylvania Advertising Distribution Department, 1100 Main St., Buffalo, N. Y.

TEST EQUIPMENT

Heath's complete line of test equipment in kit form is described in their attractive 40-page 1954 catalog.

Each instrument is illustrated with photographs and schematics. Specifications and applications are detailed. Included are an antenna impedance meter, audio wattmeter, isolation transformer, bar generator, tube checker, grid-dip meter, laboratory generator, and the other and better known items of the regular Heath Kit line.

Amplifiers, receivers and amateur radio equipment are also described.

Write to the Heath Co., Benton Harbor, Mich., for this one. END

**Bargain in Broadcast Quality
TAPE RECORDER MECHANISM 38.75**

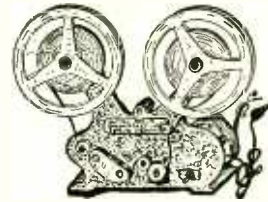

MODEL 90 "ULTRA-AUDIO" TAPE TRANSPORT MECHANISM COMPLETE WITH HIGH QUALITY RECORD-PLAY-ERASE HEAD, INDUCTION MOTOR, ACCESSORIES, AND HIGH QUALITY PLASTIC BASE RECORDING TAPE.

USE WITH ANY HI-GAIN AMPLIFIER

The "Ultra-Audio" tape transport mechanism comes complete with convenient terminals and full instructions which permit its application to your present amplifier, radio-phonograph, or other audio unit, for the making, reproduction, and erase of tapes. Just as any standard tape recorder—but at unbelievable quality and fidelity! This unit is ideal for Hi-fi enthusiast, the experimenter, the radio Ham, or commercial user. It is identical to that provided for our radio-broadcast outlets. No experience required to follow simple instructions and comprehensive circuit diagrams to connect to almost any radio or audio unit for full life-like performance!

Records—Reproduces—Erases, At Two Speeds

Simple change-over mechanism permits operation at either 7 1/2 or 3 1/2 inches per second speeds. A number of circuit diagrams are provided to enable even the novice to construct special amplifiers, etc., at minimum cost to obtain results far surpassing recorders selling for many hundreds of dollars. Unit will operate with any amplifier capable of being excited by crystal mike or magnetic phono—and with most radios. Unit comes complete, ready to connect and use. Operates in either horizontal or vertical position. Provided with convenient mounting lugs. MONEY BACK GUARANTEE.

FIRST COME—FIRST SERVED

Order from
EQUIPMENT—SERVICE DIVISION

**ULTRA-AUDIO BROADCASTING SYSTEM
BOX 243, SAN DIEGO (12), CALIFORNIA**

(Shipped pre-paid on cash-with-orders—otherwise charges collect. Cash with order on all C.O.D.'s.)

**PLAY RECORDS
through ANY RADIO**

with

Bud Wireless Phono Oscillator

only **\$9.00**



Now you can "Broadcast" from your record player to your radio set up to 100 feet away with Bud Wireless Phono Oscillator Model WO-6.

NO UNSIGHTLY INTERCONNECTION WIRES REQUIRED. Sound transmits directly to any clear channel on your radio. Simply connect the phono pick-up to the oscillator, plug into any wall outlet and the unit is ready to operate. Will match any crystal pick-up. By adding a phono motor and pick-up, a highly efficient wireless record player may be assembled at a moderate cost. Will play records through any number of radios simultaneously. Tone and volume regulated directly from the radio. Unit comes completely assembled including tubes. Grey Hammered Finish case, 4 1/2" x 2 1/2" x 2 1/2". Operates on 110-120 Volts AC or DC. Complete instructions included.

Order your Bud Phono Oscillator today. Send Check or Money Order. We pay postage. Add 3% tax in Ohio. Money refunded if not satisfied.

MAIL THIS COUPON TODAY

Radio & Electronic Parts Corp.
3235 Prospect Ave., Cleveland 15, Ohio

I enclose \$..... please send me at once
Bud WO-6 Phono Oscillators.

Name.....

Address.....

City.....State.....

When answering advertisements,

Please mention

RADIO-ELECTRONICS

RADIO-ELECTRONICS

The COMPLETE line



DR Double-Reentrant Projectors

Paging & Talk-Back Speakers

for EVERY



ALNICO-V-PLUS Driver Units

Dual Speakers

Public Address need!

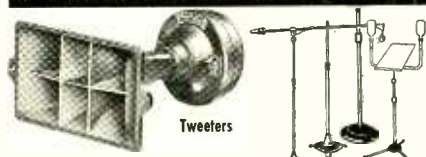

Tweeters

FULL-GRIP, VELVET-ACTION Mike Stands

WRITE NOW for FREE Catalog 553

ATLAS SOUND CORP.
1443 39th St., Brooklyn 18, N. Y.
In Canada: Atlas Radio Corp., Ltd., Toronto, Ont.

WHILE THEY LAST!

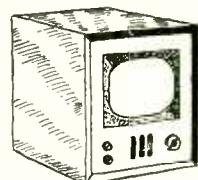

10" TV REMOTE "SLAVE" SETS

HERE'S YOUR CHANCE TO GET THAT EXTRA SET FOR PLAYROOM, BEDROOM, KITCHEN, ETC.!!

These are COMPLETE, OPERATING slave units. Hook up to any standard TV receiver (only 4 soldered connections) to reproduce any tuned TV channel. COMPLETE SCHEMATIC & WIRE-UP DATA SUPPLIED. Operates on 110V. DC; AC conversion data included.

- FEATURES:**
- 19 TUBES including 10BP4. ALL 90 DAY GUARANTEED
 - H.V. OSC. POWER SUPPLY... detachable unit.
 - 4" HVY. DUTY PM SPEAKER.
 - MAJOR STANDARD PARTS INCLUDE: Def. Yoke, Focus Coil, Horiz. & Vert. Outputs, two 10H-100ma Chokes, 150ma Sel. Rect., Electrolytics, Controls, etc.
 - HANDSOME WALNUT VENEER & LEATHERETTE CABINET (20 1/2" x 17" x 14 1/2").

!! PARTS ALONE WORTH SEVERAL TIMES THE PRICE !! Perfect condition - used. Shipped Railway Exp. **\$23.95**

- ROTARY BALL-BEARING SWIVEL ASSEMBLY**
Designed for TV TABLE SETS; perfect for HVY. CHASSIS SERVICING & DISPLAY WORK. Rugged hardware mtd. between 1 3/8" x 1/4" masonite plates. Shpg. wt. 5 lbs. \$2.95
- RM-38A CONTROL UNITS (LN)** \$2.95
Mine" of jacks, Plugs, Switches, Cables, etc.
- BLOWER WHEEL & HOUSING** ... Use with any small motor. Moulded bakelite housing.
Type 22 (3" O.D.)-22 \$1.95
Type 23 (3 1/2" O.D.)-23 \$1.95
3 Mid.-600VDC OIL CONDENSER (O.D. 2" x 2") 69c
..... 3/4 1.95
- SINGLE EARPHONE UNITS** ... 300 ohm Imped. 89c
..... \$1.69 pr.
- CRYSTAL MIKE (1 3/4" x 1/4")** ... High fidelity, hi-imped. Rubber shock mtd. Less housing 1.29
ALUMINUM HOUSING for above mike15

STOP!! LOOK!! SAVE!! ... with the NEW "Jumbo Radio Electronics Parts Kit"

Chock-full of: SWITCHES, SOCKETS, WIRE, RESISTORS, CONDENSERS, COILS, CONTROLS, PHOTOFACTS, ETC. PARTS & DIAGRAMS, ETC. ETC. **\$3.95**
Shpg. wt. 20 lbs.

- ALNICO MAGNET SPECIALS** ... Pol. Bar. 9/16"x7/32"x3/32" 12/1.00 100/7.50
"U" TYPE "X" 1/2"x3/8"x1/8" 12/5.00
- ALNICO MAGNET KIT** ... Powerful Bar, Block, "U", Rod, etc. Kit of 10 asstd. 1.98
- WRITE FOR LATEST "ALNICO" SUPPLEMENT**
EXPERIMENTAL TUBES ... for Test, Research, etc. Fil. tested. Kit of 40 asstd. revg. types 1.98
- "DIRECT FACTORY SPEAKER REPAIRS SINCE 1927"**
Min. Order \$3.00. 20% deposit req. on all C.O.D.'s. Please add sufficient postage-excess refunded.

LEOTONE RADIO CORP.
67 Day Street
New York 7, N. Y.

PRACTICAL COLOR TELEVISION, by "the coordinated efforts of many RCA service technicians". Published by the RCA Service Co., Inc., Camden, N. J. 8 1/2 x 11 inches, 58 pages plus fold-in schematic. Price \$2.00.

The TV service technician has been eagerly awaiting a manual which will give him some idea of the problems and practices of color television. This book is intended to give him that information. Therefore it presupposes that "the reader is well versed in the basic operating principles of television", in other words, that he is a skilled black-and-white television technician, and needs no explanation of principles and techniques employed in standard TV servicing.

As might be expected, the book begins with a study of the basic principles of color, excellently elucidated and clarified by illustrations in color (though the "self-explanatory" Figure 8 would have been improved by a few words of explanation). Development of the color signal is then taken up, together with a general description of the compatible color TV system and the RCA tri-color kinescope.

The second section of the book covers color receiver circuitry, and contains a more detailed description of color television principles, brought out in the discussion of the circuits. Section III is called "Color Installation and Service". It covers everything from showing the customer how to operate the receiver to aligning color circuits. Colored illustrations are again used freely to illustrate correct color purity and convergence adjustments and to show balance for color as well as black-and-white.

Another series of color pictures show the effects of various misadjustments, as well as a normal picture. Accompanying text deals with troubleshooting and fault correction.

A glossary of color television terms, a short bibliography, and a large (10 x 36-inch) schematic of an RCA color television receiver complete the book. The schematic is a particularly well done job, and is probably the first readable diagram of a complete color TV receiver to be printed.—FS



"I called you to oil my rotor—it has an annoying squeak."

Here's how to make HIGH FIDELITY mean what it says!



... a complete guide to better "hi-fi" equipment and results

Just Out! ... HIGH FIDELITY TECHNIQUES

by John H. Newitt
Staff, Mass. Inst. of Technology
494 pages, 203 illustrations. Price \$7.50

Get better results from "hi-fi" by knowing all about it!

This big new book by one of the nation's acknowledged experts brings you the complete "low-down" on modern sound reproduction methods and equipment. It shows exactly how to get best results at minimum cost; discusses all details of circuitry, components and equipment; covers the service angles; compares the different methods—and is chock full of how-to-do-it tips and ideas.

IT PAYS TO KNOW!

Here are just a few of the subjects covered: What to look for in high-fidelity equipment—what to avoid • Getting production to suit your taste • Some unusual "hi-fi" combinations • Hi-fi vs. P.A. type speakers • Loudspeaker construction and performance • Adjusting bass reflex cabinets • Controlling distortion • A novel horn system • Baffles • Getting rid of "overhang" • The best reproducer enclosure • Selecting a woofer-tweeter combination • Sound-proofing materials • How grillwork affects attenuation. Output transformer specifications and what they mean • Special hi-fi circuits • Proper crossover frequencies • Do's and don'ts of volume expansion • Practical ways to suppress noise • A good tone control • Negative feedback and how to use it • Pre-amps and equalizers • Amplifier construction hints • Judging commercial amplifiers • Minimizing tuner distortion • Avoiding chatter and cross-talk • Limiter-discriminator vs. ratio detector FM circuits • All about records and record players • Selecting turntables and pick-up cartridges • A comprehensive course in magnetic recording • Pick-up resonance, its cause and cure • Choosing a recorder • Tips for custom builders • Special installation problems. • Typical "hi-fi" installations • Bass-reflex calculations and design charts ... and dozens of other subjects. Read it for 10 days AT OUR RISK! Use coupon.

10-Day Free Examination

Dept. RE-24, Rinehart Books, Inc.,
Technical Division,
232 Madison Ave., New York 18, N. Y.

Send HIGH FIDELITY TECHNIQUES by Newitt for 10-day FREE examination. If I decide to keep the book, I will then remit \$7.50 plus postage. Otherwise, I will return book postpaid promptly and owe you nothing. (If you send cash with order, we pay postage—same return privilege with money refunded.)

Name.....

Address.....

City.....Zone.....State.....

OUTSIDE U.S.A.—Price \$8.00 cash only. Money back if book is returned postpaid in 10 days.

SOUND POWERED HEAD AND CHEST SET

Navy Type—No Batteries Required—Ideal for TV Antenna Installations and many other uses. 20 Ft. Cord. Used Tested: **\$5.95 EA.**



TELEPHONE WIRE FOR THE ABOVE

COMBAT TYPE—2 Cond. Twisted, Rubber Covered, Medium Weight, W-130. @ .01¢ per Ft.
FIELD WIRE—2 Cond. Twisted, Weatherproof, Heavy Duty, W-110—525 Ft. Roll **\$4.75**
COPPER WELD WIRE—Weatherproofed, 2 Cond. Solid. 1200 Ft. Roll. \$10.00. Per Ft. @ .01¢ per Ft.

TG-34A KEYS

PORTABLE—115 or 230 V. @ 50 to 60 cycles—KEYER TG-34A is an automatic unit for reproducing audible code practice signals previously recorded in ink on paper tape. By use of the self contained speaker, the unit will provide code practice signals to one or more people or provide a keying oscillator for use with a hand key. The unit is compact, in portable carrying case, and complete with tubes, photo cell, and operating manual. Size: 10 1/4" x 10 1/2" x 15 1/16". Shipping weight: 45 lbs. **BRAND NEW \$24.95**—In original Box—While They Last...

COAXIAL CABLES:

RG-8/U (SPECIAL) 51.5 ohms. Same size as RG-8/U. Prices: 1 to 100 ft. @ 8¢ per ft.—100 to 500 ft. @ 7 1/2¢ per ft.—500 to 1000 ft. @ 7¢ per ft.—1000 ft. Rolls @ 6 1/2¢ per ft.
RG-34/U—71 ohms. 145 ft. length. **\$15.00**

AERIAL WIRE—Phosphor Bronze #16 Strand—ed, 200 lb. test. Weatherproof, 150 Feet **\$1.50** on Reel. RL-3 with Clips.....

ATTN.: TELEVISION FRINGE AREAS
AIRCRAFT GUY CABLE—3/32" 7 x 7 Strand, Weatherproofed, Galvanized, Preformed—920 lb. Test. This cable has been tested and proven in many fringe areas over many years—millions of feet in use. PRICES: 4 1/2¢ per Ft.—1000 Ft. @ 4¢ per Ft.—5000 Ft. @ 3 1/2¢ per Ft.

FREE CATALOG

LOADED WITH TRULY OUTSTANDING "BUYS"!—SEND FOR YOUR FREE COPY NOW!

Address Dept. RE • Minimum Order \$5.00
Prices F.O.B., Lima, O. 25% Deposit on C.O.D. Orders

FAIR RADIO SALES
132 SOUTH MAIN ST. • LIMA, OHIO

THE NEW TV DYNATRACER

- TRACES TV SIGNALS AND VOLTAGES
- LOCATES DEFECTIVE COMPONENTS
- REQUIRES NO ADDITIONAL EQUIPMENT

This sensationally new piece of test equipment is ideal for trouble-shooting television sets in the home or in the shop. The "DYNATRACER" will outperform more expensive testers and should pay for itself on the very first repair.

A Must For Every TV Technician
SPECIFICATIONS: The "DYNATRACER" is a self-powered quality test instrument designed to trace TV signals through any Video, Sound, Sync, AFC, Horizontal or Vertical Sweep Circuit—will isolate trouble to a stage or component.

ADDED FEATURE: The "DYNATRACER" will also trace voltages (50/500 V. AC/DC) and instantly locate open, shorted, intermittent or leaky (up to 20 MEGOHMS) condensers, resistors, coils, XFormers, etc.

10 DAY MONEY-BACK GUARANTEE
Instruction and Trouble-Shooting Book Enclosed

Cut out advertisement, attach name and address with \$5.00 bill, check or money order and mail to

Century ELECTRONICS CO.
8509-21st Ave., Dept. 110, Brooklyn 14, N. Y.



Free!
Get More Service Calls with **EICO DECALS**
For Store Windows & Cars.
Write EICO
Brooklyn 11, N.Y. Dept. DC-2

PRINCIPLES OF RADAR, (Third Edition) by J. Francis Reintjes and Godfrey T. Coate (members of the Staff of the Radar School Massachusetts Institute of Technology). A publication of the Technology Press, Massachusetts Institute of Technology. Published by McGraw-Hill Book Co. 330 W. 42nd St., New York, N. Y. 6 1/2 x 9 3/4 inches, 985 pages. Price \$7.75.

Like the two preceding editions, this book is intended primarily for those interested in the basic principles and applications of pulse radar. The discussions of circuits and components are sufficiently detailed and complete to satisfy the aim of the book, yet are general enough to be useful to engineers, technicians, and students in other electronic fields employing similar circuit components and techniques.

The first six chapters are devoted to the low-frequency elements of the radar system. This includes servomechanisms and control circuits, pulse generators and wave-shaping networks and their application to modulators, indicators, and receivers. The remainder of the book is devoted to high-frequency elements including u.h.f. vacuum-tube oscillators, klystrons, magnetrons, wave guides, directional couplers, attenuators, T-R circuits and devices, antennas, receiver input circuits, and u.h.f. propagation.—RFS

PRINCIPLES OF ELECTRONICS by L. T. Agger. Published by St. Martin's Press, 103 Park Ave., N. Y. 17, N. Y. 8 1/2 x 5 1/2 inches. 340 pages. Price \$3.75.

The first four chapters are an introduction to electronics, dealing with the physics underlying electronics. Following these, the author devotes chapters to vacuum tubes, rectification, voltage and power amplifiers, controlled rectifiers, oscillators, modulators and detectors, the cathode-ray tube, and photo-cells.

In general, the book deals only with principles and basic applications, omitting elaborate circuits and special electronic equipment.

Written at a sub-engineering level, it is an excellent book for electronic technicians.—JK



BLAK-RAY SELF-FILTERING ULTRA-VIOLET LAMP

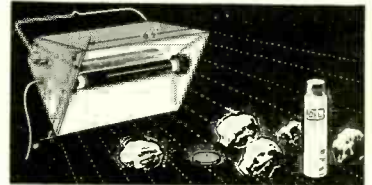

BLAK-RAY 4-watt lamp, model X-4, complete with U-V tube. This lamp gives long-wave ultra-violet radiation having a wave-length of 3654 to 4000 angstrom units. Some of the substances made to fluoresce visibly when illuminated by U-V light are certain woods, oils, minerals, milkstone, cloth, paints, plastics, yarn, drugs, crayons, etc. This lamp is self-filtering and the invisible U-V rays are harmless to the eyes and skin. Equipped with spectral-finish aluminum reflector. Consumes only 4 watts and can be plugged into any 110 volt 50-60 cycle A.C. outlet. Will give 2000 to 3000 hours of service. It weighs but 1 1/4 lbs. Approved by the Underwriters Laboratories and has a built-in transformer so that it may be safely used for long periods when necessary. Extra U-V tubes are available.

Ship wt. 4 lbs. **\$16.75**
ITEM NO. 128
UNUSUAL BUY (Shp. Chgs. 70¢)

POWERFUL ALL PURPOSE MOTOR

Sturdy shaded pole A.C. induction motor. 15 watts, 3000 rpm. 3"x2"x1 1/4"; 4 mounting studs; 7/8" shaft, 3/16" diameter; 110-120 volts, 50-60 cycles. A.C. only. When geared down, this unit can operate an 18" turntable with a 200 lb. dead weight. Use it for fans, displays, timers and other purposes. Ship wt. 2 lbs. **\$2.45**
ITEM NO. 147
UNUSUAL BUY (Shp. Chgs. 35¢)

WATT HOUR METER

Leading makes—reconditioned. Ideal for trailer parks. 100-110 volts, 60 cycles, 2-wire A.C. 5 amp. Heavy metal case 8 1/2" x 6 1/4" x 5". Easy to install. Ship. wt. 14 lbs. **\$4.50**
ITEM NO. 33
NOW ONLY (Shp. Chgs. \$1.25)

WESTERN ELECTRIC BREAST MIKE

Lightweight 1 lb. carbon microphone. Aircraft type. Breastplate mounting, adjustable 2-way swivel. Easily fastened straps. For home broadcasts, communications etc. Complete with 6 foot cord, hard rubber plug. Shaded-dized plate, non-rusting finish. Ship. wt. 2 lbs. **\$2.25**
ITEM NO. 152
NEW LOW PRICE (Shp. Chgs. 35¢)

AMAZING BLACK LIGHT

250-watt ultra-violet light source. Makes fluorescent articles glow in the dark. Fits any lamp socket. For experimenting, entertaining, unusual lighting effects. Ship. wt. 2 lbs. **\$2.45**
ITEM NO. 87
A SAVING AT (Shp. Chgs. 35¢)

250 POWER TELESCOPE LENS KIT

Make your own high powered 6 ft. telescope! Kit contains 2" diam., 75" focal length, ground and polished objective lens and necessary eye pieces. Magnifies 50x to 250x. Full instructions. Ship. wt. 1 lb. **\$2.95**
ITEM NO. 123
YOU SAVE AT (Shp. Chgs. 10¢)

HUDSON SPECIALTIES CO.
25 West Broadway, Dept. RE-2-54
New York 7, N. Y.

I am enclosing full remittance for items circled below. (Be sure to include shipping charges.)
OR, my deposit of \$..... Ship balance C.O.D.
MINIMUM C.O.D. ORDER \$5.00.
C.O.D. ORDERS ACCEPTED ONLY WITH 20% DEPOSIT
INCLUDE SHIPPING CHARGES.

Circle Items Wanted
87 147 33 152 125 123

Name Please Print Clearly
Address
City Zone State

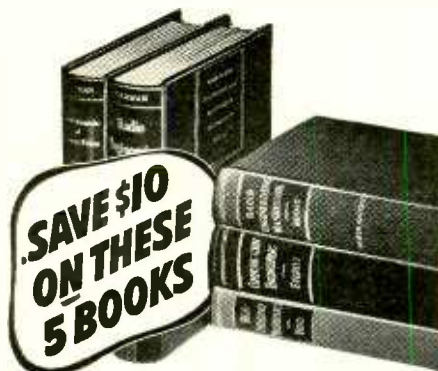

**SAVE \$10
ON THESE
5 BOOKS**

Special Offer On This Complete **RADIO ENGINEERING LIBRARY**

The Famous Library that Brings High-powered Help on the Whole Field of Radio Engineering. Places Authoritative Facts, Standards, Data, Practice, and Theory At Your Fingertips.

Now offered at a special low price, the Radio Engineering Library brings you almost 4000 pages of tested methods, standards, data, and accepted practice. This Library will help solve hundreds of problems for designers, researchers, engineers, and students in any field based on radio.

Written by leading radio engineers, these books cover circuit phenomena, networks, tube theory, vacuum tubes, amplification, measurements, etc.—give specialized treatment of all fields of practical design and application. They provide you with a complete and dependable encyclopedia of facts.

5 volumes, 3872 pages, 2770 illustrations

- Eastman's **FUNDAMENTALS OF VACUUM TUBES**, 3rd Edition
- Terman's **RADIO ENGINEERING**, 3rd Edition
- Everitt's **COMMUNICATION ENGINEERING**, 2nd Edition
- Hund's **HIGH FREQUENCY MEASUREMENTS**, 2nd Edition
- Henny's **RADIO ENGINEERING HANDBOOK**, 4th Edition

SEND NO MONEY

Special Low Price—Easy Terms

On this special offer you get this Library for \$37.50, instead of \$47.50. You save \$10 and may pay on easy terms. Mail coupon below to examine the Library FREE for 10 days. No obligation. These books are recognized as standard works; you are bound to need them. So take advantage of this special money-saving offer. Mail coupon at once!

McGraw-Hill Book Co., Dept. RE-2
327 West 41st St., New York 36, N. Y.

Send for 10 days' FREE trial, the RADIO ENGINEERING LIBRARY. If not satisfied I will return books. Otherwise I will send \$7.50 plus delivery charges then; and \$6 a month for 5 months. (Reg. price \$47.50, you save \$10.)

Name.....

Home Address.....

City & State.....

Employed by.....RE-2

We'll pay Delivery Charges if you enclose \$7.50 first payment WITH coupon. Same return privilege for full refund.

(Offer applies to U. S. only)

PRACTICAL TELEVISION ENGINEERING, by Scott Helt. Published by Rinehart Books, Inc., 232 Madison Ave., New York, N. Y. 6 x 9 inches, 744 pages. Price \$7.50.

It is unfortunate that this book carries the word "engineering" in its title, because that may discourage many technicians from attempting to read it. The book only slightly resembles what might be expected of an engineering text. There is very little higher mathematics, and, where it does appear, there is enough text to enable the service technician or student to bypass it without any loss of technical continuity.

The book plainly emphasizes TV transmitting and broadcasting. It covers both theoretical and practical study of lenses, lighting, cathode-ray tubes, oscillographs, electron tubes for image pickup, synchronizing generators, video amplifiers and cathode followers, regulated power supplies, television receivers and transmitters, and broadcasting techniques. The chapter devoted to synchronizing generators is unusually well written. The book ends with a chapter on u.h.f. and color television.

Practical Television Engineering can be understood by any technician with a thorough knowledge of radio. For the engineer and technician alike, it is full of practical information, especially in TV broadcasting and transmission.—JK

AM-FM SERVICING SHORT-CUTS, by Milton S. Kiver. Published by Howard W. Sams & Co., Inc., Indianapolis 5, Indiana. 5½ x 8¾ inches. 136 pages. Price \$1.50.

In math books we have often found the illustrative problems at the end of a chapter more instructive and illuminating than the non-practical material preceding it. Mr. Kiver has probably had the same experience, since in his newest book he covers the theoretical aspects of servicing, then follows by practical case histories. Hum, noise, low-volume distortion, partial set operation, factory-based troubles, intermittents, set oscillation, etc. are discussed . . . but not dismissed. Numerous case histories following a preliminary discussion bring a practical tone to this book, not ordinarily found in texts on the subject.—MC. END



RESMOND

STOP

VOLUME CONTROL NOISE!

New 6 oz. spray can
Net to Servicemen **\$2.25**

Contains Amazing New

PERMA-FILM

- ★ **Cleans!** dirt and oxidation immediately on contact.
- ★ **Lubricates!** One drop eliminates scratch, hum and noise.
- ★ **Protects!** assures continued top performance.

2 oz. bottle
Net to Servicemen **\$1.00**

Perfect Contact Restorer—cleans & restores volume controls, band switches, push button assemblies, electrical contacts. NO NOISE is not a carbon tet solution.

Available in 8 oz. bottles and quart cans.

Nearest distributor . . . or write

ELECTRONIC CHEMICAL CORP.
813 Communipaw Ave., Jersey City 4, N. J.

Preferred for Original Equipment Proven for Replacement

OXFORD Speakers

Available from leading jobbers!

OXFORD ELECTRIC CORP.
3911 S. Michigan Ave., Chicago 15, Ill.
EXPORT: ROBURN AGENCIES, N.Y.C., N.Y.
In Canada: Atlas Radio Corp., Ltd., Toronto

V-M

HIGH FIDELITY

936^{HF}

RECORD CHANGER

ATTACHMENT

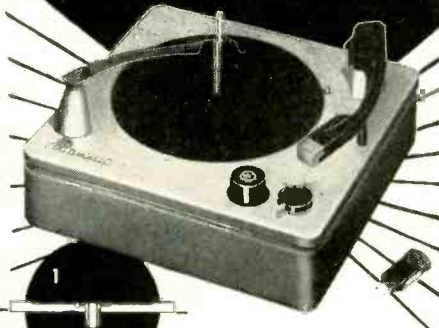

Exclusive laminated, balanced, precision-formed turntable!

Model 936HF, \$69.95* list.

Model 935HF, \$59.95* list.
(less metal pan)



Patented tri-o-matic @ spindle!

Leads in Features that help you profit!



Exclusive die cast tone arm!



Exclusive 4-pole, 4-COIL motor!

The custom-engineered 936HF is the first changer specifically designed for high fidelity performance. It helps you win more profitable hi-fi sales and satisfied customers. Comes complete with two plug-in heads and V-M 45 Spindle.

*Slightly higher in the west.

Many more deluxe features.

Made by V-M Corporation, World's largest manufacturer of phonographs and record changers exclusively.

V-M Portable HIGH FIDELITY P-A Package. Model 960 changer, \$64.50* list. Model 160 amplifier and 10" Jensen speaker, \$66.50* list.



THE VOICE OF MUSIC

MAIL COUPON FOR SPECIFICATIONS

V-M Corporation, Benton Harbor 10, Michigan
Send full details on the V-M 936HF
and the V-M high fidelity P-A package

NAME _____
FIRM _____
ADDRESS _____
CITY _____ STATE _____

ADVERTISING INDEX

All Channel Antenna Corp.	89
Allied Radio Corp.	7
American Microphone Co.	24
American Phonocorp.	106
Amplifier Corporation of America	134
Arkey Radio Kits, Inc.	93
Astron Corp.	17
Atlas Sound Corp.	143
Audel Publishers	132
Barry Electronics	146
Belden Manufacturing Co.	111
Bell Telephone Labs.	129
Brooks Radio & TV Corp.	100, 101
Burstein-Applebee Co.	128
CBS Hytron (Division of Columbia Broadcasting System)	97
Capitol Radio Engineering Institute	15
Centralab—Div. of Globe Union	18
Century Electronics	144
Channel Master Corp.	22, 23
Chicago Standard Transformer Corp.	108
Cisin, H. G.	142
Cleveland Institute of Radio Electronics	11
Collins Audio Products	94
Commissioned Electronics	110
Concord Radio	133
Cordover & Co., Carl	87
Cornell-Dublier Electric Corp.	110
Corona	8
Coyne Electrical & TV Radio School	117, 125
DeVry Technical Institute	9
Doc's Radio Tools	87
Douglas Instrument Co.	89
Edie Electronics	132
Electro-Voice, Inc.	8
Electronic Chemical Corp.	145
Electronic Instrument Co., Inc.	28, 126, 139, 144
Fair Radio Sales	144
G and H Wood Products Co.	12
General Industries Co.	90
General Test Equipment	87
Gernsback Publications	149
Granco Products, Inc.	133
Haldorson Transformer Co.	130
Harvey Radio Co., Inc.	115
Health Co.	73
Hickok Electrical Instrument Co.	72-83 inclusive
Hudson Specialties	109
Hughes Research & Development Labs.	144
Indiana Technical College	89
Instructograph Co.	99
International Correspondence Schools	13
Jackson Electrical Instrument Co.	116
Kay-Townes Antenna Co.	102, 103
Leotone Radio Corp.	143
Littlefuse, Inc.	105
Mallory & Co., Inc. P. R.	Inside Back Cover
McGraw-Hill Book Co.	145
Moss Electric Distributing Co.	90, 91
National Electronics of Cleveland	137
National Radio Institute	19, 20
National Schools	5
New Jersey Television Supply	139
Opportunity Adlets	113
Oxford Electric Co.	145
Permaflux Corp.	114
Precise Development Corp.	140
Precision Apparatus Co., Inc.	120
Pres-Probe Co.	13
Progressive "Edu-Kits" Inc.	39
Pyramid Electric Co.	85
RCA Institutes, Inc.	27
RCA Victor Division (Radio Corporation of America)	Back Cover
Rad-Tel Tube Co.	121
Ratetone Manufacturing Co.	119
Radio & Electronic Parts Corp.	142

RADIO SCHOOL DIRECTORY

PAGE 147

Candler System Co.	
Capitol Radio Engineering Institute	
Commercial Trades Institute	
Grantham School of Electronics	
Indiana Technical College	
Indianapolis Electronic School	
Milwaukee School of Engineering	
RCA Institutes, Inc.	
Tri-State College	
Valparaiso Technical Institute	
Western Television Institute	

Radio-Television Training Ass'n	25
Raytheon Manufacturing Co.	6
Rider, Inc., John F.	95
Rinehart Books, Inc.	88, 107, 136, 138, 143
Sams & Co., Inc., H. W.	16, 130
Service Instruments Co.	112
Shure Bros., Inc.	16
Simpson Electric Co.	93
Skyline Manufacturing Co.	137
Sprayberry Academy of Radio	71
Stan-Burn Radio & Electronics	135
Standard Coil Products Co.	21
Steve-El Electronics Corp.	120
Stromberg-Carlson Co.	118
Sun Parts Distributors Ltd.	132
Superec Electronics	136
Superior Instrument Co.	123
Supreme Publications	123
Sylvania Electric Products	14
Tah	141, 148
Tallen Co., Inc.	93
Television Communications Institute	108
Teltron Electric Co.	128
Transamerica Electronics	138
Transvision, Inc.	134, 135
Trio Manufacturing Co.	Inside Front Cover, 3
Tung-Su Electric Co.	12
Turner Co.	12
Ultra Audio Broadcasting	142
United Technical Labs.	135
Utah Radio Products Co., Inc.	113
V-M Corporation	146
Video Specialties	113
Waldom Electronics	124
Wen Products Co.	87
Westinghouse Electric Corp.	26
Wheatland Tube Co., Inc.	121
Windsor Electronic Tube Co.	118
Zingo Products	89

Sensational Saving For STANDARD BRAND users

OF THE 5 TOP-LEADING TUBE MANUFACTURERS

- FULLY GUARANTEED
- INDIVIDUALLY BOXED
- FIRST QUALITY

NO SECONDS OR REHASHED "BARGAINS" YOU CAN PLACE YOUR CONFIDENCE IN OUR DEPENDABLE, NEW TUBES.

Tube Orders Over \$25.00, with full remittance, PREPAID to you in U.S.A.

Type	Net	Type	Net	Type	Net
0A2	.90	6AX5GT	.80	12BA6	.65
0A3/VR75	1.03	6B8	.75	12BD6	.75
1A7GT	.77	6B8A	.80	12BE6	.84
1A7GT	.77	6B8B	.80	12BH7	.85
1A7GT	.77	6B8C	.83	12BY7	1.05
1A7GT	.77	6B8D	.89	12CZ7	1.10
1A7GT	.77	6B8E	.89	12DA6	.65
1A7GT	.77	6B8F	.89	12DA7	.64
1A7GT	.77	6B8G	.85	12SF5	.70
1A7GT	.77	6B8H	.85	12SH7	.63
1A7GT	.77	6B8J	.85	12SJ7	.55
1A7GT	.77	6B8K	.85	12SK7	.61
1A7GT	.77	6B8L	.85	12SL7GT	.65
1A7GT	.77	6B8M	.85	12SN7GT	.75
1A7GT	.77	6B8N	.85	12SQ7GT	.55
1A7GT	.77	6B8P	.85	12SR7	.69
1A7GT	.77	6B8Q	.85	12SX7GT	1.10
1A7GT	.77	6B8R	.85	14F7	.75
1A7GT	.77	6B8S	.85	19BG6G	2.05
1A7GT	.77	6B8T	.85	25A5	1.20
1A7GT	.77	6B8U	.85	25B06GT	1.25
1A7GT	.77	6B8V	.85	25L6GT	.62
1A7GT	.77	6B8W	.85	25W4GT	.65
1A7GT	.77	6B8X	.85	25Z5	.70
1A7GT	.77	6B8Y	.85	25Z6GT	.59
1A7GT	.77	6B8Z	.85	28D7	1.55
1A7GT	.77	6B9A	.85	35A5	.62
1A7GT	.77	6B9B	.85	35B5	.60
1A7GT	.77	6B9C	.85	35C5	.62
1A7GT	.77	6B9D	.85	35L6GT	.65
1A7GT	.77	6B9E	.85	35W4	.45
1A7GT	.77	6B9F	.85	35W5	.70
1A7GT	.77	6B9G	.85	35Z7	.75
1A7GT	.77	6B9H	.85	35Z8	.88
1A7GT	.77	6B9I	.85	35Z9	.88
1A7GT	.77	6B9J	.85	35Z10	.88
1A7GT	.77	6B9K	.85	35Z11	.88
1A7GT	.77	6B9L	.85	35Z12	.88
1A7GT	.77	6B9M	.85	35Z13	.88
1A7GT	.77	6B9N	.85	35Z14	.88
1A7GT	.77	6B9P	.85	35Z15	.88
1A7GT	.77	6B9Q	.85	35Z16	.88
1A7GT	.77	6B9R	.85	35Z17	.88
1A7GT	.77	6B9S	.85	35Z18	.88
1A7GT	.77	6B9T	.85	35Z19	.88
1A7GT	.77	6B9U	.85	35Z20	.88
1A7GT	.77	6B9V	.85	35Z21	.88
1A7GT	.77	6B9W	.85	35Z22	.88
1A7GT	.77	6B9X	.85	35Z23	.88
1A7GT	.77	6B9Y	.85	35Z24	.88
1A7GT	.77	6B9Z	.85	35Z25	.88
1A7GT	.77	6B9AA	.85	35Z26	.88
1A7GT	.77	6B9AB	.85	35Z27	.88
1A7GT	.77	6B9AC	.85	35Z28	.88
1A7GT	.77	6B9AD	.85	35Z29	.88
1A7GT	.77	6B9AE	.85	35Z30	.88
1A7GT	.77	6B9AF	.85	35Z31	.88
1A7GT	.77	6B9AG	.85	35Z32	.88
1A7GT	.77	6B9AH	.85	35Z33	.88
1A7GT	.77	6B9AI	.85	35Z34	.88
1A7GT	.77	6B9AJ	.85	35Z35	.88
1A7GT	.77	6B9AK	.85	35Z36	.88
1A7GT	.77	6B9AL	.85	35Z37	.88
1A7GT	.77	6B9AM	.85	35Z38	.88
1A7GT	.77	6B9AN	.85	35Z39	.88
1A7GT	.77	6B9AO	.85	35Z40	.88
1A7GT	.77	6B9AP	.85	35Z41	.88
1A7GT	.77	6B9AQ	.85	35Z42	.88
1A7GT	.77	6B9AR	.85	35Z43	.88
1A7GT	.77	6B9AS	.85	35Z44	.88
1A7GT	.77	6B9AT	.85	35Z45	.88
1A7GT	.77	6B9AU	.85	35Z46	.88
1A7GT	.77	6B9AV	.85	35Z47	.88
1A7GT	.77	6B9AW	.85	35Z48	.88
1A7GT	.77	6B9AX	.85	35Z49	.88
1A7GT	.77	6B9AY	.85	35Z50	.88
1A7GT	.77	6B9AZ	.85	35Z51	.88
1A7GT	.77	6B9BA	.85	35Z52	.88
1A7GT	.77	6B9BB	.85	35Z53	.88
1A7GT	.77	6B9BC	.85	35Z54	.88
1A7GT	.77	6B9BD	.85	35Z55	.88
1A7GT	.77	6B9BE	.85	35Z56	.88
1A7GT	.77	6B9BF	.85	35Z57	.88
1A7GT	.77	6B9BG	.85	35Z58	.88
1A7GT	.77	6B9BH	.85	35Z59	.88
1A7GT	.77	6B9BI	.85	35Z60	.88
1A7GT	.77	6B9BJ	.85	35Z61	.88
1A7GT	.77	6B9BK	.85	35Z62	.88
1A7GT	.77	6B9BL	.85	35Z63	.88
1A7GT	.77	6B9BM	.85	35Z64	.88
1A7GT	.77	6B9BN	.85	35Z65	.88
1A7GT	.77	6B9BO	.85	35Z66	.88
1A7GT	.77	6B9BP	.85	35Z67	.88
1A7GT	.77	6B9BQ	.85	35Z68	.88
1A7GT	.77	6B9BR	.85	35Z69	.88
1A7GT	.77	6B9BS	.85	35Z70	.88
1A7GT	.77	6B9BT	.85	35Z71	.88
1A7GT	.77	6B9BU	.85	35Z72	.88
1A7GT	.77	6B9BV	.85	35Z73	.88
1A7GT	.77	6B9BW	.85	35Z74	.88
1A7GT	.77	6B9BX	.85	35Z75	.88
1A7GT	.77	6B9BY	.85	35Z76	.88
1A7GT	.77	6B9BZ	.85	35Z77	.88
1A7GT	.77	6B9CA	.85	35Z78	.88
1A7GT	.77	6B9CB	.85	35Z79	.88
1A7GT	.77	6B9CC	.85	35Z80	.88
1A7GT	.77	6B9CD	.85	35Z81	.88
1A7GT	.77	6B9CE	.85	35Z82	.88
1A7GT	.77	6B9CD	.85	35Z83	.88
1A7GT	.77	6B9CE	.85	35Z84	.88
1A7GT	.77	6B9CF	.85	35Z85	.88
1A7GT	.77	6B9CG	.85	35Z86	.88
1A7GT	.77	6B9CH	.85	35Z87	.88
1A7GT	.77	6B9CI	.85	35Z88	.88
1A7GT	.77	6B9CJ	.85	35Z89	.88
1A7GT	.77	6B9CK	.85	35Z90	.88
1A7GT	.77	6B9CL	.85	35Z91	.88
1A7GT	.77	6B9CM	.85	35Z92	.88
1A7GT	.77	6B9CN	.85	35Z93	.88
1A7GT	.77	6B9CO	.85	35Z94	.88
1A7GT	.77	6B9CP	.85	35Z95	.88
1A7GT	.77	6B9CQ	.85	35Z96	.88
1A7GT	.77	6B9CR	.85	35Z97	.88
1A7GT	.77	6B9CS	.85	35Z98	.88
1A7GT	.77	6B9CT	.85	35Z99	.88
1A7GT	.77	6B9CU	.85	35Z100	.88
1A7GT	.77	6B9CV	.85	35Z101	.88
1A7GT	.77	6B9CW	.85	35Z102	.88
1A7GT	.77	6B9CX	.85	35Z103	.88
1A7GT	.77	6B9CY	.85	35Z104	.88
1A7GT	.77	6B9CZ	.85	35Z105	.88
1A7GT	.77	6B9DA	.85	35Z106	.88
1A7GT	.77	6B9DB	.85	35Z107	.88
1A7GT	.77	6B9DC	.85	35Z108	.88
1A7GT	.77	6B9DD	.85	35Z109	.88
1A7GT	.77	6B9DE	.85	35Z110	.88
1A7GT	.77	6B9DD	.85	35Z111	.88
1A7GT	.77	6B9DE	.85	35Z112	.88
1A7GT	.77	6B9DF	.85	35Z113	.88
1A7GT	.77	6B9DG	.85	35Z114	.88
1A7GT	.77	6B9DH	.85	35Z115	.88
1A7GT	.77	6B9DI	.85	35Z116	.88
1A7GT	.77	6B9DJ	.		

RADIO SCHOOL DIRECTORY

BUILD your own TV Set

YES, actually build a valuable TV Set right at home. At the same time learn all about installing, repairing, servicing—and get ready for a Big-Pay Job in America's fastest-growing, most exciting industry. The CTI TV Train-at-Home Plan is preparing hundreds for bigger pay TODAY—and a brighter Future TOMORROW. No experience needed. We supply easy-to-understand instructions—made clear with hundreds of charts, diagrams, photos—plus TWENTY KITS of Parts, Professional Equipment and Tools. Get a TV Set to ENJOY. Get set to ENJOY a TV Future. Make money in spare time while taking Course. THOUSANDS SUCCEEDING! So can You. Send today for big FREE Book, "You Can Succeed in Television."

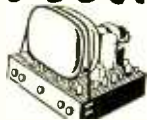

COMMERCIAL TRADES INSTITUTE
Dept. T27-2, 1400 Greenleaf Ave., Chicago 26, Ill.

MORE JOBS than graduates

Demand for our engineering graduates exceeds supply. Effective placement. Study in this world-famed college established 1884. Quarters start March, June, Sept., Jan. Approved for Korean Vets.

Bach. Sc. degree in 27 months

Complete Radio Eng. courses . . . TV, UHF and FM. Also Mech., Civil, Elec., Chem., Aero. and Adm. Eng.; Bus. Adm., Acct. Small classes. Well-equipped labs. Modest costs. Prep. courses. Write Jean McCarthy, Director of Admissions, for Catalog and Campus View Book.

TRI-STATE COLLEGE
2424 College Avenue, Angola, Indiana

TV REPAIRMEN MAKE TOP MONEY!

In just 39 weeks, you can get complete TV service training! Streamlined course gives you all essentials for a good job as service technician. Graduates in great demand; jobs are plentiful in this growing field. Other courses in electronics, radio operation and maintenance. Day or evening classes; modern equipment. Opportunity for employment in local industry.

Write for Catalog 111 Today
INDIANAPOLIS ELECTRONIC SCHOOL
312 E. Washington, Indianapolis 4, Ind.

RADIO ENGINEERING DEGREE IN 27 MONTHS

Intensive, specialized course including strong basis in mathematics and electrical engineering, advanced radio theory and design, television. Modern lab. Low tuition. Self-help opportunities. Also B.S. degree in 27 months in Aeronautical, Chemical, Civil, Electrical, and Mechanical Engineering. G. I. Gov't approved. Enter March, June, September, December. Catalog.

INDIANA TECHNICAL COLLEGE
152 E. Washington Blvd., Fort Wayne 2, Indiana

CODE SENDING RECEPTIVE SPEED

Be a "key" man. Learn how to send and receive messages in code by telegraph and radio. Commerce needs thousands of men for jobs. Good pay, adventure, interesting work. Learn at home quickly through famous Candler System. Quality for Amateur or Commercial License. Write for FREE BOOK.

CANDLER SYSTEM CO.
Dept. 3-B, Box 928, Denver 1, Colo., U.S.A.

RADIO-TV ELECTRONICS

CREI graduates in big demand. Accredited by Engineers Council for Professional Development. New classes start every month. Free placement service for grads. Courses offered—Radio Engineering, Broadcast or TV Engineering, TV, FM, AM Servicing. Write for free catalog. Approved for Vets.

CAPITOL RADIO ENGINEERING INSTITUTE
Dept. RE, 3224—16th St., N.W., Washington 10, D. C.

GET INTO ELECTRONICS

You can enter this uncrowded, interesting field. Defense expansion, new developments demand trained specialists. Study all phases radio & electronics theory and practice: TV; FM; broadcasting; servicing; aviation, marine, police radio. 18-month course. Graduates in demand by major companies. U.S. or equivalent required. Begin Jan., March, June, Sept. Campus life. Write for catalog.

VALPARAISO TECHNICAL INSTITUTE
Dept. C Valparaiso, Ind.



Get Your F.C.C. LICENSE Quickly!

Correspondence or residence preparation for F.C.C. examinations. Results guaranteed.

An FCC commercial operator license means greater opportunities and higher pay. We are specialists in preparing you, in a MINIMUM OF TIME, to pass FCC examinations for all classes of licenses. Beginners get 2nd class license in 5 weeks and 1st class in 3 additional weeks. Write for free booklet.

GRANTHAM SCHOOL OF ELECTRONICS
Dept. 101, 6064 Hollywood Blvd., Hollywood 28, Calif.

RCA INSTITUTES, INC.
A service of Radio Corporation of America
350 West 4th St., New York 14, N. Y.

OFFERS COURSES IN ALL TECHNICAL PHASES OF RADIO, TELEVISION, ELECTRONICS

Approved for Veterans
Write Dept. RC-54 for Catalog

EARN MORE MONEY—BE A PROFESSIONAL TELEVISION SERVICE TECHNICIAN

STEP INTO THE TOP PAY \$5,000—\$10,000 A YEAR CLASS. 7 MONTHS' SHOP TRAINING QUALIFIES YOU.

If you want to reach your goal as a Successful Service Technician you will need plenty of "KNOW HOW" to qualify for the better servicing jobs or profitable shop ownership.

SEND FOR FREE BOOK TODAY!

WESTERN TV offers real experience on live equipment in our BIG SHOPS AND LABORATORIES in the shortest practical time under expert instructors. Graduates are in big demand because they have the "field experience" necessary for immediate "bench" or supervisory positions. You learn every phase of Radio and TV servicing (AM, FM, VHF, UHF). WTI men win fast promotion . . . can demand better pay . . . develop highly profitable businesses of their own with the latest and most PRACTICAL PERSONALIZED TRAINING BEHIND THEM. You concentrate all your time on being a PROFESSIONAL TV SERVICE TECHNICIAN—non-essential math and engineering theory omitted. YOU CAN EARN WHILE YOU LEARN. Special Finance Plan.

APPROVED FOR VETERANS. Find out how you can get into the TOP PAY GROUP—Send for this fact-packed book NOW!

WESTERN TELEVISION INSTITUTE America's Leading Television Servicing School

Western Television Institute Dept. E-2-4
341 W. 18th St., Los Angeles 15, Calif.
Without obligation, please send FREE fully illustrated booklet. (No salesman will call.)

NAME _____ AGE _____
ADDRESS _____
CITY _____ ZONE _____ STATE _____

BECOME AN ELECTRICAL ENGINEER



Bachelor of Science Degree in 36 months.

Major in Electronics or Power. Now, prepare for a career in these rapidly expanding fields.

This school will prepare you to become an engineer, technician or service man. Previous military, academic or practical training may be evaluated for advanced credit.

Enter Both Radio and Television

In 12 months you can attain the Radio-Technician's certificate. An added 6 months course qualifies you for the Radio-TV Technician's certificate and the Degree of "Associate in Applied Science." The Technician's course is the first third of the program leading to a Bachelor of Science Degree in Electrical Engineering with a major in Electronics.

Also offered: 12-month Radio-TV service course; 12-month Electronics or Electro Technician Courses; 6-month Electrical Service Course and 3-month refresher and general preparatory classes.

Terms Open April, July, Sept, January.

Famous for its Concentric Curriculum. Faculty of specialists. 50,000 former students. Annual enrolment from 48 states and 23 overseas countries. Non-profit. 51st year. Courses approved for Veterans. Residence courses only.



MILWAUKEE SCHOOL OF ENGINEERING

MILWAUKEE SCHOOL OF ENGINEERING
Dept. RE-254, 1025 N. Milwaukee
Milwaukee 1, Wisconsin

Send: Free 45-page "Your Career" booklet describing Electrical Engineering Courses; Booklet on Careers in Radio-TV.

I am interested in _____ name of course _____

Name _____ Age _____

Address _____

City _____ Zone _____ State _____

If veteran, indicate date of discharge _____

HI-FI POWER SUPPLY



SOLA constant voltage power transformer, mounted on chassis with (2) actual rectifier sockets.

NEW MFGD BY DUMONT Filter System, 400VDC/250MA to filter system, 5V/6A (30% regulated) and 12.6VCT/6A or 2X 6.3V/6A (common tap). With filter condensers, choke and rectifier tubes. \$18.98

CONDENSER SPECIAL 2 MFD 1000 VDC 330 VAC \$25.00 'CD' MFR Lots of 10

OIL CONDENSERS WAREHOUSE CLEARANCE SALE RECTANGULAR CASE

KITS AND COMPONENTS Oil Condensers Assorted. 5 for \$1.25 Electrolytics Assorted. 5 for 1.25 Silver & mica Cntrs. 15 for 1.25

'TAB' PICK 'EM \$1.00

'TAB' THAT'S A BUY

WAREHOUSE CLEARANCE

Antenna Mast Sections MS49 & MS50 Veeder Root Counter 3 digit 85c; 3 for \$2.50

'LENK' 180 WATT PERFECT BALANCE SOLDERING GUN No other soldering gun offers all these features at any price.

CRYSTAL DIODES 1N21 Lots of 100 40c ea Smaller qty .85c; 10 for \$5.00

OIL CONDENSER SPECIAL 2MFD 600VDC Case dimensions, not including insulators 1/4x1/4x3/4x1/4

TELEVISION ANTENNA

VUE CONICAL Broad response, all channel, powerful for fringe areas. \$8.95 FOLDED DIPOLE HI & low antennae, all channel, sturdy construction. \$4.95

TV & COAX CABLE 300 Ohm Twineax, Heavy duty 65 mil copper TV lead in. per ft. 2c; 100 feet. \$1.39

ONE YEAR GTD PICTURE TUBES 7J7A .95 10B4A .95 12" Glass .12.00

EXECUTIVE DRILL KIT must be for the Engineer or Serviceman. Includes 200H 1/4" Heavy Duty drill with 1/4" HSS bits

DC POWER SUPPLY

0 to 12 VDC/2 Amp. Variable DC supply. Un-cased and completely built-inpt. 115V/60 cy. Usable LAB supply.

FEDERAL 'ITT' SELENIUM BATTERY CHARGER RECTIFIER 10 to 150 VOLT, 100 to 1500 mA. Replaces your old inefficient sulfide rectifier w/new selenium type. SPECIAL. \$11.98

SELENIUM RECTIFIERS 1/2 WAVE FOR RADIO & TV Current List Price Qty

RECTIFIER XFMRs Primary 115V/60 Cyc Secondary 0-9-12-18-24-36V

RECTIFIER CHOKES 4 Amp .07 Hy. 6 Ohm \$7.95 12 Amp .01 Hy. 1 Ohm \$29.95

SELENIUM RECTIFIERS We specialize in Rectifier Power supplies to specifications. Immediate delivery.

Rectifier & Transformer up to 140V/30V 115V/60 cy inputs. up to 28VDC at 4 amps. \$19.98

VARIABLE VOLTAGE TRANSFORMERS POWERSTAT-GR-STACO #10 132V/1.25A/LN \$7.98

RHEOSTAT SALE 2 ohm 50W Model J. 2.25; 5 for 10.00

TUBES

Table of vacuum tubes with part numbers and prices. Includes 0A2, 0A3, 0B2, 0B3, etc.

*From This Special List We Ship \$10.00 and Up Tube Orders At Our Expense (Post-paid) Within Continental Limits of U.S.A.

Table of vacuum tubes with part numbers and prices. Includes 6X5, 6Y6, 6X4, etc.

C 'TAB' FOR HI-FI

TAB308 Pre Amp & Pwr Amp 8 Watt 20 to 20K Sim. Imp. L22 Jewel. \$32.25

AUDIO AMPLIFIERS READY TO GO MODEL AMP 5 HI-FI 5 watt AC Amplifier plus built in Pre-Amp.

100 WATT SEC PHOTOFLASH KIT

Includes DX Flash Lamp, Batted Flash, Flash Lamp Holder & 8" Reflector & Cable, Power Transformer & Ten 100MFD/350VDC .50 W.S. Condensers.

FILAMENT TRANS.

2.5V/2A @ 79c; 2 for \$1.49; 10 for \$6.49

TRANSFORMERS

All 115 V 60 Cyc Input TV & CR pwr Xmfr up to 20" tubes. Hi VOLTS to 20 KV (w/quadrubler CRT) ALL TYPES. PL & FL

'ZIMPHONE' INTERCOM

2 PHONE SET PREPAID CLEAR AS A BELL SPEAK FROM HOUSE TO HOUSE ROOM TO ROOM

AUDIO COMPONENTS

GE RPX041 Cart. Gold Tone \$5.25 GE RPX050 Triple Play Cart 4.98

TAB PHOTOFLASH LAMP

'Tab' Replaces Max. Each US/W SPRG/FA104 150 55.98 No. 1 AMGL0 5804X 100 10.98

FILTER CHOKES

12H/80ma/H'Sid/3KVins 2.25 10H/125ma/UTC/CR/ H'Sid/1KVins

866A KIT and XFORMER

2 Tubes, Sektis, xmfr, 115V/60Cyc Inpt, output 2.5VCT/10A/ \$4.98

TUBE SPECIALS

YOU PICK THEM 39c ea lots of 10 Cracked base or broken key

ELECTROLYTIC CONDENSERS

Your selection of 10 at 59c each or smaller quantity at indicated prices.

INFRARED SNOOPERSCOPE

Image-Converter, Tube Hi-sensitivity am-plied dealer. dia. Willemite screen-data & tube, ea. \$7.98; 2 for \$13.98

STORAGE BATTERIES

#25-2 GE PORTABLE BATT. \$10.00 4V/18AH BATT Gould 2.99

YOU PICK THEM 39c ea

TESTED & 90 DAY GUARANTEED ORDER NOW, WHILE THEY LAST

SPEEDWAY UTILITY KIT

The serviceman's workshop, kit includes 200J Jacob chisel, 1/2" drill, ass'd drill bits

THAT'S 'TAB' THAT'S A BUY

Dept. 2RE 111 LIBERTY STREET, NEW YORK 6, N. Y., U.S.A.

None... in a Million

A well-known TV and radio set manufacturer reports not one field reject during a 12-month period in which he used over 1,000,000 Mallory FP Capacitors. Yes, it's hard to believe but it happened. And it's

Proof Positive of Mallory Capacitor Dependability

Odds are staggering against such a record but they are all on your side... if you use Mallory Capacitors.

You can bet your bottom dollar that jobs stay done when you install Mallory Capacitors. That means no loss of time and money on call-backs!

Don't miss a sure thing. The Mallory FP Capacitor line is complete. There's a rating for every set. They are the only Fabricated Plate Capacitors on the replacement market. And they cost no more than ordinary capacitors.

And be sure to use Mallory Plascaps[®] for plastic tubular replacements. Permanently secured leads... no off-center cartridges... no premature shorts.

Prove to yourself what manufacturers and thousands of servicemen know —
**YOU CAN ALWAYS DEPEND ON
MALLORY CAPACITORS.**



P. R. MALLORY & CO. Inc.
MALLORY

CAPACITORS • CONTROLS • VIBRATORS • SWITCHES • RESISTORS
RECTIFIERS • POWER SUPPLIES • FILTERS • MERCURY BATTERIES
APPROVED PRECISION PRODUCTS

P. R. MALLORY & CO. Inc., INDIANAPOLIS 6, INDIANA

They look alike...

...but what a difference!



These RCA types today give you . . .

RCA receiving tubes provide the superior performance and reliability usually associated with higher priced specialty designed types. That's because RCA receiving tubes are constantly being improved to meet the changing requirements of radio and television applications.

For instance, the RCA-5U4-G features a new electrolytic coating on its channel filament which produces a uniform, hard emitter, leading to greatly increased life over the older version.

Or take the RCA-6W4-GT. This type now uses a new RCA-developed carbonized plate-coating material which has improved heat-dissipating properties, thus contributing to longer tube life and increased reliability.

The RCA-6AL5 now utilizes double helical heaters to insure low hum and pinched cathodes to minimize cathode shift within the mount. These features make possible greatly reduced microphonics.

The superior performance of *regular* RCA receiving tubes—at *regular* prices—eliminates unnecessary call-backs, assures you of greater customer satisfaction, results in increased profits for you.

When you sell a receiving tube, your reputation and profit depend on its *performance* and *reliability*.



So, you just can't afford to buy anything less than the best in receiving tubes . . . and that's RCA.

Longer Life



Superior Performance



At No Extra Cost



RADIO CORPORATION of AMERICA

ELECTRON TUBES

HARRISON, N. J.