

RADIO — ELECTRONICS

DECEMBER 1952

LATEST IN TELEVISION • SERVICING • AUDIO

ANTENNAS FOR THE NEW
U.H.F. TV CHANNELS
See page 4

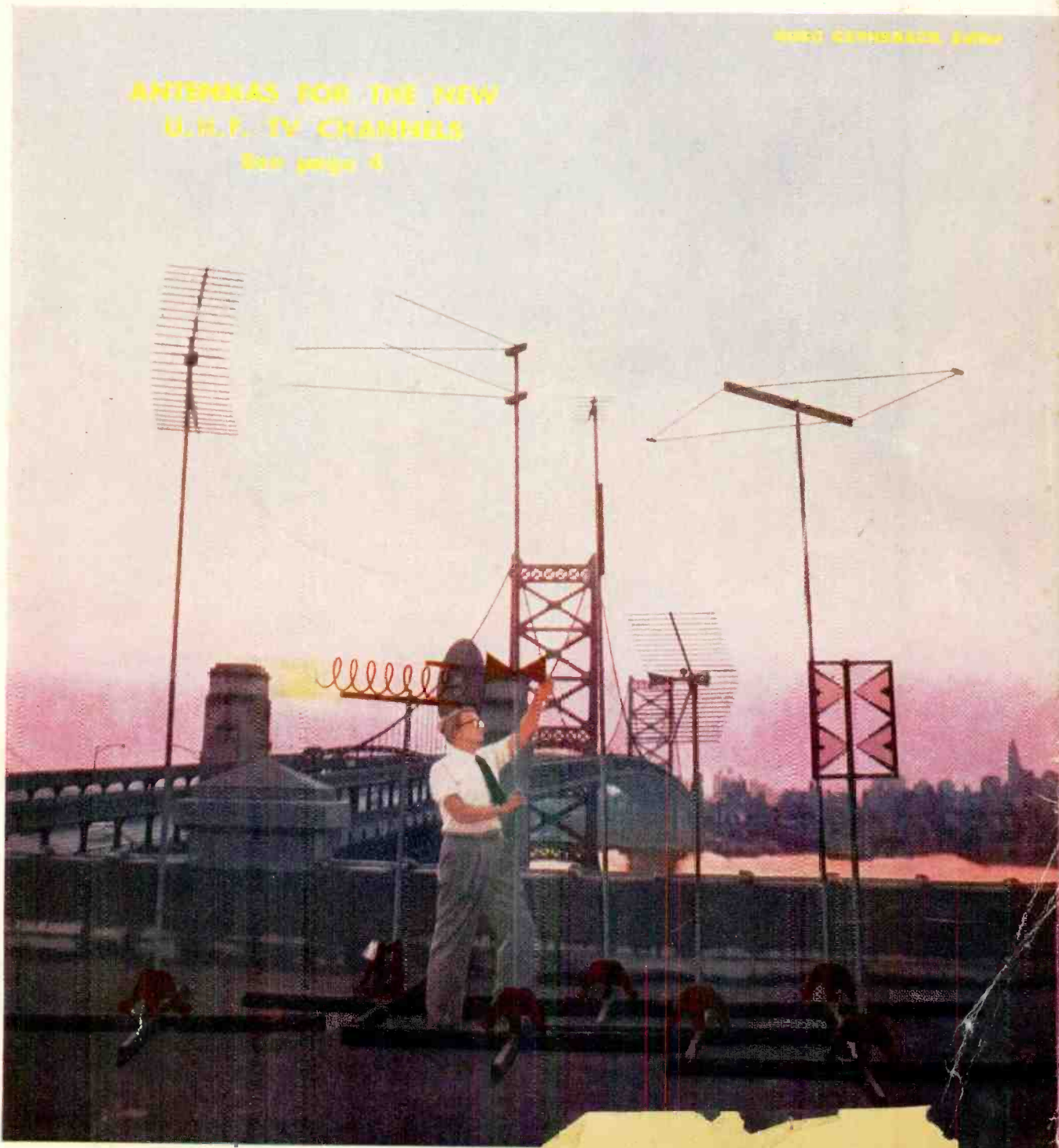

30¢

U. S. and
CANADA

In this issue: Audio Equalizer D
Electronic Flame

EDM C BERGER 11-54
434 OGDEN AVE
JERSEY CITY N J

REVOLUTIONARY



NEW!

Extra long-playing

"Personal" type RCA radio batteries

These RCA long-life batteries have completely revolutionized the design and performance of "personal" type portable radios. They've opened up a brand-new replacement market for you that *never before existed*.

Think of it . . . the revolutionary, new RCA VS216, 6 7/2-volt "B" Battery plays newly designed "personal" type portable radios *twice* as long as ordinary 6 7/2-volt batteries. The new, companion RCA VS236 1 1/2-volt "A" Battery (size G) provides up to *five times* the life of ordinary "A" batteries (size D).

New "personal" type portable radios designed to use one VS216 and two VS236 batteries can play up to *10 times longer without a battery change* than previous models using one 6 7/2-volt "B" battery and one 1 1/2-volt "A" bat-

tery of the ordinary type. This new battery complement offers savings in battery operating cost of as much as 25%!

Secret of the longer useful life of the new RCA VS216 "B" Battery is its use of "crown-type," alkaline dry cells. These cells use their active ingredients more effectively than do ordinary cells—resulting in greatly increased playing time.

The new RCA Victor Super "Personal" radio, model 2B400 series, has been designed to use the new RCA "balanced-life" battery complement. Tens of thousands of these as well as other makes of new "personal" type portables have been sold all over the country, creating a *ready-made* battery replacement business for you. It's alive, real and profitable today . . . ACT NOW. TMK®



RADIO CORPORATION of AMERICA

RADIO BATTERIES

HARRISON, N. J.

HOW YOU CAN *plan* for success IN TV-ELECTRONICS

Send today for this free CREI booklet

You have a greater chance for success if you sincerely believe that success doesn't just *happen*. For every man who reaches the top on luck or looks, tens of thousands come up the planned way. The planned way means outlining your objectives, choosing the means of reaching your objectives, and having a burning ambition to succeed. You must plan your TV-Electronics career carefully, because these are fields where the rewards go to the man with technical knowledge.

When you read CREI's fact-packed booklet, called "Your Future in the New World of Electronics," you will get a complete picture of the electronics industry—where it is going—and how you can go forward with it.

This is a field expanding so rapidly that the most optimistic experts fall short in their predictions.

Consider the 2,980 radio stations and the 111 TV stations now operating plus the 2,073 more made possible by the FCC "unfreeze." Consider the 18,626,860 TV sets and over

100,000,000 radios now in operation. Consider the many positions to be filled by these and other developments. This year CREI is celebrating its 25th Anniversary. Since 1927 CREI has provided thousands of professional radiomen with technical educations. During World War II, CREI trained thousands more for the Armed Services. Leading firms now use CREI courses for group training in electronics at company expense; among them are United Air Lines, Canadian Broadcasting Corporation, Trans-Canada Airlines, Sears Roebuck & Co., Bendix Products Division All-American Cables and Radio, Inc., and RCA-Victor Division and Machlett Laboratories.

CREI courses are prepared by recognized experts, in a practical, easily-understood manner. You get up-to-date study materials; your work is under the personal supervision of a CREI Staff Instructor who *knows* and *teaches* you what industry needs. You choose your own hours of study *at home*. Upon completion you join the many CREI graduates who have found their diplomas keys-to-success in Radio, TV and Electronics. CREI alumni hold many top positions in America's leading firms.

and
find
out!

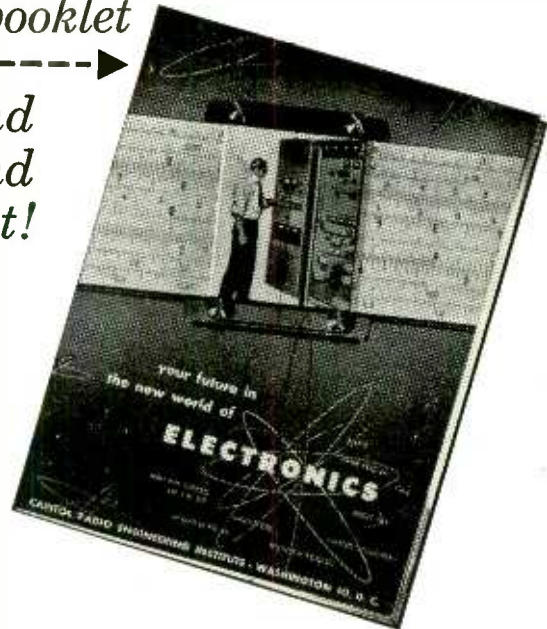

At your service is the CREI Placement Bureau which finds positions for students and graduates. Although CREI does not guarantee jobs, the bureau now has more requests for personnel than it can fill. Talk to men in the field and check up on CREI's high standing in electronics instruction. Determine for yourself right now that your earnings are going to rise with your knowledge—and that you will rise *with* this booming industry. All this CREI offers you, provided you sincerely want to learn. Fill out the coupon and mail it today. We'll promptly send you your free copy of "Your Future in the New World of Electronics." The rest—your future—is up to you.

CREI resident instruction (day or night) is offered in Washington, D. C. New classes start once a month.

VETERANS: If you were discharged after June 27, 1950 let the new G.I. Bill of Rights help you obtain CREI resident instruction. Check the coupon for full information.

MAIL COUPON FOR FREE BOOKLET

CAPITOL RADIO ENGINEERING INSTITUTE

Dept. 1412D, 16th & Park Rd., N.W., Washington 10, D. C.

Send booklet "Your Future in the New World of Electronics" and course outline.

CHECK TV, FM & Advanced AM Servicing Aeronautical Radio
FIELD OF Practical Television Engineering Engineering
GREATEST Broadcast Radio Engineering (AM, FM, TV)
INTEREST Practical Radio Engineering

Name

Street

City Zone State

Check Residence School Catalog GI Information

RADIO-ELECTRONICS is published monthly by Gernsback Publications, Inc., at Erie Ave., F to G Streets, Philadelphia 32, Pa. Entered as second class matter September 27, 1948 at the Post Office at Philadelphia, Pa., under the Act of March 3, 1879. Copyright 1952 by Gernsback Publications, Inc. Text and illustrations must not be reproduced without permission of copyright owners.
POSTMASTER: If undeliverable send form 3578 to: RADIO-ELECTRONICS, 25 West Broadway, New York 7, N. Y.

RADIO - ELECTRONICS

Formerly RADIO-CRAFT • Incorporating SHORT WAVE CRAFT • TELEVISION NEWS • RADIO & TELEVISION*

Hugo Gernsback
Editor-in-Chief

M. Harvey Gernsback
Editorial Director

Fred Shunaman
Managing Editor

Robert F. Scott
W2PWG, Technical Editor

Mortimer Bernstein
Associate Editor

I. Queen
Editorial Associate

Matthew Mandl
Television Consultant

Angie Pascale
Production Manager

Wm. Lyon McLaughlin
Tech. Illustration Director

Sol Ehrlich
Art Director

Lee Robinson
General Manager

John J. Lamson
Sales Manager

G. Aliquo
Circulation Manager

Robert Fallath
Promotion Manager



ON THE COVER

Measurements and tests on new u.h.f. TV antennas on roof of one of the RCA buildings at Camden, N. J. Vertical bars at rear are part of Philadelphia bridge, not a new antenna.

Color original courtesy of RCA

CONTENTS

DECEMBER 1952

Editorial (Page 29)

How to Enter the Electronic Industryby U. S. Department of Labor 29

Audio (Pages 30-41)

Audio Equalizer Designby N. H. Crowhurst 30
Direct-Coupled Amplifierby Wilbur J. Hantz 33
Improved Fidelity in the Portable Phonoby John Horway 34
Push-Pull Driversby George Fletcher Cooper 36
Electronic Music—the Easiest Wayby V. Fastenoekels 39

Theory and Engineering (Pages 42-43)

Electronic Flameby Thomas E. Fairbairn 42

Servicing—Test Instruments (Pages 44-52)

Plated Chassis 44
Low Cost VTVMby Julion P. Freret 46
Confidence is Solubleby James M. Hartley 48
Radio Detonation of Blasting Caps 49
Circuit Shortsby Robert F. Scott 50

Television (Pages 52-59)

More UHF Convertersby Fred King 52
Case Book of a TV Diagnosticianby Larry A. Quinlan 54
TV Service Clinic.....Conducted by Matthew Mandl 56
TV Service Notes, Part II.....by John B. Ledbetter 58

Amateur (Pages 60-62)

A Compact Low-Power Transmitterby Jack D. Gallagher 60

Electronics (Pages 62-76)

Saturated-Core Light Flasherby Erwin T. Levey 62
The Rotalyzer 76

Construction (Pages 78-86)

ROK Receiver.....by Cpl. Milton Kalashion 78
More RF Gain on 160 Metersby James L. Fugote 84

New Design (Pages 87-90)

New Tubes 87

Departments

Radio Month ...	8	Radio-Electronic	Miscellany	122
Radio Business ..	18	Circuits	Communications	124
New Devices ...	92	Try This One ..	Electronic	
With the		Question Box ..	Literature ...	126
Technician ...	98	Technotes	Book Reviews ..	128
New Patents ...	102	People		



MEMBER Audit Bureau of Circulations

Vol. XXIII, No. 15

EXECUTIVE, EDITORIAL and ADVERTISING OFFICES: 25 West Broadway, New York 7, N. Y. Telephone REctor 2-8630. Gernsback Publications, Inc. Hugo Gernsback, President; M. Harvey Gernsback, Vice-President; G. Aliquo, Secretary.

SUBSCRIPTIONS: Address correspondence to Radio-Electronics, Subscription Dept., Erie Avenue, F to G Sts., Philadelphia 32, Pa., or 25 West Broadway, New York 7, N. Y. When ordering a change please furnish an address stencil impression from a recent wrapper. Allow one month for change of address.

SUBSCRIPTION RATES: In U. S. and Canada, in U. S. possessions, Mexico, South and Central American countries, \$3.50 for one year; \$6.00 for two years; \$8.00 for three years; single copies 30¢. All other foreign countries \$4.50 a year, \$8.00 for two years; \$11.00 for three years.

BRANCH ADVERTISING OFFICES: Chicago: 100 E. Ohio St., Tel. Superior 7-1796. Los Angeles: Ralph W. Harker, 1127 Wilshire Blvd., Tel. Madison 6-1271. San Francisco: Ralph W. Harker, 582 Market St., Tel. GARfield 1-2481. FOREIGN AGENTS: Great Britain: Atlas Publishing and Distributing Co., Ltd., London E.C.4. Australia: McGill's Agency, Melbourne. France: Brentano's, Paris 2e. Holland: Trilectron, Heemstede. Greece: International Book & News Agency, Athens. So. Africa: Central News Agency, Ltd., Johannesburg. Capetown; Durban, Natal, Universal Book Agency, Johannesburg. Middle East: Steimatzky Middle East Agency, Jerusalem. India: Broadway News Centre, Dadar, Bombay #14, K. L. Kannappa Mudalliar, Madras 2. Pakistan: Paradise Book Stall, Karachi 3. *Trademark registered U.S. Patent Office.

RADIO-ELECTRONICS

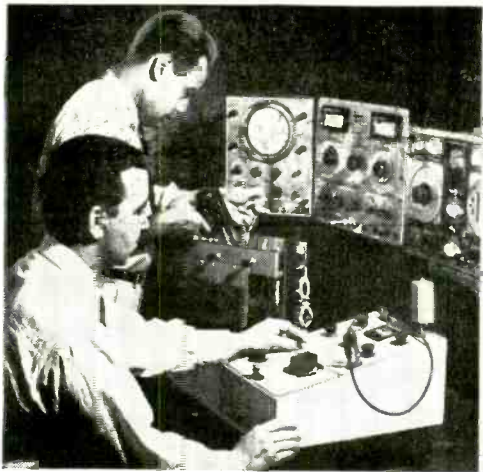

EARN MORE MONEY AS AN EXPERT
 Get Shop-Method Training at Home in **RADIO TELEVISION ELECTRONICS**
One Master Course - One Low Tuition
LEARN ALL PHASES - EARN WHILE YOU LEARN

AS A NATIONAL SCHOOLS GRADUATE THERE'S A PLACE FOR YOU IN THIS EXPANDING INDUSTRY...Never before such a demand for you! For never before such a growing industry as today's Television, Radio and other Electronic fields. This industry needs you... TODAY... and it needs you as a trained man... the kind of man you will be as a National Schools graduate. So don't wait. Start your National Schools training NOW...and enjoy big money, job security, SUCCESS!

LEARN from EXPERTS! BE A SUCCESSFUL MAN YOURSELF! You learn from men who are themselves successful Radio, Television and Electronics technicians. You learn the *practical* way... by *doing*... with equipment we send you. **And you advance quickly, step by step. Get ALL the facts from FREE book and sample lesson. Mail coupon below NOW. Absolutely no obligation.**

You can qualify FAST for these big-pay jobs...plus many more

Radio Station Technician • Your own Sales and Service Shop • District Service Manager • Inspector Technician • Aircraft Radio Inspector • Special Govt. Positions • Service Specialist • Sound Truck Operator • and many others!

ONLY NATIONAL SCHOOLS GIVES YOU THIS PROFESSIONAL MULTI-TESTER



Ready to use. Easy to operate. Light enough to carry on service calls.

DRAFT AGE? National Schools training helps you get into special service classifications—get higher grades, better pay!



NATIONAL SCHOOLS GRADUATES IN BIG DEMAND. You'll find National Schools graduates in good jobs everywhere. For these are the jobs National Schools *trains* you for. Such complete, shop-method home training can be *your* ticket to success...your key to the job happiness you've always wanted. It's up to you. Mail coupon NOW!

FRIENDLY GUIDANCE AS STUDENT AND GRADUATE. Our special Welfare Department is constantly at your service. Helps you with your technical and personal problems. Gives you the benefit of its wide industry contacts and experience in helping you after graduation. **Write National Schools, 4000 South Figueroa St., Los Angeles 37, California.**



All yours at no extra cost!

GET YOUR TRAINING FROM THE RADIO-TV CAPITAL OF THE WORLD

Let National Schools—a *resident* technical trade school for nearly 50 years—train you at home for today's unlimited opportunities in Radio-TV.



NATIONAL SCHOOLS APPROVED FOR G. I. TRAINING
 Los Angeles, Calif. • Est. 1905 • In Canada: 193 Hastings St., Vancouver, B.C.

ACT NOW

YOU GET ALL THE PARTS INCLUDING TUBES for this superheterodyne receiver... and lots of other equipment...to keep!

NATIONAL SCHOOLS, Dept. RG-122
 4000 South Figueroa Street
 Los Angeles 37, California

Mail in envelope or paste on postal card

Send me FREE book "My Future in Radio-Television and Electronics." Also a FREE sample lesson. I understand no salesman will call on me and that there is no obligation.

NAME _____ AGE _____

ADDRESS _____

CITY _____ ZONE _____ STATE _____

VETS! Check here if you are a veteran.

Don't put it off! Mail coupon NOW!

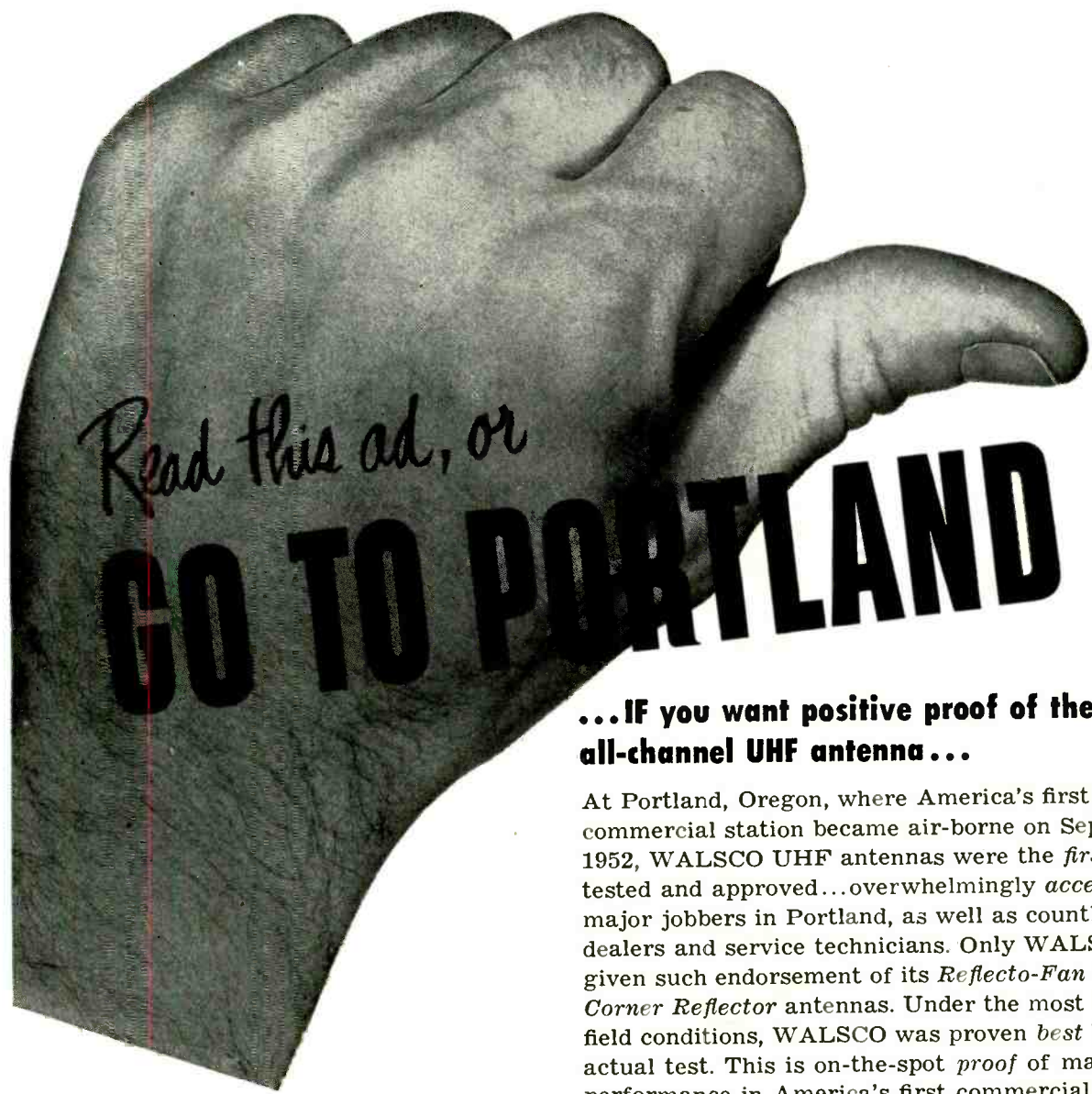

Read this ad, or

GO TO PORTLAND

...IF you want positive proof of the finest, all-channel UHF antenna...

At Portland, Oregon, where America's first UHF commercial station became air-borne on September 20, 1952, WALSCO UHF antennas were the *first* to be tested and approved...overwhelmingly *accepted* by the major jobbers in Portland, as well as countless dealers and service technicians. Only WALSCO was given such endorsement of its *Reflecto-Fan* and *Corner Reflector* antennas. Under the most strenuous field conditions, WALSCO was proven *best* by actual test. This is on-the-spot *proof* of matchless performance in America's first commercial UHF area.

Just mention our name in Portland. You'll get positive assurance that WALSCO UHF antennas are the most efficiently designed...and of sturdier construction. Unconditionally guaranteed for one full year.

WALSCO

UHF

REFLECTO FAN **CORNER REFLECTOR**



**WRITE FOR
COMPLETE INFORMATION**

Walter L. Schott Co.
3225 Exposition Place
Los Angeles 18, California

Gentlemen:
Please send me complete technical information on the new WALSCO UHF antennas...*Reflecto-Fan* and *Corner Reflector*.

Name _____
Address _____
City _____ State _____

Overseas Representative: Ad Auriema, Inc.
89 Broad St., New York 4, N. Y.

RADIO-ELECTRONICS

Prepare Now... in spare time at Home... for a New,

PROFITABLE, INTERESTING FUTURE

TELEVISION RADIO - ELECTRONICS

RADIO CHIEF OF ILE DE FRANCE
FRENCH LUXURY LINER PRAISES D. T. I.

Radio Chief—Jean Desmas Says:

"DeForest's Training, Inc., of Chicago, is known not only throughout Europe, but also in many parts of the world as one of America's finest Television, Radio and Electronics training centers."



JACK DEMPSEY
Former World's Heavyweight Champion
TELLS WHY HE'S PROUD
TO BE WITH **D.T. I.**



Prepare At Home Or In Our Chicago Laboratory!

See for yourself how readily you may prepare at home, or in our modern Chicago laboratories, for a better job or business of your own in one of America's fastest-growing fields—TELEVISION-RADIO-ELECTRONICS.

If you train at home you get (1) the use of a 16-mm. movie projector and 16 reels of animated movies to help you learn important points faster... easier, (2) modern lessons and (3) sixteen shipments of electronic parts enabling you to get valuable practical experience from over 300 projects—including building and keeping the electronic equipment shown below. And upon completing training, you have the optional privilege of building and keeping a big 17-INCH TV set at moderate added cost. Get the full story. Mail coupon today!

- I have been greatly impressed with D.T.I.'s wonderful spirit of friendliness and sincere determination to help its students make good in Television-Radio-Electronics.
- I admire its remarkable 20 year record of helping men build brighter futures.
- I also admire the business policy of its management and the thoroughness of its large faculty of instructors.
- Never have I heard young men praise a school as enthusiastically as do the students and graduates of D.T.I. They are its best boosters.

LAUD D. T. I.'s HOME MOVIES IN CONGRESS

D.T.I.'s remarkable home training benefit of visual training MOVIES has been praised from the floor of the House of Representatives in Washington, D. C. and recorded in The Congressional Record.

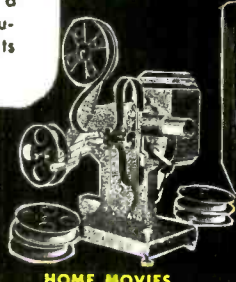

HOME MOVIES

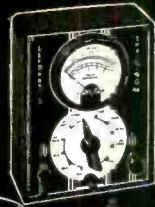

MULTIMETER

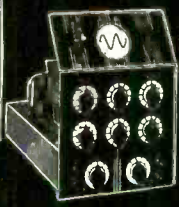

OSCILLOSCOPE



5-TUBE RADIO

R-F SIGNAL GENERATOR



MILITARY SERVICE!

If subject to military service, the information we have for you should prove very helpful. Mail coupon today.



De FOREST'S TRAINING, INC.
AFFILIATED WITH
De VRY Technical INSTITUTE
CHICAGO 14, ILLINOIS



MAIL COUPON TODAY!

Dept. RE-12-1
DE FOREST'S TRAINING, INC.
2533 N. Ashland Ave., Chicago 14, Ill.

I would like your Opportunity News Bulletin showing "89 Ways to Earn Money in Television-Radio-Electronics"; also, the folder showing how I may prepare to get started in this thrilling field.

Name _____ Age _____
 Address _____ Apt. _____
 City _____ Zone _____ State _____

CADMIUM SULPHIDE CRYSTALS are the equal of germanium, selenium, and other semiconductors for rectifier and transistor applications, according to a paper delivered by G. Strull of Northwestern University at the recent National Electronics Conference in Chicago. J. G. Krisilas of American Phenolic Corp. presented data on the use of liquid dielectrics for coaxial cables and fittings. Tests cited by Mr. Krisilas show liquid-insulated cables have eight times the power-handling capacity and half the corona loss of solid-dielectric types.

U.S. AND CANADA radio amateur licenses are now valid in either country. The 1951 radio treaty, now in effect, also extends reciprocal operating privileges to civilian and military aircraft, and to public-utility and private mobile two-way radio installations.

"CINERAMA" MOTION-PICTURE projection system, now drawing capacity audiences in New York City, creates startling realism through the use of a 51-foot-wide semicircular screen, and a multi-channel "stereophonic" sound system. Three film projectors flash overlapping images which fill almost the full field of vision, giving the viewer a sense of actual participation in the scene; while five speaker systems spaced across the width of the panoramic screen, and fed by separate sound tracks, place the apparent source of sound directly at the position of the

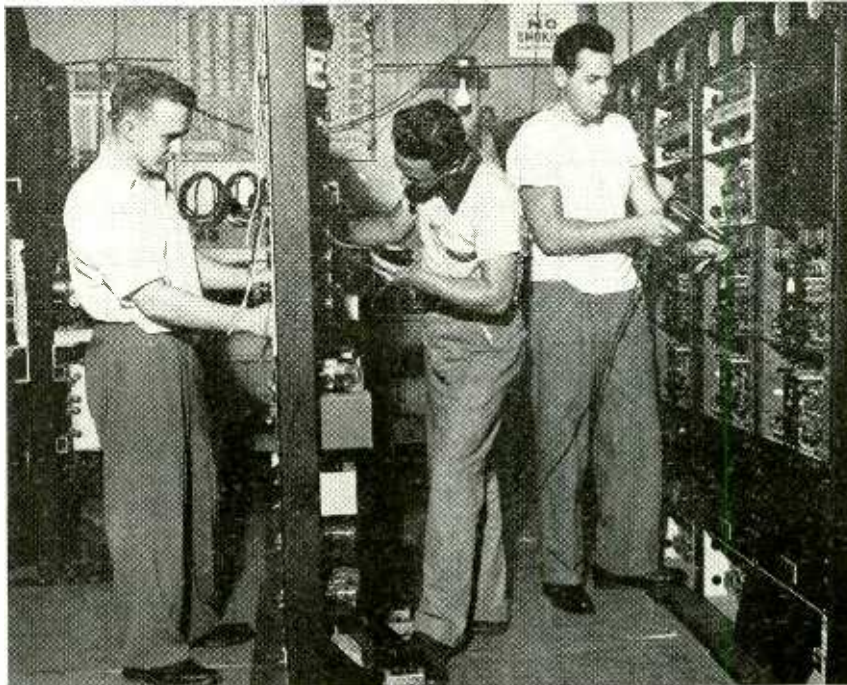

Installing the multi-channel sound system for the first public showing of *Cinerama*.

object. An extra sound track carries the combined effects of all the others as a protection against breakdown in any part of the complex sound system.

The photograph shows part of the multi-channel sound installation. Showings of *Cinerama* have been scheduled for other cities in the near future.

JAPAN BARS U.S. TAPE recorders in patent dispute. Tokyo Tsushin Kogyo (Tokyo Communications Industry) has obtained a court order halting the import, use, or sale of American tape recorders, claiming its Japanese patents—issued in 1940—antedate ours.

MERLIN H. AYLESWORTH, former president of NBC, died September 30 in New York City at the age of 66. An attorney and outstanding utilities executive, Mr. Aylesworth was named president of NBC at its founding in 1926, and was largely responsible for the development of commercially sponsored programs, nation-wide network broadcasting, and the establishment of Radio City in New York as a broadcast center. Following his retirement from NBC in 1936, Mr. Aylesworth became president and chairman of the board of RKO, and later joined the Scripps-Howard newspaper chain as publisher of the New York *World-Telegram*. During the recent war he served as executive consultant to the Office of Inter-American Affairs.

\$200 MILLION YEARLY power bill is TV's boon to the public utilities industry, Dr. Charles B. Jolliffe, RCA vice-president, told a recent conference of utility executives. This represents only receiver consumption, said Dr. Jolliffe, and power companies will benefit still further from increased use of electricity and fuel as families spend more time at home, as well as from new transmitter and studio installations.

VENEZUELA'S FIRST TV station, now under construction in Caracas, the capital, is expected to go on the air in December. The government-operated station, using RCA equipment throughout, will offer cultural programs.

(Please turn to page 14)

Merit's TV full-line offers the most complete line possible for universal replacement plus exact replacements where required. A new Merit TV Replacement Guide No. 405—including universal components and exact replacements for over 6000 models and chassis—can be obtained from your Jobber or by writing:
MERIT COIL AND TRANSFORMER CORP.,
4425 N. Clark Street, Chicago 40.

Merit IF-RF Coils include a complete line of TV replacements.



**MERIT FOR MAXIMUM COVERAGE
WITH MINIMUM STOCK**

New in the Merit line of practical recommendations is the Model HVO-9 AUTOFORMER for exact replacement in RCA Hoffman and Hallicrafters. Designed for picture tubes 21" and up.

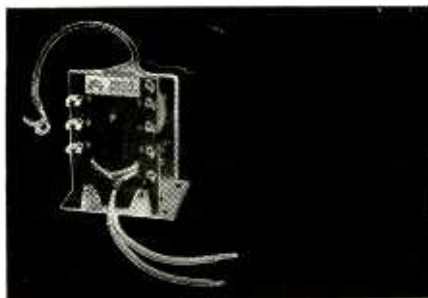

BURTON BROWNE ADVERTISING

FREE

MONEY MAKING FCC Commercial Radio Operator LICENSE INFORMATION

TELLS HOW—

WE GUARANTEE TO TRAIN AND COACH YOU AT HOME IN SPARE TIME UNTIL YOU GET

YOUR FCC LICENSE

If you have had any practical experience—Amateur, Army, Navy, radio repair, or experimenting.

Ours is the only home study course which supplies FCC-type examinations with all lessons and final tests.

TV ENGINEERING INCLUDED IN OUR TRAINING & COACHING

TELLS HOW—

OUR AMAZINGLY EFFECTIVE JOB-FINDING SERVICE HELPS CURE STUDENTS GET BETTER JOBS. HERE ARE JUST A FEW RECENT EXAMPLES OF JOB-FINDING RESULTS:

GETS CIVIL SERVICE JOB

"Thanks to your course I obtained my 2nd phone license, and am now employed by Civil Service at Great Lakes Naval Training Station as an Equipment Specialist."
Kenneth R. Leiser, Fair Oaks, Md., Del., McHenry, Ill.

GETS STATE POLICE JOB

"I have obtained my 1st class ticket (thanks to your school) and since receiving same I have held good jobs at all times. I am now Chief Radio Operator with the Kentucky State Police."
Edwin Healy, 264 E. 3rd St., London, Ky.

GETS BROADCAST JOB

"I wish to thank your Job-Finding Service for the help in securing for me the position of transmitter operator here at WCAE, in Pittsburgh."
Walter Koschik, 1442 Ridge Ave., N. Braddock, Pa.

GETS AIRLINES JOB

"Due to your Job-Finding Service, I have been getting many offers from all over the country, and I have taken a job with Capital Airlines in Chicago, as a Radio Mechanic."
Harry Clare, 4537 S. Drexel Blvd., Chicago, Ill.

TELLS HOW—

EMPLOYERS MAKE JOB OFFERS LIKE THESE TO OUR GRADUATES EVERY MONTH!

Letter from Chief Engineer, Broadcast Station, North Carolina. "Need men with radiotelephone 1st class licenses, no experience necessary. Will learn more than at average station for we are equipped with Diesel Electric power, transmitting and studio equipment."

Telegram from Chief Engineer, Broadcast Station, Wyoming. "Please send latest list available first class operators. Have November 10th opening for two combo men."

Letter from Chief Engineer, Broadcast Station, Texas. "Please send list of latest licensed graduates."

These are just a few of the examples of the job offers that come to our office periodically. Some licensed radioman filled each of these jobs; it might have been you!

HERE IS YOUR GUARANTEE

If you fail to pass your Commercial License exam after completing our course, we guarantee to continue your training without additional cost of any kind, until you successfully obtain your Commercial license, provided you first sit for this examination within 90 days after completing your course.

**ACT NOW!
Get All 3 FREE**

HERE'S PROOF FCC LICENSES ARE OFTEN SECURED IN A FEW HOURS OF STUDY WITH OUR COACHING AT HOME IN SPARE TIME:

Name and Address	License	Lessons
Lee Worthy, 2210 1/2 Wilshire St., Bakersfield, Cal.	2nd Phone	16
Clifford E. Vogt, Box 1016, Dania, Fla.	1st Phone	20
Francis X. Foerch, 38 Beucier Pl., Bergenfield, N. J.	1st Phone	38
S/Sgt. Ben H. Davis, 317 North Roosevelt, Lebanon, Ill.	1st Phone	28
Albert Schoell, 110 West 11th St., Escondido, Cal.	2nd Phone	23

CLEVELAND INSTITUTE OF RADIO ELECTRONICS

Carl E. Smith, E.E., Consulting Engineer, President
Desk RE-47, 4900 Euclid Bldg., Cleveland 3, Ohio



Your FCC ticket is Recognized in All Radio Fields as Proof of Your Technical Ability.

MAIL COUPON NOW

Cleveland Institute of Radio Electronics
Desk RE-47—4900 Euclid Bldg., Cleveland 3, Ohio
(Address to Desk No. to avoid delay.)

I want to know how I can get my FCC Ticket in a minimum of time. Send me your FREE booklet, "How to Pass FCC License Examinations" (does not cover exams for Amateur License), as well as a sample FCC-type exam and the amazing new booklet, "Money-Making FCC License Information."

Tell me about your Television Engineering Course.

Name.....
Address.....
City..... Zone..... State.....
Paste on 2 cent postcard or send air mail.

1902-1952



**ELECTRICAL AND ELECTRONIC
WIRES AND CABLES**

*—For the Automotive, Appliance, Motor,
Radio, and Television Industries*

**Belden Manufacturing Company
Chicago 80, Illinois**

RADIO-ELECTRONICS

THE ONLY COMPLETE CATALOG FOR EVERYTHING IN TELEVISION, RADIO AND INDUSTRIAL ELECTRONICS

**your 1953
ALLIED free!
236-PAGE CATALOG
complete...value-packed**

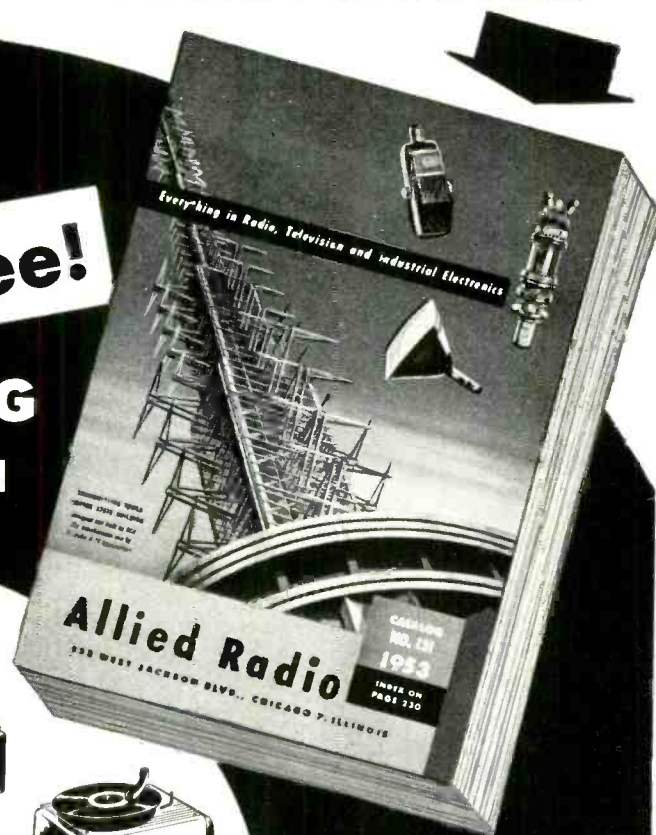

Send for it Today!

Here's the *one* authoritative, complete Buying Guide to *Everything in Electronics*—packed with the world's largest selections of quality equipment at lowest, money-saving prices. See the latest in TV, AM and FM receivers; High-Fidelity Custom Sound components; latest P.A. Systems and accessories; recorders; Amateur receivers, transmitters and station gear; specialized industrial electronic equipment; test instruments; builders' kits; huge listings of parts, tubes, tools, books—the world's *most complete stocks* of quality equipment.

ALLIED gives you every buying advantage: speedy delivery, expert personal help, lowest prices, liberal time payment terms, assured satisfaction. Get the latest 1953 ALLIED Catalog. Keep it handy—and save time and money. Send for your FREE copy today!

the world's largest stocks

- TV and Radio Parts
- Test Instruments
- Hi-Fi and P.A. Equipment
- Television & Home Radios
- Recorders and Supplies
- Amateur Station Gear
- Builders' Supplies
- Equipment for Industry

quick, expert service

EVERYTHING IN ELECTRONICS

ALLIED RADIO
World's Largest Radio Supply House

free

Send Today for Radio's Leading Buying Guide

EASY-PAY TERMS

Take advantage of ALLIED'S liberal Easy Payment Plan—Radio's best terms—only 10% down, 12 months to pay—no interest if you pay in 60 days. Available on Hi-Fi and P.A. units, recorders, TV chassis, test instruments, Amateur gear, etc.

TV & HI-FI SPECIALISTS

To keep up with developments in TV and High-Fidelity, look to ALLIED! Count on us for all the latest releases and largest stocks of equipment in these important fields. If it's anything in Television or High-Fidelity equipment—we have it in stock!

ALLIED RADIO CORP., Dept. 2-M-2
833 W. Jackson Blvd., Chicago 7, Illinois

Send FREE 236-Page 1953 ALLIED Catalog

Name _____

Address _____

City _____ Zone _____ State _____

This TV team is what you need



Redskin

MOLDED TUBULAR
CAPACITOR

Chieftain

DRY ELECTROLYTIC
CAPACITOR

for sure television capacitor replacements

When you replace television capacitors you want to *know* that your replacements won't cause "headaches" in unnecessary call-backs because of premature failure. You *can* be sure that these Sangamo TV replacements will live up to their reputation. Used as original equipment, they're "tops" for dependable replacements.



THE REDSKIN is a molded paper tubular, especially adapted to television. It's easy to work with—the leads are securely imbedded in a hard plastic case and have been especially designed to resist breakage. The REDSKIN is strong and it's dependable at 85° C, even under extreme humidity.

THE CHIEFTAIN is a dry electrolytic that fits anywhere! Tiny, but durable, it is ideal for application in tight spots beneath a chassis. Bare tinned-copper wire leads make it easy to mount. Maintains uniform capacity when subjected to high ripple currents at 85° C.

REMEMBER . . . these are only two of a complete line of mica, paper and electrolytic capacitors that will take care of practically any replacement requirement in the radio and television field.



Those who know



...choose Sangamo

SANGAMO ELECTRIC COMPANY

MARION, ILLINOIS

for the ultimate **in sight and sound**
Baline[™]

5 and 10 ELEMENT YAGIS

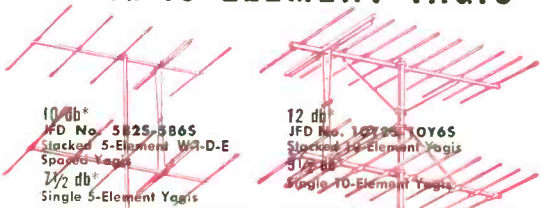

10 db*
 JFD No. 5825-5865
 Stacked 5-Element W.D.E.
 Spaced Yagis

12 db*
 JFD No. 10Y25-10Y65
 Stacked 10-Element Yagis
 Spaced Yagis

1 1/2 db*
 Single 5-Element Yagis
 *Gain over a tuned folded dipole, tested and attested to by the Hazeltine Corporation, leading electronic research laboratory.

Single JFD 10-Element High-Band BALINE Yagis

Channels	Models	List Price
7-13	10Y7-10Y13	\$13.85

Single JFD 10-Element Low-Band BALINE Yagis

Channels	Models	List Price
2	10Y2	\$31.85
3	10Y3	
4	10Y4	\$28.45
4 and 5	10Y45	\$33.90
5	10Y5	\$28.45
6	10Y6	\$25.70

Stacked JFD 10-Element BALINE Yagis

Channels	Models	List Price
2	10Y25	\$63.70
3	10Y35	
4	10Y45	\$56.90
4 and 5	10Y455	\$67.80
5	10Y55	\$56.90
6	10Y65	\$51.40
7-13	10Y75-10Y135	\$27.70

Include JFD Baline Matching Transformers at No Extra Charge

Single JFD 5-Element High-Band BALINE Yagis

Channels	Models	List Price
7-13	587-5813	\$ 7.50
7 and 9	5879	\$10.75

Single JFD 5-Element Low-Band BALINE Yagis

Channels	Models	List Price
2	582	\$17.60
3	583	
4	584	\$16.65
4 and 5	5845	\$22.05
5	585	\$16.65
6	586	\$15.85

Stacked JFD 5-Element BALINE Yagis

Channels	Models	List Price
2	5825	\$35.20
3	5835	
4	5845	\$33.30
4 and 5	58455	\$44.10
5	5855	\$33.30
6	5865	\$31.70
7-13	5875-58135	\$15.00
7 and 9	58795	\$21.50

Include JFD Baline Matching Transformers at No Extra Charge

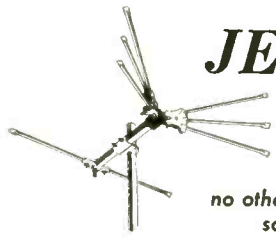

JETENNA[™]

*no other fan conical assemblies
 so fast, performs so well!*

Series with 1" seamless aluminum square crossarm and seamless aluminum elements reinforced with heat-treated aluminum dowels.

No. JeT160	Single Bay	Up to 8.8 db*	\$12.50 List
No. JeT161	2 Bay	Up to 12.5 db*	\$26.40 List
No. JeT164	4 Bay	Up to 15.5 db*	\$56.80 List

Series with 1" seamless aluminum square crossarm and butt-seam aluminum elements with heat-treated aluminum dowels.

No. JeT660	Single Bay	Up to 8.8 db*	\$ 9.75 List
No. JeT661	2 Bay	Up to 12.5 db*	\$20.70 List
No. JeT664	4 Bay	Up to 15.5 db*	\$45.40 List

*Performance tested and figures verified by the Hazeltine Corporation, Little Neck, N. Y., World Famous Research Laboratory.

JFD MFG. CO. BROOKLYN 4, N. Y. BENSONHURST 6-9200

*World's Largest Manufacturer of
 TV Antennas and Accessories*

**REGISTERED
 TRADEMARK



BALINE AND JETENNA INSPIRED EARRINGS

VITAL BOOKS FOR THE TV Service Technician

"Servicing TV in the Customer's Home"

Saves you time, work and chassis-hauling on outside TV service calls. Shows you how to make successful repairs on the spot using these methods: employing VTVM and capacitor probe to trace down trouble; "tube-pulling" to diagnose trouble by observing audio and picture effects; performance tests through analysis of test pattern; adjustment techniques developed for field servicing. Saves time, avoids chassis removal. 96 pages, 5½ x 8½".
ORDER TC-1. Only \$1.50



"Making Money in TV Servicing"

Tells how to start and operate a profitable TV service shop. Covers: overall planning, initial investment, selecting location, finances, budget control, work control, overhead, service charges, purchasing, operating and personnel problems, service contracts, customer relations, collections, advertising, etc. Written by a successful authority in the TV service field—sound, practical advice. 136 pages, 5½ x 8½".
ORDER MM-1. Only \$1.25



"Television Antennas" New 2nd Edition

A complete treatment of TV receiving antennas, based on actual field experience. Shows how to select proper antennas for given locations; explains how to install and solve troubles. Chapters on: antenna principles; construction; analysis of all commercial types; full installation data and short-cut hints; TV antenna problems and trouble-shooting. Fully illustrated. 224 pages, 5½ x 8½".
ORDER TAG-1. Only \$2.00



"Television Tube Location Guides"

VOL. 3. Shows tube positions and functions in hundreds of important TV sets. Helps save servicing time. Often, looking at the picture or listening to the sound, provides the clue to the trouble. Frequently, a tube failure is the cause. This guide, with its clear, accurate tube placement and function diagrams, makes trouble diagnosis and tube replacement quick and easy, without removing chassis. 192 pages. All new diagrams continuing coverage from Vol. 2.
ORDER TGL-3. Only \$2.00



VOL. 2. Over 200 pages of tube placement diagrams not included in Vols. 1 and 3.
ORDER TGL-2. Only \$2.00

VOL. 1. Over 200 pages of diagrams not in Vols. 2 and 3.
ORDER TGL-1. Only \$1.50

"Photofact Television Course"

A full, easy-to-understand explanation of TV principles, operation and practice. Covers Cathode Beam Formations and Control, Beam Deflection Systems, Beam Mod. and Synch.; analyzes CR tubes, camera tubes, voltage supplies, saw-tooth generators, sync. circuits, control functions, antenna circuits, RF input tuning, IF systems, AGC, DC restoration, etc.; with full bibliography and glossary. 208 pages, 8½ x 11".
ORDER TV-1. Only \$3.00



HOWARD W. SAMS & CO., INC.

Order from your Parts Jobber today, or write direct to Howard W. Sams & Co., Inc. 2205 East 46th Street, Indianapolis 5, Ind.

My (check) (money order) for \$..... enclosed. Send the following books:

TC-1 MM-1 TAG-1
 TGL-3 TGL-2 TGL-1 TV-1

Name.....

Address.....

City..... Zone..... State.....

THE QUARTER CENTURY Wireless Association, an organization of radio amateurs who have been licensed for 25 years or more, will hold its fifth anniversary dinner meeting at 7 p.m., Friday, December 5, at the historic Fraunce's Tavern, in New York City. The Association, founded only five years ago, now has over 550 members.

NEW LEAD-IN FOR U.H.F.-TV installations, developed jointly by RCA and Anaconda, has unique construction that gives it low losses and high resistance to weathering and abrasion. Each Copperweld conductor floats on a spiral polyethylene thread inside a sleeve of the same material. The sleeves



are supported and spaced only by point contact with each other and with bosses molded in the corners of the rectangular outer jacket. Known as ATV-270, the new line is ½ inch wide and ⅜ inch thick, has a characteristic impedance of 270 ohms, with losses of 3.6 db per 100 feet at 500 mc, and 5.1 db per 100 feet at 900 mc.

ELECTRONIC INSTRUMENTS for medical research and therapy, and developments in the use of various forms of atomic energy in medicine were to be discussed by leading scientists, engineers, and physicians at the fifth annual AIEE Conference on Electronic Instrumentation and Nucleonics in Medicine. The conference was to meet November 24 and 25, at the Hotel New Yorker in New York City.

RECTANGULAR TUBES now make up 99% of the total output of TV kinescopes, according to the report of the Radio-Television Manufacturers Association for August, 1952. Tubes 18 inches and larger made up 68% of the total, and practically all were 16 inches or larger.

MUSIC REPRODUCTION from the viewpoints of the musician, scientist, and home listener, is the subject of a series of monthly lecture-demonstrations being given at the Engineering Societies Building in New York City. The series started in November and will run till April. It is sponsored by the Basic Science Division of the AIEE.

A COMPUTER CONFERENCE sponsored jointly by the AIEE, IRE, and ACM (Association for Computing Machinery) will be held December 10, 11, and 12, at the Park Sheraton Hotel in New York City. Eighteen papers on computer input and output equipment will be presented during the three-day conference.

ELECTION RETURNS, aided by electronics, reached voters sooner this year than four years ago. Electronic computers, set up in the central studios of the larger radio networks, added and

tabulated the vote at a rate exceeding that which has been possible in any previous election.

According to E. J. Quinby, director of research of the Monroe Calculating Machine Co., which supplied the computers used by NBC, the use of electronic computing equipment also makes reports on trends—calculated from all the significant factors—possible with a speed and completeness never before known. Heretofore intuition has been a large factor in such reports, as tabulation and study of even a fraction of the pertinent data would take much more than the available time.

ELECTRONIC SCALES, often used to measure weights of moving railroad cars, have been adapted to highways by engineers of the U. S. Bureau of Public Roads. Gross weight, speed, axle loads, and axle spacings are measured in a fraction of a second when a truck rolls across an inconspicuous platform in the road.

Strain gauges (wires of known resistance) change value when stretched or compressed by the weight of the vehicle. Changes are recorded instantly on the screen of a calibrated oscilloscope.

At present, a six-man party equipped with portable loadometers can weigh only about 200 trucks in eight hours, at a cost of about \$125. Truckers often take roundabout routes to avoid being delayed at a weighing station.

With the electronic scales, trucks can be weighed without causing traffic tie-ups, and overloaded trucks can be spotted quickly.

EDUCATIONAL TV on a national educational network is believed possible in 1953, according to George Probst, chairman of the Chicago Committee on Educational Television. A conference of educators from nineteen states was called to consider the plan of a committee that had been named by Mayor Joseph M. Darst, of St. Louis. The conference commended the FCC for tentatively setting aside 209 channels for educational use. Mayor Darst warned that unless some use is made soon of the channels they might be "forever lost to education."

Raymond H. Wittcoff, St. Louis manufacturer, chairman of the Mayor's Committee on Educational Television, and Mr. Probst were named co-chairmen of an eleven-member committee to formulate a working plan for the network before summer.

HI-FREQUENCY TRANSISTORS are now a practical possibility, according to the results of recent research. RCA has recently announced the development of experimental transistors that operate "at frequencies well up in the 10-200-mc band, and one of which reached a frequency as high as 225 mc." Thus they are suitable for TV and FM bands. B. N. Slade, transistor engineer for RCA, has discovered that frequency response depends on the spacing between the contact points and also on the resistivity of the germanium crystal. END

NOW

MORE TV SET OWNERS ENJOY BETTER TELEVISION with B-T UNIT SYSTEMS



More and more SERVICE TECHNICIANS are using the B-T UNIT SYSTEM to plan and install Master TV Systems for VHF and UHF, for 1 Set or for 2000, and without outside engineering assistance. And today hundreds of thousands of set owners enjoy the benefits of Better Television

The B-T UNIT SYSTEM was designed expressly for the Service-Technician to help him meet the various problems which arise in his work. The B-T UNITS are intended for use wherever the Technician finds any one or all of the following requirements to exist: Amplifying Weak Signals . . . Handling Multi-directional Signals without a Rotator . . . Multi-set Distribution from a Single or Multiple Antenna Installation. (See Typical Applications)

B-T UNITS include:

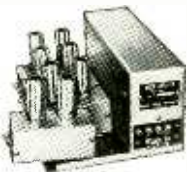

MIXER AMPLIFIER MA-4

- Basic Chassis and Power Supply **\$52.50**
- Individual Channel Plug-in Amplifier Strips **\$19.50**
- UHF Conversion Strip To be announced

DISTRIBUTION AMPLIFIER DA-8

No Loss Distribution to 8 Sets **\$87.50**



DISTRIBUTION AMPLIFIER DA-2

No Loss Distribution to 2 Sets **\$39.50**

COMMERCIAL ANTENSIFIER CA-1

All Channel Line Amplifier—27db Gain **\$77.50**



The B-T UNIT SYSTEM is the result of exhaustive study projects conducted by Blonder-Tongue Laboratories, whose research facilities are entirely and continuously devoted to Better Television. All B-T UNITS are broad band, and require no channel tuning or band-switching.

TYPICAL APPLICATIONS

FOR USE	MA-4 plus Individual Channel Strips	CA-1 All Channel Line Amplifier	DA-8 Each Feeds 8 Sets	DA-2 Each Feeds 2 Sets
WEAK SIGNALS	✓	OR ✓		
MULTI-SET DISTRIBUTION			✓	✓
MULTI-ANTENNA INSTALLATIONS	✓			
COMMUNITY TV SYSTEMS	✓	✓	✓	✓

NOTE: These Units may be used alone or in any number of combinations. See Your Distributor, or Write to B-T Service Department for full specifications of B-T Units and Accessories.

Standard RTMA Warranties Apply



BLONDER-TONGUE LABORATORIES, INC.
Westfield, New Jersey

Prices shown are list

YOU

make more money
when you replace with

RAYTHEON PICTURE TUBES



RAYTHEON PICTURE TUBES
GIVE YOU ALL THESE ADVANTAGES:

A brand new tube — Raytheon makes only new tubes of finest quality. Raytheon Picture Tubes have new glass, new guns, new screens.

Top quality — Raytheon Picture Tubes are the precision products of a multi-million dollar concern that has specialized in the design, development and manufacture of only top quality electron tubes for more than 26 years. During all this time RAYTHEON has never compromised with quality.

A thoroughly tested tube — *Raytheon Picture Tubes* and their components are given *101 rigid quality tests and checks* to insure electrical and mechanical perfection.



Right... for Sight!

An established brand name — Raytheon Picture Tubes don't need to be "sold" to your customers — thanks to Raytheon's national advertising and reputation for making only the finest quality tubes.

Service — *Raytheon Picture Tubes* are readily available through your Raytheon Tube Distributor.

A 1-year warranty — *Raytheon Picture Tubes* are guaranteed for 1 year from date of installation — a warranty backed by Raytheon — one of America's leading tube manufacturers.

THESE RAYTHEON PICTURE TUBE
ADVANTAGES ADD UP TO:

Satisfied customers — Raytheon Picture Tubes will give your customers the finest picture, the finest performance possible. They'll build your reputation as a competent and thoroughly dependable Service Dealer — put you in line for repeat business and the business of your customers' friends.

More profit! — You'll save time on replacement jobs when you use *Raytheon Picture Tubes* because you work with complete confidence that their quality is uniform and will complement your skills. Saving time means more profit for you.

RAYTHEON MANUFACTURING COMPANY

Receiving Tube Division

Newton, Mass., Chicago, Ill., Atlanta, Ga., Los Angeles, Calif.

RAYTHEON MAKES ALL THESE

RECEIVING AND PICTURE TUBES • RELIABLE SUBMINIATURE AND MINIATURE TUBES • GERMANIUM DIODES AND TRANSISTORS • WACCELONIC TUBES • MICROWAVE TUBES



Excellence in Electronics

RADIO-ELECTRONICS

Here's your Opportunity



to prepare for a good job or a business of your own in TV SERVICING

There are today more good jobs open in TV Servicing than there are trained and experienced men to fill them. Yes, thousands of opportunities exist now for good-pay jobs offering employment security for years and years to come. Thousands of TV Servicing jobs are going begging. Do you want one of them?

Experts agree, that because of the critical shortage of trained and experienced TV Servicemen, and the tremendous future growth of the industry, no vocational field today offers more opportunities than TV Servicing.

The Big New Industry with a Great Future

Television is just in the beginning stages of its big industrial boom. Look at these amazing facts:

- Lifting the freeze on new TV stations will open many new TV areas and will improve the coverage of existing areas. The result will be an enormous demand for TV receivers.
- Within a few years over 1000 TV stations will be telecasting compared with 108 TV stations now on the air.
- Nearly one-half of all families living within the present TV areas do not yet own TV receivers.
- The new trans-continental video network plus better and more interesting programs plus larger viewing screens and color TV will increase the installation of new receivers, will induce present owners of 12-inch and smaller size viewing screens to buy newer model receivers.
- The power increases of many existing stations and improved reception range of current receivers will result in receivers being installed and serviced in the fringe areas of present stations.
- Under the FCC proposal, over 70 per cent of all communities will be served by UHF channels exclusively. This means TV servicemen must know UHF receivers before the new UHF stations in their area are opened.
- No one yet knows how great the industrial TV market will be.

RCA Institutes Home Study Course prepares you for a Career in TV Servicing

The addition of the RCA Institutes TV Service Training to your present radio-electronics experience will qualify you to step out and grasp the golden opportunities that now exist in television—America's fastest growing industry.

Learn at home—in your spare time—while you study the practical *how-to-do-it* techniques with *how-it-works* information. Easy-to-read and easy-to-understand lessons under the supervision of RCA engineers and experienced instructors quickly train you to qualify for the many good jobs now waiting for trained TV servicemen. Don't pass up this lifetime opportunity for financial security and a bright future in TV. Learn TV Servicing from RCA—pioneers and leaders in radio, television and electronic developments.

RCA Institutes conducts a resident school in New York City offering day and evening courses in Radio and TV Servicing, Radio Code and Radio Operating, Radio Broadcasting, Advanced Technology. Write for free catalog on resident courses.

Send for FREE BOOKLET

Mail the coupon—today. Get complete information on the RCA INSTITUTES Home Study Course in Television Servicing. Booklet gives you a general outline of the course by units. See how this practical home study course trains you quickly, easily. Mail coupon in envelope or paste on postal card.

MAIL COUPON NOW!

RCA INSTITUTES, INC., Home Study Department RE-1252
350 West Fourth Street, New York 14, N. Y.

Without obligation on my part, please send me copy of booklet "RCA INSTITUTES Home Study Course in TELEVISION SERVICING." (No salesman will call.)

Name _____ (please print)

Address _____

City _____ Zone _____ State _____



RCA INSTITUTES, INC.
A SERVICE OF RADIO CORPORATION OF AMERICA
350 WEST FOURTH STREET, NEW YORK 14, N. Y.

Complete control of materials and manufacturing procedures



makes Tung-Sol Tubes dependable!

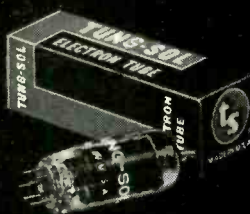

You can build a reputation on Tung-Sol Quality

TUNG-SOL
RADIO, TV TUBES, DIAL LAMPS

TUNG-SOL ELECTRIC INC., Newark 4, N. J.
Sales Offices: Atlanta • Chicago • Culver City
Dallas • Denver • Detroit • Newark

Tung-Sol makes All-Glass Sealed Beam Lamps, Miniature Lamps, Signal Flashers, Picture Tubes, Radio, TV and Special Purpose Electron Tubes.



BAROMETER of the PARTS INDUSTRY

During October, 66 of the leading 400 manufacturers of radio-television-electronic parts and equipment made changes in their lines. Actually there was an increase in "change activity" as compared to September. In price revisions by the number of manufacturers and products affected, the following summary illustrates the comparative trend for the months of September and October.

	No. of Manufacturers	
	September	October
Increased prices	6	13
Decreased prices	8	11

	No. of Products	
	September	October
Increased prices	454	68
Decreased prices	21	49

For a summary of the most active product categories, see the following table:

Product Group	Increased Prices		Decreased Prices		New Products		Discontinued Products	
	No. of Mfrs.	No. of Products	No. of Mfrs.	No. of Products	No. of Mfrs.	No. of Products	No. of Mfrs.	No. of Products
Antennas & Access.	4	16*	5	32*	17	140*	5	48*
Capacitors	0	0	0	0	1	75**	0	0
Controls & Resistors	0	0	0	0	1	103	0	0
Sound & Audio Prod.	2	4*	0	0	14	78*	10	39*
Test Equipment	2	3**	0	0**	3	3*	3	7*
Transformers	0	0**	0	0	4	42**	2	8*
Tubes	5	45*	6	17*	9	76*	2	2**
Wire & Cable	0	0**	0	0**	2	52*	0	0**

* Increase over September
** Decrease from September

Comment: The trend toward introducing new items continues as it has for the past five months. It is noticeable at this time that a greater number of manufacturers are involved than in the past. Tube and antenna manufacturers are showing more activity than in the past four months.

This data is prepared by the staff of United Catalog Publishers, Inc., 110 Lafayette Street, New York, publishers of RADIO'S MASTER, the Official Buying Guide of the Parts Industry.

Merchandising and Promotion

The Walter L. Schott Co., Los Angeles, is offering a new metal storage tray to service technicians who purchase Walsco "50-Line" packages through distributors. The tray holds up to 20 sliding-lid plastic containers which are labeled for the hardware items they hold.

The General Electric Tube Department launched what it believes to be the first program of its kind in making cooperative billboard advertising available to TV service technicians through G-E tube distributors. Early reports indicate that the plan is meeting with marked success.

(Please turn to page 22)

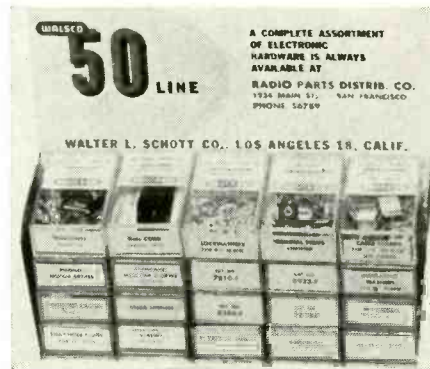

(Above)—Walsco "50-Line" hardware assortment storage tray. (Below)—G-E's billboard sign aids local technicians.



J. E. SMITH
President
National Radio
Institute
Washington, D. C.



I Will Train You at Home for Good Pay Jobs, Success in RADIO-TELEVISION



YOU LEARN SERVICING by practicing with equipment I furnish

You build valuable Multitester (at left) as part of my Servicing Course. You use it to make many tests, get practical experience, make **EXTRA** money fixing neighbors' radios in spare time. Many of my students earn \$5, \$10 a week extra while learning. I send you many other kits too. You build a modern Radio. You build many circuits common to Radio and Television. All equipment is yours to keep. Read about and see other equipment in my free book. Mail card below.



YOU LEARN COMMUNICATIONS by practicing with equipment I furnish

As part of my Communications Course I send you kits of parts to build the low power broadcasting transmitter shown at right and many other circuits common to Radio and Television. You use this equipment to get practical experience putting a station "on the air," performing procedures demanded of Broadcast Station operators. I train you for FCC Commercial Operator's License. Mail Card for Sample Lesson and 64-Page Book. **FREE!**

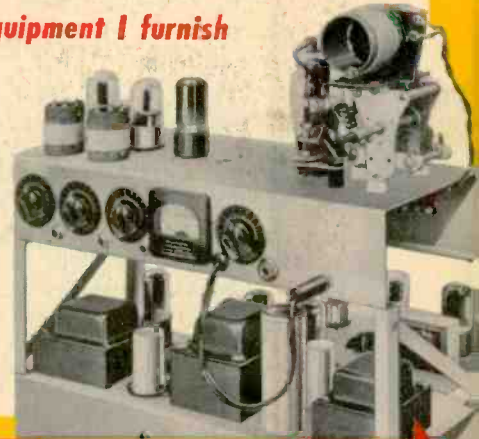

TELEVISION is Today's Good Job Maker

In 1951 over 15,000,000 homes had Television sets, more are being sold every day. 108 TV stations are already operating, over 1800 are now authorized and many hundreds are expected to be on the air in 1953. This means new jobs, more jobs and better pay for trained men. The time to act is **NOW!** Start learning Radio-Television servicing or communications. Want to get ahead? America's fast growing industry offers good pay, a bright future and security. Cut out and mail card now. J. E. Smith, President, National Radio Institute, Washington, D. C.

**There are Good Jobs, Good Pay, Success
in Radio-TV! SEE OTHER SIDE**

CUT OUT AND MAIL THIS CARD NOW

Sample Lesson & 64-Page Book

Both FREE

This card entitles you to Actual Lesson on Servicing, shows how you learn Radio-Television at home. You'll also receive my 64-Page Book, "How to Be a Success in Radio-Television." Mail card now!

NO STAMP NEEDED! WE PAY POSTAGE

Mr. J. E. SMITH, President,
National Radio Institute, Washington 9, D. C.

Mail me Lesson and Book, "How to Be a Success in Radio-Television." (No Salesman will call. Please write plainly.)

NAME AGE

ADDRESS

CITY ZONE STATE

A B C D E

The ABC's of
SERVICING

How to Be a
Success
in RADIO-
TELEVISION

Train at Home to Jump Your Pay as a RADIO-TV Technician



**J. E. Smith, President
National Radio Institute**

The men whose letters are published below were not born successful. At one time they were doing exactly as you are doing now... reading my ad! But they acted. They decided they would know more... so they could earn more! They acted! Mail the card now for my 2 books FREE.

There's a Bright Future for You in America's Fast Growing Industry

Do you want good pay, a job with a bright future, security? Would you like to have a profitable business of your own? If so, find out how you can realize your ambition in the fast growing RADIO-TELEVISION industry. Even without Television, the industry is bigger than ever before. 105 million home and auto radios, 2900 Radio Broadcasting Stations, 108 TV Stations with 1800 more now authorized. Expanding use of Aviation and Police Radio, Micro-Wave Relay, Two-Way

Radio for buses, taxis, etc., are making opportunities for Servicing and Communications Technicians and FCC Licensed Operators.

You Learn by Practicing with Kits I Furnish

With both my Servicing Course and my NEW Communications Course I send you many Valuable Kits of Parts. They "bring to life" theory you learn in my illustrated texts. Mail card for my big 64-page book. It shows photos of equipment you build from kits I send.

My Training Includes Television

Both my Servicing and Communications Courses include lessons on TV principles. You get practical experience by working on circuits common to both Radio and Television. My graduates are filling jobs, making good money in both Radio and Television. Remember, the way to a successful career in Television is through experience in Radio.

Send NOW for 2 Books FREE Mail the Postage-Free Card NOW!

What will YOU be doing one year from today... will you be on your way toward a good job of your own in a Radio and Television service shop or business? Decide now that you are going to know more and earn more! ACT NOW! Take the important first step to a career and security. Send the postage-free card now for my FREE DOUBLE OFFER. You get Actual Servicing Lesson. Also my 64-page book, "How to Be a Success in Radio-Television." Read what my graduates are doing, earning; see equipment you practice with at home. Mail card now. J. E. SMITH, President, National Radio Institute, Washington 9, D.C. Our 39th year.

I TRAINED THESE MEN



Handicapped but Successful

"I am now Chief Engineer at WHAW. My left hand is off at the wrist. A man can do... if he wants to." R. J. Bailey, Weston, W. Va.



\$10 a Week In Spare Time

"Before finishing, I earned as much as \$10 a week in Radio servicing, in my spare time. I recommend NRI." S. J. Petrucci, Miami, Fla.



Control Operator, Station WEAN

"I received my license and worked on ships. Now with WEAN as control operator, NRI course is complete." R. Arnold, Rumford, R. I.



Trained Men Make Money In TV

"I am now servicing Television. Your course enabled me to repair TV receivers without any trouble." R. Currier, Fair Haven, Vt.



Has Growing Business

"Am becoming expert Technician as well as Radiotriician. Without your course this would be impossible." P. Brogan, Louisville, Ky.



Got First Job Thru NRI

"My first job was with KDLR. Now Chief Engr. of Radio Equipment for Police and Fire Dept." T. Norton, Hamilton, Ohio.

Find Out What RADIO-TV Offers You

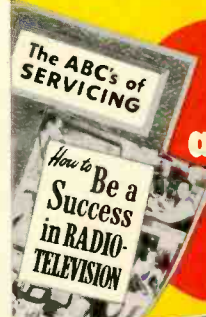

**SAMPLE LESSON
and 64-PAGE BOOK
Both FREE**

**Cut out and mail
postage-free card today!**

Make Extra Money While Learning

Keep your job while training. Many NRI students make \$5, \$10 and more a week extra fixing neighbors' Radios in spare time while learning. I start sending you special booklets that show you how to service sets the day you enroll. Multi-Tester you build with parts I furnish helps discover and correct Radio troubles.



Want Your Own Business?

Many N.R.I. trained men start their own business with capital earned in spare time. Let me show you how you can be your own boss... Robert Dohmen, New Prague, Minn., (whose store is shown at right) says, "Am now tied in with two television outfits and do warranty work for dealers. Often fall back to N.R.I. textbooks for information on installing Television sets."



FIRST CLASS
Permit No. 20-R
(Sec. 34.9, P.L. & R.)
Washington, D.C.

BUSINESS REPLY CARD

No Postage Stamp Necessary If Mailed In The United States

4c POSTAGE WILL BE PAID BY
NATIONAL RADIO INSTITUTE

16th and U Sts., N.W.

Washington 9, D. C.

SUPERIOR PERFORMANCE

OF SYLVANIA PICTURE TUBES NOW PROVED BEYOND ALL DOUBT



HERE'S THE FULL REPORT!

LIFE TEST MAGNETIC TUBES United States Testing Company Hoboken, N. J.			Test No. 1-5526 Date 10-11-52 Engineer A.S.M.
Mfr.	Tubes Tested	Tubes Failed	Point Quality
A	8	3	76
B	8	4	79
C	8	6	62
D	8	4	74
E	8	4	67
F	8	5	42
G	8	4	52
H	8	5	30
SYLVANIA	8	0	93

Exhaustive tests by United States Testing Company prove Sylvania Picture Tubes out-last, out-perform all others tested!

● Hour after hour for over 1,400 consecutive hours, Sylvania Picture tubes were tested side by side with tubes of 8 other manufacturers. The chart at right tells the remarkable performance record. Note that only Sylvania Picture tubes showed no failures. Here's the conclusion of the U. S. Testing Company Report: "On the basis of an ultimate Life Test Evaluation of the eight tubes of each brand tested, it is our

opinion, that the averaged overall qualities measured on the Sylvania Tubes were superior to the averages of the other brands tested."*

*United States Testing Company, Inc., Test No. E-5526.

We'll be glad to send you full details of this report. Send your request to Sylvania Electric Products Inc., Department R-2712, 1740 Broadway, New York 19, N. Y.

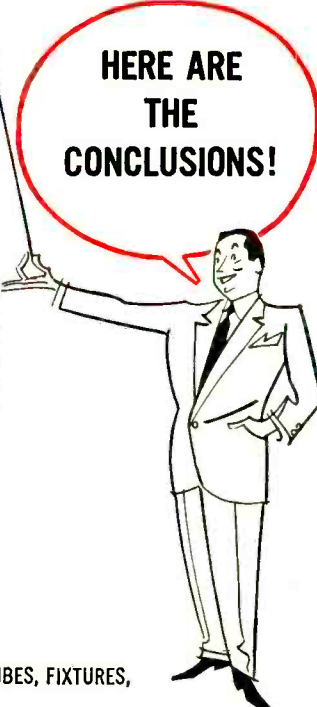

HERE ARE THE CONCLUSIONS!

SYLVANIA



RADIO TUBES; TELEVISION PICTURE TUBES; ELECTRONIC PRODUCTS; ELECTRONIC TEST EQUIPMENT; FLUORESCENT TUBES, FIXTURES, SIGN TUBING, WIRING DEVICES; LIGHT BULBS; PHOTOLAMPS; TELEVISION SETS



Weller Electric Corp., Easton, Pa., has launched a Christmas promotion at the distributor level aimed to capture extra Christmas gift sales. It suggests Weller electric soldering guns as "per-



fect gifts for servicemen, mechanics, hobbyists, and homecraftsmen." The guns are being shipped to distributors in colorful holiday wrappers.

Atlas Sound Corp., Brooklyn, N. Y., has developed a new display stand for

..... **USED BY THE MILLIONS!**

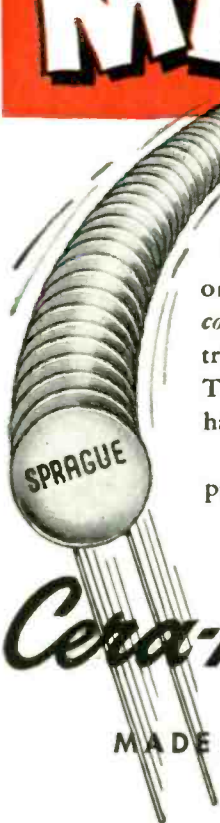

You'll find Sprague Cera-mite disc ceramics in practically every major TV and radio set on the market today!

There's a good reason for their widespread use: Not only are Cera-mites *dependable*—the Cera-mite line is *complete!* These tiny capacitors are now made in a tremendous range of values from 1 to 30,000 mmf. This means that *one* line—the Cera-mite line—will handle *all* your ceramic replacement problems.

Write for Bulletin M-479 to Sprague Products Company, 81 Marshall St., North Adams, Massachusetts.

INSIST ON

Cera-mite* Capacitors

MADE BY



© T.M.

THE WORLD'S LARGEST CAPACITOR MANUFACTURER

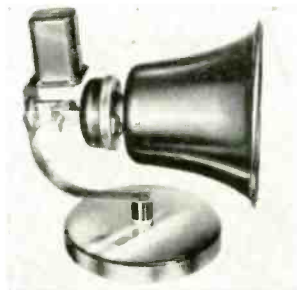

point-of-sale exhibition and merchandising of its speakers at parts distributors.

Hickok Electrical Instrument Co., Cleveland, featured a handy point-of-sales display as part of its fall dealer-jobber promotion on its line of radio-TV probes and accessories.

Technical Appliance Corp., Sherburne, N. Y., has been canvassing service technicians and installers throughout the country in an effort to locate the oldest operating Taco TV antenna. One hundred dollars will be awarded to the service technician who locates the antenna, and a free new installation will be given to the customer who owns the Taco antenna. Complete details of the contest, which will end early in 1953, are available from Taco distributors.

Westinghouse Electric Corp., TV-Radio Division, conducted a series of more than one hundred TV service clinics throughout the nation early this fall. A demonstration on an actual chassis, valuable short cuts in troubleshooting, and servicing tips were presented.

RADIO-ELECTRONICS



Leonard C. Lane,
B.S., M.A.
President of Radio-Television
Training Association,
Exec. Dir. of Pierce School
of Radio and Television

AMAZING NEW TRAINING PLAN

NOW . . . YOU CAN BECOME A LICENSED* TV TECHNICIAN

LICENSED TV MEN MAKE MORE MONEY

**AT NO EXTRA COST!
YOU GET A ROUND TRIP TO
NEW YORK CITY**

FROM ANYWHERE IN THE U.S. OR CANADA—I pay your way to New York and return. PLUS 2 FREE weeks, 50 hours of advanced instruction and shop training at the **PIERCE SCHOOL OF RADIO & TELEVISION**. You use modern electronics equipment, including student-operated TV and Radio stations. You go behind the scenes of New York's big Radio-TV centers to study first hand. And I give you all this **AT NO EXTRA COST!** (Applies to complete Radio-TV course only.)

Only RTTA makes this amazing offer.

EXTRA FEATURES THAT MEAN MORE MONEY FOR YOU!

Thousands of new job opportunities will be available for you right in your own state, now that the government has lifted restrictions on new TV stations. My simple, successful methods can **PREPARE YOU NOW** to take your place in America's booming TELEVISION and Electronics industries . . . help you get the success and happiness that you always wanted out of life. You learn the practical, easy way by using actual parts and equipment in the 15 big Radio-TV kits I send you, including a **COMPLETE TV RECEIVER** . . . yours to build and keep.

My Advanced Training Prepares You For Better Jobs

Then, after you finish your training for a position as a full-fledged TV Technician—where you can write your own ticket and choose from dozens of fascinating careers—I don't stop there! I continue to train you—**AT NO EXTRA COST**—to qualify for even better pay in the **BETTER JOBS** that demand FCC licenses, with my . . .

FREE* FCC COACHING COURSE
PREPARES YOU AT HOME FOR YOUR
FCC LICENSE
THE BEST JOBS IN TV AND RADIO
REQUIRE AN FCC LICENSE
Given to every student at **NO EXTRA COST** after
TV Theory and Practice is completed.

Earn Extra Money in Spare Time
Make as much as \$25.00 a week in your spare time while learning—repairing Radio-TV sets. Many of my students pay for their entire training from spare time earnings almost from the very beginning . . . start their own service business.

FREE EMPLOYMENT ASSISTANCE. My vocational adviser will show you how you can have a good-paying career in the locality of your choice.

I GET MY GRADUATES GOOD PAYING JOBS

"As Merchant Ship Radio Officer, I receive \$867. for 40-day trip. Your training helped me get this fine position."
—Stanley Nawrocki

I now hold a fine airlines position at LaGuardia Field, New York City, thanks to your excellent training."
—Joseph Rosenberg

"Your excellent instruction helped me get my present job as an airport radio mechanic for American Airlines."
—Eugene E. Basko

"Thanks to your training, I qualified for a good job as a Receiver Tester at Federal Television and Radio."
—Paul Frank Seier

Many others working at NBC, RCA, CBS, Dumont, Philco, Emerson, Admiral and other leading firms.

RADIO-TELEVISION TRAINING ASSOCIATION

1629 Broadway, Radio City Station, New York City 19, N. Y.

Approved as a Correspondence School under the laws of the State of New York

**SET-UP YOUR OWN HOME LABORATORY
WITH THE 15 BIG TELEVISION-RADIO
KITS WE SEND YOU (At No Extra Cost)**

**YOU BUILD
AND KEEP
ALL THESE
UNITS**



—INCLUDING BIG SCREEN TV RECEIVER,
plus Super-Het Radio Receiver,
R.F. Signal Generator, Combination
Voltmeter-Ammeter-Ohmmeter,
C-W Telephone
Receiver, AC-DC
Power Supply.
Everything
Furnished
Including
All Tubes, and
Big TV Tube

NOW! **Advanced FM-TV Training
For Men Who Know Radio**
Prepares You For Higher Pay Jobs
In A Few Months
COMPLETE theory and practical training course . . . complete with kits including large screen TV receiver.
FCC License Coaching Course Included FREE.

VETERANS!

**MAIL COUPON
TODAY**
MY SIMPLE
METHODS
MAKE SUCCESS
EASY

THIS SCHOOL FULLY APPROVED TO TRAIN VETERANS UNDER NEW G.I. BILL! If discharged after June 27, 1950—CHECK COUPON BELOW!



NO SALESMAN WILL CALL!

Mr. Leonard C. Lane, President
RADIO-TELEVISION TRAINING ASSN.
1629 Broadway, Radio City Station
New York 19, N. Y. Dept. R-12.

Dear Mr. Lane:
Mail me your **NEW FREE BOOK** and **SAMPLE LESSON** that will show me how I can make **BIG MONEY** in TELEVISION. I understand I am under no obligation and no salesman will call.

Name _____ Age _____
Address _____
City _____ Zone _____ State _____

I am interested in: Radio-TV Advanced FM-TV
VETERANS: If qualified under new G.I. Bill, check here



**BOTH
FREE
New
Illustrated
Book plus
Sample
Lesson**

Someone would love
to give you a WELLER Gun
for Christmas



And someone else would love to get a Weller Gun from you! *Handy* to give—*dandy* to get—Weller Guns delight every hobbyist and homecraftsman. *Because you can do so many jobs with a Weller—faster, easier, neater!* Drop a hint to your wife that you want a Weller Gun. And put Weller Guns on your Christmas list, too. You won't have to shop for them; your nearby Radio and Electronic Parts Distributor has these famous tools.

INSTANT HEAT
means no delay—
no wasted time
or current.



DUAL HEAT

Switch instantly to high or low heat to suit job.

EXCLUSIVE TIP-GRIP
assures full constant heat longer tip life.

DUAL SPOTLIGHTS

let you see clearly— even in dark corners.

SHATTER-PROOF HOUSING

PERFECT BALANCE—LONGER REACH

LOW-COST, REPLACEABLE TIPS
Change in just a few moments.



The real JACK-OF-ALL-TRADES

For fast, easy soldering—repairing furniture finishes—model railroading—removing gold hardened putty—mending rain spouting—making costume jewelry—cutting rubber and composition floor tile—dating and re-grooving auto tires—dozens of other jobs.



READY PACKAGED FOR CHRISTMAS GIVING

WELLER Guns come "ready-to-give"—in colorful Christmas gift wrappings. Your nearby Radio and Electronic Parts Distributor has them on display. Visit his store and try the sharpshooting WELLER Electric Gun for yourself. You'll find it the ideal Christmas gift—to give or to receive.

4
MODELS
from \$8.95

WELLER ELECTRIC GUN Model WD-135

Weller



828 Packer Street
Easton, Pa.

ELECTRIC GUNS Better From Grip to Tip!

The Finest Soldering Tool for the Finest Craftsmen

Merit Coil & Transformer Corp., Chicago, announced a new "Auto Radio Replacement Guide" which includes i.f.-r.f. coils and transformers.

Channel Master Corp., Ellenville, N. Y., completed a full-length sound and color movie on the subject of TV receiving antennas, titled, "The Antenna is the Payoff." Ed Thorgerson, sports commentator, is the narrator.

Ward Products Corp., Cleveland, published a new booklet, "Ward for You in '52," in presentation of its new *Signature* TV antennas.

General Electric Tube Department announced the names of the three first-place winners of its recent business-building contest for radio and TV service technicians. The winners are: Russell J. Cummings, C&W Television Service, Inc., Cambridge, Mass.; Grant Maloy, The Harris Co., San Bernardino, Calif.; and D. J. Young, Young's Radio & Television, Chicago. Each of the top winners received a Dodge panel truck. One hundred other winners received their choice of matched golf clubs, jewelry, or a fishing kit.

New Plants and Expansions

Sylvania Electric Products dedicated its new Electronics Division headquarters at Woburn, Mass. The plant is described as the most modern of its type in the world. The company also announced that a new plant is under construction in Drummondville, Ontario, for the manufacture of electronic devices for Canadian defense purposes by its wholly owned Canadian subsidiary, Sylvania Electric, Ltd.

Javex, manufacturer of electronic devices, recently moved all its activities, formerly conducted in Garland, Texas, to a newly erected plant on a 25-acre site in Redlands, Calif. The company also announced the opening of a new Midwestern office in Chicago.

Plastic Capacitors, Inc., Chicago, was formed as a new firm in the electrical, electronics, and nuclear fields, with Stephen Meskan, formerly with Condenser Products Co., as president and general manager.

Business Briefs

... The Audio Fair—West Coast, scheduled for February 5 to 7 in Los Angeles, is being planned by Southern California sound equipment manufacturers, representatives, and distributors.

... RCA Tube Department renewal sales manager H. F. Bersche recently predicted a renewal market for tubes, parts, and test equipment which will reach a sales volume of one billion dollars by 1955, and more than two billion by 1960.

... The RTMA admitted seven new members to the Association: Daystrom Electric Corp., Poughkeepsie, N. Y.; Delco Radio Division, General Motors Corp., Kokomo, Ind.; Eldico of New York, Inc., Douglaston, N. Y.; Investors Diversified Services, Inc., Minneapolis; Johnson Electronics, Orlando, Fla.; Lyman Electronic Corp., Springfield, Mass.; and Rockbar Corp., New York City.

END

Extra profits for servicemen!

NOW you can add UHF to the thousands of VHF Super Fans presently installed in your area, with Channel Master's exclusive new Ultra-Dapter, Model No. 414. In 5 minutes you can convert any Super Fan into an all-channel VHF-UHF antenna. See your distributor for details.

VHF *and* UHF

Now! Get all 82 channels

with the *new*

CHANNEL MASTER ULTRA FAN

model no. 413

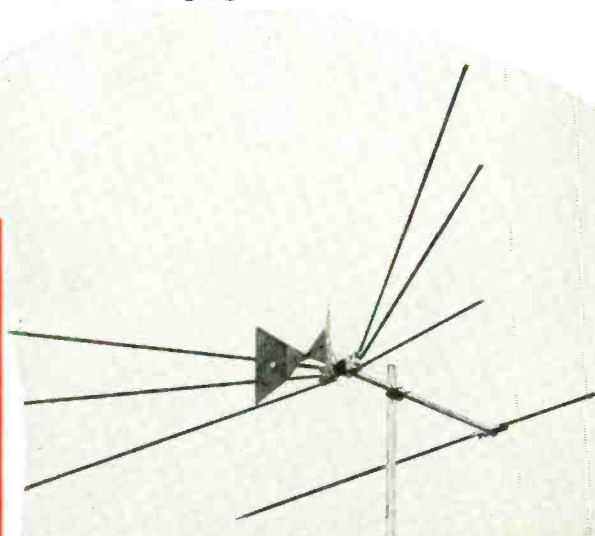

Write for literature on Channel Master's new complete line of UHF antennas including such models as these:

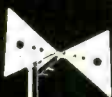

Ultra Bow Model No. 401

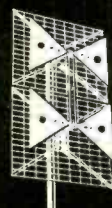

Ultra Bow with screen reflector Model No. 403

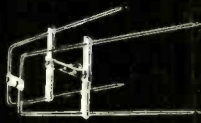

Ultra Vee Model No. 404



Today's most advanced ALL-VU* antenna.

*All VHF, All UHF

Featuring:

- **2 great antennas in 1 —**
A genuine, high gain Super Fan on VHF, and an all-channel Triangular Dipole and reflector for peak UHF reception.
- **Electronic inter-action filter —**
Automatically isolates VHF and UHF bands, eliminates inter-action. Ultra Fan operates with only a *single* transmission line to TV set.
- **"Free space" terminals —**
Channel Master's exclusive UHF "free space" terminals prevent accumulation of dirt and moisture which gradually reduce picture quality in ordinary UHF installations.
- **Famous Channel Master engineering —**
The Ultra Fan is an *integrated* VHF-UHF antenna that give uniformly high gain over *all* TV channels, from 2 through 83.

HORIZONTAL POLAR PATTERNS (Relative Voltage)

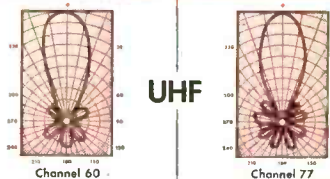
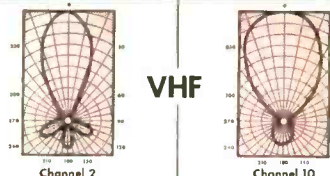

GAIN CURVES

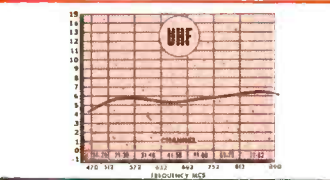
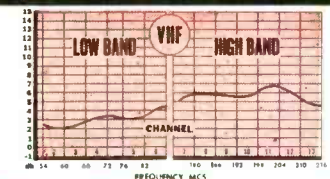

Can be stacked for additional gain.

MEMBER



CHANNEL MASTER CORP. ELLENVILLE, N. Y.

It splits seconds even faster

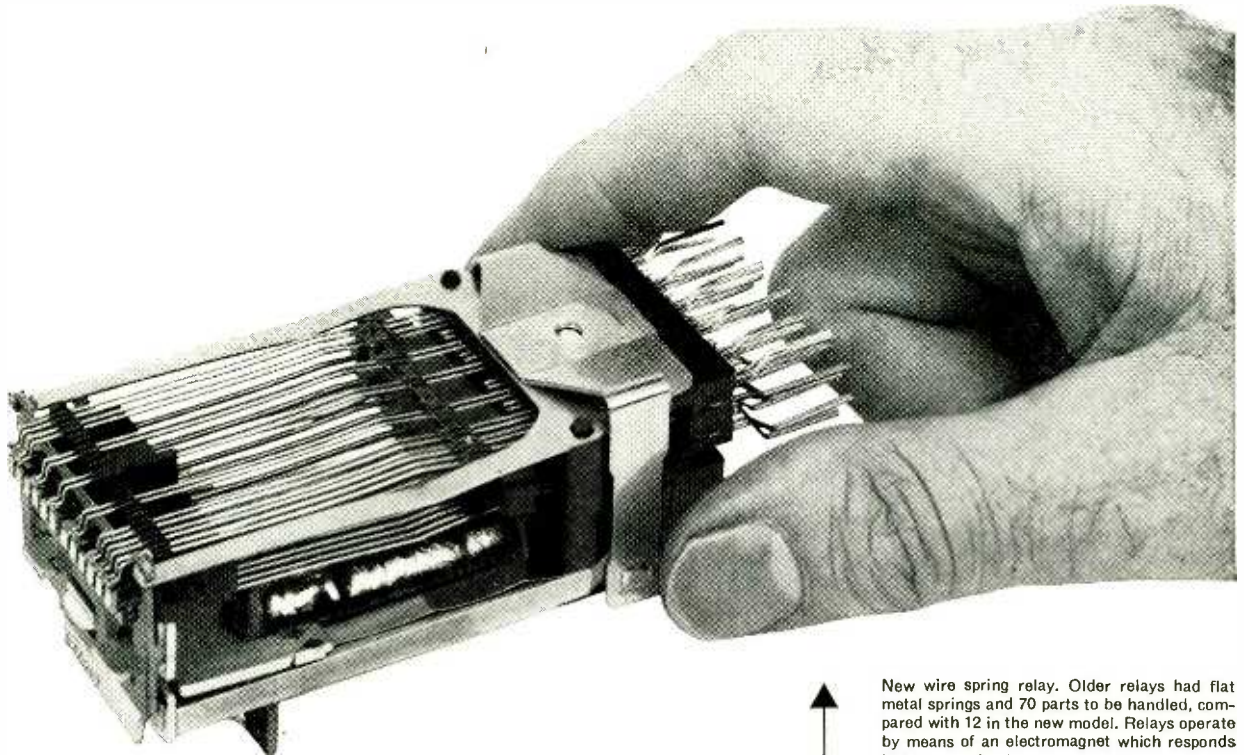

IN A split second, relays, which are high-speed switches, set up dial telephone connections. Then they are off to direct the next call. Yet even this speed is too slow for Bell Laboratories scientists in quest of still faster switching.

Scientists and engineers devised a new relay — the wire spring relay — and worked out the production problem with Western Electric, manufac-

turing unit of the Bell System. This is twice as fast, uses less power and costs less to make and maintain.

With speedier relays, switching can be done with less equipment . . . and calls go through faster. The wire spring relay is a practical example of how Bell Telephone Laboratories and Western Electric pool their skills to improve telephone service while keeping its cost down.

New wire spring relay. Older relays had flat metal springs and 70 parts to be handled, compared with 12 in the new model. Relays operate by means of an electromagnet which responds to high-speed pulses.

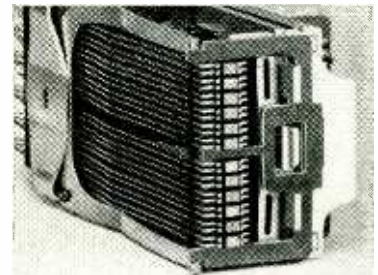

New relays must be able to operate one billion times—equal to once-a-second for 30 years. Employing a sound recorder as a precision vibrator, Bell scientists learned to evaluate the effect of sideways motion on relay life. Such rubbing motion is limited to one-thousandth of an inch in the new relays.



Dynamic Fluxmeter, developed by Bell Laboratories, indicates flux build-up in intervals of 25 millionths of a second. Precise information like this was essential to higher speed operation.

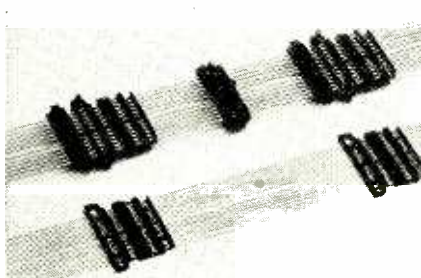

Relay springs as they come from Western Electric molding machine, before being cut apart for use. Molding technique saves time and money . . . makes possible the maintenance of precise adjustment.

Bell Telephone Laboratories



IMPROVING TELEPHONE SERVICE FOR
AMERICA PROVIDES CAREERS FOR CREATIVE
MEN IN SCIENTIFIC AND TECHNICAL FIELDS

RADIO-ELECTRONICS

ASTRON SERVES UP SATISFACTION

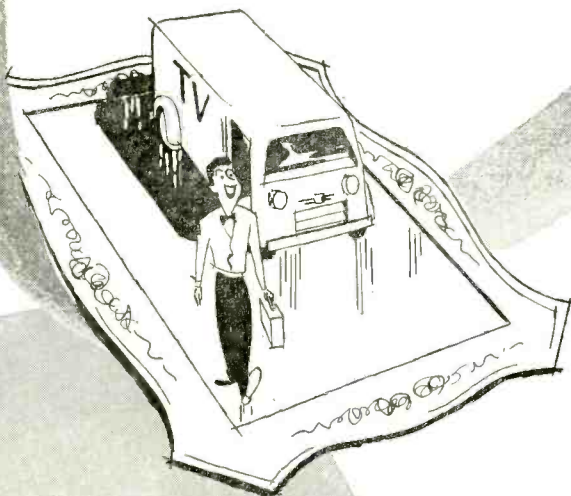

on *Every* Service Call

When you replace with Astron Capacitors you are equaling or bettering original equipment—add to this:

- The service your customer expects
- The exact performance characteristics you demand
- Reduced call-backs everyone demands

And you have a few of the reasons why Astron Capacitors help “serve up satisfaction” to your customers. Alert jobbers are stocking Astron Capacitors—make sure you talk to your supplier today— or write to us for the name of the Astron Distributor nearest you. Send for catalog AC-3.



ASTRON

C O R P O R A T I O N

255 Grant Avenue • E. Newark, N.J.

DEPEND ON . . . INSIST ON . . . **ASTRON**



In the CBS-Columbia design laboratories, Al Goldberg takes some important readings with the EICO Model 221 Vacuum Tube Voltmeter and a Model 555 Multimeter, as Harry R. Ashley looks on.

Mr. Al Goldberg, Assistant Chief Engineer of CBS-Columbia and Harry R. Ashley, President of EICO, inspecting the use of the EICO Model 221 Vacuum Tube Voltmeter and Model HVP-1 High Voltage Probe at the Sweep Frequency Troubleshooting Position on the CBS-Columbia Television production lines.

KITS-Wired Instruments

For Laboratory Precision at Lowest Cost—the Leaders Look to EICO!

WHY does CBS-Columbia, Inc., one of America's great headline-makers in Television set production, use EICO Test Instruments on both its new Television production lines and in its design laboratories?

BECAUSE like Emerson, Tele-King, Teletone, Majestic, and many another famous TV manufacturer coast to coast, CBS-Columbia knows that

- ONLY EICO TEST EQUIPMENT DELIVERS ALL 10 EICONOMICAL FEATURES**
1. Laboratory Precision
 2. Lowest Cost
 3. Lifetime Dependability
 4. Speedy Operation
 5. Rugged Construction
 6. Quality Components
 7. Latest Engineering
 8. Super-Simplified Assembly and Use Instructions
 9. Laboratory-Styled Appearance
 10. Exclusive EICO Make-Good Guarantee

Before You buy any higher-priced equipment, be sure You look at the EICO line—in *Wired* as well as *Kit* form! Each EICO product is jam-packed with unbelievable value. YOU be the judge—compare, see EICO instruments today—in stock at your local jobber—and **SAVE 50%! Write NOW for FREE newest Catalog 12-C FOLLOW THE LEADERS...INSIST ON EICO!**

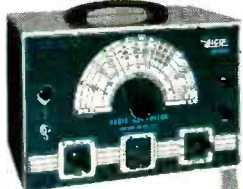

NEW 377K SINE & SQUARE WAVE AUDIO GEN. KIT \$31.95. WIRED \$49.95

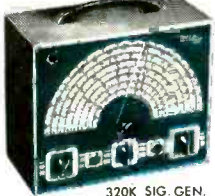

320K SIG. GEN. KIT \$19.95. WIRED \$29.95
322K SIG. GEN. KIT \$23.95. WIRED \$34.95



360K SWEEP GEN. KIT \$34.95. WIRED \$49.95



315K DELUXE SIG. GEN. KIT \$39.95. WIRED \$59.95



1040K BATTERY ELIM. KIT \$25.95. WIRED \$34.95



1171K RES. DECADE BOX KIT \$19.95. WIRED \$24.95



NEW 536C MULTIMETER KIT \$12.95. WIRED \$14.90. 1000 OHMS/VOLT

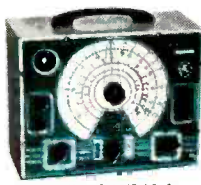

950K R-C BRIDGE & R-C-L COMP. KIT \$19.95. WIRED \$29.95



145K SIG. TRACER KIT \$19.95. WIRED \$28.95



221K VTVM KIT \$25.95. WIRED \$49.95



CRA PIX TUBE ADAPTOR for Tube Tester \$4.50



NEW 565K MULTIMETER KIT \$24.95. WIRED \$29.95. 20,000 OHMS/VOLT



425K 5" PUSH-PULL SCOPE KIT \$44.95. WIRED \$79.95



HIGH VOLTAGE PROBE \$6.95



ELECTRONIC INSTRUMENT CO., INC.
84 Withers Street, Brooklyn 11, N. Y.

Prices 5% higher on West Coast. Due to unstable conditions prices and specifications are subject to change without notice.

How to Enter the Electronic Industry

... Valuable Advice for Electronics Careers by the Government ...

By the U. S. Department of Labor

ELECTRONICS employers hire most of their workers through their own personnel offices. Qualified applicants desiring electronics employment should contact these offices. Many firms have arrangements with universities and technical or trade schools which provide trained workers. The State employment services will help place prospective electronics workers and furnish them with information on local employment conditions.

Individuals planning careers in electronics manufacturing should prepare themselves for their future jobs. The type and extent of preparation, of course, will depend upon the occupation selected. Executive and professional positions usually require a college degree in engineering or business administration.

Persons without previous experience who wish to enter sub-professional jobs or skilled occupations can obtain qualifying training or experience by attending trade or technical schools or by becoming apprentices in the desired trade. Prospective students should select a school with a good reputation because the quality of instruction is very important. Information on trade and technical schools can be obtained from State education departments, the United States Office of Education of the Federal Security Administration, Washington 25, D.C., and educational associations, such as the National Council of Technical Schools, 2601 16th Street N.W., Washington, D.C.

Persons planning to attend schools should also check with prospective employers as to the extent to which graduates are accepted as trained workers. Information on apprenticeships can be obtained by contacting employers or by writing the Bureau of Apprenticeship, United States Department of Labor, Washington 25, D.C.

Assembly and processing jobs require little preparation beyond elementary education and basic aptitudes, such as manual dexterity and an ability to follow simple instructions.

Higher executive and administrative positions are generally filled by promotion. Junior positions are usually filled by college graduates. Electronics products are highly technical. Therefore, engineering training is valuable in sales, production, and purchasing positions.

Engineering jobs are usually filled by graduates of recognized engineering schools and universities, but skilled workers and trade-school graduates are sometimes advanced into these positions. Many manufacturers prefer graduates of universities which grant degrees in radio engineering, and some prefer engineers with post-graduate training. Research and development positions generally require more academic training than production engineering positions. Only a few universities grant first degrees in radio or electronic engineering. Therefore, many electrical engineers or physicists with specialization in electronics are hired each year.

Persons planning engineering careers should complete an engineering course at a recognized engineering school or university. Information on universities, colleges, and technical schools offering engineering training can be obtained by writing the United

States Office of Education, Federal Security Agency, Washington 25, D.C., or the Engineers Council for Professional Development, 25-33 West 39th Street, New York 18, N. Y.

For such skilled workers as machinists, tool-and-die makers, millwrights, electricians, or carpenters, apprenticeship is one of the best ways to enter the industry. These jobs are very similar to their counterparts in other industries, and previous experience in the trade is usually enough qualifying experience for immediate employment.

Electronic technicians need a knowledge of theoretical electronics before they can be considered skilled, and until they acquire it they can never advance very far in this occupation. This knowledge can be acquired in several ways. One can start out as a helper or apprentice and learn it on the job. Some of the best technicians are self-taught radio amateurs who acquired both the theoretical and practical aspects through home study and experimentation. This method requires ability, self-discipline, and initiative. Moreover, electronics is fast advancing beyond the home tinkering stage and is beginning to require equipment beyond the financial abilities of most amateurs.

One of the best ways to prepare for these jobs is by attending a good grade, technical, or vocational school where one can acquire basic theory and familiarity with testing and measuring equipment.

The armed services provide excellent electronics experience and training and have excellent service schools. Young men entering the Armed Forces who are interested in electronics work should try to attend one of these schools and seek assignment to a communications group. Technicians with military electronics training are usually familiar with the types of equipment produced by manufacturers who employ the greatest number of electronic technicians. For this reason, many employers prefer workers with military electronics experience. Electronics research and development have become so expensive that military has outstripped civilian electronics development, and technicians trained in manufacturing, operating, or repairing military equipment are often the only technicians available with this experience.

In addition to the basic theoretical knowledge and familiarity with test and measuring equipment, electronic technicians need specialized practical experience which is usually acquired by on-the-job training.

Even unskilled assembly jobs require some training and the ability to distinguish colors and shapes of parts and to follow simple instructions. Applicants for such jobs are often given aptitude and personality tests to determine their fitness for employment.

The great majority of electronics manufacturing jobs require only limited training. Some firms place new workers directly on the production lines where they receive on-the-job training from experienced workers and supervisors. Other firms have special training courses and practice production lines where they prepare workers for the main assembly line.

EDITOR'S NOTE

The above is slightly condensed from an article in an important brochure recently published by the U.S. Department of Labor, in cooperation with the Veteran's Administration. This is a 30-page booklet entitled, "Employment Outlook in Electronics Manufacturing." Some of the chapters are: "The Electronics Industry," "How Electronics Products are Made," "Electronics Workers," "Working Conditions and Earnings," "Employment Outlook," "Outlook in Individual Occupations," "How to Enter the Industry."

There are numerous illustrations, charts and statistics; rates of pay; average weekly hours in radio, television, and related products manufacturing; labor turnover rates in radio, television, etc. In addition there are numerous photographs, all of interest to those who wish to enter the industry.

There are also several appendices: "Electronics has many

Applications," "Percentage Distribution of Workers in Electronics Manufacturing," "Percentage Distribution of Professional and Skilled Workers in Radio, Television, and Related Products Manufacturing by Occupation," as well as a great deal of other valuable information.

The editors of RADIO-ELECTRONICS thought so well of the brochure that it was decided to display this information in a prominent position, to make sure that all of our readers would be certain to see it.

To those who wish to obtain the brochure, it is known as Bulletin #1072 in the Occupational Outlook Series. It is for sale by the Superintendent of Documents, U. S. Government Printing Office, Washington 25, D.C. The price is 25c. This being a government publication, do not send stamps—only money order or check.

AUDIO EQUALIZER DESIGN

Basic circuits for restoring original sound characteristics in record-reproducing systems

By N. H. CROWHURST

AMPLIFIERS for reproducing various types of recordings—discs, tape, wire, or sound-on-film—require some form of equalization to compensate for the special frequency characteristics of each type. For example, in making disc recordings—still the most nearly universal type—the low frequencies are deliberately attenuated to prevent the recording stylus from cutting over between adjacent grooves on strong bass notes; the high frequencies are over-emphasized to help them override the disc surface noise and the anticipated losses in the average reproducer.

Fig. 1 shows the general character of a disc recording curve. Practically all recording equalization curves are based on a *maximum rate of boost or drop of 6 db per octave*. (6 db is equivalent to a *voltage ratio of 2 to 1*. An octave is a *frequency ratio of 2 to 1*.) This is the steepest slope obtainable with simple single-section combinations of resistance and capacitance. Each manufacturer uses what he considers to be the right amount of bass reduction and high boost for the record speed, playing time, groove spacing, and disc material. (The chart on page 42 of March, 1952, RADIO-ELECTRONICS shows the *playback* equal-

approach to equalizer design is quite unnecessary if you understand and use the right methods. An equalizer has to provide a definite boost (or drop) in the response of a circuit between two specified frequencies. The *amount* of boost or drop may be expressed in decibels, or as a voltage ratio (db units are generally used in audio work). Since the two limit frequencies—called “turnover points”—are usually fairly far apart (at least in standard recording practice) an ideal equalizer would have the characteristics shown in Fig. 2. The response of the circuit (E_1) is perfectly flat up to the lower turnover point (F_1); then it drops *uniformly* to the desired level (E_2) at the high-end turnover frequency (F_2); then flattens out again.

Fig. 3 shows two basic resistance-capacitance equalizer circuits. The arrangement at *a* is for high-frequency boost; *b* is for low-frequency boost. (Inductors can be used instead of capacitors—with the opposite characteristics, of course—but capacitors are generally used because they are free from hum-pickup troubles, and are usually much less expensive than inductors. This article will deal only with capacitor type equalizers.)

Both circuits are essentially voltage dividers. In *a* the top resistive element (R_1) is short-circuited at the highest frequencies by capacitor C_H . In *b* the lower resistor (R_2) is open-circuited at low frequencies by the capacitor C_L . Two mistakes are commonly made in dealing with these circuits:

1. It is assumed that they produce ideal steps with a slope of 6 db per octave (like Fig. 2), and that the turnover frequencies are exactly at the opposite ends of the step. The actual slopes are invariably less than 6 db, and the turnover points are never exactly at the ends.

2. The effects of the input and output impedances in the circuit where the equalizer is connected are neglected.

The most important actual characteristics of each circuit can be found by checking its response at three frequencies. Two of these are the turnover frequencies F_1 and F_2 ; the third (F_3) is the geometric midfrequency $F_3 = \sqrt{F_1 \times F_2}$. F_3 is useful because the actual response curve has its steepest slope at this point.

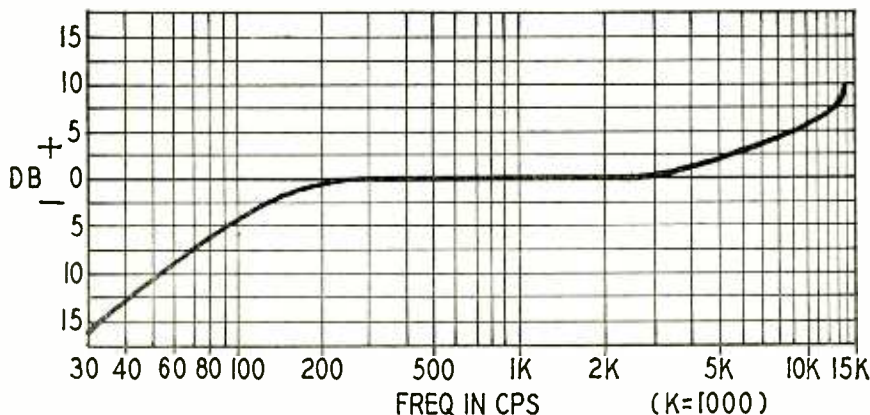

Fig. 1—Typical equalization curve used in making commercial disc recordings. Playback equalizer must have opposite characteristics for ideal reproduction.

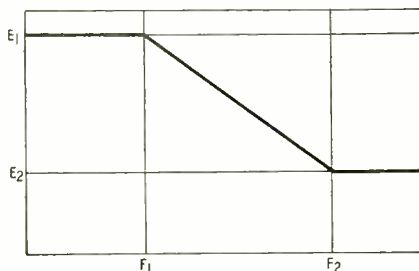

Fig. 2—Ideal equalizer characteristic.

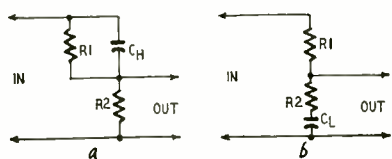

Fig. 3—Basic R-C equalizer circuits. (a) High-end boost. (b) Low-end boost.

ization required for some of the most popular brands of disc recordings. These curves are just the *opposites* of the recording characteristics.)

Equalizer circuits look deceptively simple: a few resistors and a capacitor or two; but even when prescribed values are used they may fail to deliver the expected results. Many articles and books on the subject safeguard themselves against this possibility with a postscript to the effect that “The foregoing method will provide rough values. *Exact values* for any specific application will have to be determined by test.” In other words, “This gives you a general idea; if you have all the necessary test equipment and enough patience, you *may* eventually get it right. If you haven’t—well, just hope for the best.”

Fortunately, this rather pessimistic

The insert in Fig. 4 is a generalized equalization curve showing the important factors. (Although this represents the performance of a high-frequency boost circuit—Fig. 3-a) it can be applied just as well to bass-boost equalizers (Fig. 3-b) by simply reversing the curve. The Fig. 4 chart shows how these factors are determined in designing a practical equalizer. Frequencies F_1 and F_2 are the "turnover" points of the curve.

The straight line A gives the relation between the over-all height of the step and the ratio $R1/R2$ or the ratio between the reference frequencies F_1 and F_2 , which is simply $(1+R1/R2)$. Curve B shows how much the response at the turnover frequencies F_1 and F_2 departs from the nearest level portion of the over-all response curve; for big steps this is very nearly 3 db. Curve C shows the difference in response between the turnover frequencies F_1 and F_2 ; curve D gives the *maximum slope* in db per octave (at the midfrequency F_3 .)

Some typical solutions based on the use of this chart are shown in Fig. 5. In Fig. 5-a, for an over-all step height of 3 db, the turnover frequencies have a ratio 1.4/1 (half an octave). The maximum slope is about 1 db per octave, and there is only about 0.5 db difference in level between F_1 and F_2 . There is a roll-off of 1.25 db between each of the turnover frequencies and the ultimate levels.

In Fig. 5-b F_1 and F_2 are separated by an octave, the maximum slope is 2 db per octave, and the difference in level between F_1 and F_2 is nearly 2 db. There is a 2-db rolloff at each end.

In Fig. 5-c F_1 and F_2 are separated by a decade, giving a 20-db over-all step, and a 14-db difference between F_1 and F_2 . Even in this case the *maximum slope* is still less than 6 db per octave, and the *average slope* over the 10-to-1 frequency range is only 4.5 db per octave.

Terminal impedances

Now for the second source of error. If an equalizer designed according to the methods in the preceding section is connected between two existing amplifier stages, the results may not conform to expectations. The predicted response would be obtained if the equalizer input voltage was the same at all frequencies. Unfortunately, the input impedance changes with frequency, and so does the voltage. The grid-circuit impedance of the following stage also changes with frequency and affects the performance. These plate- and grid-circuit imped-

Fig. 4 (above right)—Generalized equalization curve (insert), and chart for finding essential characteristics with actual circuit combinations. "A" is the over-all height of the step; "B" is the height of the roll-off at each end of the step; "C" shows the net boost (or drop) between the turnover frequencies F_1 and F_2 ; and "D" gives the maximum slope at the midfrequency point F_3 .

Fig. 5 (below right)—Typical curves derived from Fig. 4. See text for method.

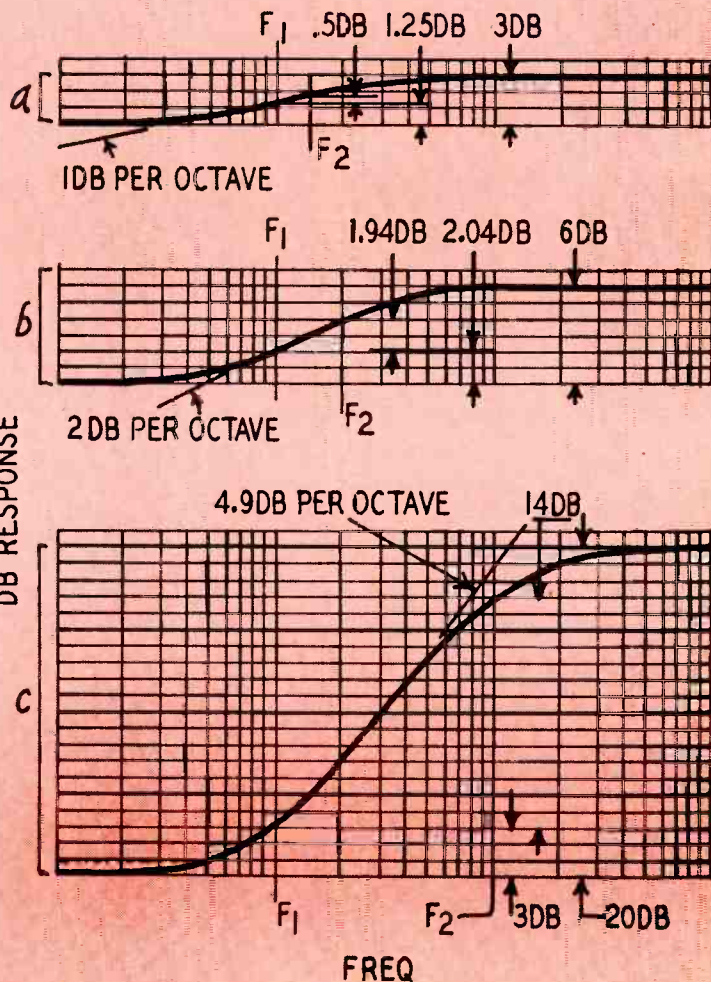
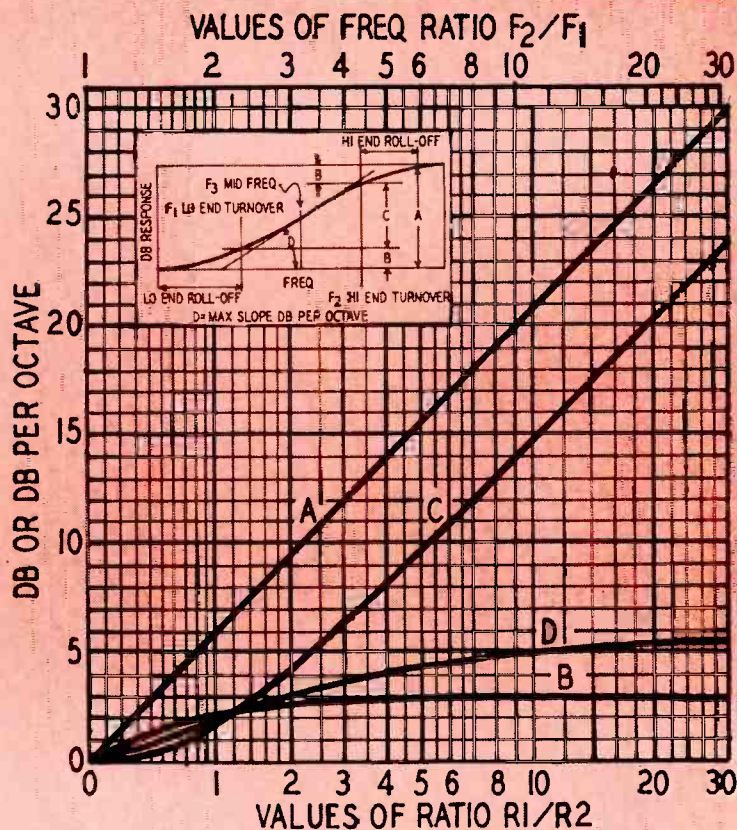

ances must be included in the design calculations for the equalizer.

Fig. 6-a is the basic circuit of Fig. 3-a modified to include these source and output impedances. The low-end turnover frequency is found by making the reactance of C_H equal to R_1 . But the remaining resistance in the loop (R_T) is now R_2 in series with the parallel combination of R_p (the plate resistance of V_1) and the load resistance R_L (Fig. 6-b). As far as frequency discrimination is concerned, R_T is the equivalent of R_2 in Fig. 3-a. The high-frequency turnover, F_p , is found by making the reactance of C_H equal to the parallel combination of R_1 and R_T (Fig. 6-c). In practice it will only be necessary to find one of these frequencies. F_1 is the easiest to calculate, and Fig 4 gives all the other relationships.

As an example, suppose that R_p is 1.5 megohms, R_L is 330,000 ohms, and R_2 is 470,000 ohms. A high-frequency-boost step of 15 db is required, starting at a low-frequency turnover of 2,000 cycles. R_p in parallel with R_L gives about 280,000 ohms net plate-circuit resistance; this added to 470,000 ohms (R_2) gives 750,000 ohms for R_T . A 15-db boost calls for a ratio R_1/R_T of 4.6 (curve A in Fig. 4), so that R_1 works out to about 3.5 megohms. A standard value of 3.3 megohms would be close enough. The circuit will show a boost of 2.9 db (curve B in Fig. 4), when C_H has a reactance of 3.3 megohms at 2,000 cycles (25 μ f).

Now the grid-circuit impedance of V_2 enters the picture. If the input capacitance (C_G), is 25 μ f, the total attenuation will be 6 db more than anticipated, because C_H and C_G form a 2-to-1 capacitive voltage divider at the highest frequencies. Using a smaller value for R_2 will reduce the effect of C_G . With R_2 equal to 100,000 ohms, R_T becomes 380,000 ohms. R_1 then works out to 1.75 megohms (standard value 1.8 megohms). C_H would then be 50 μ f for a 2,000-cycle low-frequency turnover. With C_G equal to 25 μ f, the added loss is only 3.5 db.

Increasing the over-all height of the step will offset this loss still further. Using a figure of 20 db, the ratio R_1/R_T will be 9. R_1 works out to $9 \times 380,000$, or about 3.3 megohms, which again calls for $C_H=25 \mu$ f to lift at 2,000 cycles. The loss due to C_G will be 6 db, leaving a net step height of 20-6, or 14 db.

In any case it pays to reduce the V_2 input capacitance to the smallest possible value. One method is to develop a large amount of inverse feedback in V_2 by using an unbypassed cathode resistor, or by operating V_2 as a cathode follower.

Bass-boost circuit

Now turning to the bass-boost equalizer following the basic circuit of Fig. 3-b. Input- and output-impedance factors are shown in Fig. 7. Here R_2 is in series with C_L (Fig. 7-a) and the balance of the circuit is the series-parallel combination shown in Fig. 7-b.

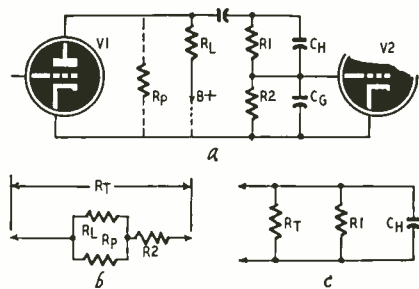

Fig. 6—(a) Complete h.f.-boost equalizer circuit showing additional elements affecting its characteristics. (b) Equivalent source impedance for finding l.f. turnover point. (c) Equivalent circuit for finding the h.f. turnover frequency.

This circuit would not work in practice because the V_2 grid circuit has no d.c. return to ground. Two workable arrangements are shown in Figs. 8 and 9, and the equivalent basic derivation is given under each. In Fig. 8, R_3 shunts all the other elements (R_2 is effectively open-circuited by C_L). This is obviously the simplest circuit to use. Fig. 9 is better where adjustable boost is required.

In this case the simplest reduction to the basic equivalent R_T is by using $(R_1 + R_2)$ instead of just R_1 (after which the value of R_2 can be subtracted). If R_3 is small compared to the other values, both R_2 and $(R_1 + R_2)$ are approximately equal to R_3 . R_1 is nearly zero and there is no step, which is what happens when C_L is effectively short-circuited by R_3 .

Turning back to the question of the errors arising from failure to take circuit impedances into account, take the example shown in Fig. 10. This network is intended to boost both ends of the frequency range. The values of R_1 and R_2 in the basic circuit of Fig. 10-a should give a lift of about 14 db at each end. If this arrangement is merely inserted between two stages, as in Fig. 10-b (ignoring for the moment the need for a d.c. grid return), the plate-circuit impedance of V_1 will reduce the h.f. boost and increase the bass boost, throwing the whole arrangement off balance. With the values shown, the plate-circuit resistance is about 330,000 ohms, R_T is 550,000 ohms, so the ratio R_1/R_2 is only about 2, giving less than 10 db top lift (ignoring possible effects due to input capacitance). For bass lift R_1/R_T is about 6, giving nearly 16 db lift.

By careful choice of values in the circuit of Fig. 10-c, using the equivalents shown in Figs. 7 and 9, R_3 will not affect the top lift materially, but its value can be adjusted to bring the bass boost to the required equal value. The values shown will give 14 db lift at each end. The reactances of capacitors C_H and C_L must be equal to R_1 and R_2 respectively at the high and low turnover frequencies. To avoid confusion the effect of grid input capacitance has been ignored; to include it, the procedure for designing the top lift will be as in the earlier example, after which the bass lift can be adjusted by R_3 as just stated.

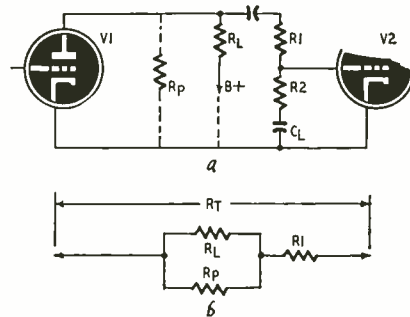

Fig. 7—(a) Low-frequency-boost equalizer. (b) Equivalent input impedance.

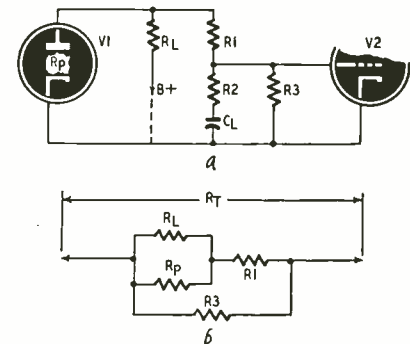

Fig. 8—Workable form of l.f.-boost equalizer, with d.c. return to ground.

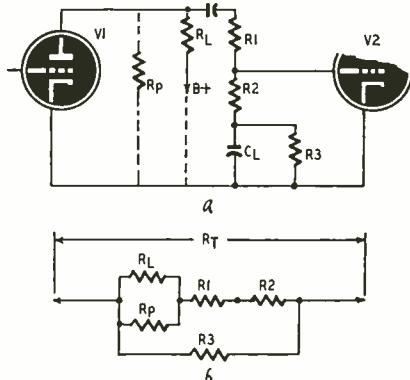

Fig. 9—Another form of low-frequency-boost equalizer. R_3 may be a variable resistor for controlling the response.

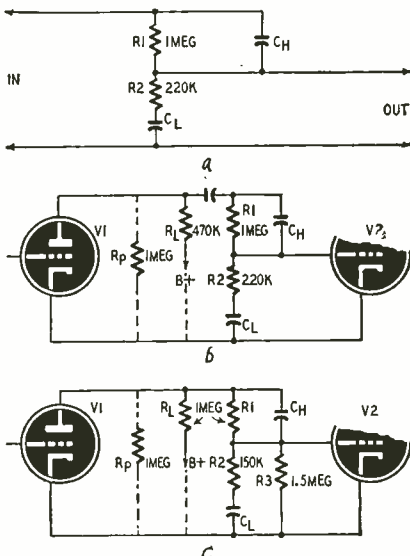
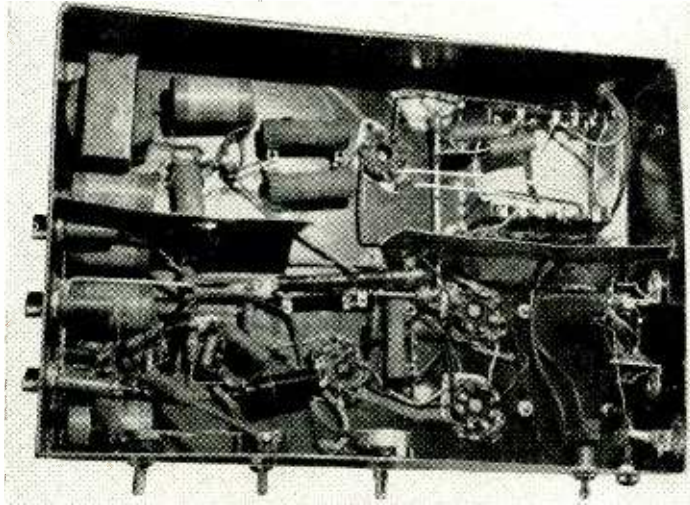

Fig. 10—Combination high-low-boost circuit. (a) Basic network. (b) Input and output circuits added. (c) Compensation for equal high- and low-frequency boost is provided by adding resistor R_3 .

DIRECT-COUPLED AMPLIFIER

By W. J. HANTZ



Under-chassis view of the amplifier. Shields between amplifier and power-supply sections cut down hum pickup in high-gain input circuits and output.

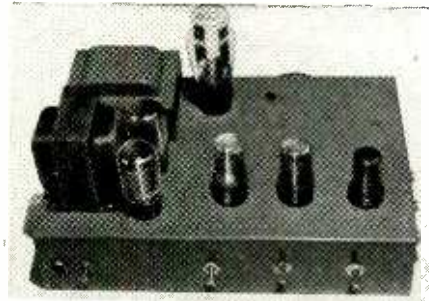

Completed amplifier chassis. Straight-line circuit layout reduces feedback problems. Input connectors at right.

Circuits old and new are combined in this amplifier for high-quality performance

AUDIO men are always looking for the ultimate in high-fidelity amplifiers. If you are one of these you had better keep on looking because you won't find it here. However, if you want to build an audio amplifier with very low hum level, good low- and high-frequency response, and a balanced-direct-coupled phase inverter, then this one is your dish.

This amplifier was constructed as a low-cost auxiliary unit for announcing outdoor sports programs.

From the circuit of Fig. 1 you can see that a single 6SC7 provides two high-impedance inputs suitable for either crystal or dynamic mikes. The mike gain controls were placed in the 6SC7 plate circuits instead of the inputs to reduce control noise and the possibility of the controls affecting the

microphone characteristics. Resistors R1 and R2 provide some decoupling to prevent the two mike circuits from interfering with each other. One grid of V2 is the mike mixer, while the other is for phono input. The paralleled plates of V2 feed into one grid of V3. The signal is impressed on the other half of V3 by cathode coupling. This inverter circuit has been used a good deal in oscilloscopes and special test equipment but rarely in audio work. It is not difficult to balance and has good frequency response. There is no cathode-bypass capacitor in the inverter stage or anywhere else in the amplifier. (When an amplifier has sufficient gain it can be made to have a much flatter frequency response, to be less susceptible to hum, and to have better stability by omitting all cathode bypasses.)

Up to now, our description hasn't covered anything new. From here on, though, any similarity to previous amplifiers—past or present—is purely accidental. Note the direct coupling between the cathode-coupled inverter and the 5881 output tubes.

Most of us know the difficulty in constructing direct-coupled amplifiers. It usually takes a wizard to balance one. However, no attempt has been made here to direct-couple the entire amplifier. This would entail a very large assortment of adjustable resistors. We have *only one* adjustable resistor here (R3) for balancing the direct-coupled circuit.

The d.c. voltage on the plates of the 6SN7 inverter-driver (approximately 100) is impressed directly on the 5881 grids. In any circuit the grid bias of

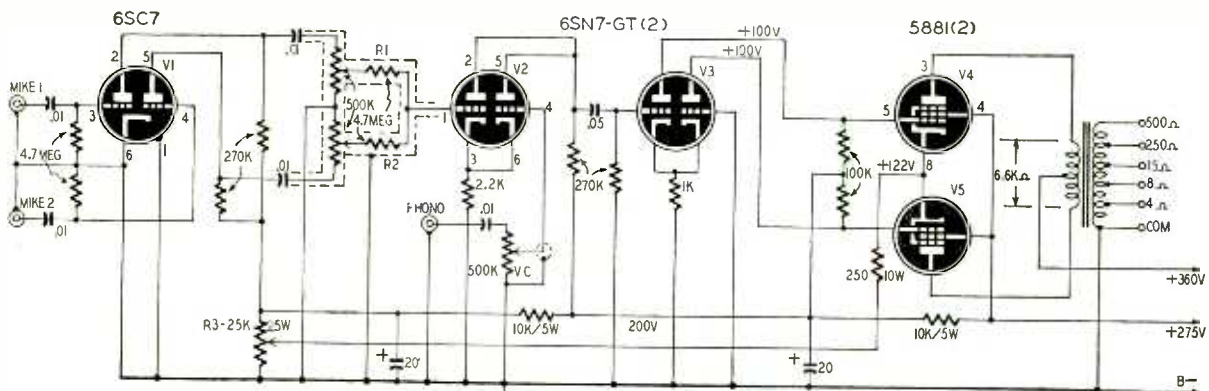

Fig. 1—Circuit of the direct-coupled amplifier and input mixer. R3 is the bias adjustment for the output tubes. DECEMBER, 1952

a tube is the potential difference between grid and cathode. Here the 5881 cathodes must be returned to a point that is more positive than the grids. In this circuit the 5881's require about 22 volts of bias. This is provided by returning the cathodes to the slider of R3, which is adjusted so that the 5881 cathodes are 122 volts positive with respect to the chassis ground. R3 does not require readjustment unless the output tubes are replaced.

If desired, you can use 6L6's instead of 5881's. The characteristics are practically identical except that the 5881's are more rugged.

Materials for amplifier

Resistors: 4—4.7 megohms, 4—270,000 ohms, 2—100,000 ohms, 1—2,200 ohms, 1—1,000 ohms, 1/2 watt; 1—250 ohms, 50 watts; adjustable; 1—25,000 ohms, 25 watts, adjustable; 1—500 ohms, 20 watts; 1—250 ohms, 10 watts; 2—10,000 ohms, 5 watts; 3—500,000-ohm potentiometers (audio taper).

Capacitors: (Electrolytic) 5—20 μ f, 450 volts. (Paper) 1—.05 μ f, 7—.01 μ f, 600 volts.

Transformers: Power transformer, 800 volts, center tapped, at 150 ma; 5 v, at 3 amp; 6.3 v, at 6 amp. Output transformer, primary impedance 6,600 ohms plate-to-plate, secondary tapped at 4, 8, 15, 250, 500 ohms (Stancor A-3801 or equivalent). Filter choke, 8-10 H, 100 ma, 500 ohms.

Miscellaneous: 1—6SC7, 2—6SN7, 2—5881 or 6L6 (see text); 1—5U4-G tubes; 1—115-v pilot lamp; 6 octal sockets, 1 pilot-lamp socket with jewel; 3 shielded input connectors; 2 single circuit phone jacks (see text); 1—s.p.s.t. toggle switch; chassis, terminals, hardware, wire, solder.

Materials for tone control

1—.002- μ f, 600-v, paper capacitor; 1—680 ohms, 1—470 ohms 1/2-watt resistors.

The power supply shown in Fig. 2 provides the well-filtered voltages needed and should be duplicated as closely as possible. If you have some other power

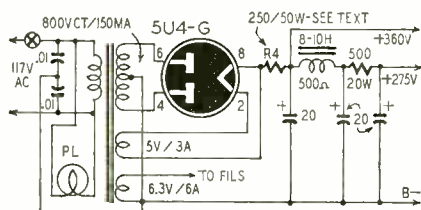

Fig. 2—Schematic of the power supply.

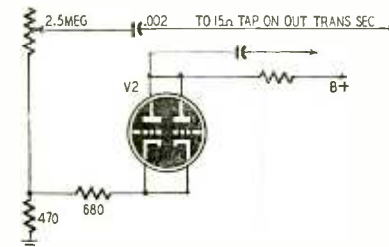

Fig. 3—Inverse-feedback tone control.

transformer or filter choke on hand, it might be advisable to make R4 adjustable. A 250-ohm choke can be used instead of R4 for even better filtering. All amplifier ground returns are made to a heavy bus which is grounded to the chassis at only one point.

No tone control has been provided because of the amplifier's excellent frequency response. Fig. 3 is a degenerative-feedback tone-control circuit which can be added to the amplifier.

The parts placement in the amplifier chassis is not critical and there was no feedback or motorboating.

IMPROVED FIDELITY for the PORTABLE PHONO

By JOHN HARWAY

THERE seems to be an opinion prevalent these days that a record player employing a 6-inch speaker and a low-cost crystal pickup deserves only the barest minimum for an amplifier. On the contrary, this is where a carefully engineered amplifier is needed most! Every trick at the audio engineer's command should be used to get the most out of the meager capabilities of the pickup and speaker.

Taking a popular portable record player, we examined it critically. The pickup was a conventional crystal type with a precious-metal stylus in a turn-over cartridge for three-speed operation. The amplifier was a simple two-tube a.c.-d.c. affair. It was nearly new and its owner considered it to be in top condition.

Testing revealed several faults. There was noticeable distortion at normal listening level. At a level sufficient for dancing in an ordinary living room, the distortion was great enough to make vocals nearly unintelligible. There was severe 60-cycle intermodulation at some frequencies, complete lack of response below 300 cycles, and a sharp resonant rise at 7,000 cycles. The 7,000-cycle peak

resulted in objectionable surface noise from the record.

A check showed there was nothing defective in the circuit; the amplifier was in "perfect" condition. The shortcomings were the natural result of a skimpy design. The 60-cycle intermodulation was the result of mounting the output transformer too close to the phono motor. In addition, the output transformer had a very small core and was completely saturated by the heavy plate current of the 70L7 output tube, a factor which had as much to do with the lack of bass response as did the 6-inch speaker. This transformer was also responsible for the 7,000-cycle resonance.

Circuit design

The logical place to start the new design would be at the output stage. But a few general plans were laid first. To keep the hum level as low as possible, it seemed advisable to use 6-volt tubes and a small filament transformer. This meant that low-drain filaments were necessary in order to avoid a costly transformer. And to get enough peak power output from the amplifier,

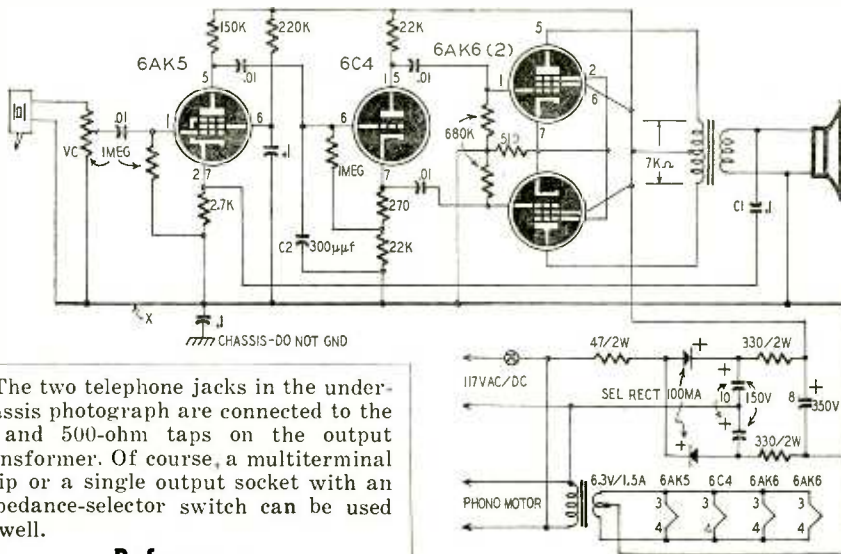

Fig. 1—Circuit of the improved phono-graph amplifier. Push-pull 6AK6's give adequate output with low distortion and minimum current drain.

The two telephone jacks in the under-chassis photograph are connected to the 8- and 500-ohm taps on the output transformer. Of course, a multiterminal strip or a single output socket with an impedance-selector switch can be used as well.

References

A Direct Coupled Amplifier with Cathode Follower, by Raymond H. Bates. *Radio & Television News*, Nov., 1949. Short Circuits, by Robert F. Scott. *RADIO-ELECTRONICS*, May, 1952. END

a plate voltage of 200 or more would be needed. The best answer was a voltage doubler, which combines economy with efficiency and compactness.

The output stage was to have the best low-frequency response possible. Good peak-power output, good low-frequency response and low hum level call for a push-pull output stage. A pair of 6AK6's fit the picture nicely, since they combine reasonable power output with low filament drain.

The output transformer selected had enough iron to be useful at low frequencies. Far from being a super-high-fidelity type, it nevertheless could be depended upon for good output at 100 cycles. Since the primary was push-pull, the core did not saturate, which left room for large bass-frequency flux excursions. And negative feedback around it would smooth out the bumps nicely.

Now the amplifier was beginning to take shape. But negative feedback calls for quite a bit more gain than is ordinarily used in small amplifiers of this type. Several combinations were tried before we settled on the circuit of Fig. 1. The 6AK5 is a high-gain pentode stage driving a cathode-follower phase inverter. This type of phase inverter was desired, for freedom from distortion and balancing troubles. The 6AK5 provided the required high gain with ease. Although primarily a v.h.f. tube, the 6AK5 is becoming increasingly popular in low-frequency equipment.

The negative-feedback loop is unconventional in some respects. The feedback circuit is a frequency-selective network between the voice-coil winding of the output transformer and the cathode of the 6AK5. This network provides a full 15 db of feedback at mid-frequencies. However, the increasing reactance of C1 reduces the feedback at low frequencies. This results in a substantial bass boost to compensate for the poor low-frequency response of the small speaker.

It was necessary to add C2 to prevent oscillation at a supersonic frequency. This capacitor, however, does not reduce the high-frequency response of the circuit. With this addition, the circuit is completely stable and noncritical in all respects.

Materials for phono amplifier

Resistors: 2—1 megohm, 2—680,000 ohms, 1—220,000 ohms, 1—150,000 ohms, 2—22,000 ohms, 1—2,700 ohms, 1—510 ohms, 1—270 ohms, 1/2 watt; 2—330 ohms, 1—47 ohms, 2 watts; 1—1-megohm potentiometer (audio taper with on-off switch).

Capacitors: (Electrolytic) 1—8 μ f, 350 volts; 2—10 μ f, 150 volts. (Paper) 3—0.1 μ f (Ceramic) 3—0.1 μ f, 400 volts, 1—300 μ f, 500 volts.

Transformers: 1 push-pull output transformer, 7,000 ohms plate-to-plate, to voice coil, 10 watts; 1 filament transformer, 117 volts, 60 cycles to 6.3 volts, 1.2 amp.

Miscellaneous: 2—100-ma selenium rectifiers; 1—6AK5, 1—6C4, 2—6AK6 tubes; 4—7-pin miniature sockets (see text and photos); chassis; 6-inch PM speaker; terminals, hardware, wire, solder.

Construction details

Most of the components of the amplifier were mounted on the *Vector* turret-type sockets of the 6AK5 and the 6C4 before the sockets were installed on the chassis (Fig. 2). This made the wiring job quite simple.

The power supply was mounted at the other end of the chassis with plenty of space in between to prevent hum pickup. See Fig. 3. The power-supply parts were not crowded together, since we have vivid memories of tightly packed power supplies overheating and blowing electrolytic capacitors.

The assembled amplifier was mounted on the motor board as shown in Fig. 4. In order to prevent hum pickup, the output transformer was mounted on the speaker, away from the motor. Because there was insufficient clearance between the motor board and the bottom of the record-player cabinet, the tubes were mounted on the end of the aluminum chassis.

The aluminum chassis is completely enclosed when mounted on the motor board. This prevents dust and grime from covering the parts and further shortening their life.

(It is possible for the operator to

Fig. 2 (below left)—Amplifier end of chassis with components mounted on turret-type sockets for extra compactness in the layout.

Fig. 3 (below right)—Power supply installed at opposite ends of chassis from amplifier cuts hum.

Fig. 4 (right)—Amplifier mounted on phonograph motor board. Mounting output transformer on speaker reduces hum from motorfield coils.

receive a nasty shock if he should touch the phono input jack or tone arm while standing on a damp floor or touching a water pipe or radiator while the line plug is polarized to make the chassis hot to ground.

To minimize shock hazard, connect a 0.1- μ f, 600-volt paper capacitor at point x in the input circuit. This capacitor may cause a slight increase in hum level. If it does, increase its size. Do not make the capacitor larger than necessary to hold the hum to a tolerable level. If you use a phono-input jack, be sure to insulate it from the chassis.—*Editor*)

The performance of this amplifier has been remarkable. Everyone hearing the record player for the first time is convinced that it has at least a 10-inch speaker. The clean, strong highs and "presence" usually attributed to costly speakers, hi-fi amplifiers and precision magnetic pickups are gratifyingly present with this circuit. Hum and noise are completely inaudible. Its success shows that the addition of less than ten dollars in parts to the amount generally spent for low-cost phonographs can result in a great improvement in the quality of this type of record player. END

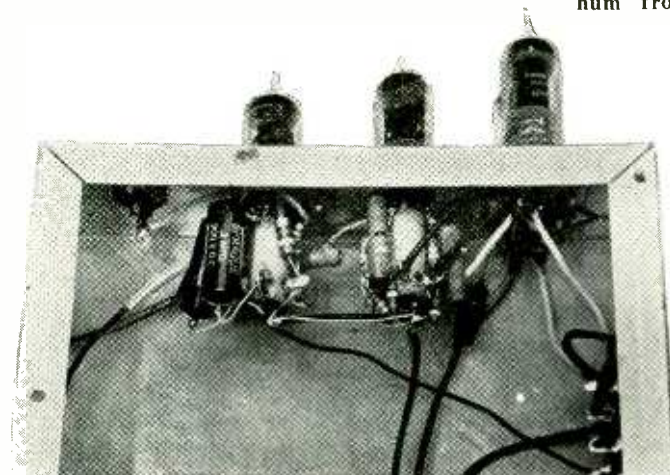
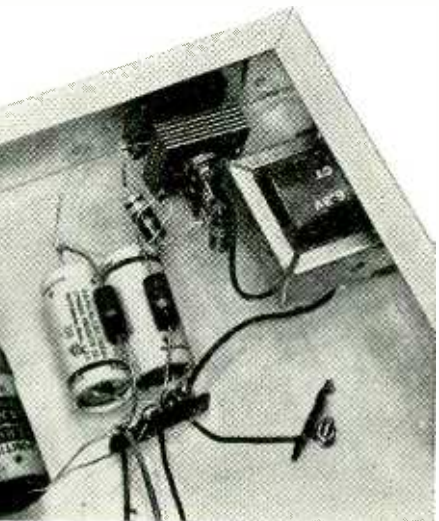
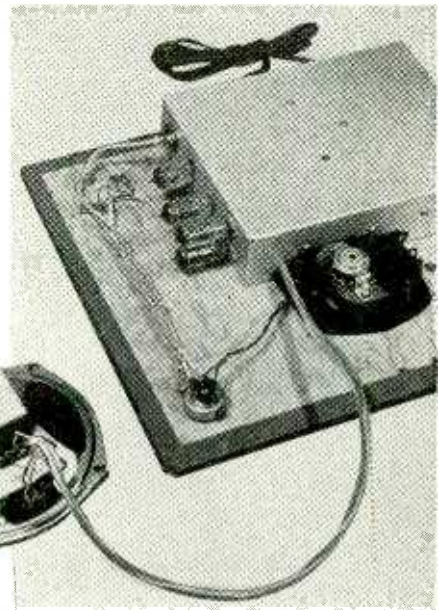

Part I—Some commonly used inverter circuits are not quite all they are cracked up to be.

By GEORGE FLETCHER COOPER

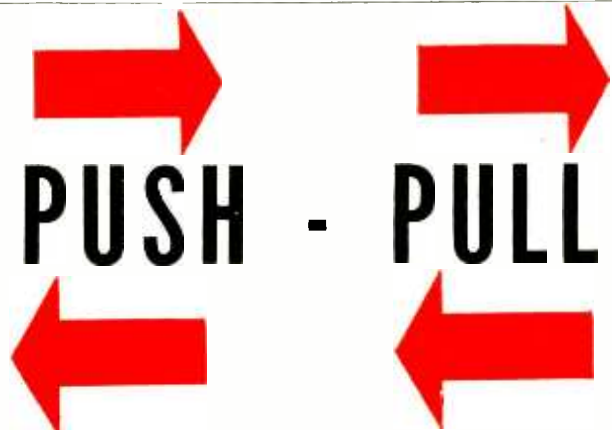

THE majority of amplifiers in the 5-watt class and higher now use push-pull output stages. I cannot even remember seeing in the technical press a description of a high-quality amplifier which was not push-pull, although single-sided amplifiers are on the market. The reasons for using a push-pull stage are fairly well known, or at least they should be. The textbooks tell all (or almost all) about it. The properly balanced push-pull stage produces no even harmonics, though that is not so important, now that we all use so much negative feedback; the output transformer has no d.c. polarization, which makes it a lot easier to design (though we must allow for at least 10% unbalance in any practical circuit) and the signal does not appear in the plate supply lead, which makes decoupling much less of a headache. There are other aspects, too, such as the possibility of pushing down toward class B working. If the tube cuts off in a single-sided stage, no amount of negative feedback will help the situation, because just at the instant of cutoff there is no gain, and thus no $A\beta$. In a push-pull stage one tube is working away to keep the gain up even when the other grid is far negative, and the feedback can do its work in keeping down the distortion.

There is not much point in using push-pull in the early stages of an amplifier, unless you want to go down to zero frequency and keep a balanced input. The electroencephalograph designers, who want to watch your brain ticking before they try to find what makes it tick, use these all-push-pull amplifiers so that they can record the push-pull signals from electrodes on your head, while eliminating the push-push voltages induced from the supply mains. But that is a special problem, and I am not sure we shall get round to it. For most of us, single-sided stages at low levels, then a phase splitter and a push-pull stage, are the answer.

When I was wondering whether to write these articles, I skimmed through a collection of commercial circuit diagrams to see what other designers thought about phase splitters. Right then I decided that phase-splitting techniques were not as familiar as I had believed, because the most commonly used circuit was a pretty poor one, with plenty of disadvantages and practically no advantages. It does seem worth-while to make a survey of

the known phase splitters and to indicate how good or bad they are.

First of all, why should we concern ourselves with making the phase splitter good? We can see the answer most clearly if we consider a class-B output stage. Fig. 1 shows in a very exaggerated way the appearance of the output from a push-pull class B stage if one half is driven twice as hard as the other. As you can see, there is quite a lot of distortion.

More serious, perhaps, is the fact that if the upper half is at maximum drive, the output power is down to $(\frac{3}{4})^2$, or little more than one-half, of the true maximum. The negative feedback could help the distortion, but it will not get back that extra power.

Another point comes out of this figure: the hard-working tube will take an additional plate current of I_1 , while the idler takes only I_2 , so that the output transformer will be subjected to a substantial magnetic flux which may (if it is not overgenerously designed) cause stability trouble at low frequencies, trouble which can be caused also by the unbalance signal back in the plate-supply unit.

There may be some more reasons for making sure that the push and pull are equal, but certainly there are no reasons for allowing them to be unequal. One of the main problems of push-pull design is therefore to make sure that the two drive halves are equal, equal at all frequencies, and that they stay equal. As we shall see, the difficulties arise when we demand equality *at all frequencies*, and when we demand that the drives shall stay equal as tubes age and supplies vary.

Two good phase splitters

The best of all phase splitters is the transformer, shown in Fig. 2. A well-designed balanced transformer will produce equal voltages across the two halves with an accuracy of 1 part in 1,000 and will certainly stay like that. The main objection to the transformer is the fact that its frequency response is not too good, and that it makes the use of negative feedback a lot more difficult. Transformers are mainly used, indeed, when other circuit demands must be met. One example is in operating a push-pull rectifier, for which the low direct-current resistance of the transformer is important; another is in driving a push-pull variable stage in a limiter or compressor, when the

gain control bias must have a low-impedance path with no time-constant to the grid. Apart from these special circuits, the interstage transformer is rare nowadays, although it was standard practice in the early days of push-pull.

Another excellent phase splitter of limited use is made up of two resistors (Fig. 3). This is of interest when the input source has no ground; for example, if a phonograph pickup or magnetic reproducing head is to work straight into a push-pull circuit. Since the same current flows in series in the two resistors they must be equal in order to give the same voltage at the two push-pull terminals, and any stray capacitances must also be equal. Mr. Cocking has described an application of this idea to the diode detector, which gives the circuit shown in Fig. 4. The ground on the tuned circuit does not affect the balance of the circuit, because to audio frequencies the tuned circuit is a very low impedance. Now that crystal diodes are so cheap I consider that a more economical solution would be obtained by putting a tap on the center of the coil and rectifying the two halves with separate diodes, but Mr. Cocking's circuit dates back to 1934.

Some circuits from life

These circuits are of course the textbook type, well suited to the student and ignored by the engineer. Let us turn to a more practical circuit, which, though very widely used, is not very satisfactory to a critical designer. It is the circuit given in Fig. 5, and is shown as Fig. 21-a on p. 383 of Terman, *Radio Engineer's Handbook*. In this circuit tube 1 is driven by the unbalanced input, while tube 2 receives its drive from the voltage divider made up of R and $(n-1)R$. We can assume that R is very large indeed and that we are using pentodes. These assumptions have no influence on the final conclusions, but they make the mathematics very easy, with gR_1 instead of

$$\frac{\mu(nRR_1/nR + R_1)}{[(nRR_1/nR + R_1) + R_p]}$$

and I know how easy it is to obtain a reputation by the simple process of blinding by science. Anyway, tube 2 has a gain of gR_1 (where g is the transconductance), so that as the voltage applied to its grid is V_1/n , we have $V_2 = gR_1 V_1/n$. We want this voltage

DRIVERS

to be equal to V_1 , and therefore $V_1 = gR_1 V_1/n$, or

$$n = gR_1$$

What could be more pleasant: just look up g in the tube handbook, choose R_1 to suit the tube and you know n right away. The total grid resistor nR [$=R+(n-1)R$] will be 100,000 ohms perhaps, so that R is known too.

The only trouble is that although the tube book may give $g=7,650 \mu\text{hos}$ —and I have seen this exactness used—a look in the JAN specifications will leave you slightly worried. Most tubes have a tolerance of about 20% on transconductance, so that if you set the circuit up with a high- g tube it will be more than 30% out of balance with a low- g tube. And, of course, there are the tolerances on the resistors, too, though you can always adjust the circuit to take account of these. But you cannot prevent the balance drifting away as the tube gets old.

Another weakness

If we redraw the circuit as shown in Fig 6, we see a new disadvantage, which we shall find is common in phase splitters. The output voltage to the push-pull stage which appears at A has passed through one tube (tube 1 of Fig. 5), while that which appears at B has passed through tubes 1 and 2. Thinking again of a class B output we can see that if we feed back to the grid (or cathode) of tube 1 we shall be feeding back around two stages for one half-cycle and around three stages for the other half-cycle. The plate capacitance of tube 2 provides at high frequencies an additional phase shift which may make the amplifier unstable. It is not uncommon with circuits of this kind to observe a short buzz of h.f. oscillations on one peak of a low-frequency signal. This effect usually is to be detected only with an oscilloscope, and its cure involves the addition of as many components as would be needed for a more sophisticated phase splitter.

Another circuit given by Terman (loc. cit. Fig 21-c) is shown in Fig 7. The drive for the lower tube is taken from a tapping point on the output transformer. Quite obviously this arrangement cannot be used unless the tubes are operating under strictly class A conditions. If you consider what will happen if the tubes are set to the class B state you will see that when the upper tube is driven positive the lower tube gets no drive at all; when the

upper tube is driven positive the lower tube is driven negative and still produces no output. Perhaps the worst feature of this circuit is the fact that if the tap is selected to give a good low-level balance with a poor tube, a high-g sample driven vigorously will oscillate in the Hartley oscillator circuit shown in Fig. 8: it is normally within 6 db of this unstable condition.

It is not impossible to find other disadvantages to this circuit in its practical applications, but it is so rarely used it doesn't seem necessary to do more than indicate it as an undesirable form.

A "simple" compromise

A third circuit belonging to this condemned class is sometimes seen. I found one example of it in a fairly recent car-radio design, though I must admit that it contained a mitigating feature. This circuit is shown in Fig 9. The drive is applied to tube 1, and the grid of tube 2 is fed from the screen of tube 1. As you remember, the signal at the screen of a tube is in the opposite phase to that at the control grid, so that if the grid-screen transconductance is g_{rs} and we connect a load resistor of $1/g_{rs}$ in the screen lead we obtain a voltage equal to the grid voltage but with reversed phase. This voltage is used to drive the grid of the other tube of the push-pull pair.

The circuit shown in Fig. 9 includes a decoupling capacitor in the common screen lead connected above the screen load mentioned in the last paragraph. When this capacitor is used, the circuit suffers from the basic defect of the three circuits discussed in this article: if the tube characteristics change, the balance is destroyed. As we saw at the beginning, a good balance is necessary if the distortion and power output are to be satisfactory. The designer of the car radio which incorporated this screen coupling avoided this difficulty by an ingenious and economical trick. He left out the dotted capacitor! When the circuit is balanced, the capacitor is not needed, because when the grid of tube 1 goes negative the screen current drops, driving the grid of tube 2 positive and increasing the screen current in tube 2 by exactly the same amount. Since the total screen current is constant, the voltage drop in the common screen resistor is constant, and the capacitor would have no alternating voltage across it: consequently it is

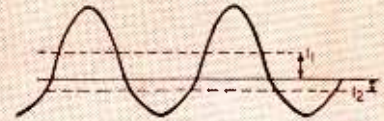

Fig. 1—What can happen to a signal.

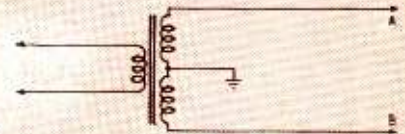

Fig. 2—This is the perfect inverter.

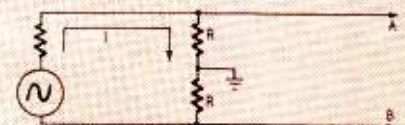

Fig. 3—Sometimes this can be used.

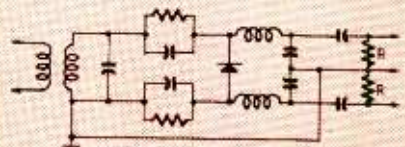

Fig. 4—One application of Fig. 3.

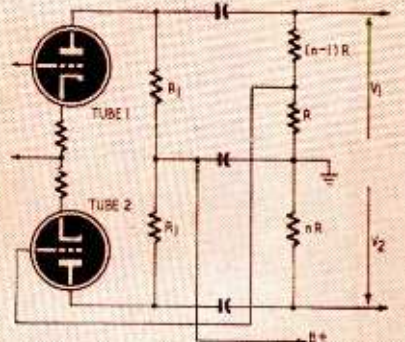

Fig. 5—One of the commonest inverters.

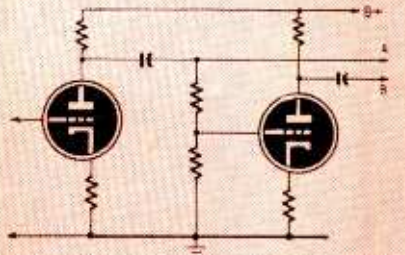

Fig. 6—This shows how Fig. 5 works.

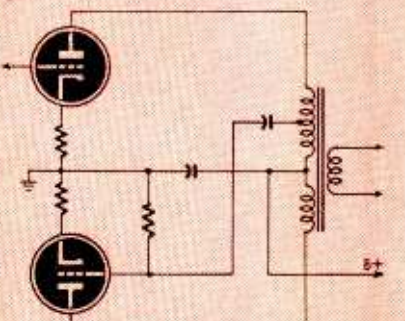

Fig. 7—Another little-used circuit.

doing no work, and can be omitted.

Suppose, however, that through wrong choice of the resistor R_1 , the grid of the second tube is driven too hard. The voltage appearing at the screen of tube 2 will be greater than that produced by tube 1 at the top of R_1 . When the grid of tube 2 goes plus, the top of R_1 will go negative. This negative voltage will be communicated back to the grid of tube 2 to help restore the balance. We have, in fact, negative voltage feedback in the screen-grid circuit of tube 2, which helps to preserve the balance.

Unfortunately, the grid-screen transconductance is too low to be of very much help in such a simple circuit. A typical value of g_{ks} would be 500 μ mhos, and the "stage gain" will only be a few decibels, which is not much to use for feedback. So this elegant balancing—although helped by a common cathode resistor—isn't really so good. Of course, if R_2 is made very large, the effect can be increased, but usually you cannot make R_2 large or you will not get any power out of the tubes. The bright boys in the class will have no doubt seen that we could put in a choke instead of R_2 , thus providing the balancing forcing action at no cost in d.c. volts. Here, however, we run into a new difficulty. The screen of a normal output tube is not a well-behaved electrode: if you drive the grid hard you get a distorted sort of wave at the screen as soon as you have any substantial screen load. This you would expect, because after all, you have a pentode drive applied to a triode. The result is that as you increase the balancing load R_2 you increase the distortion fed back from the screen circuit into the grids, and the result can be quite unpleasant. My experience is that all these trick circuits which save two components or so usually degrade the system down to the "all right for the price" class.

The tube circuits which we have considered in this article can be seen to have one feature in common: the drive for the pull section is derived from the push section in a way which depends on a knowledge of the gain of a tube stage. As a tube transconductance can vary over a 2:1 range, there is not

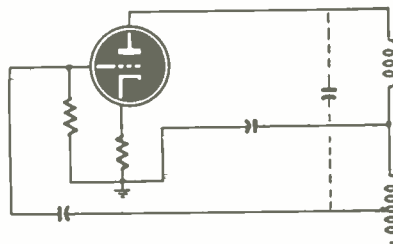

Fig. 8—Oscillator hidden in Fig. 7

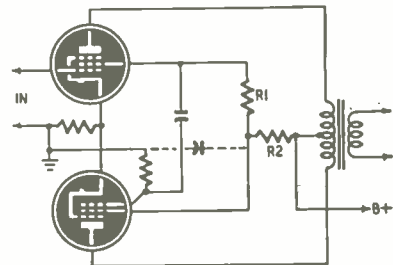

Fig. 9—Inverter with three defects.

much hope that the push and the pull will be equal, or if they start equal there is not much hope that they will stay that way. Obviously the designer who wants to get the best performance must think up some better method. Two basic types of solution have been found. One is to use the same current passing through two separate load resistors; the other is to use very large amounts of negative feedback. These solutions will be discussed in later articles.

It is only fair to add that in condemning these widely used circuits I am not suggesting that the designer who uses them does not know his job. It is merely that while their job is to produce plenty of output which does not sound too bad, my job always seems to be to produce plenty of output which gives less than 1%, or 0.5% or whatever the specification says, of distortion. What is worse, there is no tube selection or trimming allowed, though I can always afford an extra tube if I want to apply more feedback. Pity the poor designer who is trying to save two cents, but if you can afford it, make it good! END

Further articles on push-pull drivers will appear in early issues.



"Some day I'm going to have to tell that surgeon next door a thing or two!"

ELECTRONICS AND MUSIC A LIST OF ARTICLES

Below is a list of the series by Richard H. Dorf published under the title "Electronics and Music." These constitute practically all the articles on electronic music published by us in recent years, with the exception of "Electronic Music—the Easiest Way," which begins in this issue.

- July, 1950—Practical electronic instruments. Page 48.
- August, 1950—Theory of musical scales. A simple tone generator. Page 42.
- September, 1950—Syncing near tone sources and thyatron generators. Page 41.
- *October, 1950—Vacuum-tube oscillator provides flexibility and reliability. Page 45.
- November, 1950—Basic L-C oscillator circuits and how to multiply their frequencies. Page 28.
- December, 1950—Nonresonant frequency divider to make a one-octave instrument cover the whole audio spectrum. Page 38.
- January, 1951—Designing tone generators for electric organs. Page 110.
- February, 1951—More on tone generators. Page 30.
- March, 1951—Circuits of the Thyratone, a solo-type electronic instrument. Page 39.
- *April, 1951—Construction details and tuning procedure of the Thyratone. Page 62.
- May, 1951—Photoelectric methods for generating tones and harmonics for desired tonal quality. Page 48.
- June, 1951—Electrostatic mechanisms in electronic tone generators. Page 45.
- July, 1951—Strobocom—precise frequency meter—measures sound accurately to hundredths of a semitone. Page 42.
- August, 1951—Tone analyzed by the formant theory of acoustic resonance. Page 40.
- September, 1951—The Hammond organ—music from spinning wheels and electronic circuits. Page 56.
- *October, 1951—Hammond organ continued: preamplifier, vibrato, reverberation, speakers. Page 44.
- November, 1951—The Baldwin, an all-electronic instrument. Page 60.
- December, 1951—The Baldwin keying and tone-color circuits. Page 30.
- January, 1952—More on the Baldwin—tone coloring and note blending circuits. Page 76.
- February, 1952—Consonata—over-all description and circuitry. Page 49.
- March, 1952—Consonata—keying, mixing, and tone injection circuitry. Page 38.
- April, 1952—New electronic instrument (Lowrey Organo) makes organ of any piano. Page 32.
- May, 1952—Solovox—construction and circuit details. Page 56.
- June, 1952—Minshall electronic organ—true organ tones with few components. Page 44.
- July, 1952—Minshall electronic organ continued. Page 48.
- August, 1952—More on the Minshall organ. Page 44.
- September, 1952—Obstacles and opportunities in building an organ. Page 48.

The issues marked with an asterisk are out of stock. Others are available (at 30¢ for 1952, 35¢ for 1951, and 40¢ for 1950 issues, except the special television issues, January 1951 and 1952, 50¢ each). All issues with electronic music articles prior to October 1950 are out of stock and cannot be supplied.

ELECTRONIC MUSIC ... the easiest way

A solo instrument
with wide keyboard range
and a variety
of tone-color effects
—simplified
circuits and mechanical
construction

By V. FASTENAEKELS

PART I

If you are intrigued by the possibilities of electronic music, but shudder at the electrical and mechanical problems involved in building a complete electronic organ (such as described in "Electronics and Music," by Richard H. Dorf, in September RADIO-ELECTRONICS and preceding issues.—*Editor*), you can get a great deal of pleasure and musical satisfaction from this relatively simple instrument which I call the *Ondiovox*. In addition, the experience gained in constructing, operating, and experimenting with it should be highly valuable if you ever decide to go on to more complex designs.

All the basic calculating and experimenting has been done, and the only test equipment needed to get it working is an ordinary volt-ohmmeter. There is still plenty of room for experiment—especially in the tone-coloring circuits. This should certainly not be laborious. It can even be thrilling, when you try some simple combination of components and get a particularly melodious or novel sound effect.

This is strictly a solo instrument—that is, it can play only one note at a time. Unskilled musicians can operate it easily. It makes a fascinating accessory to a piano or reed organ; or it may even become a basic element in an all-electronic musical system of your own.

The electronic and electrical sections of the instrument are as easy to build as any standard radio or amplifier. The keyboard may be salvaged from an old piano or harmonium. This article will

cover the electrical circuits of the instrument. Because of space limitations keyboard modifications (or construction—if you prefer to make your own), mechanical details, and the metal-frame console will be described in the second installment.

Basic design

A block diagram of the system is given in Fig. 1. All fundamental keyboard tones are generated by a simple multivibrator. Individual notes are produced by changing the time constant of an R-C circuit. The basic keyboard range of the tone generator covers three octaves: from F in the second octave below middle C to E in the second octave above middle C (approximately 85 to

640 cycles). With auxiliary switching the low end can be extended to 27 cycles—the lowest tone on a standard 88-note piano.

The vibrato circuit consists of an 8-cycle oscillator and a buffer amplifier. Vibrato amplitude is controlled by an ordinary potentiometer, and the circuit may be switched off completely if desired.

The outputs of the tone generator and vibrato oscillator are combined in the mixer tube. This tube has a third input from the "attack" circuit, which controls the rise time of the key tones to simulate wind, percussion, or bowed instrument characteristics.

The mixer stage is followed by an isolating transformer, and a series of

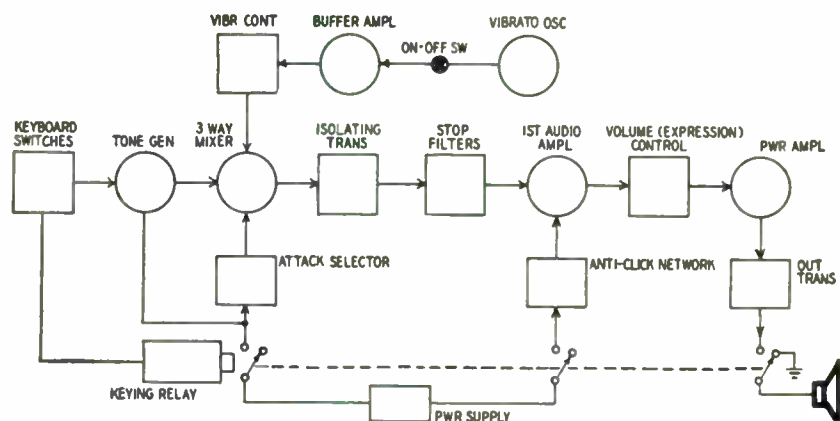

Fig. 1—A block diagram of the *Ondiovox*. The relay blocks noise and keying clicks.

pulse. This is coupled through the .001- μ f capacitor to the control grid (pin 4) of the 6SJ7 mixer tube.

The vibrato oscillator

In this circuit the left-hand triode of the 6SL7-GT is a phase-shift sine-wave oscillator. Each R-C section of the feedback network between plate and grid shifts the signal phase approximately 60 degrees at a frequency of about 8 cycles per second. The three sections give the total shift of 180 degrees required for oscillation. (Other frequencies are shifted more or less than 180 degrees by the constants of the feedback network, and do not reach the grid in the correct phase to maintain oscillation.) Losses in the feedback filter are more than compensated by the voltage gain of the triode. The right-hand triode is a direct-coupled buffer amplifier whose output is fed through the "vibrato-control" potentiometer to the suppressor grid (pin 3) of the 6SJ7.

The attack circuit

The 6SJ7 is the workhorse of the instrument. It not only modulates the output of the tone generator at the 8-cycle vibrato frequency, but also provides control over attack time.

In all pentodes, the screen grid has the greatest degree of control over the plate current. In voltage amplifiers like the 6SJ7, the screen voltage also determines the amplification factor of the tube. In this circuit, the screen of the 6SJ7 (pin 6) is supplied from the 0.25-

μ f capacitor C2. This capacitor is charged from two sources: The 105-volt battery supplies a steady *negative* charge through the 2.2-megohm resistor, which cuts off the plate current of the tube. When the relay contacts are closed by pressing any of the keys, the power

d.c. flowing through the windings, a push-pull plates-to-line type, such as the Thordarson T-22S90 or UTC 0-10 will give maximum primary impedance.

Tone-color circuits

An infinite variety of tone colors can

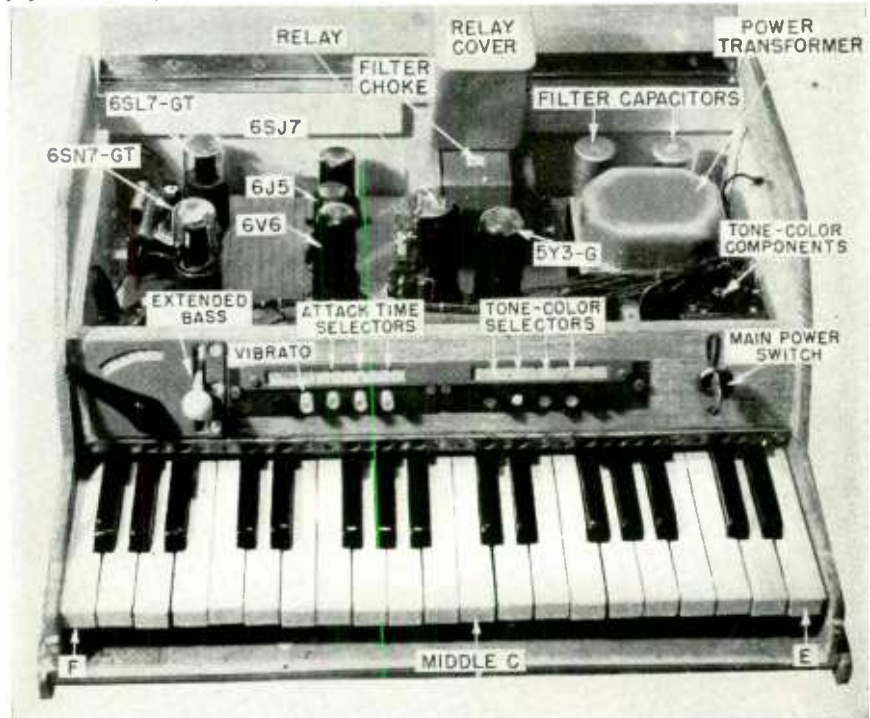

Fig. 6—General layout of the chassis, keyboard, and main operating controls.

supply provides about 170 volts *positive* at the common terminal of the three attack resistors. The time required for the screen capacitor to charge to this new voltage depends on the attack resistor selected. In the FAST position the combination of 10,000 ohms and 0.25 μ f has a time-constant of 0.0025 second. In this time the screen voltage rises to 63% of the difference between -105 and +170, or about +68 volts. After about 4 time-constants (0.01 second) the screen reaches the full 170 volts, less a small drop in the attack resistor due to the screen current. Thus the 6SJ7 swings from cutoff to full gain in approximately 0.01 second.

In the MEDIUM position the 250,000-ohm series resistor increases the time required for the 6SJ7 to reach full gain to 0.25 second; and in the SLOW position it takes about four seconds.

There is no current drain on the 105-volt battery, so it should last as long in the equipment as it would on the shelf. If you want to eliminate the battery altogether use the simple regulated supply shown in dashed lines in the power-supply diagram (Fig. 5).

The plate of the 6SJ7 is coupled through a 0.1- μ f capacitor to the primary of a low-level plate-to-line transformer. The capacitor blocks d.c. from the primary to prevent any drop in inductance due to core magnetization. A high-fidelity type is not essential, but the primary impedance should be as high as possible for good low-frequency response. Since there is no unbalanced be produced with various combinations

of resistance, capacitance, and inductance across the secondary of the isolating transformer. Only a few representative effects are shown in Fig. 2. These were obtained with components that happened to be available.

Audio amplifier

Except for the volume (expression) control, this part of the circuit is perfectly straightforward. In order to obtain the greatest ruggedness and freedom from noise with foot-pedal operation the expression control is made up of individual fixed resistors on a 21-point wafer switch. The values are given in Fig. 4. The mechanism will be described in the next installment.

Power supply

The power supply too follows standard practice. See Fig. 5. The series-connected neon lamps across the output act as a bleeder and provide some regulating action to hold the output voltage constant. The circuit in dashed lines may be added to replace the 105-volt battery in Fig. 2.

Construction

The general layout of all components can be seen in Fig. 6. The entire assembly (except for the keyboard switches and frequency-controlling resistors) can be mounted on a 7 x 17 x 2-inch chassis. Each resistor in the frequency-control circuit is mounted directly behind its associated key on a long terminal board. This part of the assembly will be described in the next installment.

(To be continued)

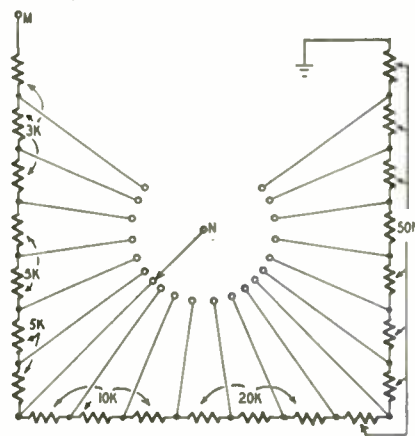

Fig. 4—Step-by-step volume control.

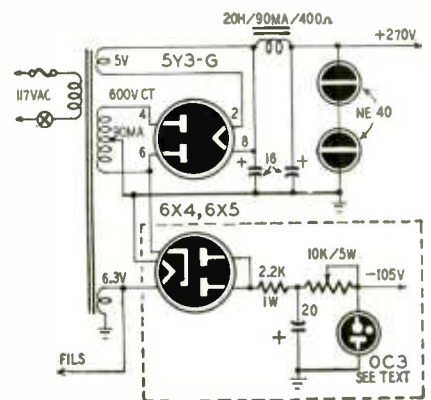
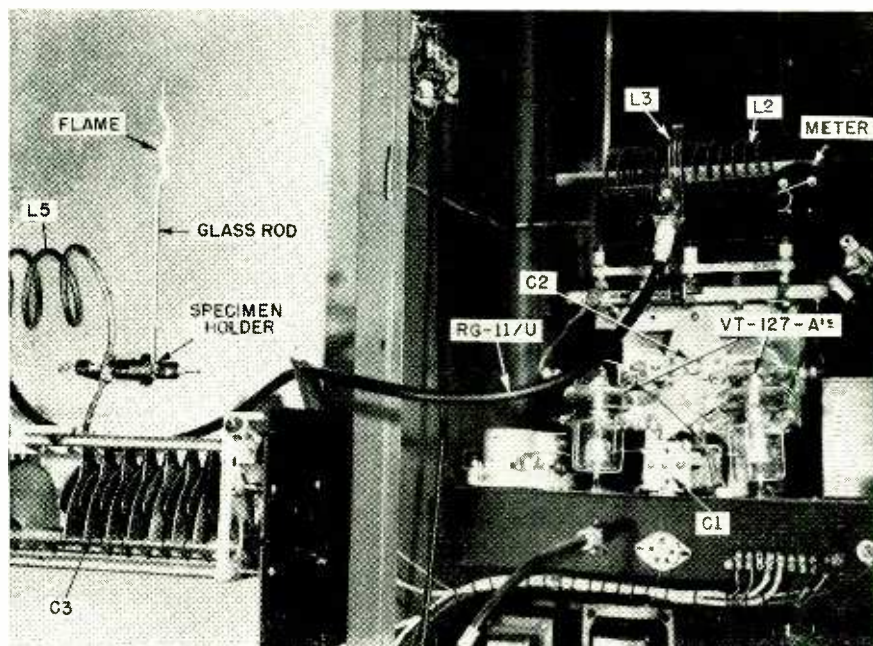

Fig. 5—Power-supply circuit diagram.



Setup of the electronic flame equipment, including the final transmitter stage. Half the parallel-resonant-circuit capacitor is beyond left edge of photo.

that are burned reduce very slowly to ash, compounds, and melted material. The flame needs little or no oxygen (but might need a supporting gas about it). Compounds can be formed which are nonconductors of current. When the plate current is turned off the flame goes out but comes on again when the current is turned on. The electronic flame looks and acts like any other fire.

No complete transmitter schematic is given, for the results can be duplicated by any 1,000-watt, high-Q short-wave transmitter, with a high-voltage output tuning capacitor a necessity. The master oscillator is a crystal-controlled 6AC7 oscillating at about 7 megacycles. It drives a 6Y6 doubler-amplifier. The 5U4 supplies B plus for these two tubes. A 6L6 doubler drives the 813 buffer amplifier at 14 mc. It supplies the final amplifier tubes, a pair of VT-127-A's, with 150 watts of grid drive. The buffer amplifier is supplied 400 volts d.c. by a pair of 816's, and the final amplifier gets 3,000 volts d.c. from a pair of 866's. A 5U4-G also furnishes grid bias for the class C final amplifier. The VT-127-A's are surplus radar tubes similar to the Eimac 100T's and 304T's. They can stand very high plate currents. This is why we can allow the electronic flame to burn in excess of $\frac{1}{2}$ ampere plate current without damage to the tubes.

The output frequency of the unit is located in the 14-megacycle amateur band. The station was operated by Wardel Mitchel, W8SYK, during experiments. (Don't forget FCC regulations with respect to unmodulated carriers.—*Editor*) The output of the final amplifier is coupled to the output circuit by a coaxial cable RG-11/U. This coupling circuit is so designed as to prevent the 3,000-volt d.c. to the final amplifier tuning tank from getting into the flame output circuit. Refer again to

Fig. 1. It is important to maintain a very high Q in the output circuit where the rod to be burned is placed.

To find the right place to put the rod to be burned on the output tank I suggest that a large highly insulated screwdriver be touched to the high-voltage point to find the place where the largest arc is drawn off. Be very careful, as an r.f. burn is bad and will jump as far as an inch to one's hand. Keep your hand back on the handle!

Tuning is the same as that of any transmitter except I recommend that the final amplifier and output tuning plate current be tuned with the final amplifier plate current *off*. It is well known that the final amplifier plate current can be tuned by watching the very small dip in the final plate current meter even though near zero. The output tank can be tuned the same way after the rod to be burned is properly placed—except we tune the output tank for the least amount of movement of the plate current meter when it is dipped by the final plate tank capacitor. After the current is turned on, touch up the final and output tanks by regular methods for the best resonance.

When resonance is reached, the end point of the metal or glass rod will burst into fire. The coupling from the final amplifier tank to the output tank can also be tuned for more or less coupling. The greatest coupling does not always make the biggest flame. About one half coupling is recommended for maximum Q.

Why does the glass or metal rod act as it does? When a parallel-resonant circuit is tuned to resonance it has a very high impedance and consequently a high voltage across it. If the Q of our circuit is high then there will be a very high voltage at a very low current across the output tank at resonance.



Fig. 2—Copper wire, steel drill and iron clothesline after burning. The single strand of clothesline was observed to burn down one inch in ten seconds.

This voltage is in the millions. Oscillating at 14 megacycles, there is no way to radiate this high power. A small six-inch rod when placed at this point offers very little impedance to the resonant tank; therefore the Q of the circuit is not affected and the high voltage will be at the end point of the rod. This high-potential energy has no place to go other than out the end point of the rod into the air. As this energy is rushing out the small end point of the rod the rod is bound to get hot. It appears that it is not the current that is making the rod hot enough to burn, but the high voltage constantly pounding away at 14,000,000 times per second. Almost anything would get hot if you pounded it at that pressure and frequency!

The temperature of the flame depends on the type of metal burning. Metals with a higher melting point will take a fraction of a second longer to reach that melting point. As long as a metal has not reached its melting point its end point remains small, giving the energy leaving it a small path out, but when its melting point is reached, the end is much larger and offers less resistance to the outgoing energy and the temperature will stay at the vapor and melting point of the metal used.

The only factor that would seem to limit the temperatures that may be attained would be the amount of energy used and the pressure behind it. In this experiment 1,000 watts appear to be sufficient to burn almost any metal.

Upon closer examination of the contents of the flame it was found to contain vapor of the element that was emitting the flame as well as a mixture of the oxide of that element. The light that comes from the flame is that which is given off from any metal when it burns, plus some ionization of the vapor by the r.f. in the tank circuit. END

PLATED CHASSIS

New production technique forecasts drastic changes in methods of production

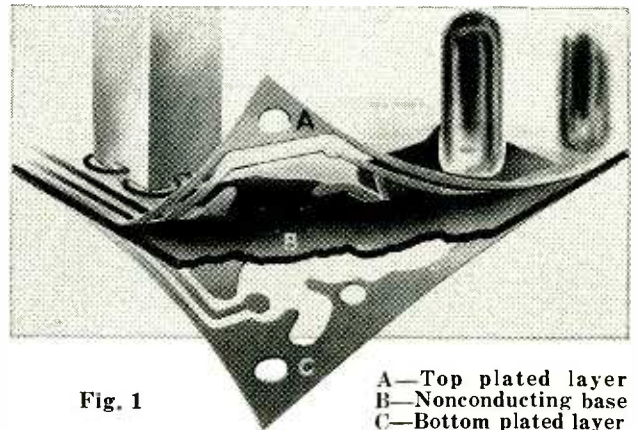

Fig. 1

A—Top plated layer
B—Nonconducting base
C—Bottom plated layer

PLACIR is the name of a new plated-circuit process used by Motorola in the construction of the 5-tube a.c.-d.c. broadcast receiver models using the HS-289 chassis. In these sets, the usual metal chassis has been replaced by a stamped plastic base appliquéd on both sides with a thin layer of copper in a pattern which duplicates the wiring layout of the receiver. Each line of the pattern is a conductor which replaces the hookup wire or bus bar used in standard wiring techniques. The metal plating extends through all holes in the chassis to connect circuits on the front with those on the rear. A cross-section drawing of one corner of the chassis is shown in Fig. 1 and the underside of the chassis is shown in Photo A.

This type of construction minimizes lead breakage through vibration and eliminates problems of hum and feedback caused by variations in lead dress.

Sockets are integral parts of the chassis. They are made by boring holes in the plate and inserting small clips which fit over the tube pins. The clips connect to the proper circuit elements through plated leads.

The outer edges of the chassis and the large plated areas in the center form the common B minus return. Other short leads carry r.f., i.f., and a.f. signals, and filament and d.c. operating voltages.

There are no printed-circuit components in the receiver. All resistors

and capacitors are conventional components soldered to the plated-circuit leads on the chassis. Photo B shows the major components mounted on the top or front of the chassis.

Servicing precautions

The circuit (Fig. 2) is conventional but the physical construction requires modifications in service methods.

Always observe the following precautions when servicing or handling plated-circuit chassis:

1. Use an isolation transformer between the set and the power line. The edges of the chassis and the large plated areas in the center are connected directly to one side of the line, so there

is a danger of a serious shock or a short circuit if the transformer is omitted and the line polarity makes the chassis hot with respect to ground.

2. Do not service the chassis on a metal plate. A short circuit is likely.

3. Handle the chassis with care. All voltage-carrying leads are exposed.

Replacing components

The unusual construction of this chassis makes it necessary to use new techniques and precautions when replacing components. Follow these rules:

1. Avoid tube breakage by removing them before starting work. Pull the tubes *straight* out. Wiggling them may deform a socket clip and cause a poor

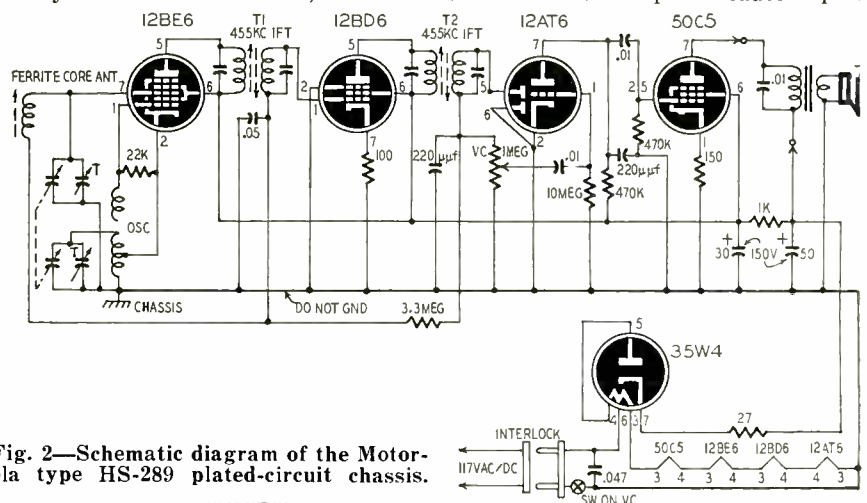
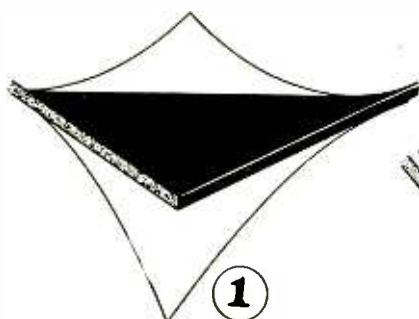
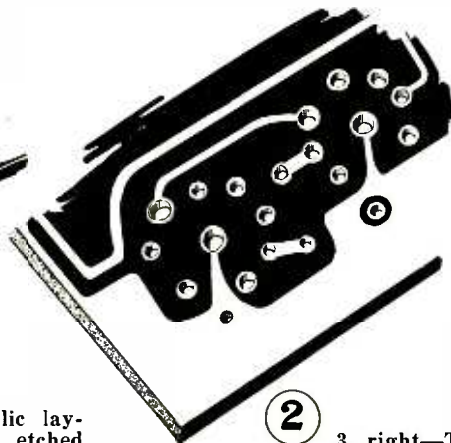

Fig. 2—Schematic diagram of the Motorola type HS-289 plated-circuit chassis.



1

1—Insulating base and two metallic layers form a sandwich. 2—Metal is etched out by photoengraving techniques, leaving metal circuit lines on nonconductive base.



2

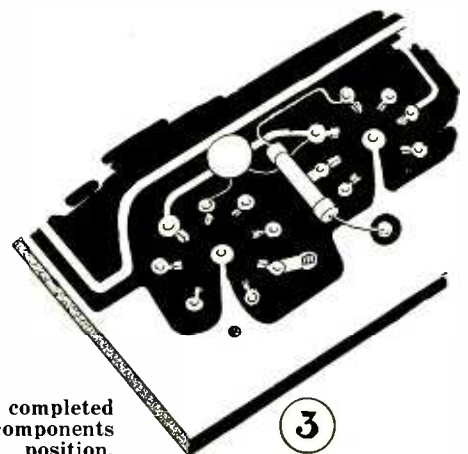

3

3, right—The completed chassis, with components soldered into position.

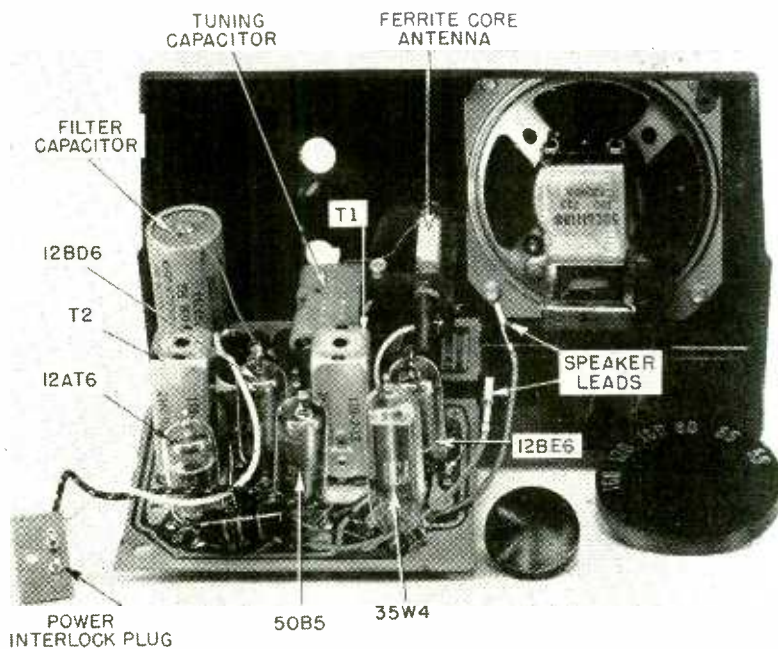
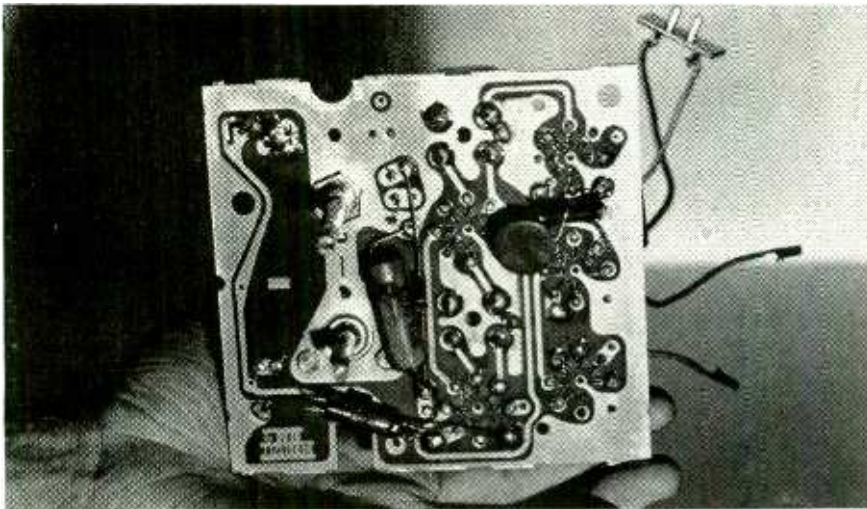

Photo A (top)—Underside of the Motorola HS-289 chassis. Photo B (bottom)—A top view of the new chassis. Photo at right shows the smart cabinet of the five-tube a.c.- d.c.-type receiver which uses the new HS-289 chassis.



- contact between it and the tube pin.
- When removing defective components, use a *small* soldering iron (60 watts or less) to avoid damage to the wiring. *Do not use a soldering gun.* The leads are very thin and too much heat will burn them or cause them to pull away from the base material.
 - Replace damaged circuit leads with regular hookup wire.
 - When removing i.f. transformers, the volume control, or electrolytic capacitor,

the recommended procedure is to immerse all lugs simultaneously in a small soldering pot. The component can then be lifted away from the chassis. If a soldering pot is not available, heat each lug individually with a *small* soldering iron, and shake off as much molten solder as possible. The component can be removed by alternately heating and loosening each lug. Take care that you do not pull the plated connection away from the chassis.

- Damaged tube clips can be removed by squeezing with pliers and then unsoldering. Snap the new clip into the hole and solder it to the lead.
- To remove resistors and capacitors, unsolder one lead at a time. Be sure to remove all solder from the holes and do not permit it to run into adjacent leads where it will cause a short circuit.
- Be extremely careful not to damage the plating while removing or replacing the volume-control mounting nut or the tuning-capacitor mounting screws.
- Insulating washers must be placed under the heads of the chassis-mounting screws when reinstalling the chassis in the cabinet. These washers prevent the screw heads from damaging the plating on the chassis.

Alignment procedure

The alignment procedure is standard. An isolation transformer should be used between the receiver and the power line to avoid shock, short circuits, and hum. If a transformer is not available, connect the low side of the signal generator output lead to the chassis or negative leg of the filter capacitor through a 0.1- μ f capacitor rated at 400 volts or higher.

Alignment Table

Sig. Gen. Connection	Sig. Gen. Frequency	Tuning Gang	Adjust. (See Fig. 3)
Pin 7 of I2BE6	455 kc	Fully open	1, 2, 3, and 4.
Pin 7 of I2BE6	1620 kc	Fully open	5 (Osc. trimmer)
Loop*	1400 kc	Tune for maximum	6 (Ant. trimmer)

*Connect signal generator across a 5-inch diameter, 5-turn loop placed at least 12 inches from the antenna of the receiver.

All circuits are tuned for maximum output on an output meter connected across the voice coil of the speaker. The signal generator should be set for 30%, 400-cycle modulation. A 0.1- μ f capacitor in series with the hot lead from the signal generator acts as a dummy antenna.

Alignment procedure is given in the table. Begin the alignment with the volume control set for maximum output. Reduce the output of the generator as the circuits are brought into resonance so the signal across the voice coil does not exceed 0.4 volt (.05 watt). This prevents the receiver from being overloaded. END

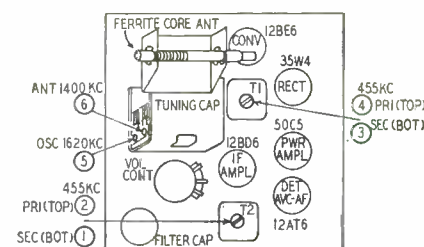
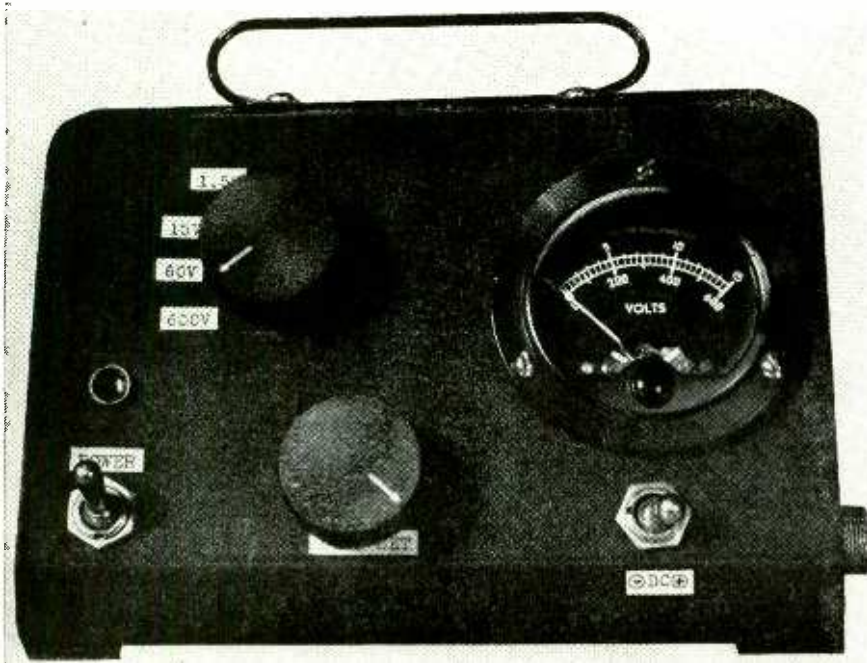

Fig. 3—Location of alignment points.



Inexpensive
electronic meter
simplifies
many servicing
tasks

LOW COST

VTVM

By JULIAN P. FRERET

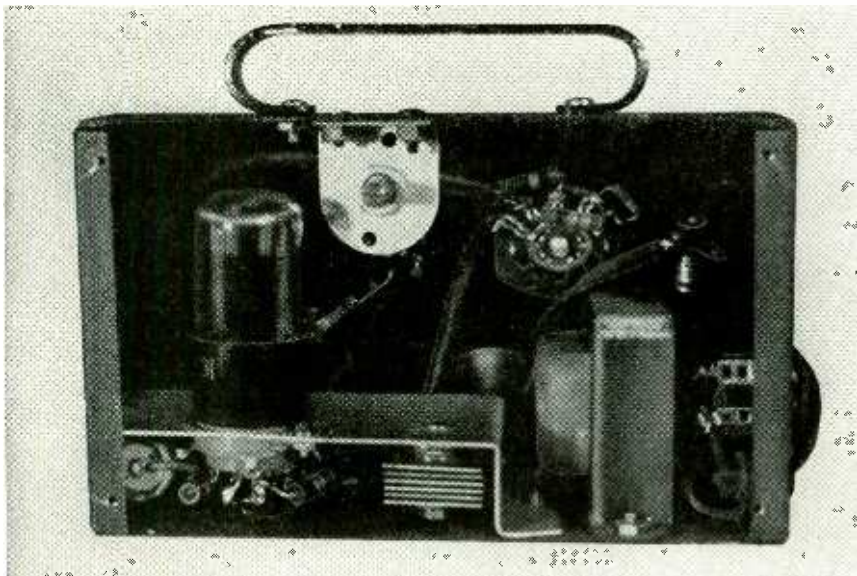

THE 20,000 ohms-per-volt multi-meter has become the basic item of test equipment for shop and laboratory. The popularity of the vacuum-tube voltmeter has also increased substantially during the past few years. With greater complexity in FM and TV receiving equipment, the v.t.v.m. has become a necessity for many jobs which require high-impedance measurements.

The home constructor and small shop owner is confronted with the dilemma of either buying a ready-made instrument, assembling a kit, or making up a meter from scrap and surplus components lying around in the extra parts department. The technician who has learned to make full use of his 20,000 ohms-per-volt meter may not feel like spending the \$50 to \$200 required for a factory job, nor even making up one of the several kits on the market ranging from \$20 upward. A home-built job may fill the bill insofar as basic measurements and ranges are concerned, and at the same time dent the pocket-book only slightly, depending, of course, upon the number of spare parts that can be gathered from the junk box.

A glance at the back issues of radio construction periodicals and at the various v.t.v.m.'s made up by acquaintances reveals that they fall into two classes: the super-duper jobs including ohms scales reading to thousands of meg-ohms, supplied with 1% resistors, 4-

RADIO-ELECTRONICS

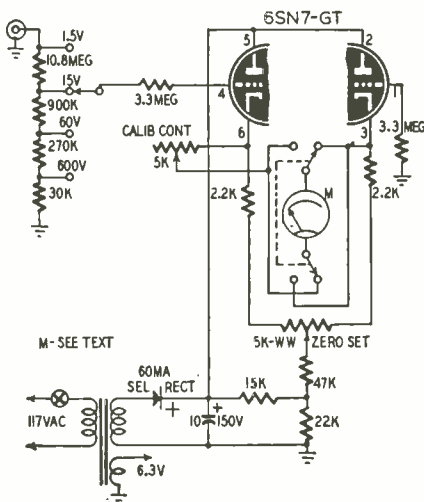

(Photo above)—Rear view of the v.t.v.m showing slotted-shaft calibration adjustment. Fig. 1 (left)—Schematic of the inexpensive v.t.v.m. Fig. 2 (below)—Schematic diagram and construction details of the rectifier-type test probe.

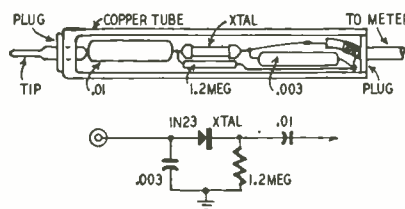

inch meters and voltage-regulator tubes (and incidentally priced out of the average shop operator's budget) and the "look-it's-no-larger-than-a-match-box!" type (accompanied by a photo showing that it is, in fact, no larger than the box of safety matches posed beside it). The latter type—the cut-toy variety—is of little practical value, and generally requires diminutive parts that are not readily obtainable.

The meter shown in the photographs was made up as a happy compromise between the extremes of high cost and tiny impracticability. Except for resistance measurements, it will perform most of the functions of the larger models at a considerable saving in original cost. Resistance measurements were omitted, as it is seldom necessary to obtain readings in excess of 20 megohms, and all values below that may be obtained with the usual high-resistance multimeter. Too, a measuring device of high input impedance for determining resistance is of limited value to the average repairman or experimenter. The additional switch and switch bank, resistances, voltage cell, and recalibrated meter-movement scale necessary for resistance measurement not only would increase the cost and complexity of the instrument but might also result in expanding its size or severely overcrowding the interior of the cabinet.

The meter was constructed in a small sloping-front sheet-steel box more or less as a novelty, as horizontal face meters always seem to necessitate leaning over to observe small changes in readings, while the vertical models on a bench or work table usually require stooping for careful scrutiny. Dimensions of the cabinet are 4 by 4½ by 7 inches long, a standard size readily obtainable from supply houses. It was adequate to house the parts without undue crowding. A miniature tube was decided against, on the basis of availability, lower replacement cost and greater ruggedness of the 6SN7. A 12AT7 might be substituted for the octal tube, with a saving of space, but the 6SN7-GT has furnished satisfactory service since the instrument was completed, and the decision against a miniature tube was apparently a wise one.

Details of construction are shown in the accompanying photographs. The power transformer is mounted directly on the floor of the sloping-face cabinet, and the switches and controls are held to the front panel by their retaining nuts. The rest of the parts are mounted on a small aluminum chassis bent out of a 3 x 4-inch piece of scrap cut down to size and drilled for the socket and various mounting lugs. The chassis is provided with sheet-metal screws to the bottom and side of the cabinet to retain it in place. The scrap pile also furnished another piece of thin aluminum, which was used for a cabinet back. The back was carefully drilled near the tube to provide ventilation and prevent overheating, which might cause inaccurate readings.

The tube filament is heated by a

transformer secondary winding rather than by a dropping resistor. (See Fig. 1.) This precaution was incorporated so that the 117-volt a.c. supply would be divorced completely from the meter circuit, since much work involves a.c.-d.c. sets, and a direct 117-volt line in either the plate or filament power supplies is likely to produce fireworks and misfortune. The high-voltage secondary of the power transformer furnishes 117 volts, which, when used with the selenium rectifier, produces a low and stable plate supply for the tube.

A word about the meter movement. The one shown was bought surplus from Sun Radio of Washington, D. C., for \$2.97, and has a 500-microampere movement with 0-15 and 0-60 volt scales. These scales lend themselves to easy multiplication and the finished instrument was designed for a.c. and d.c. ranges of 0-1.5-, 0-15-, 0-60-, and 0-600-volt full-scale measurements, which have proved the most handy around the shop. Any other low-current movement that may be available can be pressed into service. Remember that the lower the basic movement the better. A 0-50 microampere movement, for example, will permit operation over a smaller portion of the tube's characteristic curve, and consequently allow greater linearity and accuracy, than a 0-1 milliampere meter. Of course, since the price of meters is generally directly proportional to their sensitivity, the limiting factor will be the expense, unless a spare meter of high sensitivity is lying around the extra-parts bin.

Resistors for the "resistance stick" are of the inexpensive half-watt variety, but were chosen with care to assure values as close as possible to 30,000, 210,000, 900,000, and 10.8 megohms. Since the basic accuracy of the meter depends directly on the tolerance of these resistors, selections were made from the stocks of a tolerant retailer after many measurements with an accurate ohmmeter. Precision or semiprecision resistors could have been substituted, but, again, the cost was the limiting factor and the more accurate and expensive units were decided against.

In the front-view photo, controls, from left to right, are: on-off switch in the power line, with pilot-bulb indicator above it, range-selector switch, balance-control potentiometer, polarity-reversing switch, and (at the side) the connectors for input leads. At the rear, as shown by the other photo, the calibration control is mounted behind the meter movement and once adjusted need not be moved unless the tube is changed or the resistance stick changes markedly in value.

The circuit is of the balanced type. The balance control makes the two halves of the dual triode draw such current that both plates are at the same potential. A change in the grid voltage of one will upset the balance and cause the meter movement to register according to the impressed voltage. The 6SN7-GT was found to have sufficiently straight characteristic curves to make

readings linear over the instrument's basic operating range, which is from -1.5 volts to +1.5 volts for full-scale movement.

Bill of materials for meter.

Resistors: 2—2,200, 1—15,000, 1—30,000, 1—47,000, 1—270,000, 1—900,000 ohms ½ watt; 1—1.2, 2—3.3, 1—10.8 megohms, ½ watt; 1—22,000 ohms, 1 watt; 2—5,000-ohm wirewound potentiometers.

Capacitors: 1—.003, 1—.01 µf, paper; 1—10 µf electrolytic, 150 volts.

Switches: 1—single-pole, 5-positions; 1 s.p.s.t., 1-d. p.d.t.

Miscellaneous: 1 60-ma selenium rectifier, 1-1N23 crystal; 1-half-wave power transformer, 117-120 volts, 40 ma or more, 6.3 volts, 1 amp or more; 1 meter, as per text, 1 6SN7-GT tube and socket for same, jack, plug material, hardware, wiring, etc.

The d.c. probe (Fig. 2) contains a 1-megohm isolating resistor which results in reduced capacitive loading of the circuit under test. Most a.c. measurements are made at higher frequencies, so it was decided that no rectifier be built into the cabinet. Instead, a probe with crystal and coupling capacitor was assembled from the junk box. It has been more than adequate for general shop and home construction work. The probe was constructed in a short section of ½-inch diameter thin-walled copper water pipe such as is used in ordinary house plumbing. Formica plugs for the ends were cut to general shape with a coping saw and turned down to size in the chuck of an electric drill. The tip consists of a screw-type earphone tip threaded into one plug. Shielded cable connects both the d.c. and a.c. plugs to the connector fitting at the side of the meter, reducing hand capacity to a negligible amount. The scale readings for a.c. measurements with the probe are a trifle higher than the actual values of potential. Since the difference is slight (about 10%—*Editor*) it can be ignored in favor of comparative measurements, or may be compensated for with a correction factor on the meter scale, if desired.

The v.t.v.m. shown has been in service for several months now. Though it lacks hairline accuracy and large-instrument versatility, it has provided creditable results for all service and the usual home-experimental type of work. An aluminum strap handle completes the job, and makes the instrument readily portable for service calls or movement about the house and shop. At a total outlay in the neighborhood of \$5 plus parts salvaged from the average spare-parts bin, it will represent an asset of far greater value to the average radioman and experimenter.

Calibration is no problem if your meter is identical to the one used in this instrument. Feed in a known voltage which has been measured on an accurate multimeter or v.t.v.m. and adjust the CALIBRATION CONTROL for a correct reading. If you use a different type of 500-µa meter, you will probably have to prepare a new dial scale or calibration chart. Use variable-voltage a.c. and d.c. supplies and an accurate meter to supply calibration points. END

CONFIDENCE IS SALABLE

By JAMES M. HARTLEY



ELECTRONIC service technicians complain constantly that the public considers them "gyps," or that that stories to that effect are printed or circulated. The associations pass resolutions; the press is appealed to; signs are posted in stores. But no one presents the technician's side of the story to the ones who count—the public!

When an automobile manufacturer wants to plug a new model, he doesn't just scream, "It's the best!" in three-inch headlines. Look at the ads. He gets down to the meat of the subject, with text and pictures to show the car's features and advantages. And when you go for a demonstration ride, the salesman shows what the car will do besides simply talking about it.

How does that apply to TV service? Well, what have we to sell? Parts? Tubes? Soldering irons? NO! All we have to sell is *know-how*. And the only time to sell it, effectively, is when you are face-to-face with your public—right in the customer's home.

Resentment—or appreciation?

Take, for instance, an intercarrier set—complaint, sound but no picture. Do you go in, open up the back, pull off the cage, slap a new 6SN7 in, wait for the picture tube to light up, button up the set, and say (nearly your first words): "It was a tube, lady. That'll be \$5.70," and bolt out of the house in 10 minutes?

If you do, that lady will soon be telling her friends: "It was such a little tube, and he was only in the house 5 minutes, and he charged me \$5.70!" (In a tone which brackets you with the James boys.)

Same set—same complaint—but this time a *service salesman* makes the call. He turns on the set before he starts to get out the tools, lets it warm up, tries the controls (you'd be surprised how often the brightness is turned full off and the customer didn't try it before she called!). All the time, he is showing his know-how by explaining what he's found out and what he's doing. (Most customers want to know what's

going on, even if it's only so they can give the details to Pop when he gets home that night.)

He explains, even before the back of the set is off, what parts of the set *aren't* giving the trouble. "We have sound," he says, "so we know right away that the tuner and the picture circuits and the sound tubes and the power supply are working. In these sets, you see, the picture and sound come all the way through the set together, and the sound is picked off just before the big tube, so that means all those tubes are working."

By this time, the back is off the set. "Well, the big picture tube is lit! I'm glad that's not burned out! So, the only place left to check is the part that produces the high voltage—in this cage, here."

The lady is nearly sure to look to see what cage, and this is a good time to ask for a dust-rag, turn off the set, and clean the dust off the big tube. (You should, anyhow, to make sure it's not leakage that's giving the trouble, and you get a reputation for neatness and carefulness in the bargain.)

Our salesman then opens up the cage and makes a spark test on the horizontal amplifier plate. "No spark there," he says. "The trouble must be in the part of the circuit before that point." He puts in a 6SN7; the face of the C-R tube shows a cooking class or something, and he starts to put the set back together as he says, "I'm glad it wasn't the 6BG6—that's a \$4.80 tube. The one that went bad is only \$2.20; so with our minimum service fee, that's just \$5.70."

Then he goes around to the front of the set, takes a look, sets the contrast and brilliance controls, goes "tsk! tsk!" gently, and says, "Have you noticed some of the people have sort of flat heads (or short legs, as the case may be)?" He gets out his mirror, goes behind the set, and adjusts the vertical controls until the picture just fills the screen and is linear, then puts the set back against the wall, saying: "There, I'm sure you'll find that will be better."

Our service salesman is out of the

house within minutes of the time our first example took; but what a different result! Our lady now boasts to all who will listen: "Why, he was only in the house a few minutes, and before he even took the back off he knew what was wrong! Why, did you know that the sound and picture go all the way through the set together, and the sound is separated right at the big tube? And he was the *niciest* man—he even dusted the insides, and he was *so* glad it wasn't an expensive tube he found bad! Why, he only had to charge me \$5.70!" (And this time, the tone of voice brackets you with Einstein and "Break the Bank.")

Pop wants to know, too

When the man of the house is around when you call, you probably have trouble keeping him out from under you as you work. But that, too, can be an asset. Every man is convinced he could have been a Steinmetz if he'd only gone to M.I.T. instead of where he did go. So your running patter is stepped up to include some technical terms, and when you spark-test the plate cap, you let him see the spark, and explain how the 15 kv is generated, "just like the ignition in your car, where the 6 volts is jumped up to 6,000." By the time you leave, you and he are fellow-experts, and you're a cinch to be called the next time the set has troubles.

Psychology at work

This idea of selling yourself as an expert is just applying what the psychology boys have been reporting for years. People have been conditioned to listen to authority, from school days on. The teacher who knew the answers without looking in the back of the book, the doctor who knows what ails you, the cop who can direct you through a strange city, all represent authority giving out with knowledge. And by a subconscious association, the technician who "talks a good game," who imparts information with his work, who *shows* he knows more than the customer by explaining something that to him is obviously simple, but to the customer is terribly complicated, is classed,

in the client's mind, as an "authority."

You don't need a club

Technicians wail, among themselves, that the public doesn't appreciate the overhead they have to carry. But what do they do to help it sink in, when they're in a position to do so? It's not hard, and shouldn't be obvious. But, when you're reaching for a tube, customers will say: "My, what a lot of tubes you have there!"

This is the point at which to say: "Yes, there's over \$120 worth of tubes in that box, and that's only what I carry with me." You are imparting by implication that you also keep an excellent stock at your shop, and, without any more effort than that, you have established yourself as a solid businessman, with a good layout. If you're an independent, with no sales-room, it's doubtful that your customers will ever see your shop, so you have to let them know that the shop is there, backing you up—that you're not just a man with a black box of tubes and tools, with an office under your hat.

Similarly, when you have to yank a chassis to the bench, explain that you're taking it there only "because I have over \$1,200 worth of instruments on the bench, and they'll tell me what's wrong much faster and more accurately." A man with \$1,200 of equipment on his bench is obviously a better repairman than the one with only a little meter in his kit, so let them know about the bench. The average set owner will respond readily to the proposition that it's easier to take a chassis to the shop than to take a shop to the set.

If you can fix the set with only your meter, apologize for taking so long to find the trouble. Tell the customer: "My bench equipment would have located the bad part sooner, but I didn't want to have to charge you for transporting the set to the shop." You get the shop idea across, and the customer is pleased that you are trying to save him money on the job.

Don't overdo it, of course. If a man talks too much about his shop, he begins to make the owner suspicious. You don't want him to wonder if you may not just be talking to cover up the fact that you haven't got a shop at all. Let your reference to the shop be natural and justified.

Remember that a service technician has only two assets, his reputation and his knowledge. Your reputation can be built up only over a long period of absolutely honest and fair dealing. But some confidence in your know-how can be imparted to the customer on your very first visit.

The active selling of your stock-in-trade, your knowledge, will keep you from being classed by your customers as "one of those gyp TV men." As proof, our shop (a bench in the cellar of our home) services only customers who have heard about us from other customers, and we have five times as many on our list today as we had a year ago!

END

RADIO DETONATION OF BLASTING CAPS

SOME time ago, a small boat conducting seismic explorations in the Gulf of Mexico was wrecked by a mysterious explosion. (Seismographic exploration—generally used in searching for oil—is the technique of mapping underground formations by setting off explosions below the surface and measuring the time required for blast waves to reach various receiving points.)

Investigation definitely established that the boat's store of blasting caps had been set off accidentally by radio waves.

Although this is the only known case of its kind, the possibility that it might happen again prompted E. I. du Pont de Nemours & Company to make a detailed study of all the factors that could conceivably cause such an accident. Their *Technical Bulletin No. 13*, released this year, gives the results of their investigation, and recommends specific methods for checking suspected hazardous areas.

The danger involves only the caps used to set off the main blast. (Dynamite and similar high explosives are detonated by mechanical shock or extremely high pressures. Blasting caps are filled with an ignition-type explosive, fired by a spark or the heat of an electric current. The shock of the cap explosion sets off the blasting charge.)

The current required to fire commercial caps ranges between 0.25 amp and 0.5 amp. Anything over 0.15 amp is considered potentially dangerous.

R.f. pickup

This much current may easily be developed if the cap is at the center of a circuit (Fig. 1-a) one half-wave long at the frequency of a nearby transmitter; or at the end of a circuit one quarter-wave long (Fig. 1-b). In the first case the blasting circuit forms a resonant dipole with the point of maximum current in the center. In the second case, the circuit acts as a quarter-wave, grounded (Marconi) antenna, with maximum current at the grounded end.

Since blasting leads are usually run along the surface, or supported on stakes over swampy ground or water, the greatest amount of energy will be picked up from horizontal transmitting antennas. Pickup is reduced if the wires are laid directly on the ground.

Danger points

AM broadcast and commercial stations constitute the greatest hazard because of their high power, relatively low frequencies (which may match the long firing leads required by ordinary safety practice), and their presence in open country where blasting may be common. FM and TV stations also use

high power, but are seldom considered dangerous since they operate at very high frequencies. Besides, their antennas are usually located on top of the tallest building available, so that blasting operations in the vicinity are fairly well shielded.

Mobile transmitters are definitely potential hazards in spite of their low power, because they may be brought directly into the blasting area.

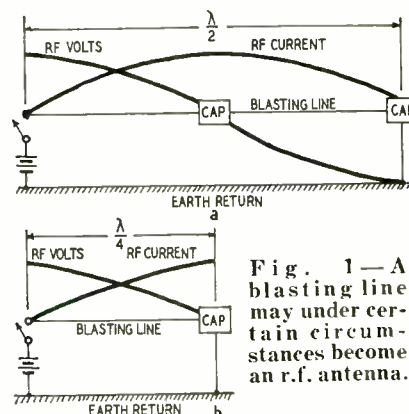

Fig. 1—A blasting line may under certain circumstances become an r.f. antenna.

Amateur, microwave-relay, radar, and loran transmitters are not usually dangerous. In the first place, they are almost always located in areas where there is little likelihood of blasting. Furthermore, they are generally characterized by one or more of the following: relatively low power; v.h.f. or u.h.f. operation; restricted radiation patterns.

Safety measures

The bulletin gives a table of minimum safe distances based on transmitter power, and allowing for all possible combinations and layouts of blasting circuits that might pick up enough r.f. energy to cause a premature explosion:

Power (Watts)	Distance (Feet)
5- 25	100
25- 50	150
50- 100	220
100- 250	350
250- 500	450
500- 1,000	650
1,000- 2,500	1,000
2,500- 5,000	1,500
5,000- 10,000	2,200
10,000- 25,000	3,500
25,000- 50,000	5,000
50,000-100,000	7,000

It also suggests an extremely simple safety test. With the blasting-circuit wires in position, a 150-ma pilot lamp (No. 47 or equivalent) is connected in place of each cap. Electric blasting should not be attempted if the bulb glows at all.

END

circuit

Unusual circuits demonstrate engineering abilities

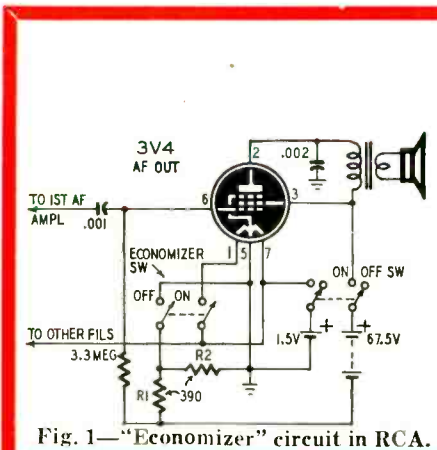

Fig. 1—"Economizer" circuit in RCA.

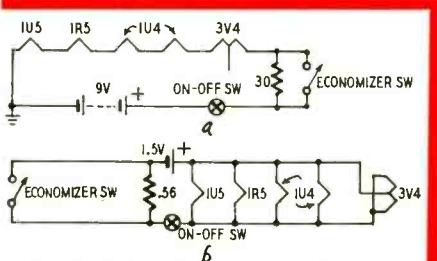

Fig. 2—"Saver" circuits in other sets.

THE comparatively short life and the high cost of dry batteries used in battery and 3-way portable radios are major disadvantages which keep many persons from using their sets more than a few months a year. For this reason, set manufacturers have developed different schemes for lengthening the life of batteries used in portable sets. These devices—called *battery economizers* or *battery savers*—may consist of built-in charging circuits like that used in the Hallcrafters *Sky Traveller*, or a switching circuit which permits the operator to reduce the drain on the batteries while listening to strong local stations.

Fig. 1 shows the battery economizer which RCA uses in its model 2B400 personal portable receiver. The ECONOMIZER switch is usually operated in the OFF position. One section connects the halves of the 3V4 filament in parallel to provide greater cathode emission and output from this stage. Approximately

3.29 volts of bias is applied to the 3V4 control grid by the voltage drop across k1.

When the switch is thrown to ON, one side of the 3V4 filament is disconnected from the battery and R2 is connected in series between R1 and ground. This raises the bias to about 4.25 volts and reduces the current drawn by the output stage.

The 2B400 uses a 1R5, 1U4, and 1U5 in addition to the 3V4 shown in the diagram. With the ECONOMIZER switch closed (OFF position) for maximum output, the life of the batteries is approximately 100 hours of intermittent service. Operating the set with the switch open (ON position) reduces the A-battery drain 50 ma and the B drain 3 ma. This raises the life of the batteries to about 130 hours.

In some receivers (Airline for example) the "saver" switch is connected across a resistor in series with one of the filament leads. See Fig. 2.

The circuit at a is used in sets with series-connected filaments. The filaments are connected in series across a 9-volt A battery. Opening the switch brings the 30-ohm resistor into the circuit and reduces the A battery drain by approximately 8 ma.

In the parallel-connected filament string at b, the 0.56-ohm resistor reduces the A drain by about 30 ma. In both of these circuits, opening the saver switch reduces the voltage on the filament string and causes the filaments to operate at lower temperature. The drain on the B battery is reduced in proportion. In circuits such as these, the values of the current-limiting resistors vary with the make and model of the receiver.

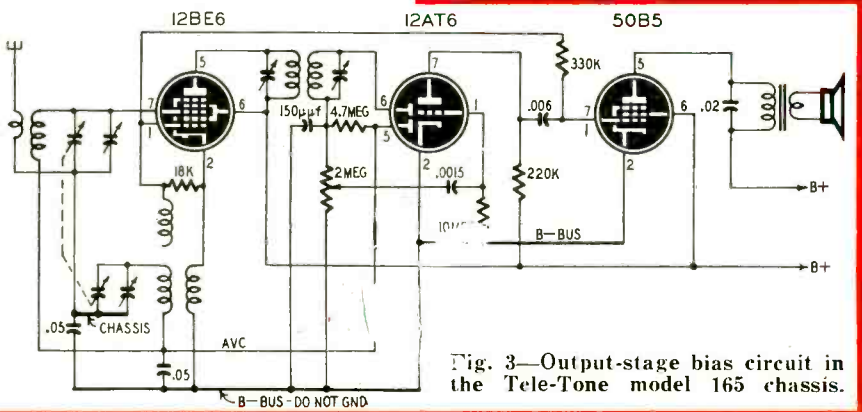

Fig. 3—Output-stage bias circuit in the Tele-Tone model 165 chassis.

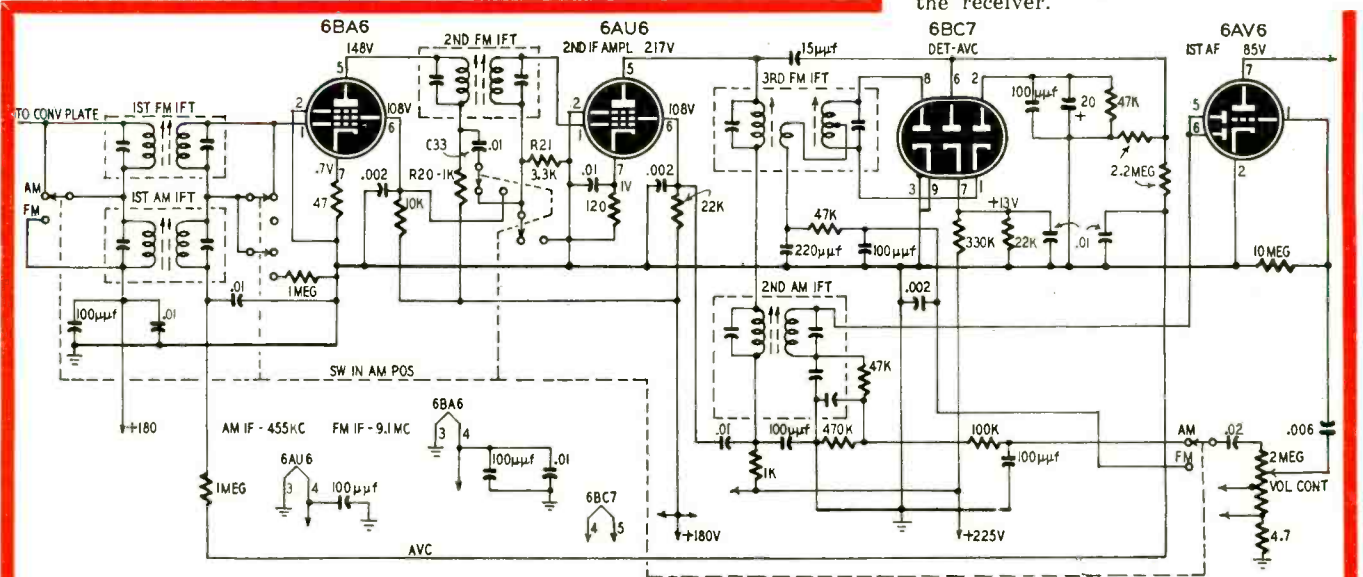

Fig. 4—Many of the recent Philco AM-FM receivers use the 6BC7 triple diode as the ratio detector and a.v.c. rectifier.

shorts

By ROBERT F. SCOTT

Novel bias circuit

In most a.c.-d.c. sets, the output tube is biased by a cathode resistor or the drop across a choke, speaker field, or resistor in the negative leg of the B supply. In these circuits, the effective B voltage on the plate is reduced by an amount equal to the drop across the biasing resistor. There is a waste of power in the resistor.

To eliminate this waste of power and available voltage, some receiver manufacturers use the voltage developed across the oscillator grid leak to bias the output stage as shown in Fig. 3. This circuit, used in the Tele-Tone model 165, eliminates the cathode biasing resistor and bypass capacitor which are generally used. This circuit is certainly not new, but it is unusual enough to be a source of trouble to service technicians who may have occasion to service the set without consulting the schematic diagram. A change in the characteristics of the 12BE6, or in the value of the oscillator grid leak can vary the bias on the output stage and cause symptoms of far more common troubles.

Leakage through the .006- μ f coupling capacitor between the plate of the 12AT6 and the grid of the 50B5 will probably cause other troubles in addition to the distorted output which is the usual result of coupling capacitor failure. The positive voltage which would appear on the oscillator grid (pin 1 of the 12BE6) would be likely to cause the oscillator to fail or operate erratically.

In one set which used this bias cir-

cuit, the set would cut out or shift frequency when operated at high volume levels or when loud passages came through. The first audio amplifier acted like a reactance tube and caused the oscillator to shift frequency or cut out entirely.

Unusual tube

While reviewing the circuits of current Philco receivers, I noticed something that I had overlooked during previous studies. For the last two years, a 6BC7 triple diode tube has been used in the 8-tube AM-FM receivers. The application of this tube is shown in Fig. 4.

Diodes connected to pins 1 and 2 and 8 and 9 are used in the ratio-detector circuit for FM reception. The diode connected to pins 6 and 7 is the a.v.c. rectifier used during AM reception. An a.v.c. delay bias of approximately 13 volts is obtained by connecting the cathode of the a.v.c. rectifier to the junction of the 330,000- and 22,000-ohm resistors in the voltage divider between B plus and ground.

Another unusual feature of these sets is the use of resistance-capacitance coupling between the first and second i.f. amplifiers for AM reception. R20 and R21 are the plate-load and grid resistors. C33 is the coupling capacitor. At the AM i.f. (455 kc), the impedance of the FM i.f. transformer windings is negligible and has little effect on the operation of the resistance-coupled circuit.

During FM reception, R20 and C33

form the plate decoupling filter. R21 is shorted out and the 6AU6 grid is returned directly to ground. The grid of the 6BA6 first i.f. amplifier and the a.v.c. line are connected to ground through the 1-megohm resistor. Sections of the selector switch short out the primaries and secondaries of the first AM and FM intermediate-frequency transformers when they are not being used. This eliminates interference by preventing signals at the intermediate frequency from entering the amplifier system. This is not necessary in the remaining stages.

Noise-compensated squelch

Some types of FM squelch circuits are comparatively ineffective in the presence of high noise levels. When the noise level is high, the limiters may draw enough current to open the squelch and permit the noise pulses to come through the speaker. To avoid nuisance noise in the output of its FM receivers, Motorola uses the noise-compensated squelch shown in Fig. 5.

In the absence of an r.f. carrier, any noise strong enough to produce limiter grid current passes through the discriminator and is fed to the grid of V1-a, the noise amplifier. A high-pass filter (C1 and R1) attenuates audio frequencies vital to good speech readability while passing the higher noise frequencies. The squelch control varies the gain of V1-a by controlling its cathode bias.

The output of the noise amplifier feeds the noise rectifier (V1-b). The rectified noise appearing across R3 is positive at the cathode and negative at the plate. A negative voltage produced by grid current in the second limiter is applied to the plate of the noise rectifier through R2.

The algebraic sum of the negative limiter-grid voltage and the positive noise voltage charges C2 and biases the grid of squelch-control tube V2-a. As long as there is no r.f. signal coming in, the voltage on the grid of V2-a varies from zero to a few volts positive, so V2-a conducts heavily and produces a large voltage drop across R4. The grid of V2-b is kept at the same d.c. potential as the plate of V2-a because it is connected to it through a 1-megohm resistor. The cathode of V2-b connects to a voltage divider which maintains it at a constant positive potential which is sufficient to cut off the audio amplifier when the squelch control tube (V2-a) is conducting.

When a modulated r.f. signal comes in, the negative limiter-grid voltage is greater than the noise-voltage output of the rectifier. The sum of the positive and negative voltages on C2 becomes sufficiently negative to cut off V2-a. With V2-a cut off, there is no voltage drop across R4. The grid of V2-b rises to the point where the grid-cathode bias is correct for normal operation. V2-b conducts and amplifies the signal applied to its grid through the arm of the volume control and the .0015- μ f coupling capacitor.

END

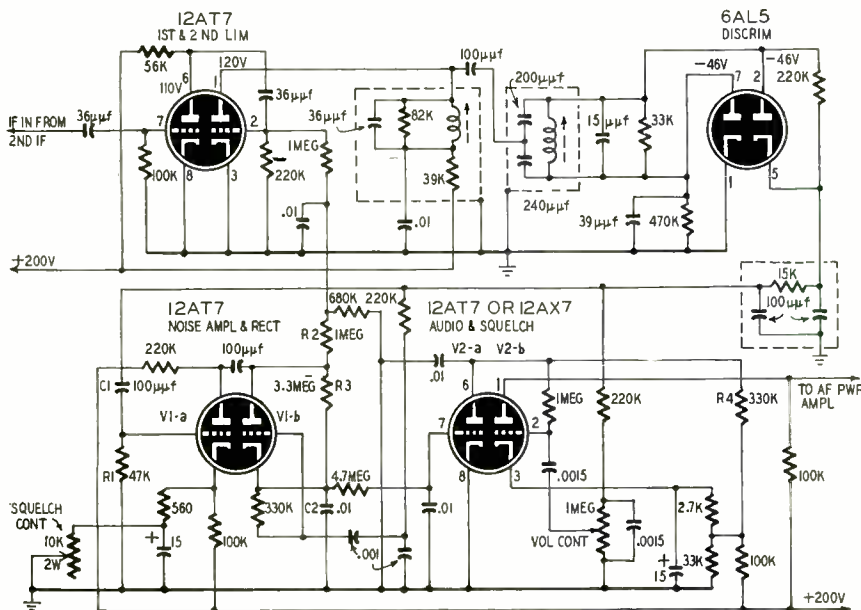

Fig. 5—Squelch circuits of Motorola Sensicon FM communications receivers. DECEMBER, 1952

General Electric's two *Translators*—for full-band or 3-channel coverage

more UHF converters

By FRED KING*

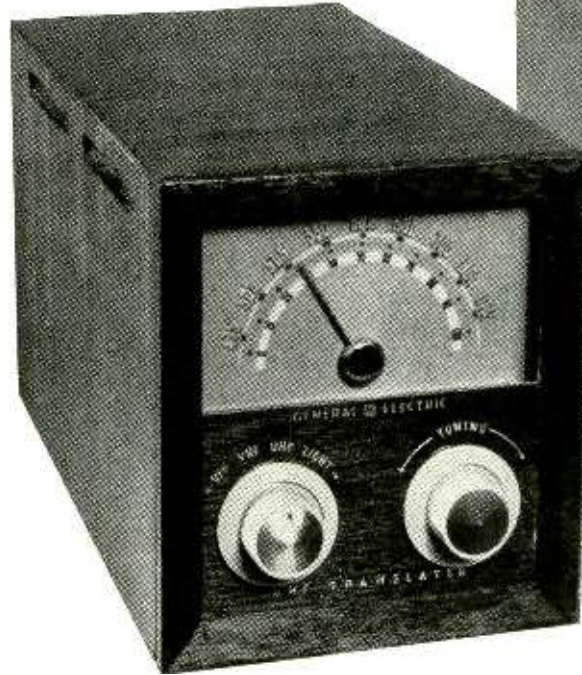

Fig. 1—G-E UHF-101 *Translator* has continuous tuning over all the new u.h.f. channels.

IN the October issue, I discussed the basic requirements for u.h.f. TV converters and described the Kingston continuous-tuning converter which employs a parallel-lines tuning system. The G-E model UHF-101 converter shown in Figs. 1, 2, and 3 employs a similar circuit in an entirely different physical arrangement. (This tuner is no longer being sold, but service technicians will run into numbers of them.)

Fig. 1 shows the appearance of this all-channel converter. The cabinet is 7½ inches high, 6¾ inches wide, and 13¾ inches deep, and is finished in mahogany veneer. The dial is calibrated in megacycles from 470 to 890, with an auxiliary 0-100 scale. A pilot lamp travels with the dial pointer and spotlights each numeral on the dial. The v.h.f. set is plugged into an a.c. receptacle at the back of the translator. The selector switch on the translator, Fig. 1, has four positions marked: OFF, VHF, UHF, and LIGHT. Throwing the selector switch to the VHF position turns on only the v.h.f. receiver and connects it to the v.h.f. antenna. The UHF position of the switch turns on the translator, disconnects the v.h.f. antenna, and connects the translator output to the v.h.f. set. The LIGHT position turns on the dial lamp for convenience in tuning. The light may be turned off by returning the switch to the UHF position after

*Chief Engineer, Radio Station WELI, New Haven, Conn.

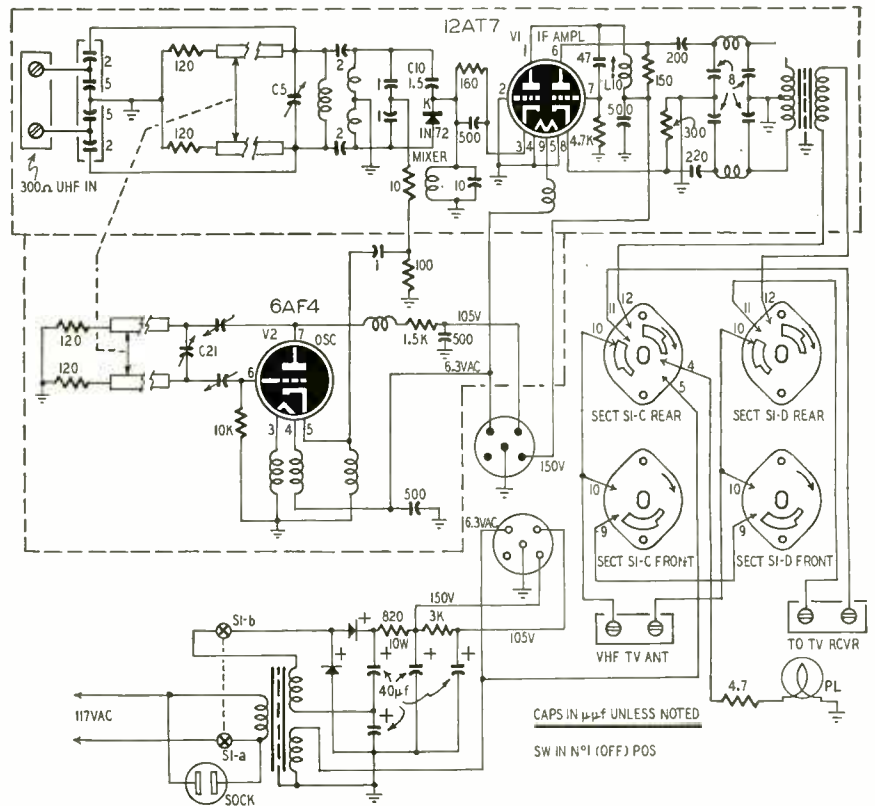

Fig. 2—Schematic of the G-E UHF-101 *Translator*. Oscillator and r.f.-input circuits are tuned by shorting bars across quarter-wave parallel lines. Switch S1 controls both *Translator* and TV receiver, selects either v.h.f. or u.h.f. input, and has extra position for turning on u.h.f. tuning-dial light if desired.

a u.h.f. channel has been selected. The right-hand knob is the tuning control.

Fig. 2 is the schematic of the UHF-101. Balanced lines tune the mixer input and the local oscillator circuit. A ganged drive-screw arrangement slides the shorting bars up and down the lines when the tuning control is varied. The 6AF4 triode oscillator is cathode-coupled to the 1N72 crystal mixer through a 1- μ f capacitor (C24). The mixer i.f. output is fed to the cathode of the first half of the 12AT7. This section is operated as a grounded-grid amplifier. The second half of the 12AT7 is a phase splitter with equal and opposite outputs taken from its plate and cathode. This allows the output circuit to be balanced to ground in the primary of the output transformer (T1), for minimum v.h.f.-noise pickup. The i.f. output is tunable between 79 and 85 mc to provide against the possibility of interference from strong local signals. If there is interference on channel 5 the slug in L10 may be adjusted from the rear of the converter to channel 6 (or vice versa). The power supply uses an isolating transformer and two selenium rectifiers in a half-wave doubler.

The diagrams in Fig. 3-a and 3-c are the alignment setup and diode detector network recommended by the manufacturer. Fig. 3-b shows the locations of the various adjustments. Precise i.f. alignment on either 79 mc or 85 mc is obtained by adjusting the slug in L10 for maximum reading on the microammeter. If one is not available the v.h.f. receiver can be connected to the translator output terminals, set on channel 5 or 6, and an ordinary v.t.v.m. connected across the picture-detector load resistor. Since u.h.f. signal generators are still scarce and very expensive, the oscillator and mixer sections can be aligned on a u.h.f. station. For oscil-

lator alignment with a station between 475 and 675 mc, after setting the dial at the proper point adjust C21 for maximum output. With a station between 675 and 890 mc, adjust the tuned-line nut "A" for maximum output. For mixer alignment adjust C5 for stations between 475 and 675 mc and nut "B" for stations between 675 and 890 mc. Both of these adjustments are made for maximum output, with the translator dial set at the proper channel frequency.

The UHF-101 will operate with all types and makes of v.h.f. receivers. It has been tested over a two-year period at u.h.f. monitoring stations maintained by WELI at New Haven, Connecticut. Reception of the Bridgeport RCA-NBC experimental u.h.f. station KC2XAK has been excellent, and there were no mechanical or electrical failures.

G-E UHF-103 translator

This 3-channel unit (Fig. 4) is designed to mount inside the v.h.f. set cabinet without affecting normal opera-

tion of the receiver on v.h.f. channels. It mounts on a bracket attached to the inside of the cabinet and can be installed easily, without removing the chassis.

When installed in the new G-E v.h.f. sets the translator's station-selector switch and a u.h.f. station dial plate are mounted behind the present v.h.f. tuning knob. On G-E sets made before the spring of 1949, the u.h.f. tuning knob and station dial plate must be installed in some convenient position on the side of the cabinet.

The translator can be set with a screwdriver to any three u.h.f. stations in the band from 470 to 890 mc. If the set is moved to a new location, the unit may be retuned as simply as the push buttons on an AM radio.

The schematic has not been released yet but units are available to the public.

We plan at present to describe the Zenith and Mallory ultra-high-frequency tuning equipment in the next article in this series. END

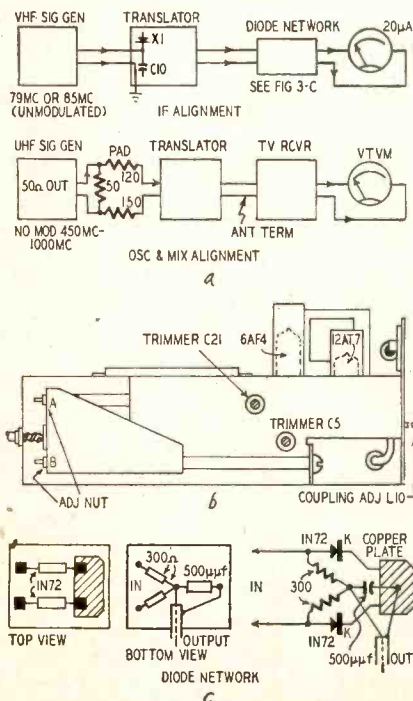

Fig. 3—Setup for Translator alignment.

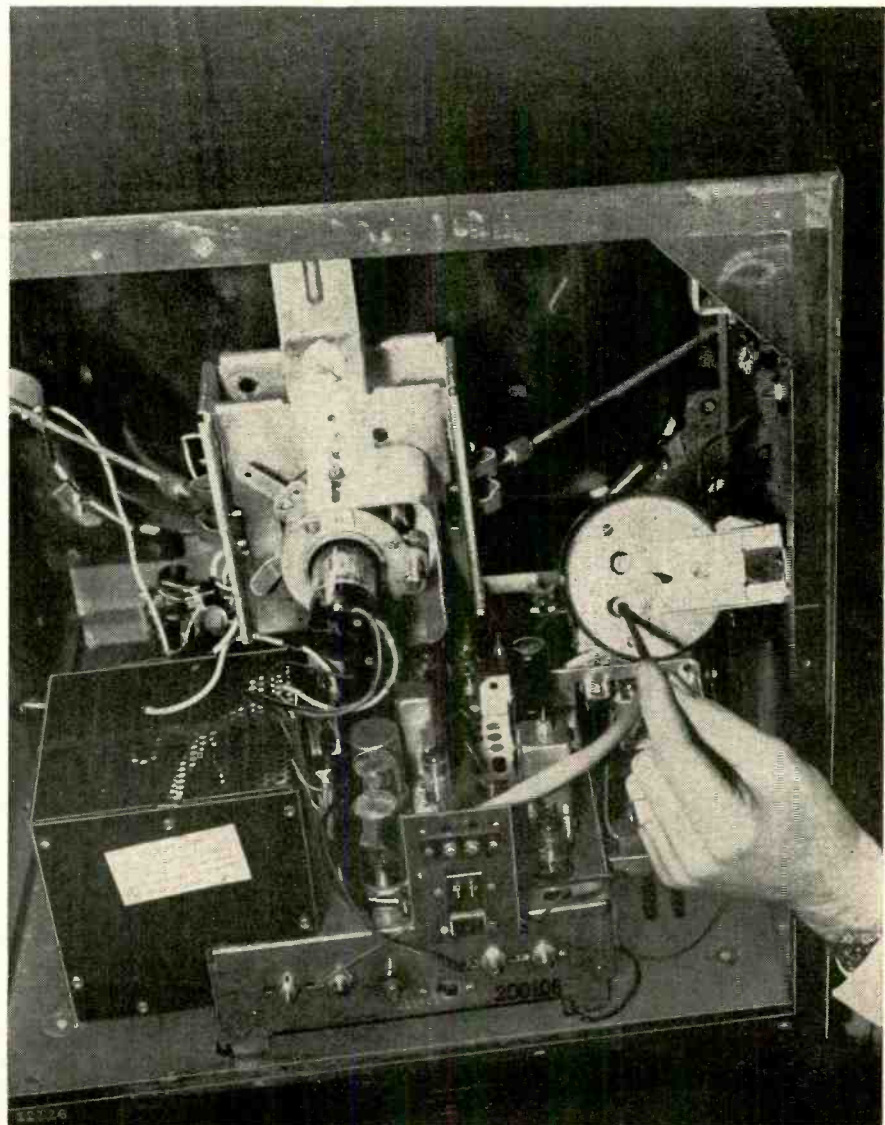
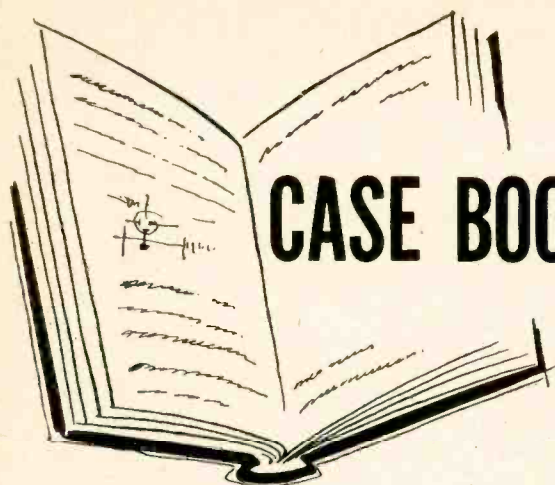

Fig. 4—Service technician making one of the screwdriver adjustments on a General Electric UHF-103 three-channel Translator mounted in a v.h.f. receiver cabinet.



CASE BOOK of a TV DIAGNOSTICIAN

By LARRY A. QUINLAN

Case 60552: Du Mont RA-109A

This is a fantastic story illustrating one of the reasons why some segments of the public mistrust the service technician. One bitter experience spread from person to person gets worse at every retelling.

A Du Mont dealer called me and told me he had sold an expensive set to a lamp manufacturer. After only four days of satisfactory operation the customer reported trouble. A relatively large service organization was handling the dealer's service. The service technician on the call took the chassis out and informed the lady of the house it would cost about \$45 to repair. The lady didn't object, but when her husband came home he blew his top.

He called the dealer and demanded to know what kind of set was being sold for the king's ransom he had paid. As a clincher he told the dealer that for \$45 he could get a Du Mont engineer to service the receiver because all the parts were still under warranty. The dealer realized that \$45 seemed like an exorbitant charge for labor. How many things *could go wrong* in a brand-new set?

This was a new model at the time and there were no schematics available. The repair card indicated that the service technician had found hum in the sound and a ripple on the picture.

With the irate customer practically breathing down the dealer's neck, I got *carte blanche* to go ahead and do the

best I could in the shortest possible time and—of course—for the lowest possible price. All service seems to be like that. Everybody wants the chassis back yesterday and a bill that represents 1939 prices.

I decided to start from scratch. There was a ripple on the picture and hum on the carrier. But there was no audible hum except when the receiver was tuned to a station. The horizontal sweep was very unstable, with a tendency to go out of sync at the drop of a hat. Trouble like this could be almost anywhere—horizontal sweep, tuner, picture i.f., video.

The most logical place to start was at the horizontal oscillator. Removing one of the horizontal sweep tubes would eliminate the probability of horizontal trouble. I could have pulled the 6K6 horizontal oscillator first, but the 6SN7 discharge tube was easier to get at. After all, why put out extra effort needlessly? Lo and behold, the hum disappeared from the sound! (The picture disappeared too, but this was due to the absence of high voltage because the 6SN7 was out of the socket.)

Checking the tube-location chart on the side of the cabinet indicated the other half of the 6SN7 was an a.g.c. clamp. It is possible to have a bad tube that has interaction between the two triode sections. At first I thought this was silly and too simple because certainly the other technician must have tried a new 6SN7 here. But since I was

doing this on my own without any preconception that the other fellow had done a job, I decided to try another 6SN7. Result—a new tube—a new set!

With that kind of luck on the first try I am now one Du Mont dealer's boy wonder. Saved the dealer \$40; got a lamp as a present from the lamp manufacturer; and who knows how much good gossip as the customer tells that story around.

Checking the 6SN7 later on a tube tester showed nothing, but testing it in another Du Mont RA-109A created the same hum on the carrier and ripple on the picture. My guess is: Some 15,750-cycle interference was getting into the a.g.c. half of the tube and was messing up the a.g.c. line, *but good*. It would be even better if one could be sure about some of these hunches.

Case 60652: Du Mont RA-147A

Complaint was: no picture, no sound. Raster was there. Seemed like trouble in the tuner, or in the first or second video i.f.'s, as these are the only parts of this receiver where picture and sound are common. Could be the power supply, but it would have to be the low-voltage section since the raster was present.

Pulling the first video i.f. tube and reinserting it immediately provided a disturbance test which gave a flash on the screen and a sound in the speaker. This quick check suggested the video i.f. strip was O.K., but a signal generator on the grid of the first i.f. gave double assurance. Black bars appeared on the screen of the CRT when the signal generator was tuned through the 20-30-mc range. Well, at least that part of the circuit seemed all right.

Next to try the tuner (see Fig. 1). All voltages going into the tuner checked O.K. Pulled the 6J6 mixer and inserted it quickly—*no* click in the speaker or flash on the CRT. Removed the 6CB6 r.f. amplifier; checked plate, screen, and cathode voltages at top of tube sockets. Tubes were heated; therefore, it seemed unnecessary to check the filament voltages.

There was no voltage on pin 1 of the 6J6 (oscillator plate), and none on pin 5 of the 6CB6 (r.f. amplifier plate). There *was* voltage on pin 6 (screen

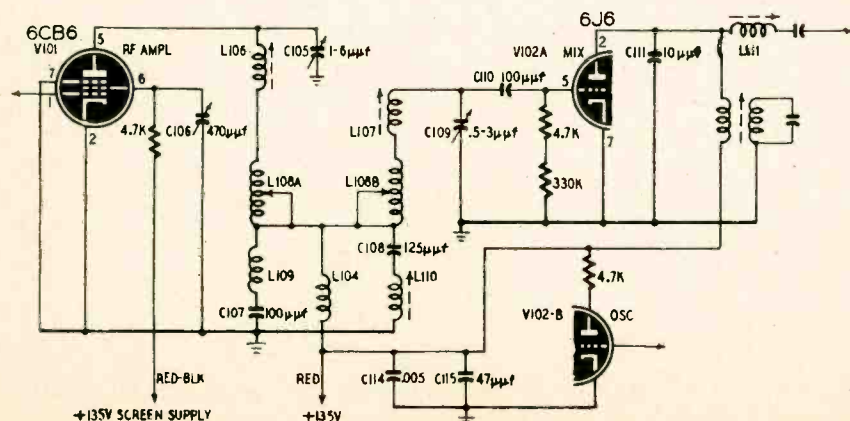

Fig. 1—Partial schematic of the Inputuner used in Du Mont RA-147A Telesets.

grid) of the 6CB6. In the Du Mont Inputuner the 135 volts B plus for the screen of the 6CB6 comes through a red and black lead and is separate from the 135-volt line to the plates of the 6J6 and the 6CB6. (These are fed through a red lead.) There was no voltage on pin 2 of the 6J6 (the mixer plate).

Nothing to do now except to remove the tuner from the chassis for careful analysis. There are five leads to unsolder before one can inspect the chassis of an Inputuner.

A resistance check from pin 2 of the 6J6 to ground gave no reading. This eliminated a short in any of the B+ bypass capacitors which might show up on a static test; of course this did not eliminate the possibility of a capacitor short under dynamic conditions. A check of the 135-volt supply line showed continuity. This suggested one of the bypasses might be breaking down under voltage.

Jumpers were used to connect the Inputuner filament, a.g.c., screen, plate, and mixer-output leads to the main chassis. The set worked and played for five hours in the shop. Next morning the set was dead again.

Checking the tuner now revealed a short from pin 2 of the 6J6 to ground. Checking the circuit suggested that trouble might possibly lie with C111, C114, or C115. These are the only bypasses to ground between the 135-volt supply and the plate of the 6J6. The short read approximately 2 ohms. Suddenly the short opened up, and the receiver began to work normally. (That eliminated the probability of capacitor trouble, because when a ceramic shorts, it usually stays shorted.)

The 2-ohm short might indicate a coil. No genius in diagnosis here because outside of the capacitors the coils are the only components in the B plus line that might cause trouble. On a visual check the sound trap, L104, L108A, L108B, L106, and L107 did not seem to be causing the trouble.

L111 was another matter. This was mounted very close to the chassis. The manufacturer had wrapped a piece of insulating tape around the coil. Touching the coil lightly with a polystyrene probe instantly created a short from pin 2 of the 6J6 to chassis. One of the L111 leads had been grounding intermittently, probably with the expansion of the wire as the chassis warmed up, or as a result of vibration.

A piece of high-voltage electrical tape fastened to the chassis and around the coil eliminated the trouble.

Case 61052: Fada S6C55

Picture closed up vertically once every 10 to 15 minutes—then righted itself almost immediately. There are about as many ways to service such a difficulty as there are service technicians, but one way which "gits thar fustest with the mostest" is to start at the midpoint of the circuit, say the grid of the 6S4, with a scope or a v.t.v.m. (See Fig. 2.) Working all the way back from the

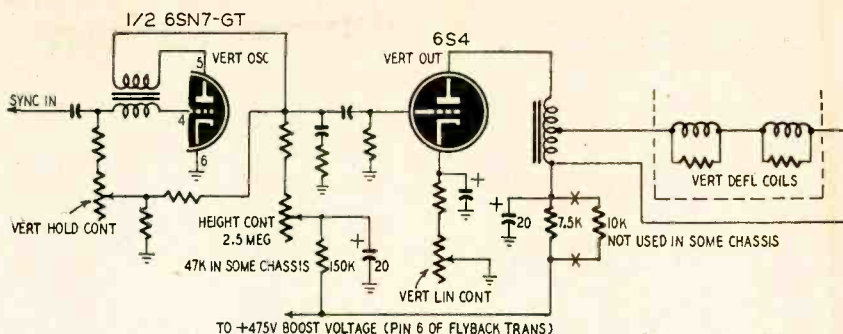

Fig. 2—Vertical sweep circuit of the Fada model S6C55 and S7T65 TV receivers.

picture tube can consume valuable time.

When the trouble shows up on the picture tube watch for any change in the v.t.v.m. reading or shrinkage in the height of the scope pattern. If there is no such change the trouble obviously lies beyond the point in the circuit where you are checking.

Both the scope pattern at the grid of the 6S4 and the picture shrank vertically after the set had warmed up for half an hour. This repeated at intervals of about 15 minutes. At each repetition there was an audible click, but it was not coming through the speaker. It was like the sound of a filter capacitor popping. Not all service technicians may have heard this sound. When the popping continues it indicates the capacitor is breaking down layer by layer. There are a number of intermittent pops until the outer layer breaks down.

Examination of the circuit showed a 20-μf filter from the slider of the height control to ground. I connected a voltmeter across this capacitor. With a 400-volt reading the picture size was satisfactory. Each time the picture shrank the needle dropped to 100 volts (sometimes with this audible pop). After each pop the needle went slowly back to 400 volts (taking about 5 seconds) and the picture height returned to normal.

This 400 volts is picked off the horizontal sweep boost circuit. A 150,000-ohm resistor (47,000 ohms in some chassis) isolates this part of the vertical sweep from the horizontal branch of the boost line. As there was no visible effect on the horizontal size of the picture, it seemed to point decisively to the 20-μf capacitor.

As a matter of routine, and to avoid callbacks in the near future, it is good practice to check the boost voltage at pin 6 of the flyback transformer. A reading of 475 is about normal. This was correct in this case, with a drop of 10 volts at each click and accompanying picture shrinkage. This confirmed the diagnosis that the trouble was on the height-control side of the 150,000-ohm resistor.

Replacing this 20-μf, 450-volt capacitor corrected the difficulty immediately and permanently. This was part of a four-section filter. The bad section was replaced with a single-unit 20-μf, 600-volt capacitor. (In cases such as this, it is advisable to replace the entire capacitor rather than the defective section alone.—Editor)

Case 61652: Fada S7T65

The complaint was that picture was not clear on most channels. No evidence of a negative-looking picture, and plenty of brightness. One service technician had suggested there might be picture-tube trouble. This is the last thing a service technician should ever mention to a customer. It's O.K. for a little tube to fail, but the customer never expects the big picture tube to go, at least not for two or three years.

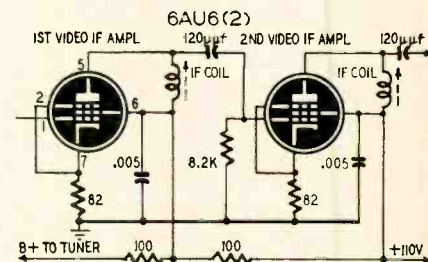

Fig. 3—Part of the Fada model S6C55 picture-i.f. amplifier B supply circuit.

Close observation of the picture showed lack of detail. This could be passed off as poor reception due to location of set or to antenna trouble. Don't brush off such a complaint as due to ignorance on the customer's part. Remember, the customer has been living with the set and knows it was once better than it is now. That's why he called for service. I emphasize this point because two service technicians preceded me on this call and both reported the set O.K.

When I went on this job I took along an indoor antenna. Turning the antenna showed no improvement on any channel. I removed the chassis and made voltage checks on the video amplifier, video detector, and the i.f. amplifiers, because these are the most logical places for this type of trouble. All checked O.K. with the exception of a reading of 20 volts positive on pin 1 of the 6AU6 second video i.f. amplifier, with the tube in or out of the socket.

Analysis of the circuit shown in Fig. 3 shows the only possible path for positive d.c. voltage to reach the grid would be through the 120-μf ceramic coupling capacitor from the plate of the first i.f. tube. Cutting the capacitor at the grid pin showed a voltage on the open end. This was a leaky capacitor with a resistance of only 120,000 ohms. END

TV SERVICE CLINIC

Conducted By
MATTHEW MANDL*

AS MENTIONED in the Clinic, we will, on occasion, pass along some of the servicing problems reported to us by readers. One of these, sent in by C. A. Dixon of Detroit, has to do with converting a TV receiver to 25-cycle operation. The set was an RCA 9T57; the power transformer has two 6.3-volt heater windings as well as a 5-volt winding for the 5U4-G rectifier filament. A conventional center-tapped secondary is used for B plus.

In order to adapt any a.c.-operated receiver from 60 cycles to 25 cycles, the power transformer must be replaced with one having a much larger core and higher-inductance windings than the original. The 25-cycle job of course will have to furnish the same circuit voltages and currents as the original. Because 25-cycle transformers are not readily available, Mr. Dixon solved the problem by getting a duplicate of the original transformer. He wired the two 60-cycle primaries *in series* across the line and connected the respective secondaries *in series* also.

The two transformers act as one, with all windings having greater inductance and the total core area doubled. This arrangement gives adequate protection against overheating for 25-cycle operation.

(Where transformers are connected in series—or parallel—all windings must be phased correctly, or the combination will not operate at all, and may even act as a dead short across the line. For series operation all secondaries must be connected so that their inductances and voltages *add*. This can be checked with an a.c. voltmeter, before final connections are made. *Only the pair of secondary windings being checked should be connected for this test. Tape up the ends of the h.v. secondaries while other windings are being tested.* RCA's TV power transformers have leads of different colors at the ends of each winding. For series operation simply connect *either* lead from one transformer to the *different-colored* lead from the corresponding winding on the other transformer.—*Editor*)

With both primaries and all corre-

*Author: Mandl's Television Servicing

sponding secondaries in series, the turns ratios are unchanged, and the same voltages are delivered as with the single transformer.

Fuse problems

Incorrect drive or a gassy horizontal output tube can cause considerable current drain. The protective fuse may be defective, or have the wrong value, and fail to blow during overload. J. S. Vazalis of Baltimore, Maryland, had this experience with a Zenith 24H20 receiver. Abnormally high current in the 6BG6-G failed to open the ¼-amp slow-blowing fuse. The excessive conduction increased the high voltage, overloaded the 1B3-GT and the 5Y3-GT low-voltage rectifier. The screen resistor of the 6BG6-G also burned out. Fortunately, the horizontal output transformer held up. This emphasizes the necessity of using exact-value fuses of good manufacture.

In many receivers the fuse value is critical. The Philco model 51-T1601, for instance, uses a 6/10-amp fuse. No other value should be used. Fuses smaller than 6/10-amp will blow out repeatedly, and a larger fuse will not give the required protection. In this receiver the filament winding of the low-voltage power transformer is protected by a *fuse link of No. 26 copper wire*. If this protective link opens, the replacement *must not be made with heavier wire*. This stresses the importance of checking the service notes for the receiver under repair to make sure the right replacement components are used.

Poor picture definition

In a Philmore CP-731D receiver using a 19AP4 tube, the picture quality is poor. Contrast seems to be lacking and shades of black and white are not true. There is not sufficient difference between dark and light signal areas to distinguish objects in the scene clearly. What could cause this trouble? G. P., Detroit, Mich.

As you probably know, this receiver uses the RCA 630 circuit to which keyed a.g.c. and a new tuner (usually a Standard Coil turret tuner) have

been added. The washed-out picture may be caused by any of the following:

Improperly aligned i.f. system.

Poor tuner tracking.

Defective a.g.c. system.

Defective d.c.-restorer system.

A combination of above troubles.

Since you have changed all tubes, you should check the d.c.-restorer system first, and all its associated resistors and capacitors. Replace the .047- μ f coupling capacitor to the grid of the picture tube, for this may be leaky.

Next, check the a.g.c. system. Too much a.g.c. bias will cut down the gain of the r.f. and i.f. systems and cause the poor picture gain you mentioned.

Finally, check the tuner tracking and video i.f. alignment with an accurately calibrated marker, sweep generator, and scope. Refer to the RCA 630 service notes for video i.f. alignment, and follow the step-by-step procedure. From your description of the symptoms, it seems very likely that poor tuner tracking and i.f. misalignment are the major causes for the poor picture quality.

Static in sound

I would like to know why there is considerable static from the sound portion of a Tech-Master model 1930 receiver. We are situated in a fringe area but it was my belief that the FM system in the receiver would prevent noises from appearing in the speaker.

I would also appreciate your giving me the length in inches of the quarter- and half-wave-length jumper bars used on double antenna arrays. W. E. R., Plymouth, Fla.

This condition is quite common in fringe areas where the signal is weak and the gain of the television receiver is increased by a.g.c. action. The noise-reducing feature of the frequency modulation sound circuit in this receiver is effective only with signals strong enough to saturate the limiter and obliterate any noise (AM) riding on the carrier. Noise will be even more pronounced if the receiver sound system is out of alignment. Proper alignment, plus a good antenna system to increase signal strength, should help considerably.

The quarter- and half-wavelength bars used on antennas depend on the lowest frequency to be used. For example, if the antenna is cut for channel 2, the quarter-wavelength spacing would be 50.5 inches and the half-wavelength 101 inches. Quarter-wavelength spacing helps the higher channels; half-wavelength spacing favors the low channels.

Sync instability

In a Tech-Master 630 type receiver the vertical sweep is unstable whenever there is a commercial or when films are shown. The receiver acts fine for other programs. I have replaced the vertical oscillator and output tubes as well as the d.c. restorer. I have also put in a new sync-separator tube without much change. What could cause this condition? F. A. R., Ridgewood 27, N. Y.

Check the tubes ahead of the sync take-off point in the video section. There is some overmodulation of the video

carrier during film commercials.

(This is generally due to large transients set up by sudden changes from black to white in printed matter and animated cartoons, and sometimes caused by 36-cycle and 84-cycle beats between the 24-frame film and the 60-field vertical scanning.—*Editor*)

This increase in signal strength is causing sync clipping in your set. A weak video-amplifier tube also could cause this by cutting off at lower signal levels. In Fig. 1 shaded area of sync tip

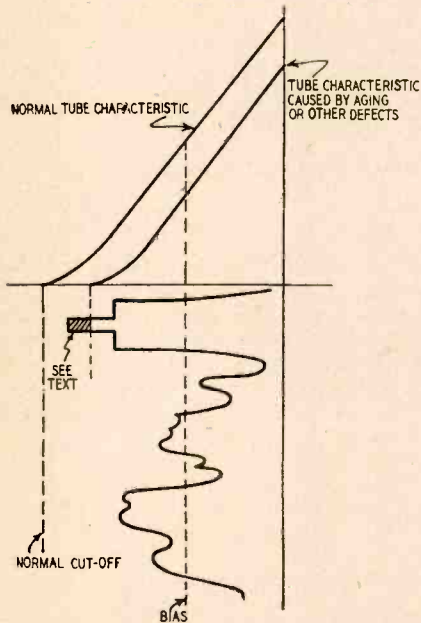

Fig. 1—Tube aging, low voltages, or circuit defects may weaken sync by clipping signal peaks (shaded portion).

is clipped when tube characteristic shifts. Because of its a.f.c. system, the horizontal sweep is not affected as much.

Poor tuner tracking or video i.f. alignment is another possible cause. Since the trouble occurs only on film commercials, it may not be worth the trouble to undertake complete realignment of the receiver. Proper setting of the contrast control might help the condition—particularly if tube replacement in the video stages improves the operation.

Horizontal instability

In a Magnavox CT-257 receiver there is horizontal instability. I can adjust it to stay in sync either during warmup or after, but not at both times. I have adjusted the horizontal oscillator circuit according to the manufacturer's instructions. How can I correct this trouble? A. A., Bronx, N. Y.

If you followed the manufacturer's suggestions in all respects and the trouble still persists, try new tubes in the modified Synchrolock circuit. First, try a new 6AU6 reactance tube, and if this doesn't help, replace the 6AL5 and the 6SN7-GT. Readjust the frequency and phase adjustments slightly after the new tubes are installed (following the procedures given in the service

notes for this receiver). Differences in emission between the two diodes of the 6AL5 or a change in the characteristics of the 6AU6 often cause the stability to be affected after warmup.

If these measures fail to help, you will have to check all parts in discriminator and reactance-tube circuits. In particular, see that the two 470,000-ohm resistors in the discriminator are within the required 10% tolerance. Make sure all voltages on the three tubes conform to those given by the manufacturer.

Snow in booster

In a Masco model MBT-13 booster I get considerable snow in the picture though the sound is not affected. There is less snow on the screen without the booster and I am wondering what the trouble could be. F. R., Pawtucket, R. I.

This would indicate that any one of the following troubles exists in the booster:

Defective tubes.

Loose sockets or wiring.

Improper tracking of tuned circuits.

Mismatch between antenna and booster, or between booster and receiver.

First, check the booster tubes and look for loose parts or defective sockets. Make sure each tube is seated firmly in the socket. Inspect wiring, to see that all parts are well soldered and check all operating voltages. Try to improve the impedance match between the booster and the receiver by varying the length of the connecting lead. Finally, you may have to check the booster tracking with a calibrated marker, sweep generator, and oscilloscope.

H.v. resistor failure

In a Philco 50-T1600 the 2-megohm resistor in the high-voltage compartment burns out repeatedly. It is connected from pin 1 of the first 1X2 to the plate cap of the second 1X2. I have replaced both rectifiers as well as the 6BQ6-GT. The high voltage can be raised or lowered by adjusting the drive trimmer. Would this have any effect on the condition? The high-voltage filter capacitors check all right. P. S., Jamaica, N. Y.

As you pointed out, the drive control affects the high voltage at the first 1X2 tube. Excessive voltage can break down the 2-megohm resistor, and the drive control should be set just below the point where left-hand stretch and center compression occurs. It is also possible that you replaced the original resistor with an ordinary radio type. An exact replacement should be used, or one recommended by the manufacturer. These are usually the deposited-carbon type, and are longer than ordinary resistors, in order to prevent flashover. Also try a new damper tube, for this also may be causing some trouble, besides the 1X2 and the 6BQ6-GT which you have already replaced.

(An identical trouble in the same receiver model was recently traced to a tiny crack in the insulation of the

filament winding for the first 1X2. An intermittent arcover between the filament winding and the flyback-transformer core—visible only in total darkness—was shorting the pin-1 end of the 2-megohm resistor to ground. As a precaution, both black-plastic-insulated filament windings were removed and replaced with high-quality polyethylene-insulated wire. This cured the trouble completely.—*Editor*)

Boost voltage

In many receivers the boosted voltage from the damper circuit supplies the plate of the horizontal oscillator. When h.v. failures occur in such receivers I find it takes considerable time to learn whether the trouble is in the oscillator or the sweep output circuit. The drive at the horizontal output grid has low amplitude and incorrect waveshape. Voltage readings at the plate and cathode of the damper show it is conducting but no pulse of any magnitude is being rectified. Voltages and resistances in the horizontal output and damper circuits are O.K. considering the lack of boost voltage. Is the horizontal oscillator off because its own parts are defective or because there is no boost voltage? Are there any short cuts for localizing the trouble? A. L. D., Nanuet, N. Y.

You should build a test power supply delivering approximately 350 volts across a bleeder network tapped at several points for lower voltages (Fig. 2).

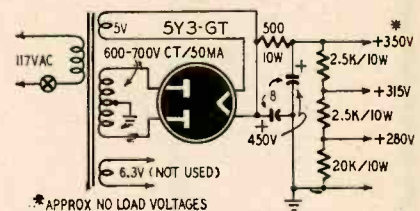

Fig. 2—Boost-voltage substitution unit.

Parts values are not too critical so long as several voltages are available. You can then disconnect the boost-voltage supply from the horizontal oscillator and apply approximately normal boosted voltage from the test supply. Check the drive waveform at the horizontal output grid for normal peak-to-peak voltage. If it is low, the trouble is in the oscillator. If the drive is normal, it indicates trouble in the horizontal output system (usually the transformer, if the tube is all right). This solves the problem of whether the boost voltage is low because of insufficient oscillator output, or because of other defects.

Some manufacturers give the ohmic values of the windings in the horizontal output transformer. In such instances continuity and resistance readings can be taken with an accurate, low-range ohmmeter. Sometimes this check is useless because the transformer breaks down only under load. If all other factors in the sweep system have been checked, a new flyback transformer will probably solve the problem. END

TV SERVICE NOTES

By JOHN B. LEDBETTER*

PART II

Horizontal pulling (Du Mont RA-112A, 113, 117A).

In most of these models, horizontal pulling can be corrected by careful re-adjustment of the a.g.c. control and alignment of the narrow-band sync amplifier i.f. transformer (Z209 in Fig. 1). The manufacturer's notes must be followed very closely. If adjustment does not correct the trouble, look for an open 2,400-ohm, 2-watt resistor (R304) in the power-supply bleeder circuit. This supplies 32 volts to the plate and screen of the sync-clipper stage. (An open resistor will be indicated by excessive plate and screen voltages on this stage.)

Horizontal pulling or bending (Stromberg-Carlson C317 series).

Check resistor R152 in the 12AU7 first sync-clipper grid circuit (Fig. 2). If this is 18,000 ohms (the value used in earlier models), replace with a 10,000-ohm unit.

Horizontal pulling at top of picture (Du Mont 112A, 113).

Check for a leaky or shorted 180- μ f plate-coupling capacitor in the 6SN7-GT sync-clipper stage (C264 in Fig. 1).

Horizontal pulling; ringing in picture; vertical hold adjustment critical (Du Mont RA-117A).

Many times the adjustable core of the 27.75-mc adjacent-channel trap (located on top side of tuner) works loose in shipment. Readjust by moving the core counterclockwise until the trouble is eliminated.

Horizontal hold extremely critical (all makes).

Insufficient filter capacitance in the B supply. If the horizontal oscillator and output tubes check good, and no apparent defect is noted in the associated circuits, try additional filter capacitance (as much as 40 μ f may be required in some models, while 8 to 20 μ f will serve in others).

Horizontal hold extremely critical (Emerson 664B).

If the horizontal oscillator and output tubes are O.K., check for low plate voltage to the horizontal oscillator. The 150,000-ohm oscillator plate resistor has a habit of increasing in value, often to 250,000 ohms or more.

Horizontal hold extremely critical or completely out of adjustment (Sentinel 401, 402, and other receivers using phase-detector horizontal a.f.c.).

Check the .047-.05- μ f, 600-volt feedback capacitor from the horizontal output transformer to the phase detector cathode. If this is leaky, also check the resistor in series with this capaci-

tor, the cathode resistor in the 6AL5 phase detector, and the plate resistor of the input triode in the 6SN7-GT horizontal oscillator. Leakage through the capacitor usually causes these resistors to change value.

No horizontal or vertical sync; picture overloaded; brightness low; sound weak; tuning eye dull green (Du Mont RA-112A, 113).

Check for a shorted 820- μ f screen bypass capacitor in the narrow-band sync amplifier stage (C233 in Fig. 1).

Insufficient width (General Electric 805, 806, 807, 809).

If operating voltages to the horizontal oscillator and output stages are normal, check for parasitic oscillation in the 19BG6-G. If this tube is good, connect a 47- μ f, 500-volt mica capacitor from pin 7 to ground. This will eliminate all parasitic oscillations.

Insufficient width (Capehart CX-33L and similar models).

Check the 0.1- μ f cathode-bypass capacitor in the 6BG6-G horizontal output stage. Also, try adding a 30- μ f, 6,000-volt capacitor from the 6W4-GT plate to ground or from the 6BG6-G plate to ground. (Later models included one or more of these changes.)

Heavy foldover on right side of picture (Du Mont RA-112A, 113, 117A, 120A).

Leaky 270- μ f coupling capacitor to the grid of the horizontal output amplifier.

Vertical lines about 10 inches in from right side of picture (Du Mont RA-119 and similar models).

Usually due to Barkhausen oscillation in the high-voltage rectifier circuit. Interchange the 1B3's or try substituting one or two new 1B3's.

Insufficient brightness on left side of raster; brightness varies with horizontal hold adjustment; sync extremely critical (Du Mont RA-112A, 113, 117A).

Replace the 50- μ f filter capacitor in the 58-volt negative bias-supply circuit (C253 in Fig. 1).

High-frequency whistle or buzz on all channels; picture and sound normal (Du Mont RA-112A, 113; Stromberg-Carlson model 17 series).

Check for a loose terminal board on the horizontal output transformer. Tighten the terminal board mounting screws; use lock-washers if necessary.

15.75-kc radiation from horizontal sweep circuit (any receiver using a metal-cone picture tube).

This trouble appears on nearby AM receivers as "birdies" or high pitched whistles every 15.75 kc on the broadcast band. Try a 500- μ f, 20,000-volt filter capacitor from the second anode lead to ground outside the h.v. compartment. Also try an 0.1- μ f, 600-volt by-

pass capacitor from each side of the a.c. line to ground.

Erratic focus (Motorola TS-53). Intermittent short between adjacent turns in the focus-coil winding. Several models have turned up with this complaint. Coil replacement is necessary in this case.

High-voltage section

No high voltage (Du Mont RA-119A; other makes).

Open filament in the 1B3-GT, or improper positioning of the filament winding on the high-voltage transformer. Try moving this winding $\frac{3}{16}$ inch away from the h.v. winding if the 1B3-GT checks good.

Slight fluctuations in brightness (all makes).

Look for an intermittent condition in the high-voltage filter capacitor. Check by disconnecting one lead. If the fluctuations stop, replace the capacitor.

Power-supply troubles

Blown fuses (Sentinel 438, 439, 440, 441, 443, 446).

The No. 8 self-tapping screw on the back of the chassis (near the interlock plug) is too long and sometimes shorts out to the plate of the 6W4-GT or 6BY5-G. Replace with a shorter screw or use several washers under the old one. *Note:* If the line fuse is a 2.5-amp Slo-Blo, replace with a 3.0-amp fuse of the same type. A few chassis have no line fuse but do have a 0.5-amp Slo-Blo fuse in the power transformer secondary center-tap return. To prevent possible damage to the power transformer, install a 3.0-amp Slo-Blo in the primary circuit in these models.

Blown fuses (Admiral 20A1, 21A1, 20T1; other makes with 6BG6-G and 6W4-GT).

When the 0.25-amp fuse in the horizontal output transformer secondary blows, check for a gassy 6BG6-G or an intermittent cathode-heater short in the 6W4-GT damper tube.

Blown fuses (Du Mont RA-109A).

If the 0.25-amp fuse in the horizontal output transformer secondary blows repeatedly, check for leakage in the 40- μ f output filter capacitor in the low-voltage supply (C288A in Fig. 3).

Replacing a 5U4G with a 5V4-G (all makes).

This is permissible if a 3-amp slow-blowing fuse is installed in the power transformer primary. Otherwise, a plate-cathode short in the 5V4-G may burn out the transformer.

Intermittent shrinkage of raster; bot-

*Engineer, WKRC-TV, Cincinnati, Ohio.

tom shrinks about 3 inches, makes proper vertical linearity impossible (Du Mont RA-109A, 116A, 119A, similar models).

Check for intermittent 40- μ f capacitors across the 220,000-ohm resistors in the bleeder network between the slider of the vertical size control and ground (C288B and C294 in Fig. 4).

Picture-tube troubles

Picture blooming; loss of high-voltage

when brightness is increased (several makes).

If the high-voltage rectifier tubes and second-anode series resistor are O.K., look for a gassy picture tube.

Magnetized picture tube (applicable only to receivers employing metal-cone tubes).

Check by holding a pocket compass a few inches from the metal cone. Demagnetize the cone by passing an unshielded focus coil, speaker field, or filter choke over the area while the coil

is energized with alternating current. *Rapid collection of dirt on picture-tube face; caused by poor dust seal between mask and picture-tube face (any make).* Cement a strip of 1/4-inch felt around the mask where it joins the face of the picture tube. Use ordinary speaker-cone cement for the job.

(Some of the above notes were taken from the author's field service notes; others were supplied through the courtesy of the manufacturers whose models are listed.) END

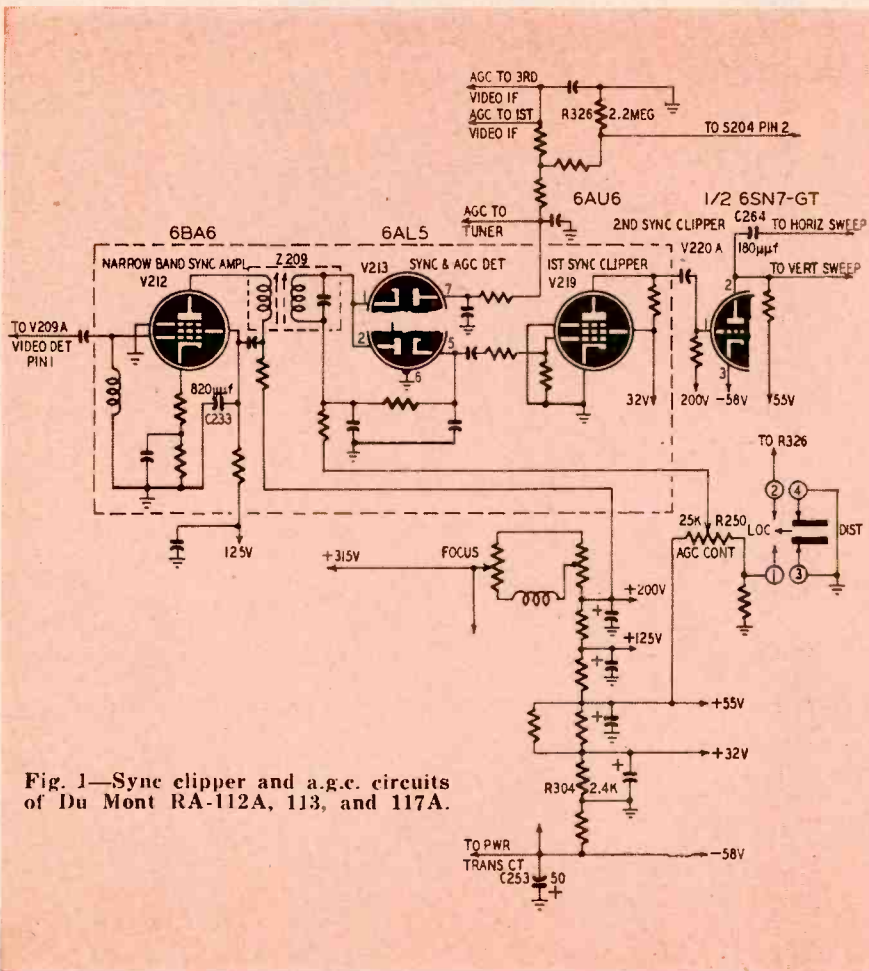

Fig. 1—Sync clipper and a.g.c. circuits of Du Mont RA-112A, 113, and 117A.

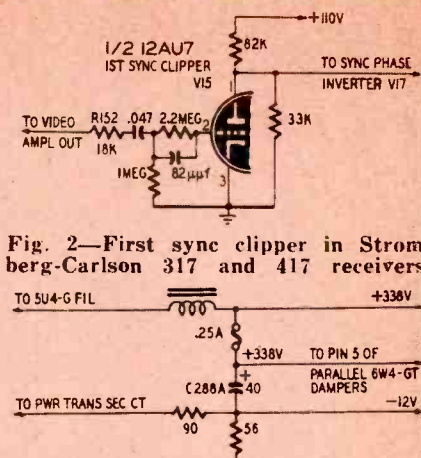

Fig. 2—First sync clipper in Stromberg-Carlson 317 and 417 receivers.

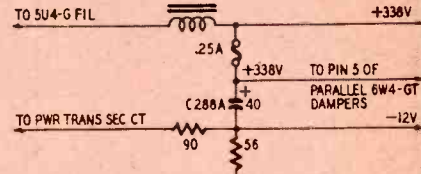

Fig. 3—Power-supply output filter circuit in Du Mont RA-109A Teleset.

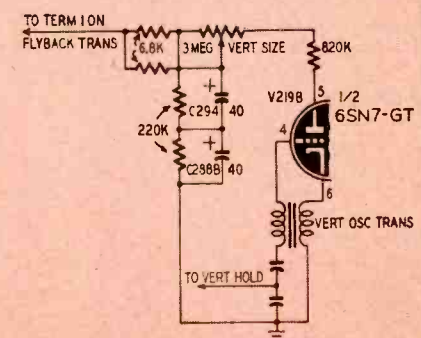

Fig. 4—Partial schematic of vertical sweep oscillator in Du Mont RA-109A.

TV DX REPORTS

TV DX hunters who have turned to stamp collecting for excitement during the last three months can start scanning the channels again during December. There are two principal dx seasons each year, and they are spread either side of the shortest and longest days of the year. The summer period is of course much longer, but the short winter season offers some good hunting, too.

Around the holidays is the time to be on the lookout for the winter dx, though there have been instances of sporadic-E skip all through December in the past. Dx will be more frequent below the Mason-Dixon Line, and it will be a good time for viewers in the

middle west and south to watch for Cuban and Mexican stations. There will be some east-west dx, too, mostly around Christmas. Distances of more than 1,300 miles are unlikely, and it will be all on the lower channels.

Tropospheric bending will drop off markedly in the colder areas, though the Gulf States, the southwest, and even the Pacific northwest may still find propagation fair to good. Elsewhere, fringe-area reception will be poor on the average.

When improved conditions for TV dx reception are on the way it will be easy to anticipate them by watching the weather. Fair, cold, and windy weather will be accompanied by weak

signals and bad fading. Rising temperatures and increasing cloudiness will mark a turn for the better.

Reception on the low channels will be best in the early morning and around sundown and shortly after; worst from noon through the next four hours. High-band dx will be conspicuous by its absence, and fringe area reception on the high channels can be expected to be far below that experienced in the fall period.

Several interesting high-channel dx reports were received during the fall, as well as hundreds of low-band reception summaries. These will be analyzed and reported on in detail at a later date. END

Details on a two-band rig
with a novel plug-in v.f.o.

A COMPACT LOW-POWER TRANSMITTER

By JACK D. GALLAGHER

THIS compact 75-watt, 2-band c.w. transmitter was designed to meet the needs of new hams who have just received their general-class licenses. While the rig will give a good account of itself on 80 and 20 meters, it is adaptable as a driver for a high-powered final. Its plug-in v.f.o. can be removed and used with any transmitter operating on 80 meters and higher frequencies. The constructor has a choice of tubes for each position, thereby eliminating the need to purchase tubes of a given type when substitutes are readily available.

The transmitter details are shown in the photographs and schematics. The oscillator-amplifier portion of the transmitter is shown in Fig. 1, while the doubler and final amplifier circuits are shown in Fig. 2. The 6AG7 oscillator uses a series-tuned Colpitts (Clapp) for stability and ease of adjustment. It is mounted in a 3 x 4 x 5-inch aluminum cabinet with an octal plug at the base which provides the necessary connections for power input and r.f. output. See photos A and B. The oscillator can be considered to be a separate unit which may be used with any transmitter, simply by mounting an octal socket in the center of a 4 x 5-inch space on the existing rig. While a 6AG7 is rec-

ommended for this type of service, a 6AC7, 6SK7, and a 6SJ7 will also work without changing socket connections. Ordinarily, pin 1 of a 6AG7 connects to the shell and suppressor grid. However, the 6AG7 which I used did not have the shell connected to pin 1. This left the tube unshielded. The tube was shielded by soldering a short lead between the shell and pin 1. This connection is shown in Photo A.

The circuitry

The oscillator operates on 160 meters. Coil L1 consists of approximately 110 turns of No. 28 enameled wire close-wound on a 1¼-inch form. The circuit is tuned by the bandset capacitor C2 and bandspread capacitor C1. The latter is a 50- μ f unit with three plates removed to give 180 degrees of bandspread on 80 meters. Note carefully that C2 must be reset each time the oscillator tube is changed or replaced. Failure to do this destroys calibration.

The 6AC7 buffer amplifier shown in Fig. 1 isolates the oscillator from the rest of the transmitter, thus preventing changes in loading from affecting the frequency calibration and stability. A 6AB7, 6SK7, or 6SJ7 can be substituted for the 6AC7 without changing the socket or circuit values. The buffer pro-

vides an ideal circuit for keying the rig.

Fig. 3 shows one section of a 12AU7 connected as a vacuum-tube keyer to minimize clicks and chirps. You can substitute a 6C4, 6C5, one-half of a 6SN7-GT, or any such small triode. The value of the capacitor between the grid and ground determines the quality of the signal. Its correct value is determined experimentally. Disconnect the transmitting antenna and listen to the signal on a receiver. Key the rig and detune the receiver to listen for the signal a few kc each side of the transmitting frequency. If you hear clicks 8 or 10 kc away, add or subtract a few μ f from the .001- μ f unit until the clicks disappear or are reduced to the point where they cannot be heard more than 3 or 4 kilocycles away.

If you don't want vacuum-tube keying, omit the portion of the circuit shown in Fig. 3. Connect the grid-cathode lead from the 6AC7 buffer to a key jack for normal cathode keying. Although we don't recommend it, you can use oscillator keying. Simply ground the grid-cathode lead from the 6AC7 buffer and remove the connection between pins 1 and 4 of the socket which takes the plug on the bottom of the oscillator chassis. The lead from pin 4 can then be connected to a key jack. You don't have to worry about having the continuously running oscillator interfering with reception on 80 or 40 meters. The oscillator is so well shielded that the signal on 80 meters will not be stronger than about an S3.

The circuits of the 6V6 doubler-amplifier and 807 final amplifier (see Fig. 2) are conventional. Disc-ceramic or mica capacitors are recommended for screen-to-cathode bypassing in the 6V6 stage, and mica capacitors are used in the final amplifier. The 47-ohm grid resistor and the plate-circuit trap consisting of 9 turns of No. 28 enameled wire wound around a 47-ohm, 1-watt resistor suppress parasitics in the 807

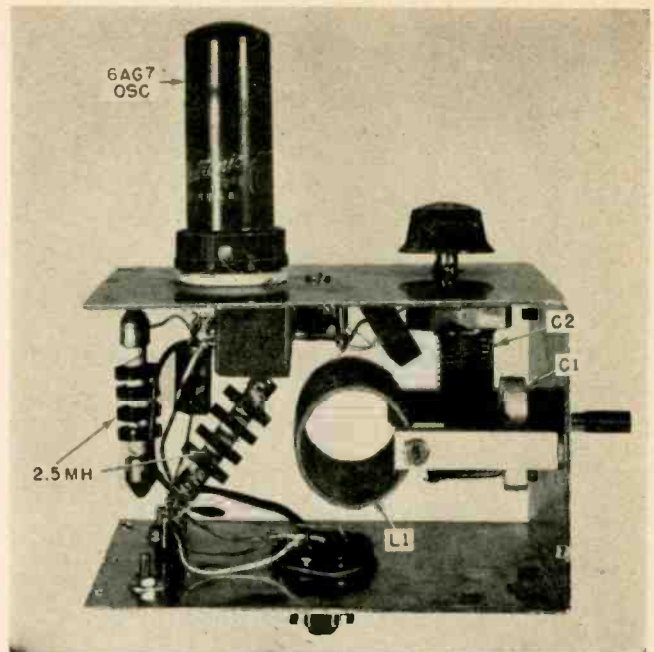

Photo A—Side view of oscillator with one-half of cabinet removed. Follow the layout closely for optimum stability.

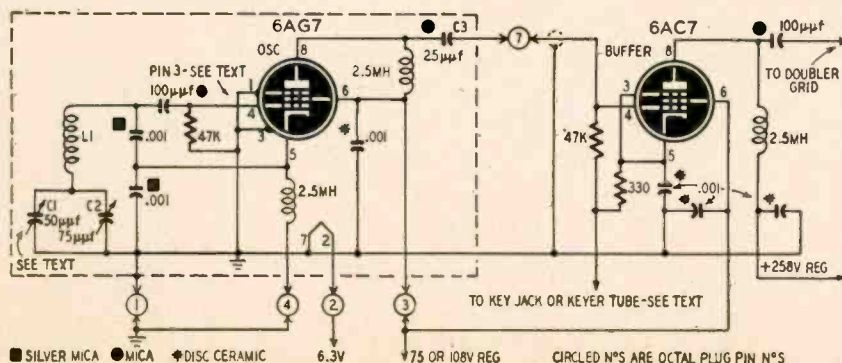

Fig. 1—The v.f.o. is enclosed by the dashed lines. The 6AC7 is the buffer.

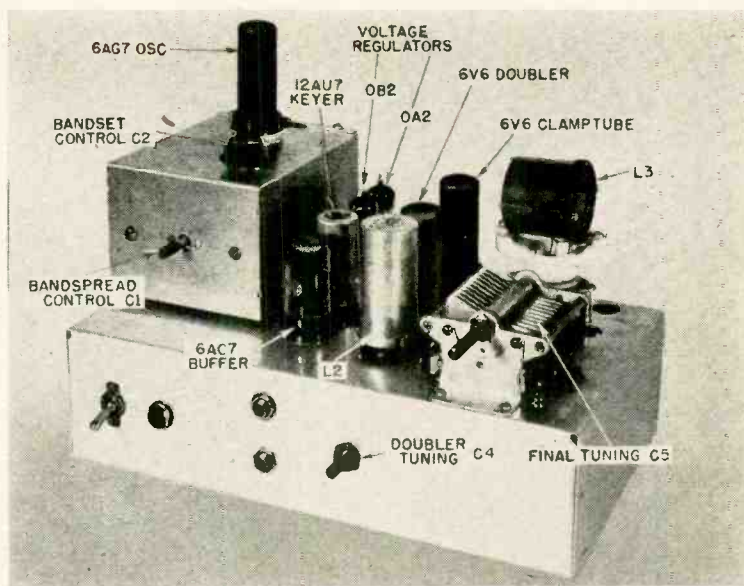
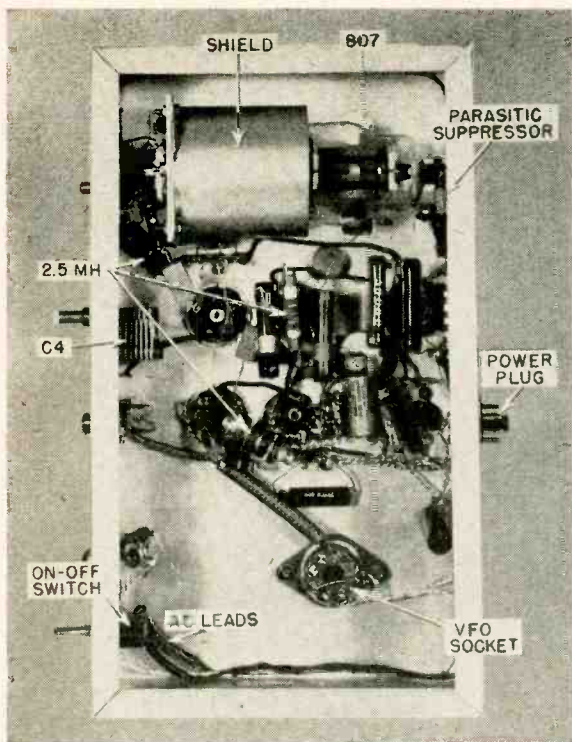

Photo B (Left)—The under side of the complete transmitter. The photo at right shows the v.f.o. plugged in for operation.

stage and minimize spurious radiations.

The triode-connected 6V6 clamp tube protects the 807 against excessive dissipation when excitation is removed. When the key is up, no bias voltage is developed across the 22,000-ohm grid resistor. The clamp tube conducts heavily and develops a large voltage drop across the 75,000-ohm screen-dropping resistor for the 807 stage. The voltage on the 807 screen is reduced far below normal, thus limiting the plate and screen currents to safe values. When the key is closed, the r.f. driving voltage causes a high negative bias to appear across the 22,000-ohm grid resistor. This cuts off the clamp tube and allows the 807 screen voltage to rise to normal.

Regulated voltage for the oscillator and for the buffer screen is obtained from series-connected 0A2 and 0B2 voltage-regulator tubes. The operating voltages for the transmitter may vary widely from those specified in Figs. 1 and 2 without affecting the performance or operation of the circuits. For instance, the oscillator may be operated from a well-filtered source of 50 volts unregulated d.c. without reducing its stability. If the oscillator is used alone to drive a 6V6 or 6L6 in another rig, the 6AG7 screen should be regulated at about 150

volts, the plate voltage should be raised to 250, and coupling capacitor C3 should be increased to 100 uuf.

The 6V6 plate coil L2 consists of 50 turns of No. 30 enameled wire close-wound on a Millen 74002 shielded form. The shield may be omitted if the 807 is always used as a doubler as would probably be the case if the unit is used to drive a high-powered final on 10 or 11 meters. The 807 plate coil L3 for 40 or 80 meters is a Bud or E. F. Johnson 5-prong, air-wound plug-in coil with the link at one end.

The transmitter is simple to adjust and no trouble should occur if care has been used in the construction. For preliminary adjustments, connect a 60- or 75-watt lamp to the link of the 807 plate coil. With the oscillator bandspread capacitor C1 set for maximum capacitance, slowly rotate C2 until a signal is heard on the receiver at 3.5 mc. With coils in place for 80-meter operation, advance C1 until a signal is heard about 3550 kc. Set the 6V6 plate tank to about 80% of maximum capacitance, then rotate the 807 plate-tank capacitor until the lamp reaches its brightest point. This should be about half of full brilliance. Readjust C4 and C5 through this point is reached. Note the

final setting of C4. If it is 50 percent or less of maximum capacitance, remove a few turns at a time from L2 until

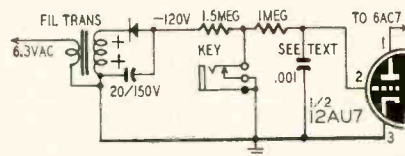

Fig. 3—Diagram of the keyer circuit. This may be replaced by direct keying.

about 75 or 80 percent of maximum capacitance is used.

For 40-meter operation, simply change the 807 plate-tank coil and repeat the operation. However, the setting of C4 should not have to be changed when changing bands. Of course, changing from one end of the band to the other with the oscillator will cause noticeable changes in the output, and small

Materials for oscillator-buffer

Resistors: 2—47,000 ohms, 1/2 watt; 1—330 ohms, 1/2 watt.

Capacitors: (Ceramic) 4—.001 uuf, disc type. (Silver mica) 2—100 uuf, (Mica) 2—100 uuf, 1—25 uuf, (Variable) 1—75 uuf, 1—50 uuf. (See text.)

Miscellaneous: 3—2.5mh r.f. chokes, 2—octal sockets, 1—octal plug, 1—1/4 inch diameter ceramic, plastic, or fiber coil form. Chassis, terminal strips, hookup wire, and tubes.

Materials for double-amplifier chassis

Resistors: 1—47, 1—22,000, 1—47,000 ohms, 1 watt; 1—47 ohms, 1/2 watt; 1—400, 1—22,500, 1—25,000, 1—50,000 ohms, 10 watts.

Capacitors: (Disc-type ceramic) 3—.001 uuf, 2—.01 uuf, (Mica) 1—100 uuf, 1—.001 uuf, 500 volts; 1—.001, 1—.01 uuf, 1,200 volts. (Variable) 1—100 uuf, midget; 1—100 uuf, 1-kv spacing or larger.

Miscellaneous: 3—r.f. chokes, 2.5 mh; 1—Millen 74002 coil form, sockets, tubes, plug-in coils for 75-watt stage, 1—12 x 7 x 3-inch chassis. (Following parts used in vacuum-tube keyer: 1—6.3-volt, 1-amp filament transformer, 1—50-75-ma selenium rectifier, 1—1.5-meg, 1—1-meg resistor, 1—.001-uf capacitor.)

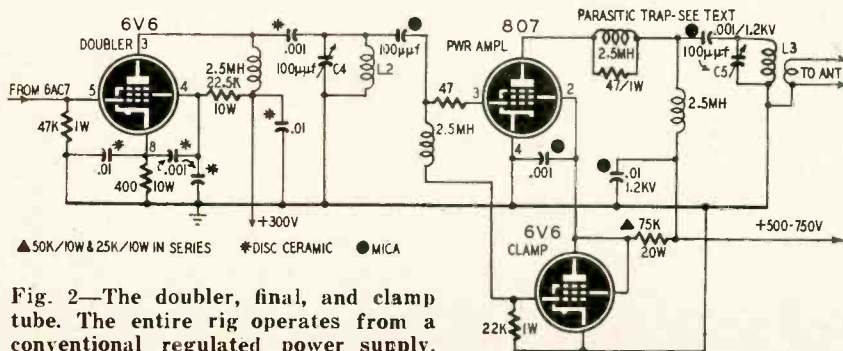

Fig. 2—The doubler, final, and clamp tube. The entire rig operates from a conventional regulated power supply.

changes in C4 and C5 should bring the output back to normal.

Before connecting an antenna tuner and antenna to the output link, listen to the signal in the receiver to make sure there are no clicks in the vicinity of the operating frequency. Switch the receiver to 20 meters and also listen to the signal. It should be clean-cut and free from chirp. END

SATURATED-CORE LIGHT FLASHER

Magnetic amplifier principles are used in this equipment.

By ERWIN LEVEY

LIGHT-FLASHING systems form the basis for many types of advertising signs and displays. The unusual effects obtainable are proven attention-getters. A number of different types of controls are used for this purpose, but each has its limitations. A mechanical system is subject to wear and is not readily adaptable to a variable flashing rate. Thermal units have limited power-handling capacity. Here too, the flashing rate is fixed, and sustained operation causes the contacts to deteriorate, resulting in erratic performance.

These objections can be overcome by the use of a saturated-core system. This is entirely nonmechanical. The flashing rate can be varied over wide limits and it can control large amounts of power.

The periodic voltage and current pulses are produced by the action of a nonlinear resonant circuit. Before explaining how it works let's review some facts directly related to its operation.

The conventional resonant circuit (Fig. 1) consists of a coil, L , some unavoidable resistance, R , and a capacitor, C . The frequency of oscillation is determined by the values of L and C :

$$F = \frac{1}{2\pi\sqrt{LC}}$$

To sustain oscillations the losses in R must be overcome by power from an external source. This type of oscillating circuit produces a sine wave—the basic a.c. waveform.

The inductance and capacitance in this case are so-called "linear" elements. That is, their values are determined purely by their physical characteristics. For example, the inductance of a coil is determined by the number of turns of wire, the size of the wire and the way it is wound, the relation between coil diameter and length, and the permeability of the core. (Permeability—or μ —is a measure of the ease with which a material may be magnetized.) The μ of air is 1, so that the inductance of an air-core coil depends only on the physical dimensions given above.

The current through an air-core coil has no effect on the inductance, since it does not change either the physical dimensions of the coil or the permeability of the air core. (The current-carrying capacity is limited, of course,

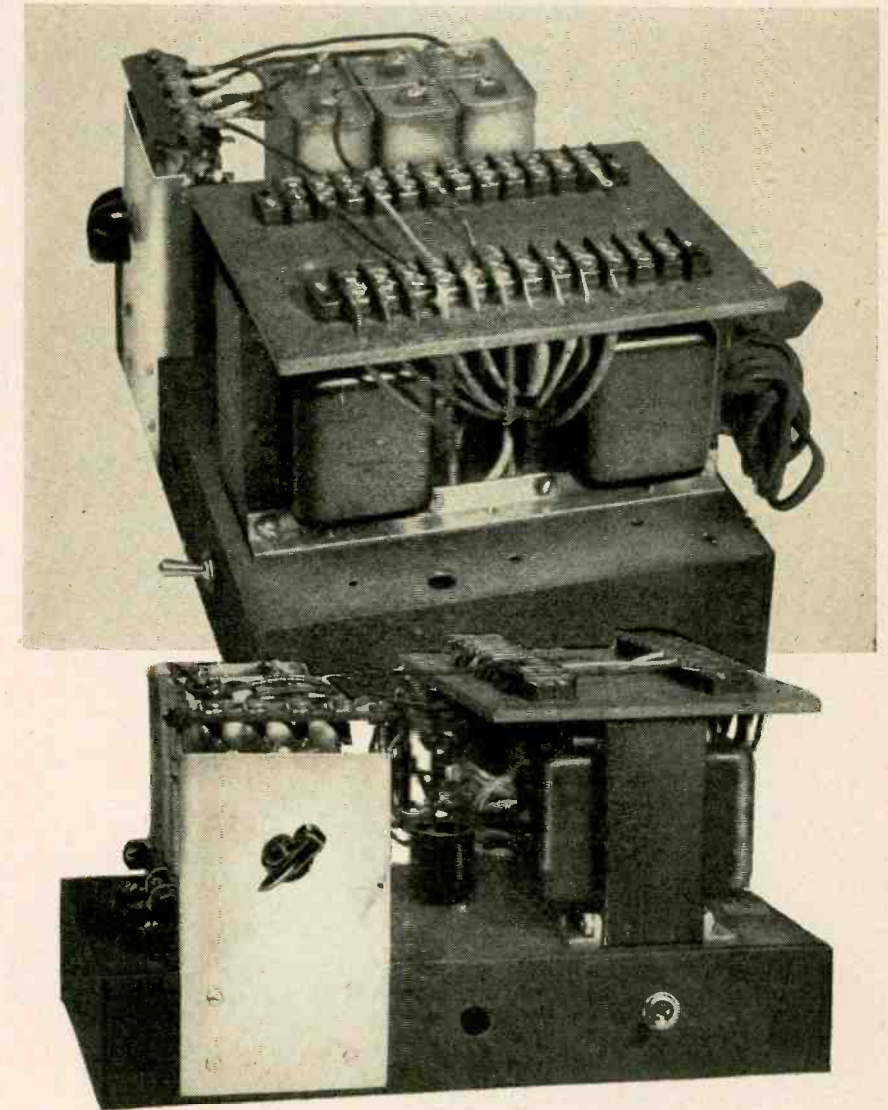

Above—Chassis assembly, showing transformer mounting and flexible terminal. Below—Front view. Control potentiometer is at left, power-supply plug at center.

by the size of the wire in the winding.)

The inductance of a coil with fixed physical characteristics can be increased by using a magnetic core with higher permeability than that of air. Certain types of iron and alloys of other materials have permeabilities ranging from 400 to 20,000.

The permeability of a magnetic material is not constant but depends on the degree to which it is magnetized by the coil current. Therefore the inductance of a coil with a magnetic core may vary over wide limits. Sometimes, of course, this may be a serious disadvantage, especially in power-supply filter chokes. These are rated in both inductance and d.c. capacity. A choke will have its rated value of inductance only if the d.c. rating is not exceeded.

If the current is increased beyond the rated value, the core becomes magnetically saturated, the inductance decreases and the choke offers less opposition to a.c. This reduces its effectiveness as a filter element, and may introduce considerable hum in the unit supplied.

On the other hand, at low values of current, the inductance is high. Therefore an iron-core reactor can be made to operate as a variable inductance, by varying the current flowing in the circuit. This is what is meant by a "non-linear" inductance.

Next, consider the circuit shown in Fig. 2. There are three elements: capacitance, resistance, and a nonlinear inductance. If an a.c. voltage is applied to the circuit and its value is increased



TRAIN FASTER—TRAIN BETTER—TRAIN EASIER
IN 10 MONTHS—OR LESS—FOR
RADIO-TELEVISION

Our 21st Year Training Men for Greater Incomes and Security in Radio-Television

I SEND YOU
18 BIG KITS

of Radio-Television parts and equipment. Much of your training will be actual construction and experimentation . . . the kind of truly PRACTICAL instruction that prepares you for your Radio-Television career.



Frank L. Sprayberry
 President
 Sprayberry Academy
 of Radio

NEW! NO OBLIGATION PLAN

You Have No Monthly Payment Contract to Sign
Pay For Your Training as You Earn and Learn

You can get into Radio-Television, today's fastest growing big money opportunity field, in *months* instead of years! My completely new "package unit" training plan prepares you in as little as 10 months or even less! *No monthly payment contract to sign—thus NO RISK to you!* This is America's finest, most complete, practical training—gets you ready to handle any practical job in the booming Radio-Television industry. Start your own profitable Radio-Television shop . . . or accept a good paying job. I have trained hundreds of successful Radio-Television technicians during the past 21 years—and stand ready to train you, even if you have no previous experience! Mail coupon and get all the facts—FREE!



Valuable Equipment Included
With Training

The new Sprayberry "package" plan includes many big kits of genuine, professional Radio-Television equipment. You perform over 300 demonstrations, experiments and construction projects. You build a powerful 6-tube 2-band radio set, multi-range test meter signal generator, signal tracer, many other projects. All equipment and lessons are yours to keep . . . you have practically everything you need to set up your own profitable Radio-Television service shop.

Earn Extra Money While You Learn!

All your 10 months of training is IN YOUR HOME in spare hours. Keep on with your present job and income while learning. With each training "package" unit, you receive extra plans and "Business Builder" ideas for spare time Radio-Television jobs. New television stations everywhere, open vast new opportunities for trained Radio-Television Technicians—and those in training. If you expect to be in the armed forces later, there is no better preparation than practical Sprayberry Radio-Television training.

YOU BUILD

the Television set and the powerful superhet radio receiver shown above. IN ADDITION to the other test units shown here (many are not shown because of lack of space). All equipment I send you is YOURS TO KEEP.

SPRAYBERRY ACADEMY OF RADIO 111 NORTH CANAL ST.
 Dept. 20-R, Chicago 6, Ill.

MAIL COUPON
TODAY!
NO OBLIGATION

I invite you to get all the facts—
FREE TO YOU 3 BIG
RADIO-TELEVISION BOOKS

I want you to have ALL the facts about my new 10-MONTH Radio-Television Training—without cost! Rush coupon for my three big Radio-Television books: "How to Make Money in Radio-Television," PLUS my new illustrated Television Bulletin PLUS an actual sample Sprayberry Lesson—ALL FREE. No obligation and no salesman will call. Mail coupon NOW!

SPRAYBERRY ACADEMY OF RADIO, Dept. 20-R,
 111 North Canal St., Chicago 6, Ill.

Please rush to me all information on your 10-MONTH Radio-Television Training Plan. I understand this does not obligate me and that no salesman will call upon me. Be sure to include 3 books FREE

Name _____ Age _____

Address _____

City _____ Zone _____ State _____



slowly from zero, the circuit will start to oscillate when a certain critical value is reached. At this point the current is limited only by the resistance in the circuit. The initial increase of voltage causes the current in the circuit to increase. Its magnetizing effect changes the core characteristics and decreases the inductance. When the inductance falls to a certain value, depending on the value of C , a resonant system is formed. The circuit will then produce sustained oscillations.

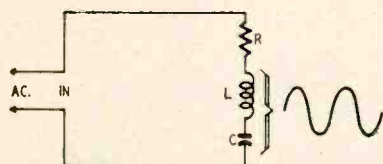

Fig. 1—Basic series-resonant oscillating circuit. Losses in R are made up by power fed in from an external source.

Although the circuit is quite simple it is extremely critical in operation. These limitations can be overcome by replacing the simple iron-core coil with a saturable reactor.

In this device (Fig. 3) the core permeability (and therefore the inductance) are controlled by d.c. Since a completely separate set of control coils is used, the resonant condition is much easier to produce. Transformers T_1 and T_2 comprise the saturable reactor.

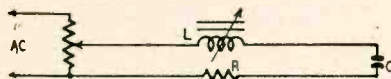

Fig. 2—Oscillating circuit with a saturable reactor as the inductive element. The inductance drops sharply when the circuit current reaches a critical value. When $X_L = X_C$ the circuit oscillates at its natural resonant frequency, regardless of the a.c. input frequency.

The a.c. voltage applied to the circuit is no longer critical. The value applied need be only below the value required to produce oscillations. This gives a wide range of control. A gradual increase in the control current reduces the inductance of the coils. A certain degree of saturation creates the proper conditions for resonance, and the cur-

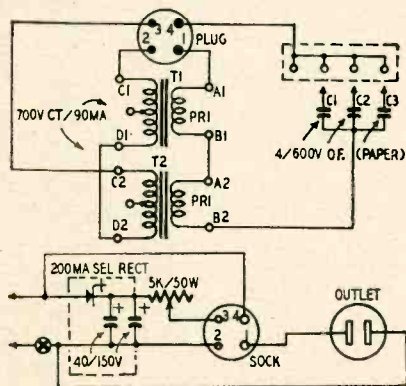

Fig. 3—Complete saturable-reactor control circuit, using d.c. for continuous control of inductance and flashing rate.

rent will start to pulsate. The sudden increase of current at resonance produces a strong a.c. flux in the core.

This opposes the unidirectional d.c. flux and reduces the degree of core saturation. This in turn *increases* the inductance and detunes the circuit from its resonant condition. The a.c. drops to a low value and the cycle repeats immediately.

The frequency at which the current pulsates depends on C , R , and the applied voltage. With a set of fixed units the flashing frequency is controllable from a single pulse every 5 seconds up to the point where the lights are lit continuously, simply by varying the d.c. saturating current.

Reactor construction

The saturable reactor was made from the primary and high-voltage windings of two identical 350-350-volt, 90-ma power transformers. The h.v. center taps are not used. A simple check will supply the necessary phasing information for connecting the windings correctly. First consider one transformer. Each of the four leads—two primary and two high-voltage—should be identified by a tag. The primary leads are marked A and B, the high-voltage leads C and D. Connect leads B and C together. Next, apply 117 volts a.c. across primary leads A and B. Then read the total voltage across terminals A and D. (Use caution here. You are dealing with dangerously high voltages!—Editor)

If the coils are phased correctly the meter will read the sum of the two individual coil voltages. In this case 700 plus 117 will give 817 volts. On the other hand, if the meter reads the difference between the two voltages (700 minus 117, or 583 volts) the h.v. leads should be reversed. If this is necessary, change the tags so that the h.v. lead connected to wire B of the primary is labeled C, and the free end of the h.v. winding is changed to D. After the leads on one transformer are phased similar tests should be made on the other.

Once the leads have been properly tagged, the two transformers can be connected as a saturable reactor. The interconnections are shown in Fig. 3. The transformer terminals are identified by the codes used for the phasing check. Mounting arrangements can be seen in the photographs. The two transformers are mounted side by side, and clamped together at the bottom by two $\frac{1}{2}$ -inch metal angles $6\frac{1}{2}$ inches long. These are tapped for 6-32 screws which fasten the assembly to the 11 x 7 x 2-inch chassis. The mounting should be as rigid as possible, for otherwise the transformers will vibrate audibly in synchronism with the power pulses. A 5 x $6\frac{1}{2}$ -inch masonite panel is fastened to the tops of the transformers with small angle brackets. (The screw heads are countersunk and are under the 12-position barrier-type terminal strips.) This arrangement is somewhat elaborate, but the flexibility it offered was a decided advantage for experiments. A simpler arrangement can be used if desired. Connections to d.c. power supply and the output receptacle are made

through a four-pin tube socket and plug.

The selenium rectifier and filter capacitor for the power supply are mounted under the chassis on a small insulating panel. Half-inch spacers are used between the board and the chassis.

A 5,000-ohm, 50-watt potentiometer connected as a rheostat is used for the main control. This is mounted above the chassis on a separate bracket.

Materials for control unit

2—Power transformers, 700 volts center-tapped, at 90 ma (Stancor P-6012 or equivalent); 3—4- μ f, 600-v oil-filled paper capacitors; 2—40- μ f, 150-v electrolytic capacitors; 1—200-ma selenium rectifier; 1—5000-ohm, 50-watt potentiometer; 1—4-pin tube socket; 1—4-pin plug; 1—2-contact outlet receptacle; 1—11 x 7 x 2-inch chassis; 1—s.p.s.t. toggle switch; 1—4-position terminal strip; 2—multiterminal barrier type strips (see photos); line cord, wire, insulating panels, hardware, solder.

The capacitors in the resonant circuit are 4- μ f, 600-volts, oil-filled paper units. Electrolytic capacitors *cannot be used here* since they are polarized and will not operate properly on a.c. The leads from the capacitors are connected to a four-terminal strip mounted on top of the rheostat bracket. The lead at the right is the common terminal. This assembly is essentially a switch which allows the capacitors to be connected in parallel as required. Capacitors are removed from the circuit by simply disconnecting the appropriate leads from the terminal screws. See that the free leads (when disconnected) do not touch any other metal part in the circuit since they are hot and will cause a short. The lamp load circuit is connected through a receptacle mounted on the rear of the chassis.

Circuit operation

Best results were obtained with a lamp load of 160 watts. For this condition only two of the capacitors are used in the circuit. The third one must be disconnected as explained above. The flashing rate may be varied with the rheostat from approximately one flash every three seconds up to several per second. The lamp load may be divided any way you wish as long as the total power adds up to 160 watts.

The pulsing rate is much higher when all three capacitors are connected in parallel. Here the load must also be 160 watts. The flashing is so rapid the bulbs appear to be flickering.

If the unit does not operate when the power is turned on make a close check of all wiring. Repeat the phasing check to make sure there are no errors in the interconnection of the two transformers. If all the details explained above have been followed carefully there should be no trouble. (This also means that the exact parts specified have been used.)

The saturable reactor and its associated d.c. power supply can be used as a regular magnetic amplifier if the capacitors are removed from the circuit. However, since it is no longer operated in a resonant state the losses are greater and only about one-half the power can be controlled compared with the flashing system. END

Check these ADVANTAGES FOUND Only in HEATHKITS

1

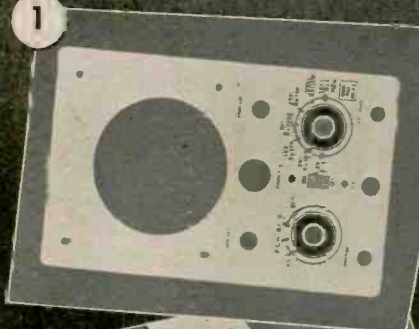

2



3



4



5

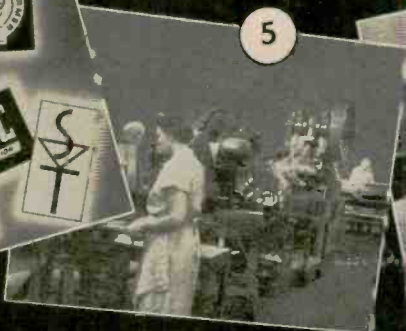

6

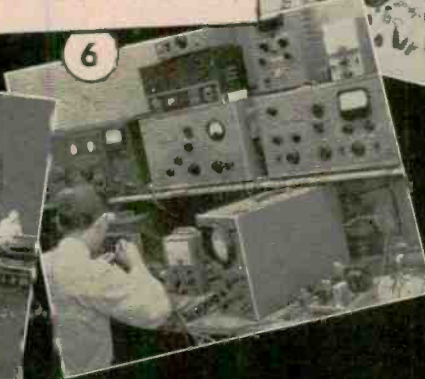

9



8



7



- ✓ **1. Baked Enamel Lifetime Finish Panels** — Oven baked finishes for maximum durability and freedom from mars, scratches and discoloration. Panels that can really take service shop and laboratory abuse.
- ✓ **2. Save Money** — You save all expensive factory wiring costs when you build your own. And, direct factory to customer sales eliminate all middle man profit. You can have a complete Heathkit laboratory or service shop for what one or two pieces of ready built equipment cost.
- ✓ **3. Modern Styling** — New "fitted panels" and formed cabinets with rounded corners present a smart, professional appearance. Dignified appearance for prestige.
- ✓ **4. Quality Component Used Throughout** — Heathkits use well known, time and quality tested components such as Simpson, Chicago Transformer, Wilkor, Allen-Bradley, Altec-Lansing, Centralab, Cich, Oak, Grigsby-Allison, Mallory and many others.
- ✓ **5. Extensive Factory Facilities** — Shearing, punching, forming, spot welding, etc. is done right in our own plant — controlled production for high quality and less cost to you.
- ✓ **6. Extensive and careful engineering** — A staff of engineers working in a modern, well equipped laboratory carefully develop Heathkits according to highest engineering practices. Your assurance of accurate, up to the minute instruments.
- ✓ **7. Complete Kits** — All the parts are right in the kit — you get all tubes, controls, transformers, meters — everything — no other components to buy. And no cutting, purchasing, or painting necessary — it's all done for you. Heathkits go together easily and smoothly.
- ✓ **8. Only Complete Line** — Over 50 kits available — Heathkits form the only complete line of kit-forming test equipment on the market. Kits for ham operators, service men, schools and audio enthusiasts.
- ✓ **9. Detailed, Complete Instruction Manuals** — Comprehensive manuals tell you exactly how to build your Heathkit. Manuals contain easy-to-follow instructions, clear, large pictorials, schematic, detail drawings, etc. They make construction easy, fun, and educational.

Nine New Heathkits This Year!

REPORT AGENT
ROCKE INTERNATIONAL CORP.
12 E. 80th ST.
NEW YORK CITY 16
WHOLESALE: 212-411-1171

The HEATH COMPANY

... BENTON HARBOR 20, MICHIGAN

NEW Heathkit "Q" METER KIT

• A HIGH QUALITY Q METER AT LOW COST.

MODEL QM-1

SHIPPING
WT. 12 LBS.

\$39⁵⁰

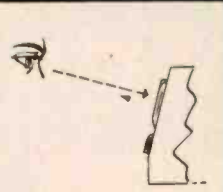
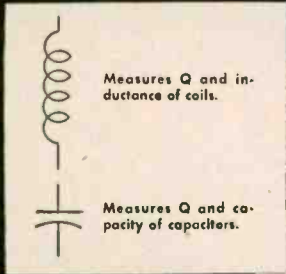

Slant face cabinet for ease in reading the meter.



• First Q METER within the price range of all.

• Read Q's of 0-500 directly on calibrated scale.

• Stable oscillator supplies R.F. frequencies of 150 kc to 18 megacycles.

• Calibrated capacitor with range of 40 mmf to 450 mmf with vernier of ± 3 mmf.

• Simple, easy operation.

• Can be used to measure small inductances or capacitors.

• Measures Q of condensers, RF resistance and distributed capacity of coils.

• Measures capacity by substitution, capacity by resonance, inductance by resonance.

• Slanted panel for convenient operation.

Another outstanding example of progressive HEATHKIT engineering. Now a highly desirable Q METER within the price range of all laboratories, schools and experimenters. No longer is it necessary to deny yourself the many measurement advantages offered by this instrument.

Use the new HEATHKIT Q METER for the following simple basic measurements: capacity by substitution, capacity by resonance, inductance by resonance and Q at the OPERATING frequency all can be read on the calibrated scales. The method used to obtain information regarding the Q of condensers, RF resistance, distributed capacity in coils, etc., is only slightly more involved. In the HEATHKIT Q METER, the generated RF signal is coupled through a cathode follower and injected across a low impedance condenser which is included in the resonant circuit under test. Large $4\frac{1}{2}$ " 50 microampere Simpson meter reads Q directly. The resonating condenser and vernier condenser are calibrated in mmf for substitution method capacity tests. The resonating condenser is also calibrated in effective capacity for resonance tests. The inductance calibration serves for rapid determination of the approximate inductance of a coil. The HEATHKIT Q METER has a generator frequency range of 150 kc to 18 megacycles. Vernier capacity covers ± 3 mmf and the resonating condenser is calibrated from 40 mmf to 450 mmf actual capacity or 40 mmf to 350 mmf effective capacity. Meter reads Q directly up to 250. Higher and lower full scale readings can be obtained by varying the injection voltage levels.

The entire kit consists of 12AT7, 6AL5, 6C4, OD3 and 6X5 tubes. 50 microampere Simpson meter, power transformer, cabinet and all other parts necessary for construction as well as instructions for assembling, testing and operation of the completed instrument.

Heathkit DECADE RESISTANCE KIT

The HEATHKIT DECADE RESISTANCE KIT is widely used by schools, experimenters and laboratories because of the extremely wide resistance range offered and the useful, dependable service provided. The DECADE consists of 5 rotary 2 deck ceramic wafer switches with silver plated contacts and twenty 1% precision resistors in a circuit which provides the resistance range of 1 ohm to 99,999 ohms in 1 ohm steps. The HEATHKIT DECADE RESISTANCE KIT is simple to construct and is housed in a beautiful polished birch cabinet with an attractive panel. The DECADE will furnish years of accurate trouble-free service.

Individual decade sections of above can be purchased separately for special applications.



MODEL DR-1
SHIPPING
WT. 4 LBS.

\$19.50

NEW Heathkit DECADE CONDENSER KIT

Extremely useful in all experimental and design work such as determination of condenser values for: compensating networks, filters, bridge impedances, tuned circuits, etc. Uses all precision silver mica condensers within $\pm 1\%$ accuracy. Values run in three decades from 100 MMFD to 0.111 MFD in steps of 100 MMFD. Smooth acting, positive detent, highest quality ceramic wafer switches make all capacitor values easy to set up and keep losses to a minimum. Low loss dielectric terminal board mounts on outside of panel for easy cleaning. Heathkit binding posts accommodate a wide variety of test leads. Comes complete with all parts, including polished birch cabinet.

Individual decade sections of above can be purchased separately.



MODEL DC-1
SHIPPING
WT. 4 LBS.

\$16⁵⁰

EXPORT AGENTS
ROCKE INTERNATIONAL CORP.
13 E. 40th ST.
NEW YORK CITY (16)
CABLE: ARRA-N.Y.

The **HEATH COMPANY**

... BENTON HARBOR 20, MICHIGAN

NEW *Heathkit* OSCILLOSCOPE KIT

• NEW WIDE BAND VERTICAL AMPLIFIER ± 2 DB 10 CYCLES TO 1 MC.



Direct plate connections for modulation tests.



Displays TV sync pulses correctly.

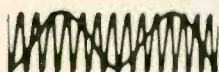

Useful to 5 mc.



Good square wave response at 100 kc.

MODEL O-8

SHIPPING
WT. 29 LBS.

\$43.50

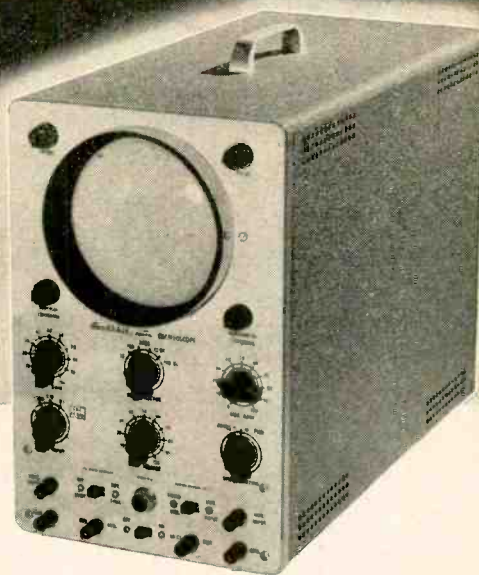

- New wider band vertical amplifier ± 2 db from 10 cycles to 1 megacycle useful to over 5 megacycles.

- High sensitivity in vertical amplifier. .025 volts RMS per inch deflection.

- New 3 step input attenuator input ranges X1, X10, X100.

- New 5CP1 intensifier type tube for greater brilliance.

- Terminal board and rear cabinet opening provisions for direct connections to deflecting plates.

- Newly styled formed and ventilated aluminum cabinet.

- Wide band sweep generator, 15 cycles to over 100 kc. Will synchronize with 5 megacycle signal.

- 10 tube circuit featuring push pull operation of vertical and horizontal amplifiers.

- Internal synchronization on either positive or negative peaks.

- Reproduces faithfully the front and back porches of TV sync pulses. Excellent square wave reproduction to over 100 kc.

- Optional Intensifier kit available for 2200 volt operation.

Proudly announcing the new 1953 HEATHKIT Model O-8 OSCILLOSCOPE featuring the finest performance ever offered in this extremely popular kit instrument. Improved wider band vertical amplifier featuring a new 3-step input attenuator affording smooth control of the excellent .025 volts per inch vertical sensitivity. Possibility of overloading the vertical input circuit is minimized. Greater band width in the vertical channel is a decided advantage to TV service men. Permits clear observation of all TV sync pulse detail and excellent square wave reproduction over 100 kc. 5CP1 intensifier type CR tube provides a brilliant trace with normal accelerating voltages. A handsome, ventilated cabinet with smooth rounded corners and a snug fitting drawn panel adds to the smartly styled professional appearance. Longer life is assured through cooler instrument operation. Push pull output stages in both vertical and horizontal amplifiers for balanced deflection of the spot. All of the many fine features of the previous model have been retained. Rear cabinet access to terminal board for direct connection to CR plates. The entire kit of all 10 tubes, parts, cabinet and panel as well as detailed construction manual for assembly and operation of the instrument included.

INTENSIFIER KIT: For extreme trace brilliance in special applications such as photography, group demonstrations or operation in brightly lighted areas an optional Intensifier kit providing 2200 volt operation of the CR tube is available. Kit includes: high voltage filter condenser, high voltage selenium rectifier, etc. \$7.50.



Heathkit

SCOPE
DEMODULATOR **PROBE KIT**

Trouble shooting or aligning TV, RF, IF and video stages requires demodulation of high frequency signals before Oscilloscope observation. The HEATHKIT SCOPE DEMODULATOR PROBE KIT was specifically developed for this application. Kit consists of a probe housing, crystal diode detector circuit, shielded cable and spade lugs. Assembly is simple and the probe will quickly prove its usefulness as an Oscilloscope accessory.

No. 337
SHIP. WT. 1 LB.
\$4.50

NEW *Heathkit* VOLTAGE CALIBRATOR KIT

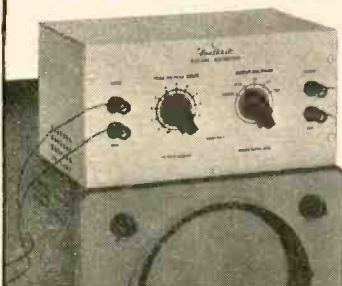

MODEL VC-1
SHIPPING
WT. 5 LBS. **\$9.50**

Use the Heathkit Voltage Calibrator with your oscilloscope to measure peak-to-peak TV complex waveshapes. TV manufacturer's specifications indicate correct peak-to-peak voltages and this kit will permit making these important measurements.

A big help to engineers in circuit work. Makes peak-to-peak voltage measurements of complex waveshapes of all kinds. Flat topped semi-square wave output of calibrator assures fast and easy measurement of any voltage between .01 and 100V peak-to-peak.

The Voltage Calibrator can remain connected to your oscilloscope at all times for instant use. "Signal" position connects signal under study directly through calibrator and into scope input circuit for direct observation. Eliminates transferring leads from calibrator. *A wonderful scope accessory.*

Heathkit ELECTRONIC SWITCH KIT



MODEL S-2
SHIPPING
WT. 11 LBS.

\$19.50

A few dollars spent for this accessory will increase the usefulness of a scope immeasurably. An electronic switch will open up a whole new field of scope applications for you. The S-2 allows TWO SIGNALS to be observed at the SAME TIME — this important feature allows you to immediately spot phase shift, clipping, distortion, etc. The two signals under observation can be superimposed or separated for individual study. Each signal input has an individual gain control for properly adjusting scope trace patterns. Has both coarse and fine frequency controls for adjusting switching time. Multivibrator switching frequency is from less than 10 cps to over 2000 cps in three overlapping ranges. Kit comes complete including 5 tubes, power transformer, all controls, instruction manual, etc. *Every scope owner should have one!*

ROCKE INTERNATIONAL CORP.
375, 40th ST.
NEW YORK CITY (16)
CABLE: ARAB-N.Y.

The **HEATH COMPANY**

... BENTON HARBOR 20, MICHIGAN

Heathkit VACUUM TUBE VOLTMETER KIT

• NEW 1½ VOLT RANGE ON 1953 VTVM.

MODEL V-6

SHIPPING
WT., 7 LBS.

\$24.50

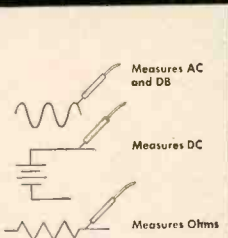
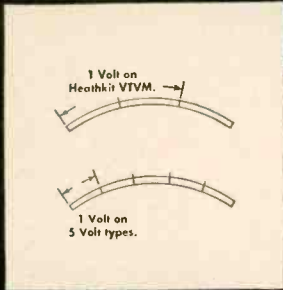

- New 1½ volt low range gives over 2" of scale per volt instead of less than ¾" found on 5 volt range type.
- Increased accuracy due to expanded scales.
- New 1500 volt DC high range gives 50% greater coverage.
- Seven ranges in all. 1½, 5, 15, 50, 150, 500 and 1500 volts DC (1000 volts maximum AC only).
- Provides proper service ranges 150 volts for AC DC work and 500 volts for AC type service.
- High input impedance, 11 megohms minimizes circuit loading.
- Variety of accessory probe kits available.
- 1% precision resistors in multiplier circuits.
- 200 microampere Simpson meter.
- Center scale zero adjust.
- Transformer operated.
- Test leads included.
- New cabinet styling.
- Large, clearly marked meter scales indicate ohms, AC volts, DC volts and DB.

The 1953 Heathkit V-6 VTVM has improved ranges! The lowest range has been moved way down to 1.5V full scale. This gives 3½" of actual scale length for the 1.5V covered — that's 2½ inches per volt!! Now you can make your low level measurements faster and with greater accuracy.

And the upper range has been moved up. Readings up to 1500V DC can be readily made with new, improved VTVM — plus readings up to 1000V on AC. Higher ranges for extended use.

New vertical chassis mounting gives added chassis space for really easy wiring — no tight corners to worry about. Uses only highest quality components throughout. Simpson 200 microampere meter movement combined with 1% precision resistors in multiplier circuit insure highly accurate and dependable readings.

AC and DC voltage ranges are 0-1.5V-5V-15V-50V-150V-500V-1500V. (1000V max. reading on AC) — a total of seven ranges for convenient, accurate readings. Instrument also measures resistance from .1 ohm to over 1 billion ohms in seven handy ranges of RX1, X10, X100, X1000, X10K, X1 Meg. — all convenient multiples of 10 with no skips. Has Db scale in red for easy identification.

New panel has tough baked on enamel finish for freedom from scratches and maximum durability. Modern styled, formed, compact cabinet with rounded edges and crackle finish is truly handsome. Comprehensive, detailed instruction manual with step-by-step instructions, figures, pictorials, etc. makes assembly a cinch.

Be sure and look over the special accessory VTVM probes below — for added usefulness.

<p>Heathkit R. F. PROBE KIT SHIP. WT. 1 LBS. \$5.50 No. 309 Extends RF range of HEATHKIT 11 megohm VTVM to 250 megacycles ± 10%.</p>	<p>Heathkit 30,000 V. D.C. PROBE KIT SHIP. WT. 2 LBS. \$5.50 No. 336 Provides DC multiplication factor of 100 for any 11 megohm VTVM.</p>	<p>Heathkit PEAK TO PEAK VOLTAGE PROBE KIT SHIP. WT. 2 LBS. \$6.50 No. 338 Reads on DC scale of any 11 megohm VTVM 5 kc to 5 megacycle range.</p>
----------------------------------------------------------------------------------------------------------------------------------------------------------------	---------------------------------------------------------------------------------------------------------------------------------------------------------------------	-----------------------------------------------------------------------------------------------------------------------------------------------------------------------------

NEW Heathkit BATTERY TESTER KIT

The new Heathkit Battery Tester measures all types of dry batteries between 1½ volts and 150 volts under actual load conditions. Readings are made directly on a three-color GOOD-WEAK-REPLACE scale that your customers can readily understand. Operation is extremely simple and merely requires that the leads be connected to the battery under test. Only one control to adjust in addition to a panel switch for A or B battery types.

The Heathkit Battery Tester features compact assembly. An accurate meter movement and wire wound control mount in the portable, rugged plastic case.

Use the BT-1 to check portable radio batteries, hearing aid batteries, lantern batteries and photo flash gun batteries.

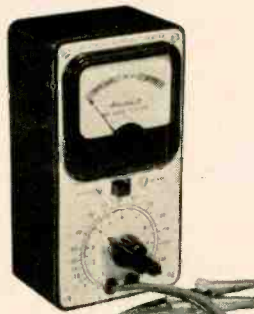

MODEL BT-1
SHIPPING
WT. 3 LBS.

\$7.50

Heathkit AC VACUUM TUBE VOLTMETER KIT

A new AC VTVM that makes possible those sensitive AC measurements required by laboratories, audio enthusiasts and experimenters. Ten full scale ranges of .01, .03, .1, .3, 1, 3, 10, 30, 100 and 300 volts RMS. 10 DB ranges from -52 to +52 DB. Frequency response within 1 DB from 20 cycles to 50 kc. Simpson 200 microampere meter with large plainly marked meter scales. Precision multiplier resistors. Two amplifier stages using miniature tubes. A unique bridge rectifier meter circuit and a clean layout of parts. Order the AV-2 today and become acquainted with the interesting possibilities offered by this instrument.

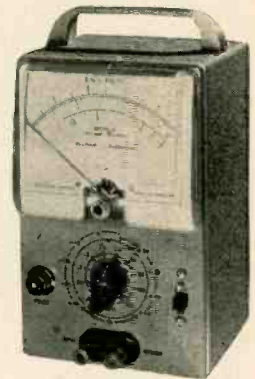

MODEL AV-2
SHIPPING
WT. 5 LBS.

\$29.50

EXPORT AGENT
ROCKE INTERNATIONAL CORP.
13 E. 40th ST.
NEW YORK CITY (16)
CABLE: ARLAB-N.Y.

The HEATH COMPANY

... BENTON HARBOR 20, MICHIGAN

NEW *Heathkit* GRID DIP METER KIT

• CONVENIENT ONE HAND OPERATION.

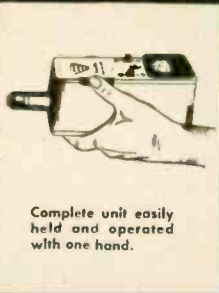
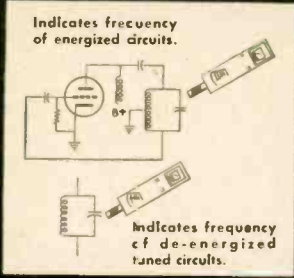

Complete unit easily held and operated with one hand.

MODEL GD-1
SHIPPING
WT. 4 LBS.
\$19⁵⁰



- New GRID DIP METER with assembled calibrated coils.
- Uses quality Simpson 500 microampere meter.
- One hand operation, extremely compact. Only 2½" wide by 3" high by 7" long.
- Variable meter sensitivity control.
- Uses newest type 6AF4 high frequency triode in a Colpitts oscillator circuit.
- Continuous coverage from 2 megacycles to over 250 megacycles in 6 ranges.
- Head phone monitoring jack.
- AC power transformer operated for maximum safety.

Here is the GRID DIP METER KIT you have been asking for. This new HEATHKIT instrument is compact, highly sensitive and easy to use. Housed in a handsome formed aluminum cabinet—rounded corners—durable oven baked finish on panel and cabinet. The entire instrument can be easily held and operated in one hand, tuning accomplished with the thumb wheel drive. This excellent design feature leaves the other hand entirely free for making circuit adjustments. The instrument with many applications—with oscillator energized, use it for finding the resonant frequency of tuned circuits, locating parasitics, determining characteristics of filter circuits, roughly tuning transmitter stages with power off, and neutralizing transmitters. Useful in TV and radio repair work for alignment of traps, filters, IF stages, peaking and compensation networks within the 2 to 250 megacycle range. With the oscillator not energized, the instrument acts as an absorption wave meter and indicates the frequency of radiating power sources. Locates spurious oscillations, as a relative indication of power in various transmitter stages, etc. Phone jack permits monitoring of AM transmitter for determination of radiated hum, audio quality, etc. (Head phones not included). Complete kit includes plug-in coils, tube, all necessary parts and detailed assembly and instruction manual.

Heathkit IMPEDANCE BRIDGE KIT



MODEL IB-1B
SHIPPING
WT. 15 LBS.

\$69⁵⁰

The HEATHKIT IMPEDANCE BRIDGE is especially useful in educational training programs, industrial laboratories and for experimental work. Use it for measuring AC and DC resistance value of resistors,

determination of condenser capacitance and dissipation factor, finding coil inductance and storage factor, electrical measurements work, etc. Quality components: GR 1000 cycle hummer, GR main control, Mallory ceramic wafer silver plated contact switches, ½% precision resistors, etc. The basic circuit is a self powered, 4 arm bridge. Choice of Wheatstone, Capacitance comparison, Maxwell or Hay bridge circuits. Resistance from 10 milliohm to 10 megohm. Capacitance 10 mmf to 100 mfd. Inductance 10 microhenry to 100 henries. Dissipation factor .002 to 1. Storage factor (Q) 1 to 1000. The IMPEDANCE BRIDGE has provisions for external generator use for measurement at other than the 1000 cycle level. Take the guess work out of electrical measurements. The HEATHKIT IMPEDANCE BRIDGE mounted in a beautiful polished birch cabinet with large easy reading panel calibrations will furnish years of accurate, trouble free measurement service.

Heathkit HANDITESTER KIT

The HEATHKIT Model M-1 HANDITESTER fulfills requirements for a portable volt ohm milliammeter. This kit features precision 1% resistors, 3 deck switch for trouble free mounting of parts, specially designed battery bracket, smooth acting ohms adjust control, beautiful molded bakelite case and a 400 microampere meter movement. 5 convenient AC and DC voltage ranges as follows: 10 - 30 - 300 - 1000 - 5000 volts. Ohms ranges 0 - 3000 and 0 - 300,000. DC milliamperes ranges 0 - 10 milliamperes and 0 - 100 milliamperes. The instrument is easily assembled from complete instructions and pictorial diagrams. Test leads are included. Carry the HEATHKIT M-1 HANDITESTER in your tool box at all times for those simple jobs and eliminate that extra trip for additional testing equipment.



MODEL M-1
SHIPPING
WT. 3 LBS.

\$13⁵⁰

EXPORT AGENT
ROCKE INTERNATIONAL CORP.
13 E. 40th ST.
NEW YORK, CITY (16)
CABLE: ARLAB, N.Y.

The HEATH COMPANY

... BENTON HARBOR 20, MICHIGAN

NEW
Heathkit

AUDIO GENERATOR KIT

• RANGE EXTENDED TO 1 MEGACYCLE

MODEL AG-8

SHIPPING
WT. 16 LBS.

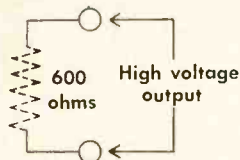

Low impedance output
High voltage output



Sine wave output
from 20 cycles to 1
megacycle.

\$29.50



- Improved design — new low price.
- Frequency coverage in five ranges from 20 cycles per second to 1 megacycle.
- Response flat 1 DB from 20 cycles to 400 kilocycles. Down 3 DB at 600 kilocycles. Down only 8 DB at 1 megacycle.
- Five calibrated output voltage ranges, continuously variable 1 mv, 10 mv, 100 mv, 1 v, 10 v.
- Low impedance output circuit. 600 ohms.
- Distortion less than .4 of 1% from 100 cycles per second through the audible range.
- New HEATHKIT universal type-binding posts.
- Durable infra-red baked enamel panel.
- Transformer operated for safe operation.
- Sturdy, ventilated steel cabinet.

A new Audio Generator with features heretofore found in only the most expensive generators. Such features as complete coverage from 20 cycles to 1 Mc — response flat ± 1 db from 20 cycles to 400 Kc, down 3 db at 600 Kc and down only 8 db at 1 Mc.

And it has calibrated output . . . Calibrated continuously variable and step attenuator output controls allow you to easily set calibrated output voltage. Moreover, distortion is less than .4 of 1% from 100 cps through the audible range.

Oscillator section consists of a two stage resistance coupled amplifier (6SJ7 and 6AK6) utilizing both positive and negative feedback for oscillator operation and reduction of distortion. Oscillator section drives a cathode follower output power amplifier (6AK6) which isolates the oscillator from variations in load and presents a low impedance output (600 Ohms). Power supply is transformer operated and utilizes 6X5 rectifier with 2 sections of RC filtering.

An unbeatable dollar value — for here is an audio generator with wide frequency coverage, excellent frequency response, stepped and continuously variable calibrated output, high signal level, low impedance output, and low inherent distortion.

Heathkit AUDIO FREQUENCY METER KIT

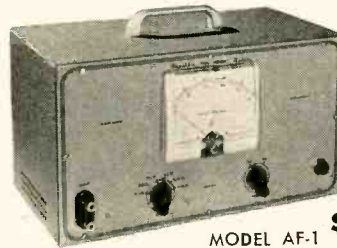

MODEL AF-1

\$34.50

SHIPPING
WT. 15 LBS.

The HEATHKIT AUDIO FREQUENCY METER provides a simple and easy way to check unknown audio frequencies from 10 cycles to 100 kc between 3 and 300 volts RMS. The instrument features 7 ranges for accuracy and wide coverage. The meter itself has a quality 200 microampere Simpson movement and large clearly marked scales. The AUDIO FREQUENCY METER is transformer operated and features a voltage regulator tube to maintain constant plate voltage on the second stage. Kit supplied complete with all necessary construction material and a detailed construction manual.

NEW *Heathkit* AUDIO OSCILLATOR KIT

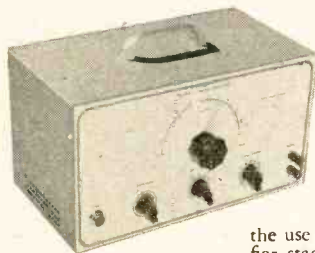

MODEL AO-1
SHIPPING
WT. 14 LBS.

\$24.50

A new Audio Oscillator with both sine and square wave coverage from 20 to 20,000 cycles . . . An instrument designed to completely fulfill the needs of the audio engineer and enthusiast — Has numerous advantages such as high level output (up to 10V obtainable across the entire range), distortion less than .6%, and low impedance output.

Special design features include the use of a thermistor in the second amplifier stage for keeping the output essentially flat across the entire range.

A cathode coupled clipper circuit produces good, clean, square waves with rise time of only 2 microseconds. Oscillator section uses 1% precision resistors in range multiplier circuit for greatest accuracy.

You'll like the operation of this fine new kit.

Heathkit SQUARE WAVE GENERATOR KIT

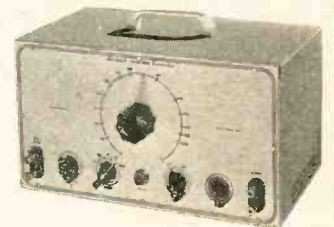

MODEL SQ-1
SHIPPING
WT. 14 LBS.

\$29.50

The HEATHKIT SQUARE WAVE GENERATOR is an excellent square wave frequency source with wide range coverage from 10 cycles to 100 kc continuously variable. This feature makes it useful for TV and wide band amplifier work as well as audio experimentation. The output voltage is continuously variable between 0 and 20 volts. The circuitry consists of a multivibrator stage, a clipping and squaring stage and a cathode follower low impedance output stage. The power supply is transformer operated and utilizes a full wave rectifier circuit with two sections of filtering. Another excellent HEATHKIT value at this remarkable low price. Kit includes all necessary construction material as well as complete instruction manual for assembly and operation.

EXPORT AGENT
ROCKE INTERNATIONAL CORP.
13 E. 40th ST.
NEW YORK CITY (16)
CABLE: ARIAS-N.Y.

The **HEATH COMPANY**

... BENTON HARBOR 20, MICHIGAN

NEW *Heathkit* VISUAL-AURAL SIGNAL TRACER KIT

• NEW NOISE LOCATOR AND WATTMETER CIRCUITS.

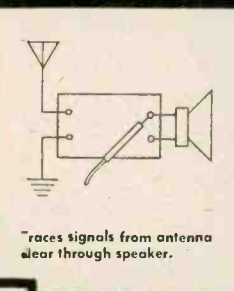
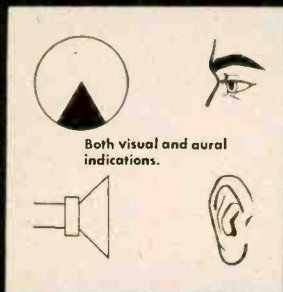

MODEL T-3

SHIPPING
WT. 8 LBS.

\$22.50



- Permits visual signal observation as well as aural operation.
- Two separate RF channels.
- Tremendous RF channel sensitivity. Adequate for actual signal detection at receiver input.
- Separate high gain RF and low gain audio channels.
- A unique and useful noise locator circuit.
- Built-in calibrated wattmeter.
- Two separate shielded probes for RF and audio application.
- Additional test leads supplied.
- Substitution test speaker and output transformer eliminates necessity for speaker removal in service work.
- Utility amplifier. Check record changers, tuners, microphones, instrument pickups, etc.
- VTVM and Scope panel terminals.
- 5 tube transformer operated circuit.

The new HEATHKIT VISUAL AURAL SIGNAL TRACER represents one of the most convenient and useful instruments the service man can use in AM, FM and TV service work. The electron ray beam indicator constantly monitors both input channels for visual observation of the signal. Now, see and hear the signal level for easier estimation of signal strength and gain per stage in a receiver circuit. Separate high gain channel and special shielded demodulator probe for RF circuit work. Low gain channel for audio circuit investigation and for use as a noise locator. In this feature, approximately 200 volts DC is applied to a suspected circuit component and the action of the voltage in the component can be seen and heard to determine satisfactory operation. This feature alone will prove tremendously helpful in locating the source of objectionable noises in coils, transformers, resistors, condensers, cold solder joints, controls, etc. A convenient wattmeter permits rapid preliminary check for voltage distribution circuit breakdown as well as transformer failures. Use the T-3 as a universal test speaker and substitution transformer and save service time by eliminating the necessity for speaker removal on every service call. Additional service uses are: as a utility amplifier for checking the output of record changers, tuners, microphones, instrument pickups, etc. Separate panel terminals permit utilization of other shop equipment such as your Oscilloscope or VTVM. Entire kit supplied complete with 5 tubes, all necessary construction material along with a detailed step by step instruction manual for the assembly and operation of the instrument.

NEW *Heathkit* CONDENSER CHECKER KIT



MODEL C-3
SHIPPING
WT. 7 LBS.

\$19.50

Announcing the new improved Model C-3 HEATHKIT CONDENSER housed in a new smartly styled professional appearing cabinet featuring rounded corners and snug fitting drawn panel. Adequate provisions for ventilation in-

sure longer instrument life through cooler operation. Use the C-3 to accurately measure those unknown condenser and resistor values. All readings of condensers and resistors are read directly on the calibrated scales. Range of condenser measurements is from .00001 mfd to 1000 mfd. Calibrated resistance measurements can be made from 100 ohms to 5 megohms. A leakage test with a choice of 5 DC polarizing voltages will quickly indicate condenser operating quality under actual voltage load conditions. The spring return leakage test switch automatically discharges the condenser under test and eliminates shock hazard. An electron ray beam indicator tube is used in a new leakage test circuit for added sensitivity. The instrument is transformer operated for safety and will prove an extremely welcome addition to your shop equipment. The kit is furnished complete with all necessary parts, test leads and includes a step by step detailed construction manual for assembly and operation.

Heathkit TV ALIGNMENT GENERATOR KIT

MODEL TS-2
SHIPPING
WT. 20 LBS.

\$39.50

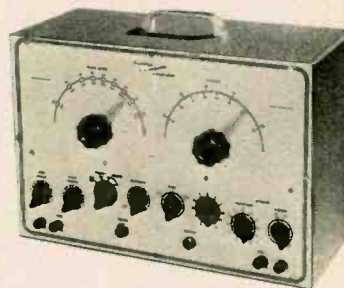

Here is an excellent TV ALIGNMENT GENERATOR designed to do TV service work quickly, easily and properly. The Model TS-2 when used in conjunction with an Oscilloscope provides a means of correctly aligning TV receivers. The instrument furnishes a frequency modulated signal covering in 2 bands the range of 10 to 90 megacycles and 150 to 230 megacycles. An absorption type frequency marker covers from 20 to 75 megacycles in 2 ranges; therefore you have a simple, convenient means of checking IF's independent of oscillator calibration. Sweep width is variable from 0 to 12 megacycles. Other excellent features are horizontal sweep voltage controlled with a phasing control — both step and continuously variable attenuation for setting the output signal to the desired level — a convenient stand by switch — and blanking for establishing a single trace with a base reference level. Make your work easier, save time and repair with confidence. Order your HEATHKIT TV ALIGNMENT GENERATOR now.

EXPORT AGENT
ROCKE INTERNATIONAL CORP.
13 E. 40th ST.
NEW YORK CITY (16)
CABLE: ARLAB-N.Y.

The **HEATH COMPANY**

... BENTON HARBOR 20, MICHIGAN

Heathkit TUBE CHECKER KIT

MODEL TC-1
SHIPPING
WT. 12 LBS.

\$29.50

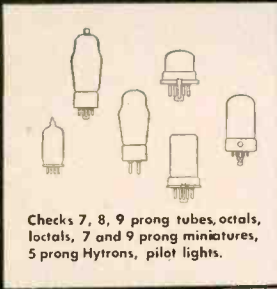

Checks 7, 8, 9 prong tubes, octals, loctals, 7 and 9 prong miniatures, 5 prong Hytrons, pilot lights.

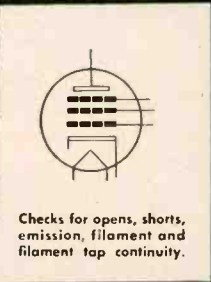

Checks for opens, shorts, emission, filament and filament tap continuity.

- Beautiful counter type birch cabinet.
- 4½" Simpson 3 color meter.
- Simplified setup procedure.
- Built-in gear driven roll chart.
- Checks emission, shorted elements, open elements and continuity.
- Complete protection against obsolescence.
- Sockets for every modern tube.
- Blank for new types.
- Individual element switches.
- Contact type pilot light test socket.
- Line adjust control.

**PORTABLE TUBE CHECKER KIT
MODEL TC-1P**

Same as TC-1 except supplied with polished birch cabinet (with removable lid) instead of counter type cabinet. Shipping weight 14 lbs. **\$34.50**

No. 365 Polished Birch Tube Checker Cabinet only. Shipping Weight 7 lbs. **\$7.50**

With the HEATHKIT TC-1 TUBE CHECKER test all types of tubes commonly encountered in AM-FM and TV receiver circuits. Test setup procedure is simplified, rapid and flexible. Tube quality is read directly on a beautiful 4½" Simpson three color BAD - ? - GOOD scale that your customers can readily understand. Panel sockets accommodate 4, 5, 6 and 7 prong tubes, octals, loctals, 7 and 9 prong miniatures, 5 prong Hytrons, a blank socket for new tubes and a contact type socket for quick checking of pilot lights. Built-in gear driven roll chart for instant reference. Neon short indicator, individual three position lever switch for each tube element, spring return test switch, line set control to compensate for supply voltage variations. At this low price, no service man need be without the advantages offered by the HEATHKIT TUBE CHECKER.

**Heathkit TV PICTURE TUBE
TEST ADAPTER**

Use your HEATHKIT TUBE CHECKER with this new TV TEST ADAPTER to determine picture tube quality. Check for emission and shorts, independent of TV power supply. Consists of standard 12 pin TV tube socket, 4 feet of cable, octal socket connector and data sheet. Quickly prove TV picture tube condition to yourself and your customer.



No. 355
Ship. Wt. **\$4.50**
1 lb.

Heathkit RESISTANCE SUBSTITUTION BOX KIT



MODEL RS-1
SHIPPING
WT. 3 LBS.

\$5.50

NEW HEATHKIT RESISTANCE SUBSTITUTION BOX KIT provides switch selection of any single one of 36 RTMA 1 watt 10% standard value resistors, ranging from 15 ohms to 10 megohms. This coverage available in 2 ranges in decades of 15, 22, 33, 47, 68 and 100. Housed in rugged plastic cabinet featuring new HEATHKIT universal type binding posts. The entire kit priced less than the retail value of the resistors alone.

**Heathkit
BATTERY ELIMINATOR KIT**

A clean 6 volt d-c supply source is definitely required for successful automobile radio servicing. Has a continuously variable d-c output from 0 to 8 volts. It can be safely operated at a steady 10 ampere level and will deliver up to 15 amperes for intermittent periods. The voltage output terminals are completely isolated from the chassis to accommodate additional service applications such as supplying bias voltages or d-c substitution voltages for battery operated tube filament circuits.

The output of the Battery Eliminator is constantly monitored by a d-c voltmeter and a d-c ammeter. The circuit features an automatic overload relay of self resetting type. For additional protection, a panel mounting fuse is provided. Build this kit in a few hours and pocket a substantial savings.



MODEL BE-3
SHIPPING
WT. 20 LBS.

\$24.50

**Heathkit
VIBRATOR TESTER KIT**

Repair time is valuable, and the Heathkit Vibrator Tester will save you hours of work. Instantly tells the condition of the vibrator under test—and the check is thorough and complete. Checks vibrator for proper starting, and the easy-to-read meter indicates the quality of output on large BAD-GOOD scales. Tests both interrupter and selfrectifier types of vibrators. Five different sockets for checking hundreds of vibrators.

Operates from any battery eliminator capable of delivering continuously variable voltage from 4 - 6V at 4 amps. The Heathkit BE-3 Battery Eliminator is ideal for operating this kit.

Faulty vibrators can be spotted within seconds and you're free to go on to other service jobs.



MODEL VT-1
SHIPPING
WT. 7 LBS.

\$14.50

EXPORT AGENT
ROCKE INTERNATIONAL CORP.
13 E. 40th ST.
NEW YORK CITY (16)
CABLE: ARLAB N.Y.

The HEATH COMPANY

... BENTON HARBOR 20, MICHIGAN

Heathkit SIGNAL GENERATOR KIT

MODEL SG-7

SHIPPING
WT. 7 LBS.

\$19.50



Modulated or unmodulated RF output.



400 cycle sine wave output.

- Step attenuated RF output.
- 6 to 1 vernier dial ratio.
- Turret mounted coil sub-assembly.
- Pre-calibrated and adjusted coils.
- Hartley RF oscillator circuit.
- Colpitts oscillator 400 cycle sine wave output.
- Modulated or unmodulated RF output.
- Frequency coverage on fundamentals 160 kc to 50 megacycles in five ranges. 51 megacycles to 150 megacycles on calibrated harmonics.
- RF output in excess of 100,000 microvolts.
- Audio output 1 1/2 to 2 volts.
- AC transformer operated.
- Professionally styled cabinet.
- Infra red baked enamel panel.

The new HEATHKIT Model SG-7 SIGNAL GENERATOR easily fulfills requirements for a controllable, modulated or unmodulated source of variable frequency. A convenient 400 cycle sine wave output is available for audio work. All RF oscillator coils are precision wound and adjusted to calibration before shipment thereby assuring maximum accuracy. The coils, band switch and tuning condenser all mount as a turret assembly so as to offer the advantage of short wiring leads and easy mounting of parts. The RF output circuit is of the low impedance type obtained by the use of cathode coupling to the output jacks. The level of RF output is varied by means of the RF step and RF output control. Use the HEATHKIT SG-7 as an RF signal source modulated or unmodulated for radio repair, laboratory work, experimental testing, 400 cycle sine wave audio testing, checking RF stages, alignment of both AM and FM IF stages, marker generator for TV alignment, etc. The kit is transformer operated and utilizes miniature tubes for ease in handling high frequency. Panel jacks and a convenient switching system permit either external or internal modulation. The entire kit is supplied complete with tubes and all necessary material as well as a detailed step by step instruction manual for the assembly and operation of the instrument.

Heathkit INTERMODULATION ANALYZER KIT



MODEL IM-1
SHIPPING WT.
18 LBS.

\$39.50

The HEATHKIT MODEL IM-1 is an extremely versatile instrument specifically designed for measuring the degree of interaction between two

signals caused by a specific piece of apparatus, or a chain of equipment. It is primarily intended for tests of audio equipment but may be used in other applications such as making tests of microphones, records, recording equipment, phonograph pickups and loud speakers. Use it for checking tape or disc recordings, as a sensitive AC voltmeter, as a high pass noise meter for adjusting tape bias, cutting needle pitch or other applications. High and low test frequency source, intermodulation section, power supply and AC voltmeter all in one complete unit. Percent intermodulation is directly read on three calibrated ranges, 30%, 10% and 3% full scale. Both 4 to 1 and 1 to 1 ratios of low to high frequencies easily set up. At this low kit price YOU can enjoy the benefits of Intermodulation analysis for accurate audio interpretations.

Heathkit LABORATORY REGULATED POWER SUPPLY KIT



MODEL PS-2
SHIPPING
WT. 20 LBS.

\$29.50

New HEATHKIT LABORATORY POWER SUPPLY provides continuously variable regulated DC voltage output

from 160 volts to 400 volts depending on load. Panel terminals supply separate 6.3 V. AC supply at 4 amperes for filament circuits. A 3 1/2" plastic cased panel mounted meter provides accurate metered output for either voltage or current measurements. Exceptionally low ripple content of .012% admirably qualifies the HEATHKIT LABORATORY POWER SUPPLY for high gain audio applications. Ideal for laboratory work requiring a reference voltage for meter calibration or for plotting tube characteristics. In service work, it can be used as a separate variable voltage supply to determine the desirable operating voltage in a specific circuit. Use it as a DC substitution voltage in trouble shooting TV circuits exhibiting symptoms of extraneous undesirable components in plate supply circuits. Entire kit, including all 5 tubes now available at this low price.

EXPORT AGENT
ROCKE INTERNATIONAL CORP.
13 E. 40th ST.
NEW YORK CITY (16)
CABLE: ARAB-N.Y.

The HEATH COMPANY

... BENTON HARBOR 20, MICHIGAN

Heathkit WILLIAMSON TYPE AMPLIFIER KIT

The new HEATHKIT WILLIAMSON TYPE AMPLIFIER incorporates the latest improvements described in Audio Engineering's "Gilding the Lily." 5881 output tubes and a new Peerless output transformer with additional primary taps afford peak power output of well over 20 watts. Frequency response ± 1 db from 10 cycles to 100 kc. allows reproduction of highs and lows with equal crispness and clarity. Harmonic and intermodulation distortion have been reduced to less than $\frac{1}{2}$ of 1% at 5 watts. This eliminates the harsh unpleasant qualities which contribute to listening fatigue. Make this amplifier the heart of your radio system to achieve the fine reproduction that is the goal of all music lovers.

The HEATHKIT PREAMPLIFIER (available separately or in combination with the amplifier kit) features inputs for magnetic or low level cartridges, crystal pickups and tuners, turnover control for LP or 78 type records, individual bass and treble tone controls each providing up to 15 DB of boost or attenuation. Special notched shafts on preamplifier controls and switches adaptable to custom installation. The preamplifier can be mounted in any position and a liberal length of connecting cable is supplied. No radio experience is required to construct this amplifier. All punching, forming, or drilling has already been done. The complete kit includes all necessary parts as well as a detailed step by step construction manual with pictorial diagrams to greatly simplify the construction.



ACROSOUND TRANSFORMER OPTION. If desired, the output transformer with the kit will be the Acrosound output transformer, type TO-300. The use of this transformer permits ultra-linear operation as described in Audio Engineering's "Ultra-Linear Operation of the Williamson Amplifier."

Heathkit FM TUNER KIT



MODEL FM-2
SHIPPING
WT. 9 LBS.

\$22⁵⁰

The HEATHKIT MODEL FM-2 TUNER specifically designed for simplified kit construction features a preassembled and adjusted tuning unit. Three double tuned IF transformers and a discriminator transformer are used in an 8 tube circuit. Smooth tuning is obtained through a 9 to 1 ratio vernier drive using a calibrated six inch slide rule type dial. The usual frequency coverage of 88 to 108 megacycles is provided. Experience the thrill of building your own FM tuner. Operate it through your amplifier or radio and enjoy all the advantages of true FM reception. Transformer operated power supply to simplify connections to all types of audio systems. The kit is supplied complete with all 8 tubes and a necessary material required for construction. A complete instruction manual simplifies assembly and operation.

PRICES OF VARIOUS COMBINATIONS

- W-2 Amplifier Kit** (Incl. Main Amplifier with Peerless Output Transformer, Power Supply and WA-P1 Preamplifier Kit) Shipping Weight 39 lbs. **\$69⁵⁰**
- W-2M Amplifier Kit** (Incl. Main Amplifier with Peerless Output Transformer and Power Supply) Shipping Weight 29 lbs. Shipped express only **\$49⁷⁵**
- W-3 Amplifier Kit** (Incl. Main Amplifier with Acrosound Output Transformer, Power Supply and WA-P1 Preamplifier Kit) Shipping Weight 39 lbs. Shipped express only **\$69⁵⁰**
- W-3M Amplifier Kit** (Incl. Main Amplifier with Acrosound Output Transformer and Power Supply) Shipping Weight 29 lbs. Shipped express only **\$49⁷⁵**
- WA-P1 Preamplifier Kit only.** Shipping Weight 7 lbs. Shipped express or parcel post. **\$19⁷⁵**

Heathkit ECONOMY 6 WATT AMPLIFIER KIT



MODEL A-7
SHIPPING
WT. 10 LBS.

\$14⁵⁰

The HEATHKIT Model A-7 amplifier features beam power, push pull output with frequency response flat $\pm 1\frac{1}{2}$ DB from 20 to 20,000 cycles. Separate volume, bass and treble controls. Two input circuits, output impedances of 4, 8, and 15 ohms. Peak power output rated at full 6 watts. High quality components, simplified layout, attractive gray finished chassis, break off type adjustable length control shafts and attractive lettered control panel.

THE MODEL A7A amplifier incorporates a preamplifier stage with special compensated network to provide the necessary voltage gain for operation with variable reluctance or low output level phono cartridges. Excellent gain for microphone operation in a moderate powered sound system.....**\$16.50**

Heathkit HIGH FIDELITY 20 WATT AMPLIFIER KIT

The HEATHKIT MODEL A-8 amplifier kit was designed to deliver high fidelity performance with adequate power output at moderate cost. The frequency response is within ± 1 DB from 20 to 20,000 cycles. Distortion at 3 DB below maximum power output at 1000 cycles is only .8%. The amplifier features a Chicago power transformer in a drawn steel case and a Peerless output transformer with output impedances of 4, 8, and 16 ohms available. Separate bass and treble tone controls permit wide range of tonal adjustment to meet the requirements of the most discerning listener. The amplifier uses a 6SJ7 voltage amplifier, a 6SN7 amplifier and phase splitter and two 6L6's in push pull output and a 5U4G rectifier. Two input jacks for either crystal or tuner operation. The kit includes all necessary material as well as a detailed step by step construction manual.



MODEL A-8
SHIPPING WT. 19 LBS.

\$33⁵⁰

MODEL A8-A features an added 6SJ7 stage (preamplifier) for operating from a variable reluctance cartridge or other low output level phono pickups. Can also be used with a microphone. A 3 position panel switch affords the desired input service.**\$35.50**

EXPORT AGENT
ROCKE INTERNATIONAL CORP.
13 E. 40th ST.
NEW YORK CITY (16)
CABLE: AREAR-N.Y.

The **HEATH COMPANY**

... BENTON HARBOR 20, MICHIGAN

Heathkit SUPERHETERODYNE RECEIVER KITS

- High gain dual iron core tuned type IF transformers
- AC transformer operation for safety
- Continuously variable tone control
- Sturdy punched and plated steel chassis
- Ideal for custom installation
- Full AVC action
- Inverse feedback for improved frequency response
- Kit supplied with all necessary construction material except speaker and cabinet. (Available separately if desired).

6 tube all wave circuit.
3 ranges, continuous coverage 550 kc to over 20 megacycles, shipping wt. 11 lbs.

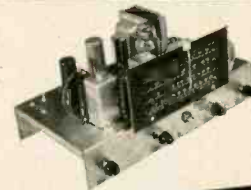

Model AR-1
\$23.50

5 tube broadcast band
550 to 1600 kc coverage,
shipping wt. 11 lbs.



Model BR-1
\$19.50

Two excellent radio receiver kits featuring clean design and open layout for simplified construction. Satisfy that urge to build your own radio receiver and select the model which meets your requirements. Both receivers feature continuously variable tone control, a radio phono switch and phono input and an AC receptacle for the phono motor. A six inch calibrated slide rule type dial with a 9 to 1 ratio vernier dial drive insures easy tuning.

SHIPPING INFORMATION

ON PARCEL POST ORDERS include postage for weight shown and insurance. (We insure all shipments.) Don't worry about sending more than the correct amount — if you send us too much, every extra cent will be promptly returned.

ON EXPRESS ORDERS do not include transportation charges. They will be collected by Express Agency on delivery.

ORDERS FROM CANADA must include full remittance for merchandise.

Orders processed on the same day received. Customers notified of unavoidable delay.

U. S. postal or express money orders, bank drafts or checks are acceptable. Do not send loose coins or stamps.

ALL PRICES SUBJECT TO CHANGE WITHOUT NOTICE

EXPORT AGENT
ROCKE INTERNATIONAL CORP.
13 E. 40th ST.
NEW YORK CITY (16)
CABLE: ARAB N. Y.

The HEATH COMPANY

... BENTON HARBOR 20, MICHIGAN

ORDER BLANK

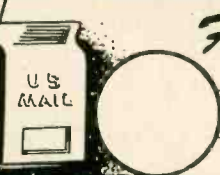

From _____

SHIP VIA

- Parcel Post
- Express
- Freight
- Best Way

(PLEASE PRINT)

QUANTITY	ITEM	PRICE	QUANTITY	ITEM	PRICE
	Heathkit Oscilloscope Kit—Model O-8 (29 lbs.)	\$43.50		Heathkit Square Wave Gen. Kit—Model SQ-1 (14 lbs.)	\$29.50
	Heathkit Intensifier Kit (0-8 only) No. 339 (1 lb.)	7.50		Heathkit AC VTVM Kit—Model AV-2 (5 lbs.)	29.50
	Heathkit Voltage Calibrator Kit—Model VC-1 (5 lbs.)	9.50		Heathkit Intermodulation Analyzer Kit—Model IM-1 (18 lbs.)	39.50
	Heathkit Electronic Switch Kit—Model S-2 (11 lbs.)	19.50		Heathkit Regulated Power Supply Kit—Model PS-2 (20 lbs.)	29.50
	Heathkit Scope Demodulator Probe Kit No. 337 (1 lb.)	4.50		Heathkit Handitester Kit—Model M-1 (3 lbs.)	13.50
	Heathkit T.V. Alignment Generator Kit—Model TS-2 (20 lbs.)	39.50		Heathkit Decade Resistance Kit—Model DR-1 (4 lbs.)	19.50
	Heathkit Q Meter Kit—Model QM-1 (12 lbs.)	39.50		Heathkit Decade Condenser Kit—Model DC-1 (4 lbs.)	16.50
	Heathkit Grid Dip Meter Kit—Model GD-1 (4 lbs.)	19.50		Heathkit Impedance Bridge Kit—Model IB-1B (15 lbs.)	69.50
	Heathkit VTVM Kit—Model V-6 (7 lbs.)	24.50		Heathkit Battery Tester Kit—Model BT-1 (3 lbs.)	7.50
	Heathkit RF Probe Kit No. 309 (1 lb.)	5.50		Heathkit Resistance Substitution Box Kit—Model RS-1 (3 lbs.)	5.50
	Heathkit HV Probe Kit No. 336 (2 lbs.)	5.50		Heathkit F.M. Tuner Kit—Model FM-2 (9 lbs.)	22.50
	Heathkit Peak-to-Peak Volt. Probe Kit No. 338 (2 lbs.)	6.50		Heathkit Broadcast Receiver Kit—Model BR-1 (11 lbs.)	19.50
	Heathkit Visual-Aural Signal Tracer Kit—Model T-3 (8 lbs.)	22.50		Heathkit Three Band Receiver Kit—Model AR-1 (11 lbs.)	23.50
	Heathkit Condenser Checker Kit—Model C-3 (7 lbs.)	19.50		Heathkit Amplifier Kit—Model A-7 (10 lbs.)	14.50
	Heathkit RF Signal Generator Kit—Model SG-7 (7 lbs.)	19.50		Heathkit Amplifier Kit—Model A-7A (10 lbs.)	16.50
	Heathkit Tube Checker Kit—Model TC-1 (12 lbs.)	29.50		Heathkit Amplifier Kit—Model A-8 (19 lbs.)	33.50
	Heathkit T.V. Tube Adapter No. 355 (1 lb.)	4.50		Heathkit Amplifier Kit—Model A-8A (19 lbs.)	35.50
	Heathkit Battery Eliminator Kit—Model BE-3 (20 lbs.)	24.50		Williamson Type Amplifier Kit (Type:)	
	Heathkit Vibrator Tester Kit—Model VT-1 (7 lbs.)	14.50		Shipped express only	
	Heathkit Audio Generator Kit—Model AG-8 (16 lbs.)	29.50		WA-P1 Preampifier Kit (7 lbs.) (Shipped exp. or p.p.)	19.75
	Heathkit Audio Oscillator Kit—Model AO-1 (14 lbs.)	24.50			
	Heathkit Audio Frequency Meter Kit—Model AF-1 (15 lbs.)	34.50			

*Please ship C.O.D. Postage enclosed for _____ lbs. Enclosed find Check Money Order for _____

Brighter, Sharper, TV Reception

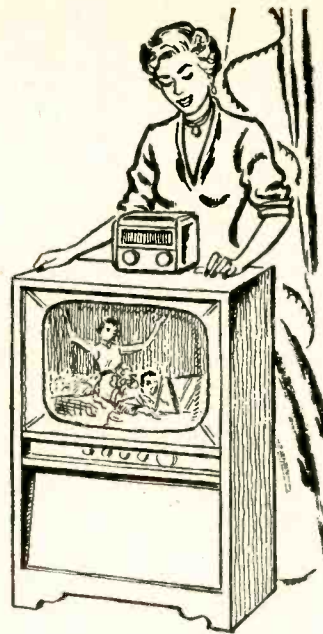

with the **TURNER** Model TV-2 Booster

You get clearer, sharper pictures with a minimum of annoying interference and snow even in weak signal areas with the TURNER TV-2 Booster. It's designed with an eye to beauty as well as outstanding performance. The rich, mahogany plastic cabinet is a handsome addition to any room . . . the high quality cascode circuit reduces noise and snow, producing an excellent picture even in extreme fringe areas.

The TURNER Booster is simple in operation. A single tuning knob permits fine adjustment for best reception of picture and audio over all 12 TV channels. The unit is quickly and easily installed on any television set. Get the best possible TV reception . . . get the TURNER Model TV-2 Booster!

The **TURNER** Company 933 17th St. N.E. Cedar Rapids, Iowa
IN CANADA:

Canadian Marconi Company, Toronto, Ont., and Branches.



EXPORT:

Ad. Auriema, Inc., 89 Broad Street, New York 4, N. Y.



- 1220 pages
- 80,000 items
- 8,000 illustrations
- 8" x 11" - 5 lbs.

Publisher's price
\$6.50—your price
through your
regular parts
distributor **\$1.95**

The right part when you need it, for service

This permanent, hard cover Official Buying Guide of the electronic-TV parts and equipment industry with its comprehensive detailed index, eliminates the need for maintaining files of small catalogs and manufacturers' literature. RADIO'S MASTER catalogs 90% of TV and electronic equipment. Not merely part number listings—complete descriptions, specifications and illustrations written and compiled by each manufacturer. Enables you to make comparisons or substitutions right now!



UNITED CATALOG PUBLISHERS, INC.
110 Lafayette St., New York 13

THE ROTALYZER

The Rotalyzer is a new instrument for measuring speed and speed variations. It may be used with any rotating shaft. First the Rotalyzer converts the rotation to a.c. If the shaft speed is uniform, the a.c. will be unmodulated. There will be only one frequency as in Fig. 1-a. If the speed varies, the a.c.

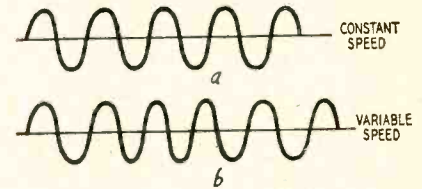

Fig. 1—Rotalyzer waveforms.

frequency will also vary. It will rise and fall about the average as in Fig. 1-b. This frequency variation is common, ordinary FM. It can be detected by a discriminator.

Fig. 2 shows the block diagram of the Rotalyzer. The tachometer is a tiny generator coupled to the rotating shaft. It contains a number of fixed magnetic poles and a coil wound on the rotating armature. (In some types the coil is fixed and the magnets are mounted on the armature.) When the generator rotates with the shaft of the device being checked, magnetic lines of force cut across the coil and generate a.c. The equation for the generator frequency is

$$F = \frac{\text{shaft RPM} \times \text{poles}}{120}$$

As long as the shaft rotates at constant speed the frequency also remains constant. If the shaft speeds up, the armature turns faster and the frequency increases. If the shaft slows down, the frequency decreases.

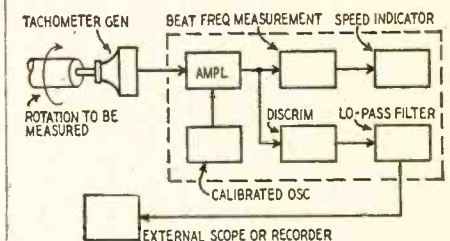

Fig. 2—Average speed is found by beat method. Discriminator shows variations.

For most purposes, an average a.c. of between 5 kc and 30 kc is convenient. For slow shaft speeds, we need a large number of poles to reach these frequencies. Some Rotalyzers have as many as 600 poles within a 2-inch tachometer.

Tachometer output is amplified. The average frequency is compared with a standard oscillator by the best method. The answer gives us the average speed.

The amplified a.c. is also impressed across an FM discriminator. This detects only the FM component. It is passed through a filter which rejects the high frequencies, leaving only the slow variations due to wow and flutter of the shaft. The variations may be recorded or observed on a scope.

The Rotalyzer can show speed changes as small as 0.1%. Average speeds of from 50 r.p.m. to 20,000 r.p.m. are easily measured. END



Why pick 'em blind?

Buying capacitors by rating without also specifying brand is like buying neckties blindfolded. You just don't know what you're getting. When it comes to capacitors, don't buy blind . . . don't trust to luck . . .

Make Sure! Make it Mallory!

When you use Mallory capacitors for all your service work, you do yourself and your customers a real favor. Mallory capacitors give long, trouble-free performance.

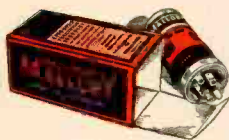

TV and radio set manufacturers accept Mallory FP's as *the* standard of capacitor quality. Operating continuously, even at temperatures as high as 185° F. (85° C.), Mallory FP's give longer, more dependable performance . . . handle higher ripple current.



Mallory Plascaps® give outstanding performance because they are completely engineered to eliminate premature shorts . . . unsoldered leads . . . off-center cartridges. And they are priced right.

You can count on Mallory FP's and Plascaps because they are backed by 25 years of capacitor research and on-the-job experience. Mallory produced the first dry electrolytic capacitors . . . pioneered developments that give you capacitors which are smaller . . . more uniform . . . more resistant to heat. And they cost no more. Don't trust to luck when you order capacitors. Always specify Mallory.

Depend on your Mallory Distributor for quality products at competitive prices.

P. R. MALLORY & CO. Inc.
MALLORY

CAPACITORS • CONTROLS • VIBRATORS • SWITCHES • RESISTORS
• RECTIFIERS • VIBRAPACK® POWER SUPPLIES • FILTERS

*Reg. U.S. Pat. Off.

APPROVED PRECISION PRODUCTS

P. R. MALLORY & CO., Inc., INDIANAPOLIS 6, INDIANA

RIDER TEK- FILE*

easy-to-use
packaged
tv
service
information—
it's
complete...
accurate...
factory-
authorized—
at
your
jobbers
now...
only

\$2 per pack

*dependable replacement parts listing beginning with Pack 57

JOHN F. RIDER
PUBLISHER, INC.

480 Canal Street,
New York 13, N. Y.

ROK RECEIVER

By CPL. MILTON KALASHIAN

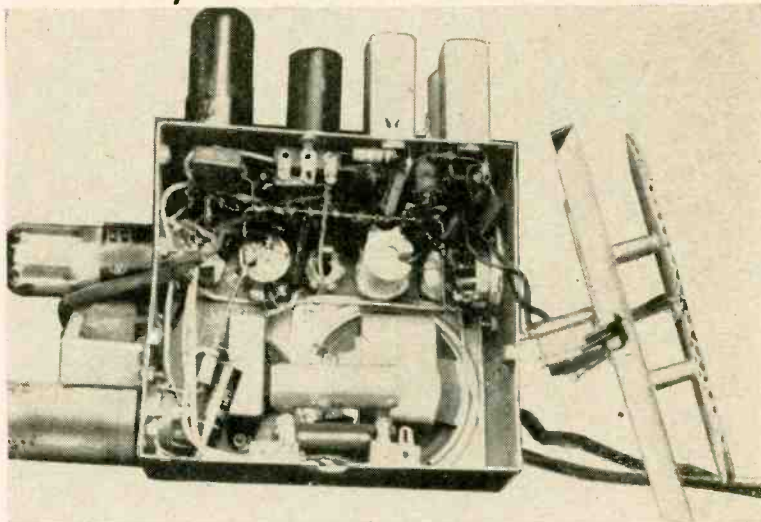

Inside the receiver. The loop antenna is mounted on the open cover at the right.

KOREA isn't quite so bad if you're a "ham" and part of a Signal Corps outfit. You're not allowed to operate a rig of your own, but when things are quiet, you may have time to do some experimenting with whatever parts you can salvage.

A big morale builder here is the good music broadcast on 1320 kc by AFRS (Armed Forces Radio Station) *Troubadour*—running a revamped BC-610. The broadcast receiver situation here was so critical, we decided to beat the shortage by building one. As a Signal Corps outfit we had 110-volt a.c. most of the time, so an a.c.-d.c. hookup (Fig. 1) took care of that. It's only a simple 5-tube superhet, loop antenna and all, with some minor changes. The only thing *really different* about this set is the way it's constructed. It had to be rugged so it could withstand a lot of abuse.

Since the only tubes on hand were the 300-ma heater types, we had to use the 130-ohm voltage-dropping resistor. This resistor is an advantage here in winter, with the temperature always well below zero. It produces quite a bit of heat and keeps the inside of the set dry. In summer the cabinet gets quite hot, but this hasn't done any damage yet. (If the same tube lineup is used on normal 117-volt lines, this resistor should have a value of 160 ohms, 20 watts. This is a standard value in resistor-type line cords and ballast tubes. If 150-ma heater tubes—12BE6, 12BA6, 12AV6, 50C5, 35W4, or their metal equivalents—are used, the dropping resistor is not needed.—*Editor*)

The loop antenna feeds a conventional 6BE6 pentagrid converter, which in turn feeds the 6BA6 i.f. amplifier through the first i.f. transformer. The second i.f. transformer drives the diode

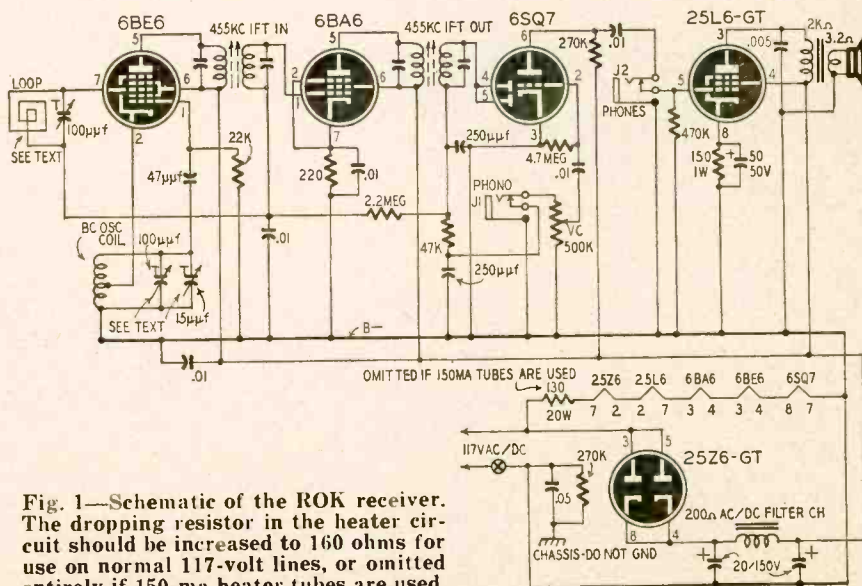

Fig. 1—Schematic of the ROK receiver. The dropping resistor in the heater circuit should be increased to 160 ohms for use on normal 117-volt lines, or omitted entirely if 150-ma heater tubes are used.

CBS-HYTRON NEWS FOR YOU...

ABOUT NEW CBS-HYTRON DIODES

CBS-Hytron guarantees its new germanium diodes *moisture-proof* . . . trouble-free. Germanium wafer is soldered directly to the base . . . no plating to flake. Universal design follows joint Army-Navy specifications. You can clip or solder these diodes into circuit. Ten popular CBS-Hytron types are ready for you. See your CBS-Hytron jobber. Or write direct for catalogue and interchangeability chart.

TECHNICAL DATA
CBS-Hytron Germanium Diodes

Type No.	Min. Forward Cur. (mA) @ 1V	Max. Inv. Cur. (mA) @ -50V	Peak Inv. Voltage @ 25° C
1N48	4.0	.850	85
1N51	7.5	1.607	50
1N52	4.0	.15	85
1N63	4.0	.05	125
1N64	Special video detector tested at 44 mc. Complete data on request		
1N65	2.5	.20	85
1N69*	5.0	.05	85
1N70*	3.0	.025	.30
1N75	2.3	.05	125
1N81*	3.0	.01	50
*IM TYPES			



Germanium Diode
Danvers, Massachusetts, U.S.A.
Broadcasting System, Inc.



Permanent X molded into end of case marks connection to germanium . . . which corresponds to cathode of vacuum tube.

New, attractive tuck-away carton fully protects CBS-Hytron germanium diodes. Note unbent leads and convenient data on inside cover.

Permanent X molded into end of case marks connection to germanium . . . which corresponds to cathode of vacuum tube.

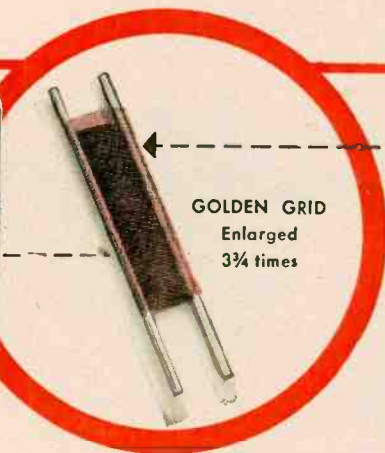

GOLDEN GRID
Enlarged
3 3/4 times

ABOUT CBS-HYTRON GOLDEN GRIDS

Hidden gold in CBS-Hytron tubes? Yes, since 1944. CBS-Hytron first used gold-plated grids in the 6AK5. Later in many transmitting types: 2E25A, 2E30, 3B4, 5516, etc. Now you will find them also in the 6BZ7, 6BQ6GT, 12A4, 12BY7, etc.

Why? Gold kills unwanted emission. Even mounted very close to a hot cathode, a CBS-Hytron gold-plated grid does not give *primary* emission. Like a sponge the gold also soaks up stray electrons. Wipes out *secondary* emission too. And foreign material vaporized onto the grid during exhaust is absorbed harmlessly by the gold plating.

Such deluxe processing costs money. But it gives you better tubes. That is why CBS-Hytron has ignored the cost. Has specified gold-plated grids for years.

ABOUT NEW, FREE CBS-HYTRON TV GUIDE

Like the popular CBS-Hytron Miniature Guide, the new CBS-Hytron Reference Guide for Television Picture Tubes is *complete*. Gives all important data . . . as well as basing diagrams . . . for 164 types. Includes *all* magnetically deflected picture tubes . . . regardless of make. Also shows electrical interchangeability of similar types.

You need this complete . . . accurate . . . helpful Guide. Keep abreast of today's confusing variety of TV picture tubes. Get the new CBS-Hytron TV Guide now. It's *free*. At your CBS-Hytron jobber's. Or write direct today.



DANVERS, MASSACHUSETTS

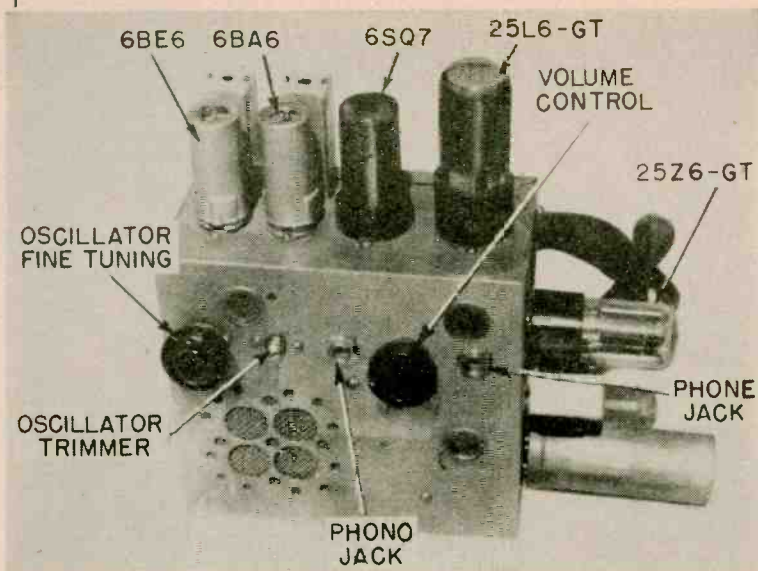

The ROK's layout was a forced blend of commercial parts and military salvage.

detector in the 6SQ7, which also furnishes a.v.c. voltage to the converter and the i.f. amplifier. The triode section of the 6SQ7 drives the 25L6 audio power amplifier. The rectifier is a 25Z6 with both sections tied together, and a choke is used rather than a resistor for better filtering. A closed-circuit jack (J1) was installed just in case we found a phonograph lying around. Another closed-circuit phone jack (J2) was wired in the grid circuit of the

25L6 for listening in with just a pair of high-impedance phones.

The combination chassis and cabinet was made from a salvaged 6 x 6 x 3-inch dynamotor box. As many parts as possible were mounted inside, including the 3-inch speaker. Since the B-minus bus goes to one side of the power line, it was not connected directly to the metal chassis; but is grounded for r.f. and audio through a .05- μ f capacitor. The 270,000-ohm resistor across the

capacitor allows the chassis to be used as a ground for voltage measurements with a v.t.v.m.

Since *Troubadour* was the only station that could be picked up 24 hours a day, the usual ganged tuning capacitor was replaced by two air trimmers—making it practically a one-station receiver. A 15- μ f air trimmer with a

Materials for receiver

Resistors: 1—4.7 megohms, 1—2.2 megohms, 1—470,000 ohms, 2—270,000 ohms, 1—47,000 ohms, 1—22,000 ohms, 1—220 ohms, 1/2 watt; 1—150 ohms, 1 watt; 1—130 ohms, 20 watt (see text); 1—500,000-ohm potentiometer with on-off switch.

Capacitors: (Electrolytic) 2—20 μ f, 150 volts, 1—50 μ f, 50 volts, (Paper) 1—.05 μ f, 1—.005 μ f, 600 volts; 5—.01 μ f, 400 volts. (Mica or ceramic) 2—250, 1—47 μ f, 500 volts. (variable) 2—100 μ f, 1—15 μ f.

Transformers: 1—2,000 ohms to 3.2 ohms a.f. output transformer; 1—455-kc input i.f. transformer, 1—455-kc output i.f. transformer; 1 broadcast type oscillator coil for 455-kc i.f.; 1 broadcast type loop antenna; 1—80 ma, 200-ohm filter choke.

Miscellaneous: 1—3-inch PM speaker; 1—6BE6, 1—6BA6, 1—6SQ7, 1—25L6, 1—25Z6, or equivalent types (see text); 2—closed-circuit phone jacks; chassis; cabinet; 5 sockets to suit tubes; line cord, knobs, terminals, wire, solder, hardware.

front-panel control knob was connected across the main oscillator-tuning capacitor to compensate for drift.

(The 100- μ f trimmers are too small to reach the lower broadcast frequencies with a standard loop antenna and oscillator coil. If you want to be able to cover the whole broadcast band, use a standard 2-gang r.f.-oscillator tuning capacitor.—*Editor*)

The loop and its trimmer were mounted on the back cover, with the loop on the outside, supported by two 1-inch insulating spacers. END

Everybody's Talking...



about the
sensational new
1953
Hi-Fidelity

PILOTUNER

FM-AM TUNER

An instant sensation. Captivates the most critical audience with its superior sensitivity, incomparable selectivity, true tone. Write for the full, exciting story of this matchless PILOTUNER... a "must" for every hi-fi enthusiast.

Also available... High Fidelity PILOTONE AMPLIFIER and PRE-AMPLIFIER, as companion units to the PILOTUNER. Truly the ultimate in superb electronic equipment.

Built by
PILOT RADIO CORP.
the name that has been a
by-word for the greatest in
precision communications
equipment since 1919.

Send NOW for free descriptive literature!

PILOT Radio Corp., 37-06 36th Street, Long Island City, New York

RADIO-ELECTRONICS

Insist upon

ELECTRONIC HARDWARE IN HANDY RE-USABLE HINGED COVER PLASTIC BOXES

it's the new

G-C 50 LINE

NOW YOU CAN BUY all your radio-TV hardware—240 different items—in sturdy, re-usable *Hinged Cover* plastic boxes. Make your work bench neater and handier. Look for . . . ask for . . . the *Hinged Cover* hardware in the G-C self-service display at your distributor.



LIST PRICE 50c
Subject to
Dealers Discount

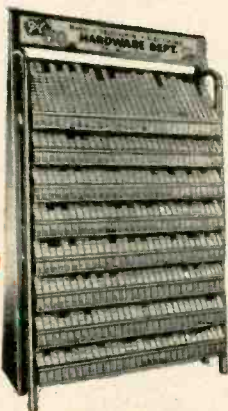

BUY WHERE YOU SEE THIS DISTRIBUTOR'S DISPLAY — HE HAS THE COMPLETE STOCK

SPECIAL OFFER TO SERVICE MEN — Handy steel rack for your bench or shop wall...holds 30 G-C Hinged Cover hardware boxes. See your distributor for details.

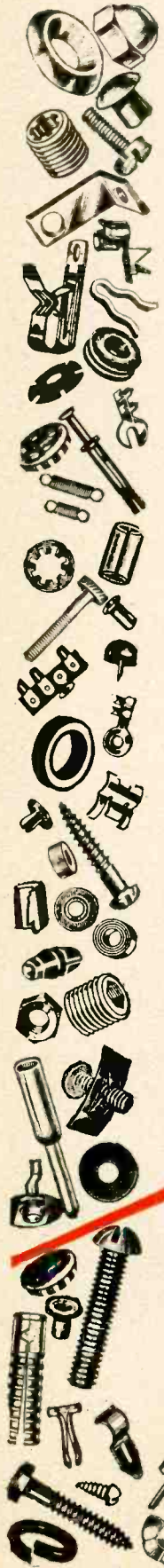
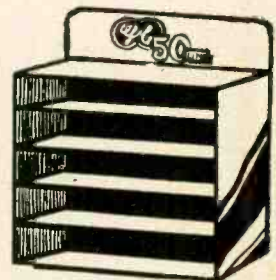

GENERAL CEMENT MFG. CO.
ROCKFORD, ILLINOIS, U.S.A.

to the
**ELECTRICAL
 ENGINEER**
 or
PHYSICIST
 with experience in
RADAR
 or
ELECTRONICS

Hughes Research and Development Laboratories, one of the nation's leading electronics organizations, are now creating a number of new openings in an important phase of their operations.

Here is what one of these positions offers you:

THE COMPANY

Hughes Research and Development Laboratories, located in Southern California, are presently engaged in the development and production of advanced radar systems, electronic computers and guided missiles.

THE NEW OPENINGS

The positions are for men who will serve as technical advisors to government agencies and companies purchasing Hughes equipment—also as technical consultants with engineers of other companies working on associated equipment. Your specific job would be essentially to help insure successful operation of Hughes equipment in the field.

THE TRAINING

On joining our organization, you will work in the Laboratories for several months to become thoroughly familiar with the equipment which you will later help users to understand and properly employ. If you have already had radar or electronics experience, you will find this knowledge helpful in your new work.

WHERE YOU WORK

After your period of training—at full pay—you may (1) remain with the Laboratories in Southern California in an instructive or administrative capacity, (2) become the Hughes representative at a company where our equipment is being installed, or (3) be the

Hughes representative at a military base in this country or overseas (single men only). Compensation is made for traveling and moving household effects, and married men keep their families with them at all times.

YOUR FUTURE

In one of these positions you will gain all-around experience that will increase your value to our organization as it further expands in the field of electronics. The next few years are certain to see large-scale commercial employment of electronic systems. Your training in and familiarity with the most advanced electronic techniques now will qualify you for even more important future positions.

How to apply:

HUGHES
 RESEARCH AND
 DEVELOPMENT LABORATORIES

*Engineering Personnel Department
 Culver City,
 Los Angeles County, California*

If you are under thirty-five years of age, and if you have an E.E. or Physics degree, write to the Laboratories, giving resumé of your experience.

Assurance is required that relocation of the applicant will not cause disruption of an urgent military project.



**Where You Need it!
 When You Need It!**

NOW—no more halted work, no more writing to the factory for missing instruction sheets. Tough identifying labels giving complete application and hook-up data are affixed to all Halldorson components. This provides maximum convenience in original installations or re-use at some later date. The same data appears on each box for instant identification.

This is only one of Halldorson's many aids designed to save your valuable time. Look to Halldorson for the biggest variety of transformer components, plus the newest for TV. Ask your distributor for your copy of Halldorson's great new catalog and TV Replacement Guide... today. The Halldorson Transformer Co., 4500 N. Ravenswood Ave., Chicago 40, Ill. Dept. RE12



HALLDORSON

QUALITY Transformers SINCE 1913

EXPORT: Intex Co., Inc., 136 Liberty Street, New York 36, N. Y. Cable Address: Intexcom, N. Y.

PLEASE MENTION
 RADIO-ELECTRONICS
 WHEN ANSWERING ADVERTISEMENTS



**EVERY
 RADIOMAN
 Can Use These
 SERVICE HINTS!**

Valuable Manual Yours—FREE!

Every page of "How to Simplify Radio Repairs" is packed with on-the-bench, practical ideas. Contains photos, charts, diagrams—no fluff—no vague theory. In plain everyday language it gives you priceless suggestions—new servicing ideas. You'll use and benefit from the experience of experts. Partial list of contents: How to Localize Trouble; How to Service Amplifiers; How to Test for Distortion; How to Test Audio Circuits; How to Test Speakers; How to Find Faults in Oscillators; How to Test Radio Parts—and it's all yours—FREE! No obligation.



SEND COUPON OR GOVERNMENT POSTCARD FOR YOUR FREE COPY TODAY!

FEILER ENGINEERING CO., Dept. 12RC2
 8026 N. Monticello Ave.,
 Skokie, Ill. (Suburb of Chicago)
 Please RUSH my FREE copy of "How to Simplify Radio Repairs."
 Name.....
 Address.....
 City..... Zpps..... State.....

RADIO-ELECTRONICS



SOLD THE MOST
(FROM COAST-TO-COAST)



People Buy Most What They See Most!

36 MILLION VIEWERS
AROUND 70 TV STATIONS
SEE ALLIANCE TV
DEMONSTRATIONS!

BECAUSE THEY'RE
SEEN THE MOST!



The Buying Impulse is there—why not Tap it?
Alliance TV spots Convince, Demonstrate
and pre-sell! Newspaper ads fit each market!
Alliance TV products are sold the most be-
cause they're seen the most!

Place your orders now for the NEW Alliance Cascamatic Booster
with the Famous "California Circuit!"
This Fully Automatic, 3-tube TV Booster pre-tuned to all VHF channels
mounts instantly on back of set—another companion item to Alliance
Tenna-Rotor and Tenna-Scope, the selective, single-control Booster.

ALLIANCE MANUFACTURING COMPANY • ALLIANCE, OHIO
DECEMBER, 1952

MORE RF GAIN ON 160 METERS

By JAMES L. FUGATE (W8UFF)

DRIVEN to a lower frequency by TVI like many other class-B amateurs, I took one last, long, fond look at ten-meter phone, and headed for the tall masts and long wires of 160.

The r.f. section of my transmitter consists of an 807 final, driven by a 6L6 harmonic-crystal oscillator. The oscillator plate-tuning capacitor is 140 μf . Having a 1 $\frac{1}{4}$ -inch coil form and some No. 24 enameled wire in the shack, I wound 70 close-wound turns for a 160-meter plate coil. Since the oscillator plate current (not counting screen current) is only about 25 ma at resonance, with the oscillator loaded, I was able to use No. 24 wire and had ample room for the necessary number of turns.

The final stage presented more of a problem. The plate-capacitor tuning is only 50 μf , which gave the right L-C ratio on the higher-frequency bands, but exactly the reverse of what I needed on 160. After considering the possibility of mounting an extra capacitor on the already overcrowded chassis, I finally decided on an outboard arrangement. The result was a 140- μf tuning capacitor and a coil mounted on a piece of $\frac{1}{4}$ -inch masonite and connected to the transmitter output-coil socket by an 18-inch length of 300-ohm ribbon line. The ribbon was soldered to the prongs of a discarded tube base. See Fig. 1. This combination worked so well that I gave up the idea of building a new output tank into the rig. Since I have had no complaints as far as TVI is concerned I saw no reason to shield it, and I eventually rebuilt it on a small chassis with the antenna coupler used for 160 and 80. The 160-meter final coil has 50 turns of No. 20 enameled wire close-wound on a 1 $\frac{1}{2}$ -inch form. The output link consists of 4 turns of No. 20 insulated wire over the cold end of the final coil.

Whenever I decide to risk TVI on the high frequencies, I just unplug the outboard circuit, plug in the original coils, and away I go.

For a while it was fun just chewing the rag around town on the 1875-1900 kc band. Then I decided I wanted to work out-of-town stations too. After all, I moved down to the lower band to get away from the locals. With the rig tuned up, and the antenna loaded just fine, I was in business again.

The fellows I worked gave me fair reports for the power and antenna I was using, but I soon found out that my receiver, which is fine on the higher frequencies, was a very sad disappointment on this band.

Checking with other fellows locally and out of town, I found this was a common complaint on 160 meters, especially with medium- and low-price receivers. Most of these have a single r.f. stage or feed the antenna right into the mixer grid coil.

Most of the local fellows whose receivers had 2 r.f. stages seemed to be hearing and working stations consist-

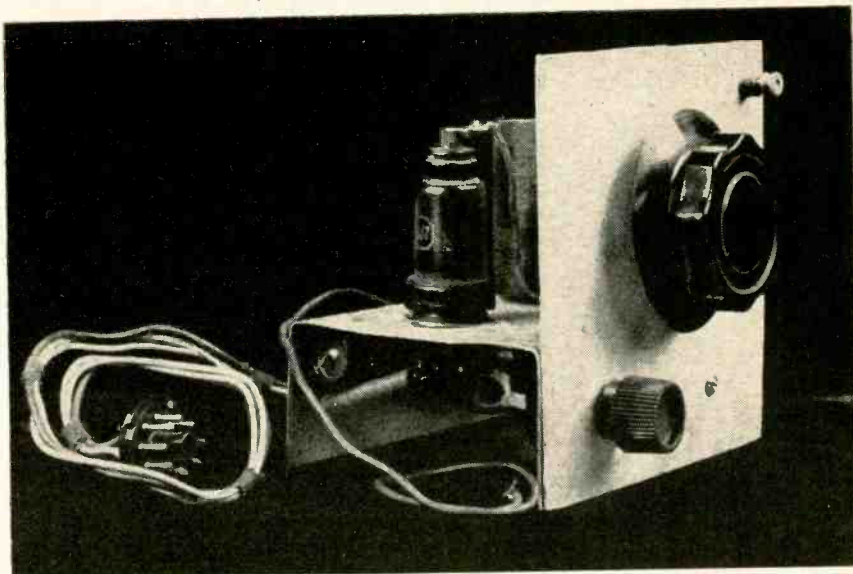

Top—The completed r.f. amplifier. The antenna coil is on top of the chassis, behind the tube. Cable and plug connect to power-supply socket on the receiver.

Right—Plenty of room underneath the amplifier chassis. The gain-control potentiometer and the r.f. choke are a bit over-size, but they both do the job very nicely.

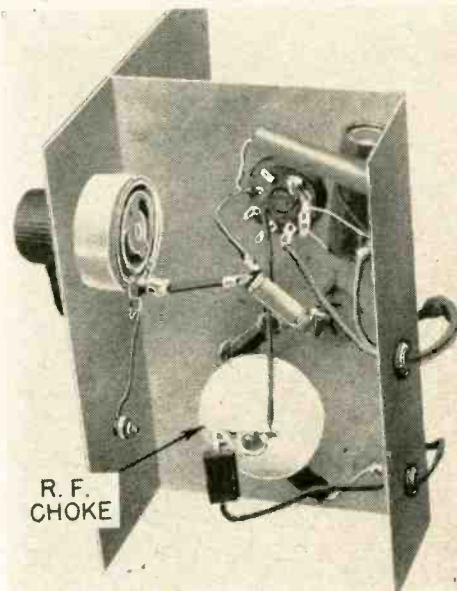

ently that I could find only with my b.f.o. turned on. With my eye on the high price of a new and better receiver, *versus* the low trade-in value of my 1947 model S-40, and my XYL's eye on the cost of groceries, I decided to give my receiver an r.f. stage.

After inventorying the junk around the shack, I found one 6K7 tube, one octal socket, $\frac{1}{2}$ -watt and 1-watt resistors of various values, a few bypass capacitors, one midget 100- μf variable, and a 10,000-ohm wire-wound volume control. I also found a fiber coil form 1 $\frac{1}{4}$ inches in diameter, and an army surplus r.f. choke. Since I had only one tuning capacitor I decided to tune the amplifier grid and put the r.f. choke in the plate circuit. See Fig. 2.

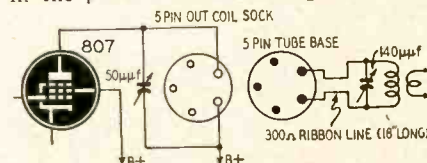

Fig. 1—Plate circuit of the final amplifier showing the outboard tank circuit.

It's New!

It's Better!

Here's Proof!

Now, we have finally found the answer in your V8 antenna. Servicemen tell us its the best antenna we have ever had. It really does the job because it pulls in stations we could not get before.

**Here's How
the new RADIART
TELEVISION
V*8 ANTENNA
Solved Mr. Hartong's
Fringe Area Headaches**

Burroughs
TELEPHONE 9-0273
Radio, inc.
711 SECOND STREET, N.W. CANTON 3, OHIO
DISTRIBUTORS OF
ELECTRONIC EQUIPMENT
WHOLESALE ONLY

October 7, 1952

Mr. William Schoneberger
Jobber Sales Manager
Radiart Corporation
3455 Vega Avenue
Cleveland, Ohio

Dear Bill,

Just a word to let you know how we feel about your new V8 antenna. As you know, our reception problem down here is difficult because of the fringe area position. Believe me, when I tell you almost everything that has come along has been tried.

Now, we have finally found the answer in your V8 antenna. Servicemen tell us its the best antenna we have ever had. It really does the job because it pulls in stations we could not get before. Attached is another reorder, please keep them coming.

Sincerely yours,
BURROUGHS RADIO INC.
D. R. Hartong
D. R. Hartong

drh/iw

**SEE FOR YOURSELF
Try One On Your
Toughest Location**

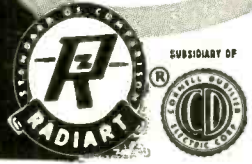

THE RADIART CORPORATION CLEVELAND 13, OHIO

VIBRATORS • AUTO AERIALS • TV ANTENNAS • ROTORS • POWER SUPPLIES

If you're in radio for pay or play—



NEW — Just off the press!
Hundreds and hundreds of
hints, kinks and shortcuts on
radio, TV, FM and audio!

Fully illustrated 112 Pages

ONLY \$1.00

If you've ever fixed a radio, tinkered with television, doped out a hi-fi circuit or fiddled with your own rig—then, mister, this book is for you! For no matter what corner of electronics you've staked out as your own—it thrives on gimmicks, hints, kinks and short cuts. And at last here's a book that has them for you. Yes, more than 600 bonafide tricks-of-the-trade sweated out the hard way by technicians and tinkerers, engineers and experimenters, hams, hi-fiers and hobbyists! Every one practical—every one original and every one guaranteed to save you time and tears! We couldn't begin to tell you here all the tips jammed into this book. The sneak preview below indicates what you'll find on just a few pages—but in the words of Al Jolson—"you ain't seen nothin' yet!" But don't believe us, please. Get your own copy today. You can buy it at leading parts distributors—or use the coupon below.

*A quick glimpse
of what's in this
book—*

- Protecting Speaker Cones • Improving A.C.-D.C. Filters
- Slow Fade on Old Sets • Increasing Electrolytic Life
- Battery Portable Distortion • Line Filters • Eliminating Ignition Noise
- Improving Tuning Eyes • Minimizing Heterodyning
- Tracking Superhets • Birdies and Oscillation • Intermittents
- Increasing Receiver Sensitivity • Tunable Hum • Hum Reduction
- Curing Modulation Hum • Heater-to-Cathode Leakage
- Overload Protection • Noise in Auto Sets • Vibrator Failure
- Excessive Line Voltage • Improving Soldering Irons
- TV Chassis Support • TV Servicing Light • Retrace Blanking Kinks
- Beam Killer • Intermittent H-V Supplies—Lead-in Noise—High-Voltage Meter Adapter
- Tool for Coax Cable—TV Antenna Phasing Unit • Ignition Noise in TV Sets • V-Beam for TV DX
- Finding Lead-in Break.

The GERNSBACK LIBRARY is Published by the publishers of RADIO-ELECTRONICS

Other GERNSBACK LIBRARY BOOKS
 You'll find helpful!

- Television Techniques • Bk. 46 _____ \$1.50
- Radio Tube Fundamentals • Bk. 45 _____ \$1.00
- Basic Radio Course • Bk. 44 _____ \$2.25
- Model Control by Radio • Bk. 43 _____ \$1.00
- High-Fidelity Techniques • Bk. 42 _____ \$1.00
- Public-Address Guide • Bk. 41 _____ 75¢
- The Cathode-Ray Oscilloscope • Bk. 40 _____ 75¢
- Practical Disc Recording • Bk. 39 _____ 75¢
- Amplifier Builder's Guide • Bk. 33 _____ 50¢
- Advanced Service Technique • Bk. 32 _____ 50¢
- Radio Questions & Answers • Bk. 31 _____ 50¢
- Unusual Patented Circuits • Bk. 30 _____ 50¢

See your distributor—or mail this coupon

GERNSBACK PUBLICATIONS, INC. Dept. 122
 25 West Broadway
 New York 7, N. Y.

Enclosed is my remittance of \$ _____
 Please send me, postpaid, the books checked below.

- 46 45 44 43 42 41
- 40 39 33 32 31 30

Name _____
 (Please print clearly.)

Street _____

City _____ Zone _____ State _____

The antenna coil can be varied to change the selectivity and sensitivity. The number of turns and spacing of the grid winding are not critical as to frequency, but will change the coupling to the antenna.

The power supply in the receiver, if not already too heavily loaded, can supply the voltages for the outboard's r.f. stage. My receiver has a plug and socket for battery operation, which I rewired to bring out the voltages.

With only the receiver on, and with r.f. and audio gain all the way up, I tuned in a fixed station 40 miles away. He was talking to several mobile stations and was just barely loud enough to read.

Then I turned on the outboard stage, and with the same antenna, I could hear him the same with the receiver audio gain about half open. One mobile station was now perfectly readable with the audio ¾ open, where before I could just barely hear his carrier with the b.f.o. on and full audio gain.

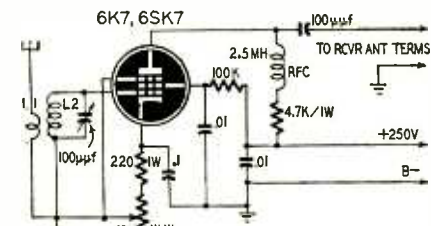

L2-72T N°22 ENAM 1-1/4" DIA; L1-20T N°22 ENAM 1/2" BELOW L2 BOTH CLOSE WOUND

Fig. 2—The circuit of the simple r.f. amplifier stage for low-price receivers.

The r.f. stage provided much more gain than expected, so I didn't attempt tuning in the plate circuit. The increased gain is more noticeable at the daytime than at night.

The potentiometer in the cathode circuit was originally provided to control regeneration if a tuned plate circuit was added, and the r.f. stage started oscillating. Although it doesn't mean much as an r.f. volume control, turning it down reduces heterodynes.

The grid coil, tuning capacitor, and grid lead were kept above the chassis, and all plate-circuit components below. There would be more gain with a small amount of coupling between plate and grid circuits, but I found it ample without this feedback.

Tuning is not critical. As a matter of fact, the tuning control can be just a 2- or 3-inch knob. I found no reason to calibrate it. I merely tune the receiver to the station first, and then adjust the r.f. tuning for maximum signal. When listening for a call the noise level can be used as an indication of resonance. Although the noise level is high, the signal gain is way over it.

Having just been transferred from a daytime job to an evening shift, this added stage enables me to hear stations in daylight which were too weak for profitable contacts before.

The higher-frequency bands seem to be good enough on my present receiver, so I haven't tried them with the r.f. stage, although I don't see why it couldn't be used with plug-in coils on any band.

END

ENGINEERS



Make this your home for important work under ideal conditions

- TV Receiver Design Eng.
- Test & Inspection Eng.
- Electronics Eng.
- Field Engineers
- Lab Technicians

TO WORK ON:

Radar, G. C. A., Mobile Radio, Auto Radio, Airborne Communication & Navigation Equipment, Television, Antennas, Microwave Equipment, Servo Mechanisms, Guided Missiles and Test Equipment.

YOU BENEFIT

from high wages, a modern, air-conditioned plant, paid vacations and holidays, group insurance and a good chance for advancement. Housing immediately available in the beautiful suburban and country areas that surround the Bendix plant.

Write Wire, Phone Mr. E. O. Cole, Dept. S

Bendix Radio

DIVISION OF BENDIX AVIATION CORP.
BALTIMORE-4, MD. Phone: TOWSON 2200

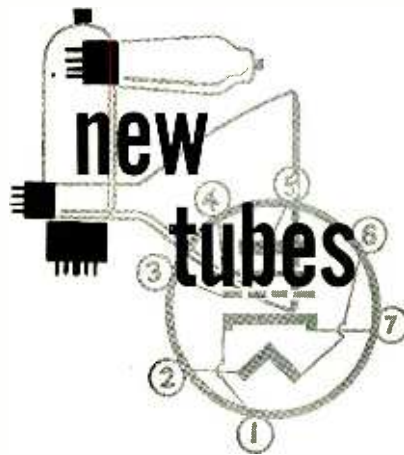

MINIATURE versions of high-transconductance metal pentodes are especially valuable as single-stage video amplifiers. With the same power ratings as their larger prototypes, the miniatures have smaller input and output capacitances, which can be used to extend the high-frequency response, increase the stage gain, or both. In addition, their smaller size and lower manufacturing cost make them ideal for TV-receiver applications.

The first of these was the 6AH6, a 7-pin miniature equivalent of the metal 6AC7. It has been used in many commercial TV sets, not only as a video amplifier, but also in i.f., sync, and horizontal a.f.c. circuits.

As a pentode, the 6AH6 has the following typical operating characteristics: Plate voltage, 300; suppressor voltage, 0; screen voltage, 150; cathode resistor, 150 ohms; plate resistance, 0.5 megohm (approx.); transconductance, 9,000 μ mhos; plate current, 10 ma; screen current, 2.5 ma; grid 1 voltage for plate current of 10 μ amp, -7 (approx.).

As a triode (suppressor and screen connected to plate): Plate voltage and cathode resistor same as for pentode operation; amplification factor, 40; plate resistance, 3,600 ohms (approx.); transconductance, 11,000 μ mhos; plate current 12.5 ma. Basing of the 6AH6 is shown on the following page.

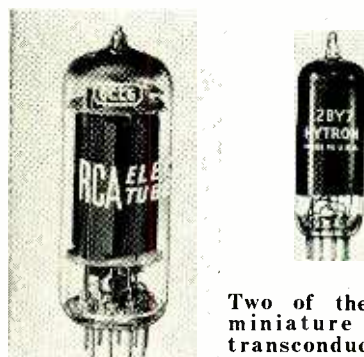

Two of the new miniature high-transconductance nine-pin pentodes.

One of the most recent, the RCA 6CL6, is a 9-pin miniature version of the 6AG7. This tube can give a voltage gain of 40 to 45, with peak-to-peak output of 132 volts, in a 4-mc-bandwidth video amplifier. The control grid and screen grid are each brought out to two

COMPLETE TRAINING FOR BETTER RADIO-TV SERVICE JOBS

ONLY \$12
for the complete 2-volume course



3 MONTHS TO PAY

Let these two great new Ghirardi training books teach you to handle all types of AM, FM and TV service jobs by approved professional methods—and watch your efficiency and earnings soar!

Completely modern, profusely illustrated and written so you can easily understand every word, these books pave the way to fast, accurate service on any type of home radio-TV-electronic equipment ever made. Each book is brand new. Each contains the latest data on the latest methods and equipment—NOT a re-hash of old-out-of-date material. Each is co-authored by A. A. Ghirardi whose famous RADIO PHYSICS COURSE and MODERN RADIO SERVICING were, for 20 years, more widely used for military, school and home study training than any other books of their type!

THE NEW Ghirardi RADIO-TV SERVICE LIBRARY

Almost 1500 pages and over 800 clear illustrations show step-by-step how to handle every phase of modern troubleshooting and servicing.

1—Radio and Television Receiver TROUBLESHOOTING & REPAIR

A complete guide to profitable professional methods. For the novice, it is a comprehensive training course. For the experienced serviceman, it is a quick way to "brush up" on specific jobs, to develop improved techniques or to find fast answers to puzzling service problems. Includes invaluable "step-by-step" service charts. 820 pages, 417 illus., price separately \$6.75.

2—Radio and Television Receiver CIRCUITRY AND OPERATION

This 669-page volume is the ideal guide for servicemen who realize it pays to know what really makes modern radio-TV receivers "tick" and why. Gives a complete understanding of basic circuits and circuit variations; how to recognize them at a glance; how to eliminate guesswork and useless testing. 417 illus. Price separately \$6.

New low price . . . easy terms

If broken into lesson form and sent to you as a "course", you'd regard these two great books as a bargain at \$50 or more! Together, they form a complete modern servicing library to help you work faster and more profitably. Completely indexed so you can look up needed facts in a jiffy. Under this new offer, you save 75¢ on the price of the two books—and have the privilege of paying in easy installments while you use them! No lessons to wait for.

10-DAY EXAMINATION PRIVILEGE

Dept. RE-122, Rinehart Books, Inc., Technical Division, 232 Madison Ave., New York 16, N. Y.

Send me GHIRARDI'S NEW 2-VOL. SERVICE LIBRARY. I enclose \$3 as my first installment and will send you \$3 a month for three months until the total price of only \$12.00 plus a few cents postage is paid. It is understood I may read the books for 10 days. Then, if not satisfactory, I will return them postage paid and you agree to refund my \$3 and cancel the remaining installments. (Books shipped postpaid if full remittance accompanies order. Same return privilege.)

Name _____
Address _____
City, Zone, State _____
Employer's Name & Address _____

OUTSIDE U.S.A.—\$19.00 cash only. Same 10-day return privilege with money refunded.

WANTED

WE NEED YOUR SURPLUS ELECTRONIC EQUIPMENT

WE PAY TOP \$\$\$ FOR:

- * RADIO RECEIVERS
- * TRANSMITTERS
- * ARC-1
- * ARC-3
- * ART-13
- * CONTROL BOXES
- * INDICATORS
- * CLAMPS
- * PLUGS
- * CORDS
- * RELAYS
- * TELEPHONE MATERIALS
- * AN CONNECTORS
- * WE BUY ANYTHING!

Write, Wire today! Tell us what you have.
TALLEN CO., Inc., Dept. RE
159 Carlton Ave., Brooklyn 5, N. Y.

"KNOW-HOW" and "WHERE-WITH"

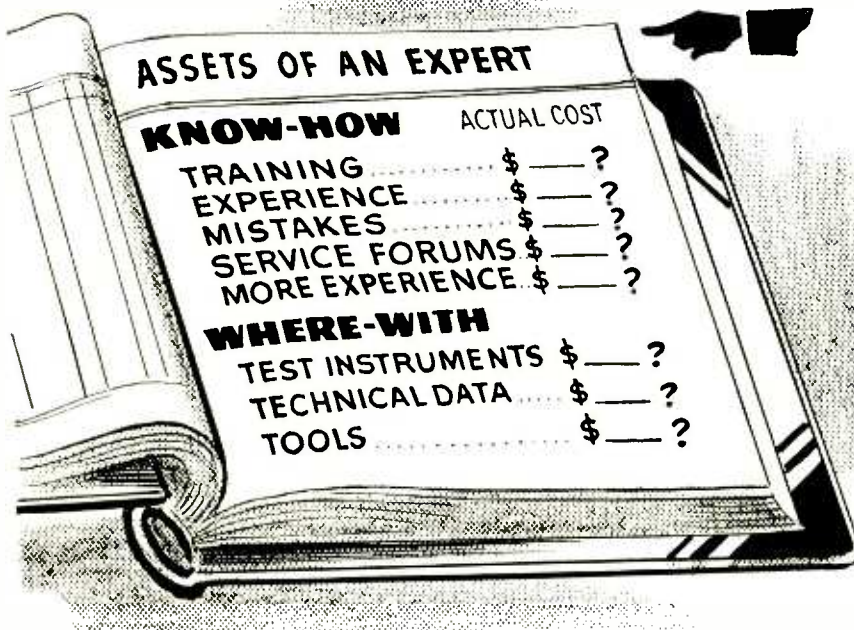

A technician with thorough electronic training and adequate experience has the "know-how" that radio and television owners will pay for when their sets are in trouble. When the technician has invested in testing instruments and other technical aids for diagnosing trouble, he has the "where-with" to help convert this "know-how" to efficiency and profits.

Every technician realizes that all of the "know-how" that it is possible to acquire (through study, experience, and mistakes) is not worth much until he can make it pay off. If he were to stop and figure how much his "know-how" actually cost him over the years, in both time and money, he would be amazed at the amount. The average technician spends thousands of dollars before he is classed as an expert. The "where-with" investment is small by comparison.

Successful service technicians always consider the dollars and cents invested in training, experience, testing instruments and other technical aids when they establish their service charges. They know that the only reason any technician can consistently locate trouble in minutes instead of hours is because, he has both the "know-how" and the "where-with".

Since 1927

SUPREME

Testing Instruments

"SUPREME BY COMPARISON"

- MULTI-METERS • TUBE TESTERS • COMPOSITE VIDEO GENERATORS • OSCILLOSCOPES
- SIGNAL GENERATORS • VACUUM TUBE VOLTMETERS
- PANEL METERS • SPECIAL PURPOSE INSTRUMENTS FOR GOVERNMENT AND INDUSTRY

Supreme, Incorporated

Greenwood 2, Mississippi

base connections. This helps in laying out the chassis wiring for minimum stray input capacitance, and the shortest possible signal leads. The cathode and suppressor have separate pin connections. This allows the suppressor to be grounded in circuits where an un-bypassed cathode resistor is used for degeneration. (If the suppressor and cathode were connected internally, the

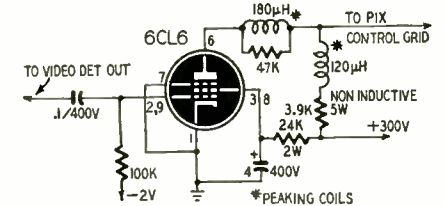

Fig. 1—A 4-mc 6CL6 video amplifier.

capacitance between plate and suppressor might feed a large fraction of the output signal back to the ungrounded cathode and set up oscillations.)

A typical 4-mc-bandwidth video-amplifier circuit suggested by RCA for the 6CL6 is given in Fig. 1. At the operating voltages shown, the zero-signal plate current is 30 ma, screen current 7 ma, input signal 3 v, and output signal 132 v, peak-to-peak. Heater rating is 6.3 v and 0.65 amp.

Another recently introduced 9-pin miniature, high G_m pentode is the CBS-Hytron 12BY7, used in some of the new Du Mont 17- and 21-inch receivers. Operating characteristics of the 12BY7 are: Plate voltage, 250; suppressor, connected to pin 1 at socket; screen voltage, 180; cathode resistor, 100 ohms; plate resistance, 110,000 ohms; transconductance, 12,000 μ mhos; plate current, 24 ma; screen current, 5 ma; grid voltage for plate current of 20 μ amp, -8. Base connections are given in the accompanying diagram.

The 6BZ7, a product of the Lansdale Tube Company, Lansdale, Pennsylvania, is a low-noise twin triode, designed specifically for cascode-amplifier service, and is used in recent Westinghouse receivers, and in the Philco "Golden-Grid" tuner. This tube is similar to the 6BQ7 (RADIO-ELECTRONICS, December,

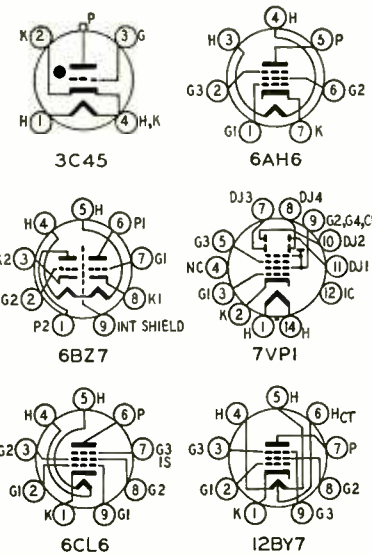

Basing diagrams of six new tube types.

1951) except for a higher transconductance of 8,000 μ hos. The 6BZ7 has a 6.3-volt, 0.4-amp heater, and each triode section has the following typical characteristics in class A operation: Plate voltage, 150; plate current, 10 ma; plate resistance, 5,600 ohms; transconductance, 6,000 μ hos; *cascode* transconductance, 8,000 μ hos; cathode resistor, 220 ohms; amplification factor, 38. Basing is shown in the accompanying diagram.

The new RCA 5726 twin diode is a "premium" version of the 6AL5, with a special vibration-proof internal structure for mobile and aircraft service. The especially rugged, pure tungsten heaters are connected in series, so that failure of either section will put both diodes out of operation. The 5726 also has slightly higher peak-voltage ratings than the 6AL5, but their general operating characteristics and basing are identical.

RCA has also announced the 12AX4-GT, a television damper tube with a 12.6-volt, 0.6-amp heater, for use in receivers with series-connected heater strings. Except for heater ratings, the 12AX4 is identical with the 6AX4 described in last month's RADIO-ELECTRONICS.



New oscilloscope tube

The RCA 7VP1 is a high-resolution, 7-inch cathode-ray tube with a medium-persistence green phosphor. Replacing the earlier 7JP1 (except for a lower ultor rating of 4,000 volts maximum), the new tube is designed to give an extremely fine, sharply focused trace for precision oscilloscope use. An improved gun design maintains constant focus over a wide range of brightness settings. Following are typical operating conditions for the 7VP1: Ultor voltage, 3,000; grid 3 (focus) voltage, 800 to 1,200; grid 1 voltage for extinction of undeflected focused spot, -84; deflection factors: DJ₁ and DJ₂, 93 to 123 volts d.c. per inch; DJ₃ and DJ₄, 75 to 102 volts d.c. per inch. Connections to the medium-shell diheptal base are shown in the accompanying diagram.

Transmitting tubes

The *Eimac* (Eitel-McCullough) 4W20000A is a radial-beam power tetrode suited for power-amplifier service up to 250 mc. As a class B linear amplifier in the output stage of a v.h.f. television transmitter, the 4W20000A can deliver a peak (sync-level) output of 20.1 kw at 216 mc. The coaxial structure of the tube, with radial con-

Announcing "Jewel case" packaging

for the WEBSTER ELECTRIC® Featheride® line of REPLACEMENT CRYSTAL CARTRIDGES

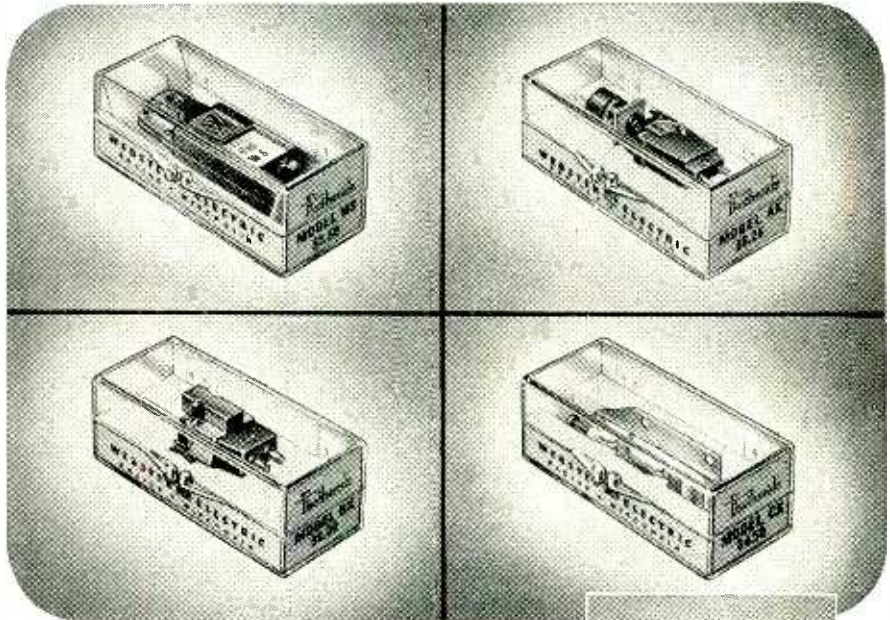

• Effective immediately every Featheride replacement cartridge will be packed for shipment in its own transparent plastic "Jewel-case" box. Each box shows the model number and list price clearly, thus making it even easier for you to stack cartridges in small, easily "get-at-able" space.

These smart new Featheride "Jewel-case" packages contain all fittings necessary for installation, complete data on performance and characteristics, and full installation instructions. . . . Now, more than ever, the Featheride line is your "best bet" for a profitable replacement business. Only a small stock is required to handle practically every replacement job. Mail coupon for new Featheride Bulletin.

SPECIFICATIONS AND DATA

Model WS—for 78 RPM replacement. Develops 1.5 volts for low output or 4.0 volts for high output. Tracks at 3/4 oz.; mounts in any 1/2 inch mounting.

Model AX—for three-speed, two-needle twist cartridge replacement. Easy to install in any arm with a standard 1/2 inch mounting. Furnished with removable twist mechanism.

Model BX—for replacement on R.C.A. automatic record changers and Columbia Record Players. Has high fidelity; is compact and light in weight; tracks perfectly.

Model CX—replacement for Featheride C3, C8, C9 and C9X. Removable flange and universal mounting bracket permit installation in any arm with 1/2 inch mounting.

Webster Electric Company, Racine, Wisconsin . . . Established 1909

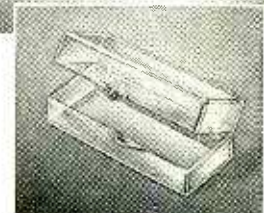

You and your customers will find countless uses for these beautiful Tenite "Jewel-cases" with hinged covers!



WEBSTER ELECTRIC
RACINE • WISCONSIN

"Where Quality is a Responsibility and Fair Dealing an Obligation"

Webster Electric Co., Dept. RE-12, Racine, Wis.
Please send me new Bulletin on Featheride Replacement Crystal Cartridges in "Jewel-case" packages.

Name _____ (Please print)
Address _____
City _____ State _____
Jobber Service Technician Other

HERE ARE ONLY A FEW OF THE BIG VALUES IN THE LATEST 148 PAGE 1953 B-A CATALOG!

FREE! Write us if you have not received it

BURSTEIN-APPLEBEE CO.
1012-14 McGee St., Kansas City 6, Mo.

Send Free B-A Catalog No. 531.
 My order is attached for items from below \$ _____ enclosed.

Name _____
Address _____
City _____ State _____

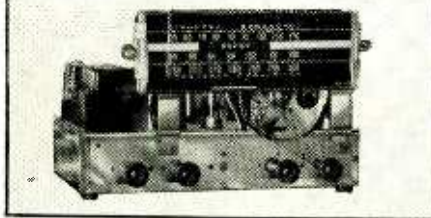

12-TUBE FM-AM CHASSIS COMPLETE \$56.88

Here at a **BIG SAVING** you get a complete celebrated make AM-FM Radio Chassis for modernizing old sets, for new custom installations, built-ins, etc.

Top make latest design, with built-in pre-amp for Phono operation with either reluctance or crystal type pick-up. Tunes standard broadcast 550 to 1700 KC and FM 88 to 108 MC.

Wide range audio response (push-pull 6V6 output) and bass boost tone control. Tubes: 6BE6, 2-6BA6, 2-12AT7, 2-6SQ7, 6SH7, 6AL5, 2-6V6GT and 5Y3GT rectifier. Attractive lighted slide rule dial.

Supplied ready to operate, complete with tubes, antennas, escutcheon and hdwe. for mtg. in a table or console cabinet, built-ins, etc. Chassis size 13 1/4" wide x 9" high x 9" deep. Cutout required for dial escutcheon 7 3/4" x 2 3/4". Operates on 115 V 60 cycle AC. Output impedance 3-4 ohms, for any PM or Co-Axial Speaker. Shpg. wt. 20 lbs. No. 31B18. ONLY \$56.88

COMBINATION DEAL \$92.88



Consists of above Chassis, a top make \$51.50 List Value 3 Speed Changer with GE Variable reluctance turnabout Cartridge and a \$32.50 List Value 12" Coaxial Speaker. DEAL NO. 31A273. Shpg. wt. 38 lbs. \$203.50 List Value. **\$92.88**

6AK5 TUBES

Made by Sylvania and bears the name "Standard" because they were originally intended for use in Standard Boosters—otherwise the identical 6AK5 you would obtain if buying tubes bearing the Sylvania name and for which you pay up to \$2.06 Net Each (List Price \$3.90 Ea.). Here you get 6 for little more than the regular price of 2 and believe us—they are perfect—newly guaranteed—a popular type widely used in Radio, TV, Boosters, etc.

No. 70A98. Pkg. of SIX 6AK5 Sylvania Made Tubes, Only. **\$4.79**

INCLUDE ALLOWANCE FOR POSTAGE—ALL OVER-PAYMENTS REFUNDED.

BURSTEIN-APPLEBEE CO.
1012-14 MCGEE ST. KANSAS CITY, MO.

tact fingers forming the connections to the internal elements, allows it to be used in resonant-cavity tank circuits. The thoriated-tungsten cathode is heated by *electron bombardment* from an internal filament. (The cathode and

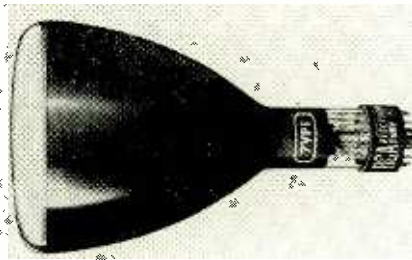

filament form a diode, with the cathode approximately 1,600 volts positive to the filament.) The anode has intake and outlet fittings for connection to the required water-cooling system. Control-grid, screen-grid, cathode, and filament contact areas require forced-air cooling.

Typical operating conditions for the 4W20000A as a class B linear amplifier in TV service, with a 5-mc bandwidth at 216 mc: Load impedance, 400 ohms; effective length of plate line, 1/4 wave; plate voltage, 5,500; screen voltage, 1,200; grid voltage, -240; plate current, 7.1 amps; screen current (approx.) 500 ma; grid current (approx.) 140 ma; peak r.f. grid voltage, 430; driving power 1,500 watts (approx.); plate power input, 39.1 kw; plate dissipation, 16.5 kw; useful plate power output, 20.1 kw.

The RCA 3C45 is a hot-cathode, three-electrode hydrogen thyratron for pulsing u.h.f. oscillators at high repetition rates (radar service). At 2,000 1/2-μsec pulses per second, the 3C45 can deliver a peak power output of 43,000 watts per pulse.

The 3C45 has a peak anode-voltage rating of 3,000 and a special slow-heating 6.3-volt, 2.3-amp indirectly heated cathode. END



"Perfect, honey—leave it right there."

burton browne advertising

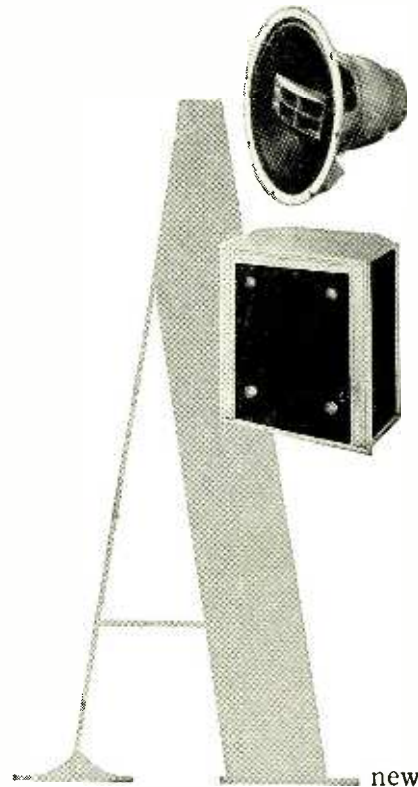

12-inch coaxial, Jensen H-222 combines a special direct-radiator unit for frequencies below 2000 cycles, with a compression-driver high-frequency unit, loaded with a six-celled horn based on the famous Jensen Hypex* formula.

Enclose the H-222 Coaxial in a Jensen Model BL-121 Back-Loading Folded-Horn Cabinet for superior acoustic performance. In this universal design, a long folded flare path expanding on the Hypex* formula, gives better bass response—even when placed on a sidewall. In a corner, walls act as extensions of the horn.

*Trade Mark Registered

JENSEN HI-FIDELITY AT MODERATE COST

Ask your Jobber or write for Brochure 1020

Jensen
MANUFACTURING COMPANY

DIVISION OF THE MUTER COMPANY
6601 S. Laramie Ave., Chicago 38, Illinois
IN CANADA:
Copper Wire Products, Ltd., Licensee

20-5377

RADIO-ELECTRONICS



TESTED IN THE LAB
PROVEN BEYOND DOUBT
ON THE ROOFTOPS
FOR UHF
AND VHF



model
CVA-500



RMS CONICAL V FRINGELEADER ANTENNAS

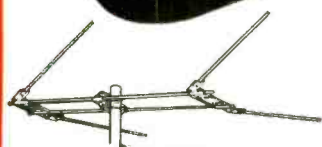

VA-100,
FRINGELEADER, JR.
4-elements cut extra long
for excellent low fre-
quency reception on vhf
and high gain on uhf.

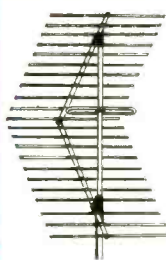

Model COR,
CORNER
ARRAY
Adapted
by RMS for
uhf, features
the character-
istic curve and
gain of a par-
abolic reflec-
tor . . . one of
the highest
gain antennas
in use today.

*H*ere's the basic uhf antenna
... adapted by RMS for present
vhf. In actual rooftop installa-
tions, FRINGELEADER has been
proven on both vhf and uhf.
Elements are cut extra-long for
good gain on the vhf low fre-
quencies . . . providing multiple
wave lengths for extremely high
gain on uhf!

Let's Be Realistic About Antennas and UHF!

Set sensitivity will be lowered by use
of uhf plug-in coil units on set front
ends . . . uhf antennas must there-
fore be high gain antennas. Where uhf is
assigned, invariably 1 or more vhf or
uhf stations will be available. If you
hope to get both uhf and vhf on a
single antenna don't choose a . . .
characteristically single channel an-
tenna! There is but one obvious,
sensible proven choice at the moment
... the RMS Fringeleader CVA-500!

RMS

2016 BRONXDALE AVENUE • NEW YORK 60

teamed together for
Better TV Picture Quality



AMPHENOL
-IN LINE*
ANTENNAS

AMPHENOL TUBULAR TWIN-LEAD

This combination of the famous Amphenol In-line Antenna and the extremely low-loss Amphenol Tubular Twin-Lead permits any TV set to present the best picture it possibly can.

The Amphenol In-line is the superior all-channel antenna. The In-line has uniform gain over the entire range of VHF channels—less variation than the 3 decibel change which determines "fuzziness." Its strong forward reception lobe practically eliminates any pick-up of unwanted secondary or reflected signals.

The Amphenol Tubular Twin-Lead provides very low-loss and constant impedance. The tubular construction minimizes the effect of moisture and dirt deposits on the concentrated field of energy and ends weather interference. Because of these characteristics, Amphenol Tubular Twin-Lead has been recommended by leading TV manufacturers and authorities for any installation where UHF is, or will be, available.



Nominal Impedance	300 ohms
Velocity of Propagation	84%
Attenuation db/100 feet	
	30 mc — .63
	60 mc — .93
	100 mc — 1.25
	200 mc — 1.82
	400 mc — 2.7
	500 mc — 3.0
	700 mc — 3.6
	900 mc — 4.2

This illustration clearly shows that the concentrated field of energy between the two conductors, which are 7 strands of #28 copper weld wire, is contained by the tubular construction. This important field of energy is unaffected by any exterior conditions.

AMERICAN PHENOLIC CORPORATION
1830 SOUTH 54TH AVENUE • CHICAGO 50, ILLINOIS



New Devices

CDR ROTOR

The Radiart Corp., 3571 W. 62nd St., Cleveland, Ohio, has designed a general-purpose antenna rotor, the CDR, which includes a modern cabinet with meter control dial and finger-tip control lever using 4-wire cable.

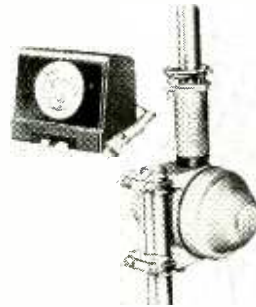

The motor features high torque, instant locking, and instantaneous reversal. It will fit all standard towers and take antenna masts up to 1 1/2 inches outside diameter. It is marketed as model TR-11.

5-INCH SCOPE

The Tube Department of the RCA Victor Division, Radio Corp. of America, Harrison, N. J., has designed a 5-inch oscilloscope, the WO-88A. Included is a 10-megohm probe with an input capacitance of less than 10 µuf. The instrument provides virtually perfect square-wave response up to 50 kc. Controls for push-pull balance and astigmatism adjustment are outside the cabinet for operating convenience.



Engineering features include plus and minus sync; 60-cycle sweep and phasing; a shield around the C-R tube gun to minimize hum pickup; push-pull circuitry in both stages of the vertical amplifier to minimize line-bounce, and direct coupling to provide quick recovery time and a frequency response flat down to d.c.

The deflection sensitivity is 25 r.m.s. millivolts or better per inch; the unit has frequency response flat from d.c. to 500 kc within minus 3 db and within minus 10 db at 1 mc; and a sweep-circuit frequency of 15 c.p.s. to 30 kc in four ranges.

SPEAKER SYSTEM

Electro-Voice, Inc., Buchanan, Mich., has announced a new public-address speaker system, the CDP (compound diffraction projector), which uses two coaxially mounted diffraction horns working from both sides of a single diaphragm. Each projector is designed for optimum air loading and



reproduction within its own range, to provide peak-free response ± 5 db to 11,000 c.p.s. Low end response is augmented by 100-c.p.s. horn taper which insures at least one-half octave added bass over that possible from larger, conventional re-entrant-type projectors. Polar distribution pattern exceeds 120 degrees at all frequencies up to 10,000 cycles.

The model 848 CDP loudspeaker system is rated at 25 watts. Impedance is 16 ohms. Finished in gunmetal gray, it has two mounting positions for the hang-up bracket, and can be installed horizontally or vertically for augmented dispersion. The unit is 10 1/2 inches wide at mouth, 20 1/2 inches high at mouth, and 20 inches deep over-all.

TUNER BRACKETS

Vidair Electronics Manufacturing Co., Lynbrook, L. I., N. Y., has added to its line bracket sets for Philco and

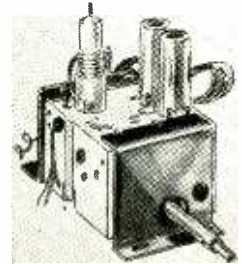

RCA TV tuners. The sets are cadmium plated. Electrical and mechanical installation instructions are included with each pair.

LOW-COST YAGIS

The LaPointe-Plascomold Corp., Rockville, Conn., has announced the new Delta line of low-cost five-, eight-, and twelve-element Yagis which incorporate a delta matching system. This delta match will replace the standard driven element of the Vee-D-X J.C. Yagi and will provide exact 300-ohm termination.



The Vee-D-X Long John and Long John Yagis will also be made with the delta match to lower the cost of these high-gain fringe-area antennas.

COPPER WIRE LEAD-IN

JFD Manufacturing Co., 6101 16th Ave., Brooklyn 4, N. Y., has introduced an all copper open-line lead-in wire with Formvar enamel for eliminating oxidation and corrosion from atmospheric conditions.

With polystyrene insulators spaced at 6-inch intervals it cuts line loss to 1/6 the usual drop experienced with 300-ohm ribbon.

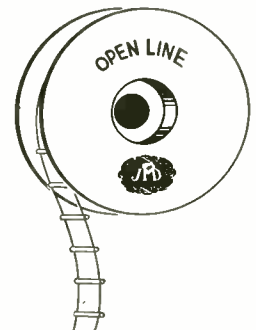

RADIO-ELECTRONICS

BUY TEST EQUIPMENT ON THIS RADICALLY NEW TIME PAYMENT PLAN

NO INTEREST!! - NO CARRYING CHARGES!!

USE CONVENIENT TIME PAYMENT ORDER BLANK BELOW

Superior's New Model 770

VOLT-OHM MILLIAMMETER

Sensitivity—1000 ohms per volt

Uses latest design 2% accurate 1 Mil. D'Arsonval type meter. • Same zero adjustment holds for both resistance ranges. It is not necessary to readjust when switching from one resistance range to another. This is an important time-saving feature never before included in a V.O.M. in this price range. • Housed in round-cornered, molded case. • Beautiful black etched panel. Depressed letters filled with permanent white, insures long-life even with constant use.

SPECIFICATIONS:

- 6 A.C. VOLTAGE RANGES: 0-15/30/150/300/1500/3000 Volts.
- 6 D.C. VOLTAGE RANGES: 0-7.5/15/75/150/750/1500 Volts.
- 4 D.C. CURRENT RANGES: 0-1.5/15/150 MA. 0-1.5 Amps.
- 2 RESISTANCE RANGES: 0-500 Ohms 0-1 Megohm.

\$14.90
NET

The Model 770 comes complete with self-contained batteries, test leads and all operating instructions.



Model 770 is an accurate pocket-size V.O.M. Measures only 3/8" x 5 7/8" x 2 1/4".

Superior's New Model TV-11 **TUBE TESTER**



• Uses the new self-cleaning Lever Action Switches for individual element testing. Because all elements are numbered according to pin number in the RMA base numbering system, the user can instantly identify which element is under test. Tubes having tapped filaments and tubes with filaments terminating in more than one pin are truly tested with the Model TV-11 as any of the pins may be placed in the neutral position when necessary. • Uses no combination type sockets. Instead individual sockets are used for each type of tube. Thus it is impossible to damage a tube by inserting it in the wrong socket. • Free-moving built-in roll chart provides complete data for all tubes. • Phono jack on front panel for plugging in either phones or external amplifier detects microphonic tubes or noise due to faulty elements and loose external connections.

Operates on 105-130 Volt 60 Cycles A.C. Hand-rubbed oak cabinet complete with portable cover

\$47.50
NET

Superior's New Model 670-A **SUPER-METER**

A combination volt-ohm milliammeter plus capacity reactance inductance and decibel measurements

SPECIFICATIONS:

- D.C. VOLTS: 0 to 7.5/15/75/150/750/1500/7,500 Volts
- A.C. VOLTS: 0 to 15/30/150/300/1,500/3,000 Volts
- OUTPUT VOLTS: 0 to 15/30/150/300/1,500/3,000 Volts
- D.C. CURRENT: 0 to 1.5/15/150 Ma. 0 to 1.5/15 Amperes
- RESISTANCE: 0 to 1,000/100,000 Ohms 0 to 10 Megohms
- CAPACITY: .001 to 1 Mfd. 1 to 50 Mfd. (Quality test for electrolytics)
- REACTANCE: 50 to 2,500 Ohms 2,500 Ohms to 2.5 Megohms
- INDUCTANCE: .15 to 7 Henries 7 to 7,000 Henries
- DECIBELS: -6 to +18 +14 to +38 +34 to +58

\$28.40
NET

ADDED FEATURE

The Model 670-A includes a special GOOD-BAD scale for checking the quality of electrolytic condensers at a test potential of 150 Volts.



Comes housed in rugged, crackle-finished steel cabinet complete with test leads and operating instructions. Size 6 1/4" x 1 1/2" x 4 1/2".

Superior's New **TV BAR GENERATOR**

THROWS AN ACTUAL BAR PATTERN ON ANY TV RECEIVER SCREEN!

Two Simple Steps

1. Connect Bar Generator to Antenna Post of any TV Receiver.
2. Plug Line Cord into A. C. Outlet and Throw Switch.

RESULT: A stable never-shifting vertical or horizontal pattern projected on the screen of the TV receiver under test.



Power Supply: 105-125 Volt 60 Cycles. Power Consumption: 20 Watts. Channels: 2-5 on panel. 7-13 by harmonics. Horizontal lines: 4 to 12 (Variable). Vertical lines: 12 (Fixed). Vertical sweep output: 60 Cycles. Horizontal sweep output: 15,750 Cycles.

TV Bar Generator comes complete with shielded leads and detailed operating instructions. Only **\$39.95** NET

New Model 200—AM and FM **SIGNAL GENERATOR**

Provides complete coverage for A.M.-F.M. and TV alignment

*R.F. Frequency Ranges: 100 Kilocycles to 150 Megacycles. *Modulating Frequency: 400 Cycles. May be used for modulating the R.F. signal. Also available separately. *Attenuation: The constant impedance attenuator is isolated from the oscillating circuit by the buffer tube. Output impedance of this model is only 100 ohms. This low impedance reduces losses in the output cable. *Oscillatory circuit: Hartley oscillator with cathode follower buffer tube. Frequency stability is assured by modulating the buffer tube. *Accuracy: Use of high-Q permeability tuned coils adjusted against 1/10th of 1% standards assures an accuracy of 1% on all ranges from 100 Kilocycles to 10 Megacycles and an accuracy of 2% on the higher frequencies.



* Tubes used: One 554 as oscillator; one 954 as modulated buffer amplifier; T-2 as modulator; 7193 as rectifier.

The Model 200 comes complete with output cable and operating instructions

\$21.85
NET

NEW TIME PAYMENT PLAN ORDER BLANK

MOSS ELECTRONIC DISTRIBUTING CO., INC. Dept. B-41, 38 Murray Street, New York 7, N. Y.

Please send me the units checked below. I am enclosing the down payment with order and agree to pay the monthly balance as shown. It is understood there will be no carrying, interest or any other charges, provided I send my monthly payments when due. It is further understood that should I fail to make payment when due, the full unpaid balance shall become immediately due and payable.

- MODEL 770 Total Price \$14.90
- \$2.90 down payment. Balance \$2.00 monthly for 6 months.
- MODEL TV-11 Total Price \$47.50
- \$11.50 down payment. Balance \$6.00 monthly for 6 months.
- MODEL 670-A Total Price \$28.40
- \$7.40 down payment. Balance \$3.50 monthly for 6 months.
- TELEVISION BAR GENERATOR Total Price \$39.95
- \$9.95 down payment. Balance \$5.00 monthly for 6 months.
- MODEL 200 Total Price \$21.85
- \$5.85 down payment. Balance \$4.00 monthly for 4 months.

- I enclose \$ _____ as down payment.
- Ship C.O.D. for the down payment.

Signature _____

Name _____

Address _____

City _____

Zone _____

State _____

TV LEAD-IN INSULATOR

Radio Merchandise Sales, Inc., 2016 Bronxdale Ave., New York 60, N. Y., is distributing a new most standoff insulator with stainless steel strapping. The strapping is joined to the buckle with a stainless-steel rivet.



RMS has assigned model Nos. MC-35 and MC-75 to the new units, which are 3 1/2 inches and 7 inches long respectively. Models DMC-35 and DMC-75 are dual type standoff insulators.

ANTENNA SELECTOR

Technical Appliance Corp., Sherburne, N. Y., have designed a low-loss triple-circuit antenna switch for selection at the receiver of signals from any one of three antennas.

The unit is packaged ready for installation. It may also be used as a receiver selector in a television showroom by switching the signals from the antenna to any one of three receivers.

MOLDED CAPACITORS

International Resistance Co., 401 North Broad St., Philadelphia 8, Pa. is now producing a low value molded capacitor, type CAS. Designed to provide small values of capacitance with exceptionally high Q for its range, the capacitor is 1 3/32 inches long by 1/8 inch in diameter. It is being manufactured in standard values from 0.22 µuf to 2.2 µuf, ± 20% standard tolerance.

Molded in thermosetting material, and protected for applications requiring an insulated capacitor, the CAS meets JAN C-20A specifications for temperature coefficient and humidity.

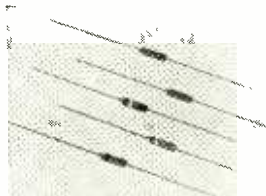

HI-FI AMPLIFIER

Fisher Radio Corp., 41 E. 47th St., New York, N. Y., is the manufacturer of the new model 50-A laboratory-standard amplifier which features high output with extremely low distortion (.05% at 5 watts, .08% at 10 watts, and 0.3 at 40 watts). Intermodulation distortion—measured, with 40 and 12,000 cycles at 4 to 1—is below 0.4% at 10 watts and less than 2.0% at 40 watts. Response is within 0.1 db from 20 to

20,000 cycles and within 1 db from 5 to 100,000 cycles. Hum and noise are better than 92 db below full output. Damping factor is 31 at the 16-ohm tap. Efficiency is better than 55% at full output as compared to 25-30% in typical class A amplifier circuits. The model 50-A measures 8 x 14 1/2 x 9 inches. It uses three 12AU7, two 6S4, two 16L4, and two 5Y4-G tubes. A meter jack and variable bias control are provided for balancing the plate currents at the output tubes.



TOOL KIT

Tele-Scopic Products Inc., 111 W. 42nd St., New York 36, N. Y., has announced a 17-unit radio-TV service-tool kit featuring slip-on deep-wall socket wrenches in eight sizes ranging from 1/4-inch to 3/16-inch, enabling the service technician to remove nuts from volume controls with long shafts and screws with long studs.

The Tele-Tool Kit also features a ratchet wrench and an extension shaft for reaching screws and nuts in normally inaccessible places. Screwdriver

blades and a handle are also provided.



MINIATURE MIKE

The Astatic Corp., Conneaut, Ohio, has released a miniature crystal microphone, model 54M3. The unit has an output of -51 db below 1 volt per microbar, and is nondirectional when mounted in its base. Recommended for



recorder, PA, conference, and other uses, its response (30 to 10,000 cycles) is flat to 1,000, rising gradually to 6,000 cycles. It is furnished with five feet of rubber-covered, single-conductor shielded cable and protector sleeve at microphone.

TeleSound CUSTOM-BUILT TV CABINETS

DIRECT FROM MANUFACTURER TO YOU—COMPARE PRICE and QUALITY!

Be price conscious! TELESOUND Wholesale Prices enable you to sell more, make a BETTER PROFIT for yourself!



H:25", D:21 1/2", W:25" Wgt: 50 Lbs.
TABLE MODEL 500 **\$42.00**

As above, for 24" Picture Tube H:31", D:24", W:27" Wgt: 60 lbs. **\$55.80**



H:40 1/4", D:22 1/2", W:25 1/4" Wgt: 60 lbs.
CONSOLE MODEL 200 **\$47.50**



H:40 1/2", D:24", W:25" Wgt: 100 lbs.
CONSOLE MODEL 800 **\$82.50**

ALL PRICES TAX INCLUDED

FAMOUS MAKE TV PICTURE TUBES
ALL STANDARD BRANDS—NATIONALLY ADVERTISED
FULL ONE YEAR GUARANTEE

DON'T BE MISLED—DEMAND GUARANTEED STANDARD BRANDS

12 1/2" Black or White	\$22.55
14" Glass Rect. (Blk)	22.55
16" Glass Round (Blk)	33.55
17" Rectangular (Blk)	33.55
19" Round (Blk)	36.85
20" Rectangular (Blk)	39.05
21" Rectangular (Blk)	43.45
24" Metal	76.45
27" Rect.	Wholesale Price on Request

Famous SUPER DeLUXE 630 CHASSIS
—YOUR CHOICE—
REGAL
or
VIDEO Model 630K3C

SMASHINGLY LOW PRICED!
\$147.50

- 30 tubes—for 16" to 24" Picture Tubes
- High Efficiency High Voltage Circuit
- Keyed AGC
- Automatic brightness control
- Special extra high gain Cascade Standard Coil Tuner
- Directly adaptable for UHF.
- 12" Quality Speaker
- Factory wired, aligned, tested.
- Complete, ready to play, including tubes, knobs and hardware
- Less CRT

DeLuxe Techmaster 2431P Chassis. Complete less CRT \$199.95
FREE OFFER! Schematic Diagram and complete 24 page service manual FREE with any of these chassis!

Here's the "PACKAGE DEAL" You've Waited for!

- ★ SAVE MONEY! Order the cabinet of your choice from the TeleSound models illustrated, in combination with the famous 630 TV Chassis, (Regal or Video), 12" speaker, and your choice of picture tube. If Video 630DX DeLuxe Chassis is desired, add \$10 to combination price. For DeLuxe Techmaster 2431P Chassis, add \$50. Check these sensationally low prices:

CABINET STYLE	COMBINED WITH Super 630 Chassis, 12" Speaker, and			
	17" CRT	20" CRT	21" CRT	24" CRT
500	\$216.25	\$222.70	\$227.00	\$272.50
200	\$221.50	\$227.90	\$232.25
800	\$254.70	\$261.15	\$265.50
1000	\$254.70	\$261.15	\$265.50

Please include 25% deposit with orders, balance C.O.D. All shipments F.O.B., NYC "Designers & Manufacturers of Custom TV and Radio Furniture"

TeleSound CORPORATION

421 West 28th Street
New York 1, N.Y.
Phone: WI 7-0719

**SMASH
HIT!**

TERRIFIC ACCEPTANCE GREETES THE NEW

**TRIO
ZIG-ZAG**
(Patent Pending)

TV ANTENNA

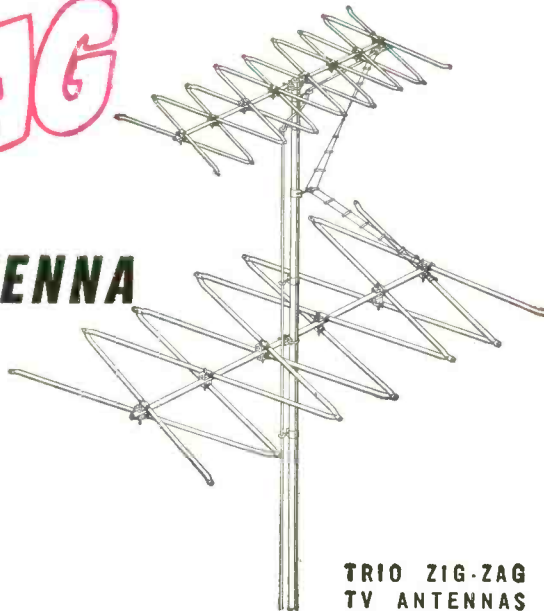

**TRIO ZIG-ZAG
TV ANTENNAS**

The sensational new TRIO ZIG-ZAG TV ANTENNA has already proven its superiority in the field. Thousands of installations have given a new high in TV reception, especially in ultra-fringe areas. Word of mouth has done the rest. TRIO'S plant capacity, taxed to the limit in an effort to supply the amazing demand for the ZIG-ZAG ANTENNA series, is being greatly expanded. Very soon now, your ZIG-ZAG ANTENNA will be supplied, and it's well worth waiting for.

ZIG-ZAG ANTENNAS have replaced every known type of installation and TRIO is proud to report that in EVERY instance the ZIG-ZAG ANTENNA has out-performed them all, even the tried and true TRIO dual-channel yagi.

TV listeners are finding that with a ZIG-ZAG ANTENNA they are no longer tied down to just one or two channels, but are getting excellent reception on channels never seen before. ZIG-ZAG ANTENNA is truly HOT on all VHF channels.

available in 8 different models, provide a new high in all-channel performance for any area, from metropolitan to ultra-fringe. Tremendous gain, sharp directivity, excellent match to 300 ohm line, sturdy vibration-proof construction and fast, easy installation tells the rest of the TRIO ZIG-ZAG ANTENNA story.
SEE THEM at your JOBBERS. WRITE for CATALOG.



TRIO ROTATOR

A worthy companion to the ZIG-ZAG ANTENNA. Tested and proven under every conceivable condition of load, weather, strain and stress. Two motors, one for each rotation direction. Positive electrical stops prevent damage of over-rotation. Positive brake action, no drift even when supporting heavy arrays in 80 MPH winds. Precision built of finest materials and UNCONDITIONALLY GUARANTEED by TRIO for TWO YEARS. SMARTLY STYLED DIRECTION INDICATOR has easy to read dial face and easy to use finger touch control. A beautiful instrument you'll be proud to own.

These ZIG-ZAG ANTENNAS provide the ultimate in extreme fringe area reception. ZZ12L provides 12-14 db. gain on Channels 2 thru 6. ZZ16H has a gain of 14 db. on Channels 7 thru 13. These antennas have very narrow forward lobe, high front to back ratio, provide high rejection in areas with co-channel interference.

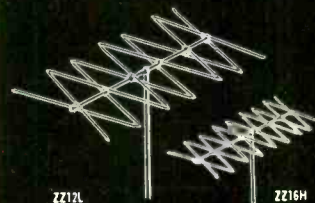

Where maximum gain is not necessary these normal fringe model ZIG-ZAG ANTENNAS are ideal. Model ZZ8L has a gain of 9 db. average on Channels 2 thru 6. The ZZ8H provides an 11 db. gain on Channels 7 thru 13. Forward lobe patterns comparable to good multi-element single channel yagi.



For near fringe area reception these ZIG-ZAG ANTENNA models provide 8-9 db. gains on all Channels 2 thru 13. ZZ6L covers Channel 2 thru 6 and Model ZZ5H covers Channels 7 thru 13. Both models have patterns similar to those of cut to chonne yagis.



These ZIG-ZAG ANTENNAS provide ALL CHANNEL reception with only ONE antenna bay. Model ZZ6A is designed for near fringe area reception of all Channels 2 thru 13, with an average gain of 9 db. Model ZZ4A is for use in suburban areas, providing an average gain of 6 db. on all Channels 2 thru 13.



TRIO MANUFACTURING COMPANY

GRIGGSVILLE, ILLINOIS

A HOT Little BOOSTER for HOT Front Ends



\$24.95
LIST

VIDEON JR. won't oscillate with the hot front ends of new sets!

PERFORMANCEWISE—It's tops

PRICewise—It's right . . . and as for customer satisfaction, you cut costly call backs when you install a VIDEON JR.

Write For Descriptive Folder And Name Of Your Distributor



Coming Soon!
The NEW Videon UHF Converter

ELECTRONIC CORPORATION

222 East Ohio Street · Indianapolis, Indiana



IT'S A SHAME

to throw away that beautiful old Console . . . replace the obsolete radio with a modern, easily-installed



ESPEY AM / FM CHASSIS

Enjoy Hi-Fidelity Reception



It is not necessary to spend a large sum of money to modernize your old radio or to become a "High Fidelity" enthusiast. ESPEY chassis provide the Highest Quality at moderate prices.

Fully licensed under RCA and Hazeltine patents. The photo shows the Espey Model 511-C, supplied ready to play. Equipped with tubes, antenna, speaker, and all necessary hardware for mounting.

NEW FEATURES—Improved Frequency modulation circuit, drift compensated • 12 tubes plus rectifier, and pre-amplifier 12A7 tube • 4 dual purpose tubes • High quality AM-FM reception • Push-pull beam power audio output 10 watts • Switch for easy changing to crystal or variable reluctance pick-ups • Multi-tap audio output transformer supplying 3.2—8—500 ohms.

Makers of fine radios since 1928.

Write Dept. RE-12 for literature and complete specifications on Model 511-C and others.

ESPEY
MANUFACTURING COMPANY, INC.
572 EAST 72nd STREET, NEW YORK 21, N. Y.

TV FRINGE BOOSTER

Industrial Television, Inc., 369 Lexington Ave., Clifton, N. J., has announced a new sub-fringe TV booster, the IT-90AB cascode autobooster, successor to the IT-90A. The unit provides a uniform gain of 26 db on the high band and 34 db on the low band. Noise factor is 7 db.



The IT-90AB has wide-band automatic tuning, on-off relay, separate high- and low-band inputs, independent gain controls for each band, and bypass switch.

D.C. RELAY

RCA Tube Department, Harrison, N. J., has announced a miniaturized d.c. relay for general use throughout the electrical systems of military aircraft. Hermetically sealed, this new type RCA-203W1 relay is a 6-pole, double-throw unit operating on 26.5 volts.

The miniaturized-type design features sturdy and compact construction, palladium contacts, moisture-free gas filling, and long operating life. It is designed to meet U.S. Air Force specification MIL-R-5757 and is engineered to provide long service under extremes of temperature, humidity, shock, vibration, and voltage variations. The relay weighs 3 ounces and can be operated in any position.



Its 6-pole, double-throw construction features palladium contacts rated to handle 2 amperes with a resistive load at 26.5 volts d.c., and 1 ampere with an inductive load at the same voltage. Contacts are arranged in a break-before-make sequence.

WIRE CLAMP

South River Metal Products Co., 377-399 Turnpike, South River, N. J., has announced a new ground rod with a special extruded aluminum wire clamp which will accommodate all ground-lead wire from No. 3 to No. 20 gauge.

The screw and nut fastening feature forces the wire to nest in the grooved slot of the clamp and prevents the ground-lead wire from slipping out.



All specifications given on these pages are from manufacturers' data.

WEATHERPROOF INTER-COM

Cleveland Electronics, Inc., 6612 Euclid Ave., Cleveland 3, Ohio, has announced a weatherproof intercom station engineered for industrial users. Built around a 4-inch weatherproof speaker with a 45-ohm dustproof aluminum voice coil, the unit includes a talk-listen switch for two-way communication. The stations can be used with a suitable a.f. amplifier to form a complete intercom system. The unit is 4 inches by 6 inches by 4½ inches deep and weighs 2 pounds 2 ounces.



GREEN BAND LINE

Todd-Tran Corp., Mt. Vernon, N. Y., has announced the new Green Band line of cosine deflection yokes and fly-back transformers. The deflection yokes



feature nylon segments for inter-coil insulation, high deflection sensitivity, good line and corner focus, coil balance to within one turn, compensated cosine design to minimize pincushioning, and ferrite cores.

Flyback transformers are constructed with the coil windings and connecting terminals completely vacuum-encased in a cast plastic dielectric so as to withstand very high voltages without flashover, corona, or breakdown. These transformers are particularly adaptable to large picture tubes requiring wide sweeps and high voltage.

SELENIUM RECTIFIER

Federal Telephone and Radio Corp., Clifton, N. J., has developed a new selenium rectifier cell rated at 36 volts r.m.s. Because the individual cells are rated at 36 volts, a rectifier

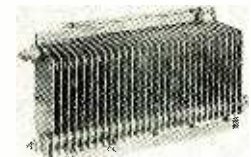

stack made up of these cells not only will withstand a higher reverse voltage, but will require fewer cells for the same voltage output. Losses are proportionately less and the efficiency of the stack is considerably increased.

MAST SECTIONS

Snyder Manufacturing Co., 22nd and Ontario Sts., Philadelphia, Pa., has



added antenna-mast sections to their line. The MIO-X masts are self-coupling and rustproof. Each section is 10 feet long.

RADIO-ELECTRONICS

For Radio and TV Servicing...

...there's an RCA VoltOhmyst to fill your needs

RCA WV-97A Senior VoltOhmyst®

Especially useful as a television signal tracer—made possible by its high-impedance, full-wave signal rectifier for direct reading of peak-to-peak voltage up to 4200 volts. Measures ac in the presence of dc . . . dc in the presence of ac. Frequency response flat from 30 cps to 3 Mc.

- Electronic ohmmeter measures resistance from 0.2 to one billion ohms.
- Directly measures complex waves from 0.2 volt to 2000 volts peak-to-peak.

- Measures rms values of sine waves from 0.1 volt to 1500 volts.
- Measures dc voltages from 0.02 volt to 1500 volts with constant input resistance of 11 megohms—1-megohm resistor in dc probe.
- Over-all accuracy on dc, $\pm 3\%$ of full scale.
- 7 non-skip ranges for resistance and ac and dc voltage measurements.
- Negative-feedback circuit provides over-all stability—all-steel case shields bridge circuits from external fields.



\$6750 complete with matched probes and cables.

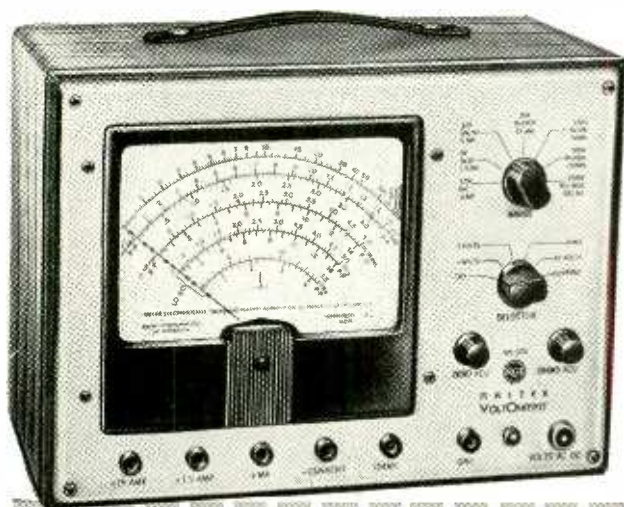

RCA WV-87A Master VoltOhmyst

Combines all the outstanding features of the Junior and Senior VoltOhmyst plus more ranges, more functions, and an easy-to-read $7\frac{1}{2}$ " meter. Measures . . .

- Peak-to-peak values of unsymmetrical complex waves from 0.2 to 2000 volts.
- Peak-to-peak values of symmetrical complex waves from 0.2 to 4200 volts.
- RMS values of sine waves from 0.1 volt to 1500 volts.
- DC voltage from 0.02 volt to 1500 volts.
- Resistance from 0.2 ohm to 1000 megohms.
- Small direct currents from 10 microamperes to 500 milliamperes.
- Large direct currents from 500 ma up to 15 amperes.

\$11250 complete with matched probes and cables.

RCA WV-77A Junior VoltOhmyst

Unquestionably the greatest value in all-electronic volt-ohmmeters. The WV-77A is factory-calibrated against the finest laboratory standards. Equipped with five ranges for measuring dc voltage, ac voltage, and resistance. Measures dc from 50 millivolts to 1200 volts; ac from 100 millivolts to 1200 volts rms; and resistance from 0.2 ohm to 1 billion ohms.

\$4750 complete with matched probes and cables.

Get complete details from your RCA Test Equipment Distributor.

RADIO CORPORATION of AMERICA
TEST EQUIPMENT

HARRISON, N. J.



TMK.®





Dependability...

an important reason why leading manufacturers prefer General Industries' 3-Speed Phonomotors

Year after year, General Industries' *Smooth Power* Phonomotors provide trouble-free performance—backing up fine radio, television and record-changer engineering with highest quality motor design and construction.

Write for complete information, including specifications, design features and dimensions. Quantity price quotations available on request.



THE GENERAL INDUSTRIES CO.
DEPARTMENT ME • ELYRIA, OHIO

"5D-201" SOLDERING FLUX

Highest quality, fully guaranteed. Used satisfactorily by service men everywhere! Order from your parts jobber or direct.

LYONART ENGINEERS

Ottawa, Ill. Trinidad, Colo.

WANTED

BD110 Telephone Switchboards, BD100 Telegraph Switchboards, BD90 Power Boards, EE101 V-F Ringers, BE72 Cabinets, FM19 Frames, RA43, REC30, KS5986, RA87, RA37, RA91 Rectifiers, BD101 Test Boards, SB6 Switchboards, Type CF1A, CF3A, CF2B Carrier Equipments. Any condition and quantity.

Box 1252-1 Radio Electronics
25 W. Broadway, New York 7, N.Y.

TIMESAVER!

TELEVISION TECHNOTES—

Gernsback Library Book No. 46
128 Pages. 58 Illustrations \$1.50

A real boon to TV service technicians. List the symptoms, causes and cures for 607 actual troubles found in scores of sets made by 27 manufacturers. Cuts down routine trouble-shooting time.



(Available at leading parts distributors)

GERNSBACK PUBLICATIONS, INC.
Publishers of RADIO-ELECTRONICS
25 West Broadway, New York 7, N. Y.

CERTIFICATION PLAN

The National Alliance of Television and Electronic Service Associations (NATESA) has presented to all its members and correspondents a plan intended to create confidence in TV set owners. In brief, the plan would include inspection of any shops requesting such service and issuing certificates and emblems to those qualifying as approved by the industry.

The inspection committee would be selected from the local service association, distributors' organizations and the Better Business Bureau. They would consider such points as shop space and office facilities, test equipment, service data, parts stocks, insurance coverage, credit record, complaint record with the BBB and distributors, and manpower.

It was not indicated what weight was to be given to shop space and office facilities. Some bills introduced to regulate servicing have indicated that the framers considered shop space a positive factor and sought to impose a minimum. On the other hand, experience with bankruptcies in the worst days of the TV contract era indicated that financial stability and quality of service tended to drop with increases in shop and office size.

A plan was also proposed for training technicians, which would include refresher courses, clinics, and final certification for technicians who qualify. The entire industry, says NATESA, would be expected to publicize the course and recommend that only certified personnel be used by certified shops.

CHILDREN GET TV

A projector-type TV receiver and two new antennas were presented to the San Diego (California) Children's Convalescent Hospital by the San Diego Electronic Association. Members of the Association, which is composed of more than one hundred professional technicians in the electronic field, have made a long-term project of their assistance to crippled children. In addition to the new equipment, they have pledged complete installation and servicing of all television and radio sets for the entertainment of the handicapped youngsters.

THE NATESA CODE

A new service code of 16 items has been promulgated by NATESA. The text follows:

1. Employ qualified personnel to assure proper service. No student shall be passed off as a technician.
2. Make proper arrangements for the protection of reserve funds on contracts.
3. Carry adequate insurance coverage.
4. Avoid trick advertising which offers to service or deliver materials under conditions which are questionable or unfair to the set owner or your fellow members.
5. Employ approved methods of doing installations and maintenance.
6. Issue a standard guarantee.
7. Have available sufficient and proper test equipment to assure a good job.

RADIO-ELECTRONICS

8. Maintain an adequate service data library.
9. Render service no later than 24 hours.
10. Install only such parts and tubes as are really necessary. Use only new parts and tubes of a quality at least equal to original equipment.
11. Leave with or return to customer all parts and tubes replaced (except where impractical).
12. Issue an itemized bill.
13. Give estimates before major work is performed.
14. Service sets in home if possible.
15. Be honest, courteous, and treat each client in a professional manner.
16. Observe the Golden Rule.

NEW CEILINGS ON REPAIRS

The Radio-TV Service Industry Advisory Committee to the Office of Price Stabilization approved a proposed OPS order clamping stricter controls on service charges. When adopted, it will supplement regulation CPR 34. Ceiling-price lists filed with the local OPS office will have to be carried on all outside calls as well as posted conspicuously in the shop. Bills will have to show separate charges for materials and labor and list any used or second-grade parts used in the repair.

The heads of both national service associations, Max Liebowitz of NETSDA and Frank Moch of NATESA, are on the Committee. According to OPS, some committee members feel the new order is still not tough enough to weed out all service chiselers.

ARTSNY TRIES NEW PLAN

A contract of co-operation between The Associated Radio-Television Servicemen of New York (City) and Transvision, Incorporated, was signed at a meeting of the membership October 16.

Under the provisions of the contract, Transvision accepts the Code of Ethics of ARTSNY as its own, will assist in publicizing ARTSNY by advertising and in its mailings to service technicians, will offer Transvision distributorships in the New York metropolitan area to ARTSNY members exclusively. Transvision will submit all its new test-instrument designs to ARTSNY for test, and will carry the ARTSNY seal on all approved instruments.

In return, ARTSNY will assist Transvision in furthering its distributorship plan, and will supply Transvision with its membership lists to help circulate information on the plan. The Association will also publicize the plan among its members, at meetings and otherwise, and will report to affiliated and other service associations on the progress and status of co-operative action with Transvision. It will also assist Transvision in its relations with manufacturers and suppliers of parts.

The meeting, which was attended by approximately 100 members, was addressed by Herbert Suesholtz, Dave Gnessin, Elmer Andrews, and Jerry Williams of Transvision. The Transvision symposium covered organizational prospects and problems, test equipment, and service techniques. **END**

DECEMBER, 1952

The Sensational New
RCP
'DO-ALL' 3
COMPLETELY SERVICES TELEVISION

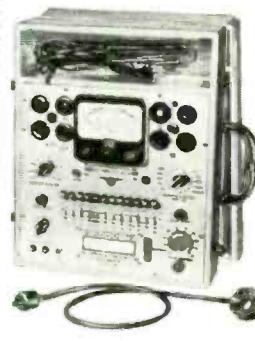
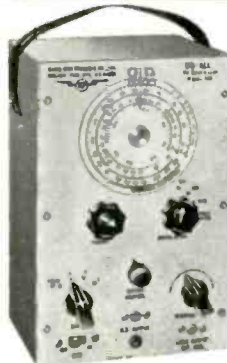

TV "Do All" GENERATOR
 MODEL 740

- IT'S A
- SIGNAL GENERATOR
 - AUDIO GENERATOR
 - PATTERN GENERATOR
 - MARKER GENERATOR

MODEL 740-Complete, **\$6950**
 Ready to operate . . . NET

TV Set & Tube Tester
 MODEL 808

- ★ A TUBE TESTER
- ★ A CA-HODE RAY TUBE TESTER
- ★ A CA-HODE RAY TUBE REACTIVATOR
- ★ A VACUUM TLBE VOLT-METER (AC-DC)
- ★ AN O-HMMETER

MODEL 808-Complete, **\$9995**
 Ready to operate . . . NET

MIDGETSCOPE
 MODEL 533M

weighs only 9 lbs.
 Size: 11 3/4" x 7 3/4" x 5 1/4"
 SENSITIVITY:—Vertical—20 millivolts (.020 volts for 1" rms deflection on CRT face.)
 Horizontal—.6 volts.

MODEL 533M-Complete, **\$9950**
 Ready to operate . . . NET

Write for the latest RCP Catalog to Dept. RE-12

RADIO CITY PRODUCTS CO., INC.

152 WEST 25th ST • NEW YORK 1, N. Y.



PEN-OSCIL-LITE

Extremely convenient test oscillator for all radio servicing: alignment • Small as a pen • Self powered • Range from 700 cycles audio to over 600 megacycles u.h.f. • Output from zero to 125 v. • Low in cost • Used by Signal Corps

• Write for information
GENERAL TEST EQUIPMENT
 38 Argyle Ave. Buffalo 9, N. Y.

Every RADIOMAN

can use these **SERVICE HINTS!**

Valuable Manual Yours—FREE

Write today—no obligation
FEILER ENGINEERING CO. Dept. 12RC2-1
 8026 N. Monticello Ave., Skokie, Ill. (Suburb of Chicago)

Every page of "How to Simplify Radio Repairs" is packed with on-the-bench, practical ideas.

From the earliest days of Radio . . .
 to the present era of Television . . .

CORNISH WIRES

"Made by Engineers for Engineers"

CORNISH WIRE CO., Inc. — 50 Church St., N. Y. C. 7

AC-DC MUSIC AMPLIFIER

Volume and tone control.
 1.5 w. output.
 See your jobber.

MICHEL MFG. CO.
 227 N Water St.
 Milwaukee 2, Wis.

a "TESCO" exclusive

the ROCKETENNA



by T-V PRODUCTS CO.

- ✓ Amazingly Powerful Reception
- ✓ Rugged All-Aluminum Construction
- ✓ Lifetime Factory Warranty

Complete factory Preassembly features sensational "Quick-as-a-Wink" construction. No Nuts or Bolts to Tighten... rugged rivet assembly prevents damage by wind and storm vibration.

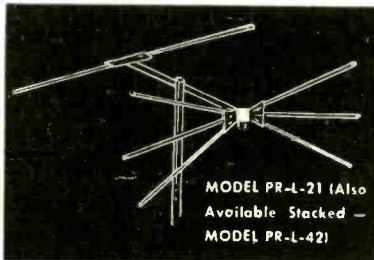
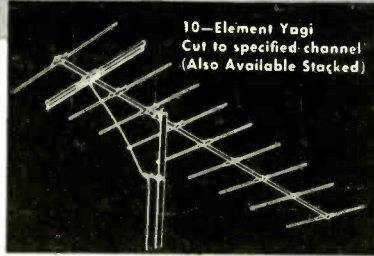

ANOTHER "TESCO" PRODUCT

T-V

Write for New Complete Catalog P

PRODUCTS CO.

152 SANDFORD ST. • B'KLYN, N. Y.



44" Flexible Shaft & Housing . . . 1/4"-1/4" female tips, setscrew	\$1.49
33 Contact Connectors (Jones #333) . . . Cable female, panel male. Off cable . . . set \$1.29	5/5.00
Rubber Shock Mounts . . . 8 lb., 1 3/4" sq., 1/4" ID	15c 8/1.00
8 Pos. Push-Button Ass'ly . . . 4 PDT, ckt. trans-fer, 7" mtg, 2 3/4" deep98
Set of 8 knobs for above49
W-110 Field Wire . . . coils 100-400 ft. Per ft. = 20 Push-Back Wire, Red, Yellow, Blue or black, 100 ft./Crystal Headphones . . . Brush Type "A" . . . 50,000 ohm imp'd. With 5ft. tipped cord	4.95
ANB-H-1 Phone Units . . . 300 ohm imp'd.98
Sound Power Tank Phones (#10-MkII) . . . Nylon diaphragm	2.49
MB-7 Leather Headbands with cord . . . Less plug39
Midget 24V. Rotary Solenoids (5/8"x7/8" O.D.) . . . 45° travel. Fully cased89
110V AC Electromagnets (7/8"x1" O.D.) . . . 800 ohm coil; 6 oz. pull. Cont. duty98
115V/230V AC Recording Motors (G.I.) . . . Silent, Recording, Less mtg. plate ass'ly & turntable. 3 3/8" sq., 2 3/4" . . . Shipping wgt. 6 lbs.	4.95
1/17 H.P. GE Motor . . . 1725 RPM, 7 Amp. 110V DC. Dble. 3/4" shaft, 5 1/2"x4 3/4" O.D. Shpg. wt. 13 lbs. Type SD	2.95

Leotone



PORTABLE RADIO-AMPLIFIER CABINET . . . Ideal for: Test, Medical or Industrial Equip. Walnut finish steel. Hinged front panel; slide rearing. 14"x8"x8". Shipping Wgt. 4 lbs.

\$2.49

Ornamental Metal Grille . . . Gold finish; diamond 2"x3/4", 12"x12" . . . 98c; 16"x16" . . . \$1.59; 18"x24" \$2.69.

Grille Cloth . . . 12"x24", Dressy Gold-Tone 69c

PL-54/JK-26 Connector set 49c 6/2.49

PL-291/JK-48 Midget Connectors . . . set 39c 6/1.98

83-1AP (M-359) Co-Ax Angle Plugs . . ea. 29c 10/2.50

Radio Hardware Treasure . . . FULL LB. CAN of: Nuts, Screws, Lugs, Washers, etc. lb. 85c 3 lbs. /2.49

Tank Periscopes (MG) . . . Precision reflector type. Demountable head & elbow 1.69

Army Gas Mask Facepiece . . . adjust, universal size. Shatterproof lenses; lens side canister 59c

Radio-TV Builders Library . . . Schematics & Data for Hams, Students, Serviciers. Kit of 20 assorted incl. Photofacts98

High Fidelity Crystal mike . . . Rubber shock mtg. 1 3/4"x1 1/4". Hi-imp'd., less housing 1.29

Aluminum Housing for crystal mike15

Hand Mike Case . . . moulded black bakelite98

— I ! BIGGEST BUY OF THE MONTH ! I —

JUMBO RADIO PARTS KIT! A "GOLD-MINE" of inventory odds & ends: COILS, CONDENSERS, SOCKETS, WIRE, SWITCHES, RESISTORS, etc. ETC. ETC. SHPG. WT. 20 lbs. **\$3.95**

"FACTORY SPEAKER REPAIRS SINCE 1927"

Min. order \$3.00. 20% deposit req. on all C.O.D.'s. Full remittance with foreign orders. Please add sufficient postage—excess refunded.

LEOTONE

RADIO CORP.
67 Dey Street
New York 7, N. Y.

Watch for our Annual Television Issue, on the stands Dec. 26. Prospects and problems of the TV service technician in new TV areas will be discussed in articles by famous writers. U.h.f. articles and circuitry will be featured in the issue, as well as articles on many phases of TV and TV servicing, and directories of TV receivers, antennas, picture tubes, and components. Don't fail to reserve your copy early!



Regency

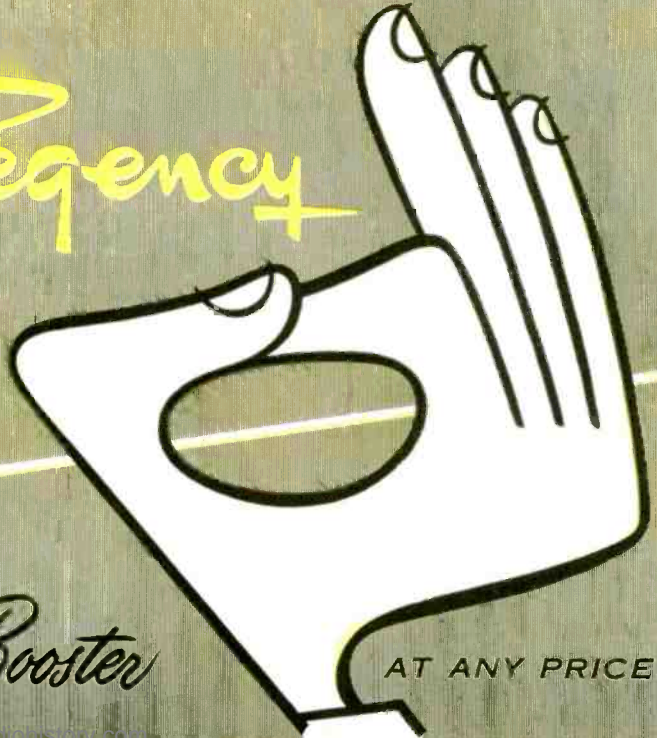

Largest Selling Booster

AT ANY PRICE!



LEARN PRACTICAL RADIO AT HOME!

Build 15 Radios

Build a Professional Signal Tracer
Build a Code Oscillator
and Learn Code!

COMPLETE, FOR ONLY
\$19⁹⁵

FREE!

• ELECTRICAL AND RADIO TESTER • RADIO TELEVISION SERVICING LESSONS • BOOK ON TELEVISION • MEMBERSHIP IN RADIO-TELEVISION CLUB • ELECTRIC SOLDERING IRON • CONSULTATION SERVICE • QUIZZES

10-DAY MONEY BACK GUARANTEE

ABSOLUTELY NO PREVIOUS TRAINING NEEDED • FREE TOOLS • NO ADDITIONAL PARTS REQUIRED
YOU KEEP ALL PARTS, TOOLS, INSTRUCTIONS • AN EXCELLENT BACKGROUND FOR TELEVISION

LEARN TROUBLE SHOOTING . . . THEORY . . . WIRING . . . CODE!

WHAT THE NEW IMPROVED 1953 PROGRESSIVE RADIO "EDU-KIT" OFFERS YOU

The Progressive Radio "Edu-Kit" offers you a home study course at a rock bottom price. Our kit is designed to train Radio Technicians, with the basic facts of Radio Theory and Construction Practice expressed simply and clearly. You will gain a knowledge of basic Radio Principles involved in Radio Reception, Radio Transmission and Audio Amplification. You will learn how to identify Radio Symbols and Diagrams; how to build radios, using regular radio circuit schematics; how to mount various radio parts; how to wire and solder in a professional manner. You will learn how to operate Receivers, Transmitters, and Audio Amplifiers. You will learn how to service and trouble-shoot radios. In brief, you will receive a basic education in Radio exactly like the kind you would expect to receive in a Radio Course costing several hundreds of dollars.

THE KIT FOR EVERYONE

The Progressive Radio "Edu-Kit" was specifically prepared for any person who has a desire to learn Radio. The Kit has been used successfully by young and old in all parts of the world. It is not necessary that you have even the slightest background in science or radio.

The Progressive Radio "Edu-Kit" is used by many Radio Schools and Clubs in this country and abroad. It is used by the Veterans Administration for Vocational Guidance and Training.

The Progressive Radio "Edu-Kit" requires no instructor. All instructions are included. All parts are individually boxed, and identified by name, photograph and diagram. Every step involved in building these sets is carefully explained. You cannot make a mistake.

THE PROGRESSIVE RADIO "EDU-KIT" IS COMPLETE

You will receive every part necessary to build 15 different radio sets. This includes tubes, tube sockets, variable condensers, electrolytic condensers, mica condensers, paper condensers, resistors, tie strips, coils, tubing, hardware, etc. Every part that you need is included. In addition these parts are individually packaged, so that you can easily identify every item.

TROUBLE-SHOOTING LESSONS

Trouble-shooting and servicing lessons are included. You will be taught to recognize and repair troubles. While you are learning in this practical way, you will be able to do many a repair job for your neighbors and friends, and charge fees which will far exceed the cost of the Kit. Here is an opportunity for you to learn radio and have others pay for it. You build a professional Signal Tracer which alone, is worth more than the price of the complete Kit.

THE PROGRESSIVE TEACHING METHOD

The Progressive Radio "Edu-Kit" comes complete with Instructions. These instructions are arranged in a clear, simple and progressive manner. The theory of Radio Transmission, Radio Reception, Audio Amplification and Servicing by Signal Tracing is clearly explained. Every part is identified by photograph and diagram; you will learn the function and theory of every part used.

The Progressive Radio "Edu-Kit" uses the principle of "Learn By Doing." Therefore you will build radios to illustrate the principles which you learn. These radios are designed in a modern manner, according to the best principles of present-day educational practice. You begin by building a simple radio. The next set that you build is slightly more advanced. Gradually, in a progressive manner, you will find yourself constructing still more advanced radio sets, and doing work like a professional Radio Technician. Altogether you will build fifteen radios, including Receivers, Amplifiers, Transmitters, Code Oscillator & Signal Tracer.

THE PUBLIC APPROVES!

COMMENTS FROM SATISFIED USERS OF THE PROGRESSIVE RADIO "EDU-KIT"
VETERANS ADMINISTRATION,
PHYSICAL MEDICINE REHABILITATION SERVICE,
WASHINGTON, D. C.

"This morning I was showing the Progressive Radio 'Edu-Kit' to one of our representatives from our Branch Office in Richmond, and already he wants me to purchase some for his hospital. . . . As indicated in previous correspondence, I took the Progressive Radio 'Edu-Kit' to our Veterans Administration Hospital at Fort Thomas, Kentucky. Both instructors and patients worked them, and they proved quite satisfactory."
ROBERT L. SHUFF,

1534 Monroe Ave., Huntington, W. Va.

"Thought I would drop you a few lines to say that I have bought a Progressive Radio 'Edu-Kit' and was really amazed that such a bargain can be had at such a low price. I have already started repairing radios and radio-phonographs. Friends were really surprised to see me get into the swing of it so quickly. The trouble-shooting tester that came with the kit is really swell, and finds the trouble if there is any to be found. Everything you say about your kit is true."
DOMINICK STRACUZZA,

111 Clarence St., London, Ontario.

"I am very satisfied with the Progressive Radio 'Edu-Kit' which I bought from you. I did not know anything about radio, but now I feel as though I have been in the radio business for years. Your kit is simple and educational. I enjoy working with it."
Order your Progressive Radio "EDU-KIT" Today, or send for further information.

Postage prepaid on cash orders—C.O.D. orders accepted in U. S. A.

BECOME A RADIO AMATEUR



GET A WELL-PAYING JOB



GO INTO A PROFITABLE BUSINESS



PROGRESSIVE ELECTRONICS CO.

497 UNION AVE., DEPT. RE-36

BROOKLYN 11, N. Y.

DECEMBER, 1952

FOR
perfection
IN
reception
IN
fringe areas
INSTALL

FINCO

20 in 1

T V A N T E N N A

- Clear pictures up to 120 miles and more from station!
- 8 driven elements on low band!
- 12 driven elements on high band!
- One antenna—one transmission line!
- High gain—low noise!
- Total weight only 8 lbs.!

The new patented FINCO Model # 400 20-in-1 Co-Lateral Antenna is constructed on an entirely different principle than any other unit in the market today. Thousands of FINCO installations are giving TV owners perfect reception in fringe areas over 100 miles away from broadcasting stations. To provide complete TV satisfaction to customers in fringe areas, use FINCO every time!

THE FINNEY COMPANY
4612 ST. CLAIR AVE. • CLEVELAND 3, OHIO

SUBSCRIPTION TELEVISION

Patent No. 2,601,505

Alexander Ellett, River Forest, Ill.
(Assigned to Zenith Radio Corp.)

This TV system garbles film programs to prevent their being enjoyed by unauthorized persons. A decoding signal printed on the film is sent along an auxiliary channel, such as a telephone wire. Subscribers are linked to the transmitter by both channels. They alone receive normal pictures. The TV transmitter uses conventional circuits.

Some of the frames in the film are inverted. The received image is unrecognizable unless these upside-down frames are again inverted in some way.

A decoding tone along the side of the film indicates an inverted frame. The tone is separated from its corresponding frame by an intermediate frame. For example, the first frame in the film carries the tone. It indicates that the third frame is upside down. Frame 3 also carries a tone, indicating that frame 5 will be inverted.

The decoding signal controls the vertical sweep at the receiver. Normally the sweep operates from the top of the picture to the bottom. In the presence of a decoding tone, the sweep voltage is reversed. It sweeps from bottom to top, inverting the inverted image so that the subscriber sees a normal picture.

FREQUENCY DIVIDER

Patent No. 2,602,140

Lyman R. Fink, Syracuse, N. Y.
(Assigned to General Electric Co.)

This system provides very large frequency stepdown ratios. For example, a 3,600 r.p.m. motor, using this divider, can drive the hour hand of a clock. This is a stepdown of 216,000:1. A quartz crystal can control a slow-moving mechanism like a stepping relay.

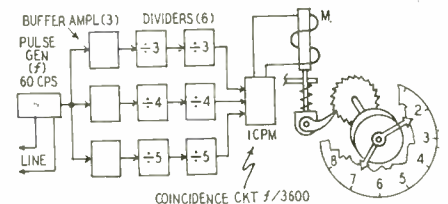

As shown, pulses of a given frequency (f) feed buffers in parallel. Each buffer is associated with a series of conventional frequency dividers, which may be multivibrators. In the example shown, the upper channel divides by 9, the middle channel by 16, and the lower channel by 25. These numbers are *prime* to each other. (None is divisible by either of the others.) For that reason, $9 \times 16 \times 25$ (3600) pulses are delivered by the pulse generator before all three channels provide pulses which coincide. Only when 3 pulses arrive *simultaneously* does the coincidence circuit trip. Thus the coincidence circuit has a frequency $f/3,600$.

When the coincidence circuit trips, it energizes magnet M and a gear wheel is advanced by one tooth. If there are 60 teeth, an hour hand can be driven directly.

Note these important requirements. Each channel stepdown ratio must be *prime* to the others. Pulses taken from the channels must be sufficiently sharp so they do not coincide with the others except at the final pulse.

PHOTOFLOOD LIGHTING

Patent No. 2,609,523

Robert A. Stein and Lee S. Wasserman
(Assigned to Globe Industries, Inc., Dayton, Ohio)

Photoflood lamps are popular light sources for amateur and professional photography. They provide much light and have a life of several hours. Ordinarily, they are plugged into line sockets and turned on ahead of time. Thus the scene is properly lit when the picture is snapped. These lamps provide so much light that they may annoy the photographer and his subject during the preparatory stage. Besides, lamp life is shortened needlessly and there is considerable current drain (several amperes for each).

Scala

OSCILLOGRAPH PROBES

Complete with Coaxial Lead and Instruction Book

A PRECISION INSTRUMENT THAT WILL MAKE EVERY TV SERVICE JOB EASIER, FASTER AND MORE PROFITABLE

FULLY ADJUSTABLE TO OPERATE WITH ANY SCOPE MADE

See your local distributor or write factory and specify model number
BZ-1 Signal Tracing Probe BZ-2 Low Capacity Probe

BZ-3 100:1 Voltage Divider Probe

SCALA RADIO CO. 2814-19th St., San Francisco 10, California



Depend on...
CONCORD

SENSATIONAL BUY!

3 SPEED AUTOMATIC PORTABLE RECORD PLAYER With AMPLIFIER

Our Low Price **\$49.50**

Plays all 3 speed records with lid closed. Volume & Tone controls on outside. Powerful 3-tube amplifier. 5" Alnico 5 PM Speaker. Play 12-10" or 10-12" and 12-7" all 3 speeds. Deluxe wood case covered in striking washable cloth. 17 1/4"x15"x8 5/8". Wt. 21 1/2 lbs. 110 V AC.



RED HOT BUY! Famous Make CLOCK RADIO

Superhet Self-starting clock-sweep - second movement. Molded plastic cabinet. Ebony. Lots of 3, **\$15.95** Each ... Single, each **\$16.95**



Walnut, lots of 3, Each \$16.95 Single, Each... \$17.95

Lowest Price Ever!

Single Speed Portable RECORD PLAYER With AMPLIFIER

Our Low Price **\$14.95**

Constant single speed motor, 2-tube amplifier, volume control and switch. 4 1/2" Alnico 5 PM Speaker. Luggage wood case 12 1/2" x 10 1/2" x 5 1/2". Wt. 9 lbs. 110 V AC.



TOP XMAS VALUE! KIDDIE PHONOGRAPH

Our Low Price .. **\$10.95**

A world of fun for the kiddies, all year round! Electric phonograph with acoustic tone arm. Colorfully decorated, sturdy, "open-face" wooden case. Designed for full quality reproduction.



Send TODAY for your copy of our latest Buyer's Guide

CONCORD RADIO

54-L VESEY STREET, NEW YORK 7, N. Y. Phone: Dlgby 9-1132

OPEN THURSDAYS UNTIL 9 O'CLOCK

VALUES GALORE!

- RADIO
- TELEVISION
- ELECTRONIC BUYER'S GUIDE

CONCORD RADIO

and it's **FREE** for the asking

CONCORD RADIO, 54-L Vesey St., N. Y. 7 Dept. C-12

Send me at once your latest Buyer's Guide, Free of Charge.

Name

Address

City State

This invention avoids the above difficulties by preheating the lamps at low voltage. Thus the scene is illuminated normally while the subject is modeled. On opening the shutter, a super-normal voltage is applied simultaneously across the photofloods. In about .01 second the lamps reach peak brightness which is maintained for about 1/25 second. The lamps are energized briefly so lamp life is extended. Because of the super-normal voltage, very high illumination is obtained.

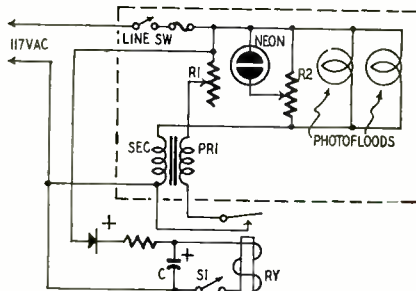

The camera shutter is synchronized with switch S1. When they are operated, the charge on C energizes the relay and the contacts are closed. Now line current flows through the primary and a high voltage is induced across the secondary of the transformer. The added power flashes the lamps briefly. As C discharges, the relay reopens and the lamps cool again.

Variable resistor R1 adjusts the high voltage across the lamps to the desired value. Tapped resistor R2 is adjusted so that the neon lamp may indicate when the voltage across the lamp equals the predetermined value.

PULSE COUNTER

Patent No. 2,607,022

Paul N. Martin, Penn Township, Pa.

(Assigned to Westinghouse Air Brake Co.)

This thyratron counter operates from pulses of any width, where the pulse interval is relatively long. For example, trains can be counted or timed as they pass. The pulse width equals the time required for the train to pass a given point. A pulse is generated by a photocell (or other device) and fed into the counter each time a train passes. The counter registers *once* for each train passing a given point.

Conventional thyratron counters, using a.c. as the plate supply, are not suitable for this type of counting. When triggered by a very narrow pulse, the tube may conduct for less than 1/20 of a second. This is because the tube de-ionizes when its plates supply goes negative. This interval is too short to operate a mechanical indicator. On the other hand, a wide pulse turns the tube on and off 60 times a second, so the count may be incorrect.

This new circuit (see diagram) normally operates with d.c. on the thyratron plate. C1 is charged to the full supply voltage. When a pulse fires the tube, the plate relay picks up its 3 sets of contacts. One set switches the plate supply from B, the d.c. source, to the a.c. line. Another

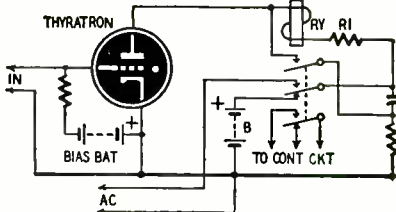

shunts C1 across both R1 and the relay. If the a.c. line makes the plate negative at the instant that the relay pulls in, the tube cuts off. C1 discharges through the relay and R1 so the relay will remain pulled in for a period somewhat longer than 1/60 of a second. When the plate becomes positive, the tube conducts. During conduction, C1 recharges to a value nearly equal to the peak a.c. line voltage, so it can again take over control of the relay during the next negative half-cycle of the a.c. line.

When the trigger pulse is removed from the grid, the grid bias takes control and the tube does not conduct during the next positive half-cycle. The relay remains pulled in until the discharge current of C1 drops to such a low value that the relay releases the armature. At this point, the back contacts reset the circuit for the next trigger pulse. **END**

... to servicemen
who really want to
learn to use the
OSCILLOSCOPE

fully and accurately!

A complete guide to using the handiest service instrument of all...
... On all kinds of jobs!...
Written so you can really understand it



MODERN OSCILLOSCOPES AND THEIR USES

By JACOB H. RUITER, Jr.
of Allen B. DuMont Laboratories, Inc.
326 pages, 370 illustrations, \$6.00



Like most servicemen, you've probably read a lot about oscilloscopes—but still don't know how to use them as well as you'd like to.

If so, here's the book you've been looking for!

In **MODERN OSCILLOSCOPES AND THEIR USES**, Mr. Ruiter starts right at the beginning. He shows how oscilloscopes are designed and how they work. Then he explains exactly how, why and where to use them. No involved mathematics. No buzzing theoretical discussions. Instead, this world famous authority gets right down to earth in answering the questions that have probably kept you from taking full advantage of the money-making service possibilities in oscilloscopes.

HOW TO HANDLE TOUGH JOBS EASIER AND FASTER



From routine troubleshooting to handling the toughest realigning and adjusting jobs, each operation is carefully explained. These include determining where and how to use the oscilloscope; how to make connections; how to adjust circuit components; how to set the controls—AND, ABOVE ALL, HOW TO ANALYZE PATTERNS. From dozens of pattern photos you see and learn to recognize patterns that are wrong, nearly right and exactly right!

SAVE HUNDREDS OF DOLLARS IN AM-FM-TV SERVICE TIME!



Busy servicemen have told us that the television service section of **MODERN OSCILLOSCOPES** alone is worth the entire price of the book. Here you get exact procedures for aligning the I-F stages; aligning V-F tuned circuits in the mixer stage; checking gain sweep circuits... and dozens of other jobs. Similar big sections cover use of the oscilloscope in AM and FM radio servicing and other electronic uses.

No other type of specific service training can mean so much to you in terms of increasing your efficiency and earning power. Use coupon today!

READ IT 10 DAYS at our risk!

Dept. RE-122, RINEHART BOOKS, Inc.
Technical Division
232 Madison Avenue, New York 16, New York

Send **MODERN OSCILLOSCOPES AND THEIR USES** for 10-DAY FREE EXAMINATION. If book is satisfactory, I will then send you \$6.00 promptly in full payment. If not, I will return book postpaid in good condition and owe you nothing.

Name

Address

City, Zone, State

Employers' Name and Address

Price outside U.S.A. \$6.50, cash only. Money back if you return book within 10 days.

PHOTOFACT USERS TELL THE EXPERT WAY TO TACKLE ANY TV-RADIO SERVICE JOB

here's what you do:

1

Determine the make and model number of the set on your bench. Use your PF INDEX to find the applicable PHOTOFACT Folder—takes just 60 seconds.



2

Reach into your PHOTOFACT library for the proper Folder. You're ready for time-saving, work-saving, expert service action.

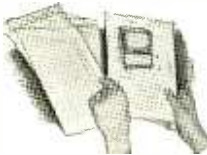

3

YOU HAVE YOUR HANDS ON THE ONE TOOL YOU'LL USE ON EVERY JOB

Here's what you find in PHOTOFACT Folders: A uniform, consistent presentation of complete service data, accurate because it's based on actual analysis of the production receiver. And here are the exclusive features—Standard Notation Schematics with voltages and wave forms right on the diagrams; chassis view photos, top and bottom, with all parts and relationships shown, all alignment points given, all parts identified; tube placement diagrams, top and bottom, all tubes and functions indicated, even socket pin locations shown, including fuse location guide and rating; tube check chart showing common troubles and tubes responsible; complete alignment instructions, including oscilloscope patterns; resistance measurements taken at every tube socket; separate photos of TV tuner, showing all parts locations and alignment points; photos of cabinet showing service controls; complete disassembly instructions; complete parts lists, each part identified by circuit symbol and keyed to schematics and photos—showing ratings, manufacturer's original part number and proper replacements available from 29 leading components manufacturers—plus—dial cord stringing instructions; special service instructions (such as horizontal sweep circuit adjustments, etc.)—everything you have a right to expect in the world's finest TV-Radio service data . . .

4

NOW HERE'S HOW YOU SAVE TIME AND EARN MORE

You're ready to tackle the job—any job—because you have all the answers instantly at your finger tips in PHOTOFACT. Here are the practical ways it works for you: Suspect a tube? Diagnose and replace the defective tube in seconds—the tube location chart shows you which one and where. Operating voltages correct? The exact answers are right on the schematic—available at a glance. Need fuse replacement? The answer's right on the tube location guide. Defective component? There's the right replacement in the parts list. For these and a hundred other problems, PHOTOFACT provides the instant, correct solution. That's why the experts use PHOTOFACT—the practical way to save time and earn more.



Yes, your PHOTOFACT Service Data is the ONE TOOL YOU'LL USE ON EVERY SERVICE JOB

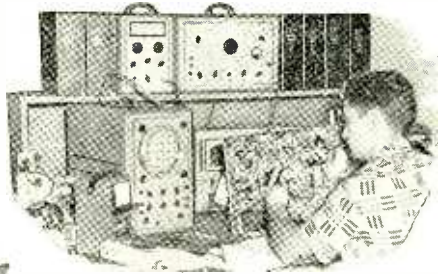

if you're not using the Expert Way—we'll prove you'll save time and earn more with PHOTOFACT service data

FREE SERVICE TECHNICIANS HERE'S OUR OFFER:

We'll send you any Photofact Folder listed in the "PF INDEX and Technical Digest." If you haven't an Index, get a Free copy from your local Photofact distributor or write us for it today. To obtain Free Folder, be sure to state Photofact Set and Folder Number exactly as shown in the Index.

NOW—learn for yourself how PHOTOFACT makes your TV and Radio repair work quicker, easier, more profitable. We want you to get and use an actual PHOTOFACT Folder. We want you to know why over 35,000 expert service technicians count on this invaluable data daily—count on it for successful, profitable business. Get your FREE Folder now. Examine, compare. Then try the Expert Way on your very next job. You'll discover why you can't afford to be without PHOTOFACT!

NOTE: Our FREE Folder offer is limited to Service Technicians only. Attach coupon to your letterhead or business card, and mention your jobber's name. Experimenters and others may obtain the Photofact Folder by remitting amount shown below.

HOWARD W. SAMS & CO., INC.

HOWARD W. SAMS & CO., INC.
2205 E. 46th St., Indianapolis 5, Ind.

I am a Service Technician. Send me Free Folder No. which appears in Photofact Set No. (as listed in the PF Index).

I am an Experimenter. Enclosed \$ Send Folder No. which appears in Photofact Set No. (TV—\$1.00. AM/FM—50c. Record Changer or Communications Receiver—75c).

Name
Address
City Zone State

EASY PAY PLAN!

PAY AS YOU EARN! Ask your distributor about this desirable plan. Only \$18.39 puts the entire profit-boosting Photofact library in your shop now!

NOVEL ELECTRONIC TIMER

The average electronic timer described in this and other magazines usually has a maximum timing range of a little over 2 minutes. Longer-timed intervals are often desirable when the equipment is used to control electric motors, heat lamps, and other appliances. One timer designed for long periods was described in the article "Long-Period Radio Timer" in the August issue. Another circuit of this general type but of different design is reprinted here from *Radio Constructor* (London, England).

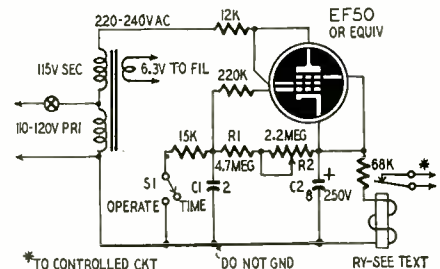

The original circuit uses a EF50 tube, but a 6AC7 or similar pentode may be used. To operate the timer, throw S1 to OPERATE and close the line switch. After the tube has warmed up, throw S1 to TIME. The tube operates as a half-wave rectifier which charges C2. As the voltage across C2 increases, a current flows through R1 and R2 to charge C1. The charge on C1 makes the grid more negative with respect to the cathode. This bias reduces the current through the tube and thereby reduces the charging rate of C2. The current through the relay increases as the charge on C2 increases. The contacts close when the relay current is slightly more than 1 ma.

The timing circuit consists of C1, R1, and R2. The values shown provide for a maximum time cycle of 5 minutes. The time can be increased to 15 minutes or more by using larger values for R1. R2 is the vernier time control. Its dial may be calibrated in minutes and fractions thereof. To cover a range of time cycles, R1 may be replaced by a tap switch and several fixed values offer selection to give the required range to R2. A telephone-type relay with a 40,000-ohm coil and contacts which close at about 1 ma was used in the original model. If you use a relay having a lower resistance but equal sensitivity, compensate for the lower resistance by increasing the value of the series resistor.

The unit is powered by a half-wave power transformer with the primary and high-voltage secondary connected in series aiding to give approximately 220-240 volts. C2 should be an oil-filled paper capacitor selected for a high internal resistance.

VIDEO COMPENSATOR

Simple combinations of resistance and capacitance can be used to improve picture detail in TV receivers which do not pass the higher video frequencies. However, it is quite a problem for the average service technician to find the right R-C combination.

ACCEPT NO SUBSTITUTE!

INSIST ON THE ORIGINAL

precise
INSTRUMENT KITS

THE HIGHEST QUALITY INSTRUMENTS IN KIT FORM

Watch for...

The NEWEST PRECISE KIT, at your distributors next month... the finest OSCILLOSCOPE you ever hoped to buy in kit form. Never before, a "scope" kit so ingeniously engineered!

THERE'S NO SUBSTITUTE BECAUSE:

PRECISE uses NO SURPLUS — only the finest components used to achieve precision-engineered products in kit form. PRECISE offers an iron-clad guaranty with every purchase. No other test instruments in kit form can offer as much accuracy, dependability, quality or value. AND PRECISE gives you an instructively illustrated, 3 color, "step-by-step" construction book — the most comprehensive in the market today!



PRECISE TEST EQUIPMENT AVAILABLE IN KIT AND WIRED FORM



MODEL 630 RF-AF-TV AND MARKER GENERATOR. For the first time in the history of the industry... SO MUCH FOR SO LITTLE! 110 MC on fundamentals, 330 MC on harmonics; Pre-tuned RF (within 1% head); AF from 20 to 20,000 cycles; variable % and Ext. Mod.; Cathode Follower and Constant Z output; Stepping Attenuator; Speech Amp.; Xtal Marker with Amp. control; RF and AF Standby; Wien Bridge AF; Colpitts RF; illuminated Drum Dials; Coax outputs; Separately tuned coils; Filtered AC; Vernier tuning; Separate RF; Shielded; 8" x 11" x 5"; Etched panel.

*Model 630KA \$38.95 (pre-assembled head) Model 630K \$33.95
Model 630W \$53.95 (Factory wired)



MODEL 999 HIGH VOLTAGE PROBE. Designed for high voltage measurements with special emphasis on Safety, Operational Simplicity and Rugged Construction. Exclusive Features: MULTIPLE INSULATION, MECHANICALLY SHOCKPROOF; CHANGEABLE TIPS; SWIVEL connection. Odds are billions of billions to 1 that no breakdown will occur! INTERCHANGEABLE RESISTORS . . . Wired Only \$4.98



MODEL 635 UNIVERSAL AF SINE, SQUARE AND PULSE GENERATOR. For accurate testing audio and video circuits. 1% Ceramic precision resistors; Wien Bridge; variable Z and cathode-follower output; minimum overshoot and roundoff through 100,000 cycles; sine waves through 200 KC. Factory wired \$52.50 \$33.50

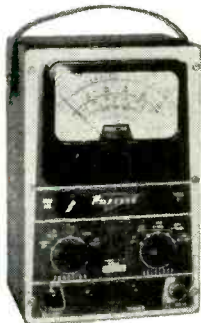

MODEL 909 VACUUM TUBE VOLTMETER. 1% Ceramic precision Resistors; Coax DC connector; FM zero alignment scale; burn-out proof circuit. Rugged oversize 4 1/2" meter \$25.98
Factory wired \$44.98

FOR COMPLETE LINE OF PRECISE KITS MAIL COUPON BELOW

MODEL 912 RF PROBE. LOWEST PRICED, factory wired Probe in the industry. Individually calibrated at 75 MC for accuracy, impedance and shunt capacity. Wired Only \$4.25

MODEL 960 CAPACITY ATTENUATOR PROBE. Reduces input C. and loading effects of an oscilloscope by 10 to 1. Adjustable for any scope. Lowest priced in the field, but still using highest quality components. Wired Only \$5.95



MODEL 610 RF SIGNAL GENERATOR. The lowest priced signal generator in the field offering—Same RF head as Model 630; 110 MC on fundamentals; 330 MC on harmonics; 60 and 480 cycle AF; Cathode-follower output; Ext. Mod.; Speech Amp.; Individually tuned coils.
Model 610KA \$28.95 (pre-assembled head) Model 610K \$23.95
Model 610W \$39.95 (wired)

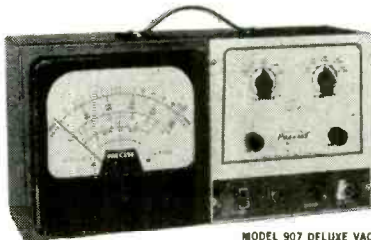

MODEL 907 DELUXE VACUUM TUBE VOLTMETER. Another PRECISE first! Vertical or Horizontal construction. GIGANTIC 7 1/2" meter movement; all the unusual values and features of Model 909 in a really DELUXE version \$38.98
Factory wired \$57.98

Prices slightly higher in the West. Prices and specifications subject to change without notice.

precise DEVELOPMENT CORP.
OCEANSIDE, NEW YORK

PRECISE DEVELOPMENT CORP. Dept. RE-12
999 LONG BEACH ROAD • OCEANSIDE, L. I., NEW YORK

GENTLEMEN: Without any obligation on my part, kindly send me the following:

- PRECISE CATALOG
- NAME OF DISTRIBUTOR NEAREST ME

NAME _____
ADDRESS _____
CITY _____ ZONE _____ STATE _____

TV DIRECT FROM THIS GREAT FACTORY TO YOU

BRINGS YOU
Finest Quality at Lowest Prices

TRANSVISION

TV KITS, WIRED CHASSIS, and SETS
CABINETS, COMPONENTS, INSTRUMENTS, and ACCESSORIES
MAKE MONEY

on Top Quality TV Picture Tubes:

- **TRADE-IN ALLOWANCE**
Make from \$2.00 to \$5.00 glass allowance on each "dud."
- **FULL 2 YR. GUARANTEE:**
Only Transvision gives you a Guarantee for 24 months.

FREE BOOKLET: "INSIDE CRT, or What You Should Know About Picture Tubes." Written by CRT experts, illustrated. It will **MAKE MONEY** FOR YOU. WRITE FOR IT NOW.

FREE CHART: Write for Picture Tube Interchangeability Chart.

COMPARE: Get the full details on the Transvision tube deal today.



New . . . TRANSVISION Picture Tube PRICES

Tube Type	Cost, WITH GLASS allowance	Cost, WITHOUT GLASS allowance
10BP4	\$11.80	\$13.80
12½" Glass (any type)	13.45	15.75
12½" Metal (any type)	14.95	16.25
14RP4	16.50	18.25
16" Metal (any type)	19.90	23.20
16" Round or Rect. (any type)	18.90	22.25
17BP4	18.90	22.25
19" Metal or Glass (any type)	23.95	28.95
20CP4	26.95	31.95

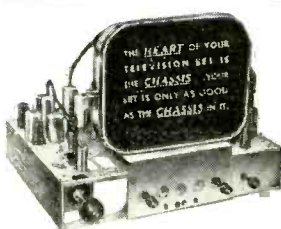

Sensational Offer:
TV \$39
KITS DOWN*

Build World's Finest Chassis—the A4

***BUILD THE FINEST CHASSIS MONEY CAN BUY** with the famous A4 Kit by Transvision. **PAY AS YOU WIRE**—only \$39 for the starting package. Easy to assemble, enjoyable, educational—gets you the most superb TV set imaginable. Easiest to service, too. Don't put it off. With these easy terms you can get started now. Also **WIRED CHASSIS** at LOW COST. The A4 in completely wired chassis form gives you the world's finest TV set, with latest circuits and extra sensitivity for fringe areas. Gives clearer, brighter picture. Easy to service and keep up to date; built to last for years. Write for amazing low prices.

SIZES: The A4 Kit and Wired Chassis are available in 17" and 20" sizes. Also with **REMOTE CONTROL**.

BEAUTIFUL TV CONSOLES
Ideal for Custom-Building or Conversion. Factory prices start from \$49. Send for Cabinet Catalog now.

MULTI-SET CONNECTORS
feed up to 5 TV Sets from 1 Antenna
Prices: Multi-Set Conn. for 2 sets . . . \$4.95 list*
For 3 or 4 sets . . . 7.95 list*
*Dealers, write for discounts



U. H. F. ADAPTERS
will be available for all Transvision Sets and Kits.

Write for Transvision's Factory Agent Plan and complete literature

FREE: EXTRA INCOME EVERY MONTH from hints in "TV and Electronics Notes." Request and send 50¢ to cover cost of plate and mailing for FREE. Monthly issues are gold mines of info on New Products, Sales, Conversion, etc. **WRITE DEPT. RE-12 TODAY!**

TRANSVISION, INC. NEW ROCHELLE, N. Y.

The schematic shows how a four-step video compensator can be added to the 630 and similar receivers. The ceramic rotary switch and all components must be shielded and located as close as possible to the video output stage to reduce stray circuit capacitance.

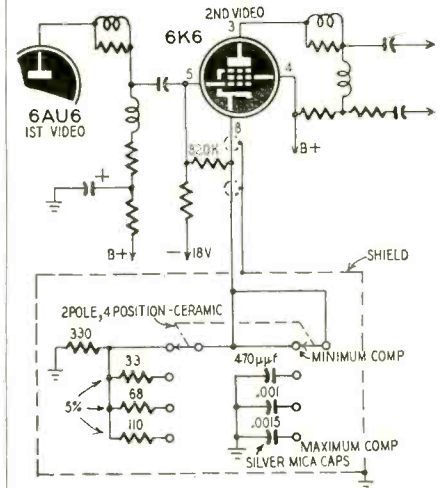

If the receiver to which compensation is to be added has the contrast control in the cathode of the video output stage, try switching different values of capacitance across it. The results will probably provide a pleasing surprise.—*Wilbur Hantz*

CARRIER-CURRENT RIG

This carrier-current transmitter is easy to construct and provides excellent communication within a radius of two or three blocks from the station. The transmitter uses a 6V6 variable-frequency oscillator modulated by a 6V6 driven from a carbon microphone. If greater output is required, use a 6L6 in the oscillator stage and raise the voltage to about 300.

L1 is a standard 2.5-mh r.f. choke tapped one-fourth the way up from the ground end. Plate coil L2 is 185 turns of No. 28 wire closewound on a ½-inch form. The plate circuit is fixed-tuned with a 900-µf mica capacitor. L3 is 20 turns of No. 28 wire closewound on a ½-inch form loosely coupled to L2. The

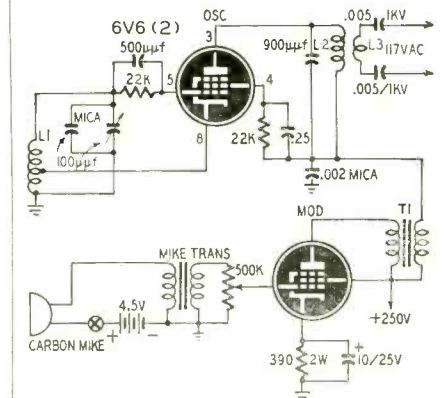

coupling between L2 and L3 should be as loose as possible with good readability and range. T1 is a universal modulation transformer rated at about 10-15 watts. A 100-ma filter choke of about 200 ohms can be substituted.

The transmitter operates at about 190 kc. We use Hallicrafters S-22R receivers for reception. The antenna terminals are connected to the power line through .005- μ f, 1,000-volt transmitting-type mica capacitors.—George R. Anglado

[If the Hallicrafters S-22R receivers are not available for reception, you will probably find suitable substitutes on the surplus market. There are a number of marine, navigation, and aircraft receivers which cover the desired tuning range. Among these are: the BC-1206 (195 to 420 kc), the Navy's ADF model (15 to 1750 kc), Navy type ARB (195 kc to 9 mc), ARC-429A (200 to 400 and 2000 to 4700 kc), and the R-2/ARN-7 (250 to 1750 kc).—Editor]

SQUARE-WAVE DEVICE

This new multivibrator-type square-wave generator, described in U. S. patent No. 2,605,403 issued to Lawrence H. Crandon, provides output pulses whose amplitude is substantially equal to the supply voltage and whose rise and decay characteristics are very steep.

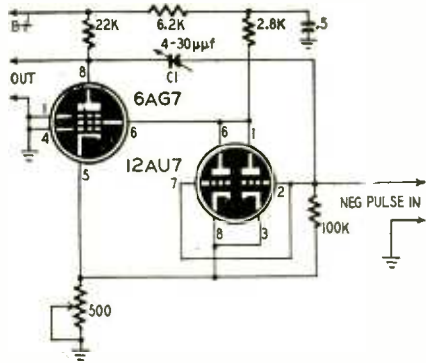

The diagram shows a practical circuit based on the patent. The 6AG7 is normally cut off and the triode is normally conducting. A negative pulse applied to the input terminal reduces the 12AU7 plate current and causes the plate voltage to rise. The decrease in plate current reduces the voltage drop across the cathode biasing resistor common to both tubes. The decrease in cathode bias makes the 6AG7 control and suppressor grids more positive (less negative) with respect to the cathode. At the same time, the increase in 12AU7 plate voltage has made the 6AG7 screen voltage more positive with respect to the cathode. The abrupt change in 6AG7 potentials causes it to conduct suddenly. Its plate current rises and makes the triode grid still more negative. This action is cumulative until the triode cuts off and the pentode is conducting heavily.

Coupling capacitor C1 begins to charge through the 100,000-ohm resistor, and the 12AU7 grid becomes more positive. This action continues until the triode again conducts. The triode plate current increases the drop across the cathode resistor and makes the 6AG7 control and suppressor grids more negative. Simultaneously, the drop in triode plate voltage makes the 6AG7 screen less positive. These changes continue until the 12AU7 is again fully conducting and the 6AG7 cut off. END

Service men — BOOST YOUR INCOME —
SAVE HUNDREDS of DOLLARS
 —these TRANSVISION Instruments are real necessities—a "must" for your shop if you are not to throw good money away.

Here's why: —

1. **TESTING**—you can accurately test Cathode Ray Tubes.
2. **REACTIVATING**—you can save many dim or worn out tubes by reactivation.
3. **SPARKING OUT ELECTRICAL LEAKAGE** — many Cathode Ray Tubes develop electrical leakage. This can now be repaired.

CRT TESTER-REACTIVATOR-SPARKER

3 instruments in 1, making a complete CRT testing and repair unit. Compact, dependable, profitable.

It's a combination of the Transvision **TESTER-REACTIVATOR** plus a **SPARKER** in one handy instrument. It **TESTS PICTURE TUBES**—measures Cathode emission, locates shorts between elements, locates high resistance shorts or leakage as high as 3 megohms. **REACTIVATES DIM TUBES. SPARKS OUT ELECTRICAL LEAKAGE** in picture tubes. Fully Guaranteed.

\$34⁹⁵ net



CRT TESTER-REACTIVATOR

2 Instruments in 1. As a **REACTIVATOR** it renews brightness, sharpness, and detail of old dim CR Tubes, without removal of tube. It's also an accurate **TESTER**: Measures Cathode emission, locates shorts between elements, locates high resistance shorts or leakage as high as 3 megohms. 110V-60 cycles; wt. 3 lbs. Fully Guaranteed.

\$19⁹⁵ net

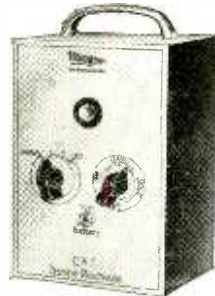

CRT TESTER-SPARKER

2 Instruments in 1. As a **PICTURE TUBE SPARKER**, it sparks out electrical leakage between elements. Saves many picture tubes and small tubes which would usually be discarded. Cathode-grid leakage is an especially common occurrence. The **Sparker** also gives a rapid check of gas condition of the tube.

As a **TESTER** it provides a variable 8,000-14,000 D.C. supply—useful for analyzing hard-to-solve deflection problems. Fully Guaranteed.

\$25⁹⁵ net



FIELD STRENGTH METER for better TV installations.

Make more efficient, more profitable TV installations, and save half the work, with the Transvision Field Strength Meter. Especially good for fringe areas—measures field strength as low as 10 microvolts. A great buy at this low price.

\$59 net



Model FSM-1, complete with tubes

Order direct from **TRANSVISION, INC.**, New Rochelle, N. Y.

RUSH THIS COUPON

TRANSVISION, INC., Dept. RE-125 NEW ROCHELLE, N. Y.

Please send

\$.....deposit enclosed; send C.O.D.in full enclosed; send prepaid.

Name..... Address.....

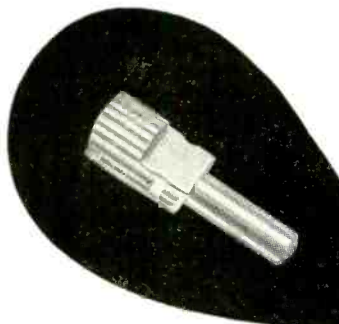

fit the right shaft
to the right
wire-wound control—
YOURSELF!

Immediately, conveniently, correctly, economically.

Just select the Clarostat wire-wound control for your electrical needs. Then select any one of 12 Pick-A-Shaft types (or even a high-voltage coupler or nylon shaft) meeting your shaft needs. A slight tap joins them together—rigidly, permanently, satisfactorily. Ideal for radio-TV and industrial purposes.

It's another Clarostat first! These new Clarostat A43, A58 and A10 wire-wound controls take field-attached shafts. And remember, only Clarostat offers 2-, 3- and 4-watt wire-wound controls.

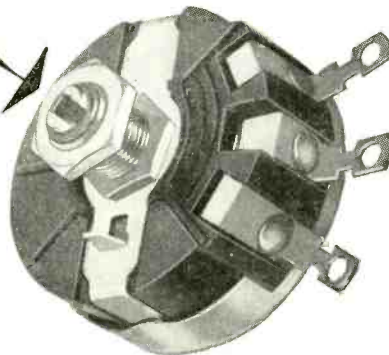

ASK YOUR CLAROSTAT DISTRIBUTOR
for these new Pick-A-Shaft wire-wound controls.
Ask for new catalog—or write us.



Controls and Resistors

CLAROSTAT MFG. CO., INC., DOVER, NEW HAMPSHIRE

In Canada: Canadian Marconi Co., Ltd., Toronto, Ontario

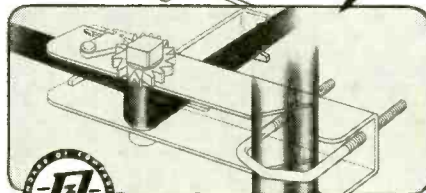
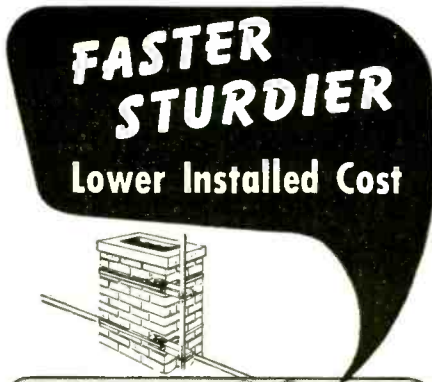

RADIART SPEE-DEE

CHIMNEY MOUNT

Model AK 85 The fastest-installed chimney mount ever devised for TV antennas! Rugged in design—simple to install. Simply thread strapping through ratchet, around chimney and back through ratchet—wind up ratchet tight—and the job's done! Heavy gauge, zinc-plated steel with large "U" bolt for up to 1 3/4" O.D. mast and full length galvanized steel strapping.

THE RADIART CORPORATION
CLEVELAND 13, OHIO

SATISFACTION
Guaranteed
OR MONEY REFUNDED!

Budget-minded radio men like
to do business with STEVE-EL

Manufactured under license
by RCA. RMA Guarantee
on all parts and ONE FULL
YEAR guarantee on picture
tube.

STEVE-EL TELEVISION SETS

STEVE-EL Television sets work where others fail because they are built of the finest materials and designed by top electronic engineers. Standard COIL CAS-CODE TUNER makes them perfect for fringe area reception.

Features:

- * Standard coil Cascode tuner. * Large Hi-Fi speaker. * Hand rubbed, stain finished genuine mahogany cabinet.
- * AGC. * Moulded condensers. * Picture tube. * Adaptable for UHF and color. * Synchronized FM audio system. * Factory wired, aligned and tested. * Mounted in cabinet.

Send for **LATEST**
"BARGAIN BOOK"

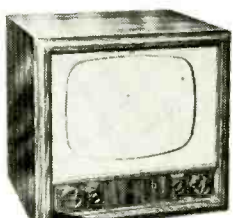

17" TABLE MODEL
\$153
COMPLETE

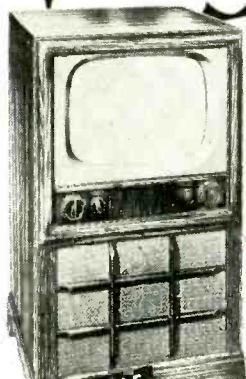

17" CONSOLE
\$171
COMPLETE

20" Console — \$191.00
21" Console — 214.00

20" Table Model—\$179.00
21" Table Model— 189.00

STANDARD BRAND
Guaranteed TUBES

Each Individually Boxed

(Manuf. of tubes refuses permission to mention name because tubes are FAR BELOW FAIR TRADE).

1A7	.89	6BH6	.86	12AU7	.89
1B3	.97	6BK7	1.23	12AV7	1.09
1H5	.76	6BQ6	1.31	12AX7	.99
1N5	.79	6C4	1.29	12BA6	.69
1S5	.79	6C7	.54	12BE6	.69
1T4	.79	6C86	.79	12BH7	.99
1U5	.79	6CD6	2.39	12SA7	.79
1X2A	.78	6J5	.59	12SK7	.77
3Q4	.94	6J6	.94	12SN7	.77
3Q5	.89	6K6	.64	12SQ7	.84
3V4	.91	6K7	.74	14A7	.68
5U4	.73	6SA7	.76	14B6	.84
5V4	.69	6SH7	.79	1486	.94
5Y3	.97	6SJ7	.78	25BQ6	1.49
6AC7	.49	6SK7	.76	25L6	.69
6AG5	1.08	6SL7	.91	25W4	.78
6AH6	.86	6SN7	.86	25Z6	.67
6AK5	1.29	6S07	.69	35L6	.86
6AL5	1.39	6T8	.99	35W4	.52
6AQ5	.68	6V6GT	.72	35Z5	.51
6AT6	.69	6W4	.69	50A5	.96
6AV6	.68	6X5	.59	50B5	.69
6AU6	.61	7C5	.74	50C6	.66
6BA6	.69	7F7	.84	50L6	.69
6BC5	.69	7K7	1.09	117Z3	.64
6BE6	.89	7N7	.84	117Z6	.93
6BG6	.79	12AT6	.65	117P7	1.69
	1.91	12AT7	.99		

Above Only Partial List of Tubes—
Send for complete list.

STEVE-EL ELECTRONICS CORP.

VISIT OUR
NEW STORE

Dept. E-12 61 Reade St., New York 7, N. Y. COrtlandt 7-0086

TV ANTENNA MODIFICATION

A great many of the older TV antennas consist of a dipole and reflector cut for channel 4 or 5. The bandwidth and the gain on the high channels can be greatly increased by converting them to double-vee types which provide a good match to 72- or 300-ohm transmission lines. You can use this same trick to improve some conicals.

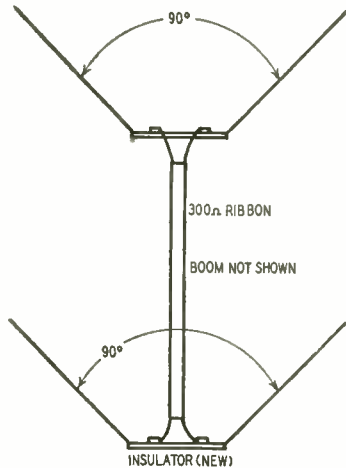

Bend the radiator dipole forward so there is a 90° angle between the ¼-wavelength elements. The reflector is usually one solid length of tubing or two pieces joined by a metallic block. In the latter case, replace the metal block with a piece of heavy plastic or fiber of the same size. If solid tubing is used, cut it in the center and mount the two pieces on a block of insulating material with the two inside ends 2-3 inches apart. Bend the reflector elements forward so they form a 90° angle. Now, connect the reflector and radiator together with a piece of 300-ohm transmission line as shown in the drawing.

The lead-in can be connected to either member of the antenna. Better try both connections if you are troubled with ghosts.—Hyman Herman

MINIATURE PLUG-IN COIL FORMS

Miniature polystyrene plug-in coils are useful and efficient in u.h.f. circuits. Unfortunately, coils are hard to assemble on these forms because heat from a soldering iron softens the plastic and distorts the pin mountings before sufficient heat can be applied to form a good joint. You can make low-loss forms which solve the problem of soldering and are less expensive than commercial forms.

Obtain a length of 5/8-inch inside-diameter polystyrene tubing and cut it to the desired length. Fit an Amphenol miniature 4-prong chassis plug into one end of the tubing and use coil cement or screws to hold it in place. The plug-in coil form thus made fits a 4-contact miniature socket. Using bakelite in the base and socket causes slightly higher r.f. losses than an all-polystyrene form and socket, but does simplify soldering problems.—I. Queen

DECEMBER, 1952

the most powerful
TV antenna ever made

**22 DB GAIN
OVER A TUNED DIPOLE**

- ✓ 10 times more powerful than stacked ten element yagis.
- ✓ Motorless ALL directional and broad band VHF-UHF reception.
- ✓ Extends fringe area reception an additional 40 miles.
- ✓ Nine antennas in one — select antenna direction by flip of a switch located near the television set.
- ✓ Pre-assembled flip out symmetrical construction.
- ✓ Patented and manufactured by All Channel Antenna Corp.—Pat. #2,585,670—2,609,803.
- ✓ Ask your local jobber for literature . . . and see the All-Channel Antenna, now on display.

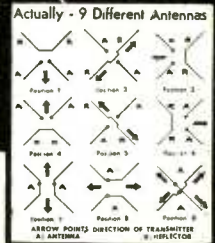
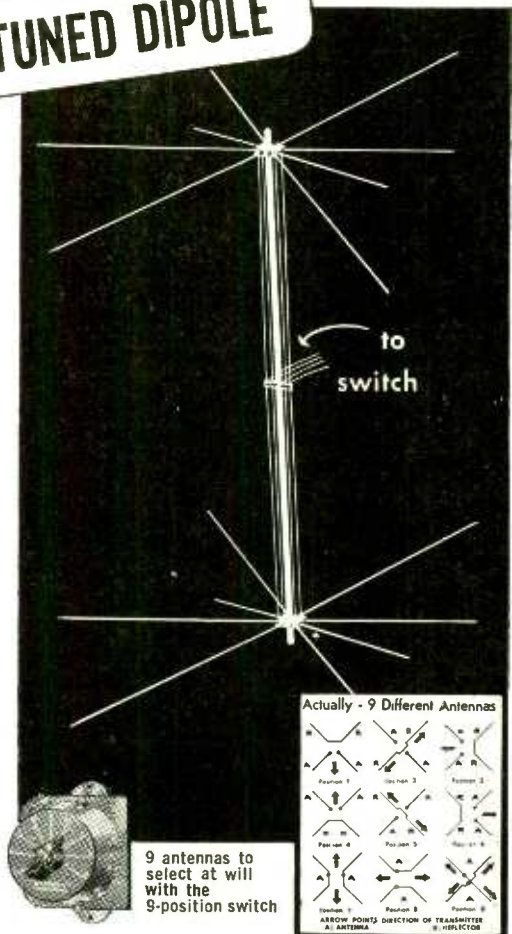

ALL CHANNEL ANTENNA

CORPORATION

70-07 QUEENS BLVD.

WOODSIDE, N. Y.

Beams the TV Set direct to the signal without a rotor, without moving parts. Brings in the best possible signal from any direction.

PRES-PROBE CONDENSER TESTER



Finds Intermittent Condensers Instantly

Pres-probe's sliding tip with variable resistance prevents condenser heating. Tests with power on. Requires no adjustment. Stops guesswork. Saves time. Convenient probe size (7/8" long). Satisfaction guaranteed.

795
NEF
Postpaid U.S.A.

See Your Dist. or Order Direct

PRES-PROBE CO.

4034 N. Sixth St., Milwaukee 12, Wis.

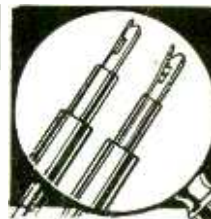

LOOK! KLIPZON FREES BOTH HANDS!

- UNIQUE SELF-HOLDING POINTS . . . bring new convenience and timesaving to service work.
- ★ V.H.F. CRYSTAL PROBES
 - ★ ADAPTORS
 - ★ STREAMLINED TEST PROBES
 - ★ CONNECTORS
 - ★ LOW LOSS — LOW CAPACITY LEADS
- See KLIPZONS at your distributor. Send for FREE folder #41.

UNITED TECHNICAL LABORATORIES
Engineers • MORRISTOWN, N. J. • Manufacturers

BANDSWITCHING COILS

Many experimenters and constructors claim that it is impossible to construct an efficient bandswitching superhet with homemade coils, without using a Q meter, grid-dip oscillator, and other laboratory type equipment. However, I find that almost anyone can do a good job of winding coils that track properly without using special equipment if he has the time and patience.

To avoid the seemingly endless job of soldering and unsoldering circuit leads each time I want to change the number of turns on a coil, I rig up a temporary plug-in circuit on the receiver. Sockets for plug-in coils are mounted on standoffs above the chassis, and five small holes are drilled in the chassis for leads.

When my experiments show that I have the correct number of turns and spacing for good tracking, I wind duplicate coils on forms of the same diameter and wire them permanently into

the circuit. The coils are mounted in space reserved for them near the band-switch. Completing the coils for all bands, I remove the coil sockets, leaving only a few small holes that are hardly noticeable when the job is completed. —B. W. Welz

NEAT PANEL MARKINGS

One of the most difficult problems in the construction of instruments and apparatus is providing neat, legible markings for controls. An excellent way of simulating expensive silk-screen printing, even on wrinkle-finish cabinets, is as follows:

Pencil in the desired legend; then carefully letter over this with photographic-album inks in white, yellow, etc. Allow the lettering to dry and then go over it as many times as necessary to get full rich colors. Shake the ink often to keep the solid pigments in solution. When finished, apply a coat of colorless fingernail polish or lacquer

(thin coil cement will do) over the lettering.—H. Zave

(If your hand is as shaky and your lettering as poor as ours, you will be able to do a much better job of labeling a panel with Millen Panel Marking Transfers or Tekni-Cals marking decals.—Editor)

MORE HINTS ON WELLER IRONS

Weller and other similar quick-heating soldering irons are handy for removing metallic filings and chips from radio chassis.

When using irons of this type for any purpose, take care not to bring the tip too close to the magnets in meters, headphones, and other delicate instruments. There is a strong magnetic field around the tip of these irons when they are on. Failure to observe these precautions may demagnetize the magnets and affect the calibration and sensitivity of magnetic measuring instruments.—O. C. Vidden

BUY WITH CONFIDENCE FROM EDLIE

#630 SUPER DELUXE 31-TUBE TV CHASSIS

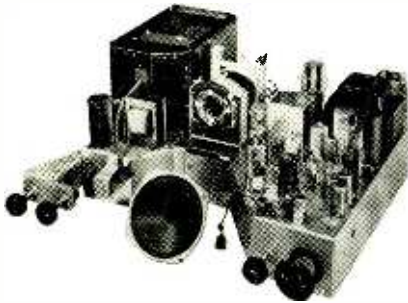

W-22", H-10 1/4", D-17", shipping weight 72 lbs.

NATIONALLY KNOWN MFR.

Licensed under RCA patents

OPERATES ALL 16" TO 24" PICTURE TUBES

Engineered in strict adherence to the genuine RCA #630, plus added features ★ ★ ★ ★ ★

NOTHING BETTER AT ANY PRICE!

- Standard Cascode Turret Tuner for DX
- Cosine 70° Deflection Yoke for Definition
- Original 630 Synch. Chain for Stability
- 16 KV for Clarity and Brilliance
- Fast Action Pulse Keyed AGC
- High Fidelity 12" PM Speaker

COMPLETE READY TO PLAY

with all tubes, hardware, universal mounting brackets, etc. (less C.R. Tube)

\$159.50

Dress Up Your Home With This



Consolette Cabinet of Artistic Design. Size 40" high x 26" wide x 23" deep. Price including mask and excise tax **\$49.95**

Extra for glass\$2.75

ONE YEAR GUARANTEE FINEST STANDARD GUARANTEED PICTURE TUBES ONE YEAR GUARANTEE

12 1/2" Black or White \$22.50	14" Glass Rect. Black \$23.50	16" Glass Round or Rect. \$22.50	17" Rect. Black \$24.50	19" Round Black \$34.50	20" Rect. Black \$34.50	21" Rect. Black \$36.50	24" Metal \$67.25
---------------------------------------	--------------------------------------	-----------------------------------------	--------------------------------	--------------------------------	--------------------------------	--------------------------------	--------------------------

\$ \$ \$

MONEY SAVER KITS FROM EDLIE ELECTRONICS

\$ \$ \$

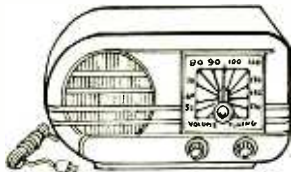

5 TUBE AC-DC SUPERHET KIT

Kit #1—Five Tube superheterodyne kit, A.C.-D.C. contains all components required to construct this latest design, highly sensitive superheterodyne broadcast receiver complete with black bakelite cabinet (excludes wire and solder)Price **\$7.95**

Extra for a kit of 5 tubes (12AT6, 12BA6, 12BE6, 35WA, 50C5). Price \$3.25.

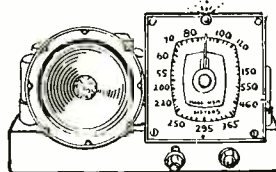

6-TUBE KIT

Kit #2—A low-priced 6 TUBE KIT designed for high sensitivity, excellent selectivity and good tone quality. Uses 25L6, 25Z6, 6SQ7, 6SA7, 6SK7, 6SK7 in an easily constructed circuit. The 6 Tube Kit is shipped with all parts, including punched chassis, resistors, condensers, coils, sockets, PM Speaker, hardware, etc.

And at a closeout price of only (less tubes and cabinet) **\$6.95**
Extra for matched set of six tubes for kit **\$3.25**

Electronic Code Practice Oscillator & Blinker Kit AC/DC or Battery Operated!

Kit #3—One of the most practical Code Practice Oscillators ever designed, yet one of the simplest to build and operate. Can be used with any number of headphones. Adjustable Pitch Control—Any type of headphone can be used. No warmup time—ready to operate instantly. Simple and safe to operate. Operates anywhere—with AC or DC power, or from a 90 volt Miniature Battery. Learn Blinker Code with flashing light. Blinker can be used as signaling device. International Morse Code included.

Kit each **\$1.95** Assembled **\$2.95**

Kit #4—Basic 1 tube training kit. Simple to construct complete with all parts one tube and headset diagrams and instructions included. Use 1-354 tube and a 67 1/2 volt Battery. Price—**\$3.95**
Kit #5—2 tube Amplifier Kit complete with 50L6, 35Z5, and 4" PM to convert Kit No. 1 to a 3 tube set for loud-speaker operation **\$4.95**

THREE TUBE PHONO AMPLIFIER

Not a Kit!
An assembled unit ready for installation using tone and volume control and six feet of rubber cord **\$2.95**
..... (Not including Tubes)
With Complete Set of Tubes\$3.95

PHONO OSCILLATOR

Not a Kit!
Wireless phono oscillator transmits recording for crystal pickups or voice from carbon mike through radio without wires. Can also be used as an intercom by using P.M. speaker as mike. Price (excluding 2" tubes) **\$2.95**
With Complete Set of Tubes\$3.95

Satisfaction guaranteed on all merchandise. All prices subject to change without notice.

WRITE FOR FREE CATALOG

EDLIE ELECTRONICS • 154 Greenwich St. • New York 6, N. Y.

HANDY CONNECTORS

Several pairs of connectors like those in the photo are handy for making experimental hookups, connections to test instruments, and temporarily substituting a good part in place of a defective one. A 2-inch alligator clip is placed on one end of a length of test lead wire

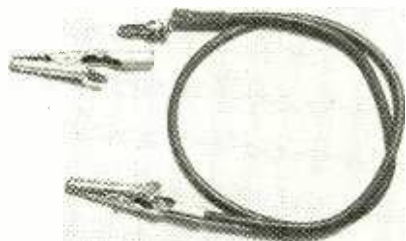

and a banana plug is placed on the other. This will plug into the end of another alligator clip or will fit banana jacks on test equipment. The size and types of jack and plugs and the length and color of test lead wire can be selected to meet individual requirements. —R. Sandretto

TV FRONT-END ALIGNMENT

Be careful when applying coil dope or other cements to lock adjustments of the front-end tuning slugs or capacitor screws. Leave the scope, sweep generator, and set operating when applying dope. Allow dope to dry before removing scope and the balance of the test equipment. Some cements contract slightly on drying and may alter the setting of the tuning slug or may run between the plates of the capacitor. The scope and sweep generator will show the slightest change in alignment as the dope dries so you can compensate for it before the settings are sealed tight. —John Crouch

MOUNTING TRANSFORMERS

When assembling radio and electronic equipment, it is common practice to mount half-shell and full-shell power transformers with the core and top shell above the chassis. This practice often increases the above-chassis height of the instrument and makes it necessary to use an unusually high cabinet.

To reduce above-chassis height, try mounting the transformer so its core is below the chassis and the top shell is above it. This reduces the above-chassis height of the transformer by the thickness of its core.

If the chassis is heavy steel, this method of mounting may eliminate some of the difficulties caused by the magnetic field around the core. The chassis serves as a shield which keeps the magnetic field below it so there is less likelihood of hum being induced in input transformers, cathode-ray tubes, and other hum-sensitive components.

If the magnetic fields around the power transformer or filter choke cause hum voltages to be induced into sensitive circuits, try rotating the troublesome component to find the position where hum is minimized before mounting it permanently in position. —John Sareda

END

STANDARD BRANDS TUBES INDIVIDUALLY BOXED
STANDARD WARRANTY New Low Prices BRAND NEW!!

0Z4 \$.49	5Y3G35	6BA649	6F6GT49	6W4GT49	19T879
1B3GT79	6AB455	6BA769	6H651	6W6GT59	25AV5GT . .95
1L459	6AC789	6BC559	6J5GT49	6X444	25B6GT . .98
1R559	6AG559	6BE652	6J669	6X5GT39	25L6GT . .49
1S469	6AG795	6BF563	6K6GT49	12AT642	25Z6GT . .45
1S559	6AH695	6BG6G 1.69	6L6GA95	12AT769	35B555
1T459	6AK585	6BH665	6SA7GT55	12AU649	35C555
1U463	6AL549	6BJ655	6SC769	12AU759	35L6GT . .55
1U555	6AQ549	6BL789	6SF552	12BA649	35W437
1X2A72	6AQ645	6BN685	6SH759	12BE652	35Z5GT . .35
3Q468	6AR549	6BQ698	6SJ749	12BH774	50B555
3Q5GT65	6AS556	6BQ798	6SL7GT59	12SA7GT56	50C555
35459	6AT641	6C444	6SN7GT66	12S6GT55	50L6GT . .54
3V459	6AU649	6C551	6SO7GT45	12SK7GT57	117N7GT 1.35
5T41.19	6AV5GT99	6CB659	6SR745	12SN7GT66	117P7GT 1.35
5U4G49	6AV641	6CD6G 1.65	6T879	12SO7GT57	117Z349
5V4G89	6B4G89	6E569	6V6GT51	19B6G 1.59	

Many other types equally low priced—include all your tube needs with your order. One of the largest stocks in the country!

Min. Order \$25.00. Terms: 25% with order, balance C.O.D.

All prices subject to change without notice. F.O.B. New York City. Mail order division.

Television Materials Corp.
 120 LIBERTY ST., NEW YORK 6, N.Y. • COlland 7-4307

RECENT BRITISH TECHNICAL PUBLICATIONS

- "AMPLIFIERS" by N. H. Crowhurst
64 pages, 38 diagrams.

"Contains more easily accessible information on amplifiers than any other this reviewer has seen." F. Shunaman in *Radio Electronics*, March, 1952.

- "FEEDBACK" by N. H. Crowhurst
64 pages, 38 diagrams.

"A new feat in audio literature. The practical technician and semi-technical 'hi-fi' fan will welcome this book." F. Shunaman in *Radio Electronics*, July, 1952.

- "MAGNETIC RECORDING" by M. L. Quartermaine
72 pages, 73 diagrams.

The theory, construction, and use of tape and wire recorders.

- "THE WILLIAMSON AMPLIFIER"
2nd Edition, 36 pages, 40 diagrams.

A reprint of the original articles in the *Wireless World* magazine and of subsequent papers by D. T. N. Williamson.

\$1.00 EACH

Postpaid U.S.A.-Canada (Trade Enquiries Invited)

SUBSCRIPTIONS TO BRITISH TECHNICAL PUBLICATIONS

- THE WIRELESS WORLD MAGAZINE. Britain's leading technical journal devoted to radio, television and electronics. Annual subscription \$4.50.
- THE WIRELESS ENGINEER. For research engineers, designers and students. Annual subscription \$7.00.

ORDER FROM

BRITISH RADIO ELECTRONICS, LTD.
 ONE THOMAS CIRCLE • WASHINGTON 5, D. C.

now...

a rear seat speaker for every model automobile



4"x6" speaker \$9.95 list

6"x9" speaker \$13.95 list

includes:

- ★ unique Aero-Tone design
- ★ 5 adaptor plugs — for every radio hook-up
- ★ plug adaptor at no extra cost
- ★ exclusive chrome-finished grille
- ★ many other outstanding features

featuring the OXFORD WEATHERPROOF SPEAKERS ORDER from your JOBBER TODAY!

Aero Manufacturing Co., Inc.
 4836 Joy Road — Detroit 4, Michigan

You can't keep up with u.h.f. TV without reading the articles in future issues of

RADIO-ELECTRONICS

WINCHARGER

NEW LOW COST TELESCOPING TV ANTENNA SUPPORT

Pat. Applied For
Wincharger... pioneer in guyed tower, presents a new design in HIGH QUALITY, RUGGED, DURABLE TV Antenna Support Masts at a budget price. Properly guyed, these masts will support large antenna arrays against high winds and heavy ice loads.

**SAFER
EASIER
FASTER**

Exclusive 3-Point SAFETY CLAMPING RING

with a smoother guying surface, provide maximum rigidity against tubes twisting and loosening inside each other due to high winds. Aids in erecting a straighter mast.



AUTOMATIC SAFETY CLIP



Assembly Tool. Snaps in place with a "click", warning that tube has been pulled out as far as it can safely go. Made of heavy-gauge spring steel wire. This is an exclusive Wincharger safety feature.

A WINCHARGER BASE FOR EVERY TYPE ROOF

Hinged Foot for flat and sloping roofs.

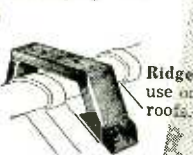

Ridge Straddler... for use on broad or ridged roofs, such as tile, etc.

Ridge Straps... A simple mounting where there is no ridge roll to bridge.



Sell WINCHARGER SAFETY and FASTER, EASIER INSTALLATION.
Sell WINCHARGER TELESCOPING TV ANTENNA SUPPORT MASTS

Order now from your jobber—or write for complete details

WINCHARGER CORPORATION
SIoux CITY 2, IOWA

30-50 MEGACYCLE CONVERTER

? Please print a diagram of a simple 30-50-mc front end that I can use ahead of a 10.7-mc i.f. strip.—E. J. U., Cleveland, Ohio

A. The circuit of a 1-tube converter is shown. Its oscillator operates on the low side of the signal frequency to provide greater stability and freedom from drift.

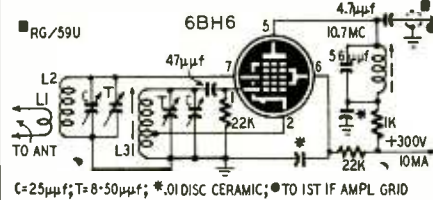

C=25µf; T=8-50µf; * .01 DISC CERAMIC; ● TO 1ST IF AMPL. GRID

A grid-dip meter should be used in adjusting the coils to cover the desired range. The oscillator tunes from 19 to 39.6 mc. The antenna circuit should tune from 29.7 to about 50.3 mc. L1 consists of 3 turns of No. 22 d.s.c. wire wound around the bottom end of L2. If you use a whip type antenna, omit L1 and use the R'9er type antenna input circuit shown in the converter described in the Question Box of the April, 1951, issue.

L2 consists of approximately 12 turns from a B & W type 3007 Miniductor. Cut it to about 16 turns and use a grid-dip meter to prune it to cover the desired range. L3 consists of 12 turns of No. 22 enameled wire wound on a National XR-50 or equivalent slug-tuned form and tapped 4 turns from the ground end.

Operating voltage for the converter can be obtained from the receiver or i.f. strip. The antenna and oscillator tuning capacitors may be a garged 25-µf unit if you have the equipment and patience to adjust the coils for good tracking. Otherwise, you can use separate controls with a vernier tuning dial on the oscillator control. The antenna tuning capacitor can then be used for peaking the signal.

PHILCO 49-901 CONVERSION

? I have a Philco model 49-901 receiver that I would like to convert from push-bar to variable-capacitor tuning. If this is practical, please print a diagram showing the changes which must be made.—V. T., No address.

A. The diagram shows the circuit of the converter stage arranged for continuous tuning. We are not sure that you will be able to use the present loop antenna with a standard 365-µf tuning capacitor. If the circuit does not track properly, try another loop. The

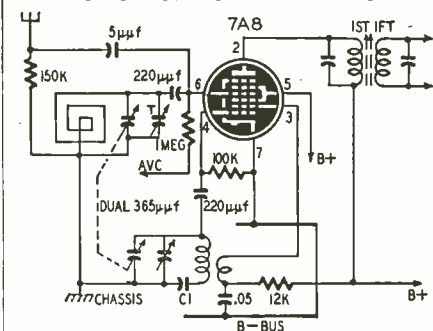

QUAM

High Fidelity

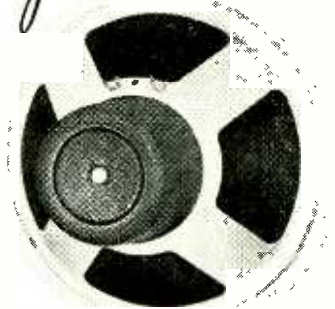

Adjust-a-Cone SPEAKERS

High Standard of Performance and Wide Range Reproduction at a Sensible Price!

8," 10" and 12" sizes . . . 12" and 15" Co-Axials . . . 3 1/2" and 5" Tweeters. Write for Catalog Today.

QUAM-NICHOLS COMPANY

521 E. 33rd Place Chicago 16, Ill.

Manufacturers of

Quam Adjust-a-Cone Speakers and Rear Seat Auto Speakers, Tru-Match Output Transformers, Quam Focalizer units and Ion Traps

\$3.00 FOR CARTOON IDEAS

RADIO-ELECTRONICS prints several radio cartoons every month. Readers are invited to contribute humorous radio ideas which can be used in cartoon form. It is not necessary that you draw a sketch, unless you wish.

Address

**RADIO-CARTOONS,
RADIO-ELECTRONICS**
25 West Broadway,
New York 7, N. Y.

oscillator coil is a standard broadcast tuning unit designed for use with a 365- μ mf tuning capacitor. The padder capacitor (C1) should be the value specified by the coil manufacturer.

The 100,000-ohm oscillator grid resistor seems a little high. If the oscillator blocks or does not function properly, change the grid resistor to about 50,000 ohms.

HASH IN POWER SUPPLY

? My 10-watt marine radiotelephone unit is powered with a vibrator-type power supply delivering 350 volts at 200 ma. There is a lot of hash in the output. Will I have much trouble converting to a dynamotor-type supply? Will I have to add filters or can I use a Genemotor without alterations?—E. D. S., Scio, Ohio.

A. Hash from vibrators and whine from dynamotors are two problems which must be licked in all battery-powered receiver, transmitter, and amplifier installations. If the equipment is not properly grounded and shielded, you are likely to have trouble regardless of the efficiency of the filters.

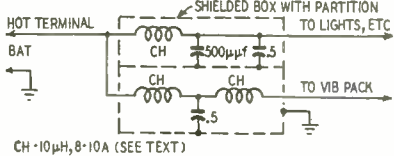

Your trouble may be caused by a defective rectifier tube or vibrator, or the buffer capacitor may be leaky or may have changed its value. Our suggestion is to give the vibrator pack and the radiotelephone unit a good overhauling before deciding to replace it with a dynamotor. You may find that the trouble is caused by a faulty component in the pack or the receiver or transmitter. If the batteries are used for lighting, ignition, or other purposes, you may find that a couple of simple filters will eliminate your trouble. The drawing shows the construction of the filters. The chokes should have an inductance of approximately 10 microhenries and should be rated at 8-10 amperes. The J. W. Miller type 5551 will do for lines where the drain does not exceed 8 amperes. The filter sections may be mounted in a metal box with a shield partition between them as shown, or they may be in separate shield cans. The shields should be well grounded.

Some dynamotors now on the market are available without any form of filtering. Others have B supply filters but no filters in the low-voltage supply circuit. Others are completely shielded and filtered so that they can be used with almost any existing equipment without modifications. A unit that is shielded and fully filtered is probably the best bet unless the transmitter-receiver unit has a good built-in filter network.

TV ANTENNA MODIFICATIONS

? TV station WSAZ-TV in Huntington, West Virginia has been shifted from channel 5 to channel 3. How can

**STAN-BURN
E. DARKE**

ANTENNAE SPECIALS

DOUBLE V 3/8"	\$2.98	1-11	12 or more
DOUBLE V 3/8" Dowel	3.48	2.45	
DOUBLE V 1/2" Dowel	3.95	2.95	
10 Element Conical 3/8"	3.55	2.55	
Folded Hi Straight Low Quick Rig 1/2" elements	4.25	3.25	
WINDOW CONICALS	4.95	3.75	
MASTS			
5 FOOT SWEDGED79	.69	
10 FOOT PLAIN	1.39	1.29	
TV WIRE			
55 MIL. 300 OHM	\$14.95	M Ft.	
72 OHM COAXIAL	45.00	M Ft.	

SPECIAL PRICES ON BRAND NEW CATHODE RAY TUBES

... FULL 1 YEAR GUARANTEE ...

GENERAL ELECTRIC	20LP4	33.60
STP4	21EP4A	33.60
J7P4	21EP4A	33.98
10BP4A	24LPA	66.55
10FP4A	108P4	\$13.00
12KP4A	12LP4	11.20
12LP4A	14CP4	15.75
12UP4B	15DP4	21.50
14EP4	16CP4	21.50
14FP4	16HP4-DP4	22.60
16AP4A	16AP4	22.60
16LP4	16RP4	22.60
16KP4-RP4	17BP4	23.70
17BP4A	17CP4	27.90
17CP4	20CP4	28.00
19AP4A	31.65	20CP4
20CP4-HP4A	32.25	16EP4

Prices subject to change without notice.

TRANSFORMERS

RCA type for 16" to 24" X045 \$3.85

G.E. Type for 16" to 24" X045 3.85

These are very special prices while they last!

DEFLECTION YOKES

Cosine Ferrite Todd Yoke 70" \$4.20

SPECIALS

4 Prong Vibrators, each \$1.25

Lots of 12 or more 1.15

Standard TV Tuners 18.95

12" Heavy Slug Speaker Special 4.98

Audio Devices, Discs, and Scotch Tape in Stock

Audio Plastic Red Oxide Plastic Tapes \$1.25

1/2 hour spool \$2.30

One hour spool \$3.30

WIRE RECORDERS IN STOCK

WILCOX GAY—Model 2A10 \$89.97

PENTRON—Model 9T3C—2 spd. Tape Recorder net 134.50

RADIO—Model RC2-HIFI Amplifier net 42.89

CRAPTS—Model RC10—AM-FM Tuner net 30.84

MEN—Model IC5—Williamson Amplifier net 99.45

AUTHORIZED DISTRIBUTORS for: General Electric, Kenrad, Tung-Sol, National Union, Jewel, De Wald, Regal, Automatic and Setchel Carlson

We carry a complete line of popular makes of radio and TV tubes, at 50% discount. Also many other special purpose and transmitting types, and all electronic parts and equipment at lowest prices. Send us a list of your requirements for prompt quotations. Terms: 20% with order. Balance COD All prices FOB New York Warehouse. Minimum order \$5.00

Write for our latest price list to Dept. RE-12

STAN-BURN RADIO and ELECTRONICS CO.
(C.B.S. THEATRE BLDG.)
1697 BROADWAY • NEW YORK 19, N.Y.

WATCH FOR OUR SPECIAL JANUARY TELEVISION ISSUE

Compare!

PROVE **EMC** SUPERIORITY!

Model 104
(20,000 ohms per volt meter)
4 1/2" SQUARE METER (50 micro-amperes-Alnico magnet)
Includes carrying strap
5 DC Voltage Ranges at 20,000 ohms volt to 3,000 V.
5 AC Voltage Ranges to 3,000 V.
3 Resistance Ranges to 20 megs.
Also 3 AC & DC Current Ranges at 5 DB Ranges **\$26.95**

Model 102
(1000 ohms per volt meter)
3" SQUARE METER
3 AC CURRENT RANGES (0-30/150/600 ma.)
Same zero adjustment for both resistance ranges (0-1000 ohms, 0-1 meg-ohms)
5 DC & 5 AC Voltage Ranges to 3,000 Volts
Also 4 DC Current Ranges **\$14.90**

Model 103
(1000 ohms per volt meter)
4 1/2" SQUARE METER
3 AC CURRENT RANGES (0-30/150/600 ma.)
Same zero adjustment for both resistance ranges (0-1000 ohms, 0-1 meg-ohms)
Same Ranges as Model 102.
Also 5 DB Ranges **\$18.75**

Model 103-S with plastic carrying strap **\$19.25**

All of the above have molded bakelite cases. Write Dept. RE-12 for Free Complete Catalog of these and other instruments. — See them at your Jobbers —

EMC Electronic Measurements Corp.
288 Lafayette St., New York 12, N. Y.
Export Dept., 303 W. 42nd St., N. Y. C.

WHEN BUYING TV CHASSIS DON'T BE MISLED—COMPARE PRICE and QUALITY!

Famous Video 630 De Luxe Chassis for extreme fringe areas • Keyed AGC • 12 Quality Sneaker • High Efficiency High Voltage Circuit • Standard Coil • New Cascade Circuit Tuner • Automatic Brightness Control • Full Four Megacycle Overall Picture Band with • Synrocloc Automatic Frequency Control • FM Radio Reception	\$142.50	Complete Less CRT
Famous 620 Licensed RCA 1953 Chassis. 20 Tubes. Automatic Gain Control. Adaptable for VHF. Operates 20" and 24" Picture Tubes.	\$114.91	Complete Less CRT
SENSATIONAL "PACKAGE DEAL" Video Chassis 20" Sheldon Tube Standard Open Face Consolelette comp.	\$205.00	20" Tube Chassis 20" Sheldon Tube Standard Open Face Consolelette comp.
	\$169.50	

SHELDON TV PICTURE TUBES ONE YEAR GUARANTEE

12 1/2" BLACK	18.60
14" RECT	19.50
15" ROUND	27.50
16" RECT	27.50
17" ROUND	25.50
18" RECT	29.50
20" ROUND	30.00
21" RECT	35.00
24" ROUND	64.50
27" RECT	Prices on request

All Prices Subject to Change Without Notice. Please include 25% deposit with orders, balance C.O.D. All shipments F.O.B. Brooklyn, N.Y. 100 PINEAPPLE STREET BROOKLYN, N.Y. PHONE: MAIN 5-5904

PINE ELECTRONICS, INC.

GROMMES AMPLIFIERS

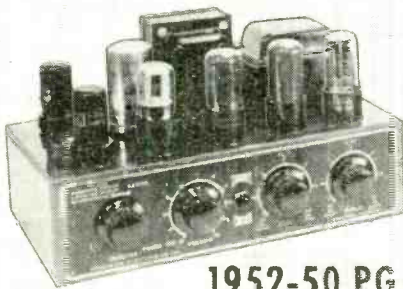

1952-50 PG

A 10 watt high fidelity single unit amplifier with unusual performance. It features extended frequency response with low distortion and plenty of reserve power. Ideal for conservative custom installations.

THE GROMMES 215BA "WILLIAMSON"

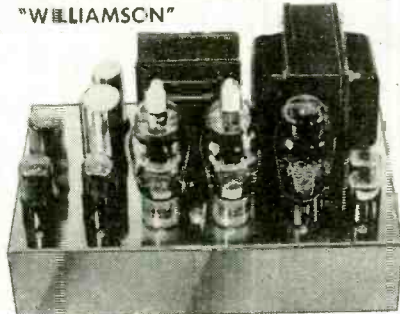

... newest addition to the famed Grommes Custom Line.

THE G SERIES



A complete line of P.A. and commercial amplifiers.

NEW TV CLARIFIER

Actually has FOUR TIMES the interference "Suck" of previous model.

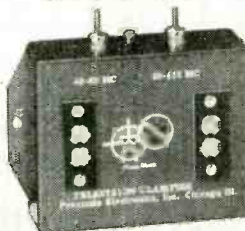

See your Jobber or
WRITE FOR CATALOG

Precision Electronics, Inc.
641-643 MILWAUKEE AVE.
CHICAGO 22, ILLINOIS

I modify a channel-5 Yagi to work on the new frequency?—E. J. Burdine, Ky. A. If your antenna is one of the broad-band Yagis, it may perform satisfactorily on channel 3. If it is a single-channel job, its elements should be lengthened. You can use short lengths of aluminum tubing which slip into or over the ends of the present elements. The folded dipole can be lengthened by cutting off the ends and inserting extensions made from tight-fitting aluminum plugs or tubing into the sections of the dipole. The new lengths of the reflector, radiator, and first, second, and third directors (in inches) may be found by dividing 5,208, 5,256, 5,304, 5,544, and 5,880, respectively, by the frequency of the low end of the TV channel to be received. For channel 3, divide by 60 mc.

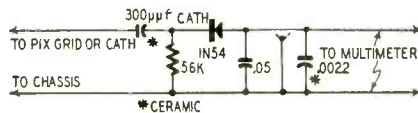

The bandwidth, gain, front-to-back ratio, and impedance of a Yagi depend on the lengths of the individual elements and the spacing between them. The antenna will probably work satisfactorily with the present interelement spacing. However, if you want to perform some interesting experiments, you can lengthen the boom (crosspiece) and experiment with the spacing and length of the elements.

For extensive experiments, you should have some form of field-strength meter to indicate the effect of minor changes in the antenna. If you have a multimeter which reads 50 or 100 µa full scale—most 20,000-ohms-per-volt multimeters do—you can use it with the adapter shown in the diagram. The meter reads the video signal applied to the grid or cathode of the picture tube. Do not connect the adapter to a receiver which has a hot chassis. Use a large 600-volt blocking capacitor in series with the lead which connects to the chassis. END

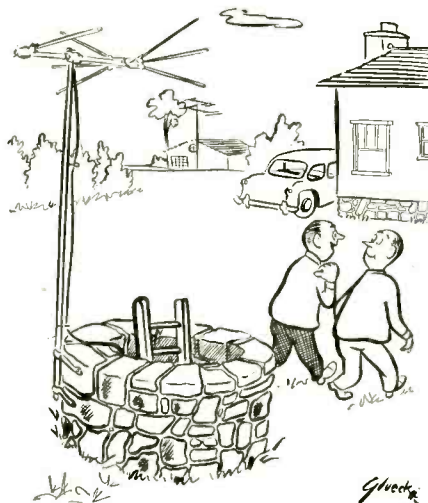

"By George, he does get perfect reception!"

Operate 2 sets from 1 Antenna

with the

TELEMATIC ADD-A-SET

TV Receiver Coupler

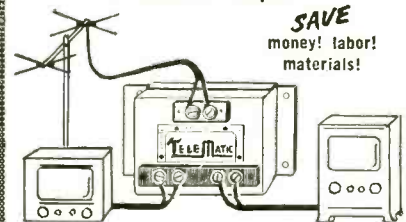

SAVE
money! labor!
materials!

- Highest efficiency transformers used.
- Operates in fringe areas.
- High pass filter action.
- No inter-set coupling.
- Eliminates soldering, screw terminal.
- Compact, mounts inside cabinet.

Sold by leading Jobbers Everywhere
Send for FREE booklet on TV INTERFERENCE



Never Before At This Price!

COMPLETE AMPLIFIER

SPEAKER, ALL TUBES
and HANDSOME CABINET

Only
\$10.75

Amazing
Fidelity

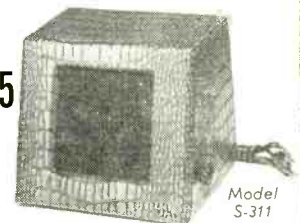

Dozens of uses!

Nearly everybody has a use for this sensational new amplifier. Use with all speed record players and eliminate special wiring and hookups to radio or TV. Use with FM tuner. Use a pair with microphones as intercom. Use for parties, meetings, baby minder, etc. Full range volume control with on-off switch. 5" Alnico 5 PM speaker. Input jack for phono or mike. Attractive cabinet covered in simulated alligator leather. 7 3/4" wide, 6 1/2" high, 6" deep. Complete with tubes: 35Z5GT, 50L6GT, 12SQ7, AC or DC 105-120 Volts, 25-60 cycles. Wt. 2 1/2 lbs. Order Model S-311.

Address Orders To Dept. RE-12
Write For Free FYI Bulletin

**WHOLESALE
RADIO PARTS CO., Inc.**
311 W. Baltimore St.
BALTIMORE 1, MD.

BIGGEST TV VALUES IN THE COUNTRY—

#630 STANDARD TV KIT

THIS OFFER MAKES TV HISTORY . . . never ever so low a price, never ever such high quality . . . Quality and improvements in components that will enable the finished chassis to operate 10", 12½" and certain 16" picture tubes . . . This STANDARD KIT consists of a complete set of parts, similar to those used in the famous RCA #630 29-tube chassis, including all tubes, speaker, resistors in correct 5%, 10%, 20% tolerances, the new Cascode Tuner and the Brooks LIFE-SIZE Instructions (less CRT & wire)

only... **\$93.78**

PULSE KEYED AGC KIT

Finest, most accurate and the easiest Kit to install in a #630 or in any other make TV receiver. Improves performance, eliminates airplane flutter and picture jumping and insures a steady picture on all channels.

COMPLETE SET OF PARTS Including 6AU5 tube & Instructions **\$4.59**

SUPER DELUXE #630 TV BASIC PARTS KIT

- PUNCHED & DRILLED CHASSIS PAN
- BRACKET & SHIELD KIT (18 items)
- VIDEO & I.F. KIT (19 items)
- POWER TRANSFORMER #201T6
- VERTICAL OUTPUT TRANSFORMER
- VERTICAL BLOCKING TRANSFORMER
- FLYBACK TRANSFORMER #211T5
- FOCUS COIL, 470 ohms #202D2
- COSINE DEFLECTION YOKE 70°

All for Only... **\$39.49** Including LIFE-SIZE TV builder instructions



INDOOR TV ANTENNA

- Newest, panorama high-gain type
- Brass 3-section chrome plated dipoles
- Absolutely tilt and tip-proof

list Price **\$5.95** special at **\$1.99**

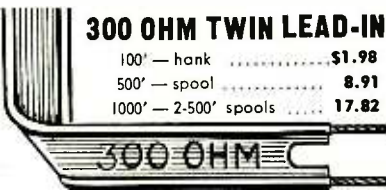

300 OHM TWIN LEAD-IN

- 100' — hank **\$1.98**
- 500' — spool **8.91**
- 1000' — 2-500' spools **17.82**



72 OHM COAXIAL CABLE

- 100' — hank **\$ 4.84**
- 500' — spool **22.99**
- 1000' — 2-500' spools **43.86**

Brooks LIFE-SIZE Edition

#630 TV KIT BUILDER—SET OF INSTRUCTIONS

BUILDING YOUR OWN #630 TV CHASSIS is now simplified with this **COMPLETE SET OF BUILDING & WIRING INSTRUCTIONS**. Covers all #630's, from the RCA 10" SET to the latest SUPER DE LUXE 31-tube 16" to 24" RECEIVER.

EVERYTHING AT A GLANCE LAYOUT CHARTS show chassis and components in actual LIFE-SIZE with instructions alongside the illustrations.

GUESSWORK IS ELIMINATED by specially prepared SCHEMATIC DIAGRAMS, LOCATION GUIDANCE, CODE CHARTS, ALIGNMENT PROCEDURE and TOP AND BOTTOM PHOTOGRAPHS OF A COMPLETED CHASSIS (assembled from these instructions) clearly showing placement of each component.

Popular priced at only... **\$2.49** Postpaid

Modernize a #630 or any TV Set

With a New

STANDARD CASCODE TUNER

For better all around performance

Complete with tubes, and step by step instructions **\$22.49**

#630 PARTS • IN SETS

- VIDEO AND I.F. KIT, 19 items..... **\$7.84**
- AGC KIT, complete with instructions..... **4.59**
- VARIABLE CONTROL KIT, 9 controls..... **5.83**
- CARBON RESISTOR KIT, 107 resistors..... **6.98**
- WIREWOUND RESISTOR KIT, 4 resistors..... **2.31**
- BRACKET AND SHIELD KIT, 18 items..... **8.63**
- ELECTROLYTIC CONDENSER KIT, 6 cond..... **7.37**
- TUBULAR CONDENSER KIT, 38 condensers... **4.28**
- CERAMIC CONDENSER KIT, 28 condensers... **3.37**
- MICA CONDENSER KIT, 11 condensers..... **1.38**
- COMPLETE SOCKET KIT, 25 sockets..... **1.57**
- 630-KIT, screws, nuts, rivets, washers, etc. ... **1.69**
- TV WIRE & SOLDER KIT, for any Set..... **1.49**

#630 TELEVISION PARTS

- RCA FRONT END TUNER, compl. w/tubes... **\$22.49**
- STANDARD CASCODE TUNER, " w/tubes... **22.49**
- ESCUTCHEON PLATE, for either tuner.... **.69**
- COMPLETE SET OF KNOBS, incl. decals... **1.34**
- COMPLETE SET OF KNOBS, gold incl. decals **2.49**
- POWER TRANSFORMER, 295ma. 201T6... **9.97**
- VERTICAL OUTPUT TRANS. 204T2... **2.69**
- VERTICAL BLOCKING TRANS. 208T2... **1.32**
- HORIZONTAL OUTPUT TRANS. 211T3... **2.98**
- HORIZONTAL OUTPUT TRANS. 211T5... **3.98**
- FOCUS COIL, 247 ohms, 202D1... **2.29**
- FOCUS COIL, 470 ohms, 202D2... **3.42**
- DEFLECTION YOKE, 60° 201D1... **2.97**
- COSINE DEFLECTION YOKE, 70° 206D1... **3.98**
- HORIZONTAL DISCRIM. TRANS. 208T8... **1.49**
- FILTER CHOKE, 62 ohms **1.47**
- WIDTH CONTROL COIL, keyed AGC... **.79**
- ION TRAP BEAM BENDER, (single) 203D1... **.79**
- ION TRAP BEAM BENDER, (double) 203D3... **.98**
- AUDIO OUTPUT TRANSFORMER (6K6)... **.69**
- HV RECTIFIER, SOCKET ASSEMBLY, double **1.37**
- PUNCHED CHASSIS PAN, cadmium plated **4.87**

SPECIAL #630 TV PACKAGE

Hints for Better Pictures on Your #630 TV
630 TV Diagram with Modifications All for only
Illustrated TV Conversion Manual **\$1.00**
Pulse Keyed AGC Circuit Diagram postpaid
RMA Resistor & Mico Code Charts

You will also receive our latest catalog and flyers with special offers in TV, Chassis, Cabinets, Picture Tubes, Parts, Radios, Portables, Auto Radios, Radio Tubes, Test Equipment, Accessories, etc., at WHOLESALE PRICES.

#630 SUPER DELUXE KIT

For the 31-tube CHASSIS that operates all 16" to 24" picture tubes . . . Tops for fringe areas . . . Peak performance for clarity, brilliance, stability and definition . . . This SUPER DELUXE TV KIT consists of a complete set of parts, including the basic components of the STANDARD KIT plus added features, more tubes, doubler components, AGC components, Cascode tuner, Cosine 70° deflection yoke, 12" speaker, etc., and the Brooks LIFE-SIZE Instructions (less CRT & wire)

only... **\$119.44**

UNIVERSAL Picture Tubes MOUNTING BRACKETS

Fits All 12½" to 21" picture tubes

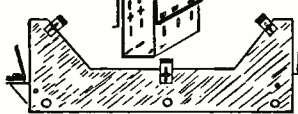

Complete— including a band that holds picture tube.

\$6.97

A PLAN TO SAVE YOU MONEY

PACKAGE DEALS—Each containing an assortment of the most desirable types and sizes, at a cost of only 1/3 than if bought separately!

Resistor & cond. code charts FREE with each order

100 ASSORTED TUBULAR CONDENSERS **\$4.69**

100 ASSORTED ½ WATT RESISTORS **3.97**

15 Asst. Radio Electrolytic CONDENSERS **4.74**

15 Assorted TV Electrolytic CONDENSERS **6.88**

100 ASSORTED MICA CONDENSERS **4.99**

100 ASSORTED CERAMIC CONDENSERS **4.99**

100 ASSORTED 1 WATT RESISTORS **5.89**

100 ASST. PILOT LIGHTS #44, 46, 47 & 51 **4.83**

100 ASSORTED SOCKETS Octal, Loctal & Miniature **3.92**

100 ASSORTED KNOBS SCREW & PUSH-ON **3.97**

10 VOLUME CONTROLS ASSORTED, WITH SWITCH **2.94**

10 VOLUME CONTROLS ASSORTED, LESS SWITCH **1.94**

BROOKS RADIO & TV CORP., 84 Vesey St., Dept. A, New York 7, N.Y. TELEPHONE Cortland 7-2359

BUY NOW! BEFORE PRICES GO UP!!!

#630 SUPER DELUXE 31-TUBE TV CHASSIS

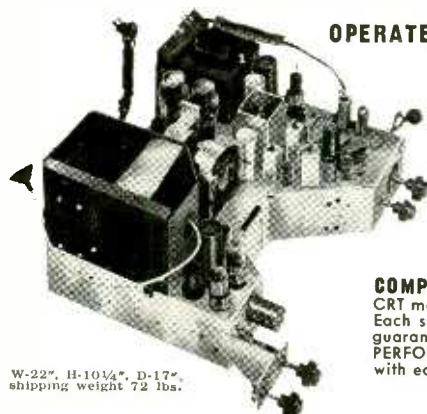

W-22", H-10 1/4", D-17", shipping weight 72 lbs.

OPERATES ALL 16" TO 24" PICTURE TUBES

Engineered in strict adherence to the genuine RCA #630, plus added features ★ ★ ★ ★ ★

NOTHING BETTER AT ANY PRICE!

- Standard Cascade Turret Tuner for DX
- Cosine 70° Deflection Yoke for Definition
- Original 630 Synch. Chain for Stability
- 16 KV for Clarity and Brilliance
- Fast Action Pulse Keyed AGC
- Large Concert-tone 12" PM Speaker

COMPLETE READY TO PLAY including all tubes and CRT mounting brackets. No charges for extras of any kind. Each set is factory aligned and air tested. All parts are guaranteed 3 months. Our booklet "HINTS FOR BETTER PERFORMANCE ON YOUR #630 TV RECEIVER" is supplied with each set.

\$167.97
(less C.R. Tube)

NATIONALLY KNOWN MFR.

Licensed under RCA patents

AND STILL 10% OFF

On these as low-as-ever prices

On a COMBINED PURCHASE

of a #630 CHASSIS, any CABINET and any PICTURE TUBE

STANDARD PICTURE TUBES

DuMont or Sheldon With a Full Year Guarantee

BRAND NEW—IN FACTORY SEALED CARTONS

10" — #10BP4A (Round, Black)	\$18.36
12 1/2" — 12LP4A (Round, Black)	24.72
14" — 14CP4A (Rectangular, Black)	26.48
16" — 16AP4A (Round, Metal, Black)	28.97
16" — 16DP4A (Round, Black)	28.97
16" — 16GP4A (Round, Metal, Black)	28.97
16" — 16TP4A (Rectangular, Black)	28.97
17" — 17BP4A (Rectangular, Black)	29.63
19" — 19AP4A (Round, Metal, Black)	34.82
20" — 20CP4A (Rectangular, Black)	39.74
21" — 21EP4A (Rectangular, Black)	44.68
24" — 24AP4A (Round, Metal, Black)	69.49

CUSTOM-BUILT CABINETS FOR #630 AND ALL OTHER TV SETS — FROM FACTORY TO YOU

5 LEADING STYLES in genuine mahogany or walnut (blond 10% extra). Ready drilled for any #630 TV chassis and cutout for any 12 1/2" to 21" picture tube at no extras in price. Also supplied with undrilled knob panel for any other TV set. EVERYTHING NECESSARY for an easy perfect assembly is included. Each cabinet is delivered complete as pictured with mask, safety glass, mounting brackets, backboard, backup, hardware and assembling instructions. Each cabinet is shipped in an air cushioned carton from FACTORY TO YOU.

The VOGUE
Most Popular Table Model.



H-24", W-26", D-23"

\$39.89

VOGUE also available for 24" or 27" picture tube
H-31", W-27", D-23"

\$62.54

The MANHATTAN
Style, Quality, Price



H-41", W-25", D-23"

\$59.37

MANHATTAN for 24" or 27" CRT
H-40 1/2", W-27 3/4", D-24" \$86.22

The STREAMLINER
Center Drop Panel
Conceals Tuning Knobs.

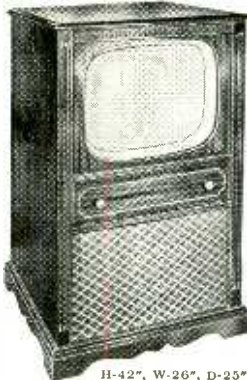

H-42", W-26", D-25"

\$74.98

The NEW YORKER
A Deluxe Cabinet
With a Piano Finish.



H-42", W-26", D-24"

\$96.87

The TOWN & COUNTRY

Patterned after the popular credenza.
Available for all size picture tubes 10" to 27"

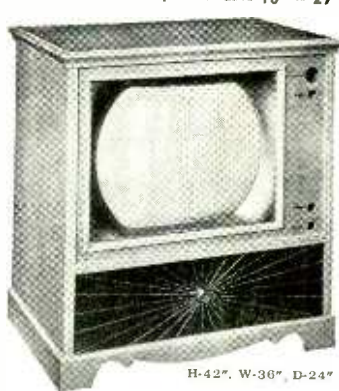

H-42", W-36", D-24"

\$109.62

With PHONO-DRAWER \$19. extra

BROOKS RADIO & TV CORP., 84 Vesey St., Dept. A, New York 7, N. Y. TELEPHONE Cortland 7-2359

KNOW TUBES

and you'll know radio RADIO TUBE FUNDAMENTALS—Gernsback Library Book No. 45. 96 Pages. \$1.00

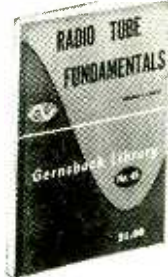

Tubes are the heart of radio, yet how many technicians really understand the theory behind them? Here's a book that lifts the cloud with a minimum of math—and no engineering talk. It's a real gem at this price.

See page 86 for coupon

GERNSBACK PUBLICATIONS, INC.
Publishers of RADIO-ELECTRONICS
25 West Broadway New York 7, N. Y.

WATCH FOR OUR JANUARY TELEVISION NUMBER



Simply attach TELECOLOR FILTER to front of set and enjoy programs in glorious color tones instead of dull black and white. GUARANTEED to give genuine color tone. Can also be used with any other filter. Once tried, you will never go back to old black and white. Write for FREE information. ORDER BY MAIL. NEW REDUCED PRICES!

Send check, M.O., cash, COD to Dept. RE-12

10 in. \$1 16, 17 in. \$3
12, 14 in. \$2 19, 21 in. \$5

HARVARD LAB. 659 FULTON ST. BROOKLYN, N. Y.

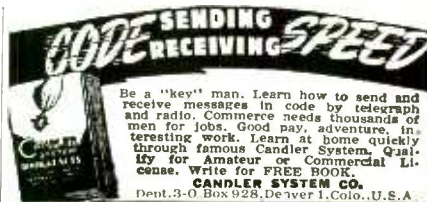

Be a "key" man. Learn how to send and receive messages in code by telegraph and radio. Commerce needs thousands of men for jobs. Good pay, adventure, interesting work. Learn at home quickly through famous Candler System. Quality for Amateur or Commercial License. Write for FREE BOOK.

CANDLER SYSTEM CO.
Dept. 3-O Box 928, Denver 1, Colo., U.S.A.

ON-THE-SPOT BATTERY RECORDER

WALKIE-RECORDALL 8 lb. miniature BATTERY RECORDER-PLAYBACK
Continuous, permanent, accurate, indexed recording at only 5c per hr. Instantaneous, permanent playback. Picks up sound up to 60 ft. Records conferences, lectures, dictation, 2-way phone & sales talks: while walking, riding or flying. Records in closed briefcase with "hidden mike"! Write for details.

MILES REPRODUCER CO., INC.
812 BROADWAY Dept. RE-12 NEW YORK 3, N. Y.

TV LINEARITY ADJUSTMENT

Service manuals on recent Sentinel TV sets state that horizontal linearity can be adjusted accurately and rapidly without relying on a bar generator or a station test pattern. Simply replace the fuse in the high-voltage cage with a 150-ma d.c. meter and adjust the linearity control until *minimum* current is obtained.

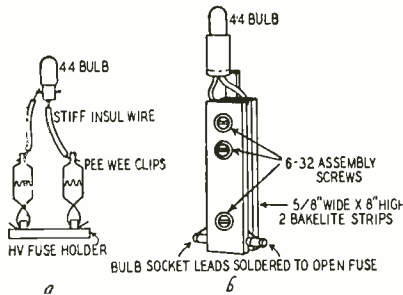

A recent *Sentinel Service Bulletin* describes a modification of this method used by Marvin Miller, of Springfield, Ohio. Mr. Miller uses a No. 44 pilot lamp and two clip leads assembled as shown at *a* in the drawing. The lamp substitutes for the meter in the original system.

The linearity control is adjusted for *minimum* glow. The drawing at *b* shows an adaptation of this device recommended by Sentinel. This tool snaps into the fuse holder. It is made from two 8 x 5/8-inch strips of bakelite with a pilot lamp holder at one end and an open fuse at the other. This raises the lamp

above the edge of the cage for easier viewing.

REPLACING BROKEN C-R TUBE BASES

When it is necessary to replace a broken base on the picture tube proceed as follows:

1. Remove the broken base by unsoldering all the pins, being careful not to damage the wires.
2. Straighten and form the wires so the new base can be easily placed on them.
3. Apply a coat of speaker cement to the glass neck of the tube and to the inside of the new base.
4. Place the new base on the tube, making certain that each wire is inside its proper pin. Hold the socket in place until the cement dries sufficiently hard to permit soldering the pins.—*Crosley Service Dept.*

WESTINGHOUSE V-2157-5 CHASSIS
Motorboating in the H-355T5 and H-356T5 models may be eliminated by a slight rearrangement of the wiring. The dashed lines in the diagram show leads to be disconnected and the heavy solid lines show the leads after modification. To make the change proceed as follows:

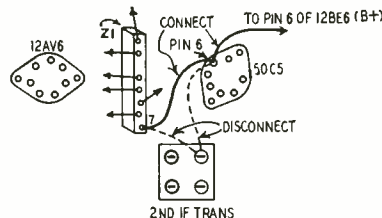

1. Remove the wire between pin 6 of the 50C5 and the second i.f. transformer. 2. Disconnect lead 7 of the capacitor-resistor assembly Z1 from the i.f. transformer and connect it to pin 6 on the socket of the 50C5. 3. Connect an insulated lead between pin 6 of the 50C5 socket and pin 6 of the 12BE6 socket.

These changes have been made in later production runs of these models. —*Westinghouse Service Notes*

CHEVROLET MODEL 986515

These sets are often very difficult to remove from the car because they are mounted so close to the air-flow heater and its controls. Sometimes service technicians have to remove the heater leg to get the set out.

I have discovered that by dropping the set down just enough to permit removal of the dial escutcheon, dial pointer, and dial-lamp holder, the set can then be pulled with ease. The dial parts are held in place by six No. 8 hex screws. Removing these parts does not constitute unnecessary work because they must be removed before any bench work can be done on this particular set. —*Richard D. J. Lytwyn*

AUTO-RADIO SERVICE HINTS

Very often we find capacitors, resistors, and other components which have broken loose because of vibration. After making the repair, we use Scotch tape to secure the new part to the chassis or other component. This prevents vibration from causing future failures of this nature.—*Floyd A. Roberts* END

STANCOR NEWS BULLETIN

NEW STANCOR TRANSFORMERS



A-4747—Input transformer for single button mic. or low imp. line to single grid. Pri.: 70 ohms; sec. 1,300,000 ohms. Turns ratio, 1:137. Ideal for mobile transmitter use.



A-3335—Output transformer for P-P plates to V.C. An economical unit used with 6V6's and inverse feedback. 10,000 to 6-8/3.2-4 ohms. Max. pri. DC, 40 ma., 10 watts.



P-6468—Filament transformer for a pair of Eimac 4-250A's where CT is operated near ground potential. Sec. 5.0V. CT, 30 amps., RMS insul. 2500V.



P-6410—Electrostatically shielded isolation transformer designed for servicing small receivers, amplifiers and test equipment. 50-60 cycle. Conservatively rated at 50 watts.

Ask your Stancor distributor for Bulletin 450R for additional information on these and other new Stancor transformers.

NEW TELEVISION REPLACEMENT TRANSFORMERS



A-8125—Vertical block oscillator. Used in over 600 models by 21 manufacturers. Turns ratio, 1:4.2; height 1 3/8". mounting centers 1 3/4".

P-8170—Power transformer, used in 48 models by Andrea, Bendix, Kaye Halbert, and Magnavox. Plate supply 380-0-380 AC volts, 220 DCMA. Rect. fil. 5V. at 3 amps., other filaments 6.3 at 1.2, 6.3 at 5.0 and 6.3 at 7.0.



P-8171—Power transformer replacement for Air King part A10109. Plate supply 375-0-375 AC volts, 225 DCMA. rect. fil. 5V. at 3 amps. Other filaments 6.3 at 2.0 and 6.3 at 9.0.

See Bulletin 451 on these new Stancor TV replacements.

STANCOR CR TUBE BOOSTER



A CR tube rejuvenator with many extra features suggested by the Stancor Serviceman Advisory Board. Acquires no soldering and no connecting to the AC line. It has extra long 18" leads between the booster and its connector. Can be installed anywhere in the set. Auto-switch permitting a choice of two degrees of brilliancy. Supplied complete with bracket and screws for chassis or cabinet mounting. **P-8192...\$2.94 Dealer's net**

FREE!

The new Stancor Transformer Simplified Television Replacement Guide, the most complete and the most concise ever published. Covers over 4400 TV models and chassis. All replacements are listed by manufacturers' original part number for instantaneous reference. Available from your distributor or from Stancor directly.



Stancor transformers are listed in Howard W. Sams Photofact Folders and in John Rider's Tek-Files
STANDARD TRANSFORMER CORPORATION
3592 ELSTON AVENUE, CHICAGO 18, ILLINOIS

AMPERITE

Studio Microphones
at P.A. Prices

Ideal for
BROADCASTING
RECORDING
PUBLIC ADDRESS

"The ultimate in microphone quality," says Evan Rushing, sound engineer of the Hotel New Yorker.

• Shout right into the new Amperite Microphone—or stand 2 feet away—reproduction is always perfect.

• Not affected by any climatic conditions.
• Guaranteed to withstand severe "knocking around."



Models
RBLG—200 ohms
RBHG—Hi-imp.
List \$42.00



"Kontakt" Mikes
Model SKH, list \$12.00
Model KKH, list \$18.00

Special Offer: Write for Special Introductory Offer, and 4-page illustrated folder.

AMPERITE Company, Inc.

561 BROADWAY • NEW YORK 12 N. Y.

Canada: Atlas Radio Corp., Ltd., 560 King St. W., Toronto

Get the NEW 1953 HUDSON CATALOG

FREE!



Keep Up-to-Date with the Latest in Radio, TV, and Industrial Electronics

The most complete buying guide of its kind! INCLUDES the latest JAN CROSS-REFERENCE GUIDE and all types of fully approved JAN COMPONENTS. Over 196 pages of the latest and largest selection of Industrial Electronic Equipment, Tubes, Test Instruments, Recording and High Fidelity Audio and Sound Equipment. Complete lines. Wide selection. All Standard Makes in stock for prompt delivery at LOWEST PRICES! Send for your FREE copy today

HUDSON
RADIO & TELEVISION CORP.

48 WEST 48th ST. • 212 FULTON ST.
New York 36, N. Y. New York 7, N. Y.

Circle 6-4060

World's
Toughest
Transformers

CHICAGO

"SPECIAL" FOR AIRCRAFT

CAT. NO. HP3-140.
Three-phase 400 cycle step-down transformer Y-Y connected. Pri: 115 volts per phase, 3 phase, 400 cycle. Sec: 28.5 volts per phase, 140 va capacity. "H" type mounting; meets MIL-T-27 Grade A, Class 1 specifications. Dimensions 2-7/8 x 2-11/16 x 3-3/4 high.



there's nothing tougher than
CHICAGO'S "Sealed-in-Steel" construction

The HP3-140 unit is just one of the many "specials" in the CHICAGO New Equipment Line in stock at HUDSON. The complete range of CHICAGO Sealed-in-Steel Transformers for every modern circuit application always in stock at Hudson for prompt delivery.

Mail this handy coupon

Hudson Radio & TV Corp. (Dept. R-12)
48 W. 48th St., New York, N. Y.

Please send FREE copy of 1953 Hudson Catalog
 Ship the following:

Name Title
Firm
Address
City Zone State

Get This Valuable Book

FREE



Just for Examining COYNE'S New 6-Volume Set

"Applied Practical Radio-Television"

ON 7 DAY
FREE
TRIAL!



Yes, you get this big, brand new book, "150 Radio-Television Picture Patterns and Diagrams Explained", absolutely FREE! Just off the press! Gives complete wiring circuits and diagrams on the latest Radio and Television Sets. Easy-to-read, large 8½ x 11" pages, with full instructions on how to read and use the diagrams. A "must" in every Radio and Television service-man's repair kit. You get this valuable book as a FREE Gift for asking to see Coyne's great new 6-book set, "Applied Practical Radio-Television"!

Here's "Know-How" That Makes You Worth More!

You'll get into the big money faster in TELEVISION-RADIO if you know where to find the answer to servicing problems. Coyne's great new 6-volume set gives you all the answers—quickly! For basic "know-how" that is easy to understand, you'll find everything you want in volumes 1 to 5 which contain over 5000 practical facts and data. They cover every step from principles to installing, servicing, trouble-shooting and aligning all types of radio and TV sets. So up-to-date it includes COLOR TV and UHF adapters and converters.

762-Page Television Cyclopedic Included

And then, for speedy on-the-job use, you get volume 6—the famous Coyne TELEVISION CYCLOPEDIA. It answers today's television problems on servicing, alignment, installation and others. In easy-to-find ABC order, cross indexed. Use this 6 volume TV-RADIO LIBRARY free for 7 days; get the valuable Servicing Book ABSOLUTELY FREE!

SEND NO MONEY! Just mail coupon for 6-volume set on 7 days free trial. We'll include book of 150 TV-Radio Patterns & Diagrams. If you keep the set, pay \$3 in 7 days and \$3 per month until \$23.00 plus postage is paid. (Cash price \$22.00). Or you can return the library at our expense in 7 days and owe nothing. YOU BE THE JUDGE. Either way, the book of TV-Radio Patterns is yours FREE to keep! Offer is limited. Act NOW!

FREE BOOK—FREE TRIAL COUPON!

COYNE ELECTRICAL & TELEVISION-RADIO SCHOOL, Dept. C2-T1
500 S. Paulina St., Chicago 12, Ill.

YES! Send 6-volume "Applied Practical Radio-Television" for 7 days FREE TRIAL per your offer. Include TV-Radio Patterns & Diagram Book FREE.

Name Age
Address
City Zone State

Where Employed
() Check here if you want library sent COD. You pay postman \$22 plus COD postage on delivery. 7-day money-back guarantee.

COYNE ELECTRICAL & TELEVISION-RADIO SCHOOL
500 S. Paulina St., Dept. C2-T1 Chicago 12, Ill.

More Leading ENGINEERS and TECHNICIANS Choose

TECH-MASTER TV KITS

C. G. McProud, Editor of *AUDIO Engineering*, writes, "... I was amazed with the speed and simplicity ... friends marvelled at the picture quality ..."

TECH-MASTER Advanced 630-Type Circuit

World's Finest TV Kit—For all tubes from 16" to 24" • Advanced standard TURRET TUNER, adaptable to U.H.F. without tools • Cascade R.F. amplifier stage • Keyed AGC circuit • Full 4 Mc band width • "Hi-Sweep" voltage multiplier system • 3-stage synchronized amplifier • 3-stage video amplifier. Model 630D24-Deluxe, (all principal components mounted) \$159.50 Model 630S24-Standard, (unassembled) \$154.50 Complete with all components, picture tube mounting brackets, speaker and all tubes (less Kine, wire and solder).



TECH-MASTER Universal AC/DC KIT

High quality TV now within reach of all. Advanced 12-channel TURRET TUNER adaptable to U.H.F. without tools • Latest type hi-gain stagger-tuned IF system in Tech-Master exclusive pre-wired Synchro-Strip • New AGC system • Maximum signal amplification, even in fringe areas • For 14" and 17" rect. tubes. Model 5116: Complete with set of 16 circuit tested tubes, hardware, instructions and picture tube mounting brackets, (less Kine, wire and solder) \$99.95



Sold by all leading Radio Parts Distributors.



Write for literature.

TECH-MASTER PRODUCTS COMPANY

443-445 BROADWAY, NEW YORK 13, N. Y.

AMERICA'S FASTEST GROWING TV ANTENNA MANUFACTURER

DAVIS ELECTRONICS

THERE MUST BE A REASON

THE REASON IS: The DAVIS SUPER-VISION is the finest antenna built for V.H.F. ALL CHANNEL and for FRINGE AREA and DX RECEPTION... A steady flow of enthusiastic letters from users all over the U.S. attests to this fact—and is outstanding proof of its UNIVERSAL ACCEPTABILITY.



HAVING TROUBLE GETTING FAR AWAY TELEVISION STATIONS UP TO 125 MILES AWAY—OR MORE?

1. EXCELLENT FOR FRINGE AREA and DX RECEIVING—and broad band receiving with high gain on all channels—2 through 13.
2. CLEARER PICTURES UP TO 125 MILES OR MORE—from the station.
3. GHOST PROBLEMS REDUCED or eliminated due to excellent pattern.
4. PROVIDES 10 DB OR MORE GAIN ON HIGH CHANNELS where gain is needed most.
5. EXCELLENT FRONT TO BACK RATIO on all channels. No co-channel interference.
6. MINIMIZES INTERFERENCE: Airplane Flutter—Diathermy and Ignition—F.M.—Neon Signs—X-Ray—Industrial—Etc.
7. ELIMINATES DOUBLE STACKED ARRAYS, and out-performs 2 bay yagis on low band and 4 bay yagis on high channels.

DAVIS ELECTRONICS

4313 WEST MAGNOLIA BLVD.
BURBANK, CALIFORNIA

Manufacturers of V.H.F. and U.H.F. Antennas
Backed by Over a Quarter Century of Electronic Experience



DAVIS SUPER-VISION

"THE ORIGINAL ANTENNA SOLD WITH A MONEY-BACK GUARANTEE"

ADVANTAGES OF THE DAVIS SUPER-VISION WITH ELECTRONIC DIPOLE SEPARATORS:

8. ONLY ONE TRANSMISSION LINE NECESSARY.
9. NO WORRY OVER POSSIBLE CHANNEL CHANGES on either high or low channels.
10. CAN BE TIPPED WITHOUT TILTING MAST to take advantage of horizontal wave lengths.
11. Can be used with ANTENNA ROTOR

AT YOUR JOBBERS, OR WRITE TO:

DAVIS ELECTRONICS 1-22
4313 West Magnolia Blvd., Burbank, California

SIRS: RUSH INFORMATION TO ME AS CHECKED BELOW:

Send Free Technical Data on new SUPER-VISION ANTENNA.

Send Name and Address of NEAREST JOBBER.

Name _____

Street _____

City _____ State _____

Julius Haber, director of advertising and sales promotion for RCA technical products, was advanced to the position



J. Haber

of director of public relations for the RCA Victor Division. Haber, associated with RCA since 1922, has devoted his entire business career to public relations, publicity, and advertising activities in electronics.

L. E. Cotsen was appointed manager of renewal sales for TUNG-SOL ELECTRIC, INC., Newark, N. J. He was formerly manager of the Eastern Division sales office.



L. E. Cotsen

Walter R. Ohlsen, previously a salesman in the Eastern Division, was advanced to the post vacated by Cotsen.

Richard A. Norman was appointed manager of manufacturing for the GENERAL ELECTRIC Cathode-Ray Tube operations at Electronics Park, Syracuse, N. Y. He was formerly superintendent of subminiature tube manufacturing at the G-E Owensboro, Ky., tube works.



R. A. Norman

Thomas H. Moss joined the TURNER Co., Cedar Rapids, Iowa, as assistant sales manager. He comes to the company from the Harper Brush Works where he was sales and advertising manager. Moss will assist sales manager H. M. Murdock in all phases of the recently expanded sales program on Turner microphones and TV boosters.



T. H. Moss

John H. Adams was appointed assistant sales manager of the ROLA Co., INC., a division of the Muter Co., Cleveland. Adams has had wide experience in engineering in the radio field and has handled both Rola and Muter products since 1946 as a direct factory man. In his new position he will discontinue all activity for the Muter Co. and concentrate his efforts exclusively on products of the Rola division.



J. H. Adams

Personnel Notes

. . . Dr. E. F. W. Alexanderson, noted radio pioneer, who retired recently from the General Electric Co., which he joined in 1902, has been appointed consultant for the RADIO CORPORATION OF AMERICA. He had previously



Dr. E. F. W. Alexanderson

served as chief engineer of RCA from 1920 to 1924. Dr. Alexanderson, who received the IRE Medal of Honor in 1919 for his invention of the Alexanderson alternator, is a Fellow and former president of the

IRE, a Fellow of the American Institute of Electrical Engineers, and has been awarded many other scientific and academic honors for his contributions to electricity, radio, and electronics.

. . . Earl Kirk was promoted to the position of distributor sales manager of I.D.E.A., INC., Indianapolis, manufacturer of Regency boosters and converters; and Edward Sheridan, formerly with the RCA Victor Engineering Products Division, joined the company as industrial sales manager.

. . . Donald MacGregor, formerly a vice-president with Zenith Radio, joined WEBSTER-CHICAGO as president, succeeding R. F. Blash, who was elected chairman of the board.

. . . Victor Welge joined P. R. MALLORY & Co., INC., Indianapolis, as associate director of engineering. He was formerly with Consolidated Vultee Aircraft Corp.

. . . William M. Jones was named division manager of the Electronics Division of THOMPSON PRODUCTS, INC., Cleveland. F. J. Weihmiller is sales manager.

. . . R. J. Yeranko, MAGNAVOX Co., was reappointed chairman of the RTMA Service Committee.

. . . Dr. Sidney J. Stein was promoted to director of research for the INTERNATIONAL RESISTANCE Co., Philadelphia. He was also appointed to the company's Operating Committee.

. . . Henry Taylor was promoted to assistant to the director of research for AEROVOX CORP., New Bedford, Mass. Peter P. Grad, formerly with the Borden Co., joined Aerovox as technical director, and Rex Nicholson, previously with Sangamo Electric Co., joined the company as research engineer.

. . . Anton C. Fisher was appointed sales and advertising manager for "Fretline" TV antennas, chimney mounts, and towers manufactured by FRETCO, INC., Pittsburgh.

. . . Mort Leslie was promoted to assistant sales manager of the JFD MANUFACTURING Co., Brooklyn, N. Y.

. . . A. H. Schenkel continues as director and president of UTAH RADIO PRODUCTS Co., Huntington, Ind., and vice-president of Newport Steel, after a recent company election. Other members of the Board of Directors of Utah Radio Products include: F. S. Gibson, Jr., chairman; B. A. Mitchell, William J. Mericka, and George H. Roderick. END

DECEMBER, 1952

WORLD'S FASTEST SELLING VOLT-OHM MILLIAMMETER



Sensitivity
1000 ohms per volt

- ★ Uses latest design 2% accurate 1 Mil. D'Arsonval type meter.
- ★ Same zero adjustment holds for both resistance ranges. It is not necessary to readjust when switching from one resistance range to another. This is an important time-saving feature never before included in a V.O.M. in this price range.
- ★ Housed in round-cornered, molded case.
- ★ Beautiful black etched panel. Depressed letters filled with permanent white, insures long-life even with constant use.

The Model 770 comes complete with self-contained batteries, test leads and all operating instructions. **\$14⁹⁰ NET**

Specifications:

- 6 A.C. VOLTAGE RANGES: 0-15/30/150/300/1500/3000 Volts.
- 6 D.C. VOLTAGE RANGES: 0-7.5/15/75/150/750/1500 Volts.
- 4 D.C. CURRENT RANGES: 0-1.5/15/150 MA. 0-1.5 Amps.
- 2 RESISTANCE RANGES: 0-500 Ohms 0-1 Megohm.

Model 770

is an accurate pocket-size V.O.M. Measures only 3 1/8" x 5 7/8" x 2 3/4"

Write Dept. RC-12 for catalog of complete line.



Manufactured and Guaranteed by
SUPERIOR INSTRUMENTS CO.
227 Fulton Street • New York 7, N. Y.

AT YOUR RADIO PARTS JOBBER

Spot TV trouble symptoms at a glance fix them twice as fast!

Now! HANDLE UP TO 90% OF TV SERVICING BY PICTURE ANALYSIS



Ghirardi's PIX-O-FIX TV TROUBLE FINDING GUIDE

New short cut way of handling television service can save you hundreds of dollars worth of time

Just Out!

Hours of tedious, time-consuming troubleshooting can be cut to minutes. Repairs can be made twice as fast! Just "dial" the new Ghirardi PIX-O-FIX TV TROUBLEFINDER GUIDE until the actual TV screen photo appearing in its "window" matches the screen picture on the defective set you are repairing. The proper Trouble Key Number also appears on the guide. This directs you to the tabulation giving all possible causes of this particular trouble and the stage or section of the receiver in which it is most likely to occur. But

this is only the beginning! The Pix-O-Fix Guide not only helps you locate the trouble quickly but then also shows you exactly how to fix it. Step-by-step repair instructions follow. In most cases, the particular component most likely to be faulty is specified. Quick tests to apply to it are explained. If part substitution is likely to be more effective than an instrument test, this is recommended.

PIX-O-FIX is applicable to all television receivers. Operation is clear and simple. Money-back guarantee if you're not more than satisfied!

NOTE! Ghirardi's PIX-O-FIX is designed and sold as a professional TV service device for servicemen—NOT as a "fix-it-yourself" gadget for use by consumers.

Only \$1. 10 DAY Money back Guarantee

Dept. RE-122 Rinehart Books, Inc., Technical Div.
232 Madison Ave., New York 16, N. Y.

Enclosed is \$1 for which please rush a PIX-O-FIX TROUBLE FINDER GUIDE. If not satisfactory, I will return it postpaid within 10 days and you guarantee to refund my \$1.

Name

Street

City, Zone, State

PRICE OUTSIDE U.S.A. \$1.25 cash—same return privilege.

Covers 24 common television troubles identified by actual TV screen photos

Covers 190 possible causes of these troubles identified and localized to the particular stage of the receiver where they are most likely to occur.

Covers 253 definite, easily understood remedies for these troubles

Covers 4,500 words in CAUSE and REMEDY section to explain step by step what to do.

The finest all-channel antenna ever made!

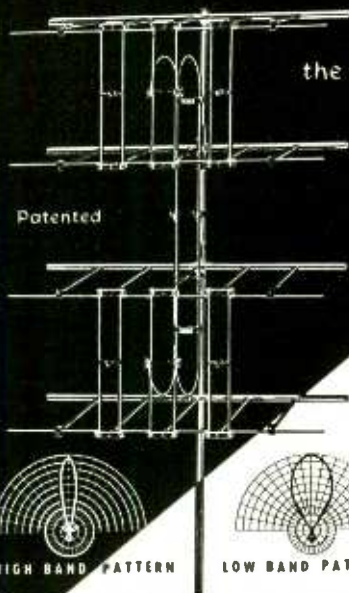

the SKYLINE

- ★ 28 fewer element connections
- ★ 8 integral elements VS. 40
- ★ Pre-assembled ★ Quick rigtime
- ★ Extra heavy—all aluminum
- ★ Amazing reception up to 150 mi.

The Skyline foldable colinear antenna possesses higher gain with respect to signal strength because the elements are integral!

No loss of signal strength through a multiplicity of mechanical connections.

Only the Skyline continues to maintain high gain with respect to signal strength over an indefinite period of time.

The Skyline colinear antenna, with its new engineering developments, is fast replacing all other types in fringe areas.

Request further information from your local dealer

SKYLINE MFG. CO. 1458C3 E. 17 St., Cleveland 14, Ohio



THE FUND'S RISE ENCOURAGING

HELP-FREDDIE-WALK FUND

It is most heartening to record the continued response to our appeal for contributions to "help Freddie walk." Freddie, as most of our readers now know, is the four-year-old son of Herschel Thomason, radio technician of Magnolia, Arkansas, and he has been without arms and legs since birth. Through the generosity of hundreds of readers, individually and in groups, the Help-Freddie-Walk Fund has grown to over \$10,000, and it is this aid which has helped make it possible for doctors to fit little Freddie with artificial legs, thus starting him on the way to becoming a useful and contributing citizen.

We would like to take this opportunity to make special mention of the following donations:

\$31.00 from the military, civilian, and contractor-technician personnel of the Communications and Electronics Engineering Division, Far East Air Logistic Force, Japan.

\$16.00 from the Purchasing Department of the United Motor Service division of General Motors Corp., Detroit, Michigan.

\$20.00 from John Abney and G. P. Handytin, Beirut, Lebanon.

\$1.21 from De Marco's Radio Shop, New Haven, Connecticut.

\$15.00 from the Staff, Committee on Electronics, Research and Development Board, Washington, D. C.

\$1.00 from Roscoe D. Conklin, Rahway, New Jersey, whose father is paralyzed and bedridden, whose brother is seriously ill with cancer of the jaw, and who knows "what heartaches are."

But our work is just beginning, for it is obvious that before Freddie reaches full maturity the mechanical appliances upon which he will always depend will have to be altered or changed completely time and time again.

Donations to this worthy cause are therefore urgently requested; no amount is too small to receive an acknowledgment and the sincere thanks of both RADIO-ELECTRONICS and Mr. and Mrs. Thomason. Make all checks, money orders, etc., payable to Herschel Thomason. Address all letters to:

HELP-FREDDIE-WALK FUND
c/o RADIO-ELECTRONICS Magazine
25 West Broadway
New York 7, N. Y.

FAMILY CIRCLE CONTRIBUTIONS
Balance as of September 19, 1952 \$ 561.50
Edith Trainor, West Hempstead,
L. I., N. Y. 10.00

FAMILY CIRCLE Contributions as of October 20, 1952 \$ 571.50

RADIO-ELECTRONICS CONTRIBUTIONS
Balance as of September 19, 1952 \$ 9,443.26
A. C., Los Angeles, California 1.00
John Abney and G. P. Handytin,
Beirut, Lebanon 20.00
Anonymous, Juneau, Alaska 10.00
Anonymous, Lafayette, Indiana ... 1.00

RADIO-ELECTRONICS

GIANT SAVINGS

for Christmas Delivery



Prices Cut on Radios & Phonos—Great to own, Wonderful to Give!

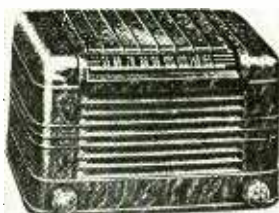

5-Tube, AC/DC Superhet RADIO

Table model radio of famous make with illuminated dial, glistening plastic cabinet, automatic volume control.

- Licensed by RCA.
- 5-Tubes, incl. rect.
- AC/DC superhet. circuit
- Alnico V speaker
- 540 to 1650 KC (560 to 182 meters)
- 6 tuned circuits
- Built-in loop antenna

Dealer Net: lots of 4: **\$14.95** ea.

The ROSE Co.

100 Park Place—Dept. E-12
New York 7, N. Y.
COrtlandt 7-6195

Tubes

Terrific Buys!
BRAND NEW STANDARD BRANDS,
FULLY GUARANTEED,
INDIVIDUALLY BOXED

024	\$.55
1B389
1X2A89
5U465
6AG580
6AL560
6AQ565
6AU660
6BC575
6BD6	1.79
6BL7	1.10
6BN699
6BD699
6CB675
6FR99
6L6GA	1.35
6L685
6SA760
6SN782
6T879
6V665
6W460
12BH7	1.10
12AU799
12AT799
12BM7	1.10
25BQ699
25L660
35L663
35W444
35Z547
39/4449
50L663

All other Tubes in Stock

PHONOGRAPHS

Guaranteed, Brand New, Sealed Cartons

2-Watt powerful amplifier, 115 V. AC, Alnico V PM Speaker, volume control switch; heavy duty constant speed motor, shock-proof, covered in beautiful simulated leather.

Single speed: Lots \$12.95 ea. of 3:
3-Speed: Lots \$16.95 ea. of 3:
3-Speed with VM Automatic Changer, plays all size records: Lots \$42.50 ea. of 3:



Radio-Phono Combination with 3-speed automatic record changer and 5-tube radio.....\$55.50

Rose Saves You Many Dollars! ANTENNA KITS

New antenna kits contain everything needed for a complete, satisfactory installation. NOW is the time to replace those old rusty worn out antennas with these brand new aluminum jobs. Enjoy the millions of dollars of TV entertainment now on the air. Don't miss a single show because of poor reception!

- No. K-21 KIT includes:
1-8 element conical antenna
75 ft. highest quality 300 ohm wire
2-6 ft. 1 1/2" steel mast sections
2 mast stand-off insulators
4 screw-eye standoffs
1 all-angle base mount
1 UL approved lightning arrester
No. K-22 KIT includes:
Same as above except that it includes 2-8 element conical antennas and 1 set of stacking bars.

Save! Dealer \$6.99 Net: Complete Kit
Terrific Buy! Dealer \$9.99 Net: Complete Kit

MIN. ORDER: \$5.00. 25% with order, balance COD. Include postage with order. All merchandise subject to prior sale. Prices subject to change without notice. FOB New York City.

New Proximity Probe

TESTS ALL TV HI VOLTAGE SUPPLY SYSTEMS

INSTANTLY checks hi-voltage transformer action-horizontal oscillator-sweep output-damper-hi-voltage rectifier, etc. Used under actual operating conditions. Determines exact procedure to trouble shoot no raster problems and intermittents. No connections—no shocks—saves time-clips in pocket. Used by professional TV servicemen for home calls and bench work. Complete instructions enclosed.

Send check or M.O. Postpaid U.S.A. Net **\$3.95** Fully Guaranteed

SERVICE PRODUCTS CO.

Box 215 Lawrence, Mass.

TELEVISION

Big demand for graduates

B.S. DEGREE in 27 MONTHS in radio including TV engineering—VHF, UHF, AM and FM. Students use over \$100,000 worth of equipment including 2 large commercial type transmitters in new TV lab. Intense specialized course includes strong basis in mathematics, science and advanced design in radio and TV.

Hundreds of young men each year are earning engineering degrees in this recognized institution. Start any quarter. Many earn a major part of expenses in this industrial center. Low tuition. Competent instruction. Thorough, intense, practical program. Also B.S. DEGREE in 27 MO. in Aeronautical, Chemical, Civil, Electrical and Mechanical Engineering. G.I. Gov't approved. Enter Dec., March, June, Sept. Free catalog. ENROLL NOW

INDIANA TECHNICAL COLLEGE
17122 E. Washington Blvd., Fort Wayne 2, Indiana



RELAYS ... WORLD'S LARGEST STOCK!



Your requirements of large or small quantities of relays can be quickly supplied from our huge stock.

Wide variety of types, all made by leading manufacturers. Each relay is brand new, inspected and fully guaranteed by Relay Sales.

- ✓ STANDARD TELEPHONE RELAYS
- ✓ SHORT TELEPHONE RELAYS
- ✓ DUAL TELEPHONE RELAYS
- ✓ SLOW ACTING RELAYS
- ✓ SEALED RELAYS
- ✓ ROTARY RELAYS
- ✓ MIDGET RELAYS
- ✓ KEYING RELAYS
- ✓ DIFFERENTIAL RELAYS
- ✓ PLATE CURRENT RELAYS
- ✓ ANTENNA SWITCHING RELAYS
- ✓ "BK" SERIES
- ✓ STEPPERS & RATCHET RELAYS
- ✓ LATCHING & INTERLOCKING RELAYS
- ✓ MECHANICAL ACTION RELAYS
- ✓ VOLTAGE REGULATORS
- ✓ OVERLOAD & CIRCUIT BREAKERS
- ✓ REVERSE CURRENT RELAYS
- ✓ AIRCRAFT CONTACTORS
- ✓ MOTOR & CONTROL DEVICES
- ✓ TIMERS
- ✓ SOLENOIDS
- ✓ RELAY ASSEMBLIES



New
RELAY SALES CATALOG NOW READY

WRITE FOR YOUR COPY TODAY



833 W. CHICAGO AVE.

DEPT. 10, CHICAGO 22, ILL.

DECEMBER, 1952

Anonymous, Jamaica, New York ..	5.00
John E. Bilane, Union, New Jersey .	1.00
Roscoe D. Conklin, Rahway, New Jersey	1.00
De Marco's Radio Shop, New Haven, Connecticut	1.21
Anthony Grande, Nutley, New Jersey	2.00
Michael Kebles, Bayonne, New Jersey	1.00
S/Sgt. Alfred D. LaFlamme, Mosu Lake, Wash.	1.00
Robert K. Marck, Detroit, Michigan Military, civilian and contractor technician personnel of the Communications and Electronics Engineering Division, Far East Air Logistic Force, Japan	31.00
H. J. Pion, Taftville, Connecticut ..	2.00
Anthony J. Punteir, Lake City, Florida	10.00
Purchasing Dept., United Motors Service Div., General Motors Corp., Detroit, Michigan	16.00
Sybil Romano, St. Louis, Missouri ..	1.00
Joe and Jean Royer, Pilot Rock, Oregon	5.00
Alan Smith, Middletown, Conn. ...	2.00
Staff, Committee on Electronics, Research and Development Board, Washington, D. C.	15.00

RADIO-ELECTRONICS Contributions as of October 20, 1952 ... \$ 9,571.47
FAMILY CIRCLE Contributions ... 571.50

TOTAL CONTRIBUTIONS as of October 20, 1952 ... \$10,142.97

MINE DETECTOR, M.D.

Mine detector outdoes X-ray. According to an item in the Montreal *Daily Star*, hospital X-rays failed to find a piece of metal imbedded in a man's arm. The injured man, Charles Hooper of Yorkton, Saskatchewan, turned to friends in the City Works Dept., who pinpointed the fragment with a mine detector used for locating buried sewer connections. Subsequent X-rays proved the mine detector right.

Radio Thirty-Five Years Ago
In Gernsback Publications

HUGO GERNSBACK	
Founder	
Modern Electrics	1908
Wireless Association of America	1908
Electrical Experimenter	1913
Radio News	1919
Science & Invention	1920
Television	1927
Radio-Craft	1929
Short-Wave Craft	1930
Television News	1931

Some of the larger libraries still have copies of **ELECTRICAL EXPERIMENTER** on file for interested readers.

December 1918 ELECTRICAL EXPERIMENTER

- Wireless Around the World, by H. Gernsback
- Harvard Hails the Naval Radio Man
- A Rotary Quenched Spark Gap, by Francis R. Pray
- A High Note Buzzer, by George F. Harrington
- Radio Around the World
- A Clever Wireless Practice Set, by T. G. Grantham
- A Perforated Tape Code Teacher, by A. E. Hersee
- An Imitation "Stage" Radio, by G. B. Pennebaker

END

New Portable Battery-Operated Spring-Motor Tape Recorder

The Magnemite*

For all field recording without AC power! Smaller and lighter than a portable typewriter, the Magnemite* actually makes field recordings that can be played on any studio console equipment. Completely self-powered, the Magnemite* does away with bulky and cumbersome generators, storage batteries and rechargers.

Just check these unusual features:

- Noiseless and vibrationless governor-controlled spring-motor assures constant tape speed.
- 100 operating hours per set of inexpensive flashlight-type dry cell batteries.
- Earphone monitoring while recording, and earphone playback for immediate quality check.
- Operates in any position, and is unaffected by movement or vibration during operation.
- Warning indicator tells when to rewind, and shows when amplifier is on.
- Broadcast models weigh 15 pounds. Slow-speed models weigh only 10 pounds.
- Requires no more desk space than a letter-head, measuring only 11 x 8½ x 5½ inches.

There's a choice of 5 different models for any recording need. High fidelity units, meeting primary and secondary NARTB standards, which record and play back frequencies up to 15,000 cycles, are available for broadcast stations, critical music lovers, and scientific research. For investigation, missionaries, reporters, and general dictation while traveling, there are units which play up to 2 hours per reel of tape.

Write today for complete descriptive literature and direct factory prices.



AMPLIFIER CORP. of AMERICA

398 Broadway, N. Y. 13, N. Y.

*Trade Mark Reg.

NEW! GONSET UHF-TV PRODUCTS

VHF/UHF GONSET LINE

Another First!
by the originators
of prefabricated
open wire line.



Gonset Part #1499

Closer spacing restricts r.f. field at UHF. 375 ohm surge impedance requires no special matching to 300 ohm circuits. Unlike "ribbon" type line using either continuous or perforated polyethylene web, the UHF attenuation of VHF/UHF GONSET LINE increases only moderately when it is wet.

UHF RHOMBIC



Gonset Part #1529

High gain and excellent directivity characteristics together with a rugged mechanical structure, all at a modest price are obtained in this optimized GONSET UHF RHOMBIC. Uniform gain of approximately 8 db from channel 14 through 65 (compared to a matched, resonant dipole). Sharp forward pattern minimizes the need for "probing" when installing. Amplitude of spurious lobes is sufficiently low to reject ghosts in over 99 per cent of installations.

UHF PARABOLIC

A parabolic sheet type antenna using a folded dipole. Construction avoids use of insulation. Ideal for use in locations where very strong rear reflections produce unusually difficult ghost problems. Gain 4 to 5 db over specified frequency range (referred to a resonant half wave dipole). Not intended for fringe area use, but rather as a moderately priced antenna having excellent rear rejection.

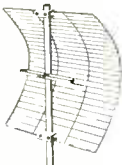

Gonset Part #1531-A	Channels 14-42
" " #1531-B	" " 25-65
" " #1531-C	" " 42-83

UHF CORNER REFLECTOR

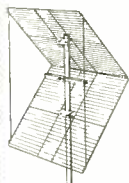

A sturdy, well designed array of the corner reflector type, using a folded dipole and 90 degree reflector. Gain of approximately 8 db is comparable to that of the GONSET UHF RHOMBIC, but forward response is somewhat broader and back response somewhat lower. Use of a folded dipole eliminates the need for an insulator, and permits a good impedance match to 300 ohm or 375 ohm line. Ideal for use where high gain is required and strong reflections from the rear make necessary an antenna which is virtually "dead" off the back.

Gonset Part #1535-A	Channels 14-42
" " #1535-B	" " 25-65
" " #1535-C	" " 42-83

GONSET CO.

RE



801 S. Main St.
Burbank, Calif.

Please RUSH new UHF-TV ENGINEERING BROCHURE

Name _____

Address _____

City _____

Zone _____

State _____

SCHOLARSHIPS HELP, TOO

Dear Editor:

I read your comment on Mr. Richards' letter in the October issue with considerable amazement, and wonder if you have considered *scholarships*. I studied in the "expensive" East—at Amherst—and tuition, room, board, books, and fees ran to around \$1,100 to \$1,200 a year. Scholarships that pay up to \$600 a year are available. I suppose an engineering school like M.I.T. costs more, but anyone who can maintain a B average and really needs the money should be able to qualify for enough scholarship funds to keep the cost down to \$1,000 a year.

If you are interested in a scholarship, apply as early as possible to the school itself, or see your high-school principal, your minister, your local newspaper (if you ever had a paper route), or any of the large fraternal organizations like the American Legion, Masons, or Odd Fellows. They may either have scholarships available, or know where you can apply for them.

IRVING L. CHIDSEY

Aberdeen, Md.

(According to the American Schools & Colleges Association, the current cost of a full school year at Massachusetts Institute of Technology is \$1,775. This includes tuition, books, fees, room and board, and insurance. In addition to the private organizations mentioned in Mr. Chidsey's letter, many states offer full or partial scholarships, based on either your school record or competitive examinations. *Editor*)

WHAT'S YOUR IDEA?

Dear Editor:

My item "Unusual Servicing Problem" on page 79 of the August issue posed the question: "How can a bad tube produce sounds and symptoms exactly like those created by a worn volume control, with these sounds audible only when the volume control slider is moved?" The volume control in this case was *not* defective.

Mr. Milton M. Schuman of Baltimore, a service technician since the "'20's," writes me that he has found this condition at times, and that it was caused by a loose tube element—usually the



"Are you sure it's a radar set we've had installed?"

WEBSTER CHICAGO—G.I.

3 Speed Record Changers

Fully automatic.
Plays all size records 7", 10", 12".
BRAND NEW.



G. I. CHANGER

OUR PRICE \$15⁹⁵

IMMEDIATE DELIVERY

\$47.50 List. 12"x12 3/4"

Long life needle incl. ORDER YOURS TODAY. Comes with RCA plug to attach to your radio or TV set. Metal base for above \$3.50. Fully guaranteed. Original factory cartons.

NOT MANY LEFT AT THIS PRICE
REPLACE YOUR OLD CHANGER NOW!
Webster #100 W/Turnover Cart. \$26.95
Webster #100-270 W/GE Cart. 32.95
Portable & Table Model Phonographs
Webster in carrying case with 3 Tube Amplifier and 5" Speaker 44.95
With 8" Heavy Speaker 47.95
Deluxe Model Equipped with GE Reluctance cartridge and Built-in Pre Amp 59.95
G I in Portable Case W/Amp 34.95
Additional \$8 for Table Model Cabinet

PHONO AMPLIFIER

3 tube amplifier 5" speaker volume and tone controls with tubes. Ready to operate. Same as used in portable phonographs \$7.95



Send \$10 on COD orders—immed. del.

JAN ELECTRONIC DIST. CO.

222 Fulton Street, N.Y. 7, N.Y.

OPPORTUNITY AD-LETS

Rates—35¢ per word (including name, address and initials). Minimum ad 10 words. Cash must accompany all ads except those placed by accredited agencies. Discount for 6 issues, 10%, for 12 issues, 20%. Misleading or objectionable ads not accepted. Copy for February issue must reach us before December 21, 1952.

Radio-Electronics, 25 W. Broadway, New York 7, N. Y.

SPEAKERS REPAIRED at wholesale prices. Guaranteed workmanship. Fast service. Amprite Speakers Service. 70 Vesey St., New York 7, N. Y.

WANTED: ALL TYPES OF RECEIVING AND TRANSMITTING TUBES. Surplus Receivers and Transmitters. Electro Mart, 163 Washington St., N. Y. C.

WANTED: ELECTRONIC COMPONENTS, ANY QUANTITY also laboratory equipment. Attractive prices. Send list to "Electronics," Box 72, Lawrence, Mass.

TUBES AND EQUIPMENT BOUGHT, SOLD AND EXCHANGED. For a fair deal send details to B. N. Genster, W2LNI, 136 Liberty, N. Y. 6, N. Y.

WE REPAIR, CONVERT, ALL TYPES OF ELECTRICAL instruments, tube checkers and analyzers, Hazleton Instrument Co. (Electric Meter Laboratory), 128 Liberty Street, New York, N. Y. Telephone—BARclay 7-4239.

WANTED—TOP PRICES PAID—Navy Selsyns 1DG, 1F, 1CT, 5CT, 5D, 5DG, 5G, 6G, 7G, etc. and BC-348, BC-221, AN/ART-13, AN/ARC-1, AN/ART-3, RTA-1B, AN/APR-4. Lectronic Research, 719 Arch St., Philadelphia, Pa.

WANTED: AN APR-4, other "APR.", "TS.", "TE.", ARC-1, ARC-3, ART-13, BC-348, etc. Microwave Equipment, everything Surplus. Special tubes, Tee Manuals, Lab Quality Equipment, Meters, Fast Action, Fair Treatment. Top Dollar! Littell, Farhills Box 26, Dayton 9, Ohio.

SWITCH TYPE TUBE TESTER, BURN-OUTS, SHORTS. Kit \$5.95. Wired and Tested \$7.95. Step-by-Step Radio Training. Write Master Kit Company, Box 206, Belleville, Ontario.

BUY WHOLESALE—25,000 ITEMS—CATALOG 254. Matthews, 1472 P2 Broadway, N. Y. C. 36.

ALL TYPES OF ANTENNAS FOR AMATEUR AND TV. Aluminum Tubing. Willard Radio, Fostoria, Ohio.

TV AND FM ANTENNAS, YAGI, CONICAL, BOW-TIE Mounts, accessories. Lowest prices. Wholesale Supply Co., Lunenburg 2, Mass.

FOR SALE: Brand New Guaranteed Quality Tested Tubes at 70% off list. Many other items. Write for circular, Williams Electronics Co., 168 Washington St., New York 7, N. Y.

ENJOY 3 COLOR TELEVISION SCREEN. SEND \$1.50. State Screen Size. Zingo Products, Dept. K, Johnstown, New York.

control grid. When the loose grid touches the screen "you get an awful racket," says my correspondent. This is usually started by vibrations from the speaker at high volume levels.

It sounds logical. And coming from an older, wiser, more experienced technician than myself, I'm inclined to accept this explanation. Does anyone have a better answer?

J. D. AMOROSE

Richmond, Va.

Mr. Amorose's Tech-Note in the August issue concerning a defective tube that gave the effect of a bad volume control reminded me of a similar experience. Turning the control past the first third of the arc would cause a muffled scraping sound, with a thump and an erratic shift in volume at full rotation. There was also too much hum.

The volume control was replaced, but with absolutely no change in results. A rather elaborate three-circuit compensator of the feedback type had been connected to the high end of the control. When this was disconnected, the noise disappeared and the hum level went down.

After many unsuccessful attempts to cure the trouble, the entire compensator unit was finally placed in a shield can with the leads brought out through shielded wire. All shielding was grounded, of course. No certain explanation was ever figured out, but this cured the trouble completely, even when the original volume control was re-installed.

R. C. SANDISON

Denver, Colo.

I read with a great deal of interest Joseph Ambrose's mystery problem "Unusual Servicing Trouble" in the August issue. It appears to me that he had a gassy 6F5, which was making the grid go positive. The gas current flowing in the grid circuit shifted the bias and varied the volume erratically from high to low.

GEORGE P. OBERTO

Richmond, Va.



"H'lo—Acme Distributors—say about that booster I called in for yesterday."

DECEMBER, 1952

SAVE WITH NATIONAL ELECTRONICS

SPECIALISTS in TV ANTENNAS

ACCESSORIES AND EQUIPMENT FOR ALL LOCATIONS

Rocket DIRECTRONIC MOTORLESS TV ANTENNA

360° Electronically Switched Beam

- No Motors
- No Roof Orientation
- No Electric Power
- No Ghosts

AX-599 Direc-tronic, As shown **\$16.95**

Flick of Switch Clears Picture Instantly
Provides same clear pictures as rotating aerials costing 4 times as much. Electronically beams in all directions with full 360° rotation. You select direction with Directronic Beam Selector located at set. Model AX-599 stacked array includes 18 bistensile aluminum elements, 1 set connecting stubs, Universal U-Clamps for mast, Directronic Beam Switch, and 75-feet of TRI-X lead in.

Model AX-59 Directronic 9-element Single... **\$10.35**

Rocket SUPER GAIN 10 ELEMENT YAGI
Designed for finest pictures in ultra-fringe weak signal areas. **TWIN-DRIVEN** for Channels 2-6—Uni-driven for Channels 7-13. Single array—11 db gain. Stacked array 14 db gain. Less mast.

Channels 2, 3 or 4... **\$21.00**
Channels 5 or 6... **\$18.60**
Channels 7-13... **\$8.50**

LOWEST PRICES ON ANTENNA ACCESSORIES

Mast Steel (Dualcoated 5' crimped) 1 1/4" O.D. **\$1.05**
Mast Steel (Dualcoated 10') 1 1/2" O.D. **1.95**
Mast Connectors for 1 1/4" O.D. mast... **.59**
Chimney Mount Complete with Straps... **1.19**
Galvanized Steel Guy Wire—1 1/2/20... **12¢ ft.**
Rocket Twin-Lead (will take up to 1 1/2" O.D.)... **1.59**
Lightning Arrestor-TV... **.69**
Galvanized Steel Guy Wire—6/20... **3¢ ft.**
Galvanized Steel Guy Wire—11/20... **12¢ ft.**
Rocket Twin-Lead—7/28 stranded... **2¢ ft.**
±100 Mil Lo-Loss 10 strand Twin Lead... **4¢ ft.**
Rocket Open Line Twin-Lead (500' reel)... **20.95**
Mast Stand-off Insulators—3" ... **.10**
Stand-off Screw Insulators—3" ... **.03**
Wall Bracket—6" clearance... **1.49**
Wall Bracket—12" clearance... **2.49**

ALL PRICES F.O.B., CLEVELAND, OHIO
Do not remit more than complete purchase price. Pay shipping charges on receipt of goods. 25% deposit on C.O.D. orders, please. Money-back guarantee.

ROCKET 5 ELEMENT YAGI
EXCELLENT PICTURES IN FRINGE AREAS

Designed for high gain with minimum interference from ghosts and noise due to directive pattern. Produces clear sharp pictures. 5 heavy aluminum elements include one folded dipole, one reflector, three directors. Strong molded insulator. Non-slip mast clamp. Completely pre-assembled, less mast.

Channels 2, 3 or 4... **\$7.95**
Channels 5 or 6... **\$6.95**
Channels 7 through 13... **\$3.95**

When ordering specify exact channel number desired.

Perfect Pictures in Fringe Areas

Rocket SUPER-FRINGE ANTENNA —FOR ALL CHANNELS

This truly sensational TV antenna is THE ANSWER to super-fringe area reception. Twenty-four driven elements provide a balanced all-channel db gain that produces astounding results at 125 or more miles from transmitter. For the ultra-fringe location, we strongly recommend this powerful antenna as the "Finest All-Channel TV Antenna On The Market Today". Model 400-E **\$27.95**

- 29 Anodized Aluminum Elements (guaranteed against staining or tarnishing)
- Solid Cast Aluminum Back-up Blocks
- Plexi-glass Hi-dielectric Insulators
- Aluminum Washers and Stand-offs
- Calcium-plated Nuts & Bolts
- 3/16" Dowel Pins
- Light Weight—no thrust bearing required on Rotor for average installation
- Size: 92" wide—80" high

Look At These Amazing Features!

- Clears pictures up to 125 miles and more from station!
- 12 driven elements on high band!
- 12 driven elements on low band!
- High Gain—low noise ratio!
- One transmission line!
- Total weight only 8 lbs.!

Conicals—8 element array... **\$3.95**
Stacked 2 Bay array with tie rods... **8.65**

Prices Subject to Change without Notice

National Electronics OF CLEVELAND
THE HOUSE OF TV VALUES

212 Delco Building, Cleveland 3, Ohio

NEW! MOSLEY WALL-THRU

For TV, FM and Amateur Transmission Line



- Fits Any Wall Up To 13" Thick!
- Completely Weather-Proof!
- For Standard Flat 300 Ohm Line or RG-59/U Co-ax Cable!
- MOSLEY Lead-In Socket Can Be Mounted Direct To Inside Plate!
- Precision Molded Polystyrene End Plates!
- Easily, Quickly Installed!

Cat. No. 625 List Price **\$1.95**

Cat. No. 625-PK WALL-THRU, complete with MOSLEY Universal TV Lead-In Socket and Plug. List Price **\$3.00**

MOSLEY ELECTRONICS

2125 Lackland Road

Overland, Missouri

OVER 50,000 TECHNICIANS HAVE LEARNED

HOW TO GET THE MOST OUT OF BASIC TEST EQUIPMENT



ONLY **40¢**
103 pages. Invaluable information that will help you re-double the value of your basic test equipment.

'SERVICING BY SIGNAL SUBSTITUTION'
A BEST SELLER FOR OVER 12 YEARS!
(NEW, UP-TO-DATE, 12th EDITION)

The Modern, Simplified, Dynamic Approach to Receiver Adjustment & Alignment Problems.

- Nothing complicated to learn
- No extra equipment to purchase
- Universal... non-obsolete
- Employs only Basic Test Instruments

Ask for "S.S.S." at your local Radio Parts Jobber or remit 40¢ in small stamps or coin directly to factory.

PRECISION APPARATUS COMPANY, INC.
92-27 MORACE HARDING BLVD., ELMHURST 4, N. Y.



QUIET...

USE
'Q-T'
FOR
**QUIET CONTROLS
and CONTACTS**



ONE DROP

- Cleans and preserves all controls and contacts
- Eliminates noise
- Retards corrosion
- Harmless to insulation and soldered joints
- Sediment-free
- No sediment on contacts

69¢

Full 3-ounce bottle

Buy a bottle today at your Grayburne parts-distributor

ONE DROP KEEPS IT ON THE "Q-T"

GRAYBURNE

103 Lafayette Street, New York 13, N.Y.

GET INTO ONE OF THESE GREATER OPPORTUNITY FIELDS

Electricity or Radio-Television

TRAIN IN THE GREAT SHOPS OF COYNE

OLDEST, BEST EQUIPPED SCHOOL OF ITS KIND IN U. S.

Come to the Great shops of Coyne in Chicago. Get practical training in TELEVISION—RADIO—ELECTRICITY—ELECTRONICS—vital in Defense Program. Prepare now for a better job in Industry or higher rating in Armed Forces.

Approved for Veterans—finance plan—enroll now, pay most of tuition later. Part time employment service while training if needed. Special tuition plan for men of Draft Age.

FREE BOOK Clip coupon for Big Free Illustrated Book. No obligation. No salesman will call. Act NOW.

B. W. Cooke, President

COYNE SCHOOL

A TECHNICAL TRADE INSTITUTE CHARTERED NOT FOR PROFIT
Established 1899
500 S. Paulina, Chicago

ELECTRICITY ★ TELEVISION
RADIO ★ REFRIGERATION ★ ELECTRONICS

B. W. COOKE, Pres.
COYNE School
500 S. Paulina St., Chicago 12, Ill. Dept. 81-H

Send FREE BOOK and details on:

RADIO-TELEVISION ELECTRICITY

NAME.....

ADDRESS.....

CITY.....STATE.....

Any or all of these catalogs, bulletins, or periodicals are available to you on request direct to the manufacturers, whose addresses are listed at the end of each item. Use your letterhead—do not use postcards. To facilitate identification, mention the issue and page of RADIO-ELECTRONICS on which the item appears. All literature offers void after six months.

VIBRATOR DATA

A guide giving the type number of James Vibrapowr vibrators designed for direct replacement in approximately 70 different models of mobile communications receivers and transmitters made by 13 of the leading communications equipment manufacturers. Also available is a 4-page bulletin, *Using Your Oscilloscope in Vibrator Maintenance*. It gives details on adjusting the scope, setting up the vibrator for testing, and on analyzing waveforms to determine the condition of the vibrator.

Available free of charge from The James Vibrapowr Co., 4036 N. Rockwell St., Chicago 18, Ill.

NEW CAPACITOR CATALOG

Catalog No. 1117 is a 7-page bulletin describing the *Stabelex-D* capacitors made by Industrial Condenser Corp. The new capacitor type is characterized by extremely high insulation resistance and Q, very low dielectric absorption, losses, and power factor, and low temperature coefficient. The long time-constant (200 days for a 10- μ f capacitor) makes these units highly applicable for use in computing and timing devices where information must be stored for extended periods.

Copies of catalog 1117 can be obtained without charge from Industrial Condenser Corp., 3243 N. California Ave., Chicago 18, Ill.

HIGH-FIDELITY BROCHURE

A 20-page booklet with sections on selecting loudspeakers, how to listen to a loudspeaker demonstration, selecting enclosures, and similar valuable information for the layman has been released by Jensen Mfg. Co. The catalog pages consolidate Jensen's high-fidelity speakers, 2-way system components and cabinets. New items of interest include a triplex 3-way complete reproducer in a back-loading folded-horn cabinet, 3-way system components, and a 12-inch compression-driver coaxial.

Request brochure 1020 from the Jensen Manufacturing Co., 6601 S. Laramie, Chicago, Ill.

DATA BOOK AND CATALOG

The new 42 page 1952 edition of the *Wheleco Data Book and Catalog* is now available. It contains prices, application recommendations and pertinent information concerning instrument sensing units and associated accessories.

Special items are resistance bulbs and wells, radiation (heat) detectors,

for dependable sound,
INDUSTRY relies on
ATLAS



DR Double-Reentrant Projectors

DEPENDABLE QUALITY:

The latest electro-acoustic research and engineering—and over 20 years of manufacturing know-how—are behind every ATLAS product.

DEPENDABLE SERVICE:

Coast-to-coast and around the world today—in every Industrial, Marine, Railroad, Military, Educational, Civic, U.S. and Foreign Government application—under every kind of climate and noise condition—ATLAS sound equipment is famous for highest efficiency and durability. That's the proof of ATLAS performance dependability.

DEPENDABLE DELIVERY:

Yes, ATLAS gives our Government highest priority. And yes, we too feel the pinch of material shortages. But our customers will continue to get our usual dependable delivery—because we believe in equitable and dependable distribution to all ATLAS users.

DEPENDABLE PROFITS:

Completeness of line, excellence of product, dependable delivery, right prices—that's the ATLAS combination that means high, steady Industrial Sound profits for You!

JUDGE for yourself. COMPARE ATLAS at your local Jobber today. See why ATLAS is the preferred line for utmost dependability. Write NOW for FREE latest Catalog 551.



Paging & Talk-Back Speakers



ALNICO-V-PLUS Driver Units



Dual Speakers

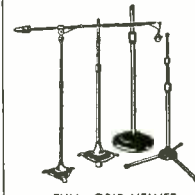

FULL-GRIP, VELVET-ACTION Mike Stands



ATLAS SOUND CORP.

1443-39th Street, Brooklyn 18, N. Y.

In Canada: Atlas Radio Corp., Ltd., Toronto, Ont.

EASY TO LEARN CODE

It is easy to learn or increase speed with an Instructograph Code Teacher. Affords the quickest and most practical method yet developed. For beginners or advanced students. Available tapes for beginner's alphabet to typical messages on all subjects. Speed range 5 to 40 WPM. Always ready—no QRMM.



ENDORSED BY THOUSANDS!

The Instructograph Code Teacher literally takes the place of an operator-instructor and enables anyone to learn and master code without further assistance. Thousands of successful operators have "acquired the code" with the Instructograph System. Write today for convenient rental and purchase plans.

INSTRUCTOGRAPH COMPANY

4701 Sheridan Rd., Dept. RC, Chicago 40, Ill.

RADIO-ELECTRONICS

LEARN CODE AND THEORY AS LOW AS \$6.95

ECONOMICAL HOME STUDY COURSES PREPARE YOU TO PASS AMATEUR AND COMMERCIAL CODE EXAMS, AND AMATEUR THEORY EXAMS THE EASY, FAST WAY. BEAT THE ADVANCED CLASS DEADLINE (closes Dec. 31).



78 RPM

3 "AMECO" COURSES AVAILABLE:

#1—NOVICE CODE COURSE. You get and keep 10 recordings (alphabet through 8 W.P.M.). Includes typical F. C. C.-type code exams. Free instruction book on learning how to send and receive code the simplest, fastest way, plus an album; plus charts to check your receiving accuracy all for the low price of only **\$7.95**

#2—SENIOR CODE COURSE. You get and keep everything given in the Novice Course except that you get 22 recordings (alphabet through 18 W.P.M.) plus typical F. C. C. type code exams for General class and 2nd class commercial telegraph licenses. All this for **\$12.95** only.

#3—COMPLETE RADIO THEORY COURSE. A complete, simplified home study theory course in radio covering the Novice Technician, conditional, general, and advanced classes—all under one cover—with hundreds of typical F. C. C. type questions to prepare you for license exams. No technical background required. You also get, FREE, one year of consultation and a guide to setting up your ham station. All for the amazingly low, low price of **\$6.95**

All Courses Have Money-Back Guarantee
Order Today or Write for Free Information

AMERICAN Electronics Co., Dept. RE12
1451 Wilkins Ave., N.Y. 59,
Tel. No. DAYTON 9-4815

UHF BOOSTER—CONVERTER



The SEC Booster-Converter is a combination VHF booster and a UHF converter in one compact unit. The unit enables any TV receiver now being manufactured to receive UHF signals and also have the booster necessary for VHF in fringe areas. It employs its own power supply, a crystal mixer and two tubes, a 6AF4 and a 6J6.

Your Cost
\$37.50
10% cash with order

ALMO RADIO CO.
509 ARCH ST. & 6205 MARKET ST.
Philadelphia, Pa.
6th & ORANGE STS. • Wilmington, Del.
4401 VENTNOR AVE. • Atlantic City, N. J.
1133 HADDON AVE. • Camden, N. J.
219 Highland Ave. • Salisbury, Md.

METERS

WESTON • SANGAMO

ALL NEW. ALL D.C. 2" SQUARE

 <p>0—5 Ma 0—15 Ma 0—50 Ma 0—100 Ma 0—200 Ma 0—300 Ma 0—500 Ma</p>	<p>\$3.29 EACH</p> <p style="text-align: center;">or 3 for \$9.00</p>
-------------------------------------------------------------------------------------------------------------------------------------------------------------------------------	-------------------------------------------------------------------------------------------------------------------

0—2 Ma **\$3.95**

Mfg's Inquiries: Lots Over 100

Cash with order. Prices subject to change without notice. California orders please include 3 1/2% Sales Tax. Approximate postage 25¢—Excess will be refunded. What Have You in Surplus? Submit

L. A. HAM SHACK
1306 BOND ST., at PICO, LOS ANGELES 15, CALIF.

special thermocouples for plastic injection and extrusion machines, and a molten metal thermocouple for ferrous metals. Essential data pertaining to thermocouples, wire sizes and resistances, and temperature-millivolt curves make this manual useful in applying indicating, controlling, and recording instruments.

Copies of Bulletin TC 9 gratis upon request from Wheelco Instruments Division, Barber-Colman Co., Rockford, Ill.

CAPACITOR CATALOGS

Pyramid Electric Co., manufacturer of capacitors, announces the publication of four new catalogs. Specifications, construction and engineering data, sizes, and prices are featured.

Catalog PG-1 lists miniature Glass-seal capacitor types PGH, PGM, and PGX. These tubular paper units function at temperatures ranging from -55° to +125° C.

Catalog IMP-1 describes molded-plastic tubular capacitors, impervious to moisture and withstanding a temperature of 100° C.

Catalog MP-2 gives detailed information on ultra-compact metallized-paper types. Minimum size and weight and self-healing qualities are characteristic of these units.

Catalog J-7 is a 32-page compilation of paper, electrolytic, oil-paper, and metallized paper capacitors.

Free copies are available on letterhead request to Pyramid Electric Co., 1445 Hudson Blvd., N. Bergen, N. J.

TACO ANTENNA CATALOGS

Three new catalogs have just been issued on the Taco line of antennas and accessories. Catalog No. 37 is a 6-page bulletin illustrating and describing unidirectional and omnidirectional FM antennas and all-band noise-reducing and master antenna systems for AM and FM.

Catalog No. 38 covers the complete line of Taco TV antennas, boosters, and hardware. Catalog No. 39 covers the Tacoplex amplified distribution systems for apartment-house, community, and store installations. Included are channel converters which change a high-band signal to a low-band frequency to reduce circuit losses, signal separators for isolating low-band signals and feeding them to separate r.f. amplifier strips or boosters, mixer units, hardware, and accessories.

Copies of these catalogs can be obtained free of charge by writing to Technical Appliance Corp., Sherburne, N. Y. In Canada, write to Stromberg Carlson Ltd., Toronto 4, Ont.

HAMMARLUND CAPACITORS

Hammarlund's new catalog No. 52 describes the firm's present line of variable capacitors for amateur, commercial, and industrial applications. Each type of capacitor is illustrated by photographs and detailed engineering drawings.

Available free of charge from Hammarlund Manufacturing Co., Inc., 460 W. 34th St., New York, N. Y. END

COLOR TELEVISION



Color TV is just one of 30 modern subjects included in new I. C. S. course in *FM and Television Servicing*. (Other up-to-date, low-cost courses—391 in all. Engineering. Business. Special technical training. High School. Study in your spare time. Set your own pace. Individual instruction from experts. Diploma awarded. I. C. S. is oldest and largest. Known and respected the world over.

FREE "SUCCESS" BOOK! 36 pages packed with worthwhile tips on "How to Succeed." Gives you step-by-step plan of action. Pocket-size edition. Man or woman— young or old—if you make \$2000 or \$20,000 a year, this book can help you. Send for it *plus* free catalogs on career that interests you.

International Correspondence Schools,
Box 2879-H, Scranton, Pa.

Please send "How to Succeed" book and catalog on course in.....
Name.....Age.....
Address.....

RADIOS
1, 2 & 3 band Electric and/or battery

TELEVISION
AC/DC Operation

TEST INSTRUMENTS
Write for FREE Catalog

ARKAY—Radio Kits, Inc.
120 Cedar St., New York 6, N. Y.

FREE

Write today for "How to Service T.V. Receivers" with the HICKOK VIDEO GENERATOR.

Hickok Electrical Instrument Co.
10814 Dupont Ave., Cleveland, Ohio

QUIET...

USE
'Q-T'

Quiets
and Preserves



Radio and Television Controls and Contacts

ONE DROP

- Cleans and preserves all controls and contacts
- Eliminates noise
- Retards corrosion
- Harmless to insulation and soldered joints
- Sediment-free—No sediment on contacts
- Does not contain any artificial coloring

69¢ Full 3-ounce bottle

Buy a bottle today at your Grayburne distributor

ONE DROP KEEPS IT ON THE "Q-T"

GRAYBURNE

103 Lafayette Street, New York 13, N. Y.

Vee-D-X takes the lead in UHF—just as it did in VHF—with performance proven antennas for every UHF requirement. Shown below is the UHF Colinear by VEE-D-X. This high gain all-channel fringe area antenna is considered by one of the world's largest set manufacturers as the finest UHF performer yet perfected. Available also as side-by-side stacked array.

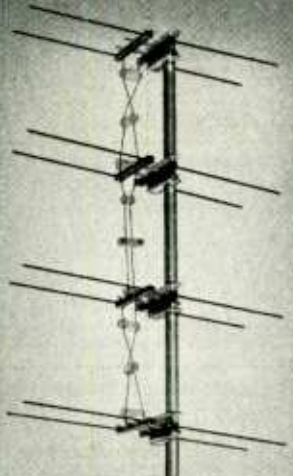

VEE-D-X
PERFORMANCE
PROVEN
UHF
ANTENNA
SYSTEMS



FREE!
 UHF ANTENNA
 GUIDE
 Tells how, what,
 and where for
 every area. Mail coupon
 for your copy.

THE LAPOINTE-PLASCOMOLD CORP.
 ROCKVILLE, CONNECTICUT

Gentlemen:
 Send.....copies of UHF Antenna Systems booklet
 NAME
 ADDRESS
 CITY..... ZONE..... STATE.....

RADIO ASTRONOMY. by Bernard Lovell and J. A. Clegg. Published by John Wiley & Sons, Ltd., 440 Fourth Ave., New York, N. Y. 5 1/2 x 7 1/2 inches, 238 pages. Price \$4.00.

Professor Lovell is already known to readers of this magazine through his article, "Radar Tracks Shooting Stars" in the July, 1951, issue. Five chapters of this book are devoted to the study of meteors by radio-echo techniques. The velocity of a number of meteor groups has been verified, at least two new daylight meteor showers have been discovered, and important studies on the orbits of meteor streams have done much to solve the question as to whether they are of solar-system or interstellar origin.

Other important work described by Professor Lovell includes the study of radio waves from the sun, from our own star system, and from points outside it. Four chapters are devoted to the signals received from our galaxy.

The aurora borealis, the moon, planets, and the zodiacal light are all discussed in connection with radio (and in some cases radar) investigations, and the possible results to be gained are estimated.

To make reading easier for the person who is neither an astronomer nor a radio technician, there are introductory chapters on fundamental astronomy and the transmission and reception of electromagnetic waves. Though an amateur astronomer may have some trouble comprehending the chapter on radio transmission and reception, the electronic technician will have little trouble with those on elementary astronomy, and will be able to follow the radio and radar techniques without any difficulty at all.—FS

RAPID TROUBLE SHOOTING AND ALIGNMENT by Harry G. Cisin. Published by H. G. Cisin, 200 Clinton St., Brooklyn 2, N. Y. 8 1/2 x 11 inches, 69 pages. Price \$2.00.

This practical book can aid TV service in many ways. Section 1 lists many troubles and shows possible causes. They are given on a combined picture-raster-sound basis. For example, certain troubles may cause abnormalities in all of these. Therefore we have three different clues to help localize the defect.

Each condition of picture, raster, and sound is given a symbol. These are combined in three-symbol codes, as in the author's earlier *Radio Doctor*. To discover a trouble, the technician looks up the symbol for each of the conditions, combines them into a code, and turns to the section under that code heading.

Section 2 gives useful data on rapid alignment. It contains hints on the use and connection of scopes, VTVM's and sweep generators. Section 3 includes a short description of the installation and service of u.h.f. antennas and tuners. Section 4 is especially valuable. It shows how to make many rapid checks. For example, there is information on testing for relative sensitivity, sync signal strength, damper potentials, crystal diodes, and others.—IQ

the only personal part of any communication system!

more LISTENING COMFORT with . . .

TELEX light weight headsets!

*MONOSET
 The modern styling and the dependability and superior performance of the TELEX Monoset have made old fashioned headphones obsolete. Magnetic.

*DYNASET
 New dynamic under-chin TELEX Dynaset, with more highs and lows of both music and speech, is the delight of radio and TV monitors. Weighs only 1.25 oz.

*TWINSET
 This lightweight 1.6 oz. TELEX Twinset pipes signal directly into the ear, blocking out ground noises and banishing listening fatigue. Magnetic.

*EARSET
 Sensitive TELEX Earset slips onto ear and is preferred by all who use single-phone headsets. Weighs only 1/2 oz. and leaves other ear free for phone calls or conversation.

Modern, lightweight, durable . . . Easily adjustable and built for hard usage. TELEX Headsets give top quality reception without the punishment of extra weight and pressure.

Office Transcribing Machines • Radio Monitoring • Telecasting • Amateur Radio • Record Stores • Theaters • Phone-Order Boards • Wired Music Installations • Commercial Communications • Electronic Laboratories.

Telex produces headsets to manufacturers' specifications

Trade Mark Standard of the World for Quality Headsets

For complete information on any of the above headsets, write

TELEX ELECTRO-ACOUSTIC DIV., Department, 4-D St. Paul 1, Minnesota

In Canada **ATLAS RADIO CORP., Toronto**

TELEX HEARING AT ITS BEST

THEORY IS EASY!

as taught by John T. Frye in

Basic Radio Course
 Gernsback Library Book No. 44
 176 Pages, 120 Illustrations.
 Durable hard cover. \$2.25

This 25-year veteran service technician-writer actually makes learning theory fun. All the fundamentals from Ohm's Law to advanced servicing stand out clearly. If you're strong on experience but weak on theory—don't pass this one up!

See page 86 for coupon

GERNSBACK PUBLICATIONS, INC.
 Publishers of Radio-Electronics
 25 West Broadway, New York 7, N. Y.

GET INTO TV SERVICING

Send for FREE 24-page illustrated booklet which tells you how to become a successful TV Technician. America's Leading TV Servicing School offers you a specialized training program that omits non-essential math & design theory. You concentrate on radio & TV servicing only. You get professional training & experience right in our fully-equipped shops & laboratories. Send for this Booklet today. Write Dept E-12. No obligation—no salesman will call.

APPROVED FOR VETERANS

WESTERN TELEVISION INSTITUTE
341 W. 18th St., Los Angeles 15, Calif.

World Famous Lincoln Engineering School Suspending Service!

Save on TEXT BOOKS



Course formerly sold for \$45!
Complete set 27 lessons, only . . .

\$5.95

• Famous radio-electrical engineering correspondence school, which graduated thousands into big-money positions, is suspending its service. High costs prevent continuing these popular courses.

• Limited number of complete courses available at fraction of tuition value.

• While they last, complete 27-lesson Electrical or Radio Course for only \$5.95 ppd. Combined Radio-Electrical courses, only \$9.95 ppd. Specify course.

LINCOLN ENGINEERING SCHOOL
Dept. 843 Lincoln, Nebr.

AUDELS TV-RADIO SERVICE LIBRARY

HERE IS LATE INFORMATION IN A HANDY FORM FOR RADIO & TELEVISION REPAIRMEN, SERVICEMEN & STUDENTS

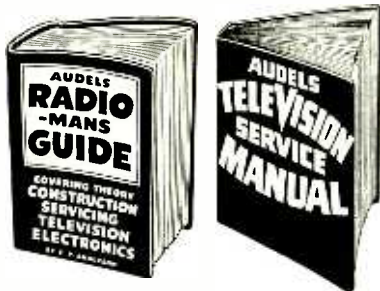

2 VOLS. \$6 COMPLETE \$1.00
IT PAYS TO KNOW!

AUDELS T.V.-RADIO SERVICE LIBRARY presents the important subjects of Modern Radio, Television, Industrial Electronics, P.M. Public Address Systems, Auto, Marine & Aircraft Radio, Phonograph Pick-Ups, etc. Covers Basic Principles—Construction—Installation—Operation—Repairs—Trouble Shooting. Shows How to get Sharp, Clear T.V. Pictures. Install Aerials—How to Test. Explains Color Systems & Methods of Conversion. 1001 Facts—Over 1260 Pages—625 Illustrations—Parts & Diagrams—Valuable for Quick Ready Reference & Home Study. Tells How to Solve T.V. & Radio Troubles—Answers T.V. & Radio Questions.

Get this information for Yourself.
7 DAY TEST—ASK TO SEE IT!

MAIL ORDER

AUDELS, Publishers, 49 W. 23 St., N. Y. 10
Mail AUDELS T.V. RADIO SERVICE LIBRARY 2 Vols. \$6 on 7 days free trial. If O.K. I will remit \$1 in 7 days and \$1 monthly until \$6 is paid. Otherwise I will return them.

Name _____
Address _____
Occupation _____
Employed by _____ RE

Unlimited Opportunities in RADIO ENGINEERING

DEGREE IN 27 MONTHS

Complete Radio Engineering course including telev., U. H. F. and F. M. Bachelor of Science Degree also in Mech., Civil, Elect., Chem., and Aero. Eng.; Bus. Adm., Acct. Extensive campus, modern buildings, well equipped labs. Low cost. Prep courses. Personalized, practical instruction. Founded 1884. Placement service. Growing shortage of engineers. Prepare now for unlimited opportunities ahead. Enter January, March, June, September. Write for catalog.



TRI-STATE COLLEGE

24122 College Ave. ANGOLA, IND.

FOR THE FIRST TIME!

For several years you've read about the Don Martin School now—for the first time—we are prepared to offer a course by mail. You can obtain your first class radio telephone operator's license from this special course. Operators are desperately needed now by radio and TV stations as well as the aircraft industry. Secure your future.

Be certain that your training is of the best, enjoy the school recognized by the profession. Write today for full information.

THE DON MARTIN SCHOOL OF RADIO AND TELEVISION ARTS AND SCIENCES
Correspondence Section
1655 No. Cherokee, Hollywood 28, Calif. HU. 2-3281.

TELEVISION-RADIO ELECTRONICS

Training in all branches television, radio and electronics. FCC exam. preparation. Write for free catalog.

COMMERCIAL RADIO INSTITUTE
(Founded 1920)

38 W. Biddle St., Baltimore 1, Md.
Approved by Maryland State Board of Education

GET INTO ELECTRONICS

You can enter this uncrowded, interesting field. Defense expansion, new developments demand trained specialists. Study all phases radio & electronics theory and practice: TV; FM; broadcasting; servicing; aviation, marine, police radio. 18-month course. Graduates in demand by major companies. H.S. or equivalent required. Begin Jan., March, June, Sept. Campus life. Write for catalog.

VALPARAISO TECHNICAL INSTITUTE
Dept. C Valparaiso, Ind.



LEARN TELEVISION

ELECTRONICS and RADIO
Engineering Laboratory and Classroom Training. Day and Evening Classes.

Write for illustrated Catalog

ELECTRONICS INSTITUTE, Inc.
21 HENRY, DETROIT 1, MICH.

RADIO and TELEVISION ELECTRONICS

in all Technical Phases
New Classes (Day & Evening)
Start 1st of Dec., Mar., June, Sept.
FREE PLACEMENT SERVICE
for GRADUATES

For Free Catalog write Dept. RC-52
RCA INSTITUTES, INC.
A Service of Radio Corporation of America
350 West 4th St., New York 14, N. Y.

RADIO ENGINEERING 27 MONTHS DEGREE IN

Intensive, specialized course including strong basis in mathematics and electrical engineering, advanced radio theory and design, television Modern lab. Low tuition. Self-help opportunities. Also B.S. degree in 27 months in Aeronautical, Chemical, Civil, Electrical, and Mechanical Engineering G.I. Gov't approved. Enter December, March, June, September. Catalog.

INDIANA TECHNICAL COLLEGE
1512 E. Washington Blvd., Fort Wayne 2, Indiana

Become an ELECTRICAL ENGINEER in 36 MONTHS

Bachelor of Science Degree — Major in Electronics or Power

It is estimated by 1955 there will be at least two positions for every engineering and technician graduate. This college offers a tested plan that permits you to enter these vast employment opportunities at an early date. Save a valuable year through optional year-round study. Receive advanced credit for prior training gained in the armed forces, other schools or field experience.

ENTER BOTH RADIO AND TELEVISION 12 months or one-third of the B. S. degree course (Electronics major)—also brings you the *Radio Technician's* certificate. An added 6-month course qualifies you for the *Radio-TV Technician's* certificate. Recent developments open unlimited opportunities for TV technicians and engineers.

THE PROVEN "UNIT CHASSIS SYSTEM" of teaching was developed here. It "breaks down" the TV set by stages. You learn every component of all types and makes — and are prepared for future design changes, including the advent of color.

12-MONTH TELEVISION SERVICE COURSE . . . trains for good servicing jobs and shop ownership in the shortest practical time under expert instructors.

Terms open January, April, July, October. Over 48,000 former students from all states and 23 overseas countries. Faculty of trained specialists. Modern laboratories and equipment.

Write for free 110-page catalog, 48-page pictorial booklet "Your Career" and "Occupational Guidance Bulletins."

MILWAUKEE SCHOOL OF ENGINEERING

NONPROFIT • FOUNDED IN 1903



Milwaukee School of Engineering
Dept. RE-1252, 1025 North Milwaukee
Milwaukee 1, Wisconsin

Without obligation send Catalog for Electrical Engineering, B. S. Degree, major in Electronics; Power; "Your Career"; Occupational Guidance Bulletin on: Radio-TV; Electrical Power; Welding; Heating, Refrigeration, Air Conditioning; Mechanical Engineering, B. S. Degree; Preparatory; Television Service.

Name _____ Age _____
Address _____
City _____ Zone _____ State _____

If veteran, indicate date of discharge _____

NEED ANY TUBES?

Make Barry your source for FAST-DELIVERY on all types. We carry all the standard brands. All tubes individually cartoned and carry Standard RMA Guarantee.

Tube Orders Over \$8.00 with full remittance Prepaid To You in USA.

Prior to shipment, all tubes INDIVIDUALLY retested (not just spot-checked) on our Hickok Mutual-Conductance Tube-Testers to insure you 100% perfect merchandise. For your maximum money's worth, buy in full confidence from TUBE-SPECIALISTS. Here is only a partial listing of our large stocks. You may order types not listed at approx. same savings.

OA2	\$.98	6AG5	..65	12AV6	..53
OB2	1.10	6AG7	..1.25	12BA6	..69
OC3/VR105		6AH6	1.00	12BA7	..90
	1.19	6AJ5	1.75	12BD6	..1.23
OD3/VR150		6AK6	..74	12BE8	..45
	.95	6AL5	..54	12C8	..79
OZ4	.59	6AN5	2.25	12H6	..75
1A7GT	.89	6AQ5	..55	12SA7	..75
1AE4	.90	6AR6	2.75	12SF5	..70
1B3GT	.81	6AT6	..63	12SG7	..70
1H5GT	.69	6AU6	..59	12SH7	..95
1N5GT	.74	6AV6	..55	12SJ7	..69
1L4	..60	6B8	..65	12SK7	..75
1LA6	..90	6BC5	..63	12SL7	..75
1N21-B	2.95	6BE6	..45	12SN7GT	..84
1N23-A	2.25	6BG6-G	1.39	12SR7-M	..75
1N23-B	3.49	6C4	..49	14F7	..80
1N34	..64	6C1B	..45	25AV5	1.25
1N34-A	..75	6CD6-G	1.55	25BQ6-GT	..79
1N44	1.21	6F6-M	..69	25L6GT	..64
1N45	1.39	6F8-G	..89	5B5	..40
1N48	..55	6G6-G	..95	5C5	..40
1N51	..51	6J5GT	..49	35L6	..69
1N52	1.71	6J7	..71	35Z5GT	..49
1N54	..89	6K7	..75	42	..65
1N63	3.81	6K6-GT	..59	50A5	..50
1N64	..72	6K7-M	..70	50L6-GT	..65
1N65	..84	6L5-G	..49	117Z6	1.00
1N67	1.23	6L6-G	1.19	304-TH	7.00
1N70	3.15	6L7	..98	304-TL	8.75
1N72	1.20	6N7-M	..98	117-A	..98
1N73	28.53	6O7-GT	..95	805	2.50
1N74	21.90	6P7-M	..80	707	1.59
1N75	3.33	6SD7	..79	811	2.95
1N81	2.58	6SG7	..88	811-A	3.50
1N84	..49	6SH7	..88	832	7.25
1X2A	..95	6SJ7-GT	..69	832-A	8.50
2B7	..75	6S7-M	..70	837	1.45
GL2C43	15.95	6SK7-GT	..60	866-A	1.55
2D21	1.35	6SL7-GT	..60	GE872-A	3.50
2E24	2.75	6SN7-GT	..75	1280	..80
2E30	2.19	6T8	..75	1613	..75
3A4	..59	6U4-GT	..65	1614	2.00
3D6/1299	..50	6V6-GT	..57	1616	..74
3Q4	..49	6W4-GT	..57	1622(16L)	1.95
3Q5GT/G	..99	6X5-GT	..52	1625	..40
3S4	..80	6Y6-G	..95	1629	..30
5FP7	1.95	7A6	..65	1631	1.50
5R4GY	1.29	7A8	..75	1632	..70
5U4-G	..55	7C7	..80	2050	1.48
5V4-G	1.10	7F7	..74	5516	5.95
5X4-G	..79	7H7	..80	5654	2.00
5Y3-GT	..43	12A6	..65	5910	..75
6AB4	..75	12AT7	..72	001	1.35
6A87	..98	12AU7	..69	9004	..39

SELENIUM RECTIFIERS

Current (Continuous)	Full-Wave		Bridge Types	
	18/14 Volts	36/28 Volts	54/42 Volts	130/100 Volts
1 Amp.	\$1.25	\$2.10	\$3.60	\$7.50
2 Amps.	2.20	3.60	6.50	10.50
2 1/2 Amps.	13.00
4 Amps.	3.75	..	8.75	..
5 Amps.	4.95	7.95	12.95	27.00
6 Amps.	5.50	9.00	14.00	33.00
10 Amps.	6.75	12.00	20.00	40.00
12 Amps.	8.50	16.00	25.50	50.00
20 Amps.	13.25	24.00	36.00	90.00
24 Amps.	16.00	31.00	39.50	98.00
30 Amps.	18.50	36.00
36 Amps.	25.50	45.00

New Selenium Rectifier Transformers
 PRI: 115 V. 50 cycles in } 4 Amps \$ 8.75
 SEC: 9, 12, 18, 24, and 36 } 11 Amps 16.75
 volts } 24 Amps 35.75
 Made to our specs for continuous, heavy-duty use.

• New Selenium Rectifier Chokes
 4 Amps.—.07 hy.—6 ohm \$7.95
 12 Amps.—.01 hy.—1 ohm \$14.95
 24 Amps.—.004 hy.—.025 ohm \$29.95

We can manufacture other Selenium Rectifiers, Selenium Rectifier Supplies, XFMRs. & Chokes. Write for literature.

• Baffle-Type SMC-100—Crystal Standards, 100 KC and 1,000 KC Bar New \$8.50

• AR-11—Complete Station for 20, 40, or 80 meters. Superhet Rcvr.—50 Watts CW w/built in 115 V.A.C. Pwr Supply. New—in compact suitcase (orig. cost over \$500) An excellent buy for only \$99.50
 • Weston Meters 0-100 micro amps. 2 1/4" Dial (Blank Scale) New Boxed. VERY Special \$5.95

BARREY ELECTRONICS CORP.

136 Liberty Street, N.Y. 6, N.Y. Rector 2-2562
 Terms: 25% with order, balance C.O.D.—Send a few cents for postage—All merchandise guaranteed. F.O.B. N.Y.C. *Please, minimum order \$2!*

ADVERTISING INDEX

Adeiman, Nat	131
Aero-Tone Mfg. Co., Inc.	111
All Channel Antenna	109
Alliance Manufacturing Co.	83
Allied Radio Corporation	111
Almo Radio Co.	127
American Electronics Co.	127
American Phenolic Corp.	92
Amperite Co., Inc.	119
Amplifier Corporation of America	123
Arky Radio Kits, Inc.	27
Astron Corporation	127
Atlas Sound Corp.	126
Audel Publishers	129
Barry Electronics Corp.	130
Belden Manufacturing Co.	10
Bell Telephone Labs.	26
Bendix Radio	87
Blonder-Tongue Labs.	15
British Radio Electronics Ltd.	111
Brooks Radio TV Corp.	116, 117
Burstein-Applebee Co.	90
Candler System Co.	102
Capitol Radio Engineering Institute	25
Chanter Master Corp.	3
Claroat Mfg. Co., Inc.	108
Cleveland Institute of Radio Electronics	9
Communications Equipment Co.	131
Concord Radio	103
Cornish Wire Co., Inc.	99
Coyne Electrical & TV Radio School	119, 126
Davis Electronics	120
DeForest's Training, Inc.	110
Edie Electronics	7
Electronic Instrument Co., Inc.	28, Inside Back Cover
Electronic Measurements Corp.	113
Espey Mfg. Co., Inc.	96
Faier Engineering Co.	82, 99
Finney Co.	102
General Cement	81
General Industries Co.	98
General Test Equipment	99
Gonsel Co.	124
Grayburne Corp.	126, 127
Greylock Electronic Supply Co.	115
Halidorson Transformer Co.	82
Harvard Labs.	117
Heath Co.	65 through 75 inclusive
Hickok Electrical Instrument Co.	127
Hudson Radio & TV Corp.	119
Hughes Research and Development Laboratories	82
Hytron Radio & Electronics Corp.	79
Indiana Technical College	122
Instructograph Co.	126
International Correspondence Schools	127
JFD Manufacturing Co., Inc.	124
Jan Electronics Distributing Co.	127
Jensen Manufacturing Co.	90
LaPointe-Piascomold Corp.	128
Leopone Radio Corp.	100
Los Angeles Ham Shack	127
Lyonart Engineers	98
Mallory & Co., Inc., P. R.	77
McGraw-Hill Book Co.	131
Merit Coil & Transformer Co.	8
Niche Manufacturing Co.	99
Miles Reproducer Co., Inc.	117
Mosley Electronics	125
Moss Electronic Distributing Co.	93
National Electronics of Cleveland	125
National Radio Institute	19, 20
National Schools	5
Opportunity Adlets	124
Pilot Radio Corp.	80
Pine Electronics	113
Precise Development Corp.	103
Precision Apparatus Co., Inc.	125
Precision Electronics	114
Pres-Probe Co.	109
Progressive Electronics Co.	101
Quam-Nichols Co.	112
RCA Institutes, Inc.	17
RCA Victor Division (Radio Corporation of America)	97, Inside Front Cover, Back Cover
Radiart Corporation	83, 108
Radio City Products	99
Radio Merchandise Sales, Inc.	91

RADIO SCHOOL DIRECTORY

Page 129

Commercial Radio Institute	131
Electronics Institute, Inc.	111
Indiana Technical College	122
Lincoln Engineering School	122
Martin School, Don	122
Milwaukee School of Engineering	122
RCA Institute, Inc.	122
Tri-State College	122
Vaiparaiso Technical Institute	122
Western Television Institute	122
Radio-Television Training Assn.	23
Raytheon Manufacturing Co.	16
Regency Div. (I.D.E.A., Inc.)	100
Relay Sales	123
Rider, Inc.	78
Rinehart Books, Inc.	87, 103, 121
Rose Company	122
Sams & Co., Inc., Howard W.	14, 104
Sangamo Electric Co.	12
Scala Radio Company	102
Schott Co., Walter L.	6
Service Products Co.	122
Skyline Manufacturing Co.	122
Sprague Products Co.	22
Sprayberry Academy of Radio	63
Stan-Burn Radio & Electronics Co.	113
Standard Transformer Corp.	118
Steve-El Electronics Corp.	121
Superior Instruments	98
Supreme Inc.	88
Sylvania Electric Products	21
Tab	132
Tallen Co., Inc.	120
Telematic Products	127
Tel-A-Ray Enterprises, Inc.	130
Telematic Industries, Inc.	114
Telesound Corp.	94
Television Materials, Inc.	128
Telex, Inc.	128
Transvision, Inc.	106, 107
Trio Mfg. Company	95
Tung-Sol Electric Co.	18
Turner Co.	76
TV Products Co.	100
United Catalog Publishers	76
United Technical Labs.	109
Vee-D-X	128
Vidcon Electronics Corp.	96
Webster Electric Co.	89
Weller Electric Corp.	24
Wholesale Radio Parts Co., Inc.	114
Winchager Corp.	112

Radio-Electronics does not assume responsibility for any errors appearing in above Index.



OF THE BEST-PERFORMING LOW-PRICED, ALL CHANNEL ANTENNA ON THE MARKET!

THE FRINGE AREA

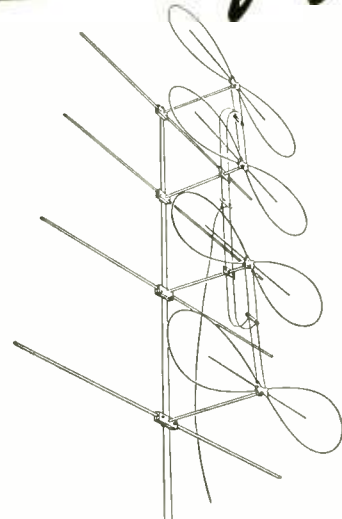

You can enjoy perfect long-range television reception for 10 days with a Fringe Area Butterfly — and it won't cost you a cent for its use.

To acquaint you with this outstanding new all-channel antenna, Tel-a-Ray will send you a Fringe Area Butterfly you can use for 10 days.

If you want to keep the Butterfly after 10 days, you may do so at a price of only \$29.95 (list price) for the four-bay array shown above. If not, send it right back.

Your only cost for using this matchless, long-range, all-channel antenna for 10 days is the shipping charge.

Give your family or customer TV reception at its best. Try a Butterfly! It's a Tel-a-Ray exclusive.

TEL-A-RAY

ENTERPRISES, INC.
 HENDERSON, KY.
 RADIO-ELECTRONICS

TUBES

Today's Best Buys

Top Quality at Terrific Savings
RTMA Guaranteed

1A7GT	\$.79	6BH6	\$.75	7W7	\$.15
1B3	1.05	6BQ6	.85	12A6	.49
1L4	.60	6B06	1.27	12A7	.80
1L6	.60	6C4	.60	12A7	.80
1L5	.95	6C6	.85	12A7	.80
1R5	.60	6CB6	.65	12A7	.80
IS4	.65	6CD6G	1.93	12A7	.80
IS5	.65	6E5	1.05	12A7	.80
1T4	.65	6H6M	.59	12BA6	.48
1U4	.60	6J5M	.65	12BA7	.80
1U5	.50	6J6	.73	12BE6	.55
1X2A	.85	6K6	.65	12J5GT	.50
2A3	1.45	6K7	.70	12K8	.49
2X2	.60	6L6G	1.05	12S47GT	.70
3A4	.65	6N7G/M	.95	12SF5M	.65
3Q4	.55	6S4	.71	12SG7	.85
5U4G	.55	6S7M	.85	12SH7	.79
5V4	.95	6SA7GT	.70	12S17	.60
5Y3GT	.45	6SC7	1.10	12S17	.65
5Z3	.85	6SC7	.75	12S17	.65
6A7	1.00	6SH7	.65	12S07	.70
6AB4	.65	6S17	.70	12SN7GT	.75
6AC7	1.10	6SK7GT	.53	12SR7	.65
6AG5	.80	6SL7GT	.65	14B6	.95
6AG7	1.40	6SN7GT	.88	19B6G6	1.98
6AH6	1.40	6SQ7GT	.65	19T8	.86
6AJ5	1.45	6T8	.86	25AV5	.95
6AK5	.95	6RV6GT	.60	25L6GT	.60
6AK6	1.20	6W4GT	.69	25W4	.80
6AL5	.65	6X4	.49	35L6GT	.53
6AQ5	.85	6X5	.59	35W4	.47
6AS5	.65	6Y8	.89	35Z5GT	.49
6AT6	.45	7AD7	1.25	50B5	.53
6AU6	.65	7C5	.70	50C5	.53
6AV6	.50	7C7	.85	50L6GT	.53
6B4	1.50	7E7	1.30	57	.75
6BA6	.85	7F7	.95	59	.75
6BC5	.56	7G7	1.30	59	1.50
6BE6	.49	7H7	.70	75	.85
6BF5	.65	7N7	.90	77	.85
6BF6	.70	7Q7	.89	78	.85
6B6G6	1.98	7V7	.95	189Y	.75

Minimum Order \$15.00

IMMEDIATE DELIVERY!
Write for quotations, many other types available. 20% Deposit with order, balance C.O.D. All tubes subject to prior sale. Prices subject to change without notice.

WRITE, WIRE, CALL—TODAY!
We Buy Anything in Electronics—
Large or small Quantities!

Nat Adelman
168 Washington St. New York 6, N. Y.
CO. 7-6091

BC 605 INTERCOM
Easily converted to an ideal inter-communications set for office, home, or factory. Original. New \$4.75 w/conversion. Diagram

24 VOLT TRANSFORMER
For operating surplus gear, toy trains, gadgets, etc. Operates from 115V. 60 cps., supplies 24 V.A.C. at 1.2 amp., herm. sealed and cas.—great buy at only **\$1.49**

This Month's Special

SA4A/APA-1 Motor Driven Coaxial Ant. Switch DPDT, Continuous Operation from 2VDC. Completely Enclosed	\$24.50
MP-22 MAST BASE Mobile Antenna Mount	4.95
SA1A/APN-1 Altitude Limit Switch for APN-1 Altimeter	7.95
ALTITUDE INDICATOR for APN-1 C-307 D Final P.A. Coil for BC610 2-3.5 MC. Variable Link	12.50
RA-74 Power Supply for Super Pro	4.89
J-17 ARC-5 Junction Box for ARC-5	69.50
J-22 ARC-5 Junction Box	7.95
SUPERSONIC CRYSTALS, Rochelle salt MOTOR-24 vdc. 3 HP 3800 rpm, New	3.49
TV LEAD-IN WIRE, 300 ohms, HI Q. Lo-Loss	50. ea
75.00	
BC306 ANTENNA TUNING UNIT, NEW	\$17.50/M FT Roll
R9/APN-4. New. With Tubes	6.95
ID6/APN-4. New. With Tubes and Crystal	75.00
A-62 Phantom Antenna	9.50

POWER TRANSFORMERS
Comb. Transformers—115V 50-60 cps Input

CT75B 600-0-600V .6A 2X5VCT/6.2A, 6.3VCT/3A, 6.3V/3A	\$12.95
CT15-2-600VCT/2A, 5V/6A	5.95
CT-15A 550VCT .085A 6.3V/6A, 6.3V/1.8A	2.85
CT-164 4200V.002A 12KV Test, 5VCT/3A 12KV Test, 6.3V/0.6A 5400V Test	12.95
CT-341 1050/10MA.—525V @ 5MA. 26V @ 4.5A 2x2.5V/3A, 6.3V @ 3A	16.95
CR-825 360VCT .340A 6.3VCT/3.6, 6.3VCT/3A	3.95
CT-626 1500V 160A 2.5/12, 30/100	9.95
CT-071 110V 200A 33/200, 5V/10, 2.5/10	4.95
CT-367 580VCT .050A 6VCT/3A	2.25
CT-99A 2x110VCT .010A 6.3/1A, 2.5VCT/7A	3.25
CT-403 350VCT .026A 5V/3A	2.75
CT-931 585VCT .086A 5V/3A, 6.3V/6A	4.25
CT-610 1250 .002A 2.5V/2.1A, 2.5V/1.75A	4.95
CT-456 300VCT 30MA 6.3V/1.3A, 5V/3A	3.45
CT-160 800VCT 100MA 6.3V/1.2A, 5V/3A	4.95

Send M.O. or Check. Shipping Chgt. C.O.D.
COMMUNICATIONS EQUIPMENT CO.
131 Liberty St. Dept. C-12, New York City 7, N. Y.

MOST-OFTEN-NEEDED 1952 RADIO DIAGRAMS AND SERVICING INFORMATION (Volume 12), compiled by M. N. Beitman. Published by Supreme Publications, 3727 W. 13th St., Chicago, Ill. 8 1/4 x 10 1/2 inches, 168 pages. Price \$2.50.

Diagrams, detailed alignment procedures, parts lists, socket-voltage and resistance tables, trouble-shooting hints, and other pertinent servicing data is supplied on nearly 500 different auto radios, AM and FM receivers, record changers and players, and intercom units made by 34 manufacturers during 1952. In addition to the obvious usefulness to radio service technicians, the books in the Most-Often-Needed series are useful references for students and engineers interested in studying and comparing circuits of modern receivers and allied equipment.—RFS
END

STATEMENT OF THE OWNERSHIP, MANAGEMENT, AND CIRCULATION REQUIRED BY THE ACT OF CONGRESS OF AUGUST 24, 1912, AS AMENDED BY THE ACTS OF MARCH 3, 1933, AND JULY 2, 1946 (Title 39, United States Code, Section 233) of RADIO-ELECTRONICS, published monthly at Philadelphia, Pa., for October 1, 1952.

1. The names and addresses of the publisher, editor, managing editor, and business managers are: Publisher, Gernsback Publications, Inc., 25 West Broadway, New York 7, N. Y.; Editor, Hugo Gernsback, 25 West Broadway, New York 7, N. Y.; Managing Editor, Fred Shunaman, 25 West Broadway, New York 7, N. Y. Business Manager, none.

2. The owner is: Gernsback Publications, Inc., 25 West Broadway, New York 7, N. Y.; H. Gernsback, 25 West Broadway, New York 7, N. Y.

3. The known bondholders, mortgagees, and other security holders owning or holding 1 percent or more of total amount of bonds, mortgages, or other securities are: None.

4. Paragraphs 2 and 3 include, in cases where the stockholder or security holder appears upon the books of the company as trustee or in any other fiduciary relation, the name of the person or corporation for whom such trustee is acting; the affiant's full knowledge and belief as to the circumstances and conditions under which stockholders and security holders who do not appear upon the books of the company as trustees, hold stock and securities in a capacity other than that of a bona fide owner.

H. GERNSEBACK, Publisher.
Sworn to and subscribed before me this 1st day of October, 1952. [Seal] Maurice Coyne, Notary Public. (My commission expires March 30, 1954.)

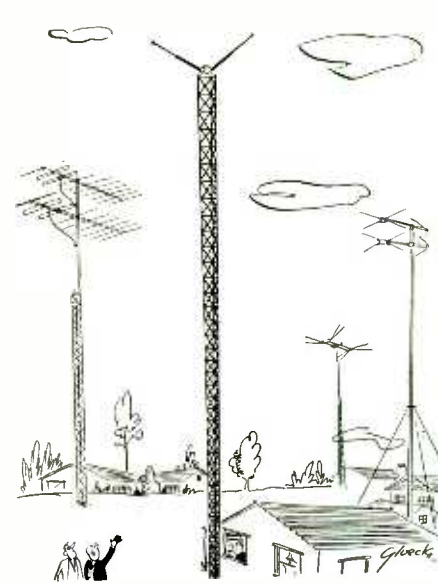

"He set out to prove he'd get reception with his little indoor antenna."



NEW! ENLARGED! REVISED!

Special Offer On This Complete RADIO ENGINEERING LIBRARY

New, Up-To-Date Editions of Famous Library Covers Whole Field of Radio Engineering. Places Latest Facts, Standards, Data Practice, and Theory At Your Fingertips

The five big volumes of the new edition of the Radio Engineering Library now include the very latest facts, standards, data, and practice. This Library will help solve hundreds of problems for designers, researchers, engineers, and students in any field based on radio.

Written by leading radio engineers, these books cover circuit phenomena, networks, tube theory, vacuum tubes, amplification, measurements, etc.—give specialized treatment of all fields of practical design and application. They provide you with a complete and dependable encyclopedia of facts.

- 5 Volumes, 3872 Pages, 2770 Illustrations
- Eastman's FUNDAMENTALS OF VACUUM TUBES, 3rd Edition.
- Terman's RADIO ENGINEERING, 3rd Edition.
- Everitt's COMMUNICATION ENGINEERING, 2nd Edition.
- Hund's HIGH FREQUENCY MEASUREMENTS, 2nd Edition.
- Henney's RADIO ENGINEERING HANDBOOK, 4th Edition.

SEND NO MONEY
Special Low Price—Easy Terms

On this special offer you get this Library for \$37.50, instead of \$43.50. You save \$6 and may pay on easy terms. Mail coupon below to examine the Library FREE for 10 days. No obligation. These books are recognized as standard works; you are bound to need them. So take advantage of this special money-saving offer. *Mail coupon at once!*

McGraw-Hill Book Co., Dept. RE-12
327 West 41st St., New York 18, N. Y.

Send for 10 days' FREE trial, the RADIO ENGINEERING LIBRARY. If not satisfied I will return books. Otherwise I will send \$7.50 plus delivery charges, then; and \$6 a month for 5 months. (Reg. price \$43.50, you save \$6!).

Name

Home Address

City & State

We'll Pay Delivery Charges if you enclose \$7.50 first payment WITH coupon. Same return privilege for full refund.

RE-12

DEDICATED TO YOU!



This great new **EICO**
FACTORY... these **NEWEST**
EICO INSTRUMENTS...

YOU made them possible with your
CONFIDENCE in EICO. We pledge to strive
with all our power, product-wise and
service-wise, to continue to merit your
trust in us.

Harry R. Ashley
President



6 NEW V-O-M KITS and Instruments

FOR LABORATORY PRECISION AT LOWEST COST



EICO New Model 536—
1000 Ohms/Volt Multimeter
Wired \$14.90. KIT \$12.90.

- 31 full scale ranges!
- DC/AC Volts: Zero to 1, 5, 10, 50, 100, 500, 5000
- DC/AC Current: 0-1 ma, 10 ma; 0.1 A, 1 Amp.
- Ohms: 0-500, 100K, 1 meg.
- 6 DB Ranges: -20 to +69.
- Large 3" 400 ua meter movement.
- High-impact Bakelite case. 6¼ x 3¾ x 2".

EICO New Model 526 1000 Ohms/Volt Multi-
meter KIT \$13.90. Wired \$16.90. As above, with 1%
precision resistors.



EICO New Model 566 1000 Ohms/Volt Multimeter KIT
\$14.90. Wired \$18.95. Ranges: same as Model 536 (left), plus
7 output voltages. Large 4½" 400 ua meter movement.

EICO New Model 556 1000 Ohms/Volt Multimeter KIT
\$16.90. Wired \$23.50. Ranges: same as Model 536 (left), plus
7 output voltages. Large 4½" 400 ua meter movement and 1%
precision resistors.

Compare these value-crammed EICO V-O-Ms with
any others at any price—at your local jobber—and
SAVE! Write NOW for FREE newest Catalog 12CA

**GIVE an EICO KIT for XMAS—
the thoughtful gift enjoyed the whole year 'round!**

EICO New Model 565
20,000 Ohms/Volt Multimeter KIT \$24.95.
Wired \$29.95.

- 31 full scale ranges!
- DC/AC/Output Volts: 0-2.5, 10, 50, 250, 1000, 5000.
- DC Current: 0-100 ua; 10, 100, 500 ma; 10 Amp.
- Ohms: 0-2000, 200K, 20 meg.
- 5 DB Ranges: -12 to +55.
- Large 4½" 50 ua meter movement.
- High-impact Bakelite case. 6¼ x 5¼ x 3".

EICO New Model 555 20,000 Ohms/
Volt Multimeter KIT \$29.95. Wired
\$34.95. As above, with 1% precision res-
istors.

ONLY **EICO** GIVES YOU ALL
10 **EICO** NOMICAL FEATURES

- Laboratory Precision • Lowest Cost • Life-time Dependability • Speedy Operation
- Rugged Construction • Quality Components • Latest Engineering • Super-Simplified Assembly & Use Instructions • Laboratory-Styled Appearance • Exclusive EICO Make-Good Guarantee.



© 1952

Prices slightly higher on West Coast. Due to unstable conditions, prices and specifications are subject to change without notice.

ELECTRONIC INSTRUMENT CO., Inc. 84 Withers Street, Brooklyn 11, New York

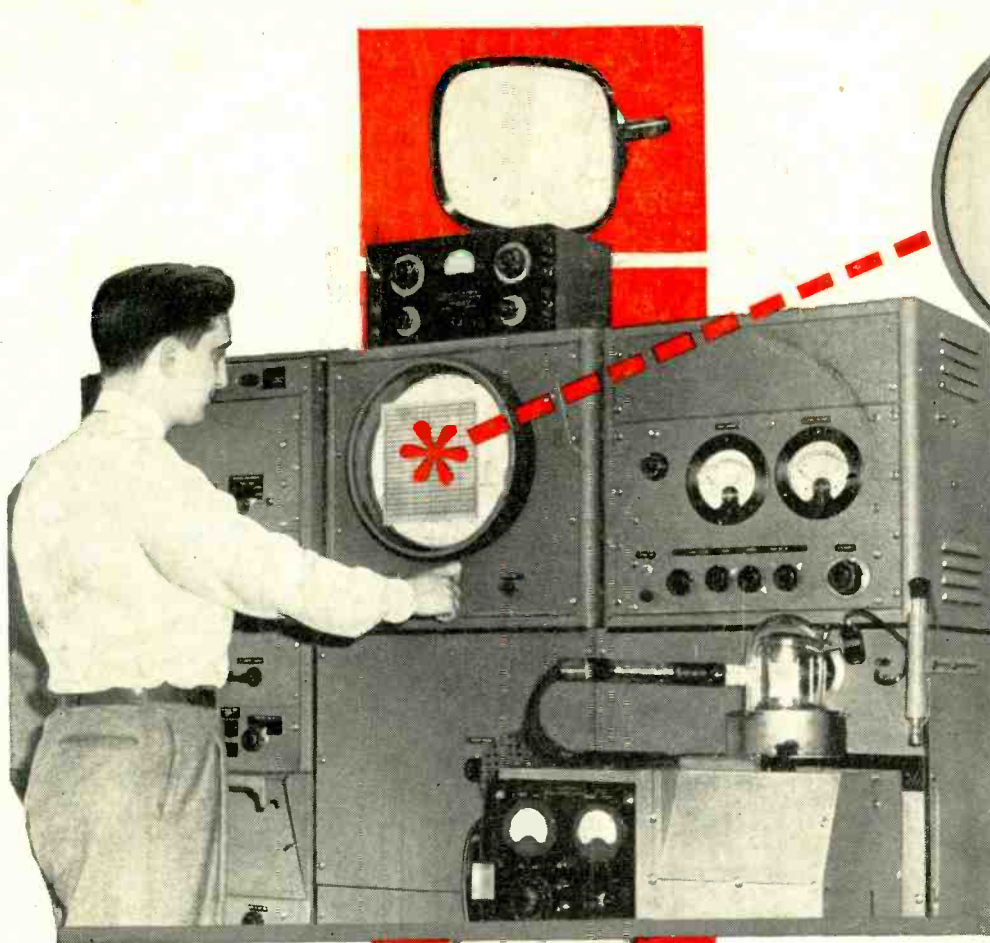

Electrical "pictograph" shows the white is right!

How we get  that's just right

for RCA picture-tube screens

MIX BLUE AND YELLOW paint and you get green. But mix "blue" and "yellow" phosphors and you get *white* . . . or what appears white to the eye. So it is that the fluorescent screen of a picture tube consists of about two billion tiny "blue" and "yellow" luminescent crystals. By the principle of *color addition*, the colored light from the individual crystals stimulates the eye to give the *impression* of white light.

The problem is you can get white that is yellowish, or white that is bluish . . . depending on the blend of the "blue" and "yellow" phosphors. Getting a white that's *just right* for picture-tube screens is

no easy trick. It calls for extremely precise *color control* of the phosphor.

RCA does it with a *spectroradiometer*. This instrument permits very accurate measurement of the *shade* of the "blue" and "yellow" phosphors. Based on this information, batches of "blue" and "yellow" phosphors are selected and blended to give the desired shade of white. Each blend is tested in a pilot run of picture tubes, and these tubes are also measured on the spectroradiometer. Only when a pilot run shows the desired white is a blend approved for production use. Result: "*Off-color*" picture tubes never reach your shop.

RCA's constant vigilance at all stages of manufacture is your assurance that only top-quality RCA Kinescopes leave the factory. In this way, RCA closely guards its own reputation . . . and yours as well.

With RCA Receiving Tubes, as well as RCA Kinescopes, TOP-QUALITY CONTROL makes the difference.



RADIO CORPORATION of AMERICA
ELECTRON TUBES

HARRISON, N. J.

TMK. ®