

JULY 1951

RADIO — ELECTRONICS

LATEST IN TELEVISION • SERVICING • AUDIO

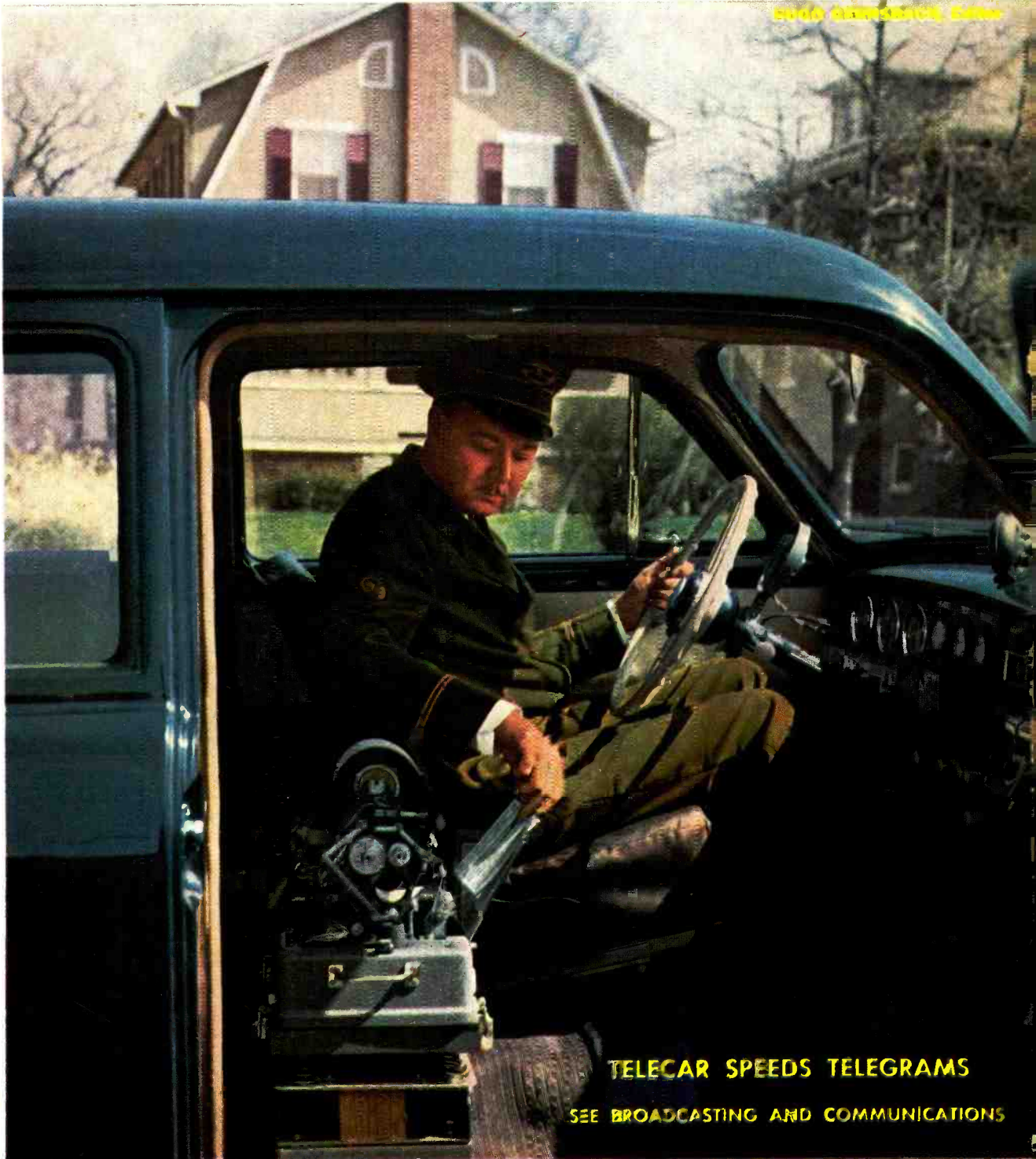

WAGO TELEGRAPH, CARR

TELECAR SPEEDS TELEGRAMS

SEE BROADCASTING AND COMMUNICATIONS

30¢
U.S. and
CANADA

***In this issue:* TV Tube Substitutions •
Field Strength Meter • Pocket Superhet**

~~FOCUSING CONTROLS, COILS, OR P.M. FOCUSERS~~

the new **DUMONT** **AUTOMATIC-FOCUS** *Teletron*

Completely Eliminates-

- FOCUSING COIL
- FOCUSING CONTROLS
- MECHANICAL FOCUSING DEVICES



17"

Provides-

- AUTOMATIC FOCUSING AT ALL TIMES
- FINE OVERALL FOCUS
- REPLACES ALL 17" GLASS RECTANGULARS WHETHER ELECTROSTATIC OR ELECTROMAGNETIC

Available soon in other sizes

DUMONT *Teletrons**

FOR COMPLETE TECHNICAL INFORMATION — WRITE:

TUBE DIVISION — ALLEN B. DU MONT LABORATORIES, INC., CLIFTON, N. J.

*Trade mark.

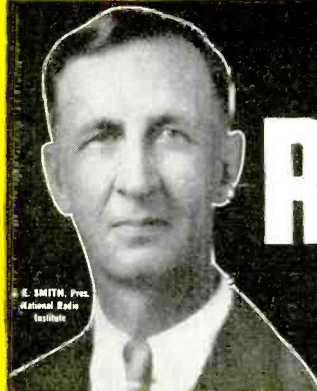

BE A SUCCESSFUL RADIO-TELEVISION TECHNICIAN

VF
7-51
7-50
98

2 FREE BOOKS SHOW HOW MAIL COUPON

America's Fast Growing Industry Offers You

Available to VETERANS under G. I. Bill

1. EXTRA MONEY IN SPARE TIME

Many students make \$5, \$10 a week extra fixing neighbors' Radios in spare time while learning. The day you enroll I start sending you SPECIAL BOOKLETS to show you how to do this. Tester you build with parts I send helps you service sets. All equipment is yours to keep.

2. GOOD PAY JOB

Your next step is a good job installing and servicing Radio-Television sets or becoming boss of your own Radio-Television sales and service shop or getting a good job in a Broadcasting Station. Today there are over 90,000,000 home and auto Radios, 3100 Broadcasting Stations are on the air. Aviation and Police Radio, Micro-Wave Relay, Two-Way Radio are all expanding, making more and better opportunities for servicing and communication technicians and FCC licensed operators.

3. BRIGHT FUTURE

And think of the opportunities in Television! In 1950 over 5,000,000 Television sets were sold. By 1954 authorities estimate 25,000,000 Television sets will be in use. Over 100 Television Stations are now operating, with experts predicting 1,000. Now is the time to get in line for success and a bright future in America's fast-growing industry. Be a Radio-Television Technician. Mail coupon for Lesson and Book—FREE.



I TRAINED THESE MEN

Chief Engineer, Police Radio
"Soon after finishing the N. R. I. course, I worked for servicing shop. Now I am Chief Engineer of WCIN WHEN, WSPK two-way FM Police Radio Installations." S.W. DINWIDDIE, Jacksonville, Ill.

She's Instructor in Television
"I have my own shop. Am authorized servicer on our 5 large manufacturers and do servicing for 7 dealers. I, I, has enabled me to build a profitable repair shop in Television." E. MILLER, Maumee, O.

340 Month Spare Time
"When I enrolled, had no idea it would be so easy to learn. Have equipped my shop out of spare time earnings. I am clearing about \$40 to \$60 a month. Full credit to N. R. I." L. D. KNIGHT, Denton, Texas.

118 Week in Spare Time
"Before finishing your course, I earned as much as \$10 a week in Radio servicing, at home in my spare time. I recommend N. R. I. to everyone who shows interest in Radio." S. J. PETRUFF, Miami, Fla.

Gets First Job Through N. R. I.
"My first job was as operator with KDLR, obtained for me by your Graduate Service Dept. I am now Chief Engineer of Police Radio Station WQQX." S. NORRIS, Hamilton, Ohio.

Retired and Thriving Before
"I'm proud of my diploma. I cannot say enough for the N. R. I. course. Regret I didn't take it years ago when I used to see your ads. Now I have a spare time shop." FRANK S. TUCKER, Hi ton Village, Va.

Graduate Dealer Salary
"I'm with Station WJ, 30 air transmitter operator. Have more than doubled salary since starting in Radio. Future looks bright, N. R. I. has been constant help to me." ALBERT, New Cumberland, Pa.

You're at Service with They
"I operate my own shop and have over 500 customers. My profits average about \$250 a month. Have had years of successful experience and I praise N. R. I. training." J. H. ADERSON, Atlanta, Ga.

I Will Train You at Home Read How You Practice Servicing or Communications with Many Kits of Parts You Get!

YOU BUILD this modern Radio receiver as part of my Servicing Course. Build this complete, powerful Radio Receiver that brings in local and distant stations. N. R. I. gives you ALL the Radio parts... speaker, tubes, chassis, transformer, sockets, loop antenna. EVERYTHING you need. You use material to get practical Radio experience. Make EXTRA money fixing neighbors' Radios in spare time while training.

YOU MEASURE current, voltage (AC DC and RF), resistance and impedance in circuits with Electronic Multimeter (above right) you build as part of my Servicing or Communications Course.

YOU BUILD this Transmitter (right), as part of my Communications Course. SEND YOUR parts to build this low-power broadcasting transmitter. You learn how to put a station "on the air," perform procedures commanded of Broadcast Station operators, make many practical tests.

YOU BUILD this Wavemeter (below) in my Communications Course with parts I send you. Use it to determine frequency of operator's and make other tests on transmitter currents. You conduct many interesting experiments.

This is just part of the equipment my students build. You keep all parts I send.

NOW! Advanced Television Practice

New, special TV kits furnished to build high-definition SCOPE... RF OSCILLATOR with flyback power supply... complete TV set... many other units. You see pulse, trapezoidal, saw-tooth wave forms. Get valuable PRACTICAL EXPERIENCE locating and correcting TV troubles. Mail coupon for facts, pictures and prices!

Keep your job while training at home. Hundreds I've trained are successful RADIO-TELEVISION TECHNICIANS. Most had no previous experience; many no more than grammar school education. Learn Radio-Television principles from illustrated lessons. Get PRACTICAL EXPERIENCE—build valuable Electronic Multimeter for conducting tests; also practice servicing Radios or operating Transmitters—experts with circuits common to Radio and Television. At left is just part of the equipment my students build with many kits of parts I furnish. All equipment is yours to keep. Many students make \$5, \$10 a week extra fixing neighbors' Radios in spare time.

Mail Coupon For 2 Books FREE
Act Now! Send for my FREE DOUBLE OFFER Coupon entitles you to actual lesson or Servicing; shows how you learn Radio-Television at home. You'll also receive my 64-page book, "How to Be a Success in Radio-Television." You'll read what my graduates are doing, earning; see photos of equipment you practice with at home. Send coupon in envelope or paste on postal. J. E. SMITH, Pres., Dept. 1GF, National Radio Institute, Washington 9, D. C. Our 35th year.

Good for Both—FREE

Mr. J. E. SMITH, President, Dept. 1GF, National Radio Institute, Washington 9, D. C.
Mail me Sample Lesson and 64-page Book about How to Win Success in Radio-Television. Both FREE. (No salesman will call. Please write plainly.)

Name..... Age.....
Address.....
City..... Zone..... State.....
 Check if Veteran Approved Under G. I. Bill

The ABC's of SERVICING
How to Be a Success in RADIO-TELEVISION

RADIO - ELECTRONICS

Incorporating
SHORT WAVE CRAFT® TELEVISION NEWS®
RADIO & TELEVISION
*Trademark registered U. S. Patent Office

formerly RADIO-CRAFT
MEMBER
AUDIT BUREAU OF CIRCULATIONS

Hugo Gernsback, Editor-in-Chief
M. Harvey Gernsback, Editorial Director
Fred Shunaman, Managing Editor
Robert F. Scott, W2PWG, Technical Editor
I. Queen, Editorial Associate
Angie Pascale, Production Manager
Wm. Lyon McLaughlin, Tech. Illustration Director
Lee Robinson, General Manager
John J. Lamson, Sales Manager
G. Aliquo, Circulation Manager
Robert Fallath, Promotion Manager

CONTENTS JULY, 1951

Editorial (Page 21)			
Service Bombshe'	By Hugo Gernsback	21	
Broadcasting and Communications (Pages 22-24)			
Telecar Speeds Telegrams (Cover Feature) ..	by Fred Shunaman	22	
Service—Test Instruments (Pages 25-32)			
Signal Generator Powered by Buzzer	by John A. Dewar	25	
BC-453 as a Service Aid	by Joseph Zelle	26	
The Customer is ALWAYS Right	by Eric Wahleen	27	
TV Tube Substitutions	by Edward J. Locke	28	
TV Field Strength Meter is Helpful	by H. O. Maxwell	31	
Money in TV Servicing	by Oliver Horning	32	
Television (Pages 33-38)			
Replacing Tuners for Higher Gain and Interference Rejection	by Matt Mandl	33	
Television Service Clinic	Conducted by Robert F. Scott	35	
TV DX Predictions		36	
V Beam for Dx	by L. A. Duck	36	
TV Trouble Lexicon	by John B. Ledbetter	37	
Audio (Pages 39-46)			
Audio Feedback Design, Part IX	by George Fletcher Cooper	39	
Electronics and Music, Part XIII	by Richard H. Dorf	42	
Rico Amplifier Operation	by Jacinto Sagrañes	45	
Universal Hi-Fi Preamplifier	by M. G. O'Leary	46	
Electronics (Pages 48-65)			
Radar Tracks Shooting Stars	by Professor A. C. B. Lovell and J. G. Davies	48	
How an Electronic Brain Works, Part X ..	by Edmund C. Berkeley	56	
Construction (Pages 66-69)			
Five-Tube Superhet Fits Pocket	by W. D. Penn	66	
Departments			
Radio Month	10	Question Box	79
Radio Business	14	Miscellany	82
New Devices	70	With the Technician	86
New Patents	72	Technotes	88
Radio Electronic Circuits	74	People	90
Try This One	76	Communication	92
		Book Reviews	93

ON THE COVER: Western Union Telecar in typical residential area, with pioneer Telecar operator Wallace Woodward at the wheel. Note microphone on steering column. Recorder cover was removed for photography, would normally be in place. Kodachrome by Avery Slack

July, 1951 RADIO-ELECTRONICS Vol. XXII, No. 10
Published monthly by Radcraft Publications, Inc. Publication Office, Erie Ave., F to G Streets, Philadelphia 32, Pa.

EXECUTIVE, EDITORIAL and ADVERTISING OFFICES: 25 West Broadway, New York 7, N. Y. Telephone REctor 2-8630. Hugo Gernsback, President; M. Harvey Gernsback, Vice-President; G. Aliquo, Secretary.
SUBSCRIPTIONS: Address correspondence to Radio-Electronics, Subscription Dept., Erie Avenue, F to G Sts., Philadelphia 32, Pa., or 25 West Broadway, New York 7, N. Y. When ordering a change please furnish an address stencil impression from a recent wrapper. Allow one month for change of address.
SUBSCRIPTION RATES: In U. S. and Canada, in U. S. possessions, Mexico, South and Central American countries, \$3.50 for one year, \$6.00 for two years; \$8.00 for three years; single copies 30c. All other foreign countries \$4.50 a year, \$8.00 for two years; \$11.00 for three years. Entered as second class matter September 27, 1948 at the post office at Philadelphia, Pa., under the Act of March 3, 1879. Printed in U. S. A. Copyright 1951 by Radcraft Publications, Inc. Text and illustrations must not be reproduced without permission of copyright owners.
BRANCH ADVERTISING OFFICES: Chicago: 520 N. Michigan Ave. Telephone Superior 7-1796. Los Angeles: Ralph W. Harker, 1127 Wilshire Blvd., Tel. MA 6-1271. San Francisco: Ralph W. Harker, 582 Market St., Tel. GARfield 1-2481. **FOREIGN AGENTS:** Great Britain: Atlas Publishing and Distributing Co., Ltd., London E.C.4. Australia: McGill's Agency, Melbourne. France: Brentano's, Paris 2e. Holland: Trilectron, Heemstede. Greece: International Book & News Agency, Athens. So. Africa: Central News Agency, Ltd., Johannesburg; Capetown; Durban. Natal, Universal Book Agency, Johannesburg. Middle East: Steimatzy Middle East Agency, Jerusalem. India: Broadway News Centre, Dadar, Bombay #14, K. L. Kannappa Mudaliar, Madras 2. Pakistan: Paradise Book Stall, Karachi 3.
POSTMASTER: If undeliverable send form 3578 to: RADIO-ELECTRONICS, 25 West Broadway, New York 7, N. Y.



New 3rd Edition SPRAGUE TV CAPACITOR REPLACEMENT MANUAL

Here—just off press—is the new Sprague Manual that tells you in a jiffy just what capacitor to use on practically any television replacement job. Includes complete electrolytic capacitor replacement data on 964 TV receivers—saves you time, paves the way to better work on practically every job!

GET YOURS... TODAY!

Ask your Sprague distributor for a FREE copy of this new Manual M-473. Or, write your name on the attached coupon and enclose 10c to cover handling and mailing and we will rush your copy directly to you!

Mail to:

SPRAGUE PRODUCTS COMPANY
81 Marshall Street, North Adams, Mass.

Enclosed is 10 cents for your M-473 TV Manual.

Name _____

Street _____

City _____ Zone _____

State _____

RADIO-ELECTRONICS for



Learn RADIO TELEVISION, ELECTRONICS

by SHOP METHOD HOME TRAINING

Let NATIONAL SCHOOLS, of Los Angeles, a practical Technical Resident Trade School for almost 50 years, train you for today's unlimited opportunities.

You receive all parts, including tubes, for building this fine, modern Superheterodyne Receiver. This and other valuable standard equipment becomes your property.

these two FREE books will tell you how

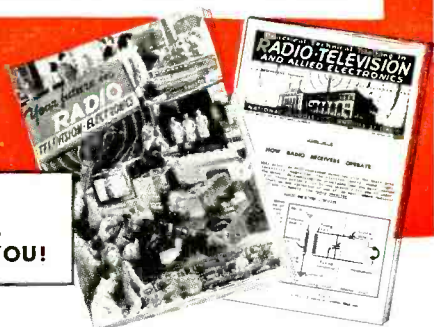

WE BRING NATIONAL SCHOOLS TO YOU!

GOOD JOBS AWAIT THE TRAINED RADIO TECHNICIAN

You are needed in the great modern Radio, Television and Electronics industry! Trained technicians are in constant and growing demand at excellent pay—in Broadcasting, Communications, Television, Radar, Research Laboratories, Home Radio Service, etc. National Schools Master Shop Method Home Study Course, with newly added lessons and equipment, can train you in your spare time, *right in your own home*, for these exciting opportunities. Our method has been proved by the remarkable success of National Schools-trained men all over the world.

Lessons and Instruction Material Are Up-to-date, Practical, Interesting

National Schools Master Shop Method Home Training gives you basic and advanced instruction in all phases of Radio, Television and Electronics. Each lesson is made easy to understand by numerous illustrations and diagrams. All instruction material has been developed and tested in our own shops and laboratories, under the supervision of our own engineers and instructors. A free sample lesson is yours upon request—use the coupon below.

You Learn by Building Equipment with Standard Radio Parts We Send You

Your National Schools Course includes not only basic theory, but *practical* training as well—you *learn by doing*. We send you complete standard equipment of professional quality for building various experimental and test units. You advance step by step until you are able to build the modern superheterodyne receiver shown above, which is yours to keep and enjoy. You perform more than 100 experiments—build many types of circuits, signal generator, low power radio transmitter, audio oscillator, and other units. The Free Books shown above tell you more about it—send for them today!

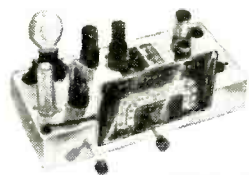

TELEVISION TRAINING A complete series of up-to-the-minute Television lessons is an integral part of your course, covering all phases of Television repairing, servicing and construction.

- Here are just a few of the interesting facts you learn with the **FREE SAMPLE LESSON**
1. How radio receivers operate.
 2. How the antenna circuit is constructed.
 3. Converting signal currents into sound.
 4. How the R-F transformer handles the signal.
 5. How the tuning circuit functions.
 6. The Radio "bands."

VETERAN'S HURRY! ACT NOW! G. I. BILL expires July 25

NOW! NEW PROFESSIONAL MULTITESTER INCLUDED



This versatile testing instrument is portable and complete with test leads. Simple to operate, accurate and dependable. You will be able to quickly locate trouble and adjust the most delicate circuits. You can use the Multitester at home or on service calls. It is designed to measure AC and DC volts, current resistance and decibels. You will be proud to own and use this valuable professional instrument.

GET THE DETAILS - SEND THE COUPON →

NATIONAL SCHOOLS

LOS ANGELES 37, CALIFORNIA EST. 1905



MAIL OPPORTUNITY COUPON FOR QUICK ACTION

National Schools, Dept. 7-RE
4000 South Figueroa Street
Los Angeles 37, California

(Mail in envelope or paste on penny postcard.)

Mail me FREE the book "Your Future in Radio-Television" and the sample lesson of your course. I understand no salesman will call on me.

NAME _____ AGE _____
ADDRESS _____
CITY _____ ZONE _____ STATE _____
 Check here if veteran of World War II



t tells how you talk

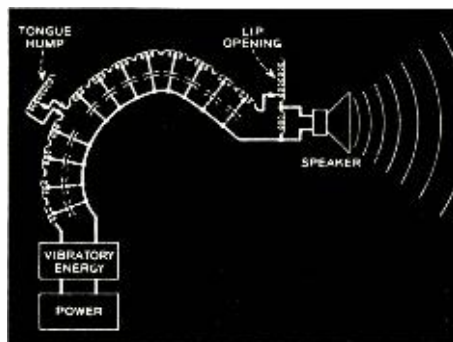

The machine at the left is saying "Ah!" It's the new electrical vocal system developed at Bell Laboratories. Top sketch shows human vocal system also saying "Ah!" The electrical model is sketched below it. Energy source at bottom of "tract" can emit a buzz sound, like vocal cord tone, or the hiss sound of a whisper.

No one else speaks exactly like you. Each of us uses different tones to say the same words. To study and measure *how* we make speech, acoustic scientists of Bell Telephone Laboratories built a model of the vocal system.

Electric waves copy those of the vocal cords, electric elements sim-

ulate the vocal tract, and, by adjustments, vowels and consonants are produced at pitches imitating a man's or woman's voice.

Using this electrical system, telephone scientists will be able the better to measure the properties of people's voices. Knowing more about speech they can find better

and cheaper ways to transmit it.

This is another step in the research at Bell Telephone Laboratories which pioneered the exact knowledge of speech. Past work in the field is important in today's fine telephone service. A still deeper understanding of speech is essential in planning for tomorrow.

BELL TELEPHONE LABORATORIES

Exploring and inventing, devising and perfecting, for continued improvements and economies in telephone service.



RADIO-ELECTRONICS for

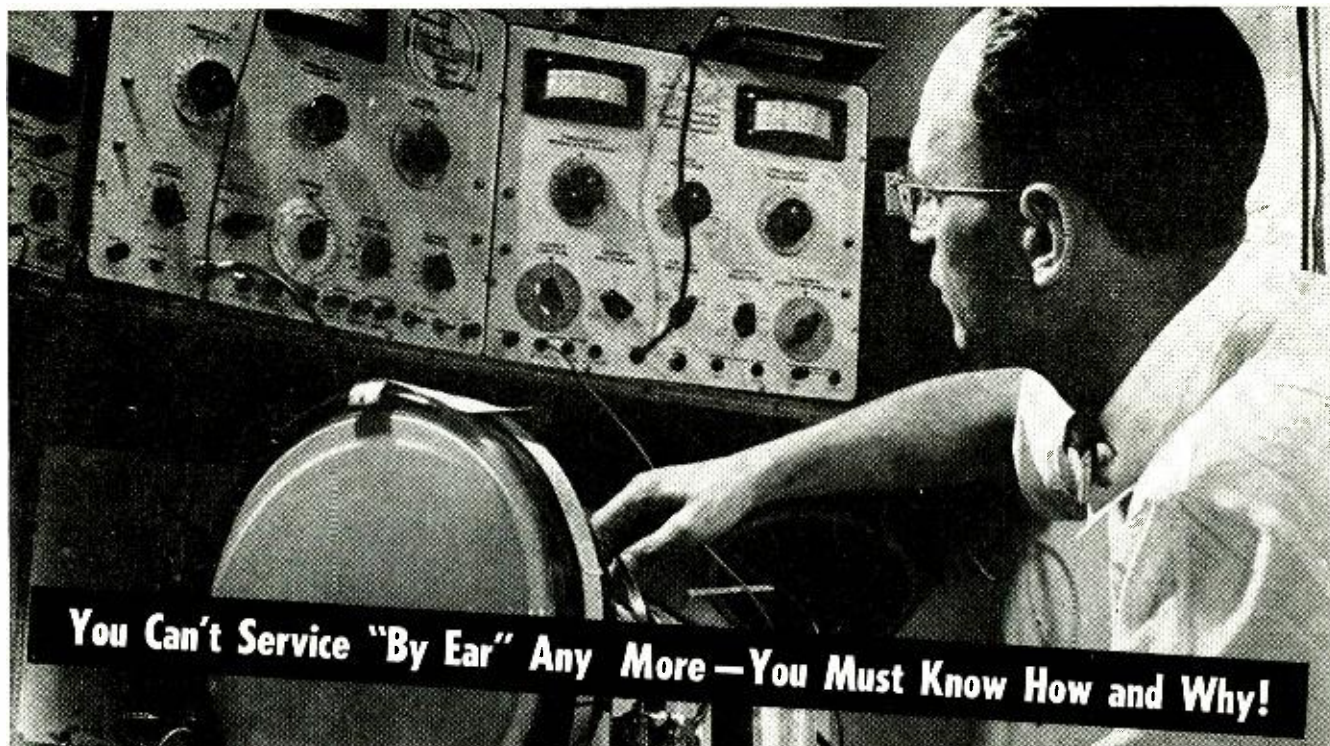

You Can't Service "By Ear" Any More—You Must Know How and Why!

CREI Technical Training Qualifies You for "Tough" Jobs—at Better Pay—in **TELEVISION & FM SERVICING!**

Screwdriver mechanics could get by in the old days of radio—but no longer. TV's complicated circuits call for skilled men—capable of using modern test equipment. Anyone in the field—if he is to stay in business—needs to know how a TV set works, why it works, and how to make it work better. Hit-and-miss methods are not only inefficient; they are unsuccessful and unprofitable.

As one manufacturer's service manager says, "If you are a TV man who can repair a set only by slow and plodding work—watch out. Pretty soon a youngster will come along with training and skill. He'll do a given job in one-quarter the time. He'll be paid twice as much per hour as you get—but the customer will still get off at half-price."

Opportunities for profitable servicing work are practically unlimited. With partial—or complete—mobilization of the electronics industry a definite possibility, a qualified serviceman will be

in line for one of two things: increased and profitable work as a civilian, either in his own shop or in essential industry; or military service, where technical electronics ability is quickly rewarded with supervisory jobs at extra pay. So, in or out of the armed services, you'll be better off with *good* technical training.

That's why more and more service men are using CREI's practical home-study course in TV-FM servicing. Designed by top-notch teachers, taught by practical TV instructors, reviewed and checked by qualified experts, kept up-to-date through direct contact with manufacturers, dealers, and service specialists, the CREI course equips you with the right "tools" to earn more money.

Start *your* preparation while there is still time! The next few months can be all-important—don't put it off. It costs you only a few minutes' time to get the facts. Mail the coupon below for complete details.

THE THREE BASIC CREI COURSES:

- ★ **PRACTICAL RADIO ENGINEERING**
Fundamental course in all phases of radio-electronics
- ★ **PRACTICAL TELEVISION ENGINEERING**
Specialized training for professional radiomen
- ★ **TELEVISION AND FM SERVICING**
Streamlined course for men in "top-third" of field

ALSO AVAILABLE IN RESIDENCE SCHOOL COURSES

CAPITOL RADIO ENGINEERING INSTITUTE

An Accredited Technical Institute Founded in 1927

Dept. 147C, 16th Street & Park Road, N. W.
Washington 10, D. C.

Branch Office:

San Francisco (2) 760 Market St.



**SEND FOR
FREE BOOKLET**

CAPITOL RADIO ENGINEERING INSTITUTE

Dept. 147C, 16th & Park Rd., N. W., Washington 10, D. C.

Gentlemen: Send me complete details of the TV and FM Servicing home study course. Also send brochure that explains the CREI self-improvement program and gives complete details and outline of course. I am attaching a brief resume of my experience, education and present position.

- Check the Field of Greatest Interest
- TV, FM & ADVANCED AM SERVICING
 - PRACTICAL TELEVISION ENGINEERING
 - PRACTICAL RADIO ENGINEERING
 - AERONAUTICAL RADIO ENGINEERING
 - BROADCAST RADIO ENGINEERING (AM, FM, TV)
 - RADIO-ELECTRONICS IN INDUSTRY

NAME _____ AGE _____

ADDRESS _____

CITY _____ ZONE _____ STATE _____

If residence school in Wash. D. C. is preferred, check here

YOU'RE ALWAYS WITH G-E PICTURE TUBES! **1ST**

FIRST with a long-term user warranty. G.E. pioneered the customer warranty on picture tubes . . . commencing with date of retail purchase . . . safeguarding your customers and you, as tube dealer, for six months after installation. By this BIG step forward, G.E. removed any worry that its picture tubes on your shelves might run beyond the manufacturer's warranty period. Now you can stock a full line with confidence. And no matter when the tubes are installed, your customers will get full-term, registered G-E warranties in every case!

FIRST to benefit from full-page tube consumer advertising. General Electric made tube history when it launched full-page tube advertising in LIFE and the POST—a continuing campaign that is reaching regularly more than 24,000,000 readers from coast to coast. As a G-E dealer, you profit directly from the tremendous G-E tube acceptance which this advertising creates.

FIRST in wide range of G-E tube types and sizes available. Round tubes and rectangular—glass, metal—small, medium, large-screen—General Electric builds virtually all types and sizes, giving you *the biggest picture-tube line*. You can service any TV set with assurance that a G-E tube will meet your needs! Conversions to larger screens often are practical—and profitable. With G-E tubes, you can give set owners the larger, easier-to-view pictures they want. And G-E Aluminized Tubes enable you to give them *brighter TV pictures!*

FIRST in proved tube quality. You can't beat G-E picture-tube performance! Quality features (example: all-glass electron-gun beading) typify the care G.E. gives to design details that make for superiority. Afterwards comes precision manufacture by ultra-modern equipment in new, well-lighted premises . . . followed by final tests which relentlessly reject any tubes with faulty screen or other characteristics. G-E picture tubes uniformly are *good tubes!* They give top owner satisfaction—build profits and prestige for *you!*

CASH IN NOW ON THESE G-E "FIRSTS!"
SEE YOUR G-E TUBE DISTRIBUTOR!

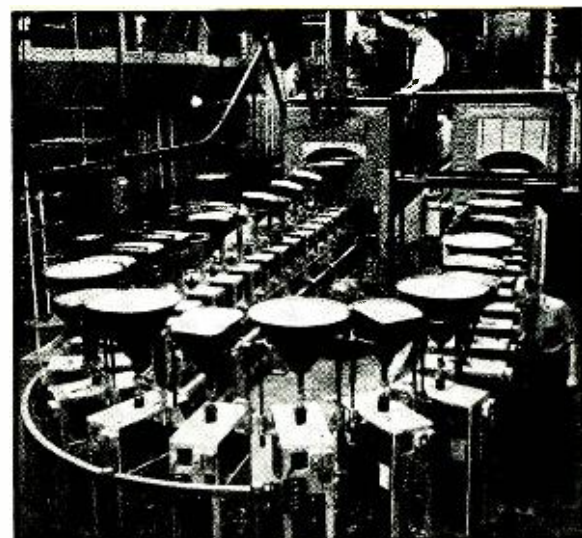
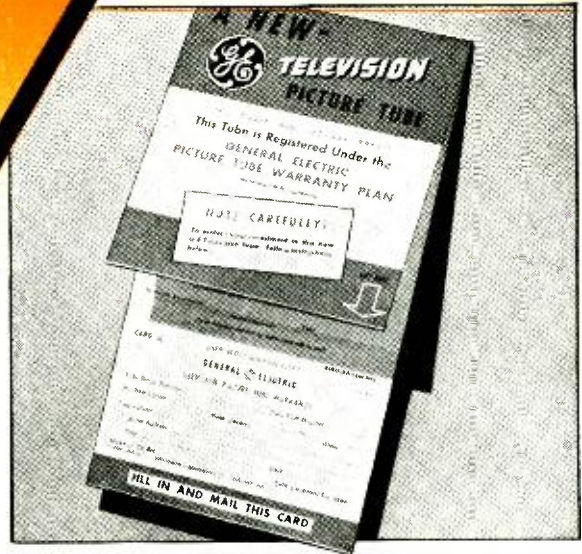

GENERAL  ELECTRIC

181-KA7

RADIO-ELECTRONICS for

NOW... GET EVERYTHING YOU NEED TO LEARN AND MASTER

TELEVISION

**RADIO-ELECTRONICS
...AT HOME!**

Use REAL commercial-type equipment to get practical experience

Your future deserves and needs every advantage you can give it! That's why you owe it to yourself to find out about one of the most COMPLETE, practical and effective ways now available to prepare AT HOME for America's billion dollar opportunity field of TELEVISION-RADIO-ELECTRONICS. See how you may get and keep the same type of basic training equipment used in one of the nation's finest training laboratories... how you may get real STARTING HELP toward a good job or your own business in Television-Radio-Electronics. Mail the coupon today for complete facts — including 89 ways to earn money in this thrilling, newer field.



Here's the REAL THING!

SET UP YOUR OWN HOME LABORATORY

ABOVE: Build and keep a real 16 INCH commercial TV receiver. Optional after completing regular training at slight additional cost.



Oscilloscope

R-F Signal Generator

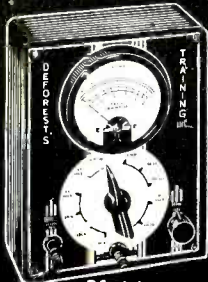

Multimeter



6-Tube Radio

D.T.I., ALONE, INCLUDES BOTH MOVIES and HOME LABORATORY

In addition to easy-to-read lessons, you get the use of HOME MOVIES — an outstanding training advantage — plus 16 big shipments of Electronic parts. Perform over 300 fascinating experiments for practical experience. Build and keep real commercial-type test equipment shown at left.

Get BOTH of these information packed publications FREE!

MODERN LABORATORIES

If you prefer, get all your preparation in our new Chicago Training Laboratories—one of the finest of its kind. Ample instructors, modern equipment. Write for details!

MILITARY SERVICE!

If you're subject to military service, the information we have for you should prove doubly interesting. Mail coupon today.



HOME MOVIES



De FOREST'S TRAINING, INC.
CHICAGO 14, ILLINOIS
A De VRY INSTITUTION

ACT NOW! MAIL COUPON TODAY!

DeFOREST'S TRAINING, INC., Dept. RE-7-H
2533 N. Ashland Ave., Chicago 14, Ill.

Without obligation, I would like your late News-Bulletin showing 89 ways to earn money in Television-Radio-Electronics... and how I may prepare to get started in this thrilling field.

Name..... Age.....
Street..... Apt.....
City..... Zone..... State.....

You just can't beat
a deal
like this!



The **Thomas**

**FREE TEST EQUIPMENT
BONUS PLAN
BENEFITS CUSTOMER, SERVICEMAN
AND PARTS DISTRIBUTOR**

Here is how the Thomas Free Test Equipment Bonus Plan works... With every Thomas Photo-Iron Picture Tube you buy is a certificate entitling you to a discount on the purchase price of any piece of Simpson test equipment. You may use as many of these Thomas certificates as you wish—up to and including the full purchase price, these certificates are redeemable at all leading Parts Distributors.

Thomas
PHOTO-TRON

**PICTURE
TUBE**



Thomas Photo-trons are *Exact*
original equipment with these 20
TV set makers and many others...

ADMIRAL • HOFFMAN • OLYMPIC • MECK • PILOT
HALLICRAFTERS • WESTINGHOUSE • SCOTT • CALBEST
STEWART-WARNER • KAY-HALBERT • MAGNAVOX
BENDIX TELEVISION • PACKARD BELL • CROSLLEY
MOTOROLA • STARRETT • IMPERIAL • TELE KING



Thomas ELECTRONICS, Inc.
PASSAIC, NEW JERSEY

10 | The Radio Month

GRASSHOPPER is the name of a self-contained automatic weather station which transmits weather data by radio. The unit is parachuted by aircraft onto inaccessible territory. It was developed by Percival Lowell and William Hakkarinen of the National Bureau of Standards for the Navy Bureau of Ships.

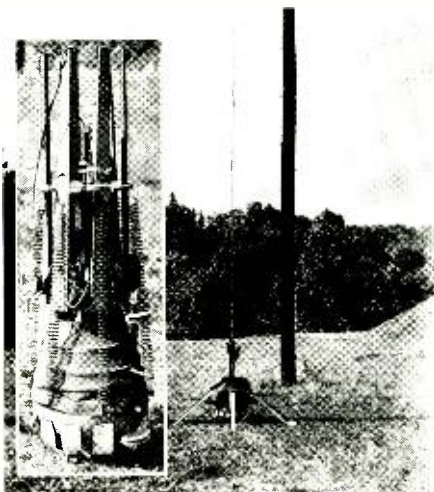

This Grasshopper sends weather data.

After the station is parachuted to earth controlled explosive charges are used to disengage the parachute, raise the station (springs released; pulling it to an upright operating position; see photo), and erect a telescoping antenna. Weather-responsive devices then cause resistance changes which switch a radio transmitter on and off at a rate translated by a receiving station into temperature, pressure, and humidity readings. The time of transmission is controlled by a clock mechanism.

The developmental model of the weather station has an output of 2 watts. Operating on a frequency of 5 megacycles, it performs reliably over land at ranges of 100 miles. The dry batteries used are good for 15 days of intermittent operation.

TILTING ANTENNAS may be used in future u.h.f. television transmitting installations if tests by RCA are any indication.

Using RCA-NBC facilities, experimental station KC2XAK in Bridgeport, Conn. (RADIO-ELECTRONICS, Aug., 1950) doubled its television signal strength in its program service area by a slight tilting of the transmitting antenna.

The antenna built for the tests was erected on one side of the Bridgeport transmitting tower. By means of a motor-driven arrangement, the antenna was rocked back and forth in a vertical arc of approximately 12 degrees to permit engineers to record the resulting variation in signal strength. Results recorded showed that the received signal was maximum when the antenna was tilted 2½ degrees up or down.

One drawback anticipated, however, is that it is possible that the gain in signal strength may increase interference with distant stations.

The experiment will be tried on v.h.f. TV channels also to see if similar improvement results.

"COMPOSITE COLOR TV," system proposed by RCA, Philco, Du Mont, Hazeltine and General Electric, will, according to Dr. W. R. G. Baker of G-E, "combine the best elements of the furthest advances in existing systems."

Particulars of the plan were stated to include utilization of the present black-and-white standards to transmit brightness or detail, and to add the necessary color information on a subcarrier contained within the video band and transmitted simultaneously with the "brightness" signal. No information was given as to whether the system had been made to work experimentally, but it was stated that the committee responsible for the new development hoped to be ready with a set of proposed standards by the end of the year.

CBS officials, just given the go-ahead sign by the Supreme Court on their color TV system, were unimpressed. "Third and most brazen attempt by a group of officials of black-and-white set manufacturers to impede the CBS system by concocting still another paper proposal," was the way Columbia described the proposed system.

WHIRLWIND ONE is the automatic computing machine doing research on Whirlwind Project now being conducted by Du Mont at M.I.T.

The project was instituted in recognition of the fallibility of human choice in analyzing the problem of distributing available u.h.f. TV channels across the nation. The aim is to eliminate human errors and guesswork. Sample data has already been fed into the machine with promising results. It is expected that a complete report on Whirlwind computations and TV station distribution results will be submitted to the FCC during its coming hearings.

RUSSELL D. VALENTINE, radio pioneer and chief engineer of WQXR, New York City, died at the age of 51, after a long illness. He had been with the station since 1929, when it was called W2XR. In 1934 it became the world's first high-fidelity broadcast station.

Mr. Valentine's radio career began in 1914, with his amateur station 2GX, whose call was known throughout the world.

ANOTHER MAJOR STEP in its self-initiated functional reorganization was announced by the Federal Communications Commission in providing for the establishment of a Broadcast Bureau to start operations June 4, 1951.

The new bureau will have an Office of the Chief and five divisions as follows: Aural Facilities, Television Facilities, Renewal and Transfer, Hearing, and Rules and Standards. The effect will be that a single bureau will be responsible to the Commission for discharging legal, accounting, and engineering functions in connection with all broadcast services.

DEBATES on the floor of Congress may be televised in the future if Rep. Jacob K. Javits, R., N. Y., has his way. He is circulating a petition among his colleagues to this effect. The opposition, to date, is stiff.

RADIO-ELECTRONICS for



EDW. H. GUILFORD
Vice President

I can train you to pass your FCC License Exams in a minimum of time if you've had any practical radio experience — amateur, Army, Navy, radio servicing, or other. My time-proved plan can help put you, too, on the road to success.

Let me send you FREE the entire story

Just fill out the coupon and mail it. I will send you, free of charge, a copy of "How to Pass FCC License Exams," plus a sample FCC-type Exam, and the amazing new booklet, "Money-Making FCC License Information."

How to Pass FCC Commercial Radio Operator License Exams



FREE

Tells where to apply and take FCC examinations, location of examining offices, scope of knowledge required, approved way to prepare for FCC examinations, positive method of checking your knowledge before taking the examination.

Get Your FCC Ticket in a Minimum of Time

Get this Amazing Booklet FREE



TELLS HOW —

WE GUARANTEE

TO TRAIN AND COACH YOU AT HOME
IN SPARE TIME UNTIL YOU GET

YOUR FCC LICENSE

If you have had any practical experience—Amateur, Army, Navy, radio repair, or experimenting.

TELLS HOW —

Employers make

JOB OFFERS Like These

to Our Graduates Every Month

Telegram, August 9, 1950, from Chief Engineer, Broadcast Station, Pennsylvania: "Have job opening for one transmitter operator to start immediately, contact me at once."
Letter, August 12, 1950, from Dir. Radio Div. State Highway Patrol: "We have two vacancies in our Radio Communication Division. Starting pay \$200; \$250 after six months' satisfactory service. Will you recommend graduates of your school?"
These are just a few examples of the job offers that come to our office periodically. Some licensed radioman filled each of these jobs . . . it might have been you!

HERE'S PROOF FCC LICENSES ARE OFTEN SECURED IN A FEW HOURS OF STUDY WITH OUR COACHING AT HOME IN SPARE TIME

Name and Address	License	Lessons
Lee Worthy 2210 1/2 Wilshire St., Bakersfield, Calif.	2nd Phone	16
Clifford E. Vogt Box 1016, Dania, Fla.	1st Phone	20
Francis X. Feorch 38 Beuler Pl., Bergenfield, N. J.	1st Phone	38
S. Sgt. Ben H. Davis 317 North Roosevelt, Lebanon, Ill.	1st Phone	28
Albert Schoell 110 West 11th St., Escondido, Calif.	2nd Phone	23

CLEVELAND INSTITUTE OF RADIO ELECTRONICS
Desk RE-31, 4900 Euclid Bldg., Cleveland 3, Ohio
(Approved for Veteran Training Under G.I. Bill)

TELLS HOW —

**Our Amazingly Effective
JOB-FINDING SERVICE**

Helps CIRE Students Get Better Jobs

Here are a few recent examples of Job-Finding results:

GETS FIVE JOB-OFFERS FROM BROADCAST STATIONS
"Your 'Chief Engineer's Bulletin' is a grand way of obtaining employment for our graduates who have obtained their 1st class license. Since my name has been on the list I have received calls or letters from five stations in the southern states, and am now employed as Transmitting Engineer at WMMT."
Elmer Powell, Box 274, Sparta, Tenn.

GETS CIVIL SERVICE JOB
"I have obtained a position at Wright-Patterson Air Force Base, Dayton, Ohio, as Junior Electronic Equipment Repairman. The Employment Application you prepared for me had a lot to do with my landing this desirable position."
Charles E. Loomis, 4516 Genesee Ave., Dayton 6, Ohio.

GETS JOB WITH CAA
"I have had half a dozen or so offers since I mailed some fifty of the two hundred employment applications your school forwarded me. I accepted a position with the Civil Aeronautics Administration as Maintenance Technician. Thank you very much for the fine cooperation and help your organization has given me in finding a job in the radio field."
Date E. Young, 122 Robbins St., Owosso, Mich.

Your FCC Ticket is always recognized in all radio fields as proof of your technical ability.

OURS IS THE ONLY HOME STUDY COURSE WHICH SUPPLIES FCC-TYPE EXAMINATIONS WITH ALL LESSONS AND FINAL TESTS.

Get All 3 FREE

MAIL COUPON NOW



CLEVELAND INSTITUTE OF RADIO ELECTRONICS
Desk RE-31—4900 Euclid Bldg.
Cleveland 3, Ohio
(Address to Desk No. to avoid delay)

I want to know how I can get my FCC ticket in a minimum of time. Send me your FREE booklet, "How to Pass FCC License Examinations" (does not cover exams for Amateur License), as well as a sample FCC-type exam and the amazing new booklet, "Money Making FCC License Information."

NAME _____
ADDRESS _____
CITY _____ ZONE _____ STATE _____
Paste on penny postcard or send air mail.

Watch
MERIT
for TV in '51

Merit is meeting the rapidly rising demand for TV replacements with a TV line as complete as current and advance information will permit
TRY MERIT FIRST FOR TV CONVERSION OR REPLACEMENT!



HVO6—Universal Ferrite core "FLYBACK" permits widest coverage.



MDF70—70° high efficiency Ferrite yoke for tubes up to 19"



MWC-1—Width linearity control with AGC winding (Automatic Gain Control).

FOCUS COILS



Free!

Write today for:

- MERIT TV REPL GUIDE AND CATALOG**
—Dec. 1950 issue. Up-to-date listing of all replacements.
- MERIT 1951 CATALOG No. 5111**
Show specs. on complete line of TV, Radio, Amateur and Industrial Transformers.

REFER TO MERIT'S LISTING in Howard Sams Photofacts



TAPE-MARKED TO HELP YOU!

Handy tape marking on every Merit Transformer shows permanent look-up data for quick reference. C.R.I.G.I.—NATED BY MERIT.



MERIT
TRANSFORMER CORP.

4443 NORTH CLARK ST., CHICAGO 40, ILL.

HERMAN T. KOHLHAAS, a former official of International Telephone and Telegraph Company, died in an automobile accident April 24.

For 42 years Mr. Kohlhaas was associated with I.T.T. and its predecessor companies, serving as editor of *Electrical Communication*, the company's technical magazine, from 1925 to 1945 when he was named assistant vice-president. He resigned in 1947.

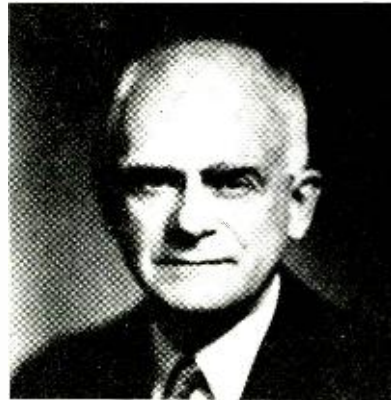

He was a fellow of the American Institute of Electrical Engineers, and a senior member of the Institute of Radio Engineers.

CONSTRUCTION WORK was completed recently on the last of 107 radio relay stations along the Bell System's new coast-to-coast communications route. Building west from Omaha and east from San Francisco, construction crews met northwest of Denver.

The final link runs zigzag across some of the nation's most rugged terrain, including the Rocky Mountains, the Sierra Nevadas, and the Coastal Range.

The new system will provide more than 100 "through" telephone circuits between Chicago and San Francisco. The route will be ready for long-distance service by late August. It is hoped that before the year's end the microwave system will be equipped also to handle coast-to-coast television.

COLOR TELEVISION received new impetus from the May 28 Supreme Court Decision upholding FCC's approval of the CBS color system. This leaves Columbia free to carry commercial as well as experimental color programs.

COLORED SOLDER is now being supplied by H. J. Enthoven & Sons of England. One of the difficulties in mass-produced assembly of electronic components is to insure that all wiring joints have been soldered. It is common practice to coat each joint with a colored lacquer on inspection.

By incorporating a colored flux in the solder it is possible to indicate the finished joint automatically, as the flux runs to the edges of the joint and remains as a permanent indicator. The coloring matter does not affect the electrical or mechanical properties of the solder. Four colors are supplied.

—end—

INDISPENSABLE!
PHOTOFAC BOOKS



Photofact Television Course. Covers TV principles, operation and practice. 216 pages; profusely illustrated, 8½ x 11". Order TV-1 Only \$3.00

Television Antennas. New 2nd edition. Describes all TV antenna types; tells how to select, install, solve troubles. Saves time; helps you earn more. 200 pages; illustrated. Order TAG-1 Only \$2.00

Television Tube Location Guide. Accurate diagrams show position and function of all tubes in hundreds of TV sets; helps you diagnose trouble without removing chassis. 200 pages; pocket-size. Order TGL-1 Only \$1.50

1949-1950 Record Changer Manual. Vol. 3. Covers 44 models made in 1949, including multi-speed changers and wire and tape recorders. Original data based on actual analysis of equipment. 286 pages; 8½ x 11"; paper-bound. Order CM-3 Only \$3.00

1948-1949 Changer Manual. Vol. 2. Covers 45 models made in 1948-49. Paper bound. Order CM-2. Only \$4.95

1947-1948 Changer Manual. Vol. 1. Covers 40 post-war models up to 1948. Order CM-1 Only \$4.95

Recording & Reproduction of Sound. A complete authoritative treatment of all phases of recording and amplification. 6 x 9". Order RR-1 Only \$5.00

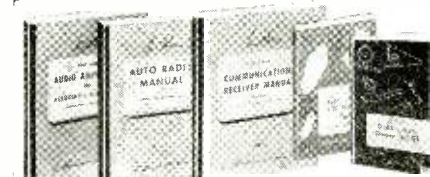

Post-War Audio Amplifiers. Vol. 2. A complete analysis of 104 well-known audio amplifiers and 12 well-known tuners made in 1949-50. 368 pages, 8½ x 11". Order AA-2 Only \$3.95

Post-War Audio Amplifiers. Vol. 1. Covers 102 amplifiers and FM tuners made through 1948. 352 pages. Order AA-1 Only \$3.95

Auto Radio Manual. Complete service data on more than 100 post-war auto radio models. Covers over 24 mfgs. 350 pages, 8½ x 11". Order AR-1 Only \$4.95

Communications Receiver Manual. Complete analysis of 50 popular communications models. 246 pages, 8½ x 11". Order CR-1 Only \$3.00

Radio Receiver Tube Placement Guide. Accurate diagrams show where to replace each tube in 5500 radio models, covering 1938-1947 receivers. 192 pages, pocket-size. Order TP-1 Only \$1.25

Dial Cord Stringing Guide. Vol. 2. Covers receivers made from 1947 through 1949. Shows you the one right way to string a dial cord in thousands of models. Pocket-size. Order DC-2 Only \$1.00

Dial Cord Guide. Vol. 1. Covers sets produced 1938 through 1946. Order DC-1 Only \$1.00

Radio-TV Industry Red Book. 2nd Edition. Complete data on replacement parts for 22,000 sets made 1938-1950, including valuable TV information. Covers all major replacements. Over 600 pages. Only \$3.95



Making Money in TV Servicing. Tested, proved methods of operating a profitable TV service business. Written by Eugene Ecklund, B. E. E., former manager of the National Service Department, Allen B. DuMont Laboratories, Inc. Covers planning, financing, work control, purchasing, service charges, advertising—plus much more. Own this practical guide to success now. Over 130 pages. Order MM-1 Only \$1.25

Order from your Parts Jobber or write direct to
HOWARD W. SAMS & CO., INC., 2201 E. 46th St., Indianapolis 5, Indiana

HOWARD W. SAMS & CO., INC.

RADIO-ELECTRONICS for

PERFORMANCE IS WHAT COUNTS!

ANCHOR'S

superiority of performance

remains unchallenged!

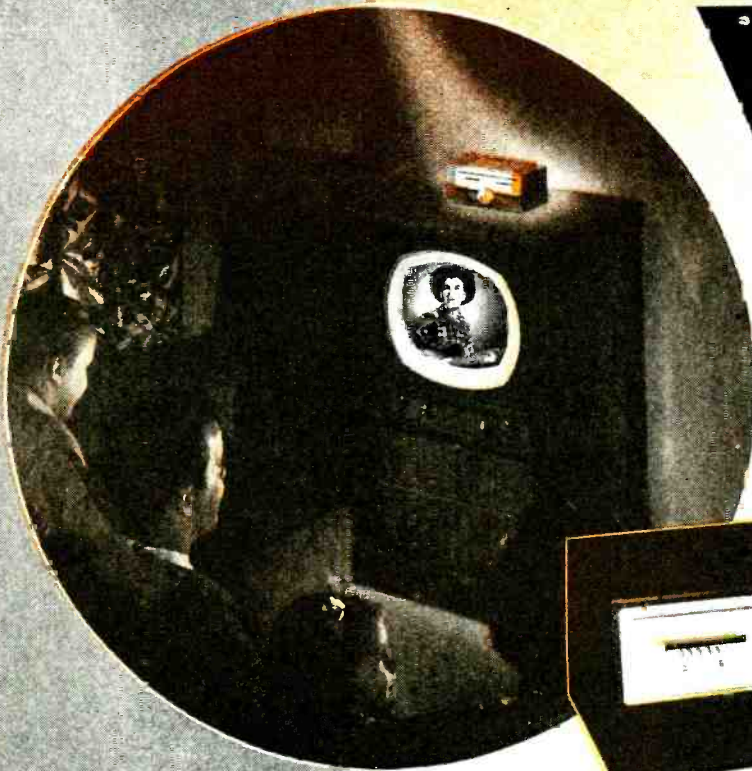

THE ANCHOR *Suburbanite*

Single-Stage Booster—for low signal areas in or near cities. Assures consistently good reception up to 75 miles.

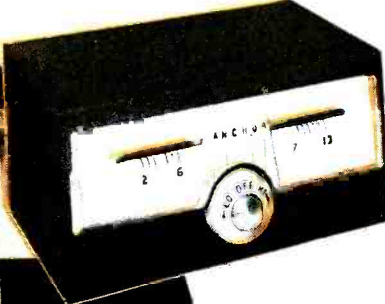
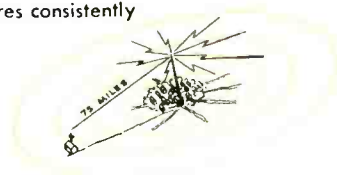

THE ANCHOR *Granger*

Two-Stage Booster—recommended for distant rural areas. Assures consistently good reception for over 100 miles.

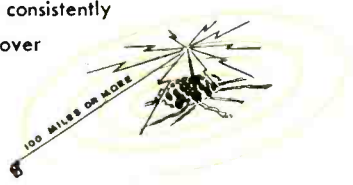

Despite critical material shortages, Anchor not only is offering the same high quality standards so widely hailed by the TV set industry, itself, but it is still making as many boosters as a year ago. To meet the current unprecedented demand, however, Anchor would have to expand, which is naturally not possible now! Therefore they have had to institute a very strict allocating system. No preference on deliveries to anyone has been or ever will be practiced.

When a booster is needed to complete a perfect installation, Anchor's outstanding performance under all conditions has made it the first choice of those who buy and sell. So always buy the *best*—first!



ANCHOR ENGINEERING ALWAYS A YEAR AHEAD!

ANCHOR RADIO CORP.

2215 SOUTH ST. LOUIS AVENUE • CHICAGO 23, ILLINOIS

HERE'S EXACTLY WHERE ASTATIC'S NEW "CAC" CARTRIDGES CAN BE INSTALLED

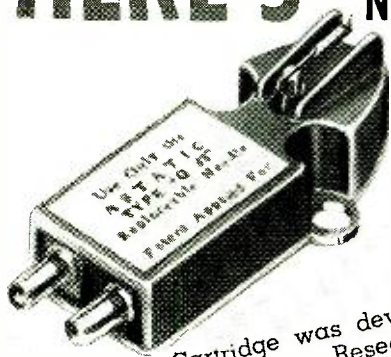

Astatic's CAC-J Crystal Cartridge was developed in conjunction with the Engineering Research and Development Department of CBS to match the recording characteristics of LP records. It is internally equalized to follow Columbia Records, Inc., ideal frequency response for the recording characteristics of LP records. Other models in the "CAC" Series were developed on the same engineering principles, and have proved capable of the same new, high level of performance.

ASTATIC "CAC" MODELS AND THE CARTRIDGES THEY REPLACE		
CAC-J REPLACES*	CAC-AG-J REPLACES	CAC-78-J REPLACES
RCA 74067 74625 75476	ELECTRO-VOICE 33 33S	ELECTRO-VOICE 32 32S
ELECTRO-VOICE 14 14S 34 34S	SHURE P71 P81A P71A P81C P71B P81CA P71C P81E P71CA P81E P81 W26A P81A W26B	SHURE P70 W23A P70A W23B P85
SHURE P73 P93MG P73A P95MG P73AR W21A P73R W21AR W53MG	WEBSTER A91 A9MI	WEBSTER A3 A3M
WEBSTER A2 A2M F12 F13M	 <p>*FITS ALL RCA 45 RPM CHANGERS AND IS STANDARD FOR COLUMBIA 102 AND 103 PLAYERS.</p>	

SPECIAL MODELS FOR PLUG-IN HEADS. Models CAC-W-J (1-mil needle) and CAC-78W-J (3-mil needle) are furnished with special terminals and fittings for quick, easy installation in record changer tone arms with plug-in heads.

LIST PRICE—All Models
 Sapphire Stylus . \$ 7.50
 Diamond Stylus . 31.00

THE Astatic CORPORATION
 CONNEAUT, OHIO
IN CANADA: CANADIAN ASTATIC LTD., TORONTO, ONTARIO

Astatic Crystal Devices manufactured under Brush Development Co. patents.

Merchandising and promotion

General Electric Tube Division, Schenectady, N. Y., released a new 107-page pocket-size handbook which lists the characteristics of every type of receiving tube likely to be found in AM, FM, or TV sets. It contains ratings and other data for fast trouble-shooting. Basing



diagrams for each of the 856 different tube types listed are also shown. The handbook is 35¢ and available at G-E and Ken-Rad distributors.

RCA Tube Department, Harrison, N. J., published a new "1951 Tube Movement and Inventory Guide" for service technicians. It is a 16-page book in chart form designed as a year-round master control covering more than 400 receiving tubes and kinescopes. The chart provides a simplified record-keeping meth-

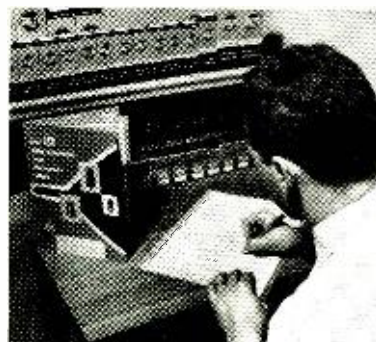

od which permits balanced inventories with a minimum of bookkeeping. RCA tube and parts distributors have it.

Sylvania Electric announced a new vest-pocket TV tube selector which lists more than 100 TV picture tube types.



It indexes them as to shape, construction, and other characteristics. The (Continued on page 18)

RADIO-ELECTRONICS for

Golden Opportunity

to prepare for better pay jobs in

Television Servicing

for men in
radio-electronics



YOU STUDY AT HOME

In your spare time, you learn pre-tested "How-to-do-it" techniques with "How-it-works" information in easy-to-study lessons. The course is based on the experience of the RCA Service Company in servicing thousands of home television receivers.



YOU KEEP WORKING ON YOUR JOB

Because you work in the radio-television-electronics industry, your job provides the laboratory work of the course. There are no kits, parts or equipment to buy. Self-employed independent radio and television servicemen are eligible for enrollment.

No vocational field offers more opportunities for "career" jobs and good pay than television—America's fastest growing industry. The demand for TRAINED and EXPERIENCED TV SERVICEMEN is growing. There is a big shortage of such men now and will be for several years to come.

PLENTY OF GOOD JOBS OPEN TODAY

Radio-Television jobbers, dealers and service companies offer lifelong opportunities with excellent salaries for qualified service technicians. Manufacturers of television receivers are looking for men with good service training as inspectors, testers and troubleshooters. Many experienced servicemen go into business for themselves. Others hold their regular jobs and earn extra money servicing TV receivers in their spare time.

Radio-electronics manufacturers busy with defense equipment contracts offer excellent job opportunities for men with a television technician background. Servicemen called into military service are further reducing the supply of skilled TV servicemen available for civilian activities. Think what television servicing offers *you* in terms of a lifetime career and financial security.

RCA INSTITUTES Home Study Course in TELEVISION SERVICING—

A Service to the Industry

Because of the critical shortage of TRAINED and EXPERIENCED TV SERVICEMEN, RCA Institutes is offering this highly specialized and practical home study course as a service to the working members of the radio-television-electronics industry. Its object is to train more *good* servicemen and to help make good servicemen *better*.

Never before has this course been available to anyone outside of RCA. It is now offered to *you*, through RCA Institutes, one of America's oldest and most respected technical training schools. The course covers most major makes and types of TV receivers. Available exclusively to men in the radio-television-electronics field. Not offered to the general public, or under G.I. Bill.

The cost is low . . . only \$9 a unit for 10 units or \$90 total, on an easy pay-as-you-learn plan. At successful completion of the course you earn an RCA Institutes certificate that can lead straight to a better job at higher pay.

★ **LOWER RATES FOR GROUPS!** Employers in the radio-electronics industry who desire to enroll six or more of their employees for this course, may do so at lower rates for the group. A special group application form is available for employers desiring to take advantage of this offer. ★

SEND FOR FREE BOOKLET. Find out complete details of the RCA INSTITUTES Home Study Course in TELEVISION SERVICING. Don't pass up this opportunity to prepare yourself for a money-making career in the television industry. Illustrated booklet explains all the features of the course. Mail coupon in an envelope or paste on a penny postcard—NOW!

MAIL COUPON NOW!

RCA INSTITUTES, INC.
Home Study Department, RE-751
350 West Fourth Street, New York 14, N.Y.

Without obligation on my part, please send me copy of booklet "RCA INSTITUTES Home Study Course in TELEVISION SERVICING." (No salesman will call.)

Name _____ (Please Print)

Address _____

City _____ Zone _____ State _____



RCA INSTITUTES, INC.
A SERVICE OF RADIO CORPORATION OF AMERICA
350 WEST FOURTH STREET, NEW YORK 14, N.Y.

JULY, 1951

Here's a "BOND"
That Money
Can't Buy...
THE
RAYTHEON
BOND
for **ELECTRONIC**
TECHNICIANS



It's a bond of integrity — a bond of ability — a bond of confidence between customer and service dealer. It's a bond resulting from Raytheon's desire to improve relationships between customers and service dealers. It's a bond of great value — yet it's yours *at no cost* if you can qualify. It's a bond that's Raytheon's investment in your future.

For more than five years the Raytheon Bond, which cash protects service dealers' 90-day guarantee on TV and Radio Repairs, has helped radio and television shops throughout the country to increase volume, build customer good will and has shielded them against attacks on their integrity. *It can do the same for you!*

Better ask your *Raytheon Tube Distributor* if you can qualify for this outstanding business asset.



RIGHT...FOR SOUND AND SIGHT



RAYTHEON MANUFACTURING COMPANY

Receiving Tube Division

Newton, Mass., Chicago, Ill., Atlanta, Ga., Los Angeles, Calif.

RADIO AND TELEVISION RECEIVING TUBES, CATHODE RAY TUBES, SPECIAL PURPOSE TUBES, SUBMINIATURE TUBES, MICROWAVE TUBES

Excellence in Electronics

COPYRIGHT 1952

RADIO-ELECTRONICS for

Put yourself in the I.C.S. HALL OF FAME*

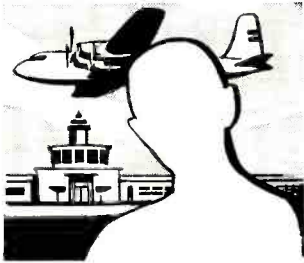

PRESIDENT of a leading airline.

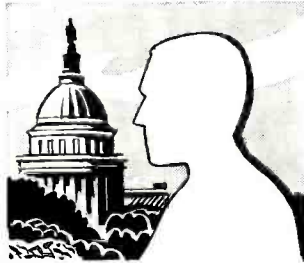

CHAIRMAN of an important national defense board.



INVENTOR of a well-known U. S. Army rifle.



DESIGNER of a famous aircraft engine.

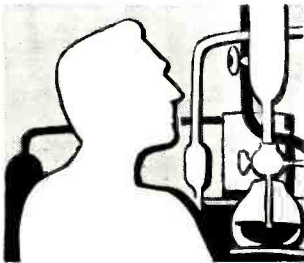

CHEMICAL DIRECTOR of nationally known research laboratory.

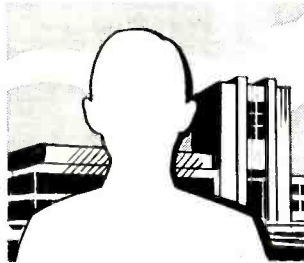

ENGINEER in charge of a famous company's engineering laboratory.

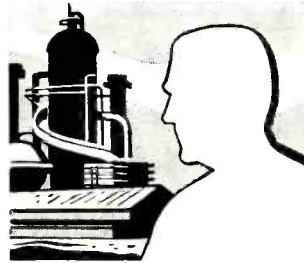

GENERAL MANAGER of one of America's largest chemical companies.



YOU

JOIN these men who have made their mark! Men who by dint of ambition, intelligence and sound, practical I.C.S. training now enjoy positions of leadership in business and industry.

The sooner you start, the better your chances of making the grade. Right now, with the criti-

cal shortage of skilled labor, trained men are becoming leaders overnight. Hundreds of I.C.S. students are reporting promotions and pay increases, earning greater security for themselves and their families. How about marking and mailing the coupon today?

**Names and positions sent on request.*

INTERNATIONAL CORRESPONDENCE SCHOOLS



BOX 2877-H, SCRANTON 9, PENNA.

Without cost or obligation, please send me full particulars about the course before which I have marked X:

- | | | | | |
|--|---|---|--|---|
| <p>Business and Academic Courses</p> <ul style="list-style-type: none"> <input type="checkbox"/> Account'g <input type="checkbox"/> Advertis'g <input type="checkbox"/> Bookkeeping <input type="checkbox"/> Bus. Law <input type="checkbox"/> Business Administration <input type="checkbox"/> Business Correspondence <input type="checkbox"/> Cert. Pub. Acct. <input type="checkbox"/> Commercial <input type="checkbox"/> Com'l Art <input type="checkbox"/> Cost Accounting <input type="checkbox"/> Federal Tax <input type="checkbox"/> First Year College <input type="checkbox"/> Foremanship <input type="checkbox"/> French <input type="checkbox"/> Good English <input type="checkbox"/> High School <input type="checkbox"/> Higher Mathematics <input type="checkbox"/> Illustration <input type="checkbox"/> Industrial Supervision <input type="checkbox"/> Motor Traffic <input type="checkbox"/> Postal Civil Service <input type="checkbox"/> Retailing <input type="checkbox"/> Retail Bus. Mgmt. <input type="checkbox"/> Salesmanship <input type="checkbox"/> Secretarial <input type="checkbox"/> Sign Lettering <input type="checkbox"/> Spanish <input type="checkbox"/> Stenography <input type="checkbox"/> Traffic Management <input type="checkbox"/> Typing | <p>Air Conditioning and Plumbing Courses</p> <ul style="list-style-type: none"> <input type="checkbox"/> Air Conditioning <input type="checkbox"/> Heating <input type="checkbox"/> Plumbing <input type="checkbox"/> Refrigeration <input type="checkbox"/> Steam Fitting <p>Chemical Courses</p> <ul style="list-style-type: none"> <input type="checkbox"/> Chemical Engineering <input type="checkbox"/> Chemistry, Analytical <input type="checkbox"/> Chemistry, Industrial <input type="checkbox"/> Chemistry, Mfg. Iron and Steel <input type="checkbox"/> Petroleum Refining <input type="checkbox"/> Plastics <input type="checkbox"/> Pulp and Paper Making <p>Civil Engineering, Architectural and Mining Courses</p> <ul style="list-style-type: none"> <input type="checkbox"/> Architectural Drafting <input type="checkbox"/> Architecture <input type="checkbox"/> Building Estimating <input type="checkbox"/> Civil Engineering <input type="checkbox"/> Coal Mining <input type="checkbox"/> Contracting and Building | <ul style="list-style-type: none"> <input type="checkbox"/> Highway Engineering <input type="checkbox"/> Lumber Dealer <input type="checkbox"/> Reading Structural Blueprints <input type="checkbox"/> Sanitary Engineering <input type="checkbox"/> Structural Drafting <input type="checkbox"/> Structural Engineering <input type="checkbox"/> Surveying and Mapping <p>Communications Courses</p> <ul style="list-style-type: none"> <input type="checkbox"/> Electronics <input type="checkbox"/> Prac. FM and Television <input type="checkbox"/> Practical Telephony <input type="checkbox"/> Radio, General <input type="checkbox"/> Radio Operating <input type="checkbox"/> Radio Servicing <input type="checkbox"/> Telegraph Engineering <p>Electrical Courses</p> <ul style="list-style-type: none"> <input type="checkbox"/> Electrical Drafting <input type="checkbox"/> Electrical Engineering <input type="checkbox"/> Electric Light and Power <input type="checkbox"/> Lighting Technician <input type="checkbox"/> Power House Electric <input type="checkbox"/> Practical Electrician <input type="checkbox"/> Ship Electrician | <p>Internal Combustion Engines Courses</p> <ul style="list-style-type: none"> <input type="checkbox"/> Auto Technician <input type="checkbox"/> Aviation <input type="checkbox"/> Diesel-Electric <input type="checkbox"/> Diesel Engines <input type="checkbox"/> Gas Engines <p>Mechanical Courses</p> <ul style="list-style-type: none"> <input type="checkbox"/> Aeronautical Eng'r's, Jr. <input type="checkbox"/> Aircraft Drafting <input type="checkbox"/> Flight Engineer <input type="checkbox"/> Forging <input type="checkbox"/> Foundry Work <input type="checkbox"/> Heat Treatment of Metals <input type="checkbox"/> Industrial Engineering <input type="checkbox"/> Industrial Instrumentation <input type="checkbox"/> Industrial Metallurgy <input type="checkbox"/> Machine Shop <input type="checkbox"/> Machine Shop Inspection <input type="checkbox"/> Mechanical Drafting <input type="checkbox"/> Mechanical Engineering <input type="checkbox"/> Mold-Loft Work <input type="checkbox"/> Patternmaking—Wood, Metal <input type="checkbox"/> Reading Shop Blueprints <input type="checkbox"/> Sheet-Metal Drafting <input type="checkbox"/> Sheet-Metal Worker <input type="checkbox"/> Ship Drafting | <ul style="list-style-type: none"> <input type="checkbox"/> Ship Fitting <input type="checkbox"/> Tool Designing <input type="checkbox"/> Toolmaking <input type="checkbox"/> Welding—Gas & Electric <p>Railroad Courses</p> <ul style="list-style-type: none"> <input type="checkbox"/> Air Brake <input type="checkbox"/> Car Inspector <input type="checkbox"/> Diesel Locomotive <input type="checkbox"/> Locomotive Engineer <input type="checkbox"/> Locomotive Fireman <input type="checkbox"/> Locomotive Machinist <input type="checkbox"/> Railroad Sect'n Foreman <input type="checkbox"/> Steam-Diesel Loco. Eng. <p>Stationary Engineering Courses</p> <ul style="list-style-type: none"> <input type="checkbox"/> Boilermaking <input type="checkbox"/> Combustion Engineering <input type="checkbox"/> Engine Running <input type="checkbox"/> Marine Engineering <input type="checkbox"/> Power Plant Engr. <input type="checkbox"/> Steam Engineering <p>Textile Courses</p> <ul style="list-style-type: none"> <input type="checkbox"/> Cotton Manufacturing <input type="checkbox"/> Loom Fixing <input type="checkbox"/> Rayon Weaving <input type="checkbox"/> Textile Designing <input type="checkbox"/> Woolen Manufacturing |
|--|---|---|--|---|

Name _____ Home Address _____ City _____ State _____

Age _____ Present Position _____ Employed by _____ Working Hours _____ A.M. to _____ P.M.

Length of Service in World War II _____

Enrollment under G.I. Bill approved for World War II Veterans. Special tuition rates to members of the Armed Forces. Canadian residents send coupon to International Correspondence Schools Canadian, Ltd., Montreal, Canada.

Attention ALL SERVICEMEN

announcing the entirely NEW

Permoflux "CHAMPION" SPEAKERS

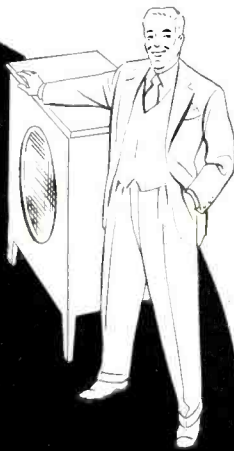

**GREATER PROFITS!
PROMPT DELIVERY!
TOP QUALITY!**

From one of America's leading manufacturers of quality speakers for original equipment comes the announcement of the new Permoflux line of "Champion" permanent magnetic speakers.

"Champion" speakers are equipped with unique universal mounting brackets and tapped yokes for ease of installation in any position. Mounting holes and transformer mountings are standard RTMA. Voice coil impedance 3-2 ohm on all "Champion" speakers. (Except 12R-8 which is 8 ohms.)

For greater profits . . . quick delivery . . . top quality, order your Permoflux "Champion" speakers from your distributor today.



Inquire about Permoflux's Complete Royal Blue Line 6" to 12" Speakers and send for the new attractively illustrated catalog "Permoflux Royal Lines No. J202."

AVAILABLE IN ALL THESE SIZES:

- 2 1/4" Sq., 4" Sq., 4" x 6" Elip., 5" Round,
- 5" P.C., 5" x 7" Elip., 6" P.C., 6" Auto, 6" x 9" Auto, 7" Auto, 8" P.C., 10" Round, 12" Round

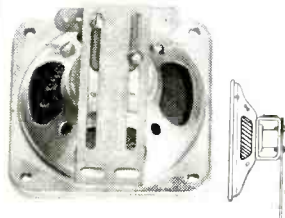

Model 4A \$5.00

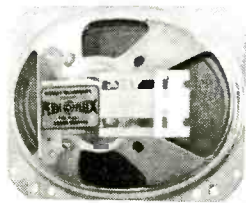

Model 46A \$5.50

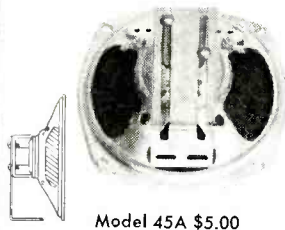

Model 45A \$5.00

PERMOFLUX
"SOUND IN DESIGN"

PERMOFLUX CORPORATION

4912 W. GRAND AVE., CHICAGO 39, U.S.A. • 263 S. VENDUGO RD., GLENDALE 5, CALIF.

Canadian Licensee . . . Campbell Mfg. Company, Toronto, Canada

guides are supplied free by distributors.

Clarostat Mfg. Co., Dover, N. H., assigned members of its sales and technical staff to attend a meeting of the Radio Technicians Guild in Boston. Demonstrations of the company's products were given and the service technicians attending were presented with Clarostat's "TV Control Replacement Manual," and other literature.

New plants and expansions

General Electric announced that it will triple the facilities of its Electronics Laboratory at Electronics Park, Syracuse, N. Y. The move will expand facilities for research and development of electronic military equipment.

Westinghouse Electric announced plans to build an electronic tube manufacturing plant on a 70-acre site in Bath, N. Y. The factory will produce electronic tubes for the armed services and for essential industries.

Business briefs

. . . The RTMA announced that radio receiving-tube sales reached an all-time high of 44,413,146 in March. Total for the first quarter of 1951 was 118,277,243, of which 22% were replacements.

. . . The RTMA also reported that 84% of the 1,822,793 TV picture tubes sold in the first quarter of 1951 were rectangular. 94% were 16 inches or larger.

. . . RCA Victor Division received a Certificate of Co-operation from the Economic Co-operation Administration for the technical assistance furnished to peoples of Marshall Plan countries.

. . . Utah Radio Products Co., Inc., was formed in Huntington, Ind., as a wholly owned subsidiary of Newport Steel Corp. The company will make radio speakers and allied products. A. H. Schenkel is president, E. V. Norfleet, secretary and treasurer, F. W. Tower, general sales manager, and M. G. Wike, sales manager of the Jobber and Industrial Division.

RADIO & TELEVISION SET PRODUCTION

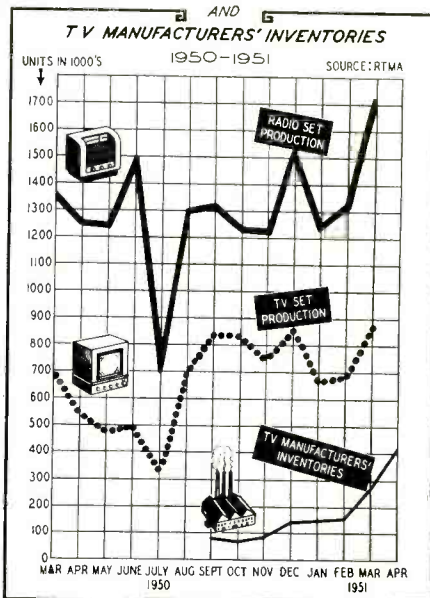

—end—

RADIO-ELECTRONICS for

TRIPLETT

Load-Chek

introduces
**Servicing
 by
 Power
 Consumption**

MODEL 660

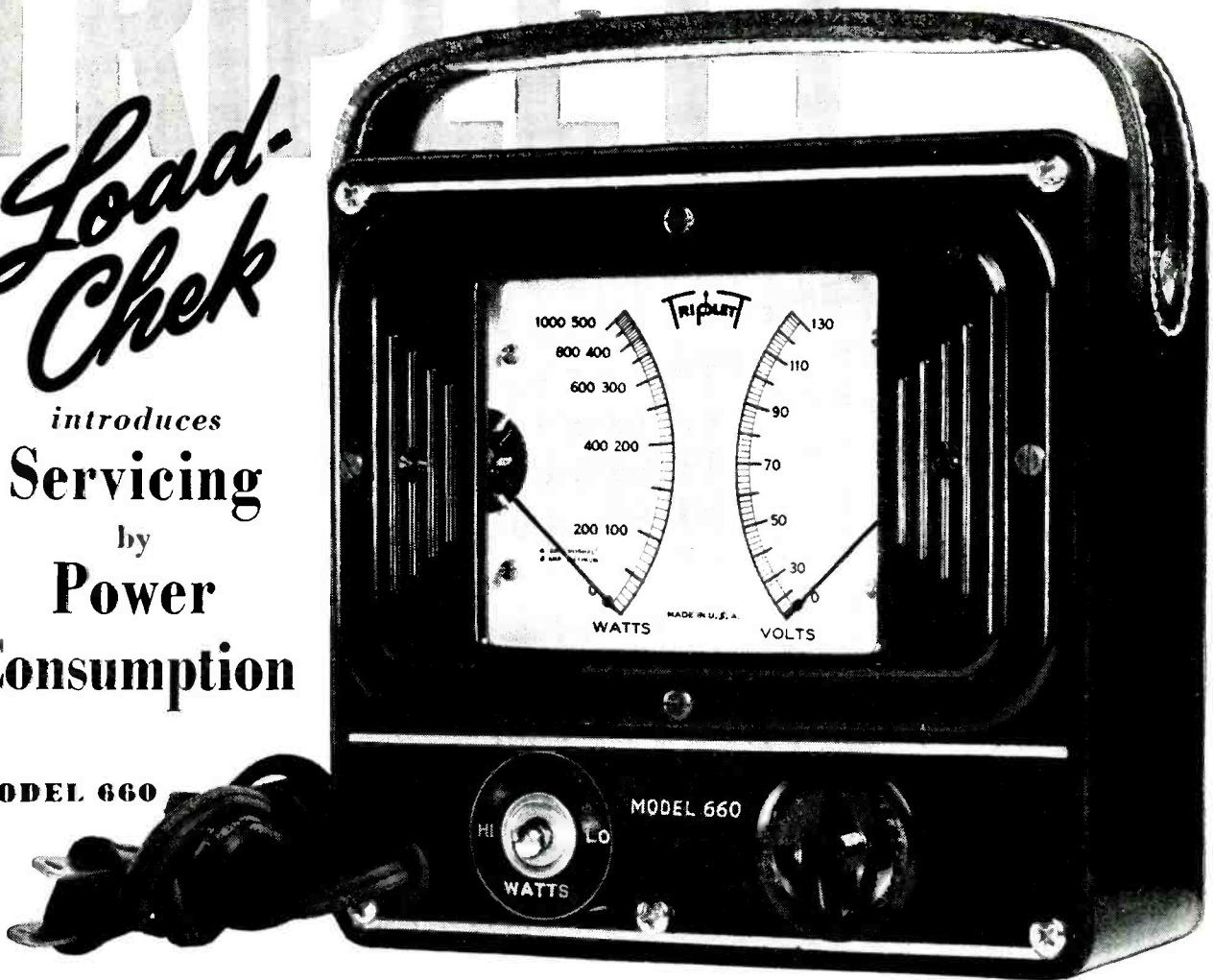

LOAD-CHEK for the first time makes it possible for every technician to utilize what is perhaps the simplest and quickest of all service methods—Servicing by Power Consumption Measurements.

Power consumption measurement has long been proved by auto-radio servicemen as a rapid method of localizing troubles in auto radios. But Triplet's new **LOAD-CHEK** is the first Wattmeter to be produced at moderate cost, and with the proper ranges, to bring this short-cut method within the reach of every radio and TV service man.

Basis of the **LOAD-CHEK** method is the tag or label on every radio and TV chassis which shows the normal power consumption. The following examples are only two of many time-saving uses of this new instrument.

LOCATING A SHORT—The chassis tag may show a normal consumption of 225 Watts. Simply plug the power cord of the chassis into **LOAD-CHEK** (there are no loose ends to connect or be in the way). Note the reading—which should be possibly 350 Watts. By removing the

rectifier tube you can determine at once which side of the tube the short is on. With a soldering iron and long-nosed pliers you can check through the chassis, locate and correct the trouble without having to lay down tools or to check with lead wires!

REPLACING BURNED OUT RESISTORS—With the chassis to be repaired plugged into a **LOAD-CHEK** MODEL 660, note the wattage reading with the burned out resistor circuit open. Now replace the resistor. Should the increase in watts be greater than that of the resistor rating being installed, it indicates that an extra load has caused the trouble which has not been cleared.

LOAD-CHEK is made-to-order for the busy service man and can help stop costly "come back" repair jobs. It's a profit-maker because it's a Time-Saver. And at its moderate cost **LOAD-CHEK** can be standard equipment on every service bench. *By all means*, inspect this versatile instrument at your distributor and place your order, for under present conditions we must fill all orders on a basis of "First Come, First Served."

SEE MODEL 660 **LOAD-CHEK** AT YOUR DISTRIBUTOR'S

FOR THE MAN WHO TAKES PRIDE IN HIS WORK

Triplet

TRIPLETT ELECTRICAL INSTRUMENT COMPANY - BLUFFTON, OHIO, U.S.A.

EICO
TEST EQUIPMENT

guards

Tele King
HIGH STANDARDS OF
TELEVISION PRODUCTION QUALITY



Tele-King Production Test Foreman James Adler and Harry R. Ashley, President of EICO, inspecting the use of the EICO Model 425 Oscilloscope and Model 221 Vacuum Tube Voltmeter at one of the important constantly alignment positions on the Tele-King television production line, New York City.

EICO KITS and INSTRUMENTS



New 555K MULTIMETER KIT \$29.95 Wired \$31.95

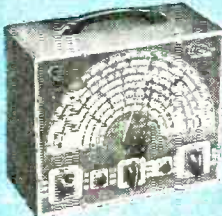

320K SIG. GEN. KIT \$19.95 Wired \$29.95
New 322K SIG. GEN. KIT \$21.95 Wired \$31.95

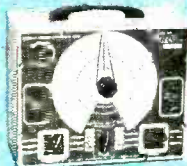

New 950K COND.-RES. COMP. BRIDGE KIT \$19.95 Wired \$29.95

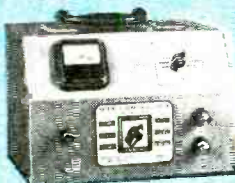

New 8040K BATTERY ELIM. KIT \$5.95 Wired \$34.95

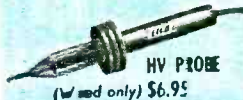

HV PROBE (Wired only) \$6.95

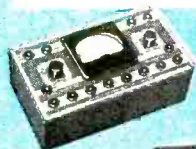

511K VOM KIT \$14.95 Wired \$17.95



New 1171K RES. DECADE BOX KIT \$19.95 Wired \$24.95



New 526K MULTIMETER KIT \$13.90 Wired \$16.90

EICO

ELECTRONIC INSTRUMENT CO., Inc.
276 NEWPORT STREET, BROOKLYN 12, NEW YORK

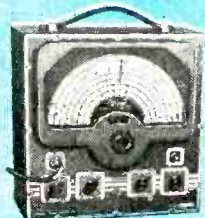

New 315K DELUXE SIG. GEN. KIT \$39.95 Wired \$59.95



New 625K TUBE TESTER KIT \$34.95 Wired \$49.95

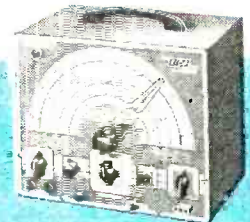

360K SWEEP CON. KIT \$34.95 Wired \$49.95



145K SIG. TRACER KIT \$19.95 Wired \$28.95

For Laboratory Precision at Lowest Cost—the Leaders Look to EICO!

No work in electronics is tougher on test equipment than the manufacture of quality television sets. Every week, every day, set production is pushed to ever greater volume, accelerated to ever faster pace—with no interruptions tolerated. Yet tests must be held to highest precision, costs must be kept to absolute minimum.

At the many vital testing positions along the production line of the great Tele-King Corporation—day after day, hour after hour—EICO instruments stand guard. From engineer to production chief to line tester, the men at Tele-King know that for speed, precision and utmost dependability, at maximum economy, they can always count on EICO instruments.

From coast to coast, in one famous TV factory after another, EICO instruments again and again prove their superiority. The top-flight TV set makers have discovered—just as over 70,000 servicemen have learned—that for the industry's greatest instrument values, at the industry's lowest costs—it's EICO!

Before you buy any higher-priced equipment, be sure you look at the EICO line! Each EICO product is jam-packed with unbelievable value. YOU be the judge—compare EICO at your local jobber today—and SAVE! Write NOW for free newest Catalog 7-C.

FOLLOW THE LEADERS...INSIST ON EICO!



New 221K VTM. KIT \$25.95 Wired \$49.95



New 425A OSC. SCOPE KIT \$44.95 Wired \$79.95

Prices 5% higher on West Coast. Due to unsettled conditions, prices and specifications are subject to change without notice.

SERVICE BOMBSHELL

. . . *Is radio servicing threatened by new competition?*

By HUGO GERNSBACK

IN OUR June issue, page 12, we reported briefly that Western Union was sponsoring a new subsidiary, *Western Union Services, Inc.*, which will soon embark in servicing various manufacturers' television receivers throughout the country.

Immediately after Western Union made this announcement late in April, a fierce storm broke over the entire servicing industry, individual service contractors and service technicians' associations denouncing Western Union and Allen B. Du Mont Laboratories, Inc., the first manufacturer to make a contract with Western Union.*

In many localities in the United States the announcement acted like a bombshell. Many of the industry's spokesmen felt that with such a powerful competitor in the business, the radio and television servicing industry was threatened with complete annihilation. The parts industry was no less disturbed. Its spokesmen felt that with such a powerful new competitor in the field, jobber and dealer parts people might be put out of business because the new competitor was powerful enough to buy directly from the parts manufacturers, eliminating the wholesaler, jobber, and distributor.

RADIO-ELECTRONICS magazine, which for over 20 years has sponsored and in many cases represented the service technician, can readily understand the disturbance that a new and powerful competitor could create.

We accordingly thought it apropos to get all the facts in hand before taking sides in the controversy.

After digesting reams of pros and cons we decided to submit a questionnaire to Western Union, which we did late in May. Here are the questions:

1. How soon will Western Union Services start active servicing?
2. In what cities or section is this service available?
3. Does the Western Union Services intend to have servicing stations nationally all over the U.S.?
4. If experience shows the plan successful, about how soon is it expected that the service may be expanded to cover larger areas, or the nation as a whole?
5. Will the Western Union Services do only strictly servicing work, or will they also have stores where television sets, radio sets, and parts are sold?
6. Will Western Union Services make only servicing calls, or will they also receive at their stores sets for repairs left by customers?
7. How many people does the Western Union Services employ at present?
8. Have you determined a price scale to customers? If so, how do you charge (hour rate, or how)?

Western Union promptly answered, not question by question, but in a general letter signed by their vice president, S. M. Barr. Here is the reply:

H. Gernsback, Editor,
Radio-Electronics,
New York, N. Y.

Replying to your letter of May 18 concerning Western Union Services Inc., there is little further we can add at this time as to our future plans beyond what you already have printed on page 12 of your June issue. Western Union Services Inc. is now in operation in its pilot service center in East Orange, New Jersey, where it offers installation and maintenance service on contract or call which, for the present, is limited to Du Mont telesets. The price scale is uniform with present Du Mont charges as indicated in your June issue. Repair service will be done either at the patron's home or in the service center as required either by the patron or the amount of repair needed. The Company has no intention of engaging in the sale of television sets, radio sets or parts, and plans to confine itself strictly to servicing activity, providing such parts as are needed in making repairs. The approach to this problem is that of a long range activity on a

national scale, but it is too early at this date to forecast the rate or the timing of expanded operations. I trust this gives you the picture we have with respect to this new service.

Western Union Services, Inc.
Signed, S. M. Barr

If Western Union Services, Inc., is vague on some of the points raised, the reason probably is that their policies have not yet sufficiently jelled for the new corporation to know their exact future plans.

It should be readily understood that the present management of Western Union Services, Inc., is not radio or television minded, having had no previous experience in the field. The management is chiefly composed of communication people. That means they will have to learn the business, which they cannot do overnight.

While we can see the future implications to the servicing industry as a whole, we feel—after consulting many people in the field—that the Western Union threat is by no means as acute as first pictured by some of the spokesmen of the servicing industry.

Most of them admit freely that it is the radio servicing industry's own fault that outside interests are now being lured into their field. Since the early 20's the service technicians, independent or employed, have never been able to get together and form a national organization through which they could become recognized all over the country. Instead the various factions fought each other continuously. When well-meaning organizers tried to launch a national association the movement always failed.

This was also true of the writer's former organization "The Official Radio Servicemen's Association" sponsored by this magazine for several years during the early 30's. It proved impossible to make the various local chapters cohere and this was the case also with the RSMA and other attempts made in the past.

Western Union's so-called threat may conceivably prove a blessing in disguise. We do not at all feel that the radio servicing industry will be hurt. On the contrary we do believe that the new competition will bring the various factions together as nothing before ever could do. It will be a powerful incentive to clean house, throw out the irresponsible radio technicians—who now abuse the public and give the entire business a black eye—and then set up a live and vigorous national servicing body.

RADIO-ELECTRONICS does not believe that Western Union will put the servicing industry out of business—they may have hard sledding themselves for some years to come—while local service organizations will be in a position to do the work better and cheaper than any big unwieldy body.

BUT THE LOCAL ORGANIZATIONS MUST FIRST CLEAN HOUSE AND BY CONCERTED ACTION PROVE TO THE PUBLIC THAT THEY DESERVE ITS CONFIDENCE.

Perhaps we can do no better than quote Mr. Mort Farr, veteran Upper Darby, Pa., servicing retailer and president of the National Appliance and Radio Dealers Association:

"The new Western Union subsidiary isn't likely to be as tough a competitor as the fly-by-night operators and screw-driver mechanics. It will be a legitimate operation, with a big overhead. The company will probably hire qualified help and won't be able to cut prices dangerously low as do some of the contractors now in business."

* See also "With the Technician" Section, page 86, this issue.

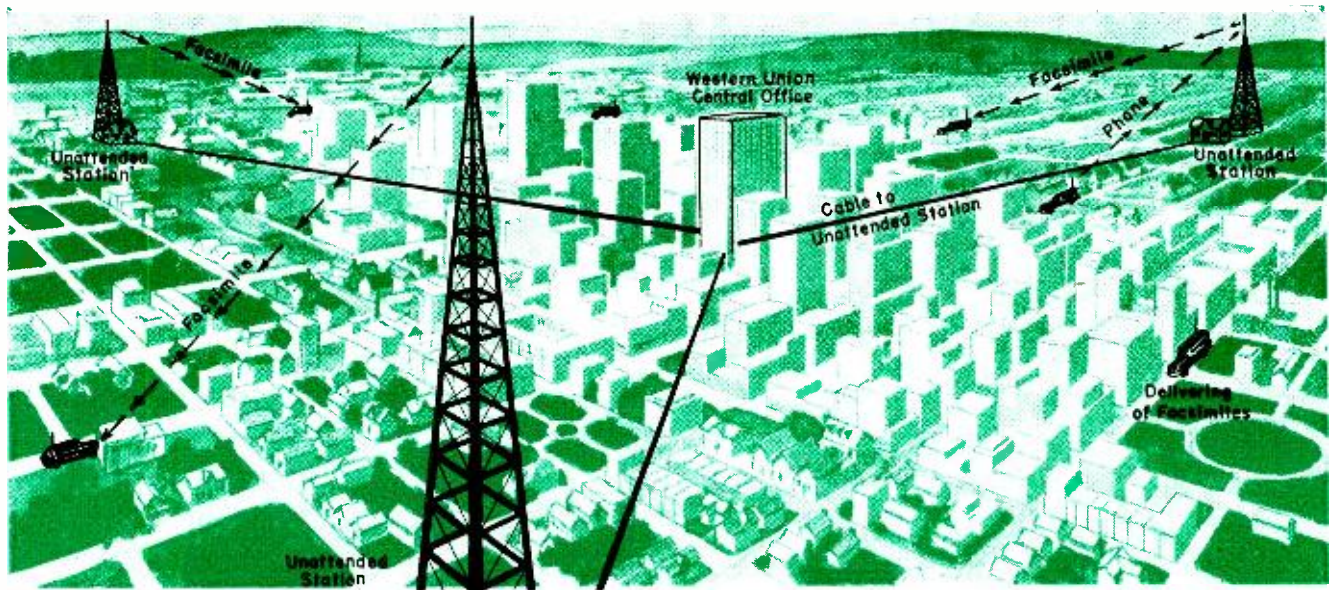

The Telecar system as it might be applied to a city of moderate size. The three unattended stations serve nine Telecars.

Telecar Speeds Telegrams

The modern telegraph messenger is facsimile-equipped

By FRED SHUNAMAN

THE observer is occasionally struck by anachronisms in the march of scientific progress—vestiges of the pre-machine age which survive in this era of electronics and nucleonics. One of these is the messenger-boy system of delivering telegrams on foot, by bicycle, or occasionally in a car. High-speed mechanized networks are in use today through which telegrams flash from origin to destination without manual retransmission at any point enroute. There are facsimile systems capable of transmitting thousands of words per minute; radio links to remote parts of the world; carrier systems, and many other techniques. These have so speeded up telegraph service since the time of Morse that the inventor would hardly believe the present system possible.

In spite of these advances the delivery system—up to a short time ago—was strongly reminiscent of the days of Morse. Since 1925, printing telegraph machines in large business houses, and, more recently, several thousand small facsimile (Desk-Fax) machines installed right on the business-man's desk, have pretty well solved the problem for large and medium-sized businesses. But for the small business and in residential areas, pick-up and delivery of telegrams—even by auto and motor bike—is still the weak spot in the telegraph service.

A method of eliminating this weak spot in our communications system has now been worked out. Already in Bal-

timore telegrams are being handed to recipients sometimes within a minute of the time they reach the city telegraph office. As the remaining "bugs" are ironed out of the system it will no doubt be extended to other parts of the country.

The Telecar

The device that will take home telegram delivery out of the 19th century is the *Telecar*, a station wagon equipped with a facsimile telegraph receiver and chauffeured by a uniformed WU telegraph messenger. Depending on point of view, it is either a radio-and-facsimile-equipped Western Union messenger or a roving branch telegraph station.

Telecars are now cruising the streets of Baltimore. With the exception of messages for the downtown business section, most telegrams received in that city are delivered by them. A telegram destined for a section of the city is routed to one of the Telecars in that territory and is received by its facsimile equipment without the driver's aid. It will even be received if the driver is temporarily absent from the car.

As soon as the telegram is finished and the Western Union messenger-driver, already cruising in his assigned area, sees the address on it, he drives immediately to that point and delivers it. He waits for an answer which he can radio back to the central office by phone. The cars are equipped with

radiophone transmitters and receivers.

The car radiophone can also be used for receiving instructions from the telegraph central office, except for the time when a telegram is actually being received.

To the radioman the idea seems a good one, sound, reasonably straightforward and simple. Thus thought also the engineers of Western Union. But the usual "bugs" were discovered during "reduction to practice," and the present system is the result of several years' experimental work.

How it operates

All the messages are sent from the central telegraph office in the heart of Baltimore. Messages destined for the business district immediately surrounding the station are handled direct by printer, facsimile, or messenger. Those for the Telecars are transmitted by wire to one of four unattended transmitting and receiving stations which are placed in a quadrangle round the outskirts of the city. They operate in the 30-50 mc range.

The actual facsimile transmitting equipment is standard or modified Telefax apparatus, familiar in many business offices. The messages, as received on printers at the main office from all parts of the nation, are put on vertical cylinders which revolve in front of a phototube. The output of the tube, modulated by the message, is amplified and inverted.

The reason for inversion is that since the light paper of the telegraph blank produces more current in the phototube than the dark letters, the message is originally a negative. Better results in transmission and reception are obtained by making it a positive—with the black letters producing the stronger signals and the light background remaining at a low level. A further advantage is that the received telegram is a positive instead of a white-on-black negative that would look unfamiliar to the average recipient.

The amplified signal is routed by wire to one of the four unattended stations, each of which has one to three Telecars allotted to it. The station is normally in a receiving condition, awaiting any messages from the Telecars. The "preamble" of the telegram contains signals which turn on the transmitter and switch the antenna from the receiver to it. An audio calling tone is then transmitted for two seconds to select the desired car. After the 2-second tone, a 2-second pause gives the car's relay equipment time to turn on the recorder. Pulses are sent to synchronize the Telecar with the transmitter, and the message is recorded.

As soon as the message is concluded, the car recording equipment is shut down automatically and the receiving equipment reverts to its stand-by condition. The unattended station is also automatically switched from transmit to receive, ready to pick up any query or message from the car.

The mobile equipment

Each Telecar is fitted up with a modified RCA CMV-2A transmitter-receiver. Its transmitter section supplies 30 watts of phase-modulated signal to transmit replies, service messages and inquiries to the unattended stations. Its receiver has an output of 1 watt.

The receiver is mounted near the rear of the car. The equipment directly ahead of it in a cabinet located behind the driver includes a *power pack*, a *standard frequency generator*, a *recording amplifier*, and a *relay bank and selector*. (See page 23 for schematic). The recorder sits beside the driver.

The recording unit

The recorder is a modified Western Union 808 unit. The telegram is "printed" in black on a yellow (Teledeltos) paper with a silvery, conductive back. The paper is fed into the recording position from a roll. When in position to record, its edges rest around two circular flanges which form it into a cylinder, down the center of which the stylus assembly travels while the rotating stylus inscribes its message. Dark marks are made on the paper whenever an impulse from the recording amplifier supplies a pulse of voltage to it.

The carriage assembly is made to travel by a threaded lead screw, against which a threaded "half-nut" is brought

into engagement by a relay-actuated solenoid when the carriage is to start in motion. Other relays provide that the stylus start in exact synchronism with the beam of light scanning the telegram at the transmitter. Still other equipment is provided to eject and cut off the telegram when complete, and even to warn the operator when the roll of telegraph blanks is running low (low tape switch).

The most important equipment is that which selects the designated Telecar for a given message, puts its recording equipment into action, and synchronizes it with the transmitter. This is the relay bank and selector unit.

Less dramatic, but equally necessary are the other sections of the apparatus already mentioned. Radio men will find the *recording amplifier* a reasonably standard unit. Its most interesting feature is the *frequency doubler*. Doubling the frequency of the Telefax signals provides more definition at the recorder while avoiding the difficulties that would be encountered with wideband circuits in the radio transmitting and receiving apparatus. The signal to noise ratio is also improved.

Following the frequency doubler is a Western Union filter designed to trap out all but the desired Telefax signals, and a balanced-to-ground push-pull amplifier, with its output connected directly to the receiving stylus.



One of the Telecar fleet in Baltimore.

The power pack consists of two dynamos which supply power to the recording amplifier and the standard frequency generator, and a vibrapack which supplies a.c. for the motor driving the carriage assembly. All the equipment, including the recorder, is powered from a single 6-volt battery which is charged from a high-current alternator-rectifier arrangement. The primary source of power is, of course, the car's engine.

The motor which rotates the stylus is driven by a special standard-frequency generator, which is a 60-cycle multivibrator controlled by a 240-cycle tuning fork. The output, furnished at exactly 60 cycles by a pair of 6V6's, keeps the recorder stylus in synchronism with the scanning beam on the cylinder of the transmitting equipment. The latter is also powered from a standard frequency generator. All that is necessary is to assure that the beam and stylus start in unison.

Selector and relay bank

The recorder is started and synchronized by signals from the receiver which branch off to the selector just before the frequency doubler. These leads carry not only the 1-, 2-, or 3,000-

cycle tones which select the desired car but also the pulses that bring the recorder into step with the transmitter and start it at exactly the right instant.

The selector is a resonant circuit made up of a Western Union 1001-A coil and any one of three capacitor combinations which tune it to any of three frequencies. They are selected with a switch which also connects the resonant circuit to the following amplifier through a coupling capacitor of suitable size for the frequency.

At the beginning of each message, a 2-second tone of one of the three frequencies is transmitted. It is picked up by the car receivers and—on the selector tuned to it—is amplified through the two halves of the 6J6. Relay LR in the plate circuit of the 6J6's second triode then closes, charging an 8- μ f capacitor through its contacts 2 and 3. When the 2-second signal stops, contact 2 drops back against contact 1 and the capacitor discharges, closing relay PRI.

The relays click

Thus begins a series of events which lasts another two seconds and prepares the equipment to start recording the telegram. Relay PRI, through its various contacts, turns on the tube filaments in the recording amplifier and supplies plate voltage to them. It also starts the vibrapack through its 3R and 4R contacts and at the same time actuates the phase magnet solenoid.

As the vibrapack starts to supply power, relay AC pulls up. Its contacts 1L and 2L supply current to the half-nut solenoid in the recorder, causing the half-nut to engage the lead screw. The carriage starts to move. Contacts 1R and 2R supply voltage to the standard frequency generator which operates the stylus motor. The stylus motor rotates only till the stop on its shaft contacts the dog brought up against it by the phase magnet, and there waits for the phasing pulse that will release it.

Two seconds after the end of the tone signal, short phasing pulses are sent. Relay LR follows them and thus charges and discharges the 8- μ f capacitor. Meanwhile the carriage is moving forward. When it has gone far enough to release the phase lock switch and thus clear the short placed across relay PH's coil by contacts 1R and 2R of relay PRI, the discharge from the capacitor closes the contacts of PH. This releases the phase magnet and causes the recorder stylus to start in step with the revolving cylinder at the transmitter.

Recording then starts, and continues till the carriage reaches the end-of-message switch and opens its contacts. This starts a series of actions involving relays PRI, PH, and R, which cause the completed telegram to feed out and be cut off by the knife. The equipment then returns to the standby state, ready to receive another telegram.

—end—

This Signal Generator is Powered by Buzzer

Filament and plate are both fed by two flashlight cells

By JOHN A. DEWAR

THIS small signal generator is useful on outside calls and in locations where a.c. power is not available. It is unusual in that it uses a small high-frequency buzzer as a vibrator for the plate supply, thus eliminating the cost, weight, and bulk of a B-battery. Since the total plate and filament consumption is only about 200 ma, two 1½-volt flashlight cells last a long time and their replacement cost is small.

No output attenuator or coupling was found necessary since the generator radiates sufficient energy to put a

good signal into the receiver. Radiation is also directional, and excellent attenuation can be accomplished by varying the angle and distance between generator and receiver. The control, in fact, is better than most potentiometers provide. The directional characteristic makes for simplicity and the elimination of external leads.

L1 is the primary of a standard broadcast antenna coil; L2, the secondary, is phased so that the tube will oscillate. L3 is a coil from a 460-kc i.f. transformer which was placed on the form with the antenna coil. The generator is designed to cover two bands, and L1 provides the feedback for both. C1 and C2 are sections of a small 2-gang condenser. One section is used to tune L2 for the broadcast band (540 to 1600 kc). The other section is connected across L3 so that both sections are in parallel to cover the i.f. range from 150 to 600 kc.

A midget output transformer is used to step up the a.c. for the plate supply and provides 100% modulation at the buzzer's audio frequency. C3 acts as a buffer capacitor and is necessary to cut down high-order harmonic peak voltages. It is advisable to shield the power supply from the r.f. section to eliminate spurious radiation.

To keep power consumption low the buzzer should have a coil resistance of 20 ohms or more. The common connection between the coil and reed is connected (in most types) to the buzzer casing, and it is necessary to insulate it from ground and make one side of the voice-coil connection to the shell. Mount so that the adjusting screw is accessible and can be set for best operation.

The generator case was made from thin, soft aluminum which can be bent without cracking, and the parts mounted directly on it. The dial con-

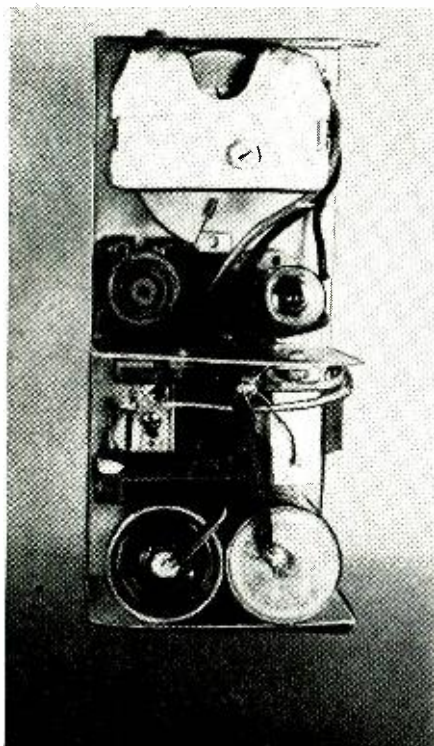

Note that the power supply is shielded.

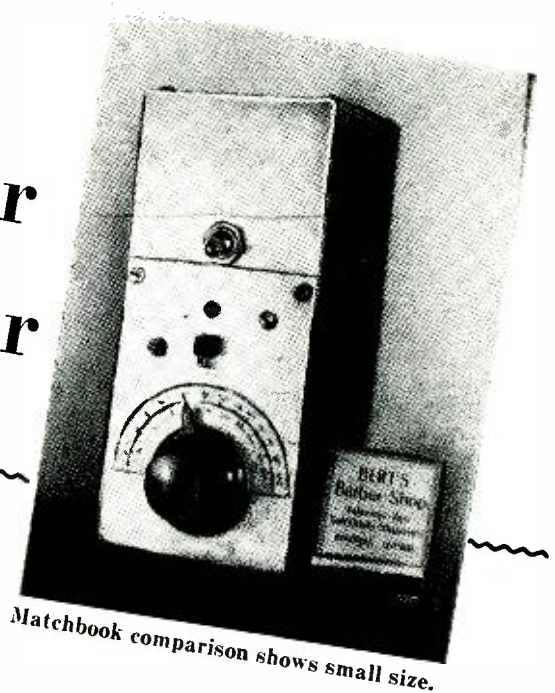

Matchbook comparison shows small size.

sists of a semicircle of paper glued to the panel and hand calibrated, either from stations of known frequency or from another signal generator. A coat of lacquer will prevent the dial from soiling with use.

The over-all size, 6¾ x 3 x 2½ inches, can be reduced further by using a midget tuning capacitor and penlite cells. Short wave bands were not included, for the sake of simplicity and also because the writer prefers to use WWV for spot frequency checks.

On repair calls sometimes, this signal generator may enable the radio technician to decide whether to "pull" a set and carry it down to the shop. In some cases, alignment can be checked by attaching a VOM to the voice coil and feeding a constant signal in from the pocket generator.

It is important to stabilize the frequency of this unit before any extensive work is done. This can be done by allowing it to warm up before calibrating it against a known broadcast station's frequency.

Materials for signal generator

- 1—replacement broadcast antenna coil; 1—coil from 450-to-460-kc i. f. transformer; 1—midget output transformer, 50L6-to-voice coil; 1—2-gang tuning capacitor, 365 µmf per section; 1—midget mica capacitor, 25 µmf; 1—paper capacitor, .01 µf, 1,000 volts; 1—resistor, 22,000 ohms, ½ watt; 1—switch, s.p.s.t., toggle; 1—switch, s.p.d.t., slide type; 1—miniature socket, 7-prong; 1—3Q4 tube, 2—flashlight cells, 1½-volt; hookup wire, dial, hardware, etc.

Note: Use ant. coil with low imped. primary.

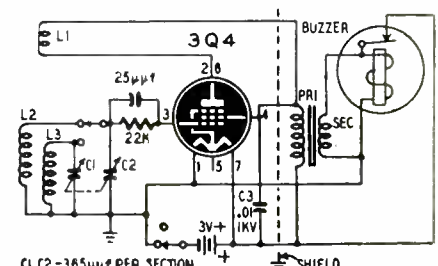

C1, C2—365 µmf PER SECTION
A simple oscillator circuit is used.
—end—

BC-453 as Service Aid

By JOSEPH ZELLE*

THE BC-453 receiver, long popular among radio amateurs for highly selective reception, also makes a handy instrument around the radio service shop. This little command set tunes from 190 to 550 kc, covering the most common intermediate frequencies of superheterodyne receivers. It works as a kind of *low-frequency* meter and makes i.f. checking very easy.

It is good policy anyway to make a quick check of the operating frequencies of every receiver that comes in for servicing. Hardly any receiver escapes some tuning or adjusting, and fundamental misadjustments thus can be spotted instantly.

To make the check, connect a lead from the BC-453 antenna post to the grid or diode plate of the second detector of the set under test. Then tune the BC-453 until you hear the signal and note the frequency on the dial. You can interpolate the dial readings closely enough for all practical purposes because these units are very stable at such low frequencies. The BC-453 may be checked against known radio-range stations for calibration. The interpolated i.f. should check with the receiver manufacturer's specifications.

If the receiver is defective, the BC-453 unit is useful as a signal tracer. Clip the same lead from the antenna post on the plate of the last i.f. amplifier, then the grid, and in this way work toward the antenna end of the set until the signal can be picked up in the BC-453. In this way, you can locate failure in a particular circuit with ease. Of course, the BC-453 must be tuned to the intermediate frequency of the set under test and the receiver stages must be at least roughly aligned. Secondly, the testing can go back only to the mixer or converter stage, where the i.f. first appears.

This surplus receiver is much more useful for aligning. With the signal generator feeding r.f. to the broadcast receiver at the high-frequency end of the band, connect the BC-453 to the grid or diode plate of the second detector to serve as an aural indicator. With the BC-453 set at the correct i.f. you can be sure the i.f. stages of the receiver will be tuned to the correct frequency.

A beat frequency of 456 kc (or whatever the i.f. may be) can be produced by beating the local oscillator either higher or lower than the incoming r.f. signal. For example, at 1500 kc, either 1956 kc or 1044 kc will produce an i.f. of 456 kc. This may cause a good deal of trouble in aligning a receiver.

In most superheterodynes, the local oscillator (first detector) tunes at a frequency higher than the incoming r.f. signal (at 1500 kc in the case above). Therefore, screw the oscillator padder tight. Then with the test setup in operation, unscrew the padder screw slowly until the i.f. signal is heard in the BC-453. This will be produced by the low-frequency side of the oscillator (or 1044 kc of the above example). Unscrew the padder still farther now, until the signal again appears in the BC-453. This is the result of the higher oscillator frequency (or 1956 kc of the example). You may be able to find only one signal, which ordinarily will be the correct setting for the oscillator.

The correct frequency for the oscillator is important for tracking. In fact, if various stations do not appear at their proper places on the receiver dial, either the i.f. or the oscillator frequency is wrong. With the correct i.f. use the frequency for the oscillator which gives better tracking. In some superheterodynes only one correct beat frequency can be tuned with the oscillator. In that case tune the oscillator to produce the required i.f. After the i.f. and oscillator frequency have been determined and tuned, trimming and padding can be done with the assurance that the receiver will track correctly over the full broadcast band.

A signal generator is not even necessary for this tuning process. First connect the BC-453 to the second detector as before, and set its dial to the required intermediate frequency. Next, tune the receiver to be serviced to the frequency of a known local broadcast station (preferably around 1,000 kc). Then tune the oscillator until the particular broadcast station is brought in on the BC-453. Should the receiver under test be so badly out of tune, that the station cannot be heard (assuming the receiver is not defective) move the lead from the BC-453 up a stage or two toward the mixer, and again try tuning the oscillator to the correct frequency. Then move the clip back, stage by stage, toward the second detector and tune the stages each time for maximum response. With the various stages now tuned so that sufficient signal is available in the final i.f. stage, the whole set can be aligned as described before. Trim and pad at the high and low ends of the dial, using local radio stations as r.f. signal sources.

When making the final tuning adjustments, remove the BC-453 coupling lead, since it loads and detunes the circuit to which it is connected. Final alignment

can be made with the serviced receiver's own audio system.

This handy service gadget is reasonable in cost on the surplus market. It requires 24 volts for the filaments and 250 volts for the B-supply. By connecting all the tube filaments in parallel, 12 volts will supply them. In some cases, where complete power and 6.3-volt filament supply is available, it may be better to replace the tubes with equivalent 6.3-volt types. Some changes in bias circuits will be necessary in the latter case.

Besides serving as an i.f. checker, the BC-453 receiver offers 360 kc of radio stations, mostly radio range and weather, on frequencies below the broadcast band.

—end—

POLYMER IMPROVEMENT

The radio man who owns a type 134 Sylvania Polymer can improve its performance quite a bit by adding a shielded d.c. test probe and jack. The shielded probe is a useful device for making dynamic tests in which critical d.c. voltage measurements must be made without detuning the receiver under test.

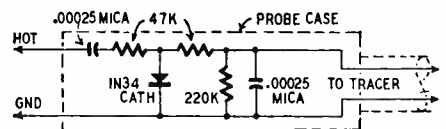

To make the addition, mount a midget open-circuit phone jack on the Polymer panel. There is plenty of room above either the AC VOLTS jack or RF VOLTS jack. Wire the high terminal of the jack directly to the MA-DC VOLTS jack inside the instrument. Use ordinary unshielded hookup wire. This connection will not interfere in any way with operation of the MA-DC VOLTS pin jack, which still can be used for milli-ampere measurements and for d.c. measurements when shielding is not required.

Ordinary microphone cable may be used for the shielded test lead. Inside the shielded test prod, connect a 1-megohm, ½-watt carbon resistor as close as possible to the probe tip. Connect the other pigtail of the resistor to the center conductor of the shielded cable. Terminate the far end of the cable with a standard phone plug. Connect the center conductor of the cable to the ball of the plug, and the cable shield braid to the plug sleeve. The figure shows the circuit inside the test prod.—Rufus P. Turner

* Technical Staff, WERE, Cleveland, Ohio.



My radio—there's something wrong with it. Fades out. Maybe you could fix it?

The Customer is ALWAYS Right!

By ERIC WAHLEN



1

After two hours—Let's try a new approach. Get a different slant on it.



2

Six hours have passed swiftly. Cause of fading still not tracked to its lair!

JULY, 1951

EVERY radio repair technician knows that often more time is spent repairing a set than can be charged to the customer. But here is the tragic tale of the inexperienced repairman who made the fatal mistake of telling his customer that a 50-cent capacitor was the cause of the trouble. Our hero has the frustrated feeling—but of course he'll know better next time.

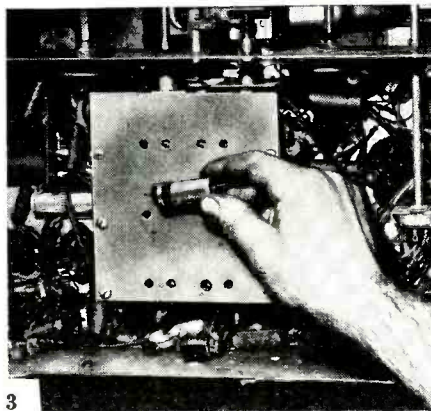

3

At last! A bypass capacitor that tests O.K. but which works only occasionally.



4

The customer is burned up too. "You got some nerve charging five bucks for that."

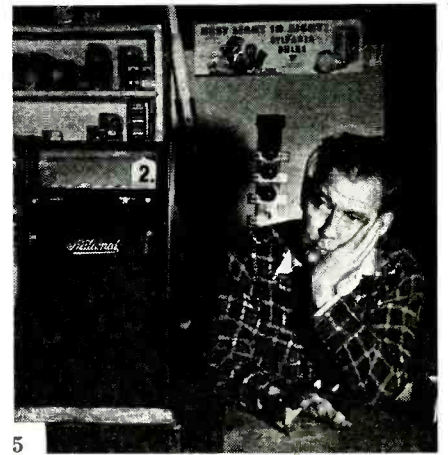

5

Our hero is slightly singed also. There must be a better word than frustration.

TV TUBE SUBSTITUTIONS

By EDWARD J. LOCKE

HOW long can the television broadcaster, and service technician continue "business as usual" if the present tube shortage continues? If the situation grows worse or even remains in its present state, the answer may well be found in the industry's ability or ingenuity to substitute older or more available tube types for those now at a premium.

The tubes listed here are types found in practically all present-day TV receivers. Some of the types listed as replacements will operate perfectly, while others may result in decreased gain, loss of picture definition, and other deficiencies, and in some cases may require circuit realignment or circuit changes. However, it is much better to return your customer's receiver in at least an operating condition than to leave him with a "white elephant," even if you have to go to considerable length to do it.

Above all, make sure that any substitutions or changes are explained so that your customer will know what to expect in the way of performance. And, for the benefit of other technicians who may service the set later, or for your own information on future calls, paste a note or circuit diagram in the back of the set, explaining the changes made.

Adapters vs. socket changes

It is probably better to make all temporary substitutions by using an adapter, rather than changing the socket or rewiring circuit connections. In some cases lack of space will rule out the adapter. Here the only alternative—unless the correct tube replacement can be obtained within a reasonably short time—is to replace the socket if a different type is required, or to change the socket connections to accommodate the new tube. Suitable adapters can easily be made up by wiring the desired type of socket into the top of a discarded tube base. Terminal connections are pulled through and soldered as indicated in the accompanying socket diagrams or by consulting a tube manual.

Tube substitutions

1X2-A (High-voltage rectifier). Replacement with a 1B3-GT will improve results in many cases (maximum and average peak plate currents of a 1B3-GT are, respectively, 17 ma and 2 ma as compared to 10 ma and 1 ma for the 1X2-A). An adapter to change from 9-pin miniature to standard octal socket is required (Fig. 1 to Fig. 2).

5AZ4 (Low-voltage rectifier). Electrical equivalent of 5Y3-GT. Replace socket or use adapter.

5U4-G (Low-voltage rectifier). Directly interchangeable with 5T4. A 5Z3 can be used with the proper adapter (4-pin to octal); rewire connections from Fig. 3 to Fig. 4. A 5R4-GY may be directly substituted if available. A 5X4-G may be used with an adapter (the socket can be rewired to accommodate either the 5U4-G or 5X4-G by tying pin 4 to pin 3, pin 6 to pin 5, and pin 7 to pin 2). *Do not* use a 5V4-G, 5W4, 5Y3-GT, or 5AZ4 to replace a 5U4-G. Socket connections are the same, but these types do not have sufficient current ratings. Early tube failure will result.

5V4-G (Low-voltage rectifier). Directly interchangeable with 5Z4-GT, and 5Y3-GT in circuits where maximum ratings of replacement are not exceeded. An adapter can be used with types 5Y4-G, or 80.

6AC7 (Sync stripper, 2nd video amplifier, or reactance tube). Directly replaceable with 6SH7. A 6SJ7 can be used as a direct replacement on an emergency basis in most sync stripper and 2nd video circuits. Operation may or may not be satisfactory in horizontal a-f-c circuits (horizontal discriminator transformer can usually be adjusted to work satisfactorily). It may be necessary to insert a 700-ohm resistor in series with original resistor for correct cathode bias. Although the gain will be reduced by substituting the 6SJ7, operation in strong-signal areas should be satisfactory. (Fig. 6).

6AG5 (Video i.f., sound i.f.). Directly replaceable with 6BC5. Check effect of interelectrode capacitance differences on alignment, especially in video i.f. chain. *Caution:* The 6AG5, 6AK5, and 6BC5 have suppressor and cathode tied together internally and then connected to pins 2 and 7 (Fig. 9). The 6AU6 and 6BA6 have cathode brought out to pin 7 and suppressor to pin 2 (Fig. 8). Just to be different the 6CB6 has cathode to pin 2 and suppressor to pin 7 (Fig. 7). If the circuit in which these tubes are to be used has cathode *and* suppressor directly grounded, no trouble occurs and all of them can be used with no socket wiring change. But if cathode bias is used, look out. It may or may not be necessary to change socket connections to pins 2 and 7, depending on which tube is replacing which (and sometimes on the set manufacturer's schematics; make sure the connections on the socket

are the same as those on the diagram). A circuit check *must* be made before substitution.

6AG5 (Reactance tube). Try a 6BC5 or 6BA6. (See Caution Above) Readjust discriminator transformer if necessary.

6AH6 (2nd video amplifier). Replace with a 6AC7 or 6SH7, using an adapter or changing socket connections as shown from Fig. 5 to Fig. 6.

6AK5 (Video or sound i.f., r.f.). In most circuits a 6AG5, 6AU6, 6BC5, or 6CB6 can be directly substituted. (See 6AG5 Caution.) Interelectrode and mutual conductance differences may require some minor circuit readjustments. See Fig. 9.

6AK6 (Horizontal oscillator). Change socket or use adapter to accommodate a 7B5, or 6K6-GT. A change in value of the series-hold resistor may be necessary.

6AK6 (Power-pentode amplifier). Replace with 6G6G and adapter if space permits

6AQ5 (Beam-power amplifier). Although its characteristics are somewhat different, a 6AR5 may be used if available, provided pin 7 of the 6AQ5 socket is tied to pin 1. A *single* 6AQ5 may be replaced with a 6AS5 if minimum Class A ratings are being used for the 6AQ5. An adapter or circuit changes from Fig. 10 to Fig. 12 will be required.

6AQ5 (Horizontal oscillator). Directly replaceable with 6AR5. No socket changes necessary unless the original circuit uses pin 7 as one of the control grid terminals. In this case, it will be necessary to tie pin 7 to pin 1 on the 6AQ5 socket to maintain circuit continuity. Series-hold resistor may require changing to keep range coverage. Fig.10.

6AQ5 (2nd video amplifier). Use a 6AR5 as direct replacement. (Check bias voltages for proper values.) Some peaking adjustments may be required in critical circuits. Fig. 10.

6AQ6 (Discriminator, 1st audio). Directly interchangeable with 6AT6. A 6AQ7-GT may be used if socket changes are made from Fig. 13 to Fig. 14. A 6SQ7-GT may be used with adapter if space permits.

6AQ7-GT (Discriminator, 1st audio). May be replaced with 6T8, 6S8 or 6AW7 in cases where the circuit permits. Check each case with the tube manual and set schematic and use adapter or rewire socket as required.

6AR5 (Video amplifier). Replacement with a 6AQ5 is not recommended but may work satisfactorily in strong-signal areas. Peaking readjustment may be required. Fig. 11.

6AS5 (Beam-power amplifier, horizon-

tal oscillator). Replaceable with a 6AQ5 or 6AR5 by using adapter or rewiring socket. The base connections are shown below in Figs. 11 and 12.

6AT6 (Discriminator, 1st audio). Directly replaceable with 6AQ6. The 6AQ7-GT has the same characteristics and may be used if the 6AT6 socket is replaced and circuit connections are changed from Fig. 13 to Fig. 14. The two cathodes of the 6AQ7-GT (pins 2 and 6) should be tied together. If the above types are not available, use a 6SQ7-GT and adapter.

6AU6 (Video and sound i.f.). Can be replaced directly with a 6BC5, 6BA6, 6AG5, or 6AK5 (see 6AG5 Caution). The 6CB6 will result in much greater gain. Addition of a tube shield, if not already in use, should be made to prevent oscillation. Solder the shield to chassis instead of riveting or bolting. This will make a low resistance joint. The 6BC5 has somewhat less gain than the 6CB6, but will still be an improvement over the 6AU6. Single 6BA6's

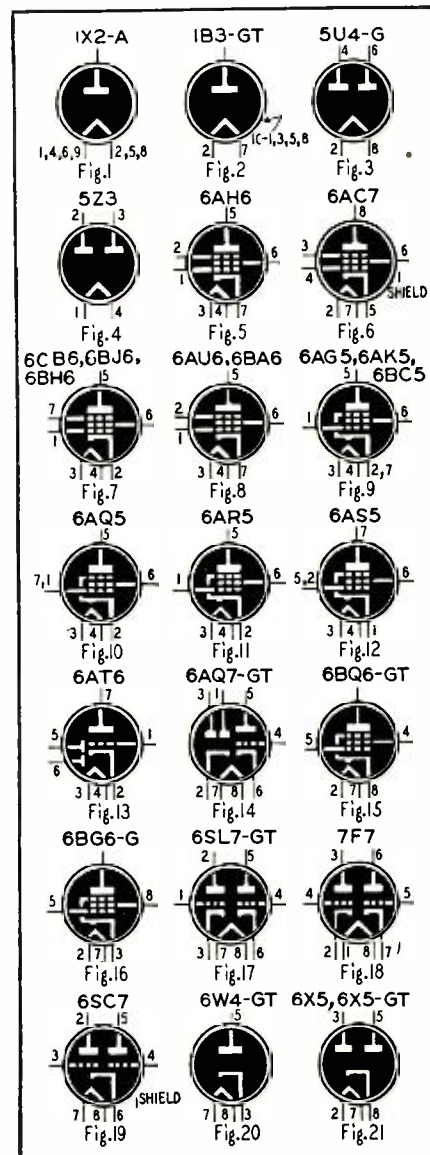

Socket connections of most tubes listed.

may be used as direct replacements in sound i.f. and in r.f. stages. In video i.f. stages it is recommended that all 6AU6's be replaced simultaneously with 6BA6's in order to maintain the same degree of interelectrode changes in each stage. Slight realignment may be necessary.

When replacing the 6AG5 or 6BC5 with a 6CB6, 6AU6, or 6BA6 it may be necessary to change the value of the original cathode resistor to obtain the proper cathode voltage (approximately 1.5 volts).

Some receivers using 6AG5's, 6BC5's, or 6AU6's take the plate voltage from a 300-volt point. When 6CB6's are used, it may be necessary to reduce this voltage by inserting a series-dropping resistor or moving the plate-supply lead to a 200-volt point.

6AU6 (Limiter, a.g.c.). The above substitutions may or may not work in these circuits without modifications or changes in parts values. Try substitutes in various receivers to note the effects (Fig. 8).

6AV6 (1st audio, bias clamp). Directly replaceable with 6AQ6 or 6AT6 (Fig. 13) with some loss in gain. A 6AQ7-GT, 6SQ7-GT, or 6SZ7 may be substituted with the proper adapter.

6BA6 (Sync amplifier). The 6CB6 and 6BC5 are replacements (see Caution on 6AG5). The 6AU6 can be used in some cases (high signal-strength locations). A 6AG5 or 6AK5 can be tried if no others are available (Fig. 8).

6BC5 (Video i.f., sound i.f.). Replaceable with 6AU6, 6AG5, 6AK5, 6BC5, or 6CB6 (see Caution on 6AG5).

6BJ6 (R.f. amplifier). Directly replaceable with 6BH6 and 6BC6, with increased gain and sharper cutoff characteristics. The 6AG5, 6AK5, 6AU6, 6BC5, and 6BA6 may be used with an adapter (Fig. 7). (Note the Caution under 6AG5.)

6BH6 (R.f. amplifier). Directly replaceable with 6BJ6 and 6BC6. The substitutions listed for the 6BJ6 may be made with an adapter as stated (Fig. 7).

6BL7-GT (Vertical oscillator). Directly interchangeable with 6SN7-GT. (6BL7-GT has greater gain than the 6SN7-GT.)

6BQ6-GT (Horizontal output). No direct substitute. A 6BG6-G can be used if socket connections are changed from Fig. 15 to Fig. 16. If the 6BG6-G does not draw proper current, change the value of the screen-dropping resistor.

6CB6 (Video i.f., sound i.f.). May be replaced with 6BC5, 6BA6, 6AU6, 6AG5, or 6AK5 in most cases (see Caution on 6AG5) (Fig. 7).

6K6-GT (Audio output, 2nd video output). A 6V6-GT or 6F6-GT can be used as direct substitute in most cases. Audio output will be increased from 4.5 watts to 5.5 watts with the 6V6-GT. It may be necessary to change the bias for distortion-free operation at all volume levels.

6S8-GT (Discriminator, 1st audio). (Used in some older models). Where only two of the three diodes are used, try a 6Q7, 6R7, 6SQ7, or 6SR7. Socket

6W4-GT (Half-wave rectifier; damper). No direct replacement. The 6X5 may work in emergencies if both plates are paralleled and socket connections changed from Fig. 20 to Fig. 21, or an adapter is made up. Paralleling the 6X5 plates will allow a peak plate current of approximately 410 ma as compared to 600 ma for the 6W4. Heater currents are different—1.2 amp for the 6W4 and 0.6 for the 6X5.

6Y6-G (Audio output). Replace with a 6U6-GT, 6W6-GT, or 6L6. No socket changes required.

7B5 (Sync separator; audio output). Change socket and rewire for 6K6-GT or 6V6-GT, or use adapter with these tubes.

7C5 (Vertical or horizontal sweep). Change socket and rewire for 6V6-GT or 6K6-GT, or use adapter.

7F8 (Vertical and horizontal sync amplifier). Try a 7F7, 6SL7-GT, or 6SN7-GT. An adapter or socket replacement will be necessary. Bias voltages should be checked and value of cathode resistor changed if necessary.

7W7 (1st and 2nd sound i.f.). Replace with a 7V7 or 6AB7 (adapter or rewiring required).

7Y4 (Low-voltage or bias rectifier). May be replaced with a 7Z4. (7Z4 has greater current-carrying capacity than 7Y4.) A 6X4 or 6X5 with adapter may be used. The socket connections of the 6X5 are shown in Fig. 21.

7Z4 (Low-voltage or bias rectifier). Do not replace with a 7Y4 if total current drain exceeds 70 ma (7Z4 supplies 100 ma). A 6W4-GT which supplies 100 ma but which has a heater current of 1.2 amp. can be substituted if the receiver power transformer is able to supply this.

12AT6 (Discriminator, 1st audio). Replace with a 12SQ7-GT and adapter.

12AU7 (1st and 2nd video amplifier; or vertical oscillator). Directly interchangeable with 12BH7 (12BH7 has greater gain). A 12SN7-GT for series-connected 12AU7 heaters) or a 6SN7-GT (for parallel-connected heaters) can be used by changing the socket where space permits or by using an adapter.

35W4 (low-voltage rectifier). Replace with 35Z5-GT and adapter.

50B5 (Beam-power output). Replace with 50L6 (adapter or socket changes).

—end—

These substitutions have been made with sets having parallel-connected heaters in mind. Heater currents may differ considerably, but that should make little difference unless a set is running dangerously near its maximum transformer capacity, or unless several heavy-current filament tubes are inserted in the same set.

Where filaments are connected in series, it is important to check the heater current of any tube to be substituted. If a lower-current tube is available, it can be shunted by a resistor. If the tube draws a higher current, substitution is less likely to be practical, although in extreme cases a resistor shunting all the other heaters may be used.

In general, when the tube available for substitution has not the same current and voltage rating as the one to be replaced, the substitution becomes a special job and must be checked carefully against the conditions of the given case. Use your tube manual!

Many other combinations or tube substitutions may be possible. Experiments with various tubes in different circuits in the course of servicing will show just how far substitutions may be carried. Remember, in closing, always to note any tube or part replacement on the chassis inside the cabinet for future reference.

Our thanks to RCA Tube Division for the photographs of tubes

connections must be changed accordingly. A 6AQ6, 6AQ7, or 6AT6 can be used with an adapter or socket replacement.

6SH7 (Pulse stripper). A 6AC7, 6SG7, 6SD7-GT, and 6SE7-GT are direct replacements. Try each type and note its effect on circuit operation. It may be necessary to connect suppressor and cathode pins on socket when using 6AC7, 6SD7, or 6SE7. Types such as the 6AG5, 6BC5, 6BH6, 7G7, 7H7, 7L7, or 7T7 will work in many cases with the proper adapter.

6SL7-GT (Vertical oscillator). Make up an adapter or rewire socket for a 7F7 (Fig. 17 to Fig. 18) or for a 6SC7 (Fig. 19) if both cathodes of the 6SL7-GT are being used in parallel. A 6SN7-GT can be used as direct replacement in some cases. Slight changes in series-hold resistor value may be required. A 7F8 with adapter may be used if bias voltages are changed.

6SN7-GT (Vertical oscillator). A 6AH7-GT, 6F8-G, or 7N7 should work with an adapter. The series-hold resistor may need to be changed. The 6AH7's heater current 0.3 amp, that of the other tubes 0.6 amp.

6V6-GT (Audio output). Directly replaceable with 6K6-GT. A decrease of approximately 1 watt may result. See 6K6-GT for bias note.

MONEY IN TV SERVICING

By OLIVER HORNING

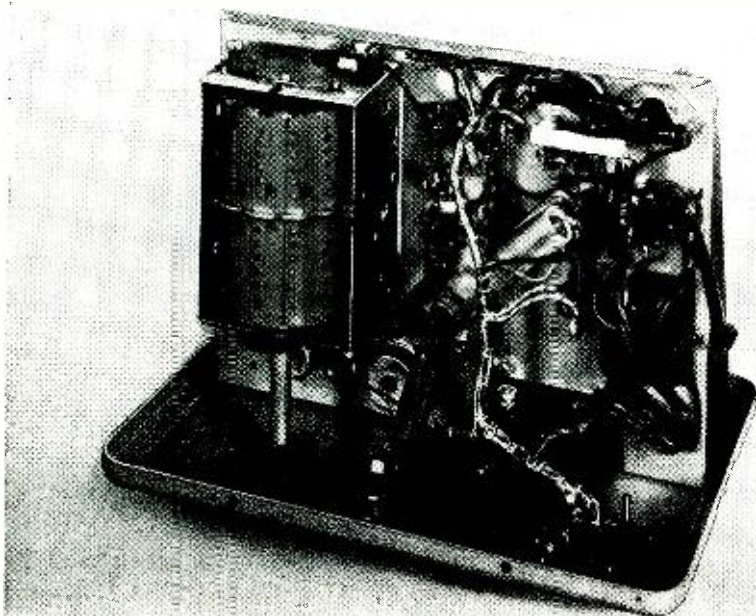

Bottom view of field strength meter shows turret tuner and simple wiring.

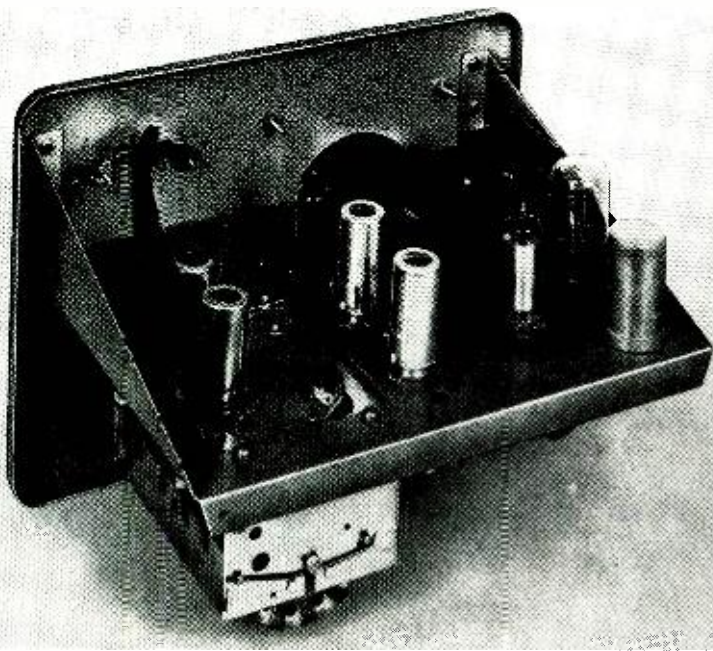

Top view of unit shows neat layout of parts and sturdy construction of frame.

plifies the detected signal and applies it to the phone jack. The phones are used to identify interference which may appear in the picture and to identify a station when its call letters are not known (see below). This feature is useful when the meter is used in areas where it is possible to receive two TV stations on the same channel. When there is no interference on the picture channel, the vertical sync pulses will be heard as a rough 60-cycle buzz.

The i.f. amplifiers are peaked so sharply that the audio carrier cannot be received when the tuner is set on the desired channel. To receive the audio carrier, the tuner must be set to the next higher channel and the fine-tuning control set to the low-frequency end of its range. Because there are breaks or gaps in the band between

channels 4 and 5 and between 6 and 7, it is not possible to receive the sound carriers of channels 4 and 6. The tuner does not tune to a frequency higher than channel 13, so the sound carrier of this channel cannot be received.

The model 488 is also useful to amateur radio operators and operators of other radio equipment which operate on subharmonics of the TV channels. By setting up the meter and measuring the strength of various harmonics, the effects of traps and tuning adjustments can be studied without making on-the-air tests. Potential sources of interference can be detected and eliminated before going on the air. The meter will also prove useful when adjusting variable capacitors and inductors in filters designed to pass or reject TV frequencies.

—end—

TV repairman Jim was up to his neck in trouble again. Two hours of chassis banging, tapping those tubes and praying for a capacitor, a transformer or something to break down, but that receiver would not act up, lose its contrast, show a negative picture, or anything else. Jim must have felt like a dentist who had scared away a patient's pain.

"I'm beginning to think," spoke up Jim, "that there isn't a thing wrong. Who ever told you to bring it here?"

"It belongs to a lady friend," explained Police Detective O'Rourke. "You must have read about her—the D.A.'s wife whose valuable ring was stolen right in her house just yesterday. . . . The Chief has me on that case."

"Oh, I do see," exclaimed Jim. "You failed to find the ring, you don't want the Chief to suspend you, so now . . ."

"No, it's not what you're thinking," interrupted O'Rourke. "It's that six-year-old brat she has for a son . . . poking his nose and fingers into everything. Says he: 'You're not *Martin Kane* . . . I know! You'll never find it. I know . . .!' That's all I hear; he was drivin' me nuts! I had to think of some excuse or favor to get me out of the house a bit."

"And there was really nothing wrong with this set? Just because you let me park my car in the alley is no reason why you should. . . ."

"But, there *was* plenty wrong with it! Sounded like that Hopalong fellow was firing a machine gun. That rat-tat-tat was also drivin' me batty."

"So that's it! Why didn't you tell me it was only a speaker rattle? And all this time I've been using my *bench* speaker."

An indignant Jim hurriedly grabbed some extension leads, attached the owner's speaker and heard a rattling cone at its worst. He gave the speaker a quick glance, then picked a scriber from among the tools on the rack behind the bench.

Poking down through the partly-torn grille cloth with the hook end of this instrument, he paused to inquire: "Why doesn't Mrs. Duffy offer a reward for the recovery of her ring?"

"Sure and she did," answered O'Rourke, "\$100 to anybody finding it."

"Not bad," remarked Jim, carefully disentangling the hooked end of the scriber from the works of the speaker, "nor would I mind buying Mrs. Duffy's brat a double-decked ice cream cone if. . . ."

"You just stopped the rattle," spoke Detective O'Rourke.

"Sure enough," said Jim, now holding a diamond-studded ring at the end of the scriber. "Who would have thought this hook would net me one hundred dollars?"

—end—

Replacing Tuners for Higher Gain and Interference Rejection

These typical tuners, used in new sets, are available for replacement purposes and can be installed easily.

By MATTHEW MANDL*

IN THE latest television receivers, among the number of improvements perhaps the most noteworthy is the exceptional gain and interference rejection of the new tuners. Added to these two features is the fact that virtually all are much more simple in construction than the older ones, and therefore are much easier to service and align. Many of these front ends are now available for replacement purposes, so the technician can improve older model receivers considerably by replacing outmoded tuners with the new. Because set owners always want to get better reception and have the latest improvements, this will be found a profitable field.

The work of installing the newer type tuners is not at all complicated. Most of the new front ends require less space than the old ones and no chassis fabrication is needed. There are only five soldered connections to make, and since the tuners are prealigned it will rarely be necessary to track them or to align i.f. stages. A variety of tuners are available, so one can easily be chosen which will match the intermediate frequency of the receiver in which it to be installed.

Typical tuners used in present-day sets which are also available for replacement purposes are: The Standard Tuner and the Spiral Tuner.

The Standard tuner

Fig. 1 is the *Standard* tuner manufactured by the Standard Coil Products Company. It is used in a number of television receivers, including some models of Admiral, Emerson, and Philco. A turret-type tuner, its rotary drum holds the necessary r.f.-mixer-oscillator coils for the 12 television channels. A schematic of the tuner appears in Fig. 2. The tubes used are a 6AG5 pentode radio-frequency amplifier, and a 6J6 double triode for the mixer and oscillator circuits.

The dashed rectangular outlines enclose the two coil sections which are switched to tune the various television channels. One coil section contains the antenna input primary as well as the coupled secondary which applies the signal to the r.f. amplifier input. The

second coil section contains the interstage transformer (primary and secondary) as well as the oscillator winding which transfers the oscillator signal into the mixer grid circuit by inductive coupling.

The inductance of the coils, combined with the interelectrode capacity of the tubes, forms the resonant circuit for the desired frequency. All coils are preset at the factory.

Five connecting wires, each color-coded as shown in Fig. 2, are provided to facilitate replacement. When the old tuner is removed from the receiver, its connections to the picture and sound grids, as well as plus-B, filament, and bias, must be established. The new tuner is then bolted to the chassis and the leads cut just short enough to reach the connecting points previously ascertained.

The white lead of the Standard tuner goes to the a.g.c. connection in sets having this feature, otherwise is connected to the bias terminal—for the bias in sets without a.g.c. is usually regulated by the contrast control.

When using this tuner for the conventional stagger-tuned i.f. system the bare lead is attached directly to the grid of the 1st picture i.f. tube and the

green lead is connected to the grid of the 1st sound i.f. tube. If, as in a few receivers, the sound i.f. is taken off after the 1st or 2nd i.f., the green lead is not used and therefore should be disconnected from the tap on L12. It is also omitted in intercarrier receivers. The coil (L12) can be removed entirely in such instances to prevent any absorption of sound intermediate frequen-

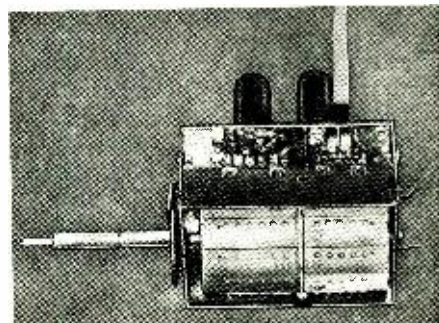

Fig. 1—Turret-type: The Standard tuner. The 68- μ f capacitor can be disconnected, opening the circuit. If a 19.75-mc trap is required, replace the 68- μ f with an 80- μ f capacitor.

Inductor L11 is designed as the first frequency in a stagger-tuned system (usually 21.8 mc). However, it can be

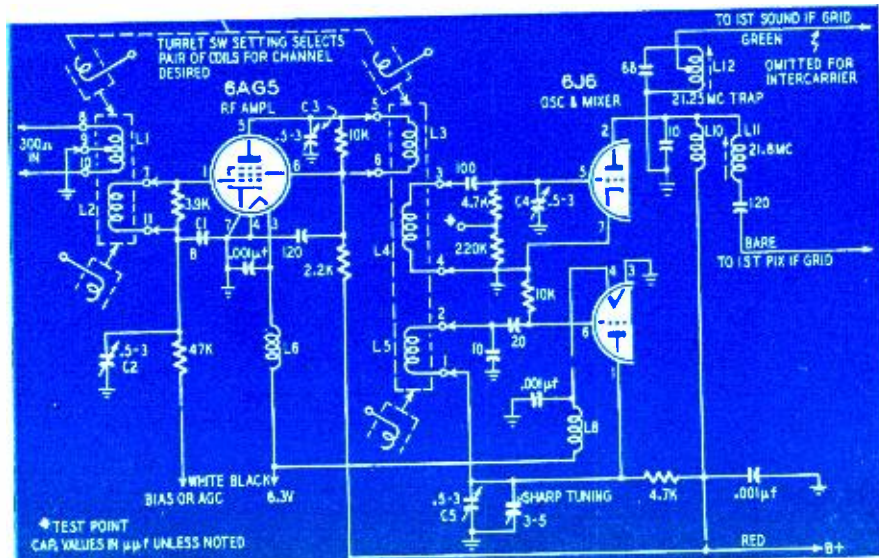

Fig. 2—Schematic of the Standard tuner: 5 connecting leads simplify replacement.

Television Service Clinic

Conducted by ROBERT F. SCOTT

A NUMBER of inquiries indicate that many readers are having trouble eliminating rounded corners and dark, blurred areas at the corners and edges of the screen. These dark areas are *neck shadows*. They are produced when the electron beam strikes the neck of the tube before it has scanned the edges of the screen.

Many complaints arise when sets have been converted to use a wide-angle tube without using the appropriate deflection yoke. With the correct yoke, most cases of neck shadow can be corrected by properly positioning the yoke, focus coil, and ion trap on the neck of the tube.

View the tube from the side and make sure that the neck is parallel to the chassis. Use shims, additional padding, or other means to raise the low end of the tube. Move the deflection yoke up against the flare of the tube and center it on the neck. Center the focus coil on the neck approximately one-quarter inch behind the deflection yoke.

Turn on the set and keep the intensity very low until the ion trap is properly set. Move the focus coil from side to side and up and down to center the raster without shadows. If the shadow is not completely removed, adjust the ion trap for maximum brightness with good line structure visible in the raster. DO NOT USE THE ION TRAP TO ELIMINATE SHADOWS IF THEY ARE PRESENT WHEN THE ION TRAP MAGNET IS ADJUSTED FOR MAXIMUM BRIGHTNESS.

If it is impossible to remove all shadows by adjusting the yoke and focus coil, try rotating the tube in its mounting. The neck of the tube may be slightly off center or tipped to one side. Rotating the tube may make it possible to remove shadows when other measures fail. Lengthen the high-voltage lead if necessary after rotating the tube.

If these procedures do not help, reverse the leads to the focus coil. This reverses the operating functions of the centering controls but does not harm the operation of the set. If the set has enough vertical and horizontal deflection voltage, you can make the picture larger and move it slightly off center so the shadow is hidden by the mask.

Poor horizontal linearity

My set is a G-E 16C110. The picture cannot be exactly centered horizontally, and the left side of the picture is fuzzy and stretched. It is hard to get the picture to fill the screen on the right side. Nothing that has been done will bring in the full picture on the left side although the left-hand wedges of all test

patterns are nearly 3/4 inch longer than those on the right.—A. L. Groves, Brooke, Va.

The trouble is probably caused by a change in the value of the 0.1- μ f C374

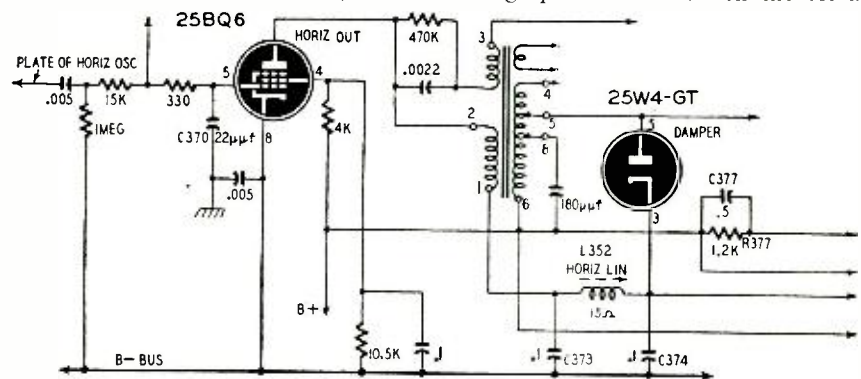

Fig. 1—Change in value of C374 capacitor affects horizontal linearity.

capacitor between the cathode of the damper tube and the B-minus bus. (See Fig. 1.) This capacitor is very critical. Improper values affect the time-constant of the damper-tube circuit and result in defective damping and poor linearity because of nonlinear current through the deflection coil. The value of this capacitor is probably too low. Try replacing it with a 0.1- μ f, 600-volt paper unit. If this does not help, try shunting it with 600-volt paper capacitors of approximately .0005 μ f until the correct value is found or it is obvious that the trouble cannot be corrected by this means.

Check the horizontal linearity coil L352 for shorted turns. The correct resistance is 15 ohms.

Check the 22- μ f capacitor (C370) between pin 5 of the 25BQ6 and ground. Leakage there could cause the troubles you are experiencing. If this unit is suspected, replace it with a 22- μ f, 500-volt silver mica unit.

Check C377 and R377 for short circuits or changes in value. R377 is 1,200 ohms and C377 is 0.5 μ f, 600 volts, paper. Replace if necessary. A short circuit or radical change in value of either of these components will change the value of current through the deflection coil and cause the picture to shift horizontally so it cannot be centered with the focus-coil adjustment.

Television interference

When my neighbor works in his garage, he creates some type of interference which causes my picture to jump around. Will a high-pass filter cure this trouble?—Alfred Martins, Avon, N. J.

Whether or not a high-pass filter will eliminate the interference depends on the type of equipment causing it. Inter-

ference caused by industrial heating equipment or modern diathermy machines can be prevented from entering the set via the antenna by connecting a high-pass filter between the set and

the lead-in. As additional precautions, try a good line filter and a shield around the receiver chassis. High-pass filters can be purchased at most radio supply houses. You can construct your own using the diagrams in Figs. 2 and 3. Fig. 2 is a filter for 300-ohm lines and Fig. 3 is for 72-ohm coaxial cable.

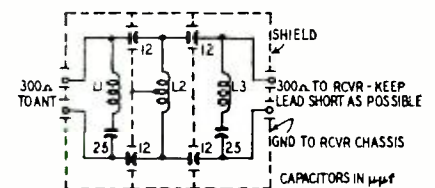

Fig. 2—Circuit of a 300-ohm filter. L1 and L3 are 15 turns of No. 20 enameled wire closewound with an inside diameter of 1/2 inch. L2 is a center-tapped coil consisting of 16 closewound turns and which has an inside diameter of 1/4 inch.

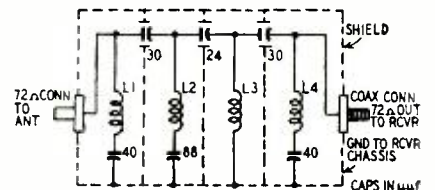

Fig. 3—A 72-ohm high-pass filter. All coils are wound with No. 22 enameled wire. Each coil is 1/2 inch in diameter and 1/2 inch long. L1 and L4 have seven turns. L2 has four and one-half turns, and L3 consists of four turns. Shield the filters for highest efficiency.

If—as is much more likely in your case—the interference is from arc welders, electric motors, or other devices which generate damped waves, it may be partially suppressed by installing line filters at the source of the trouble. This is a job for the owner of the of-

fending equipment. If he does not take measures to eliminate the interference, contact the radio inspector in your district or write to the Secretary of the Federal Communications Commission, Washington 25, D. C. If the interference is not frequent, it might be wiser to overlook it.

Stabilizing line voltage

My set is an RCA 6T72. Every time my electric refrigerator comes on, there is a noticeable change in picture size and contrast. Does this interference harm the set in any way? How can I eliminate this condition? I've tried connecting the set to different outlets in the house without any noticeable improvement.—John Stronski, Baltimore, Md.

The trouble is caused by excessive voltage drop on the power lines when the refrigerator comes on. Most likely, this drop is on the line between the distribution panel and the receptacles. This can be checked by measuring the voltage across the line in the various receptacles and lamp sockets when the refrigerator is running. If the voltage is low on the receptacles but not on the lighting circuit, the voltage drop is confined to the line feeding the receptacles. The effect is not harmful, but may be annoying. You can eliminate it by having a special heavy line run to the refrigerator outlet. If the voltage drops on the lighting circuits as well, it may be caused by using too small a wire between the meter and distribution panel. Have an electrician check the lines for voltage drop and install heavier lines where necessary.

If it is impractical to change the pow-

er lines, install a constant-voltage transformer between the receptacle and the TV set.

X-burn

My set has a 17BP4 rectangular picture tube. For the last few weeks, I have noticed a brown cross consisting of lines running from the diagonally opposite corners of the screen. What causes this and how can I remove it?—David Bender, Dayton, Ohio.

The brown stain is an ion burn. The cross—called an X-burn—is characteristic of rectangular picture tubes. It corresponds to the round or oval ion spot on round tubes. There is nothing that can be done to remove the burn but you can take steps to prevent it from getting worse and you may be in time to avoid serious damage to the gun structure.

The 17BP4 uses a single-magnet type ion trap. Slip the ion trap over the neck of the tube just in front of the tube base. Rotate it so the magnet is opposite the high-voltage connector. Turn on the receiver with the brightness control set to a low-intensity position. If a raster appears, move the trap slowly forward while twisting it slightly from side to side. Reduce the setting of the brightness control as the intensity of the raster increases. The brightest raster should be obtained with the ion trap magnet *behind* the flags (pole pieces) on the gun of the tube. Replace the trap with one having a stronger magnet if the brightest raster is obtained with the trap ahead of the flags. (If the raster does not appear when the brightness control is turned slightly above half-

way, turn off the set and swing the magnet around to the opposite side of the neck.)

Advance the brightness control until the raster is slightly brighter than normal. Adjust the focus control until the line structure is clearly visible in the raster. Touch up the setting of the ion trap with the brightness control set to the maximum position at which good line focus can be maintained.

Always check the setting of the ion trap whenever the chassis has been moved from the cabinet or the set has been moved about. The ion trap should always be checked whenever the focus coil is moved or the focalizer adjusted.

—end—

V BEAM FOR DX

By L. A. DUCK

A simple but excellent antenna for TV fringe reception (if you have the necessary space) is the V-beam shown in Fig. 1. It has very high gain and sharp directivity. The V contains 70 half-wave elements, all working and all beam-forming. The dimensions shown are for channel 13.

The booster at the antenna end is needed because the antenna has an impedance of 800 ohms, and the signal would get lost on a 300-ohm line. A Regency booster is specified because it uses 6J6 tubes in a circuit that is very efficient on channel 13. Most other

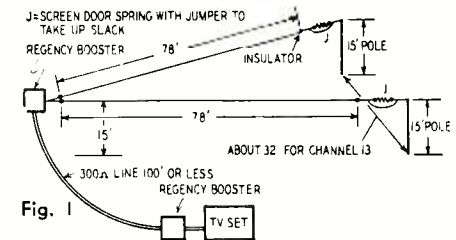

Fig. 1

boosters use 6AK5's which have a higher internal noise level and the boosters do not have much gain on the high channel 13.

Orienting the 78-foot legs is simple. Lay one wire on the ground, and stretch the other in the general direction of the transmitter to be received. Walk the far end of the stretched wire back and forth. Two definite signal peaks will appear, with almost complete lack of signal between these two points. These maximum points are where the two 15-foot antenna masts are to be located.

The 78-foot length is used because a shorter one will give less gain while a longer one will cause time-delay effects. A 150-foot length would tend to cross two picture elements. This delay is independent of frequency, so the antenna can be used just as well with any channel. However, the separation of the legs does depend on the frequency, but the exact separation is not critical because the booster is tightly coupled to the antenna. Tuning the booster changes the effective separation of the legs.

—end—

TV DX Predictions for July

Television reception conditions in July will be generally similar to those observed during June. The sporadic-E skip season will have ridden over its peak for 1951 in the latter part of June, but will continue with considerable momentum through July. Tropospheric propagation will be generally good over all sections of the country.

As sporadic-E skip development is more or less directly associated with solar phenomena, major openings usually recur on a cycle of about 27 to 28 days, the period required for one complete solar rotation with respect to the earth. Thus, the best indication of when to expect important skip developments will be the dates when the most widespread and strongest openings occurred in June. The most active periods will probably be between the 11th and 14th and the 22nd through the 25th, though short bursts of sporadic-E reception may be expected on the lower channels almost any time during July.

The most likely time of day to watch for openings will be the late morning hours and the period between 5 and 10 pm, local Standard Time. A few openings will develop after midnight; these will offer late-retiring eastern

viewers an opportunity to look for far-western stations.

Usually July produces at least one strong aurora borealis display. Such events are usually only an annoyance to TV viewers. The net effect of the multipath reflections from the auroral curtain is a picture fuzziness not unlike the snow of fringe-area reception. When aurora effect is noted, or when the northern lights are visible, owners of directional arrays equipped with rotators will do well to swing the beams north and try all channels. Much remains to be learned about v.h.f. propagation via the aurora, and careful observation may well contribute to this end.

Tropospheric refraction will spring some surprises during July, particularly on the high-band channels. Especially during the late hours of the evening, on nights when the air is stable and calm, and the barometer high, the high channels may produce dx up to several hundred miles. Watch the daily weather maps in your local newspapers, and try the high channels when large stable high-pressure areas are shown near your locality.

—end—

TV TROUBLE LEXICON

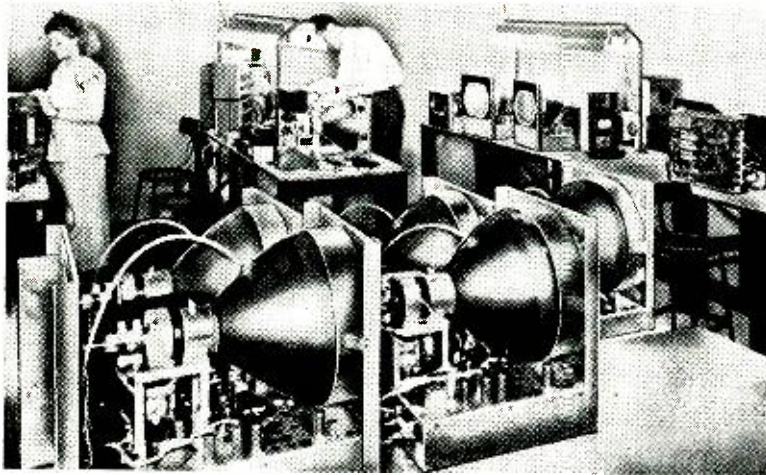

(Courtesy Midwest Radio & Telev. Corp., Cincinnati, Ohio)

Laboratory technicians checking TV receiver troubles in final assembly line.

Hallicrafters

T-54, 505, 506. No picture (raster and sound O.K.). Defective 6C4 oscillator tube.

Insufficient width, width control ineffective. Open 47,000-ohm plate resistors in 12SN7-GT horizontal amplifier. (See Fig. 1.)

505. Picture deflected toward upper right of screen (vertical or horizontal centering controls ineffective). Leaky .05- μ f, 6-kv coupling capacitor C73 (Fig. 1), .0005- μ f, h.v. 6-kv capacitor

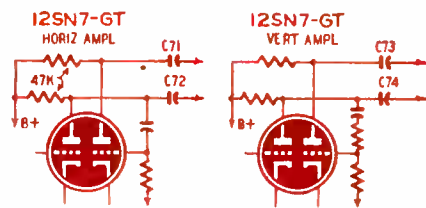

Fig. 1—Horizontal and vertical amplifier circuits of Hallicrafters 505.

C72. (A defect in one of the other deflecting capacitors may cause deflections to upper left, lower right, lower left, etc).

No raster (sound normal). Defective 6C4 r.f. power-supply oscillator. Improper setting of r.f. power-supply trimmer. Check range of capacitor where oscillator falls in and out of oscillation; adjust trimmer to its maximum capacitance within this range. This provides maximum operating stability of r.f. oscillator.

Insufficient picture height. Defective 12SN7-GT vertical oscillator or vertical amplifier. Change in value of vertical height control. Defective plate resistor R78, vertical oscillator, mfrs. diagram.

*Engineer, WKRC-TV

JULY, 1951

Erratic picture, crackling in audio. Excessive dirt and moisture on base and socket of picture tube. H.v. arcing. Impending failure of filter capacitor. Defective (leaky) h.v. oscillator trimmer capacitor.

T-67. Intermittent picture, variation in intensity. Arcing at base of 1B3-GT or picture tube. Intermittent contact between filament leads and base pins of 1B3-GT. Check for evidence of arcing; resolder base pins, socket connections.

Kinescopes

Cathode-heater shorts. If a resistance check between these elements shows a low-resistance short, try flashing or burning it out with a temporary application of 110 v. c. or other high-voltage low-current source. Typical indication of this trouble is a low-intensity, washed-out picture.

Magnavox

CT214, -218, -221. Picture weaves and ripples on changing scenes (certain scenes distorted). Defective 6AL5 sync separator. (Replace this tube even though it checks good.) Defect in d.c. restorer circuit.

Horizontal oscillator failure. Defective horizontal oscillator tube. Defective grid coupling capacitor.

Stretching of picture (left side) after few minutes operation. Picture linearity returns to normal if set is allowed to cool. Adjustment of horizontal speed or horizontal drive causes left-hand side of picture to jump or move suddenly. Defective 6BG6-G.

Cross-modulation interference on strong signals. (R.f. amplifier operating on nonlinear portion of curve and acting as detector). Excessive signal over-

More Trouble Shooting Tips On Common Faults In TV Receivers

By JOHN B. LEDBETTER*

loading r.f. stage. Remedy: Remove grid return and solder to chassis ground (at point of lead shield ground). In exceptional cases, padding the antenna may be necessary.

Small picture segments (regularly spaced) displaced from main body of picture. Defective 6BG6-G, causing spurious oscillation.

Motorola

TS-5. No raster. Misadjustment of ion trap. Defective 6V6-G horizontal oscillator, 6J5 horizontal discharge, 6BG6-G horizontal output, or 1B3-GT h.v. rectifier. Open or shorted primary in horizontal output transformer. Open 1B3-GT filament winding.

Small raster. Weak 6BG6-G. Weak 5U4-G low-voltage rectifier. Shorted .03- μ f horizontal deflection coupling capacitor C122 or .05- μ f C123. Shorted vertical deflection coupling capacitors C86B (50 μ f) or C87B (10 μ f). Low line voltage.

Trapezoidal or nonsymmetrical raster. Improper ion trap adjustment. Incorrect focus coil adjustment. Defective deflection yoke.

Wrinkles on left side of raster. Defective 5V4-G damper.

Picture smear. Low bias on 6AU6 first video amplifier or 6AC7 second video amplifier. Leaky .05- μ f video amplifier coupling capacitors C61 or C62. (See Fig. 2.)

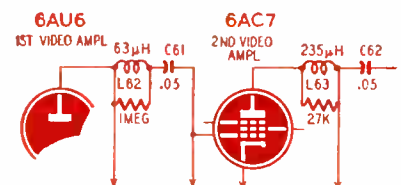

Fig. 2—Coupling circuits of the video amplifier as used in the Motorola TS-5

Poor resolution (picture stable). R.f. tuner or video i.f. badly out of alignment. Open peaking coils in 6AL5 video detector plate (L59 or L60), or in first or second video amplifier plates (L62 or L63). (See Fig. 2.)

TS-5 (VK-101). Sound bars (stippled effect) in picture. Improper adjustment

of fine tuning control. Low-frequency trap L50 open, shorted, or misadjusted.

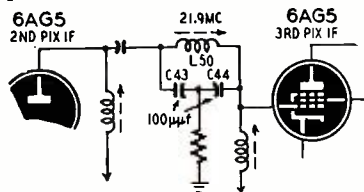

Fig. 3—Low-frequency trap trouble.

Open or shorted 100-µmf parallel-trap capacitors C43 or C44 (see Fig. 3).

Poor focus. Low line voltage. Open 1,000-ohm resistor R116 in series with focus coil and focus control.

Vertical black lines in picture. Defective 6BG6-G horizontal output or 6V6-GT horizontal oscillator. B+ lead to tuner picking up horizontal pulses. Replace with shielded lead and reroute so that 250-volt end ties to terminal strip end of 39,000-ohm resistor R67 in the screen-grid lead of V-14. Ground the shield at several points.

TS-9. Loss of brightness. Defective 1B3 or 6BG6-G. Open or leaky h.v. filter condenser. Increase in value of 820,000-ohm filter resistor R108 in h.v. supply.

TS-18. Poor vertical linearity. Defective 6SL7-GT vertical output. Defective 22-meg feedback resistor R61 (vertical output to vertical oscillator). (Fig. 4.)

Poor vertical sync. H.v. corona arcing. Open .01-µf integrating capacitors in 12SN7-GT sync clipper output.

Loss of vertical sync. (Not corrected by adjustment of vertical hold control or replacement of vertical oscillator and amplifier tubes). Check value of 1,000-µmf grid capacitor C69. (Fig. 4.)

No vertical deflection. Defective 12SN7-GT vertical oscillator or 6SL7-GT vertical amplifier. Defective .05-µf coupling capacitor C72 or .01-µf charging capacitor 1/2 12SN7-GT.

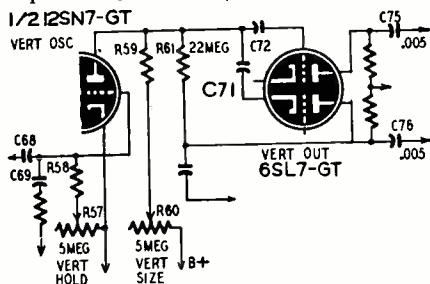

Fig. 4—Causes for vertical troubles.

tor C71. Failure of vertical hold or vertical size controls R57 and R60. (Fig. 4.)

Insufficient height. Defective 6SL7-GT vertical output tube. Defective vertical size control R60. Open h.v. coupling capacitors C75 or C76 (.005µf, 6,000 v.) from vertical amplifier plates. Shorted 250-µmf r.f. filter capacitor C77. Shorted ballast tube, causing excessive heater voltage on vertical amplifier. (Fig. 4.)

Vertical jitter. Vertical hold control needs readjusting. Defective 250-µmf vertical oscillator coupling capacitor C68. (Fig. 4.)

Vertical bars on left half of picture. Defective damping resistors R88 or R51 across primary and secondary of horizontal blocking transformer T5. (Fig. 5.)

Poor horizontal linearity. Defective horizontal sawtooth capacitors C62 (680-µmf) or C63 (900-µmf). (Fig. 5.)

No horizontal deflection. Defective 12SN7GT horizontal oscillator. Defective horizontal hold or horizontal size control (R49 or R53). Failure in horizontal oscillator blocking transformer

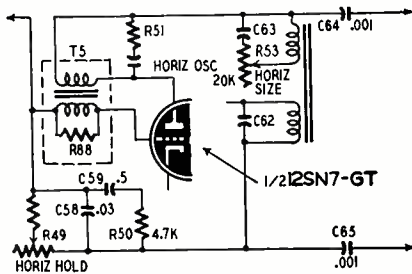

Fig. 5—Horizontal circuits of TS-18

T5. Shorted horizontal sawtooth capacitors C62 or C63 (680 and 900-µmf). (See Fig. 5.)

Insufficient width. Defective 12SN7-GT horizontal oscillator, defective horizontal size control R53. Open h.v. coupling capacitors C64 or C65 (.001-µf, 6,000 volts) going to horizontal deflection plates. Open .03-µf capacitor C58 across horizontal hold control and series resistor. Defective ballast tube, causing low heater voltage on horizontal oscillator. (Fig. 5.)

Horizontal fold-over (left of picture). Incorrect setting of horizontal hold control. Increased values in horizontal sawtooth capacitors C62 or C63 (680 and 900-µmf). (See Fig. 5.)

Excessive picture size, low brightness. Defective 25L6-GT h.v. supply oscillator or 1B3-GT h.v. rectifier.

10VK12. Poor vertical linearity. Defective linearity control. Shorted 100-µf cathode capacitor in vertical output stage.

12VK11RA. Black horizontal line at bottom of picture. Improper adjustment of vertical hold or vertical centering controls; defective vertical hold control. Defective 6SN7-GT clipper, 6J5-GT vertical oscillator, or 6V6-GT vertical output.

VT-71M. "Pie-crust" oscillation covering entire screen. Picture-tube mount touching shield cover of r.f. h.v. power supply. Insulate with cardboard or fiber strip.

Horizontal white line (stationary). Defect in h.v. supply; open or leaky filter or bypass condensers. Check to see that

line is not a burn-in from a possible previous failure of vertical scan.

VT-105, 107; VK-106. Horizontal white line (moves with adjustment of vertical hold control). Defective 6SN7-GT vertical oscillator or vertical amplifier. Defective vertical coupling or sweep discharge capacitors.

Olympic

DX950. Vertical damping bar on left of screen. Defective 6BG6-G horizontal output or 6W4 damper. Misadjustment of horizontal drive control. Insufficient value in deflection yoke capacitor (replace original 47-µmf unit with higher capacity, up to about 100 µmf). Insufficient shielding between deflection yoke and video amplifier stages. Yoke leads too close to other kinescope leads.

Philco

48-700, 1000, 1001, 1050, etc. Weak reception, instability. Defective 6J6. Dirty, loose contacts on turret. Defective contact springs on turret.

Intermittent picture and sound. Same as above. Look also for cold-solder joints in tuner.

48-1001. Vertical black line on picture. Caused in early models by regeneration from the 0.1-µf capacitor connected from the 6BG6-G screen to ground. Remove capacitor entirely (this has been done in all later production models).

48-1000, 1050. Weak sound and picture. Defective 6J6. Shorted 10-µf 6J6 plate filter capacitor C409 or 22-µmf grid coupling capacitor C404.

1075. Picture jumps, tears horizontally (to right). Defective 6BG6-G. Defective leads on 0.5-µf capacitor C522 connected from 5V4-G damper to horizontal deflection coils.

48-2500 (Projection). Poor linearity on background objects. Improper adjustment of keystone magnets inside optical barrel. Adjust according to manufacturer's specifications.

49-1475. Fine tuning control ineffective. Defective 6AL5 picture discriminator which controls automatic tuning.

48 Series. Sound bars on channel 4. If bars are eliminated when one of the sound i.f. tubes is removed, they are being caused by a beat between channel 4's video carrier and 3rd harmonic of sound i.f. Realign sound i.f. at 22.0 mc and realign video i.f. 100 kc lower.

48 and 49 Series. Receiver drift. Defective 6J6 oscillator. Improper alignment of sound i.f. Signal too weak to operate a.f.c. In earlier models, drift can be reduced by installing improved discriminator transformer and 10-µmf negative-coefficient oscillator grid-tank compensating capacitor (available in kit form as Philco part No. 45-9535).

Audio Feedback Design

Part IX—Discussing mu-beta effect in design of feedback amplifiers.

By GEORGE FLETCHER COOPER

EVERY writer on feedback opens with a light barrage of mathematics, in which the gain of an amplifier with feedback is shown to be

$$K' = \frac{K}{1 + K\beta}$$

Where K is the gain without feedback, and β is the attenuation of the feedback path. Then there is a discussion of this, and out of the hat comes $K = 1/\beta$. Blinded with science, the reader rubs his hands and reaches for

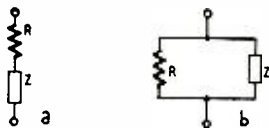

Fig. 1—Two-terminal network problems.

a soldering iron. Obviously, however, the gain without feedback is not always large, and if we are concerned with low-gain amplifiers, or with effects at the edge of the band, we must go back to the basic equation. We can write this in the form:

$$K' = \frac{1}{\beta} \times \frac{K\beta}{1 + K\beta}$$

When we work in decibels, we have:

$$20 \log \frac{1}{\beta} + 20 \log \left(\frac{K\beta}{1 + K\beta} \right)$$

You will notice an interesting term enclosed in the parentheses. This is what we have been looking for, because: the first term on the right-hand side is just the traditional approximation; the second term is the gain component of what is called the "mu-beta effect." This unexpected name was provided by the godfathers. Dr. Bode uses μ (mu) where we have used K. In the classical papers you will find the fundamental equation written

$$G = \frac{\mu}{1 - \mu\beta}$$

In this form, β is negative in the important regions if we have negative feedback, while I have assumed that we would let the signs look after themselves by using the table given in Part VIII. We must watch this rather carefully now, because the mu-beta effect calculator is designed from the Bode notation.

Before going on to discuss the refine-

ments in calculation which are provided by the exact formula, let us look at the reasons for using it. Some of them will probably never affect some of my readers, but in special circuit designs this technique is invaluable. For one thing, it takes the use of positive feedback out of the cut-and-come-again class, and there's a big future in positive feedback, if only to help out in the component shortage.

The first use of the exact equation is to check what happens at the edges of the band when the gain of the amplifier varies. If you look up the JAN specifications for the tubes you are using (British readers will find their valves in the Services Preferred List), you will see that when the maker says boldly, $g_m = 5,000$ micromhos, he really means something between 4,000 and 6,000, or, if you are not a military customer, even wider limits. Roughly speaking, that means that the gain per stage can vary over a range of about 4 decibels: in three stages, 12 db, will be the range for a typical audio amplifier.

Actual stability, under these conditions, may be a headache in its own right, but the maintenance of a specified frequency response often may cause a lot of trouble. A batch of tubes on the high side may result in the measured

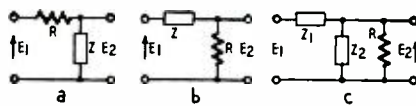

Fig. 2—Some typical impedance problems in four terminal network analysis.

frequency response falling outside the customer's limits. Try telling him his tubes are too good!

The second major use for the exact equation is in one of these multiple feedback loop amplifiers we discussed in Part VII. If we want to design this right to the bitter end, we must determine the gain and phase characteristics of the first subamplifier with its positive feedback to draw the phase and amplitude responses for the complete amplifier, to which the main negative feedback is applied.

A mu-beta calculator

These more refined calculations became really practicable in October, 1949, when Jean Felker of the Bell Laboratories published a paper called "Calculator and Chart for Feedback

Problems" (*Proc. I.R.E.* 37, 1204). The calculator is a sort of circular slide rule for performing the necessary phase and amplitude calculations.¹

Let us go back to the mathematics again, and see what we are dealing with. The mu-beta effect is

$$\frac{K\beta}{1 + K\beta}$$

In general, both K and β include a phase shift. Let us take the total phase shift in the amplifier and feedback network at a particular frequency to be θ . This is the phase which we use when we draw the Nyquist diagram. Since we now have to watch our signs, we must notice that in the middle of the working range $\theta = 180^\circ$, while at the danger point for stability, $\theta = 0$. Thus when you draw diagrams like Fig. 5 of Part III, you must put the phase zero at the bottom, and the point B (marked 150° in Fig. 5/III) becomes 30° . θ is thus what we have called the phase margin. We can write the mu-beta effect as

$$\gamma \angle \phi = \frac{|K\beta| \angle \theta}{1 + |K\beta| \angle \theta}$$

Where γ (gamma) is the magnitude of the mu-beta effect, and ϕ is the phase. We know the phase shift in the feedback network, because we can calculate it using the templates: call this ψ (psi). The phase shift through the amplifier is then $(180 + \phi - \psi)$. When ψ is zero, this is $(180 + \phi)$ instead of the value without feedback, $(180 + \theta)$.

The gain of the amplifier is γ decibels plus the ideal gain, $20 \log \frac{1}{\beta}$ db. These

Greek letters have been used because they are the same as those in the Felker paper: the only difference is

¹ Available from Graphimatics, 201 N. Taylor Ave., Kirkwood 22, Mo.

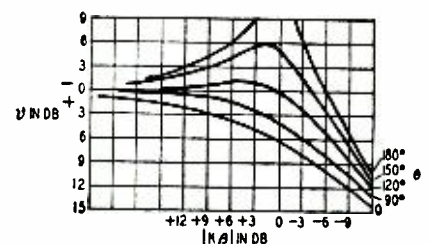

Fig. 3—Impedance forms plotted in db.

that our β must have a negative sign.

For some purposes it is rather useful to turn the mu-beta effect upside-down. Let us write v (upsilon) = $1/\gamma$. Then

$$v / -\phi = \frac{1 + |K\beta| / \theta}{|K\beta| / \theta} = 1 + \frac{1}{|K\beta| / \theta}$$

I did not do this bit of mathematics just to show how clever I am: this particular form is rather a useful one. Consider the impedance shown in Fig. 1-a. Z is any impedance, and R is a resistance. Taken together the impedance is $R + Z$, and this can be written $R(1 + Z/R)$.

Remembering that Z is a general impedance, we can write this as

$$R(1 + \frac{Z}{R} / \theta')$$

If we put $\theta = -\theta'$ and $K\beta = R/Z$ the impedance of the two-terminal network is thus $Rv / -\phi$.

In much the same way, the admittance of the circuit in Fig. 1-b is

$$\frac{1}{R}(1 + \frac{R}{Z} / \theta')$$

and we put $K\beta = Z/R$ and also put $\theta = \theta'$, to make the admittance equal

$$\frac{1}{R} v / -\phi$$

We can go even further, and apply this expression to the networks of Fig.

2. If we take the ratio $\frac{E_1}{E_2}$, which is the most useful when we want to convert to decibels, we have for this ratio:

- a. $= 1 + |R/Z_1| / \theta'_1$;
- b. $= 1 + |Z/R_2| / \theta'_2$;
- c. $= (1 + |R/Z_1| / \theta'_1) \frac{Z_2}{R_2} / \theta'_2$.

Even the impedance forms are useful in decibels, because when we connect an impedance as the plate load of a pentode, the gain is $g_m Z$, or $(20 \log g_m + 20 \log Z)$ decibels. For that reason, the curve of v given as Fig. 3 shows v in decibels.

We could, of course, proceed to use those curves to determine the mu-beta effect, but the Felker calculator is much more convenient. This chart is reproduced as Fig. 4. The rotatable arm should be cut out, fastened to a suitable

backing of thin card or plastic, and attached to the center of the circular chart. One end of the moving arm is longer than the other, and in use this end moves over the upper semicircle, which represents the mu-beta phase scale.

Figs. 5 and 6 have been constructed to enable us to work out an example. Three circuits of 6 db per octave are assumed, with characteristic frequencies at 1, 2, and $4\sqrt{2}$. The most feedback which could be applied without instability is 21 db, and for this example we shall assume that we are applying 15 db of feedback. We therefore construct the second scale, marked MU-BETA, with its zero at the 15 db down level on the GAIN BELOW MAXIMUM scale. In Fig. 6 we provide a new phase scale, working down from a zero at the old 180° level.

Using the calculator

Now take the calculator. At $\omega = 2$, we have mu-beta = +4db and $\theta = 50^\circ$: find the point where mu-beta = +4 and mu-beta phase = 50°. It is up near the top left-hand side (I almost wrote corner) of the chart. Turn the rotating arm until it passes through this point, and read off the mu-beta effect magnitude, on the arm itself, and the phase, on the semicircular scale. We find +2.3 db, 40°. Repeating the calculation at other points, we get +6.2 db, 92° at $\omega = 2\sqrt{2}$, and so on. All these values have been plotted in on Figs. 5 and 6; on Fig. 5 you will remember that this mu-beta effect is the deviation of gain from what we expect in the simple theory. We use the mu-beta scale for plotting the response. As you can see, the "flat" gain is about 1.5 db below the zero determined by the simple theory. The phase shift is, at most frequencies, much less with feedback, but at the edge of the working band it rushes sharply upward. You can see how dangerous this can be in a multiple-loop amplifier, by considering the values at $\omega = 4$: with feedback the gain is 1.5 db above the standard value, but the phase shift has practically hit the 180° mark. As a subamplifier in a complicated multiloop system this particular system could give you enough headaches for a lifetime.

Suppose that in place of the gain we planned, the amplifier has in it rather old tubes, or low-limit tubes. The gain without feedback K , which we are calling mu in this article, may have dropped 6 db. The feedback term, β , remains the same, however, so the product $K\beta$ (mu-beta) is down 6 db. The mu-beta scale zero, on the left of Fig. 5, should now be set at 9 db on the "gain below max" scale. At $\omega = 2$ we have $\mu\beta = -2$ db $\theta = 50^\circ$, so that the $\mu\beta$ effect is +0.2db instead of +1.6db. As $\omega \rightarrow 0$, the response, for $(\mu\beta) = 9$ db and $\theta = 180^\circ$, is 2.6 db: the response therefore has risen 2.8 db at $\omega = 2$ for this low-gain case, instead of 3.1 db for the normal-gain case. The mid-band gain has dropped 1.1 db.

I am not inclined to discuss this application of the mu-beta calculator any

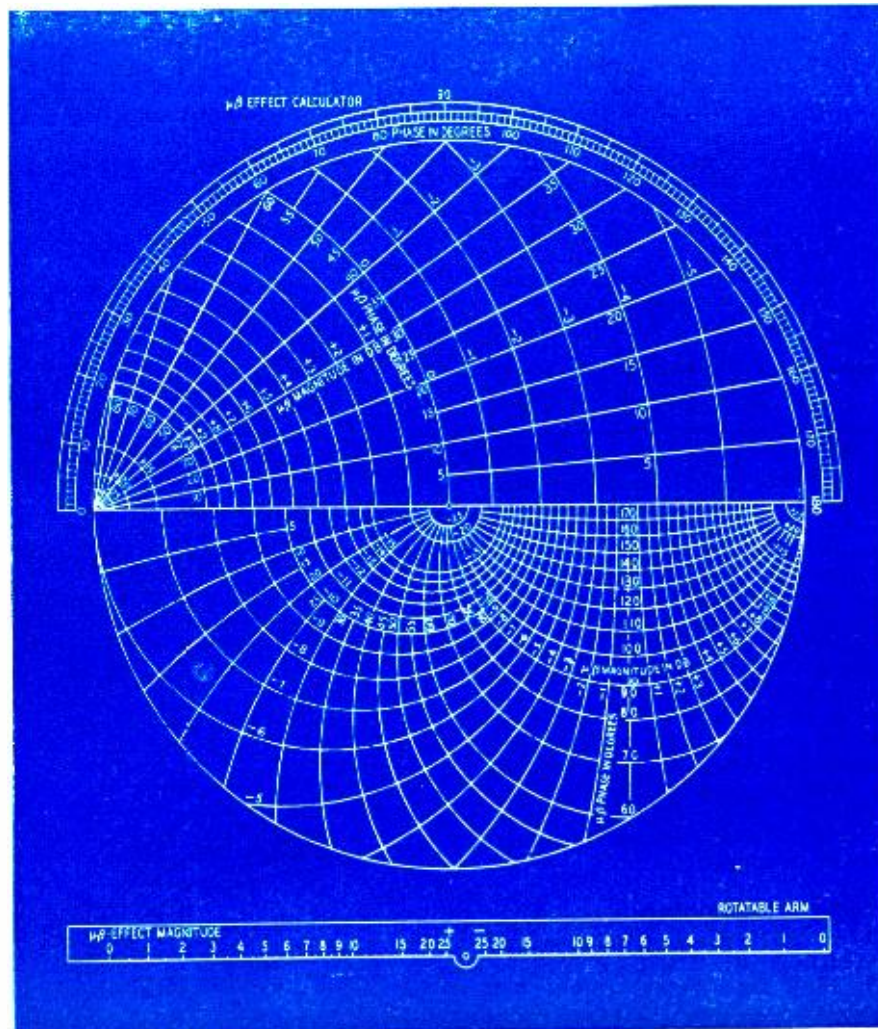

Fig. 4—This is a simplified version of the Felker chart described in the text.

further. The time that would be spent reading further discussion can be spent more profitably in working out some examples with the aid of the calculator itself. However, here is an important thing to be aware of: When the feedback network contains reactances, which usually will be capacitors, the response calculated is that which appears at the output of the feedback network. Therefore it is necessary to subtract the response of the feedback network from the calculated response given by the mu-beta calculator to get the response for the over-all system. This is shown in the basic equation:

$$\text{gain} = 20 \log \frac{1}{\beta} + \text{mu-beta effect.}$$

Here is another use for the mu-beta calculator: It can be used for calculating the stability margin directly. As you

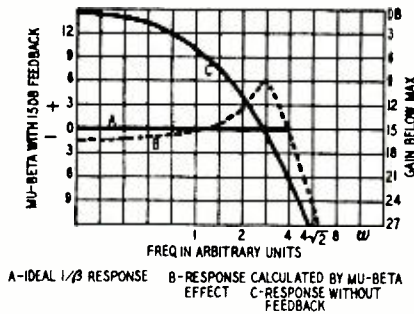

Fig. 5—Three design curves of amplifier.

may remember, we showed in Part VI that a quantity called the stability margin was a very useful measure for the safety of a design. This quantity is

$$\frac{K'}{K} = \frac{1}{1 + K\beta}$$

in our notation. The mu-beta effect, you will remember, is

$$\gamma = \frac{K\beta}{1 + K\beta} = \frac{1}{1 + \frac{1}{K\beta}}$$

If we have a value of, say, 6 db for $K\beta$, and we calculate the $\mu\beta$ -effect corresponding to -6 db, the quantity we ob-

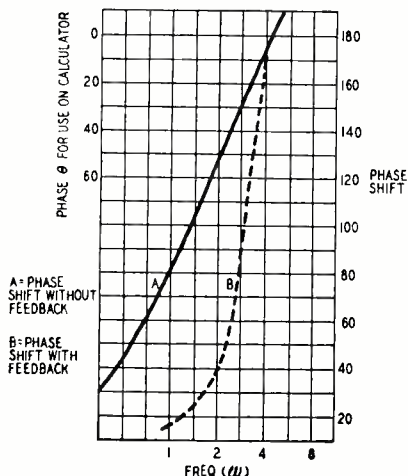

Fig. 6—Two curves showing phase shift.

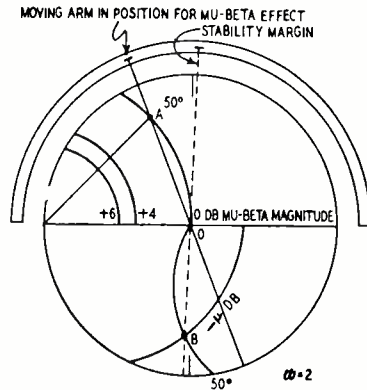

Fig. 7—The calculator solves a problem.

tain is the stability margin. Let us draw up a table from Figs. 5 and 6:

$\omega =$	1	1.4	2	2.8	4
$K\beta = \mu\beta$					
	= +10	+7.5	+4.2	-1	-6.3 db
$\theta = 97^\circ$		75°	50°	26°	4°
$\mu\beta$ effect					
	= -0.8	+0.3	+2.3	+6.2	-0.5 db
Stability Margin					
	= -10.8	-7.3	-1.8	+7.2	+5.8 db

The last line was calculated directly, taking the (-10 db, 97°), (-7.5 db, 75°) etc. points on the chart. This means that it is not necessary to pass through the response, mu-beta effect, over-all response system in order to check the stability margin. When the feedback path has a nonuniform response this can be very helpful, because all that need be done is to plot the two pairs of curves, for mu-beta and for beta, and then determine the stability directly.

There is a very attractive phrase which you can find in British patents: "Having now particularly described and ascertained the nature of the invention . . ." Well, we've done that, but just in case the explanation has not been sufficiently certain, Fig. 7 shows how the calculator is actually set to fish out the results at $\omega = 2$. The point marked A is at mu-beta = +4.2 db, mu-beta phase = 50°: the rotating arm OA has been turned until the edge passes through this point, and the mu-beta effect is read off at A on the scale printed on the arm. The phase of the mu-beta effect is read off on the circular scale. For the stability margin we hunt out point B, -4.2 db, 50°, and twist the arm to pass through this point. The stability margin is read off from the arm.

Wary readers may have noticed that almost everything I have discussed in this series of articles deals with the analysis of feedback circuits, and not the synthesis. We guess a circuit, and test it, on paper, to see if it will work. Nearly everything in the field of circuit design boils down to this in the end: The main differences appear in the methods of testing. At one extreme you wire up the circuit and pray; at the other extreme you test on paper in such a general way that you never come to a practical answer. These articles are aimed at a reasonable compromise. They

do provide all the information needed by the average professional designer, but at the same time I hope that they are not too forbiddingly mathematical for the man who wants to build just one amplifier, but wants to build it right. Anyway, you can always skip the mathematics.

The important thing to learn here is: mu-beta simplifies design work.

(continued next month)

VARIABLE LOUDNESS CONTROL

Loudness controls are special volume controls which provide increasing amounts of bass and treble boost as the volume is reduced. This compensates for the variations in response of the human ear so the output of the amplifier will appear balanced at all volume levels. Tapped volume controls provide a limited amount of compensation. This is greatest when the arm of the control is resting on the tapped point. Step type controls require a large number of components. They are difficult to construct and require special care in shielding to prevent hum pickup and feedback.

A continuously variable loudness control requiring only seven inexpensive components is described in a release by I.R.C. The circuit of this control is shown at a and its physical construction is shown at b. R1, R2, and R3 are IRC controls type Q11-133, M13-137, and M13-128 respectively. The first is a standard type control and the others are multisections designed for making dual, triple, and quadruple controls. The curve c shows the increase in bass and treble boost as the control is turned toward the minimum-volume position.

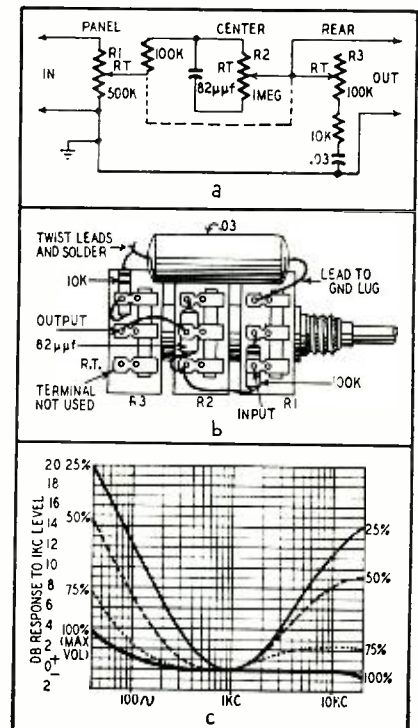

This control has a 6-db insertion loss which must be made up elsewhere in the amplifier if full output is to be realized.

Electronics and Music

Part XIII Stroboconn, precise frequency meter, measures sound accurately to hundredths of a semitone

By

RICHARD H. DORF*



Photo A—Discs used in Stroboconn.

WHILE this series is concerned with electronic musical instruments, the *Stroboconn*¹ is so closely allied with electronic music and so useful with electronic organs as well as more conventional acoustic instruments that it should be of great interest to all who work with both electronics and music.

The Stroboconn is in essence an extremely accurate frequency meter. It was specifically designed as an aid in tuning musical instruments, by the manufacturer of the Connsonata—an electronic instrument we shall describe

later in the series. It is also highly effective in the laboratory and in industry for measuring vibrations, oscillations, and other periodic phenomena within its frequency range.

The instrument is in effect a super-stroboscope. Twelve discs, each a replica of the one shown in Photo A, revolve at different speeds. Each disc corresponds to a note of the tempered musical scale and revolves faster than the preceding lower one by a ratio of almost exactly the 12th root of 2. A special large neon lamp is excited by a microphone-fed amplifier. When the microphone is placed near a source of sound—a piano tone, for example, or an organ note—the neon lamp flashes at the frequency of the sound, illuminating the discs stroboscopically. If the speed of one of the discs is such that the number of black segments passing a given point per second is the same as the audio frequency being measured, the pattern appears to stand still. Calibrations on the Stroboconn then indicate the frequency. All 12 discs can be seen through small windows, as Photo B shows.

Photo C is a photograph of one of the windows, exposing a segment of the disc behind it in motion. As Photo A indicates, each disc has seven concentric rings of patterns, each ring having twice the number of black portions as the adjacent inner one. Thus each disc takes care of the same note in seven succeeding octaves. In Photo C the narrow part of the window exposes the innermost ring on the disc. The first three rings are invisible because the frequency being measured corresponds to that of the fourth ring, in which the stopped pattern can be seen. This tone apparently has some harmonic structure, for the fifth and sixth rings are also stopped, though they are illuminated less well.

Electronic circuitry

The most essential requirement for accuracy in an instrument of this kind is that the motor driving the discs run at constant speed. In the Stroboconn this regulation is provided by driving the motor with a tuning-fork-excited amplifier, diagrammed in Fig. 1. The tuning fork is made of a special alloy, called Connivar, which has an extremely low temperature coefficient. The metal is so stable that the accuracy of the fork varies only a maximum of .002 percent per degree Centigrade. For musical purposes a pitch accuracy of

RADIO-ELECTRONICS for

*Audio Consultant, New York

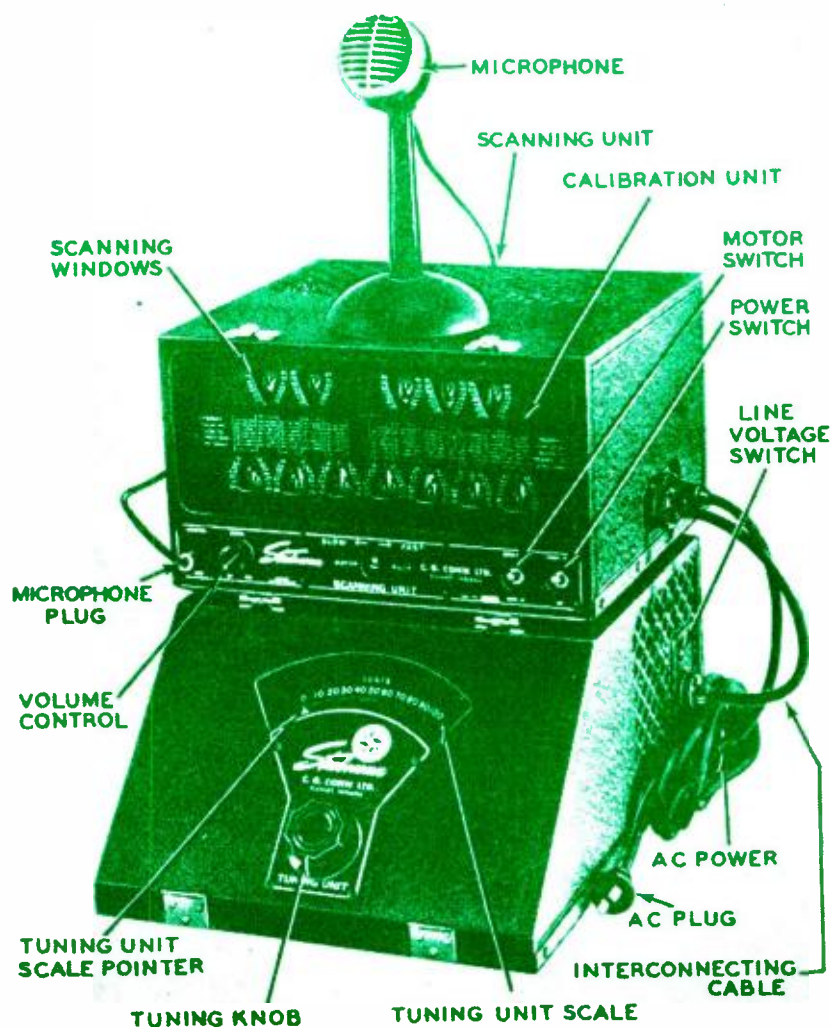

Photo B—The Stroboconn is in two sections. In use they are removed from covers and the scanning unit placed atop the tuning unit. Either an air or contact microphone may be employed, being placed near source of sound.

0.1 percent is considered very high and few people (if any) can perceive pitch variations so small. In continuous operation the entire instrument, including gears, fork, and all other variants, is accurate to within .05 percent.

The fork is driven by a regenerative circuit, in which respect it resembles electronic oscillators. The pickup coil (Fig. 1) drives the first grid of a 6SC7. The plate output is fed to the grid of the second section, part of whose plate load is the fork drive coils. Thus the output of the fork is fed back in the correct phase to furnish driving signal, the driving power being supplied by the B-voltage source, a standard rectifier-filter combination.

The fork-controlled signal is then fed through a 6SN7-GT phase inverter to a push-pull-parallel 6V6-GT output stage. The secondary of the output transformer drives the synchronous disc motor.

The normal frequency of the tuning-fork oscillator is 55 cycles, but the frequency can be varied at will. Photo D shows the fork and the sliding weights whose position can be changed to vary resonant frequency. The varying mechanism is operated by a knob which appears at the bottom of the lower unit in Photo B.

The upper of the two units in which the Stroboconn is mounted contains the motor, discs, and flashing amplifier, diagrammed in Fig. 2. The amplifier is entirely conventional: a voltage amplifier, phase inverter, and push-pull output stage. A special, large, U-shaped neon lamp is fed by the secondary of the output transformer. The lamp is large enough to provide light behind all the discs, which are translucent.

The power connections in Figs. 1 and 2 are rather confusing. The scheme is shown better in Fig. 3, an extract from the other two diagrams. Two power switches are supplied. One, called the POWER SWITCH, is in series with one side of the 117-volt a.c. line and a protective fuse. The other, the MOTOR-RUN WARM-UP switch, is a double-pole, double-throw unit. In the warm-up position in which it appears in Fig. 3 (and with the power switch closed) 117-volt, 60-cycle power is fed to the motor and the output of the tuning-fork amplifier is dummy-loaded by a 500-ohm, 50-watt resistor. After the motor and fork have warmed, the switch is thrown to the run position in which the motor is connected to the fork amplifier and the flashing amplifier power transformer is energized. After the flashing amplifier has warmed up, the instrument is ready for use.

The discs are run by the motor through a system of gears. Since the 12th root of 2 is not a rational number—it can be carried to an infinite number of decimal places—the gear ratio from one disc to the next is not quite correct; no one has yet been able to design gears with a nonintegral number of teeth! It is so close to correct, however, that the difference is not perceptible.

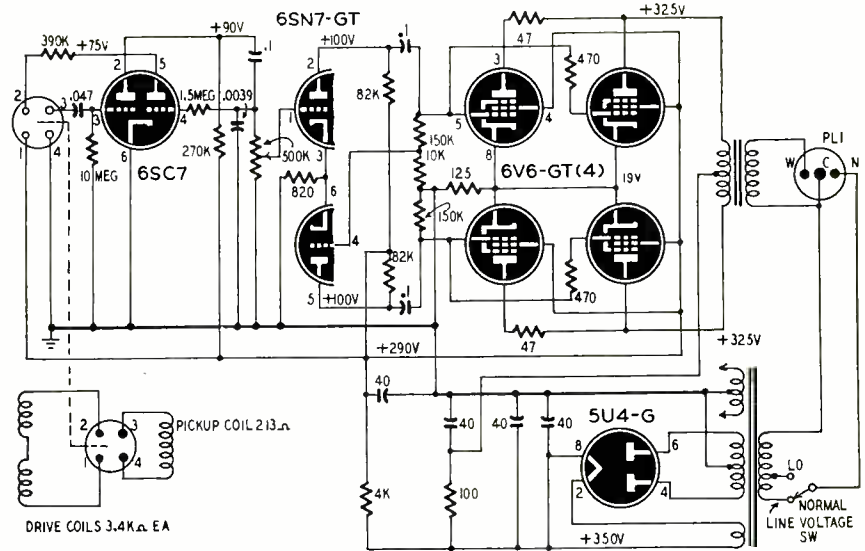

Fig. 1—The motor of the Stroboconn is driven by this tuning-fork-controlled amplifier. The fork is made of Connivar, has very small temperature co-efficient.

Reading frequency

The normal position for the tuning fork control is at zero. The tuning fork weights are then set so that the oscillation frequency for the synchronous motor is 55 cycles per second. The motor is so geared to the discs that the A disc rotates at 27.5 revolutions per second. The first (inner) ring has two black portions so that a black portion appears in a given position 2 times 27.5, or 55 times, per second. The fourth ring has 16 black portions; thus one appears 16 times 27.5, or 440 times, per second. If the signal fed into the microphone is at 440 cycles, the lamp will flash once each time that a black mark appears in the fourth ring and the marks will appear to stand still. At 440 flashes per second, however, each black mark of the first ring is illuminated 8 times each time it appears, so it does not stand still. As a result the fundamental frequency of whatever

tone is being measured is indicated by the innermost stopped pattern. Octave harmonics of the tone are indicated by the stopping of additional rings toward the outer edge of the disc (or the wide portion of the window).

Each ring of each disc is numbered around the windows in accordance with the ordinal number of the note. The calibration strip between the two sets of windows indicates the exact frequency of each note, based on an A of 440 cycles. That calibration is not necessary, of course, for routine instrument tuning, but is helpful for other purposes.

Interpolation

Probably the feature most responsible for the Stroboconn's versatility in both music and nonmusic applications is the ingenious provision made for reading with great accuracy any frequency within its range. The basis of this is the knob-controlled, calibrated sliding

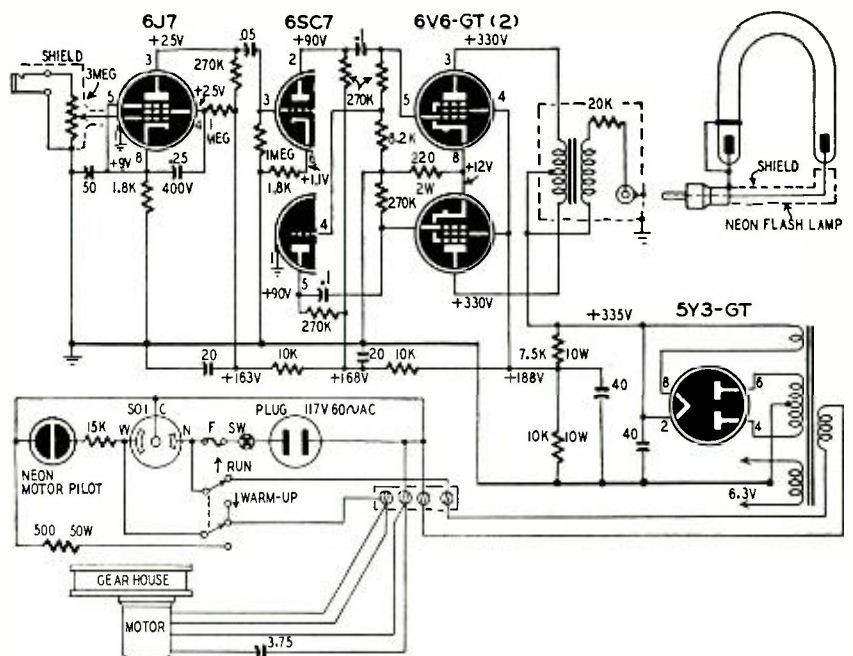

Fig. 2—Diagram of the scanning unit. The neon flash lamp is of special design.

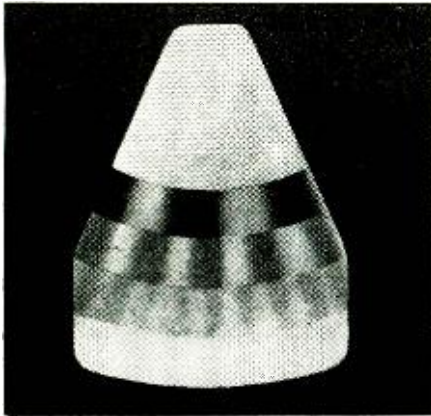

Photo C—Photo of a scanning disc in operation shows stroboscope patterns.

weight on the tuning fork. Referring again to Photo B, as the tuning unit knob is rotated the pointer on the scale above it reads the frequency change in terms of hundredths of a semitone. These small intervals are known as *cents*. Since the musical scale is built on a logarithmic, not an arithmetic, basis, a cent represents a constant *percentage* change in frequency rather than a constant numerical change. A semitone or halftone (the interval between, say, C and C \sharp or E and F) represents a frequency ratio between the two pitches of the 12th root of 2 (see August, 1950, issue). One cent therefore represents a ratio of

$$12\sqrt[12]{2/100}$$

which works out to approximately .058%. As an example, a 1-cent increase in the frequency of A-440 is 440×1.00058 , or 440.25 cycles.

In practical terms the meaning of the

above is quite simple. If the middle A is sounded on a piano or organ being tuned with the Stroboconn, ring No. 57 should stand still. Suppose it rotates very slowly to the right, indicating the tone is sharp, then to tune it to exact pitch the tuner adjusts the musical instrument until the pattern stands still. Or, to find out just how sharp it is, he rotates the tuning unit control upward from zero until the pattern stands still. If the pointer is then at 1 cent, he knows it is 0.25 cycle sharp.

Tuners rarely need to know how sharp or flat a tone is except for the "stretching" techniques described below. Of greater value is the fact that any frequency of an oscillator, or vibration, or anything else in laboratory or industry may be measured in this way. A book of tables is furnished with the Stroboconn. With its aid the operator can discover the exact frequency (to five significant figures) of anything that can be either fed to the flashing amplifier or picked up by the microphone. He merely manipulates the tuning knob until one of the patterns is stationary, then refers to the tables for the frequency.

Piano tuning

The old-time piano tuner was usually a craftsman of great skill and years of experience. Many of the best of them started their careers in piano factories, working up by stages to the exacting job of adjusting new pianos before they were shipped. Expert tuning has always required an intimate knowledge of piano construction, a first-class ear for pitch, and much practical experience.

One of the reasons that tuning has never been a purely mechanical job is

that an expert tuner does not actually tune the piano notes to theoretically correct pitch, except in the middle octaves. The overtones of a struck string are not true harmonics of the fundamental but are instead slightly sharper—higher in pitch—than the true harmonics would be. If the entire piano is tuned to exact pitch, the upper overtones of the middle octaves are sharper than the corresponding fundamentals of the upper octaves. Too, the upper harmonics of the lower octaves are sharper than the corresponding fundamentals of the middle octaves. The result is, as any musician who has ever heard a piano so tuned will instantly say, that it does not "sound right."

To make it sound more natural, the tuner "stretches." He tunes the upper

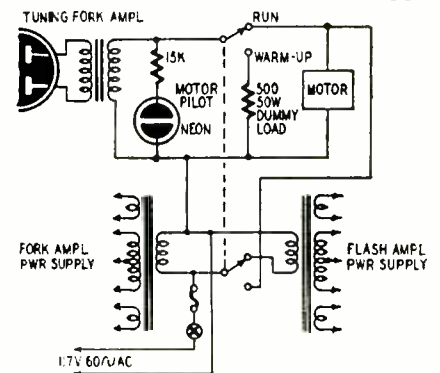

Fig. 3—The motor start circuit redrawn.

octaves sharp and the bass ones flat. Most tuners, aware of the fallacy of tuning an entire instrument to true pitch, balk at the idea of using an electromechanical device.

However, the variable, calibrated pitch adjustments of the Stroboconn overcome the difficulty. After a little experiment, a tuner determines just how sharp or flat each note of these "stretched" octaves should be tuned to suit his and his clients' tastes and he notes the pitch change in cents. In future tunings, he needs merely to shift the tuning knob according to his notes and tune for a stopped pattern. The time saved and the accuracy gained are well worth while. The accuracy is especially valuable when two pianos, to be used in duo-piano playing, are tuned, for then it is essential that they correspond. For tuning the lower octaves it is not even necessary to experiment and make notes. The tuner simply adjusts the piano so that with the pointer on zero cents, the higher overtones of the bass notes, which appear in rings outside that of the fundamental, give stopped patterns. In this way, he is actually tuning the overtones of the notes to true pitch, not the fundamentals, which will automatically be slightly (and desirably) flat.

In next month's article we shall begin our discussion of tone coloring in electronic instruments. Following that article on this important phase of electronic music we shall present a detailed description of the Hammond organ.

J. C. Conn, Ltd., Elkhart, Ind.

—end—

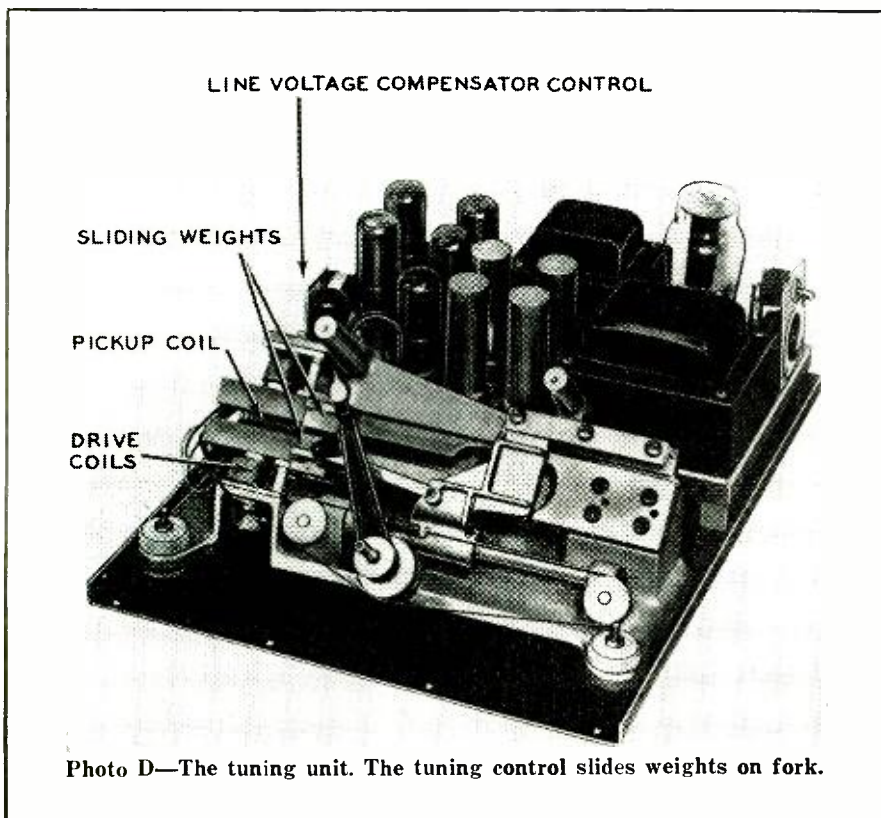

Photo D—The tuning unit. The tuning control slides weights on fork.

Rico Amplifier Operation

Hi-Fi operation obtained only by proper adjustment of three channels

By

JACINTO SUGRANES

THE circuits of the three-channel Rico amplifier were discussed in some detail in last month's issue. Now let's look into the adjustment and operating procedure for getting the best results from the amplifier.

The first step, once the circuits are wired up and in working order, is to adjust the bias on the three pairs of output tubes. This is an important adjustment, because the 2A3's are fairly sensitive to changes in bias, and any unbalance in any of the three pairs will introduce distortion. Furthermore, this balance should be checked at frequent intervals. This is not difficult, because the metering circuits are all built in.

Fig. 1 shows the phase inverter and push-pull output stage of one of the three channels. The other two channels are identical except for the values of the components marked C1 and R1, and these have no effect on the adjustment procedure.

The bias is adjusted by setting potentiometer R3 until the plate currents of the two tubes are equal. Switch S1 back and forth between positions 1 and 2 until the meter readings for these two positions are equal. Actually the meter reads the voltage drop across the two halves of the output transformer winding and not the plate currents. The d.c. resistance of the two windings therefore must be equal, as is usually the case with the better output transformers. In the Rico amplifier, pilot lamps are connected to a second deck on the meter switch, so that a lamp indicates which plate circuit the meter is measuring. Colored jewels for these lamps can be selected in color pairs to make identification easier.

If the two halves of the transformer winding are not equal, the balance can be checked by measuring the plate current of each of the tubes. This can also be arranged by switching, but a somewhat simpler method is to install closed-circuit jacks in each plate circuit and



Home Installation showing professional appearance of the Rico amplifier

plug in the meter to the circuit being measured. The meter should have a 100-ma full-scale deflection, as the normal plate current of each tube in this circuit is about 50 ma. A third way to check the bias is to measure the voltage directly from grid to cathode, but this requires a vacuum-tube voltmeter and therefore is not as easy to build in. The method described is adequate.

The bias for the 2A3's is developed across the 720-ohm resistor in series with each filament, half of the 160-ohm potentiometer R3, and the series fila-

ment string made up of the 12AH7's and the 12SC7 shunted by the 250-ohm resistor. The bias on each of a pair of 2A3's cannot be varied independently of the other, and R3 is used only to balance the pair. If for any reason the bias is not correct for the tubes when balanced, it must be adjusted by changing the value of the 720-ohm resistors in the filament circuits until the combined current for each pair of 2A3's is about 100 ma. This will change after use, and should be checked.

A 1-ma meter need not be used in the

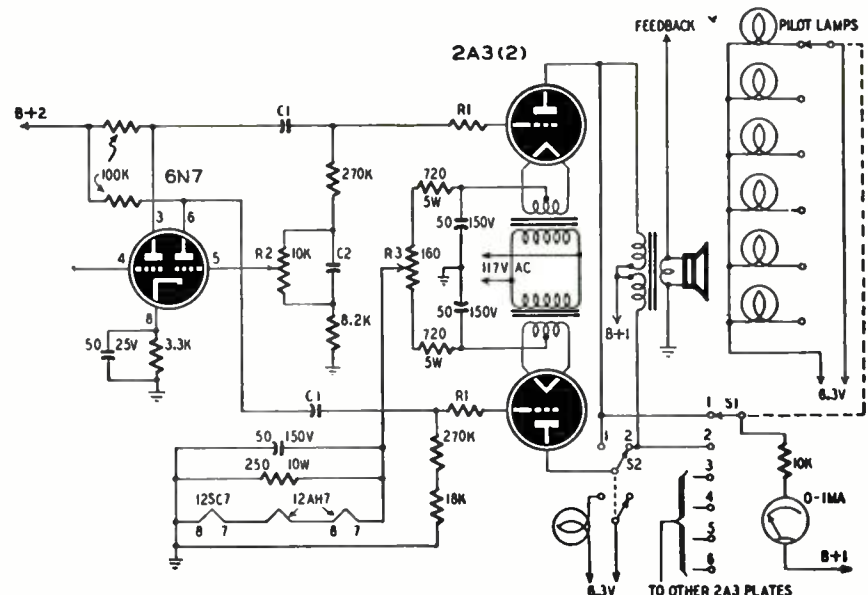

Fig. 1—Phase inverter and push-pull output stage of one channel.

plate metering circuit, as almost any unit of less than about 500-ma full-scale reading will do. It is necessary only to adjust the resistance in series with it so that normal plate current produces a reading well up on the scale. The actual value of the resistance is not important, as the meter is used only as a comparator and not to obtain actual values.

Phase inverter setting

For good push-pull operation, the voltage supplied to the output tube grids must not only be 180° out of phase, but must also be equal in amplitude. Phase inversion in this amplifier is adjusted by the potentiometer R2. The inverter itself is simply a dual triode in which a fraction of the output of one section is fed to the grid of the other.

To adjust the inverter, set switch S2 to position 1. This connects the two plates of the output stage in parallel, so that if the signals on the two grids are equal and 180° out of phase, the amplified signal on the plates will be cancelled. Then adjust R2 until the signal is no longer heard at the speaker. Any convenient signal source may be

applied to the amplifier input. Almost any record that is convenient may be used. This adjustment must be made for each of the three channels, and the other two channels must be silenced during the operation. Once the phase inverter is balanced, lock the controls securely and switch S2 back to position 2. S2 also controls a pilot lamp which indicates which position it is in. The phase inverter adjustment is fairly stable and normally needs no resetting unless the inverter tube or the output tubes are changed.

Each channel has its own volume control. These are used to adjust the over-all balance among the three channels. All except the tin-eared can usually do a good job of this by using a record as a test signal. Use a good quality record, preferably a familiar piece with full orchestra. This method is perhaps better than using an audio oscillator at the input, because the frequency ranges at the output overlap, and the only simple way to get an over-all response curve would be to use a calibrated microphone near the speakers.

These individual volume controls can be used as tone controls, but it is better

to leave them alone once they are adjusted. Separate tone controls are provided in the treble and bass channels (R3 and R8 in complete schematic, June issue).

Two gain controls are used in the amplifier input circuit. One is the usual potentiometer type, the other a compensated gain control. The potentiometer is adjusted so that the maximum signal which can be expected at the input will not overdrive the amplifier. This can be done by playing a loud record while making the adjustment. The compensated volume control is used as the general control. It keeps the balance between highs and lows regardless of how softly the amplifier is played.

While the large number of controls on this amplifier give it an unusual degree of flexibility, they also make the adjustments somewhat more complicated. The correct setting for each of the controls depends on the setting of the others, so that some trial and error will be necessary to get the best results. But the discriminating music lover should get many hours of enjoyment from this amplifier.

—end—

Universal Hi-Fi Preamplifier

By M. G. O'LEARY

THE recommended G-E reluctance pickup preamplifier is designed to start boosting the bass at a turnover point of about 780 cycles. This turnover is a good average for American 78-r.p.m. records, but where the recorded turnover point is as low as 500 cycles, the bass may be excessive. London 78-r.p.m. records and most other European 78-r.p.m. pressings have a turnover of around 250 to 300 cycles. Many of these are superb recordings but they sound atrocious on our reproducers with the high bass-boost point.

The recommended G-E preamplifier can easily be modified to give a variable bass turnover point at the cost of a selector switch and a few paper capacitors. In Fig. 1 the assembly shown within the dotted lines replaces the usual .01- μ f capacitor in series with the 33,000-ohm resistor and ground. The table shows the values. The 2.2-megohm resistors may be used to prevent switch

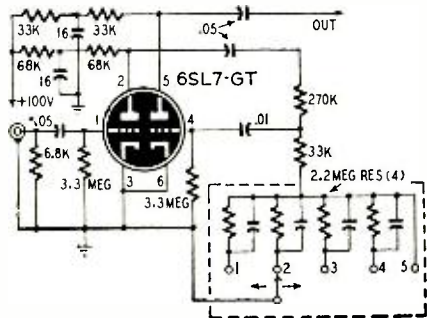

Fig. 1—Variable bass turnover circuit.

clicks. The switch itself should be of the shorting type.

Most American records will sound best at position 1, but some will sound better at positions 2 or 3. European recordings will probably be most satisfactory at positions 3 or 4. LP's will probably sound best on positions 1 or 2. Position 5 is optional and is only included where the amplifier might be used with a low-level microphone.

Position 5 might be substituted by a 2-megohm variable resistor to provide for a variable bass boost. However, this is not recommended, as the amount of boost provided without it is normally required, and, if anything, more than this amount of boost may be necessary to compensate for amplifier and speaker shortcomings or low-level playback. It seems logical to use the equalization in the preamplifier to equalize the recording characteristics. Another stage in the amplifier proper can be designed to boost the bass to compensate for the other factors. Otherwise compensation in the preamp stage only, to be flexible enough to compensate for all records at many reproducing levels, would be extremely complicated.

The additional bass-boost stage is shown in Fig. 2. The 2-megohm variable control gives a variable boost from flat to about 18 db at the very low frequencies. C1 should be found by experiment. If the amplifier and speaker have a good bass response, C1 at .01 μ f will

probably best equalize for the apparent loss of bass due to low-level playback. With poorer speakers and less expensive amplifiers, other values of C1 may give better results.

Finally, if the amplifier and speaker system have a good treble response, one

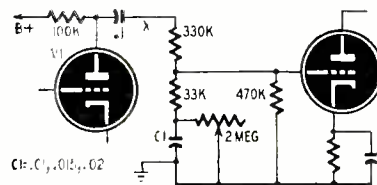

Fig. 2—Additional bass-boost stage.

of the standard tone controls consisting of a plate bypass capacitor in series with a variable resistor can be added to control the excessive brilliance of reproduction resulting from the treble-pre-emphasis in the recordings. Here again the capacitor value can best be determined by experimenting. If such a control is added at point X in Fig. 2,

Table of RC Values

Switch Position	Capacitor Value (μ f)	Bass Turnover Point (Cycles)
1	.01	780
2	.015	500
3	.02	390
4	.025	310
5		flat

use .015 to .02 μ f if V1 is a low- μ triode. This should give a treble turnover of approximately 1,000 cycles.

—end—

GET IT!

1951 ALLIED catalog

free!

the only complete
up-to-date catalog for
**Everything in Radio, Television
and Industrial Electronics**

212 value-packed pages



Send for it today!

Here's the only *complete, up-to-date* Buying Guide to TV, Radio and Industrial Electronics—packed with the world's largest selections of quality equipment at lowest, money-saving prices. See the latest in TV, AM and FM receivers; radio-phonos; new Sound Systems and P.A. equipment; High-Fidelity Custom Sound components; recorders and accessories; full selections of newest Amateur receivers and station gear; test instruments; builders' kits; huge listings of parts, tubes, tools, books—the world's *most complete stocks* of quality equipment.

ALLIED gives you *every* buying advantage; speedy delivery, expert personal help, lowest prices, assured satisfaction, liberal time payment terms. Get the latest 1951 ALLIED Catalog. Keep it handy—it will save you time and money. Send for your FREE copy!

ALLIED IS YOUR TELEVISION HEADQUARTERS



To keep up with TV, depend on ALLIED! Count on us for the latest releases and largest stocks of picture tubes, component parts, antennas and accessories—plus the latest in TV tuners and kits. If it's anything in TV—depend on ALLIED!

ALLIED RADIO

the World's Largest Radio Supply House

EVERYTHING IN ELECTRONICS

THE WORLD'S LARGEST STOCKS

Radio Parts Unlimited
Test Instruments
Television & Home Radios
P.A. and Hi-Fi Equipment
Amateur Station Gear
Supplies for Industry

QUICK, EXPERT SERVICE

SEND TODAY FOR RADIO'S LEADING BUYING GUIDE

free



ALLIED RADIO CORP.
833 W. Jackson Blvd., Dept. 2-G-1
Chicago 7, Illinois

Send FREE 212-page 1951 ALLIED Catalog No. 126

Name _____

Address _____

City _____ Zone _____ State _____

Radar Tracks Shooting Stars

Using radar echoes, the speeds of meteors coming from outer space are recorded at 100,000 miles per hour

By PROF. A. C. B. LOVELL and J. G. DAVIES*

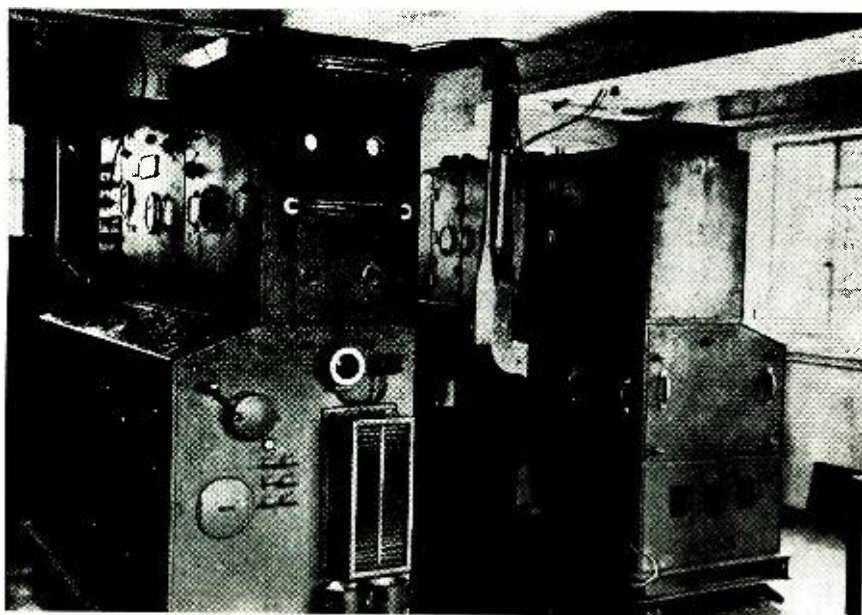

Fig. 1—Search transmitter at Cheshire, England, uses ex-army radar equipment.

METEORS, or “shooting stars,” are tiny pieces of stone or iron which rush into the earth’s atmosphere at speeds thousands of times faster than an express train. Fortunately for us they get very hot by friction in the highest layers of the atmosphere and burn up.

*Jodrell Bank Experimental Station (University of Manchester) Cheshire, England.

They rarely penetrate lower than about 50 miles above the earth’s surface. In this process of evaporating they leave a trail of light several miles long.

Until recently the visual or photographic study of these meteor trails was the only way to obtain information about them. Although they could not be observed in daylight, and although their study was severely handicapped by

cloud or bright moonlight, we knew that 100,000 millions of these pebbles were pouring into the earth every 24 hours. We also knew that occasionally the earth rushed through an extraordinary concentration of this debris, producing what is known as a meteor shower. But in spite of more than 100 years of observation the astronomers do not know for certain where these vast numbers of pebbles come from.

During the last few years radio has been used to study these meteors and several of the outstanding problems are beginning to be solved. In this article we shall describe some of the basic radio techniques which are now in use.

Meteor detection by radio

When the meteor burns away in the high atmosphere it leaves behind for a very short time a dense trail of electrons, as well as the streak of light by which we see it. This electron trail enables us to detect the meteor by radio. The fundamental process is very simple. A radio wave sets the electrons in the trail into vibration, and while they are oscillating they reradiate a small amount of the energy in the incident radio wave. This energy will travel back toward the earth, and if we have a sensitive enough receiving set, we can detect these radio waves which are scattered from the trail. Both pulse and c.w. methods are used. The frequencies used are generally higher than 20 mc, otherwise one gets trouble from the reflections from the ionized E and F regions, and the results are difficult to interpret.

There are many more faint meteors than bright ones. Thus the more sensitive the apparatus the more meteors will be detected. For example, in a pulse equipment, using a peak transmitter power P , an aerial with a power gain G , a receiver noise factor F , and a wavelength λ , it can be shown that the faintest meteor detectable will depend on:

$$G\sqrt{\frac{P\lambda^3}{F}}$$

In this article we shall first describe a pulse apparatus working on 72 mc in which the transmitter power and receiver sensitivity were such that the number of echoes seen corresponded very closely with the number of meteors which could be seen by a single visual observer on a clear night.

72-mc pulse apparatus

In this apparatus—now in use at the Jodrell Bank Experimental Station in Cheshire, England—an ex-army radar transmitter forms the basis of the meteor transmitter shown in Fig. 1. The transmitter consists of an oscillator stage with two British Service tubes, type VT-98 triodes (Fig. 2). These run

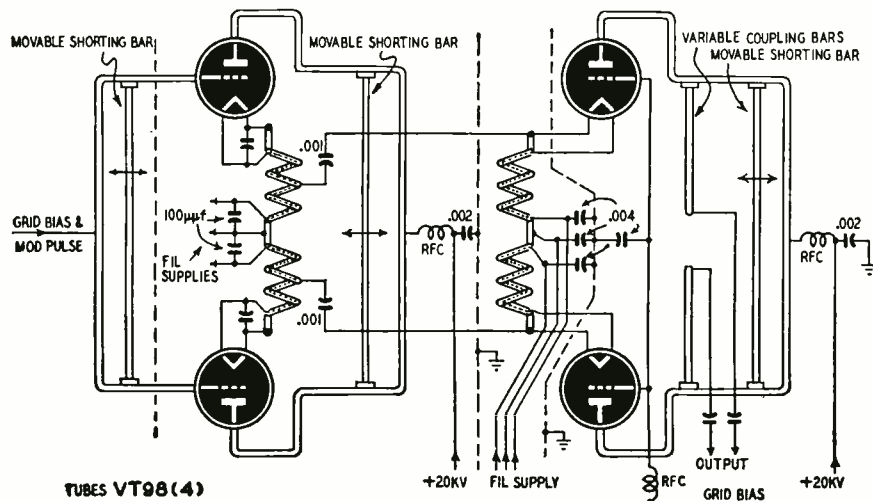

Fig. 2—Radar transmitter circuit has 50-kw output with 8-microsecond pulses.

*They "test-fly" rockets for pennies
—to save the taxpayer Millions*

One way to make America stronger is to give our Armed Forces more and better weapons—built without wasting the nation's defense dollars. An example how this can be done is seen in our vital *guided missiles program*.

Using an electronic calculator—an analogue computer developed by RCA Laboratories for the U. S. Navy—the designs of guided missiles can now be tested in the drawing board stage, to save time and money. Information representing the rocket's design is fed into RCA's calculator. Other information represents flight conditions, and the two are then combined to show how the rocket performs . . . at any split second.

Millions of defense dollars — thousands of hours — are saved by these mathematical "test flights." And RCA's calculator will test any man-made device that flies or swims . . . planes, ships, bullets, shells, rockets, submarines.

See the latest in radio, television, and electronics at RCA Exhibition Hall, 36 West 49th St., N. Y. Admission is free. Radio Corporation of America, RCA Building, Radio City, New York 20.



Models of guided missile and bomber about to meet on the plotting board of RCA's computer.

New electronic computer at RCA Laboratories "test-flies" rockets before they are built.



RADIO CORPORATION of AMERICA
World Leader in Radio — First in Television

at 20 kv on the plates and are tuned with resonant lines in the plate and grid circuits. The oscillator is cathode-coupled to a grounded-grid amplifier stage of two similar tubes, and the output is tapped off the plate lines. This transmitter gives a peak power of about 50 kv for 8-microsecond pulses at a

is used, but more often it is the array of Yagi elements mounted on an old army searchlight shown in Fig. 3. This gives a beam of ± 10 degrees width, and can be pointed at any part of the sky. The output of the receiver is displayed on an A-scope display, which can be seen in Fig. 4. It also goes to an auto-

mc, two fixed beamed aeri-als are used, each consisting of six Yagi elements, shown in Fig. 6. The signals from these two aeri-als are fed separately into two intensity-modulated displays and photographed on a continuously moving film. An echo from a long-duration meteor trail on this apparatus is shown in Fig. 7. The pulses are doubled for easy identification of the short-duration echoes against the noise background.

Such radio techniques enable observations to be made in daylight. Through this ability some striking discoveries have been made. The apparatus described above has been used at Jodrell Bank since 1946, and a remarkable sequence of intense meteor showers only active during the summer daytime was discovered in the summer of 1947.

Measurement of velocities

Perhaps the greatest hindrance to rapid progress in the study of meteors has been the very great difficulty of measuring the speed with which they enter the atmosphere. Since they are travelling at a speed of nearly 100,000 miles per hour, it is not surprising that this measurement has been hard to make. Without an exact knowledge of the speeds of meteors it is not possible to decide where they come from—nor even to decide whether they are all localized in the solar system or whether some come from interstellar space. It was therefore important to develop radio methods for velocity measurement. The one to be described was developed at Jodrell Bank and has been in regular use since 1947 for measuring these high velocities.

The radio echo seen on the apparatus described above comes from the completed electron trail of the evaporated meteor. The velocity recorder works by studying the echo from the trail *while it is being formed*. The apparatus measures the speed with which the electron trail is made. While the trail is being formed there are intensity fluctuations in the echo returned to the receiver which are exactly analogous to the fluctuations in the light near the edge of a sharp shadow on a screen—the familiar optical phenomenon known as diffraction. The fluctuations in amplitude to be expected as the meteor passes the per-

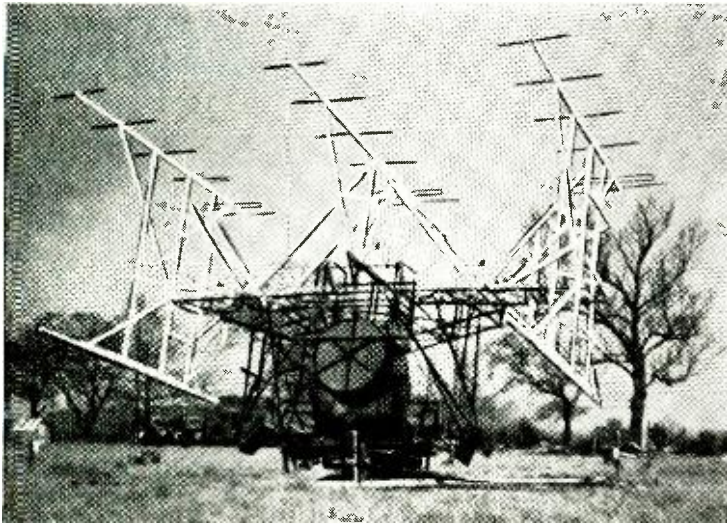

Fig. 3—A Yagi antenna mounted on army searchlight scans sky.

repetition frequency of 600 pulses per second. The filament supplies are fed to the cathodes via coaxial ("unity-coupled"—*Editor*) chokes, which also act as coupling transformers.

The receiver is a normal superhet with grounded-grid triodes in the first two stages to give maximum sensitivity. The i.f. is at 10 mc, and has a bandwidth of 1 megacycle. Negative pulses can be applied to the suppressors of three of the five i.f. tubes to suppress the receiver during the transmitter pulses, and to blank out unwanted echoes from the local hills.

Both transmitter and receiver are connected to the same aerial system with a spark-gap switching arrangement. Sometimes a simple dipole aerial

matic recorder which will be described later.

A photograph of a typical echo from a meteor trail is shown in Fig. 5. The number of meteors seen with this apparatus is close to that seen by a visual observer under good dark sky conditions, and is normally from 2 to 10 per hour. When the showers occur the hourly rate rises to 50 or 60 for several nights in succession. During a remarkable event on October 10, 1946, it increased by 5,000 times to 160 per *minute* between midnight and 3:30 a.m. On this occasion the earth passed close to the Giacobini-Zinner comet, and was bombarded for six hours as it crossed the orbit.

In similar piece of equipment on 73

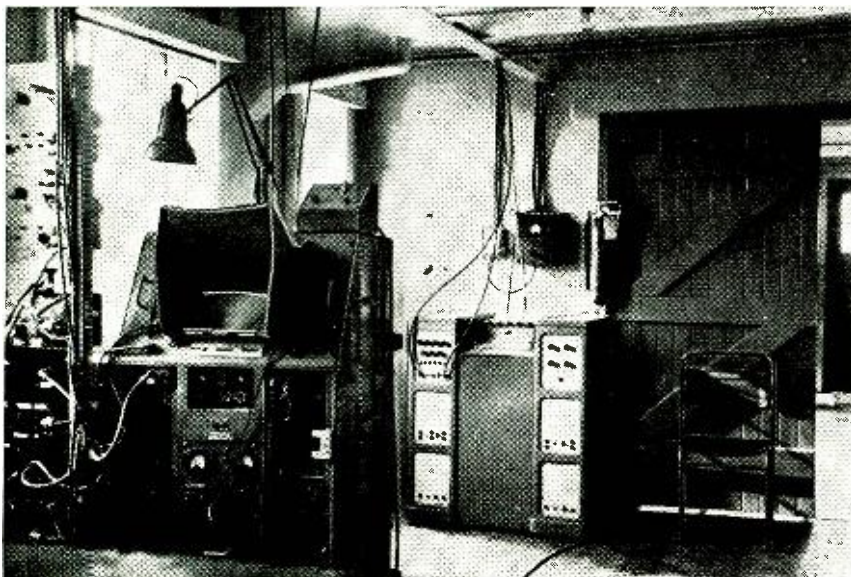

Fig. 4—Receiver at Jodrell Bank site is viewed on A-scope unit seen here.

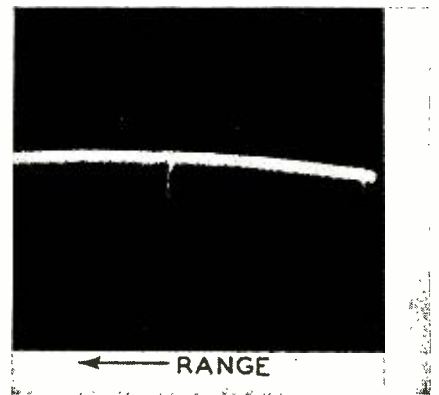

Fig. 5—A picture of a meteor trail.



Here's how YOU
 can sell more
 Picture Tubes
 WITH
 HYTRON'S NEW
 EASY BUDGET PLAN!



GUESS YOU NEED A NEW PICTURE TUBE - THAT'LL COST YOU ABOUT \$50.00.



OUCH, I CAN'T AFFORD IT - I DON'T HAVE THAT MUCH CASH

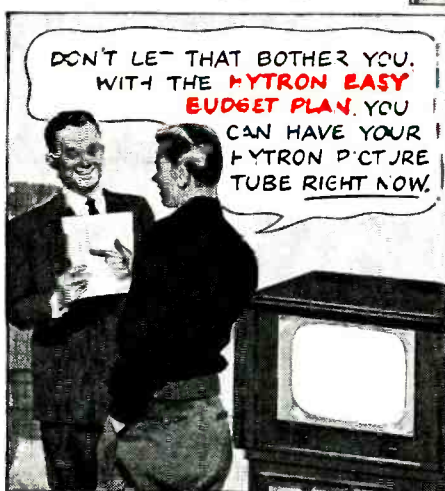

DON'T LET THAT BOTHER YOU. WITH THE **HYTRON EASY BUDGET PLAN**, YOU CAN HAVE YOUR HYTRON PICTURE TUBE RIGHT NOW.

ANOTHER HYTRON FIRST FOR YOU!

No need to miss that profitable picture-tube sale — just because the customer doesn't have the cash. The original Hytron Easy Budget Plan saves the sale. Gives you a competitive edge. Hytron has arranged the details for you. A national credit organization, with facilities in all TV areas, stands ready to serve you.

Find out how you can put this wonderful, timely Hytron plan to work right now! Write for complete information today.

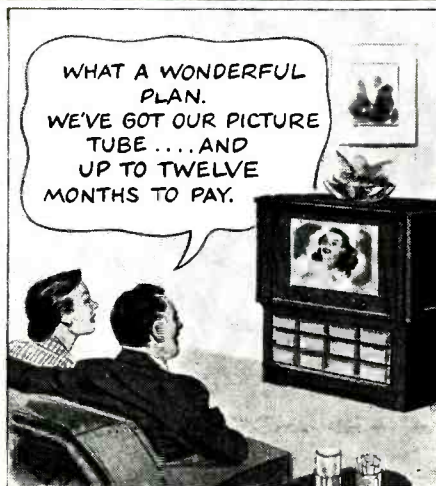

WHAT A WONDERFUL PLAN. WE'VE GOT OUR PICTURE TUBE . . . AND UP TO TWELVE MONTHS TO PAY.

**ANOTHER
 HELPFUL SERVICE
 FOR YOU FROM . . .**



MAIN OFFICE: SALEM, MASSACHUSETTS

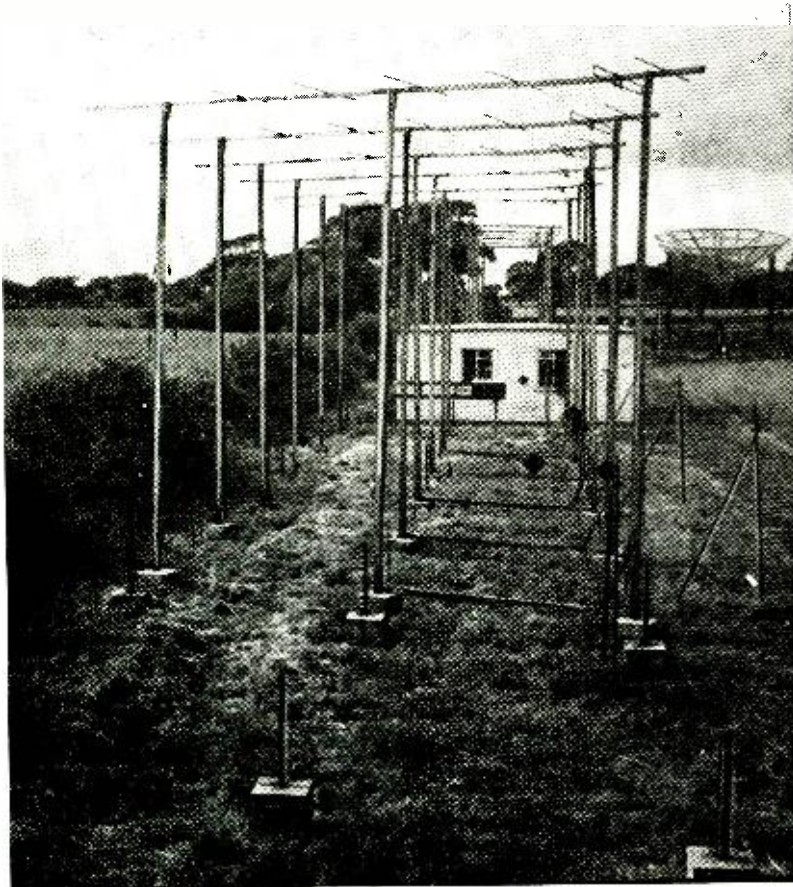

Fig. 6—Two fixed beam antennas are used on 73 mc, each having 6 Yagi elements.

pendicular point from the station to the trail are shown in Fig. 8. The horizontal spacings OA, OB, OC, etc., can be shown to be $1.2\sqrt{R\lambda}$, $1.9\sqrt{R\lambda}$, $2.3\sqrt{R\lambda}$. λ is known, the range R can be measured on an A-scope display. Hence if we can measure the time T_{AB} for the trail to form from A to B etc., then the velocity of the meteor is given by: AB/T_{AB} etc. The great difficulty is in measuring these time intervals. If

typical values, $\lambda = 4m$, $R = 300 km$, are inserted, we see that OA is only about 1 km. But an average meteor is moving at about 40 km per second, hence the time interval between O and A is only of the order of 0.025 seconds or 25 milliseconds.

In the velocity recorder, which can be seen in Fig. 4, photographs are taken of two cathode-ray tubes, each with a single-stroke time base. One time base lasts for about 10 milliseconds, and is used to measure the range of the meteor by standard radar methods; the second time base lasts for 0.1 seconds, and displays the first 60 echo pulses received side by side. A photograph of these pulses appears in Fig. 9. The time bases are triggered simultaneously, by the first echo pulse received that is greater than a given amplitude—about twice the receiver noise level. The transmitter is pulsed at 650 pulses per second, so that the separation between pulses is 1.5 milliseconds. Thus the time intervals between the maxima and minima can be measured with great accuracy.

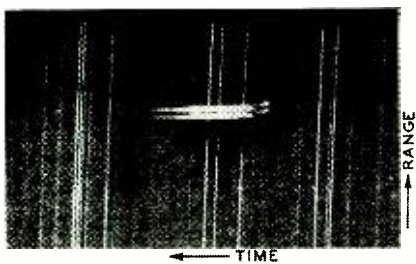

Fig. 7—Long duration meteor trail echo.

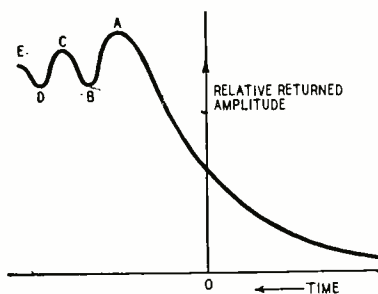

Fig. 8—Meteor position amplitude curve.

detail below, and a schematic of the discriminator unit appears on page 54.

In addition, a set of relays is triggered from the discriminator. This flashes a light onto a clock, recording the time of occurrence, and, after the photograph has been taken, operates the camera motor and resets the instrument for the next echo. The direct signal from the transmitter, and the echoes from ground sources nearby, are removed by suppressing the receiver for the period during and immediately after the transmitter pulses.

The discriminator operates on the duration of a single echo pulse. This is equal to the transmitter pulse length, and is about 8 microseconds, while the duration of a single noise impulse is determined by the receiver bandwidth and is 2 or 3 microseconds.

The circuit diagram is given in Fig. 11, and the waveforms in Fig. 12. Tubes V1, V2, V3-a, and V4 form an a.v.c. amplifier with cathode follower output, the receiver noise at the cathode of V3-a being about 20 volts peak-to-peak, and positive in sign. V5 is a limiter stage, with about -20 volts bias on the grid. Hence it is normally cut off, but begins to conduct as soon as any signal rises much above the noise level. Grid current limits the signal at about twice the receiver noise level, producing waveform B (Fig. 12) on the plate of V5. V7 comprises the discriminator stage, in effect an infinite impedance detector circuit, and a cathode follower, the output from which is shown at C in Fig. 12. On the leading edge of the pulses, the first half—originally only passing about 150 microamperes—is cut off, and the cathode falls at a rate determined by its stray capacitance. On the return stroke, however, the tube conducts heavily, and hence returns very rapidly to its original potential. This is important, as interference caused by ignition systems frequently consists of a train of impulses with very little interval between them, and such interference could be confusing.

The effect of this circuit is first to reduce all impulses to the same amplitude, and then to give them an amplitude that depends on the duration

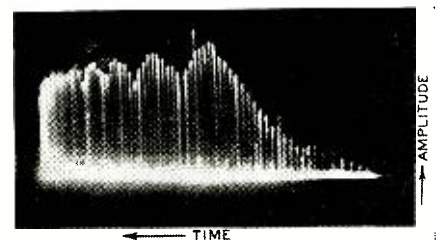

Fig. 9—Recorder unit time base photo.

The recorder unit

A block diagram of the recorder is given in Fig. 10. The output from the receiver is fed to the cathode-ray tubes via an amplifier, and is also used to trigger the time bases via the discriminator unit. This unit is required to separate the echoes from impulses caused by atmospherics or ignition systems. Its operation will be described in

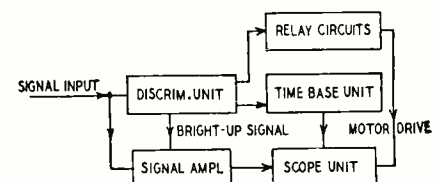
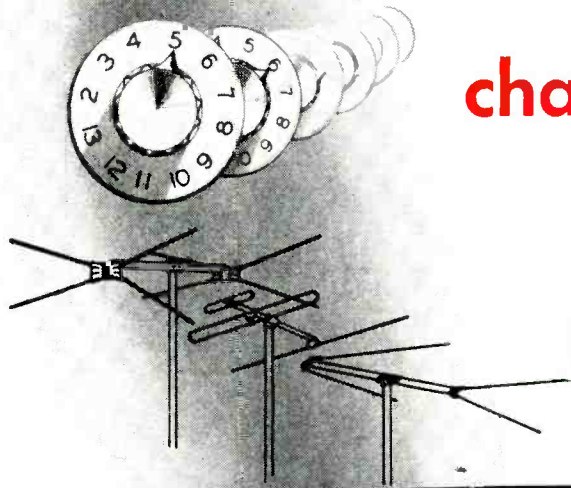

Fig. 10—Recorder unit, block diagram.



channel for channel

model for model

RADIART TV ANTENNAS

Outperform ALL Others!

regardless of price!

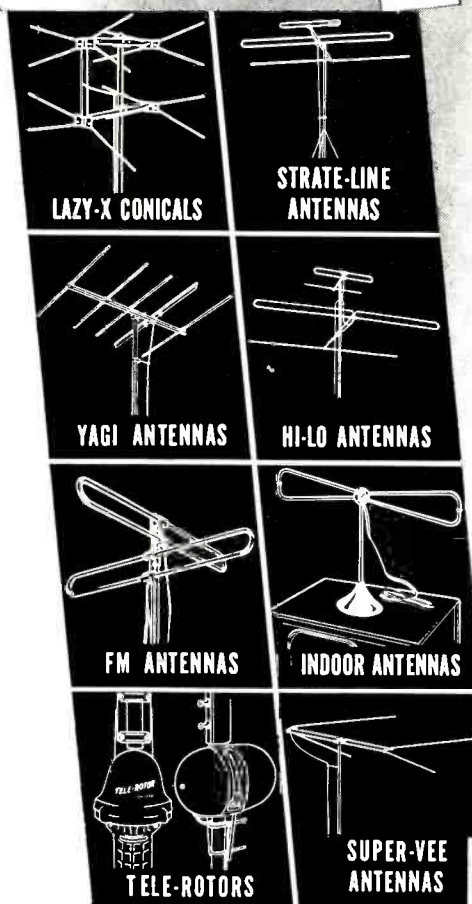

★ We can't make all the antennas in the world . . . so we make the best of it. Whatever the need . . . whatever the location . . . there is a **RADIART** antenna that will do the job better — and at no greater cost! Servicemen everywhere prefer **RADIART** antennas because of their many advantages! Easily and quickly installed . . . they stay up without maintenance and costly call-backs. The fine manner in which they perform is a credit to the installation company! AND . . . the complete variety of types makes it easy for servicemen to select the best antenna for his area. Recommended by all good distributors.

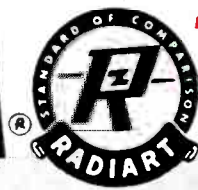

IT'S RIGHT WHEN IT'S RADIART

THE **RADIART** CORPORATION
CLEVELAND 2, OHIO



• ROTATORS • VIBRATORS • AUTO AERIALS • TV ANTENNAS • POWER SUPPLIES

2 New Trio Products

TRIO TV ROTATOR AND DIRECTION INDICATOR

TWO HEAVY DUTY MOTORS For Trouble-free • Two Direction Rotation

Here's the rotator that provides the ultimate in trouble-free dependable operation. Designed to support the heaviest TV arrays — even in 80 M.P.H. winds! This outstanding rotator has undergone extensive tests for three years, standing up under every abuse and temperature extremes.

Here, indeed, is the rotator that abolishes TV callback problems!

Two Heavy Duty Motors

Two 24 volt motors are used — one for clockwise and one for counter-clockwise rotation. Even if children play with the unit and leave it on continuously, a motor cannot burn out since load on a single motor is never on more than 50% of the time!

Positive acting electrical stops at both ends of 360° turn eliminates lead damage.



Indicator always shows exact antenna position.

Compare These Features

- Cast TENSALLOY aluminum mast holder withstands 4500 lbs. bending movement.
- 1 1/16 steel shaft withstands 4500 lbs. bending movement.
- Automatic Electro-Mechanical Brake — reduces coasting to minimum
- Can be fastened to any pipe up to 2" OD
- Two direction rotation
- All-aluminum case — no cast zinc!
- Numbered terminal boards on rotator and indicator
- Turns 1 RPM, lifetime lubricated
- Ball-bearing end thrusts on shafts
- Ideal for 10, 6 and 2 meter amateur use

NEW TRIO *All Aluminum* TOWER

Weighing less than a pound per foot, this sturdy, extremely handsome, all weather-proof triangular tower represents a great refinement in streamlined appearance and installation ease over all others. Its all-aluminum components permit the most flexible arrangements for construction of the *exact* tower needed for *any* installation.

Tower may be raised from horizontal position in heights up to 40 feet. For additional height, sections may be added from *bottom*.

Comes in 5 foot sections, a bottom section, a top section and as many center sections as desired.

FEATURES

- Sturdy, Yet Light In Weight — Less Than A Pound Per Foot
- Forever Rust Proof
- High Quality Extruded Aluminum
- Interchangeable Sections
- Preferred Riveted Construction . . . No Welded Joints
- Dual Swivel Base — 180° and 360° permits vertical or horizontal plane mounting
- Low Installation Cost
- Completely Cartoned For Protection In Shipping — Compact Storage

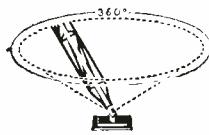

Dual Swivel Base
180° and 360°

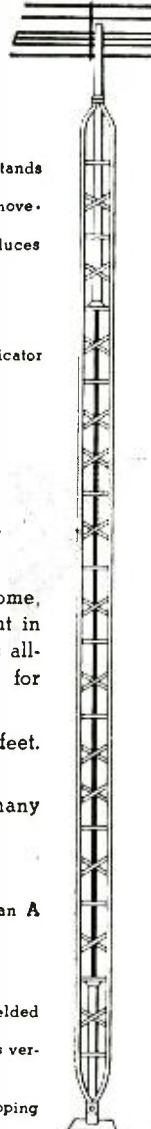
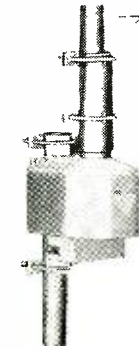

TRIO YAGIS

Lead the Field . . .

TRIO DOUBLE FOLDED DIPOLE

(Model 304)



Here is the popular TRIO Double Dipole TV Antenna. With 10 db forward gain and a front-to-back ratio of 25 db, it is unexcelled for extreme fringe areas. Available for each of 12 TV channels. Easily stacked for additional gain. Reinforced fittings for extra strength — extra rigidity!

- Exact Impedance Match To 300 ohm Line!
- Sturdy Construction — Light Weight
- Partially Assembled!

TRIO 2-CHANNEL YAGIS

(Models 445 & 479)



Rapidly becoming the most popular — most wanted TV antenna in America. Available for channels 4 and 5, and channels 7 and 9. Provides gain on two channels equal to any two conventional 4-element yagis!

- Full 10 db Gain On 2 Channels!
- Less Weight Per Gain Than Any Other TV Antenna!

TRIO PHASITRON Now available separately

(Model No. PC-500)



The TRIO PHASITRON, originally sold only as part of the TRIO Controlled Pattern TV Antenna System, is now available separately for TV set owners who want to get the very best results from their sets and antennas, or to hams and other experimenters.

PHASITRON acts as a continuously variable tuning club and will provide an exact impedance match between line and booster and helpful in matching output impedance of booster to set input impedance. Due to exact matching, losses in line become negligible and set performance greatly improved.

May also be used to coordinate input from two or more antennas to provide added balanced output to set. Write for full details.

NEW TRIO TV ACCESSORY CONTROL UNIT

(Model No. RY-1)



A handy control unit that hides away inside or in back of the TV set and provides an automatic line switch for booster, rotator, TV lamp or other accessories. By plugging the line cords from these accessories into the TRIO Control Relay Unit, all accessories are turned on with the one switch controlling the TV set. Quickly installed without making any wiring changes in set.

THOMPSON CORPORATION

AFFILIATED WITH TRIO MANUFACTURING CO.
GRIGGSVILLE, ILLINOIS



Trio MFG. CO.

GRIGGSVILLE, ILLINOIS

How an Electronic Brain Works

Part X—The product of two binary numbers.

By EDMUND C. BERKELEY* and ROBERT A. JENSEN

IN THE two previous articles we discussed how a brain built around electronic tubes can store information, add, and subtract; and we drew up schematics for an adder and a subtracter (RADIO-ELECTRONICS, June 1951, page 39).

The basic components which are required for an electronic brain have been

* Author: *Giant Brains*, John Wiley & Sons, Inc.

labeled as we have indicated in the table below:

Symbol	Name
A	an AND circuit, or gate
O	an OR circuit, or buffer
E	an EXCEPT circuit, or inhibitory gate
nP	a delay line, delaying pulses for n pulse times
F-F	an electronic switch, or flip-flop

Now let us see how we can use these

components to design an electronic multiplier, which can multiply two binary numbers together and give the product.

A circuit which will multiply is shown in Fig. 1. It contains 17 components, which are connected by lines bearing arrows, along which pulses travel in one direction. This circuit has seven input lines, numbered terminal 1 to terminal 7, and one output line, num-

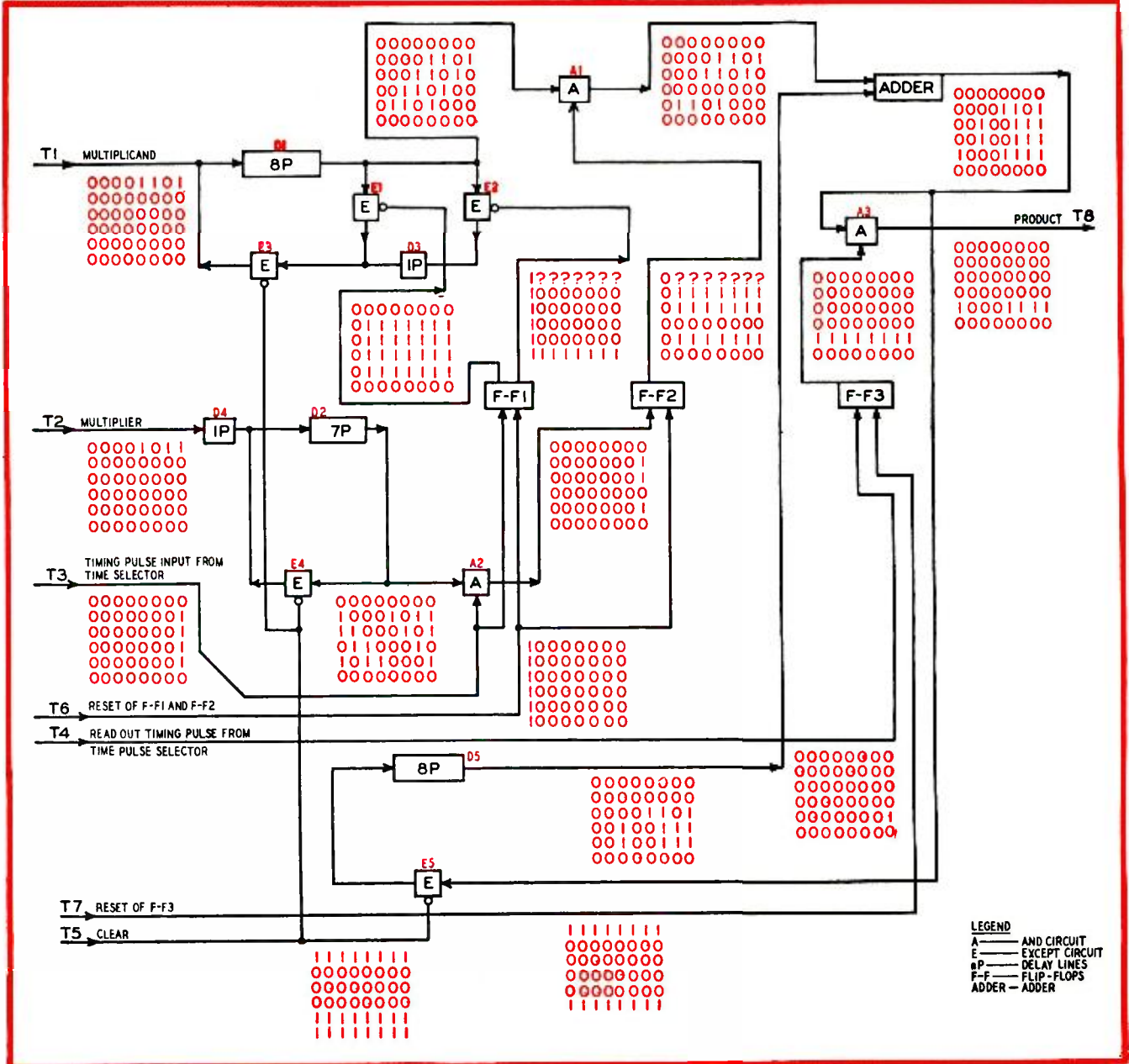
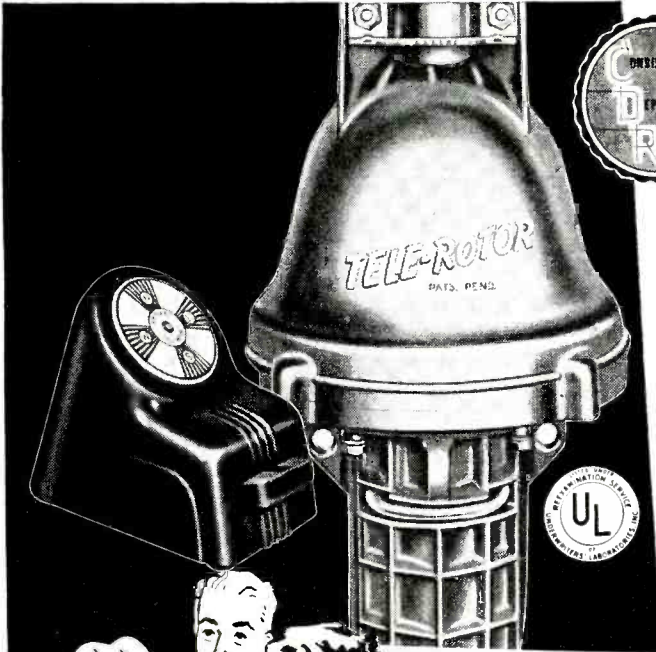

Fig. 1—This multiplier circuit has 17 components. There are 7 input lines and 1 output line where the product appears.



TELE-ROTOR

This heavy-duty TELE-ROTOR has no match! It's more powerful... will turn any TV antenna array under any weather conditions. Easily installed... it is trouble-free in performance. Easiest of all to operate!

MODEL TR-2... rotator with "compass control" cabinet having illuminated "perfect pattern" dial... (uses 8 wire cable)..... \$49.95



You Can't Beat A

TELE-ROTOR CUB

The new TELE-ROTOR "CUB" is ideal for average installations. The same husky motor as the Heavy-Duty model... the "CUB" is the fastest and easiest of all rotators to install. All-In-Line design... with true in-line thrust between antenna and mast. The 3/4" STEEL shaft rotates on a case hardened steel ball... with in-line reamed oilless bearings.

MODEL 502A..... Rotator with plastic control cabinet having indicating meter for "hairline" tuning. (Uses 5 wire cable)..... \$44.95

MODEL 501A..... rotator with control cabinet having end-of-rotation signal. Light flashes every 7.2° showing antenna is turning. (Uses 5 wire cable)..... \$34.95

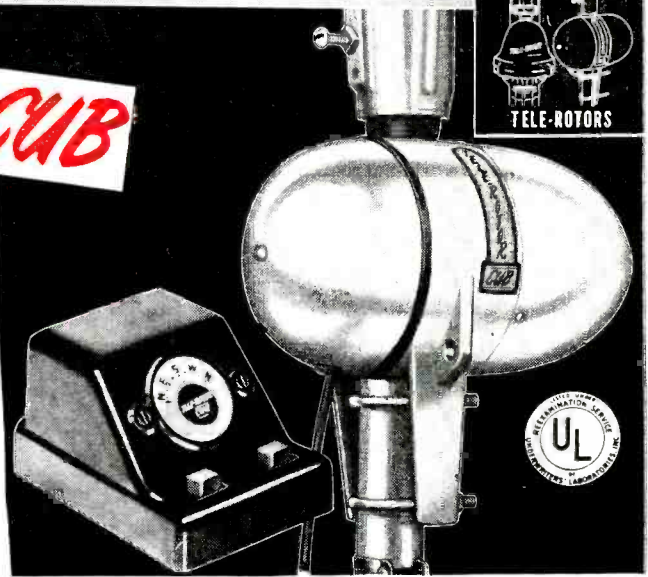

THE RADIART CORPORATION CLEVELAND 2, OHIO

CORNELL-DUBILIER SOUTH PLAINFIELD, N. J.



bered terminal 8. The result of the multiplication, the product, comes out on the output line, and the two factors of the multiplication, the multiplicand and the multiplier, come in on lines T1 and T2.

All information travels through this circuit in pulses serially along one line, and so the scheme of the circuit could operate for binary numbers as large as 50 or 100 digits, just by altering the length of the delay lines. To explain the circuit operation, we shall assume that we are going to multiply two four-digit binary numbers. We shall multiply binary number 1101 (one-one-oh-one, or one eight plus one four plus no two's plus one one, or thirteen) by the binary number 1011 (one-oh-one-one, or one eight plus no four's plus one two plus one one, or eleven). The answer will be 10001111 (the sum of 128, 8, 4, 2, and 1, or 143, which of course equals 13 times 11). Since the answer will be eight binary digits long it is convenient to specify that the multiplier circuit operates in six machine cycles, each handling eight pulses corresponding to eight binary digits. The reason for eight pulses is obvious; that for six cycles will appear later.

This example of multiplication, by the way, is the same example worked out with relays that was discussed in the December, 1950, article of this series, Part III. The comparison of the multiplication there using relays and the multiplication here using electronic tubes is instructive, if any reader cares to look it up.

In the first cycle, the multiplicand 1101, in the form of a series of eight pulses, or a binary number, 00001101, enters along line T1. The number shows the timing of these pulses represented in order from right to left, the earliest pulse being at the right.

Note well that on any line where the direction arrow points to the right, a regular binary number will represent pulses in the proper time sequence. We have avoided writing binary numbers, or series of pulses, on lines directed to the left because the sequence of pulses and the regular way of writing digits in the number would be opposite. For later cycles, we write the binary numbers of eight digits one under another. This helps to see without difficulty the pattern of as many as 40 or 48 consecutive pulses.

The series of eight multiplicand pulses go into the 8-pulse-time delay line D1, and they will accordingly issue in cycle 2 as 00001101, and apply for admission at the door of AND circuit A1, EXCEPT circuit E1, and EXCEPT circuit E2.

FLIP-FLOP F-F1 controls admission to the EXCEPT circuits E1 and E2. Because of the pattern of reset pulses (see later discussion) coming to this flip-flop, the EXCEPT circuit E1 is inhibited, while E2 is not inhibited. Consequently, the pulses go through E2, and through the one pulse-time delay line D3, through the noninhibited EXCEPT circuit E3, and round the loop through D1 again. As a

result, the multiplicand is shifted, to the left one digit and the output from the delay line D1 of the numbers applying for admission to the AND circuit A1 is therefore as follows:

Cycle	Number
1	00000000
2	00001101
3	00011010
4	00110100
5	01101000
6	00000000

In the first cycle also, the multiplier 1011 enters as a series of pulses 0000-1011 into the one pulse-time delay line D4 and the seven pulse-time delay line D2, and goes round the loop through delay line D2 in such a way that there issues from the loop the following numbers:

Cycle	Number
1	00000000
2	10001011
3	01100010
4	11000101
5	10110000
6	00000000

The first digit is carried around to the eighth digit's place by D2 and E4 in each cycle. Because the delay line is only 7 pulses long it advances the pulses one step. In cycle 3, for instance, we no longer have the number 1011 at the right-hand side, but 101, the other one having been attached to the end (left side) of cycle 2, where it replaces the zero that would otherwise be there. The first digit in any one of these numbers, in the sequence in which they pass through the circuits, is at the right, and the last one at the left. This follows our regular practice in adding or multiplying on paper, but not in writing down figures. These numbers now continue and apply for admission at the door of AND circuit A2.

The other line going into AND circuit A2 is line T3, called "timing-pulse input from time-pulse selector," and the pulses (or numbers) that come in on this line are as follows:

Cycle	Number
1	00000000
2	00000001
3	00000001
4	00000001
5	00000001
6	00000000

These are standard pulses and would accordingly apply for any four-digit multiplier.

Their purpose is, we shall see later, to allow a single digit of the multiplier to go through the AND circuit, and the timing is such that just the proper digit of the multiplier is allowed to go through the AND circuit.

Now an AND circuit performs the operation of "both," i.e., logical multiplication, operating digit by digit, pulse by pulse. Consequently, the numbers that issue from the AND circuit are the logical product, according to the following very simple table, of the numbers coming in:

	0	1
0	0	0
1	0	1

So the numbers (or pulse series) coming out of AND circuit A2 are now:

Cycle	Number
1	00000000
2	00000001
3	00000001
4	00000000
5	00000001
6	00000000

The output of AND circuit A2 leads to the "set" side or left side of FLIP-FLOP 2. The "reset" side or right side of FLIP-FLOP 2 receives a series of reset pulses (see later discussion) as follows:

Cycle	Number
1	10000000
2	10000000
3	10000000
4	10000000
5	10000000
6	10000000

These are the two inputs of the flip-flop. So what comes out?

A flip-flop conducts on one side and not on the other side, depending on the last pulse that has come in on either side. Specifically:

Input:		Output:	
Last Pulse Received on		Conducting on	
Left Side	Right Side	Left Side	Right Side
1	0	1	0
0	1	0	1

The operation of a flip-flop is ambiguous, not defined, if the last pulse comes in simultaneously on both left and right sides. So before any inputs are acceptable to a flip-flop there must be no cases of 1 and 1 occurring at the same time.

Applying this rule we can calculate the output of FLIP-FLOP 2 as follows:

Cycle	Input		Output	
	Left Side	Right Side	Left Side	Right Side
1	00000000	10000000	0???????	1???????
2	00000001	10000000	01111111	10000000
3	00000000	10000000	01111111	10000000
4	00000001	10000000	00000000	11111111
5	00000001	10000000	01111111	10000000
6	00000000	10000000	00000000	11111111

Wherever we see a zero on one side of the flip-flop output, we must see a one on the other side. This is merely equivalent to saying that one side or the other, but not both sides, of the circuit are conducting at any given time.

We may note that the output of the right side of FLIP-FLOP 2 is not used in this circuit, but is available and might be useful somewhere else in the computer. The output of the left side, however, goes to AND circuit A1 and is there very useful. The flock of 1's on cycles 2, 3, and 5 allows the shifted multiplicand to go through A1 in the case of the first, second, and fourth multiple, and this is precisely what we want. Furthermore, the fourth multiple of the multiplicand will never be more than 7 digits, and so the change of the flip-flop at time 8 in each cycle does not interfere with the multiples of the multiplicand.

ADDER at cycle 2 takes in the first multiple of the multiplicand, adds it to 0 coming in on the other line, and passes it around the loop through the noninhibitory EXCEPT circuit E5 to the partial sum register, the 8 pulse-time delay line D5. One cycle later this first multiple comes out, going to the adder. But now it is matched in time (cycle 3) with the second multiple, and the adder produces the sum of the two of them, and

Rauland Now Offers The First
**LOW FOCUS VOLTAGE
 ELECTROSTATIC TUBE**

Rauland's new low potential electrostatic-focus picture tube is not just a "defense period" substitute but a permanent and major advance in television cathode ray tube development

FOCUSES with D.C. voltage already available from the receiver's power supply.

ELIMINATES focusing coils and magnets—saves critically scarce copper and cobalt.

REQUIRES NO re-engineering of present television chassis . . . **NO** added high voltage focus circuit . . . **NO** added receiver tubes—**NO** additional components except an inexpensive potentiometer.

BETTER in all ways! Not only saves materials but also gives an actual improvement in picture quality because the over-all focus is better . . . and because it is completely stable in focus under considerable variations in voltage.

This new Rauland development is now available in substantial quantities in 17 and 20 inch rectangular tubes. For further information, address...

THE RAULAND CORPORATION



Perfection Through Research

4245 N. KNOX AVENUE • CHICAGO 41, ILLINOIS



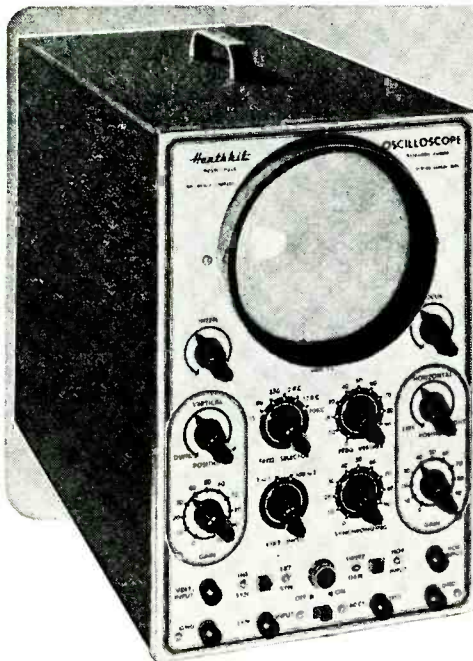

Heathkit MODEL 0-6... PUSH-PULL... 5" OSCILLOSCOPE KIT

The new Heathkit 5" Push-Pull Oscilloscope Kit is again the best buy. No other kit offers half the features—check them. Measure either AC or DC on this new scope—the first oscilloscope under \$100.00 with a DC amplifier.

The vertical amplifier has frequency compensated step attenuator input into a cathode follower stage. The gain control is of the non frequency discriminating type—accurate response at any setting. A push-pull pentode stage feeds the CR tube. New type positioning control has wide range for observing any portion of the trace. The horizontal amplifiers are direct coupled to the CR tube and may be used as either AC or DC amplifiers. Separate binding posts are provided for AC or DC. The multivibrator type sweep generator has new frequency compensation for the wide range it covers: 15 cycles to over 100,000 cycles.

The new model 0-6 scope uses 10 tubes in all, including 5" CR tube. Has improved amplifiers for better response useful to 2 megacycles. Tremendous sensitivity .04V RMS per inch horizontal—.09V RMS per inch vertical. Only Heathkit Scopes have all the features.

New husky heavy duty power transformer has 50% more laminations. It runs cool and has the lowest possible magnetic field. A complete electrostatic shield covers primary and other necessary windings and has lead brought out for proper grounding.

The new filter condenser has separate sections for the vertical and horizontal screen grids and prevents interaction between them. An improved intensity circuit provides almost double previous brilliance and better intensity modulation.

A new synchronization circuit allows the trace to be synchronized with either the positive or negative pulse, an important feature in observing the complex pulses encountered in television servicing.

Model 0-6..... Shipping Wt. 24 lbs.

\$3950

The kit is complete: all tubes, cabinet, transformer, controls, grid screen, tube shield, etc. The instruction manual has complete step-by-step assembly and pictorials of every section. Compare it with all others and you will buy a Heathkit.

NEW INEXPENSIVE Heathkit ELECTRONIC SWITCH KIT

The companion piece to a scope—Feed two different signals into the switch, connect its output to a scope, and you can observe both signals—each as an individual trace. Gain of each input is easily set (gain A and gain B controls), the switching frequency is simple to adjust (coarse and fine frequency controls) and the traces can be superimposed for comparison or separated for individual study (position control).

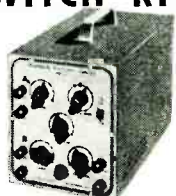

Model 5-2 Shipping Wt. 11 lbs.

\$1950

Use the switch to see distortion, phase shift, clipping due to improper bias, both the input and output traces of an amplifier,— as a square wave generator over limited range.

The kit is complete; all tubes, switches, cabinet, power transformer and all other parts, plus a clear detailed construction manual.

New MODEL V-4 A

Heathkit VTVM KIT

The new Heathkit Model V-4A VTVM Kit measures up to 30,000 Volts DC and 250 megacycles when used with accessory probes—think of it, all in one electronic instrument more useful than ever before. The AC Voltmeter is so far and extended in its response (± 1 db from 20 cycles to 2 megacycles) that it eliminates the need for separate expensive AC VTVMs.

The new 200 microampere, $4\frac{1}{2}$ " streamline meter with quality Simpson movement (five times as sensitive as the commonly used 1 MA meter) has a shatter proof plastic meter face for maximum protection. Meter has all the desirable scales and indicates AC volts, DC volts, ohms, db (direct reading), and even has a special zero center marking for quick FM alignment.

There are six complete ranges for each function. Four functions give total of 24 ranges. The 5 volt range allows $33\frac{1}{3}\%$ of the scale for reading 1 volt, as against only 20% of the scale on the 5 volt types.

New $\frac{1}{2}\%$ ceramic precision resistors are the most accurate commercial type available—you find the same make and quality in the finest laboratory equipment selling for thousands of dollars. The entire voltage divider decade uses these $\frac{1}{2}\%$ resistors.

Both AC and DC voltmeter measurements use a push-pull electronic voltmeter circuit, and the meter circuit makes the meter burn-out proof. Electronic ohmmeter circuit measures resistance over the amazing range of 1/10 ohm to one billion ohms, all with internal 3 volt battery. Ohmmeter batteries mount on the chassis in snap-in mounting for easy replacement.

Voltage ranges are full scale—3 Volts, 10 Volts, 30 Volts, 100 Volts, 300 Volts, 1000 Volts. Complete decoding coverage without gaps.

The DC probe is isolated for dynamic measurements. Negligible circuit loading. Gets the accurate reading without disturbing the operation of the equipment under test. Kit comes complete: cabinet, transformer, Simpson meter, test leads, complete assembly and instruction manual.

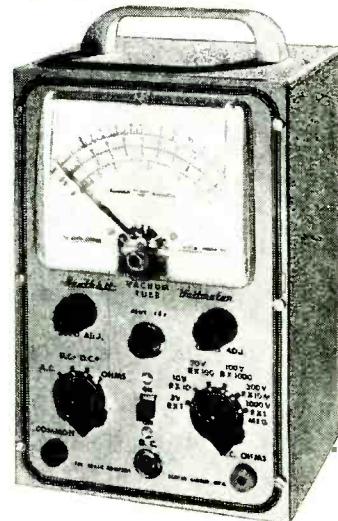

Model V-4A... Shipping Wt. 8 lbs.

Note New Low Price

\$2350



Heathkit 30,000V DC PROBE KIT

A new 30,000 V DC Probe Kit to handle high voltages with safety. For TV service work and all other high voltage applications. Sleek looking—Two color molded plastic—Red body and guard—jet black handle. Comes with connector, cable, and PL55 type plug. Plugs into Heathkit VTVM so that 300V scale is conveniently multiplied by 100. Can be used with any standard 11 megohm VTVM.

\$550

No. 336 High Voltage Probe Kit.....Shipping Wt. 2 lbs.

Heathkit RF PROBE KIT

This RF Probe Kit comes complete with probe housing, crystal diode detector, connector, lead and plug and all other parts plus clear assembly instructions. Extends range of Heathkit VTVM to 250 Mc. $\pm 10\%$. Works on any 11 megohm input VTVM. Specify No. 309 RF Probe Kit.



Shipping Wt. 1 lb. \$550

EXPORT AGENT
ROCKE INTERNATIONAL CORP.
12 E. 40th ST.
NEW YORK CITY (16)
CABLE ARLAS N.Y.

The HEATH COMPANY

... BENTON HARBOR 20, MICHIGAN

NEW Heathkit TV ALIGNMENT GENERATOR KIT

Here is an excellent TV Alignment Generator designed to do TV service work quickly, easily, and properly. The model TS-2 when used in conjunction with an oscilloscope provides a means of correctly aligning television receivers.

The instrument provides a frequency modulated signal covering, in two bands, the range of 10 to 90 Mc. and 150 to 230 Mc.—thus, ALL ALLOCATED TV CHANNELS AS WELL AS IF FREQUENCIES ARE COVERED.

An absorption type frequency marker covers from 20 to 75 Mc. in two ranges—therefore, you have a simple, convenient means of frequency checking of IF's, independent of oscillator calibration.

Sweep width is controlled from the front panel and covers a sweep deviation of 0-12 Mc.—all the sweep you could possibly need or want.

And still other excellent features are: Horizontal sweep voltage available at the front panel (and controlled with a phasing control)—both step and continuously variable attenuation for setting the output signal to the desired level—a convenient instrument stand-by position—vernier drive of both oscillator and marker tuning condensers—and blanking for establishing a single trace with base reference level. Make your work easier, save time, and repair with confidence—order your Heathkit TV Alignment Generator now!

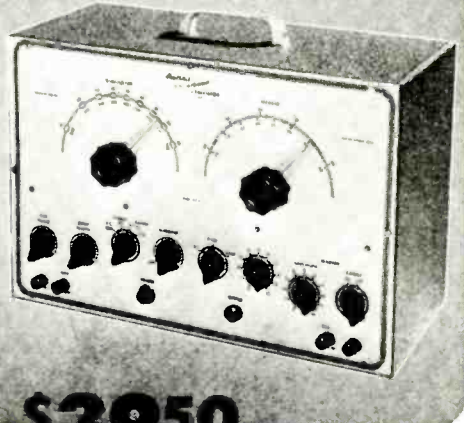

\$3950

Model TS-2
Shipping Wt.20 lbs.

Heathkit SIGNAL GENERATOR KIT

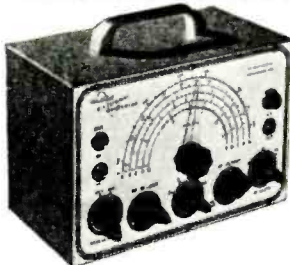

Model SG-6
Shipping Wt.
7 lbs.

\$1950

The new Heathkit Signal Generator Kit has dozens of improvements. Covers the extended range of 160 Kc to 50 megacycles on fundamentals and up to 150 megacycles on useful calibrated harmonics; makes this Heathkit ideal as a marker oscillator for TV. Output level can be conveniently set by means of both step attenuator and continuously variable output controls. Instrument has new miniature HF tubes to easily handle the high frequencies covered.

Uses 6CA master oscillator and 6CA sine wave audio oscillator. The kit is transformer operated and a husky selenium rectifier is used in the power supply. All coils are precision wound and checked for calibration making only one adjustment necessary for all bands.

New sine wave audio oscillator provides internal modulation and is also available for external audio testing. Switch provided allows the oscillator to be modulated by an external audio oscillator for fidelity testing of receivers. Comes complete, all tubes, cabinet, test leads, every part. The instruction manual has step-by-step instructions and pictorials. It's easy and fun to build a Heathkit Model SG-6 Signal Generator.

Heathkit SIGNAL TRACER and UNIVERSAL TEST SPEAKER KIT



Model T-2
Shipping Wt.7 lbs.

\$1950

The popular Heathkit Signal Tracer has now been combined with a universal test speaker at no increase in price. The same high quality tracer follows signal from antenna to speaker—locates intermittents—finds defective parts quicker—saves valuable service time—gives greater income per service hour. Works equally well on broadcast, FM, or TV receivers. The test speaker has an assortment of switching ranges to match either push-pull or single output impedances. Also tests microphones, pickups and PA systems. Comes complete: cabinet, 110V 60 cycle power transformer, tubes, test probe, all necessary parts, and detailed instructions for assembly and use.

Heathkit TUBE CHECKER KIT

Test your tubes the modern way—dynamically—the simplest, yet fastest and surest method—your Heathkit has a switch for each tube element and measures that element—no chance for open or shorted elements slipping by, all the advantages of the mutual conductance type without the slow cumbersome time consuming setups. Checks for opens, shorts, each element individually, filament and filament tap continuity, and emission.

This Tube Checker has all the features—beautiful 3 color BAD-?-GOOD meter—complete selection of voltages—roller chart listing hundreds of tubes including the new 9 pin miniatures—finest quality Centralab lever switches—high grade birch, counter-type cabinet—continuously variable line adjust control—every feature you need to sell tubes properly. The most modern type tube checker with complete protection against obsolescence. Uses only the best of parts—rugged oversize 110V 60 cycle power transformer, finest of Mallory and Centralab switches and controls, complete set of sockets for all type tubes with blank spare for future types. Fast action, gear driven roller chart quickly locates the setting for any type tube. Simplified switching cuts necessary testing time to a minimum and saves valuable service time. Simple method allows instant setup of new tube types without waiting for factory data. No matter what the arrangement of tube elements is, the Heathkit flexible switching method easily handles it. Order your Heathkit Tube Checker Kit today and see for yourself that Heath again saves you two-thirds and yet retains all the quality. Complete with instructions, all parts, and cabinet.

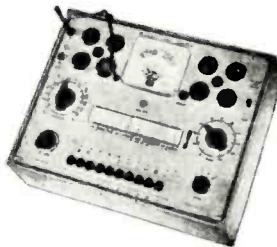

Model TC-1
Shipping Wt.
12 lbs.

\$2950

Heathkit CONDENSER CHECKER KIT



\$1950

Model C-2
Shipping Wt. 6 lbs.

Checks all types of condensers—paper, mica, ceramic, electrolytic. All condenser scales are direct reading and require no charts or multipliers. Covers range of .00001 MFD to 1000 MFD. A Condenser Checker that anyone can read. A leakage test and polarizing voltage for 20 to 500 V provided. Measures power factor of electrolytics between 0% and 50% and reads resistance from 100 ohms to 5 megohms. The magic eye indicator makes testing easy.

The kit is 110V 60 cycle transformer operated and comes complete with rectifier tube, magic eye tube, cabinet, calibrated panel and all other parts. Has clear detailed instructions for assembly and use.

NEW Heathkit HANDITESTER KIT



A precision portable volt-ohm-milliammeter. Uses only high quality parts—All precision 1/2% resistors, three deck switch for trouble-free mounting of parts, specially designed battery mounting bracket, smooth acting ohm adjust control, beautiful molded bakelite case, 400 microamp meter movement, etc.

DC and AC voltage ranges 10-30-300-1000-5000V. Ohms range 0-3000 and 0-300 000 Range Milliampers 0.10 Ma, 0-100 Ma. Easily assembled from complete instructions and pictorial diagrams.

\$1350

Model M-1
Shipping Wt. 3 lbs.

REPORT AGENT
ROCKE INTERNATIONAL CORP.
12 E. 40th ST.
NEW YORK CITY 16
ABIE 48148-N.Y.

The HEATH COMPANY

... BENTON HARBOR 20, MICHIGAN

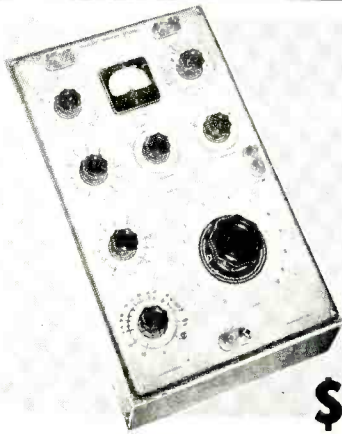

NEW *Heathkit* IMPEDANCE BRIDGE KIT

This Impedance Bridge Kit is really a favorite with schools, industrial laboratories, and serious experimenters. An invaluable instrument for those doing electrical measurements work. Reads resistance from .01 Ohms to 10 megohms, capacitance from .00001 MFD to 100 MFD, inductance from 10 microhenries to 100 henries, dissipation factor from .002 to 1, and storage factor from 1 to 1000. And you don't have to worry about selecting the proper bridge circuit for the various measurements—the instrument automatically makes the correct circuit when you set up for taking the measurement you want. Bridge utilizes Whearstone, Hay, Maxwell, and capacitance comparison circuits for the wide range and types of measurements possible. And it's self powered—has internal battery and General Radio 1000 cycle hummer. No external generator required—has provisions for external generator if measurements at other than 1000 cycles are desired.

\$6950

Model IB-1B Shipping Wt. 15 lbs.

Kit utilizes only highest quality parts. General Radio main calibrated control, General Radio hummer, Mallory ceramic switches, excellent 200 microamp zero center galvanometer, laboratory type binding posts with standard 3/4 inch centers, 1/2% precision ceramic-body type multiplier resistors, beautiful birch cabinet and really calibrated panel. (Headphones not included.)
Take the guesswork out of electrical measurements—order your Heathkit Impedance Bridge Kit today—you'll like it.

Heathkit LABORATORY RESISTANCE DECADE KIT

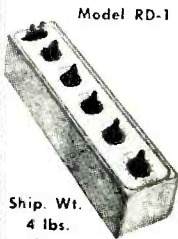

Model RD-1
An indispensable piece of laboratory equipment—the Heathkit Resistance Decade Kit gives you resistance settings from 1 to 99,999 ohms IN ONE OHM STEPS. For greatest accuracy, 1/2% precision ceramic-body type resistors and highest quality ceramic wafer switches are used.

Ship. Wt. 4 lbs.

\$1950

Designed to match the impedance bridge above, the Resistance Decade Kit has a beautiful birch cabinet and attractive panel. It's easy to build, and comes complete with all parts and construction manual.

NEW *Heathkit* SINE and SQUARE WAVE AUDIO GENERATOR KIT

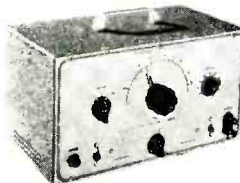

Model AG-7
Ship. Wt. 15 lbs.

\$3450

We proudly present the NEW MODEL Sine and Square Wave Audio Generator Kit. Designed with versatility, usefulness, and dependability in mind, the AG-7 gives you the two most needed waveshapes right at your fingertips—the sine wave and the square wave.

The range switch and plainly calibrated frequency scale give rapid and easy frequency selection, and the output control permits setting the output to any desired level.

A high-low impedance switch sets the instrument for either high or low impedance output—on high to connect to high impedance load, and on low to work into a low impedance transformer with negligible DC resistance.

Coverage is from 20 to 20,000 cycles, and distortion is at a minimum—you can readily trust the output waveshape.

6 tubes, quality 4 gang tuning condenser, power transformer, metal cased filter condenser, 1/2% precision resistors in the frequency determining circuit, and all other parts come with the kit—plus, a complete construction manual. A tremendous kit, and the price is truly low.



**MAIL TO THE
HEATH COMPANY
BENTON HARBOR 20,
MICHIGAN**

ORDER BLANK

From _____

- SHIP VIA
- Parcel Post
 - Express
 - Freight
 - Best Way

Quantity	Item	Price	Quantity	Item	Price
	Heathkit Oscilloscope Kit — Model O-6			Heathkit R.F. Probe Kit — No. 309	
	Heathkit VTVM Kit — Model V-4A			Heathkit H.V. Probe Kit — No. 336	
	Heathkit FM Tuner Kit — FM-2			Heathkit R.F. Signal Gen. Kit — Model SG-6	
	Heathkit Broadcast Receiver Kit — Model BR-1			Heathkit Condenser Checker Kit — Model C-2	
	Heathkit Three Band Receiver Kit - Model AR-1			Heathkit Handitester Kit — Model M-1	
	Heathkit Amplifier Kit — Model A-4			Heathkit Power Supply Kit — Model PS-1	
	Heathkit Amplifier Kit — Model A-6 (or A-6A)			Heathkit Resistance Decode Kit — Model RD-1	
	Heathkit Tube Checker Kit — Model TC-1			Heathkit Impedance Bridge Kit — Model IB-1B	
	Heathkit Audio Generator Kit — Model AG-7				
	Heathkit Battery Eliminator Kit — Model BE-2				
	Heathkit Electronic Switch Kit — Model S-2				
	Heathkit T.V. Alignment Gen. Kit — TS-2				
	Heathkit Signal Tracer Kit — Model T-2				

On Parcel Post Orders, include postage for weight shown and insurance. (We insure all shipments.)

On Express Orders, do not include transportation charges—they will be collected by the Express Agency at time of delivery.

Enclosed find Check Money Order for _____

Please ship C.O.D. Postage enclosed for _____ lbs.

ALL PRICES SUBJECT TO CHANGE WITHOUT NOTICE

EXPORT AGENT
ROCKE INTERNATIONAL CORP.
12 E. 40th ST.
NEW YORK CITY (16)
CABLE: ARLAN N.Y.

The HEATH COMPANY

... BENTON HARBOR 20, MICHIGAN

RADIO-ELECTRONICS for

sends that around the loop to the partial-sum register again. In this way, the multiplication proceeds by successive addition of selected shifted multiples, and a breakdown of the problem will then appear as follows:

Multiplication	Partial Sum at Cycle
1101	
× 1011	

1101	2
+ 1101	

= 100111	3
+ 0000	

= 100111	4
+ 1101	

= 10001111	5

We must now get the final answer 10001111 out of the circuit into some other part of the machine where we can make use of it. We use FLIP-FLOP 3, operating it with a "readout timing pulse from the time selector" on the left side as follows:

Cycle	Number
1	00000000
2	00000000
3	00000000
4	00000000
5	00000001
6	00000000

together with a reset pulse on the right side of the flip-flop will then be as follows:

Cycle	Number
1	11111111
2	00000000
3	00000000
4	00000000
5	00000000
6	11111111

Here is where—and why—we need a cycle 6 in the multiplier circuit: to be certain that no stray pulses come out on the output line after we have received the product. The output of FLIP-FLOP 3 accordingly will then appear as follows:

Cycle	Number
1	00000000
2	00000000
3	00000000
4	00000000
5	11111111
6	00000000

This is the input on one side of the AND circuit 3. The other input coming from the adder is:

Cycle	Number
1	00000000
2	00001101
3	00100111
4	00100111
5	10001111
6	00000000

and as a result it may be seen the output is:

Cycle	Number
1	00000000
2	00000000
3	00000000
4	00000000
5	10001111
6	00000000

In order to clear the multiplicand, the multiplier, and the partial-sum registers, the EXCEPT circuits 3, 4, and 5 are used. The input to all of them comes in on line T5, and is in the usual listing,

"PENN can shout from more rooftops than any other Tower Maker"

Product Development Engineering Made PENN the Best Seller

The roofs of America "sprout" more towers by Penn than by any other manufacturer. The reason? Penn's constant product development engineering which has produced the following:

- (1) The Teletower itself
- (2) the Thrifttower
- (3) the Tenna-Mast Hardware Line
- (4) the adjustable roof mount
- (5) the universal motor mount
- (6) the built-in base
- (7) Penn's new self-supporting tower that carries two hundred fifty pounds head load without guying.

STAY TUNED IN . . . WITH TELETOWERS!

PENN Teletowers Thriftowers Tenna-Mast Hardware

PENN BOILER & BURNER MFG. CORP., LANCASTER, PA.



- Gives full cross-reference listing of exact and duplicate replacements
- Tells when to replace—and what tests to make
- Tells how compliance, tracking pressure, weight affect reproduction and record wear
- Explains old-style and modern cartridge differences—illustrates finger-tip compliance test
- Gives best model for each type of installation
- Reveals how to make cartridge replacement sales . . . how to give your customers more record enjoyment

**It's More than a Chart . . .
it's Today's Most Complete
and Helpful Replacement Guide!**

● Use this Chart to get your share of the \$70,000,000 replacement market. It gives you exact replacements for the many thousands of E-V cartridges used in original equipment of leading manufacturers. It gives you the models that replace most cartridges listed in PHOTOFACT Folders. It tells you what to use for replacements in RCA, Columbia, Admiral, Motorola, Sears, and most other players.

**You Can Make Most Cartridge
Replacements with Fewer E-V Models!**

Electro-Voice

421 CARROLL STREET • BUCHANAN, MICHIGAN
Export: 13 E. 40th St., N.Y. 16, N.Y., U.S.A. Cables: Arlab
PHONO PICKUPS • MICROPHONES • HI-FI SPEAKERS • TV BOOSTERS

Electro-Voice, Inc., Dept. E7-1
421 Carroll St., Buchanan, Michigan
Send FREE Cartridge Replacement Chart.

Name.....
Address.....
City.....Zone.....State.....

- Service-Technician Dealer Record Fan

**Send for
your FREE
Replacement
Chart today**

as follows, and after this the multiplier, the multiplier and partial-sum registers are ready for new signals.

Cycle	Number
1	11111111
2	00000000
3	00000000
4	00000000
5	11111111
6	11111111

In the same way, to reset the flip-flops, the input of standard pulses from the time-pulse selector is as follows:

Cycle	Flip-Flop 1 and 2	Flip-Flop 3
1	10000000	11111111
2	00000000	00000000
3	10000000	00000000
4	10000000	00000000
5	10000000	00000000
6	10000000	11111111

The circuit is, of course, a block diagram. To convert it into working hardware, a good deal of attention will have to be given to the shape of pulses, the precise detailed timing of them, microsecond delays due to the length of cables along which they are traveling, etc. Descriptions or circuits of the components inside the blocks were given last month.

It should be emphasized once more that there are many ways in which the circuit can be improved, or otherwise designed. Some improvements will doubtless occur to readers of this article.

For example, F-F1, E1, and E2 can be avoided if we give up optional storage of the multiplicand unchanged in register D1; that is, if we make sure that the multiplicand and the multiplier do come in simultaneously to the multiplying circuit. Actually, in a serial computer it will be more convenient to have the multiplicand come in at one time and wait in the multiplicand register until the multiplier is ready and comes in at a later time. The circuit in Fig. 1 has provided for this second more convenient scheme.

Acknowledgment is made to Henry W. Schrimpf for many of the features of the multiplying circuit in this article.

Division

If we replace the adder by a subtractor, and put in some kind of circuit for comparing the divisor with the partial remainder from successive subtraction, and in still other ways modify the circuit of Fig. 1 so that we can use the method of dividing that was illustrated in Part IV (January, 1951) of this series for a relay computer, then we can design a division circuit for binary numbers.

But divisions do not occur as often as multiplications. Studies made some time ago in the Harvard Computation Laboratory indicated that a division occurred once for about every fourteen multiplications. So why spend money on equipment for division, which you may use less than 8% of the time, if we can get division some other way?

You can get the result of dividing the number M by the number K if you multiply M by the reciprocal of K, which is 1/K. And you can get the reciprocal 1/K by a process using multiplication. First, find some kind of reasonable first

approximation X_n ; second, use the following formula over and over:

$$X_n = X_{n-1} \times (2 - KX_{n-1}).$$

It can be shown that a reasonable first approximation X_1 is any number between 0 and $2/K$.

For example, suppose that we want to find $1/3$, which we know is equal to .33333 to five decimals, and suppose that we start off with a guessed first approximation .5. Then:

$$\begin{aligned} X_1 &= .5 \text{ (guess)} \\ X_2 &= .5 [2 - 3(.5)] = .25 \\ X_3 &= .25 [2 - 3(.25)] = .3125 \\ X_4 &= .3125 [2 - 3(.3125)] = .33203 \\ X_5 &= .33203 [2 - 3(.33203)] = .33333 \end{aligned}$$

Thus we can get a fine result with just a few steps in multiplication. We can have our computer carry out division by programming our computer. We yield time; we save equipment. Over and over again this kind of compromise occurs in computer design. Division by successive multiplication, with special circuits for sensing good first approximations (which saved on the number of multiplications necessary), was the process built into the Harvard Mark II computer, now at the Naval Proving Ground, Dahlgren, Va.

This kind of scheme for use in automatic computers was first proposed, we believe, by Prof. Howard H. Aiken of Harvard.

(continued next month)

AUTOMATIC-FOCUS KINE

New picture tube with built-in-automatic focus has been announced by Du Mont. It eliminates the need for a focus coil, a focus control or other focusing methods used in magnetic and electrostatic kinescopes.

The new tube, the 17KP4, is an all-glass rectangular, magnetic-deflection, electrostatic-focus tube, with a gray-filter face plate and an external conductive coating. It is designed to work with an anode voltage of 16,000 and a maximum negative bias value of 125 volts.



"Left, I said! Wassamatter, aren't you tuned in?"

JULY, 1951

"CONICAL-V-BEAM"*

*Registered Trademark



"Just as Good"

- IS A FABLE!

Don't be 'sold' an imitation

BE BRAND CONSCIOUS — DEMAND a genuine TELREX for the ultimate in TV reception. Many imitations short cut and cheapen the product so that results are often disappointing.

The genuine TELREX "CONICAL-V-BEAM" is manufactured in 24 models—one to meet every TV reception problem, whether in a primary, secondary, fringe, or extreme fringe area.

The TELREX "CONICAL-V-BEAM" is the only antenna devised supplying FULL AUDIO and VIDEO BANDWIDTH and highest Signal to Noise Ratio!

The TELREX "CONICAL-V-BEAM" gives longer lasting customer satisfaction than any other antenna, irrespective of price.

Millions of installations all over the Americas' attest to the Telrex claim that NO OTHER antenna can perform as well as a "Conical-V-Beam."

Get a genuine TELREX "CONICAL-V-BEAM" —
SEE AND HEAR THE DIFFERENCE.

NEW VANGUARD

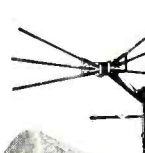

VU 2X-8
\$8.80
List

Four Low Cost Models
Write for Form V-2

DEALERS — SERVICEMEN —

"TELREX NEWS" can be mailed direct to your place of business. This timely service periodical contains the most authentic antenna technical data available. It's FREE — Write on your Company letterhead or post card with Company stamp.

"CONICAL-V-BEAMS" are produced under Re-issue Patent No. 23,346

THE SKILL TO DESIGN...
THE FACILITIES TO PRODUCE...
THE ABILITY TO DELIVER

Telrex INC.

CONICAL-V-BEAMS

AMERICA'S STANDARD OF COMPARISON

ASBURY PARK 9, NEW JERSEY

Over 43,000 Technicians Have Learned

HOW TO GET THE MOST OUT OF BASIC TEST EQUIPMENT

Why Not You, Too?

SERVICING by SIGNAL SUBSTITUTION

A BEST SELLER FOR OVER 9 YEARS! (NEW, UP-TO-DATE, 12TH EDITION)

The Simple, Modern, Dynamic Speed Approach To Receiver Adjustment and Alignment Problems, AM-FM-TV.

- Nothing complex to learn
- No extra equipment to purchase
- Universal — non-obsolete
- Employs Only Basic Test Equipment



only 40¢

100 pages. Invaluable information that will help you re-double the value of your basic test equipment.

Ask for "S.S.S." at your local Radio Parts Jobber or order direct from factory.

PRECISION APPARATUS COMPANY, INC. • 92-27 Horace Harding Blvd., Elmhurst 4, N. Y.

www.americanradiohistory.com

5-Tube Superhet Fits Pocket



**Featuring big set performance,
this subminiature receiver was
built with hearing aid methods**

By W. D. PENN

Photo of the little set. It uses five tubes for full coverage of AM band.

types under extreme conditions of temperature and humidity. Resistors are $\frac{1}{2}$ -watt units, $\frac{3}{32}$ inch in diameter and $\frac{3}{8}$ inch long.

Signal pickup is obtained directly from the r.f. input coil. Although there is some directive effect with this method of pickup, it is not nearly so sharp as with loop antennas. The input coil is tuned with an iron core mechanically connected to the tuning core of the oscillator coil. The plate load of the r.f. stage consists of an untuned choke coupled to the converter stage through an R-C network.

The only available subminiature converter tube, the type 2G21, has a B drain of 1.5 ma at $22\frac{1}{2}$ volts and an A drain of 50 ma at $1\frac{1}{4}$ volts. These drains are much too heavy for satisfactory battery life. Consequently, instead of using a standard converter circuit, a modified form of autodyne circuit is used with a single pentode tube used as both oscillator and mixer. The oscillator section consists of a tuned plate circuit which is coupled to a bifilar winding in the filament leads. The r.f. signal is fed to the control grid and the i.f. component is obtained by placing the i.f. coupling coil in the screen circuit.

Each i.f. coupling impedance is a single parallel-tuned circuit instead of the usual coupled-circuit type. The coil is placed in a powdered-iron cup which increases the inductance and shields the coil from other components. Moveable iron cores passing through the center of the cups tune these coils. For frequencies above the i.f. of 455 kc., the impedance of the parallel resonant i.f.

MIDGET radio receivers have always aroused a great deal of interest. Back issues of RADIO-ELECTRONICS reveal many ingenious receivers designed to be carried by the listener. However, to the author's knowledge, none of these has been a true *pocket* radio receiver and at the same time having such desirable features as the following:— Complete coverage of standard AM band with a calibrated single dial control; no external antenna; complete self-contained unit of light weight, batteries included, in one small case; long and economical battery life; and high-fidelity response.

Techniques and components originally developed for hearing aids, together with the use of powdered iron core tuned r.f. and i.f. circuits make all these features possible.

General design

The set is a five-tube superheterodyne, using a germanium diode second detector. All five tubes are Raytheon type CK522AX pentodes. These are low-drain filamentary type hearing-aid tubes which operate with a $1\frac{1}{4}$ -volt filament supply and a $22\frac{1}{2}$ -volt B supply. A single mercury cell such as a Mallory RMB-4 or

Sprague S16A is used for A-supply. Plate and screen voltages are provided by a $22\frac{1}{2}$ -volt hearing-aid B-battery such as Eveready No. 412-E or its equivalent.

Total filament current for the five tubes is 100 ma and total B-current is approximately 1.5 ma. With these current drains, the A-battery gives about 40 hours use and the B-battery lasts slightly longer. The total cost per hour of operation will average around 3 cents; a quite reasonable figure.

The set consists of one r.f. stage followed by a converter, two i.f. stages, a germanium diode second detector, and transformer-coupled a.f. amplifier. Fig. 1 shows the circuit. Iron-core tuning is used in both the r.f. and i.f. sections of the set for greatest compactness.

The input of the r.f. amplifier and the oscillator portion of the converter are tuned by a single slide-rule type dial which is calibrated from 550 to 1600 kc. The i.f. is 455 kc. A hearing-aid type potentiometer in the grid circuit of the a.f. amplifier is used for volume control and also includes the ON-OFF switch. A.v.c. is applied to the r.f. stage and the two i.f. stages.

All electrical components are of the subminiature type. Capacitors are of the "micro-size" variety, using ceramic dielectric to obtain minimum size for a given capacitance. In addition, ceramic capacitors are more reliable than paper

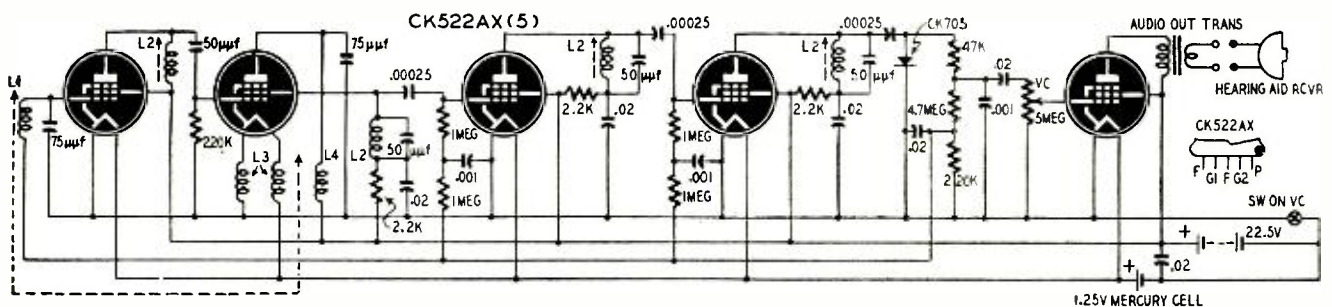

Fig. 1—Circuit of the receiver. It is a complete superheterodyne with a.v.c. and uses five subminiature pentode tubes.

coils is capacitive and bypasses the screen for r.f. signals. The r.f. coil L2 is also placed in a cup like that in which the i.f.'s are mounted.

The i.f. cans also hold the resistors and capacitors associated with them, thus tending to keep each stage in a shielded unit.

The output of the last i.f. stage is fed to a shunt-connected germanium diode detector of very small size such as Raytheon type CK705. The shunt type circuit is necessary to isolate the d.c. plate voltage from the detector. The diode second detector feeds a single a.f. stage which is transformer-coupled to a magnetic type hearing-aid earphone. The transformer for coupling the 50-ohm magnetic receiver to the output tube is wound on a core $\frac{3}{4} \times 1\frac{1}{2} \times \frac{5}{32}$ inches. The turns ratio is 5,000/100 so that the 50-ohm earphone appears as a plate load of approximately

$$\left(\frac{5,000}{100}\right)^2 \times 50 = 125,000 \text{ ohms}$$

Permeability tuning

The inductance of a coil due to the presence of an iron core is given by the equation:

$$L_c = L_w \left(\frac{a}{A} \right) (P-1) + 1$$

in which

- a=cross sectional area of iron core,
- A=cross sectional area of coil winding,
- P=effective permeability of iron core,
- L_w=inductance of coil without iron core,
- L_c=inductance of coil with iron core.

The effective permeability of the core is a function of the ratio of length to diameter of the core and is best expressed in graphical form. Fig. 2 is a set of curves showing the relation between the effective permeability of cylindrical iron cores and the permeability of the core material itself. These curves were prepared by W. J. Polydoroff, a pioneer worker in the field of permeability tuning. Each of these curves shows the effective permeability as a function of the permeability of the core material for various ratios of core length to diameter, L/D. If the coil and core are not the same length, an addi-

tional correction factor is necessary. The true effective permeability is then $P_t = P(L)^{1.3}$ in which L is the core length, and l is the coil length. This is the value of permeability to be used in the equation for L_c if the coil and core lengths are unequal.

To cover the AM band of 550 kc to 1600 kc requires a tuning range of $1600/550 = 2.91$.

Since the resonant frequency of a tuned circuit varies inversely as the square root of the inductance, a change in inductance of $(2.91)^2 = 8.5$ is required to tune from 550 kc. to 1600 kc. Using a core 0.875 inch long and 0.200 inch in diameter gives

$$L/D = \frac{.875}{.2} = 4.37.$$

With this ratio of L/D and a material with a permeability of 30, Fig. 2 shows that an effective permeability of 11 can be obtained, thus giving a tuning range of 3.32. For an i.f. of 455 kc., the oscillator must then tune from 1005 kc to 2281 kc, a range of 2.26. This corresponds to an inductance change of approximately 5.11. To make the oscillator and r.f. stages track with the same core movement, several schemes can be used. The oscillator coil can be wound differently in shape or size, the iron core can be made a different size or shape, or an oscillator core of different permeability may be used. The latter method is used in this set. For the same L/D ratio of 4.37 and an inductance change of 5.11, Fig. 2 shows that a core with a permeability of about 6 is needed.

Since it is hard to get iron cores of specified permeability or to check the permeability of available cores, it may be easiest to wind two identical coils to cover the broadcast band, on the best core material available. Then turn or file down the oscillator core, checking frequently with a signal generator, till you have the correct range as given above.

The r.f. tuning coil consists of 200 turns of No. 36 enamelled wire wound on thin-walled bakelite tubing $\frac{7}{8}$ inch long with an inside diameter of 0.200 inch. The oscillator coil is wound on a similar form. The plate winding has

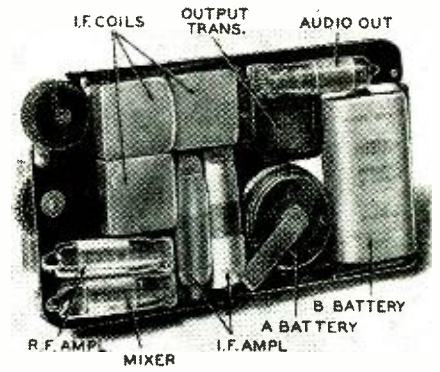
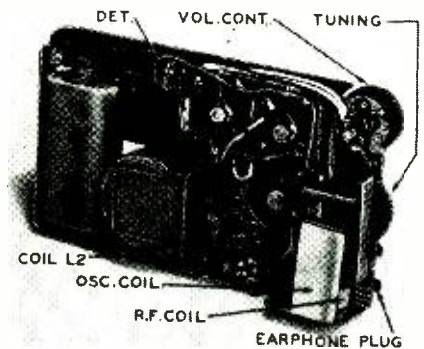

Photo of one side of the bakelite chassis showing how the tubes are mounted.



A view of the other side of the chassis which shows the slug tuning mechanism.

210 turns of No. 38 enamelled wire wound next to the bakelite form. To obtain optimum coupling between the plate and cathode windings, a cathode winding consisting of a bifilar winding of 200 turns of No. 36 enamelled wire is wound over the plate winding. The three i.f. coils and the coil in the plate circuit of the r.f. stage are alike and consist of 300 turns of No. 32 enamelled wire wound on a $\frac{3}{16}$ inch diameter form $\frac{1}{4}$ inch long.

Output and fidelity

The power output of the audio stage is about 1 milliwatt, which is sufficient to drive the receiver to a sound level of 120 db above the normal threshold of hearing. The tiny hearing-aid earphone is so small that it may be nestled in the ear without an eartip or other means of support. For the best sound quality, a hearing-aid type molded earpiece should be used.

Some may object to the use of a receiver instead of a loudspeaker as an output device. A loudspeaker, in addition to being much larger in size, would also require more driving power and therefore, larger batteries, thus removing the set from the true pocket-size class.

Actually, a personal pocket radio should not use a loudspeaker, even if it were possible to do so. The advantage of not having one is that you can listen to programs of your own choosing without disturbing others. This is a real advantage in crowded places such as stadiums, etc. In addition, it is possible to get better audio fidelity than can be obtained with even a large loudspeaker.

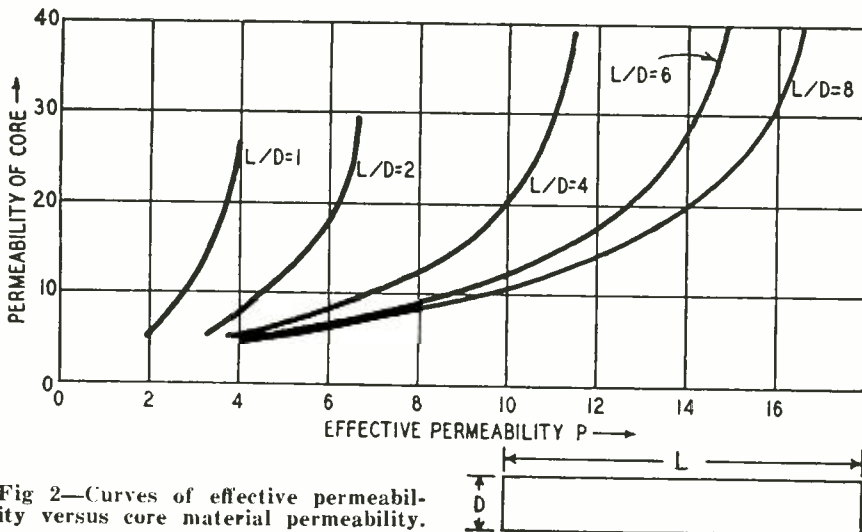

Fig 2—Curves of effective permeability versus core material permeability.



... **SERVICEMEN, AMATEURS,
TECHNICIANS SELECT—**

American Beauty SOLDERING IRONS

for
**TOP SOLDERING
PERFORMANCE!**

Outstanding performance coupled with durability of construction make American Beauty electric soldering irons the choice of discriminating users in all fields

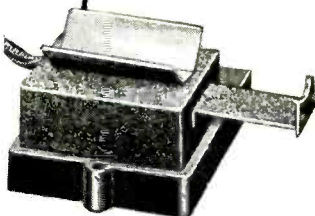

TEMPERATURE REGULATING STAND

Providing heat-regulation for all sizes of electric soldering irons, this stand is adjustable for all heats up to full working-temperature. Assures longer life of iron and tip.

For descriptive catalog pages write Dept. S-23

AMERICAN ELECTRICAL HEATER CO.
DETROIT 2, MICH.

122

This is so because the receiver, working directly into the ear, radiates into a small closed cavity which provides a fairly efficient load for all frequencies. A loudspeaker radiates into a much larger space and is not efficiently loaded, especially at low frequencies.

The sensitivity and selectivity are good, and reception is reliable in all but the most unfavorable surroundings.

Construction

Mechanically, the set is constructed of units which are mounted on a bakelite chassis. The two tuning coils are mounted side by side and fastened to the chassis with an adjustable bracket so that the coils can be accurately aligned with the tuning cores. The cores are mounted on a rack which is geared to the tuning knob. Each of the i.f. inter-stage coupling units is mounted in a metal box which fits into cutouts in the

Coil Winding Data for Receiver

Coil	Turns	Wire Size (AWG)	Length (inches)	Diameter (inches)
L1	200	36	7/8	0.225
L2	300	32	1/4	3/16
L3	200*	36	7/8	0.300
L4	210	38	7/8	0.225

*100 turns in each half
Use enamelled wire for all coils

bakelite chassis. Battery contacts, transformer, volume control, and socket for the plug-in receiver cord are all fastened to the bakelite chassis which can be removed as a single unit from the plastic covering case.

The tube sockets are also set into the bakelite chassis and are held in place with cement. The tubes are inserted into the sockets and are bent over so they lie flat against the chassis. This must be done with care so that the glass around the tube leads does not crack.

The photographs indicate the layout of the little receiver. The batteries take up about a third of the space on the chassis, and the rest of the parts are laid out to avoid oscillation. All the wiring is point to point and is kept as simple as possible. This layout has proved excellent and should be followed.

The plastic case which houses the complete unit, including both of the batteries, is 4½ inches long, 2½ inches wide and 1 inch thick. The complete unit with batteries weighs 9 ounces. The controls, dial, and plug-in connection for the receiver cord are located at one end of the case for convenient operation while being carried in the pocket. The plastic case is in two sections, the lower section being removable to allow replacement of batteries.

Materials for receiver

Resistors: 3—2,200, 1—47,000, 2—220,000, ohms; 4—1, 1—4.7 megohms, 1/3 watt; 1—5 megohms, hearing-aid type volume control.
Capacitors: 4—50, 2—75, 3—250 μ mf, 3—.005, 6—.02 μ f, ceramic.
Miscellaneous: 5—CK522AX tubes; 1—CK705 germanium diode; 1—hearing-aid type output transformer; 1—s.p.s.t. switch on volume control; 1—hearing-aid earphone; 1—1/4-volt mercury cell; 1—22½-volt B-battery; 1—socket for earphone cord; bakelite chassis, hookup wire, assorted hardware.
Note: use smallest sizes obtainable for all parts.

—end—

GREYLOCK TUBES

• JULY-AUGUST SPECIALS •

RTMA 90 Day Guarantee. 5% off on lots of 100 or more, assorted. For other type tubes and parts, see catalog.

Type	Each	Type	Each
1L4	\$.59	6SA7GT	\$.79
1S5	.49	6SD7GT	.79
1T4	.59	6SK7GT	.79
1U4	.59	6SN7GT	.89
1X2A	.99	6SQ7GT	.59
3A4	.49	6U4GT	.89
3Q4	.69	6V6GT	.79
3S4	.69	6W4GT	.69
3V4	.69	6X4GT	.59
6AG5	.99	6X5GT	.79
6AK5	1.09	12AV6	.59
6AL5	.69	12AU7	.99
6AQ5	.69	12AV7	1.49
6AR5	.69	12AX7	.99
6AS5	.79	12BA6	.79
6AU6	.69	12SA7GT	.79
6AV6	.59	12SK7GT	.79
6BA6	.69	12S8GT	1.09
6BA7	.69	19BG6G	1.49
6BG6G	1.29	25L6GT	.79
6BQ6QT	.99	25Z5	.59
6CB6	.79	35Z5GT	.59
6CD6G	1.79	50B5	.79
6J5GT	.49	50C5	.79
6S4	.69	50L6GT	.79
		117Z3	.59

FREE Send for complete up-to-date Greylock Catalog today. Dept. C-7

GREYLOCK ELECTRONICS SUPPLY CO.
115 Liberty Street - New York 6, N. Y.

OPPORTUNITY AD-LETS

Advertisements in this section cost 35¢ a word for each insertion. Name, address and initials must be included at the above rate. Cash should accompany all classified advertisements unless placed by an accredited advertising agency. No advertisement for less than ten words accepted. Ten percent discount six issues, twenty percent for twelve issues. Objectionable or misleading advertisements not accepted. Advertisements for September, 1951 issue must reach us not later than July 21, 1951.
Radio-Electronics, 25 W. Broadway, New York 7, N. Y.

WANTED: MN/215AP6 BLOWERS 28 VDC-1/100HP/7000 R.P.M. A-1 Refrigeration Service, 13833 San Antonio, Norwalk, Calif.

SPEAKERS REPAIRED at wholesale prices. Guaranteed workmanship. Builders wanted. Amprite Speaker Service, 70 Vesey St., New York 7, N. Y.

TUBES, PENNSYLVANIA VIBRO, ROGERS REL21 \$1.10 delivered. ATLAS, Levis, Quebec, Canada.

RAPID RADIO REPAIR by John D. Burke—168-03 90th Avenue, Jamaica, N. Y. Postpaid \$1.25.

MAGAZINES (BACK DATED) - FOREIGN, DOMESTIC - Arts, Books, booklets, subscriptions, pin-ups, etc. Catalog 10¢ (refundable). Ciccone's, 86-22 Northern Blvd., Jackson Heights, N. Y.

USED CORRESPONDENCE COURSES and Educational Books Bought, Sold, Rented, Catalog Free. Educational Exchange, Summerville, Ga.

AMATEUR RADIO OPERATOR LICENSE PREPARATION. Correspondence course. Low Cost. Personal coaching. Federal Electronics Institute, 15 E. Putnam, Dept. F, Greenwich, Conn.

WILL BUY ALL ART-13 type 47A \$220.00, ART-13/type 47 \$150.00, BC 318's \$85.00, AR-3 complete \$750.00, R77 Receivers only \$100.00, ART-1's \$600.00. Ship via Express (C.O.D.) subject to inspection by J. H. Finnegan, 19 Washington Avenue, Little Ferry, N. J.

WE REPAIR, EXCHANGE, SELL ALL TYPES OF electrical instruments, tube checkers and analyzers. Hazleton Instrument Co. (Electric Meter Laboratory), 110 Liberty Street, New York, N. Y. Telephone—BARclay 7-4239.

WANTED: AN APR-1, other "APR-", "ARR-", "TS-", "TE-", "AR-1", "ARC-3", ART-13, everything Surplus. Special tubes, Tech Manuals, Lab quality Test Equipment, etc. Describe, price in first letter. Littell, Farhills Box 26, Dayton 9, Ohio.

RADIO PARTS—New and Used—20 Pound Assortment \$2.50 plus shipping. MNA Radio, 9903 Lorain, Silver Spring, Maryland.

RADIO—TELEVISION—ELECTRONICS—TUTORING \$5 per lesson—Mo, Tech., 3907 North 25th Street, St. Louis 7, Missouri.

FIVE ELEMENT TV YAGI BEAMS, Aluminum Tubing, etc. Write for prices, Willard Ratcliff, Postoria, Ohio.

AMATEURS—RADIO AND ELECTRICAL RESEARCH Engineering. By Twillmann, R.R.#1, Chesterfield, Mo.

U.H.F. IMPEDANCE BRIDGE

This instrument is a flexible and accurate impedance bridge for measurements at frequencies from 70 to 1,000 mc, an important range for TV and other services. Conductance and susceptance are directly indicated over a range 1 to 400 millimhos. This is equivalent to 1,000 to 2.5 ohms. Unlike conventional l.f. bridges, the calibration readings are independent of frequency, once a single adjustment is set. The instrument is manufactured by General Radio Co. and is known as type 1602-A admittance meter.

The bridge is a junction of five coax arms (Fig. 1). A u.h.f. generator is connected to the rear fitting. At the

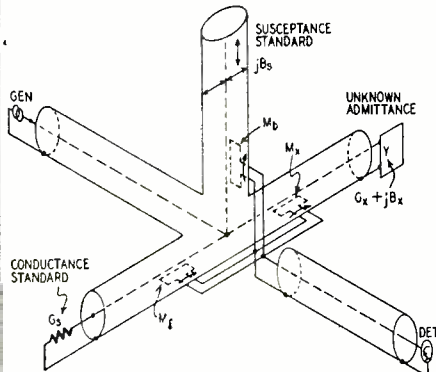

Fig. 1

front is an outlet for a detector. This may be a converter and u.h.f. receiver combination. The other three arms are terminated in a standard conductance, a standard susceptance, and the unknown admittance. The conductance is a 50-ohm resistor. The susceptance is an adjustable stub which is set for one-eighth wavelength for each measurement. Therefore the standard conductance and susceptance are known at every frequency.

The detector measures the sum of three induced voltages picked up by the three variable loops (Fig. 1). Each loop has a voltage which is proportional to its mutual inductance and to the current in the line. The right-hand loop picks up a voltage equal to $M_x I_x$ which is proportional to $M_x (G_x + jB_x)$. M_x is set by a pointer which slides along the "multiplying factor" scale. Then it remains only to determine the unknown G_x and B_x .

When the detector indicates balance, the M_x loop voltage is equal and opposite to the sum of the other two loop voltages. Equating resistive and reactive voltages, we find

$$M_x G_x + M_b G_b = 0$$

$$M_x B_x + M_b B_b = 0$$

As noted previously, G_b and B_b are fixed. The mutual inductances M_x and M_b are controlled by pointers sliding along the conductance and susceptance scales. Therefore the unknowns may be calculated or determined directly from the calibrated scales.

Besides measuring directly in terms of susceptance and conductance, the bridge can be used to match terminations, to lines, measure reflection coefficient, etc.

—end—

YOUR BEST BUY IN POWERFUL P.A.



IMMEDIATE DELIVERY FROM ALLIED!

Here's the outstanding 30 Watt Sound System buy of the country—KNIGHT—tops for power, quality, value. Just check these features: Covers up to 25,000 square feet outdoors or up to 4,000 persons indoors. Full 30 watts usable output at 3 db down, ± 2 db from 40 to 20,000 cps on phono and microphone; 3 inputs—two for high-impedance mikes, one for phono, each with individual volume control; tone control attenuates treble 15 db at 10,000 cps. Complete system includes: 30 watt amplifier and tubes, Electro-Voice unidirectional "Cardax" microphone with adjustable floor stand and 20' cable; two 14.7 oz. Alnico V magnet General Electric 12" "Safused" PM speakers, each with 30' cable; portable carrying case, 16 3/4 x 12 3/4 x 25". For 110-120 volts, 60 cycle A.C. Shpg. wt., 75 lbs.

93-372. Complete System (less phono) \$118.75 top. Only \$17.81 down, \$8.92 monthly for 12 months

93-340. 3-Speed Phono Top with dual crystal cartridge for above system. Only \$16.95

Headquarters for P.A. and Hi-Fidelity

ALLIED carries the world's largest stocks of P.A. amplifiers and systems—8 to 80 watts. Look to ALLIED, too, for High-Fidelity amplifiers, tuners, speakers, and all other Custom Sound components and accessories.

FREE 212-PAGE ALLIED CATALOG



Write today for the only complete Buying Guide to everything in Sound, Radio and Television. Make your selections from the world's largest stocks at lowest money-saving prices. You save time and effort and get the best when you order from your ALLIED Catalog. Send for your FREE copy now.

ALLIED RADIO

ALLIED RADIO CORP., Dept. 2-GG-1
833 W. Jackson Blvd., Chicago 7, Illinois

Send FREE 212-PAGE ALLIED Catalog
 Ship the following: _____

\$_____ enclosed. Full Pay.

Part Pay. (bal. C.O.D.)

Name _____

Address _____

City _____ Zone _____ State _____

UNIVERSAL BRACKETS

Jensen Mfg. Co., 6601 So. Laramie, Chicago, Ill., announces a set of brackets for their Viking line of speaker models from 3 1/2 inches to 6 inches in size.

The unit package is the Viking CTM Universal Bracket Set which is used in mounting speakers to the chassis in small radio repair work, and also provides transformer mounting facilities. A metal clamp strip with channels holds the speaker in position at any predetermined height above the chassis. The transformer mounting bracket



is a separate piece which can be attached several ways to solve most space problems. Included is an illustrated instruction sheet.

TRANSCRIPTION ARM

General Electric, Syracuse, N. Y., announces a professional tone arm, the FA-21-A, designed to mount the G-E variable-reluctance cartridge, RPX-050. Minimum mass and friction is obtained by using magnesium alloys and cone type bearings. It is designed for lateral transcriptions, and will mount on machines whose dimension from the

center of the turntable to the edge of the mounting surface is approximately 15 inches or less.

The stylus is located by an arrow on the arm so that it may be accurately positioned for playback of transcrip-



tons. Adjustable stylus pressure is provided by a precision spring loading system calibrated in ounces and grams.

SENSITIVE METER

Hickok Electrical Instrument Co., 10531 Dupont Ave., Cleveland, Ohio, has developed a high-sensitivity battery volt-ohm-milliammeter with a 5-inch meter and the following ranges: 20,000 ohms/volt d.c., 5,000 ohms/volt a.c. Volts a.c. and d.c.: 2.5, 10, 50, 250, 1,000, 5,000. Output volts: 2.5, 10, 50, 250, 1,000. Milliamperes, d.c.: 2.5, 10, 50,



250, 1,000. Microamperes, d.c.: 0 to 50. Amperes, d.c.: 0 to 10. Decibels: -30 to +55 in five ranges. Ohms: 0 to 1,000, 5-ohm center scale, 0 to 10,000 50-ohm center scale, 0 to 1 meg., 5,000-ohm center scale, 0 to 100 meg., 500,000-ohm center scale.

The instrument weighs 2 3/4 pounds and measures 5 3/4 x 8 3/4 x 2 1/2 inches. Test leads are furnished.

PLATE TRANSFORMERS

Standard Transformer Corp., 3580 N. Elston, Chicago, Ill., is marketing two new lines of plate transformers, the Stancor PT and PC series. These have insulated leads to provide protected routing to circuit; no exposed terminals; no difficult cutouts needed. The PT mounting provides a direct



protected path to the anodes of rectifier tubes with heavily insulated high-voltage leads coming out of the top of the transformer. The primary is brought out the bottom for concealed subchassis wiring.

The PC mounting is for units requiring single-ended rectifiers where safety is achieved through all leads being brought out the bottom of the transformer for subchassis wiring.

SIGNAL GENERATOR

Radio City Products Co., Inc., 152 W. 25th St., New York City, is marketing a new wide-range model 706A signal generator which provides continuous coverage of 150 kc to 220 mc. There are eight ranges, including six on fundamental frequencies through 55 mc.



Accuracy is within 1%. Adjustment and recalibration is readily available by air trimmers.

Thorough shielding and stability of calibration is claimed. Modulation is at 400 cycles, with provision for external modulation and variable modulation percentage control.

Other features are high and low r.f. signal output, ladder type step attenuator and 6 1/2-inch dial with vernier tuning.

DX 630 CHASSIS

Video Products Co., Red Bank, N. J., announces a modified version of its 630 TV chassis which can be used for fringe-area reception.

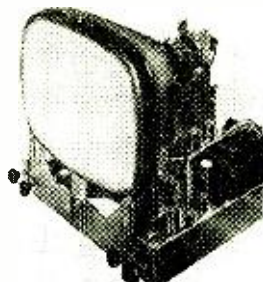

The Super-Video-630-DX contains circuit features which bring its sensitivity

up to 4 uv, making it possible to receive good programs in many fringe locations without boosters or complex antenna systems.

T.V. ANTENNA SWITCH

Mosely Electronics, Overland, Mo., announces a new 3-position TV antenna switch that can be mounted inside or on the back of the TV set. It is designed



to supply efficient switching facilities in any TV installation where up to three antennas are used and where installation of a flush type unit is not feasible.

The new unit has a special constant-impedance rotary switch with low-resistance silver-to-silver contacts on high-grade phenolic insulation enclosed in a molded plastic case. Switch positions are clearly marked on the face of the unit. Leads of standard 300-ohm transmission line provide easy connection to set and to three antenna lines. Mounting screws are furnished.

T.V. KIT

Tech-Master Products Co., 443 Broadway, New York, N. Y., has marketed

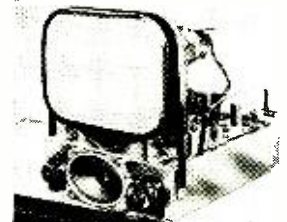

a budget-priced television kit accommodating up to 14-inch rectangular tubes. The kit features a.c.-d.c. operation, a hi-gain stagger-tuned i.f. system, new 12-channel turret type tuner, a.g.c. system, and 2-knob control providing automatically synchronized picture and sound.

The main chassis is completely "above ground" and convenient test points are located on top of the i.f. Synchro Strip for easy and efficient testing. No further i.f. alignment is necessary since the tuner and i.f. "Synchro Strip" come prewired, tested, and aligned. Furnished complete with instructions, components, hardware, speaker, picture tube mounting brackets, and all tubes (less kine).

RECORD CHANGER

Webster-Chicago Co., 5610 Bloomingdale Ave., Chicago, Ill., is introducing its model 106 record changer to replace the model 356. It automatically plays all three speeds of records in all three sizes. No adapter is needed for the 7-inch records.

The velocity-trip mechanism provides jam-free change with minimum record wear. Other features include an automatic needle-set-down point, automatic stop, and muting switch.



The Super-Video-630-DX contains circuit features which bring its sensitivity

All specifications given are obtained from manufacturers' data.

RADIO-ELECTRONICS for

Seletron SELENIUM RECTIFIERS

May be up your alley, too!

AS THEY ARE FOR THE BRUNSWICK-BALKE-COLLENDER COMPANY

The new "Tel-E-Foul" photo-electric Foul Indicator produced by The Brunswick-Balke-Collender Company, famous manufacturer of bowling equipment, includes 75 MA SELETRON miniatures in its electronic circuits.

SELETRON Selenium Rectifiers are the choice of an increasing number of manufacturers in diversified fields because they are so thoroughly dependable under all types of grueling conditions. SELETRON is available in the miniature sizes required for radio, TV and other electronic circuits, all the way up to heavy duty power stacks used in a wide range of industrial applications.

Whenever you meet up with a power conversion problem, no doubt SELETRON engineers can be of substantial assistance in recommending the right rectifier for your needs. Write us today!

Illustrated above is the "Tel-E-Foul" control box. When the bowler oversteps the foul line the electronic beam conveyor can trip the camera light to flash above the alley. A 75 MA SELETRON miniature is built into the control box on each bowling lane.

Seletron

SELETRON DIVISION
RADIO RECEPTOR COMPANY, INC.
Since 1922 in Radio and Electronics

Sales Dept.: 251 W. 19th St., New York 11, N. Y. • Factory: 84 N. 9th St., Brooklyn 11, N. Y.

CORD SHORTENER

Coilzit Products, 25 57 Steinway St., Long Island City, N. Y., is marketing a cord shortener which eliminates the need for cutting and splicing. Surplus wire is wound about this device, and a pair of forceps of electric wire can be held safely.



SMALL MICROPHONE

Shure Bros. Inc., 225 W. Huron St., Chicago, Ill., announce a new small edition of the standard Unidyne dynamic microphone. The small version, model 55B, is an ultra cardioid approximately one-half the size of the



model 55 and retains all the important directional qualities.

A large air-gap clearance and rugged coil construction plus smooth frequency response and high efficiency are claimed by the manufacturer.

TV BOOSTER

Mark Simpson Mfg. Co., 32 28 49th St., Long Island City, N. Y., has developed a 2 stage booster for poor reception areas. The Super Sky Chief Booster avoids over loading the TV set by providing a 2 knob control which makes it possible to vary the gain desired.

This booster has eight tuned circuits with a 10 db gain on channels 2 through 13. It has full 4.5 mc bandwidth.

Other features include a pilot light,



which lead microphone for the TV receiver and, in the off position, the switch connects the TV receiver directly to the antenna.

PHONO EQUALIZER

Radio Shack Corp., 167 Washington St., Boston, Mass., is marketing a play-back equalizer, type HL 16, for use with the G.E. variable-reluctance cartridges.

It incorporates a 6-position switch which provides correction for the response curves used by domestic and European manufacturers of 78, 45 and 33 1/3 r.p.m. records. It is inserted between the pickup and preamplifier. It is supplied complete with wire and plug.



RESISTANCE CHECKER

Clippard Instrument Lab., Inc., 1125 Bank St., Cincinnati, Ohio, announces a high-speed automatic resistance comparator capable of testing as many as 17 resistors per minute for grading or matching or checking factory output.

The PR-5 is housed in a steel cabinet and is completely self-contained. After warmup and zero adjustment, the standard resistor is connected to two terminals and resistors to be checked are placed across the "unknown" terminals.



The 4-inch Weston meter is graduated in percent, and is calibrated in 3 full scale ranges: -5 to +5%, -25 to +30%, and -50 to +100%. Accuracy is better than 1% over entire range from 100 ohms to 100 megohms.

MOISTURE METER

Weston Electrical Instrument Corp., Tagliabue Instruments Division, 614



Frelinghuysen Ave., Newark, N. J., is producing the Tag Moisturonic Moisture Meter, model 8008, for testing the moisture content of materials.

The instrument comes in two forms: one with a scale calibrated for use with lumber, wood, plaster, and wood products, and the other with linear graduations for manufacturers and processors to use in establishing calibration tables for other materials in which moisture content is an important problem.

The instrument can be used with any material capable of accommodating electrode probes. It is portable, with an over-all range of from 2,000 ohms to 20,000 megohms.

FREQUENCY MONITOR

Radio Corp. of America, Engineering Products Dept., Camden, N. J., announces an AM frequency monitor, RCA Type BW-11A, for use in broadcast stations.

The monitor will directly indicate in cycles-per-second the magnitude and direction of the transmitter frequency



deviation from its assigned channel in the range of 500-2,000 kc. It reveals deviation range (readable to 1 cycle) of plus or minus 30 cycles with an accuracy of plus or minus 10 parts per million. Stability is better than 1 part per million. A warning-lamp system

indicates failure of either transmitter carrier or monitor crystal oscillator or other features.

ION-TRAP

Indiana Steel Products Co., Valparaiso, Ind., is marketing the E-ZEE-ON ion



trap which can be easily adjusted and which possesses a uniform field pattern.

It is made of one piece of permanently magnetized Cunife and requires no manual clamping. It slips onto the tube neck and permits adjustment with one hand.

ELECTRIC KNIFE

Ungar Electric Tools Inc., 615 Ducommun St., Los Angeles, Cal., are marketing the 540 combination knife tip designed for cutting, stripping, and marking plastics and insulation materials. This brass tip is interchangeable with the other tips in the lightweight Ungar handle and cord set and threads onto the heating unit of the 776 Ungar.



DX ANTENNAS

LoPointe-Plascomold Corp., Windsor Locks, Conn., announces the develop-



ment of two new methods of stacking the VEE-D-X JC Yagi. Special phasing harnesses are now being manufactured to convert the regular JC Yagi into a horizontal or vertical 4-stacked antenna.

These arrays are designed for long-distance, single-channel reception, with the vertical type recommended for flat terrain and the horizontal type for hilly and mountainous areas.

HI-PERM CERAMIC

D. M. Steward Mfg. Co., Chattanooga, Tenn., announce production of Lavite ferrites, which combines high permeability with low electrical losses, permitting the reduction of size and weight in electrical products.

This ceramic compound is recommended for use in horizontal output

transformer cores, permeability-tuning cores, and in printed circuits from 1 to 200 mc.

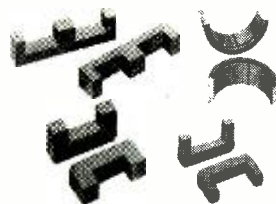

SPIRAL ANTENNA

Hi-Lo TV Antenna Co., 3540 N. Ravenswood Ave., Chicago, Ill., is distributing a spiral antenna 20 inches high and 32 inches wide. It is claimed that this design provides good reception of

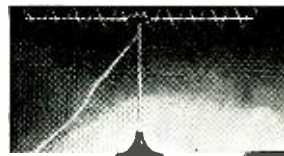

signals received in areas of high interference. It can be tuned to high and low TV channels. A floor model with metal base is also manufactured.

ALUMINUM TOWER

Alprodco, Inc., Kempton Ind., announces production of a large-diameter aluminum tower which can accommodate all popular rotators. A rotator adapter kit is available as an accessory, or an adaptor plate can be purchased separately.

The present model features an increase in strength of 22% over the previous model. Steps are now included as standard equipment.

CONICAL V BEAMS

Telrex Inc., Asbury Park, N. J., is distributing a low-cost Vanguard series of conical V-beams which incorporate the essential features of the standard Telrex models. This series is available in four models, including single- and double-stacked types.

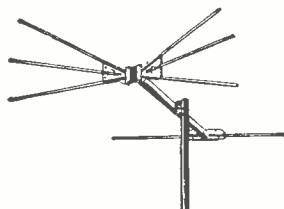

CATHODE-RAY TUBE

Allen B. Du Mont Laboratories, Inc., Instrument Division, 1000 Main Ave., Clifton, N. J. has a new type 5YP1 cathode-ray tube, with a deflection factor of 12-Volts per inch deflection for each kv applied to anode No. 2.

It employs an intensifier for increased brightness and smaller spot size, and is useful in wide-band equipment or where high sensitivity is required at low and medium accelerating potentials.

The plates of the type 5YP1 are spaced to provide maximum sensitivity

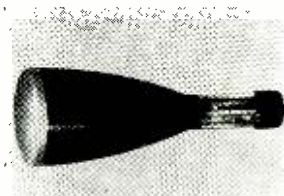

commensurate with distortion-free performance over three inches as the usable vertical scan of the tube.

Input capacitance to the vertical deflection plates is 1.7 μmf.

—end—

HERE'S HELP—



Now—in 1800 pages

All data, basic knowledge, methods and theory of Radio, Television, Electronics, digested into 32 Sections in complete, quick to find, easy to read Handbook form.

Plan every operation in Radio-TV and Electronics with this library set consisting of The Radio Electronics Handbook and the Video Handbook. These Handbooks will be your litelong tools—you will use them every day on the board, at the bench, in the field. Use them for construction, production, installation, operation—use them for adjusting, troubleshooting, measuring and testing. They will be your invaluable aid in research, design, development, manufacturing or maintenance. With data and servicing procedures complete, they will make your work faster, better, easier.

They give complete coverage of everything in Radio, TV and Electronics—and you will find them easy to use—everything is presented in plain language—all terms explained; schematics, working diagrams and pictures are clearly illustrated for fast and easy understanding.

The Radio Electronics Handbook and the Video Handbook are works of complete authority prepared by the well-known engineers Scheraga & Roche, under the direction of William F. Boyce, famous for the preparation of hundreds of handbooks and manuals for the U. S. Signal Corps, Navy Communications, Air Force Electronics Section, Western Electric Co., General Electric Co., Bell Laboratories, R. C. A., Sylvania, DuMont Laboratories, National Radio Co. and many others.

These Handbooks are endorsed by leading schools for instruction and reference. The armed services make them available to their technicians in libraries, schools and in the field. Engineers, Draftsmen, Laboratory and Production men in every industry have purchased over 50,000 of these books for use in their work.

500 Radio jobbers keep them constantly in stock for the convenience of their service and industrial customers. These are the most commonly used books in Radio & TV.

Contents are too long and complete to describe here—so, see them at your Radio jobber, your bookstore, or send for them on free examination. See for yourself what they will do for you.

SEND NO MONEY

10 DAY FREE EXAMINATION

SPECIAL OFFER:

Save one dollar—get both handbooks as shown above in library set for \$10.90.

“COUPON”
BOYCE ROCHE BOOK CO.
 Caldwell 47, New Jersey
 Send () Library Set (2 books) @ \$10.90
 () Radio Electronics Handbook @ \$5.95
 () Video Handbook @ \$5.95

In ten days I will send price plus postage, or I will return books postpaid.
 (Offer good in U.S.A. and to men in Armed Services overseas only.)
 Name _____
 Address _____
 Employed by _____
 Save postage—we pay postage and packing if you send money NOW. Money back on same return privilege.

VARIABLE INDUCTANCE PICKUP

Patent No. 2,531,689
 Henry L. Kalmus, Chicago, Ill.
 (Assigned to Zenith Radio Corp.)

This phono pickup can be made light and compact. The accompanying illustration shows the principle of operation. A small coil L is fixed to the stylus. As the stylus vibrates it drives

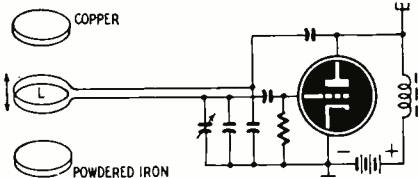

the coil alternately toward the copper disc and the powdered iron. The inductance of L is decreased when it approaches the copper, but motion toward the iron increases the inductance. These changes provide frequency modulation of the ultrasonic oscillator.

The FM wave is transmitted by the antenna and may be intercepted with a nearby receiver. Any type of discriminator converts the wave to audio. The detector may be followed with a.f. amplifier stages to increase the power.

IMPROVED TRANSISTOR

Patent No. 2,502,479
 Gerald L. Pearson, Millington and William Shockley, Madison, N. J.
 (assigned to Bell Telephone Labs, Inc.)

A transistor is made of a semiconductor such as germanium to which an “impurity” is added to control the flow of electric charges. When arsenic is added to germanium, it becomes an N-type semiconductor. This means that conduction takes place when the germanium is made negative with respect to a metal contacting it. When aluminum is added, the germanium becomes a P-type substance; that is, it conducts when it is positive with respect to a metal surface or point contact on it.

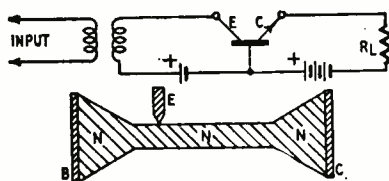

This invention relates to improvements over early transistors. The transistor made in accordance with this invention is shown in the figure. It is composed of a long, thin, N-type germanium crystal with enlarged ends. At each end is a metal surface, which may be a film of solder. A tungsten or phosphor bronze point contacts the thin portion.

Positive charges or “holes” flow from the emitter E into the N-type semiconductor. These move toward the negative collector C and away from the positive base B. The long, thin portion of the transistor increases the output impedance, a desirable feature. It also permits more intense internal fields to accelerate the holes, thus reducing heating and transit time effects. A large metal surface contact at C (instead of a point contact) decreases noise.

If desired, a P-type semiconductor stub may be used as emitter instead of the catwhisker. This also reduces noise.

3-DIMENSIONAL OSCILLOSCOPE VIEWING

Patent No. 2,541,041
 James L. Whittaker, Princeton, N. J.
 (Assigned to Radio Corp. of America)

This oscilloscope measures 3 variables simultaneously. Horizontal and vertical positioning of the spot indicates 2 of the variables. The third is measured by the apparent distance of the spot from the observer. A stereoscopic method provides depth of vision for this purpose.

This invention may be used to find the azimuth, elevation, and range of a target. In the diagram shown, circuits A and B have outputs which vary

with azimuth and elevation, respectively. A deflects the spot vertically while B controls it horizontally.

A third circuit C has an output which depends upon the range of the target. This voltage controls a switching circuit which deflects the beam to the right and the left alternately. The amount of deflection increases with range. Therefore for each target there is a pattern of 2 spots which appear alternately and whose separation increases with longer range.

Optical or mechanical arrangements may be used to provide stereoscopic viewing. While the spot is deflected to the right, only the right eye is permitted to see it. Then when the spot is in its other position, only the left eye is permitted to view it. When the switching is periodic and rapid there is a sensation of seeing only a single spot which is located some distance from the observer. As the

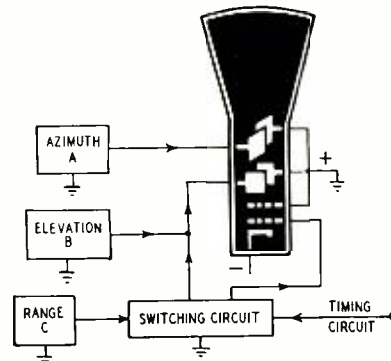

range increases, the deflection is greater and the spot seems further from the viewer.

To prevent confusion, the deflection trace is blanked out by a suitable voltage applied at the scope grid.

SELF-FOCUSING AMPLIFIER

Patent No. 2,538,488
 Walter K. Volkers, Schnectady, N. Y.
 (Assigned to Volkers & Schaffer, Inc.)

A direct-coupled amplifier passes low frequencies down to and including d.c. It therefore transmits undesirable drift and fluctuations due to random emission, supply voltage variations, etc. This interference is called defocusing, as it “blurs” the original signal. Defocusing may result in overloading, noise, and distortion. Several self-focusing methods are described here.

The figure shows a crystal phono pickup and a 2-stage d.c. amplifier. The control- and screen-grids of V1 are returned to taps P1, P2 on the cathode resistor R1. By choosing these taps correctly, drift is cancelled out by the negative feedback. The a.c. is bypassed through C and cannot be fed back.

The divider R2, R3 is another self-focusing arrangement. If the B-voltage varies due to aging of parts or changes in line input, the cathode voltage is affected. For example, if the supply in-

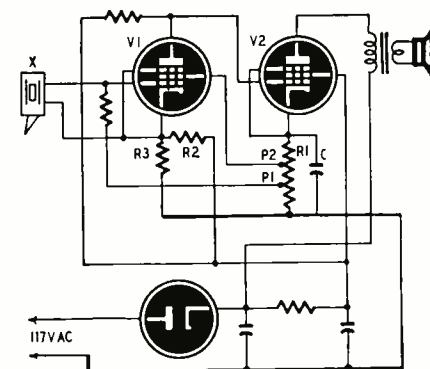

creases, so does the amplifier gain. However, the increased bias of V1 reduces its gain so there is no defocusing.

The pickup is shown connected to the cathode of V1 instead of ground. This is done to reduce hum. If it were connected between grid and ground as usual, any ripple across R3 would be impressed across the tube. With the connections that are shown, only a fraction of the ripple is present.

COINCIDENT CIRCUIT

Patent No. 2,538,500

Leon Bess, Boston, Mass.

(Assigned to United States of America as represented by the Secretary of the Navy)

Output is obtained from this circuit only when two simultaneous signals are fed to it. One signal (*T*) must be negative. The other (*C*) may be either negative or positive. *C* must appear simultaneously with *T* to produce output.

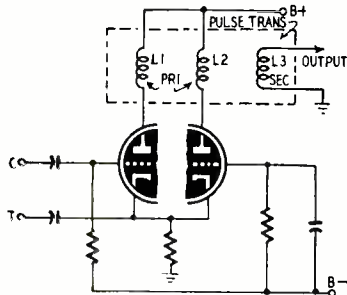

Ordinarily both triodes are blocked by the large cathode resistor. A negative *T* unblocks them. Due to symmetry, equal currents flow through L1 and L2. These are similar coils but oppositely wound, therefore no output is induced in L3. When a signal is applied at *C*, greater or less current flows through L1. This destroys the coil balance, permitting output to flow in L3. The phase of this current depends upon whether *C* is negative or positive.

In a practical case *T* may be timing or sync pulses. The circuit does not operate unless *C* happens to coincide with a timing pulse. It cannot operate as a result of noise or interference between timing pulses. If the control pulses *C* are positive, they must be smaller than *T*.

D.C. TO A.C. CONVERTER

Patent No. 2,540,825

James M. Lafferty, Schenectady, N. Y.
(assigned to General Electric Co.)

A direct-coupled stage can amplify d.c. but its gain and stability are not as high as those of a conventional R-C coupled amplifier. It is often better to convert the d.c. signal to a.c. before amplifying. This invention discloses a combination of electrometer tube and square-wave supply. These amplify the d.c., then convert it to a.c. Then the a.c. may be amplified as desired.

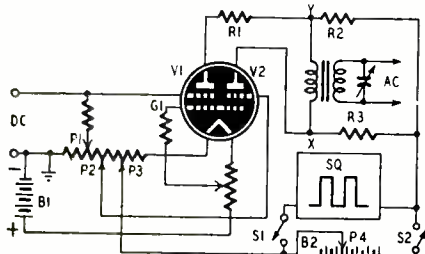

The tube may be a G-E type 5675 "split" electrometer. It has two similar sections, V1, V2, with common filament and common space-charge grid G1. The tube is designed for low leakage between elements and to ground. It operates with very low voltages to minimize ionization and noise. G1 neutralizes the space charge around the filament, thus increasing the space current for a given low plate voltage.

The electrometer is in a bridge circuit. R2, R3 are arms of this bridge. The third is made up of V1 in series with R1. V2 is the fourth arm. Tube bias, space charge, and anode voltage are adjustable by means of P1, P2, P3, P4. These are set to balance the bridge with S1 open and S2 closed. Therefore, with zero d.c. signal, no potential difference appears between terminals X, Y.

Now the square-wave generator SQ is substituted for B2 by closing SW1 and opening SW2. It must have the same amplitude as the battery. With square-wave input, the bridge still remains balanced until a d.c. signal is fed to V1. This changes the resistance of V1 so a voltage appears between X and Y. This voltage is a square wave like SQ. The a.c. is induced into the secondary of the transformer which is tuned for maximum output. Stages of a.c. amplification can follow.

—end—

HICKOK Announces

new television VIDEOMETER

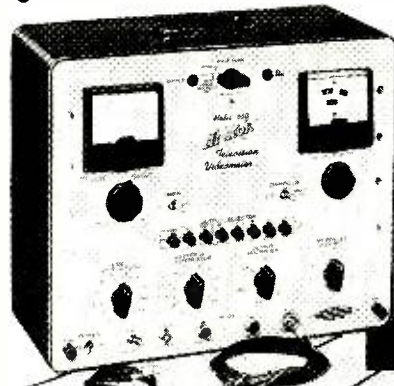

QUICKLY-ACCURATELY IDENTIFIES TROUBLE IN ANY SECTION OF A TV SET

Covers all TV channels, all on fundamentals.

Metered RF output 1 to 10,000 microvolts for precise sensitivity checks.

Crystal controlled for highest accuracy.

A TV transmitter in miniature. Provides substitute video amplifier, 5 cycles to 4 mc. with gain of 0 to 10.

Delivers video pulses of 60, 900, 15,750 cycles and 315 kc, singularly or in any combination.

Pulses can be used directly, metered in peak-to-peak volts or to modulate the self-contained RF oscillator.

MODEL 650

The HICKOK Model 650 Videometer is the first instrument of its kind to accurately and rapidly solve your servicing problems with the necessary tests to visually identify trouble in any section of a TV receiver.

An all-purpose video generator. Provides an electronically accurate bar or dot pattern on the screen of any TV receiver— independent of station operation. Can be used as a TV transmitter to simultaneously transfer a program to any number of TV receivers— on any desired channel.

THE HICKOK ELECTRICAL INSTRUMENT CO.

10531 DUPONT AVENUE

CLEVELAND 8, OHIO

Send me full information on the new HICKOK Model 650

NAME _____

STREET & NO. _____

CITY _____

ZONE _____

STATE _____

WHEN WRITING ADVERTISERS PLEASE MENTION RADIO-ELECTRONICS

IF You are buying or building a TAPE RECORDER

OR you are a RECORDER ENTHUSIAST

don't fail to read A. C. Shoney's dynamic new booklet

ELEMENTS of SINGLE AND DUAL TRACK TAPE RECORDING and 1001 APPLICATIONS

3rd printing, increased to 144 pages! Price still \$1.00 postpaid

Order today. Enclose dollar bill, check or money order

Booklet mailed same day

AMPLIFIER CORP. of AMERICA
398-2 Broadway, New York 13, N. Y.

NEW CONDENSER TESTER

Finds Intermittent Condensers Instantly



Pres-probe's sliding tip with variable resistance prevents condenser heating. Tests with power on. Requires no adjustment. Stops guesswork. Saves time. Convenient probe size (7/8" long). Satisfaction guaranteed.

NET 795
Postpaid U. S. A.

See Your Dist. or Order Direct

PRES-PROBE CO.
4034 N. Sixth St., Milwaukee 12, Wisc.

there's only ONE APPROVED POWER SUPPLY

Patent Pending

New Low Cost "BJ" JUNIOR Save Time, Money Servicing DC Equipment

Demonstrate and test car and marine radios . . . relays, phone circuits, instruments, other low voltage devices. End costly storage battery failures with Electro's dependable filtered Power Supply. Exclusive conduction cooling doubles rectifier power rating, assures lowest cost per ampere output over other types and dissipates over 3 times the heat. Quality components withstand high overloads. 6 Volts, 1 to 12.5 amps. continuous output.

Model "B" 6 Volt DC Power Supply 1 to 20 Amps. for Heavy Duty Applications

OVER 2 MILLION Battery Radios Offer Huge PROFIT Market!



New Model "B" BATTERY ELIMINATOR with Selenium Rectifier

Battery radios in city and rural areas offer you big profit opportunities. Converts any 1.4 volt, 4 to 6 tube battery radio to an efficient AC radio. Turns into a 115 volt 50/60 cycle outlet. Gives years of dependable hum-free reception at lowest cost. Guaranteed for three years.

SEND COUPON **ELECTRONIC EQUIPMENT**

Electro Products Labs. 4507-JS Ravenswood Ave., Chicago 40, Ill. Send literature, name of nearest source.

Name.....
Address.....
City..... State.....

IN CANADA: ATLAS RADIO CORP. LTD., TORONTO

HIGH-VOLTAGE CUT-OUT

Autotransformers are often used to compensate for variations in line voltage. Some equipment such as a.c.-d.c. receivers are easily damaged when the line voltage rises above normal. Other types fail or work poorly when the voltage is too low.

Described in *Radio Constructor* (London, England), is a novel device which breaks the circuit to the equipment when the voltage rises above a pre-determined level. The circuit is shown at *a* in the illustration. In the original circuit—designed for use on 220-volt lines—R1, R2, and R3 are 5,000, 10,000, and 10,000 ohms respectively. The bleeder current is 10 ma or more. The values on the diagram are for 117-volt lines.

A portion of the voltage across the bleeder is rectified and applied to a neon lamp through a limiting resistor R4 and the coil of a relay. When the voltage reaches a given level, the lamp ignites and draws enough current to cause the relay to pull in, thus breaking the supply line to the external appliance.

Resistor R4 is the normal current-limiting resistor recommended for use

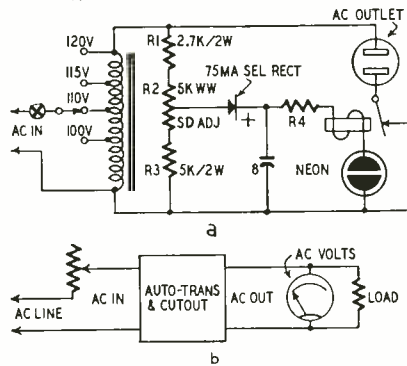

with neon lamps. Use the value specified for the lamp you select. The neon lamp can be replaced by 0B3 or 0C3 voltage-regulator tubes. In this case, R4 should limit the current to 30 ma for the 0B3 or 40 ma for the 0C3. The relay must pull in at a current within the range of the neon or voltage-regulator tube. The relay contacts must be heavy enough to handle the current drawn by the external circuit.

To calibrate the unit, use the setup shown at *b*. If the equipment is to operate at 110 volts, set the tap on the transformer and the variable resistor in series with the line so approximately 115 volts is applied to the load. Slowly advance R2 until the neon lamp or voltage-regulator tube fires and opens the relay contacts. Check the setting by turning off the unit to extinguish the lamp, then vary the input voltage between 110 and 120 volts to make sure that the relay always opens as soon as the voltage exceeds 110.

MORE BASS BOOST

Variable bass-boost circuits like that shown in the diagram are widely used in amplifiers and receivers. They usually work well at high volume but are unsatisfactory when the volume is turned down. Additional bass boost can be provided by adding R1 and C1 in an

inverse feedback network. Connect the free end of C1 to point A, one side of the 500-ohm winding on the output transformer. If the amplifier oscillates, reverse the connections to this winding. If the transformer has no 500-ohm winding, connect the feedback loop to either of the output plates at B or C. Using either of these connections is

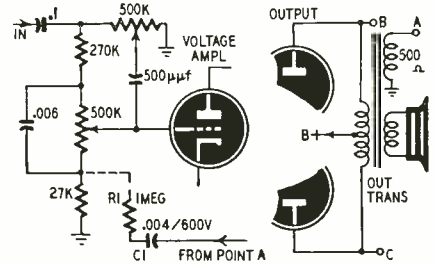

likely to increase the hum level, particularly if the power supply is not highly filtered. Therefore, it may be necessary to install additional filter capacitors and decoupling resistors in the circuit. R1 may be made variable and a switch may be installed to open the loop when maximum output from the amplifier is desired.—*M. Ort*

REMOTE ANTENNA DIRECTOR

A remote direction indicator for rotatable shortwave, FM, and TV antennas was described in *Ohmite Ham News*. An Ohmite type RB-2 direction-indicating potentiometer is installed at the antenna with its shaft connected to the rotating portion of the antenna mast through a 1-to-1 drive mechanism. It is connected to the control box at the receiving position through 3-wire cable. The control switch may be a double-pole unit which has one of its poles connected to control the motor of the rotator.

The meter scale should be calibrated in compass points as shown in the

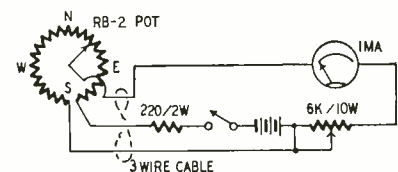
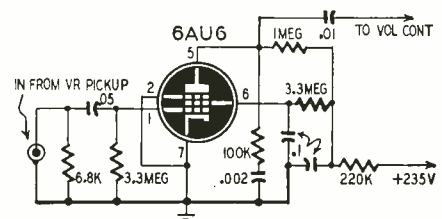

diagram. South is at the ends of the scale and north is in the center. West and east are one-quarter and three-quarter scale, respectively.

PHONOGRAPH PREAMPLIFIER

Most preamplifier-equalizers for G-E variable-reluctance pickups use the now familiar circuit with the triode sections of a 6SC7 connected in cascade. A 6AU6 pentode is used as a phono preamplifier in the G-E model 752 and 753 receivers. This circuit is shown in the diagram.



AUTOMATIC ANTENNA MATCH

Tuned loops, open and shorted stubs, Q-bars, and delta- and T-match systems have been devised for matching transmission lines to antennas to provide a low standing-wave ratio. With these systems, the frequency range is limited to narrow bands and the antenna cannot be operated efficiently on harmonics without making adjustments on the matching system.

This system is devised to match almost any balanced line to antennas having high or very low radiation resistances. It is suitable for feeding rhombics, V-beams, folded dipoles, all-channel TV antennas, stacked arrays, and many other types of antennas requiring 2-wire feed lines. An antenna cut for 80 meters will work equally well on 40, 20, and other harmonics. The only difference is in the radiation patterns.

Two methods of applying the automatic match are shown in Fig. 1. D1 is equal to the spacing between conductors of the transmission line, and D2 is just enough spacing to prevent voltage breakdown. In receiving and low-power transmitting antennas, D2 may be the insulation of two wires taped together. For transmitters of 500 or 1,000 watts, D2 may be approximately 3/8 inch. We have used 72-ohm coaxial cable for the

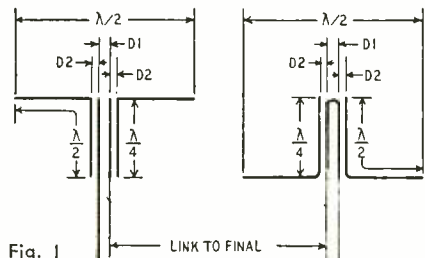

Fig. 1

quarter-wave section. The inner conductors were connected to the antenna and the outer conductors connected to the transmission line. In this case, D2 is the spacing between the conductors of the coax, and D1 is adjusted so the outer conductors present the same impedance as the transmission line. In other tests, the matching section consists of No. 12 wires taped together with 3/8-inch spacing between pairs to match 300-ohm ribbon. For other open-wire lines, the matching sections should be made of wire having the same diameter and spacing as the transmission line.

This system has been used to feed antennas having up to six reflectors. The only necessary adjustment was trimming the radiator and matching section. Rhombic and V-beam antennas are matched by cutting two legs long enough to include an additional one-quarter wavelength at the lowest usable frequency.

The standing wave ratio of an antenna cut for 200 mc dropped from 3:1 at 150 mc to 1:1 at 200, then rose slowly to only 1.6:1 at 250 mc. This shows clearly that antennas cut for the lowest frequency can be used at considerably higher frequencies.—A. L. Munzig
—end—

For Dependable Installations

RELY ON PENN TV ANTENNA MOUNTS

UNIVERSAL PEAK ROOF MOUNT PRA-148

Adjustable to fit any peak roof. Complete with cadmium plated nuts and bolts. Designed for quick easy installations. Takes masts from 3/4" to 2".

Write for complete information on the Penn TV line.

TELEVISION PRODUCTS CO.
3336-38-40 Frankford Ave., Phila. 34, Pa.

EASY MONEY!
JUST SELL US STUFF AND THINGS!
Look what we will PAY you for it:
(Excellent Used Is OK Unless Otherwise Specified)

TELETYPE

TG-7	\$250.00	Model 12	\$200.00
TG-26	175.00	Model 14	50.00
TG-27	125.00	Model 15	250.00
TG-37	220.00	Model 19	300.00
RA-8	100.00	Type 133A	175.00
Re-perforator for Model 15 or 19.....\$50.00			

TEST EQUIPMENT

I-96	\$40.00	TS-120 UP	\$150.00
I-100	75.00	TS-148	125.00
TS-12 AP (2 parts)	100.00	TS-174 U	40.00
TS-13/AP	150.00	TS-175 U	65.00
TS-34/AP	125.00	TS-323 UR	100.00
Spectrum Analyzer, 10 cm			\$200.00
Spectrum Analyzer, 3 cm			400.00
Spectrum Analyzer, 1 1/4 cm			500.00

MISCELLANEOUS

T-47 ART-13 or ATC, good	\$75.00	DY-17 good	\$40.00
T-47A ART-13, good	125.00	BC-312 or BC-342, good used, unmodified	55.00
BC-348-Q or -R, unmodified (we will send you a DW-28 so you can unmodify yours)	60.00	R77 ARC-3, good	\$220.00
J-68 ARC-3, good	\$30.00	RT-18 ARC-1, good	200.00
DY-98/ARC-1, new	9.50	T-67 ARC-3	75.00
BC-788-C	25.00	R-98 ARN-5A	20.00
I-152-A	15.00	ARB (CRV 46151) recvrs, good used, unmodified	\$20.00
BC-639 with RA-42	110.00	FT-224 back plate for control box, new	1.00
LP-21 LM loops for ADF	\$7.00	Deyhydrators	1.00
I-81-A Indicators	\$2.50	I-82-A	\$3.50
Perf. used OK		BC-374-A control box	\$1.00
FT-224 back plate for control box	1.00	R-5 ARN-7	Will pay \$10.00. Must not be modified.
C-4 ARN-7	\$4.00	BC-1333	\$15.00
NR-9-B or -C	4.00	PE-237	7.50
R-5A ARN-7	50.00	BC-1306	20.00
SCR-522-A	25.00	BC-453	10.00
SCR-522-B	30.00	BC-946	10.00
SCR-522-C	35.00		

Plugs, mounts, racks, harnesses, cords needed for all above items. TOP PRICES. Send list.

TUBES
(New, original cartons only)

3BP1	\$1.75	723 A B	\$3.50
301A	2.00	WE 310A, 324A	.50
832A	4.00	WE 329A, 274A	.50
829B or 3E29	4.00	WE 120A, 121A	.35

ROTARY

PE-109	\$15.00	EICOR I-100-A	\$7.50
PE-98	10.00	PU-16 AP	7.50

Any 14 or 28W inverter, output 115V, 400 cyc, 1 phase, 1 to appx. 2 amp. (115 to 250 VA) \$5.00 before shipping, tell us what you have and its condition, and we will send purchase order and instructions. DO NOT SHIP BEFORE GETTING IN TOUCH WITH US. BECAUSE WE MIGHT BE OVERBOUGHT ON YOUR ITEM. If you have something interesting not listed above, please write us. Cash terms to suit you, although we prefer to pay immediately after receipt and inspection. Ask your banker for our Dun and Bradstreet rating.

G. L. ELECTRONICS
905 S. VERMONT AVE. • LOS ANGELES 6, CAL.

WANTED

- PE-237 POWER SUPPLY
- GN-58 GENERATOR
- T306 TRANSMITTER RECEIVER

BEST PRICES—NO QUANTITY TOO BIG,
NONE TOO SMALL.

WRITE TODAY
GIVING DETAILS TO —

Box P-51-7, c/o Radio-Electronics, 25 W. Broadway, N.Y.C.

REK-O-KUT presents a New
Continuously Variable-Speed
Turntable of Broadcast Quality

Plays at any speed from 25 to 100 R. P. M., without "wow!"

Speed can be varied while in operation to produce sound effects.

Now for the first time... a continuously variable turntable of Broadcast Quality at a popular price. Ideal for record collectors, musicians, singers, disc jockeys, broadcast stations, music schools, dance studios, skating rinks, gymnasiums, etc. Plays through amplifier, radio, TV set or phonograph. Operates on 50 or 60 cycles.

Model CVS-12 (illustrated)
Chassis, motor and turntable... \$84.95 net.
Model CVS-12P, mounted in portable case with 16" dual stylus pickup... \$124.95 net.

3-Speed 12" Transcription Turntable

Recommended by outstanding music critics. Invention-type motor designed for smooth, quiet, vibration-free operation. 3 speeds, 78, 45 and 33 1/3.

Model LP-743 \$54.95 net.

Write for Illustrated Catalog of REK-O-KUT Line of Hi-Fidelity Recording Instruments, Phonographs, Transcription Tables, Accessories.

REK-O-KUT CO.
38-11 A Queens Blvd., L.I.C., N. Y.

Consecrated to Quality Output and Golden Rule Service

ASTRON

Fixed Capacitors and
RF Interference Filters

Write for catalogue

ASTRON CORPORATION — 255 Grant Ave., East Newark, N. J.

Single-Dual- and Triple-Section

TYPE PRS ELECTROLYTICS



• Aerovox "Dandees", of course! Tubulars encased in aluminum containers. Especially suitable for tight spots. Single or multiple sections. Insulated stranded wire leads and safety sleeves. Common-negative wire lead. Vented for excessive gas pressure.

Normally supplied with etched foil for utmost compactness, but plain foil also available. High-

purity foil aluminum minimizes corrosion possibilities. Vented for excessive gas pressures. Insulating jacket. Mounting strap. Widest selection of voltages and capacitances. Single-, dual-, triple-, and quad-section units.

Ask your jobber for these Aerovox "Dandees." See listings for any voltage and capacitance combination.



CAPACITORS • VIBRATORS • TEST INSTRUMENTS

For Radio-Electronic and Industrial Applications
 AEROVOX CORPORATION, NEW BEDFORD, MASS., U. S. A. • Sales Offices In All Principal Cities
 Export: 41 E. 42nd St., New York 17, N. Y. • Cable AEROCAP, N. Y. • In Canada: AEROVOX CANADA LTD., Hamilton, Ont.

HUGO GERNSBACK'S

GREAT SCIENCE FICTION NOVEL IS MUST READING

Listen: "NO BOOK in two generations, no book since Jules Verne, has undertaken to do what Hugo Gernsback in the first decade of our century has here so outstandingly achieved."

LEE DE FOREST, Father of Radio.

Forty years ago, Hugo Gernsback, Father of Modern Science Fiction, in this book, **RALPH 124C 41+**, predicted and described in startling detail, radar, the learn while you sleep method, television, televised operas, plastics, night baseball, blood transfusion, wire recording, micro film and a host of other scientific achievements—all undreamed of in 1911—but part of everyday life today.

All of these and scores more, not as yet realized, are found in his remarkable prophetic book. For Hugo Gernsback's prophecies are based not on

fantasy but on the logical projections of established scientific facts.

RALPH 124C 41+ is the first and most remarkable true science fiction novel ever written! A whacking good adventure story that takes place in 2660 AD—but it is far more than fiction!

To technically minded people, **RALPH 124C 41+** is the most complete and accurately documented catalog of scientific prophesy ever published. It was originally written in 1911 and published in book form in 1925. Now, because of its tremendous importance as a work of accurate, scientific prediction of the future, it has been reissued in a new, second edition.

Hugo Gernsback's writings were the spark that started many of today's top radio engineers and scientists on their way. Now again, this new edition of **RALPH 124C 41+** may well be the inspiration for a new generation of pioneers of science.

RALPH 124C 41+ is the kind of book you should read. Order your copy now, only \$2.50 postpaid. The supply is limited.

RADIO PUBLICATIONS

25 West Broadway New York 7, N. Y.

MAIL THIS COUPON TODAY

RADIO PUBLICATIONS

25 West Broadway, New York 7, N. Y.

Gentlemen:

Send me a copy of **RALPH 124C 41+** postpaid, at once. My remittance of \$2.50 is enclosed.

NAME

STREET

CITY ZONE STATE

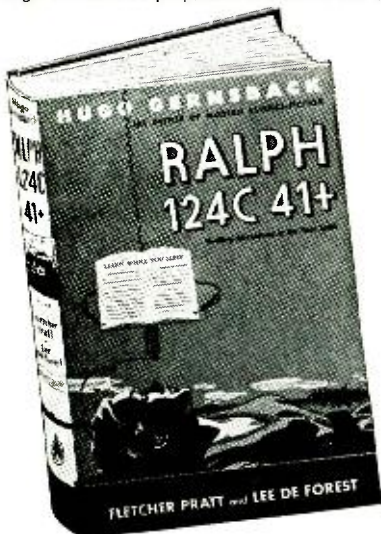

PROTECTING SPEAKER CONES

Most service technicians have accidentally punctured a speaker cone at one time or another while working on a set or carting it to or from the shop. Although such accidents are rare, there is always a chance that it will happen on your next servicing job. A simple protective cover will prevent this and make it less likely to drop bits of solder, metal filings, and dirt between the voice coil and pole piece.

For speakers from 4 to 8 inches in diameter, cut a 10-inch disc from 1/4-inch plywood or similar material. Draw two lines at right angles through the center. With these lines as centers, begin 1 inch from the rim and cut four slots 2 3/4 inches long as at *a* in the figure. They should be just wide enough to pass the square shank on the head of a small carriage bolt. When you finish the slots the disc will look like a lathe faceplate. Make four clamps from strap iron (see *b* in the drawing) and drill holes to pass the shafts of the bolts.

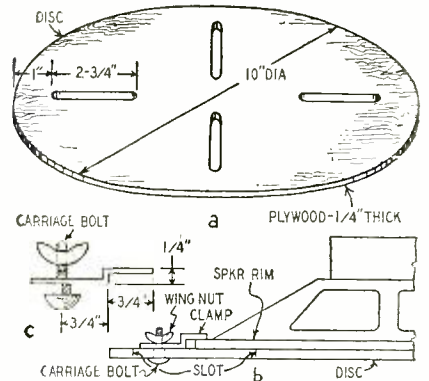

The disc is fastened to the front of the speaker by four small Z-shaped clamps slipped over the shafts of the bolts and held against the rim of the speaker with the wing nuts. The slots grip the shanks of the bolts and prevent them from turning while the nuts are being tightened. (see drawing at *c*.)

For speakers ranging between 8 and 15 inches in diameter, cut the disc at least 17 inches in diameter. The slots should be approximately 4 3/4 inches long and should start about 3/4 inch from the rim.—Francis Robbins

BUILT-IN ANTENNA FOR FM

To install a built-in antenna on FM receivers and tuners simply replace the standard line cord with a flexible, rubber-covered, three-wire cord. Connect two of the conductors to the power supply and line plug. One end of the third wire connects to the antenna terminal, and the other end is cut to approximately 6 feet and taped.

If a three-conductor cable is not available, take a 6-foot length of insulated wire and tape it to the power cord with cellophane tape.

The third wire has some direct pickup plus additional pickup through capacitive coupling to the line. The system is used by some commercial receivers. This type of antenna can be used with AM sets as well, if the signals override the static on the line.—Arthur Trauffer

Technical Bulletins

EACH \$1.00 Postpaid Foreign \$1.25

Simplified technical information on many subjects of everyday usefulness, written in simple, easy-to-understand language. They contain no complicated mathematics, chemical and electrical theories, and are not based on the assumption that the reader has had a technical training.

(102) Cleaning Products for Many Purposes—Over 35 effective chemical cleaners that you can make and sell.

(110) Electroplating Non-Metallic Objects—Includes wood, leather, plaster, glass, flowers, insects, fabrics. Complete directions.

(114) Thermostats Easily Made—Designing and making automatic control units of many types for maintaining uniform temperatures, automatic furnace regulation, safety controls to prevent overheating, etc.

(115) Glue Molds for Casting Novelties—Making flexible glue molds for casting small objects, using plastics, magnesite.

(119) Electroplating with Alloys—Bronze, brass and cadmium-silver. Improves finish and provides durable coating.

(123) Mirror Silvering—Make money resilvering old mirrors and making new ones. Colored, front-surface, transparent and photo mirrors.

(124) Soldering All Metals—Includes aluminum and die-cast alloys. Secrets of using the right flux and correct technique.

(125) Buffing & Polishing—All details on correct polishing. How to select the right abrasive for different kinds of metal. Gives wheel speeds, types and sizes of motors for best results.

(129) Coloring Metals Chemically—Tested formulas and directions to produce durable finishes in many colors on brass, copper, iron, aluminum and their alloys by chemical processes.

(130) Glass-Working Technique—How to cut, drill, grind and mount glass correctly; includes cutting of circles and internal openings.

(132) Working with Plastics—Covers all details of cutting, tooling, bending, cementing and polishing. Enumerates various kinds. Shows how to design articles. Includes using liquid plastics.

(139) Rubber Molds for Casting Novelties—Used for same purpose as glue molds but where greater elasticity is required.

(141) Recording Thermometer—How to make device to record room temperatures over 12-hour periods on a disk. Has alarm-clock mechanism.

(146) Simplified Casting Methods—Making small castings of soft metals without use of sand molds. For novelties, toys, etc.

(147) Drills and How to Use Them—How to use drills in different metals, plastics and other materials. How to sharpen correctly. Includes charts giving speeds and rate of drilling.

(149) Electroplating with Copper, Nickel, Chromium, Zinc, Lead and Cadmium—Enables anyone to do this fascinating work on a small scale.

(156) Home-Maintenance Formulas & Repairs—Includes a large number of simple, effective solutions for everyday household problems.

TECHNIFAX, 520 N. Michigan Ave. Chicago 11, Ill.

Enclosed find \$..... for which send the following Technical Bulletin at \$1.00 each (Foreign \$1.25) as indicated by numbers:

Name _____

Address _____

City & State _____

RE-7-51

B-SUPPLY USES OLD TUBES

The next time you start to hook up an experimental power supply and find that you don't have a suitable rectifier, look around and see if you can find a 25L6, 35L6-GT, 50B5, or similar out-

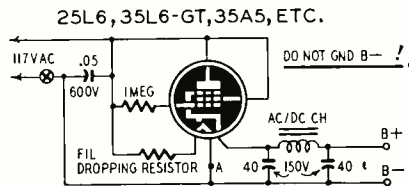

put tube that is weak or not being used. The circuit shows how these tubes can be connected as half-wave rectifiers. The filament-dropping resistor should be selected to supply the correct voltage to the heater or heaters. Other tubes can be connected in series and inserted at A on the diagram.—M. G. Williams

BRUSH FOR SPEAKER CEMENT

Some makes of speaker cement do not have a brush or applicator built into the bottle cap. Consequently, the brush always gets hard and must be discarded. I prevent this by drilling the bottle cap to pass the handle of a small metal-handled glue brush. The handle is then soldered solidly to the cap with an airtight joint. The tip of the brush will not harden because it is immersed in cement when not in use.—Manuel E. Silva

TRANSMITTING-TUBE CHECK

You can tell when your transmitting tubes are going sour if you will make a note of the plate-current readings of new tubes for a given load and plate voltage with the transmitter operating normally. When a tube starts to lose emission, the plate current will begin to drop off from its former fixed value and its output will be less. Class B modulators are checked by watching for a decrease in the static plate current. A gassy tube will cause a higher-than-normal plate-current reading.—Norris C. McKamey

LONGER LIFE FOR METERS

The life and accuracy of the sensitive movement of a 20,000-ohms-per-volt multimeter can be prolonged by keeping the function switch set to A.C. VOLTS whenever the meter is being carried on outside jobs. Setting the meter to read a.c. voltage damps the meter movement by shunting it with the low resistance of the instrument rectifier. This damping action greatly reduces pivot wear caused by bouncing while in transit. This fact can be verified by setting the meter to DC VOLTS and giving it a quick jerk. The meter will swing wildly upscale. Try an a.c. range and note how much the needle is damped.

The meter can also be protected against vibration and sudden jolts by setting the function switch to a high current range. This damps the movement by loading it with the current shunts. This method is not recommended. The meter will burn out if you forget to switch the meter before measuring voltage.—Milton Kalashian, WINXT

FREE! Just For Examining **COYNE'S** New 5-Volume Set

APPLIED PRACTICAL RADIO-TELEVISION

Get this Book of TV PICTURE PATTERNS & WAVE FORMS—FREE! Gives you dozens of actual TV Test Patterns and wave forms—tells how to use them to shoot trouble and repair TV sets quicker, easier. Money-making short cuts that help you get ahead in Television. It's yours FREE!

Complete Practical — Up-to-Date!

This book is our gift to you for examining Coyne's brand new 5-volume set APPLIED PRACTICAL RADIO-TELEVISION. Here is the most completely up-to-date set of reference books in America! 1500 easy-to-understand pages; 1000 illustrations—covers all phases of radio and television. Tells you how to install, service, trouble shoot, align all types of radio and television sets. "Break-down" photos help you understand quicker.

Sensational Free Book Offer Send No Money!

Mail coupon now to get this great new 5 volume set and the FREE Book of Picture Patterns. Use the set 3 days. If you keep the set, pay just \$3.00 after 7 days and \$3.00 a month until \$18.50 plus postage is paid. (Cash price \$15.00.) If not 100% satisfied with set send it back and owe us nothing. EITHER WAY THE BOOK ON TV PICTURE PATTERNS IS YOURS FREE. Coupon is just a request to see set and get Free book of picture patterns. This offer is limited. ACT NOW!

FREE ON 7 DAYS TRIAL

MAIL COUPON NOW!

COYNE ELECTRICAL & TELEVISION-RADIO SCHOOL
500 S. Paulina St., Dept. 71-11 Chicago 12, Ill.

Rush "APPLIED PRACTICAL RADIO-TELEVISION" on 7 days' FREE TRIAL, per offer above.

Name _____ Age _____

Address _____

City _____ Zone _____ State _____

Where Employed _____

Check here if you want set sent C.O.D. You pay postman \$15.00 plus C.O.D. postage. Same money-back guarantee of satisfaction.

BUILD THIS RCP KIT!

IT'S EASY! IT'S FUN! IT SAVES YOU MONEY!



MODEL 345K SUPER VACUUM TUBE VOLTMETER

COMPLETE KIT ONLY **\$26.95**

NOTHING ELSE TO BUY!

MORE THAN 150,000 RCP INSTRUMENTS IN USE TODAY . . . PROVE THEIR SUPERIORITY

Now you can get in KIT form the best professional test equipment made by Radio City Products Co. You get kits that are complete with all necessary parts and easy-to-follow assembly instructions. There is nothing else to buy! Yes, an RCP kit provides an enjoyable few hours in construction and instruction plus a finished test instrument at a tremendous saving!

Features: long scale 1 1/2" meter in burn out proof meter circuit—electronic balanced bridge type push pull circuit—negligible current drawn due to high input impedance of 25 megohms—Isolation Probe—center of ohm scale 10 ohms—5 ohmmeter ranges reading from 2 ohms to 1 billion ohms (1000 megohms). 20 voltage ranges 0-1000 volts including AC and DC—Complete D.B. meter. Discriminator alignment scale with zero center permitting operation in both directions. Operates on 105-130 volts, 50-60 cycles—Extra heavy panel, case and chassis. Size 10" x 6" x 5". Weight 8 3/4 lbs. Shipping weight 11 lbs.

Buy from your Jobber • Insist on RCP Write for Catalog RE-7

RADIO CITY PRODUCTS CO., INC.

152 West 25th St.  New York 7, N. Y.

FREE to Radio-TV Service Technicians



the new fact-packed
PF INDEX!
(PHOTOFACT INDEX AND TECHNICAL DIGEST)

- ★ Each issue packed with authoritative articles on TV, Radio, latest servicing techniques
- ★ Latest complete Index to PHOTOFACT, world's finest service data

Don't miss a single issue! Be sure to get your PF INDEX—the valuable new publication you'll read from cover to cover—and use at your bench every working day.

PF INDEX brings you complete, fully illustrated discussions of latest developments in Radio and TV. Keeps you up-to-date on new circuit designs, latest testing methods, time-saving repair techniques, good shop practices—helps you operate a better, more profitable business.

Have all this practical, authoritative information plus the complete Index to PHOTOFACT Folders—the quick reference guide to the world's finest service data. PF INDEX is worth dollars to you—and costs you nothing. Get your FREE copy today!

Ask Your Jobber for It!

HOWARD W. SAMS & CO., INC.

Get the current PF Index from your Parts Jobber, or write us direct on your letterhead (or enclose business card). Address: Howard W. Sams & Co., Inc., 2201 E. 46th St., Indianapolis 5, Ind.

FREE

Send FREE copy of the current PF Index

Name.....

Address.....

City.....State.....

THERMAL SHUNT

While studying the effect of heat on the value of resistors and other components used in electronic equipment, the Telecommunication Research Establishment, a branch of Britain's Ministry of Supply, found that small composition resistors can be ruined by heat when using standard soldering techniques. The heat from the soldering iron may cause the value of the resistor to increase or decrease by 20% or more. *The body temperature of the resistor should be restricted to 100° C and preferably 50° C if permanent change in the initial value is to be avoided.* In most cases, the temperature rise does not reach the critical value when the length of lead between the body and soldered joint is at least 1/2 inch.

Leads 1/2 inch long are prohibitive in most miniature apparatus, so a *thermal shunt* was developed to dissipate the unwanted heat and prevent it from reaching the body of the component. The shunt consists of a crocodile clip with copper bars 1/8 inch thick, 1/4 inch wide, and 1 1/2 inches long sweated to its jaws. The shunt is clamped to the resistor lead so it is at least 1/16 inch from the body of the resistor and from the soldering lug. It should be left in this position for at least 15 seconds after the iron is removed from the joint.

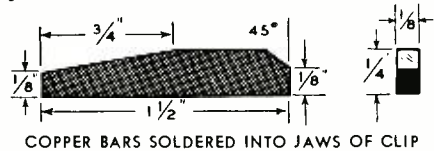

COPPER BARS SOLDERED INTO JAWS OF CLIP

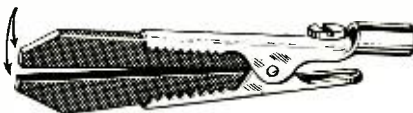

(a) SHUNT DIMENSIONS AND CONSTRUCTION.

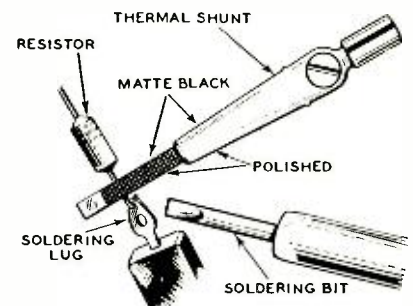

(b) SOLDERING SET-UP USING THE SHUNT.

The construction of the shunt is shown at *a* and method of using it is shown at *b* in the drawings. The surface next to the resistor should be finished with a flat black paint. The opposite side should be polished so heat will be radiated away from the resistor.

This will be found to be a useful device to have around the shop or laboratory. With the trend today to smaller components, the need for direct applications of small amounts of heat is becoming more important. Not only resistors, but miniature capacitors require careful handling.

—end—

NOW IN BOOK FORM

John T. Frye's outstanding series on the fundamentals of radio servicing!

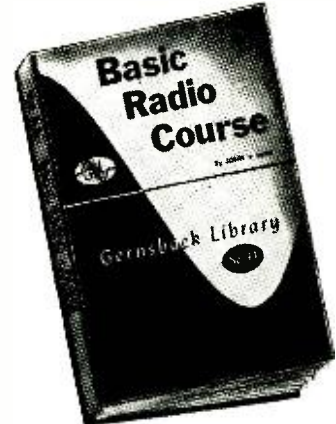

Only \$2.25

176 Pages

130 Illustrations

First Gernsback Library Book with Durable hard-cloth cover

One of the finest books on fundamentals ever written for the practical service technician. BASIC RADIO COURSE starts with Ohm's law, then takes you through the circuits of a modern radio set and tells you how and why they work. It's actually a pleasure to read because the author believes learning should be fun. He talks the service technician's language and isn't afraid to make you smile once in a while. But BASIC RADIO COURSE doesn't skimp on facts. It gives you all the technical information you'll find in a higher priced book. But, you'll enjoy reading it and you'll save money.

PUBLISHED BY REQUEST

BASIC RADIO COURSE was published at the request of many radio men who read, enjoyed and learned from John Frye's series on the fundamentals of radio servicing which concluded only recently in RADIO-ELECTRONICS. It can help the experienced technician as well as the beginner. Order your copy today.

TWENTY-SIX CHAPTERS

The Electron Theory • Ohm's Law and the Resistor • What is Induction? • Capacitance • How Capacitors are Made • Reactance, Impedance and Phase • Resonant Circuits • Transformers—How They Work • The Diode Vacuum Tube • Triode and Tetrode Tubes • The Pentode Vacuum Tube • Vacuum Tube Characteristics • The Power Supply • Power Supply Types • Sound and Loudspeakers • The Power Output Stage • The Voltage Amplifier • Demodulating the R. F. • Receiver Selectivity • The Converter Stage • Some Oscillator Circuits • How To Trap a Signal • Signals in Space • Receiver Refinements • Instruments and Tools • Service Techniques.

Order your copy from your distributor or MAIL THIS COUPON TODAY

Radcraft Publications, Inc., Dept. 71
25 West Broadway
New York 7, N. Y.

My remittance for \$2.25 is enclosed. Please send me a copy of Book No. 44, BASIC RADIO COURSE postpaid.

NAME.....

STREET.....

CITY.....ZONE.....STATE.....

RADIO-ELECTRONICS for

SENSITIVE 4-TUBE REGENERATIVE RECEIVER

? I would like to see a diagram of a 4-tube short-wave regenerative receiver using any of the following tubes: 12SA7, 12SQ7, 6K6, 35Z5-GT, and 50L6-GT. Please show how my 4-prong coils (see inset) can be used in the circuit which you prepare. I want to use a pair of crystal phones, so include a means of silencing the speaker when the phones are plugged in.—E. S., Toronto, Ont.

feedback winding determine the ease with which the detector goes in and out of oscillation as the regeneration control is varied. The direction in which the feedback winding is wound determines whether the set will oscillate or not. If the circuit does not oscillate with your coils, transpose the connections between the ends of the tickler and pins 1 and 4 on the coil form. Try different values of resistance for the

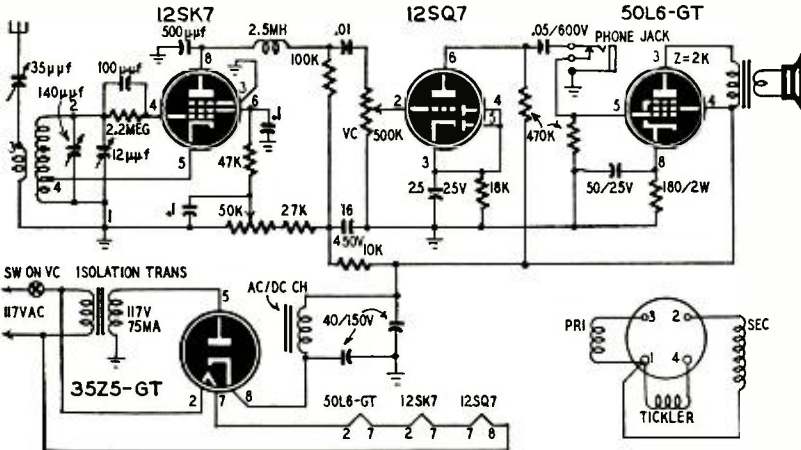

A. The circuit of a sensitive regenerative set is shown in the diagram. The tube heaters are connected in series across the a.c. line. The B-supply is taken from the secondary of a small isolation transformer. If this type of transformer is not available, you can use two 6.3-volt, 2-ampere filament transformers connected back-to-back.

The size of the detector grid-leak and the number of turns on the tickler or

oscillator grid-leak and use the value that provides the smoothest control over regeneration.

The performance of the set can be slightly improved by shunting the 100,000-ohm plate resistor with an audio choke of 300 henries or more. Use an audio transformer with primary and secondary connected in series (in the direction giving best results) for this choke, if you have one on hand.

STACKING TELEVISION ANTENNAS

? I have four 300-ohm Yagi antennas which are cut for channel 13. Please show how I can stack these so that the array will match a 300-ohm transmission line. How much gain can I expect by stacking the antennas?—M. H. H., Pittsburgh, Pa.

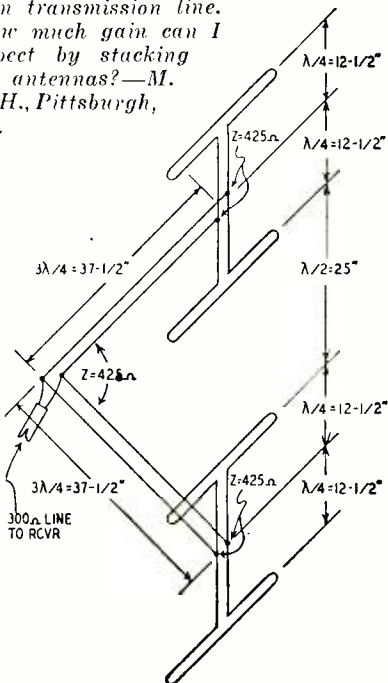

A. With correct interbay spacing and a perfect match to the transmission line, a 4-bay stacked antenna will have a theoretical gain of approximately 6 db over that of one of the antenna sections used alone. This assumes that the signal strikes all the antennas equally with respect to phase and amplitude. Therefore, the maximum gain is possible only when the signal is free from multipath reflections. Location in this case is important.

Stack the antennas one-half wavelength apart and connect them in pairs with 425-ohm matching sections as shown in the diagram. The centers of the matching sections connect to two 3/4-wavelength 425-ohm sections which are connected in parallel across the 300-ohm lead-in. The 425-ohm matching sections may be 1/2-inch tubing spaced 4 1/2 inches or No. 12 wire spaced 1 1/2 inches.

This stacking arrangement can be used for TV antennas cut to other frequencies and having different impedances. The length of the matching sections and the interbay spacing in wavelengths will remain constant. The spacing and size of the conductors used in the matching sections are determined by the impedances of the line and antennas.

DUAL SPOTLIGHTS

Banish All Shadows

With New Light Duty Soldering Gun

It's the newest convenience in soldering. Twin Spotlights on your new 135-watt WELLER Soldering Gun completely eliminate shadows; you see clearly even in the darkest chassis.

Pull the trigger of your WELLER Gun, heat and light come on together—in just 5 seconds!

No more waiting, wasted current, or blind soldering. Your WELLER Gun pays for itself in a few months!



NEW
135-WATT
WELLER
SOLDERING
GUN

Specially Designed for TV and Radio Work

- **DUAL SOLDERLITE**—Two prefocused spotlights completely eliminate shadows—let you see clearly what you are soldering.
- **OVER/UNDER DESIGN**—Tube construction braces tip and improves visibility.
- **5-SECOND HEATING**—No waiting. Saves power. Pull the trigger and you solder!
- **LONGER REACH**—Slides easily into deep chassis, reaches the tightest corners.
- **GREATER CAPACITY**—Smaller, lighter, with greater soldering capacity.
- **TRIGGER-SWITCH CONTROL**—Adjusts heat to the job. Saves current—no need to unplug gun between jobs.
- **DUAL HEAT**—Single heat 100 watts; dual heat 100/135 watts; 120 volts, 60 cycles. Handles all light-duty soldering.

See new Models WS-100 and WD-135 at your distributor, or write for bulletin direct.

• **SOLDERING GUIDE**—Get your new copy of "Soldering Tips"—revised, up-to-date and fully illustrated 20-page booklet of practical soldering suggestions. Price 10¢ at your distributor, or order direct.



WELLER

ELECTRIC CORP.

828 Packer Street, Easton, Pa.

TRANSVISION

ANNOUNCES

NEW LOW PRICES
on 17"-20" TV KITS, SETS,
CHASSIS and CABINETS

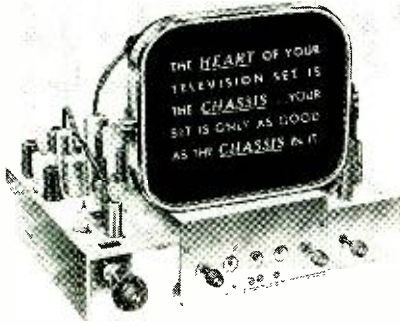

SAVE UP TO 50%!

Transvision makes the finest TV KITS, SETS, and WIRED CHASSIS that money can buy. PRICED AMAZINGLY LOW. Kits are easy to assemble. Give top quality picture and sound. Ideal for both hobbyists and dealers.

BEAUTIFUL NEW CABINETS
Write for Catalog RE

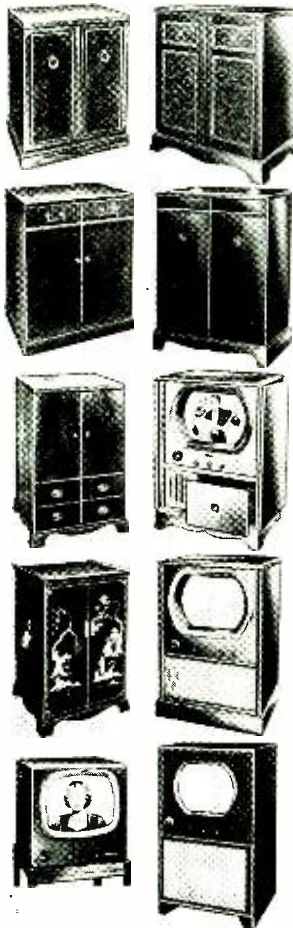

Write for Prices and Details Today!

TRANSVISION, INC.
Dept. RE NEW ROCHELLE, N. Y.

BAND-REJECTION FILTER

? Please print a circuit of a filter network which will attenuate by 3 db or more all signals between 880 and 3,400 cycles. This filter is to be used in a 200-ohm audio line.—M. T., Peru, Ind.
A. A band-rejection filter having the characteristics you want would be diffi-

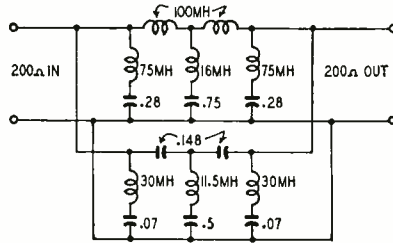

cult to design and construct, so we have prepared this circuit which should do the job for you. It consists of a three-section high-pass filter network cutting off at 3,400 cycles paralleled by a three-section low-pass filter cutting off at 880 cycles. Both of the filter units being designed for 400-ohm lines, there will be a slight mismatch in each. The existing mismatch should not be great enough to affect the performance of the circuit as a whole.

It is recommended that the high- and low-pass filters be shielded from each other. The shunt inductors should be mounted so their axes are at right angles to each other.

ANTENNA TUNING COUPLER

? I use a 300-foot long-wire antenna for broadcast and international short-wave reception. I would like to have details on constructing a coupler for tuning the antenna system for optimum performance on any frequency and coupling it to a receiver which has terminals for a doublet antenna.—G. T., Little Rock, Ark.

A. The diagram shows a tuner that should do much to improve the perform-

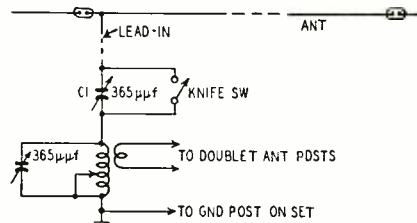

ance of your antenna. Two 365-µf capacitors are used. C1 is in series with the antenna and effectively shortens it. The parallel-tuned circuit has the effect of lengthening the antenna. The coil consists of approximately 30 turns of No. 12 or 14 bare wire on a 2½-inch form. The turns should be spaced the diameter of the wire. A small clip should be provided for shorting out turns when necessary. The pickup loop is 3 turns of No. 18 hookup interwound with the turns at the antenna end of the large coil.

Remember, however, that short-wave station signals are often weak. In some cases it might be advisable to use special directional antennas.

ELIMINATING NECK SHADOW

? I am having trouble eliminating shadows on the left and lower right sides of the 12LP4 picture tube in my TV set. I've tried replacing the 6BG6-G and 5V4-G damper tube, but new tubes don't remove the shadow. Can you help me to correct this condition?—N. LaS., Torrington, Conn.

A. The dark areas or shadows on your picture are probably neck shadows caused by obstruction of the electron beam before it reaches the sides of the screen. This condition exists when the deflection yoke or focus coil is too far back on the neck of the tube. It may also occur when the neck of the tube is not centered in the focus coil. Make sure that the neck of the tube is horizontal and parallel to the chassis and that it is centered in the deflection yoke and focus coil. Try moving the focus and deflection coils as far forward as possible. Transpose the leads to the focus coil. Reversing these leads will reverse the relative operation of the centering adjustment screws but will not affect the operation of the set. Misadjustment of the ion trap magnet may cause the trouble, too.

Sometimes small shadow areas can be eliminated by moving the picture slightly off center and advancing the width control. This does not remove the shadow, but hides it behind the mask.

Neck shadow also has been traced to a distorted picture tube in which the axis of the neck is not in line with the axis of the bulb. Close examination will show the neck to be slightly off center or to be cocked off at an angle. Rotating the tube in its mount will often remove shadows which will not respond to more conventional treatment.

PHONO MIXER PANEL

? Please print a diagram of a non-electronic mixing and volume-control panel for use with three phonograph pickups, without interaction.—P. C., Haverford, Pa.

A. Interaction between the controls can be minimized by connecting isolat-

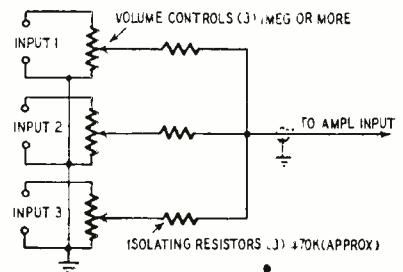

ing resistors in series with the arm of each control as shown in the diagram. The value of each isolating resistor should be approximately one-half the resistance of each control. Use the smallest value which will prevent interaction. This setup can be used for an indefinite number of controls. The only disadvantage is that the signal input may drop and a tone-control effect is noticed if several controls are simultaneously set at zero.

PHOTO TIMER

? I would like to have a diagram of a photo timer having three controls for setting the timed interval from 0.1 second to 100 seconds. If possible, please design the circuit around a 117L7-GT and a 2,500-ohm plate relay.—H. W. H., Irwin, Pa.

A. This circuit will time intervals from 0.1 second to 101 seconds in decade

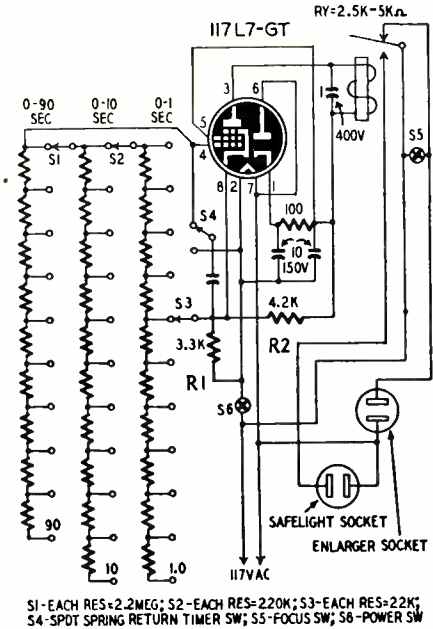

steps of 0.1 second. For high accuracy, the resistors in the timing circuit should be matched pairs of 5% or better.

Calibrate the timer on the 0-100-second range using a stop watch for measurements. If the timed interval is too long increase R1 and decrease R2 slightly. If it is too short, make R1 larger and R2 smaller. Slight changes in calibration can be made by varying the tension on the relay spring. Remember that absolute accuracy of timing (if required) depends on stable line voltage regulation.

TRANSFORMER SPECS

? Please give specifications on the output transformer used in the sound alarm described on page 31, October, 1950, issue.—E. H., Columbus O.

A. Any plate-to-voice coil output transformer will do the job. However, it is advisable to use one having a primary impedance of 20,000 ohms or more. Your best bet will be to use a standard intercom input transformer which may have a secondary impedance of 38,400 ohms or higher.

Many constructors use standard output transformers connected in reverse when small PM speakers are used as microphones. Pickup improves in almost all cases where the output transformer is replaced with a standard intercom input transformer. It should be remembered that specialized input transformers are so designed as to give maximum transfer of energy with minimum pickup of noise and hum. Also, various input impedances can be matched more readily.

—end—

You DON'T have to know the language

University LOUDSPEAKERS



You can be certain that in any language, anywhere in the world, it's UNIVERSITY for top acoustic reproduction... for every indoor and outdoor installation! UNIVERSITY "progressive engineering" works constantly to meet the new needs of sound casting techniques as they develop. Thus, UNIVERSITY loudspeakers keep in step with the times through design by farsighted experts, plus field-tested performance that means trouble-free operation.

You need the TECHNILOG

Get your free copy! The new 1951 Technical Catalog for sound technicians, installation engineers, and service personnel. Write for your copy now — address Desk 52.



UNIVERSITY LOUDSPEAKERS • INC

80 SO. KENSICO AVE. WHITE PLAINS, N. Y.



REFLEX TRUMPET MODEL PH

with MODEL PA-30 DRIVER UNIT



Typical of dependable UNIVERSITY reflex trumpets for indoor and outdoor use. Made of heavy castings and thick gauge spacings exact to precise formulae for superior excitatory properties. Sturdy, serrated adjustable mounting bracket simplifies installation and assures positive grip. Exclusive set-screw arrangement prevents driver unit from working loose. All parts chemically treated prior to application of hard-baked enamel finish for maximum protection against weather and corrosive agents. PMA adapter facilitates pipe mounting.

The Book that takes Drudgery out of Mathematics

Only \$1.00 postpaid

ELEMENTARY MATHEMATICS

SOLVES EVERYDAY PROBLEMS HELPS YOU GET AHEAD IN LIFE

How many times have you lost money because of a mistake in figuring? Do you know how to figure quickly and correctly? Can you figure discounts, interest rates, taxes and all the other calculations you meet up with in your daily life?

Are you having trouble qualifying for Civil Service Exams or Armed Services Promotions, because you're not up on mathematics?

Here is the book that gives you a good background in mathematics; that takes all the irritation and drudgery out of it. You don't need to be scared of mathematics, because here's the subject explained without frills, without useless computations. Here's the book for men in radio jobs; for business men; technicians and craftsmen, explaining and answering everyday mathematic problems in easy-to-understand words and illustrations.

Yes, it's the key to a simple understanding of mathematics. It's a real home-study course in mathematics for the man who's alert to its importance in the world today.

ELEMENTARY MATHEMATICS
● EASY — SIMPLIFIED — PRACTICAL ●

CONTENTS OF BOOK

CHAPTER I. Arithmetic — Addition — Subtraction — Multiplication — Division.

CHAPTER II. Factoring and Cancellation — Fractions — Decimals — Percentage — Ratio — and Proportion.

CHAPTER III. The Metric System.

CHAPTER IV. How to Measure Surfaces and Capacity (Geometry).

CHAPTER V. Powers and Involvement — Roots and Evolution.

CHAPTER VI. Mathematics for the Manual and Technical Craftsman — Thermometer conversions — Graphs or Curve Plotting — Logarithms — Use of the slide Rule.

CHAPTER VII. Special Mathematics for the Radio Technician.

CHAPTER VIII. Commercial Calculations — Interests — Discounts — Short Cut Arithmetic.

CHAPTER IX. Weights and Measures — Useful Tables.

ONLY \$1.00 POSTPAID

Send Stamps, Cash or Money Order.

Send Today for Your Copy of This Indispensable Book. It Can Be Hurdled Readily in Your Pocket. (Size 6 x 9 in.)

TECHNIFAX
528 N. Michigan Ave. Chicago 11, Ill.

AUTOMATIC M-90 AUTO RADIO



- Six Tube Superheterodyne • Three Gang Condenser • Powerful, Long-Distance Reception • Fits All Cars, Easy Installation
- Mounting Brackets Included
- 6 Tube model M90.....*\$53.87

Approx. shipping weight (11) eleven pounds.

MAIL US YOUR ORDERS

All orders filled within 24 hours. Standard Brand tubes 50% off list

Bill Sutton's Wholesale Electronics
Fifth at Commerce Fort Worth, Texas

MICRO CIRCLE CUTTER

FOR METAL WOOD • PLASTICS

- Micrometer type size control
- Extra heavy duty beam
- Special beam locking mechanism

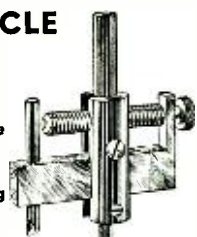

At all dealers

Model	Type	Size	Price
1	Round shank	4 inch	\$5.00
1	Square shank	4 inch	5.00
5	Round shank	6 inch	7.50

PRECISE COMPANY 942 Kings Highway
BROOKLYN 23, NEW YORK

THE FUND TOPS \$8,000.



HELP-FREDDIE-WALK FUND

It has been a source of great gratification to us to note that the Freddie Fund with this month has reached \$8,176.78.

Little three-year-old Freddie, as our readers know by this time, is the completely legless and armless son of Herschel Thomason, Arkansas radio technician.

Freddie still has to make constant trips to the North where his doctors are fitting him with the necessary appliances so in time he will be able to walk and use artificial legs and arms. The case is greatly complicated by the fact that Freddie has not a vestige of either arms or legs and there are no stumps on which to fit appliances. In time he will have to use his body muscles to obtain articulation for the artificial arms and legs.

The FAMILY CIRCLE Magazine, which also became interested in Freddie's case, continues to be high on the list of contributions which we report below:

FAMILY CIRCLE magazine contributions.

Balance as of April 19, 1951	\$253.95
A Prayerful Mother—New Hartford, N. Y.	2.00
Susan R. Baker—New Castle, Ill.	5.00
Mr. & Mrs. William F. Barnes—Chicago, Ill.	5.00
Lucy B. Bloch—Los Angeles, Calif.	3.50
Mr. and Mrs. J. L. Boyd—Charlotte, N. C.	6.00
Mr. & Mrs. James Brightwell—Belmont, W. Va.	1.00
Mrs. C. Portland, Oregon	2.00
Mrs. John M. Clausen—Rainier, Oregon	1.00
Eleanor Clementi—Pueblo, Colo.	1.00
Mrs. Jean R. Duff—Peekskill, N. Y.	5.00
Mrs. Gladys A. Donnelly—East Orange, N. J.	10.00
Mrs. George Eshelman—Quarryville, Pa.	2.00
Mrs. Charles J. Falso—Cincinnati, Ohio	1.00
Mrs. F. Faider—Brooklyn, N. Y.	2.00
Mrs. F. Goulet—Philadelphia, Pa.	.50
Mrs. Charles D. Grafton—Philadelphia, Pa.	2.00
Elizabeth J. Griffin & Tris—Cheyenne, Wyo.	2.00
Mrs. A. Grow—Trail, Oregon	1.00
Catherine T. Haley—Chicago, Ill.	1.00
Mrs. W. E. Hyatt—Glendale, Calif.	10.00
Mr. & Mrs. Fred E. Jenni—Horicon, Wis.	5.00
Sara Joyner—Richmond, Va.	1.00
Mr. & Mrs. Chester R. Kennedy—Pittsburgh, Pa.	10.00
Mrs. E. F. Kennedy—Philadelphia, Pa.	1.00
Mrs. E. F. Kalacny—Englewood, Colo.	2.00
Ruth Lapp—Syracuse, N. Y.	2.00
Jean McDowell—Philadelphia, Pa.	1.00
Mrs. George D. Manderbach—Wyomissing, Pa.	1.00
Mrs. D. Newton—El Cajon, Calif.	1.00
Mr. & Mrs. S. Wm. Patis—Chicago, Ill.	6.00
Ardelle Quinn & Mother—Glendale, Calif.	1.00
Roger & Carole Rapp—St. Louis, Mo.	1.00
Nettie Rickert—Bellmore, N. Y.	3.00
Donald L. Sandberg and Family—Long Beach, Calif.	5.00
Mrs. E. K. Schoen—Phoenix, Ariz.	2.00
Rachel Schwartz—Brooklyn, N. Y.	1.00
Mrs. S. Smith—Burlington, Vt.	1.00
Mrs. Barbara J. Triche—El Segundo, Calif.	5.00
Mrs. E. Wesley—Oakland, Calif.	5.00
Mrs. L. L. Whitehead—Washington, D. C.	2.00
Mr. & Mrs. L. F. Williams—Chapel Hill, N. C.	6.00
Mary Witkowski—Painesville, Ohio	1.00

FAMILY CIRCLE contributions received up to May 18, 1951.....\$379.95

RADIO-ELECTRONICS for

IF IN DOUBT,

THROW IT OUT!

That is our rule for raw materials going into Planet electrolytic capacitors. The manufacturing standards set for high-quality Planet capacitors will not allow compromise in the matter of materials and components.

Aluminum foil, condenser paper, chemicals — all items used in our electrolytics — are purchased against strict specifications from thoroughly reliable sources, then subjected to exhaustive analysis and tests before usage.

Screening out all possible trouble at the source makes the finished product trouble-free — eligible to bear the Planet trademark.

For complete information, write for the latest Planet Catalog, C-2.

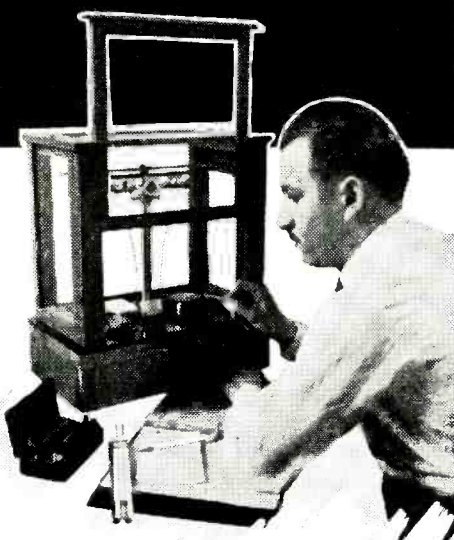

PLANET MANUFACTURING CORPORATION
225 Belleville Avenue, Bloomfield, N. J.



JFD "Little Giant" TWIN LEAD LIGHTNING ARRESTER

Protects TV Sets Against Lightning and Static Charges

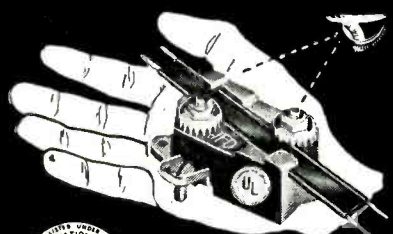

No. AT105
\$125
List

SFEING IS BELIEVING!

ONLY JFD Lightning Arresters offer you these exclusive patented features...

1. Patented strain-relief Retaining Lip which prevents pulling or straining against contact points.
2. You actually see positive contact made with lead-in wire.
3. Lead-in contact remains fully visible at all times.
4. No wire stripping. No Arrester Cover to Hide Poor Contacts!

At Your Jobber or Write Direct

JFD MANUFACTURING CO., Inc.
6101Q 16th AVENUE, BROOKLYN 4, N. Y.
FIRST in Television Antennas and Accessories

LEARN

Television - Radio - OR Electricity
IN THE GREAT SHOPS OF **COYNE**



TRAIN QUICKLY!
OLDEST, BEST EQUIPPED SCHOOL of ITS KIND in U.S.
Young and Older Men

Come to the Great Shops of Coyne in Chicago. Get practical training in TELEVISION-RADIO or ELECTRICITY — vital in Defense Program. Prepare now for a better job or better service rating.

START NOW — PAY LATER

You can finance most of your tuition, pay for it later in easy monthly payments. Special plan for men of Draft Age. Part time employment service available. GI APPROVED

FREE BOOK Clip coupon for Big Free Illustrated Book. Indicate below, course that interests you. No salesman will call. Act NOW.

An Institution not for Profit

B. W. COOKE, Pres.
COYNE Electrical & Television-Radio School,
500 S. Paulina St., Chicago 12, Ill. Dept. 81-81H

Send FREE BOOK and full details on:
 TELEVISION-RADIO ELECTRICITY

NAME.....

ADDRESS.....

CITY..... STATE.....

We are also pleased to report the following collection made:

\$5.00 contributed by the Yadkin Valley Radio Club of North Wilkesboro, N. C. through the efforts of Robert M. Harvey.

RADIO-ELECTRONICS CONTRIBUTIONS

Balance as of April 19, 1951.....	\$7,691.83
A Friend—Dayton, Ohio.....	4.00
A Friend—Mingo Junction, Ohio.....	1.00
Fred A. Anderson—Wilmington, Dela.....	1.00
Anonymous—Oakland, Calif.....	1.00
Anonymous—Wallingford, Conn.....	1.00
Anonymous—Chicago, Ill.....	.50
Anonymous—Lake Odessa, Mich.....	2.00
Anonymous—Lake Odessa, Mich.....	2.00
Anonymous—St. Louis, Mo.....	1.00
Anonymous—Hysham, Mont.....	1.00
Anonymous—Gilead, Nebr.....	1.00
Anonymous—Manchester, N. H.....	1.00
Anonymous—Bernardsville, N. J.....	1.00
Anonymous—Lanikai, Hawaii.....	1.00
F. Blum—Newark, N. J.....	1.00
E. F. Bowman—St. Louis, Mo.....	1.00
George Checkas—Dallas, Tex.....	1.00
Addie Lee Domangue—Houma, La.....	5.00
H. W. Fisk—San Francisco, Calif.....	2.00
Alexis Hebert—Southbridge, Mass.....	1.00
Sigmund S. Kahn, M.D.—Brooklyn, N. Y.....	5.00
Anthony Kolwaczyk—Dudley, Mass.....	1.00
Soul Kozuch—Orange, N. J.....	2.00
Frederick M. Levin—Philadelphia, Pa.....	1.00
Fred Lynn—Brooklyn, N. Y.....	3.00
H. D. McBride—Los Angeles, Calif.....	1.00
Wm. F. McGowan—Alameda, Calif.....	10.00
Floyd A. Marsellos—Houston, Tex.....	5.00
J. A. Mencos—Ticuisati, Guatemala, C. A.....	1.00
Joseph M. Morrone—Philadelphia, Pa.....	5.00
Geo. W. Oleson—San Jose, Calif.....	2.50
Walter O. Paquette—Southbridge, Mass.....	1.00
James H. Parsons—Charleston, W. Va.....	10.00
Joseph Pillero—Maspeth, N. Y.....	5.00
A. V. Predki—Detroit, Mich.....	2.00
George Roberts—Willow Grove, Pa.....	2.00
D. R. Scroggin—Lake Forest, Ill.....	3.00
Theo. L. Seybold—Washington, D. C.....	1.00
John Sohanohak—Camden, N. J.....	5.00
Stanley Sekal—Utica, N. Y.....	2.00
Max B. Stern—Salt Lake City, Utah.....	1.00
John Tensen—Gothenburg, Sweden.....	1.00
Doug Wilson, W9GWE—Fort Wayne, Ind.....	1.00
Yadkin Valley Radio Club— No. Wilkesboro, N. C.....	5.00
RADIO-ELECTRONICS contributions.....	\$7,796.83
FAMILY CIRCLE contributions.....	379.95
Total received to May 18, 1951.....	\$8,176.78

MORE ON DOC GAINES' BOOSTER

The coil data was inadvertently omitted from the article "Home Built Booster Increases TV Range" in the June issue. Herewith the necessary data, as well as a photo of the booster which arrived too late to be published with the article.

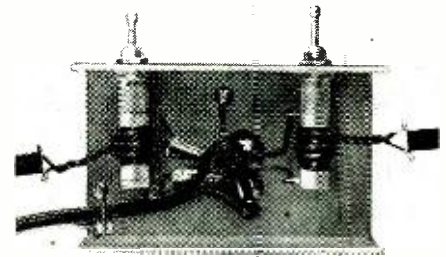

Since layout is often as important as circuit at very high frequencies, the photo may be helpful to constructors. The bottom of the tube socket is seen in the center of the chassis, and the two tuning slugs project from the front when the unit is turned upright.

Coil Data For Booster

Channel	Coil	Turns	Length (inches)	Remarks
2 to 4	L2 and L3	11	11/16	Insulated from L1 or L4 Wound over L2 or L3
	L1 and L4	3	11/16	
5 and 6	L2 and L3	7	11/16	Insulated from L1 or L4 Wound over L2 or L3
	L1 and L4	3	11/16	
7 to 13	L2 and L3	3	11/16	Insulated from L1 or L4 Centered on L2 or L3
	L1 and L4	1		
	L5		1/4	Closewound on 1/4 in. dia. form. No. 22 enamelled wire

Use No. 19 enamelled wire, coil form Millen 69045 or equivalent for L1, L2, L3 and L4.

Radio Thirty-Five Years Ago
In Gernsback Publications

HUGO GERNSBACK Founder	
Modern Electrics	1908
Wireless Association of America	1908
Electrical Experimenter	1913
Radio News	1919
Science & Invention	1920
Television	1927
Radio-Craft	1929
Short-Wave Craft	1930
Television News	1931

Some of the larger libraries still have copies of ELECTRICAL EXPERIMENTER on file for interested readers.

**JULY, 1917
ELECTRICAL EXPERIMENTER**

- Testing Radio Units with Dummy Antenna, by Frank C. Perkins
- A Human Radio Outfit
- How the Government Seals Radio Apparatus
- How Radio Brought the News to the Farm
- Wireless on the American Submarine Chasers, by Samuel Cohen
- Light-Weight Radio Transmitter and Receiver
- Amateur and Experimental Radio Research, by Raymond Francis Yates
- Wireless Telephone Hook-up

Largest Selling Booster

AT ANY PRICE !

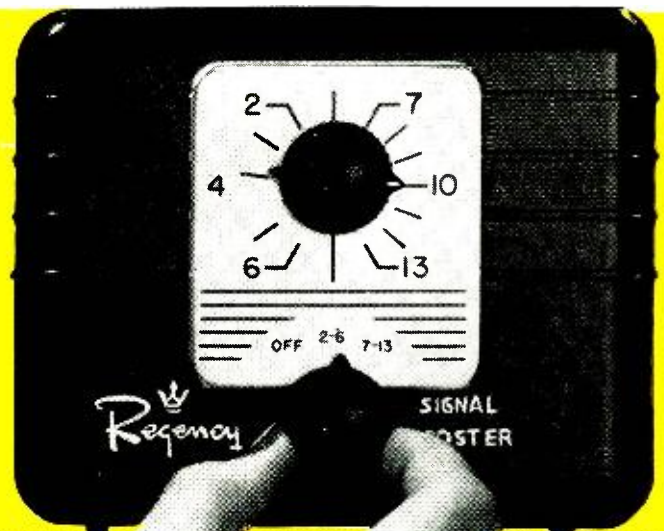

Regency

TUBES

Every Critical Type

We Buy First Quality Tubes for Cash!

Fully Guaranteed • Brand New • Immediate Delivery

1R5
1T4
1U4
354
3V4
6AL5
6AR5
6BA6
6SA7GT
6SK7GT
6SN7GT
6V6GT
6X5GT
12BH7

69¢

183GT
154
3Q4
6AB4
6A55
6AQ5
12A8GT
12AU7
12SA7GT
12SK7GT
12SQ7GT
35L6GT
50L6GT

79¢

1X2
5V4G
6AC7
6AG5
6AH6
6BC5
6BG6G
6BQ6G
6CD6
6J6
6T8
12AT7
12SN7GT

99¢

WRITE TODAY FOR COMPLETE LISTING!

Terms: 25% with order, balance C.O.D. All merchandise subject to prior sale, F.O.B. New York City

TeleVision Materials Corp.

114 LIBERTY ST., NEW YORK 6, N.Y. - COrtlandt 7-4307

the "High Quality"

AUDIO AMPLIFIER

For the Critical Music Lover



BROOK
Model 10C3

- Handsome appearance
- ALL TRIODES for the utmost in naturalness.
- Exclusive Brook circuits & transformers.
- Listening fatigue reduced to a minimum.
- Inputs compensated for any type of phono-pickup, TV, FM & AM receiver.

Write for Technical Bulletin, detailed Distortion Analysis & booklet "Better Listening"

Brook Electronics, Inc., Dept. EG-1
• • • 34 DeHart Place, Elizabeth, New Jersey

TV PARTS

Complete Stock For Fast Delivery . . . at Rock-Bottom Prices

TV TRANSFORMERS

57TO11—Vert. Output Transformer
Replacement for 201T1. 1,000 ohms per Imp. Turns ratio 10:1. Mount center 1 19/32x1 3/4 \$2.95

43TO11—Vert. Output Transformer
Same as above. Mount. center 2 13/16 \$1.79

16TB11 Vert. Block. Osc. Transformer
Replacement for 208T2. Mount. center 1 1/2 1/4 \$1.49

21TB11 Vert. Block. Osc. Transformer
Same as above. Mount. center 2" \$1.19

70° DEFLECTION YOKE Special!

Compare This Price! **\$4.50**
Model DYB-130

Lowest Price Conical Array
CAN BE STACKED FOR FRINGE AREAS
HAS 8 INTERCHANGEABLE ELEMENTS
SNYDER MODEL XA-44



\$4.95
less mast

Complete TV-FM band. Hi-tensile 3/8" aluminum alloy elements. Includes mast clamp for use with poles up to 1 1/4". Can be used with any type lead-in 72-300 ohms.

Write for Free "FYI" Bulletin
Address Orders to Dept. RE-7 or Call
Mulberry 2134

WHOLESALE

RADIO PARTS CO., Inc.

311 W. Baltimore St.
BALTIMORE 1, MD.

PEN-OSCIL-LITE

Extremely convenient test oscillator for all radio servicing; alignment • Small as a pen • Self powered • Range from 700 cycles audio to over 600 megacycles u.h.f. • Output from zero to 125 V. • Low in cost • Used by Signal Corps • Write for Information.

GENERAL TEST EQUIPMENT
38 Argyle Ave. Buffalo 9, N. Y.

CONVERSION DATA!

See Ad—
Page 78

for MOTOROLA VF103
see PF INDEX No. 27

FREE—GET IT NOW!

ELECTRONIC LITERATURE

Any or all of these catalogs, bulletins, or periodicals are available to you on request direct to the manufacturers, whose addresses are listed at the end of each item. Use your letterhead—do not use postcards. To facilitate identification, mention the issue and page of RADIO-ELECTRONICS on which the item appears. All literature offers void after six months.

BUSINESS GUIDES AND FORMS

A new 4-page catalog lists items designed to simplify billing and filing, and to enable the service technician to provide faster and more efficient service. Among the items listed are TV service contract forms, job tickets, radio and TV service record forms, and *Radio Service Standard Rate Book*, designed to assist the technician to prepare a fair bill for services and material in the shortest possible time.

The catalog is available from Oelrich Publications, 4135 N. Lawler Ave., Chicago 41, Ill. Gratis.

SELENIUM RECTIFIER CATALOG

A new illustrated catalog describes the Seletron line of miniature selenium rectifiers as well as a selected group of high-current units. The catalog also illustrates some typical circuit applications of selenium rectifiers.

Available from Sales Department, Seletron Division, Radio Receptor Co., Inc., 251 W. 19th St., New York 11, N. Y. Gratis.

TRAINING-AIDS BROCHURE

Sylvania is distributing a brochure listing their wall charts, lesson folders, TV servicing booklets, color-code and radio symbol charts, and tube manuals. Available from Sylvania Electric Products Inc., Emporium, Pa. Gratis.

INDEX TO SUPREME MANUALS

The new *Complete Index to Most-Often-Needed Radio and Television Servicing Information* is a cross reference to the contents of all the volumes in the Most-Often-Needed diagram series published by Supreme Publications. Available from Supreme Publications, 3727 W. 13th St., Chicago 23, Ill. Gratis. Send 3c stamp for postage.

TV ANTENNA GUIDE

"TV Tenna Tips" is a pocket-size reference manual containing useful data on TV antennas, installation problems, dimensions of antenna elements, channel frequencies, and answers to a number of questions most often asked by TV service technicians. Available from Snyder Mfg. Co., 22nd and Ontario Sts., Philadelphia 40, Pa. Gratis.

QUARTZ CRYSTALS CATALOG

Catalog No. 51 issued by The James Knights Co. is a 5-page illustrated brochure describing the JK line of quartz crystals and crystal ovens. Crystals for oscillators, filters, and transducers are available in the frequency range between 3 kc and 100 mc. Available from The James Knights Co., Sandwich, Ill. Gratis.

SAVE ON THESE STANDARD TUBES

1B3	1.40	616G	1.65	12S17	.95
1HS6T	1.45	60A7	1.75	12S7	1.35
1LA4	1.45	65A7	1.75	12S07	1.35
1LA6	1.45	65C7	1.20	12S7	1.75
1LB4	1.45	65F5GT	1.10	12S07	1.25
1LC6	1.45	65G7	1.20	12S7	1.25
1LC6	1.45	65G7	.95	12Z3	.85
1LD5	1.65	65J7	1.20	14A7	1.05
1LE3	1.45	65K7	1.20	14C7	1.05
1LG5	1.55	65L7GT	1.35	14F8	1.35
1LH4	1.45	65N7GT	1.65	14F7	1.20
1LNS	1.55	65P7	1.20	14Q7	1.35
1NS6T	1.20	65S7	.95	14H7	1.10
1QS5T	1.20	67B	2.20	14N7	1.35
1RS	1.20	6V6GT	1.50	14Q7	1.05
1S4	1.20	6W4	1.50	14R7	1.25
1S5	1.00	6X5GT	1.30	15	.49
1T3C	1.10	6Y6	1.25	24A	.80
1T5GT	1.25	744 XXL		25L6	.90
1U4	1.10	7A5	1.20	25Z6GT	1.20
1V	1.30	7A6	1.20	26	.59
2A3	1.45	7A7	1.20	27	1.65
2A5	1.15	7A8	1.20	28D7	1.35
2A6	.95	7B4	1.20	30	.75
2A7	.95	7B5	1.20	31	.55
2B7	.95	7B6	1.20	31	.55
2C4	1.10	7B7	1.20	33	.59
3Q5GT	1.10	7B8	1.20	34	1.20
3S4	1.05	7C4	1.25	35/51	.75
3V4	1.35	7C5	1.25	35A5	.90
5U4G	1.20	7C6	1.25	35B5	1.25
5V4G	1.85	7C7	1.10	35C5	1.25
5W4	.95	7E6	1.10	35L6GT	1.25
5X4G	1.10	7E7	1.10	35W4	1.05
5Y2GT	1.90	7F7	2.00	35Z5	.95
5Y4G	.85	7F8	2.15	35Z3	.88
5Z3	.95	7H7	1.75	35Z4	.75
6A4	1.10	7H8	1.75	35Z5	1.75
6A3	1.35	7I7	1.30	36	1.65
6A6	1.25	7J7	1.65	37	.65
6A7	.95	7K7	1.30	38	.75
6A8	1.10	7V7	1.30	39/44	.65
6AC5GT	1.30	7Y4	.90	41	.75
6AC7	1.90	117L7/M7		42	.82
6AG5	1.90			43	.75
6AH6	2.50	117N7	1.70	45	.75
6AU5	1.90	117P7	1.70	47	.95
6AK5	2.60	117Z3	.85	47	.95
6AK6	1.90	117Z6	1.40	48	2.75
6AL5	1.65	12A	1.25	48	.95
6AL7	1.95	12A6	.95	50A5	1.25
6AQ5	1.75	12ARGT	.95	50B5	1.40
6AT6	1.30	12AH7GT	.95	50C5	1.25
6AV6	1.70	12AT6	1.30	50L6GT	1.25
6AV6	1.30	12AT7	1.30	50Y6	1.05
6BA6	1.50	12A7	1.25	51	1.25
6BE6	1.50	12A7	1.25	58	.70
6BE6G	2.20	12AU7	1.95	57	.85
6C4	1.10	12AV6	1.30	58	.85
6C6	.85	12AW6	1.30	59	1.75
6D6	.85	12BA6	1.45	70L7	1.65
6E5	1.00	12BE6	1.55	71A	.90
6F5	.80	12L7	1.05	75	.75
6F6	1.20	12K7	1.05	76	.75
6F6GT	1.00	12K8	1.60	78	.75
6G5	.75	12L8	1.60	80	1.05
6G6	1.25	12S47	1.10	80	1.05
6G7GT	1.55	12S57	1.60	82	1.25
6K6GT	1.15	12SF7	1.00	83V	1.35
6K7	1.45	12SG7	.90	84/6Z4	1.05
6L6	1.95	12SH7	.95	85	1.05

TV ANTENNA CATALOG

The new VEE-D-X catalog No. 51 includes technical information on their complete line of television receiving antennas and accessories such as towers, switch boxes, lightning arresters, and various types of antenna installation hardware.

Available from LaPointe-Plascomold Corporation, Windsor Locks, Conn. Gratis.

TV TRANSFORMER CATALOG

The 1951 edition of Stancor's TV transformer catalog and replacement guide contains 36 pages of information relating to replacements for power, audio, blocking-oscillator, and deflection transformers, filter chokes, deflection yokes, and focus coils for over 900 TV models and chassis made by 71 manufacturers. Also listed are mechanical and electrical specifications on 75 Stancor transformers and related components for TV replacements and conversions.

Available from Standard Transformer Corp., 3580 Elston Ave., Chicago 18, Ill. Gratis.

STAMPED CIRCUITS BOOKLET

A 16-page illustrated booklet, "Electronic Circuit Production by Die Stamping Explained," describes a die-stamping process used for mass-producing electronic and electrical circuits. Also available is a 20-page catalog listing and illustrating terminal strips, connectors, plugs, pin-board assemblies, and special sockets for various types of electron tubes.

Available from Franklin Airloop Corp., 43-20 34th St., Long Island City 1, N. Y. Gratis to interested parties upon request.

TV ANTENNA CATALOG

The Brach line of TV antennas, antenna couplers, matching transformers, and lightning arresters and other accessories are described and illustrated in catalog 51-T. This catalog is constructed like a standard manila folder to simplify filing, and is punched to receive additional inserts.

Available from Brach Mfg. Corp., 200 Central Ave., Newark 4, N. J. Gratis.

—end—



Suggested by Richard H. Rogers

I think I must have hit the jackpot. It's been going for 3 days

BARRY JULY SPECIALS
ALL MERCHANDISE FULLY GUARANTEED

● **ULTRA-COMPACT MULTIMETERS**
3 1/2" x 2" x 1 1/4"
AC & DC: 0-15V; 0-150V; 0-750V.
DC: 0-150 MA.
OHMS: 0-100,000 OHMS.
With Leads, Battery & Instructions. Brand new, boxed.
only **\$8.65** postpaid

● Magure Deluxe AM Mobile 75 meter Xmtr., New. Complete. Not Surplus, factory price \$69.00—Only a few left **\$25.00**

SELENIUM RECTIFIERS
F.W.B., FWCT, 3Φ, Volt. DBLR, etc.
Finest materials, workmanship and immediate deliveries.

Full Wave Bridge Types

18/14 Volts	36/28 V.	54 40 V
2 amps \$2.50	5.75	\$5.25
4 " 4.00	7.50	
8 " 6.00	8.50	
12 " 8.00	10.00	
24 " 12.00	20.00	

Selenium Rectifier X1MR. 110V. 60 Cy/6, 12, 24, 30 & 36V @ 4 Amp. New. **\$3.95**
SPECIAL TYPES TO ORDER—Inquire for quantity prices

- 304-TH or 304-TL New Jan Original Boxes (Eimac) **\$13.95**
- 304-TH New Jan Original Boxes (Eimac) **\$13.95**
- 450-TH JAN—Eimac @ **\$29.95**

Many other special purpose and transmitting types at attractive prices. Write

In Stock Now—Many Others Not Listed
Top quality, tested tubes—branded and guaranteed

0A2	1.60	6AH6	1.80	6Y6G	.95
0B2	1.65	6AK5	1.60	12A7	1.35
0Z4 0Z4G	.85	6AL5	1.65	12AU7	1.10
1B3GT	1.25	6AU5GT	1.59	12BA6	.85
1U4	.80	6AU6	.95	12BH7	1.70
1X2A	1.59	6BA6	.90	12SK76T	.90
2B7	.35	6B06GT	1.45	25L6	.90
3Q4	.90	6B5G	1.65	50A5	1.25
3S4	.97	6BL7GT	1.59	50B5	.95
5T4	1.75	6IS6GT	.60	50L8	.85
5U4G	.80	6I8	1.40	955	.40
5V4G	1.10	6S67	.95	2E24	4.75
5X4G	.90	6SN7GT	1.00	2E26	3.75
6AC7	1.40	6T8	1.40	2E30	2.40
6AG5	1.30	6W4GT	.80		

Phone: Rector 2-2563 Cable: Barrylect, N. Y.

BARRY ELECTRONICS CORP.
136 Liberty St., New York 6, N. Y.
\$5.00 Min. Order—25% Deposit with orders
Send Full Remittance to Save C.O.D. Charges
ALL MERCHANDISE FULLY GUARANTEED
Subject to prior sale and some price variations

Every RADIOMAN can use these SERVICE HINTS!
Valuable Manual Yours—FREE
Write today—no obligation

FEILER ENGINEERING CO. Dept. 7RC1-1
8026 N. Monticello Ave., Skokie, Ill. (Suburb of Chicago)

Television is moving fast—Keep up with it in **RADIO-ELECTRONICS**

LET US PUT THIS 19 1/2-INCH MAMMOTH NEW 1951 19 1/2 Picture

MIDWEST TELEVISION
In Your Home on 30 DAYS TRIAL

Don't buy any radio or television receiver until you've seen the new 1951 Midwest line—the finest in 31 years.

FACTORY-TO-YOU

SEND THIS COUPON ON 1c POST CARD FOR NEW 1951 FREE 4 COLOR MIDWEST CATALOG

MIDWEST RADIO & TELEVISION CORP.
Dept. 38P, 909 Broadway, Cincinnati 2, Ohio

NAME _____
ADDRESS _____
CITY _____ ZONE _____ STATE _____

G&H RADIO PARTS SERVICE
53 VESEY STREET - NEW YORK 7, N.Y.

* VOLOMETERS

*Reg. Trade Mark for Volt-Ohm-Milliammeter

from the New E M C ECONOMY LINE

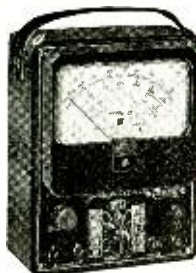

MODEL 104
(20,000 ohms per volt meter)

- 4½" SQUARE METER (50 microamperes—Alnico magnet)
- Includes carrying strap
- 5 DC Voltage Ranges at 20,000 ohms/volt to 3,000 V.
- 5 AC Voltage Ranges to 3,000 V.
- 3 Resistance Ranges to 20 megs. Also 3 AC & DC Current Ranges at 5 DB Ranges.

\$26.35

MODEL 102

(1000 ohms per volt meter)

- 3" SQUARE METER
- 3 AC CURRENT RANGES (0-30/150/600 ma.)
- Same zero adjustment for both resistance ranges (0-1000 ohms, 0-1 megohms)
- 5 DC & 5 AC Voltage Ranges to 3,000 Volts
- Also 4 DC Current Ranges.

\$14.90

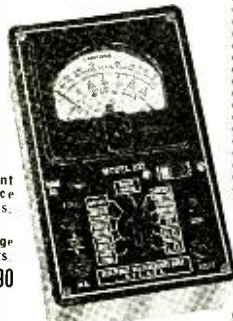

MODEL 103
(1000 ohms per volt meter)

- 4½" SQUARE METER
- 3 AC CURRENT RANGES (0-30/150/600 ma.)
- Same zero adjustment for both resistance ranges (0-1000 ohms, 0-1 megohms)

Same Ranges as Model 102. Also 5 DB Ranges.
Model 103-S with plastic carrying strap **\$19.25**



All of the above have round cornered, bakelite, molded cases.

Export Dept., 303 W. 42nd St., N.Y.C.

Write Dept. B-7 for Free Catalog

Gives More Measurement Value Per Dollar



Jobs are looking for men again!

CREI TRAINING OFFERS PROFITABLE CAREERS IN TV-RADIO-ELECTRONICS

Whether you want a career in the electronics industry, or plan to enter military service, CREI Residence School training is your key to a better job at higher pay. Important firms like RCA-Victor, Bendix, and United Air Lines use CREI training for their technicians. During World War II CREI trained thousands for the Armed Services.

SEND FOR ILLUSTRATED FREE CATALOG.

Get details of course and school, with survey of job opportunities. Classes start twice a month. Veterans' Training available under GI Bill. July 25, 1951 is deadline for most veterans. Don't delay! Write now.

CAPITOL RADIO ENGINEERING INSTITUTE

An Accredited Technical Institute Founded in 1927
Dept. 307C, 16th & Park Rd., N. W., Wash., 10, D. C.

DU MONT-WU COALITION

All sections of the service industry have reacted vigorously to the proposed Du Mont-Western Union coalition in television servicing (RADIO-ELECTRONICS, June, page 12). General opinion is that in the long run, service by over-large organizations will prove uneconomical, but that many independent organizations will be ruined while the proposition is being proved.

Television Contractors Association of Philadelphia has presented probably the best reasoned-out reaction to the plan. In a release from their executive secretary, Paul V. Forte, reporting on a recent meeting of the organization, it was made clear that the members believed:

"That there was nothing illegal or illegitimate in the Du Mont-Western Union arrangement" . . . but Du Mont was probably acting in disregard for the best interests of television; and that the arrangement" foreshadowed the disintegration of many service contracting businesses across the country," if and when the intentions of Western Union to operate on a national basis were realized.

In view of the fact that "this is a free country and anyone can go into business if he has the money . . ." TCA could see no sense in issuing probably fruitless resolutions of condemnation, but felt that it was the duty of the service industry to obtain full information on the proposed action, so that the various sections of the industry could take whatever actions might be deemed useful to protect the future of the independent service contractor.

To this end, 20,000 copies of a news story and editorial in the association's publication, *The TV Tamer*, have been printed for wide distribution throughout the service and related fields. Interested parties may obtain copies from Paul V. Forte, Executive Secretary, TCA, 158 North 20th St., Phila., Pa.

MORE LEGISLATION

Two more states, Wisconsin and New Jersey, have come out with bills designed to affect television and radio servicing. At the time of writing, both bills had been referred to committee.

The Wisconsin law proposes setting up a Board of Examiners in radio and television. All persons desiring to engage in "radio and television electronics" for profit or compensation must obtain a certificate of registration which is obtained by paying a \$25 examination fee and passing an examination in theory, practical knowledge, and skill in the manipulation of equipment and tools. Apparently the term "radio and television electronics" means radio and television servicing to the legislators of Wisconsin, as the registration does not apply to dealers.

Attempts to practice without the certificate would be punishable with a maximum penalty of \$100 fine plus three months' imprisonment.

The New Jersey bill, like a number of others recently introduced, seeks to provide that funds paid in advance for

Be Safe! Be Sure!
with a FULL-SIZED
VEE-D-X ARRESTER



COSTS NO MORE THAN A MIDGET

2 WIRE RW-200 \$125 LIST	4 WIRE RW-204 \$150 LIST
--	--



2-WIRE RW-300 \$200
LIST

For extra heavy duty. An air gap plus resistors provide double protection.

THE LAPOINTE PLASCOMOLD CORP.
Windsor Locks, Conn.

WANTED TO BUY

Large and small quantities of new or used electronic government or manufacturers' surplus tubes and equipment. Highest prices paid. State quantity, condition and best price in first letter.

Box No. F-2 c/o Radio-Electronics
25 West Broadway
New York 7, N. Y.

OUR AUGUST ISSUE

Big-tube conversions for existing television receivers will be featured in several articles in the August issue of RADIO-ELECTRONICS. This is an issue that no television repair technician can afford to miss. Reserve your copy now!

7 HARD TO GET ITEMS AT BIG SAVINGS TO YOU

AMAZING BLACK LIGHT



250-watt ultra-violet light source. Makes fluorescent articles glow in the dark. Fits any lamp socket. For experimenting, entertaining, unusual lighting effects. Ship. wt. 2 lbs. ITEM NO. 87 A SAVING AT **\$2.45**

LITTLE GIANT MAGNET

Lightweight 4 oz. ALNICO permanent magnet. 1 3/4" x 1 1/2". Lifts more than 20 TIMES ITS OWN WEIGHT! Ideal for hobbyists, experimenters. Shipping weight 3/4 lbs.



ITEM NO. 159 BIG VALUE AT **\$2.45**

POWERFUL ALL PURPOSE MOTOR



Sturdy shaded pole A.C. induction motor. 15 watts, 3000 rpm. 3"x2"x1 3/4"; 4 mounting studs; 7/8" shaft, 3/16" diameter; 110-120 volts. 50-60 cycles. A.C. only. When geared down, this unit can operate on 18" turntable with a 200 lb. dead weight. Use it for fans, displays, timers and many other practical purposes. Ship. wt. 2 lbs. ITEM NO. 147 UNUSUAL BUY **\$2.45**

WATTHOUR METER

Leading makes — completely overhauled, ready for service. 100-110 volts, 60 cycles, 2-wire A.C. 5 amp. Heavy metal case 8 1/2" x 6 1/4" x 5". Easy to install. Shipping weight 14 lbs. ITEM NO. 33 NOW ONLY **\$4.50**



WESTERN ELECTRIC BREAST MIKE



Lightweight 1 lb. carbon microphone. Aircraft type. Breastplate mounting, adjustable 2-way swivel. Easily fastened straps. For home broadcasts, communications etc. Complete with 6 foot cord, hard rubber plug. Sherardized plate, non-rusting finish. Ship. wt. 2 lbs. ITEM NO. 152 NEW LOW PRICE **\$1.50**

TELEPHONE TRANSMITTERS

Genuine transmitters made by Kellogg, Western Electric, Stromberg Carlson. Work on two dry cells. For P.A. systems, intercoms, other practical uses. Shipping weight 1 lb. ITEM 160 REAL VALUE **\$2.45**



250 POWER TELESCOPE LENS KIT

Make your own high powered 6 ft. telescope! Kit contains 3" diam., 75" focal length, ground and polished objective lens and necessary eye pieces. Magnifies 50x to 250x. Full instructions. Ship. wt. 1 lb. ITEM NO. 123 YOU SAVE AT **\$2.95**



HUDSON SPECIALTIES CO.
40 West Broadway, Dept. RE-7-51
New York 7, N. Y.

I am enclosing full remittance for items circled below. Shipping charges included.

OR, my deposit of \$..... Ship balance C.O.D.
MINIMUM C.O.D. ORDER \$5.00.
C.O.D. ORDERS ACCEPTED ONLY WITH 20% DEPOSIT
INCLUDE SHIPPING CHARGES.

Circle items wanted

87	159	147	33	152	160	123
----	-----	-----	----	-----	-----	-----

Name..... Please Print Clearly.....
Address.....
City..... Zone..... State.....

television servicing be placed in a trust fund and that monthly withdrawals shall be equivalent to the proportion one month bears to the time of the contract. The preamble states that this has become necessary because "numerous persons have paid in advance sums of money for service contracts and thereafter have failed to receive said service due to the financial failure of the service organizations, resulting in financial loss to the inhabitants of this State . . . the unscrupulous tactics of such organizations tend to harm ethical businessmen and to discredit the television industry generally."

PIX TUBE WARRANTY

Warranty problems on picture tubes are likely to produce more than the average number of warranty headaches for the television service contractor due to the slow movement of television sets in late spring. Picture-tube makers since late last year have cut down their warranty from one year to six months, and the result is that some replacement tubes may be out of warranty before they are sold.

General Electric and Ken-Rad have met the situation by arranging that picture tubes sold through their franchised distributors and dealers have warranty protection for six months from date of purchase by the actual consumer.

That the matter is an important one may be gathered from dealers who estimate that from 1 to 15% of their television picture tubes show defects within the first 90 days. After that, the number of defects drops to a figure that can be ignored.

LARGER INVENTORY

Joint recommendation of the Radio and Television Manufacturers' Association and the Better Business Bureaus that television contractors keep larger stocks of parts in order to render prompter service met with a sharp reaction from parts of the service industry.

In a letter addressed to Robert C. Sprague as RTMA board chairman, Frank Moch, president of the National Alliance of Television and Electronic Service Associations, points out that the recommendation is out of order because "it does not take into consideration the fact that the TV manufacturer and distributor, and not the service contractor, have accepted fees to guarantee the replacement of parts."

NEW COUPON SERVICE PLAN

Pay-by-the-call television service contracts are being issued by a Brooklyn concern. The plan calls for payment by the customer of fees ranging from \$45 for a 10-inch receiver to \$85 for a 20-inch job. A number of coupons are given the customer, ranging from five for the lowest-priced contracts to nine for the most expensive. He surrenders one coupon for each call and can turn the unused balance in for refund at the end of the year. —end—

At CONCORD You PAY LESS

for...

FM TUNER

SAVE 50%

Enjoy clear, static-free reception of your favorite music and sport events—convert to FM for less than \$10.00 with this exclusive Concord FM tuner. Easily converts any AM record FM tuner. Easily converts any AM receiver, phono amplifier or PA system for FM. Covers the entire 88-108 FM band. Tuning and on-off controls on front panel with terminals for connection of 300 ohm twin lead antenna or back. Extremely easy to install. Uses a 7F8 in a tremodyne circuit, plus a 6H6 rectifier. Size of chassis, 6-3/4 x 4 x 4-1/8". Complete with tubes. For 110-120 volts AC-DC. **9.95** 99-9502J--Shpg. Wt. 2 lbs.... Net.

BARGAIN CONICALS



High quality conical TV antennas designed for superior performance. Full-hard elements and all-aluminum construction provide maximum strength and eliminate excessive weight and rust problems. Broad band reception on all TV channels plus FM are yours with these Concord conicals. High signal-to-noise ratio, excellent front-to-back ratio, matches 72, 150, or 300 ohm input impedance. Ridged U-bolt mast clamp bracket set at proper balance point prevents antenna from slipping or twisting on mast. Fits masts up 1-1/2" O.D. Supplied less mast.

Single Bay. (Not Illustrated). 28-24265J--Wt. 6 lbs. **4.45**
Double Bay. (Illustrated). 28-24266J--Shpg. Wt. 12 lbs. 8.95

300 OHM FLAT TWIN LEAD.
Per 1000 ft. \$25.00 Per 100 ft. \$2.75.
19-17141J. Per ft. **3¢**

EMERGENCY UNIT



Smooth, quick-action emergency tire pump and fire extinguisher. Compact...easily mounted in limited space. Highly effective against oil, gas or electrically caused combustion. **2.75** 99-6549J. Net.

FREE NEW! 1951 SUMMER BUYER'S GUIDE

CONCORD RADIO

CONCORD RADIO CORP. Dept. JG-51
901 West Jackson Blvd., Chicago 7, Illinois

Enclosed \$..... (Include shipping charge)
Rush me the following equipment,

99-9502J--FM Tuner
 28-24265J--Single Bay Conical
 28-24266J--Double Bay Conical
 19-17141J--300 Ohm Twin Lead
 99-6549J--Emergency Unit
 Send FREE Summer Buyer's Guide

Name.....
Address.....
City..... Zone..... State.....

FILL IN AND MAIL TODAY

PLATT SAVES YOU MORE



JULY SPECIAL! BC-454 RECEIVER

3 to 6 MC. less tubes, in bent cases, excellent for used parts... **ONLY \$2.95**



BC-223 TRANSMITTER

A 30 watt Transmitter ideal for ship-to-shore or Ham Btg. Crystal or MO control on four pre-selected channels, 2000 to 3250 KC. Use of 3 plug-in coils, five tubes:

- 2 #01 and 3-16, and TU 17-18-25 tuning units.
- TRANSMITTER \$39.95
- TUBES 5.95
- TUNING UNITS 2.25 ea.
- PE-125 VIBRATOR POWER SUPPLY FOR BC-223 \$18.95

BEACON RECEIVER BC-438

Manufactured by Detroit



Frequency Range—300 KC to 100 KC. IF Frequency—142.5 KC Receiver Sensitivity—2 Microvolts for 10 Milliwatts output. Output Impedance—300 ohms and 4000 ohms to be selected internally. Power Output—150 Milliwatts. Volume control—RF Gain Control. Power Supply 24-28 Volts Aeroplane Battery. Current—1.0 Amperes. 6 tubes.

\$10.95

BRAND NEW—ONLY

BEACON RECEIVER BC-1206-C

Manufactured by Satchell-Carlson

Frequency Range—195 KC to 420 KC. IF Frequency—115 KC. Receiver Sensitivity—3 Microvolts for 10 Milliwatts output. Output Impedance—300 Ohms and 4000 Ohms to be selected internally. Power Output—230 Milliwatts. Volume Control—RF Gain Control. Power Supply—24-28 Volts Aeroplane Battery. Current—.75 Amperes.

\$10.95

BRAND NEW—ONLY

PRE-AMPLIFIER MODEL K-1



The K-1 is used to amplify output level for microphones and phonographs. Operates on 24-28 VDC, can be converted to 110 AC. Comes complete with PL 55 plug and 2 foot 119-B cord. 2 terminal blocks and instruction book. BRAND NEW

\$4.95

FIELD TELEPHONES



Army surplus, completely reconditioned and electrically tested, using 2 flashlight cells and a pair of interconnecting wires.

GUARANTEED—like new... **ONLY \$15.95**

WRITE FOR OUR FREE CIRCULAR!

MINIMUM ORDER \$2.00

Immediate Delivery—Send 25% deposit on C.O.D. order. All shipments F.O.B., N.Y.C. (N.Y.C. residents add sales tax to your remittance.)

PLATT ELECTRONICS CORP.
Dept. B, 489 Broome St., N.Y. 13, N.Y.
Phones: WO 4-0827 and WO 4-0828

NEW ADDRESS

still the same best buys

NEW MOBILE POWER UNITS w/FILTERS

- DM21M 14v in 230v 90ma out..... \$8.50
- BD77L 14v in 1050v 35 ma out..... \$15.00
- PE73 28v in 1050v 350ma out..... \$24.00
- PE94C (for SCR522) 28v in..... \$15.00
- PE98 (for SCR522) 14v in..... \$65.00
- MP10G dual for TA2 24v in..... \$75.00
- PE86 24v in 230v 50ma out..... \$4.50

Shipped Rail Exp. or Freight Collect

LONG ISLAND RADIO COMPANY

P.O. Box 474, Montrose, Penna.

You can't beat RADIO-ELECTRONICS for complete coverage of RADIO, TELEVISION, AND AUDIO

WESTINGHOUSE H-196

An elliptical shadow which produced an eclipse-like effect on the lower left side of the TV picture was finally

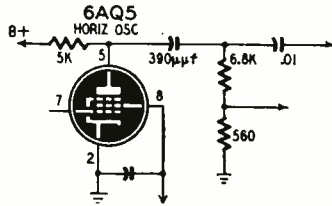

traced to failure of the 390-µF capacitor at the plate of the 6AQ5 horizontal oscillator tube. The position of this capacitor is shown in the diagram. Be sure to check the 6,800-ohm, ½-watt resistor, as it may have been damaged.

—Frank Jusaites

CROSLY TV SETS

Horizontal sweep sing in the 10-401, 10-404, 10-412, and 10-418 can be caused by the bracket of the horizontal output transformer vibrating at a sub-harmonic of the 15,750-cycle horizontal sweep frequency. Transformers in later sets do not cause this trouble because their cores and brackets have been dipped in wax.

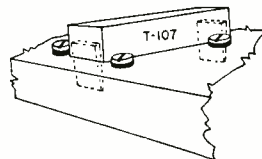

This trouble can be corrected by inserting small wedges between each end of the transformer and the chassis as shown.—Crosley Service Dept.

HALLICRAFTERS SX-42

Reception was normal on all bands except the 55–108 megacycle band. The trouble was traced to resistor R-6, a 2,200-ohm, ½-watt unit which is used only on the highest band. Replacing the unit with a similar ½-watt unit corrected the trouble for a few weeks. Replacing it with a 2-watt resistor eliminated a recurrence of the trouble.

The tuning meter read normal on FM. The lowest no-signal reading was S-8 for AM reception on all bands. All components in the tuning meter circuit checked good. The 6AG5's in the r.f. stages checked good on a mutual conductance tube tester. Finally, we substituted several 6AG5's and found two which brought the no-signal reading down to S-0. Apparently, many tubes which checked good on the tester lacked sufficient emission to bring the meter to zero in the bridge circuit.—Robert H. Marshall

LOW PICTURE BRIGHTNESS

When low picture brightness is not caused by a defect in the receiver, check the position of the ion trap. If adjusting the trap does not correct the trouble, possibly metal filings may be short-circuiting the magnets. Remove filings with a magnetized screwdriver.

If there is no evidence of a magnetic short circuit, the magnets may be weak. Try a new ion trap.—John T. Bailey

EASY TO LEARN CODE

It is easy to learn or increase speed with an Instructograph Code Teacher. It is the quickest and most practical method yet developed. For beginners or advanced students. Available tapes from beginner's alphabet to typical messages on all subjects. Speed range 5 to 40 WPM. Always ready—no QRM.



ENDORSED BY THOUSANDS!

The Instructograph Code Teacher literally takes the place of an operator-instructor and enables anyone to learn and master code without further assistance. Thousands of successful operators have "acquired the code" with the Instructograph System. Write today for convenient rental and purchase plans.

INSTRUCTOGRAPH COMPANY

4701 Sheridan Rd., Dept. RC, Chicago 40, Ill.

HAVE YOU A JOB FOR A TRAINED TECHNICIAN?

We have a number of alert young men who have completed intensive training in Radio and Television Repairing. They learned their trades thoroughly by working on actual equipment under personal, expert supervision. If you need a trained man, we invite you to write for an outline of our course, and for a prospectus of the graduate. No fees, of course. Address:

Placement Manager, Dept. P108-7

COMMERCIAL TRADES INSTITUTE
1400 Greenleaf Chicago 26

RL9 or RL7 Interphone Amplifier (convert to High Fidelity Phone Amp. or Spec. Amp. Comp. w/12A6, 12SL7, 2 Choker XFRMR. DYN. for 24 operation, etc. \$2.29

PHOTO PRINT-DRYERS
Consists of microelement insulating frame 9 3/4" x 10" 110V 60 cy 75c

Code Practice Key
MNTD on bakelite base 1 1/2 x 4 1/2 x 3" Adjustable. Tungsten Contacts. \$1.20 ea. Key Less Bakelite base .79c

MS49 and MS50 Fish Pole Antenna 74" long. Both for 49c
RC-60S INTERPHONE AMPLIFIER
Easily converted to an ideal inter. Communications set for office home or factory. Original. New w/conn. Diagram \$4.49

872 FIL XFRMR
Pri: 115-125V 60cy Sec: 2x2.5/20A \$8.95
CHIME XFRMR
Pri: 110V 60 cy Sec: 24V/1A \$1.25
POWER XFRMR
Pri: 110V 60 cy Sec: 4V/16A 2.5V/175A Ideal for 2x2 & 2x1 Tubes \$1.95
Tuning Units for BC-375 & 191 Diag. for Convert. to VHF Freq. Meter in Oct., 1950 Original. TU-7 450—6200KC TU-8 6200—7700KC TU-9 7700—10000KC TU-20 500—5000KC Price \$2.49 ea.



BC 604 DM Transmitter FM 20-28 MC 11 & 15 Mtr. Can be operated on 10 Mtr. 10 Channel push button control w/tubes meter. Less stats. Good used. w/dyn. Sold as is. \$15.95

CRYSTALS Low Freq.

FT-241. A holder 3/2" Pin spacing, for ham and general use. Xtal controlled. Signal Generators. Q-5'RS, S.S.B. Exciters (Nov. QST) marked in army Mc harmonic frequencies—Directions for deriving fundamental frequencies enclosed. Listed below by fundamental frequency, fractions omitted.

370	419	445	485	512	391	447
372	420	446	486	513	392	448
374	422	455	487	514	393	450
375	423	458	488	515	394	451
376	424	459	490	516	395	452
377	425	461	491	518	396	454
379	427	462	492	519	397	455
380	429	468	493	520	398	456
381	430	469	494	522	400	457
383	431	470	495	523	401	463
384	433	472	496	525	402	465
385	434	473	497	526	403	498
386	435	474	502	527	404	500
387	436	475	503	529	405	501
388	437	476	504	530	406	538
412	438	477	505	531	407	540
413	440	479	508	533	408	each
414	441	480	507	534	409	each
415	442	481	508	536	411	\$1.49
416	443	483	509	537	each	
418	444	484	511	539	each	

Rated Concerns Send P.O. Minimum Order \$3.00 Send M.O. or CHK. Mdse. Guardt. Shpg. Charges Sent C.O.D. Price F.O.B. N.Y.C. Phone Di. 9-4124

COMMUNICATIONS EQUIPMENT CO.

131 Liberty St. Dept. C-7 New York City 7, N. Y.

Please Mention **RADIO-ELECTRONICS** When You Write to Advertisers

GENERAL ELECTRIC 810

A white vertical bar, shaped like a half moon and approximately 1 inch wide, appeared on the screen after the set had operated normally for 15 or 20 minutes. After the shadow appeared, plate and screen voltages on the 6BG6-G were low and anode voltage dropped to 3,000. We noticed that the blue fluorescence disappeared from the 6BG6-G at the moment that the voltages dropped. The trouble cleared up when the horizontal output transformer was replaced. By applying heat externally to the old transformer, we found that the primary would open when the unit approached normal operating temperature. The transformer cooled so rapidly that the high-resistance open circuit could not be detected.—*T. R. Odenath*

CURE FOR SYNC BUZZ

Sync buzz may be annoying when the contrast control is turned a little above normal on Motorola sets using TS-14B, TS-23B, TS-52B, and similar chassis. This trouble can be cleared up by making a minor change in the biasing arrangement for the video amplifier. Disconnect the lower end of the 1-megohm grid resistor from the arm of the contrast control and connect it to the cathode of the audio amplifier. By providing a cleaner source of bias for the video amplifier, this circuit modification minimizes sync buzz.—*Edward Tanrath*

RCA 9T240 AND OTHERS

The symptom was a raster but no

sound or picture. All common causes of this trouble were investigated without finding the fault. The trouble was caused by an open heater in the first video amplifier section of the 12AU7. Failure in this section of the tube causes the bias on the a.g.c. line to cut off the common audio-video i.f. amplifier stages, thus killing the sound as well as the picture. This trouble can appear in other RCA sets which have the same video amplifier and a.g.c. biasing arrangement.—*James J. McNamara*

WESTINGHOUSE CHASSIS V-2150-176

To reduce horizontal wobble under strong-signal conditions and to increase the contrast range, decrease the value of resistor R437 (between pins 6 and 7 of the 6AU6 a.g.c. tube) from 5,600 to 3,300 ohms.

To improve horizontal linearity, replace the 680- μ f horizontal discharge capacitor C427 with a 330- μ f unit.

These changes have been made in late runs of the V-2150-176 chassis used in models H-619T12 and H-619-T12U.—*Westinghouse Service Notes*

HICKOK 534 TUBE TESTER

If the meter pointer swings wildly when a tube is inserted in the rectifier sockets for checking, look for the trouble in the 150-ohm wire-wound resistor in series with button P-3 and one side of the power transformer secondary. This is a current-limiting resistor. Probably it is shorted.—*Wilbur J. Hantz*

COLLINS FM TUNER CHASSIS



MODEL RD-1C

A COMPLETE FM TUNER, EXCEPTING POWER SUPPLY, IN THIS COMPACT FORM!

NOT JUST A FRONT-END, BUT COMPLETE WITH 10.7 MC IF AMPLIFIER AND DETECTOR!

Build a high-fidelity, permeability tuned FM tuner which requires only a simple power supply and amplifier to make it work. Tuner completely aligned at the factory, ready to operate. All instructions, tubes, and circuit details furnished. Its voltage requirements may be taken from your audio amplifier or AM radio.

• High sensitivity • No drift • Permeability tuning • Complete tuner • ECONOMICALLY PRICED AT **\$29.95**

SEND YOUR ORDER IN NOW FOR IMMEDIATE DELIVERY.

COLLINS AUDIO PRODUCTS CO.

P. O. Box 368

Westfield, N. J.

Low-Priced for QUICK SALE! TV TUBES—All Black

Sheldon, Zetka & Other Standards
Tubes Guaranteed Individually Boxed.

024A	\$.81	6AK5	\$.19	6SK7	\$.09	14R7	\$.17	51.27
146	1.00	6AK6	1.19	6SL7GT	1.19	14W7	1.27	3.00
147GT	1.10	6AL5	.99	6SN7GT	1.09	19BG6	3.00	1.44
183GT	1.32	6AQ5	.99	6SQ7GT	.92	19T8	1.44	1.99
185 255	1.51	6AR5	.92	6S5	.78	25B06GT	1.99	.89
186	.74	6AS5	.99	6T8	1.41	25L6GT	.89	1.00
1C7G	.74	6A57G	5.39	6U7G	1.23	25W4GT	1.00	.70
1D7G	.74	6AT6	1.49	6V6 or GT	.99	25Z6GT	.70	1.29
1F4	.74	6AUSGT	1.69	6W4GT	.89	28D7	1.29	1.23
1F5G	.74	6AUG	.99	6W6GT	.99	30	1.23	1.59
1G4GT	.74	6AV5GT	1.11	6X4	.74	32L7G	1.59	.89
116G	.84	6AV6	.74	6X5GT	.74	35L6GT	.89	.62
114	.74	6B7	1.21	6V6G	.94	35W4	.62	1.01
11A6	1.30	6B8	1.49	7A6	.89	35Z5GT	.74	1.62
11C5	1.30	6BA6	.89	7B4	.89	35Z5GT	.74	1.44
11C6	1.30	6BA7	1.19	7B6	.89	46	1.62	1.09
11D5	1.30	6BD5	1.35	7C5	.89	50A5	1.09	.99
11N5	1.30	6BD6	1.35	7C5	.89	50A5	1.09	.99
11NSGT	1.00	6BE6	.89	7E5	1.21	50B5	.99	.89
1R5	1.00	6BGG	2.40	7F7	1.01	50B5	.99	1.09
154	.74	6BM6	.99	7G7	1.33	50L6GT	.89	1.40
155	.89	6B16	1.49	7M7	.99	56	.89	1.40
174	1.30	6B7E	.99	7N7	1.48	57	.99	1.40
1U4	.97	6BQ6GT	1.59	7N7	1.10	85	1.09	1.40
1U5	.89	6C5	.83	7Y4	.89	VR90	1.40	1.95
1U6	1.10	6C6	.99	7Z4	.84	VK150	1.40	1.95
1K2 1X2A	1.32	6C6G	2.99	12A6	1.34	CEJ1	12.50	1.95
2A3	1.49	6F6G	.90	12A8GT	1.10	2E22	1.95	1.95
2A4	1.49	6G6G	1.32	12AT7	1.64	2C44	1.95	1.95
2A5G	.84	6H6	.93	12AU7	1.19	2J21A	22.50	1.95
2A6	.44	6J5 6J5GT	.74	12AX7	.99	2J32	22.50	1.95
2A7	.84	6K6	1.35	12BE6	.89	304TL	17.50	1.95
2K2 879	.69	6J7 or GT	.81	12BE6	.89	304TL	17.50	1.95
3A4	1.00	6J6G	1.49	12BH7	1.89	58P1	3.50	1.95
3ABGT	2.46	6K3	1.28	12BY6GT	1.10	815	3.95	1.95
3C4	.99	6K7	.82	12M6	.89	702A	4.95	1.95
354	.99	6K8	1.48	12J7GT	1.10	702A	4.95	1.95
3V4	1.45	6L6	1.45	12SL7GT	1.20	702A	4.95	1.95
5A4	2.25	6GG6	1.98	12Q7GT	.89	715A	12.50	1.95
5U4G	.83	6L7	1.19	12SA7GT	1.08	720E1	24.95	1.95
5V4G	1.19	6R6	1.90	12S7GT	1.01	805	3.45	1.95
5W4	.83	6N7 or GT	1.19	12SF5GT	1.01	805	3.45	1.95
5Y4	.89	6Q7	1.12	12S7GT	1.12	807	1.59	1.95
5Y3GT	.62	6R6G	1.28	12SH7 or GT	1.10	815	3.95	1.95
5Z5G	1.10	6T7	.90	12SJ7 or GT	.82	815	3.95	1.95
5Z4	1.18	6S4	.81	12SK7 or GT	.89	838	4.95	1.95
6A6	1.32	6S8	1.32	12SL7GT	1.20	902A	2.95	1.95
6A8A	1.19	6A7 or GT	1.09	12T7GT	1.49	981	.39	1.95
6A87	1.39	6S87Y	1.19	12SQ7GT	.89	CK1005	.59	1.95
6AC7	1.44	6SCT	.59	12Z3	1.32	900A	.79	1.95
6AF7	1.00	6E7	1.00	14N7GT	1.09	900B	.79	1.95
6AG5	1.32	6SCT	1.00	14B6	1.09			1.95
6AG7	1.60	6SH7 or GT	.84	14B8	1.09			1.95
6AH6	1.91	6S7 or GT	.90	14C7	1.09			1.95

Special All American Kit—5 Tubes—\$4.29

All Standard & National Known Tubes. Many below wholesale.

14" rect.\$23.25
17" rect. 37.49
20" rect. 56.94
16" rect. or rd.\$36.49
19" rd. metal 56.41

ALL FACTORY GUARANTEED
Extra Discounts—25 or more 5%; 100 or more 10%

Power Transformers 115V. 60 Cycles

Secondary	Type	Mtg. Weight	Centers	Type	Stock No.	Your Cost
80 Mil. 600V. CT 80 Mil. A	A	2 3/4" x 2 7/8" x 4 lbs.	3 1/4"	A	4034	\$ 3.90
90 Mil. 400V. CT 90 Mils. Square Case	B	3 1/4" x 3 1/4" x 3 1/4" x 3 1/4" 5 lbs.	3 1/4"	B	4013	2 25
160 Mil. 850V. CT 160 Mils. C	C	3" x 3 3/4" x 9 lbs.	3"	C	21549	4 15
160 Mil. 625V. CT 160 Mils. B	B	2 1/2" x 2 7/8" x 5 1/2 lbs.	2 1/2"	B	4055	3 75
200 Mil. 800V. CT 200 Mils. D	D	3" x 3" x 14 lbs.	3"	D	24526	4 15
250 Mil. 800V. CT 250 Mils. B	B	3" x 4 1/2" x 14 lbs.	3"	B	4085	7 50
305 Mil. 768V. CT 305 Mils. D	D	17 lbs. (Matched Pair) Plate & Filament	17 lbs.	D	3029	6 25 per pair

Filament & Step-Down Transformers

Secondary	Type	Mtg. Weight	Centers	Type	Stock No.	Your Cost
5V. 6 amps. 1 3/8" x 2" 2 1/2 lbs.	A	1 3/8" x 2" 2 1/2 lbs.	1 3/8"	A	4043	\$ 1.99
5V. 24 amps. 3" x 3 1/4" 8 lbs.	B	3" x 3 1/4" 8 lbs.	3"	B	3043	7 50
5.0V. 6 amps. 5 lbs. 3" x 3 1/4" 8 lbs.	C	3" x 3 1/4" 8 lbs.	3"	C	3039B	4 25
24V. 5 amps. 2 1/2" x 3 3/16" 6 lbs.	C	2 1/2" x 3 3/16" 6 lbs.	2 1/2"	C	4032	4 95
32V. 2.5 amps. 2 1/2" x 1 1/4" 6 lbs.	A	2 1/2" x 1 1/4" 6 lbs.	2 1/2"	A	4036	1 95
37V. 5 amps. 2 3/4" x 2 3/4" 6 lbs.	D	2 3/4" x 2 3/4" 6 lbs.	2 3/4"	D	3042	6 95
60V. 1.3 amps. 2 7/8" x 2 3/4" 6 lbs.	C	2 7/8" x 2 3/4" 6 lbs.	2 7/8"	C	41182	8 75
120V. 20V. 5.0 amps. 6 1/2 lbs.	C	6 1/2 lbs.	6 1/2"	C		

Mica Kits 100 assorted \$5.95
Ceramic Kits 100 assorted 5.95
Resistor kits 100 assorted 3.79
Electrolytics 40x20-150V Tubular 39c
20 Mid 25V Tubular 15c
20 x 20x20 F Type 45c
450 25 x 20 49c
50x30x20 x 20 69c

PHONOGRAPH SPECIALS
Complete
Single Speed \$16.95 3 Speed single needle \$19.90 3 speed auto. \$54.20

Phono Amplifier \$2.69 Ea. (Less Tubes) Buy 6 and Save \$1.00 ON/OFF Volume Control Uses 35Z5-50L6 & 12SQ7 3 Tubes for above. \$2.62

LATEST 30-TUBE 630 TV CHASSIS
Finest for fringe area reception. RCA licensed. Takes all picture tube types from 16" to 20" round or rectangular. Complete with 12" RCA Speaker with Hi-Gain Standard Coil Tuner \$133.50 (Less C. R. Tube) Available with DuMont Input Tuner-FM Radio (Less C. R. Tube) \$143.50.

Battery Operated SIGNAL TRAKER KIT
Complete with steel cabinet, speaker, all components, tubes and easy-to-follow instructions. \$9.95 (less batteries).

Part Specials Vibrators 5"	1.65	1.49	Replacement Output Trans. for 50L6, 6V6, 6K6, 6F6, 354, 3V4	49c
4 Prong 6 Volt 5 1/19 8"	1.92	1.73		
T.V. H. V. Cartwheel 12"	5.59	5.04		
500 Mmf. 10 KV 49c	6.85	6.17		
500 Mmf. 15 KV 59c			Push-Pull Outputs for 50L6, 6V6, 6K6	65c
500 Mmf. 20 KV 69c				
P.M. Speakers 10 or more 5" PM	2.10	1.90	Controls 1 Meg. w/sw 3" Shaft	54c
Alnico #5 Each each 8" Dynamic 450 or held	2.20	2.00		
4"	1.59	1.44		

1/2 Meg w/sw 3" Shaft	54c
1 Meg. w/DP switch 1" Knurl Shaft	49c
1/2 Meg w/sw 49c 1" Knurl Shaft	49c
10K w/sw 3/4" shaft 100 K w/sw 3/4" shaft	39c
100 K control 1/4" milled shaft	24c
250 K control 3/4" milled shaft	24c

Terms: 20% cash with order, balance C.O.D. All prices F.O.B. New York City warehouse. Minimum order \$5.
NOTE: Availability of merchandise subject to prior sale. Prices subject to change without notice.

STEVE-EL ELECTRONICS CORP.
Dept. RC-7 65 Reade St. New York 7, N. Y.
COTland 7-0086

"BEST SELLER" TV LITERATURE PACKAGE

- Hints for better pictures on 630TV
 - 630TV diagram with modifications
 - Illustrated TV conversion manual
 - Pulse keyed AGC circuit diagram
 - RMA resistor & mica code charts
- Plus latest catalogs & flyers

ALL FOR ONLY **\$1.00** POSTPAID

630 TV CHASSIS PARTS

- RCA FRONT END TUNER, compl. w/tubes \$22.49
- STANDARD TURRET TUNER, com. w/tubes 22.49
- ESCUTCHEON PLATE, for either tuner .69
- DUMONT, INPUT TUNER, comp. w/tubes 22.49
- COMPLETE SET OF KNOBS, incl. decals 1.34
- COMPLETE SET OF KNOBS, (Gold) 2.49
- POWER TRANSFORMER, 295ma. 201T6 9.97
- VERTICAL OUTPUT TRANS. 204T2 2.69
- VERTICAL BLOCKING TRANS. 208T2 1.32
- HORIZONTAL OUTPUT TRANS. 211T1 2.47
- HORIZONTAL OUTPUT TRANS. 211T3 2.98
- HORIZONTAL OUTPUT TRANS. 211T5 3.98
- FOCUS COIL, 247 ohms. 202D1 2.29
- FOCUS COIL, 470 ohms. 202D2 3.42
- DEFLECTION YOKE, 60° 201D1 2.97
- DEFLECTION YOKE, 70° 206D1 3.98
- FILTER CHOKE, 62 ohms 1.47
- ION TRAP BEAM BENDER, (single) 203D1 .79
- ION TRAP BEAM BENDER, (double) 203D3 .98
- AUDIO OUTPUT TRANSFORMER (6K6) .69
- PUNCHED CHASSIS PAN, cadmium plated 4.87
- 630-KIT, screws, nuts, rivets, washers 1.69
- HI VOLTAGE CAGE ASSEMBLY, complete 3.73
- VOLTAGE DIVIDER SHIELD & COVER, 1.79
- FOCUS COIL BRACKETS .49
- CATHODE RAY TUBE SOCKET, 18" leads .39
- HV KINESCOPE LEAD, with clip .39
- TV 6' LINE CORD, with both plugs .29
- VIDEO AND I.F. KIT, 19 items 7.84
- ELECTROLYTIC CONDENSER KIT, 6 cond. 7.37
- TUBULAR CONDENSER KIT, 37 cond. 4.28
- CARBON RESISTOR KIT, 107 resistors 6.98
- WIREWOUND RESISTOR KIT, 4 resistors 2.31
- BRACKET AND SHIELD KIT, 18 items 8.63
- TERMINAL STRIP KIT, 18 strips .59
- OCTAL WAFER SOCKET KIT, 13 sockets .72
- MIN. WAFER SOCKET KIT, 10 sockets .63
- MIN. MOLDED SOCKET KIT, 2 sockets .22
- CERAMIC CONDENSER KIT, 28 cond. 3.37
- MICA CONDENSER KIT, 11 condensers 1.38
- VARIABLE CONTROL KIT, 9 controls 5.83
- HV FILTER CONDENSER, 10KV-500MMFD .48
- HV FILTER CONDENSER, 20KV-500MMFD .79

630 KIT-BUILDER'S INSTRUCTION PACKAGE
Step by step instructions, diagrams, layout charts, etc.
For STANDARD 29-TUBE CHASSIS **\$2.49**
Or DOUBLER 31-TUBE CHASSIS

KEYED AGC KIT

Keyed pulse, fast action, AUTOMATIC GAIN CONTROL KIT to modernize a 630 or any other TV receiver. Improves performance, giving a steady picture on all channels. Eliminates airplane flutter and picture jumping. Complete set of parts includes: SOCKET, 6AU6 TUBE, BRACKETS, WIDTH CONTROL COIL, CONDENSERS, RESISTORS.

COMPLETE WITH EASY TO FOLLOW STEP-BY-STEP ASSEMBLY INSTRUCTIONS AND DIAGRAMS ONLY **\$4.59**

TELEVISION CONVERSION KITS

Convert any 10" TV SET to a LIFE-SIZE 16" to 20" MODERN TV RECEIVER
ASSEMBLED KIT FOR 630 CHASSIS
Includes - SUB-CHASSIS, FLYBACK TRANSFORMER, 1B3 TUBE, CONDENSERS, RESISTORS, 16" MOUNTING BRACKETS, STEP BY STEP INSTRUCTIONS **\$15.98**
UNASSEMBLED KIT FOR ANY CHASSIS SAME SET OF COMPONENTS **\$13.98**
KITS also supplied with UNIVERSAL MOUNTING BRACKETS \$3.99 extra

SPECIAL SUMMER OFFER! CUSTOM-BUILT AUTO RADIOS

Known Mfr. . . . Licensed By RCA
6-TUBE SUPER (8-Tube Performance) Installs easily in 15 minutes. Appearance and tone quality equal to expensive radios supplied by car manufacturers.
FORD 1949-50-51 PLYMOUTH 1949-50-51
DODGE 49-50 CHEVROLET 49-50-51
STUDEBAKER 50-51 HUDSON 48-49-50-51
YOUR PRICE **\$41.97**
List Price \$59.95 COMPLETE READY TO INSTALL

BROOKS RADIO & TELEVISION CORP.
84 Vesey St., Dept. A, New York 7, N. Y.

Dr. Oliver E. Buckley, former president of Bell Telephone Laboratories, was appointed chairman of the newly created Science Advisory Committee of the OFFICE OF DEFENSE MOBILIZATION by President Truman. Dr. Buckley will continue his association with BELL LABORATORIES as chairman of the board. Dr. Mervin J. Kelly, former executive vice-president, was elected president to succeed Dr. Buckley.



Dr. O. E. Buckley

Bill C. Scales was named general sales manager of the Cathode-ray Tube Division of ALLEN B. DU MONT LABORATORIES, Inc., Clifton, N. J., according to an announcement by Irving G. Rosenberg, general manager of the division. Mr. Scales has been with Du Mont since September, 1949. His most recent position was southwestern regional sales manager for the Receiver Sales Division.



Bill C. Scales

Robert E. Burrows joined THOMAS ELECTRONICS, INC., Passaic, N. J., cathode-ray tube manufacturer, as general sales manager. Mr. Burrows has had 22 years experience in the radio, appliance, and television fields. He was associated with such companies as General Electric Supply, Westinghouse Electric Supply, and Meissner Manufacturing Division of Maguire Industries.



Robert E. Burrows

Emil J. Maginot was appointed manager of advertising for CORNELL-DUBILIER ELECTRIC CORPORATION, South Plainfield, N. J. Mr. Maginot has been associated with the electronics industry for over 25 years. For more than nine years he held sales and advertising executive positions with the National Union Radio Corporation.



Emil J. Maginot

William H. Rous, sales manager of the AMERICAN PHENOLIC CORP., Chicago, was elected a vice-president of the company. Mr. Rous began his association with the company as assistant to the president, Arthur J. Schmitt.



William H. Rous

CRYSTAL-CLEAR LUCITE MASKS
Frame in Rich Gold Leaf Finish
Overall Dimensions

10"	Round	9 1/2" x 11 1/4"	\$3.47
12 1/2"	Round	11 7/8" x 13 3/8"	4.78
14"	Rect.	11 1/2" x 14"	4.52
16"	Round	13 1/16" x 16 1/4"	5.97
16"	Rect.	12 3/4" x 16 1/8"	5.84
17"	Rect.	13 9/16" x 16 7/8"	5.97
19"	Round	15 3/8" x 19 1/2"	7.69
20"	Rect.	15 3/8" x 19 1/2"	7.98
24"	Round	20 7/8" x 26 1/2"	14.65

(Including Set of Rosettes)

CRT TUBE MOUNTING BRACKETS FOR 630 FOR 12 1/2" PICTURE TUBES

As Pictured Complete **\$1.96**

FOR 16" PICTURE TUBES

Complete With Front Supports (pictured above on 12 1/2" set) **\$2.98**

UNIVERSAL MOUNTING BRACKETS

Fits All Picture Tubes Complete—incl. band that holds picture tube **\$6.97**

PLASTIC OPEN MASKS
FOR RECTANGULAR PICTURE TUBES
For recessing in conjunction with safety glass—Standard grey color

16"	— 14 1/8" x 17 3/16"	\$1.87
17"	— 14 1/8" x 17 1/4"	1.87
20"	— 17 3/8" x 23 3/8"	2.98

NO-GLARE TELEVISION FILTERS

For Better, More Clearly Defined Pictures
IMPROVES CONTRAST. ELIMINATES TELEVISION GLARE. SHARPENS PICTURE IMAGE
SIZES TO FIT ALL SETS IN SMOKE OR BLUE COLORS

FOR ROUND OR RECTANGULAR PICTURE TUBES

10"	8" x 10 1/2"	\$.89
12 1/2"	9" x 12 1/2"	1.26
14"	10 1/2" x 15"	1.47
16"	12" x 16 3/8"	1.92
17"	13 3/8" x 17 3/8"	2.16
19" or 20"	15 1/2" x 19 1/2"	2.44

BROOKS RADIO & TELEVISION CORP.
84 Vesey St., Dept. A, New York 7, N. Y.

RADIO-ELECTRONICS for

AMPERITE

Studio Microphones at P.A. Prices

Ideal for BROADCASTING RECORDING PUBLIC ADDRESS

"The ultimate in microphone quality," says Evan Rushing, sound engineer of the Hotel New Yorker.

- Shout right into the new Amperite Microphone—or stand 2 feet away—reproduction is always perfect.
- Not affected by any climatic conditions.
- Guaranteed to withstand severe "knocking around."



Models
RBLG—200 ohms
RBHG—Hi-imp.
List \$42.00

"Kontak" Mikes
Model SKH, list \$12.00
Model KKH, list \$18.00

Special Offer: Write for Special Introductory Offer, and 4-page illustrated folder.

AMPERITE Company, Inc.
561 BROADWAY • NEW YORK 12, N. Y.
Canada: Atlas Radio Corp., Ltd., 560 King St. W., Toronto

• ATTENTION •

Radio Service Dealers, Hams, Engineers and Experimenters. Quality Merchandise at

REGULAR DISCOUNTS

We are the established firm looking for new accounts. Only well known standard brands (no surplus), such as GE and Hytron tubes at regular discounts. Sylvania condensers, IRC and Centralab resistors and volume controls, Burgess and Eveready batteries. Olson and Victor speakers, EICO, Precision and Sylvania test equipment and instruments, Chicago and T. J. Taylor transformers, etc.

We also have a complete stock of TV replacement parts, masks, etc.

ALL ORDERS FILLED SAME DAY RECEIVED. NO ORDER TOO LARGE OR TOO SMALL. WHOLESALE ONLY.

We want satisfied customers. Get acquainted with us first. Send us a list of your requirements. Write for our regular Bulletin.

COAST ELECTRONIC SUPPLY CO.
527 W. Main Street, Alhambra, California
Phone: ATlantic 9-4361.

CONVERSION DATA!

See Ad—Page 78

For RCA Victor 730TV1 see PF INDEX No. 26

FREE—GET IT NOW!

PLEASE MENTION RADIO-ELECTRONICS when you write to advertisers

Personnel notes

... Don G. Mitchell, president of SYLVANIA ELECTRIC PRODUCTS, INC., accepted the 1950 Howard G. Ford Award for his company's achievements in sales growth in 1950. The award was made by the Sales Managers' Association of Philadelphia.

... W. H. (Terry) Dunning, formerly a member of the advertising staff of the General Electric Company in Syracuse, N. Y., joined P. R. MALLORY & COMPANY, Indianapolis, Ind., as advertising manager.

... William "Bill" Slawson joined JOHN F. RIDER PUBLISHER, INC., New York City, as general sales manager. He was formerly distributor sales manager of Federal Telephone and Radio Corporation.

... Richard H. Dorf, formerly an associate editor of RADIO-ELECTRONICS magazine, was appointed Electronics Project Engineer of the Brach Manufacturing Division of the GENERAL BRONZE CORPORATION, Newark, N. J.

... William J. Nezerka, vice-president and general sales manager of THE TURNER COMPANY, died recently in his home in Cedar Rapids, Iowa.

... Louis C. Kunz was appointed product manager for cathode-ray tubes in the Tube Divisions of GENERAL ELECTRIC. He was formerly section engineer on cathode-ray tubes in Syracuse.

... Dr. Adolph H. Rosenthal, formerly director of physics, was elected vice-president and director of research and development of FREED RADIO CORPORATION, New York City.

... Joseph Y. Resnick, formerly general manager, was elected chairman of the board of the CHANNEL MASTER CORPORATION, Ellenville, N. Y. Harry Resnick was named president and general manager. Harold Harris was elected vice-president in charge of sales and engineering, and Judge Louis E. Berger was elected to the Board of Directors.

... David DeWitt was appointed vice-president in charge of research for the RADIO RECEPTOR COMPANY, INC., Brooklyn, N. Y. Devereaux Martin was named assistant to the president, and Allan Easton manager of communications engineering.

... Raymond W. Andrews, former merchandising manager of the Radio Tube & Television Picture Tube Divisions of SYLVANIA ELECTRIC PRODUCTS, INC., was promoted to manager of factory sales.

—end—

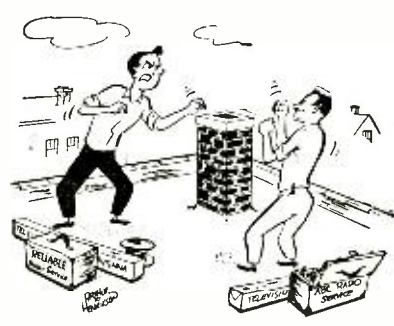

Suggested by Arthur A. Henrikson

NIAGARA'S RED HOT SUMMER SPECIALS

REMOTE CONTROL FOR THE THING!!

(PLUS \$1.00 BOOK FREE)

The answer to the "Remote Control" experimenter's dream! A completely wired, 3 tube remote control unit, originally used as Electronic Brain for remote thermo-static control of electric blankets. Can be used, with slight modification, to control model trains, planes, trucks, remote on-off for radios, open and close garage doors from your car, or to remotely control any device in accordance with your own ingenuity. And that's not all! With each unit we will give you absolutely free, one copy of Genesee Library's popular new book "Model Control by Radio," 112 pages, containing more than 125 illustrations, diagrams, tables and formulas, examined with full of theory and practical uses for Electronic Remote Control.

Remote Control Unit, including Fil. X-ray, 300 ohm plate circuit "trigger" relay, completely wired, circuit diagram and above described book—less tubes.

ALL FOR ONLY..... **\$5.50**

Shipping Wgt. 3 lbs.

A NIAGARA SPECIAL

WEBSTER CHICAGO

AUTOMATIC RECORD CHANGER

TYPE 100—SERIES



A fortunate purchase makes it possible for us to offer these fine, new record changers at less than regular manufacturer's cost. Made by Webster-Chicago and only introduced on the market a few months ago as one of their latest models. Plays 12, 10 or 7 inch records at 33 1/3, 45, or 78 R. P. M. New spindle centrally located. Balanced arm assures light needle pressure and long wear. Needle-tip (included) for standard or micro-groove records. Inside-out records played without any adjustment. Pickup arm comes to rest position after last record has played. Complete factory packed and sealed record changers, normally listing at \$47.50—while they last.

Shipping Wgt. **\$24.85**

LIMITED QUANTITY

ASTATIC 2 STAGE TV BOOSTER

(MODEL AT-1)



New 4 Tube Booster for "difficult" areas. High gain, sensitive, 2 stage circuit. Covers all 12 channels, with separate peaking controls for Picture and sound. Recessed pilot lite, uses 4-6AK5 tubes (supplied) for 72 or 300 ohm line, 110V., 60cy AC only.

REAL MAHOGANY CABINET. Instructions Wt. 6 lbs. LIST \$49.50. SPECIAL..... **\$29.10**

ALLIANCE TENNA-ROTOR

TV ANTENNA ROTATOR



New Alliance Rotator, completely remote controlled. Automatic rotation control shows exact position of antenna at all times. Moving light shows position while antenna rotating. Set pointer to position desired and antenna automatically turns to that position and stops! 1 RPM instantly reversible. Weather proof construction. Lifetime lubricated. Fits masts up to 1 3/4". Uses 4 wire control line. Less cable. Includes instructions. Shpg. wt. 14 lbs. **\$26.43**

4 Wire control ribbon for Rotator 100 \$0.50
H.—\$4.50; Per Foot.....

THRUST BEARING SUPPORTS UP TO \$4.95
200 lbs.

Niagara Radio Supply Corp. Phone DIsby 9, 1132-34
Dept. C7 160 Greenwich Street, New York 6, N. Y.

IMMEDIATE DELIVERY ON AUTO RADIOS

Custom built for all popular 1949-1950 and 1951 automobiles: Chevrolet, Ford, Plymouth, Dodge, Studebaker, Henry J, and Hudson.

Every radio is a powerfully built, 6 tube, super-heterodyne with RF stage and 3 gang condenser for sensitive, long distance reception. Latest miniature tubes used, with beam-power output and oversize Alnico V loudspeaker, giving plenty of volume with excellent tone. Includes Automatic Volume Control and has low battery drain.

Each model radio is Custom-Built, designed for the individual automobile and can be mounted within 4 minutes with no cables, no brackets, no holes to drill.

When ordering, indicate type automobile:

Your Price, all **\$41.97** Complete

YOUR MONEY RETURNED IN FULL—

If the New Regency Television Booster fails to improve your television enjoyment! Bring your picture out of the snow and reduce interference!

- Push-Pull Neutralized triode design assures high gain without adding snow.
- No external impedance matching devices required.
- Inductive tuning assures same high-gain wide-band operation on all channels.
- Single knob tuning control.
- Underwriters approved with 90 day RMA guarantee.

LOWEST Price—ONLY **\$19.11**

MODEL NFRD—RADIO NOISE FILTER

If it doesn't work, send it back!

We absolutely guarantee that our Model NFRD will eliminate all line noises when properly connected to radios, television sets, short wave sets, motors, electric shavers, refrigerators, vibrators, oil burners, transmitters, and all other sources of interference. This unit will carry up to 12 amperes or 1 1/2 KW of power and may be used right at the source of interference or at the radio. Small size only 3"x1 1/2"x7 1/2". Very low price only

Each **\$1.95**

A SCIENTIFICALLY DESIGNED PHONO SCRATCH FILTER

Resonated at approximately 4500 cycles effectively reducing objectionable needle scratch without altering the brilliancy of reproduction. Contains a HI-Q SERIES resonated circuit. Tested by means of an audio oscillator and an oscilloscope to give 22 db attenuation with very low signal loss.

EASY TO ATTACH

Just two wires to clip on. Compact Price **\$1.98**

THREE TUBE PHONO AMPLIFIER

An assembled unit ready for installation using tone and volume control and six feet of rubber cord **\$2.95**

(Not including Tubes)

With Complete Set of Tubes **\$3.95**

PHONO OSCILLATOR

Wireless phono oscillator transmits recording for crystal pick-ups or voice from carbon mike through radio without wires. Can also be used as an intercomm by using P.M. speaker as mike. Price (excluding tubes) **\$2.95**

With Complete Set of Tubes **\$3.95**

NEW HIGH FIDELITY 12" COAXIAL SPEAKER

Because of the very low price, we cannot mention the well-known manufacturer's name. Has a built-in dividing network—an ideal Woofer-Tweeter combination. Rated at 12 watts, impedance 8 ohms. Price **\$18.50**

Satisfaction guaranteed on all merchandise
All prices F.O.B. New York City
WRITE FOR FREE CATALOGUE C7

RADIO DEALERS SUPPLY CO.

154 Greenwich St. New York 6, N. Y.

A TASTE FOR SERVICING

Dear Editor:

I read with pleasure your article, "Five Service Aids," by Jesse Dilson, in the March issue. I have gone Mr. Dilson one further and have used my tongue as a test instrument several times. While visiting a friend's home, he dug up a little a.c.-d.c. set. If nothing lit it was a good bet that there was an open filament. But the only test equipment available would be a flashlight cell.

By placing one terminal of the battery to one of the filament prongs of the tube, and then bridging from the other battery terminal to the other filament prong, it is easy to tell if the filament is open. The tongue is very sensitive, and there is a distinct tickling sensation if the filament is O.K.

L. ESLE BOND

Buckhamton, W. Va.

ERROR ON OUR PART

Dear Editor:

On page 12 of your April issue you have an item about Maddida which contains some misstatements.

Maddida was invented, designed, constructed and sold by Northrup Aircraft, Inc., of Hawthorne, Cal., and our part was limited entirely to a purchase of the first production model. Credit should be given to the Navy for its contribution to the purchase of this machine.

ROBERT R. WILLIAMSON
STEVENS INSTITUTE OF TECHNOLOGY
Hoboken, N. J.

CORRECTION

There is an error in the miscellaneous-notes column of the picture-tube replacement table on page 38 of the May, 1951, issue. Notes *a* (no exterior coating), *b* (triode gun), and *c* (2.5-volt heater) are shown opposite the 12LP4. These notes apply only to the 12CP4. The space opposite the 12LP4 should be blank. The 12TP4 does not have an exterior conductive coating so the letter *a* should be opposite it in the right-hand column.

Deflection angles were omitted from three of the column headings. Deflection angles for the 16-inch metal round tubes are in the right-hand column. The 17-inch glass rectangular tubes have a 70-degree diagonal or 65-degree horizontal deflection angle. The 19-inch glass round tubes have a 66-degree deflection angle.

The 19-inch metal round tube (19A-P4-A, B-C-D) was not listed because there is no direct replacement for it.

We thank Pat Neels, of New York, N. Y. for these corrections.

NOTICE TO VETERANS

Veterans, the deadline for entering or re-entering training under the G.I. Bill of Rights is rapidly approaching. World War II veterans discharged prior to July 25, 1947, who plan to enter or resume training must do so before July 25, 1951, or they will lose their educational benefits. Veterans discharged after July 25, 1947, have four years from the date of discharge to begin training.

—end—

Metal Grille with diamond (1 1/2x3 1/4), 12x12—
98c 12x12—\$1.85; 16x24—\$1.99; 18x18—\$1.98;
18x24—\$2.25; 18x24—\$2.69; 24x24—\$3.49

DPDT Toggle (A&H)
6A/125V, 7/16" Shank, Fully
cased; short bat. 12 5.00
1" Amber Jewel Ass'ly
DC bay 3/1.00

Leotone

115V. AC Motor 1750 RPM, 4-1/2"
3/4" shaft, 1/2" x 2 1/2" x 1 1/2" \$1.49
Rubber Shock Mounts . . . 8 lb., 1 3/4" 15c 8/1.00
Ball Bearings . . . 6 lb., 1 1/2" I.D. 1 1/2" 23c 5/1.00
GT Tub. Cartons . . . 3 1/2" L. printed 100/ .98
6V. Hi-Freq. Buzzer . . . Fully adjust.69
Radio Hardware . . . FULLY STOCKED
of Nuts, Screws, Taps, etc. 69c 3/1.98

2 Powerful "Alnico Magnets"
1 1/2" x 1 1/2" x 1/4" \$1.29

Alnico Magnet Kit . . . Powerful
Bar, Black, 1 1/2" Rod, Kit of
10 parts 1.98

ALWAYS FOR "ALNICO MAGNET" SUPPLEMENT

Portable DC Ammeter . . . 0-15 Amps, 3 1/2" mtr.
for fan coil, metal case, 36" test leads, WITH
DATA FOR EASY CONVERSION TO "VOLT-OHM-
MILLI-AMMERE" SPECIAL \$3.95
18 FT. Whip Antenna . . . 4' steel spring, auto. 2.49
MS-53 Mast Sock . . . 30" to ext. 18 ft. whip39
Hi-Fidelity Crystal Mike . . . 1 1/2" imp'd, rubber
backing, 1/2" dia. 1.29
Aluminum Housing for crystal mike15

BARGAIN KITS!! . . . KNOBS, 25 ass'd. 5.98
Rotary Selector Switches . . . Kit 6 ass'd. 1.75
Wafer Sockets . . . 4 to 8 pin, 12 ass'd.49
Wire-Wound Resistors . . . 5-20W, 17 ass'd. 1.29
1W. Resistors . . . 500-ohm, 25 ass'd.79
Mica Padders—Trimmers . . . Kit of 15 ass'd.79
Dial Scales . . . 1/2" x 1 1/2" 2.49
Dial Escutcheons . . . all shapes, 25 ass'd. 2.49
Dial Windows . . . glass, acetate, 12 ass'd. 1.29
Moulded White Condensers (micamold) 1.98
00001 to 20000, 200-600V, 50 ass'd. 1.98

Midget Plug-Jack . . . PE-201/JK-48 39c 6/1.98
Wall Jack for HI-55 type plugs 29c 4/1.00
6V. Pilot Bulbs . . . screw, jap. 10 39c 100 3.50
52G Fuses . . . 1, 3 or 6A., 250V. 12c 5/1.00
Polystyrene . . . 12" lengths, ROD: 3/4" 10c
3/4" 36c; 5/8" 55c; 3/4" 79c; 1"
1 1/2" 1.00; 2" 1.40; 3" 1.80
17c; 3" 1.36c; 3 1/2" 1.42c; 4"
Cabinet Draw Slides . . . Ball-bearing, 1 1/2" (9" ext.)
\$2.10; 1 1/2" (1 1/2" ext.) \$2.25; 1 1/2" (1 1/2" ext.) 2.39
Speaker Baffle . . . 4 1/2" x 12 1/2" 3.25
Cabinet Lid Support for CONSOLES, CHESTS,
spring return, self-holding to 70° 49c 6/2.49
5" Speaker Baffle . . . 4 1/2" x 12 1/2" 1.9c 6/1.00
Grille Cloth . . . Ivory Tan, Brown, 10" sq. 19c 6/1.00
Lorgnette Phone-Mike with 4 ft. cord & plug.
1 1/2" dia. 2.49
Portable Record Player Case . . . beautiful fan
toothette, wood inside: 17 1/2" x 14" x 8 1/2" 4.95

FACTORY SPEAKER REPAIRS SINCE 1927—
Mail Order \$3.00, 20% deposit on all COPIES.
Please add sufficient postage—express refunded.
Full refundance with foreign orders

LEOTONE RADIO CO.

67 Doy Street,
New York 7, N. Y.

CONVERSION DATA!

See Ad—
Page 78

For RCA Victor 630TS
see PF INDEX No. 25

FREE—GET IT NOW!

EVERY RADIOMAN Can Use These SERVICE HINTS!

Valuable Manual Volumes—FREE!

Every page of "How to Simplify Radio Repairs" is packed with on-the-bench, practical ideas. Contains photos, charts, diagrams—to help you visualize theory. In plain every-day language it gives you priceless suggestions—new servicing ideas. You'll use and benefit from the experience of experts. Partial list of contents: How to Localize Trouble; How to Service Amplifiers; How to Test for Distortion; How to Test Audio Circuits; How to Test Speakers; How to Find Faults in Oscillators; How to Test Radio Parts—and it's all yours—FREE! No obligation.

SEND COUPON OR PENNY POSTCARD FOR YOUR FREE COPY TODAY!

FEILER

FEILER ENGINEERING CO., Dept. 7RC1
8026 N. Monticello Ave.,
Skokie, Ill. (Suburb of Chicago)

Please RUSH my FREE copy of "How to Simplify Radio Repairs."

Name: _____
Address: _____
City: _____ Zone: _____ State: _____

PRACTICAL WIRELESS ENCYCLOPAEDIA, by F. J. Camm. Published by George Newnes Ltd., London, England. 5 3/4 x 9 inches, 372 pages. Price 21 shillings.

This encyclopedia is a comprehensive collection of words, terms, phrases, and formulas commonly employed in radio, television, electronics, and allied fields. It is illustrated with schematic and pictorial diagrams, drawings, tables, and graphs where necessary.

Some American readers would probably have trouble finding or understanding some terms in the encyclopedia because of differences in American and British terminology. For example, there is no definition of a storage battery as such, but almost 20 full pages and 27 illustrations are devoted to the *accumulator* which is the British equivalent.—RFS

APPLIED ELECTRONICS ANNUAL, 1951, edited by R. B. Blaise. Published by British-Continental Trade Press, Ltd., 222 Strand, London, England. 7 3/4 x 9 3/4 inches. Price \$8.00.

This useful manual contains a number of interesting articles which cover the practical applications of electronics. Each of the articles was written by an expert in his field, and together, survey the industry. "Marine Electronic Equipment," "Printed Circuits" and "Television in Britain" are articles which will be enlightening to the American reader.

In addition to the twenty-four articles, there are a number of directory services which, although they could be more complete, are valuable. These include a directory of the radio and electronics industry which lists the manufacturers of radio and electronic apparatus throughout the world.

COLOR TELEVISION NOTEBOOK, by Edward M. Noll. Published by the Paul H. Wendel Publishing Co. for Television Technicians Lecture Bureau, P.O. Box 1321, Indianapolis, Indiana. 8 1/2 x 11 inches, 45 pages. Price \$1.00.

A complete explanation of the principles of color television, with detailed descriptions of the CBS and RCA systems and a shorter discussion of the CTI method. The special features and advantages of each are impartially analyzed and information on receiver adaptation and special circuits (crispening, color phasing) is given.

ELECTRONIC SHORTCUTS FOR HOBBYISTS, Sylvania Electric Products Inc., Electronics Division, 1740 Broadway, New York 19, N. Y. 6 x 9 inches, 33 pages. Price, \$.25.

This booklet contains 24 crystal diode circuits expressly chosen for their general interest to experimenters and hobbyists. For example, an interval timer, a crystal-powered photo-electric relay, a radio-operated garage door opener, a light-duty electroplater and others are included. The descriptions of construction and operation are straightforward, and the illustrations and diagrams clear. Ratings and characteristics of Sylvania germanium diodes are appended in a 2-page table.

JULY, 1951

Practical, Popular-priced Books on RADIO•AUDIO•SERVICING

TWO NEW \$1.00 BOOKS



No. 43—MODEL CONTROL BY RADIO. By Edward L. Safford, Jr., 112 pages. An authority in the field of radio control gives you the first complete book on the subject. For beginner and expert. Tells you what radio control is, how it works and how to construct not only component parts but a complete system as well. Illustrations explain each step.

No. 42—HIGH-FIDELITY TECHNIQUES. By James R. Langham, 112 pages. You've never seen a technical book like it! Just as he'd talk to you across the work bench, RADIO-ELECTRONICS' popular audio writer tells you how to design your own equipment and how to get top performance from it. Takes the double talk out of high-fidelity work.

THREE IMPORTANT 75¢ BOOKS

No. 41—PUBLIC-ADDRESS GUIDE. 80 pages. This handy book shows the service technician the way to extra income in big-paying PA work. Covers installation, maintenance and construction.

No. 40—THE CATHODE-RAY OSCILLOSCOPE. 112 pages. A "must" for servicing TV, FM and AM receivers and in amateur operation! Tells in simple, but technically sound language, how the 'scope works and how to use it.

No. 39—PRACTICAL DISC RECORDING. 96 pages. Tells you how to make good disc recordings. Covers every phase, theory as well as technique. A full chapter is devoted to each component.



10 POPULAR 64-PAGE BOOKS — 50¢ EACH



No. 29—HANDY KINKS AND SHORT CUTS. A treasury of time savers! Antennas, power supplies, test equipment, phonographs, amplifiers. Easy reference. Illustrated.

No. 30—UNUSUAL PATENTED CIRCUITS. A gold mine of important hook-ups. Control circuits, detectors, amplifiers, power supplies, foreign circuits.

No. 31—RADIO QUESTIONS & ANSWERS. Answers the tough ones on circuit diagrams, amplifiers, receivers, transmitters, meters and test equipment.

No. 32—ADVANCED SERVICE TECHNIQUE. A "must" for the advanced service technician! Covers specialized problems of servicing not usually found in ordinary textbooks.

No. 33—AMPLIFIER BUILDER'S GUIDE. For the designer and builder of audio equipment. Covers a variety of amplifiers with power outputs from 8 to 30 watts.

No. 34—RADIO-ELECTRONIC CIRCUITS. For the experimenter—circuit diagrams of intercom systems, power supplies, voltmeters, electronic relays, receivers, etc.

No. 35—AMATEUR RADIO BUILDER'S GUIDE. For the "ham" who builds his own. Receivers, transmitters, antennas, converters, etc. Practical construction data.

No. 36—RADIO TEST INSTRUMENTS. Practical construction data on signal tracers, capacity meters, portable and bench multi-checkers, voltmeters, etc.

No. 37—ELEMENTARY RADIO SERVICING. How to get started and keep going! Planning the shop, circuit checks, signal tracing—other fundamental servicing problems.

No. 38—HOW TO BUILD RADIO RECEIVERS. Describes 18 modern sets including short wave, broadcast, vhf, portable, ac-operated, ac-dc, miniatures—types for every fan.

THE GERNSBACK LIBRARY

SEE YOUR DISTRIBUTOR OR MAIL THIS COUPON TODAY

RADCRAFT PUBLICATIONS, INC.
25 West Broadway, New York 7, N. Y.

Enclosed is \$..... for which please send me postpaid, the books checked below.

- 29 30 31 32 33 34 35 36
 37 38 39 40 41 42 43

Name.....

Street.....

City..... Zone..... State..... 71



RADIO COURSES

Preparatory Mathematics, Service, Broadcast, Television, Marine Operating, Aeronautical, Frequency Modulation, Radar.

Classes now forming for the Fall term beginning October 1st Entrance exam. Sept. 17th.

Veterans. Literature.

COMMERCIAL RADIO INSTITUTE
(Founded 1920)
58 West Biddle Street, Baltimore 1, Md.

LEARN DAY and EVENING CLASSES TELEVISION

ELECTRONICS-RADIO
Modern Laboratory Instruction in

- SERVICING
- BROADCAST OPERATING
- ELECTRONIC and TV ENGINEERING

WRITE FOR ILLUSTRATED CATALOG

ELECTRONICS INSTITUTE, Inc.
21 HENRY, DETROIT 1, MICH.

G.I. APPROVED



RADIO ENGINEERING

FM—Television—Broadcast

Police Radio, Marine Radio, Radio Servicing, Aviation Radio and Ultra High mobile applications. Thorough training in all branches of Radio and Electronics. Modern laboratories and equipment. Old established school. Ample housing facilities. 7 acre campus. Small classes, enrollments limited. Our graduates are in demand. Write for catalog.

Approved for Veterans

VALPARAISO TECHNICAL INSTITUTE
Dept. C VALPARAISO, INDIANA

AUDIO ENGINEERING SCHOOL

Practical engineering training in Audio fundamentals, Disc, Film, Magnetic Recordings, and Audio frequency measurements. Studio training simulates Broadcast, Motion Picture, Television, and Commercial Recording work.

Approved for Veterans

HOLLYWOOD SOUND INSTITUTE, Inc.
1040-E North Kenmore, Hollywood 27, Calif.
Specify if Veteran or Non-Veteran

CODE SENDING RECEIVING SPEED

Be a "key" man. Learn how to send and receive messages in code by telegraph and radio. Commerce needs thousands of men for jobs. Good pay, adventure, interesting work. Learn at home quickly through famous Candler System. Qualify for Amateur or Commercial License. Write for FREE BOOK.

CANDLER SYSTEM CO.
Dept. 3-H, Box 928, Denver 1, Colo., U.S.A.

RADIO COURSES

- RADIO OPERATING • CODE
- RADIO SERVICING • ELECTRONICS
- F.M. TELEVISION

Preparation for Civilian, Maritime, Army and Navy license requirements.

Write for Catalog TE

YMCA

TRADE & TECH. SCHOOL
229 W. 66 St., N. Y. 23
ENdicott 2-8117

RADIO ENGINEERING DEGREE IN 27 MONTHS

Intensive, specialized course including strong basis in mathematics and electrical engineering, advanced radio theory and design, television. Modern lab. Low tuition. Self-help opportunities. Also 27-month courses in Aeronautical, Chemical, Civil, Electrical, and Mechanical Engineering. Approved for G.I.'s.

Enter, Sept., Dec., March, June. Catalogue.

INDIANA TECHNICAL COLLEGE
157 E. Washington Blvd., Fort Wayne 2, Indiana

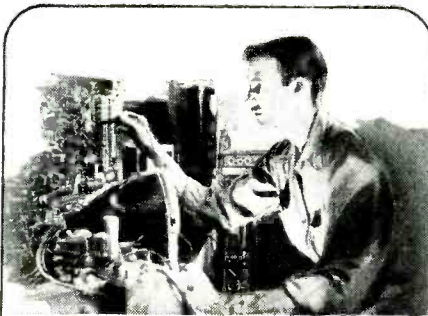

ENTER RADIO TELEVISION

thru this Proven Plan

As a young man with a career to build, you may today be interested primarily in training for Radio — and perhaps for TV. But — *who knows* . . . you may some day have both the desire and opportunity to climb further and become an Electrical Engineer! Here, then, is a world-renowned educational plan that permits you to use your Radio training as a major stepping-stone to an even greater career.

IN 12 MONTHS BECOME A RADIO TECHNICIAN

Train here for radio shop operator or serviceman, mobile receivers and all types of transmitters, and for supervision of service personnel. You may then advance immediately, or at any future date, into courses described below.

IN 6 ADDITIONAL MONTHS you become a Radio-Television Technician

An additional 6-months course gives you intensive TV Technician's training — under the *personal guidance* so necessary in this expanding field.

ALSO...YOUR RADIO COURSE IS FULL CREDIT TOWARD THE B.S. DEGREE IN ELECTRICAL ENGINEERING

The Radio course, while complete in itself, is *one-third* of the college program (major in Electronics). Further — you are guided scientifically toward specialization beyond basic engineering training.



B.S. DEGREE IN 36 MOS.
Military, practical or prior academic training evaluated for advanced credit. Terms open July, October, January, April.

MILWAUKEE SCHOOL of ENGINEERING

Technical Institute • College of Electrical Engineering

FREE—Write for "Occupational Guidance Manual" and 1951 Catalog.

MILWAUKEE SCHOOL OF ENGINEERING
Dept. RE-751, 1020 N. Broadway
Milwaukee, Wis.

Without obligation, mail Occupational Guidance Manual on:

- Radio-TV Electrical Power Welding
 Heating, Refrigeration, Air Conditioning
- Also send 1951 Catalog for Electrical Engineering, B.S. degree in Electric Power Electronics

Name.....Age.....

Address.....

City.....Zone...State.....

Check if World War II Veteran

ATTENTION...

A NEW department of the DON MARTIN SCHOOL OF RADIO AND TELEVISION ARTS AND SCIENCES . . . for instruction and training in—TELEVISION—incorporating:

Production: Writing, Directing, Producing, Acting, Staging, Lighting.

Engineering: Transmission, Receiving, Camera and Studio, Operation, Theory of Video, Pickup and Reproduction.

Approved for veterans.

THE DON MARTIN SCHOOL OF RADIO AND TELEVISION ARTS AND SCIENCES

1655 No. Cherokee, Hollywood 28, Calif. HU. 23281.

Prepare Now! RADIO ENGINEERING

B. S. DEGREE IN 27 MONTHS

Complete Radio Engineering course incl. Telev., U.H.F. and F.M. BS Degree Courses also in Mech., Civil, Elect., Chem. and Aero Eng.; Bus. Adm., Acct. Extensive campus, modern buildings, well equipped labs. Low cost. Prep. courses. Personalized instruction. Heavy demand for graduates. Placement service. Founded in 1884 Prepare now for the civil and military opportunities ahead. Enter Sept., Jan., March, June. Write for Catalog.

TRI-STATE COLLEGE

2471 COLLEGE AVE. ANGOLA, INDIANA

TELEVISION

PREPARE FOR A GOOD JOB!

COMMERCIAL OPERATOR (CODE)
RADIO SERVICEMAN

TELEVISION SERVICING
BROADCAST ENGINEER

Approved for Veterans
SEND FOR FREE LITERATURE

BALTIMORE TECHNICAL INSTITUTE

1125 Eutaw Place, Dept. C, Baltimore 17, Md.



RADIO and TELEVISION

Thorough Training For Men and Women in All Technical Phases

APPROVED FOR VETERANS

DAY—EVENINGS WEEKLY RATES
FREE PLACEMENT SERVICE FOR GRADUATES
For Free Catalog Write Dept. RC-51

RCA INSTITUTES, Inc.

A Service of Radio Corporation of America
350 WEST 4TH STREET NEW YORK 14, N. Y.

AUDIO (SOUND) ENGINEERING HOME STUDY TRAINING

Practical, easy-to-understand lessons, written by competent Audio Engineers and Educators, prepare you for a better job and a good future in the Television, Radio, Motion Picture, and Recording Industries.

Write today for details—Learn while you earn!!

HOLLYWOOD TECHNICAL INSTITUTE

Div. RE
4925 Santa Monica Blvd., Hollywood 27, California

BE YOUR OWN BOSS!

MAKE MORE MONEY



In "CASH IN" you now get THE real money-makers — dozens of profitable tested mail order plans, confidential business secrets, dozens of practical tested formulas, successful tested schemes — actual experiences of men who have started on a shoestring with less than \$10 capital. 25c a copy postpaid. Send U. S. stamps, money order, or coin.

25c

40,000 WORDS IN TEXT

NO ADS ALL "MEAT"!

Money Back Guarantee

NATIONAL PLANS COMPANY
1966 BROADWAY, NEW YORK 23, N. Y.

RADIO-ELECTRONICS for



Dear Om: Wondering what to do with your excess xmtg. special purpose and receiving tubes and equipment?



I'll buy all types of new tubes in small or large quantity and pay you highest cash offer.

B. N. GENSLER
W2LNI
New York 6, N. Y.

135 Liberty St.

Send list of quantities and types. Indicate whether now and in original cartons.

SCARCE RADIO TV TUBES

TUBES BOUGHT, SOLD, and TRADED SEND YOUR WANT and TRADE LIST!

Many Types Available for IMMEDIATE DELIVERY—WRITE NOW!

Radio and TV servicemen, experimenters, amateurs . . . we have many types of scarce tubes ready for immediate shipment. Don't use make-shifts or spend valuable time looking for tube sources. Try Electro FIRST . . . and get the tubes you need without delay. Get complete list and Electro's low prices. It's FREE . . . write today!

ELECTRO SALES 429 West Randolph St. Chicago 6, Illinois

TELEVISION RECEIVER—\$1.00

Complete instructions for building your own television receiver. 16 pages—11"x17" of pictures, pictorial diagrams, clarified schematics. 17"x22" complete schematic diagram & chassis layout. Also booklet of alignment instructions, voltage & resistance tables and troubleshooting hints.—All for \$1.00. Write for free catalogue.

CERTIFIED TELEVISION LABORATORIES
Dept. C, 5507-13th Ave., Brooklyn 19, N. Y.

ON-THE SPOT BATTERY RECORDER

WALKIE-RECORD-ALL 8 lb. miniature BATTERY RECORDER-PLAYBACK

Continuous, permanent, accurate, indexed recording at only 5¢ per hr. Instantaneous, permanent playback. Picks up sound up to 60 ft. Records conferences, lectures, dictation. 2-way phone & sales talks; while walking, riding or flying. Records in closed briefcase with "hidden mike"! Write for details.

MILES REPRODUCER CO., INC.
812 BROADWAY Dept RE7 NEW YORK 3, N. Y.

WANTED "SO" TYPE RADAR PARTS

Write or Phone

World Wide Packing & Shipping Co.
350 Pearl St. Brooklyn, N. Y. MA 4-8371

TV CONVERSIONS

This important subject will be covered in a number of articles and features in the August issue of **RADIO-ELECTRONICS**. Fundamentals, techniques, and pitfalls will all be covered by experienced and authoritative authors. Information on replacement components will be tabulated. Reserve your copy now!

WAVE MECHANICS (second edition) by J. Frenkel. Published by Dover Publications Inc., 1780 Broadway, New York, N. Y., 5 3/4 x 8 1/4 inches, 309 pages, 1950, vol. 1. Price \$3.50.

The first volume of a projected three-volume series, this book covers elementary quantum statistics, wave mechanics, light, and matter. The author combines the chronological development of wave theory with critical analysis of the problems encountered by Newton, Schrodinger, Fermi, and other investigators.

This is a good primer for the person who is interested in an analysis of wave mechanics and modern physics, but higher math is essential.

ALTERNATING-CURRENT CIRCUITS (third edition) by Russell Kerchner and George Corcoran. Published by John Wiley & Sons, Inc., New York, N. Y. 6 1/4 x 9 1/4 inches, 598 pages. Price \$5.50.

This book covers the theory and practice of a.c. circuits. It presupposes knowledge of integral and differential calculus on the reader's part. Energy measurement in polyphase circuits, electric filter theory, and power-system short-circuit calculations are among the topics covered. End-of-chapter problems with some answers are included.

THEORY AND DESIGN OF TELEVISION RECEIVERS, by Sid Deutsch. Published by McGraw-Hill Book Co., 330 West 42nd St., New York, N. Y. 6 x 9 inches, 536 pages, 1951. Price \$6.50.

This is a text, written on the engineering level, which can appeal to the service technician as well as the student. The author has combined lucid description of TV circuit behavior with direct, full presentation of theory—no simple feat. Although mathematics is not avoided it is used judiciously.

One of the more interesting parts of the book is the antenna and r.f. chapter. It is complete and varied, including a description and analysis of airplane disturbance and interference effects, with a chart on fading plotted against relative airplane distance.

The service technician and advanced amateur will profit from the chapters on servicing and fundamentals. A complete list of questions for students is provided at the end of each chapter.

A complete index and list of tables, as well as detailed table of contents is included. There are numerous illustrations.

SEMI-CONDUCTORS, by D. A. Wright. Published by John Wiley & Sons, Inc., 440 Fourth Avenue, New York, N. Y. 4 1/2 x 6 3/4 inches, 130 pages, 1950. Price \$1.75.

This book gives an elementary account of the properties of semiconductors, and covers the theory of electron flow in them or across the boundary between them.

It brings the reader up to date in this new field of electron physics and presents material otherwise found only in periodical literature.

—end—



Special Offer On This Complete RADIO ENGINEERING LIBRARY

New, Up-To-Date Edition of Famous Library Covers Whole Field of Radio Engineering. Places Latest Facts, Standards, Data, Practice, and Theory At Your Fingertips

The five big volumes of the new edition of the Radio Engineering Library now include the very latest facts, standards, data, and practice. This Library will help solve hundreds of problems for designers, researchers, engineers, and students in any field based on radio.

Written by leading radio engineers, these books cover circuit phenomena, networks, tube theory, vacuum tubes, amplification, measurements, etc.—give specialized treatment of all fields of practical design and application. They provide you with a complete and dependable encyclopedia of facts.

- 5 Volumes, 3872 Pages, 2770 Illustrations
- Eastman's FUNDAMENTALS OF VACUUM TUBES, 3rd Edition.
- Terman's RADIO ENGINEERING, 3rd Edition.
- Everitt's COMMUNICATION ENGINEERING, 2nd Edition.
- Hund's HIGH FREQUENCY MEASUREMENTS, 2nd Edition.
- Henney's RADIO ENGINEERING HANDBOOK, 4th Edition.

SEND NO MONEY

Special Low Price — — Easy Terms

On this special offer you get this Library for \$34.50, instead of \$39.00. You save \$4.50 and may pay on easy terms. Mail coupon below to examine the Library FREE for 10 days. No obligation. These books are recognized as standard works; you are bound to need them. So take advantage of this special money-saving offer. *Mail coupon at once!*

McGraw-Hill Book Co., Dept. RE-7
327 West 41st St., New York 18, N. Y.

Send for 10 days' FREE trial, the RADIO ENGINEERING LIBRARY. If not satisfied I will return books. Otherwise I will send \$4.50, plus delivery charges, then; and \$5 a month for 6 months. (Reg. price \$39.00; you save \$4.50).

Name

Home Address

City & State

We'll Pay Delivery Charges if you enclose \$4.50 first payment WITH coupon. Same return privilege for full refund.

RE-7

Build 15 RADIOS AT HOME

With the New Improved 1951
Progressive Radio "EDU-KIT"
ONLY
\$10.95

FREE TOOLS WITH KIT
ABSOLUTELY NO KNOWLEDGE OF RADIO NECESSARY
NO ADDITIONAL PARTS NEEDED
EXCELLENT BACKGROUND FOR TELEVISION



WHAT THE PROGRESSIVE RADIO "EDU-KIT" OFFERS YOU

The Progressive Radio "Edu-Kit" offers you a home study course at a rock bottom price. Our Kit is designed to train Radio Technicians, with the basic facts of Radio Theory and Construction Practice expressed simply and clearly. You will gain a knowledge of basic Radio Principles involved in Radio Reception, Radio Transmission and Audio Amplification.

You will learn how to identify Radio Symbols and Diagrams; how to build radios, using regular radio circuit schematics; how to mount various radio parts; how to wire and solder in a professional manner. You will learn how to operate Receivers, Transmitters, and Audio Amplifiers. You will learn how to service and trouble-shoot radios. In brief, you will receive a basic education in Radio exactly like the kind you would expect to receive in a Radio Course costing several hundreds of dollars.

THE KIT FOR EVERYONE

The Progressive Radio "Edu-Kit" was specifically prepared for any person who has the desire to learn Radio. The Kit has been used successfully by young and old in all parts of the world. It is not necessary that you have even the slightest background in science or radio.

The Progressive Radio "Edu Kit" is used by many Radio Schools and Clubs in this country and abroad. It is used by the Veterans Administration for Vocational Guidance and Training.

The Progressive Radio "Edu-Kit" requires no instructor. All instructions are included. All parts are individually packaged, and identified by name, photograph and diagram. Every step involved in building these sets is carefully explained. You cannot make a mistake.

PROGRESSIVE TEACHING METHOD

The Progressive Radio "Edu-Kit" comes complete with instructions. These instructions are arranged in a clear, simple and progressive manner. The theory of Radio Transmission, Radio Reception and Audio Amplification is clearly explained. Every part is identified by photograph and diagram; you will learn the function and theory of every part used.

The Progressive Radio "Edu-Kit" uses the principle of "Learn By Doing." Therefore you will build radios to illustrate the principles which you learn. These radios are designed in a modern manner, according to the best principles of present-day educational practice. You begin by building a simple radio. The next set that you build is slightly more advanced. Gradually, in a progressive manner, you will find yourself constructing still more advanced radio sets and doing work like a professional Radio Technician. Altogether you will build fifteen radios, including Receivers, Amplifiers and Transmitters.

THE PROGRESSIVE RADIO "EDU-KIT" IS COMPLETE

You will receive every part necessary to build 15 different radio sets. This includes tubes, tube sockets, variable condensers, electrolytic condensers, mica condensers, paper condensers, resistors, tie strips, coils, tubing, hardware etc. Every part that you need is included. In addition, these parts are individually boxed, so that you can easily identify every item.

TROUBLE-SHOOTING LESSONS

Trouble-shooting and servicing lessons are included. You will be taught to recognize and repair troubles. While you are learning in this practical way, you will be able to do many a repair job for your neighbors and friends, and charge fees which will far exceed the cost of the Kit. Here is an opportunity for you to learn radio and have others pay for it.

FREE EXTRAS IN 1951

- ELECTRICAL AND RADIO TESTER
- ELECTRICAL SOLDERING IRON
- BOOK ON TELEVISION
- RADIO TROUBLE-SHOOTING GUIDE
- MEMBERSHIP IN RADIO TELEVISION CLUB
- CONSULTATION SERVICE
- QUIZZES

Order your Progressive Radio "EDU-KIT" Today, or send for further information. Postage prepaid on cash orders. C.O.D. orders accepted in U.S.A.

PROGRESSIVE ELECTRONICS CO.

497 UNION AVE.
DEPT. RE-49 BROOKLYN 11, N. Y.

ADVERTISING INDEX

Aerovox Corporation	76
Allied Radio Corporation	47, 69
American Electrical Heater Company	68
Amperite Company	91
Amplifier Corporation of America	73, 96
Anchor Radio Corporation	13
Astatic Corporation	14
Astron Corporation	75
Barry Electronics	85
Bell Telephone Laboratories	6
Boyce-Roche Book Company	72
Brook Electronics	84
Brooks Radio Dist.	90
Buffalo Radio Supply	97
Capitol Radio Engineering Institute	7, 86
Certified TV Laboratories	95
Cleveland Institute of Radio Electronics	11
Coast Electronic Supply Company	91
Collins Audio Products	89
Commercial Trades Institute	88
Communications Equipment Company	88
Concord Radio Corporation	87
Coyne Electrical School	77, 82
DeForest's Training, Incorporated	9
DuMont Laboratories, Allen B.	Inside Front Cover
Electro Products Laboratories	74
Electro Sales	95
Electro-Voice Manufacturing Company	64
Electronic Instrument Company	20
Electronic Measurements Company	86
Feiler Engineering Institute	85, 92
G and G Radio Dist.	85
G L Electronics	75
General Electric Company	8
General Test Equipment Company	84
Gensler, B. N.	95
Greylock Electronic Supply	69
Heath Company	60, 61, 62
Hickok Electrical Instrument Company	73
Hudson Specialties	87
Hytron Radio & Electronics Corp.	51
Instructograph Company	88
International Correspondence School	17
JFD Manufacturing Company	82
La Pointe-Plascomold Corporation	86
Leotone Radio Corporation	92
Long Island Radio Company	88
Mallory & Co., Inc., P. R.	Inside Back Cover
McCraw-Hill Book Company	95
Merit Transformers Company	12
Midwest Radio and TV Corp.	85
Miles Reproducer Company	95
National Plans Company	94
National Radio Institute	3
National Schools	5
Niagara Radio Supply	91
Opportunity Adlets	69
Penn. Boiler & Burner Mfg. Company	63
Penn TV Products	75
Perfection Electric Company	96
Permaflux Corporation	18
Planet Manufacturing Company	82
Platt Electronics	88
Precise Company	81
Precision Apparatus Company	65
Pres-Probe Company	73
Progressive Electronics	96
RCA Institutes, Inc.	15
RCA Victor Division (Radio Corporation of America)	Back Cover
Radiart Corporation	53, 57
Radio City Products	77
Radio Corporation of America	49
Radio Dealers Supply	92
Radio Receptor Company, Inc.	70

RADIO SCHOOL DIRECTORY

(Page 94)

Baltimore Technical Institute
Candler System Company
Commercial Radio Institute
Electronics Institute, Inc.
Hollywood Sound Institute
Hollywood Technical Institute
Indiana Technical Institute
Martin School, Don
Milwaukee School of Engineering
RCA Institutes, Inc.
Tri State College
Valparaiso Technical Institute
YMCA Trade & Technical Institute

Rauland Corporation (The)	59
Raytheon Manufacturing Company	16
Regency (Div. I.D.E.A. Inc.)	83
Rek-O-Kut Corporation	75
Sams & Company, Inc., Howard W.	12, 78, 84, 91, 92
Sprague Products Company	4
Steve-El Electronics Corporation	89
Sutton's Wholesale Electronics, Bill	81
Technifax	77, 81
Television Materials, Inc.	84
Telrex, Incorporated	65
Thomas Electronics	10
Thompson Corporation	55
Transvision, Incorporated	80
Trio Manufacturing Company	55
Triplet Elec. Instrument Company	19
University Loudspeakers	81
Weller Electric Corporation	79
Wells Sales	98
Wholesale Radio Parts	84
World-Wide Packing & Shipping Company	95
Radio-Electronics does not assume responsibility for any errors appearing in the above index.	

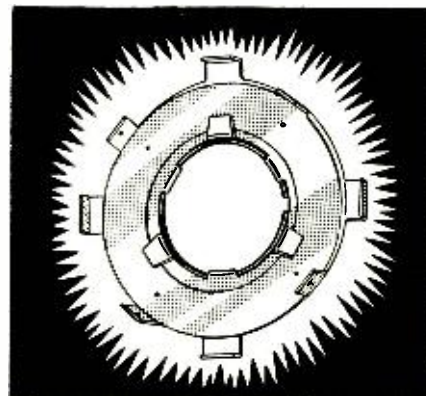

Center TV Pictures in 3 Seconds with the NEW BeamaJuster



1. Snap BeamaJuster on back cover of tube yoke. (Fits any standard yoke and any size tube.)
2. Rotate BeamaJuster as shown here for approximate centering of picture.
3. Make final adjustment by sliding outer plate of BeamaJuster vertically or horizontally.

Now service men can center TV pictures in 3 seconds instead of 20 to 30 minutes. The new Perfection BeamaJuster eliminates costly and complicated centering controls of the register type. It also replaces mechanical centering controls which tilt the focus coil to center the picture and require numerous springs, wing nuts and special brackets. Once set, the BeamaJuster keeps the picture centered. No drifting!

Order from your supplier!

PERFECTION ELECTRIC CO.

2645 South Wabash Ave., Chicago 16, Illinois

Also Makers of B.O. (Barkhausen Oscillation) Eliminators, Perfection Speakers and Ion Traps.



AMERICA'S most advanced the TWIN-TRAX SERIES TAPE RECORDERS

models for —> professional
—> semi-professional
... and —> experimental use

WRITE TODAY for 12-page 1951 catalog. Fully illustrated, containing complete technical specifications and direct factory prices.

AMPLIFIER CORP. of AMERICA
398-7 Broadway, New York 13, N. Y.

RADIO-ELECTRONICS for

RADIOMEN'S HEADQUARTERS * * * WORLD WIDE MAIL ORDER SERVICE!!!

Portable Public Address Amplifier

Brand new Portable Public Address System complete with everything, including Speaker, Mike and Tubes. Comes in expensive-looking portable case with genuine leather handle and airplane luggage covering. Only \$29.95 complete. Order a half dozen, then rent each out for as little as \$3.00 a day, and enjoy an income from that source alone of \$6500.00 a year. BUT, make certain that you get a substantial deposit on each rental, because these amplifiers are so classy looking that many customers will be tempted to lose their deposit and keep your Public Address System.

BUFFALO RADIO SUPPLY

219-221 Genesee St.,
Dept. RE-7
Buffalo 3, New York

BEST BUY OF THE MONTH

MAGNAVOX DIVIDING NETWORKS

for low and high
Frequency Speakers

MAGNAVOX HIGH FIDELITY RECORD DEMONSTRATORS

Sensational Bargain in Brand New Record Demonstrators (Built for Columbia by Magnavox)

- Amplifier designed in conjunction with the speaker to be capable of bringing you the storm and fire of Wagnerian opera or the light liting melody of Debussy with equal realism.
- Oversize 12" speaker • Inclined sounding board
- Console Cabinet approximately a yard wide and a yard high
- 2 tone controls—Treble and bass—as well as 2 volume controls
- A pickup that is as gentle as a beam of winter sunshine. Intended to leave records in new condition after demonstration.
- 78 and 33 1/2 R.P.M. Originally a 3 speed motor, but Columbia had the sleeve on the motor shaft for 45 R.P.M. removed, so the R.C.A. doughnuts could not be played. This can be re-installed for a few cents, if you must play the doughnuts.
- No expense was spared in producing these record demonstrators. They were Columbia's weapon in the savage, relentless and costly war between the titans in the record business, that only ended when R.C.A. started to market 33 1/2 R.P.M. records under its own label.
- This buy of a lifetime is guaranteed to please you. Price only \$60.00. A quick sellout is certain at this low price. Rush your order.
- Extra Special—We have a few of the Magnavox amplifiers alone, brand new and identical with the amplifier in the record demonstrator listed above. These have the separate bass and treble tone controls and volume control, and are complete with tubes. Believe it or not, we are letting these prizes go for a \$20.00 bill each. A bargain like this would be unbelievable before Korea, let alone now.

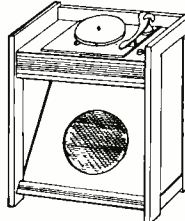

Calculated crossover frequency for 50% of power to each speaker 400 cycles. Calculated crossover for distribution of 2/3 of the audio output to woofer and 1/3 total output to tweeter is 800 cycles. Includes inductance and capacity sections. Input impedance usable with any speakers. Will handle up to 120 watts of audio power. Similar equipment is catalogued by other manufacturers up to \$35.00. Your special bargain at \$3.00 complete, with nothing else to buy.

SENSATIONAL TV BOOSTER KIT

Latest circuit utilizing greatly improved push-pull circuit for maximum gain.

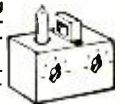

Perfect operation on higher channels where other boosters fail. 3 tubes.

Ceramic butterfly condensers. Coil sets for either low or high channels. 110V 60 cycle. Built up \$29.95. Save half by buying the kit and wiring the parts together from the schematic and pictorial diagrams furnished. Kit \$14.95.

Remote Control Unit



Aluminum case 4 x 3 x 3 containing 2 control buttons, 2 potentiometers, triple coil switch, 4 knobs, phone jack, and gear mechanism, including 8 binding J.A.N. connectors to fit box. \$1.39

WIRE STRIPPERS

- No Tool Box Complete Without it
- A Big Time and Labor Saver
- S t u r d y Construction Hardened Steel
- Precision Milled Cutters—Easily Replaced
- Black Finish for Rust Protection
- Automatic Grip Release After Stripping



Automatic SIMPLE DURABLE INEXPENSIVE 4-Hole Blade. Takes Wires Up To 1/4" O.D. Gauges No. 14 and Smaller. Sold on a money-back guarantee. NOW \$2.95

BOMBSIGHT POWER UNIT

SUPER SPECIAL. Each unit is brand new, contains 8 electric motors or generators, 6 of which are of the permanent magnet type; relays; and numerous valuable precision resistors plus a multitude of the ordinary kind, in addition to many condensers and radio transformers. All for only \$9.95.

LINE FILTERS

TYPE "A"—Each unit contains two 4 Mfd. oil filled condensers and a high inductance 50 Amp. choke in fully shielded case. Suitable heavy current connectors are provided to attach to the input and output connectors at each end of the filter from your input and output wires. A filter with innumerable uses on oil burners, refrigerators, boats, automobiles and wherever noise is to be suppressed or interference abolished. A \$17.00 value for \$2.98.

TYPE "B"—Heavy duty line filter consisting of 2 condensers and R. F. choke in plated steel case. Conservatively rated at 4 amps and 600 volts. Perfect for refrigerators, oil burners, power supply input to signal generators or to block out almost any interference you can think of. Super special \$1.75 each or 10 for \$5.00

NEW 18-WATT UTILITY AMPLIFIER KIT

Kit Model 5A, high quality wide range 18-watt public address amplifier. Matched component parts. 3-stage, high-gain circuit with push-pull 7C5 output tubes. Dual inputs for mike, phono or radio tuner. Fully shielded. Universal output to match any speakers used. Fully variable tone control on output. Complete with all parts and tubes. Super Special, \$16.95.

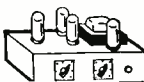

WE ARE LOOKING FOR TUBES

and other surplus. Large or small quantities. Send your list for our bid.

MOTOR DRIVEN

Bandswitching Tuning Turret 4 bands above 100 Mc. #14 silver plated coil wire. Tuning condensers, driving motor diagram included. Only . . . \$2.95

A. C. RELAYS

Coil	Specification	Contact Amperes	Net.
6-8V	S.P.S.T. N.O.	3	\$1.50
12-15V	S.P.S.T. N.O.	3	1.25
25-30V	3P.S.T. N.O.	3	2.00
25-30V	S.P.S.T. Normally Closed	3	2.00
55V	S.P.S.T. Normally Open	10	2.50
110V	D.P.D.T.	3	2.00
110V	S.P.S.T. Normally Closed	15	3.00

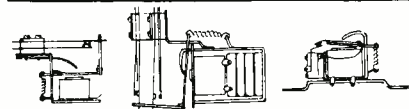

D. C. RELAYS

Coil	Specifications	Contact Amperes	Net.
800 ohms 10m.a.	D.P.D.T.	3	\$2.00
2000 ohms 4.5m.a	S.P.D.T. Hermetic	3	2.75
2000 ohms 1 m.a.	S.P.D.T. Hermetic	3	3.75
12 Volts	D.P.D.T. Midget	3	.60
45 Volts	D.P.D.T. 85.P.S.T.N.O.	3	1.70

PE-98 DYNAMOTORS

12 V. input—12 V, 150V. & 300V outputs. Used with SCR522. New \$39.95

WORLD'S LARGEST STOCK

Coaxial and "AN." Connectors. Write for prices on types desired. IMMEDIATE DELIVERY

SCR-625 METALLIC MINE DETECTOR

For ferrous or non-ferrous metals, traces underground pipe lines, detects buried treasure. \$69.50

35MM SLIDE PROJECTOR & ENLARGER

Most terrific photographic bargain of the 20th century. A fine precision instrument with many features!!

- Takes roll film or 2x2 slides.
- Automatic slide changer furnished.
- No more waiting for enlargements to enjoy your candid shots. All you need is a flat surface to project on.
- Has 300 W 110V Bulb, but 6V, 12V, 32V, or 220V available.
- 8 precision ground, optical glass elements in optical system. No other projector on the market has more.
- Automatic rewind of film.
- Heat absorbing filter.
- Use as an enlarger for making your own prints of any desired size.
- Plano-Convex Micaeus Condenser.
- 5" focus Brown-Violet coated, double anastigmat F3.5 lens.
- Swivel projector head; projector tilts to any angle on base.
- Brand New Society for Equal Education Model AAA Projector. Super Special \$50.00.
- Same 6 V. Projector without slide injector and coated lens \$37.50
- 35 mm 150 W Projector similar to above, less slide injector and coated lens \$17.50

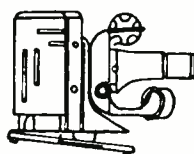

115 V., 60 Cycle TRANSFORMERS

Size of Set	Secondary	Price
4-5 Tubes	*650V.—40Ma.—5V. & 2.5 or 6.3V.	\$1.75
5-6 Tubes	*650V.—45Ma.—5V. & 2.5 or 6.3V.	1.90
6-7 Tubes	*675V.—50Ma.—5V. & 2.5 or 6.3V.	2.35
7-8 Tubes	*700.—70Ma.—3V. & 6.3 or Two 2.5V.	3.00
7-8 Tubes	700V.—70Ma.—5V. & 6.3 (25cy.)	4.50
8-9 Tubes	700V.—90Ma.—5V.—3A. 2.5V.—3.5A. 2.5V.—10.5A.	3.50
9-11 Tubes	700V.—5V. & 6.3V. at 4A.	3.50
10-15 Tubes	600V.—150Ma.—5V. & 6.3V.	4.00
File Xfmr.	12V.—40VA.	1.35
File Xfmr.	5V.—4 Amp. 10,000 V. Insulation	1.95
File Xfmr.	6.3—15A., 6.3—15A.	4.95
Isolation	115V. to 115V.—3A. Can be used as auto xfmr. to double or halve voltage	3.95
Isolation	6.3 to 6.3—5A. Can be used as auto xfmr. 10,000V. insulation	1.25

*Specify whether 6.3 or 2.5V. Filament is desired.

PHONO SCRATCH ELIMINATOR

Consists of 2 condensers and powdered iron core choke connected in filter network. Same as used in most jukeboxes. Connects instantly between pick-up and amplifier \$2.00

KITS & ASSORTMENTS

- Mica Condensers 100 for \$4.95
- Ceramic Condensers 15 for .95
- Wire wound resistors including adj. & tapped 12 for 1.00
- Rotary Switches 8 for 1.75
- Grid & Pl. Tube Caps. 50 for 1.00
- Coil forms asst. 50 for 1.00
- Knobs Assorted 40 for 1.00
- Fuses Asst. 100 for 1.95
- Spaghetti Slewing Asst. 75 for 1.00
- Solder Lugs 300 for 1.00
- Bakelite Terminal Boards 15 for 1.00
- Micro Switches 3 for 1.00
- TV Osc. & RF Coils 8 for 1.00
- Rubber Grommets 40 for 1.00
- Dial Scales 12 for 1.00

Antenna loops of Hi-Q, high efficiency type—\$1.35 each or 4 for \$1.00
Push button call letter assortments. Complete with all United States, Canadian and Mexican stations in each assortment. Per set \$2.25 or 37 sets for \$5.00

Terrific bargain in 6 pole, 6 throw 3 deck wafer switches with silver plated contacts. Non-shorting type. Perfect for test equipment. Controls 36 circuits. Costs you 36 cents, or 3 for a dollar. Note: One of these switches is also included with our asst. of 8 rotary switches for \$1.75 that is advertised elsewhere on this page.

PHONOGRAPH MOTORS

- 78 R.P.M. 60 cycle, Rim Drive \$ 3.50
- 78 R.P.M. 60 cycle, Gear Drive 3.95
- 33 R.P.M. 60 cycle Gear Drive 3.95
- 78, 45, 33 R.P.M. 60 cycle, Gear Drive Continuously Variable Speed \$ 8.00

RELAYS FOR EVERY PURPOSE

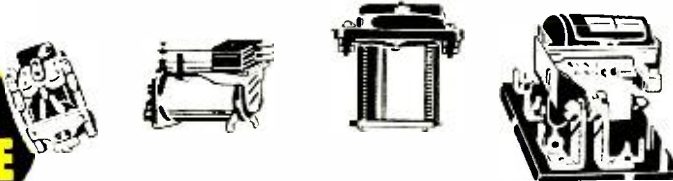

Over a Million in Stock!

Whether you require large quantities of relays for production runs or single units for laboratory or amateur work, Wells can make immediate delivery and save you a substantial part of the cost.

Our capable engineering staff is prepared to offer assistance in the selection of correct types to suit your exact

requirements.

Each relay is brand new, standard make, inspected, individually boxed and fully guaranteed.

The following list represents only a tiny portion of our relay stock. Write or wire us for information on types not shown.

STANDARD DC TELEPHONE RELAYS				
Stk. No.	Voltage	Ohmage	Contacts	Unit Price
R-806	115*	900	1A	\$2.05
R-161	6	10	2B&1A	1.10
R-100	24	600	2A&1C	2.45
R-289	40	3300	5A	2.20
R-518	85/125	6500	1C	3.60
R-266	150	6500	1A	2.45
R-633	180/350	10,000	1C&5Amps.	2.90
R-664	110*	...	2B&1A/Oct.Skt.	2.45
R-684	115*	...	1C	2.45
R-264	220*	...	1B	2.45
R-564	220*	...	1B&3A	2.45
R-667	6	.75	1B/10Amps.1A/3Amps.	1.45
R-632	6	12	5A&1C	1.25
R-154	6/12	200	1A	1.50
R-517	12	250	2A	1.50
R-777	12/24	70	1A&1B	1.50
R-578	24/48	2500	1B&1A	1.30
R-116	85	3000	1B	3.05
R-583	110	3300	1A	2.20
R-631	100/125	3300	2A	1.90
R-827	150	6500	2A, 1B	2.45
R-623	150	6500	1C&2A	2.45
R-571	150	7000	1B	2.45
R-565	150	7000	1A&2B	2.45
R-545	110/250	7000	1C	2.45
R-124	300	12,000	1A	1.55
R-511	24	200	W/Micro N.O.	3.05
R-160	6	12	3C&3A	1.30
R-591	6	40	1B&1C	1.35
R-592	12	160	1B&2C	1.35
R-155	12	100	4A&4B	1.45
R-520	200/300	14,000	2C	3.45
R-159	6	50	2A	1.35
R-158	6	50	4A	1.35
R-576	12	200	2A	1.35
R-153	12	200	1C&1A	1.55

SLOW ACTING				
Stk. No.	Voltage	Ohmage	Contacts	Unit Price
R-547	24	200	1C-Slow Bk.	\$1.80
R-548	48	1000	1B-Slow Mk.	2.00
R-128	50	2100	1C-Slow Bk.	2.80
R-525	12/24	200	1C/10Amps.S.Mk.	1.55
R-794	12	3 Coils, 16 Ohms ea.	3B&3A/15Amps.S.Mk.	3.35

CONTACTORS				
Stk. No.	Voltage	Ohmage	Contacts	Unit Price
R-188	24	200	1A/75Amps.	\$3.70
R-183	24	60	1A/50Amps.	3.45
R-187	24	100	1A/50Amps.	3.70
R-554	24	85	2A/100Amps.	5.90
R-788	100*	...	3B&2A	5.45
R-682	115*	35	5A/10Amps.	6.10
R-767	24*	20	2A/10Amps.	3.70
R-180	12	25	1A/50Amps.	4.05
R-657	24	50	4A/100Amps.	6.95
R-265	24	60	1A/100Amps.	3.45
R-535	24	70	1A/100Amps.	4.80
R-556	24	70	1A/100Amps.	4.80
R-557	24	100	1A/50Amps.	3.85
R-178	24	100	1A/100Amps.	4.80
R-727	10	20	1A/20Amps.	1.85
R-608	24	125	1A/200Amps.	2.80
R-184	28	50	1A/100Amps.	4.90
R-719	24	10	1A/200Amps.	4.90
R-182	28	80	1A/25Amps.	2.40
R-244	75*	265	1A/20Amps.	2.20
R-659	12	7.2	2A/20Amps.	1.70
R-681	12/15	16	2A/15Amps.	1.55
R-552	24	70	4A/50Amps.	5.35
R-185	24	100	1A/50Amps.	3.45
R-186	24	132	1A/50Amps.	4.35
R-817	24	150	1A/50Amps.	3.45
R-534	14	45	1A/30Amps.	2.05
R-223	28	150	1A/40Amps./48 VDC	1.70
R-680	6	3	1A/50Amps.	3.90
R-677	6	3.5	1A/50Amps.	3.90
R-532	6	15	1A/50Amps.	3.90
R-676	12	16	1A/50Amps.	3.90
R-678	12	18	1AUX/25A	3.90
R-656	12	100	1A/50Amps.	3.90
R-553	24	55	1A/50Amps.	2.60
R-679	24	80	1A/50Amps.	4.05
R-610	24	80	1A/50Amps.	3.90
R-555	24	100	1A Dbl. Bk.	2.05
R-533	24	150	1A/50Amps.	4.80
R-717	24	200	1A/50Amps.	4.05
R-703	12	20	2A/25Amps.	3.45
R-748	24	60	2A/25Amps.	2.80
R-655	24	60	1A/30Amps.	2.45
R-655	24	80	1A/50Amps.	2.45
R-654	24	150	2A/40Amps.	6.05
R-742	24†	70	2A/25Amps.	2.40

ROTARY RELAYS				
Stk. No.	Voltage	Ohmage	Contacts	Unit Price
R-709	6/8	1	12 Pos.3 Water	\$3.90
R-197	9/16	70	2C	1.45
R-713	9/14	125	1C&1A	2.05
R-198	9/14	125	3B,3A,1C	2.05
R-616	28	7	5B&1A	1.90
R-712	24	200	2B	2.05
R-711	24	200	2C&1B	2.05

Stk. No.	Voltage	Ohmage	Contacts	Unit Price
R-573	28	200	1C&1B	2.05
R-284	28	200	4C&1B	1.45
R-200	24/32	275	3C&1B	2.05
R-766	24	230	12 Pos.8 Deck	4.90
R-809	28	7	1B&12 Pos.W/7" Shaft for Wafers	2.45

W-E TYPE 'E' RELAYS				
Stk. No.	Voltage	Ohmage	Contacts	Unit Price
R-736	18/24	600	3C	\$1.50
R-585	12	650	2C	1.30
R-287	12/24	650	2C	1.30
R-164	24/32	1000	1A	1.50
R-646	24/48	1300	1B	1.50

DIFFERENTIAL RELAYS				
Stk. No.	Voltage	Ohmage	Contacts	Unit Price
R-208	120	2000	2C/3Amps.	\$2.45
R-209	220/250	8000	1C/3Amps.	3.10

SEALED RELAYS				
Stk. No.	Voltage	Ohmage	Contacts	Unit Price
R-658	6	35	2C/Octal Plug	\$3.45
R-125	24	300	2C/Octal Plug	3.45
R-261	12/24	1900	1C/5 Pin Plug	3.75
R-673	48/150	7500	1C/5Amps.	2.80

VOLTAGE REGULATORS				
Stk. No.	Voltage	Ohmage	Contacts	Unit Price
R-745	6	2	1A/10Amps.	\$1.05
R-780	24	350	1C/6Amps.	1.05
R-509	6/12	35	1B/2Amps.	1.05

SPECIAL RELAYS				
Stk. No.	Voltage	Ohmage	Contacts	Unit Price
R-503	12/32	100	3A,2C	\$2.80
R-749	600	...	Max.28Amps.	7.45
R-804	550*	...	1B/38Amps.	4.35
R-250	115*	...	Adj.Cir.Bk.--04--16A	17.50
R-579	220*	...	1B	8.70
R-294	27.5	200	1B	5.35
R-686	115*	...	2C	6.10
R-246	115*	...	1B	11.20
R-246A	115*	...	1A	11.20
R-611	24*	...	1A/30Amps.	5.35
R-283	12	125	1C/10Amps.	1.25
R-614	18/24	60	1A/15Amps.	4.35
R-262	...	200	1C	4.70
R-245	12	25	4" Micalox Lever	1.20
R-527	6/12	50/50	In Series	1.20
R-544	12/24	60/60	1C	2.05
R-255	1A	1.20
R-669	75*	400 Cycle	1B,1A	1.20
R-660	6	...	3/8" Stroke	1.20

SPECIAL!

CO-AXIAL RELAY

D153746 SPDT, 6VDC, 19 OHM coil. Designed to accommodate 75 watts maximum. Perfect for all types of antenna switching. Designed for using standard 83-1SP Coaxial fittings. Part of RAX-1 Equipment. No. R-845-\$6.95 ea

BASIC CONTACT ASSEMBLIES SHOWN IN UNOPERATED NORMAL POSITION

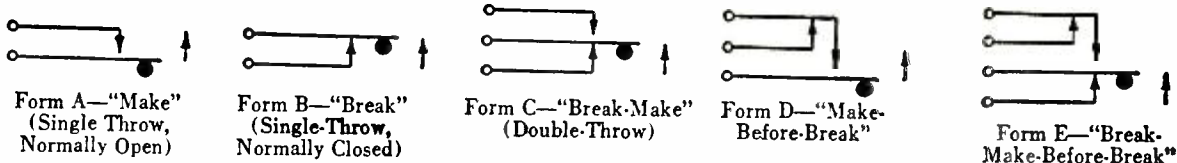

WRITE FOR
WELLS CATALOG

TELEPHONE
SEeley 8-4143

833 W. CHICAGO AVE., DEPT. R-Y, CHICAGO 22, ILL.

Don't let comebacks pick your pocket!



A recent survey among hundreds of servicemen reveals that more of them prefer Mallory Vibrators than all other brands combined. Why? To avoid the problem of costly comebacks! Their solution is . . .

Make Sure! Make it Mallory!

Performance, quality, sound design . . . those are the reasons why servicemen say they prefer Mallory Vibrators. They help cut down on comebacks, permit more time for profitable work.

Mallory led the first commercial vibrator development and today supplies more original equipment vibrators than all other makes combined . . . has always stayed in close touch with *your* field service needs. Mallory gives you a better vibrator, available in a complete line, meeting required specifications. And Mallory Vibrators cost no more.

Don't just order vibrators! Don't take chances with comebacks! Make it Mallory . . . and make sure of positive starting, quiet operation and long life!

Depend on your Mallory Distributor for precision quality at competitive prices.



P. R. MALLORY & CO. Inc.
MALLORY

CAPACITORS • CONTROLS • VIBRATORS • SWITCHES • RESISTORS
• RECTIFIERS • VIBRAPACK® POWER SUPPLIES • FILTERS
*Reg. U. S. Pat. Off.

APPROVED PRECISION PRODUCTS

P. R. MALLORY & CO., Inc., INDIANAPOLIS 6, INDIANA

"SERVING THE COMMUNITY"
YOUR NEIGHBORHOOD RADIO-TELEVISION TECHNICIAN



We use **RCA TUBES**

for long life and dependable performance

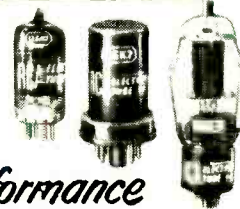

Let's talk about you...

You're the radio and television serviceman up the street or around the corner who helps the show go on. The full importance of your services is not recognized until somebody's receiver goes bad. Then you're needed . . . just as a policeman or a doctor or a fireman is needed when the occasion arises. You're that important to your community.

We think people ought to be told about you. So, we decided to talk about you in a full-color display you can

place in your window and on your counter . . . to remind folks that you—the radio and television technician—recognize and live up to your responsibilities as a member of the community.

We owe it to you—and you owe it to yourself—to sell your community on your services. Your local RCA Tube Distributor has a complete packaged promotion built around the Community Service theme. See him today.

Keep informed—keep in touch with your RCA Tube Distributor.



RADIO CORPORATION of AMERICA
ELECTRON TUBES

HARRISON, N. J.