

JANUARY, 1951

**RADIO &
TELEVISION
NEWS**

RADIO-ELECTRONIC

Engineering

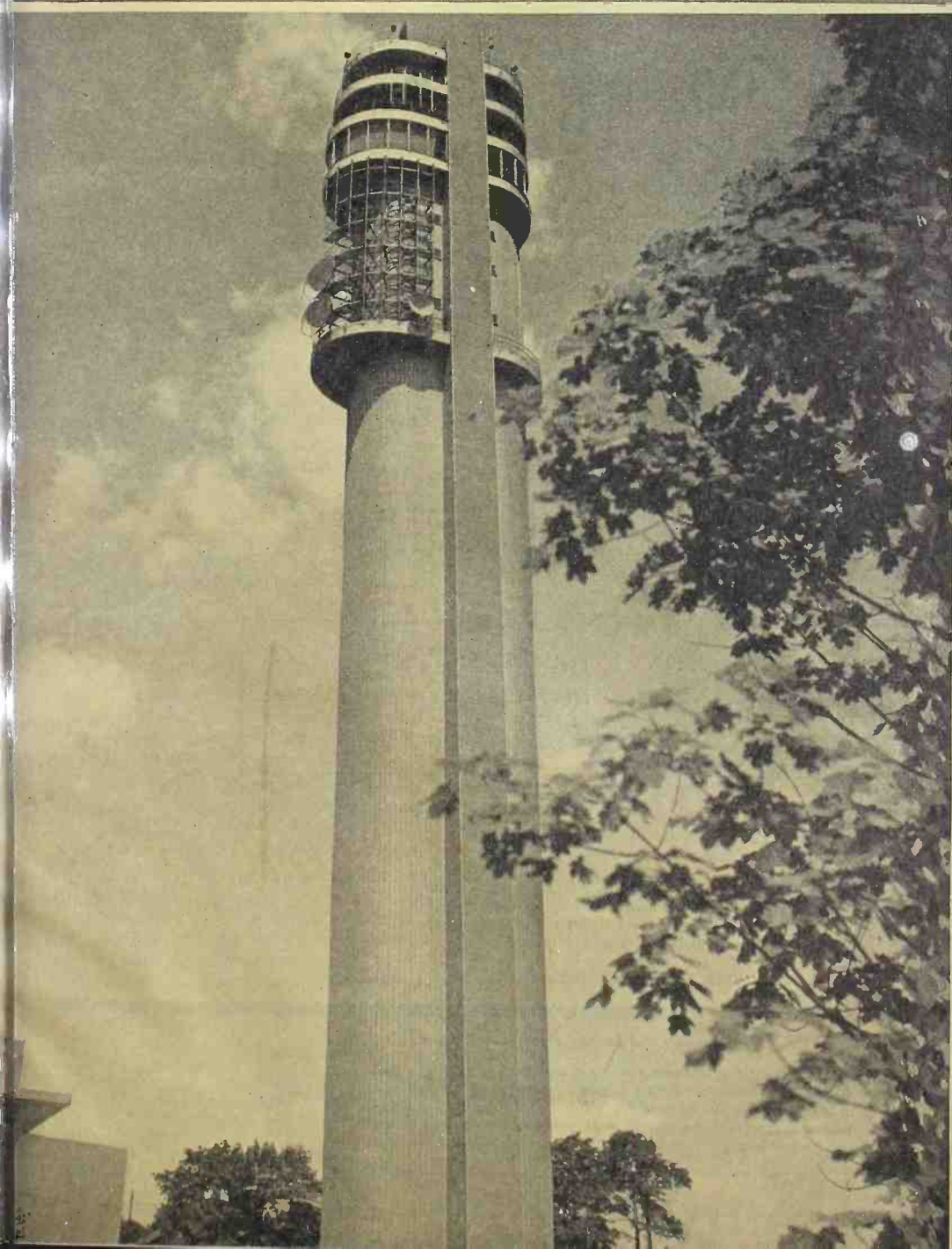

TELEVISION

RADAR

ELECTRONICS

RESEARCH

COMMUNICATIONS

MAINTENANCE

RADIO-ELECTRONIC

Engineering

Trade Mark Registered U.S. Patent Office No. 432907

ELECTRONICS • COMMUNICATIONS • TELEVISION • RESEARCH • AUDIO

JANUARY, 1951

PHASE SENSITIVE STRAIN GAUGE SYSTEM.....	Alvin B. Kaufman	3A
ATTENUATION & SWR FOR TRANSMISSION LINES....	David C. Pinkerton	7A
ELECTRONIC TONE GENERATOR DEVELOPMENTS.....	S. L. Krauss and C. J. Tennes	8A
NEW TECHNIQUES IN MICROWAVE SPECTROSCOPY...	William E. Good	10A
PULSE CODE MODULATION.....	Liscum Diven and Sidney Moskowitz	12A
MICROWAVE MEASUREMENTS (Part 2).....	J. Racker	15A
MULTI-LAYER COIL CALCULATOR NOMOGRAPH.....	S. Yamasita	32A

DEPARTMENTS

NEWS BRIEFS.....	20A	PERSONALS.....	24A
NEW PRODUCTS.....	22A	NEW TUBES.....	26A
TECHNICAL BOOKS.....	28A		



RADIO-ELECTRONIC ENGINEERING is published each month as a special edition in a limited number of copies of RADIO & TELEVISION NEWS, by the Ziff-Davis Publishing Company, 185 N. Wabash Avenue, Chicago 1, Illinois.

VOLUME 16, NUMBER 1, Copyright, 1950, Ziff-Davis Publishing Company

COVER PHOTO—Courtesy of Federal Telecommunication Labs., Inc.

This experimental microwave relay tower is a part of the Federal Telecommunication Laboratories in Nutley, N. J., and was built for use with the microwave relay developmental program instituted some time ago. Several different microwave antennas may be seen located at various points near the top of the tower.



PHASE SENSITIVE STRAIN GAUGE SYSTEM

By ALVIN B. KAUFMAN

A phase sensitive, capacitively balanced a.c. bridge is useful for strain gauge measurements.

IN measuring resistance changes of small magnitude it has been common practice to employ a Wheatstone bridge circuit. The bridge is operated from a direct or alternating voltage source depending upon numerous factors.

For the oscillographic recording of strain gauge phenomena it has been standard practice to employ an a.c. voltage on the bridge with a frequency of from 400 to 4000 cycles. 1000 cycles is probably the most common frequency used. The unbalanced a.c. output voltage of the bridge is amplified, and then rectified into a d.c. signal whose amplitude corresponds to the resistive changes in the bridge.

Basically this system is very simple and it has been employed successfully with test equipment for the measurement of resistance, capacitance, or inductance. It is the fact that a.c. measurements are affected by these three factors that causes trouble with the measurement of resistive strain gauges, for a bridge may be perfectly balanced for direct current but show a considerable output when an a.c. supply is used as an energizing source. This is due to the stray wire and cable capacities that exist across the arms of the bridge and unbalance it capacitively. The inductive effect of any wiring can generally be ignored, being of small value.

This effect is normally not encountered, where the resistive element to be measured is placed physically close to the measuring equipment or bridge, as little capacity would then exist across this leg of the bridge and resistive balance could be accomplished. Where the resistive element is placed at the end of a long cable, then both resistive and capacitive balancing must be accomplished as indicated previously. Even where a full or half bridge circuit is

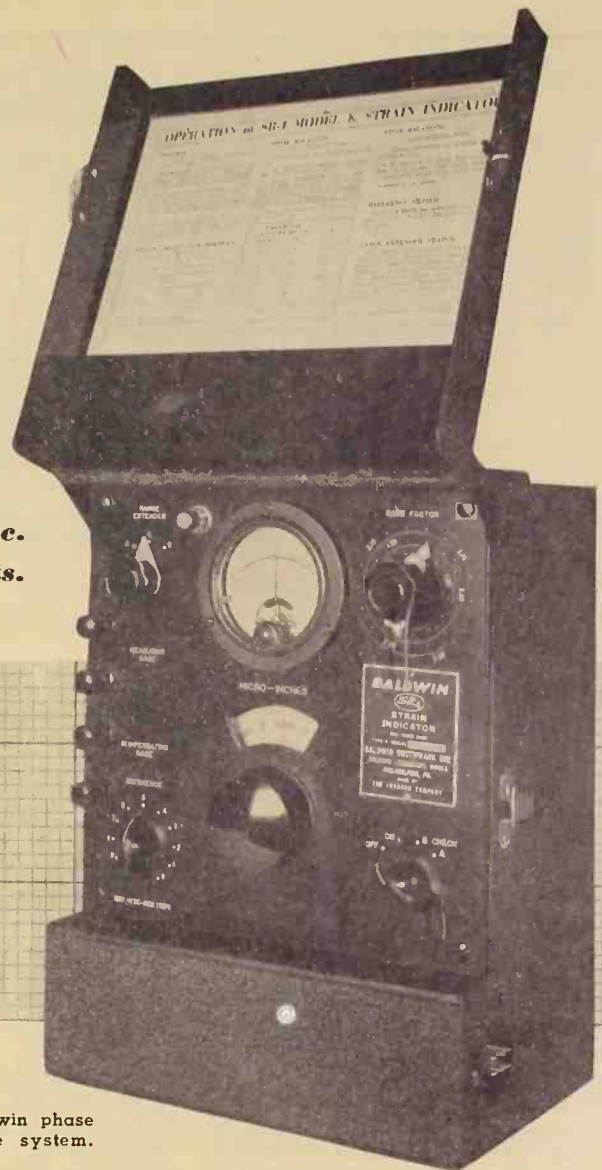
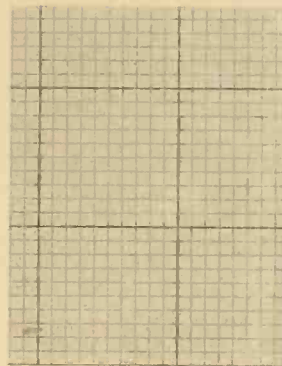
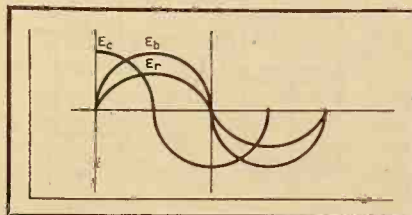

Fig. 1. Commercial Baldwin phase sensitive strain gauge system.

employed with equal wire lengths in all legs of the bridge, the capacities are still variable enough in nature to make capacitive balancing a must.

A circuit of this type if not balanced capacitively will have a poor null point and possibly non-linear characteristics. If the capacity unbalance is severe, blocking, reduction of gain, and other effects may occur. Balance can be accomplished by resistive means alone, but this leads to any second harmonic (from the signal source) not being canceled and a good null can not be accomplished.

Fig. 2. A set of curves for demonstrating phase detection theory.



A further difficulty with this system is that any subsequent change of wire capacities with movement or vibration gives a fraudulent strain signal, with or without capacitive balancing.

With the common a.c. Wheatstone bridge balanced, an unbalance in either direction can produce a signal of one sign (or direction) only regardless of the sign of the strain. To allow indication and recording of tension or compression strain, it is common practice to unbalance the bridge resistively one way or the other so that any subsequent strain will cause an increase or decrease of meter indication, and an opposite deflection of the galvanometer from its manually mechanically set zero. This system is known as the "carrier" system from its similarity to radio transmission systems.

The need for capacity balance and offset zero balance with its chance of ambiguity (with high strains) may be eliminated by the use of a phase sensitive strain gauge system; such a sys-

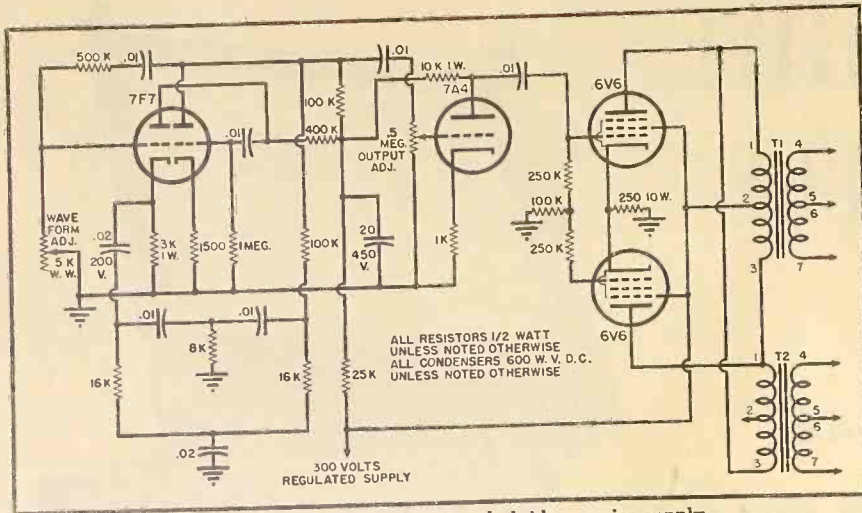

Fig. 3. Circuit of a typical 1000 cycle bridge carrier supply.

tem impervious to capacity indication is indicated.

The phase sensitive strain gauge system consists almost entirely of the same components used with the carrier system. Both employ Wheatstone bridge circuits, conventional a.c. amplifiers, audio oscillator bridge power supplies, and detection or demodulator circuits. It is the difference in detection that makes the two systems unlike, like day and night.

The phase sensitive detector depends for its action upon the fact that capacitive signals are 90° or 270° out of phase and will average out to zero if referenced to the bridge supply voltage. The resistive component is either in phase or 180° out of phase and therefore will average out a signal as indicated by Fig. 2.

The detector may be of several varieties, two of which will be discussed in this article. Possibly the simplest is shown in Fig. 7, a one tube detector whose function is similar to a phase controlled thyatron. The plate of the tube is supplied with a.c. from the

bridge oscillator, either in phase or 180° out of phase with the potential applied to the bridge. With no amplifier signal applied to its grid, the cathode resistor is adjusted until the output meter or galvanometer is at half scale deflection. If the signal applied from the bridge amplifier to the grid of the tube is in phase with the plate voltage it will cause the plate current to increase to a new level, and vice-versa with a 180° out of phase signal. Any other signal will average out as indicated on Fig. 2. Although only a half wave circuit is shown, it is possible to use a full wave connection, with the aid of a center tapped oscillator output transformer and a dual triode tube.

As with any modulation system, the carrier frequency must be a minimum of 10 times and preferably 20 times or higher than the signal intelligence to be carried. With a standard meter or galvanometer, inertia prevents the meter needle or galvanometer mirror from following the carrier high frequency and only the average current level of the tube will be indicated.

Fig. 4. Circuit of a typical phase sensitive strain gauge amplifier.

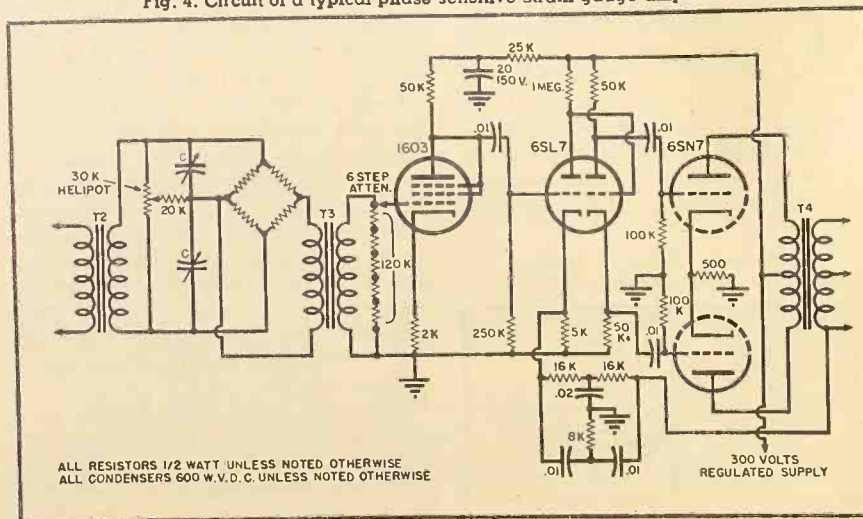

This particular detection circuit has several disadvantages not found in the next circuit to be discussed. The carrier frequency must be high to prevent the galvanometer response from showing excessive carrier hash on the oscillograph recording. The signal is not well suited for viewing or recording with an oscilloscope as the oscilloscope high frequency response would allow a high degree of carrier signal to be present. With zero signal and a balanced bridge, there is still a high value of static tube current, too high for many galvanometers.

The ring demodulator does not have these defects, and its operating characteristics and configuration is entirely different. Many texts mention this circuit under discussion of "Non-linear Modulators" or "Copper Oxide Modulators". These modulators have found their widest application in telephone work and in laboratory apparatus and very little detailed information is available in electronic literature. Perhaps one of the most detailed discussions of such modulators appears in the AIEE³, with emphasis on telephone components. No information was found relative to the use of vacuum tubes in this service.

Functionally the ring (de)modulator is an electronic synchronous vibrator without moving parts. In practical operation the demodulator makes use of a carrier frequency voltage that is considerably greater than the signal voltage that is to be modulated upon the carrier (or bridge supply voltage). As a result, the carrier acts essentially as a high frequency switch, causing the individual rectifiers to conduct or fail to conduct the applied signal (or amplifier output) voltage according to the polarity of the applied carrier frequency voltage, with the signal voltage having very little control over the action because of its small voltage. Since the carrier and signal voltages are applied to conjugate terminals of the bridge or modulator, resistance effects of the rectifiers are balanced and the carrier produces no output signal from the modulator. The ring or double balanced modulator differs from simpler bridge modulators in having little or no term of carrier or signal (carrier) frequency in its output. The output polarity of such a demodulator depends upon the phase relationship between the carrier and signal voltages. Phase reversal, as with the bridge passing through balance, causes a reversal of the d.c. output current of the modulator. The action of the modulator to capacitively phased signals is similar to that of the other demodulator, and its operation is electronically the same except that the amplifier output voltage is rectified as if by a mechanical synchronous vibra-

tor, operating at bridge supply frequency (or carrier). Thus the amplifier output voltage is constantly referenced to the bridge voltage. As with a synchronous vibrator, any reversal of input voltage to the vibrating contacts allows this voltage to be rectified (or go through) reversed.

The carrier signal must be approximately ten times greater than the signal potential to allow satisfactory switching efficiency. This factor may vary widely depending upon the quality of the copper oxide rectifiers used, or the characteristics of diode vacuum tubes, when used.

Copper oxide rectifiers have the bad fault mainly of poor balance resistively, rather than capacitively, carrier components being passed when conducting, or where inverse impedances are not all the same. Optimum matching conditions vary widely depending upon the characteristics of the rectifiers used in the ring demodulator. With copper oxide rectifiers and ordinary carrier frequencies up to five or six thousand cycles satisfactory terminating resistors (or impedance) may be as high as 1000 ohms, while the internal impedance of the carrier generator should be as low as possible. Higher frequencies of four or five megacycles require much lower terminating impedances because of the increased importance of the shunt capacitances in the copper oxide rectifiers and subsequent bypassing of signal frequencies. Referring to Fig. 8, it may be seen that for maximum transfer of power $Z_i = Z_o = R$ where $R = R_c R_n$ and R_c, R_n are respectively the conducting and non-conducting resistance of the rectifiers.

The internal impedance of the galvanometer rarely matches its own optimum external impedance, necessary to obtain critical damping. Therefore when critical damping for oscillographic recording is required, the conditions for optimum matching may be entirely different over those required for direct meter reading of static and dynamic strains of low frequency. Where damping is not an important factor, impedance matching should be in direct proportion to the internal resistance of the indicating meter, while for dynamic recording it should be in proportion to the internal impedance of the galvanometer plus its required series resistance for proper damping, and this should include the resistance factor of the output transformer, if of any appreciable magnitude. Here optimum matching is when $Z_o = R_i$, where Z_o is the output impedance and R_i is the load resistance as outlined above.

The choice of vacuum tube or "cold" rectifier involves many criteria. Of course the advent of germanium rectifiers and improved selenium rectifiers

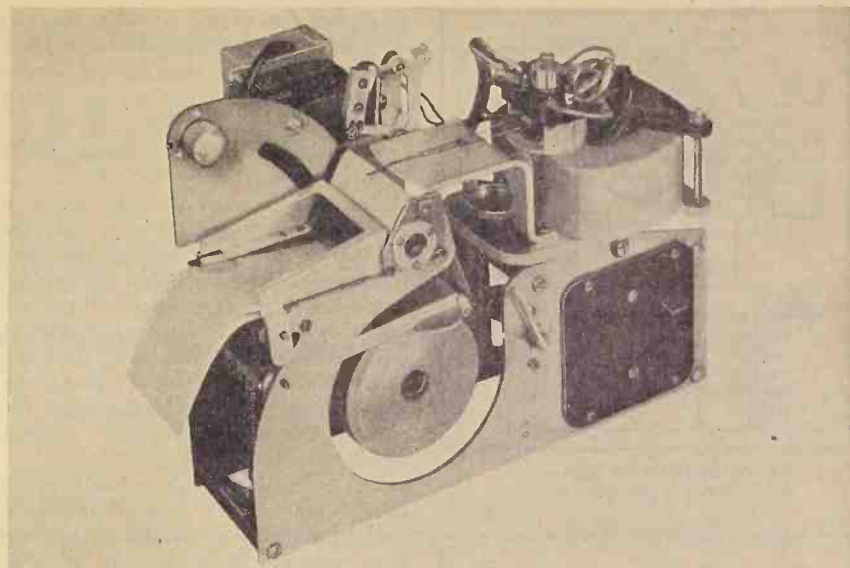

Fig. 5. Typical direct recording galvanometer.

has altered engineering design to a large extent. The use of "cold" rectifiers indicates long life with little attention. Their suitability for audio uses are not debatable. For laboratory testing or measuring devices, the non-linear operating portion near zero rectifier current and subsequent non-linearity of recording may not be satisfactory. The use of high vacuum hot diode rectifiers is not a cure-all; here the Edison effect may cause irregularities unless all tubes are selected as a matched set, to show equal plate to cathode current without plate potential. This effect is most apparent near zero signal output. Both types of rectifiers may in their type have different static and dynamic characteristics. Matching static characteristics will not, then, necessarily insure perfect operation of the demodulator.

For measuring equipment the author felt that the use of vacuum diodes over selenium or copper oxide rectifiers was desirable for several factors. Their characteristics are fairly stable with temperature variation, aging, and their forward to inverse impedance is better and more stable than any of the "cold" rectifiers. Admittedly, filament stabilization is necessary if long term drift is to be held to a low value. The whole unit may be operated from a constant voltage transformer, thus stabilizing plate and filament voltages.

Although the author has had no experience with *Sylvania* Varistors types 1N40 and 1N41, the combination of four matched germanium crystal diodes designed especially for use as a ring demodulator would possibly be worthy of experimental incorporation into this system, providing a more compact unit with easily interchangeable detection components.

The over-all system then, consists of an audio oscillator feeding the bridge its a.c. power and the ring demodulator its phase referencing voltage. The amplifier is basically a peaked amplifier designed to amplify any bridge unbalance signal and feed its output power into the ring demodulator. Each of these sectional components will be discussed. A similar system is employed in *Baldwin Southwark's* commercial unit, "SR-4 Strain Indicator".

The 1000 cycle bridge carrier supply shown in Fig. 3 utilizes a conventional Wien bridge for the generation of the 1000 cycle audio note. It is not particularly hard to adjust, care being taken, however, to adjust the value of the 5K waveform rheostat to a value, as indi-

Fig. 6. Circuit diagram of a phase sensitive modulator (detection circuit).

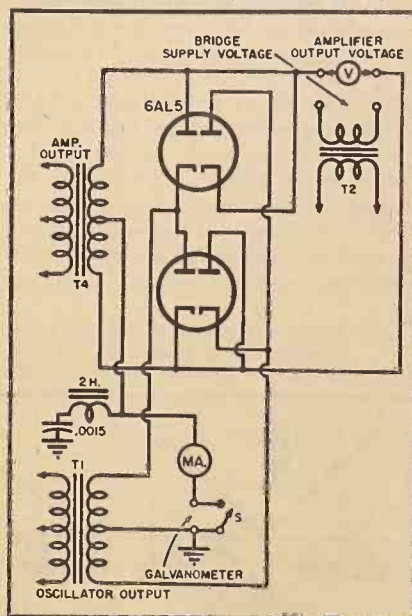

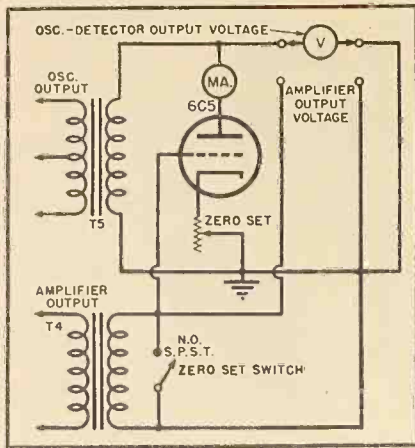

Fig. 7. Circuit of a phase sensitive detector (detection circuit).

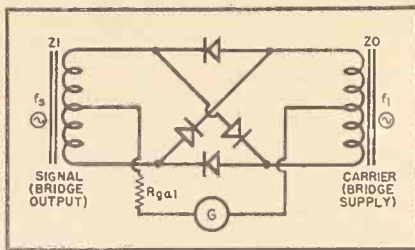
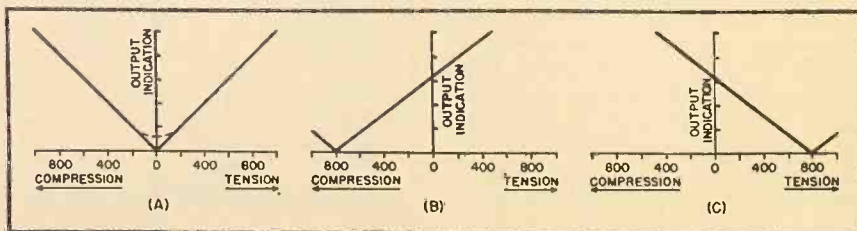

Fig. 8. Circuit of a copper oxide ring demodulator.

cated oscillographically, for low distortion output. The volume control is then adjusted to give a selected bridge or oscillator output voltage on the appropriate meter. This voltage must be held fairly close if a high degree of accuracy is required. The output transformers were designed especially to match ten to twenty channels, approximately, but are suitable for operation into a one gauge channel or the ring demodulator. Their characteristics are the same; ten thousand ohms impedance plate to plate to an output winding of approximately 17 ohms center-tapped and capacitively balanced to ground. The transformer is a *Hollytran* No. 2089. This allows better than ten watts output with heavy channel loading. The output voltage level applied to the strain gauge bridge is limited by the wattage dissipation of the gauges selected. A safe value is generally around $\frac{1}{8}$ watt per gauge, or about 25 milliamperes gauge current, on aluminum

Fig. 9. (A) Dotted line shows effect of improper capacity balance with the standard carrier system. (B) and (C) show how bridge is resistively unbalanced so that the direction of galvanometer swing indicates the sign of the strain.



or copper, decreasing with the thermal conduction of other materials. For operation into single channels a center tapped transformer of higher output impedance could be used.

The design of the oscillator power supply is regulated by three factors. It is desirable to have a stable output in both frequency and voltage, and the production of a good fundamental note containing few harmonics. There are numerous circuits meeting these requirements possibly better than the unit discussed in this article; however, this design is a matter of choice depending to a large degree upon the use of the equipment and economic dictates.

The schematic of the amplifier will require many more detailed comments, containing as it does the bridge circuit, special feedback, and a wide variety of vacuum tubes. One of the oscillator output transformers has its full voltage connected to a full strain gauge bridge with its associated balancing network. A half bridge could be employed, with the aid of a center tap on the bridge supply transformer; this is commonly used in multi-channel installations, but results in half the available output of a full active bridge. Generally only two gauges are active in most installations⁶.

The resistive section of the balancing network is used to balance the bridge by referring to the amplifier output voltmeter. The bridge could also be balanced resistively by noting the output current through the galvanometer. The last method, however, would not allow capacitive balancing of the bridge, as the ring demodulator is insensitive to capacity signal voltages.

Capacitive balancing is generally unnecessary where this unbalance signal is not of too high a level. Quantitative values cannot be given, the tolerance depending largely upon the strain gauge amplifier, and not the ring demodulator. The degree of amplification and the signal level the amplifier can handle without excessive distortion are the limiting factors. Thus with a simple one or two tube amplifier of low gain, capacitive unbalance of *one to several microfarads* has been noted to cause little change in output indication. With

the amplifier presented in the article, capacitive unbalance of less than ten thousand $\mu\mu\text{fd}$. caused little error. The resultant error with excessive capacitive signal is due to blocking of the input amplifier tube, drawing of grid current and the inability of this overloaded stage to follow the capacitive and resistive signal as applied to the grid.

Harmonics in the bridge power supply are not balanced in the bridge where resistive balance alone is used, for $Z_o = \sqrt{R^2 + X_c^2}$. Thus Z would be of a different value for each harmonic frequency; then the leg with capacitive value would not balance at the harmonic frequencies and only a poor null could be obtained with the standard carrier system. With phase detection the null would not be affected, this capacitive harmonic signal averaging out. However with both systems this harmonic signal would appear in the output signal as hash on the galvanometer trace. This is another reason for using capacitive balancing where possible. The severity of the hash will depend upon the harmonics in the bridge supply and the degree of amplification.

The amplifier input transformer selection, and the general design of the amplifier, should be based on the fact that amplifier phase shift must be kept low so that bridge resistive change signals are referenced to the demodulator signal completely in or out of phase. Any magnitude of phase shift would cause the resistive signals to average lower and capacitive signals deviating from 90° or 270° will not average out to zero. Generally at frequencies of 1000 to 4000 cycles there is little phase shift in the average amplifier.

The input transformer primary should match the bridge output impedance while the secondary should be of as high an impedance as practical. *UTC* transformers LS-12, LS-12X, and A-12 meet these requirements and have excellent shielding for reduction of stray pickup. These transformers have multi-impedance inputs of 50 to 600 ohms and secondaries from 80 to 120 thousand ohms. Optimum matching of the bridge to the input transformer exists when: $Z_o \text{ Bridge} = Z_1 \text{ Transformer}$. A bridge with four equal resistive legs has an output impedance, formula simplified: $Z_o = R$ (one leg of bridge). The secondary of the transformer should be loaded with a step attenuator of the same impedance as the output of the transformer. A potentiometer is not advisable, as constant accurate gain reference could not be made.

When oscillator power requirements allow design where considerable harmonics might appear on the bridge, a band pass input transformer tuned to

(Continued on page 27A)

Attenuation & S W R for Transmission Lines

By DAVID C. PINKERTON

General Electric Co.

These two graphs show how the VSWR varies along a line due to its attenuation, and how the actual attenuation is increased by the VSWR.

THE GRAPH of "Input Standing Wave Ratio versus Total Transmission Line Attenuation" shown as Fig. 2 is a plot of the standing wave voltage or current ratio at points of a long transmission line that is terminated in an open or short circuit (infinite VSWR). The abscissa of any point on this curve is the characteristic attenuation of the line times the distance of the point from the end of the line, or more simply the attenuation the line would have if it were flat.

To apply this graph to any specific problem where the load end VSWR is known and the input VSWR is desired, first find the abscissa (attenuation) corresponding to the known load end VSWR and add to this the attenuation of the line in question (when flat). The input VSWR will correspond to this new abscissa. This procedure is equivalent to replacing the actual load with a length of open (or short) circuited transmission line of the same characteristics and having an attenuation just great enough to give the desired VSWR.

The attenuation of a transmission line usually referred to, and tabulated, is the characteristic attenuation or the attenuation the line would have, per

unit length, if it were terminated in its characteristic impedance. If the line is not flat, however, the actual attenuation is greater because of the standing waves. This actual attenuation is given in Fig. 1 as a function of the load end VSWR and attenuation if flat.

The use of both graphs can be best illustrated by an elementary problem. Assume that a 100 foot length of solid dielectric transmission line is being used to load an antenna. This line is listed as having an attenuation of 6 db. per 100 feet and the antenna has a VSWR when coated with ice of 2. What is the input VSWR presented to the transmitter and what will be the actual line attenuation?

By reference to Fig. 2, it is found

that the antenna can be replaced with a short circuited line 4.8 db. long. Thus our input VSWR is the same as that of a shorted line 10.8 db. long or approximately 1.2:1.

The actual line attenuation can be found directly from Fig. 1 as 6.5 db. or an increase of one half decibel due to the mismatch.

In deriving the equations from which these graphs have been made, repetition of fundamental transmission line theory can be avoided by selecting appropriate equations from the book *Communication Engineering* by W. L. Everitt as starting points. Eqt. 45, page 158, gives the input impedance of a short circuited transmission line of

(Continued on page 27A)

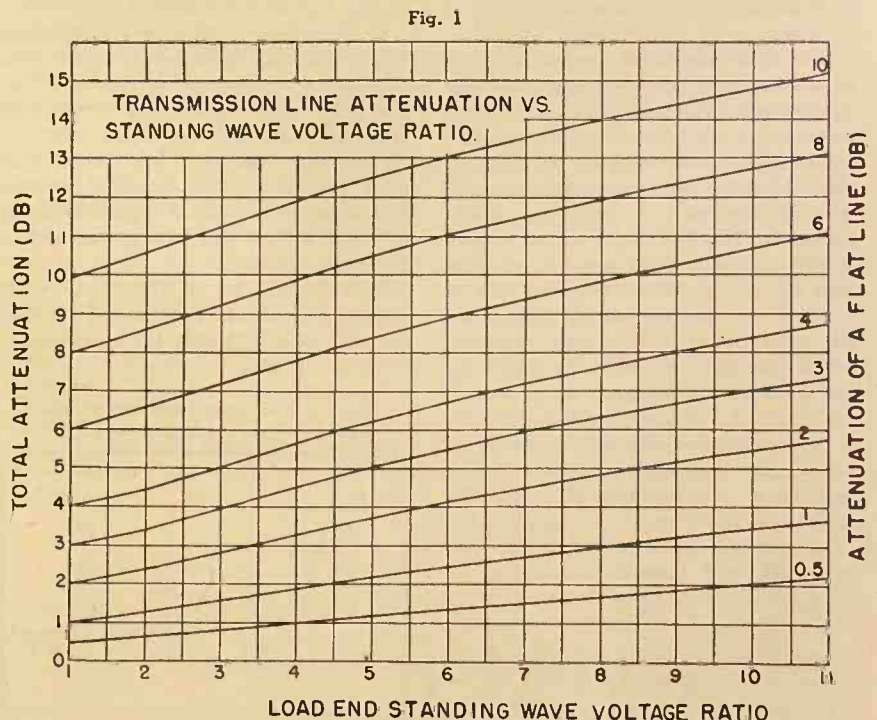
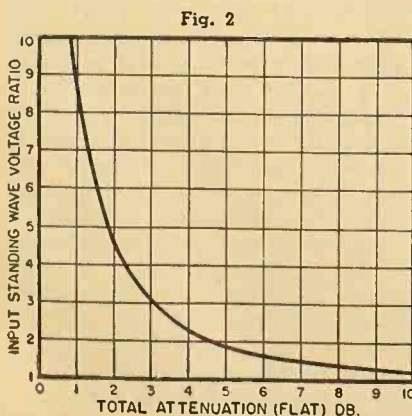

ELECTRONIC TONE GENERATOR Developments

By **S. L. KRAUSS**
and **C. J. TENNES**

Electronic Div., C. G. Conn, Ltd.

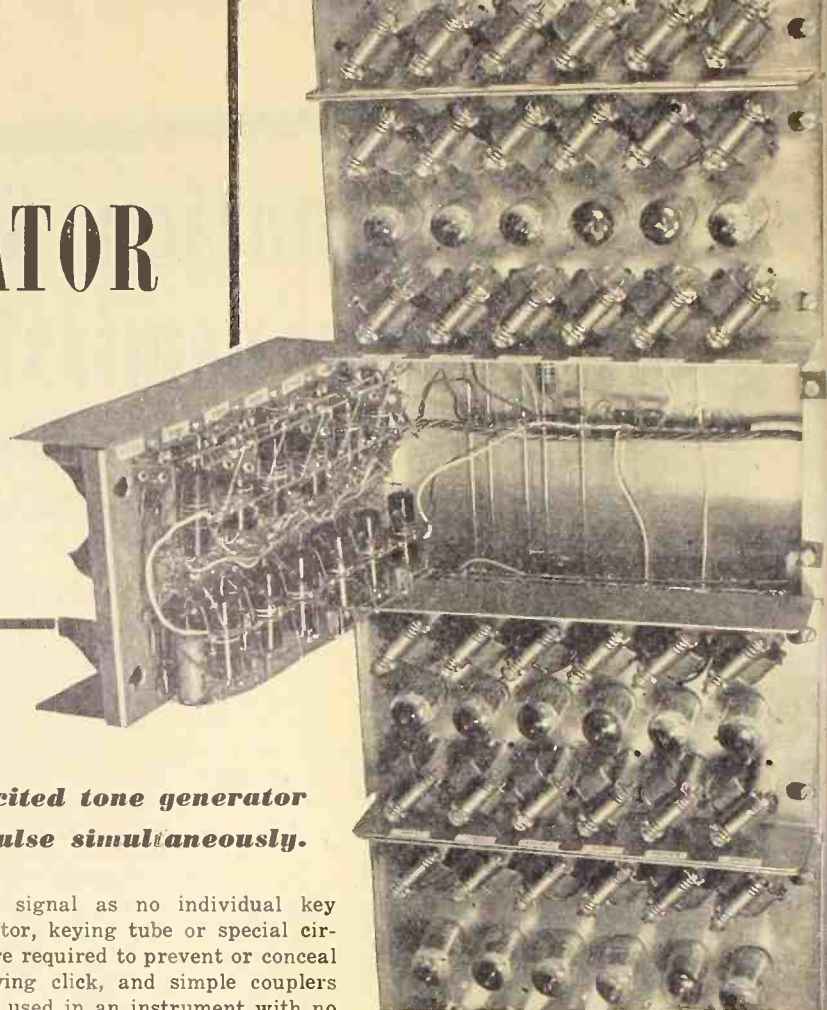

Development of a triode self-excited tone generator producing a sine wave and a pulse simultaneously.

THE TONE generators to be described produce two tone characters simultaneously. The nonsinusoidal tone developed is of particular interest because of its unique character and ready acceptance in the electronic organ field. Listener preference trends will be discussed in reference to the tone character evolved.

The generator units are of compact construction, use inexpensive tubes and a minimum of electrical components for economical manufacture and ease of service.

The tone generators used in the electronic organs manufactured by the Connsonata Division of C. G. Conn, Ltd. are of the self-excited oscillator type. These generators employ a patented circuit which produces simultaneously a sinusoidal and a pulse waveform. (Fig. 2). The sinusoidal signal is generally referred to as the "flute" tone, and filtered to various degrees, may be used alone as well as an ingredient of registration with other types of tones. The pulse signal is the source for the nonsinusoidal organ voices such as string, reed, vox-humana, and diapason.

The generators are inoperative until a key is depressed and potential is applied to a controlling element. This avoids the transients or clicks inherently generated when a continuous tone is keyed, and permits control of the attack and decay characteristics within the oscillator circuit itself. A generator which requires simply closing a single circuit for proper keying has an advantage over one which produces a con-

tinuous signal as no individual key attenuator, keying tube or special circuits are required to prevent or conceal the keying click, and simple couplers may be used in an instrument with no special precautions to prevent feed-through, cross-talk, or extraneous pick-up in the keying cables. By selecting an optimum impedance for the keying circuit, these desirable characteristics may be retained without imposing rigid requirements of performance upon the keying circuit components.

In September 1949 a general purpose single manual Connsonata organ was introduced which incorporated a different pulse tone signal than previously used, and the customer-dealer reaction to the more brilliant instrument was most favorable. The excellent tremolo and smooth keying characteristics of this instrument also contributed to this favorable reception.

The generators in this instrument employ individual remote-cutoff pentode tubes in each oscillator, the basic circuit for which is shown in Fig. 5.

Fig. 2. The two waveforms produced by the oscillator of Fig. 4.

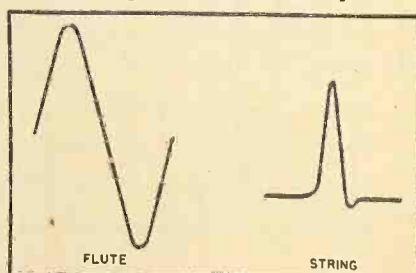

Fig. 1. A completely assembled rank of tone generators. Each section may be swung back as shown.

Basically this is a Hartley oscillator which is inoperative until potential is applied to the screen grid from the keying circuit through R_1 and keying bypass C_3 . The latter may be graded from a small value in the higher notes to effect very rapid keying, to a relatively large value for the pedal tones where it is desired to simulate the slow speaking characteristics of organ pipes. A sinusoidal potential at very low frequency is applied to the grid through R_1 to effect tremolo when desired, and may be graded to produce maximum tremolo on the higher manual tones, and little or none in the pedal range. The cathode circuit is the source of the pulse tone which is graded and mixed with that of other generators in the organ, and subsequently amplified. The sinusoidal tone is developed across R_2 , combined, amplified, and filtered. Normal differences in the tube characteristics and commercial tolerances on component parts have a negligible effect on the quality and intensities of the signals produced. The oscillator may be tuned over a range of approximately 4 semitones by varying the air gap of transformer L . A vernier screw adjustment is provided for this purpose.

The preference expressed for the pulse tone character of the pentode generators spurred development work on a more economical triode generator having the equivalent musical capabilities and smaller size, for versatile application and ease of manufacture. The basic problem was to duplicate the tone, keying, and tremolo characteristics of the pentode circuit without sacrificing the reliability and stability already achieved in the existing generator designs. Initial evaluation was on the basis of simple comparison of the signal on an oscillograph, and listening tests. However, listening tests on a rank of generators judged quite similar individually, disclosed that very minute differences in harmonic content of the individual tones produced by two instruments are glaringly apparent when intervals or common chords are compared. Pitch and intensity are of prime importance in comparing complex tones. It was noted that a pitch difference of a hundredth of a semitone or an intensity difference of less than 1 db. may lead to misjudgment in a listening comparison. Audio memory is a factor, so for consistent evaluation the generators compared must be keyed alternately and auditioned from the same reproducer.

Harmonic analysis of tones compared by listening, correlated with oscillographic patterns, made it possible to develop a keener analysis of oscillographic patterns such that the laborious job of measuring individual harmonics was limited to final designs.

The triode tone generator circuit developed is shown in Fig. 4. Performance-wise the triode generator duplicates the pentode generator in that it produces the desired pulse signal simultaneously with an essentially sinusoidal flute signal. The tremolo is good and easily applied. The attack and release is controllable by altering the RC plate keying network.

Economy is achieved by the use of dual triode tubes giving two notes for each envelope and socket. The number of solder joints and connections per generator is low because eight terminals of a socket serve for two notes. The transformer secondary and potentiometer are replaced with a simple mixing circuit for the flute signal. Orderly proportioned components provide excellent note to note uniformity which dispenses with individual grading or leveling of the pulse signal level required in the pentode design. The transformers use standard small EI laminations and the coils are wound on plastic bobbins. A negligible potential difference exists between the coil and the transformer frame giving freedom from electrolysis.

A rear view of a typical octave of 12 generators is shown in Fig. 1. Extensive

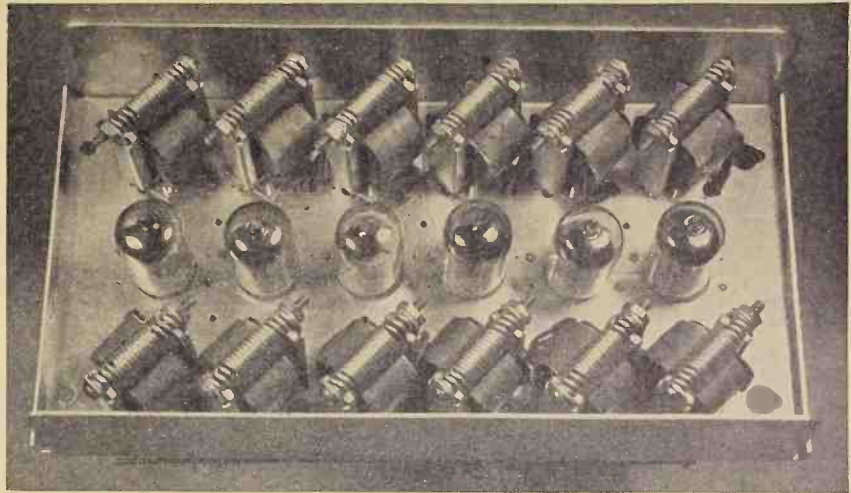

Fig. 3. Top view of a single section, showing tuning adjustments on top of the coils.

use has been made of the well-known bus bar wiring scheme. Bias and tremolo potentials, flute and pulse signals and heater and ground connections are made in this manner. Flexible leads are attached to the bus wires and are terminated in the wiring channel on which the individual chassis are mounted. The opportunity to disconnect generators easily is of special advantage in service since trouble may be localized quickly. A front view is shown in Fig. 3. The units measure approximately 6" x 9" for the first two octaves of generators, and 4-3/4" x 9" for the remainder with an over-all depth of 3-1/2". A complete rank of generators consisting of 84 generators occupies a space 35" long x 9" high and 4-1/4" deep, and represents a substantial saving in space requirements over previous designs.

An assembled rank is shown in Fig. 1. The sections of the chassis which are folded forward provide ample protection for the unit when handled, and sufficient stiffness to eliminate vibration resulting from shipment or high intensity audio within the console. Tuning is accomplished by adjustment of the hexagon nut at the top of each coil with a small wrench, and since the variable air gap is opposite the tuning nut, the presence of the tuning tool has negligible effect on the magnetic circuit.

One of the octave chassis is shown swung into position for service, this

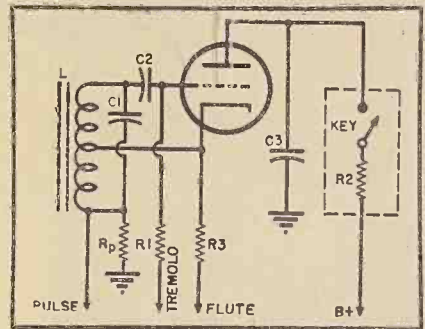

Fig. 4. Circuit diagram of the new triode tone generator circuit.

being effected by a lip on the edge of the chassis which hinges on the wiring channel.

Conclusion

The circuit developed provides, economically, performance equal to that of the pentode generator currently being manufactured. The results have been verified not only by electrical measurements, but by marked artist and listener preference expressed by those who have heard engineering models which utilize the new generator. Electrical measurements, oscillograph patterns, and the like are not infallible guides in producing musical instruments, and while they are consistent and do not tire like the human machine, must be supplemented by critical listening tests.

Fig. 5. Circuit diagram of the pentode tone generator circuit previously used.

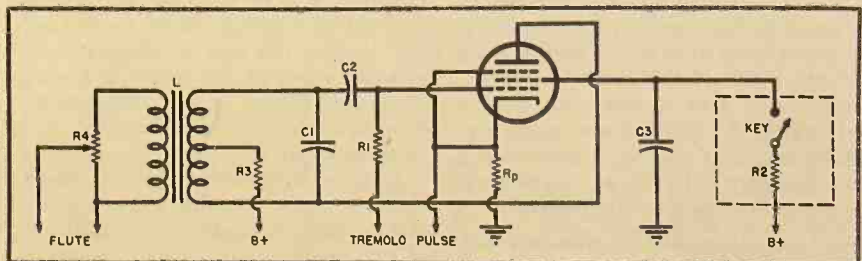

By **WILLIAM E. GOOD***
Westinghouse Research Laboratories

Special low-noise input circuits, crystal mixing circuits, and accurate frequency measuring techniques have been developed.



Fig. 1. A portion of the microwave spectroscope including the oscilloscope, the klystron and its power supply.

NEW TECHNIQUES in Microwave Spectroscopy

THE science of microwave spectroscopy is based on the sharp line resonant absorptions that various gases exhibit throughout the microwave region. This region may be defined as covering a range of about 3000 mc. to 300,000 mc. The frequencies at which these sharp absorptions occur are characteristic of the particular kind of gas so that an accurate measurement of the frequency of an absorption will serve to identify the gas or molecule that caused it. Compared with a cavity wavemeter in the microwave region, the effective Q of one of these lines at low gas pressure is very high—of the order of 100,000. This means that a line may have a half-width of a third of a megacycle at 30,000 mc., thus making it possible and also necessary to have a method of accurately measuring these frequencies.

*Now at General Electric Co., Electronics Park, Syracuse, New York.

The simplest type of microwave spectroscope consists of a klystron, a section of wave guide in which the gas under study is placed, and a crystal detector. If the frequency of the klystron is varied or swept over a range of a few megacycles and an absorption line occurs in this region, a dip will appear in the electrical output of the crystal detector at the particular frequency for that gas. The shape of the absorption is very similar to that of an ordinary tuned circuit. In practice this type of spectrograph (often called a video system because the rate of sweep and the amplifiers are in the audio and video region) is limited in sensitivity by the large noise output of the crystal, to a value of about 10^{-8} cm⁻¹.

A more complicated type of microwave spectroscope, called a Stark-modulated system, is capable of a sensitivity of 10^{-8} cm⁻¹ or better. This type of sys-

tem was first built by R. H. Hughes and E. B. Wilson¹ and involves making use of the property of these absorption lines that they will split or actually change frequency when a d.c. electric field is applied to the absorbing gas. This property is called the Stark effect. In practice a low frequency (6 kc. to 100 kc.) oscillating d.c. field is applied to an insulated metallic septum which extends the full length of the wave guide absorption cell. A tuned amplifier is connected between the crystal detector and the scope. It is tuned to the same frequency as the Stark modulation frequency—say 85 kc. The only way for the crystal to detect an 85 kc. signal is for the microwave frequency to be near or on an absorption line. Then the moving of the absorption line—first onto the microwave frequency and then off

This article is based on a paper presented at the 1950 National Electronics Conference.

from it—causes an absorption modulation at 85 kc. If a large amplitude square wave is used on the center electrode, and the detected output from the 85 kc. amplifier is put on a scope, an undisplaced absorption line will appear at its correct frequency, and in addition a displaced line or lines will appear near by depending on the nature of the gas. If a phase sensitive detector is used, the undisplaced line can be made to appear as a positive pip and the displaced lines or Stark components will appear as negative pips.

The system shown in Figs. 1 and 2 is a Stark-modulated system (for other systems see references 1, 2, 3) operating at 85 kc. and with a nominal bandpass of about 1500 cycles. There are switchable, low-pass RC filters after the phase sensitive detector to reduce the bandpass to as low as 50 cycles. A crystal filter in the 85 kc. amplifier itself can be connected to make the bandpass approximately 10 cycles. The narrower the bandpass can be made, the better the signal-to-noise ratio becomes; however, this does require that the rate of sweeping the klystron be reduced in order to pass the necessary information for the reproduction of the absorption line. However, within limits, this is not too difficult if a long persistence scope is used. With a 50 cycle bandpass a 2 c.p.s. sweep frequency has been found to be sufficiently slow to give good reproduction of the line providing the klystron is adjusted to cover only a few megacycles during the time of the sweep.

Ordinarily a silicon crystal detector is thought of as having an i.f. impedance of 300 to 400 ohms—however this is only true when the r.f. power into the crystal is of the order of one milliwatt. In a microwave spectroscopy, the microwave power level at its highest is about one milliwatt and at its lowest is about one microwatt or less. Over this power range the impedance of a typical crystal⁴ may vary from 300 to 5000 ohms—tending to flatten off at the higher resistance at low power levels and to flatten off at the low resistance value at the higher power levels, and to change rapidly in between. Also, each individual crystal has its own limits, which may vary widely from the example cited.

This problem of a wide range of crystal or antenna impedances is not usually encountered in communications work. In this i.f. range it is quite straightforward to design a low noise input circuit to give a signal-to-noise ratio approaching one for a single value of antenna impedance if the other requirements are not too stringent.

The other requirements for the case of a widely varying generator impe-

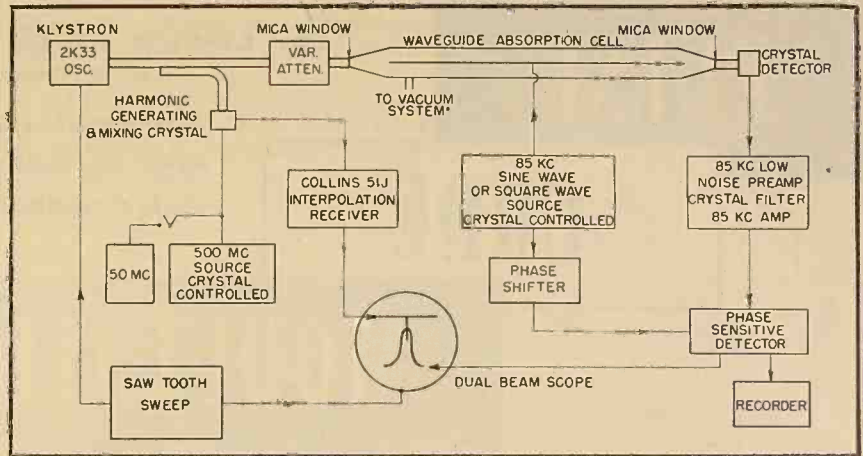

Fig. 2. Block diagram of the Westinghouse Stark-modulated microwave spectroscopy.

dance are lenient because the frequency is low (85 kc.) and the bandpass is narrow (1.5 kc.). However, Fig. 4 shows the results of signal-to-noise measurements on a typical transformer-coupled input circuit at 85 kc. for a *National* HRO receiver and for one used in a *Westinghouse* built 85 kc. amplifier. A noise figure of one ($F=1$) means that all the noise generated comes from the thermal noise of the resistor (i.e., generator resistance or crystal impedance) and none from the circuit elements or the tubes. A noise figure of one is the perfect situation which is never quite reached. The curve for the HRO shows a good noise figure ($F=1.6$) for a generator or antenna impedance of about 200 ohms but for values of generator impedance larger or smaller than this, the noise contributed by the circuit elements and the tube become much greater than that from the source itself so that any signal information that the generator carries will be masked.

A capacitance divided input circuit

was tried with various ratios of the two condensers and a typical result is also shown in Fig. 4. This is the type of circuit used in the "R-9 er" preamplifier and is equivalent to a transformer coupled circuit—however it is much easier to change the ratio of the two condensers than it is to change the number of turns on a coil. The combination is always resonated to 85 kc. and it was found that as the value of the bottom condenser was decreased the noise figure also decreased at the higher generator impedances, without changing appreciably at the low impedance end. This resulted eventually in using a series tuned resonant circuit as shown in the lowest curve in Fig. 4. If the appropriate *LC* ratio is chosen, the noise figure may be kept low over a wide range of generator impedances, which is the condition we wished to obtain.

From the characteristics of the 12AT7 dual triode, it might be expected to have a lower equivalent noise resistance than

(Continued on page 30A)

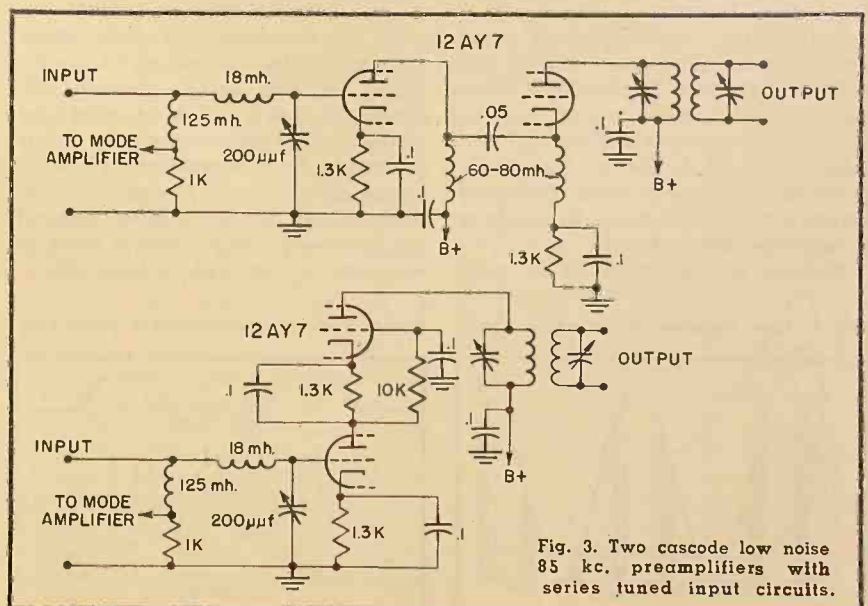

Fig. 3. Two cascode low noise 85 kc. preamplifiers with series tuned input circuits.

PULSE

CODE

MODULATION

By **LISCUM DIVEN** and **SIDNEY MOSKOWITZ**
Federal Telecommunication Laboratories, Inc.

A discussion of pulse modulation systems used in multiplex communications, with major emphasis on pulse code modulation.

RECENT trends in electronics have led to the development of a number of forms of multiplex communication, involving the transmission of several voice channels over a single radio frequency link. In the usual system, the messages to be sent are applied to a number of individual channel modulators, the outputs of which are combined in a common unit. The resultant complex signal is used to modulate a high frequency radio transmitter. This r.f. signal is received and demodulated at a distant point where the individual channels are then separated from the group signal and demodulated.

Frequency Division

There are two principal methods of multiplexing; frequency division and time division. In frequency division, each audio signal is applied as modulation to a separate carrier frequency. These modulated carriers are combined and are then used to modulate the radio transmitter. In order to maintain channel separation, complex filter networks are required, involving considerable bulk and expense. Furthermore, nonlinearities in common units such as amplifiers or repeater stations will produce harmonic distortion. The intermodulation products thus generated will fall into other channels, resulting in interchannel crosstalk.

Because of limitations as to radio

frequencies available, and because of the comparatively large bandwidths required by multiplex systems, the radio transmitter carrier frequency is usually in the v.h.f. or u.h.f. region, where line-of-sight transmission conditions prevail. Where the distances to be covered are large, one or more repeater stations are required. These repeaters must meet the above-mentioned linearity requirements, and since such distortion is cumulative, the number of repeaters which may be cascaded is limited. A further limitation is that of signal-to-noise ratio. The noise to be overcome principally consists of the thermal agitation noise generated in the input stage of the r.f. receiver. This noise will also add in a cumulative manner, necessitating an increase in transmitter power to maintain a given signal-to-noise ratio.

Time Division

These difficulties have led to the development of various forms of pulse communication, in which the modulation process consists of the alteration of some characteristic of a pulse. These modulated pulse channels may be multiplexed in time, rather than in frequency, as shown in Fig. 4A, where the relative time positions of the pulses are shown for a three-channel system. Multiplexing in such systems is relatively simple, no filters being required and nonlinearities in common units or repeaters do not lead to crosstalk.

The simplest form of pulse modulation is known as Pulse Amplitude Modulation or PAM and is illustrated in Fig. 1, in which an audio frequency signal is sampled by a train of pulses occurring at a rate of f_p pulses per second. As a result of this time sampling process, the pulse amplitude is made to vary in accordance with the intelligence. It can be shown that the sampling rate must be at least twice the highest audio frequency,¹ assuming that a perfect filter is used at the demodulator to remove the sampling frequency and its sidebands from the output circuits. To allow the use of practical filters, it is customary to use a somewhat higher sampling rate. A good approximation is:

$$f_p = 2.5f_a \quad (1)$$

where f_a is the highest audio frequency to be transmitted.

This system, although simple, has several disadvantages. Since the signal is amplitude modulated, all common units must operate linearly, in order to avoid distortion. Such stages are wasteful of power. The distortion that does exist limits the number of repeaters which may be cascaded for long distance transmission. Similarly, the signal-to-noise ratio deteriorates with increasing number of repeaters.

Pulse Duration and Position Modulations

Noise on pulse carriers may be considerably reduced by slicing, as shown in Fig. 4B. All noise appearing above the amplitude level "aa" and below the amplitude level "bb" has been essentially eliminated by the process of amplitude slicing. Of course PAM is no longer possible, since such an amplitude limiting process would also remove part of the modulation. However, if the width, or duration, of the pulse is varied in accordance with the audio (Pulse Duration Modulation) or the time of occurrence of the pulse is varied

Fig. 1. Time sampling of an audio signal.

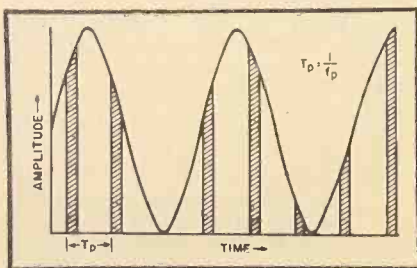
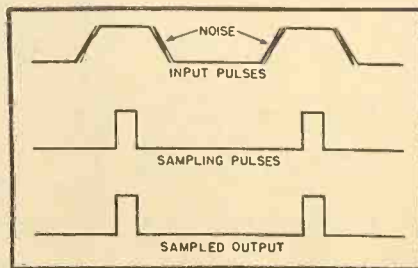

Fig. 2. Time regeneration of a pulse train.



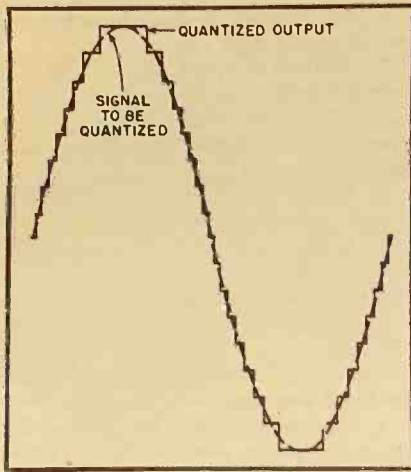

Fig. 3. Quantization of an audio signal.

(Pulse Position Modulation), noise reduction by amplitude slicing is possible. In Fig. 4B, the pulses, for simplicity, have been drawn with instantaneous buildup and decay times. In practice, bandwidth limitations require that the pulse have finite rise and fall times. Therefore, noise will still be present on the pulse edges, as shown in the upper illustration of Fig. 2. Use of these systems does not completely eliminate noise, but results in an inherent improvement factor similar to that obtained in FM systems. Noise appearing at the repeater stations will still be cumulative, but to a far smaller degree.

Further advantages of these systems include the following:

1. Non-linearity of repeaters does not result in amplitude distortion of the audio signals.
2. The constant amplitude nature of the signal causes transmission to be relatively independent of fading.
3. The above-mentioned noise improvement factor may also be applied to interchannel crosstalk.
4. Fewer repeater stations are required for a given distance and transmitter power.

At the same time, certain disadvantages remain, namely:

Fig. 6. Pulse output of an ideal low-pass filter of cut-off frequency f_c .

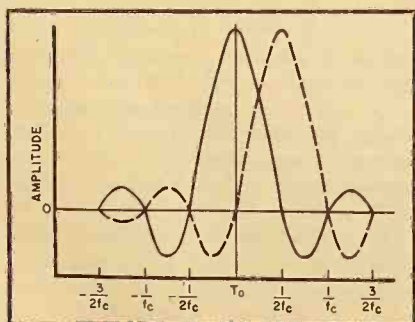

1. Since some noise is still present, there is a maximum limit on the number of repeater stations which may be used.

2. To obtain the advantages of these pulse systems, the pulse shape must be preserved to a reasonable degree.

At the receiver input, a certain signal-to-noise ratio is required for the system to be operative, which is known as the threshold. Below this value the signal cannot be distinguished from the noise, whereas, above this threshold the output signal-to-noise ratio will be equal to the input signal-to-noise ratio, added to the improvement factor of the system. For example, if the input S/N is 20 db. and the improvement factor is 20 db., the output S/N will be 40 db.

It would be advantageous to utilize a system of transmission where this dependence on input S/N could be considerably reduced. Referring once more to Fig. 2, if a small section of the center of the pulse could be selected by a train of sampling pulses, the noise on the edges could be completely elim-

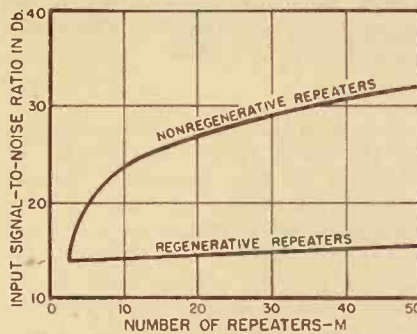

Fig. 5. Input signal-to-noise ratio vs. number of repeaters for constant output signal-to-noise ratio.

inated. This process, known as time sampling, will also remove the modulation in the systems discussed up to this point.

Pulse Code Modulation

Such a procedure suggests a form of modulation whereby the pulses may take any one of several discrete amplitudes, their time position remaining fixed. The simplest form would be a pulse which takes one of two such amplitudes, either on or off. Since the receiver now has only the job of recognizing whether a pulse is present or absent, a very simple system may be visualized, without severe requirements as to pulse shape.

These pulses could represent the modulation by some form of code, the most familiar of which is ordinary Morse code. The advantages of code transmission under adverse conditions are well-known. The code used on teleprinters is another example. To transmit a more complex signal, such as voice, a given amplitude can be repre-

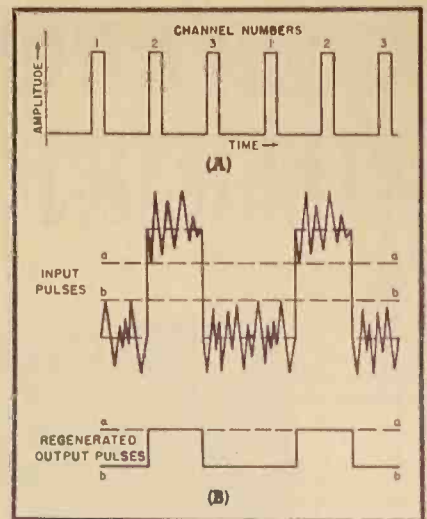

Fig. 4. (A) Multiplexing by time division. (B) Amplitude regeneration of a pulse train.

sented by a certain group of pulses. Such a code may be described by:

b —the base, or the number of amplitudes which the pulse may have.

n —the number of code pulses, or digits used.

The number of discrete amplitudes, or levels, which can be transmitted is then:

$$L = b^n \quad (2)$$

The simplest form, in which b is equal to 2, is the binary system, a table of which is shown in Fig. 8. Higher base systems, such as ternary ($b=3$), quaternary ($b=4$), etc. may be used, but will not be discussed here. Our familiar numerical system of decimal representation uses the base 10, but for any system, a particular level, L_i , may be expressed as

$$L_i = a_0 b^0 + a_1 b^1 + a_2 b^2 \dots a_n b^n \quad (3)$$

Fig. 7. Signal-to-noise improvement for pulse code modulation.

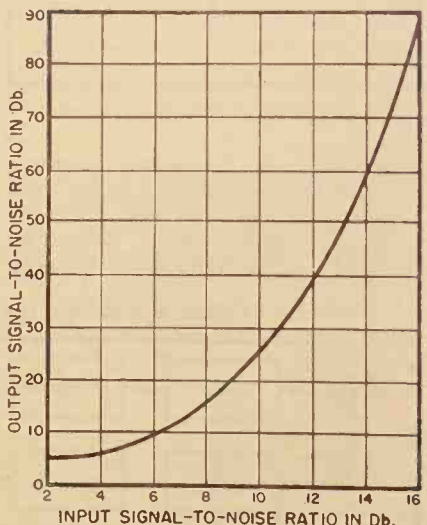

	4	3	2	1	0	— Powers of Two	
0	0	0	0	0	0		
1	0	0	0	0	1		2 ⁰
2	0	0	0	1	0		2 ¹
3	0	0	0	1	1		
4	0	0	1	0	0		2 ²
5	0	0	1	0	1	1 = Pulse	
6	0	0	1	1	0	0 = No Pulse	
7	0	0	1	1	1		
8	0	1	0	0	0		2 ³
9	0	1	0	0	1		
10	0	1	0	1	0		
11	0	1	0	1	1		
12	0	1	1	0	0		
13	0	1	1	0	1		
14	0	1	1	1	0		
15	0	1	1	1	1		
16	1	0	0	0	0		2 ⁴
17	1	0	0	0	1		
18	1	0	0	1	0		
19	1	0	0	1	1		
20	1	0	1	0	0		
21	1	0	1	0	1		
22	1	0	1	1	0		
23	1	0	1	1	1		
24	1	1	0	0	0		
25	1	1	0	0	1		
26	1	1	0	1	0		
27	1	1	0	1	1		
28	1	1	1	0	0		
29	1	1	1	0	1		
30	1	1	1	1	0		
31	1	1	1	1	1		
	16	8	4	2	1	— Digit Weight	

Fig. 8. Binary code (32 levels).

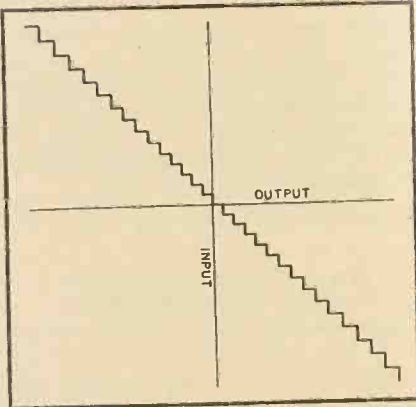

Fig. 9. Compression characteristic.

where $a_0, a_1, a_2, \dots, a_n$ are constants which define the amplitude of the digit. It will be seen that each digit has a certain definite weight, defined by its exponent. The digits are customarily

written in reverse order, with the lowest weight digit at the right. For example, in decimal notation, the number: $243 = 3(10)^0 + 4(10)^1 + 2(10)^2$. (In this discussion, zero has been considered as a number, and is one of the amplitudes being represented.) From this point on, it will be assumed that the code used is binary and all formulas apply to the use of binary code only.

It is now necessary to examine in more detail the requirements of the generation of such a code. We have already stated that the basic process involved in any system of pulse modulation is time sampling of the audio signal. Since our code groups can only represent any one of a number of discreet amplitudes, the generation of pulse code modulation requires a further process, known as quantization. This is illustrated in Fig. 3.

The complex wave is approximated by a wave having a finite number of amplitude levels, each differing from the preceding by one "quantum." The size of these amplitude steps determines the closeness with which the wave will be approximated. The height of each step, h , is then:

$$h = E/L \dots \dots \dots (4)$$

where E is the peak-to-peak amplitude of the audio signal. The number of steps to be used depends on several factors. The more levels used, the more faithful is the reproduction of the signal, but the smaller will be the height of each step for a given audio amplitude. The quantizing device must be able to recognize the difference between two adjacent levels and send the level whose amplitude is nearest to that of the signal. The greater the number of levels used, the larger is the number of code pulses required to represent these levels.

The essential elements of a basic PCM system include the following:

1. Audio signal to be transmitted.
2. Sampler, which samples this signal at discreet time intervals.
3. Quantizer, to divide this signal into a fixed number of discreet amplitude levels.
4. Coder, to transform the quantized signal into the PCM code.
5. R.f. transmitter, to transform the video frequency PCM signal to a radio frequency signal suitable for transmission over an r.f. path.

6. R.f. receiver, to transform the received signal back into video.
7. Regenerator, to sample the received signal both in time and amplitude. This regenerator removes noise from the pulse and restores the original pulse shape.
8. Decoder, to transform the PCM signal into quantized PAM.
9. Low-pass filter, for demodulation of this PAM.
10. Received audio signal.

These are shown in Fig. 10 in block diagram form.

Additional elements required would be the following:

1. Timing generator to produce the necessary pulses required for the above operations.
2. Some form of synchronization system to maintain the proper time relationships between the transmitted and received pulses.

3. One or more repeater stations, if a long path is contemplated.

4. Mixing and separating devices when a multichannel system is used.

Having now described the processes involved in the production of PCM, it is useful to investigate some of the problems introduced by these processes, and determine some of the properties of Pulse Code Modulation.

Quantization Distortion

Since, in the process of quantization, the signal is only approximated, errors are introduced which give rise to a form of distortion. The maximum possible error in representing a given level is equal to half a step. This distortion caused by the inherent error consists of a number of harmonics and modulation products between signal components and the sampling frequency. These spurious frequencies are distributed throughout the audio spectrum, and when the modulating signal is a complex wave, merge into a flat band of frequencies having the characteristics of noise. In fact, the term quantization noise is used frequently, but to avoid confusion with other forms of noise, the term distortion is to be preferred.

The mathematical analysis of this distortion is rather involved, but a good approximation is:

$$D = \left(\frac{2}{\sqrt{\sigma L}} \right) 100 \dots \dots \dots (5)$$

where D = total harmonic distortion in per-cent

L = the number of levels

Using (5), the distortion in a 16 level system is seen to be 7%, in a 32 level system, 3.5%, and in a 64 level system, 1.7%.

In addition to the quantization distortion, it is possible for a small disturbance in any part of the circuit

(Continued on page 30A)

Fig. 10. Block diagram of a typical pulse code modulation system.

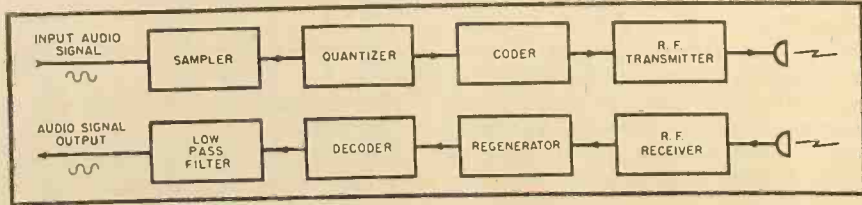

MICROWAVE MEASUREMENTS

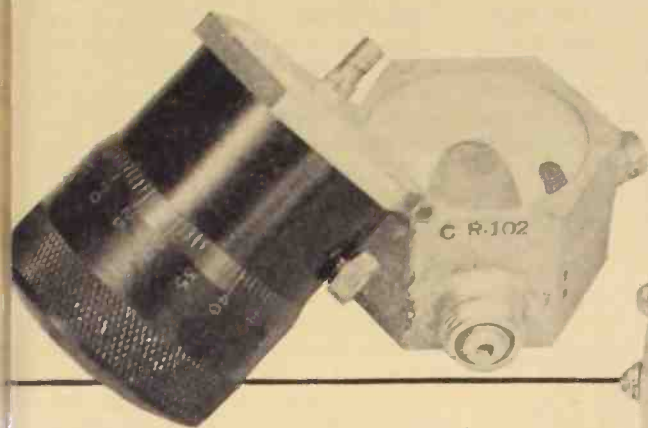
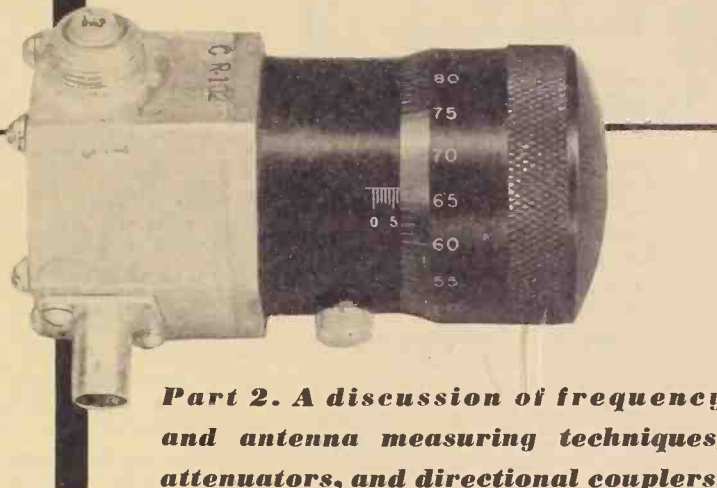

Fig. 1. Interior (left) and exterior (right) views of a typical cavity wavemeter.



Part 2. A discussion of frequency and antenna measuring techniques, attenuators, and directional couplers.

By **J. RACKER**

Federal Telecommunication Labs.

IN THE FIRST article covering this subject, the methods of determining the impedance and power of equipment operating at microwave frequencies were covered. In this article frequency and antenna measurement techniques will be considered as well as the design of microwave attenuators and directional couplers, these latter components finding widespread application in test procedures.

Frequency Measurement

There are two basic types of frequency measuring equipment, namely, primary and secondary frequency standards. In a primary equipment, the standard for frequency measurement is a highly accurate and stable signal generator. The output of this generator is then compared with the signal under test. In a secondary equipment, the frequency of the signal under test is determined directly on an instrument that has been frequency calibrated by some primary standard. A secondary standard is, of course, never as accurate as a primary standard.

A true primary frequency standard consists of a stable oscillator with which a clock is synchronized for comparison with standard time. The National Bureau of Standards maintains seven crystal controlled oscillators which are trimmed so that their main frequency provides a time indication in exact agreement with astronomical observation of the U. S. Naval Observatory. One of these oscillators provides frequency multiples for radio transmission from Station WWV. The accuracy achieved in these transmissions is better than 1 part in 10^7 .

Microwave frequency standards do not require such high accuracy because of the limitations placed on their utilization by existing measuring equipment and techniques. Therefore, synchronization to the national standard of frequency can be omitted. In fact, any good oven-controlled crystal oscillator can be used as the basis for a microwave standard. In some cases the crystal frequency is compared with a standard frequency broadcast where additional accuracy is required.

Fig. 2 is a block diagram of a typical primary frequency standard test

setup. The crystal oscillator, which is usually temperature controlled in a crystal oven, is operated at about 50 kc. to 100 kc. where maximum stability and accuracy can be achieved. The output of the oscillator is passed through several stages of frequency multiplication. The signal from one of these stages is compared with a standard broadcast signal to check crystal frequency stability.

An accurately calibrated tunable oscillator, whose frequency can also be compared with that of the standard broadcast signal, is mixed with the output of the last stage in the frequency multiplier chain. This enables tuning to any desired frequency within a limited range at the microwave output. In order to assure a high degree of accuracy, the ratio between the multiplied crystal frequency $n_1 f_0$ and the oscillator frequency f_1 must be at least:

$$n_1 f_0 / f_1 \geq 5 \quad (1)$$

For a ratio of 5, the accuracy of the variable microwave frequency is determined one-sixth by the tunable oscillator and five-sixths by the crystal controlled oscillator. The stability of the tunable oscillator is also a function of the maximum allowable frequency shift so that for greatest accuracy the frequency shift should be as small as possible.

The mixed frequency, i.e., $n_1 f_0 + f_1$, is then further frequency multiplied up to approximately 1000 megacycles. The final stage of multiplication usually em-

Fig. 2. Block diagram of a microwave primary frequency standard.

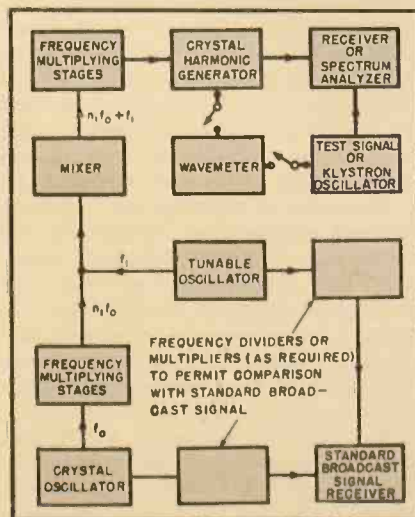

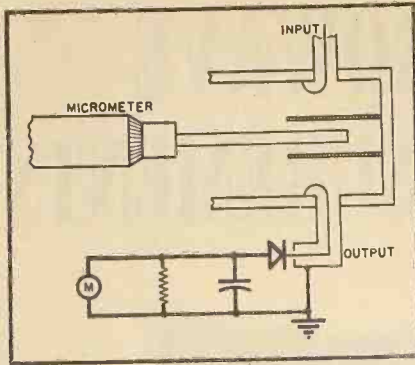

Fig. 3. Simplified schematic of a wave-meter such as that shown in Fig. 1.

employs a lighthouse triode. Beyond this frequency one must resort to either a velocity-modulation type of multiplier tube such as a klystron or traveling-wave tube, or to a crystal harmonic generator. The former type of multiplier is capable of producing sizeable power output in the microwave region but is somewhat difficult to adjust if it is desired to cover a range of frequencies. Crystal rectifier multipliers, on the other hand, may easily be adjusted in frequency but suffer from very low power output due to their low multiplier efficiency and limited allowable input at the fundamental.

The crystal harmonic generator is used in most primary frequency standard equipments. The crystal, silicon or germanium, is mounted in a holder similar to those used for microwave mixers and placed in a section of coaxial line or wave guide depending upon the frequency range desired. The harmonics generated by the crystal are then transmitted down the line and appropriate cavities are used to select the frequency desired. In order to assure efficient radiation the crystal must be matched to the transmission line. This can be done by transmitting the desired frequency into the line and adjusting the crystal position for maximum current.

As previously indicated, the power which these crystals can handle without overloading or burning out is limited. Some of the crystals designed to operate in the vicinity of 1000 megacycles can handle several watts of power without being damaged, but most of the higher frequency crystals can handle only a few tenths of a watt. Strength of some of the harmonics (10 to 50 harmonics

Fig. 5. Test setup for the comparison method of gain measurement.

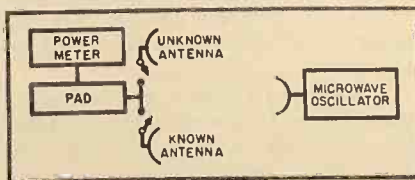

of a v.h.f. signal have been used) is as low as 0.05 microwatt. In this latter case a receiver is required with a sensitivity of about 10^{-8} microwatts. The microwave standard is mixed with that of a test frequency in the input of the receiver and a zero beat obtained between the two frequencies. The receiver may combine the function of a spectrum analyzer so that the zero beat can be obtained visually on the CRT screen.

When a higher order of power is desired for test purposes the procedure is usually to determine the frequency of a klystron oscillator by mixing it with that of the crystal multiplier output as indicated above. Then the output of this oscillator is used as the frequency standard. In this way a source of considerable microwave power of accurately known frequency may be obtained. However in this case, it is important to note, the oscillator frequency must be checked at each reading, otherwise the test will not be a primary one.

When a wave guide is used to propagate the higher order harmonics, no difficulties are ever encountered with lower harmonics or with the fundamental itself because the wave guide acts as an excellent high pass filter.

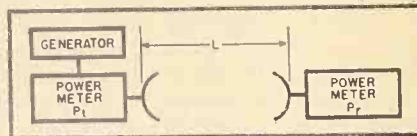

Fig. 4. Test setup for measuring the gain of two identical antennas.

When a coaxial line is used for the transmission of energy, it is sometimes necessary to employ tuned stubs or filters in the line to eliminate the stronger lower-order harmonics.

At the lower frequencies, sufficient power is obtained from the crystal to directly calibrate a wavemeter. For exact frequency measurements, the test signal is first introduced into the wavemeter, which is adjusted for maximum current. Then the test signal is removed and primary standard power is applied. The frequency of this signal is then varied for maximum wavemeter reading and this frequency is, of course, the same as that of the test signal.

While it is necessary to utilize a primary standard for determining frequencies with a high degree of precision, most laboratory requirements do not demand precision of this order. For routine measurements, resonant sections of coaxial lines or wave guides may be used as frequency measuring devices.

One form of wavemeter which uses a re-entrant cavity is shown in Fig. 1. In this cavity the resonant frequency is varied by moving the plunger by means

of the micrometer mechanism. A simplified schematic of this unit is shown in Fig. 3. The microwave energy is fed into the cavity through the r.f. loop. Another loop picks up the energy and detects it through a crystal rectifier. The transmission loss in the cavity will be very high for all frequencies other than those right around the resonant frequency. Hence, for frequencies that are considerably off resonance, no energy will be picked up by the crystal loop. Around resonance the transmission loss is low, and crystal current will increase. Maximum crystal current will be obtained at the resonant frequency.

The procedure for measuring frequency is to introduce the microwave energy in the r.f. plug. Then the micrometer is varied until maximum meter reading is obtained. A calibration curve is usually supplied with the wavemeter which indicates the resonant frequencies corresponding to the reading of the micrometer. Through the use of this calibration curve the frequency of the test signal is determined.

Two possible sources of error exist when wavemeters of either the coaxial or cavity type are used over wide temperature and humidity ranges. The first of these is due to the temperature coefficient of expansion of the metal. The percentage change in resonant frequency is equal to the percentage change in the linear dimensions of the cavity. In the case of steel this amounts to approximately 10 cycles per megacycle per degree centigrade. An increase in temperature produces an increase in wavelength and a decrease in frequency. Cavities of invar steel have a temperature coefficient of about one-tenth this value.

The second source of error is due to the change in dielectric constant of the medium filling the cavity as either the temperature or relative humidity is changed. Where precise measurements are required, it is necessary to employ sealed cavities filled with dry air to minimize the humidity effects.

Antenna Measurements

The antenna characteristics of interest are impedance, power gain, and radiation pattern. The impedance can be measured by methods previously described.¹ Therefore, in this article we will be concerned only with the gain and radiation measurements.

First we assume the case of an antenna of unknown gain, with no other antenna of known gain available for comparison, but two of these antennas are available for testing. In this case the setup is shown in Fig. 4. The distance L between antennas should be at least equal to:

$$L \geq 2 \frac{D_{eff}}{\theta} \quad (2)$$

This minimum distance is required because, as shown in a previous article², the antenna does not act as a point source but generates a wave of finite area equal to the effective area D_{eff} of the antenna. This area projects in the direction of the major lobe until the projected line crosses the theoretical beam line, which assumes a point source. In order for the antenna to be considered equal to a point source, which is the assumption of the gain question, the minimum distance L , given by Eq. 2, must be maintained. To be on the safe side, this distance should be exceeded by as much as possible.

The antenna should be oriented to provide maximum signal at the receiver. Knowing the power transmitted, P_t , and the power receiver, P_r (calibrated signal generators and receivers can be used or appropriate power meters), the gain of the antenna can be determined by the following equation:

$$\frac{P_r}{P_t} = \left(\frac{G\lambda}{4\pi L} \right)^2 \quad (3)$$

where λ , the wavelength, and L , the distance, are in like units. This equation can be expressed in decibels by:

$$G_{db} = 10 \log_{10} G \quad (4)$$

Once an antenna of known gain is available, measurement can be made by the comparison method shown in Fig. 5. In making the gain comparison the safest method is direct substitution whereby the standard gain antenna is physically interchanged with the antenna under test. In this way, one can be sure that the field strength is identical for both antennas. The gain of the unknown antenna is:

$$G = G_{known} \frac{P_2}{P_1} \quad (5)$$

where P_2 is the power output of the unknown antenna and P_1 is the power output of the known antenna.

In making the comparison the sensitivity of the receiver must be constant. This requires that the impedance of the antenna and gain standard be accurately matched to the line, or that they be adequately isolated by an attenuating pad so as not to react on the receiver. Furthermore, since any impedance mismatch between antenna and transmission line will subtract from its gain, maximum gain will be realized only when mismatch is eliminated.

A situation may arise whereby there are only two antennas of unknown gain and different type with no standard available for comparison measurements. In this case the setup of Fig. 4 is first used to determine the transmission loss, α , between the two antennas; the transmission loss is equal to:

$$\alpha = \frac{P_r}{P_t} = \left(\frac{\lambda}{4\pi L} \right) G_1 G_2 \quad (6)$$

Then by the comparison method, the relative relationships between the two gains is determined, namely:

$$\eta = \frac{G_1}{G_2} \quad (7)$$

Substituting the value for G_2 , given by Eq. (7), in Eq. (6) we obtain:

$$G_1 = 4\pi \frac{L}{\lambda} \sqrt{\alpha \eta} \quad (7a)$$

and similarly, G_2 is equal to:

$$G_2 = 4\pi \frac{L}{\lambda} \sqrt{\frac{\alpha}{\eta}} \quad (7b)$$

Attenuators

At many points throughout the articles in this series and in the measurements articles in particular, a pad was inserted between generator and load. The pad in these cases was employed to isolate these two elements and, in effect, provide a good match for both the generator looking into the load and the load looking back into the generator. In equipment where there is power available for dissipation, as for example the local oscillator output in a mixer or in

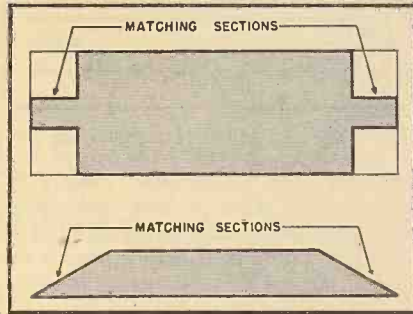

Fig. 7. Resistive plates for wave attenuators showing matching sections.

primary frequency measuring setups, an attenuator represents the simplest method of achieving a low standing-wave ratio.

A matched attenuator is a pad whose impedance, looking in from either the load or generator end, is equal to the characteristic impedance of the line. A number of such attenuators, both fixed and variable, are manufactured and they are designed to be used with specific types of standard coaxial lines or wave guides. The effect of such an attenuator is indicated in Fig. 8, which plots the voltage standing-wave ratio of a line terminated in a short circuit versus the pad attenuation. It is readily seen that by increasing the attenuation sufficiently the standing-wave ratio can be reduced to meet almost any requirement, provided that sufficient power is available for a high attenuation loss.

There are three basic types of attenuators. The first consists of a lossy transmission line. At frequencies where coaxial lines can be used (up to about 3000 mc.) the attenuation is obtained

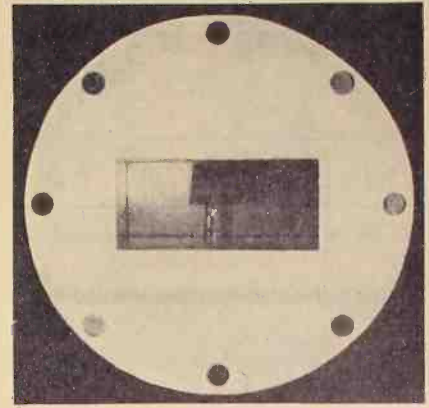
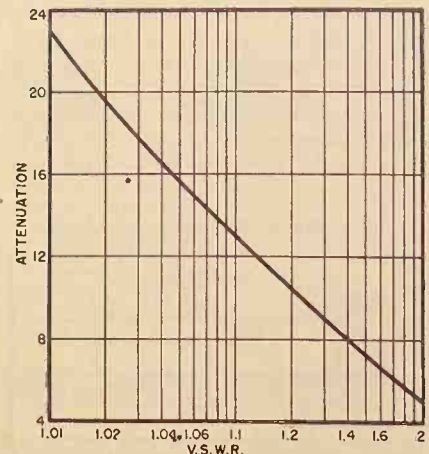

Fig. 6. Tapered section of attenuator matching into a 50 ohm resistor.

through the use of a highly resistive center conductor material. For a small attenuation or in cases where long lengths of line can be tolerated, the RG-21/U lossy cable can be used. This cable, which has a characteristic impedance of 53 ohms, uses a nichrome center conductor to obtain an attenuation of 0.46 db. per foot at 1000 mc. and 0.82 db. per foot at 3000 mc. This line is useful for isolation of a receiver from a generator, such as the antenna comparison measurement shown in Fig. 5, where the RG-21/U functions as both a pad and a transmission line. In this case, the receiver is likely to be located at a considerable distance from the antenna so that an attenuation of 40 to 80 db. is readily obtainable.

Where a high attenuation is required over a relatively short distance, the center conductor must have greater resistivity. For minimum frequency sensitivity, this resistivity is obtained by coating a dielectric, such as glass, with a thin film of resistive material such as nichrome. The unit resistance of such an attenuating element can be controlled by controlling the thickness of metallic deposit. If the thickness of metallic de-

Fig. 8. Chart showing change in voltage standing-wave ratio with attenuation.



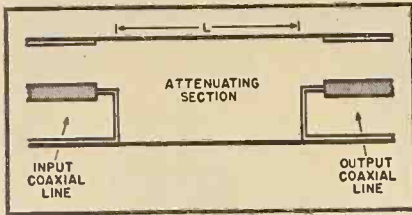

Fig. 9. Cut-off wave guide attenuator.

posit is made less than the depth of penetration³, σ , the frequency sensitivity can be kept low.

When the resistivity of the inner conductor is very high, the assumption of R much less than ωL , made in the formula for characteristic impedance, i.e.:

$$Z_0 = \sqrt{\frac{R + j\omega L}{G + j\omega C}} \dots (8)$$

is no longer accurate. For such a line the characteristic impedance is no longer a pure real number. If the attenuator is to be reflectionless it is necessary to provide a transformer matching section which usually consists of a quarter wave line of inner conductor having lower resistance per unit length. If a variable attenuator is desired, a telescoping section, which can slide over the resistive film, can be used. In order to preserve a good match looking into either end of such a variable attenuator, an additional tapered resistance matching section is mounted on the telescoping metallic sleeve.

A similar type of resistive attenuator may be constructed for use with wave guides by inserting a resistive plate in the wave guide in a plane parallel to the electric field. Suitable plates for this purpose may be made in several ways. One consists of coating a strip of bakelite or other dielectric with carbon or equivalent type of resistive film. Another consists of coating a glass vane in a similar manner to that used for the coaxial lines. In order to vary the attenuation the strip may be lowered in a slot through a slot in the broadside, (thereby increasing area of resistive material) or alternatively, the strip may be moved across the guide from an initial position close to the guide walls towards the center. As the plate is moved toward the center of the guide in the region of stronger electric fields, higher losses occur. In the 10,000 megacycle region, units six inches long have

Fig. 11. Wave guide directional coupler.

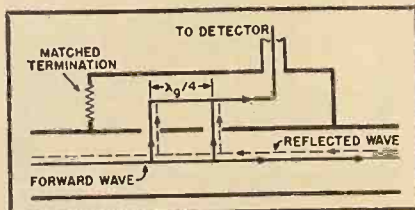

been made to give a maximum attenuation of approximately 60 db. through the use of the resistive plates.

In order to effect matching it again becomes necessary to use matching sections. These sections can be effected by a tapering plate, as shown in Fig. 6, or through use of resistive ribbons (Fig. 7).

It has been shown³ that a wave guide acts as a high pass filter passing only those frequencies above its cut-off frequency (for a particular mode). Below the cut-off frequency the wave guide attenuates the signal in accordance with the following formula:

$$\alpha = 8.7 \times \frac{2\pi}{\lambda} \sqrt{1 - \left(\frac{\lambda_0}{\lambda}\right)^2} \text{ db. per unit length} \dots (9)$$

The value for the cut-off wavelength, λ_0 , can be obtained by use of formulas³ and appropriate nomographs.

A typical wave guide cut-off attenuator as shown in Fig. 9 employs the principle indicated by Eq. (9). One of the most important features of the cut-off attenuator is that its attenuation

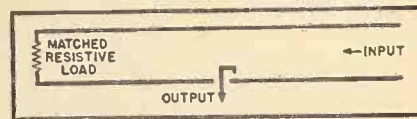

Fig. 10. Voltage divider attenuator.

constant can be predicted exactly by theory, and with certain limitations, the attenuator may be considered a primary standard. If only one mode exists in the cut-off tube, the attenuation constant is given exactly by Eq. (9). However, if more than one mode is excited in the cut-off tube, Eq. (9) is not exact. Therefore, great care must be exercised in the design of these units to prevent or minimize modes other than the primary one. A problem also exists in reducing the standing-wave ratio of such a unit, since a large portion of the wave is reflected, and it is frequently necessary to terminate both ends in lossy cable to keep the reflected wave to a minimum.

The third method of attenuation can be considered to be a capacity voltage dividing network. In such a unit, shown in Fig. 10, a probe is inserted in the transmission line and picks up only a small portion of the transmitted energy. The main portion of the energy is dissipated in the termination at the end of the line. Since it is possible to determine the amount of energy picked up by the loop compared to the total energy transmitted down the line, the attenuation constant can be determined. Furthermore, since the power picked up by the loop is a function of its depth of penetration into the line, a variable attenuator can be designed by increasing and decreasing depth of loop penetration.

In many applications it is desirable to measure only the forward or reflected wave. In a reflectometer, for example, only the reflected wave is measured. This instrument is frequently used in conjunction with a tuning operation, adjustments being made for minimum reading in the reflectometer. The basic circuit of the directional coupler is shown in Fig. 11. In this case the coupler is designed to pick up the forward wave. Some of the energy traveling down the guide in the forward direction is coupled into an auxiliary guide, through two coupling holes. Since the distance to the detector traveled by a wave going into the first hole is the same as a wave going into the second hole, both waves arrive in phase.

If a wave is reflected at the termination, however, and enters the two holes, the wave entering the first hole will travel a quarter of a wave additional distance than the wave going into the second hole. Hence, the wave will arrive at the detector 180 degrees out of phase and will be cancelled out. A matched termination at the end of the auxiliary guide prevents reflections at this point.

The coupling is a function of the size, number, and position of coupling holes, and of frequency of operation. It can be made reasonably constant over a band of frequencies, a typical example having a variation of 1 decibel in 20 over a 15 per-cent band.

The directivity of the coupler is defined as the ratio of the power fed into the detector when the measured wave travels in the preferred direction to that which would be fed to the detector if the direction of this wave were reversed—equal power being used at the input in both cases. This quantity is expressed in decibels by the following equation:

$$D = 10 \log_{10} (P_p/P_r) \dots (10)$$

where D is the directivity in db., P_p is the power in detector for preferred wave, and P_r is the power in the detector for the reverse wave.

The directivity of a coupler is a measure of its ability to discriminate in favor of a wave traveling in the preferred direction and, as such, is a criterion of its effectiveness.

BIBLIOGRAPHY

1. Racker, J., "Microwave Measurements, Part I," RADIO-ELECTRONIC ENGINEERING, December, 1950.
2. Racker, J., "Microwave Antennas," RADIO-ELECTRONIC ENGINEERING, October, 1950.
3. Racker, J., "Microwave Transmission Lines," RADIO-ELECTRONIC ENGINEERING, March, 1950.
4. Racker, J., "Microwave Propagation and Site Planning," RADIO-ELECTRONIC ENGINEERING, November, 1950.
5. Racker, J., "Microwave Components," RADIO-ELECTRONIC ENGINEERING, April, 1950.
6. Racker, J., "Microwave Techniques," RADIO-ELECTRONIC ENGINEERING, February, 1950.
7. Racker, J., "Microwave Transmitters," RADIO-ELECTRONIC ENGINEERING, May and June, 1950.
8. Racker, J., "Microwave Receivers," RADIO-ELECTRONIC ENGINEERING, July and August, 1950.
9. Husten and Lyons, "Microwave Frequency Standards," AIEE, May, 1948. p. 436.

In this panel are illustrated standard models of HELIPOT multi-turn and single-turn precision potentiometers—available in a wide range of resistances and accuracies to fulfill the needs of nearly any potentiometer application. The Beckman DUODIAL is furnished in two designs and four turns-ratios, to add to the usefulness of the HELIPOT by permitting easy and rapid reading or adjustment.

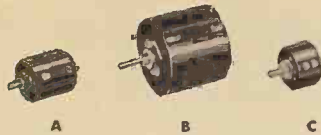

MODELS A, B, & C HELIPOTS
 A—10 turns, 46" coil, 1-13/16" dia., 5 watts—resistances from 10 to 300,000 ohms.
 B—15 turns, 140" coil, 3-5/16" dia., 10 watts—resistances from 50 to 500,000 ohms.
 C—3 turns, 13-1/2" coil, 1-13/16" dia., 3 watts—resistances from 5 to 50,000 ohms.



MODELS D AND E HELIPOTS
 Provide extreme accuracy of control and adjustment, with 9,000 and 14,400 degrees of shaft rotation.
 D—25 turns, 234" coil, 3-5/16" dia., 15 watts—resistances from 100 to 750,000 ohms.
 E—40 turns, 373" coil, 3-5/16" dia., 20 watts—resistances from 200 ohms to one megohm.



MODELS F AND G PRECISION SINGLE-TURN POTENTIOMETERS
 Feature both continuous and limited mechanical rotation, with maximum effective electrical rotation. Versatility of designs permit a wide variety of special features.
 F—3-5/16" dia., 5 watts, electrical rotation 359°—resistances 10 to 100,000 ohms.
 G—1-5/16" dia., 2 watts, electrical rotation 356°—resistances 5 to 20,000 ohms.

LABORATORY MODEL HELIPOT

The ideal resistance unit for use in laboratory and experimental applications. Also helpful in calibrating and checking test equipment. Combines high accuracy and wide range of 10-turn HELIPOT with precision adjustability of DUODIAL. Available in eight stack resistance values from 100 to 100,000 ohms, and other values on special order.



MODELS R AND W DUODIALS
 Each model available in standard turns-ratios of 10, 15, 25 and 40 to 1. Inner scale indicates angular position of HELIPOT sliding contact, and outer scale the helical turn on which it is located. Can be criven from knob or shaft end.
 R—2" diameter, exclusive of index.
 W—4-3/4" diameter, exclusive of index. Features finger hole in knob to speed rotation.

FOR PRECISION POTENTIOMETERS

come to Helipot

For many years The HELIPOT Corporation has been a leader in the development of advanced types of potentiometers. It pioneered the *helical* potentiometer—the potentiometer now so widely used in computer circuits, radar equipment, aviation devices and other military and industrial applications. It pioneered the DUODIAL—the turns-indicating dial that greatly simplifies the control of multiple-turn potentiometers and other similar devices. And it has also pioneered in the development of many other unique potentiometric advancements where highest skill coupled with ability to mass-produce to close tolerances have been imperative.

In order to meet rigid government specifications on these developments—and at the same time produce them economically—HELIPOT has perfected unique manufacturing facilities, including high speed machines capable of winding extreme lengths of resistance elements employing wire even less than .001" diameter. These winding machines are further supplemented by special testing facilities and potentiometer "know-how" unsurpassed in the industry.

So if you have a problem requiring *precision potentiometers* your best bet is to bring it to The HELIPOT Corporation. A call or letter outlining your problem will receive immediate attention!

*Trade Marks Registered

The versatility of the potentiometer designs illustrated above permit a wide variety of modifications and features, including double shaft extensions, ganged assemblies, the addition of a multiplicity of taps, variation of both electrical and mechanical rotation, special shafts and mounting bushings, high and low temperature operation, and close tolerances on both resistance and linearity. Examples of potentiometers modified for unusual applications are pictured at right.



3-GANGED MODEL A HELIPOT AND DOUBLE SHAFT MODEL C HELIPOT
 All HELIPOTS, and the Model F Potentiometer, can be furnished with shaft extensions and mounting bushings at each end to facilitate coupling to other equipment. The Model F, and the A, B, and C HELIPOTS are available in multiple assemblies, ganged at the factory on common shafts, for the control of associated circuits.

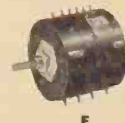
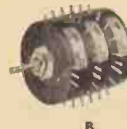

MULTITAPPED MODEL B HELIPOT AND 6-GANGED TAPPED MODEL F
 This Model B Helipot contains 40 taps, placed as required at specified points on a coil. The Six-Gang Model F Potentiometer contains 19 additional taps on the middle two sections. Such taps permit use of padding resistors to create desired non-linear potentiometer functions, with advantage of flexibility, in that curves can be altered as required.

THE Helipot CORPORATION, SOUTH PASADENA 4, CALIFORNIA

NEWS BRIEFS

NEW TEST CHAMBER AT MIT

A half-million pound test chamber is now being used in the Acoustics Laboratory at the Massachusetts Institute

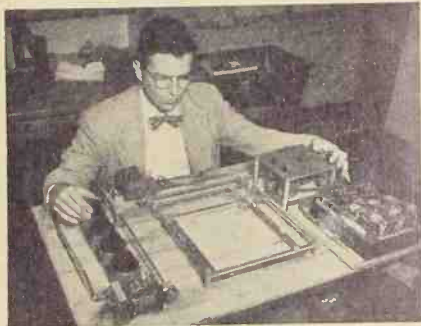

of Technology for fundamental research to make possible quieter homes and factories.

The scheme for sound measurement used in the new MIT equipment has essentially three parts. A uniform steady sound is pushed toward one side of a wall to be tested. On the other side is a microphone which picks up the sound which gets through the test sample. As the microphone moves, the sound it finds is amplified and recorded on a super-precise electronic mapping device. Dr. Jordan J. Baruch, who designed the electronic recording device, is shown watching the stylus as it draws a sound "contour map" from information transmitted automatically.

This sound-measuring method was first proposed during World War II by Prof. L. L. Beranek, now technical director of the MIT Acoustics Laboratory, and the equipment has been built under the direction of Dr. Richard H. Bolt and Professor Beranek.

EXPERIMENT WITH ELECTRONS

As a result of bombardment with 800,000-volt electrons, or cathode rays, in experiments at the *General Electric* Research Laboratory, bread, meat, and other foods have been preserved for periods as long as a year without refrigeration. The rays kill molds and other organisms which normally cause such foods to spoil.

Elliott J. Lawton of the *General Electric* Research Laboratory, who reported his findings to the National Academy of Sciences at its autumn meeting, stated that it was too early to predict

possible commercial applications. However, he added, sterilization by cathode rays should be particularly attractive for materials which would be damaged or destroyed by the heat required to sterilize them by usual methods.

Mr. Lawton also pointed out that his experiments represent a continuation of those begun in 1925 by Dr. W. D. Coolidge, now director emeritus of the *GE* Research Laboratory, who first produced cathode rays of high intensity in the open air and studied their effects.

NBS ELECTRONIC COMPUTER

The National Bureau of Standards Eastern Automatic Computer was unveiled recently before key military leaders and government officials by Dr. E. U. Condon, Director of NBS, and Lt.

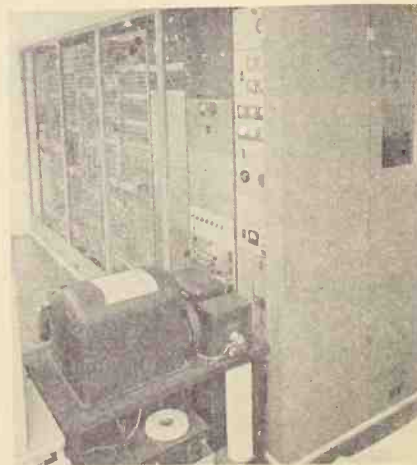

Gen. E. W. Rawlings, Comptroller of the Department of the Air Force.

According to Dr. Condon, SEAC is the first automatically-sequenced, super-speed computer to be put into useful operation. Designed and constructed in twenty months, SEAC was sponsored by Office of the Comptroller, Department of the Air Force, and designed and constructed by NBS. It is being operated by the NBS to provide a fast and powerful computational tool for the Air Force Project SCOOP (Scientific Computation of Optimum Programs), and for the solution of important, unsolved general scientific and engineering problems.

A view of the SEAC with operator's control table is shown. Power-supply control and meter panels are directly accessible. The teletype keyboard and

printer are used for direct input and output with numbers and instructions coded in hexadecimal notation. Indirect operation is also possible through the use of punched paper tape.

APPOINTMENTS AT ILL. TECH.

Dr. Haldon A. Leedy, Director of Armour Research Foundation of Illinois Institute of Technology has announced the appointments of Dr. Christopher E. Barthel, Jr. as assistant director in charge of personnel, and Dr. E. H. Schulz as acting chairman of the physics department. Dr. Schulz will continue as chairman of electrical engineering research, a position he has held since June, 1947.

In his new position, Dr. Barthel will be responsible for recruitment operations, professional development, and personnel administration for a group of almost 700 technical and non-technical staff members.

Dr. Schulz was assistant professor of electrical engineering at the University of Texas and Illinois Tech before joining the Foundation in 1946, and during the war was in charge of various phases of a military training program concerned with electronics and radio at IIT.

TV TUBE PRODUCTION

Sylvania Electric Products Inc., has geared its Ottawa, Ohio plant to high-speed production of television picture tubes with the investment of heavy automatic equipment for mass quality production.

Two types of automatic sealing machines are used to speed the sealing of electron gun mounts to the finished glass bulbs. The metal cone and glass neck assembly are placed on the machines which automatically carry them through a series of heating, sealing and tempering operations to provide vacuum-tight, mechanically strong bonds between glass and metal.

Shown are electron gun mounts and finished glass bulbs being sealed to-



gether in an automatic rotary typewriter machine. Here, the operator is removing an assembled tube which is ready for automatic exhaust and processing
(Continued on page 24A)

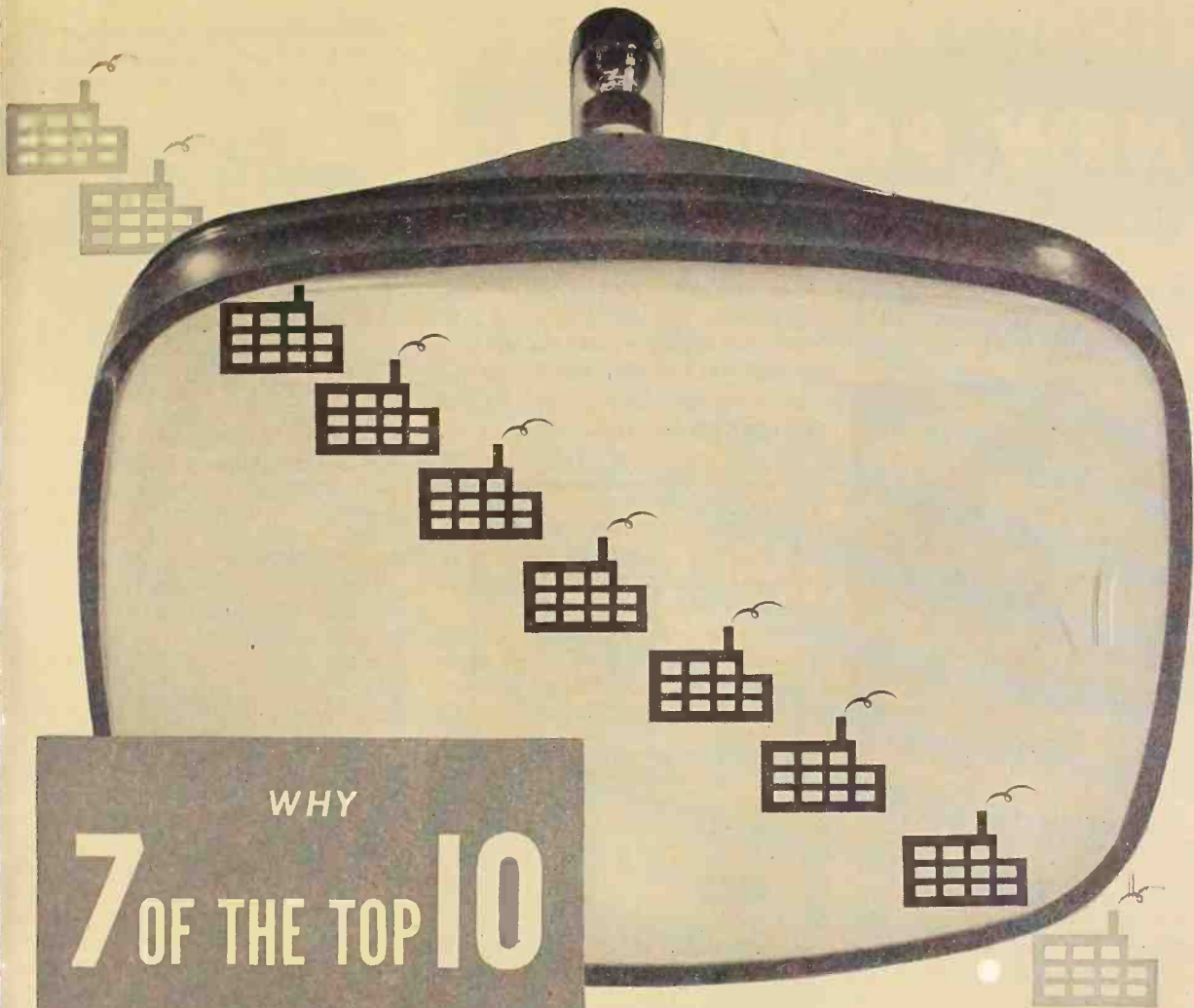

WHY
7 OF THE TOP 10

TELEVISION SET
 MANUFACTURERS USE

SYLVANIA

PICTURE TUBES

The important reasons behind the steadily increasing demand for Sylvania TV Picture Tubes are: (1) high quality performance, (2) broad national recognition.

Sylvania's picture tube experience includes leadership in 4 specialized fields . . . all basic to TV picture tube production. These are *radio, electronics, lighting, and phosphors.*

A Sylvania tube engineer, for example, invented the famous Ion Trap now generally adopted, under special Sylvania license, by other leading picture tube makers.

Sylvania's 25 years of lighting research, including advances in phosphors and filamentary wire techniques and coatings, has also contributed to the outstanding clarity and long life of Sylvania picture tubes.

Popular TV show tells millions

Set owners are being kept informed of Sylvania's leadership by the big, popular television show, "*Beat the Clock*," on CBS-TV. Every week this program emphasizes Sylvania's unique background and the fine quality of all Sylvania products, thus assuring you that Sylvania picture tubes are an added selling aid to the sets you manufacture.

New folder, giving complete descriptions and ratings of all Sylvania TV Picture Tubes is yours for the asking. For your copy address: Sylvania Electric Products Inc., Dept. R-1301, Emporium, Penna. *Sylvania Representatives are located in all foreign countries. Names on request.*

SYLVANIA  ELECTRIC

RADIO TUBES; TELEVISION PICTURE TUBES; ELECTRONIC PRODUCTS; ELECTRONIC TEST EQUIPMENT; FLUORESCENT TUBES, FIXTURES, SIGN TUBING, WIRING DEVICES; LIGHT BULBS; PHOTOLAMPS; TELEVISION SETS

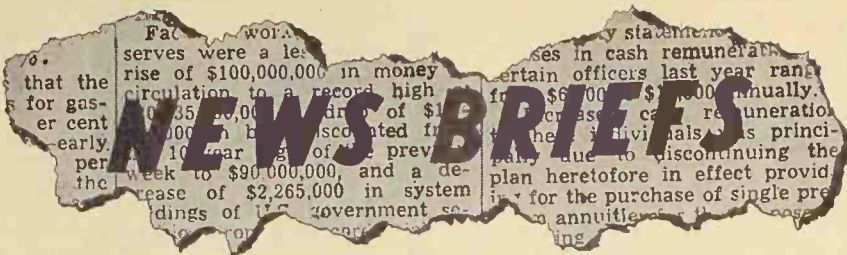

NEW TEST CHAMBER AT MIT

A half-million pound test chamber is now being used in the Acoustics Laboratory at the Massachusetts Institute



of Technology for fundamental research to make possible quieter homes and factories.

The scheme for sound measurement used in the new MIT equipment has essentially three parts. A uniform steady sound is pushed toward one side of a wall to be tested. On the other side is a microphone which picks up the sound which gets through the test sample. As the microphone moves, the sound it finds is amplified and recorded on a super-precise electronic mapping device. Dr. Jordan J. Baruch, who designed the electronic recording device, is shown watching the stylus as it draws a sound "contour map" from information transmitted automatically.

This sound-measuring method was first proposed during World War II by Prof. L. L. Beranek, now technical director of the MIT Acoustics Laboratory, and the equipment has been built under the direction of Dr. Richard H. Bolt and Professor Beranek.

EXPERIMENT WITH ELECTRONS

As a result of bombardment with 800,000-volt electrons, or cathode rays, in experiments at the General Electric Research Laboratory, bread, meat, and other foods have been preserved for periods as long as a year without refrigeration. The rays kill molds and other organisms which normally cause such foods to spoil.

Elliott J. Lawton of the General Electric Research Laboratory, who reported his findings to the National Academy of Sciences at its autumn meeting, stated that it was too early to predict

possible commercial applications. However, he added, sterilization by cathode rays should be particularly attractive for materials which would be damaged or destroyed by the heat required to sterilize them by usual methods.

Mr. Lawton also pointed out that his experiments represent a continuation of those begun in 1925 by Dr. W. D. Coolidge, now director emeritus of the GE Research Laboratory, who first produced cathode rays of high intensity in the open air and studied their effects.

NBS ELECTRONIC COMPUTER

The National Bureau of Standards Eastern Automatic Computer was unveiled recently before key military leaders and government officials by Dr. E. U. Condon, Director of NBS, and Lt.

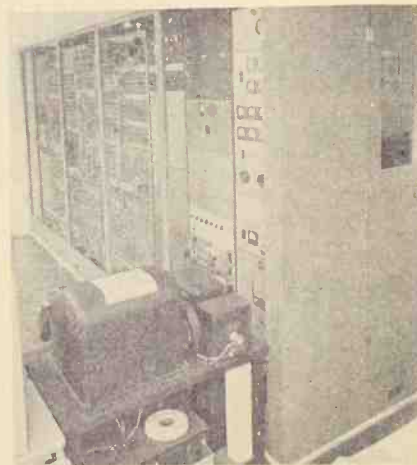

Gen. E. W. Rawlings, Comptroller of the Department of the Air Force.

According to Dr. Condon, SEAC is the first automatically-sequenced, super-speed computer to be put into useful operation. Designed and constructed in twenty months, SEAC was sponsored by Office of the Comptroller, Department of the Air Force, and designed and constructed by NBS. It is being operated by the NBS to provide a fast and powerful computational tool for the Air Force Project SCOOP (Scientific Computation of Optimum Programs), and for the solution of important, unsolved general scientific and engineering problems.

A view of the SEAC with operator's control table is shown. Power-supply control and meter panels are directly accessible. The teletype keyboard and

printer are used for direct input and output with numbers and instructions coded in hexadecimal notation. Indirect operation is also possible through the use of punched paper tape.

APPOINTMENTS AT ILL. TECH.

Dr. Haldon A. Leedy, Director of Armour Research Foundation of Illinois Institute of Technology has announced the appointments of Dr. Christopher E. Barthel, Jr. as assistant director in charge of personnel, and Dr. E. H. Schulz as acting chairman of the physics department. Dr. Schulz will continue as chairman of electrical engineering research, a position he has held since June, 1947.

In his new position, Dr. Barthel will be responsible for recruitment operations, professional development, and personnel administration for a group of almost 700 technical and non-technical staff members.

Dr. Schulz was assistant professor of electrical engineering at the University of Texas and Illinois Tech before joining the Foundation in 1946, and during the war was in charge of various phases of a military training program concerned with electronics and radio at IIT.

TV TUBE PRODUCTION

Sylvania Electric Products Inc., has geared its Ottawa, Ohio plant to high-speed production of television picture tubes with the investment of heavy automatic equipment for mass quality production.

Two types of automatic sealing machines are used to speed the sealing of electron gun mounts to the finished glass bulbs. The metal cone and glass neck assembly are placed on the machines which automatically carry them through a series of heating, sealing and tempering operations to provide vacuum-tight, mechanically strong bonds between glass and metal.

Shown are electron gun mounts and finished glass bulbs being sealed to-



gether in an automatic rotary typewriter machine. Here, the operator is removing an assembled tube which is read for automatic exhaust and processing

(Continued on page 24A)

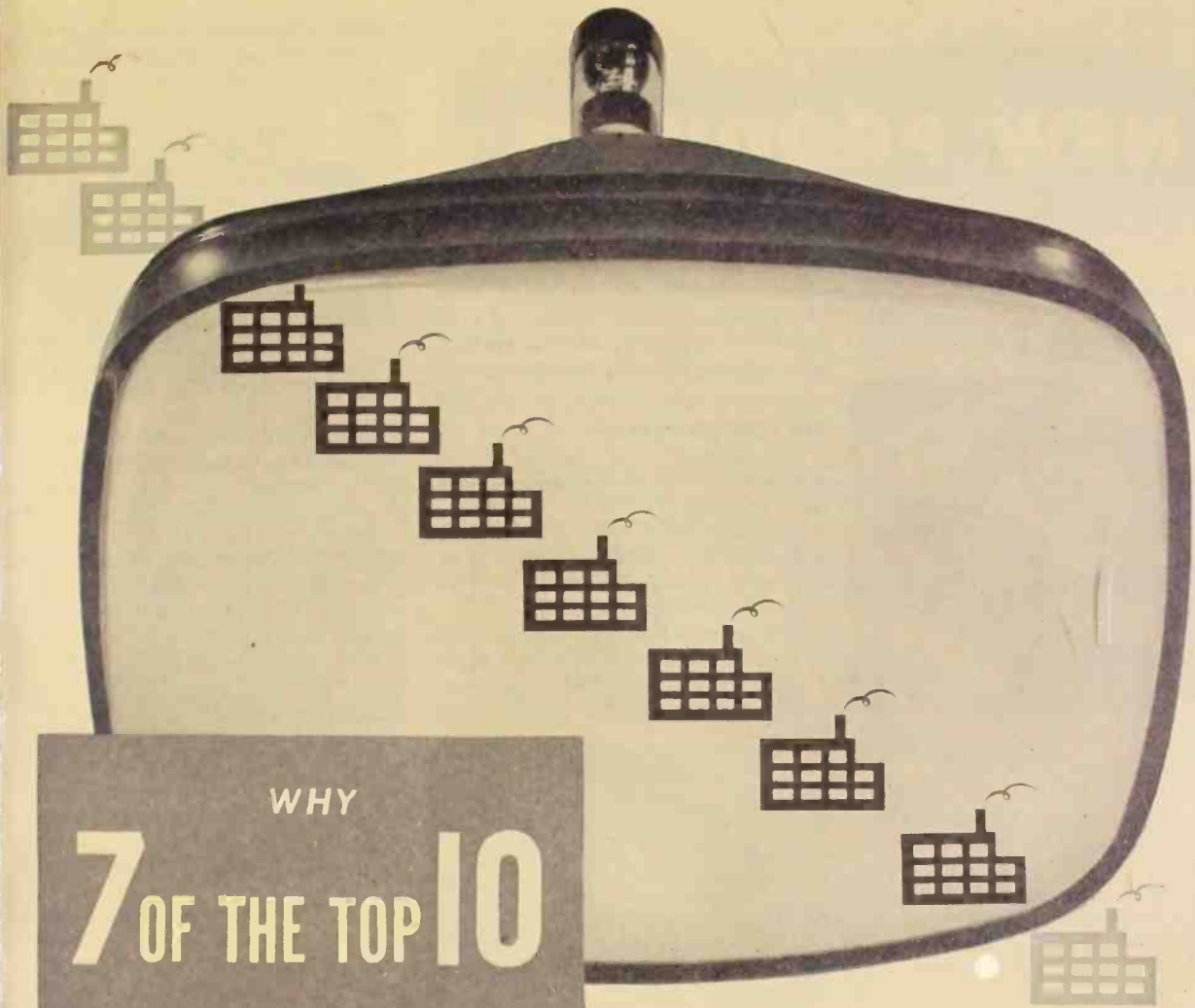

WHY
7 OF THE TOP 10
TELEVISION SET
MANUFACTURERS USE
SYLVANIA
PICTURE TUBES

The important reasons behind the steadily increasing demand for Sylvania TV Picture Tubes are: (1) high quality performance, (2) broad national recognition.

Sylvania's picture tube experience includes leadership in 4 specialized fields... all basic to TV picture tube production. These are *radio, electronics, lighting, and phosphors.*

A Sylvania tube engineer, for example, invented the famous Ion Trap now generally adopted, under special Sylvania license, by other leading picture tube makers.

Sylvania's 25 years of lighting research, including advances in phosphors and filamentary wire techniques and coatings, has also contributed to the outstanding clarity and long life of Sylvania picture tubes.

Popular TV show tells millions

Set owners are being kept informed of Sylvania's leadership by the big, popular television show, "*Beat the Clock*," on CBS-TV. Every week this program emphasizes Sylvania's unique background and the fine quality of all Sylvania products, thus assuring you that Sylvania picture tubes are an added selling aid to the sets you manufacture.

New folder, giving complete descriptions and ratings of all Sylvania TV Picture Tubes is yours for the asking. For your copy address: Sylvania Electric Products Inc., Dept. R-1301, Emporium, Penna. *Sylvania Representatives are located in all foreign countries. Names on request.*

SYLVANIA ELECTRIC

RADIO TUBES; TELEVISION PICTURE TUBES; ELECTRONIC PRODUCTS; ELECTRONIC TEST EQUIPMENT; FLUORESCENT TUBES, FIXTURES, SIGN TUBING, WIRING DEVICES; LIGHT BULBS; PHOTOLAMPS; TELEVISION SETS

NEW PRODUCTS

RADIATION DETECTION METER

Westinghouse Electric Corp., Box 2099 Pittsburgh, Pa., is now producing



the Universal Roentgen Meter, a radioactivity-measuring instrument.

This meter is equipped with multiple scales, either four, five or six, which make possible fine readings in all ranges of radiation. The four scale model covers four ranges of radiation: zero to half a milliroentgen; zero to five milliroentgens; zero to 50 milliroentgens; and zero to 500 milliroentgens.

POTENTIOMETER

The Helipot Corp., South Pasadena California, is introducing its model AJ potentiometer, a 10-turn pot that is said to occupy no more panel space than an ordinary copper penny.

Developed especially for aircraft and guided missile control and telemetering equipment, this potentiometer has a wire wound resistance element 18" long, contained in a case, the diameter of which is but $\frac{3}{4}$ ". The AJ model is



available in special resistance values of 100 to 50,000 ohms with accuracies of plus or minus .5 per-cent and also of plus or minus .1 per-cent. The power rating is 2 watts.

Double shaft extensions may be pro-

vided, as may tap connections at almost any point on the coils. Bulletin No. 108 containing complete details is available upon request from the manufacturer.

SIDE REGISTER CONTROL

An electronic side register control that automatically and accurately maintains the lateral position of a moving web of material on slitting, re-winding, and other processing machines is announced by General Electric's Control Division, Schenectady 5, N. Y.

This side register control responds to a signal from a printed line on paper, plastic, or cloth of $\frac{1}{32}$ -in. minimum width. According to GE engineers, the



control ignores all signals from printing adjacent to the guide line on the trailing edge of the scanning sweep. It also follows broken lines of the same width, and will not change web position if the web breaks.

Two components make up the side register control, a rotary lens web scanner, and a thyatron control panel. The scanner features a tilting mounting bracket with adjustable stops to allow operation on either diffused or specular scanning. The direction of scanning can be selected by a panel-mounted switch, and the red- and blue-sensitive phototubes will handle most color contrasts.

LABORATORY AMPLIFIER

Hermon Hosmer Scott, Inc., 385 Putnam Ave., Cambridge 39, Mass., has announced an improved version of its 210-A amplifier.

The new type 210-B Dynaural amplifier has the following technical speci-

fications: frequency response flat from 12 to 22,000 cycles; harmonic distortion less than 0.5% at full 20 watts output;



first-order difference-tone intermodulation less than 0.1% at full output; automatic loudness control to compensate for the insensitivity of the ear at low volumes; hum level 84 db. or more below full output; and the Dynaural Noise Suppressor which is reported to virtually eliminate record scratch and rumble without affecting the music response.

ADMITTANCE METER

General Radio Company, 275 Massachusetts Ave., Cambridge 39, Mass., has announced Type 1602-A u.h.f. admittance meter for making impedance measurements at ultra-high frequencies.

The admittance meter can be used to measure conductances and susceptances of either sign, from one millimho to 400 millimhos (100 ohms to 2.5 ohms) over a frequency range from 70 to 1000 mc. Accuracy is $\pm 5\%$. The admittance components can be easily converted to impedance by using a Smith chart or Smith-chart slide rule.

This meter can also be used as a comparator to indicate equality of one admittance to another, or degree of departure of one from the other. Simple generator and detector equipment is available for use with the meter.

INSULATING LAMINATE

The Richardson Company, 2793 Lake St., Melrose Park, Illinois, has developed a new paper-base phenolic lami-

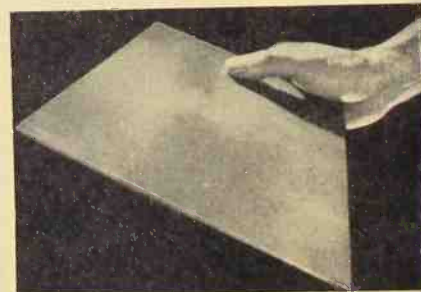

nate, offering an unusual combination of properties for use in h.f. insulating applications.

The new electrical laminate, designated Insurok Grade T-812, retains all the properties of Insurok T-725, although the new grade has lower moisture absorption than T-725, and much higher insulation resistance (1,000,000 megohms after humidity condition $\frac{1}{16}$ " sheet).

Grade T-812 is available in a complete range of sheet sizes and thicknesses.

RADIO RELAY SYSTEMS

Radio Engineering Laboratories, 36-40 37th Street, Long Island City, N. Y., has developed FM radio relay equipments for multi-channel radio telephone communications service, designed for oil and gas pipe line companies, telephone and telegraph services, utilities,

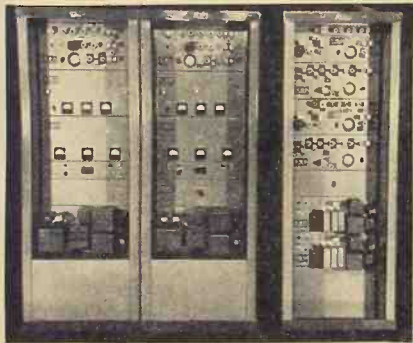

mining organizations, airlines, and railroads. These circuits may at the same time also be used for telemetering and remote control service.

The three different series, REL-757, REL-752, and REL-755 are for the 900 mc., 450 mc., and 150 mc. bands respectively. A choice of models in each series allows up to 28 regular 4 kc. channels, in addition to order service and telemetering circuits.

Both transmitters and receivers employ direct crystal control, and standard vacuum tubes are used throughout. Specifications for any radio relay system will be drawn up by REL engineers to meet all service requirements.

REMOTE CONTROL SYSTEM

A system for remote control of microwave parabolic antennas in the field at distances up to 1500 ft. is now being offered to broadcasters by the RCA Engineering Products Department, Camden, N. J.

This system consists essentially of a rotatable field mount and a remote control unit equipped with switches and indicating devices. The design of the field mount provides for both azimuth and tilt positioning of the parabola, and will withstand a wind velocity of 120 miles per hour. The parabola is driven with 1/6 hp. motors providing a torque

of 10,500 inch pounds at 1 r.p.m., which is sufficient to operate the mechanism under severe icing conditions.

The standard power required for operation of the positioning system is 115 volts, 60 cycles, single phase, 6.8 amps. Equipment for operation on 220 volts can also be provided. Control of the saucer-shaped reflectors from greater distances may be achieved with the use of additional control equipment.

DECIMAL COUNTING UNITS

Berkeley Scientific Co., 23rd and Wright Sts., Richmond, California, is now in production on two new high

speed models of the direct-reading Berkeley Decimal Counting Units.

Model 706 has a maximum counting rate of 200,000 pulses per second, with a 2.5 microsecond resolution of pulse pairs. Signal input requires a negative pulse of 50 to 150 volts peak amplitude negative with respect to B plus. Model 707 has a maximum counting rate of 1,000,000 pulses per second, with an 0.8 microsecond resolution of pulse pairs. Signal input requires a negative pulse of 120 to 180 volts peak amplitude negative with respect to B plus.

Both units are designed for scale-of-10 operation and provide reading from (Continued on page 28A)



- 17 TUBES INCLUDING 5" CRT.
- 10 MILLIVOLT SENSITIVITY
- 12 MEGACYCLE BANDWIDTH
- DEFLECTION PLATES AVAILABLE ON TERMINAL BOARD
- CONTINUOUSLY VARIABLE CALIBRATOR
- SWEEP MAGNIFICATION 5 TIMES SCREEN SIZE
- GOOD TRANSIENT RESPONSE
- TRIED AND PROVEN CIRCUITS
- CRT CALIBRATION GRID

WRITE FOR SPECIFICATION DATA SHEET RE

\$349⁵⁰ LIST
Complete with low capacity probe

A
NEW
12 MC OSCILLOSCOPE
MODEL
T-601-A



Now! A top quality engineer's oscilloscope combining ALL the features of a laboratory instrument in one convenient size, light-weight, low cost unit. Compare feature for feature with models many times the price!



TELEVISION EQUIPMENT CORP.
238 WILLIAM ST., NEW YORK 7, N. Y.
IN CANADA THE AHEARN & SOPER CO LTD OTTAWA

Personals



R. P. CLAUSEN has been appointed chief engineer of the Radio Tube Division, *Sylvania Electric Products Inc.* Prior to joining *Sylvania* in 1946 as superintendent of the plastics plant at Warren, Pa., Mr. Clausen served in the U. S. Navy as its Bureau of Ordnance's representative on proximity fuse tubes. He was formerly associated with the *National Aluminate Corp.*, the *Diamond Alkali Co.*, the *Solvay Process Co.*, and the *J. R. Watkins Co.*



IVAN S. COGGESHALL, general traffic manager of *Western Union Telegraph Company's* overseas communications, has been elected president of the Institute of Radio Engineers for 1951. Mr. Coggeshall, who is noted for his activity in the adoption of electronic methods and devices in the telegraph and submarine cable field, will succeed Raymond F. Guy, manager of radio and allocation engineering of the *National Broadcasting Company.*



REAR ADMIRAL MAURICE EDWIN CURTS, USN, has been designated Navy Member of the Research and Development Board, succeeding Rear Admiral R. P. Briscoe, Assistant Chief of Naval Operations, who has been assigned as Commander, Amphibious Force, Atlantic Fleet. A graduate of the U. S. Naval Academy, Admiral Curts was in charge of radio and sonar research at the Naval Research Laboratory from 1936 to 1938.



FLOYD MAKSTEIN was recently appointed manager of the newly expanded field engineering department of *Emerson Radio and Phonograph Corporation*, N. Y. In his new duties, Mr. Makstein will be directly responsible for the activities of a corps of field engineers who visit various distributor territories and operate in the field. These men will assist *Emerson* distributors in conducting dealer technical meetings and investigating field engineering conditions.



DR. JOHN W. McNALL has been appointed division engineer of the research department of the *Westinghouse Lamp Division* at Bloomfield, N. J. Dr. McNall will direct the electron emission, gas discharge and physical measurements sections of the department. In 1940 Dr. McNall was awarded the B. J. Lamme Scholarship and under this grant did graduate work at MIT, receiving his Doctor of Philosophy degree in physics in 1942.



PERRY C. SMITH, formerly Manager of Scientific Instruments Engineering of the *RCA Victor Division*, has joined the staff of the Research Division of the *Burroughs Adding Machine Company* as Supervisor of the Special Devices Department. Mr. Smith, a past Vice-President and President of the Electron Microscope Society of America, and currently Chairman of the Bibliography Committee, holds about thirty patents on electron optics.

News Briefs

(Continued from page 20A)

Practically all *Sylvania* glass TV picture tubes require an outside graphite bearing coating which is sprayed on after the tubes have been completely processed. Infrared lamps are used to dry the exterior coating as the tubes pass around automatic rotary spraying equipment.

ELECT AES OFFICERS

The newly elected chairman of the San Francisco Section of the Audio Engineering Society is Dr. Vincent Salmon, Stanford Research Institute.

Other officers elected are: Harold Lindsay, *Ampex Electric Corp.*, vice chairman; Frank Haylock, secretary; Myron J. Stolaroff, *Ampex Electric Corp.*, treasurer; and Walter T. Selsted, Jack Hawkins, and Ross Snyder, executive-board members.

OFFICE OF BASIC INSTRUMENTATION

A new office has been established at the National Bureau of Standards to coordinate a program of evaluation and improvement of instruments for measuring basic physical quantities.

The Office of Basic Instrumentation will coordinate Bureau projects in basic instrumentation, maintain liaison with sponsoring agencies, and arrange for cooperative work on special problems. In addition, it will survey all work in progress in NBS laboratories to determine its pertinence to instrumentation projects, arrange for the evaluation of new instrumentation developments, and direct theoretical and experimental studies of original designs for improved means of measurement not specifically covered by other projects at the Bureau.

The concept of the office was developed jointly by NBS, the Office of Naval Research, the Office of Air Research, and the Atomic Energy Commission.

SCREEN CHEMICALS FOR COLOR TV

The Tungsten and Chemical Division of *Sylvania Electric Products Inc.*, Towanda, Pa., has announced two groups of fluorescent powders for the development of color television picture tubes.

The two groups of TV color phosphors, which are now available in engineering sample quantities, include sulphide and oxide types in the three basic TV colors: red, green, and blue. The oxide powders are of relatively fine texture while the sulphides are of about the same particle size as those now used in standard black and white picture tubes.

The color TV phosphors now being supplied by *Sylvania* are being made available to stimulate exploration of

various types of screen material pending standardization of TV color techniques by the radio-television industry. As soon as these industry standards are established, *Sylvania* plans to have color TV phosphors available in commercial quantities.

100-KV ELECTRON MICROSCOPE

At the recent annual meeting of the Electron Microscope Society of America held in Detroit, *RCA* engineers described a new high-resolution electron microscope for the study of structural details of relatively thick specimens of biological and plant tissues.

A detailed description of the new 100-kv microscope was presented to the society in a paper co-authored by Dr. Reisner, Dr. Robert G. Picard, and Edmund G. Dornfeld. According to Dr. Reisner, the new instrument makes possible useful direct magnifications of 1000 to 20,000 diameters and is greatly simplified for easier operation and maintenance. Also disclosed at the meeting was a high-voltage d.c. power supply for the new electron microscope.

NEW LITERATURE

Booklets on Electronics

International Business Machines Corp., 590 Madison Avenue, New York 22, N. Y., is offering two recent publications on electronics.

"Electrons at Work" describes briefly the operation to the electronic tube and its application to electronic calculators and business machines.

"Fundamentals of Electronic Calculation" discusses commercial and technical application of *IBM's* electronic calculating machines, and describes some of the work of the *IBM* Technical Computing Bureau.

Both of these booklets may be obtained free of charge by writing to *International Business Machines Corp.*

Radiant Glass Panels

Corning Glass Works, Corning, New York, now has available a folder describing the new Pyrex brand E-C Radiant Glass Panels for use as a heat source for industrial application.

Essentially, these panels consist of Pyrex brand heat-resisting glass plates with a fired-on electrically conducting coating on the surface.

The size and shape of the glass may be varied as required, and the electrical resistance of the coating can be controlled for various voltages and powers. The heating panel element is mounted in a suitable frame with insulation and connections, and is ready for operation simply by connecting to a source of power.

The folder, available from the Tech-

nical Products Division of *Corning Glass Works*, gives engineering properties, sizes, ratings, prices, and typical applications.

Subject Index

A subject index to technological documents issued in Volume XI of the *Bibliography of Scientific and Industrial Reports* is now available from the Office of Technical Services, U. S. Department of Commerce, Washington 25, D. C., at \$1.00 a copy.

This new index enables researchers to locate reports on any subject carried by the *Bibliography* in the period January-June 1949. The index to Volume X may also be purchased at \$1.00, and checks or money orders should be made payable to the Treasurer of the U. S.

The *Bibliography*, now issued monthly, lists additions to the collection of foreign and domestic technical reports, and information on the contents of the collection in any particular field may be secured upon request.

Casting Resin

A circular recently published by the National Bureau of Standards describes methods used in determining the necessary properties of a special casting resin developed by NBS to improve the stability of electronic circuits.

Many resins tested by NBS failed to meet the requirements of low viscosity, low coefficient of expansion, low dielectric constant and power factor, and high leakage resistance. This circular describes test procedures and results, and presents illustrations of apparatus used in the preparation of this resin. Formulae and preparation techniques are also given.

Circular 493, Development of the National Bureau of Standards Casting Resin, is available from the Superintendent of Documents, U. S. Government Printing Office, Washington 25, D. C., for 10c a copy.

Exhibiting and Controlling Instruments

A complete 28-page illustrated catalog describing new developments in exhibiting and controlling flow instruments for all industries has been published by *Fischer & Porter Company*.

The basic *Fischer & Porter* devices for coupling a primary metering element to a secondary or exhibiting instrument are discussed in this catalog along with the "Magnabond" magnetic clutch and the electric impedance bridge transmitting systems.

Copies of Catalog 50 may be obtained by writing the company at 50 County Line Road, Hatboro, Pa.

Coil-Proved
SQUARE, ROUND OR RECTANGULAR
LARGE OR SMALL

PARAMOUNT
Spiral-Wound
PAPER TUBES

Lengths from 1/2" to 30"
Inside Perimeters, .450" to 25"

PARAMOUNT Paper Tubes facilitate coil winding—insure coil accuracy and stability. Proved by use, they have become standard with leading manufacturers of electrical, radio and electronic products. Here you are sure to obtain the exact size and shape you need for coil forms and other uses... from stock arbors, or specially engineered to your specifications. *Hi-Dielectric. Hi-Strength. Kraft, Fish Paper, Red Rope*, or any combination, wound on automatic machines. Tolerances plus or minus .002" • Also Shellac Bonded Kraft Paper Tubes for absolute moisture resistance.

WRITE ON COMPANY
LETTERHEAD FOR
STOCK ARBOR LIST
OF OVER 1000 SIZES

PARAMOUNT PAPER TUBE CORP.
613 LAFAYETTE ST., FORT WAYNE, IND.
Manufacturers of Paper Tubing for the Electrical Industry

NEW TUBES

IMPROVED PHOTOTUBE

The RCA 5819 head-on multiplier phototube introduced about a year ago is now nearly five times as sensitive as



the original tube, according to an announcement by the RCA Tube Department, Harrison, N. J.

In addition to greatly increased sensitivity, the improved 5819 features greater cathode-collection efficiency, high current amplification, shorter over-all length, and other design improvements. The spectral response of this tube covers the range from 3000 to 6400 angstroms.

Designed for scintillation-counter work, the 5819 utilizes a "head-on" construction with a photo-cathode measuring 1½ inches in diameter on the inner glass surface of the face end of the tube.

GEIGER COUNTER TUBE

The Raytheon Manufacturing Co., Newton, Mass., is now using a colloidal graphite dispersion as a coating on the outside of their CK1026 radiation counter tubes. This durable coating on the outside of the tube performs the function of a mechanical contact, per-



mitting a clip to be snapped on the tube without danger of scratching the surface when forced on or off.

Manufactured by the Acheson Colloids Corporation, this colloidal graphite coating known as "drag" dispersion #154 was selected because it is chemically inert, electrically conductive, opaque, and because it adheres tenaciously to any glass surface despite surface scratching.

The CK1026 has the features of all glass construction, self quenchability, 800-950 volt operation, long life halogen atmosphere, and the ability to operate in a wide temperature range.

DOUBLE TRIODE

A double triode receiving type tube for wide angle vertical deflection in large TV picture tubes which will handle the entire vertical deflection system has recently been developed by the Radio Tube Division of Sylvania Electric Products Inc., Emporium, Pa.

Designed to meet demand by TV set designers and manufacturers for specific tube characteristics with ample out-



puts for vertical deflection in the largest TV picture tubes now available, the 6BL7GT includes two identical triode sections, each providing high gain, high plate current, and low plate resistance.

Features of the 6BL7GT also make it particularly well-suited for cathode follower applications. Used as a line amplifier each triode section will provide a good five volt signal in 75 ohm coaxial cables.

RCA TUBES

Picture Tube

Among the many new tubes announced by the Tube Department of RCA, Harrison, New Jersey, is the 19AP4-B directly viewed picture tube of the metal-cone type for use in TV receivers.

The 19AP4-B has a high-efficiency, white fluorescent screen on a face made of frosted Filterglass to provide increased contrast and reduced specular reflection. This tube has a deflection angle of approximately 66°, large screen area in relation to tube diameter, an ion-trap gun which requires only a

single-field, external magnet, and a small-shell duodecal 5-pin base.

Except for its frosted face, the



19AP4-B is identical with and directly interchangeable with the 19AP4-A.

Super-Power Beam Triode

Unique in design, the RCA-5831 super-power beam triode features a symmetrical array of unit electron-optical systems embodying a mechanical structure which permits close spacing and accurate alignment of the electrodes to a degree unusual in high-power tubes.

It is primarily of importance in high-power c.w. applications and in international broadcasting service. In unmodulated class C service, the 5831 has a maximum plate voltage rating of 16,000 volts, a maximum plate input of 650 kilowatts, and a maximum plate dissipation of 150 kilowatts.

Magnetron

The 2J50 now available from RCA is a magnetron of the internal-resonant circuit type intended for pulsed oscillator service, such as radar, at a fixed frequency of 8825 megacycles per second. This tube has a maximum peak power input rating of 260 kilowatts.

When operated with a peak anode voltage of 12,000 volts, the 2J50 is capable of giving a peak power output



of 45 kilowatts at a duty factor of 0.001. The output circuit of the 2J50 consists of a loop joined to a coaxial line feeding into a matched junction to a waveguide terminated in a standard waveguide coupler.

The wave guide flange and the mounting flange are made so as to permit use of the 2J50 in applications in which a pressure seal is required.

Image Orthicon

RCA has also announced a new television camera tube RCA-5826 intended for studio use and other television applications where the lighting can be controlled. Utilizing a photocathode which has the same spectral response as the companion outdoor pickup type RCA-5820, this new studio camera tube permits portrayal of colors in nearly their true tonal gradation.



Because of its features, the 5826 can be substituted for the earlier studio type 5655. Requiring a minimum light level of only $\frac{1}{4}$ of that required by the 5655, the 5826 makes it possible to reduce substantially the amount of illumination and correspondingly the air conditioning needed in the studio.

Phase Sensitive

(Continued from page 6A)

The bridge frequency would lower the harmonic content in the amplified signal to a considerable extent.

Depending upon application, the strain gauge bridge signal may be of low value, in the order of microvolts. For this reason a low noise, non-microphonic tube was selected for the first amplifier. Although the 1603 is not a late model tube its characteristics are better than many later high g_m television tubes which characteristically have high hum levels. The use of a selected triode, 7A4, 6J5 is also suitable.

The rest of the amplifier is pretty well straightforward in design, including the incorporation of a Wien bridge network in the feedback loop to lower the amplifier gain at any but the carrier frequency. The feedback lead must be on the right side of the output transformer or degeneration instead of amplification at the signal frequency will occur. This feature causes the amplifier to reject harmonics and stray hum pickup etc.

The output transformer, a *Thermadore* SQ 30, has a primary impedance of 15,000 ohms plate to plate, and a secondary of 500 ohms center tapped. The exact characteristics of this transformer will vary with the output tubes selected, and with the galvanometer load impedance. Due to the stepdown output transformer, little power is re-

quired from the output tubes to produce the few milliamperes of galvanometer current. The bridge power supply conversely requires high output for supplying numerous power consuming bridge circuits.

The galvanometer output may contain oscillator supply fundamental frequency components due to inadequate dynamic and static balancing of the ring demodulator rectifiers. Where visual observation of a meter is the only requirement, this is of no importance. For oscillographic observation, this hash may make reading of the oscillograph record unnecessarily hard. This ripple or hash component may be reduced considerably by the aid of a series tuned filter, of high Q , across the galvanometer. The d. c. resistance of the filter must be much lower than the galvanometer resistance or the filtering action may be inadequate. As condensers of high capacity are generally fixed and an optimum match might be difficult to obtain with fixed values of capacitance and inductance, a variable UTC VI-C13 inductor is used in the filter circuit. The filter inductance may be changed with an Allen wrench and adjustment made to peak the filter while viewing the oscilloscope scan.

The amplifier gain is sufficient to give satisfactory recordings of 1×10^{-5} strain,

better or worse depending upon the associated oscillograph and galvanometers.

REFERENCES

1. Henney, Keith, "Radio Engineering Handbook," McGraw-Hill Book Co.
2. Terman, Frederick E., "Radio Engineers Handbook," McGraw-Hill Book Co.
3. A.I.E.E. Vol. 58, June 1939.
4. Kaufman, Alvin B., "Oscillographic Strain Gauge Recording," RADIO-ELECTRONIC ENGINEERING, Sept. 1950.
5. Kaufman, Alvin B., "Stress & Strain Determination," RADIO-ELECTRONIC ENGINEERING, Nov. 1950.

Attenuation & SWR

(Continued from page 7A)

characteristic impedance Z_0 , length l , and propagation constant $\gamma = \alpha + j\beta$ as:

$$Z_{in} = Z_0 \tanh \gamma l = Z_0 \tanh (\alpha l + j\beta l) \quad (1)$$

$$\frac{Z_{in}}{Z_0} = \tanh (\alpha l + j\beta l) = \frac{\sinh (\alpha l + j\beta l)}{\cosh (\alpha l + j\beta l)} \quad (2)$$

By substituting the proper hyperbolic identities in this equation and then reducing to separate the real and imaginary parts, the following results:

$$\frac{Z_{in}}{Z_0} = \frac{\sinh \alpha l \cosh \alpha l + j \cos \beta l \sin \beta l}{\cosh^2 \alpha l \cos^2 \beta l + \sinh^2 \alpha l \sin^2 \beta l} \quad (3)$$

From this equation it is found that

PRECISION PAPER TUBES are best for COILS...

ANY
SIZE
ANY
SHAPE
ANY
LENGTH

Round
Oval
Square
Rectangular

- No coil forming after winding
- Wire saved by closer engineering of coil
- Automatic stacking
- No side bow

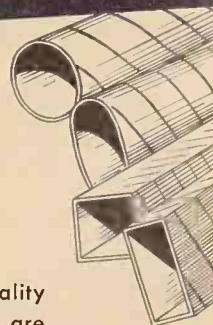

Precision gives you plus quality at no extra cost. Coil bases are formed under heat and pressure... result, a coil base weighing less... greater strength... more thorough insulation... more effective resistance to moisture and heat. All at minimum cost. Any coil is a better coil if it has a Precision base. Precision Di-formed Paper Tubes made to your special specifications of finest dielectric kraft, fish paper, cellulose acetate or combinations.

Write for Free Sample and Complete Mandrel List of Over 1,000 Sizes, Today!

PRECISION PAPER TUBE CO.

2063 W. Charleston St.,
Chicago 47, Ill.

Plant No. Two, 79 Chapel St., Hartford, Conn.

when $\beta l = 0 + n\pi$ the imaginary term is zero and the real term is a minimum. Thus, when $\beta = n\pi$:

$$\frac{Z_o}{R_{min}} = \frac{\cosh \alpha l}{\sinh \alpha l} = \coth \alpha l \quad (4)$$

where R_{min} is the minimum value of the real component of the input impedance. Also when $\beta l = \pi/2 + n\pi$ the imaginary part is again found to be zero and the real part is now a maximum, and:

$$\frac{R_{max}}{Z_o} = \frac{\cosh \alpha l}{\sinh \alpha l} = \coth \alpha l \quad (5)$$

where R_{max} is the maximum value of the real component of the input impedance. From (4) and (5):

$$\left(\frac{R_{max}}{R_{min}}\right)^{1/2} = \coth \alpha l = \text{VSWR} \quad (6)$$

To prove that $(R_{max}/R_{min})^{1/2} = \text{VSWR}$, equate the power at the two points, assuming the power loss between them to be negligible:

$$(\text{VSWR})^2 = \frac{E^2_{max}}{E^2_{min}} = \frac{E^2_{max}}{E^2_{min}} \times \frac{E^2_{min}/R_{min}}{E^2_{max}/R_{max}} = \frac{R_{max}}{R_{min}} \quad (7)$$

Equation (6) should be carried one step more in order to put it into the terms from which Fig. 1 is plotted:

$$\text{VSWR} = \coth \alpha l = \coth (0.115A) \quad (8)$$

where A is the transmission line attenuation when flat in decibels. The term αl is in nepers.

To derive an equation expressing the curves of Fig. 2, a good starting point is Eq. 86 on page 175 of *Communication Engineering* by W. L. Everitt:

$$W_i = \text{Power input} = E_R I_R \left[\cosh 2\alpha l + \left(\frac{R_R}{R_o} + \frac{R_o}{R_R} \right) \frac{1}{2} \sinh 2\alpha l \right] \quad (9)$$

In this equation a resistive load end impedance R_R is used and the load end VSWR is:

$$\text{Load end VSWR} = \frac{R_R}{R_o} = S_1 \quad (10)$$

where $R_o = Z_o$, the characteristic impedance, $E_R I_R$ is the power delivered to the load. Thus the actual line attenuation in decibels is:

$$A_2 = 10 \log_{10} \frac{W_i}{E_R I_R} = 10 \log_{10} \left[\cosh 2\alpha l + \frac{1}{2} \left(S_1 + \frac{1}{S_1} \right) \sinh 2\alpha l \right] = 10 \log_{10} \left[\cosh 0.23A_1 + \frac{1}{2} \left(S_1 + \frac{1}{S_1} \right) \sinh 0.23A_1 \right] \quad (11)$$

Thus an expression is obtained for the actual attenuation in decibels in terms of the load end VSWR and the characteristic attenuation, A_1 , of the line. The curves of Fig. 2 are obtained by substituting values in this equation.

TECHNICAL BOOKS

"RADIO COMMUNICATION AT ULTRA HIGH FREQUENCY"

by John Thomson, Prof. of Physics and Electrical Engineering in the Royal Naval College, Greenwich, England. Published by *John Wiley & Sons, Inc.*, 440 Fourth Ave., New York 16, N. Y. 203 pages. \$4.50.

In the past few years, ultra-high frequency research has been generally in the field of detection and location of targets for war use. As a result, little has been published on corresponding advances which have taken place in radio communications.

This is a concise and well-illustrated treatment of both theoretical and practical matters which points the way toward possible great improvements in u.h.f. communications. The book is largely written from the war and post-war work of the author and his recent colleagues in the Royal Naval Scientific Service. Recent discoveries are thoroughly treated, stressing advances that can be adapted to radio use.

Future devices and systems may be anticipated by the many ideas presented which are still in the developmental stage.

"TRANSMISSION LINES AND NETWORKS"

by Walter C. Johnson. Published by *The McGraw-Hill Book Company*, 330 W. 42nd St., New York, 18, N. Y. 361 pages. \$5.00.

The author has presented in this book a unified treatment of the theory of transmission lines and four-terminal networks, with applications to both the power and the communication field.

Part I covers transmission lines in a general way and is applicable to both power and communications. Part II covers the general theory of four-terminal networks and applies this theory to attenuators, impedance-matching networks, and filters.

Recent advances, such as modern transmission-line charts and their use for both lossy and lossless lines, and microwave lines including measurements and impedance matching are also presented. A wide selection of both theoretical and practical problems together with a large number of numerical examples is contained in the text.

The presentation from basic material to the special considerations of various frequency ranges makes this book suitable for both power and communications engineers and the student who has studied calculus and elementary a.c. circuit theory.

New Products

(Continued from page 23A)

a remote indicator. They can be arranged in banks to provide any desired total count capacity and units are interchangeable without adjustment.

STRAIN RECORDER

A strip chart strain recorder for continuous measurement of surface strain in structures or machines by means of SR-4 resistance wire strain gauges is announced by *The Baldwin Locomotive Works*, Philadelphia, Pa.

The recorder is an electronic type instrument designed and calibrated for use with two SR-4 gauges having a resistance of 120 ± 1.2 ohms and a sensitivity factor between 1.9 and 2.2. Avail-

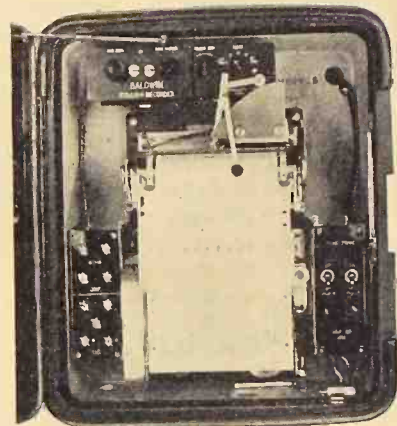

able ranges in the instrument are 0-2000, 0-5000, and 0-10,000 microinches per inch. It provides ten chart speeds within a range of $\frac{1}{4}$ inch to 720 inches per hour or 12 inches per minute. Instruments are available with full scale traverse speeds of one, three or five seconds without overshoot.

This instrument is the counterpart of the Baldwin SR-4 Disc Chart Strain Recorder and is provided with controls and simple adjustments for gauge factor, range, and coarse and fine zero settings grouped across the top of the instrument inside the door. Precision measurement of gauge resistance variations is made by a 1000 c.p.s. bridge circuit. Electronic parts of the instrument are mounted on the back of the case, protected by a gasketed cover.

TIMER

Berkshire Laboratories, P. O. Box 70D, Concord, Mass., has announced its new Model 1-U Labmarker which permits the use of either positive or negative pulses, or both at once.

The Labmarker is a wave-shaping device for producing timing marks in cathode-ray oscillography and has a pulse duration of one-third of a cycle. Pulse amplitude is one-half of the r.m.s. input voltage; and frequency range, 2

cycles to one megacycle. The oscillograms show the output waveforms of the Model 1-U and a record timed with the instrument.

It is a compact, self-contained unit

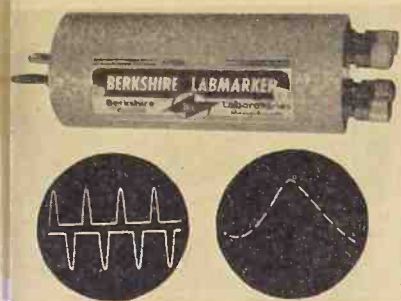

and may be plugged into the terminals of a suitable oscillator. No other power source is required.

TIMING MOTORS

A new line of standardized a.c. timing motors of the synchronous hysteresis type has been announced by the A. W. Dayton Company of Waterbury, Connecticut.

Outstanding features of these timing motors are the high starting and running torque, and extremely quiet operation. They run at full synchronous speed over a wide range despite variations as great as 25% in line voltage. There is also a considerable range of speeds and current ratings.

Motors fitting standard specifications

ERRATUM:

There was an error in Fig. 2, P. 8A of the November issue in the article titled "An Improved Audio Amplifier." The wiring between the cathode of the first 12AX7 and the 4-position switch should be as shown below:

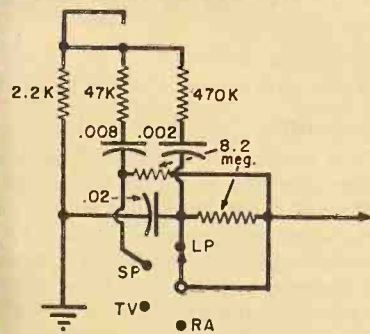

PHOTO CREDITS

- Pages
 3A..... Baldwin Southwark Div.
 5A..... The Sanborn Co.
 8A, 9A..... C. G. Conn, Ltd.
 10A..... Westinghouse Elec.
 15A, 17A.. Federal Telecommunication Labs.

are available immediately from stock, or complete timers incorporating these motors can be especially designed and supplied for volume requirements.

DUO-CONE SPEAKER

A 15-inch Duo-Cone Speaker designed especially for use in high-quality reproducing systems at both high and low power levels has been announced by the Tube Department of RCA at Harrison, N. J.

Designated Type 515S2, this speaker features high sensitivity over a useful range of 40 to 12,000 c.p.s., and has a power-handling capability of 25 watts of audio power.

The unique vibrating system and magnet structure utilized in the 515S2 consist of a duo-cone, and two voice coils operating in two separate air gaps excited by a single, 2-pound Alnico V magnet. The duo-cone is constructed with large "woofer" cone and small "tweeter" cone each so mounted in its individual housing that the large cone is effectively a continuation of the small

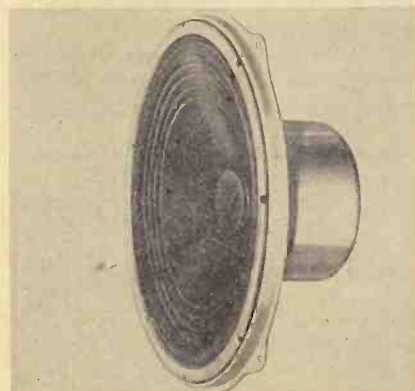

cone. The large cone is driven by a 2-inch voice coil to produce the low frequencies, and the small cone is driven by a 3/4-inch voice coil to produce the high frequencies.

CATHODE-RAY OSCILLOSCOPE

Television Equipment Corp., 238 William St., New York 7, N. Y., is announcing Model T-601-A cathode-ray oscilloscope which has been designed for laboratory engineering use.

Among the many features of this new model are: 17 tubes including 5" CRT, 10 millivolt sensitivity, 12 meg. bandwidth, deflection plates available on terminal board, continuously variable calibrator, sweep magnification 5 times screen size, good transient response, and CRT calibration grid.

A specification data sheet may be obtained by writing the company.

FLOW COUNTER

Tracerlab, Inc., 130 High St., Boston 10, Mass., has just announced the completion of the first production run of SC-16 Windowless Flow Counters.

This instrument is a low background radiation counter designed for operation in either the Geiger or proportional regions. It is essentially a shielded



counter tube into which solid samples are inserted directly, and through which a constant gas flow is maintained to prevent air contamination.

A unique feature of this instrument is that it is equipped with a three position rotating platform which has three recesses for holding standard size sample containers such as planchets and brass rings and discs for filter paper. One position is for sample loading, one for pre-flushing, and the third for counting.

Greatest PORTABLE of them all!

REVOLUTIONARY MODEL 400

Weight approx. 62 lbs.

AMPEX
MAGNETIC TAPE RECORDER
15,000 cps · 7 1/2 inches per second
HALF TRACK!

- Extended range 15,000 cycle half-track recording at 7 1/2 inches per second.
- Incredible performance that equals or exceeds most full-track 15 i.p.s. recorders.
- Saves 75% on tape by combining 132 min. of recording on a single 2408-ft. N.A.B. reel.
- Can be furnished with Single Track Heads.

Write for Complete Specifications and Control Arrangement

AMPEX ELECTRIC CORPORATION
 San Carlos, California

STANDARD OF THE GREAT RADIO SHOWS

Spectroscopy

(Continued from page 11A)

the 12AY7 and thus a better noise figure for the same circuit components. However, when several 12AT7's were compared with several 12AY7's using the same input circuits the results showed the 12AY7 tubes to be superior (Fig. 5). Finally, the 12AY7 tube was tried in a cathode coupled circuit and found to be slightly inferior to the cascode circuit, as might be expected.

Fig. 3 shows two versions of the cascode circuit which were found to give almost identical results as far as noise figure vs. generator impedance is concerned.

With the cascode circuit and the 12AY7 preamplifier tube incorporated in the Stark-modulation system, the 23,534.71 mc. line of O¹⁷C¹⁸S³² gas which has an absorption coefficient of $2.0 \times 10^{-8} \text{ cm}^{-1}$, in its natural isotopic abundance, was seen to be about 2½ times noise. The sweep rate was 2 c.p.s. and the bandpass was set at 50 cycles. Selection of detecting crystals (1N26) is still necessary but the difference between crystals is not as great as it was. Also the magnitude of the microwave power is no longer critical in adjustment.

The method we have used for accurately measuring frequencies in the microwave region is very similar to one used at lower frequencies. This consists of generating a series of equally spaced harmonics and then interpolating between them with a calibrated communications receiver. At lower frequencies a multivibrator driven by a crystal controlled oscillator can be used to generate a series of harmonic frequency markers with a base frequency of, say, one megacycle. In the microwave region a base spacing of 500 mc. has been found convenient. A silicon (1N26) crystal detector makes an excellent harmonic generator when driven with a source of 500 mc. power. If this source of energy is exactly 500 mc., then the generated harmonics form a series of accurate low power frequency markers throughout the microwave region. If this harmonic generating crystal is

Fig. 4. Noise figure vs. generator impedance for three types of inputs at 85 kc. A diode noise source was used.

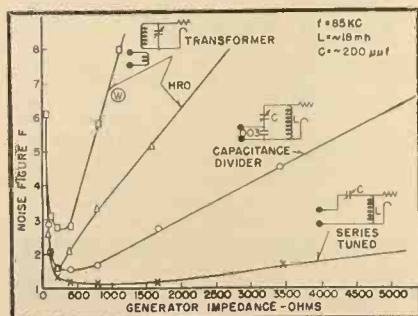

placed in the wave guide and the microwave power from a klystron is allowed to mix in this same crystal, a beat note will occur between the markers and the klystron signal. If a communications receiver is connected to the crystal and tuned to say 20 mc., the receiver will indicate a signal at plus and minus 20 mc. from each 500 mc., marker as the klystron is tuned over its frequency range. If the receiver is tuned from 0 to 250 mc. it is easy to see that the region between any two markers can be completely covered and we have a system for measuring any frequency in the microwave region. This is true if we can identify which 500 mc. marker is being used. Fortunately this rough measurement for identifying the marker can be done with a cavity type wavemeter or in some cases, with known microwave absorption lines. If extreme accuracy is desired ($\pm 20 \text{ kc.}$), it is convenient to use an interpolating receiver that is well calibrated ($\pm 20 \text{ kc.}$). This is not usually possible with a receiver that will tune as high as 250 mc. but it is possible with one that tunes to say 25 or 30 mc.

In order to have complete frequency coverage and still use a 0-30 mc. receiver, we have introduced still another

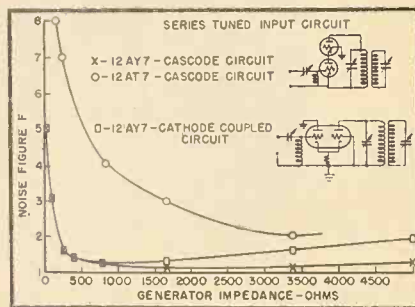

Fig. 5. Noise figure vs. generator impedance for various tubes and circuits at 85 kc.

signal into the harmonic generating crystal. It has been found that if a 50 mc. signal of a volt or so amplitude is applied to the harmonic generating crystal that not only $\pm 50 \text{ mc.}$ sidebands are formed on each 500 mc. harmonic but also side bands at $\pm 100 \text{ mc.}$, $\pm 150 \text{ mc.}$, $\pm 200 \text{ mc.}$, $\pm 250 \text{ mc.}$, etc. This gives a complete set of standard frequency markers spaced every 50 mc. throughout the microwave region and now permits complete coverage using an interpolation receiver with a tuning range of 0 - 25 mc. We have used *Hallcrafters* and *Hammarlund* receivers for this purpose. We are now using the new *Collins* 51-J receiver which is ideally suited for this task because of the extreme accuracy ($\pm 2 \text{ kc.}$) of its own calibrated dial.

The microwave spectrograph de-

scribed in this paper is the result of the combined efforts of Dr. D. K. Coles, Dr. R. H. Hughes and the author. I wish to acknowledge the able assistance of Mr. A. Hartwick who has done all of the electronic construction for this instrument. The photograph was taken by Mr. Don Glasser.

REFERENCES

1. Coles, Donald K., "Microwave Spectroscopy, Advances in Electronics," Vol. 11, 1950. Academic Press Inc.
2. McAfee, Jr., K. B., Hughes, R. H., and Wilson, Jr., E. Bright, "The Review of Scientific Instruments," Vol. 20, No. 11 821-826, Nov. 1949.
3. Sharbaugh, Harry A., "The Design and Construction of a Stark-Modulated Microwave Spectrograph." The Review of Scientific Instruments, Vol. 21, No. 2, 120-135, February 1950.
4. Torrey, H. C., and Whitmer, C. A., "Crystal Rectifiers," Vol. 15, Fig. 11.1, page 334. Radiation Laboratory Series First Edition, McGraw-Hill Book Co.
5. Sulzer, P. G., "Noise Figures for Receiver Input Circuits," Tele-Tech, page 40, May 1949.
6. Goldberg, H., and Crosby, Jr., E. L., "Series Mode Quartz Crystal Oscillating Circuit." Proc. of the National Electronics Conference, 1947, Vol. 3, page 240.

Pulse Code Mod.

(Continued from page 14A)

preceding the quantizer to cause a change in signal amplitude equal to one level. For example, the unmodulated height of a pulse which is to be quantized is usually adjusted to be midway between levels. Referring to Fig. 3, the pulse height might be set to be midway between level 7 and level 8. A change in height of one-half step is then required before a change in code is registered. However, if the unmodulated pulse height were just below level 8, any infinitesimal signal, such as might be caused by hum, noise or crosstalk in preceding circuits, would cause a change of one level. If K is considered to be the ratio of the output signal of a fully modulated channel to the output produced by such an extraneous disturbance, then, in the most pessimistic case, the terminal signal-to-noise ratio is:

$$K = L \dots \dots \dots (6)$$

For a 64 level system, K would be 36 db.

Bandwidth

It is possible to transmit a train of pulses occurring at a rate $2f_c$, through a filter of cutoff frequency f_c , if adjacent pulses are allowed to overlap. This may be shown by means of Fig. 6, which illustrates the shape of a pulse which has been sent through an ideal low pass filter. A similar pulse whose maximum amplitude occurs at a time $T = 1/2f_c$ may be superimposed on the first pulse as represented by the dotted line. It will be seen that the maximum of one pulse coincides with the zero of the other. There is no interaction between the two pulses at times T_0 and $T = 1/2f_c$. If the two pulses are time sampled at these times, they may be separated

without confusion. The time delay between these two pulses is $\frac{1}{2}f_0$, which is equal to the width of the input pulse. If this interval of time is defined as a *baud*, the baud-rate may be considered to be $2f_0$.

Since in PCM it is only necessary to recognize the presence or absence of a pulse, the distortion of the pulse shape is not important. In practice, a low-pass filter is placed at the output of the pulse transmitter to restrict the transmitted bandwidth. If this filter is designed to have a transmission characteristic of Gaussian error form, the pulses will have no overshoot.

The total baud rate at the filter input will be the product of the sampling pulse rate, the number of code pulses, and N , the number of channels:

$$\text{Bandwidth} = 0.5(2.5f_0 n N) = 1.25f_0 n N \quad (7)$$

A 24 channel system, utilizing 64 levels and an 8 kc. sampling rate, would have an output video bandwidth of only 576 kc., which is considerably smaller than that of other pulse transmission systems of similar channel capacity.

Signal-to-Noise Ratio

The eventual limitation of the sensitivity of any system of transmitting intelligence is the thermal agitation noise present at the input stage of the receiver. In determining the effect of such noise on PCM, it is assumed that a positive noise burst will be registered as a false pulse, where no pulse should be present. Similarly, a negative noise burst will remove a pulse, where a pulse should be present. Based on this assumption, and a knowledge of the statistical nature of noise (the likelihood that a noise burst will exceed a given voltage threshold), it has been shown that, assuming f_0 has been defined as above:

$$S/N_0 \text{ (db.)} \approx 2.2 S/N_1 \text{ (power)} \quad (8)$$

where S/N_0 is the output signal to noise ratio in db.

S/N_1 = input signal to noise ratio in power. Eq. (8) has been plotted in Fig. 7.

It is important to note that, unlike other systems, the output S/N in db. is proportional to the input S/N in power. Fig. 7 shows that a relatively small increase in input S/N results in a large improvement in output S/N . For an input signal-to-noise ratio of only 15 db., an output S/N ratio of 68 db. is obtainable. If this input ratio were increased to 23 db., the output noise would be that caused by an error in decoding occurring only once every three months!

The effect on signal-to-noise of cascading a number of repeater stations has been shown in Fig. 5. With

"straight" non-regenerative repeaters;

$$S/N_0 \approx \frac{2.2}{M} S/N_1 \quad (9)$$

where M is the number of repeaters.

By use of regenerative repeaters, a vast improvement results, as shown in the lower curve. In this case:

$$S/N_0 = 2.2 (S/N_1) - 10 \log M \quad (10)$$

It is assumed that the gain in each repeater is just sufficient to overcome the loss in the preceding transmission path. The significance of (10) is that only a slight (2db.) increase in input signal-to-noise ratio is required to extend the chain of repeaters to 50. Since the curve levels off, it is seen that there is no theoretical limit to the number of repeaters which may be used. As suggested earlier, the signal can, in fact, be completely regenerated. Tests of a working system have shown that there is no way of determining, by ear or by measurement, whether the signal is being transmitted by direct wire or by radio.

The preceding discussion indicates that the same performance may be expected in discriminating against other small signals, such as crosstalk from other channels. Far more crosstalk can be tolerated, since the only requirement is recognition of the presence or absence of a pulse. With regenerative repeaters, the entire system capability for crosstalk may be the same as that of each repeater "hop", since such crosstalk will be non-cumulative.

Compression and Expansion

It has been pointed out that the quantization distortion is roughly inversely proportional to the number of levels. If the modulating signal is a complex signal (such as speech), with a high peak to average ratio, during a large portion of time, the signal voltage will vary over a relatively small number of levels. When the percentage of modulation is low, distortion will be considerable, since this is equivalent to using a system with only a few levels.

It is therefore customary to quantize in a nonlinear manner, with the steps spaced closer together near the zero axis, as shown in Fig. 9. The ratio of signal amplitude to the number of steps is maintained approximately constant, regardless of percentage of modulation, thus reducing the distortion which would otherwise be present. This is done by use of a compressor, a device which has a large gain for small signals and a small gain for large signals. If this compressor precedes the quantizer, a small signal will swing over a larger number of steps than if the compressor were not present.

At the receiver, an expander, having the inverse characteristic, must be used

to restore the original dynamic range of the system. Such an expander would have a small gain for small signals and a large gain for large signals. An additional advantage is obtained in that discrimination against small extraneous signals results. Thus an improvement in signal-to-noise and crosstalk ratios is obtained, as long as such spurious signals are generated between compressor and expander. The signal-to-noise ratio at the terminals, usually the limiting factor (36 db. in a 64 level system), is improved to the same degree as the compression. For example, with 26 db. compression, this ratio would become 62 db.

BIBLIOGRAPHY

1. Oliver, B. M., Pierce, J. R. and Shannon, C. E. "The Philosophy of PCM", *Proc. IRE*, v. 36, pp. 1324-1331, Nov., 1948.
2. Deloraine, E. M. and Labin, E. "Pulse Time Modulation", *Electrical Communication*, v. 22, n. 2, pp. 91-98, 1944.
3. Clavier, A. G., Panter, P. F. and Dite, W. "Signal-to-Noise Improvement in a Pulse Count Modulation System", *Electrical Communication*, v. 26, n. 3, pp. 257-262, Sept., 1949.
4. Clavier, A. G., Panter, P. F. and Dite, W. "PCM Distortion Analysis", *Electrical Engineering*, v. 66, n. 11, pp. 1110-1122, Nov., 1947.
5. Goodall, W. M. "Telephony by Pulse Code Modulation", *BSTJ*, vol. XXVI, n. 3, pp. 395-409, July, 1947.
6. Black, H. S. and Edson, J. O. "PCM Equipment", *Electrical Engineering*, v. 66, n. 11, pp. 1123-1125, Nov., 1947.
7. Grieg, D. D. "Pulse Count Modulation", *Electrical Communication*, v. 24, n. 3, pp. 287-296, Sept., 1947.
8. Meacham, L. A. and Peterson, E. "An Experimental Multichannel Pulse Code Modulation System of Toll Quality", *BSTJ*, vol. XXVII, n. 1, pp. 1-46, Jan., 1948.
9. Moskowitz, S. and Racker, J. "Pulse Communication", *RADIO-ELECTRONIC ENGINEERING*, v. 11, n. 3, p. 14, Sept., 1948.
10. Knight, A. E. "Elementary Binary Mathematics", *RADIO-ELECTRONIC ENGINEERING*, v. 13, n. 4, p. 7, Oct., 1949.



HAVE YOU A JOB FOR A TRAINED TECHNICIAN?

We have a number of alert young men who have completed intensive training in Radio and Television Repairing. They learned their trades thoroughly by working on actual equipment under personal, expert supervision.

If you need a trained man, we invite you to write for an outline of our course, and for a prospectus of the graduate. No fees, of course. Address:

Placement Manager, Dept. P-106-1
COMMERCIAL TRADES INSTITUTE
 1400 Greenleaf Chicago 26

SPEND YOUR WAY TO \$\$\$ SECURITY!

How you spend what you make is more important than how much you make! How you manage income: control household, personal expenses; organize spending and saving determines degree of your financial peace of mind. The "KWIK-GLANCE" simplified method of keeping track of income and outgo has happily solved money problems for 100,000 users. A year's service in one volume, \$1.25 complete. Write for FREE descriptive folder.

MAY PUBLISHING COMPANY
 537-C So. DEARBORN CHICAGO 8, ILL.

ELECTRONIC EQUIPMENT • PARTS

AN Conn.	COILS	RELAYS	LARGE STOCK
APC's	(R.F. & A.F.)	RESISTORS	OF OTHER ITEMS
BINDING POSTS	CONTROLS	SNOCK MTS.	
CABLE	CRYSTALS	SOCKETS	LET US QUOTE
CAPACITORS	FILTERS	SOLLENOIDS	YOUR NEEDS
CERAMICOM'S	FUSES	SPAGHETTI	
CERAMICS	HARDWARE	SWITCHES	
CHOXES	KNOBS	TRANSFORMERS	WRITE, WIRE
CIR. BKRS	POTENTIOMTRS (servo-pulse)	PHONE	WALKER S 9642
	(line-casting)	IRON-CORE	
		SLUGS	

Universal general corp. 324 CANAL ST. N. Y. C.

MULTI-LAYER COIL CALCULATOR NOMOGRAPH

By S. YAMASITA

A nomograph for determining multi-layer coil inductance on the basis of the H. A. Wheeler inductance equation.

AN EXAMPLE will serve to illustrate the use of this nomograph. Assume a coil of one inch mean diameter ($2a$) and a width and thickness of one-half inch (b and c), wound with 500 turns of no. 27 d.c.c. wire. A line is drawn through the "mean diameter" and "width" scales to the reflect axis, then back to the "mean diameter" scale through the "thickness" scale. A line is then drawn vertically until it intercepts

the curve, and then horizontally to the right-hand side of the graph. From this point, a line is drawn to the proper point on the "mean dia." scale, thus locating a point on the "cross axis." A straight line through this point and the proper point on "total no. of turns" scale locates the inductance. By proper manipulation, the nomograph can assist greatly in designing a coil of a specified inductance.

$$L = \frac{.8 a^2 n^2}{6a+9b+10c} = \text{MH.}$$

