

"A Step On the Stairs" in Story Form

# Radio Digest

EVERY  
WEEK

ILLUSTRATED PROGRAMS

TEN  
CENTS

Vol. XVI No. 11 Copyright 1926 by  
Radio Digest Publishing Co.

Title Reg. U. S.  
Pat. Off. &  
Dom. of Canada

MARCH 20, 1926



*A Study of Hoover as a Real Radio Fan; Fourth Installment of "A Step On the Stairs";  
Ladies Like to Hear KOA's Chat; How to Prepare for and Serve the Company Dinner*

# SOS MYSTERY PLAY MAKES HIT OVER AIR

## "A STEP ON THE STAIRS" IS HIGHLY PRAISED

### Congratulatory Letters and Telegrams Pour Into Radio Digest from Radio Authorities

Letters and telegrams from all sections of the country confirm the opinions expressed by studio directors and Radio entertainment specialists that the Radio mystery story, "A Step On the Stairs," written especially for Radio Digest, came at the psychological moment when a change in the trend of broadcast programs seemed imperative.

The dramatization of the story into Radario form by Fred Smith has supplied the happy medium between the super abundance of jazz and the extremes of the classical.

Here is the telegram from J. Andrew White, king of descriptive announcers in New York:

"'Step On the Stairs' has them all licked Best thing of the kind I've heard. Played straight by listening at home with the lights turned low, so this is not apple-sauce. Heaviest congratulations.—J. Andrew White."

### Shut-Ins Like Play

A shut-in so blind she had to have another writer her letter for her sent this message as typical of the most critical of all kinds of listeners; to the WNAC station at Boston—conservative old Boston:

"I want to send you just a line to tell you how much I enjoyed the first installment of 'A Step On the Stairs.' It is such a relief from the constant jazz and popular songs that are played so much every day they are monotonous. I am a shut-in and nearly blind, so you can understand what the Radio means to me. I wish I might have some more drama and readers as I enjoy them very much. Long live WNAC!"

The letter is signed by Mrs. H. M. Young, 14 Lander street, East Lynn, Mass.

After he had finished the third installment, Fred Smith of Cincinnati, who put in Radario form the story appearing in Radio Digest, came up to Chicago to meet Robert J. Casey, the author. Radio Digest had sought these two men, unknown to each other, but each the best to be found for their respective tasks, to perform this work for the Radio public.

### Is Radio History

"How did you get hold of Casey?" was the first question asked by Mr. Smith on his arrival in Chicago. "He has the rare combination of ability as a fiction writer and a knowledge of Radio technique. He knows how to utilize these faculties and has done so in this very remarkable story."

"This is Radio history," said Mr. Smith later, when, with the editors of Radio Digest, he met Mr. Casey at the Hotel La Salle. The two men set next to each other in the grill where a booth had been reserved. The Chicago man was of medium height, plainly dressed, undistinguished except for a heavy gold signet ring that made his soft, well cared for hands more noticeable. His hair was short and his face confirmed the ancestry of his name, especially when the Celtic blue eyes popped wide open at vivacious moments of the table conversation. On the other hand, Mr. Smith was the artist, precise as a professor, speaking at all times with the perfect English and adhering to form even to the manner with which he held his teacup—he had tea—and crooked his little finger, just so. But a man and a man's man with full appreciation for the red-blooded elements in the story. He wore glasses and the hair was thin above his well developed forehead. The two men, side by side, represented a wide range in a new kind of literature.

"'A Step On the Stairs,' is something that we have been approaching from various angles for several years. It will mark a decided point in the development of Radio art," said Mr. Smith.

### St. Paul Fans Excited

"We had a big crowd in the studio and turned out the lights," wrote E. H. Gammons of Station WCCO, St. Paul-Minneapolis, "and everybody in the place got a great kick out of it."

"The most amusing thing in connection with the broadcast was that hardly had we completed it when telephone calls began to come in complaining that some station, FYX, had come on the air and blanketed us. In fact one St. Paul listener was so excited about it that he didn't get the call letters and accused one of the small 50-watt stations in town of having come on the air, and stated that he was going to take the matter up with the department of commerce. It so happened that the station he had in mind happens to have an 'F' and a 'Y' in its code call."

From the many letters written, it is ob-

## DAINTY MARY BRIAN OUR COVER BEAUTY

THAT perfect oval so ardently desired by the connoisseurs of beauty in the feminine head, genus homo, seems approximately attained by the maiden on the Radio Digest cover this week. She is Miss Mary Brian, another of the famous 1926 Wampas Stars, whose face is often seen in the pictures of the Paramount brand.

You know the story of the lucky thirteen who make the Wampas cast each year. All the great motion picture producing companies on the Pacific coast present their young and most promising hopes to the consideration of the Western Association of Motion Picture Advertisers. There is a vote among the members of the association. The thirteen who stand highest are the Wampas stars for the year. Experience has shown that these chosen ones make good and become real stars of the screen.

Take another look at the picture, that flawless, oval contour, and you will not wonder that she is one of the Wampas Stars of 1926.

vious that the trick of turning out the lights while listening to the drama over the air adds 100 per cent to the thrill. It may not be generally known that a darkened room usually adds to the illusions in Radio. When the Radario especially provides for a darkened room the effect is even more noticeable.

## Mike Starts to Vanish But Mystery Is Solved

### Temporary Disappearance Caused by Man Dragging Connection

NEW YORK.—"Mike, mike, who's got the mike?" was the query of Ralph Wentworth, one of WEA's announcers, recently at a celebration broadcast direct from Carnegie hall, when he suddenly saw the microphone vanishing from him. He was then telling the Radio audience about the parade of the colors which had just taken place.

The temporary disappearance of "mike" was caused by one of the New York friends of Senator Ashurst of Arizona, the orator of the day, rushing forward to greet the senator and not noticing the wire connection to the microphone stretched across the floor. Wentworth managed to clutch "mike" in time to prevent any real break in his descriptions of events for the Radio audience.

## Five Veterans of Civil War Broadcast at Station KOA

DENVER, Colo. — KOA's performers during the last year have ranged in ages from a 4-year-old prodigy—Phillip Cooper, Colorado's youngest Radio artist—to five 80-year-old survivors of the Denver Drum Corps, an organization inspired by the Civil war.

Because of death, the drum corps has been reduced from an original group of fourteen persons to a quintet.

# NEWS BRIEFS FROM THE BROADCASTERS

## KGO TO PICK CHAMPION FIDDLER OF WEST

### KFI Gives Artist-Composer Series— Punch and Judy at WLIB— Gilda Gray at CKAC

Old fiddlers from all over the West will gather around the KGO microphones, Saturday night, March 27, and give the world a taste of the music of a generation ago, which is still calculated to tickle the feet.

KFI is presenting an artist-composer series. One of the recent artists to appear at this station was Alice Barnett. Songs and compositions by this American composer were featured during the entire program. Arrangements are now being made for early programs by Charles Wakefield Cadman, Homer Grunn, Hallette Gilberte, Heinrich Tandler and Carrie Jacobs Bond.

The squeaky voices of Punch and Judy may be heard nightly over the microphone of WLIB, Chicago. Uncle Walt, who is directing the Radio appearances of these well-known puppets, describes them so well that many kiddies throughout the United States enjoy this new bedtime feature.

Gilda Gray, famous Follies dancer, pleased Canadian fans recently when she gave advice to girls on beauty and dancing, over the microphone of CKAC, Montreal. She gave her talk in French.

Sidelights on boxing in Mexico will interest sport fans over WPG, Atlantic City, Saturday. James Monahan, former intercollegiate lightweight champion of Lafayette college, will talk about his recent experience as referee in this interesting neighbor republic.

The novel feature of WBAL's Saudman circle, which goes on the air every Monday and Thursday evening from 6 to 6:30 p. m., Eastern time, is a Radio serial story for children. "The First Days of Man," an historical story written especially for young folks by Frederick Arnold Kummer is the present serial.

"Memories of Jennie Lind and Clara Schumann," is the title of the program to be given by Anna Barbash, soprano, at WPG, Monday evening.

"Winds, Clouds and Rain" is the subject to be discussed for fifteen minutes over KGO, Monday evening, March 22, by Major Edward I. Bowie, weather man for the western part of the United States. Major Bowie will be remembered by KGO listeners for other talks about how the facts concerning the weather are gathered, charted and forecasts made twice daily in the San Francisco office of the Weather bureau.

Community singing on a large scale is being encouraged by WGN, Chicago. Every evening from 6:55 to 7 p. m., Central time popular ballads and well-known tunes are presented by an ensemble of WGN artists. Listeners are invited to join in.

And still they come! Here is another old fiddler, Andy Hidee, who will broadcast from WLW, Cincinnati, Saturday evening, March 20, at 9 p. m. Central time. He places the fiddle between his knees and bows it like a cello. The other member of the team is Walter Harlan, accompanist.

Fans who listened to Bishop Frederick Fisher recently at WBPI, New York, enjoyed some of the thrills of the hunting trip in India of Kermit and Theodore Roosevelt. Bishop Fisher has been in India with the Roosevelts.

Each month will end attractively at WJZ, New York, with a recital by two favorite Radio artists, Godfrey Ludlow, Australian violinist, and Lolita Cabrera Gainsborg, pianist. These Sunday evening concerts will include the sonatas of well-known composers.

S. L. Rothafel, popularly known as "Roxy," to thousands of listeners, bid a temporary farewell to his many Radio friends recently from Station WEA. He will broadcast again next autumn when his new theater opens.

During the first week in March, WOR devoted one-half hour each afternoon to talks by outstanding authors of the day. Martha Ostenso, author of "Wild Geese," Homer Croy, author of "West of the Water Tower," and Charles Hanson Towne, author of "Tinsel" were among the speakers.

# CONTENTS

Radio Digest, Illustrated, Volume XVI, Number 11, published Chicago, Illinois, March 20, 1926. Published weekly by Radio Digest Publishing Co. (Incorporated), 510 N. Dearborn Street, Chicago, Illinois. Subscription rates yearly, Five Dollars; Foreign Postage One Dollar additional; single copies Ten Cents. Entered as second class matter at the post office at Chicago, Illinois, under the Act of March 3, 1879. Title Reg. U. S. Patent Office and Dominion of Canada. Copyright 1926 by Radio Digest Publishing Co. All rights reserved.

All the Live News of Radio.....	1 to 11
Secretary Hoover Is Real DX Fan.....	4
Fair Listeners Love KOA Chats.....	5
"A Step On the Stairs," Radio Digest Prize Story, Fourth Installment, by Robert J. Casey.....	6
An Evening at Home with the Listener In; A Chart in Eastern Time, showing when to listen in for stations.....	10
Women's Page; Index to Women's Programs.....	11
Advance Programs for the Week.....	13 to 21
Editorials, Indi-Gest and Condensed by Dielectric.....	22
A B C Radio Fundamentals for Everybody, Part XI—Radio Receiver Circuits (Continued), by Milo Gurney.....	23
How to Stop Blooming and Man-Made Static, Part VI—Dr. Hull's Amplituner, by the Technical Staff.....	25
1926 Model Four-Filter Super-Heterodyne, Part II—Part Alterations and Drilling, by the Technical Editor.....	27
News from the Radio Clubs.....	29
Reader's View.....	29
Directory of Radiophone Broadcasting Stations, Part I (Revised).....	31

## Looking Ahead

Peleg Turner Speaks from the Tomb and curses the murderer of his brother, Jeremiah, next week in "A Step On the Stairs." Milford Jones reappears, somewhat the worse for his absence. The best part yet of Mr. Casey's serial will make startling disclosures next issue.

"Radio Owes an Incalculable Debt to the American Boy," says Secretary of Commerce Hoover and he has reference to the ingenuity and inventiveness of boys as they, through Boy Scout and Y. M. C. A. organizations, worked out many problems that have puzzled their elders. Radio Digest has an interesting Boy Scout story about ready for release.

Intense Interest Has Been Shown Throughout the Country in the dramatization of the Radio Digest mystery play. Wherever it has been put on the air listeners have reported surprise and delight at the unusual effects produced. At the Gold Medal Station WCCO Minneapolis-St. Paul, the players made up for their parts. See pictures and story in Radio Digest.

Causes and Locating of Man-Made Static will be the subject of the next article in the Blooming and Interference series. The number of electrical devices in common use that cause clicks, hums and rattle in Radio receivers is surprising.

Assembly and Wiring of 1926 Four-Filter Super is taken up in the third article on this receiver which will appear next week. Large as this receiver is, the wiring is comparatively simple, since the audio amplification is all wired when installed and the shielding is the negative filament circuit.

Readers of Milo Gurney's A. B. C. Series will next get a brief discussion of the super-heterodyne receiver from a theoretical viewpoint. The Rolls Royce of Radio is not so complicated as it sounds but a fair knowledge of what is happening in one is most helpful to the constructor.

### Newsstands Don't Always Have One Left

WHEN YOU WANT

# Radio Digest

YOU WANT IT!

BE SURE OF YOUR WEEKLY COPY  
BY SUBSCRIBING NOW

SEND IN THE BLANK TODAY

Publisher Radio Digest,  
510 N. Dearborn St.,  
Chicago, Illinois.

Please find enclosed check M. O. for Five Dollars  
(Six, Foreign) for One Year's Subscription to  
Radio Digest, Illustrated.

Name .....

Address .....

City..... State.....



# TO PICK GREATEST ANNOUNCER

## COMMISSION DESIRE OF ZENITH COUNSEL

### ASSAILS PRESENT KIND OF RADIO ADMINISTRATION

Believes Radio Commission More Equitable Form of Supervision—Organized Labor Also Makes Kick

By L. M. Lamm

WASHINGTON, D. C.—Strenuous demands that congress take the administration of the Radio law out of the hands of the department of commerce and establish a Radio commission were made during the closing hours of the hearings on the Dill Radio bill, which lasted for several days before the senate committee on interstate commerce, of which Senator Watson, of Indiana, is chairman.

Irving Herriott, counsel for Station WJAZ, of the Zenith Radio corporation, and E. F. McDonald, Jr., president of the firm, told the committee that he did not believe that the secretary of commerce should be clothed with his present broad powers for Radio regulation or with those provided for in the Dill and White bills.

He asked that a commission be appointed by the president and that the control of Radio be taken away entirely from the department of commerce.

#### Says Hoover Can Divide Station Time

Mr. Herriott in opening his testimony gave the history of the Zenith station and some of its troubles which terminated in the federal courts in Chicago, and in which it is expected a decision will soon be rendered. He went on record distinctly as in favor of a bill for Radio regulation and seemed to favor the Dill bill except in that he wants a commission instead of the power being delegated to the department of commerce.

He took the position, in answer to questions of the committee that if the secretary of commerce now has the power, under the present law, to assign wave lengths he must also have the power to divide time for the stations. He called the committee's attention to the fact that Radio is still in its infancy but he predicted that the time is not now far distant when power will be transmitted by Radio for various purposes.

#### Labor Would Divest Hoover of Power

The number of stations owned by one firm, said Mr. Herriott, should be limited in the bill under consideration. In contention of his suggestion for the Radio commission he said that it could handle the matters more expeditiously and he thought that a provision should be made in the bill "for a fair division of time for everyone."

W. J. H. Strong, representing the Chicago Federation of Labor, told the committee that the Dill bill is not scientifically drawn and that it is not in the interest of public policy. He made suggestions for almost all of the sections of the bill.

He told the committee that Radio should be declared a public utility and that it should be taken away from the department of commerce and placed under the interstate commerce commission. He said that he does not favor the United States government owning any Radio stations.

## Rochester, N. Y., Giving Programs Over WGY

Former Silent Night of Schenectady Station Now Feature

SCHENECTADY.—Wednesday, heretofore a silent night for WGY, has become one of the biggest nights for the station, and it is sure to gain in popularity with the listeners. That evening is given over, practically entirely, to Rochester, N. Y., and that city has thus far provided three outstanding programs.

The symphony orchestra of the Eastman theater is heard at 6:45 o'clock and this is followed at 8 o'clock by a program by Eastman School of Music pupils, the Little Symphony orchestra, the Rochester Symphony orchestra, or other Rochester talent. The Little Symphony orchestra and the Rochester Symphony orchestra are under the direction of Eugene Goossens. WHAM of Rochester broadcasts all Rochester features simultaneously with WGY.

#### 150,000 Swedish Licenses

WASHINGTON, D. C.—The number of Swedish Radio licenses issued up to the end of February, this year, amounts to about 150,000, according to a report to the department of commerce from Stockholm.

## PASS LAW AGAINST LOUD RADIO NOISES

MOUNT VERNON, N. Y.—There will be no loud noises from Radio receivers or phonographs in this little town, if the aldermen have anything to say about it. The common council announced recently that an ordinance had been passed fixing a penalty of a \$5 fine or five days in jail on the owners of phonographs or Radio sets that make too much noise. The aldermen said they hoped the ordinance would check the efforts of "merchants seeking to attract attention by increasing the volume on their loud speakers."

## TEXAN SEPARATES VOICES OF SEXTET

CINCINNATI.—Nearly every fan boasts of some performance of his set which makes it quite the best, but the broadest claim for selectivity is made in a letter received by Station WSAI, of the United States Playing Card company, here, in which the writer, a Texan, insists that he uncrambled the voices of the Bicycle sextet at will. At times he served to his guests a tenor solo, regardless of the fact that five other voices were being broadcast at the moment, or occasionally shifted to a duo with the tenor and baritone.

## DID YOU SCENT SCENT SHE SENT?



Ruth Fallows is the girl with the atomizer in the above picture taken in the WJZ studio, New York. She was telling her sisters of the Radio audience all about the beautiful scents that come from atomizers and she became so engrossed in her story that she really thought she could send out the odor, just as she was sending out her voice. At least, that's the impression she caused in the studio and, according to letters from fair listeners, she almost succeeded in doing that very thing.

## NEW LOCATION AIDING WGBS TRANSMISSION

Fans in Greater New York Are Getting Better Reception

NEW YORK.—Since moving its transmitter from the congested downtown district, WGBS, here, has practically been deluged with letters from listeners reporting that the new location in Astoria has greatly increased the strength of the Gimbel Brothers' station.

Before this step was taken WGBS was heard with excellent quality in all parts of the country, but a great many Radio fans right in Greater New York, principally parts of Brooklyn, found it difficult to tune in to the station. This was due entirely to the mass of steel and other air obstructions in the midtown district.

One of the main features in connection with the new transmitting plant is the fact that it is built on a peninsula of land, and surrounded by water on three sides.

## Metropolitan Theater Now Operating from New Studio

BOSTON.—The Metropolitan theater here recently opened its own studio broadcasting through WNAC, the Shepard Stores, with an extensive and exceptional broadcasting program.

The studio has been highly praised by those who are competent to know of the modern mechanical equipment in the average broadcast studio. Every effort has been made by the Metropolitan theater to make this new studio ahead of the times. The latest and the most approved microphones have been installed. Radio engineers have designed the most efficient mixing panels.

#### Radio Conference at Geneva

GENEVA.—Invitations have been issued to all broadcasting concerns in Europe to attend an international conference in Geneva beginning on March 25. The organizing body is the office international de Radiophonie. The main question to be settled is the definite repartition of wave lengths.

# WINNER WILL BE SELECTED BY LISTENERS

## Third Gold Cup Award

Annual Contest in Which Fans Will Choose Favorite Announcers to Start Next Week

For the third consecutive year the millions of Radio listeners numbered among the invisible audience will have the opportunity of selecting the world's most popular Radio announcer. Who will be selected this year to bear the coveted title and receive the handsome solid gold cup offered by Radio Digest in its third annual Gold Cup Award?

Two gold cups have already been awarded. In 1924, George D. Hay, formerly of WMC and WLS, now director of WSM, won the much desired trophy. In 1925, Graham McNamee, WEAF's chief announcer, topped the list and won the prize. In 1926—who will win?

#### McNamee Won Cup in 1925

The race last year was by far more thrilling than in 1924. Graham McNamee, George Hay, Henry Field and Gene Rouse were all possible winners at various stages of the voting. The jockeying up and down of the more popular contestants provided listeners with many surprises.

But when the final count of the 1,161,659 votes cast was made and McNamee's total reached nearly 200,000, the race was over. At that, Henry Field was a close second.

D. P. R. Coats, announcer for CKY, Winnipeg, Manitoba, led the list of Canadian announcers last year, and was presented with a silver loving cup. This precedent will be followed again this year, and the high Canadian announcer will receive a beautiful silver loving cup.

Radio listeners clamor anew to know who is the world's champion announcer. And to gratify the wishes of the great army of listeners, Radio Digest is again undertaking to aid them in making their selection.

#### Contest Begins Next Week

The Gold Cup Award is a permanent institution. As long as broadcasting stations continue to broadcast, the Gold Cup Award will be conducted annually by Radio Digest. Each year a solid gold trophy will be awarded to the world's most popular Radio announcer.

Watch the next issue of this publication for further announcements concerning the contest and how it will be decided this year. Full details will be given, and the first official ballot will appear. It is important to have every ballot, beginning with number 1.

In the meantime members of the invisible audience are advised to listen carefully to the various styles of announcing they hear nightly. What kind suits you the best, who pleases the most?

Say it with ballots, beginning next week.

## Each City Has Program On Manitoba's Station

Each Point in Province Can Tell of Its Attractions

WINNIPEG, Canada.—CKY, "Manitoba's Own Station," operated by the telephone system which is owned by the people of the province, is now broadcasting programs by remote control from all the principal cities and towns outside Winnipeg.

The whole purpose of these broadcasts is that of giving each point in the province an opportunity of going on the air and telling the world about its local attractions. The programs are put on officially by the town councils or boards of trade. The broadcasts are performed by the telephone system in the interests of the province.

Private commercial advertising is barred and on this understanding the work is performed at rather less than actual cost. Manitoba is the only province in the Dominion of Canada operating its own broadcasting system and providing broadcasting facilities of this kind to its outlying towns. There are no other broadcasters in Manitoba.

# Secretary Hoover Is Real Fan

*UNCLE Sam's Radio Spokesman Keeps Receiving Set Near His Desk and Enjoys DX Hunting as Well as Local Programs—Conferences Aid Wireless Progress*

By L. M. LAMM

**H**ERBERT HOOVER, erst-while food administrator of the United States, present secretary of commerce, adviser to the President, and friend of the Radio fans of the country, is himself a diligent fan. He has been called "Czar of the Air," but the title does not suit him. He does not like it.

From time to time the secretary has had all kinds of sets in his home for his personal use, from a small crystal to the most up-to-the-minute tube set. He has tried all these out so that he will better be able to know the conditions under which the fans who have small sets operate. It is known that he has himself experienced many of the inconveniences to which the owner of the small set is subject and for that reason he has all kinds of patience with the kicks of listeners in which reach him almost daily.

Mr. Hoover now has several Radio sets in his own home. One of them, however, is his "pet" and that is installed in his own private study, right alongside his desk, where he does a great deal of work at night. This study has a large open fireplace and it is said that frequently when he is trying to solve a problem he will stop in the middle of his work, light his pipe and play with the dials.

He gets considerable "kick" out of the quality of the programs and the reception. Mr. Hoover is also very much interested in loud speakers and has tried out many of them. Manufacturers of sets and speakers who think that they each have something out of the ordinary frequently send their sets to the secretary to see what he thinks of them.

The secretary is not the only one in his family who is a Radio fan. He has a very handsome set installed in his living room for the use of his family. Mrs. Hoover shares interest with the distinguished secretary in this art. His son, Herbert, who is now away, has been interested in Radio for many years. He has been an amateur and has been very active in his experimental work with Radio. It was probably through this son that Mr. Hoover became so much interested in the subject. It is also through this son that the secretary has a direct contact with the amateur operators of the country.

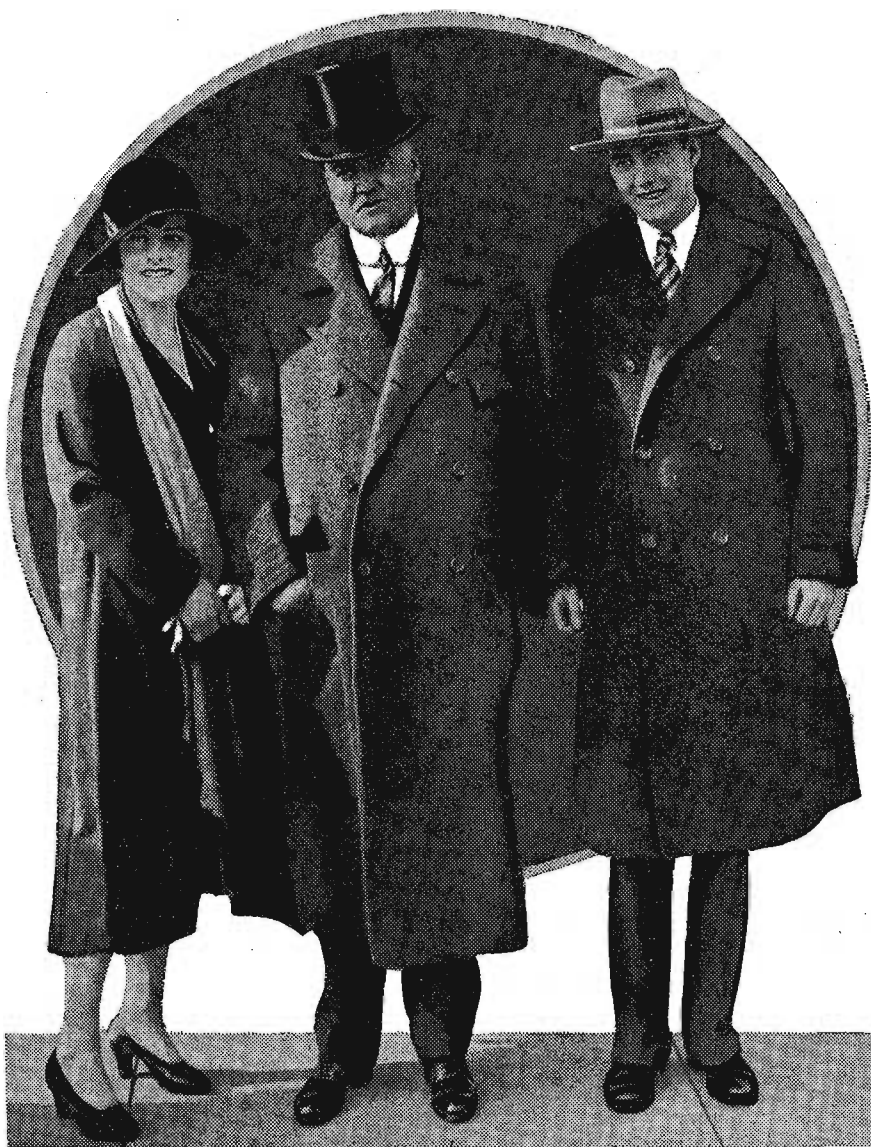

Sometimes the amateur broadcasters think they get rather a poor show and have to take a lot of abuse from the Radio public in general. One of the most ardent amateurs in the country is Herbert Hoover, Jr., who is seen above with his famous dad, who is the voice of Uncle Sam on all Radio rights and authority. Beside the secretary is Mrs. Herbert Hoover, Jr. So the amateurs should be well represented at Washington. Below is a group well known to Radio fans. Left to right are W. E. Harkness, assistant vice-president American Telephone & Telegraph Co., in charge of Station WEAJ, New York; A. Atwater Kent, Philadelphia; Secretary of Commerce Hoover and Congressman Arthur M. Free of California.

**E**VER since Radio has been an active subject in the department of commerce, and that means practically ever since Mr. Hoover has been secretary, he has been strong for the American boy as one of the greatest assets of the Radio industry. His appeal has always been for the boys of the country and he has looked out consistently for their rights in legislation and regulation, as well as those of the amateurs in general.

Mr. Hoover has always stood for the motto of the service to the public of the broadcasting stations. He believes that this is the real sum and substance of Radio broadcasting at this time.

Many Radio problems are presented to Mr. Hoover daily and, although he has a large corps of assistants to help him, he is fond of dealing with the subject himself. At the present time there are three outstanding problems. They include interference, applications for new broadcasting stations for which no wave lengths are available, and applications for increases in the power of the present stations.

Mr. Hoover frequently talks over the Radio at functions but he does not frequent broadcasting stations, although there are two first-class stations near at hand in Washington, WRC of the Radio Corporation of America and WCAP of the Chesapeake and Potomac Telephone company. He has, of course, been through these and other stations and knows about them thoroughly, being an engineer of note himself.

The secretary is best known, perhaps, throughout the Radio field in all of its branches as chairman of the various Radio conferences, of which he has called four since he has been in charge of the department of commerce.

He has a proclivity for running conferences and is most successful in this field. At the first Radio conference which he convened, about five years ago, there were only some twenty-five people present. This number has increased each succeeding year, until the last conference, held in the autumn of 1925, brought to Washington more than 600, representing every Radio interest, including represent- (Continued on page 12)

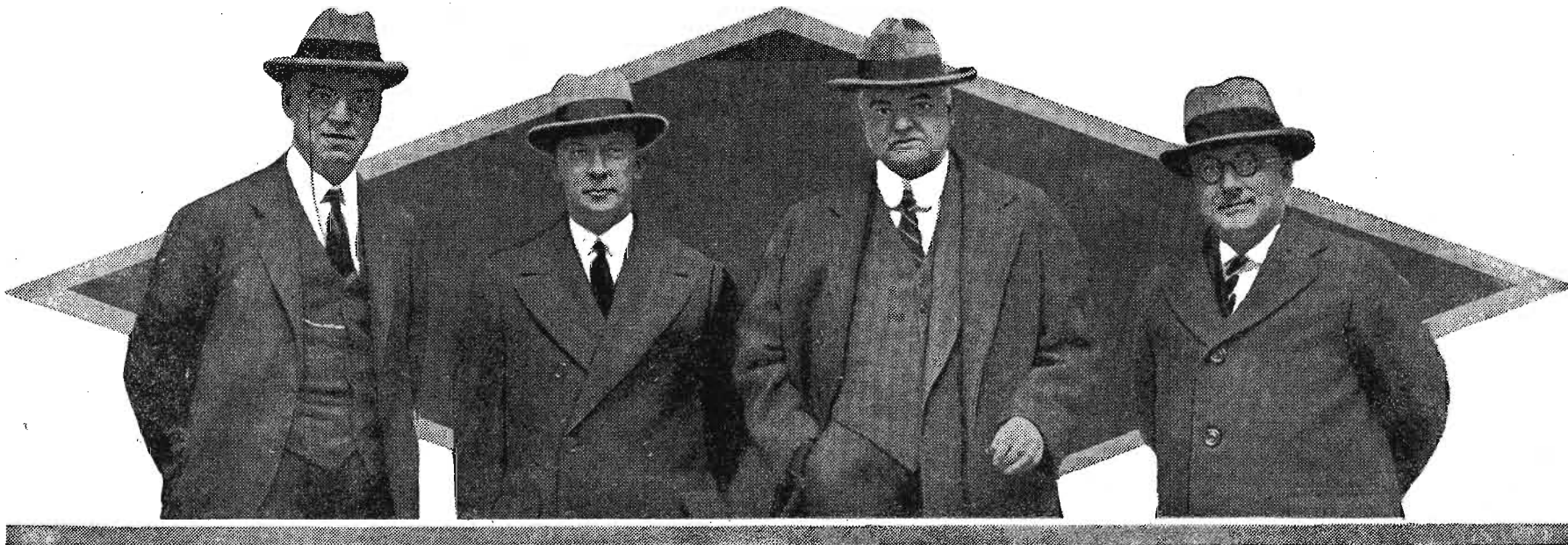



# Fair Listeners Love KOA Chat

## DENVER Station Broadcasts Snappy Matinee Program to Please Housewives and Mountain Maids Remote from City Shops and Social Conveniences

By HAROLD P. BROWN

**D**ID you ever know a woman to be "up in the air" about her clothes, her health or what to get for luncheon that would be different and more pleasing than the usual thing?

Quite likely, or you never knew a woman.

Possibly you may know Mrs. Ruth Drumm Witting of Denver. You certainly know her if you live within range of KOA, the "mile-high broadcasting station" of the General Electric company, located at Denver. And, by all means, if you are a woman listener in that widespread area you know Salle Dee and Clara Hoover, both of the same station. All three of these ladies may be "up in the air" a mile high from the sea level but they have all these important things that women are most interested in, down to the last word, in the microphone.

Out where the West begins, women are women, just the same as they are anywhere else. Don't ever doubt that. And if you want special confirmation of the statement it is only necessary that you tune in KOA during one of the triweekly women's matinees indicated on the Radio Digest program pages.

**O**H, IT'S healthy in Colorado, up there on the mountain roads, of course! You step a little harder on the accelerator and keep your eye pretty close to the highway as you

A nerve tonic? Certainly! Leave it to Mrs. Witting. Just tune in on one of those mid-afternoon relaxing and corrective exercises for women—"Over now, touch the floor with the tips of your fingers, One! Two! Three! . . . Fill your lungs with fresh air . . ." and all the while the piano creases out the effort of exertion.

Just to visualize her listeners a little more clearly, Mrs. Witting often conducts a gymnastic class in the KOA studio.

**L**ET'S all just forget everything else of the day's routine," says Mrs. Witting to the visible and invisible listeners, "and I can positively assure you if you will take this tonic according to prescription you will feel greatly benefited. Correct daily exercise, giving every little muscle, every little blood vessel, every nerve and tissue a chance to function and carry on the necessary reconstruction of the body, is better by far than all the pills and elixirs in the world. Keep physically well by keeping mentally well. Keep mind and body in harmony by gymnastics."

Mrs. Witting administers her "nerve tonic" in special doses for those who wish to reduce, for others who wish to build up and for all who wish to especially cultivate poise and posture.

Women love Salle Dee (right) because she brings to the listeners of KOA, Denver, the shop windows of the city and describes latest styles. Health and beauty are broadcast from the same station by Mrs. Ruth Drumm Witting (below), and kitchen technique and art of cooking by Clara Hoover (in circle).



Mrs. Witting is followed by a lively half-hour interlude of special music, which includes the latest song hits, chats along airy lines and other incidental features.

Now here is a secret that some folks will be surprised to hear: Following the interlude comes "Clara Hoover." That is just a "nom de Radio!" Her real name is— Pardon! That would be telling too much, more than the lady desires. Anyhow, she is a very highly esteemed society matron of Denver. If you know your Denver society, you may recognize her through the cover-all apron and broad headband as she is pictured here.

**C**LARA HOOVER, as she is known, has analyzed the kitchen and cooking problem down to the last and final —

And don't forget that "women are women" wherever you go—the same problems, the same heart cravings, the same worries—from Augusta, Maine, to Catalina Island, East or West. So Mrs. Hoover says:

"Because the woman's daylight hours are split three ways by family responsibilities, business cares and club activities, Radio talks on these subjects by those who have made of them a special study should prove not only interesting but profitable to those concerned. Especially should this be true of the kitchen and cooking—that never-ending bugaboo to many women." After that she lifts a figurative carving knife and lays open the various mysteries behind the kitchen door. Even a dull minded husband, eavesdropping on the loud speaker, should (Continued on page 12)

begin to climb the rugged flank and make the sharp curves, but you can't help seeing the cottage up there on the terrace and the thought flashes through your mind, "Man, but this country would be poor picking for a doctor!"

True enough! Still, it doesn't change the fact that women are women where the West begins the same as they are anywhere else. And that accounts for Mrs. Witting who talks health and beauty into the homes of the mountain folks. Mrs. Ezra McPeak, twenty miles up the Pike road, may never have seen a beauty doctor, but she is interested in knowing how to fix her hair and she has those "dizzy spells" and a "touch of lameness" in her "joints" just the same as the casual shopper on Fifth avenue, New York, or the "Boul. Mich." in Chicago.

# a STEP ON the STAIRS

By ROBERT J. CASEY

Radio Dramatization by FRED SMITH

Illustrations by HILMER C. OLSON

## Synopsis of Preceding Chapters

**G** RIM and ghostly mystery settled down on the old manor house of the Turners on Pelican Bay shortly before events chronicled in this story. The manse had come down through one hundred and fifty years of sea-faring Turners and then Jeremiah Turner was found dead with a bullet in his head on the hearth of the gun-room floor. They carried his body out the door reserved exclusively for the removal of the dead masters of the house. Soon after, the body of Peleg Turner, a brother, followed the same course. He seemed to have died from natural causes.

Lawyer Ardwyn, his executor, summoned the relatives for a weird seance in the deep shadowed hunt-room, lighted only by a candelabra. A letter left with the attorney had stated that the departed Peleg would attempt to communicate his discoveries beyond the grave through the Radio. The story opens with the party assembled. Only John Carton, a favorite nephew, is missing. He had been suspected of the crime. Henry Mills, the caretaker, had been startled by the arrival of a man in a gray overcoat from the stormy waters of the bay. The man said he had been called to the meeting, but Hari Singh reported later to Henry that he had never arrived at the house.

The clock struck twelve. There was a scratching sound in the receiver. A few syllables were uttered. Then followed an interruption. The voice of the announcer at F.Y.X., a nearby broadcasting station, called for help and a shot was fired. The listeners who were sitting in absolute darkness rushed for the locked exits in confusion. They already had heard ghostly sounds on the stairs and a mysterious tapping similar to an SOS signal. Finally, when a bit of candle was lighted, it was found that Milford Jones, one of the guests, was missing.

Tolliver, another guest, was appointed to investigate the F.Y.X. shooting. He found that a stranger had broken into the broadcasting station, shot the engineer and escaped unidentified. The wounded man was taken to a hospital but Tolliver discovered a trail of blood and picked up a letter which he handed to Ardwyn at the table. Just as the lawyer was about to open it Mary Williams, a friend of Carton, and sought in marriage by another cousin, Henry Graves, accidentally knocked the only candle to the floor.

In the darkness that followed Ardwyn felt the hair of a woman brush his hand and his wrist was caught in a savage bite. Another candle was lighted. The letter had disappeared.

Mary was suspected. When the other guests left the room for coffee and sandwiches Ardwyn showed her a locket which she admitted was her own. He had found it caught on his watch chain.

Then she showed him a pair of shoes left by some mysterious visitor who apparently had come through the locked and barred door of death. Mary dared Ardwyn to wait for the intruder's return. The candle stub sputtered out. Mary was heard to scream she had touched a corpse. The other guests rushed into the room and found Ardwyn and Mary both sprawled on the floor unconscious.

THE STORY CONTINUES.

## CHAPTER SEVEN

### Hail to the Prodigal

**T**HE candle flared reluctantly as Henri Singh applied the match and cast a dim radiance over a scene of chaos. Ardwyn, the lawyer, sat where he had fallen beside a chair near the door. Blood was trickling down his face from a cut in his forehead.

Mary Williams, white and silent, lay on the floor. In her outstretched hand—fluttered by the drafts in which the storm came over the worn sills about the trembling house—was a white scarf. As the crowd stood in an awed circle about them, Miss Williams slowly opened her eyes and Ardwyn attempted to raise himself.

"What happened, Mr. Ardwyn?" inquired Hari Singh.

"Blessed if I know," replied the lawyer hazily. "The front door is barred. But the front door opened just like she said it would. And somebody came in. I think I collided with the edge of the door in the dark."

"Who said someone was going to come in?" broke in Maurice Tolliver. "Do you mean to tell me you were waiting for somebody to come in here and rap you one on the coco?"

"The Sahib is in pain, Mr. Tolliver," Hari Singh cut in. "Would you please not question him?"

"Never mind, Hari Singh," Ardwyn told him. "My head is clearing. And one must talk sooner or later."

"I may say, Mr. Tolliver, that your supposition is correct. Miss Williams was expecting someone to come in through the front door and we sat here waiting for the visit."

"It certainly is beyond me," Tolliver went on irrepressibly. "I guess I ain't very inquisitive. But I'm tellin' the world that if any ghost or banshee or what not wants to come in through that door or go out, there ain't goin' to be any interference from me. I'm stayin' here until daylight when I may feel safe about goin' home on the bay road. What happened to Miss Williams?"

Hazel Stanton, who had been holding the wrist of the prostrate girl, looked up at him.

"She's just fainted, I think," she said. "Offhand I'd say she has had a horrible fright."

"No worse than she gave me with that shriek of hers," declared Tolliver. "People with nerves like that shouldn't play around in the dark."

"Miss Williams' nerves are easily the best in this company," Ardwyn declared, still huskily. "She shamed me into staying here and if I hadn't bumped into the door or whatever it was, I probably should have fainted myself."

"What did she see after the door opened?" inquired the girl with the red hair.

"I don't know that she saw anything, Miss Stanton," the lawyer told her. "It was pretty dark in here. And I was only vaguely conscious of what was going on. I think she said something about colliding with a corpse. . . ."

**A** CORPSE. . . . The voice was Hari Singh's but barely recognizable. "That bears out what I said. I recognized the white scarf the minute I saw it. With my own hands I put it about the shoulders of Peleg Turner before they laid him in his cof-

fin. . . . It was his mother's scarf. I couldn't be mistaken in it. . . ."

Ardwyn interrupted him.

"She's coming around now," he said. "Stand back a little and give her quiet. We can ask her a little later to tell what happened to her."

"Seems to me you're showing her a lot of consideration," snapped Aunt Helen.

"I don't think I quite understand what you mean, Mrs. Holmes," retorted Ardwyn.

"Well, I notice this. Trouble just seems to be a-followin' her around. It always does follow these flighty young girls. There have been some funny goin's on in this house tonight and this girl has been mixed up in all of them."

"For that matter, Mrs. Holmes, we have all of us been mixed up in them. It's a bit early to go fixing our suspicions upon one person—particularly before we know what to suspect them of."

And Mrs. Holmes' shrill plaint was not repeated.

On the fringe of the crowd, however, she found sympathy in the whispered commendation of Cousin William.

"I think you're just right about that,"

he told her in a half whisper. "Yes, indeed. I don't trust that Williams woman, either. And I'd trust Jezebel farther than I would that red-headed hussy who's rubbing her wrists."

"Virtue is its own reward, like I always says, Cousin William," Aunt Helen told him as one philosopher to another, "and I knew trouble was a-comin' when I first laid eyes on these girls. That red-headed Stanton woman is a bad lot, I'm tellin' you that, Cousin William. Mary Williams is bad enough. But I'll tell you somethin' for your own good an' don't breathe it to a soul. Hazel Stanton is worse. . . . Would you believe it, when some woman in this room was chawing the hand off of Ardwyn, that Stanton woman wasn't in her chair!"

"What?"

"I'm not fooling you, Cousin William. I'd not be makin' a joke out of anything so serious an' solemn as this. But she—certainly—was—not—in—her chair."

"But, Aunt Helen, what surprises me is how you noticed it. You had fainted. . . ."

"I recovered, my boy. I ain't never fainted so bad yet that I couldn't tell when evil was goin' on around me. It's just the natural unconscious feeling I have about sin an' wickedness. I know when they're around. The girl seems to be openin' her eyes. She looks groggy but I guess she'll be all right."

"Miss Williams needs all the air she can get," Ardwyn said. "I should suggest that all of you go back to the library and finish your coffee. If Hari Singh will get me a bandage and some hot water I think I can take care of the first aid work."

There was no audible objection to the program. The movement back toward the library was quick enough and concerted enough to be classed as a stampede.

**A** RDWYN took Miss Stanton's place at the girl's side. "They are gone, Miss Williams," he said to her. "Was there something you wished to say to me?"

"I was not so brave as I had thought," she replied weakly. "I didn't know it would be like that." She shuddered. "It was a dead man, Mr. Ardwyn. I felt his flesh. It was clammy and cold. And instead of trying to hold him I tried to get away."

"Don't bother to talk about it," he suggested to her. "You are all unstrung and probably couldn't remember what happened even if you tried. I should like to get you a stimulant if you wouldn't mind being alone a minute or two."

"I have no choice," she answered. "Anywhere in this house I should feel uneasy. I do not think I shall be any worse off here than elsewhere. The dead man went out with the shoes. He probably will not be back again."

"Just what do you suppose a dead man would want with shoes?"

"I'm sure I don't know. I don't know why a dead man should leave a comfortable grave on such a night as this. . . . All I know is that one did. But don't mind me. I shall be all right with the candle lighted and the door to the hall open. I think I am only half awake now. Nothing seems to matter—and I was dreaming just a moment ago of Milford Jones. I seemed to see him going out through that front door. I seemed to see him dying to keep up the old tradition. . . . But I was not alarmed about it. . . . Oh, don't mind me, Mr. Ardwyn. I'm quite all right, only weak and dizzy."

"I'll get you a stimulant and be back in a moment," he said rising. "Surely we have had our share of excitement for one night."

The girl was vaguely conscious of his footsteps becoming less and less noticeable on the bare parquet floor of the hall. Then came the old silence and the old sounds—the clock, the storm, the muffled voices—and one more dire if no

## \$500 in Gold

FOR THE SOLUTION OF

## "a Step On the Stairs"

REPRINTS NOW AVAILABLE

**N**ATION WIDE interest has been created by this thrilling mystery story. Listeners in sunny California, chilly Maine, the Province of Quebec and old Louisiana are endeavoring to solve the tangle of clues. Because this is true, and so many people are attempting to win part of the \$500 in Gold prizes which are being offered, a reprint of the first four installments, complete in every detail, has been printed and may be had for the nominal charge of twenty-five cents, in coin or stamps, to cover the cost of handling. If you have missed one or more of the preceding installments you will want this reprint to help you solve the mystery and win a prize. Address your letter to the Mystery Story Editor, care of Radio Digest. Besides the story there appears in the reprint a number of questions which may be helpful in formulating the solution.

The story, "A Step On the Stairs," is written by Robert J. Casey, an author whose works in the literary world need no introduction. Furthermore he is well versed in the needs of such fiction for Radio presentation. His work, in turn, is being Radio dramatized by Fred Smith, Managing Director of the United States Radio Society, who can be counted among the first few men to write and present Radio plays.

Read the story and hear it played weekly from the selected stations. Don't miss this thriller, whether or not you intend to submit a solution!

The chosen stations, which will broadcast "A Step On the Stairs" in Radio play form, are given on page thirteen. The days and the hours are listed.

### THE PRIZES

The prizes are seventeen in number. First prize is \$250; second prize

is \$100; third to seventeenth prizes inclusive, are \$10 each. In the event of a tie for any prize offered, a prize identical in all respects with that tied for will be awarded to each tying contestant.

### HOW TO WIN A PRIZE

Nine installments of Mr. Casey's story will be published consecutively each week. The first appeared in the February 27 issue. His tenth and final installment will not appear until the prize winning solutions have been selected by the judges. The solution nearest correct, that is, nearest to unravelling the mystery accurately, will win. The method of preparing the solution—its neatness, legibility, etc.—shall be considered in the selection of the winning solution. It should not be difficult for the average reader to study the story carefully and arrive at a logical solution.

### RULES OF CONTEST

1. The contest opened with the February 27 issue. All solutions must be received by Radio Digest not later than midnight of Saturday, May 1. The ninth installment of the story will appear in the April 24 issue. The author's intended and final chapter will appear in the May 15 issue of Radio Digest, together with the announcement of the winners' names.

2. The contest is open to everyone except employes of Radio Digest and their families.

3. Contestants pay no fee and need not be subscribers to Radio Digest. Solutions, however, must be written upon but one side of paper, and names and addresses should be written or printed plainly.

4. The decision of the judges, to be named later in the contest, will be final.



# BEGIN NOW to Read This Thrilling Mystery Story and Hear It Played Over the Air. Perhaps Your Solution Will Win One of the Many Prizes.

less familiar. A step was descending the stairs.

Mary Williams came back to full consciousness with a quick intake of her breath.

"Who's that?" she demanded in a voice no more than audible. "Who is it?"

The steps came nearer. They turned at the hall door and a figure slipped stealthily into the room.

"A man!" she whispered. "A man!" And then in a hushed tone that combined awe, amazement, and the fervor of a prayer: "John . . . John Carton. . . You have come back to me. I thought you were dead."

## CHAPTER EIGHT

### The Body in the Snow

WITH an alert eye watching the hall door, John Carton stole across the room and dropped to his knees on the floor between the fireplace and the huge leather chair from which the girl had partly risen.

"I was in the linen closet at the head of the stairs," he explained rapidly. "I overheard what that man said to you and I guessed you might be alone. I had to talk with you."

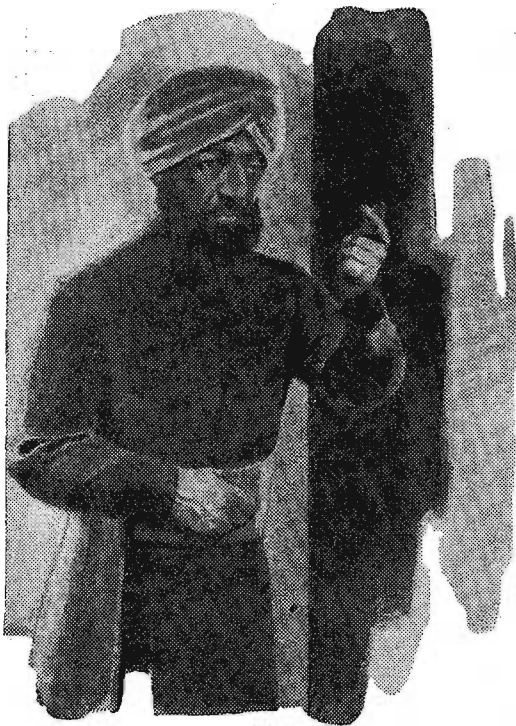

"John, where have you been?"

"I can't tell you that. I can't tell you anything until this night is over and the police are in the house."

"The police?" she repeated almost unbelievably. "John, do you . . . want the police . . . here?"

"Why not?"

"But, boy, they have been looking for you. They have been accusing you of murder. Don't you know that?"

"I know it. Somebody killed Jeremiah Turner. I was here. I went away. It looks like what the police would call a prima facie case."

"But you didn't kill him?" she pleaded. "You won't lie to me, will you, John? You didn't kill him. Tell me you didn't kill him!"

"No," he said slowly and a bit coldly. "I didn't kill Jeremiah Turner."

"I knew it, John. I felt it—always. . . . But, oh, you don't know the weariness of all these months I have put in waiting to hear you say it. . . . Who did kill him?"

"I can't talk about that, Mary. There isn't time."

"You are shielding somebody."

"I am not shielding anybody."

"Why did you run away?"

"Hush, Mary, don't work yourself into

hysteria. I tell you there isn't time to talk about these things now."

"What did you come back for?"

"To prevent another murder. It's on the books for tonight. I know it just as surely as I know I shouldn't be here now. And I am beginning to wonder if after all I can stop it."

"Murder?" The girl's voice was a trifle skeptical. "Are you sure you are telling me the truth, John?"

"I haven't time to give you evidence, Mary. You've got to believe what I tell you."

"Are you sure Hazel Stanton had nothing to do with your going away and that she has nothing to do with your return?"

He showed some signs of irritation.

"Who is Hazel Stanton?" he inquired.

"I never heard of her."

"Don't tell me that, John. I saw the two of you there under the porte-cochere on the night of the murder. I saw her red head in the moonlight. And I saw your white face as you talked to her. . . . I have tried to trust you, John. Why won't you give me a chance?"

"I can't explain, Mary," he admitted helplessly. "I can't say anything that will make you believe in me. But you have to believe in me without explanation. You have to. I came here to tell you . . ."

BEFORE he could finish, the murmur in the library grew ominously louder and the voice of Ardwyn was heard in the kitchen beyond.

"Hari Singh," he was calling. "Hari Singh, where are you? Isn't there anyone in this house knows where the medicine chest is?"

"They're coming back," gasped John Carton. "I didn't know they were in the library. . . . I'm caught!"

"There is some way to open the front door," she told him. "It's been open oftener to-night than in the hundred and fifty years this house has been standing here."

He drew back from her.

"Hush, Mary," he told her. "You don't know what you are talking about. Only corpses have ever gone through that door."

"At least one live man went through it tonight," she countered hastily. "And you've got to get out of here."

"I'll let them take me before I'll try to get out through that door," he declared with finality.

"And I guess the game is up. Here's someone now."

"Hari Singh!" breathed Mary.

The Indian looked at the pair as casually as if he had expected to find them there.

"This way, Sahib," he said. "And be quick about it."

"Go with him and God help you," the girl commanded him.

"Good-bye, Mary," he whispered hastily. And he moved rapidly about the table to the door where Hari Singh stood waiting for him. A moment later the side door creaked open and slammed and the guests were moving diffidently back into the room.

"THOUGHT I heard someone in here talking," volunteered Henry Graves from a point beyond the candle light. "Funny, isn't it?"

"What did Ardwyn send us back here for, anyway?" demanded Tolliver.

"My reputation will never survive this night," sighed Aunt Helen.

"Where is Ardwyn?" growled Henry Graves.

"I'll be there presently," called the lawyer from the hallway. "Hari Singh must have put the medicine in the safe."

He pushed through the group at the door and carried a glass of white fluid to Mary Williams.

"I found it at last," he said. "It's a simple sedative. You'd better drink it. You'll need it before dawn. . . . Didn't I hear Hari Singh in here a moment ago? What became of him?"

"I don't know," the girl replied dully. "I heard him say something and then the side door slammed. Maybe he went out."

"Why should he go out in a storm like this?"

"I don't know. I just thought he had gone out."

Tolliver sniffed.

"Why get excited about it, Ardwyn?" he asked. "What's there to be surprised about if anybody in this festive madhouse take a notion to go out runnin' around in the snow or walkin' on his hands or imitatin' a sea lion? Maybe he did go out. An' I'll bet if he did you'll find him wearin' a straw hat."

"Please be quiet, Mr. Tolliver," advised Ardwyn. "If Hari Singh went out he had some good reason for going. Hari Singh is sane—whatever may be said for the rest of us."

A whistle of wind and the banging of the side door interrupted him.

"That's the door now. Who came in?"

lift him alone." His voice was unsteady from over-exertion.

"Lift whom?" demanded Mary Williams in sudden panic. "What is he talking about? Oh, Mr. Ardwyn, what has happened now?"

"Who is it, Hari Singh?" the lawyer asked him.

"I do not know his name," the Indian replied, "I found him out there in the snow. I think he is dead."

"Dead," shrieked Mary Williams in wild hysteria. "Dead. . . . He can't be dead. He was alive only a moment ago."

Who was it that came in the awful front door as Mary and Ardwyn sat watching? How did



The Indian looked at the pair as casually as if he had expected to find them there. "This way, Sahib," he said. "And be quick."

she get Peleg Turner's funeral scarf in her hand? Why has John Carton returned? Whose murder did he seek to prevent? And whose body has Hari Singh brought in from the blizzard? Can it be that John Carton has returned to prevent a murder only to be felled himself? Read the fifth installment of Robert J. Casey's story next week in Radio Digest. Perhaps some of these questions will be answered.

# KTNT BOSS THROWS JAVELIN AT HOOVER

## CHARGES SECRETARY HAS FAVORED SOME FIRMS

### Seeks Senator to Instigate Administration of Radio Affairs Alleged to Be Mismanaged

WASHINGTON.—A senatorial investigation of the department of commerce administration of Radio was asked recently by Norman Baker, owner and operator of Calliophone Studio K-"TNT" of Muscatine, Iowa, and president of the American Broadcasters, an organization composed of independent stations.

Mr. Baker charges discrimination in the radio affairs as administered by the department of commerce, stating that the department is mostly interested in the passage of the White and Dill Radio bills because the officials have violated the laws so many times that they now seek protection.

### Wants Chain Stations on Same Wave

Before the committee on interstate commerce of the senate, Mr. Baker viciously attacked the department of commerce's activities, and suggested many changes in the Dill bill. He suggested no power over 500 watts be allowed for stations when broadcasting simultaneously, and such stations be located 500 miles or more apart, thus preventing complete monopoly of the receiving set dials which now is the case when a number of stations are connected together.

He urges the same wave length for all stations operating in a chain, and answered those who claimed it is impossible by advising the committee he has filed for patent on such a system that will enable any number of stations to broadcast simultaneously on the same wave without interference.

### Denounces Hoover as Villian

Baker branded as false, or misrepresentations, the data supplied by the departments on some Radio matters, claiming it may have been done to mislead the public.

He further asserted that the department of commerce has discriminated in the allocation of wave lengths, putting capital and powerful interests on the few select wave bands above 280 meters and crowding over 459 stations together between 200 and 280 meters, with great interference. He said there were open wave lengths in New York city, supposedly held for favorites or some powerful station, perhaps WJZ at Boundbrook. He attacked WJZ, the 50,000-watt station at Boundbrook, as to their right, under an experimental license, to broadcast programs and advertising with higher power than others are authorized to use.

Mr. Baker stated he can produce sufficient evidence of discrimination to warrant a complete investigation of the Radio administration in America, which he will start as soon as arrangements can be made with a senator to introduce the resolution in the senate. He added that the White and Dill bills should be defeated because they protect the "interests" more than the public.

## TOWNS OF PANHANDLE PLAINS GIVING SERIES

### Artists from Different Points in Region Perform at WDAG

AMARILLO, Texas.—The Panhandle Plains publicity programs that have been scheduled at Station WDAG, the Martin broadcast station of this city, have been very successful in their efforts to entertain the Radio world.

The closing series of these programs will be broadcast beginning March 23. During the following three weeks, artists from many different towns in the Texas Panhandle Plains region will be heard over WDAG.

The towns to be represented are: Canadian, March 23; Crosbyton, 24; Post City, 25; Booker, 26; Estelline, 27; Follett, 29; Hedley, 30; Idalou, 31; Lockney, April 1; Miami, 2; Muleshoe, 3; Perryton, 5; Plainview, 6; Spearman, 7; Stratford, 8; Wellington, 9; Ralls, 10; Lorenzo, 12; Mobeetie, 13; Channing, 14. All of the programs will begin at 9 p. m., Central time.

## Program on 10 Watts Power Is Received Across Country

PROVIDENCE, R. I.—What appears to be a new broadcasting record was made recently when a program sent from WGEM, here, with but 10 watts of power was received on a loud speaker in the state of Washington. A post card giving the time and the selections played was received at the station saying that the program came in clearly through slight interference from KFWI.

## DEMPSEY NERVOUS WHEN FACING MIKE

DENVER.—To Jack Dempsey there probably is one ordeal less trying than facing the microphone for a swing at static. That, say Denver sports writers and observers, is a good stiff battle in a squared circle.

Giant that he is, the heavyweight champion can show his wares before an audience of any size without flinching and, as he declared recently over KOA here, is prepared to defend his title against any challenger, but punching static is an entirely different story.

"Before starting his talk over the General Electric station, the champion was plenty nervous," observed the sports editor of one Denver paper. "First he stood on one foot and then on the other while being introduced to Radio listeners by Freeman H. Talbot, studio director. Next, he slid one hand into his pocket and finally put the other at his back."

In launching his Radio talk, Dempsey explained that his happiest days were the struggles of his early career.

"On all sides," he continued, "I am being asked when I am going to defend my title. In answer, I want to say, I am in the greatest shape of my career. I am ready to defend my title against any man in the world, Harry Wills preferred."

"Negotiations for this bout are shaping up so that I am sure a definite announcement will be made in a few weeks."

## ANNOUNCER'S CALL IS IDENTIFICATION

### David Lipton, Radio Director of Balaban & Katz, Gives Call to Cash Check

CHICAGO.—Speaking of the power of the press, the power of the screen and the like, hear this tale of the power of Radio. David Lipton, announcer and Radio director of the Balaban & Katz theaters, who broadcasts over WMAQ, WGN and WEBB, walked into a bank the other day to cash his weekly pay check. Having no account, being a Radio man, he was asked for identification.

He searched vainly through his pockets without finding anything to prove his employment with the firm.

"Say," he asked the teller, "Have you a Radio set?"

"Sure have," answered the money man, "the wife and I listen to it every night."

"Well then," said Lipton, "See if you can recognize this." "WMAQ," he called forth in true Radio fashion, "Broadcasting an organ program direct from the auditorium of the Balaban & Katz Chicago theater."

"You're the Balaban & Katz announcer," cried the teller promptly, "say that was a fine program you gave us last night. Have Fossler play 'Mother Machree' for us some evening," he continued gleefully as he passed the two dollars over the counter to the hard-working man.

## Cupid Makes Conquest At Hollywood Station

### Billie Dunn and Tom Breneman in Studio Romance

HOLLYWOOD.—Although listeners could only hear the call letters KFWB as the program came over the Warner Bros. "mike," it was really station LOVE broadcasting. Billie Dunn, popular studio pianist of the movie station, thought the day a little warm even for a California winter when a big, handsome newcomer from the East walked into the studio and announced that he was a singer. Later she confessed she capitulated when the singer, Tom Breneman, sang "Take This Rose."

One day the pair showed up at the studio with the announcement of the engagement and shortly afterward cupid finished the job. Now they are back at KFWB, Billie Dunn's fingers twinkling just a little more as she plays and Tom Breneman sings his ballads with just a little more sentiment, a perfectly happy Radio-romantic couple.

### WLW Is City Mouth-Piece

CINCINNATI.—Col. C. O. Sherrill, city manager of the city of Cincinnati, has appointed Powel Crosley, Jr.'s broadcasting station WLW, the official mouth-piece of the city. Messages of importance to listeners all over the country will be sent through the station.

# The New Radio Book

## HOW TO



**Operate Sets  
Construct Parts  
Improve Reception  
Understand Radio  
Assemble Circuits**

REVISED EDITION

### FREE With One Year's Subscription to Radio Digest

THE revised edition now contains the greatest assemblage of facts and hints, from actual everyday practice, ever gotten together. Edited by the technical staff of Radio Digest, it supplies the demand for a book covering every phase of Radio from a simple explanation of Radio reception to a technical explanation of the different parts of a set which leads to the best reception possible. The sections on selecting and making sets develops the different types of sets and circuits with diagrams to explain same. A seven tube super-het on a panel 7x18 inches, complete with all instructions, illustrations describing the wiring and actual size template is described. Just the thing for a portable this summer. Do you know how to get the best out of your set? "How to Operate" gives detailed information on the operation of all the well-known sets. The list of stations which is complete and revised, now contains all stations classified according to call letter, states and wave lengths. The section of workshop kinks will save the home constructor time and money.

Now is the time to take advantage of the exceptional offer as listed in the coupon for your convenience.

Hartland, Wisc.  
"The five tube Traveler, described in your wonderful book 'Radio Receivers' is a 'wow.' It is impossible to go wrong with your new system of wiring pictures. We tour the country ever night."

**This Handy Radio Reference Book Is Yours Today**

**Use the Coupon—Mail Today**

RADIO DIGEST, 510 N. Dearborn St., Chicago, Ill. 3-20-26

Enclosed find five dollars for one year's subscription to Radio Digest including FREE the New 124 Page Radio Book called "Radio Receivers—How to Operate and How to Make." Not good through subscription agents or agencies.

NAME.....  
ADDRESS.....  
CITY..... STATE.....



# WHEN KYW PICKS UP THE CONGRESS



**R**ATING with the most beautiful studios in the country, the Congress hotel pickup of Westinghouse Station KYW, is pleasing in its simplicity. The best of furniture and equipment are found therein. The Congress studio has its own staff, the members of which are shown above. At the left in the circle is Miss Eulalie Kober Stade, accompanist and pianist. In the group, left to right, are Miss Stade, Edwin Boroff, director of Congress studio; Miss Florence Pauley, soprano; and Harold H. Isbell announcer. KYW's studios are scattered all over the Chicago loop district. One is located in the Hearst building, and another, probably the most elaborate of the three, is in the Fine Arts building. The transmitter is on the Congress hotel. While its rated power is 25,000 watts, KYW uses but 2,000.

## RADIO SERVICE ASKS FOR LARGER BUDGET

### PLAN TO SPEND MONEY TO LESSEN INTERFERENCE

#### New Offices Would Be Placed at Strategic Points and Night Headquarters Force Added

WASHINGTON.—An increased appropriation of \$125,000 is recommended for the Radio service of the department of commerce in the appropriation bill for that department just reported to the house by the appropriations committee.

Plans have already been made by the Radio service for the utilization of the increased money to decrease interference. Deputy Commissioner Arthur J. Tyrer, of the bureau of navigation, gives the following account of how the money will be spent:

"We believe we should locate offices in the present centers of sending stations, at strategic points. In each of these sub-offices we should have an assistant inspector and one clerk. The new offices that we propose are at Dallas, Memphis, Los Angeles, Portland, Ore.; Pittsburgh, Buffalo, Denver, St. Louis, Minneapolis and Omaha.

#### Would Put On Night Inspectors

"At each of these new offices that we propose to locate, we would have an assistant inspector and one clerk. We are proposing to put one new man at each of the nine headquarters ports for night duty. Perhaps the most important broadcasting period is from 7 to 12 o'clock at night and at the present time our men who go on duty at 9 o'clock in the morning are continuing until along in the evening with their work. But it is rather heavy for them, so we propose to put on a night man at each of the headquarters ports.

"Then we propose to have one additional assistant inspector at Boston, New York, Baltimore, Atlanta, San Francisco, Seattle, Chicago and two at Detroit.

#### To Get Three New Radio Trucks

"We propose to get three new Radio-equipped trucks for locating sources of interference. We propose eventually to have one in each district. We tried one in the Detroit district first, to make sure that it would do what we thought it would do.

"During the time this Detroit truck has been in actual operation it has located 30 sources of serious interference and required the owners of transmitting stations to remedy the same. During this time 53 cities in five states were visited; 48 amateur, 15 broadcasting, 11 commercial, and 14 ship stations were inspected."

At the present time the Radio section is working under an allowance of only \$220,525 but the bureau of budget recommends \$354,000 for the fiscal year 1927. This was cut by the committee to \$335,000 but it is understood that an effort will be made to have the appropriation increased when it is taken up on the floor of the house.

## Call for Aid Over Radio Brings Relief To Widow and Children of Storm Hero

### Family of War Veteran who Fought Raging Seas on Santa Monica Bay Receives \$3,800 After Story Is Told to Listeners In at Station KNX

HOLLYWOOD.—When raging seas and unheard-of high tides swept in on the Santa Monica bay district near Los Angeles during the latter part of February, threatening destruction to piers and shipping and wrecking many of the cottages that had been built on the beach, a war veteran named Harry Hoover was one of the tireless ones who worked night and day saving the lives and property of those who lived on the shore. During the height of the storm he was swept out to sea and, presumably, because his strength had been exhausted in his fight for others, was unable to beat his way to shore and was drowned, leaving a widow and three small children.

The word of Harry Hoover's death came to G. Allison Phelps, Town Crier at Station KNX in Hollywood, who, with the permission and help of Naylor Rogers, manager of the station, decided to call on the Radio audience to help the grief-stricken and penniless widow. At the time word came of Hoover's death, the station was booked solid with toll programs but sponsors came forward and donated five,

ten and fifteen minutes each so the Radio audience could be told of the tragedy of the drowning, as well as the greater tragedy that faced the surviving little family.

The response was immediate, people phoning in their donations, and others, finding it impossible to get KNX by telephone, came in person to the studio to hand in their contributions. At 12 o'clock, when the station usually signs off for the night, about \$800 had been received and the telephone service still was paralyzed with incoming calls, so gathering a few of the artists together KNX continued on the air with a special Harry Hoover program that lasted until 4:30 in the morning.

A few days later G. Allison Phelps took a check for \$3,800 to Mrs. Hoover; contributions were still pouring in from all over the country, and means and ways of erecting a fully-paid-for home were being completed.

"It is a thing like that that gets under a man's skin," said Naylor Rogers afterwards, "and that makes this Radio game the biggest and most interesting one I know of."

## BALABAN AND KATZ ENTER RADIO FIELD

### CHICAGO THEATROWNERS EMPLOY FOUR STATIONS

#### Choice Bits of Musical Programs and Entertainment Are Broadcast by Remote Control

CHICAGO.—Balaban and Katz, owners of the Chicago, Roosevelt, Uptown, Central Park and Tivoli theaters, Chicago, have completed arrangements with stations WMAQ, WGN, WEBB and KYW whereby the choice bits of their musical programs are broadcast at intervals during the week.

Studios have been constructed in the theaters controlled by Balaban and Katz and are hooked up with the various stations by remote control.

Stage presentations are broadcast as well as the studio numbers, and the various stars appearing on the programs entertain Radio audiences during the period of their engagement.

The famous Sunday noon concerts of the Chicago theater are broadcast through WGN. The Balaban and Katz Radio review every Saturday night and the dinner hour organ concerts by Dean Fossler are nightly features from the Chicago theater through WMAQ. From WEBB every Tuesday night at 9 o'clock, Uptown theater entertainment is broadcast, as well as every Thursday afternoon between 3 and 4 o'clock.

KYW broadcasts midnight shows from the stage of McVicker's theater Wednesdays and Fridays.

Forbes Fairbairn, former Hearst staff correspondent in Europe and later director of stations WTAS and WCEE, has been appointed director of the Balaban and Katz Radio presentations.

## Leon H. Wood Is Heard On Large Grace Church Organ

NEWARK, N. J.—Leon H. Wood, Orange, N. J., organist, was heard over WOR recently on the Grace Church organ, which is generally said to be one of the six largest church organs in the world.

The organ has taken nearly five years to build and is just now completed. It contains 300,000 square feet of lumber, has over 9,000 pipes and over 500 miles of wire. Of further interest, it takes two 20-horsepower electric motors to supply wind for this instrument, furnishing 15,000 cubic feet of air per minute.

## Rochester Philharmonic Is Putting Concerts Upon Air

ROCHESTER, N. Y.—The Rochester Philharmonic orchestra has joined the list of notable symphonic bodies that are broadcasting their concerts by "going on the air." This happened recently when its program was carried by both WGY at Schenectady and WHAM at Rochester. Although other concerts have been broadcast from the Eastman theater and its kindred institution, the Eastman School of Music, this was the first broadcasting of an entire performance by the Philharmonic, the famous orchestral unit conducted by Eugene Goossens.

## French Chamber Rejects Tax

PARIS.—The French chamber, after a heated debate recently, rejected the proposal to inflict a flat rate tax on all receiving sets in France. The tax was condemned as undemocratic and vexatious and as likely to interfere with a useful branch of public instruction.

**PLEDGE CARD**

**Radio Digest**  
PROGRAMS  
Illustrated  
Reg. U. S. Pat. Off. & Dom. of Canada

**I WON'T BLOOP CLUB**

**I pledge myself to operate my Radio set to reduce radiation or blooping. If I am unable to make my present set operate properly, I further pledge myself to replace it with a receiver that will create less interference.**

Make of my set:	Signature .....
Number of tubes is:	Address .....
	City and State.....

**I am cooperating in this campaign with Station.....**

Upon mailing this pledge to Radio Digest, "I Won't Bloop Club" membership card suitable for wallet or framing will be issued.

**H**AVE you offered to do your share in improving broadcast reception by co-operating with the thousands of members of the I WON'T BLOOP club? Listeners from Alaska to Cuba have joined this movement of the Radio Digest to clear the air, and already reports are reaching our offices telling of improved conditions brought about by neighbors getting together and eliminating dial interference.

Broadcasting stations, newspapers and Radio clubs which have secured chapters in the club and who are acting as individual units of the club, are sending in daily lists.

Do you belong to a Radio club? If so, have the club pass resolutions to follow an I Won't Bloop policy. Get the members' pledges. Fill one out yourself. Do it today. Then follow the pledge to operate your receiver properly.

AN EVENING AT HOME WITH THE LISTENER IN IN EASTERN TIME

Table listing radio stations by call letters, location, and broadcast times for Saturday through Friday. Includes stations like AT9, CFCA, WQO, WRC, etc.

Table listing radio stations by call letters, location, and broadcast times for Saturday through Friday. Includes stations like WQO, WRC, WWSB, etc.

STATIONS IN ORDER OF WAVE LENGTHS

Table listing radio stations in order of wave lengths, with columns for Meters, Call, and Station Name. Includes stations like WOK, WGH, WTB, etc.

'Mixing Panel' Handles Program on Five Mikes

WHT Engineer Installs Device to Control Group Broadcast

CHICAGO.—Overcoming one of Radio's most persistent difficulties, Reeve O. Strock, chief engineer of WHT here, has installed a "mixing panel" in the control room of the station.

SAYS SECRET RADIO SYSTEM PERFECTED

PRIVATE COMMUNICATION POSSIBLE, IS CLAIM

Devise Involves Use of Three Wave Lengths with Set Working by Combinations

LONDON.—J. D. Chisholm, president of Secret Wireless, Ltd., giving evidence before the broadcasting investigation committee here, said recently his company had perfected a system of secret radio which enables signals to be received only by those for whom they are intended.

KOA Is Preparing for Big International Music Week

DENVER.—Eight full days of melody, embracing more than one hundred widely varied airway attractions, are planned for an international Radio audience next May.

Eliminate License Invaders

"Our system will eliminate the evaders, and the increased demand for the new type of instrument will reduce the price of tube sets. By selling 6,000,000 copies of our weekly programs at two cents each, the broadcasting companies will secure a sufficient revenue.

Name Sixteen Stations as Reliable for Calibration

WASHINGTON.—Sixteen code and broadcasting stations have been found by the bureau of standards to maintain sufficiently constant frequencies (or wave lengths) to justify their use in the calibration of radio sets.

KPRC in New Studios

HOUSTON.—Station KPRC, Houston Post-Dispatch, has been formally installed in their suite of studios in the new building of the newspaper.



# TABLE SERVICE FOR COMPANY DINNER

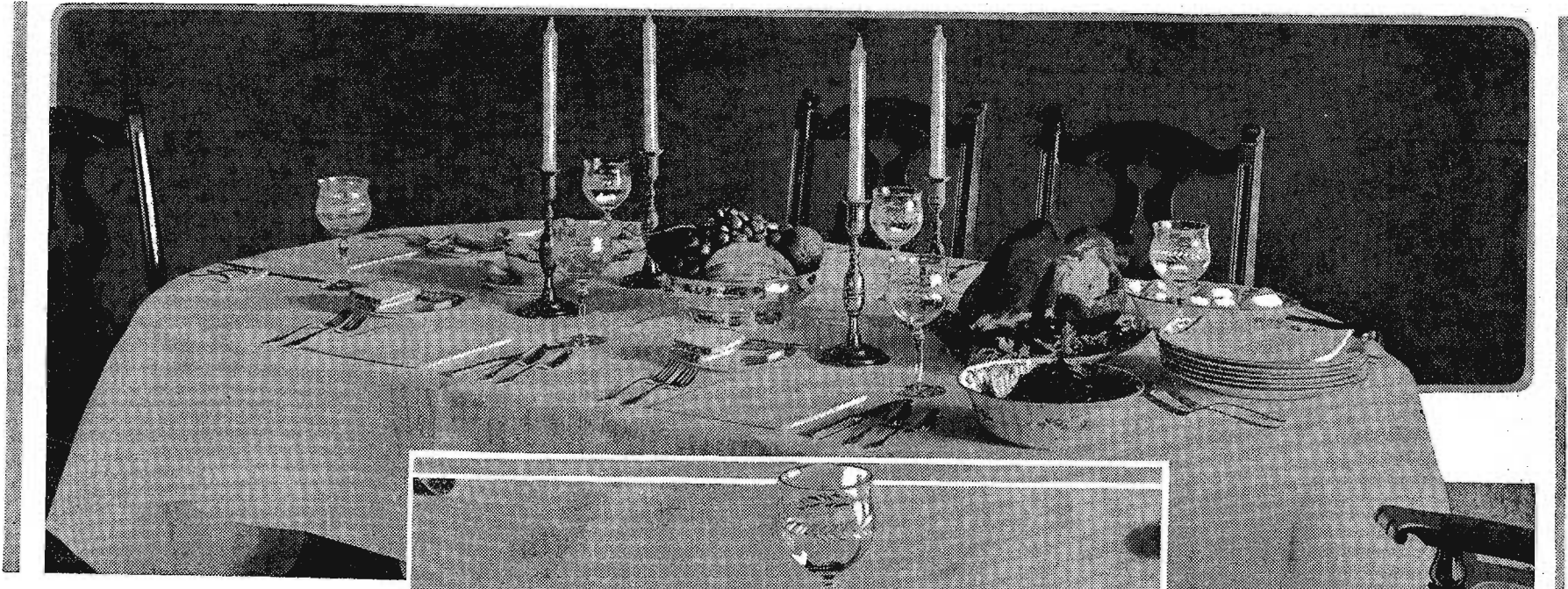

## BE WELL PREPARED TO SERVE COMPANY

HOUSEWIFE MUST LEARN TO BE GOOD HOSTESS

Success of Entertaining Depends Largely on Way in Which Work Has Been Organized

Have you heard, and do you regularly listen for Betty Crocker's Radio talks? Miss Crocker is nationally known as a home food specialist who is broadcasting from a dozen of the country's largest stations. By special arrangement Radio Digest has secured a series of exclusive articles by Miss Crocker dealing with her current Radio talks. These broadcasts are made through WEEL, WEAF, WCAE, WGR, WEAR, WWJ, WDAF, WJAR, WHT, WFI, KSD, KFI, and WCCO, the Gold Medal station at Minneapolis-St. Paul. All of Miss Crocker's recipes and discussions are based upon actual investigations and work of herself and her assistants in model kitchens.—Editor's Note.

By Betty Crocker

IS AN unexpected guest a calamity in your home, or are you the kind of a home-maker who is equal to any such emergency? Is a company dinner a real pleasure for your family, or is it occasion that they all dread? Perhaps you really like to entertain, but have not learned how to do it easily.

Whether or not you entertain easily depends largely upon the way in which you plan and organize your work. Some women never seem to know the limit of their endurance. Because they like to give pretty parties and nice dinners, they plan elaborate refreshments and expensive decorations and then wear themselves out carrying out their plans. I am not thinking of parties particularly, but of entertaining in any sense of the word. It seems to me that it is the duty of every home-maker to organize her work so that she can easily entertain an unexpected guest for dinner or have a party for Johnny's birthday without making an invalid of herself or giving the family a case of nerves.

Plan in Advance

Some of you may find that you are attempting to do unnecessary things when you entertain. Cut out the unessentials, and you will find that you can have as nice a tea or dinner or party and with much less trouble. My way of planning in advance for the dinner or party may not be your way at all, but I always find that it is easier to make my plans on paper. I like to go over all the details very carefully ahead of time, so that I know just exactly what I am going to do, and when, and how I am going to do it. The refreshments are planned and the grocery order made out some time in advance. All of the staples, such as sugar, butter, eggs, and Gold Medal flour should be purchased in advance, leaving the more perishable things to come on the day you expect to use them.

In the ordinary household, it is necessary to plan the refreshments according to the equipment. For instance, for the evening party, it may not be possible to serve a certain dessert if you do not have enough of the right kind of dishes. It may be necessary to change your plans for dinner when you consider that you do not have several sets of forks. Such little things make a great deal of difference in the ease with which any party

(Continued on page 12)

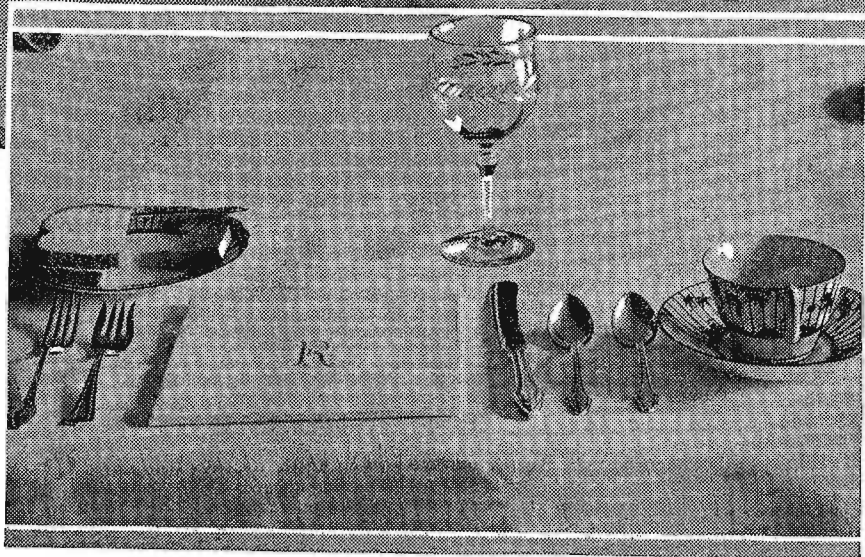

The table arrangements shown here were made in the home of L. A. Tripp, commercial manager of Station KFI, Los Angeles. KFI is one of the thirteen stations from the Atlantic to the Pacific coast which broadcast the Betty Crocker Home Service talks three times each week and over which Betty Crocker's famous Radio cooking schools are held. This table arrangement was made according to specifications outlined by Miss Crocker.

By Betty Crocker

SHOULD the bread and butter plate be placed at the right or the left of the plate?

If salad is served with the dinner course, where should it be placed?

How can I serve dinner to ten guests without being away from the table most of the time?

These and similar questions often puzzle the hostess who wants to have the correct service and yet does not have a maid to assist her. Perhaps a few rules to which you can refer occasionally will help the next time you forget whether the salad fork should go outside or inside the dinner fork.

Correct Arrangement of Silver

In laying the table, the silver should be placed one inch from the edge of the table and at right angles to it. The knife should go at the right of the plate with the cutting edge turned toward the plate. All spoons to be used are placed at the right of the knife with the bowls up. Forks are placed at the left. It is easy to know how to place the silver if you remember that it is always arranged in the order in which it is to be used from the outside in; that is, the first piece of silver to be used will be the farthest from the plate.

In case you are serving a meal in which knives are unnecessary, the forks may be placed at the right of the plate instead of the left. The water glass is placed at the right near the tip of the knife and the bread and butter plate at the left at the tip of the fork. The bread and butter spreader is placed across the bread and butter plate parallel to the edge of the table and with the handle turned toward the dinner plate.

Even Napkin Has Its Place

The napkin is placed at the left with the loose edges parallel to the forks and the edge of the table.

Salts and peppers may be placed in front of each guest or between two covers if they are to serve for two guests.

For serving the company dinner, the service should be simple if there is no older daughter or maid to help. A cocktail may be placed on the table before the guests enter the dining room. After the cocktail dishes are removed, soup may be served at the table by the hostess if you have a soup tureen, otherwise, it should be served from the kitchen. The service may be simplified by omitting either the soup or the cocktail, as that

will mean serving one course instead of the two.

Holiday Feast Setting

For Thanksgiving or any holiday feast, it seems more fitting to have the meat, whatever it may be, carved at the table. In addition to carving the meat, the host also serves all vegetables to be served on the dinner plate. Perhaps the eldest daughter sitting near can assist him. When meat is carved at the table, the carving knife and fork should be placed directly in front of the host, that is about ten inches from the edge of the table. The carving knife should be placed at the right and the fork at the left with space between them for the platter. All other necessary serving silver should be placed at his right. If you would keep peace in the family, be sure that the carving knife is sharp.

The warm dinner plates should be placed immediately in front of the host, then the platter placed in the space left for it and all vegetable dishes arranged at his right, as is most convenient.

Placement of Accessory Dishes

Accessories such as celery, olives, and jelly, may be arranged conveniently on the table in such a way as to help make the table a really pretty picture. When it is time to serve these foods, ask the guest nearest each to serve himself and pass it on around. Do not forget the necessary spoon or fork to go with each of these foods.

If the salad is served with the meat course, it should be placed at the left of each cover. Vegetables served in small dishes are also placed at the left. It is easy to remember that all service dishes are placed at the left with the exception of the beverage, which is placed at the right.

After one course of a dinner has been served, all foods and serving dishes should be removed first, then the dishes from in front of each guest. The table should be cleared of all soiled dishes and of all food dishes used in one course before the next course is served.

It pays to plan the service of your meal according to the china and silver on hand. If the service is carefully planned, it will not be necessary for the hostess to leave the table more than two or three times during the dinner.

A loud speaker extension in the kitchen is an excellent aid for the woman Radio listener.

## SHORT WAVES

By Marcella

Now to let in the young boy friends, Cecil and Harold, on the personal life of their microphone heroines. Leona Teget of KMA, Shenandoah, Ia., is 22 years of age; 5 feet 9 inches tall; 135 pounds heavy; very pretty and practical; has blue eyes, light brown hair, and lots of talent. Yes, Harold, she is still single and I have no doubt but what she would be pleased to correspond with you. She was leading soloist of the Grinnell Glee club and now teaches Science in the Shenandoah high school. She's athletic, witty, versatile and a 100 per cent all around American type of girl.

And Cecil, who inquires about Ormah Carmean of the same station, will be pleased to learn that she, too, is single, very pretty and full of fun, has coal black hair, rosy cheeks and fair blue eyes, weighs 118 pounds, stands 5 feet 5 inches high, and has lived just 20 years. Don't trifle, however, as she is very sincere and has no make-believe in her. Yes, she does considerable announcing, and she also is associate program director. She attended Tarkio college, Tarkio, Mo.

"H.G.L.," another young man—not a sheik, he notes—admires Ruth Etting of WLS, Chicago, and would know more of her. You should read his praise, "sweetest voice on the air," etc. His hopes are to be dashed in the main, however, for she is married. Anyhow, she is pretty, blonde, has blue eyes, weighs 112 pounds, and was born about a quarter century back at David City, Nebraska.

Leo Fitzpatrick, the "Merry Old Chief" of WJR, is the target of C.E.H. Was Leo always an entertainer? No, except through the news columns. He entertained in that fashion by writing feature stories for the Kansas City Star. When Radio came along he just took hold of WDAF and made it famous. Last year WJR wanted him bad and acquired him. Speaking of his entertaining abilities, he did travel Chautauqua for one summer, but that was after he made WDAF famous, and as a result of the latter achievement.

No, Ethel, this is not Gene Rouse announcing, but I do smoke occasionally. I know Gene, however, and he'll bear me up that I am not him. Where is Gene? I don't know. He did go down to KFJF for an engagement, but I believe it was only for a visit and not a permanent affair. I'll have to hunt him up for you. Yes, "Tot" Kay, WSB's "Little Colonel" entertains me very much.

Speaking of nice, married announcers, D. R. P. Coats of CKY, Winnipeg, is one. Daddy's pride, Baby John Coats, got near the mike while a program was going on and let loose with a series of yells. Papa Coats was able to handle the situation. He stepped to the microphone and announced, "The solo you have just heard was contributed by John Coats." It happens that Winnipeg had a noted tenor, a John Coats, singing there that very day. Many applause cards were drawn by the impromptu solo.

An unsigned note from Terra Haute, Ind., requests information as to the where—

(Continued on page 12)

SHORT WAVES

By Marcella

(Continued from page 11)

abouts of three ex-Nighthawks: Don Johnson, Lee Mansfield and Willard Robison. Dean Pitzer, WDAF's Nighthawk chief, tells me that Don Johnson was an operator and did not turn before the mike. Leo Fitzpatrick used to refer to him with the instructions, "Crank the little flivver, Don, and let's go home." Don is directing a new station at Miami, Fla., which is waiting for its license. Lee Mansfield has not played for a Nighthawk frolic for about a year. The crack blind pianist is playing here, there and everywhere. My good informant tells me he last heard him playing for a St. Louis cabaret. Willard Robison, before he became the prima donna he now is, did a great deal of Nighthawking. The chief feels quite proud of the record that followed for Don, now well known for his compositions, "Deep Elm," "Peaceful Valley," "Rythm Rag," and many others, is an exclusive Victor artist and a unit of the great Paul Whiteman orchestra.

Harry Snodgrass, "The King of the Ivories," with J. M. Witten, his partner and ex-WOS announcer, are on the air again. They have added Earl Holbeck, soloist, to their act, and although the advance schedule is not announced, Marcella knows that they appeared not long ago at WREO, Lansing, Mich., and more recently, Feb. 23 to 27, broadcast from KDKA, E. Pittsburgh.

What deep secret would you like to know about your favorite broadcast star? Drop me a note, girls and boys, and I'll do by best to answer here. MARCELLA.

HOOVER IS RADIO FAN

(Continued from page 4)

atives of the listeners, the Radio dealers, manufacturers and others.

Some months prior to the conference, through his staff, Mr. Hoover lets the public know that the conference is to be called. He then sends out invitations to those who have attended former conferences and others whom he may have

learned about. They are asked to let him know if they intend to be at the conference and from the many names he receives he makes tentative committee selections to be added to when the conference actually convenes.

In addition to these tentative committee selections, a program is mapped out so that when the conference actually convenes it will have some basis on which to work. The conference is opened by the secretary in which he generally outlines what has happened since the last conference and tells what he hopes the conference will take up and accomplish.

After a few formal speeches from the floor, the committees are formally appointed by the conference and they get to work on their various programs and when they have reached a conclusion they report back to the full conference which either adopts or rejects them.

While Mr. Hoover has both his critics and his friends it has been generally conceded that these conferences have been one of the most helpful influences in Radio development in this country. Mr. Hoover's official position puts him at the center of all activities where he has the difficult job of trying to please everybody. This is humanly impossible and that there has been no serious friction or reflection on his work seems to speak well for the confidence felt in him by the majority of broadcasters, Radio goods manufacturers and the fans themselves.

LADIES LOVE KOA CHAT

(Continued from page 5)

be able, after one of these discourses, to conduct a raw steak from the butcher's block through the intricacies of the culinary department of his household to the place of honor in the center of the family table.

Naturally, Mrs. Hoover goes into the chemistry of cooking as well as the psychology of the arrangement of dishes and the balancing of menus. One thing that may interest the dull-minded husband in particular is her consideration for the household budget.

Women "a mile high" or wherever they may be are invariably interested in clothes. They may not all have the smart shopping streets and boulevards of the big cities but that does not diminish their interest in the ravishing gowns and hats

and other things, frilly and not so frilly, to be seen in the windows. When Mrs. McPeak on the Pike road, twenty miles from Denver, wants to go window shopping she tunes in 322.4 meters for Salle Dee. It's no use trying to imitate Miss Salle's talk. She just does it in her inimitable style as one smart, talkative woman to another. She knows the unspoken questions in Mrs. McPeak's mind and answers them before they could possibly be asked under any circumstance. They all love Salle Dee. She brings them the pretty things almost as vividly as though they were looking through the Denver Dry Goods plate glass windows with their own eyes. She not only tells them the modes of the moment but she gives a fair forecast of what is to come!

Freeman H. Talbot, the KOA studio director, although a mere man, sees in these triweekly matinees for women the fulfillment of a dream. He was sold long ago on the idea that in certain respects women are women over and over again. Out of this conclusion he evolved the afternoon programs that have brought him many thousands of letters from gratified women listeners.

PREPARE FOR COMPANY

(Continued from page 11)

may be managed. By planning ahead of time, you can avoid many last-minute flurries and inconveniences.

Be Well Prepared

Naturally, what is easy for one may be hard, or even impossible for another. One of my friends bakes fancy Gold Medal flour rolls at the last minute for dinner. She has made them so often that it is not at all difficult for her to shape them and see that they rise and bake just right, even in the midst of the many other dinner preparations. Perhaps your specialty is baking powder biscuits or sweet bread or a special pudding, or salad. In any case, it is well to have a few special recipes and a number of stock menus. Serve a special dinner occasionally to your family until you have mastered it. Then you will always have a dinner that you can fall back on and be sure that it will be a success when you have a guest. Don't fuss around about everything but take pride in showing your husband and family how easily you can entertain.

One of my favorite emergency recipes is the cheese and bacon sandwich. This is a hot sandwich quickly prepared and substantial as well as delicious. With it I usually serve coffee or hot chocolate, some kind of pickles or relish, and a dessert. Another menu easily prepared in an emergency is creamed tuna fish on toast, with buttered peas or a salad, a fruit dessert and a hot beverage. The number of courses served should be determined by the amount of preparation and serving that you must do yourself. Many women plan a dinner of many courses without recognizing the fact that the serving will keep them away from the table most of the time and that means a table without a hostess.

Meat Loaf Is Convenient

A good meat loaf is delicious and most convenient for a company dinner because it can be put into the oven to bake before the rush of last minute preparations.

Here is the recipe for a very good meat loaf which has been tested in our kitchen: 2 cups bread crumbs, 2 tbsp. Gold Medal flour, 2 1/2 tsp. salt, 3/4 tsp. pepper, 1 small onion chopped fine, 1/4 tsp. paprika, 1/4 tsp. mustard, 1/8 tsp. sage, 1 1/2 cups milk, 1 egg, 1/2 lb. ground beef, 1/2 lb. ground veal, 1/2 lb. ground pork.

Method: Mix bread crumbs, flour and seasoning together. Combine with the meat. Combine milk with the beaten egg. Add gradually to the meat mixture. Mold into a loaf. Strips of bacon may be placed over the top. Bake two hours in a moderate oven, 375° F. This will make eight servings. An attractive platter may be arranged by placing carrots or beets at the ends of the meat loaf or a border of spiced red apples may surround the loaf.

Cheese and Bacon Sandwich

Here is the recipe for cheese and bacon sandwich: 3 eggs, 3/4 lb. cheese, 1 1/2 tsp. table sauce, 3/4 tsp. salt, 1/2 tsp. paprika, few grains cayenne pepper, 3/4 lb. bacon, 8 slices bread.

Method: Beat the eggs until light. Add the cheese grated or put through a food chopper. Add other ingredients and mix well. Spread on eight slices of bread cut one-third inch thick. Cut bacon in very thin slices, the length of the bread. Make bacon still thinner by pressing with a broad knife. Cover cheese mixture with bacon and bake eight or ten minutes under a gas flame or in a very hot oven.

WOMEN'S PROGRAMS INDEX

Table with columns for days of the week (Saturday, Monday, Tuesday, Thursday, Wednesday, Friday) and radio stations (Eastern, Central, Mountain, Pacific). Each entry includes time and program description.



# ADVANCE PROGRAMS FOR THE WEEK

Midnight at WOC, Davenport and "A Step On the Stairs." Left to right: Mary Williams, Henry Graves, (Mrs. C. H. Walsh in charge of "props"), Lawyer Frederick Ardwyn, Aunt Helen, Cousin William, Station WYX announcer and the revolver.



Here are also closeups of the two leading women characters. In the left corner is Marigold Cass as Mary Williams and in the right corner Lola A. Straw as Aunt Helen. Fans will be surprised to find Aunt Helen so attractive.



Saturday, March 20

### Headliners Today

Eastern	Central	Mountain	Pacific
7:30 p. m.	6:30 p. m.	5:30 p. m.	4:30 p. m.
WSM (282.8m-1060kc) Barn dance.			
8:10	7:10	6:10	5:10
WEEI (348.6m-800kc), Boston symphony.			
8:25	7:25	6:25	5:25
WJZ (454.3m-660kc), WGY (379.5m-790kc), WRC (468.5m-640kc) Philharmonic students' symphony series.			
9	8	7	6
WHAS (399.8m-750kc) Oratorio, "Stabat Mater," choir.			
WOAW (526m-570kc) "A Step On the Stairs."			
WHR (245.8m-1220kc) Spirituals.			
9:30	8:30	7:30	6:30
WLW (422.3m-710kc) "A Step On the Stairs."			
10	9	8	7
KTHS (374.8m-800kc) Old-fashioned favorites.			
10:30	9:30	8:30	7:30
WBAP (475.9m-630kc) Hired Hands little symphony.			
11	10	9	8
KHJ (405.2m-740kc) San Diego Army and Navy academy band.			
KFO (428.3m-700kc) Musical travelogue.			
KPRC (298.9m-1010kc) The Phonons.			
11:45	10:45	9:45	8:45
WSB (428.3m-700kc) Hired Help Skylark.			
12	11	10	9
KFI (467m-640kc) Hollywood string quartet.			
KPNF (263m-1140kc) Old-time fiddling.			
4:30 a. m.	3:30 a. m.	2:30 a. m.	1:30 a. m.
KFWI (225.4m-1330kc) Pajama party.			

Saturday, silent night for: CFAC, CFCA, CFCA, CNRA, CNRC, CNRE, CNRM, CNRR, CNRT, CNRV, CNRW, KFD, KFKX, KFMX, KFRU, KFUD, KFX, KLY, KMA, KOAC, KOB, KQP, KSAC, KXG, KTAB, KUOA, KWSC, WABQ, WBAL, WCAL, WCG, WDD, WEAD, WEBJ, WEBW, WEMC, WGBF, WGPC, WGRP, WGR, WGST, WHAD, WHAZ, WHN, WHO, WIP, WJAR, WJAZ, WKAO, WKAR, WLIT, WLWL, WMAZ, WOAL, WOS, WRVA, WTAG, WTIC, WWJ.

### Eastern Time Stations

CHIC, Toronto, Can. (356.9m-840kc), 10:30 p. m., dance program, Al Linton's orchestra.  
 CKAC, Montreal, Can. (410.7m-730kc), 7:15 p. m., Windsor hotel concert orchestra; 8:30, studio program; 10:30, Windsor hotel dance orchestra.  
 CKCL, Toronto, Can. (357m-840kc), 6:45-7:45 p. m., Lowe Brothers' symphonic orchestra.  
 CNCO, Toronto, Can. (356.9m-840kc), 4 p. m., instrumental quintet; Elsie White, soprano; 8, Charles E. Bodley and his dance orchestra; Madeline Bell, soprano; Edgar Smith, bass.  
 CNRO, Ottawa, Can. (434.5m-690kc), 8 p. m., Chateau Laurier concert orchestra; 9, Markowski trio; Lucien Labelle, cellist; Chateau Laurier dance orchestra.  
 KDKA, Pittsburgh, Pa. (309.1m-970kc), 6:30 p. m., Westinghouse band; 8:30, Westinghouse employees' band.  
 WBBR, New York, N. Y. (272.6m-1100kc), 8 p. m., Carl Park, violinist; 8:30, Fred Twaroschik, tenor.  
 WBZ, Springfield, Mass. (333.1m-900kc), 6:45 p. m., Hotel Lenox ensemble; 7:30, Winifred Beaver, pianist; Hotel Kimball studio; 7:45, Repertory theater orchestra; 8:15, musical program, Hotel Brunswick studio; 9:15, Old First church orchestra; Hotel Kimball studio.  
 WCAE, Pittsburgh, Pa. (461.3m-650kc), 1 p. m., Floridan's orchestra; 6:30, dinner concert, William Penn hotel; 7:30, Sunshine Girl; 8:15, Youngstown artists.  
 WCX, Detroit, Mich. (516.9m-580kc), 6 p. m., dinner program, Goldkette ensemble.  
 WEA, New York, N. Y. (491.5m-610kc), 7:45-8 a. m., morning prayer services; 5-6 p. m., Vincent Lopez and orchestra; 6-7, Hotel Waldorf-Astoria; 8:30, Shakespearian hour, "Macbeth"; 9:30, WEA musical comedy troupe; 10, Vlasso Kollitsch, violinist; 10:10, Ross Gorman and orchestra; 11-12, Vincent Lopez and orchestra.  
 WEAR, Cleveland, Ohio (389.4m-770kc), 7 p. m., Hotel Statler orchestra; 12 p. m., Wornack's singing syncopators, Far East restaurant.  
 WEEI, Boston, Mass. (348.6m-860kc), 7:10 p. m., D.

## Schedule for "a Step On the Stairs" Broadcast as a Play EPISODE FOUR

### THE SETTING

THE scene of our drama continues in the high-beamed hunt-room, the room that has been the scene of strange and mysterious crimes, of the Turner manse. Most of the guests, however, have gone into the library where Aunt Helen is serving coffee and sandwiches to all but Mary Williams, who has remained in the hunt-room, ostensibly because of fatigue, but in reality to wait for the return of the owner of a pair of wet shoes which had been left beside her chair. Mary persuades Ardwyn to remain with her. The candle goes out, and almost immediately in the darkness comes a cold draft of air. A moment later Mary cries out in anguish, Ardwyn does not respond, a body falls to the floor, there is a choked curse, a slamming door, and the others rush in, lights in hand, to find Ardwyn with a nasty gash in his forehead and blood all over his face, while Mary Williams lies upon the floor in a faint, with a white scarf in her hand—a scarf that had been buried with Peleg Turner.

### THE CAST

Frederick Ardwyn.....Peleg Turner's lawyer  
 Aunt Helen Holmes.....A relative  
 Henry Graves.....A mysterious man Mary had known formerly  
 Hari Singh.....Indian servant of Peleg Turner  
 Mary Williams.....A youthful guest  
 Maurice Tolliver.....A youth and relative  
 Hazel Stanton.....A young lady  
 John Carton.....Nephew of Peleg Turner  
 Cousin William.....A relative

### WHERE AND WHEN TO DIAL

WOC, Davenport, Palmer School of Chiropractic. Fourth episode at 10:30 p. m., Central time, on Friday, March 19. Fifth episode same time March 26. Dial 483.6 meters or 620 kilocycles.  
 WOAW, Omaha, Woodmen of the World. Fourth episode at 8 p. m., Central time, on Saturday, March 20. Dial 526 meters or 570 kilocycles.  
 KGO, Oakland, Calif., General Electric company. Fourth episode at 9:45 p. m., Pacific time, on Saturday, March 20. Dial 361.2 meters or 830 kilocycles.  
 KOA, Denver, General Electric company. Fourth episode at 9:40 p. m., Mountain time, on Monday, March 22. Dial 322.4 meters or 930 kilocycles.  
 WCCO, Minneapolis-St. Paul, Gold Medal station. Fourth episode at 10:05 p. m., Central time, on Tuesday, March 23. Dial 416.4 meters or 720 kilocycles.  
 WGY, Schenectady, General Electric company. Fourth episode at 8:15 p. m., Eastern time, on Friday, March 19. Fifth episode same time March 26. Dial 379.5 meters or 790 kilocycles.  
 WMAQ, Chicago, Chicago Daily News. Fourth episode at 9 p. m., Central time, on Wednesday, March 17. Fifth episode same time March 24. Dial 447.5 meters or 670 kilocycles.  
 WNAC, Boston, Shepard Stores. Fourth episode at 7 p. m., Eastern time, on Thursday, March 18. Fifth episode at same time March 25. Dial 280.2 meters or 1070 kilocycles.  
 WEAN, Providence, R. I., Shepard Stores. Play broadcast by direct wire from WNAC, Boston, on same schedule as WNAC therefore. Dial 270.1 meters or 1110 kilocycles.  
 WHO, Des Moines, Bankers Life Insurance company. Fourth episode at 2:30 p. m., Central time, on Monday, March 22. Dial 526 meters or 570 kilocycles.  
 WRC, Washington, Radio Corporation of America. Third episode at 8:15 p. m., Eastern time, on Friday, March 19. Fifth episode same time March 26. Dial 468.5 meters or 640 kilocycles.  
 WLW, Cincinnati, Crosley Radio corporation. Fourth episode at 8:30 p. m., Central time, on Saturday, March 20. Dial 422.3 meters or 710 kilocycles.  
 WOR, Newark, N. J., L. Bamberger & Co. Fourth episode at 10:30 p. m., Eastern time, on Saturday, March 20. Dial 405.2 meters or 740 kilocycles.  
 WSB, Atlanta, the Atlanta Journal. Dial 428.3 meters or 700 kilocycles. Schedule to be announced over air.  
 KGW, Portland, Ore., the Portland Oregonian. Dial 491.5 meters or 610 kilocycles. Schedule to be announced over air.  
 KTHS, Hot Springs National Park, Ark., the New Arlington hotel. Dial 374.8 meters or 800 kilocycles. Schedule to be announced over air.  
 WBAP, Fort Worth, Texas, the Star-Telegram. Dial 475.9 meters or 630 kilocycles. Beginning in April. Schedule to be announced.

and I. Slade company program; 8:10, Boston symphony orchestra.  
 WFI, Philadelphia, Pa. (394.5m-760kc), 1 p. m., Tea Room ensemble; 3, concert, National Blind Camp Fire Girls of Overbrook; 6:30, Bellevue Stratford hotel concert orchestra; 7, Bellevue Stratford dance orchestra; 8:15, piano recital; 11, Bellevue Stratford dance orchestra.  
 WGBS, New York, N. Y. (315.6m-950kc), 1:35 p. m., Alois Van Meyer, tenor; 1:40, Katherine Connolly, soprano; 1:50, Sidney Torsion, bass-baritone; 2, Galet orchestra; 3, Bud Fischer's Happy players; 6:30, Vincent Storey trio; 8:40, Crete Carton, musical comedy star; 9, Kips Bay Boys' club minstrels; 10:30, Arrowhead Inn orchestra.  
 WGCP, New York, N. Y. (252m-1190kc), 3 p. m., orchestra; 3:30, studio program; 4, orchestra; 8:30, Strickland's orchestra; 9, Ukulele Bob McDonald; 9:20, June Lee, singing vagabond; 9:40, Totman and Gallant, guitar duets; 10, Yama Yama Boys; 10:30, Strickland's orchestra; 11-1 a. m., Jbsen night.  
 WGH, Clearwater, Fla. (266m-1130kc), 6:30-7:30 p. m., dinner music; 7:30-7:45, Giles W. Quarles, "The Monkey Man"; 8:30-9:30, Caroline Lee, "The Virginia Girl" and her Spanish guitar; Marion Hoffman, pianist; 11:45-1 a. m., WGH.  
 WGR, Buffalo, N. Y. (319m-940kc), 2:30 p. m., WGR's afternoon program.  
 WGY, Schenectady, N. Y. (379.5m-790kc), 6:30 p. m., Onondaga hotel concert; WFBL; 8:25, WJZ; 10:30, Hotel Van Curler orchestra.  
 WHAR, Atlantic City, N. J. (275m-1090kc), 2 p. m., Seaside hotel ensemble; 8, Seaside hotel trio.  
 WIP, Philadelphia, Pa. (508.2m-590kc), 1 p. m., organ recital; 3, the Filipino orchestra; 6:05, Benjamin Franklin hotel concert orchestra; 8:30, debate, Lebanon Valley and Ursinus college; 10:05, El Patio dance orchestra; 11:05, organ recital, Germantown theater.  
 WJAR, Providence, R. I. (305.9m-880kc), 1:05 p. m., Zike's Bon Ton orchestra.  
 WJR, Pontiac, Mich. (516.9m-580kc), 7 p. m., Jean Goldkette's Petite symphony orchestra; soloists; 9, Jean Goldkette's serenaders; soloists; 10, Jean Goldkette's Victor Recording orchestra; 11:30, "The Merry Old Chief" and his "Jewett Radio Jesters."  
 WJZ, New York, N. Y. (454.3m-660kc), 11 a. m., Philharmonic children's concert; 1 p. m., Knickerbocker grill orchestra; 4:30, Hotel Lorraine grill orchestra; 7, U. S. Navy program; 8, happenings in Congress; 8:25, Philharmonic society student concert, WRC, WGY.  
 WLIT, Philadelphia, Pa. (394.5m-760kc), 12:02 p. m., Stanley theater organ recital; 2, Rose Tree cafe orchestra; 4:30, Bobby Lee and his Original Cotton Pickers; 7:30, Benjamin Franklin hotel concert orchestra.  
 WMAK, Buffalo, N. Y. (266m-1130kc), 6:15-7:15 p. m., dinner music; 7:45-8:30, musical program; 8:30-9, musical program, Wolff's Furniture House, Inc.; 9-10:30, musical program; 10:30-11, musical program, Maltop, Inc.  
 WMCA, New York, N. Y. (340.7m-880kc), 6 p. m., Olcott Vail and his Hotel McAlpin string ensemble; 6:30, Parody orchestra; 7, Jack Denny's orchestra; 10:30, Norman Pearce, readings; 11, Ernie Golden and his Hotel McAlpin orchestra; 12, McAlpin entertainers.  
 WNYC, New York, N. Y. (526m-570kc), 7 p. m., song recital; 7:35 p. m., Herman Newman, pianist; 8, Metropolitan Museum of Art concert, directed by David Mannes; 10, popular songs; 10:10, Harriette Weems, dramatic readings.  
 WOO, Philadelphia, Pa. (508.2m-590kc), 11 a. m., organ recital; 12:02 p. m., Golden's crystal tea room orchestra; 4:45, organ recital; 7:30, Adelphia hotel dinner dance orchestra.  
 WOR, Newark, N. J. (405.2m-740kc), 2:30 p. m., Lucy Bernard, pianist; 2:45, June and Annette Lee; 3, Lucy Bernard; 3:30, Zil's Central Park Casino tea music; 6:30, Jacques Jacobs' Hotel Shelton ensemble; 7:30, Van's Collegians; 9:15, La Forge-Berumen Saturday evening musicale; 10:30, "A Step On the Stairs," fourth installment mystery play, direction Bruce Conning; 11, Katinka orchestra.  
 WPG, Atlantic City, N. J. (299.8m-1000kc), 6:45 p. m., Arthur Scott Brook, organist; 7, Hotel Traymore dinner music; 9, Hotel Ambassador concert orchestra; 10, Nick Nichols' dance orchestra; 11, Elks' home.  
 WRC, Washington, D. C. (468.5m-640kc), 12 noon, Homer L. Kitt studios' organ recital; 1 p. m., Hamilton orchestra; 7, U. S. Navy band; WJZ; 8:30, Philharmonic orchestra; WJZ; 10:30, Meyer Davis' Swanee syncopators.

# RUSSIAN STRING QUINTET AT KNX

## High Lights of the Week

UNPRONOUNCEABLE titles to musical selections or tongue twisting composers' names mean nothing to the Hired Hand or his little symphony. Every Saturday night this famous organization struggles with these jaw breakers. Orchestra selections hitherto taboo because announcers feared to announce them are being successfully brought to light at WBAP.

Claudia Muzio, whose golden tones have enchanted opera audiences all over the United States, will sing for millions of listeners Sunday evening when she is heard over the WEAJ chain. The western headliner of the evening is the Russian string quintet at KNX.

A continuity program proclaiming spring to the Radio world is the Monday feature at WOS, Davenport. Famous spring songs of great composers will be reviewed. "Memories of Jennie Lind and Clara Schumann" is the title of the program to be given this same evening by Anna Barbash, soprano at WPG, Atlantic City.

Artur Argiewicz, a master of the violin who began his musical education under the eyes of Brahms, will broadcast Tuesday from KGO, Oakland. Argiewicz studied with Joa-

chim, Ysaye and Kreisler, traveling with the latter over Europe, taking lessons between concerts.

Wednesday evening, March 24, KOA will offer another novelty program. Part one, scheduled for 8:15 o'clock, will be a mock trial, to be conducted by prominent attorneys who represent the leading luncheon clubs of Denver. As the feature of part two, Hickville will stage an old-fashioned box-supper and auction party. Si Perkins, who runs the post office and general merchandise store, is expected to contribute much to the success of the gathering. Farmers for miles around will be in attendance, it is reported.

On the equator is the interesting city of Singapore where orientals and occidentals meet. Bishop Titus Lowe recently returned from this strange tropical city will talk Thursday at WIP, Philadelphia.

The Victor hours of music over the WJZ chain have attracted the attention of fans since the famous Radio scoop of the broadcasting of Marion Talley's Radio debut. This Friday two favorites of the Metropolitan Opera company will give the program, Madame Maria Jeritza, soprano, and Emilio de Gogorza, baritone.

WLW, Cincinnati, Ohio (422.3m-710kc), 7 p. m., popular organ concert, Johanna Grosse; 7:40, Secretary Hawkins Radio club; 8, Johanna Grosse; 8:15, Fred Bosters recording orchestra; 9, old fiddler; 9:30, Don Bosters recording orchestra.

WMAQ, Chicago, Ill. (447.5m-670kc), 12 noon, harmonica lesson, H. A. Langdon; 5:15 p. m., Topsy Turvy time; 6, Chicago theater organ; 6:30, Hotel La Salle orchestra; 8, Dav and Pratt; 9, Balaban and Katz's Chicago theater radio revue.

WMBB, Chicago, Ill. (250m-1200kc), 7-8 p. m., Trianon duo; Edith Stonehouse, soprano; Edwin House, baritone; Rosalind Wallach, violinist; Preston Graves, pianist; 9-11, Trianon orchestra; Woodlawn theater orchestra; McFarvin and Belber; Joe Miller, tenor; Clinton Keithley; Bob Bennett, celeste specialties.

WMC, Memphis, Tenn. (499.7m-600kc), 8:30 p. m., Memphis plectrum orchestra.

WOAW, Omaha, Neb. (526m-570kc), 5:30 p. m., Manna Kea trio; 6, Kaliko Kids; 8, "Step On the Stairs"; 10:30, Frank Hodek and his Nightingale orchestra; 11, Arthur Hays, organist.

WOC, Davenport, Iowa (483.6m-620kc), 5:45-6 p. m., chimes concert; 9-10:30, Mrs. V. E. Edwards, soprano; Harry Yeazelle Merer, tenor; Erwin Swindell, pianist; 11-12, Le Claire hotel orchestra.

WOK, Chicago, Ill. (217.3m-1300kc), 4:30-7 p. m., Capitol theater organ; Howard Will, tenor; 10-1 a. m., Tearney's Town club orchestra; Carl Lorraine's Pershing Palace orchestra; Husk O'Hare's Coconut Grove orchestra; Capitol theater program; studio program.

WORD, Batavia, Ill. (275m-1090kc), 7 p. m., Webster hotel orchestra; 9-10, musical program.

WQJ, Chicago, Ill. (447.5m-670kc), 3-4 p. m., Koffee Klatsch; Jerry Sullivan, percolator; Rose Vanderbosch, soprano, pianist; Hal Lansing and his uke; 7-8, Jack Chapman and his concert orchestra; John Zwick, concert pianist; Alice Guernsey, violinist; Shepherd Lovine, tenor; 10-3 a. m., Jack Chapman and his Rainbo Skylarks; Jerry Sullivan; Rose Vanderbosch, soprano and pianist; Hal Lansing and his uke; Everett George Opie, character reader; Clarence Theders, tenor; Joe Warner, character songs; Oxford, harmony singers; Rita McFawn and Mary Bieber, harmony duo; West Brothers, Hawaiian guitar duettists; Gail Bantell; Melodians; artists.

WRR, Dallas, Tex. (245.8m-1220kc), 12-1 p. m., musical program; Dr. Fred Freeland, pianist; Helen Cul-

Fitzgerald Music company dinner hour; 8-9, Lyric string trio; Eunice Wynn, ballads; Dan Gridley, Irish tenor; 9-11, program, Reeve-Gartzmann, Inc., Oakland Six dance orchestra.

KFWI, San Francisco, Calif. (225.4m-1330kc), 1:30-3:30 a. m., Pajama party, Glenn Kennedy's dance orchestra; intermission soloists; Eddie Stott and Sadie Woodside, entertainers.

KGO, Oakland, Calif. (361.2m-830kc), 8:10 p. m., "The Pink Lady"; 10-12, Girvin-Deuel's California Collegians.

KGW, Portland, Ore. (491.5m-610kc), 12:30-1:30 p. m., concert, First National bank and the Security Savings and Trust company; 6-7, concert, Olds, Wortman and Kings company; 9-12, dance music, Indian grill of Multnomah hotel.

KHJ, Los Angeles, Calif. (405.2m-740kc), 8-10 p. m., program, Motor Transit company, San Diego Army and Navy academy band; 10-11, Don Clark's Biltmore hotel dance orchestra.

KJR, Seattle, Wash. (384.4m-780kc), 8:30-10 p. m., L. C. Warner company studio program.

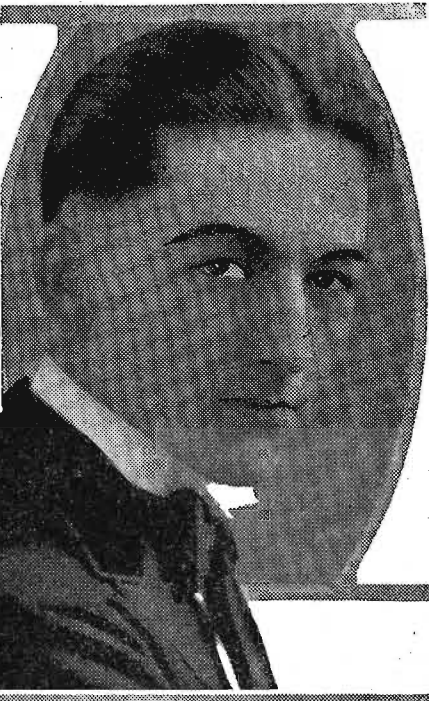

When the nimble fingers of Gladys Hubner, left, pluck the strings of her harp at WCCO, fans are listening to a young harpist whose concert work is attracting the attention of Minnesota musicians. Above is John G. Heyn, a popular pianist at KTHS.

## Saturday, March 20

WREO, Lansing, Mich. (265.5m-1050kc), 6-7 p. m., Speed-Wagon serenaders; Gold Standard ensemble; 10-12, dance program, WREO, Speed-Wagon serenaders.

WTAG, Worcester, Mass. (268m-1120kc), 12:05-2 p. m., WTAG orchestra; 3-5, tea dansant music, WTAG orchestra.

WTAM, Cleveland, Ohio (369.4m-770kc), 12:15-1:30 p. m., Austin Wylie's Vocalion recording orchestra; 6-7, Guy Lombardo and his Royal Canadians; 8-9, Carl Rupp and his Hotel Hollenden orchestra; 9-12, Joes and his gang.

WTIC, Hartford, Conn. (475.9m-630kc), 6:30 p. m., "Skinny and his gang"; 6:50, Hotel Bond trio; 8:30, Martha Blake, pianist; 10:30, Emil Heimberger's Hotel Bond orchestra.

WWJ, Detroit, Mich. (352.7m-850kc), 12:05 p. m., Jules Klein's hotel Statler orchestra; 3, Detroit News orchestra; 6, dinner concert; 8, "C. T. S. and his performing Elks"; 9:30, WEAJ; 10:30, dance program.

### Central Time Stations

KFAB, Lincoln, Nebr. (340.7m-880kc), 5:30-6:30 p. m., dinner concert; 8:30-10:30, variety program; 12-2 a. m., orchestra entertainment.

KFNF, Shenandoah, Iowa (263m-1140kc), 7 p. m., Scotch concert; 11, old time fiddling.

KFVE, University City, Mo. (240m-1250kc), 9:15 p. m., Lincoln entertainers, studio organists, Solon Nealey, harmonica duo.

KLDS, Independence, Mo. (440.9m-680kc), 8 p. m., studio program.

KMA, Shenandoah, Iowa (252m-1190kc), 9-11 p. m., pipe organ recital, William Howie.

KMOX, St. Louis, Mo. (280.2m-1070kc), 12:30 p. m., organ recital, Arthur Utt; 3, string ensemble, soloists; 6, organ recital, Arthur Utt; 6:30, Mrs. Jaques Landree, organist; 7, orchestra; Mrs. James Burgin, violinist; 8, mixed program; James Haley, old-time fiddler; 9, orchestra, "Colonel 6121", Fred Nordman, songsters; 10, orchestra.

KPRC, Houston, Texas (296.9m-1010kc), 12 noon, Sylvan Beach entertainers, Ceell Sisson; 7:30 p. m., Universal Bible class; 8, Frank Tilton, pianist; 10, The Phantoms, "ghost of the air"; 11, dance music.

KSD, St. Louis, Mo. (545.1m-550kc), 7 p. m., New Grand Central theater orchestra.

KTHS, Hot Springs National Park, Ill. (374.8m-800kc), 9-9:45 p. m., Eastman hotel orchestra; 9:45-9:50, the Phantom voice; 9:50-10:30, Arkansas Traveler male quartet; 10:30-11:15, New Arlington hotel orchestra.

KYW, Chicago, Ill. (535.4m-560kc), 1 p. m., Commonwealth Edison company concert; 1-2, Joska DeBabary and his orchestra, Congress hotel; Coon-Sanders orchestra; 4, frolic, KYW; 6-7, dinner music, KDKA; 8:30-11:30, Congress classic, KYW; 1 a. m., Congress carnival, KYW; 1-2 a. m., "Insoulia club"; Sanders original Nighthawks, Congress hotel.

WAMD, Minneapolis-St. Paul, Minn. (243.8m-1230kc), 6:15 p. m., George Osborn and his orchestra; 7:10, popular musical program; Harmony twins, Fred Roble, Bob Melcher, orchestra; 11:30, organ recital, Clifford Perry.

WBAP, Fort Worth, Tex. (475.9m-630kc), 12:05-12:30 p. m., musical program; 6-6:30, Chief Gonzales' Texas hotel orchestra; 7:30-8:30, musical numbers, Mrs. W. D. Smith; 9:30-11, Hired Hands' little symphony.

WBBM, Chicago, Ill. (226m-1330kc), 4-6 p. m., Harry and Sandy; Court Banks; Johnny Black; Russell Meyers; Jack Pennewell and Freddy Palmer; 8-9:30, Jack Crawford's Alemito orchestra; Barber Shop Three; 9:30-11, Sandy and Harry; Moulton Rouge orchestra; William E. Anderson, steel guitarist; Sy Berg; Fred Jacobson, 11-2 a. m., Sunset quartet; Two Jays; Charle Garland; Spencer, Lavergne and Shayne, xylophonists; Barber Shop Three; Jack Crawford's Alemito orchestra, Claire Matthews; Lloyd Falch; Arlston trio.

WCCO, Minneapolis-St. Paul, Minn. (416.4m-720kc), 12:30 p. m., Emmet Long's Golden Pheasant orchestra; 6:15, Dick Long's Nankin cafe orchestra; 8:15, musical program; 10:05, Dick Long's Nankin cafe orchestra.

WDAF, Kansas City, Kan. (365.6m-820kc), 3:30-4:30 p. m., Star's string orchestra; 6-7, organ music, Pantages theater; Trianon ensemble; 11:45, Nighthawk frolic.

WEBH, Chicago, Ill. (370.2m-810kc), 3-4 p. m., special features; 7, Oriole orchestra; 8, Dorothy Herman Blum, soprano; 9, Oriole orchestra; 9:45, James Murray, tenor; Oriole marimba band; 11, Oriole orchestra, 12, James Murray, tenor; 1 a. m., Pat Ward, songs; 2, Frank Greif, songs.

WFAA, Dallas, Tex. (475.9m-630kc), 3:30-4 p. m., Raymond Roy Harrison, pianist and singer; 4:30-5, Noel Shaw, pianist; Fred Priest, singer; 6:30-7:30, Baker hotel orchestra; 8:30-9:30, Woodmen of World program; 11-12, Jack Gardner's orchestra.

WGES, Oak Park, Ill. (250m-1200kc), 5-7 p. m., baritone, basso, pipe organ; 8-9, orchestra, organ, contralto; 11-1 a. m., organ, comedian, tenor, features.

WGN, Chicago, Ill. (302.8m-990kc), 12:40-2:30 p. m., Drake concert ensemble, Blackstone string quintet; 2:30-3, Lyon and Healy artists; 3:30-4:15, tea time music, Marshall Field's tea room orchestra; 4:30-5,

organ recital, Edward Benedict; 6:30-7, dinner concert, Drake concert ensemble, Blackstone string quintet, old-time favorites; 8-9, studio program; 9-10, popular program, Freda Leonard, Jewel Barnette, Correll and Gosden; 10:10-10:20, old-time favorites; 10:20-10:40, the playshop.

WHAS, Louisville, Ky. (399.8m-750kc), 3:30-4 p. m., Louisville Music and Radio company; 4-5, Harmonica band; 7:30-9, Barney Rapp's orchestra; "Stabat Mater," choir.

WHT, Chicago, Ill. (399.8m-750kc), 10 a. m., Jean Sargent's program; juvenile program and studio features; 11, Mike Rizzo, boy violinist; 12, organ recital, Al Carney; 6 p. m., classical program; Al Carney, organist; Grayling's string trio; W. A. Dyckman, basso; Leola Aikman, soprano; Hugh Aspinwall, tenor; (238m-1260kc), 7:45-9:15, musical features, Cinderella cafe orchestra; (399.8m-750kc), 9:30, Kitchen Klenzer; 9:50, symphony; 10:30, Cinderella cafe orchestra; 12, "Four Hour League," Pat Barnes and Al Carney.

WIBO, Chicago, Ill. (225.4m-1330kc), 2-4 p. m., program for shut-ins; Ted Florito, pianist; Dan Russo, violinist; Marie Tully, songs; readings, Wayne Myers; Lenore Friedman, soprano; Pearl Holtzman, pianist; Walter Barnitz, tenor; Ed Sander, baritone; Howard Payne, banjoist; Jarvis and Creedan, songster; 6-8, Robert Wessling, baritone; Ruth Ford, contralto; Mrs. Fay, soprano; Ruth Buhl Flick, reader; Frances Scheib, soprano; S. Leonard, baritone; WIBO string trio.

WJJD, Mooseheart, Ill. (370.2m-810kc), 12-1 p. m., Palmer House symphonic players; Palmer House trio, 2-3, Howard L. Peterson, organist; 4-5, Palmer House quintet; 5:30-7, dinner hour; 8-9, Palmer House Victorians; 10-11, Palmer House Victorians; 12-1 a. m., Palmer House Victorians; Jack Nelson.

WKRC, Cincinnati, Ohio (325.9m-920kc), 10 p. m., Marion McKay and his orchestra; 11, Marie Turner, blues singer; 11:15, Marion McKay and his orchestra.

WLIB, Chicago, Ill. (302.8m-990kc), 7-7:20 p. m., Uncle Walt's Punch and Judy show; 7:20-7:30, Correll and Gosden; 7:30-8, studio program; 11-11:20, Correll and Gosden; 11:20-1 a. m., dance music; Correll and Gosden.

WLS, Chicago, Ill. (344.6m-870kc), 1 p. m., dinnerbell program; 12, national burn dance and WLS "Twin-Wheeze."

pepper, blues singer; John Thorwald, baritone; J. Elliott Frank, Radio poet laureate; 6-7, Jack Gardner's orchestra; 8-9, original spirituals, David Gulon; 12-1 a. m., organ, George Perfect.

WSAI, Cincinnati, Ohio (325.9m-920kc), 7:50 p. m., WSAI Radio chime concert, Robert Badgley; 8:15, Bicycle Playing Card sextet; 12, Freda Sanker's orchestra.

WSB, Atlanta, Ga. (428.3m-700kc), 8 p. m., Atwater Kent; 10:45, Hired Help Skyark.

WSM, Nashville, Tenn. (282.6m-1060kc), 6:30 p. m., Francis Crag's orchestra; 8, barn dance program and other features.

WSOE, Milwaukee, Wis. (245.8m-1220kc), 3 p. m., musical program, Fourth Annual Home show; 8, Fourth Annual Milwaukee Home show frolic.

### Mountain Time Stations

KFAU, Boise, Idaho (280.2m-1070kc), 8 p. m., musical program.

KFWA, Ogden, Utah (261m-1150kc), 4-5 p. m., organ recital, Paramount theater; 5-8, Ogden Radio dealers program; 9-10:30, music, Paramount theater; 10:30-12, Olive Reeves and his orchestra.

KFXF, Colorado Springs, Colo. (250m-1200kc), 8:30 p. m., dance music, Rosemary Gardens.

KOA, Denver Colo. (322.4m-930kc), 12:15 p. m., Rialto theater organ recital, Marjorie Nash; 9, dance program, Harmony Peerless orchestra; 10:30, Scheurman's Colorado orchestra.

### Pacific Time Stations

KFI, Los Angeles, Calif. (467m-640kc), 5:30-6 p. m., Harmony duo; 6, nightly doings; 6:30, vest pocket program; 6:45, Radiatorial period; 7-8, Al Wesson's dance orchestra; 8-9, Robert Hurd, tenor; 9-10, Hollywood string quartet; 10-11, Packard Radio club; 11-3 a. m., KFI midnight frolic.

KFOA, Seattle, Wash. (454.3m-660kc), 7-8:15 p. m., musical program; 8:30-9:30, all-artist program; 9:30-11, Jackie Souder's Club Lido serenaders.

KFON, Long Beach, Calif. (322.4m-1280kc), 8-6:30 p. m., Brayton's theater organ; 7-7:30, studio program; 7:30-9, Long Beach Municipal band; 9-11, KFON artists' frolic.

KFWB, Hollywood, Calif. (252m-1190kc), 6-7 p. m.,

KMTR, Hollywood, Calif. (238m-1260kc), 6-7 p. m., Starr Piano company studio; 8-10, KMTR concert orchestra, Edmund Foerstel, guest conductor.

KNX, Hollywood, Calif. (336.9m-890kc), 5:30 p. m., Leighton's orchestra; 6:30-7, Atwater Kent orchestra; 7:30-10, KNX feature program; 10-11, Ambassador hotel dance orchestra; 11-3 a. m., Filmland frolic.

KOWW, Walla Walla, Wash. (256.3m-1170kc), 8-12 p. m., studio program and music.

KPO, San Francisco, Calif. (428.3m-700kc), 1-2 p. m., Rudy Seiger's Fairmont hotel orchestra; 2:30-3:30, Art Brannagan and his orchestra; 3:30-5:30, Cyrus Trobbs' Palace hotel orchestra; 6:35-7:30, Waldemar Lind and the States Restaurant orchestra; 8-9, musical travelog, Deane H. Dickason; 9-12, Fairmont hotel orchestra; Maurice Gansky, tenor; Merton Bories, pianist.

KPSN, Pasadena, Calif. (315.6m-950kc), 8-9 p. m.,

KTAB, Oakland, Calif. (239.9m-1250kc), 9-9:30 a. m., prayer service; 12-1 p. m., concert.

Louise Klos trio; 9-10, dance orchestra.

## Sunday, March 21

### Headliners Today

Eastern 5 p. m.	Central 4 p. m.	Mountain 3 p. m.	Pacific 2 p. m.
WTIC (475.9m-630kc)	Organ recital.		
6:20	5:20	4:20	3:20
WCAP (468.5m-640kc)	Vesper string ensemble.		
7:20	6:20	5:20	4:20
WEAF (491.5m-610kc)	WEEL, WCAP, WOO, WJAR, WGR, WCAE, WWJ, WOC, WCCO, WGN, WEAR, KSD, WTAG, Capitol theater gang.		
8	7	6	5
WBZ (333.1m-900kc)	Music school concert.		
9:15	8:15	7:15	6:15
WEAF (491.5m-610kc)	WEEL, WCAP, WOO, WJAR, WGR, WCAE, WSAI, WWJ, WOC, WCCO, WGN, WEAR, KSD, WTAG, Atwater Kent program.		
10	9	8	7
WJZ (454.3m-660kc)	WGJ (379.5m-790kc) Godfrey Ludlow, violinist.		
10:30	9:30	8:30	7:30
WAMD (243.8m-1230kc)	Harmony Hurricanes.		
12	11	10	9
KFWB (252m-1190kc)	Movie frolic.		
KNX (336.9m-890kc)	Russian string quintet.		

Sunday, silent night for: CFAC, CHIC, CKNC, CNRA, CNRC, CNRE, CNRM, CNRO, CNRR, CNRT, CNRV, CNRW, KFAB, KFAU, KFKX, KFBU, KFOA, KFVE, KFWA, KFXF, KLX, KMA, KMTR, KOAC, KOB, KOWW, KSAC, KSD, KWSC, PWX, WABQ, WAHG, WCAD, WCAR, WCAU, WDAF, WDBO, WEAQ, WEEB, WEBW, WFI, WGBF, WGES, WGHV, WGRP, WGST, WHAD, WHAS, WHAZ, WIP, WHJZ, WJJD, WJR, WKAF, WKAQ, WKAR, WMAQ, WMAZ, WMC, WNYC, WOI, WRC, WRVA, WSB, WSM, WTAM.

### Eastern Time Stations

CHIC, Toronto, Can. (356.9m-840kc), 5 p. m., George H. Graham, organist.

CKCL, Toronto, Can. (357m-840kc), 3-4 p. m., Hopo United church; 4-4:55, service for men, Central Y. M. C. A.

KDKA, Pittsburgh, Pa. (309.1m-970kc), 11 a. m., services; 4 p. m., organ recital, Dr. Charles Heinrich; 4:45, services, Shattside Presbyterian church; 6:30, dinner concert; 7:15, chimes, Calvary Episcopal church; 7:45, services.

WBAL, Baltimore, Md. (245.8m-1220kc), 6:30-7:30 p. m., twilight program, WBAL concert orchestra.

WBRR, New York, N. Y. (272.6m-1100kc), 10 a. m., Watchtower instrumental trio; Fred Twarosch, tenor;



# CLAUDIA MUZIO OVER WEAF CHAIN

## Sunday, March 21

I. B. S. A. choral singers; Bible lecture, Judge Rutherford; 2 p. m., Sunday concert, talk; 9, evening service.

**WBZ, Springfield, Mass. (333.1m-900ke), 10:45 a. m.**, Church of the Unity music Philharmonic male quartet; 6 p. m., Golden Rule hour of music; Ary Dulger, violinist; Alexander Blackman violist; George Brown, cellist; Hans Ebell, pianist and assisting soloists; 7, Copley Plaza orchestra; 8, concert, Al Newton music school; Edith Magrath, contralto; Anna MacKinnon, soprano; Marion Horner, contralto; Mary Pueclarell, violinist; string quartet, Donald Dewire, Sigmund Romaszewicz, Harold McNeil; Frederick Bradshaw, accompanist; Alice A. Glover and Alice Nay; 9, William Self, organist; Norman V. Moon, tenor; Florence



One of the Jays of WBBM, Chicago, is Corinne Jordan, accompanist, above. Coming events cast their shadows before them. This time the immense outline on the right is Jack Crawford, leader of the Alemitte orchestra at WBBM.

9:15, Parody orchestra; 10:30, Twin Oaks orchestra; 10:45, Arthur West's sirens.

**WOO, Philadelphia, Pa. (508.2m-590ke), 2:15 p. m.**, musical exercises, Bethany Sunday school; 6, organ recital, Clarence K. Bawden; 7:30, services, Bethany Presbyterian church; 9:15, WEAF.

**WPG, Atlantic City, N. J. (299.8m-1000ke), 3:15 p. m.**, Arthur Scott Brook, organist; Mrs. Fred Plum, soprano; 4:15, St. James Episcopal church; 9:15, Hotel Ambassador concert orchestra; 10, Arthur Scott Brook, organist; William Neilson, bass.

**WREO, Lansing, Mich. (285.5m-1050ke), 10 a. m.**, chimes, Plymouth Congregational church; 10:30, Plymouth Congregational church; 7 p. m., Central M. E. church.

**WTAG, Worcester, Mass. (268m-1120ke), 4-5:30 p. m.**, men's conference; 7:20-9:15, WEAF; 9:15-10:15, WEAF.

**WTIC, Hartford, Conn. (475.9m-630ke), 5 p. m.**, Prof. Harry B. Jepson, organist; 9, Nevada Van der Veer, contralto; Sascha Jacobsen, violinist.

**WWI, Detroit, Mich. (352.7m-850ke), 10:30 a. m.**, Temple Beth El; 2 p. m., Detroit News orchestra; 4, organ recital; 7:20, Capitol theater family; 9:15, operatic stars.

### Central Time Stations

**KFAB, Lincoln, Nebr. (340.7m-880ke), 4-5 p. m.**, vesper services; 9-11, musicale.

**KFKU, Lawrence, Kan. (275m-1090ke), 4 p. m.**, third all-musical Fine Arts vesper, Fraser hall.

**KFMX, Northfield, Minn. (336.9m-890ke), 7-8 p. m.**, vespers.

**KFNF, Shenandoah, Iowa (263m-1140ke), 10:45 a. m.**, First M. E. church; 2:30 p. m., Golden Rule song service; 6:30, service, Golden Rule circle; 7:30, Christian church.

**KFRU, Columbia, Mo. (499.7m-600ke), 7:30 a. m.**, service; 9:20, Burrall Bible class; 7:30 p. m., Columbia Baptist church.

**KLDS, Independence, Mo. (440.9m-680ke), 11 a. m.**, Stone church; 3 p. m., program, William Jewell college; James A. Yates, baritone; Kathleen Kelly, violinist; Mildred Norcoroff, pianist; R. K. Burehard, reader; 6:30, Vesper service; mixed quartet; Nina Smith soprano; Lulu Lentell Tyrell, contralto; George Anway; tenor; Frank Russell, bass; 9:15, Men's

10:50 a. m., Plymouth Congregational church; 3 p. m., Bible study; 4:10, House of Hope Presbyterian church; 6:20, Second Church of Christ, Scientist; 8:15, WEAF.

**WEBB, Chicago, Ill. (370.2m-810ke), 10:40-12 noon**, Seventh Church of Christ, Scientist; 5-6 p. m., twilight musical; 7-9, selected artists' program.

**WFAA, Dallas, Tex. (475.9m-630ke), 6-7 p. m.**, Bible class, First Presbyterian church; 7:30-8:30, First Methodist Episcopal church; 8:30-9:30, sacred music recital; Cyrus Barcus, cornetist; 11-12, Ligon Smith and his orchestra.

**WGES, Oak Park, Ill. (250m-1200ke), 10:15-12 noon**, services, Austin M. E. church; organ choir; 5-7:40 p. m., Moody Bible school program, pipe organ; 11-12, organ, mezzo-soprano.

**WGN, Chicago, Ill. (302.8m-990ke), 11:45-1 p. m.**, Chicago theater organ recital; 1-2, Chicago theater performance; 2-3, Lyon and Healy organ recital, soloists; 3-4, Chicago Philharmonic orchestra; 4-5, Chicago Musical college concert; 8:15-9:15, WEAF; 9:15-10, popular program; 10-10:10, Sam 'n' Henry; 10:10-10:20, old-time favorites; 10:20-11, popular program.

**WHAD, Milwaukee, Wis. (275m-1090ke), 3:15 p. m.**, Milwaukee Turnverein symphony orchestra.

**WHAS, Louisville, Ky. (399.8m-750ke), 10 a. m.**, Virginia Avenue Methodist church; 4:30-5:30 p. m., choral service.

**WHB, Kansas City, Mo. (365.6m-820ke), 9:40-10:45 a. m.**, Linwood Boulevard Christian church; 11:15-12:30, Independence Boulevard Christian church; 8-9:14 p. m., service; 11:15-1 a. m., Linwood theater Radio feature, Morrill Moore, organist; Don Anchors, "poet of the common folks."

**WHO, Des Moines, Iowa (526m-570ke), 11 a. m.**, services, St. Ambrose cathedral; 7:30-8:15 p. m., Bankers Life trio; Myrtle Williams, soprano; Stewart Watson, haritone; 11-12, Bankers Life Little Symphonie orchestra.

**WHT, Chicago, Ill. (399.8m-750ke), 12 m.**, Sunday dinner sacred concert, vocal and organ; 12:45, special program for shut-ins and sick; 1:15, shepherd time for the kiddies; 1:30, Aerial Girls program; 1:45, Radio Rangers; 2, fellowship program; 2:30, missionary program; 2:45, orchestra concert and afternoon services; Chicago Gospel tabernacle; 5:30, vesper concert; 6, young women's council; 6:30, concert, tabernacle band and choir; sermon, Paul Rader; 9:30, request program; 10:30, Paul Rader, back home hour.

Palmer little symphony orchestra, Erwin Swindell; Paul Viperman, tenor; 8:30-7, services; 8:15-9:15, WEAF; 10-11:30, musical program, Palmer little symphony; soloists.

**WOK, Chicago, Ill. (217.3m-1300ke), 1-2 a. m.**, Tearney's Town club orchestra; Carl Lorraine's Pershing Palace orchestra; Husk O'Hare's Coconut Grove orchestra; 6-1 a. m., Tearney's Town club orchestra; Carl Lorraine's Pershing Palace orchestra; Husk O'Hare's Coconut Grove orchestra; Capitol theater musical; studio program.

**WORD, Batavia, Ill. (275m-1090ke), 10 a. m.**, I. B. S. A. service; 2:30 p. m., Chicago Rapid Transit company; 3:30, Bible lecture; 6, I. B. S. A. service; 6:30, Uncle Sam; 8:45, Webster trio; 9, I. B. S. A. service; Webster trio and I. B. S. A. choral singers.

**WOS, Jefferson City, Mo. (440.9m-680ke), 9:30 a. m.**, Christian church; 5 p. m., vesper service; 7:30, First Christian church.

**WQJ, Chicago, Ill. (447.5m-670ke), 9:30-11:30 a. m.**, services, Peoples church, Dr. Preston Bradley; choir; Clarence Eddy, organist; 3-4 p. m., St. Ita's senior choir, boys' choir; Mrs. William O'Grady, organist; violin duets, solos, trios, quartet selections; 8-10, Jack Chapman and his Rainbo Gardens orchestra; Henrietta Nolan, violinist; Jeannette Van Lennep, mezzo-soprano; Ascan W. Kittner, pianist and baritone; Lorena Anderson, soprano.

**WRR, Dallas, Tex. (245.8m-1220ke), 10:45 a. m.**, First Baptist church; 7:30 p. m., First Baptist church; 9-10, Elk chanters.

**WSAI, Cincinnati, Ohio (325.9m-920ke), 3-4:30 p. m.**, WEAF; 7:45, WSAI Radio chime concert, Robert Badgley; 8, sermonette; 8:15, WEAF.

**WSB, Atlanta, Ga. (428.3m-700ke), 5 p. m.**, Oakhurst Presbyterian church; 3, North Avenue Presbyterian church.

**WSM, Nashville, Tenn. (282.8m-1060ke), 10:30 a. m.**, First Presbyterian church.

**WSOE, Milwaukee, Wis. (245.8m-1220ke), 7:30 p. m.**, services, M. E. church.

### Mountain Time Stations

**KFXF, Colorado Springs, Colo. (250m-1200ke), 11 a. m.**, First Presbyterian church; 5 p. m., "Penitence—Pardon—Peace," Maude choir; 7:30, First Methodist church.

**KOA, Denver, Colo. (322.4m-930ke), 11 a. m.**, First Baptist church; 3 p. m., music hour; KOA orchestra and station artists; 7:45, First Baptist church.

**KUOM, Missoula, Mont. (243.8m-1230ke), 9:15 p. m.**, religious and classical music; sermon, Rev. G. W. Shepard.

### Pacific Time Stations

**KFI, Los Angeles, Calif. (467m-640ke), 4-5 p. m.**, vesper service; 6:30, nightly doings; 7-7:30, program, A. H. Grebe and company, Synchrophase string ensemble; 7:30-8, Robert Hurd, tenor; Clara Belle Patten Wallace, contralto; 8-9, Dan L. McFarland, organist; 9-10, Harry Keiper's Movieland dance orchestra; 10-11, Packard Six dance orchestra.

**KFN, Long Beach, Calif. (232.4m-1280ke), 2:30-4 p. m.**, Long Beach Municipal band; 7:45-9, service, First Church of Christ, Scientist; 9-10, Bert Pedersen's dance orchestra.

**KFWB, Hollywood, Calif. (252m-1190ke), 9-11 p. m.**, Sunday night movie frolic, Jack Smith's dance orchestra.

**KGO, Oakland, Calif. (361.2m-830ke), 11 a. m.**, First Presbyterian church; 3:30 p. m., KGO Little Symphony orchestra; James Gerard, tenor; 7:30, First Presbyterian church.

**KHJ, Los Angeles, Calif. (405.2m-740ke), 4-5 p. m.**, Masonic service; 7-8, First Methodist Episcopal church; 8-10, program, Martin Music company; Ruth Pitts, soprano; John Martin, concert pianist.

**KIR, Seattle, Wash. (384.4m-780ke), 11-12:30 p. m.**, First M. E. church; 5-6, Spargur string quartet; 7:15-7:30, organ recital, Mrs. Montgomery Lynch; 7:30-9, First M. E. church; 9-10:30, Puget Sound Savings and Loan association orchestra.

**KNX, Hollywood, Calif. (336.9m-890ke), 12:45-1:45 p. m.**, Paul Einstein's concert orchestra; 2-4, City Park Board program from Westlake Park; 6:30-7, Unitarian church service; 8-9, First Presbyterian church of Hollywood; 9-10:30, program, Beverly Hills Nurseries; Russian string quartet.

**KPO, San Francisco, Calif. (428.3m-700ke), 9:45-10:45 a. m.**, services; 5-6 p. m., Marshall W. Giselman, organist; 6-6:30, Waldemar Lind and the States Restaurant orchestra; 6:35-8:35, Palace Hotel orchestra; 8:35-10, Rudy Seiger's Fairmont hotel orchestra.

**KPSN, Pasadena, Calif. (315.6m-950ke), 8:45-9:45 p. m.**, Maryland Artists' ensemble.

**KTAB, Oakland, Calif. (239.9m-1250ke), 11-12:30 p. m.**, church service; 7:45-9:15, church service; 9:30-11, concert.

## Monday, March 22

### Headliners Today

Eastern 4 p. m.	Central 3 p. m.	Mountain 2 p. m.	Pacific 1 p. m.
WIP (394.5m-760ke)	"Japan," talk.	7:30	4:30
WFAA (475.9m-630ke)	The Gleeman.	8:30	5:30
WBAP (475.9m-630ke)	Harmonic Professional quartet.		
WBZ (333.1m-900ke)	Marinbaphone concert.		
WMAK (265.3m-1130ke)	New Olympic theater program.		
		7	6
WBZ (333.1m-900ke)	Composers' night.		
WHAZ (379.5m-790ke)	Grand concert, vocal society.		
WTIC (475.9m-630ke)	Marjorie Kay entertainers.		
		7:10	6:10
WOS (440.9m-680ke)	Spring program.		
		9	7
KPRC (296.9m-1010ke)	Kiwars' glee club.		
KSD (545.1m-550ke)	Double-bano artist's recital.		
WEAF (491.5m-610ke)	WOO, WJAR, WCAP, WTAG, WCAE, WSAI, Grand opera, "Le Nozze di Figaro."		
WGST (270m-1110ke)	Georgia Tech. glee club.		
WTZ (454.8m-660ke)	Arion male chorus.		
		8:30	7:30
WGR (319m-940ke)	Popular two-piano program.		
WTIC (475.9m-630ke)	Beethoven program.		
		11	8
WSAI (325.9m-920ke)	Community program.		

Munday, silent night for: CNRA, CNRC, CNRE, CNRM, CNRO, CNRR, CNRT, CNRV, CNRW, KFAU, KFDK, KFEQ, KFMX, KFWA, KHJ, KLDS, KPSN, KUOA, KYW, WBBM, WBCN, WCAD, WCBQ, WCAO, WEBB, WEBJ, WEBW, WENR, WGBS, WJGS, WKAQ, WHAS, WHT, WIBO, WIP, WIAZ, WJED, WGN, WLBB, WLS, WMAQ, WMBB, WQAI, WOC, WOK, WORD, WQJ, WRC, WREO.

### Eastern Time Stations

**CKNC, Toronto, Can. (356.9m-840ke), 10-12 p. m.**, Toronto Conservatory of Music, instrumental trio; Frank Blachford, violinist; Leo Smith, cellist; Alberto Guerrero, pianist; Verdi mixed quartet.

**KDKA, Pittsburgh, Pa. (309.1m-970ke), 12:20 p. m.**, Trinity church Lenten service; 6:30, dinner concert; 9, Ruid light opera hour.

**WBAL, Baltimore, Md. (245.8m-1220ke), 6:30-7:30 p. m.**, WBAL dinner orchestra; 7:30-8, Frederick Weaver, organist; 8-9, Melvin Moritz, baritone; Paul Hoegan,



chorus; Robert Miller, organist; Elizabeth Tanner Hitchcock, soprano.

**KMA, Shenandoah, Iowa (252m-1190ke), 12:15-1:15 p. m.**, service; 4, church choir music; 5, Bible class.

**KNOX, St. Louis, Mo. (280.2m-1070ke), 9 p. m.**, popular program, Skouras Brothers' Sunday Night club.

**KPRC, Houston, Texas (296.9m-1010ke), 7:30 p. m.**, South Main Baptist church; 9:30, Baytown Band of Humble Oil and Refining company.

**KSD, St. Louis, Mo. (545.1m-550ke), 8:15 p. m.**, WEAF.

**KYW, Chicago, Ill. (535.4m-560ke), 11 a. m.**, Central church; 2:30 p. m., chapel service, Chicago church federation; 4:30, studio concert; 7, Chicago Sunday Evening club service; 9:30, classical concert, Commonwealth Edison company.

**WAMD, Minneapolis, Minn. (243.8m-1230ke), 10:30 a. m.**, First Unitarian church; 2:45 p. m., popular musical program; 6:15, George Osborn and his orchestra; 6:45, Arthur H. Faust, Leone Faust and their Radio stock company; 9:30, Gayle Wood, baritone hurricane.

**WBAP, Fort Worth, Tex. (475.9m-640ke), 11 a. m.**, First Presbyterian church; 5-6 p. m., Travis Avenue Baptist church; 9:30-11, Chief Gonzales' Texas hotel orchestra.

**WBBM, Chicago, Ill. (226m-1330ke), 12:30-2 p. m.**, classical program; William P. Zimmer, tenor; Harold Morava, lyric tenor; Kantor A. Krutz; Sandy Meek and Harry Sosnik; Edna Wheeler Ballard, harpist; Little Caruso and the Moulin Rouge operatic quartet; 4-6, Tip trio; Jack Crawford's Alemitte orchestra; Barber Shop Three; Ziegler Sisters; Two Jays; Harold Anderson; Charlie Garland; Rudy Winter; Floyd Faleh; 8-10, Jack Crawford's orchestra; quartet; Maurice Silverman; Paulino Stiffler A-Bass, violinist; Rudy Winter; Floyd Faleh; Hazel McBroom; 12-2 a. m., Nutty club.

**WCAI, Northfield, Minn. (336.9m-890ke), 8:30 a. m.**, Norwegian church service; 9:15, evening service.

**WCBD, Zion, Ill. (344.6m-870ke), 8 p. m.**, mixed quartet, celestial bells; Mrs. Crow, Ralph Bull; Florence Farrar, contralto; P. F. Reid, baritone; Esther Naffziger, pianist; Ruth Beem, reader.

**WCCO, Minneapolis-St. Paul, Minn. (416.4m-720ke),**

**WIBO, Chicago, Ill. (225.4m-1330ke), 2-4 p. m.**, Sunday afternoon concert, faculty Uptown Conservatory of Music; 6-8, dinner concert; WIBO quartet and trio; 10-12, popular program; Russell Duke; Elsie Orr, soprano; Eugene Wallenius, baritone; Marie Tully, songs; Wayne Myers, reader; Erwin Cornelius, songs with uke; William Anderson, steel guitarist; Lenore Friedman, soprano; Pearl Holtzman, pianist.

**WJJD, Mooseheart, Ill. (370.2m-810ke), 7:45 a. m.**, Catholic services; 9:40-10:30, Protestant services; 3-4 p. m., Mooseheart Sunday concert.

**WKRC, Cincinnati, Ohio (325.9m-920ke), 6:45 p. m.**, services, Walnut Hills Christian church, Rev. J. Castleberry; sacred music, instrumental and vocal; 10, Kodet classical program; 11:15, dance program, Marion McKay and his orchestra.

**WLBB, Chicago, Ill. (302.8m-990ke), 5-6 p. m.**, chamber musical program.

**WLS, Chicago, Ill. (344.6m-870ke), 6 p. m.**, prelude; 7-7:55, WLS Little Brown church in the vale; WLS studio trio; Ralph Emerson, organist.

**WLW, Cincinnati, Ohio (422.3m-710ke), 9:30 a. m.**, school, editorial staff of Sunday school publications; 11, Seventh Presbyterian church, Jesse Halsey, minister; 3 p. m., choir; Latonia Baptist church; 7:30, services, First Presbyterian church; 8:30, a "Spring" program, H. & S. Pogue company orchestra.

**WMBB, Chicago, Ill. (250m-1200ke), 3-5 p. m.**, Trianon orchestra; Woodlawn theater orchestra; Lucille O'Hara; Bob Duffy; Tommie Hughes, Ted Graham, popular concert; 7:40-9, Fifth Church of Christ, Scientist; 9-11, Trianon orchestra; Woodlawn theater orchestra; Scetty Welch, Madison Sisters; Billie Allen Hoff; Johnnie Miller; the Wonder Harmony boys.

**WMC, Memphis, Tenn. (499.7m-600ke), 10:30 a. m.**, Second Presbyterian church.

**WOAI, San Antonio, Tex. (394.5m-760ke), 11 a. m.**, First Presbyterian church; 7:30 p. m., Central Christian church; 9:30, Super-heterodyne hour of music.

**WOAW, Omaha, Nebr. (526m-570ke), 9 a. m.**, chapel service; 1:30 p. m., matinee program; 6, Bible study period; 9, chapel service.

**WOC, Davenport, Iowa (483.6m-620ke), 1-2:30 p. m.**,

# MARIA JERITZA, EMILIO DE GOGORZA

## POPULAR CONCERTS INDEX

Saturday, March 20			
Eastern 7:30 p. m.	Central 6:30 p. m.	Mountain 5:30 p. m.	Pacific 4:30 p. m.
WFAA			
WAMD, WLS	7	6	5
WBBM, WEAQ, WENR, WGBS, WLS, WMAQ, WNYC	8	7	6
10	9	8	7
KFAB, KPRC, WBBM, WEBH, WENR, WGN, WLS, WMBB, WREO	9	8	7
11	10	9	8
KFVE, KPWB, KNX, KTHS, WBBM, WMBB, WOK, WQJ, WRC	12 m.	10	9
12 m.	11	10	9
1 a. m.	12 m.	11	10
2	1 a. m.	12 m.	11
3			
4			
5			
6			
7			
8			
9			
10			
11			
12			
1 a. m.			
2			
3			
4			
5			
6			
7			
8			
9			
10			
11			
12			
1 a. m.			
2			
3			
4			
5			
6			
7			
8			
9			
10			
11			
12			
1 a. m.			
2			
3			
4			
5			
6			
7			
8			
9			
10			
11			
12			
1 a. m.			
2			
3			
4			
5			
6			
7			
8			
9			
10			
11			
12			
1 a. m.			
2			
3			
4			
5			
6			
7			
8			
9			
10			
11			
12			
1 a. m.			
2			
3			
4			
5			
6			
7			
8			
9			
10			
11			
12			
1 a. m.			
2			
3			
4			
5			
6			
7			
8			
9			
10			
11			
12			
1 a. m.			
2			
3			
4			
5			
6			
7			
8			
9			
10			
11			
12			
1 a. m.			
2			
3			
4			
5			
6			
7			
8			
9			
10			
11			
12			
1 a. m.			
2			
3			
4			
5			
6			
7			
8			
9			
10			
11			
12			
1 a. m.			
2			
3			
4			
5			
6			
7			
8			
9			
10			
11			
12			
1 a. m.			
2			
3			
4			
5			
6			
7			
8			
9			
10			
11			
12			
1 a. m.			
2			
3			
4			
5			
6			
7			
8			
9			
10			
11			
12			
1 a. m.			
2			
3			
4			
5			
6			
7			
8			
9			
10			
11			
12			
1 a. m.			
2			
3			
4			
5			
6			
7			
8			
9			
10			
11			
12			
1 a. m.			
2			
3			
4			
5			
6			
7			
8			
9			
10			
11			
12			
1 a. m.			
2			
3			
4			
5			
6			
7			
8			
9			
10			
11			
12			
1 a. m.			
2			
3			
4			
5			
6			
7			
8			
9			
10			
11			
12			
1 a. m.			
2			
3			
4			
5			
6			
7			
8			
9			
10			
11			
12			
1 a. m.			
2			
3			
4			
5			
6			
7			
8			
9			
10			
11			
12			
1 a. m.			
2			
3			
4			
5			
6			
7			
8			
9			
10			
11			
12			
1 a. m.			
2			
3			
4			
5			
6			
7			
8			
9			
10			
11			
12			
1 a. m.			
2			
3			
4			
5			
6			
7			
8			
9			
10			
11			
12			
1 a. m.			
2			
3			
4			
5			
6			
7			
8			
9			
10			
11			
12			
1 a. m.			
2			
3			
4			
5			
6			
7			
8			
9			
10			
11			
12			
1 a. m.			
2			
3			
4			
5			
6			
7			
8			
9			
10			
11			
12			
1 a. m.			
2			
3			
4			
5			
6			
7			
8			
9			
10			
11			
12			
1 a. m.			
2			
3			
4			
5			
6			
7			
8			
9			
10			
11			
12			
1 a. m.			
2			
3			
4			
5			
6			
7			
8			
9			
10			
11			
12			
1 a. m.			
2			
3			
4			
5			
6			
7			
8			
9			
10			
11			
12			
1 a. m.			
2			
3			
4			
5			
6			
7			
8			
9			
10			
11			
12			
1 a. m.			
2			
3			
4			
5			
6			
7			
8			
9			
10			
11			
12			



# ZA TO SING FRIDAY OVER WJZ CHAIN



**WKAF, Milwaukee, claims a pianist whose playing has charmed Kings and Queens. Viola Sontag, above, is the artist whose appearances at this station have been well received by her invisible audience. In the center is Willie the Weeper, or Ernest Rogers of WSB, Atlanta.**

## DANCING

### Central Time

**Saturday, March 20:**  
Wjr, Wnye, Wpg; 10, Waa; 8:55, Wgy; Wbbh, Wwb, Wmbb, Wye, Wreo; 9:10, Kths; 9:30, Kths, Wgbs; 9:30, Kths, Wgbs; 9:30, Wre; 10, Kfve; wa, Koa, Kpo, Weaf; 9:30, Wre, Wwta; 10:05, Wcco; 10:30, Wama; 10:45, Wgbs; 11, Kkg, Kwa, wb, Kpo, Webb, Wfaa; 9:30, Wwo, Woc; 11:30, oa; 11:45, Wdaf; 12, wa, Kgo, Kgw, Knx, gbu, Wjld.

**Monday, March 22:**  
S, gep; 9, Weel, Wgbu; 9:30, Wama; 9:35, Wba; 9:35, Wnye; 10, Ww, Wbbm, Wwaf; 10:45, Wba; 10:50, Kfoa, Wwep; 11, Kgw, Koll; 11:30, Wgo, Wgr, Wwh; 11:45, Wdaf; 12, Kx, Kpo.

**Tuesday, March 23:**  
Webb, Wgbu, Wmbb; 9:30, Wgbs, Wgy; 9:35, Wnye; 10, Ww, Wbbm, Wwaf; 10:45, Wba; 10:50, Kfoa, Wwep; 11, Kgw, Koll; 11:30, Wgo, Wgr, Wwh; 11:45, Wdaf; 12, Kx, Kpo.

**Wednesday, March 24:**  
Wex, Wbbh, Wgbu; 9:30, Wba; 9:35, Wba; 9:35, Wnye; 10, Ww, Wbbm, Wwaf; 10:45, Wba; 10:50, Kfoa, Wwep; 11, Kgw, Koll; 11:30, Wgo, Wgr, Wwh; 11:45, Wdaf; 12, Kx, Kpo.

**Thursday, March 25:**  
Wjr, 9, Webb, Weel; 9:30, Wba; 9:35, Wba; 9:35, Wnye; 10, Ww, Wbbm, Wwaf; 10:45, Wba; 10:50, Kfoa, Wwep; 11, Kgw, Koll; 11:30, Wgo, Wgr, Wwh; 11:45, Wdaf; 12, Kx, Kpo.

**Friday, March 26:**  
Wjr, 9, Webb, Weel; 9:30, Wba; 9:35, Wba; 9:35, Wnye; 10, Ww, Wbbm, Wwaf; 10:45, Wba; 10:50, Kfoa, Wwep; 11, Kgw, Koll; 11:30, Wgo, Wgr, Wwh; 11:45, Wdaf; 12, Kx, Kpo.

George H. Hemus, bass; Fred Shantz, baritone; Virginia Newman, pianist.  
**KOA, Denver, Colo.** (322.4m-930kc), 12:15 p. m., Rialto theater organ recital, Marjorie Nash; 6:30, Brown Palace string orchestra; 8:30, KOA orchestra and staff artists; 9:30, music, KOA; 9:40, "A Step on the Stairs."  
**KUOM, Missoula, Mont.** (243.8m-1230kc), 8 p. m., music.

### Pacific Time Stations

**KFI, Los Angeles, Calif.** (467m-640kc), 5:30-6 p. m., Owen Fallon's Californians; 6, nightly doings; 6:15, travel guide; 6:30, vest pocket program; 6:45, Radio-torial period; 7-8, old-time New England barn dance; 8-9, Packard Eight dance orchestra; 9-10, program, Walter M. Murphy Motors company, Misha Gegra orchestra; 10-11, program, Meiklejohn Brothers.  
**KFOA, Seattle, Wash.** (454.3m-660kc), 12:30-1:30 p. m., Lions club program; 5:15-5:30, Around the Towne; KFOA; 7-8:15, Sherman Clay and company studio program; 8:30-10, Goodrich Silvertown Cord orchestra.  
**KFON, Long Beach, Calif.** (232.4m-1280kc), 6-8:30 p. m., Brayton's theater organ; 6:30-7, amusement information; 7-8, investor's hour, with music; 8-9, Press-Telegram studio; 9-11, KFON studio program.  
**KFWB, Hollywood, Calif.** (252m-1190kc), 6-7 p. m., dinner music, Fitzgerald Music company; 7:30-8, program, Dr. Ralph Mitchell and associated dentists; "Friendly Donists" orchestra; 8-9, Bill Hatch's Oakland Country club orchestra; 9-10, program, Star Motor Car company, Million-Dollar Four orchestra; Tom Brennan, baritone; Sol Hoopii's Hawaiians; 10-11, Warner Brothers' frolic.  
**KGO, Oakland, Calif.** (361.2m-830kc), 3-4 p. m., Mildred Wright, whistler; Ellen Clarke, pianist; Mrs. J. B. Sarrett, singer; Doris Lee, pianist; 6-6:55, Wiley B. Allen company; 8, Arion trio.  
**KJR, Seattle, Wash.** (384.4m-780kc), 8:30-10 p. m., Post-Intelligencer studio program.  
**KLX, Oakland, Calif.** (508.2m-590kc), 6:30-7 p. m., Athens Athletic club orchestra; 8-9, program; 9-10:30, Lake Merritt Ducks.  
**KMTR, Hollywood, Calif.** (238m-1260kc), 7:15 p. m., Y. M. C. A. musical program; 8-10, KMTR concert orchestra, Loren Powell, director; 10-11, Starr Piano company studio.  
**KNX, Hollywood, Calif.** (336.9m-890kc), 5:30 p. m., Leighton's cafeteria orchestra; 6:30-7, Atwater Kent orchestra; 7-7:30, Mutual Motors mirth contest; 7:30-8, program, Overall's Furniture company; 8-9, program, L. W. Stockwell company; 9-10, KNX feature program; 10-11, Goodrich Silvertown Cord dance orchestra; 11-12, Ray West's Coconut Grove dance orchestra from Ambassador hotel.  
**KOWW, Walla Walla, Wash.** (256.3m-1170kc), 8-10 p. m., program Walla Walla college; 10-11, Jensen's Varsity Vagabonds.  
**KPO, San Francisco, Calif.** (428.3m-700kc), 1-2 p. m., Rudy Seiger's Fairmont hotel orchestra; 2:30-3:30, matinee program; 6:40-7, Waldemar Lind and the States restaurant orchestra; 7-7:30, Rudy Seiger's Fairmont hotel orchestra; 8-9, Uda Waldrop, organist; 9-10, KPO and KFI; 10-11, Cabirians' orchestra; 11-12, Henry Halsted's orchestra.  
**KTAB, Oakland, Calif.** (239.9m-1250kc), 12-1 p. m., concert; 8-10, program.  
**KWSC, Pullman, Wash.** (348.6m-860kc), 7:30-9 p. m., Clarkston Commercial club.

**WKAF, Milwaukee, claims a pianist whose playing has charmed Kings and Queens. Viola Sontag, above, is the artist whose appearances at this station have been well received by her invisible audience. In the center is Willie the Weeper, or Ernest Rogers of WSB, Atlanta.**

Eastern	Central	Mountain	Pacific
9 p. m.	8 p. m.	7 p. m.	6 p. m.
KDKA (309.1m-970kc) Opera quartet, Little symphony.			
WIP (508.2m-590kc) Old songs and recitations.			
WSB (428.3m-700kc) Dixie string band.			
WBAL (245.8m-1220kc) Melodies of Not So Long Ago.			
WET (365.6m-820kc) McPherson college male quartet.			
EKO (361.2m-830kc) Artur Argiewicz.			
WCCO (416.4m-720kc) "A Step On the Stairs," mystery drama.			

**Tuesday, silent night for:** CFCA, CHIC, CKNC, CKY, CNRC, CNRE, CNRD, CNRW, CNRT, KFKA, KFKA, KUOA, KFUD, KFVA, KYX, KOA, KOAC, KOB, KOWW, KUOM, KTAB, KWSC, WABQ, WABQ, WABQ, WBBR, WCAD, WCAL, WCAP, WCAP, WCAP, WHD, WHAZ, WIAD, WJAZ, WKAF, WKAQ, WLW, WMAK, WMAZ, WOI, WOS, WRVA, WSMB, WSUI, WTAM, WTIC.

### Eastern Time Stations

**CKAC, Montreal, Can.** (410.7m-730kc), 7:15 p. m., Windsor hotel dinner concert; Raoul Duquette, cellist; 8:30, special broadcast announced; 10:30, Windsor hotel grill room orchestra.  
**CNRA, Moncton, Can.** (291.1m-1030kc), 7 p. m., Juvenile program; 8, studio program; Marion Murray, pianist; Mrs. Gordon Armstrong, soprano; Prof. Joseph Surette, violinist; R. Gander, baritone; G. H. McQuarrie, banjoist; T. Walsh, contralto; 10, CNRA orchestra.  
**KDKA, Pittsburgh, Pa.** (309.1m-970kc), 12:20 p. m., Trinity church Lenten service; 6:30, dinner concert; 8:30, sacred song half hour; 9, Little Symphony orchestra; Pittsburgh opera quartet; Etta Cunningham, soprano; Sarah Logan, contralto; Malcolm Thompson, tenor; Harve Lauderbaugh, bass; 11:35, concert, Grand theater.  
**WBAL, Baltimore, Md.** (245.8m-1220kc), 6:30-7:30 p. m., WBAL dinner orchestra; 7:30-8, WBAL quartet; 8-9, musicale, Leslie Fricke, mezzo-soprano; George Bolek, pianist; James Wilkinson, baritone; 9-10, band concert; United States Naval academy band; 10-11, musical scenario, "Melodies of Not So Long Ago," Broughton Tall; vocal and instrumental artists; Joseph Swickert, narrator.  
**WEZ, Springfield, Mass.** (333.1m-900kc), 6:45 p. m., Hotel Lenox ensemble; 7:15, Hotel Kimball orchestra; 8, special features.  
**WCAE, Pittsburgh, Pa.** (461.3m-650kc), 6:30 p. m., dinner concert; 8, WEAF; 8:30 p. m., WEAF; 10, Moment's musicale; 11, Kenyon theater.  
**WCAP, Washington, D. C.** (468.5m-640kc), 7-12:30 p. m., U. S. Navy band orchestra; WEAF; dance music, Company "C," 121st Engineers, National Guard.  
**WCAU, Philadelphia, Pa.** (277.6m-1080kc), 7:30, Snellenburg Choral society; 8:15, The Three Brothers; 8:35, Theater Digest; 8:55, recital; 9, Malls' Merry minstrel; 9:30, Robert Fuser, blind Gospel singer; 10, Sam Gold, murmuring baritone; 10:30, Cathay Tea Garden dance orchestra.  
**WCX, Detroit, Mich.** (516.9m-580kc), 6-7 p. m., dinner program, Goldkette ensemble; 10-2 a. m., Red Apple club.  
**WEAF, New York, N. Y.** (491.5m-610kc), 7:45-8 a. m., morning prayer services; 11, Marie Saumell, pianist; 11:25, Marie Saumell, pianist; 11:50, Marie Saumell, pianist; 12 noon, Lenten services, Greater New York Federation of Churches; 5 p. m., Vincent Lopez and orchestra; 6, dinner music, Hotel Waldorf-Astoria; 7, Alan Harris, songs; 7:10, Columbia university French course; 7:30, American composers' program; 8, musical program; 8:30, Gold Dust Twins, WEEL, WFL, WCAE, WGR, WVEV, WOC, WJAR, WCCO, WLLB, WEAR, KSD; 9, Eveready hour, WEEL, WFL, WCAE, WGR, WWJ, WOC, KSD, WJAR, WCCO, WTAG, WGN, WEAR, WSAI; 10, moment musicale, WEEL, WFL, WWJ, WGR, KSD, WCAE, WEAR, WTAG; 10:30, Vincent Lopez and orchestra, WEEL, WFL, WWJ, WGR, KSD, WCAE, WTAG, WEAR; 11-12, Ross Gorman and orchestra.  
**WEAO, Columbus, Ohio** (293.9m-1020kc), 7 p. m., chimes; 7:30, fraternity program.  
**WEI, New York, N. Y.** (272.6m-1100kc), 7 p. m., Dan Barnett's orchestra; 7:30, Robert Soffer, pianist; 7:45, Kathryn Connolly, soprano; 8:15, W. H. Melvin, tenor, Norman Hensfield, accompanist; 8:30, Raymond dance orchestra, direction Charles Heyman.  
**WEEI, Boston, Mass.** (248.6m-860kc), 2:30 p. m., Adele Brahm, soprano; 9:05, Eugene's singing orchestra;

## FARMERS' PROGRAMS INDEX

### Farmer Dinner Concerts

#### Daily Except Sunday

**CENTRAL TIME**  
KFNF, 12:15-1:35 p. m.  
KMA, 11:30-12:30  
KSO, 12:30-1:30 p. m.  
WLS, 12 noon.

#### Saturday, March 20

Eastern	Central	Mountain	Pacific
1 p. m.	12 noon	11 a. m.	10 a. m.
KPRC (296.9m-1010kc) Farmers' educational and musical program.			
1:45	12:45 p. m.	11:45	10:45
WOI (270m-1110kc) Soils, questions and answers.			
8	7	6 p. m.	5 p. m.
KDKA (309.1m-970kc), Farm program.			
9:05	8:05	7:05	6:05
KFAB (340.7m-880kc), "Preparing for State Fairs," L. Frisbie; "Increasing the Farm Income," H. Ewer.			
9:30	8:30	7:30	6:30
KFAU (280.2m-1070kc), Agricultural talk, question box.			

#### Sunday, March 21

Eastern	Central	Mountain	Pacific
3:30 p. m.	2:30 p. m.	1:30 p. m.	12:30 p. m.
WFAA (475.9m-630kc), Sunday hour for farmers.			

#### Monday, March 22

Eastern	Central	Mountain	Pacific
12 noon	11 a. m.	10 a. m.	9 a. m.
WRC (468.5m-640kc), Fifty Farm flashes.			
1:15 p. m.	12:15 p. m.	11:15	10:15
WOC (483.6m-620kc), "Starting the Sows and Their Sucklers Off Right," John Eward.			
WEAO (293.9m-1020kc), Timely Economic Information for the farmer, C. J. West.			
1:35	12:35	11:35	10:35
KSAC (340.7m-880kc), "Sorghum Seed Treatment," D. Porter. "Use Early Pastures with Care," J. Lumb.			
1:45	12:45	11:45	10:45
WOI (270m-1110kc), "Some Common Animal Parasites," E. Benbrook.			
WMAQ (447.5m-670kc), Radio farm school.			
7	6	5 p. m.	4 p. m.
WGY (379.5m-790kc) Agricultural program.			
7:45	6:45	5:45	4:45
WSOE (246m-1220kc) Hog Raising.			
8	7	6	5
KFKU (275m-1090kc), "The Agricultural Situation," Prof. John Isa.			
WOS (440.9m-680kc), Livestock questions and answers.			
WTAG (267.7m-1120kc), "Raspberry Growing," W. H. Thies.			
8:15	7:15	6:15	5:15
KSAC (340.7m-880kc), "Feeding the Lamb for the Early Market," H. Reed. "Rations Which Agree with Chickens," H. Steup.			
8:30	7:30	6:30	5:30
KUOA (289.8m-1000kc), "Farm Philosophy," Cy Adams; "What I See As I Travel Over South-west Arkansas," H. Thatcher. "What I See As I Travel Over Northwest Arkansas," J. Barnett. "What I See As I Travel Over Southeast Arkansas," E. Whitaker. "What I See as I Travel All Over Arkansas," T. Roy Reid.			
8:45	7:45	6:45	5:45
WCCO (416.4m-720kc) Farm lecture.			
WOI (270m-1110kc), "Fertilize your Fruit Trees," Prof. Pickett.			
WTIC (475.9m-630kc), "Why More Alfalfa Will Pay," Ben Southwick.			
9:05	8:05	7:05	6:05
KFAB (340.7m-880kc), "Alfalfa and Clover Varieties," T. Kieselback. "What to Expect from Cherries," F. M. Coe.			
10	9	8	7
KOAC (280.2m-1070kc) Agricultural question box. "Managing the Poultry Breeding Flock," A. Lunn.			
10:30	9:30	8:30	7:30
KOAC (280.2m-1070kc), "Spring Management of Bees for Honey Production," H. Seullen.			
10:45	9:45	8:45	7:45
KOAC (280.2m-1070kc), "What Does the Future Hold for the Apple Grower?" Clayton Long.			
11:05	10:05	9:05	8:05
KGO (361.2m-830kc), Farm program.			

#### Tuesday, March 23

Eastern	Central	Mountain	Pacific
11:30 a. m.	10:30 a. m.	9:30 a. m.	8:30 a. m.
KFAB (340.7m-880kc), "How Much Do Our Poultry Cost?"			
12 noon	11	10	9
WRC (468.5m-640kc) Fifty Farm flashes.			
1:15 p. m.	12:15 p. m.	11:15	10:15
WEAO (293.9m-1020kc), "Vegetables," Getting the Jump on the Buss, L. M. Montgomery.			
WOC (483.6m-620kc), "International Poultry Parasites," A. Phillips.			
1:35	12:35	11:35	10:35
KSAC (340.7m-880kc), "Spring Care of the Strawberry Bed," A. Scholth.			
1:45	12:45	11:45	10:45
WMAQ (447.5m-670kc), Radio farm school.			
WOI (270m-1110kc), "Animal Husbandry," H. H. Klidde.			
7:10	6:10	5:10 p. m.	4:10 p. m.
WEAO (293.9m-1020kc), "Fruits: the Question of Varieties," F. G. Charles.			
7:15	6:15	5:15	4:15
WKAR (285.5m-1050kc), "Vaccination in Veterinary Practice," I. Huddleson.			
7:30	6:30	5:30	4:30
WKAR (285.5m-1050kc), "Poultry Plant Sanitation," James Boyd.			
7:45	6:45	5:45	4:45
WKAR (285.5m-1050kc), "Getting More for Our Wool," V. Freeman.			
8	7	6	5
KSAC (340.7m-880kc), "Making Butter and Cheese on the Farm," K. Renner.			
9:30	8:30	7:30	6:30
KOA (322.4m-930kc), Farm question box, George Wheeler.			
11	10	9	8
CNRY (291.1m-1080kc), "Fragrant Flowers for Farm Firesides," F. E. Buck.			

#### Wednesday, March 24

Eastern	Central	Mountain	Pacific
12 noon	11 a. m.	10 a. m.	9 a. m.
WRC (468.5m-640kc), Fifty farm flashes.			
1:15 p. m.	12:15 p. m.	11:15	10:15
WOC (483.6m-620kc), "Profitable Dairy Feed for Every Month—November to May," O. Reed.			
1:30	12:30	11:30	10:30
WFAA (475.9m-630kc), Sears-Roebuck Agricultural program.			
1:35	12:35	11:35	10:35
KSAC (340.7m-880kc), "Repairing the Farm Machinery," Claude Shedd. "Dormant Spray," W. Martin.			
1:45	12:45	11:45	10:45
WMAQ (447.5m-670kc) Radio Farm school.			
WOI (270m-1110kc), Poultry husbandry.			

Eastern	Central	Mountain	Pacific
1:50 p. m.	12:50 p. m.	11:50 a. m.	10:50 a. m.
KFKX (288.3m-1040kc), "A B C's of Dairying," C. Long.			
8	7	6 p. m.	5 p. m.
WOS (440.9m-680kc), Evening market hour, poultry questions and answers.			
9:05	8:05	7:05	6:05
WTIC (475.9m-630kc), "Controlling Insect Pests," M. Swenk. "Dairy Dots and Don'ts," H. Davis.			
10:30	9:30	8:30	7:30
KWSC (348.0m-860kc), "Contribution of Science to the Dairy Industry," "Relation of Bacteriology to the Quality of Manufactured Dairy Products," E. Ellington. "Extension Work in 1925," W. Underwood.			

#### Thursday, March 25

Eastern	Central	Mountain	Pacific
12 noon	11 a. m.	10 a. m.	9 a. m.
WRC (468.5m-640kc) Fifty Farm flashes.			
1:15 p. m.	12:15 p. m.	11:15	10:15
WEAO (293.9m-1020kc), "Fruits: How Shall we Cultivate?" Wendell Paddock.			
WOC (483.6m-620kc), "The Soy Bean—Inoculation Makes More Valuable," J. Hackelmann.			
1:35	12:35	11:35	10:35
KSAC (340.7m-880kc), "Fertilizers for the Vegetables and Flowers," E. Wells. "Farm Fences," W. Ward.			
1:45	12:45	11:45	10:45
WMAQ (447.5m-670kc) Radio farm school.			
WOI (270m-1110kc), Farm crops.			
7:15	6:15	5:15 p. m.	4:15 p. m.
WKAR (285.5m-1050kc), "Feeding Cows on Pasture," R. Addy. "Milking Machines," J. Burnett. "Food Value of Milk," P. Lucas.			
8	7	6	5
KSO (242m-1240kc) Farm talk.			
WEAO (293.9m-1020kc), "Vegetables—Potatoes, More of Them per Acre," I. Montgomery.			
8:30	7:30	6:30	5:30
WOI (270m-1110kc), "Soy Beans for Iowa," F. Wilkins.			
9:30	8:30	7:30	6:30
KOA (322.4m-930kc) Farm question box.			

#### Friday, March 26

Eastern	Central	Mountain	Pacific
12 noon	11 a. m.	10 a. m.	9 a. m.
WRC (468.5m-640kc) Fifty Farm Flashes.			
1:15 p. m.	12:15 p. m.	11:15	10:15
WOC (483.6m-620kc) Special Farm Service Day.			
KTIS (374.8m-800kc) Farmers' Radio Chautauqua.			
1:35	12:35	11:35	10:35
KSAC (340.7m-880kc), "Getting			

# PUPIL OF BRAHMS PLAYS AT KGO

## Tuesday, March 23

4. Crimson Ramblers; 6:05, George Joy and Nell Cantor; 8:10-30, WEAJ.  
**WFI**, Philadelphia, Pa. (394.5m-760ke), 1 p. m., Tea Room ensemble; 3, Philadelphia Music club; 6:30, Bellevue Stratford concert orchestra; 7, Bellevue Stratford dance orchestra; 8:30-11:30, WEAJ.  
**WGSS**, New York, N. Y. (315.6m-950ke), 10:30 a. m., Anne Allen, soprano; 3:10-3:30-3:50 p. m., B. Abrens, baritone; 7, Arrowhead Inn concert orchestra; 8, Y. M. H. A. vocalion forum; 8:30, Threshold players' production, direction Clare Tree Major; 9, Crystal Palace orchestra; 10:30, Arrowhead Inn dance orchestra.  
**WGCP**, New York, N. Y. (252m-1190ke), 3 p. m., Norman Secon, pianist; 3:20, Isabelle Henderson, soprano; 3:35, Max Heith, violinist; 3:45, Twentieth Century entertainers; 4:10, Frankie Meadows, songs; 4:20, Leslie McLeod, tenor; 4:30, Katherine Adolph, soprano; 4:45, Ukulele Boj, Donald.  
**WGH**, Clearwater, Fla. (268m-1130ke), 6:30-7:30 p. m., Harold Crocker's Gater orchestra; 7:30-7:45, Giles W. Quarles, "King of the Mandelgale"; 8:30-9:30, Florence Ailin, soprano, Mary Douglas, accompanist; 11:45-1 a. m., Harold Crocker and his Gater orchestra.  
**WGR**, Buffalo, N. Y. (319m-940ke), 2:30 p. m., WGR's afternoon program; 6:30, Vincent Lopez's Hotel Statler dance orchestra, Harold Gleser, director; 8, WEAJ.  
**WGY**, Schenectady, N. Y. (279.5m-790ke), 2 p. m., Julia Selfert, violinist; 2:30, Stephan E. Bolsclair, organist; 6:30, Porter E. Potts' Hotel Van Curler orchestra; 7:45, WRC; 8:30, WJZ; 9, WJZ; 9:40, song recital, Mirlam Nelson Park, Ellen Waite, accompanist; 10, "Grand Tour," WJZ.  
**WHAR**, Atlantic City, N. J. (275m-1090ke), 2 p. m., Seaside hotel trio; 7:30, "Glimpses Through the Stage Door," Mort Eisenman; 8, Seaside hotel trio.  
**WHN**, New York, N. Y. (361.2m-850ke), 12:30 p. m., Lexington organ recital; 2, Loew's State theater overture and vaudeville; 3:15, Lexington orchestra; 4, tea time hour; 6, Treasureland Neighbors; 6:30, Everglades orchestra; 7, Iceland orchestra; 7:30, Will Oakland's chateau; 8, people's hour; 11:30, Al Rayne's entertainers; 12, Harry Richman and his entertainers.  
**WIP**, Philadelphia, Pa. (508.2m-590ke), 1 p. m., organ recital; 3:15, Velov Saxophone sextet; 6:05, Monte Cross, "old-timer"; 6:15, Nelson Maples and his S. S. Levathan orchestra; 8:15, program, International Students' House of University of Penna.; 9, old songs and recitations, Frances G. Kinsley Entertainment company; 10:05, Eno's weekly movie talk; 10:30, Fugoda cafe orchestra.  
**WJAR**, Providence, R. I. (305.9m-980ke), 1:05 p. m., Providence Biltmore concert orchestra; 7:30, musical program; 8:30, WEAJ.  
**WJR**, Pontiac, Mich. (516.9m-580ke), 7 p. m., Glover-Watson square dance orchestra; 8, Jean Goldkette's orchestra.  
**WJZ**, New York, N. Y. (454.3m-660ke), 12 noon, Trinity Lenten service; 1 p. m., Hotel Pennsylvania lunch orchestra; 4:35, Hotel Commodore concert orchestra; 7:30, WRC; 8:30, Deltah half hour of romance, "Gems of Romance," WGY; 10:45, George Olsen's Pennsylvania grill orchestra.  
**WLIT**, Philadelphia, Pa. (394.5m-760ke), 11 a. m., organ recital; 12:20, Lenten services; 12:55, Arcadia cafe concert orchestra; 2, Arcadia cafe concert orchestra; 4:30, recital; 7:30, Dream Daddy's bedtime stories.  
**WLWL**, New York, N. Y. (288.3m-1040ke), 9 p. m., piano; 9:30, Premier male quartet; 9:45, music; 10:15, Premier male quartet; 10:30, The Commonweal.  
**WMAK**, Buffalo, N. Y. (266m-1130ke), 6:15-7:15 p. m., dinner music.  
**WMCA**, New York, N. Y. (340.7m-880ke), 11 a. m., Ida Bailey Allen's homemaker hour; 12 noon, Jack Cohen, popular pianist; 6 p. m., Olcott Vall and his Hotel McAlpin string ensemble; 6:30, Parody orchestra; 7:30, Twin Oaks orchestra; 7:45, Arthur West's sirens; 8, Pace institute program; 10:30, Tango orchestra; 11, Emie Golden and his Hotel McAlpin orchestra; 12, McAlpin entertainers.  
**WNYC**, New York, N. Y. (526m-570ke), 7:10 p. m., The Canadians; 8, orchestral program; 9, song recital; 9:45, piano and violin recitals.  
**WOD**, Philadelphia, Pa. (508.2m-590ke), 11 a. m., organ recital; 12:02 p. m., Golden's crystal tea room orchestra; 4:45, organ recital; 7:30, Sesqui-Centennial concert.  
**WOR**, Newark, N. J. (405.2m-740ke), 6:40 p. m., studio program; 7, Copenhagen quartet.  
**WPG**, Atlantic City, N. J. (299.8m-1000ke), 6:45 p. m., Arthur Scott Brook, organist; 7, Ellis home dinner music; 8:15, Cecile Steiner, violinist; Margaret Irwin, pianist; Reed Hamilton, baritone; 9, Chalton-Eaddon Hall dual trio; 10, Hotel Traymore grill dance orchestra; 10:30, Karl Bonowitz, pianist; 11, Silver Slipper supper club.  
**WRC**, Washington, D. C. (468.5m-640ke), 12:30 p. m., Lenten service, Keith's theater; 1, Hotel Washington orchestra; 7:30, United States Marine band, WJZ, WGY; 10:30, W. Spencer Tupman and his Hotel Mayflower orchestra.  
**WTAG**, Worcester, Mass. (268m-1120ke), 12:05-2 p. m., WTAG orchestra; 8-9, concert program; 9-11, WEAJ.  
**WTAM**, Cleveland, Ohio (389.4m-770ke), 12:15-1:30 p. m., Guy Lombardo and his Royal Canadians; 6-7, Guy Lombardo and his Royal Canadians.  
**WWJ**, Detroit, Mich. (352.7m-850ke), 12:05 p. m., Jules Klein's Hotel Statler orchestra; 3, Detroit News orchestra; 6, dinner concert; 8, WEAJ.

## Tuesday, March 23

Central Time Stations  
**KFAB**, Lincoln, Neb. (340.7m-880ke), 5:30-6:30 p. m., dinner concert; 8:30-10:30, University of Nebraska.  
**KLDS**, Independence, Mo. (440.9m-680ke), 6:30 a. m., devotional service; 8:15 p. m., Glenn Bennion, tenor; J. M. Sexton, bass; Mrs. J. M. Sexton, soprano; Virginia Henry, contralto; Velma Young, pianist; Harry Stockwell, baritone; John Wahlstadt, tenor; George Howerton, organist; 11:30, midnight program; Herbert Johnson, boy organist.  
**KMA**, Shenandoah, Iowa (252m-1190ke), 6-7 p. m., May Flower trio; 9-11, May's mandolin music.  
**KMOX**, St. Louis, Mo. (280.2m-1070ke), 12:30 p. m., Arthur Utt, organist; 6, Arthur Utt; 6:30, Mrs. Jacques Landree, organist; 7, orchestra; Dwight Nelson, tenor; 8, operalogue, "Faust," Luciano Carolo, Italian tenor; orchestra; 9, "Colonel 6121"; orchestra; old-time dance music; J. O. Sturdy; 10, orchestra; Hausman Brothers, banjo specialists.  
**KPRC**, Houston, Tex. (296.9m-1010ke), 7:30 p. m., Billio Mack's orchestra; 8:30, Frank Tilton, pianist.  
**KSD**, St. Louis, Mo. (545.1m-550ke), 7 p. m., WEAJ.  
**KSO**, Clarinda, Iowa (241.8m-1240ke), 7-7:15 p. m., Finlay and Hutchings; 7:30-9:30, Berry's orchestra.  
**KUOA**, Fayetteville, Ark. (299.8m-1000ke), 8 p. m., Harry E. Shultz, baritone.  
**KYW**, Chicago, Ill. (535.4m-560ke), 12:05-1:30 p. m., concert, Commonwealth Edison company; 1-2, Joska DeBary and his orchestra, Congress hotel; Con-Sanders; 4, afternoon frolic; 6-7, dinner concert, KDKA; 8-9, musical program, KYW; Henrietta Nolan, violinist; Banjo Bill Haid; Eulale Kober Stage, pianist; Melody quartet; 9, music, KYW, Commonwealth Edison company; 10-12, KYW; 11, Con-Sanders orchestra; 1 a. m., insomnia club, Con-Sanders orchestra.  
**WBAP**, Fort Worth, Tex. (475.9m-640ke), 12:05-12:30 p. m., musical program; 6-8:30, Chief Gonzales' Texas hotel orchestra; 7:30-8:30, Prof. J. B. Talliferro, pianist; 9:30-11, concert, College of Industrial Arts of Denton, Tex.  
**WBBM**, Chicago, Ill. (226m-1330ke), 4-6 p. m., Sandy and Harry; Arnold Stephenson; Sidney Nireman, pianist; Harry Morava, tenor; Russel Myers; 8-9, Sandy and Harry; Moulton Rouge orchestra; Phil Flemming,

tenor; Jean St. Anne, French baritone; Christian A. Grimm, composer-pianist; Bob York, tenor; 9-12, Jack Crawford's orchestra; Ariston trio; Barber Shop Three; Pete Kules; Ziegler Sisters; Norris Worthley, tenor; Two Jays; Charlie Garland; Floyd Balch; Vivian Sheffer, contralto.  
**WCBD**, Zion, Ill. (344.6m-870ke), 8 p. m., mixed quartet, cornet quartet; Mrs. Thomas, Mrs. La Rose, duets; Ida Peterson, soprano; Carl Newcomer, saxophonist; George Beem, marimba soloist; Alice Peters, violinist; Richard F. Hiro, pianist; Mrs. Hulda Klammer, reader.  
**WCCO**, Minneapolis-St. Paul, Minn. (316.4m-720ke), 2:30 p. m., Dick Long's trio; 7-9, WEAJ; 10:05, "A Step On the Stairs."  
**WEBH**, Chicago, Ill. (370.2m-810ke), 3-4 p. m., special

Howard Serhson, tenor; Al Carney, organist; Jack Marshall, pianist; 10:10, dance music; 12, Pat Barnes and Al Carney.  
**WIBO**, Chicago, Ill. (225.4m-1330ke), 2-4 p. m., program for shut-ins; Ted Fiorito, pianist; Dan Russo, violinist; Marie Tully, songs; Wayne Myers, reader; Ed Wallace, songster; Jennie Navigato, soprano; 6-8, dinner concert; Chester Newman, baritone; Bernice Taylor, soprano; Charlotte Edwards, contralto; Eugene Wallenius, baritone; Ruth Buhl Flick, reader; Helen Collar, pianist; string trio; 12, midnight jamboree; Dan Russo, violinist; Ted Fiorito, pianist; Marie Tully, songs; Wayne Myers, reader; Ruby Rossini, songster; Russell Duke, Gail Bandell, Jimmy Cairns, Harry Davis.  
**WJAD**, Waco, Tex. (352.7m-850ke), 8:30-10 p. m.,

WEAF; 9-9:30, WEAF; 10-11, musical program, Crescent orchestra.  
**WOK**, Chicago, Ill. (217.3m-1300ke), 4:30-7 p. m., Capitol theater organ; Pat Hoster, tenor; 10:1-30 a. m., Tearney's Town club orchestra; Carl Lorraine's Pershing Palace orchestra; Husk O'Hare's Coconut Grove orchestra; Capitol theater program; studio program.  
**WOOD**, Grand Rapids, Mich. (242m-1240ke), 9-10 p. m., "Ye Olde Tyme Sonse Feste," Claude Lee, Roy Clark, Emma Rola, Sally Stimpkins, Beth Garrison, Regent Little symphony orchestra; 10-11, Van Wyck instrumental quartet; Ruth, Roland, Paul and Loren Van Wyck; 11-12, Henry Ford old-time dance, Bill Dallavo and his orchestra.  
**WORB**, Batavia, Ill. (275m-1090ke), 7 p. m., Public Service company; 7:45, Bible; 11-11:45, Public Service company program.  
**WQJ**, Chicago, Ill. (447.5m-670ke), 7-8 p. m., Jack Chapman and his Rainbo Gardens concert orchestra; Anne Brownstein, pianist; Kenneth Sterling, baritone; Leo Miller, violinist; Milton Sherman, pianist; Kane McDuffee, whistler; 10-1 a. m., Jack Chapman and his Rainbo Skylarks; Jerry Sullivan, Rose Vanderbosch; Hal Lansing and his uke; Everett Opie, character reader; Merrill Carder, baritone; Ila Shannabrook, soprano; Will Rossler; Romo Vincent, boy baritone; Johnny Poat, baritone; Tell Taylor; Harold Olson, baritone; artists; 1-2, Ginger hour, Jack Chapman, the Ginger man; Little Skylarks.  
**WRR**, Dallas, Tex. (245.6m-1220ke), 6-7 p. m., Jack Gardner's orchestra; 8-9, musical program, Montgomery, photographer.  
**WSAI**, Cincinnati, Ohio (325.9m-920ke), 5:30 p. m., twilight musicale; 7, Mabley and Carew orchestra; 8, WEAJ; 9:30, Hawaiian guitars.  
**WSB**, Atlanta, Ga. (428.3m-700ke), 8 p. m., Dixie string band; 10:45, Yaarab temple band.  
**WSM**, Nashville, Tenn. (282.8m-1060ke), 10 p. m., Beasley Smith's orchestra.  
**WSOE**, Milwaukee, Wis. (245.8m-1220ke), 9 p. m., classical musical program.  
**WSUI**, Iowa City, Iowa (483.6m-620ke), 12:30 p. m., Esther Dyke, soprano.

## Mountain Time Stations

**CNRV**, Regina, Can. (476m-640ke), 8 p. m., studio concert program.  
**KFAU**, Boise, Idaho (280.2m-1070ke), 7:30 p. m., children's program, Margaret Cunningham; 8:10, program, KFWA, Ogden, Utah (260.7m-1150ke), 4-6 p. m., organ recital, Paramount theater; 5-5, Ogden Radio dealers program.  
**KFXF**, Colorado Springs, Colo. (250m-1200ke), 8:30 p. m., Clifford Brown, Fred Weber, Allen Mathies, Kenneth Brown, quartet; Mary Smith, soprano; Dalsy Ann Thompson, contralto; Bennie Wreath, violinist; Frances Curtis, pianist.  
**KOA**, Denver, Colo. (322.4m-930ke), 12:15 p. m., Riato theater organ recital, Marjorie Nash; 6:30, Brown Palace string orchestra.

## Pacific Time Stations

**CNRV**, Vancouver, Can. (291.1m-1030ke), 8:30 p. m., musical program; 8:30, Anthony Pallas, Harold Hamer, Hawaiian guitarists; John Terstrand, tenor; 10:30, Cabaret Belmont orchestra; Bebe Muller, soprano.  
**KFI**, Los Angeles, Calif. (467m-640ke), 5:30-6 p. m., Charles Beauchamp, tenor; 6, nightly doings; 6:30, vest pocket program; 6:45, Radiatorial period; 7-8, dance music; 8-9, Screen Artists' instrumental quartet, Virginia Flohri, soloist; 9-10, Louise Klos trio; harp, cello and violin; 10-11, Packard ballad hour of popular song hits.  
**KFOA**, Seattle, Wash. (454.3m-660ke), 12:30-1:30 p. m., Kivans club program; 5:15-5:30, Around the Town, KFOA; 7-8:15, Olympic Calpel Refining company; 8:30-10, Rhodes department store; 10-11, Jaskie Souder's Club Lido serenaders.  
**KFON**, Long Beach, Calif. (232.4m-1280ke), 6-6:30 p. m., Brayton's theater organ; 6:30-7, amusement bulletin; 7-8, studio program; 8-9, Press-Telegram studio; 9-11, Long Beach Aero club frolic.  
**KFWB**, Hollywood, Calif. (252m-1190ke), 6-7 p. m., dinner music, Fitzgerald Music company; 8-9, Patrick Marsh dance orchestra; 9-10, program, Alexandria Tailors; Dave Ward and his band; Alexandria Tailors' orchestra; 10-11, Warner Brothers frolic.  
**KGO**, Oakland, Calif. (361.2m-830ke), 4-5:30 p. m., Hotel St. Francis concert orchestra; 8-9, Eveready program; Arthur Argievicz, violinist; Lev Shorr, pianist; 9:10-9:30, Ricketty Backetty Radio minstrels; 10-12, Girvin-Dougl's California Collegians.  
**KHJ**, Los Angeles, Calif. (405.2m-740ke), 8-10 p. m., program, Builders Finance association; 10-11, Don Clark's Billmore hotel dance orchestra.  
**KJR**, Seattle, Wash. (384.4m-780ke), 7-8:30 p. m., musical program, Cornish school; 8:30-10, Puget Sound Savings and Loan association orchestra.  
**KMTR**, Hollywood, Calif. (238m-1260ke), 6-7 p. m., Starr Piano company studio; 8-10, KMTR concert orchestra.  
**KNX**, Hollywood, Calif. (336.9m-890ke), 5:30 p. m., Leighton's cafeteria orchestra; 8:30-7, Atwater Kent orchestra; 7-7:45, program, Roy L. Donley, Inc.; 8-9, program, Globe Ice Cream and Weber Bread companies' Killgrove's Junior Symphony; Tom Mitchell, baritone; 9-10, program, Western Auto Supply company's Western Giant Cord orchestra; J. Howard Johnson, tenor; 10-12, movie night, Ambassador hotel, Bay West's Coconut Grove dance orchestra.  
**KPO**, San Francisco, Calif. (428.3m-700ke), 1-2 p. m., Rudy Selger's Fairmont hotel orchestra; 2:30-3:30, matinee program; 3:30-4:30, Cyrus Trobbs's Palace hotel orchestra; 6:40-7, Waldemar Lind and the States Restaurant orchestra; 7-7:30, Rudy Selger's Fairmont hotel orchestra; 8-9, studio program; 9-10, Mona Motor Oil trio and Gypsy and Marta close harmony team; 10-11, Palace hotel orchestra; 11-12, Henry Holsted's orchestra.  
**KPSN**, Pasadena, Calif. (315.6m-950ke), 8-9 p. m., Adolf Tandler instrumental group.  
**KTAB**, Oakland, Calif. (239.9m-1250ke), 12-1 p. m., concert.

## Wednesday, March 24

### Headliners Today

Eastern 8 p. m.	Central 7 p. m.	Mountain 6 p. m.	Pacific 5 p. m.
WGR (319m-940ke) Audubon Terrace Meadowlarks.			
WLB (365.6m-820ke) Old favorite songs.			
			6
KDKA (309.1m-970ke) Balcony scene from "Romeo and Juliet."			6:30
9:30	8:30	7:30	6:30
WGHB (266m-1130ke) "The Virginia Girl" and her uke.			
10:15	9:15	8:15	7:15
KOA (322.4m-930ke) Mock trial.			
11	10	9	8
WSM (282.8m-1060ke) Shriners.			
12	11	10	9
KFWA (260.7m-1150ke) Merry Mad Music Makers.			
1:30 a. m.	12:30 a. m.	11:30	10:30
KJR (384.4m-780ke) "Keep Joy Radiating Order of Bats."			

Wednesday, silent night for: CNIC, CKNC, CNRA, CNRC, CNRE, CNRR, CNRT, CNRV, KFAU, KFD, KFEQ, KFKU, KUOA, KFXF, KGO, KIDS, KMMJ, KOB, KPSN, KTAB, WABQ, WBAL, WBAP, WBBR, WCAD, WCAL, WCBD, WEBW, WFAA, WGBF, WGSB, WGCP, WGST, WHAR, WHAZ, WIP, WJAD, WJAZ, WLWL, WMC, WOA1, WOAW, WOI, WPG, WRC, WREO, WRR.

## CLASSICAL CONCERTS INDEX

Saturday, March 20			
Eastern 6 p. m.	Central 5 p. m.	Mountain 4 p. m.	Pacific 3 p. m.
WGX, WEAJ, WMCA, WREO.			
6	5	4	
KGO, KYW, WEAR, WENR, WMAQ, WNYC, WOAW, WOK, WRC.			
7	6	5	
KDKA, KFNF, KOIL, KSD, KYW, WBBR, WGN, WMBB, WNYC, WOAW, WQJ.			
9	8	7	
KFOA, KPRC, KHJ, KYW, WHAS, WIP, WLW, WORD, WSAI, WSOE.			
10	9	8	
KNX, KYW, WEAJ, WMAQ, WMC, WOAW, WOC, WORD.			
11	10	9	
12	11	10	9
WOAW.			

Sunday, March 21			
Eastern 6 p. m.	Central 5 p. m.	Mountain 4 p. m.	Pacific 3 p. m.
WCAU.			
7:20	6:20	5:20	4:20
WCAE, WCAU, WEAJ, WEAR, WEEI, WJAR, WTAG, WWJ.			
8	7	6	
KYW, WAMD, WBZ, WEAR, WGSS, WGCP, WKAQ, WLS, WOHD.			
8	7	6	
KFDM, KPRC, KSD, WBZ, WCAU, WCBD, WCCO, WEAR, WGY, WHAR, WHT, WNYC, WQJ.			
9:15	8:15	7:15	6:15
WEEL, WJAR, WTAG.			
10	9	8	
KHJ, KNX, KTHS, KYW, WCCO, WFAA, WNYC, WOC, WQJ, WSOE.			
11	10	9	
KFVE, KHJ, KNX, KPO, KTHS, KYW, WHN, WKRC, WOC.			
12	11	10	9
1 a. m.	12 m	11	10
KNX.			

Monday, March 22			
Eastern 6 p. m.	Central 5 p. m.	Mountain 4 p. m.	Pacific 3 p. m.
KGO, WCX, WEAJ, WMCA, WREO, WWJ.			
6	5	4	
KMA, WCCO, WEAJ, WEAR, WHAD, WJR, WOAW, WOK.			
8	7	6	
KFNF, KSD, WBBR, WBZ, WCAU, WCX, WHAR, WHT, WJAR, WLW, WMBB, WTAG, WTIC.			
8	7	6	
KFOA, KGO, KHJ, KPRC, WBBR, WCCO, WBZ, WCAE, WEEI, WHAD, WHO, WJAR, WLW, WORD, WOS.			
9	8	7	
KMA, KPO, KPRC, KSD, KTHS, WAMD, WCCO, WEAJ, WHAD, WJAR, WOAW, WSUI, WTAG.			
11	10	9	
KGW, KHJ, KMA, KSD, KTHS, KWSC, WHN, WSAI.			
12	11	10	9
1 a. m.	12 m	11	10
KHJ.			

Tuesday, March 23			
Eastern 6 p. m.	Central 5 p. m.	Mountain 4 p. m.	Pacific 3 p. m.
WBZ, WCX, WEAJ, WMCA, WREO, WWJ.			
7	6	5	
KGO, KMA, WEAR, WEI, WGSS, WHAD, WJR, WMAQ, WOAW, WOK, WOR, WTIC, WWJ.			
8	7	6	
KFNF, KSD, KYW, WBZ, WCAE, WCAU, WCNX, WEAR, WEEI, WGR, WHAR, WHT, WLS, WMBB, WQJ, WRC, WTIC.			

features; 7, Oriole concert orchestra; 8, Oriole marimba band, special numbers; Kathryn Forbes, soprano; 9-9:45, musical bits, Balaban and Katz's Uptown theater; 9:45, Oriole orchestra, dance music; 12:30 p. m., Bernard Weber, tenor; Oriole trombone duo; Mark Fisher, songster.  
**WFAA**, Dallas, Tex. (475.9m-630ke), 12:30-1 p. m., Jeff J. Sandell, pianist and monologist; 1:30-2, Edgar Norris, pianist and singer; 2:30-3, Baker Hotel Symphony Five; 3:30-4, Arthur Emerson, tenor; Maris Cruz, pianist; 4:30-5, Ewen Hall, tenor; Johnnye Davis, pianist; 6:30-7:30, Baker hotel orchestra; 8:30-9:30, School of Music, Southern Methodist university; 11-12, Anna Pinkerton Baker, singer; 12-12:30 a. m., Harold Clark, tenor; Noel Shaw, pianist.  
**WGBF**, Evansville, Ind. (236.1m-1270ke), 12:20 p. m., L. Maxwell company musical program; 9, musical program.  
**WGES**, Oak Park, Ill. (250m-1200ke), 5-7 p. m., tenor, organ, features; 8-9, flute duo, orchestra pipe organ; 11-1 a. m., pipe organ, tenor, soprano, features.  
**WGN**, Chicago, Ill. (302.8m-990ke), 12:40-2:30 p. m., concert, Drake concert ensemble, Blackstone string quintet; 2:30-3, Lyon and Healy artists; 3-8:30, Bridge luncheon; 8:30-4:15, Tea Time music, Marshall Fields tea room orchestra; 4:30-5, organ recital, Edward Benedict; 6:30-6:45, Drake concert ensemble, Blackstone string quintet; 6:45-7, old-time favorites; 8-9, WEAF; 9-10, popular program; 10-10:10, Sam "n' Henry"; 10:10-10:20, old-time favorites; 10:20-10:40, the Playshon; 10:40-11, popular program.  
**WHAD**, Milwaukee, Wis. (275m-1060ke), 6:15-10 p. m., Wisconsin artists' series.  
**WHAS**, Louisville, Ky. (389.8m-750ke), 7:30-9 p. m., Eddie Rossion and his orchestra.  
**WHB**, Kansas City, Mo. (365.6m-820ke), 7-8 p. m., organ, Morrill Moore; 8-9, August Zander, bass, George Howerton, accompanist; Elite quartet; 9-10, McPherson college male quartet.  
**WHO**, Des Moines, Iowa (526m-570ke), 7:30-8 p. m., Raleigh quintet; 8-9, varied musical program; 11-12, Bankers Life "Cora Sugar" orchestra.  
**WHT**, Chicago, Ill. (399.8m-750ke), 12 m., Al Carney's complimentary organ recital; 6, dinner organ recital, Al Carney; 6:40, Grayling's string trio; 6:50, Diamond quartet Loftis; 9:15, (238m-1260ke), Claderella cafe orchestra; 9:35, Kitchin Klensner entertainers; 9:50,

popular song selections, W. Enlos Simmons, Ray, S. W. Henslee.  
**WJJD**, Moseheart, Ill. (370.2m-810ke), 12-1 p. m., Palmer House symphonic players; Palmer House trio; 2-3, Howard L. Peterson, organist; 4-5, music, Moseheart children; 5:30-7, Jack Nelson; Palmer House symphonic players; Palmer House Victorians; Howard L. Peterson, organist; 8-9, children; 10-11, Gard studio; Bushmore ensemble singers; Palmer House Victorians; 12:30 a. m., Knights of the Burning Candle.  
**WKRC**, Cincinnati, Ohio (325.9m-920ke), 10 p. m., Alvin Roehr and his Hotel Alms orchestra; 10:30, organ recital, Eugene Perazzo; 11, Doc Howard's Cuvier-WKRC entertainers; orchestra, male quartet.  
**WL1B**, Chicago, Ill. (302.8m-990ke), 7-7:20 p. m., Uncle Walt's Punch and Judy show; 7:20-7:30, Correll and Gosden; 7:30-8, WEAJ; 11-11:20, Correll and Gosden; 11:20-1 a. m., dance music; Correll and Gosden.  
**WLS**, Chicago, Ill. (344.6m-670ke), 12 noon, Ford and Glenn; 6 p. m., Ford and Glenn; 6:40, Ralph Emerson at Barton organ.  
**WLW**, Cincinnati, Ohio (422.3m-710ke), 4 p. m., sermon, Rev. Henry C. Koch; 6:30, sonata in A Major for violin and piano; Johannes Brahms; 7:30, Piano Memories, Mary Louise Woseczek; 8, old time review, Crosley Burnt Corkers; 9, Formica orchestra.  
**WMAQ**, Chicago, Ill. (447.5m-670ke), 6 p. m., Chicago theater organ; 6:30, Hotel La Salle orchestra; 7:40, musicale, U. of C.; 9:20, Arion male chorus.  
**WMBB**, Chicago, Ill. (250m-1200ke), 7-9 p. m., Tri-annon duo, Genevieve Barry Burnham, coloratura soprano; Robert Malone, grand opera tenor; 9-11, Tri-annon orchestra; Woodlawn theater orchestra; Oxford girls; Lou Sievers, comedy songs; Joe Warner, character sketches.  
**WMC**, Memphis, Tenn. (499.7m-600ke), 8:30 p. m., Hugh Sandidge; 11, Brillig's novelty orchestra.  
**WOAI**, San Antonio, Tex. (394.5m-760ke), 7:30-8:30 p. m., Gebhardt Mexican players.  
**WOW**, Omaha, Neb. (526m-570ke), 6 p. m., Hugo G. Heyn, violinist; Emil B. Hoffman, pianist; 8:50, orchestra; 9, de luxe program; 10:30, Herb Fiermann and his orchestra; 12, Rialto theater alarm.  
**WOC**, Davenport, Iowa (483.6m-620ke), 5:45-6 p. m., chimes concert; 7-7:30, WEAJ; 7:30-8, WEAJ; 8-9,



# FAMOUS SPRING SONGS THROUGH WOS

Wednesday, March 24

### Eastern Time Stations

**CKAC, Montreal, Can. (410.7m-730ke), 1:45 p. m.,** luncheon music.

**CNRO, Ottawa, Can. (434.5m-690ke), 8 p. m.,** Chateau Laurier concert orchestra; 8:45, Trio Nolet, M. Edouard Gosselin, violinist; M. Victor Nolet, violinist; Madam Victor Nolet, pianist; Chateau Laurier dance orchestra.

**KDKA, Pittsburgh, Pa. (309.1m-970ke), 12:20 p. m.,** Trinity church Lenten services; 6:30, dinner concert; 8, Little Symphony orchestra; Barbara Bess Wellman, contralto; Ray W. Penn, baritone; balcony scene from "Romeo and Juliet," Grace Thomson and Frederick G. Rodgers.

**WBZ, Springfield, Mass. (333.1m-900ke), 6:30 p. m.,** Hotel Kimball orchestra; 6:45, Hotel Lenox ensemble; 7, Hotel Kimball orchestra; 8, Aurelia Cornier, lyric soprano; Alwyn E. W. Bach, baritone; 8:30, accordion selections, Angelo Catterucci; 8:45, Wesley Merritt, pianist; 9, WBZ concert company; 10:05, Leo Reisman and his Hotel Brunswick orchestra.

**WCAE, Pittsburgh, Pa. (461.3m-650ke), 6:30 p. m.,** dinner concert, William Penn hotel; 8, WEAF; 8:30, WEAF; 9, quartet; 10, Kramer's orchestra.

**WCAU, Philadelphia, Pa. (277.5m-1080ke), 6:45 p. m.,** dance orchestra; 7:35, recital, N. Snellenburg and company; 8:10, Kane's Musical Night's adventures; 10:30, Carl Ziehrns and Lou Herscher; 10:45, Frank Cook, old-time songs; 11, Artie Blitng's Cheer-up club.

**WCX, Detroit, Mich. (516.9m-580ke), 6-7 p. m.,** dinner program, Goldkette ensemble; 8-9, program.

**WEAF, New York, N. Y. (491.5m-610ke), 7:45-8 a. m.,** morning prayer services; 11:05, Irving Cresse, pianist; 11:30, Irving Cresse, pianist; 11:40, Columbia university lecture; 12 noon, Lenten services, Greater New York Federation of Churches; 4 p. m., Ray Nichols' Recording orchestra; 4:30, Lulu Phillips, soprano; 4:45, story hour of New York Public Library; 5, Vincent Lopez and orchestra; 6, dinner music; Hotel Waldorf-Astoria; 7, synagogue services, United Synagogue of America; 7:30, chamber music; 8, Two-in-One Man and Shinola Boys, WTAG, WCAE, WSAI, WCAP, WJAR, WWJ, WEEL, WOO, KSD, WOC, WCCO; 8:30, Davis saxophone octet, WOO, WCAE, WSAI, WCAP, WJAR, WTAG, WEEL, WGR; 9, Ipana Troubadours, WEEL, WCAP, WWJ, WCCO, WGR, KSD; 10, "A Trial by Jury," Gilbert and Sullivan operetta; 11-12, Hughie Barrett and orchestra.

**WEAO, Columbus, Ohio (293.9m-1020ke), 8:15 p. m.,** Martins Melody orchestra; 8:45, Martins Melody orchestra.

**WEBJ, New York, N. Y. (272.5m-1100ke), 8 p. m.,** Kenwood Klub orchestra; 8:45, Anthony Wayne, the singing reporter; 9, Ruth Pachner, soprano, accompanied by Lillian Kroll; 9:15, McLean's dance orchestra.

**WEEI, Boston, Mass. (248.6m-860ke), 3:05 p. m.,** E. Payson Re and his orchestra; 6:13, Joe Rines and his Hunters' Cabin orchestra; 8-10, WEAF.

**WFI, Philadelphia, Pa. (394.5m-760ke), 1 p. m.,** Tea Room ensemble; 3, Ethel P. Echard, soprano; Laurence J. Mellon, baritone; Kathryn Martin, accompanist; 6:30, Bellevue Stratford concert orchestra; 7, Bellevue Stratford dance orchestra.

**WGBS, New York, N. Y. (315.6m-950ke), 3:10 p. m.,** Hilda Bergsoll, mezzo-soprano; 3:30, Hansen and Howard; 6:30, Jersey Collegians; 7, inspirational half hour.

**WGCP, New York, N. Y. (252m-1190ke), 3 p. m.,** Eva Rosenbergs, pianist; 5:20, Bobby Grey, songs; 3:45, "Three Harts"; 4:10, Al Wilson's, entertainers; 4:30, Jeanne A'Dair, composer; 4:45, Tracy Mohr; 5:10, Ora Welsh, pianist; 7, studio program.

**WGHB, Clearwater, Fla. (266m-1130ke), 6:30-7:30 p. m.,** Graham Prince and his orchestra; 8:30-9:30, Caroline Lee, "The Virginia Girl," and her Spanish guitar; Marlon Hoffman, pianist; 11:45-1 a. m., Graham Prince and his orchestra.

**WGR, Buffalo, N. Y. (319m-940ke), 2:30 p. m.,** WGR's afternoon program; 6:30, Gospel Melodists; 8, Audubon Terrace Meadowlarks; 8:30, WEAF; 10, popular program, E. A. Willis Wall Paper stores; 10:30, popular program, Mrs. Vernon Curtis and assisting artists; 11, Bingham's dance orchestra.

**WGY, Schenectady, N. Y. (379.5m-790ke), 7 p. m.,** Eastman theater program, WEAM; 8:05, WEAM.

**WHR, New York, N. Y. (361.2m-830ke), 6 p. m.,** people's hour; 8, Vogue entertainers; 9:30, Daven Radio entertainers; 10, Roseland dance orchestra; 10:30, Anatol Friedman; 11, Silver Slipper orchestra; 11:30, Melody club orchestra; 12, Cotton club orchestra.

**WIP, Philadelphia, Pa. (508.2m-590ke), 1 p. m.,** Ghibel tip room orchestra; 3, Caroline Sherwood Montani and Nicola Montani vocal studio; 6:05, Benjamin Franklin hotel concert orchestra; 7, Uncle Wip's bedtime stories; Dorothy Perl, pianist.

**WJAR, Providence, R. I. (305.9m-980ke), 1:05 p. m.,** Al Billincoff and his Green Acre Lodge orchestra; 7:30, musical program; 8, WEAF; 8:30, WEAF; 9, musical program; 10, WEAF.

**WJP, Pontiac, Mich. (516.9m-580ke), 7 p. m.,** Jean Goldkette's symphony orchestra; soloists; 9, Winter Haven Radio hour; 11:30, "The Merry Old Chief."

**WJZ, New York, N. Y. (454.3m-660ke), 12 noon,** Trinity church Lenten services; 1 p. m., Hotel Madison concert and dance orchestra; 4:15, Waldorf-Astoria tea music; 7, Hotel Commodore concert orchestra; 8, Helen Davis, banjoist; Sydney Koppel, pianist; 8:30, Lewisohn free chamber music concert; 10:45, George Olsen's Hotel Pennsylvania grill orchestra.

**WLIT, Philadelphia, Pa. (394.5m-760ke), 12:20 p. m.,** religious service; 12:30, organ recital continued; 2, Arcadia cafe concert orchestra; 7:30, Dream Daddy's bedtime stories; 8:15, recital; 10, Arcadia cafe dance orchestra; 10:30, Salsore Elza and orchestra.

**WLWL, New York, N. Y. (288.3m-1040ke), 9:15 p. m.,** musicale; 9:30, McEvoy concert; 10, chamber music.

**WMAK, Buffalo, N. Y. (266m-1130ke), 7:30-8 p. m.,** musical program; 8-9, Bovin orchestra; 10-11 Woodcliffe orchestra.

**WMAZ, Mason, Ga. (261m-1150ke), 10-11 p. m.,** Business and Professional Women's club; 11-12, Peerless quartet; Ralph Tabor, pianist; George Armes, saxophonist.

**WMCA, New York, N. Y. (340.7m-880ke), 6 p. m.,** Olcott Vail and his Hotel McAlpin string ensemble; 6:30, Ernie Golden and his Hotel McAlpin orchestra; 3, Coughlan entertainers; 10:30, Parody club orchestra; 10:45, Van and Schenck; 11, Hofbräu Haus entertainers; 11:30, Jack Denny's orchestra; 12 m., McAlpin entertainers.

**WNYC, New York, N. Y. (526m-570ke), 5:45 p. m.,** Agnes Vernon's juveniles; 6:30, songs; 7:35, piano recital; 8, German Irving Place theater ensemble; 9, instrumental specialty; 9:30, violinist; 9:45, pianist.

**WOO, Philadelphia, Pa. (508.2m-590ke), 11 a. m.,** organ recital; 12:02 p. m., Golden's crystal tea room orchestra; 4:45, organ recital; 7:30, Sylvania dance orchestra; 8-9, WEAF; 9, talk about the Wissahickon; 9:35, address, Rev. Forest M. Dagar; 10, Fox theater studio program; 10:30, Sylvania dance orchestra.

**WOR, Newark, New Jersey (405.2m-740ke), 6:30 p. m.,** Jacques Jacobs' Hotel Shelton ensemble; 7:30, George Eberhart's Katinka orchestra; 9:30, Weehawken glee club and orchestra.

**WRC, Washington, D. C. (468.5m-640ke), 12:30 p. m.,** scrvice, Keith's theater; 1, Lee House, trio; 4:15, Meyer Davis' Le Paradis band; 5, organ recital, Homer L. Kitt studio.

**WREO, Lansing, Mich. (285.5m-1050ke), 6-7 p. m.,** Speed-Wagon serenaders; Gold Standard ensemble.

**WRVA, Richmond, Va. (256.3m-1170ke), 8:15 p. m.,**

Flaxington Harker, organist; 9:15, Blackston Military academy; 11, "Carry Me Back to Old Virginia."

**WTAG, Worcester, Mass. (268m-1200ke), 12:05-2 p. m.,** WTAG orchestra; 6-7, dinner music; 8-8:30, WEAF; 8:30-9, WEAF; 9-10, concert; 10-11, WEAF.

**WTAM, Cleveland, Ohio (389.4m-770ke), 12:15-1:30 p. m.,** Austin Wylie's Vocation Recording orchestra; 6-7, Carl Rupp and his Hotel Hollenden orchestra; 8-11, public Auditorium program; 11-1 a. m., Guy Lombardo and his Royal Canadians.

**WTIC, Hartford, Conn. (475.9m-630ke), 6:30 p. m.,** Hotel Bond trio; 8, Benjamin M. Knox and vocalists, 8:15, Laura C. Gaudet, pianist; 9:30, organ recital.

**WV, Detroit, Mich. (352.7m-850ke), 12:05 p. m.,** Jules Kleinf's Hotel Statler orchestra; 3, Detroit News orchestra; 6, dinner concert; 8, News orchestra and soloists; 9, dance program; 10, WEAF.

### Central Time Stations

**CNRW, Winnipeg, Can. (384.4m-780ke), 7:50 p. m.,** musical program, Irvine Plumm and his Fort Garry hotel orchestra; 8:50, Canadian National Railways' Transcona shops' brass band; Mrs. D. J. Edwards, contralto; 10, supper-dance program, Irvine Plumm and his Fort Garry hotel orchestra.

**KFAB, Lincoln, Neb. (340.7m-880ke), 5:30-6:30 p. m.,** dinner concert; 8:30-10:30, Harmony Boys, vocal and piano; Slick Merriam, pianist; Harriet Cruise, oriole of the air; Gloomy Gus entertainer; Master six orchestra.

**KFMX, Northfield, Minn. (336.9m-890ke), 9-10 p. m.,** musicale.

**KFRU, Columbia, Mo. (499.7m-600ke), 6:15 p. m.,** dinner music.

**KMA, Shenandoah, Iowa (252m-1190ke), 6-7 p. m.,** music; 9-11, songs and clog dancing, Bob and Babe Riddle, Willy Cunningham, the farmer Scotchman, Bessie Caskey.

**KMOX, St. Louis, Mo. (280.2m-1070ke), 12:30 p. m.,** Arthur Utt, organ recital; 6, Arthur Utt, organist; 6:30, Mrs. Jacques Landree, organist; 7, orchestra; debate; 8, orchestra, operadique; 9, orchestra, song cycle, Negro songs Harriet Robinson; 10, popular program, orchestra.

**KPRC, Houston, Texas (296.9m-1010ke), 7:30 p. m.,** Jack Wilrich's orchestra; McMillian's dancing academy; Virginia Wilrich, piano accompanist; 8:30, Max E. Shipe, tenor; Mrs. Harmon Whittington, pianist; 9, Rice institute student band; 11, music.

**KSD, St. Louis, Mo. (545.1m-550ke), 7 p. m.,** WEAF; 7:30, Hotel Statler concert orchestra; 8, WEAF.

**KSO, Clarinda, Iowa (241.8m-1240ke), 7:30-8:30 p. m.,** vocal and instrumental; 8:30-9:30, Delphos high school.

**KYW, Chicago, Ill. (535.4m-560ke), 12:05-1 p. m.,** concert, Commonwealth Edison company; 1-2, Joska DeBabary and his orchestra; Coon-Sanders orchestra; 6-7, dinner music, KDKA; 8, Sherwood school of music; 10-12:30 a. m., midnight revue; Coon-Sanders orchestra; 10:40-11:10, Henri A. Keates, organist, McWickers theater; 1 a. m., Coon-Sanders orchestra.

**WAMD, Minneapolis, Minn. (243.5m-1230ke), 7:10 p. m.,** American composers' program; 11, Skyrocket frolic; George Osborn and his orchestra.

**WBAP, Fort Worth, Texas (475.9m-630ke), 12:05-12:30 p. m.,** music; 6-6:30, Chief Gonzales' Texas hotel orchestra.

**WBBM, Chicago, Ill. (226m-1330ke), 4-6 p. m.,** Harry and Sandy; Edna Wheeler Ballard, harpist; Harold Morava, lyric tenor; Johnny Black; Court Banks; Ralph Bothof; 8-10, Barber Shop three; Jack Crawford's orchestra; Verdi mixed quartet; Sy Berg and Bib Witt; Philip Nilles, tenor; Rudy Winter; Phloidy Fatch; 12-2 a. m., Jack Crawford's orchestra; Charley Garland; Two Jays; Harold Anderson, accompanist; Floyd Fatch; Aniston.

**WCCO, Minneapolis, Minn. (416.4m-720ke), 12 a. m.,** Francis Richter, pianist; Ward Allen, violinist; Lou Emmel, baritone; 7 p. m., WEAF; 9, Nash-Finch concert orchestra; 11:30, Eddie Dunstetter, organist.

**WCOA, Pensacola, Florida (222m-1350ke), 7 p. m.,** instrumental trio, Max H. Heinberg, violinist; Imogene Jones, pianist; Ray Dinsmore, cellist; Frank Howland, banjo ragonist; Mrs. Terrell Covington, vocalist; Clara Frenkel and John Frenkel, in dialogue and songs; Mrs. Sybil Mitchell, pianist and soloist; Max J. Heinberg, violinist; Eddie Collins, saxophone solos; Eddie Collins, Rainbow dance orchestra.

**WEBH, Chicago, Ill. (370.2m-810ke), 3-4 p. m.,** special features; 7, Oriole concert orchestra; 8, Florence Behrend, singer; Oriole string trio; 9-10, Dennis Sisters, Oriole orchestra; Frank Bordner; Oriole marimba band; 11-12:30 a. m., Oriole dance orchestra; songs, Irene Beasley's songs, Florence Behrend; Dennis Sisters; Oriole dance orchestra.

**WFAA, Dallas, Texas (475.9m-630ke), 1:30-2 p. m.,** Raymond Roy Harrison, pianist and singer; 2:30-3, Ernest Wayland, pianist and singer.

**WGES, Oak Park, Ill. (250m-1200ke), 5-7 p. m.,** violin, basso, pipe organ, tenor; 8-9, orchestra, contralto, soprano, pipe organ; 11-1 a. m., Coyne serenaders, pipe organ comedian, tenor, pianist.

**WGN, Chicago, Ill. (302.8m-990ke), 12:40-2:30 p. m.,** concert, Drake ensemble, Blackstone string quintet, 2:30-3, Lyon and Healy artists; 3-3:30, Auction Bridge game; 3:30-4:15, Tea Time music, Marshall Field tea room orchestra; 4:30-5, organ recital, Edward Benedict; 6:30-7, Drake concert ensemble, Blackstone string quintet, old-time favorites; 8-9, studio program; 9-10, WEAF; 10-10:10, Sam H. Henry; 10:10-10:30, old-time favorites; the Playshop; 10:40-11, popular program.

**WHAD, Milwaukee, Wis. (275m-1090ke), 6:15-7 p. m.,** organ recital, Arthur Blchler; 10:30-11:30, dance hits, Wisconsin Roof orchestra; 11:30-12:30 a. m., request organ recital, Edmund Fitch, organist.

**WHAS, Louisville, Ky. (399.8m-750ke), 7:30-9 p. m.,** K. & I. orchestra.

**WHB, Kansas City, Kansas (365.5m-820ke), 7-8 p. m.,** "Old favorite songs," St. Benedict's Maur Hill orchestra.

**WHO, Des Moines, Iowa (526m-570ke), 6-7 p. m.,** Bankers Life symphonic orchestra; 7:15-8:15, Irene Dorans Little symphony orchestra; 8-8:15, Capitol theater artists; Kate Miller, whistler, Maude Hughes, accompanist; Harry Lewis, popular songster; 9-12, dance program.

**WHT, Chicago, Ill. (399.8m-750ke), 12 m.,** Al Carney's complimentary organ recital; 6-7:30, Genevieve B. Burnham, soprano; Peter Forstner; Howard Will, tenor; Grayling's string trio; Helen Bauh, pianist; 7:45-9:15, Cluderella Cato orchestra; 9:30, Al Carney and Pat Barnes; 10:05, Ray-O-Vac concert; 11:15, Cinderella Cafe orchestra; 11:30, Pat Barnes and Al Carney; 12, Pat Barnes and Al Carney.

**WIBO, Chicago, Ill. (225.4m-1330ke), 2-4 p. m.,** Shuttins program; Ted Fiorito, pianist; Dan Russo, violinist; songs, Marie Tully; Wayne Myers, reader; Madeline Hammond, songs; Max Webb, pianist; songs, the Jordans; Al Benson, Gall Bandell; 6-8, Dorothy Rae, soprano; Charles Champlin, baritone; Florence Osterman, contralto; Earl Raymond Bigelow, pianist; string trio; 10-12, popular program; William Molnare, tenor; Erwin Cornelius, song and uke soloist; Lenore Friedman, soprano; Herbert Schlosser, accompanist; string trio.

**WKAF, Milwaukee, Wis. (261m-1150ke), 10-11 p. m.,** Campus Skylarks; Robert F. Hall, Irish and German character songs.

**WKRC, Cincinnati, Ohio (325.9m-920ke), 6 p. m.,** Alvin Roehr and his Hotel Alms orchestra; 8:15, Oliver Plunkett, tenor; 9, concert orchestra; 9:40, orchestra.

**WLIB, Chicago, Ill. (302.8m-990ke), 7-7:30 p. m.,** Uncle Walt's Punch and Judy show; 7:30-7:30, Auld Sandy; 7:30-8, WEAF; 11-11:20, Correll and Gosden; 11:20-1, dance music; Correll and Gosden.

**WLS, Chicago, Ill. (344.6m-670ke), 12 a. m.,** Ford and Glenn; 6 p. m., Ford and Glenn; 6:40, Ralph Emer-

son at our Barton organ; 7:15, WLS picture concert; 7:45, Grace and Ralph "At home"; 8, WLS theater production, "Fog"; 8:30, Geo. Goforth band; 10, Metropolitan church choir; Negro spiritual production, 11-1 a. m., WLS circus with Geo. Goforth band.

**WLW, Cincinnati, Ohio (422.3m-710ke), 4 p. m.,** shuttins program, by Wm. Duning; 6:30, joint recital, Cecile Falkenstein, pianist; Ira Falkenstein, violinist; 7, Hotel Gibson orchestra; 7:40, Hotel Gibson orchestra; 8, American composer program, Omicron Chapter of the Sinfonia fraternity; 9, concert, Tenth Infantry band; 10, the Cincinnati Zither players; 10:20, Further Radio adventures, Senator Schultz; 10:40, Crosley male quartet; 11, Maids of Melody, Grace Donaldson and Hortense Rhodes; 11:15, Johanna Grosse, organist.

**WMAQ, Chicago, Ill. (447.5m-670ke), 4:45 p. m.,** pupils, Cosmopolitan school of music; 6, Chicago theater organ; 6:30, Hotel La Salle orchestra; 8:20, Fullerton Presbyterian church choir; 8:55, WMAQ players.

**WMBB, Chicago, Ill. (250m-1200ke), 7-8 p. m.,** Trianon duo; Monte Blue, tenor; Eleanor Kaplan, violinist; Edwin House, baritone; Preston Graves, pianist; 9-11, Trianon orchestra; Woodlawn theater orchestra; Cecil and Esther Ward; Hawaiian guitar specialties; Billie Allen Hoff, blues singer; Ed Wallace, tenor; Ted Graham, baritone.

**WQAI, San Antonio, Texas (394.5m-760ke), 8:30 p. m.,** army night, Fort Sam Houston.

**WOC, Davenport, Iowa (483.6m-620ke), 4-4:45 p. m.,** musical program; Sidney Milbanks, tenor; 5:45-6, chimes concert; 7-7:30, WEAF; 9-9:30, Erwin Swindell, organist; 9:30-10:30, musical program, Augustana college.

**WOK, Chicago, Ill. (217.3m-1300ke), 4:30-7 p. m.,** Capitol theater organ; studio program; 10-1:30 a. m., Tearney's Town club orchestra; Carl Lorraine's Pershing Palace orchestra; Husk O'Hara's Coconut Grove orchestra; Capitol theater program; studio program.

**WOOD, Grand Rapids, Mich. (242m-1240ke), 9-10 p. m.,** Willard Battery hour; Moke Martin, Paul Estabrook, Helen Neuman, Bill Dallavo and his Regent Roof orchestra; 10-12, popular program, Bob and Hazel McOsker, Sid Goldman, Friedrich Music house tenor; Bill Dallavo and his orchestra.

**WORD, Batavia, Ill. (275m-1090ke), 7-7:45 p. m.,** "North Shore Line"; 9, I. B. S. A. service; 11, program.

**WOS, Jefferson City, Mo. (440.9m-680ke), 8:15-10 p. m.,** news, students, State School of Mines and Metallurgy; 10, Noland Wrightman, Milo Durkan.

**WQI, Chicago, Ill. (447.5m-670ke), 7-8 p. m.,** dinner concert, Jack Chapman and his Rainbo Gardens orchestra; Carl Pfau, tenor; Helen Holman, soprano; Katherine Parrish, pianist; 10-1 a. m., Jack Chapman and his Rainbo Skylarks; Herman Techtent, baritone; Lena Kirk, soprano; Melodians; Clarence Theders, tenor; Joe Warner, character songs; Oxford girls, harmony singers; Gail Bandell, Sunshine girl; artists; 1-2, Ginger hour, Jack Chapman the Ginger man, Little Skylarks.

**WSAI, Cincinnati, Ohio (325.9m-920ke), 7 p. m.,** WEAF; 7:30, WEAF; 10:15, string quartet.

**WSB, Atlanta, Ga. (426.3m-700ke), 10:45 p. m.,** Baltimore orchestra.

**WSM, Nashville, Tenn. (282.8m-1060ke), 7:15 p. m.,** Francis Craig's orchestra, Hotel Hermitage; 8, Mary Cornelia Malone, soprano, and Daisy Hoffman, pianist; 10, Shriners' program.

**WSOE, Milwaukee, Wis. (245.8m-1220ke), 9 p. m.,** Candygram soloists.

### Mountain Time Stations

**KFWA, Ogdan, Utah (260.7m-1150ke), 4-5 p. m.,** organ recital, Paramount theater; 5-6, Ogdan Radio dealers program; 9-10, Olie Reeves and his orchestra; 10-11, "Happy Mad Music Makers"; 11-12, Olie Reeves and his orchestra.

**KOA, Denver, Colo. (322.4m-930ke), 12:15 p. m.,** Rit-alto theater organ recital, Marjorie Nash; 8, Scheuerman's Colorado orchestra; 8:15, novelty program, Hickville party; 10-12, Broadmoor Rhythm Rustlers.

### Pacific Time Stations

**KFI, Los Angeles, Calif. (467m-640ke), 5:30-6 p. m.,** Jim Jack and Jean trio; 6, nightly doings; 6:30, vest pocket program; 6:45, Radiolator period; 7-7:30, program, A. E. Grebe and company, Synchronphase string ensemble; 7:30-8, Nick Hearts' detective story; 8-9, program, Ventura Rejuven company; 9-10, popular program, Chevrolet Motor company; 10-11, Owen Fallon's Californians; Jackie Lucas, soloist.

**KFOA, Seattle, Wash. (454.3m-660ke), 12:30-1:30 p. m.,** Rotary club program; 5:15-5:30, Around the Towne; KFOA; 7-8:15, Hopper Kelly company studio program; 8:30-10, studio program, Taggart motor company.

**KFON, Long Beach, Calif. (232.4m-1280ke), 6-6:30 p. m.,** Brayton's theater organ; 6:30-7, amusement information; 7-8, Investor's hour with entertainment; 8-9, Press-Telegram studio; 9-10, program, Sam Abrams, the tailor; 10-11, Oriole dance orchestra.

**KFWB, Hollywood, Calif. (252m-1190ke), 5-6 p. m.,** Big Brother's children's hour; 6-7, dinner music, Fitzgerald Music company; 8-9:30, Bill Hatch's Oakmont Country club dance orchestra; 9:30-10, Mutual Motors joke contest; 10-11, Warner Brothers' frolic.

**KGO, Oakland, Calif. (361.2m-830ke), 4-5:30 p. m.,** concert orchestra, Hotel St. Francisco; 6-6:55, dinner concert.

**KHJ, Los Angeles, Calif. (405.2m-740ke), 8:15-10:30 p. m.,** program, Southern California Edison company; Mildred Ware, contralto; Nicholas Hearne, Jr., pianist; Optimist male quartet; Frederick Mac Murray, viola; Carolyn Le Fevre, violinist; Monrovia trio; 10:30-11:30, Don Clark's Baltimore hotel dance orchestra.

**KJR, Seattle, Wash. (384.4m-780ke), 8:30-10 p. m.,** Post Intelligence studio program.

**KLX, Oakland, Calif. (508.2m-90ke), 8-9:45 p. m.,** studio program; 9:45-10:30, Athens Athletic club orchestra.

**KMTR, Hollywood, Calif. (238m-1260ke), 8-10 p. m.,** KMTR concert orchestra, Loren Powell, director; Dan Gridley, tenor; 10-11, Starr Piano company studio.

**KNX, Hollywood, Calif. (336.9m-890ke), 5:30 p. m.,** Leighton's cafeteria orchestra; 6:30-7, Atwater Kent orchestra; 7-8, studio program; 8-9, program, Security Trust and Savings bank; 9-10, program, Joe Daley's 165 grocery stores; 10-11, dance music; 11-12 midnight, Ambassador hotel dance orchestra.

**KOWW, Walla Walla, Wash. (256.3m-1170ke), 12-1 p. m.,** Kiwanis club; 8-10, Violet Reser Hughes program.

**KPO, San Francisco, Calif. (428.3m-700ke), 1-2 p. m.,** Rudy Seiger's Fairmont hotel orchestra; 2:30-3:30, matinee program; 6:40-7, Waldemar Lind and the States Restaurant orchestra; 7-7:30, Rudy Seiger's Fairmont hotel orchestra; 8-9, Atwater Kent artists; 9-10, Goodrich Silvertown Cord orchestra; 10-11, Waldemar Lind and the States Restaurant orchestra; 11-12, Henry Halsted's orchestra.

**KTAB, Oakland, Calif. (239.9m-1250ke), 12-1 p. m.,** concert; 8-10, program, Western States Life Insurance company.

**KWSC, Pullman, Wash. (348.6m-860ke), 7:30-9 p. m.,** George Hunt, banjoist; Geneva Byers, whistler; jazz skill, Maudie Bartsche, Louise Fletcher; Dale White-skill, reader.

## NEWS BULLETINS

### Daily Except Sunday

Eastern	Central	Mountain	Pacific
9:45 a. m.	8:45 a. m.	7:45 a. m.	6:45 a. m.
KDKA (309.1m-970ke), 10			
WGN (302.8m-990ke), 10:35	9:35	8:35	7:35
WCCO (416.4m-720ke), 11	10	9	8
WOAI (394.5m-760ke), 12 n.	11	10	9
CPCA (356.9m-840ke); KDKA (309.1m-970ke); KPRC (296.9m-1010ke), 12:30 p. m.	11:30	10:30	9:30
WCAE (461.3m-650ke), 12 n.	11	10	9
KGW (491.5m-610ke); KNX (336.9m-890ke), 1:15	12:15 p. m.	11:15	10:15
WOAI (394.5m-760ke), 3:45	2:45	1:45 p. m.	12:45 p. m.
WEAS (389.8m-750ke), 4	3	2	1
WCX (516.9m-580ke), 4:30	3:30	2:30	1:30
WCAE (461.3m-650ke); WFAA (475.9m-630ke), 5	4	3	2
CPCA (356.9m-840ke), 6:30	4:30	3:30	2:30
WPG (299.8m-1000ke), 7	6	5	4
KOIL (278m-1080ke); WOC (483.6m-620ke), 7:15	6:15	5:15	4:15
WMAK (265.6m-1130ke); WOAI (394.5m-760ke), 8	7	6	5
WMBF (384.4m-780ke); WMCMA (340.7m-880ke), 9	8	7	6
WSAI (325.9m-920ke), 9:30	8:30	7:30	6:30
KPO (428.3m-700ke), 10	9	8	7
KLX (508.2m-940ke), 10:45	9:45	8:45	7:45
WEBE (370.2m-810ke), 11	10	9	8

### Sunday

Eastern	Central	Mountain	Pacific
8 p. m.	7 p. m.	6 p. m.	5 p. m.
WMAK (265.6m-1130ke), 8:15	7:15	6:15	5:15
WEBH (370.2m-810ke), 9	8	7	6
WPG (299.8m-1000ke), 12	11	10	9
KFWB (252m-1190ke), 11	10	9	8

KYW, "The World Crier," broadcasts news every half hour from 8 a. m. to 2 a. m.

Eastern	Central	Mountain	Pacific
8:10 p. m.	7:10 p. m.	6:10 p. m.	5:10 p. m.
WAMD (243.8m-1230ke) Glee club, 8:45	7:45	6:45	5:45
WIP (308.2m-590ke) Happy Hour quartet, 8:30	7:30	6:30	5:30
KDKA (309.1m-970ke) Masque and Whig club, 9	8	7	6
WBZ (333.1m-900ke) Angelus quartet, 9:30	8:30	7:30	6:30
WFAA (475.9m-630ke) Choral club, 10	9	8	7
KPRC (296.9m-1010ke) Novelty harmonica orchestra, 10:10	9:10	8:10	7:10
WIP (508.2m-590ke) Bishop Titus Lowe of Singapore, 10:15	9:15	8:15	7:15
WJZ (454.3m-660ke), WRC (468.5m-640ke), Record Boys, 10:30	9:30	8:30	7:30
WBAP (475.9m-630ke) Novelty program, Camp Fire Girls, 10:30			

LAWYERS PUT ON MOCK TRIAL AT KOA

Thursday, March 25

WEAO, Columbus, Ohio (293.9m-1020kc), 8:15 p. m., music; 8:45, music; 10, Fort Hayes hour of music. WEEL, Boston, Mass. (248.6m-860kc), 7:30 p. m., Olde Homestead group; 8-10, WEAF. WFL, Philadelphia, Pa. (394.5m-700kc), 1 p. m., Tea Room ensemble; 3, club program. "Afternoon with Griggs"; 6:30, Bellevue Stratford concert orchestra; 7, Bellevue Stratford dance orchestra; 8-11, WEAF. WGBS, New York, N. Y. (315.6m-950kc), 9 p. m., Crystal Palace orchestra; 9:30, Old-time Minstrels; 10:30, dance orchestra. WGPC, New York, N. Y. (252m-1190kc), 3 p. m., Ore Welsh, pianist; 3:30, Frank Gallasi, ukulele; 3:45, studio program; 4:45, Doris Freedman, songs; 5:10, Chas. Coleman, pianist; 10:30, Irving Firstenberg, pianist; 10:45, Frankie Meadows, songs; 11, Piotti and Val, songs; 11:15, Katherine Adolph, soprano; 11:30, Strickland's orchestra; 12-2:00 a. m., midnight frolic. WGHB, Clearwater, Florida (266m-1130kc), 6:30-7:30 p. m., Belleair Estate orchestra; 8:30-10, Belleair estates; 11:30-1 a. m., frolic. WGR, Buffalo, N. Y. (319m-940kc), 2:30 p. m., WGR's afternoon program; 6:30, Vincent Lopez Hotel Statler dance orchestra, Harold Giesler, director; 8, WEAF; 9, WJAF. WGY, Schenectady, N. Y. (379.5m-790kc), 6:30 p. m., Ten Eyck Trio; 7:45, program, Syracuse university; WFLB, 9, WJZ; 10, "Night in Country Store," Con Husker's orchestra; 11:30, organ recital, Stephen E. Bolsclair; WFLB. WHAR, Atlantic City, N. J. (275m-1090kc), 2 p. m., Seaside hotel trio; 8, Seaside hotel ensemble; 9, concert; 11, Follies Berere orchestra. WHN, New York, N. Y. (361.2m-830kc), 12:30 p. m., Lexington organ recital; 1:30, overture and vaudeville from Loew's Metropolitan theater; 3:15, Lexington orchestra; 4, Tea time hour; 6, Treasureland Neighbors; 6:30, People's hour; 7, musical program; 8, WFLB Oakland's Chateau; 10:30, Leroy Smith's orchestra; 11, Joe Ward, singer; 11:30, Eveready orchestra; 12, Al Raymo's entertainers. WIP, Philadelphia, Pa. (508.2m-590kc), 1 p. m., Gimbel tea room orchestra; 3, Pearl Heebner, pianist; DeLee Luckenbach, soprano; Minciva Rose Chadman, soprano; Ethel Greenberg, violinist; Sylvia Stanni, soprano; Flora Ripka, accompanist; 6:05, Pagoda cafe orchestra; 7, Uncle Wip's bedtime stories; Mildred Dowbenko, songs; 8:15, The Happy Hour quartet; 8:45, concert, Institute of Musical Art; 10:20, Nelson Maples and S. S. Levichan orchestra. WJAR, Providence, R. I. (305.9m-980kc), 1:05 p. m., Joe McNamara and his Twin Elm orchestra; 8, Robert W. Powers orchestra; 9-11, WEAF. WJR, Pontiac, Mich. (526.9m-580kc), 7 p. m., Jean Goldkette's symphony orchestra soloists; 9, Jean Goldkette's orchestra; 10, Jean Goldkette's Victor Recording orchestra. WJZ, New York, N. Y. (454.3m-660kc), 12 n. Trinity Lenten service; 1 p. m., Hotel Pennsylvania orchestra; 4:35, Hotel Commodore tea music; 7, Hotel Vanderbilt concert orchestra; 7:45, Judge, Jr. S. Markel's orchestra; 9, Royal Typewriter salon orchestra, WGY, WCAD; 10:15, the Record Boys, WRC; 10:45, Freddie Rich and Hotel Astor dance orchestra. WLIT, Philadelphia, Pa. (394.5m-760kc), 12:20 p. m., religious services; 12:35, Benjamin Franklin hotel concert orchestra; 2, Arcadia cafe concert orchestra; 4:30, Alike Wightman, pianist; 7:30, Dream Daddy's bedtime stories. WLV, New York, N. Y. (288.3m-1040kc), 8:30 p. m., McInerney's entertainers; 9, piano solo; 9:45, song; 10:30, violin solo; 10:40, musicale. WMAK, Buffalo, N. Y. (266m-1130kc), 0:15-7:15 p. m., dinner music. WMCA, New York, N. Y. (340.7m-880kc), 6 p. m., Olcott Vail and his Hotel McAlpin string ensemble; 6:30, Parody orchestra; 7:30, Twin Oaks orchestra; 7:45, Arthur West Sirens; 10:30, Tango orchestra; 11, Ernie Golden and his Hotel McAlpin orchestra; 12 m., McAlpin's entertainers. WNYC, New York, N. Y. (526m-570kc), 7:35 p. m., resume of meeting of board of estimate; 8, concert program; 9, instrumental trio; 9:30, popular songs and novelties; 10:10, board of education lecture service. WOO, Philadelphia, Pa. (508.2m-590kc), 11 a. m., organ recital; 12:02 p. m., Golden crystal tea room orchestra; 4:45, organ recital; 7:30, Adelphia dance orchestra. WOR, Newark, N. J. (405.2m-740kc), 6:30 p. m., Jacques Jany's Hotel Shelton ensemble. WPG, Atlantic City, N. J. (299.8m-1000kc), 6:45 p. m., Arthur Scott Brook, organist; 7, Elks home dinner music; 8:15, U. of Pa. male quartet; 10, Atlantic City Estates' dance orchestra; 11, Silver Slipper supper club. WRC, Washington, D. C. (468.5m-640kc), 1 p. m., Hotel Mayflower orchestra; 7, New Willard hotel orchestra; 8:30, Radio movie, WJZ; 9, Royal Salon orchestra; WJZ, WGY, WCAD; 10:45, Meyer Davis' Le Paradis band. WREO, Lansing, Mich. (285.5m-1050kc), 6-7 p. m., Speed-Wagon serenaders; Gold standard ensemble; 8:15, Red Broadcasting orchestra; Reo string quartet; Thos. E. Metzger, fiddler. WRVA, Richmond, Va. (256.3m-1170kc), 8:10 p. m., Edgeworth frolic and music feast; 9, moment musical trio; 9:30, soloist and novelty numbers; 10, Country fiddlers; 11, Carry Me Back to Old Virginia. WTAG, Worcester, Mass. (268m-1120kc), 12:05-2 p. m., orchestra; 4:30, entertainment; 8-8:30, WEAF; 9-10, WEAF; 10-11, WEAF. WTAM, Cleveland Ohio (389.4m-770kc), 8:30-10 a. m., music appreciation program; 12:15-1:30 p. m., Guy Lombardo and his Royal Canadians; 6-7, Austin Wylie's Vocal Recording orchestra. WTIC, Hartford, Conn. (475.9m-630kc), 6:50 p. m., Hotel Bond trio. WWJ, Detroit, Mich. (352.7m-850kc), 12:05 p. m., Jules Klein's Hotel Statler orchestra; 3, Detroit News orchestra; 6, dinner concert; 8, WEAF.

Central Time Stations

KFKU, Lawrence, Kan. (275m-1090kc), 7:15 p. m., Ray Wright, tenor; Mildred Newby, pianist; 8, senior piano recital, Arlo Hults. KFRU, Columbia, Mo. (499.7m-600kc), 6:30 p. m., religious news service; 9-11, musical program. KIDS, Independence, Mo. (440.9m-680kc), 8:15 p. m., Independence mandolin and guitar club concert. KMA, Shenandoah, Iowa (252m-1190kc), 11:30-12:30 p. m., Fairham trio; May's Flower Lady, Lina Ferguson; 9-11, Delmonico Dreamers' dance orchestra. KMOX, St. Louis, Mo. (280.2m-1070kc), 12:30 p. m., organ recital, Arthur Utt. KPRO, Houston, Texas (296.9m-1010kc), 7:30 p. m., Blanchard's dance orchestra; 8:30, Skyline studio concert; 9, C. A. Durkee and his novelty harmonica orchestra. KSD, St. Louis, Mo. (545.1m-550kc), 7 p. m., WEAF; 7:30, Esmeralda Berry Mayes, pianist; 8, WEAF; 9, WEAF. KSO Clarinda, Iowa (241.8m-1240kc), 7-8 p. m., music, Baker and Anderson. KUOA, Fayetteville, Ark. (299.8m-1000kc), 9 p. m., organ recital, Ozark orchestra. KYW, Chicago, Ill. (535.4m-560kc), 12:05-1 p. m., concert, Commonwealth Edison company; 1-2, Joska DeBarry and his orchestra; Coon-Sanders orchestra; 2:35-4, KYW; frolic; 6-7, dinner music, KDKA, KYW; 9, music, Commonwealth Edison company; 10:40-11:10, Coon-Sanders orchestra; 1-2 a. m., "Insomnia club," Coon-Sanders orchestra. WAMD, Minneapolis, Minn. (243.8m-1230kc), 6:15 p. m., George Osborn and his orchestra; 7-10, St. Olaf church male glee club. WBAF, Fort Worth, Texas (475.9m-630kc), 12:05-12:30 p. m., Ward's Trail Blazers; 6-6:30, Chief Gonzales'

GENERAL TALKS AND SPEECHES

Table with columns for Eastern, Central, Mountain, and Pacific time zones, listing radio stations and their broadcast times for talks and speeches on Saturday, March 20, Monday, March 22, Tuesday, March 23, Wednesday, March 24, Thursday, March 25, and Friday, March 26.

complimentary organ recital; 6, dinner organ recital, Al Carney; 6:30, Hugh Aspinwall, tenor; Grayling's string trio; 6:45, Swedish program; 9:15, Cinderella cafe orchestra; 9:30, Kitchin-Klenzer Classics; 9:50, Jack Turner, singer; Jack Marshall, pianist; 10:10, U. S. L. entertainers; male quartet; 11:30, Pat Barnes and Al Carney; 12, Pat Barnes and Al Carney. WIBO, Chicago, Ill. (225.4m-1330kc), 2-4 p. m., program for shut-ins; Ted Fiorito, pianist; Dan Russo, violinist; Marie Tully, singer; Wayne Myers, reader; Dorothy Dillow, soprano; the Jordans; 6-8, dinner concert; Chester Newman, baritone; H. Caldwell, pianist; William Molnaire, tenor; string trio; 7:30-8, Swedish program; 12, midnight jamboree; Dan Russo, violinist; Ted Fiorito, pianist; songs, Marie Tully; Wayne Myers, monologist; Louis Webb and Bertha Webb, songsters; Gall Bandell, Jimmy Cairns, Dean Stevenson. WJAD, Waco, Texas (352.7m-850kc), 8:30-10 p. m., Baylor Bear band. WJED, Mooseheart, Ill. (370.2m-810kc), 2-3 p. m., Howard L. Peterson, organist; 4:5, music, children; 5:30-7, Jack Nelson; Palmer House symphonic players; Howard L. Peterson, organist; Palmer House Victorians; Salvation Army band; 12:30 a. m., Palmer House Victorians; Jack Nelson. WKAF, Milwaukee, Wis. (261m-1150kc), 8:30-10 p. m., Trxie Ann Troy and her Royal Hawallians; Al Nitz, tenor; Anita DeWitte Hall, celeste. WKRC, Cincinnati, Ohio (325.9m-920kc), 10 p. m., Eugene Perazzo, organist; 10:30, Swiss Garden program; 11, popular song recital; 11:15, Marion McKay and his orchestra. WLFB, Chicago, Ill. (302.8m-990kc), 7-7:20 p. m., Uncle Walt's Punch and Judy show; 7:20-7:30, Correll and Gosden; 7:30-8, WEAF; 11-11:20, Correll and Gosden; 11:20-11:30, dance music; Correll and Gosden. WLS, Chicago, Ill. (344.6m-670kc), 12 a. m., WLS, studio trio; 6 p. m., WLS studio trio; 6:40, Ralph Emerson at our Barton organ; 7:15-7:55, WLS trio solo concert. WLW, Cincinnati, Ohio (422.3m-710kc), 4 p. m., piano recital, Adelaide Apfel; 6:15, musical handshakes, Bob Groenke and Jim Mischler; 7, dinner hour concert, Hotel Gibson orchestra; 9, Ladies Brass band, United Spanish War Veterans, Auxiliary No. 27, Dayton, Ohio; 10, Three Minute message from the U. S. Civil Service department; 10:05, popular concert, Dorothy Melody boys; 11, The Buckeye male quartet; 12:15, Night Howls, Crosby Sky terriers. WMAQ, Chicago, Ill. (447.5m-670kc), 8 p. m., Chicago theater organ; 6:30, Hotel La Salle orchestra; 0, U. of Chicago talk; 9:30, program. WMBB, Chicago, Ill. (250m-1200kc), 7-8 p. m., Trionon duo; Russian music; 9-11, Trionon orchestra; Woodlawn theater orchestra; Scotty Welch and the Madison sisters; Lucille O'Hara, soprano; Clinton Keithley, tenor; Bob Duffy, whistler, baritone. WMC, Memphis, Tenn. (499.7m-600kc), 8:45 p. m., Cotese ensemble. WOA, San Antonio, Texas (394.5m-760kc), 8:30 p. m., Mistletoe Melody maids. WOAW, Omaha, Neb. (526m-570kc), 6 p. m., Dorothy Chenoweth Lowden, harpist; E. M. Mills, trumpeter; 0:20, Manna Kea trio; 6:50, Randall's Royal Funtelle orchestra; 10:30, Herb Felerman and his orchestra; 12, Roseland Radio Frolic. WOC, Davenport, Iowa (483.6m-620kc), 5:45-6 p. m., chimes concert; 7-7:30, WEAF; 7:30-8, Moline Ploymen; 8-9, WEAF; 9-10, WEAF; 11-12, LeClaire hotel orchestra; Peter MacArthur, baritone. WOJ, Ames, Iowa (270m-1110kc), 8 p. m., Home Economics orchestra. WOK, Chicago, Ill. (217.3m-1300kc), 4:30-7 p. m., Capitol theater organ; studio program; 10-1:30 a. m., Tearney's Town club orchestra; Carl Lorraine's Pershing Palace orchestra; Husk O'Hare's Coccanut Grove orchestra; Capitol theater program; studio program. WORD, Batavia, Ill. (275m-1090kc), 8 p. m., Webster hotel concert trio; 8:30, recital, Cosmopolitan school of music. WQJ, Chicago, Ill. (447.5m-670kc), 7-8 p. m., Jack Chapman and his Rainbo Gardens orchestra; Clement Laskowski, tenor; 10-11 a. m., Jack Chapman and his Rainbo Skylarks; Jerry Sullivan; Rose Vanderbosch, soprano and pianist; Hal Lansing and his uke; Lew Butler; Anne Kelm, mezzo-soprano; Bert Davls; Marie Politt, artist; 1-2, Ginger hour, Jack Chapman and his Little Skylarks. WRR, Dallas, Texas (245.8m-1220kc), 6-7 p. m., Jack Gardner's orchestra; 8-9, fraternity program, marimbaxophone and vibraphone player. WSAI, Cincinnati, Ohio (325.9m-920kc), 7 p. m., music; 7:30, WEAF; 8-10, WEAF. WSB, Atlanta, Ga. (428.3m-700kc), 8 p. m., Ray-O-Vae Twins; 10:45, Charles A. Sheldon, Jr., organist. WSOE, Milwaukee, Wis. (245.8m-1220kc), 9:30 p. m., old-fashioned musical program; Underwood's Quadrille orchestra.

Mountain Time Stations

CNRC, Calgary, Can. (435.8m-688kc), 9 p. m., Jack Rushton's serenaders; Frank Hieck, pianist; Gladys Foster, violinist; Jack Rushton, saxophonist. KFAU, Boise, Idaho (280.2m-1070kc), 8 p. m., program, Sampson Music company. KFWA, Ogden, Utah (260.7m-1150kc), 4-5 p. m., organ recital, Paramount theater; 5-6, Ogden Radio dealers program. KFXF, Colorado Springs, Colo. (250m-1200kc), 8:30 p. m., Russ Kemp's orchestra. KOA, Denver, Colo. (322.4m-930kc), 12:15 p. m., Riato theater organ recital, Marjorie Nash; 6:30, Brown Palace string orchestra. KUOM, Missoula, Mont. (243.8m-1230kc), 8 p. m., musicale.

Pacific Time Stations

KFI, Los Angeles, Calif. (467m-640kc), 5:30-6 p. m., Packard Six dance orchestra; 6, nightly doings; 6:30, vest pocket program; 6:45, Radioblorial period; 7-8, program, students University of Southern California; 8-9, Clara Belle Patten Wallace, contralto; 9-10, program, Chickering hall; 10-11, Jose Arias and his Mexican orchestra. KFOA, Seattle, Wash. (454.3m-660kc), 12:30-1:30 p. m., The Young Men's Business club; 5:15-5:30, Around the Towne, KFOA. KFOR, Long Beach, Calif. (232.4m-1280kc), 6-6:30 p. m., Brynton's theater organ; 6:30-7, amusement information; 7-7:30, Spanish lesson; 7:30-8, municipal band concert; 8, book chat; 8:15-9, Long Beach municipal band; 9-10, studio program. KFWB, Hollywood, Calif. (252m-1190kc), 6-7 p. m., dinner music, Fitzgerald Music company; 8-9, program, Corduroy Tire company; Corduroy Tire orchestra; Albert Keglovich, violinist; Estelle Shake, blues singer; 9-10, program, Don P. Smith, Inc., Dlanamoon orchestra, Sol Hoopii's Hawaiians and Ashley Sisters, vocal duets; 10-11, Warner Brothers' frolic. KGO, Oakland, Calif. (361.2m-830kc), 8-9 p. m., Conn Marinba band, trio; 9-10, Saima Bloomquist, pianist; Finnish music program; Martha Jalava, soprano; 10-11, Brokaw and orchestra. KHJ, Los Angeles, Calif. (405.2m-740kc), 8-10, p. m., program, Jell Well Desert company; 10-11, Don Clark's Biltmore hotel dance orchestra. KJR, Seattle, Wash. (384.4m-780kc), 7-8:30 p. m., Eureka mixed quartet; 8:30-10, Puget Sound Savings and Loan Association orchestra; 10:30-12, "Keep Joy Radiating Order of Bats." KMTR, Hollywood, Calif. (238m-1260kc), 6-7 p. m., Starr Piano company studio; 8-10, KMTR concert orchestra, Loren Powell, director. KNX, Hollywood, Calif. (336.9m-890kc), 5:30 p. m., Leighton's cafeteria orchestra; 6:30-7, Atwater Kent orchestra; 7-8, program, H. L. Crockett company, 8-9, program, Willys-Overland dealers; 9-10, KNX feature program; 10-11, Brazier's Mountain Park program; 11-12, Ambassador hotel dance orchestra. KOWW, Walla, Walla, Wash. (256.3m-1170kc), 12-1 p. m., Rotary club program; 8-10, old time dance



BISHOP LOWE OF SINGAPORE AT WIP

Thursday, March 25

music. Prescott Fiddlers; 10-11, music; 11-11:30, organ concert.
KPO, San Francisco, Calif. (428.3m-700kc), 1-2 p. m., Rudy Sieger's Fairmont hotel orchestra; 2:30-3:30, matinee program; 3:30-4:30, Cyrus Trotter's Palace hotel orchestra; 6:40-7, Waldemar Lind and the States Restaurant orchestra; 7-7:30, Rudy Sieger's Fairmont hotel orchestra; 8-9, KPO quartet; 9-10, Avon string quintet; 10-11, Cabriants' orchestra; 11-12, Henry Halsted's orchestra.
KPSN, Pasadena, Calif. (315.6m-950kc), 8-9 p. m., Pasadena Chamber of Commerce.
KTAB, Oakland, Calif. (239.9m-1250kc), 12-1 p. m., concert; 8-10, program.

Friday, March 26

Headliners Today

Table with 4 columns: Eastern 8 p. m., Central 7 p. m., Mountain 6 p. m., Pacific 5 p. m. Listing various radio stations and their programs.

Friday, silent night for: CFAC, CHIC, CKNC, CKY, CNCR, CNRM, CNRD, CNRR, CNRW, KFAU, KFEQ, KFKU, KFWA, KFXF, KGO, KFAU, KLDS, KPCB, KPSN, KUOA, KUOM, PWX, WBBR, WCAD, WCBD, WEAO, WEBW, WGBS, WGST, WHAZ, WIP, WJAZ, WKRC, WLW, WLWL, WMAK, WNAD, WRC, WREO, WRVA, WSAI, WSMB, WSUI, WTAM.

Eastern Time Stations

CKAC, Montreal, Can. (410.7m-730kc), 1:45 p. m., luncheon trio.
CNRA, Moncton, Can. (291.1m-1030kc), 8 p. m., CNRA Little symphony orchestra; Raymond Leger, violinist; R. Wade, trumpeter; Alyre LeBlanc, trombonist; Mr. Cooke, drummer; Mrs. Irvine Malcolm, pianist; Percy Bolyea, bassoon soloist; Gordon Douglas, bass; 10, orchestra.
CNRT, Toronto, Can. (356.9m-840kc), 6:30 p. m., dinner concert, Luigi Romanelli and his King Edward hotel concert orchestra; 9, Canadian Melstersingers, quarter numbers, solos; Kathleen Irwin, accompanist; 11, dance program, Luigi Romanelli and his King Edward hotel concert orchestra.
KDKA, Pittsburgh, Pa. (568.1m-970kc), 6:30 p. m., dinner concert, 9, Victor hour of music.
WBAL, Baltimore, Md. (245.8m-1220kc), 6:30-7:30 p. m., dinner program; 7:30-8, quartet; 8-9, Lubov Breit Keefer, pianist; 9-10, string trio; John Wilburn, tenor.
WBZ, Springfield, Mass. (333.1m-900kc), 6:30 p. m., Hotel Kimball orchestra; 7, music story period, Helen Leavitt; 8, Edwin J. McEnelly and his orchestra; 8:30, concert, Hotel Vendome; 9, Victor concert, Mme. Marie Jeriza, soprano of the Metropolitan Opera company and Enrico De Gogorza, baritone, WJZ.
WCAE, Pittsburgh, Pa. (461.3m-650kc), 6:30 p. m., dinner concert, William Penn hotel; 8, Chilcott quartet; 9:30, WEAF; 10:30, WEAF.
WCAP, Washington, D. C. (468.5m-640kc), 6-12:30 p. m., Mozart string quintet; John H. Thompson and Company, Inc., Washington realtors; music and playlet; the Little orchestra of the U. S. Navy band; WEAF; Warden Park hotel music.
WCAU, Philadelphia, Pa. (277.6m-1080kc), 6:45, Hotel Pennsylvania concert orchestra; 7:30, Snellenburg instrumental trio; 8:30, Singing Groundhog; 8:45, the Bryan Girl; 9, Regina Crookers; 9:15, Dwight Strickland, "poetician"; 9:30, the Sea Gulls; 10:30, Myers' musical architects.
WCX, Detroit, Mich. (516.9m-580kc), 6-7 p. m., dinner program, Goldkette ensemble; 8-9, program; 9-10, dance music, Jean Goldkette's Breeze Blowers.
WEAF, New York, N. Y. (491.5m-610kc), 11:05 a. m., Beatrice Schwab, soprano; 12 noon, Lenten services under auspices of Greater New York Federation of churches; 4 p. m., Madeline Hunt, "The Girl from Mexico"; 4:30, Conrad Thibault, baritone; 5, Vincent Lopez and orchestra; 6, dinner music, Hotel Waldorf-Astoria; 7, Michael Markless dance orchestra; 7:45, Dicken's corner; 8, Harpells Candy Boys; 8:30, Eagle Neutrodyne trio; 9, City Service quartet and orchestra; WEEI, WOO, WEAR, WGN, KSD; 9:30, the Vikings, WJAR, WGR, WTAC, WCAE, WOC, WVVJ, KSP, WEAR, WCAP; 10, Whittall Anglo-Persians, WEEI, WCAP, WJAR, WTAC, WCAE, WOC, WCG, WGR, WOC, WKSJ, WEAR, WGN; 10:30, Antonio Lanasa tenor; 10:45, Eleanor Bahngte pianist; 11, Ben Bernie and orchestra.
WEBJ, New York, N. Y. (272.6m-1100kc), 7 p. m., Bronx Ritz theater ensemble; 7:45, Milton Yokeman, tenor, accompanied by Norman Hennesfeld; 8, Jeanne A'Dair, singing composer; 8:15, Joseph Zabolov, baritone; 8:30, Al Ciccone and his Harlem Tea Garden orchestra.
WEEI, Boston, Mass. (246.6m-860kc), 12:15 a. m., service Keith's theater; 8:05 p. m., Wm. Murphy, baritone; Maxine Murphy, accompanist; 5, Frankie Ward and his orchestra; 8:13, Joe Rines and his Hunter's Cabin orchestra; 7:30, Whittall Milk company program; 8, musicale; 8:30, Neapolitan Ice Cream company program; 9, WEAF, musicale; 9:30, Carter's Incas; 10, WEAF; 10:30, Scooty Holmes and his orchestra; Imperial marimba band.
WFI, Philadelphia, Pa. (394.5m-760kc), 1 p. m., Tea Room ensemble; 3, Sequi Centennial program; 6:30, Bellevue Stratford concert orchestra; 7, Bellevue Stratford dance orchestra.
WGBS, New York, N. Y. (315.6m-950kc), 1:30 p. m., Leonard Garfunkel, pianist; 5:10, Suzanne Stone, harpist; 6, Uncle Geobee; 6:30, Anzell's orchestra.
WGCP, New York, N. Y. (252m-1190kc), 3 p. m., Rosa Elvira George, pianist; 3:30, Sherman and Neal, songs; 3:45, Marie Kalla, songs; 4:10, Alfred Hall, baritone; 4:20, Miriam Davis, songs; 4:45, Rubey Cowan, entertainer; 5:10, Clarence Proff, pianist; 7, China Royal orchestra; 7:30, Billy Hiefield, singing pianist; 8, Mitt Simpson, comedian; 8:15, studio program.
WGHB, Clearwater, Florida (268m-1330kc), 6:30-7:30 p. m., Mandaly orchestra; 8-10, diversified program, Bill Ewin and L. W. Joys "The Beattroubadours"; 11:45-1 a. m., Harold Crocker and his Gater orchestra.
WGR, Buffalo, N. Y. (319m-940kc), 2:30 p. m., WGR's afternoon program; 6:30, Clef trio; 7:30, WEAF; 9, Winger's Crescent Park entertainers; 9:30, WEAF; 10:30, Hewitt Humorists; 11, Vincent Lopez's Hotel Statler dance orchestra, Harold Gleaser, director, John T. Gundersen, Jr., organist.
WGY, Schenectady, N. Y. (379.5m-790kc), 2 p. m., Asia Restaurant orchestra; 7, Eastman theater orchestra; WHAM; 8:15, fourth episode of mystery

play, "A Step on the Stairs"; 8:30, WGY orchestra; 9, Victor program WJZ, Maria Jeriza, metropolitan soprano and Emilio De Gogorza, baritone; 10, play, "Border Lines," Emma S. Backus.
WHAR, Atlantic City, N. J. (275m-1090kc), 2 p. m., Seaside hotel trio; 8, Seaside hotel trio.
WHN, New York, N. Y. (361.2m-830kc), 6 p. m., People's hour; 7, Harry Richman and his entertainers; 7:30, Melody club orchestra; 8, Uncle Robert's chat; 10, Roseland dance orchestra; 10:30, Anatol Friedland; 11, Twin Oaks orchestra; 11:30, Kit Kat club orchestra; 12, Silver Slipper orchestra; 12:30 a. m., Avalon club orchestra.
WIP, Philadelphia, Pa. (508.2m-590kc), 1 p. m., Gimbel tea room orchestra; 6:05, Benjamin Franklin hotel concert orchestra; 7, Uncle Wip's bedtime stories; Anna Daney and Sarah Reed, piano solos.
WJAR, Providence, R. I. (305.9m-980kc), 1:05 p. m., Howard and Harris; 8, musical program; 8:30, Gorman's Jolly Bakers; 9, musical program; 9:30, WEAF; 10, WEAF; 10, Providence-Biltmore dance orchestra.
WJAZ, Pontiac, Mich. (516.9m-580kc), 6 p. m., Jean Goldkette's symphony orchestra; soloists; 9, Mulkey Celebrities.
WJZ, New York, N. Y. (454.3-660kc), 12:15 p. m., music from Brick Presbyterian church; 1, Hotel Ambassador trio; 4:35, Hotel Astor tea orchestra; 7, Hotel Commodore concert orchestra; 7, New York University concert orchestra; 8, Sundial shoe serenaders; 8:30, Bonnie Laddies; 10:30, Hotel Lorraine grill orchestra.
WKAR, Lansing, Mich. (285.5m-1050kc), 8-9 p. m., State department program.
WLIT, Philadelphia, Pa. (394.5m-760kc), 12:20 p. m., religious service; 12:35, Arcadia cafe concert orchestra; 2, Arcadia cafe concert orchestra; 2:30, playlet, students national school of oratory and elocution; 8, sports talk; 8:15, talk; 8:30, recital; 10, Morning Glory club; Arcadia cafe dance orchestra; Zoehrens and Herscher, popular songs; 10:30, Rufus and Rastus; 11, continuation of Morning Glory club concert; musical comedy stars.
WMAZ, Macon, Ga. (261m-1150kc), 9-10 p. m., A. L. Glasco, Negro spirituals; 10-11, Prof. Joseph Maerz, pianist.
WMCA, New York, N. Y. (340.7m-890kc), 6 p. m., Olcott Vail and his Hotel McAlpin string ensemble; 6:30, Ernie Golden and his Hotel McAlpin orchestra; 7:30, Sach's Muesteal Monarchs; 8:50, Broadway Assn.; 9, Hardman hour of music; 10:30, Parody orchestra; 10:45, Van and Schenek; 11, Hofbrau Haus entertainers; 11:30, Jack Denny's orchestra; 12 m., McAlpin entertainers.
WNYC, New York, N. Y. (526m-570kc), 6:20 p. m., songs; 7:35, concert program; 8:30, violin recital; 9:30, instrumental features.
WOO, Philadelphia, Pa. (508.2m-590kc), 11 a. m., organ recital; 12:02 p. m., Golden's crystal tea room orchestra; 4:45, organ recital; 3:30, Adelpia dance orchestra; 8, WOO orchestra; 9:25, Fox theater program; 10, WEAF; 10:30, Sylvania dance orchestra.
WOR, Newark, N. J. (405.2m-740kc), 6:40 p. m., studio program; 7, Copenhagen quartet.
WPG, Atlantic City, N. J. (299.8m-1000kc), 6:45 p. m., Arthur Scott Brook, organist; 7, Hotel Traymore dinner music; 8:15, Sol Kanadis, Chick Leonard entertainers; 9, Hotel Traymore concert orchestra; 9:30, dance orchestra; 10, James' Salt Water Taffy Boys dance orchestra; 11, Jean Weizer, organist.
WRC, Washington, D. C. (468.5m-640kc), 12:30 p. m., service, Keith's theater; J. Meyer Davis' New Willard hotel orchestra; 3:30, U. S. Marine band; 5, W. Spencer Tupman's hotel Mayflower orchestra.
WRED, Lansing, Mich. (285.5m-1050kc), 6-7 p. m., Speed-Wagon serenaders and Gold Standard ensemble.
WRVA, Richmond, Va. (256.3m-1170kc), 7 p. m., Hotel Richmond orchestra; 8:10, Art Perkins and his ukulele; 8:40, Cadman's "Morning of the Year," song cycle, mixed quartet, violin, piano; 10, Hotel Richmond winter garden orchestra; 11, Carry Me Back to Old Virginia.
WTAG, Worcester, Mass. (268m-1120kc), 12:05-2 p. m., WTAG orchestra; 8:15-9:30, concert; 9:30-10, WEAF; 10-10:30, WEAF.
WTAM, Cleveland, Ohio (389.4m-770kc), 12:15-1:30 p. m., Guy Lombardo and his Royal Canadians; 6-7, Carl Rupp and his Hotel Hollenden orchestra.
WUTC, Hartford, Conn. (475.9m-630kc), 11:25 a. m., Laura C. Gaudet, pianist; 12:05-1 p. m., Travelers club orchestra; 6:30, Hub trio; 8:15, Waterbury community night.
WWJ, Detroit, Mich. (352.7m-850kc), 12:05 p. m., Jules Kjolhn's Hotel Statler orchestra; 3, Detroit News orchestra; 6, dinner concert; 8, Thaddeus Wronski singers; 9:30, WEAF; 10:30, dance program.

school of Hawaiian musicians; 8:30-9:30, Tom D. Collins and the Gibson mandolin and guitar club.
WGBF, Evansville, Ind. (238.1m-1270kc), 8 p. m., Hennighof Nolan company, musical program; 11, D. X. Hunting club.
WGES, Oak Park, Ill. (250m-1200kc), 5-7 p. m., duo, mezzo-soprano, quartet, organ; 8-9, orchestra pipe organ soprano, tenor, pianist; 11-1 a. m., banjo fiends, organ; Coyne orchestra, comedian, uke girl.
WGN, Chicago, Ill. (302.8m-990kc), 12:40-2:30 p. m., luncheon concert, Drake ensemble, Blackstone string quintet; 2:30-3, Lyon and Healy artists; 3:30-4:15, Tea Time music, Marshall Field's tea room orchestra; 4:30-5, organ recital, Edward Benedict; 6:30-7, concert ensemble, Blackstone string quintet; 8 time favorites; 8-9, WEAF program; 9-10, WEAF program; 10-10:10, Sam 'n' Henry; 10:10-10:20, old-time favorites; 10:20-10:40, the Playshop; 10:40-11, popular and dance program.
WNAD, Milwaukee, Wis. (275-1090kc), 6:15-7 p. m., organ recital, Arthur Richter; 8:30-10, Marquette university studio program, vocal, string quartet, orchestra.
WHAS, Louisville, Ky. (399.8m-750kc), 7:30-9 p. m., concert.
WHB, Kansas City, Mo. (365.6m-820kc), 7-8 p. m., Sweeney Radio orchestra.
WHO, Des Moines, Iowa (526m-570kc), 7:30-9 p. m., Bruce Lybarger, violinist; Masonic quartet; Arman Jackson and Henry Lewis, Hawaiian guitarists; Stewart Warden, baritone; 11-12, dance program, Bankers Life "Corn Sugar" orchestra.
WHT, Chicago, Ill. (399.8m-750kc), 12 m., Al Carney's complimentary organ recital; 6, classical program; dinner organ recital, Al Carney; Grayling's string trio; Helen Raub, pianist; Charles Hussey, basso; 6:50, Ray-O-Vac concert; 9:15, musical features; Cinderella Cafe orchestra; 9:30, novelties; 11:30, Pat Barnes and Al Carney; Cinderella Cafe orchestra; 12, Pat Barnes and Al Carney.
WIBD, Chicago, Ill. (425.4m-1330kc), 2-4 p. m., Shuttlesworth program, Ted Fiorito pianist; Dan Russo, violinist; Marie Tully, songster; readings, Wayne Myers; songs, Rita McPaw and Mary Bieber; Louise Lockifer, reader; Clifford Berge, violinist; Al Benson, Gail Bandell; 6-8, dinner concert; Joe North, baritone; Evelyn Nelson, pianist; Florence Osterman, contralto; Ray McKay, baritone; Elsie Orr, soprano; Mary Thrash House, pianist; string trio; 10-2 a. m., popular program; Marie Tully, songs; Dan Russo, piano; Ted Fiorito, pianist; Wayne Myers, vocalist; songs, the Jordans; Ruby Rossini, Lauretta Giles, Tommy Smith.
WJAD, Waco, Texas (352.7m-850kc), 8:30-10 p. m., dance orchestra.
WJJD, Mooreshead, Ill. (370.2m-810kc), 12-1 p. m., Palmer House symphonic players; trio; 2-3, organ hour, Howard L. Peterson; child artists; assembly of 1,250 children; 5:30, instrumental hour; Palmer House symphonic players; Jack Nelson; Victorians; 6:40, Billy Van; 8-9, children's hour; 10-11, feature hour; Ronald Harold C. Kessinger; Palmer House Victorians; Jean St. Anne; 12:30 a. m., Knights of the Burning Candle.
WLIB, Chicago, Ill. (302.8m-990kc), 7-7:20 p. m., Uncle Walt's Punch and Judy show; 7:20-7:30, Correll and Gosden; 7:30-8, program; 11-11:20, Correll and Gosden; 11:20-1 a. m., dance music; Correll and Gosden.
WLS, Chicago, Ill. (344.6m-670kc), 12 a. m., Ford and Glenn; 6 p. m., Ford and Glenn; 6:40, Ralph Emerson at our Barton organ; 7:15, WLS studio trio picture concert; 7:45, Jeanette Kling, reader; 8, H. D. Sadler, feature; 8:30, Illinois Wesleyan glee club minstrels; 9, Young American artists series; 9:30, Nash band; 10:15-11, Ford and Glenn music shop.
WMAQ, Chicago, Ill. (447.5m-670kc), 6 p. m., Chicago theater organ; 8:30, Rosseter Cole, George Simons; 9, lecture, U. of C.; 9:20, La Salle Extension university quartet.
WMBB, Chicago, Ill. (250m-1200, 7-8 p. m., Trioan duo; Vella Cook, contralto; Frank Bordner, baritone; McCredy and Hart, Harmony duo; 9-11, Trioan orchestra; Woodlawn theater orchestra; Joe Warner, character song; Andy Anderson, baritone, rned Stevenson, musical saw; Bob Bennett, piano, novelties.
WMC, Memphis, Tenn. (499.7m-600kc), 8:30 p. m., Cooper's Hawaiians; 11, frolic.
WQAI, San Antonio, Texas (394.5m-760kc), 8:30 p. m., San Antonio College of music.
WOAW, Omaha, Neb. (526m-570kc), 6:20 p. m., Francis Potter's banjo orchestra; 6:50, Gilbert Jaffy, violinist; Nat Young, pianist; 10:30 Frank Hodek and his Nightingale orchestra.
WOC, Davenport, Iowa (463.6m-620kc), 4-5 p. m., Crescent orchestra; 5:45-6, chimes concert; 7:30-8:30, Broadway Presbyterian church choir; 8:30-9, WEAF; 9-9:30, WEAF; 10:30, "A Step on the Stairs," mystery drama, Episode V.
WOK, Chicago, Ill. (217.3m-1300kc), 4:30-7 p. m., Capitol theater organ; studio program; 10-1:30 a. m., Tearney's Town club orchestra; Carl Lorraine's Pershing Palace orchestra; Husk O'Hare's Coconut Grove orchestra; Capitol theater organ; studio program.
WOOD, Grand Rapids, Mich. (242m-1240kc), 9-10 p. m., Robert Hazenberg and Robert DeJonge, saxophonists; Alida Vandenberg, pianist; Douglas Latio, violinist; Lillian DeBree, accompanist; Benjamin and Edwin Van Houten, harmonists; 10-11, classical concert; H. P. Vaughn, baritone; Melissa Dvorak, pianist; 11-12, Regent Roof Radio frolic, Bill Dallavo and his orchestra.
WORD, Batavia, Ill. (275m-1090kc), 7 p. m., "North Shore Line"; 9-10, musical program; 11-12, program.
WOS, Jefferson City, Mo. (440.9m-680kc), 8:20, program, Springfield chamber of commerce; Boy Scout band.
WQJ, Chicago, Ill. (447.5m-670kc), 7-8 p. m., dinner concert, Jack Chapman and his Rainbo Gardens orchestra; Henrietta Nolan, violinist; H. Bundy; Billy Harris, pianist; Sheppard Levine, tenor; 10-1 a. m., Jack Chapman and his Rainbo Skylarks; H. Lucille Long, woman harmonica player; Eleanor Terry; Romo Vincent, boy baritone; Merrill Carder, baritone; Johnny Post, baritone; Tell Taylor; Harold Olson, baritone; Clark's Hawaiian trio; artists; 1-2, Ginger hour, Jack Chapman the Ginger Man and Little Skylarks.
WRR, Dallas, Texas (245.8m-1220kc), 6-7 p. m., Jack Gardner's orchestra; 8-9, Mrs. Thomas H. Littlepage's musical program; 11-12 a. m., novelty program.
WSB, Atlanta, Ga. (428.3m-700kc), 8 p. m., G. M. A. glee club; 10:45, entertainment.
WSM, Nashville, Tenn. (282.8m-1060kc), 7:15 p. m., Francis Craig's orchestra; 8, Vanderbilt university, 10, Southern quartet and glee club.
WSOE, Milwaukee, Wis. (245.8m-1220kc), 5:10 p. m., twilight campfire, Boy Scouts; 9, Candygram review.

play, "A Step on the Stairs"; 8:30, WGY orchestra; 9, Victor program WJZ, Maria Jeriza, metropolitan soprano and Emilio De Gogorza, baritone; 10, play, "Border Lines," Emma S. Backus.
WHAR, Atlantic City, N. J. (275m-1090kc), 2 p. m., Seaside hotel trio; 8, Seaside hotel trio.
WHN, New York, N. Y. (361.2m-830kc), 6 p. m., People's hour; 7, Harry Richman and his entertainers; 7:30, Melody club orchestra; 8, Uncle Robert's chat; 10, Roseland dance orchestra; 10:30, Anatol Friedland; 11, Twin Oaks orchestra; 11:30, Kit Kat club orchestra; 12, Silver Slipper orchestra; 12:30 a. m., Avalon club orchestra.
WIP, Philadelphia, Pa. (508.2m-590kc), 1 p. m., Gimbel tea room orchestra; 6:05, Benjamin Franklin hotel concert orchestra; 7, Uncle Wip's bedtime stories; Anna Daney and Sarah Reed, piano solos.
WJAR, Providence, R. I. (305.9m-980kc), 1:05 p. m., Howard and Harris; 8, musical program; 8:30, Gorman's Jolly Bakers; 9, musical program; 9:30, WEAF; 10, WEAF; 10, Providence-Biltmore dance orchestra.
WJAZ, Pontiac, Mich. (516.9m-580kc), 6 p. m., Jean Goldkette's symphony orchestra; soloists; 9, Mulkey Celebrities.
WJZ, New York, N. Y. (454.3-660kc), 12:15 p. m., music from Brick Presbyterian church; 1, Hotel Ambassador trio; 4:35, Hotel Astor tea orchestra; 7, Hotel Commodore concert orchestra; 7, New York University concert orchestra; 8, Sundial shoe serenaders; 8:30, Bonnie Laddies; 10:30, Hotel Lorraine grill orchestra.
WKAR, Lansing, Mich. (285.5m-1050kc), 8-9 p. m., State department program.
WLIT, Philadelphia, Pa. (394.5m-760kc), 12:20 p. m., religious service; 12:35, Arcadia cafe concert orchestra; 2, Arcadia cafe concert orchestra; 2:30, playlet, students national school of oratory and elocution; 8, sports talk; 8:15, talk; 8:30, recital; 10, Morning Glory club; Arcadia cafe dance orchestra; Zoehrens and Herscher, popular songs; 10:30, Rufus and Rastus; 11, continuation of Morning Glory club concert; musical comedy stars.
WMAZ, Macon, Ga. (261m-1150kc), 9-10 p. m., A. L. Glasco, Negro spirituals; 10-11, Prof. Joseph Maerz, pianist.
WMCA, New York, N. Y. (340.7m-890kc), 6 p. m., Olcott Vail and his Hotel McAlpin string ensemble; 6:30, Ernie Golden and his Hotel McAlpin orchestra; 7:30, Sach's Muesteal Monarchs; 8:50, Broadway Assn.; 9, Hardman hour of music; 10:30, Parody orchestra; 10:45, Van and Schenek; 11, Hofbrau Haus entertainers; 11:30, Jack Denny's orchestra; 12 m., McAlpin entertainers.
WNYC, New York, N. Y. (526m-570kc), 6:20 p. m., songs; 7:35, concert program; 8:30, violin recital; 9:30, instrumental features.
WOO, Philadelphia, Pa. (508.2m-590kc), 11 a. m., organ recital; 12:02 p. m., Golden's crystal tea room orchestra; 4:45, organ recital; 3:30, Adelpia dance orchestra; 8, WOO orchestra; 9:25, Fox theater program; 10, WEAF; 10:30, Sylvania dance orchestra.
WOR, Newark, N. J. (405.2m-740kc), 6:40 p. m., studio program; 7, Copenhagen quartet.
WPG, Atlantic City, N. J. (299.8m-1000kc), 6:45 p. m., Arthur Scott Brook, organist; 7, Hotel Traymore dinner music; 8:15, Sol Kanadis, Chick Leonard entertainers; 9, Hotel Traymore concert orchestra; 9:30, dance orchestra; 10, James' Salt Water Taffy Boys dance orchestra; 11, Jean Weizer, organist.
WRC, Washington, D. C. (468.5m-640kc), 12:30 p. m., service, Keith's theater; J. Meyer Davis' New Willard hotel orchestra; 3:30, U. S. Marine band; 5, W. Spencer Tupman's hotel Mayflower orchestra.
WRED, Lansing, Mich. (285.5m-1050kc), 6-7 p. m., Speed-Wagon serenaders and Gold Standard ensemble.
WRVA, Richmond, Va. (256.3m-1170kc), 7 p. m., Hotel Richmond orchestra; 8:10, Art Perkins and his ukulele; 8:40, Cadman's "Morning of the Year," song cycle, mixed quartet, violin, piano; 10, Hotel Richmond winter garden orchestra; 11, Carry Me Back to Old Virginia.
WTAG, Worcester, Mass. (268m-1120kc), 12:05-2 p. m., WTAG orchestra; 8:15-9:30, concert; 9:30-10, WEAF; 10-10:30, WEAF.
WTAM, Cleveland, Ohio (389.4m-770kc), 12:15-1:30 p. m., Guy Lombardo and his Royal Canadians; 6-7, Carl Rupp and his Hotel Hollenden orchestra.
WUTC, Hartford, Conn. (475.9m-630kc), 11:25 a. m., Laura C. Gaudet, pianist; 12:05-1 p. m., Travelers club orchestra; 6:30, Hub trio; 8:15, Waterbury community night.
WWJ, Detroit, Mich. (352.7m-850kc), 12:05 p. m., Jules Kjolhn's Hotel Statler orchestra; 3, Detroit News orchestra; 6, dinner concert; 8, Thaddeus Wronski singers; 9:30, WEAF; 10:30, dance program.

school of Hawaiian musicians; 8:30-9:30, Tom D. Collins and the Gibson mandolin and guitar club.
WGBF, Evansville, Ind. (238.1m-1270kc), 8 p. m., Hennighof Nolan company, musical program; 11, D. X. Hunting club.
WGES, Oak Park, Ill. (250m-1200kc), 5-7 p. m., duo, mezzo-soprano, quartet, organ; 8-9, orchestra pipe organ soprano, tenor, pianist; 11-1 a. m., banjo fiends, organ; Coyne orchestra, comedian, uke girl.
WGN, Chicago, Ill. (302.8m-990kc), 12:40-2:30 p. m., luncheon concert, Drake ensemble, Blackstone string quintet; 2:30-3, Lyon and Healy artists; 3:30-4:15, Tea Time music, Marshall Field's tea room orchestra; 4:30-5, organ recital, Edward Benedict; 6:30-7, concert ensemble, Blackstone string quintet; 8 time favorites; 8-9, WEAF program; 9-10, WEAF program; 10-10:10, Sam 'n' Henry; 10:10-10:20, old-time favorites; 10:20-10:40, the Playshop; 10:40-11, popular and dance program.
WNAD, Milwaukee, Wis. (275-1090kc), 6:15-7 p. m., organ recital, Arthur Richter; 8:30-10, Marquette university studio program, vocal, string quartet, orchestra.
WHAS, Louisville, Ky. (399.8m-750kc), 7:30-9 p. m., concert.
WHB, Kansas City, Mo. (365.6m-820kc), 7-8 p. m., Sweeney Radio orchestra.
WHO, Des Moines, Iowa (526m-570kc), 7:30-9 p. m., Bruce Lybarger, violinist; Masonic quartet; Arman Jackson and Henry Lewis, Hawaiian guitarists; Stewart Warden, baritone; 11-12, dance program, Bankers Life "Corn Sugar" orchestra.
WHT, Chicago, Ill. (399.8m-750kc), 12 m., Al Carney's complimentary organ recital; 6, classical program; dinner organ recital, Al Carney; Grayling's string trio; Helen Raub, pianist; Charles Hussey, basso; 6:50, Ray-O-Vac concert; 9:15, musical features; Cinderella Cafe orchestra; 9:30, novelties; 11:30, Pat Barnes and Al Carney; Cinderella Cafe orchestra; 12, Pat Barnes and Al Carney.
WIBD, Chicago, Ill. (425.4m-1330kc), 2-4 p. m., Shuttlesworth program, Ted Fiorito pianist; Dan Russo, violinist; Marie Tully, songster; readings, Wayne Myers; songs, Rita McPaw and Mary Bieber; Louise Lockifer, reader; Clifford Berge, violinist; Al Benson, Gail Bandell; 6-8, dinner concert; Joe North, baritone; Evelyn Nelson, pianist; Florence Osterman, contralto; Ray McKay, baritone; Elsie Orr, soprano; Mary Thrash House, pianist; string trio; 10-2 a. m., popular program; Marie Tully, songs; Dan Russo, piano; Ted Fiorito, pianist; Wayne Myers, vocalist; songs, the Jordans; Ruby Rossini, Lauretta Giles, Tommy Smith.
WJAD, Waco, Texas (352.7m-850kc), 8:30-10 p. m., dance orchestra.
WJJD, Mooreshead, Ill. (370.2m-810kc), 12-1 p. m., Palmer House symphonic players; trio; 2-3, organ hour, Howard L. Peterson; child artists; assembly of 1,250 children; 5:30, instrumental hour; Palmer House symphonic players; Jack Nelson; Victorians; 6:40, Billy Van; 8-9, children's hour; 10-11, feature hour; Ronald Harold C. Kessinger; Palmer House Victorians; Jean St. Anne; 12:30 a. m., Knights of the Burning Candle.
WLIB, Chicago, Ill. (302.8m-990kc), 7-7:20 p. m., Uncle Walt's Punch and Judy show; 7:20-7:30, Correll and Gosden; 7:30-8, program; 11-11:20, Correll and Gosden; 11:20-1 a. m., dance music; Correll and Gosden.
WLS, Chicago, Ill. (344.6m-670kc), 12 a. m., Ford and Glenn; 6 p. m., Ford and Glenn; 6:40, Ralph Emerson at our Barton organ; 7:15, WLS studio trio picture concert; 7:45, Jeanette Kling, reader; 8, H. D. Sadler, feature; 8:30, Illinois Wesleyan glee club minstrels; 9, Young American artists series; 9:30, Nash band; 10:15-11, Ford and Glenn music shop.
WMAQ, Chicago, Ill. (447.5m-670kc), 6 p. m., Chicago theater organ; 8:30, Rosseter Cole, George Simons; 9, lecture, U. of C.; 9:20, La Salle Extension university quartet.
WMBB, Chicago, Ill. (250m-1200, 7-8 p. m., Trioan duo; Vella Cook, contralto; Frank Bordner, baritone; McCredy and Hart, Harmony duo; 9-11, Trioan orchestra; Woodlawn theater orchestra; Joe Warner, character song; Andy Anderson, baritone, rned Stevenson, musical saw; Bob Bennett, piano, novelties.
WMC, Memphis, Tenn. (499.7m-600kc), 8:30 p. m., Cooper's Hawaiians; 11, frolic.
WQAI, San Antonio, Texas (394.5m-760kc), 8:30 p. m., San Antonio College of music.
WOAW, Omaha, Neb. (526m-570kc), 6:20 p. m., Francis Potter's banjo orchestra; 6:50, Gilbert Jaffy, violinist; Nat Young, pianist; 10:30 Frank Hodek and his Nightingale orchestra.
WOC, Davenport, Iowa (463.6m-620kc), 4-5 p. m., Crescent orchestra; 5:45-6, chimes concert; 7:30-8:30, Broadway Presbyterian church choir; 8:30-9, WEAF; 9-9:30, WEAF; 10:30, "A Step on the Stairs," mystery drama, Episode V.
WOK, Chicago, Ill. (217.3m-1300kc), 4:30-7 p. m., Capitol theater organ; studio program; 10-1:30 a. m., Tearney's Town club orchestra; Carl Lorraine's Pershing Palace orchestra; Husk O'Hare's Coconut Grove orchestra; Capitol theater organ; studio program.
WOOD, Grand Rapids, Mich. (242m-1240kc), 9-10 p. m., Robert Hazenberg and Robert DeJonge, saxophonists; Alida Vandenberg, pianist; Douglas Latio, violinist; Lillian DeBree, accompanist; Benjamin and Edwin Van Houten, harmonists; 10-11, classical concert; H. P. Vaughn, baritone; Melissa Dvorak, pianist; 11-12, Regent Roof Radio frolic, Bill Dallavo and his orchestra.
WORD, Batavia, Ill. (275m-1090kc), 7 p. m., "North Shore Line"; 9-10, musical program; 11-12, program.
WOS, Jefferson City, Mo. (440.9m-680kc), 8:20, program, Springfield chamber of commerce; Boy Scout band.
WQJ, Chicago, Ill. (447.5m-670kc), 7-8 p. m., dinner concert, Jack Chapman and his Rainbo Gardens orchestra; Henrietta Nolan, violinist; H. Bundy; Billy Harris, pianist; Sheppard Levine, tenor; 10-1 a. m., Jack Chapman and his Rainbo Skylarks; H. Lucille Long, woman harmonica player; Eleanor Terry; Romo Vincent, boy baritone; Merrill Carder, baritone; Johnny Post, baritone; Tell Taylor; Harold Olson, baritone; Clark's Hawaiian trio; artists; 1-2, Ginger hour, Jack Chapman the Ginger Man and Little Skylarks.
WRR, Dallas, Texas (245.8m-1220kc), 6-7 p. m., Jack Gardner's orchestra; 8-9, Mrs. Thomas H. Littlepage's musical program; 11-12 a. m., novelty program.
WSB, Atlanta, Ga. (428.3m-700kc), 8 p. m., G. M. A. glee club; 10:45, entertainment.
WSM, Nashville, Tenn. (282.8m-1060kc), 7:15 p. m., Francis Craig's orchestra; 8, Vanderbilt university, 10, Southern quartet and glee club.
WSOE, Milwaukee, Wis. (245.8m-1220kc), 5:10 p. m., twilight campfire, Boy Scouts; 9, Candygram review.

play, "A Step on the Stairs"; 8:30, WGY orchestra; 9, Victor program WJZ, Maria Jeriza, metropolitan soprano and Emilio De Gogorza, baritone; 10, play, "Border Lines," Emma S. Backus.
WHAR, Atlantic City, N. J. (275m-1090kc), 2 p. m., Seaside hotel trio; 8, Seaside hotel trio.
WHN, New York, N. Y. (361.2m-830kc), 6 p. m., People's hour; 7, Harry Richman and his entertainers; 7:30, Melody club orchestra; 8, Uncle Robert's chat; 10, Roseland dance orchestra; 10:30, Anatol Friedland; 11, Twin Oaks orchestra; 11:30, Kit Kat club orchestra; 12, Silver Slipper orchestra; 12:30 a. m., Avalon club orchestra.
WIP, Philadelphia, Pa. (508.2m-590kc), 1 p. m., Gimbel tea room orchestra; 6:05, Benjamin Franklin hotel concert orchestra; 7, Uncle Wip's bedtime stories; Anna Daney and Sarah Reed, piano solos.
WJAR, Providence, R. I. (305.9m-980kc), 1:05 p. m., Howard and Harris; 8, musical program; 8:30, Gorman's Jolly Bakers; 9, musical program; 9:30, WEAF; 10, WEAF; 10, Providence-Biltmore dance orchestra.
WJAZ, Pontiac, Mich. (516.9m-580kc), 6 p. m., Jean Goldkette's symphony orchestra; soloists; 9, Mulkey Celebrities.
WJZ, New York, N. Y. (454.3-660kc), 12:15 p. m., music from Brick Presbyterian church; 1, Hotel Ambassador trio; 4:35, Hotel Astor tea orchestra; 7, Hotel Commodore concert orchestra; 7, New York University concert orchestra; 8, Sundial shoe serenaders; 8:30, Bonnie Laddies; 10:30, Hotel Lorraine grill orchestra.
WKAR, Lansing, Mich. (285.5m-1050kc), 8-9 p. m., State department program.
WLIT, Philadelphia, Pa. (394.5m-760kc), 12:20 p. m., religious service; 12:35, Arcadia cafe concert orchestra; 2, Arcadia cafe concert orchestra; 2:30, playlet, students national school of oratory and elocution; 8, sports talk; 8:15, talk; 8:30, recital; 10, Morning Glory club; Arcadia cafe dance orchestra; Zoehrens and Herscher, popular songs; 10:30, Rufus and Rastus; 11, continuation of Morning Glory club concert; musical comedy stars.
WMAZ, Macon, Ga. (261m-1150kc), 9-10 p. m., A. L. Glasco, Negro spirituals; 10-11, Prof. Joseph Maerz, pianist.
WMCA, New York, N. Y. (340.7m-890kc), 6 p. m., Olcott Vail and his Hotel McAlpin string ensemble; 6:30, Ernie Golden and his Hotel McAlpin orchestra; 7:30, Sach's Muesteal Monarchs; 8:50, Broadway Assn.; 9, Hardman hour of music; 10:30, Parody orchestra; 10:45, Van and Schenek; 11, Hofbrau Haus entertainers; 11:30, Jack Denny's orchestra; 12 m., McAlpin entertainers.
WNYC, New York, N. Y. (526m-570kc), 6:20 p. m., songs; 7:35, concert program; 8:30, violin recital; 9:30, instrumental features.
WOO, Philadelphia, Pa. (508.2m-590kc), 11 a. m., organ recital; 12:02 p. m., Golden's crystal tea room orchestra; 4:4

# Radio Digest Illustrated

Reg. U. S. Pat. Off. & Dom. of Canada

Published by the  
**RADIO DIGEST PUBLISHING CO.,**  
(Incorporated)  
510 North Dearborn Street  
Chicago, Illinois

Telephones: Superior 7323, 7324, 7325, 7326, 7327

E. C. RAYNER, Publisher

Eastern Office, Park-Lexington Building, 247 Park Ave.,  
New York. Telephones: Ashland, 8144, 8145, 8146

Member of the Audit Bureau of Circulations  
241

PUBLISHED WEEKLY

SUBSCRIPTION RATES

Yearly in U. S. and Possessions and Canada, \$5.00  
Foreign postage, \$1.00 additional. Single copies, 10 cents.

Vol. XVI Saturday, March 20, 1926 No. 11

## Farm Radio Breaks Monotony

**G**IVEN her choice between a Radio and an electric washing machine, the average farm woman will take the Radio. She'd rather have a telephone than a water heater and a piano than stationary laundry tubs.

So says Mrs. H. M. Dunlap, wife of a man from the farm who has been elected to serve his district in the state legislature for thirty-two years. She herself has done all kinds of farm work and knows every phase of farm life in her forty-nine years on the farm.

The farm woman prefers escape from monotony rather than from drudgery, she explains. That is why the preference for Radio, the telephone and the piano over purely labor-saving devices. Her statement is based on a report representing the farm home life of 2,200,000 persons living on 445,987 farms in 237 communities. It is not merely hearsay.

We are glad that Radio helps the farm woman with her burden. It makes the drudgery seem less arduous, for we all can work and live happier with music in our souls.

## "Step On the Stairs" Is Hit

**A**LWAYS at the outset of a brand new enterprise, while it may have been enthusiastically prearranged and planned, there is that moment of doubt when we wonder if the enterprise is going to "go over."

That was the feeling of Radio Digest when "A Step On the Stairs" was planned and started on its way to the stations to be broadcast as a serial mystery drama.

Would the public like it? Did the lines hold their interest? Could it be done so as to please the fans and make them want more?

New York greeted it with a tremendous ovation. J. Andrew White, the famous sports announcer, said, "A Step On the Stairs" has them all licked. It's absolutely the best thing of its kind I've heard played." Minneapolis-St. Paul's applause, too, was abundant. The Pacific coast was free with congratulations. Chicago met the serial play and was conquered.

And we are glad. We would not want to sponsor and promote an enterprise that is not popular. We hope the public likes this new form of Radio entertainment, and wish to get individual expressions from listeners.

## Laughs in the Studios

**B**BROADCASTING stations, like other places, have their little laughs. Humorous happenings repeat themselves at the studios. Among the more common jokes is the entertainer who has his or her telephoned, telegraphed and written applause "planted" or arranged. It's bound to arrive, and many times does before the entertainer has appeared at the microphone.

The thousands of saxophonists, according to Radio program directors, who represent themselves to have been with the original Brown Brothers saxophone sextet, always draw a chuckle. Evidently the sextet was an army at one time or other.

The effusive maidens, worldly unwise, who formerly were matinee idol or movie hero worshippers, enter the comic side of broadcasting by their persistent correspondence. But the wives of the announcers don't mind. They are good sports.

In the same picture fits the adolescent male who hears a rippling soprano and henceforth falls in love. Many are the disillusionments when these youths learn their sopranos are past middle age and have married sons and daughters.

The "Big Business Men" from most anywhere, who are big hearted and willing to entertain their friends over the microphone, make up another class of amusing studio pests. You would think they were doing the stations a big favor, but tactful studio directors are usually able to handle the situation.

So broadcasting stations are human, after all. There are many laughs guaranteed at any studio, but we can't tell you all of them for that would spoil the illusion. Then perhaps you'd lose your interest in the mystery of the microphone.

## RADIO INDI-GEST

### Fable of the Chimes

Davenport was busy sending  
Chimes, as they so often do—  
And far off in Indiana,  
Listening in and talking, too,  
Two old men sat near a speaker  
—One was very much impressed  
By the beauty of the chimes and  
His old crony he addressed:

"Them there chimes is mighty pretty!"  
—But the other did not hear.  
"Said those chimes is mighty pretty!"  
He repeated loud and clear.  
Still the other did not hear him—  
—Only shook his old gray head—  
So the first one fairly shouted:  
"Chimes is BEAUTIFUL!—I said."

But the other could not hear him  
And once more he shook his head  
And confessed again he couldn't  
Hear a "bloomin' word" he said!  
"I can't hear a thing you're sayin'"  
—These sad words his friend he tells—  
"I can't hear a word you're speakin'"  
For them gosh-danged ornery bells!"  
**CHARLES ALLEN BRANHAM**

### What Will Red Grange Do for a Job?

Fairice, Alaska.

Dear Indi-Gest: Thanks for telling me what made Oglahooa tern red.

Here is dyeagram of my new invenshun to ship ice by Radio so the people down to WJAX can get as much water in lumps as they want for thirty8cents. It works kinda cause I tried it out on some eskimauxes and when I turned on the juice, they wanted to use the head

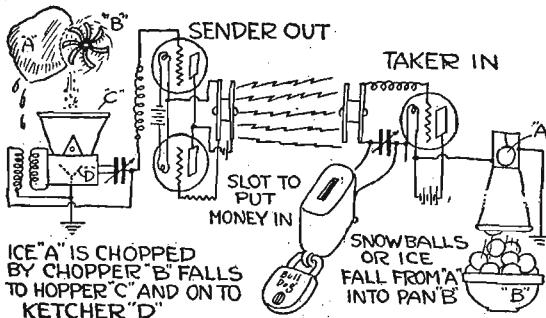

phones for ear muffs. Doc Cook herd of it and told the warden to tell me I'm a genius. So's his uncle.

All you have to do is put the thirty8cents in the slot and turn the dial to the amt of ice wanted and it will come out in frozen snowballs redy to be served. I'm smarter than the averidge person. Always as ever,  
**KITTLE DRUMMER**

### All Right Mildred, Call the Roll

Both Noah and his son, Ham, made the Famous Fans club. Nominations are now in order.

Adam is the next celebrity for your consideration. He has been nominated by three persons. H. Gordon Hooton puts him up for membership because he did not get his "head set" on Eve and "transformer," and by H. M. Boorn because he sacrificed a rib to get a loud speaker. J. S. Neal adds that Adam should have special recognition because the speaker was made out of spare parts.

### On My Ray De Yo

I bought myself a nine tube set,  
Just twelve more payments to be met—  
There's nothing that I shouldn't get  
**ON MY RAY DE YO.**

A station down in Alabam'  
Gives a pretty good program,  
But all I get is bam—bam—BAM!  
**ON MY RAY DE YO.**

I thought I'd like to hear Denver—  
My set would surely bring in her.  
The best I heard was whir—whir—WHIR!  
**ON MAY RAY DE YO.**

Some friends of mine did me beseech  
To try to tune in on Palm Beach.  
I tuned in only screech—screech—SCREECH!  
**ON MY RAY DE YO.**

The paper is before me now—  
A farmer wants to trade a cow.  
I think I'll see what he'll—al—LOW!  
**ON MY RAY DE YO.**

MELANCOLUMN

### A. Conan Doyle—Ask It Not To

Dear Indi: See where a mouse was killed when it short-circuited the system at CKAC. Maybe that's where all the squeals were coming from. Hope its ghost don't come back to haunt us.  
**SHOBIE**

### Pay Cash and Save Receipts

This is to warn Radio fans not to buy Radio supplies on credit because if shops will recharge batteries they will do the same thing on other accessories.  
**INDI**

## Holding Up His End



## Condensed

BY DIELECTRIC

Somewhere I read a criticism of darky melodies to the effect they were presented too frequently. Maybe so, but I'm wondering if that person listened to the Tuskegee quartet as they sang from the studio of Station WSB, Atlanta. There are some correspondents to Radio Digest who express a preference for jazz to the exclusion of classical music. They were well answered recently in the Reader's View column. These negro melodies are an essential part of American musical history and never so well rendered as by trained NEGRO singers.

Station WGY, Schenectady, selected one of the old melodious Italian grand operas to entertain their Radio listeners—an opera containing at least one aria familiar to all, "The Last Rose of Summer," from Martha. The spirited singing of the chorus was particularly enjoyable, if not the most so of the entire opera. Surely Martha is easily understood.

What has happened to Station WMBF? During the presentation of a dance program we had to await the completion of several numbers before learning the identity of the station. Let WMBF remember there are several broadcasting stations in that booming state, some of which reach farther north and with greater power than it. The station calls demand slight effort on the part of the announcer and must be given as requested.

Despite my good friend, The Third Trombone Player, I am not a soak nor even moist by Volsteadian measurement, yet my dials were carefully set to WRC's wave to listen to the fiery oratory of Senator Edwards, of New Jersey, who preceded Senator Brookhart, of Iowa. The idea of a "forum" as arranged by this Washington, D. C., station is a good feature. It allows us folks back home to hear our brilliant representatives talk on subjects they think we want them to talk about. We do. It sometimes happens they don't take the side we take, though. Until these gentlemen spoke over the Radio, no one knew the anti-saloon league was a super-state, involving entanglements—in spirit at least.

Listening to Radio features seldom make one dizzy, except where a learned professor talks on an abstract thesis, or three stations on low meters play the Charleston in thirds. However, Station WLS, Chicago, made some dizzy flights from Georgia to South Dakota and back, covering the country housing their many stores—the Sears-Roebuck stores of course. Anyone familiar with the cities visited could readily picture them as the director of the tour described various streets with their landmarks. This proved to be an entertaining diversion.

I can find no especial reason for lingering around Billy Penn's statue to overhear what Station WOO has to offer, though at times on the way down from WOAW, or WHO, I stay in Philadelphia a moment or two. On the last occasion it was to find a clear harmonic of the station on about 260 meters. This time listeners were being entertained with dance music from the Hotel Sylvania. The music was not bad at all and, in fact, our stay was beginning to become pleasurable when it came time to sign off for the night. Then the announcer dismissed his unseen audience in a perfunctory manner never approached in the experience of Dielectric by any other station. Really frigid.



# ABC Radio Fundamentals for Everybody

## Chapter XI—Radio Receiving Circuits (Cont.)

By Milo Gurney

**I**N the fall of 1922, a considerable furor was created in Radio circles by the advent of a group of circuits called reflex. In these, one or more tubes were so connected as to do double duty through functioning as both radio and audio frequency amplifiers. In these first circuits, the current at radio frequencies went through the tubes progressively, into the detector and then, at audio frequencies, went through the amplifying tubes a second time in 1, 2, 3 order. The straight reflex was followed by another system termed Inverse Duplex. In this system, the energy at radio frequencies first goes through the tubes in 1, 2, 3 order, as before, but the audio frequencies are passed back through the tubes in 3, 2, 1 order. This gives a better balance in that minimum radio frequency energy and maximum audio frequency energy are on the first tube, while maximum radio frequency currents and minimum audio frequency values are on the third tube.

In both systems, either a crystal or tube detector might be used, with the latter favored because of increased stability. In many cases these circuits functioned acceptably, although as a rule they were lacking in sufficient selectivity and were difficult to keep in a condition of sensitivity just below oscillation.

### In Defense of Reflex

In defense of the circuit, it is but fair to state that the prime reason for its present lack of popularity rests upon the fact that the early efforts showed the need of added research. It is readily possible at present to construct reflex circuits which are not only more selective but compare favorably with many circuits which are less involved in critical constructional details.

A typical reflex circuit is shown in figure 26. This is a three tube idea using a crystal as detector, and comprising a total volume output equivalent to five tubes. The circuit indicates no radical departures from standard reflex circuits, while it is dependent, as all other reflex circuits are, upon a correct balancing of

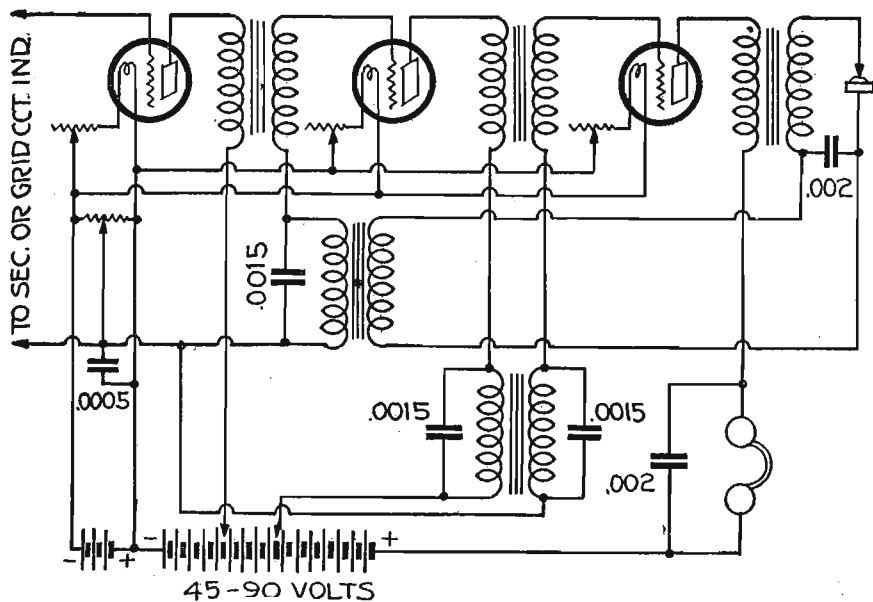

Figure 26

capacities together with the strict avoidance of interstage coupling for successful operation.

### Hazeltine Starts Avalanche

As outlined in last week's article, great credit is due Professor Hazeltine, inventor of the neutrodyne method of oscillation suppression. His work acted as the incentive for a multiplicity of engineers (and others) to bring onto the market a host of "dynes" and what have you, which, as might be expected, were mostly bad. Here and there, of course, there were tuned radio frequency circuits which were worthy of the purchaser's serious consideration.

The outstanding effort along this pathway was marked by this year's offering of circuits which rely upon the Wheat-

stone bridge method of balancing for the suppression of undesirable oscillations. This system has not only been successfully employed in the construction of that which is termed as "straight" tuned radio frequency circuits, but has also found its application entirely feasible and of material benefit when used in circuits of the reflex type.

### How of Wheatstone Bridge Circuits

A complete digest covering not only the principle, but its application to circuits of the above-mentioned class, was published under the author's name in a series of articles entitled "Recent Advances in Tuned Radio Frequency." These appeared in Radio Digest beginning with the May 29, 1925, issue.

However, in order that those following

this series may gain an insight into the method or principle underlying this system, figure 27 is shown as typical of the idea. In explanation, the theory upon which these circuits work is that through the adjustment of the relation existing between the arms of the circuit as shown at points C-1, C-2, C-3 and C-4, the current or signal may be caused to flow only in a forward direction from the input to the output circuit.

Therefore, because of this one-way action, feedback through the tube which causes oscillation is prevented, while a further, very essential, gain is had in both

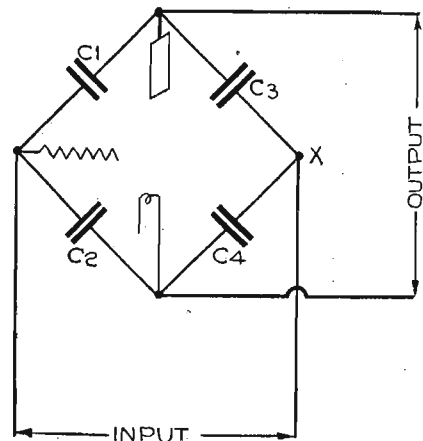

Figure 27

selectivity and signal strength because of the absence of any opposed circuit coupling action.

### Reflex Combined in Bridge

The circuit shown in figure 28 should be of unusual interest to those who are experimenting. It not only employs the Wheatstone balanced bridge principle, but also includes the use of tuned impedance

(Continued on page 24)

# No More Static!



**N**EWEST, most startling invention eliminates static under all weather conditions. No loss of volume. Everything comes in clear and strong. No more exasperating buzzes, squeaks, and howls.

Start to enjoy the pleasure of your radio. Install a Static Eliminator and you can forget all about static forever. And not only that. You will increase the selectivity of your set—you will be able to tune out other stations easier, sharpen signals, remove noises, lessen interference, and prevent re-radiation. Over a half million Static Eliminators in use now. Thousands being sold daily. You will be enthusiastic too when you hook it up to your set and hear the amazing difference.

### Amazing Low Price

**\$1.00**  
Postpaid

This wonderful new invention sells for only \$1.00. Users say it's easily worth ten times this price because it produces such a wonderful improvement in receiving power and clearness of all radio sets.

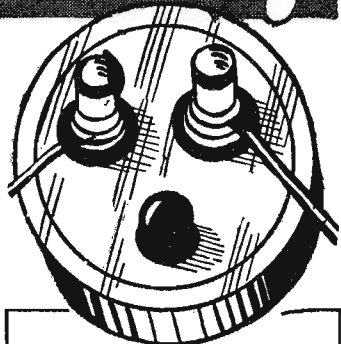

**STATIC** Eliminator fits all makes of radio sets. A child can hook it up in half a minute. Lasts a lifetime.

The Static Eliminator is sturdily made to give many years of perfect service. A simple, but effective device that hooks up to any make of set in 30 seconds. Complete, easy to follow directions included with every Eliminator. You will be amazed at the immediate improvement in your results. Mail coupon for your Eliminator now.

### Satisfaction Guaranteed

You will be delighted with the results of this remarkable instrument. That's why we guarantee absolute satisfaction. Money back if Static Eliminator is returned within 5 days. Don't be without it another day. Begin at once to know the real joy of receiving all stations without interference. Mail this coupon with a dollar bill—**TO-DAY!**

### Mail This Coupon NOW

**STATIC ELIMINATOR COMPANY,**  
625 United Bank Bldg.,  
Cincinnati, Ohio

Gentlemen: I ENCLOSE \$1.00 for which please send me one **STATIC ELIMINATOR** as advertised. You will return my money if I return Eliminator in five days.

Name .....  
Address .....  
City..... State.....

### "MARVELOUS!" Users Write

"I find your Static Eliminator to be the most wonderful addition to a radio set in all my experience. It sure does the work."—J. J. Aldrich, 172 N. 4th St., Columbus, Ohio.

"Your Static Eliminator is a great help. It gives me a wide receiving range. Last night in less than one hour, I had about 15 different stations."—R. D. Smith, Box 365, Clermont, Florida.

"Am surprised at the wonderful results I am obtaining. I am now receiving stations with clearness that is truly remarkable."—Thos. C. Smith, 2582 Parve Ave., New York.

"I like the Eliminator fine. I wouldn't sell it if I couldn't get a n o t h e r."—Burt W. Thompson, Homer, Mich.

## STATIC ELIMINATOR CO.

625 United Bank Building  
Cincinnati, Ohio

**for DISTANCE**  
Use a Beldenamel Aerial

**THE** reason for the unusual efficiency of a Beldenamel Aerial is the great care exercised in its construction. Beldenamel Aerial Wire is made of several strands of pure copper, each coated with many layers of baked Beldenamel. The enamel coating prevents corrosion of the wire surface, and thereby offers a low resistance to the antenna current.

Ordinary bare copper aeriels corrode, and the volume and range of the set decreases. A Beldenamel Aerial never corrodes, and therefore the volume and range are not diminished by corrosion. Try a Beldenamel Aerial, in place of your old aerial, and hear the difference.

**Interesting Facts About Beldenamel Aerial Wire**

Made in 100 and 150 feet lengths to avoid splicing for lead-in wire.

Furnished in distinctive striped carton that is a safeguard against substitution.

Endorsed by leading radio engineers as the best and most efficient aerial.

Mail the Conpon for Free Illustrated Booklet

**Belden**

**BELDEN MANUFACTURING CO.**  
2310M South Western Ave., Chicago

Please send me your booklet entitled "Helpful Hints for Radio Fans."

Name.....  
Address.....

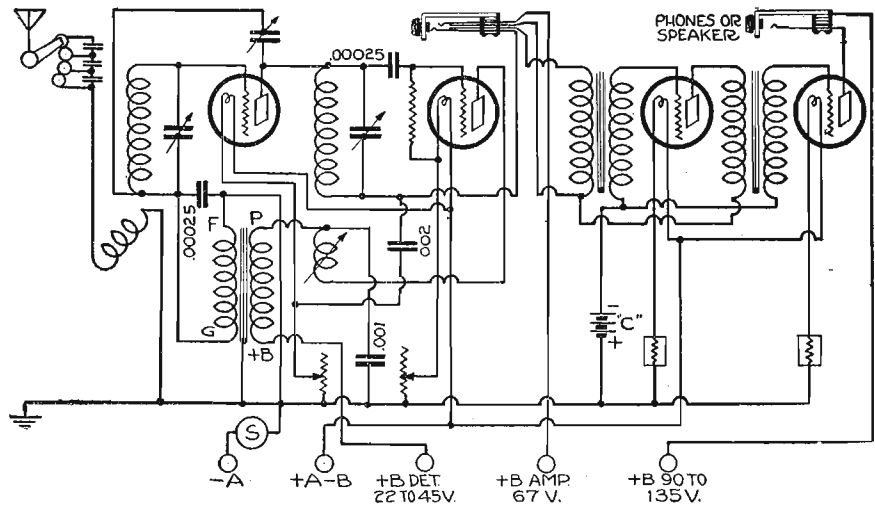

Figure 28

**ABC'S OF RADIO SETS**

(Continued from page 23)

in the detector circuit. To make it even more interesting, to this tuned impedance is coupled a combination of inductive and capacitive regeneration.

For fear that some rabid fan may still not be satisfied, and also in order to show

been marketed in "kit" form by several concerns.

Its regeneration is controllable through varying the inductive relation of the tickler employed, while its successful operation is, in a large measure, dependent upon both a careful selection of tubes to be used and the adjustment of the grid leak employed. It has the objection of

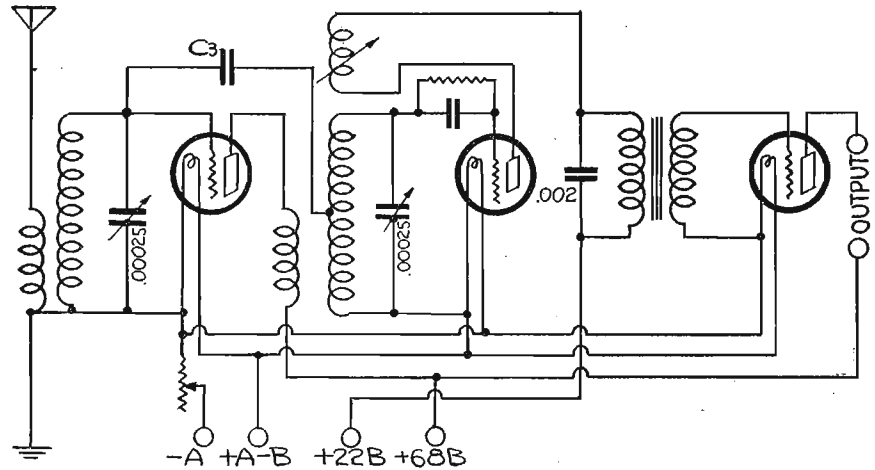

Figure 29

some of the complex possibilities of circuit combinations—which work—a stage of reflexing is included.

With reference to this circuit, I desire to warn that no values are given at this time, as the circuit will no doubt be offered later in a constructional series. Then a complete treatise will be given.

Another method, or rather application, of the use of tuned radio frequency is shown in figure 29. This uses a stage of tuned radio frequency in combination with a regenerative detector, the former employing the neutrodyne principle for the suppression of annoying oscillations. Properly constructed, this combination has proven very successful and has

only being capable of being balanced over a narrow wave band, such balancing not being independent of frequency, though its total operation is to be accepted as most satisfactory.

Out of pity, I shall refrain from pointing out the "fly in the ointment" chargeable to many so-called balanced circuits, in hopes that, from experience, those who are "mothering" such circuits will be taught the error of their ways.

(In the next article, the super-heterodyne will be described and explained by Mr. Gurney. Read what this author has to say regarding the "king" of circuits.—Editor's Note.)

**New Type of Ray**

Prof. C. E. Wynn-Williams, of the University of North Wales, England, has discovered a new type of ray, which he declares fills an important gap between broadcasting and Millikan rays.

While these new rays can penetrate air for several inches, they are stopped by all solids, even by gold leaf. X-rays can penetrate one-half inch of lead, as also can the recently discovered Millikan rays. Prof. Wynn-Williams suggests the new rays lie between ultra-violet and x-rays.

The scale of the different type of rays is:

- 1, Millikan rays (one 500,000,000th of an inch);
- 2, Gamma rays;
- 3, X-rays;
- 4, gap (new rays);
- 5, Ultra-violet rays;
- 6, Light rays (one 50,000th of an inch);
- 7, Infra-red and heat rays;
- 8, Gap;
- 9, Broadcasting rays, or waves, (up to 25 miles).

An investigation into the conditions for sparking between two electrodes revealed the new rays, which showed their presence by ionizing air so as to make it conduct electricity, as do the x-rays and the ultra-violet.



True cascade amplification has long been the goal of radio engineers because it would utilize practically the theoretical maximum of each tube and give results hitherto undreamed of. The new Crosley 5-tube RFL's incorporate this feature --- and their performance is nothing short of revolutionary... RFL-60...\$60, RFL-75...\$75 without accessories.

Add 10 per cent to all prices west of the Rockies

THE CROSLEY RADIO CORPORATION, Cincinnati, Ohio

**CROSLEY RADIO**

BETTER · COSTS LESS



**Photogravures of Your Favorite Artists**  
**GALLERY of RADIO STARS**

Suitable for Framing or Placing in Your Album

BY SPECIAL arrangement, Radio Digest is able to offer its readers a great opportunity to secure fine photogravures of their favorite Radio stars at practically no cost.

Radio fans will be able now, by this very special offer, to have pictures of their favorite artists and announcers before them when they listen in.

All that is necessary to secure photogravures from the Gallery of Radio Stars is to send the coupon published each week in Radio Digest, accompanied by ten cents to cover the cost of mailing and postage. Where a series of three photogravures is desired, it will only be necessary to send twenty-five cents and three consecutively numbered coupons clipped from Radio Digest. Remittance must accompany the coupon. Cash at your risk. Add 5 cents to personal checks for exchange.

WITH COUPONS **Only 10c Each -- 3 for 25c** To cover cost of mailing and postage

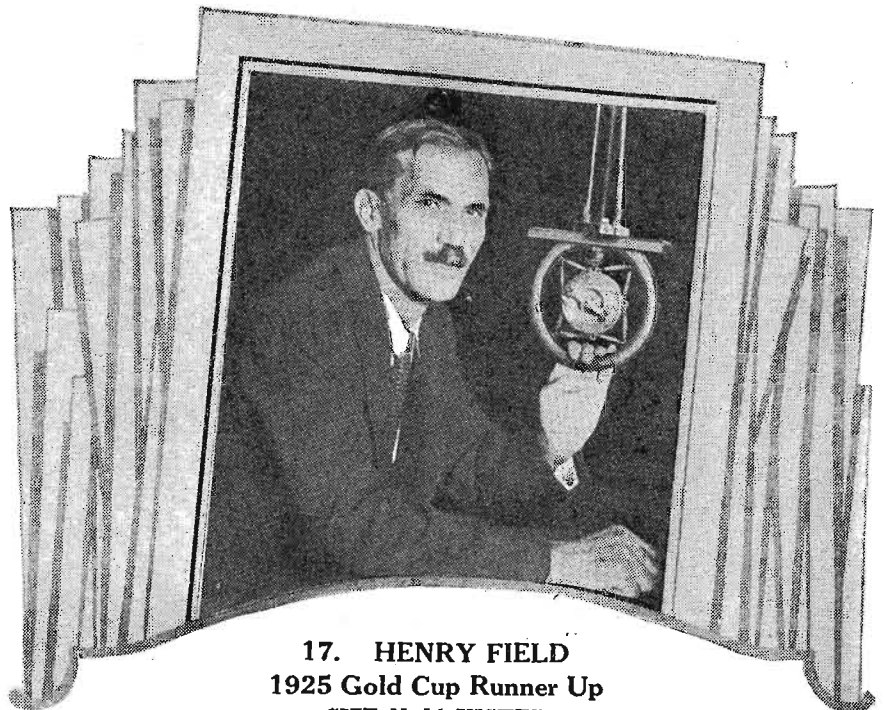

**17. HENRY FIELD**  
1925 Gold Cup Runner Up  
SIZE 11x14 INCHES

**Select Your Favorites from the Gallery of Radio Stars**

- |  |  |
|--|--|
| 1 Wendell Hall, king of ukulele ditties                  | 23 Art Gillham, "The Whispering Pianist"                                       |
| 2 Graham McNamee, 1925 Gold Cup announcer                | 24 Paul Greene, announcer at WSAI, "bridge voice"                              |
| 3 Jack Little, popular wandering balladist               | 25 Harry Ehrhart, "Dream Daddy" of WLIT  |
| 5 Coon-Sanders' "Nighthawks" at KYW                      | 26 Correll and Gosden of "Kinky Klds Parade" fame, at WEBH and other stations. |
| 6 George Hay, 1924 Gold Cup announcer                    | 27 Norman Brokenshire, popular at WRC, WJZ                                     |
| 7 Harmony Girls, Edith Carpenter, Grace Ingram           | 29 Jane Novak, Blues Singer of Twin Cities, WCCO                               |
| 8 Ford and Glenn, Lullaby Boys of WLS                    | 30 Jean Sargent, the original, now at WHT                                      |
| 9 "Roxy" Rothafel of WEAJ fame                           | 31 Ralph Emerson, popular organist at WLS                                      |
| 10 The Hired Hand, famous "Substitute Announcer" of WBAP | 32 Edna Adams, of KPRC   |
| 12 Bob Emery, Big Brother of WEEI                        | 33 Pat Barnes, vaudeville announcer at WHT                                     |
| 13 "Bill" W. G. Hay, ex-KFKX, now of WLIB                | 38 Walter Wilson, "Uncle Bob" of KYW   |
| 14 Happiness Boys, jovial singers of WEAJ                | 40 Ray-O-Vac Twins, known country-wide   |
| 15 Lambdin Kay, "Little Colonel" of WSE                  | 41 Art Linick, KYW's Mrs. Schlagenhauer  |
| 16 Leo Fitzpatrick, "Merry Old Chief," WJR               | 42 Fred Hamm of WTAS, now WLIE, fame   |
| 17 Henry Field, 1925 Gold Cup runner-up                  | 43 Meyer Davis' Le Paradis orchestra of WRC                                    |
| 18 Al Carney, organ favorite at WHT                      | 46 D. R. P. Coats, 1925 Silver Cup announcer                                   |
| 20 Vincent Lopez, No. 1 Pennsylvania orchestra           | 47 Gene Rouse, WOAW's popular announcer  |
| 21 E. L. Tyson, pleasing voice at WWJ                    | 49 Iris Ruth Pavey, KOA's invisible stage beauty                               |
|  | 51 Ipana Troubadours, on the WEAJ Chain.                                       |

If your favorites are not in this list, send in a request to have them included in the Gallery of Radio Stars.

**COUPON NO. 13**

This coupon entitles the holder to one photogravure selected from the Radio Digest Gallery of Radio Stars when accompanied by ten cents to pay the cost of mailing and postage.

Three consecutively numbered coupons entitle the holder to three photogravures when accompanied by 25 cents. Remittance must accompany the coupon. Cash at your risk. Add 5 cents to personal checks for exchange.

Order by Number.....  
Radio Digest Publishing Co., 510 N. Dearborn St., Chicago



# How to Stop Blooping and Man-Made Static

## Part VI—Dr. Hull's Amplituner

By the Technical Staff

IT MIGHT be well at this point in the series to insert a brief resume of what has gone before so that those just joining the movement for a better ether can follow clearly. In the first article, it was clearly shown, by excerpts from the reports of various investigating committees, that squealing interference, otherwise known as "blooping," is the direct fault of the broadcast listeners. Some

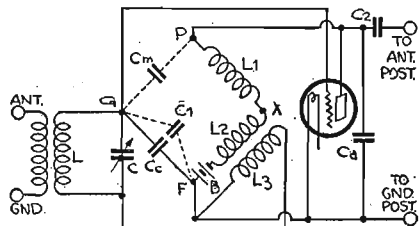

Figure 12

add to this trouble unintentionally, others do it knowingly with total disregard of the rights of others—and then complain about the blooping of their neighbors. Their own blooping is done "so very little" that it is not to be considered.

### What Has Gone Before

The second part took up the subject of how and why various types of receivers

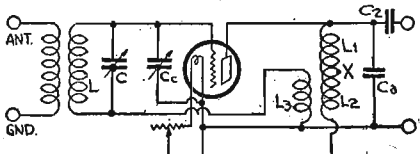

Figure 13

can squeal, and cause interference, and it was explained that the types known as "single circuit regenerative" and "three circuit regenerative" are not the only offenders by any means. We then got into correct receiver operation with some rules for the novice and old-timer alike, and some suggestions for charting the dials as a help against committing this breach

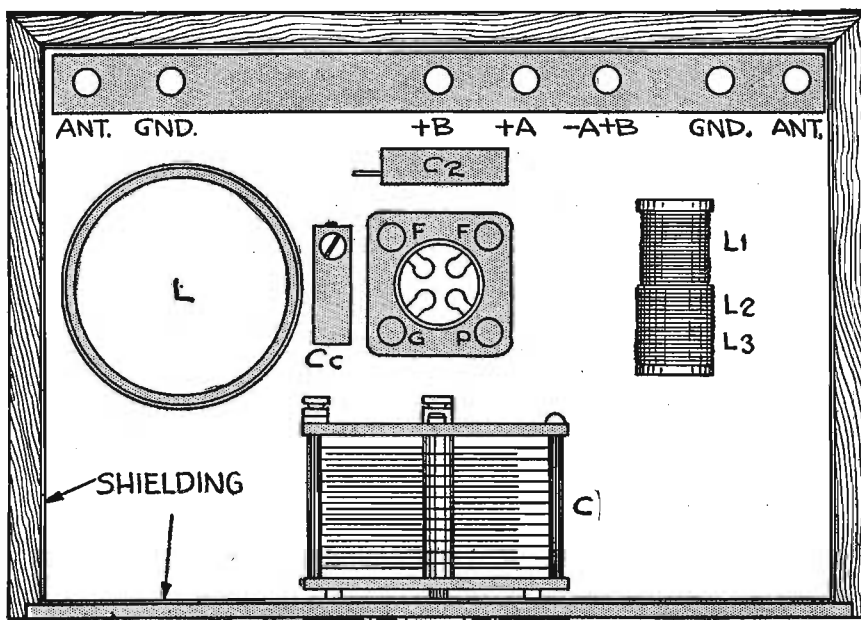

Figure 14

of Radio etiquette. The fourth installment went into the construction of the Penetrola, a commercially available device which is a true one-way repeater that permits the entrance of radio frequency energy to the set but does not permit any, in the form of oscillations, to back up into the aerial circuit.

Last week, the DeForest anti-radiation device was explained, and sufficient data was given for the insertion of the two small parts necessary to accomplish DeForest's method. At the same time, an input arrangement that would prevent suppers from radiating, was presented. Those who built their own could add this

very easily. Perusing back through some of our old issues of the various publications on the market we have come across a very interesting article in the August, 1924 issue of QST, the official organ of the American Radio Relay league, by Dr. Lewis M. Hull, on the construction of a one way repeater which he chose to call the Amplituner. While exact winding data on the construction of the output coil of his device was not given, this has been worked out in the laboratory and full constructional data is now available.

### The RFL Bridge

The circuit of this device, drawn for discussion in a bridge arrangement, is

shown here as figure 12. To quote Dr. Hull's article: "It consists of a balanced bridge having two inductive and two capacitive arms. The incoming signal is impressed between the grid and filament of an amplifier tube across the two opposite terminals G and X of the bridge. The amplified voltage in the plate circuit of this tube is impressed across the other pair of opposite terminals P and F. The capacity between the grid and plate of the tube, Cm, and the associated wires, constitutes one capacity arm. The capacity between the grid and filament C1 is increased by a small adjustable parallel condenser Cc upon which the final adjustment is made. Once the balance is attained, the compensating condenser Cc is locked.

"The inductive arms consist of two coils L1 and L2 in series in the plate circuit

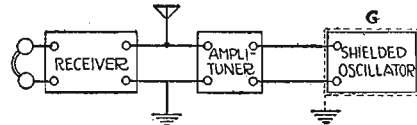

Figure 15

of the tube. The lower terminal of the input circuit is brought to the same a.c. potential as the point X between coils L1 and L2 by the use of coil L3 which is equal to and unity-coupled with L2. The only reason for using L3 is to keep the voltage of the plate battery B off the grid of the tube; if the battery were not present, the lower end of the input coil L would be connected directly to X."

This arrangement of Dr. Hull's gives a balance of capacity and inductance around the tube, such that radio frequency currents can enter the tube from coil L and will appear at the output terminals considerably amplified, but cannot pass from the output terminals, back through the tube, into coil L.

To further quote from QST: "In practice, the amplifier is required to do two (Continued on page 26)

**Turn Your Phonograph into a Loud Speaker**



**with a Fultone LOUD SPEAKER UNIT**

**Big Price Reduction Now Only \$3.00**

This unit is the secret behind the unparalleled success of Fultone Speaker. Its large diaphragm and bobbins of fine wire are protected from injury by a heavy nickel-plated case through the back of which adjustment is made by means of a special key. The pole pieces are not made from a solid piece of iron but are assembled from 15 laminations of carefully chosen steel.

**Use on Your Phonograph**

Edison Adapter.....25c  
Columbia or Pathe.....20c  
Brunswick .....30c

**HALL & WELLS, Inc.**  
4600 Lincoln Ave. Chicago, Ill.

**FITS ANY MAKE**

**MAKE THAT SET BATTERYLESS \$1**

We will tell you how to make any radio set or circuit operate hum-free and successfully WITHOUT A, B, or C Batteries for . . . . .

You can now make an **Electric Light Socket Radio Receiver** out of practically any Battery operated set, radio circuit or parts, and eliminate forever all A, B and C batteries, chemicals, chargers, continuous trouble, upkeep expense, disappointments and save easily \$75 a year.

Tested and endorsed by Popular Radio, Radio Broadcast, Radio News and all highest and leading authorities, and engineers, as being powerful, practical, perfect, dependable and constant in performance.

REMEMBER, YOU DON'T HAVE TO JUNK OR THROW AWAY YOUR OLD SET OR PARTS; THEY CAN NOW BE MADE INTO AN UP-TO-DATE ELECTRIC RADIO, THE LATEST AND BEST IN RADIO PERFECTION AND PLEASURE.

Send \$1.00 and we will mail you booklet containing 29 new and hitherto unpublished diagrams, information and literature, showing how to transform any old or new radio set, circuit and parts into an Electric Radio.

**ATTENTION!**

Radio Dealers, Set Builders, Fans, Experimenters and the Trained Men of Radio

Powerola is the Greatest and Sole Remaining "All Year 'Round," Money Making Proposition in Radio Today.

Powerola uncabineted receivers and units enable you, at surprisingly low prices, to supply almost every wish and demand of the people in your Town for a powerful, successful and popular-priced electric radio in a cabinet of their own selection.

Powerola enables you to make electric sets, or convert old or new sets or parts into electric sets, at handsome and continuous profits.

Act quickly before your territory is gone. Send \$1.00 for booklet, and ask for literature, terms and prices at once.

**POWEROLA RADIO CORP. [Dept.] 1845 Broadway NEW YORK**

### HELP STOP BLOPING

(Continued from page 25)

things besides preventing the backward flow of current from the output terminals to the antenna. First, it must have a capacitive reactance between the output terminals which is equivalent to that of the 'average' antenna in order to allow the direct connection to its output terminals of any receiver designed to operate from an antenna; second, when such a receiver is connected to the output terminals, the resonance load in the plate circuit of the amplifier tube must be of such magnitude as to impress an amplified voltage upon this receiver.

"The provision of a suitable 'antenna-like' impedance, which will allow the receiver to retain its original tuning characteristics does not necessarily mean a fulfillment of the second requirement. A design for the output circuit was finally selected which allows the Amplituner to be operated into any receiver whose tuner is designed to operate at wave lengths from 200 to 600 meters; the receiving (set) tuner may be either single or double circuit, tuned by either series or parallel condenser, or it may consist of a so-called 'untuned' primary closely coupled to a tuned secondary, such as is used in commercial neutrodyne receivers. The design consists merely of the use of a continuous coil for inductances  $L_1$  and  $L_2$ , having an inductance of about 500 microhenries, shunted by a capacity at CA of 500 mmf., which gives an effective range of capacity between the output terminals of 300 to 450 mmf., between 200 and 600 meters."

#### The Parts Needed

When the circuit is drawn in the usual schematic fashion to which constructors are accustomed, it appears as in figure 13. The same identification numbers are used in both illustrations but  $C_m$  and  $C_1$  are missing in this second diagram since they are inherent within the tube. The input coil L can be any of the antenna couplers on the market for use in neutrodynes or tuned radio frequency hook-ups to be tuned with a variable condenser of .00035 mfd., shown as capacity C. The small adjusting condenser, used to bring the grid-filament capacity up to the plate-grid capacity, may be any of the small balancing condensers on the market and we would suggest the Walbert listing at \$1.00 with a range of 4 to 75 micro-microfarads or the Bremer-Tully listing at \$0.90 and going up to 30 micro-microfarads.

A vernier dial such as the Mar-co is advisable although not absolutely essential. The coil  $L_1$  and  $L_2$  is made with 190 turns of number 36 dsc. wire on a 3/4-inch tube, occupying a winding space of just a little less than 1 1/4 inches. At one end, and wound tightly over that half of the coil known as  $L_2$ , wind on 95 turns of the same wire for coil  $L_1$ . The fixed condenser Ca is of .0005 mfd. capacity while the condenser  $C_2$  is anything from .01 mfd. to .5 mfd. A suggested arrangement is shown in figure 14 and this unit may be nicely put behind a 7" by 9" panel. The rheostat is placed below the condenser dial and both are centered on the 9" dimension.

#### Should Be Shielded

This unit to be really effective, should be entirely shielded with some such material as number 26 half hard sheet brass, readily obtainable almost anywhere and, in Chicago, from Stebbins Hardware Co. A piece is cut exactly the same size as the panel and placed back of it, the condenser and rheostat holes being cut out a little larger to prevent grounding of live leads. The cover of the cabinet used should also be lined, with flexible wires connecting it to the rest of the shielding which is, in turn, connected to the negative A lead. The coils should be placed so that they are well away from the shielding and small bakelite or hard rubber pillars cut from tubing will do this nicely. The socket also, might well be lifted up away from the bottom shield.

#### Balancing

In connection with the balancing, we again quote Dr. Hull's article: "The method of balancing the Amplituner brings out a very important effect, namely the change of intra electrode capacities in an audion tube when the electron current is flowing. In a commercial anti-regenerative amplifier (standard neutrodynes) local oscillations may be prevented by balancing the tube capacities with the filament unlighted and neglecting the unbalance which follows lighting the filament. But the writer has found that this change may cause as much as 2 to 4 micro-microfarads difference in the grid-plate effective capacity of a receiving tube when the filament is turned to full brilliancy. This is sufficient partially to nullify the one-way action of the Amplituner and to allow radio frequency to creep back through the Amplituner into the antenna. Accordingly, the final adjustment is made as follows."

The following suggestion of Dr. Hull's may not be convenient for everyone to use but is preferable to the usual method of putting a small piece of paper on one of the filament springs while neutralizing. However, if a shielded oscillator (single circuit receiver) is not available, the old system will come pretty close to perfect

neutralization. To resume from the original article: "With the filament lit to full brilliancy, the amplifier is placed in the circuit shown in figure 15. The shielded oscillator represents an oscillating regenerative receiver. A receiving set is connected directly to the antenna as shown at the left. This set uses two stages of radio frequency amplification, a detector and an audio amplifier.

"Both this set and the Amplituner are tuned to the wave length of an incoming C. W. signal. The oscillator G is then tuned to produce a beat note with the incoming signal and the operator listens at the headset T while he adjusts the compensating condenser Cc of the Amplituner. The adjustment is made with a long handle (a one-foot stick whittled to screw-driver edge at one end) so the operator can keep his body away from the Amplituner. At some adjustment of Cc the beat note between the incoming signal and

the oscillator G disappears. This 'null point' indicates a complete suppression of the backward flowing current from oscillator G to the antenna. . . . It is possible to make the adjustment at 350 meters and then to operate the Amplituner from 250 to 600 meters without putting into the antenna enough energy to cause interference to other receivers on other antennas nearby."

There you have the complete story on Amplituner as worked out by one of Radio's leading engineers and a pioneer in the development of bridge circuits. All parts with the exception of the special output coil are standard and most of our readers can build Amplituner out of spare parts lying around.

(Beginning with the next installment of this series, the discussion will be on man-made static, and means for checking up on it will be shown, together with remedies.—Editor's Note).

### R. F. Circuits on High Waves

I am certain that there are fans whose sets, especially of radio frequency circuits, will not oscillate on high waves. I overcame this difficulty by shunting a .001 fixed condenser from the plate of the de-

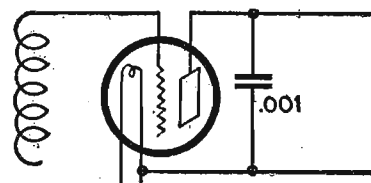

detector to the positive of the A. One may need different capacities for other sets, but my receiver works out best with a .001, as shown in the above diagram. Clarence Miller, 601 North 6th St., Kansas City, Kansas.

# Radiotone Loud Speaker

Now Only \$19.95  
Was \$25.00

The BEST  
Radio Affords

\$1.00  
down!



#### "A Wonder"

says user:—

"The Loud Speaker is a wonder. I never heard anything like it. I put it to a little test a few nights ago and it was heard clear and loud nearly one-half mile from my place through an open window."

Burton W. Cooswell,  
Brockton, Mass.

## Makes Your Radio Complete

The Radiotone is the last word in sound reproduction and amplification for radio sets. It is super-sensitive. Brings in distant stations with full volume so every one in the room can hear distinctly and easily. Wonderful clearness and absolute purity of tone. No distortion. No crowding in front of the loud speaker to hear announcements.

The Radiotone has a 14-inch horn made of Thorite in one piece without seam or joint, acoustically correct. This eliminates the metallic clang you often hear in other loud speakers. The reproducing unit is entirely enclosed at the base of the horn. The well balanced construction does away with all vibrations. The Radiotone has a graceful shape with a beautiful black florduline finish. It stands 23 inches high and weighs only 15 lbs. No extra batteries needed for the Radiotone—just plug it in as you do your head set. Nothing to wear out or get out of order. Sent complete with cord and plug.

## 30 Days Trial!

When the Radiotone comes, there's nothing to pay. Use it freely at our risk, on trial for 30 days. See how much more use and fun, you and all the family get from your radio with this loud speaker. See how loud, clear and distinct the Radiotone brings in all stations—better than any other loud speaker you've ever heard, giving you the best that is in your set. After 30 days trial if you think you can get along without the Radiotone, return it to us and we will refund your dollar plus all transportation charges. No red tape. The trial costs you not a cent.

### Straus & Schram, Dept. R-8413 Chicago, Ill.

Enclosed find \$1. Ship special advertised Radiotone Loud Speaker, I am to have 30 days free trial. If I keep the Radiotone, I will pay you \$3.00 monthly, total reduced price, \$19.95. The Radiotone is to become my property as soon as you receive the final payment. If not satisfied, I am to return it within 30 days and you are to refund my money and any express charges I paid.

Radiotone Loud Speaker No. Y8728A—\$19.95

My Name .....  
(Head of the family must sign this order. If you are not of age, have your parent or guardian order for you.)

My Street Address .....  
R.F.D. or Box No. ....

My Post Office ..... My State .....

My Shipping Point ..... I have lived in this Town ..... years

And before that I lived in ..... Town ..... State ..... for ..... years

Occupation is ..... Age ..... Married ..... or Single .....

Give names of merchants who know you personally

Name ..... Town ..... State .....

Name ..... Town ..... State .....

If you have ever bought goods on credit by mail, tell us from whom. If there is anything else you wish to tell us about yourself, write on a piece of paper and enclose it with this coupon. But the coupon alone, fully filled out, ought to do. That's all we want to know and we're ready to ship the goods at once. No formalities. No C.O.D. We trust rich and poor alike when they merely show us that they are honest.

## \$3.00 a Month

But if you decide to keep the Radiotone, pay only \$3.00 a month until you have paid the special reduced price—only \$19.95. See if you can equal this offer anywhere on such amazingly liberal terms. You'll scarcely feel those small monthly payments. Surely, now, you can afford to have the Radiotone—the best loud speaker—and get the most fun out of your radio set for all the family.

## Send Coupon NOW!

Seize this opportunity on this special offer. Only \$1.00 with the coupon brings the Radiotone on 30 days' trial, satisfaction guaranteed, your dollar refunded if not satisfied. Send the coupon now while this special offer lasts.

**Straus & Schram**  
Dept. R-8413 Chicago, Illinois



# 1926 Model Four-Filter Super-Heterodyne

## Part II—Parts Alterations and Drilling

By the Technical Editor

SINCE a special means of coupling the oscillator pick-up coil into the grid circuit of the first detector (mixer) is used in this set, it will be necessary to add a few turns to the Cruver coil specified. You will note that, at that end of the secondary which is away from the primary, there is quite a space between the last turn and the end ring. In this end ring of Bakelite there is a terminal for one end of the secondary. On the end ring, measure about an inch each side of this terminal screw and drill a small hole through the end ring at each of these points, just large enough to pass a 4-36 machine screw.

In the space between the last secondary turn and this end ring, there are about five wire grooves on each longitudinal bar and on these wind two parallel turns of either number 24 or number 26 dsc. wire, securing the ends to the 4-36 screws just put in the end ring. These two turns will later be connected to the pick-up coil of the oscillator coupler to transfer energy into the first grid circuit without extending this first grid circuit clear across the set to the oscillator section.

### Daven Amplifier Changes

We are going to use the binding posts on the Daven Super-Amplifier unit as connecting posts for the batteries to the whole set, and our circuit is going to have negative B connected to negative A; a change or two must therefore be made in the wiring of the Super-Amplifier. As it comes to you, the bus wire connecting the three negative posts on the sockets is connected to the binding post marked negative A, and the binding post marked plus A is connected to negative B binding post. The connection between the three negative filament socket terminals and the negative A post is to be broken and this bus connected to the negative B binding post. The strap connecting plus A post with negative B post is removed. This leaves negative A without connection to anything within the Super-Amplifier.

Consider now the oscillator coupler as supplied by National Master Radio Supply company. Of the two windings on the outer tube, the larger is the grid coil, the smaller is the plate coil. Hold it with grid coil uppermost; now find the protruding terminal of that end of the plate coil nearest the grid coil, in other words the terminal of the upper end of the plate coil. Revolve coil until this terminal is toward you, the grid coil still being uppermost. Directly below this terminal, in

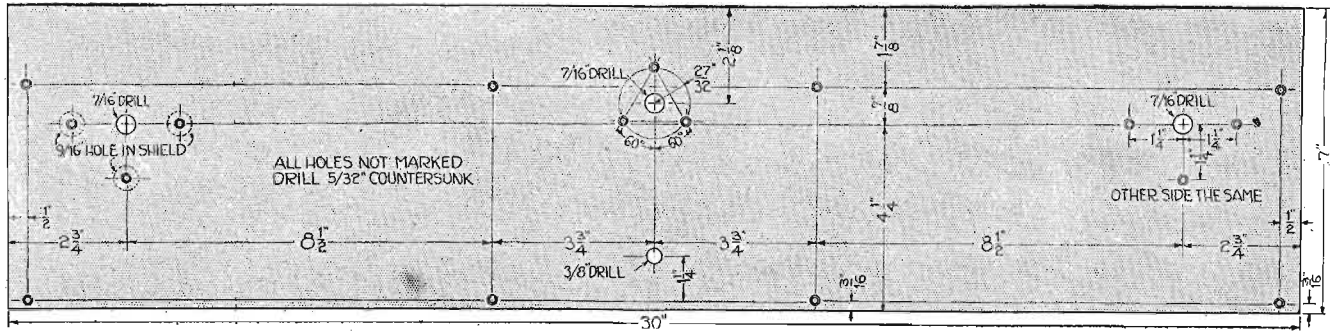

Figure 2

be used to support this unit on the sub base with a small right angle bracket.

Getting now to the drilling. Figure 2, gives the dimensions for making a drilling template for the front panel and front panel shield. Four pairs of holes, in vertical relationship, will be noticed across the face of the panel. These are for the Kelbrackets. The four holes grouped at the left end are for the input

has been made, lay it on and either paste or clamp it to the front of the panel. Center punch all holes with punch and hammer and remove template carefully as hole sizes must be followed from it. A piece of the sheet brass must be cut to the exact same size as this front panel and, for the drilling of the two together, I would suggest the following procedure. Have someone hold the panel tightly on

The panel and the brass sheet can now be separated for separate treatment. Each of the eight bracket mounting holes in the panel is countersunk from the front for which job I suggest a Yankee 45-degree countersink. Now countersink the three outer holes in each condenser group and the three outer holes of the potentiometer group. Turning now to the brass shield, drill out the three outer holes of the left

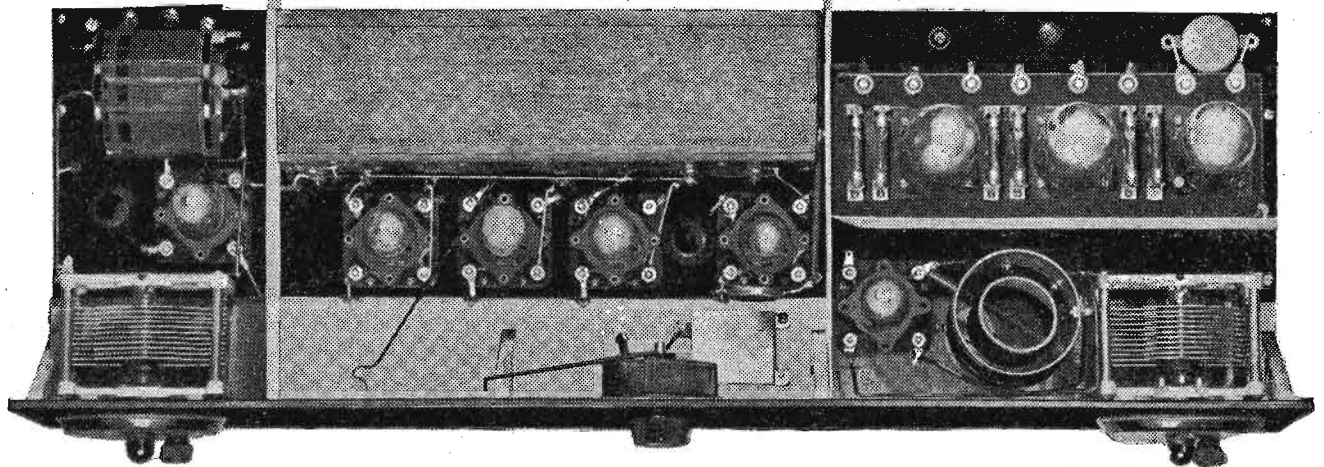

Figure 5

tuning condenser, while those at the right end, in a group, are for the oscillator condenser. The group of four in the center near the top are for the General Radio

the brass sheet which is to go behind it and drill the hole in the lower left corner and the hole in the lower right corner very carefully, watching to see that panel and sheet do not slip out of exact alignment. Do this drilling on a flat wooden surface and the brass will drill out cleanly without breaking out or tearing.

Having put in these holes, slip a round head machine screw through each and put a hex nut on the back, drawing them up tight to hold the panel and sheet tightly together and flat. You can now go ahead with the rest of the holes with confidence that all will coincide, in Bakelite and brass, when through. Drill all holes through first with a 9/64 or 5/32-inch drill and then put through the larger holes called for by the condenser shafts, the potentiometer shaft and the switch.

condenser group with any drill up to 9/16 and ream out to that size. This will give clearance of the shield around the three mounting posts of the left condenser. It might be stated at this point that, if readers wish the drilling templates in blue print form and full size, they will be sent on receipt of 40c, sent to Dept. 5 of Radio Digest, 510 N. Dearborn St., Chicago, Ill.

Figure 3 gives the dimensions on holes contained in the sub base and its shield. These are both 29 3/4 inches long but, referring to the right end of figure 3, you will note that the sub base is but 7 inches wide while the brass sheet placed under it is 9 3/4 inches wide, with their rear edges coinciding. Two sizes of holes are shown scattered over this layout, without indication as to size. The smaller are 9/64 (Continued on page 28)

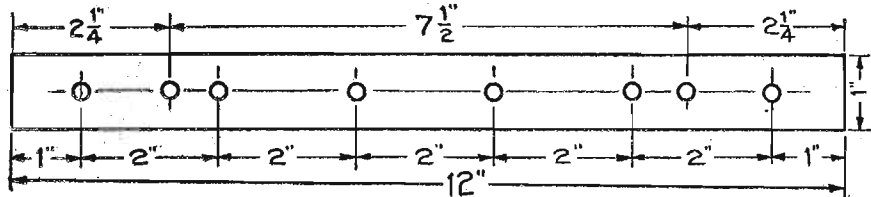

Figure 4

the space between the bottom turn of the plate coil and the lower end of the tube, drill a hole for a 6-32 machine screw to

potentiometer. Below this group is a single larger hole for the toggle switch. When the full size drilling template

**HERE IT IS—RADIO FANS**

The Beautiful De Luxe Log You've Always Wanted

**The Wonder Radio Log**

Rich seal grain binding, stamped in gold; top edge gilt, 144 pages, size 5 x 7 1/2. Printed on heavy bond paper. Lists the Broadcasting Stations three convenient ways: by Call Letters; by Kilocycles and Meters; by Location and Owners. Includes the 24 page WONDER Radio Diary and WONDER Distance Map. Ample space for keeping log and for changes and additions.

**IT DELIGHTS ALL WHO HAVE IT — WILL DELIGHT YOU**

"I have sold or seen practically every log issued for five years but until the WONDER arrived I had never seen a complete log. It has no rival."

"It is just wonderful and what I have been looking for. Enclosed is an order from a friend."

"One of the best logs we have seen. Very attractive and accurate."—Radio Digest.

"It is a real Wonder. I never expected anything so complete. I am proud to show it to my friends."

"It is a work of Art and the most complete and best log I have ever seen."

Don't confuse the WONDER with any log you have ever seen.

Order your copy today. PRICE \$1.00 Postpaid.

**THE WONDER RADIO LOG CO., 707 So. Dearborn St., Chicago**

**Steinite** Low Loss Interference Eliminator

No Radio Set Complete Without It

Select stations at will. With music and voices crowding the air the average set fails to bring in the desired stations properly. The **Steinite Interference Eliminator** shuts out local and other interference. You get one station at a time, the one you want, and tune in loud and clear. Operates on any set—attach to aerial wire and to set—no changes—no extra tubes or batteries. Greatest Dollar Value in Radio Today. **OVER 300,000 SOLD**

**Improved Results With Tube or Crystal** Try entirely at my risk the wonderful improvement this inexpensive little device will make in the reception of your set. Improves results on both crystal and tube sets that use any kind of aerial except loop antenna. Clears up reception wonderfully, increases volume, and partially absorbs static. **MONEY-BACK GUARANTEE.**

Mrs. Famous 1,500 Mi. Steinite 1-Tube Set, \$6; Long Distance Crystal Set, \$6; Steinite Crystal 50¢—3 for \$1

**STEINITE 5-Tube Set—\$29.75**

FREE Descriptive Literature on request.

Put this interference eliminator on your set and note amazing improvement. No tools needed—install in a moments time. Connect with set and follow simple instructions. Money back promptly if not delighted. \$1.00 postpaid anywhere in U. S. when cash with order.

References: Exchange National Bank, Atchison Savings Bank. Order today—a dollar bill will do.

**STEINITE LABORATORIES, 161 Radio Bldg., ATCHISON, KANSAS**

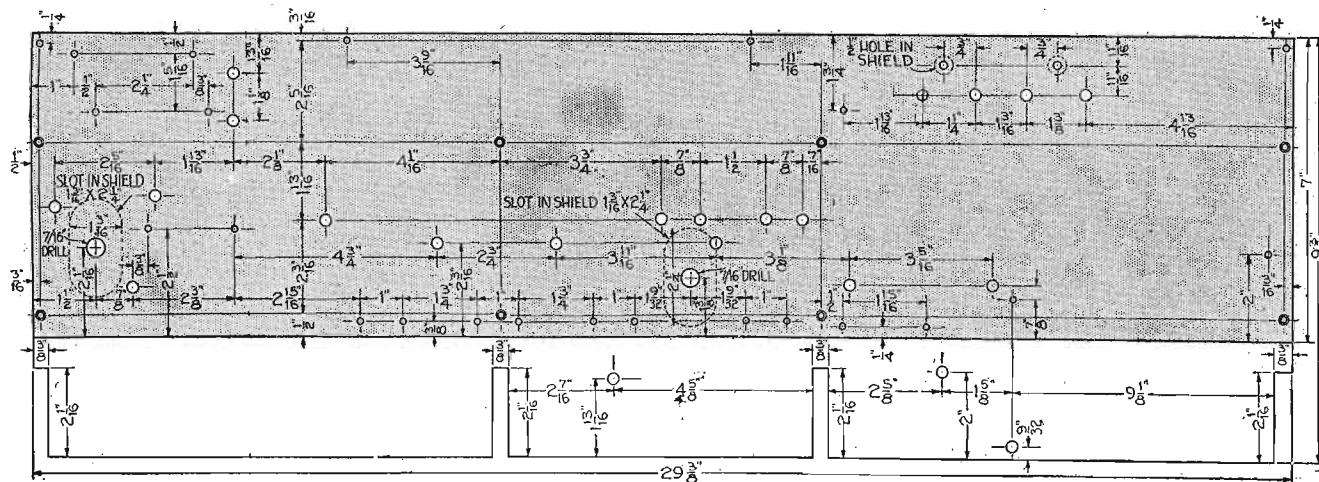

Figure 3

**FOUR-FILTER SUPER**

(Continued from page 27)  
 or 5/32 while the larger are 1/4 inch. Eight of these smaller holes are encircled to indicate countersinking from the upper side so that flat-head screws can hold sub base and brass to the brackets. At the left and in the center will be noted a larger hole for the Bradleys. The small holes placed in the upper left and upper right corners (rear left and

rear right) serve no other purpose than to hold base panel and its brass together while drilling. With someone to hold the two pieces with rear edges lined up, drill through these corner holes and then insert 6-32 machine screws with hex nuts. All holes passing through both base and brass can now be drilled. Then separate

base panel and the brass sheet drilled with it, and cut out in the brass sheet as shown by dotted lines, for the Bradleys, 1 3/8 by 2 1/4 inches. The four slices in the front edge of the brass can also be taken out; these pass the brackets from above sub base level to below. At the rear edge of the illustration, over toward

the right, there are two holes, marked with dotted lines to indicate 1/2-inch hole in shield. Drill these through the brass separately as they provide clearance around two binding posts later, one for 45 volts and one for 67 1/2 volts.

We now turn our attention to the Kel-brackets. As supplied, they would raise the sub base too high above the lower edge of the front panel and the Daven Super-Amplifier tubes would not permit the cover to close. As these brackets are aluminum, they can be easily sawed with a hack saw. Measure up 3/4 inch from the bottom on the front leg of each bracket and the same on each rear leg, marking with a finely pointed instrument to get these all exact. Then saw each off. As supplied, the front surface of this bracket is 6 5/8 inches, so when this length has been removed the remainder is 6 1/8 inches long and the top point will be 7/8 inch from top edge of front panel.

Figure 4 shows the drilling of the small Bakelite strip which mounts on the rear surface of the two center brackets, under the sub base, for the six Amperites. It should be noted that two of these holes, the two used to secure strip to the brackets, are countersunk. Figure 5 is a top view of the completed assembly, while figure 6 is the bottom view. Experienced assemblers can probably proceed with the mounting of the parts but novices should wait for the next article.

(The changes in apparatus, and the drilling, having required so much space, it will be necessary to handle the assembly as part of the next article which will also begin the wiring.—Editor's Note).

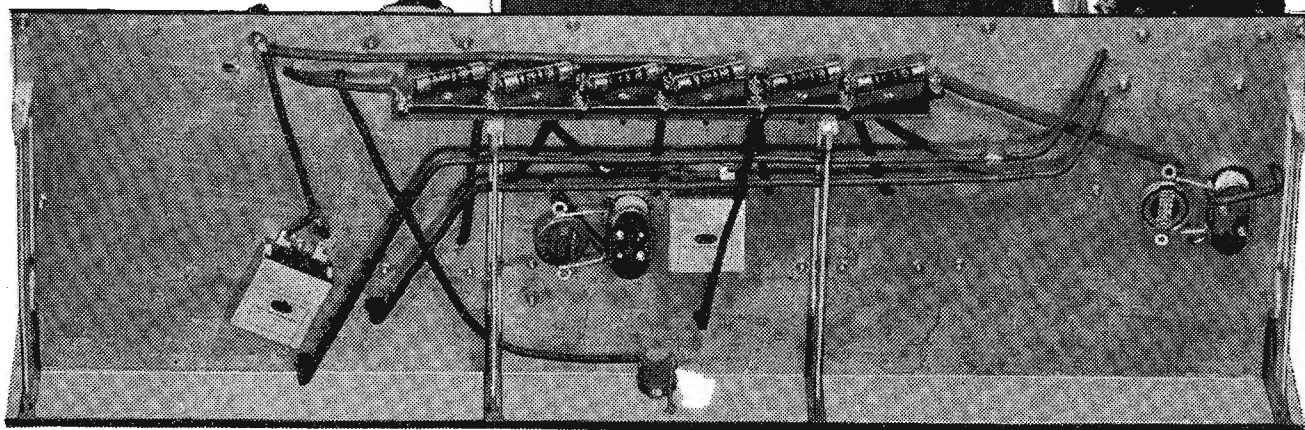
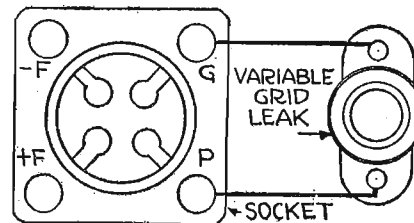

Figure 6

**Increasing Efficiency of Tubes**

The efficiency of tubes in a set can often be increased by putting a grid leak,



preferably a variable one, across the grid and plate of the tubes.—Frank Knight, 40 Grenadier Road, Toronto, Can.

for **BETTER TUNING**

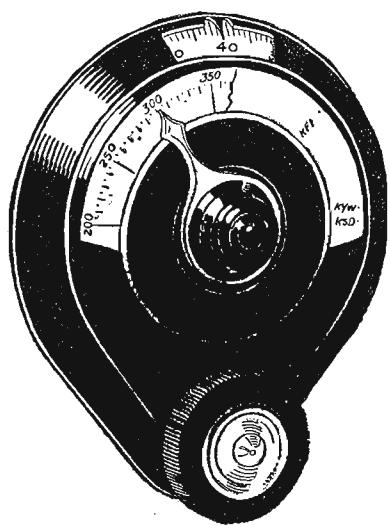

Use the **B-T Tuning Control**

Fits condensers turning either way. Pointer reads in wave lengths or station call letters, dial reads in degrees.

Geared 12 to 1 with not the slightest indication of backlash or lost motion.

Beautifully finished in black and gold or in brown and gold. Adds to the efficiency and appearance of any receiver.

Black and gold finish.....\$2.50

Brown and gold finish..... 3:50

**Stop That Noise!**

That ringing sound you hear where the panel is jarred. It's a microphonic noise caused by the vibration of the elements within the tube.

STOP IT effectively by the use of a B-T Silent Socket on your detector.

The Silent Socket may also be used on the first audio stage with good results or if desired throughout the entire set. Price \$1.25.

The regular type UL Socket is the same as the Silent Socket without the absorbers. Both types take the old or the new UX tubes without the use of an adapter. Good sockets are important. Use B-T Type UL.

Price.....75c each  
 —Send for circulars.

PIONEERS OF BETTER TUNING

**BREMER-TULLY MFG. CO.**  
 532 South Canal Street CHICAGO, ILL.

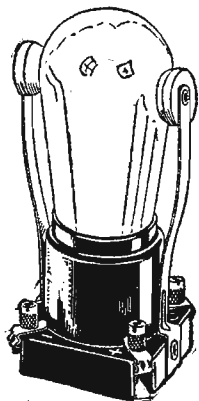

**BIG PRICE REDUCTION**

**Fultone**  
 Trade Mark

THE FORD of LOUD SPEAKERS

**\$6.50**

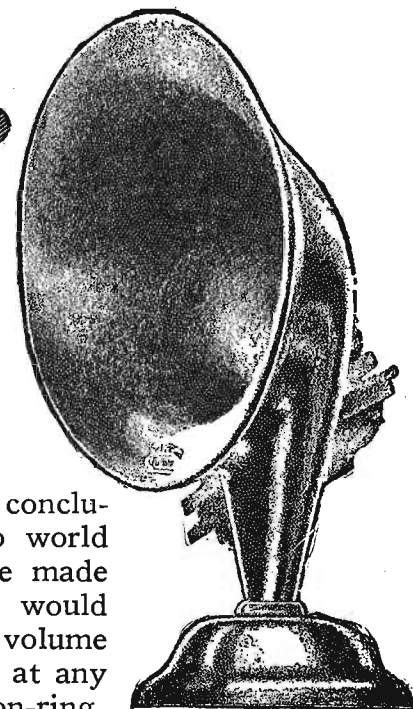

Fultone Loud Speaker has conclusively proven to the radio world that a reproducer could be made and sold at \$6.50 which would handle music or speech in volume as perfectly as any speaker at any price. The horn is solid, non-ringing and wide-throated enough to handle the powerful reproduction from super-heterodyne or reflex. The adjustable diaphragm permits matching Fultone to any receiver and "B" battery voltage.

**Tear Off, Fill in, Mail Now**

The Fultone speaker will be shipped on a satisfaction or money back basis on receipt of price in money order or currency. The coupon is provided for your convenience in ordering if your dealer cannot supply you.

HALL & WELLS, Inc., 4600 Lincoln Avenue, CHICAGO, ILL.  
 Enclosed is \$.....for which ship me ( )  
 Fultone Speaker.....( ) Fultone Unit at once, my money to be refunded if I am not satisfied and return this merchandise within 5 days.  
 NAME .....  
 ADDRESS .....  
 CITY AND STATE.....

**HALL & WELLS, Inc.**  
 4600 Lincoln Ave. Chicago, Ill.



**The Reader's View**

**Why WJZ Programs Were Out—and In**  
 You will be pleased to note the Radio Corporation of America's reply to my recent request with reference to listing programs from WJZ in Radio Digest:  
 "Your letter complaining that the programs of Station WJZ were not published in the Radio Digest at hand, and I think a brief explanation of the situation would clarify matters considerably.  
 "The Radio Digest requires programs three weeks in advance in order to have them published in advance in that periodical. In the past we have not felt that we could issue programs three weeks in advance that were accurate and preferred not to have our programs published unless they were absolutely correct. With the coming of high power for WJZ, our programs are being booked further in advance than ever before. Therefore, at the present time, it is possible for us to supply the Radio Digest with programs three weeks in advance that are practically correct. You will find our programs now in the Radio Digest and think that henceforth they will appear in that publication with regularity.—The Radio Corporation of America."  
 This information will be gratefully received by the readers of your magazine, particularly in view of the far reaching territory of this new superstation.—R. H. W., Winona, Minn.

**Attention: T. H. of Okemah**

T. H. of Okemah, Okla., asks, "Whad'ya mean Just?" If he will go to the public library and look up "just, adv." in Webster's International dictionary, he will find, in addition to definitions he mentioned, "now, or a moment ago." Why abuse the announcers? I like to have them tell the numbers just rendered and by whom.  
 He further states: "Any moron ought to be able to recognize a piece of music after it has been broadcast 100 or 150 times." Of course we are not all morons and perhaps that is why a great many of us do enjoy announcing of numbers and cannot see things from his standpoint.—L.M.R., Sterling, Ill.

**Announce Call Twice**

Let me add to your many timely remarks on improved announcing, a suggestion that I feel would add greatly to the enjoyment of the vast multitude of listeners.  
 In addition to announcing frequently, give station letters at start and AGAIN at the end of each announcement. Many announcers start with the call letters and all the letters may not be understood. If given again at the end, we have another chance.  
 All stations desire above all else wide publicity and the good will of the listeners. Above method, practiced consistently, will greatly help them to achieve that goal.—W.E.D., Philadelphia, Pa.

**Place for Jazz**

Answering E.I.S., Butler, Pa.: I heartily agree with him regarding jazz. Let's have it all put on about 510 or 520 kilocycles. But why condemn one of the most beautiful toned instruments because some so-called musicians can evidently do nothing with the saxophone except shatter the listener's nerves and eardrums with jazz? Has E.I.S. ever tuned in on KOA or KFOA? He can hear some real music from saxophones at these stations.  
 Now I would suggest that you put jazz where E.I.S. asks but also include with it (Continued on page 30)

**Here and There with the Radio Clubs**

An educational committee has been appointed by the Spokane Radio Listener's association to direct the work of giving Radio set owners a better understanding of how to operate their sets most efficiently and recognize sources of interference. A Radio survey to cover the entire city of Spokane has been announced and a questionnaire was published in the Spokane Chronicle. The information gathered will be used in the campaign against interference being carried on by the association and the Washington Power company.  
 \* \* \*  
 The program committee of the Butte, Montana, Radio club has interest and enthusiasm in the meetings at a high pitch due to the schedule of unusually interesting speakers arranged. At one of the most recent meetings, the speaker was H. W. Manning, of the Mountain States Telephone and Telegraph company, who included in his talk a discussion of the use

of vacuum tubes in long distance telephone work. The members then inspected the entire local telephone exchange from batteries to switchboards.  
 \* \* \*  
 Eastern clubs, attention! Send in your news. Tell us what you are doing.  
 \* \* \*  
 A Radio club is being formed in Portsmouth, Ohio, to be known as the Scioto Radio club. Its object is "to improve the condition of Radio reception in the city of Portsmouth and vicinity and clear the air of avoidable causes of interference to Radio listeners." Copies of the by-laws, constitution, application blank and membership cards used by other clubs are desired by Frank R. Sodaro, Box 341, Portsmouth, Ohio.  
 \* \* \*  
 The city of Cheney, Washington, announces a Radio club with full arrangements completed for a place to meet, officers, instructors and speakers. James S.

Lane, of the Normal school faculty is chief of instructors; Leon Swank is president.  
 \* \* \*  
 The Grand Rapids Radio Listeners' league now has over 700 members! A drive is on for a total of 3,000. That's ambition when there are only 7,000 set owners in the city. The way applications are pouring in, it surely looks as if this drive would be successful. The live-wire club even has its service expert in the person of Ewald A. Stein, who runs down interference for the members. Locating four such cases in one week, he cleared the air for nearly twenty per cent of the membership. He finds it possible to average about two calls a night, but when each "cure" clears the air for a score of others, this is plenty. The league can be reached at P. O. Box 558, Grand Rapids, Michigan.  
 \* \* \*  
 Up in Victoria, B. C., everyone has to have a receiving license, so when the Victoria Radio club wanted to send out a questionnaire they had a 100 per cent list. The card which was sent to every set (Continued on page 30)

**No More "B" Batteries on Your Radio**

At last, a practical reliable "B" battery eliminator for your radio. Does away with "B" batteries; no charging; no replacing. Always 100% efficiency in "B" current. The most revolutionary development in radio.

**Genuine Fansteel Balkite "B" Eliminator Sent for Only**

**\$1.00 Down**



The Balkite "B" is connected to your radio just like "B" batteries and attached to an ordinary electric light socket. Replaces "B" batteries entirely and furnishes "B" current direct from regular house lighting current. Always gives current equal to four new and fresh 22½ Volt dry "B" batteries. For sets of five tubes or less. Simplifies radio receiving. More convenient, more economical and more efficient than dry or wet "B" batteries. Operates storage battery or dry cell tubes and gives tubes longer life. Entirely noiseless. Creates no disturbance in reception. Has no bulbs, nothing to break, wear out, replace or get out of order. Requires no change in your set, no extras to buy. Operates from 110-120 AC, 60 cycle current. Measures 8 3-16 inches by 8 inches by 3¼ inches. Current costs only 1-20 of a cent per hour.

**\$5.00 a Month, if satisfied after trial**

Only \$1.00 with the coupon below brings the Balkite "B" to your home on trial. Try it out thoroughly before you pay another penny. See how it improves reception. See how much more convenient than using batteries. Judge for yourself how it will save you money and make your radio set more enjoyable. Then, if not satisfied, send it back at our expense and we'll refund your \$1.00 plus all transportation charges. If you decide to keep the Balkite "B," start paying only \$5.00 a month until you have paid the total price of only \$35.00. That's the price others ask for spot cash. We give you the lowest cash price on easy monthly payments you will never feel.

**Send Coupon**

Don't miss this opportunity to get the genuine Balkite "B" at the rock-bottom cash price on easy monthly payments. Send coupon now while this offer lasts. Order by No. Y-8578A, \$1.00 with coupon; \$5.00 a month; total price \$35.00.

**STRAUS & SCHRAM**  
 Dept. R5413 Chicago, Ill.

**STRAUS & SCHRAM, Dept. R5413 Chicago**  
 Enclosed find \$1.00. Ship special advertised Balkite "B" Battery Eliminator. I am to have 30 days free trial. If I keep it, I will pay you \$5.00 monthly. If not satisfied, I am to return it within 30 days and you are to refund my money and any express charges I paid.  
**Balkite "B" Battery Eliminator, No. Y8578A, \$35.00**

Name.....  
 St., R. F. D. or Box No.....  
 Shipping Point.....  
 Post Office..... State.....

**Gets Everything But Noise!**

Read this convincing letter from a man who has "listened and marveled":

"Omaha, Nebraska, February 10, 1926.

Kane Antennae Co., Gentlemen:  
 I received 2BD, Aberdeen, Scotland, on a "Kane Antennae," during the recent International Tests. Reception was officially verified by Radio Broadcast Magazine who conducted the tests. I built the Antennae a year ago from one of your blue prints. It has more than met expectations in the elimination of outside electrical interference, as well as in increased volume and distance.  
 GUY H. CRAMER."

**Improves Reception 60%**

Entirely eliminates all power noises such as leaky transformers, generators, motor hums, Deico Plants, etc. Cuts static and regeneration howls and squeals in two. Dr. Gehrig of Oakland, Cal., says it improves his reception fully 60 percent. Do away forever with disagreeable noises.

**\$1.00 Brings BLUE PRINT Complete Working Drawings** and full instructions for erecting this wonderful Antennae. Just send \$1.00 (a check will do. Stamps not accepted). A limited number available. Send TODAY.

**KANE ANTENNAE CO.**  
 Dept. 823C, 3034 W. Van Buren St., Chicago, Ill.  
 Dealers—Send at Once for Attractive Proposition.

**KANE ANTENNAE**

### VICTORIA FIGHTS INTERFERENCE

Name..... Address.....

Description of Interference.....

When Last Heard: Date..... Hour..... Audibility.....

Length of Time } Persistent } For How Long  
 Continuous } Intermittent }

Can You Hear Programme Through Noise.....

Does Trouble Recur Nightly..... At Same Time.....

What Station (Wave Length) MOST Affected..... What LEAST.....

Will You Cooperate with Us in Locating Interference and Our Effort to Clear the Air.....

Will You Act on Your Local Committee.....

I Have a..... Tube } Set  
 Number } Crystal } Make

Card used by the Victoria (B.C.) Radio club to aid in stopping various kinds of interference. The information is carefully tabulated and put in use.

### WITH THE RADIO CLUBS

(Continued from page 29)  
owner is reproduced here with and the information this brought it has been of inestimable value in clearing the ether of noises. With this card was a letter:  
"The Victoria Radio club has been requested by the Dominion government to undertake a campaign to lessen interference in this district. The club invites your cooperation and requests you to supply data as to interference experienced by yourself in the past few days. By filling in and returning the enclosed stamped post card as early as possible you will greatly aid this work."

Radio clubs! Insist on every member reading the series of articles now appearing in Radio Digest on the subject of blooping and man-made static. It is the largest collection of authoritative data on the subject yet published. Practical application of all points brought up can be discussed at meetings for the benefit of all.

### The Reader's View

(Continued from page 29)

all those screeching sopranos and all singers of operatic stuff in a foreign tongue, and put "breezy announcing, Ford fiddling, infant prodigy stuff and the rest of the high-class RURAL entertainment" where the majority can get at it.—J.W.McC., Bovey, Minn.

Sit Down, T. H. Okemah!

In the Radio Digest of February 27 under title of "Whad'yamean Just?" T. H. Okemah of Oklahoma criticizes broadcast-

### CLASSIFIED ADVERTISEMENTS

Classified advertisements in Radio Digest produce results. Have you a receiving set to sell? Do you want to buy a Radio? A classified advertisement in this column will sell your set.

Rates are twenty cents a word for each insertion, five per cent discount for four insertions, ten per cent for thirteen insertions, fifteen per cent for twenty-six insertions, twenty per cent for fifty-two insertions. Name and address to be included at above rate. Cash should accompany order. Minimum of ten words. Objectionable and misleading advertisements not accepted. Forms close three weeks prior to date of publication, which is Saturday.

### BLUE PRINTS

Super-Het, Ryan's Simplest Possible 7-Tube Set. Complete instructions, actual size template. How to make a loop. All for 50 cents. Book Dept., Radio Digest, 510 North Dearborn Street, Chicago.

### MISCELLANEOUS

Photos of Your Favorite Radio Stars. Ten cents and coupon appearing on another page of this issue will entitle you to one of the photos from Radio Digest gallery of stars. Radio Digest, 510 North Dearborn Street, Chicago.

### TELEGRAPHY

Telegraphy—Both Morse and Wireless taught thoroughly. Big salaries. Wonderful opportunities. Expenses low; chance to earn part. School established fifty years. Catalog free. Dodge's Institute, Sixth St., Valparaiso, Ind.

ing stations for announcing the names of familiar melodies. Objection is also made to the use of the word "just" in announcements such as: "You have just heard, 'Let Me Call You Sweetheart,'" etc.

These criticisms of Okemah's are hardly worthy of consideration, but in behalf of listeners in general and particularly for Okemah's information I wish to say that I also consulted the dictionary (Webster's New Ideal). I found as one definition of the word "just": "Now, or but a moment

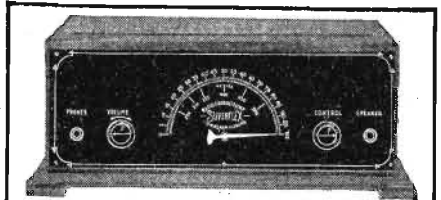

### The wonderful SUPERFLEX radio

NEW CIRCUIT—ONE DIAL (one condenser—pat. pndg.) Not reflex. Volume, Clarity, Distance, Selectivity.

Sample to Rated DEALERS. TEST ONE. RADIO PRODUCTS CORPORATION, (Inc.) 3816 N. 28th St. Birmingham, Alabama

### A & B Battery \$2 Charger ONLY

### SATISFACTION GUARANTEED

Charges any type of storage A or B battery, or auto battery, using a few cents worth of ordinary house current. Cannot injure battery and lasts for years. Complete directions enclosed—anyone can operate. No "Extras" to buy.

Why pay \$10.00 to \$18.00 for a charger when you can get this splendid GUARANTEED R. B. Charger by mailing us two dollars (bills, money order, check or stamps). Enclose 10c in coin or stamps to pay mailing costs. If not satisfied, return within 5 days and we will refund your money. Act at once. TODAY.

R. B. Specialty Company Dept. 23, 308 East Third, Cincinnati, O.

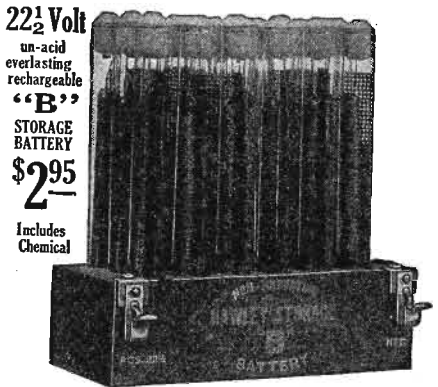

22 1/2 Volt un-acid everlasting rechargeable "B" STORAGE BATTERY \$2.95 Includes Chemical

ago." Therefore Okemah's objection is over-ruled and there is no reason why announcers should not use the word "just," just as they have been doing.

So far as it being necessary to announce the name of a song that is familiar to nearly every one, such as, "Let Me Call You Sweetheart," Okemah should realize that broadcasting stations are not being operated for his or her sole benefit. He or she may be quite familiar with all the popular songs but it should be remembered that there are thousands of people throughout the United States alone who are hearing many of the songs for the first time. Okemah may not survive the shock when I say that only a few days ago I heard, "Let Me Call You Sweetheart" for the first time.—A.J.P., Cement City, Michigan.

### BODINE TWIN-EIGHT R.F. COIL

A remarkable new radio frequency transformer that combines a very limited magnetic field with tremendous amplification. Very sharp tuning. For a satisfaction use TWIN-EIGHTS.

Price \$3.00 each, \$9.00 per set of 3 matched coils.

At your dealer or sent postpaid upon receipt of check or money order. Wiring diagrams free.

BODINE FOLDING LOOP AERIAL. Wonderfully efficient. Large enough to give good signal pick-up, but folds to fit in small box. Beautifully finished in mahogany and satin silver. The best loop at any price. Standard loop \$8.50. Equipped with 5 point tap switch \$10.00. Write for folder.

BODINE ELECTRIC CO. 2260 W. Ohio St., Chicago, Ill.

### Yale GROUND HOG DOUBLES POWER AND DISTANCE

Marvelous newly-invented ground gives 100% improved reception. Doubles power and distance. Stops leakage. Reduces static. Stops fangling even in mid-summer. Results never before equalled, users say. Satisfaction Guaranteed.

Proven absolutely essential to clear, powerful distance reception. Draws and holds moisture indefinitely. Highly sensitive to radio energy. SEND NO MONEY—To introduce, we offer to those who act at once, regular \$5.00 size for only \$2.00. Send name today and pay \$2.00 plus 17c postage on delivery. Or send only \$2.00 with order and save postage. FREE—Full description of Ground Hog and big money making agent's offer on request—write today.

Yale Specialty Supply Co. 1805 Grand Ave., Kansas City, Mo.

### Nightingale 6-tube Set with Integral Loud Speaker \$75

A wonderful, sharp tuning set of beautiful tone, made complete in our own factory. Five tube assembly suffices for most stations, but volume can be tripled by using 6 tube terminal. No wasteful neutralizing condensers but perfect balance of parts. See Nightingale dealer or write to THE GUTHRIE CO., GRAFTON, OHIO

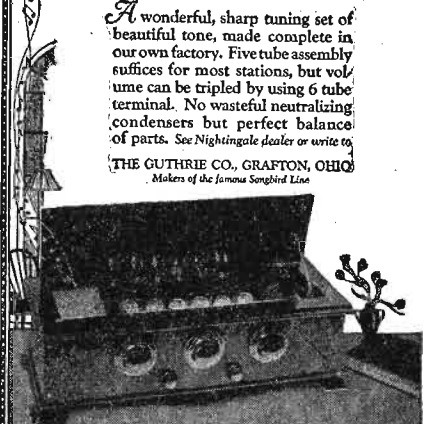

Makers of the famous Songbird Line

### FOR CLEAR, QUIET "B" POWER



### RADIO Storage "B" Battery

12 Cells 24 Volts Lasts Indefinitely—Pays for Itself Economy and performance unheard of before. Recharged at a negligible cost. Delivers unflinching power that is clear, pure and quiet. Approved and listed as Standard by leading Radio Authorities, including Pop. Radio Laboratories, Pop. Sci. Inst. Standards, Radio News Lab., Letax, Inc., and other important institutions. Equipped with Solid Rubber Case, an insurance against acid and leakage. Extra heavy glass jars. Heavy rugged plates. Order yours today!

SEND NO MONEY Just state number of batteries wanted and we will ship day order is received. Extra Offer: 4 batteries in series (96 volts), \$10.50. Pay expressman after examining batteries. 6 per cent discount for cash with order. Mail your order now!

WORLD BATTERY COMPANY 1219 So. Wabash Ave., Dept. 76 Chicago, Ill. Makers of the Famous World Radio "A" Storage Battery

Prices: 6-volt, 100 Amp. \$11.25; 120 Amp. \$18.25; 140 Amp. \$24.00. All equipped with Solid Rubber Case.

### World STORAGE BATTERIES

Set your Radio Dials at 210 meters for the new 1000 watt World Storage Battery Station, WSB, Chicago. Watch for announcements.

### A "RADEX" Tuning Chart

Shows by dial numbers, wave length to which set is tuned. Tells where to place dials for any station. Identifies programs received without announcement. Adapted to any set. Send 25c Coin or Stamps. RADEX, Box 143-S, CLEVELAND, O.

### RADIO We want to hear from hard-hitting radio dealers operating live-wire stores who want to make the best jobber connection in America.

### DEALERS

Our eight big warehouses furnish you with the finest products in radio. And we ship fast.

### WANTED

Write today on your letterhead for big catalog of nationally advertised lines. Ask for AE 1006

WAKEM & McLAUGHLIN, Inc. 225 E. ILLINOIS STREET, CHICAGO, ILL.



### 6-Volt Storage Radio "A" Battery

Most amazing battery value ever offered! A genuine World 6-Volt Radio "A" Battery with 25 ampere capacity for only \$5.00! Just the thing for Trickle Charger. Famous World Quality assured. Equipped with

### Solid Rubber Case

an assurance against acid and leakage. Order Now. We ship same day—by express C. O. D. subject to your examination on arrival. Extra Offer: 5% discount for cash in full with order. ACT TODAY!

### World WORLD BATTERY CO.

Dept. 148, STORAGE BATTERIES 1219S. Wabash Ave., Chicago

KDKA WEAZ WGN WJS KHD KGO KFAP WJY KOP

### BASE NOTES FULLY AMPLIFIED!

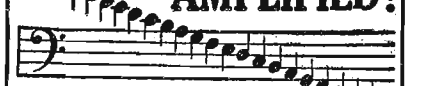

There is no variation in amplification over the entire range of musical frequencies with Thordarson Autoformers. No note is too low—no note is too high to be fully amplified by the Autoformer.

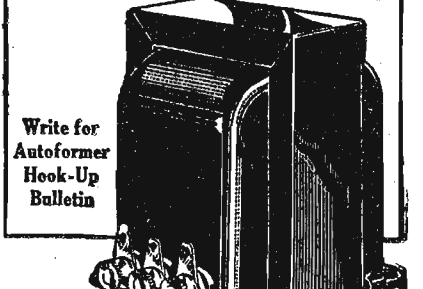

### THORDARSON Autoformer

Trade-Mark Registered

### All Frequency Amplifier

### An Entirely New Instrument—Not "just another transformer"

As the world's oldest and largest exclusive makers of transformers, we have led for years in broadening their amplifying range. In the Autoformer we have finally developed an all-frequency amplifier—a new instrument capable of fully amplifying all notes audible to the human ear. Thus the deepest notes of the grand organ, bass viol, tuba, English horn, etc., at last are brought out as clearly as the highest treble. Improved long distance reception and better volume control are further advantages.

### Write for Autoformer Bulletin

Autoformer amplification is for those who seek the finest reproduction of programs to be had. May be used with any set in place of regular audio transformer hook-up. Full directions, with diagrams, supplied with each instrument. Autoformers are \$5 each.

Sold by leading dealers THORDARSON ELECTRIC MFG. CO. CHICAGO



# Radiophone Broadcasting Stations

## Corrected Every Week—Part I

### United States

**AT9**, Fort Bragg, N. C. 434.5m-690kc. 750 watts. U. S. Government. Announcer, Lieut. James Y. LeGette. Slogan, "The Pioneer Broadcasting Station of the Army." Tues, Thurs, Sat, 8-9:55 pm, dance music, talks, bands, fights. Sun, 8-9:55 pm, service. Eastern.

**KDKA**, E. Pittsburgh, Pa. 309.1m-970kc. 1,000 watts. Westinghouse Elec. & Mfg. Co. Announcer George S. Ryan. Slogan, "The Pioneer Broadcasting Station of the World." Daily ex Sun, 9:45-10 am, 11:55, time, 12, market reports, weather; 2:30-5:30, music; 7, 9:55, time, daily except Sun, Sat; 12:15 pm, 7:45 pm, talks. Daily ex Sat, Sun, 8:30 pm, 8:45, concert; 9:55, time. Sat, 8:45 pm, concert; 9:55, time. Tues, Thurs, 10:30 pm, Sun, 9:45 am, 3 pm, 3:45, 6:45. Eastern.

**KDLR**, Devils Lake, N. Dak. 230.6m-1300kc. 5 watts. Radio Elec. Co.-Wilson Ins. Agency. Daily ex Sun, 12:10 pm; weather; 6:15, markets. Mon, 9:30-11:30 pm. Sun, 11 am; church; 4:30-6. Central.

**KDYL**, Salt Lake City, Utah. 245.8m-1220kc. 50 watts. Newhouse Hotel. Announcer, Gene Pack. Slogan, "Out on the Great Divide." Daily ex Sun, 3-4 pm, 6:30-8, news, music, entertainment. Sun, 11-1 am. Mountain.

**KDZB**, Bakersfield, Calif. 209.7m-1430kc. 100 watts. Frank Siefert.

**KFAB**, Lincoln, Neb. 340.7m-880kc. 1,000 watts. Nebraska Buick Auto Co. Announcer, Gayle Grubb. Daily ex Sun, 9:30-9:55 am, weather reports; 3-4 pm. Mon, Tues, Wed, Fri, 10:30-11 am, home economics; 1:15-1:30 pm, talks; 3:30-4 pm, 5:30-6:30, 8:05-8:30, college of agriculture; 8:30-10:30, Tues, Sat, 8-4 pm. Sat, 9:30-9:55 am; 5:30-6:30 pm, 8:30-9:30. Sun, 4-5 pm, 9-11. Central.

**KFAD**, Phoenix, Ariz. 272.6m-1100kc. 100 watts. Electrical Equip. Co.-McArthur Brothers Mercantile Co. Announcer, Arthur C. Anderson. Slogan, "The Voice of the Atwater Kent Radio." Daily ex Sun, Mon, 6-7 pm, 8-9. Daily ex Sun, Wed, 6-7 pm; 9-11, concerts, news, stocks. Mountain.

**KFAF**, San Jose, Calif. 217.3m-1380kc. 50 watts. Alfred Fowler.

**KFAJ**, Boulder, Colo. 260.7m-1150kc. 100 watts. Univ. of Colo. Announcer, F. M. Orsborn. Tues, Sat, 9 pm, time, music, addresses by faculty. Thurs, 7:30 pm; Sat, 2:30-5 pm, sports. Mountain.

**KFAU**, Boise, Idaho. 280.2m-1070kc. 750 watts. Boise H. S. Announcer, Hoyt Cooper. Slogan, "Idaho Station." Daily ex Sat, Sun, 4-4:45 pm, markets, weather, news. Mon, 7:30-9 pm, concert. Thurs, 8-10 pm, concert. Sat, 7:30-8:30 pm. Sun, 7:30-8:30 pm, church service. Mountain.

**KFBB**, Havre, Mont. 275.1m-1090kc. 50 watts. F. A. Buttrey Co. Announcer, C. O. Boettger. Daily ex Sun, 12:45 pm, music, markets, weather, reports. Mountain.

**KFBC**, San Diego, Calif. 215.7m-1390kc. 100 watts. W. K. Azbill. Sun, 9-10 am, Bible lesson, sermon. Pacific.

**KFBK**, Sacramento, Calif. 247.8m-1210kc. 100 watts. Sacramento Bee. Mon, Thurs, Sat, 7:30-10 pm. Mon, 6 pm. Pacific.

**KFBL**, Everett, Wash. 223.7m-1340kc. 100 watts. Less Bros. Daily, 7:30-8:30 pm. Pacific.

**KFBS**, Trinidad, Colo. 238m-1260kc. 15 watts. School District No. One.

**KFBU**, Laramie, Wyo. 270.1m-1110kc. 500 watts. Bishop N. S. Thomas.

**KFCB**, Phoenix, Ariz. 238m-1260kc. 125 watts. Nielsen Radio Supply Co. Announcer, E. A. Nielsen. Slogan, "When It's Wintertime in Michigan, It's Summer Time Down Here." Daily ex Sun, 8-8:15 am. Mon, Wed, 8-9 pm. Sat, 7-8 pm; 12-2 am. Mountain.

**KFCD**, Boise, Idaho. 278.6m-1080kc. 50 watts. St. Michael's Episcopal Cathedral. Announcer, E. Mark Hamford. Sun, 11:15-12:30 pm, 7:30-9:15. Mountain.

**KFDM**, Beaumont, Tex. 315.6m-950kc. 500 watts. Magnolia Petroleum Co. Announcer, Magnolene Mike. Slogan, "Kall for Dependable Magnolene." Tues, Fri, 12:30-12:55 pm, band concert; 7-7:30, children's hour; 8-10:30, concerts. Sun, 11-12 m, 8-9 pm. Central.

**KFDX**, Shreveport, La. 249.9m-1200kc. 100 watts. First Baptist church. Announcer, Hugh Claycomb. Sun, 10:50 am, 7:45 pm. Wed, 9-10 pm. Central.

**KFDZ**, Minneapolis, Minn. 230.6m-1300kc. 10 watts. Harry O. Iverson.

**KFEC**, Portland, Ore. 247.8m-1210kc. 50 watts. Meier & Frank Co., Inc. Daily ex Sun, 12 m, weather, reports; 4-5 pm, music; 6:30 pm, weather, crop, markets, reports. Sat, 11 am-12 m, children's hour. Pacific.

**KFEL**, Denver, Colo. 254.1m-1180kc. 50 watts. W. L. Winner. Inc. Announcer, Eugene P. O. Fallon. Daily ex Sun, 11 am, 2 pm, 4, 5. Tues, 9-10 pm; Thurs, 8-12 midnight. Mountain.

**KFEQ**, Oak, Neb. 267.7m-1120kc. 500 watts. J. L. Scroggin. Announcer, C. Scroggin. Daily ex Sun, 2-3 pm, orchestra. Sun, 4:30-6 pm. Central.

**KFEY**, Kellogg, Idaho. 232.4m-1290kc. 10 watts. Bunker Hill & Sullivan Mining & Con. Co. Announcer, Walter C. Clark. Slogan, "Voice of the Coeur D'Alenes." Mon, Wed, 6-7 pm. Sat, 9-11 pm. Sun, 6-7 pm. Pacific.

**KFFP**, Moberly, Mo. 241.8m-1240kc. 50 watts. First Baptist Church. Announcer, Granville Ray Boots. Slogan, "The Gospel Messenger of the Air." Central.

**KFGA**, Boone, Ia. 225.4m-1330kc. 10 watts. Cray Hardware Co. Announcer, Harold E. Wilcox. Slogan, "Daniel Boone Station." Wed, 8-9 pm. Sun, 3-4 pm. Central.

**KFH**, Wichita, Kan. 267.7m-1120kc. 500 watts. Hotel Lassen. Daily ex Sun, 9-11 am; 1-2 pm; 9-10. Tues, Thurs, Sat, 12:15-1:15 am. Sun, 9:45 am, church; 7:15 pm; 9:15. Central.

**KFHA**, Gunnison, Colo. 252m-1190kc. 50 watts. Western State College of Colorado. Announcer, E. Bessel Wickham. "Where the Sun Shines Every Day." Tues, Fri, 6:30 pm, bedtime story; 8 pm, musicale; 10:30, orchestra. Mountain.

**KFHL**, Oskaloosa, Iowa. 239.9m-1250kc. 10 watts. Penn College.

**KFI**, Los Angeles, Calif. 468.5m-640kc. 4,000 watts. Earle C. Anthony, Inc. Announcer, Robert Hurd. Slogan, "The Radio Central Station." Daily ex Sat, Sun, 5:30-11 pm. Sun, 10-11 am, 4-5 pm, 6:30-11, 11-12:30 pm, first and third Sunday of month. Pacific.

**KFIF**, Portland, Ore. 247.8m-1210kc. 100 watts. Benson Tech. School.

**KFIO**, Spokane, Wash. 265.3m-1130kc. 100 watts. North Central High School.

**KFIQ**, Yakima, Wash. 256.3m-1170kc. 100 watts. First Methodist Church. Announcer, Dr. I. M. Miller. Wed, 7:30 pm, organ. Sat, 7 pm. Sun, 11 am, 7:30 pm. Pacific.

**KFIU**, Juneau, Alaska. 225.4m-1330kc. 10 watts. Alaska Elec. Light & Power Co. Announcer, O. E. Schombell. Mon, Wed, Fri, 6-7 pm. Alaskan.

**KFIZ**, Fond du Lac, Wis. 272.6m-1100kc. 100 watts. Daily Commonwealth and Wisconsin Radio Sales, Inc. Announcer, Albert Mayer. Daily ex Sun, 5 pm, music, news, markets, weather. Central.

**KFJB**, Marshalltown, Iowa. 247.8m-1210kc. 100 watts. Marshall Elec. Co. Announcer, E. N. Peak. Slogan, "Marshalltown, the Heart of Iowa." Daily ex Sun, 10 am, markets. Tues, Fri, 8:30 pm. Central.

**KFJC**, Junction City, Kan. 218.8m-1370kc. 10 watts. R. B. Pezan.

**KFJF**, Oklahoma City, Okla. 260.7m-1150kc. 500 watts. National Radio Mfg. Co. Announcer, Hired Hand. Slogan, "Radio Headquarters." Daily ex Sun, 9:40 am, 12:15 pm, markets; 2:15, markets; 6:30, weather news, 6:30-7:30. Mon, Thurs, Fri, Sat, 8:15-10:45 pm. Wed, 11-12 midnight. Sun, 2:30-4 pm; 10-11:45. Central.

**KFJJ**, Astoria, Ore. 245.8m-1220kc. 10 watts. E. E. Marsh and Liberty theater. Announcer, E. E. Marsh. Wed, 9-10 pm, organ. Sun, 12:30-1:30 pm. Sun, 10:30-11 pm. Pacific.

**KFJM**, Grand Forks, N. D. 277.6m-1080kc. 100 watts. University of North Dakota. Slogan, "Grand Forks

the Educational Center of the State." Daily ex Sun, Thurs, 6-7 pm. Central.

**KFJP**, Portland, Ore. 265m-1140kc. 50 watts. Ashley C. Dixon & Son. Mon, Tues, Wed, Thurs, 7:30-9 pm. Mon, 8-8:45 pm. Tues, Thurs, 9-10:30 pm. Wed, 8-8:30 pm. Fri, 12:30-1:15 am. Sat, 1:30-3 pm. Pacific.

**KFJV**, Fort Dodge, Iowa. 245.8m-1220kc. 50 watts. Tunwall Radio Co. Announcer, Carl Tunwall. Daily, 5:30 pm, markets, news, weather, bulletins. Sun, 11 am, church; 8:15 pm, orchestra. Central.

**KFJZ**, Fort Worth, Texas. 254.1m-1180kc. 50 watts. Southwestern Baptist Theological Seminary.

**KFKA**, Greeley, Colo. 272.6m-1100kc. 50 watts. Colorado State Teachers' College. Announcer, John Henry Shaw. Mountain.

**KFKU**, Lawrence, Kan. 275.1m-1040kc. 500 watts. University of Kansas. Announcer, John F. Patt. Slogan, "Up at Lawrence on the Kaw." Mon, Thurs, 6:55-8 pm. Central.

**KFKX**, Hastings, Neb. 288.3m-1040kc. 5,000 watts. Westinghouse Elec. & Mfg. Co. Slogans, "The Empress of the Air," "The Pioneer Re-Broadcasting Station of the World." Daily ex Sun, 5:15-6:15 pm. KDKA programs. Daily ex Sat, Sun, 9:30 am, 10:30, 12:30 pm, markets. Mon, Wed, Fri, 9-11 pm, music. Sat, 9:30 am, 10:30, 12:30 am. Central.

**KFKZ**, Kirksville, Mo. 225.4m-1330kc. 10 watts. F. M. Henry. Mon, 8-9 pm, dance music. 1st and 3rd Mon, Radio plays. Sun, 3:30-4:30 pm, classical music. Central.

**KFLB**, Albuquerque, N. M. 254.1m-1180kc. 100 watts. U. & N. M. Announcer, Phillip S. Donnell. Slogan, "The Sunshine Center of America." Central.

**KFLU**, San Benito, Texas. 236.1m-1270kc. 10 watts. Benito Radio Club. Announcer, R. W. Thacker. Slogan, "Heart of the Magic Valley." Mon, Thurs, Sat, 8:30-10 pm, concert. Sat, 8:30 pm, Sunday school lesson. Central.

**KFLV**, Rockford, Ill. 228.9m-1310kc. 200 watts. Swedish Evangelical Mission Church. Announcer, A. T.

ex Sun, 1 pm, music. Tues, Wed, Fri, 8 pm. Sun, 11 am, services; 7:30 pm, irregularly. Central.

**KFPR**, Los Angeles, Calif. 230.6m-1300kc. 500 watts. Los Angeles Co. Forestry Dept. Irregular schedule.

**KFPW**, Cartersville, Mo. 258.5m-1190kc. 20 watts. St. John M. S. church, S. Slogan, "Keeping Pace with Christ Means Progress." Tues, Fri, 8-10 pm, popular program. Sun, 1-3 pm, chapel service. Central.

**KFPY**, Spokane, Wash. 265.3m-1130kc. 100 watts. Symons Investment Co. Announcer, E. B. Craney. Daily ex Sun, Tues, 7-7:45 pm. Wed, 9-12. Thurs, 10-11 pm. Sat, 11-12 midnight. Sun, 9:45-10:30 am; 9-10 pm. Pacific.

**KFQA**, St. Louis, Mo. 280.2m-1070kc. 1,500 watts. The Principia. Thurs, 8 pm. Sun, 8 pm, church service. Central.

**KFQB**, Fort Worth, Tex. 508.2m-590kc. 1,000 watts. The Searchlight Pub. Co. Announcer, John R. Denning. Daily ex Sun, Wed, 8:30-9:30 pm. Sun, 8:30 am, 10, 3 pm, 4, 6, 7, 9, 7:30. Central.

**KFQD**, Anchorage, Alaska. 227.1m-1320kc. 100 watts. Chovin Supply Co.

**KFQP**, Iowa City, Iowa. 223.7m-1340kc. 10 watts. George S. Carson, Jr. Wed, 8-9 pm. Central.

**KFQU**, Alma, Calif. 217.3m-1380kc. 100 watts. W. Riker. Announcer, Arthur J. Landstrom. Daily ex Mon, 9-10 pm. Sun, 11-12 m, 9-10 pm. Pacific.

**KFQW**, North Bend, Wash. 215.7m-1390kc. 50 watts. The Photo Radio and Elec. Shop. Announcer, Carl F. Kulerin. Slogan, "At the Western Entrance of Snoqualmie Pass." Thurs, 8-9 pm. Sun, 8:45-10 pm. Pacific.

**KFQZ**, Hollywood, Calif. 225.4m-1330kc. 50 watts. Taft Radio Company. Tues, Fri, 9-11 pm. Pacific.

**KFRB**, Beville, Texas. 247.8m-1210kc. 250 watts. Hall Brothers. Temporarily off the air.

**KFRG**, San Francisco, Calif. 215.7m-1390kc. 100 watts. City of Paris Dry Goods Co. Tues, Thurs, 8-9 pm. Sun, 8-9 pm. Pacific.

**KFRU**, Columbia, Mo. 490.7m-600kc. 500 watts. Steph-

"Keeping Friends with All." Daily ex Sun, 4-5 pm. Zenith hour, stocks, markets, time. Mon, Wed, Fri, 9-10 pm, music. Mon, Wed, 10-11 pm. Sun, 9-12 midnight, music. Mountain.

**KFWB**, Hollywood, Calif. 252m-1190kc. 500 watts. Warner Brothers.

**KFWC**, San Bernardino, Calif. 211.1m-1420kc. 50 watts. L. E. Wall.

**KFWF**, St. Louis, Mo. 214.2m-1400kc. 250 watts. St. Louis Truth Center. Slogan, "The Voice of Truth." Announcer, Rev. Charles H. Hartmann. Tues, 8 pm. Thurs, 7 pm, 7:45. Sat, 10 pm. Sun, 10:45 am; 7:45 pm. Central.

**KFWH**, Chico, Calif. 254.1m-1180kc. 100 watts. F. Wellington Morse, Jr. Slogan, "Kind Friends We're Here." Daily ex Sun, 10:30-11:30 am, 6:15-6:30 pm, news, music. Mon, Wed, Fri, 8-10 pm, 12-1:30 am; Sun, 9:30 am. Pacific.

**KFWI**, South San Francisco, Calif. 225.4m-1330kc. 500 watts. Radio Entertainments, Inc. Mon, Wed, Thurs, Fri, 1-2 pm. Mon, Wed, Fri, 8-9 pm. Mon, 9-12 pm. Wed, Fri, 9-1 am. Thurs, 10-12 midnight. Sat, 1:30-3 am. Sun, 10 am, 1-2 pm, 8-12 midnight. Pacific.

**KFWM**, Oakland, Calif. 206.8m-1450kc. 500 watts. Oakland Educational Society.

**KFWO**, Avalon, Calif. 211.1m-1420kc. 250 watts. Major Lawrence Mott-Signal Corp. Slogan, "Kataling for Wonderful Outings." Daily, 12:30-1:30pm, 7:30-9. Tues, Fri, Sun, 5-6 pm. Pacific.

**KFWU**, Pineville, La. 238m-1260kc. 100 watts. Louisiana, La.

**KFWV**, Portland, Ore. 212.6m-1410kc. 50 watts. Wilbur Jerman. Daily ex Sun, 6-7 pm; 7-7:30; 8-11.

**KFXB**, Big Bear Lake, Calif. 202.6m-1480kc. 500 watts. Bertram O. Heller. Announcer, Charles Stillwell. Slogan, "Rim of World Super Station." Daily ex Sun, 5 pm, news, weather, road reports. Pacific.

**KFXC**, Santa Maria, Calif. 209.7m-1480kc. 100 watts. Santa Maria Valley Railroad Company.

**KFXD**, Logan, Utah. 205.4m-1460kc. 100 watts. Service Radio Co.

**KFXE**, Colorado Springs, Colo. 249.9m-1200kc. 500 watts. Pikes Peak Broadcasting Company. Announcer, W. D. Pyle. Slogan, "The Pikes Peak Station." Daily ex Sun, 4:30 pm. Mon, Tues, 8:30-10:30 pm. Thurs, Sat, 9-11 pm. Sun, 10:45 am, 7:30 pm. Mountain.

**KFXH**, El Paso, Texas. 241.8m-1240kc. 50 watts. Bledsoe Radio Company. Announcer, Chuck Swann. Slogan, "The Voice of the Rio Grande." Mon, Wed, Fri, 8-10 pm. Mountain.

**KFXJ**, Colorado. 215.7m-1390kc. 10 watts. Mountain States Radio Distributors, Inc. (Portable).

**KFXM**, Beaumont, Texas. 227m-1320kc. 10 watts. Neches Elec. Co.

**KFXR**, Oklahoma, Okla. 214.2m-1400kc. 15 watts. Classen Film Finishing Company.

**KFY**, Flagstaff, Ariz. 205.4m-1460kc. 50 watts. Mary M. Costigan.

**KFYF**, Oxnard, Calif. 205.4m-1460kc. 10 watts. Carl's Radio Den. Announcer, Carl Newcomb. Slogan, "The Radio Voice from the Radio Den." Daily ex Sun, 5-6 pm, weather, crops, news, music. Pacific.

**KFYJ**, Houston, Texas. 238m-1260kc. 10 watts. Houston Chronicle Pub. Co.

**KFYO**, Texarkana, Tex. 209.7m-1440kc. Buchanan-Vaughan Co. Central.

**KFYB**, Bismarck, N. D. 247.8m-1210kc. 10 watts. Hoskins-Meyer, Inc.

**KGO**, Oakland, Calif. 361.2m-820kc. 4,000 watts. Gen. Elec. Co. Announcer, Howard I. Milliland. Daily ex Sun, 7:15-7:45, 8:15 am, exercises; 8:30, duffly strength; 11:30 am, luncheon concert. Daily ex Sat, Sun, 1:30 pm; Sat, 12:30 pm, markets, weather. Mon, Wed, Fri, 3 pm, music. Daily ex Sun, Mon, 4-5:30 pm, concert orchestra. Mon, Tues, Wed, Fri, 6-7 pm, music. Mon, Tues, Thurs, Sat, 8-10 pm, lecture, music. Tues, Thurs, Sat, 8-12. Mon, 6:30-6 pm, Children's half hour. Mon, Tues, Wed, Thurs, Fri, 7 pm, stocks, markets, weather, news, Thurs, 5:30-6:30 pm, boys' hour. Fri, 5-5:30 pm, girl's half hour. Sun, 11-12 m, 8 pm, church services; 3:30-5 pm, Little Symphony orchestra. Pacific.

**KGTT**, San Francisco, Calif. 206.8m-1450kc. 50 watts. Glad Findings Temple.

**KH**, Honolulu, Hawaii. 270.1m-1110kc. 500 watts. Marion A. Mulrony. The Honolulu Advertiser. Announcer, Raymond A. Tilford. Daily, 7:30-9 pm. Tues, Thurs, Sat, special program. Sun, 11 am, 7:30 pm, 1:50 meridian. 2 1/2 hours earlier than Pacific.

**KGW**, Portland, Ore. 491.5m-610kc. 500 watts. Portland Morning Oregonian. Announcer, Dick Haller. Slogan, "KGW, Keep Growing Wiser." Mon, Wed, Fri, 9:45-11:30 am. Tues, Thurs, Sat, 10-11:30 am. Mon, Wed, Fri, 7:15-7:30 am, exercises. Daily ex Sun, 12:30-1:30 pm. Mon, Tues, Wed, Thurs, Fri, 7:30-7:45 pm, utility service. Mon, Tues, Wed, Fri, 8-9 pm. Mon, Tues, 9-10 pm. Tues, Sat, 10-12. Wed, 9-11 pm. Fri, 9-10:30 pm; 10:30-12, Hoot Owls. Sun, 10:30-12 noon, 7:30-9 pm. Pacific.

**KGY**, Lacey, Wash. 245.8m-1220kc. 50 watts. St. Martins College. Announcer, Sebastian Ruth. Slogan, "Out Where the Cedars Meet the Sea." Sun, Tues, Thurs, 8:30-9:30 pm. Pacific.

**KHJ**, Los Angeles, Calif. 405.2m-740kc. 500 watts. Los Angeles Times. Announcer, John S. Daggett. Slogan, "Kindness, Happiness, Joy." Daily ex Sun, Mon, 7 am, 7:30, 12 m, 1:30 pm, 2:30, 3:30, 5:30, 11. Mon, 7-7:30 am, 12-1:30 pm. Sun, 10-12:30 pm, 6-7:30, 8-11. Pacific.

**KHQ**, Spokane, Wash. 272.6m-1100kc. 500 watts. Louis Wasmer, Inc. Slogan, "In the Friendly City." Pacific.

**KIAF**, Sittenger, Minn. 422.3m-710kc. 500 watts. Steele Co. Slogan, "Far from the Madding Crowd." Mon, Wed, Fri, 7-8 pm. Sun, 2-3 pm. Central.

**KJBS**, San Francisco, Calif. 220.4m-1360kc. 5 watts. Julius Brunton & Sons Co. Announcer, Edward Ludes. Daily ex Sun, 9-10:40 am; 2-3:30 pm. Mon, Wed, 8-10 pm. Fri, 8-11:30 pm. "Royal Order of Smoked Herring." Pacific.

**KJR**, Seattle, Wash. 384.4m-780kc. 1,000 watts. Northwest Radio Service Co. Announcer, Ross W. Swift. Slogan, "Radio Headquarters." Daily ex Sun, 10:30-11:30 am, educational program; 1:30-3 pm, matinee; 3, time; 5-6 pm, stocks, time; 6, time; 7-8:30, 8:30-10, 11-12:30. Sun, 11-12:30 pm, service; 6-6 pm, 7-9, 9-10:30. Pacific.

**KLDS**, Independence, Mo. 440.9m-680kc. 1,000 watts. Reorganized Church of Jesus Christ of Latter Day Saints. Announcer, Arthur E. Church. Tues, 6:30 am, 8 pm, 11:59. Thurs, 8 pm. Fri, 6:30 am. Sat, 8 pm. Sun, 11 am, 3 pm, 6:30, 9. Central.

**KLS**, Oakland, Calif. 249.9m-1200kc. 250 watts. Warner Bros. Radio Supplies. Announcer, S. Warner. Slogan, "The City of Golden Opportunity." Sun, 10-11 am. Pacific.

**KLX**, Oakland, Calif. 508.2m-590kc. 500 watts. Oakland Tribune. Announcer, Charles H. Gabriel, Jr. Slogan, "Where Rail and Water Meet." Mon, Fri, 4-7:30 pm; 8-10:30. Tues, Thurs, Sat, 7-7:30 pm. Wed, 8-11:30 pm. Pacific.

**KLZ**, Denver, Colo. 265.3m-1130kc. 250 watts. Reynolds Radio Co. Announcer, Mrs. William D. Reynolds. Slogan, "Its a Privilege to Live in Colorado." Wed, Sat, Sun, 9 pm. Mountain.

**KMA**, Shenandoah, Iowa. 252m-1190kc. 500 watts. May Seed & Nursery Co. Daily ex Sun, 11:30-12:30 pm, 6-7, 9-11. Sun, 4-6 pm. Central.

**KMJ**, Fresno, Calif. 234.2m-1280kc. 50 watts. Fresno Bee. Mon, Wed, Fri, 7:15-9:15 pm. Pacific.

**KMMJ**, Clay Center, Neb. 228.9m-1310kc. 1,000 watts. M. M. Johnson Co. Daily ex Sun. 1:30 pm, 7:30. Central.

**KMO**, Tacoma, Wash. 249.9m-1200kc. 100 watts. Association Station. (Love Electric Co.) Mon, Wed, Fri, 6-7 pm, popular program; 9-10, artist's program. Pacific.

## CHALLENGE!

**ONE DOLLAR** will be paid to the Radio fan submitting the most errors in any one station's listing in this directory. Letters must reach Radio Digest office not later than one week from date of issue corrected. Readers are not limited to correcting one station, but such corrections must be certified by the stations themselves, and NOT by comparison to other so-called accurate broadcasting directors and lists. Readers also must live in same state or province as stations corrected are located. Station verifications must accompany corrections.

That's just how sure Radio Digest is that this broadcasting station directory is correct! To make the challenge fair for everyone, broadcasting stations and their employes are barred from this offer. Why? Because the broadcasters are the source of all the data given herein. They are (or should be) interested enough to answer the inquiry sent them every time data on their station appears. This inquiry contains a proof of their last listing and must either be corrected or O'K'd as correct and

returned to the Digest. Nevertheless, sometimes the stations are careless and mistakes are made. But Radio Digest is so sure of the exactness of this directory that this challenge is made unconditionally.

With reference to the directory: It appears in six parts, serially continuously; the first four parts are station data listings, arranged alphabetically; the fifth part is a state, city index of stations; the sixth part is a wave length index. The information contained in each station data listing is given in the following order: Call letters, city, state, wave length used, watts antenna input, owner's name, announcer's name, slogan used if any, name of listener in "club," schedule of operating hours, and kind of time used, as "Central," "Mountain," etc.

Six successive issues of Radio Digest will give one the most complete and accurate list of broadcasting stations obtainable. This service is original with this publication, and has been maintained from the start. Right of reproduction without permission of any or all of the data contained herein is denied.

Frykman. Fri, 8:30 pm. Sun, 12:30 pm, service for shut-ins (Swedish); 9:30, service (English). Central.

**KFLX**, Galveston, Texas. 239.9m-1250kc. 10 watts. George R. Clough.

**KFLZ**, Anita, Iowa. 272.6m-1100kc. 100 watts. Atlantic Automobile Co. Operated by Walnut Grove Hog Remedy Co. Announcer, H. A. Marshall. Daily ex Sun, 11:50-12:30 pm, question box, markets. Wed, 8:30-10 pm. Central.

**KFMQ**, Fayetteville, Ark. 299.8m-1000kc. 750 watts. U. of Arkansas. Mon, 7:30 pm. Tues, Thurs, 8 pm. Central.

**KFMH**, Sioux City, Iowa. 260.7m-1150kc. 100 watts. Morningside College. Announcer, Jesse C. Ducommun. Wed, 9:15 pm. Central.

**KFMW**, Houghton, Mich. 263m-1140kc. 50 watts. M. G. Sateren (announcer). Sun, 3-4:30 pm.

**KFMX**, Northfield, Minn. 336.9m-890kc. 500 watts. Carlton College. Announcer, Merrill O. Bolten. Daily 10:25-10:30 am, time. Tues, 9:30-10 pm, lecture. Wed, 9-10 pm, concert. Fri, 10-11 pm, organ. Sun, 7-8 pm. Central.

**KFNH**, Shenandoah, Iowa. 263m-1140kc. 500 watts. Henry Field Seed Co. Announcer, Henry Field. Slogan, "Friendly Station in a Friendly Town." Daily ex Sun, 12:15-1:35 pm; 2:45-4, rocking chair time; 7-9 pm. Sun, 10:45 am, 2:30 pm, 3-4, services; 6:30-7:30, Golden Rule; 7:30-8:30, church service. Central.

**KFOA**, Seattle, Wash. 454.3m-660kc. 1,000 watts. Rhodes Dept. Store. Slogan, "The Gateway to the Orient." Daily ex Sat, Sun, 12:30-1:30 pm. Daily ex Sun, 10-10:30 am, homemakers hour, 3-4 pm, women's clubs; 5:15, Times Bulletin, concert. Daily ex Sun, Thurs, 8:30-10 pm. Times program. Mon, Wed, Fri, 6:45-8:15 pm, studio music. Tues, Fri, Sat, 10-11:30 pm, orchestra. Central.

**KFOB**, Burlingame, Calif. 225.4m-1330kc. 50 watts. Burlingame KFOB Inc. Tues, 8-11 pm. Thurs, 9-11 pm. Sat, 8-12. Pacific.

**KFON**, Long Beach, Calif. 232.4m-1290kc. 500 watts. Nichols & Warner, Inc. Slogan, "Where Your Ship Comes In." Daily ex Sun, Mon, 10-11 am; 2:30-5 pm; 6-11. Mon, 10-11 am; 6-11. Sun, 2:30-4 pm; 8-9. Pacific.

**KFOO**, Salt Lake City, Utah. 236.1m-1270kc. 250 watts. Latter Day Saints University. Announcer, Don C. McEae.

**KFOR**, David City, Neb. 225.4m-1330kc. 100 watts. David City Tire & Elec. Co. Slogan, "The Voice of David City." Mon, 7-9 pm. Central.

**KFOT**, Wichita, Kan. 230.6m-1300kc. 50 watts. College Hill Radio Club. Announcer, Leon Garnett. Slogan, "Radioating Church." Sun, 11-12:30 pm; 7:30-9, church services. Sun, 9-10:30 pm, music. Central.

**KFOX**, Omaha, Neb. 247.8m-1210kc. 100 watts. Board of Education. Technical High.

**KFOY**, St. Paul, Minn. 252m-1190kc. 500 watts. Beacon Radio Service. Daily ex Sun, 10 pm. Sun, 3:30-4:30 pm. Central.

**KFPL**, Dublin, Texas. 252m-1190kc. 15 watts. C. C. Baxter, announcer.

**KFPM**, Greenville, Texas. 241.8m-1240kc. 10 watts. The New Furniture Co. Announcer, Dave Ablowich, Jr. Slogan, "The New Furniture Co., the Home of Good Furniture." Located at Greenville, Texas, Where You Find "The Blackest Land, the Whitest People." Daily

college. Mon, Tues, Thurs, Fri, 6:15 pm. Fri, 12-2 am. Wed, 9-11 pm. Sun, 7:30 pm; 9:20, 7:30 pm. Central.

**KFRW**, Olympia, Wash. 218.8m-1370kc. 50 watts. "The Loy Memorial." United Churches of Olympia. Slogan, "Make the World a Brotherhood." Thurs, 9-10 pm. Sun, 11-12:30 pm. 7:30-9. Pacific.

**KFSG**, Los Angeles, Calif. 275.1m-1090kc. 500 watts. Angeles Temple. Tues, Thurs, Fri, Sat, 3:30-4:30 pm. Tues, 6:30-7:30 pm. Wed, 2:30-4:30 pm; 6:30-7:30. Thurs, Fri, Sat, 7:30-11 pm. Sun, 10:30-12:30 pm, 2:30-4:30, 7-9:30. Mon, silent. Pacific.

**KFUL**, Galveston, Texas. 258.5m-1160kc. 50 watts. Thomas Gregg & Bros.

**KFUD**, St. Louis, Mo. 545.1m-550kc. 500 watts. Congregational Theological Seminary (Lutheran). Announcer, Herin H. Hohenstein. Mon, 8 pm. Wed, 9:15 pm. Sun, 4 pm, 9:15. Central.

**KFUP**, Denver, Colo. 234.2m-1280kc. 50 watts. Fitzsimons General Hospital, Educational and Recreational Dept.

**KFUR**, Ogden, Utah. 223.7m-1340kc. 100 watts. Peery Building Co. Tues, Thurs, Sat, 9:50-11:50 pm, dance music. Mountain.

**KFUS**, Oakland, Calif. 256.3m-1170kc. 50 watts. The Gospel Radio. Slogan, "The City of Opportunity." Pacific.

**KFUT**, Salt Lake City, Utah. 250.7m-1150kc. 100 watts. University of Utah. Mon, Wed, Fri, 12-1 pm. Mon, 12 m. Wed, Fri, 12:20 pm. Mountain.

**KFUU**, Oakland, Calif. 220.4m-1360kc. 50 watts. Mathewson Motor Co. Announcer, H. C. Colburn. Slogan, "The Voice of Automobile Row." Daily ex Sun, 10:45-11:45 am; 6:30-7:15 pm. Tues, Thurs, 8-10 pm. Sat, 6:30-2 am. Sun, 8-9:30 pm. Pacific.

**KFVD**, San Pedro, Calif. 205.4m-1460kc. 50 watts. McWhinnie Elec. Co.

**KFVE**, University City, Mo. 239.9m-1250kc. 500 watts. Film Corp. of America. Daily ex Thurs, Sun, 9:15 pm. Central.

**KFVG**, Independence, Kan. 236.1m-1270kc. 15 watts. First Methodist Episcopal church. Sun, services.

**KFVH**, Manhattan, Kan. 218.8m-1370kc. 15 watts. Whan Radio Shop. Announcer, Herbert Wahn. Slogan, "Kansas Fans Very Happy." Daily ex Sun, 12 m, markets. Daily ex Sun

# Your Home— Deserves This Radio

## Compact—Fits any Corner— A Beautiful Piece of Furniture

of genuine five-ply mahogany with built-in loud speaker of great volume and superb tone and spacious compartments for all batteries and other accessories—not a single wire being visible.

MODEL 6-F-1

New and Improved  
**FRESHMAN  
MASTERPIECE**

*The* Worlds Greatest  
Radio Value

Freshman's latest sensation has a real appeal to the women of the home. It is compact and comparatively small, giving it preference over clumsy consoles. Contains an especially large tone chamber, made by the manufacturer of the world's foremost phonograph.

When not used as a radio, it can be entirely closed. The top is stationary and provides an attractive resting place for vases and other ornaments, so essential to the women of the house.

**The Radio Receiver Women  
Have Been Waiting For**

*Write for interesting literature  
describing this wonder set in detail.*

**Sold on Convenient Terms by  
Authorized Freshman Dealers,  
who also Install and Service Them**

**Chas. Freshman Co., Inc.**

Freshman Building . . . New York  
2626 W. Washington Blvd., Chicago

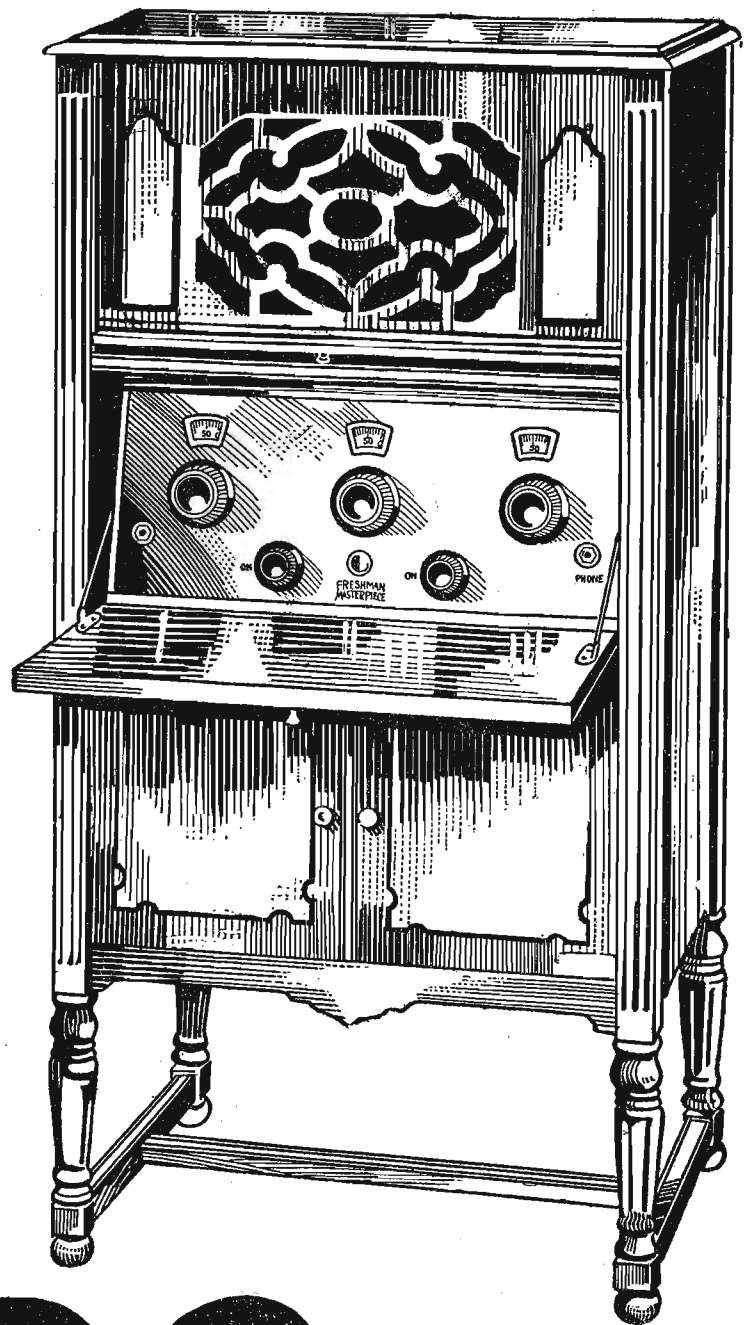

# \$99.50