

Price 15 cents

RADIO DESIGN

OFFICIAL ORGAN OF THE
RADIO
INTERNATIONAL GUILD

ROBERT HERTZBERG

Editor

In this issue:

Introducing
The New Pilot

UNIVERSAL
SUPER - WASP

15 to 650 Meters By The
Turn of a Knob - - Plug-
in Coils Eliminated.

Volume 3
Number 4

First 1931
Issue

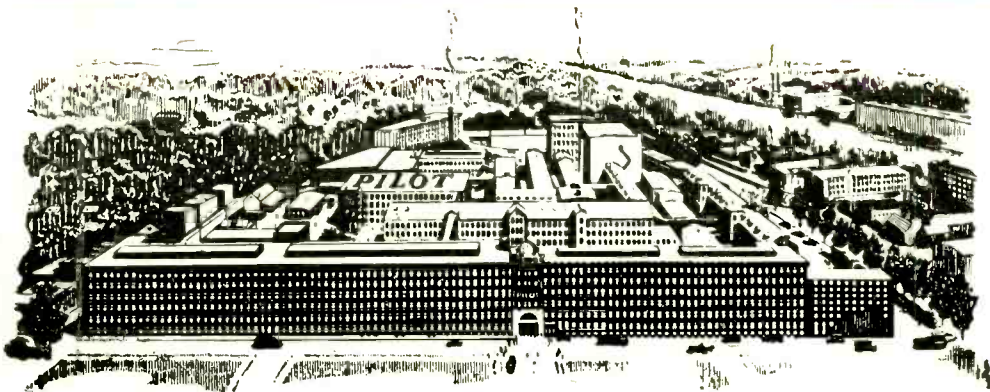

The New Pilot plant at Lawrence, Mass.

LARGEST PLANT IN THE WORLD OWNED AND OPERATED BY A RADIO MANUFACTURER

The steadily increasing international demand for Pilot Products has necessitated the continued expansion of the Pilot Radio Plant—until today it occupies what is the largest single Radio manufacturing unit in the world. Pilot has proven its ability to produce quality at reasonable prices and now Pilot is in a position to increase quantity by the same safe and conservative methods which have characterized the growth of the Pilot organization thus far.

Pilot makes more of what goes into its products under one roof than does any other radio manufacturer... and you the user of Pilot Radio Products benefit thereby because Pilot prices are always low and Pilot quality always the highest.



PILOT RADIO & TUBE CORP.

LAWRENCE, MASS.

CHICAGO OFFICE: 234 S. WELLS STREET

SAN FRANCISCO OFFICE: 1278 MISSION STREET

I will train you at home



Here's Proof

to fill a **BIG PAY** Radio Job!

If you are earning a penny less than \$50 a week, send for my book of information on the opportunities in Radio. It is free. Clip the coupon NOW. Why be satisfied with \$25, \$30 or \$40 a week for longer than the short time it takes to get ready for Radio.

Radio's growth opening hundreds of \$50, \$75, \$100 a week jobs every year

In about ten years Radio has grown from a \$2,000,000 to a \$1,000,000,000 industry. Over 300,000 jobs have been created. Hundreds more are being opened every year by its continued growth. Men and young men with the right training—the kind of training I give you—are needed continually.

You have many jobs to choose from

Broadcasting stations use engineers, operators, station managers and pay \$1,800 to \$5,000 a year. Manufacturers continually need testers, inspectors, foremen, engineers, service men, buyers, for jobs paying up to \$15,000 a year. Shipping companies use hundreds of Radio operators, give them world wide travel at practically no expense and a salary of \$85 to \$200 a month. Dealers and jobbers employ service men, salesmen, buyers, managers, and pay \$30 to \$100 a week. There are many other opportunities too.

So many opportunities many N. R. I. men make \$5 to \$25 a week extra while learning

The day you enroll with me I'll show you how to do 10 jobs, common in most every neighborhood, for spare time money. Throughout your course I send you information on servicing popular makes of sets; I give you the plans and ideas that are making \$200 to \$1,000 for hundreds of N. R. I. students in their spare time while studying.

Talking Movies, Television, Wired Radio are also included

Radio principles as used in Talking Movies, Television and home Television experiments, Wired Radio, Radio's use in Aviation, are all given. I am so sure that I can train you satisfactorily that I will agree in writing to refund every penny of your tuition if you are not satisfied with my Lessons and Instruction Service upon completing.

64-page book of information FREE

Get your copy today. It tells you where Radio's good jobs are, what they pay, tells you about my course, what others who have taken it are doing and making. Find out what Radio offers you, without the slightest obligation. ACT NOW.

J. E. SMITH, President
National Radio Institute Dept. ON-47
Washington, D. C.



I will give you my new 8 OUTFITS of RADIO PARTS for a home Experimental Laboratory

You can build over 100 circuits with these outfits. You build and experiment with the circuits used in Crosley, Atwater-Kent, Eveready, Majestic, Zenith, and other popular sets. You learn how these sets work, why they work, how to make them work. This makes learning at home easy, fascinating, practical.

Back view of 5 tube Screen Grkl A. C. set—one only of many circuits you can build.

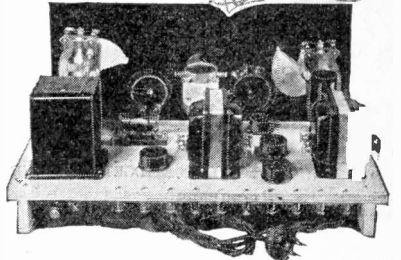

I am doubling and tripling the salaries of many in one year and less Find out about this quick way to

BIGGER PAY

FILL OUT AND MAIL THIS COUPON TODAY

J. E. SMITH, President, National Radio Institute, Dept. ON-47, Washington, D. C.
Dear Mr. Smith: Send me your book. This request does not obligate me.

Name

Address

City State



\$100 a week

"My earnings in Radio are many times greater than I ever expected they would be when I enrolled. They seldom fall under \$100 a week."
E. F. WINBORNE,
1414 W. 48th St.,
Norfolk, Va.



Jumped from \$35 to \$100 a week

"Before I entered Radio I was making \$35 a week. Last week I earned \$110 servicing and selling Radios. I owe my success to N. R. I."

J. A. VAUGHN
3715 S. Kingshighway,
St. Louis, Mo.



\$500 extra in 6 months

"I find I made \$500 from January to May in my spare time. My best week brought me \$107. I should have taken it long ago."

HOYT MOORE
R. R. 3, Box 919,
Indianapolis, Ind.

Lifetime Employment Service to all Graduates

RADIO DESIGN

OFFICIAL ORGAN OF THE RADIO INTERNATIONAL GUILD

ROBERT HERTZBERG, *Editor*

Vol. 3
No. 4

CONTENTS OF THIS ISSUE

First
Issue
1931

- | | | | |
|---|----|--|----|
| THE NEW PILOT UNIVERSAL SUPER-WASP.
<i>By Robert Hertzberg</i> | 4 | NEW TUBES FOR THE K-110 MODEL SUPER-WASP
<i>By Alfred A. Ghirardi</i> | 42 |
| OPERATING HINTS ON THE UNIVERSAL SUPER-WASP. | 17 | HOW TO LEARN THE CODE
<i>By H. K. Bradford</i> | 47 |
| AN UP-TO-DATE LIST OF THE SHORT-WAVE BROADCASTING STATIONS OF THE WORLD | 19 | NEW PILOT PARTS | 50 |
| ROLLING UP FROM RIO
<i>By Zeh Bouck</i> | 29 | THE IGNORANCE OF EXPERTS
<i>By Robert S. Kruse</i> | 52 |
| THE PILOT MIDGET AND CONSOLETT RECEIVERS | 36 | QUESTIONS AND ANSWERS | 54 |
| RADIO SYMBOLS AND ABBREVIATIONS | 40 | WHEN POWER PACKS GET HOT GIVE THEM AIR | 58 |
| | | A. "FLEA POWER" SHORT-WAVE TRANSMITTER | 60 |
| | | SPEAKER BAFFLE CHART | 63 |



RADIO DESIGN MAGAZINE

Is Published By

RADIO DESIGN PUBLISHING CO., INC., Lawrence, Mass.

RADIO DESIGN Magazine is published quarterly, or four times during the year. The subscription price for the four issues is 50 cents for the United States and all other countries of the world. Checks and money orders should be drawn to the order of Radio Design Publishing Company, Inc.; U. S. coin as well as U. S. stamps accepted. Remittances for foreign subscriptions should be made by international postal money order. Subscriptions are always started with the current issue unless otherwise ordered. Single copies of current and back numbers, 15 cents each. The contents of this magazine may be reprinted by other publications if full credit is given. The editors will be glad to cooperate by supplying illustrations.

SUBSCRIBERS: PLEASE NOTIFY US PROMPTLY IF YOU CHANGE YOUR ADDRESS, WRITE OR PRINT YOUR NAME AND NEW ADDRESS CLEARLY.

*The only edition available to the public
— — The Officers' Radio Manual Used
by the Signal Corps*

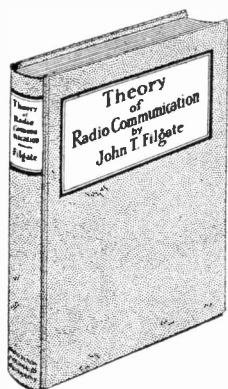

251 Pages
200 Illustrations
6 by 9".

Theory of Radio Communication

by

JOHN T. FILGATE, M. S.,

First Lieutenant, Signal Corps, U.S.A.

Formerly Instructor in Communication Engineering
at the United States Army Signal School.

The edition is
limited; order your
copy now. Sent
postpaid anywhere for

\$2.00

Mail your orders to the
**RADIO DESIGN
PUBLISHING CO., Inc.**
LAWRENCE, MASS.

"**Theory of Radio Communication**" has been used as the officers' radio manual at the United States Army Signal School at Fort Monmouth, N. J., for several years, and its fame in the service is widespread. As issued at the Signal School it is a bulky mimeographed volume; as published by the Radio Design Publishing Company it is a handsome, stiff-covered book of 251 pages and 200 illustrations. Exclusive permission to publish Lieut. Filgate's monumental work was obtained from the War Department. As a text book and reference volume for the more advanced radio experimenter and student, "**Theory of Radio Communication**" is extremely valuable. It is devoted entirely to radio theory in general, and barely touches on purely military signalling. The book has been adopted as a standard text by many colleges and universities having Signal Corps R.O.T.C. units.

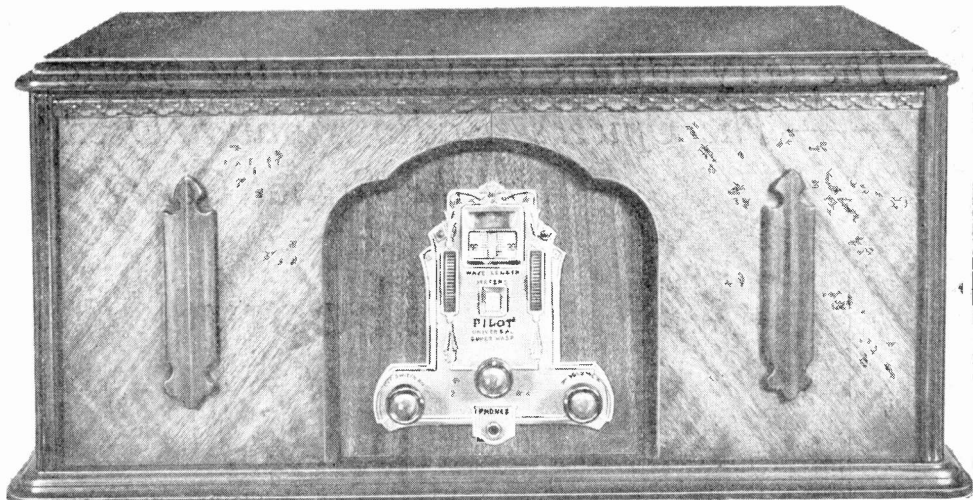

A completed Universal Super-Wasp in its handsome walnut cabinet

The New Pilot UNIVERSAL SUPER-WASP

Good-by plug-in coils! This remarkable combination wave receiver covers the unprecedented wavelength range of 15 to 650 meters in seven steps, which are selected from the front of the set by the turn of a knob. Its features of design and construction are advanced and exclusive.

By ROBERT HERTZBERG

SHORT-WAVE broadcasting, as distinctly distinguished from amateur short-wave telegraphy, began attracting the interest of radio experimenters about two years ago, and quickly developed into an indoor sport of considerable proportions. It lured back to the radio fold many former DX fans of the 1920-1925 period who had dropped out of the "game" because chain broadcasting and high power had robbed it of its early glamor. The mere possibility of hearing voice and music from Europe and the Antipodes revived the old fever, and soon thousands were hanging breathlessly on vernier dials, swearing at the fading and the interference, and enjoying themselves thoroughly.

EARLY SETS SATISFACTORY

At first these people were satisfied with "junk box" receivers operating on batteries and possessing hand capacity and many of the

other troubles associated with elementary regenerative sets. However, they had been spoiled by the efficient all-electric broadcast receivers already on the market, and they began to demand comfort with their thrills. In an effort to fill their needs, radio engineers spent some effort on the receiver problem, and in quick succession there appeared a series of improved sets. First, the simple regenerative tuner took on an untuned screen-grid R. F. stage and a little shielding. Then a *tuned* screen-grid job with double shielding made its commercial appearance. Batteries still remained a nuisance to those people who had outgrown the spilling-acid-on-the-rug stage, but A. C. short-wave operation, when successful at all, was usually a laboratory accomplishment and therefore unfit for the public. Finally David Grimes and John Geloso, Pilot engineers, discovered the source of the mysterious tunable hums that caused so much

trouble, wiped them out with a few simple expedients, and produced the A. C. Super-Wasp, the first completely A. C. operated short-wave receiver on the market. Brought out in September, 1929, this set has enjoyed a phenomenal sale throughout the world, its popularity strengthening its sponsor's conviction that the short-wave fan was maturing and that his ranks were being increased by new converts who were never fans before but who were adopting the short-wave hobby because it was interesting.

THOSE PLUG-IN COILS

There was still one feature of short-wave operation that caused concern, and that was the matter of plug-in coils. The early receivers used a maximum of three coils, which could be inserted and removed without much trouble because the sets were wide open. However, as the benefits of shielding became evident and the number of coils per set rose to as high as ten (five pairs to cover a range from 15 to 500 meters), the coils themselves became a nuisance. Getting them in and out of necessarily tight shield cans was an operation that tested the temper and bruised the knuckles, and left the set owner in no mood to make delicate adjustments on hair trigger dials. Anticipating a reaction to this situation, the Pilot Company laid out an engineering program more than a year ago that had as its final object a short-wave or, rather, combination wave receiver possessing the following features:

THE REQUIRED FEATURES

- (1) *No plug-in coils. The set must remain closed, and all wave shifting must be done from the front panel.*
- (2) *The minimum wavelength must be*

around 15 meters, and the maximum not less than 550, to take in the regular broadcast band as well as all the short-wave channels. The experience gained from the previous Super-Wasps indicated the desirability of this coverage. Many people used these sets for regular entertainment reception when the short waves were not obliging, as they sometimes are not!

(3) *The detector regeneration control must not affect the tuning to any appreciable degree. A requisite to insure dependable logging.*

(4) *The power pack must be part of the chassis, not a separate unit dangling in the back.*

(5) *The tuned screen-grid R. F. stage, having demonstrated its effectiveness, must be retained.*

(6) *The audio system must be full grown, using a respectable output stage that would do justice to a good dynamic speaker. Squeaky amplifiers using a 227 output tube are forbidden, and the set must sound like a 1931 set even if it is a short-wave job!*

(7) *It must have connections for a phonograph pick-up.*

(8) *The laboratory air so closely identified with previous short-wave sets must be shaken off, and the new receiver must be worthy of a place in the living room, or at least in the corner of the library or reading room. There must be nothing flouney about it, but it must graduate from the raw-aluminum-panel stage.*

(9) *It must be in kit form for easy home assembly.*

(10) *The price must be reasonable.*

THE TASK ACCOMPLISHED

This was a rather large order, but neither expense nor effort was spared. John Geloso,

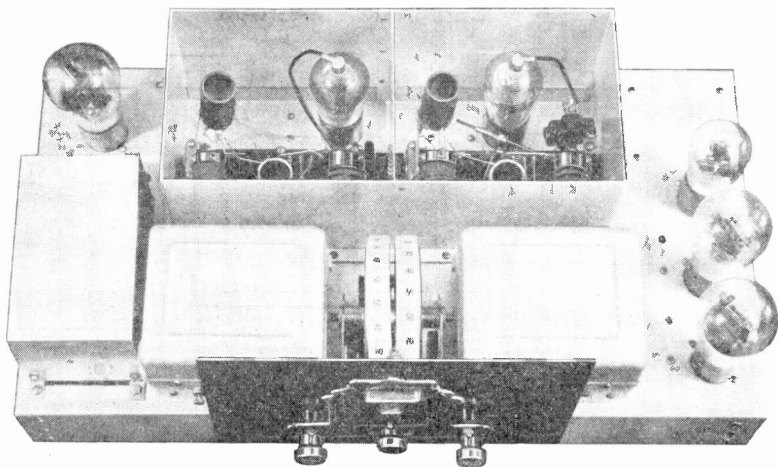

Top view of an assembled Universal, with the cover of the R.F.-detector shield removed to show the coils and switches inside.

chief engineer of the Pilot company, devoted himself to the mechanical side, which ended in the development of a switching mechanism of highly ingenious construction. David Grimes, then research chief of the company, assisted by Edgar Messing, concentrated on the circuit, producing one that works superlatively well in spite of the existence of a natural obstacle in the form of a lumped switching device.

A SLICK SET

The finished receiver, just emerged from the laboratory and ready for the hands of short-wave fans, is known as the "Universal Super-Wasp," and more than meets the requirements originally laid down for it. In the writer's opinion the set is the slickest job of its kind ever produced. It covers the unprecedented range of 15 to 650 meters, with all the coils fixed inside the chassis, and with any one of the seven overlapping ranges instantly available by the mere twist of a little knob on the front panel. It is difficult to describe the utter simplicity and convenience of this control, which does for short-wave reception what the self-starter did for the automobile. You merely turn the knob, and you hear a sharp little click, and the range you are set to appears marked on a small scale. That's all there's to it; no wrestling with coils, no loosening of shield tops, no pulling the set off the table.

CONSTRUCTION DETAILS

The screen-grid R. F. amplifier stage and the screen-grid detector stages, respectively, are enclosed within a large common shield can having a partition in the center. Each is provided with four small fixed coils mounted on

the edge of a molded bakelite switch housing. This housing, a marvelous example of the bakelite molder's art, contains a shaft bearing fifteen thin cams, which are brought into play against fifteen plunger contacts. The two switches, alike except that one is left-handed and the other right-handed, are lined up on the aluminum chassis, their shafts terminating in a worm gear. This is driven by a smaller gear which is coupled to the control knob on the panel by a steel shaft and a universal joint.

The R. F. or antenna coils contain two windings apiece, a primary and a secondary. One end of each is left grounded, and the other ends terminate at the plunger contacts on the antenna switch. The detector or interstage coils also have two windings apiece: a combination primary and tickler and a grid coil or secondary, arranged the same way. The tuning condensers for each stage are split units, each consisting of a small section of 130 mmf. maximum and a larger section of 415 mmf. maximum. They have a common rotor but separate stator connections, the latter brought out to contacts on the switches. In addition, there is a fixed loading condenser of .0004 mf. mounted inside the stage shields. If the small sections are designated as A and the large as B, and the loading condenser as C; and the four coils, in the upward value of their inductance, as 1, 2, 3 and 4, the seven combinations are as follows:

WAVE RANGES

Range 1, 15 to 22 meters: coils 1 and condensers A.

Range 2, 21 to 40 meters: coils 2 and condensers A.

Range 3, 39 to 75 meters: coils 3 and condensers A.

SCHEMATIC DIAGRAM

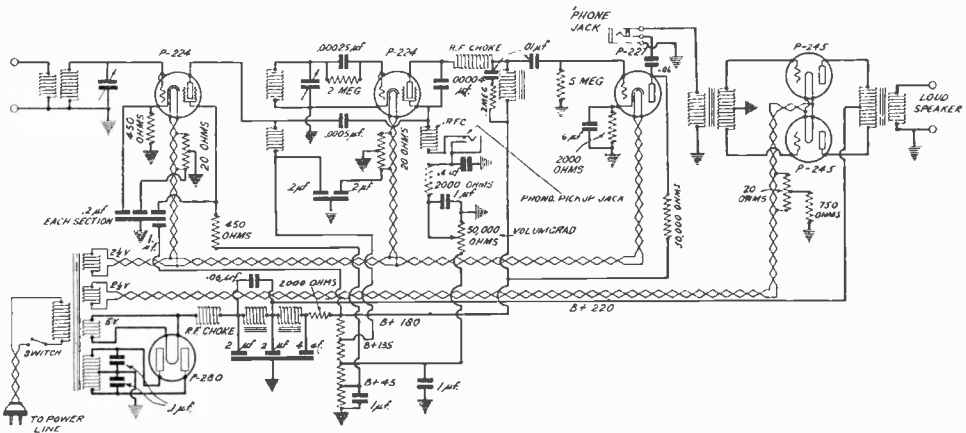

This schematic diagram of the Universal is a functional hook-up, and does not show the actual connections to the cam switches.

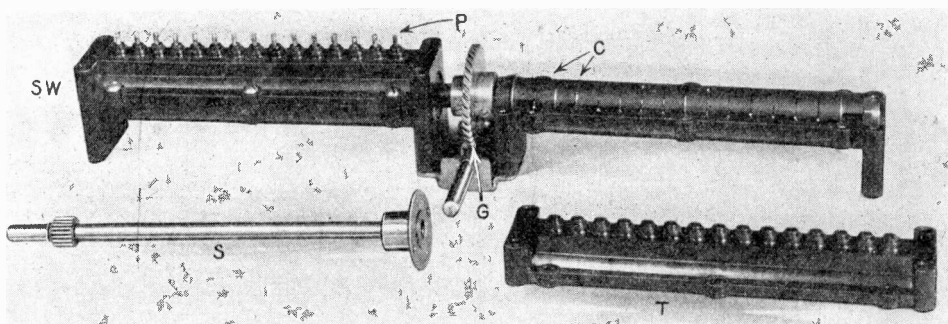

Close-up of the pair of cam switches, with one opened up to show the arrangement of the cams and the split construction of the housing.

Range 4, 70 to 144 meters: coils 3 and condensers A and B.

Range 5, 140 to 270 meters: coils 4 and condensers A.

Range 6, 250 to 500 meters: coils 4 and condensers A and B.

Range 7, 470 to 650 meters: coils 4 and condensers A, B and C.

The primary and tickler windings of both coils 3 are each tapped in one place, part of the winding being used for wave range 3 and all for wave range 4. The primaries and ticklers of both coils 4 are tapped in two places, for use on ranges 5, 6 and 7.

The entire operation of the set, it may be seen, depends on the smooth functioning of the cam switches. The sequence of the latter has been worked out very carefully, so that the shortest paths are made for the lowest wave ranges. Of course, there is some capacity between contacts, but this is far less troublesome than it would appear. Dozens of different switching arrangements were tried, and this one finally chosen because it worked so smoothly.

SCHEMATIC DIAGRAM

Examination of the schematic diagram of the Universal reveals that the method of coupling the R. F. tube to the detector is somewhat out of the ordinary. It was adopted after exhaustive research by Grimes and Messing and is as reliable as it is simple. It was necessary to use a single winding for both primary and tickler in order to simplify the switching arrangement, and the present scheme works to perfection. The regenerative action of the detector is controlled by a potentiometer regulating the detector screen voltage, a method that does not alter the tuning.

The rest of the circuit is not unusual. The first audio tube, a 227, is impedance coupled to the detector, the earphone jack being con-

nected in its plate circuit. The shunt system of feeding the plate voltage to this tube is employed to permit the use of a grounded earphone jack on the front panel, for the protection of the operator. The output stage uses a pair of 245's in push pull.

The power system uses a regular 280, which, being a rather prolific source of R. F. disturbance, is pretty well isolated by buffer condensers across the high voltage transformer secondary and an R. F. choke in the plus lead. These help enormously in eliminating hum and other noises.

SET PARTIALLY ASSEMBLED

In kit form for home assembly, the Universal is supplied about 35% assembled and wired. The power transformer, the filter chokes, the filter condenser block and the audio transformers are already mounted in place. The entire coil assembly is completely wired at the factory. All the parts are accurately prepared and go together without trouble. A set can be assembled and wired complete in about three evenings with the aid of a few simple hand tools. A small false front panel is supplied, this fitting snugly into a handsome walnut table style cabinet. In this cabinet the Universal is fit for any room in the house, and not for the workshop alone. The various accompanying photographs give a better idea of the receiver than any mere description.

A PERFORMING SET

The wide wavelength range of the Universal makes it a versatile receiver that lives up to its name. It is first and foremost a short-wave set, and as such is highly sensitive and selective. The writer will not give the usual performance of short-wave authors by mentioning a string of foreign stations a yard long picked up on it. Every radio man knows that short-wave reception is a gamble and involves patience, skill and a dash of luck. Used

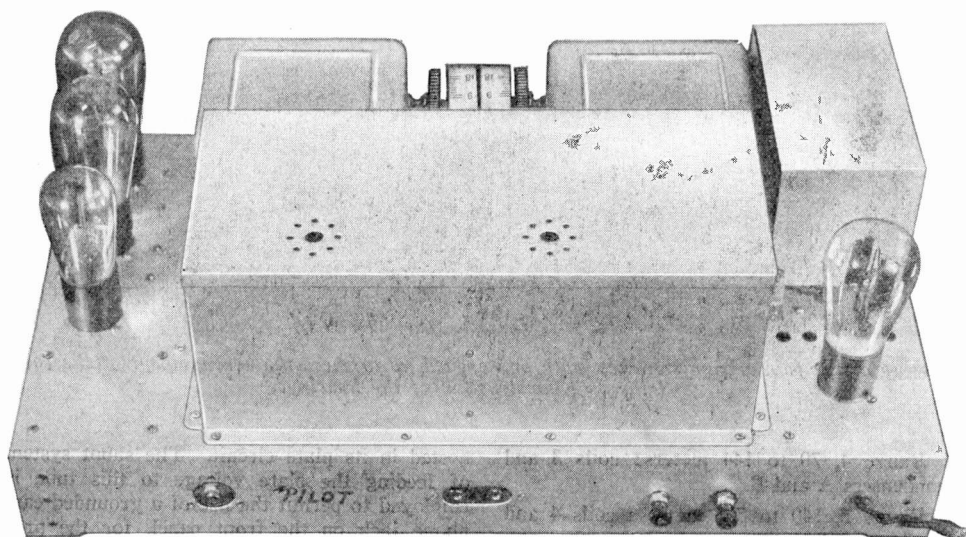

Back view of a completed Universal Super-Wasp, showing the back edge with the phonograph pick-up jack, loud speaker tip jacks, aerial and ground binding posts and line cord (left to right).

properly, it has brought in and will bring in most everything worth hearing on this earth.

On the regular broadcast band the selectivity with only one tuned R. F. stage naturally does not approach that of broadcast receivers having from three to seven such stages. However, it is enough to allow comfortable separation of local stations. Incidentally, the Universal really covers the very low and very high ends of the broadcast band, which most broadcast receivers do not. It will bring in funny little stations you never knew existed.

The Universal's coverage of the ship calling waves will endear it to the hearts of thousands of ex-operators, and to amateurs who like to hear a little *good* operating as a change from the CQ parties on the amateur bands. One thing is certain: the owner of a Universal is never lacking in radio signals. He can sweep the whole wide spectrum between 15 and 650 meters without raising his elbows, and he is bound to run into something that will amuse or interest him. His only problem is getting to sleep some time.

Assembly and Wiring Instructions

The Universal Super-Wasp is supplied in complete kit form for easy home assembly. As with all the other famous Pilot kits, the parts are accurately prepared with all necessary holes, and fit together without trouble. The builder does not have to supply a nut or bolt of his own, *all* hardware and special little fixtures being included.

For convenience in packing and shipping, the heaviest units of the set are mounted in their proper places on the chassis, so the builder is spared the work of assembling them. The following parts are mounted on the under side of the chassis: the power transformer, the audio transformers, the detector audio choke, the filter condenser block, and the wave changing shaft and indicating scale. On the top of the chassis, just above the power transformer, are the two filter choke coils which form part of the rectifier system.

The complete antenna and detector cam switches, with the eight coils mounted in place on them and connected to the proper contacts, are screwed to the top of the removable tray that forms the center of the receiver. In assembling and wiring these coils and switches, the Pilot company not only saves the constructor of the set considerable labor, but also assures him of an accurate job. There are thirty connections on the cams, and the average constructor would get at least one of them wrong if he tried to do the wiring himself. It is not necessary to remove the switches from the tray at any time. Leave them alone and you will have no trouble.

In the way of tools you will need the following: A screw driver with a thin 4 or 6 inch blade; a pair of pliers with a long tapering nose; a spintite wrench to fit the small nuts used throughout the set; a pair of side

John
Geloso

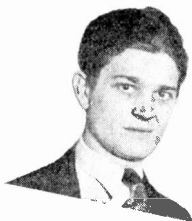

David
Grimes



cutting pliers for cutting wire; and a good soldering iron. With the latter you will also need a roll of good grade rosin core solder.

As the Universal is rather heavy and the edges of the chassis are sharp, protect the top of your work table with pieces of thick cardboard or a piece of old oilcloth.

GETTING STARTED

Unpack each piece of apparatus from the kit separately, identify it by its markings, and consult the blueprint in order to determine just where it is supposed to fit. Dispose of all the boxes and line up the parts on the back edge of your table, so that they are out of the way but still accessible. Empty the various little envelopes and packages of nuts, bolts, and washers into several saucers or shallow dishes. Tack up the blueprint on the wall in front of you, so that you can consult it without having it get in the way of the set itself.

Before attempting any of the assembly work, read the following instructions carefully and study the full size blueprint furnished with the kit. Start the work by first removing the center shield can and the removable tray holding the coils and switches. In the kit these parts are fastened to the chassis by machine screws passing into the latter. Put aside the shield and the chassis itself.

The assembly of the tray is quite simple and should not take more than about an hour. Mount the tube sockets in the position shown, making certain that the connection lugs face in the proper direction. The .0005 mf. and the .00004 mf. fixed condensers are mounted on top of each other with the long 6-32 screws and the special hex spacers you will find in one of the hardware packages. Prepare these condensers with soldering lugs before screwing them in place. Mount the various resistors, by-pass condenser blocks, and R. F. choke coils as indicated. Do not mount the .01 mf. condenser on the upper left hand choke coil as yet. This is placed after the tray is screwed back on the chassis.

The by-pass condenser blocks are supported by "U" shaped straps. Fasten the straps loosely with screws, push the condensers under them, and then tighten up on the screws.

Note carefully that some of the mounting

Important Note:

Use a lock washer with every screw in the entire set.

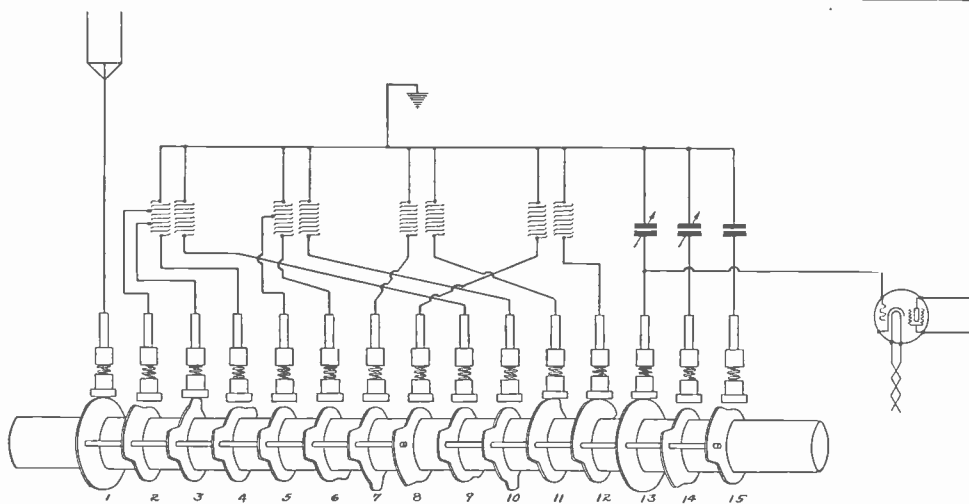

A break-down view of one of the cam switches showing the relative positions of the cams on the shaft.

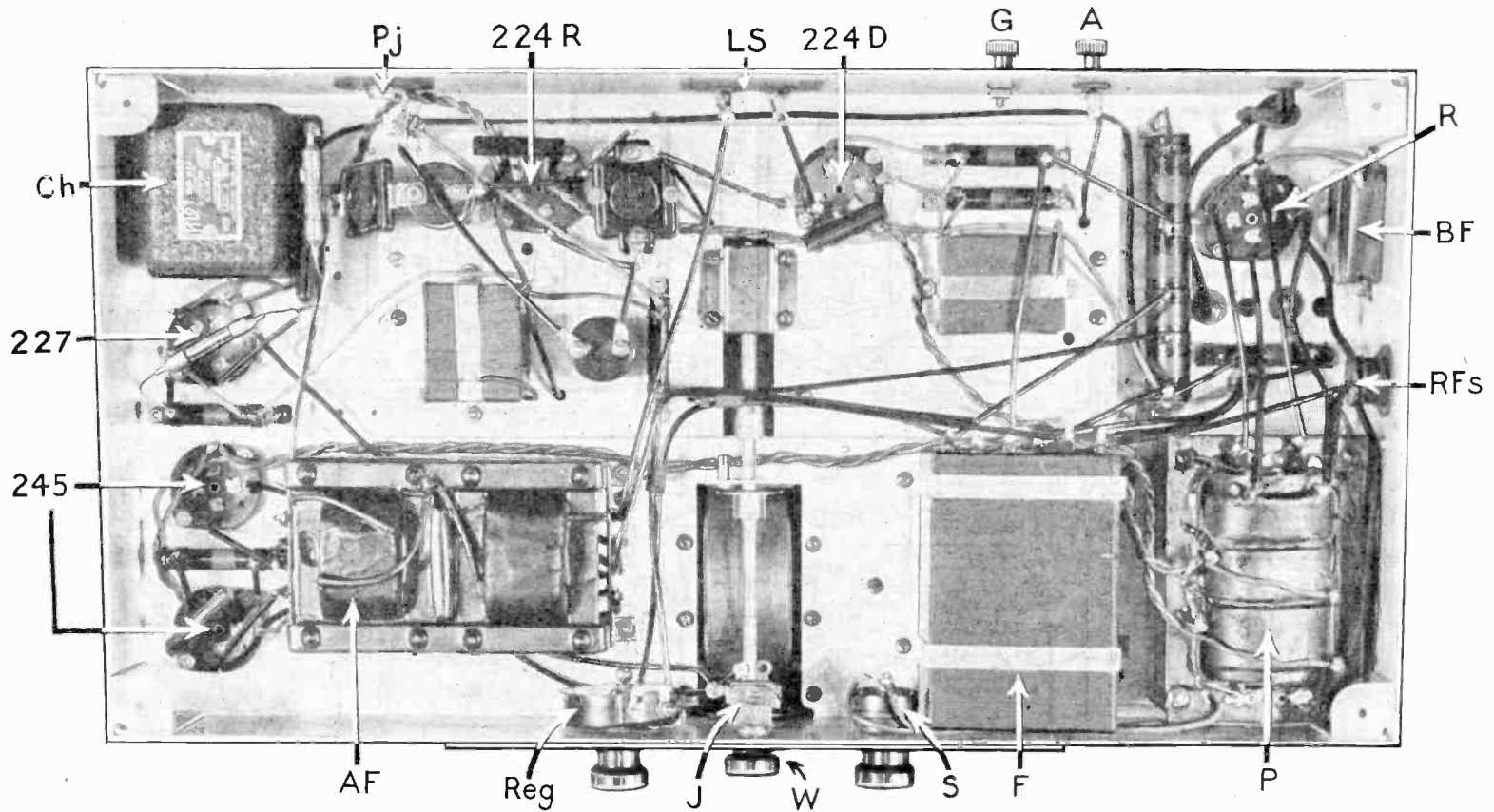

Actual photograph of the underside of a wired Universal Super-Wasp. Designations as follows: Pj, phonograph jack; 224R, R. F. amplifier socket; LS, loud speaker jacks; 224D, detector socket; G, A, ground and aerial binding posts; R, rectifier socket; BF, buffer condenser; RFs, small R. F. choke; P, power transformer; F, filter condenser block; S, line switch; W, wave changing knob; J, earphone jack; Reg, regeneration control; AF; audio transformer unit; 245, amplifier tube sockets; 227, first audio socket; Ch, detector audio choke.

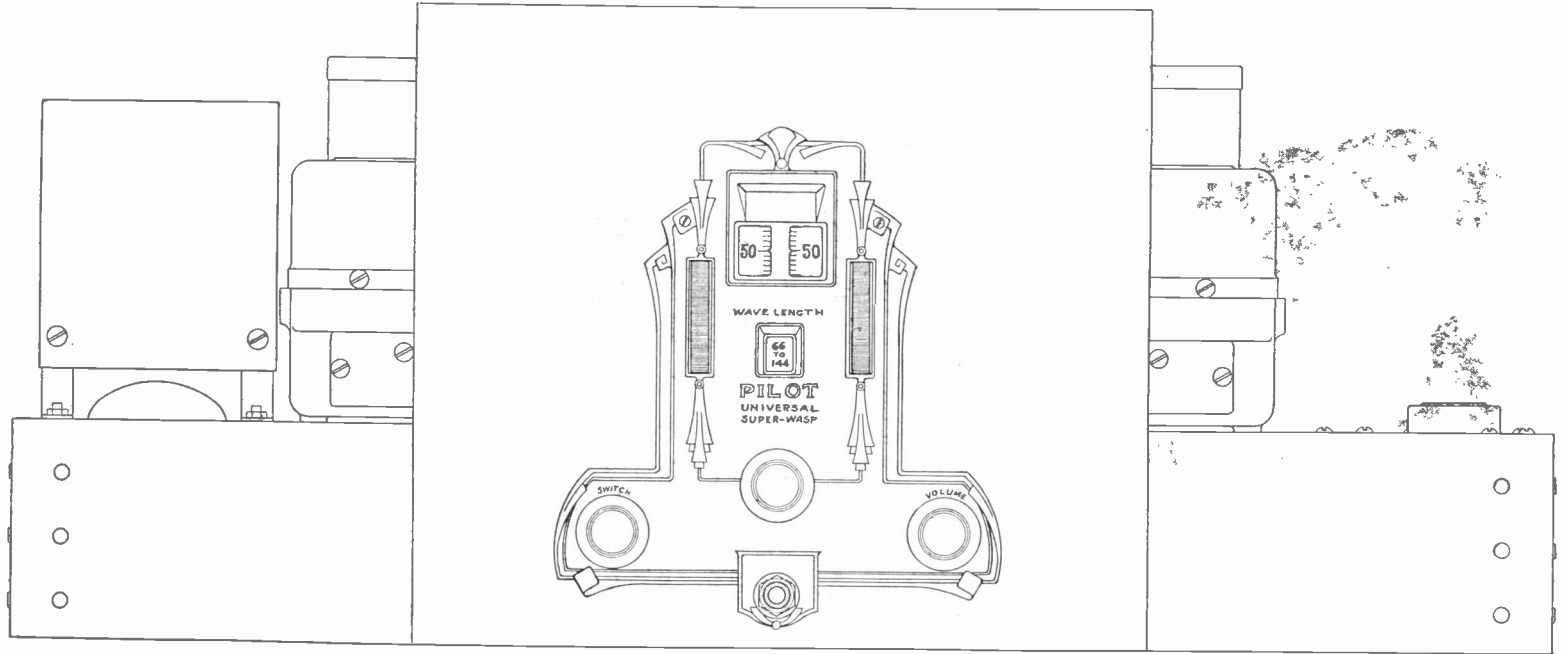

Front view of a Universal Super-Wasp, without the cabinet but with the square front panel plate.

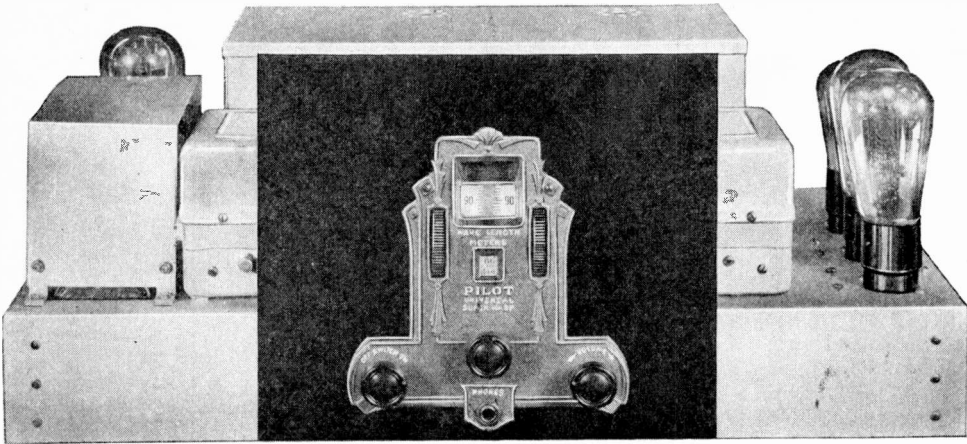

Appearance of the Universal Super-Wasp without the cabinet.

screws for the various parts also hold soldering lugs. Do not fail to put these on the first time, as they are quite necessary for ground connections. In handling the tray be extremely careful not to bend or damage the coils. Rest the tray on its edges and you will have no trouble.

Put aside the tray after mounting all the parts and start on the chassis. You will find that you can do the work most conveniently if you rest the chassis on the end containing the power transformer and the choke coils, as these units are very heavy and prevent the chassis from falling over. With the set standing up in this manner, you can reach around to both sides. To protect the choke coils while you are working on the receiver, leave its aluminum cover in place. You will not have to remove it until you do the wiring later.

SOCKETS FIRST

First mount the four tube sockets, using the screws that came packed in their boxes. Then mount all the fixed resistances. Fasten the fuse clips in the holes just below the rectifier tube socket, being careful to keep them completely insulated from the aluminum. Push the small bakelite washers into the holes with the handle of the screw driver, and then tighten up the mounting screws with the larger bakelite washers on both sides of the chassis.

On the back edge of the chassis mount the phonograph pick-up jack and the loud speaker tip jacks on the bakelite plates that are already fastened to the aluminum. Also mount the aerial and ground binding posts. Note that the ground post merely connects with the chassis and does not have any wires running to it. The aerial post, of course, must be thoroughly insulated, suitable bakelite washers being provided as with the fuse clips.

With this much done you are now ready to

mount the variable condensers and the dial. First remove the audio transformer unit. Take the right hand or R. F. condenser and slip it into the right hand bushing of the dial assembly. Do not tighten the dial set screws as yet. Drop the dial into the opening in the center of the chassis and put screws through into the base of the dial. In the same fashion slip screws into the mounting studs of the condenser. Do not tighten any of the screws completely. Two of the condenser mounting screws must be slipped through the space between the filter condenser block and the power transformer. This is a rather tight corner but you can get the screws in with the aid of the long nose pliers. Slide the detector condenser into the other side of the dial, and put its three screws through the chassis. Now tighten all the mounting screws and the entire assembly will be strong and rigid.

You can not get the two variable condensers mixed, because one is right handed, and the other is left handed and the shafts will fit the dial only one way.

ADJUSTING DIALS

Remove the condenser covers by loosening the four screws in each. Pull out the plates so that the condensers are set for minimum capacity. Place the bronze panel plate on the front of the set, slipping it over the shaft of the wave changing mechanism. Do not fasten it, but just hold it in place with your fingers so that you can turn the two dials until they read zero. Then tighten the set screws in the bushings of the dials, remove the front panel plate and replace the condenser covers. In handling the covers be careful not to bend the little fixed loading condensers screwed to the backs of the variable condensers. Put the audio transformer unit back in place, being careful not to push out the square-headed

screws set in the chassis. Also be careful that the input end of the unit faces in the direction shown on the blueprint.

FRONT EDGE ASSEMBLY

The bronze escutcheon plate, the square false front panel, the line switch, the earphone jack, and the regeneration Volumrad are all mounted at the same time on the front of the chassis. First the square plate goes against the chassis and the bronze plate slips into the opening and over the edges of the tuning drums. These are held in place by the switch, the jack, and the Volumrad. Tighten the mounting nuts of the three latter units very carefully, so as not to scratch the bronze plate. Adjust the latter so that the bakelite tuning controls turn easily and do not scrape against it. In one of the hardware envelopes you will find two tiny 4-36 screws. These are used to fasten the top corners of the bronze plate.

With this done you have completed the work on the chassis and can now drop the tray into the large opening behind the variable condensers. Fasten the tray temporarily with two or three screws around its edge. On its under side, you can now mount the remaining .01 mf. fixed condenser directly on the R. F. choke coil next to the detector socket. Bend the lugs of this condenser so that it rests at an angle of about 45 degrees.

On the back of the square panel plate you will find a little bracket fitted with a soft rubber bushing. This is for the dial light.

Simply push the bulb and its socket into this bushing, with the connection lugs at the top. You can move it up and down a little to obtain even illumination of the tuning scales.

With all parts now mounted in place, you are ready to do the wiring. File off the point of the soldering iron so that it is bright and clean and free of pits. Keep an old rag handy so that you can wipe it off every now and then when it gets dirty. Begin with the primary circuit of the power transformer, connect the flexible cord to the fuse clips, the transformer lugs, and the line switch, as shown. Then do the wiring on the rectifier system. Be careful to keep the high voltage leads free and clear of all other connections. Proceed with the filament circuit of the 245 tube and the filaments of the 224 and 227 tubes. Solder the center tap resistances directly on to the socket lugs after the wiring is already in place.

THE WIRE

For the filament connections use the flexible rubber covered wire furnished with the kit and twist the wires together. For all the other connections use the tinned copper wire and cover it with lengths of black spaghetti tubing. In doing this soldering, hold the iron to the joints long enough to melt in the solder and the rosin thoroughly. If the iron is held to the joint only for a second, the rosin is not likely to melt out of the joint, and the connection will be a very poor one.

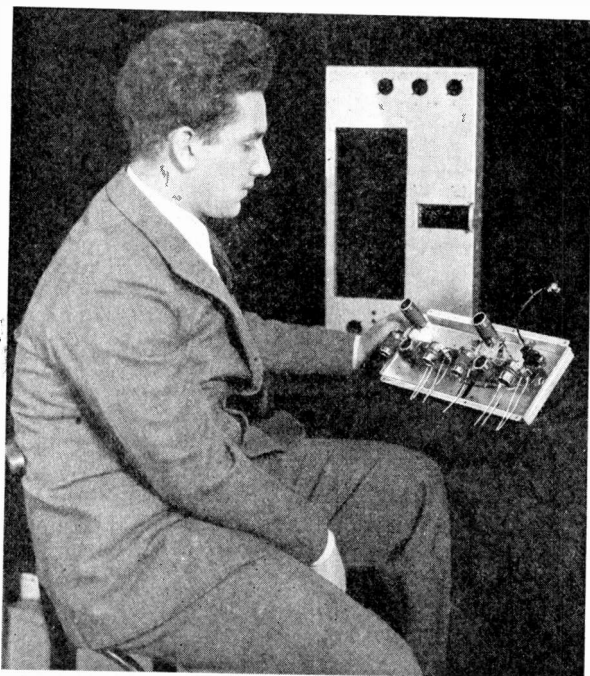

Mr. Messing is shown here holding a complete coil tray, with the coils and switches mounted in place. Behind him is a blank chassis. Note the large rectangular cut-out in the latter; this takes the tray assembly.

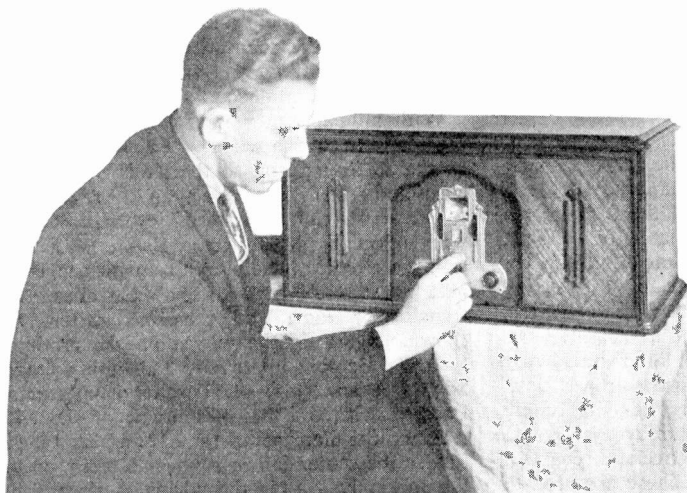

*A twist of the wrist,
and you can sweep the
whole radio spectrum
from 15 to 650 meters
with the Universal
Super-Wasp.*

Note that the .5 megohm and .2 megohm resistors are supported directly by their connection wires.

On the top side of the chassis there is comparatively little wiring to be done. You merely have to make a few connections to the variable condensers, using the wires already soldered to the contacts on the cam switches. In following the blueprint, notice that where a wire goes completely through the chassis, the hole is marked with the same number in both the top and bottom views.

THE WAVE CHANGER

After finishing all the wiring and checking it carefully, you have to make only a final adjustment on the wave changing mechanism. You will notice on the shaft of the detector switch, right next to the gear, a little disc with a notch in its edge. Turn the gear so that the notch comes directly next to a similar notch cut in the edge of the bracket holding the largest coil. In this position the switches are set to the fourth band. Turn the wavelength shaft so that the figures "70 to 144" appear. Then couple the wave changing shaft to the short gear shaft by means of the coupling provided. As the wavelength knob is now turned, it will operate the switches in the proper sequence, and the various wavelength ranges will be indicated by the figures that

appear in the opening in the bronze plate above the word "Pilot." As this scale comes into position, you will hear a very definite click from the shaft mechanism.

Rest the set flat on its base, and remove the few screws that held the tray temporarily in place. Slide the big shield can into place over the coils and fasten it permanently by putting screws through its edge, through the edge of the tray, and into the chassis itself. The holes for these screws in the chassis are tapped, no nuts being necessary.

To put the set in actual operation you need now only put the tubes in their sockets and to connect the aerial and the ground. The aerial may be the usual size, a length of a hundred feet being just about right. The ground connection should be made to the water or steam pipe.

With all the controls on the front panel, and with no plug-in coils to confuse things, the operation of the "Universal" is very simple. You simply select any one of the seven wave ranges by turning the wave changing knob. Snap the switch on, wait for the tubes to warm up, and you are ready to start your reception. To operate this set most comfortably, simply rest your thumbs on the edges of the control knobs. The regeneration control is handled in the usual manner. For further instructions in this regard see the article on the two pages following.

Preliminary announcements of the Universal Super-Wasp appearing in national magazines aroused considerable interest among people who are not radio constructors or experimenters but who want to get into the short-wave "game". To meet their demands, the Pilot company has decided to sell the UNIVERSAL in complete factory built form as well as in kit form. Radio dealers throughout the country will handle this set and will be glad to show it to you or your friends.

Operating Hints on the Universal Super-Wasp

"Zero Beating" and Proper Use of Regeneration Control Explained; Also When to Listen on the Seven Wave Ranges.

THE operation of the Universal Super-Wasp is simple, but like with any sensitive radio receiver, there is a wrong way as well as the right. For the benefit of Universal owners who are new to the mysteries and delights of the short waves, we will offer some practical suggestions.

After finishing the assembly and wiring of the set, insert the six tubes, connect the line plug to the nearest outlet, and snap on the switch, which is represented by the knob in the lower left corner of the front escutcheon plate. The two sockets in the center shield can each take a P-224. The single socket behind the choke assembly takes the P-280 rectifier, and the three sockets along the right edge a P-227 and two P-245's, with the latter nearest the front of the set.

MUST HAVE JUICE

Make sure the fuse sits tightly in the clips. The tubes should light when you turn on the switch. If they do not, look to the power outlet and make sure you have "juice" there. Also test the fuse for continuity. If you have followed the blueprint carefully you are not likely to have made a mistake in the filament wiring, as this is very plain.

AERIAL AND GROUND

Any aerial of ordinary dimensions may be used with the Universal. If you put up a new one, have its top section run to about 100 feet. Use No. 14 or No. 12 solid wire, or preferably seven strand No. 22. Insulate it well, and tape up the joint between the horizontal piece and the lead-in if you can't solder it out in the open. For a ground, make the usual connection to a cold water pipe or a steam pipe. If you live in a private house, try to run the ground wire through the cellar to the street side of the water main.

ACCESSORIES

In the way of accessories you need a loud speaker and a pair of earphones. A magnetic

speaker may be used, but a dynamic is much to be preferred. It must have its own source of field current, as the power circuit of the Universal itself cannot be used for the purpose.

Earphones are cheap. It is a good idea to buy more than one pair, as sometimes a distant station that is too weak to be understandable on the loud speaker can be heard perfectly on the phones, and you may have some visitor who would like to enjoy the reception. If you use two pairs, connect them in series. Push the tips into a phone plug (the Pilot No. 275 is recommended); this fits in the earphone jack on the front of the set, just under the wave changing knob.

Until you become thoroughly familiar with the set and have recorded the dial settings of the more consistent short wave stations, always do your preliminary tuning with the phones on. You will find it much easier to control regeneration and to locate tell-tale heterodyne whistles than with the loud speaker. After finding a station, simply pull out the phone plug and it will come through the speaker.

REGENERATION AND OSCILLATION

In searching for short-wave broadcasting or telephone stations, throw the set into oscillation by advancing the regeneration or volume knob *very slowly* until you hear a soft rushing sound. As you continue to turn, the noise will build up quickly in intensity and then drop off in an abrupt click. The condition of the set during the first rushing period is known as "regeneration," and in it the set is extremely sensitive. The condition just beyond regeneration is "oscillation." If you keep the set in oscillation, and turn the tuning dials slowly, you will hear a whistle when you run into a broadcasting station. With this whistle may be mixed voice or music. To clear up the signal, simply turn back the volume knob until the set crosses the border line and slides back into regeneration.

"ZERO BEATING"

If the station is fairly strong, the program

will come through free of the whistle. However, if it is weak, the whistle will dominate the voice, as this whistle is caused by the beating or "heterodyning" of the carrier wave of the station and the oscillations generated in the detector circuit. The carrier wave carries much further than the voice or music that modulates it, and can be detected at great distances even though the modulated portion is altogether indistinguishable.

Sometimes it is possible to hear a station fairly well by "zero beating" it. This is the process of throwing the receiver into oscillation, and then tuning it very carefully so that the frequency or wavelength of the oscillations generated in the set is *exactly* the same as that of the station being received. No whistle will then be heard, but the voice or music will be heard, though not very clearly.

There is no whistle when a station is "zero beated" because the incoming radio signals and the locally generated oscillations are of the same frequency, and the beating or heterodyning between them is zero. A whistle is heard only when there is a slight *difference* in frequency, the pitch of the whistle being equal to the actual arithmetical difference in the figures. For instance, if you encounter a station transmitting on say 6000 kilocycles, you will hear a nice squeal if your set is in oscillation and you tune it to 5999 or 6001 kc. The effect is the same with either adjustment, as the difference in either case is one kilocycle.

In receiving code stations, the tuning operation is a little easier, as heterodyning is always resorted to. Simply keep the set oscillating, and you will run into code stations by the hundred.

WHEN TO LISTEN

Because of the vagaries of short-wave transmission, it is important to know what to expect on various wavelengths at different times of the day and night. A few general suggestions can be made, but the short waves are notorious for their disobedience of the few laws that have been laid down on them. You are likely to hear stations on certain wavelengths at certain times when you should not hear them at all; also, you may "fish" for a week for stations that you heard beautifully during all of the previous week, and not find a sign of them.

The first of the seven ranges of the Universal Super-Wasp, 15 to 22 meters, can pretty definitely be reserved for daylight use up to the early afternoon. If you are an early riser, or can spend a little time at the dials during the morning, you are likely to pick up many foreign broadcasting and telephone stations with good strength and clarity. If you make a habit of listening a few minutes after

breakfast, by way of relaxation, you will undoubtedly build up quite a log.

The second range, 21 to 40 meters, is doubly useful. The lower part takes in daylight reception until twilight, and as darkness approaches you will find the bottom half starting to wake up.

GOING UP

As you start going up in wavelength, the darkness-daylight propensities become less marked, and you will find activity more general. On the third range, 39 to 75 meters, is the greatest single group of stations, clustered around 49 meters. This really marks the upper limit of the relay broadcasting channels, but there are many other interesting stations all up along the higher bands. On the fourth range, for instance, 70 to 144 meters, you will find the 80-meter amateur radio-telephone band, which is crowded with amateur stations engaged in two-way conversation. At the top of this range and on the bottom of the fifth, 140 to 270 meters, are many police and television transmitters.

From the top of the fifth range, through the whole sixth range and also the bottom of the seventh, you have the entire 200-550 meter American broadcast system. If you continue up the seventh range and can read the code, you will have much sport listening to the 600 meter ship and shore stations.

The tuning of the Universal on the first five ranges is quite sharp. On the higher waves, it is, of course, somewhat broad compared to the selectivity obtainable with a regular broadcast receiver. For this no apologies are made, as the set uses only one R. F. stage as against a minimum of three in broadcast receivers. However, it separates the powerful local stations in such crowded radio districts as New York and Chicago and brings them in with plenty of volume and fine quality. In extreme cases where there is a bothersome station in the vicinity, a simple wave trap will help eliminate it.

For detailed information about the short-wave broadcasting stations of the world, see the new list appearing on page 19 of this issue.

PHONOGRAPH PICK-UP

To use a phonograph pick-up with the Universal, simply plug it into the jack on the back of the chassis. The regeneration control acts as volume control.

For best results from the Universal Super-Wasp, use Pilotron radio tubes.

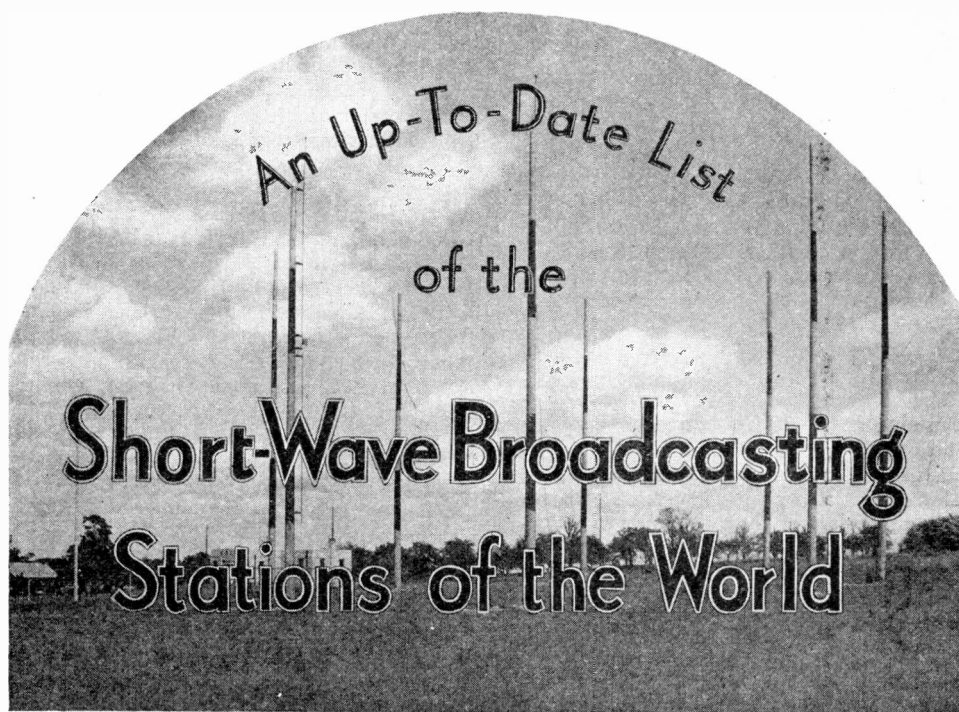

This title cut shows the new short-wave aerial system employed by station KDKA, East Pittsburgh, Pennsylvania, U. S. A.

WITH the appearance of its issue of Winter, 1929, RADIO DESIGN established itself as the main source of information about the short-wave broadcasting stations of the world. Until that time, thousands of radio fans who had discovered the short-wave game were entirely without real "dope" on the numerous short-wave transmitters that were popping up in various corners of the globe, and many of them were only moderately successful in picking up foreign stations because they knew nothing about their wave lengths or hours of operation. The five pages of schedules that appeared in the magazine were eagerly read, and set owners who previously had never heard trans-oceanic programs quickly located the faraway stations on their dials.

As new information became available as the result of strenuous efforts on our part, it was published in succeeding numbers, a total of twenty-seven pages of extremely valuable data having already appeared. No other radio magazine in any part of the world can boast of this service to its readers. Indeed, most of the other periodicals have been peculiarly blind to the tremendous growth of interest in the short waves, with the outcome that RADIO DESIGN has risen to a high position of popularity in every country where short-wave listeners exist.

As short-wave broadcasting is still an experimental business and has undergone numerous changes during the past twelve months, we recently decided to pool all the data that have accumulated, check them carefully, and then publish a new and up-to-date list. All this has involved a huge amount of work, but we are glad to say that it has been worth while.

We have exchanged letters with stations in Siam and Russia, Holland and New Zealand, Canada and the Argentine; studied every radio magazine published in the whole world, culling bits of information here and there; sifted hundreds of reports from individual listeners; and spent many sleepless nights with our own Super-Wasp. The majority of the stations have been identified very definitely; some have chosen to ignore the letters of inquiry addressed to them, so the statements about their activities are duly qualified. This list does not include dozens of stations shown on other lists, because we know that most of them are not actually on the air or have never existed except on their license blanks. The compilation is as complete as the confused conditions of short-wave broadcasting permit it to be, and we present it to our readers as the best thing of its kind ever published. It should be of inestimable value to every user of a short-wave receiver.

UNITED STATES

Schenectady, N. Y.—The General Electric Company operates an assortment of short-wave stations, the two best known outfits being W2XAF, on 31.48 meters, or 9,530 kilocycles, and W2XAD, on 19.56 meters, or 15,340 kilocycles. These usually relay the regular programs of WGY, which is part of the National Broadcasting Company's network, and on occasions broadcast special features for the benefit of Europe, South America or Australia. W2XAF operates daily from 5:30 to 11:00 p. m., and W2XAD daily, except Saturday, from 1:00 to 3:00 p. m., Eastern Standard time.

The following stations are also licensed for transmission, but do not operate on a regular schedule. They are likely to be heard at any time of the day or night, participating in casual conversation with the Antipodes or broadcasting messages of cheer to Arctic explorers: WXO, W2XAH, W2XAK, W2XAZ, W2XH, W2XK and W2XAC. They may use any of these frequencies: 1,604, 2,398, 3,256, 4,795, 6,425, 8,650, 12,800 and 17,300 kilocycles.

New York, N. Y.—The Columbia Broadcasting System, 485 Madison Avenue, New York, operates W2XE in conjunction with WABC, the key station of its net. The actual transmitter is located at Cross Hassock Bay (on the road leading into the Rockaways) and works on 49.02 meters, or 6,120 kilocycles. It relays the regular programs of WABC, and is on the air continuously from about 7:30 a. m. to 1:00 a. m. the next morning. A good station to test on because of its consistent operation.

New York, N. Y.—Aviation Radio Station, Inc., 27 West 57th Street, New York, operates W2XAL in conjunction with WRNY, which is on the regular broadcast band. The main short-wave transmitter is on 49.9 meters, or 6,040 kilocycles; occasionally 11,800, 15,250 and 21,460 kilocycles are used. All the actual apparatus is at Coytesville, N. J., on the Palisades, across the Hudson River from New York. The full schedule is as follows: Sunday, 4:30 to 7:30 p. m.; Monday 9:30 a. m. to 1:30 p. m. and 5:30 to 9:00 p. m.; Tuesday, 9:30 a. m. to 1:30 p. m. and 5:30 to 11:30 p. m.; Wednesday, 12:30 noon to 4:00 p. m.; Thursday, 9:30 a. m. to 1:30 p. m. and 9:30 p. m. to 12:30 midnight; Friday, 1:00 to 1:30 p. m. and 3:30 to 9:30 p. m.; Saturday, 9:30 a. m. to 1:30 p. m. and 8:00 p. m. to 12:00 midnight. All times Eastern Standard.

New York, N. Y.—The National Broadcasting Company, 711 Fifth Avenue, is using a powerful short-wave transmitter experimentally in conjunction with WJZ, at Bound Brook, N. J. This is Station W3XAL, on 49.1 meters, or 6,100 kilocycles. It has no definite schedule, but is usually heard during the early afternoon and at about midnight, E. S. T. The regular WJZ programs are relayed, the short-wave transmissions being identified by frequent announcements. This station evidently is making a big noise in the ether, judging from listeners' letters.

Springfield, Mass.—The Westinghouse Electric & Mfg. Company operates W1XAZ (not W1XAD, as many people seem to think) on 31.35 meters, or 9,570 kilocycles. It relays all

This neat and compact installation is W2XAL, the short-wave link of station WRNY, at Coytesville, N. J. Mr. J. F. McLaughlin, chief engineer, is shown taking a reading on the wavemeter.

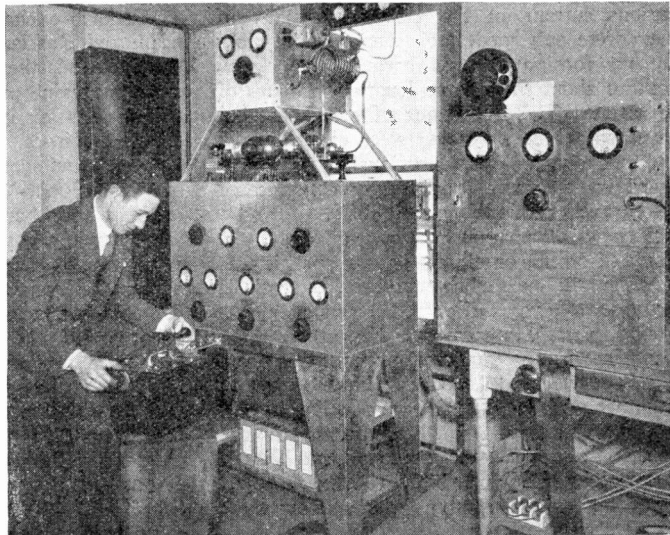

RADIO DESIGN wishes to thank a number of its readers for sending in very valuable information about the short-wave stations. Without their assistance this complete list would hardly have been possible.

The Honor Roll is as follows: John Clark, 360 Moncada Way, San Francisco, Cal.; J. Gratien Bordeleau, P.O. Box 228, Grand Mere, Province of Quebec, Canada; Stannard Smith, 1823 Crenshaw Blvd., Los Angeles, Cal.; J. J. Montgomery, West End Irma Street, Tavares, Fla.; and Fred Easter, 3353 Southside Avenue, Cincinnati, Ohio.

HOLLAND

PCJ, Eindhoven, Holland, is probably the most widely heard of all short wave stations. Transmits on 31.28 meters, or 9590 kc., on following schedule, E.S.T.: Wednesday, 11:00 a.m. to 3:00 p.m.; Thursday, 1:00 p.m. to 3:00 p.m., and 6:00 p.m. to 10:00 p.m.; Friday, 1:00 to 3:00 p.m., and 7:00 p.m. to 1:00 a.m. Saturday morning. Announcements are made in Dutch, English, French, German and Portuguese, all by the same man!

There is also a whole nest of short-wave radio telephone stations engaged mainly in traffic with the Dutch East Indies. These may usually be heard during the early morning hours, between about 5:00 and 10:00 a.m., E.S.T. There are PCK on 16.28 meters, PCV on 16.81 and PCL on 26.1; also, PCO on 15.68, PCS on 16.6 and PCM on 16.12. They are operated by the Dutch State Post Telegraph Service and are located at Kootwijk, Holland.

DUTCH EAST INDIES

Java has become known as the island of short-waves because of the number of stations on it. PLE, in Bandoeng, on 15.93 meters, broadcasts programs on Tuesdays from 8:40 to 10:40 a.m., E.S.T. There are at least six other phone stations, which frequently transmit phonograph records while the apparatus is being adjusted. These are PMB on 14.55 meters, PLF on 16.8, PLG on 18.8, PLR on 28.2, PLW on 36.92 and PMC on 16.52. They are usually heard in the early morning working with Holland.

The Sourabaya Radio Society operates an amateur station PK3AN on 49.7 meters. This is being heard in the United States between 6:00 and 9:00 a.m., E.S.T.

AUSTRALIA

VK3UZ, Nilsens Broadcasting Service,

Vol. 3, No. 4, Radio Design

Bourke St., Melbourne. 34 meters, music Monday and Wednesday, 3:00 to 5:00 a.m. E. S. T.

The Amalgamated Wireless, Ltd., Wireless House, 47 York Street, Sydney, operates a string of important stations, as follows: in Sydney, VLK, 28.5 meters, Anglo-Australian telephone service; VK2ME, 18.3 meters, alternate channel. VK2ME, 31.28 meters, relay broadcasting channel, taking programs from various Australian stations. VK2ME, 37.69 meters, Australia-New Zealand phone. Melbourne: VK3ME, 31.55 meters, relaying the Melbourne stations. Suva, Fiji Islands, VP1A, 20.8 meters, telephone to Australia.

VK2ME on one or the other of its various waves has been heard quite frequently in the United States during the early morning hours.

NEW ZEALAND

ZLW, Wellington, on 27.3 meters, testing with VK2ME over the radiophone circuit; early morning hours in the U. S. A.

ZL3ZC, Broadcasting Service, Ltd., Edison Hall, 230 Taum St., Christchurch. On 50 meters, Wednesday 10:30 p.m. to midnight, and Saturday 2:30 to 4:00 a.m. E. S. T.

BRITISH EAST AFRICA

VQ7LO, Nairobi. Has been using a number of waves, but is most likely to be heard on 31.2 meters.

INDIA

VUS, Calcutta.—English and Hindu programs are broadcast on 25.27 meters between about 8:00 and 10:00 a.m. E. S. T.

ARGENTINA

While there do not appear to be any regular short-wave broadcasting stations in the Argentine, there are a number of radio-telephone stations that operate frequently and are heard by many American listeners. LSX, on 28.99 meters or 10,350 kilocycles, is the most consistent performer. It transmits test programs of music usually between 8:00 and 10:00 p.m., E.S.T., all programs ending with the "San Lorenzo" march.

Other stations are LSH, on 28 and 30 meters; LSN, on 30.3 meters; and LSG, on 15.2 meters. All of these stations are located at Monte Grande, just outside of Buenos Aires, and are operated by the Trans-Radio Internacional.

BRAZIL

According to letters received, there is a station MTH on 48 meters in Rio de Janeiro, operated by the Radio Club of Brazil. The

call letters belong to Great Britain, and we cannot explain how or why they are used in Brazil.

SIBERIA

Station *RV15*, located at Khabarovsk, Siberia, on 70.2 meters, is heard quite easily on the West Coast, and occasionally as far east as Ohio. Its own announcements of its schedules are conflicting, but it seems to be on the air regularly between 2:30 and 7.30 a.m., Pacific time. English is used freely and the station may readily be identified.

A station *RA48*, in Tomsk, Siberia, has been reported by one man, but nothing definite is known about it.

GERMANY

A station at Zeesen regularly rebroadcasts the programs of the Berlin stations. It is on 31.38 meters, and operates between 8.00 a.m. and 7.30 p.m., E.S.T. Its owners are the Reichs-Rundfunk-Gesellschaft, Potsdamer Strasse 4, Berlin W9, Germany.

There is also a station at Doberitz, on 67.25 meters or 443.4 kc. It transmits Monday, Wednesday and Friday from 5.00 to 6.00 a.m. and 1.00 to 2.00 p.m., E.S.T.

There is also a flock of short-wave phone stations in Germany, engaged in communication with South American cities. We know that their call letters all begin with DH, but we have not been able to obtain authentic information about them.

AUSTRIA

Station *UOR2*, in Vienna, broadcasts on 49.4 meters or 6,072 kc., Tuesday and Thursday, between 7.00 and 8.00 a.m., E.S.T., and on 25.42 meters or 11,800 kc. on Wednesday and Saturday beginning at about 6.00 a.m. Vienna, by the way, is pronounced "Ween" by the natives.

CZECHOSLAVIA

Station *OKI*, at Podedbrady, is on 14.28 and several higher waves. Telephony is used now and then, the main purpose of the station being to contact direct with the United States for the handling of telegraphic traffic.

NORWAY

A 60-kilowatt station in Oslo is now broadcasting on 135 meters. While this is not really a "short" wave, it is well below the broadcast band. It falls in the middle of the experimental television channels of the United States, so the "hash" in that neighborhood may prevent reception here.

UNITED STATES

Bolinas, Cal., Station *KEL*, on a number of waves, seems to be quite active, occasionally using radio telephony to Hawaii; 43.7 meters is one reported wavelength. There is also *KEZ*, on 28.85 meters.

HAWAII

KIO, at *Oahu*, on 25.68 meters or 11,680 kc., is engaged in commercial telephone traffic with *KEL*, and has been reported by many people in the States. No regular schedule is followed.

PHILIPPINE ISLANDS

KIXR, relaying the programs of *KZRM*, has been flitting from wave to wave, 31 meters apparently being the latest. Its schedule in E.S.T. is daily, 5.00-6.00 p.m.; 11.15 p.m. to 12.15 midnight; 2.00 to 4.00 a.m.; and 5.00 to 10.00 a.m. Owners: Radio Corporation of the Philippines, Plaza Morago, Manila, P. I.

HONDURAS, CENTRAL AMERICA

HRB, *Tegicigalpa, Honduras*, is an old favorite. Uses 48.62 meters or 6170 kc., and is on the air Monday, Wednesday, Friday and

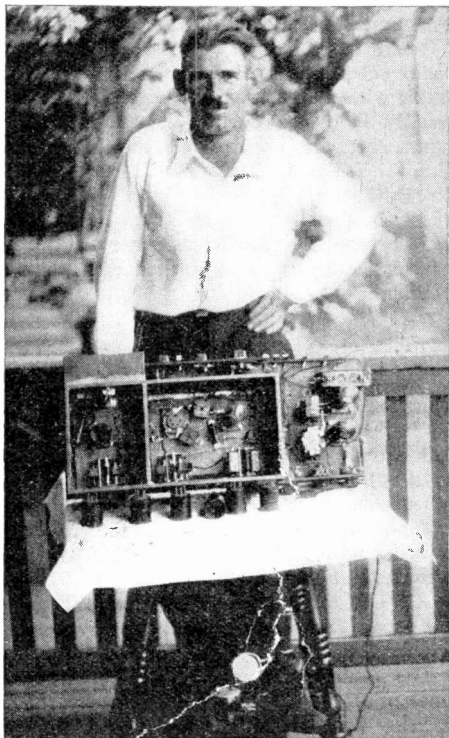

This comfortable looking gentleman is Fred Easter, of Cincinnati, Ohio, who has furnished RADIO DESIGN with much valuable data concerning short-wave programs.

Vol. 3, No. 4, Radio Design

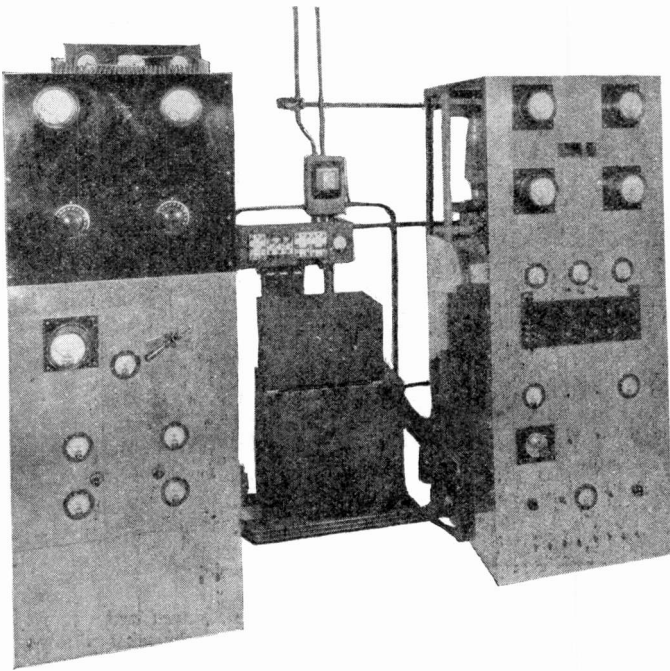

This business-like looking outfit is W9XAA, the powerful short-wave voice of the Chicago Federation of Labor. It operates on a frequency of 6080 kilocycles, and is heard in many corners of the earth.

the programs of WBZ, Springfield, and WBZA, Boston, and is on the air morning, afternoon and evening.

Long Island City, N. Y.—The Radio Engineering Laboratories, 100 Wilbur Avenue, operate experimental station W2XV on 34.68 meters, or 8,650 kilocycles, on Wednesday and Friday evenings from 8:00 to 10:00 p. m. E. S. T. Occasional tests are made during the daytime on 17.34 meters, or 17,300 kilocycles, and on 60.3 meters, or 4,975 kilocycles.

Philadelphia, Pa.—WCAU, the Philadelphia key station of the Columbia Broadcasting System, has W3XAU on the short waves assortment with it. Two waves are used: 31.28 or 6,060 or 9,590 kilocycles, and 49.5 meters, program kilocycles. These stations take their schedule from New York and their operating the same as W2XE's.

Pittsburgh, Pa
& Mfg. Company—The Westinghouse Electric W8XK (relaying) operates the world-famous on a sliding schedule the programs of KDKA) Sunday, Tuesday, Thursday and Saturday, as follows: 8:00 a. m. to 11:00 a. m., 19.72 meters, or 15,210 kilocycles; noon to 1:00 p. m., 25.25 meters, or 11,880 kilocycles; 5:00 p. m. to midnight, 48.86 meters, or 6,140 kilocycles. Many special programs are put on at other times.

Chicago, Ill.—The Great Lakes Broadcasting Company, 310 South Michigan Avenue, operates W9XF in connection with WENR, whose programs it relays. The station itself is located at Downers Grove, Ill., about twenty-three miles southwest of Chicago. A wavelength of 49.83 meters, or a frequency of 6,020 kilocycles, is used. We do not have its exact operating schedule, but it is on the air most of the day and evening. Chicago time is six hours slower than Greenwich time.

Chicago, Ill.—The Chicago Federation of Labor is taking quite an interest in the short waves, its short-wave transmitter W9XAA being very active. This works with WCFL, the Federation's regular broadcasting station, from which it takes its programs. The wavelength is 49.34 meters, or 6,080 kilocycles. The schedule in E. S. T. is as follows: 6:00 to 7:00 a. m. daily, except Sunday, 7:00 to 8:00 p. m. daily, 9:30 to 10:15 p. m., daily, and 11:00 p. m. to midnight, daily. Reports of reception may be addressed to 623 South Wabash Avenue. Chicago.

TIME SIGNALS

Short-wave set owners can check their watches much more accurately with the time signals set out by Stations NAA and W9XAM than they can by attempting to follow the so-called "correct time" announced by most of the regular broadcasting stations.

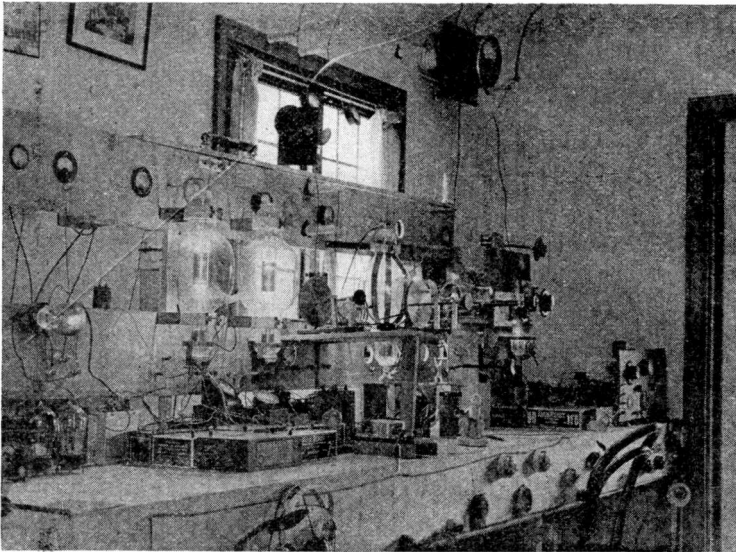

This foreign looking station, obviously home made, is G2NM, owned and operated by Gerald Marcuse, an English amateur. It is one of the most efficient stations on the air, and its success in reaching the British colonies was directly responsible for the establishment of the Chelmsford station G5SW.

NAA, the famous U. S. Navy station at Arlington, Va., transmits Naval Observatory time on 74.72, 37.36 and 24.9 meters every day, beginning at 11:55 a. m. and 9:55 p. m., E. S. T., and at 2:55 p. m. on 37.36 meters alone. No announcements are made in voice, but the signals are easily recognized. They consist of a series of high-tone dots, each impulse representing a second. At the end of the five-minute period a single dash (a noticeably longer signal) indicates the exact hour. The NAA time signals are absolutely accurate, ships in all parts of the world depending on them for the correction of their chronometers and for the charting of their positions. It is interesting to compare this Naval Observatory time with the time given by some broadcasting stations and to note the difference.

W9XAM, owned by the Elgin National Watch Company and located at Elgin, Ill., operates on 62.56 meters, or 4,795 kilocycles on the following schedule (Hours indicated are Central Standard Time, one hour slower than Eastern Standard): 7:55 to 8:00 a. m., daily except Sunday; 9:55 to 10:00 a. m., daily except Sunday; 11:55 to 12:00 noon, daily except Sunday; 1:55 to 2:00 p. m., daily except Saturday; and Sunday; 3:55 to 4:00 p. m., daily except Saturday and Sunday; 5:55 to 6:00 p. m., daily except Saturday and Sunday; and 9:55 to 10:00 p. m., daily except Sunday.

These transmissions are also in voice being used. During the five-minute period, impulses are sent every second except

the 29th, 55th, 56th, 58th and 59th second of each minute, which are omitted for reference purposes. The last signal is a long dash, the beginning of which indicates the exact hour.

GREAT BRITAIN

Chelmsford, G5SW. This is the short-wave relay link of the British Broadcasting Corporation, transmitting the regular BBC programs for the benefit of the British colonies. Operates on 25.53 meters, or 11,751 kilocycles. Hours: 7:30 to 8:30 a. m., and 2:00 to 7:00 p. m., E. S. T. Signs off with the midnight chimes of "Big Ben" in London.

G2NM, Gerald Marcuse, "The Ranch," afeur ning-on-Thames, Berks, England. A station with an international reputation to the was Mr. Marcuse who demonstrating to the British that short-wave broadcast is now on colonies was really possible. Days from 1:30 the air on 20.95 meters, for the benefit of to 3:00 p. m., E. S. T., for American listeners.

ROUMANIA

Bucharest. The Electrical Technical Institute of the University of Bucharest is operating an experimental station on 21.5 meters, Wednesdays and Saturdays, afternoons, E.S.T. Reports are to be sent to the Institut Electrotechnique Universitaire, Rue Victor Emanuel III, 16, Bucharest, Roumania, Europe.

Vol. 3, No. 4, Radio Design

Saturday from 8.15 to 11.00 p.m. Central Standard Time. It expects soon to be on the air every night. Kenneth H. See is manager, and the Tropical Radio Telegraph Company, with headquarters in Boston, Mass., is the owner.

JAPAN

We understand that a station JIAA in Tokyo is operating on 37 meters, testing with KEL in California after 6.00 a.m. E.S.T. It is probably part of a new trans-Pacific radio-telephone service.

ITALY

Station I3RO in Rome is a regular visitor to the United States. It uses 25.4 meters or 11810 kc. and 80 meters or 3750 kc. May usually be heard during the afternoon along the East Coast.

SIAM

The interest of the royal family in radio has led to the establishment of several fine stations. These are: HS1PJ, 16.9 meters, 7.30 to 8.30 a.m., E.S.T., on Saturday; HS2PJ, on 29.5 meters, 8.00 to 11.00 a.m. E.S.T., Tuesday, Friday and Saturday; and HS4PJ, 37.6 meters, schedule unknown. Announcements are made in French, English, German, and Siamese. A swell letter of acknowledgement that is well worth framing is the reward of those who send in reports of reception. Address Royal Siamese Post and Telegraph Department, Bangkok, Siam.

FRANCE

While there are few real short-wave broadcasting stations in France, there is a nest of radiophones, mostly at Saint Assise, which conduct a regular service between France and Buenos Aires, Rio de Janeiro, and Saigon, French Indo-China. Their calls all begin with F, and they are distributed between 14 and 38

meters to the extent of about ten different transmitters. A knowledge of French is useful with these.

INDO-CHINA

The city of Saigon harbors a number of stations, including FZS on 16.32 meters and FZR on 18.5 meters, for the link to France, and an independent station of considerable power that specializes in broadcasting. The latter is on 49 meters and is owned by the Indo-Chinese Film Corporation. The schedule: Monday, Friday and Wednesday, 4.30 to 5.30 a.m. Pacific time; Tuesday, Thursday and Saturday, 4.30 to 7.15 a.m., Pacific time. Each musical number is preceded by the stroke of a gong.

MEXICO

Station XDA in Mexico City, which makes such a big hole in the ether with its modulated telegraph signals, has become articulate and now broadcasts news dispatches in voice every day at 2.30 p.m., E.S.T. The wavelength is 20.5 meters. Reports of reception may be sent to the Trans News Agency, 13 Colon Street, Mexico City.

CANADA

Winnipeg, Station VE9CL (formerly CJRX) relays the programs of CJRW during the early evening hours. The waves of 52.5 and 48.5 meters are used. Owned by J. Richardson & Son.

Bowmanville, Ontario, VE9GW, on 49.2 meters or 6095 kc., relays the programs of CKGW. Week days schedule: 6.45 to 8.00 a.m., 3.00 p.m. to midnight; Sunday, 12.30 p.m. to midnight, E.S.T. Owned by Gooderham and Worts, Ltd. Address reports of reception to Mr. W. A. Shane, Station Engineer, R.R.4, Bowmanville, Ontario, Canada.

SHIP AND SHORE STATIONS

Much interesting reception has been pro-

This is a reduced reproduction of the "OSL" or acknowledgement card issued by station VE9GW. It is printed in two colors and is well worth saving. Any listener reporting VE9GW's signals will receive one.



vided by the radio telephone experiments conducted between a number of Atlantic liners and shore stations in New Jersey, Canada and England. The *Leviathan*, WSBN, uses 72.9, 68.3, 35.89 and 33.98 meters. The *Olympic*, GLSQ, and the *Majestic*, GFWV, use 22.5, 34.1 and 72.7 meters. The *Homeric*, GDLJ, uses 24.23 and 70.2 meters. Other vessels are being equipped with radio telephone apparatus.

The American shore stations are all in New Jersey. They are WOO, Deal, on 17.52, 23.36, 34.76, 63.13 and 96.03 meters; WND, Ocean Township, on 16.36, 22.4, 32.7 and 44.4 meters; WLO, Ocean Township, on 14.01, 18.44, 28.44 meters; WMI, Deal, on 15.14, 20.5 and 30.9 meters; and WNC, Ocean Township, on 15.61, 20.73 and 30.77 meters.

The Canadian stations are all at Drummondville. They are CGA, on 16.5, 26 and 32.12 meters; CJA, on 23.7; and UZA, on 62.7 meters.

The British stations are as follows: GBU, Rugby, on 16.10, 24.41, and 30.15 meters; GBW, Rugby, on 16.54, 20.77 and 30.64 meters; GBS, Rugby, on 16.39, 24.69, and 33.26 meters; GBX, Rugby, on 18.56 and 27.5 meters; and GBK, Bodmin, on 16.57, 26.1 and 32.4 meters.

LAST MINUTE NEWS

A slight delay in the publication of this issue enabled us to gather some last minute news supplementing the preceding material. Here it is:

VATICAN CITY STATION A SUCCESS

The newest sensation on the short waves is unquestionably HVJ, the powerful and very efficient station installed in the Vatican City, Italy, under the personal supervision of Marconi himself. The formal inaugural of the station on February 12th was heard by delighted listeners all over the country, the signals coming in with remarkable strength and clarity during the morning and early afternoon. The success of the station is now assured.

Two wavelengths are used: 50.26 meters and 19.84 meters. The first just about clears the uncontrolled babel in the 49-meter region, while the second pushes through in daylight like the proverbial ton of bricks. We understand that the antenna power is about twelve kilowatts.

As the station is intended to have a universal appeal, announcements are made in several languages. English is used freely, and short-wave set owners are having no difficulty in identifying the transmissions. The station is now on the air daily at 6:30 a.m., E. S. T., on 19.84 meters; and at 10:30 a.m., on 50.26 meters.

ULTRA-SHORT WAVES FROM GERMANY

The famous Telefunken company has erected a special ultrashort wave experimental transmitter in the neighborhood of Berlin, and broadcasts regular programs of phonograph music on 7.05 meters. The schedule is from 11:30 a.m. to 1:30 p.m., Eastern Standard Time, on Tuesdays and Thursdays. Here's a chance to do some really short wave work, if you have the special but simple equipment.

FRANCE GETS BUSY

Not to be outdone by the Italians, who now have two very fine short-wave stations, the French are erecting a colonial station of their own. This is nearing completion at Pontoise, a suburb of Paris, and should be in operation by about the time this issue appears. No definite wavelengths have been announced; they probably will be chosen after tests have been made with the major French colonies. The government is evidently taking no chances on having the station miss fire, as G5SW did,—an antenna power of thirty kilo-

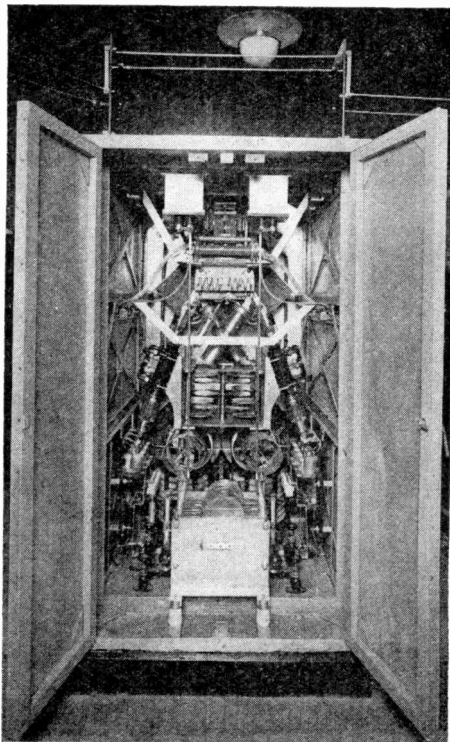

This cabinet, upon close inspection, turns out to be a well designed radio-frequency power amplifier stage, employed at station GBW, England, in its short-wave radio telephone transmitter.

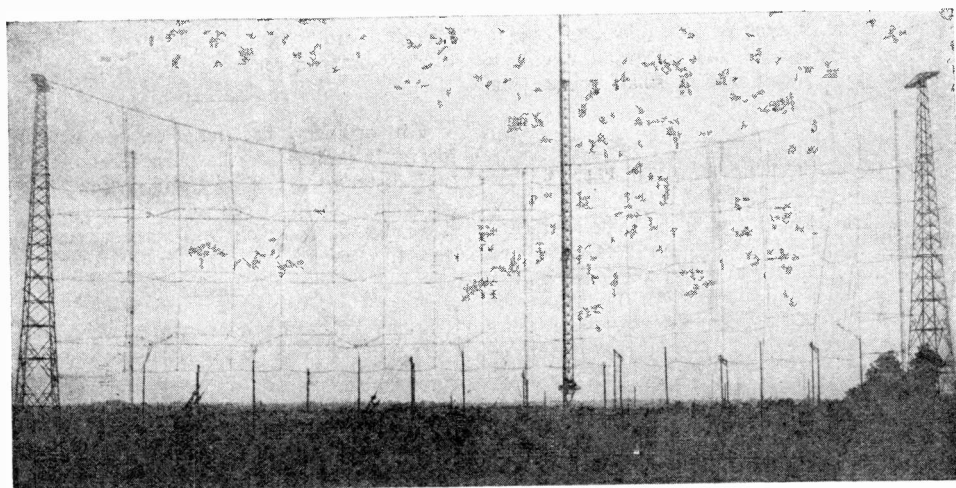

This is one of the short-wave transmitting aerials of station GBW, England. It is of the reflector type, concentrating the radiated energy in the direction of the United States

watts being contemplated for regular use.

In passing, it is pertinent to note that Great Britain, with its truly "far flung" empire, has had the rottenest kind of luck with the short waves as a means of cementing the ties of the colonies with the home country. Holland has PCJ; Italy has I3RO; The United States has W8XK and W2XAF,—all reliable and highly successful stations that penetrate to the far corners of the globe. Great Britain has G5SW, but its single, inflexible wave of 25.53 meters length has failed utterly to reach the very places where it is wanted most. Other stations operate on a sliding schedule of frequencies to meet different transmission requirements, but not G5SW.

The British have become considerably "het up" over the matter, and a change for the better seems imminent. In fact, we understand that the present experimental transmitter at Chelmsford will soon be replaced by a duplex outfit situated near the long-wave station at Daventry, and that at least two different waves will be employed.

BOMBAY, INDIA

An experimental short-wave station has opened at Bombay, India, but it is on 49.1 meters, which is just too bad as far as American listeners are concerned. As with the Calcutta station, VUS, announcements are made in both English and the native tongue.

JAVA FOR BREAKFAST AGAIN

In addition to the government stations previously listed, there are now a number of amateur stations on the island of Java broadcasting musical programs. They are on usually between 6:00 and 11:00 a.m., Eastern Standard Time, with power varying from a

half to one kilowatt. These stations are identified as follows:

PMY, Bandoeng, 58 meters; PK1AA, Weltevreden, 75 meters; PK3AN, Sourabaya, 49.7 meters; PK2AF, Djocjacarta, 50 meters; PK6KZ, Macassar, Celebes, 25.5 meters; and PK2AG, Samarang, 95 meters. Java truly is the "isle of the short waves."

HOT STUFF FROM AFRICA

A short-wave broadcasting station at Rabat, Morocco, is on the air Tuesdays, Thursdays, and Saturdays, between 8:00 a.m. and 9:00 a.m., E. S. T., on 24 meters, and on Saturdays and Sundays between 4:00 and 5:00 p.m. on 48 meters. Announcements are made in French. Interval signals between programs are produced by a metronome, and the programs end with the playing of the French national anthem, *La Marseillaise*. This station has been reported by a number of American listeners.

DETAILS OF THE SAIGON STATION

This article is turning out to be a lesson in geography. We will now take the class to Indo-China (get out your maps and globes), where an exceedingly power short-wave transmitter broadcasts regularly. This station, F3ICD, is located in Chi-Hoa, a few miles out of the city of Saigon, and is operated by the Compagnie Franco-Indochinoise de Radiophonie. A power of 12 kilowatts is used on a wavelength of 49 meters. The announcements are "Hello, hello, this is Radio Saigon" (*Allo, Allo, ici Radio Saigon*). Programs are transmitted on Wednesdays and Sundays, but you have to be an early bird to catch them: between 4:00 and 7:00 in the morning on the West Coast, where they are heard quite well.

There are two other stations in Saigon: a government station on 24.91 meters operating on a telephone and telegraph circuit to France and Japan, and a small private station on 31.5 meters.

CINCINNATI RETURNING WITH PLENTY OF "PUSH"

We are glad to publish some authentic "dope" about W8XAL, the short-wave unit of WLW, Cincinnati, Ohio. This station formerly used a power of 250 watts on a frequency of 6060 kilocycles (try your conversion charts on this) but this outfit is being replaced by a new one of ten kilowatts rating. It should be on the air by the time this issue reaches you.

TIME SIGNALS

We have some more data on time signal transmission. The full details on NAA, Arlington, Va., are as follows: waves, 12,045 kc., or 24.9 meters; 8870 kc., or 33.82 meters; 4015 kc. or 74.7 meters; 690 kc., or 434.5 meters; and 113 kc., or 2653 meters. Times of transmission in Greenwich Mean Time: 0257-0300 on all of the foregoing frequencies except 12,045 kc.; 0757-0800 on 8870 kc. and 113 kc.; 1657-1700 on all wavelengths and also on 16,060 kc., or 18.68 meters.

Station NSS, Annapolis, supplements this service with additional transmission, as follows: 17.8 kc., or 16,840 meters, 12,045 kc., or 24.9 meters; and 16,060 kc., or 18.68 meters. Times (G. M. T.): 0257-0300 on 17.8 and 12,045 kc.; 0757-0800 on 17.8 kc.; 1657-1700 on 16,060 kc. and 17.8 kc.

REVIEW

For the benefit of many readers who may have missed some of the previous numbers of *RADIO DESIGN*, which contained many useful hints on short-wave reception, we are reviewing them here.

First of all, we want to tell every short-wave set owner to take a piece of paper, an envelope and one American dime, and to write to the Superintendent of Documents, Government Printing Office, Washington, D. C., for a copy of Miscellaneous Publication No. 84, entitled "Standard Time Conversion Chart." Of all useful gadgets, this is certainly IT.

As you may be aware, time is different in different parts of the world, and it is very easy to get all mixed up trying to figure out the differences. This time conversion chart is just what its name implies: it enables you to determine the time in any part of the world without involving any calculating whatsoever. It consists of two pieces of card-

board, one movable, the other fixed. You simply turn the smaller piece with your finger, and you read off the desired time.

An ordinary flat map of the world is perfectly useless for the purpose of determining distances. Get yourself a small globe, stick pins in it to represent the stations you have heard, and you will have a really interesting exhibit.

Many listeners who formerly were able to hear the various trans-Atlantic radiophone stations very clearly now complain that most of the transmissions sound like Greek. The explanation is that the signals are probably "scrambled," so that they become unintelligible on ordinary receivers and therefore cannot be followed by people who have no business eavesdropping on them. There are various methods of "scrambling," the commonest being the suppression of one of the side bands of the transmitted wave.

With the trans-oceanic and ship-to-shore telephone traffic assuming large proportions, and with the number of short-wave sets increasing daily, we can hardly blame the telephone company for making the transmissions secret. The patrons of the radiophone services usually do not realize that their voices are spread over most of the world, and they get just as intimate in their conversations as they do over the privacy of a land-line circuit. Most short-wave fans have no interest in the matrimonial, financial or personal affairs of the trans-Atlantic telephoners, so the occasional announcement of the stations' call letters in the "clear" will more than satisfy them.

Don't think that you are hearing a foreign station every time you pick up an announcement in a language other than English. Some of the American stations, particularly WGY, put on special Spanish programs for the benefit of the South American countries, and until you hear the announcer say "W2XAF" or "W2XAD" in nice, clear American, you may believe you are in tune with Madrid.

Short Wave Fans

If you pick up any new short wave stations, or obtain any "dope" that will interest other listeners, please drop us a line. We will publish the information for the benefit of everyone.

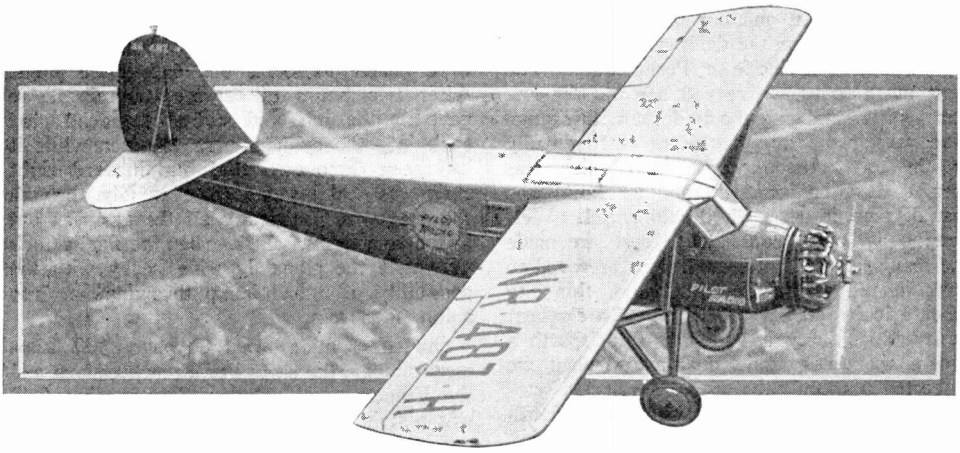

Rolling Up From Rio

The Last Leg of the Historic Flight of the "Pilot Radio" Around South America

By ZEH BOUCK

THE "Pilot Radio" took-off from the Campo Alphonse, Rio de Janeiro, early Monday morning, the 1st of September, 1930. This was really our start for home, and with good luck we hoped to make Roosevelt Field, New York, in eight days and eight hops—Bahia, Natal, Para, Cayenne, Port of Spain, Puerto Rico, Miami, and New York. The motor of the plane had been overhauled in Sao Paulo, and though forced down by a sticking valve on the return flight to Rio, we figured that by now the valve guide had been worn in and our troubles were definitely behind us. New York and the cheering throng at Roosevelt Field were just beyond the horizon as we sailed forth over the beautiful harbor of Rio, stretching south in a double horse-shoe on each side of the Pao de Assucar. The sun had burned away the morning mist before we turned our tail on Copocabana and roared confidently west toward Bahia.

Two hours later the motor coughed, roughened up, and lost revs. A sticking valve again! Just east of Campos, Eddie Burgin picked a field and set the plane down. We were almost instantly surrounded by a crowd of ferocious looking natives that made up in machetes what they lacked in teeth. Armed with nothing but wrenches, Yancey and Burgin clambered out of the plane, tapped the valve back into place, and packed the rocker box with grease. We took-off again through

the mass of Brazilian humanity that parted respectfully on each side of our whirling prop like the waters of the Red Sea about the Israelites. An hour later we passed over the Aeropostale Field at Victoria. We spotted the field mentally, and recalled its position when, a half hour later, we returned with another sticking valve!

We made our third take-off a half hour later, but with the time out it was obvious that we could never make Bahia that evening. We raced the shadows and dropped down on the Aeropostale field at Caravellas, just as the sun made a three point landing behind the western hills. We spent the night at a tiny hotel kept by a bird fancier, lulled to sleep at eight o'clock by the warbling of a hundred different species. We were up at three a. m., broke fast and paid our bill, which, all inclusive—dinner, rooms and breakfast for the three of us—came to fifty-six milreis. This is fifty-six thousand reis—five dollars and a half American money!

We were four thousand feet in the air before the sun sent up the first rays from the rim of the Atlantic, regilding the faded gold on the under surface of our wings. We had wasted an hour in returning to Victoria the preceding afternoon, and the gas situation was becoming unpleasantly problematical. To save miles, we cut across the fifty kilometres of water between Cayru and Bahia.

Gassing up was subjected to the usual

mañana technique, and our late take-off from Bahia put Natal on the dark end of the flight. So we landed at Recife or Pernambuco. The next morning as we revved her up, the exhaust stacks stabbing the twilight with orange blue darts, we found the motor cutting badly on the left magneto. The faulty plug was located, but, badly stuck, another hour was lost digging it out with a cold chisel. Welcoming a day of comparative rest, we made the short hop to Natal, and were prepared to bask in the friendly hospitality of this city when I looked at our tail wheel. An eloquent gesture to Yancey and Burgin called forth a groan, that was made unanimous when we inspected a completely wrecked wheel assembly. Recalling our past experience with South American welding, it looked like a week's stay in Natal. But to our gratified amazement my high school French elicited the fact that the Aeropostale mechanics could and would do the necessary welding "aujourd'hui"—gratified amazement that my French worked and that the job could be so expedited.

We had considered our hop from Natal to Para one of the most hazardous in our flight, having given a believing ear to the myths of danger about the delta of the Amazon. But instead of finding it a desolate and dangerous region, it was our relief and genuine luck to discover the most consistent stretch of well populated and excellent flying country we had looked down upon since the Argentine pampas.

THAT STICKING VALVE

I write "luck," because just seven hours after taking-off from Natal, while right over the center of the legendary bad lands, our motor conked again with a sticking valve. Forced down, Eddie picked a field that any airport might envy as a runway, and glided in to his usual perfect landing. Once again we were immediately surrounded by natives, but of a wilder variety—more distinctly Indian. They watched Burgin and Yancey curiously as they tapped back the valve and hopefully stuffed the rocker box, but scattered when the motor was started. They watched our take-off from behind bushes and small trees. An hour and a half later we were over the Para River and had located our landing field, a farm belonging to a Frenchman who had marked the preferred runway with flags. We had covered 1475 kilometres in just eight hours and a half.

In landing on the rather rough field the fork in the tail wheel assembly was badly bent. This was straightened after a fashion, and refitted at four o'clock in the morning.

But still additional troubles added to the intriguing possibilities of a consistently sticking valve. The spark plug we had put in at Recife had gone haywire. It had been de-

signed for a French motor and had broken down in our J-6. We had been and still were unable to locate our own spare plugs. After two hours of repeated cleanings, we gave up the job, and stuffed the dead plug back into the cylinder. In the meanwhile it had been discovered that our inboard right tank was leaking gas quite rapidly through the gauge, so practically all the gas was put in the port tanks, which, when we finally took off, made the plane fly wing heavy with the possibility of a bad bump throwing her into a left hand spin.

Our destination was Cayenne, 930 kilometres away, the capital of French Guiana and the French penal colony. The landing field was a strip of grass fifty feet wide and swept consistently by a cross wind. The approach was to side-slip down the slope of a high hill, clipping the top branches of the trees, and slip her clean to the ground to counteract the cross-wind. Eddie made one of the most difficult landings of the flight, and it is to his skill and credit that the side-swiping motion did no more damage than to wreck the already weakened tail fork.

With the tail skid repaired, but still with a leaking gas tank and a Champion motorcycle sparkplug in our number two cylinder, we took-off at daybreak the next morning, after a restful night spent in a hospital presided over by French nuns. We careened down the narrow runway, but took-off with plenty to spare and headed north for Port of Spain, Trinidad. Our course cut across the Delta of the Orinoco, north of Georgetown, for three hundred miles of the worst flying country I have ever seen. The tropical forest is unbroken except for muddy rivers, the estuaries of the Orinoco. There is neither habitation nor beach, nor any sort of place where an airplane could be put down, or its

In this article, the last of a series of three, Zeh Bouck takes up the story of the "Pilot Radio" South American Good Will Flight from Rio—where he left the reader in the last issue of RADIO DESIGN. Bouck was the flight engineer and radio operator on all the history making flights of the "Pilot Radio." This plane was the first to fly from the United States to Bermuda, and the first to circumnavigate South America. This article tells the story of what we believe to be the first successful aircraft SOS—the first time an airplane has made contact, through a distress call, with a land station which stood by with aid until assured of a safe landing.

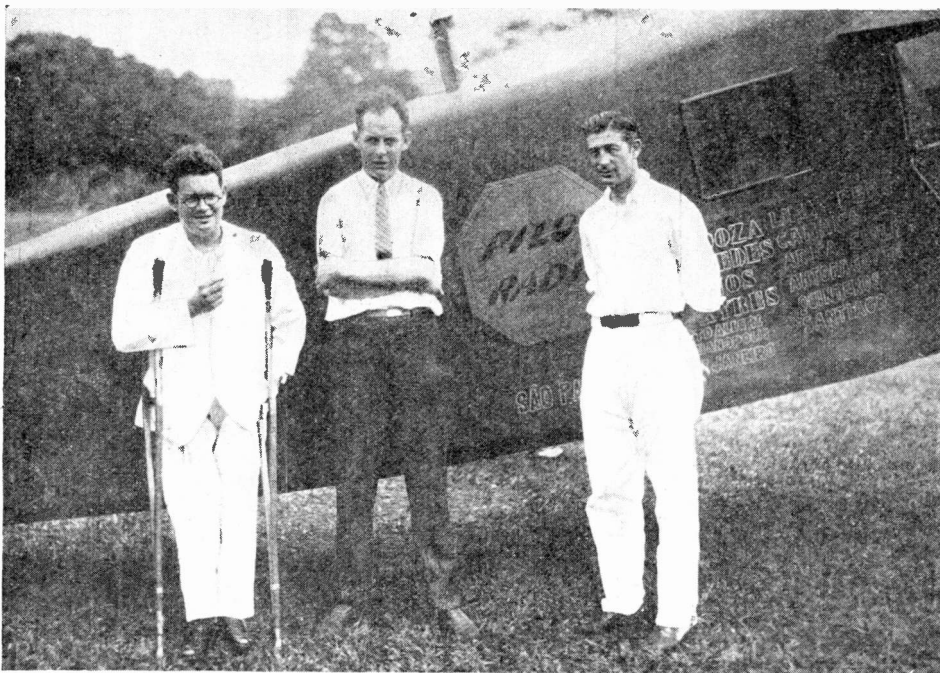

The "Three Musketeers" of the air, posed for one of the last photographs of the "Pilot Radio". Left to right: Zeh Bouck, Lewis Yancey and Emil Burgin. Notice the names of the cities painted on the side of the plane.

occupants seek succor should they escape a crash—an interesting observation, made silently by all of us, with attentive ears tuned to the motor. Ordinarily the valve stuck only once every eight hours, but rules are made to be proved by exceptions.

Fog and rain drove us out to sea as soon as we began to feel fairly comfortable about being over the worst of the hop. Here, with land a faint hazy line ten miles to our left, we had to dodge repeated squalls that were building up into a hurricane. Flying low, skimming ten to fifty feet over the water, we'd fly between the dark storm centers, blinded by rain even in these comparatively calm areas, and tossed about by violent bumps.

As the southern coast of Trinidad loomed up through the mist, we could see that it was clearing to the north, while an apparently endless line squall was building up in the southern and western areas. Yancey, however, determined to brave the latter, as we had been informed that an excellent landing field existed in the neighborhood of the oil wells. And so we crashed head-on into the worst bit of weather we had yet encountered. Skimming over the palm trees, visibility was less than five hundred feet, the torrent sweeping back over the glass windows of the cabin like a tidal wave. We cut across the south west-

ern point of the island, and headed out to sea over the Gulf of Paria—into fog and worse rain. With our wheels almost in the water, I, personally, figured it was a case of a friendly obit to "Three good will fliers." I grabbed a bundle of clothing and packed it between myself and the cabin gas tank, to prevent the tank from going through my ribs in the crash. Just then Yancey got his bearings, and ordered Burgin to cut into the right. As we picked up the shore line, we found it still clearing to the north, and the sun was shining when we flew over Port of Spain. I tossed the bundle of clothing to the floor. However, neither Burgin nor Yancey wanted to land on Queens Park, and decided to fly south again in search for the field near the oil wells, which, by the way, never existed! So back we went, into the storm, with the motor spitting from rain in the carburetor, a quarter hour's supply of gas in a fast leaking tank, and a valve just about due to stick after eight hours of flying!

Back we went, headlong into the torrential rain, and sure enough, thirty-five miles south of Port of Spain, the valve stuck! We picked out an old race track, soggy and overgrown with tropical foliage, and Eddie prepared to slip her in. I tossed all our baggage aft into the radio compartment, and Yancey climbed in after it—to get as much weight

in the tail as possible and reduce the probability of the plane going over on its back as the wheels sank in the soft stuff. Once more I placed the bundle of clothing where it would do the most good. Eddie slipped over the fence, stalled the plane, and pancaked. As the wheels touched, the tail raised, but dropped again as we slushed to a quick stop, a hundred feet from the fence! Congratulations were very much in order all around. The only damage was to the tail wheel fork. A new fork was forged in a local shop while we enjoyed the hospitality of the British operators of the oil wells.

The next day I motored up to Port of Spain, and the following morning, ten minutes after I directed the placing of a white landing "T" on Queens Park, the "Pilot Radio" droned over the hills and came in for an easy landing.

BACK ON AMERICAN SOIL

We lay over in Port of Spain for two days, checking the motor, reaming the valve guide that had given us so much heart ache, and painting on the fuselage the names of all our stops since Rio. We took-off for Puerto Rico just before sunrise, Wednesday morning, the eighth of September, flying north through the sombre pass known as the Dragon's Mouth. We flew up the parabola of the Windward and Leeward Islands, watching each spot of land climb over the horizon as the last island sank beneath the sea behind us. Coming in south of the Virgin Islands, the ceiling dropped and we dodged rain squalls north of Puerto Rico, heading in the Pan American field at San Juan, virtually out of the mist. Here our wheels touched American soil for the first time since the "Pilot Radio" rolled down the soggy turf of France Field, Canal Zone, some three months before.

Eddie taxied the plane up to the passenger depot, and Yancey unfolded himself stiffly from a posture that, after eight hours of flight, was approaching rigor mortis. As Burgin unstrapped himself, I gesticulated eloquently to a gaping hole under the right wing, where, when I had last cast an eye in that direction, the gas gauge had wobbled uncertainly in the slip-stream.

"Thank the Lord!" breathed Eddie. "That thing is gone at last! We'll patch the hole and let the motor get some gas for a change. That's the last of our troubles! Jack, my lad, and we're in the U. S. A. now!"

That evening Captain Yancey opened the door between our adjoining rooms.

"How about a schedule with WHD, New York, tomorrow?"

"Okay with me. What time shall we make it? We're taking off with a pretty big load, so I'll probably have to stay up forward until

noon. Then we'll want some weather from the Pan Am stations, and we'll probably have a few TR's and other traffic from Miami. How about cabling them to standby at three, Eastern daylight saving time?"

"Right-o!"

And we turned in early, under a vast net that kept the heat in and the bats and mosquitos out.

As a last gesture of Latin American "mañana," our car was late at the hotel the following morning, and when finally the motor was warm, the exhaust flames stabbed almost invisibly into the morning light. It was exactly seven o'clock Eastern daylight saving time when Burgin turned the plane around at the far end of the field, revved the motor wide open and let up on the brakes. The "Pilot Radio" lurched forward, but picked up speed rapidly on a fast runway. As the Pitot tube jabbed the wind, the airspeed needle swung over—40—50—60—70—80 miles an hour. Not sure what she would do with the load, Eddie held her down, taking the whole field, and then zoomed her over the bay. Perhaps the old ship knew it was her last take-off, and bit the air like a pursuit plane with a glorious toss of her droning motor.

From San Juan we skirted the north coast of Puerto Rico, then hopping across the ninety miles of water to Haiti, with a few minutes out, circling Santo Domingo, hit by the tropical hurricane a week before.

GOOD RADIO CONTACT

Our next water hop was sixty miles over the Windward Passage. We cut to the north at Guantanamo, heading for Sama on the north coast of Cuba. At 11:00 I crawled aft to the radio shack, let out the antenna and after listening for a few moments, called the Pan American station CMG, at Camaguey, Cuba, then about 250 miles west of us. We informed them that we were going straight through to Miami, without stop, and asked for a general weather report. He gave us the WX at Camaguey and a report of probably fine weather over the Bahamas, clean in to Miami. We told CMG that we would not pass anywhere near them, and would probably hit the ocean again to their north east.

We heard several planes working WKDL, at Miami, but were unable to pick up WKDL for some reason. We called CMG again and asked for the exact wave of WKDL, but still no luck in picking her up, though CMG reported through to us that we were QSA at WKDL. Other Pan American stations, as far south as Trinidad, were coming in with good signal strength.

Shortly after noon, CMG shut down for work on their transmitter, and I transferred

my attentions to CMM at Bayamo, Cuba, then about one hundred miles due south west.

At 1:25 we sent through the following position report to Miami, five hundred miles to the north west.

"AT 1:00 15 MILES NORTH POINT SAMA HEADING FOR GREAT RAGED ISLAND."

At 1:51 we sent the following messages, also to WKDL.

"STANDARD OIL MIAMI—ARRIVE ABOUT FIVE REQUIRE TWO HUNDRED GAS AND TEN STANAVO 140—YANCEY."

"ROY MARTIN MIAMI BEACH—WILL ARRIVE PAN AMERICAN AIRPORT ABOUT FIVE—YANCEY."

These three messages were sent direct to Miami, but, as I still could not hear WKDL, I received my acknowledgements through CMM.

At 2:30 we sent through a TR to CMM that we were passing over Racoon Cay. A quarter of an hour later, CMM was still pounding in, and I told him that I was going to shift to a lower wave (we were operating under two licenses, the American W2XBQ and the Argentine LU4A, which provided us with a liberal allowance of frequency channels) for a schedule with New York. As I bid him cheerio, I said that I'd probably not work him later, when I returned to the Pan American 54 meter wave, as by that time I should undoubtedly be receiving WKDL. With a final 73 (best regards), I signed off, with ten minutes left for the necessary shift. The change-over included removing and replacing two receiving coils, one transmitting coil, the retuning and reneutralization of the

transmitter and the shortening of the antenna. I was ready for New York at 2:59½.

At 3:00, just as I cut in the generator, one cylinder of the motor quit cold—undoubtedly a sticking valve. Hitting only on eight cylinders, the motor roughened. Burgin cut her down to about fifteen hundred r.p.m. to lessen the strain. I reeled in the antenna and went forward, to ease the flying and for instructions.

The situation was interesting—out over the open ocean in a land plane with motor trouble. With a glance at his chart, Yancey told me to raise someone quick, and I went aft again. A quick juggling of coils, neon tubes, dials and the antenna reel, consuming exactly one minute, and I was back on the Pan-American calling wave. CMM was my best bet, but to make sure that someone would reply, I interspersed the call with SOS. Before the roar of the dynamotor died down in the ear 'phones, CMM was back at me with a quick "K" (go ahead). I told him we were having motor trouble, and please standby for position report and further instructions.

Yancey knew exactly where we were. He passed me back a sheet of paper, and the following messages went back and forth in quick succession:

"POSITION SIXTY MILES WEST SOUTHERN POINT LONG ISLAND."

"LAT 22 R 25 LONG 75 R 45 HEADING GREAT EXUMA ISLAND."

"ALTITUDE 4,000 FEET BUT LOSING IT AS MOTOR IS REVVED BACK."

"HOW FAR TO ISLAND?"

"ABOUT FORTY MILES."

"HOPE YOU MAKE IT."

"SO DO WE."

Form PAA-CD-30-1-30

WEATHER REPORT

FROM Havana TIME 2 R 30 DATE May 17
 To: Yancey W2XBQ

GROUP 1	General Weather Conditions	<u>clear</u>	
	Horizontal Visibility	<u>unlimited</u>	
	Height of Base of Lower Predominating Clouds	<u>4000</u>	Feet
GROUP 2	Amount of Sky Covered with Lower Predominating Clouds	<u>two</u>	Tenths
	Total Amount of Sky Covered with Clouds	<u>four</u>	Tenths
	Direction of Surface Wind	<u>South East</u>	
GROUP 3	Force of Surface Wind	<u>Ten</u>	M. P. H.
	Weather Conditions During Preceding Hour	<u>same</u>	
GROUP 3	Barometer Reading	<u>30.101</u>	Thermometer Reading <u>80 wet 82 dry</u>
REMARKS	<u>Field dry</u>		
	<u>Nash</u>		

Reproduction of a typical weather report received on board the "Pilot Radio" from the Pan-American Airways system. Reports of this kind, sent out regularly, safeguard numerous planes flying over the Pan-American routes.

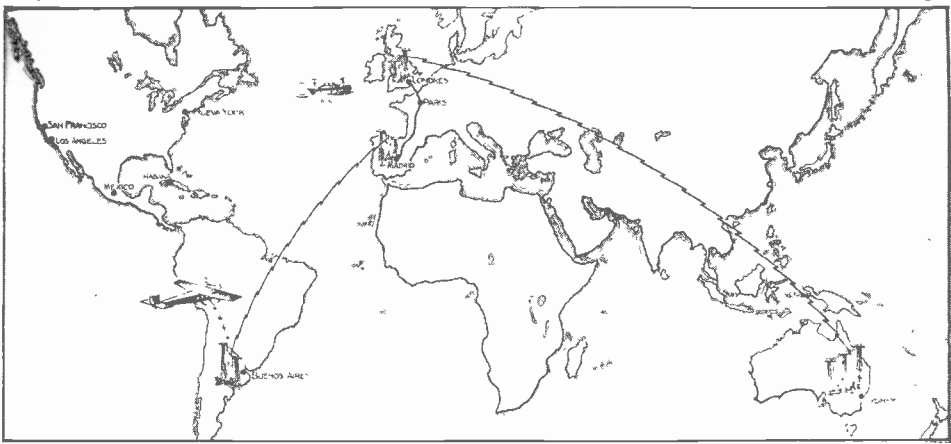

This map shows the path followed by the radio signals during the history-making achievement of the "Pilot Radio" in telephoning to Sydney, Australia, while flying over Buenos Aires, Argentina.

"WILL YOU REQUIRE AID?"

"SURE WILL IF WE GO DOWN ON WATER."

"AM GOING TO CHARGE BATTERY FOR A FEW MINUTES. PLEASE QRX THIS WAVE. WILL BE BACK SOON OR BEFORE ANYTHING HAPPENS."

"SHALL WE SEND OUT A PLANE FOR YOU?"

"DON'T KNOW WE MAY MAKE IT."

At twenty minutes after three Great Exuma Island crawled over the horizon.

"ISLAND SIGHTED TEN MINUTES MORE TO GO ALTITUDE 1,000. PRAYERS ARE IN ORDER."

"OKAY OM WE'RE PRAYING FOR YOU."

"DON'T TAKE ME SERIOUSLY YOU MIGHT SINK US. ARE THERE ANY SHARKS AROUND HERE?"

"HELL YES PLENTY."

"STILL LOSING ALTITUDE BUT THINK WE'LL MAKE IT."

"OVER LAND EVERYTHING OKAY. SEARCHING FOR LANDING PLACE. WILL WORK YOU FROM GROUND IF WE DON'T CRACK UP. ISLAND INHABITED. TOWN AT NORTH END."

But landing places were scarce, and so was time. Choosing among several beaches and a stretch of what looked like hard sand between a beach and a low hill, Eddie picked the latter, and signaled to me that he was landing. I sent through my last message to CCM.

"LANDING NOW SEE YOU TEN MINUTES IF OKAY 73."

I reeled in the antenna, opened all switches and crawled forward. Again I threw our baggage back in the radio shack to get the weight aft. Yancey went back after the

baggage, and braced himself against a cross member and the flooring.

I piled the bundle of clothing between myself and the gas tank and braced myself, grabbing a cross member above my head. I noticed that my hands were perspiring—I had been working like hell during the twenty seconds just passed—and I figured that I had better wipe them on my knees or they'd slip like a greased pig. Eddie was slipping the ship in at the moment, about twenty feet off the ground. I glanced down, and the place looked better than ever. So I didn't bother wiping my hands, and I turned around to remark to Yancey:

"Hell, this is going to be a cinch."

Eddie straightened out the plane—she began to settle—the wheels touched—and the Atlantic ocean poured over the motor and windshield! Things happened. There was a queer grinding noise, discordant cymbals and drums, two dull thuds, and I was lying on my back, on the top of the plane, with the spare parts, pistons, rings, valves, guides, valve springs, raining down upon me from under the seat I had been sitting on a split second before! Right in front of me, in the radio shack, was Yancey standing on his head. He had been so well braced that he had gone over with the plane. I bent my head backward, and saw Burgin hanging upside down from his safety belt, like a monkey on a trapeze. To my left, a half inch from my head, were the storage battery and the dynamotor which had torn loose from the floor, now on the roof. I understood the two thuds. Something salty—blood or acid from the battery I figured—was trickling down my face. I considered my probable disfigurement momentarily, until I realized that it was sea

water, scooped up by the heater in the floor, now dropping down from above.

The door was jammed. Yancey, who had by now righted himself, crawled through the window and opened it from the outside, and we all slipped out onto the wing, none of us hurt beyond cuts, bruises and a general shaking up. We had landed in a swamp. Those smooth hard sands were two feet under crystal clear water! The wheels had not turned over once!

A few moments later we had tossed some of our luggage from the plane, now filled with a foot of water, to a dry spot beyond the wing tip. As I sat on a bag gazing mournfully at the "Pilot Radio" ignominiously on her back, I saw a puff of smoke arise forward, where the gravity tank was located under the instrument board. One of our six tanks blew up before Yancey was altogether clear, blowing off the skin of his right arm. And hour later only a pall of black smoke hung over the scene of our crash.

The skeleton of the plane still lies there on its back—black and rusty against Exuma's sands. May the tropic rains fall warm and sweet upon her!

RESUME

Looking back on the flight and even considering its disastrous end, the enterprise as a whole was successful from both aeronautical and radio points of view. Ours was the first land plane ever to encircle South America. Our direct communication experiments, with the Pan American stations along our course, and with New York City from such distant points as Santiago de Chile and Buenos Aires, prove that aircraft flying can be made as safe as steamer transportation, and that at no time need an airplane ever be out of immediate touch with its home port, even if flying on the other side of the world.

Our relay experiments with the International Telephone and Telegraph Company at Buenos Aires, in which we telephoned from the flying plane to our families in America, and to prominent people as far away as Sydney, Australia, establish the prophetic fact that the passengers of the great air liners of the future will have at their disposal telephonic conveniences even exceeding those which we today enjoy in our own homes on terra firma.

Aterrizaja suave!

SEX NO BAR TO SUCCESS FOR THIS RADIO FAN, WHO USES A PILOT K-115 MODEL SUPER-WASP RECEIVER

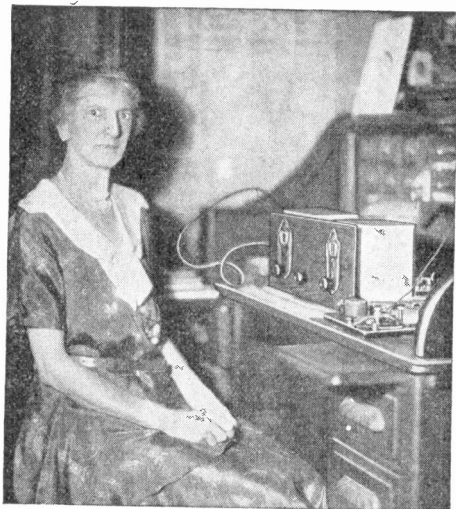

We are pleased to publish herewith a photograph of Mrs. Lillian C. Manahan, 4005 Troost Avenue, Kansas City, Mo., whose adventures on the short waves, as related by her in the Fall issue of RADIO DESIGN, aroused considerable interest among Guild members. Although without any previous radio experience, Mrs. Manahan assembled and wired her own A.C. Super-Wasp from the directions furnished with the kit, and has enjoyed reception from stations in practically all parts of the world.

Mrs. Manahan is now studying the code, her practice buzzer set being visible in the accompanying photograph just to the right of the Super-Wasp receiver. She is making rapid progress, and expects soon to build her own short-wave transmitter so that she may join the increasing army of radio fans who find the short-waves a wonderful hobby.

For the benefit of inquiring readers, and to save Mrs. Manahan considerable correspondence, we might mention that her receiver is a regular K-115 model A. C. Super-Wasp with the K-111 power pack. The new Universal Super-Wasp is recommended to people seeking a later and even better receiver.

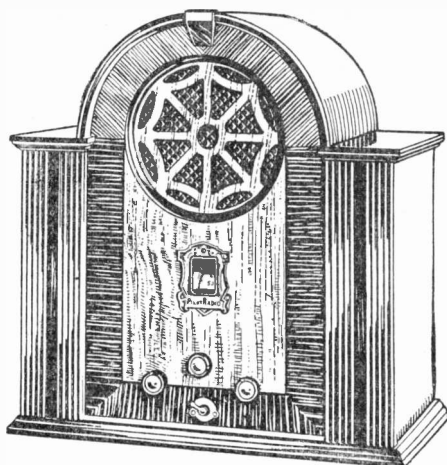

Front view of the new Midget receiver.

New "Midget" and "Consolette" Broadcast Receivers

Tone Control, Phonograph Pick-Up Jack, Illuminated Dial With Knob Control, Improved Circuit—Features of New Models.

SINCE their introduction last Fall (see *RADFO DESIGN*, Volume 3, No. 3), the Pilot "Midget" broadcast receiver has been improved in many respects, and it has been supplemented by a larger set known as the "Consolette."

The chassis has been strengthened mechanically, shield cans added to the screen-grid tubes, the sensitivity and selectivity of the circuit increased considerably, and a marvelous tone control installed. The original set was a very good one and achieved quick popularity, but the new one is simply better—although the price has not been increased.

BEAUTIFUL CABINET

The Midget cabinet is beautifully made of two-tone walnut and is strong and durable. Real wood is used—not the sawdust compositions found in so many sets on the market today. The dynamic loud speaker occupies the rounded top section, and is securely anchored in place.

NEW CONTROL ARRANGEMENT

The controls on the front of the set have been rearranged. The tuning dial is now of the knob-operated type and is clearly illuminated by a hidden bulb set inside the

escutcheon plate. The indicating scale is white with large, readable figures, and is marked in kilocycles instead of with mere position numbers. Thus the user can consult his newspaper for the frequency of a desired station and adjust the dial directly to the proper position. The tuning knob is the one in the center. Just below it is the line switch, of the lever type.

THE TONE CONTROL

The small knob to the left is the tone control, and represents a 50,000 ohm variable resistance which is connected in series with a fixed condenser. (See the schematic diagrams on page 38 and 39 for the details of this arrangement.) Turning the knob to the left emphasizes the low notes; to the right, the high notes. By means of this effective device, you can actually change the tone of voice and music to meet your own tastes or to suit the acoustical requirements of the particular room in which the set is being used.

SMOOTH VOLUME CONTROL

The knob to the right is the volume control, which in the A. C. model, is a 4000-ohm potentiometer. This acts as a variable short circuit on the primary of the antenna coupler

and also increases the negative bias on the R. F. amplifier tubes as it is turned to the minimum volume position. This scheme provides absolute cut-off on even the strongest local stations. The control is smooth and quiet; you can reduce the music to a whisper or raise it to dance-hall volume and still retain the same level of faithful reproduction.

SIX TUBES USED

The A. C. Midget uses six tubes: three P-224 screen-grid, one P-227, one P-245, and one P-280.

The whole set is 17 inches wide, 18½ inches high and 8¾ inches deep. It is available in four models for 50-60 cycle alternating current and one for direct current. The D. C. receiver uses four P-201A's and two P-171A's, and is made for 110 volts only. It has the same external appearance as the A. C. set, the chassis being different in construction.

Pilot "Midget" Receivers:

- for 115 volts (110-120), 50-60 cycles,
A.C.—No. S-155 Code: ZOCEF
- for 220 volts (210-230), 50-60 cycles,
A.C.—No. S-155A..... Code: ZUVUH
- for 125 volts, 50-60 cycles, A.C.—
No. S-155F Code: ZOTAV
- for 240 volts, 50-60 cycles, A.C.—
No. S-155B..... Code: ZOLIP
- for 110 volts, D.C.—No. S-156.... Code: ZUSBE

THE "CONSOLETTIE"

The new Pilot "Consolette," using the same chassis and loud speaker as the Midget, is a charming little Queen Anne model that presents no problem of placement in the home. It harmonizes everywhere, for it is quietly dignified and richly beautiful in its combination of mahogany and two-tone walnut. It is a closed model, with sliding doors of burl walnut veneer and antique metal knobs. It stands 33 inches high, 19½ inches wide and 13 inches deep.

Giving full-sized console quality of reproduction, the Consolette is an exceptionally dependable and durable receiver, and like the Midget is a real investment in radio satisfaction. The five models are as follows:

Pilot "Consolette" Receivers:

- for 115 volts (110-120), 50-60 cycles,
A.C.—No. C-157 Code: ZAYNO
- for 220 volts (210-230), 50-60 cycles,
A.C.—No. C-157A Code: YAWTY
- for 125 volts, 50-60 cycles, A.C.—
No. C-157F..... Code: YEZAV
- for 240 volts, 50-60 cycles, A.C.—
No. C-157B Code: YATPO
- for 110 volts, D.C.—No. C-158.... Code: YEYEV

An illustrated pamphlet describing these new receivers will be mailed free of charge to readers of RADIO DESIGN. Simply ask for the set folder.

An Explanation

Circumstances beyond our control made it necessary for us to skip the customary Winter issue of RADIO DESIGN. The present issue is a combination Winter-Spring issue, and is Number 4 of Volume 3.

The subscriptions of all subscribers will be extended so as to include four full issues.

FOR SHORT-WAVE LISTENERS

Please do not ask us to identify unknown short-wave stations from which you have picked up snatches of voice or music. It is absolutely impossible for us or anyone else to do so, as there are now dozens of stations on the air, and there is no way of keeping track of their programs. If you do not pick up the call letters the first time, the best you can do is note the dial readings and try again another time.

Another thing: listen carefully when you do hear announcements being made. We receive many reports of reception giving impossible call letters or mentioning stations that do not even exist. Short-wave reception is interesting, but don't let your imagination run away with you.



TRADE MARK

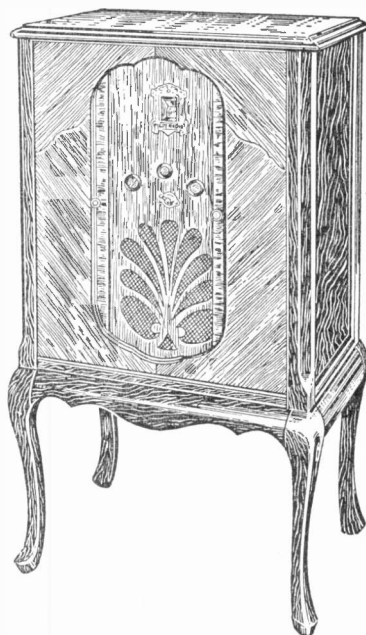

Front view of the Consolette receiver, with the doors pushed open to show the controls and the loud speaker grille.

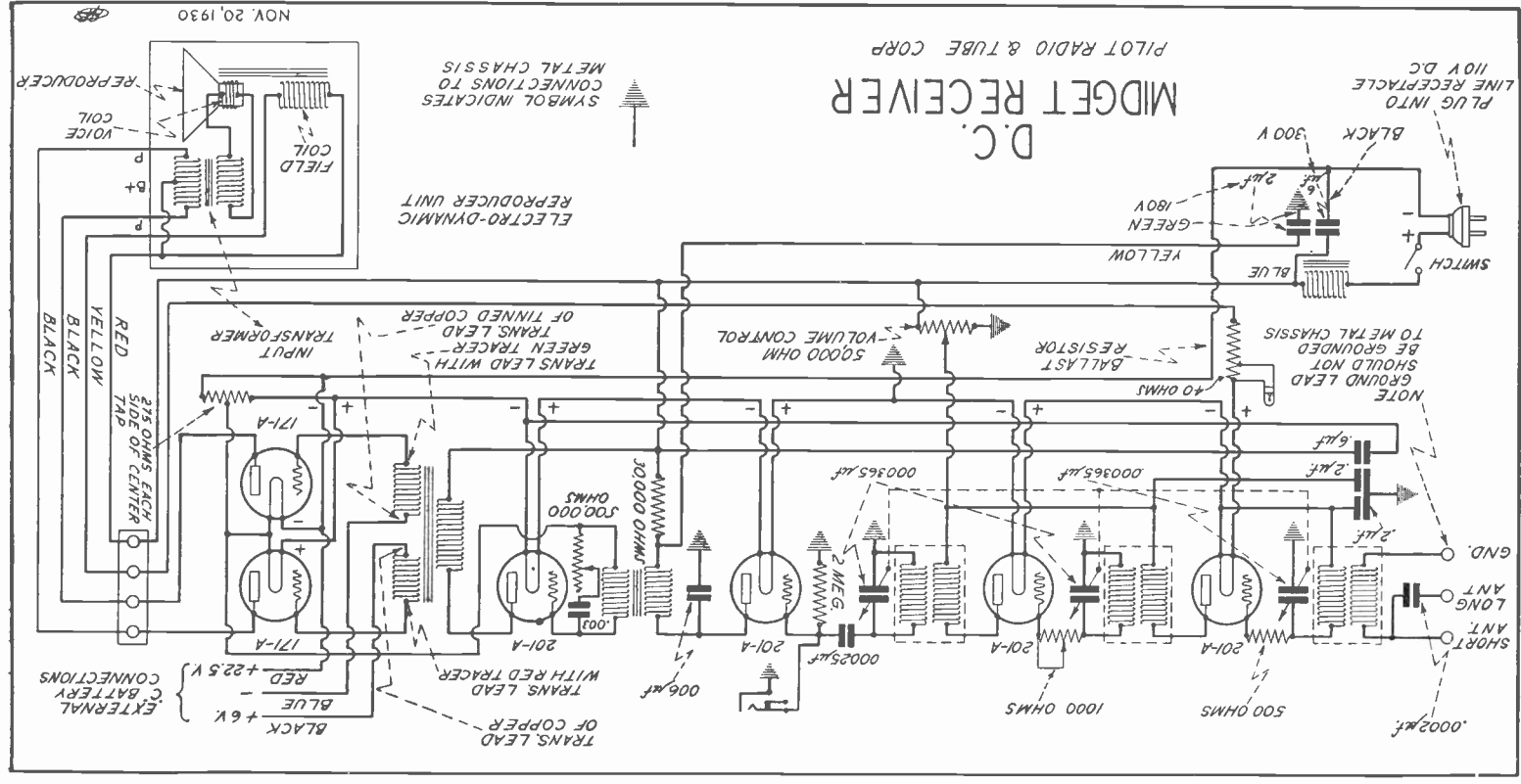

The series-parallel arrangement of the filament wiring of the D.C. set is a bit confusing at first, but if the connections are traced out carefully they will be quite understandable. Particular care should be paid to the "C" battery leads, and to the caution against grounding the chassis.

NOV. 20, 1930

Symbols and Prefixes Used in Radio Work

THE tremendous growth of the radio art has resulted in the invention of many new electrical devices unheard of a few years ago. These, together with such well-known parts as coils, condensers, resistances, etc., make the total number of different components used in radio receivers very large.

In order to represent these pieces of equipment in their proper relation in drawings and schematic circuit diagrams, conventional symbols have been devised. It is unfortunate that no absolute standardization of radio symbols is being accepted in radio work at the present time, but the following table contains most of the symbols which have become well-known through more or less popular usage, and which are used in all RADIO DESIGN circuit diagrams. While some of them may appear strange to novices in the radio game, they will soon learn to use them with ease in their circuit diagrams. It is fortunate that the symbols have been so chosen that they really suggest quickly to one's mind the apparatus which they are intended to represent.

It would be well for every reader to acquaint himself thoroughly with these symbols, in order that he may thoroughly and quickly understand circuit diagrams and be able to draw neat and electrically correct circuit diagrams of his own, which can easily be understood by anyone else versed in the radio art. It must be remembered that a radio circuit diagram is built up simply by connecting several of these symbols together properly. We suggest that you select some circuit diagram in this issue of RADIO DESIGN and see if you can give the name of every part shown. Then attempt to re-draw the circuit yourself, using the proper symbols. In this way you will obtain practice both in remembering the symbols, and in drawing and tracing out circuits.

RADIO PREFIXES

It happens that many of the commonly known measuring units used in electrical work are either too small or too large for convenient use in expressing electrical quantities in radio work. Instead of using large, cumbersome numbers or complicated decimal numbers to indicate the multiple or fractional parts of these units, it has become customary to make use of standard prefixes ahead of the original units, for simplifying calculations and avoiding errors.

The student of radio should familiarize himself with these terms, so that he may become proficient in understanding and using them. A list of the more common prefixes is given below. Here again there is no absolute standardization in the representation of these symbols:

<i>Prefix</i>	<i>Meaning</i>
"deci"	one-tenth part of
"centi"	one-hundredth part of
"mil or milli" ..	one-thousandth part of (symbol M)
"micro"	one-millionth part of (symbol μ)
"micromicro" ..	one-millionth of one millionth (symbol $\mu\mu$)
"deka"	10 times
"hekta"	100 times
"kilo"	1,000 times
"mega"	1,000,000 times.

Most of the symbols have been taken from the letters of the Greek alphabet. For instance, μ is the Greek letter pronounced "mu".

From the foregoing list we see that "deci" means that the new unit is 0.1 of the common unit. Thus a "decimeter" is 0.1 of a meter.











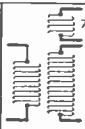





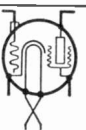







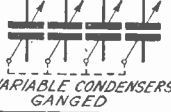
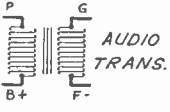

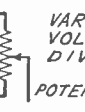

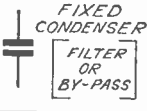
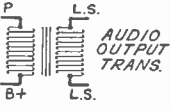

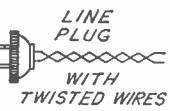
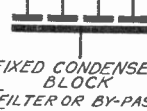
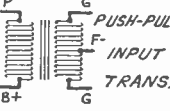



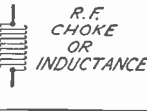
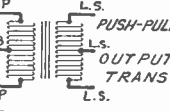



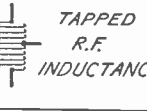
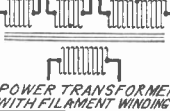



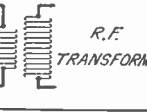
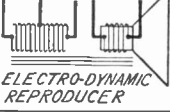
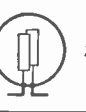

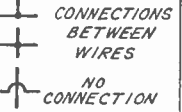
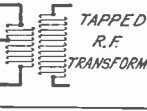
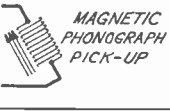

Likewise a "milliampere" (MA) is $\frac{1}{1000}$

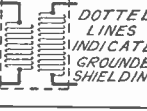
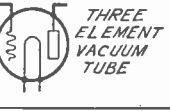
or 0.001 of an ampere. A microhenry is $\frac{1}{1,000,000}$ part (0.000001) of a henry. A

microfarad is 0.000001 of a Farad. Instead of saying that a condenser has a capacity of 0.00035 microfarads we can say that it has a capacity of 350 micromicrofarads. For convenience in typesetting, the Greek letter "mu" is usually represented by the English letter "m". Thus, the very common abbreviation for microfarad is "mfd." or sometimes merely "mf".

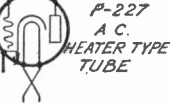
A "centimeter" of inductance is equal to $0.001 \left(\frac{1}{1000} \right)$ of a microhenry. This unit does not follow the general rule.

The prefix "kilo" means that the new unit is 1,000 times as large as the common unit. Thus one "kilocycle" (kc.) equals 1,000 cycles. Likewise, one "megohm" equals 1,000,000 ohms, etc.

 ANTENNA	 TICKLER THREE CIRCUIT TUNER	 P-222 BATTERY OPERATED SCREEN GRID TUBE	 TAPPED RESISTOR VOLTAGE DIVIDER	 SWITCH
 GROUND ALSO INDICATES CONNECTIONS TO METAL CHASSIS	 A.F. CHOKE OR INDUCTANCE	 P-224 A.C. SCREEN GRID TUBE	 CENTER- TAPPED RESISTOR ACROSS FILAMENT	 EARPHONES
 VARIABLE CONDENSER	 TAPPED AUDIO CHOKE	 P-281 HALF-WAVE RECTIFIER FILAMENT TYPE	 VARIABLE RESISTOR RHEOSTAT	 BATTERY
 VARIABLE CONDENSERS GANDED	 AUDIO TRANS. B+ G F-	 P-280 FULL-WAVE RECTIFIER FILAMENT TYPE	 VARIABLE VOLTAGE DIVIDER POTENTIOMETER	 FUSE
 FIXED CONDENSER FILTER OR BY-PASS	 AUDIO OUTPUT TRANS. P L.S. B+ L.S.	 FULL-WAVE RECTIFIER RAYTHEON TYPE	 FILAMENT BALLAST RESISTOR	 LINE PLUG WITH TWISTED WIRES
 FIXED CONDENSER BLOCK [FILTER OR BY-PASS]	 PUSH-PULL INPUT TRANS. P G B+ F G	 TWO-ELEMENT VOLTAGE REGULATOR TUBE	 VOLT METER	 LINE PLUG RECEPTACLE
 R.F. CHOKE OR INDUCTANCE	 PUSH-PULL OUTPUT TRANS P L.S. B L.S. P	 THREE- ELEMENT VOLTAGE REGULATOR TUBE	 AMMETER	 THERMO ELEMENT
 TAPPED R.F. INDUCTANCE	 POWER TRANSFORMER WITH FILAMENT WINDINGS	 PHOTO- ELECTRIC CELL	 MILLI- AMMETER	 ANTI-CAPACITY SWITCH
 R.F. TRANSFORMER	 ELECTRO-DYNAMIC REPRODUCER	 NEON TUBE	 MICRO- AMMETER	 CONNECTIONS BETWEEN WIRES NO CONNECTION
 TAPPED R.F. TRANSFORMER	 MAGNETIC PHONOGRAPH PICK-UP	 ELECTRO- LYTIC RECTIFIER	 MICRO- VOLTMETER.	 TELEPHONE JACKS
 DOTTED LINES INDICATE GROUNDED SHIELDING	 THREE ELEMENT VACUUM TUBE	 DRY ELECTROLYTIC RECTIFIER	 GALVANOMETER	 CRYSTAL DETECTOR
 VARIOMETER	 P-227 A.C. HEATER TYPE TUBE	 FIXED RESISTOR	 BINDING POSTS	 LAMP

New Tubes for the Super-Wasp

Simple Changes Necessary to Adapt the Battery Operated K-110 Model Super-Wasp for the Use of the New 2-Volt Dry Cell Tubes; Arrangements to Work from Storage Battery or Dry Cells

By ALFRED A. GHIRARDI

EDITORIAL INTRODUCTION

For many years, people living in rural or other districts not supplied with electric power have been seriously handicapped by the lack of satisfactory dry-cell operated radio tubes and receivers. The 199-type tube, which at one time was hailed as the solution of the problem, has been an admittedly notorious failure, its characteristics being irregular, its behavior microphonic and its life short.

With the recent introduction of the new 230-series of two-volt tubes, which have already demonstrated their superior qualities, the dry-cell market appears due for a revival. We have adapted them for use in the battery-model Super-Wasp, and have found them satisfactory in every respect. Radio fans who have long desired one of these famous combination short and broadcast wave receivers, but who lack electric power or battery charging facilities, can now realize their dreams and enjoy worldwide reception with ordinary No. 6 dry cells as their source of filament current. The standard Pilot K-110 Super-Wasp kit is used with only one very slight change in the filament wiring.

OPERATION of the battery model K-110 Super-Wasp receiver by dry cell "A" batteries has at last become a practical reality, made possible by the development of new 2-volt dry cell tubes. These new tubes, the 230, 231 and 232, are of rugged construction. Their filaments are oxide coated, ensuring long life if they are operated at their rated filament, plate and grid voltages. They are also non-microphonic. These advantages over the old 199 type of dry cell tube will be realized at once by anyone who has used the latter.

The three new tubes are the 230, which is a general purpose tube; the 231, a power output tube, and the 232, a screen-grid amplifier tube. All three have 2-volt filaments, the 230 and the 232 drawing .06 ampere normal filament current, and the 231 drawing 0.13 ampere. The low current consumption of these tubes will be apparent when it is remembered that a single 201-A type tube draws a filament current of 0.25 ampere.

In response to insistent demands from read-

ers of RADIO DESIGN who own K-110 Super-Wasp receivers, we undertook to find out whether the 2-volt tubes could be used successfully in the set, and if so, just what circuit arrangement would permit these tubes to operate with maximum efficiency and economy.

Our tests show that these tubes can be used in the Super-Wasp without any sacrifice in sensitivity or selectivity, and furthermore that only one slight wiring change in the set is necessary.

The characteristics of the three new tubes follow:

THE 230 TUBE

The 230 Tube: This is a general purpose tube for use either as detector or amplifier.

Filament voltage—2.0 volts.

Filament current—0.06 ampere (60 milliamperes).

Detector plate voltage—45 volts (grid return to positive).

Amplifier plate voltage (max.)—90 volts.

Amplifier grid voltage—4.5 volts.

THE 232 TUBE

The 232 Tube: This is an improved screen grid battery operated tube designed for use primarily as a radio-frequency amplifier in circuits designed especially for it.

Filament voltage—2.0 volts.

Filament current—0.06 ampere.

Plate voltage (max.)—135 volts.

Screen grid (max.)—67.5 volts.

Grid bias voltage—3 volts.

THE 231 TUBE

The 231 Tube: This is an improved power amplifier tube for supplying undistorted volume from battery operated receivers where economy of plate current is important. It is intended for use only in the *last stage* of an audio frequency amplifier.

Filament voltage—2.0 volts.

Filament current—0.130 ampere.

Plate voltage (max.)—135 volts.

Grid bias voltage—22.5 volts.

For the last audio stage, the use of the 231 power amplifier is recommended to give best tone quality and loud speaker results. No output coupling or filter device is required in the plate circuit of this tube.

Mr. Ghirardi operating the revised K-110 model Super-Wasp, which uses dry batteries for both filament and plate supply. The loud speaker is of the magnetic cone type.



USING DRY CELL "A" BATTERY

We realize that the owners of Super-Wasp receivers who may want to use these new tubes will naturally fall into two classes.

(a) Those who desire to use dry cells for filament current supply.

(b) Those who desire to use their present six-volt storage "A" battery for filament supply, taking advantage of the low filament consumption of the tubes.

USING DRY CELLS

To use dry cells for filament supply it is necessary first to remove from the set the 15 ohm tapped resistance which is at present connected in the filament circuit of the screen grid tube. Connect together the wires which went to its two outside terminals. Remove the wire which ran to its middle tap terminal, and replace it by connecting a longer wire (about 12 inches) to the .01 mf. fixed condenser terminal, in its place. This lead is for the—3 volt "C" battery connection for the new screen grid tube. The .01 mf. bypass condenser still remains in the set. It is not practical to use a resistor for "C" bias with the new tube. This completes all of the wiring changes necessary in the set. The C-9 volt binding post at the rear of the set will connect to the minus terminal of a 22½ volt "C" battery instead of 9 volts, because the new power tube requires 22½ volts of "C" voltage.

The total filament current drain of the set with the new tubes is 0.31 ampere. The normal recommended discharge rate for a standard 6-inch dry cell used as an "A" battery is between 0.125 and 0.25 ampere. Maximum battery economy is obtained if the discharge rate per cell is about 0.125 ampere. In order to obtain the most economical arrangement of 6-inch dry cells for the "A" battery for this set, we use four dry cells connected two-series

(to obtain 3 volts) and two-parallel (to reduce the total drain to 0.15 ampere per cell). The voltage of two new dry cells connected in series is approximately 3.0 volts. The difference between this voltage and the 2 volts required by the tubes is absorbed in the filament rheostat which is at present on the front panel of the set. As the batteries get old, their voltage drops, so the setting of this rheostat can be advanced to compensate for this.

REVISED CIRCUIT

The connections for the entire receiver and batteries are shown in Fig. 1. Use four 6-inch dry cells for the "A" battery. A 4½ volt "C" battery with a 3 volt tap, and a separate 22½ volt "C" battery, will also be required. Carefully follow this diagram when making the wiring change in the set, and when connecting the batteries. When the "A" batteries are new, the tubes will have their correct filament voltage if the rheostat arm is set at about its halfway position. As the dry cells get old this setting will have to be changed slightly. It would be well to connect an inexpensive filament voltmeter having a full range scale of 0 to 4 volts, across the filament circuit as shown. The Readrite No. 314 0-4 volt voltmeter is satisfactory for this purpose.* The investment of a few dollars for a meter of this kind is well worth while, for it will enable you to set the filament voltage to the correct value at all times. It is difficult to judge the correct values by noting the brilliance of the filaments of these tubes, for they light only to a dull red glow during normal operation. The use of a voltmeter will also enable you to tell when your dry batteries are exhausted, for the volume and clarity of reproduction suffers greatly if the filament voltage falls below 1.5

* If your dealer does not carry this meter, write to the 20th Century Mail Order Corp., Chicago, Ill.

volts. Also, the life of the tubes will be shortened materially if the filaments are operated above the rated 2 volts. Operating them at too low a voltage will crystallize the filaments, resulting in short life.

USE OF 6 VOLT STORAGE BATTERY

For those who desire to use their present six volt storage "A" battery for filament supply, taking advantage of the low current consumption of these tubes, the arrangement shown in Fig. 2 is most practical. The 15 ohm tapped resistor must be removed from the set as described above. Then the 10 ohm section of this resistor must be connected in the A-C + filament line as shown. It happens that this value of resistance just drops the 6 volts to the correct value for the filaments. The rheostat on the set will give a satisfactory control of voltage from 1.6 volts to 2.25 volts when the battery is fully charged. It will also provide proper control as the battery discharges. For full-charge condition the correct voltage will be applied to the tubes when the rheostat is set about $\frac{1}{4}$ from its zero-resistance position. Again, we recommend the use of a filament voltmeter for the reasons mentioned.

It is likely that some people will think of using only one cell of a six-volt storage battery for filament supply, figuring that this would give them the necessary 2 volts. This is not recommended as it will cause unequal drain on the three individual cells of the battery and will shorten its life. The arrangement shown in the diagram provides equal drain from all of the cells and the battery can be re-charged in the usual way. The current consumption is only about one-third of what it was when standard 222, 201-A and 112-A tubes were used in the set. The "B" battery drain has also been reduced considerably, so that a set of medium sized 45-volt "B" batteries will give about 400 hours of actual service if the set is used about 2 hours per day.

NEW 2-VOLT BATTERY

A new form of non-rechargeable two-volt battery which is claimed to give 1,000 hours of service is shortly to be put on the market by the National Carbon Company, makers of Eveready batteries. This battery was designed especially for the operation of the new two-volt tubes. If it is used, the arrangement shown in Fig. 1 is satisfactory. The filament rheostat should then be set permanently at its zero resistance position. We have not had the opportunity to try this battery yet, but if it meets its manufacturer's claims it should be very satisfactory.

DIAL LIGHTS

If a six-volt storage battery is used for filament supply, it will be necessary to reconnect the two dial lights across the 6 volt line, as shown in Fig. 2. The same six-volt bulbs can be used.

If the four dry cells are used for filament supply it will not be practical to use the dial lights at all, since 2-volt or 2.2-volt dial light bulbs require 0.25 ampere each. This makes a total dial light current of 0.5 ampere, which is more than the tubes in the set require. If this drain is put on the dry cells it will greatly shorten their life. We advise you to remove your present dial light bulbs from their sockets to prevent current drain through them. Use the set without dial lights.

SET OPERATION

The set should be operated in exactly the same way with the new tubes as it was with the old tubes. We have found that due to slight non-uniformity of these tubes it is sometimes necessary to add a few turns of wire to the tickler winding of one or more of the detector coils in order to obtain regeneration over the full range of the dial. In most cases, regeneration control with the new tubes with proper filament, grid and plate voltages, is even more satisfactory than it was with the old tubes.

(Continued on next two pages)

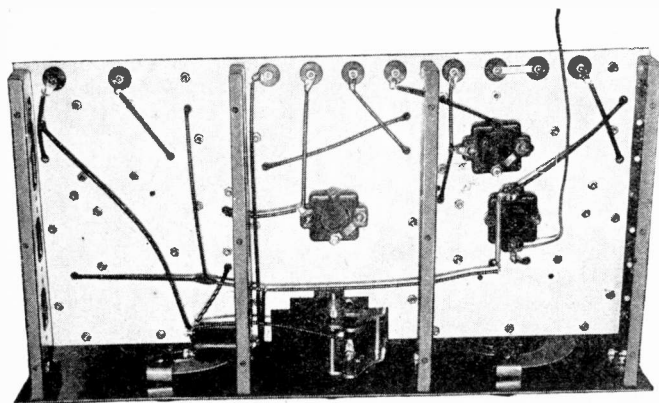

Under view of the K-110 chassis, showing the new wiring. The wire running out beyond the edge of the sub-panel is the new "C" battery connection.

SCHEMATIC DIAGRAM

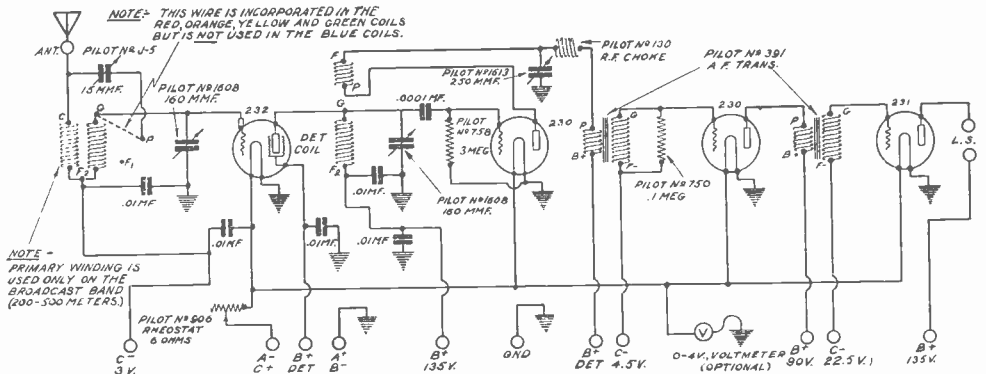

NOTE DO NOT TRY TO WIRE THE SET WITHOUT READING AND FOLLOWING THE INSTRUCTIONS CAREFULLY.

The revised schematic wiring diagram of the K-110 model Super-Wasp. This should be compared with the diagrams in the Pilot No. 7 data sheet, copies of which may be obtained for a 2-cent stamp to cover postage.

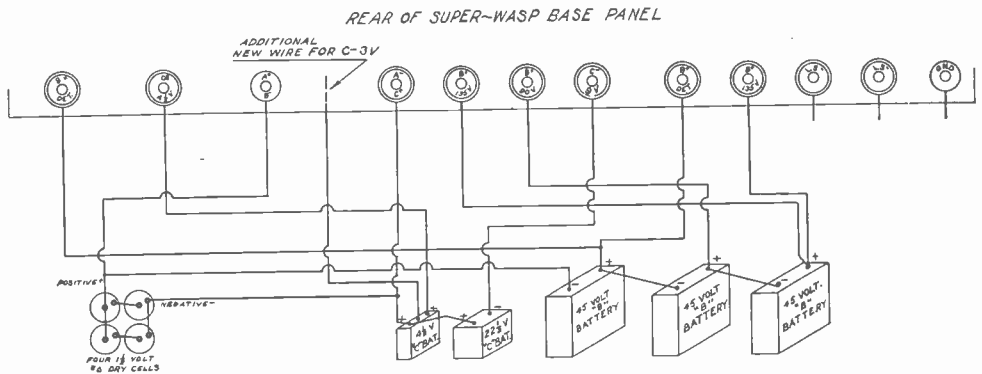

Fig. 1: The wiring layout when dry cells are used for the filament supply

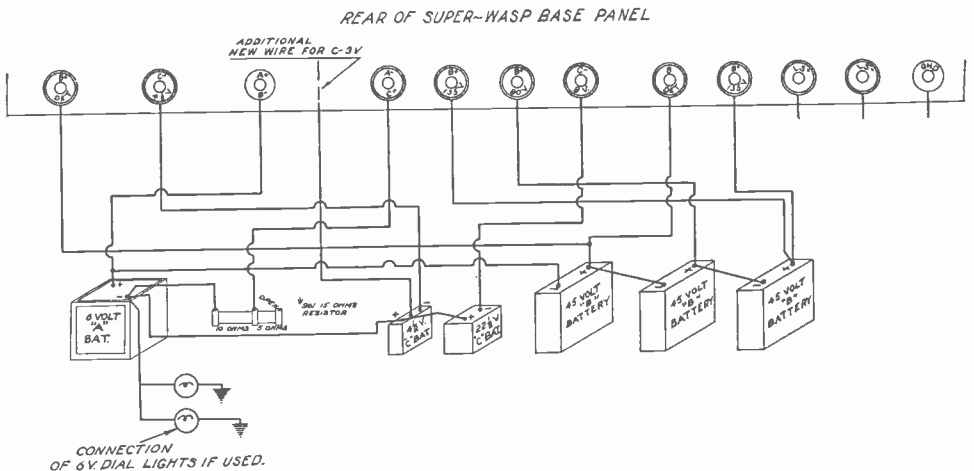
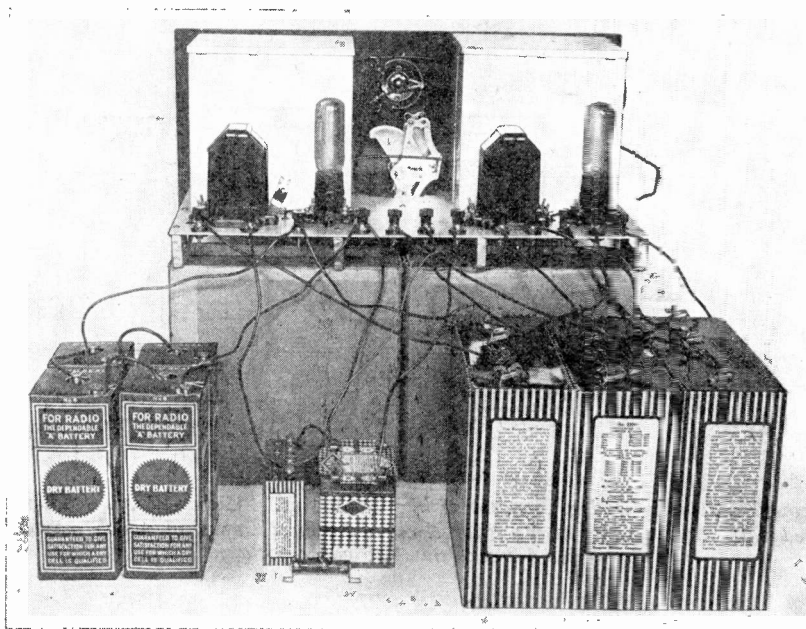

Fig. 2: The wiring layout when a regular six-volt storage "A" battery is used.



The complete layout of the revised K-110 model Super-Wasp, showing the set with the new tubes, the dry cells used for "A" current (left) the "C" batteries (center) and the "B" batteries (right).

BATTERY HINT

Dry cell batteries give the longest service when they are treated carefully. They should be kept away from radiators and heating ranges, as they dry up and become useless if subjected to high temperatures. NEVER test them by tapping a screwdriver across their terminals and noting the fatness of the spark. This is an extremely foolish and wasteful method.

NOTE

The K-110 model Super-Wasp will be continued in its present kit form, designed for 6-volt tubes. The Pilot factory cannot supply the kits already prepared for 2-volt tubes. The necessary changes can be made by the individual purchaser so easily that it is cheaper for him to do the work himself rather than demand a special kit.

A Well Arranged Super-Wasp

The illustration to the right shows an unusually well arranged K-115 model A. C. Super-Wasp, constructed by Mr. Ray L. Walker, 1205 Jenifer Street, Madison, Wisconsin. The home-made cabinet, of white pine stained walnut, is 50 inches high, 23 inches wide and 12 inches deep, and contains the receiver proper at the top; a switching panel; and in the center, a glass covered power shelf, on which are mounted the K-111 power pack and a K-120 booster unit. The

bottom section of the cabinet is occupied by a loud speaker. The top is hinged to allow access to the set itself and to facilitate the insertion and removal of the plug-in coils.

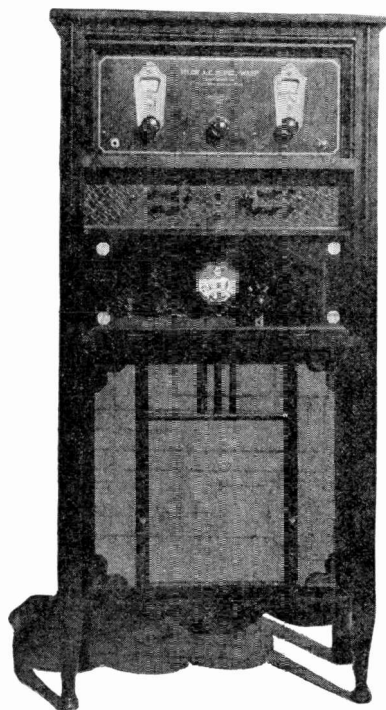

Vol. 3, No. 4, Radio Design

How to Learn the Code

By H. K. BRADFORD*

EDITOR'S NOTE

The article on amateur radio by K. B. Warner, which appeared in Fall issue of RADIO DESIGN, aroused considerable interest among short-wave set owners whose main aim heretofore has been the phone and broadcasting stations only. So many have asked for further "dope" that we are presenting herewith an article on the most important feature of amateur radio operation—the code. Once you learn how to handle the dots and dashes everything else becomes very easy.



H. K. Bradford

POSSIBLY the first thing the prospective code student wants to know is, "How long is it going to take?" Of course, the time required to gain a fair speed in receiving and transmitting code varies with different students, but experience over a number of years with students of all kinds enables us to say, with a degree of safety, that any one with a real desire to master code can attain a speed of 10 words per minute in from one to three months, spending an average of six hours a week in study and practice.

Learning code is much like learning to drive an automobile. It is largely a matter of co-ordination between ear and hand, as in automobile driving there must be close coordination between eye, hands and feet. That is, one must learn to think in terms of audible dots and dashes; one must learn to transfer his "dot and dash" thoughts into mechanical dots and dashes with his finger tips—and the whole process must be more or less automatic, just as an experienced automobile driver manipulates the controls automatically.

ONLY ONE RADIO CODE

Fortunately for us, there is only one code used in ordinary radio-telegraph communication. This is true, not only for our United States, but for the world, regardless of language. The code symbols are standard. This code is known as the International Morse Code, the Continental Morse Code, or simply, the Continental Code. It is slightly different from the American Morse Code, but that won't make any difference to us as the American Morse Code is used only for land line telegraphy.

In the accompanying table are given all the alphabet characters in code, along with the numerals and punctuation marks.

* Commercial Operation & Maintenance Consultant, National Radio Institute.

Now how shall we go about getting these code characters into our heads, and how can we attain to a reasonable facility in their use? First, memorize the table. There are various ways of going about doing this, and the student should give some thought to his particular mental processes in order that he can decide on the simplest method of memorizing for him. Some people receive a more lasting impression of things they hear, others are more greatly impressed by what they see. The former learn by hearing, the latter by seeing.

THE PROCESS OF LEARNING

As learning and memorizing are nothing more than the storing away of mental pictures, our method of tackling the table will depend on whether we are more responsive to things we hear or to things we see. Most people learn more rapidly by the visual process, but people who learn orally really have the advantage when it comes to code, for code requires alert hearing and almost instantaneous transfer of audible dots and dashes into mental pictures of words and phrases.

Suppose we are in the larger class of those who learn visually. Our aim will be to get a mental picture of the entire table just as it appears on the page. Then when we hear a certain number of dots and dashes, we will immediately refer to the place in the table (in our mind, of course) where this particular symbol appears and simply read off the English character it represents.

The easiest way to obtain a mental picture of the whole code is to copy it on paper just as it appears here. After you have made about three copies, *thoughtfully*, lay all your copies and the original aside and see how far you can get without referring to any copy. You should be able to write out at least half the characters. Then refer to a correct copy,

fill in those you didn't know and correct any errors you made.

Now start a new copy from memory. This time you will get many more than the first time. Check and complete the second copy, lay it aside and make a third copy, continuing the process until you can get the whole thing absolutely correct. When you can do this, you will know that you have learned your code A, B, C's.

If you think you will be able to make better progress by the aural method of learning, read over the table *out loud*. Pronounce the dots and dashes "dit" and "da". Then the letter "a" will be "dit-da", "b" will be "da, dit, dit, dit", and so on. Read over the table in this way several times. Then lay it aside and see how far you can get without it. Refer again to the table for the ones you missed and try again. Each time over you will get more of the characters and you will make fewer errors. When you are reasonably sure that you have it down "pat", make a copy on paper. If your copy is correct you are ready to go on and work with combinations of characters—words.

A SIMPLE PRACTICE SET

For the next step some kind of simple transmitting key circuit is essential. This may be a buzzer arrangement, but a simple audio oscillator is much to be preferred. A simple audio oscillator can be built from spare radio parts. Fig. 1 shows the wiring arrangement and includes a list of parts required.

For practicing receiving, an automatic code transmitting machine is most practicable. It is not absolutely essential that the student of code purchase one of these machines, as many students make good progress by listening in

on slow speed code stations and copying their signals. A Super-Wasp receiver will bring in dozens of such stations.

When using the audio oscillator, the signal note should be of a frequency between 500 and 1000 cycles. These frequencies lie between the first and second "c's" above middle "c" on the piano keyboard and so the frequency of the oscillator can be checked easily. The higher frequencies between 800 and 1,000 cycles are more desirable than frequencies near 500, as the ear is more sensitive to them and will not become fatigued as rapidly.

When you first start to use the key, transmit each letter 25 or 30 times from memory—listening in on the earphones and checking up on the lengths of the dashes and the spacing between the dots and dashes. The dot should be sustained over a period of one count. At the beginning, sustain the dash over a count of four and later reduce this to a count of three. Many students have a tendency to shorten the dash, and as they gain speed it becomes indistinguishable from a dot. Do not be afraid of making the dash too long, because more often it is too short. Spacing between two characters of a letter should be equal in time to one dot, between two letters, 3 dots, and between two words, 5 dots.

An excellent idea is to transmit words from a dictionary in sequence, selecting a group under each letter heading. Constant repetition of the first few letters is extremely helpful.

The key is operated with the index finger, using the second finger and thumb to stabilize the movement of the hand. The hand should be held fairly rigid. All the flexibility should be in the wrist. The arm should be free to the elbow and should supply the energy to the

	A		I		R
	B		J		S
	C		K		T
	D		L		U
	E		M		V
	F		N		W
	G		O		X
	H		P		Y
			Q		Z
	1		2		PERIOD
	2		3		INTERROGATION
	3		4		BREAK (DOUBLE DASH)
	4		5		WAIT
	5		6		END OF MESSAGE
	6		7		END OF TRANSMISSION
	7		8		
	8		9		
	9		0		
	0				

Above is the Continental Code, used for radio work all over the world. There are numerous abbreviations and punctuation marks, but only the more important ones are shown.

hand for operating the key. The portion of the arm above the elbow remains entirely stationary. See Fig. 2.

PRACTICE SIGNALS PLENTIFUL

Abundant material for code listening and copying practice may be found on the high frequency bands above 3,000 kc. Amateur stations may be heard mostly between 3,500 and 4,000 kc., 7,000 and 7,300 kc., and 14,000 and 14,400 kc.; while radio-telegraph stations may be found well distributed throughout the high-frequency spectrum. Some types of commercial work demand slow code speeds, some as low as 5 words per minute.

The student who has the sound symbols well in mind will find this speed a good starting point. Do not attempt to "copy" the code in your mind at first. Much better progress will be made using a pencil and paper. Letters such as c, f, l, m, o, q, and y will be picked out more consistently than letters of shorter time duration. Confusion between letters such as f and l, y and q, w and g, etc., which consist of the same symbols but in reversed order, should be overcome at the start. Many students make a practice of memorizing these groups independently. This is a poor policy, as it will result in confusion. Each time a mistake is made in copying, only the letter missed should be reviewed. Do not stop if you miss a letter in a message, but continue right on and get the next one if possible. Time spent in trying to recollect the letter missed is wasted. Do not lift the pencil from the paper until a complete word is copied and do not let the code get ahead of your writing. See that you are not more than one letter behind the signal. If you have finished writing one letter, your mind is clear to concentrate on the next letter.

ADVANCE CAREFULLY

When you can copy 80% or more of the letters in a message correctly, progress on to a slightly higher speed. Greater code speeds than you can comfortably handle will tend

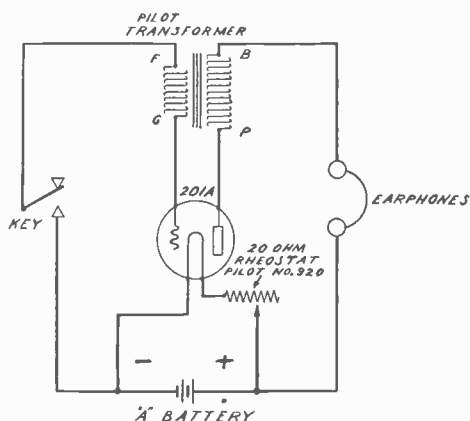

Figure 1: Circuit of a simple audio oscillator suitable for use as a code practice instrument. No "B" battery is necessary, the filament battery supplying enough plate voltage to make the circuit oscillate. A No. 391 transformer is used.

to make your work inaccurate, whereas code which you can easily copy 100% will not help you materially in increasing your speed.

You can easily compute your code speed at any time with a knowledge of the time taken to copy a message and the average word length. Code speeds are based on an average word of 5 letters. You can judge that you are handling code fairly fast when you have trouble in writing it as fast as you can read it, as writing speeds vary from 15 to 25 or more words per minute.

Practice will enable you to interpret a complete sentence in your mind. At this stage of the game, you will find the ether inviting. You'll want to own a short-wave transmitter and make radio friends in Africa and China and Hoboken. Incidentally, carrying on friendly conversations in this way is the best possible means of gaining speed, accuracy and self-confidence.

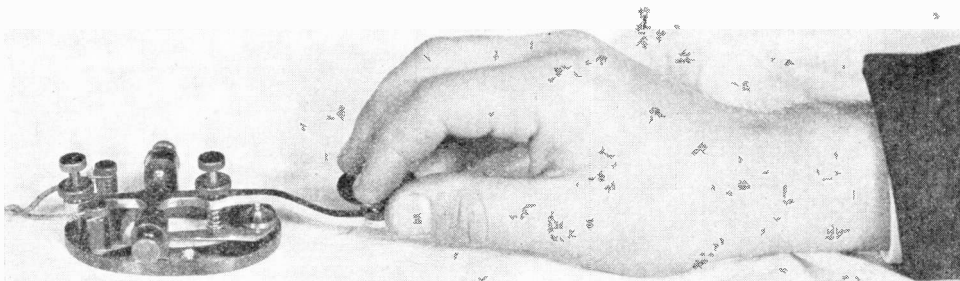

Figure 2: This is the simplest and most comfortable way of operating a radio key. Note the natural position of the wrist and the fingers.

New Pilot Parts Announced

Heavy Duty Power Pack for A.C. Receivers; Power Transformer for Amplifiers and Transmitters; Short Wave Transmitting Condenser

A NUMBER of new products of interest to radio constructors and experimenters has been brought out by the Pilot Radio & Tube Corporation. These will be on the market by about the time this issue of RADIO DESIGN appears.

K-139 POWER PACK

First there is a new heavy-duty power pack to supplement the well-known K-111 and K-112. This is called the K-139, and is designed to meet the power requirements of practically any modern A. C. radio receiver. It is factory assembled and wired, and is sold all ready for use. It has a formed steel base $14\frac{1}{2}$ inches long and $6\frac{1}{4}$ inches wide, and stands 6 inches high. The whole unit is finished in the beautiful black Japanese lacquer characteristic of Pilot power apparatus.

There are three models of this power pack, identical in size and appearance but intended for different line voltages. Each may be used on either of two voltages, depending on which of two pairs of clips is used for the line fuse. This arrangement is made possible by the simple means of tapping the primary of the power transformer.

The maximum direct current output, for plate supply, is 125 milliamperes at 300 volts. This is enough for the largest receivers em-

ploying two 245's in push pull in the output stage. Lower voltage values down to 45 are available from a dividing resistor, and adjustment of them is made possible by an additional variable resistor in the "B" plus lead. The filament windings for the lighting of A. C. tubes are as follows: 4 volts at 6 amperes, for a variety of European tubes; $2\frac{1}{2}$ volts at 12 amperes, for 227 and 224 tubes; $2\frac{1}{2}$ volts at 3.5 amperes, for two 245's, and 5 volts at 2 amperes for 112A's or 171A's. The connection plate is molded bakelite with screw terminals.

Catalog listings are as follows:

- 125 milliampere power pack, for 110 or 125 volts—No. K-139—Code: YADAT.
- Same power pack for 210 or 230 volts—No. K-139G—Code: YAFOZ.
- Same power pack for 230 or 250 volts—No. K-139H—Code: YEELJ.
- (for 50-60 cycle A. C. only).

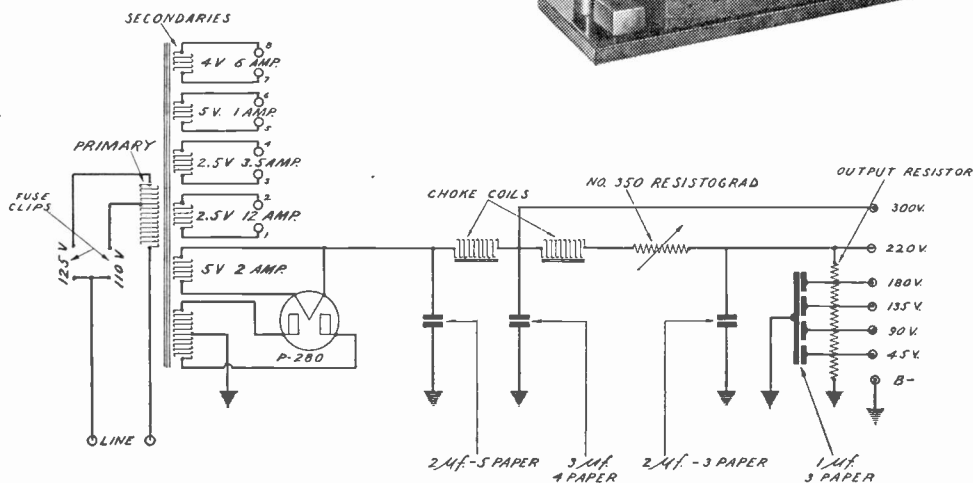
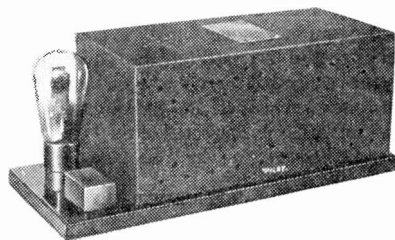

Upper right: appearance of the K-139 power pack. The small box in front of the rectifier tube is a cover for the fuse clips. Above: Complete wiring diagram of the K-139.

No. 445 POWER TRANSFORMER

The new No. 445 power transformer will appeal to constructors of voice amplifiers and to builders of low-powered amateur short-wave transmitters, as it is ideally suited for both purposes. It has three secondary windings: $7\frac{1}{2}$ volts at $3\frac{1}{2}$ amperes, to light two 281 rectifier tubes; $7\frac{1}{2}$ volts at $3\frac{1}{2}$ amperes, to light two 210 or 250 tubes; and 1200 volts, center-tapped, to deliver a maximum of 140 milliamperes of direct current through a filter system using the No. 443 choke coil and the No. 444 filter condenser block. For operating two 250's in a voice amplifier, or for two 210 tubes in a short-wave transmitter, this combination cannot be surpassed for effectiveness and economy.

The No. 443 choke has an inductance of 32 henries at 145 milliamperes. The No. 444 condenser block has three sections: 2 mf. and 3 mf., 900 volt working rating, and 3 mf., 650 volt working rating.

The same steel case is used for all three units. This is 5 inches by $4\frac{3}{4}$ inches by $5\frac{1}{4}$ inches high, finished in black Japanese lacquer. The connection plates are of molded bakelite with screw terminals.

Catalog listings are as follows:

- Power transformer for 210 or 250 tubes, for 115 volts (110-120)—No. 445—Code: YAWEP.
- Same transformer for 220 volts (210-230)—No. 445A—Code: YAWYT.
- Same transformer for 125 volts—No. 445F—Code: YAYSO.
- Same transformer for 240 volts—No. 445B—Code: YAYLJ. (for 50-60 cycle A. C. only).
- 32 henry choke coil—No. 443—Code: YIUGM.
- Filter condenser bloc—No. 444—Code: YOBLO.

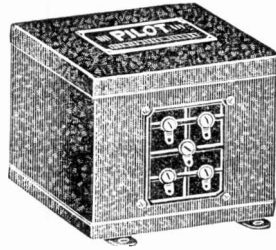

The No. 445 power transformer. The case is made of steel, finished in black Japanese lacquer, and is equipped with four strong mounting legs. The secondary windings terminate at screw-type binding posts on a molded bakelite plate.



TRADE MARK

No. 3022 TRANSMITTING CONDENSER

Of special interest to amateur operators is the new Pilot No. 3022 Vaultype transmitting condenser. This is identical in size and appearance with the regular No. 3042 double receiving condenser, but has double spacing between the plates and a 1000-volt operating rating. Each of the two sections has a maximum capacity of 74 mmf.; when the two stators are connected together, the maximum is 148 mmf.

This condenser has a rigid die-cast aluminum frame, with a pressed aluminum cover that protects the plates from dust and injury. The instrument may be mounted flat on a baseboard, or from either end. The $\frac{1}{4}$ inch shaft extends $\frac{7}{8}$ inch from both ends.

Special Vaultype transmitting condenser
—No. 3022—Code: YASLE.

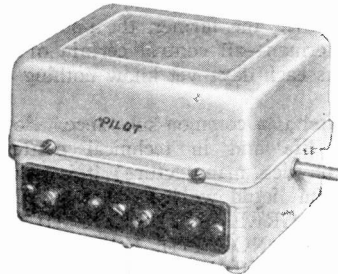
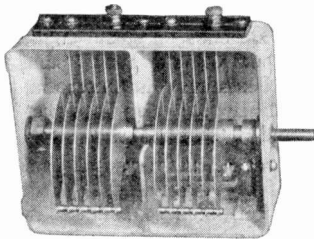

Left: The No. 3022 transmitting condenser with the cover removed to show the unusually wide spacing between the plates. Right: the condenser with its dust-proof cover in place.

The Ignorance of Experts

By ROBERT S. KRUSE



Robert S. Kruse

IN radio we are taught to honor the experts. The newspapers work steadily to keep the name of expert shining and glittering. The slightest word of an expert is paraded down the leading column of the radio page—and sometimes the front page, too. The expert knows everything—exactly! Great is the expert! Put your faith in him; stop your own thinking machinery and let him decide everything for you.

We expect too much from the experts. They are human, too, and quite probably call themselves by the much less magical names of engineer or scientist. Now, to be sure, the scientist and the engineer have studied, but also they are still studying, which seems to show plainly that something remains for them to learn. They admit this without urging because a student is usually humble by reason of his suspicion that our best is only a beginning.

Our engineer and scientist have learned to say, "I don't know." That is not an admission of ignorance unless one lets it go at that, for one can't start learning until one knows that there is something to learn.

Let us put it another way. Suppose we were to go to a highly successful farmer and ask him what makes the grass grow. What may the man say? He can fall back on osmosis, the catalytic action of chlorophyll in the presence of sunlight, the assimilation of nitrogen from the air. Has anything then been explained? Have we any more idea than before why the grass grows while the same materials put into a test tube simply decay? We have not, because we have not explained LIFE. Nothing is commoner than life—it swarms around us through every moment of existence—we carry it around inside ourselves—yet in five thousand years of written human history we have never managed to even suspect what it actually is.

The poultryman, the cattleman, the dog fancier, the gardener, the farmer, the immunologist, the fisherman—all control certain of its manifestations each day—yet know nothing of it.

Again—water is a common substance. Both in ordinary life and in technical matters (chemistry, physics, manufacture) it is easily the most useful liquid we have—yet we DO NOT EVEN AGREE ON ITS CHEMICAL COMPOSITION NOR THE MANNER IN WHICH IT DISSOLVES SUBSTANCES.

There is nothing on the earth about which we know so much in an exact way as we do of electricity—yet even here we have barely

learned enough to learn the probable extent of our ignorance. We have learned that the phenomena of electricity seem to extend through the whole universe. Now then—is electricity actually the "universe substance"—do we actually live in an electronic cosmos—or are there other things which are quite as universal and which we have merely not traced down so carefully? If the electron is the unit from which the universe is built up, is life also electronic? Is intelligence electronic?

No replies are available now—except opinions only. One man may say that the basic motive power of the universe is a chemical one, another may say that it is simply mechanical inertia and will eventually play out, while a third may say that the force is a conscious will of some sort known as God. None of the three can prove anything.

Well then, if there is no good answer forthcoming on the growing of the grass blades in your yard, the nature of the water in your kitchen faucet or the kind of life that actuates the flies on the wall, is it remarkable that no quick answer is forthcoming when the radio engineer is asked to explain the electromagnetic field generated by broadcasting stations? It was possible to see and feel the grass and the water, but the radio wave we cannot see or hear or smell or feel or in any way observe except through the indirect medium of electrical apparatus.

THE SACRED THEORY

Obviously, almost, we cannot prove with certainty that there really is such a thing as an electromagnetic field or wave; it may be no more than a convenient mathematical fiction like the "radiation resistance" of the older radio books and the mysterious "entropy" found in books on steam engineering. It may seem odd to take much pains over a thing whose existence is uncertain and which is quite likely to be an incorrect bit of imagining and nothing more.

However, that is nothing new. History is full of the wrecks of discarded theories and no serious student believes that our present theories are "right" to the extent of never needing readjustment. A theory fortunately can be used before it is perfected just as we can drive automobiles today though it is a certainty that they will be much better in the future. When better automobiles are made

we will not use the present ones. So, too, with the theories. Twice in your lifetime and mine the theory of light has been changed. In the last 15 years we have three times modified our ideas as to the way in which radio signals travel, yet even at this moment we know that our latest theory is not correct at 5 meters. Very soon we will build another theory and live in it for a while, while we make short expeditions forward into the unknown.

ONLY DEAD THEORIES—

This does not mean that all theories are wrong but simply that they are alive. It is only dead theories that do not change. The remark does not apply only to radio. The laws of 1800 seem absurd to us and very certainly the laws of 1931 will be laughed at in their turn. Several of our present religions have added definite moral force to human existence, but since religion has been going under for thousands of years most of the present ones, and probably all of them, may in turn be expected to disappear. The government of this country is on the whole a good one, yet 200 years from now there will most certainly be better ones. There is much about all of these things which we feel to be faulty, and many of us think we know the nature of the faults. Still we seem poorly justified in taking that as an excuse for abandoning law, religion and citizenship in favor of sitting on the curb while the parade goes by.

No, even a weak theory is useful. We may not know *what* makes a magnetic line go, and we need not be sure that there even is such a thing, but until the truly great (of whom there are very few) devise better understanding for us, we ordinary folks can do little better than to use the existing theories as starting points for our own little expeditions. One may live in a house even if the roof does leak.

I do not see that we need even be discouraged at our failure to comprehend everything provided only that we continue to learn something. Even the inspired, who suddenly envision one new thought clearly, may quite easily fail in something else. The mathematical genius forgets his house number and the philosopher cannot pay his taxes.

All of us seem to need facility in saying "I don't know." There is no harm in that as long as we keep it coupled with, "How can I find out?" To be sure, most of us will never find out anything tremendously important in science or in the closely related field of religion, but that in no way prevents us from enjoying the thrill of *finding out for ourselves*.

We may need to buy ready-made advice from the doctor and the lawyer and possibly have ready-made politics fed to us by the newspaper, but radio constantly offers inter-

esting questions that all of us are able to look into.

Please do not understand me to be arguing for household radio laboratories! That would be a calamity. Most of us would be like an unskilled man in a room full of fine tools. Take what you have; your radio receiver and your watch, if you observe them carefully, can set enough problems for you in a week to keep you thinking for the rest of the year. Very probably most of those problems can be solved in your own room with no equipment except what I have already mentioned plus a calendar, some paper and a pencil.

Of course, there is no reason for refusing help; even a household authority ought to know what the other authorities have said. This is made easy for us in 1931. It isn't necessary for us nowadays to travel to Syracuse in Sicily to learn what Archimedes thinks because Archimedes and all his followers have been reduced to print and assembled in one building. Now I have very little use for parrotting the sayings of books, but I am still willing to admit that the public library is much taller than it seems and may even reach most of the way toward the star of our intellectual desire.

Testing Hint

In testing a set with a voltmeter, it is sometimes difficult to reach certain points with the short probing pins usually supplied with the instrument. If you experience trouble of this kind, simply fasten the tips of the pins to Mueller spring clips, and snap the latter over the shanks of any two long-bladed screwdrivers that you happen to have on hand.

The screwdrivers can be manipulated very easily, and will make the testing of the inaccessible parts a quick and simple matter. The wooden handles of the tools provide plenty of insulation, so you may make readings on high voltage circuits without fear of being "bitten."

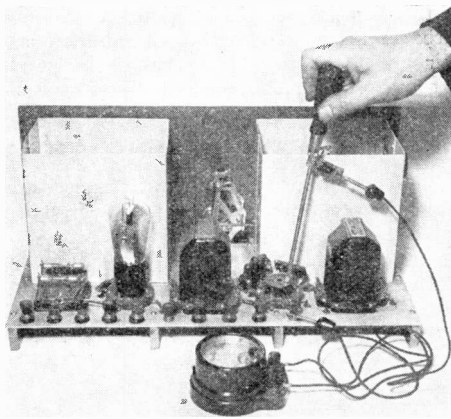

Questions and Answers

IMPORTANT NOTICE

Because of the great amount of work involved in the handling of our technical mail, which amounts to as much as 1500 questions a week, we have been forced to limit our free service to questions concerning only such apparatus mentioned or described in RADIO DESIGN or produced by the Pilot Radio & Tube Corporation. We can no longer answer letters dealing with the following subjects: service problems on obsolete or current factory-built receivers, or home-made sets of individual design; the drawing of special hook-ups to fit odd collections of parts; the design of new circuits, sets or parts; criticism or analysis of proposed ideas; and the identification of unknown stations.

Correspondents are requested to write plainly and clearly (we are not mind readers), to sign their full names and addresses, and to send either U. S. stamps or stamped and addressed envelopes along with their letters.

Readers desiring special technical assistance not covered by the foregoing rules should refer to page 69 of this issue.

REGARDING TRANSFORMER WINDINGS

1. I have a power transformer which is designed to furnish filament and plate supply for 2.5 volt tubes and the 245. At present I am only using one of the 2.5 volt windings for the tubes in the receiver. I use earphones, not having built the audio amplifier yet. Will I damage the other 2.5 volt winding by operating the transformer this way with the winding left open?

Answer: You can operate your transformer with any of the low voltage windings left open without fear of damaging it. No current flows through the winding when its terminals are left open.

ELIMINATING NOISES IN RECEPTION

2. Reception with my set is accompanied by scratchy noises. How can I locate and remedy this trouble?

Answer: Noises accompanying reception must be traced by the process of elimination. First test to find if they are due to electrical interference in the immediate vicinity. Noises of this kind may be due to natural static, disturbances from electrical appliances or machinery, disturbances from trolley or power lines, etc. To do this, first disconnect the antenna. Connect the antenna and ground binding posts of the set together with a short piece of bare wire. If the noise stops or diminishes in intensity you will immediately know that the interference is coming from the outside and not from the receiver itself.

To determine if the "B" supply is noisy, connect a pair of earphones or the loud speaker in series with a 1 mf. fixed condenser across the output terminals of the eliminator. By listening in the earphones you can tell whether the noise originates in the "B" power unit or not.

Noises are often caused by defective tubes. It is well to test all tubes in another set (possibly a neighbor's set) when noises are troublesome. Corroded tube prongs and poor contact with the springs in the sockets will also cause noises. In many cases, noises are caused by improperly soldered joints in the wires. The slightest mechanical vibration of the wires causes grating sounds in the loud-speaker. This can be located by wiggling the connecting wires in the set while it is turned on.

Sometimes grating noises are heard when the tuning condensers are turned. This is caused by the fact that the rotor or stator plates are bent out of line and touch or scrape against each other, causing a partial short circuit. This can be determined by carefully examining the condensers. The plates can be bent back into place carefully with a pen-knife or small screwdriver.

PHONES-SPEAKER CHANGEOVER SWITCH

3. A clever suggestion has been sent to us by Mr. B. Williams, of Washington, D. C. Fig. 1 shows the arrangement used with the Super-Wasp receiver for quickly changing over from

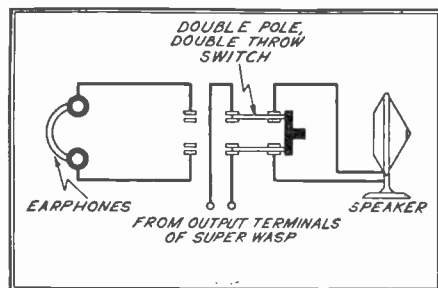

Figure 1: A simple changeover arrangement for the Super-Wasp.

ear phones to speaker without having to plug in or out of jacks.

Instead of connecting the speaker or phones to the regular binding posts on the receiver, two pieces of wire are twisted and run from the loud speaker terminals on the output transformer on the A. C. Super-Wasp, or loud speaker binding posts on the battery operated Super-Wasp to the center terminals of a double-pole double-throw switch.

Connect the speaker to one pair of terminals on the switch, and the earphones to the remaining two terminals. When either is desired for use it is only necessary to flip the switch over to one side or the other. This is very convenient when receiving distant stations where the station is located with the earphones, tuned to maximum volume, and then switched on to the loud speaker. Midget switches suitable for this purpose may be purchased in most radio stores.

ELIMINATE HOWL IN SUPER-WASP BOOSTER UNIT

4. Mr. Collingbourne of Messrs. Huttenback Lazarus & Sons, Ltd., of Singapore, offers a suggestion for eliminating the audio howl which sometimes results when a K-120 booster unit is added to the K-115 A. C. Super-Wasp. The circuit diagram of this booster is shown on page 47 of the Vol. 2 No. 4 issue of RADIO DESIGN.

Mr. Collingbourne recommends that the detector, first and second audio stages be fed from the B+ 180 volt terminal of the K-111

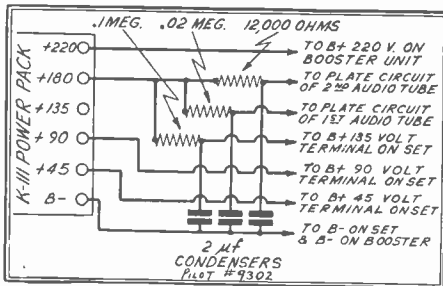

Figure 2: How one user of Super-Wasp eliminates howl in his set.

power pack through resistances whose respective values are 100,000, 20,000, and 12,000 ohms, as shown in Fig. 2. The low voltage terminal of each of these resistors is connected to B— through a 2 mfd. condenser. This arrangement is recommended for those stubborn cases of howl which the ordinary precautions of keeping all grid and plate leads short and direct, etc., will not help. Fig. 2 shows all of the “B” connections between the set and power pack and booster when this arrangement is used. It is necessary to break the

common B+ connection of the first and second audio tubes in the set. Separate B+ lines for the two audio tubes are run as shown in Fig. 2.

A. C. NOMENCLATURE

5. What is meant by the frequent references to “A. C.,” “frequency” and “cycles” in RADIO DESIGN?

Answer: A. C. is the abbreviation for “alternating current.” Alternating current is a type of electricity that is described by its name—it alternates. It flows first in one direction through the circuit, then it reverses and flows in the opposite direction. A complete flow of current first in one direction and then in the opposite direction is called “one cycle.” The number of cycles occurring in one second is called the “frequency” of the current. Thus 60 cycle A. C. is alternating current which flows first in one direction and then in the opposite direction, 60 times a second.

ELECTRIC LIGHT LINE DATA

6. Can a D. C. power pack be used on A. C.?

Can an A. C. power pack be used on D. C.?

Can a 25 cycle power pack be used on a 60 cycle A. C. line?

Can a 60 cycle power pack be used on a 25 cycle A. C. line?

How can I find out the voltage and frequency of my electric light circuit?

Answer:

A D. C. power pack cannot be used on A. C.

An A. C. power pack cannot be used on D. C.

A 25 cycle power pack can be used on a 60 cycle line in some cases.

A 60 cycle power pack cannot be used on a 25 cycle A. C. line under any conditions!

You can find out the voltage and frequency of the current supplied by your electric light company either by examining the name plate on your electric light current meter or by inquiring of your local electric power company.

WINDING DATA ON SUPER-WASP COILS

7. Will you kindly publish the complete winding specifications for the Super-Wasp antenna and detector coils?

Answer: Following are the winding data for the Super-Wasp coils. The Pilot No. 185 blank plug-in coil forms are employed:

Antenna Coils: Number of turns of wire connected between prong No. 1 and prong No. 2 with jumper wire from prong No. 1 to prong No. 4:

Red ring—14.2-28 meters, 4¾ turns.

Orange ring—27.1-53 meters, $9\frac{1}{2}$ turns.

Yellow ring—51.2-101 meters, $20\frac{1}{2}$ turns.

Green ring—99.3-202 meters, $47\frac{1}{2}$ turns.

Blue ring—220-500 meters, 100 turns (secondary) from prong No. 1 to No. 2, 27 turns (primary) from prong No. 2 to No. 5.

Windings of all but blue ring coil wound centrally on form. Blue ring coil has primary (small winding) placed at top end of form, $\frac{1}{8}$ inch space between primary and secondary windings.

Detector Coils:

Red ring— $3\frac{1}{4}$ turns from prong No. 1 to No. 2 (grid winding), 5 turns from prong No. 3 to prong No. 4 (tickler).

Orange ring— $7\frac{1}{2}$ turns from prong No. 1 to No. 2 (grid winding), 6 turns from prong No. 3 to prong No. 4 (tickler).

Yellow ring— $16\frac{1}{2}$ turns from prong No. 1 to No. 2 (grid winding), 7 turns from prong No. 3 to prong No. 4 (tickler).

Green ring— $46\frac{1}{2}$ turns from prong No. 1 to No. 2 (grid winding), 15 turns from prong No. 3 to prong No. 4 (tickler).

Blue ring—99 turns from prong No. 1 to No. 2 (grid winding), 27 turns from prong No. 3 to prong No. 4 (tickler).

All tickler windings are $\frac{1}{8}$ -inch below the grid windings. Windings are placed centrally on coil forms.

Use No. 24 double silk covered wire for all but the blue ring coils. Use No. 28 double silk covered wire for the latter.

The coils must be wound very carefully, as even $\frac{1}{2}$ turn of wire on the grid windings of the short wave coils will make an appreciable difference in the wavelength range. The windings on the blue ring coils are double layer bank-wound in 6 turn sections. Windings on all other coils are single layer straight wound.

After winding the coils by hand it may be necessary to add or remove a fraction of a turn of wire or more to the individual coils due to the variations in inductance caused by tightness or looseness of the winding, etc.

AIR SCOUT RECEIVER OSCILLATION CONTROL

8. I built the Air Scout receiver described in the second issue of RADIO DESIGN several

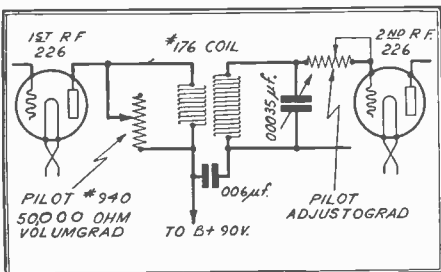

Figure 3

years ago. Can you suggest any improved method of controlling the oscillation and volume in this set?

Answer: Connect a Pilot No. 1001 (1000 ohm) Adjustograd in the grid lead to the second R. F. tube. Connect a Pilot No. 940 50,000 ohm Volumgrad (as a variable resistance-middle terminal and one end terminal) across the primary winding of the R. F. coil in the second stage. The Adjustograd will control the oscillation and the Volumgrad will give smooth volume control. The connections are shown in Fig. 3.

NEW 2 VOLT DRY CELL TUBES

9. Is it possible to use the new 232 type dry cell tube in an old battery set which uses either 199 or 201-A tubes at present?

Answer: No! The 232 type tube is a screen grid tube and requires R. F. coils designed especially for screen grid tubes. You could adapt your set to use the new 230 general purpose 2 volt tube, by making the proper changes in the wiring of your set. We advise you to read the article on the new 2 volt tubes printed elsewhere in this issue of RADIO DESIGN.

HEATING-UP NOISE IN A. C. SET

10. What causes the peculiar "ring" or howl in my electric receiver when it is first turned on? This noise disappears after a few seconds.

Answer: The peculiar noise you speak of is usually due to the expansion of the cathode during the warming up period in either the 227 or 224 tubes. The noise originates in the detector tubes and the only practical cure is to try different tubes in the detector socket until one is found that does not produce this noise. A majority of tubes will not produce this noise. Usually a tube which does produce this noise is perfectly satisfactory for use in the R. F. or A. F. stages, so it need not be discarded.

SHARPEN BROADCAST TUNING OF SUPER-WASP

11. My K-115 Super-Wasp works perfectly on the short waves but several stations interfere with each other when I use the blue ring broadcast coils. Is there any remedy for this?

Answer: In some localities it is possible that the two tuned circuits used in the Super-Wasp receivers do not provide sufficient selectivity to separate the programs from powerful nearby broadcasting stations. This need not appear strange when we remember that most modern broadcast receivers are now employing from four to six tuned stages to obtain the necessary amount of selectivity!

When Power Packs Get Hot Give Them Air

Grounded Socket Terminals and Lack of Ventilation Cause Overheating and Subsequent Failure of Instruments

LATELY we have received quite a few letters from people who have been experiencing trouble due to overheating of their power packs. We have asked a great many of them to send their entire outfits to us for inspection and test, and in addition have requested them to furnish us with a detailed description of the installation of the set in the cabinet, etc. The information we have obtained by following up these complaint cases has proven highly interesting and instructive, and we decided to print it here for the benefit of any other readers who may be experiencing similar troubles.

SHORT CIRCUITS IN SUPER-WASP

First we received so many reports of excessive heating of the K-111 power pack used with the A. C. Super-Wasp that we became suspicious. We had tested this power pack in every conceivable way and had never experienced any difficulty with it.

In practically every one of the complaint cases we found that the K-111 power pack had heated up so badly that the impregnating wax in the power transformer had melted and run out at the bottom. A careful examination of the set revealed that all of the wiring had been put in exactly as shown on the blueprint. The tubes tested out O. K. Then we noticed something: The tube sockets had been mounted on the aluminum base panel exactly as they had been taken out of their boxes. When soldering the wires to the socket lugs the constructor applied about five times as much solder as was necessary, allowing large globs of it to run down between the soldering lugs and the metal panel. Of course this made electrical connection between the lugs and the grounded panel, causing short circuits with resulting heavy current drain on the power transformer and dangerous overheating. On some of the sets only the filament lines were grounded and shorted, on others both filament and plate lines were shorted, damaging both

the power transformer and rectifier tube. After we had removed this excess solder the sets worked perfectly.

To avoid this trouble, bend the soldering lugs on the sockets up to an angle of about 45 degrees when mounting the sockets. Make sure that no solder runs down between the lugs and the panel. Do not apply any more solder to the joint than is necessary to make good electrical connection between the wires and the lugs. Hold the soldering iron on the joint long enough to make the solder *flow freely* and form a thin covering layer over the joint. A large lump of solder at the joint is not necessary.

VENTILATION

During this interesting investigation of ours we ran into another very common trouble arising in connection with excessive heating of the power pack in some of the larger 6, 7 and 8 tube sets. The excessive heating was caused by the fact that little or no ventilation was provided in the set installation to dissipate the normal heat produced by the tubes and the power transformer. We must remember that a current is being sent through the filament of each tube in the set in order to heat it up, so that electrons will be emitted either from the filament itself or from a cathode. This heating process is going on continuously while the set is operating. The natural result is that the heat from the filament is conducted by conduction and radiation to all other parts of the tube. The glass bulb on the tube conducts this heat to the surrounding air, heating it up. Power tubes such as the 171-A, 245 and 250 and the 280 rectifier tubes give off quite a bit of heat, as you will easily find out if you hold your hand over one of them when your set is in operation.

WHY SHORTS OCCUR

If the cabinet is entirely closed, without provision for ventilation, the temperature in-

side may rise to a point sufficient to melt the wax out of the condensers and the transformers in the power pack. When this protective insulating wax runs out, short circuits are bound to occur. Well, what are we going to do about it? We cannot prevent the heat from being developed, because it is essential to the proper operation of the tubes.

GETTING RID OF THE HEAT

Let us turn for a moment to a consideration of the ordinary automobile engine, with which you are undoubtedly familiar. Power is produced in the engine by the explosion of gasoline in the cylinders. Of course this produces a considerable amount of heat, which would soon heat the entire engine up red hot and burn our bearings, etc., if no provision were made to get rid of it. Remember this important point—we must get rid of the heat. In the automobile engine the heat is dissipated—gotten rid of—either by circulating water around the cylinder walls and cooling this water by the air which is sucked through the radiator opening by a fan, or else by a system of direct cooling by air circulated around the cylinders, as in the Franklin air cooled engine, and in most airplane engines.

THE RADIO PROBLEM

The same solution can be applied to our radio set problem, only the heat developed is not large enough to necessitate the use of circulating water or forced air cooling system. All we need to do is provide openings in the

back and bottom of the cabinet, to let cool air in at the bottom and let it out at the top of the back after it has been warmed by the tubes and power pack and has risen in accordance with the well-known fact that warm air rises.

PRODUCING A DRAFT

Simple enough, isn't it? Yet many of the sets we inspected had been placed in air-tight cabinets with absolutely no provision for ventilation of any kind. Of course the power packs heated up dangerously, as they simply could not get rid of their heat fast enough. Remember that there will not be much circulation of air around the set if openings are made only at the back of the cabinet. Make openings at both the bottom and back so the air sweeps over the entire set. If your cabinet is of wood, simply drill a number of $\frac{1}{2}$ inch to $\frac{3}{4}$ inch holes spaced about one inch apart through it. If it is of metal you will have to drill a larger number of small holes closer together. Drill the holes where they will not be covered over by the set or anything else. Remember, the holes must allow free passage of the air; they are not effective if covered up.

If a console cabinet is used, you can leave the entire back of the cabinet off. You can keep the dust out by nailing a piece of fine mosquito screening on a wooden frame and fastening this to the back of the cabinet. The screen allows fairly good circulation of air but prevents the rapid accumulation of dust in the cabinet and over the set.

This illustration shows the fine amateur station built and operated by Albert E. Lane, 121 Linden Road, Roselle, New Jersey, call letters W2BOE. The transmitter, along the right wall, is a push-pull MOPA (master oscillator power amplifier) affair, using two 227's feeding two 224's feeding two 210's. The receiver, on the small table in the background, is K-115 model A. C. Super-Wasp.

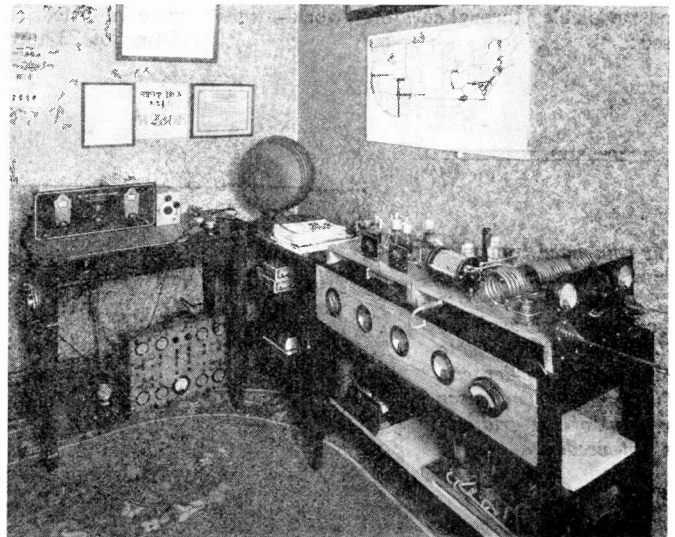

A "Flea Power" Short-Wave Transmitter Using Receiver Parts

With a 201A tube fed by a K-111 power pack, this simple outfit produces fine, clear signals for amateur communication purposes.

Super-Wasp owners: You can use your present K-111 power pack for this transmitter as well as for the receiver, and thus save the expense of a separate power supply unit. Build this little transmitter and go "on the air."

THE one-tube short-wave transmitter shown on page 53 of the Volume 3, Number 3 issue of RADIO DESIGN aroused a great deal of interest, and many readers asked about building this outfit with Pilot parts and using it on a K-111 power pack. The requests for "dope" were so numerous that we built an actual transmitter, following the general description given in *The Radio Amateur's Handbook*. It worked without trouble the first time it was turned on, and was so easy to make that we are sure many short-wave fans will find it interesting.

A piece of wood 12 inches long and 10 inches wide was used as the baseboard. Any dry piece of lumber is satisfactory; no expensive bakelite panels or sub-panels are needed. The following parts—all of standard Pilot make and available throughout the world—were used:

REQUIRED PARTS

- 1—No. 3021 regular Vaultype variable condenser.
- 1—No. 130 radio frequency choke coil.
- 1—No. 213 four prong socket.
- 4—No. 58 mica fixed condensers, .006 mf.
- 1—No. 51 mica fixed condenser, .00025 mf.
- 1—No. 54 mica fixed condenser, .002 mf.
- 1—No. 807 fixed condenser, .6 mf.
- 1—No. 356 center-tapped resistance, 50 ohms.
- 1—No. 953 fixed resistance, 10,000 ohms.
- 6—No. 29 plain binding posts.
- 1—No. 1274 plain bakelite dial.

The parts were arranged as shown in the illustration on this page. In addition to the material listed, the set uses a grid coil consisting of 23 turns of No. 24 cotton covered

The completed transmitter assembled on a board. CF are the by-pass condensers across the filament; CB the plate blocking condensers. The midget condenser in front of the grid coil is not needed.

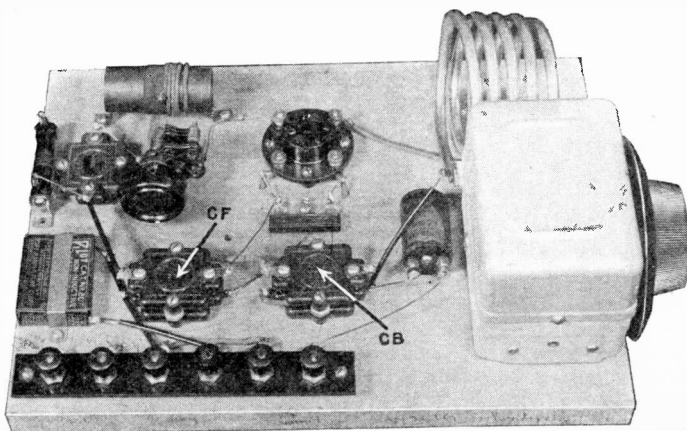

be used, as it is not advisable to switch the transmitting aerial around. Keep all the tubes running constantly, and simply flip the double pole switch to change from reception to transmission, or vice versa.

TUNING UP

The tuning of the transmitter must be done carefully and properly, and need only be done once. The only accessory needed for the purpose is an absorption loop of No. 18 wire. This loop should be about two inches in diameter. One end is twisted around the screw base of a flashlight bulb (which should be the smallest size obtainable) and the other end is soldered to the connection in the bottom of the base. Use very little solder and make sure it does not spill over and short circuit the bulb.

Switch on the K-111 power supply, having first connected the telegraph key to the posts marked "key." Set the variable condenser to full capacity, make sure that the 201A is burning, and press the key. While holding the key down, bring the loop slowly toward the inside end of the plate coil. The lamp should begin to glow, indicating that the set is working. Hold the loop parallel to the turns of the coil.

If the bulb does not light when very close to the coil, release the key and go over the connections. It is doubtful if there will be any hitch to the proceedings, as the transmitter is so simple as to be practically foolproof.

GETTING ON THE AIR

The only remaining thing to be done is to put the transmitter actually on the air. The process is as follows:

After the lamp is glowing properly, snap the feeder clip on the second turn from the inside of the plate coil, making sure it does not touch the adjacent turns. Hold the lamp loop steady in a position where it lights with a fair degree of brilliance, and—holding the key down with a book—turn the dial of the condenser *slowly* down from the present full position of 100. As you do so, the lamp will grow dimmer, finally going out altogether, probably

around 85 or 90. As you continue to turn, the lamp will pick up again, getting brighter as the dial moves. Finally it will go out completely, probably around 50, indicating that the set has stopped oscillating.

Turn the condenser back to where the lamp first went out, around 85 or 90, between the two bright positions. The transmitter is now tuned to the antenna and the outfit is "on the air."

CHECKING THE NOTE

At this time bring the receiver into use. Disconnect the receiving aerial and listen on the 20 meter coils until you pick up the signals from the transmitter. The transmitter, of course, is working on the 40 meter band, but if you listened on 40 meters for the true wave you would get such loud signals that you could not determine the purity of the note. On 20 meters it will sound much weaker.

The signal should be a pure, clean whistle, without growl or "mush." If the note is rough or unsteady, move the feeder clip back and forth, rechecking each time with the flash light loop. Once the best position has been found, leave the outfit alone.

The transmitter illustrated on these pages was made by the editor of *RADIO DESIGN* and used successfully in New York under the call letters W2CTG. It is now on the air from Lawrence, Mass., as W1BRZ.

FOR CODE ONLY

Please note that this transmitter can be used only for dot and dash transmission, and that it involves a knowledge of the radio code. Many people would like to go on the air with radio telephone transmitters, and not use code at all, but they are cautioned that they must know the code anyway in order to obtain the highly necessary amateur radio operator's license required by the government.

Short-wave radio telephony is not an easy science, and is much too complicated for the beginner. Start off with a simple "flea power" transmitter like this one, get some experience on the air, and you will naturally graduate into bigger outfits. Short-wave transmitting is interesting because so many different combinations of circuits and parts are possible. If you like to experiment you will find a transmitter an instructive and useful toy.

For complete details on obtaining licenses, learning amateur practices and traditions, handling traffic, etc., we again refer you to the *Radio Amateur's Handbook*, that veritable gold mine of information. An amateur without a *Handbook* is like a carpenter without a hammer; it's the basic tool of the profession. Although *RADIO DESIGN* does not publish this book, it handles it as a service to its readers, and can fill orders without delay at the regular price of \$1.00 per copy, postpaid anywhere.

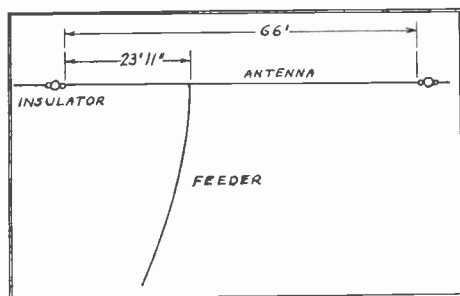

The 40-meter aerial for the transmitter must have exactly these dimensions.

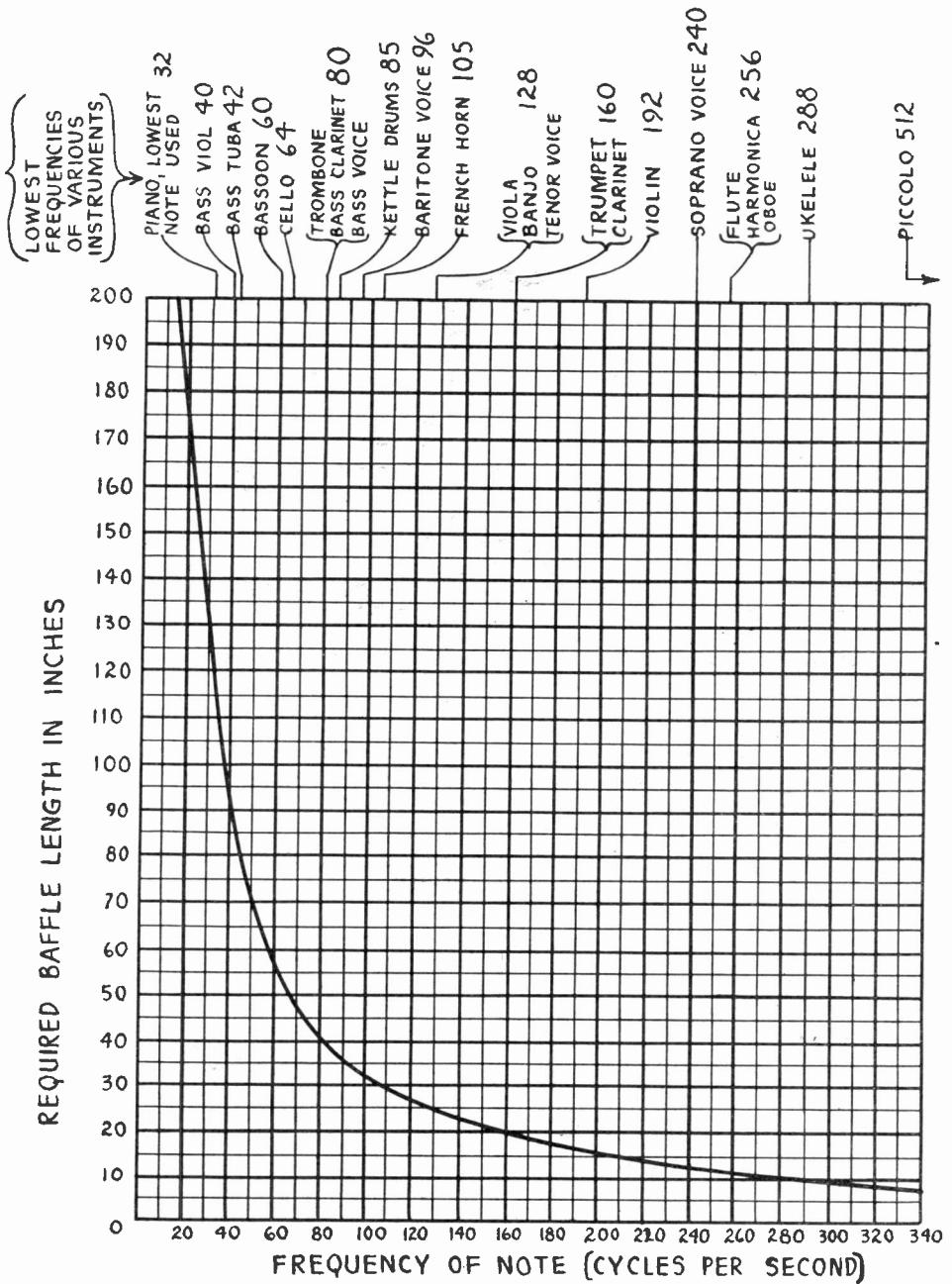

BAFFLE LENGTH REQUIRED FOR FULL REPRODUCTION OF NOTES OF VARIOUS FREQUENCIES FROM A FREE EDGE CONE.

This interesting chart, worked out by Alfred A. Ghirardi, is well worth saving. It is of particular value to experimenters who put their loud speakers into cabinets or baffles of their own.



Above: Reproduction of the novel acknowledgment card used by station NRH, Costa Rica. Below: Leslie F. Satterly, of Patchogue, L. I., an active member of the Radio International Guild, in front of the microphone of station WPOE.

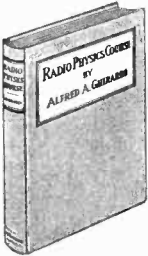

**WHAT DO
YOU KNOW
ABOUT RADIO?**

HERE IN THIS
ONE BOOK
YOU WILL FIND ALL THE IN-
FORMATION YOU NEED FOR A
COMPLETE UNDERSTANDING
OF RADIO RECEIVERS, TELE-
VISION AND THE TALKIES.

▼ ▼ ▼

**THE
RADIO PHYSICS COURSE**

By **ALFRED A. GHIRARDI, E.E.**
Associate Editor Radio Design Magazine,
formerly Technical Consultant to
The Pilot Radio & Tube Corporation
362 pages, 350 illustrations, Price \$2.50
The Foremost Text Book on Radio!
Now Published by

Radio Technical Publishing Co.,
A22 W. 21st ST. NEW YORK CITY



Vol. 3, No. 4, Radio Design

Pilot Broadcast Receivers



The new Pilot Midget and the new Pilot Consolette are of outstanding popularity in their respective classes and are as favored among broadcast listeners as Pilot short-wave receivers are among short wave fans.

The Pilot Midget is a leader in the Midget field, because it is painstakingly designed and built to give long service. Too many Midgets have been built for a quick clean-up by fly-by-night manufacturers who care only how fast they *sell* and not how long they *serve*.

The Pilot Consolette, with its greater baffling area due to its larger cabinet, is the most substantial value in the Consolette models. Its depth of tone amazes all who hear it. Its dainty beauty and compact proportions make it desired by the woman of the home whether the room in which she must place it be large or small.

PILOT Consolette

\$79.50 Less Tubes

AC MODEL—2-P224 Screen Grid TRF, 1-P224 Screen Grid Power Detector, 1-P227 First Audio, 1-P245 Audio Output, 1-P280 Rectifier.

DC MODEL—4-P201-A's and 2-P171-A's.

Dimensions: Height, 33 in.; width, 19½ in.; depth, 13 in.

Illuminated Dial . Knob Control
Tone Control - Phonograph Connection

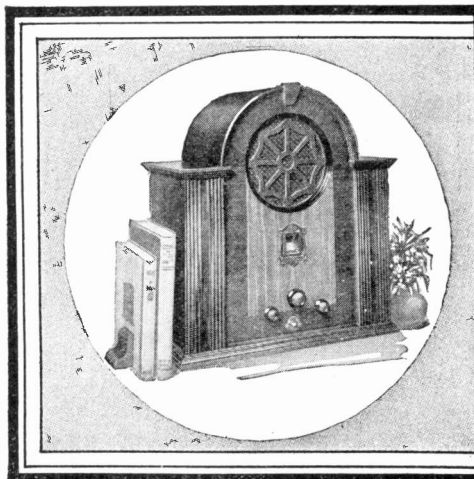

PILOT Midget

\$59.50 Less Tubes

ACMODEL—2-P224 Screen Grid TRF, 1-P224 Screen Grid Power Detector, 1-P227 1st Audio, 1-P245 Audio Output, 1-P280 Rectifier.

DC MODEL—4-P201-A's, 2-P171-A's.
Dimensions: width, 17 in.; height, 18½ in.; depth, 8¾ in.

Illuminated Dial - Knob Control
Tone Control
Phonograph Connection

PILOT RADIO & TUBE CORP.

LAWRENCE, MASS.

GOOD NEWS FOR SHORT-WAVE FANS!

The manufacture of the
K-110 and K-115 Models of
the famous original



SUPER-WASP



will be continued



THE advent of the new Universal Super-Wasp does not mean the end of the K-110 and K-115 models of the original Super-Wasp. This world famous receiver will be continued without change, as it fills a definite need in the short-wave field. Of course it does not have the features of the brand-new Universal, but it still is a fine set and is particularly suitable for use in amateur stations because of its flexible construction. The Super-Wasp was the receiver that really opened the short waves to the home listener, and in the minds of many people its very name is synonymous with short waves.

THE K-110 is the battery model, using one 222 screen-grid tube and three 201A's. The K-115 is the A. C. model, using one 224 and three 227's and operating entirely off a K-111 power pack (furnished separately). Both sets use a

stage of tuned R. F. amplification, regenerative detector and two stages of A. F., with double shielding. A wave length range of 15 to 500 meters is obtained with five pairs of plug-in coils. The two models are alike in general appearance and dimensions, being 18 inches long, 7½ inches high and 9½ inches deep when assembled. They are supplied only in kit form, with front panels but without cabinets.

THE K-110 is described in detail in a 12-page folder, identified as Data Sheet No. 7. The K-115 is described in a 16-page booklet, known as Data Sheet No. 115. These contain much interesting technical data on short-wave receiver design. You can obtain copies from the main Pilot office at Lawrence, Mass., by merely sending a two-cent stamp to cover mailing. The receivers themselves may be examined at radio stores throughout the country.

K-115 Kit — \$34.50

K-110 Kit — \$29.50

K-111 power pack — \$16.50 *tubes extra.*



TRADE MARK



The A. C. Super-Wasp



TRADE MARK

MADE IN THE WORLD'S LARGEST RADIO PARTS PLANT

MADE IN THE WORLD'S LARGEST RADIO PARTS PLANT

New Parts For The Constructor

THE acknowledged leader in the radio parts field, Pilot is keeping up with radio developments and is constantly bringing out new products for experimenters, constructors and service men. The new items listed below will interest all three groups.

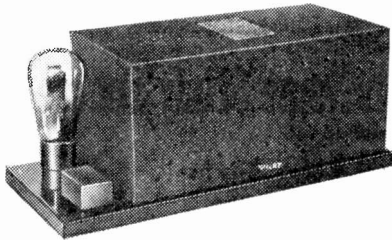

K-139 Power Pack

A HEAVY duty pack that will take care of practically any receiver. Formed steel base, $14\frac{1}{2}$ by $6\frac{1}{4}$ by 6 inches overall. Factory assembled and wired. Maximum D. C. output 125 milliamperes at 300 volts. Filament windings: 4 volts, 6 amperes; $2\frac{1}{2}$ volts, 12 amperes, $2\frac{1}{2}$ volts, $3\frac{1}{2}$ amperes; 5 volts, 2 amperes. Power transformer is tapped; same pack may be used on either 110 or 125 volts, 50-60 cycles A. C.

Price \$24.00

No. 3022 Transmitting Condenser

THE transmitting amateur will welcome this newest Pilot "Vaultype" condenser. Has two separate sections, with common rotor; maximum capacity per section 74 mmf.; total maximum 148 mmf. Double spacing between plates. Cast aluminum frame, pressed cover. Very strongly built. Dimensions: $4\frac{7}{8}$ " long, 4" wide, $3\frac{3}{8}$ " high. May be mounted in any position. $\frac{1}{4}$ " shaft from both ends.

Price \$2.75

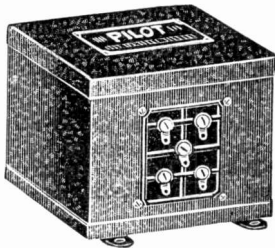
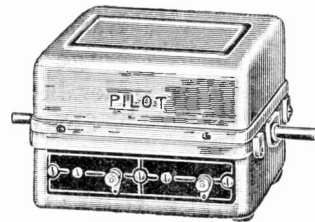

No. 445 Transformer

IDEAL for voice amplifiers using two 250 tubes or amateur transmitters using one or two 210 tubes. Built in strong steel case 5 " by $4\frac{3}{4}$ " by $5\frac{1}{4}$ " high, finished in beautiful black Japanese lacquer. High voltage winding: 1200 volts, center-tapped, to deliver maximum of 140 milliamperes. Two $7\frac{1}{2}$ volt, $3\frac{1}{2}$ ampere secondaries for the filaments of the 281 rectifiers and the 210's or 250's. Should be used with Pilot No. 443 choke coil and No. 444 filter condenser block.

Price \$12.00

Send 2 cents in stamps for your copy of the Pilot Catalog.

PILOT RADIO & TUBE CORP.

Lawrence, Mass., U. S. A.

RADIO and TELEVISION \$3 Home Study Course *Only*

*Valuable Lesson Helps, Code Chart,
Books and Supplies Furnished FREE!*

This most unusual offer is a part of the nation-wide good-will campaign of Station WCFL, Chicago. Secured in any other way such a course would cost you a lot of money, but WCFL needs your friendship and, as a means of getting acquainted, makes you this astonishing offer—

Complete Radio and Television Home Study Course

With ALL These Supplies:

Handy Loose-Leaf Flexible Lesson Binder
Radio and Television Pocket Dictionary
Simplified Radio Electric Theory
Eleven Valuable Lesson Study Helps
Radio Code Chart and Study Help
Large Radio Schematic and Templates
Membership in WCFL Radio Study Club
WCFL Radio Magazine for One Year.

All for Only \$3—Nothing More for You to Buy!

WCFL, the only station owned and operated by Organized Labor, is now engaged in a desperate battle for the preservation of the freedom of the air and for equitable radio facilities for the toiling masses. In this struggle against oppression, WCFL urgently needs your moral support, and to gain your friendship makes you the unusual offer listed above.

WCFL is a pioneer in radio and television experimentation. It was the first station to broadcast television on an aural wave-length, and is now engaged in world-wide short-wave tests—W9XAA, 6080 k.c. and 11,840 k.c. The results of these costly experiments are available to you through the WCFL Radio and Television Home Study Course.

More than 85,000 students are now enrolled. The course is in its second year of successful operation. Many of our students earn money right from the start servicing radio sets. Here is your big opportunity. Grasp it today.

WCFL Radio Study Club, 629 So. Wabash Ave., Chicago, Ill.

WCFL Radio Study Club, 629 So. Wabash Ave., Chicago, Ill.

For the attached Three Dollars enroll me in the WCFL Radio Study Club and send me the WCFL Radio and Television Home Study Course, and the booklets, lesson helps, code chart and supplies just as listed above, also WCFL Radio Magazine for one year.

Name

Street Address

PostofficeState

NEED HELP?

WRITE TO US AT ONCE!

WE OFFER something new in Radio. Our Specialty is supplying Radio Information of any nature. If you need a circuit diagram for any manufactured Receiver or Kit; want the answers to puzzling radio problems or questions; service information for that cranky set, or diagrams for a set you want to build or rebuild, CALL ON US.

THIS SERVICE IS UNDER THE PERSONAL SUPERVISION OF MR. ALFRED A. GHIRARDI, formerly Technical Consultant to the Pilot Radio & Tube Corporation, and Associate Editor of Radio Design Magazine.

RATES REASONABLE

Write at once for FREE Circular and Rate Card

RADIO TECHNICAL SERVICE BUREAU

36-B Stuyvesant Street

New York City

"Radio Amateur's Hand Book"

by the Headquarters Staff of the American Radio Relay League

This is the seventh and latest edition of a book that has become so popular that it is generally referred to as the amateur's "bible." More than 100,000 copies have been sold to radio fans all over the world, and orders for it continue to arrive in every mail.

The handbook contains 218 pages and over 200 illustrations. It is written in clear, understandable English, and is free of all the confusing mathematics that no one ever reads. It was written for YOU, the practical experimenter and constructor who wants to know the how's and why's. Contains all the most advanced "dope" on short-wave reception and transmission.

\$1.00

Postpaid

*We carry this book in stock,
and can ship immediately*

Radio Design Publishing Co.
Lawrence, Mass.

RADIO DESIGN

OFFICIAL ORGAN OF THE RADIO INTERNATIONAL GUILD

A whole year's subscription to "Radio Design" costs only fifty cents. You receive at least four copies of the magazine, and frequent bulletins containing much interesting "dope." Fill out this convenient coupon TODAY.

*U. S. stamps and money orders accepted.
Foreign subscriptions must be paid by international money order.*

Radio Design Publishing Co., Inc.,
Lawrence, Mass.

Enclosed find fifty cents to cover one year's subscription to "Radio Design."

Name

Street and Number.....

City and State.....

Keep The Sheriff Away



YOU, and thousands of others, are in the radio business to **MAKE PROFITS**. The National Trade Magazine, "RADIO," shows you the way to profits by better merchandising methods . . . by tried-and-true systems of profit promotion. Tells you the news of the industry. Latest on midget sets. Complete service man's section. News Flashes. Tube Selling Data. Financial Page. Review of Recorded Music. And 20 other departments of vital interest to every radio man who wants to **SUCCEED**. You Too???? Then send \$2.00 for a **FULL YEAR SUBSCRIPTION TO "RADIO"**. It will be the best investment you ever made.

**One Idea May
Alone Be Worth
the Price of the
Full Year Service**



**Profit From the
Experiences of
Others...IT PAYS!**

Send \$2.00 and the Coupon Today—NOW!

Publishers of "RADIO," 428 Pacific Building, San Francisco, Cal.	
<i>I want to profit from the advice printed in "RADIO."</i>	<i>Here is \$2.00 for a FULL YEAR subscription. Start it at once.</i>
Name	RD
Street and Number	
City	
State	

*We are authorized mail order
representatives for the
full line of genuine*

PILOT  RADIO
PRODUCTS

PILOT products are not sold directly to individuals from the factory. If you cannot obtain what you want from your nearest dealer, write to us. We carry a complete stock of sets, kits, tubes, parts and accessories at all times. As our location is a central one, and we fill orders immediately, we can get apparatus to you very quickly. Thousands of satisfied customers and friends all over the United States will testify to our fine service.

We have all the new Pilot merchandise: the sensational Universal Super-Wasp kit, the K-139 power pack, the No. 445 power transformer and the No. 3022 transmitting condenser. Also, the famous K-110 and K-115 models of the original Super-Wasp, the K-111 and K-112 power packs and every part you could possibly want for short-wave or broadcast receivers.

*A copy of our big 44-page catalog
containing detailed descriptions, prices,
directions for ordering, etc., is yours
free for the asking. Please write your
name and address plainly.*



20TH CENTURY
MAIL ORDER CORP.

204 Jackson St., Chicago, Ill.

BLUEPRINTS

ONLY 10[¢] EACH

These drawings average 24 by 30 inches, and show the sets full size. They are clear and understandable, and you will be proud to tack them to your wall.

Use the coupon below, merely checking off the blueprints you want. Postal money order or U. S. Stamps accepted. Do not send coins through the mail.

**Universal Super-Wasp
BP-136**

Complete layout and wiring of the sensational new "Universal," described in this issue.

**A. C. Super-Wasp
BP-115**

Full-size assembly and wiring blueprint of the first A. C. short-wave receiver, described in the Fall 1929 issue.

**Pilot "Pre-Selector"
BP-126**

The last word in broadcast receivers. Fully described in the Spring issue. Blueprint is full size and shows all details of the construction.

**Screen-Grid
BP-122 (P.E.6)**

Full-size assembly and wiring of the K-122, K-123 and K-124 sets. Only a limited number available; order now.

**Battery Operated Super-Wasp
BP-110**

Several thousands of these sets, in daily use, testify to the sound design of the original Super-Wasp. Every short-wave fan should have a copy of this blueprint.

**245 Push-Pull Amplifier
BP-113**

A high-quality power amplifier using two 227's and two 245's. Suitable for radio, phonograph and public address work.

Check Here	RADIO DESIGN PUBLISHING CO., INC. LAWRENCE, MASS.
BP-136	Enclosed find....., for which
BP-115	send me blueprints checked at left. (Please write plainly
BP-126	and give your full
BP-122	name and post office
BP-110	address.)
BP-113	Name
	Address

for DEPENDABILITY

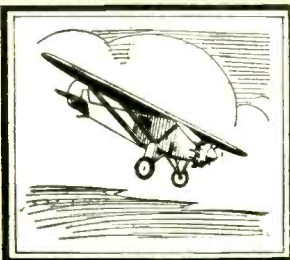

Pilotron Tubes furnished Transmission and Reception on Pilot flight communication.

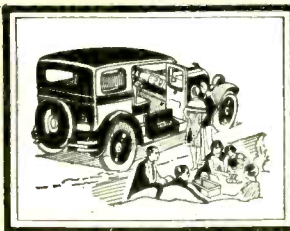

The Auto Pilot uses up least car space, is easiest to install.

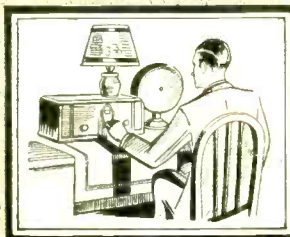

Licensed Amateurs, Custom Set Builders and Radio Engineers endorse Pilotrons.

UP IN THE AIR—flying across great open stretches of sea to the little isle of Bermuda, to the furthestmost ends of South America, making world records and keeping in touch with New York every minute of the day and night with a Pilot Super-Wasp Set, relying all the time on the Dependability of Pilotron Radio Tubes.

Camping miles from anywhere—enjoying some favorite program with your Auto-Pilot Screen Grid receiver and knowing that you can depend on your Pilotron Radio Tubes under all conditions.

The Professional—operating on world wide reception—keen and alert, must avoid confusing tube noises—crackles and distortion—and with dependable Pilotron Radio Tubes in every socket he enjoys the thrill of “pulling in” messages from far away.

You too—under all conditions—on any set will appreciate the difference that dependable Pilotron Radio “long life” Tubes give to the reception of radio broadcast programs.

PILOTRON RADIO TUBES



ENDORSED BY PROFESSIONALS

LICENSED BY RCA

PILOT RADIO & TUBE CORP.
Lawrence, Massachusetts

Chicago Office: 231 S. Wells St.

San Francisco Office: 1278 Mission St.

The Entire World of Radio

ON A SINGLE KNOB

15 TO 650 METERS

NO COILS TO CHANGE



PILOT UNIVERSAL SUPER WASP RECEIVER

Pilot's wonderful wave band changing switch, incorporated in the new Universal Super-Wasp, revolutionizes the short wave art. No longer need numerous coils be changed to cover the various wave bands. No longer need dial settings change each time the same distant stations are tuned in. You can log permanently all the stations you can get throughout the world, you can tune from the short waves to the high ship waves without removing your hand from the single control knob.

Universal Features Revolutionizing the Short Wave Art

Complete coverage all wave bands from 15 to 650 meters *without coil changing*. Complete A. C. operated *chassis in cabinet*. (Also available in battery model) . . . All Metal Chassis . . . Highly sensitive and selective circuit . . . Screen Grid TRF amplifier *plus* Screen Grid Detector . . . 227 First Audio Stage . . . Two 245's in push-pull output stage . . . Stations can be logged *permanently on dial* . . . Regeneration control does not alter tuning . . . Provision for *Phonograph Pick-up* . . . Earphone Jack on *Front Panel* . . . Illuminated Dials . . . Handsome Walnut Cabinet . . . Most advanced construction yet used for short wave work . . . In kit form for easy home assembly; no drilling or cutting, all parts fully prepared.

NOTICE TO "HAMS": Pilot will continue building the original Super-Wasp in kit form for licensed amateurs and others who want to spread the tuning on their pet wave bands and add their own audio features. A. C. and battery models.

Pilot Universal Super Wasp **\$85.00** A. C. Model (K-136) in Kit Form

PILOT RADIO & TUBE CORP., Lawrence, Mass.



Chicago:
234 S. Wells Street

New York:
525 Broadway

San Francisco:
1278 Mission Street

OFFICES IN PRINCIPAL COUNTRIES OF THE WORLD