

RADIO DESIGN

HANDBOOK OF CONSTRUCTION FOR STUDENTS & SET BUILDERS

HOW TO BUILD THE PILOT TELEVISION RECEIVER

WASP Short Wave Receiver Has World-Wide Range
HOW TO DESIGN A. C. Tube Sets for Best Results
RADIO PHYSICS COURSE for High School Students
250 POWER AMPLIFIER, and Other New Equipment

Edited by
M. B. SLEEPER



Vol. 1, No. 3

10c PER COPY

Fall Issue

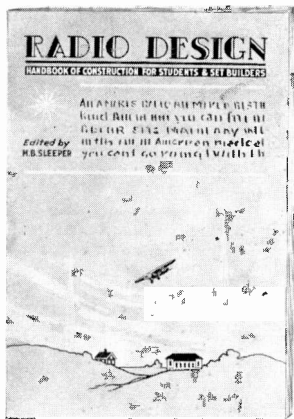

The Greatest VALUE Ever Offered in the History of Radio Set Building

All About Television

By special arrangement with the Pilot Electric Mfg. Co., Inc., of Brooklyn, N. Y., RADIO DESIGN will publish all the details of Television equipment which is being developed by the Pilot engineers.

The Pilot Company is leading in this new science, and is now making tests to determine the practicability of broadcasting regular television programs, by which people and their actions can be seen with the Radio Eye.

Get all this official information right from Television Headquarters, as it is published in Radio Design. Keep posted on what Pilot is doing, learn how to build television receivers, and how to instal them. READ RADIO DESIGN.

RADIO PHYSICS COURSE

The Radio Physics Course, now appearing serially in Radio Design, is the course which A. A. Ghirardi has been teaching for four years in the Hebrew Technical Institute, New York City, one of the foremost technical trade schools in this country. This course is suitable for all high school students. Read it in RADIO DESIGN.

Beginners, who have never built radio sets before, find Radio Design an adequate guide for constructing successful sets which give as good results as the finest commercial equipment. Many successful professional set builders started in business by following designs created by the authorities whose articles are published in Radio Design. *Read the offer below.*

Students, who realize the importance of understanding the underlying principles of radio equipment, will find the Radio Physics Course, in Radio Design, just the useful information they need to explain the thousand strange effects which have seemed so mysterious. Don't permit yourself to be ignorant of these fundamentals. *Read the offer below.*

Custom Set Builders—don't let the other fellow take away your trade this Fall. Prepare yourself—be ready to give your customers the very latest designs in all-electric sets, short wave equipment and super-range receivers. And make sure your prices are low enough to meet all competition. Get on your toes—*Read the offer below:*

25c Four issues of RADIO DESIGN, equal to a 200-page book, mailed to your home, bringing in the four issues the details of the latest and finest designs, worked out with scientific precision—Also, these issues will contain Part 1 of the complete Radio Physics Course.

SEND 25c IN COIN OR STAMPS TO

RADIO DESIGN PUBLISHING CO., Inc.
103-A BROADWAY
BROOKLYN, NEW YORK, U.S.A.

RADIO DESIGN

HANDBOOK OF CONSTRUCTION FOR STUDENTS & SET BUILDERS

M. B. SLEEPER, *Editor*

GERSON LEWIS, *Associate Editor*

Published Quarterly by

RADIO DESIGN PUBLISHING COMPANY, INC.

EDITORIAL OFFICES:

103 Broadway, Brooklyn, N. Y.

Phone, Greenpoint, 9604

Ten cents per copy, twenty-five cents per year in the U. S. A. and foreign countries. Radio Design is published on the first of September, November, January and March. When subscriptions are received before the publication of No. 4 of any volume, the subscription is started with the No. 1 of that volume and back numbers sent if available, except on renewal subscriptions.

(Application for entry as second class matter made at Brooklyn, N. Y., September, 1928.)

Vol. 1

September, 1928

No. 3

YOU WANT TO KNOW—

WHETHER it's going to be a set for yourself or for one of your customers, before you spend real, United States money for radio parts you want some pretty definite assurance that the design you're going to follow has been worked out with expert skill and scientific thoroughness.

So, if you ask, "What has RADIO DESIGN done to assure me that the sets shown in this issue are going to be worth 100% satisfactory to me or my customers?" the answer is:

Concerning television, the information on this subject comes directly from the Pilot Electric Mfg. Company, which is television headquarters. The article is by M. B. Sleeper, who has been connected with this work since its inception, and has been O. K.'d by John Geloso, chief engineer of the Pilot Company, and inventor of the Pilot television transmitter and receiver. In the coming issues these two men will keep RADIO DESIGN readers posted concerning further television developments.

The first model of the Wasp short wave receiver was built in R. S. Kruse's laboratory, it was tested by him, and in its final form bears his O. K. As further proof of its successful performance, Wasp sets are at this time of writing in use by the U. S. Army in a number of points in this country. A standard Wasp has been used for the ground station in tests with the Pilot Airplane Radio Laboratory, too. During these tests, using a 20-ft. wire for an antenna and an automobile chassis as a ground, signals from California and North Dakota were picked up in the daytime.

The A. C. power packs have been in use in the RADIO DESIGN laboratory during the seven months which have been spent in working out the Air Hound receiver. The A and B packs have given several thousand hours of operation during the development and life tests on the Air Hound.

U. K. Krohne, who wrote the article on the power packs, is a German instrument maker by trade, and a wonderfully skillful designer of radio equipment. Now an American citizen, he is the man who made the master scanning discs for the Pilot television equipment, and constructed the precision amplifying apparatus for the television transmitter.

Frank T. Sullivan, whose name appears in the article describing the Air Hound receiver, is Pilot's test engineer, the man whose job it is to find fault with everything. Give Sullivan the parts for any new set and the layout drawings and he will assemble it, test it, check it and before he is through discovers so many faults that you feel ashamed to have let him see the design at all. But that's his job—finding out mistakes before they get out to trouble others, and he never lets one slip by. So you can feel pretty sure of the Air Hound, since he has passed judgment on it.

Many readers remember Alfred A. Ghirardi as associate editor of Radio Engineering when that paper was published by M. B. Sleeper. For three years he has been instructor of radio and electricity at the Hebrew Technical Institute in New York City.

The Radio Physics Course which starts in this issue of RADIO DESIGN is exactly the course that Ghirardi has been teaching his boys. It is for that reason that it is being published here—because it takes up such subjects as have been found useful to those who are seriously interested in radio, and presents them in a way which has already been found understandable.

Gerson Lewis, whose article on the taper-tuned receiver appears in this issue, is associate editor of RADIO DESIGN, and is in charge of the RADIO DESIGN laboratory. He is one of those unusual fellows who can assemble any kind of a set and make it work right the first time. His success with the taper-tuned sets is no exception. It is the finest design we have seen for a high-power, single-control receiver, and embodies the most sensible method for overcoming the disadvantages found in other one-dial sets.

Now about the short wave converter, with which S. W. stations can be heard on any broadcast set. This article is by E. Manuel, who is export manager of the Pilot Company. He knows what's what in radio in every part of the world.

An old-timer at short wave reception, Manuel has devoted much time to the S. W. converter because, in foreign countries, there is a tremendous interest in American broadcasting, and he has found that with the converter any set in any country can bring in American short wave stations.

The 250 power amplifier, which also supplies B voltages for any receiving set, is described by W. R. Kaye. This is a subject which he is eminently fitted to discuss, for, among other things, he is in charge of the transformer winding department at the Pilot factory, and in this capacity Kaye "knows his transformers."

These brief notes are given so that you will know that the equipment described in RADIO DESIGN is not the paper guess-work of inexperienced men, but apparatus skillfully planned by experienced engineers, chosen by this publication to assure your success and to establish your confidence in RADIO DESIGN—No wild ideas, but real stuff that you know is right.

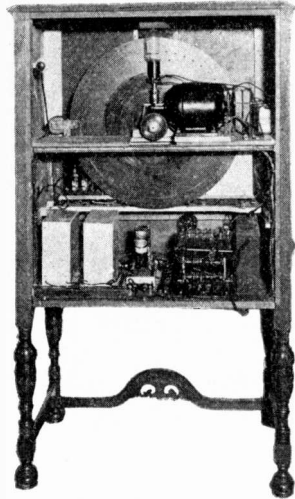

Fig. 1. E. Manuel, sitting before the television transmitter. The insert is the transmitting amplifier. Right, the combination television and broadcast receiver.

ALL BROADCAST STATIONS CAN TRANSMIT TELEVISION

By M. B. SLEEPER

NOW you can build your own television receiver! You can get in at the very beginning of a new science—vision carried by invisible waves—a science so entirely new that its future developments and applications are still to be determined by those who are ready to undertake the pioneer work of understanding television, and thinking in terms of its possibilities.

When the first intelligible radio telegraph signals were transmitted over a useful distance, no one expected that the foundations was being laid for a world-wide communication system of tremendous commercial and political importance.

No one dared to suggest that the first successful demonstration of radio telephony was the precedent of the entertainment now provided for every modern home in every civilized part of the globe.

The most profound students of radio engineering did not have the slightest idea, when the activities of American amateurs were legislated down below 200 meters, that short waves were to become so vital that they must be split and allocated by international agreement.

Nor did the founder of the Pilot Electric Mfg. Company imagine, when the concern was organized twenty years ago, that he would give to the American public the first practical and successful means of seeing by radio, meeting through the efforts of the Pilot engineering staff the tremendously involved problems which have baffled scientists in their efforts, during the past 50 years, to extend vision beyond the range of the human eye.

PILOT PIONEERS TELEVISION

On Aug. 14, 1928, John Geloso, Chief Engineer of the Pilot Company, achieved the first long distance television transmission when he looked into the Radio Eye, shown in the accompanying il-

lustrations, and saw the moving likeness of Mrs. Geloso, 8 miles away, on the other side of the Hudson River.

For months, two groups of engineers had been working in the Pilot Laboratories to evolve a method of transmitting and receiving images of living, moving objects. The specifications which had been giving them were:

1. Radio vision as clear as newspaper illustrations.
2. Full reproduction of details—not merely outlines or silhouettes.
3. Transmission from any broadcast station without altering in any way the equipment of the station.
4. Transmission within a 10-kilocycle band, to prevent interference with other broadcast stations.
5. A television receiver made up of standard parts, so designed that it can be assembled easily and cheaply by set builders.

By the first of August the Geloso system had passed the elementary stages. During the second week of August the equipment was rebuilt in portable form, and the transmitter taken to Station WRNY on the west side of the Hudson River, and the receiver installed 8 miles away in New York City.

And it worked! The first television transmission, on Aug. 14th, was tuned in as easily and quickly as broadcast signals. As soon as the strange-sounding signals came in on the loud speaker, the switch was thrown to the Radio Eye, and while a group of half a dozen engineers watched the small enclosure, Mrs. Geloso was seen to walk before the transmitter. She smiled with a little embarrassment at the extraordinary part

Figures 2 and 3. A combination Radio Eye for receiving television, and broadcast set. A snap switch changes the radio circuit from loudspeaker to Radio Eye. The moving objects or animated picture appear in the opening of the tuning control. This receiver, developed by Pilot Electric Mfg. Company, is



the first commercial broadcast and television set ever built. What will follow, what will be the future applications of the Radio Eye, no one can tell, but to-day we have actual television at broadcast wavelengths, making pictures as clear as any printed in the daily newspapers.

she was playing, waved her hand, and in a moment stepped aside. Others appeared before the transmitter, each readily recognizable.

This private demonstration was repeated for the benefit of newspaper reporters on August 21st, at Philosophy Hall, New York University.

Meanwhile, work has been under way to develop receiving equipment capable of even more perfect vision. The actual production of receiving sets and equipment for the use of television set builders is being pushed ahead as rapidly as possible, for the Pilot Company realizes, of course, that transmission is of no value without apparatus for receiving.

Now that the equipment is being made available, television broadcasting is a regular feature on WRNY. Moreover, the Pilot Company is preparing to furnish television transmitters to other stations throughout the United States. Thus seeing as well as hearing by radio will soon be a part of regular programs.

What is also of great importance, a start has been made toward the development of special features which will make television highly entertaining, offering far more than a mere opportunity to see people bow and smile before the Radio Eye.

YOU CAN BUILD YOUR OWN RADIO EYE

The first real Radio Eye is not merely a laboratory demonstration. It works, and works marvelously well. Considering the few months which have elapsed since the inception of the idea, the equipment is truly wonderful. It is far more perfect than the early broadcast sets.

This work was undertaken by the Pilot Company as part of its policy of keeping faith with the set builders who look to Pilot to supply them with apparatus in keeping with the very latest developments in radio art.

Much has been published about "television bunk," and much has been justified, for a number of companies have gone so far as to advertise scanning discs, for example, to receive the WRNY television transmission when the Pilot engineers themselves did not know how many holes would be used in the final transmitter disc.

But in making out specifications for this television work the whole idea was to open the field to experimenters, to make it possible for them to get into this new science, and to encourage them in pushing ahead just as they did in the beginning with radio telegraphy, then radio broadcasting, and finally with short waves.

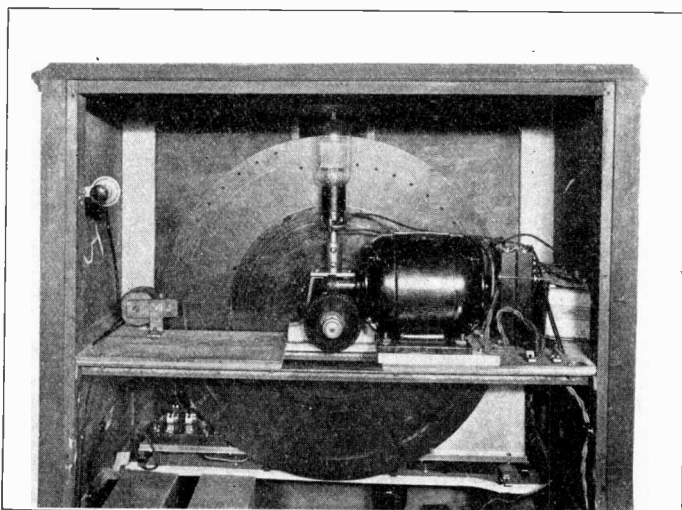

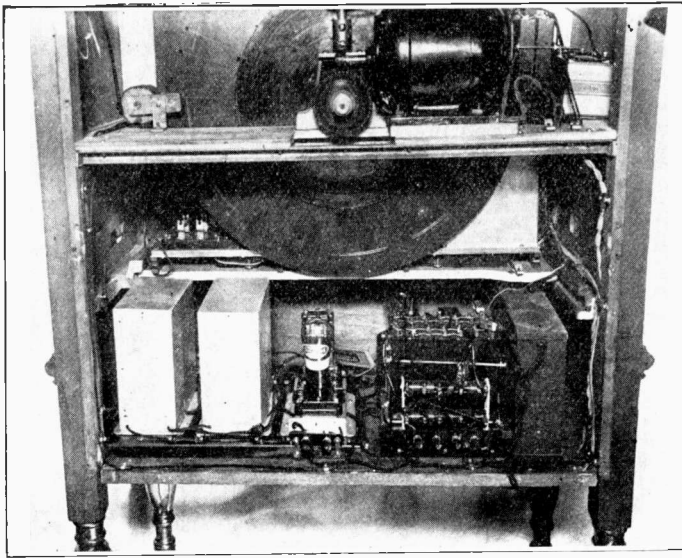

Fig. 4. Detailed view of the amplifier and power pack.

The specifications previously enumerated explain why it is possible for set builders, working in their home laboratories, to use standard parts for building television receivers, adding only such special devices as the disc, motor and the neon lamp.

The accompanying illustrations show how the first Radio Eye was arranged at the front and at the rear. However, there are various modifications which were made in the circuit, accounting for the discrepancies between the wiring diagram and the parts shown on the pictures.

On the upper shelf are the television disc, beveled Bakelite gears, synchronous motor, and the two 2 mfd. condensers.

Below, at the front, is the receiver, shielded from the amplifier and power equipment at the rear. The last three tubes and the resistance coupling units are enclosed in three cans. One can, as you will see, has been removed. To the right is one of the new Pilot 250 type power packs, used to provide the plate voltage for the audio amplifier and neon tube.

At the extreme right is a small Pilot B pack. That was not in the circuit, however, for it was found that 90 volts of B battery gave much better results on the R.F. and detector tubes.

As you will see from the diagram, the radio end is a standard receiver, to which the special audio amplifier has been added.

IMPORTANT NOTES ON TELEVISION PARTS

Scanning Disc: Most of the scanning discs which have been offered for sale are not worth the material used to make them. Some are even made out of thin hard rubber, others of tin or galvanized iron. Even if the holes were accurately located they would be worthless because they do not run true.

Pilot engineers have found it necessary to use sheet aluminum $3/32$ ins. thick, reinforced by a disc of somewhat smaller diameter, as you will see in Fig. 3.

Never buy a disc unless the shaft is furnished with it. Any slight eccentricity will absolutely ruin reception.

The mounting for the disc must have ball-bearings of the finest quality, of the type to take up end-thrust from the gears.

The master disc, from which others are being made for regular production, called for such a degree of accuracy in locating the holes that it was necessary to rebuild what was already a precision machine, in order to locate the openings in such a way that they would not overlap, nor leave spaces between the holes.

Subsequent discs are being produced by a photographic method, for the cost of machining scanning discs one-by-one would make the price prohibitive.

Neon Lamp: Another vital element in the television equipment is the neon lamp.

Until the advent of television, very little was known about neon lamps except as they were applied to electric signs. The production of a suitable type of lamp is not merely a matter of sealing metal elements in a globe filled with neon gas.

The whole combination of the quantity and purity of the gas, the metals used for the elements, and their arrangement and shape determine the results to be obtained.

The illumination must change from zero light over the entire surface of the elements to a brilliant illumination over the entire surface.

If the lamp has a tendency to shine more brightly in one part than in another, reception is spoiled, just as a photograph is sometimes partly light-struck.

The light response of the lamp must be accurately matched to the response of the photo-electric cells at the transmitter. The degree of illumination must be proportioned to the voltage applied to it. If a slight increase in the voltage brings the lamp to full brilliancy, the picture is just a bright blur. On the other hand, if the illumination is very low until the maximum voltage is applied to it, the picture is very dark.

A special Pilot neon lamp of exceedingly low resistance has been developed. There is only the slightest voltage drop across it, yet it handles the high power required for clear images.

Synchronous Motor: A synchronous motor of

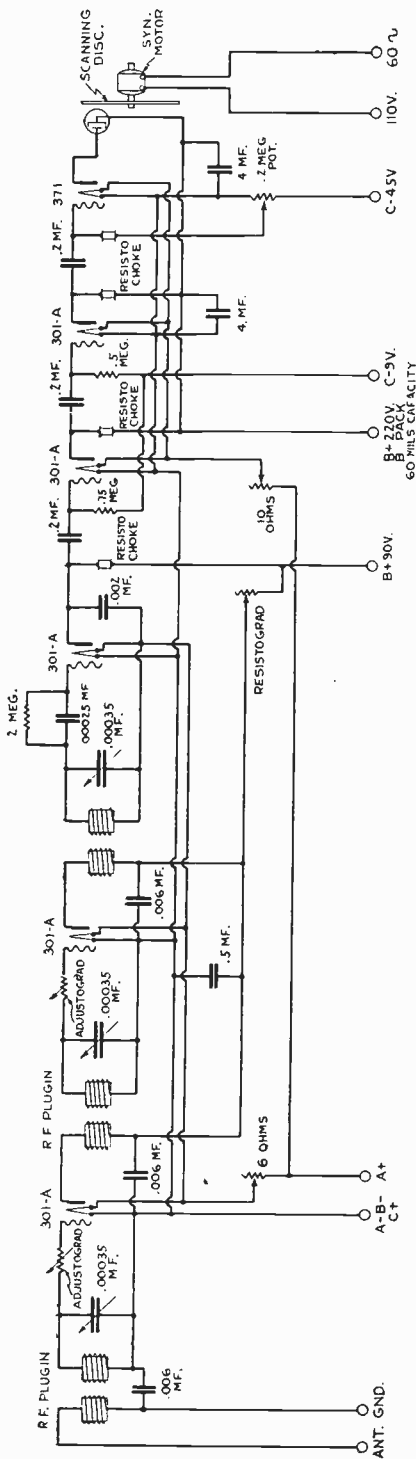

Fig. 5. Complete schematic of the Pilot television receiver. The Resistochokes are combined resistances and R. F. chokes.

1/20th horse-power has been developed by Pilot to turn the disc. This is a very simple and inexpensive type, requiring no external regulation. It is simply plugged into the light socket like any other electrical appliance.

Radio Circuits: The radio circuits are standard, as is shown by the wiring diagram. Three Pilot

No. 176 broadcast plug-in coils are used, tuned by No. 1617 Pilot .00035 mfd. condensers. Adjustors are used in the grid circuits of the first two tubes to prevent oscillations.

In the original receiver, Pilot Redi-Blox were used to simplify the assembly. To prevent interaction between the radio circuits and the audio end, the receiver was completely shielded, except at the front, where a Micarta panel was used.

Audio Amplifier: There is so much opportunity for difference in opinion regarding the quality of audible reproduction that even a fairly large degree of distortion can be permitted such an amplifier.

For television reception, on the other hand, where distortion appears visually, the amplification is either perfect or imperfect.

Consequently, Pilot engineers found it necessary to develop a special audio amplifier that gives such perfect reproduction that it is not even possible to see the distortion.

The three audio stages are assembled with Redi-blox. Instead of using the small stopping condenser ordinarily supplied, you will see that a pile of condensers are employed to give a total capacity of .06 mfd.

Only two grid leaks are used. The other resistances are displaced by special units, mounted like grid leaks, but in the form of bobbins which serve as a combination of resistance and R.F. choke. In this type of amplifier a plain resistance is not adequate, for it does not keep out the radio frequency distortion. Hence specially developed Resistochokes.

All three A.F. tubes take 220 volts, supplied from the heavy duty B power pack. This may seem strange, considering that 301-A tubes are used, but with the resistors employed and the C battery specified, this gives the best results.

Power Pack: Ordinary B power packs cannot be used for the Radio Eye because, ratings to the contrary, we have not found any which will deliver 220 volts at 60 mils without overloading the chokes and causing A.C. distortion.

The unit shown here is the new Pilot 250 power amplifier from which the heavy current is drawn.

HOW TO OPERATE THE RADIO EYE

With the equipment assembled and wired according to the diagram, the television signal is tuned in by means of a loud speaker connected in place of the neon tube, or by putting a pair of phones in the plate circuit of the detector tube. As soon as the signals are brought up to maximum intensity, the phones are cut out and the motor started. With the disc rotating at full speed, the set must be retuned to bring the signals in at the center of the resonance curve of each stage. Then the potentiometer on the 371 tube must be adjusted as well as the Resistograd in the plate circuit to the detector.

The process is very simple; it actually takes less than a minute to adjust the controls to bring in television clearly. The details of the method are clear enough when you are watching the effects of the tuning on the reception.

ADDITIONAL INFORMATION ON TELEVISION BROADCAST

If you want additional information on the equipment described, or concerning television broadcasting from other stations in the United States, send your inquiries addressed to Television Dept., Radio Design, 103 Broadway, Brooklyn, New York. In this way you can get additional details direct from the Pilot laboratories.

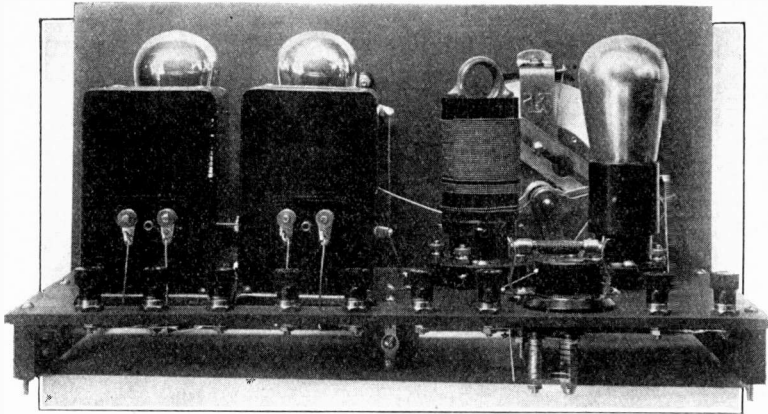

Fig. 1. The Pilot Wasp has a world-wide receiving range.

SHORT WAVE PILOT WASP HAS WORLD-WIDE RANGE

By JOHN GELOSO

THE new Pilot Wasp short wave receiver, for 17 to 500 meters, certainly should be the last word in this type of equipment. The coils and the set were designed with the assistance of R. S. Kruse, recognized authority in this country on short wave communication. To speed up the progress of the work, the Pilot Airplane Radio Laboratory was used to carry the engineers back and forth between the Pilot factory and Kruse's laboratory at Hartford, Conn. Such a long distance collaboration would be difficult ordinarily, but the two cities are less than an hour apart via the big Stinson monoplane.

WASP COILS WIDELY RECOGNIZED
 News travels very fast among radio engineers. The first coils were hardly produced when F. E. Handy, from A. R. R. L. Headquarters, sent down a hurry call for coils to use in a new receiver. The Officers' Radio School at Fort Monmouth, N. J., ordered a quantity of complete kits to be assembled by their students. A Wasp receiver, set up in the shadow of the Statue of Liberty, is handling U. S. Army traffic.

Wasp coils were ordered for use in the short wave equipment designed for the Byrd South Pole Expedition, which will carry 28 receivers.

Fig. 2. This is the Pilot Airplane Radio Laboratory, used for the development of aircraft radio equipment. This photo, taken at the Stinson Field, shows I. Goldberg, president of the Pilot Company, with Bert Hassell, the Rockford to Stockholm flier, who has been found in Greenland.



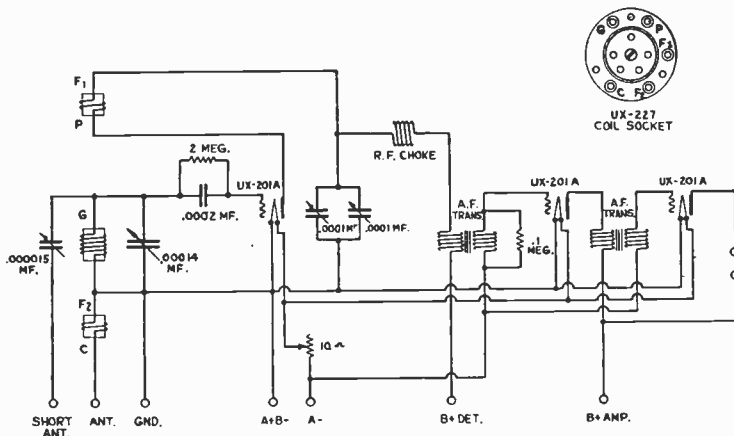
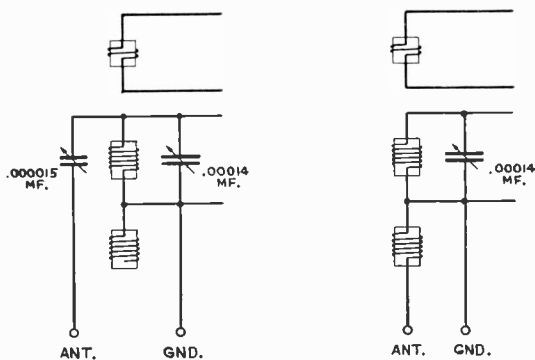

Fig. 3. Above, complete circuit of the Pilot Wasp. Fig. 4, below, at left, direct-coupled antenna. Fig. 5, right, inductively coupled antenna.



OFFICIAL WASP DESIGN

Short wave receivers are not the simple matter that set builders expect them to be, judging from experience with broadcast sets. Short waves are very particular. They will not produce good results in the obliging manner that broadcast signals come in on slip-shod sets. Nor is careful workmanship any assurance of success.

Short waves insist on designs which are based upon a thorough familiarity with the vagaries of high frequencies, as well as the most careful assembly and wiring. Accordingly, we worked out an official Wasp short wave design, simple enough for everyone to build, and taking into account all the special kinks which must be considered, known only to those who have had long experience with this sort of equipment.

In other words, you can't take a schematic diagram of a short wave receiver and put the parts together according to your own ideas of what looks well or is convenient.

Such an outfit will prove to be a most unsatisfactory bag of tricks. You must follow, to the letter, the layout shown in the accompanying illustrations.

WASP ALSO RECEIVES BROADCAST

While the Wasp is intended primarily as a short wave receiver, many splendid reports have been received concerning its operation on broadcast waves.

The five coils provided have colored Bakelite finger rings by means of which the wave length ranges can be identified. They are as follows:

Fig. 6. The set of five Wasp coils covering all wavelengths from 17 to 500 meters. Each coil is identified by its colored Bakelite handle.

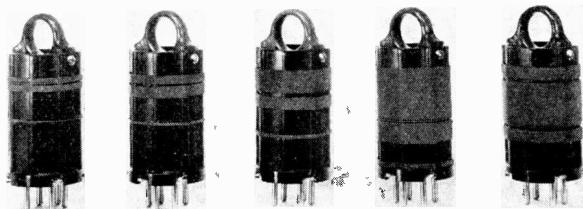
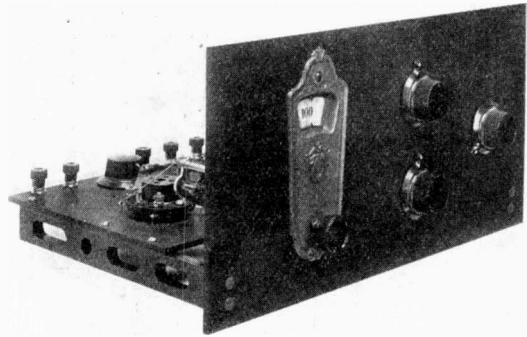

Fig. 7. The illuminated dial controls the wavelength. The two center knobs regulate regeneration. When the broadcast coil is used, the upper midjet condenser is put at maximum. For other coils, the condenser is set at minimum. All regulating is then done with the lower condenser. On the right is the rheostat knob.



Red ring.....	17 to 30 meters
Orange ring.....	30 to 52 "
Yellow ring.....	45 to 105 "
Green ring.....	93 to 203 "
Blue ring.....	200 to 500 "

These wave length ranges apply when the primary coil is not used, but the antenna coupled directly to the grid by the 5-plate midjet condenser, as shown in Fig. 4.

The Wasp will bring in broadcast stations at full loud speaker volume over a range of several hundred miles. Moreover, it is a convenient check, when the set is first finished, to try it out on broadcast waves, to make sure it is operating properly.

OFFICIAL WASP PARTS

Following is a list of parts which are required for assembling the official Wasp receiver:

- 1 No. 180-4 set of Twin-Coupler plugin coils
- 1 No. 1282 Pilot illuminated dial
- 1 No. 1608 Pilot .00014 mfd. condenser
- 2 No. J-23 Pilot .0001 mfd. midjet condenser
- Ⓛ No. J-5 Pilot .00015 mfd. midjet condenser
- 1 No. 910 Pilot 10-ohm rheostat
- 1 No. 50-D Pilot .0002 mfd. fixed condenser
- 1 No. 761 10-meg. grid leak
- 1 No. 750 Pilot .1 meg. grid leak
- 4 No. 50 Pilot grid leak clips
- 3 No. 206 Pilot UX sockets
- 2 No. 391 Pilot A. F. transformers
- Ⓛ No. 212 Pilot UY socket
- Ⓛ No. 35 Pilot 1-in. Bakelite brackets

- 1 7 by 14-in. Westinghouse Micarta front panel
- Ⓛ 7 by 13-in. Westinghouse Micarta base panel
- 9 Pilot engraved binding posts

You will also need a length of spaghetti tubing, a few feet of No. 18 tinned copper wire, two dozen tinned soldering lugs, and some machine screws and nuts.

HOW TO ASSEMBLE THE WASP

The accompanying illustrations show very clearly how the parts should go together, so if you layout your panels carefully in accordance with the official panel patterns you should have no trouble at all. Fig. 3 gives the schematic diagram and Fig. 11 the actual layout as the wiring will appear in the set. All the front panel parts should be assembled first, then the base panel parts assembled and wired as far as possible. Do not fasten the two panels together until that much has been completed.

It is very important to use only rosin-core solder. Do not use soldering paste under any circumstances. Be sure that you get the terminals of the sockets in the positions shown in Fig. 11.

As you put on the wiring, compare the directions of the wires and also the neatness of your workmanship with the photographs and the diagram in Fig. 11.

HOW TO OPERATE THE WASP

When you have completed the assembly, plug in one of the five coils, insert the tubes, and connect a six volt storage battery from A+ to A-. Try

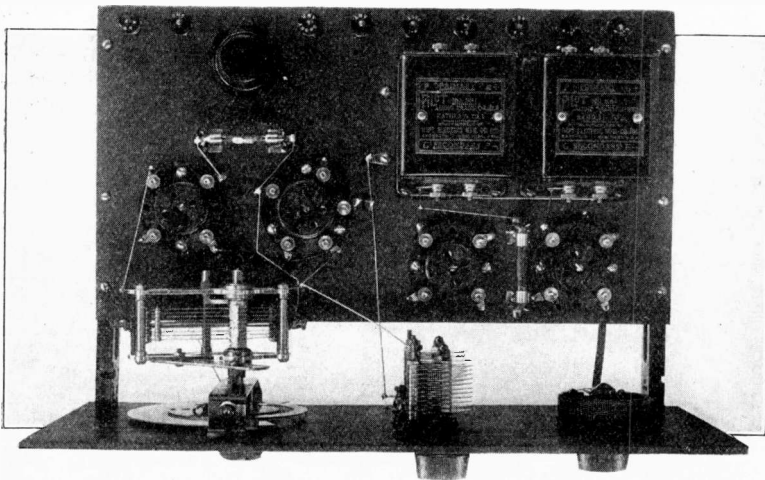

Fig. 8. In these illustrations, the No. 381 Pilot A. F. transformers are shown. The Wasp kit, however, contains two of the new No. 391 transformers. The .1-meg. grid leak, between the two A. F. tubes, is connected across the secondary of the first transformer to prevent howls when the set goes in and out of oscillation.

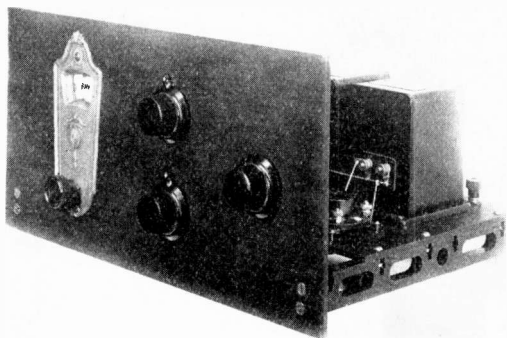

Fig. 9. By using a resistance-coupled amplifier, the Wasp can be employed for receiving the various television signals, broadcast from station 3XK at 46.72 meters. The present schedule goes on from 8.00 to 9.00 P. M., Eastern Standard Time, on Mondays, Wednesdays, and Fridays. The transmitter is of 250 watts, and is being heard all around the country.

the rheostat to see that the tubes light properly. Then hook on the B battery, 90 volts from B— to B+Amp., with a tap at 45 volts to B+DET. Attach your telephones to the binding post at the rear. If you have a regular broadcast antenna, hook it on to the binding post marked SHORT ANT. If you have a small indoor antenna about 20 feet long, use the ANT. binding post.

When you use the broadcast coil, set the upper midget condenser on the front panel at maximum. For all other coils set this condenser at minimum capacity.

Tune with the big condenser for wave length, and adjust the lower condenser for regeneration. You will also have to regulate the small condenser at the rear of the base panel, in order to get a setting which will permit the coils to oscillate over the entire range.

Beyond this, you must just experiment to get your own experience. There is a great deal of short wave broadcasting now, not only in the United States but in foreign countries as well. If you want to learn the code, you will have the whole world at your finger tips. In this issue of Radio Design an up-to-date list of code and broadcasting stations is given so that you can locate the calls you hear.

RESULTS OBTAINED FROM THE STANDARD WASP RECEIVER

Already quite a number of reports have come in on actual results obtained with the Wasp receiver. For example, Staff Sgt. Edwin A. Redding, Jr., in charge of the U. S. Signal Corps Station 2 SC, and WVP, Ft. Wood, N. Y., reports that "The Wasp was used in preference to three other short wave receivers at this station." This set was constructed according to official specifications.

A very interesting communication was received from E. F. Whitcomb, 244 Gold Street, Brooklyn, New York. He sent a photostat copy of an acknowledgment received from station 4QG, Brisbane, Australia. The card states that an examination of the Official Log confirms Mr. Whitcomb's report of reception.

George L. Jones, Hazardville, Connecticut, reported on August 20th that he had received 5 SW, Chelmsford, England, on 24 meters, every night during the previous week. Reception was obtained with an 18 ft. antenna strung across a room about 1½ ft. from the ceiling.

It is very interesting to observe the strange things which happen on short waves. Station WRNY, for example, reports that their short

Fig. 10. There is no complicated wiring on the Wasp, even under the sub panel. The grid condenser is held in place by the screws which pass through the grid leak clips. Refer to this view as you assemble your set, for it will help you to put on the wiring correctly.

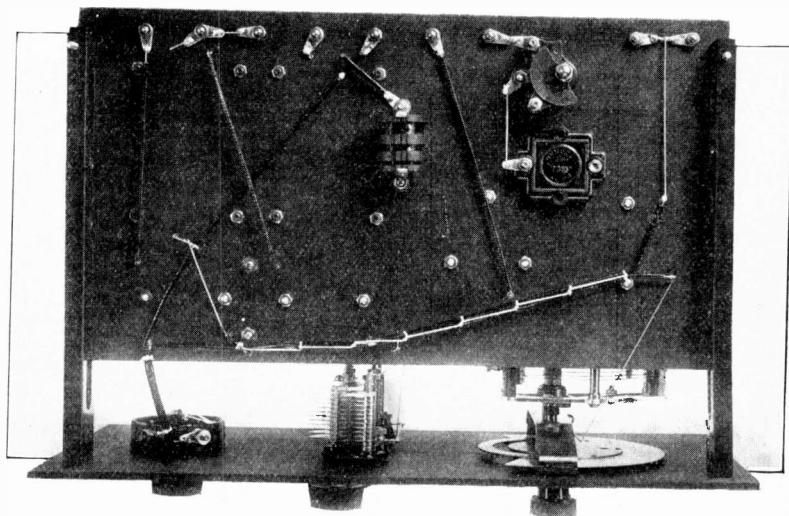

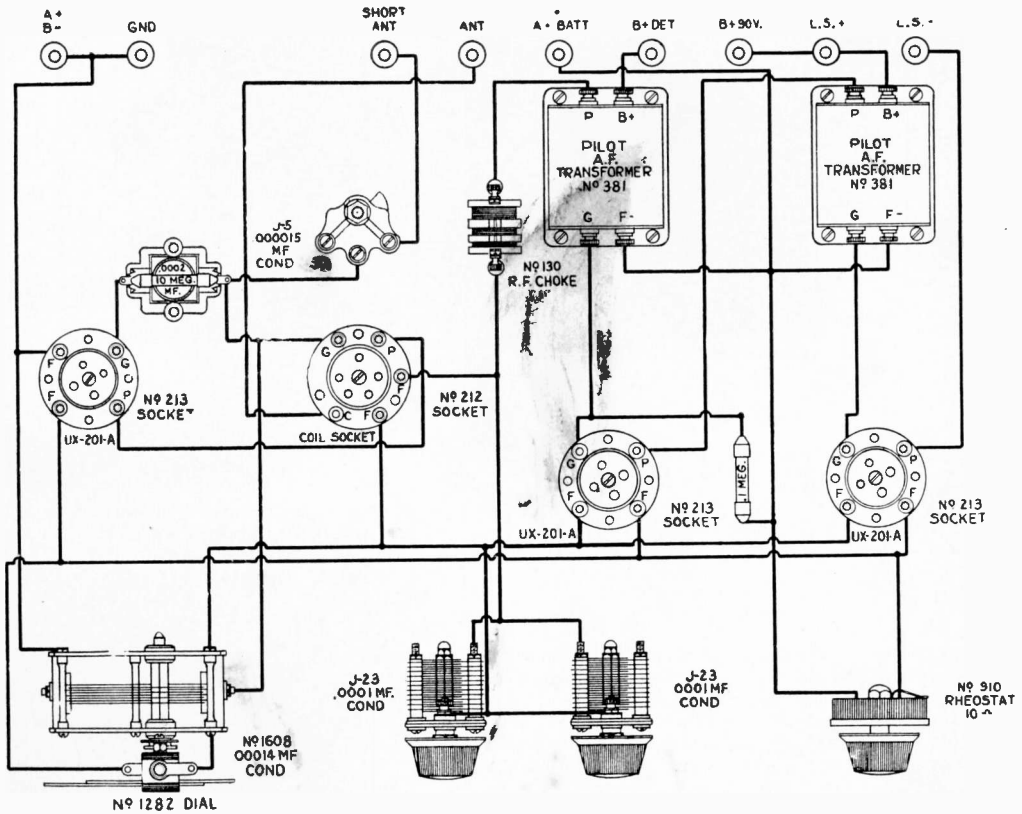

Fig. 11. Picture wiring diagram of the Wasp short wave receiver.

wave transmitter is heard by more people in Australia than in New York City. In other words, if you are within a few hundred miles of a short wave station you may not hear it as well as signals from stations two or three thousand miles distant. On the other hand, the radio operators on the transatlantic ships find that they can pick up KDKA or WGY, on short waves, as soon as they are out of New York harbor, and hold the signals all the way across the Atlantic.

Sometimes amateur stations and commercial stations as well are difficult to hear, not because of lack of efficiency at the receiving set but because of defects in the installation at the transmitter, which cause a slight swinging of the frequency. You will notice occasionally that when signals appear to be fading, if you change the tuning condenser you can tune along with them, indicating that the fading is actually due to changing frequency at the transmitting end.

If you hear a peculiar short staccato note sounding steadily, but with varying pitch, you will learn to recognize it as a radio photograph transmitter or one of the short wave television transmitters. Again, you will hear a high-speed telegraph transmitter, clipping off a hundred words or more a minute.

Telephone or broadcast reception takes a little experience and skill to bring in any satisfactory manner, but once you learn where to hunt for the foreign broadcast stations you will have no further difficulty.

BOOK REVIEW

Radio Amateur's Handbook by F. E. Handy, published by American Radio Relay League, 211 pages, over 200 illustrations, \$1.00.

The Radio Amateur's Handbook which we reviewed in our last issue is now in its second printing of the third edition. It has been most fully revised and brought up-to-date.

The Handbook still leads as a text on short-waves and has more authentic material crammed in it than any other book we have ever seen. F. E. Handy, the author, is Communication Manager of the A.R.R.L. and knows just what both the beginner and the old ham want to know about building and operating short wave receivers and transmitters. He has done a difficult job very nicely in the Handbook. Whether you have been in the game since "way back when," or whether you are just starting you should have a copy of the Handbook right beside you on the workbench.

As John Geloso pointed out in his article on the Wasp set, short waves have many strange characteristics. Many of these puzzling things are discussed and explained in Handy's Handbook.

The Radio Amateur's Handbook can be obtained from the Book Dept., Radio Design, 103 Broadway, Brooklyn, N. Y. Bound in a paper cover, it costs \$1.00 postpaid, or \$2.00 in a cloth binding.

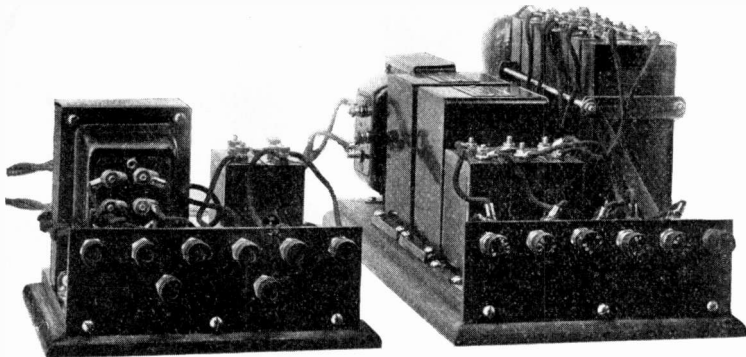

Fig. 1. Standard Pilot A and C power pack, and the B power pack.

HOW TO DESIGN A. C. TUBE SETS FOR BEST RESULTS

By U. K. KROHNE

EVERY custom set builder who is planning for big business this fall is now selecting designs for all-electric sets. You and I may have our pet circuits that call for battery-type tubes, but Mr. General Public, and particularly Mrs. General Public, feel that any set that can't be hooked onto the floor would be a discredit to the modern home.

Now, the clever set builder knows that the real business comes from selling Mr. and Mrs. Public what they want—not what we think they would want if they knew better.

The catch is right here: Custom-built sets can't be exorbitant in price. Usually, they have to be cheaper than factory jobs. Yet the battery sets which worked just as well with a little junk slipped in here and there aren't A. C. sets by a long shot.

YOU CAN'T FOOL THE A. C. CIRCUITS

No, sir. You can't put anything over on the 110 volts, and you have to toe the mark when you use the new tubes.

That is, you must have the best there is for the A and B supply circuits, and you must design the receiver with great care to provide the proper C biases.

If you use poorly designed power transformers they will burn up sure as fate. This applies to the use of separate transformers for A and B supply, as well as to the single transformers which furnish both A and B voltages.

The A supply must deliver a heavy current, and operate continuously for hours at a time. Therefore a heavy core and heavy winding must be employed, together with a type of case which will permit the degree of cooling necessary to the design of transformer.

B eliminators for A.C. tubes must deliver a greater amount of current than is required for 301-A's. That is, 301-A's draws 2.5 to 3.0 milliamperes, while the 326 draws 6.0 mils and the 327, 5.0 mils in the plate circuit.

Therefore, where a set using four 301-A's and a 371 would draw 30 mils, a similar set using A.C. tubes will draw about 45 mils.

Many B power packs are able to handle 30 mils all right, but at 40 to 50 mils the voltage drops

way below the values necessary to operate the A.C. tubes, and with this increased current through the chokes, the inductance of the chokes drops from the rated value of 30 henries down as low as 5 or 10 henries. Then, under this overload, there is a strong A.C. hum, usually blamed on the tubes or the set.

A POWER PACK DETAILS

In Fig. 1, at the left, is an illustration of the Pilot A pack, with the picture diagram in Fig. 2. This kit comprises the following parts:

- 1—No. 386 Pilot Filament Transformer
- 1—No. 959 Pilot double bias resistance
- 1—No. 951 Pilot single bias resistance
- 2—No. 801 Pilot .1 mfd. by-pass condensers
- 1—No. 718 Pilot binding post strip
- 1—No. 719 Pilot base board
- 1—No. 723 Set of flexible leads
- 1—Package of wood screws

To this should be added a No. 200 Pilot potentiometer of 200 ohms, to be used as a voltage control, if you want it.

The A transformer will operate one to three CY-327 tubes, one to five CX-326 tubes, and one or two CX-371 tubes.

If the receiving set is made up of the 327 tubes entirely, three or four can be operated from the transformer.

You will see that two special wire-wound resistors are supplied. The No. 951 resistor is to give 45 volts C bias on the 171 tube, while the 959 resistor is for biasing the R. F., detector, and first audio tubes.

PLATE CURRENT DETERMINES C BIAS

The C bias for the tubes is obtained by the drop across the resistor when the plate currents flow through them.

The resistance values are such that the correct grid biases will be obtained when the rated voltages are applied to the tubes.

Now, if an inadequate eliminator is used, the voltages will be below the rated values, and the C

bias will not be right. That is why you must use first class B power equipment.

HOW TO USE THE A PACK

Different circuits, with different combinations of tubes, require various arrangements for the grid bias. The standard Pilot No. 4 A pack has resistors to provide biases which are correct for the tuned R. F. receiver, described in Radio Design No. 2, and for the receiver shown in the accompanying illustrations, diagrams for which are given in Figs. 5 and 7.

In Fig. 5 you will see that binding posts are indicated in three different ways, to show those which should be connected to the A pack only,

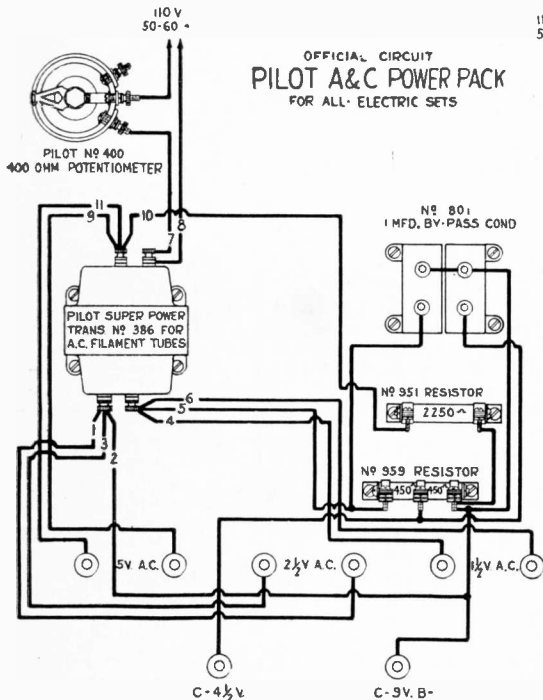

Fig. 2. Left. Picture wiring of the A and C power pack. Fig. 3. Right. Diagram of the B power pack. The 387-A transformer has only two primary terminals, but it runs either a BH or 280 tube.

those to go to the B pack only, and those to be connected to both A and B packs.

For economy of space, the binding posts, as you can see in Fig. 7, were just machine screws with battery thumb knots to take the leads.

Since the bias resistors are supplied, no separate C batteries are needed.

On the other hand, for the Air Hound set, equipped with three 327 tubes, the bias resistors are both of 2,250 ohms.

ARRANGEMENT OF THE B POWER PACK

The B power pack is shown at the right in Fig. 1, with its diagram in Fig. 3. Here is the list of parts supplied with the kit:

- 1—No. 387-A Pilot B transformer
- 6—No. 9302 Pilot 2 mfd. filter condensers
- 1—No. 9110 Pilot .1-.1 mf. buffer
- 1—No. 9000 Pilot condenser block clamp
- 2—No. 377 Pilot 30-henry chokes

- 1—No. 960 Pilot B resistance
- 3—No. 801 Pilot 1 mfd. by-pass condensers
- 1—No. 213 Pilot socket
- 1—No. 720 Pilot binding post strip
- 1—No. 721 Pilot baseboard
- 1—No. 724 Set of flexible leads

The 280 type tube is recommended for this set, although a BH Raytheon can be used if you prefer.

NOTES ON THE B PACK

In the standard kit, a buffer condenser is supplied, to be used in the regular way with a Raytheon tube, or connected as shown in Fig. 3 for the 280.

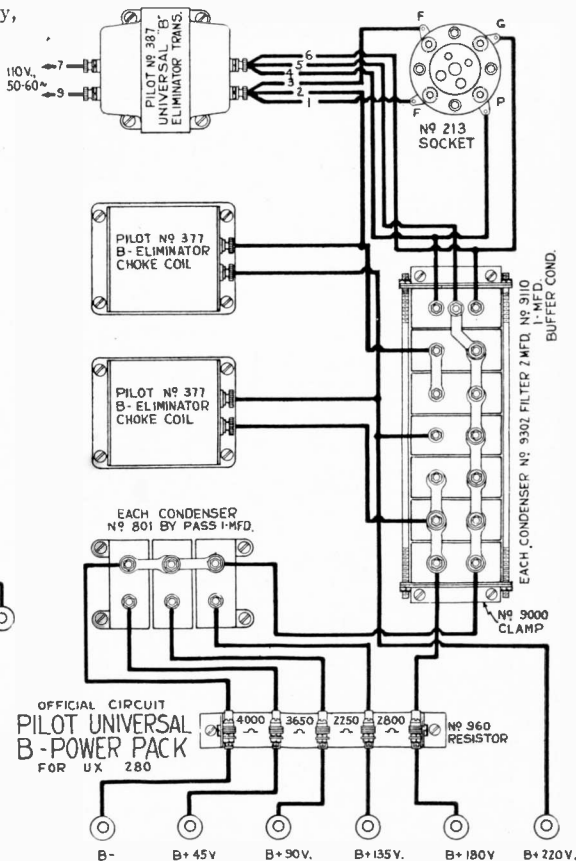

OFFICIAL CIRCUIT
PILOT UNIVERSAL
B-POWER PACK
FOR UX 280

You will see that binding posts are provided for 180 volts and 220 volts. If you use the power pack on old style receivers, where separate C batteries are employed, so that you will not need the biases from the resistors in the A pack, you should use the 180-volt binding post to get 180 volts on the 171 tube. If you use the A pack and the bias resistors, you must connect to the B+ 220-V. binding post so that you will have 40 volts extra to use for biasing.

A RECEIVER FOR EXTERNAL POWER SUPPLY

Figs. 5 and 7 show the circuit for a set similar to the Air Hound, arranged for external A and B power packs. This set has a stage of tuned R.F. with a super-charger control, regenerative detector, and two stages of audio amplification with an output impedance to operate the loud speaker. In addition, the set is provided with a jack for a phonograph pickup. When the phonograph pickup

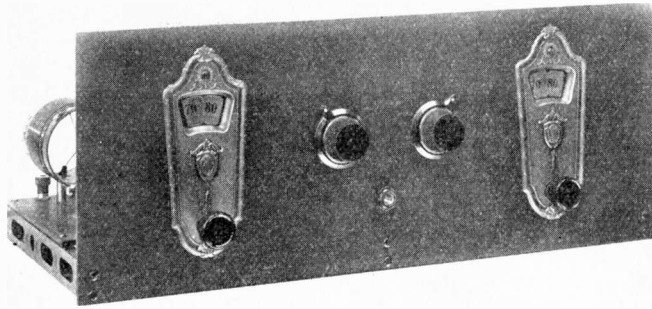

Fig. 4. A very handsome effect is given by the new dials.

is plugged in, it operates the detector, giving two stages of audio amplification.

The set is assembled on a 7 x 18-in. front panel, with a 7 x 17 in. base panel supported on three No. 35 Pilot brackets.

Following is a list of parts required:

- 1 No. 801 Pilot 1 mfd. by-pass condenser
- 3 No. 35 Pilot 1 in. Bakelite brackets
- 1 No. 130 Twin Coupler R.F. choke
- 1 No. 52 Pilot .0005 mfd. condenser
- 2 No 1255-W Pilot Bakelite knob
- 4 Pilot engraved Bakelite binding posts

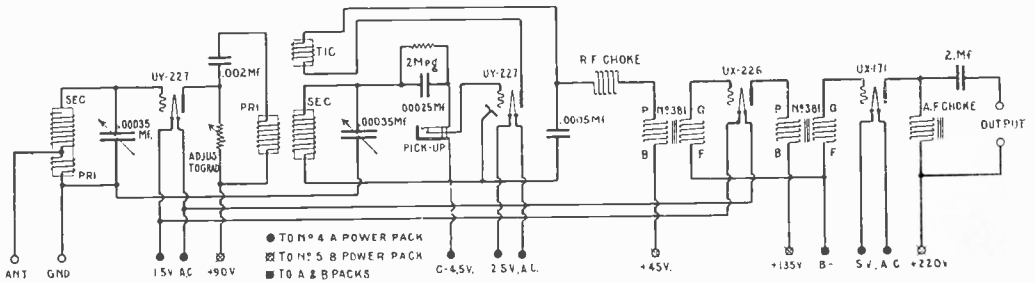

Fig. 5. Circuit for the all-electric set, equipped with jack to take a phonograph pick-up. Note the legend for power pack connections.

- 2 No. 1617 Pilot .00035 mfd. condensers
- 1 No. 350 Pilot Resistograd
- 2 No. 1282 Pilot illuminated dials
- 1 No. 1165 Pilot midget jack
- 1 No. 54 Pilot .002 mfd. condenser
- 1 No. 121 Twin-Coupler three circuit tuner
- 1 No. 123 Twin-Coupler R.F. coil
- 1 No. 51M .00025 mfd. condenser
- 1 No. 756 Pilot 2 meg. grid leak
- 1 No. 211 Pilot UY socket
- 3 No. 205 Pilot UX sockets
- 2 No. 381 Pilot A.F. transformers
- 1 No. 383 Pilot output choke

- 1 7 by 18 by $\frac{1}{8}$ in. Westinghouse Micarta panel
- 1 7 by 17 by $\frac{1}{8}$ in. Westinghouse Micarta panel

No detail description of the assembly is necessary since it is well illustrated in the accompanying pictures, and in the wiring diagrams.

It should be noted that the No. 52 fixed condenser is screwed into the rear terminal of the Resistograd, and a lead for connection drawn off from this common point.

The grid condenser, No. 51-M is mounted under the base panel, and held in place by screws passing

Fig. 6. Rear view of the all-electric four-tube receiver.

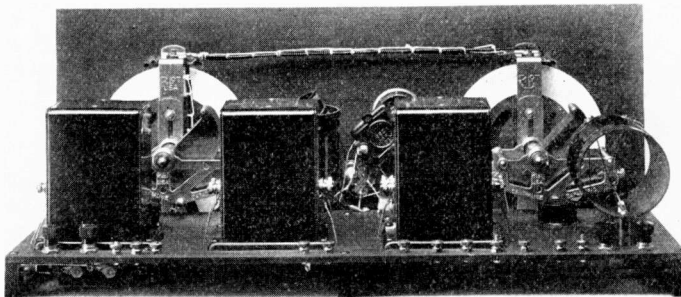

through the grid leak clips, through the base panel and into the threaded bushing of the condenser.

Some of the leads in this set are cabled as much to improve the appearance of the set as to keep the leads properly separated from others in which a 60 cycle hum might be induced.

The operation of the set is similar to that of the Air Scout. An ordinary broadcast antenna is required with a first class ground connection.

The two condensers control the tuning, while the volume in the R.F. and detector stages is regulated by the Resistograd and tickler coils respectively. Once you are familiar with the operation of the set, you can adjust the Resistograd per-

pression that a hum is set up when 326 tubes are used. That is more probably due to the extra filament wiring which must be run around the receiver, inducing slight A. C. currents in the R. F. circuits.

The question frequently arises as to whether the A power transformer can be mounted right in the radio set without making trouble. Ordinarily this arrangement is entirely satisfactory. In the Air Hound, for example, there is no hum to be heard, even when no broadcast signals are coming in.

Usually A. C. interference is only caused from a filament transformer when it is overloaded

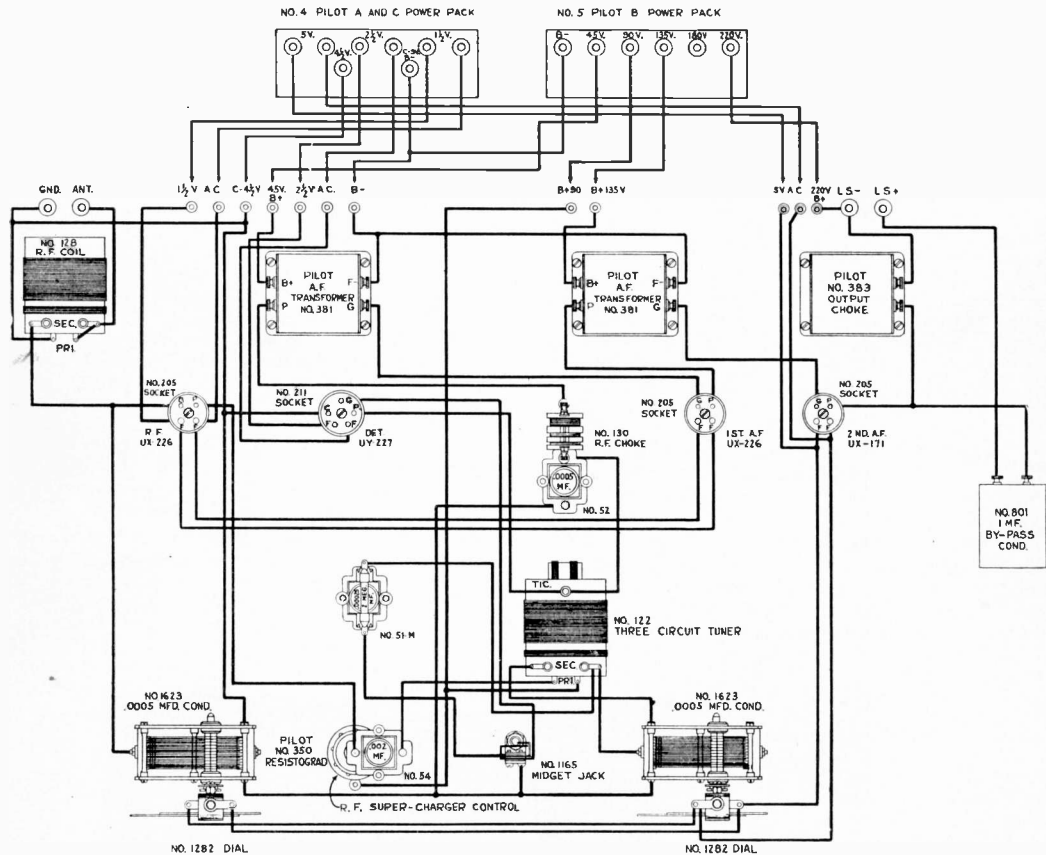

Fig. 7. This set employs separate power packs for A and B. Note the connections for the phonograph pick-up.

manently and control the volume with the tickler alone.

This set has a loud speaker range of 1,000 or 2,000 miles, and is sufficiently selective to meet all ordinary cases of interference.

SPECIAL NOTES ON A. C. SETS

There is now a decided tendency toward using all 327 tubes rather than specifying 326 tubes for the R. F. and first audio.

The reason is simply that construction is greatly simplified by using all 327 tubes, and the actual efficiency obtained from them is just as great as from the 326 tubes.

Some set builders have been under the im-

pression that a hum is set up when 326 tubes are used. That is more probably due to the extra filament wiring which must be run around the receiver, inducing slight A. C. currents in the R. F. circuits.

USING POWER AMPLIFIER

If you want something very fine indeed, assemble an A. C. set such as is shown in Fig. 7, or the regular Air Hound, but leave off the last A. F. stage. Instead connect the plate of the first audio tube directly to the new 250 power amplifier. Then you will have radio reception of the very finest quality and you can use one of the new dynamic speakers. Moreover, if you use the circuit shown in Fig. 7, with a jack to cut in a phonograph pick-up, you can get the 250 power amplifier results for phonograph reproduction.

Be very careful in the selection of your phonograph pick-up. There are several types which have been dumped on the market, and are being offered at very low prices, but the quality of reproduction is on a par with the cost. Have the dealer demonstrate the operation of the pick-up for you. Otherwise you may get some-

Radio is playing an important part in the promotion of safe flying. At all the Army posts weather reports are exchanged by radio early every morning. As the day progresses, if any change in atmospheric conditions occur, supplementary reports are sent out at once.

When the Airplane Radio Laboratory is to

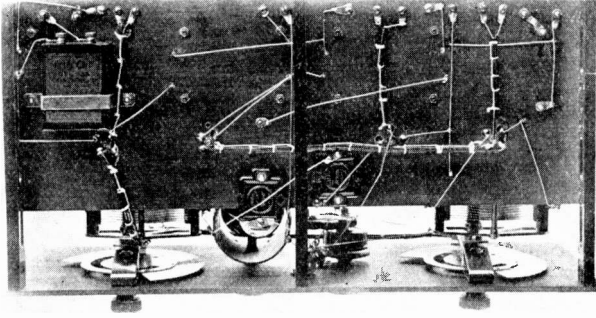

Fig. 8. Here you can see how much it improves the appearance of a set to cable the leads. This keeps the filament wires away from the grid leads, and also reduces the A. C. hum. Filament leads for different types of tubes can be cabled together.

thing that sounds like the old-fashioned canned music, instead of quality from the amplifier that is superior to that from the phonograph from which, on the new style records, we get music that sounds like the original orchestra or the artist himself.

THE PILOT AIRPLANE RADIO LABORATORY

The Pilot Airplane Radio Laboratory has flown more than 12,000 miles during test flights for trying out airplane radio equipment and on trips carrying Company officials on emergency flights. Between 250 and 300 men connected with the radio industry have been up as passengers on trips around the country.

start on long flights, a report is first obtained from Mitchel Field, adjacent to Curtiss Field, as to conditions along the route which the plane is to cover. Probably within the next year, planes will be able to get additional information in flight from weather reporting ground stations.

Experience gained during the operation of the Pilot plane indicates that radio reception of weather reports is practical on commercial planes operating on regular schedule, even tho the pilot is flying alone. The use and practicability of radio for privately operated ships is doubtful, however, for the radio equipment must have the same informed attention that is given to the other parts of the ship, and radio equipment, until more ade-

Fig. 9. In many ways it is better to use separate A and B packs, for this method of construction simplifies the design and wiring of the set, and keeps all the A. C. equipment away from the radio frequency circuits. This can be seen by comparing these illustrations with those of the Air Hound.

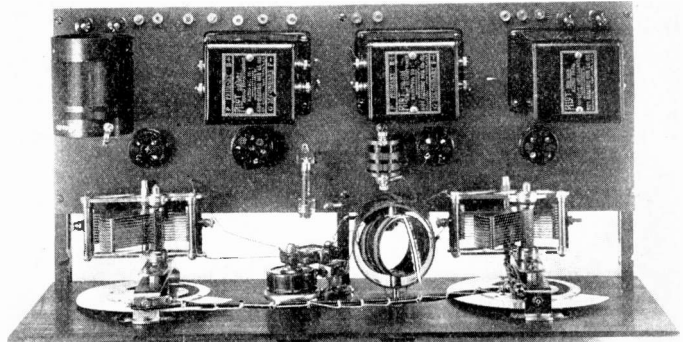

Thanks to the dependability of the Stinson ship and its Whirlwind motor, as well as the skill of Louis Meier, the pilot, the big monoplane has never had a forced landing.

Among the cities to which the ship has flown are Washington, Detroit, Chicago, Cleveland, Boston, Baltimore, and Hartford. The plane is a well-known visitor at Fort Monmouth, N. J., where the laboratories of the U. S. Signal Corps are located, as well as the Officers' Radio School.

quate service is provided at airports might be as much trouble as it would be worth.

In fact, the whole matter of radio equipment for aircraft, and the methods of its use, will undergo considerable revision within the next two years. Much has been learned concerning this subject by Pilot engineers, for it is only under actual average flying conditions—not merely pleasant-day hops around a flying field—that the scope and the limitations of airplane apparatus can be determined.

CITIZEN C 179 X

Short Wave Transmitting Stations of the World

10-20 METERS

Note—The International Amateur "10 meter band" reaches from 10 to 10.7 meters and many additional stations can be heard there, especially by daylight at long distances only.

Wave-length meters	Call	Location of Station	Wave-length meters	Call	Location of Station	Wave-length meters	Call	Location of Station
10.	1RG,	"Radiogormale," Lake Como, Italy	15.641	PQW,	Alfragide, Lisbon, Portugal (Beam)	16.71	WBQ-WEBQ,	Rocky Point, N. Y.
11.	AGK,	Nauen, Germany	15.7	WFX-WEFX,	Rocky Point, N. Y.	16.78	WBC-WEQC,	Rocky Point, N. Y.
12.25	AGA,	Nauen, Germany	15.707	GLW,	Dorchester, England (Beam)	16.93	KUN-KEUN,	Bolinas, Calif.
13.5	POF,	Nauen, Germany	15.707	GLG,	Royal Air Force, England	17.	SPI,	Rio de Janeiro, Brazil
13.5	AGA,	Nauen, Germany	15.740	GLG,	Royal Air Force, England	17.	cg2BR,	Chelmsford, England
13.88	WNI),	Ocean Township, N. J.	15.740	low	Royal Air Force, England	17.	2BR,	Chelmsford, England
14.	KDKA,	East Pittsburgh, Pa.	15.86	low	Royal Air Force, England	17.	NKF,	Bellevue Anacostia, D. C.
14.08	KWE-KEWE,	Bolinas, Calif.	15.93	WDS-WEDS,	Rocky Point, N. Y.	17.	PCCG,	Malabar, Java
14.09	2XBC-WBU,	Rocky Point, N. Y.	16.	WHR-WEHR,	Rocky Point, N. Y.	17.	KFUM,	SS. Idalia
14.1	KEL,	Bolinas, Calif.	16.	AGA,	Nauen, Germany	17.	KKC,	Palo Alto, Calif.
14.13	WQA-WEQA,	Rocky Point, N. Y.	16.	WSS,	Rocky Point, N. Y.	17.	KNW,	Palo Alto, Calif.
14.25	AG9,	Nauen, Germany	16.	NKF,	Rocky Point, N. Y.	17.2	KNN,	Honolulu
14.28	FW,	Sainte Assise, France	16.	JPP,	JYZ, Tokyo	17.2	AGC,	Nauen, Germany
14.29	KMM-KEMM,	Bolinas, Calif.	16.02	WTT,	Rocky Point, N. Y.	17.3	WKI,	Newark, N. J.
14.4	KSS-KESS,	Bolinas, Calif.	16.02	2XG,	Rocky Point, N. Y.	17.4	ANE,	Bandong, Java
14.8	WGG,	New York	16.077	VNB,	Klipheuvael, S. Africa (Beam)	17.4	ANH,	Malabar, Java
14.8	WQQ,	Rocky Point, N. Y.	16.146	GBJ,	Bodmin, England (Beam)	17.5	WKC,	Newark, N. J.
14.85	WQX-WEQX,	Rocky Point, N. Y.	16.17	2XT,	Rocky Point, N. Y.	17.5	GBL,	Leafeld, England
14.91	WQY-WEQY,	Rocky Point, N. Y.	16.216	GBI,	Grimsbay, England (Beam)	17.5	GBM,	Leafeld, England
14.93	2XS,	Rocky Point, N. Y.	16.286	VWZ,	Kirkee, Bombay (Beam)	17.7	GBO,	Leafeld, England
14.95	AGA,	Nauen, Germany	16.35	WND,	Ocean Township, N. Y.	18.	KFD,	Denver, Colo.
15.	GLS,	Ongar, England	16.41	WEM-WEEM,	Rocky Point, N. Y.	18.27	POF,	Nauen, Germany
15.	CG2BR,	Chelmsford, England	16.49	WLL-WELL,	Rocky Point, N. Y.	18.3	PQS,	Alfragidi, Lisbon, Portugal (Beam)
15.	2XAW,	Schenectady, N. Y.	16.574	GBK,	Bodmin, England (Beam)	18.3-18.7	2XAP,	Schenectady, N. Y.
15.	CH,	Quilicura, Chile	16.6	WLL,	Rocky Point, N. Y.	18.3-18.7	4XK,	San Juan, P. R.
15.	PUC,	Curacao	16.7	KNW,	Palo Alto	18.36	PRHA,	Lourenco Marques, Portuguese, E. Africa
15.08	YNB,	Capetown, S. Africa				18.62	KEB,	Oakland, Calif.
15.5	SPU,	Rio de Janeiro, Brazil				18.8	AND,	Tjilitin, Java
15.576	SPU,	Santa Cruz, Brazil (Beam)				18.	PCLL,	Kootwijk, Holland

Note—The international amateur "20-meter band" reaches from 20.8 to 21.4 meters and many additional stations may be heard there. It is a long-distance wave and at its best when one or both stations are in daylight, i.e., both the transmitter and your receiver.

Twenty-meter stations are frequently very weak nearby and loud at a distance of 1000 miles or more.

20. WSS, Rocky Point, N. Y.
 20. 2XAW, Schenectady, N. Y.
 20. TUK, Tomsk, Siberia
 20. AGK, Nauen, Germany
 20. CH, Quilicura, Chile
 20. NAL, Navy Yard, Washington, D. C.
 20. NEPQ, SS. Relief
 20. OCTN, Mourillon, Toulon, France
 20. PCH, Schevevingen, Netherlands
 20. POX, Nauen, Germany
 20. PCRR, Kootwijk, Holland
 20. GER, Winchester, England
 20. PUC, Curacao
 20. GLSQ, SS. Olympic
 20. RRP, Nijini Novgorod, U. S. S. R. (Russia)
 20. J-1PP, Tokyo
 20.25 JB, Johannesburg, S. Africa (B. C.)

20.3	ANF, Tjililin, Java	22.02	WGY, Schenectady (B. C.)	25.	HZA, Saigon, Fr. Indo China	28.5	FDRL, Leningrad, U. S. S. R. (Russia)
20.5	JKZB, Tokyo, Japan	22.09	GLH, Dorchester, England (Beam)	25.	PCRR, Kootwijk, Holland	28.58	KMM-KEMM, Bolinas, Calif.
20.69	PCH, Scheveningen, Netherlands	22.1	2XE, Richmond Hill, N. Y.	25.3	FFW, St. Assise, France	28.8	AND, Tjililin, Java
20.8	NKF, Bellevue, Anacostia, D. C.	22.180	Rio de Janeiro, Brazil (No call)	25.5	5DH, Dollis Hill P. O., England	28.8	KSS-KESS, Bolinas, Calif.
21.	PCTT, Kootwijk, Holland	22.24	WAJ-WEAS, Rocky Point, N. Y.	25.5	AGB, Nauen, Germany	29.	PCH, Scheveningen, Netherlands
21.	NKF, Bellevue, Anacostia, D. C.	22.38	FY, Bordeaux, France	25.5	B82, Brussels, Belgium	29.	JPS, Sapporo, Japan
21.	RKV, Moscow, U.S.S.R. (Russia)	22.5	WBD, Ocean Township, N. J.	25.5	NKF, Bellevue, Anacostia, D. C.	29.	NKL, Arlington, Va.
21.127	PCH, Scheveningen, Netherlands	22.8	OLO, SS. Slamet	25.728	VIZ, Melbourne, Australia	29.226	OCNG, Nogent-le-Rotrou, France
21.4	WDJ, Harrison, Ohio	22.90	WOWO, Ft. Wayne, Ind. (B. C.)	26.	GBH, Grimsby, England (Beam)	29.282	PCH, Scheveningen, Netherlands
21.4	KDZ, Point Barrow, Alaska	23.	2XAA, Houston, Me.	26.	AGA, Nauen, Germany	29.3	PCH, Scheveningen, Netherlands
21.48	WIK, Rocky Point, N. Y.	23.	KNN, Honolulu, T. H.	26.	AGC, Nauen, Germany	29.3	6XI, Bolinas, Calif.
21.5	WIK, New Brunswick, N. J.	23.	PKH, Soerabaya, Java	26.	FAMJ, SS. Jean d'Arc	29.3	KEL, Bolinas, Calif.
21.5	PKP, Medan, Sumatra, I. E. I.	23.	RAU, Tashkent, Turkistan, U. S. S. R.	26.	ICJ, Bengazi, Cyrenaire, Libya	29.3	SPW, Rio de Janeiro
21.5	IPP, Tokyo, Japan	23.18	RLT, Tommot, U. S. S. R. (Russia)	26.	VJS, Rabaul, New Guinea	29.5	KNR, Clearwater, Calif.
21.5	GBO, Leafield, England	23.25	WNP, SS. "Bowdoin"	26.086	WNU, New Orleans, La.	29.5	PCTT, Kootwijk, Holland
21.5	GBL, Leafield, England	23.3	FFW, Sainte-Assise, France	26.086	GBK, Bodmin, England (Beam)	29.71	WOX-WEQX, Rocky Point, N. Y.
21.5	GBM, Leafield, England	23.4	WBQ, Schenectady, N. Y.	26.2	ANC, Tjililin, Java	29.8	3LO, Melbourne, Australia (B. C.)
21.5	WOP-WEOP, Rocky Point, N. Y.	23.5	GRM, Osaka, Japan	26.269	CG, Montreal, Canada	29.83	WQY-WEQY, Rocky Point, N. Y.
21.57	KTF, Midway Island	24.	KTA, Guam, P. R.	26.3	KDKA, East Pittsburgh, Pa.	30.	IXAR, Manila, P. I.
21.63	WPE-WEPE, Rocky Point, N. Y.	24.	KNN, Honolulu, T. H.	26.3	WDJ, Harrison, Ohio	30.	2XI, Schenectady
21.7	5DH, Dollis Hill, England	24.	2XAD, New York	26.92	2XAG, New York City	30.	GBL, Leafield, England
21.75	WGT-WEGT, San Juan, P. R.	24.	GBL, Leafield, England	27.	AGB, Nauen, Germany	30.	GBM, Leafield, England
21.8	RRU, U. S. S. R. (Russia)	24.	JES, Osaka, Japan	27.	ANH, Malabar, Java	30.	GBO, Leafield, England
21.8	GLS, Ougar, England	24.	GBO, Osaka, Japan	27.	PCPP, Kootwijk, Holland	30.	IBK, Kagoshima, Japan
21.8	KFB, Oakland, Calif.	24.	PKE, Amboina, D. E. I	27.	PKX, Java	30.	JSK, SS. Shingo, Maru
21.8	KTA, Guam, P. I.	24.	KNN, Honolulu, T. H.	27.	RCRI, Central Lab., Leningrad, U. S. S. R. (Russia)	30.	ANK, Malabar, Java
21.8	HJC, Bogota, Colombia	24.	2XAD, New York	27.5	KKC, Palo Alto, Calif.	30.2	PCJJ, Eindhoven, Holland
21.8	KIL, Bolinas, Calif.	24.	GBL, Leafield, England	27.5	PCMM, Kootwijk, Holland	30.5	ARCX, SS. Nielsen, Alonso
21.6	Schenectady	24.3	JEW, Osaka, Japan	27.6	5DH, Dollis Hill, England	30.5	PTQ, Quartel, Brazil
22.	KTA, Guam	24.5	SSW, Chelmsford, England	27.9	WKI, Newark, N. J.	30.6	NAL, Navy Yard, Washington, D. C.
22.	VIT, Townsville, Queensland, Australia	24.6	GDKB, SS. Dorsetshire	27.9	WKL, Newark, N. J.	30.7	EAM, Madrid, Spain
22.	VIX, Sydney, N. S. W., Australia	24.7	KFD, Denver, Colo.	28.	FUL, Beyrouth-Djeideite, Lebanon, Syria	30.91	2XAL-WRNY, Coteyville, N. J. (B. C.)
22.	RABL, Habarovsk, Siberia	24.9	FW, Sainte-Assise, France	28.15	KNN, Honolulu, T. H.	31.	6XBH-KFQU, Alma (Holy City), Calif. (B. C.)
22.	VIZ, Rabaul, New Guinea	25.	GLQ, Ongar, England	28.25	POW, Nauen, Germany	31.	SAD, Flottans Stations, Stockholm, Sweden
22.	RTRL, Tiflis, Georgia, U. S. S. R. (Russia)	25.	CI, Drummondville, Can. (Beam)	28.4	KWE-KWE, Bolinas, Calif.	31.	TVT, SS. Soldvijk
22.	KGBB, SS. Ungara	25.	VIV, Melbourne, Australia (Beam)	28.5	WQA-WEQA, Rocky Point, N. Y.		
			25.		SPW, Rio de Janeiro, Brazil		
					2MIE, Sydney, Austral		

31-04	8XAG, Dayton, Ohio	32-5	IDX, Amara, Italy	34-	RAV, Tashkent, Turkestan, U. S. S. R.	(B. C.)	DS, H. M. S. Renown
31-39	WFX-WEFX, Rocky Point, N. Y.	32-69	WND, Ocean Township, N. J.	34	RKV, Moscow, U. S. S. R.		3LO, Melbourne, Australia
31-5	PKP Medan, Sumatra	32-77	2XAF, Schenectady (B. C.)	34	VNB, Capetown, S. Africa		KTA, Guam, P. R.
31-73	WDS-WEDS, Rocky Point, N. Y.	32-84	WEM-WFEM, Rocky Point, N. Y.	34	(Beam)		LPO, Buenos Aires
31-8	AYG, Guayra, Venezuela	32-98	NPG, Puget Sound, Wash.	34	XDA, Mexico City, Mex.		NPM, Honolulu, T. H.
31-96	WHR-WEHR, Rocky Point, N. Y.	32-98	WLL-WELL, Rocky Point, N. Y.	34-013	GBJ, Bodmin, England		OCBR, Rabat, Morocco
22	2FC, Sydney, Australia, (B. C.)	33	iFC, Royal Frederico Cesi School, Rome, Italy	34-168	(Beam)		ANF, Tjillin, Java
32	2XG, New York City	33	6XAR, San Francisco, Calif. (B. C.)	34-168	GBI, Grimsby, England		FUT, Toulon-Mourillon, France
32	2YT, Poldhu, England	33	AQE, SS. Sir James Clark Ross	34-2	HBC, Berne, Switzerland		SAB, Goteborg, Sweden
32	3LO, Melbourne, Australia	33	CHO, Telegraphic Administration, Oslo, Norway	34-2	RDI, Petzavodsk, U. S. S. R.		KGH, Hillsboro, Ore. (B. C.)
32	6XAR-KJBS, San Francisco, Calif. (B. C.)	33	KDO, Rome, Italy	34-2	KNN, Honolulu, T. H.		2XAP, San Juan, P. R.
32	8XAO-WCX-WJR, Detroit, Mich. (B. C.)	33	OCCO, Conakry, Fr. W. Africa	34-4	VWZ, Kirkee, Bombay, India		4XK, San Juan, P. R.
32	9XD, Radio Club of Zurich, Zurich, Switzerland	33	OCDJ, Issy les Moulineaux, France	34-483	VWZ, Kirkee, Bombay, India		NPM, Honolulu, T. H.
32	9OC, Tel. & Radio SVC, Berne, Switzerland	33	OCTN, Mourillon, Toulon, France	34-6	(Beam)		FUM, Montebourg, France
32	ANE, Malabar, Java	33	VZDK, SS. Jervis Bay	34-78	Standard Wave for Ships		GLYX, SS. Derbyshire
32	ARDI, SS. C. A. Larsen	33	KTF, Midway Island	34-86	KWT, Palo Alto, Calif.		KEL, Rolinas, Calif.
32	CF, Drummondville, Montreal (Beam)	33	WQC-WEQC, Rocky Point, N. Y.	35	iPP, Tokyo, Japan		KFVM, SS. Idalia
32	FL, Eiffel Tower	33-2	KUNW, Palo Alto, Calif.	35	iRG, "Radiogiornale," Lake Como, Italy		KGBB, SS. Ungava
32	HVA, Hanoi, Fr.	33-33	KUN-KEUN, Bolinas, Calif.	35	2XG, Ocean Beach, N. J.		NPC, Puget Sound, Wash.
32	IDO, Rome, Italy	33-37	AQE, SS. Sir James Clark Ross	35	2XI, Schenectady		NPU, Tutuila, Samoa
32	JB, Johannesburg, S. Africa (B. C.)	33-42	NAJ, Great Lakes, Ill.	35	BXW, Gibraltar, N. Front		OLO, SS. Slamet
32	LH, Hiroshima, Japan	33-5	WNBT, Elgin, Ill. (B. C.)	35	Straits Settlements		PCRR, Kootwijk, Holland
32	LY, Bordeaux, France	33-5	VNB, Klipheuvai, S. Africa (Beam)	35	BXY, Stonecutters Island, Hong Kong		WOBD, SS. Radio
32	OCNG, Nogent-le-Rotrou, France	33-58	KUN-KEUN, Bolinas, Calif. Italy	35	BYB, Whitehall, R. C., England		6XF, Los Angeles, Calif.
32	PCLL, Kootwijk, Holland	33-708	iFC, Royal Cesi School, Rome, Italy	35	BYC, Horsea, England		WJID, New York
32	PKX, Java	33-88	DGP, S., Cap Polonio	35	BZE, Matara, Ceylon		WCFL, Chicago, Ill. (B. C.)
32	VIS, Sydney, Australia	34	KNW, Palo Alto, Calif.	35	BZF, Aden, Arabia		NAA, Arlington, Va.
32	VIZ, Rabaul, New Guinea	34	LPI, Buenos Aires	35	NPM, Honolulu, T. H.		NKF, Bellevue, Anacostia, D. C.
32-128	CG, Drummondville, Montreal (Beam)	34	NAJ, Great Lakes, Ill.	35	OCDA, Dakar, Fr. W. Africa		NKL, Arlington, Va.
32-397	GBK, Bodmin, England	34	PCUU, Hague	35	VKQ, Garden Island, Sydney, Australia		Standard Wave for All Ships
32-5	2NM, G. Marcuse, Caterham, England (B. C.)	34		35	WGY, Schenectady		WLC, Rogers, Mich.
		34		35	WOO, Rocky Point, N. Y.		6XAX, California (Portable)
		34		35	KGDU, SS. Four Winds		2XAP, New York City
		34		35	PCMN, Kootwijk, Holland		AND, Tjillin, Java
		34		35	WJF, Detroit, Mich.		IDO, Rome, Italy
		34		35	5DH, Dollis Hill, England		JKV, Kanawa, Japan
		34		35	BZC, Portsmouth, England		KFZQ, SS. Robador
		34		35	School, Portsmouth, England		SKB, MS. Gripsholm
		34		35			3XQ, Mountain Lakes, N. J.
		34		35			2XI, Schenectady
		34		35			GBA, Tobermorey, Scotland
		34		35			ISF, Chisimajo, It. Somaliland
		34		35			JPS, Sapporo, Japan

38.	PCUU, Hague	41-95	FW, St.-Assise, France	44-03	KZA-KZB, Los Angeles	47.	SUC2, Abu Zabal, Cairo, Egypt
38.38	KEUN, Bolinas, Calif.	41-95	VIS, Sydney	44-03	KOO, Houston, Texas	47.	ICX, Massawa, Eritrea
38.5	ANDIR, Malabar, Java	42.	RTRL, Tiflis, Georgia, U. S.	44-03	WPI-WAQ, Newark	47.	KTA, Guam
38.5	FUE, Mengam, France	42.	S, R.	44-03	SPI, Rio de Janeiro	47.	SPM, Helsinki, Finland
39.	KAV, Norddeich, Germany	42.	VIT, Townsville, Queensland, Australia	44-48	WAJ-WEAJ, Rocky Point, N. Y.	47.	KNN, Honolulu
39.	OCMV, Mont Valerien, France	42.	RRP, Nijini Novgorod, U. S.	44-5	SPI, Rio de Janeiro	47.4	OCTU, Tunis, Tunis
39.	OCRU, Rufisque, Fr. W. Africa	42.	S, R.	44-62	WBO, Dearborn, Mich.	48.	OCNG, Nogent - le - Rotrou, France
39.5	JFAB, Taipei, Formosa	42.	PCUU, Hilversum, Holland	44-71	KPZH, Fairbanks, Alaska	48.	KNW, Palo Alto, Calif.
39.5	OHK, Vienna, Austria	42.	SGT, MS, Suecia	45.	ICK, Tripoli	48.05	KSZ, McConney, Texas
39.8	AGC, Nauen, Germany	42.	VIZ, Rabaul, New Guinea	45.	OCMV, Mont Valerien, France	48.05	KYI, Kings Mill, Texas
	40-50 METERS	42.	5XH, New Orleans	45.	NPG, San Francisco	48.05	KINT, Palo Alto, Calif.
	<i>Note</i> —The international amateur "40-meter band" is the busiest of all the bands because it is both a good semi-local and "extreme D-X" wave. In addition, it has some of the properties of 20 meters and will work well into daylight before failing. It reaches from 41 to 42.8 meters.	42.08	KDZ, Pt. Barrow, Alaska	45.	KEG, Vancouver, Wash.	49.	ICF, Messina, Sicily
40.	IXAO, Belfast, Mc.	42.50	TFA, Reykjavik, Iceland	45.	OCNG, Nogent - le - Rotrou, France	49.	WHD, Sharon, Pa.
40.	NQW, SS, Mexico	42.5	FUA, Bizerta-Sidi-Abdullah, Tunis	45.	ArM, Meteorological Hut, Oslo, Norway	49.15	KNR, Clearwater, Calif.
40.	NAS, Pensacola, Fla.	42.51	SS, Masilia	45.	LAX, Rome, via Socioa 80, Italy	49.5	KVR, Las Vegas, Nev.
40.	B82, Uccle, Belgium	42.83	WJF, Detroit, Mich.	45.	KEU, Los Angeles	49.5	KMV, Bandini, Calif.
40.	NOSW, Coco Solo, C. Z.	42.83	WTI, Evansville, Ind.	45.02	KYU, Wichita Falls, Texas	49.5	TFA, Reykjavik, Iceland
40.	6XBR-KFWB, Los Angeles (B. C.)	42.98	NPG, San Francisco	45.02	WHW, Highland Park, Ill.	49.57	OCTU, Tunis, Tunis
40.	WNU, New Orleans	42.95	KDKA, East Pittsburgh, Pa.	45.32	KEFZ, Pt. Barrow	50.	KWT, Palo Alto, Calif.
40.	KFHW, SS, Pointsetia	43.	WIZ, New Brunswick, N. J.	45.43	KEH, Panhandle City, Texas	50.	SAJ, Karlesburg, Sweden
40.	NPG, San Francisco	43.	VGIL, SS, Canadian Commander	45.43	KFE, Ponca City, Okla.	50.	2XAC, Schenectady
40.	BAM, Tahiti	43.	IMA, Rome, Via Bramante 3, Italy	45.77	KQS, Lone Pine, Calif.	50.	2XH, Schenectady
40.	NAJ, Great Lakes, Ill.	43.	ArE, Meteorological Hut, Bergen, Norway	45.77	KQT, Los Angeles	50.	WBZ, Springfield, Mass. (B. C.)
40.2	AGC, Nauen, Germany	43.	JOC, Orichishi, Japan	46.	OAA, The Mossig Weini Aim-lof 13, Austria	51.	AIN, Casablanca
40.2	ANC, Tjililin, Java	43.05	FW, St.-Assise, France	46.	OCMY, Mont Valerien, France	51.	SAD, Flottans Stations, Stockholm, Sweden
40.5	J-1AA, Iwatsuki, Japan	43.14	2XAI, Newark, N. J.	46.	KNN, Honolulu	51.	TSB, SS, Helder
40.5	SPX, Rio de Janeiro	43.2	WAQ, Newark, N. J.	46.	BVJ, Dartmouth, England	51.5	WQN, Rocky Point, N. Y.
40.5	JBK, Kagoshima, Japan	43.33	WOP, WEOP, Rocky Point, N. Y.	46.06	KGT, Fresno, Calif.	52.	VAS, Lewisburg, Nova Scotia
40.5	OCBA, Bamaku, Fr. Sudan	43.45	WPE, WEPE, Rocky Point, N. Y.	46.06	KGE, Medford, Ore.	52.	WGW, Vieques, P. R.
40.5	IAA, Iwatsuki, Japan	43.45	WLK, Wheelwright, Ky.	46.48	WND, Ocean Township, New Jersey	52.	WLW, Cincinnati, O. (B. C.)
40.6	OHK, Vienna, Austria	43.52	WLI, Cleveland, Ohio	46.5	TSB, Norwegian SS, Helder	53.	NPU, Tutuila, Samoa
41.	SMHA, Stockholm, Sweden	43.6	KOS, Pampa, Texas	46.99	KGH, Hillsboro, Ore.	53.	ZWT, Bremerhaven, Germany
41.3	NKF, Bellevue, Anacostia, D. C.	43.74	KTA, Guam	47.	POZ, Nauen, Germany	53.5	AJF, Konigwusterhausen, Germany
41.5	ECBA, Bamako, Sudan	44.	WOB, SS, Radio	47.	DNSC, Royal Danish Dockyard, Copenhagen	53.54	KWJJ, Portland, Ore. (B. C.)
41.7	GDKB, SS, Dorsetshire	44.	OCMV, Mont Valerien, France	47.	SPI, Rio de Janeiro	54.	NBA, Balboa, C. Z.
		44.	KTA, Guam	47.	Dolhis Hill, England (call not known)	54.	8XJ, Columbus, Ohio
		44.	WOO, Rocky Point, N. Y.	47.		54.	WEAO, Columbus, O. (B. C.)
		44.	GFA, Air Ministry, London	47.		54.4	NKF, Bellevue, Anacostia, D. C.
		44.	SAA, Karlskrona, Sweden	47.		54.5	WQN, Rocky Point, N. Y.

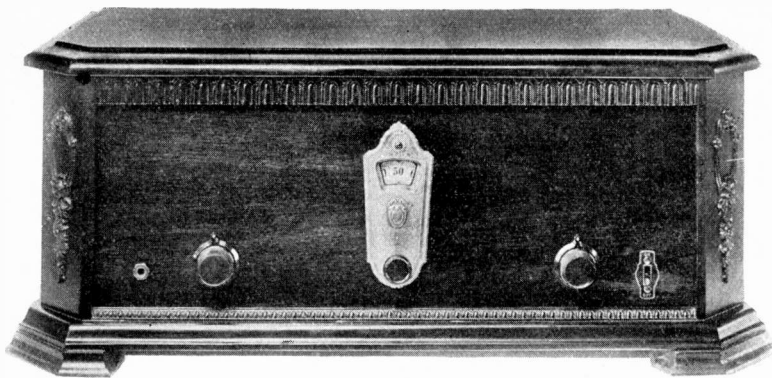

Fig. 1. This gives you an idea of the appearance of the finished set.

TAPERED TUNING MAKES ONE-DIAL SET HIGHLY EFFICIENT

By GERSON LEWIS

IF you have played around with the construction of single control receivers, you probably know that there is a whole lot more to it than just ganging up the condensers and matching coils. It is almost impossible, even for the experienced professional set builder, to build a set of conventional coils and condensers into a single-dial receiver and have every tuned stage exactly in step over the complete frequency range. Even if the coils and condensers are matched, the capacities and inductances due to the wiring, the internal capacities of the tubes, the effect of metal objects near the coils—all add together to unbalance the tuning of the individual stages and decrease the efficiency of the receiver, if not to make it altogether impossible to operate on account of whistles and squeals.

After a great deal of careful laboratory work, I came to the conclusion that the conventional tuned R. F. amplifier would have to be changed for use in single-control tuned R. F. sets built by professional set builders. The result was the Tapered Tuning system of construction.

TAPERED TUNING BIG IMPROVEMENT

Experiments proved that in a single control set employing straight line frequency or modified straight line frequency condensers, the set could not be balanced up by tuning in a station and set-

ting each condenser until maximum volume was obtained. If this was done at one setting of the dial, since each condenser would be at a slightly different setting than the others, as they were all rotated together to tune in another station, the stages would be unbalanced again due to the fact that the variation of capacity of this type of condenser is not proportional to the angle of movement of the rotor plates. Therefore even though all the condensers had been moved through the same angle the variation of capacity of each one would be different. This effect was especially noticed at the lower wavelengths, where the tuning is sharp.

In the Taper-Tuned Receiver each stage is designed to have a different sharpness of tuning. Starting at the first stage the tuning is broad. As the signal travels through toward the detector, each stage is more sharply tuned than the preceding one. The detector stage is designed to give knife-like selectivity without cutting sidebands. In this way, by constructing the coils and laying out the set so that the stages are all electrically similar, any slight detuning of one or more of the broad stages has no effect on the volume or operation of the receiver. The proof that this theory is sound lies in the wonderful performance of the Taper-Tuned Receiver. The tuning is sharp

Fig. 2. The newer Pilot variable condensers have mounting legs so that they can be secured to the base board of the set.

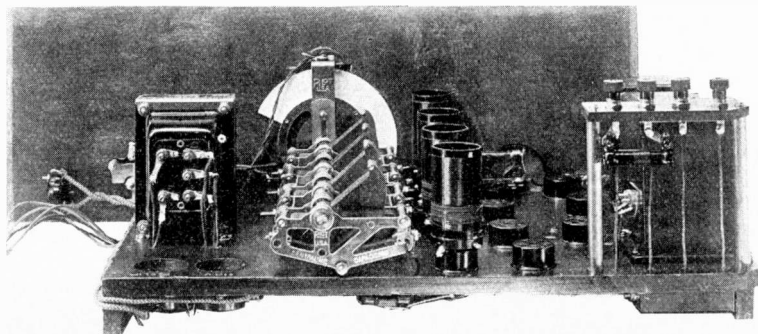

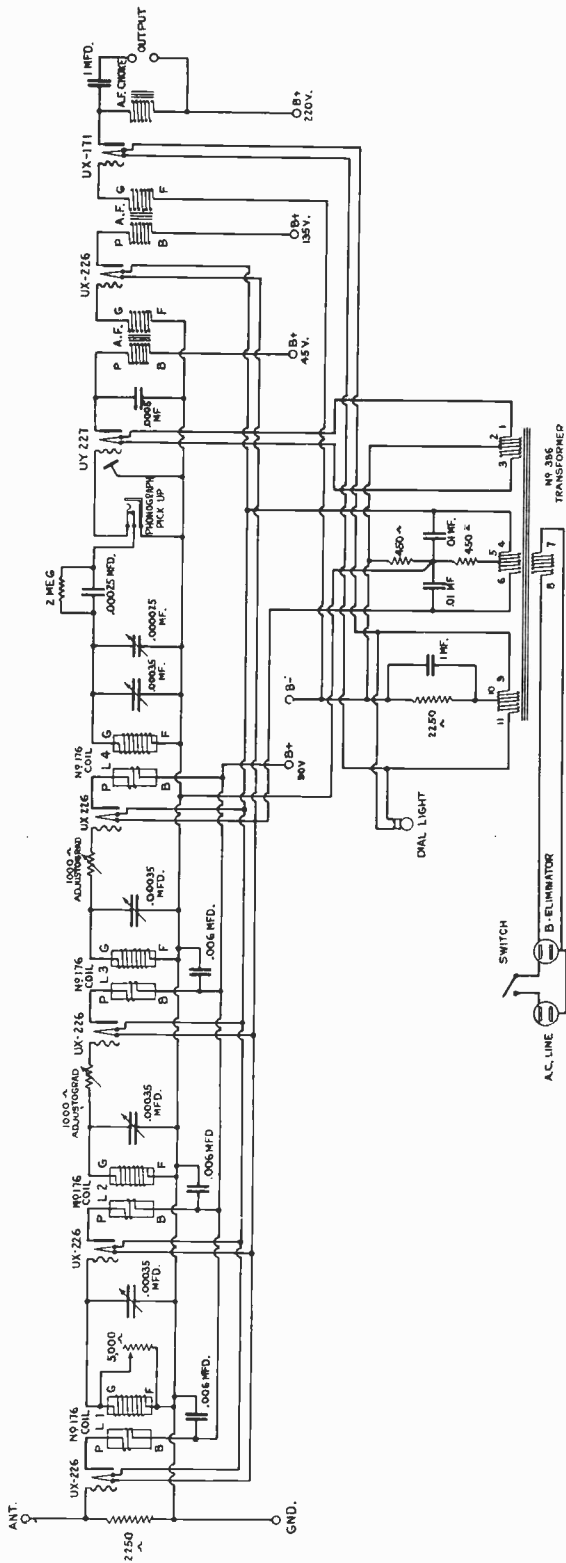

Fig. 3. All the wiring of the set is shroun except for the B-pack. That is separate, but mounted in the cabinet. See Figs. 6 and 7.

enough so that distant stations can be tuned in through the locals in New York City. The three stages of tuned R. F. with the close coupling give it tremendous sensitivity. The high grade audio amplifier gives wonderful tone quality when used with a good speaker, and the single tuning control gives ease of handling.

LOSSER METHODS ARE INEFFICIENT

There are two practical ways to make a tuned R. F. stage tune broadly. One is to insert resistance directly into the tuned circuit; the other is to use close coupling between the primary and secondary coils. The first method is a lossier method and materially reduces the signal strength. The second method actually increases the signal strength, the practical limit being set by conditions of oscillation which develop if the coupling is made too tight. The latter method of broadening the tuning was adapted since it was found that tremendous increase in sensitivity could be obtained and by proper design of coils and circuit the oscillation tendency could be controlled very easily.

GREATER SENSITIVENESS OBTAINED

Referring to the circuit diagram you will see that the set employs an untuned antenna circuit with a 2,250-ohm resistance connected between antenna and ground. The ground goes to the common grid return line so that the proper grid bias is put on this tube.

This is followed by a stage of tuned R. F. amplification which is purposely made rather broad when considered in comparison with our modern sharply tuned R. F. stages. Oscillation is controlled by a 5,000-ohm Elecotrad non-inductive resistance shunted across the secondary of this coil. This resistance is of the proper range to control oscillation perfectly over the entire wavelength range of 550 to 200 meters and at the same time is high enough to prevent any decrease in signal strength. By having this control on the front panel it is possible to keep the set under the oscillation point over the entire range, resulting in remarkable sensitivity. It also acts as an excellent tone control, for the volume can be reduced to a whisper by its use.

The second and third stages have slightly sharper tuning, and employ the popular "grid suppressor" means of oscillation control. The detector stage tunes very sharply and extra line control for DX is obtained by the midget condenser.

The phonograph pick-up jack is placed ahead of the detector tube, just after the grid leak and condenser, so that the detector tube is used as an amplifier when the phonograph pick-up is plugged in. This results in more volume.

The audio amplifier employs two high quality audio transformers, and a 171-A power tube feeding into an output filter circuit.

The A. C. line switch controls the A and C power pack unit and the B power pack.

COMPLETE OUTFIT IN 21-IN. CABINET

The complete receiver, with A and B power

RADIO PHYSICS COURSE FOR HIGH-SCHOOL STUDENTS

By ALFRED A. GHIRARDI

Chapter I—How Sound Waves Are Changed to Electrical Vibration and Back to Sound Waves Again

1. Broadcasting System Outlined: Radio broadcasting, as we know it to-day, has for its object the transmission of sound waves—speech or music—from central distributing points, called broadcast stations, over long distances to the homes of thousands of people. The distance over which sound can be transmitted directly is very limited.

method is that it makes it possible to have a number of stations broadcasting at one time and still be able to select the program from any one station desired, without interference from any of the others. It is this latter feature which makes practical our modern broadcasting system where a large number of high-powered stations are operating at one time in the same locality, while the listener is able to select any one of them at will by tuning his receiver.

An outline picture of the system is shown in

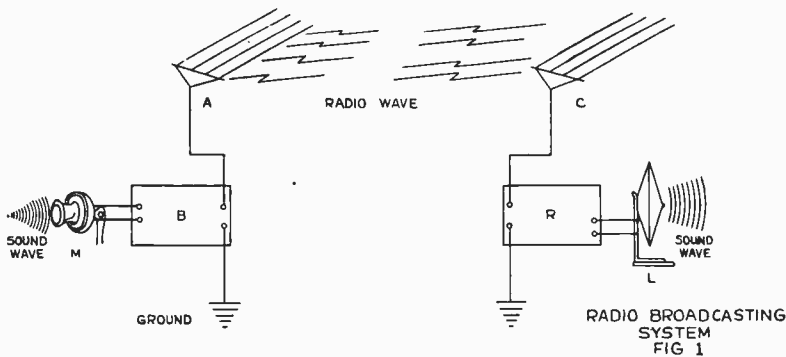

Fig. 1. Left, the transmitting station with the receiver at the right.

Even loud whistles or sirens can only be heard over distances of a few miles. An ordinary speaker's voice cannot be heard intelligibly over distances greater than a few hundred feet.

Consequently, some means other than the direct transmission of sound must be employed in modern radio broadcasting, where programs are to be sent over thousands of miles. The great servant of man, electricity, provides this means and is the main factor in the ever-growing radio industry.

Instead of transmitting the sound or speech waves directly, as in the case of one person talking to another across a room, they are converted into corresponding electrical waves by suitable apparatus in the broadcasting station. These electrical waves are then radiated or sent out in all directions from the aerial of the station through the atmosphere for miles around to the receiving aerials of listeners scattered over the entire country. The electrical waves striking the aerials of the receiving stations set up currents which flow through the receiving apparatus. The function of the receiving set is first to detect and strengthen or amplify these feeble currents and then to convert them back into sound waves similar to the original sound sent out from the broadcasting station.

Thus, you see, electricity can be employed as an intermediate agent, due to the fact that we are able to transmit certain electrical waves over long distances very easily through the atmosphere without wires, while it is impossible to do this with sound waves. Another valuable advantage of this

Fig. 1. Starting at the left, the man who is speaking sets up sound waves which are converted into corresponding electrical current impulses by the microphone M. These current impulses are sent into the transmitting apparatus B where they are combined with the wave-carrying current. The resulting current, flowing in the transmitting aerial A, produces electric waves which are transmitted in all directions. At the receiving aerial C these waves set up electric currents which flow into the receiving set R. Here they are detected and amplified sufficiently so that when they are sent into the loudspeaker L, they are converted back into sound waves which are loud enough to be heard by the listener. This outline of the complete broadcasting system should be studied very carefully since a thorough understanding of the main function of each unit will make the study of the subject interesting and simple.

2. Sound: Sound is the form of vibrating motion in an elastic medium which affects the auditory organs and produces the sensation of hearing. If we strike an ordinary bell so as to set it vibrating, it will produce a ringing sound. If the bell is large and the force with which it is struck is comparatively small, a series of slow vibrations are produced, resulting in a low note. If the bell is small and it is struck a strong blow, a series of rapid vibrations are set up, resulting in a high note.

When the bell vibrates, it beats the air in front of it and thus compresses it, while at the same instant the air in back of the body is rarified.

These changes of pressure occur very rapidly and are transmitted from molecule to molecule of air in the form of expanding spheres of increased pressures and decreased pressures which travel outward in all directions. Any elastic body will transmit sound.

The speed or velocity with which sound waves travel depends upon the substances in which they are moving. They travel at the rate of 1084 feet per second in air, and about 18,400 feet per second in tempered steel. The velocity of sound in various substances is given in the following table:

Substance	Velocity of Sound in Feet per Second
Air at 0°C.....	1,084
Ash, along fibres.....	12,200
Brass.....	8,900
Copper.....	11,300
Cast iron.....	13,200
Glass.....	17,050
Lead.....	2,150

and will be used almost entirely in our discussion.

If we could devise apparatus for measuring the very small variations in air pressure caused by a simple sound wave at any particular point, we would find that these variations could be shown in picture form by the wavy line or curve of Fig. 2a, where vertical distances represent pressure and horizontal distances represent time. The axis or horizontal line represents the normal atmospheric pressure. When the sound wave comes along, the pressure gradually increases to a maximum from P to A, then decreases from A to B, further to C, then increases again from C to D at which point the pressure is again the same as at the beginning. The next wave would continue similarly along DEFGH. Point A, which is the crest of a wave, represents a point of condensation because at this point the air is condensed or compressed. Point C, which is at the hollow of a wave is a point of rarefaction, since at this point the air pressure is lessened or rarefied.

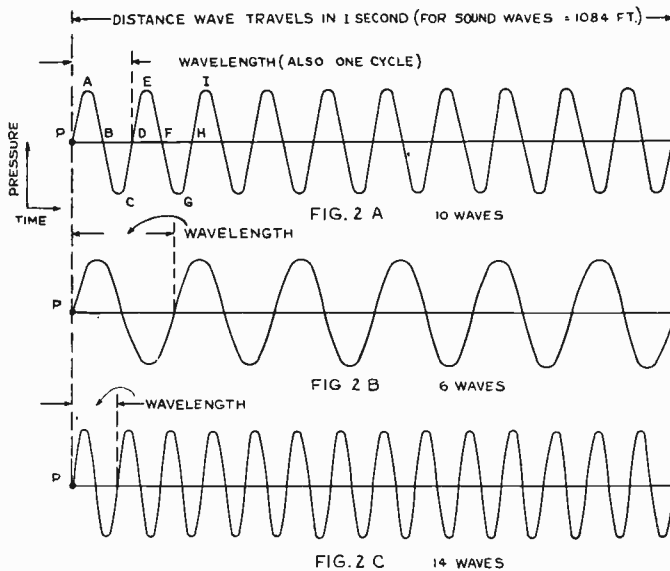

Fig. 2. Illustrating the terms cycle, wavelength, and frequency.

Mahogany, along fibres.....	14,500
Steel, tempered.....	18,400
Water, fresh.....	4,700
Water, salt.....	4,770

When a person speaks, his vocal cords vibrate and set up tiny waves in the air which travel out in all directions. When these strike the ear drum of the listener, each pulse pushes a little against it, causing it to vibrate inward for each pulse, outward again during each interval between pulses. These vibrations actuate the auditory nerves, producing the sensation of sound to which the brain responds. The number of these back and forth vibrations of the drum per second is the same as the number of pulses of the wave that arrive at the ear per second. That is, it is the same as the frequency of the wave. The higher this frequency, the shriller this sound seems to the brain. What we really hear then is the frequency, not the length of the wave. Frequency is always a more characteristic property of waves than the wave length, or distance one wave travels before the next starts,

It must be remembered that the actual pressure variations due to sound are very small. The variation due to the weakest sound which a person with average hearing can hear is in the order of .00000015 pounds per square inch. A painfully loud sound would produce a pressure variation of about .015 pounds per square inch. A consideration of these figures shows that the human ear is an extremely sensitive and delicate instrument, since it is able to detect these minute pressures.

One of the most important distinguishing characteristics of a wave is its frequency. Any wave, a water ripple on the smooth surface of a pond, a sound wave, or a radio wave, consists of a succession of tiny impulses, moving along one after another. Simple waves, produced by a single to-and-fro vibrating motion, have a succession of regular crests and troughs as shown in Fig. 2a. A complete wave, or cycle as it is commonly called, is the part of the wave between one crest and the following similar crest. The length of a complete wave is called the wavelength. This may also

be defined as the distance the wave disturbance moves while the vibrating body makes one complete vibration or cycle.

This term is similar to the familiar term "wavelength" assigned to broadcasting stations, with the exception that in that case it refers to the radio wave instead of the sound wave.

4. Frequency: The number of complete waves or cycles that pass a fixed point in one second is called the frequency. To show the relation between these familiar terms more clearly, let us refer again to Fig. 2, a. Suppose we have an instrument at point P which is producing the sound wave shown, having a frequency of 10 cycles, or complete waves, per second. Then in one second the disturbance will travel 1084 feet—this being the velocity of sound waves in air—taking it to point Q. In the space between P and Q there are 10 complete waves, because 10 waves have been produced during the second. Therefore, the

wavelength is less. The relation between frequency and wavelength is:

$$\text{Wavelength} = \frac{\text{Velocity of propagation}}{\text{frequency in cycles per sec.}}$$

The Greek letter λ (lambda) is used to represent the wavelength. Therefore for sound in air

$$\lambda = \frac{1084}{\text{frequency in cycles per sec.}}$$

5. Pitch: When discussing sound, frequency refers to the pitch of the sound. Low pitched sounds, like those of the bass violin, are low in frequency; high pitched sounds, like those of a flute, are high in frequency. The normal human ear is able to detect sounds of frequencies as low as 16 and as high as 20,000 cycles per second. The frequencies of the sound waves created by the human voice during the course of ordinary conversation average 800 cycles. The actual limits of

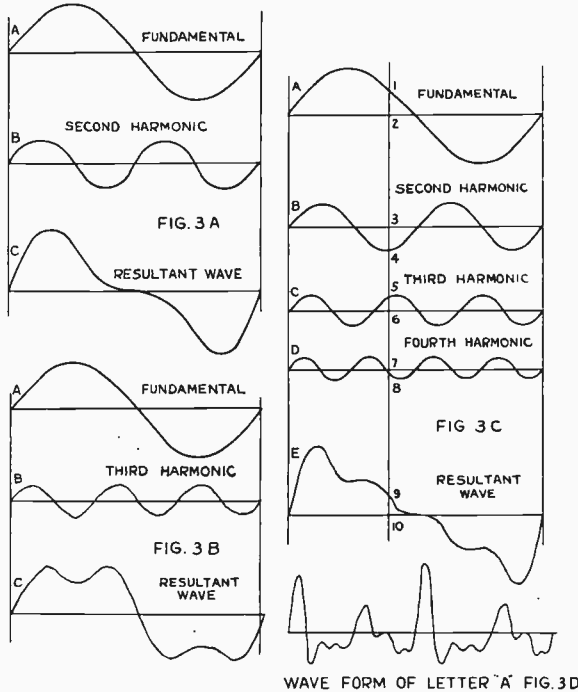

Fig. 3. Diagrammatic representations of electric waves.

frequency of the sound is 10 cycles per second.—Frequency is always expressed as the number of cycles per second. The wavelength will be equal to the total distance PQ divided by the number of waves between P and Q, or $\text{wavelength} = 1084 \div 10 = 108.4$ ft.

Now suppose the instrument at P is made to produce a sound wave of lower pitch, having a frequency of 6 cycles per second. This wave is shown in Fig. 2, b. Then in one second the disturbance travels 1084 feet as before, but since there are only six waves produced during this time interval, the length of each individual wave must be longer than in the previous case.

In Fig 2, c, the instrument is producing a wave of higher pitch, having a frequency of 14 cycles per second. In this case the wavelength is $1084 \div 14 = 77.4$ feet. It is evident from this illustration that as the frequency is decreased, the wavelength becomes greater, and as the frequency is increased

audibility depend of course on the sensitiveness of the hearing facilities of the individual as well as the intensity of the sounds themselves.

6. Harmonics: Heretofore we have considered the most simple kinds of sound waves, that is, the "pure," fundamental, or sine-wave sound. This type of sound consists of but one vibration frequency and is very rare. A pure sound seems very flat when heard by the ear and has no musical value.

When we hear a musical sound, we have no difficulty in recognizing the particular kind of instrument that produces it. The sound of the violin, the piano, etc., each has its own peculiarities. The characteristics which enable us to assign a sound to its source are called the quality or timbre of the tone. The physical explanation of timbre is that most sounding bodies vibrate not only as a whole, but also in various parts as does the string of a piano. The quality of a note is determined

by the presence of tones of higher pitch, called harmonics, whose frequencies are multiples of the fundamental or lowest tone. To take a concrete case, let us consider the middle C string of a piano, Fig. 4. When this is set into vibration by striking the key, the whole string vibrates as a unit, producing vibrations of a fundamental frequency of 256 cycles per second. At the same time, the string also vibrates in parts, producing harmonic vibrations whose frequencies are exact multiples of the fundamental. That is, it will produce a second harmonic whose frequency is $256 \times 2 = 512$ vibrations, or cycles, per second, and possibly a fourth harmonic of 1024 cycles. Thus while the fundamental passes through one cycle, a harmonic

same wave A with its second, third, and fourth harmonics.

The sound waves created during the course of human speech are very interesting due to their wide variation of form. In Fig. 3d, the waves form of a common vowel is shown by the same graphical representation employed in previous illustrations.

7. Musical Instruments: The sounds created by musical instruments are practically always complicated and contain many harmonics. The violin produces a very strong third harmonic, while some of the notes produced by a flute are perhaps the purest of any sounds that are generated by musical instruments.

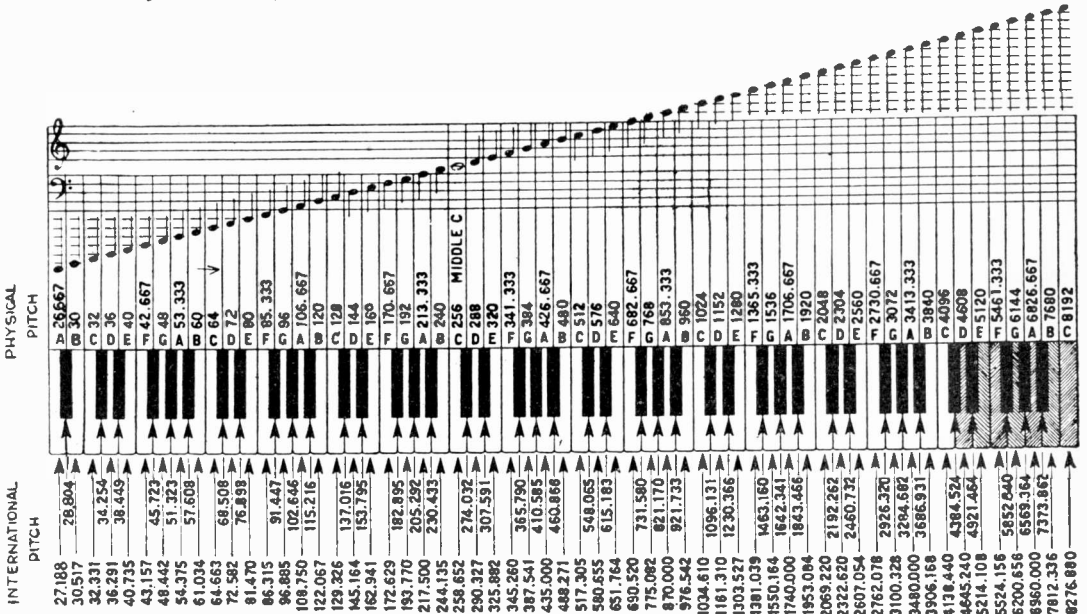

Courtesy of National Bureau for Advancement of Music.

Fig. 4. The complete piano key-board, showing the frequencies of the notes.

passes through a number of cycles, depending upon what harmonic it is.

Higher harmonics than the fourth are seldom encountered in ordinary practice. Consequently the single middle C piano string is really producing four sound waves of different frequencies at one time. These four waves do not exist separately in the air, but combine to form a resultant wave which is different from any of its components. This is the wave which affects our ear.

To show how simple waves of differing frequencies can combine to produce a resultant wave different from each of them, let A in Fig. 3a, represents one cycle of a fundamental sound wave. The horizontal distances, called abscissa, represent time, and the vertical distances represent air pressure. Next, B, the wave of twice the frequency, is the second harmonic wave, emitted simultaneously with A. The resultant wave form is then represented by C. The wave C is not symmetrical and does not resemble either of its component waves A or B. Also, notice that its frequency is the same as that of the fundamental. Fig. 3b, shows the resultant wave C produced by the combination of the same fundamental wave A, with its third harmonic B. Fig. 3c, shows the resultant wave produced by the combination of the

8. Sound Sensation: The sensation of sound as relayed to the human brain by the auditory nerve presents an interesting and important study. Two sounds, which have the same physical amplitude but which differ in frequency, do not sound equally loud. It requires a much greater amplitude in low than in high tones to produce equal loudness sensation.—Notice the difference in amplitude of vibration, between one of the high note strings of a piano and one of the low note strings, even though the sound from the two is equally loud.

The energy of the vibration is proportional to the square of the frequency, the amplitude remaining constant. That is, if we had three sounds having equal amplitudes but frequencies of 20, 40 and 60 cycles respectively the physical energies would be in the ratio of 1, 4, and 9. However, these energy ratios do not exactly represent the loudness of the sounds as they would be heard by the ear because, for equal energies, the human ear hears sounds of very high frequency louder than those of very low frequency, and sounds of mid or normal frequency better than either. Thus it is evident that a loudspeaker emitting low sounds from an organ selection is really handling a much greater amount of energy than when emitting the

higher notes of a violin selection, even though the two sound equally loud.

Fig. 4 shows the keyboard of a modern piano. The lowest note on the keyboard has 27 vibrations per second, and the highest has 4096, on the physical scale. Middle C represents a frequency of 256 cycles. The lowest C has 32 cycles. The C above this is an octave of it, and has a frequency of 64 cycles. The octave of a frequency is a frequency twice as large. For instance, low C has a frequency of 32, the second octave a frequency of 64, the third octave 128, the fourth octave, middle C, 256, the fifth octave 512, and so on.

The practical range of frequencies, with the attendant harmonics, employed in the playing of a selection on a piano ranges from about 32 to 6000 cycles per second. This allows for the lower and higher keys which are seldom used. This is approximately the range of sound frequencies which are broadcast over the radio. Among the various familiar musical instruments the bass violin goes down to the lowest frequency of 40 cycles and the piccolo and piano employ frequencies as high as 996 cycles.

9. Radio, Heat, and Light Waves: If we heat a piece of iron or steel, such as a hack saw blade, in a gas flame, it gets hot. Continuing the heating, causes the blade to change color first turning a dull red, then a bright "cherry red" to slightly orange and finally white hot. In this simple experiment a series of waves of different frequencies are produced, giving rise to the different effects noted. When heat is applied to the blade, it sets the molecules of the iron into vibration, producing heat waves which are radiated in all directions. As more heat is applied, the molecules vibrate faster and faster, causing the radiated waves to follow one another more closely, i.e., the frequency is increased and the wavelength decreased.

These waves coming off at higher and higher frequencies produce the sensation of light and of changing color ranging from dull red, for the lowest frequency, to cherry red, orange, and finally bright yellow at the highest frequency. Just as the pitch of a sound is determined by the frequency of vibration of the body which produced it, so the color of light is determined by the frequency of the vibration producing it. The color red is produced by vibrations of lower frequency than those of the color yellow. Other colors are produced by vibrations whose frequencies are between and above these extremes in the order red, orange, yellow, green, blue, violet.

So far we have discussed sound waves produced by mechanical vibration of the air, having frequencies between 16 and 20,000 cycles per second, and in our experiment we produced heat waves and light waves. These three types form only a small portion of all the classes of waves known to science today. The entire series is divided into bands for convenience. Starting with low frequencies we have the sound waves consisting of simple mechanical between 16 and 30,000 cycles per sec. Above these we have the waves employed in radio, ranging from 30,000 to 3,000,000 cycles per second. Then come the short radio waves and radio heat waves recently discovered by Dr. E. H. Nichols, comprising a range from 3,000,000 cycles to 300,000,000,000 cycles. Above these lie the heat waves, then the ordinary light waves, and ultra-violet light waves or rays. These latter rays are given off by X-ray tubes, the sun, and the electric arc. Following these we have the X-rays and then

the gamma rays which are the shortest known at the present time. Above these is unexplored region of waves still shorter than the gamma rays. The wave series is shown in Fig. 5, with the approximate frequency limits for each band. The divisions of radio, heat, light, and ultra-violet light waves are made merely for convenience. They really all belong to one series, since they are all electro-magnetic waves which travel through space at the rate of 300,000,000 meters or 186,000 miles per second, and differ from each other physically only in the frequency of their vibration or wave length. These electric waves are of an entirely different nature than sound waves, since waves are not electrical and consist of actual to and fro motions of the air particles. The speed of the

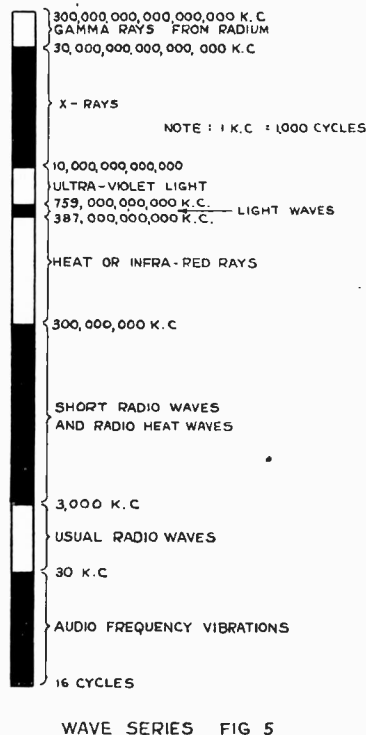

Fig. 5. Frequency greatly alters the aspect of vibrations.

electric waves is so great that they can be considered to move between any two points practically instantaneously. The difference in frequency gives the various kinds of electric waves the properties which are peculiar to them. Thus, radio waves travel with perfect ease through practically all substances, while light and heat waves do not.

Just exactly what these radio waves are, and how they travel, we do not know—any more than we know what electricity is. But just as with the case of electricity, we know how they behave under various conditions, and we are finding out more and more about controlling them for our own use. The question of how they travel is being investigated by many of our most brilliant scientific men and, it is safe to say that the time is not far off when we will know as much about the behavior of radio waves as we do now about simple electric currents. It is these radio waves which

make modern radio broadcasting possible, and their production and use in broadcasting stations will be treated in a later chapter.

Chapter 2—About Electric Currents and Things Which Happen in Electrical Circuits

THE study of radio broadcasting necessarily includes a thorough understanding of the action of electric currents since the transmitting and receiving stations deal entirely with electricity. While it is impossible to present a complete electrical course here, an attempt will be made to give enough of the fundamentals to enable the average person to grasp the material in the succeeding chapters and to act as a review for others.

10. Current Flow: The flow of electricity

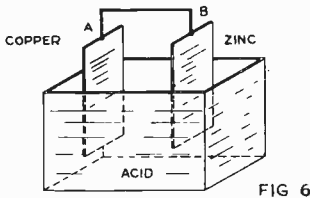

FIG 6

Fig. 6. The elements of an electric battery.

through a wire is always a puzzling thing to the novice, possibly because the action is not directly visible to the naked eye. We really do not know what electricity is, any more than we know what gravity or magnetism is. But like many other things, we can learn to use it and control it by studying its various peculiarities. Many theories have been advanced by prominent scientists to explain the reasons for the observed behavior of electric currents. The one most commonly accepted at present is the electron theory.

11. Electron Theory: It is generally known that all matter, such as the paper upon which this is printed, consists of small particles called molecules. These molecules may be further subdivided into what we call atoms. Thus a grain of ordinary table salt may be considered as consisting of many tiny particles, molecules, of salt held together by some force of attraction. These molecules cannot be divided into smaller molecules of salt, but each one can be divided into atoms of different chemical substances. One molecule of salt can be split up into an atom of sodium and one of chlorine. Each atom in turn is believed to be made up of a center nucleus having a positive charge of electricity, around which revolves a number of small negative charges called electrons. Under normal conditions, the positive charge of the nucleus is equal to the sum of the negative charges around it, so that a state of balance exists. Atoms of different substances differ merely in the number of negative electrons surrounding the nucleus.

At least one of these electrons is loose or free to circulate around among its neighbors. When an electric current flows, what really happens is that these free electrons move along the length of the wire, the movement giving rise to the various external effects which we associate with an electric current. Thus an electric current is merely a stream of free

electrons passing through a conductor in the opposite direction to which we usually ascribe to the electric current. Substances in which the loose electrons move around easily are called good conductors. Among these are gold, silver, copper, brass, and iron. Substances in which there are no free electrons or very few, are called insulators. These include porcelain, mica, and dry air.

12. Voltage: We have seen that the movement of electrons along a conductor constitutes an electric current. However, if we take a piece of copper wire and hold it in our hand, no electric current flows, since there is no force or tendency to make the electrons move. We must apply some external force to the wire, called voltage, to produce the current. If we take a strip of copper wire and one of zinc, partly immersed in a solution of dilute sulphuric acid, and connect them with a wire, AB—Fig. 6, chemical action will take place and electrons will be removed from the copper and given to the zinc. This results in the copper plate having less than its normal number of electrons and the zinc plate having more than its number. The result is an unbalancing of the charges, and electrons will flow from B through the wire to A tending to equalize the charges again. This constitutes the flow of an electric current and we say the current flows through the wire from A to B. We have here a simple electric battery where A is the positive terminal and B is the negative terminal. The battery serves the purpose of causing a continuous flow as long as chemical action continues at the zinc that is, as long as a voltage is present.

13. Current: An electric current consists of a flow of electrons. If we measure the number of electrons flowing past a given point in a circuit in a unit of time, one second, we have a measure of the current. The unit of current measurement is the ampere. Current is usually measured by means of an instrument called an ammeter.

It must be remembered that a current of electricity cannot flow in a conductor unless

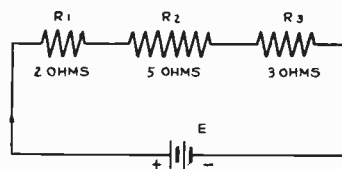

SERIES CIRCUIT FIG. 7

Fig. 7. How resistances are wired in series.

there is some force or potential applied to it. Just as no water can flow in a pipe unless there is some pressure applied.

14. Resistance: When current flows through a conductor, it encounters opposition or resistance, just as water flowing through a pipe encounters resistance due to friction between it and the walls of the pipe. The resistance to current flow depends on the material of which the conductor is made. Silver has the least resistance, annealed copper is next lowest. The resistance also depends on the length, a conductor three feet long having three times

the resistance of one that is one foot long, other things being equal.

Resistance is also inversely proportional to the cross sectional area of the conductor. Conductors of large diameter have less resistance than conductors of small diameter. The resistance of most conductors also increase as the temperature is increased.

15. Ohm's Law: We have now considered the three fundamental things about electric currents—first the flow of electrons, constituting an electric current; second, the potential or force which causes the current flow; third, the resistance or natural opposition which every conductor offers to the flow of current through it. There is a fundamental relationship between these three factors, known as Ohm's Law.

If current in amperes is denoted by I , potential, or pressure, is denoted by E , and resistance by the letter R , then Ohm's Law states that the current in amperes is equal to the potential in volts divided by the resistance in ohms;

$$\text{that is } I = \frac{E}{R} \quad (2)$$

In order to fix this relation more clearly in mind, let us consider a few examples dealing with electric circuits.

(a) The filament of a vacuum tube has a resistance of 24 ohms. What current will flow through it when connected across a 6 volt storage battery?

$$\text{Ans. } I = \frac{E}{R} = \frac{6}{24} = 0.25 \text{ Ampere.}$$

(b) What potential must be applied across a resistance of 24 ohms in order to send a current of 0.25 amperes through it?

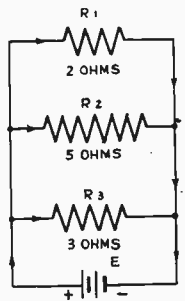

PARALLEL CIRCUIT
FIG 8

Fig. 8. Resistances connected in parallel.

$$\text{Ans. } I = \frac{E}{R} \text{ or } E = I \times R$$

Therefore $E = 0.25 \times 24 = 6$ volts.

(c) A 6 volt storage battery is connected across a resistance and the current flowing is found to be 0.25 amperes. What is the value of resistance?

$$\text{Ans. } I = \frac{E}{R} \text{ or } R = \frac{E}{I}$$

$$\text{Therefore } R = \frac{6}{0.25} = 24 \text{ ohms}$$

From these examples it will be seen that if any two of the above expressions either potential, resistance, or current are known, the remaining one can be found by applying Ohm's Law.

16. Series Circuits: In order for current to flow in any conductor, the circuit must be complete. In actual electrical circuits, parts are connected in either of two ways, or in a combination of the two. When they are connected in such a way that the total current of the circuit flows through all of them, they are said

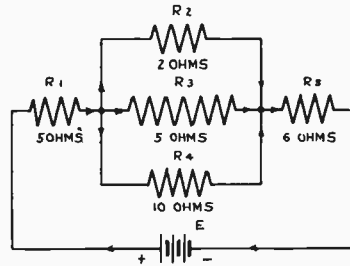

SERIES PARALLEL CIRCUIT FIG. 9

Fig. 9. These resistances are wired in series-parallel.

to be in series. If two or more resistances are connected in series as in Fig. 7, the total resistance is equal to the sum of the separate resistances.

In Fig. 7 the total resistance is:
 $R = R_1 + R_2 + R_3$ (3)

If $R_1 = 2$ ohms, $R_2 = 5$ ohms, $R_3 = 3$ ohms, and $E = 20$ volts, then the total resistance is $R = 2 + 5 + 3 = 10$ ohms, and the current flowing in the circuit is:

$$I = \frac{E}{R} = \frac{20}{10} = 2 \text{ amperes.}$$

17. Parallel Circuits: When parts of a circuit are connected so that the total current is divided between them, as in Fig. 8, they are said to be in parallel with each other. When resistances

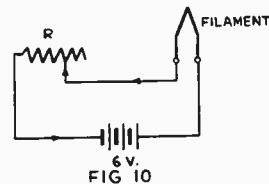

Fig. 10. A rheostat in series with a tube.

are connected in parallel, the total resistance is expressed by the formula:

$$R = \frac{1}{\frac{1}{R_1} + \frac{1}{R_2} + \frac{1}{R_3}} \quad (4)$$

Taking the same value of resistance as in the previous example, the total resistance R of the three resistances connected in parallel is:

$$R = \frac{1}{\frac{1}{2} + \frac{1}{5} + \frac{1}{3}} = 0.99 \text{ ohms.}$$

From this it can be seen that connecting the resistances in parallel lowers the total resistance, since more paths are provided for the current flow.

18. Series-Parallel Circuits: If the parts of the circuits are connected so that some of them are in series and some are in parallel with each other, then the total resistance can be found most easily by reducing the entire circuit to an equivalent series or parallel circuit, depending upon the combination. Thus in Fig. 9 we have R_2 , R_3 and R_4 connected in parallel and this combination in series with R_1 and R_5 is connected across the 6-volt battery. To find the total resistance of the circuit first find the total resistance of R_2 , R_3 , and R_4 , and then consider the circuit as consisting of this resistance connected in series with R_1 and R_5 .

Let $R_1 = 5$ ohms, $R_2 = 2$ ohms, $R_3 = 5$ ohms, $R_4 = 10$ ohms, $R_5 = 6$ ohms.

The total resistance of R_2 , R_3 , and R_4 , is then

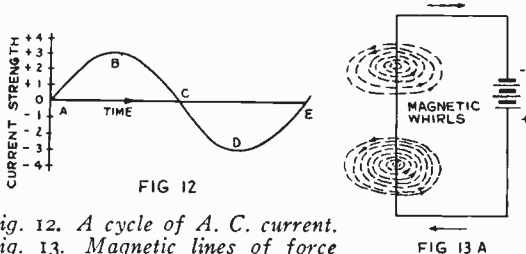

Fig. 12. A cycle of A. C. current.
Fig. 13. Magnetic lines of force around conductors.

$$R = \frac{1}{\frac{1}{2} + \frac{1}{5} + \frac{1}{10}} = 1.25 \text{ ohms.}$$

The total resistance of the complete circuit is:
 $R = 1.25 + R_1 + R_5 = 1.25 + 5 + 6 = 12.25$ ohms.

The total current flowing through the circuit is

$$I = \frac{E}{R} = \frac{6}{12.25} = 0.49 \text{ ampere.}$$

19. Rheostats: As stated previously resistance in a circuit opposes the flow of electric current. There is a certain amount of resistance in every electric circuit due to the connecting wires, etc. In some cases extra resistance is added intentionally to reduce the current flowing. An example of this is seen in the use of rheostats, or adjustable resistances, in the filament circuits of ordinary vacuum tubes in radio receiving sets. Here the current from a storage battery flows through the filament of the tube and heats it to incandescence. The amount of current flowing is regulated by connecting a variable resistance R in series with the filament, Fig. 10.

Resistances are made in a variety of forms, depending upon their particular use. Low resistances for radio work are usually made of wire wound on some suitable insulating material. Very high resistances of several thousand ohms or more are made either of impregnated paper, or coated with carbon particles, or consist of a glass thread coated with a very thin layer of metal. Other adjustable high resistances make use of carbon or graphite discs or powder which may be pressed together tightly to decrease resistance, or allowed to separate to increase resistance. A clear mental

picture of resistance may perhaps be obtained by the following consideration.

If we take a piece of wire of any definite diameter, length and material, it has a certain value of resistance. If we make the wire twice as long, its resistance will be twice as much, if we decrease its length the resistance will be decreased. Now if we keep its length constant but increase the diameter, or cross sectional area, the resistance will decrease; if we decrease the diameter, resistance increases.

Kinds of Current: Fundamentally the electricity itself is always the same in any current no matter whether it is produced by chemical action in a battery, by a generator, or any other way. Electricity, as we deal with it in our lives, however, is usually in the form of one of three types of electric currents. When the current flows in but one direction through a circuit it is known as direct current, commonly abbreviated D. C. This is the kind of current sup-

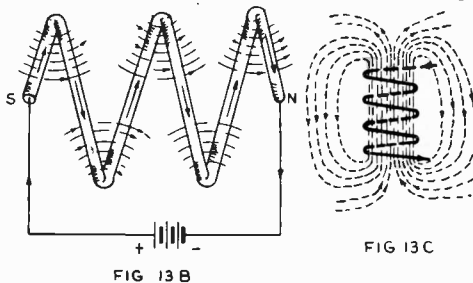

plied by all forms of batteries, and flows from the positive terminal of the battery, through the circuit to the negative terminal. If the current flows in one direction, but is pulsating, that is, increases and decreases in strength, it is known as pulsating current. If the current not only varies in strength but also changes its direction of flow many times a second it is called an alternating current, commonly abbreviated A. C. This difference in the way in which the current flows through a conductor gives rise to various effects, which will be studied later. (To be continued.)

THE TAPER-TUNED RECEIVER

(Continued from page 43)

30 enameled wire. The first coil contains 65 turns in the primary; the second contains 60 turns; the third contains 50 turns; and the last is the regular coil with a 25 turn primary. The primary coils are all wound so they start 1/16 inch from the filament end of the secondary. The secondary coils are left untouched. Be sure to wind the wire tightly on the forms and connect the ends correctly. When the coils are finished the top end of the secondary should go to grid and bottom end to filament return. The top end of the primary goes to B+ and the bottom end to P. The primary is wound in the same direction as the primary.

When wiring the set, the location of all wires in the input circuit of the R. F. and detector tubes should be kept short and as nearly similar for each stage as possible. The plate leads should also be short. The two wires going to the oscillation control on the front panel should be located very carefully to prevent feedback from the other stages. The coils may be placed as close as 3/2 ins. between centers without interference.

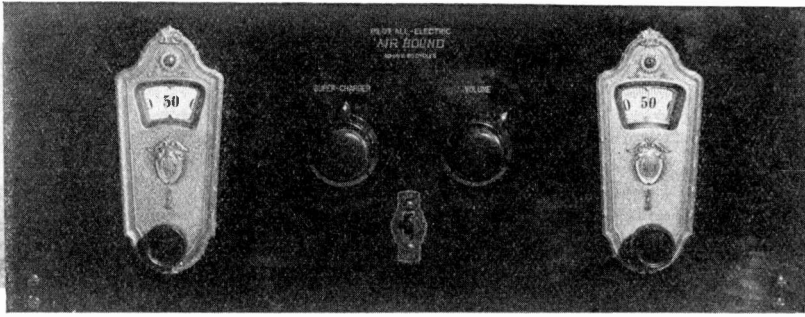

Fig. 1. An ideal design for an all-electric broadcast receiver.

ALL-ELECTRIC AIR HOUND IS MARVEL OF RADIO DESIGNERS' SKILL

By FRANK T. SULLIVAN

MANY people seem to have the idea that it is now much cheaper to buy manufactured receivers than to build one or have one built by a custom set builder.

It may seem that such should be the case this season, but it is not. Radio Design is just as much interested in showing new types of all-electric receivers to be built at the lowest possible prices, as the set manufacturers, and as far as bringing cost down, Radio Design seems to have been more successful.

Witness the Air Hound all-electric receiver. In tests which we have made, this set has done just as much and has done it just as well as very much more expensive receivers. In fact, in some ways, it is a little better than other types.

As for cost, the complete kit of parts comes to less than \$45.00. Add a simple table cabinet, and you will have as fine an outfit as is sold up to \$100.00.

Moreover, you must remember this about custom built receivers—each part is a finished piece of merchandise, while manufactured receivers are made up very crudely and, generally, designed so that several parts can be hidden under each little box inside the cabinet.

If anything goes wrong, it is expensive and takes quite a little while to have the set repaired. On a custom built receiver, each part is an individual unit which can be removed and replaced at once.

This is an important matter to the set owner. Usually, if a set is going to go wrong, it is the morning before some important event is to be broadcast. Repairing a manufactured set is then a matter of days. On the other hand, a custom built receiver can be fixed up in perhaps half an hour.

Again, a standard design of receiver, built by an established custom set builder, does not become an orphan, as is the case with so many manufactured receivers built by companies that seldom stay in business more than a year. Consequently, it is always possible to get competent service for a custom built outfit, and repair parts are always available.

AIR HOUND IS A LABORATORY DEVELOPMENT

When you tune in on the Air Hound you will

realize at once the skill and cleverness which is built into the design of the receiver. It is extremely sharp, although it can be adjusted to give broad tuning. Out in the country, or when you are fishing for DX late at night, too much selectivity is a disadvantage. As soon as you learn how to handle the two adjustments marked Super-Charger and Volume, you will be able to regulate the degree of selectivity as well as the range of volume.

The set is absolutely free of hum, all the tricks of operation have been eliminated, and the design is so thoroughly substantial that, once the outfit is installed, it should function without any service whatever for an indefinite length of time.

The filament lighting transformer gives the correct voltage for the tubes specified, and does not burn out the tubes as has been the case with so many manufactured receivers. With the tubes specified, the life should be from 2000 to 4000 hours. The radio frequency circuit is highly efficient, being equipped with an R.F. Super-Charger which serves for local reception as a neutralizer, and on DX makes it possible to bring in stations at full loud speaker volume which otherwise would be heard only with the telephones. In the audio end, the new moisture-proof transformers are employed with an output filter. This gives excellent quality in the amplifier circuit, while the filter protects the loud speaker from being burned out by excessive current and further improves the reproduction. The Air Hound, mounted in a suitable cabinet, measures up to the latest standards of appearance. The vernier tuning dials have attractive bronze plates, and are lighted indirectly by small bulbs which shine through the celluloid scales. With two walnut Bakelite knobs at the center, to match the front panel, the Air Hound will please the most fastidious customers.

AIR HOUND CIRCUIT DATA

The Air Hound uses three CY 327 tubes for R.F., detector, and first audio with a CX 371-A as a power amplifier in the last stage. This not only simplifies the wiring but positively assures freedom from all A.C. hum. With the No. 386 filament transformer these tubes will give as long life or longer than the CX 326 tubes.

The filament supply circuit, you will see, is

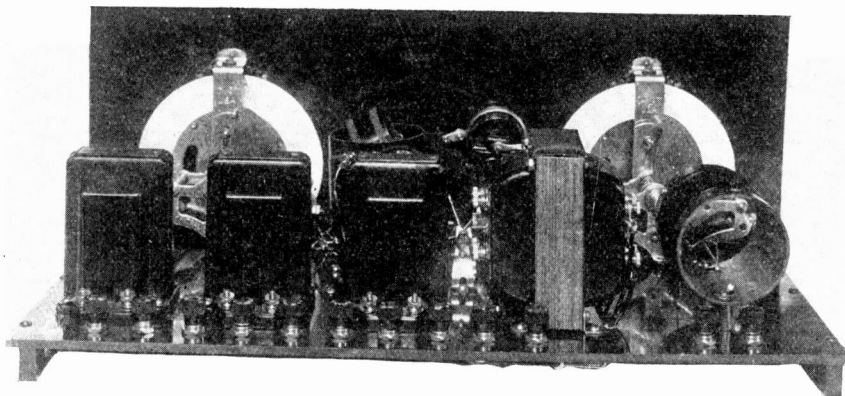

Fig. 2. A special feature of this set is the moisture-proof transformers and filter.

different from that specified for the standard Pilot No. 4 A and C power pack. The reason is that a special arrangement must be employed to give the correct biases on the three 327 tubes.

Cunningham specifies 9 volts on the 327, when used as a detector, with 90 volts on the plate, and, for R.F. and A.F. amplification 9 volts bias with 135 volts on the plates.

This works out very nicely in the Air Hound because it is possible to use one biasing resistor in the center tap lead of the 2.5 volt winding of the filament transformer, since the bias values of all three tubes are the same.

A separate resistance of 2250 ohms in the center tap lead of the 5-volt winding puts the bias of 45 volts on the grid of the 371-A in the last amplifying stage.

You will notice that, although separate primary and secondary windings are furnished on the antenna coil, the primary and secondary are connected together in series, with the an-

tenna and ground across the primary alone and tuning condenser across both coils. We have found this the most satisfactory way, although you can use inductive coupling, putting the tuning condenser across the secondary only, if you desire.

The R.F. Super-Charger circuit in the R.F. stage comprises a .002 mfd. condenser with a Resistograd. The center terminal of the Resistograd is threaded into one terminal of the fixed condenser, and a lead brought off at this point for connection to the plate. The purpose of this adjustment is to bring the R.F. tube to the point of maximum sensitiveness for DX reception, or to neutralize it for local reception.

The detector circuit is the conventional 3-circuit tuner arrangement, and has an R.F. choke in the plate circuit to keep high frequency currents out of the amplifier.

The audio amplifier uses the new moisture-proof transformers, with an output filter, con-

Fig. 3. This set is complete in itself except for the No. 5 B power pack.

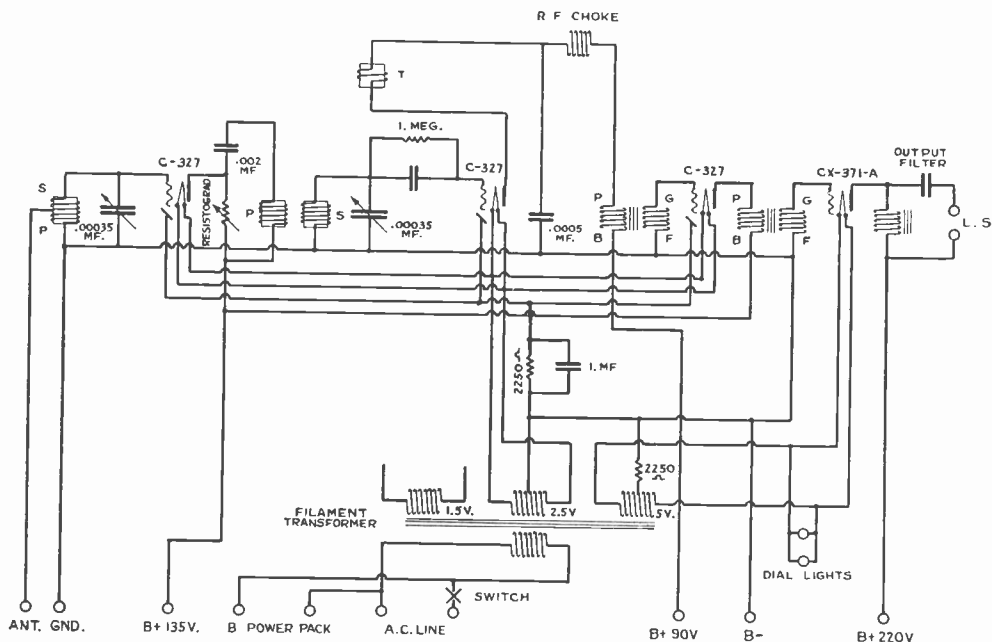

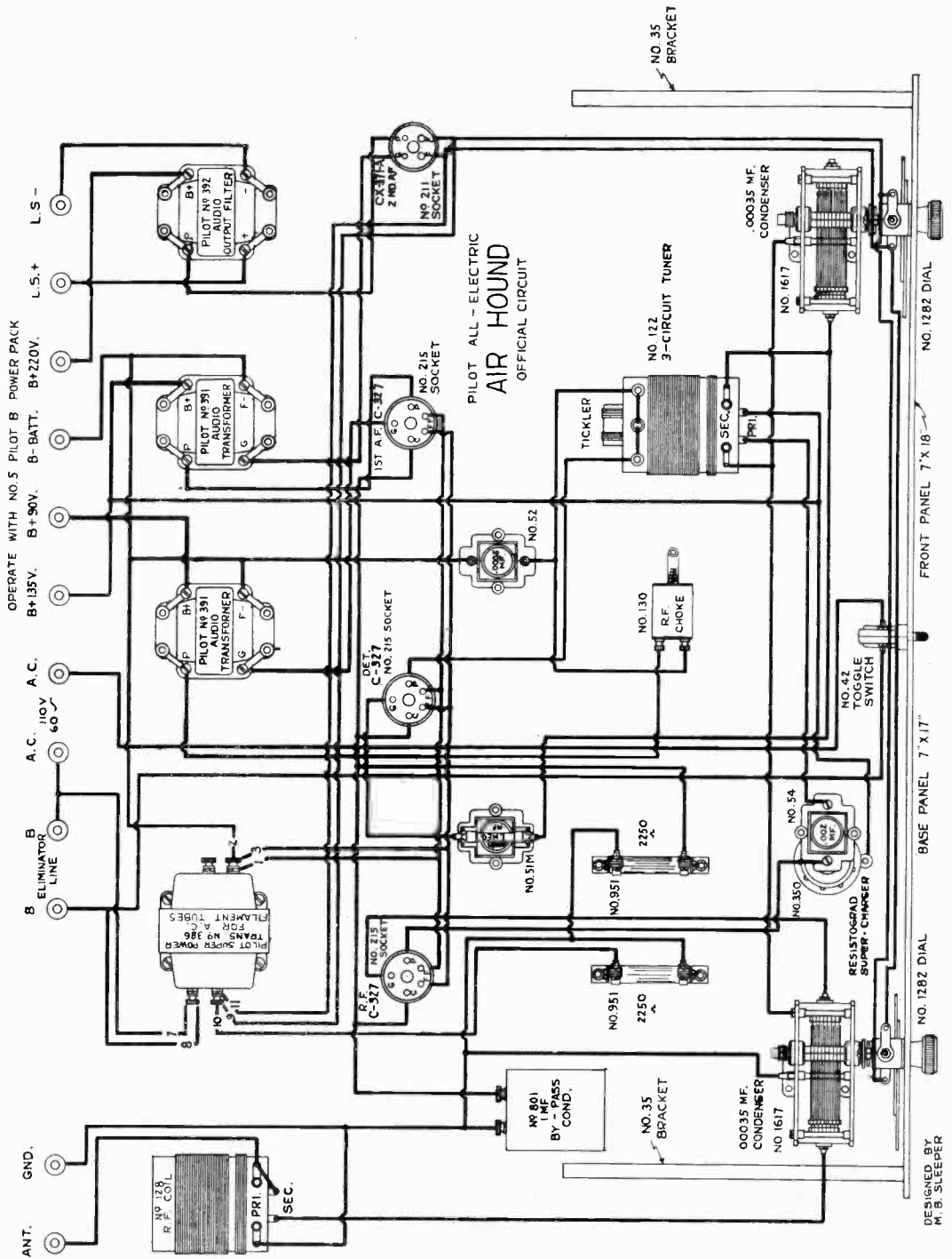

Fig. 4. The parts are arranged in this diagram in the same relative positions as they are mounted on the finished set.

taining a heavy choke coil and by-pass condenser, in a case which matches the appearance of the A.F. transformer.

HOW THE AIR HOUND IS OPERATED

Once you learn how to tune the Air Hound, you will find it very easy to get adjustments for

maximum signal strength on local, or fish for distant stations. For near-by stations, turn the Resistograd almost all the way in, and put the tickler coil of the 3-circuit tuner in a position for maximum regeneration. This will keep the R.F. tube from oscillating, and permit you to get the volume adjusted with the tickler. The

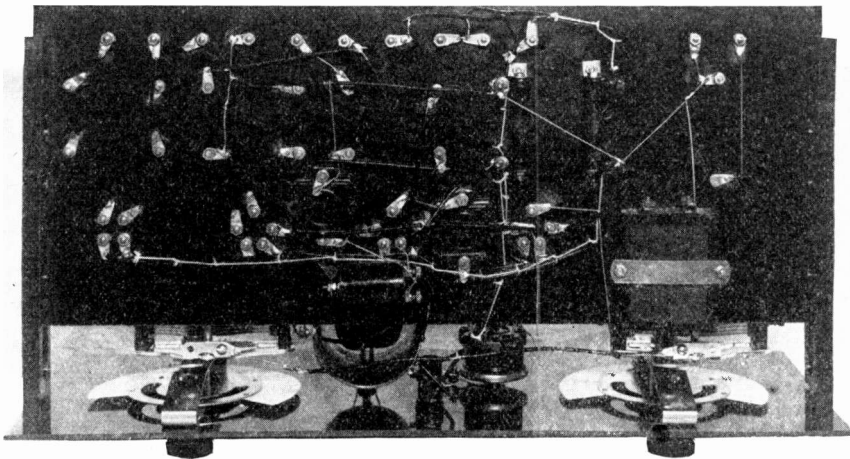

Fig. 5. For an all-electric set, this wiring is unusually easy to put on.

left hand variable condenser will tune a little lower on the scale than the right hand condenser, unless you use inductive coupling.

When you want long distance reception, turn the Resistograd out a little bit, and it will throw the circuit into oscillation so that you can pick up squeals. Then by balancing the adjustment of the Resistograd against the setting of the tickler work the controls together until you bring the station up to full volume. You will have to readjust the tuning slightly, at the same time.

Until you learn how to handle the controls, the set may make some squeals but once you understand how to set the adjustments, you will have no trouble from this.

ASSEMBLING THE SET

Following is the complete list of parts for the Air Hound:

- 1—7 by 18 by 3/16 ins. Walnut Micarta front panel.
- 1—7 by 17 by 3/16 ins. Micarta sub-panel.
- 1—Twin-Coupler No. 123 R. F. coil.
- 1—Twin-Coupler No. 121 three circuit tuner.
- 1—Twin-Coupler No. 130 R. F. choke.
- 2—Pilot No. 1282 illuminated dials.
- 2—No. L-43 5 volt lamp for illuminated dials.

- 2—Pilot No. 1617 .00035 mfd. tuning condensers.
- 1—Pilot No. 350 Resistograd with 1255 W knob.
- 1—Pilot No. 42 toggle switch.
- 1—Pilot No. 54 .002 mfd. fixed condenser.
- 1—Pilot No. 51 M .00025. mfd. grid condenser.
- 1—Pilot No. 58 .006 mfd. fixed condenser.
- 1—Pilot No. 801 1. mfd. by-pass condenser.
- 1—Pilot No. 386 filament transformer.
- 2—Pilot No. 951 2250 ohm wire wound grid bias resistors.
- 2—Pilot No. 35 1 in. Bakelite brackets.
- 2—Pilot No. 391 audio transformers.
- 1—Pilot No. 392 audio output filter.
- 3—Pilot No. 215 UY sub-panel sockets.
- 1—Pilot No. 214 UX sub-panel socket.
- 1—Pilot No. 754 1 meg. grid leak.
- 12 Pilot engraved Bakelite binding posts.

Mount all the parts on the front panel and do as much wiring as you can. In the past there has been some misunderstanding about the two contacts, shown in Fig. 4, on the No. 1282 dials. These are contacts for the electric bulb which illuminates the dial. You will see that they are connected to the 5 volt A.C. supply running to the socket of the 371-A tube.

When you mount the R.F. Super-Charger, thread the rear terminal of the Resistograd into the .002 mfd. condenser, and then mount the Resistograd on the front panel. Check the ar-

Fig. 6. Compare this illustration with the picture wiring diagram.

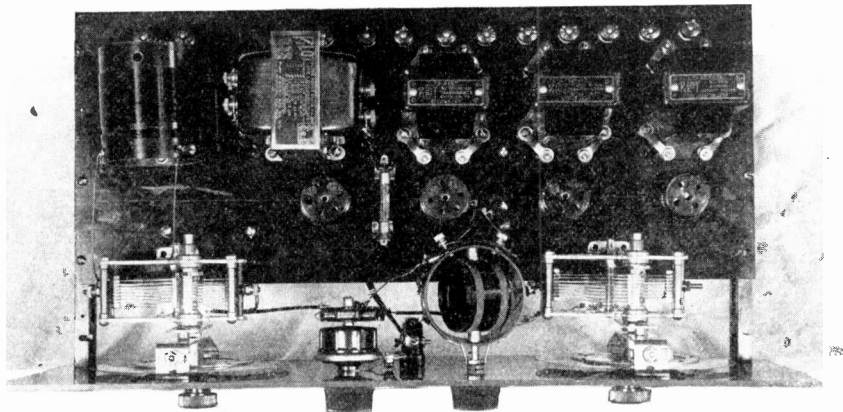

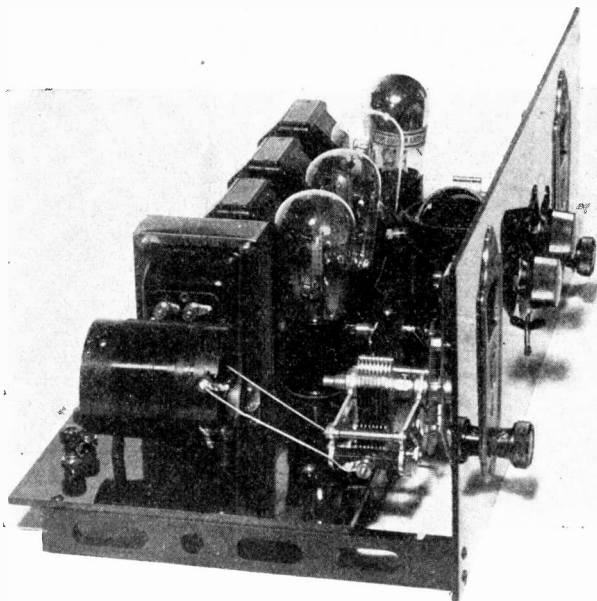

Fig. 7. *The Air Hound has a distinctly commercial appearance about its compact design.*

rangements of the parts as shown in the illustrations against your assembly work as you proceed.

Fig. 6 shows the method of obtaining connections for the two A.F. transformers and filter. Double lugs are slipped over the binding posts and on to the screws which hold the transformers to the base panel. Then all connections are made to the mounting screws underneath the panel. In this way, no wires need to be brought up to the top of the base panel.

It is recommended that you use the official panel patterns in laying out the set, so that the parts will fit properly and all errors avoided. These panel patterns are full size, and can be applied directly to the Micarta panels and the centers of the holes marked through with a center punch.

Do not use soldering paste. All lugs on Pilot equipment are silver plated. Consequently they take rosin core solder very easily. Just watch out that you apply heat enough for the solder

to melt and run freely. Use No. 18 tinned copper wire. Cut this in lengths about 20 ft. long and stretch the wire about 2 ft. Then, laying the wire down on the floor carefully, cut it into 18-in. lengths. That will give you straight pieces which can be bent neatly into the necessary shapes.

Where insulation is required, use small Empire tubing. Do not use wire with cotton insulation, for that collects moisture in the damp weather and makes short circuits for the R.F. currents.

NEW CONDENSER FEATURES

This season the Pilot variable condensers, 1500 and 1600 series, are made with shafts which can be removed without disturbing the plates. The condensers can be mounted at either end, giving clockwise or anti-clockwise rotation. Mounting feet are provided, so that they can be mounted on the sub panel.

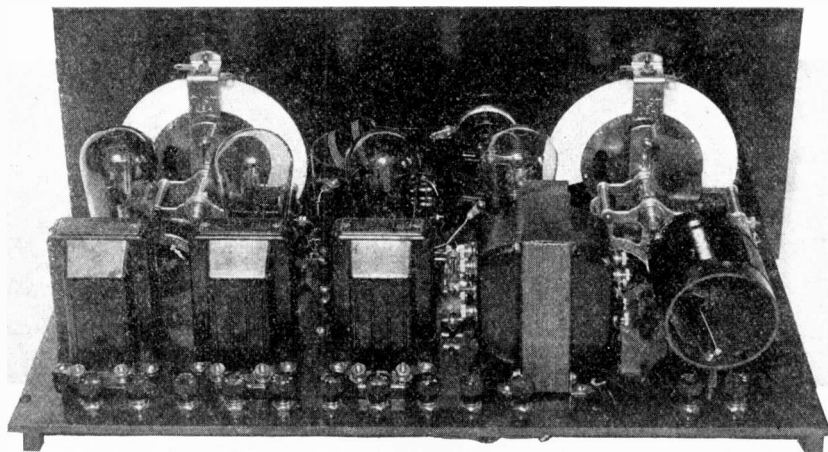

Fig. 8. *The new A.F. transformers and filter are contained in polished Bakelite cases*

HOW TO MAKE ANY BROADCAST SET TUNE TO SHORT WAVES

By E. MANUEL

IN foreign countries the short wave adapter has suddenly become the most important adjunct to broadcast receivers. Where ordinary broadcast sets can bring in only a few local stations, in some places not more than two or three, the short wave adapter makes any city a neighbor to countries thousands of miles away.

For example, such stations at WGY, KDKA and WRNY can be picked up readily, on their short wave transmitters, from Buenos Aires, 6,000 miles away; Rio de Janeiro, nearly 5,000 miles away; the Phillipine Islands, 11,000 miles distant, and Australia, half-way around the world.

In the United States, the short wave adapter makes it possible to receive transmitters in foreign countries equally distant.

There are Pacific Coast stations which can be heard in New York, for they send their regular programs of short wave and broadcast transmitters simultaneously. Similarly, the eastern stations can be heard on the Pacific coast. WRNY, for example, sends all programs on two transmitters.

Of course, for the very finest short wave reception and the maximum efficiency the standard Wasp circuit is recommended in preference to the Converter, but exceedingly fine results can be obtained with the Converter on practically any type of receiver, whether it is operated from batteries or A.C. supply.

However, the one tube in the Converter must have a battery supply for the filament, because if it is run from A.C. there will be an objectionable hum. If you use a 201-A tube in the Converter, that will require four dry cells to run the filament. A 199 can be operated for longer time on three dry cells, but the 199 is not quite as good for broadcast receiving. This filament battery is only needed if you have an A.C. operated receiver. If your broadcast set is battery operated, then the filament of the tube in the Converter can be run from your 6-volt storage battery.

WORLD-WIDE RANGE AT LOW COST

It will cost you about \$10.00 and an evening's

time to give your broadcast set a world-wide receiving range. The few parts for the Converter can be assembled in two or three hours. Following is a shopping list that shows what you need:

- 1 Micarta panel 9 x 7 x 3/16 ins.
- 1 Micarta sub panel 8 x 7 x 3/16 ins.
- 1 No. 1282-L Pilot illuminated dial.
- 1 No. 920 Pilot 20-ohm rheostat.
- 2 No. 1252-W Pilot Bakelite knobs
- 2 No. J-23 Pilot midget condensers.
- 1 No. 206 Pilot UY socket.
- 1 No. 212 Pilot UX shock-proof socket.
- 1 No. 50-D Pilot .0001 mfd. grid condenser.
- 1 No. 761 Pilot 10-meg. grid leak.
- 1 No. 1608 Pilot .00014 mfd. condenser.
- 2 No. 35 Pilot 1-in. brackets.
- 1 set of 5 Twin-Coupler plug-in coils.
- 6 Pilot engraved Bakelite binding posts.

CONSTRUCTION NOTES

The two panels can be cut from a piece of Micarta 7 x 18 x 3/16 in. There are varieties of finishes, so that you can choose the sort of panel material that will match the set you have at present.

You will notice that two No. 1252-W knobs are in the parts list. These are walnut finished Bakelite, to match the knob on the illuminated dial. One controls the rheostat, while the other is for the midget condenser on the right hand side of the front panel.

Black Bakelite knobs are furnished with the rheostat and midget condenser, but by substituting the walnut knobs you can make the front panel more attractive in appearance.

The front panel carries the rheostat, tuning condenser, and one J-23 midget regeneration control. On the base panel are the shock-proof tube socket, plug-in coil socket, J-23 condenser for regeneration control at broadcast wave lengths, grid leak, and binding posts. Under the sub-panel are the grid condenser, antenna series, variable condenser, and R.F. choke.

HOW TO ASSEMBLE THE CONVERTER

Mount the illuminated dial on the front panel at the center and up high enough so that the

Fig. 1. This little unit, added to any broadcast receiver, will bring in all the short wave stations. None of the tuning controls on the set are used. All tuning is done with the illuminated dial on the con-

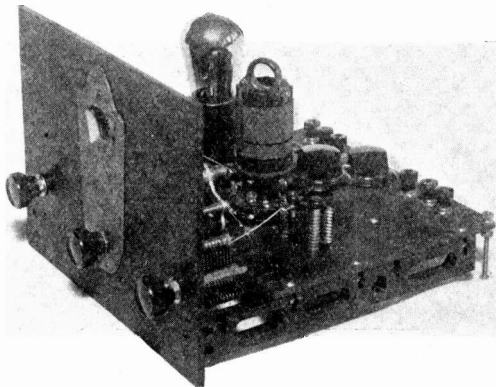

verter. At the left is a rheostat, and at the right, a midget condenser which regulates the regeneration. Different coils are plugged in according to the wave-length range desired.

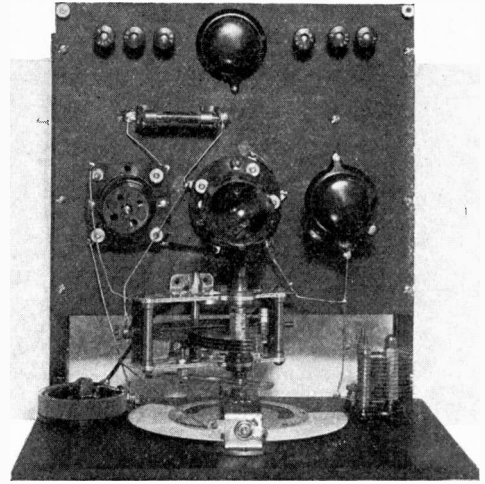
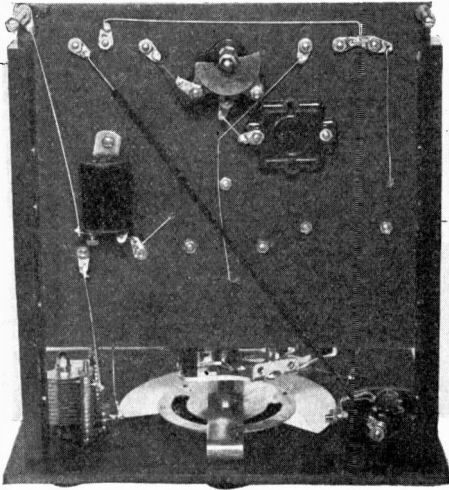

Figs. 2 and 3. Top and bottom views showing details of the converter.

bottom of the mounting bracket is $\frac{5}{8}$ in. above the bottom of the front panel. The centers for the rheostat and midget condenser are 1 in. from the edge and 2 in. up from the bottom of the front panel.

The holes for fastening are Bakelite brackets on the front panel are $1\frac{1}{2}$ in. from the edge. The lower hole is $\frac{5}{8}$ in. up from the bottom of the front panel, and the upper hole is $1\frac{1}{8}$ in. from the bottom of the panel. When the parts have been put together, fasten the base panel to the brackets so that the rear of the base panel extends out beyond the brackets $\frac{5}{8}$ in. Space the tube socket, coil socket, and midget condenser along a line $2\frac{1}{2}$ ins. from the front of the base panel. The grid condenser and grid leak go directly behind the two sockets and between them. The six binding posts and the antenna series condenser are lined up $\frac{3}{4}$ in. from the rear of the sub panel. The R.F. choke is underneath the panel and behind the J-23 condenser.

There is a trick to mounting the J-23 condenser. The two screws which hold the fixed plates are used for mounting. Make two holes for these screws through the base panel and

fasten them with nuts underneath. Note also that a $\frac{1}{2}$ -in. hole must be made to accommodate the nut on the end of the shaft.

The coil socket must be mounted in such a way that the C and F posts are toward the front, and the tube socket with the F and P toward the front.

CONNECTING AND OPERATING THE CONVERTER

Schematic and picture wiring diagrams are clear and can be followed readily. The only catch is that the lower contact on the lamp socket of the vernier dial must be connected to the front F post on the tube socket, and the upper lamp socket terminal soldered directly to the frame of the dial.

To attach the Converter to your broadcast receiver, connect the flexible lead, shown at the right in Fig. 6, to a brass pin which you can insert in the plate contact hole of the detector socket in your set. If there are any R.F. tubes in the set, remove them as well as the detector.

Connect four dry cells in series across 'A+'

Fig. 4. The wiring of the converter is only a matter of putting on a dozen leads. Each joint must be soldered perfectly, for short waves—high frequencies—have a way of doing strange things that do not happen in ordinary broadcast receivers.

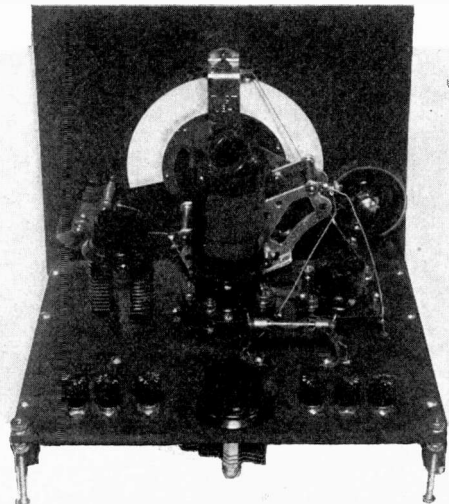

Under the base panel, at the rear, is the little antenna series condenser which must be adjusted until the circuits oscillate smoothly. To the left is the R. F. choke, and on the right the grid condenser. This is held by the same screws which pass through the grid leak clips.

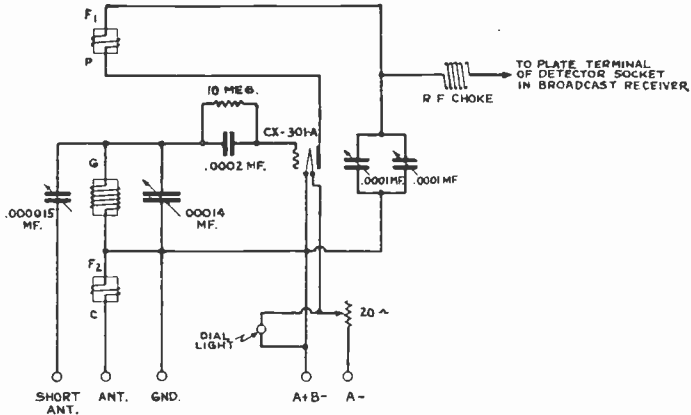

Fig. 5. Schematic of the short-wave converter.

and A—on the Converter, or to a six volt storage battery, and connect the B—binding post to the B—terminal on the broadcast receiving set.

If you want to use your regular broadcast antenna, connect it to the SHORT ANT. on the Converter. If you have a 20-ft. indoor antenna put it on ANT. Do not use two antenna on the set.

For short wave reception, put the J-23 condenser which is mounted on the base panel at zero, with the movable plates all the way out. Plug in any of the coils except the broadcast coil, tune in your station with a variable condenser, and use the midget on the front panel as a volume control.

If you are using an antenna connected to the SHORT ANT., adjust the small condenser at the rear of the base panel until the circuit oscillates at any setting on the tuning dial.

There are many tricks about operating this set that you will have to learn by actual experience. The rheostat setting has a considerable influence on the results. Changing the value of the grid leak makes quite a difference. If, when you tune out of oscillation, the set squeals, put a 1-meg. resistor across the secondary of the first audio transformer.

To tune broadcast stations, plug in the broadcast coil and set the J-23 condenser at the base panel at maximum capacity, and operate as before.

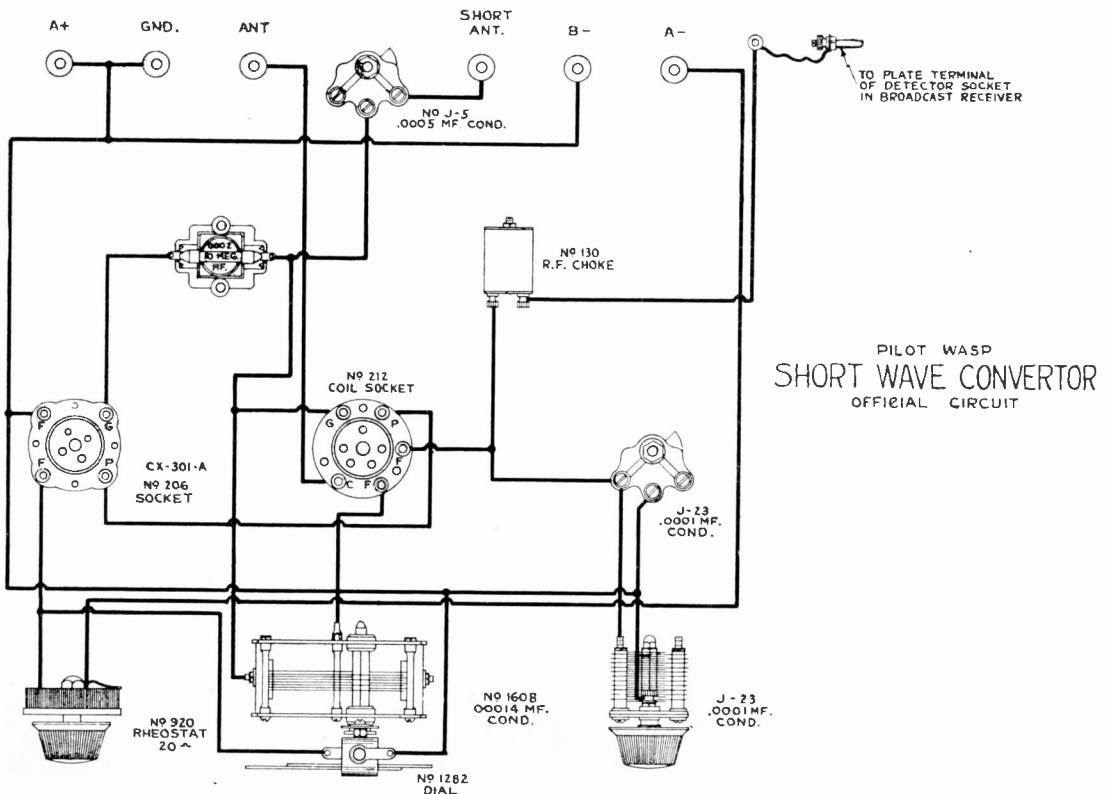

Fig. 6. The actual arrangement of the parts and the wiring are shown here.

LAST MINUTE NOTES ON TELEVISION

THINGS are happening very rapidly in the field of television developments. Much that is appearing in the radio press contributes more to confusion, unfortunately, than to progress.

Before we can all talk the same language about television, we must agree as to what a television transmitter is. By the nature of the word, a "television transmitter" is one which transmits actual images of moving or still objects.

A device which can transmit only black and white objects is distinctly a silhouette transmitter, and not a televisor.

Thus, when we refer to the Pilot television transmitter, or televisor, it is understood that, at the receiving end, true, detailed images will be seen. The eyes appear distinctly, the teeth show when the person smiles, and the smoke of a cigarette is clearly visible.

One of the fascinating things about television receiving is the strange, positively ghost-like appearance of the images. When the receiver is slightly out of phase, the images float across the opening like spirit pictures.

Reference is made frequently to the screen of the television receiver. There is no screen. That is probably the reason for that fact that television images look like nothing you have ever seen before. They are not reproduced on any flat surface, as is the case with printed pictures or photographs. They are formed from individual dots of light from the flashing neon lamp, these dots being distributed by the holes in the scanning disc in such a way as to form a complete image at each revolution of the scanning disc. This is similar to the method employed for projecting moving pictures, where one picture after another is thrown on the screen in such rapid succession that the eye receives the impression of continuous movement.

Altho the Pilot Company will be ready very shortly to supply television transmitters to all broadcasting stations, the only one in operation at this time of writing is at WRNY, the Radio News station operated from the studio in the Hotel Roosevelt, New York City. Station WRNY transmits television on both the standard broadcast transmitter and the short wave transmitter for five to ten minutes starting on the hour, every hour that they are on the air. This is the first station to provide a daily television schedule for experimenters, and the only station sending television on broadcast waves.

The use of broadcast waves is highly important, since the vagaries of short wave transmission are avoided. It is enough to handle the television receiver without having to contend with the peculiarities of short waves. On the other hand, the short wave transmitter at WRNY can be used if you are far enough away to get good reception.

Several papers which have published articles about apparatus for Pilot television have recommended the use of ordinary fan motors to turn the disc, the speed being controlled by variable high resistors. The authors, it may be suspected, have not had much experience with television, or they would know that this method is not practical. It is absolutely necessary to have a synchronous motor for the disc. If the A.C. supply at the transmitter and receiver are not perfectly synchronized, the images will move slowly across the opening, but

that is not objectionable. In fact, it adds to the mysterious impression you will get as you "see the transmission."

On the other hand, with a variable-speed motor, if you do succeed in putting it in step for a moment, the unstable resistance of the rheostat will change just enough to throw the images out again, or else someone will turn on an electric light and drop the line voltage sufficiently to slow down the motor.

It is no economy to buy a cheap motor. Get a Co-cycle motor in the first place if you want clear reception.

The scanning disc, as has been pointed out elsewhere, must be a precision job. We have used discs of aluminum and of brass. The former is a little easier to handle, but the finest discs are made of brass, 3/32 in. thick.

First, holes are drilled .022 in. in diameter. Then each hole is filed out .026 in. square. During the filing process the workmanship is tested frequently by revolving the disc, with a light held behind it, to test for overlaps or spaces between the circles formed by the holes. Given the best equipment for receiving television, if there is the slightest error in the location of holes, the images will be distorted. It is clear, therefore, that a cheap disc is the expensive one.

Inevitably some parts manufacturers have started to advertise apparatus for television which is entirely unsuitable. This is even true of one or two highly reputable concerns. You must be careful, therefore, to satisfy yourself that any equipment advertised for television has actually demonstrated its ability to perform.

One company, for example, is showing resistance coupled amplifier kits which we know cannot give good television reception because we have already found the ordinary amplifier, however well it may sound on broadcasting, to be entirely inadequate for television. Every company selling television apparatus should give you the answer to this question, "Have you actually used these parts in a televisor, and how can I be sure that the results were genuinely satisfactory?"

Personally I have always doubted the significance of amplification curves of audio transformers which are so commonly shown to prove that the transformers give perfect, straight-line amplification. Television has demonstrated that such curves are absolutely meaningless. If the transformers were as perfect as the curves show them to be, the transformers would be just the thing for television amplifiers. But when you see the amplification results in the televisor, you know that, curves or no curves, transformers are not perfect.

More than that, it seems as if we do not want perfect audio amplification for perfect visual reception. If you tune in your set to get the best music from WRNY, and then switch to the televisor when the television program starts, you will have to retune your set. And when you are getting the best television, you will not get good musical reproduction.

Why this is so we cannot explain yet, but we shall understand this, and many of the other strange phenomena as we delve further into this fascinating science.

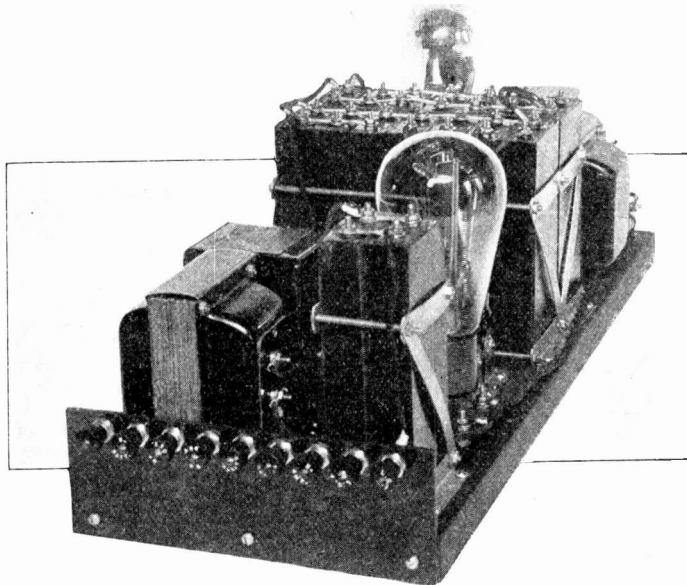

Fig. 1. This power amplifier also supplies all B voltages to the set.

HOW TO BUILD A POWER AMPLIFIER AND B SUPPLY

By WILLIAM R. KAYE

THE first model of the 250 power amplifier was not intended for radio builders, but was constructed to please a group of four hundred girls who gather for lunch every noon on the sixth floor of the Pilot factory.

It happened in this way. These girls, who wind transformers, operate the filter condenser machines, and assemble rheostats, got the idea that, working in a radio factory, they ought to have music with their meals.

So we built the original power amplifier for their use, hooked it up to a simple receiver, and ran leads out to some big Racon loud speakers.

We had to wind a special power transformer and extra heavy chokes, and make special filter

condensers to handle the high voltage. But that was all right because it kept the girls happy. Since then, we have piped the music to other floors, so that everyone can enjoy it.

Soon after the first amplifier was finished, John Geloso came along and, looking at it, said, "Ah, that's just what I need to supply B voltage to the television receiver."

To keep peace all around, we made up a dozen sets of parts. One amplifier was used to operate a Racon dynamic speaker for dance music. The power amplifier gives much better music for dancing than can be obtained from ordinary amplifiers because it brings out the low notes which supply the rhythm of the music. Another went into a public address system

Fig. 2. This unit is built to stand up under all conditions, and without attention.

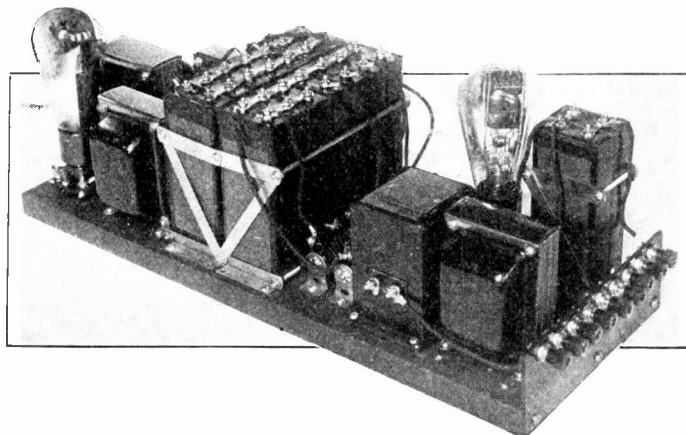

and so on until our small supply of parts was exhausted.

Checking up on their performance, we found that they were all giving such splendid service, and cost so little for the magnificent results delivered, that we decided to build the transformers, chokes, and filter condensers in regular production. That's the story of the new No. 402, 375, and 9501 units required for the 250 amplifier. All other parts required are standard Pilot devices.

HOW TO USE THE 250 UNIT

The power amplifier should be connected to the first A. F. stage of any receiving set. Only when exceptional volume is needed should it be put on the second stage.

No B power pack is required for the receiving set, because the power amplifier is equipped with terminals for 45, 90, 135, 180, and 400 volts. The 400-volt post is to handle any special equipment.

- 1—No. 402 Pilot power amplifier transformer
- 3—No. 375 Pilot 85-mil choke coils
- 1—No. 381 Pilot A. F. transformer
- 14—No. 9501 Pilot 500-volt 1. mfd. filter condensers
- 2—No. 9302 Pilot 300-volt 2. mfd. filter condensers
- 1—No. 956 Pilot 1,200-ohm resistor
- 2—No. 960 Pilot B pack resistors
- 2—No. 213 Pilot Bakelite UX sockets
- 2—No. 9000 Pilot condenser clamps
- 1—No. 9001 Pilot condenser clamp
- 1—Binding post strip
- 1—Base board 19 x 7 $\frac{1}{4}$ x $\frac{3}{4}$ in.
- 40— $\frac{1}{2}$ -in. No. 6 R. H. wood screws
- 8—1-in. No. 6 R. H. wood screws

The illustrations show how the brackets are arranged to hold the bank of fourteen 1. mfd. condensers. Do not squeeze them too tightly, but see that they are firmly clamped. Connecting links are supplied with the kit to slip

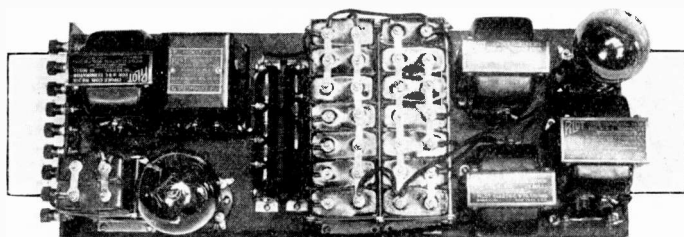

Fig. 3. Not an inch to spare, yet the parts are not crowded.

The power transformer is fitted with binding posts as follows:

Nos. 1, 2, 3 deliver 7.5 volts and up to 2.0 amperes. No. 2 is the center tap. This winding lights the rectifying tube, CX-381.

Nos. 4, 5, 6 deliver 7.5 volts and up to 2.0 amperes. No. 5 is the center tap. This winding lights the power amplifier tube, CX-350.

Nos. 9 and 10 deliver 600 volts at .06 ampere.

This is the high voltage which is rectified for the B supply of the amplifier tube.

Nos. 7 and 8 are for connection to the A. C. supply. This must be of 110 to 120 volts, 50 or 60 cycles.

The voltage drop in the rectifier tube, chokes, and resistors brings the output voltage down to 400 on the amplifier tube.

Because of the high potential employed in this unit, it is important to put the amplifier in a well-protected place where no one will get his hands on it by accident. If you can do it, arrange a lever-operated switch so that, when the cabinet is opened at the back, the current to the power transformer will be cut off.

SUGGESTIONS ABOUT ASSEMBLING

The base board must be of well-seasoned wood, 19 by 7 $\frac{1}{2}$ in., and $\frac{3}{4}$ in. thick. Fig. 3 gives the general plan of the layout, with further details in the picture wiring diagram, Fig. 6. Start the assembly at the power transformer end, and work across. Space each part carefully, and make sure that each device is fastened down securely. The complete list of parts is as follows:

over the condenser binding posts as shown in Fig. 3. Check each condenser carefully to make certain that it is a No. 9501, and not one of the two No. 9302 condensers mounted separately for the output filter.

When you mount the two resistors, compare the terminal markings with those shown in Fig. 5. If you make a mistake and reverse the position of one of the resistors you will not get the right voltages at the binding posts.

A special set of clamps with short rods are provided for the two No. 9302 condensers. These are of 2. mfd., and are of a lower voltage rating, since they are connected in the output filter.

CONNECTIONS TO YOUR SET

No changes in the receiver are necessary when you use this amplifier except that you will have to switch the leads from your present B pack to the posts on the amplifier.

On the amplifier is a post marked PLATE INPUT in the diagrams. This is the only lead running to the receiving set. If you are going to use only the first A. F. stage in your set, disconnect the wire running to the P contact on the socket of the first audio tube. Then connect the lead from the power amplifier to the P post on the socket.

If you use the second stage in your set, go through the same process, removing the wire running to the P post on the second audio socket, and put on that post the lead from the amplifier.

This puts 135 volts on the tube in the set to which the power amplifier is connected, as

you will see by referring to Fig. 5. If you want a higher or lower voltage on that tube, change the resistor end of the lead running from B+ on the No. 381 transformer. For 90 volts put the lead on the terminal of the resistor which is connected to the 90-volt binding post. To get 180 volts on the last tube you are using in the set, change the lead to the resistor terminal connected to the 180-volt binding post.

USE WITH TELEVISION AMPLIFIER

When you use the power amplifier as the plate supply for a television receiver you will not need some of the parts specified. Leave out the power tube socket No. 381 transformer, the output choke and 2. mfd. condensers, and the No. 956 resistor. Connect the remaining parts according to the diagrams.

Without the load of the amplifier tube, the voltage at the 180-volt binding post will be

Never use cotton insulation for the wiring on the power amplifier. In damp weather the cotton will absorb moisture and offer leakage paths for the current to flow where it does not belong.

Be very careful about the soldered joints. Don't apply so much heat and solder that you will damage the instruments. Have your iron very hot and perfectly clean, so that the solder will flow freely and quickly.

There is some misunderstanding in the minds of set builders concerning the relative merits of the 310 and 350 tubes. Either tube can be operated on 400 volts plate supply, although the 310 takes 35 volts C bias and the 350 requires 70.5 volts.

When you consider that the 310 has an amplification factor of 8 against 3.8 for the 350, it may appear that the 310 is a better tube. That is not true, however.

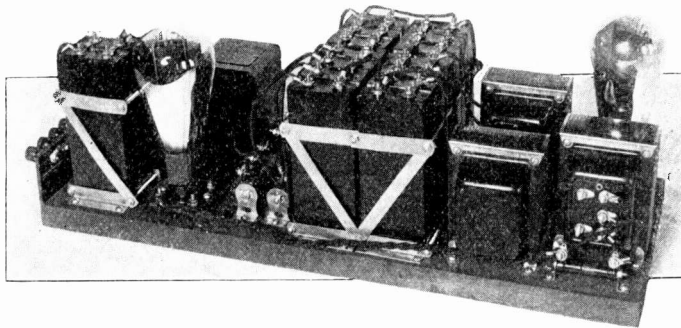

Fig. 4. The shape of the base panel fits most console compartments.

approximately 220 volts, as specified in the television receiver diagram. This is the only type of heavy duty power supply now available that can supply sufficient voltage, without overloading, at 60 mils drain.

SPECIAL NOTES

If you are not familiar with this type of equipment, the following notes will be helpful.

The undistorted output of the 350 tube is 3,250 milliwatts, while the 310 can handle only 1,500 milliwatts without distortion. In order to obtain the most perfect reproduction, a big reserve of power must be available to handle the low notes. From the figures given, you can see that, when the 310 is at its maximum, the 350 is delivering only half its rated power.

In the average home, high amplification is not

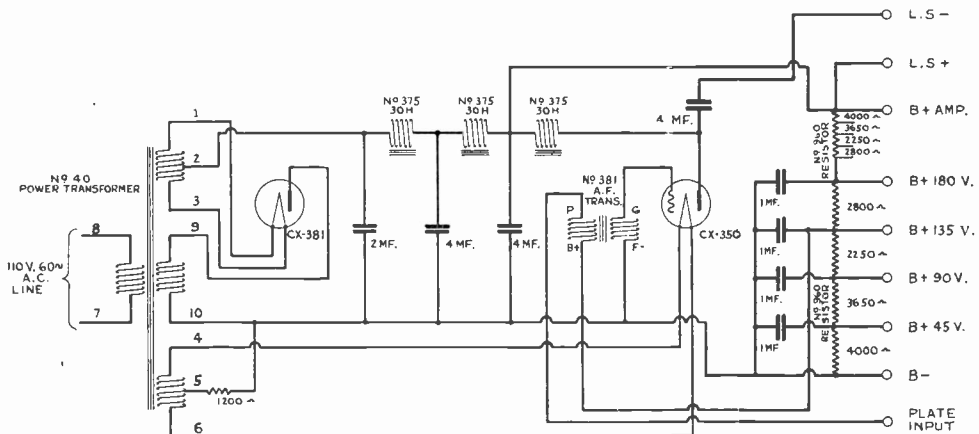

Fig. 5. Schematic diagram of the amplifier and B voltage supply.

important, for big volume is more often objectionable. Quality is the thing. And that is what the 350 tube will give you.

Put a good dynamic speaker on this power amplifier, connect up your old set, and you will think you have a whole new receiver. The power amplifier is an excellent adjunct to a battery-operated set, since it furnishes all the

BOOK REVIEWS

The Radio Manual, by G. E. Sterling, edited by R. S. Kruse. Published by D. Van Nostrand Co., Inc. Over 900 pages and more than 1,000 illustrations.

Perhaps for the first time we have in one handbook an entire course of training for the Department of Commerce's examination for any grade of operator's license. It was prepared by two men who were perhaps best fitted to do so; R. S. Kruse and G. E. Sterling. Sterling is Radio Inspector and Examining Officer of the Radio Division of the Department of Commerce. Kruse, who edited the Radio Manual, was for the past five years Technical Editor of QST, the official organ of the American Radio Relay League.

The sixteen chapters, carry the reader from elementary circuits right through to the details of the newest commercial equipment, so that a beginner, with hardly any knowledge of electricity, can get from the book a thorough knowledge of radio operation.

The book is a thorough compilation of radio information, and has some new information which had never been published. It has a complete description of the Western Electric 5 K.W. transmitter in use at most of the large broadcasters; and a description and circuit diagram of the W.E. superheterodyne receiver type 6004-C, as well as a most complete description of the standard Navy 2-K.W. spark transmitter. A very valuable section, worth the price of the entire book, is devoted to Radio Laws and Regulations, and handling and abstracting traffic.

Complex mathematics have been avoided and the different topics, introduced in a well-planned sequence. The mechanical make-up of the book is generally praiseworthy.

The Radio Manual is now on the press and will be ready October first. The regular price of the publication will be \$6.00. By a special arrangement with the publishers, Radio Design can offer this book to its readers at the special price of \$4.95 postpaid. Orders should be sent to the Book Department, Radio Design Magazine, 103 Broadway, Brooklyn, N. Y.

Practical Television, by E. T. Lerner, published by D. Van Nostrand. Price \$3.75, 172 pages, 100 illustrations.

This first up-to-date book written on the subject Practical Television gives the layman a clear understanding of the fundamentals and principles of seeing by radio. The first part of the book is devoted to the work of early pioneers, starting with Abbe Caselli, who in 1862 sent drawings and diagrams over wire. The use of selenium, which was the first light sensitive element known, and its characteristics are discussed as an introduction to the development of the modern photo-electric cell.

A chapter is devoted to the use of the cathode ray as a light sensitive cell. This method is one which has been more highly developed in Europe than in the United States. Much space is given to the Baird Television and to trans-atlantic television.

Whether you intend to build television receivers, experiment, or just want to have a working knowledge of this new art.

This book will be mailed to you postpaid if you will send \$3.75 to Radio Design, Book Department, 103 Broadway, Brooklyn, N. Y. This is a special introductory offer to Radio Design readers.

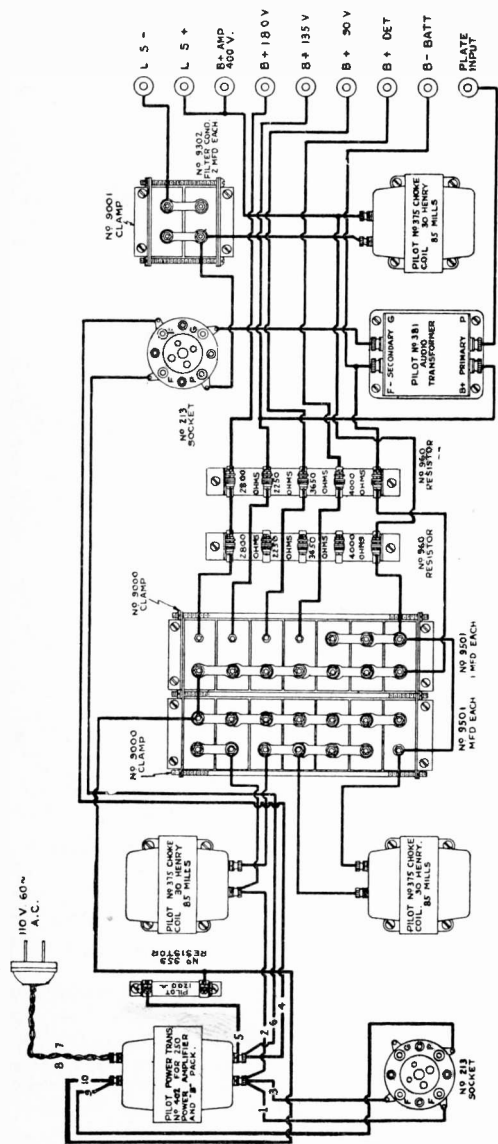

Fig. 6. You can follow the layout of the parts as shown here, for they are laid out just as in Fig. 3

B voltages, and plugs directly into the lamp socket. Then you will need only the storage battery to light the filaments in the set itself. No current is drawn from the storage battery to light the tubes in the power amplifier.

Read what BIG money these fellows have made in the RADIO BUSINESS

\$375 One Month Spare Time



"Recently I made \$375 in one month in my spare time installing, servicing, selling Radio sets. And, not so long ago, I earned enough in one week to pay for my course."
EARLE CUMMINGS,
 18 Webster St., Haverhill, Mass.

\$1597 In Five Months



"The N. R. I. is the best Radio school in the U. S. A. I have made \$1597 in five months. I shall always tell my friends that I owe my success to you."
HENRY J. NICKS, Jr.,
 302 Safford Ave., Tarpon Springs, Fla.

\$1164 Spare Time Profits



"Look at what I have made since I enrolled, \$1,164—money I would not have had otherwise. I am certainly glad I took up Radio with N. R. I. I am more than satisfied."
HENRY B. HEIKINEN,
 123 W. Erie St., Chicago, Ill.

Over \$1000 In Four Months



"My opinion of the N. R. I. course is that it is the best to be had at any price. When I enrolled I didn't know a condenser from a transformer, but from December to April I made well over \$1000 and I only worked in the mornings."
AL JOHNSON,
 1409 Shelby St., Sandusky, Ohio.

I will show you too how to start a spare time or full time Radio Business of Your Own without capital



J. E. SMITH Pres.

Radio's amazing growth is making many big jobs. The world-wide use of receiving sets and the lack of trained men to sell, install and service them has opened many splendid chances for spare time and full time businesses.

Ever so often a new business is started in this country. We have seen how the growth of the automobile industry, electricity and others made men rich. Now Radio is doing the same thing. Its growth has already made many men rich and will make more wealthy in the future. Surely you are not going to pass up this wonderful chance for success.

More Trained Radio Men Needed

A famous Radio expert says there are four good jobs for every man trained to hold them. Radio has grown so fast that it simply has not got the number of trained men it needs. Every year there are hundreds of fine jobs among its many branches such as broadcasting stations, Radio factories, jobbers, dealers, on board ship, commercial land stations, and many others. Many of the six to ten million receiving sets now in use are only 25% to 40% efficient. This has made you a big chance for a spare time or full time business of your own selling, installing, repairing sets.

So Many Opportunities You Can Make Extra Money While Learning

Many of our students make \$10, \$20, \$30 a week extra while learning. I'll show you the

plans and ideas that have proved successful for them—show you how to begin making extra money shortly after you enroll. G. W. Page, 1807-21st Ave., S., Nashville, Tenn., made \$935 in his spare time while taking my course.

I Give You Practical Radio Experience With My Course

My course is not just theory. My method gives you practical Radio experience—you learn the "how" and "why" of practically every type of Radio set made. This gives you confidence to tackle any Radio problems and shows up in your pay envelope too.

You can build 100 circuits with the Six Big Outfits of Radio parts I give you. The pictures here show only three of them. My book explains my method of giving practical training at home. Get your copy!

I Will Train You At Home In Your Spare Time

I bring my training to you. Hold your job. Give me only part of your spare time. You don't have to be a college or high school graduate. Many of my graduates now making big money in Radio didn't even finish the grades. Boys 14, 15 years old and men up to 60 have finished my course successfully.

You Must Be Satisfied

I will give you a written agreement the day you enroll to refund your money if you are not satisfied with the lessons and instruction service when you complete the course. You are the only judge. The resources of the N. R. I. Pioneer and Largest Home-Study Radio school in the world stand back of this agreement.

Get My Book

Find out what Radio offers you. My 61-page book, "Rich Rewards in Radio" points out the money making opportunities the growth of Radio has made for you. Clip the coupon. Send it to me. You won't be obligated in the least.

Address

**J. E. Smith, Pres.
 Dept. 9G3**

**National Radio Institute
 Washington, D. C.**

This Book points out what Radio offers you Get a copy!



This coupon is good for a FREE copy of my Valuable Book. Mail it NOW!

J. E. Smith, President, Dept. 9G3, National Radio Institute, Washington, D. C.

Dear Mr. Smith: Send me your book. I want to know more about the opportunities in Radio and your practical method of teaching at home in spare time. This request does not obligate me to enroll and I understand no agent will call on me.

Name Age
 Address
 City State

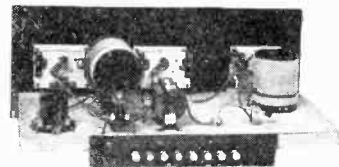
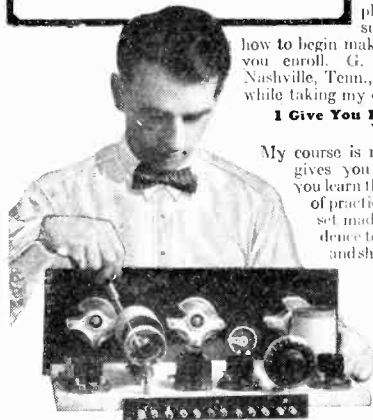

the Important RADIO BOOKS

Here is a specially selected group of radio books which you will find in constant use on the desks of radio engineers and custom set builders. These books will bring your library up to date.

SIGNAL CORPS OFFICERS' RADIO MANUAL

1929 EDITION. Used by all officers of the Signal Corps as a reference book on radio subjects. Completely illustrated with circuits and diagrams. Explains newest equipment, including dynamic speakers and television, as well as newest circuits used in the Signal Corps.

Price, postpaid \$1.00

PRACTICAL TELEVISION

By E. T. LARNER. The only modern book on this new subject. Written for experimenters who are working on television development. 172 pages, 100 illustrations.

Price, postpaid \$3.75

RADIO AMATEUR'S HANDBOOK

By F. E. HANDY. The third, revised edition. All about short wave transmitters and receivers. Entirely "how to make it." Used as a guide by amateurs all over the world. 211 pages, 200 illustrations.

Price, postpaid \$1.00

THE RADIO MANUAL

By G. E. STERLING and R. S. KRUSE. This is the most complete book on modern commercial radio communication that has ever been written. 900 pages, 1,000 illustrations.

Price, postpaid \$4.95

Combination Offer **\$9.95**
These 4 books, postpaid

Radio Design Pub. Co., Inc.
103 Broadway, Brooklyn, N. Y.

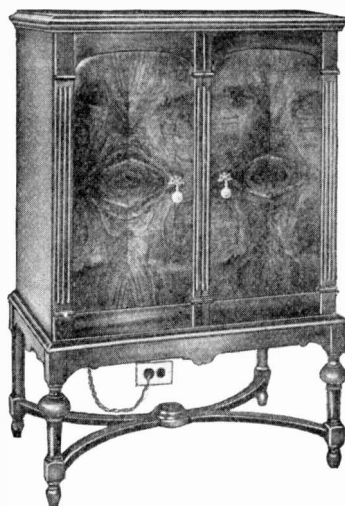

Cabinets for PILOT TELEVISION SETS and BROADCAST RECEIVERS

This type of cabinet is approved by John Geloso for the Pilot Television receiver. Also used for radio sets, with built-in loudspeaker. Write for prices on this and other beautiful cabinets.

MAXWELL RADIO CORPORATION
98 South 6th Street, Brooklyn, N. Y.

TWIN COUPLER

Twin Coupler Coils are sold in KRESGE, KRESS, GRANT, and other stores thruout the U. S. A., Canada, and foreign countries



*Largest Radio Coil
Manufacturers in
the United States*

GENERAL OFFICES AND FACTORY
TWIN COUPLER CO., Inc.
POUGHKEEPSIE · NEW YORK

A.L. FAIRIS

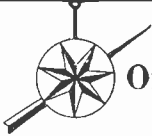

Box 83, Station W
Brooklyn, New York
**Official M. B. Sleeper
Panel Patterns**

Be sure you're right when you assemble expensive radio parts. Use the Official Panel Patterns so as to reproduce exactly and efficiently the sets shown in Radio Design.

Pilot Air Hound: Panel patterns of this new all-electric high-quality broadcast set - - - \$1.00

Short-Wave Wasp: 10,000-mile range, 17 to 500 meters, finest of short-wave sets. Panel patterns. \$1.00

250 Power Amplifier: Combination 250 power amplifier and B supply for receiving sets, patterns. \$0.50

Pilot Scanning Disc: Full mechanical drawings of Official Pilot scanning disc. O.k'd by John Geloso. \$1.00.

PILOT TELEVISION RECEIVER

On September 15th John Geloso will release the hook-up of the redesigned Pilot Television Receiver. Complete patterns and circuit, with all constants and data - - - - - \$1.00

ALL PANEL PATTERNS SENT POSTPAID



are included in the Merriam Webster, such as *aerograph, broadtail, credit union, Babaism, patrogenesis, etc.* New names and places are listed such as *Cather, Sandburg, Stalin, Latvia, etc.*

Constantly improved and kept up to date.

WEBSTER'S NEW INTERNATIONAL DICTIONARY

Get The Best

The "Supreme Authority"

in courts, colleges, schools, and among Government officials both Federal and State.

452,000 entries including 408,000 vocabulary terms, 32,000 geographical subjects, 12,000 biographical entries. Over 6,000 illustrations, and 100 valuable tables.

Send for Free, new, richly illustrated pamphlet containing sample pages of the New International

G. & C. Merriam Company
Springfield, Mass.

IF YOU CAN'T BUY WHAT
YOU NEED FROM
YOUR LOCAL DEALER,
ORDER FROM

SPEED

Fastest Radio Mail Service in the World

SPEED is headquarters for all Pilot parts and Twin Coupler coils, as well as special television apparatus.

SPEED can furnish the kits for building the Pilot television receiver, special amplifier, and power pack, as well as discs, neon lamps, and synchronous motors, all officially OK'd by John Geloso, for WRNY television.

SPEED carries in stock the kits for the Air Hound, Wasp short wave set, 250 power amplifiers, No. 4A power pack, and No. 5B power pack, as well as all the separate parts for sets described in Radio Design.

AND Speed ships all orders post-paid the day they are received. Remember, Speed is

AS NEAR AS YOUR MAIL BOX

SEND STAMP FOR
LATEST PRICES

SPEED

A CORPORATION

FOR RADIO BUILDERS SUPPLIES

103-A Broadway, Brooklyn, N. Y.

PILOT PRESENTS NEWEST

Engineered, Built and Merchandised



Test-and-check is the motto of Pilot engineers who control production.

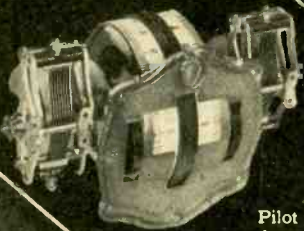

Pilot provides this handsome drum dial with fast and slow-motion wheels to make tuning quick and sure.



Illuminated knob-type vernier drum—built to Pilot precision standards.



Introducing a new family of moisture-proof bakelite case transformers—audio, push-pull and output transformers, output filter, B choke.

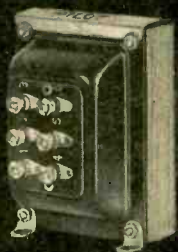

Universal A and B pack transformers, approved type for latest A. C. tubes and circuits.

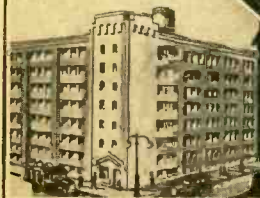

Where Pilot Radio Parts Are Made.

PILOT ELECTRIC M'FG. CO.

323 BERRY ST.

BROOKLYN, N.Y.

INC.

TRADE MARK



REGISTERED

"WORLD'S LARGEST RADIO PARTS PLANT"