

RADIO-CRAFT

HUGO GERNSBACK, Editor

**STATIC-FREE
F. M. RADIO !**

See Page 9



U. S. No. 1 AIRPORT

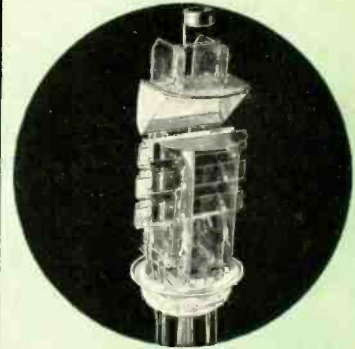

ELECTRON MULTIPLIER



EDISON LIVES AGAIN!

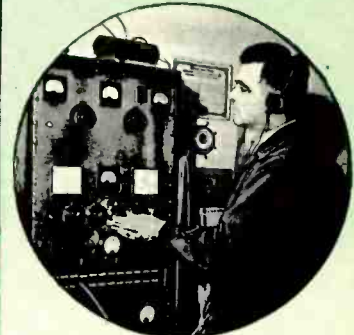

W6MBD AIDS MOVIES

JULY

25c

U. S. AND CANADA

**RADIO'S GREATEST MAGAZINE
MAKING A TUBE TESTER-ANALYZER • VOLTAGE REGULATORS
TRIODE-OUTPUT AMPLIFIER • 3-IN-1 SET • NEW A. F. TUBES**

Two New Super Values on Page 15 • Two New Super Values on Page 15 • Two New Super Values on Page 15 • Two New Super Values on Page 15 • Two New Super Values on Page 15 • Two New Super Values on Page 15 • Two New Super Values on Page 15 • Two New Super Values on Page 15 • Two New Super Values on Page 15 • Two New Super Values on Page 15

THE NEW CHANNEL-ANALYZER

Follows The SIGNAL from Antenna to Speaker

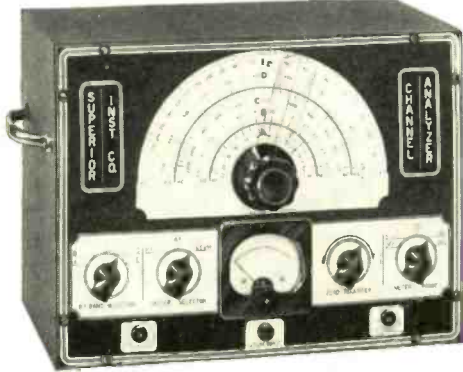

The well-established and authentic SIGNAL TRACING METHOD of locating the very circuit in which there is trouble, and the very component that causes the trouble, is now for the first time available at a price any radio serviceman can afford.

The CHANNEL-ANALYZER will

- * Follow signal from antenna to speaker through all stages of any receiver ever made.
 - * Instantly track down exact cause of intermittent operation.
 - * Measure both Automatic-Volume-Control and Automatic-Frequency-Control voltages and circuits without appreciably loading the circuit, using built-in highly sensitive Vacuum-Tube Voltmeter.
 - * Check exact gain of every individual stage in receiver.
 - * Track down and locate cause of distortion in R.F., I.F., and A.F. amplifier.
 - * Check exact operating voltage of each tube.
 - * Locate leaky condensers and all high-resistance shorts, also show opens.
 - * Measure exact frequencies, amount of drift and comparative output of oscillators in superhets.
 - * Track down exact cause of noise.
- The Superior Channel-Analyzer comes housed in shielded cabinet and features an attractive etched aluminum panel. Supplied complete with tubes, three specially engineered shielded input cables, each identified as to its purpose. Also full operating instructions. Size 13" x 10" x 6". Shipping weight 29 pounds. Only

\$19⁷⁵

THE NEW MODEL 1280 SET-TESTER

Combines Models 1240 and 1250

A complete testing laboratory in one unit, the Model 1280 combines the Models 1250 Multitester and 1240 Tube Tester. (See specifications of each below.)

- * Instantaneous Snap Switches Reduce Actual Testing Time to Absolute Minimum.
- * Spare Socket and Filament Voltages Up to 120 Volts. Make the Model 1280 Obsolescence Proof.
- * Latest Design 4 1/2 D'Arsonval Type Meter.
- * Works on 90 to 125 Volts 60 Cycles A.C.



Even those servicemen who through past purchases know they can always get SUPER-VALUES from Superior, will be amazed and delighted when they read the specifications of this all-purpose instrument and then note the unbelievably low price. The Model 1280 features a 4 1/2" D'Arsonval type meter for easy reading of the various scales, and in line with our new policy of stressing appearance as well as serviceability in our new 1200 line of test equipment, our Model 1280 utilizes an aluminum etched panel, designed for beauty as well as ruggedness. The primary function of an instrument is, of course, to make measurements accurately and when designing test equipment this is our first thought. However, we also appreciate the important part the appearance of an instrument plays in the impression a serviceman makes on his customers, especially on home calls. We have, therefore, paid special attention to the outward design of all of our new instruments. For instance, the panel of this Model 1280 is made of heavy-gauge aluminum and etched by a radically new process which results in a beautiful, confidence inspiring appearance.

Model 1280 comes complete with test leads, tabular data and instructions. Shipping weight 18 pounds. Size 13" x 11" x 6 1/2". Our net price ..

\$19⁷⁵

Portable cover \$1.00 additional

THE NEW MODEL 1250 MULTITESTER



Etched aluminum panel

Specially designed electronic rectifier enables linear A.C. scale, high stability and little or no temperature drift.

Here is an opportunity to acquire a Multi-Service, Precision Engineered Instrument, for less than you would have to pay for an ordinary Volt-Ohm Milliammeter. Besides making the usual volt, resistance and current measurements (both A.C. and D.C.) this unit accurately measures the CAPACITIES of mica, paper and electrolytic condensers, INDUCTION of coils, chokes and transformers, DECIBEL gain or loss, of power amplifiers and public address systems, WATTS output of amplifiers, receivers, etc.

SPECIFICATIONS

- Complete A.C. and D.C. Voltage High and Low Capacity Scales
- and Current Ranges .0005 to 1 mfd. and .05 to 50 mfd.
- D.C. Voltage:—0-15, 0-150, 0-750 3 Decibel Ranges
- A.C. Voltage:—0-15, 0-150, 0-750 -10 to +19, -10 to +38, -10 to +53
- D.C. Current:—0-1, 0-15, 0-150, 0-750 ma.
- A.C. Current:—0-15, 0-150, 0-750 Inductance: 1 to 700 Henries
- 2 Resistance Ranges Watts: Based on 6 mw. at O.D.B.
- 0-500 ohms. 500-5 megohms in 500 ohms .006000 to 600 Watts

Model 1250 works on 90-120 volts 60 cycles A.C. Comes complete with test leads, tabular charts and instructions. Shipping weight 9 lbs. Size 9 1/2" x 11" x 6 1/2". Our net price ..

\$11⁸⁵

Portable cover \$1.00 additional

THE NEW MODEL 1240 TUBE TESTER

Instantaneous snap switches reduce actual testing time to absolute minimum.



Tests all tubes 1.4 to 117 volts.

Sockets for all tubes— No adapters.

Superior is proud to offer the newest and most practical tube tester ever designed. Unbelievably low in price—unbelievably high in performance.

- * Tests all tubes, 1.4 to 117 volts, including 4, 5, 6, 7, 7L, octals, loctals, Janium Jr., Peanut, single ended, floating filament, Mercury Vapor Rectifiers, etc. in fact every tube designed to date.
- * Spare socket included on front panel for any future tubes.
- * Tests by the well-established emission method for tube quality, directly read on the GOOD ? BAD scale of the meter.
- * Tests shorts and leakages up to 2 megohms in all tubes.
- * Tests leakages and shorts in all elements AGAINST all elements in all tubes.
- * Tests BOTH plates in rectifiers.
- * Tests individual sections such as diodes, triodes, pentodes, etc., in multi-purpose tubes.
- * Latest type voltage regulator.
- * Features an attractive etched aluminum Panel.
- * Works on 90 to 125 volts 60 cycles A.C.

Model 1240 comes complete with instructions and tabular data for every known type of receiving tube. Shipping weight 12 pounds. Size 6" x 7 1/2" x 10 1/2". Our Net Price ..

\$11⁸⁵

Portable cover \$1.00 additional

SUPERIOR INSTRUMENTS CO. 136 LIBERTY ST., DEPT. RC7 NEW YORK, N. Y.

**What's WRONG
in this circuit—**

**If You're NOW
in Radio**

You should be able to analyze this circuit and know the trouble in *two minutes* without making a single test of any of the parts. If you can't you're probably are losing profits to better trained Radio Technicians. Don't waste a moment, find out NOW why many men with years of Radio experience are enrolling for the N. R. I. Course. Mail Coupon.

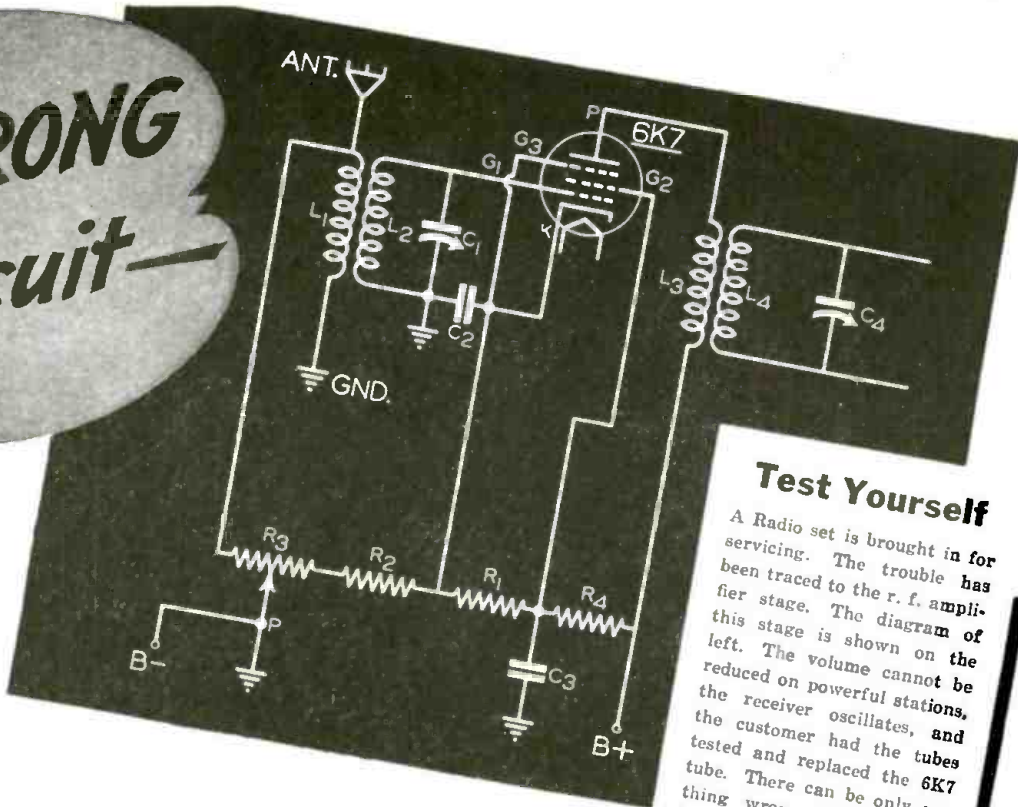

Test Yourself
A Radio set is brought in for servicing. The trouble has been traced to the r. f. amplifier stage. The diagram of this stage is shown on the left. The volume cannot be reduced on powerful stations, the receiver oscillates, and the customer had the tubes tested and replaced the 6K7 tube. There can be only one thing wrong. What is it? The correct answer will be found on this page.

**I TRAINED
THESE MEN
AND
HUNDREDS
MORE**



J. E. SMITH, President
National Radio Institute

**If You're NOT in Radio Now
Here's How You Can Train To**

BECOME A RADIO TECHNICIAN



Chief Operator Broadcasting Station
When I completed 20 lessons, I obtained my Radio Broadcast Operator's license and immediately joined Station WMPC where I am now Chief Operator.—HOL- LIS F. HAYES, 327 Madison St., Lapeer, Mich.

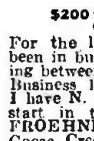

\$200 to \$300 a Month in Own Business
For the last two years I have been in business for myself, making between \$200 to \$300 a month. Business has steadily increased. I have N. R. I. to thank for my start in this field.—ARLIE J. FROEHNELT, 300 W. Texas Ave., Goose Creek, Texas.



\$10 to \$25 a Week in Spare Time
I am now making from \$10 to \$25 a week in spare time while still holding my regular job as a machinist. I owe my success to N. R. I.—WM. F. RUPP, 611 Green St., Bridgeport, Penna.

I Give You A Professional Servicing Instrument

This instrument makes practically any test you will be called upon to make in Radio service work on both spare time and full time jobs. It can be used on the test bench, or carried along when out on calls. It measures A. C. and D. C. voltages and currents; tests resistances; has a multi-band oscillator for aligning any set, old or new. You get this instrument to keep as part of your N. R. I. Course.

If you've never had Radio Training or experience, the problem above will be difficult for you to solve, even in an hour or so. But if you're interested enough to try—it's a sure sign that you will be interested in learning how to become a Radio Technician by training at home nights with N. R. I.

**Why Many Radio Technicians
Make \$30, \$40, \$50 a Week**

Anyone can tune a Radio set—many have the limited knowledge of Radio necessary to build a one or two-tube receiver from the articles in this magazine; but relatively few have the knowledge necessary to locate and fix the countless troubles which arise in a modern, complicated home or auto Radio—and to do this correctly, and fast enough to make real profits and build up a satisfied list of customers who will come back again. Relatively few persons, too, can operate or maintain broadcasting, aviation, commercial, experimental Radio stations, loudspeaker systems, commercial electronic devices or handle the many other jobs which require a working knowledge of Radio. Television promises many good jobs for Radio Technicians soon. That's why many Radio Technicians enjoy good pay, plenty of opportunities for advancement—and why there are many opportunities for Radio Technicians to hold other

jobs and make \$5 to \$10 a week extra money fixing Radios in their spare time, starting soon after they enroll.

**Many Make from \$5 to \$10 a Week
in Spare Time While Learning**

The N. R. I. Course quickly teaches you the fundamental principles of Radio and Television. It also gives you practical experience building circuits, making experiments with Radio parts which you get as a part of the Course. And in addition, the N. R. I. Course teaches you many practical Radio jobs that you can cash in on soon after enrolling. You start learning these "Extra Money Jobs" just as soon as you enroll. That is why many make from \$5 to \$10 a week in spare time while learning and pay for their Course this way.

Answer to Problem Above: Resistor R1 is open. As current no longer flows through the bleeder network, volume cannot be controlled on strong stations, as maximum bias cannot be obtained. It oscillates as bias will be very small and screen voltage too high. This gives high cathode current, causing tubes to lose their emission quickly.

**Find Out How We Teach
Radio and Television**

Act today. Mail coupon now for Sample Lesson and 64-page book. They're FREE. They point out Radio's spare time and full time opportunities and those coming in Television; tell how you can train at home nights in spare time to be a Radio Technician; show more than 100 letters from men successful in Radio who started in this way. Read N. R. I.'s Money Back Agreement. Mail Coupon in an envelope or paste on a penny postcard . . . NOW.

J. E. SMITH, President, National Radio Institute
Dept. OGX Washington, D. C.

Sample Lesson FREE

I want to prove our Course gives practical, money-making information, that it is easy to understand—what you need to master Radio. My sample lesson text, "Radio Receiver Troubles—Their Cause and Remedy," covers a long list of Radio receiver troubles in A. C., D. C., battery, universal, auto, T.R.F., superheterodyne, all-wave, and other types of sets. And a cross-reference system gives you the probable cause and a quick way to locate and remedy these set troubles. A special section is devoted to receiver check-up, alignment, balancing, neutralizing, testing.



GOOD FOR BOTH 64 PAGE BOOK FREE

MR. J. E. SMITH, President, Dept. OGX
National Radio Institute, Washington, D. C.

Mail me FREE, without obligation, Sample Lesson and 64-page book "Rich Rewards in Radio," which tells about Radio's opportunities and explains your 50-50 method of training men at home. (No salesman will call. Write plainly.)

(Please Check)
 I AM doing Radio work now I am NOT doing Radio work
 NAME..... AGE.....
 ADDRESS.....
 CITY..... STATE..... 14X1

RADIO-CRAFT

HUGO GERNSBACK, *Editor-in-Chief*

N. H. LESSEM
Associate Editor

THOS. D. PENTZ
Art Director

ROBERT EICHBERG
Trade Digest Editor

R. D. WASHBURNE, *Managing Editor*

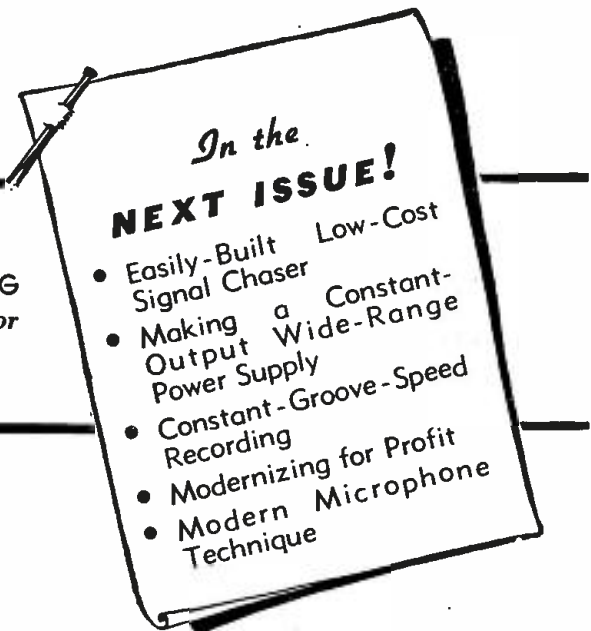

Contents JULY, 1940 Issue

VOLUME XII -- NUMBER 1

Mailbag	3
Editorial: The Obsolete Serviceman	Hugo Gernsback 7
The Radio Month in Review	8

SERVICING

Replacing I.F. Coil Windings	L. V. Sorensen 11
Rebuilding Transformers Is Profitable	Thomas A. Gross & Arthur A. Link 14
New Circuits in Modern Radio Receivers—No. 34	F. L. Sprayberry 16
RADIO SERVICE DATA SHEETS:	
No. 280—Wilcox-Gay Model A-70 "Recordio" (Chassis Model 9J9) Home Recorder Radio-Phonograph	18
No. 281—Ditto	20
Service Questions & Answers	19
Operating Notes	21
Your Fellow Serviceman Builds a Signal Tracer Test Unit	R. B. Olson 22
How to Build a Practical Tube Tester and Set Analyzer-Adapter	Joseph J. Pire 24
Resistors and Condensers for Use in Audio-Frequency Amplifiers	43
R.M.A. Transformer Color Code	43

TEST INSTRUMENTS

Your Fellow Serviceman Builds a Signal Tracer Test Unit	R. B. Olson 22
How to Build a Practical Tube Tester and Set Analyzer-Adapter	Joseph J. Pire 24

SOUND

Case Histories—No. 10—P.A. System for Ball Games, Etc.	26
A Triode Direct-Coupled Amplifier with Non-Frequency-Discriminating Scratch Suppressor	A. C. Shaney 27
Case Histories of P.A. Sales—No. 11—Church Sound Set-up ..	29
Sound Engineering—No. 7	30
More from the Day's Mail of the F.C.C.	31
"Transitional" P.A. System	H. T. Ziegler 32
High School Students Build Transmitting Station—W7PU	33
Resistors and Condensers for Use in Audio-Frequency Amplifiers	34
Specialized A.F. Tubes	F. M. Perot 36
"Enhanced" Stereophonic Sound	R. D. Washburne 47

ELECTRONICS

Specialized A.F. Tubes	F. M. Perot 36
Radio-Operated Device Detects Storms 100 Miles Away	37

ENGINEERING

The ABC of Electronic Automatic A.C. Voltage Regulators	H. S. Manney 38
---	-----------------

TELEVISION

Recent Engineering Developments	41
---------------------------------------	----

EXPERIMENTERS

A "3-in-1" Battery Portable	Charles R. Leutz 42
R.M.A. Transformer Color Code	43
Choosing an F.M. Antenna	Arthur H. Lynch 44

RADIO DEVELOPMENTS

Miniature Training Battlefield Uses Radio	46
Radio Guards Against Fire and Theft	46
"Enhanced" Stereophonic Sound	R. D. Washburne 47
Radio Project of the National Youth Administration	49
South Seas Recording Expedition	49
Preview of the Radio Parts National Trade Show	50

DEPARTMENTS, ETC.

Mailbag	3
The Radio Month in Review	8
New Circuits in Modern Radio Receivers—No. 34	F. L. Sprayberry 16
RADIO SERVICE DATA SHEETS (See Servicing)	18-20
Service Questions & Answers	19
Operating Notes	21
Case Histories of P.A. Sales—No. 10	26
P.A. System for Ball Games, Etc.	26
Ditto: No. 11—Church Sound Set-up	29
Sound Engineering—No. 7	30
The Latest Radio Apparatus	53
Radio Trade Digest	59
Shop Notes—Kinks—Circuits	63



Published by Radcraft Publications, Inc. Publication office: 29 Worthington Street, Springfield, Mass. Editorial and Advertising Offices: 20 Vesey Street, New York City. Chicago Advertising Office: RADIO-CRAFT, 520 North Michigan Avenue, Chicago, Ill.

RADIO-CRAFT is published monthly, on the first of the month preceding that of date; subscription price is \$2.00 per year in U. S. and Canada. (In foreign countries, \$2.50 a year to cover additional postage.) Entered at the post office at Springfield as second-class matter under the act of March 3, 1879.



Foreign Agents:

London—Gorrings's American News Agency, 9A Green St., Leicester Square, W. C. 2, England.

Paris—Messageries Dawson, 4 Rue Faubourg, Poissonniere, France.

Melbourne—McGill's Agency, 179 Elizabeth St., Australia.

Dunedin—James Johnston, Ltd., New Zealand.



Text and illustrations of this magazine are copyright and must not be reproduced without permission of the copyright owners.



Copyright 1940 Radcraft Publications, Inc.

SECONDS MAP IDEA

Dear Editor:

● I WISH to second Mr. Barber of Canada's idea published in your May issue. A large-scale map of the world is something I have wanted for a long time.

My ideal map would be a combination, physical and relief with the principal cities, amateur radio divisions (principal), commercial shortwave stations, etc. Changing conditions of the world soon out-date a political map.

Since most people place a map on the wall, I think a 10 x 12 ft. one too large. It seems to me a 4 x 6 ft. is the better size.

Please keep your magazine for the Serviceman. I like your streamlined style.

DEAL LOVELL,
Waukomis, Okla.

LIKES HEARING-AID ARTICLE

Dear Editor:

● THANK you for the excellent article, on the design and construction of a wearable, tube-type hearing-aid, in the May issue. A similar article on the construction of a box-type battery unit would be welcome.

I am one of the hard-of-hearing and have long been interested in the possibilities of tube amplification for hearing-aids.

If I am not mistaken this is the first time that all the necessary parts for the assembly of such a hearing-aid have been made available. Previously, items like cases, cords and battery boxes had to be made up special. This is a real milestone in the development and use of this type of hearing-aid. It presages a larger market for hearing-aids. Assembly and sale of these hearing-aids by radio and sound men brings the price down to a figure that most of the hard-of-hearing can afford to pay. The price of commercial units is heavily padded with sales costs. Large numbers of the hard-of-hearing cannot pay these high prices. Most of those that do buy the commercial units find the high price a hardship.

At the present time there are a large number of cheap, impractical carbon-microphone hearing-aids sold. Many of them are sold by mail. The price ranges from \$25 to \$75. Most of these people would be a lot better off if they had tube-type hearing-aids assembled for them by local radio men. Even if compensation for auditory frequency discrimination is not perfect—the results could not possibly be as bad as

LES Correspondence Courses in RADIO and ELECTRICAL ENGINEERING

ELECTRICAL ENGINEERING Get good grade. Prepare yourself, at low cost, for secure future. Modern, simplified, you can understand quickly.

RADIO ENGINEERING Extra fine course in radio. Publishes your address, photo-electric work. Trains you to be super-service man, real vacuum tube technician. Exper. kits furnished. Diploma on completion.

Tuition, \$25; either course. Deferred payment plan. Get copies of school catalogs, student magazines, complete details. **SEND NOW!**

FREE

LINCOLN ENGINEERING SCHOOL, Box 931-C19, LINCOLN, NEBR.

RADIO TECHNOLOGY

RCA Institutes offer an intensive course of high standard embracing all phases of Radio and Television. Practical training with modern equipment at New York and Chicago schools. Also specialized course and Home Study Courses under "No obligation" plan. Catalog Dept. RC-40.

RCA INSTITUTES, Inc.
A Radio Corporation of America Service
75 Varick St., New York, 1154 Merchandise Mart, Chicago

RADIO COURSES

Start September

- RADIO OPERATING—BROADCASTING
- RADIO SERVICING—A practical course
- RADIO AMATEUR CODE • TELEVISION
- ELECTRONICS—1 yr. day course 2 yrs. eve.

Day and Evening Classes. Booklet Upon Request.

New York Y.M.C.A. Schools
4 W. 64th Street New York City

those produced by the "carbon"-type hearing-aids. Any radio or sound man can quickly find out which type of response will work best by a test with an amplifier having a complete set of response controls. A full-range audio signal generator will tell him the same thing. A tone control takes care of most cases. Of course it is advisable to obtain an audiogram and recommendations of an otologist whenever possible. Like every other phase of sound amplification, the assembly and sale of hearing-aids must be mixed with a generous portion of brains.

I hope you will see fit to publish other articles on hearing-aids from time to time.

CLARENCE KADOW,
San Francisco, Calif.

APPRECIATES SOUND ARTICLES

Dear Editor:

● I AM just writing to tell you how much I have enjoyed the articles on sound and amplifiers, by Mr. A. C. Shaney. They have filled a real need for me, as I was and am very much interested in amplifiers and their design. I have 2 at present, one for my personal use for my phono records and one that I rent to churches, etc.

I am very much interested in the design of components and am wondering if Mr. Shaney could be persuaded to write an article on output transformer design. Although I personally am fairly conversant with power transformer design, I don't know how much of this knowledge would apply to outputs. I am sure such an article would find many readers like myself to welcome it. Thank you again for the fine series of articles in the past.

C. L. WEATHERWAX,
Chicago, Ill.

WHAT PRICE RADIO-CRAFT!

Dear Editor:

● I JUST walked 6 blocks with a blister on my heel to get my 41st copy of *Radio-Craft*; so much for my present opinion of *Radio-Craft*.

I hadn't taken the matter seriously until in the more recent issues when I began to read more and more pro-Xmitter and program articles. They brought to mind: Czechoslovakia, Poland, Denmark and Norway.

After each of these issues I'd settle down gradually like a glass of water which has had a seltzer tablet dropped in it.

For the Serviceman, *Radio-Craft* is the magazine; whenever it decides not to be the magazine for the Serviceman, the Serviceman will be looking for the magazine. Daggonnit that may be a little blunt but it's gospel.

REEVES RADIO REPAIR,
Kansas City, Kans.

THE DATA SHEET PROBLEM AGAIN

Dear Editor:

● YOUR streamlining of *Radio-Craft* was OK. I would like to see the schematics like Nos. 276 and 277 put in the center as pgs. 670 and 671 of May issue, and full-page ads or Latest Radio Apparatus on the backs of these schematics so we can take them out and file them without taking some part of an interesting item out of the magazine which I also keep filed.

ERNEST P. ALLEN,
Felton, Del.

Believe it or not, but we try to back-up diagrams, etc., which radio and sound men are likely to file, with material of a less "filing" nature; but where, as in the case of *Radio-Craft*, readers find they want to file nearly every article (some readers want to file one story, others another, etc.; some

YOU CAN BECOME A MONEY-MAKING RADIO EXPERT

WITH THE **New SPRAYBERRY**
Personalized
HOME TRAINING in RADIO and TELEVISION

You Learn Easily In Your Spare Hours
By Doing Many Experiments with Up-To-Date Equipment

Here's a really fine, up-to-the-minute Radio and Television Training that's specially designed to give you quick results. **TRAINING PREPARES YOU FOR GOOD RADIO JOBS . . . AT EXCELLENT PAY.** My training starts right at the beginning of Radio . . . unfolds each subject in a simplified, logical, understandable style. You easily learn: Television, Electronics, Facsimile Radio, Radio Set Repair and Installation Work, etc.

NO PREVIOUS EXPERIENCE NEEDED It makes no difference what your education has been. I can fit you for a good-paying Radio job. Your success is my full responsibility.

YOU GET PROFESSIONAL TEST EQUIPMENT PLUS EXPERIMENTAL OUTFITS
. . . Includes 146 Radio Parts (to build complete Receiver), Tools, All-Wave, All-Purpose Analyzer, and Experimental Outfits for conducting actual experiments with your own hands.

I Supply

EARN WHILE YOU LEARN My **BUSINESS BUILDERS** show you how to put your equipment to practical use in handling actual money-making Radio Service Jobs shortly after you begin training.

SERVICEMEN
I offer Advanced Training for those already in Radio. Get complete details in my FREE 24-page book *The Sprayberry Course* is Sold Under a Money-back Agreement

RUSH COUPON for BIG FREE BOOK

SPRAYBERRY ACADEMY OF RADIO
F. L. Sprayberry, Pres.
320-G University Place, N.W.,
Washington, D. C.

Please send me FREE copy of "HOW TO MAKE MONEY IN RADIO."

Name Age
Address
City State
Tear off this coupon, mail in envelope or paste on penny postcard. Servicemen—Check here

RADIO plus TELEVISION *mastered by pre-tested Training*

No matter where you are or what you do, National has a complete training plan for you—to fit your circumstances. National's Plan is for those seeking immediate shop-training as well as for those who cannot give up present employment and income. Mail coupon for FREE literature.

NATIONAL SCHOOLS

NATIONAL SCHOOLS, Dept. RC-7
4000 So. Figueroa St., Los Angeles, Calif.

Please send free Literature and full details

NAME AGE
ADDRESS
CITY STATE

Be a RADIO SERVICE EXPERT
LEARN AT HOME IN SPARE TIME

Clear, simple, fascinating lessons—practical work with experimental kits—make training easy and fast. Up to date R.T.A. methods, under personal guidance of prominent engineer and educator, highly endorsed by leaders in radio industry. Spare-time profits soon pay for training.

START NOW—have your own business or fit yourself for well paid work with radio dealers, in factories, police, marine or television fields. **DON'T DELAY!**

Send **AT ONCE** for complete information and Big Opportunity **BOOK FREE!**

RADIO TRAINING ASS'N. OF AMERICA
4525 Ravenswood Ave. Dept. RC-70 Chicago, Ill.

RADIO JOBS

Go to men with modern technical training. You need something more than just "good intentions" to get ahead in Radio. Today's opportunities go to the men with **TECHNICAL TRAINING**. Our "Tested Plan for a Future in Radio and Television," tells YOU how modern training can equip you for a better job and more money. Write for your **FREE COPY**. State if interested in home study or one year residence course.

CAPITOL RADIO ENGINEERING INSTITUTE
Dept. RC-7 3224-16th St., N.W. Wash. D. C.



Alfred A. Ghirardi AND HIS BIG 3

OF Radio SERVICE WORK RADIO PHYSICS COURSE

BASIC FUNDAMENTALS

Here's your start in Radio! From this one big, short-cut, self-instruction book of nearly 1,000 pages you will get a thorough training in Radio Fundamentals including Sound, Television, Cathode-Ray Tubes, etc.—all the essentials, all the background. No math—no previous training necessary. Ghirardi makes everything crystal-clear and easy to understand. That's why it's used and praised by more radio schools and students than any other radio text in the world!

These are just a few of the main topics covered in this great book — Principles of Sound, Elements of Electricity, Magnetism, Inductance, Capacitance, Circuits, Broadcasting, Receiving, Vacuum Tubes, Amplification, Superhets, Speakers, etc., etc.

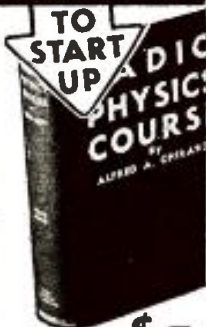

972 PAGES \$4
508 ILLUS.
856 REVIEW QUESTIONS

MODERN Radio SERVICING

LEARN HOW with this!

Here is the famous Ghirardi training course in practical radio service work complete in this 1300-page book. It's an illustrated "gold mine" of servicing knowledge, starting with a complete 420-page treatment of servicing instruments and continuing with nearly 900 more pages of a complete step-by-step procedure course in trouble-shooting, testing, aligning and repairing all makes of sets—all based on practical experience. Here's what you learn:

- Test Equipment — Theory and Descriptions of all Commercial Instruments. How They Work, Construction Data.
- Troubleshooting — Newest short-cut methods.
- Repairing—Advanced "Factory Methods" explained fully.



1300 PAGES \$4
708 ILLUS.

RADIO Trouble Shooter's HANDBOOK

WORK with this!

Here's a new kind of servicing reference manual, a time-saver for service men—different from anything you've ever seen before. It's chock-full of factory-checked "bench data" that will speed up every service job you do! It's the greatest mass of practical working data ever assembled in one book.

- 3,313 Case Histories — Trouble Symptoms and Remedies, compiled from actual service records.
- I.F. Peaks—Alignment Data for over 15,000 Superhets.
- Other Data — Auto-radio, Install. and Servicing Data; Noise Elimination; Servicing Home Recorders and Intercomunicators; and 40 more useful data tables and charts.



518 PAGES \$3
134 ILLUS.

MAIL COUPON TODAY!

RADIO & TECHNICAL PUBL. CO., Dept. RC-70
45 Astor Pl., New York

Send postpaid, with 5-Day Money Back Guarantee:

RADIO PHYSICS COURSE \$4. (\$4.50 foreign)

MODERN RADIO SERVICING \$4. (\$4.50 foreign)

RADIO TROUBLE-SHOOTER'S HANDBOOK \$3. (\$3.50 foreign)

BOTH SERVICING BOOKS at Special Combination Price \$6.50 (\$7 foreign)

Name

Address

City

State

Please send FREE illustrated descriptive literature.

USE THEM 5 DAYS — OUR RISK.

even file the Latest Radio Apparatus items Mr. Allen suggests as backing articles!) it's a "tough job" to avoid a certain amount of backing-up of one story by another—and both worth filing! Maybe the solution some of our readers have found—viz., 2 copies of each issue of *Radio-Craft*—is worth more general application!—Editor

LIKES NEW STREAMLINED ISSUES

Dear Editor:

● CONGRATULATIONS to your new "streamlined" issue. From your most excellent editorial to the last page your magazine is "better than ever."

The new layout is splendid and I believe makes the advertising more prominent, especially for some of the more unobtrusive ads.

I used to find it more or less annoying to try and read an article continued in the back of the magazine while trying to follow a diagram in the front part.

Thanks for H. S. Manney's most timely articles. Am quite sure more of the same will be appreciated by others as well as myself.

Please include me in Mr. A. C. Shaney's request for replies by readers interested in engineering research and design.

HERBERT R. ROACH,
Vancouver, B. C., Canada.

Thank you, thank you!—Editor

SERVICEMAN FROM CEYLON

Dear Editor:

● NO doubt you will be surprised to receive this letter from far-away Ceylon, but I think it is time that a Serviceman from the "tropics" wrote to you about conditions relating to radio we experience "down here." I have been a reader of *Radio-Craft* for the last 4 yrs. and have to thank you for keeping me in touch with the latest developments in radio.

Radio servicing down here is much more difficult than what you experience in America. We have to service in addition to American radios, English, Continental, and even Japanese sets! Furthermore American manufacturers cannot or will not understand the action of tropical humidity on coils and transformers. Oh yes, some of them shove the radios into humidity chambers, etc., but I can tell you from experience that this only meets the trouble halfway. Most of the troubles encountered with coils are so simple to prevent that we Servicemen cannot understand why such radios were sent out. For instance one radio manufacturer sent out sets with I.F. transformers wound on cardboard formers. These transformers were all wound over and looked like a perfectly good job, but the manufacturer forgot to wind the last turns of the coils in contact with the cardboard—result "green spot" within a month, and a couple of good headaches.

If *Radio-Craft* is interested in knowing exactly how to "tropic-proof" radios by a Serviceman in the tropics I will be glad to supply the information, gratis. (How about "Marine-izing Radio Sets," in the June, 1940, issue of *Radio-Craft*, Mr. deJong? We'd like to receive your comments after checking-over this article.—Editor)

I have serviced radio sets ranging from the McMurdo Masterpiece, National, down to midget A.C.-D.C. radios, and not one of these sets has even the ghost of an idea of a tropic-proofed coil. The McMurdo radio output transformer developed "green spots" within 2 mos. The National I.F. transformer konked (due to a silly bit of sticking plaster on the I.F. plate coils) and

these are sets guaranteed tropic-proofed!

Now I want to thank you for the fine articles in *Radio-Craft* on public address, especially those by Mr. A. C. Shaney. Our public address systems are the most popular in Ceylon due to their being built here (all coils wound here). None of those complete amplifiers advertised (I had an A.C.A. 64-watter and one of the coils konked when the governor was speaking; 6L6 valve [tube] holders started shorting and goodness knows what else) so I scrapped it and ever since have used circuits in your magazine to build amplifiers, and out of more than 1,000 jobs we have had not one serious failure.

Re your 1940 Television-Radio Reference Annual, I do not see a way to obtain a copy as I have a standing order with a bookseller to supply *Radio-Craft* until further notice. If you would send me a copy I will be grateful.

With regard to letters appearing in your February "Mailbag," I am sure readers of your magazine like myself will be more interested in the radio service side. Those readers who want transmitting articles can read a magazine like *All Wave Radio*. (No longer published. How about the monthly magazine, our contemporary, *Radio & Television*?—Editor)

I trust that this letter will be of some interest to your readers and I hope *Radio-Craft* will carry on the good work it is already doing.

J. A. DEJONG,
Colombo, Ceylon.

Radio-Craft was immensely pleased to receive this exceptionally constructive and informative letter, and we look forward to soon again hearing from Mr. deJong. Mail between "the States" and Ceylon, however, requires some time to complete a round-trip.—Editor

ROOTS FOR HEARING-AID AMPLIFIER

Dear Editor:

● THANK you very much for the article published in *Radio-Craft* for May, 1940, about the latest miniature hearing-aid amplifier, which is something that I have been looking for, for quite some time and hoping that I will see more of this type of information soon, such as a more powerful hearing-aid to be used in offices operating from the electric line.

GODSCHALL'S RADIO SERVICE,
Morrill Godschall,
Coastville, Pa.

A BOUQUET FOR A. C. SHANEY

Dear Editor:

● I WISH to compliment you, A. C. Shaney and H. A. Fogel, on your very fine article in the April issue describing "A Low-Cost Pushbutton Amplifier." I am sure that there would be a considerable interest in the research and design of such amplifiers.

I would also like to suggest that a few more articles on recording and recording equipment would be very acceptable. Also articles in line with the one by H. S. Manney, "The ABC of Db., Vu, Mu," etc. Your idea of a *Streamlined Magazine* is a definite improvement.

MAX F. SELBY,
Los Angeles, Calif.

THE NEW TUBES SITUATION

Dear Editor:

● IN a recent issue of *Sylvania News* there is an article by M. F. Balcolm concerning the proposed RCA standardization plan.

The article deplores the fact that other manufacturers were not called into consultation with RCA in the evolution of this new idea. The article is right. All manufacturers should get together and work out a feasible plan, in order to reduce the number of overlapping or equivalent tube types.

The tube situation, at present, is truly chaotic—so many tubes available, with new ones being introduced at the drop of a hat, that the average Serviceman and dealer has a difficult time getting acquainted with and stocking them. Now, if the tubes were introduced at a slower rate—without letting the fruits of research go to pot—we could still have new tube types and do away with the hectic state of affairs we have. If the manufacturers would give more exhaustive tests to tubes, in manufacturing and in the field of actual life tests—before giving them to the public, we would have a better chance to take advantage of the wonders of modern engineering.

But, no, we rush into everything. The tendency is away from conservative engineering practice. It is towards lack of confidence on the part of the buying public, on the part of even the industry at large. Tubes, today, in comparison with those of yesterday, which lasted for years as compared to months, today, are strictly not as good as it is possible to make them—and we all know it. What is going to be done about it?

WILLARD MOODY,
New York City.

WANTS INTERFERENCE LOCATOR ARTICLE

Dear Editor:

● AFTER obtaining views and some desirable features regarding a sensitive portable receiver to be used in noise elimination work, from Servicemen of my acquaintance, am listing below these suggestions with the request you publish such an article in your publication, *Radio-Craft*, at your earliest convenience—

- (1) Compactness, low-drain tubes to reduce battery bulk and weight.
- (2) Sensitivity and highly directional; a built-in loop is desirable.
- (3) Optional loudspeaker, phones or milliammeter as level indicators.
- (4) Substantial metal case to withstand abuse and to afford shielding.
- (5) Simplicity of construction.
- (6) Portability.

According to Servicemen that have been approached, such an article will be welcomed.

MOSS RADIO SERVICE,
E. H. Moss,
Waco, N. C.

CORRECTION: "MIDGET A.C.-D.C. AMPLIFIER"

Dear Editor:

● I WOULD like to know if there has been a correction published on the Midget A.C.-D.C. Amplifier described in the January, 1940, issue of *Radio-Craft*.

There is no connection from the power supply to the screen-grids and plate of the 70L7GT. I would like further information on this amplifier.

I am a steady *Radio-Craft* and *Radio and Television* newsstand reader.

TED GAUMONT,
New York, N. Y.

The 3,000-ohm resistor should connect not to the ground side of the 10-mf. condenser but to the opposite side. Sorry.—Editor

NOW AVAILABLE—

The Famous MEISSNER ANALYST

Completely Wired and Tested
Ready to Operate

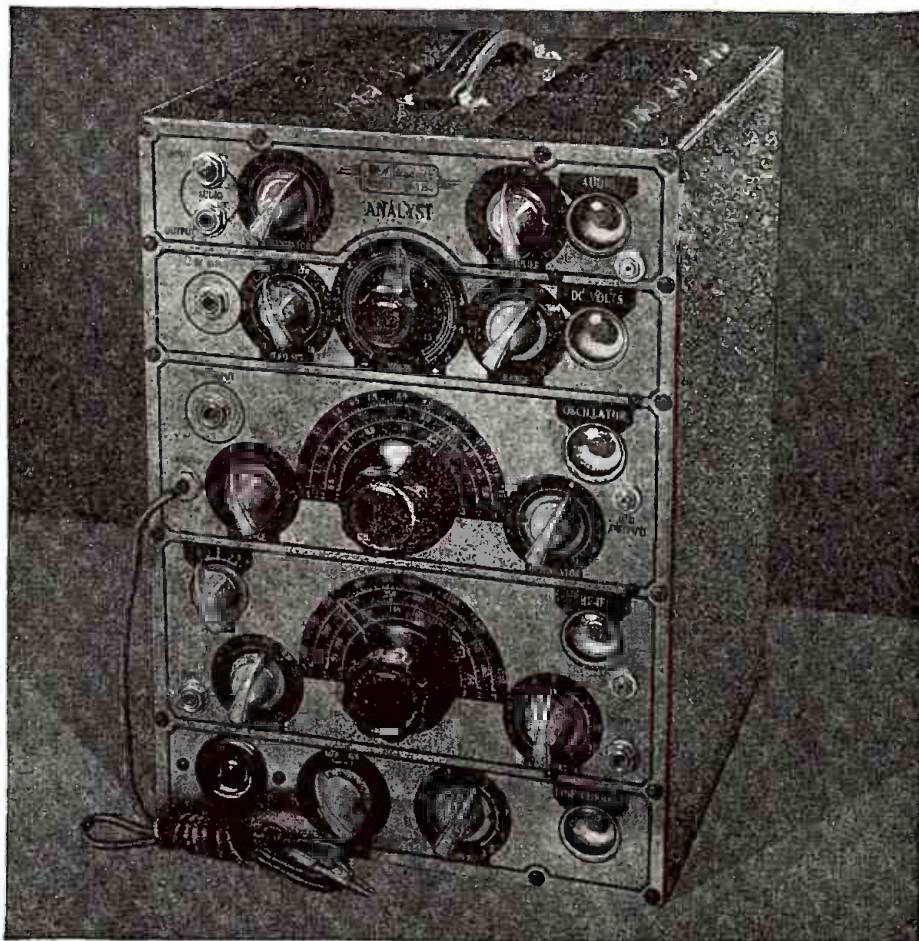

The Key to More Profitable Servicing!

In every section of the country, enthusiastic servicemen are praising the dependable performance of the Meissner Analyst. The endorsement of technicians who know the problems encountered in the service field can mean only one thing—Dollar for Dollar, Feature for Feature—The precision built Analyst is the best buy!

Today the Analyst is supplied completely assembled, wired and laboratory tested. Designed and engineered with an eye on future requirements, it is ready to "go to work" for you the same day you place it on your service bench... master of every service problem, the Analyst does a complete job, paving the way to more profitable operation.

We couldn't improve the Analyst by hanging an extra fifty dollars on its price. But don't take our word for that... Compare it with any instrument available on the market today. Or, best of all, ask the man who uses one!

Complete Meissner ANALYST, Model 9-1025, Only \$88.50 net

INSTRUCTION MANUAL

Get your copy of this big NEW 168-page book, "How to Build Radio Receivers". Contains added material on Frequency Modulation theory and design principles as well as complete instructions on the Analyst. See your Jobber or send 50c at once to the address below. Order it today!

COMPLETE CATALOG FREE

Meissner's entire line of receiver components and complete kits is described and illustrated in this big 48-page catalog. Over 600 items of vital interest to the serviceman and experimenter. Write for your free copy today. A postal card will do!

ADDRESS DEPT. C-7

Meissner MT. CARMEL ILLINOIS

"A FAMOUS NAME FOR TWO DECADES"

★ ★ ★ THREE STAR RADIO VALUE

You receive valuable subscription to **RADIO-CRAFT** PLUS A FREE COPY of 1940 Radio-Television Reference Annual

WITH our compliments, we want to send a copy of the 1940 RADIO-TELEVISION REFERENCE ANNUAL to you FREE, if you will simply take advantage of RADIO-CRAFT magazine's special subscription offer NOW. This offer is being made for a limited time only.

The 1940 RADIO-TELEVISION REFERENCE ANNUAL has 68 pages, large size 8½ x 11½, with over 170 illustrations. The contents of this book has never appeared before in handy book form. Its pages cover practically every branch of radio sound, public address, servicing, television, construction articles for advanced radio men and technicians, time and money-saving kinks, wrinkles, useful circuit information, "ham" transmitters and receivers, and a host of other data.

The Annuals have always been regarded as a standard reference work for every practical branch of radio operation and service. This 1940 edition ably sustains this reputation. Every radio man wants a copy of this valuable book. Just as this book will be of unquestionable value to you, so, too, will every monthly issue of RADIO-CRAFT. This magazine brings you big value every month. It keeps you intelligently informed about new developments in radio and television. You want the news, want it fully but concisely, want it first—that is why you should read RADIO-CRAFT regularly.

This very special offer is made for just one purpose—we want you as a regular subscriber. The Annual, whose contents appears at the right, is not sold, but a copy is FREE to you if you subscribe now.

SAME SIZE AS RADIO-CRAFT



THIS COUPON BRINGS YOU THE ANNUAL

RADIO-CRAFT • 20 VESEY STREET • NEW YORK, N. Y.

Gentlemen: Enclosed you will find One Dollar for which enter my subscription to RADIO-CRAFT Magazine for Eight Months. Send me ABSOLUTELY FREE and POSTPAID, my copy of 1940 RADIO-TELEVISION REFERENCE ANNUAL.

This is a new order Extend My Present Subscription

NAME ADDRESS

CITY STATE

DON'T DELAY — MAIL TODAY! RC-740

Read the summary of contents in this FREE BOOK!

THE 1940 RADIO-TELEVISION REFERENCE ANNUAL contains a collection of the best and most important articles. Covering as they do nearly every branch of radio, they form a handy reference works. In addition, many time and labor-saving kinks, circuits and wrinkles, tried and tested by practicing Servicemen, experimenters and radio fans have been included. This book cannot be bought anywhere at any price. Yet it is yours by merely subscribing. Use the convenient coupon below.

BEGINNER'S SIMPLE INEXPENSIVE CONSTRUCTION ARTICLES

Beginner's Breadboard Special - a 1-Tube High-Gain All-Wave Receiver—Wiring Pointers for Radio Beginners—A Watch Charm Size 1-Tube Set—Beginner's Simple Volt-Milliammeter—Making a 1-Tube Broadcast Loop Receiver—A.C.-D.C. Power Supply for Battery Portables—A 1-Tube Short-Waver with Band Coil Switching.

MORE ADVANCED SET CONSTRUCTION

The "High-Seas 4" Broadcast Lamp Radio—How to Build a 6-Tube 1.4-Volt Short-Wave Superhet for the "Ham" or Short-Wave Fan—Build the "Lunch Box 5" Super Set - a Broadcast Battery Portable—How to Build a Plug-Together 8 Tube Broadcast Set—The "5-in-4" All-Wave Radio for A.C. Operation—An Easily-Built 3-Tube Midset Broadcast Superheterodyne Receiver.

THE SERVICEMEN'S SECTION

Bass Tone Control—Simplified Variable Selectivity—Practical Servicing Pointers—Servicing Universal A.C.-D.C. Receivers—Killing the "Intermittent" Bug—A Service Shop A.C. to D.C. Power Supply—Sideline Money for Servicemen—Adding A.V.C. to any Screen-Grid T.R.F. Receiver—Iron Particles in Speaker Air Gap.

TEST INSTRUMENTS

A Useful Neon Lamp Tester—An Inexpensive Output Meter—Making Milliammeter Multipliers—Home-Made Frequency Modulator—The Busy Servicemen's V.T. Volt-Meter.

PUBLIC ADDRESS AND AMPLIFIERS

Build this Combination A.C.-D.C. Radio and Inter-Communicator—Speaker Placement in P.A. Work—The Design and Construction of an Inexpensive All-Push-Pull 10-Watt Amplifier—Obscure Sources of Hum in High-Gain Amplifiers—How to Build a High-Fidelity 5-Watt Versatile Amplifier.

"HAM" SECTION

Ultra-High Frequency Antennas—The Beginner's Low-Cost Xmitter—Modulator Meter—Phone Monitor—The Beginner's "Ham" Receiver—2½ Meter Acorn Transceiver.

TELEVISION

How to Build a 441 Line T.R.F. Television Receiver—Useful Notes on Television Antennas.

MISCELLANEOUS

Simple Photo-Cell Relay Set Up—Making a Burglar Alarm—How to Build A.C.-D.C. Capacity Relay—How to Make a Modern Radio Treasure Locator.

USEFUL KINKS, CIRCUITS AND WRINKLES

Making a Flexible Coupler—Two-Timing Chime—A Simple Portable Aerial—An Improvised Non-Slip Screw-Driver. NOTE: The book contains numerous other useful Kinks, Circuits and Wrinkles, not listed here.

(approximately)

45 ARTICLES

(approximately)

170 ILLUSTRATIONS

68 BIG PAGES

**RADIO-CRAFT
20 VESEY STREET
NEW YORK, N. Y.**

RADIO-CRAFT

"RADIO'S GREATEST MAGAZINE"

. is the Radio
Serviceman really becoming
as obsolete as the Dodo?

"THE OBSOLETE SERVICEMAN"

By the Editor — HUGO GERNSBACK

ONE of the greatest failings of the human race, no doubt, is that we always think that the grass on the other fellow's lot is greener than ours. Likewise, for ages, the average business man has maintained that there was no worse business than his own and that every other was better. The equivalent is true of professional men.

This recalls the fable which I recounted in these pages some time ago about the Patent Examiner in the United States Patent Office of the year 1870 who resigned his official position because he had become convinced that everything worthwhile and important had been invented, and he saw no future in patents! This misguided and unimaginative individual, if he were alive today, would, no doubt, feel foolish about his prediction, because some of the century's greatest inventions were made between the years 1870 and 1900. To mention only a few, the telephone, motion picture, induction motor, X-rays, airplanes, radio, television, and thousands of other important and revolutionary inventions, were made after he made his ridiculous statement.

After this prelude, I feel it my duty to the servicing industry to publish an excerpt from a letter from a Pennsylvania reader just to hand:

"As a radio Serviceman, I am not only one indigenous to a particular town or city, but also one that has scouted around to various other cities. I can say that the profession of radio service is in a sorry state everywhere. Numbers is the cause. The great number of real 'honest to goodness' radio Servicemen, 'half-baked' radio Servicemen, 'pseudo' radio Servicemen, 'rooky' correspondence-school Servicemen, are the seat of the trouble. It is like a political situation of more candidates than voters. The set service situation in the meantime has changed, on account of the guarantee covering the time payment period, so that the large retail outlets of radio hire their own Servicemen specializing on their particular makes, with the result that independent Servicemen get only the antiques. Then finally, he catches up with practical experience on the modern sets a year or two after the dealer has released his hold on the customer's set, but only to a limited extent. The dealer is still the preferred service call, particularly if he has an up-to-date service department."

In this age of competition, every trade, every profession, every business, faces a host of problems which admittedly are not simple nor easy to overcome; and just as every business man thinks that his business is the world's worst, so the average Serviceman thinks that the Radio Serviceman is obsolete, and that he might just as well get into another business because his own holds no future.

This is exactly the same reasoning as the legendary case of the Patent Examiner of the year 1870, who thought that everything worthwhile had been invented!

The greatest trouble with the Radio Servicing Industry is not that there is too much competition, but a tremendous lack of imagination and a great lack in understanding the fundamentals of the business. Fortunately, not all Radio Servicemen think in the same vein as our correspondent. Indeed, we know of hundreds of independent Servicemen who make an excellent living and who make money year after year, despite all the imaginary handicaps cited by our correspondent. These are the Servicemen, however, who make

use not only of their opportunities, but of their imagination and intelligence plus their native American "horse sense."

Our correspondent believes that one of the greatest troubles is that the Radio Dealer gets too great a hold on the customer and thereby shuts out the independent Radio Serviceman from the picture. He forgets, first, that there are over 20 million radio sets in this country, all of which will require servicing at one time or another. A large proportion of these sets will not be serviced by the Dealers, because in many instances a Dealer did not sell them. But, even if all of the sets were thus serviced by the Dealers who sold them originally, the indictment would still be very heavy against our correspondent, because he admits that the Dealer's Servicemen are better than he is.

The local Serviceman is not worth his salt if he cannot gain the confidence of his town, since admittedly, a fair percentage of customers go to the Dealer from whom the set was bought; yet if the Serviceman has gained the confidence of his community, there is no reason whatsoever why he should not be called in when there is trouble and when a set needs to be serviced.

That is, however, only a very small part of the story. Radio Servicing, today, is not primarily concerned with radio sets in peoples' homes. Radio is far bigger than that and the Serviceman who can only see set repairing and selling a few supplies here and there, is licked from the start.

What about public address? It's as important, if not more important to the Radio Serviceman today than radio sets. The Radio Serviceman who takes no interest in sound, misses the best part of his trade. Then there are, of course, many other avenues from which an up-to-date and imaginative Radio Serviceman derives revenue today. They are the motion picture houses whose sound equipment must be serviced. Particularly in the smaller cities, it is the up-to-date Radio Serviceman who has the confidence of the motion picture houses who gets this trade, which as a rule, is quite lucrative. There are frequent installations to be made where special radio features are required. The well-to-do who require custom made or built-in radios or public address equipment are to be had in practically all towns—if you know how to get to them and talk their language. So are churches, halls, and fair grounds. Our correspondent happens to live in one of the Great Lakes' towns. In such towns we have boats galore, which require radio receiving and radio transmitter installation, now that marine radio is getting into its full swing. And what about automobile radio servicing? It is still a growing trade, and as a rule, radio sets in the smaller cities are serviced by car-radio men, not by auto dealers.

Every factory, even the smaller plants; every department store; many restaurants, can make good use of the small talk-phones, now so popular throughout the country for intercommunication work in office or factory.

Electronics, too, is in the rising tide and for the wide-awake Radio Serviceman many installations can be made for the new-type electronic radio burglar alarms, crowd-counters and dozens of other electronic applications.

So, before you become convinced that the Radio Serviceman is fast becoming as obsolete as the proverbial Dodo, it might be a good idea to take an inventory of yourself and see whether or not your seeming liabilities can become assets.

• THE RADIO MONTH IN REVIEW •

The "radio news" paper for busy radio men. An illustrated digest of the important happenings of the month in every branch of the radio field.

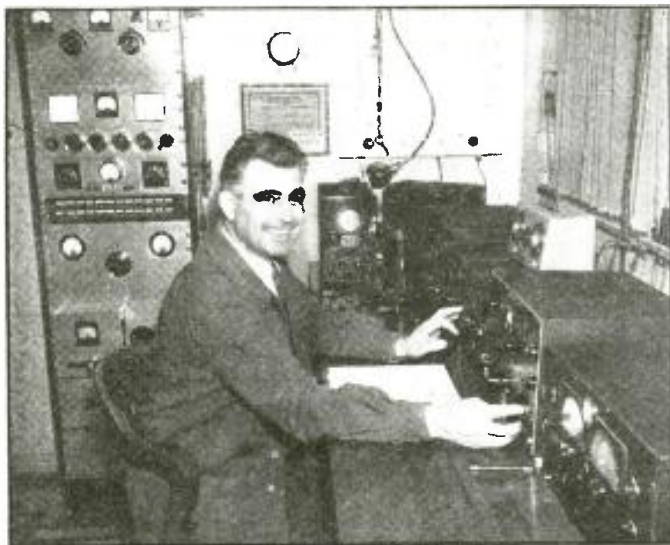

W6MBD AIDS MOVIES

Harry Leonard is 20th Century-Fox sound man and—in his spare time—a veteran amateur radio operator. Through his shortwave station W6MBD he solved the problem of contacting a motion-picture crew in far-away Argentine filming background scenes for "Down Argentine Way." After receiving an OK from the Argentine government, the crew was reached via station LU7BK, an Argentine amateur station operated by Osvaldo R. Riso Puesur, and contact maintained for 40 mins. over a 2-way radio hookup covering 7,000 miles.

TELEVISION

THE most active field of radio last month was television. All eyes turned toward the Federal Communications Commission; but occasional glances in other directions were noted here and there.

'Round-the-world flier Howard Hughes will soon headline the news when the fact sinks-in that his commercial affiliate, Hughes Productions Division of Hughes Tool Co., last month applied to the Federal Communications Commission for permission to build an 8-station California telly and frequency modulation network! Here's the lowdown on the stations, some of which are to transmit telly, some "F.M.," and some both: Los Angeles, telly sight-and-sound on 66 to 72 mc., with 10 kw.; San Francisco, ditto; "portable, area of California," telly and F.M. on 301.25 and 305.75 mc., 25 watts; Frazier Peak (Ventura County), relay telly and F.M. on 307.25 and 311.75 mc., 25 watts; Junipero Serra Peak (Monterey County), relay telly and F.M. on 319.25 and 323.75

mc.; Copernicus Peak (Santa Clara County), relay telly and F.M. on 307.25 and 311.75 mc., 25 watts; Los Angeles, frequency modulation broadcast station, 43.2 mc., 1 kw.; San Francisco, frequency modulation broadcast station, 43.2 mc., 1. kw. This West-coast general set-up roughly parallels the General Electric telly and F.M. set-up now operating on the East-coast. An important point not previously brought out by any writer (insofar as this department is aware) is the fact that a coastwise frequency modulation radio system would give U.S. listeners, in the event that any unfriendly group should attempt to jam an F.M. program, a tremendous advantage over foreign radio listeners dependent upon the amplitude modulation system which, every day, is being jammed by enemy transmitters. Next step to be taken, *pronto*, is to equip our Air, Navy and Army units with "un-jammable" F.M. radio apparatus . . .

Baseball opened the West Coast outdoor telly season last month when W6XAO, Don Lee Television System, aired pick-ups by its mobile unit of Big League Pacific Coast



THOMAS A. EDISON LIVES AGAIN!

In 2 well-done film productions, Metro-Goldwyn-Mayer immortalizes the life and work of the "Wizard of Menlo Park," Thomas A. Edison. The first of the pictures, "Young Tom Edison," has already been released. In it the boyhood of Young Tom was re-enacted with remarkable feeling by Mickey Rooney (see photo, left). The second picture of the series, "Edison, The Man," is to be released shortly. Spencer Tracy, who, as the photo above-right demonstrates, shows a striking resemblance to Mr. Edison, takes the title role. Both pictures are recommended to all science-minded people since in them are beautifully portrayed the heartbreaking trials and tribulations of a farsighted young inventor who almost singlehandedly fought a smug, self-contented world in order to introduce the many of his amazing inventions which have so radically changed our modes of living and made this a much better world in which to live. Our hats are off to Metro-Goldwyn-Mayer and both these entire casts.

baseball games at Hollywood Park. The telephoto camera viewed activities from 1st base; the wide-angle camera snagged the grandstand post. . . . F.C. Commissioner Fly: "As soon as the industry is ready to go ahead, the Committee is"; witnesses at the F.C.C. hearing: "The industry is ready to proceed as soon as it receives word from the Commission." Stalemate?

Just as a presidential election put broadcasting on its feet in 1920, so too will it get telly off its knees, it seems from the reports in Radio Daily last month that the television reporter will make his appearance at the 1940 Republican National Convention in Philly, next month. Bell Labs.' coaxial cable will pipe N.B.C.'s mobile and studio pick-ups to N.Y.C.; Philco, with its xmitter in the Friendly City, has no such problems.

SHORT WAVES

NOT since this department was first published has it recorded such encouraging news as the report, last month, that shortwave and ultra-shortwave radio may soon end the "incurable" status of trichinosis victims. The Univ. of Buffalo reported to the N.Y. State section of the American Physical Society, *Science Service* states, that radio diathermy will kill this germ (a parasite indigenous to under-done pork). Artificial fever machines soon may be set-up to send their "death rays" into the dreaded trichinosis bug before the meat even leaves the packing house. . . .

Station WBBM's shortwave listening post in Chicago now records war propaganda and newscasts from various parts of the world simultaneously. These recordings are later edited for J. O. Weaver's "Propaganda Parallel" spot. Super-Pro and Hallicrafters receivers regularly pick up the airings of Tokio, Moscow, Berlin, Paris, London and Rome, and transmissions from the Lowlands and Scandinavian countries. . . . New QRM eliminator: Lily Pons. When the wife of Andre Kostelanetz found the going tough due to ham jamming, during lengthy ham-fests with a friend in South America, Miss Pons discovered a lane through the ether could be cleared by announcing her stage name and then launching into song. . . . Last month U.P. reported that the Federal Government is anxious that people do not mistake Forest Service "smoke jumpers" for Martians, as they parachute to earth, even though they resemble "a combination of deep sea diver and grotesque figure from lands unknown." Attribute a portion of their strange appearance to the shortwave 2-way radio set they carry as part of the fire-fighting paraphernalia with which they float through the air (with more or less ease).

F. M.

JUST an old die-hard? Robert J. Rockwell, broadcasting technical supervisor at Crosley's station WLW, last month voiced the impressions of many technicians when he said (to quote *Variety*) that one reason frequency modulation programs sound more natural is that the "amplifier" (it is fairly safe to assume that Mr. Rockwell is taking into account the sideband-cutting which takes place in superhets., the I.F. channel of which is usually aligned to pass a bandwidth of about 5 kc. each side of the carrier—*Editor*) and reproducer of the F.M. receiver ordinarily is designed for high-fidelity reproduction, in contrast with the usual or A.M.-type radio set which is designed to reproduce only to about 5,000

cycles; and hence, the crumpling of paper, for example, sounds less natural when being reproduced from an "A.M." set because the timbre of paper being crumpled is mainly due to frequencies above 5,000 cycles. And the main reason F.M. is staticless and requires only low-power transmitters, is that it operates on short wavelengths; a condition equally true for A.M. programs on shortwaves. . . . Judged from some standpoints, it was startling news to learn that the sunspots, which last month raised merry hob with wire and radio communication facilities throughout the world, affected frequency modulation transmitters and receivers not one whit. . . . RCA-N.B.C. last month requested the F.C.C.'s blessings on a 5-city F.M. set-up (eventually, a chain?): Washington, Cleveland, Chicago, Denver, and San Francisco. . . . World Broadcasting System, not to be caught napping, says, please, we would like to go into New York, Chicago and Los Angeles, with F.M. . . . A green light from the F.C.C. regarding F.M. standards, etc., as the result of its 8-day inquiry, is expected during May. Major problems: commercialization of programs, channel width (desired standard is 200 kc.), high power (the boys want a top of at least 50 kw.), and a sufficient number of channels to accommodate this new baby, already crying lustily from growing pains.

RADIO ABROAD

A "COUNTER-BLITZKRIEG," just introduced for the first time in this "war of the future—today" by tiny Holland, last month helped stop a Nazi putsch dead in its tracks the first day. Radio reports that Nazi plane troop-landings were being made at given points were the signal for dashes to the respective spots by Lincoln-Mercury cars equipped with machine guns and anti-aircraft artillery that decimated the parachutists, or "men from Mars" (as one paper called the invaders) . . .

When the Vatican began to broadcast a program that was said to attack Nazi suppression of religious instruction, the program was jammed for its duration by a station "1/100th-mc. from the Vatican's frequency," a newspaper reported last month. The jamming station was said to have been the little-used German station DJW. . . .

Said Leonard Carlton, in his column, "Listening In": "Police of Ghent, Belgium, have arrested several communists charged with using a secret radio transmitter to jam French broadcasts."

BROADCASTING

RADIO, and the music world generally, lost a leading figure when Josef A. Paster-nack, 59, the noted Polish orchestra conductor, died of a heart attack last month in a rehearsal studio of the National Broadcasting Co. He had just started rehearsal for a nation-wide network program when he was stricken with the fatal attack. . . . The antipathy of "the newspaper" for "the radio" became so great some time ago that some newspapers refused to mention radio or even to print radio air programs. This hysteria has given way to reason, and the spectre which some newspapers had been nursing faded further into the limbo of nasty dreams when Princeton University last month announced its research findings. The School of Public and International Affairs of Princeton University has found upon survey that radio is increasing newspaper circulation, instead of reducing the number of readers, because people find their news

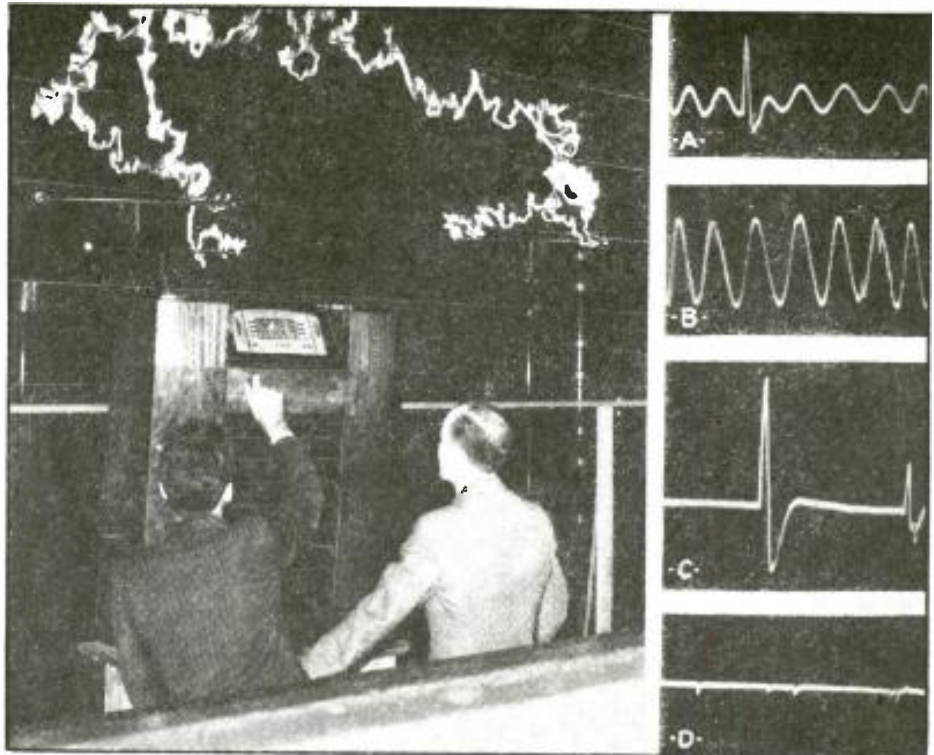

STATIC-FREE F.M. RADIO! (COVER FEATURE)

A sort of "bringing the mountain to Mohammed" test of a frequency modulation receiver's ability to reject static and receive only the program of the station to which it is tuned was conducted by General Electric Co., last month, as shown above. The G.E. set was set-up inside Steinmetz Hall, at the New York World's Fair, and the 1,000,000-volt generator set in operation. On A.M. the static crashes completely drowned-out the program that on F.M. was marred only by a slight buzz. Curves A and C at right show the effect, as seen on a cathode-ray tube, of a simulated static impulse on the R.F. and A.F. circuits, respectively, of an A.M. receiver; curves B and D show the equivalent effects in an F.M. receiver.

appetite is whetted for the extensive newspaper fare by the radio news "teasers."

GLEANINGS

PROBING Red infiltration into vital U.S. communication systems, the Dies Committee last month heard Fred M. Howe, 52, a marine radio operator and one-time secretary-treasurer of the N.Y. local of the American Communications Association (C.I.O.), testify that Communists influenced by Soviet Russia control a number of key marine radio stations ashore and afloat (including the Government station, NAM, at Norfolk, Va., as well as the communication facilities of Postal Telegraph and Globe Wireless). "In time of war they plan to tie-up these communications and help put the Soviet system over in the United States," he said, according to INS. . . . Writing in *The New York Press* (magazine), G. Harris Danzberger, an editor of a facsimile newspaper, *The Radio Press*, at

the New York World's Fair, presents an easily-understandable description of how fancy machines transmit and receive pictures, but fails to offer any arguments in favor of fancy that might help lift home fancy from the doldrums in which it now finds itself. Nevertheless, Mr. Danzberger is firmly convinced that ". . . the facsimile newspaper is as certain as radio, television, or 'wire pictures'" . . . In a newspaper story entitled "Women Fill Many Jobs in Manufacture of Radio Tubes—Vie with Men in Major Factories," it is pointed out that there are about 1,000,000 vacuum tubes in operation 24 hours a day over the Bell System's more than 94 million miles of wire lines. . . . When John F. Cassidy, leader of the Brooklyn division of the Christian Front, and 15 others came to trial in Brooklyn Federal Court, last month, 43 persons donned headphones and listened for an hour to sound recordings of alleged seditious statements which G-men said had been made by John A. Viebrock, a defendant, in the home of informer Denis A. Healy. . . . A

U.S. NO. 1 AIRPORT

LaGuardia Field, the nation's No. 1 airport, has a complete Western Electric public-address system. Here shown (encircled) are 2 of 30 specially-designed loudspeakers on the loading platform. They have a 360° area of coverage with no interference between them. A total of 85 loudspeakers, including 3 rotunda "cobra" speakers, at 15 different information centers announce arrival and departure of planes and disseminate other information. Only 1 of the 5 microphones at the ticket counters can work at a time, eliminating inter-ruptions.



• THE RADIO MONTH IN REVIEW •

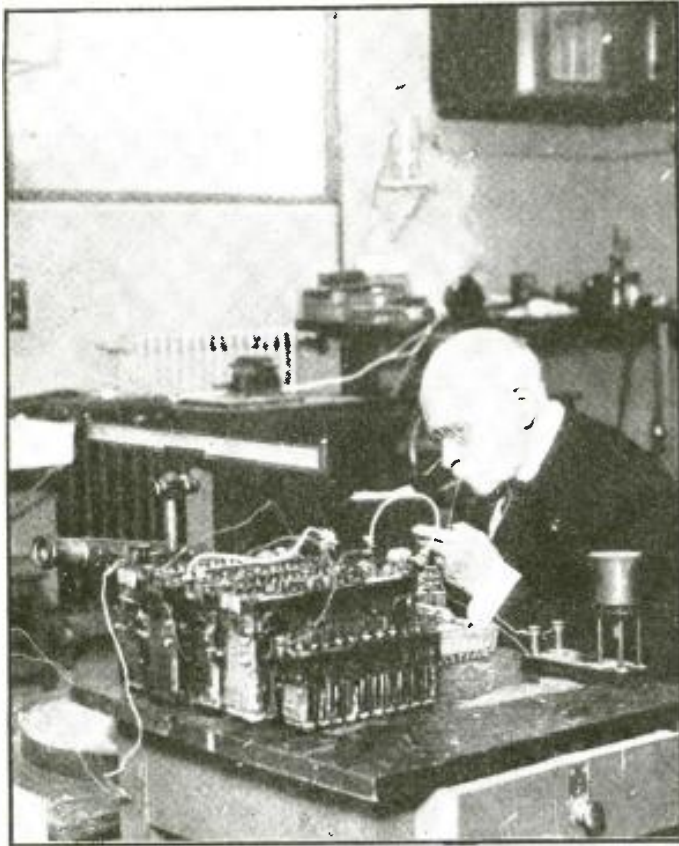

PROFESSOR BRANLY
1844 - 1940

The famous French Physicist Edouard Branly, in his laboratory, a few years before his recent death in Paris at the age of 95. Born at Amiens, Oct. 23, 1844, he lived to see radio advance from its first steps which his *coherer* (almost earliest form of detector) help it take in 1891 to its present status as an industry. Guglielmo Marconi in his well-known English Channel experiments utilized a Branly coherer. Until his death this French Savant was Professor of Physics at Catholic Institute, Paris. France has lost one of its grand old men; the radio world mourns his passing.

(Photo — Wm. Martin-Hurst; by cooperation of World-Radio [London].)

military parade down New York's 5th Ave., last month, introduced an innovation. Sidewalk observers heard via sound trucks the conversations between land officers and overhead airplane fliers.

One of the newest things in home recording equipment, the *Recordio* (see the Radio Service Data Sheets in this issue of Radio-Craft), was thrown to the lions last month and escaped unscathed. In order to exploit the uses of this Wilcox-Gay product, the local distributor made *Recordio* records of station KFEL staff members, doing their stuff on various commercials, and then aired these "Recordio-ings" over KFEL to illustrate how well home-discings made with the same equipment would sound. . . .

Lambda Lambda Mu is the name of an honorary radio fraternity at Baylor University, *Radio Daily* reports. Its membership is limited to 20 persons. (Lambda is the Greek word used to signify wavelength; Mu, micro.) . . . What effect will the Havana Treaty have on radio servicing? Well, for one thing, it's going to make a gosh-awful lot of work for Servicemen readjusting pushbutton-tuned sets. For example, when WOV in New York switched from 1130 to 1100 kc., Davega (chain radio stores) alone received 5,000 calls to "fix the buttons."

Epitaph to a swarm of bees: "Killed in action." The "action" was that of a large swarm of bees which tried to blitzkrieg a windcharger belonging to Mr. I. M. Kennedy of Moorreesburg, Cape Colony. When the smoke of battle drifted away the "charger still whirred merrily—over a pile of dead bees which couldn't learn to keep their noses out of what was none of their business. . . .

William P. Lear, well known for his development of the Lear Direction Finder, has applied his knowledge of directional radio equipment to perfect a blind-bombing device demonstrated to government officials last month. In the case of foggy weather, for example, the Lear device makes it possible for a pilot to fly blind to an enemy objective and to drop his bomb load when his stop watch indicates that the proper flight time has elapsed. The equipment is

said to consist essentially of a direction-finding loop receiver tuned-to and directed toward a radio transmitter at the home airport, and a gyro-compass.

New York police solved the problem of enforcing the "no noise" edict, in the case of radio-equipped cabs, by straddling the fence. The radio-equipped 50% of the city's 11,138 cabs must be wired through the meter (cost of each wiring job: \$2.75 to \$3.25), so that the set cannot operate unless a passenger is being carried, Commissioner Lewis J. Valentine ruled.

Taxi-fleet owners admitted that radio-equipped cabs had the best drivers, and that insurance company studies show that the radio receivers do not increase accidents (an old fallacy). . . .

MORE TELEVISION

SPEAKING before the House of Lords, in London, Lord Chatfield stated that the Admiralty had devised a telly set-up which permitted a warship's captain to watch shells falling on the enemy. The suggestion that a system which would permit an airplane to televise enemy operations and to transmit these operations to a wall-size screen at a receiving post in an airdrome or airplane carrier, however, was shelved as requiring too-heavy and cumbersome equipment. Hey, N.B.C., show them how you picked-up images and transmitted them by telly, from an airplane, a short time ago! . . . "In insisting on keeping the television art open for any and all developments and improvements, the F.C.C. is working for the best interests of television progress," Allen B. DuMont press-released last month. . . . The Du Mont system of television is 100% flexible—the receiver automatically adjusts itself to any transmitted line or frame frequency—and hence may continue for some time to plead a strong case for an independent channel. This, despite RCA's offer to the F.C.C., last month, in the hope that it would help overcome the present deadlock, that "if the F.C.C. licenses transmitters to broadcast television programs to the public on standards in addition to those

now in use, and will specify what such standards are to be, the Radio Corporation of America is prepared now to build television receivers so that they will also receive television programs from such transmitters." However it would seem that the item which we have italicized, if applied to the Du Mont system, would tend to nullify the advantage of flexibility claimed for the Du Mont system, since no change could be made in the line and/or frame characteristics of a Du Mont transmitter until the F.C.C. had granted permission to make the change, when and if the F.C.C. first established the change as a new "standard." . . . What is the cost of changing-over an "R.M.A.-standards" telly xmitter for operation on another channel? Replying to this quiz, RCA's Elmer W. Engstrom (Director of Research) told the F.C.C. last month that the cost would be about \$100,000, for a station such as the one atop the Empire State Building in New York City. . . .

FLASH: A new American telly DX record was hung up last month when N.B.C. programs from the Empire State Building in N.Y.C. were picked-up by an N.B.C. engineer in Merchandise Mart, Chicago! Details in next issue, on this 749-mile record.

Confirming this department's observation, last month, on pg. 712, that there did not seem to be much the F.C.C.'s telly re-hearings would unearth that had not been uncovered in the preceding hearing, the Radio Section of *Variety* (the entertainment world's daily) reported: "Little new factual or opinion testimony was derived from the 5 days of resumed quizzing of executives and experts." . . .

Neat wordage, in Variety, anent the telly hearings and the probability that television will be used as a political football, come election time: ". . . the suggestion of monopoly has the same appeal to a good many legislators as the aroma of roast missionary to a cannibal." . . .

Theatre-size television equipment may soon be an actuality with RCA equipment, Pres. David Sarnoff last month told the Interstate Commerce Committee. Later in the month company stockholders saw images on a 4½ x 6 ft. screen as reflected from a 16-inch concave mirror; the mirror, in reflecting the intensely-bright image from a 5-in. C.-R. tube operating at 56,000 volts, magnified the 441-line image over 20 times, the *New York Sun* reported. This expedient is said to produce the optical equivalent of an F. 0.7 projection lens but at far less cost and over 4 times the lens-speed.

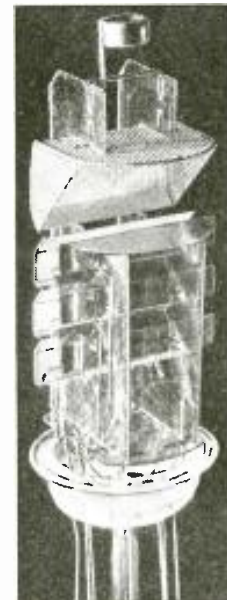

ELECTRON MULTIPLIER

Internal structure of the new Western Electric electron multiplier, electrostatically focused. This gas-filled photocell develops a far greater electrical output with a low intensity of illumination than does a standard photocell connected to an ordinary high-gain amplifier tube. In fact it has an amplification factor of about 1,000 times with the maximum plate voltage of 750. The maximum current output is about 2 milliamperes. The sensitivity is 50 ma./lumen.

REPLACING I.F. COIL WINDINGS

Last month the servicing of R.F. coils was described. This month the theory and practice of replacing I.F. coil windings is discussed in detail. These articles by a factory technician present much valuable and practical information previously unpublished.

L. V. SORENSEN

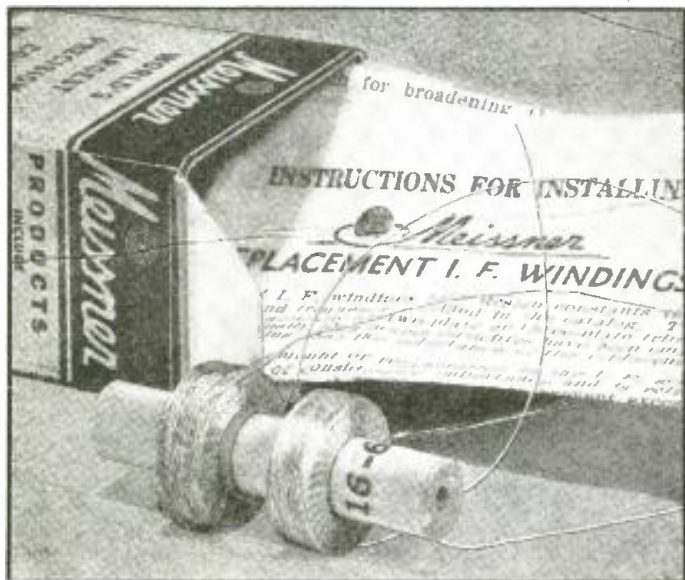

Commercially available I.F. windings fill the gap for Servicemen between the service call and the obtaining of a complete factory, exact-replacement transformer.

THERE are 2 general plans of repair procedure when an I.F. transformer fails: (1) replace the entire unit; and, (2) replace only the coil windings.

Each plan fits a definite set of circumstances but many Servicemen, failing to realize this, or hesitant to follow the most appropriate plan, have turned-out repair work with which they were not satisfied, and which in some cases did not satisfy their customers. In order to aid Servicemen to turn out the best repair job with the minimum expenditure of time and at a maximum of profit, the writer has prepared the following discussion of the problem as far as it concerns I.F. transformers, giving typical examples of trouble and showing which plan of procedure applies best.

REPLACEMENT WINDINGS

It is obvious upon comparing the price of a replacement I.F. coil winding with the price of a complete replacement I.F. transformer that the MATERIAL cost in replacing only the defective winding is less than the cost of replacing the entire transformer, yet few Servicemen can afford to replace only the coil winding when a satisfactory replacement transformer is available! The labor involved in installing and adjusting the coil windings more than offsets the difference in cost of replacement parts; however, there is a very definite place for Replacement I.F. Coil Windings.

(A) The following list gives a number of typical cases where it is better, more convenient, or more desirable to replace only the coil winding, rather than to substitute a complete and new transformer:

WHEN TO USE REPLACEMENT WINDINGS

(1) When there is no replacement transformer small enough to fit in the position occupied by the original transformer.

(2) When the shield on the original transformer has special mounting feet, brackets, shields or other structural elements attached that would be difficult to transfer to the proposed replacement transformer, or if the shield has holes, notches or other cut-outs that would require considerable labor to duplicate on the replacement transformer.

(3) Where a standard replacement transformer would look unsightly in a highly polished or otherwise ornamented custom-built receiver whose owner is particularly proud of the appearance of his set.

(4) Where the MATERIAL COST for repair parts must be kept to an absolute minimum and an extra hour of work is not prohibitive.

(5) Where the defective transformer has a circuit not available in a replacement I.F. transformer in which case it is usually possible to replace the one defective coil winding instead of searching for a complete replacement winding or complete replacement transformer.

Typical of such cases are A.F.C. discriminator transformers, delayed A.V.C. transformers with 2 secondaries, step-down ratio output transformers having the diode load across only part of the secondary, step-down ratio input or interstage I.F. transformers in which the grid has been tapped-down to obtain low gain-per-stage so that several stages might be used.

(B) DISASSEMBLY

The following information details the general rules to follow in replacing an I.F. coil winding. Some of the steps may seem obvious as the list of rules is read, but if the task of replacing a coil winding is undertaken without planning each step, it is quite possible that, as mentioned in the preceding article on R.F. coils, some necessary information will be lacking because the

defective coil was torn down without adequate inspection.

(1) The first step in preserving all possible information is to determine the position of the trimmer adjusting screw on the defective coil. This presupposes that a diagnosis of trouble can be made without disturbing any of the trimmer adjustments or that each trimmer is moved only a little from its original setting and then re-set to its original position as near as can be done by watching the position of the slot in the adjusting screw.

When the defective coil is located, its trimmer position should be noted by counting the number of turns of the adjusting screw required to run the trimmer from its exactly original setting (as indicated by the position of the slot in the adjusting screw) to its maximum-capacity setting, counting to the nearest 1/8-turn. THIS DATA SHOULD BE WRITTEN DOWN.

In some cases this data may not be absolutely necessary and in many cases is not required for a satisfactory repair, but in those cases where it is required, this data is invaluable and therefore should always be taken. Actually it takes less time to take this information than it does to read about it. It should be made a regular part of the routine of coil replacement.

(2) Make careful notes concerning the color code of the transformer leads and the terminals in the receiver to which the leads connect, then remove the transformer from the set and remove the shield can from the transformer.

(3) Draw a sketch of the coil assembly showing the winding direction of ALL coils and the terminals to which all coil leads connect. A convenient notation for showing the winding direction is to draw an arrow in such a position that it could be considered the outside turn of wire, and the point of the arrow could be considered the end of the wire.

Note that some I.F. transformers have coils wound in opposite directions, therefore checking the winding direction of only one coil is not a safe procedure! Inspect all of the coils.

(4) Examine the trimmer to determine the number of plates in each section. In most cases the trimmer sections on one base are of identical construction and capacity, but in some cases, the number of plates in one section may be different than the number in the other. Care should be taken to properly record this data so that the repaired coils may not be connected to the wrong trimmers.

(5) If the trimmer has 2 or 3 plates of ordinary size, select a replacement coil assembly that most closely approaches the specifications of the original winding.

If the secondary of the original coil has unusual connections, or is tapped at a place that is obviously not close to the center of the coil, it will save time if only the defective primary is replaced rather than to spend time trying to find or make a complete coil assembly that answers all of the requirements.

If the coil is of the band-expanding or

ARTICLE QUIZ

See if you can answer the following 5 questions before continuing with this article. The answers are given in the foregoing portions of the article identified by the respective letters:

- (A) In what instances may it be preferable to replace only I.F. coil windings rather than the entire coil assembly?
- (B) What is the disassembly procedure and proper sequence?
- (C) In reassembling the I.F. unit, what are the precautions which must be observed?
- (D) How is the inductance of the Replacement I.F. Winding adjusted to secure proper tuning characteristics?
- (E) What is the proper procedure for determining the correct degree of coupling between the respective coils to achieve proper sensitivity and selectivity (including wide bandpass)?

variable-selectivity type, see the special section in the latter part of this article concerning the repair of such transformers.

If the trimmer that tuned the defective coil has more than 3 plates of ordinary size, it probably has unusually high capacity requiring a coil of low inductance to tune properly. The procedure in replacing such coils will be discussed in a following paragraph.

(C) REASSEMBLY

(6) Having obtained the correct replacement coil, install the new winding on the trimmer so that the *winding directions of all coils agree with the winding directions of the corresponding original coils.*

(7) Connect the coil leads to the proper terminals in accordance with the sketch previously made. The notes given under the subheads **CAPACITY COUPLING** and **LITZ WIRE** will aid in doing a good job of connecting the coil assembly.

(8) Space the coils approximately the same as the original coils were spaced, temporarily fasten them in place, reassemble the transformer, mount and connect it in the receiver.

(9) Align the I.F. amplifier in the usual manner and check for sensitivity and selectivity as described in the section **ADJUSTING COUPLING**. When the selectivity and sensitivity are satisfactory, disassemble the transformer to fasten the coils permanently in place, and moisture-proof them in accordance with directions given in the section **COIL TREATMENT**.

The transformer should then be reassembled to the chassis, reconnected, and the entire set re-aligned.

LITZ WIRE

Many I.F. coils are wound with Litz ("Litzendraht"—a multiple-wire conductor, each strand being enamel-insulated) wire and consequently there must be Litz-wire replacement coils to give performance equivalent to the original coils.

Even though the Litz wire is a little more difficult to handle than a solid wire of the same cross-section, yet once the knack of it is acquired, no difficulty will be experienced. As explained in last month's article on Replacement Primaries for R.F. coils, the wire, no matter how small, can easily be cleaned of its fabric and enamel insulation by using a piece of very fine sandpaper, doubled, drawing the wire between the abrasive surfaces which have first been rubbed together to take off the initial sharpness and the high spots which tend to grab the wire. The enamel *must* be thoroughly cleaned from *each strand* or else a good joint can not be made. Solder will not stick to a few bright scratches through the enamel.

When the wires have been cleaned in the required places, the individual strands of the wire should be loosely twisted together

with the fingers and tinned with *rosin-cored solder* to form a single solid wire which is easy to attach to the trimmer terminals. If an attempt is made to attach the Litz wire without soldering the individual strands together, considerable difficulty will be experienced in trying to get all of the fine ends twisted around the desired terminals and in keeping them away from all other objects. In spite of careful work, some one of the fine ends is likely to come unwrapped from the lug and short-circuit to another terminal unless the strands are all first fastened together as described above.

(D) ADJUSTING INDUCTANCE

The ordinary Replacement I.F. Winding has been designed to work with either a 2-plate or a 3-plate trimmer of ordinary dimensions. The coils for use with condensers having more than 3 plates must be of lower inductance because of the higher tuning capacity employed.

The proper value of inductance can best be determined by comparing the adjustment of the trimmer as the set was received, with adjustment of the trimmer when the new coils are installed. If the trimmer does not have too many plates, it is probable that when the replacement coil is installed, resonance may be passed-through at a capacity setting near the minimum capacity of the condenser. Turns should be removed from the coil in groups of about 25 turns at a time (on a 456 kc. coil), followed by a "peaking" test, until the trimmers "peak" at a setting approaching the original trimmer setting. The inductance of the replacement winding is then close enough to the original value to give good performance.

Note: the coils should not be closer together than the spacing of the original coils when making the test lest over-coupling cause a double hump in the resonance curve that is immediately noticeable on a cathode-ray oscilloscope and frequency-modulated oscillator, although it may not cause difficulty with the conventional output meter method of aligning.

(E) ADJUSTING COUPLING

In the event that the replacement coils have a shape and size considerably different than the original coils, it is probable that for proper coupling on the new coils, the spacing between coils will not be the same as the spacing between the original coils. *If the coils are too far apart*, the sensitivity will be poor and atmospheric changes will cause greater sensitivity changes than when the coils are properly spaced.

If the coils are too close together, the selectivity curve will be very broad and will have 2 resonant points so that a single station may be tuned-in at 2 distinctly different dial settings close together or it may be impossible to separate 2 stations of approximately equal amplitude operating on adjacent channels.

The most convenient equipment to use for checking coupling on I.F. transformers is a cathode-ray oscilloscope and a frequency-modulated oscillator, but equally as satisfactory results can be obtained with the conventional service oscillator and output meter if a little care and patience are exercised.

The problem is to space the coils in the I.F. transformer so as to get as much sensitivity as possible without obtaining a poor selectivity curve.

When the coils are quite far apart, the sensitivity will be poor and the selectivity good. As the coils are brought closer together, the sensitivity will improve progressively while the selectivity changes but little. Eventually, however, the sensitivity will cease to improve as the coils are moved progressively closer together and the selectivity curve will begin to change noticeably near the resonance point, first becoming flat on top, then double-humped as the spacing between coils is still further reduced.

If the I.F. amplifier is of the ordinary type, the spacing should be made no smaller than that coupling which just begins to flatten the selectivity curve at resonance. In the case of band-expanding I.F. transformers, there should be no flattening of the response curve in the selective position of the selectivity control, and either a definite flattening or even double-humping in the BROAD position of the selectivity control should exist. Those Servicemen not possessing cathode-ray oscilloscopes can make the necessary tests by tuning their signal generator slowly through the intermediate frequency, meanwhile observing their output meter which should swing smoothly up to a peak and then smoothly down again in the case of a transformer with fixed selectivity; or should go through 2 maxima in the case of a band-expanding transformer in its broad condition.

In testing, it is suggested that the new coils be spaced the same as the original coils for the first test; and, that the spacing be changed 1/16-inch in whichever direction is indicated by the first test before the second test is made. If the I.F. system showed a "double hump" in its selectivity curve after alignment, the coils should be moved farther apart. Conversely, if the first test showed good selectivity, the coils should be moved closer together.

It is probable that the 1/16-inch movement is enough to go from the over-coupled to the under-coupled condition, or vice versa. If not, move the coils another 1/16-inch for the next test. If the coupling did change from under-coupled to over-coupled, or vice versa, in the first 1/16-inch movement of the coils, it is suggested that a position midway between the first and second positions be tried, which, in all probability, will be quite satisfactory for both sensitivity and selectivity.

CAPACITY COUPLING

When a circuit is drawn for an I.F. transformer, the extremely important stray capacity that exists between the plate end of the primary and the grid end of the secondary is never shown, yet this capacity has a very strong influence on the gain of the transformer.

The capacity coupling between the 2 sections of, for example a Meissner 2-plate I.F. trimmer condenser is only 0.35-mm.f. and the capacity coupling between the sections of a (Meissner) 3-plate trimmer of the same design is only 0.07-mm.f., yet this small difference of only 0.28-mm.f. makes a considerable difference in the gain of the transformer.

Similarly, it follows that capacity coupling between leads is important whether the leads are the heavy hookup wires running

• SERVICING •

from the trimmer to other points in the radio set, or the coil leads running from the coils to the trimmer terminals. These coil leads should run to the trimmer terminals in a direct manner without draping closely around the other coil in the assembly. The hookup leads likewise should run from the trimmer terminals straight past the coils to the openings in the chassis for the passage of these leads.

In triple-tuned I.F. transformers, this subject of capacity coupling is extremely important. Due care should be exercised to see that the capacity between the high-potential leads of all 3 coils is kept as low as practical by properly spacing coil leads and hookup leads.

COIL TREATMENT

The best treatment to protect radio coils against the effects of moisture and to minimize electrolytic corrosion is to cover the coil with high-quality "radio coil wax." The more wax that is used the longer is the protection against moisture, but regardless of how much is used, some moisture will get in. The most logical treatment is a thorough coating either by means of brush or by dipping the coil assembly into the wax pot, but in either case care should be exercised to see that no wax gets into the trimmer or even on the lugs thereof, for it easily creeps up the lugs into the trimmer causing high losses (poor Q) and causes the trimmer to drift badly after adjustment.

The wax, in addition to protecting the coil against moisture and corrosion also effectively fastens the coil in place on the dowel except when the set runs at a very high temperature, as in the case of some auto-radio sets, in which case the high temperature may melt the wax. In such cases, only "radio cement" or Meissner High "Q" Lacquer should be used.

BAND-EXPANDING TRANSFORMERS

Band-expanding I.F. transformers usually have 3 windings; 2 are the main tuned circuits and are about the same size as the coils in standard I.F. transformers. In series with 1 of these windings is a relatively small number of turns of wire wound under, over, or adjacent to the other main winding. These few turns, closely coupled to the second winding, furnish the extra coupling required to produce a broad selectivity curve.

These turns are so few that they can easily be counted and if it is necessary to replace 1 of the main windings on such a transformer, the required number of turns of wire (No. 36 D.C.C. is satisfactory if Litz is not available) can be wound over or adjacent to the required coil. If these few turns were initially wound under one of the main windings a satisfactory repair can be made by winding an equal number of turns beside the coil as close to it as convenient. Extreme care must be exercised to see that the winding directions are correct and that the coil ends are connected to the proper terminal or else the transformer will not "expand" properly.

This article has been prepared from data supplied by courtesy of Meissner Mfg. Co.

The next article, appearing in August *Radio-Craft*, will discuss the problem of replacing I.F. transformers.

CONCERNING Fig. 3, page 752, 1940's **PORTABLES**, the values of the following parts in the Majestic MODELS 5BD and 5BDR diagram are:

(1) volume control potentiometer, 0.3-meg.; (2) fixed condenser shunting the volume control potentiometer, 250 mmf.; (3) dropping resistor in series with heater (filament) of the type 70L7GT tube, 300 ohms, 2 watts, wire-wound.

SHOW PREVIEW 2 OF 22 NEW MODELS

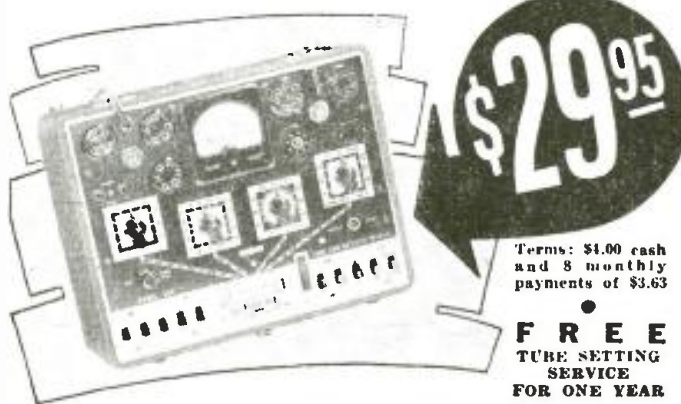

Terms: \$1.00 cash and 8 monthly payments of \$3.63

FREE
TUBE SETTING
SERVICE
FOR ONE YEAR

IN producing Model 589 there has been no compromise in the circuit design or materials. The same manufacturing methods, careful inspection and accurate calibration is incorporated in this instrument as in all other SUPREME testers. It will pay you to investigate and see this tester before you buy. Its price is the lowest at which a GOOD tube tester can be built.

MODEL 589 TUBE AND BATTERY tester has a completely modernized circuit. The tube test sockets are not wired directly to the circuit, but, instead, pass through the patented SUPREME Double Floating Filament Return Selector system which automatically re-connects all tube elements to any possible tube base arrangement. Due to the fact that any or all elements of each socket can be rotated to any desired position, only one socket of each type is necessary. Tests every type of tube from 1.4 volts to full line voltage at its correct anode potential under proper load. Tests separate sections in multi-purpose tubes. Checks all leakages, shorts, open elements and filament continuity with a neon lamp. A circuit insert is provided for checking noise, leakage, loose and bad connections. The battery testing circuit of the Model 589 provides the proper load at which each battery is to operate, plainly marked on the panel, for all 1.5, 4.5, 6.0, 45 and 90 volt portable radio types. The condition of the battery is indicated on an English reading scale.

This is the fastest and easiest tester to operate. Just "follow the arrows"—you can't go wrong. Roller type tube chart with brass geared mechanism lists tubes in logical numerical order. Each tester carries a one year free tube setting service. SUPREME engineering and construction PLUS the best materials the market affords, make the 589 your biggest dollar value. You will be proud to own this instrument.

MODEL 599 TUBE AND SET TESTER is very similar in appearance to the Model 589, and includes all the features and advantages of this instrument. In addition, it provides the following ranges:

0.2 TO 1500 D.C. VOLTS—5 carefully selected ranges—0/6/15/150/600/1500 volts. 1000 ohms per volt STANDARD sensitivity.

0.2 TO 600 A.C. VOLTS—4 A.C. ranges—0/6/15/150/600 volts. Rectifier guaranteed with instrument and fully protected from overload damages. **0.2 M.A. TO 600 M.A.**—3 direct current ranges 0/6/60/600 allow measurement of screen, plate, "B" supply and D.C. filament loads.

0.2 TO 600 OUTPUT VOLTS—0/6/15/150/600—ideal for alignment. No button to hold down—no external condenser necessary.

0.1 OHM TO 20 MEGOHMS—4 ranges 0/200/20,000 ohms, 0/2/20 megohms. A low range at high current with 3.5 ohms center scale.

ELECTROSTATIC—ELECTROLYTIC LEAKAGE TEST—Sensitive calibrated 20 megohm range provides excellent leakage test of paper and electrolytic condensers.

Just as the 589 is your best value in a tube and battery tester, the 599 is your best value in a combination tube tester, battery tester and set tester. Remember, you have all the features of the 589 PLUS a complete A.C. DC volt. ohm, megohm, milliammeter, at a cost of only 47c per range.

Dealer Net Cash Price

\$39.50

Terms: \$4.50 cash; 9 payments of \$4.33.

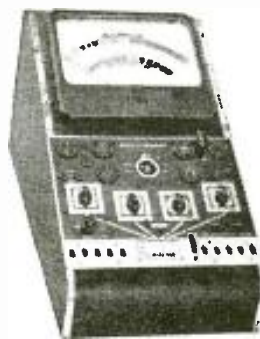

Illustrated above is the Model 589 in a counter type metal case. This model is available with option of 7" or 9" illuminated meters. Has two neon lamps for sensitive or super-sensitive tests.

SUPREME

SUPREME INSTRUMENTS CORP.
GREENWOOD, MISSISSIPPI, U. S. A.

SEE US AT THE PARTS SHOW
BOOTHS 821 AND 823

Metal cabinets as illustrated for the Model 589 at left and 599 above are identical—can be used either in a horizontal position or vertical position by merely reversing the instrument panel. Write for information.

A NEW BOOK ON PUBLIC ADDRESS

An important announcement about the greatest book on the subject of sound and allied subjects appears on Page 52 of this issue. **TURN TO THE ANNOUNCEMENT NOW!**

Simplest WAY TO REPLACE **BALLASTS**

4 STANDARD TYPES of Amperite Regulators replace over 200 types of AC-DC Ballast Tubes now in use. . . . Has patented automatic starting resistor.

List \$1.00

WRITE FOR REPLACEMENT CHART "S"
Amperite Co., 561 Broadway, N. Y. C.

AMPERITE

FREE!

THE HAMMARLUND RADIO CATALOG

HAMMARLUND NEW "40" RADIO CATALOG

The latest Hammarlund catalog with complete data, illustrations, drawings and curves on the entire Hammarlund line. Address Department RC-74 for your free copy.

HAMMARLUND MFG. CO., INC.
424-438 West 33rd Street, New York City



A—Spraying the rewound coil; B—rewound coils ready for electric oven (rear); C—potting rebuilt A.F. units.

REBUILDING TRANSFORMERS IS PROFITABLE

Radio men can save money by having transformers rebuilt to modern performance standards that incorporate latest improvements.

THOMAS A. GROSS and ARTHUR A. LINK

It has always been customary to *rebuild* large industrial and broadcast transformers but until recently no service has been offered to the user of small transformers. However, one manufacturer has developed methods to rebuild power and audio transformers, and choke coils, which usually surpass their original performance and allow new applications. Hence, by "rebuilding" we do not mean merely repairing a defective transformer but actually redesigning it to incorporate the latest materials and engineering developments.

Of course, winding individual coils is more expensive than making them by standard production. *The saving is effected by making use of the laminations and casing.*

Fortunately lamination dimensions are standardized among the manufacturers, and stock mandrels and insulation can be used for rebuilding, thus lowering somewhat the expense of the winding of special coils. As for the actual laminations, only the worst of these are subject to aging.

"Aging" means the loss of the laminations' original properties due to changes in the molecular structure of the material. In the cheaper grades of silicon steels having less than 2% silicon the hysteresis losses become larger after a few years. Electric motors and cheap power transformers generally use core materials having 2% or less silicon content.

The other core losses are due to eddy currents flowing through the lamination

stack. To reduce this effect the core is laminated to present as high resistance as possible to the eddy currents. The quality of a transformer can be in part estimated from the thickness of the laminations. Number 29 gauge (0.014-in.) is excellent; while No. 24 gauge (0.025-in.) is about the worst used in present-day transformers.

In general the quality of transformer laminations 5 years ago was superior to the quality today as competition among manufacturers has tended to lower the standard used.

RECENT DEVELOPMENTS IN TRANSFORMERS

Transformer manufacturers have kept pace with the industry by developing new designs to work with new tubes and circuits. But more important has been the progress made in using new materials and engineering improvements in the manufacture of transformers.

Each manufacturer keeps the formulas for the materials he uses, as a closely guarded secret, however there are some significant developments which might be mentioned.

The most spectacular innovation in recent years is *glass insulation*. This material which is known as "Fiberglas" has properties impossible to find in organic insulations. This material is now used for magnet wire insulation and in tape form to separate layers of wire in transformers. The tem-

perature resistance compares favorably with that of asbestos yet has much greater strength and electrical resistance. We have tested transformers made of this spun glass and find that they do not burn out before incandescence! This material is costly however and it is therefore used only on the better grades of transformers. Other new materials which have tremendous importance include improved insulating varnishes and potting materials.

Insulating varnishes play a very important part in maintaining the life of a transformer. They must be excellent insulators, impervious to moisture, chemically stable and their solvents must not dissolve the enamel insulation on the wire. The grade of varnish used has an important bearing upon the performance and the price of the transformer. It is interesting to note that black varnishes rate about 30% better in both electrical resistance and mechanical durability. The introduction of black varnishes has made possible the production of high-voltage transformers more economically. A few years ago, for example, Neon sign transformers burned-out because the ozone created by the high voltage, reacted with the varnish, producing nitric acid which attacked the wire.

The choice of *potting compounds* depends largely upon the type of transformer used. Power transformers require a potting compound which has a clay filler to conduct heat away rapidly. High-voltage transformers must use compounds having a rubber base for insulation. Audio-frequency transformers must use expensive compounds which will not attack any of the materials used in the unit. The selection of potting compounds often involves as many as 30 specifications to insure perfect results.

We mentioned the problems of the manufacturer, to insure the greatest possible performance, to give you an insight as to the care which enters into a transformer.

Considerable progress has been made in engineering as well, but few of these developments have been used because of the market demand for cheaper transformers. Occasionally however there have been ideas which at the same time lower costs and improve performance. Rebuilt transformers can be made to incorporate these new ideas in design as well as the latest materials.

A winding machine designed especially for coil rebuilding differs from those used on regular production jobs by having in-

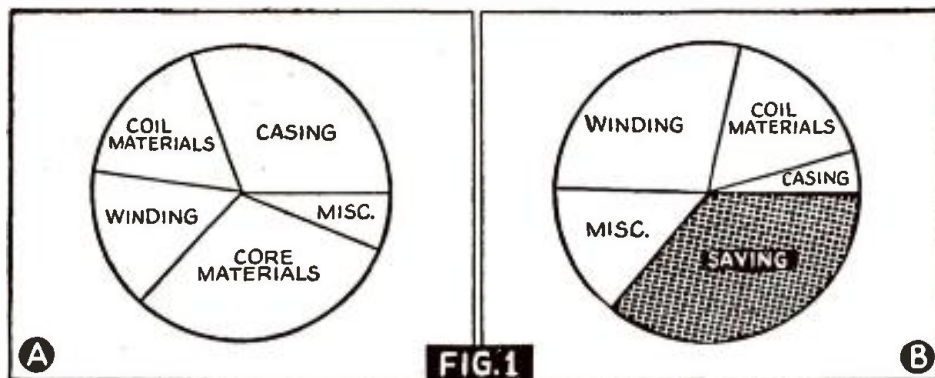

The production expenses averaged over a large number of transformers of varied types are shown in pie diagrams A and B. The proportions for new transformers are given by A; and B shows the cost for rebuilding. The shaded area represents the saving made possible by rebuilding. Note that the winding and miscellaneous costs are considerably greater for rebuilt transformers but that the core and casing more than make up for the difference.

SERVICING

dividual motors, revolution counters and speed controls (see Fig. A).

TECHNICAL CONSIDERATIONS

Not all transformers and chokes use the same materials in their laminations. What is used for a filter choke would not be suitable for an audio transformer. In the former the core materials must work well under high permeability and A.C. flux densities whereas in A.F. transformers the core must have a high permeability at very low A.C. flux densities. The problems in determining whether a given type of core material is suitable for a given application are very involved so we have prepared Table I which shows what your old transformer can be made into.

TABLE I—POSSIBILITIES FOR REBUILDING TRANSFORMERS

Original Service	Possible Rebuilt Designs
B.C. Power Smoothing Chokes;	Same as left-hand column
Other Cheap Power Trans.	
Swinging Chokes	Same, and Modulation Transformers not Having D.C. in Secondary
High-Quality Smoothing Chokes	Same as Original or Modulation Transformers, Swinging Chokes, Power Transformers
Modulation Transformers Not Designed for D.C. in Secondary	(Same as original, Plus)— High-Grade Power, Large Audios, Swinging Chokes
Modulation Transformers (D.C. in Secondary)	(Same as original, Plus)— Power, Smoothing Chokes, Audio Outputs
High-Quality Audios	(Same as original, Plus)— Audio Equalizers, Filters, Modulation Transformers with no D.C. in Secondary
Audio Outputs and High-Quality Power	(Same as original, Plus)— Modulation Transformers with D.C. in Secondary

This table does not include all of the possibilities. For example it is frequently possible to make a swinging choke into a modulation transformer designed to carry D.C. provided that the laminations are so shaped that an air-gap can be made. Needless to say there are limitations due to power ratings. A 50-watt modulation transformer cannot be made into a 500-watt power unit.

CONCLUSION

The purpose of this article is merely to suggest that you investigate the possibilities of transformer rebuilding. Some radio service shops throw away hundreds of dollars worth of valuable transformers just because the windings are burned-out. No one would think of throwing away a burned-out motor; and yet, the advantages are even greater in the case of transformers.

There are probably several transformer companies in your locality (if you live in a city) well able to handle all of your repair jobs. If not, your editor can probably send you a list of manufacturers equipped to handle transformer rebuilding.

This article has been prepared from material supplied by courtesy of Electronic Applications.

TWO NEW INSTRUMENTS

AT RECORD-BREAKING LOW PRICES

THE NEW MODEL 1230

SIGNAL GENERATOR

with FIVE STEPS of SINE-WAVE AUDIO

SPECIFICATIONS

RADIO FREQUENCIES from 100 K.C. to 90 Megacycles in 7 bands by front panel switch manipulation. All direct reading and accurate to within 1% on I.F. and Broadcast bands. 2% on higher frequencies. The R.F. is obtainable separately or modulated by any one of the five Audio Frequencies.

AUDIO FREQUENCIES: 5 steps of SINE-WAVE audio 200, 400, 1000, 5000 and 7500 cycles; WITH OUTPUT OF OVER 1 VOLT. Any one of the above frequencies obtainable separately for servicing P.A. hard-of-hearing aids, etc.

ATTENUATOR: Late design, full-range attenuator used for controlling either the pure R.F. or modulated R.F.



CIRCUIT: The Model 1230 employs an improved electron coupled oscillator circuit for the R.F. affording positive protection against frequency drift and a Hartley oscillator circuit for the A.F. section.

DIAL MANIPULATION: Large 5 1/2" dial etched directly on front panel, using a new mechanically perfected drive for perfect vernier control.

APPEARANCE: The front panel is etched by a recently perfected process which results in a life-long attractive finish and the instrument comes housed in a streamlined shielded cabinet.

CURRENT SOURCE: The Model 1230 operates on 90 to 130 Volts A.C. or D.C. any frequency.

The Model 1230 comes complete with tubes, shielded cables, molded carrying handle and instructions. Size 14" x 6" x 11". Shipping weight 15 pounds. Only **\$1285**

THE NEW MODEL 1220

WORLD'S LOWEST PRICED

5000 OHMS PER VOLTER!!

Extremely valuable because of its high sensitivity, the Model 1220 is an all-purpose tester that permits resistance measurements up to 3 Megohms, with only a 3 V. self-contained flashlight battery and reads directly down to 0.2 ohm.

SPECIFICATIONS

- * 6 D.C. Voltage Ranges: 0-3-10-50-250-500-5,000 volts
- * 3 A.C. Voltage Ranges: 0-15-150-1,500 volts.
- * 4 Resistance Ranges: 0-3000 ohms, with 15-ohm center, direct reading to 0.2 ohm; foregoing base range multiplied by 10, by 100 and by 1,000, to read up to 3 Meg. with self-contained 3 V. flashlight battery.
- * 4 D.C. Current Ranges: 0-200 microamperes; 0-2-20-200 milliamperes, using wire-wound shunts.
- * 3 Output Meter Ranges: Same as A.C. Voltage Ranges.
- * 3 Decibel Ranges: From -2 to +58 D.B., based on .006 watt in 500 ohms.
- * Uses full-sized 3" square 0-200 microammeter, with 2% accuracy and finely damped movement, contained in a handsomely designed, square molded Bakelite case.



Model 1220 comes complete with cover, self-contained battery, test leads and instructions. Only...

\$1045

SUPERIOR INSTRUMENTS COMPANY

136 Liberty Street

Dept. RC-7

New York, N.Y.

IN A CLASS BY ITSELF!

Hot in 1 1/2 minutes. Designed by experts of thermostatically controlled devices, Excellent for radio repairing and similar light work. Listed by Underwriters Labs. Pat. Applied For. Send for Circular.

VANATTA MFG. CO.
ONTARIO, CALIFORNIA

KWIKHEAT

AUTOMATIC

CAN NOT OVERHEAT
IF LEFT ON CONTINUOUSLY



SOLDERING IRON

GET A REAL ELECTRIC SHAVER ABSOLUTELY FREE!

Complete details as to how it is possible to get a Real Electric Shaver FREE, appear on Page 48 of this issue. TURN TO IT NOW!

SOLAR RED-CAPS
Smaller Diameter Dry Electrolytics

SPEED Servicing

Write for Catalog

SOLAR MFG. CORP. Bayonne, New Jersey

WRITE TODAY ABOUT YOUR

FREE, INDIVIDUAL ADVICE ON SPECIAL OR STANDARD AMPLIFIERS

AMPLIFIER CO. OF AMERICA

17 WEST 20th STREET, NEW YORK, N. Y.

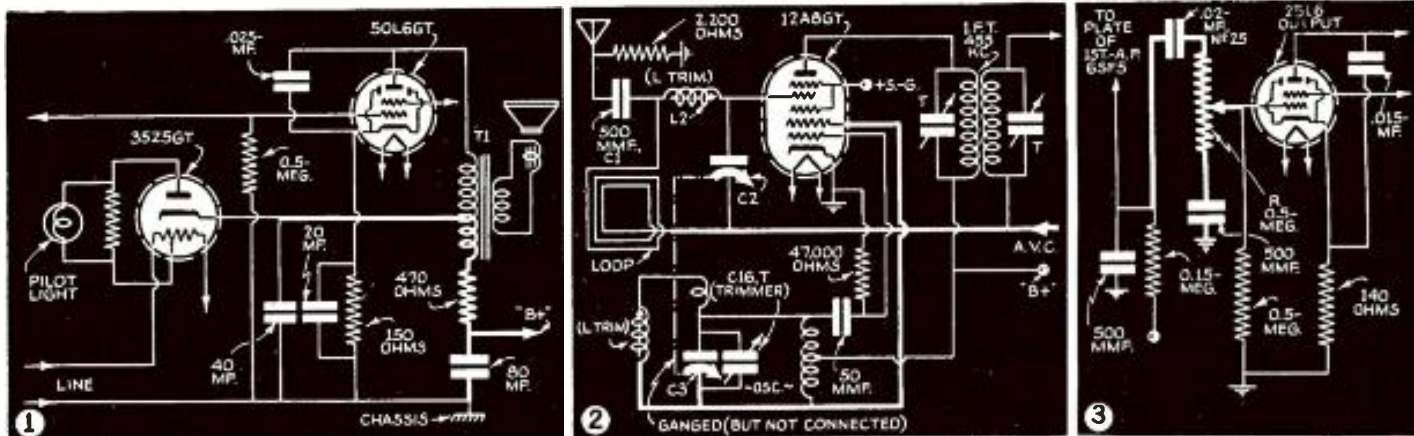

NEW CIRCUITS IN MODERN RADIO RECEIVERS

In this series, a well-known technician analyzes each new improvement in radio receiver circuits. A veritable compendium of modern radio engineering developments.

F. L. SPRAYBERRY

No. 34



(FIG. 1.) NEW CIRCUIT USES OUTPUT TRANSFORMER AS PART OF FILTER

RCA MODEL 5Q66.—Many of the advantages of push-pull operation, using only one output tube in addition to improved filtering by phase opposition rather than brute force, and higher plate voltages are achieved by this circuit.

The new output filter circuit is shown in Fig. 1. The D.C. components in the primary of T1 form fields of opposite polarity, and although not equal, the net field is equal to their difference which is small compared to the usual circuit. This means that a smaller transformer can be used; or that with the usual transformer saturation is less likely.

Any hum component in the signal of the 50L6GT plate circuit is canceled by an equal reverse phase component in the lower-half of the primary transformer T1. The 470-ohm series resistor acts as a filter; and also dissipates the power due to the signal voltage generated in the lower-half of the primary of T1.

This circuit represents the first substantial advance made in output and filter circuits for A.C.-D.C. sets since their introduction.

(FIG. 2) COMPLETELY-ISOLATED GANG TUNING CONDENSERS

SILVERTONE MODELS 6407A, 6408A AND 6409A.—The rotors of the 2-gang condenser

used in this set are neither grounded nor connected to each other electrically.

The 1st-detector—oscillator circuit of these receivers is shown in Fig. 2. Through this complete isolation of both condensers, the A.V.C. isolation and filter condenser is not needed, and the cathode of the detector—oscillator may be operated at ground potential even though a tapped-coil design of oscillator circuit is used. For this type of circuit, however, the tuning condensers must be completely shielded chiefly to prevent detuning effects through body-capacity. The tuning range is increased slightly and the circuit is simplified.

(FIG. 3.) SERIES-PARALLEL TONE CONTROL

CROSLEY MODELS 739, 7739, J-739 AND J-7739.—A more effective, wide-range tone control having a series and a shunt element is used in these receivers.

The circuit in Fig. 3 shows the tone control to be composed of the coupling unit (0.02-mf.), the potentiometer R, and the 500 mmf. condenser. The coupling condenser may be regarded as part of the series element of the tone control because its value with that of the potentiometer determines the upper frequency limit of the signal which can be fed to the power amplifier grid.

The coupling condenser (item 250.02-mf.) and the part of R between it and the slider forms the series tone control element.

The greater this resistance value the greater is the circuit discrimination against the passage of high-frequency energy. This resistance, by limiting the charging current of the coupling condenser (0.02-mf.) progressively increases the signal drop across it as the frequency is increased, and as the resistance is increased, or both.

The potentiometer between the slider contact and the 500 mmf. condenser forms the shunt tone control element which of course, bypasses increasing energy of the signal circuit to ground as the frequency is increased. However, for any setting of the tone control there is far less energy loss and less change in grid input impedance of the 25L6 tube than for the ordinary shunt-type tone control. This tone control has practically no effect on the total signal energy or total volume. This action is made possible through the series limiting action and favorable selection of capacity for the shunt element.

(FIG. 4.) SAME TUNING INDICATOR USED BOTH FOR AMPLITUDE AND FREQUENCY MODULATION RECEPTION

STROMBERG-CARLSON MODEL 455.—An ordinary electric eye 6U5 or 6G5 tube is used for resonance indication in the usual way for amplitude modulation and in a similar way for frequency modulation reception.

As will be seen in Fig. 4, the control-grid of the 6U5/6G5 tube is switched to the

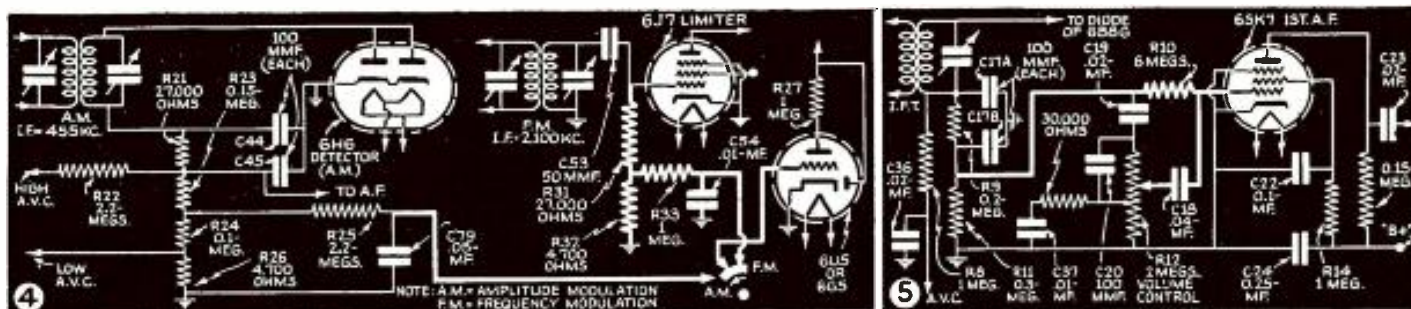

SERVICING

A.V.C. circuit when amplitude modulation reception is desired; but it is switched to a resistance network in the limiter grid-return for indicating resonance of frequency modulation signals.

The limiter control-grid has no bias and of course grid rectification will start as soon as any signal is received. Within practical limits the negative voltage at the point of contact to the tuning indicator grid will be proportional to the I.F. carrier at this point in the circuit. If the frequency modulation I.F. bandwidth is comparable to the total carrier frequency swing the tuning indicator will indicate the correct resonance accurately. If the I.F. band width is larger than the total carrier swing and the discriminator is linear over the entire I.F. band the resonant point will be broad but reception will be good for any full resonant indication of the electric eye. When a sufficient part of the I.F. carrier swings beyond the I.F. band to cause unsatisfactory receptions the indicator will also show an off-resonance condition due to decreased averaged carrier strength.

(FIG. 5.) A.V.C. EXTENDED TO AUDIO AMPLIFIER INPUT

TRUTONE MODELS D1091 AND 6C143.—Using a 3-stage high-gain audio amplifier, this automotive receiver extends the A.V.C. action to the 1st A.F. amplifier to give a more uniform output with less critical action of the volume control.

The audio input makes use of a 6SK7 tube with a separate A.V.C. connection from the detector diode return as in Fig. 5. This is the only bias furnished to the 6SK7, and is supplied through a 6-meg. series resistor. A minimum signal will bias the tube sufficiently to handle all of the A.F. component available at the volume control. Maximum output of the audio-frequency amplifier is achieved at about 2 volts on the 6SK7 control-grid which means that the distortion will be negligible for practically any bias of the grid in the range provided by this circuit. Having a more sensitive A.F. amplifier than in the ordinary circuit this receiver can make use of a greater part of the full sensitivity of the high-frequency portion of the set.

PORTABLE MIKE STAND

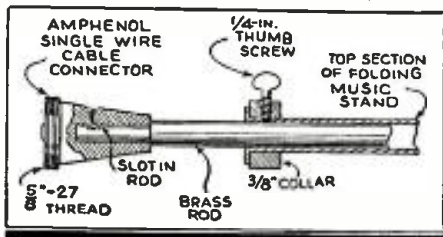

● A GOOD mike stand for portable P.A. systems can be made from a folding music stand, which can be bought for less than a dollar, if you don't have one.

Drive a tapered punch into the end of the top section of tubing, to remove the dent which holds the music table in place. Ream out an ordinary shaft collar to a snug fit and drive it up to the shoulder on the top section. Substitute a thumb-screw for the set-screw. Take a piece of brass rod the same length as the tubing sections and of sufficient diameter to slip easily into the last section. (This is usually 5/16-inch.) Dress-down one end of this rod to fit into the cable opening of a single-wire mike connector and set the set-screw tightly.

This stand will extend to almost 6 feet and folds up to about 18 inches, and will fit all mikes with standard 5/16-inch mountings.

E. H. DISNEY,
Lowry City, Mo.

N. U. SIXTY DAY SPECIAL

Limited May 1 to June 29

DACO TUBE TESTER

MODEL 303 P5 FEATURES

- Enclosed in Portable Leatherette Case
- Extra Large, Full Vision Meter
- Standard R.M.A. Circuit
- Snap-Switch Control
- Neon Short-Leakage Test
- All Filament Voltages from 1 to 117 Volts
- Provisions for Latest Tube Types
- Spare Sockets for New Types, Preventing Obsolescence
- High Quality Parts Used Throughout
- Complete, Easy Reference Tube Chart
- Ruggedly Constructed Throughout
- Simplified Operation
- Tests Pilot Lights
- Tests Ballast Tubes

SEE YOUR N. U. DISTRIBUTOR OR SEND COUPON GET IT FREE THE N. U. WAY

You get this Daco Model 303 P5 Tube Tester by depositing only \$12.00 with your N.U. distributor. By buying N.U. Tubes, Condensers, and Batteries, you earn purchase points and on completion of 650 purchase points in 2 years, your deposit will be rebated. Join thousands of other N.U. dealers; have the best equipped shop in town. Over 50,000 completed deals in our 10 years of successful operation of this plan.

NATIONAL UNION RADIO CORPORATION
57 State Street, Newark, N. J.

RC-740
NATIONAL UNION RADIO CORPORATION
57 State St., Newark, N. J.

- Please reserve one for me.
 Please have your salesman show it to me.

Name

Address

City State

WARNING TO RADIO-CRAFT READERS

Radio-Craft has no representatives in the field soliciting subscriptions, in the "door to door" fashion. Pay no money to any person who comes to your home, store or service shop and represents himself as being an agent for Radio-Craft. Subscriptions may be safely obtained only from authorized subscription agencies, whose names we shall be glad to furnish, or directly from us by mail. Address your letter to Subscription Dept., Radio-Craft, 20 Vesey St., New York, N. Y.

PATENTS—TRADE MARKS

Booklet concerning Inventions & Patents
Form "Evidences of Conception" with
instructions for use and "Schedule of
Government and Attorneys Fees"—Free

LANCASTER, ALLWINE & ROMMEL
Registered Patent Attorneys

436 Bowen Bldg. Washington, D. C.

YOU ARE WELCOME

to one of our fine Illinois Time-Tested
Tubular Paper Condensers, free and
postpaid, if you'll just send us the
name of your jobber. Write NOW!

ILLINOIS CONDENSER CO., Inc.
1160 N. Howe St. Chicago, Ill.

WILCOX-GAY MODEL A-70 "RECORDIO" (Chassis Model 9J9)
HOME RECORDER RADIO-PHONOGRAPH

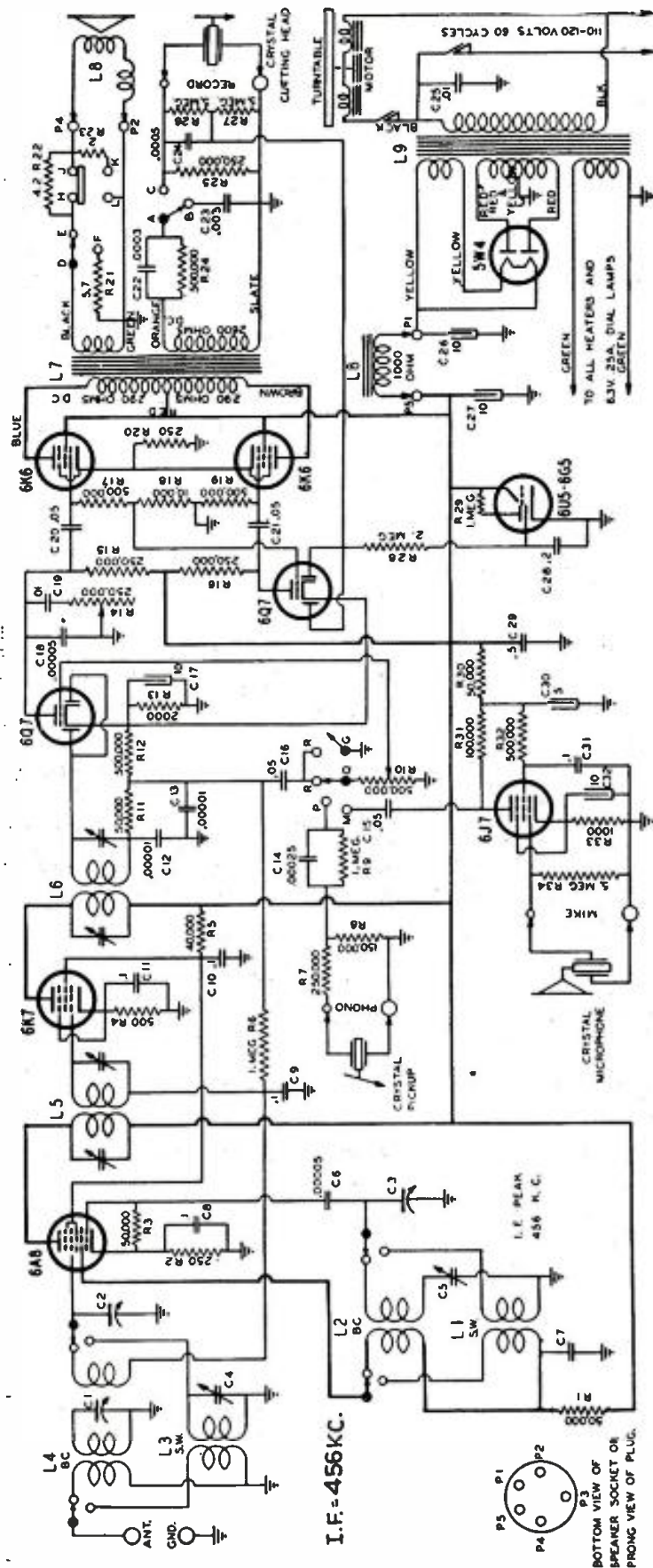

9-Tube Superhet.; 2 Bands (Broadcast and Foreign Short-wave); Visual Tuning Indicator; Automatic Volume Control; Crystal Microphone; Crystal Phono Pickup; Crystal Cutting Head; Pushbutton Switchover.

See Data Sheet 280 for additional data.



VOLTAGE CHART (Model A-70 "Home Entertainer" type Recordio)

Chassis Model 9J9—Recordio A-70

Line Voltage115 Aerial disconnected.
P1 to GND.360 All voltage measurements
P5 to GND.260 made against ground (chassis)
P1 to P5 (spkr. field)—100 :is) except as noted.

Tube	Position	Plate	S.-G.	Cath.
6A8	1st.-Det.	260	80	2.8
	Osc.	260		
6K7	L. F.	260	80	3.8
6Q7	2nd.-Det.	100*		1.8
6Q7	Inverter	100*		1.8
6J7	Mike Amp.	35 to 60*	35*	1.3
6K6	Output	250	260	17.5

NOTE: This is a typical voltage analysis made by use of standard 1,000 ohms/volt meter, using the 300-volt scale for plate and screen-grid voltage readings.

*Not actual voltages due to large values of resistance in circuit between supply voltage and point of measurement. These voltage values may vary considerably, depending upon the resistance of voltmeter used.

The above voltages should be considered as being approximate, as difference in line voltage, type of testing equipment used, normal tolerance limits of component parts in the chassis, all have an effect upon these readings. A tolerance of 10% is usually considered permissible.

The crystal devices used with RECORDIO (cutting head, playback cartridge, microphone) function with greatest efficiency when operated at normal room temperature.

If operation of these units is attempted while cold, the low audio frequencies will be noticeably predominant and a slight loss of volume will be noticed. Also in playing records, either commercial or home recordings, a pronounced rumble may accompany the reproduction. This is due to the "stiffness" of the crystal unit and its mounting within its cartridge while cold.

Extremely low temperatures have no effect upon the crystal units other than noted above.

Extremely HIGH temperatures, however, do have a detrimental effect upon the crystals. These crystal units should never be subjected to temperatures greater than 120° F. The crystals begin to soften at 125°, and will be permanently damaged under these conditions.

ALIGNMENT.—An OUTPUT METER or other indicating device should be used for accuracy in making ganging adjustments.

If an output meter is not available, the indicator eye (6U5) may be used as an output indicator as follows:
(a) Depress pushbutton No. 4 "To Record Radio".
(b) Disconnect cutting-head from chassis.
(c) Adjust volume control to near maximum.

(Continued on Data Sheet 281)

•SERVICING•

Service Questions & Answers

HUM

(164) J. J. Chatman, Monroe, Louisiana.

(Q.) I have a Westinghouse model WR310. It plays good, that is, with a fair volume, on our local station, but when the aerial is connected it has a loud 60-cycle hum. The filter condensers are good and I substituted the screen-grid and bypass condensers but the results were the same on the broadcast stations. However it picks up foreign stations very well and without any hum. Plate and screen-grid voltages are normal.

(A.) The hum which you describe is usually termed modulation or resonance hum. In most cases, this condition is produced by insufficient capacity of the input filter condenser, or an open-circuited line filter or bypass condenser. Should these components check satisfactorily, direct your attention toward leaky grid filter condensers in all A.V.C.-controlled tubes. Employ the substitution method to test these condensers. Try a good ground connection. In some cases, a 100-mmf. antenna series condenser or a 10,000-ohm carbon resistor connected across antenna and ground has helped.

INTERMITTENT

(165) Marion Asher, Pawnee, Ill.

(Q.) I have a Philco, chassis type 60. While playing it snaps off at most any time and sometimes can be brought back by snapping the switch off and on. It will come back to normal every time the cap of the type 78 tube is touched. I have had the tubes tested and all are OK. Please advise me where to look for the trouble.

(A.) An open-circuiting screen-grid bypass condenser, Mr. Asher, is the usual cause for the condition described. However, any of the bakelite-encased units may produce the trouble. Check each bypass unit by picking at the pigtailed emerging from within the case, while the receiver is operating or in operating order.

DISTORTION

(166) David Cernicky, Belle Vernon, Pa.

(Q.) I'd like to have some information on a Majestic Model 15 radio set. I have checked all tubes and they all seem to be OK. Yet when the set came in for repairs it was dead. It had a shorted 0.1-mf. condenser bypassing the 2,000-ohm resistor in the plate circuit of the 1st type 24A tube. I also replaced the 2,000-ohm resistor. The type 80 tube was weak so I replaced it.

Now when the set is turned on it plays OK for a few minutes and then distortion sets in accompanied by a small hum. I have checked all resistors and condensers, and also went to the extent of replacing each unit, but still the same conditions persist. I changed both filter condensers at the same time but this had no effect on the operation of the set. I also replaced all of the weak tubes that were in the set but with no improvement in results. The speaker is OK. If after the set is distorting I shunt either the 100,000-ohm or 300,000-ohm resistors in the grid circuit of the type 47 tube with a resistor of the same value or lower the distortion then clears up, and the set then plays for a while after which it finally distorts again. Disconnecting the 200,000-ohm resistor in the same circuit the set plays

longer without distortion. I replaced this resistor but it didn't help. I checked filament voltages when the set was playing OK, and after it distorted, and they were the same. I also checked the voltage on both sides of the high-voltage winding of the power transformer while the set played OK and also when it distorted. There was no change.

The funny part about this set is that when the set plays OK the plate voltages check about 220 to 230 volts on the various tubes with about 100 V. on the screen-grids of the 24A and 51 tubes, and about 200 volts on the screen-grid of the 47. The detector tube has 90 volts on the plate with about 100 V. on the screen-grid. When the set distorts the 230 V. readings drop to about 180 V. The 100 V. readings drop to about 80 volts. With a poor type 47 in the set the voltages remain constant. I cannot understand what could cause this after everything tests OK, especially after replacing all condensers and resistors. I also checked the filament voltage of the type 80 tube for a drop after distortion but it did not change. When the distortion sets in there is no clicking sound or crackling, but a smooth, gradual change. All antenna, R.F. and I.F. coils check OK also. I would appreciate any information on this condition.

(A.) From your description of distortion experienced with a Majestic model 15 receiver, it appears that the 0.01-mf. coupling condenser between the 2nd-detector and the output tube is leaky. Replace this unit with a 600-V. condenser.

"PEAKED OSCILLATIONS"

(167) Ben Sweedan, Detroit, Mich.

(Q.) I have a Kennedy radio set, model 12-SG, on which I cannot obtain any information. The complaint is very peaked oscillations throughout the entire band. All tubes, resistors, condensers and voltages appear normal. The ganged tuning condensers have no shields.

(A.) The tuning condenser gang of the Kennedy SG-12 receiver should be shielded. However, your trouble lies with an open-circuited plate, screen-grid or cathode bypass condenser. We suggest that each bypass be bridged with a 0.1-mf. condenser during operation.

CORONADO AUTO SET

The owner of a Coronado 6-tube car-radio receiver complained that his set had developed a roaring noise and inability to pick up stations outside of town.

The noise was present when setting-up the set on the bench and stopped when the I.F. tube was tapped. Tubes all tested good, and I traced the noise down the grid lead to underneath the chassis. I connected my voltmeter to the plate of the I.F. tube and noticed a slight change in voltage when the noise stopped. The trouble seemed to be in the I.F. bypass condensers to the cathode and screen-grid. I then connected the voltmeter to the cathode of the I.F. tube and found a voltage change of several volts when moving the cathode bypass condenser (which was open-circuiting). I replaced the condenser with a new 0.1-mf. unit and the trouble was cleared.

H. A. SCHORNSTEIN,
Hasco Radio-Television Co.,
Roseburg, Ore.

PROFITABLE
ANSWER TO THOSE



HEADACHE
JOBS!

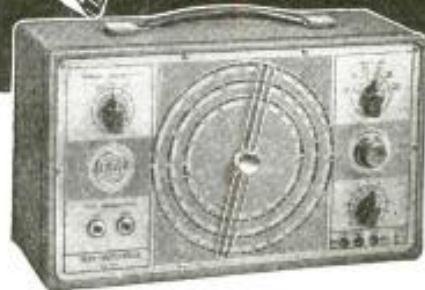

New RCA Test Oscillator #167

\$34⁵⁰

ACCURATE, EASY-
READING DIAL

FULL 1.0 VOLT R.F.
MAXIMUM OUTPUT

100-30,000 KC
FUNDAMENTALS

If you're the kind of serviceman who wants to make money on modern, complex receivers—the *tough* jobs—this new RCA #167 Test Oscillator was made for you! It has the range you want for today's receivers . . . high output for single-stage alignment, or for sets misaligned completely. Its big new dial scale makes readings certain and precise. Trim, attractive, business-like appearance wins customer-confidence.

Study its features . . . see it at your RCA Distributor's. \$34.50 is all it costs! Don't buy *any* test oscillator until you've seen how much RCA can give you for so little!

Check These RCA Value Features!

- 6 Ranges: 100 to 30,000 K.C.
- 400-cycle 8-volt Audio
- Complete Shielding
- Harmonics of 6th Band for U.H.F.
- Precision, New-type Dial
- Metal Tubes—Compact, Stable
- 2% Accuracy

Over 335 million RCA radio tubes have been purchased by radio users.



Test
Equipment

RCA Manufacturing Co., Inc., Camden, N. J.
A Service of the Radio Corporation of America

"Constant-Groove-Speed Recording" is the title of an article on disc sound-recording in August Radio-Craft. Don't miss it!

WILCOX-GAY MODEL A-70 "RECORDIO" (Chassis Model 9J9)
HOME RECORDER RADIO-PHONOGRAPH

9-Tube Superhet.; 2 Bands (Broadcast and Foreign Shortwave); Visual Tuning Indicator; Automatic Volume Control; Crystal Microphone; Crystal Phono Pickup; Crystal Cutting Head; Pushbutton Switchover.

See Data Sheet 281 for additional data.

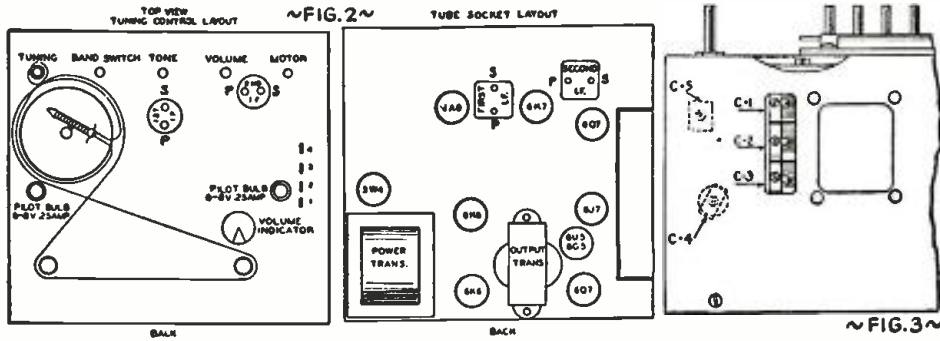

(Continued from Data Sheet 280)

Connect signal generator to control-grid of 6A8 tube. Make connection to side of middle section (C2) of condenser Rang. (FIG. 3).

Signal Gen. Frequency	Dial Position	Wave-Band	Trimmer Number
456 kc.	1,500 kc.	Broadcast	2nd. I.F.-S*
" "	" "	" "	" "
" "	" "	" "	1st. I.F.-S
" "	" "	" "	" -P

Connect signal generator to ANT. and GND. terminals.

See Fig. 2 for location of I.F. trimmers.

Turn condenser gang to full maximum capacity and check position of dial pointer with reference line on the scale, just to the right of 550 kc. calibration.

600 kc.	600 kc.	Broadcast	L.F. Pad. (C-5)
1400 kc.	1400 kc.	"	Osc. (C-3)
1400 kc.	1400 kc.	"	Det. (C-2)
1400 kc.	1400 kc.	"	Pre-SEL. (C-1)
Not used.** 15-16 mc. Shortwave Pre-SEL. (C-4)			

See Fig. 3 for location of trimmers C1 to C5. It is advisable to repeat the entire alignment procedure to correct the slight effect one adjustment may have upon the other.

As resonance is approached by adjustment of the trimmers, the signal generator attenuator should be adjusted for a minimum signal that will provide a low reading on the output indicator.

*If the trimming condenser on the secondary of the 2nd I.F. transformer is adjusted throughout its full range, 2 "peaks" will be observed. The correct peak is one of lowest capacity in the adjustment of the trimmer. The I.F. trimming condensers when properly adjusted will rest at approximately 1 1/2 turns from the fully-closed position.

**Connect antenna to receiver, and adjust dial so that no station is received. Advance volume control until a fair volume of noise is received. Adjust trimmer for greatest noise.

DEPTH OF CUT.—The depth of cut may be observed by holding the record in such a position that a light is reflected from the grooves. If the depth of cut is correct, the grooves will appear to be about as wide as the spaces between them.

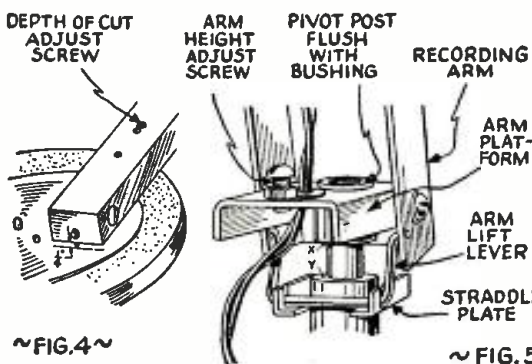

Provided a new cutting stylus, or one known to be in perfect condition, is being used, the correct depth of cut may be gauged by permitting the cuttings to remain upon the record until completed, then rolling the cuttings into a hard ball. The size of the ball thus obtained should be approximately 3/8-in. in diameter, for the 6 1/2-in. record.

It is well to **FIRST TRY A NEW CUTTING STYLUS** before making any adjustments, to preclude the necessity for a complete readjustment. The point and cutting edges of the stylus are razor sharp, and it is obvious that if the cutting stylus should bump or scrape against the turntable or other metal object, it would be dulled and rendered useless.

The depth of cut is regulated by an adjustment of the flat-head screw on the top of the recording arm, Fig. 4.

Turning the screw to the right (clockwise) increases the depth of cut.

Turning the screw to the left (counter-clockwise) decreases the depth of cut.

In some of the early RECORDIO models the adjusting screw was threaded throughout its full length, although only the lower portion of the screw over a span of approximately 3/8-in. contributes to the useful range of adjustment. If the adjusting screw is turned in a clockwise direction so as to raise the spring holding lug to the upper threaded portion of the screw, the adjustment will have passed through a "dead-center" position, which will cause a bobbing up-and-down movement of the cutting head.

If it is found that when using a new cutting stylus, the depth of cut is too shallow, and the adjusting screw has been turned to the full clockwise position in the later models, or to the upper limit of the useful range in the older models, this is an indication that the balance spring is too strong. Its tension may be decreased by spreading the coils of the spring with a pair of diagonal cutting pliers.

HEIGHT OF RECORDING ARM ADJUSTMENT.—The components of the recording arm assembly are positioned so that the cutting head is parallel, and the stylus is per-

pendicular to the record surface (Fig. 6), which condition obtains ONLY with the nose of the recording arm adjusted to the correct height of 1/4-in. above the record surface.

An adjustable stop (arm height adjusting screw; (Figs. 5 & 6) is mounted on the arm platform to provide a means for adjusting the height of the recording arm. With a blank record on the turntable and a cutting stylus inserted in the cutting head, the arm height adjustment should be made so that the bottom of the recording arm is 1/4-in. from the record surface as shown in Figs. 4 & 6.

The importance of the arm height adjustment may be judged by a study of Fig. 6. Note that the balance spring serves to hold the knife edge pivot of the cutting head mounting, fully seated in the V-shape trunnion bearing of the cutting head mounting bracket. Also, that the "pull" of the spring is slightly downward, as well as horizontal.

The initial tension and length of the balance spring must be such that when adjusted to the proper tension to produce the correct depth of cut, the spring holding lug will be positioned on the adjusting screw as shown, to create a slight downward "pull" on the cutting head mounting.

As the stylus end of the cutting head is raised and lowered slightly, when cutting records which are not perfectly flat, the cutting stylus varies from its perpendicular plane, and the angle of the cutting edges of the stylus also varies. This tends to produce a varying depth of cut which would place a varying load on the motor, resulting in a variation in the average pitch or tone of the recorded music or speech. This effect is commonly called "wow". However the spring tension, and consequently the stylus pressure, also varies. This variation in stylus pressure opposes the effect of the varying stylus position, resulting in a substantially uniform depth of cut.

It can be seen that if the balance spring were adjusted to a horizontal position with respect to the plane of the cutting head—

- (a) the downward "pull" of the spring would be lost, resulting in a pronounced variation in the depth of cut when cutting a record having a slightly warped surface.
- (b) the cutting stylus would have a tendency to chatter or dig into the record, due to the "dead-center" position of the spring.

It can also be seen that if the arm were adjusted to an incorrect height above the record surface, the cutting stylus would not be perpendicular, and the tendency towards a greater variation in the depth of cut, which would be more pronounced, would not be fully compensated by the counteracting effect of the varying tension of the balance spring.

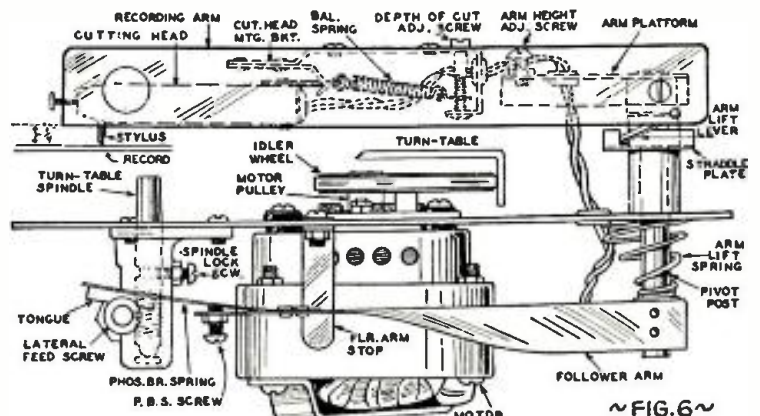

OPERATING NOTES

DO YOU WANT AN OPERATING NOTES DEP'T?

We can't print these useful field notes if we don't get them; so shoot yours in today. We pay for them at space rates.

Operating Notes may be addressed to the attention of the Operating Notes Editor, *Radio-Craft* magazine, 20 Vesey St., New York, N. Y. Although these Notes ordinarily should represent faults found repeatedly in a particular set model, these Notes also may be on an individual set, provided the fault which is described represents an unusual service job. (These Notes presuppose that all tubes have been properly checked, and eliminated as possible sources of trouble.)

Trouble in . . .

. . . . RCA VICTOR HIGH-FIDELITY MODELS HF2, HF4, and U130

Inoperative or no A.V.C. action—also distortion—may be due to an open R.F. or a shorted grid coupling condenser in the 1st radio-frequency stage; no A.V.C. may be carried by a shorted or open 0.05-mf. R.F. bypass condenser in the A.V.C. network value. Distortion may be traced to the 6F6 output tubes not being matched closely enough.

. . . . BELMONT 420

An audible whistle may be caused by the resistor in the cathode of the type 38 tube changing in value. However, also check the control grid resistor.

. . . . MAJESTIC 15

When the complaint is "receiver dead," the trouble may be due to a burned-out antenna coil. Replace it with a new antenna coil, and use an antenna coupling condenser. Check the power supply buffer condenser in the primary for a short or open, and in replacing this unit, use one of a higher voltage rating.

. . . . ATWATER KENT 424

If this receiver operates fair but has poor sensitivity, it may be due to improper alignment or to the shielded lead from the antenna being defective or broken. Also check synchronous vibrator for an open or partly-shortened buffer condenser; if defective, replace with a new unit as the points on it are usually pitted because of the breakdown of the buffer condenser.

. . . . UNITED MOTOR SERVICES CORP. MODEL B.O.P.4036

A "receiver inoperative" call may be occasioned due to the type 85 combined 2nd-detector, A.V.C. & A.F. amplifier tube not functioning properly because the resistor associated with the A.V.C. network has changed in value; or another source of this fault may be an open push-pull input transformer to the audio-frequency amplifier.

. . . . SPARTON 594

Another "dead" complaint is sometimes caused by the type 75 2nd-detector & A.V.C.-tube 100-ohm cathode resistor, in Sparton 594's, being opened; or the 0.5-meg. volume control may be defective. Also replace the type 78 combined 1st-detector and oscillator tube; and check the 25Z5—it may have flashed. If the latter condition is found, replace the filter condenser as they also have a habit of opening and healing again, causing the flashing of the rectifier.

. . . . ATWATER KENT HI, H2

Failure of this set model to operate may be due to an open antenna choke. If OK, check the I.F. trimmer for a short, and if it is found defective, replace it with a new I.F. transformer and realign.

. . . . WELLS-GARDNER SERIES 5D

If this receiver refuses to align properly on the shortwave band, the fault may be caused by a defective 1st-detector shortwave trimmer condenser; replace to cure. Low volume may be caused by the type 42 power tube plate-to-cathode bypass condenser being open or shorted; replace with one of higher value.

. . . . KOLSTER K-80

An inoperative Kolster K-80 may be due to any of the following: open choke to type 227 2nd-detector plate; 227 oscillator cathode resistor opening up or shorting (value 0.1-meg.), no A.V.C. control due to an open 500-mmf. grid coupling condenser in the A.V.C. tube; or, low audio output caused by one or both of the 247-type output tubes being defective or not matching properly.

. . . . HAMMARLUND HQ-120X, Short-wave Model

Receiver operative and not operative due to the following condition. In this model as well as some other models using crystal phasing 2 causes have been found for the receiver not working properly in the PHASING position but operating OK with the crystal out: No. 1, a split crystal; No. 2, crystal phasing switch not making good contact. Clean and check contacts, and if found faulty, replace with a new switch.

GEO. F. BAPTISTE,
Howard, R. I.

. . . . PHILCO 37-610

I had a service call on a Philco model 37-610, on which the complaint was intermittent hum and crackling noises. Checked all tubes which were perfect. Concluding that the faulty operation perhaps was due to a filter unit I left a loaner radio at the house and took the set to my shop. I left it playing for 10 hours and then checked the set completely but could not find any trouble. The set was then returned to owner who complained that his loaner was in the same condition as his own set! I thereupon checked his power line and found that some one had installed an extension light but had made a very poor connection, and that when some one walked across the floor it jarred this wire and made a high-resistance leak, causing the above trouble. I soldered the connection and the trouble was cured.

JAMES ALLEN,
Detroit, Mich.

. . . . FADA 190 ALL-WAVE

An inoperative receiver frequently is caused by an open or defective A.F. choke; also, an open 1st A.F. plate resistor. The 1st A.F. is a 6F5 coupled to a pair of 6F6's used in push-pull. Check the 1st A.F. plate-to-grid coupling condenser for leakage. If found to be defective, replace this 0.05-mf. unit with one of a higher voltage rating. Also check the plate resistor for its rated value of 50,000 ohms. Check the 5Z4 rectifier input filter condenser as well as the output condenser for leakage, in that these sometimes puncture and heal again, causing the stated trouble. In making the above repairs it is not necessary to touch any of the trimmers.



What's your future in Radio?

You don't need to gaze into a crystal globe—just look around you. Television—radio facsimile—electronics in industry; these and other developments are crystallizing right under your very nose TODAY. Here lies the future of the servicing industry, here lies YOUR future in radio . . . IF you are ready to capitalize. Know as much about these developments as you know about a superhet—OR ELSE see the most profitable part of your business go to a competitor. Read carefully the contents of the following books—and Order Today!

SERVICING BY SIGNAL TRACING

By John F. Rider

Use the system of servicing which is proved and endorsed—fastest—most modern—the system you can apply to all receivers regardless of age, type or make. Servicing by Signal Tracing operates independently of every limiting factor heretofore encountered. In this new book you learn how all receivers are brought to a common servicing level. You learn how components receive a functional check while the circuits are in an operative condition. Over 360 pages—hard covers—only \$2.00.

THE OSCILLATOR AT WORK

By John F. Rider

JUST OFF THE PRESS!

Get your money's worth—NOW! This new book tells all about ALL oscillators. It explains the theory by means of simple illustrations, diagrams and curves. It gives you the practical facts you need to combine theory and practice. Get your copy TODAY! 256 pages—illustrated—\$1.50.

OTHER RIDER BOOKS YOU NEED

The Cathode Ray Tube at Work—336 pages—450 illustrations—\$2.50. Hour a Day with Rider Books on subjects you should know—Hard Covers—60c each. And of course—All Eleven Rider Manuals.

JOHN F. RIDER, Publisher 404 FOURTH AVE. NEW YORK CITY

Servicemen! Radio Technicians! Engineers! Get the bigger and better Sylvania Technical Manual . . . 272 pages of vital tube information—complete data and diagrams for 374 types of tubes. Gives operating conditions, characteristics and circuit applications for Standard Glass tubes, "G," "GT," Loktal, Metal, Majestic and Special types. Also data on Television amplifiers, Cathode-Ray tubes, etc. Send 35c for your copy today. Hygrade Sylvania Corporation, Dept. RC70, Emporium, Pennsylvania.

DUMONT
Precision Built Condensers
at your nearest jobber or write to
DUMONT ELECTRIC CO., INC.
314-316 BROADWAY NEW YORK, N. Y.
PAPER — MICA — ELECTROLYTIC

Your Fellow Serviceman Builds a

SIGNAL TRACER TEST UNIT

Dear Editor:

I have been a Serviceman for the past 4 years and a constant reader of your worthy and helpful magazine.

The enclosed article (printed below.—Editor) describes an instrument I built 2 months ago. I have found it very useful. I believe a good many Servicemen who cannot afford the more elaborate signal tracers, will find this instrument very useful and inexpensive.

R. B. OLSON

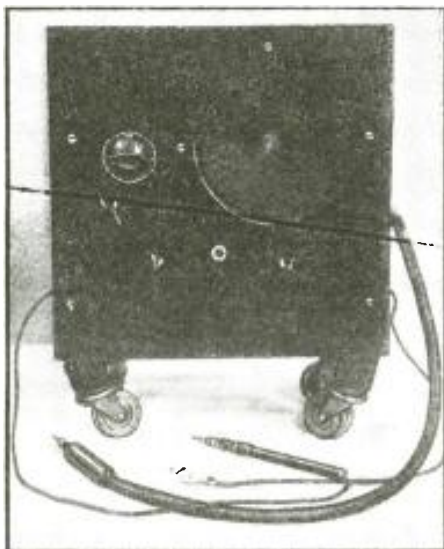

The completed Signal Tracer. Caster feet make it easy to move the Tracer to any job on the testbench. This instrument permits testing of an entire receiver from antenna to speaker. Microphones, record players, etc., also may be tested.

SIMPLE. That one word completely describes this Signal Tracer. Simple in use and simple in construction. Any Serviceman can easily build it in a short time.

USES

Being untuned it is more convenient than the tuned type of signal tracer. It permits you to go from R.F. to I.F. stages of a radio set without twisting any dials. Simply touch

the test prod to the grid or plate of the tube.

You can check the entire receiver from antenna to speaker. It is a simple procedure to locate the source of hum, distortion, oscillation or any other ailment of a radio set. The audio section is also very useful for testing microphones, record players, etc.

All that is needed to build this handy instrument, is a radio receiver and a few parts. Parts are all standard, no specials. There are no trick circuits and no tedious calibration. The radio set should have diode detection and a good A.F. system. The better the audio system the better this instrument will work. Of course, any old "radio" with the required audio system, could be used. Power detection or gridleak detection could be used. However, the diode detector and its method of volume control make the simplest circuit.

PRELIMINARIES

Clean up the chosen radio chassis and start work. Remove all R.F. and I.F. coils, gang condensers, and waveband switches. Take out all wiring, condensers and resistors in R.F. and I.F. stages. Leave the filament wiring connected to the last I.F. stage. This last I.F. stage will be an untuned R.F. amplifier in the finished instrument.

No changes are made in the circuit from the plate of the detector on through to the speaker. Also no changes are made in the power supply, except perhaps to add filter condensers to reduce hum.

Coaxial cable may be used for the R.F.-I.F. input lead. We used the instrument for some time using ordinary fixture wire for the R.F.-I.F. input lead. When constructing

this cable connect the 10 mmf. condenser to the prod end of the cable. The method of connecting this cable to the instrument is optional. We soldered it right into the circuit. That way it is always handy. Do not make these leads too long. The shorter the better. We mounted our Signal Tracer on casters. This allowed us to roll it right up next to the receiver under test, thus requiring leads only 2 feet long.

The A.F. lead may be made from microphone cable or fixture wire. The 25,000-ohm resistor should be connected at the prod end. Another lead should be made about 2 feet long, with an alligator clip attached at one end. The other end should be soldered to the chassis of the instrument. This lead is always connected to the chassis of the radio set under test.

HOW TO USE

A phone jack should be connected to the plate of the output tube through a 0.25-mf. condenser.

In servicing a "dead" receiver connect the R.F. probe to the grid of the 1st R.F. tube and tune the receiver for a signal. Proceed on through from grid to grid until you find the dead stage. When you reach the detector stage change to the I.F. lead.

This same procedure is used for tracing hum, distortion or any other ailment to its source. When checking for noise, hum or motorboating, do not confine your testing points to the grid and plate elements of the tubes. Check also the screen-grid, cathode and suppressor-grids with the instrument. Many times the trouble can be traced to these elements and then to its source.

The phones are used when testing on a weak signal. They are also useful for detect-

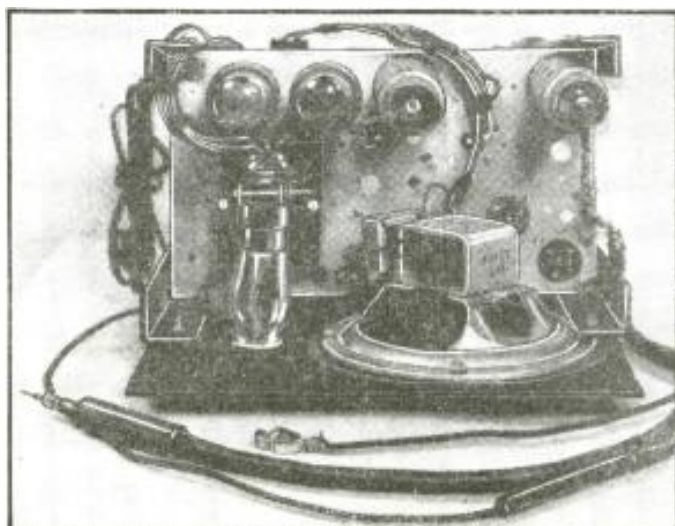

This top view of the chassis shows the placement of the key components.

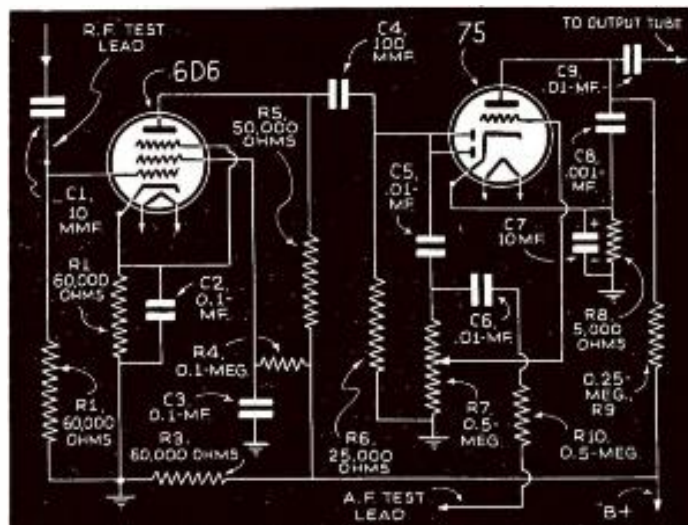

The schematic of the Signal Tracer illustrates the simplicity of this test unit.

• TEST INSTRUMENTS •

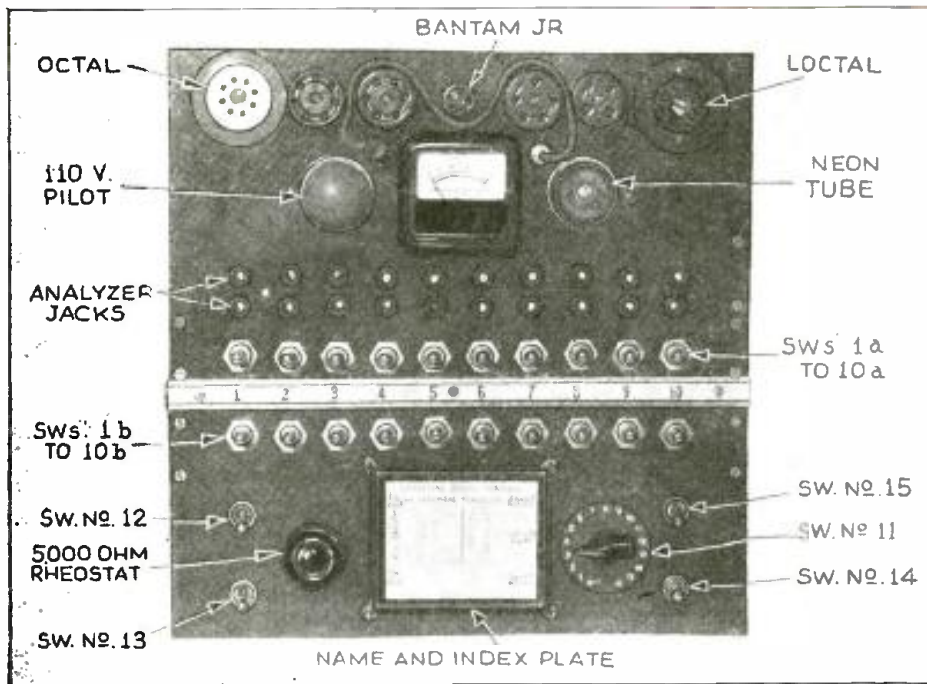

The Tube Tester and Set Analyzer-Adapter made by the author and here described was developed after study of many testers. Its "full floating filament-test" switching system permits testing all today's tubes.

← This practical Tube Tester and Set Analyzer Adapter enables the technician to test all the types of tubes so far announced.

How to Build a Practical TUBE TESTER AND SET ANALYZER-ADAPTER

JOSEPH J. PIRE

MOST of the commercial tube-testing units, in the opinion of many technicians, have too much complication in circuit design, charts to set dials by, etc., and are somewhat unwieldy. Charts are all right for a while, but there are too many new types of tubes brought out day after day, in ceaseless procession, and the very best tube tester with charts, etc., soon becomes an antique piece of equipment.

With the above in mind, it was decided to construct a simple unit that would be capable of meeting the following requirements:

- Simple to operate, no charts to use;
- Easily constructed at low cost;
- Able to select voltages from 0 V. to 115 V.
- Test all types of tubes, old as well as new;
- Require no adapters;

- Test for open filaments;
- Test cathode leakage;
- Test for shorts and leakage, hot or cold, between all elements;
- Test all tapped-filament tubes;
- Include a real full-floating-filament tube tester, such that filaments may terminate even in top connections;
- Able to incorporate an analyzer circuit within one instrument if such system is desired;

All of these conditions have been met in the Tube Tester and Set Analyzer-Adapter here illustrated and described.

LEFT-SECTION CIRCUIT

Let us consider the final circuit, of this Practical Tube Tester, in 2 sections: (1) left section; and, (2) right section.

The left section consists of 2 rows of S.P.D.T. switches, with dead-center, or OFF

position in the middle. These switches are numbered from 1 to 10 with sub letters (a) for upper row and (b) for bottom row. The 1st 8 numbers are connected to the tube socket terminals, through proper switching; No. 9 is left blank, No. 10 goes to the cap or top of the tube. With No. 9 blank, a provision is made for the future, when a 9-pin tube may appear.

This section also consists of 3 bus-bars A, B and C. The upper row of switches, with their center terminal, connect to the tube socket terminals and may be connected to bus-bar A when up, or when to the center terminals of the bottom row of switches. These bottom terminals may be connected to bus-bar B when up, or to bus-bar C when in the down position. When the upper row of switches is in mid-position all tube elements are entirely disconnected from the tester; also when the lower row of switches

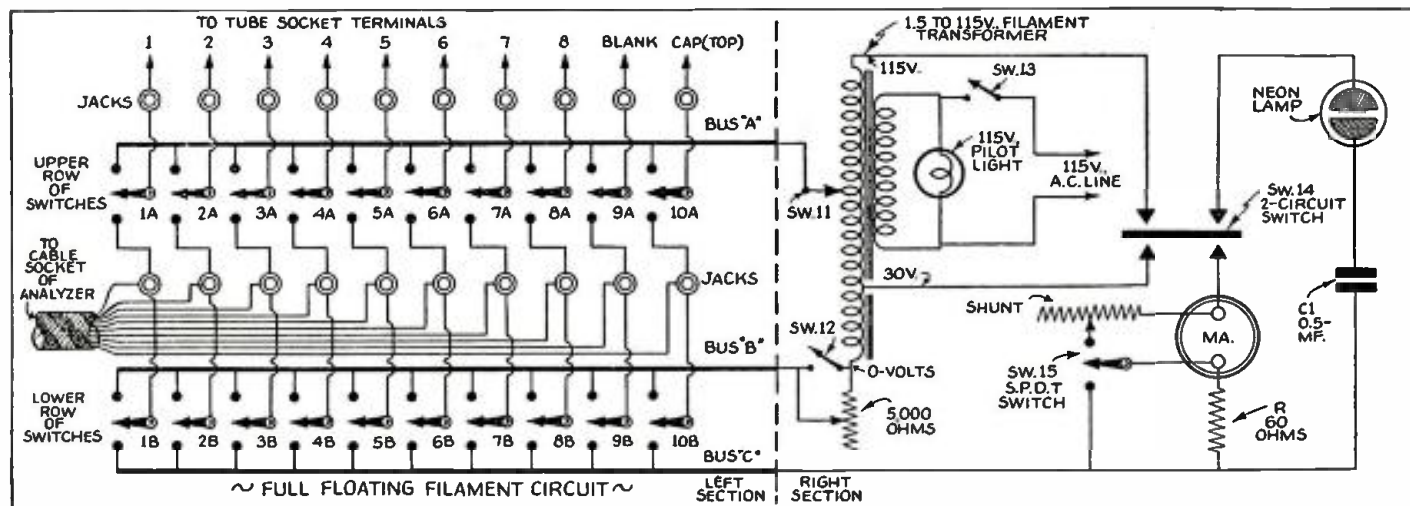

The practical Tube Tester and Set Analyzer-Adapter features a full-floating filament testing circuit.

•TEST INSTRUMENTS•

ing slight cases of noise, hum or distortion. Using the phones you may also operate the radio set under test at full volume and still be able to hear the signal from any one point in the radio receiver.

Gain-per-stage measurements may be made very easily. Connect an output meter to the phone jack on the Signal Tracer. Feed a modulated signal from your signal generator into the antenna circuit of the "radio" under test. Keep this signal at a low level to prevent overloading and excessive A.V.C. action. Connect the Tracer to each successive grid and note the output meter reading. These readings can then be converted into gain-per-stage figures.

You may also want to add a tuning eye to the circuit. A tuning eye in this circuit is practically useless for measuring gain-per-stage, because of the small amount of R.F. amplification. However a tuning eye may be used to advantage if its grid is brought out to a pin-jack. It can then be used to indicate the presence or absence, and the approximate amount, of A.V.C. voltage. It can be connected to the A.V.C. system of a radio receiver to be aligned and used for visual indication of correct alignment.

The real test for any instrument is use on the bench. The instrument described here has proved its worth to us through daily use on a very busy testbench.

LIST OF PARTS

CONDENSERS

One Sprague mica condenser, 10 mmf., C1;
Two Sprague paper condensers, 0.1-mf., 400 V., C2, C3;
One Sprague mica condenser, 100 mmf., C4;
Three Sprague paper condensers, 0.01-mf., 400 V., C5, C6, C9;
One Sprague mica condenser, 0.001-mf., C8;
One Sprague electrolytic condenser, 10 mf., 35 V., C7.

RESISTORS

Two I.R.C. resistors, 60,000 ohms, ½-W., R1, R3;
One I.R.C. resistor, 400 ohms, ½-W., R2;
One I.R.C. resistor, 0.1-meg., 0.5-W., R4;
One I.R.C. resistor, 50,000 ohms, ½-W., R5;
Two I.R.C. resistors, 25,000 ohms, ½-W., R6, R10;
One I.R.C. resistor, 5,000 ohms, ½-W., R8;
One I.R.C. resistor, 0.25-meg., ½-W., R9;
One Clarostat volume control, 0.5-meg., R7.

MISCELLANEOUS

Two Amphenol 6-prong sockets;
Two Goat Radio Co. tube shields;
Two ft. Amphenol coaxial cable.

HINT TO P.A. MEN

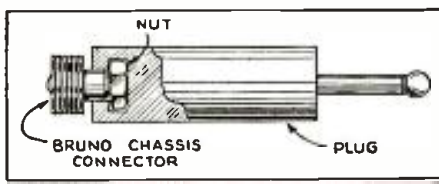

● IF you ever find yourself in the same predicament I was—that of having amplifiers with both Bruno-type mike input connectors and jack-type mike inputs—install Bruno connectors on all mike cables, install the Bruno chassis connector in the end of a metal-sleeved plug and you are through changing cable connectors to fit the amplifier in use.

CARL GRAHAM,
Canton, Ohio.

NON-OBSOLESCENCE VIBRATOR TESTER

TRIPLET
MODEL 1671

Push Button Operated

- ★ Tests All Standard 6-Volt Vibrators
- ★ Easy to Operate—Roll Chart Shows Button Settings
- ★ Uses Standardized 5000 Ohms—8 Mfd. Load
- ★ RED • DOT Lifetime Guaranteed Instrument
- ★ Flexible Push Button Switching Permits Placing Proper Voltages on Each Reed, Guarding Against Obsolescence

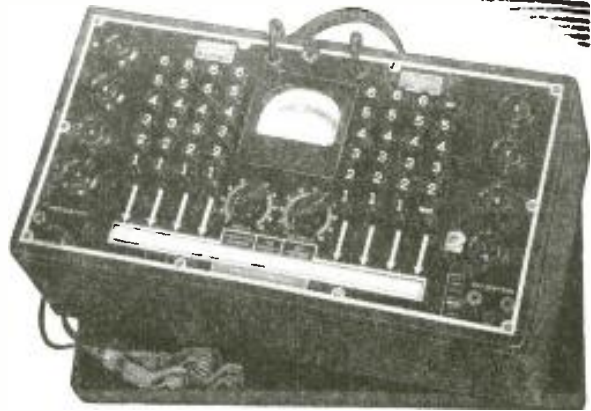

Another anti-obsolescence feature is the special adapter with leads included with accessories, with which it is possible to check new vibrators without waiting for instructions from the factory. It also permits checking vibrators not suited for present socket hook-ups or base arrangements. Model 1671 has a three-scale instrument: 0-10 volts scale shows input voltage to vibrator for start or running tests Two-zone, two-color merit scale shows vibrator condition as GOOD or BAD

. . . . 0-100 scale permits inter-comparison of vibrator output under standardized input conditions. Tester is fused against shorted vibrators.
Dealer Net Price **\$39.84**

NEW ROTARY SWITCH VIBRATOR TESTER

MODEL 1672 is the same as Model 1671 but has rotary switch control. New speed roll chart simplifies settings. Has anti-obsolescence features similar to Model 1671. A real buy at
Dealer Net Price **\$29.84**

The New 1940-41 Line of Triplett Test Equipment Will Be Displayed in Booths 619-621—Chicago Radio Parts Show

Write for Catalog—Section 167 Harmon Drive

THE TRIPLET ELECTRICAL INSTRUMENT COMPANY
Bluffton, Ohio

SOMETHING HAS
REALLY HAPPENED IN
RESISTORS!

You'll never know how amazingly different, how outstandingly better a wire wound resistor can be until you've tried Sprague Koolohms and compared 'em with anything else on the market today. For Koolohms are just as different from ordinary resistors as day from night. Leading engineers have heralded them as the outstanding development in 20 years. Already they're specified for many of the toughest industrial jobs—and they're "tops" for any radio use you can name. Ask your jobber! Catalog free.



DON'T MISS THIS SPRAGUE RADIO INTERFERENCE MANUAL

Finest book of its kind ever written! Tells what to do, how to do it to eliminate all types of man-made radio noise. Dozens of diagrams. 25c net.

SPRAGUE



Wire insulated before winding
Layer windings . . . more resistance in less space

The only truly insulated wire wounds

5% accuracy guaranteed

Automatic overload indicator

Now available in 5-watt fixed;
10-watt fixed and adjustable.
Non-inductive units at lowest prices ever.

SPRAGUE CONDENSERS
KOOLOHM RESISTORS
TEST EQUIPMENT
SPRAGUE PRODUCTS CO. NORTH ADAMS, MASS.

is in mid-position they in turn are disconnected from bus-bars B and C.

Set Analyzer.—Now right at this point it becomes apparent that a Set Analyzer circuit may be incorporated into the tester with ease. This was done by introducing pin-jacks, one on each side of the upper row of switches, as shown.

Now with the lower row of switches in mid-position all we have to do is to extend a cable circuit from the lower row of jacks to an analyzer plug. The switches in the upper row being in the *down* position we have an independent circuit from the radio set chassis (through analyzer cable and plug) to the tube terminals of the tester. Voltage and resistance measurements may be made. If we introduce a milliammeter into any of these jacks, and place the corresponding switch, in upper row, in mid-position, we open that circuit and may measure the current in this circuit the same as in any other set analyzer.

RIGHT-SECTION CIRCUIT

So much for the left section proper; the *right section* consists of the usual transformer, indicating devices, etc. From the left section the bus-bars are extended into the right section.

Bus-bar A is connected to the voltage selector switch No. 11; any voltage from 1.5 to 115 V. may be selected. This switch is in the OFF position at either end of its extreme rotation. Bus-bar B is connected to the zero-V. point through switch No. 12 (see later). Bus-bar C or LOAD, is connected to the indicating meter through 2-circuit switch No. 14 when in the *down* position, the other side of the meter being connected to the usual 30-V. tap of the filament transformer.

The milliammeter is shunted by a 25-ohm rheostat, and there is also a 60-ohm resistor in series with bus-bar C when switch No. 15 is in the *up* position. When switch No. 15 is in its *down* position the shunt is thrown out of the circuit and the 60-ohm resistor is shorted out. The purpose of the shunt and the series resistors is to protect the meter when mercury-vapor tubes are tested.

When 2-circuit switch No. 14 is in its *up* position the meter is entirely disconnected from the circuit and the neon lamp is brought into the circuit through a 0.5-mf. condenser, full 115 V. being used. No resistor is used across the neon tube as is the practice with many such devices.

Nothing up to now was said about switch No. 12 and the rheostat it shunts. This was introduced into bus-bar B so that the filament voltages may be lowered from 1.5 V. *down*. When this switch is in its *down* position it shorts the rheostat. The resistance value of this rheostat is 5,000 ohms.

All switches are wired to work in *up* and *down* position. The standard system of numbering is used on the tube sockets and also on switches 1 to 8.

TEST PROCEDURE

Now let us take a tube and see what may be done; assume all switches on the board to be in their *down* position. Now let us take, for example, a 6A8-type tube. Set selector switch No. 11 to 6.3 V.; since the 6A8 has pins 2 and 7 for filament terminals, we throw switch 2a in the upper row, to *up*; switch No. 7b in the lower row, also *up*; this will place the filament across 6.3 V. Now throw switch No. 13, the line switch, *up*. Since the cathode of the 6A8 terminates at pin 8, we also throw switch No. 8b to *up*, and observe the meter.

If we desire to know if there is any

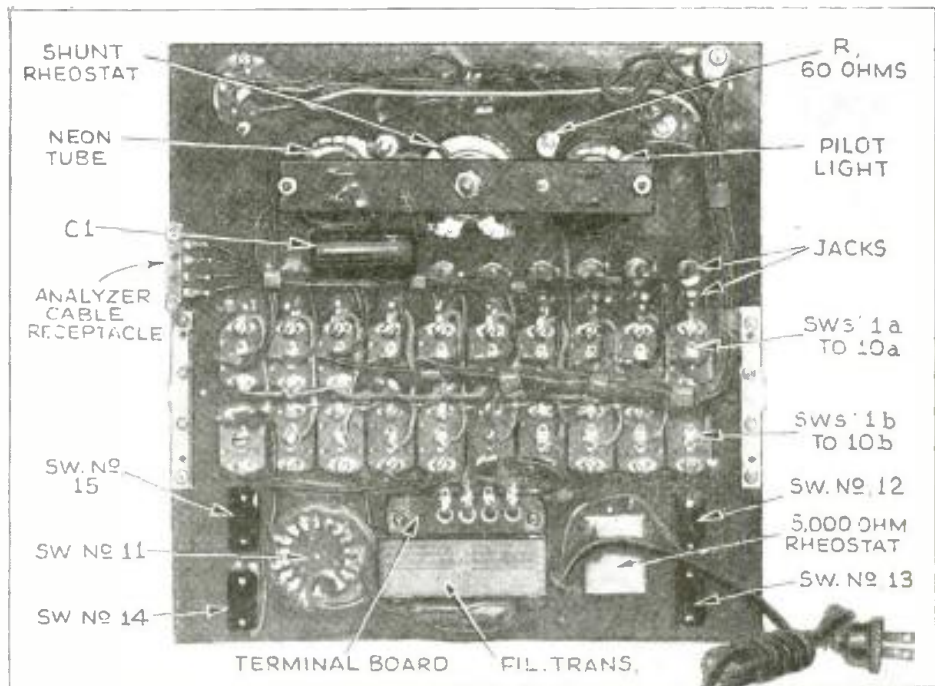

A compact design has been achieved in this Tube Tester and Set Analyzer-Adapter.

cathode leakage all we have to do is to place switch No. 8b in mid-position and again observe the meter.

Suppose the filament is burned-out, or open, all that is necessary to do is to throw switch No. 14 *up* (neon circuit) and throw switch 2a *down*. The neon tube will not light if the filament is open. This test also may be made to check for shorts when the tube is either hot or cold between any elements. For test of leakage, the tube has to be hot, of course. In case a cold short is to be tested for, turn voltage selector switch No. 11 to its *off* position. In either case 115 volts is applied, through neon and condenser, across bus-bars B and C.

From the foregoing it will be observed that the instrument is very versatile and is capable of performing quite a number of functions. The filaments may terminate anywhere, even at the top or cap. Still with plenty room on the panel for future sockets, 4, 5, 6, 7, comb., octal, loctal and bantam jr. sockets were used. As stated before, the standard system of numbering is used. The socket wiring was omitted for clarity of the diagram. Since everyone is acquainted with this part it was thought it could be left off.

Single-deck construction was used, making the wiring very easy and limiting the depth of the case to 2 1/4 inches.

Practical Servicemen → will have no difficulty making the chassis for this test instrument.

LIST OF PARTS

- One bakelite panel, 12 x 12 ins., obtained from Radio Wire Television, Inc.;
- One each, NaAid, 4, 5, 6 and 7 combination sockets;
- One octal socket, obtained from Radio Wire Television, Inc.;
- One loctal socket, obtained from Radio Wire Television, Inc.;
- One Bantam, Jr., socket, obtained from Radio Wire Television, Inc.;
- One Yaxley 17-point selector switch, No. 32117J;
- One Yaxley plate for above;
- Twenty Cutler-Hammer S.P.D.T. switches, dead-center type;
- One Hubbell 2-circuit switch;
- One Cutler-Hammer S.P.D.T. switch;
- Two Cutler-Hammer S.P.S.T. switches;
- One wire-wound resistor, 60 ohms, 2 W.;
- One Carter rheostat, 25 ohms;
- One Bradley rheostat, 5,000 ohms;

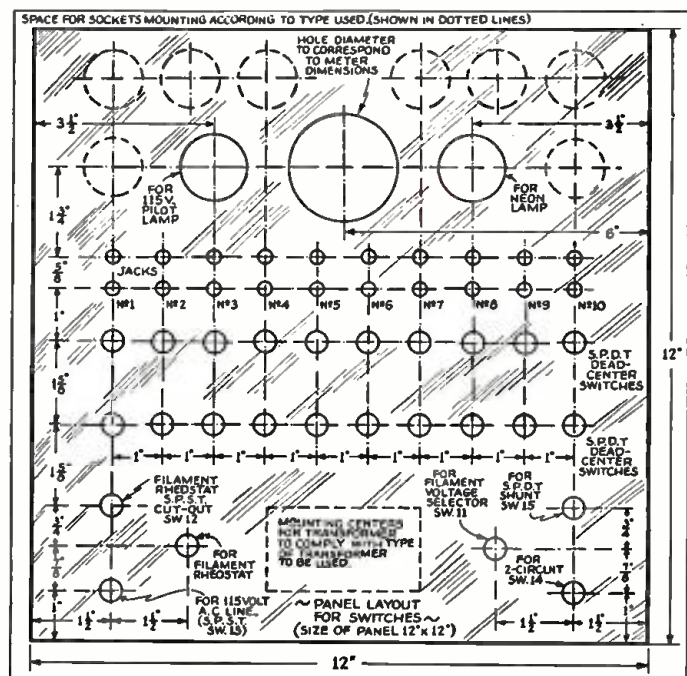

• TEST INSTRUMENTS •

It's a **FIND**
at this price!

RCP SALES
PROMOTER

Model 308
Series D

ONLY \$25.95*
DEALER NET

See what
it does!

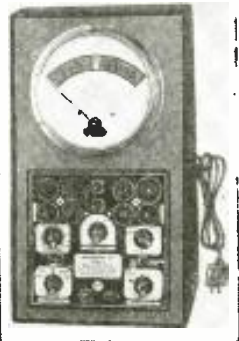

- * Tests all new miniature tubes . . . all ballast tubes
- * Noise and hum test for tubes showing otherwise "good"
- * Sensitive neon tests for shorts and leaks
- * Spare sockets for future tube developments
- * Checks pilot, head and miniature lights
- * Jumbo 9 inch meter

And that's not all! Model 308 (Series D) is a quality instrument through and through. Fine product of RCP progressive experience. Skillfully designed with an eye to the future. A find for the money, it's something to see your nearest jobber about at once, or send for new RCP Catalog No. 122—just out—with the complete facts.

* For other 308 Models and other test equipment see catalog or your local jobber.

RADIO CITY
PRODUCTS CO. INC.
88 PARK PLACE, N. Y. C.

YOU ASKED FOR . . .

QUALITY at a PRICE

Here it is!

Readrite
RANGER

Model
432-A



Only \$17.85 Net

- RED • DOT Lifetime Guaranteed Triplett Meter
- Sockets for All Tubes Including new 1.4-volt Miniatures
- Filament Voltages from 1.1 to 110—A Safeguard Against Obsolescence
- Precision Indicating Instrument with Two Highest Quality Sapphire Jewel Bearings
- Separate Line Control Meter
- Neon Shorts Test
- Etched Panel of outstanding NEW Design
- Approved RMA Circuit

TODAY'S outstanding tube tester value—a guaranteed quality portable tester at a price you can afford to pay. Checks Locals, Single Ends, Bantam Jr., the 1.4-volt Miniatures, Gaseous, Rectifier, Ballast, the High Voltage Series (including 11726G) and others recently announced. Direct Reading GOOD-BAD meter scale. Positively will not deactivate 1.4 volt or other type tubes.

The New 1940-41 Line of Readrite Meters and Testers Will Be Displayed in Booth 818—Chicago Radio Parts Show.

WRITE FOR CATALOG
SECTION 716 COLLEGE AVENUE

READRITE METER WORKS, Bluffton, Ohio

- One Sprague condenser, 0.5-mf.;
- Twenty Yaxley jacks;
- One G.E. pilot lamp, 115 V.;
- One G.E. neon lamp, 115 V.;
- Two receptacles, for neon and pilot lamps;
- One Readrite square milliammeter, 0-50 ma.;
- One Jones 10-terminal receptacle;
- One Jones 10-terminal plug;
- One NaAld analyzer plug, cable and adapters;
- One line cord and plug;
- One home-made case, 12 x 12 x 2½ ins. deep;
- One home-made name plate;
- One home-made strip numbered 1 to 10;
- Hardware, etc.

ADDENDUM: THE ANALYZER-ADAPTER

The instrument is complete as a tube tester, but it is not a complete combination of a tube tester and set analyzer in a strict sense of the word, since an analyzer requires a voltmeter and a milliammeter, with proper switching to obtain the desired readings of voltages and currents.

The milliammeter within the tube tester is used for nothing else besides measuring the emission current of tubes under test.

As per the rear-view photograph, a 10-

point receptacle (or a socket) is included in the instrument. A branch wire is taken from each jack on the bottom row and terminated at the respective terminal of this receptacle (see Left-Section portion of diagram).

For analyzer tests all that is required then is a 10-pin plug, to be inserted into the above receptacle and the circuit thus extended, through cable, analyzer plug and its associated adapters, to the radio chassis and to an outside volt-milliammeter.

With the above information it will be seen that the instrument affords operation as an *analyzer-adapter* rather than as a full analyzer.

All of the connections from the bottom row of jacks, as well as the 10-terminal receptacle, receptacle plug, cable, analyzer plug and its associated adapters (also socket wiring), were not shown for the sake of making the salient points of the diagram clear.

Note that the text refers to numerals 1 to 10 with sub letters (a) and (b); the schematic, though, shows these as capital letters (A) and (B). However this should not cause any confusion as any reference to these letters also is in connection with the respective numbers; and the bus-bar letters "A" and "B" and "C" in the circuit, are identified in the text as bus-bar letters (A, B and C).

CASE HISTORIES OF P.A. SALES

No. 10—P.A. System for Ball Games, Etc.

A HELP in the summer lull in the radio business is what I have found in Public Address equipment.

Recently, attending one of the evening softball games I noticed the need for an address system. I contacted the league committee but found their funds were limited and they couldn't afford either to buy or rent a system. An idea struck me, if the radio programs could be put on and sponsored profitably, why couldn't this?

I propositioned the league committee with my idea, and found them heartily in favor, so I talked to different merchants, and shortly had a wide variety of sponsors. The cost to each was very small, ranging from \$1 to \$3 per game, and 2 games being played every evening. For this charge they received announcements between innings, and halves of innings (generally 50 to 100 words per announcement), and in checking the results from these advertisements I found the merchants were very well pleased with results. I also noticed that the attendance to the games increased greatly, lots of people even sitting in their cars and watching the games, for the play-by-play description of the games came out very clear and distinct even to those sitting 500 or 600 feet from the players.

My system hasn't cost me more than \$160 to rig up, and I have realized a gross of nearly \$300 from this season's games, making a handsome profit for a few hours in the evenings, and paying for the cost of my system.

I have the speakers mounted on the roof of my '30 Chevrolet service truck, and the amplifier and motor-generator mounted on the inside of the truck. The speakers I use with satisfactory results are a pair of 3½ ft. trumpets fed by a single Racon unit with a Y adapter, and 2 Jensen P.M. speakers covering the sides. The amplifier is a parallel push-pull 2A3 job of 30 to 40

watts output. My microphone is a Universal crystal hand mike that cost me \$14 and the power for the system comes from an old Dodge generator that I rewound for 60-cycle A.C., coupled to a small washing machine engine that I paid \$35 for. I traded a radio set that cost me around \$50, wholesale, for the amplifier, Racon unit and horns. The Jensen speakers netted around \$12 apiece; I put them in homemade baffle boxes made of plywood covered with auto top material, and if I do say so, it makes a very nice set-up for use at the ball-games, or for street bally-hoo, rodeos, etc. Am submitting a drawing of the field showing set-up.

DON M. ELLIS,
Santa Maria, Calif.

Don received 8th prize in the 3rd section of the \$4,000 P.A. Contest Radio-Craft sponsored last year.

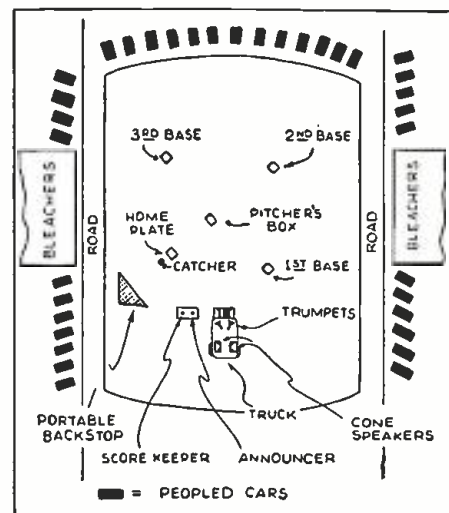

Many Radio-Craft readers have requested a really modern audio amplifier utilizing triodes. The multi-feature amplifier here described is a high-fidelity semi-triode job which answers these requests. Power output is about 15 W. with under 1.5% total harmonic distortion from a pair of 2A3's; at 5% total harmonic distortion the amplifier will deliver 30 W.

The Triode Direct-Coupled 30-W. Amplifier. The controls, etc., are identified as follows: (1) phono input, (2) radio input, (3) radio volume control, (4) phono volume control, (5) expessor, (6) timing, (7) low-frequency equalizer, (8) high-frequency equalizer, (9) pilot, (10) master switch.

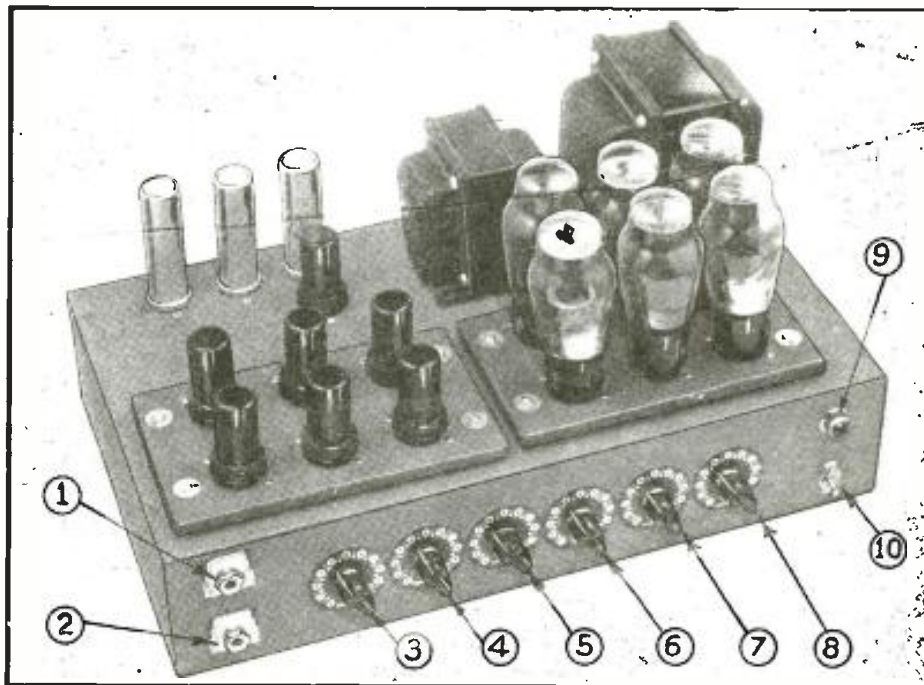

A TRIODE DIRECT-COUPLED AMPLIFIER

With Non-Frequency-Discriminating Scratch Suppressor

A. C. SHANEY

THIS unusual amplifier has been developed for a group of music lovers and technicians who are profound in their belief that triode power output amplifiers are incomparable in quality.

A discussion of the comparative quality obtained from pentodes, tetrodes, and triodes would bring up a number of questions which are both varied and complex. Notwithstanding academic objections (which are advanced by beam power enthusiasts) a 2A3 offers a number of very desirable circuit features, including low plate resistance, which makes it particularly adaptable for feeding output loads which have a pronounced impedance-changing characteristic with variable frequency. Its single-control-grid construction avoids regulation problems encountered in multi-grid output tubes. Its unusual power handling ability provides for the attainment of 15.6 watts at 1.4% total harmonic distortion, from a pair of 2A3's, under ideal conditions (which are rarely attained).

In order to carry the triode idea out within the basic direct-coupled circuit, a pair of 6SJ7's operated as triodes, are used as push-pull voltage amplifiers.

ADDITIONAL FEATURES

In designing this amplifier it was decided to build-in a number of desirable features which would enable the music lover to derive maximum enjoyment from his audio equipment. The following features were therefore incorporated:

- (1) Push-Pull Expansion, with Variable Time Delay.
- (2) Non-Frequency-Discriminating Scratch Suppression.
- (3) Independent Low-Frequency Equalization.
- (4) Independent High-Frequency Equalization.
- (5) Choice of Optional Push-Pull or Single-Ended Input Circuit.
- (6) Dual Grid Inversion.

THE PUSH-PULL EXPANDER

A contemporary reviewer of the advancement in the electronic art, said for the year of 1934 "volume expansion in radio sets came in with a boom and went out very quietly."

There is no doubt that volume expansion has been subjected to a considerable amount of misuse which may have led it into disrepute through careless design or operation. Unquestionably, many of the circuits developed in the rush to present volume expansion to the public presented a number of objectionable circuit characteristics which overbalanced the benefits of volume expansion. A number of tricky circuits involving microphonic tubes were presented. Many experimenters indiscriminately added these circuits to existing amplifiers and found, among other things, overload distortion was being caused by expander circuits. This proves, beyond any doubt, that an expander to really "do its stuff," must be specifically designed into an amplifier, and cannot be indiscriminately added to any existing unit.

There is no better argument for volume expansion than the fact that the Bell Telephone Laboratories, in demonstrating their stereophonic recordings at Carnegie Hall in April, 1940, introduced a new technique of "enhancing" music, which among other things, involved nothing more nor less than exaggerated expansion. It is true that some technicians will advance the theory that a properly recorded selection does not require expansion. While such may be the case, few selections are properly recorded and nearly all can be "enhanced" by use of the correct type of expansion.

Though no expansion standardization exists in the present stage of the art, the writer believes it is only a question of time before recordings are offered to the public with a coefficient of compression notated on each record. In playing the record back, the playback equipment would be set to a

coefficient of expansion equal to the coefficient of compression so that the ultimate rendition would be heard in the same dynamic range as it was originally played. Actual experience has shown that many records may be improved when properly expanded. Furthermore, listeners who condition their hearing to expanded music, will never again enjoy "flat" or unexpanded renditions.

The technical problems involved in designing an acceptable expander are comparatively simple. They are mainly centered about the selection of suitable circuit constants so as to provide minimum distortion, wide-range variable time delay, and suitable precautions for avoiding overload at maximum expansion.

Minimum distortion may be maintained by utilizing push-pull expansion. Wide-range variable time delay is made available by the use of push-pull signal voltage amplification and full-wave rectification for obtaining control voltages for the expander circuit.

The simplest way of avoiding overload under conditions of maximum expansion is to incorporate a loss, when the expander is placed in the circuit, which is exactly equal to the greatest expansion encountered, so that under conditions of maximum expansion, the rated power output of the amplifier is not exceeded.

NON-FREQUENCY-DISCRIMINATING SCRATCH SUPPRESSOR

When the Non-Frequency Discriminating Scratch Suppressor developed in our laboratories was first described, for the first time in any radio magazine, in the October, 1939, issue of *Radio-Craft*, it created a considerable amount of interest. It was therefore decided that additional work be done on this project until a highly-perfected circuit could be made available. The circuit as finally employed is virtually an inverted expander and operates on the principle that

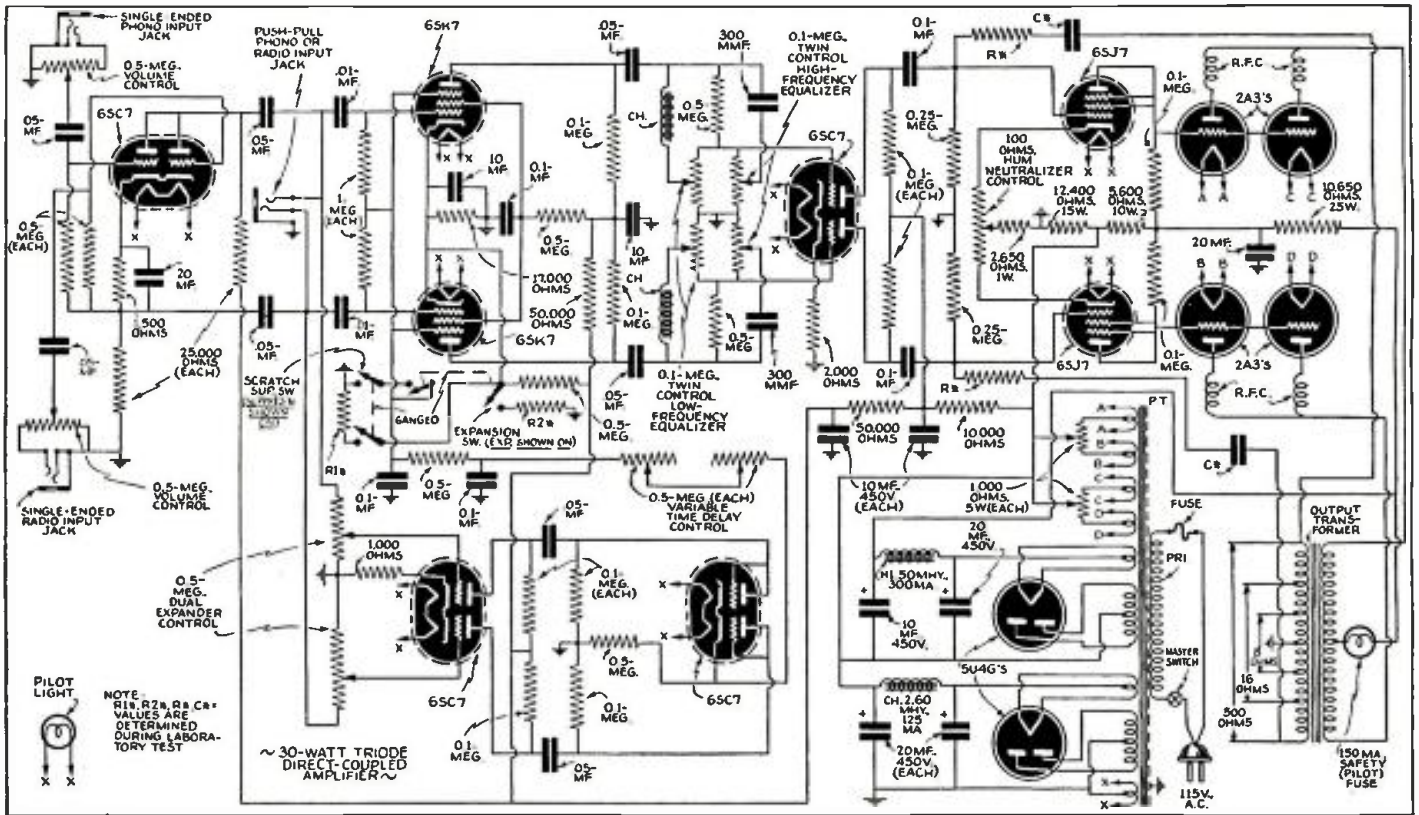

scratch may be separated from signal by the difference of the average level of each.

If we were to design an ideal scratch suppressor, it would be necessary to find a number of differential characteristics which would provide for the simple separation of scratch from signal. The fallacy of cutting high frequencies in an attempt to suppress scratch is of course obvious. When the upper audio spectrum is effected, it alters the higher harmonics of any tone. Some so-called scratch filters eliminate, or greatly attenuate, all frequencies above 3,000 cycles. While it is true that the ear may be conditioned to this type of reproduction, unconditioned listeners would immediately notice the limited range of such a system. It is therefore apparent, that in order to separate scratch from signal, frequency response should not be altered.

In attempting to find methods for suppressing scratch, the following 2 solutions presented themselves:

(1) Inasmuch as scratch is a conglomerate of indiscriminate frequencies, and music is characterized by discrete frequencies, it seemed possible to develop a set of discrete and indiscrete filters, each feeding into control-grids of a differential amplifier arranged so that when a preponderance of indiscrete frequencies were present, the volume would drop, and when a preponderance of discrete frequencies were present, the volume would maintain its average level. This effect would ultimately produce lower levels when scratch was present and normal levels when definite signals were being reproduced.

(2) Scratch is not objectionable at high-level outputs, but gradually becomes more and more objectionable as the signal level decreases, only because the signal-to-scratch ratio has decreased. It follows that an effective method of decreasing objectionable scratch is to automatically lower the overall gain of the amplifier at low levels and maintain its average level at normal levels.

The latter method seemed to offer a simpler solution. In the process of the development of this circuit, it was found that the functions of both the expander and the suppressor could be combined in the same pair of tubes, it being only necessary to increase the level above predetermined average for expansion and to decrease it for scratch suppression.

It was further found, that the speed of scratch suppression needed adjustments for different selections, because of the fact that the sensitivity of the ear does not change instantaneously with changes in level. To provide a wide degree of time delay control, a full-wave rectifier is employed, which couples to a separate push-pull control voltage amplifier. The use of full-wave rectification (which doubles the frequency of the rectified voltage) provides for small capacitative filters which thereby enable the use of high-speed control circuits without introducing hash into the signal control-grids of the expander - scratch-suppressor circuit. The degree of expansion and suppression is controlled by the "Expressor" control (which is a contractual abbreviation for expander - suppressor).

THE LOW-FREQUENCY EQUALIZER

Even-order harmonics introduced in single-ended circuits are, as is well known, canceled in push-pull stages. It was therefore decided to utilize push-pull low-frequency equalization so that all even harmonics introduced into the circuit by equalization would be canceled at the output.

The Low-Frequency Equalizer employed, has been completely described in the Nov., 1939, issue of *Radio-Craft* (Page 269). It is designed to provide a 15 db. cut and boost at 40 cycles, with a gradual tapering of control up to 1,000 cycles. Its overall range is 30 decibels, which is more than adequate for compensation of existing deficiencies in speakers, phono pickups, microphones, and radio tuners.

HIGH-FREQUENCY EQUALIZATION

The High-Frequency Equalizer follows the Low-Frequency Equalizer principles. It is

also employed in a push-pull fashion. Its operating principles were also described in the Nov., 1939, issue of *Radio-Craft*. The revised circuit, however, provides for a 15 db. cut and boost at 15,000 cycles, providing a tapering control down to 2,000 cycles. For special equalization applications, these equalizers may be replaced by push-pull audio spectrum controls, the operating principles of which were described in the Dec., 1939, issue of *Radio-Craft* (Page 342).

THE BASIC AMPLIFIER

The basic amplifier is composed of four 2A3's to provide for minimum distortion under maximum expansion. A pair of 6SJ7 triodes provide more than adequate voltage to drive the four 2A3's in a strict class A condition. One 5U4G furnishes voltage for the output power tubes, while another supplies fixed-bias for the driver tubes and plate voltage for the expander - suppressor tubes as well as the dual-grid inverter.

Independent balancing controls are provided for matching plate currents of the 2A3's. Individual anti-parasitic filters are inserted in the plates of all output tubes to prevent the slightest trace of transient distortion under any condition of operation. Push-pull inverse feedback is employed to insure an extended low-frequency response down to 20 cycles.

THE BALANCED FEEDBACK CIRCUIT

Although feedback is generally used for reduction of distortion, hum, and output plate resistance, none of these corrective measures is necessary in this amplifier. A balanced frequency-discriminating feedback network is employed, however, to compensate for odd-order harmonics introduced in the output transformer and for frequency correction. The inverse feedback circuit employed is of a distinct frequency-discriminating type. The value of the resistors and condensers in this circuit are dependent upon the design and construction of the output transformer employed. They are therefore not given. It is important, however, that a balanced output transformer be used in order to attain a balanced inverse feed-

•SOUND•

back signal. Otherwise it would be impossible to provide for balanced frequency equalization.

PUSH-PULL SINGLE-ENDED INPUT

A push-pull signal may be coupled directly into the grids of the 6SK7 tubes. For single-ended signals, however, such as a grounded phono pickup or radio tuner a 6SC7 inverter is added. This is of the degenerative type. A dual-grid tube is used so as to provide for electronic mixing of 2 independent input circuits. Each grid is equally efficient in providing an inverted signal to the push-pull 6SK7 tubes.

The overall gain of the amplifier, with controls set for flat response and no expansion, is 75 db. For microphone work, an additional preamplifier stage should be added. A suitable circuit was given in the Nov. 1939 issue of *Radio-Craft*, pg. 302.

POWER OUTPUT RATING

This amplifier is rated at 22.5 watts at 2.5% total harmonics. It will deliver 30 watts at 5%.

This article has been prepared from data supplied by courtesy of the Amplifier Company of America.

ONE - OF - A - KIND

**Special Amplifiers and Sound System Installations
Custom-Built to Your Specifications!**



Because the requirements for no two amplifiers or sound systems can be exactly alike, our designing and production staff has been geared to create special amplifiers to meet your exclusive needs.

This one-of-a-kind amplifier can be built to your individual specifications and is guaranteed to solve all of your particular requirements, at no extra costs.

Send your rough specifications to our chief engineer, and see what twenty years of specialized amplifier engineering can mean to you in terms of professional advice and lower costs.



All Special and Standard Amplifiers Bear Our Usual Five Year Guarantee

AMPLIFIER COMPANY OF AMERICA

17 W. 20th STREET

NEW YORK, N. Y.

CASE HISTORIES OF P.A. SALES

No. 11—Church Sound Set-up

I HEARD an official of a local church state that he needed something to increase their attendance. I suggested a public address system to be installed with speakers in the tower and auditorium. I carried them to a nearby town where such an installation was made and they OK'd it next day.

The cost of equipment with 40% profit was \$430. The charge for myself and a helper was \$12.50 a day for installation. This took 3 days which made a total of \$37.50 labor, added to the above this made a total sale price, with profit, of \$467.50.

The purpose of the installation was twofold: 1st, to have loud speakers in the tower to send out chimes and organ music over this section of the city. Second, to have ample amplification for the auditorium. As the officials only wanted the sound to be projected in 2 directions from the tower we needed 2 overrated speakers in trumpet-type baffles with an amplifier to make a coverage of about 1/2-mile in 2 directions. They demanded perfect fidelity and also to have volume controls on each speaker.

We selected a 60-watt high-fidelity amplifier which does not have to be driven hard for the coverage necessary therefore having negligible distortion. We selected two 25-watt P.M. speakers in trumpet-type baffles, for the tower to give distance to the projected sound. We selected two 25-watt P.M. speakers with wall-baffles for the auditorium. You notice that we are giving ample power ratings which are necessary for real fidelity. We installed constant-impedance attenuator pads in each speaker

line so that the tower speakers and the auditorium speakers could be run at different levels. An automatic record player with crystal pickup and a radio tuner were installed, with the amplifier, in a beautiful cabinet. Two velocity wide-range mikes were included, one for the pulpit and one for the organ pit. Separate faders were provided on the control panel for the microphones, the record player and the radio tuner.

Separate speaker attenuators solved the problem of speaker level control and are vitally important for this type of installation. The auditorium speakers were moved about until the reverberation and acoustic feedback were at a minimum. Output level meters were put between the attenuator pads and the speakers so that the amount of volume needed could be given from the control panel without having to judge the outside level. Different amounts of volume were tried until a satisfactory level was found and a record was made for the meters so that the volume could be set quickly.

Finally we would like to urge anyone contemplating such an installation to allow about 30% more power handling capacity for the speakers and amplifier than needed and he will have no complaint on the fidelity.

L. B. TOOLEY,
Clarksville, Texas

Mr. Tooley's prize was No. 11, in the 2nd Section of the \$4,000 P.A. contest "R.-C." sponsored last year.

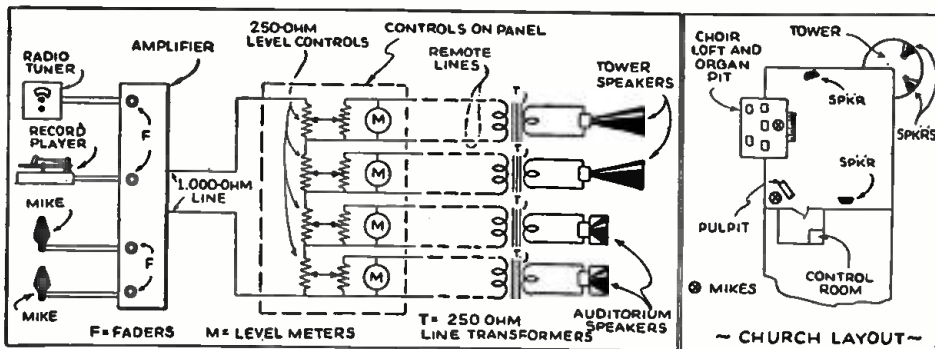

The NEW DOENUT Horn



**Provides
Wider
Angle
Coverage**

**Model
DX8B**

An entirely new development in exponential horns which provides unique features never obtainable before.

- Spreads high frequencies over a wide angle.
- Weatherproof.
- Wide frequency range.
- No metallic sound.

Write for complete details

WRIGHT-DeCOSTER, Inc.

2251 University Ave., St. Paul, Minn.
Export Dept.: M. Simons & Son Co., New York
Cable Address: "Simontrol"

Canadian Representatives:
Wm. F. Kelly Co., 1207 Bay St., Toronto, Ontario
Taylor & Pearson, Ltd., Edmonton, Alberta

WEBSTER PHONO-MOTOR



Self-starting, rim-driven, constant-speed (78RPM). Friction-drive is preferable wherever driving torques are low and quietness is all important, as in a phonograph. Motor with 9" felt covered turntable operates on 117 volt, 60 cycle only. Shipp. wt. 6 lbs. Price Each ... **\$2.69**

WE REQUIRE A 25% DEPOSIT WITH ORDER
Write for Our Latest Bargain Parts Bulletin
ARROW SALES COMPANY
819 W. RANDOLPH ST., DEPT. RC-7, CHICAGO, ILL.

SOUND ENGINEERING

*Free Design and Advisory Service
For Radio-Craft Subscribers*

Conducted by A. C. SHANEY

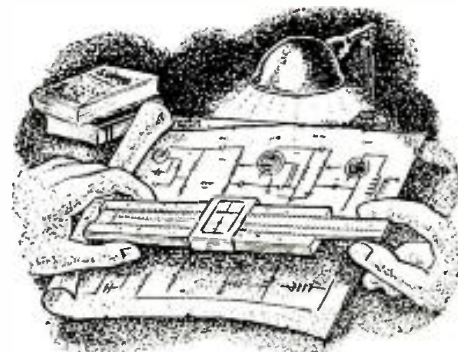

This department is being conducted for the benefit of RADIO-CRAFT subscribers. All design, engineering, or theoretical questions relative to P.A. installations, sound equipment, audio amplifier design, etc., will be answered in this section. (Note: when questions refer to circuit diagrams published in past issues of technical literature, the original, or a copy of the circuit should be supplied in order to facilitate reply.)

No. 7

13-W. MIKE AND PHONO AMPLIFIER

The Question . . .

I would like to construct an amplifier with 2 inputs, one each for phonograph and microphone (both high-impedance), using the following tubes: a 6F5 for voltage amplifier, a 6N7 for driver or inverter, a push-pull 6V6 for power amplifier, and an 80 rectifier.

Please favor me with a diagram, or you may publish it through *Radio-Craft* (I am a subscriber) using the above tubes; also showing resistance in capacity values for class AB1; and, if possible, the amplifier should be capable of handling an undistorted power output of 13 watts. I would appreciate it very much if you could help me.

LUZON GAMBOA,
Caloocan, Rizal, Philippines

The Answer . . .

The circuit diagram of the type of amplifier you desire is given in Fig. 1. As a 3-stage amplifier of the type you request

would not have sufficient gain for microphone operation, I have added an additional 6F5 preamplifier stage.

Although you requested a circuit using an 80 rectifier, this particular tube is not recommended for a push-pull 6V6 amplifier, operating in class AB1, for the simple reason that the current requirements of the amplifier closely approach the recommended maximum output current for this type of rectifier. A 5U4G rectifier has therefore been used.

The power transformer employed should be capable of delivering approximately 310 volts at 150 milliamperes. The output transformer should have a plate-to-plate impedance of 3,600 ohms. The amplifier will develop approximately 13 watts with 5% harmonic distortion.

Although a feedback circuit is employed from the 500-ohm tap of the output transformer this circuit element may be omitted. It is, however, highly recommended in order to maintain low distortion and good response. A conventional "high cut" tone control circuit is employed in the grid circuit of the inverter tube.

It will be noted that the phono input jack automatically disconnects the preamplifier tube. If it is desired to fade from phono to microphone, the phono fader control illustrated in Fig. 1A should be used. If electronic mixing is desired between both inputs, then the circuit given in Fig. 1B should be employed.

The only special precaution required in wiring this amplifier is to avoid hum pick-up in either of the 6F5 stages.

20-WATT 6L6 AMPLIFIER—FREEZING ELECTROLYTICS

The Question . . .

I have been a *Radio-Craft* subscriber for a number of years, as every progressive radio Serviceman should be. Your department, Sound Engineering, is very interesting and I would like to submit a problem of my own.

I would like to have a circuit for an amplifier employing a pair of push-pull 6L6 output tubes driven by a pair of resistance-coupled 6SJ7 pentodes and having, in addition, a 6SJ7 microphone preamplifier and a 6C5 or similar tube for coupling to a phono pickup. If your diagram would give all values of condensers and resistors it would save me a lot of experimenting.

Another thing I have had difficulty with is the electrolytic condensers freezing in cold locations (such as a skating rink). What type of condenser is the least affected by low temperatures?

S. BEYER,
Sioux Lookout, Ontario, Canada

The Answer . . .

A circuit diagram of the type of amplifier you desire is given in Fig. 2. A balanced output transformer is employed so as to provide

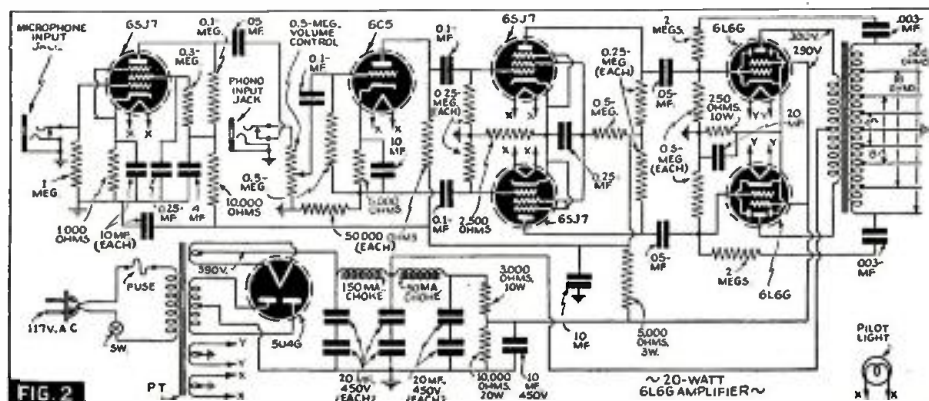
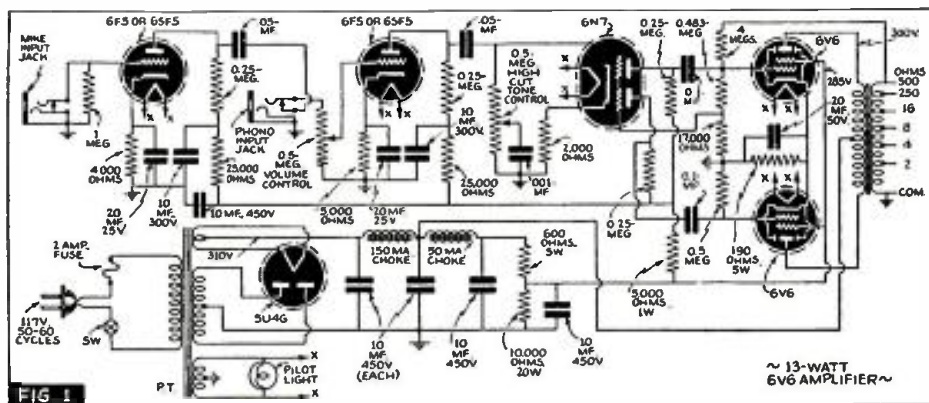
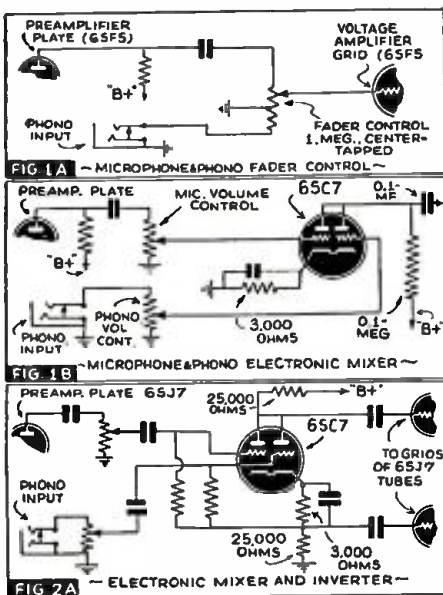

•SOUND•

a balanced feedback loop directly into the push-pull stage. A 6C5 is employed for phase inversion.

The power transformer should be capable of developing approximately 390 volts at 175 ma. The output transformer should have a plate-to-plate impedance of 6,600 ohms. The amplifier will develop approximately 20 watts at 5% total harmonics.

It will be noted that series filter condensers are used in order to provide an adequate safety margin in the power supply circuit. Although mixing facilities are not provided, they can be incorporated by employing the mixing circuit given in Fig. 2A.

As for the trouble you are experiencing with electrolytic condensers in cold locations, you might be interested to know that all electrolytic condensers, regardless of make, become practically inoperative at temperatures in the neighborhood of -40° , or less, F. This is due to the fact that the ionizing agent, i.e., the hydrogen atom present in the water content of the electrolyte freezes, causing a cessation of electrolytic action. However, since the composition of most electrolytes involves a large proportion of *etholene glycole* (similar to the material used in automobile radiators), the freezing point of the ionizing agent is greatly retarded until very low temperatures are reached.

The popular misconception is that electrolytic condensers lose a large percentage of their capacity, and that this is the major cause for their lowered filtering efficiency, with decreasing temperature. Actually, the increasing series resistance that is noted as the temperature lowers, is the more important factor and changes more rapidly and to a greater extent than the change in capacity.

In all cases, any loss of filtering efficiency due to low temperature is temporary, and these characteristics come right back to normal with any increase in temperature without damage to the condenser.

If a device is to be operated at sub-zero temperatures of below -20° C., and there is no chance of the apparatus heating up which would have a tendency to bring the condenser back to normal, an electrolytic condenser should not be used.

In freezing temperatures, an electrostatic type of condenser should be employed. You will find, however, that the cost of this type of condenser (employing paper or similar dielectric) will be prohibitive in cases where high capacities are required.

On the other hand, from a practical sense, there are very few cases where the temperature reaches low enough to upset the operation of the apparatus for any appreciable period of time. This is generally due to the fact that the condenser warms up either from its own internal heat where high ripple might be found, or the equipment's heat.

IT'S RCA FOR UNMATCHED QUALITY...UNBEATABLE LOW PRICES!

A REVOLUTIONARY
SPEAKER
DEVELOPMENT
BY RCA

New RCA Accordion Edge Speaker
BIG IN PERFORMANCE... SMALL IN SIZE

Here is a radical step forward in speaker engineering! The new RCA Accordion Edge Speaker provides unheard of travel of the free-edge diaphragm because of bellows action. Its performance will

amaze you. Small size will surprise and please you.

Listed below are some of the features of this new speaker. They prove that *now* a small speaker can be a *quality* speaker.

* Ultra sensitivity * Remarkable frequency characteristics * Excellent quality at high or low volume * Sealed voice coil * Exceptionally smooth response * Compact $7\frac{1}{2}'' \times 3\frac{1}{2}''$ * Large Alnico permanent magnet * Ideal for new or replacement work * 6 ohm voice coil * 3 watts average capacity * Superior performance at low cost * Matching transformer can be added to permit wide variety of matching impedances.

Get in touch with your RCA Commercial Sound Distributor for full details.

Any sound system sounds better equipped with RCA Radio Tubes



Commercial Sound

RCA Mfg. Co., Inc., Camden, N. J. • A Service of Radio Corporation of America

MORE FROM THE DAY'S MAIL OF THE F.C.C.

FROM Pittsburgh comes a letter asking the Federal Communications Commission to bar all "Confucius Says" jokes from the air. However, the Commission does not have authority under the law to direct radio station licensees to broadcast or to refrain from broadcasting such programs.

A New York man complains that a local station declined to give him time on the air to broadcast a particular speech. Under the Communications Act, broadcast station licensees are not deemed to be common carriers and they may therefore, with the exception of certain broadcasts by legally qualified candidates for public office, refuse to accept material offered.

Another New Yorker inquires whether it

will be permissible to broadcast a particular program. The Commission does not have authority to censor programs, and it is not the policy of the Commission to render such advance opinions. It is the duty of each station to determine whether the broadcasting of a certain program will be in the public interest and in accordance with the law.

A Shickshinny, Pa., woman charges that a certain station broadcast 2 musical compositions similar to those composed by herself. This is a matter of private concern between the woman and the station, and the Commission has no jurisdiction.

Several letters imply that the Commission has "ruled" various persons off the air.

The Commission has entered no order denying any individual the right to broadcast, nor would it have authority under its statute to do so.

A McGuffy, Ohio, firm inquires if it can use telegraph facilities in connection with the proposed gift of a carload of onions to the holder of a lucky number. Though the Communications Act prohibits broadcast of "any advertisement of or information concerning any lottery, gift enterprise, or similar scheme, offering prizes dependent in whole or in part upon lot or chance," the Act does not contain a similar prohibition with respect to the use of wire facilities of common carriers engaged in communication service.

"TRANSITIONAL" P. A. SYSTEM

The Problem: *You Need a Public Address System But Cannot Afford a Professional Job; Nor Can You Afford to Be Without Any at All. What to Do?*

The Solution: *Hook Up a "Transitional" P.A. System—One Utilizing a Radio Receiver—Until You Can Afford a Regular One; But Don't Be Without Any.*

H. T. ZIEGLER

THIS article explains how to convert any good radio receiver into a complete sound system for taverns, restaurants, clubs, and other places where people meet. People like music, but not if it breaks their ear-drums in one part of a room and cannot be heard in another. Entertainers and even customers like to sing through a mike. You can earn real money this summer by putting some "push" and "oomph" into "Sweet Adeline."

Note that it is always best to use a factory-built amplifier; but, when circumstances do not justify the cost of a tailor-made sound system, almost any radio set can be made to furnish entertainment for up to 250 persons.

WHAT KIND OF SET TO USE?

The average radio set has an audio-frequency amplifier with an output of 3 to 5 watts. Sound specialists consider this sufficient power to cover an audience of 250 persons. With the sound coming from a single speaker housed in the radio cabinet, the sound is concentrated in the immediate vicinity of the radio set. But mount the loudspeaker in a baffle and install it, together with a second (permanent-magnet or "P.M.") speaker-and-baffle, high on the walls on each side of the room, and inclined to direct the sound downward, and you will be surprised at the increase in coverage.

This method of obtaining audio amplification has never been popular because everyone has had at least one unpleasant experience with the auxiliary speakers. The idea was good, but the installations were always of the makeshift type. An old magnetic speaker was dug out of the cellar; with no thought of matching it to the radio set, and without any baffle, the speaker was set on a shelf and expected to reproduce music. Sometimes the speaker played with a beautiful rasping tone; more often it just let out little tinny squeaks.

Good-quality P.M. speakers mounted on large baffles (about 36 x 36 ins.) will actually produce better tone than the original speaker installed in the cabinet.

The following system is complete, including a good double-button microphone, adjustable floor stand, and a phono record player. The mike can be left out if it is



Take 1 radio set, add a microphone and loudspeakers, and you have: a Transitional P.A. System.

not required. Record players can be purchased from \$5.65 all the way up, depending entirely on the purchaser's pocketbook.

WHAT ADDITIONAL EQUIPMENT TO BUY?

The following parts will be required, in addition to the radio set, and can be bought for under \$20: 2—36 x 36 in. plywood wall baffles; 2—8-in. P.M. dynamic speakers; 1 universal speaker-matching transformer; 1 streamlined double-button carbon microphone; 1 adjustable microphone floor stand; 1 carbon mike adapter kit (consisting of parts shown in Fig. 2); 2 Amphenol ACS-4 sockets; 2 Amphenol PM-4 plugs.

INSTALLING THE SPEAKERS

The 8-in. P.M. speakers must first be mounted on the baffles. Four wood screws for each speaker are sufficient. If the baffles are not finished in a color to harmonize with the walls, they can easily be repainted to suit. The baffles should be mounted high on

the wall, inclined so that the bottom part of the baffle touches the wall.

Up to 100 feet of cable can be used between the radio set and each speaker. Remember this when selecting the spot for the speakers. Ordinary heavy rubber-covered lamp cord can be used to connect the speakers. This type of cable usually costs about 1½¢ per foot.

There are only 2 connections to make at the speaker. Be sure to solder these connections. Hiding the wire connecting the speakers to the radio set is purely a matter of ingenuity. Every installation will differ. Take advantage of moldings along which the wire can be tacked. The well-installed job will have the wires running through the walls behind the plaster.

CONNECTING THE SYSTEM

To install this system a few simple changes are necessary in the radio receiver itself.

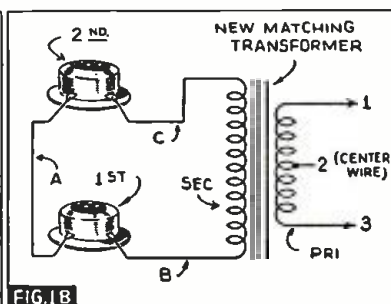
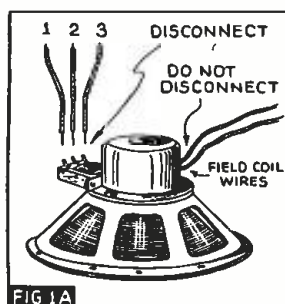

← These picture diagrams (left) show how the loudspeakers are connected (see text).

Except for the mike → the parts shown here are included in the carbon mike adapter kit (see text).

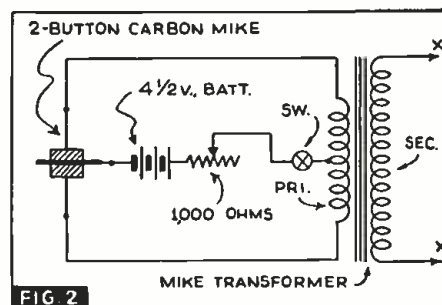

• SOUND •

Disconnect the wires running from the radio chassis to the speaker transformer (Fig. 1A). If the transformer is mounted on the chassis, it may be necessary to remove the chassis to disconnect the wires. If the radio set has an electrodynamic speaker—and most radio receivers have—do not disconnect the wires going to the speaker field coil. This field coil is a part of the radio filter system; and if the wires are disconnected, the receiver will have no "B" voltages.

Mount the new matching transformer on either the chassis or the radio-cabinet wall. Connect the wires just removed from the old transformer primary to the new transformer primary (Fig. 1B). If the set has 1 output tube, there will be 2 wires; if the set has push-pull tubes, there will be 3 wires. *Note:* The outside wires can be reversed; but if there are 3 wires, the center wire must be the one formerly on the center-tap of the old transformer.

When ordering the transformer, it is usually best to specify the *universal* type as this will permit a perfect match between any radio-set output and the new speakers. Complete instructions are always included with this type of transformer.

Run 1 wire from each of the secondary taps of the transformer to each of the sockets as shown in Fig. 1B. Connect a

single wire from contact No. 1 on the first socket to contact No. 1 on the second socket; run a single wire from contact No. 2 on the first socket to one side of the transformer secondary; run a single wire from contact No. 2 on the second socket to the other side of the transformer secondary. (The sockets have flanges for mounting on the wall of the radio cabinet.)

INSTALLING THE MIKE

Drill a single hole in the chassis to accommodate the microphone voltage control which has the off-on switch mounted on the back for cutting off the battery when not in use.

The mike transformer, which is supplied with the carbon mike kit mentioned in the parts list, can be mounted on the chassis or the radio-cabinet wall. All the mike connections are shown in Fig. 2.

NOTE: If there are no phonograph input jacks on the radio set, the author will supply instructions for connecting the mike and phono. Include make, model and tube lineup of receiver. If speaker cables must run more than 100 feet, a line-matching transformer will be necessary. Cables can then be run as long as necessary.

This article has been prepared from material supplied by courtesy of Allied Radio Corp.

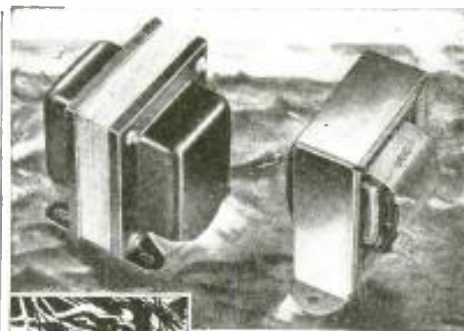

**UTAH
TRANSFORMERS
ARE "Dressed"**

FOR ROUGH WEATHER

● "The weather-resistance of a skipper on a fishing smack"—that's what they say about Utah Transformers.

A non-corrosive, protective coating of cellulose acetate provides absolute insulation—prevents breaking down, even under extremely high humidity and other atmospheric conditions, which are so frequently destructive to ordinary transformers. The high safety factor of their insulation is proved by the extra hours of satisfactory performance of the Utah transformers, which are standard equipment in millions of receivers throughout the world.

Precision manufacturing and the use of other scientifically selected materials such as high silicon content steel, used in all laminations, make Utah Transformers uniformly dependable. These fully guaranteed transformers are individually boxed, with complete instruction sheets.

Utah Transformers are sold through parts jobbers everywhere. If you do not have your copy of the new Utah illustrated catalog containing complete information about the transformer line and other Utah products—write for it today—there is no obligation. **UTAH RADIO PRODUCTS COMPANY**, 826 Orleans Street, Chicago, Illinois. Canadian Office: 560 King Street West, Toronto Cable Address: Utaradio, Chicago.



**TRANSFORMERS
SPEAKERS - VIBRATORS
UTAH-CARTER PARTS**

HIGH SCHOOL STUDENTS BUILD TRANSMITTING STATION—W7PU



TUCKED away in a corner of the Tahoma High School at Maple Valley, Washington, is a little room that is the pride and joy of 16 students and the envy of the rest. It is a radio room, the home of W7PU, a 150-watt amateur shortwave station built by the boys themselves and now in daily communication with other "hams" in all parts of the world.

The Tahoma enterprise came about as a recreation project of the Work Projects Administration. The 16 boys, ranging in age from 14 to 16 years, obtained from school officials permission to use the manual training shop outside school hours and under the supervision of B. C. Sutton, a WPA instructor, went to work.

Undeterred by a little thing such as lack of money the boys talked their project up with such success that enough material, second-hand of course, was donated to make their station a possibility. A little money was needed for power supply apparatus and that—\$6.57—was contributed, too.

In building the station the boys learned, under the tutelage of the WPA instructor, the name and function of every minute part as well as the proper placement of each instrument. They learned how to build a station and how to repair it if anything went wrong—even before they learned its operation. The boys subsequently learned the dot-dash code, and all the fundamentals required to pass the F.C.C. examination for operators' licenses.

When the station was ready for operation the boys announced through newspapers that they hoped to hear from other "hams" and were staggered by the response. They received 250 calls in the first 10 days, and in no time at all had logged 67 different countries.

With Mr. Sutton acting as chief of the technical staff, and members of the club acting as 1st and 2nd assistants, the boys now take turns in 2-man continuous duty from 3:30 p.m. until midnight daily.

RESISTORS AND CONDENSERS

For Use in Audio-Frequency Amplifiers

The preferred characteristics of resistors and condensers for use in A.F. amplifiers are here described.

ARE there any prerequisite characteristics for resistors and condensers intended for use primarily in audio-frequency amplifiers? Jot down your recollection of what these prerequisites may be and then compare your listing with the pros and cons which this article presents.

RESISTORS

Resistors for audio-frequency amplifiers (public address systems, the A.F. sections of radio receivers, etc.) present to some extent the same general problems as resistors for general radio apparatus use, with the exception that the magnitude of the currents in A.F. amplifier circuits is ordinarily higher than in the R.F. circuits, with the result that high power dissipation is more often encountered.

For the lower-power applications, that is, below 2 watts, the *Carbon or Composition* type of resistor is most economical. When plate circuit resistors, grid bias resistors, voltage dividers, etc., requiring resistor ratings above 2 watts are needed, the *Wire-Wound* resistor offers the only practical solution.

There are many types of wire-wound resistors available, but the same considerations govern the choice among them. These are:

- (1) Temperature rise
- (2) Mounting
- (3) Insulation of resistor
- (4) Safety of construction

Wire-wound resistors are ordinarily rated on the basis of NEMA classification, which permits a 250° C. temperature rise. Vitreous enamel and cement-coated resistors will have this temperature rise, while bakelite molded wire-wound resistors will usually be designed to have a temperature rise limited to 100° C.

Care must be exercised in the use of resistors which will reach temperatures as high as 250° C., because organic insulations associated with most electrical and radio components will not withstand such temperatures. The general practice is to limit the temperature rise of the resistor by using a unit having a higher watts rating than actually required. The temperature rise of a resistor, up to its full rating, is approximately in direct proportion to the watts power which it dissipates.

When mounting "high-wattage" resistors, care must be exercised in the location of the resistors with respect to other components, such as condensers, which may be seriously damaged by high temperatures. The resistor mounting must also insulate the resistor from ground and from other circuit components. Vitreous enamels and cements ordinarily used on resistors are not good electrical insulators, and no dependence should be placed on them for insulating the resistor away from chassis or other parts.

High resistance values in wire-wound resistors are ordinarily produced by the use of very fine resistance wire, as small as 1 mil. in diameter. Experience has shown that these very fine wire resistors are not

reliable for permanent installation, particularly in locations of high humidity. Most resistor manufacturers reduce the rating of the higher-value resistors using such fine wire, even though the resistor is physically large enough to handle a higher power, because the wire will not safely carry the currents involved.

Recently a new type of wire-wound resistor has appeared which uses no very fine wires, but produces the high resistance values by a specially-insulated, larger-diameter resistance wire, which can be wound by special methods into a very small space. This new type of resistor also has a completely-insulated ceramic surface which can be mounted directly in contact with chassis or other circuit parts, without the insulation restrictions placed on enamel or cement-coated units.

CONDENSERS

Condensers for audio amplifier use are usually one of the 4 major types, as follows

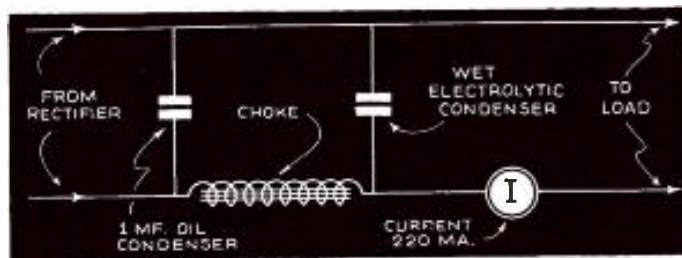

(they are described in this order):

- (1) Paper Condensers
- (2) Oil Condensers
- (3) Wet Electrolytics, or
- (4) Dry Electrolytics

The major factors of importance in all 4 of these types of condensers are: stable capacity, voltage rating, power factor, and leakage resistance or leakage current; but each of these types has its own special characteristics and applications, which should be given consideration in their use in amplifiers and associated power supply.

(1) *Paper Condensers*.—The *Paper* type of condenser is so well known to radio men as to require almost no description, but its characteristics are of extreme importance and are not sufficiently understood in all cases.

Paper condensers are used for small capacity filters, bypass applications, and as coupling units. It is extremely important that these condensers have stable capacity and high leakage resistance. Proper vacuum drying and impregnation of the condenser sections is essential to obtain and preserve satisfactory leakage resistance, and careful control of the quality of the dielectric paper is needed to obtain these characteristics initially. Low leakage resistance causes ineffective filtering, and in coupling applications causes direct coupling which may reduce gain, cause distortion, or cause motor-boating. A minimum satisfactory leakage resistance is of the order of 10 megohms per microfarad. Care must be observed to oper-

ate these condensers within their voltage rating on both A.C. and D.C. The A.C. rating is ordinarily only 1/3 of the D.C. rating.

(2) *Oil Condensers*.—*Oil* condensers are basically high-quality paper condensers impregnated in dielectric oils which allows them to be operated at higher voltages and temperature extremes. Careful vacuum-pressure technique is necessary, together with special dielectric oils, to produce the required improvement in characteristics which the oil condenser has over the paper types. When proper materials and manufacturing methods are employed, the oil condenser becomes the most stable and satisfactory of all condenser constructions.

In A.F. amplifier work, oil condensers are used for high-voltage filter and coupling applications, and should be used where very wide temperature variations, or extreme temperature conditions are encountered. Certain synthetic dielectric oils are claimed to have superior characteristics from the standpoint of space factor or heat conductivity, but they are inferior to high-quality mineral oil condensers at very low temperatures because of a rapid loss of capacity and increase in power factor.

Voltage rating must be taken into account in the application of oil condensers, and commercial units are ordinarily marked with their rated voltage.

In power supply filter circuits where the D.C. operating voltage plus the A.C. ripple voltage will exceed the surge voltage rating of electrolytic condensers, then oil condensers should be used. Where amplifier equipment is to be permanently mounted outdoors, or where severe climatic conditions prevail, oil condensers should be given consideration for filter applications.

(3) *Wet Electrolytic Condensers*.—*Wet Electrolytic* condensers were the first of the compact, high-capacity filter units, and although they have been largely replaced by the dry electrolytic condenser they still have certain particular fields of usefulness. They are used primarily for power supply filters.

In amplifier power supplies, the wet electrolytic condenser should be chosen where high D.C. voltage, of the order of 500 volts, and conditions of high A.C. ripple are present. The wet condenser can safely handle higher A.C. ripple currents than the dry, because its construction is such as to more rapidly dissipate the heat generated.

When manufactured with properly-formed anodes and correct type of electrolyte, the wet electrolytic condenser is a reliable, low-cost, compact filter condenser, which can be operated over a wide temperature range, and which will withstand considerable abuse from the standpoint of momentary overloads without serious loss of characteristics.

At very low temperatures, this type of condenser has a decreasing capacity and increasing power factor, and will freeze at freezing temperatures. They will return to normal at room temperature, but are not recommended for outdoor installation.

•SOUND•

OPPORTUNITY AD-LETS

Advertisements in this section cost 15 cents a word for each insertion. Name, address and initials must be included at the above rate. Cash should accompany all classified advertisements unless placed by an accredited advertising agency. No advertisement for less than ten words accepted. Ten percent discount for six issues, twenty percent for twelve issues. Objectionable or misleading advertisements not accepted. Advertisements for August, 1940, issue must reach us not later than June 7th.

Radio-Craft • 20 Vesey St. • New York, N. Y.

AGENTS WANTED

300% PROFIT SELLING GOLD LEAF LETTERS FOR store windows: Free samples. Metallite Company, 451 North Clark, Chicago.

BOOKS AND MAGAZINES

ASSURE YOURSELF OF GREATER PROFITS BY doing radio service jobs more quickly. Authentic service guides show you the way to locate and correct troubles in any radio receiver. Gernsback Official Radio Service Manuals show you how to complete more repair jobs in less time—how to earn more money by faster servicing. Read the advertisement which appears on page 40 of this issue.

WE HAVE A FEW HUNDRED RADIO ENCYCLOPEDIAS, by S. Gernsback, second edition, originally and at \$3.98. Book has 352 pages, weight 3 lbs., size 9 x 12 inches. Red morocco—keratol flexible binding. Send \$2.40 in stamps, cash or money order and book will be forwarded express collect. Technifax, 1915 So. State Street, Chicago, Illinois.

ELECTRICAL SUPPLIES

FLUORESCENT AC DAYLIGHT LIGHTING FOR desk; office; windows; home. Latest sensation. 50% discount. Literature FREE. McGee Radio, F-2053, Kansas City, Mo.

EDUCATIONAL COURSES

USED CORRESPONDENCE COURSES AND EDUCATIONAL books bought, sold, rented, exchanged, catalog free. V. W. Vernon, Henagar, Alabama.

CORRESPONDENCE COURSES AND EDUCATIONAL books, slightly used. Sold, rented, exchanged. All subjects. Satisfaction guaranteed. Cash paid for used courses. Complete details and bargain catalog FREE. Write Nelson Company, 500 Sherman, Dept. G-242, Chicago.

PRINTING

BOND LETTERHEADS, UNRULED STATEMENTS, OR 6% envelopes, four lines printed, 100—50c; 300—\$1.00. Prepaid. Cards, 100—35c, Belleville, 907 West Roosevelt, Philadelphia, Pa.

RADIO

WE BUY AND SELL USED RADIO TESTING EQUIP-ment. Time payments if desired. Harold Davis, Inc., Jackson, Miss.

ANY RADIO DIAGRAM, 25c. SPECIFY MANU-facturer, model. Radio magazine free. Supreme Publications, 3727 West 13th, Chicago.

MAJESTIC RADIO PARTS AND MANUALS PRIOR 1936. Parts for Majestic refrigerators. Send for catalog. G & G Company, 2429 Wabash, Chicago.

A BARGAIN SOMEONE WILL SNAP UP! ARVIN car-radio set used little. List, about \$80; sell for \$25. Push-pull output affords high quality and power; set is selective and very sensitive. R. Bernard, 40 Manning Ave., No. Plainfield, N. J.

ATTENTION DEALERS, SELL WRIGHT SPEAKERS, WARD-LEONARD relays, resistors, CONSOLIDATED VOLUME CONTROLS, SUPREME INSTRUMENTS, ILLINOIS CONDENSERS, Gernsback, Manuals, Sentinel Radios. Send for catalog. Anchor Radio Distributing, Dryden Rd., Ithaca, New York.

HARD-TO-GET RADIO DIAGRAMS. TRY USUAL sources first. If you can't get them, try us. Price, 75c to \$1.50 if we succeed; no charge if we don't. You lose nothing! Send no money—write first giving fullest information. Enclose return-addressed, stamped envelope. We have helped many Servicemen, experimenters and radio fans. We may help you. Allan Stuart, 1015 Wilson Ave., Teaneck, N. J.

WILL SWAP TEST EQUIPMENT, CAR-RADIO SET, radio books, experimental receivers, camera or what do you want—for IP-501 receiver, airplane-cloth speaker, magnetic detector, navy tuner, deForest Audion control box, W.E. 18-inch free-edge magnetic-type cone speaker, or what old apparatus have you? R. Bernard, 40 Manning Ave., No. Plainfield, N. J.

STAMPS

THREE SCARCE SETS, NOW OBSOLETE, 25c. WITH new customer, gift: Box 211, Malden, Mass.

TECHNICAL ART SERVICE

DRAFTING AND ART SERVICE—A COMPLETE Service for the Industrial and Commercial Marketers. If your business or plant can't afford a designing or drafting staff, don't let this stop you from going ahead with that new product you intend marketing, or that fine detailed drawings and highly retouched photographs. Any mechanical, electrical or radio problem can be solved for you by our associated staff of designers, draftsmen and artists, and technical copywriters. Write for any additional information as to methods and price for this service. Tec-Art Drafting Service, 228 Charlotte Terrace, Roselle Park, N. J.

RESISTORS AND CONDENSERS

Certain special types of wet electrolytic condensers, known as "regulating wet condensers," are manufactured for applications where it is desirable to keep the D.C. plate voltage supply from building up too rapidly before the tubes are warmed up.

Wet electrolytic condensers should always be mounted vertically.

(4) *Dry Electrolytic Condensers.*—The Dry Electrolytic condenser is the most compact, high-capacity, low-cost filter condenser available. It finds its greatest field of usefulness in filter and bypass applications, such as plate supply filters and cathode resistor bypass.

Various constructions of dry condenser are available, such as (a) hermetically sealed, (b) paper cased, (c) metal can, etc. The conditions of use govern the choice of construction, but for longest life in permanent installations, the sealed-can type of dry condenser should be chosen.

In amplifier work, the dry condenser is used wherever high capacity is required. Care must be exercised to operate the condensers within their voltage rating, and to observe polarity, as overvoltage or reversed polarity cause high leakage current, with consequent heating and drying out of the electrolyte.

When properly designed and manufactured, the dry electrolytic condenser has low leakage current, low power factor, and stable capacity under very wide conditions of operating temperature and use.

The more familiar types of dry condensers are available for operation at D.C. working voltages up to 450 V. In general, for a given physical size of condenser, the higher the capacity, the lower the voltage rating.

Recently, high-capacity dry condensers with D.C. working voltages up to 800 V. have become available, and are of particular use in high-voltage amplifier power supplies. Dry condensers may be mounted in any position.

GENERAL RULES FOR CHOOSING CONDENSERS

The specific choice of a particular type of condenser depends, of course, upon the exact conditions of the application. It is possible, however, to give a general rule which will guide this choice:

In general, the dry electrolytic condenser should be used for filter circuits where the D.C. drain is up to 100 ma.

When the D.C. exceeds 100 ma., but is less than 200 ma., the wet electrolytic condenser should be used.

If the D.C. drain from a power supply filter system exceeds 200 ma., use wet electrolytic condensers in parallel; 1 condenser for each 200 ma., or use oil condensers.

A simple expedient which can sometimes be used when the D.C. drain just exceeds 200 ma., for example 220 ma., is to use a 1 mf. oil condenser as the filter input condenser, followed by the choke and wet electrolytic condenser. See Fig. 1.

This article has been prepared from data supplied by courtesy of Sprague Products Company.

RADIO IN A FISHBOWL!

Don't throw stones, if you visit General Electric's "Phantom House" at the 1940 Golden Gate International Exposition at San Francisco, Calif., unless you want to risk breaking transparent glass walls! This 5-room, full-size model home, equipped with every electrical convenience, includes the studio of international broadcast station KGEI, which transmits Exposition programs to Asia, So. Africa, the Antipodes and Latin America.

BOGEN SOUND SYSTEMS

Sound Specialists!

Servicemen!

1940 IS A SOUND YEAR

Increase your sales with BOGEN

BOGEN Equipment Offers You—

- Exclusive performance features.
- Popular prices to minimize competition.
- National acceptance and prestige to inspire customer confidence.
- Most complete selection of equipment in the country to help concentrate your sales efforts.

VISIT OUR EXHIBIT AT THE
RADIO PARTS NATIONAL TRADE SHOW
ON JUNE 11, 12, 13 AT THE
STEVENS HOTEL, CHICAGO
BOOTH NO. 1029 STEINMETZ AVENUE
ALSO ROOMS 535A, 536A, 537A

Buy BOGEN and you buy the BEST

Literature available at your jobber
or write

DAVID BOGEN CO.

663 Broadway New York, N. Y.

Largest Manufacturer devoted exclusively to production of sound systems—amplifiers—recording and intercommunication equipment and sound accessories.

Please Note

RADIO-CRAFT has MOVED
its New York General, Editorial and Advertising offices
to NEW QUARTERS. Please
address all correspondence to

RADIO-CRAFT
20 VESEY STREET
NEW YORK CITY, N. Y.

DIRECT-COUPLED AMPLIFIERS



Write For Complete Details and Amplifier Preparation

AMPLIFIER COMPANY OF AMERICA
35 45 WEST 20TH STREET NEW YORK CITY, NEW YORK

FILMGRAPH
VOICE AND MUSIC RECORDINGS

PERFECT SOUND on film recording can now be had with FILMGRAPH at only 25c per hour (this is cost of film only—no other expense). Permanent play-back. The only device capable of making lengthy recordings and play-back. Closing out several demonstrator models at special price. Complete 1940 line now ready. MILES REPRODUCER CO., INC., Dept. RC, 812 Broadway New York City

SPECIALIZED A.F. TUBES

A well-known tube manufacturer has found that most tube problems in audio-frequency amplifiers are best solved by the use of particular types of tubes, specifically designed for A.F. amplifier service; and here tells how these "sound" tubes differ from radio-frequency and "ordinary" audio-frequency types. Input, mixer, output and rectifier types require particular attention; but many characteristics are prerequisites in all types of specialized sound tubes.

F. M. PERET



SOUND is no longer a novelty or an experiment—it is a big and rapidly-expanding industry. Its engineers, manufacturers and users of amplifiers and public address equipment have for a long time realized the need for a line of tubes engineered and constructed to meet the particular requirements of sound equipment service. These sound men therefore will be interested to learn that National Union Radio Corp. has just introduced a complete line of special or "Sound X/tra" tubes designed specifically for sound work.

One of the major requirements for a satisfactory sound installation is that it must give reliable and trouble-free service under all operating conditions and particularly when operated by persons who are not technically minded and who have little or no knowledge or experience in the proper handling and operation of such equipment. Under such operating conditions the equipment must be of the highest quality throughout and designed so as to be practically foolproof.

HOW "SOUND" TUBES DIFFER

One of the most difficult problems for the manufacturers and users of sound equipment has been to obtain tubes which were uniform, reliable and sufficiently free from microphonics, hum and noise. Many improvements have been made in amplifier design—better frequency response, higher gain, more sensitive microphones, greater output, volume expansion, and many others. All of these have contributed much to improved performance and have helped materially to promote the use of sound equipment. Unfortunately, however, these same improvements have also seriously aggravated the tube problem. Hum, microphonics and noise are far more serious with the modern, high-efficiency sound system than with the older, low-gain, poor-quality amplifiers.

Undoubtedly the most serious of the tube problems has been to obtain a satisfactory A.F. head-end or input tube. Here the full gain of the amplifier, 100 to 130 db., is effective in amplifying any tube noise. Obviously such service is far more severe than any encountered in normal radio-frequency amplifiers, and as a consequence, tubes designed primarily for radio receiver applications have not proven good enough to insure reliable service under these

severe conditions.

Second most serious tube problem has been a good A.F. mixer tube. In most amplifier arrangements, the mixer is usually next to the input stage and therefore has considerable gain after it to accentuate tube noises.

Next in importance come A.F. output tubes with characteristics sufficiently uniform so that matching of tubes is unnecessary.

Rectifiers must be provided which are reliable.

And finally, but far from least important, general reliability, uniformity, rugged construction and extremely close

selection limits are required for all types of tubes intended to be used primarily in A.F. amplifier work.

In the past, several of the tube companies have made more or less half-hearted and sporadic attempts to develop special tubes for such applications but until recently, no tube company has made any real, concentrated and planned attempt to furnish a complete line of tubes specifically engineered and constructed for this one type of service alone.

National Union engineers have made another major contribution to the industry by developing a complete line of special tubes for this service. These new tubes are called Sound X/tra and have been announced only after many months of intensive research, life testing and field trial. Each type in the Sound X/tra line has been very carefully selected for its suitability for sound use. Each type is specifically constructed and very carefully tested and selected. In addition to special tests for characteristics, high emission, low gas, uniformity of plate and screen-grid cur-

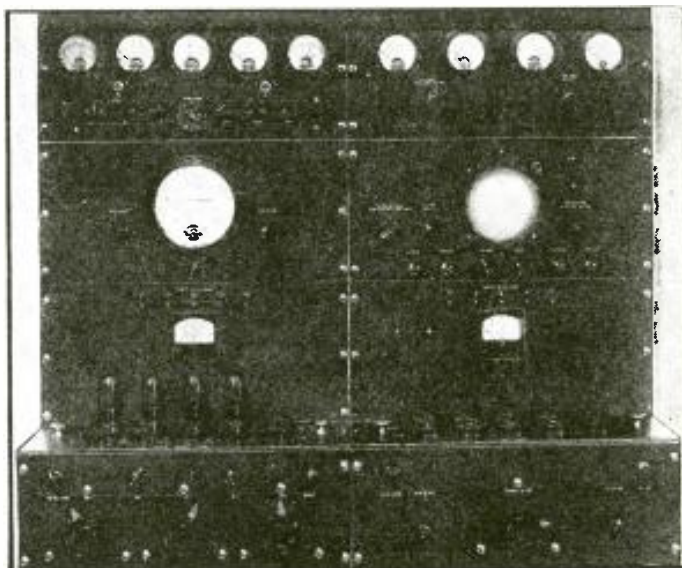

Special equipment has been developed for checking the new sound-type tubes as to noise, hum and microphonics. Meters and a cathode-ray tube are used.

rents, etc., every tube is individually tested on special laboratory equipment for hum, noise and microphonics.

At the present time the National Union Sound X/tra line comprises the following 13 popular types:

THE FIRST 13 SPECIALIZED SOUND TUBES

6J7G	6L6G	5U4G
6N7G	6V6G	5V4G
6L7G	6F6G	5Y3G
6C5G	6K6G	6X5G
		83

Basic characteristics of the Sound X/tra types are identical with standard tubes of the same type number so that Sound X/tra tubes may be substituted for standard types in existing equipment where the utmost in performance and trouble-free service is required.

CONSTRUCTION

Outstanding among the Sound X/tra types is the 6J7G Sound X/tra. This type has been completely redesigned to make it a truly super tube for high gain, high-quality amplifier and public address work.

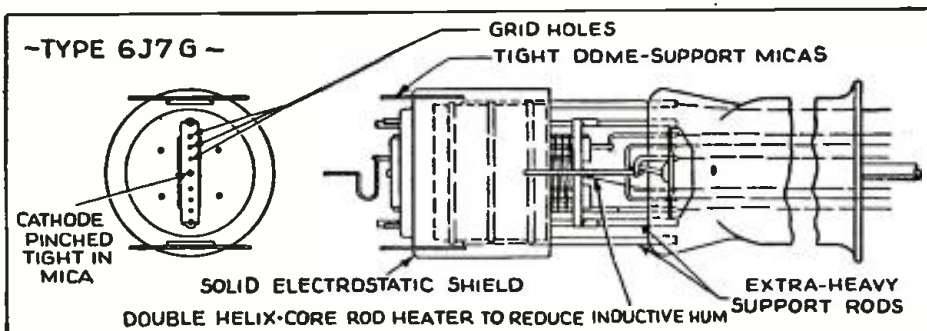

Drawing shows how one of the Sound X/tra tubes differs from preceding types of tubes used in A.F. work.

ELECTRONICS

Special construction has been used throughout, incorporating extra-heavy and rugged supports with special micas to insure freedom from noise and microphonics. A double-helix heater with insulating core rod is used to insure freedom from hum. Extensive laboratory and field comparisons between the 6J7G Sound X/tra and Standard 6J7G and 6J7 metal tubes, indicates that with the 6J7G Sound X/tra, the hum output is reduced an average of 15 db. and that the gain of the amplifier may be increased an average of 40 db. before microphonic feedback or spill-over occurs. The above average figures prove conclusively that the new Sound X/tra tube is far superior to any of the so-called special tubes now available on the market.

The 6N7G Sound X/tra has been designed primarily for mixer service. Here noise and microphonics are the major problems. Like all of the Sound X/tra types, the 6N7G is constructed with extra-rugged supports and special micas to eliminate element vibration even under the most severe operating conditions.

Sound X/tra output tubes, types 6F6G, 6K6G, 6V6G and 6L6G are all tested and selected to very close limits. Characteristics are held within such close tolerances that matching for push-pull stages is unnecessary.

The 13 types now available in the Sound X/tra line are intended for use as replacements for standard types in existing equipment and also for use in new equipment. From time to time additional types will be added.

Our engineers are now developing several new basic tube designs to suit the particular requirements of the sound amplifier field. Information on these new developments will be released within the near future.

RADIO-OPERATED DEVICE DETECTS STORMS 100 MILES AWAY

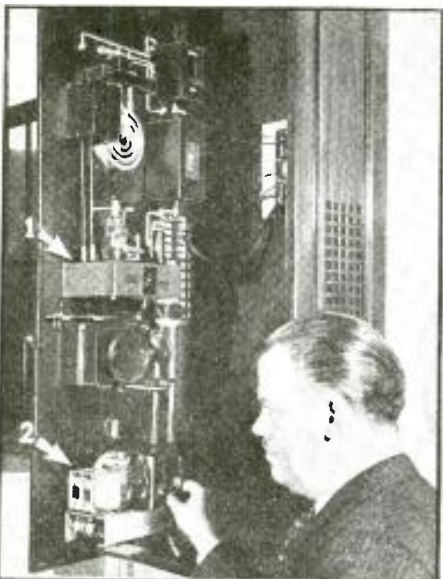

(Photo—A. Eriss)

On the wall of the System Operating room in the Consolidated Edison Building, 1st Ave. and 41st St., N.Y.C., is the above-shown invention of Richard J. Lombard, report operator for the company, for indicating the approach of storms. The photo shows the interior of the Storm Detector, with its inventor. It uses a 4-tube "atmospheric-static receiver" (arrow 1) to actuate a neon tube, the flashes of which, picked up by a photocell and amplified, operate a relay which rings a set of chimes. In the lower part of the housing is a 4-tube government time and weather-signals receiver (arrow 2). When the chimes begin to ring rapidly (indicating storm near) outside powerhouse attendants are cautioned to watch load demands.

Announcing A SENSATIONAL NEW CUSTOM BUILT SCOTT WITH TONE UNEQUALLED IN RADIO HISTORY

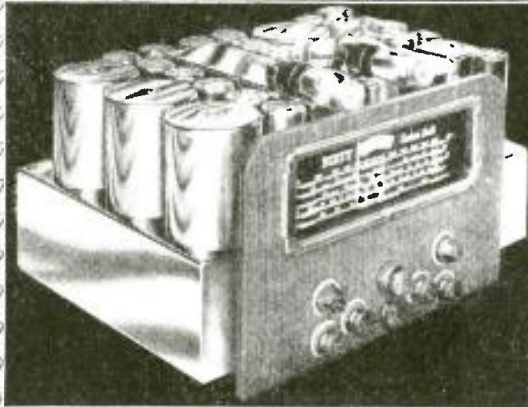

OFFERS BOTH
*Frequency
Modulation*
AND REGULAR
RECEPTION

MOST FAR-REACHING INVENTION IN RADIO FOR TWENTY YEARS

RADIO science now offers a startling new invention . . . FREQUENCY MODULATION. Not just an improvement of our present radio system, but an entirely new system of transmission and reception! Static and "noise" have finally been conquered. Even in the heart of a crashing storm, or with X-Ray or other powerful electrical equipment right alongside, reception from the new Custom Built SCOTT FREQUENCY MODULATION receiver, within the service area of the F.M. Stations, remains undisturbed. Only the serene and changeless beauty of the inimitable Scott tone is revealed.

TONE UNEQUALLED IN RADIO HISTORY

The very peak of high fidelity . . . up to 15,000 cycles . . . is now transmitted on direct studio F.M. broadcasts . . . A tonal range 2 to 3 times greater than that used

in present broadcasting. Programs are reproduced by the new Scott F.M. receiver with such amazing perfection . . . so free of static and noise . . . you are tempted to pinch yourself to make sure you are not actually present in the studio or concert hall.

5 YEAR GUARANTEE—30 DAYS TRIAL

New F.M. transmitters are being rapidly installed. Prepare now for this magnificent new reception. The new far advanced Scott offers both F.M. and regular receiver on one chassis, or new F.M. Tuner alone, for easy connection with present receivers in F.M. service areas. Precision custom built to same quality and performance standards that have won for the Scott universal recognition as "World's Finest Radio". 30 days home trial and extended terms in U.S.A. Sold only direct from our Laboratories. Be first. Write for details now.

GET SPECIAL INTRODUCTORY OFFER!



E. H. SCOTT RADIO LABORATORIES, INC.
4404 RAVENSWOOD AVE., DEPT. 24M40, CHICAGO, ILL.

Send all facts, special offer, Scott record review, and order blank. NO obligation.

Name

Address

STUDIOS: CHICAGO, NEW YORK, BUFFALO, DETROIT, LOS ANGELES

July Radio and Television

A "Loop" Portable for the B. C. Band
Charles R. Leutz
Extending the Tuning Range of Your Receiver

Part 2—Frequency Modulation Converter—The Audio Amplifier System
Ricardo Muniz, E.E.

2½ & 5 Meter Transmitter
Milton Meyerowitz, W2EVO

A Beginner's Radio Test Set and "Bug" Finder
Charles R. Leutz

A Modern Superhet. 5-Tube Broadcast Receiver

5, 10 and 20 Meter Receiver
Harry D. Hooton, W8UPX

Besides all the new departments—Applied Radio, Radio Patents, Latest Hookups, Electrical Experiments, etc.

Re: "F.C.C. Contemplates Survey of Amateur Radio Service"

In May *Radio-Craft*, pg. 673, discrepancies occurred in interpreting and reporting a recent F.C.C. release. Here are corrections kindly brought to our attention by the American Radio Relay League's assistant-secretary, John Huntoon: ". . . it is stated that (1) 'ham portables and portable-mobile units may be operated without licenses'; and, (2) must be operated while in motion!" Instead, the original F.C.C. release states that amateurs can operate portable and portable-mobile stations 'without separate license'; and that a ". . . portable amateur station may not (word left out of story!) operate while in motion" (portable-mobile amateur stations may operate either while in motion or at rest).

The ABC of Electronic Automatic A. C. VOLTAGE REGULATORS

The advantages and disadvantages of the automatic electronic voltage regulator are discussed from an engineering standpoint. Practical examples such as might arise in practice are used in description of these important devices. The article contains considerable information not generally available.

H. S. MANNEY

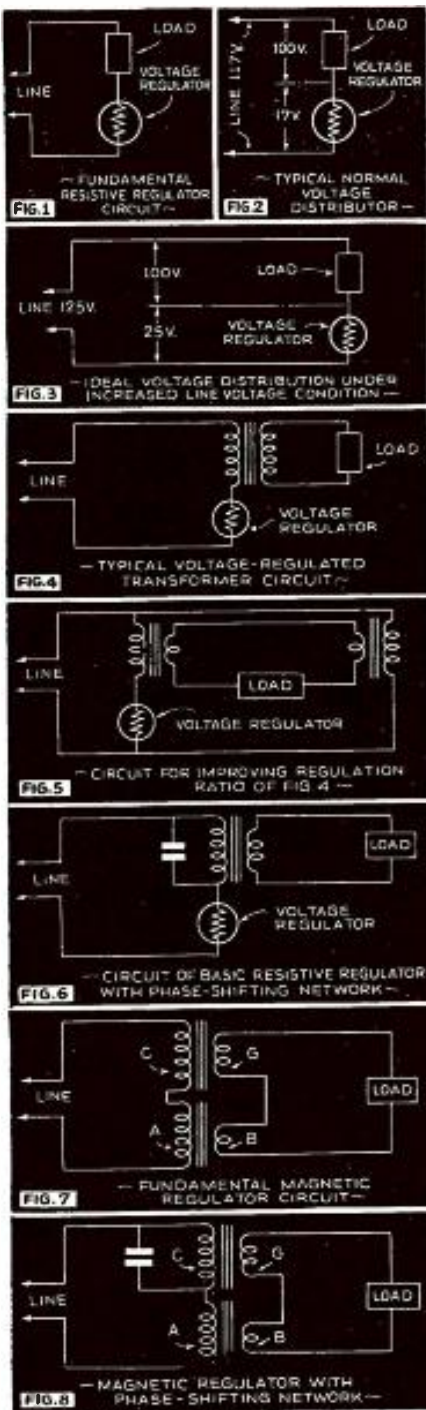

Automatic electronic voltage regulators may be resistive (Figs. 1 to 6) or magnetic (Figs. 7 and 8 above, and Figs. 9 to 11 on the second page of this story). The fundamental resistance-type regulator is shown in Fig. 1; the fundamental magnetic type, in Fig. 7. Note the "Typical Magnetization Curve," Fig. 3, on the facing page.

THE Automatic Electronic Voltage Regulator may be broadly defined as a device, without moving parts, which maintains a constant voltage at its output terminals, while its input voltage varies over a comparatively wide range. Automatic regulators may also be broadly classified into 2 types, viz., (1) Resistive, and (2) Magnetic.

THE RESISTIVE TYPE

The resistive type of regulator employs a special non-linear resistance element in series with the load.

This resistor is usually an iron wire encased in a hydrogen-filled glass bulb. The wire is essentially a current limiter. In other words, its resistance varies with the voltage developed across it in such way as to provide a practically constant current through it within its operating voltage range. A number of complex factors are involved in the design of such a ballast.

In order to insure rapid action, the area surrounding the wire is filled with hydrogen under a predetermined pressure, so as to conduct the heat away from it as rapidly as possible. The ballast must, of necessity, always be connected in series with the regulator supply. A fundamental circuit is shown in Fig. 1. With this circuit arrangement, any change in line voltage will appear as an increase across the ballast itself. For example, if a normal line voltage is 117 volts, and the ballast is designed for a 17-volt drop, 100 volts will appear across the load, as indicated in Fig. 2. Should the line voltage increase to 125 volts, the 8-volt increase appears across the ballast, as illustrated in Fig. 3 (left).

In actual practice, however, this close tolerance cannot be maintained. Furthermore the nature of the load will greatly determine the degree of regulation maintained. If the load is purely resistive and does not change in resistance, the change in voltage which appears across the load will indicate the change of current through the ballast under the varying line voltage conditions.

In A.C. work, however, the load usually takes the form of a transformer, Fig. 4. This in turn introduces an additional complication, as any slight increase in current through the ballast will produce a corresponding increase of flux lines within the core, which in turn will produce a corresponding increase of voltage in the secondary of the transformer. For ideal regulation under these conditions, the transformer should be designed so that it operates at, or close to, its saturation point. This means that an increase of current through the primary will not produce a proportionate increase of flux lines in the core. Although the increase is not proportionate there is a slight increase, and this becomes the limiting factor in maintaining close regulation.

CORE SATURATION

In making the above statements it was assumed that the reader is fairly familiar with magnetic phenomena. To further clarify the theory involved, in this type of regulator, core saturation is further explained in Fig. 3 (curve). It will be noted that a given number of ampere turns will produce a given amount of flux lines within the core.

If we start at point A, it will be noted that a proportionate increase of ampere turns will produce a proportionate increase of flux lines. This holds true as long as the operating range is kept within the linear portion of the magnetization curve. Once the operating point passes point B, the magnetization characteristic is no longer linear. An increase of ampere turns from W to Z produces a comparatively slight increase of flux lines.

The saturation point of an iron core depends upon the type of steel employed in its construction. Carbon- and silicon-steel laminations will be saturated at about 85,000 lines-per-sq. in. If a transformer is designed to operate at this flux density, it can readily be seen that an increase in line voltage of Fig. 4 will produce a comparatively slight increase across the transformer primary, while the major portion of the increased voltage will appear across the voltage regulator.

REGULATION

The term *voltage regulation* as commonly used in electrical engineering work refers to the increase in voltage resulting when the load current is decreased from the rated value to 0, expressed as a percentage of the terminal voltage at full load current. In A.C. voltage regulation work, it is best to calculate the percentage change from a given normal. In other words, if 110 volts represents a normal voltage then an increase to 120 volts will represent a line

change of $+\frac{10}{110}$ or +9.1%. A decrease in

voltage from 110 to 90 volts would represent a regulation of $-\frac{20}{110}$ or -18.2%. Ex-

pressed mathematically, the relation becomes

$$R = \frac{E\Delta}{E_N} \times 100$$

where R = percentage regulation
EΔ = line change
E_N = normal line

This same formula may be used in calculating regulation of any voltage regulating device.

For convenience in differentiating the various degrees of regulation the term

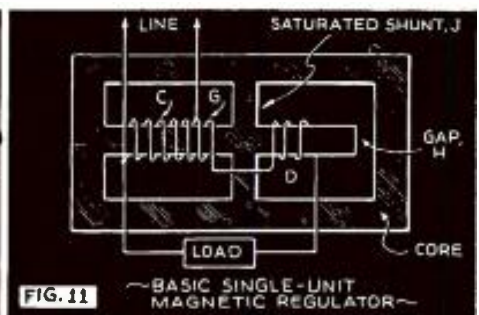
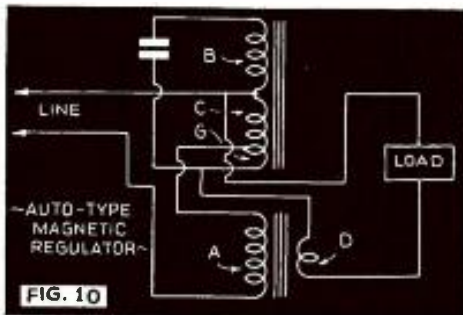
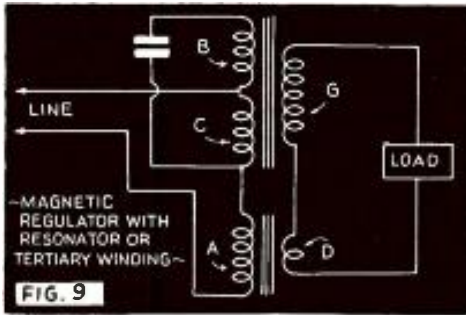

"Regulation Ratio" may be used. This may be defined as the ratio of the regulation of the line to the regulation of the load. For example, if a line changes $\pm 20\%$ and the load changes $\pm 1\%$, the regulation ratio is said to have a regulation ratio of 20. In other words the load regulation is 20 times better than the line regulation. This convenient expression may be used to rapidly compare the effectiveness of various regulators.

A laboratory set-up, similar to Fig. 4, was made, wherein the secondary of the transformer was connected to a non-reactive load. Under ideal conditions, it was found that this system had a regulation ratio of 4.06. In other words, a line change of from 90 to 130 volts produced a secondary voltage change of from 128 to 140 volts.

The regulating ratio however is materially improved within a narrower operating range. For example, when this same setup was subjected to a line change of from 100 to 120, it had a regulation ratio of 10. In other words the secondary changed from 135 to only 138 volts. While this particular example is not intended to represent the limitations of this type of regulator, it is being cited merely to acquaint readers with its possibilities.

There are 2 common variations of this circuit which may be employed to further increase its regulation ratio. If, for example, we know in advance that the secondary voltage will change by 3 volts, it is feasible to connect the auxiliary transformer across the line, as illustrated in Fig. 5, and have its secondary arranged to buck the voltage rise developed in the original secondary, so that the increase in line will produce a corresponding increase in the bucking secondary, and thereby provide a substantially constant output.

The basic resistor type of regulator as originally illustrated in Fig. 4, may also be improved by introducing a phase-shifting device such as a condenser across the transformer primary, as illustrated in Fig. 6. Under this arrangement, a number of complex factors are involved, which will be covered in detail under "Magnetic Regulators." This circuit however is capable of a regulation ratio of 11.4. In other words a line change of from 90 to 130 volts produces a secondary change of from 122 to 126 V.

One disadvantage of the resistive type of regulator is that it is comparatively sluggish in action and does not compensate for instantaneous transient voltage surges. Furthermore, the temperature surrounding the ballast will affect the output voltage. Also, changes in load current will affect both its regulation and output voltage.

Its economy, however, and simplicity of design and application, make this type of regulator admirably adapted for a wide variety of applications involving the use of constant current loads.

THE MAGNETIC TYPE

The magnetic type of regulator is similar to the resistive type with the exception that an unsaturated magnetic coil is placed in

series with the load (instead of the resistive regulator) as basically illustrated in Fig. 7. The operating density of the core of the series inductance is so arranged that the voltage developed across the primary of the transformer remains constant while the major portion of the increase of line voltage appears across the series inductance.

As some increase in voltage does take place in the secondary of the transformer, this change may be reduced by adding a secondary winding on the series inductor and connecting it so as to buck the original secondary winding. Under these conditions of operation, a voltage ratio of 5 may be obtained. To simplify our nomenclature, the circuit elements of Fig. 7 have been labelled as follows:

Transformer CG will be called the main transformer.

C—transformer primary

G—transformer secondary

Transformer AD will be called the compensating transformer.

A—compensating primary

D—compensating secondary

In order to improve the regulation ratio of this type of a device, a condenser is placed across the primary C as illustrated in Fig. 8. This condenser produces 3 helpful effects: (1) It changes the phase angle of the voltage developed in G in such a manner as to improve its regulation characteristics under the conditions of varying line voltage and varying load. (2) It saturates the core. (3) It resonates the primary winding of the main transformer so as to maintain a fixed voltage across the circuit at a predetermined frequency.

As the frequency at which the circuit will resonate is a function of the inductance of the primary of the coil and the capacity of the shunt condenser, it will be found that a relatively high-value capacity will be required. This may be in the order of 30 mf. or 40 mf. for the type 150 VA regulator. To decrease costs, and simplify construction, an additional winding (B) is added in series with the transformer primary which is known as the resonator or tertiary (3rd) winding.

This winding furnishes a comparatively higher inductance so that a lower-capacity condenser may be employed. A circuit of this arrangement is illustrated in Fig. 9. A correctly-designed regulator of this type is capable of a regulation ratio of 36. In other words, a primary change in voltage from 90 to 130 volts will produce a secondary change from 110 to 111 volts. This type of regulator reacts practically instantaneously to any change in line

voltage. Its time constant is approximately 1/30th of a second.

It may be designed to provide a constant output voltage with either a variable line voltage, a variable load, or both. As one of the elements (main transformer) operates at a relatively high magnetic density, it attains a high operating temperature. Its heat rise may be as much as 60° C.

Where it is not necessary to isolate the load from the power line, the regulator may be constructed as an autotransformer, as illustrated in Fig. 10. It will be noted that the winding G becomes additive to C winding.

The voltage distribution developed across each of the windings under various conditions of load and line voltage is given in Table I. These tests were made with a resistive load.

TABLE I—Voltage Distribution

Circuit	Line Voltage	90	110	130	Load
Compensator Pri		100	92	92	Full
A		60	69	67	½
		30	44	69	None
Compensator Sec.		14.5	13	13	Full
D		8.	8.6	10	½
		3.9	6.	8.3	None
Primary		70	75	77	Full
C		76	77	80	½
		76	78	80	None
Secondary		117.5	125	129	Full
(C + G)		127	130	132	½
		129	132	134	None
Tertiary		300	322	330	Full
(C + G + B)		328	332	339	½
		332	338	345	None
Tertiary Current		1.22A	1.41	1.57	Full
		1.5	1.6	1.7	½
		1.6	1.67	1.75	None
Primary Current		3.25A	2.75	2.7	Full
		1.6	1.65	2.0	½
		.4	1.2	1.7	None
Load		127	128	128	Full
(C + G - D)		127	127	127	½
		127	127	127	None

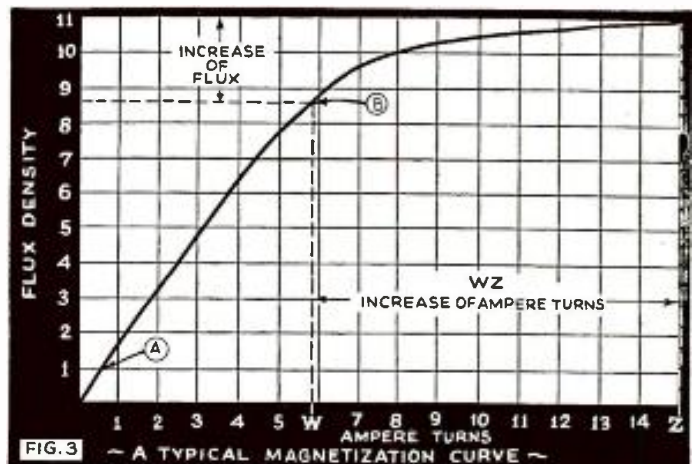

For Better Servicing - For Bigger Profits— USE GERNSBACK MANUALS AND BOOKS!

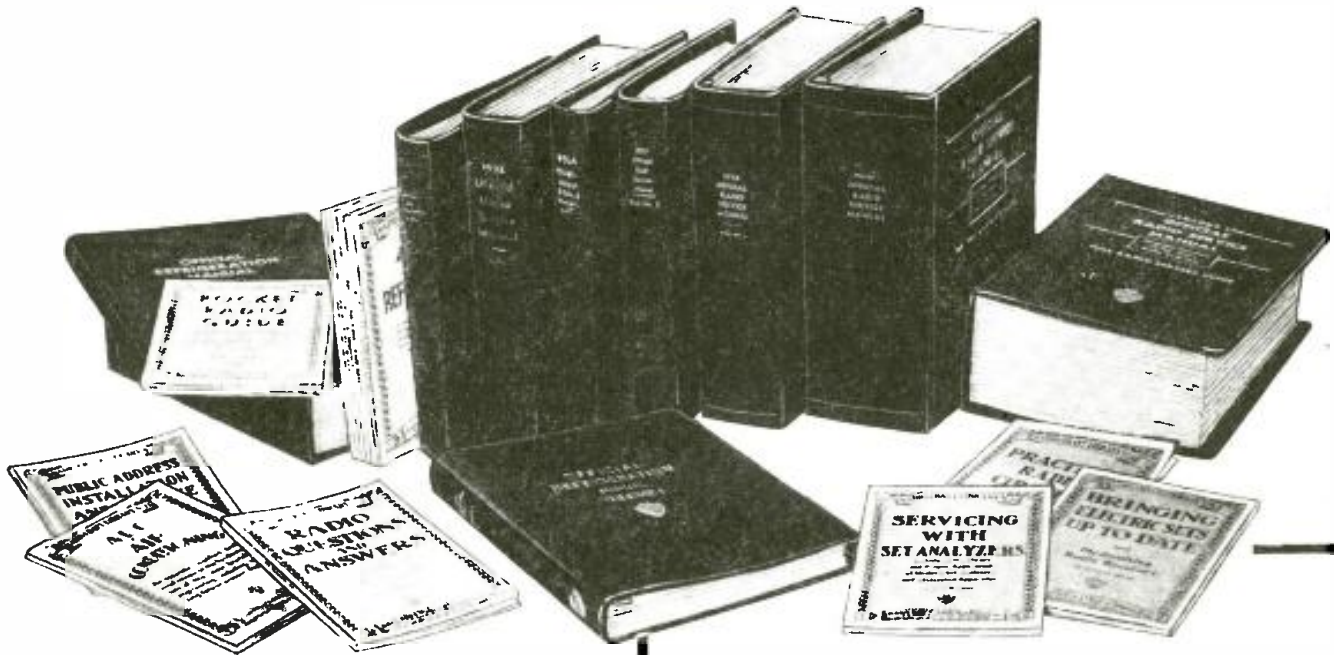

SINCE 1931 Servicemen have been buying more GERNSBACK OFFICIAL RADIO SERVICE MANUALS year after year. The authentic material, easily accessible diagrams and complete service data make them invaluable to dealers and radio Servicemen. *Without a Gernsback Service Manual at the repair job, there's time and profit lost.* Your service kit or laboratory is incomplete without all the GERNSBACK OFFICIAL RADIO SERVICE MANUALS. There are GERNSBACK MANUALS for servicing auto-radios, also refrigeration and air conditioning equipment.

VOLUME 7 OFFICIAL RADIO SERVICE MANUAL

Over 1,800 Pages • Over 3,000 Illustrations • Stiff, Leatherette, Looseleaf Covers • Size 9 x 12 Inches • Net Weight 10½ lbs. **\$10.00**

1936 OFFICIAL RADIO SERVICE MANUAL

Over 1,200 Pages • Over 2,500 Illustrations • Stiff, Leatherette, Looseleaf Covers • Size 9 x 12 Inches • Net Weight 8 lbs. **\$7.00**

1935 OFFICIAL AUTO-RADIO SERVICE MANUAL

Over 240 Pages • Over 500 Illustrations • Flexible, Leatherette, Looseleaf Covers • Size 9 x 12 Inches • Net Weight 1¾ lbs. **\$2.50**

1934 OFFICIAL RADIO SERVICE MANUAL

Over 400 Pages • Over 2,000 Illustrations • Flexible, Leatherette, Looseleaf Covers • Size 9 x 12 Inches • Net Weight 2¾ lbs. **\$3.50**

1932 OFFICIAL RADIO SERVICE MANUAL

Over 1,000 Pages • Over 2,000 Illustrations • Flexible, Leatherette, Looseleaf Covers • Size 9 x 12 Inches • Net Weight 4½ lbs. **\$5.00**

OFFICIAL REFRIGERATION SERVICE MANUAL

(Volume II)
Over 352 Pages • Over 300 Illustrations • Flexible, Leatherette, Looseleaf Covers • Size 9 x 12 Inches • Net Weight 1½ lbs. **\$5.00**

OFFICIAL AIR CONDITIONING SERVICE MANUAL

Over 352 Pages • Over 600 Illustrations • Flexible, Leatherette, Looseleaf Covers • Size 9 x 12 Inches • Net Weight 2¾ lbs. **\$5.00**

To order these famous Manuals, see or write to your jobber or favorite mail order house. If more convenient, mail coupon directly to publishers.

RADCRAFT PUBLICATIONS, Inc.
20 VESEY STREET NEW YORK, N. Y.

RADIO-CRAFT LIBRARY SERIES

Get into the swing of reading instructive, authoritative books on technical subjects—radio, air conditioning and refrigeration. It's the easiest, quickest and most inexpensive way to improve your knowledge on these topics. In this series, popularly known as the RADIO-CRAFT LIBRARY SERIES, are all the titles necessary to your personal advancement. Only by careful study of these enlightening books, can you gain adequate experience in fields of radio, air conditioning and refrigeration. Each book is uniform. The volumes measure 6 x 9 inches—contain 64 pages, and have stiff, flexible covers. PRICE 50c PER BOOK. All books are sent to you postpaid.

Here Are The Titles:

Book No. 2 MODERN VACUUM TUBES	Book No. 16 PRACTICAL RADIO CIRCUITS
Book No. 3 THE SUPERHETERODYNE BOOK	Book No. 17 SERVICING WITH SET ANALYZERS
Book No. 6 BRINGING ELECTRIC SETS UP-TO-DATE	Book No. 18 POINT-TO-POINT RESISTANCE ANALYSIS
Book No. 9 AUTOMOBILE RADIO AND SERVICING	Book No. 19 PRACTICAL RADIO KINKS AND SHORT CUTS
Book No. 10 HOME RECORDING AND ALL ABOUT IT	Book No. 20 THE CATHODE-RAY OSCILLOSCOPE
Book No. 13 ABC OF AIR CONDITIONING	Book No. 21 BREAKING INTO RADIO SERVICING
Book No. 14 POCKET RADIO GUIDE	Book No. 22 NEW RADIO QUESTIONS AND ANSWERS
Book No. 15 ABC OF REFRIGERATION	Book No. 23 PRACTICAL PUBLIC ADDRESS

—EACH BOOK IN THIS SERIES—50c

RADCRAFT PUBLICATIONS, Inc., 20 VESEY ST., NEW YORK, N. Y.
Gentlemen: Enclosed find my remittance of \$..... for which send me, POSTPAID, the Manuals or Books indicated below by a cross (x) in the panel.

() Volume 7 @ \$10.00 () 1936 Manual @ \$7.00 () 1934 Manual @ \$3.50
() 1935 Auto-Manual @ \$2.50 () 1932 Manual @ \$5.00
() Refrigeration Manual (Vol. 2) @ \$5.00 () Air Conditioning Manual @ \$5.00

RADIO-CRAFT LIBRARY SERIES @ 50c EACH

Circle book numbers wanted: 2 3 6 9 10 13 14 15 16 17 18 19 20 21 22 23

Name Address

City State

(Send remittance in form of check or money order; register your letter if you send cash or unused U. S. Postage Stamps.) RC-740

•ENGINEERING•

The disadvantages of this type of unit are that it is comparatively bulky and costly. These are offset, however, by its unusual regulation ratio. It may be designed to produce any desired voltage for operation on any kind of a device.

OTHER MAGNETIC REGULATORS

There are many other variations of magnetic regulators which are composed of either 1 or 2 magnetic components. One popular single-unit device employs both a saturated magnetic shunt and air gap within the transformer proper, as illustrated in Fig. 11. In this circuit the shunt J is operated at a comparatively high density, at increased line voltage more flux lines pass through the bucking coil D and gap H, so

that the effective voltage which appears across the load, remains practically constant. Here too, a greater regulating ratio may be obtained by adding a tertiary winding and its associated condenser, as used for the 2-piece magnetic elements.

CONCLUSION

The problems encountered in maintaining both a constant voltage and constant current to a given load are many and varied. While this discussion is not intended to be a comprehensive treatment of regulators, it is hoped that it will lead the way to a clearer understanding of the operating principles involved in the operation of this type of equipment.

RECENT ENGINEERING DEVELOPMENT

FOLLOWING are brief descriptions of a few of the many recent developments in General Electric's laboratories. They show how the various divisions of radio are progressing step-by-step.

Television.—Developments in television equipment include a television-studio microphone, of high-fidelity velocity type, with adjustable bi-directional, uni-directional, and nondirectional characteristics to care for the various contingencies arising in program production.

The studio control equipment now provides for a maximum of 6 channels and the means for switching instantly or for fading gradually from one channel to another; and has full monitoring and automatic brightness control, which supplements the manual control and accurately maintains the "black" level during sudden background changes.

The image transmitter features *low-level modulation*, greatly reducing equipment size and power loss. That portion of the lower sideband which is not to be transmitted is removed at low power level in the vestigial sideband filter, and consequently the high-power amplifiers are required to pass only that band of frequencies which is radiated as useful power; the duty on the amplifiers is reduced and large filter equipment in the high-power circuits is eliminated. When the transmitter is operated in conjunction with an image relay transmitter, the conversion of the radio frequency of the image signal at low power level eliminates distortion which might be caused by detection and remodulation.

The sound transmitter is a high-fidelity unit having an audio channel extending from 20 to 15,000 cycles.

Radio.—*Frequency modulation* transmitters utilize the first really fundamental change in the system for broadcasting since its inauguration 2 decades ago. Its appeal is the promise it offers of truly noise-free, high-fidelity broadcasting, so the transmitters were designed to provide a harmonic distortion of less than 1½% for modulating frequencies between 30 and 7,500 cycles, and less than 3% up to 15,000 cycles.

Deviation in response is less than ± 1 db. between 30 and 15,000 cycles with the high-frequency *preaccentuation filter* omitted, and the frequency-modulated carrier noise level is at least 60 db. below "100% modulation."

A preaccentuation filter for the higher audio frequencies, similar to the RMA standard for television sound channels, is included to increase further the ratio of signal to noise at the relatively weaker higher frequencies. An input of minus 10 db. is sufficient to produce "100% frequency modulation." In addition, the mean assigned carrier frequency is maintained within a deviation of ±0.01% by a new circuit.

The high performance characteristics are obtained at any assigned mean frequency in the 30 to 44 megacycle band. The frequency swing to be used for "100% modulation" will probably be ± 60 kilocycles, but the equipment will produce a swing linear with the modulating voltage up to ± 80 kilocycles.

Police and Utility Communication.—For police and fire departments, public utility companies, etc., special units have been developed. All meet the new, more strict frequency-stability standards of 0.003% for mobile units and 0.02% for land stations required by the F.C.C., and all provide improved transmission fidelity and reliability under adverse operating conditions. All station-house transmitters incorporate automatic level control.

A *remote control unit* was produced which provides for the operation of a transmitter as much as several miles distant, and for the amplification and selection of signals from remote pick-up receivers. This self-contained unit will control, mix, and monitor combinations of 6 audio channels; 2 remote pick-up receivers, telephone line, velocity microphone, tone oscillator, and monitor receiver.

The 15-watt ultra-highfrequency mobile transmitter was adapted for loudspeaker operation, for traffic direction and in emergencies where commands must be given to crowds, motorists, firemen, etc. Provision was also made so that the output of the mobile receiver can be switched into the projection loudspeaker, so that the operator may leave the car and yet still be able to receive police alarms while directing traffic or engaged in other duties!

Radio Receivers.—Introduction of low-voltage tubes, in conjunction with Alnico speakers, reduced the peak potential of receivers to about 200 volts, rather than the 500 volts of previous receivers.

Electromedical Apparatus.—The spark gap of an electrosurgical unit, literally the heart of the apparatus must, for best operation, be fixed as to space between the tungsten buttons which form the actual gap. Regardless of the amount of heat generated at this point, normal expansion of the tungsten buttons or of the shank to which they are fastened must not affect the gap separation measurably. With the *self-compensating gap* of a new unit which has been developed there is no appreciable change in the spacing of the gaps even under long-continued operation. The natural tendency of the tungsten buttons to expand toward one another under heat, is offset by the expansion of the anchored heavy metal shank to which the tungsten is affixed.

Also provided in this unit are 2 separate and distinct high frequency oscillating circuits, each intended for a specific purpose.



**LET THE HIGH LINES
MAKE PROFITS FOR YOU!**

**SELL GTC
PORTA-POWER**

CONVERTS BATTERY OPERATED
RADIOS TO ALL-ELECTRIC

MODEL "P"
For 6 volt radios
"Twin-Powered"



Converts 98% of all 6 volt radios. Vibrator disturbance is eliminated. High fidelity performance assured. List price \$13.95.

MODEL "L"
For 2 volt radios



Supplies "A", "B" and "C" power to 4 to 8 tube battery-operated radios using 2 volt tubes. List price \$9.95.

MODEL "U"
For 1½ volt portable
or farm radios



Powers any portable or battery radio using 1½ volt tubes. Provides "A" and "B" power. List price \$7.50.

MODEL "G"
For 1½ volt radios
of 4, 5, or 6 tubes



For 1½ volt radios of 4, 5, or 6 tubes requiring more power than Model "U" provides. List price \$9.50.

Be sure to stop in Booth
1008 at the National
Radio Parts Show to
see the complete line of
GTC PORTA-POWER
for electrifying Battery
Radios of all types.

GENERAL TRANSFORMER CORP.
1754 W. VAN BUREN ST. • CHICAGO, ILLINOIS

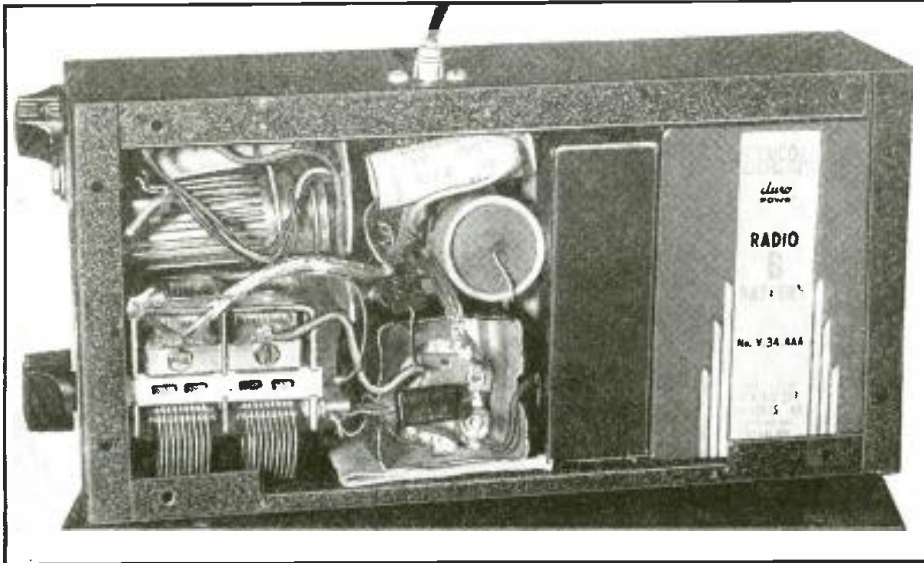

This article describes a pocket-size portable radio set centered around the type 1D8GT tube used as a combined triode R.F. amplifier, diode A.V.C. and detector, and pentode A.F. amplifier.

◀ View of the completed "3-in-1" Battery Portable with the bottom plate removed.

A "3-IN-1" BATTERY PORTABLE

CHARLES R. LEUTZ

THE new 1D8GT tube released not long ago, lends itself to many interesting applications (*), some of which may suggest to technicians newer and better ways of doing things. The 1D8GT has 3 separate tubes within one glass envelope, a triode portion suitable for either R.F. or A.F. amplification; a diode suitable for detection and automatic volume control; and, a pentode for the power audio-frequency output circuit. The filament only consumes 1/10 of an ampere direct from a 1½ volt "A" battery. The total plate consumption at a maximum of 90 volts is only slightly over 6 milliamperes.

Following is a description of a compact portable receiver centered around this tube. The overall dimensions of the receiver are comparatively small—10 x 5 x 3 ins.—so that the unit can be carried in an overcoat pocket, a briefcase or an overnight bag.

THE 3-IN-1 CIRCUIT

The multi-unit tube is used as per the circuit diagram given in Fig. 1 wherein the triode is the tuned R.F. amplifier, the diode is a detector and A.V.C., and the pentode is the audio output amplifier. The antenna transformer T1 and detector transformer T2 are both high-gain type and accordingly the sensitivity is relatively high. By holding an antenna lead a foot or so long it is possible to obtain ample volume from local broadcast stations. Using an indoor antenna 15 to 25 feet long, out-of-town stations can be received at night, in addition to all locals.

*See "The 'Baseball Special'—A 1-Tube Broadcast Receiver," Radio-Craft, May, 1940.

The receiver can be used with a single or double headphone, or with a 5-in. permanent-magnet dynamic speaker; the latter is optional and can be mounted in a separate case.

The schematic diagram given in Fig. 1 is self-explanatory. The 800-ohm resistor in the "B" negative lead is used to obtain a drop in potential to apply to the pentode control-grid for the necessary bias. The 2,000-ohm resistor and 0.1-mf. condenser in the detector transformer plate-return lead is an R.F. filter or decoupler to eliminate parasitic feedback. The balance of the circuit is strictly conventional.

PARTS PLACEMENT

Figure 2 gives the essential dimensions. The carrying case is a standard unit finished in black wrinkle baked enamel. The receiver components are mounted on a sub-base, a piece of 1/16-in. sheet aluminum 5¼ ins. x 4¾ ins. wide. The double gang

condenser is mounted on this base, using the center-lines shown. The octal socket and volume control switch are mounted on brackets according to the dimensions given. The antenna transformer, T1, is used without the shielding case; but the detector transformer, T2, is left in its metal container and mounted as shown. The remaining parts—resistors, condensers, etc.—can be located in any desired arrangement that lends itself to short connections.

Figure 2 also gives the center-line locations for the condenser tuning shaft, volume control shaft and phone jack.

After completing the wiring, the receiver can be tested outside the container case. After satisfactory tests, the complete receiver on its sub-base is mounted within the cabinet first, the 2 "B" batteries are inserted next and the "A" battery last. The battery leads should be long enough so the batteries can be inserted in place without difficulty. Before screwing the cover of the

At right, diagram of the "3-in-1" set. It is just a straight-forward stage of T.R.F. feeding a diode detector driving an A.F. pentode.

Below, completed "3-in-1" Portable; antenna plugs into jack on right side. Set fits into overcoat pocket or a briefcase.

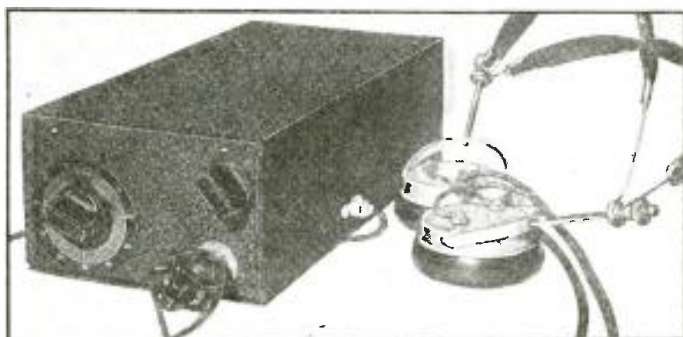
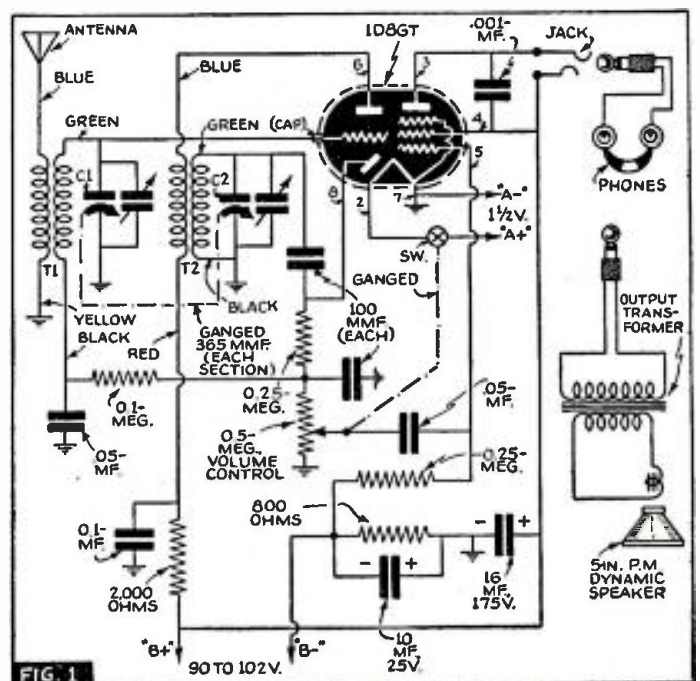

EXPERIMENTERS

case into place, small pieces of cardboard should be inserted to hold the batteries rigid. The sub-base can be held to the container case with one or two machine screws if desired.

A complete bill of materials is given showing the parts used. Equivalent substitutes may be used if the electrical values are identical and the physical dimensions of each part are not exceeded. Transformers T1 and T2, must be iron-core and capable of high gain and uniform response over the entire tuning range if good results are to be expected.

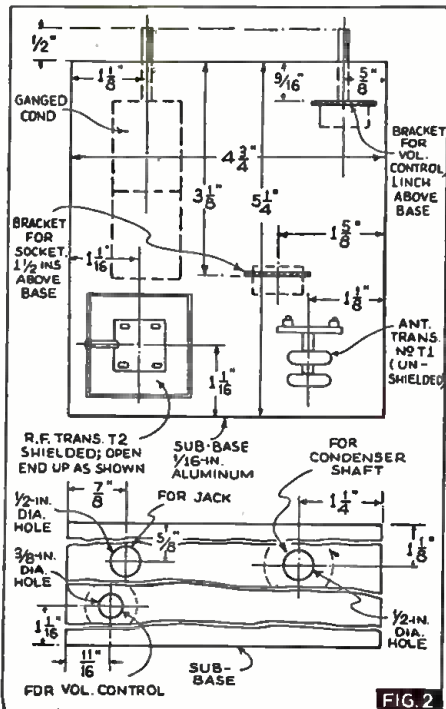

LIST OF PARTS

- One RCA type 1D8GT tube;
- One Meissner antenna R.F. transformer, No. 14-1496, T1;
- One Meissner detector transformer, No. 14-1497, T2;
- One Meissner compact 2-gang tuning condenser, No. 21-5214, each section 356 mmf., C1, C2;
- One Clarostat 0.5-meg. volume control, with switch (V.C.-SW.);
- One Centralab resistor, 800 ohms, 1/2-W.;
- Two Centralab resistors, 0.25-meg., 1/2-W.;
- One Centralab resistor, 2,000 ohms, 1/2-W.;
- One Centralab resistor, 0.1-meg., 1/2-W.;
- Two Cornell-Dubilier paper condensers, 0.05-mf., 200 V.;
- One Cornell-Dubilier paper condenser, 0.1-mf., 200 V.;
- One Cornell-Dubilier dry electrolytic condenser, 10 mf., 25 V.;
- One Cornell-Dubilier dry electrolytic condenser, 16 mf., 175 V.;
- Two Cornell-Dubilier mica condensers, 100 mmf.;
- One Cornell-Dubilier mica condenser, 0.001-mf.;
- One General "A" cell, No. 2-F-1, 1 1/2 V.;
- Two General "B" batteries, No. V-34-AAA, 51 V.;
- One Parmetal case, 10 x 5 x 3 ins., No. B4508 and cover No. BP4508;
- One American Phenolic Co. octal socket;
- One P.R. Mallory open-circuit jack, No. 701;
- One P.R. Mallory phone plug, No. 75;
- One Cannonball die mold pair headphones;
- One Utah 5-in. P.M. dynamic speaker (optional);
- Two Meissner tuning knobs, No. 25-8221;
- Miscellaneous: 1 grid clip, 1 tube shield, 10-ft. pushback wire No. 18, 2 "B" and 1 "A" battery plug connectors, 1 antenna plug and socket, 1 tuning indicator plate, 1 piece 1/16-in. sheet aluminum 5 1/4 x 4 3/4 ins., 4 ft. No. 16 flexible rubber-covered wire for battery leads, 1 roll resin-core solder.

RMA TRANSFORMER COLOR CODE

THE following information should be on file in every radio service shop as being the color codes recommended by RMA (see illustration).

In cases of use of single primary and/or single secondary, the top portion of the diagrammed windings should be used to indicate the color coding. Where polarity of primary and/or secondary is not a factor, both outside leads may be the same color as indicated. Where polarity must be indicated, the Brown and Yellow leads shall indicate the start of the primary winding and the start of the secondary winding respectively. In the case of an output transformer, the Black lead shall be the start of the secondary. (Note: Many output transformers have solder lugs for the secondary, rather than leads. In this case the primary leads only are marked according to RMA coding.)

Color Coding of Power Radio Transformers

- Black—Primary leads.
- Black—Common of tapped primary.
- Black and Yellow—50/50 stripes—tap of primary.
- Black and Red—50/50 stripes—finish of primary.

- Red—Plate leads of High-Voltage secondary.
- Red and Yellow—50/50 stripes—H.V. Center-tap.
- Yellow—Rectifier filament leads.
- Yellow and Blue—50/50 stripes—Rectifier Center-tap.
- Green—Filament winding No. 1.
- Green and Yellow—50/50 stripes—Fil. Center-tap.
- Brown—Filament winding No. 2.
- Brown and Yellow—50/50 stripes—Fil. Center-tap.
- Slate—Filament winding No. 3.
- Slate and Yellow—50/50 stripes—Fil. Center-tap.

THORDARSON MFG. CO.

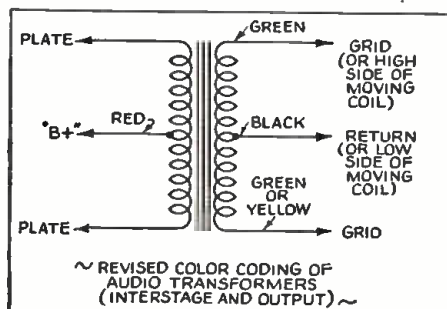

SMASHING VALUES OUT OF THE BIG NEW
FREE
LAFAYETTE CATALOG



DELCO AUTO VIBRATORS

Here's your chance to take advantage of a real price scoop! Each of these genuine Delco vibrators is brand new, in perfect condition, and packed in its original factory carton. We have only a limited quantity available, so place your orders now and avoid disappointment. Diagrams show wiring scheme.

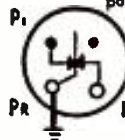

Delco No. 5050673. 4-prong, non-syn. 1 5/8 x 3 5/8". For '38-'39 Chev. Olds. **69¢**
K1088.....

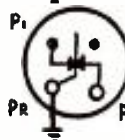

Delco No. 5060845. 4-prong, non-syn. As above but smaller. 1 1/2 x 3 1/8". For later models. **69¢**
K1060.....

POWER TRANSFORMER

Take advantage of these bargain prices NOW. Universal both electrically and physically. Brackets with "H" type slots permit mounting in all positions. Windings tapped for universal use for class "B" sets.



Pri. for 115 volts, 50-60 cycles. Secondary: 165-310-310-165 v. at 115 ma.; 2.5 v.c.t. at 3 amps.; 2.5 v. at 3.5 amp.; 5 v. tapped at 1.25/1.25/2.5 v. at 5 amps.; 2.5 v. tapped at 1/1.5 v. at 7.25 amp.; 4tr x 3 3/8"; con-ters 1 1/2 - 2 1/2". K5630. **\$1.10**



SINGLE UNIT\$1.35

RIM DRIVE PHONO MOTOR with 9" TURNTABLE



A powerful, constant speed (78 r.p.m.) rim driven motor at a price far below its actual worth. Complete with 9" turntable having a flocked covering. Operates on 110 volts, 60 cycles a.c. Compact and sturdy. Only a limited quantity in stock. K176. Special. **\$1.95**

BUY BY MAIL OR IN PERSON

At one of our 7 convenient stores. Either way you're sure to get better service—greater value.

- 100 Sixth Ave., New York, N. Y. • 901 W. Jackson Blvd., Chicago, Ill.
- 265 Peachtree St., Atlanta, Ga. • 110 Federal St., Boston, Mass.
- 24 Central Ave., Newark, N. J.
- 542 E. Fordham Rd., Bronx, N. Y. • 90-08 166th St., Jamaica, L. I.

LAFAYETTE RADIO

RUSH COUPON NOW

LAFAYETTE RADIO
DEPT. 3G-100 SIXTH AVE., NEW YORK, N. Y.

- I ENCLOSE \$.....RUSH ATTACHED ORDER
- PLEASE RUSH NEW FREE CATALOG No. 80

NAME.....

ADDRESS.....

CITY.....STATE.....

DO YOU WANT A SIGNAL TRACER?

Read August Radio-Craft, which will contain an article on how to make a simple, inexpensive Signal Tracer. Reserve your copy today!

CHOOSING AN F.M. ANTENNA

Simple Designs Are Sufficient When the Frequency Modulation Stations Are Within a Reasonable Distance, But More Complex Systems Are Desirable As We Approach the Fringe of the Service Area.

ARTHUR H. LYNCH

THE interference-free, high-quality broadcast reception which Major Armstrong's system of wide-band frequency modulation makes possible, even during local thunderstorms, is becoming more important as summer approaches.

ANTENNAS FOR DX "F.M."

There is no doubt that amplitude modulation broadcasting on the regular channels is very seriously and adversely affected by static. And the idea that simply going to the ultra-high frequencies to avoid static is enough, is not borne out by the facts. There is plenty of static on the "ultra-highs"—to say nothing of auto ignition and other forms of man-made interference, which become very much worse up there. Whenever that statement is questioned, the questioner is either not acquainted with the performance of "high-fidelity" receivers, on the ultra-highs, or he speaks from misinformation, gleaned from some other source, where all the factors have not been included.

Frequency modulation, even in its present state, will mean a great reduction of interference and a much greater enjoyment of radio programs this summer.

With the power being assigned to the stations which are going on the air with F.M. and with conditions as they are now, it is safe to assume that good reception from the average F.M. station, without the use of special antennas will be limited to 50 miles. Much greater distances are being covered regularly by Major Armstrong's own station, at Alpine, N. J., and by the Paxton, Mass., station of the Yankee Network, but they can not be considered typical. It is with a view to securing the best results for the audiences of the less favored transmitters that the following suggestions for improving receiving conditions, by the use of suitable aeriels, are given.

ON THE "FRINGE"

Without delving into the technicalities of the "whys and wherefores," it is indicated as a fact that, if a station is received with more than twice the strength of a station on the same or an adjacent channel, only the stronger of the 2 frequency modulation stations will be heard. Doubtless there will be many locations where the receiver will be much nearer to one than another station, both of which may be on the same or adjacent frequencies. In such cases, special precautions will make it possible to eliminate the nearer and more powerful station, while interference-free reception may be had from the weaker, more distant station.

To supply details for a single, satisfactory antenna for receiving all present F.M. stations, at a considerable distance, is not now possible. Some of the transmitters are being used with horizontal and others are being used with vertical antennas; a third group utilizes an antenna which is said to afford radiation in both planes at the same time! For best results, the antenna at the receiver, should be in the same plane as the transmitting antenna. Except for those "local" installations, where practically any old piece of wire will do the trick, it is

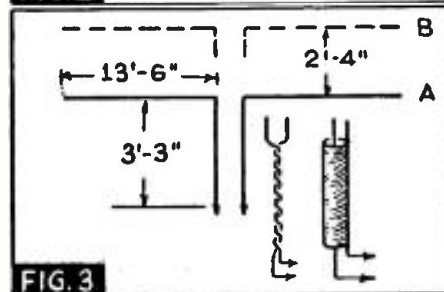
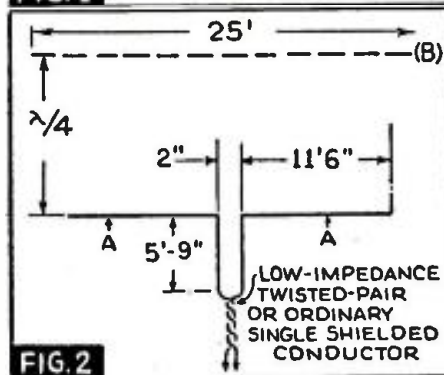
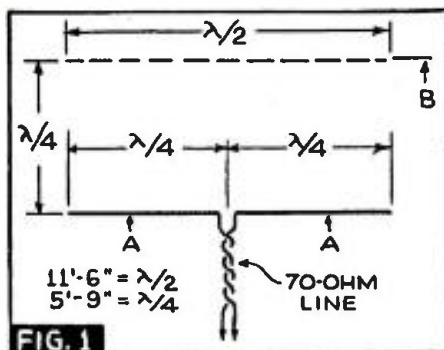

desirable, therefore, to determine the "polarization" of the desired transmissions and set up the receiving aerial or aeriels accordingly.

CHOOSING THE ANTENNA

An antenna which is very simple to construct, requires but little room and shows a considerable improvement over most of the antennas which are of random length, is the common half-wave doublet, shown in Fig. 1A. Dimensions are given for the middle of the F.M. band and the resonance frequency is not sharp enough to require changes for other portions of the band. This type of aerial is bi-directional, and when used horizontally, favors the 2 directions which are at right-angles to the aerial itself. Almost any form of twisted-pair may be used. Flexible, shielded, single-wire line may be used, also. Such an antenna may be made uni-directional, by the simple expedient of setting up another wire, behind it, with relation to the desired station. The reflector wire's length is not critical. It should be about 10% longer than the aerial proper, and separated from it by approximately 5 feet, as indicated in B.

As the distance from the transmitting station increases, or as we approach a high-power station in an unwanted direction, the need for improving the particular antenna to suit our purpose becomes more acute. The arrangement shown in Figs. 2A and 2B is known as 2 half-waves, in-phase. In the desired direction, Fig. 2A, will show a 50% improvement over Fig. 1A, but will not be as good as Fig. 1B. Figure 2B should be at least half-again as good as Fig. 1B.

Where the room is available, the extended double zep type of antenna, shown in Figs. 3A and 3B, will be found to be even more helpful. The antenna shown in Fig. 3A is about as good as 1B and better than 2A, but not quite as good as 2B. By all odds, the arrangement of 3B is the best. Under a given set of circumstances, a transmitter would have to increase its power 500% to produce as good a signal in 1A as in 3B. In addition to a marked forward "gain" the 3B antenna has a marked ability to reject signals from the direction to its rear.

ROTARY ANTENNAS

It will be noted that all the antennas, shown as B, include reflectors and they are uni-directional in character. As their directional properties increase, the need for having them aimed directly at the desired station becomes more necessary.

To secure the greatest benefit from a group of F.M. stations in different directions, while cutting down the interference from undesired stations, it is desirable to use self-supporting metal tubes in place of the wire which is used for fixed antennas. Such tubing and supporting frameworks are common practice with many commercial services as well as many amateur stations. Design drawings, with full details for making several different types of frames may be had without charge from the Premax Products Division of the Chisholm-Ryder Co., Niagara Falls, N. Y. Information on rotating mechanisms, suitable tubing and the various combinations in which elements may be employed is also included.

VERTICAL AERIALS

Any of the foregoing antennas may be used in a vertical assembly where it is desired to receive vertically-polarized transmissions. In most such conditions, however, it is doubtful that the reflectors will be used because of the mechanical problems which they present. By having any of the foregoing antennas set up vertically, it is very easy to make them cover all directions by the simple expedient of rotating the reflector, while the antenna proper, remains fixed.

LONG WIRE AERIALS

When an antenna is several wavelengths long it has rather marked directional properties. As the number of wavelengths, which the wire contains, is increased the direction of best reception becomes nearer and nearer a point opposite the free end. This is shown in Fig. 4. Such a long wire has been used at the Long Island City headquarters of the Radio Engineering Laboratories, to receive

TREASURE LOCATORS

BLUE PRINTS and INSTRUCTIONS

INTRODUCTORY OFFER SEVEN FOLDERS

\$3

POSTPAID



TECHNIFAX CONSTRUCTION PATTERN SERIES

For Building the Following Treasure Finders and Prospecting Outfits

Folder No. 1. The "Radioflector Pilot"—consists of a 2-tube transmitter and 3-tube receiver. Principle: radiated Wave from transmitter loop is reflected back to receiver loop. Emits visual and aural signals. Tubes used: two 1A5G—two 1N5G—one 1H5G.

Folder No. 2. The "Harmonic Frequency Locator"—Transmitter radiates low frequency wave to receiver, tuned to one of Harmonics of transmitter. Using regenerative circuit. Emits aural signals. Tubes used: one 1G6G—one 1N5G.

Folder No. 3. The "Beat-Note Indicator"—Two oscillators so adjusted as to produce beat-note. Emits visual and aural signals. Tubes used: Three type '30.

Folder No. 4. The "Radio-Balance Surveyor"—a modulated transmitter and very sensitive loop receiver. Principle: Balanced loop. Emits visual and aural signals. By triangulation depth of objects in ground can be established. Tubes used: Seven type '30.

Folder No. 5. The "Variable Inductance Monitor"—a single tube oscillator generating fixed modulated signals and receiver employing two stages R.F. amplification. Works on the inductance principle. Emits aural signals. Tubes used: six type '30.

Folder No. 6. The "Hughes Inductance-Balance Explorer"—a single tube Hartley oscillator transmitter and sensitive 3-tube receiver. Principle: Wheatstone bridge. Emits aural signals. Tubes used: two type '30—one type '32—one type '33.

Folder No. 7. The "Radiodyne Prospector"—a completely shielded instrument. Principle: Balanced loop. Transmitter, receiver and batteries enclosed in steel box. Very large field of radiation and depth of penetration. Emits aural signals. Tubes used: two 1N5G—one 1G4G—one 1H5G—one 1Q5—one 1G4.

With any one of these systems you can construct instruments to locate buried treasures, metal war relics, mineral deposits, subterranean water veins, oil deposits (under certain circumstances), buried gas and water pipes, lost objects, tools and treasures sunken in water, etc. Each set of blueprints and instructions enclosed in heavy envelope (9 1/2" x 12 1/2"). Blueprints 22" x 34"; eight-page illustrated 8 1/2" x 11" folder of instructions and construction data **50¢**

Add 5¢ for postage

The complete set of seven folders..... **\$3.00**
(Sent postpaid)

TECHNIFAX

RC-740

1917 S. STATE ST. CHICAGO, ILL.

TECHNIFAX 1917 So. State, Chicago, Ill.

Enclosed herewith \$..... for which mail to address below.

Treasure Finder No. 1, 2, 3, 4, 5, 6, 7.

Complete set of seven folders.

NAME

ADDRESS

CITY STATE

RC-740

weak signals from the Paxton, Mass., station, while cutting out interference from the powerful Alpine, N. J., station, but a few miles away. The wire used for that purpose was 5 wavelengths long. The best signal from Paxton was received when the wire was pointing 20° off the actual direction of the station. Where the need for such discrimination exists, the same result may be obtained without the need for so much property, if several elements are used in a fixed or a rotary beam, as outlined previously, but the long wire is interesting.

ALL DIRECTIONS

In an attempt to attract the greatest number of listeners, without regard to the form of antennas they may be using, some of the F.M. broadcasters have gone to antennas of the form shown in Fig. 5. It is claimed that both horizontal and vertical radiation results. Similar antennas have been suggested, for receiving, in locations where several F.M. broadcasters are using different forms of antenna polarization.

ABOVE ALL

It should be remembered that F.M. is being carried out on the ultra-high frequencies. Best performance of any antenna, on those frequencies, is obtained as its height above surrounding objects is increased.

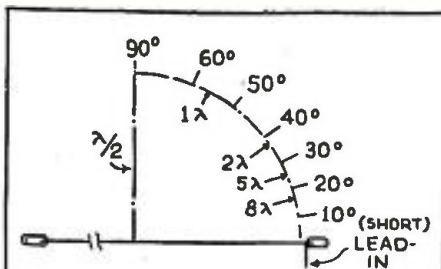

~RADIATION OF MAIN LOBE ON LONG HORIZONTAL ANTENNAS~

FIG. 4

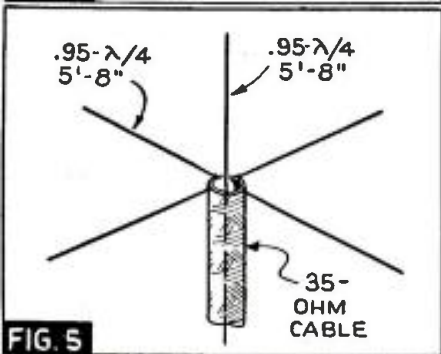
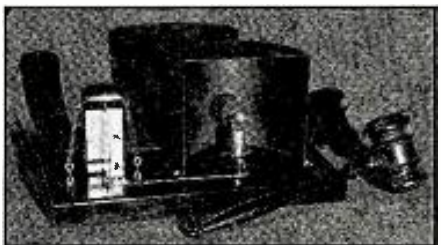

FIG. 5



Piezoelectric Demonstrator

Bell Laboratories developed the above-illustrated device for demonstrating the production of electricity by stresses in crystals (notably quartz and, shown here, Rochelle salt); that is, for showing how mechanical and electrical energy are interlinked. Whanging the crystal (left) with the gavel generates up to 2,000 volts which is ample to light the neon lamp in the housing at right.

FREE 172 PAGE CATALOG

EVERYTHING IN RADIO
At Lowest Prices!

YOU NEED THIS BOOK
Get your ALLIED Catalog now! You can't afford to be without it if you're a Serviceman, Dealer, P. A. Man, Amateur or Builder! It's the biggest, most complete Radio Catalog out today—your Guide to real money-savings.

60 New Sets. Real Radio hits—new "Camera" and 3 way Portables, new European reception compacts, plastic phonos, radios, home recorder combinations, etc.

New P. A. 18 New Sound Systems—7 to 75 watts—for Electricians, Rental, Orchestras, School, churches, etc. New Ideas—new applications—new low prices—Time Payment Plan—1 Day Trial Offer, etc.

Servicemen. New Test Equipment—new tools and gadgets—more than 15,000 quality replacement parts. Big Special Bargain Section.

Builders. Count on ALLIED for all the new kits and builders supplies. You can depend on ALLIED as your Radio Supply Headquarters because ALLIED is the 100% Radio House.

ALLIED RADIO CORP.

833 W. Jackson Blvd., Dept. 2-G-0
Chicago, Illinois

Send your FREE 1940 Radio Supply Catalog.

Name

Address

City State

DATAPRINTS

TESLA-ODIN HI-FREQ. COILS

20c Ea. in order for 10 (Data and Drawings only.)

36" Sp'k Tesla-Oudin Coil 40c (1 K.W. Exc. Trf. Data, included FREE!)

8" Sp'k Tesla-Oudin Coil 40c (1/4 K.W. Exc. Trf. Data, included FREE!)

3" Sp'k Oudin; 110 Vt. "Kick Coil" type.....40c

3" Sp'k Tesla Works on Ford Sp'k Coil40c

1" Sp'k Violetta Hi-Freq. Coil.....40c

Model Warships—Get List of Plans

Induction PIPE & ORE LOCATOR

Induction Type, Data40c
Radio Type40c

More DATAPRINTS 40c each!

5 Meter Superhet.	Electric Refrigerator
1/2 Meter Tr. & Rec.	Resistance Measuring Bridge
20 A.C. Probs. & Ans.	Weld. Transf. 2 K.W. Rewinding Armatures
20 Telephone Hook-ups	String Galvanometer
100 Mech. Movements	20 Simple Bell Circuits
20 Motor Hook-ups	Steel Wire Recorder!
Television Hook-up	Water Wheels or Turbines
20 Elec. Party Tricks	Photo Cell and Relay
Solenoids and Magnets—get list.	Ring 4 bells: 2 Wires
Fry Eggs on Ice!	20 Tesla Trays
Experimental Telephone	Polarized Relay
Radio Control for Models	Induction Balance
Diathermy Apparatus	
Inductor Organ	

Special Prices: 4 prints \$1.00; 10 for \$2.00; Single, 40c each. Get New Catalog 100 A.

The DATAPRINT Co.
Lock Box 322C, Ramsey, N. J.

• RADIO DEVELOPMENTS •

MINIATURE TRAINING BATTLEFIELD USES RADIO

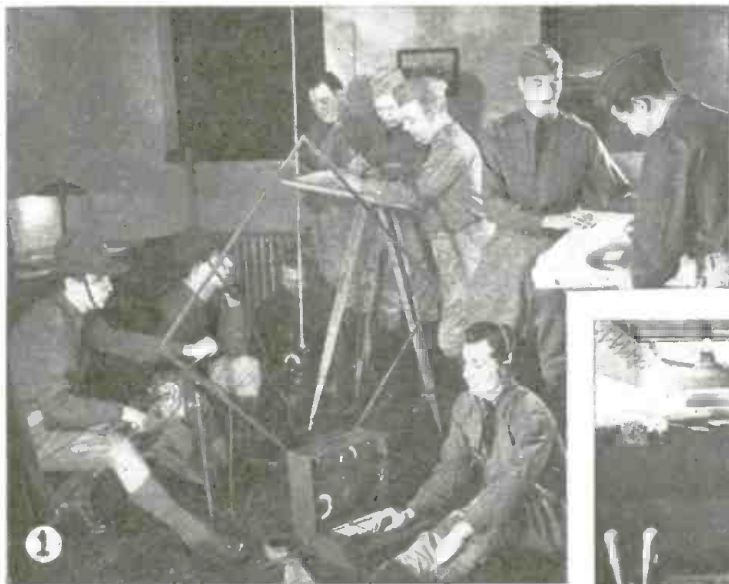

By using toy cannon, soldiers, trucks, etc., placed on a miniature battlefield located in the basement of the 108th Field Artillery Armory in Philly, National Guard artillerymen, radio operators, observers, etc., are getting important training in war strategy at very low cost. The "battlefield" is a small scale (1 ft. to 1,000 yds.) of an actual military range at Ft. Sill, Okla. As shown in photo 3, observers equipped with radio sets are stationed at strategic points on the battlefield and one in the cockpit of the fuselage (arrow). Their observations are relayed by radio operators to the 2nd-floor firing control room (photo 1) where firing directions are relayed by radio back to the operators who in turn call out the instructions to the gunners. Notice the soldier at the extreme left working a hand generator which supplies juice for the radio equipment. The air observer is shown in photo 2, in fuselage, radioing "hits" to the control room. Actual gun fire is used to destroy the "enemy."

RADIO GUARDS AGAINST FIRE AND THEFT



The American District Telegraph Co. recently demonstrated the latest devices based on radio principles to foil burglars and detect smoke in air-conditioning systems. In photo A smoke bombs are ignited to demonstrate the workings of a photo-electric cell smoke detector located in an air duct. Immediately upon "seeing" the smoke, the photo-electric circuit functions to shut off the air-conditioning apparatus, preventing the spreading of the fire and, at the same time, sends an alarm to headquarters. In photo B are shown 2 "phonet-alarms" located in the ceiling of a bank vault. These are sound alarms to guard against burglary.

Each box contains a crystal-type microphone and an A.F. amplifier. The sound of drilling, picks, torches and other burglar tools is easily detected and sent to police headquarters. In photograph C the innocent-appearing safe door is in itself a safe-guard against burglars. The door acts as one plate of a capacity-operated radio alarm while the hand of the burglar acts as the other. The mere approach of a hand or a body to the safe door causes an alarm to be sent to headquarters. All wiring is completely concealed and the sensitivity of the equipment can be adjusted to operate upon approach to within 3 ft. of the safe door.



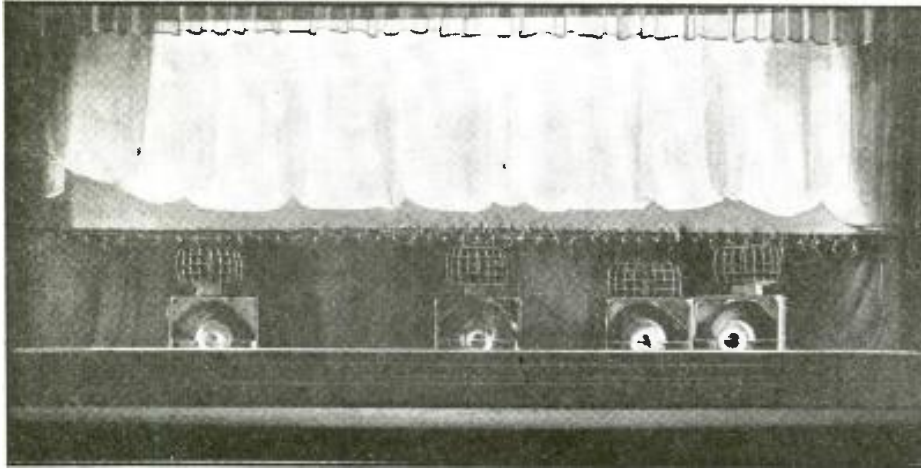

Invisible, behind a gossamer curtain, to the thousands of persons interested in sound who attended the demonstration of Enhanced Stereophonic Sound at Carnegie Hall last month were the 4 special loud-speaker combinations shown above. Each combination consists of a folded-back horn for low notes and a multi-cellular horn for the "highs." (The curtain was bathed in light that slowly changed color.)

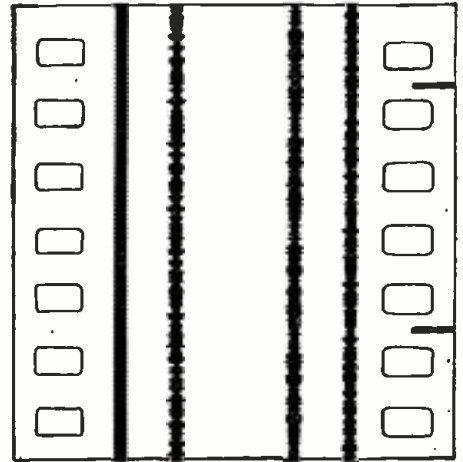

Enlarged view of negative film after initial recording. On the left is the control channel; on the right, the 3 sound channels. (Also see photo at right, pg. 712, June Radio-Craft.)

"ENHANCED" STEREOPHONIC SOUND

A development having far-reaching implications is a new system for controlling the volume of sounds recorded on film; and automatically controlling the playback volume. It was demonstrated by Bell Telephone Laboratories last month, to an invited audience at Carnegie Hall (New York City), that orchestral music for example can be reproduced from film recordings at whisper level or at 10 times normal volume!

R. D. WASHBURNE

IN the hands of a competent conductor, as Dr. Leopold Stokowski last month ably proved, the new "Enhanced" Sound-on-Film technique which the latest application of radio tubes makes possible can afford hitherto unattainable sound effects. These effects reach a zenith when combined with a previously-shown 3-Dimension Sound (Stereophonic) method* applied to film recording and playback.

An immediate application of Enhanced Sound (with or without benefit of the 3-Dimension technique) which comes to mind is in talking motion pictures. Acoustic effects "quite beyond the capabilities of instruments or artists" are conveniently and automatically achieved. Audience psychology can be played upon, as never before, with the intense throb of jungle drums, great crashes of thunder, wide ranges in voice and orchestral volumes, etc. Many other applications soon will be found.

*See "The Third Dimension in Sound," by the writer, in Radio-Craft for May, 1934.

Anent the consensus of opinion concerning the auditorium demonstration we quote a heading from the *New York Times* of the following day, to wit:

Sound Waves 'Rock' Carnegie Hall as 'Enhanced Music' Is Played

'Stereophonic Reproduction' Demonstrated by Bell Laboratories—Tones Near Limit That the Human Ear Can Bear

WHY "ENHANCED" STEREOPHONIC SOUND?

Why is it that symphonic music, for example, heard over a radio set or the loudspeakers of a public address or sound-movie system fails to produce the same effect we experience when listening to the original production in an auditorium? The answers, that lead to the conclusion that certain improvements in sound technique are in order, are interesting.

A full symphony orchestra utilizes air

vibrations at nearly all the frequencies the ear can hear, and it uses volumes of sound from about the lowest that can be heard in an ordinary hall or auditorium to volumes 100 million times greater. The frequency range of such an orchestra, in other words, runs from the neighborhood of 40 cycles per second to perhaps 14,000 cycles; and the volume range extends from about 30 db. above the threshold of hearing to 110 db., a total range of 80 db.

In contrast with these ranges radio and sound-picture systems have frequency ranges only from 5,000 to 8,000 cycles wide; and volume ranges from 35 to 50 db.

Moreover a listener in an auditorium receives an added effect from the distribution of the sound in space, i.e., a recognition of different sounds coming from different sources.

The following technical description of the new sound technique which tends to solve these problems is adapted from "Stereophonic Reproduction from Film," by Dr.



Amplifying and control equipment of the stereophonic system. A. R. Soffel of Bell Telephone Labs. is shown observing the channel levels on a cathode-ray tube monitor.

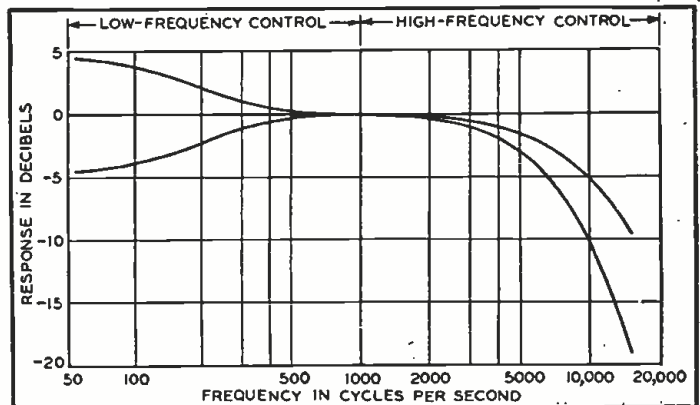

The frequency characteristics, above, of the stereophonic system are controlled by the 6 keys atop the enhancement control unit. (See photo at left, on pg. 712, June Radio-Craft.)

RADIO DEVELOPMENTS

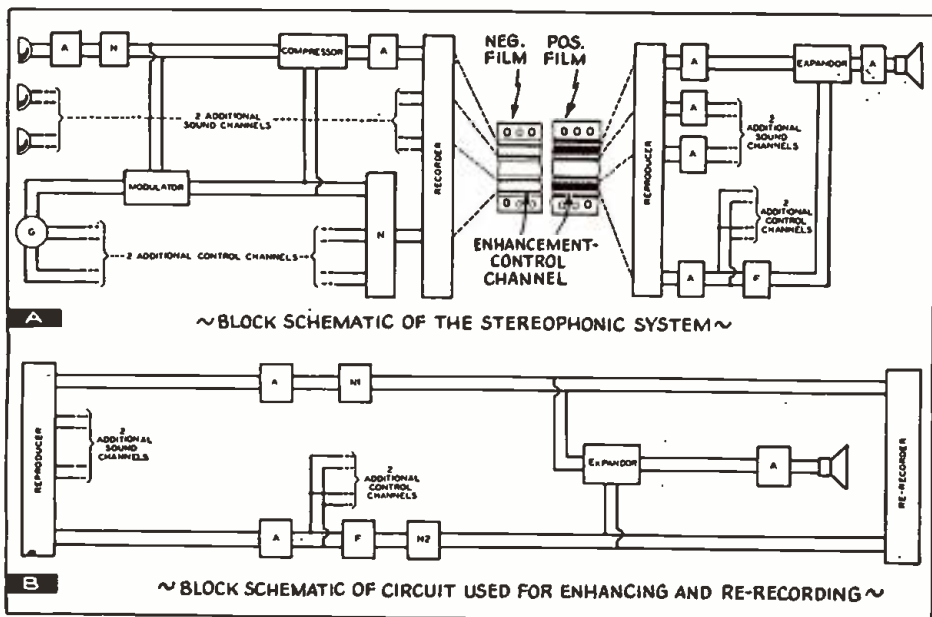

Harvey Fletcher, Director of Physical Research at the Labs., writing in the May, 1940, issue of *Bell Laboratories Record*.

MORE PROBLEMS

Ordinary recording and reproduction places no such demands on the equipment as does the stereophonic system. Sound-picture systems transmit a frequency range of less than 8,000 cycles, while the stereophonic system employs a band nearly twice

as wide. The entire recording and reproducing system had to be designed for this greater range.

In addition much greater precautions had to be taken to reduce noise and distortion. An extremely quiet system is required so that music at very low volumes, much lower than used in sound-picture systems, is not marred by the noise, and this is made more difficult because of the wider frequency range, which gives a wider band for the entrance of noise.

Finally, there is the matter of increased volume range. The maximum volume range that can be placed on a film is less than 50 db., while the stereophonic system, with the 10-db. increase and decrease provided by the enhancement control, requires a range of 100 db.

The seemingly impossible task of recording a program having a volume range of 100 db. on a film that will receive only a 50-db. range was accomplished as follows.

SEQUENCE OF OPERATIONS

The music as it is picked up by the microphones is passed through a *compressor*, one being provided for each of 3 channels. These allow the music currents to pass to the film-recording equipment in their normal volume range up to about 45 db.; higher volumes are reduced by the compressor so that the limit of the film recording is not overstepped.

At the same time an "enhancement" record is made on another track on the film of just the time and extent of these reductions.

At the reproducing end the music currents generated in photoelectric cells from a light beam passing through the film are carried through an *expander* before reaching the loudspeaker. The action of the expander is controlled by the signal obtained from the additional (or "enhancement") light-track. At any point where the original program was reduced in volume by the compressor; this signal will cause the expander to increase the volume by just the right amount. (See Fig. A.)

THE "ENHANCEMENT" CHANNEL

To control the compressor at the recording end, a small amount of the program current is taken from the circuit just ahead of the compressor and is rectified. This rectified current modulates a single-frequency current, which then controls the compressor and also forms the signal placed on the 4th track on the film.

Since there are 3 channels, and the amount and time of compression will vary from one to another, 3 control signals must be recorded on the film, one for each of the 3 channels. *These are all recorded on the same track on the film by allowing the 3 rectified currents to vary independently the strength of 3 alternating currents of different frequencies!* These 3 modulated currents control their respective compressors and are then combined and recorded as the 4th track on the film.

A positive of this first film is reproduced while the original conductor listens and manipulates the *enhancement controls* (see left-hand photo, bottom of pg. 712, June *Radio-Craft*) to modify the frequency and volume ranges of the 3 channels to secure an effect that more nearly conforms to his interpretation. As the conductor listens to the reproduction of the original recording, and manipulates these controls, a *second film is made of the enhanced program.*

A block schematic for this phase of the operation is Fig. B (which shows only 1 channel, however).

On the new film, the 3 program *sound* tracks are the same as on the original film except for the frequency modifications. The *control* track, however, has been modified by the manipulation of the enhancement control so as to cause greater or less expansion when the program is subsequently reproduced.

The new film made as a result of this process thus represents the enhanced program, and is the one used for all subsequent reproductions.

In conclusion, we ask: Will Motion Pictures soon accept this opportunity to raise the standard of its film entertainment?



Get This Electric Dry Shaver
ABSOLUTELY FREE!

JUST THINK OF IT—you can get absolutely FREE, the useful DRY ELECTRIC SHAVER which is shown at the left. This ELECTRIC DRY SHAVER is sent to you by the publishers with a one-year subscription to RADIO-CRAFT.

Here Are the Features of The ELECTRIC DRY SHAVER

Constructed of metal with attractive red bronze finish. Scientifically constructed to give a perfectly clean shave. 5-foot rubber insulated cord and plug. Constructed to last for many years.

Operates from 110-volt, 60-cycle A.C. electric line. Carries a two-year manufacturer's guarantee. A fine quality, self-sharpening toilet necessity.

Send your subscription to RADIO-CRAFT for One Year (12 issues) and receive absolutely FREE one of these remarkable Electric Dry Shavers. New subscribers are accepted or you may extend your present subscription another twelve months. Mail your remittance of \$2.00 (plus 25c for shipping charges on Shaver) to the publishers. (Canada and foreign \$2.75.) You will receive your DRY ELECTRIC SHAVER immediately by return mail. Use coupon below to enter your subscription.

RADIO-CRAFT

20 Vesey Street, New York, N. Y.

RADIO-CRAFT, 20 Vesey Street, New York, N. Y.

Gentlemen: Enclosed find my remittance of \$2.00 for which enter my subscription to RADIO-CRAFT for one year (12 issues). Send me immediately FREE ELECTRIC DRY SHAVER (Canada and foreign \$2.75). In U. S. add only 25c additional to cover shipping charges on Shaver.

New Subscriber Extend Present Subscription

Name

Address

City State

(Send remittance by check, money order or unused U.S. Postage Stamps. Register letter if you send cash or stamps.) RC-7-40

WE SHIP ELECTRIC DRY SHAVER THE SAME DAY YOUR SUBSCRIPTION ORDER IS RECEIVED.

CLIP COUPON—
AND MAIL!

RADIO PROJECT of the *National Youth Administration*

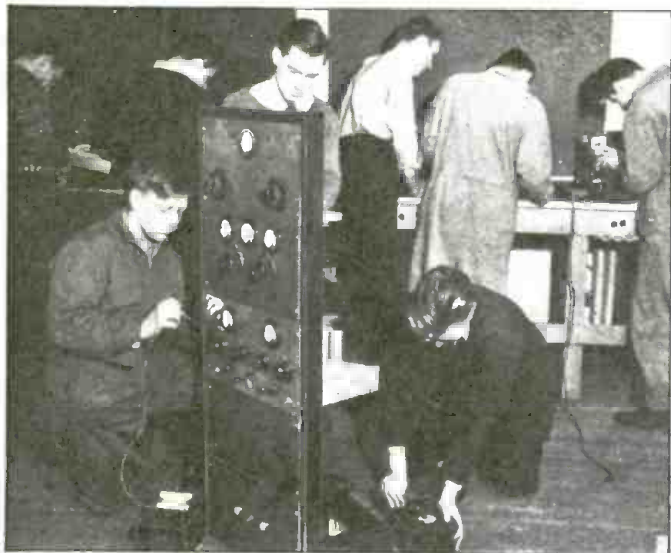

HALFWAY between the Equator and the North Pole, on the Bay of Fundy in Maine, is a site known as Quoddy Village, housing one of the greatest Government Youth Training Centers of the National Youth Administration. Here over 500 youths, ranging in age from 18 to 25, are able to acquire *actual work experience* in over 20 trades—among which *radio* is one of the newest and the most popular. These youths come from families earning under \$2,000 per year; selection is by quotas based on the population of the New England States and New York State. Work is limited by law to helping public tax-supported agencies which supply all the material—the N.Y.A. assists only with labor. Thus many police and other public agencies are building radio equipment with the aid of N.Y.A. labor.

1—N.Y.A. youths are shown completing a 200-W., ham-radio transmitter. Each youth is given 5 months of employment and training, receiving about \$ 3 per month "clear" after all expenses are deducted.

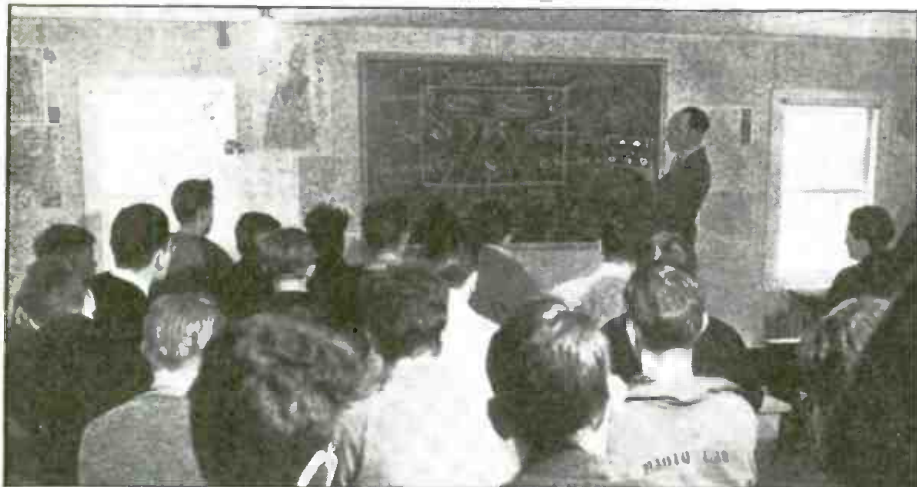

2—N.Y.A. junior workers adjusting controls of a 2,500-W. transmitter, sent to Quoddy Village by the C.A.A., soon to be modified for ham radio. The Quoddy N.Y.A. is now building the new Maine State Police radio system which is to comprise 2 headquarters stations and 15 mobile units; in the near future the system will include 6 headquarters points and about 95 mobile units.

3—The radio work experience class in session. Those boys are receiving classroom instruction in all phases of radio. They are "junior workers" (not students) inasmuch as they turn out useful radio equipment for actual service.

SOUTH SEAS RECORDING EXPEDITION



1—The brothers Bruce and Sheridan Fahnestock, at one of their recording machines with which they plan to build up a collection of musical recordings throughout the South Seas, particularly in Torres, Banks, Santa Cruz, the Solomon Islands and the New Hebrides. They set sail late in January and expect to be gone for 2 years. This is the 2nd of a series of expeditions. The native Himeni (community singing) and music of the big drums will be particularly studied. At least 20 network broadcasts are due via N.B.C. Gas and wind generators supply power.



2—The Fahnestock boys, charting their course on a map of the South Pacific ocean. The radio equipment (a philanthropy of Helen Fahnestock Hubbard) aboard their 137-ft. long 3-mastered schooner, *Director II*, includes the following: *transmitters*, 1—1,000-W., on 3 to 30 mc. (listen for KWAH); 2—100-W., for expeditionary use, on 6 to 30 mc. and 7 to 60 mc.; a 20-W. ultra-H.F. launch portable on 40 to 112 mc.; 2—3-W. ultra-H.F. 7-lb. pack units on 40 to 80 mc.; 2—1/10-W. portables on 112 mc.; 1—60-W., 600-meter emergency unit; and, a 5-W., 3 mc. airplane unit. *Receivers* cover 90 to 112 kc.

Pre-View Radio Parts

The 1940 Radio Parts National Trade Show, at the Stevens Hotel, Chicago, Ill., opens Tuesday, June 11 and closes Friday, June 14. Managing Director of the Show is K. A. Hathaway. Below are listed the highlights of many of the manufacturers who have display booths at the Show. Take this issue along with you when you go to the Show and use these pages as a guide for visiting the booths in which you're interested.

ALLIANCE MFG. CO.—BOOTH 416. Outstanding feature will be the display of a new recorder. A complete line of phonograph and radio-tuning motors also will be shown.

AMERICAN LAVA CORP.—BOOTH 616. An interesting and educational display illustrating many of the custom-tailored parts made in steatite ceramic, Alsimag.

AMERICAN PHENOLIC CORP.—BOOTHS 1021 & 1023. Complete line of sockets and connectors, aircraft products, polystyrene insulation, coaxial cables and other new and unusual items.

AMERICAN RADIO HARDWARE CO., INC.—BOOTH 826. Complete line of testing equipment parts in metal and in plastics, together with a display of drums, pilot-light sockets and special formings.

AMERICAN TELEVISION & RADIO CO.—BOOTH 831. Of exceptional interest will be a display of midget phonograph inverters for use with A.C.-D.C. phono-radio portable combinations. Other features of this display will be auto- and farm-radio replacement vibrators, inverter and polarity-changer vibrators and vibrator-operated rectifier power supplies.

AMPERITE CO.—BOOTH 931. Aside from its regular line of velocity microphones and ballast tubes this company will feature its new PG dynamic microphone, Kontak mike model KKH with hand volume control, and a display showing the use of a Kontak mike with the home radio.

ASTATIC MICROPHONE LAB., INC.—BOOTH 727. Complete line of microphones, phonograph pickups, recording heads, mike stands, and other accessories. Be on the look-out for new models on display for the first time.

ATLAS SOUND CORP.—BOOTH 503. An interesting demonstration is planned

to point out the construction and operation of the "Dyna-Flux" compression-type speaker units. Featured also will be the new "Morning Glory" reflexed sound projectors. Don't miss the display of photographs showing typical P.A. installations. All this will be in addition to the regular line of 1940 speaker developments and accessories.

BELL SOUND SYSTEMS, INC.—BOOTH 402. Besides its complete line of sound and intercommunication systems, this company will feature its recording equipment, and especially, the model RC2P with built-in amplifier.

BLILEY ELECTRIC CO.—BOOTH 928. Of special interest will be the educational display of the various steps involved in the manufacture of a finished quartz crystal. In addition the company's regular line of quartz crystals and mountings will be shown.

WILLIAM BRAND & CO.—BOOTH 824. Exhibit will show the outstanding features of new American-made flexible varnished tubing and saturated sleeving. This material heretofore was entirely imported. A complete line of electrical insulation materials—such as mica films, varnished cloth, papers, tapes and composites—also will be shown.

BROWNING LABS., INC.—BOOTH 325. Of great interest will be a display of components and complete adapters for the reception of frequency modulation programs. Also shown will be a line of amateur radio equipment as well as precision frequency monitors for police, marine and other special services.

BRUSH DEVELOPMENT CO.—BOOTH 415. One of the interesting features of this exhibit will be a new crystal record cutter and phonograph pickup particularly suited for high-quality recording and reproducing. This will be in addition to its complete line of crystal microphones, headphones,

record cutters, pickups, and hearing-aid components.

BUD RADIO, INC.—BOOTHS 820 & 822. The products of this company to be put on display include transmitting, neutralizing and receiving types of variable and fixed air-dielectric condensers; band switching and plug-in transmitting coils; receiving coils and kits; ceramic and bakelite coil forms; transmitter kits; chassis, racks, cabinets and panels; accessories (dials, switches, knobs, etc.); and other shortwave component parts.

BURGESS BATTERY CO.—BOOTH 10. Be sure to get a copy of the revised issue of this company's portable battery replacement guide—gratis to every visitor requesting it. Of exceptional interest is the display of the new type M30 "multi-ply" 45-V. "B" battery weighing only 1 lb., 11 ozs.

CARRON MFG. CO.—BOOTH 715. Aside from their regular line of speaker replacement parts and accessories, R.F., I.F., antenna, and choke coils, this company will have on display a new signal-tracing amplifier, beat-frequency oscillator and a frequency modulation kit. Recording discs will also be shown.

CONSOLIDATED ELECTRIC LAMP CO.—BOOTH 423. Products to be displayed are CHAMPION radio tubes, plug-in resistors (ballast tubes), incandescent and fluorescent lamps; VULCAN electric soldering irons, melting pots (for solder, wax and glue), and heating units of all types.

CONTINENTAL CARBON, INC.—BOOTH 418. Display consists of composition resistors of 4 different types; wire-wound resistors, cement and vitreous-enamel coated, also wire-wound resistors encased in ceramic tube; "filternoys" and auto-radio suppressors; paper-dielectric condensers.

CONTINENTAL ELECTRIC CO.—BOOTH 301. A feature display will be the demonstration of sound transmitted

National Trade Show

by a light beam. In addition, a complete line of photoelectric cells, mercury-vapor rectifier tubes, vacuum gauges, photo relay units, and A.C.-operated fence controllers, will be shown.

CORNELL-DUBILIER ELECTRIC CORP.—BOOTH 1027. Be sure to get your free copy of the "Capacitor Manual for Radio Servicing" for all standard sets at this booth. Complete line of Dykanol, paper, mica and electrolytic condensers featuring types BR—"Beaver" and EZ electrolytic units.

HUGH H. EBY, INC.—BOOTH 724. A dynamic display showing how the electric eye and various associated units operate will be featured at this booth. Also shown will be a complete line of photoelectric alarm systems, binding posts, molded instrument sockets, plugs, tip-jacks, etc.

EICOR, INC.—BOOTH 409. Of particular interest will be the smallest practical dynamotor ever offered to the trade—and a similar unit made of transparent material to show the exact construction and operation. In addition a complete line of engine-driven generators for all purposes will be displayed; as well as a complete line of dynamotors used for radio transmitting and receiving, and a line of D.C. to A.C. converters.

EITEL-McCULLOUGH, INC.—BOOTH 429. The interesting highlight of this exhibit will be a display of new multi-element transmitting tubes—Eimac types 152T₄ and 304TL.

GENERAL CEMENT MFG. CO.—BOOTH 728. New radio service aids, never before available, will be on display. These are all items said to be urgently needed by the Serviceman. A new 1941 catalog will be distributed gratis.

GENERAL TRANSFORMER CORP.—BOOTH 1008. A complete line of G.T.C. Porta-Power units which enable battery radio receivers to be operated from 110-V. lines; also complete line of fluorescent lamp auxiliary equipment,—and "Snippie," the cuttersnipe.

HAMMARLUND MFG. CO., INC.—BOOTH 926. On display will be the HQ-120-X communications receiver and the new Super-Pro series 200. Special display will be given to a number of new and interesting items in addition to the regular line of parts.

HICKOK ELECTRICAL INSTRUMENT CO.—BOOTHS 629 & 631. In addition to all its standard testing equipment, including a complete line of meters, this company will give special display to its latest TRACEOMETER.

HOWARD RADIO CO.—BOOTHS 420 & 422. Don't miss this interesting and educational display. Component parts used in communications receivers and their evolution from raw materials will be displayed.

HYTRON CORP.—BOOTHS 212 & 214. The chief theme of this exhibit will be a presentation of the design, manufacture and testing of radio receiving tubes. This will include an explanation of the interesting and intricate details of modern radio tube construction. Equipment showing the application of transmitting tubes, especially the ultra-high-frequency types, will be on display.

INDIANA STEEL PRODUCTS CO.—BOOTHS 720 & 722. A presentation of representative types of magnets as used in radio and instrument designs. There will be a group of interesting gadgets containing permanent magnets which will catch your fancy.

INSULINE CORP. OF AMERICA—BOOTHS 417 & 419. In addition to a display of a "revolutionary" idea in metal goods, such as cabinets, chassis, amplifiers, etc., the complete I.C.A. 1941 line of automobile radio antennas and accessories will be shown.

E. F. JOHNSON CO.—BOOTH 118. An entire line of radio transmitting equipment including both amateur and broadcast components. Condensers, inductors, tube sockets, insulators, antenna equipment, Q antennas and hardware will all be featured.

KENYON TRANSFORMER CO., INC.—BOOTH 408. A completely new line of plug-in type transformers will be displayed. Replacing a transformer of this type is as simple as replacing a radio tube.

LECTROHM, INC.—BOOTH 912. Complete line of vitreous enameled wire-wound resistors of the fixed and semi-variable types.

LES LOGAN CO.—BOOTH 501. Lightweight bakelite and heavy metal telegraph keys, practice sets, buzzers and semi-automatic speed keys will be on

display. Two new models, Nos. 500 and 501, will be on actual demonstration.

MEISSNER MFG. CO.—BOOTHS 623 & 625. The center of attraction in this company's display will be a new 10-tube frequency modulation "Receptor," which can be connected to any radio receiver for receiving F.M. In addition the complete line of radio kit receivers, amateur equipment, test instruments and radio servicing replacement items will be on display.

JAMES MILLEN MFG. CO., INC.—BOOTH 630. Complete line of radio communications products, newly designed for maximum ease of construction, as well as components such as variable condensers, dials, sockets, inductors, power supplies, etc.

MILLION RADIO & TELEVISION—BOOTH 910. Complete line of signal generators, micro-volters and other test instruments as well as sound equipment.

MIMS RADIO CO.—BOOTH 1011. Rotary beam equipment and accessories, direction indicators, field strength meters and numerous illustrations of various applications of these will be on display. A surprise is promised in the way of 2 new products.

NATIONAL CARBON CO.—BOOTHS 424 & 426. Will feature batteries for portable radio sets especially the new line of "Minimax" batteries designed especially for portable set service.

NATIONAL CO., INC.—BOOTH 13. An interesting display will be a type NHU transmitter mounted in a clear lucite cabinet. A full line of sets, transmitters, and component parts such as parallel-feed chokes 10-to-1 ratio type N dials, wide-band tank units covering from 10 to 160 meters will be shown.

OHMITE MFG. CO.—BOOTH 119. Complete and exceptionally extensive line of close-control rheostats, wire-wound resistors, and power-tap switches. Ask to see the new sizes.

OXFORD-TARTAK RADIO CORP.—BOOTH 829. The feature item of the display of replacement and public-address speakers will be a new de luxe 12-in. Permag speaker.

PARK METALWARE CO., INC.—BOOTH 624. New tools for the radio man including shock-proof screwdrivers

Order your copy NOW—the only

P. A. HANDBOOK

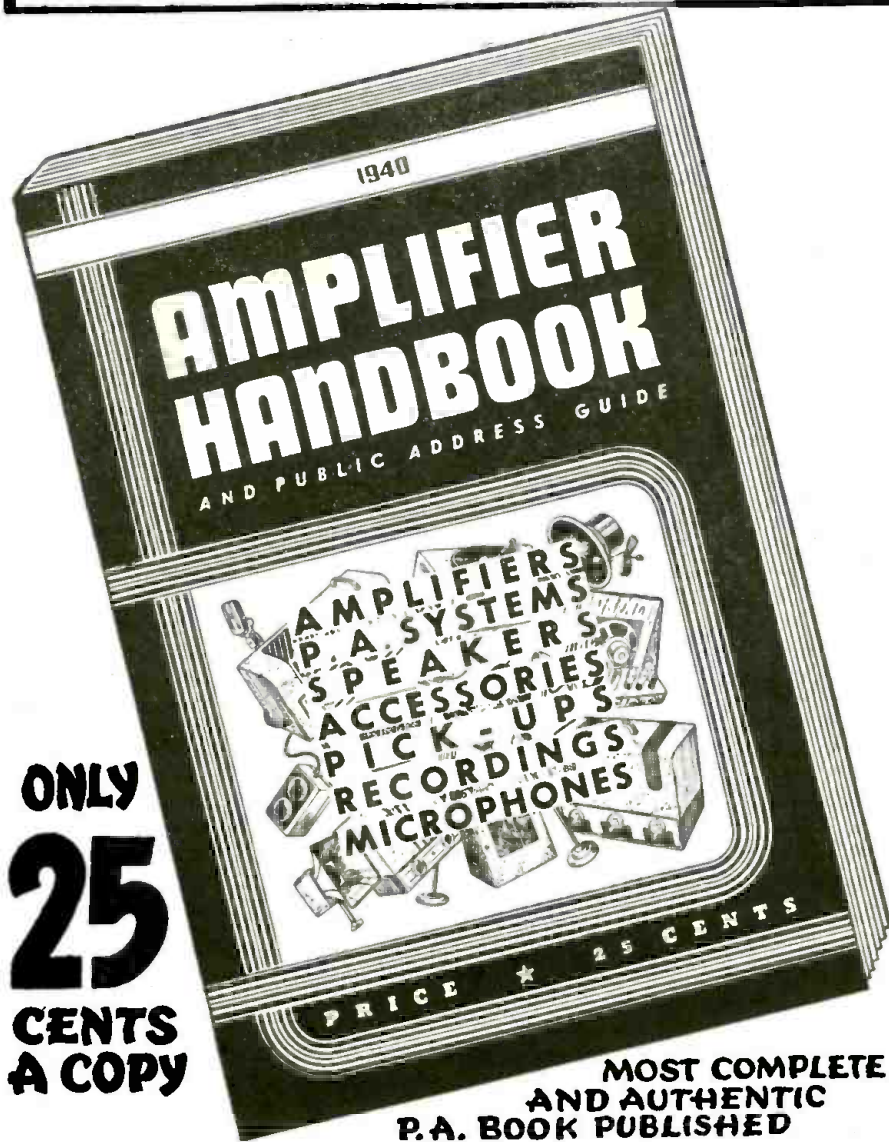

ONLY
25
CENTS
A COPY

**MOST COMPLETE
AND AUTHENTIC
P. A. BOOK PUBLISHED**

THAT no book has yet been published which covers amplifiers and sound systems (also kindred systems) in one complete, authentic volume is almost unbelievable. Yet, it is a fact, there is no book in print which covers Public Address from A to Z. To bridge this wide-spread gap, RADIO-CRAFT will publish a complete, magnificent volume on Public Address of such magnitude—so complete and authoritative—that every man engaged in radio can have both a theoretical and practical knowledge of the function and operation of sound systems. The editorial pages are so filled with instruction and replete with illustrations that the volume fully justifies its title of 1940 AMPLIFIER HANDBOOK AND PUBLIC ADDRESS GUIDE. This great HANDBOOK on Public Address should be read and studied by those who consistently build, service and sell sound equipment.

A MATCHLESS VOLUME
As complete as you would expect to find any engineering handbook—this is how the radio or P. A. man finds the AMPLIFIER HANDBOOK AND PUBLIC ADDRESS GUIDE, with essential technical data compiled from an exceptionally large number of sources, the volume covers nearly a hundred different subjects coordinating every conceivable branch or sub-division of Public Address.

THE CONTENTS
To actually show the scope and magnitude of the AMPLIFIER HANDBOOK AND PUBLIC ADDRESS GUIDE, an analysis of the contents is found at the right, showing the breakdown of the material featured within each particular section. A thorough reading of the contents shows the completeness of this book.

RADCRAFT PUBLICATIONS ■ 20 VESEY STREET ■ NEW YORK, N. Y.

RADCRAFT PUBLICATIONS, INC. ★ 20 VESEY STREET ★ NEW YORK, N. Y. RC-740

Gentlemen: Enclosed find my remittance of 25c for which send me POSTPAID, one copy of your NEW—1940 AMPLIFIER HANDBOOK AND PUBLIC ADDRESS GUIDE.

Send me others, for friends, also POSTPAID @ 25c each.

Name Address

City State

Remit by check or money order; register letter
if you send cash or unused U.S. Postage Stamps.

A Resume of the Contents of the AMPLIFIER HANDBOOK AND PUBLIC ADDRESS GUIDE

FOREWORD

INTRODUCTION

Definitions—decibels, frequency, input, output, impedance, etc.

SECTION I—SOURCE

Carbon microphones (single-button and double-button)
Condenser microphones
Velocity (ribbon) microphones
Dynamic microphones
Crystal microphones (sound-cell types, crystal diaphragm types)
Cardioid microphones
Contact microphones
Phonograph pickups (magnetic types, crystal types)

SECTION II—AMPLIFIERS

Voltage Amplification

Design of resistance-coupled voltage amplifiers

Commercial voltage amplifier

The Power Stage

Class A amplifiers

Class AB amplifiers

Class AB₁ amplifiers

Class AB₂ amplifiers

Class B amplifiers

When to apply class A, AB, and B amplification

Power Supplies

Half-wave rectification

Full-wave rectification

Voltage doublers

Filter Circuits

Power supply regulation, etc.

Practical Hints on Amplifier Construction

Microphonism

Placement of components

Tone compensation

Inverse feedback

Remote control methods

SECTION III—DISTRIBUTION

The Loudspeaker

Dynamic speakers

Speaker performance (frequency response, efficiency)

High-fidelity speakers

Speaker Baffles and Housings

Outdoor speaker installations

Power cone speakers

Radial (360° distribution) speaker baffles

SECTION IV—COORDINATION

Input impedance matching

Matching speakers to P.A. installations

Phasing speakers

Effect of mismatching speakers to amplifier output

A typical P.A. installation (in a skating rink)

SECTION V—USEFUL PUBLIC ADDRESS DATA AND INFORMATION

Speaker matching technique

The ABC of Db., VU, Mu, Gm and Sm

Charts and formulas useful to the practical P.A. sound man

Handy index to important articles on public address and sound

Order Your Copy NOW—

*Clip Coupon and
Mail Today!*

•RADIO DEVELOPMENTS.

and a new Phillips and Xcelite combination screwdriver will be displayed. Look for a surprise in a new item.

PERMO PRODUCTS CORP.—BOOTH 1031. The feature of the display of phonograph needles and recording stylii will be a new Fidelitone needle for playback and a Permo Point stylus for home-recording. Semi-technical information regarding needles will be distributed gratis.

PREMAX PRODUCTS—BOOTH 830. Vertical radiators, rotary beam antenna elements and accessory equipment including steel, Monel and aluminum masts for marine and police use, and antenna units will be displayed.

QUAM-NICHOLS CO.—BOOTH 117. Complete line of replacement speakers including dynamics, P.M. dynamics, and "Permanics" will be shown; also, the Permanic microphone. A new junior line of replacement speakers will be introduced.

RADIO CITY PRODUCTS CO.—BOOTH 7. An interesting display of test instruments, from "Midget" to "Jumbo" types, for all radio servicing work. Look especially for the new series of model 414 testers.

RADIO MFG. ENGINEERS, INC.—BOOTH 730. Outstanding among the complete receivers and accessories for ultra-highfrequency and standard short-wave reception will be the new model RME-99 communications receiver.

RAYTHEON PRODUCTION CORP.—BOOTH 614. An interesting display of its complete and exceptionally extensive line of radio tubes.

RCA MFG. CO., INC.—BOOTH 9 & 11. This display will feature power tubes, receiving tubes, test equipment and the model AR-77 amateur receiver.

READRITE METER WORKS—BOOTH 618. Complete line of test equipment for all servicing needs.

REK-O-KUT CORP.—BOOTH 1017. Featured among its display of recorders and feed mechanisms will be a dual-speed recorder using a new-type drive for the turntable.

ROLA CO., INC.—BOOTH 627. The display of its complete line of speakers will feature new 6 and 8 in. units of both the electrodynamic and permanent-magnet types, all of a new-style construction.

WALTER L. SCHOTT CO.—BOOTH 1013. An interesting display of tools, cabinet refinishing kits, and chemicals. Featured will be an unusual staple driver.

SHURE BROTHERS—BOOTH 109 & 111. An interesting, dramatized display showing how a cardioid microphone can

improve 9 out of 10 sound systems. In addition the complete line of microphones, pickups, stands, and accessories will be on display.

SIMPSON ELECTRIC CO.—BOOTH 729 & 731. Complete line of test instruments, including tube testers, combination set testers, the "micro-tester" and a line of small portable instruments.

SOLAR MFG. CORP.—BOOTH 104. The main feature of the exhibit of a complete line of fixed condensers, including wet and dry electrolytics, and paper and mica types, will be the smaller-diameter dry electrolytic Red-Caps for replacement service work.

SPEAK-O-PHONE RECORDING & EQUIPMENT CO.—BOOTH 305. The outstanding feature will be a display and demonstration of a new line of acetate discs. The complete new line of recording equipment, consisting of 7 newly-designed units, will be shown.

SPRAGUE PRODUCTS CO.—BOOTH 921 & 923. The entire line of condensers and Koolohm resistors will be shown as well as several action display pieces. The new de luxe Tel-Ohmike and the redesigned Interference Locator will be shown for the first time.

STANDARD TRANSFORMER CORP.—BOOTH 113 & 115. Complete new line of transformers, kits and power packs will be shown.

SUPREME INSTRUMENTS CORP.—BOOTH 821 & 823. Dynamic demonstrations showing how the new method of dynamic tracing works will be given. The 1940-'41 line of radio testing instruments—22 models in all—will be interestingly displayed.

THORDARSON ELECTRIC MFG. CO.—BOOTH 216 & 218. Among the new line of amplifiers to be displayed will be a special studio amplifier for broadcast service and a 12-W. mobile amplifier. Also see the new book for the tyro ham.

TRANSFORMER CORP. OF AMERICA—BOOTH 6. Complete 1940 line of Clarion sound equipment including sound systems, recorders, school systems, intercommunication systems, sound-on-film systems, record and transcription players, microphones, speakers and accessories.

TRIMM RADIO MFG. CO.—BOOTH 428. An interesting display of the complete 1940 line of headsets.

TRIPLETT ELECTRICAL INSTRUMENT CO.—BOOTH 619 & 621. Complete line of radio testing equipment and precision meters.

UNITED ELECTRONICS CO.—BOOTH 323. Complete line of transmitting and mercury-rectifier tubes for radio transmission, industrial and electro-

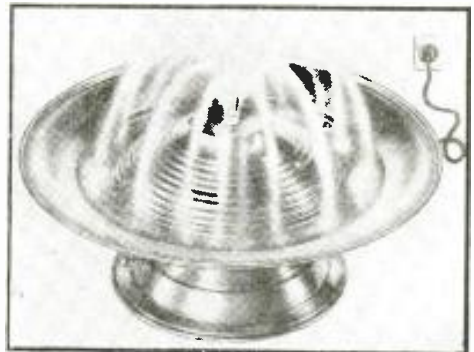

Extra Profits for Radio Men Selling Electric Humidifiers

IT doesn't take a salesman to sell this Humidifier. You can do it on a single demonstration. The unit talks for itself. This electric Fountain Humidifier is 14" in diameter and sprays into the air eight streams of water which rise 5" above fountain head and then fall back into the pond. The Humidifier is made of heavy spun aluminum (scratch-proof surface) and is available in five different attractive colors—Bronze, Chrome, Copper, Red and Green. No water connections are needed—merely plug into the 110-Volt, 60-Cycle A.C. line and turn the switch;—no pipes, no rubber connections, no messy fittings. Complete evaporation does not damage the mechanism.

In winter, the Fountain Humidifier adds healthful moisture to the air, evaporating as much as a pint of water in 24 hours. In summer, it is a charming, useful attraction and provides the pleasant, trickling sounds of falling water which suggests comfort and coolness. A drop of perfume added to the water will diffuse any room odor. Operating cost is only a few cents monthly.

Price complete, ready to use, with 8 ft. silken cord and switch on base (F. O. B. N. Y. C.) shipping weight 9 lbs. **\$14.95**

Distributors, jobbers and dealers write for prices

JOSEPH H. KRAUS COMPANY

123 Liberty Street New York, N. Y.

JOSEPH H. KRAUS COMPANY
123 Liberty St., New York, N. Y.

Gentlemen: Enclosed you will find my remittance of \$14.95 for which ship me one ELECTRIC FOUNTAIN HUMIDIFIER (F. O. B. New York City). Send me details for

- JOBBERS and DISTRIBUTORS**
 DEALERS and SERVICEMEN

Name

Address

City

State

(Remit by check or money order; register letter if you send cash) **RC-740**



SWINGS INTO ACTION

Primarily the aim of the Association is to return to the Distributor, the Dealer and the Serviceman the profits which are legitimately HIS! This can only be accomplished by raising the standards of ethics of merchandising within the Industry.

Names of Member Jobbers in your territory will be supplied if you will address the Executive Secretary of the Association.

Office of the Executive Secretary
5 West 86th Street New York, N. Y.

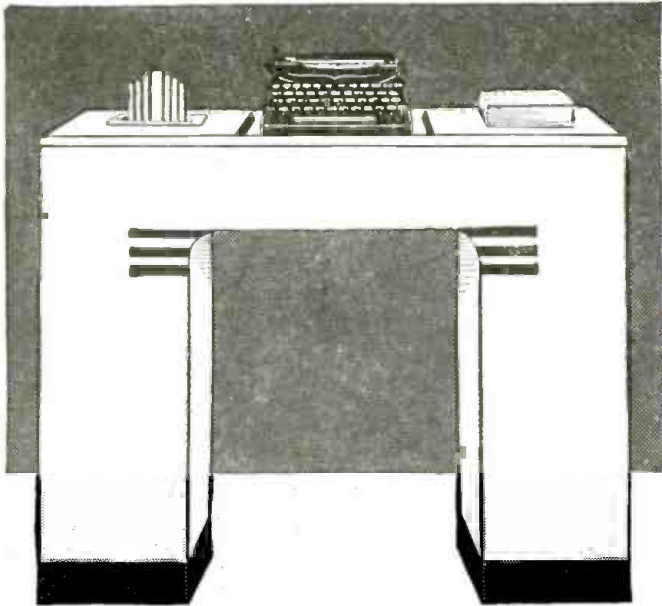

**THIS
BEAUTIFUL DESK
for only \$1.00 EXTRA**

**WITH ANY
REMINGTON
PORTABLE TYPEWRITER**

The
COMBINATION
FOR AS LITTLE AS
10¢ A DAY

How easy it is to pay for this combination of desk and Remington Deluxe Noiseless Portable Typewriter! Just imagine, a small good will deposit with terms as low as 10c a day to get this combination at once! You will never miss 10c a day. Yet this small sum can actually make you immediately the possessor of this amazing office-at-home combination. You assume no obligations by sending the coupon.

A beautiful desk in a neutral blue-green which will fit into the decorations of any home—trimmed in black and silver—and made of sturdy fibre board—is now available for only one dollar (\$1.00 extra) to purchasers of a Remington Noiseless Portable Typewriter. The desk is so light that it can be moved anywhere without trouble—it is so strong that it will hold six hundred (600) pounds. With this combination of desk and Noiseless Deluxe Portable Typewriter, you will have a miniature office at home. Learn the complete details of this offer. Mail the coupon today.

THESE TWO EXTRA FOR YOU

LEARN TYPING FREE

To help you even further, you get free with this special offer a 32-page booklet, prepared by experts, to teach you quickly how to typewrite by the touch method. When you buy a Noiseless you get this free Remington Rand gift that increases the pleasure of using your Remington Noiseless Deluxe Portable. Remember, the touch typing book is sent free while this offer holds.



SPECIAL CARRYING CASE

The Remington Deluxe Noiseless Portable is light in weight, easily carried about. With this offer Remington supplies a sturdy, beautiful carrying case which rivals in beauty and utility the most attractive luggage you can buy.



SPECIFICATIONS

ALL ESSENTIAL FEATURES of large standard office machines appear in the Noiseless Portable—standard 4-row keyboard; back spacer; margin stops and margin release; double shift key and shift lock; two color ribbon and automatic ribbon reverse; variable line spacer; paper fingers; makes as many as seven carbons; takes paper 9.5" wide; writes lines 8.2" wide. There are also extra features like the card writing attachment, black key cards and white letters, touch regulator, rubber cushioned feet. These make typing on a Remington Deluxe Noiseless Portable a distinct pleasure. Thousands of families now using the Remington Deluxe Noiseless Portable know from experience how wonderful it is!

MONEY BACK GUARANTEE
The Remington Noiseless Portable Typewriter is sold on a trial basis with a money back guarantee. If, after ten days trial, you do not wish to keep the typewriter, we will take it back, paying all shipping charges. You risk nothing in buying a Remington Portable Typewriter on terms as low as 10c a day.



**MAIL
COUPON
NOW!**

Remington Rand Inc., Dept. 189-7
465 Washington St., Buffalo, N. Y.

Tell me, without obligation, how to get a Free Trial of a new Remington Deluxe Noiseless Portable, including Carrying Case and Free 32-page Typing Instruction Booklet on terms as low as 10c a day. Send Catalogue.

Name.....
Address.....
City.....State.....

•RADIO DEVELOPMENTS.

medical use. Technical tube manuals will be available.

UNIVERSITY LABS.—BOOTH 413. Complete line of speakers and projectors including model CR booster speaker, speaker projectors featuring "floating rubber" cone speaker mounting, reflex loudspeakers and many other types.

UTAH RADIO PRODUCTS CO.—BOOTH 1018 & 1020. Featured will be the complete line of speakers, transformers, vibrators, etc., plus several new products not yet revealed.

WARD PRODUCTS CORP.—BOOTH 922 & 924. Complete line of auto-radio antennas and accessories will be shown.

VACO PRODUCTS CO.—BOOTH 19. Complete line of Ambery plastic handle screwdrivers, 93 different numbers in all, will be displayed.

WARD LEONARD ELECTRIC CO.—BOOTH 106. In addition to their complete line of relays this company will display an entirely new line of relays for antenna transfer and break-in operations. Also included will be a display of wire-wound resistors and rheostats.

WEBSTER CO.—BOOTH 116. A complete new line of Webster-Chicago microphones will be shown for the first time. This will be in addition to the display of a Master amplifier as well as a new development in interphones.

WINCHARGER CORP.—BOOTH 1022. Feature display will be the 6-V. de luxe Wincharger; it charges form-radio storage batteries. The complete line of Winchargers for farm-lighting plants and an antenna tower, also will be shown.

WIRT CO. BOOTH 825. Dynamic demonstration of the process of manufacturing radio parts which include switches, resistors, volume controls, etc.

LAST-MINUTE ADDITIONS

AEROVOX CORP.—BOOTH 208. Complete line of condensers and interesting movie called "Behind the Aerovox Label." . . . **AMERICAN MICROPHONE CO.—BOOTH 828.** New microphones, models D4, D4T and AT2; also a surprise in yet another new mike . . . **CLAROSTAT MFG. CO., INC.—BOOTH 620 & 622.** Colorful display of complete line plus several surprise new items . . . **DAVID BOGEN CO., INC.—BOOTH 1029.** Look for new annunciators for interphone systems, sound equipment with electronic tone correctors, recording equipment and accessories . . . **HYGRADE SYLVANIA CORP.—BOOTH 18 & 20.** Dynamic educational display of over-size Loctal tube construction; displays will feature importance of tube replacement . . . **PRESTO RECORDING CORP.—BOOTH 925.** Extensive merchandising plan, home-recording discs and needles will be stressed, this in addition to display of portable recorders, etc. . . . **EARL WEBBER CO.—BOOTH 1022.** Don't miss display of "Official Radio Service Laboratory" . . . **WEBSTER ELECTRIC CO.—BOOTH 421.** Complete line of phono pickups and recording heads . . . **WARNER PRODUCTS CORP.—BOOTH 435.** Interesting display of photoelectric equipment as applied to industry.

SUPER BARGAINS

Practically all of the attractive items listed here are brand new, others are reconditioned like new; but ALL are in PERFECT WORKING ORDER. In many cases, the parts alone total more than the price we are asking. 100% satisfaction guaranteed or your money refunded. ORDER FROM THIS PAGE. Use the convenient coupon below. Include sufficient extra remittance for parcel post charges, else order shipped express, collect. Any excess will be refunded. C.O.D. shipments require 20% deposit. If full remittance accompanies order, deduct 2% discount. Send money order, certified check, new U. S. stamps. No C.O.D. to foreign countries.

ORDER TODAY LIMITED QUANTITIES PROMPT SHIPMENTS ASSURED

G.E. INDUCTION DISC MOTOR FOR RECORDING PLAYBACK AND DISPLAY PURPOSES



Substantially constructed by General Electric, this ball-bearing motor is a high-quality phonograph unit. Its power and smooth-running make excellent home recording work. Its speed, governor-controlled, is variable both below and above 78 r.p.m. For 110 volts, 60 cycles, A.C. Solid less turntable and shaft, 7 1/2" diameter x 5 1/2" high. Shp. Wt. 1 1/2 lbs. Packed in Original Box.

ITEM NO. 81 YOUR PRICE \$3.95

SUPER SPECIAL 3 1/2 R.P.M. SYNCHRONOUS MOTOR

There are 101 uses for a synchronous motor making only 3 1/2 revolutions per minute. Ideal for crowd-catching store-window displays, agitating film-developing tanks, as an electric winch on model motor boats, as derrick motor in erector sets, etc. Built-in high-ratio step-down gears provide amazing amount of power. Made by Haydon Mfg. Co. of Waterbury, 2" in diameter x 2 1/2" x 1" thick overall. Shp. Wt. 2 lbs.



ITEM NO. 76 YOUR PRICE \$1.95

A.C. "SQUIRREL CAGE" SYNCHRON. MOTOR



Self-starting shaded pole motor designed for radio chassis for Push Button Tuning. High speed, powerful. One lubrication lasts lifetime. Excellent for model railroad trains, small boats, humidifier water pumps, etc. 1/2" long shaft, 3/16" diameter. Complete with brass mounting posts, 2 1/2" x 2" x 2 1/4" overall. For 110 volts, 60 cycles, A.C. only. Shp. Wt. 4 lbs.

ITEM NO. 77 YOUR PRICE \$1.35

MECHANICAL FLASHLIGHT

This battery-less flashlight generates its own power merely by pressing handle. Gives strong light whenever needed. Costs nothing to maintain. Amazing new miniature dynamo operates flashlight. Pocket size, 4 3/4" x 2" x 1". Shp. Wt. 2 1/2 lbs.



ITEM NO. 88 YOUR PRICE \$1.70

MOTOR FOR ROTATING RADIO BEAM ANTENNA

One Revolution per Minute



Built by Honeywell as a temperature regulator for coal fired furnaces but ideal for many other uses, especially for rotating beam antennas on the roof for directional beaming and reception of radio signals. Built-in commutator switching permits turning antenna from north-south to east-west direction from remote point. Constructed for hard usage. Has double-end shafts geared down to about one revolution per minute. Ideal for window displays and other slow-moving mechanical motions. 110 volts, 60 cycles, A.C. only. 6 1/2" x 6 1/2" x 4 1/2". Shp. Wt. 10 lbs.

ITEM NO. 82 YOUR PRICE \$5.95

AMAZING BLACK LIGHT!

Powerful 300-Watt Ultra-Violet Bulb



The best and most practical source of ultra-violet light for general experimental and entertainment use. Makes all fluorescent substances brilliantly luminous. No transformers of any kind needed. Fits any standard lamp socket. Made with special filter glass permitting only ultra-violet rays to come through. Brings out beautiful opalescent hues in various types of materials. Swell for amateur parties, plays, etc., to obtain unique lighting effects. Bulb only. Size of bulb. Shp. Wt. 1 lb.

ITEM NO. 87 YOUR PRICE \$2.00

SUPER MAGNET

LIFTS MORE THAN 20 TIMES ITS OWN WEIGHT

LITTLE GIANT MAGNET. Lifts 5 lbs. easily. Weighs 4 oz. Made of ALNICO new high-magnetic steel. Complete with keeper. World's most powerful magnet ever made. The experimenter and hobbyist will find hundreds of excellent uses for this high quality permanent magnet. Measures 1 1/2" x 1 1/2". Shp. Wt. 3/4 lbs.



ITEM NO. 86 YOUR PRICE \$1.00

BRAND NEW! BATTERYLESS BIKE-LITE

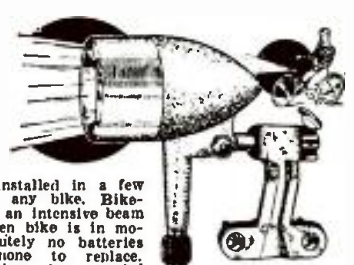

Can be installed in a few minutes on any bike. Bike-Lite throws an intensive beam of light when bike is in motion. Absolutely no batteries needed—none to replace. Costs nothing to operate! Small, built-in generator, turned by the bike wheel supplies unending current. Most economical headlight yet. Guaranteed for lasting performance. All metal construction with beautiful silver finish and polished chromium-plated reflector. Armature operates with a powerful Alnico General Electric permanent magnet. Measures 4" x 5 1/4". Complete with bulb and instructions, ready to attach. Shp. wt., 3 lbs.

ITEM No. 90 YOUR PRICE \$2.10

SEWING MACHINE MOTOR

For electrifying foot-treadle sewing machines and replacing burned-out motors on electrified machines. Powerful and high-speed; numerous other uses. Ideal as handy grinder-polisher motor. Small, compact, flat on two sides, requiring a minimum of space. Speed controllable by foot-pedal rheostat (available optionally for \$3.75). Its 3/4" diam. shaft is available with or without pulley (pulley 15c extra). Completely enclosed and dirt proof. Measures 3 1/2" x 5" x 2" overall. Shp. Wt. 7 lbs.



ITEM NO. 79 YOUR PRICE (motor only) \$3.75

HUDSON SPECIALTIES CO., 40 West Broadway, N. Y. C.

WE HAVE NO CATALOG. IT'S EASY TO ORDER—CLIP COUPON—MAIL NOW ORDER FROM THIS PAGE

HUDSON SPECIALTIES CO., 40 West Broadway, Dept. RC-740, New York, N. Y.
 I have circled below the numbers of the items I'm ordering. My full remittance of \$..... (include shipping charges) is enclosed.
 OR my deposit of \$..... is enclosed (20% required), ship order C.O.D. for balance. (New U. S. stamps, check or money order accepted.)
 Circle Item No. wanted: 76, 77, 79, 81, 82, 86, 87, 88, 90
 Name Address
 City State

Send remittance by check, stamps or money order; register letter if you send cash or stamps.

•LATEST RADIO APPARATUS•

"CHARGIT" FLASHLIGHT STORAGE BATTERY

Chargit Corp.
Anderson, Ind.

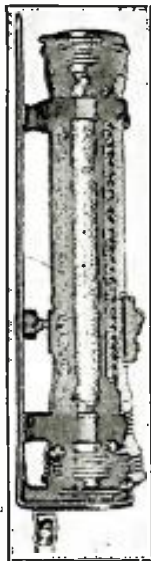

← This flashlight is designed to clip into a mounting that fastens to a car's steering column. The contact opposite the off-on switch wires the flashlight battery to the car battery. Note fuse at extreme lower end of mounting.



→ Cross-section view of the special lead-plate storage battery. Note multi-cell construction; the cells are paralleled.

THIS ingenious device is a small-space lead "plate" rechargeable storage battery of such dimensions as to fit ordinary flashlights. The battery is permanently sealed, non-spilling, non-corrosive, and requires no refilling. The unit measures 7 ins. long and has an outside diameter of 1 1/4 ins. The electrolyte is a special non-liquid formula which permits the use of the battery in any position. Designed primarily for use in an automobile where the car battery recharges the storage cells *automatically* when the latter is placed in its holder (note that it also may be adapted to recharging in the home). A rectifier charger is available for recharging from A.C. lines when used in the home. The flashlight operates for about 2 1/2 hrs. before the battery requires recharging.

LIVE LATHE CENTER

Ideal Commutator Dresser Co.
Sycamore, Ill.

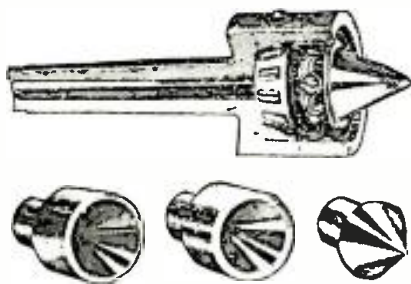

THIS item is good news for those Servicemen who do motor repairing as a sideline. It is especially useful for turning-down commutators on motor armatures. The center fits into the tailstock of the lathe and turns on 2 sets of bearings, one being a ball type and the other a Timken roller type. Three different center pieces or inserts are available. That is (1) a male insert for work already centered, (2) plain female insert for uncentered work, and (3) female insert with 3 raised lands for uncentered work having a flat or burred keyway. These inserts are quickly removed by means of a knock-out screw. The center turns with the work making possible high-speed turning at high precision.

ELECTRIC PHONOGRAPH

Music Master Mfg. Co.
508 S. Dearborn St., Chicago, Ill.



THE model A electric phonograph uses a high-grade crystal pickup with a frequency response which does not cut off below 10,000 cycles per second; and a P.M. dynamic speaker. The output stage of the amplifier uses a type 70L7GT tube.

CONDENSER ANALYZER

Solar Mfg. Corp.
Bayonne, New Jersey



THIS condenser analyzer checks condensers while they're at work in the circuit. Model BQC tests quickly whether the condenser is open, shorted or intermittent, and also indicates R.F. impedances and power factor. A built-in Wien bridge gives separate capacity measurements from 10 mmf. to 70 mf.

MOUNTING STRAP FOR GROUPING CONDENSERS

Sprague Products Co.
North Adams, Mass.

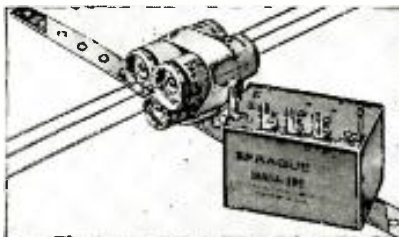

SUPPLIED free of charge upon request to jobbers with the purchase of Sprague condensers is the metal mounting strap illustrated. Its purpose is to hold any combination of Sprague "Atom" condenser units in a single, compact assembly in order to replace condenser plugs which for one reason or other cannot be duplicated in a single unit. In many cases several individual tubular condensers strapped together as illustrated form a smaller over-all unit than the actual single unit replacement block.

2-UNIT CAR-RADIO SET

The Crosley Corp.
Cincinnati, Ohio

HERE illustrated is one of the 5 new Crosley auto-radio receiver models. The model A-160 is a 6-tube 2-unit receiver—

the speaker being mounted separately, way behind the grille on the dashboard. The set itself mounts under the dash with the controls protruding conveniently for direct tuning. In addition to manual tuning, 5 pushbuttons are provided for the popular stations. Set measures 5 ins. high, 5 1/4 ins. wide and 12 1/4 ins. deep.

EMERSON PORTABLES

Emerson Radio & Phonograph Corp.
111 Eighth Ave., New York, N. Y.



ILLUSTRATED is one of a large group of portable models recently announced. It is model 338, a 3-way portable operating on self-contained batteries, 110 V. A.C. and/or 110 V. D.C. Other features include "innerceptor" loop antenna, 5-in. P.M. dynamic speaker, automatic volume control, "miracle tone chamber," completely automatic power switch-over. Two individual output tubes, 1 for battery operation and 1 for A.C.-D.C. power operation.

UNBREAKABLE MERCURY RELAY

Durakool, Inc.
1010 N. Main St., Elkhart, Ind.

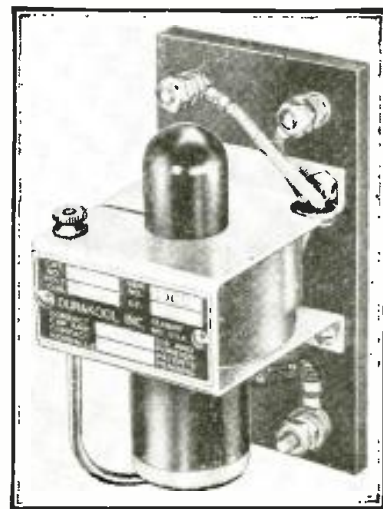

THE mercury switch body is made of metal and hence unbreakable. The contacts of the relay are hermetically sealed, making the unit suitable for use in corrosive or explosive atmospheres. The relay may be operated up to 300 times per minute and requires no maintenance or attention. No glass is used in its entire construction. Contact resistance is as low as 0.002-ohm. On A.C. as little as 1 W. is required for normal closing operation and only 1.5 W. for normal opening operation. On D.C. the operating energy required is but 0.25-W.

• LATEST RADIO APPARATUS •

"CARBON-X"

General Cement Mfg. Co.
Rockford, Ill.

A VAILABLE in small 2-oz. bottles this compound is claimed by the manufacturer to quiet noisy volume controls when it is applied to the defective spot of the volume control element.

HIGH-OUTPUT CRYSTAL MIKE

Universal Microphone Co., Ltd.
Inglewood, Calif.

THIS handsome-looking mike has an output level of 48 db. below 1 V. per bar (the bar, in sound work, is equal to 1 dyne per sq. cm.). Its frequency range is 50 to 6,000 cycles per second. Known as the model KO, it is a desk-type instrument having chrome face and grille, and statuary bronze base.



ANTENNA RELAY

Meissner Mfg. Co.
Mt. Carmel, Ill.

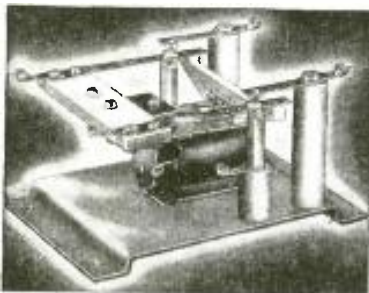

P RIMARILY designed for automatic transfer of antenna from a transmitter to a receiver in an amateur station set-up. Well-adapted to any type of high-frequency switching, it provides a double-pole, double-throw arrangement. The contacts are large and wide opening—designed to handle heavy loads. A 1-kw. transmitter may be switched without danger of arcing or burning. The contact arms are arranged for a "straight-through" feed—transmitter connections at one end and antenna at the other. All insulation is ceramic.

U.-H.F. RECEIVER FOR A.M. AND F.M.

The Hallicrafters
2611 S. Indiana St., Chicago, Ill.

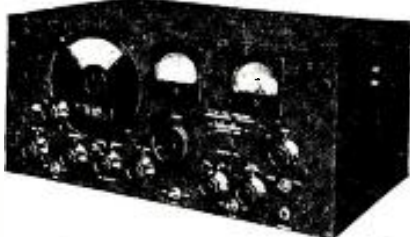

T HE receiver has continual coverage of 27 to 145 megacycles in 3 ranges of 27 to 46, 45 to 84, and 81 to 145 mc.; and provides for reception of both amplitude and frequency-modulated signals. Model S27 is a communications-type receiver using acorn tubes throughout the R.F. and converter systems. Other features include voltage regulations for oscillator, converter and meter circuits; extra-wide band spreading; improved automatic noise limiter, separate

A.M. and F.M. detectors; type 1852 limiter, expanding I.F. including wide bandpass in F.M. position; push-pull audio output with phase inversion, and others. Fifteen tubes in all are used.

2-SPEAKER SOUND MOVIE UNIT

Victor Animatograph Corp.
Davenport, Iowa

D ESIGNED to add greater portability to sound movie equipment, this unit houses 2 speakers in a single carrying case, avoiding the inconvenience of carrying 2 cases in addition to the projector and amplifier.

MODULATION MONITOR

The Triplett Electrical Instrument Co.
Bluffton, Ohio

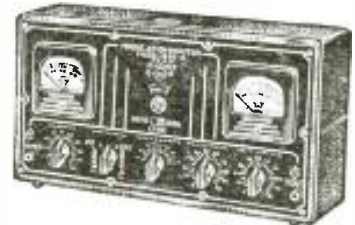

T HE model 1696 modulation monitor when coupled to the amateur radio transmitter output shows the carrier reference level, and the percentage of modulation. The latter is indicated on a specially-designed high-speed meter. An instantaneous neon flasher indicates when the percentage of modulation has exceeded the predetermined setting which can be from 40 to 120 per cent. Peaks of very short duration are instantly detected. Use of the monitor assists in complying with F.C.C. regulations. Connects to 100 to 130 V. A.C. line.

"FLEX-ANGLE" AUTO ANTENNA FOR ALL CARS

The Ward Products Corp.
Cleveland, Ohio

T HE unit is single mounting and can be adjusted to a vertical position on any auto body contour without resorting to the use of the special parts for angle compensation. It is possible to adjust the antenna to a vertical position through a range of 16° which is considered ample for any cowl contour.



"TALK-A-PHONE" POWER STAGE UNITS

Talk-A-Phone Mfg. Co.
1847 S. Millard Ave., Chicago, Ill.

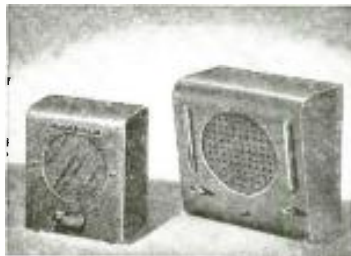

A NEW line of paging system power amplifiers with built-in speakers for use in conjunction with standard intercommunication master stations. They are available in 5 and 15 W. sizes and are swell for paging and similar systems wherever such booster units are required. Any number of these power stages may be connected together and operated from 1 channel of any intercommunication master station. Small unit in photo is 2-way; larger, only amplifier and loudspeaker.

NEW HOME-RECORDING NEEDLE

Permo Products Corp.
6415 Ravenswood Ave., Chicago, Ill.

T HE new Permo Point home-recording needle is made by electrically welding a special alloy to a drawn shank material, resulting in a rugged needle which provides exceptionally long life with low surface or background noise. The needle fits all standard recording machines and cuts

standard-size record grooves; unlike steel needles, it has a uniform radius. Longer-lasting than steel; more rugged than sapphire, it is claimed.

TRANSMITTER FILTER CONDENSERS

Cornell-Dubilier Electric Corp.
South Plainfield, N. J.

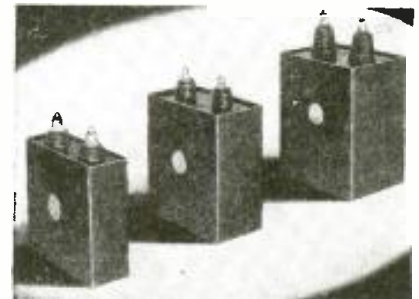

T YPE TK Dykanol condensers provide characteristics well suited to high-voltage transmitter applications. Has D.C. working voltages from 6,000 to 25,000 V. in a wide range of capacity values. The units have an insulation resistance of 8,000 megohms per microfarad. The terminals are cork gasketed and pressure-sealed, extending through glazed porcelain insulators which provide high, dielectric and mechanical strength. All units may be safely operated at 10 per cent continuous over-voltage.

OUTPUT ATTENUATOR FOR INDIVIDUAL SPEAKER CONTROL

Clarostat Mfg. Co.
285 N. Sixth St., Brooklyn, N. Y.



A DISTORTIONLESS means of controlling the volume of individual loudspeakers in a sound system is provided by the

Mr. Radio Serviceman:

WE WANT TO SEE YOU - - At the 3rd Annual RSA Convention • June 14 • Stevens Hotel • Chicago

★ Meet leading figures in the industry. ★ Attend Technical lectures in each subject. ★ Hear and See the F. M. Lecture and complete Demonstration. ★ Attend the R. S. A. Extension School to be held Friday 2:00 to 5:00 P. M., June 14.

★ R. S. A. is the only national organization for radio servicemen, and is accepted and endorsed throughout the industry. The R. S. A. record of achievements is noteworthy. Meet with us and hear our plans for the future.

Write for Your Advance Copy of the Program of the 3rd Annual RSA Convention

MAIL THIS COUPON NOW!

RADIO SERVICEMEN OF AMERICA, INC.
304 S. Dearborn St., Chicago, Ill.

Name

Address

City State

I am interested in RSA Membership. Tell me about it.....

I am enclosing \$4.00 for National dues and initiation. Covers dues up to Jan. 1, 1941.....

(Does not include Local Chapter dues where Local Chapters are organized.)

RC-740

Let's Grow Together
in 1940!



RADIO SERVICEMEN OF AMERICA, Inc.

JOE MARTY, JR., EXECUTIVE SECRETARY
304 S. DEARBORN STREET, CHICAGO, U.S.A.

new series CIB output attenuator here illustrated. Capable of dissipating 10 W. at any setting. Compact 1-hole mounting, insertion loss is below zero. The db. range is in 3-db. steps up to 24 and then a 6-db. step, with final step to infinity. Stock resistance values are 8, 15, 50, 200, 250 and 500 ohms.

60-W. AMPLIFIER

The Webster Co.
5622 Bloomingdale Ave., Chicago, Ill.



THIS new 60-W. amplifier unit, housed in a modern, wrinkle-finish case, incorporates such features as electronic mixing of 2 high-gain microphone inputs, multi-stage inverse feed-back, voice coil and line-impedance outputs, illuminated no-glare glass panels, and locking-type input plugs. Four type 6C6 beam power output tubes are used. The amplifier is claimed to be flat from 50 to 10,000 cycles, with a gain of 125 db.

ELECTRIC PHONOGRAPH

Andrea Radio Corp.
48-20 48 Avenue, Woodside, N. Y.

THE model G-20 Andrea-Gram portable electric phonograph incorporates electric motor, amplifier and crystal pickup. The

motor is self-starting, constant speed, 78 r.p.m., rim-driven. The speaker is a 6½-in. alnico P.M. dynamic type. The amplifier has a power output of 1.8 W. with an automatic tone-compensating volume control. Designed for operation on 110-125 V., 60 cycles A.C.

PRESSURE-GRADIENT DYNAMIC MICROPHONE

Amperite Co.
561 Broadway, New York, N. Y.

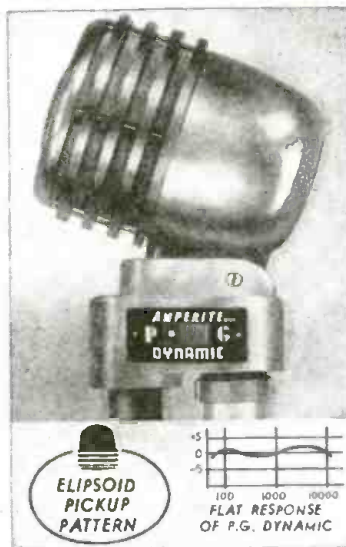

KNOWN as the Amperite P.G., this new pressure-gradient dynamic microphone is claimed to have an audio range from 40 to 10,000 c.p.s. It has an improved ellipsoid

pick-up pattern which reduces power line noise pick-up to a minimum. Its output is high, -55 db. All models are equipped with a switch and cable connector.

The P.G. unit's diaphragm follows air-particle velocity where amplitude is a gradient of the pressure. Thus the familiar mechanical sound due to diaphragm peaks is eliminated. In contrast, ordinary dynamic-mike amplitude is restricted from following air-particle velocity due to the stiffness of the diaphragm and the damping of the closed rear chamber.

NEW DYNOPTIMUM TUBE TESTER

Radio City Products Co.
88 Park Pl., New York, N. Y.



THE model 308 series D tube tester here illustrated incorporates a 9-in. meter and is designed to provide versatility, non-obsolescence and speedy operation. The instrument incorporates the "Dynoptimum" test circuit and has provisions for testing all tubes including the new miniature types. Tests tubes for noise, hum, shorts, leakage, and characteristics under R.M.A. specified loads. Provisions are also made for future tubes. The tester is available in counter, and combination counter and portable models.

including the new miniature types. Tests tubes for noise, hum, shorts, leakage, and characteristics under R.M.A. specified loads. Provisions are also made for future tubes. The tester is available in counter, and combination counter and portable models.

All the worthwhile
Radio Trade News
of the past Month—
Digested for busy
radio men.

RADIO Trade Digest

A PLEDGE: — To
print the important
news of the radio
industry; to review
major news events;
to help point a path
to radio profits.

IMPORTANT HAPPENINGS OF THE MONTH IN THE RADIO INDUSTRY

No. 23

JULY, 1940

No. 23

BLITZ BOOMS BIZ FOR U. S. AS EUROPEAN FIRMS WASHOUT

*Continent's Ill Wind Blows Good to Domestic Mfrs. & Exporters
As War Blacks Out Peace-Time Industry
And Keeps Ships in Home Ports*

Reports from belligerent nations—both aggressors and defenders—are unanimous in showing that every effort is being bent to turn out new and more deadly arms in greater quantities. To further this end men are being drawn from peace time factories and put to work producing war essentials. Such shipping as the belligerents still maintain is concentrated principally upon bringing such essentials as food and raw materials for munitions into their country, while outgoing boats are routed as directly as possible to the points from which such war needs will be shipped. While these outward bound vessels are not invariably sent in ballast, they are usually lightly laden to override mines and to achieve maximum speed. Cargoes which they carry are such as to occupy little space and command high prices (e.g., camera lenses from Germany) to accumulate foreign exchange. Radio apparatus does not fall into this category.

As "Salesman Sam" department has told you in the past, European concerns have long held important positions in the South American radio field. It is now that U.S. mfrs. & exporters can begin to win this business, which should logically be theirs.

This is especially true in the F.M. field, so suited to tropical transmissions.

SAW WAR IN WARSAW



Battery-operated, antennaless G.E. portable taken by Dr. Henryk Szoskies to Warsaw, Poland, furnished his only contact with outside world when Nazi blitzkrieg cut all communications. Above, A. A. Brandt (left), G.E. distrib., presents new console to Dr. Szoskies now in N. Y.

TELLY'S BLACKOUT



New York Herald-Tribune, arch foe of bureaucracy, published the above cartoon under the title of "That Long Nose of Government Again" as comment on FCC sabotage of commercial television.

AEROVOX SCHOOLS EMPLOYEES

Aerovox employees learn all about the products they make by voluntarily attending a company school one evening per wk. Course lasts 16 to 20 wks. and includes lectures, demonstrations, examination. Aerovox employees also have baseball, basketball and other sports teams holding regular competition in the New England leagues. And, yes—they have a company orchestra for dances, etc. Three cheers for Aerovox!

ZENITH TO PLUG F.M. AFTER FCC STANDARDS

*Com. McDonald Reveals Zenith's
Experiments With Telly Over
Regular Telephone Wires*

Although Zenith is operating an F.M. transmitter regularly, 16½ hours every day, the company will not produce any F.M. receivers until the F.C.C. has set standards for the width of the band and the wavelengths to be employed, stated Commander E. F. McDonald, Jr., President, at the annual convention of Zenith wholesale distributors of the U.S. and foreign countries, in Chicago. However, he seems to be definitely in favor of F.M. broadcasting since it has none of the economic hurdles presented by television.

Commander McDonald reiterated his strong stand that telly for general use is "still around the corner for the stock salesmen only." An interesting revelation was the fact that Zenith is experimenting with television over telephone wires which, it feels, offers an economic solution to the telly problem because programs would be paid for. Incidentally, Commander McDonald makes no mention of the likelihood of sponsored telly programs this Fall. Zenith does not intend manufacturing refrigerators, washing machines nor any other products allied with radio, McDonald said.

TELLY GOES BIG SCREEN

Advance indications of a new field for the Serviceman were seen when RCA demonstrated a 4¼ x 6 ft. television image—the precursor of large-screen television for theatre installation. When American theatres are television equipped (as were several British theatres before the blitzkrieg) hundreds of men will be needed to keep the apparatus functioning smoothly.

Another heartening indication was seen in a survey, conducted by *Radio Daily*, which was said to indicate that television set sales in New York were running 100 a wk. during the mo. of April.

SOUND BUSINESS MEN AT RCA, CAMDEN



On visit to RCA Camden hq. commercial sound sales engineers met the section's officials. Shown l. to r. are: Front row: George Ewald, Mgr.; John Yost, Sales, Cleveland; S. D. McIntosh, Sales, Dallas; H. V. Somerville, Sales, Kansas City. Second row: G. V. Swisher, Engineer Sound Section; C. A. Lahr, Sales, San Francisco; H. L. Sommerer, Mgr. of RCA mfg.; P. B. Reed, Sales, Atlanta; A. W. Schneider, Sales, New York City. Rear row: George Cole, Asst. Mgr.; Walter LaChicotte, Product Eng.; E. T. Jones, Adv.; A. Ward, Eng. and A. C. Linguist, Sales, Chicago.

TELEVISION IMAGE TUBES STILL LABORATORY PRODUCTION JOB

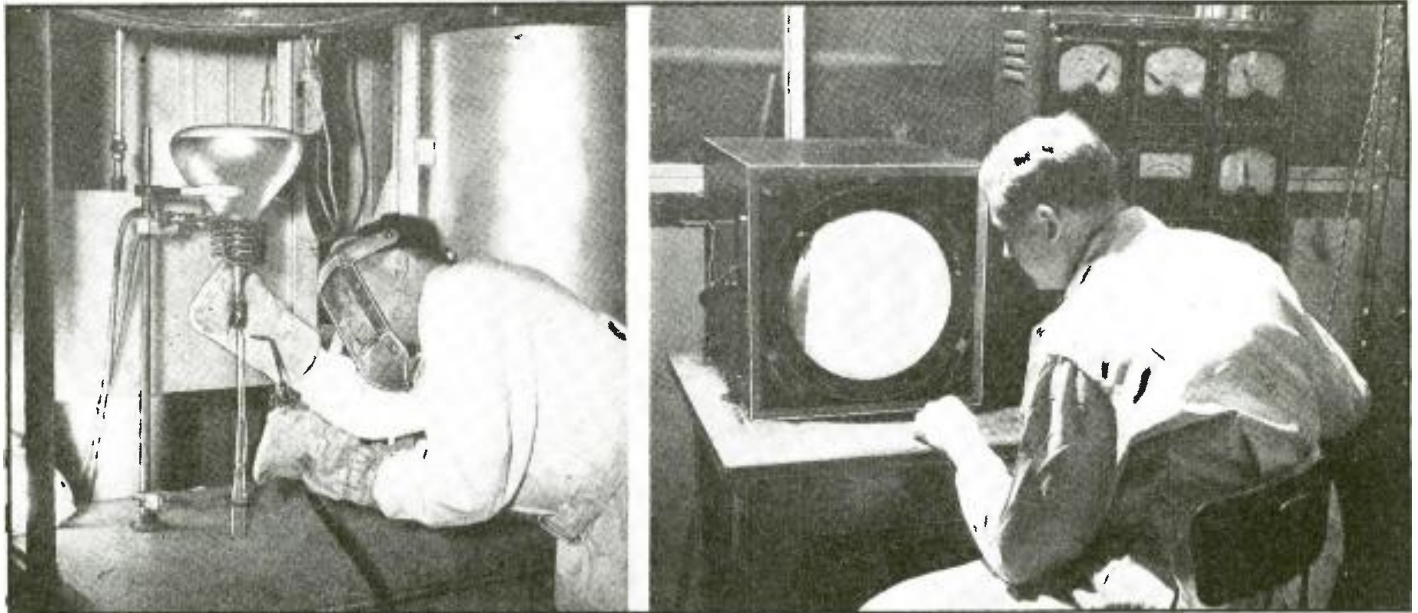

At present stage of television art, manufacture of tubes is still handwork for experts. A picture above shows operator in protective mask and asbestos

gloves making final seal-off on tube after last gas has been exhausted. At right is dynamic test of completed tube which will be used in 12" set.

Sales Helps and Deals

New Paths to More Business
(How Leading Mfrs. Help YOU Make Money)

A simplified time chart printed in English, Spanish, Portuguese and French enables radio listeners to convert time in any zone to time in any other zone—which often must be done by shortwave listeners. The chart carries a minimum of G.E. promotion.

PHILCO has a new record of well- and poorly-reproduced music to demonstrate efficiency of its phono-radio jobs.

With rumors of telly commercialization being revived, ESSO marketers put a telecast on for the 200 persons attending a gathering at the Advertising Club of N. Y.

A new set of "envelope stuffers" has been prepared by PHILCO for the use of distributors, dealers & Servicemen. Campaign highlights "PHILCO parts are better & cost no more"; also carries sale of accessories, including phono needles, cabinet polish, etc.

Personal

HELEN BERGOVEY is conducting a course of radio-script writing at the Writers' School, N.Y.C.

NORMAN B. NEELY is exclusive sales rep. of CINEMA ENGINEERING CO., Burbank, Calif.

WILLIAM F. TERRY, former ass't purchasing agent for STEWART-WARNER radio parts, has been appointed radio div. sup't in charge of production.

PAUL ECKSTEIN, who has been working in the Co.'s home office, has been placed in the southeastern territory as a radio & appliance field man.

RAY H. LUEBBE, counsel of GENERAL ELECTRIC'S appliance & merchandise dept. in Bridgeport, has been named ass't gen. counsel of the co.

G.E. ("ED") DeNIKE for 9 yrs. adv. mgr. of NATIONAL UNION RADIO CORP. has been made the co.'s N.Y. State district sales mgr. with hq. at 76 Monroe St., Geneva, N.Y. He will cover Northeastern Pa. & all N.Y. State except metropolitan N.Y.C.

W.S. HARTFORD, sales mgr. of THOR-DARSON, had his picture taken with the boys of the SHULER SUPPLY CO., New Orleans, while on his 3 wks. business trip through the South.

MERRITT E. TOMPKINS, pres. of ASSOCIATED MUSIC PUBLISHERS, INC., has become gen. mgr. of BROADCAST MUSIC, INC.

FRANK MURPHY has been appointed sales eng. for CLAROSTAT MFG. CO. in the Chicago area where he will work together with L. G. CUSHING.

ALEXANDER NORDEN, Jr., has been elected v.p. of L. S. BRACH MFG. CORP.

LOUIS E. DEAN for 6 yrs. radio director of CAMPBELL-EWALD AD. AGENCY has joined ARTHUR KUDNER, INC. as an exec.

E. H. MCCARTHY of New England, C. A. MALLIET, Mid-Atlantic, W. R. McALLISTER, South & Southeast, E. J. DYKSTRA, East-Central, and R. E. KANE, West-Central, district sales managers, attended conferences at the FARNSWORTH plant.

SYLVANIA SALES HELPS FEATURE NOVELTY

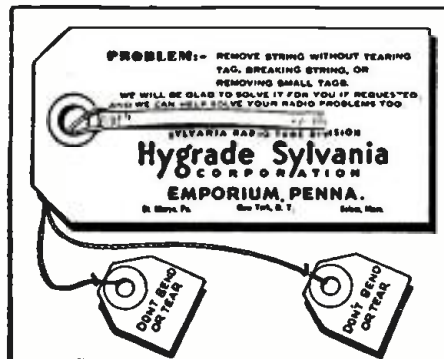

A Above, is tricky tag carrying Sylvania message, and, on reverse, pictures of product. Persons baffled by puzzle are invited to visit dealer for solution.

At left, Jiminy Cricket (Conscience) tells Pinocchio (Public) that its radio needs new tubes. Sylvania's are suggested.

AN EDITORIAL

By Artie Dee

What does Mrs. Radio Listener do when her set goes haywire? Nine times out of 10 she calls in the elevator man if she lives in an apartment bldg. or the local handyman if she is a ruralite, points to the offending apparatus and says, "It don't play. See, can you fix it, Joe?"

Second Choice

Joe, who knows how to replace a blown fuse in a house inlet box, does what he can—if anything. Probably he makes the set worse than it was. Then, and only then, does Mrs. Listener phone for you, the Serviceman. Why is this?

Through careful education on your part, Mrs. Listener has been trained to expect the worst. Oh, of course, you personally are not to blame—it's the other fellow down the street. He's the chap who all too often uses salvaged parts in making a repair job. He's the fellow who offers guarantees and fails to live up to them. He's the lad who is very ready to issue a guarantee when he's getting the job but backs out of it when something goes sour. He's the man who promises to have the set ready at a certain time & doesn't; who says that he cannot put a price on the job until after he has taken the chassis apart & then charges about 3 times what it's worth; who leaves "bugs" in a set such as returning a phono-radio with the radio end OK but the phono switch noisy. You know him, don't you?

Exams Wanted

Can't we have a national voluntary organization of Servicemen who have passed rigid examinations & received licenses? If we fellows in the service industry don't do something like that—and pretty soon—before we know Mr. Whiskers will do it for us.

Maybe that wouldn't be so bad, either. It would enable capable, conscientious Servicemen to earn a living and would drive the inefficient & undependable out of business, but let's do it ourselves. How about it?

Servicemen interested in forming a national body to regulate charges & practices are invited to write Editor, R.T.D., Radio-Craft, 20 Vesey St., New York, N. Y.



We take a bow—9 days after we reported that move was on foot to investigate the FCC, it came up in the Senate but was pigeonholed . . . less than 2 weeks after we wrote the FCC suggesting that the green light be given competing telly systems announcement was made that DuMont (RCA's chief competitor) had been granted a construction permit. . . . Answers to questions: Eugene Martin of American Television Corp. writes that co.'s busy on picture generator, magnetic mine telephone, and installation of speaker systems in "U.S. Army ships." Whatever happened to their proposed inter-store telly network?

Pathe out with phono-radio recorder under \$100. Remember way back when RCA had a job doing those things and costing several hundred—it must have been 8 yrs. ago. . . . Tom Adrian Cracraft has a new card advertising his electronic orchestra—which incidentally may be a regular attraction at the N.Y. World's Fair and over certain F.M. stations. It seems to be new

vogue for short commercial transcriptions; e.g. Lucky Strike, Oakite, etc. . . . Heavy RCA campaign will sell sound systems in over 25 educational, religious, industrial and other pubs.—radio pubs too.

The Detroit cops are planning a switch to FM in order to overcome city interference. . . . The sizes of those dual speakers in the new G.E. sets are 6½ & 14 ins. . . . Hytron is discontinuing its G series of tubes & substituting GTs. . . . Stromberg-Carlson, very FM conscious, says new system will give biz a lift & went down to the FCC with technical data boosting new system.

New merchandising plans have been outlined to RCA commercial sound salesmen. Willard Storage Battery Co. estimates \$70,-500,000 of storage and dry batteries will be sold during 1940 & says that farms used 4,400,000 radio sets last yr.—if you serviced all those at \$3 a yr. that would be a nice hunk of change. . . . NBC has issued its 1st rate card for shortwave programs to Latin America in Spanish, Portuguese and English. . . . Neville Miller, pres. of NAB, says the ASCAP demand for 100% pay increase is excessive as radio now pays ASCAP 5 times as much as any other industry.

Roycraft Co. of Minneapolis sold a Philco 115 to the Johnsons of Osseo, Wis. When building burned, set was dug out of ruins with cabinet destroyed, dial window melted & whole job enveloped in cake of ice. Set was dried out, new line cord replaced burned-off one and set plugged-in. It worked perfectly. (Hey, Johnson, what started the fire?) . . . Barber & Howard, Inc., mfrs. of coils & winders, have opened a Duplicate Coil Winding Dept. to replace I.F., R.F. & osc. coils to order.

"New Yorker," "Time," "Life" & "S.E.P." will carry Stromberg-Carlson's ads of FM.

PUTTING FIRE INTO SALES



Book matches printed in black and 2 shades of blue feature Cornell-Dubilier capacitors & 30th Anniversary; serve as pocket reminder to all smokers.

SAFE ELECTRIC CUTTER FOR CHILDREN RETAILS AT \$1 AND HAS NOVELTY APPEAL FOR SIDELINE

Excuse Me for Cutting In... BUT - THIS IS FOR YOU . . .

COMPLETE IN COLORFUL BOX WITH CUT-OUT OF SHIPPY AND HIS PALS

RETAILS FOR \$1

Just press the switch and "Snippy" cuts the wire!

Known as "Snippy," this little cuttersnipe operates from 105-125 V. A.C. with vibrator motor. It is a good example of what an enterprising radio parts manufacturer (General Transformer Corp.) can do to bring in some sideline shekels without too great an investment. A 110-volt winding on a regular laminated transformer core makes a "chattering" armature activate the cutting blades. The outer shell is a plastic moulding, brightly colored.

BIZ. OPP. — CASH IN NOW

Dear Editor:

I will be highly obliged if you will put me in touch with some manufacturers who have no representation in India and who can supply Radio Sets with the following:

- (1) A.C./D.C. 220 volts.
- (2) Must be allwave—12.5-49 meters; 50-95; 175-555.
- (3) Complete with tubes.
- (4) Must be in decent cabinets.
- (5) Must be tropic-proof.
- (6) The most important factor is the price which should not be too much, i.e., it should be between 10 to 15 dollars, maximum. If interested, write to me at the address given.

P. C. UPPAL,
101-C, Irwin Road,
New Delhi, India

TELLS "INSIDE" STORY

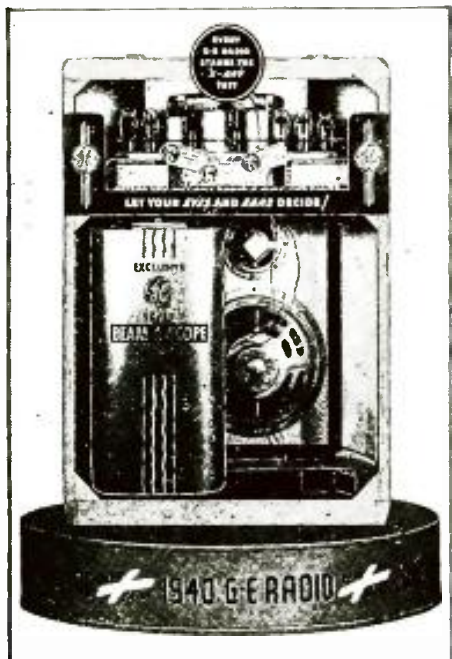

New G.E. display tells inside story of set, showing chassis, dual (tweeter & boomer) speakers, and exclusive "Beam-a-scope" built-in loop antenna which simplifies installation.

Salesman Sam Says:—

Data issued by U. S. Gov't. Far more detailed information is available from the Bureau of Foreign & Domestic Commerce, Washington, D. C. Publications to request are: World Radio Markets covering countries wanted & The Electrical & Radio World Trade News.

JAPAN—4,666,000 receivers in use by population of 80,000,000. The annual market is from 800,000 to 900,000 sets, most of which are domestic receivers. Importation of radio equipment is limited and controlled. The small amount of radio equipment imported is mainly for public use and presumably for use by the Japan Broadcasting Corp. Regular television broadcasts are scheduled to begin in the summer of 1940. Receivers will probably sell for about 500 Yen (about \$120).

IRELAND—Since Ireland is in the "combat" zone, American ships are not permitted in its waters. This has considerably affected the importation of radio equipment. At present there are about 164,000 sets in use by 3,000,000 population.

BRAZIL—1,000,000 sets in use by population of 45,000,000. The annual set market is very good, numbering about 100,000 sets. Radio business is highly competitive with 85% to 90% of all receivers being sold on the time-payment plan. 80% of receivers sold are of the 4 to 6 tube variety, the 5-tube all-wave table models leading by substantial margins. All receivers, in addition to any other wavebands they may have, must cover 2,300 to 2,500 kc. and 4,770 to 4,900 kc. bands. Excessive humidity precludes special cabinet and parts construction, with emphasis on the cabinets. Electric service is available in all principal centers and many smaller localities; the supply being 120 volts, 50 cycles. Line fluctuations are bad, varying from 105 to 130 volts.

DENMARK—Extenuating circumstances; don't bother (about 820,000 sets in use by population of 4,000,000).

\$'s & No.'s

\$97,490,047 WORTH of orders received by G.E. in the 1st quarter of 1940. This is an increase of 12% over the same period for 1939 for which the figure was \$86,882,953.

\$598,852 IS THE operating profit for the 1st 9 months ended Jan. 31, 1940 of the fiscal year of the Zenith Radio Corp. A dividend of \$1.00 per share was voted April 25, 1940 to stockholders of record on April 15th.

\$41,236,000 NET INCOME is GE's record for 1939. This is equivalent to \$1.43 a share of common stock which compares favorably with the 96c per share in 1938—an increase of 49%.

4,000,000 AUTO-RADIO SETS by the end of 1940 is the mark for which Philco is shooting, aided by its new shortwave auto receiver—the first of its kind ever to be put out commercially. The set retails at \$49.95 including aerial and is expected to be a best seller of the year, according to C. E. Carpenter, Philco auto-radio development official.

RADIO BIZ. UP \$35,000,000, according to Radio Daily. Total amount spent for advertising in the United States was \$1,602,000,000 with radio advertising jumping approx. \$35,000,000. Total radio figure for 1939 was \$175,000,000, 3rd highest group in the field of national media. Highest point ever reached was in 1929—\$2,340,000,000.

Changes & New Addresses

Where to Reach Old and New Companies

DR. ALFRED N. GOLDSMITH, consulting engineer on radio, television, motion pictures, electrical & allied arts, has moved to 580 Fifth Ave., New York, N. Y.

G. E. DeNIKE of National Union is now located at 76 Monroe St., Geneva, N. Y.

WHITE HARDWARE CO., Savannah, Ga., is new Farnsworth distributor.

SPECTOR SALES ASSOCIATES, 17 E. 42 St., N.Y.C., has been appointed exclusive distributor for Clough-Brengle instruments in N.Y., N.J., Pa. (east of Altoona), Del., Md., D.C. and New England.

ORGANIZES CABLES & BELTS

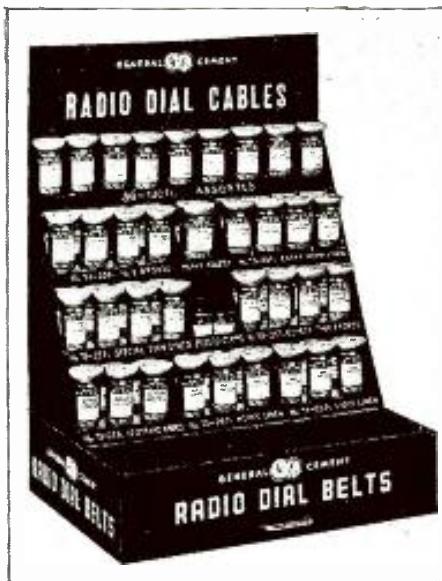

General Cement Mfg. Co. has prepared new display to organize radio dial belts, cables, eyelets & clamps into convenient merchandising unit. While designed primarily for jobbers unit should be handy for big and busy Servicemen.

TIMELY TELLY TRENDS

● Add coincidences: Two weeks after RTD editor commented to NBC that Lowell Thomas' news program would be better if dressed up with pictures & maps, station began radiating Esso Reporter—a program of news comments illustrated with pictures & maps. You're welcome, boys.

● G.E. has dropped prices of telly receivers from \$75 to \$200 depending on the model.

● Allen B. DuMont now licensed to telecast in N.Y.C. is still eager to have telly left flexible. This co. claims its 14-in. tube will remain operative & free from ion blemish for about 3 yrs.

● Featured in the G.E. exhibit at the 1940 N.Y. World's Fair will be television, running continuously and with receivers occupying twice as much space as last yr.

● Stromberg-Carlson featured television & F.M. at the opening of the Home Show in Rochester, N.Y.

● As telly's U.H.F. sound channels are relatively static-free, NBC is now sending its regular network music over W2XBS' wave about 3 hrs. nightly when television programs are not occupying the band.

OFF THE PRESS

TUBE DATA BOOK. Sylvania Production Corp., Newton, Mass. A complete listing of all radio receiving tubes including technical data, graphs, fundamental circuits, etc.

TUBE DATA CHART. Same co. 24 pages. A complete chart of all radio receiving tubes up-to-date, including physical dimensions, socket connections, pilot lights and plug-in resistor "tubes".

CATALOG SHEET. American Phenolic Corp., Chicago, Ill. Lists steatite tube sockets, polystyrene crystal holder sockets, socket hole punching dies and 3 interesting displays of sockets, connectors and insulation material.

CATALOG No. 16. Operadio Mfg. Co., St. Charles, Ill. 24 pages. Complete line of matched sound equipment, school sound distribution systems, public address accessories, etc.

CATALOG No. 152. Shure Bros., Chicago, Ill. 8 pages. Complete line of up-to-date microphones, phono pickups and replacement cartridges for the latter.

FOLDER. United Teletone Corp., New York, N. Y. 4 pages. Complete line of public address speakers and air-column sound projectors.

SERVICE MANUAL. For replacing plug-in resistor "tubes". Clarostat Mfg. Co., Brooklyn, N. Y. 32 pages. Gives all essential data to make easier for the Serviceman the task of replacing plug-in resistor "tubes" of all types. In tabular form, it lists manufacturers' names, model number, the tube number, type of resistor, base wiring, Clarostat replacement number.

1940 CATALOG, Spring-Summer edition. Allied Radio Corp., Chicago, Ill. 168 pages. 32 pages devoted to all types of radio receivers, including portables; 27 pages devoted to sound systems and accessories; the balance of the book devoted to parts and everything else from soup to nuts.

1940 CATALOG. Spokane Radio Co., Inc., Spokane, Wash. 235 pages. A spiral-bound, well-prepared collection of manufacturers' literature on everything in radio and sound equipment.

PUBLIC ADDRESS CATALOG. Terminal Radio Corp., New York, N. Y. 12 pages. Lists a complete line of public address am-

•SHOP NOTES—KINKS—CIRCUITS•

plifiers, tuners, microphones, speakers, record players and accessories.

CATALOG. Rex Rheostat Co., New York, N. Y. 12 pages. Slide type rheostats for laboratory and special uses. Available in all sizes and ratings.

SHEET. Amplifier Co. of America, New York, N. Y. An announcement that the co. is prepared to manufacture transformers for all special purposes.

CATALOG No. 122. Radio City Products Co., New York, N. Y. 12 pages. Lists large variety of test equipment including tube checkers, multi-testers, analyzers, signal generators, V.-T. voltmeters, etc.

SHEET. Universal Microphone Co., Inglewood, Calif. Lists a recording and playback turntable.

FOLDER. Harvey-Wells Communications, Inc., Southbridge, Mass. Lists a group of marine radio telephones. Folder describes

10- and 25-watt marine instrument models.

CATALOG SHEET. National Union Radio Corp., Newark, N. J. Lists a new line of long-life dry battery, distributed exclusively by radio service dealers.

FOLDER. Hytron Corp., Salem, Mass. Describes a cooperative tube sale plan whereby dealers receive a special metal display cabinet with each 50 bantam tubes order—all at a special price.

BOOKLET. John Meek Industries, Chicago, Ill. Titled "How to Match Speaker Systems." Answers many everyday problems concerning multi-speaker systems and their connection to public address amplifiers. Available gratis.

"BLUE BOOK." Earl Webber Company, Chicago, Ill. 8 pages. The "Blue Book of Instrument Values" was prepared to give radiomen a better means of judging the value offered by new 1940 service instruments. Available gratis.

SHOP NOTES—KINKS—CIRCUITS

HOME-MADE PANEL CUTTER

● HERE is a panel cutter which will cut holes in steel or bakelite panels for sockets, meters, etc. This tool was made from an ordinary round-shank machine drill which was broken, and a new point ground on. Drill a 1/4-in. hole through the shank. This is easily done with a hand drill (a little turpentine applied speeds-up drilling).

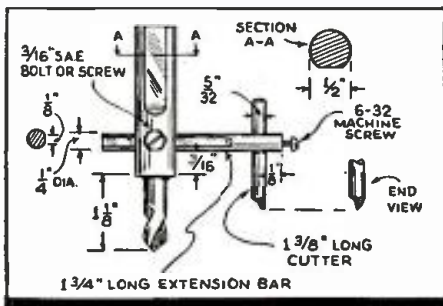

Next take a 1/4-in. steel shaft from a discarded volume control (most of these are steel) and file part of it flat 1/8-in. wide, as shown; the bolt keeps it from turning.

Drill a 5/32-in. hole in the end not filed, 1/8-in. from end to outside of hole.

Take a broken off 5/32-in. steel drill about 1 3/4-in. long, and grind point on as shown. Drill a hole and tap for a 6-32 machine screw in the end of the shaft to hold the cutter. The complete job can be done in a half-hour. In use, this device, which I have used for 3 years, is held in the ordinary brace.

OLE FUGLESTAD,
Powers Lake, N. Dak.

SINGLE-CONTROL FADER

● HERE is a useful circuit. It consists of a volume control so connected that fading between any 2 inputs may be achieved by manipulating only 1 control. It will be noticed that the junction of the two inputs is connected to the moving arm of the potentiometer, the grid of the 1st tube being

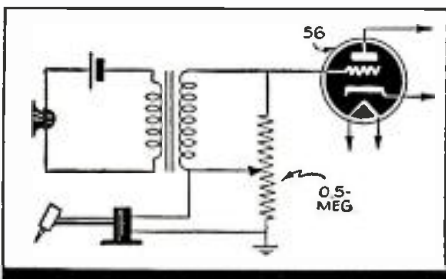

connected to one end and the other end going to ground.

By moving the arm to one side, one of the inputs is shorted and the other is connected across the input circuit of the tube. Moving the arm to the other side reverses the position, shorting the 2nd input, and connecting the 1st one to grid and cathode of the input tube.

B. M. TANNA,
Satya Sadan,
Santa Cruz, India.

A.C. CALIBRATOR

● THE idea illustrated here is simply to make use of the A.C. voltages available at the sockets of any standard commercial tube tester, that is, the heater or filament voltages. The actual voltages will come pretty close to the value indicated on the instrument panel of the tube tester.

For accurate work, however, it should be checked with an A.C. voltmeter of the low-resistance, 2%, full-scale accuracy, type. A copper-oxide rectifier and D.C. meter working from it are never better than 5% accurate and, in general, are not as reliable as the

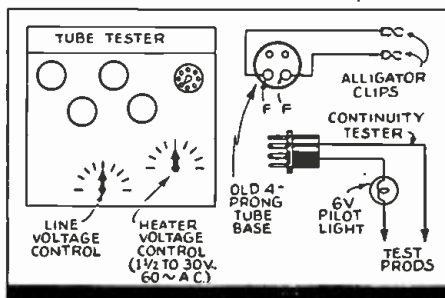

preceding type of meter, for this particular work. The values of A.C. voltage available for calibrating a vacuum-tube voltmeter, or 6H6 output meter, are controlled by the filament switch and the line voltage control of the tube tester.

The assembly is simple, convenient and a practical necessity. It may also be used to construct a pilot light continuity indicator for testing pilot lights, or any low-resistance circuit.

WILLARD MOODY,
N. Y. C.

ELECTROMAGNETS FROM DISCARDED A.F. TRANSFORMERS

● EXCELLENT electromagnets for relays, etc., can be made from discarded audio-frequency transformers by simply cutting out part of the core, as shown in these illustrations, with a hacksaw. This opens the

FREE! VERY LATEST PROFIT GUIDE
Everything in RADIO!
at lowest prices!

COMPLETE SELECTIONS GUARANTEED QUALITY
Faster Delivery
Most complete stocks of Universal and Exact Duplicate Replacement and Repair Parts Tubes, Aerials, Cabinets, Radio Sets and Amateur Equipment.

P.A. EQUIPMENT
Separate amplifiers or complete systems with any desired assortment of speakers, horns, baffles and microphones. Everything from 5 to 100 watts. Prices that save money for you.

ELECTRICAL APPLIANCES
Extra profits for you! Standard Brand Electric Irons, Grills, Toasters, Percolators, Waffle Irons, Vacuum Cleaners, Clocks, Mixers, etc., at lowest prices.

MAIL THIS COUPON TODAY

The RADOLEK Co.
601 W. Randolph St., Chicago, Dept. C-43
Send the latest Radio Profit Guide FREE.

Name

Address Dealer?.....

Experimenter?..... Serviceman?..... Amateur?.....

IF ITS RADIO
ALL YOUR RADIO NEEDS

Here in this one big book you will find everything you need in radio... sets, parts and supplies... public address systems... amateur equipment... testers and kits... your nationally known favorites at lowest possible prices. Write today for this big valuable catalog and save money.

FREE CATALOG
PROMPT SERVICE

BURSTEIN-APPLEBEE COMPANY
1012-14 McGEE STREET, KANSAS CITY, MISSOURI

SERVICE MANUAL

427 DIAGRAMS OF MOST SERVICED RADIOS

DIAGRAMS YOU NEED

In one handy manual you have all the diagrams of the most often serviced radios today. Over 80% of all sets you service every day are included. These important, hint-giving, trouble-shooting circuits make your job easier, permit faster and better repairs every time.

HOW TO SAVE TIME

Circuit data, hints, information are time-savers and money-makers for you. Let this diagram manual be your guide to bigger profits and easier service work. Why work blindfolded when 4 out of 5 diagrams you will ever need are included in this new, low-priced manual. Compiled by M. Beitman, radio serviceman, noted author, teacher of Radio in Chicago schools.

NEW EDITION

Get your copy of this radioman's biggest time-saver. No need to spend big money for bulky, space-wasting manuals. Only \$1.95 today, brings your copy of the handiest "on-the-job" handbook of useful diagrams. (Models 1926 to date.) Well printed diagrams, with alignment data, and parts lists. Large size 8 1/2 x 11 inches. New edition available at low price.

4 OUT OF 5 CIRCUITS YOU NEED

COMPLETE \$1.95 POSTPAID

FREE EXAMINATION COUPON

Supreme Publications
3727 West 12th Street
Chicago, Illinois

Ship complete Service Manual. I may return the manual for a full cash refund if I am not satisfied.

I am enclosing \$1.95, send postpaid.

Send C.O.D. I will pay postman \$1.95 and a few cents postage.

NAME

Write address below and send this corner.



ELEMENTARY MATHEMATICS

EASY — SIMPLIFIED — PRACTICAL

HERE is a book for the business man, the technician and craftsman explaining and answering every operation and meaning with interpreting illustrations and examples. It is the key to a simple understanding of many perplexing problems in daily life. In clear, positive and definite language, the author popularizes and clarifies every subject and helps the reader to overcome any apparent difficulty in the study of mathematics.

A real home study-course in mathematics for the student or the man who wants to achieve proficiency or desires to brush-up on his knowledge.

Entire Chapter on Special Mathematics for the Radio Technician

CONTENTS OF BOOK

- CHAPTER I. Arithmetic—Addition—Subtraction—Multiplication—Division.
- CHAPTER II. Factoring and Cancellation—Fractions—Decimals—Percentage—Ratio—and Proportion.
- CHAPTER III. The Metric System.
- CHAPTER IV. How to Measure Surfaces and Capacity (Geometry).
- CHAPTER V. Powers and Involutions—Roots and Evolution.
- CHAPTER VI. Mathematics for the Manual and Technical Craftsman—Thermometer conversions—Graphs or Curve Plotting—Logarithms—Use of the Slide Rule.
- CHAPTER VII. Special Mathematics for the Radio Technician.
- CHAPTER VIII. Commercial Calculations—Interests—Discounts—Short Cut Arithmetic.
- CHAPTER IX. Weights and Measures—Useful Tables.

ONLY 50c POSTPAID

TECHNIFAX
1917 S. State St. RC-740 Chicago, Ill.
Send Stamps, Cash or Money Order.

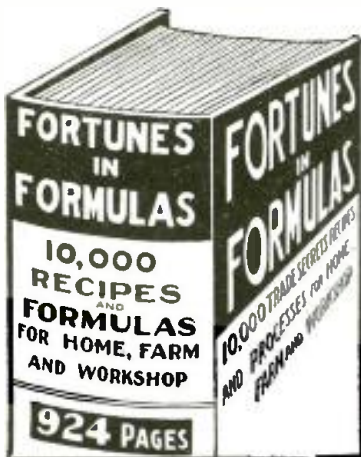

NOW!

The greatest and most important formula book in print. It contains over 10,000 trade secrets, recipes and processes for home, farm and workshop.

Chock-full of money-making ideas for cosmetics, soaps, perfumes, antiseptics, water-proofing, photography, lacquer, paints, cements, preservatives, fumigants, insecticides, etc.

Book also contains following important chapters: Useful Workshop Laboratory Methods, fully illustrated. Complete Buyer's Guide, where to buy materials at wholesale prices; Measuring Made Easy; Latin Names of Drugs and Chemicals Translated into English. Completely indexed. In short, this is a Wonder Book of Useful Knowledge! Worth its weight in gold.

Book is up-to-date and has the newest methods—latest discoveries—countless thousands of ideas—which you will find useful. Remember—there are actually over 10,000 clearly described formulas, processes, recipes—MANY NEVER BEFORE REVEALED.

This good book has 924 pages, printed on good paper. Size is 8 1/2" x 5 1/2".

Send for a copy of this veritable gold mine TODAY. You will never regret it. Remember, great fortunes are often made on formulas. sent postpaid anywhere \$1.49 in U.S. (Canada and foreign countries 25c extra for postage.)

Send Money order, check, unused U.S. stamps or cash. (Register all letters containing cash.)

NATIONAL PLANS INSTITUTE

248-R Fifth Avenue New York, N. Y.

Visit your nearest newsdealer and buy a copy of



A popular comic edited by HUGO GERNSBACK

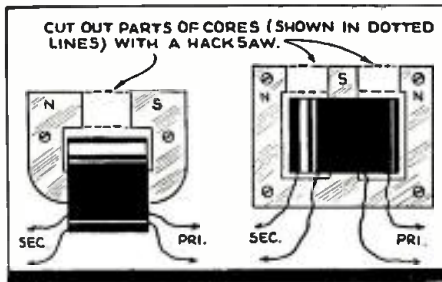

magnetic circuit to form an electromagnet when the secondary is used. By using a push-pull transformer taps of different values can be obtained.

CLIFF R. ANDERSON, Andover, Ill.

CONNECTING A PHONO PICKUP

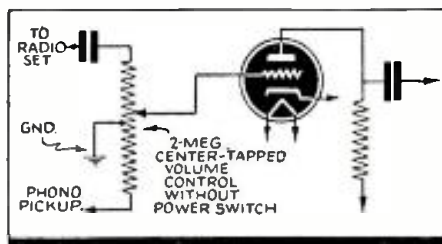

HERE is a simple circuit, which has helped the writer get extra cash, for adding and controlling a phono pickup to radio sets. Just change the power switch and tone control, and use a center-tapped volume control to control volume of phono and radio.

STANLEY ZLOTKOSKI, Jeannette, Pa.

EMERGENCY ALIGNMENT PROCEDURE

WHEN confronted with a superhet, which is suspected of being slightly out of alignment, and the I.F. peak frequency is not readily available or a suitable generator is not at hand, the following procedure will be found helpful. Connect a vacuum-tube

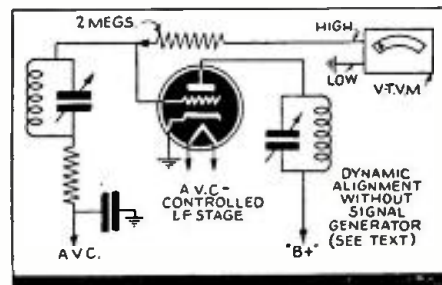

voltmeter to one of the A.V.C.-controlled grids through a 2-meg. resistor, with the low side to the cathode, or chassis in A.C. sets. Tune-in the strongest signal available. Peak the I.F. transformers for maximum indication on the V-T.Vm., starting with the last stage and working towards the 1st. Then peak the R.F. circuits, if any, in the same manner. If the I.F. circuits are not too far out this will give remarkable results. If the oscillator tracks properly, it will indicate that the I.F. transformers are peaked at approximately the correct frequency.

BERNARD SEAMON, Wiscasset, Maine.

DON'T LOOK NOW BUT—

We believe that you'll be glad you reserved a copy of August Radio-Craft, when you see the article "Making a Constant-Output Wide-Range Power Supply." How's this? 1% regulation under a load change of 300%!

Index to advertisers

BROADCASTING

Radio Corp. of America.....Back Cover

PUBLIC ADDRESS EQUIPMENT

Amplifier Co. of America.....15, 29, 35
Arrow Sales Co.29
David Bogen Co.35
John Meck IndustriesInside Back Cover
Miles Reproducer Co.35
RCA Mfg. Co., Inc.31
Utah Radio Products Co.33
Wright-DeCoster, Inc.29

PUBLISHERS

Data Print Co.45
National Plans Inst.64
Radcraft Publications, Inc.40, 52
Radio & Technical Pub. Co.4
John F. Rider, Inc.21
Supreme Publications63
Technifax45, 64

RADIO PARTS

Amperite Corp.13
Dumont Elec. Co.19
General Transformer Corp.71
Hammarlund Mfg. Co.13
Illinois Condenser Co.17
Solar Mfg. Corp.15
Sprague Products Co.23

RADIO SETS

E. H. Scott Radio Lab., Inc.37

RADIO SUPPLY HOUSES

Allied Radio Corp.45
Burststein-Applebee Co.63
Hudson Specialties Co.55
Lafayette Radio Corp.43
Radolek Co.63

SCHOOLS

Capitol Radio Eng. Inst.3
Lincoln Engineering School3
National Radio Institute1
National Schools3
New York YMCA Schools3
Radio Training Assoc.3
RCA Institutes3
Sprayberry Academy of Radio3

TEST EQUIPMENT

Meissner Mfg. Company5
Radio City Products Company58
RCA Mfg. Co., Inc.19
Readrite Meter Works26
Superior Instruments CompanyInside front cover, 15
Supreme Instruments Corp.13
Triplett Electrical Instruments23

TUBES

Hygrade Sylvania Corp.19
National Union Radio Corp.17

MISCELLANEOUS

Classified Section25
Joseph H. Kraus & Company53
Lancaster, Allwine & Rommel17
National Radio Parts Distributors Assoc.53
Radio Servicemen of America58
Remington Rand, Inc.54
Vanatta Mfg. Company15

(While every precaution is taken to insure accuracy, we cannot guarantee against the possibility of an occasional change or omission in the preparation of this index.)

Radiomen . . . make **BIG MONEY** with **AUDIOGRAPH** Sound Systems

These **LOWER PRICES**
Help You Sell



25-Watts mobile . \$36.00

Complete for 6v. battery and 110v. ac operation—no external packs. Use with any high impedance microphone. Has 4 and 8 ohm outputs. Battery saver switch cuts battery drain between announcements. Optional phono top with built-in phono motor, \$21.00 net additional.

Available with heavy duty speakers and bullet baffles or in portable carrying case as illustrated. See catalog for complete listings.

30-Watts 4-channel . . . \$27.00

Separate control for four independent microphones and phono input. Output variable from 2 to 500 ohms. Dual action tone control. New multi-channel input circuit provides greater utility and wider range of applications. Reduces to three tubes functions formerly requiring six tubes. Less noise, lower cost.

Complete portable system illustrated at right has two heavy duty 12-inch pm dynamic speakers each with 50 ft. cables. Large size assures ample baffle area. Net only . . . \$57.00

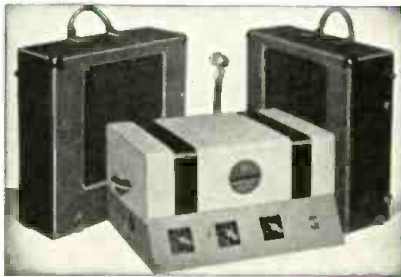

15-Watts 3-channel . \$17.40

Now you can have a low cost amplifier with simultaneous operation and separate control for two microphones and phono input. Uses push-pull 6L6G beam power tubes in output. Impedances 4 and 8 ohms. Dual action tone control. Both single and dual speaker portable systems are listed in the new complete 1940 AUDIOGRAPH catalog. Write for your copy today.

8-Watts \$11.97

Value that only AUDIOGRAPH can offer. A complete 8-watt amplifier including output transformer for use with any 8-ohm speaker. Has microphone and phono inputs, dual action tone control, three high gain stages, etc. Use with any high impedance microphone.

Complete portable system illustrated on left, with 8-inch pm speaker, aero-linen case, 25-ft. speaker cable, less microphone and tubes, dealer net only \$20.40.

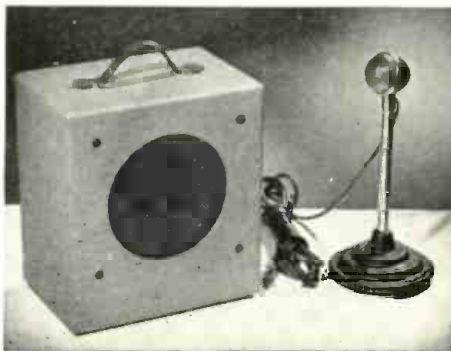

Get Extra Profit!

Rent and Sell
these **LOW COST**
AUDIOGRAPH
Sound Systems

Here is an opportunity for every radioman to make big profits in the sound field. You can rent or sell AUDIOGRAPH Sound Systems to schools, clubs, churches, etc., and for political or advertising work.

In every community there are huge profit possibilities. Because AUDIOGRAPH equipment is sold at low prices—only to authorized sound men—you can be certain of meeting all competition and making full profits.



ACT NOW—Big Season Ahead!

I can help you get started in this field—as we have already helped hundreds of other successful sound specialists.

AUDIOGRAPH quality and performance is world famous—and now with unequalled production methods, we can offer this new 1940 Line at prices that shatter all previous standards of sound value.

Write for the new 1940 AUDIOGRAPH Catalog today, or ask your own radio parts distributor to show you these sensational models. From eight to one hundred watts, there is a model for every purpose—each one an outstanding value!

John Meck

New 1940 Catalog
write today!

AUDIOGRAPH Sound

product of

John Meck Industries

1311 W. Randolph Street...Chicago, U.S.A.

FREE... "How to Design and Match Speaker Systems"

Send at once copy of your new booklet written by John Meck—we understand it contains complete data on design of suitable speaker systems for all restaurant, hotel, school, stadium, etc., installations.

CLIP and Mail today!

Name

Address

City

State

Radio Would Have Made The Pony Express A Local!

Back in 1860 the wonder of the day was the picturesque Pony Express. Racing horses in relays, riders carried the mail 1960 miles from St. Joseph, Missouri, to Sacramento, California, in 10 days. Radio messages would cover the same distance in a fraction of a second.



What a difference the Services of RCA would have made in 1860...



Henry Wells

Communication is the life-line of civilization. Up to a hundred years ago, civilization spread slowly, because communication could travel no more swiftly than the gallop of a horse.

In contrast, if the West were being opened up today, the Services of RCA would coordinate developments with instantaneous communication. Portable broadcasting equipment would go wherever pioneers went. Over nation-wide broadcasting networks a running history of progress and achievement would be heard by millions. R. C. A. Communications would keep two-way contact between our scattered outposts and forty-three foreign nations.

Young men, following the classic ad-

vice, would "go West" carrying RCA Victor Pick-Me-Up Portable Radios. And through the RCA Photophone, motion picture audiences in the East would hear as well as see the saga of the winning of the West. Lonely settlers would carry into the wilderness their favorite musical selections on Victor and Bluebird Records.

Yes...the Services of RCA in every field of radio and sound could have contributed immensely to building our country in 1860. But...the contribution they could have made is in no sense greater than the actual contributions they are making to our civilization today.

RCA Manufacturing Company, Inc.
National Broadcasting Company • RCA Laboratories
Radiomarine Corporation of America
R. C. A. Communications, Inc. • RCA Institutes, Inc.



RADIO CORPORATION OF AMERICA RADIO CITY, N. Y.