

# RADIO-CRAFT

HUGO GERNSBACK, Editor

## RECORDING STUDIO



**MEDIEVAL SOUND!**

See Page 713



TELLY NEWS PLANE

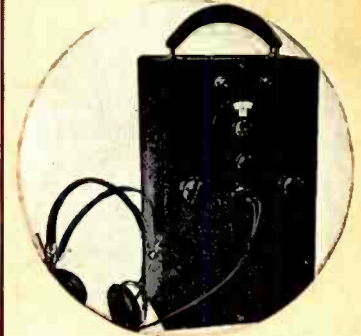

2-TUBE SUPERHET.!



STEREOPHONICS



P.A. HORN STYLING

JUNE RADIO'S GREATEST MAGAZINE

25c

PRACTICAL SOUND RECORDING • 30-WATT A.C. - D.C. AMPLIFIER

MAKING A VACUUM-TUBE VOLTMETER • SERVICING R.F. COILS

IN U.S. AND CANADA



# THREE STAR RADIO VALUE

You receive valuable subscription to **RADIO-CRAFT** PLUS A FREE COPY of 1940 Radio-Television Reference Annual

WITH our compliments, we want to send a copy of the 1940 RADIO-TELEVISION REFERENCE ANNUAL to you FREE, if you will simply take advantage of RADIO-CRAFT magazine's special subscription offer NOW. This offer is being made for a limited time only.

The 1940 RADIO-TELEVISION REFERENCE ANNUAL has 68 pages, large size 8 1/2 x 11 1/2, with over 170 illustrations. The contents of this book has never appeared before in handy book form. Its pages cover practically every branch of radio sound, public address, servicing, television, construction articles for advanced radio men and technicians, time and money-saving kinks, wrinkles, useful circuit information, "ham" transmitters and receivers, and a host of other data.

The Annuals have always been regarded as a standard reference work for every practical branch of radio operation and service. This 1940 edition ably sustains this reputation. Every radio man wants a copy of this valuable book. Just as this book will be of unquestionable value to you, so, too, will every monthly issue of RADIO-CRAFT. This magazine brings you big value every month. It keeps you intelligently informed about new developments in radio and television. You want the news, want it fully but concisely, want it first—that is why you should read RADIO-CRAFT regularly.

This very special offer is made for just one purpose—we want you as a regular subscriber. The Annual, whose contents appears at the right, is not sold, but a copy is FREE to you if you subscribe now.

**SAME SIZE AS RADIO-CRAFT**

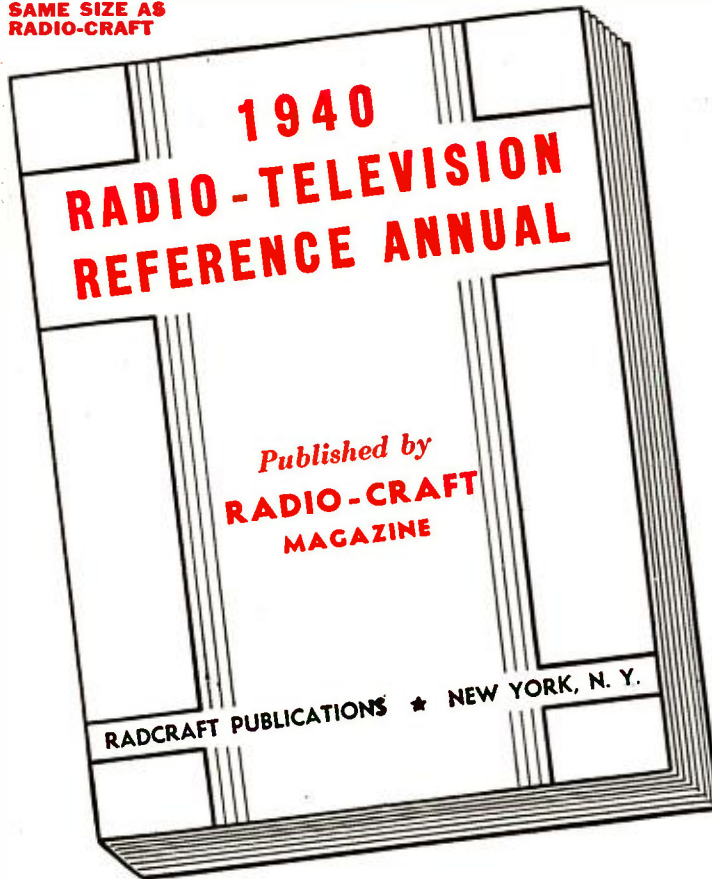

**THIS COUPON BRINGS YOU THE ANNUAL**

**RADIO-CRAFT • 20 VESEY STREET • NEW YORK, N. Y.**

Gentlemen: Enclosed you will find One Dollar for which enter my subscription to RADIO-CRAFT Magazine for Eight Months. Send me ABSOLUTELY FREE and POSTPAID, my copy of 1940 RADIO-TELEVISION REFERENCE ANNUAL.

This is a new order  Extend My Present Subscription

NAME ..... ADDRESS .....

CITY ..... STATE .....

**DON'T DELAY — MAIL TODAY!** RC-640

**Read the summary of contents in this FREE BOOK!**

THE 1940 RADIO-TELEVISION REFERENCE ANNUAL contains a collection of the best and most important articles. Covering as they do, nearly every branch of radio, they form a handy reference works. In addition, many time and labor-saving kinks, circuits and wrinkles, tried and tested by practicing Servicemen, experimenters and radio fans, have been included. This book cannot be bought anywhere at any price. Yet it is yours by merely subscribing. Use the convenient coupon below.

### BEGINNER'S SIMPLE INEXPENSIVE CONSTRUCTION ARTICLES

Beginner's Breadboard Special - a 1-Tube High-Gain All-Wave Receiver—Wiring Pointers for Radio Beginners—A Watch Charm Size 1-Tube Set—Beginner's Simple Volt-Milliammeter—Making a 1-Tube Broadcast Loop Receiver—A.C.-D.C. Power Supply for Battery Portables—A 1-Tube Short-Wave with Hand Coil Switching

### MORE ADVANCED SET CONSTRUCTION

The "High-Seas 4" Broadcast Lamp Radio—How to Build a 6-Tube 1.4-Volt Short-Wave Superhet for the "Ham" or Short-Wave Fan—Build the "Lunch Box 5" Super Set - a Broadcast Battery Portable—How to Build a Plug-Together 3-Tube Broadcast Set—The "5-in.-4" All-Wave Radio for A.C. Operation—An Easily-Built 3-Tube Midget Broadcast Superheterodyne Receiver.

### THE SERVICEMEN'S SECTION

Bass Tone Control—Simplified Variable Selectivity—Practical Servicing Pointers—Servicing Universal A.C.-D.C. Receivers—Killing the "Intermittent" Bug—A Service Shop A.C. to D.C. Power Supply—Sideline Money for Servicemen—Adding A.V.C. to any Screen-Grid T.B.F. Receiver—Iron Particles in Speaker Air Gap.

### TEST INSTRUMENTS

A Useful Neon Lamp Tester—An Inexpensive Output Meter—Making Milliammeter Multipliers—Home-Made Frequency Modulator—The Busy Servicemen's V.T. Volt-Meter.

### PUBLIC ADDRESS AND AMPLIFIERS

Build this Combination A.C.-D.C. Radio and Inter-Communicator—Speaker Placement in P.A. Work—The Design and Construction of an Inexpensive All-Push-Pull 10-Watt Amplifier—Obscure Sources of Hum in High-Gain Amplifiers—How to Build a High-Fidelity 5-Watt Versatile Amplifier.

### "HAM" SECTION

Ultra-High Frequency Antennas—The Beginner's Low-Cost Xmitter—Modulator Meter—Phone Monitor—The Beginner's "Ham" Receiver—2 1/2 Meter Acorn Transceiver.

### TELEVISION

How to Build a 441 Line T.B.F. Television Receiver—Useful Notes on Television Antennas.

### MISCELLANEOUS

Simple Photo-Cell Relay Set Up—Making a Burglar Alarm—How to Build A.C.-D.C. Capacity Relay—How to Make a Modern Radio Treasure Locator.

### USEFUL KINKS, CIRCUITS AND WRINKLES

Making a Flexible Coupler—Two-Timing Chime—A Simple Portable Aerial—An Improvised Non-Slip Screw-Driver. NOTE: The book contains numerous other useful Kinks, Circuits and Wrinkles, not listed here.

(approximately)

**45 ARTICLES**

(approximately)

**170 ILLUSTRATIONS**

**68 BIG PAGES**

**RADIO-CRAFT  
20 VESEY STREET  
NEW YORK, N. Y.**

J. E. Smith, Pres.  
National Radio  
Institute  
Est. 25 Years

# I WILL TRAIN YOU TO START A SPARE TIME OR FULL TIME RADIO SERVICE BUSINESS WITHOUT CAPITAL

**N. R. I. MEN  
WORK IN THESE  
BRANCHES, TOO**

**I Trained These Men**

## These Men Have SPARE TIME BUSINESSES



"I repaired many Radio sets when I was on my tenth lesson. I really don't see how you can give so much for such a small amount of money. I made \$600 in a year and a half, and I have made an average of \$10 to \$20 a week—just spare time."  
**JOHN JERRY**  
1529 Arapahoe St., Denver, Colo.

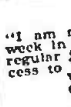

"I am now making from \$10 to \$25 a week in spare time while still holding my regular job as a machinist. I owe my success to N. R. I."  
**WM. F. RUPP**  
611 Green Street, Bridgeport, Pa.



"I am doing spare time Radio work, and I am averaging from \$700 to \$850 a year. Those extra dollars mean so much—the difference between just barely getting by and living comfortably."  
**JOHN WASHKO**  
97 New Cranberry, Hazleton, Penna.

**I Trained These Men**

## These Men Have FULL TIME BUSINESSES



"For the last two years I have been in business for myself making between \$200 to \$300 a month. Business has steadily increased. I have N. R. I. to thank for my start in this field."  
**ARLIE J. FROEHNER**  
300 W. Texas Ave., Goose Creek, Texas

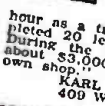

"Before taking your Course I earned about 17 1/2 cents per hour as a truck driver. When I completed 20 lessons I started service work. During the last two years I have made about \$3,000 in Radio. I now own my own shop."  
**KARL KELLY**  
409 W. Calhoun St., Magnolia, Ark.



"I am making between \$50 and \$60 a week after all expenses are paid, and I am getting all the Radio work I can take care of."  
**H. W. SPANGLER**  
126 1/2 S. Gay St., Knoxville, Tenn.



(Above) Broadcasting Stations employ operators, installers, maintenance men and Radio Technicians in other capacities and pay well.



(Above) Radio Jobbers and Dealers employ installation and service men at good pay.

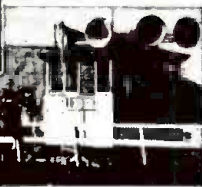

(Above) Loud Speaker System is another field for Radio Technicians.



(Left) Police, Aviation and Commercial Radio are newer fields for which we give the required knowledge of Radio.

The world-wide use of Radio has made many opportunities for you to have a spare time or full time Radio service business of your own. Four out of every five homes in the United States have Radio sets which regularly need repairs, new tubes, etc. Servicemen can earn good commissions too, selling new sets to owners of old models. Even if you have no knowledge of Radio or electricity, I will train you at home in your spare time to sell, install, fix, all types of Radio sets; to start your own Radio business and build it up on money you make in your spare time while learning. You don't need to give up your present job or spend a lot of money going away to school to become a Radio Technician. Mail coupon for my 64-page book. It's Free—it shows what I have done for others—what I am ready to do for you.

### STOP DREAMING, START EARNING IN A GOOD PAY JOB LIKE ONE OF THESE

Radio broadcasting stations employ engineers, operators, Radio Technicians and pay well. Radio manufacturers employ testers, inspectors, foremen, servicemen in good-pay jobs with opportunities for advancement. Radio jobbers and dealers employ installation and servicemen. Many Radio Technicians open their own Radio sales and repair businesses and make \$30, \$40, \$50 a week. Others hold their regular jobs and make \$5 to \$10 a week fixing Radios in spare time. Automobiles, police, aviation, commercial Radio, loudspeaker systems, electronic devices, are newer fields offering good opportunities to qualified men. Television promises to open many good jobs soon.

### WHY MANY RADIO TECHNICIANS MAKE \$30, \$40, \$50 A WEEK

Radio is already one of the country's large industries even though it is still young and growing. The arrival of Television, the use of Radio Principles in industry, are but a

few of many recent Radio developments. More than 28,000,000 homes have one or more Radios. There are more Radios than telephones. Every year millions of Radios get out of date and are replaced. Millions more need new tubes, repairs, etc. Over 5,000,000 auto Radios are in use and thousands more are being sold every day. In every branch Radio is offering opportunities—opportunities for which I give you the required knowledge of Radio at home in your spare time. Yes, the few hundred \$30, \$40, \$50 a week jobs of 20 years ago have grown to thousands.

### MANY MAKE \$5 TO \$10 A WEEK EXTRA IN SPARE TIME WHILE LEARNING

The day you enroll I start sending Extra Money Job Sheets which start showing you how to do Radio repair jobs. Throughout your Course I send plans and directions that made good spare time money \$200 to \$500—for hundreds while learning. I send you special Radio equipment to conduct experiments and build circuits. This 50-50 method of training—with printed texts and conducting experiments—makes learning at home interesting, fascinating, practical.

### FIND OUT WHAT RADIO OFFERS YOU MAIL THE COUPON BELOW

Act Today. Mail the coupon now for Sample Lesson and 64-page book. They're free. They point out Radio's spare time and full time opportunities and those coming in Television; tell about my course in Radio and Television; show you letters from men I trained, telling what they are doing and earning. Read my Money Back Agreement. Find out what Radio offers YOU! MAIL COUPON in an envelope or paste on postcard—NOW!

**J. E. SMITH, President**  
National Radio Institute, Dept. OFX  
Washington, D. C.

### YOU LEARN ABOUT TELEVISION, INTERCOMMUNICATING SYSTEMS, ELECTRONIC CONTROL DEVICES

The N. R. I. Course is up-to-the-minute. It gives you the ground-work you need for all profitable Radio fields. You get complete training in modern Television systems. How to install, adjust, cover, Television sets are kept right in step with new developments. You also learn about practical electronic control equipment, including photoelectric counting and safety devices, electric eye burglar alarms, fire and smoke detectors, and wireless remote control units. The N. R. I. Course is not only basic but highly practical.

## SAMPLE LESSON FREE

I want to prove our Course gives practical, money-making information, that it is easy to understand—what you need to master Radio. My sample lesson, "Radio Receiver Troubles—Their Cause and Remedy," covers a long list of Radio receiver troubles in A.C., D.C., battery, universal, auto, T.R.F., superheterodyne, all-wave, and other types of sets. And a cross reference system gives you the probable cause and a quick way to locate and remedy these set troubles. A special section is devoted to receiver check-up, alignment, balancing, neutralizing, testing.

You can get this lesson Free by mailing the coupon.

**Mail Now**

## GOOD FOR BOTH 64 PAGE BOOK SAMPLE LESSON FREE

**J. E. SMITH, President, National Radio Institute**  
Dept. OFX, Washington, D. C.

Without obligating me, mail Sample Lesson and 64-page Book Free. No salesman will call. I am particularly interested in the branch of Radio checked. (Please write or print plainly.)

- Radio Service Business of My Own
- Spare Time Radio Repair Work
- Service Technician for Retail Stores
- Broadcasting Station Operator
- Loud Speaker Systems, Installations and Service
- Auto Radio Installation and Service
- Television Station Operator
- All-around Servicing Technician

(If you have not decided which branch you prefer—mail coupon now, for information to help you decide.)

Name ..... Age .....

Address .....

City ..... State ..... 14X1



# RADIO-CRAFT

HUGO GERNSBACK, *Editor-in-Chief*

N. H. LESSEM  
*Associate Editor*

THOS. D. PENTZ  
*Art Director*

ROBERT EICHBERG  
*Trade Digest Editor*

R. D. WASHBURNE, *Managing Editor*

*In the*  
**NEXT ISSUE!**

- Easily-Built Tube and Set Tester
- Special Tubes for Sound Use!
- Servicing I.F. Coils
- Frequency Modulation Antennas For Best Reception
- Rebuilding Transformers
- A New Triode-Output 30-Watt Amplifier!
- "3-in-1" Portable Set
- Sound System from a Radio Set!
- Preview of the Radio Parts Show

## Contents JUNE, 1940 Issue

VOLUME XI -- NUMBER 12

Mailbag .....	707
Editorial: The Television Muddle .....	Hugo Gernsback 711
The Radio Month in Review .....	712

### SERVICING

Marine-izing Radio Sets .....	Charles R. Leutz 715
New Circuits in Modern Radio Receivers—No. 33 .....	F. L. Sprayberry 718
Servicing R.F. Coils .....	Lawrence V. Sorensen 720
Servicing Questions & Answers .....	722
<b>RADIO SERVICE DATA SHEETS:</b>	
No. 278—G.E. Model HJ-1205 .....	723
No. 279—Ditto .....	725
Operating Notes .....	724
Build This Direct-Reading Type V.-T. Voltmeter .....	Rufus P. Turner, <i>W1AY</i> 726
Measuring High Values of A.C. Voltage and Current with a Low-Range Meter .....	Gerald J. Laubenthal 728
Servicing Puzzler—Solved by the Use of Test Equipment .....	729
Distortion Helps Test Telly .....	731

### TEST INSTRUMENTS

Build This Direct-Reading Type V.-T. Voltmeter .....	Rufus P. Turner, <i>W1AY</i> 726
Measuring High Values of A.C. Voltage and Current With a Low-Range Meter .....	Gerald J. Laubenthal 728
Servicing Puzzler—Solved by the Use of Test Equipment .....	729

### SOUND

The Use of Dual Loudspeakers .....	I. J. Kear 730
Case Histories of P.A. Sales—No. 9 .....	731
Distortion Helps Test Telly .....	731
Speaker Matching Technique .....	H. S. Manney 732
Profits in Recording—Part II (Conclusion) .....	Sam M. Harper 735
Sound Engineering—No. 6 .....	737
Hooking-up That Extra Speaker .....	Tracy Diers 738
Bridge Rectifier Delivers 500 W. With Receiver Tubes .....	Leonard Nussbaum 739
Universal 25-Watt Amplifier Operates from 6-Volt Battery or 110/220-Volt A.C.-D.C. Line .....	A. C. Shaney 740

### ELECTRONICS

Latest Electromechanical Reverberation Control .....	742
--	-----

### ENGINEERING

The Use of Dual Loudspeakers .....	I. J. Kear 730
Speaker Matching Technique .....	H. S. Manney 732
Sound Engineering—No. 6 .....	737
Latest Electromechanical Reverberation Control .....	742
Magnetic Beam Lands U.S. Navy Planes Blind .....	748

### EXPERIMENTERS

Hooking-up That Extra Speaker .....	Tracy Diers 738
A 2-Tube Superhet.—With Pentagrid Regenerative 2nd-Detector .....	R. D. Washburne and Leonard Lasky 744

### RADIO DEVELOPMENTS

Magnetic Beam Lands U.S. Navy Planes Blind .....	748
1940's Portables .....	N. H. Lessem 750

### CONSTRUCTION ARTICLES

Build This Direct-Reading Type V.-T. Voltmeter .....	Rufus P. Turner, <i>W1AY</i> 726
Bridge Rectifier Delivers 500 W. with Receiver Tubes .....	Leonard Nussbaum 739
Universal 25-Watt Amplifier Operates from 6-Volt Battery or 110/220-Volt A.C.-D.C. Line .....	A. C. Shaney 740
A 2-Tube Superhet.—With Pentagrid Regenerative 2nd-Detector .....	R. D. Washburne and Leonard Lasky 744

### DEPARTMENTS, ETC.

Mailbag .....	707
The Radio Month in Review .....	712
New Circuits in Modern Radio Receivers .....	F. L. Sprayberry 718
Servicing Questions & Answers .....	722
RADIO SERVICE DATA SHEETS (See Servicing) .....	723, 725
Operating Notes .....	724
Case Histories of P.A. Sales—No. 9 .....	731
Book Reviews .....	734
Latest Radio Apparatus .....	753
The Radio Public Asks .....	760
Radio Trade Digest .....	761
Shop Notes—Kinks—Circuits .....	766



### PREVIEWING THE RADIO PARTS TRADE SHOW!!

Don't miss the forthcoming July issue of Radio-Craft! It will contain special feature descriptions of the outstanding displays to be found at the booths of foremost radio equipment manufacturers displaying their wares at the annual Radio Parts Manufacturers' National Trade Show, Inc., Stevens Hotel, Chicago, June 11 to 14, incl.



Published by Radcraft Publications, Inc. Publication office: 29 Worthington Street, Springfield, Mass. Editorial and Advertising Offices: 20 Vesey Street, New York City. Chicago Advertising Office: RADIO-CRAFT, 520 North Michigan Avenue, Chicago, Ill.

RADIO-CRAFT is published monthly, on the first of the month preceding that of date; subscription price is \$2.00 per year in U. S. and Canada. (In foreign countries, \$2.50 a year to cover additional postage.) Entered at the post office at Springfield as second-class matter under the act of March 3, 1879.



#### Foreign Agents:

London—Gorrings's American News Agency, 9A Green St., Leicester Square, W. C. 2, England.  
Paris—Messageries Dawson, 4 Rue Faubourg, Poissonniere, France.  
Melbourne—McGil's Agency, 179 Elizabeth St., Australia.  
Dunedin—James Johnston, Ltd., New Zealand.



Text and illustrations of this magazine are copyright and must not be reproduced without permission of the copyright owners.



Copyright 1940 Radcraft Publications, Inc.

**HIGH-SPEED LIGHT RELAY**

Dear Editor:

● ON Page 214 of the October, 1939, issue of *Radio-Craft* you published a typical light-relay circuit.

The Phototube is an RCA type 922, and the Amplifier an RCA type 2051.

I wish to employ this circuit for a high-speed light relay, and would like to know the appropriate values of the following:

- R1—Grid-bias potentiometer
- R2—Bleeder resistor
- R3—Anode Current Limiting Resistor
- Condenser across relay (if needed)
- Grid Resistor (proper value for high speed)
- Winding on relay magnet, etc.

I want the relay to respond when the beam of light striking the Phototube is broken. Also, I should like to know, in terms of volts and amperes, the amount of current that energizes the relay. I believe an ordinary step-down transformer will serve to heat the 2051.

PETER G. NICKLES,  
Philadelphia, Pa.

It is felt that the reply to Mr. Nickles may be of considerable general interest, and hence, we present it below.

"Component values are shown in the enclosed diagrams (reproduced here—Ed.).

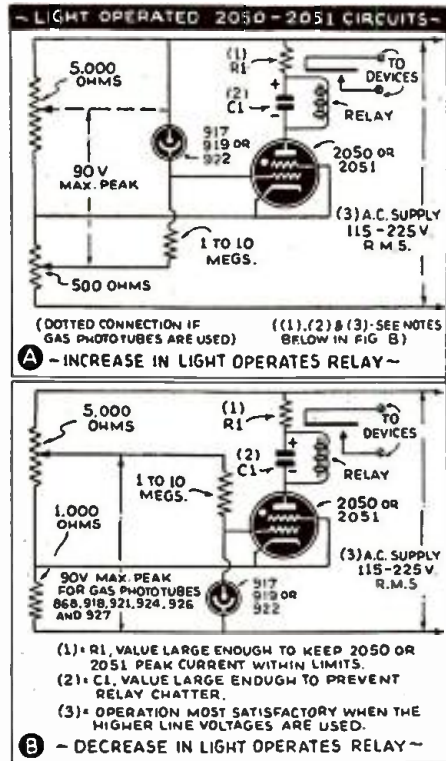

"The size of the condenser across the relay depends upon the constants of that relay and should be just large enough to prevent relay chatter. It is suggested that, for the relay winding, a resistance value of 500 to 2,000 ohms be used. The size of the grid resistor will depend somewhat upon the amount of light used and will have little effect upon the speed of operation. This is true, because the speed of operation is determined largely by the frequency of the A.C. line. A filament transformer will be satisfactory for supplying filament voltage to the 2051."

**THE "HARMONIC CONVERSION" ARTICLE**

Dear Editor:

● I HAVE carefully checked my article entitled "Newest Hi-Fi 9-Tube Superhet. Introduces 'Harmonic Conversion'" in the

Dec., 1939, issue). The patent number, 1,040,141 directly under the word Harmonic in the title is wrong. The right patent number is 2,140,141.

In the article I omitted several comparatively important items. When aligning the harmonic amplifier a fairly strong signal should be fed into the control-grid of tube No. 13 (harmonic converter tube) because the control-grid is affected by the fundamental frequency and does not control the harmonic frequency. This is a very good place to connect the signal source. Between 0.1- and 0.5-volt input of radio frequency is required for proper alignment.

The oscillator plate voltage resistor, that is, the resistor which is tapped from a higher voltage source, should be approx. 0.1-meg. for the 2A7 tube oscillator section because the plate draws 2 ma. at 100 V. The tube I had in mind when I wrote the article was a 56 tube with 5 ma. of plate current. This tube is used in the latest receiver.

P. WILSON REDCAY,  
Sinking Springs, Pa.

**"'3-IN-2' A.C.-D.C. MIDGET AMPLIFIER"**

Dear Editor:

● IN regard to the circuit of the "'3-in-2' A.C.-D.C. Midget Amplifier" by Mr. H. S. Manney in *Radio-Craft*, Jan., 1940, there was a slight mistake made in the drawing. One side of the 3,000-ohm resistor is tied to the ground when it should have been tied to the screen-grid of the 50L6GT output tube.

I tried this amplifier for inter-office communication work. It works very nicely after making the slight change mentioned above and changing the 70L6GT input section from a triode voltage amplifier to a pentode circuit.

JACK C. FACLIE,  
Pleasanton, Texas.

**WANTS MORE "BATTERY-OPERATION" ARTICLES**

Dear Editor:

● THIS is the first time that I have written to your wonderful magazine. I am in the country here, so we have no advantages of A.C. power lines.

We country people would like to see more tips on battery-operated test equipment, new circuits, etc.

Also battery-operated mobile P.A. systems, and tips on running same.

Your magazine is tops, but would like to see the "'B'-battery radio-man" helped out.

Your constant reader for 6 years.

A. CLAYTON,  
Verlo, Sask., Canada.

**RE: "SSSS OR SOS?"**

Dear Editor:

● I HAVE just read your "News from Abroad" section in the March, 1940, issue of your very instructive and interesting publication. There has been so much said and written about the use of the "SSSS" (submarine sighted) signal, that I would like to add my bit in clearing up the matter.

At the moment that England declared a state of war existed, I was entering the port of Cobh (Queenstown), Ireland, and made 2 more voyages into British ports afterwards. I received the distress call from the *Athenia*, and calls for aid from numerous other vessels, including the one from the *S.S. Blairlogie*, whose crew was rescued by my vessel and brought into New York as the first sea warfare victims to be landed at an American port.

From conversations with the rescued

**STOP! LOOK! EARN!**

**I'LL TRAIN YOU TO MAKE GOOD MONEY in RADIO AND TELEVISION**

**I'll Prove That You Can Have a Good Job in Radio... or a Business of YOUR OWN**

I offer you a new and altogether different type of practical Training for a money-making career in Radio and Television. No matter if you desire to BE YOUR OWN BOSS in your own business, or hold down a good job in Radio, my Personalized Training will quickly give you the useful knowledge to win success. I make it EASY for you to get started.

**YOU LEARN RIGHT AT HOME in SPARE TIME... EARN from the START**

YOU DO PRACTICAL EXPERIMENTS with real Radio Equipment with your own hands. Thus the principles of Radio become crystal-clear to you. The valuable spare-time BUSINESS BUILDERS I supply will show you how to put this knowledge to work in handling profitable Radio services jobs while learning.

**YOU GET PROFESSIONAL TEST EQUIPMENT plus EXPERIMENTAL OUTFITS**

**146 RADIO PARTS RADIO TOOLS All-Purpose Analyzer**

**I GIVE YOU CLOSE PERSONAL COACHING SERVICE**

**NO PREVIOUS EXPERIENCE NEEDED**

It makes no difference what your education has been. My Training starts at the beginning of Radio, covers in a simple understandable style all essential subjects including Television, Electronics, Facsimile, Radio, Radio-Set Repair and Installation.

**READ WHAT THIS STUDENT SAYS**

**Earned \$250, Since Starting Course**

"I have only completed one third of the Sprayberry Course and I find it very interesting, which makes it easy to learn. By devoting several hours' spare time daily to studying and servicing I have made about \$250 gross since starting the Course." Earl W. Hostetter, R. No. 4, Lebanon, Pa.

**SERVICEMEN**

I offer Advanced Training for those already in Radio. Get complete details in my FREE 52-page Book.

**REMEMBER — THE SPRAYBERRY COURSE IS SOLD UNDER A MONEY-BACK AGREEMENT**

**RUSH THIS COUPON FREE for BIG FREE BOOK**

**DON'T DELAY! ACT NOW!**

**SPRAYBERRY ACADEMY OF RADIO**  
F. L. Sprayberry, Pres.  
320-F University Place, N.W., Washington, D. C.  
Please send me FREE copy of "HOW TO MAKE MONEY IN RADIO."

Name ..... Age .....

Address .....

City ..... State .....

Tear off this coupon, mail in envelope or paste on penny postcard. Servicemen—Check here ☐



• Your experience is a valuable asset in preparing for a career in the professional field. Many top engineers and others in radio today turned their "hobby into a career" and now enjoy good technical jobs. You have the same opportunity, by applying your inherent love for radio to a planned, proven course of training. C.R.E.I. courses are selected by men in the industry who realize that technical training is the difference between "just a job" and a real future in radio! Among our students are many amateurs who are now heading into good engineering jobs . . . hundreds of men in more than 300 broadcasting stations . . . more than 700 radlomen in the Navy . . . scores of airways men. C.R.E.I. training must bring results. May we show you why?

**Write for FREE Book of "A Tested Plan"**

To enable us to send you complete information, please state briefly your background, education and present position—and whether you are interested in home-study or residence training.



**CAPITOL RADIO Engineering Institute**

Dept. RC-6, 3224 16th Street, N. W., Washington, D. C.

**RADIO plus TELEVISION** mastered by pre-tested Training

No matter where you are or what you do, National has a complete training plan for you—to fit your circumstances. National's plan is for those seeking immediate shop-training as well as for those who cannot give up present employment and income. Mail coupon for FREE literature.



**NATIONAL SCHOOLS**

NATIONAL SCHOOLS, Dept. RC-6  
4000 So. Figueroa St., Los Angeles, Calif

Please send free Literature and full details

NAME \_\_\_\_\_ AGE \_\_\_\_\_  
ADDRESS \_\_\_\_\_  
CITY \_\_\_\_\_ STATE \_\_\_\_\_

**Be a RADIO SERVICE EXPERT**  
LEARN AT HOME IN SPARE TIME

Clear, simple, fascinating lessons—Practical work with experimental kits—make training easy and fast. Up to date R.T.A. methods. Under personal guidance of prominent engineer and educator, highly endorsed by leaders in radio industry. Spare-time profits soon pay for training.

**START NOW**—have your own business or fit yourself for well paid work with radio dealers, in factories, police, marine or television fields. DON'T DELAY!

Send AT ONCE for complete information and Big Opportunity. **BOOK FREE!**  
**RADIO TRAINING ASS'N. OF AMERICA**  
4525 RAVENSWOOD AVE., Dept. RC-60, CHICAGO, ILL.

**LES Correspondence Courses in RADIO and ELECTRICAL ENGINEERING**

**ELECTRICAL ENGINEERING** Get good grasp of wide electrical field. Prepare yourself, at Low Cost, for secure future. Modern, simplified, you can understand quickly.

**RADIO ENGINEERING** Extra fine course in radio, public address, photo-electric work. Trains you to be super-service man, real vacuum tube technician. Exper. kits furnished. Diploma on completion. Tuition, \$25. either course. Deferred payment plan.

**FREE** Get copies of school catalogs, student magazines, complete details. SEND NOW!

LINCOLN ENGINEERING SCHOOL, Box 831-C18, LINCOLN, NEBR.

**RADIO TECHNOLOGY**

RCA Institutes offer an intensive course of high standard embracing all phases of Radio and Television. Practical training with modern equipment at New York and Chicago schools. Also specialized courses and Home Study Courses under "No obligation" plan. Catalog Dept. RC-40.

**RCA INSTITUTES, Inc.**  
A Radio Corporation of America Service  
75 Varick St., New York, 1154 Merchandise Mart, Chicago

"wireless operator" of the ex-*Blairlogie*, and from chance meetings with 2 other British wireless (radio) men, and my own observations of calls for aid while I was at sea, I believe that my information is correct.

The letter "S" is used to designate the sighting on an enemy submarine by belligerent vessels, or of an attack being made by the submarine; while the letter "R" is used to signify that the vessel has sighted or has been attacked by an enemy surface raider, such as warships or merchant vessels being used as raiders. The letter is repeated 4 times, to form the call "SSSS" or "RRRR," merely to attract attention, following the formula that a distress call must be of a peculiar and unusual character to attract the attention of radio operators who are occupied with other calls on traffic at the moment that the distress call is broadcast.

As to the official or unofficial nature of the 2 calls, I cannot say. When asked about this, the radio operator of the ex-*Blairlogie* told me that he had never heard or seen any official reference to the 2 calls. He stated that he used the call himself after having heard it sent by 1 or 2 other vessels previously attacked or sunk. In fact, he himself used the conventional "SOS" also, to make sure that attention was attracted.

If this information is of any aid, you may use it as you wish, publishing it, or in any other way, disposing of it.

BYRON B. BODIFORD,  
Formerly 1st Asst. Radio Officer,  
"S.S. American Shipper,"  
U. S. Lines,  
1 Broadway, New York, N. Y.

(Vessel laid up because of neutrality law restrictions.)

We feel sure Mr. Bodiford's letter to "Mailbag" interested *Radio-Craft* readers as much as it did us. Perhaps, too, some of these readers may wish to contribute their bit "for the record"—what do you say, fellows?

In this connection we print, below, a release from the Federal Communications Commission, subsequent to the one printed in March *Radio-Craft*, containing further "official" comment on this subject which is so much in the news these days.

**MORE ABOUT "SSSS"**—The marine radio call letters "SSSS," reported used in the European war zone and mentioned in a recent Federal Communications Commission release, are not intended to rival "SOS" as a distress signal, the Commission is further informed.

It is pointed out that "SSSS" means, in effect, "keep away from us," while the better-known "SOS" has just the opposite meaning.

In the World War "SSSS" was adopted by the allies and was not used by neutrals, and to that extent was not, strictly speaking, an international signal, whereas "SOS" was recognized for the shipping of all nations. In the World War "SSSS" was not used as a call of distress, but was a warning to other ships that a submarine was nearby or actually threatening the vessel sending out such a call. It was the understanding that even were the ship sinking because of the submarine, the internationally-recognized "SOS" would be used to summon aid.

tember, 1939 (page 179), that it takes 5 watts of electric energy to kill. I find frequently that trade journals give an entirely false impression on the threshold value of electric current or energy which can produce dangerous electric shock or death. The figure you have mentioned is approximately 150 times too large, for people have been killed with a voltage as low as 11, and the body resistance may be assumed to be 5,000 ohms or more.

You may wish to bring these matters to the attention of Littelfuse, and if you do, I shall be glad to know what comments, if any, they have to make on the question. I hope you may see fit to correct the misinformation you have given your readers—a rather dangerous sort of information to put into their minds, as I am sure you will agree.

F. J. SCHLINK, M. E.  
Washington, N. J.

This letter was sent to Littelfuse, Inc., and their most informative reply is printed below. In view of the extremely high voltages employed in television receivers (for example) it is felt that Servicemen should be made thoroughly familiar with the physiological properties of these high potentials.

**Dear Mr. Schlink:**

Regarding your comments on our vacuum type "Video" Littelfuses described in the September issue of *Radio Craft*, I think you are right, in that an expression of lethal shock in terms of watts, isn't very accurate. From all the references we've been able to find on the subject, it is the current (amperes) which is the deciding factor as far as intensity of the shock is concerned. And it seems that about 1/2-milliamperes is at the threshold of feeling for most people, and that most people can carry about 30 milliamperes before involuntary muscular contraction takes place. On the other hand, some people have been killed by current as low as 10 milliamperes, and perhaps even less judging from the reference you cited where a voltage as low as 11 volts was lethal. In all probability the body resistance was less than 5,000 ohms in this instance.

A good deal of study regarding lethal shock has been done during the last few years. Perhaps you have done some of it yourself. A good deal of this work was done in connection with the use of electric fences. And this work is summarized quite well in the "Electric Fencing Handbook" (published by the Electric Fencing Handbook Publishers of Muncie, Indiana); and the Electrical Testing Laboratories, 80th Street and East End Ave., New York City, also have a report (their No. 3338) which I think you would find very interesting.

In our literature we recommend these fuses for protection against lethal shock, although we do it without assuming responsibility. We feel that it's a very good precaution, albeit perhaps not a perfect one; but nevertheless it would take away the hazard in perhaps 95% of the cases where high voltages are concerned. A few years ago we provided Professor William Max of New York University with fuses of 1/200-ampere rating, but not evacuated, which apparently were quite satisfactory for protection against lethal shock.

We're interested in hearing more about

**THE ENIGMA OF LETHAL ELECTRIC SHOCK**

Dear Editor:  
• IT seems to me that you have performed poor service to your readers in stating, in the article "Getting Into Television Servicing" in your issue of *Radio-Craft* for Sep-

**RADIO COURSES**

Start September

RADIO OPERATING—BROADCASTING

- RADIO SERVICING — a practical course
- RADIO AMATEUR CODE • TELEVISION
- ELECTRONICS—1 yr. day course 2 yrs. eve.

Day and Evening Classes. Booklet Upon Request.

**New York Y.M.C.A. Schools**  
6 W. 64th Street New York City

## • MAILBAG •

this subject; and if you can give us any more information you think we ought to have, we'll welcome it, I assure you.

E. V. SUNDT, President,  
Littelfuse, Inc.,  
Chicago, Ill.

### BODY-CAPACITY ALARM

Dear Editor:

● I AM writing in regard to the article on the Body Capacity Alarm on page 31 of the July, 1939, issue of *Radio-Craft*.

I am very much interested in this Alarm. I have constructed it according to the information in the article.

I have had difficulty in keeping the circuit stable and to make it operate smoothly. It seems to be very erratic in operation.

I use a Leach relay. The coil has a resistance of 4,500 ohms. The core is designed for A.C. operation.

The oscillator coil consists of 2—100-millihenry R.F. chokes connected in series and mounted close together on a dowel.

How can I make this alarm sensitive up to about 10 or 12 feet?

ROYDON PERRY BURNS,  
Long Beach, Cal.

The following comments, on the above inquiry, by the originator of the circuit, will also answer other *Radio-Craft* readers who may have experienced the same effects.

Dear Mr. Burns:

The instability and lack of sensitivity of the capacity relay constructed as described is probably caused by the fact that low-"Q" coils were used.

In general the lower the losses in the coils the more sensitive the relay will be. A sensitivity of 3 or 4 feet is about all that can be expected with good stability.

The type of relay used is not important as long as it operates and does not have too great a spread between the operate and non-operate currents.

F. H. SHEPARD, JR.,  
Merchantville, N. J.

### RE: SPRAY-SHIELDING TUBES

Dear Editor:

● IN your issue for Feb., 1940, there is a letter in the Mailbag from E. P. Siddall of Victoria, B. C., in which he comments on an operating note of mine published on page 352 of December, 1939, issue regarding home-made spray shielding for tubes.

I am afraid that my letter could not have made my point clear. What I meant to bring out in my operating note was that a standard, glass 27 tube worked, but that the owner insisted on one that looked like the original, the reason for the liquid solder coating was psychological—not technical.

I might state that we have a very large foreign population in this city and they have some strange ideas on radio replacement parts; if the original condenser should be colored blue, many of them would insist on the replacement being blue!

GUY E. MCALLAN,  
c/o Trinity Auto Electric,  
Fernie, B. C.

### CORRECTION: 110-V. D.C. AMPLIFIER

Dear Editor:

● IN the diagram of the 110-volt D.C. Amplifier on pg. 115 of the August issue of *Radio-Craft*, and sent in by myself, the grid condenser of the 6C5 was marked 100 mmf. instead of the correct value, 500 mmf.

The smaller size would unduly limit the lower frequencies.

GEORGE DUFF,  
Wynyard, Sask.

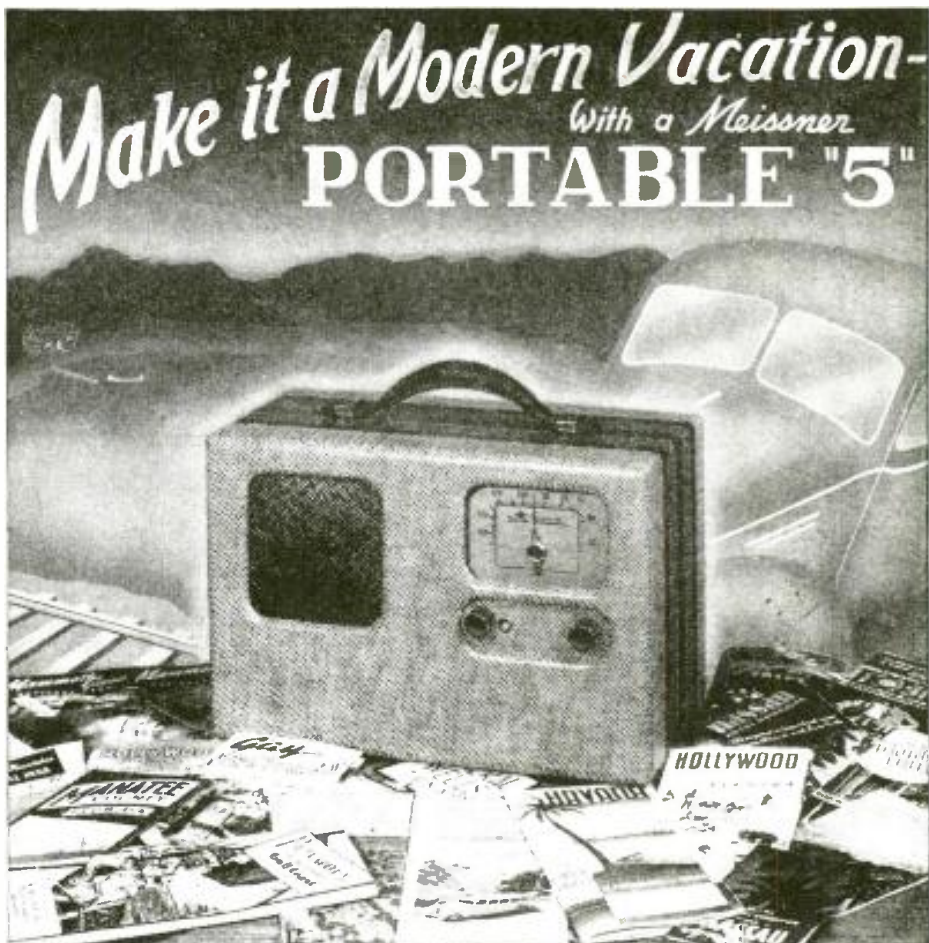

## Where-ever you go—

Whether you travel by rail—strike out on the open road—or take life easy in a cabin in the pines—you can have radio with you by including a Meissner Portable "5" in your vacation plans.

Keep abreast of the times—the latest news the minute it happens—it's yours with this highly efficient little receiver. It'll take the place of your daily paper. And even if you're one of those who want to forget about the news for awhile—there'll still be evenings when you'll enjoy musical entertainment—you won't have to miss those favorite programs you've been keeping up with.

The Portable "5" is a sensitive, 5-tube super-het, using latest types of 1.4-volt tubes. Completely self-contained, with batteries and built-in loop antenna—just turn it on for reception anywhere! Beautiful brown-tone aviation luggage style case is only 8½" x 6½" x 13" and complete set weighs only 15 pounds.

And—best of all—this remarkable set is furnished as one of the famous Meissner Complete Kits! All parts are supplied (except tubes and batteries), with Meissner super-clear instructions, pictorial and schematic wiring diagrams. So simple a twelve-year-old could have it working in a few hours! No special tools required.

See your Meissner Parts Jobber at once and get acquainted with the possibilities of this receiver. Not "just another battery set" but a full-fledged portable super with dynamic speaker. A ready companion for any adventure under any conditions!

### SEND FOR COMPLETE MEISSNER CATALOG

Your copy of the big 48-page general catalog is ready and waiting. Contains complete listings descriptions and illustrations of the entire line of Meissner Kits, ready-built units and radio accessories. A post-card will bring yours at once!

ADDRESS DEPT. C-8  
Meissner  
MT. CARMEL  
ILLINOIS  
"A FAMOUS NAME FOR TWO DECADES"

Order your copy NOW—the only

# P. A. HANDBOOK

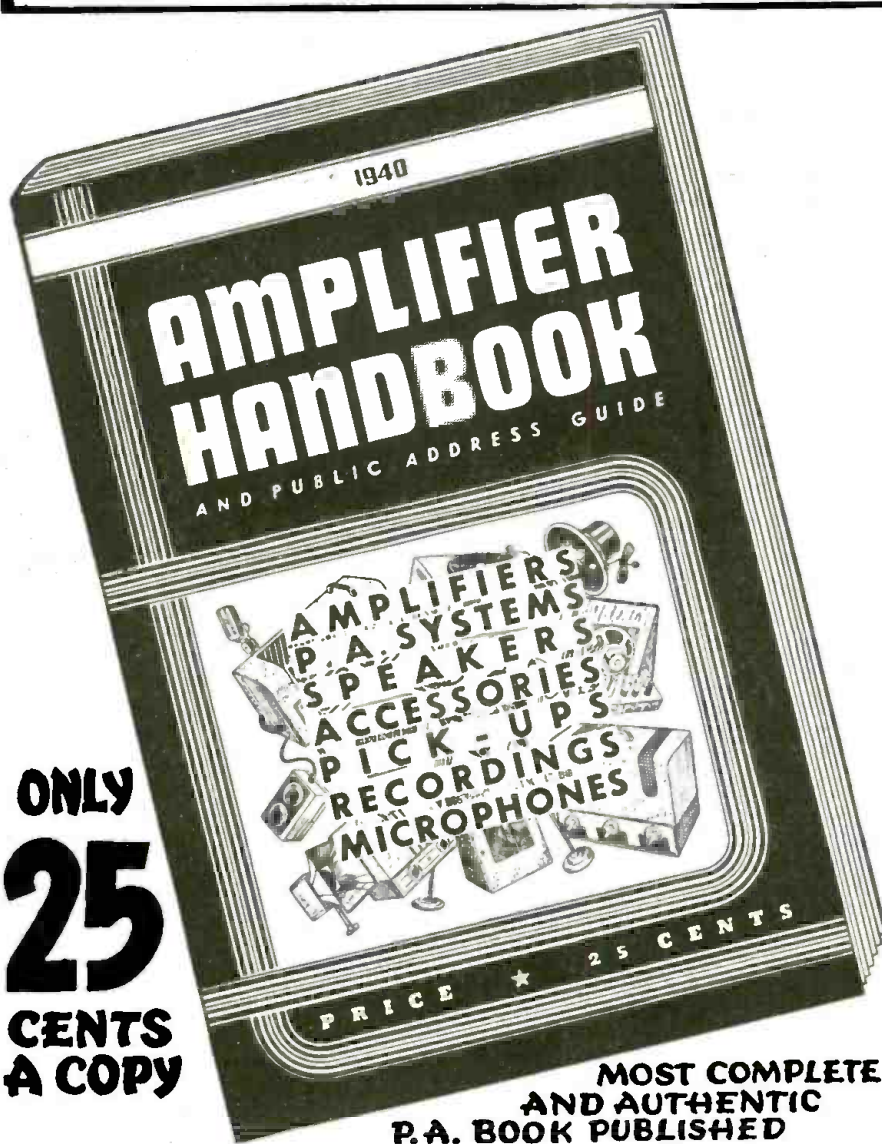

ONLY  
**25**  
CENTS  
A COPY

THAT no book has yet been published which covers amplifiers and sound systems (also kindred systems) in one complete, authentic volume is almost unbelievable. Yet, it is a fact, there is no book in print which covers Public Address from A to Z. To bridge this wide-spread gap, RADIO-CRAFT will publish a complete, magnificent volume on Public Address of such magnitude—so complete and authoritative—that every man engaged in radio can have both a theoretical and practical knowledge of the function and operation of sound systems. The editorial pages are so filled with instruction and replete with illustrations that the volume fully justifies its title. **1940 AMPLIFIER HANDBOOK AND PUBLIC ADDRESS GUIDE.** This great HANDBOOK on Public Address should be read and studied by those who consistently build, service and sell sound equipment.

#### A MATCHLESS VOLUME

As complete as you would expect to find any engineering handbook—this is how the radio or P. A. man finds the **AMPLIFIER HANDBOOK AND PUBLIC ADDRESS GUIDE.** With essential technical data compiled from an exceptionally large number of sources, the volume covers nearly two hundred different subjects coordinating every conceivable branch or sub-division of Public Address.

#### THE CONTENTS

To actually show the scope and magnitude of the **AMPLIFIER HANDBOOK AND PUBLIC ADDRESS GUIDE,** an analysis of the contents is found at the right, showing the breakdown of the material featured within each particular section. A thorough reading of the contents shows the completeness of this book.

**RADCRAFT PUBLICATIONS ■ 20 VESEY STREET ■ NEW YORK, N. Y.**

RADCRAFT PUBLICATIONS, INC. ★ 20 VESEY STREET ★ NEW YORK, N. Y. RC-640  
Gentlemen: Enclosed find my remittance of 25c for which send me POSTPAID, one copy of your NEW—**1940 AMPLIFIER HANDBOOK AND PUBLIC ADDRESS GUIDE.**

Send me ..... others, for friends, also POSTPAID @ 25c each.

Name ..... Address .....

City ..... State .....

Remit by check or money order; register letter  
if you send cash or unused U.S. Postage Stamps.

## A Resume of the Contents of the AMPLIFIER HANDBOOK AND PUBLIC ADDRESS GUIDE

### PREFACE

#### INTRODUCTION

#### CHAPTER I—FUNDAMENTALS

Vacuum Tube as Amplifier—Ratings—Bells and Decibels—Harmonics—Distortion—Attenuation—Gain—Ohm's Law—Bridge Circuits—Rectification—Microphonics—Condensers—Resistors—Impedance—Phase—Resonance—Inductance—Frequency—Magnetism—Shielding.

#### CHAPTER II—VACUUM TUBES

Voltage Amplifiers—Power Amplifiers—Control and Indicator Tubes—Rectifiers—Ballast and Regulator.

#### CHAPTER III—CIRCUIT ANALYSIS

Inputs—Coupling—Degeneration (Inverse Feedback)—Frequency Compensation—Outputs—Push-Pull—Phase Inversion—Class A, A. B, A<sub>1</sub>, etc.—Hum-Bucking—Automatic Gain Control—Spectrum Control—Time-Delay—Tone Compensation—Voltage Dividers—Swinging Chokes—Beam Power—Push-Pull.

#### CHAPTER IV—MICROPHONES

Carbon—Condenser—Electrodynamic—Ribbon (Velocity)—Crystal—Lapel—Uni-directional (cardioid)—Electromagnetic—Transducers.

#### CHAPTER V—AMPLIFIERS AND PREAMPLIFIERS

A. C.—D. C.—A. C.—D. C. (120 V.)—A. C.—D. C. (0 V. D. C. - 120 V. A. C.)—Mobile—Portable—Multi-Channel—Biphonic—Preamplifiers—Monitors.

#### CHAPTER VI—LOUDSPEAKERS

Magnetic—Dynamic—P. M. Dynamic—Crystal—Horn Units.

#### CHAPTER VII—HORNS AND BAFFLES

Flat—Infinite—Octave Resonance—Exponential—Flares—Labyrinths—Pseudodynamic—Biphonic.

#### CHAPTER VIII—AMPLIFIER COMPONENTS

Resistors—Condensers—Transformers—Chokes—Fuses—Sockets—Chassis and Housings—Meters—Name Plates and Bezels—Terminals—Jacks and Plugs—Switches—Frequency Filters—Bias Coils—Tone and Volume (Attenuator) Controls—Pads—L. T. H. etc.

#### CHAPTER IX—POWER SUPPLIES

Power Lines—Batteries—Converters and Generators—Rectifier Tubes—Dry Rectifiers—Vibrators and Inverters—Bias Supplies—Field Exciters—Ballasts and Regulators.

#### CHAPTER X—ACCESSORIES

Coin Phonographs—P. A. Tuners.

#### CHAPTER XI—RECORDING AND PLAYBACK

Pickups—33-1/3 and 78 r.p.m. Turntables—Film, Disc and Wire—Recorders—Lateral and Vertical (hill-and-dale) Recording—High Fidelity Recording and Playback—Accessories.

#### CHAPTER XII—MATCHING AND MIXING

Input to Amplifier—Amplifier to Line—Line to Speakers—Pads—Attenuators—Matching Amplifiers—Booster Amplifiers.

#### CHAPTER XIII—ACOUSTICS

Absorption—Reverberation and Echo—Low-Level Distribution—High-Level Distribution.

#### CHAPTER XIV—SELLING SOUND

Ethics—Who are the prospects?—What are reasonable charges?—Sidelines—Accounting—Advertising and Publicity.

#### CHAPTER XV—SCHOOL SOUND SYSTEMS

#### CHAPTER XVI—CALL SYSTEMS

Railroads—Hotels—Restaurants.

#### CHAPTER XVII—INTERCOMMUNICATORS

Wire Type—Wireless—Radio Type—Switchless—Multiple Station.

#### CHAPTER XVIII—TALKIES

Soundheads—Amplifiers—Loudspeakers—Sound-on-Film—Sound-on-Disc—Home Talkies—Commercial Talkies.

#### CHAPTER XIX—HEARING AIDS

Tubeless—Tube Type.

#### CHAPTER XX—MISCELLANEOUS APPLICATIONS

#### CHAPTER XXI—FORMULAS AND TABLES

#### CHAPTER XXII—TEST EQUIPMENT

Multi-Meters—C.-R. Oscilloscope—A. F. Oscillators—Output (Level) Indicators—V. T. Voltmeters.

#### CHAPTER XXIII—INSTALLATION PROCEDURE

Placement of Equipment (Microphones, Amplifiers, Loudspeakers)—Use of Woofers and Tweeters—Wiring—Indoors and Outdoors—Portable and Mobile Set-Ups—Permanent Installations.

#### CHAPTER XXIV—SERVICING

Order Your Copy NOW—

*Clip Coupon and  
Mail Today!*



# RADIO-CRAFT

"RADIO'S GREATEST MAGAZINE"

. . . . the fly in the television ointment is in the tinkering.

## THE TELEVISION MUDDLE

By the Editor — HUGO GERNSBACH

Of all the great inventions to benefit mankind, it would seem that Television has been singled out, for no good reason, to have placed in its path obstacle after obstacle. It is doubtful if any invention could be cited that has had the trials and tribulations of television. Even the invention of the telephone, which had its own share of troubles, cannot be excepted from this, because while patent litigation went on for years the public was not deprived of the use of the benefits of the telephone.

In recent years television was made the football not only by dissension within the industry itself, but by politics in the form of the Federal Communications Commission.

No one has ever pretended that television has been perfected or that it has become a stabilized art. Yet those who have expended fortunes in the orderly progress of making television available to mankind, are themselves continuously under criticism and fire. Therefore whatever has been accomplished is immediately nullified by scaring the public in such a manner that television today stands discredited.

When radio was young and we did not—fortunately—have a Federal body to supervise the art, radio progressed rapidly in a normal, evolutionary manner paralleling other great inventions. Whenever such an invention is made, the public has been taught not to believe that the millennium has been reached and that the early models are perfect.

When radio started, we first had only crystal sets. Millions of these were in use only to become obsolete when the radio tube made its triumphant entry. Then quickly whatever models were in use became obsolete or nearly obsolete within the year, yet the public did not seem to mind because with highly technical and specialized inventions, it is impossible to expect perfection. It was thus also with the automobile. Early cars became obsolete in from 1 to 2 years. Even today when so-called perfection has been reached, a brand new car once it has run 500 miles is for all purposes an old car and the owner can only recover part of his investment if he wants to sell that car. The same is exactly true of any model radio set which you buy today. While it may give service for some time to come, radio sets, too, become obsolete soon. And with the recent invention of Frequency Modulation, it appears certain that most radio sets in use today will be obsolete in a few years, as the swing is entirely towards that system.

It seems to us that all the bickering and senseless fighting within the radio industry on one side, and from the Federal Communications Commission on the other, is particularly unfortunate at a time when real technical progress has been made by some of our large radio corporations who have invested millions in television.

No one has ever seriously questioned in this country the American system of broadcasting whereby radio sets can be operated free of any Government tax, as is not the case almost universally in other parts of the world. Instead of taxing the use of the radio set, the American system makes the advertiser pay for his broadcasting privilege and, in this manner, the American public not only gets the world's best programs, but gets these programs free.

The same system, of course, would have to be used for television as well, where the advertiser would pay the expense of broadcasting. The Federal Communications Commission, recognizing the wisdom of this American institution, recently announced that television could operate under limited com-

mercial sponsorship beginning September 1st. Then late in March, the F.C.C. had a change of heart and created chaos in the television industry by suddenly reversing its former decision and called for more hearings in order to determine whether it would not be better to delay commercial television from September 1st to some subsequent date.

The Commission then speaks of the "fluid state of the art" and wants more research and experimentation. The F.C.C. seems to be unduly alarmed, that overnight television might be changed completely, in such a manner that all receivers now in use would become completely obsolescent. The Commission, however, gives no inkling that any revolutionary television invention is in sight or is even being contemplated.

As far as is ascertainable, it would seem unlikely at the present time that such a thing might occur in the very near future. If television sets could now be sold at \$25 or even \$50 a set—making it possible for millions of people to invest in such sets—the nervousness and trepidation of the F.C.C. might be understandable. But the pathetic part of the muddle is that television sets today cannot be bought under \$150, which alone makes it unlikely that even 10,000 of such sets could possibly be marketed in 1940. The reason for this logic is plain. To begin with, there are only a few transmitters operating in the United States today. So widely separated are the transmitters that only a few big cities have television programs available. As this is written, there are in actual daily use less than 8 television transmitters, far too few to even begin to think of universal television.

It is no longer a secret now to state that in 1939 there were sold less than 2,000 television receivers in the United States—and this includes the whole country. It seems quite certain that the few people who bought these television sets hardly expected perfection when they themselves knew that there were television programs for only a few hours every day. Most of the owners, probably, bought their receivers more for the sake of curiosity and not with any idea to make a permanent investment.

For a long time to come television sets—because of their necessarily inherent complexity—*must* be comparatively expensive. Mass production of low-priced television receivers is not anywhere in sight at the present time, and therefore the public in general could not be hurt—the Federal Communications Commission notwithstanding.

Rather than rendering a service to the public at this time, the F.C.C. in our opinion, is consistently pursuing a destructive policy as far as television is concerned. Their latest blast has only served to create more chaos, not only within the public's mind but with the jobbing and retailing trade as well. Thus, late in March when the F.C.C. ruling was made public, the radio trade became greatly incensed at the Commission's action which directly jeopardized investments that jobbers and dealers had made in television receivers.

No sane person contends that the public should not be safeguarded. The public should and must be protected, but it seems the height of foolishness to continuously yell "wolf" when no wolf has as yet been born and when it is not likely that one will make an early appearance.

If the industry were left alone for one year, to work out its own problems and its own salvation, perhaps television would get somewhere. What we need is more television and less tinkering with it.

# • THE RADIO MONTH IN REVIEW •

*The "radio news" paper for busy radio men. An illustrated digest of the important happenings of the month in every branch of the radio field.*



**TELLY NEWS PLANE**  
In a surprise move, N.B.C. last month took aloft a United Airlines flying lab. fully equipped with television transmitting equipment, and gave ground viewers the thrill of their lives, when suddenly, they saw on the screens of their receiving tubes New York City and environs as they look from the air! It is estimated about 10,000 persons saw this historic telecast. Images sent from the airplane on 0.104-meter to the Empire State Bldg. were re-transmitted over W2XBS on about 6 meters. Radio-Craft had camera men in readiness to cover this event but the test was completed before the final notice was received. (See photo on cover.)

## TELEVISION

**R**ADIO Problem No. 1 last month was—and still is—Television. It's generally agreed that the corner has been rounded, it now remains only to determine how fast telly can travel in the straightaway . . . . The F.C.C. on March 23 suspended the earlier ruling which had set Sept. 1 as the date to inaugurate limited commercial television (see May *Radio-Craft*, pg. 648); nation-wide comments on this move resulted in an explanatory broadcast, April 2, over the Mutual and N.B.C. networks by F.C. Commissioner Fly, who pointed out that television is "uniquely different" from the automobile, motion pictures, and radio broadcasts; according to reports, an early date has been set upon which hearings are to be held by the F.C.C. to "re-explore" the television field, although what information it is expected to gain which was not obtained or available in previous, extensive

hearings, is not made clear . . . . "Television Relaying," so important in achieving television service over long distances, was the subject of an entire address by G.E.'s Dr. W. R. G. Baker; and later, of an 8-pg. illustrated booklet . . . . The famous Easter Parade up New York City's 5th Ave. was seen, by television, 250 miles away on the 4,872-ft. peak of Whiteface Mountain, New York; this longest telly transmission from N.B.C.'s transmitter in the Empire State Bldg. was made possible by a relay through General Electric's station in the Helderberg mountains near Schenectady. Later, religious services in N. Y. C. were televised in the combined observatory and meteorological station atop Whiteface . . . . We quote from an RCA/N.B.C. release: ". . . . regular N.B.C. network programs will be transmitted over the static-free television channel of station W2XBS," starting March 20. The wavelength (about 6 meters) of station W2XBS "is so far removed from the wavelengths used by nature," continues the item,

"that a severe thunderstorm is inaudible on the television channel, and a bolt of lightning causes no more than a tiny click." Programs will be selected from both networks, may include some specially designed for the new service, and will extend from 7 to 9 P. M. each evening except when regular telly programs are being aired. Maybe sponsors will get an additional and new type of coverage for the same price? . . . . That Shakespearean classic, "Julius Caesar," has been groomed for television. Thus modernized it includes fade-ins of movie sequences; costumes and characterizations, too have been streamlined, but only 3 little words (not "the" 3 little words) of the text have been changed . . . . The "Esso Television Reporter," in a pioneer telly news series, has made his appearance on the screen of the C.-R. tube. United Press pictorial items—photos, etc.—illustrative of the day's news follow each other on the screen in rapid succession as reporter Wm. Spargrove spels the news.

## SOUND

**A**N unusually practical application of sound recording was reported by *U. P.* last month. Students at the Pasadena Junior College who are training to be salesmen make recordings of their sales talks. These recordings are played-back in class, and weaknesses in the selling technique are then easily detected and analyzed . . . . A combination electronic cathedral chimes and public address system was the gift of Count and Mrs. Fredric Thorne-Rider to the University of California. The gift represents a complete system including a set of chimes, a keyboard, power amplifier, automatic clock for striking on the hour, and 4 loudspeakers. The system is so arranged that music from Royce Hall auditorium or the words of a speaker in the Hall may be heard in a radius of several miles from the campus.

## BROADCASTING

**A**PICTURE of death and destruction at sea, as heard over the radio waves, is suggested by the music of "SOS," a rendition of the American composer, Robert Braine, which the Westinghouse Radio Orchestra,



STEREOPHONIC—"ENHANCED" SOUND-ON-FILM

As we go to press, Bell Telephone Laboratories is scheduled to demonstrate stereophonics (3-dimension sound) in talking motion pictures, using the equipment shown here. Triple soundtracks on the film are reproduced over 3 speakers. An additional film-track produces "enhancement"—automatic volume control; the degree of sound-expansion—up to more than 10 times normal!—Dr. Leopold Stokowski is shown, above (at Mr. Snow's left), introducing in recordings is reproduced in a photocell upon playback in reproducer shown in photo at right. (See "How Controlled Sound Aids a Student," *Radio-Craft*, May '36.)

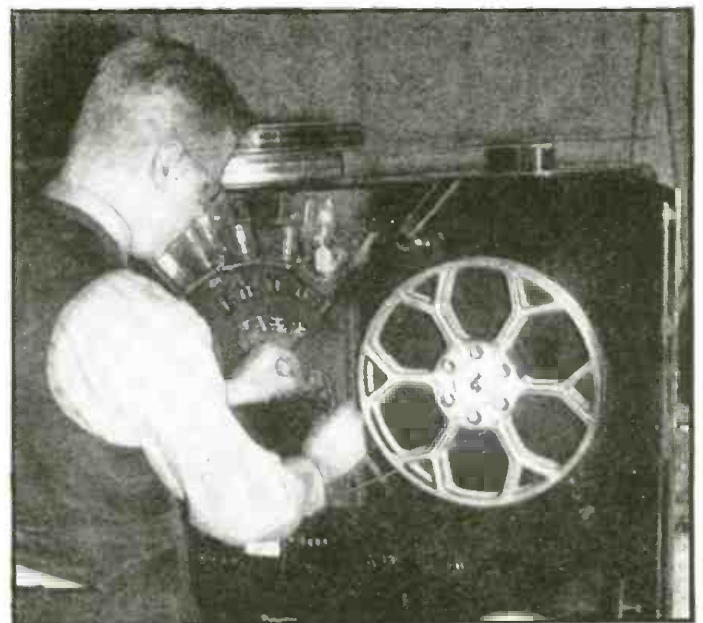

# • THE RADIO MONTH IN REVIEW •

"100 Men of Melody," last month aired over a 98-station N.B.C. network. The sinking of a Greek steamer off the coast of Georgia, in 1927, inspired Braine who was in the control room of a New York radio station when the order "QRT-SOS" (stop transmitting—distress signal) closed down all transmitters except those handling the contacts with the stricken steamer . . . . A justly-deserved reward, in the form of a handsome plaque, was presented to 50,000-watt WOR via chief engineer J. R. Poppele, by F. R. Lack, representing the Western Electric Co., for being on the air in 1939 for 8,221 hours—the full assigned time on the air—without a single interruption due to equipment failure . . . . The House of Representatives wrote into the 1941 Interior Dept. appropriation bill a ban on the use of funds for radio dramatizations designed to influence legislation. Rep. Edw. Gossett (D.), of Texas, had denounced as "propaganda," certain of the programs. (The studio set-up has been described in *Radio-Craft*.) . . . . Sequel to the story this department ran some time ago, about the hitchhiker who waited for a radio-equipped car, was the one which *U.P.* released last month. When John Friday stopped his car for a hitchhiker, he was asked what was the apparatus on his instrument board. Informed that it was a radio set, the tourist said, "Oh, go ahead, I'll wait for somebody else." . . . . Jack Johnstone, director-author of the new WOR-Mutual series "Who Knows?", stresses sound effects in all his scripts . . . . Here's one for Ripley. Mr. Martin Brunnhuber, of Port Richmond, Staten Island (N. Y.), heard WOR's first broadcast in 1922. Mr. Brunnhuber has never had but one set, and is still using it. "I never shut off the radio," he wrote in a letter to WOR, "it goes on and on, just as long as you broadcast, no battery, no power, no expense." It's a crystal set . . . . Patent No. 2,193,102, granted to Winfield R. Koch, Haddonfield, N. J., and assigned to R.C.A., describes a "radio dictaphone." Sounds (remarks, confessions, etc.) picked-up by a microphone, which may be concealed in a person's clothing, are radiated by a tiny transmitter which is similarly concealed. The signal may be picked up by a radio receiver in an adjacent room, etc., the same as with any of the "wireless microphones" described in past issues of *Radio-Craft* . . . . First news of the arrival of Britain's *Queen Elizabeth*, completing a dangerous trans-Atlantic dash to America, was transmitted over WOR, after receipt of the information from WOR newsmen aboard a radio-equipped Eastern Air Lines transport who had spotted the ship . . . . Most teachers feel they're doing right well if they handle a class of 50 pupils, but 2 teachers of English at Schenectady, N. Y.,

have more than 20,000 pupils in their classes. Their students are Spanish-speaking people in Central and South America who are learning the English language by radio, over General Electric's international station WGEO, according to a recent check of correspondence to this station . . . . Will Mexico sign the Havana agreement regarding the reallocation of wavelengths, etc.? President Cardenas has told Ambassador Josephus Daniels "yes," but the 4-nation (Cuba, Canada, U. S., Mexico) radio treaty is not yet filed in Havana . . . . A sound-trailer, advertising the radio program "Information Please," is scheduled to be shown on the screen of the Warner-Stanley Theatre the week prior to the showing of the "Information Please" movie reel, in return for spot announcements on the KDKA air show "Movie Magazine" . . . . When more than 50 iceboats and ice scooters shot along the ice at 40 to 60 miles per hour, in the Bay Shore (Long Island, N. Y.) Tuna Club's International Iceboat Regatta, shooting right along with them was a radio-transmitter-equipped ice scooter. Reports of progress were picked-up OK from the transmitter—a 7-lb. "mike-mitter"—by a receiver a mile away and sent from there to WOR which rebroadcast the pick-up . . . . Employees of United Broadcasting Co. stations in Cleveland have special license numbers for their automobiles again this year . . . . Workmen digging for WMCA's new transmitter site at Kearney, N. J., unearthed tree stumps in the salt marsh which may have high archeological value; the find threatens to upset existing ideas of the origin of New Jersey.



MEDIEVAL SOUND (Cover Feature)

Patrons of the "Ivanhoe," one of Chicago's most outstanding night club restaurants, now have something new to talk about. It's the Sound Recording Studio, shown here and on the cover of this issue of *Radio-Craft*. Messages recorded here or on an RCA Victor portable recorder mounted on a tea-wagon produce local hilarity when played-back over the "Ivanhoe's" public address system. Afterwards, the discs may be mailed to relatives or friends. (See following page for further details of this modern set-up in a Middle Ages atmosphere.)

## RADIO ABROAD

WORLD WAR I gave us, among other important contributions to radio, the Superheterodyne; so far, World War II seems to have given us a new system of radio broadcasting which makes it impossible for aircraft to use these transmissions as points for taking radio bearings. According to an item in the *N. Y. Times*, last month, a secret British radio invention accomplishes the above-mentioned result . . . . Plenary indulgence bestowed by Pope Pius XII to the faithful gathered last Easter in St. Peter's Square, was extended to all who heard the blessing over the Vatican's radio station . . . . Said to be a "new secret weapon" of the British Navy, facsimile is fast finding acceptance by John Bull as a lightweight substitute for television on ships, planes, etc.; a 25-lb. fancy job takes the place of telly equipment weighing "tons," according to an item to the *N. Y. Times* . . . . A Hollander was sentenced in Rotterdam to 6 years in prison for



P.A. HORN STYLING

Illustrated in one of the "spots" on the cover of this issue of *Radio-Craft* is the new loudspeaker design shown here. A weatherproof speaker having wide frequency range and good coverage, in more compact design, is achieved by reflecting the output of a short trumpet equipped with a P.M. dynamic horn-unit, it was announced last month by Atlas Sound Corp. Its name: "Morning Glory" Projector.

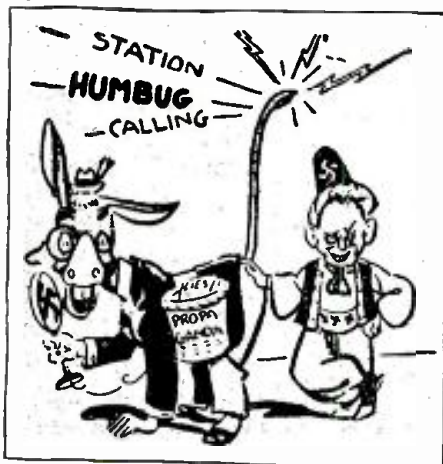

### FM/AM RELAY

Last month "staticless radio" demonstrated its superiority when 4 frequency modulation stations tied-up with 4 amplitude modulation stations. The all-FM network, which reached from New York City nearly to Canada, linked AM stations without recourse to wire lines!

### "LORD HAW-HAW"

Thorn in the side of official England is that mysterious propagandist with the witty delivery, "Lord Haw-Haw" who broadcasts nightly at 9:15 from Germany. The *London Daily Express* last month cartooned him as shown above. Who is he?

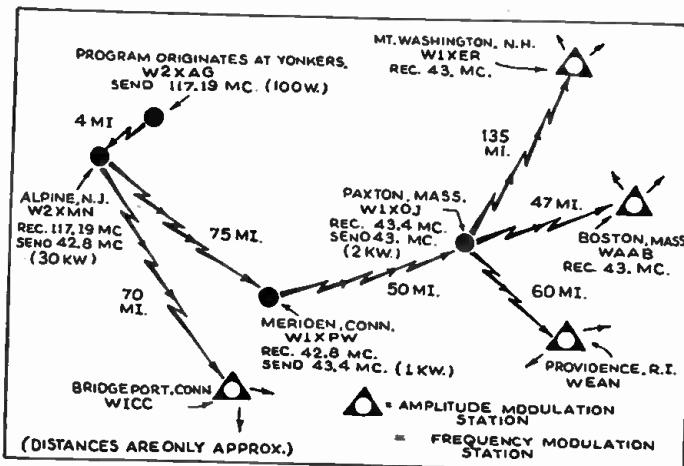

## • THE RADIO MONTH IN REVIEW •

broadcasting Netherlands weather conditions to Germany . . . An extensive "radio spy squad" is said to be operating in England to locate German agents sending from "secret" transmitters; ordinarily, however, reports *U. P.*, much information regarding German plans is obtained from the easily-decoded messages sent by these stations . . . Pending the consideration of a drastic tax bill by its Parliament, Denmark has forbidden factories to sell many items, including radio tubes. In London, the Board of Trade has announced a ban on the importation of many items, including radio sets. . . . Calling itself the "New Broadcasting Co.," an unlicensed broadcast station, said to be somewhere on the Continent, is waging a "Stop the War" campaign by programs directed to the British; the announcer speaks in excellent English . . . The death penalty for 2 French citizens will be meted out, if they are caught, a military tribunal sitting in Paris has decided. These men are "radio traitors," now broadcasting regularly to France over German stations.

### SHORT WAVES

"**A**LL is not gold that glitters," 'tis said, nor is it always plain sailing with police radio transmitters. For example, *United Press* last month reported that the shortwave radio transmitter of the Fort Worth Police Department sometimes gets into other peoples' backyards. Greatest-distance city so far to report the messages is Victoria, Australia . . . Proponents of the Armstrong system of wide-band frequency modulation were surprised and pleased to hear the Radio Corp. of America tell the F.C.C. that frequency modulation could and should be given commercial channels in the ultra-shortwave region. R.C.A. is said to have valuable patents on frequency modulation independent of Armstrong . . . A weekly series of broadcasts over station WGAN, Portland, Ore., is building goodwill for the station and for ham radio. The programs are based on the book well-known in ham radio circles, "200 Meters and Down," and dramatize the actual exploits of radio amateurs . . . Television, and European shortwave schedules, are included in the daily radio program listing in *The New York Sun*.

### MEDIEVAL SOUND

**A** UNIQUE union of 20th Century scientific progress and the romance of the Middle Ages has been accomplished in Chicago, where an RCA sound recording and amplifying system has been installed in a perfect counterpart of a medieval stone castle—the "Ivanhoe," one of the city's outstanding night club restaurants.

The Ivanhoe is an outgrowth of a boyhood hobby of Ralph Jansen, its owner and manager, who revelled in the adventures of Scott's heroes. The hobby-business started in a single store front, soon swallowed up the better part of a city block with its numerous dining rooms, 6 bars, underground "Catacombs," and garden. Mr. Jansen has also on display his priceless collection of ancient weapons and armor, some dating back to the 5th Century.

Highlight of the sound installation is a modern Recording Studio, where patrons may record their songs or messages to friends at a charge of one dollar a record. (See photo on cover and on pg. 713.) Installing the RCA Portable Instantaneous Recorder as a venture, Mr. Jansen soon found he had an increasingly profitable side line, and a valuable advertising medium as

well. Records cut in the studio have been sent to every state, and to the principal countries of the world—each disc an advertisement for the restaurant as well as a message.

A new wrinkle being introduced during the dinner and supper hours is a variation of the "Man on the Street" radio idea, utilizing the recording equipment. A glib-tongued announcer wheels the instrument through the dining rooms asking patrons their views on senseless questions and recording the answers. The records are then played back over the public address system, providing a hilarious interlude in the program.

Special phonograph records are used to provide weird sound effects for the "Catacombs," entrance to which is gained by way of an elevator which gives the illusion of dropping hundreds of feet into the earth. Other records are used to make "skeletons" talk.

Adding to the medieval atmosphere of the place are strategically-placed suits of armor, like knights on guard. Behind each mailed figure is a concealed loudspeaker reproducing music or entertainment from the public address system or, on occasion, such bizarre announcements as "Mister Smith is wanted on the phone."

Throughout the many halls, nooks, dining rooms and bars which make up the Ivanhoe, are loudspeakers to provide music from the orchestra. Records are substituted when the band is off duty.

The dual-channel sound system consists of two 24-watt amplifiers, velocity microphones, switching apparatus and a radio chassis, all mounted in a special control cabinet. In addition, there is a portable public address system which can be used anywhere in the building. B. J. Sullivan, RCA Sound Engineer, sold the equipment and supervised the installation.

Radio broadcasts and sports events are "piped" through the restaurant on occasion. Additional speakers are installed in the garden where a crystal pool is stocked with trout to be caught on tackle furnished by the house—and rushed to the kitchen for cooking.

### TELEVISION HEARING REOPENED!!

**T**ELEVISION promotional activities on the part of the Radio Corporation of America has prompted the Federal Communications Commission to order a further hearing, beginning April 8, to determine whether research and experimentation and the achievement of higher standards of television transmission are being unduly retarded by this company, its subsidiaries, or other licensees, and whether the effective date for the beginning of limited commercial operation should be changed from September 1 to some subsequent date. *Meanwhile, that section of the new rules permitting restricted commercialization is suspended pending further order.* (Italics ours.—Editor)

The current marketing campaign of the Radio Corporation of America is held to be at variance with the intent of the Commission's television report of February 29. Such action is construed as a disregard of the Commission's findings and recommendations for further improvement in the technique and quality of television transmission before sets are widely sold to the public.

The question of the present status of television transmission and the feasibility of its general reception by the public was the subject of the recent extensive hearings

before this Commission. Because of the fluid state of the art and the continuance of research and experimentation, the Commission declined for the time being to establish television transmission standards. Authority to issue such standards is of course vested only in the Commission. Recommendations to insure that the standards when issued would be based upon a sufficiently advanced technical state of the art were incorporated in the report of February 29.

"Actual demonstration to members of the Commission," the report pointed out, "indicates the need for further improvement in the technical quality of television." The Commission stressed the need of continued research in various significant phases of the field involving the number of lines and the number of frames per second, the retentive quality of screens, the mechanics of scanning, the problem of various screen sizes with particular reference to larger screens, the problem of polarization and the related question of the type of antennas, and various alternative methods of synchronization. Inherently this research and experimentation has potentialities of great value to the public.

The intent of the Commission was to give the industry further opportunity to move forward in an orderly manner and upon a sound scientific basis without causing injury to the public and resultant injury to the new industry itself, particularly to other manufacturers cooperating in seeking to bring about video improvements through experimentation rather than crowding the market with present-day receivers which may soon become obsolete. Economic loss to the public, the report warned, would be occasioned by "premature purchase in a rapidly advancing field."

Not all types of television transmission can be received by any receiver. In the present state of the art it is impossible to decide what type of transmitter will be made standard. More research and experimentation will be necessary, and is being conducted, before any such standardization can be achieved. Receiving sets constructed or on the market today may not be capable of receiving television programs from standardized television transmitters when the art has sufficiently advanced to permit such standardization. Public participation in television experimentation at this time is desirable only if the public understands that it is experimenting in reception and not necessarily investing in receiving equipment with a guarantee of its continued usefulness. Television is here to stay, but conceivably present day receivers may for practical purposes be gone tomorrow.

Promotional activities directed to the sale of receivers not only intensifies the danger of these instruments being left on the hands of the public, but may react in the crystallizing of transmission standards at present levels. Moreover, the possibility of one manufacturer gaining an unfair advantage over competitors may cause them to abandon the further research and experimentation which is in the public interest and may result in crowding them into the market with apparatus at present-efficiency levels. Rapid advance is desirable—but television is of great and permanent significance to the public. It is therefore of greater importance that the task be done thoroughly and with an eye to television's potential usefulness to the public. These are the goals which the Commission deems the public interest to require.

Above is the exact text of the F.C.C. order which rescinded the earlier authorization of limited commercial television, Sept. 1, as published in May *Radio-Craft*, pg. 648.

# MARINE-IZING RADIO SETS

*Tens of thousands of portable and semi-portable sets because of their increasing popularity will undoubtedly find their way aboard small pleasure craft and in ocean-side cottages this Spring and Summer. High-corrosive humidity will play havoc with them, resulting in frequent servicing—unless the sets are given a thorough going-over, or "marine-ized," by Servicemen along the lines outlined in this article.*

CHARLES R. LEUTZ

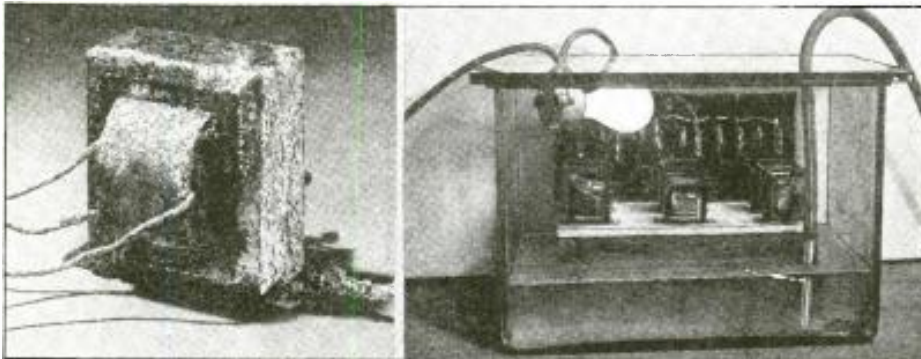

The transformer shown at the left was exposed to a saline humidity of 85% at 120° F. for 3 months. It is a good example of corrosion forming on marine-radio receiver components. At the right is shown the setup used by Thordarson to test their weatherproof "Tropex" transformers under conditions of high humidity and temperature. Show these illustrations and the accompanying article to set-owners who complain that their portable set, which operated so nicely in the city, refuses to work properly for very long at shore locations.

**M**ARINE radio equipment, operated under conditions of severe humidity, is subject to service difficulties not ordinarily encountered at inland locations. Salt air moisture and high humidity can rapidly deteriorate any ordinary radio receiver. The extensive use of brass, bronze and other non-corrosive metals aboard ship for mechanical devices is well known. Electrical and radio equipment for marine service also requires special design considerations.

## SETS SUBJECT TO BREAKDOWN

Now that low-cost portable and semi-portable receivers and record players have become so popular, it is anticipated a good number of these units will be used aboard small pleasure craft and in ocean-side cottages. Few low-cost receivers, however, are designed to withstand marine service conditions and a large volume of service business can be expected from these quarters.

The same problem exists in regard to automobile radio receivers used in the vicinity of salt air moisture and especially where the car may be left outdoors for long periods. The engine heat is instrumental in excluding moisture from automobile receivers when the car is used a good deal and kept in a closed garage over night.

*When receivers operated under the above conditions are brought in for service there is an ideal opportunity for the Serviceman to explain the situation and instead of simply making repairs, arrange to have the set altered to prevent further breakdowns, or at least less frequent interruptions.*

The special considerations involved in making the alterations necessary for doing a thorough job are discussed below, under the most important headings.

## AERIAL SYSTEM

Existing aerials may have corroded unsoldered joints which are a source of noisy

operation and should be checked thoroughly. Ordinary glass, composition or unglazed porcelain aerial insulators are unsatisfactory for marine service. Rather than patch or repair old aerials, an effort should be made to sell the customer a new aerial system.

For aerial, stand-off and lead-in insulation a low-loss material having a low moisture absorption factor should be used; one of the Polystyrene-base insulating materials such as Amphenol 912-B, available in rods, is suggested. For the elevated aerial wires, 7-strand No. 22 phosphor-bronze wire is entirely satisfactory. For a receiver the lead-in can consist of rubber-covered solid or flexible copper wire. The joints in the aerial or between the elevated wire and lead-in should be carefully soldered (using resin-core solder) taped and varnished. Where the aerial is also used for a transmitter, a low-loss coaxial cable lead-in is suggested, complete with moisture-proof fittings.

Receivers with self-contained loops, when operated on boats and within a metal cabin, may prove entirely unsatisfactory, due to signal shielding. In such cases provision should be made to couple an outdoor aerial to the loop; or still better, couple the aerial to an antenna transformer, the latter being connected to replace the loop. Another solution calls for the use of a deck-type outdoor loop such as that used for direction finders. The loop's direction control is located inside the cabin and the connection between the loop and receiver may be a transposed cable for the broadcast band or a coaxial cable if the installation is for allwave reception.

## EXCLUDING MOISTURE

In commercial practice, lifeboat radio apparatus is designed and constructed to be housed in a water- and moisture-proof cabinet. The lids are fitted with rubber

gaskets. In addition, when the apparatus is not in use, an electric lamp bulb or heater unit is left connected within the apparatus cabinet to exclude moisture.

The same system can be applied to broadcast receivers when operated under conditions of extreme humidity or salt air moisture. All that is necessary is to arrange a relay to automatically connect the lamp bulb or heater unit when the receiver is turned off. In place of the moisture-proof cabinet, the broadcast receiver can be fitted with an oilcloth or rubber hood or jacket cemented to the necessary shape and size. This jacket can be placed over the receiver when it is not in use and facilitates the action of the lamp or heater unit.

The size lamp or number of lamps required depends wholly on the size of the receiver cabinet. For a small set a 10-watt lamp is satisfactory. For a large console cabinet it may be necessary to use 2 or 3 40-watt lamps depending upon how severe the humidity conditions may develop. As the heating units require considerable power the idea is not suitable to small sets operated from batteries or from a power plant of limited capacity.

## R.F. COILS

The radio-frequency transformers and coils in some low-cost sets are untreated, the finished unit relying on the cotton- or silk-covered enameled wire for protection. Such coils upon collecting moisture are subject to severe losses. At the coil terminal lugs, the wire insulation has been removed to allow soldering, exposing a bare wire of small diameter. Under conditions of salt air moisture, the bare wire will corrode and gradually disintegrate, causing an open-circuit.

The coils can be treated for marine service by covering the windings, terminal leads and connections with a thin coat of low-loss moisture-proof insulating coil dope. Preference is given dopes having a Polystyrene base (such as Amphenol 912, which has a very low moisture absorption factor, and an exceptionally low R.F.-loss factor). The coils must be thoroughly dry before being given the treatment, and if necessary, they can be removed and then baked for about an hour at 110° F. to exclude all moisture. The above-mentioned dope is clear and transparent, and upon air drying, forms a hard, permanent surface. Ordinary insulating varnishes are not suitable for treating R.F. coils. This may seem like a lot of work but pleasure craft owners are prepared to pay for the type of service they require.

R.F. leads consisting of an insulated wire run in copper braid collect moisture, causing mis-alignment and added losses. Where possible the R.F. leads may be replaced by a bare rigid wire; otherwise it is suggested that the leads be insulated with low-loss moisture-proof Polystyrene beads.

# SERVICING

## CONDENSERS

**Variable Condensers.**— Variable condensers must make good connection between the shaft and frame. Rotating shaft contacts should be kept clean and supplemented with a pigtail flexible connector if it is not already supplied. The pigtail should be soldered to the rotor shaft, the condenser frame and the chassis, installing a separate pigtail at each rotor element of the condenser; that is, a 3-section condenser should have 3 pigtails.

Trimmers and padders associated with the variable condenser unit if of the open type should be examined and cleaned if necessary, prior to aligning the receiver. After alignment, the trimmers and padders can be given a coat of low-loss coil dope, thus rendering the adjustment permanent, mechanically and electrically, as well as moisture-proof.

**Fixed Condensers.**—Molded mica condensers are entirely satisfactory for marine service and should be used where possible at a reasonable cost, for example for capacity values up to about .01-mf.

High-grade electrolytic condensers may be used but preference should be given to types mounted within waxed cartons rather than metal containers. The applications should be confined to cathode-bias bypass and power filter units. Other small condensers required should be a high-grade paper type mounted in a moisture-proof waxed cylinder or box.

## RESISTORS

**Controls.**— Wire-wound volume and tone controls while ideal for ordinary service, should be eliminated if possible for marine service due to the tendency to corrode at the windings or sliding contact, causing imperfect connections and noisy operation. When replacing controls preference should be given to units having non-rusting aluminum shafts.

**Fixed Resistors.**— Alloy resistance wire is very susceptible to the action of salt air moisture. This is particularly true in regard to alloy wires of small diameter and at points where the wire is joined to copper terminals. Resistors wound with bare resistance wire or where a portion of the winding is left exposed for adjustments of resistance values should never be used for marine service. As a matter of fact the best high-grade, ceramic-coated resistors are subject to failure after extended service under these unusual conditions. Where a heavy-duty wire-wound resistor is required, the highest grade vitreous-enameled units must always be used and a spare kept available.

Carbon fixed resistors should be avoided as corrosion often develops between the copper wire pigtails and the carbon element. Molded metallized resistors are entirely satisfactory for marine equipment. Carbon controls are suggested in place of wire-wound units where slight load is involved.

In the case of A.C.-D.C. receivers or other units using a line cord resistor, corrosion may be expected in the resistance wire or where the alloy wire is connected to the plug or set terminals. Failure may be avoided by replacing the cord resistor with a modern tube type resistor of the socket plug-in style.

## A.F. TRANSFORMERS

Audio-frequency transformers mounted in a metal case which has been filled with a sealing compound may be expected to be moisture proof. However, unmounted transformers, including speaker output transformers may prove to be a source of trouble. The coil windings are invariably impregnated with wax but very often bare copper is left exposed where the leads connect to terminals. Another point of failure, where moisture is not excluded, is within the coil at the point where the fine wire windings are connected to the flexible terminal leads.

Unmounted A.F. transformers should be given a complete coat of moisture-proof dope, covering all the surface including the terminal wires and terminals. Defective unmounted transformers should be replaced with a mounted and sealed type if possible.

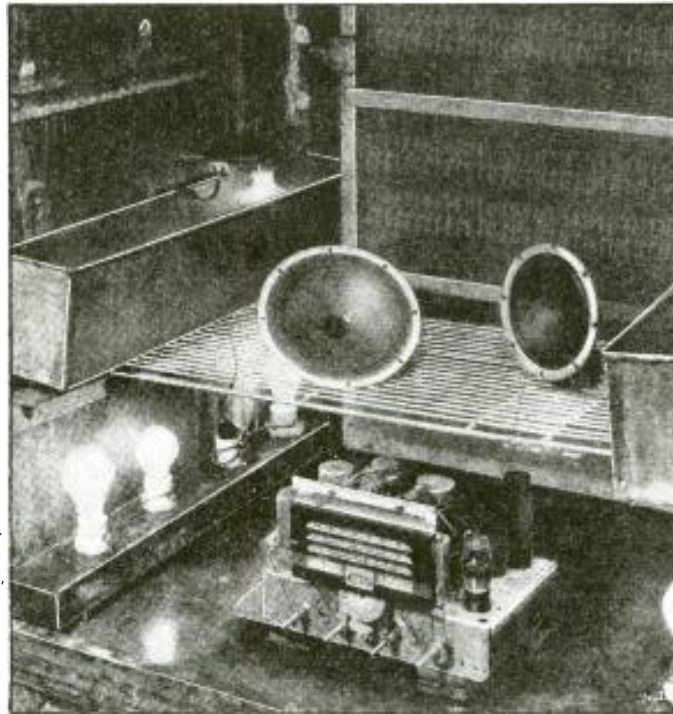

General Electric's radio receivers designed for southern climates, where conditions of high temperature and humidity constantly prevail, are tested in this "torture room." The apparatus is proven in a room which duplicates weather conditions more adverse than any it will probably encounter during its entire life. Heavy humidity at high temperature is maintained for periods which alternate with cooling periods that precipitate the moisture into all parts of the equipment undergoing test. Actual operating conditions for receivers used aboard ships and at seaside cottages are reproduced inasmuch as the humidity is of a corrosive nature. "It's an ill wind ('salt air') that brings no good . . ."—to Servicemen!

## TUBE AND SOCKET CONTACTS

Under conditions where considerable moisture is collected, tube sockets may fail, usually breaking-down between the plate contact and adjacent terminals. Such break-downs are common in wafer-type sockets. Where some of the receiver circuits may be operated at high voltage, for example 6L6G power tubes at 400 volts, socket insulation and exclusion of moisture become very important.

In such cases the protective hood and heater unit previously described is essential. Corrosion often develops between tube and socket contacts, thus causing noisy operation. The contacts can be cleaned periodically with very fine crocus paper and given a very thin coat of white vaseline. Tube grid contacts should be treated in the same manner. Where sockets continually give trouble due to moisture, or if permanent operation is desired, the exist-

ing sockets can be replaced by molded units of Polystyrene base. The latter-type sockets have high electrical insulation, low R.F. loss and practically no moisture absorption.

## DRY BATTERIES

The construction of dry batteries has been improved upon substantially in recent years and most types are suitable for marine service. However, where several batteries are packed closely together moisture may cause trouble.

For example in a portable set where the different batteries cannot be separated by an air space, the batteries should be given a thin coat of paraffine or bees wax, preferably the latter, and extended service can then be expected. Otherwise a piece of insulating material should be placed between batteries and the material must have low moisture absorption qualities.

## MOTOR-GENERATORS

On the medium-size and larger yachts the ship's power supply is invariably 110 volt direct current. The receivers used on such boats are usually for 110 volt A.C. operation and some means, either a dynamotor, rotary converter or motor-generator, is provided to change the ship's supply to A.C. These electromechanical machines require attention to keep the collector rings, commutators and brushes in good, smooth operating condition, otherwise sparking and noisy operation will result. The rings and commutators can be kept smooth with very fine crocus paper and treated lightly with commutator compound. The mechanical bearings must be kept properly lubricated at all times.

The 6, 12 and 32 volt D.C. ship's power plants can also be used to operate dynamotors; or the 6-volt supplies are useful to feed power supplies of the vibrator type. As a matter of fact, for small boat installations, standard automobile receivers lend themselves to convenient and efficient installation.

## VIBRATION

Many small and even some of the large pleasure craft are subject to considerable mechanical vibration especially when starting, stopping or running in reverse. Under the above conditions any radio receiver contain-

ing microphonic tubes cannot give satisfactory service. Furthermore the vibration sets up a state of continuous mechanical stress in various parts of the receiver assembly. Small parts, unless securely anchored, will also vibrate and eventually the connecting leads will break. Mechanical joints unless securely fastened with lock washers will loosen.

Excessive vibration can be greatly reduced by mounting the receiver on sponge rubber pads. In instances where the vibration is unusually severe, and communications traffic is to be handled, the solution of the problem consists in mounting the receiver by a spring suspension.

## MISCELLANEOUS

**Soldering.**—In repairing marine radio equipment, acid-core solder or acid soldering flux must always be avoided, as its use will

(Continued on page 719)

# SAVE ON CONTROLS...



- ★ They always fit... and they'll handle almost all replacement jobs.
- ★ Plug-in shafts... easier to install... fewer "Specials" required.
- ★ One stock does the work of two... Use midgets to replace both midgets and the larger, standard-size controls.
- ★ Small in size... Designed for real dependability.



by Using **MIDGETS**

*Universally!*

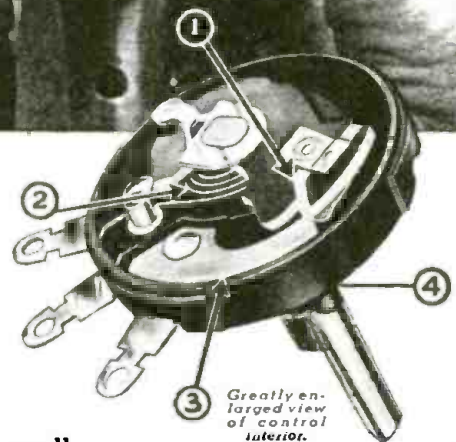

Greatly enlarged view of control interior.

Although IRC Controls are made in every type for every radio need, there is a fast-growing trend on the part of servicemen and jobbers to concentrate on IRC Midget Controls for every replacement need. And it is a logical move! It means stock simplification in that a small supply of IRC Midgets equips you for the big majority of jobs. It means using replacement controls

you are sure will fit—even in the smallest of modern sets. It means easier installations, thanks to the exclusive IRC plug-in shaft features. Above all, it means real dependability, for IRC Midgets have every engineering feature of the larger size "standard type" IRC Controls.

Certainly, it is a trend well worth your while to investigate. A study of their possibilities will quickly convince you that IRC Midgets offer the biggest savings in time, space and stock simplification, plus the utmost in true dependability.

## The Only Midgets With EVERY STANDARD-SIZE CONTROL FEATURE

When you buy an IRC Midget you get an exact miniature of the famous IRC standard "CS" Control. Nothing has been left-out. Not a single important design feature has been changed. Exclusive features include (1) IRC 5-Finger "Knee-Action" Silent Element Contactor; (2) IRC Spiral Spring Connector; (3) IRC Metallized-type Resistance Element; and, (4) Thrust Washer used to avoid end play in shaft.

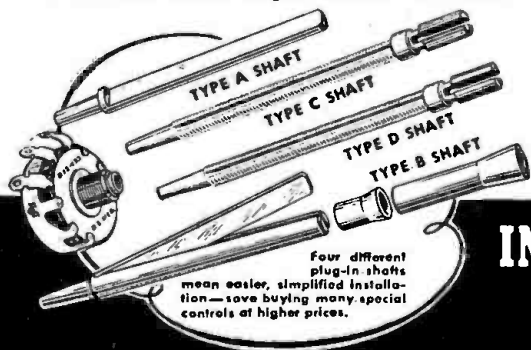

Four different plug-in shafts mean easier, simplified installation—save buying many special controls at higher prices.

## INTERNATIONAL RESISTANCE COMPANY

401 N. Broad St., Phila., Pa.

In Canada: 187 Duchess St., Toronto, Ont.

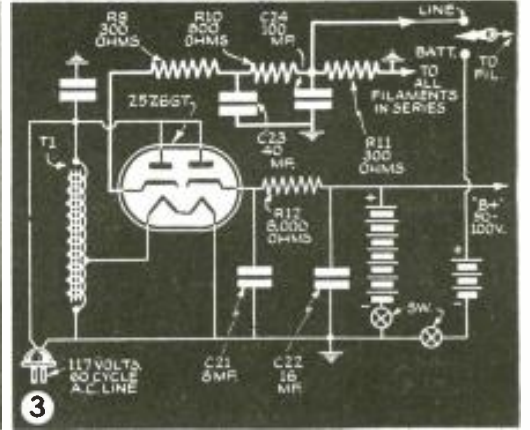
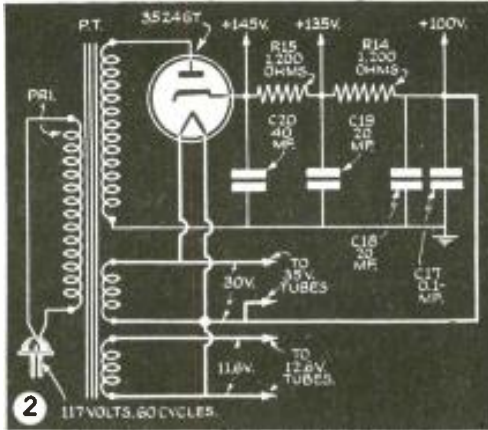
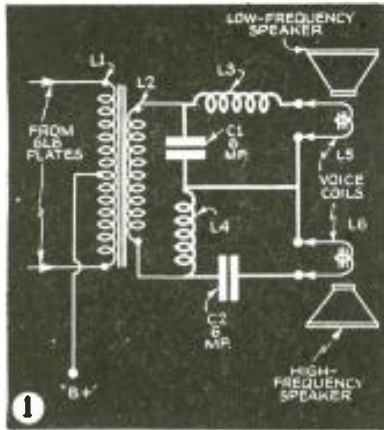

# NEW CIRCUITS IN MODERN RADIO RECEIVERS



*In this series, a well-known technician analyzes each new improvement in radio receiver circuits. A veritable compendium of modern radio engineering developments.*

F. L. SPRAYBERRY

No. 33

**(FIG. 1) SELECTIVE SPEAKER COUPLING**  
STROMBERG-CARLSON MODEL 480.—The Bass and Treble speakers are not only designed to favor their own frequency ranges but the coupling circuits to them are designed to select their respective tone ranges progressively.

The output winding L2 of the output transformer as shown in Fig. 1 is designed to match the entire sound output system (speaker, network, and coupling system). Primarily the series circuit C1-L4 may be regarded as a frequency-selective voltage divider. As the frequency decreases the greater drop will be across C1, while as the frequency increases, the greater voltage drop will be across L4.

Moreover the combination C1-L3 comprises a low-pass L filter while combination L4-C2 comprises a high-pass L filter. Thus, with decreasing frequency the output power from the transformer is progressively shifted to the low-frequency speaker voice coil L5 and for high frequencies it is shifted to the high-frequency voice coil L6.

**(FIG. 2) ALL HEATERS MAINTAINED AT HIGH AVERAGE D.C. VOLTAGE**

AIRLINE MODEL 93BR-719A.—A common connection of both heater windings on the power transformer is connected to the +100 volt filter output instead of to ground so as

to maintain the average heater voltage at this value. Connections of the power supply and heaters are shown in Fig. 2.

Since this is a higher voltage than that for most of the plates and screen-grids there can be no heater-to-plate leakage current. Insofar as this leakage would cause hum in tubes of high dynamic plate resistance in audio circuits such hum would be eliminated as well as tube noises arising from this source. This wiring has advantages over the usual A.C. - D.C. set wiring as in the latter the heater average voltage varies from relatively large positive to negative values in those heaters connected nearest the rectifier element line connection.

In Fig. 2 for example the total voltage from any part of the rectifier heater to its cathode cannot exceed 75 volts while in an ordinary series heater circuit it may reach 300 volts. Such conditions are too favorable for ionization.

**(FIG. 3) HIGH-VOLTAGE RECTIFIER SEPARATES PLATE AND FILAMENT SUPPLY FUNCTIONS IN A.C. - BATTERY SET**

MAJESTIC MODELS 1BR50 AND 1BR50-P.—One rectifier element provides for the plate and screen-grid supply potentials in the usual half-wave rectifier circuit, while the other rectifier element supplies all the filaments within the actual receiver in series.

This connection as in Fig. 3, greatly simplifies the line-to-battery changeover. The filament supply is adequately filtered with low-value resistors R9 and R10 and condensers C23 and C24, and the filament voltage is stabilized with resistor R11.

An autotransformer is used at the line input for supplying the 25Z6GT filament circuit.

**(FIG. 4) TONE CONTROL ON PHONOGRAPH CIRCUIT ONLY**

FADA MODELS P-50, PL-50 AND PUL-50.—Since the major purpose of the tone control on this set is to reduce record surface noises it is wired in the phonograph pickup circuit only so that it is not in use during regular radio reception.

The connections including the phonograph motor are shown in Fig. 4. The lower end of the detector tuning coil of this small T.R.F. receiver is fed through a shield to the phonograph volume control tap or slider. The tone control is connected directly across the volume control as shown and is of the "low C - high R" type as required across high-resistance circuits. For radio operation, a single-pole double-throw switch simply shorts the phonograph volume control connection to ground and opens the phonograph motor circuit.

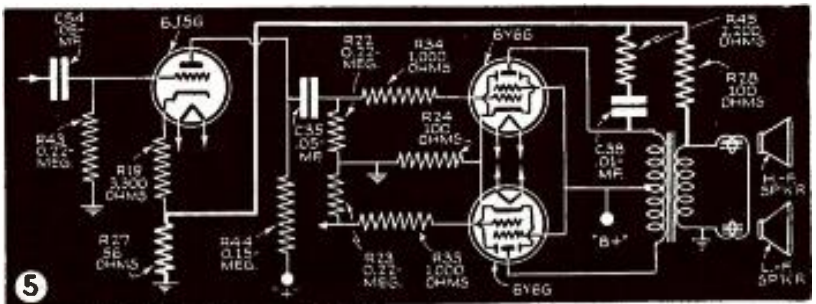
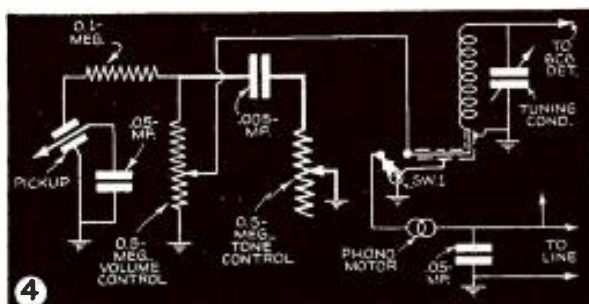



# •SERVICING•

(FIG. 5) FREQUENCY-SELECTIVE DEGENERATIVE CIRCUIT

GENERAL ELECTRIC MODEL HJ-1205.—The feedback factor in this degenerative circuit is made to vary with frequency in such a way as to produce maximum degeneration at low frequencies and progressing toward no degeneration at high frequencies. This extends the audio range in the low frequencies and permits higher output at high frequencies.

This comes about through the circuit as shown in Fig. 5. The feedback voltage introduced into the cathode of the 6J5G tube is obtained from the junction of 2 sources: the voice coil winding, and one of the output plates. A resistance-capacity network—R27, R28, R45 and C38—is arranged so that at low frequencies the degeneration is maximum, obtained principally from the voice coil. At low frequencies the reactance of C38 is so high that it and R45 have little effect on the circuit operation.

At higher frequencies however, when the reactance of C38 is lower, the voltage available at the top of R27 from the plate of the upper 6Y6G is of increasing importance. It is however, in nearly opposite phase with respect to the feedback voltage from the voice coil and partially cancels the degeneration voltage, thus reducing the feedback factor. This factor approaches zero at the highest audio frequencies.

## MARINE-IZING RADIO SETS

(Continued from page 716)

accelerate disintegration of joints. Resin-core solder must be used exclusively and will prove entirely satisfactory.

**Gang Switches.**—Most gang switch designs employ a self-cleaning, wiping contact system. Therefore, without lubrication, the switches are kept clean by frequent use. Where the receiver is used principally for the broadcast band, the band switch should be moved over the remaining positions at least once a day to keep all contacts in good condition. The above principles also apply to ganged power switches.

**Speaker Voice Coils.**—Voice coils should be examined carefully; and, especially, at the point where the flexible leads connect to the coil winding and to the terminals. Exposed copper should be covered with coil dope.

**Audio Volume.**—Operating a receiver loudspeaker within a cabin, the requirements for audio power output are practically the same as in the case of a residential installation. However if an extra loudspeaker is required for operation on deck, out in the open, the necessary power for satisfactory operation increases tremendously, as the sound waves, being unconfined, dissipate rapidly.

An analogy can be given by considering an automobile being driven out on an open road and the same automobile being driven through a tunnel. In the open the available reflecting surfaces are at a minimum and accordingly the noise is at a minimum. Passing through the tunnel, the reflecting surfaces are at a maximum and the "apparent noise" from the automobile reaches many times that noticed in the open. Accordingly, and before anticipating or guaranteeing specific audio volume aboard medium or large yachts, make actual tests to determine the A.F. power output needed.

The attention of Servicemen is called to the following references to articles, in past issues of *Radio-Craft*, which may be useful in discussing with customers marine radio receiver (and transmitter) installation and service.

"Marine Radio Telephone Installation and Servicing," March, 1940.

"Marine Radio Telephone—Latest Field for Servicemen," Sept., 1939.

## TWO NEW INSTRUMENTS

AT RECORD-BREAKING LOW PRICES

THE NEW MODEL 1230

### SIGNAL GENERATOR with FIVE STEPS of SINE-WAVE AUDIO

#### SPECIFICATIONS

RADIO FREQUENCIES from 100 K.C. to 90 Mcgacycles in 7 bands by front panel switch manipulation. All direct reading and accurate to within 1% on I.F. and Broadcast bands. 2% on higher frequencies. The R.F. is obtainable separately or modulated by any one of the five Audio Frequencies.  
AUDIO FREQUENCIES: 5 steps of SINE-WAVE audio 200, 400, 1000, 5000 and 7500 cycles WITH OUTPUT OF OVER 1 VOLT. Any one of the above frequencies obtainable separately for servicing P.A. hard-of-hearing aids, etc.  
ATTENUATOR: Late design, full-range attenuator used for controlling either the pure R.F. or modulated R.F.



**CIRCUIT:** The Model 1230 employs an improved electron coupled oscillator circuit for the R.F. affording positive protection against frequency drift and a Hartley oscillator circuit for the A.F. section.  
**DIAL MANIPULATION:** Large 5/2" dial etched directly on front panel, using a new mechanically perfected drive for perfect vernier control.

**APPEARANCE:** The front panel is etched by a recently perfected process which results in a life-long attractive finish and the instrument comes housed in a streamlined shielded cabinet.

**CURRENT SOURCE:** The Model 1230 operates on 90 to 130 Volts A.C. or D.C. any frequency.

The Model 1230 comes complete with tubes, shielded cables, molded carrying handle and instructions. Size 14" x 6" x 11". Shipping weight 15 pounds. Only

**\$12<sup>85</sup>**

THE NEW MODEL 1220

WORLD'S LOWEST PRICED

### 5000 OHMS PER VOLTER!!

Extremely valuable because of its high sensitivity, the Model 1220 is an all-purpose tester that permits resistance measurements up to 3 Megohms, with only a 3 V. self-contained flashlight battery and reads directly down to 0.2 ohm.

#### SPECIFICATIONS

- \* 6 D.C. Voltage Ranges: 0-3-10-50-250-500-5,000 volts.
- \* 3 A.C. Voltage Ranges: 0-15-150-1,500 volts.
- \* 4 Resistance Ranges: 0-3000 ohms, with 15-ohm center, direct reading to 0.2 ohm; foregoing base range multiplied by 10, by 100 and by 1,000, to read up to 3 Meg. with self-contained 3 V. flashlight battery.
- \* 4 D.C. Current Ranges: 0-200 microamperes; 0-2-20-200 milliamperes, using wire-wound shunts.
- \* 3 Output Meter Ranges: Same as A.C. Voltage Ranges.
- \* 3 Decibel Ranges: From -2 to +58 D.B., based on .006 watt in 500 ohms.
- \* Uses full-sized 3" square 0-200 microammeter, with 2% accuracy and finely damped movement, contained in a handsomely designed, square molded Bakelite case.



Model 1220 comes complete with cover, self-contained battery, test leads and instructions. Only

**\$10<sup>45</sup>**

## SUPERIOR INSTRUMENTS COMPANY

136 Liberty Street

Dept. RC-6

New York, N.Y.

### WARNING TO RADIO-CRAFT READERS

*Radio-Craft* has no representatives in the field soliciting subscriptions, in the "door to door" fashion. Pay no money to any person who comes to your home, store or service shop and represents himself as being an agent for *Radio-Craft*. Subscriptions may be safely obtained only from authorized subscription agencies, whose names we shall be glad to furnish, or directly from us by mail. Address your letter to Subscription Dept., *Radio-Craft* Magazine, 20 Vesey St., New York, N. Y.

## DUMONT

Precision Built Condensers

at your nearest jobber or write to

DUMONT ELECTRIC CO., INC.

514-518 BROADWAY NEW YORK, N. Y.

PAPER — MICA — ELECTROLYTIC

QUALITY ABOVE ALL

**SOLAR**

CAPACITORS

Write for Catalog

SOLAR MFG. CORP.

BAYONNE, N. J.

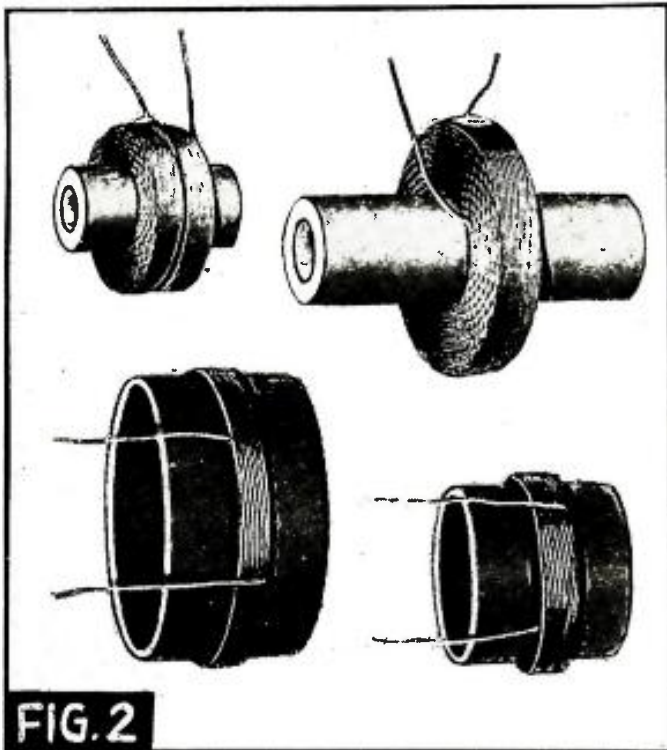

FIG. 2

Typical replacement of primary windings.

**T**HE question of replacements for defective radio-frequency coils has long been a nightmare to Servicemen. Many of these technicians, realizing the amount of design-work embodied in such coils, have insisted upon exact duplicate replacements or that the defective coil be repaired by a coil company. In either case, considerable delay often resulted.

Most Servicemen apparently have not realized that the part of the coil that fails in normal service is the part which was manufactured to rather broad tolerances of inductance, and that this part (the primary) can easily be replaced since it has only a minor influence on the "tracking" of the receiver circuits. Therefore, if the defective primary is replaced, the original coil with its accurately-controlled secondary inductances can be salvaged.

The Serviceman can give best service to his customers, when R.F. coils fail, if he is familiar with replacement primary windings and knows how to use them, and repairs the coil himself.

#### REPAIRS—IN DETAIL

The advantages of being able to repair radio frequency coils are obvious to every Serviceman. It remains only for him to convince himself that he, personally, can do the job.

Many Servicemen, who are well able to correct trouble in any make or type of receiver, hesitate to tackle the repair of an R.F. coil because of inadequate knowledge about the design constants of such coils, or because they believe that only trained feminine hands can properly handle the fine wire used. The first objection has been overcome by studies made by the Meissner Mfg. Co. which has determined that for any Broadcast-band Antenna or R.F. coil, one of 3 values of inductance will serve admirably, and as far as replacements for Shortwave primaries are concerned, these primaries usually consist of only a few turns of wire which can be replaced with an equal number of turns of No. 36 S.S.E.

The question of ability to handle the fine wire of which broadcast primaries are made can easily be settled after a few minutes' practice with a piece of sandpaper and a piece of No. 36 S.S.E. or No. 38 S.S.E. wire, or the outside lead of one of the replacement primary windings. (If the outside lead should break off too short, a few turns can always be peeled off the coil to give the required lead length without materially altering the performance of the coil. This, of course, positively is *not* true in the case of secondaries, which must be held to close tolerance of inductance.)

It has been found that if a piece of No. 00 sandpaper is folded and cut in accordance with the sketch in Fig. 1 and is held between the thumb and forefinger the insulation—first the fabric, then the enamel—can easily be stripped off of the wire no matter how fine the wire, if appropriate pressure is used on the sandpaper while sanding the wire. Much too little pressure will require a long time to strip the insulation, while too great a pressure will break the wire. A few moments' experiment will quickly inform the Serviceman of the proper pressure to use. There is one point that should be stressed, and that is, that in his determination not to break the lead, the Serviceman should not make the mistake of failing

## Serviceing R.F. COILS

*This article, No. 1 of a series, shows Servicemen how to repair radio-frequency coils so as to save the time and money otherwise involved in making exact replacements or in waiting for factory repairs. Much valuable and practical information you cannot find in books is published here for the first time.*

LAWRENCE V. SORENSEN

to properly clean off the enamel. If the latter insulation is merely scratched through in a few places, it is not possible to make a good connection. The solder will not stick to the few bright scratches so made. The wire must be thoroughly cleaned.

A few trials at cleaning size 38 enameled wire will soon convince the Serviceman that he can do just as good a job of cleaning the wire without breaking it as can the trained fingers of feminine coil operators, although undoubtedly he will be somewhat slower. A trick that may help to avoid breaking the wire, is to rub the 2 surfaces of the sandpaper together before attempting to remove any insulation. This action removes the high spots on the sandpaper which tend to grab the conductor, and makes the action of the sandpaper smoother and much easier to control.

#### REPLACEMENTS—STEP-BY-STEP

The following section is a step-by-step set of directions for replacing a defective primary on a radio-frequency coil. A typical group of replacement Primary Windings is shown in Fig. 2. Some sections of the directions may seem obvious when read, but may easily be overlooked until too late if the task of replacing a defective primary is started without careful consideration of each step, in sequence, because once a coil has been torn apart it may be too late to observe certain details, that it may be necessary to know, in order to properly complete the job.

(1) Make a clear diagram of all leads connecting to the coil terminals, marking the color of each wire and the position that the coil occupied in the receiver. This should be done carefully and rechecked before, or as, the wires are removed. (See Fig. 3.)

(2) In removing the leads from the coil, take care to put no unnecessary strain on the coil terminals lest the lugs move and perhaps break off some lead from a good winding attached to the lug. If the hook-up wires are hooked through and twisted around the coil terminal so that it is difficult to get them loose, it is best to cut the wires, close to the lug. After being cut, the short pieces of wire are usually easy to remove or, if such is not the case, the ends had best be left attached to the lugs and the hook-up wire merely soldered to the lugs without going through or around them when the coil is re-installed.

(3) Carefully examine the defective winding, which is to be replaced, in order to determine the winding direction and the lugs to which the ends of the winding connect. This information should be carefully recorded. A convenient method of designating winding direction is to use an arrow pointing as if its shaft were the outside end of the coil, and the head of the arrow were the end of the wire. (See Fig. 4.)

(4) The exact location of the winding on the form in relation to the other windings should be recorded, and the defective winding removed carefully to avoid damage to other windings or connections. (See Fig. 5.)

(5) If the defective winding consists of only a few turns of wire wound adjacent to, over, or between the turns of a secondary, this winding can be replaced with an equal number of turns of No. 36 S.S.E. or 36 D.S.C. wire.

(6) If the defective winding was of the "Universal" or honeycomb type, a (Meissner) replacement primary should be chosen as near the physical size of the original winding as possible, and yet be able to slip into place. In some cases, unfortunately, lugs or other windings interfere with slipping onto the coil form a new winding close to the size of the defective winding. In such cases a new primary just large enough to slip over the obstruction should be selected and fastened in place by means of small hard-wood wedges held in place by wax, or "radio cement." (See Fig. 6.) (Make certain that the winding direction is correct.)

The inductance of the replacement winding selected is determined by the type of coil being repaired. A Broadcast R.F. coil

takes the highest inductance, approximately 7.5 millihenries; an antenna coil for use with an outside antenna takes the lowest inductance, approximately 1.7 millihenries; while an antenna coil for an inside or "hank" antenna takes a value between the other 2, approximately 2.25 millihenries. Since these divisions have been so clearly drawn after a study of the replacement problems by the Meissner Manufacturing Company, there should be no doubt in the Serviceman's mind as to which value to select.

(7) Connect the replacement winding leads in accordance with the notes previously made concerning winding direction and connections.

(8) Check the coil for continuity on all windings and re-install it in the receiver in accordance with the notes made in section 1.

(9) Align the receiver, and adjust the coupling if necessary as described in the following paragraphs.

**WINDING DIRECTION**

When a Serviceman is called upon to repair a radio-frequency coil from which the defective winding has already been removed, or has been so badly damaged that the winding direction can not be discovered, there are 4 questions that must be answered:

- (1) Which lug was the antenna or plate connection?
- (2) What was the probable inductance of the coil?
- (3) Where was the winding located?
- (4) Which way was the outside end of the winding pointing?

If there is no data to show which lug was connected to the antenna or plate, the question must be answered from an inspection of the coil, or an answer must be assumed and the coil repaired and rewired accordingly.

If there is any kind of a coupling condenser used it will be found connected from the grid end of the secondary to the plate or antenna end of the primary, which immediately establishes a certain lug as the plate or antenna connection. The coupling condenser may take the form of 2 metal plates separated by a piece of mica and attached to the coil form by means of rivets or lugs (Fig. 7A). It may be a loop of heavy wire circling the secondary near the grid end (Fig. 7B). (This form is used only with solenoid or bank-wound coils.) It may be a few turns of insulated wire wrapped closely round another insulated wire forming what is commonly known as a "Gimic" (Fig. 7C). In any case, the purpose of the capacity coupling is to transfer energy from the primary to the secondary.

In the case of "choke coupling," used frequently in R.F. coils, the choke is either at right-angles to the secondary, or at a considerable distance from it, and the coupling condenser constitutes the sole means of coupling between primary and secondary. Unless the coupling condenser is properly wired to the coil and into the receiver, practically no coupling would exist in the coil concerned. The winding direction of the primary in this type of coupling has prac-

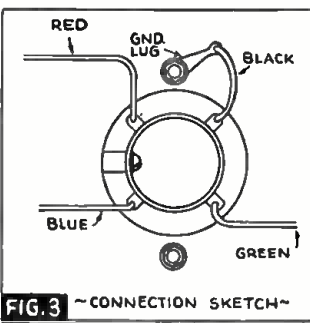
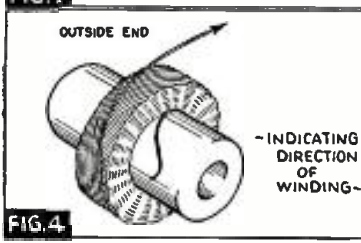
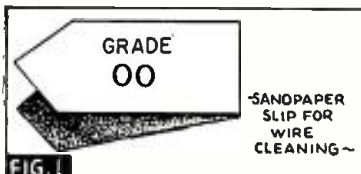
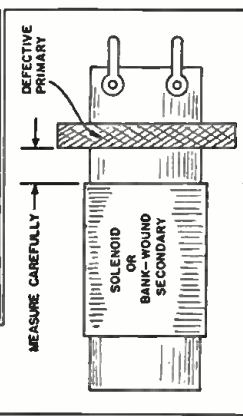

FIG. 3 ~ CONNECTION SKETCH ~  
~ RECORD THE EXACT POSITION OF WINDING ~



tically no effect on the gain of the coil, and it may accordingly be connected either way.

In the case where both magnetic and capacity coupling are employed, the purpose of the capacity is to hold up the gain at the high-frequency end of the band. The capacity coupling aids the magnetic coupling in such cases. Should a primary be connected reversed, the capacity coupling would oppose the magnetic coupling and would produce inferior performance at all frequencies and approximately zero amplification at some one frequency resulting in decreased sensitivity at all frequencies but especially poor sensitivity at the one frequency where the magnetic and capacity coupling cancelled.

In some antenna coils, especially in sets with only 2 sections in the tuning condenser, the stray capacity between the "hot" end of the primary and the "hot" end of the secondary is used to buck out the magnetic coupling at some frequency above the band (in frequency) for the purpose of improving the rejection of interfering signals in that frequency range. In superheterodyne receivers this improves the "Image Ratio" of the set. With the exception of this case, which is by no means universal, the rule for capacity coupling on radio-frequency coils is that **THE WIRES LEADING AWAY FROM THE COUPLING CONDENSER MUST GO AROUND THE COIL FORM IN OPPOSITE DIRECTIONS.**

In the event that no physical coupling condenser exists, and no data is available to tell which were the "hot" and "cold" ends of the primary, the corresponding lugs should be chosen arbitrarily and the primary connected "capacity aiding," that is with the wires from the grid of the secondary and the "hot" end of the primary going around the coil form in opposite directions. (See Fig. 8.)

**ALIGNMENT**

After repairing a coil and re-installing it in the receiver, the circuits should, of course, be aligned. The normal practice should be followed, using some form of service oscillator for a signal source, connected through a satisfactory dummy antenna to the radio set. The usual values of dummy antenna are 200 mmf. for the broadcast

band of sets intended for use with an outside antenna, 85 mmf. for the broadcast band of sets using a "hank" antenna and 400 ohms of resistance for shortwave bands.

If the repaired coil is used on the broadcast band, the circuits should be aligned at 1,400 kc. and then "tracking" checked at 600 kc. If the set originally "tracked" well and the coil has been repaired as directed above, it will "track" well after the repair. Of course, there is usually no chance to find out how well the set "tracked" before the repair, but in the case of multiband sets, it is reasonable to assume that if all of the other bands track well, that the band having the defective coil also tracked well.

When tracking is poor at the low-frequency end of the repaired coil and is good on all other bands, the coupling on the repaired coil probably needs adjustment, but if tracking is poor in the same direction on all bands it is probable that the gang condenser is off its normal value by a small amount.

An experienced Serviceman sometimes bends the plates of the condenser to improve tracking but *this remedy should not be attempted by some one not thoroughly familiar with the work.* If the plates are bent to improve tracking, the adjustment should be made on a band that has not had a primary replaced, and then the primary adjusted on the broadcast band to obtain good tracking at 600 kc.

If the circuit appears to require more capacity at 600 kc. than the gang condenser supplies, the coupling is too tight and should be loosened by moving the primary farther away from the secondary; while if the condenser seems to be supplying too much capacity, the coupling is too loose and should be tightened by moving the primary closer to the secondary or, in the case of solenoid windings, closer to the center of the secondary. The latter case is likely to occur when the replacement primary had to be larger than the original in order to slip over some obstruction.

A convenient method of checking tuning capacity at 600 kc. is to insert between the plates of the tuning condenser a thin piece of celluloid while watching the output meter. This adds a little capacity to 1 section of the tuning condenser without chang-

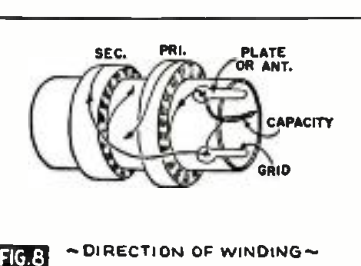
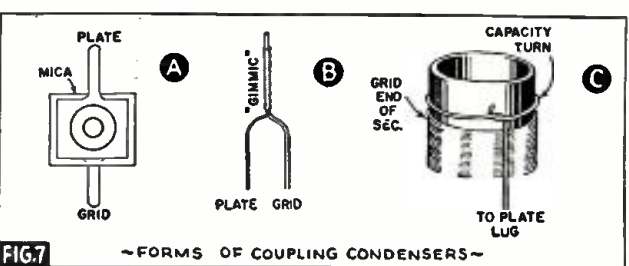
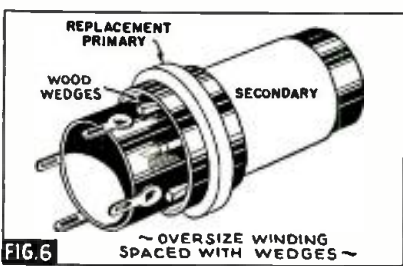

SERVICING  
QUESTIONS & ANSWERS

"FLUTTERY" RECEIVER

(161) Alfred F. Authier, Brooklyn, N. Y.  
(Q.) As I have an Emerson model 106 6-tube set using 1-6D6, 1-6A7, 1-43, 1-6F5, 1-6H6 and 1-25Z5 I am asking you why the set gets fluttery when I return it to the cabinet? It starts to get fluttery 1/2-hour after putting into cabinet and has never failed but when it is out of the cabinet it never gets fluttery or drops in volume! Can you inform me why and what causes this trouble?

I have replaced the dual 12-12 mf. condensers and also put in a line cord that eliminates some of the heat that was causing some of the trouble. Still, when it is in the cabinet, it does not remain natural or normal but it gets fluttery or fluffy like one who has a cold or is hoarse. Also, the set stops playing but when I put a wire across the wavetrap trimmer condenser and the antenna coil trimmer condenser the set functions.

(A.) The set you refer to does not have sufficient ventilation and the change in operation still is due to heat developing. You can drill the bottom of the cabinet with additional ventilating holes, or mount the set in a larger cabinet. It may be necessary to change the trimmers to air-dielectric type.

FADING

(162) M. V. Carey, Baltimore, Md.

(Q.) I have trouble with a Montgomery Ward "Airline" radio set model 62-308. When this set has been operating for a half-hour or so the station to which it is tuned disappears. The local stations are absolutely blocked while distant stations are received but are weak.

The Magic Eye closes and opens all right even when stations cannot be received.

When the volume control is turned on full there is a weak, distorted sound. When the A.C. switch is turned off and then on the set operates for awhile.

Can you enlighten me as to what causes this trouble?

(A.) Undoubtedly your set has a faulty bypass or coupling condenser. The trouble should be localized as described in "Emergency Servicing Without Test Meters," (August, October, 1939 and January, 1940 issues of *Radio-Craft*), and the defective condenser replaced.

Once one condenser has gone bad, it is often well to install a complete new set of paper and electrolytic condensers in the receiver to restore original operating condition.

FAULTY SELECTIVITY

(163) Clell Richards, Fairland, Okla.

(Q.) An "Airline" (Montgomery Ward) 5-tube receiver is giving me trouble. One station can be heard with normal volume at around 600 kc. The tuning control has no effect on reception except to slightly reduce the volume of the one station. None of the trimmer or padder condensers in the tuning circuit have any effect whatever. All coils, condensers and resistors check OK. All voltage and current readings are normal.

(A.) Failure of your Airline receiver to operate can be traced definitely to the oscillator circuit. Since you do not state the model number of the receiver, more detailed information cannot be given.

However, we suggest that a careful check of the oscillator coil, oscillator grid leak and coupling condenser be made.

"What Are Rider Manuals?  
Let Me Tell You..."



**B**ACK in the early days of simple regenerative sets there was no need for Rider Manuals. But when reflex circuits, stabilized T.R.F. stages, superhets and compact construction appeared, the serviceman needed more than just a diagram to do profitable work. Then, as today, he needed the COMPLETE servicing information that only Rider Manuals could give him. He needed complete and dependable data on alignment, I-F Peaks, parts lists and parts values, voltage ratings of condensers, wattage ratings

of resistors, coil resistance data, and all the other information which is vital if you are to know just what the manufacturer put in that receiver. Nowhere else can you find ALL IN ONE PLACE the essential servicing information contained in the complete set of Rider Manuals. Nowhere else can you so easily and so quickly find just what you need.

"I'm telling you there never was a service that compared in completeness, clearness and value with Rider Manuals. And, with the complicated sets they're turning out today, there never was a time when they were so necessary. Proof is that you will find practically every successful serviceman in the country has a complete set of Rider Manuals. Take my advice—don't try to 'get by' with just a few of them. Get them all. Remember, having the information you'll do better work—do it faster—and make more money."

YOU NEED ALL RIDER MANUALS

Volume	Price	Covering	Volume	Price	Covering
X	\$10.00	1938-43	V	\$7.50	1934-35
IX	10.00	1938-39	IV	7.50	1933-34
VIII	10.00	1937-38	III	7.50	1932-33
VII	10.00	1936-37	II	7.50	1931-32
VI	7.50	1935-36	I	7.50	1920-31

**VOLUME XI—OUT IN MAY**  
New arrangement provides for 25% more sets.  
New How It Works section.  
New pocket handbook.  
New Index (cross-indexed).  
All these services at no increase in price.

JOHN F. RIDER, PUBLISHER, Inc.

404 FOURTH AVENUE, NEW YORK CITY

Export Division: Rocke-International Elec. Corp., 100 Varick St., N. Y. C. • Cable: ARLAB

ing the tuning of the other circuits. If the meter reading increases when the celluloid is inserted the capacity is too low or the coupling is too tight. If the meter reading decreases, the capacity may be correct or high. Coupling should then be tightened until the celluloid slip test just shows too little capacity, and then loosened slightly.

CONCLUSION

If care is taken to see that the replacement winding is properly placed (coupling adjusted if necessary) and proper attention is given to the winding direction and connections, there should be no difficulty whatsoever to prevent the Serviceman from giving his customer a satisfactory job in much less time than would be required to obtain an exact duplicate replacement coil

or to return the defective coil to a coil manufacturer to be repaired or duplicated.

Next month: "Servicing I.F. Coils."

Silvered-Mica Condensers

According to Cornell-Dubilier Elec. Corp., the new type of fixed condensers known as "silvered mica" have many advantages. The thorough binding of the silver coating to the mica results in uniform and low capacity-temperature coefficient (+0.002% per deg. C.), and excellent retrace characteristics. Test voltage, up to 1,000 V. Molded in low-loss red bakelite, as protection against physical damage and change of electrical characteristics, a Q of 3,000 to 5,000 can be obtained; capacity tolerance is 5%.

# Radio Service Data Sheet

## GENERAL ELECTRIC MODEL HJ-1205

12-Tube Superheterodyne; A.C. Operation; 3 Bands (540-1,600 kc., 2,300-7,000 kc., 7,000-22,000 kc.); Power Output (undistorted), 8.5 W.; A.V.C.; Tone Monitor; "Eye" Tube; Built-in, Rotatable "Beam-a-Scope" Antenna; Dual P.M. Dynamic Speakers, 1—12in. and 1—6½ in.; 11 Pushbuttons (Keys), including keys for Phono, or Television Audio Channel.

See Data Sheet No. 279 for additional information.

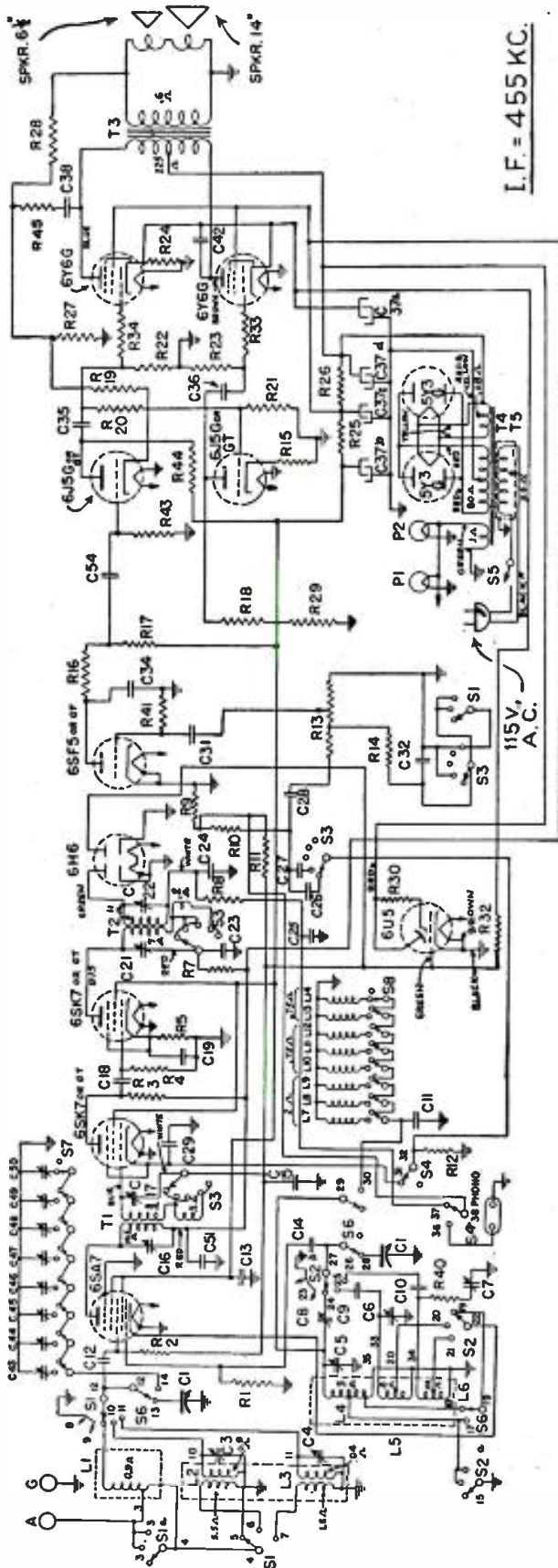

- CONDENSERS**
- C1 Tuning coil ant. trimmer
  - C2 0.01-mf. mica
  - C3 0.01-mf. paper
  - C4 0.01-mf. trimmer
  - C5 0.003-mf. paper
  - C6 47-mf. mica
  - C7 0.05-mf. paper
  - C8 20 mf. 25 V. dry elec.
  - C9 30 mf. 30 V. dry elec.
  - C10 40 mf. 35 V. dry elec.
  - C11 150 mf. mica
  - C12 0.1-mf. paper
  - C13 47-mf. mica
  - C14 47-mf. mica
  - C15 0.1-mf. paper
  - C16 47-mf. mica
  - C17 0.05-mf. paper
  - C18 100 mf. mica
  - C19 47-mf. mica
  - C20 0.01-mf. trimmer
  - C21 0.01-mf. trimmer
  - C22 0.01-mf. trimmer
  - C23 0.01-mf. trimmer
  - C24 0.01-mf. trimmer
  - C25 100-mf. mica
  - C26 0.01-mf. paper
  - C27 470-mf. mica
  - C28 0.01-mf. paper
  - C29 0.01-mf. paper
  - C30 0.003-mf. paper
  - C31 47-mf. mica
  - C32 0.05-mf. paper
  - C33 20 mf. 25 V. dry elec.
  - C34 30 mf. 30 V. dry elec.
  - C35 40 mf. 35 V. dry elec.
  - C36 0.01-mf. 1,000 V. paper
  - C37 1.45-mf. ant. trimmer
  - C38 47-mf. mica
  - C39 0.01-mf. trimmer
  - C40 20-mf. 25 V. dry elec.
  - C41 30-mf. 30 V. dry elec.
  - C42 40-mf. 35 V. dry elec.
  - C43 100-mf. mica
  - C44 47-mf. mica
  - C45 47-mf. mica
  - C46 47-mf. mica
  - C47 20-mf. 25 V. dry elec.
  - C48 100-mf. mica
  - C49 100-490-mf. ant. trimmer
  - C50 100-490-mf. ant. trimmer
- RESISTORS**
- R1 22,000 ohms, carbon
  - R2 10,000 ohms, carbon
  - R3 47,000 ohms, carbon
  - R4 530 ohms, carbon
  - R5 530 ohms, carbon
  - R6 100-490 ohms, carbon
  - R7 100-490 ohms, carbon
  - R8 530 ohms, carbon
  - R9 100-490 ohms, carbon
  - R10 0.1-mf. paper
  - R11 0.05-mf. paper
  - R12 100-490 ohms, carbon
  - R13 100-490 ohms, carbon
  - R14 530 ohms, carbon
  - R15 530 ohms, carbon
  - R16 100-490 ohms, carbon
  - R17 1,000 ohms, carbon
  - R18 47,000 ohms, carbon
  - R19 47,000 ohms, carbon
  - R20 6.45G
  - R21 5.15G
  - R22 5.15G
  - R23 5.15G
  - R24 5.15G
  - R25 5.15G
  - R26 5.15G
  - R27 5.15G
  - R28 5.15G
  - R29 5.15G
  - R30 6U5
  - R31 6U5
  - R32 6U5
  - R33 6U5
  - R34 6U5
  - R35 6U5
  - R36 6U5
  - R37 6U5
  - R38 6U5
  - R39 6U5
  - R40 6U5
  - R41 6U5
  - R42 6U5
  - R43 6U5
  - R44 6U5
  - R45 6U5
  - R46 6U5
  - R47 6U5
  - R48 6U5
  - R49 6U5
  - R50 6U5
  - R51 6U5
  - R52 6U5
  - R53 6U5
  - R54 6U5
  - R55 6U5
  - R56 6U5
  - R57 6U5
  - R58 6U5
- COILS**
- L1 Beam-a-scope
  - L2 Band ant. coil
  - L3 Band ant. coil
  - L4 Band ant. coil
  - L5 Band ant. coil
  - L6 Band ant. coil
  - L7 Band ant. coil
  - L8 Band ant. coil
  - L9 Band ant. coil
  - L10 Band ant. coil
  - L11 Band ant. coil
  - L12 Band ant. coil
  - L13 Band ant. coil
  - L14 Band ant. coil
  - L15 Band ant. coil
  - L16 Band ant. coil
  - L17 Band ant. coil
  - L18 Band ant. coil
  - L19 Band ant. coil
  - L20 Band ant. coil
  - L21 Band ant. coil
  - L22 Band ant. coil
  - L23 Band ant. coil
  - L24 Band ant. coil
  - L25 Band ant. coil
  - L26 Band ant. coil
  - L27 Band ant. coil
  - L28 Band ant. coil
  - L29 Band ant. coil
  - L30 Band ant. coil
  - L31 Band ant. coil
  - L32 Band ant. coil
  - L33 Band ant. coil
  - L34 Band ant. coil
  - L35 Band ant. coil
  - L36 Band ant. coil
  - L37 Band ant. coil
  - L38 Band ant. coil
  - L39 Band ant. coil
  - L40 Band ant. coil
  - L41 Band ant. coil
  - L42 Band ant. coil
  - L43 Band ant. coil
  - L44 Band ant. coil
  - L45 Band ant. coil
  - L46 Band ant. coil
  - L47 Band ant. coil
  - L48 Band ant. coil
  - L49 Band ant. coil
  - L50 Band ant. coil
  - L51 Band ant. coil
  - L52 Band ant. coil
  - L53 Band ant. coil
  - L54 Band ant. coil
  - L55 Band ant. coil
  - L56 Band ant. coil
  - L57 Band ant. coil
  - L58 Band ant. coil
  - L59 Band ant. coil
  - L60 Band ant. coil
  - L61 Band ant. coil
  - L62 Band ant. coil
  - L63 Band ant. coil
  - L64 Band ant. coil
  - L65 Band ant. coil
  - L66 Band ant. coil
  - L67 Band ant. coil
  - L68 Band ant. coil
  - L69 Band ant. coil
  - L70 Band ant. coil
  - L71 Band ant. coil
  - L72 Band ant. coil
  - L73 Band ant. coil
  - L74 Band ant. coil
  - L75 Band ant. coil
  - L76 Band ant. coil
  - L77 Band ant. coil
  - L78 Band ant. coil
  - L79 Band ant. coil
  - L80 Band ant. coil
  - L81 Band ant. coil
  - L82 Band ant. coil
  - L83 Band ant. coil
  - L84 Band ant. coil
  - L85 Band ant. coil
  - L86 Band ant. coil
  - L87 Band ant. coil
  - L88 Band ant. coil
  - L89 Band ant. coil
  - L90 Band ant. coil
  - L91 Band ant. coil
  - L92 Band ant. coil
  - L93 Band ant. coil
  - L94 Band ant. coil
  - L95 Band ant. coil
  - L96 Band ant. coil
  - L97 Band ant. coil
  - L98 Band ant. coil
  - L99 Band ant. coil
  - L100 Band ant. coil
- TRANSFORMERS**
- T1 6SK7
  - T2 6SK7
  - T3 6Y56
  - T4 6X4
  - T5 6X4
- SWITCHES**
- S1 Ant. band switch
  - S2 Osc. band switch
  - S3 Tone switch
  - S4 Phono switch
  - S5 Power switch
  - S6 Manual switch
  - S7 Ant. section touch tuning switch
  - S8 Osc. section touch tuning switch
- TUBES**
- 6U5 6U5
  - 6SK7 6SK7
  - 6Y56 6Y56
  - 6X4 6X4
- OTHER COMPONENTS**
- PI 1.000 ohms, carbon
  - P2 47,000 ohms, carbon
  - P3 47,000 ohms, carbon
  - P4 47,000 ohms, carbon
  - P5 47,000 ohms, carbon
  - P6 47,000 ohms, carbon
  - P7 47,000 ohms, carbon
  - P8 47,000 ohms, carbon
  - P9 47,000 ohms, carbon
  - P10 47,000 ohms, carbon
  - P11 47,000 ohms, carbon
  - P12 47,000 ohms, carbon
  - P13 47,000 ohms, carbon
  - P14 47,000 ohms, carbon
  - P15 47,000 ohms, carbon
  - P16 47,000 ohms, carbon
  - P17 47,000 ohms, carbon
  - P18 47,000 ohms, carbon
  - P19 47,000 ohms, carbon
  - P20 47,000 ohms, carbon
  - P21 47,000 ohms, carbon
  - P22 47,000 ohms, carbon
  - P23 47,000 ohms, carbon
  - P24 47,000 ohms, carbon
  - P25 47,000 ohms, carbon
  - P26 47,000 ohms, carbon
  - P27 47,000 ohms, carbon
  - P28 47,000 ohms, carbon
  - P29 47,000 ohms, carbon
  - P30 47,000 ohms, carbon
  - P31 47,000 ohms, carbon
  - P32 47,000 ohms, carbon
  - P33 47,000 ohms, carbon
  - P34 47,000 ohms, carbon
  - P35 47,000 ohms, carbon
  - P36 47,000 ohms, carbon
  - P37 47,000 ohms, carbon
  - P38 47,000 ohms, carbon
  - P39 47,000 ohms, carbon
  - P40 47,000 ohms, carbon
  - P41 47,000 ohms, carbon
  - P42 47,000 ohms, carbon
  - P43 47,000 ohms, carbon
  - P44 47,000 ohms, carbon
  - P45 47,000 ohms, carbon
  - P46 47,000 ohms, carbon
  - P47 47,000 ohms, carbon
  - P48 47,000 ohms, carbon
  - P49 47,000 ohms, carbon
  - P50 47,000 ohms, carbon
  - P51 47,000 ohms, carbon
  - P52 47,000 ohms, carbon
  - P53 47,000 ohms, carbon
  - P54 47,000 ohms, carbon
  - P55 47,000 ohms, carbon
  - P56 47,000 ohms, carbon
  - P57 47,000 ohms, carbon
  - P58 47,000 ohms, carbon
  - P59 47,000 ohms, carbon
  - P60 47,000 ohms, carbon
  - P61 47,000 ohms, carbon
  - P62 47,000 ohms, carbon
  - P63 47,000 ohms, carbon
  - P64 47,000 ohms, carbon
  - P65 47,000 ohms, carbon
  - P66 47,000 ohms, carbon
  - P67 47,000 ohms, carbon
  - P68 47,000 ohms, carbon
  - P69 47,000 ohms, carbon
  - P70 47,000 ohms, carbon
  - P71 47,000 ohms, carbon
  - P72 47,000 ohms, carbon
  - P73 47,000 ohms, carbon
  - P74 47,000 ohms, carbon
  - P75 47,000 ohms, carbon
  - P76 47,000 ohms, carbon
  - P77 47,000 ohms, carbon
  - P78 47,000 ohms, carbon
  - P79 47,000 ohms, carbon
  - P80 47,000 ohms, carbon
  - P81 47,000 ohms, carbon
  - P82 47,000 ohms, carbon
  - P83 47,000 ohms, carbon
  - P84 47,000 ohms, carbon
  - P85 47,000 ohms, carbon
  - P86 47,000 ohms, carbon
  - P87 47,000 ohms, carbon
  - P88 47,000 ohms, carbon
  - P89 47,000 ohms, carbon
  - P90 47,000 ohms, carbon
  - P91 47,000 ohms, carbon
  - P92 47,000 ohms, carbon
  - P93 47,000 ohms, carbon
  - P94 47,000 ohms, carbon
  - P95 47,000 ohms, carbon
  - P96 47,000 ohms, carbon
  - P97 47,000 ohms, carbon
  - P98 47,000 ohms, carbon
  - P99 47,000 ohms, carbon
  - P100 47,000 ohms, carbon

The model HJ-1205 is a 3-band A.C. operated receiver employing 12 General Electric pre-tested tubes in a superheterodyne circuit. The receiver is equipped with 11 feather-touch tuning keys, 8 of which may be set up for favorite stations. The 3 remaining keys allow power control, manual tuning and phonograph or television audio reception. Each model is also equipped with the new Super Beam-a-scope; a highly efficient, self-contained antenna circuit. Other features of design include: dual dynapower speakers (See "The Use of Dual Loudspeakers," in this issue of *Radio-Craft*), floodlighted station-key finder, visual dial, iron-core I.F. transformers, automatic tone compensation, automatic volume control, and push-pull output.

**SUPER BEAM-A-SCOPE**

The Super Beam-a-scope is essentially a tuned coil antenna wound on a frame and shielded by a Faraday screen against electrostatic disturbances. This construction favors the desired signal over a local man-made noise source in 3 ways. First, since any noise source is composed of 2 components—electrostatic and electromagnetic fields—the Super Beam-a-scope may be revolved so that a null point is found where no voltage is produced from these 2 components. Due to the fact that this null point is very sharp, it is very unusual that any desired station will be in a direct line with the rejected noise signal and thereby have its signal strength reduced appreciably.

In the second place, the Super Beam-a-scope eliminates the external return path to ground present in the case of an unshielded antenna. This reduces or eliminates local man-made noise sources in much the same way as a shielded antenna lead-in does in an ordinary antenna installation.

In the third place the Super Beam-a-scope discriminates against the electrostatic component of an incoming wave in comparison with the electromagnetic component, because of the Faraday shield. Since the electrostatic component of a local noise source is a great deal larger than the electromagnetic component, this rejection property brings about an enormous increase in signal-to-noise ratio.

The above operation is only available on the broadcast band and in this position the Super Beam-a-scope is also the 1st tuned grid circuit. On the "C" and "D" bands, the Super Beam-a-scope is grounded at the grid end thus preventing absorption spots due to loop resonance. (See "How the Beam-a-scope Works," *Radio-Craft*, April 1939.)

(Continued on Data Sheet 279)

# OPERATING NOTES



*Pocket Size*  
**TRIPL**

## Volt-Ohm-Milliammeter

5000 Volts (Self-Contained)

**MODEL 666-H \$14.50**

Size: 3-1/16" x 5-7/8" x 2-1/8" Net Price

Model 666-H Volt-Ohm-Milliammeter is a complete pocket-size tester with AC and DC Voltage Ranges to 5000 Volts (self-contained). AC-DC Voltage at 1000 ohms per volt, 0-10-50-250-1000-5000; DC Milliampers 0-10-100-500; Resistance 0-300 ohms, shunt type circuit; 10 ohms reading at center scale; 0-250,000 ohms, series type circuit; 3700 ohms at center scale. Higher resistance measurements available by using external batteries. Selector switch for all instrument readings. The ideal Pocket Volt-Ohm-Milliammeter for amateurs, radio technicians, industrial engineers, research. Black molded case and panel, completely insulated... with RED•DOT Lifetime Guaranteed Measuring Instrument... Dealer Net price \$14.50

Model 666... Same as above, but with voltage ranges to 1000 volts... Dealer Net Price \$14.00

## New Volume Unit Meter

Volume Unit Meters for measurement of sound or noise levels. New approved design. Steady state reference of 1 Milliwatt. Calibrated for 600 ohm line. Has 0-100% scale; also reads minus 20V.U. to plus 3 V.U.

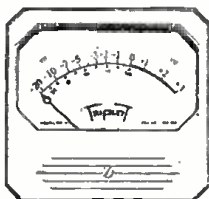

Triplet manufactures precision electrical indicating instruments in 23 case styles—2" to 7", round, square, fan and portable.

WRITE for CATALOG! Section 166 Harmon Drive

THE TRIPL

Bluffton, Ohio

## Trouble in . . .

### . . . WILCOX-GAY 6T11

Due to the high surge voltage encountered, the 1st filter condenser usually shorts or the electrolyte decomposes and capacity drops to a low level. Replacing the original with the recommended 8 mf. 450 V. unit does not help as the trouble only appears again.

Probably the best and most economical repair is to connect two 16 mf., 450 V. electrolytics of the small tubular style in series, plus to minus, with the free ends of proper polarity connected to the rectifier filament and ground. This combination gives 8 mf., 900 V. working. Both condensers should be of exactly the same type and manufacture so that the voltage drop across them is divided equally. Leave the original can above-chassis for appearance sake, but disconnect it. This system may be used on many other sets that use heater-type receiving tubes and filament-type power rectifier, where high surge is found.

L. W. KRIZAN,  
Chicago, Ill.

### . . . RCA-VICTOR 8Q1 (export model)

Complaint: Reception weak and distorted. This condition can usually be traced to an open 270,000-ohm, 1/4-watt carbon resistor which is the plate load of the triode section of the 6Q7 tube. Replacement of this resistor (RCA Stock No. 12199) will cure this trouble.

### . . . RCA-VICTOR 5Q5, 5Q55, 5Q56, & 6Q7 (export models)

Complaint: Dead. The usual defect in these models is the 12,000-ohm, 3 1/2-watt resistor (RCA Stock No. 31389) which supplies voltage to the screen-grids of the 6K7 and 6SA7 tubes. Replace preferably with a carbon resistor of correct value and watts rating. The wirewound resistor which is supplied with these sets very frequently increases in resistance value.

ELDON AHWAI,  
Trinidad, British West Indies.

### . . . MAJESTIC 300

On the Majestic Model 300, I had a tube burn-out. It was a special tube, type 2S in the 2nd-detector stage. I substituted a type 24A and grounded the grid of the tube to the chassis with perfect results. The customer is satisfied with the new tube, and doesn't want exact replacement now.

WALTER T. STEVENSON,  
Fort Riley, Kansas.

### . . . A.C.-D.C. SETS

Burn-outs of one section of duodiode rectifiers (such as 25Z5's) in sets of the A.C.-D.C. variety with the plates connected in parallel are frequent. A cure for this trouble is two 100-ohm, 2-watt resistors, one in series with each plate. This job will build up customer confidence.

### . . . MAJESTIC 90

A Majestic 90 was brought into the shop, with a complaint of intermittent squealing. Channel analysis revealed the presence of the squeal in all stages, thereby pointing toward the power supply. An electrolytic was open. When you make the replacement, put in the entire block, not just one of the compact type for the defective one.

### . . . ATWATER KENT 42 AND OTHER T.R.F. SETS

The gain of these old sets may be increased, with the addition of a few inches of wire, in 5 minutes. Merely connect an extra winding as shown here, using No. 30

DCC wire. The winding should be moved up and down till highest gain results. This

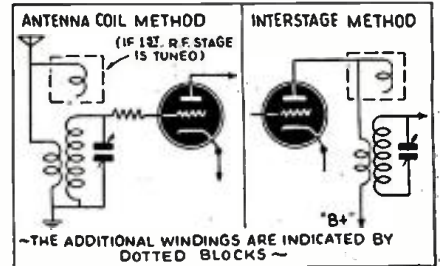

method is successfully used on the later midget sets, and will prove successful on the old sets.

FORREST FRANTZ,  
Coplay, Pa.

### . . . STROMBERG-CARLSON 400 SERIES

In case the dial pointer in any of the 400 series receivers becomes bent during transportation or handling, so that it rubs either against the background of the dial or the glass, it is a simple matter to correct this without removing the chassis from the cabinet.

Simply adjust the pointer so that it is approximately in the middle of the dial and reach in from behind and lift the slide, to which the pointer is attached, until it is just off the slide bar. Then, holding the slide between the thumb and first finger, bend it in the appropriate direction so that when it is replaced on the slide bar, the pointer will be in the proper operating position.

STROMBERG-CARLSON Solder Nuggets.

### ZENITH 6J230

Low voltage overall in the Zenith model 6J230 will, in most cases, be located by removing the copper can housing the power transformer and vibrator, and replacing the 8 mf. condenser located on the outside of the choke.

### ZENITH 8S129

High screen-grid voltage on the 8S129 Zenith is due to the 5,800-ohm section of the Candohm resistor, which opens. Just bridge the terminals with a 5-W. type of the same resistance value. It would be wise to replace the 11,000-ohm section at the same time as breakdown of this section is sure to occur shortly after the receiver gets back to the customer.

### ZENITH 120158

Great difficulty was experienced in lining-up a Zenith model 120158. In the first place, the complaint was reading off-scale and low volume, and much time was wasted. I finally decided to try pot luck and replace the 50-mmf. condenser in the oscillator circuit (C4 on factory diagram), and presto, the set lined-up and performed as good as ever.

### WESTINGHOUSE WR-271

The Westinghouse WR-271 also gave plenty of trouble, which was a very quick cut-off, in fact so quick was this intermittent reception it was impossible to get the test prods into the circuit before the set would return to normal. Anyway (as usual!) everything but the right unit was suspected. By keeping the test prod on the plate, and watching when the break appeared, a quick deflection of the meter was noted. This happened 7 times in 5 minutes. The answer is, cut out and replace the 1,000-ohm resistor supplying plate voltage to the 6K8 oscillator-and-modulator tube, and your trouble will be ended.

F. NOSWORTHY,  
St. Johns, Newfoundland.

# Radio Service Data Sheet

## GENERAL ELECTRIC MODEL HJ-1205

12-Tube Superheterodyne; A.C. Operation; 3 Bands (540-1,600 kc., 2,300-7,000 kc., 7,000-22,000 kc.); Power Output (undistorted), 8.5 W.; A.V.C.; Tone Monitor; "Eye" Tube; Built-in, Rotatable "Beam-a-Scope" Antenna; Dual P.M. Dynamic Speakers, 1—12 in. and 1—6½ in.; 11 Pushbuttons (Keys), including keys for Phono, or Television Audio Channel.

See Data Sheet No. 278 for additional information and complete service diagram.

(Continued from Data Sheet 278)

### LOUDSPEAKERS

The voice coils are accurately and permanently centered at the factory and should seldom give trouble. In case a voice coil needs recentering it will be necessary to replace the entire cone and voice coil assembly.

Note: In no case should the magnet be removed from the assembled position without remagnetizing after replacing it.

### SPECIAL SERVICE DATA

The following information will be found very useful in servicing receivers if a vacuum-tube voltmeter or similar voltage measuring instrument is available.

#### (1) Stage Gains†

- (a) Antenna post to converter grid  
Band "B" (Beam-a-scope connected) \*—3 V. at 1,000 kc.  
Band "C" (Beam-a-scope disconnected) \*\*—3 V. at 4 mc.

- Band "D" (Beam-a-scope disconnected) \*\*—3 V. at 18 mc.
- (b) Converter grid to 1st 6SK7 grid, 30 at 455 kc.
- (c) 1st 6SK7 grid to 2nd 6SK7 grid, 6 at 455 kc.
- (d) 2nd 6SK7 grid to 6H6 det. plate, 70 at 455 kc.

(2) A 400-cycle signal of 0.04-V. across volume control will give ½-W. speaker output.‡ (Volume Control turned to maximum)

(3) Average D.C. voltage developed across oscillator grid resistor (R1) with gang closed.

- Band "B".....6.5 V.
- Band "C".....7 V.
- Band "D".....2.8 V.

†Variations of +10%, -20% permissible.  
\*Use I.R.E. dummy antenna.  
\*\*Use 70 mmf. condenser between signal generator and antenna post.

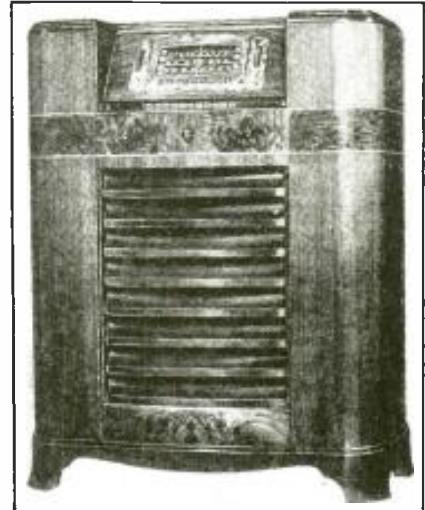

G.E. model HJ-1205 dual-loudspeaker receiver.

### ALIGNMENT PROCEDURE

The alignment procedure is given in table form. Use the designated "dummy" antenna in making each individual alignment. The I.F. alignment may be performed with the chassis removed from the cabinet and the Beam-a-scope disconnected. The R.F. alignment on "C" and "D" bands should be performed with the Beam-a-scope disconnected and a 70 mmf. mica condenser between the signal generator and the point of input. The H.F. alignment on "B" band should be performed with the chassis and Beam-a-scope mounted in the cabinet and properly connected.

#### I.F. ALIGNMENT WITH OSCILLOSCOPE\*

Band-switch Setting	Input Frequency	Tone Control Position	Point of Input	Trimmer	Comments
(1) Band B	455 kc. and 30 kc. Sweep	Bass	1st I.F. 6SK7 Grid	2nd I.F. Sec. 2nd I.F. Pri.	Condenser gang at minimum capacity—vertical input to ground and junction at R8, R9, and R10. Adjust trimmers in order mentioned for a single curve of maximum amplitude. The resulting curve on the "Bass" position is shown in Fig. 2a.
(2) Band B	455 kc. and 30 kc. Sweep	Bass	Converter 6SA7 Grid	1st I.F. Sec. 1st I.F. Pri.	The expanded curve taken with tone control at "Treble I" is shown in Fig. 2b. Excess sensitivity over "Bass" tone position indicates regeneration.
(3) Band B	455 kc. and 30 kc. Sweep	Bass	Converter 6SA7 Grid	All I.F. Trimmers	
(4) Band B	455 kc. and 30 kc. Sweep	Treble I	Converter 6SA7 Grid		

#### I.F. ALIGNMENT WITH OUTPUT METER\*

(1) Band B	455 kc. Modulated	Bass	1st I.F. 6SK7 Grid	2nd I.F. Sec. 2nd I.F. Pri.	Condenser gang at minimum capacity—manual key depressed—output meter connected across voice coil—volume control at maximum—input as low as practical. Adjust all trimmers in order listed for maximum output. NOTE—Do not attempt alignment in the expanded position.
(2) Band B	455 kc. Modulated	Bass	Converter 6SA7 Grid	1st I.F. Sec. 1st I.F. Pri.	
(3) Band B	455 kc. Modulated	Bass	Converter 6SA7 Grid	All I.F. Trimmers	

#### R.F. ALIGNMENT

(1) Band B					Mechanically adjust dial pointer to first line at left-hand end of dial scale with condenser gang fully meshed. Connect output meter across voice coil.
(2) Band C	6 mc. Modulated	Bass	Antenna Post**	Osc. (C6) Ant. (C7)	Set pointer to 6 mc. mark and align C6. Peak C3 for maximum output.
(3) Band D	21 mc. Modulated	Bass	Antenna Post**	Osc. (C7) Ant. (C4)	Set pointer to 21 mc. mark and align C7. Peak C4 while rocking gang condenser. The image of any signal on the "D" band should be 910 kc. below input signal. Example: 15 mc. image 14.09 mc.
(4) Band B	580 kc. Modulated	Bass	Antenna Post***	Osc. Padder (C8)	Set dial pointer to 580 mc. mark and tune in signal with C8.
(5) Band B	1,500 kc. Modulated	Bass	Antenna Post***	Osc. (C5)	Adjust C5 for maximum output in vicinity of 1,500 kc. while rocking gang condenser.
(6) Band B	580 kc. Modulated	Bass	Antenna Post***	Osc. Padder (C8)	Retrim C8.
(7) Band B	1,500 kc. Modulated	Bass	Antenna Post***	Osc. (C5)	Repeak C5.

\*Use "dummy" antenna consisting of 0.05-mf. condenser between signal generator and point of input.  
\*\*Use a "dummy" antenna consisting of 70 mmf. condenser between signal generator and point of input with "Beam-a-scope" disconnected.  
\*\*\*Use an I.R.E. "dummy" antenna as shown in Fig. 3 between signal generator and the point of input.

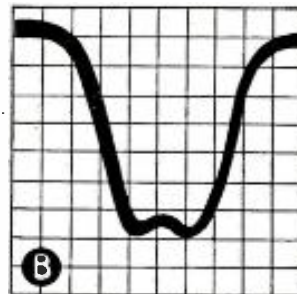
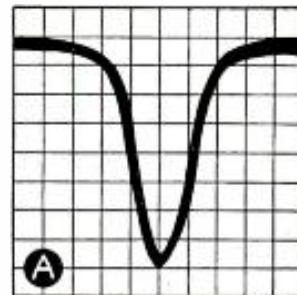

Fig. 2. I.F. curves. A, sharp position; B, expanded position.

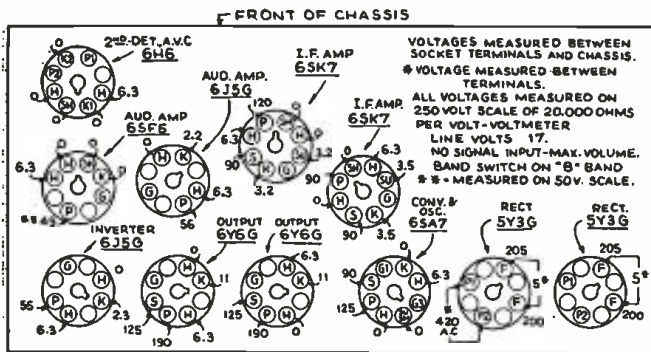

Fig. 4. Normal socket voltages.

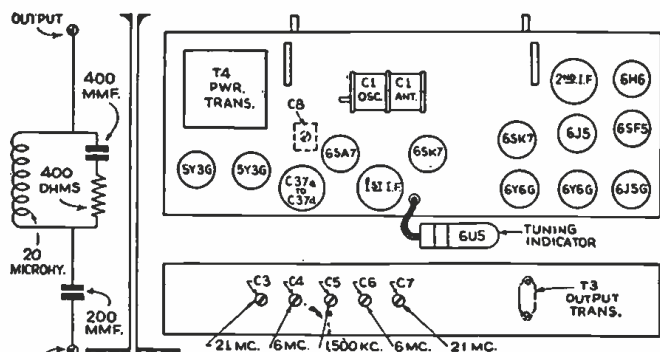
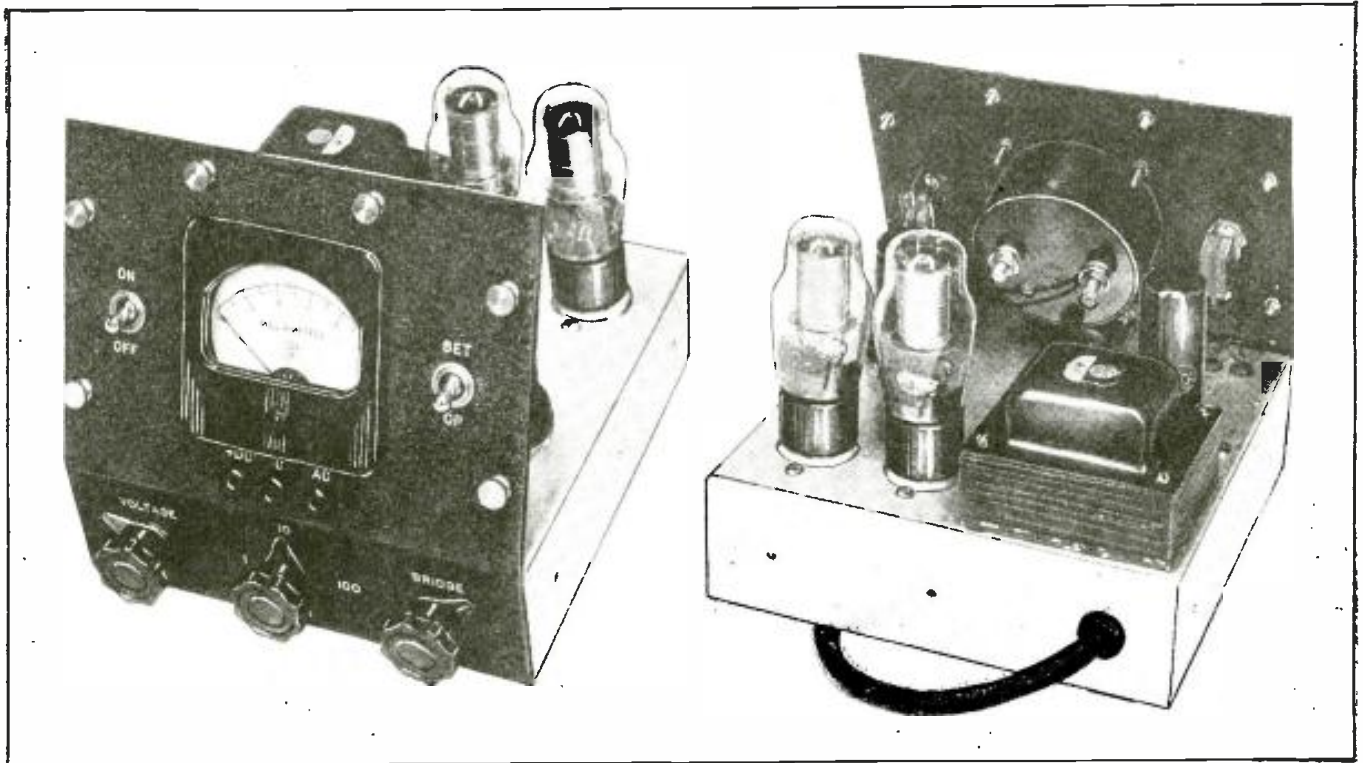

Fig. 1. Location of trimmers and, Fig. 3, circuit of I.R.E. dummy antenna.



*Build this Direct Reading Type*

## V.-T. VOLTMETER

*Constructional data for a modern, easily-built instrument with good sensitivity and stability. Convenience and reliability are obtained at a minimum of expense.*

RUFUS P. TURNER, *W1AY*

**T**HE scope of usefulness of the Vacuum-Tube Voltmeter in every type of radio work is now too well-known for recapitulation here. Everywhere, engineers, Servicemen, and amateurs are awake to the multitudinous applications of this instrument in radio measurements and appreciate its indispensability in very-high-frequency tests.

### V.-T. VM. TYPES

Vacuum-tube voltmeters in present general use fall into 2 main categories: (1) the more or less unpopular, though tolerated, *slide-back* type in which an unknown voltage deflects a sensitive tube-plate meter and the tube-grid bias voltage is adjusted to reset the meter to its original static reading (the peak value of the unknown voltage being equal to this bucking bias and read on a second meter); and, (2) *direct-reading* types in which the indicating meters are provided with special non-linear scales reading in peak volts or with standard scales interpreted by reference to graphs and charts.

The slide-back meter does not permit rapid manipulations and is not immensely useful except for measuring static voltages. Voltages that are constantly changing, such as those encountered in receiver alignment, are not readily followed with this instrument. And, because of the special meter scales or graphs and charts required, the second type is not easily built at home.

The vacuum-tube voltmeter shown here

is direct-reading, employing a regular 0-1-ma. meter as the indicating instrument with provision for multiplying the meter range for full-scale deflections of 1, 10, 100, and 500 peak volts. The instrument is inexpensive and possesses a good degree of accuracy. It may be built in a few hours, and no engineering tricks are necessary to secure ready and continuously-stable performance. Complete A.C. operation is afforded by this completely self-contained instrument.

### BASIC CIRCUIT

The basic circuit is one which was popularized sometime ago by Root, W9EHD, and the writer has added refinements which result in more stable performance and increased usefulness. Voltage regulation of the tube plate potential, for example, insures accuracy during long-term measurements and renders the instrument immune to line-voltage variations to the extent encountered in most localities. At the same time, this refinement, which is obtained through the use of 2 simple VR150 tubes, obviates the necessity of repeated resetting of the meter to zero. Unlike the basic circuit, also, is the method employed to set the proper operating voltage. Here, a potentiometer on the output side of the power supply is utilized, and the voltage regulator circuit maintains constant input to this resistor.

The values of the meter bridge resistors have been altered somewhat to permit

easier balancing, and the meter balancing resistor has been so altered in its resistance value that sufficient "leeway" is provided in its adjustment. The original 6Q7 voltmeter tube has been replaced with a 6SQ7 which affords lower input capacity, making the instrument more serviceable at the higher radio frequencies and eliminates the long, tube-top control-grid lead which very often will be affected by stray fields.

In developing this instrument, several layouts were tested with identical good results, which would indicate that the duplicator may exercise his own taste with regard to the placement of parts and arrangement of controls on the front panel. One warning need be heeded, however—the 6SQ7 tube must be mounted as close as possible to the input terminals and the range switch, Sw.1 (see Fig. 1).

### CONSTRUCTION

The complete circuit diagram is shown in Fig. 1. Unknown A.C. or D.C. voltages are applied to the banana-jack terminals at the left. Terminal C is a common, used for connection with one of the A.C. or D.C. input leads, while separate A.C. and D.C. jack terminals are provided for the other lead. The A.C. voltages may be of low, audio, or radio frequency.

The *meter range selector* is comprised by the single-pole, 4-position rotary switch, Sw.1, and an input voltage divider made up of R2, R3, R4, and R5. As may be seen, this



selector permits full-scale deflections of 1, 10, 100, and 500 volts.

The rotary switch is of isolantite construction to minimize losses when measuring radio-frequency voltages, and for the same reason the leads from this switch to the input terminals and to the 6SQ7 socket are kept as short as possible.

Resistor R2 will have to be made up of two 20-megohm units connected in series, R3 of a 5-megohm in series with a 4-megohm resistor, and R4 of 0.5-meg. and 0.4-meg. in series, since the values shown in the diagram cannot ordinarily be obtained as single units.

The triode section of the 6SQ7 is "fix-biased" by a 1.4-volt type bias cell secured in its holder close to the underside of the tube socket. In mounting this cell, care must be taken that the black electrode hangs down or is vertical, *never up*. If regular chassis-panel construction is employed and it is planned to use the instrument with the panel alternately perpendicular and parallel to the top of the work table, the cell may be mounted with its black electrode perpendicular to the chassis and facing the front panel. The cell then will never be improperly slung unless the unit is laid face down.

The indicating meter is a good 0-1 ma. instrument and is connected in a bridge circuit balanced by the 50,000-ohm volume control-type resistor, R6. Sw.2 is a double-pole, double-throw toggle switch which enables the meter to be switched in (in the SET position) as a regular 1000 ohms/volt D.C. voltmeter to check the plate voltage, and (in the OPERATE position) to its usual place in the V-T. Vm. circuit. The meter multiplier resistor, R9, transforms the milliammeter into a 0-500 V. D.C. voltmeter in the SET position of Sw.2.

The two VR150 voltage regulator tubes are connected in series, as shown, between "B<sub>+</sub>" and "B<sub>-</sub>" with the 5,000-ohm, 25-watt semi-variable resistor, R11, to limit the current through them to 30 milliamperes. Resistor R10 is a 0.1-meg. volume control-type variable resistor used to set the plate voltage to exactly 250 (read at half-scale on the meter when Sw.2 is in the SET position).

## ADJUSTMENT

When the wiring of the unit has been completed and checked, it will first be necessary to adjust the voltage regulator in the following manner.

Remove the connection from the "B<sub>+</sub>" end of R10 and insert a 0-50 ma. D.C. milliammeter in the lead (marked "X") to the first VR150 plate terminal. The slider on R11 is then moved along, with the power switched on, until the inserted meter reads exactly 30 milliamperes, the rated current for the VR150's. At this point, the slider is fastened securely, the milliammeter removed from the circuit, and the connections restored. The power supply will then deliver 300 volts of regulated D.C. to the potentiometer, R10, and the instrument will be ready for its initial adjustment.

Before proceeding to the adjustment, set the milliammeter needle carefully to zero on the scale by means of the zero-adjuster screw, throw the meter switch, Sw.2, to SET, and switch on the power. In this position of the meter switch, the instrument becomes a 0-500 D.C. voltmeter and as the heaters of the 5Z4 warm up, the needle will rise to some value between zero and 300 volts, depending upon the setting of R10. Set R10 such that the proper operating voltage of 250 is indicated by the exact half-scale deflection of the meter.

Then, with Sw.1 set on any range, Sw.2 is thrown to the OPERATE position and the meter bridge circuit balanced by adjust-

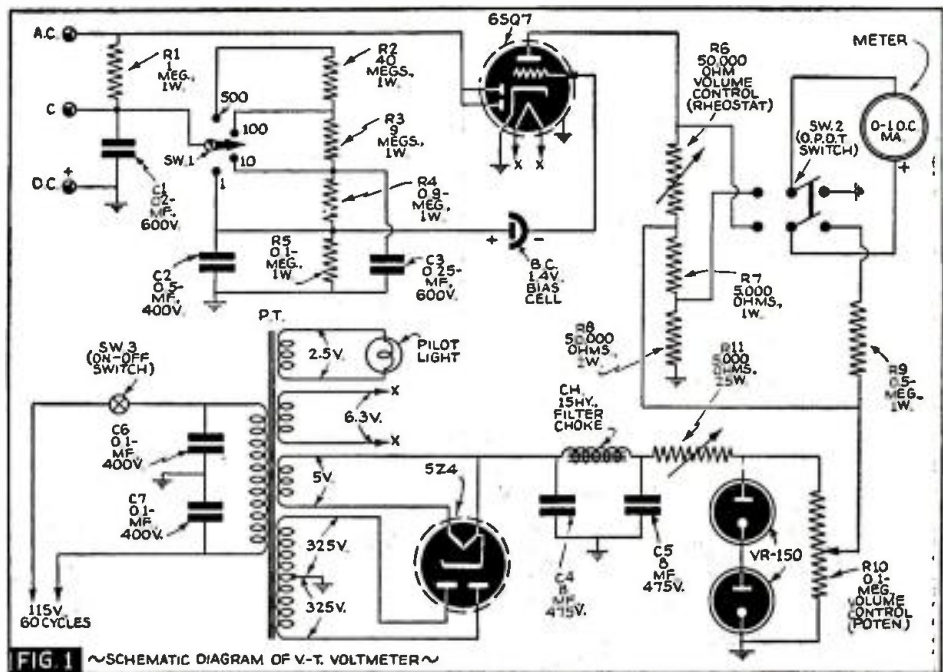

FIG 1 ~SCHEMATIC DIAGRAM OF V-T. VOLTMETER~

ing R6 until the meter reads exactly zero. At this setting, R6 should be about half of its maximum resistance value. The meter must be set to zero for each range selected by Sw.1, although the initial deflection will rarely ever be more than 20 or 30 microamperes if the instrument has once been set to zero on another voltage range.

When the V-T. Vm. is subsequently turned on after it has once been set to zero, the meter needle will rise rapidly with the warming up of the tubes to a high deflection, usually near full-scale, and will then settle back to zero.

## ACCURACY

After it has been "zeroed," the vacuum-tube voltmeter will be ready for checking against several standard voltages obtained through a suitable transformer and potentiometer and applied to the A.C. input terminals. A good A.C. voltmeter of known accuracy may be used to check these test voltages, but the operator must bear in mind that the A.C. meter will indicate r.m.s. values, while the vacuum-tube voltmeter will show corresponding peak voltages. Thus, the A.C. meter readings should be approximately 7/10th of those indicated by the V-T. Vm. Further tests may be made with known D.C. potentials applied to the D.C. input terminals.

Inaccuracies revealed by this test will most likely be traced to departures from indicated values in resistors R2, R3, R4, and R5. It is difficult to obtain highly-accurate commercial resistors in the highest of these values, and it will pay the builder to interchange several "identical" resistors in these 4 positions if discrepancies show up in this direction.

## LIST OF PARTS

### CONDENSERS

One Aerovox paper tubular, 0.02-mf., C1;  
One Aerovox paper tubular, 0.5-mf., C2;  
One Aerovox paper tubular, 0.25-mf., C3;  
Two Aerovox "Dandee" midget tubular electrolytic, 8 mf. each, C4, C5;  
Two Aerovox tubular, 0.1-mf., C6, C7.

### RESISTORS

One I.R.C. BT1 1 meg., insulated, R1;  
One I.R.C. BT1 40 megs., 1 watt, insulated (made up of two 20-meg. resistors in series), R2;  
One I.R.C. BT1 9 megs., 1 watt, insulated (made up of one 7- and one 2-meg. resistor in series), R3;

One I.R.C. BT1 0.9-meg., 1 watt, insulated (made up of one 0.5-meg. and one 0.4-meg. resistor in series), R4;  
One I.R.C. BT1 0.1-meg., insulated, R5;  
One I.R.C. potentiometer, 50,000 ohms, metallized, R6;  
One I.R.C. BT1 5,000 ohms, 1 watt, insulated, R7;  
One I.R.C. BT2, 50,000 ohms, 2 watts, insulated, R8;  
One I.R.C. BT1 0.5-meg., insulated, R9;  
One I.R.C. potentiometer, 0.1-meg. metallized, R10;  
One I.R.C. type DHA power resistor with slider, 5,000 ohms, 25 watts, R11.

### TUBES, ETC.

Two RCA VR150 voltage regulator tubes;  
One RCA 6SQ7;  
One RCA 5Z4.  
One Centralab type 2542 Isolantite single-pole, 4-position rotary switch, Sw.1;  
One H-H, 1/2-in. stem, double-pole, double-throw toggle switch, Sw.2;  
One H-H, 1/2-in. stem, single-pole, single-throw toggle switch, Sw.3;  
One Mallory 1.4-volt bias cell, B.C.;  
One Mallory bias cell holder;  
One U.T.C. Type R1 power transformer; 325-0-325 V. at 40 ma.; 5 V.; 6.3 V.; 2.5 V.; P.T.;  
One U.T.C. type PC4 midget filter choke, 15 henries, Ch.;  
One Simpson 0-1 ma., model 27, 3-in.-sq. milliammeter, meter;  
Four National Type CIR-8 ceramic octal tube sockets;  
Three National Type FWE banana jacks, A.C., +D.C., C.;  
Three Gordon fluted finger-grip knobs with transparent pointers;  
One A.C. cord with male plug;  
Six miniature live-rubber grommets for meter and switch leads through chassis;  
Six thumb-screws for fastening front panel to case;  
One Par-Metal cadmium-plated chassis, 7 x 7 x 2 ins. high;  
One 1/16-in. aluminum panel, 7 x 7 ins., bent along a line 2 ins. from bottom (as shown in front view photograph);  
One steel case. This is 7 x 7 x 6 1/4 ins. high. It may be formed-up and spot welded at little expense out of 0.054-inch steel by any local sheet metal shop to fit the chassis and sloping front panel. Such a case reduces the susceptibility to stray fields.

Save Servicing Time  
**MAKE MORE MONEY**

**New RCP**

MODEL 414  
(Open Face)

**Master  
Multi-  
Purpose  
Meter**

ONLY  
**\$21.95\***

NET



RCP's system of AC measurements insures higher accuracy, greater ruggedness, far more sensitivity (2000 ohms per volt). A.C. scales linear, coinciding with D.C. Eliminates crowded calibration and confusion in reading. Model 414 includes direct reading capacity meter, 5 individual ranges measuring from .0001 to 300.0 MFD. Capacity scale easy to read from end to end. Five ohmmeter ranges, with self-contained power supply measuring from .05 ohms to 15 megohms. A total of 42 ranges for measurement of Output, A.C. volts, D.C. volts, D.C. current, inductance and Capacity Resistance. Masterly engineered, with many unique features. RCP Model 414 far outclasses the ordinary type of multi-range, multi-purpose meters. Money never bought a better value! Available in a variety of combinations to suit individual service requirements. Model 414P, portable as illustrated, \$24.50.

\*Other models with 7" and 9" meters.  
Write for new Catalog No. 122

**RADIO CITY**  
PRODUCTS CO. INC.  
88 PARK PLACE, N. Y. C.

**A "LAB" to  
fit your pocket**

**Readrite  
RANGER**

MODEL  
**739**

**\$9.90**

Dealer Net  
Price



**A.C.-D.C.  
VOLT-OHM-MILLIAMMETER**

Pocket Volt - Ohm - Milliammeter with Selector Switch. Molded Case. Precision 3-Inch Meter with 2 Genuine Sapphire Jewel Bearings. AC and DC Volts 0-15-150-750-1500; DC MA. 0-1.5-15-150; High and Low Ohms Scales. Dealer Net Price, including all accessories, \$9.90

WRITE FOR CATALOG

SECTION 616 COLLEGE AVENUE

**READRITE METER WORKS, Bluffton, Ohio**

The compact, professional-appearance test instrument and its metal case. A low-range A.C. voltmeter plus a low-voltage, high-current, filament-type transformer are combined into a modern, highly-useful servicing test instrument.

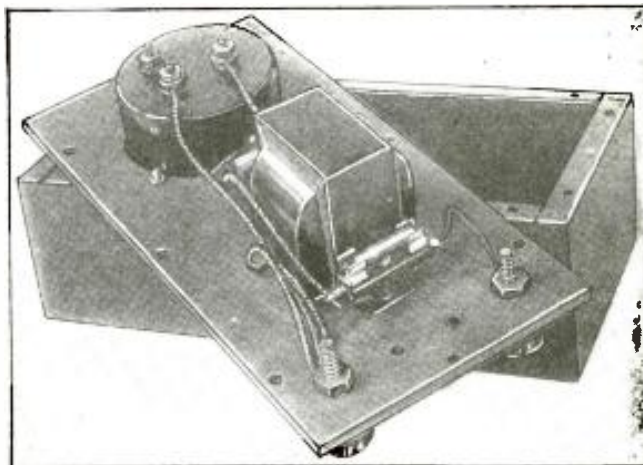

**MEASURING HIGH VALUES OF A.C. VOLTAGE AND CURRENT WITH A LOW-RANGE METER**

GERALD J. LAUBENTHAL

**O**FTEN a technician has an occasion when he would like to know the value of the applied potential or the amount of current a particular appliance is actually drawing, but the need will not warrant the cost of such a meter. This need can be filled with a low-range A.C. voltmeter operating in conjunction with a transformer. For current measuring, the transformer is used as a current transformer, and for voltage measurements it is used as a voltage step-down transformer.

The current transformer is nothing out of the ordinary. It is simply an ordinary transformer used to "ratio-down" current in the same manner that it does voltage, and is connected in the circuit in a somewhat different fashion.

In all transformers the product of the amperes, multiplied by the number of turns, in the primary P must equal that of the secondary S (when the losses in the transformer are neglected). Since the instrument (transformer and meter) is to be calibrated the losses will automatically be taken into account and as a result can be neglected.

With this fact in mind it is evident that a transformer with a high turns-ratio will have a large current flowing in the winding S of a few turns while a small current will be flowing in the winding P containing many turns. This is what occurs in the current transformer; the current to be measured is allowed to flow through the winding S and the meter is used to measure the current flowing in the winding P as shown in Fig. 1.

For general radio shop purposes, a low-voltage, high-current filament transformer can be used satisfactorily. The writer used a 110-V. to 2.5-V. 8-amp. filament transformer in conjunction with a 15-V. Triplett A.C. voltmeter with the multiplier removed, making it about a 3-V. meter that drew about 70 ma. for full-scale deflection.

It is not advisable to use a rectifier-type meter on account of the low operating current and the uneven characteristics of the rectifier. For best results, the current that is allowed to flow in winding S should not exceed 60% of the manufacturer's rating. Beyond this point the core will start to saturate and the magnetic flux will not be in direct proportion to the magnetizing current.

To obtain a high degree of accuracy the instrument should be calibrated with another meter. However if another meter cannot be had, a fair degree of accuracy can be obtained by using new electric light

bulbs operating at rated voltage for load and using the formula:

$$\text{Amps.} = \frac{\text{Total watts of bulbs burning}}{\text{Applied volts} \times 0.85}$$

This is assuming a power factor of 85% which is about the average for distribution systems. When using this method the instrument should be calibrated several times at different times of the day and an average taken, throwing out any set of values that seem to be radical.

For voltage measurements the meter and transformer are connected as shown in Fig. 2. If the meter is accurately calibrated in volts to start with, calibration for this arrangement of the instrument is not necessary, as the potential can be obtained by multiplying the meter reading by the turns-ratio of the transformer. In the writer's case potential calibration was necessary on account of removing the multiplier to reduce the voltage range of the meter. The potentials to be measured by this instrument should not exceed the manufacturer's rating more than 25% and then should be used for only short intervals at this overrating.

A combination of the 2 arrangements is shown in Fig. 3 using a D.P.D.T. switch to make the changeover from one set-up to the

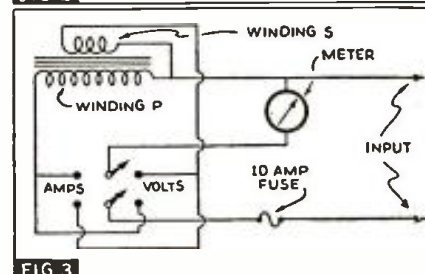
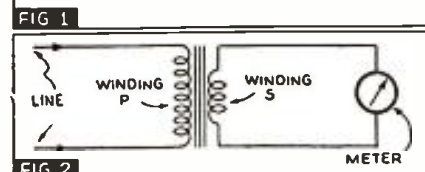
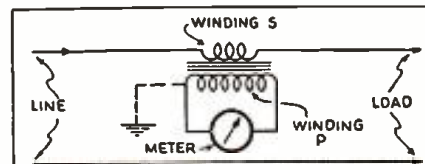

## •TEST INSTRUMENTS•

other. This changeover should never be attempted while the instrument is connected to any circuit. A 10-A. fuse was inserted in one of the legs of the input circuit to prevent damage to the instrument if voltage was accidentally applied while the change-over switch was in the "Current" position.

**WARNING:** When using the transformer as a current transformer as shown in Fig. 1 the secondary to which the meter is connected should always be kept in a closed circuit and under no condition should it be opened when power is flowing in the other winding of the transformer for it is possible to start an arc that could result in serious injury to the operator. As a safety precaution one side of the meter circuit should be grounded if the transformer is to be connected in circuit having a voltage exceeding 220 V.

### SERVICING PUZZLERS (Solved by the use of test equipment)

● **Fading, Hum, and Defective Tuning Eye.**  
A 15-tube RCA receiver model 15-K was brought in with complaints of fading, noise, too much hum, distorted tone and a defective tuning eye. A check of the tubes disclosed that 2 needed replacing. One had an open element, the other leakage between elements, according to my Weston meter.

Using an audio oscillator in checking the audio amplifier (in conjunction with an output meter) fading and noise were indicated. The trouble was run right into the speaker. With the ohmmeter, which would read 0.25-ohm easily, a resistance varying between 0 and 4 ohms was found in the voice coil; sweating its connections removed this trouble. With the exception of hum the audio amplifier checked OK, and had a flat response over most of the audio band.

Leaving the output meter connected, the hum was easily read on the Low scale. When the volume control was retarded, the hum decreased, indicated trouble ahead of the audio amplifier. By shorting-out the grids of the preceding tubes, the hum was localized in the stage between the 2nd-detector and 1st audio tubes. By grounding the metal case of the volume control (a replacement control) the hum disappeared. Since the A.C. on-off switch was mounted on this case, 60-cycle A.C. was being fed by capacity coupling into the 1st audio tube.

Using an R.F. signal generator and output meter, and by moving the oscillator up stage by stage, fading was localized in one of the I.F. stages. Check disclosed no defective parts. Removing the I.F. tube and connecting the signal generator from the chassis to the plate end of the I.F. transformer primary still indicated fading when the signal generator was not connected to the chassis; but, when connected right across the transformer primary, the fading disappeared. Ohmmeter disclosed a varying resistance between the chassis and the grounded end of the plate bypass condenser. A soldered connection solved this trouble.

By progressing forward with a V.-T.-Vm. and taking readings where D.C. voltages were supposed to be developed, it was found that the tuning eye control voltage was erratic, caused by a defective potentiometer. A new one brought the tuning eye back to normal.

Using my R.F. signal generator, and feeding an I.F. signal into the I.F. amplifier, I started the check for distortion. Using the oscilloscope as indicator, and varying the modulation of the signal generator with the wobulator, side-band cutting was very noticeable beginning about 1.5 kc. Using the instructions given in Rider's Manual

## ONE - OF - A - KIND

**Special Amplifiers and Sound System Installations  
Custom-Built to Your Specifications!**

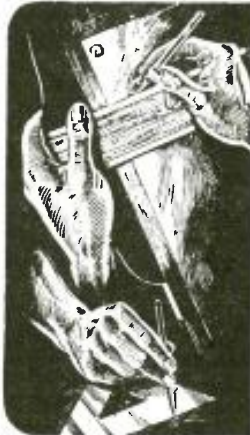

Because no two sound system requirements can be exactly alike, our designing and production staff is geared to create a special amplifier that meets your individual needs.

This One-of-a-Kind amplifier will cost no more than a mass production, all-purpose unit which may not so completely solve your sound problem.

Send your rough specifications to our chief engineer, and see what twenty years of specialized amplifier engineering can mean to you in terms of professional advice and lower costs.



**All Special Amplifiers Have Our Usual Five Year Guarantee**

**AMPLIFIER COMPANY OF AMERICA**

17 W. 20th STREET

NEW YORK, N. Y.

No. 7, which calls for flat-topping by using an oscilloscope, I very carefully realigned all R.F. and I.F. stages, which brought the set up to fine fidelity and at the same time improved its sensitivity and selectivity.

GORMAN L. BEDFORD

### ARE YOU HAVING ANY FUN?

THE present crop of radio sets are that certain way . . . for instance . . . a new RCA K-80, right out of the carton, has pushbutton tuning likely to break your thumb or index finger! A new Westinghouse 374-L arrives at the customer's home, direct from the warehouse of the distributor—and what do you suppose? The set is an RCA K-80 chassis, the knobs stick out too far, but the set plays swell, so the customer says OK she will keep it! However, they did do one thing—included an RCA K-80 instruction sheet!

General Electric sets are best of all. An H-107 arrives in factory-sealed carton, pushbutton tuning inoperative . . . and it is necessary to replace the entire permeability tuning system. A "bargain package" radio set arrives in sealed carton, is opened for inspection (we no longer trust anybody) and one of the pushbuttons is completely missing . . . ditto a Westinghouse 172, RCA T62 . . . not to mention several others. An Emerson arrives with the wrong batteries (it is a portable) . . . ditto a Zenith. A service call is made on a General Electric and the set is discovered to be a particularly brutal job of conversion to A.C.-D.C., with the plate of an audio driver tube connected to the cathode of the output tube, a beam power type, too! Further, perfect coupling was secured, since there was no bypass across the cathode resistor (which was of wrong value, anyhow)!

Sometimes, the radio receiver we take out of the carton does work without being serviced—and it is then we are so tickled we do not know what to do—it is such a unique experience!

WILLARD MOODY,  
New York, N. Y.

### NEXT MONTH—

That Tube Tester and Set Analyzer you've been asking for will be featured in a construction article in July Radio-Craft. Reserve a copy at your local newsstand today!!

## The NEW DOENUT Horn



Provides  
Wider  
Angle  
Coverage

Model  
DX8B

An entirely new development in exponential horns which provides unique features never obtainable before.

- Spreads high frequencies over a wide angle.
- Weatherproof.
- Wide frequency range.
- No metallic sound.

Write for complete details

### WRIGHT-DECOSTER, Inc.

2251 University Ave., St. Paul, Minn.  
Export Dept.: M. Simons & Son Co., New York  
Cable Address: "Simontrice"

Canadian Representatives:  
Wm. F. Kelly Co., 1207 Bay St., Toronto, Ontario  
Taylor & Pearson, Ltd., Edmonton, Alberta

### WEBSTER PHONO-MOTOR



Self-starting, rim-driven, constant-speed (78RPM). Friction-drive is preferable whenever driving torques are low and quietness is all important, as in a phonograph. Motor with 9" felt covered turntable operates on 117 volt, 60 cycle only. Shipp. wt. 6 lbs. Price Each . . . **\$2.69**

WE REQUIRE A 25% DEPOSIT WITH ORDER  
Write for Our Latest Bargain Parts Bulletin  
**ARROW SALES COMPANY**  
619 W. RANDOLPH ST. DEPT. RC-6, CHICAGO, ILL.

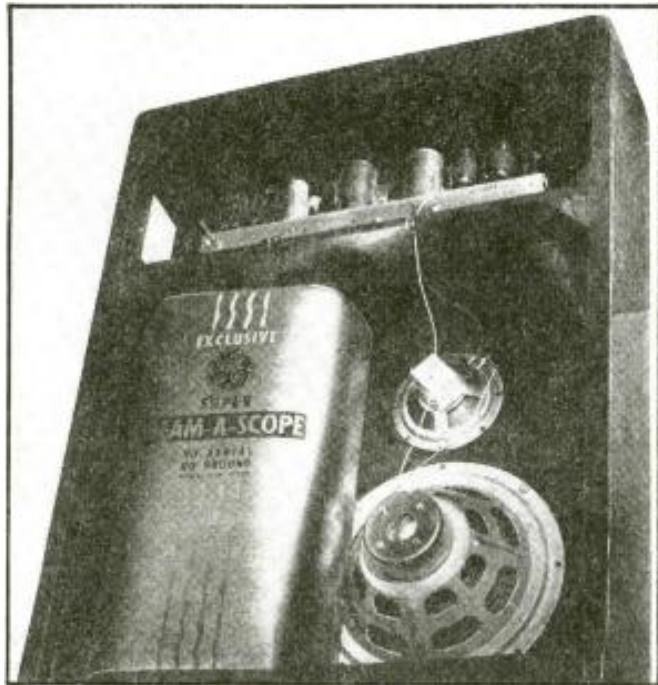

**T**HE difficulty of supplying the necessary field-coil power has been a restraining influence on attempts to use multiple speakers in the past. With the advent of permanent-magnet loudspeakers, this obstacle was removed. The engineer is now free to choose a combination of loudspeakers best suited to the desired result.

**Frequency Absorption.**—It often happens that, due to absorption by furniture, carpets and draperies, much of the high-frequency output of the loudspeaker in a radio receiver fails to reach the listener's ears. To alleviate this condition the 6½-in. speaker used in the G.E. dual-speaker radio set pictured here, is mounted at the top of the speaker baffle. The small diameter aids in this respect, for the center of the speaker is thereby nearer the chassis shelf. This all helps to get the high frequencies nearer to ear level.

**Frequency Distribution.**—Another problem is that of obtaining adequate distribution of the high frequencies over a wide angle. This is due to the fact that the diaphragm radiates the high frequencies in the form of a beam. The width of this beam depends upon the ratio of the diameter of the diaphragm to wavelength of the sound to be radiated, the larger this ratio, the sharper the beam. Now if a single speaker is chosen of sufficiently large diameter to be a good low-frequency unit, the high frequencies will be correspondingly restricted to a narrow beam.

Obviously, *dual speakers*—1 small and 1 large—offer a solution, for the smaller unit contributes wider angle high-frequency distribution, while the larger unit supplies adequate low-frequency radiation.

**Amplitude Distortion.**—If, in order to get the advantages of the high-frequency performance of a small speaker, it alone is used, a serious condition arises at the low frequencies. In order to move a sufficient volume of air the small diaphragm must undergo large axial movement. In so doing, distortion of the sound usually results, due to the limit of the elasticity of the diaphragm suspension being reached at the extremes of its movement. This is the consideration which led to the choice of a 14-in. speaker for the low frequencies. The large diaphragm can move the same volume of air with correspondingly smaller excursion.

**Fundamental Resonances.**—Most all receivers make use of the improved efficiency of the loudspeaker at its *fundamental resonance* to compensate for the limited baffle area which the cabinet provides. It often results in a peaked low-frequency characteristic which is unpleasant because of the dominance of this narrow range of tones. This condition is much less severe when 2 dissimilar speakers are used, as their resonances are staggered to provide this compensation over a wider frequency range with greater uniformity. A further advantage of the combined speakers is that their frequency characteristics may be made

## The Use of DUAL LOUDSPEAKERS

*The factors in choosing a speaker combination to produce a desired result, as compared to attempting to obtain the same result through the use of a single loudspeaker, are discussed by a factory technician in charge of receiver engineering.*

I. J. KAAR

complementary to each other. By proper choice of units one speaker will fill in where the other is deficient. The importance of this can best be realized from study of the sound pressure curves shown in Fig. 1.

**Series or Parallel Drive?**—For successful operation of multiple speakers equal consideration must be given to the *type of drive*. First is the question of series or parallel connection of the 2 speakers. This is answered largely by the type of output stage driving them. If the amplifier is a *constant-current* source, such as is approximated by a pentode or beam power output stage, the speakers should be connected in *parallel*. This will prevent the power delivered at resonance from rising due to the shunting effect of the speaker which is off resonance.

The impedance of a conventional loudspeaker is usually about 15% higher than the D.C. resistance of the voice coil at about 400 cycles. Above this frequency the impedance rises due to the inductance of the voice coil windings. Below 400 cycles it changes little except for the fundamental resonance region where the impedance rises rapidly to a peak at the resonant frequency. At this peak the resistance is several times that which is measured at 400 cycles. Below resonance the impedance drops to approximately the D.C. resistance of the coil windings. With constant current it is clear that the power delivered at resonance will be higher by the ratio of the resistance at resonance to the resistance at the 400-cycle reference point. The effect of a 2nd speaker not at resonance shunted across the one which is at resonance is obvious.

With *constant voltage* drive, which is nearly that of a triode or negative voltage feedback stage, the speakers may be connected in *either series or parallel*, the choice being determined by the result wanted. The series connection was chosen for the new G.E. receivers (as for instance the model HJ-1205 here illustrated) because the current fed to the speaker which is not resonating is reduced by the impedance rise of the one that is. This further reduces the peaking effect and smooths the low-frequency response. (The 2 voice coils in series are fed by a single secondary on the output transformer; no crossover network is used or needed. See Data Sheet in this issue.—*Editor*)

**Results.**—The 2 sound-pressure curves (Fig. 1) show the improvement effected by the 6½-in. and 14-in. combination over the single 14-in. speaker. These characteristics were taken under identical conditions with the microphone located midway between the axes of the 2 loudspeakers. The single 14-in. speaker characteristic was obtained simply by disconnecting the 6½-in. unit, and repeating the test. The same amount of electrical power was supplied in both cases.

*This article has been prepared from data supplied by courtesy of General Electric Co.*

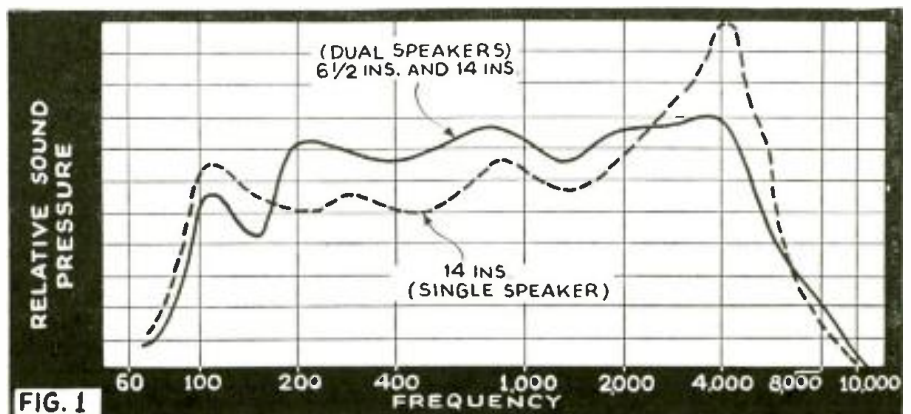

FIG. 1

CASE HISTORIES OF  
P.A. SALES

No. 9

MY first P.A. order came to me on July 5, 1938 when an electrician friend of mine and I were talking over a big contract he had just received from a local novelty firm. This company wanted a call system installed in their plant which occupied 1 floor of a downtown building.

I quoted my price for an 8-watt system, including 2 mikes and two 12-in. speakers of the P.M. type, and got the job. Troublesome noise from the electric razor test-bench was soon corrected by connecting the amplifier to another 110-volt house circuit.

I purchased a duplicate system from my profits on the job and placed it on sale in the shop. Many people tried the amplifier but none had the purchase idea in mind.

It gathered dust for almost 4 months until one day while reading through *Radio-Craft* I ran across an article suggesting the loan of small amplifiers to local women's club meetings, and immediately contacted a well known neighborhood club.

The women were so delighted with the idea of speaking through a mike that, after using the system off and on for 3 meetings, they purchased it at list price.

Since then I have sold 7 systems of the same type to similar organizations and two 20-watt jobs to local orchestras.

My shop is now equipped with two 8-watt systems for any neighborhood affair, which are so simple to hook-up and operate that they do not require my leaving the shop to run them.

The sound car is always in good demand and has proved, beyond a question of a doubt, to be a prized asset to my radio business.

P.A. does pay provided one does not worry about someone else having a better chance of doing the business.

CHRIS PALGEN,  
Chicago, Ill.

Chris won the 12th prize in the 1st Section of the \$4,000 P.A. Contest sponsored by Radio-Craft last year.

**DISTORTION HELPS  
TEST TELLY**

RADIO engineers have continually aimed to reproduce the waves created by music or the human voice free from distortion and in their natural form. The development of good amplifiers in radio receivers, or public address and sound motion picture apparatus, has all been directed towards distortion-free operation.

But in seeking apparatus for testing television circuits, RCA engineers found that waves having the maximum possible distortion were frequently the most valuable. So called "pure" waveforms or "sine" waves, of even, smooth slope would provide little or no indication of the time delay which improper circuits imposed. This delay was important since it might put white edges on dark objects in the television image or cause other difficulties.

But if the circuits were tested with "square" waves, having the maximum distortion from the pure form, it was relatively easy to tell whether the time delay was satisfactory. Hence a special square-wave generator capable of producing waveforms with straight sides and tops has been made available by the RCA Mfg. Co. for television service laboratories and manufacturers.

*Hot off the Press....*

This New 52-Page  
**RCA SOUND  
CATALOG!**

★  
Get a copy today  
from your nearest  
**RCA Sound  
Distributor!**



**Here are the contents of this catalog**

ACCESSORIES • AMPLIFIERS: Cables for Amplifier Remote Controls, Input Transformer, Mixer and Mixer Pads, Panels for Amplifier Cabinet, Remote Control Devices, Signal Mixer Units • ANTENAPLEX (Standard) • ANTENAPLEX (Multi-Wave) • Baffles • CARILLON (Electric Bells) • COMPLETE SOUND SYSTEMS • CONTROL CABINETS • HEARING AIDS • INTER-OFFICE COMMUNICATING SYSTEMS ("Telekoms") • MASTER CONTROL SYSTEMS (De Luxe) • MASTER CONTROL SYSTEMS (Junior) • MICROPHONES • MICROPHONE STANDS • MOBILE SYSTEMS • PORTABLE ADDRESS SYSTEMS • PUBLIC ADDRESS SYSTEMS (Series Systems) • RECORDING EQUIPMENT: Recording Blanks • 16 m.m. PROJECTOR • SOUND POWER TELEPHONES • SPEAKERS: Baffles, Field Supply Units, Housings, Matching Transformers • TURNTABLES • VOLUME CONTROLS

*Any sound system sounds better equipped with RCA Radio Tubes*



*Commercial Sound*

RCA Mfg. Co., Inc., Camden, N. J. • A Service of Radio Corporation of America

**A NEW BOOK ON  
P. A.**

An important announcement about the greatest book on the subject of sound and allied subjects appears on Page 710 of this issue. **TURN TO THE ANNOUNCEMENT NOW!**

WRITE TODAY  
ABOUT  
YOUR  
**AMPLIFIER PROBLEM**  
FREE  
INDIVIDUAL  
ADVICE ON SPECIAL  
OR STANDARD AMPLIFIERS  
AMPLIFIER CO. OF AMERICA  
17 WEST 20th STREET, NEW YORK, N. Y.

Our new address!

**RADIO-CRAFT**  
20 Vesey Street New York, N. Y.

**NEW AUDIOGRAPH  
Sound Catalog**

AUDIOGRAPH Sound Systems represent the latest in Sound Engineering and Design—a complete line plus pre-tested accessories.

**NEW LOWER PRICES**

Outstanding quality and performance at prices that help you meet any competition.

**WRITE FOR FREE COPY**

**JOHN MECK INDUSTRIES**  
1313 W. Randolph St., Chicago, Ill.

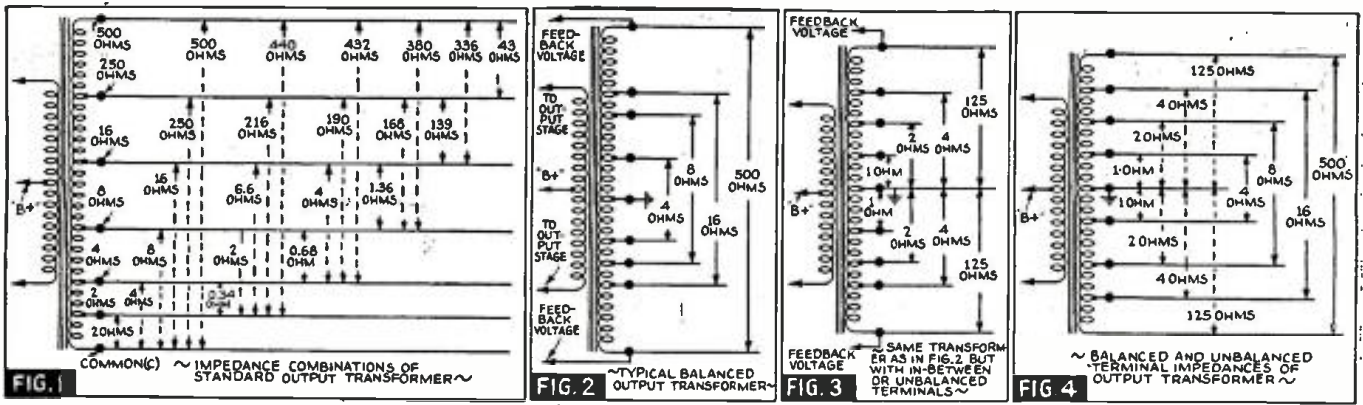

# SPEAKER-MATCHING TECHNIQUE

*A technical description of a number of unusual methods of matching the output of an amplifier to a wide variety of speaker loads. Many seldom used, but highly effective methods are disclosed. Every P.A. technician and amplifier enthusiast should read this article.*

H. S. MANNEY

THE fundamental principles involved in matching an amplifier to various loads have been discussed in an article titled "A.F. Amplifier Load-Matching Technique" in the March, 1940, *Radio-Craft* (see pages 538, 539 and \*575), covering simple calculations involved in determining the power distribution in speaker networks.

For the sake of simplicity, the effects of phase angle displacement will not be considered.

### IMPEDANCE OF IN-BETWEEN TAPS

In order to simplify calculations involved in determining the impedances between taps, Fig. 1 shows all possible impedance combinations in a standard output transformer equipped with 2/4/8/16/250/500-ohm terminals.

It will be noted that 18 terminal impedances are available as tabulated below:

Ohms Impedance	Between Terminals	Ohms Impedance	Between Terminals
0.34	2 & 4	43	250 & 500
0.68	4 & 8	139	16 & 250
1.36	8 & 16	168	8 & 250
2.0	C & 2	190	4 & 250
2.0	2 & 8	216	2 & 250
4.0	C & 4	250	C & 250
4.0	4 & 16	336	500 & 16
6.6	2 & 16	380	500 & 8
8.0	C & 8	440	500 & 2
16.0	C & 16	500	500 & C

### BALANCED OUTPUT TRANSFORMERS

Balanced output transformers are inter-coupling units of special design, wherein the center-tap is grounded and each side of the line equally balanced to ground. An input push-pull transformer may be considered as a balanced transformer. Likewise, an inter-stage push-pull transformer is balanced as both its primary and secondary windings are center-tapped. A typical balanced output transformer is diagrammed in Fig. 2.

These transformers are used in special applications. They are particularly recommended for use in all push-pull multi-stage

amplifiers employing inverse feedback. In fact, it is the most effective method of introducing feedback within such an amplifier, so that the feedback loop embraces the output transformer.

A balanced output transformer may feed into a balanced or unbalanced load. Balanced loading results when the output transformer is loaded in a conventional manner. If a load is connected across its corresponding terminals, the correct reflected load faces the power output stage. If balanced construction is employed in the amplifier and the transformer, the voltages appearing on either half of the loaded or unloaded secondaries, will be identical. This transformer, however, offers a number of other valuable methods of loading. Figure 3 shows the same balanced output transformer with unbalanced loading terminals.

As is well known, the impedance of a winding is directly proportional to the square of its number of turns. Thus, if the balanced 500-ohm winding is to be loaded in an unbalanced fashion only one-half of the winding is loaded. The impedance of this half equals the square of 1/2 (or 1/4), of the original terminal impedance, or 125 ohms. Therefore, if a 125-ohm load is connected across either half of the 500-ohm winding, it will be found that the correct reflected load faces the power output tubes.

The voltages, however, developed in either half of the balanced output, may not be exactly alike, because the co-efficient of coupling from the primary to the loaded half, may not be the same as the co-efficient of coupling to the unloaded section. Therefore, the balanced feedback voltages may be upset (if feedback voltages are not developed in this winding, this unbalanced loading will not otherwise affect the performance of the amplifier). Fig. 4 shows both the balanced and unbalanced terminal impedances of the transformer.

Different terminals of this output transformer may be loaded in an unbalanced fashion to provide the effect of balanced load. For example, if a 4-ohm speaker is connected across the 2-ohm terminals on one side of the transformer, and an 8-ohm speaker is connected across the 4-ohm terminals on the other side of the transformer, as illustrated in Fig. 5, then, not only will the reflected load be correct, but the feed-

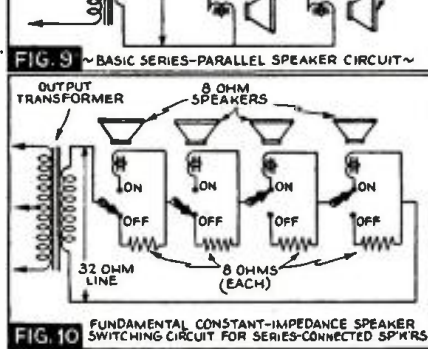
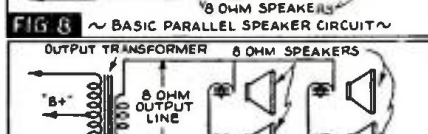
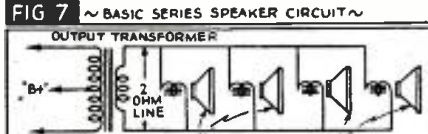
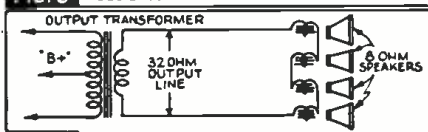
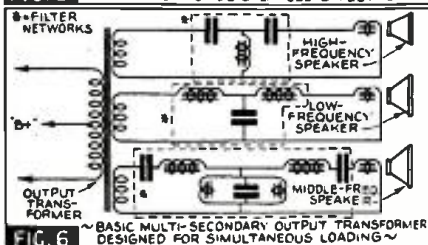
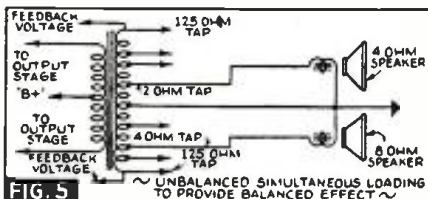

\* Editor's Note: A typographical error in reprinting Mr. Shaney's formula occurred on page 575 of the March, 1940 issue of *Radio-Craft*. The square root should not have included -1. The correct formula follows:

$$Z_x = Z_1 \left( \frac{\sqrt{Z_2}}{Z_1} - 1 \right)^2$$

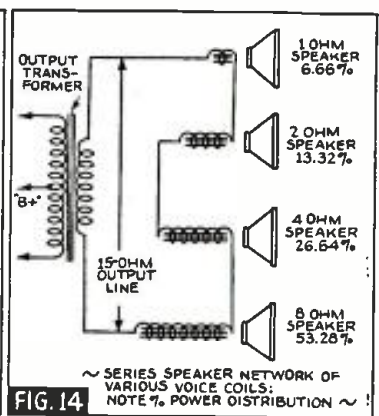
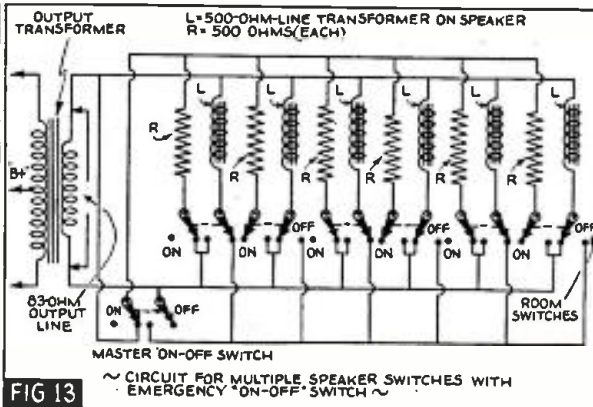
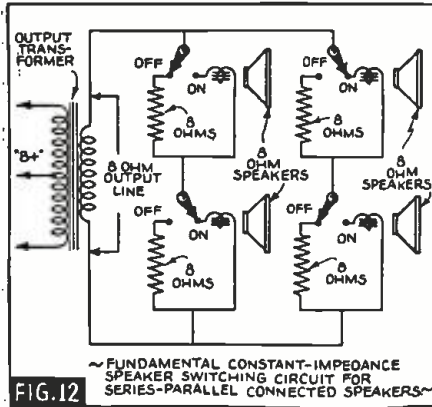

back voltages developed in either half of the 500-ohm winding may be considered for all practical purposes, equal. Furthermore, the output power of the amplifier will divide equally between both speakers.

This particular type of transformer offers a wide variety of load matching power-distribution combinations. Formulas involving practical applications are covered under the heading "Fundamental Formulas for Power-Distribution Calculations".

### MULTI-SECONDARY OUTPUT TRANSFORMERS

Transformers may be constructed with a number of insulated secondaries so as to feed 2 or more groups of speakers. Sometimes, these insulated secondaries may also be connected to frequency-discriminating networks, so as to provide for efficient coupling of high-, low-, and middle-frequency speakers. Such a basic circuit is shown in Fig. 6.

If a multi-secondary transformer is employed, it is important to know whether or not the unit was designed for simultaneous loading of all secondaries or single secondary loading. Naturally, the reflected plate load impedance will not be correct if the transformer is incorrectly used.

### POWER DISTRIBUTION SYSTEMS

In coupling a number of speakers to an output transformer, they may be connected either in series, or in parallel, or in series-parallel. The relative advantages and disadvantages of each method are outlined below:

#### Series Connections

- (1) Advantages
  - A. Relatively higher impedance lines used.
  - B. Relatively lower line losses.
  - C. Continued operation even though 1 speaker voice coil shorts.
- (2) Disadvantages
  - A. If 1 voice coil opens, all speakers go dead.
  - B. If identical speakers are not used in the same network, marked frequency discrimination occurs.

#### Parallel Connections

- (1) Advantages
  - A. No breakdown occurs if one voice coil opens.
  - B. Simplicity of wiring.
- (2) Disadvantages
  - A. Relatively lower impedance lines are used.
  - B. Relatively larger line losses are encountered.
  - C. Entire speaker system goes dead if 1 voice coil shorts.

Figures 7 and 8 illustrate typical series and parallel speaker arrangements. Figure 9 shows a typical series-parallel arrangement. One decided advantage of this latter arrangement is that when 4 identical speakers are connected in series-parallel, the

terminal impedance of the network is equal to the impedance of a single speaker.

### CHANGING LOADS—AND THEIR EFFECT ON REFLECTED IMPEDANCES

If a transformer having a turns ratio of 1 to 17.7 is used for matching a 2,500-ohm plate load into an 8-ohm speaker line, it is evident that any variations in the 8-ohm line will produce corresponding variations in the reflected impedance facing the tubes. For example, if two 16-ohm speakers are connected in parallel, across the 8-ohm line, the reflected load will be correct. If 1 of the speakers is switched out of the circuit, the reflected load will approximately double.

In order to avoid this condition, it is desirable to insert a dummy load resistor in place of the speaker should it be necessary to switch the speaker out of the circuit. Figure 10 shows a fundamental dummy load switching arrangement for parallel speaker distribution systems. Similarly, Fig. 11 shows a fundamental dummy load switching arrangement for series speaker distribution systems; and Fig. 12 shows a fundamental dummy load switching arrangement for series-parallel distribution systems.

For some applications, particularly in school room systems, it is sometimes desirable to provide a single master switch in addition to individual room selector switches, which will enable the operator to automatically switch all speakers into the system for emergency use. Figure 13 shows 1 method of accomplishing this result. It is to be noted that when the emergency switch is in the "on" position, all speakers are placed into the line circuit, regardless of whether their corresponding "on-off" switch is in the "on" or "off" position.

### FUNDAMENTAL FORMULAS FOR POWER-DISTRIBUTION CALCULATIONS

**Series Formula.** In a series speaker network, the power delivered to a speaker is proportional to the ratio of the speaker impedance to the entire series network impedance. Expressed mathematically this becomes

$$W\% = \frac{Z_s}{Z_{sL}} \times 100$$

wherein:

W% = percentage of power delivered to speaker

Z<sub>s</sub> = impedance of speaker

Z<sub>sL</sub> = impedance of series line

Figure 14 shows a network wherein 1-, 2-, 4-, and 8-ohm speakers are con-

nected in series, to provide a series line impedance of 15 ohms which may be connected to a 15-ohm terminal of an output transformer. Under this arrangement, the percentages of power delivered to the various speakers in this network are approximately distributed as follows:

Voice Coil Impedance	Percentage of Power
1	6.66%
2	13.32%
4	26.64%
8	53.28%

**Parallel Formula.** In a parallel speaker network, the power delivered to a speaker is inversely proportional to the ratio of the speaker impedance to the impedance of the speaker line. Expressed mathematically it becomes:

$$W\% = \frac{Z_{pL}}{Z_s} \times 100$$

wherein:

W% = percentage of power delivered to speaker

Z<sub>s</sub> = impedance of speaker

Z<sub>pL</sub> = impedance of parallel line

Figure 15 shows a network wherein 1-, 2-, 4-, and 8-ohm speakers are connected in parallel, to provide a parallel line impedance of 0.533-ohm, which may be connected to a 0.533-ohm terminal of an output transformer. Under this arrangement the percentages of power delivered to the various speakers in this network are approximately distributed as follows:

Voice Coil Impedance	Percentage of Power
1	53.28%
2	26.64%
4	13.4%
8	6.7%

**Series Parallel Formula.** In a series-parallel network, the power delivered to the speaker is proportional to the ratio of the speaker impedance to the total series branch impedance, and inversely proportional to the

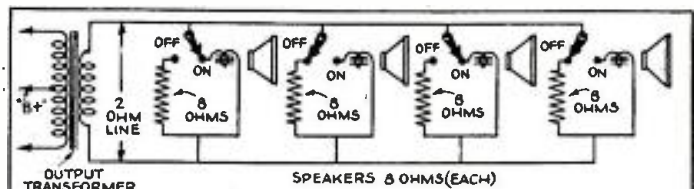

FIG. 11 ~ FUNDAMENTAL CONSTANT-IMPEDANCE SPEAKER SWITCHING CIRCUIT FOR PARALLEL-CONNECTED SPEAKERS ~

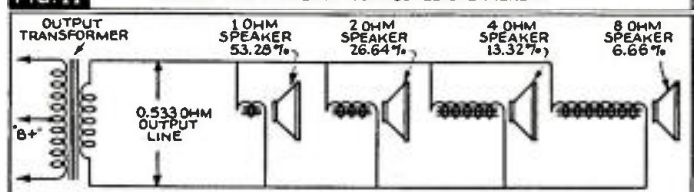

FIG. 15 ~ PARALLEL SPEAKER NETWORK OF VARIOUS VOICE COILS; NOTE % POWER DISTRIBUTION ~



**"HE SAYS THEY SHOULD HAVE USED UTAH SPEAKERS"**

There are important reasons for this increasing preference for Utah speakers among sound equipment men. They recognize the time proved dependability, uniformity and consistent high quality.

When Utah speakers are used, the benefit of these outstanding features, as well as many others, are obtained.

1. Special Utah phenolic resin cement treatment provides an extra sturdy voice coil assuring maximum safety under EXTREME OVERLOADS.
2. Completely dust-proofed.
3. All cementing operations completely cured before final test, assuring perfect centering, made possible THE MODERN METHOD—use of THERMO-PLASTIC cements throughout.
4. Rugged formed-steel cone housing for maximum strength and rigidity—rust-proofed, aluminum finish.
5. All diaphragms are lacquer treated to assure minimum moisture absorption.
6. Cone and spider assembly selected for maximum power handling and tone quality and minimum distortion and break-up.

*There is a Utah Speaker for every original equipment or replacement requirement.*

Utah speakers are distributed nationally through carefully selected, recognized parts jobbers and dealers. Look for the famous Utah trade mark on the carton. If your supplier can't furnish Utah speakers, write us direct.

**UTAH RADIO PRODUCTS CO.**  
826 ORLEANS STREET CHICAGO, ILLINOIS  
Canadian Sales Office: 560 King Street West  
Toronto, Canada  
Cable Address: Utaradio—Chicago

Three of the 90 different models of Utah Speakers



ratio of the impedance of the series branch to the line impedance. Expressed mathematically we have:

$$W\% = \frac{Z_s Z_L}{(Z_{sb})^2}$$

wherein; W% = percentage of power delivered to speaker

Z<sub>s</sub> = impedance of speaker

Z<sub>L</sub> = impedance of the output line

Z<sub>sb</sub> = impedance of the series branch

Figure 16 shows a network wherein 1-, 2-, 4-, and 8-ohm speakers are connected in series-parallel to provide a speaker line impedance of 2.4 ohms, which may be connected to a 2.4-ohm terminal of an output transformer. Under this arrangement, the percentage of power delivered to the various speakers is as follows;

Voice Coil Impedance	Percentage of Power
1	26.64%
2	53.28%
4	6.66%
8	1.32%

These 4 speakers could also have been connected, as diagrammed in Figs. 16A and 16B, to provide 2 other ratios of power distribution.

**POWER DISTRIBUTION CONTROL**—by selecting appropriate matching transformers.

It can be seen from the parallel, series, and series-parallel formulas that it is feasible to predetermine the amount of power to be fed into any speaker by selecting one of suitable voice coil impedance. Likewise, a matching transformer may be employed between the voice coil and the line. The impedance of the primary of the speaker transformer may be so selected, as to provide the required power distribution. For example, it is evident, that if two 1,000-ohm line transformers were connected to a 500-ohm line, the power distribution would be equal between both speakers. Similarly, any complex grouping of speaker transformers may be employed. For a specific example, let us assume that a country club installation requires the following power distribution from a 50-watt amplifier equipped with a 500-ohm output line:

Location	Amount of Power Required (watts)
Auditorium	20
Recreational Hall	10
Adult Dining Room	5
Children's Dining Room	5
Play House	4
Lawn	3
Garage	2
Kitchen	1

Assuming for the sake of simplicity that a single speaker is to be used at each of the

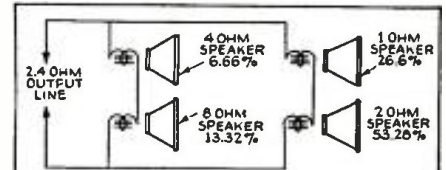

**FIG. 16** SERIES-PARALLEL SPEAKER NETWORK OF VARIOUS VOICE COILS; NOTE % OF POWER DISTRIBUTION

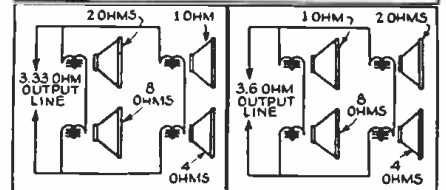

**FIG. 16A** **FIG. 16B** OTHER COMBINATIONS OF SERIES-PARALLEL NETWORKS; CALCULATE THE POWER DISTRIBUTION IN EACH SPEAKER

locations, the correct power distribution can easily be obtained by utilizing speaker matching transformers of the following impedances:

Location	Primary Impedance of Speaker Transformer (ohms)
Auditorium	1,250
Recreational Hall	2,500
Adult Dining Room	5,000
Children's Dining Room	5,000
Play House	6,750
Lawn	8,333
Garage	12,500
Kitchen	25,000

When all of these impedances are connected in parallel, the speaker line impedance becomes 500 ohms, and correctly matches the amplifier output.

The desired primary impedances can be calculated from the following formula:

$$Z_p = Z_L \frac{W_o}{W_s}$$

wherein: Z<sub>p</sub> = primary impedance of the speaker matching transformer  
Z<sub>L</sub> = amplifier output line impedance

W<sub>o</sub> = watts output of amplifier  
W<sub>s</sub> = desired watts into speaker transformer

**CONCLUSION**

While this article is not intended to be a comprehensive treatment of the subject of speaker matching technique, it is hoped that it will bring the reader a step closer toward solving some of his installation problems.

The writer will be pleased to answer all questions on this subject, if letters are accompanied with a self-addressed and stamped envelope.

**BOOK REVIEWS**

**BROADCAST RECEIVERS AND PHONOGRAPHS FOR CLASSROOM USE (1939).** Published by Committee on Scientific Aids to Learning, 41 East 42 St., New York, N. Y. Size, 6 x 9 ins., paper cover, illustrated, 95 pgs.

This report, prepared by John V. L. Hogan and R. M. Wilmotte, has been revised to take into account comments made by a number of educators and others, and hence presents the first, complete and accurate technical description of how radio may be best applied to schools.

The National Research Council's "Committee on Scientific Aids to Learning" has done a grade A job in presenting the essential factors in the selection of broadcast receivers and phonographs for classroom use. No technician interested in selling and installing radio and sound equipment can consider himself progressive until he has looked into the possibilities of installations in schools. In this connection, "Broadcast Receivers and Phonographs for Classroom Use" is an invaluable open sesame.

**Table of Contents:** Quality of Reproduction; Broadcast Receivers; Phonographs, Radio-Phonograph Combinations and Phonograph Attachments; Equipment for the Rural School; Some Underlying Engineering Considerations; Improvement of Classroom Acoustics; General Observations Concerning Prices; Broadcast Receivers; Phonographs; Radio-Phonograph Combinations; Phonograph Attachments; Equipment for the Rural School.

**SOUND WAVES—Their Shape and Speed,** by Dayton Clarence Miller (1937). Published by The Macmillan Co. Size, 6 x 8 1/2 ins., cloth cover, 71 illustrations, 164 pgs. Price, \$2.75.

This book is mainly a description of the Phono-deik (sound analyzing device) and its applications. However, it also presents a thorough analysis of sound and tone quality. The approach is mainly the result of a series of investigations made at the Sandy Hook Proving Ground.



# PROFITS IN RECORDING

*A manufacturers' representative concludes his description of how Servicemen may go about setting-up an "instantaneous recording" business for making spot recordings, on aluminum or acetate blanks, which may be immediately played back.*

SAM M. HARPER

PART II (Conclusion)

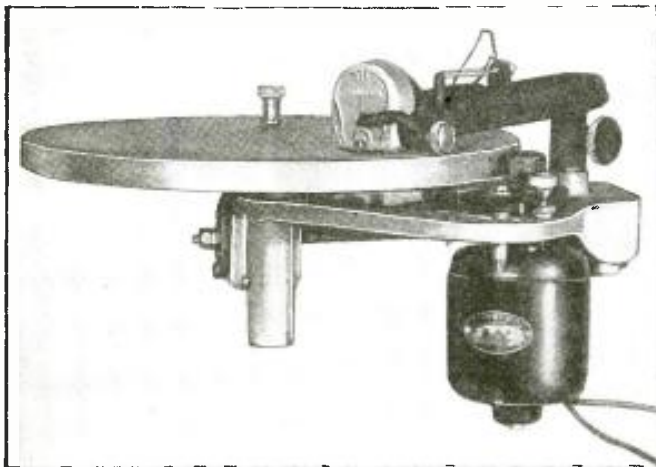

The Speak-O-Phone model 9M Basic Recording Mechanism is shown at left. Cuts 96 lines per inch at 78 r.p.m.; comes complete with cutting arm, recording head, heavy aluminum turntable (rim-driven), rubber silencing pad, and constant-speed motor. Servicemen will find it fits into almost any radio-phonograph cabinet, and that therefore it may be used on most modernizing or rebuilding jobs. Records on aluminum or acetate.

caused by movements on the floor. The front of the studio will, of necessity, have to consist of not only the lower portion being of heavy construction, double material, but should consist of 1 or 2 large, clear-view windows.

Drapes should be hung on all 4 walls at the time of installation. It may be found that at a later date some of the drapes will have to be taken off the walls, however, due to an extra deadening effect which may arise as a natural result in the process of recording. Care should be exercised in not getting the room too dead as this will overcome all effects of brilliance in recording piano and musical reproductions, and hence, they will not appear lifelike.

## SPEAKERS AND MIKES

In addition to the recorder in the studio you should also build a remote loudspeaker which should preferably be hung towards the ceiling at an angle facing the floor. This speaker should be of sufficient size and proper design to handle a wide range of frequencies. There is one psychological effect that might be mentioned here, i.e., if your speaker is of very high quality your customer will immediately notice the difference in quality when he plays the record back on his own reproducer thus giving you an opportunity to sell additional playback equipment at some later date.

Regarding microphones to be used in the enclosed-type studio it is suggested that you adhere to the types of microphones supplied by the manufacturer. There is one simple reason for this and that is the microphone manufacturer has built a microphone with a curve especially adapted to work with amplification used in that particular job. There are not any 2 manufacturers that use the same frequency curve in their amplifier. Most of these amplifiers are designed with a very definite cut-off below 300 c.p.s. and with a slight rise at 5,000 c.p.s. The low frequency cut-off is necessary to prevent line harmonics, and turntable and gear rumble.

If a different type of microphone is designed we would suggest that you purchase this unit from the manufacturer of the recorder for reasons stated above.

Most recorders have built-in provision for monitoring the recording either by meter or headset. The headset type of monitoring is far superior to the meter type due to errors caused by the dampening effect of the meter. (This is the author's opinion.—Editor)

## TIPS ON STARTING TO RECORD

When you start recording on acetate it is better for you to run a few test cuts on the record which you are to record which will permit you to adjust the depth of the cut. You will thus not run any chances of ruining an expensive recording. Before you start recording you will have to coach your customer in microphone technique and ad-

## RECORDING STUDIO

The first problem confronting the prospective studio operator is the matter of a suitable studio from which he is going to operate. Practically every dealer's store has ample space which can be devoted to the studio. Contrary to general thought it is NOT absolutely necessary to have a de luxe, soundproof room in order to make good recordings. The type of space available, however, does definitely limit the type of microphone equipment to be used.

When no space is available to build a completely enclosed studio it is suggested that the equipment be set up in one of the corners of the store. The walls in the corners should be hung with drapes to a distance of about 10 feet from the room corner. The microphone should be placed so that the performer faces the corner. Placement of this type will prevent reflections from too many walls and will result in better recordings.

If a piano is used in a setup of this type, it is suggested that a second microphone be used for the piano pick-up. This second microphone should be one of the various contact-type microphones now available on the market. This latter-type microphone should be fastened securely to some portion of the piano, preferably the sounding board. If the floor is of soft material and covered by heavy carpet it might be found necessary to place some sort of solid material such as glass coasters between the piano legs and the floor to overcome lack of brilliant piano effects during recordings. (\*)

When the studio is to be a closed type it is well to enclose all 3 sides with a double thickness of lumber or celotex. The floor unless of some soft, non-resonant (non-vibrating) material should also be covered with a double wall; or else some type of non-resonant material. This is to prevent noise from filtering into the studio, that is, noise

\* See "Simple Technique for Making Home Talkies," Radio-Craft, March and April, 1939.

THE Serviceman or dealer contemplating setting up a recording enterprise, the first and most important thing for him to do is to make a thorough study of the market for instantaneous recordings in his immediate vicinity. He should base this study upon the amount of business that he can reasonably expect to get from each and every type of prospect once he has become established.

After the desired type of recorder and accessory equipment has been selected\*, the immediate problem confronting the prospective studio operator is the matter of proper studio design, technique, operation and promotion of his services. None of these problems are difficult but they are important and should be given a good deal of thought.

\*See "Profits in Recording," Radio-Craft, May 1940.



The Record-O-Phone model RC-2 Portable Recorder—Playback instrument, illustrated above, affords immediate playback. Has crystal microphone; can be used independently as a P.A. system. Also provides for connection into radio set or P.A. system. Crystal cutter; 78 r.p.m.



At left is shown the RCA model MI-4814 Turntable for making high-quality recordings even on transcription-size discs 16 ins. in dia.; the leadscrew and cutting head are shown at lower-right. Instrument has heavy, rim-drive table; records at 78 or 33 1/3 r.p.m.; used with any available recording amplifier. Cutting mechanism is removable as shown. Has magnetic cutter, and magnetic

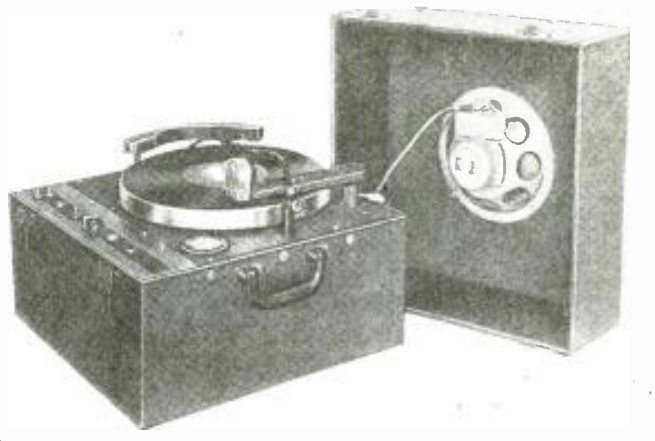

pickup. The new, Electrical Industries Mfg. Co.'s Leach model C-12 (kit) and CA-12 (completely assembled—see photo at right) Recorder-Playback instrument, can be assembled per instructions and drawings, or can be obtained "ready to go." Has special G.E. Co. split-phase, capacity-type, constant-speed motor. Crystal pickup; magnetic recorder. Cuts 12-in. blanks at 78 r.p.m.

just the placement of the microphone to prevent ruining the recording.

This can be done easiest by having the person go through the regular motions of recording but without actually recording on a record.

Your instructions to the customer should be complete so that once the actual recording is begun it can go right through without a hitch.

Constant monitoring is necessary to prevent both overcutting and undercutting. The gain, however, should not be run up and down thoughtlessly. It has been found in practice that if the gain controls are set at a pre-determined point, depending upon the volume necessary to handle the volume of your customer, that you have to make only minor adjustments during the actual recording—such as lowering the occasional peaks and bringing up the low volumes. It is not suggested, however, that the low passages be brought up by the gain control because this sometimes destroys the intentional contrast of the recording.

Before starting to record, make sure that the recording needle is sharp, otherwise you stand a good chance of turning out a recording with "wows" painfully present. This can be understood when you realize that the amount of material cut by the needle is not always the same, and when a deep cut comes along the needle being dull does not cut fast and clean, thus slowing down the turntable. A variation of only 5% in turntable speed will change the pitch of a note 1/2-key and even the untrained listener can readily recognize a 1% variation. These variations arise from many sources generally connected with the turntable and driving mechanism.

## PLAYBACK

Instantaneous recordings can be played back immediately and should be an actual "mirror" of the person's voice, etc.

You should be careful not to play back the record at high volume. Play it back at approximately the same level at which it was recorded. If in your selection of recording equipment you were particular as to frequency response you should be able to turn out recordings that are the equal of commercial records.

Any system intended for the reproduction of speech and music should be capable of transmitting each tone from the lowest frequency to the highest in its exact original proportion if a perfect reproduction is to be attained. Going back for a moment to a

previous statement regarding the amplifier curve being cut-off below 300 c.p.s.—this is a necessary limitation because, due to the inherent qualities of the cutting head, if the intensity of the lower frequencies were not reduced, the amplitudes of the wavers of the grooves would be so great as to cut into the adjoining groove.\*

## RECORDS

Most of your recordings will probably be made on acetate records because your customer recognizes the black color of most acetate records and immediately connects it with the commercial disc. The coated disc while it offers quieter recordings and somewhat wider frequency response suffers in comparison with the aluminum disc as regards life. The coated disc has a rather short life while the aluminum disc will last for years. The studio operator must watch his stock of coated discs and always keep fresh ones on hand. Coated discs have a tendency to dry out and when this happens not only does the recording become noisier but due to the hardness of the material the life of the cutting needle is considerably shortened, whereas, when recording on aluminum records none of these troubles are encountered and since a diamond needle is used it lasts practically forever. Due to the lower initial cost of aluminum discs the studio operator is able to offer recordings at a much more attractive price than when coated discs are used. This lower price appeals particularly to schools and group recordings.

The recording machine should be cleaned and oiled regularly. The thread cut from coated discs gets entangled around the motor drive shaft, spindle shaft and in the gears, and unless removed will, very definitely, affect the turntable speed and stability. A good grade of oil such as S.A.E. No. 10 motor oil or special dynamo oil such as Sinclair Cordymo should be used throughout the mechanism. If the tracking mechanism is one that incorporates a driving pulley between the motor shaft and the turntable rim this idler pulley bearing should be taken care of and cleaned religiously; else dirt will collect, and wear will take place which will tend to make the pulley run unsteadily and set up a noise that will be transferred to the recordings.

Since most recording studios will eventually be operated by radio dealers one of the methods of getting customers at the lowest possible expense is entirely in your hands.

\*See "Pickups on Parade," Radio-Craft, May and June, 1935.

You should maintain a good portable recorder which should be taken on service jobs, etc., because the Radio Serviceman is one of the few business men having something to sell who is actually INVITED into the customer's home. It certainly would be a business builder to make a short recording of some member of the household, thus acquainting them with a service you have to offer.

Recording, both home and studio, is definitely here and it behooves radio dealers and Servicemen to grasp it at once before it is taken over bodily by some other group. A studio properly equipped and operated can very easily and quickly become as important as any other phase of your business and certainly more profitable than some of them.

The author of this article is Manufacturers' Representative for The Turner Co.

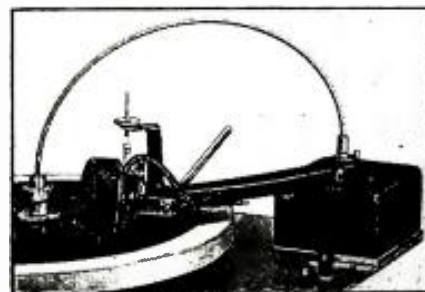

The Sound Apparatus Co.'s Simplex Recording Mechanism shown above makes possible recordings "with absolute uniformity," states the manufacturer, on all types of record materials, on any turntable, with any recording head. The radial-drive, flexible shaft of this recorder is said to operate without backlash; a wormgear ratio of about 5,000-to-1 permits the use of lower-torque motors than usual.

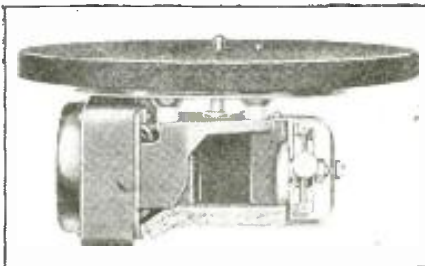

Here is a compact assembly. The General Industries Co.'s popular model RG Heavy-Duty Electric Recording Motor, for building-up recorders; model RG cuts up to 12-in. records at 78 r.p.m.; model RG3, at 33 1/3 r.p.m. Unit is direct-drive, governor-controlled; motor is self-starting induction type.

# SOUND ENGINEERING

Free Design and Advisory Service  
For Radio-Craft Subscribers

Conducted by A. C. SHANEY

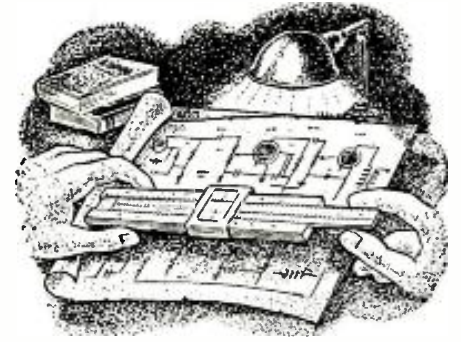

This department is being conducted for the benefit of RADIO-CRAFT subscribers. All design, engineering, or theoretical questions relative to P.A. installations, sound equipment, audio amplifier design, etc., will be answered in this section. (Note: when questions refer to circuit diagrams published in past issues of technical literature, the original, or a copy of the circuit should be supplied in order to facilitate reply.)

No. 6

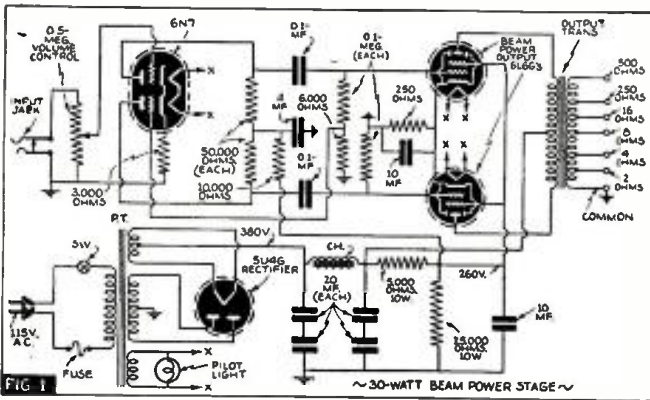

## 30-WATT POWER STAGE

### The Question . . .

Please give me a sketch of a 25- or 30-Watt Booster Amplifier using a pair of 6L6's in the output and a suitable driver. Please include a method of coupling to a standard amplifier.

MYLE H. CANDEE,  
Candee Radio Shop,  
Pasco, Washington.

### The Answer . . .

A circuit diagram of a 2-stage booster amplifier with a self-contained power supply is given in Fig. 1. This unit uses a pair of 6L6G tubes in a conventional circuit. You will note that a high-impedance input circuit is employed, which makes it excellent for bridging across the output of any amplifier. This amplifier can be connected directly to a 500-ohm tap of any standard amplifier.

driver amplifier be kept at a minimum. Otherwise, excessive hum will be present in the output of the power amplifier.

Because no grid current is drawn by the power amplifier, any number of these may be connected across any driver amplifier so as to provide higher power outputs of 60, 90, or 120 watts. The output transformer of the power stage should have a primary impedance of 6,600 ohms, and may be obtained from any transformer supplier. The power transformer should be capable of delivering 380 volts at 200 ma. No special precautions need be taken in constructing this unit.

## 25-WATT HIGH-FIDELITY AMPLIFIER

### The Question . . .

Kindly give me some information on a P.A. amplifier I am going to build. I would

like a design on an amplifier using remote control on 2 microphones and 1 phono input. Two additional microphones and 1 other phono input should also be incorporated. Electronic mixing should preferably be employed. The circuit should also include constants for a dual tone control for independent (individual) variation of bass and treble frequencies. The output may be standard, using 6L6 in inverse feedback, delivering about 18 to 30 watts of output (good tone quality).

Please describe such an amplifier, and if possible, give all values and parts.

I am a subscriber of your magazine *Radio-Craft*, and can hardly wait for it to arrive each month. I think your magazine is the best technical publication for the radio Serviceman and sound man.

Keep up the good work in the radio and sound field for the year of 1940. The articles and designs you describe are very interesting, and I hope that you will keep this Sound Department running continuously in your magazine, giving new designs and latest technical data as it becomes available. I would like to see articles and design information on remote control P.A. systems, dual tone control circuits, etc.

CLYDE E. RASMUSSEN,  
San Francisco, California.

### The Answer . . .

A circuit diagram of the type of amplifier you desire is given in Fig. 2. This amplifier will deliver 26 watts at 5% total distortion, 20 watts at 1%, and 10 watts at 0.9%.

It will be noted that 6 6SF5 input tubes are employed. They all utilize the method of remote control system described in the Dec., 1939 issue of *Radio-Craft* (see page 342). This control circuit is admirably adapted for either remote or local control. If remote control is to be employed, naturally, the ½-meg. volume control is located at some remote point and is connected to

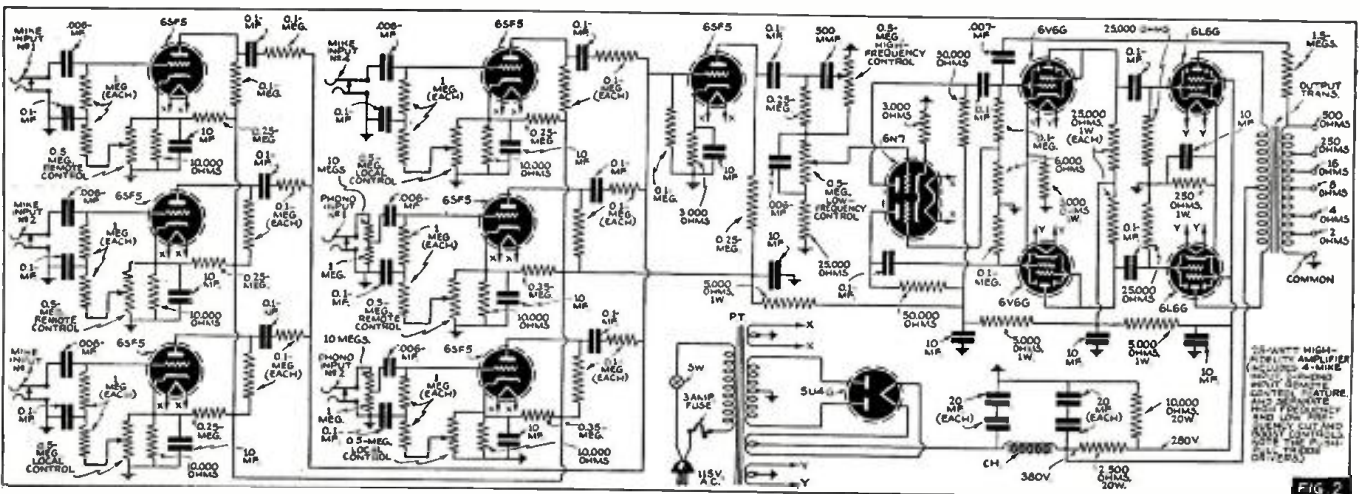

**WRIGHT**  
**W**  
**INC.**



**WRIGHT**  
*Verified*  
**SPEAKERS**  
**MAKE CUSTOMERS**  
**AND FRIENDS**

*Catalogue mailed on request*  
**WRIGHT, Inc.**  
St. Paul, Minn.

SOUND MEN WILL WELCOME

**New! ATLAS SOUND**  
**'MORNING GLORY'**  
Double Re-entrant Type Projectors



\* Here you have the ultimate in high acoustic conversion efficiency... NEW "Morning Glory" Projectors and "Dyna-Flux" Permanent Magnet Compression Type Speaker Units... 100% STORM-PROOF, COMPACT, and EXPONENTIAL AIR COLUMNS. \* The new line offers air column sizes for all p. a. purposes. Three driver units are also available... with varied power ratings. \* You'll welcome this new achievement in speaker design... allows the use of super-powered p. a. speakers at a price within your reach.

\* Write for CATALOG F-40 now!  
**ATLAS SOUND CORPORATION**  
1446-39TH STREET      BROOKLYN, NEW YORK

**FILMGRAPH**  
VOICE AND MUSIC RECORDINGS

PERFECT SOUND on film recording can now be had with FILMGRAPH at only 25c per hour (this is cost of film only—no other expense). Permanent play-back. The only device capable of making lengthy recordings and play-back. Closing out several demonstrator models at special price. Complete 1940 line now ready.  
MILES REPRODUCER CO., INC., Dept. RC,  
812 Broadway      New York City

the amplifier with a 3-wire unshielded cable. If local control is desired, the volume control should be mounted directly on the amplifier chassis.

For simplicity sake, the same volume control method is employed for all input channels. As this particular circuit will not handle large voltages, the phono input signal is attenuated by a 10-meg. and 1-meg. resistor network, so that if 1 volt is fed into the input, only 0.1-volt is applied to the grid of the phono input tubes. The plates of the input channels are all interconnected through 0.1-mf. blocking condensers and isolating 0.1-meg. resistors.

The 2nd 6SF5 stage is of conventional design and feeds into a 6N7 inverter which utilizes separate high-frequency and low-frequency accentuating and attenuating controls. The output of the inverter feeds

a pair of 6V6G's as triode-connected drivers, which in turn drive a pair of 6L6G's in the standard 32-watt condition. Inverse feedback is employed around the output transformer into the 6V6G driver grids. The power supply is of conventional design and utilizes two 450-volt series connected electrolytic condensers for safety. An appropriate bleeder system is employed to stabilize the screen-grid supply. Careful filtering in the power supply circuit assures minimum hum.

Special precautions should be taken in wiring up the input stages, as hum may be picked up by any of the input grid leads. Overall gain of the amplifier is approximately 120 db. The phono input gain is approximately 90 db. The power transformer should be capable of delivering 300 volts at 250 ma.

**HOOKING-UP THAT EXTRA  
SPEAKER**  
TRACY DIERS

**A**LL of us at some time or another have wanted to attach an extra speaker to a radio set. It is really a simple job. Anyone who is handy with tools and has a rudimentary knowledge of electricity should be able to hook 1 or more extra speakers to his radio receiver. The ability to read electrical diagrams will help since you may have to look up the circuit of the set you have.

The first thing to decide is whether you want to use a *magnetic* or a *dynamic* speaker. My advice is by all means use a dynamic. Recently as a result of the discovery of new alloys it is possible to make dynamic speakers with *permanent-magnet* fields that are equal in every respect to the older type employing *electro-magnet* fields. These new permanent-magnet field speakers are similar in every respect to the older, dynamic type from the fidelity standpoint. The permanent-magnet speaker requires only 2 wires which is also an advantage over the electrodynamic speaker which requires 2 leads which carry a high voltage.

You will find that the dynamic speaker will be superior in every respect to the magnetic but we shall discuss hooking-up both. We shall start with the magnetic type first.

If your radio receiver has a magnetic speaker it will be simple. Just attach your extra magnetic speaker across the terminals of the one that has been built into the set. Most radio sets, however, have dynamic speakers, and it is then a little more complicated. Every dynamic speaker has what is known as an *output transformer* connected to it. Notice Fig. A which is a photograph of a typical dynamic speaker showing its output transformer. This output transformer has 5 connections. Three of these have what is called high impedance; the remaining 2 have low impedance, which is just the opposite. The magnetic speaker must be connected across the high-impedance terminals. The only way to determine which is high and which is low is by trial and error since we are assuming you have no instruments.

**OPERATING TEST**

Turn on the radio set and connect 1 wire from the magnetic speaker to one of the 5 contact points on the transformer. Touch the other wire to the other contact points, one at a time. When you hit the high-impedance leads your speaker will begin to play. When you have the correct connections solder them on. If you wish, you may connect a switch in series with the magnetic speaker leads, to shut it off at will.

Hooking up a dynamic speaker is a little more trouble but it is worth it. Practically all the permanent-magnet dynamic speakers



You need only a soldering iron, flux, and a screw-driver.

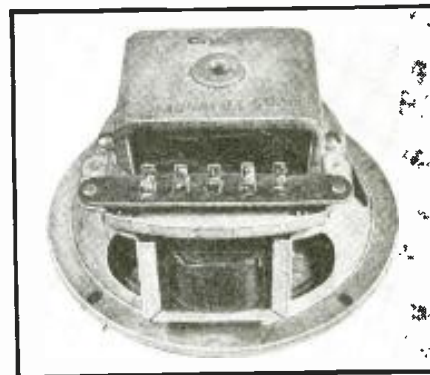

Typical dynamic speaker. Output transformer is at front; connection posts, on top.

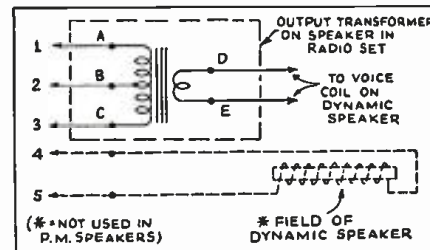

Leads 1 to 5, incl., connect to set. A magnetic speaker connects to 1; and a dynamic to D and E.

# •SOUND•

have a voice coil impedance of 6 to 8 ohms. When you buy the speaker ask the salesman what its voice coil impedance is so there will be no error.

Now it will be necessary to find out what the voice coil impedance of the output transformer in your radio is. To do this you may either write to the radio manufacturer, stating the serial number of the chassis or if you understand electrical diagrams you may look it up yourself in Rider's or Gernsback's Manual.

If you find the impedance of your output transformer in the radio set to be between 6 and 8 ohms you may proceed. The extra dynamic speaker is to be connected across the 10-W-impedance end of the output transformer. You can find the low-impedance end in the same way as previously described for finding the high-impedance side. Turn on the radio set and connect one wire from the extra dynamic speaker to one of the connections on the transformer. Place the other wire on each of the transformer connections in turn until you hit the correct pair. If any pair of connections gives you a heavy spark at the

terminals don't leave the wires on as these are the wrong points and if left on too long you may burn-out the voice coil of the new speaker.

When you strike the correct connections your extra dynamic speaker will immediately begin to play. All you need do now is put a switch in the circuit and solder up all connections.

This method of connecting the permanent-magnet speaker may introduce a bit of distortion in some sets. If it is very noticeable it means that you must put a new output transformer in your radio receiver. This transformer must have connections for 2 speakers and must also match your output tubes. Unless you know something about radio don't do it.

The above method of connecting your extra dynamic speaker was based on the assumption that your output from the radio set was between 6 and 8 ohms. If you find that your set varies much from this impedance range you will have to put a new output transformer in, which as we said is a job only for someone who knows something about radio.

## BRIDGE RECTIFIER DELIVERS 500 W. WITH RECEIVER TUBES

Leonard Nussbaum

**S**IMPLE to construct, this trouble-free system will double the rectified output from your present power transformer. Ideal for public address systems, transmitters, power amplifiers, etc., outputs up to 500 watts may be obtained from receiving tubes! See Fig. 1.



Fig. 1. Completed rectifier; extreme right, tapped keying bleeder connected across the output.

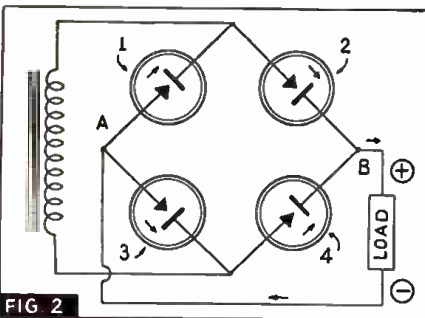

FIG 2

With both plates of each tube connected in parallel, from 200 to 500 milliamperes—double the manufacturer's rating—may be passed, depending upon whether type 80's, 82's or 83's are used. Two pairs of plates always being in series at any stage of the performance, from 700 to 1,000 volts may be fed to the input.

Three 5-volt windings are necessary on the filament transformer. Three separate filament transformers may be used if desired or 2 additional windings added to the original. Good insulation such as several layers of fish-paper must separate the windings as the full voltage to be rectified is impressed between. So that the insulation materials are also in series it is a good plan to connect the middle winding to the 2 tubes shown at the extreme right of the circuit diagram of Fig. 3.

How the circuit actually works can best be understood from Fig. 2. Remember that current can flow only from plate to filament in the direction of the arrows. When the upper end of the power transformer's secondary shown at the left is positive the current flows through 2 in the direction of the arrow (it cannot flow through 1), passes through B to the load and returns through 3 to the negative or bottom end of the winding. When the cycle changes the bottom end of the secondary winding at the left becomes positive. The current then flows through 4 past B (it cannot pass through 2 against the arrow) to the load and returns through A to 1, thence to the negative or top end of the winding.

The input voltage from the power transformer will be double that secured by the conventional center-tap method because the end voltage of the secondary winding is not halved by the center-tap which is not used. An additional advantage of the system is that a transformer having no center-tap may be used.

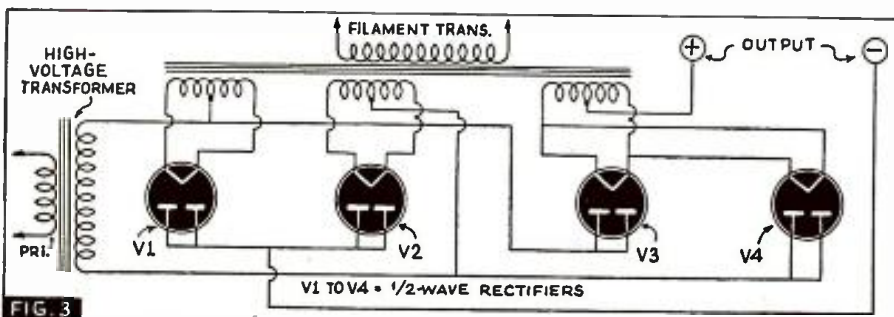

FIG 3



**A** SIMPLE circuit gives you an effective tone compensating system to boost or attenuate the bass and treble frequencies independently of each other. It may be incorporated in your present amplifier or receiver.

It is the same system used in the finest THORDARSON Amplifiers. All you need is a T-14C70 choke, 4 resistors, 5 condensers, 2 THORDARSON R-1068 tone controls, and a 6C5 tube.

Complete details and instructions are available in the THORDARSON AMPLIFIER GUIDE 346-D.



### AMPLIFIER GUIDE

A 32-page Guide giving, in addition to the Dual Tone Control, diagrams and instructions on 10 Amplifiers and other information of considerable value. Available at your THORDARSON Distributors for 15c.

## THORDARSON

ELEC. MFG. CO., CHICAGO  
TRANSFORMER SPECIALISTS SINCE 1895

### GET A REAL ELECTROPLATING KIT ABSOLUTELY FREE!

Complete details as to how it is possible to get a Real Electroplating Kit FREE, appear on Page 746 of this issue. TURN TO IT NOW!

### DIRECT-COUPLED AMPLIFIERS



Write For Complete Details and Attractive Proposition  
**AMPLIFIER COMPANY of AMERICA**  
35-45 WEST 30TH STREET NEW YORK CITY, NEW YORK

# UNIVERSAL 25-WATT AMPLIFIER

*Operates from 6-Volt Battery or 110/220-Volt A.C.-D.C. Line*

*This article discusses the design and construction of an unusually versatile amplifier for domestic and foreign fields. Important to sound men is the fact that it performs with maximum efficiency and minimum current consumption with either a battery or power line supply.*

A. C. SHANEY

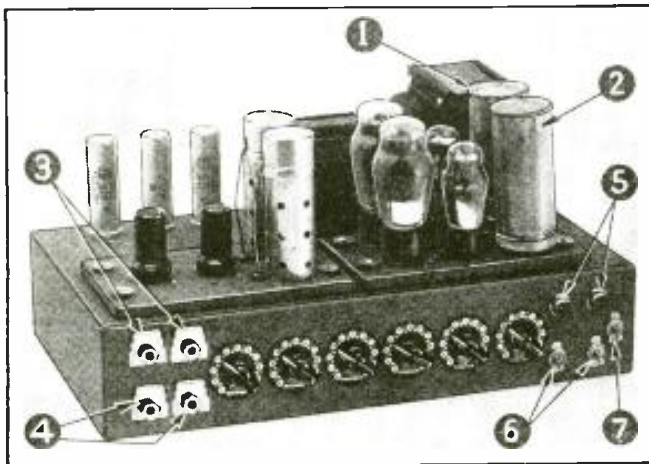

Fig. 1. The components in the photo of the Universal 25-W. Amplifier are identified as follows: (1) and (2), vibrators; (3), microphone inputs 1 and 2; (4), phono inputs 1 and 2; the controls, l. to r., are: gain controls for mikes 1 and 2, gain controls for phonos 1 and 2, and L.F. and H.F. controls; (5), l. to r., master and standby pilots; (6), l. to r., master on-off and idler switches; and (7), economizer switch.

IN designing an amplifier capable of performing equally well from 6 volts D.C., 110-V., A.C./D.C. and 220-V., A.C./D.C. it is necessary, of course, to work out the universal power supply so that ideal conditions are attained, regardless of the power source. The design of each individual supply offers its specific problems. For example: In designing a unit for operation from a 6-volt storage battery, the essential requisites are (1) to produce the greatest amount of audio power with a minimum storage battery current drain; and, (2) to incorporate an effective economizer circuit for maximum current saving during low power output and "idle" periods.

For 110/220-V. A.C. operation, no particular problems are involved, although, here, too, the attainment of the greatest amount of power with the least amount of distortion is a prime requisite. For 110/220-V. D.C. operation, the equivalent to A.C. operation should be available. In designing a unit to meet the above conditions, it is also important not to hamper the operation of the amplifier under any one condition, because of the wide range of power sources with which the amplifier can be used.

### THE VIBRATOR SUPPLY

For the past 2 years, a considerable amount of work has been done in improving the design of vibrators, so that at the present writing, a group of specially developed vibrators are available, which offer a dependability heretofore not available. Furthermore, the vast amount of research work done in perfecting the application of vibrators to high-power amplifiers, has definitely

proved the advisability and feasibility of employing these units in amplifiers of the type described.

### VIBRATORS

Although 2 vibrators are shown in the photograph of the amplifier (see Fig. 1), only 1 vibrator is employed at a time. In other words, for 6-volt operation, the 6-volt vibrator (toward the rear of the amplifier) is utilized. For 110/220 volts D.C., the other vibrator is used. For A.C. operation, neither vibrator is employed.

Both vibrators utilize the same type of construction. The special power transformer was very carefully designed to provide optimum operating conditions for the vibrators. In designing the transformer, particular care was exercised to avoid core saturation under any operating condition. Furthermore, the transformer exciting current was kept at a minimum for highest efficiency.

### 110/220-VOLT A.C. OPERATION

For normal power line work, 2 auxiliary taps are provided on the transformer, as diagrammed in Fig. 2. No special circuit problems are involved, as conventional operation is utilized. The unusual feature is the use of two 6X5G rectifiers. These rectifiers were selected so as to provide a common heater circuit with all other amplifier tubes, and thereby facilitate switching of the heaters to the storage battery or to the transformer filament winding. Two paralleled rectifiers are employed so as to secure adequate current.

### 110/220-VOLT D.C. OPERATION

For direct-current, 110- or 220-volt operation, a conventional vibrator circuit is employed. A triple-pole 2-way switch is used to change the circuit from 110-volt operation to 220-volt operation. The same vibrator is used for both applications. A 2,000-ohm, 10-watt resistor is inserted in series with the driving coil when operating from 220 volts, so as to enable the use of the same driving coil for both applications.

### 6-VOLT OPERATION

A D.C. relay is employed in the 6-volt circuit, which automatically switches the heater circuit from the 6-volt winding directly to the storage battery, when operation from this source of power is desired. The usual 6-volt center-tap winding is now used in conjunction with the 6-volt vibrator for stepping the storage battery voltage up to the required high A.C. voltage. It is of course necessary to remove the "110/220" vibrator and insert the correct "6-volt" unit. During 6-volt operation, 2 important current saving features are available.

(1) Idler Switch—An idler switch disconnects "B" supply from the amplifier, but keep the heaters on. Under this condition, the tubes are ready for operation, but a considerable saving is affected during idling periods.

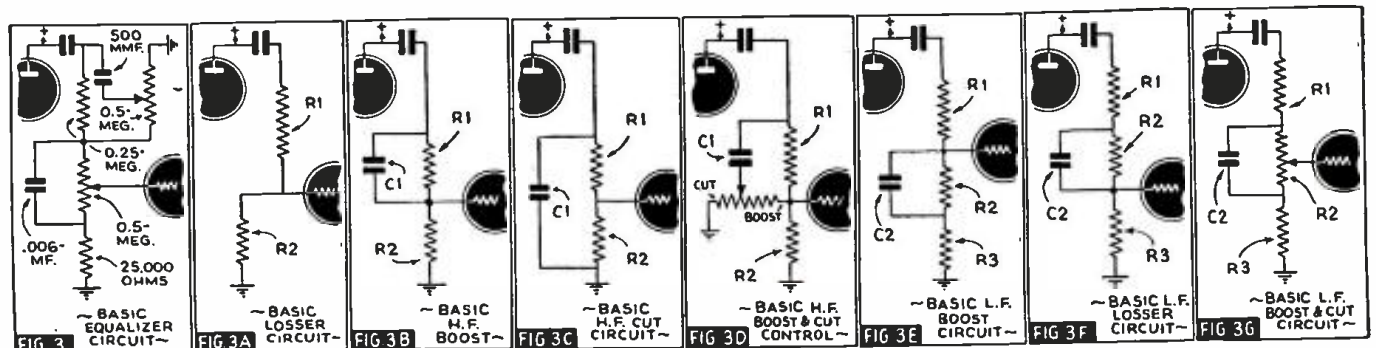

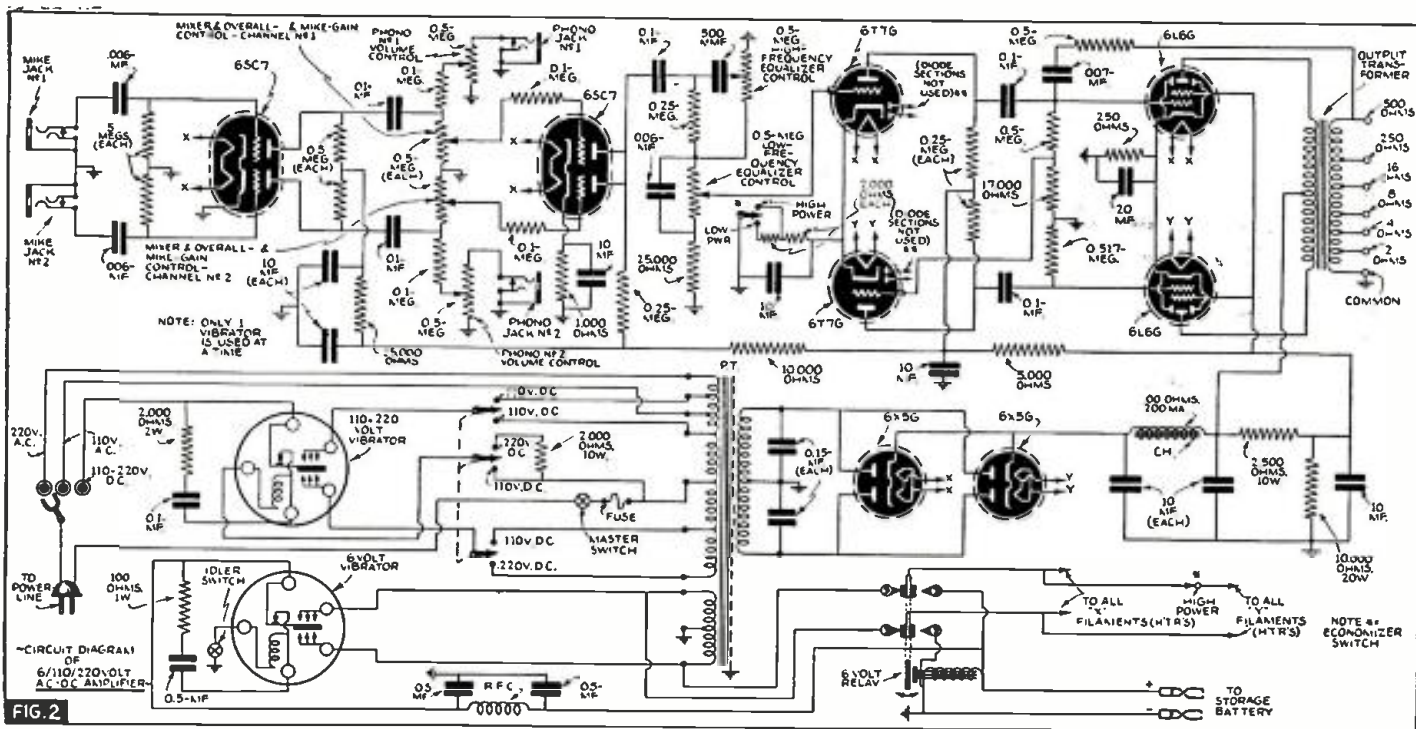

(2) Economizer Switch—An economizer switch, essentially a power-decreasing circuit, is used whereby the amplifier, instead of delivering 25 watts, delivers approximately 10 watts. Under these conditions of operation, the amplifier acts as a single-ended unit. One rectifier, 1 output tube, and 1 6T7G inverter are entirely disconnected, thereby effecting the following saving:

Tube		Watts Saved	
6L6G	Filament	6.3 V. @ 0.9-A.	5.67
	Plate	360 V. @ 0.05-A.	18
	Screen-grid	270 V. @ 0.008-A.	2.16
6T7G	Filament	6.3 V. @ 0.15-A.	.95
	Plate	250 V. @ 0.0012-A.	3
6W5G	Filament	6.3 V. @ 0.9-A.	5.67
Total			35.45

As the efficiency of the vibrator is approximately 60%, more than 35.45 watts is saved. In actuality, approximately 47 watts are saved. This means a reduction in battery current of nearly 8 amperes. Furthermore, the loading on the vibrator is greatly reduced. This lower power application also makes available an optional low-power amplifier for smaller gatherings.

The economizer switch can also be employed during the 110/220-volt A.C. or D.C. operating periods to effect similar savings in power consumption. In changing the output stage from a push-pull to single ended, the bias resistor of the inverter stage must also be changed in order to assure correct bias under both operating conditions. For single-ended operation, the resistance value of the bias resistor is doubled, because only half the plate current is available for the production of the bias voltage.

**ELECTRICAL CIRCUIT**

The amplifier employs a minimum number of tubes to produce the desired gain and flexibility of operation. A single 6SC7 pre-amplifier tube provides for two high-gain microphone inputs. An additional 6SC7, with suitable control-grid-circuit volume controls, provide for 2 additional phono inputs. Two 6T7G high-mu triodes were selected for phase inversion. Two separate equalizers are inserted in the control-grid of the inverter tube for individual high-frequency and low-frequency accentuation and attenuation.

**THE EQUALIZER CIRCUIT**

Figure 3 shows the complete equalizer circuit. This equalizer circuit is unique in that it employs no reactors or inductances. Its operating principle is outlined in Figs. 3A to G, incl.

Figure 3A shows the basic attenuator circuit wherein a loss is introduced. This loss in voltage is directly proportional to the ratio of

$$\frac{R1}{R1 + R2}$$

If a 10 db. boost is desired, approximately a 10 db. loss should be incorporated. If a condenser C1 is inserted across R1 (Fig. 3B) and thereby boosted. If the condenser, however, is bypassed to ground instead of to grid, the high frequencies are further attenuated, as illustrated in Fig. 3C. If a control is introduced so as to provide a circuit change from Fig. 3B to Fig. 3C, as illustrated in Fig. 3D, then we have a combination high-frequency boost and cut control.

If a limiting resistor (R3) is inserted between R2 and ground, as illustrated in Fig. 3C, and another condenser (C2) placed across resistor R2, the bass boost effect will take place if the grid is at the high end of R2. This is brought about by the reactance of the condenser increasing at lower frequencies, thereby increasing

$$R2 + R3$$

$$\frac{R1 + R2 + R3}{R3}$$

for the lower frequencies, which effect produces a bass boost. If the grid, however, is connected to the low end of R2, as illustrated in Fig. 3F, then the voltage applied to the grid is proportional to

$$\frac{R1 + R2 + R3}{R1 + R2 + R3}$$

As the reactance of the condenser (C2) increases at lower frequencies, a smaller proportion of the total voltage is applied to the grid thereby providing an effective bass cut. If a control is introduced so as to provide a circuit change from Fig. 3E to Fig. 3F, as illustrated in Fig. 3G, then we have a combination high-frequency boost and cut control. By combining Figs. 3G and

3D, we have our original equalizer circuit Fig. 3.

**FEEDBACK CIRCUIT**

A frequency-discriminating feedback network is employed, which loops the output transformer. Although this circuit appears to be fed back into one of the output tubes, in actuality, it reaches the other push-pull in 6T7G phase-inverter tube. When single-ended operation is employed; this feedback circuit considerably reduces the residual 2nd-harmonic distortion of the 6L6G output stage.

**CONCLUSION**

This amplifier brings to the Serviceman, radio dealer, and P.A. technician, a multi-use device for all unusual applications. Its design can also be altered so as to accommodate either 32-volt D.C. or 25-cycle power lines. For economy sake, the amplifier is available for operation from any one or combination of power supplies. Fool-proof design has been employed throughout so that it is impossible to damage the amplifier should it accidentally be connected to improper power line sources. A suitable fuse is incorporated in the 110-volt circuit so as to avoid damage to either the transformer or the vibrator.

The author will be pleased to answer any questions relative to this versatile amplifier, if a stamped and self-addressed envelope is enclosed. Simply address inquiries c/o Radio-Craft.

This article has been prepared from data supplied by courtesy of Amplifier Co. of America.

**DON'T MISS THIS—**  
**A NEW TRIODE-OUTPUT 30-W. AMPLIFIER**  
 Next month Mr. Shaney will describe a 30-W. Direct-Coupled Push-Pull Amplifier using triode output. Other features will include non-frequency discriminating scratch filter, audio spectrum control and volume expansion—the first modern high-fidelity triode output amplifier delivering 30 watts of power. Be on the lookout for it!

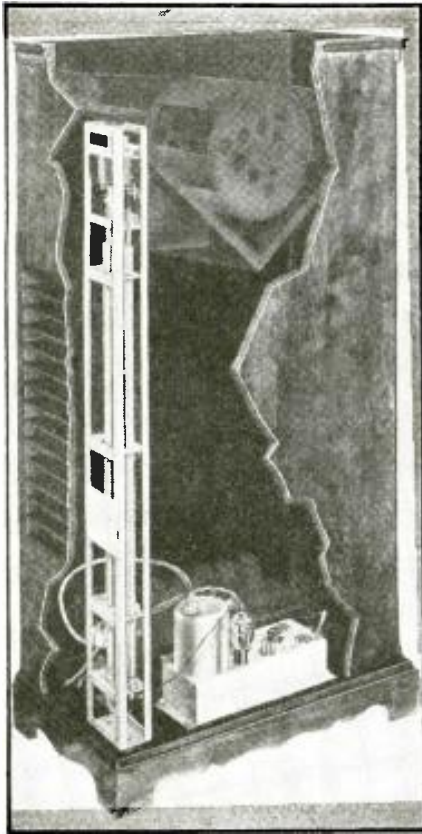

Cutaway view of the Hammond tone cabinet showing the shape and location of the new reverberation control unit. (See details in drawing, Fig. 1.)

**R**EVERBERATION, or "echo" as it is often termed, is in varying degree present in all music, in fact in practically all sound. Hitherto, the degree of reverberation accompanying music has been determined only by the character of the structure in which the music is played—its size, its shape and the degree of smoothness and rigidity of its walls, ceiling and floor.

It happens that organ music, probably more than any other type, is greatly improved by the proper degree of accompanying reverberation. Organ music, therefore, usually sounds less pleasing to the ear when heard in small or acoustically "dead" enclosures.

But, now the genius of Laurens Hammond has devised a unique correction of this situation—"Reverberation Control," considered the most significant improvement in organ music since the introduction of the Hammond Organ itself. By means of Reverberation Control, a remarkable electromechanical unit included in an ordinary Hammond Organ tone cabinet, it is possible to provide the most desirable degree of reverberative effect for any given enclosure. Even in the worst possible location from an acoustical standpoint—a small sound-proofed broadcasting studio or out-of-doors—the Hammond Organ with Reverberation Control will produce organ music with the full ringing beauty heretofore heard only in great edifices of stone or brick.

The reverberation unit is a small device connected to the electrical system. It is never located in the console but is either built into the output cabinet or supplied as an attachment for an existing output unit. Only one such device is needed no matter how many tone cabinets may be employed.

**EFFECT OF REVERBERATION**

The Hammond reverberation unit is provided with an adjustable control whereby

*Latest Electromechanical*  
**REVERBERATION CONTROL**

*This device—newest member of the rapidly growing Electronic Music family—is able to put just the right amount of "echo" into organ music, making an organ in the smallest chapel sound as though it were being played in a massive stone church!*

the amount of reverberation may be controlled to suit the taste and general type of music to be played. With the unit in operation it will be found that when the keys of the organ are suddenly released, the sound does not stop immediately, but persists with decreasing strength for a period of time depending upon the setting of the control. The "attack" of the notes is likewise slightly less prompt. All playing tends to become more legato (lengthened out) in character.

The use of the unit does not actually increase the volume of tone, if air pressure measurements are made. Nevertheless, listeners mostly agree that the tones are "fuller and richer." Tonal effects, for one thing, seem altered by reverberation because of the overlap between tones which are dying away and those which are part of the notes being played.

Reverberation always brings with it the phenomenon known as "room pattern." The pattern referred to is that of "standing waves" which are set up within the room or auditorium, whereby a listener situated at any particular point hears individual frequencies with different degrees of loudness. In the Hammond Reverberation Unit, which is an electromechanical device, this is, of course, no exact physical counterpart of the room. "Room pattern" is created nevertheless. Here reverberation is secured by multiple reflection of wave motions traveling through paths of different lengths and therefore operates on the same principle as does reverberation in an actual room. The unit makes an organ located in a small carpeted living room sound as well as the same organ would in an auditorium of medium size. Heretofore it has always been necessary to provide chambers in order to secure the best reverberative effects.

and about 4 feet in length, and of an additional small electrical amplifier.

These parts are mounted inside a standard, vertical 20-watt output cabinet as shown in Fig. A. The units are also available in a relatively small and inconspicuous steel box, especially designed to be attached to the back of a popular size of vertical cabinet now in use throughout the country. Only one Reverberation Unit need be employed, no matter how much output equipment is used in the organ installation.

Electrical connections to the reverberation unit are made between the organ console and the output cabinet. Part of the electrical signal from the console passes around the reverberation unit and produces a part of the tone in the same manner that it has always done previously. A part of the electrical energy, however, passes into the unit itself where it energizes a small moving coil of the same type and general design as would normally be used to operate a dynamic loudspeaker. When the coil moves it does not radiate any appreciable sound, however, but instead, is made to actuate a very small aluminum cage to which are fastened a multiplicity of small helical steel springs and levers (see Fig. 1). One of these springs in turn actuates a Rochelle-salt crystal. The latter produces a new electrical signal which is amplified in the small extra amplifier. The signal from this amplifier is mixed with the original organ signal and fed to the output cabinet and to as many additional output cabinets as may be required. The principle of operation of the spring system is described hereafter.

**PRINCIPLE**

Sound waves may be propagated for considerable distances in speaking tubes. In this case a column of air, as long as the tube, has imparted to it at one end a wave of varying air pressure which is propagated along the column of air with the velocity of sound. It is obvious that at one particular instant the words themselves are repre-

**THE REVERBERATION UNIT**

The Hammond Reverberation Unit consists of a small electromechanical unit of only a few square inches in cross-section,

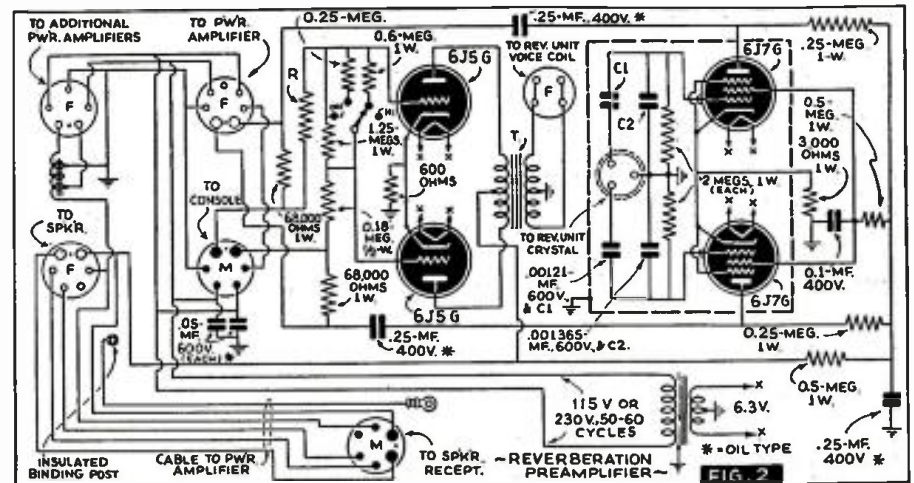



sented by particular points of pressure in the tube. A long word is a long disturbance, and a short word is a very local disturbance.

Now the property of carrying sound waves is, of course, not unique to air, but may occur in all kinds of columns other than columns of air or gases. For a column of substance to transmit sound, it is only necessary that the column shall have uniformly distributed mass and uniformly distributed elasticity. The ratio of the one to the other determines the velocity at which the propagation of sound waves will take place. In the springs used in the Hammond Reverberation Unit, which are of different sizes, the velocity may be as low as 40 to 50 feet a second, which is from 20 to 25 times slower than the velocity of sound in air.

A helical spring constitutes a much better medium for transmitting sound, for certain purposes, than does a speaking tube, because there is an inappreciable amount of friction produced by the longitudinal modes of vibration of the spring. Thus, sound may be transmitted for long distances through springs without appreciable loss in intensity.

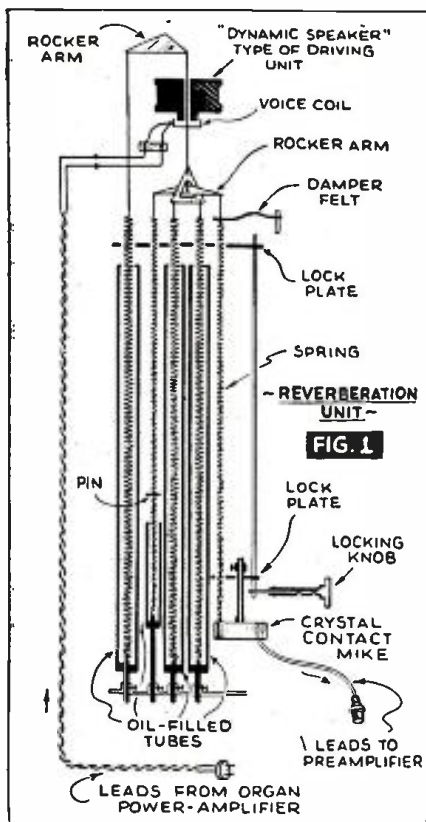

The helical springs used in the sound transmission system of the Hammond Reverberation Unit provide a very convenient mechanism in which to control the average length of path, the total amount of reflected energy, and the amount of damping. A path 100 feet long in air is only 5 feet "long" in the spring! Because the velocity of sound in the spring is so much slower than it is in air, we are able, speaking in metaphors, to "fold up a big auditorium into a little box."

Where we need a spring 6 feet long, and cannot make the box that long, we "fold up" the spring by the use of small aluminum rocker arms. Where we want a total reflection point, we need only fasten the spring to something which is heavy and cannot move. Where we want a partial reflecting



... for the first time  
a line of TUBES  
DEMONSTRABLY BETTER

STOP!

Hunting for Matched Tubes  
Microphonics • Hum •  
Endless Replacements  
and Call-Backs

SEE YOUR N. U. DISTRIBUTOR  
NOW

FOR PUBLIC ADDRESS  
BROADCASTING STATIONS  
COIN MACHINES  
ELECTRIC PHONOGRAPH  
MOTION PICTURE  
AMATEUR  
AND EXPERIMENTAL WORK



Thirteen SOUND XTRA types now available. SOUND XTRA Types can be substituted for the same type in the regular line. They are DEMONSTRABLY BETTER.

In order to accomplish this outstanding performance in SOUND XTRA types modifications in construction are incorporated.

SOUND specialists have long hoped for extra quality tubes engineered specifically for the requirements of SOUND work . . . they're here now in National Union SOUND XTRA Types.

For More Information Write

NATIONAL UNION RADIO CORPORATION  
57 STATE STREET, NEWARK, N. J.

TUBES • CONDENSERS • BATTERIES • SOUND EQUIPMENT

point, corresponding to the perforated plug in the speaking tube described above, we merely join the spring to another section of spring of slightly different size. By choosing the correct "mismatch" sizes we can control with great exactness the amount of energy that will pass from one spring to the other, compared to the amount reflected. Calculation is simplified by the "theory of long lines" of telephony.

Finally, when we want energy flowing down to a spring to die, and so not come back, we carry the spring down into an open tube filled with oil. The total "damping" is thus controlled with accuracy, because no appreciable energy is lost in those springs which do not terminate in oil. The unit contains five lengths of spring, four tubes filled with oil, and two rocker arms. The number of important different lengths of path from the input to the out-

put is an enormous number, because it rises geometrically from the number of reflecting points.

The mathematical study and development of such a system is far too complicated to be told here. Theoretically, it should be possible to duplicate exactly the acoustical conditions of any particular auditorium.

Oh, for the Life of a Serviceman

The postoffice received a letter addressed to "Mr. Iks, service man, Decatur, Ill." The letter was delivered to Fay Ickes, on the chance that he was the one meant. When Mr. Ickes opened the letter he read: "My husband has dybeetus and has to be insulated twice a week. Please send the insulation right away."—Decatur (Ill.) Review.

# A 2-TUBE SUPERHET.—

*With Pentagrid Regenerative 2nd-Detector*



The 2-Tube Superhet., (See Fig. 2 for identification of controls.) with crystal headphones. The tuning range is about 540 to 1,600 kc.

**E**ARLY superheterodynes were complicated affairs employing many tubes. The introduction of the *pentagrid converter* (combined oscillator and 1st-detector in one envelope) was a blessing which permitted much-needed simplification and economy. Now a new application has been devised for the converter which points the way to further simplification. The latest circuit uses a pentagrid converter as a regenerative 2nd-detector so effectively that it is possible to build a superheterodyne which consists only of a converter and a 2nd-detector, and which has no intermediate frequency amplifier as such, but still has sufficient overall gain to be practicable for many uses, and is therefore almost the last word in superheterodyne simplicity.\*

The receiver which is the subject of this article was built according to the foregoing principles. To utilize the economies which its unconventional circuit makes possible, it was decided to construct the set in portable, self-contained form. The National Union 1A7G was selected for both converter (oscillator—1st-detector), and 2nd-detector applications because of its high conversion gain, small size, and battery economy.

### STABLE REGENERATION

The resultant receiver is compact and as simple as a T.R.F. set, having a minimum of parts and tubes, while at the same time retaining all the advantages of a superheterodyne in the form of high, uniform selectivity, and sensitivity, with the added advantages of *stable regeneration* in a tube which operates at a constant frequency and the possibility of using this regeneration for the reception of C.W. telegraph signals; or, to assist in locating and tuning-in weak, modulated signals, as in any T.R.F. set having a regenerative detector and utilizing it to locate DX stations by "beat reception."

The features of this "pioneer" set are listed as follows:

### FEATURES OF 2-TUBE SUPERHET

- (1) Full superheterodyne operation with only 2 tubes.

\*See "Some Modern Aspects of Frequency Conversion in Superheterodynes," Radio-Craft, June, 1940.  
\*\*The senior author of this article originated a series of experimental 1-tube superhet. circuits which were first published in Radio News magazine in 1925.

*A unique 2nd-detector circuit, developed by National Union's engineers at the suggestion of the senior author, makes possible the reduction of the superheterodyne to its ultimate simplicity. For the first time, it is shown how to utilize the pentagrid converter as an "unmixer" or 2nd-detector, still retaining a portion of this tube's "conversion gain" feature!*

R. D. WASHBURNE and LEONARD LASKY

- (2) Introduces, for the first time, the use of 2 pentagrid tubes—1 as a converter or oscillator - modulator (1st-detector), and the other as an "inverter" or regenerator - demodulator (2nd-detector)—only.
- (3) Amplification in 2nd-detector due to what may be termed "inversion gain".
- (4) Electron-coupled regeneration.
- (5) Constant regeneration at the intermediate frequency (456 kc.), at any predetermined level, regardless of changes in tuning (signal frequency—540 kc. to about 1,600 kc.).
- (6) Non-radiating zero-beat reception permits C.W. code reception, and DX broadcast pickup, without producing a whistle in nearby receivers.
- (7) Completely self-contained battery-portable; may be used as an experimental or emergency set.
- (8) Minimum current drain of any superhet. receiver.
- (9) Fully shielded.
- (10) Highly selective (can be made to cut sidebands by using variable-selectivity I.F. transformers; selectivity remains fixed regardless of changes in tuning, changing only with signal intensity as with any superhet.).
- (11) High fidelity (2nd-detector feeds directly into Rochelle-salt crystal headphones—the resulting tone quality is a revelation even to radio "old-timers", and suggests crystal-detector fidelity).

### WHY A PENTAGRID CONVERTER AS 2ND-DETECTOR?

The unorthodox method here described of using a pentagrid converter as a 2nd-detector was developed with a view to pointing the way toward more compact radio receiver design. With the recent advent of small-space components—primarily, miniature tubes—it was felt that more attention should be paid to means for obtaining augmented performance from whatever tubes were eventually chosen to compose a small-space radio receiver.

Starting with the knowledge that the "pentagrid converter" successfully and efficiently combines in 1 envelope the function of mixing or modulation that previously required 2 tubes, it was felt that the inverse operation of "unmixing" or demodulation could be accomplished with comparable efficiency in a second tube of roughly equivalent design operating as a "pentagrid inverter." As the nearest available tube was—another tube of the same type, a duplicate of the modulator tube was selected as the demodulator tube; it then remained only to find in the demodulator circuit a substitute for the local oscillator in the modulator circuit. It was elected to utilize regeneration in the 2nd-detector circuit for the several reasons previously mentioned in this article, and to depend upon this action to establish the dynamic characteristics necessary for obtaining in the demodulator, an approximate equivalent (or "inversion gain") of the "conversion gain" which helps make the pentagrid converter such an efficient tube as a modulator.

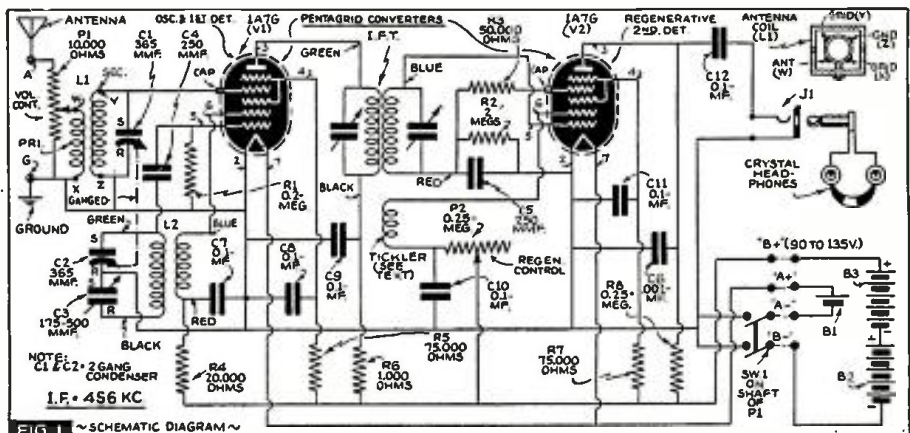

FIG 1—SCHEMATIC DIAGRAM—

The results were so promising that experiments are continuing in this direction. However, it should be apparent to even the casual reader that what is needed is a special tube having characteristics that more nearly suit the requirements of service as a 2nd-detector; a tube that has, for example, interelectrode characteristics more suitable to receiving an intermediate frequency on the control-grid, and plate characteristics better adapted to feeding an audio-frequency output from the plate of the tube to a succeeding, A.F. power amplifier. Even using existing tubes, though, as here described, better results have been obtained than could be secured with any other known circuit using 2 tubes; the expression "better results" takes into account the selectivity, operating ease, sensitivity and headphone volume (using crystal phones) achieved in the 2-Tube Superhet.

**CIRCUIT**

As may be seen from a study of the circuit diagram, Fig. 1, the 1st tube is used in a strictly conventional frequency converter arrangement. The 2nd tube serves as combined I.F. amplifier and demodulator. The 2 tubes are coupled by a standard I.F. transformer to which has been added a tickler winding. The fact that there is only 1 I.F. transformer is in itself an economy because high-quality I.F. transformers are relatively expensive. Resistance-capacity coupling is provided to the crystal earphones, which because of their high impedance permit of a reasonably high plate load impedance and hence maximum audio output volume.

**I.F. TRANSFORMER**

The I.F. transformer is a standard unit to which a tickler coil has been added. The operation which must be performed on the I.F. transformer is not as difficult as it may sound.

The coil is removed from its shell by taking off the cap-nut on top of the can and pulling the unit out of the bottom by its leads. The tickler consists of 12 turns of No. 20 D.C.C. wire random-wound on the lower end of the coil form.

Since the coils on the transformer are covered completely with wax, it is difficult to determine the direction in which they are wound. Therefore, the tickler may be wound in either direction, and its leads connected later so that oscillation is obtained; if the 2nd-detector circuit refuses to oscillate when the set is completed, reverse the tickler leads. The tickler coil should be wound right next to the lower coil of the transformer. The turns may be held in place by painting with Duco cement. The ends of the coil are insulated with spaghetti and brought out of the bottom of the can with the other leads. No special lugs or terminals are needed.

The I.F. transformer, as supplied, is intended to be connected into the circuit so that the upper coil (next to the condensers) will be the grid coil and the lower coil, the plate coil. However, in the present case these functions are reversed and the lower coil, to which the tickler is close-coupled, is the grid coil. To do this the color-coded leads should be connected as shown in the circuit diagram, rather than according to the manufacturer's instruction sheet. When the operation has been completed, the transformer is replaced in its can. Care should be taken in handling the coil so as not to damage it.

**CONSTRUCTION**

Aside from the I.F. transformer, which is modified as just described, the other parts are standard. The antenna and oscillator coils were selected to cover the broadcast band, although other frequency ranges may be covered with suitable coils.

The set was built up in professional fashion with all parts, including the batteries, mounted on the front panel. The chassis is attached to the front panel by the mounting studs of the volume and regeneration controls. (See Figs. 2 and 3 for drilling specs.) The batteries are strapped to the front panel with a 1/16 x 1 in.

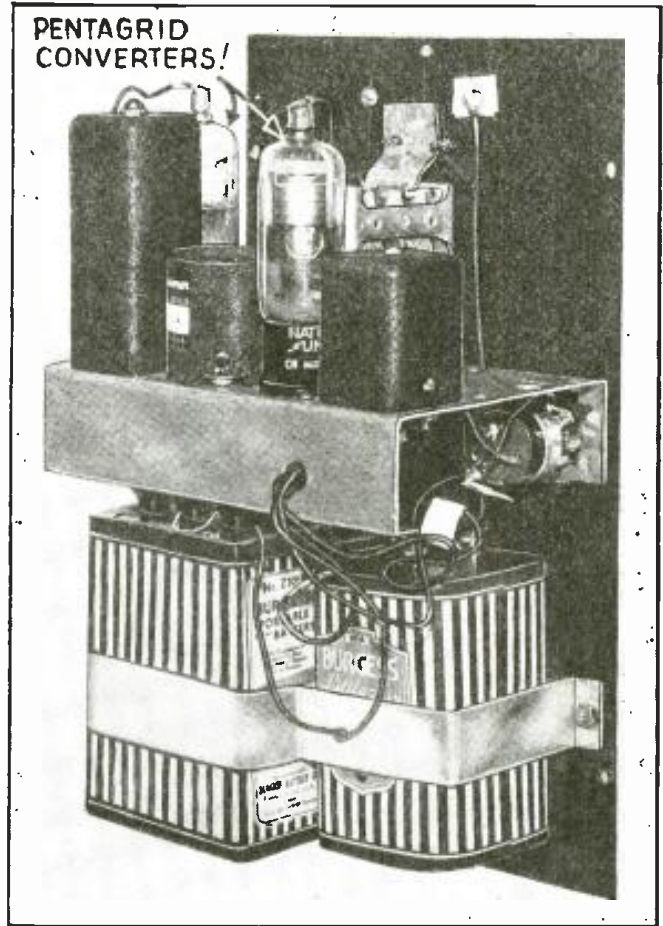

Rear view of completed 2-Tube Superhet. (See Fig. 3 for layout details.)

aluminum band which is suitably bent. A 12 x 6 x 7 in. steel cabinet which should withstand much rough handling is amply large. No special shielding or other precautions were found to be necessary. The pictorial diagram, Fig. 1A, will help you wire the receiver. Use 135 V. of "B" voltage if you want more volume.

**ADJUSTMENT**

In placing the set in operation for the first time, the following procedure should be used: First determine that the 2nd-detector circuit can oscillate properly. This may be done by listening for a slight hiss in the phones as the tube goes into oscillation when the regeneration control, P2, is turned up. If no oscillation is apparent the tickler connections should be reversed. No difficulty should be encountered in making the circuit oscillate.

Then with the circuit just oscillating a signal should be tuned-in. The usual beat note will be heard. The I.F. transformer should then be adjusted to give maximum output volume. This may be conveniently done by placing the 2nd-detector circuit on the edge of oscillation and adjusting 1 of the I.F. transformer tuning condensers until the circuit falls out of oscillation. The regeneration control is then advanced until the circuit is again just oscillating, and the I.F. transformer again adjusted until oscillation ceases. This procedure should be repeated until the primary and secondary are tuned to precisely the same frequency.

The intermediate frequency is nominally 456 kc. However, any frequency within the range of the transformer may be used if desired. It will be found that at the lowest frequency at which the transformer may be set, the 2nd-detector circuit refuses to oscillate at all. Progressively higher frequencies should be tried until satisfactory oscillation is obtained. In general the I.F. should be the lowest at which the 2nd-detector circuit oscillates uniformly while the tuning condensers are tuned over the broadcast band, because at this intermediate frequency the gain of the set seems to be at maximum.

This is equivalent to requiring that the

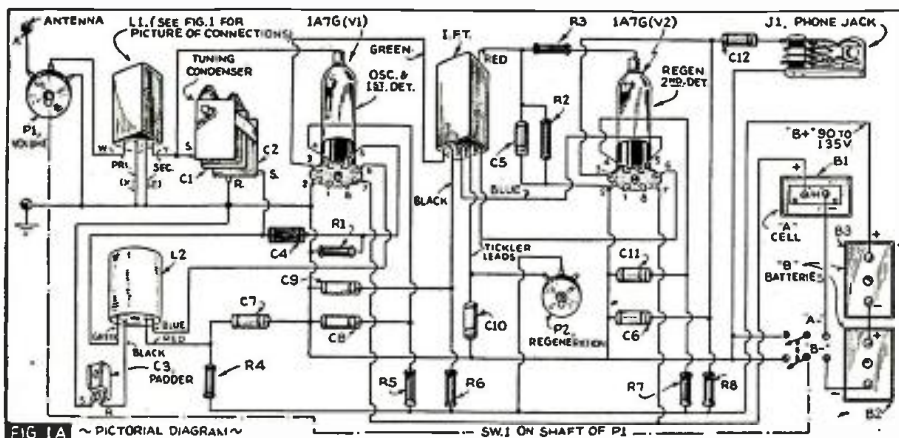

## HEAVY-DUTY Electrolytics

● When building "rigs" intended for constant service, be sure you use heavy-duty electrolytics. To do otherwise is simply penny wise pound foolish.

And that's why AEROVOX continues to manufacture and offer its full-sized, heavy-duty electrolytics despite the overwhelming interest in those ultra-compact inexpensive types. AEROVOX offers both classes, but urges a proper appraisal of their heavy-duty and normal-duty classifications.

Likewise, there are applications calling for "wets" rather than "drys," and AEROVOX again offers both choices.

Ask for CATALOG . . . .

New 1940 catalog contains more pages, more items, more choice. Ask jobber for your copy—or write us direct. Also ask about free subscription to monthly Research Worker.



GET this electric clock advertising sign! Made of sturdy, satin-finish metal, illuminated with two lamp bulbs. Separate switch controls light so clock operates at all times. Movement is self-starting. Convenient size, 13 1/2" high, 20" wide . . . complete with your name imprinted on illuminated glass panel . . . \$6. Without name but with plain glass panel \$5. Write for complete description and picture to Hygrade Sylvania Corporation, Dept. RC60, Emporium, Pa.

number of tickler turns be the minimum necessary for satisfactory oscillation at any particular intermediate frequency. It is of course easier to adjust the intermediate frequency to the number of tickler turns than vice versa. Since the gain and selectivity of the set depend largely on the adjustments of the I.F. transformer, these adjustments should be made with great care.

After the I.F. transformer is properly tuned, the padder condenser, C3, may be adjusted so that the broadcast band is covered by the tuning range of the variable condensers, C1 and C2. Then finally the trimmer condensers are adjusted so that C1 and C2 are in alignment, this adjustment being made with the set tuned-in on a signal at the high-frequency end of the broadcast band. These adjustments are easy.

### OPERATION

In operation the set performs just like any other, more conventional superheterodyne. For ordinary broadcast reception the regeneration control is set at a point just below that at which oscillation begins, and the set is tuned in the same manner as any other. In fact the circuit need never actually oscillate at all. *It would be possible to mount the regeneration control on the chassis inside the set instead of on the front panel, and once set, never hardly ever touch it!* A person operating the set would then seldom bother about the regeneration. However, the regeneration control was mounted on the front panel in the set shown in the photographs for possible use if a beat note should be desired, and also so as to be handy for adjustment to compensate for battery wear. The ability to secure a beat note comes in handy for receiving C.W. (continuous wave) code signals, or for locating DX broadcast stations.

For best results a good antenna and ground should be used. However, satisfactory operation may be obtained using only a "hank" or short length of wire for an antenna; and no ground. The trimmer condenser on C1 should preferably be adjusted with the antenna connected, as its setting changes slightly with the length of the antenna used.

### APPLICATIONS

The set described in this article may be used just as is, as a convenient portable

# FREE- REAL ELECTROPLATING OUTFIT



Now —  
You Can ELECTROPLATE  
EASILY WITH A BRUSH

SOMETHING new for radio men—something which gives you the opportunity to make additional profits—or to improve your type of service. Here's an ELECTROPLATING KIT amazingly simple to operate—you just Electroplate with a Brush!

### NOT A TOY!

Electroplate for profit, hundreds of things in the household—ashtrays, fixtures, water faucets, worn brackets, door knobs, musical instruments, jewelry and silverware and other articles. It's an indispensable piece of equipment—plate articles in hotels, apartments, office buildings, medical and dental offices, factories, schools, laboratories, etc. Exactly the same outfit (but larger) is used professionally by electricians, radio service men, automobile repair shops, etc. Requires one single dry cell 1 1/2-volt battery to operate.

You can electroplate tarnished receiver parts, escutcheons, contacts, worn radio parts and accessories, and display chassis. Put this REAL ELECTROPLATING KIT to use immediately—make it the most useful article in your shop or laboratory. And, you can get it absolutely FREE (except for slight mailing cost).

Subscribe today to RADIO-CRAFT for One Year (12 issues) and receive absolutely FREE this ELECTROPLATING KIT. New subscribers are accepted or extend your present subscription twelve months. Mail remittance of \$2.00 (plus 10c for shipping charge on kit) to the publishers. (Canada and foreign \$2.85). You will receive your FREE, REAL ELECTROPLATING OUTFIT by return mail. Use coupon below to enter subscription.

## RADIO-CRAFT

20 Vesey Street New York, N. Y.

RADIO-CRAFT RC-640  
20 Vesey Street, New York, N. Y.

Gentlemen: Enclosed find my remittance of \$2.00 for which enter my subscription to RADIO-CRAFT for One Year (12 issues). Send me FREE, ELECTROPLATING OUTFIT (Canada and foreign \$2.85). In U. S. add only 10c additional to cover shipping charges on kit.

New Subscriber  Extend Present Subscription

Name .....

Address .....

City ..... State .....

(Send remittance by check, money order or un-used U. S. postage stamps. Register letter if you send cash or stamps.)

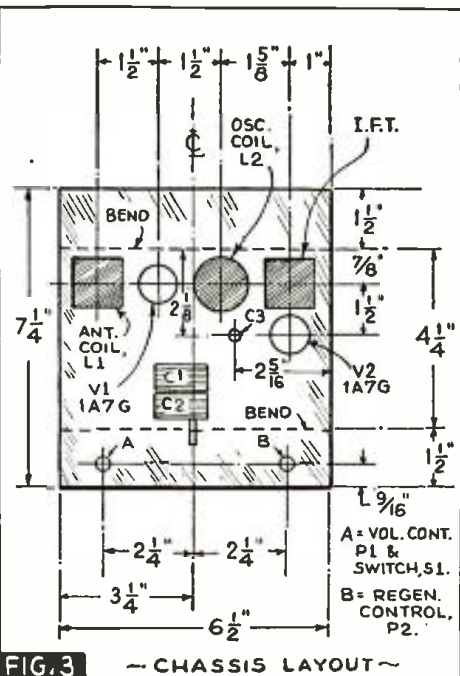
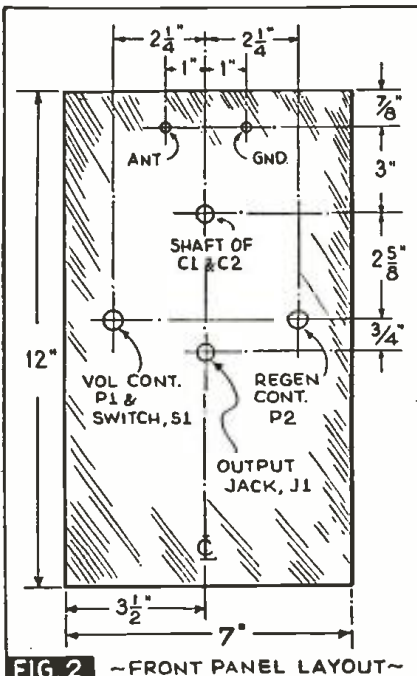

# • EXPERIMENTERS •

broadcast receiver. It is compact and easily carried.

*But the real significance of this set with its unusual circuit is that it shows the way to new superheterodynes employing fewer tubes and built with greater economy than ever before achieved.*

## LIST OF PARTS

### COILS

- One Meissner Antenna Coil, No. 14-2436, L1;
- One Meissner Oscillator Coil, No. 14-4243, L2;
- One Meissner I.F. Transformer, No. 16-5714, I.F.T.

### CONDENSERS

- One Meissner 365 mmf., 2-section variable, No. 21-5214, C1, C2;
- One Meissner 175-500 mmf. padding, No. 22-7005, C3;
- Two Aerovox 250 mmf., mica, type 1466, C4, C5;
- One Aerovox 0.001-mf. mica, type 1466, C6;
- Six Aerovox 0.1-mf. 200 V. paper tubular, type 284, C7, C8, C9, C10, C11, C12.

### RESISTORS

- One I.R.C. 10,000 ohms, type D14-116 midget potentiometer, P1;
- One I.R.C. 0.25-meg., type D13-130 midget potentiometer, P2;
- One I.R.C. 0.2-meg., ½-watt, type BT½, R1;
- One I.R.C. 2 megs., ½-watt, type BT½, R2;
- One I.R.C. 50,000 ohms, ½-watt, type BT½, R3;
- One I.R.C. 20,000 ohms, ½-watt, type BT½, R4;
- Two I.R.C. 75,000 ohms, ½-watt, type BT½, R5, R7;
- One I.R.C. 1,000 ohms, ½-watt, type BT½, R6;
- One I.R.C. 0.25-meg., ½-watt, type BT½, R8.

### TUBES

- Two National Union type 1A7G, V1, V2.

### MISCELLANEOUS

- One pair Brush Development Co. feather-weight, wafer-thin, high-impedance (80,000 ohms), high-fidelity (60 to 10,000 cycles), Rochelle-salt crystal headphones;
- Two Amphenol octal sockets, type MIP;
- One Yaxley headphone jack, No. 704, J1;
- One National dial, type BM with No. 1 scale;
- One I.R.C., D.P.S.T. switch, No. 42, S1;
- One Burgess 1½-volt "A" battery, No. 4FA, B1;
- Two (or 3) Burgess 45-volt "B" batteries, No. Z30N, B2, B3;
- Cabinet, knobs, hardware, phone plug, binding-posts, etc.

# Announcing A SENSATIONAL NEW CUSTOM BUILT SCOTT WITH TONE UNEQUALLED IN RADIO HISTORY



OFFERS BOTH  
*Frequency Modulation*  
AND REGULAR  
RECEPTION

## MOST FAR-REACHING INVENTION IN RADIO FOR TWENTY YEARS

**R**ADIO science now offers a startling new invention . . . **FREQUENCY MODULATION**. Not just an improvement of our present radio system, but an entirely new system of transmission and reception! Static and "noise" have finally been conquered. Even in the heart of a crashing storm, or with X-Ray or other powerful electrical equipment right alongside, reception from the new Custom Built SCOTT FREQUENCY MODULATION receiver, within the service area of the F.M. Stations, remains undisturbed. Only the serene and changeless beauty of the inimitable Scott tone is revealed.

in present broadcasting. Programs are reproduced by the new Scott F.M. receiver with such amazing perfection . . . so free of static and noise . . . you are tempted to pinch yourself to make sure you are not actually present in the studio or concert hall.

### 5 YEAR GUARANTEE—30 DAYS TRIAL

New F.M. transmitters are being rapidly installed. Prepare now for this magnificent new reception. The new far advanced Scott offers both F.M. and regular receiver on one chassis, or new F.M. Tuner alone, for easy connection with present receivers in F.M. service areas. Precision custom built to same quality and performance standards that have won for the Scott universal recognition as "World's Finest Radio", 30 days home trial and extended terms in U.S.A. Sold only direct from our Laboratories. Be first. Write for all details now.

### TONE UNEQUALLED IN RADIO HISTORY

The very peak of high fidelity . . . up to 15,000 cycles . . . is now transmitted on direct studio F.M. broadcasts . . . A tonal range 2 to 3 times greater than that used

### GET SPECIAL INTRODUCTORY OFFER!



**E. H. SCOTT RADIO LABORATORIES, INC.**  
4404 RAVENSWOOD AVE., DEPT. 24K40, CHICAGO, ILL.

Send all facts, special offer, Scott record review, and order blank. NO obligation.

Name .....

Address .....

STUDIOS: CHICAGO, NEW YORK, BUFFALO, DETROIT, LOS ANGELES

**FEATURES IN JUNE  
RADIO & TELEVISION**

March of Radio—illustrated.  
Pigmy 1-Tube All-Electric Receiver, H. G. Cisin, M.E.  
Constructing a DX Portable, Chas. R. Leutz.  
Frequency Modulation Converter—How to build it with only 5 tubes.  
Television—Latest Technical Advances and Construction Hints.  
"Easy Set Building"—One-Tubers in New Circuits!  
Power-Supply Design Factors, Chas. T. Koltz, W2BKZ.  
10-Meter Mobile "Rig," H. G. McEntee, W2FHP.  
New! Electrical Experimentation!  
Latest Radio Patents  
Question Box  
FOTO-CRAFT  
Photos with a Purpose, Kate Smith  
Color Separation Negatives—How to Make

**A BIG SURPRISE IN STORE  
FOR YOU!**

Be sure to read the announcement which appears on the Inside Front Cover of this issue . . . DO IT NOW!

---

**YOU ARE WELCOME**  
to one of our fine Illinois Time-Tested Tubular Paper Condensers, free and postpaid, if you'll just send us the name of your jobber. Write NOW!  
**ILLINOIS CONDENSER CO., Inc.**  
1160 N. Howe St. Chicago, Ill.

**FREE!**

**HAMMARLUND  
NEW "40"  
RADIO CATALOG**

The latest Hammarlund catalog with complete data, illustrations, drawings and curves on the entire Hammarlund line. Address Department RC-64 for your free copy.

**HAMMARLUND MFG. CO., INC.**  
424-438 West 33rd Street, New York City

# •RADIO DEVELOPMENTS•

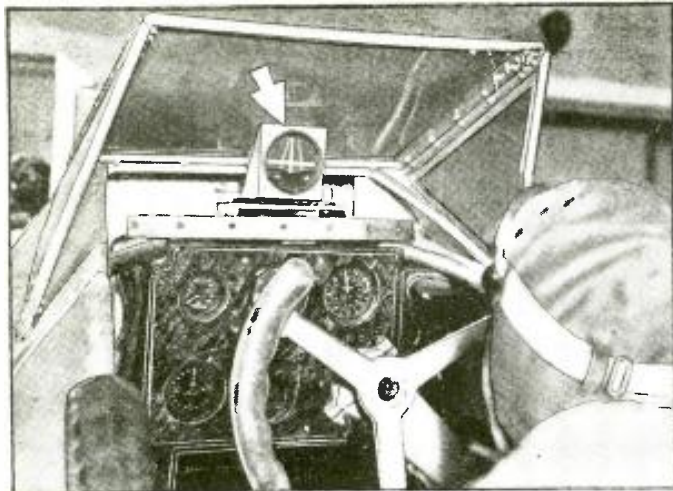

A Navy pilot watches the crossed-pointer indicator installed in the cockpit of his plane as he prepares to come in for a blind landing at the Naval Air Station, Lakehurst, N. J.

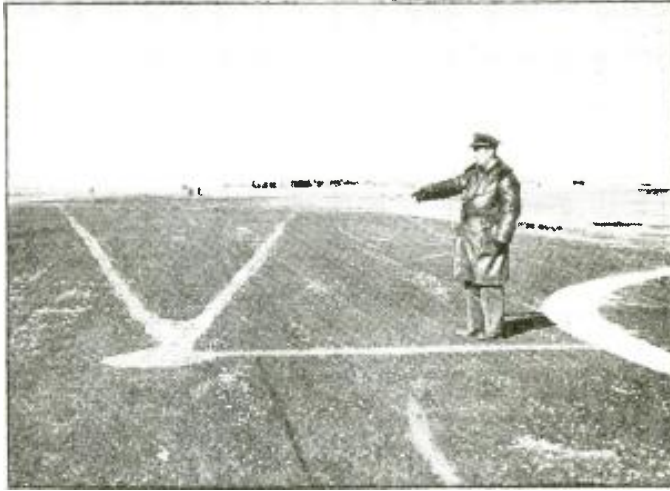

The airfield at Lakehurst, N. J., showing the newest arrangement of the buried cables which are laid in the form of nearly rectangular loops and form a "V" stretching nearly 3,000 ft. long.

## MAGNETIC BEAM

### Lands U.S. Navy Planes Blind

*Believing that the several existing radio systems for blind landing are too complicated, and unreliable, the U.S. Navy developed this highly simplified magnetic beam system which has been successfully proven in field tests.*

**T**HE Navy Department, believing that there might be better ways of providing blind-landing guidance than by any one of the several radio systems which have been widely publicized in recent months, has been quietly working for the last 2 years on a system which is radically different from all others and which gives promise of being the simplest and most reliable of any system yet devised.

The Navy's system does not rely for its operation on the as yet unproved stability of 100,000-kilocycle radio beams and associated radio transmitters and receivers but uses instead the stable and wholly controllable 500-cycle electromagnetic field surrounding 2 long cables laid on each side of the runway and energized by 500-cycle current.

#### LAKEHURST INSTALLATION

The first installation of the Navy's system was completed and tested last Summer at the U.S. Naval Air Station at Lakehurst, New Jersey, the home port of the famed airship *U.S.S. Los Angeles* and the scene of the *Hindenburg* disaster. Officials of the Army, Navy, C.A.A. and of the commercial airlines who have flown and tested the Navy's system favor its simplicity, reliability and freedom from the faults usually encountered in blind-landing systems.

The inventor of the system, Mr. Edward Nelson Dingley, Jr., senior Radio Engineer in the Navy's Bureau of Engineering, has cited, as an example of the system's freedom from unpredictable factors, the fact that the very first trial flight at Lakehurst was not only entirely successful but that the glide path was found to follow exactly the line it was designed to follow and the system has continued to operate in this satisfactory manner without redesign or readjustment.

#### STRAIGHT LINE GLIDE PATH

In the Navy system the glide path may be designed to have any desired shape with such a degree of accuracy that no trial and error adjustments are necessary to eliminate bends and kinks. Most aeronautical experts are of the opinion that the ideal glide path is one which is (a) horizontal at an altitude of about 1,000 feet for a distance of about 2,000 feet; then (b) descends along a straight, diagonal line at any angle of 3 or 4 deg. to a point about 100 feet above the earth; at which point it (c) becomes a true parabola thus checking the descent of the airplane with a constant vertical deceleration to the landing point where contact is made with the ground at an angle of about 1 deg. to the horizontal. The Navy's system permits the complete fulfillment of this pilot's dream of perfection.

An outstanding feature of this 500-cycle system is the complete absence of such complex components as costly super-frequency radio transmitters and receivers with their myriad circuits and vacuum tubes which are liable to maladjustment and sudden failure.

The heart of the Navy's system is a sturdy 500-cycle

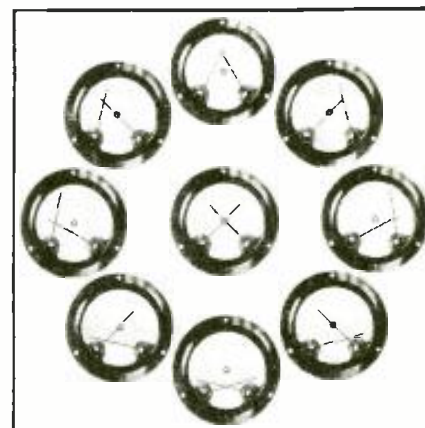

Nine views of the cross-pointer instrument. Each view shows the position taken by the cross-pointers when the airplane is in the same position relative to the glide path that the view occupies relative to the center view.

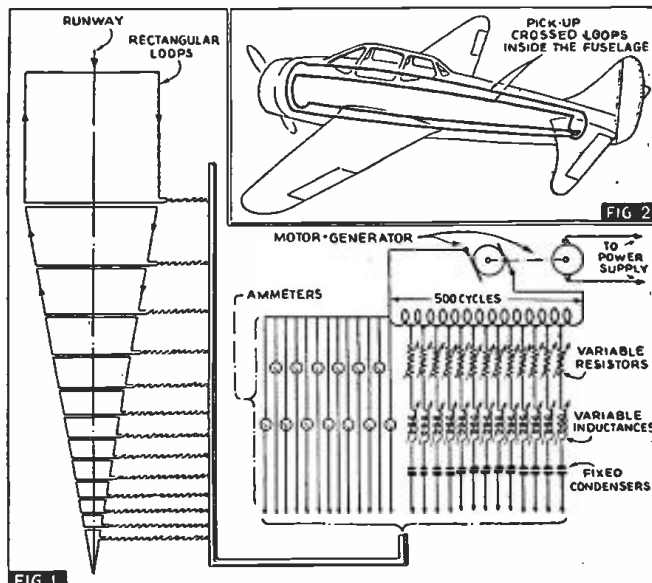
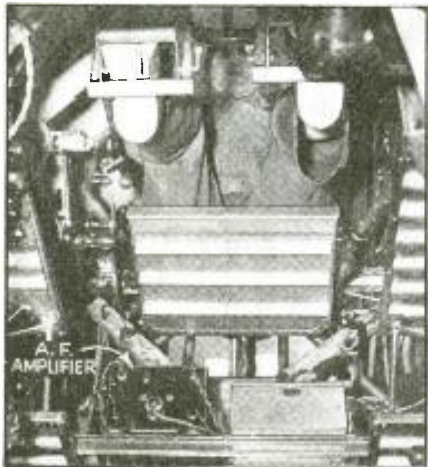

Fig. 1 shows the ground system consisting of a series of nearly rectangular loops of insulated cable buried in the ground in such a fashion as to form a long "V" which is bisected by the runway. Figure 2 shows the position of the 2 collector loops in the airplane. The newest ground system is shown here.

# RADIO DEVELOPMENTS



Underneath view of the magnetic-beam blind-landing system. The 2-stage A.F. amplifier at lower-left amplifies the 500-cycle current picked-up by the crossed loops, installed inside the fuselage, which are shown in Fig. 2. The battery box for the amplifier is the unit, in the photo, at lower-right.



Control panel for the new U.S. Navy blind-landing system. Current supplied by a 500-cycle motor-generator is fed through this panel to the buried cables which set up the magnetic beam (which has a range of 9,000 ft.).

panying drawing (Fig. 1), in such a fashion as to form a long "V" which is bisected by the runway.

The largest ground loop carries a 500-cycle current of about 15 amperes and the progressively smaller ground loops carry proportionately smaller amounts of current so that an airplane flying from the large end of the "V" toward the landing point at the small end of the "V" must constantly reduce its altitude in order to maintain a constant induced voltage in its collector loops. The magnetic glide path thus produced is not a series of steps because the magnetic fields contributed by the various ground loops blend together to form a perfectly smooth glide path.

The 500-cycle magnetic field is not appreciably distorted or modified by the presence of steel framework buildings or reinforced concrete runways or even by the network of railroad tracks which cross and re-cross the ground cables at Lakehurst.

## THE AIRPLANE EQUIPMENT

The airplane equipment consists of 2 collector loops, a 2-channel A.F. amplifier tuned to 500-cycles, and a cross-pointer indicator.

The collector loops consist of 3/8-inch-diameter flexible fabric-covered cables containing 100 enameled No. 26 wires. These cables are secured to the inner walls of the fuselage, as shown in the accompanying drawing (Fig. 2), in such a way as to form two 100-turn loops at right-angles to each other and making angles of 45-degrees with the horizontal.

The input terminals of the 2 channels of the A.F. amplifier are connected respectively to these 2 loops and the amplified signals are delivered from the output terminals of each channel to the 2 movements of the cross-pointer instrument.

The cross-pointer instrument (only 1 instrument is required) contains 2 rectox dry-disc-rectifier-type 0-5 volt A.C. voltmeters mounted in a single case as shown in the 9 views of the instrument in the accompanying photograph. Each of these 9 views shows the position assumed by the cross-pointers whenever the airplane is in the same position relative to the glide path as is occupied by the view in question (the point of pointer intersection) relative to the center view.

## OPERATION

Because the distance between the 2 ground cables is always equal to twice the altitude of the glide path at any point considered, it follows that at an altitude of 1,000 feet at the start of the glide path, the entrance is 2,000 feet wide thus allowing a generous area in which to make the first contact.

As is the case at most airfields, the Lakehurst station is equipped with a low-power A-N (dot-dash, dash-dot) type, intermediate frequency radio beacon and because the airplane carries a beacon receiver as a part of its standard equipment, it was decided to locate one leg of this beacon along the 500-cycle-equipped runway as an additional aid to the pilot in locating the entrance to the glide path.

In operation, the pilot flies at an altitude of 1,000 feet, as indicated by the barometric altimeter and follows the regular A-N or radio beam from a point 15 or 20 miles away until he reaches the entrance of the glide path. At this point the cross-pointers of the 500-cycle system snap into position and show his exact location with respect to the glide path. From this point until his wheels contact the ground, the pilot needs only to fly his plane in such a way as to hold the crossed pointers on the bull's-eye in the center of the instrument; the radio beacon is no longer needed or used.

# Learn RADIO

with Ghirardi's BIG  
1-Volume Radio  
Training Course

Here's the "break" you've been waiting for! Now you can get into the profitable profession of Radio without long and expensive schooling. Ghirardi's great tested, short-cut training course gives you a sound and thorough grounding in Electricity, Radio, fundamentals and then Television, Sound, Cathode-Ray Tubes, etc. Yes! The "whole works"—all in one big, handy, self-instruction book you'll enjoy reading at home in spare time. Best of all, it's economical—and what a bargain—you get everything complete, the entire 36-section course bound in one handsome, big 972-page volume for the amazingly low price of only \$4. Just think of it!

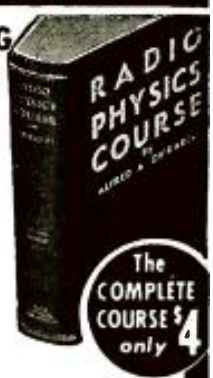

The COMPLETE COURSE \$4 only

## EASY AS A. B. C.

It's really easy and a pleasure to learn Radio "the Ghirardi way." Every detail is explained so clearly and simply. That's why it's used by more radio schools and students than any other radio text in the world. It's just as easy to understand it whether you've had previous training and experience, or whether you've had none at all. You don't even need a knowledge of math! Just see what you get:

- 36 VOLUMES IN 1—972 PAGES—508 ILLUS.
- 1. Radio Broadcasting System. 2. Sound, Speech, Music. 3. Electron Theory; Elec. Current. 4. Elec. Units; Ohm's Law; Resistance. 5. Elec. Circuits; Batteries. 6. Magnetism. 7. Electro-magnetism. 8. Electromagnetic Induction. 9. Inductance. 10. Capacitance; Condensers. 11. A.C. Circuit. 12. Filters. 13. Measuring Instruments. 14. Radio Waves. 15. Broadcasting. 16. Receiving. 17. Vacuum Tube Principles. 18. Vacuum Tube Characteristics. 19. Vacuum Tube Construction. 20. Vacuum Tube Detector and Amplifier Action. 21. Radio Frequency Amplification. 22. "Superhets." 23. R. F. Amplifiers; Tuning Coils. 24. Audio Amplifiers. 25. Speakers. 26. Battery Operated Receivers. 27. Power-Supply Units. 28. Elec. Receivers. 29. Automobile and Aircraft Radio. 30. Phono Pickups; Sound Systems. 31. Shortwave. 32. Photoelectric Cells; Cathode-Ray Tubes. 33. Television. 34. Antennas and Grounds. 35. Testing; Servicing. 36. Sound Films. 37. Self-Review Questions.

## MAIL THIS COUPON NOW

RADIO & TECHNICAL PUBLISHING CO.  
45 Astor Place, New York, Dept. RC-60

Here is my \$4 (\$4.50 foreign). Send me 1 RADIO PHYSICS COURSE postpaid, under your 5-day Money-Back Guarantee.

NAME .....

ADDRESS .....

CITY ..... STATE .....

Send me free descriptive illustrated literature.

Test It 5 Days—OUR Risk!

Our NEW Address  
**RADIO-CRAFT**  
20 VESEY STREET  
NEW YORK, N. Y.

**NOW!**

**FORTUNES FORMULAS**

10,000 RECIPES AND FORMULAS FOR HOME, FARM AND WORKSHOP

10,000 TRADE SECRETS REVEALED AND PROTECTED FOR HOME, FARM AND WORKSHOP

924 PAGES

The Great-est and most important formula book in print. It contains over 10,000 trade secrets, receipts, recipes and processes for home, farm and workshop.

Check-full of money-making ideas for cosmetics, perfumes, antiseptics, water-proof ink, photography, lacquer, paints, cement, preservatives, fumigants, insecticides, etc.

Book also contains following important chapters: Useful Workshop Laboratory Methods, fully illustrated, Complete Buyer's Guide, where to buy best materials at wholesale prices; Measuring Made Easy; Latin Names of Drugs and Chemicals Translated into English. Completely indexed. In short, this is a Wonder Book of Useful Knowledge Worth its weight in gold.

Book is up-to-date and has the newest methods—latest discoveries—countless thousands of ideas—which you will find useful. Remember—there are actually over 10,000 clearly described formulas, processes, recipes—MANY NEVER BEFORE REVEALED.

This huge book has 924 pages, printed on good paper. Size 8 1/2" x 5 1/2"

Send for a copy of this veritable gold mine TODAY. You will never regret it. Remember, great fortunes are often made on formulas.

\$1.70 per copy, sent postpaid anywhere **\$179** in U. S. (Canada and foreign countries 25c extra) postage.

Send money order, check, unused U.S. stamps or cash. (Register all letters containing cash.)

**NATIONAL PLANS INSTITUTE**  
246-R Fifth Avenue New York, N. Y.

## THE GROUND SYSTEM

The ground system consists of a series of nearly rectangular loops of insulated cable laid on the ground, as shown in the accom-



Photo—Zenith Radio Corp.  
In the Springtime a young man's fancy, etc. . . . and portable radio.

Here is a concise article that analyzes the features which characterize the battery, and battery - electric, portable radio and radio - phono sets for 1940. Several representative schematic circuits are included for reference in servicing, etc.

## 1940's PORTABLES

N. H. LESSEM

**T**HERE is one thing which all portables have in common . . . a handle; the same handle with which the radio industry pulled itself out of a rut last Summer. It is admitted in all quarters that were it not for the sudden "boom" in portable receivers in the Summer of 1939, the radio industry would have had to crawl into a hole to hibernate.

This Summer, while the picture is a bit rosier, portables by all indications will again represent the major portion of the hot months' radio business. We will endeavor in this article to give a brief cross-section of 1940's crop of portable receivers. The representative models here illustrated are described below.

Portables can be roughly divided into 3 main classifications: (1) the strictly battery-operated job; (2) the 3-way receiver which operates on A.C., D.C. and/or batteries; and, (3) the phono-radio combinations.

### BATTERY PORTABLES

The receivers in this classification are more or less similar in circuit design and in performance—varying only in their outer appearance. Without exception they are superheterodynes, 4 or 5 tubes, of which the first 3 almost invariably are a 1A7G, 1N5G, and a 1H5G. The tubes used in the output circuit vary with the different manufacturers, several using a 1C5G and others a 1A5G. Those receivers which use a 5-tube circuit employ an extra 1N5G as an additional I.F. stage for increased sensitivity. Typical of the receivers in this classification is the Stewart-Warner model 02-4A chassis, the schematic circuit of which is reproduced in Fig. 1.

### 3-WAY PORTABLES

By far the most popular type of portable receiver falls into this classification, which

is quite natural since these sets may be operated practically anywhere. On the beach they will work on self-contained batteries; in the home or hotel room they may be plugged into the 115-V. electric outlet either A.C. or D.C. Receivers in this classification differ from each other in only 2 respects, viz., (1) the manner in which they switch from battery to power operation, and (2) the rectifier and output stages of their circuits.

In general 3 methods of battery-to-power (and vice-versa) switch-over are employed, namely, by the use of an automatic relay; by mechanical switching; and by means of "floating" the batteries across the output of the rectifier circuit.

Typical of the 1st method is the Pilot portable model T-1451. (See schematic diagram, Fig. 2.) The relay is in the cathode circuit of the rectifier tube and is energized when the power cord is plugged into the line and the rectifier tube has become suf-

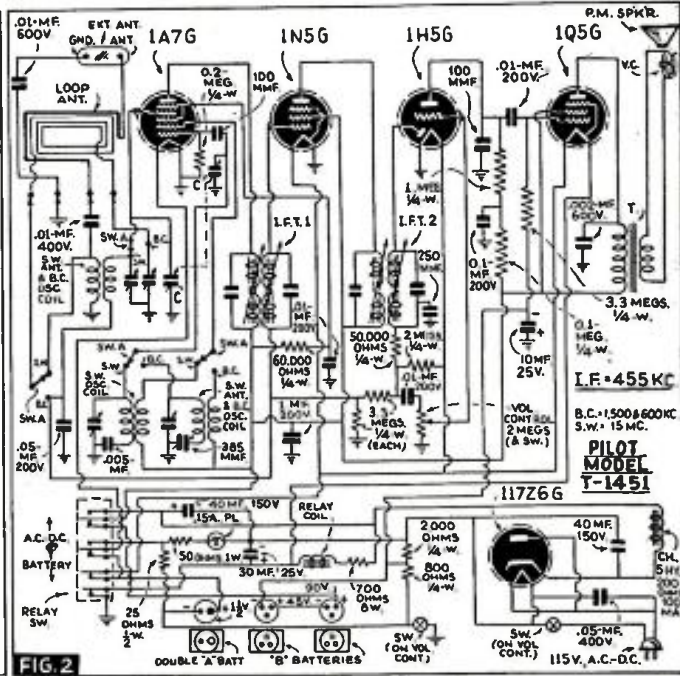
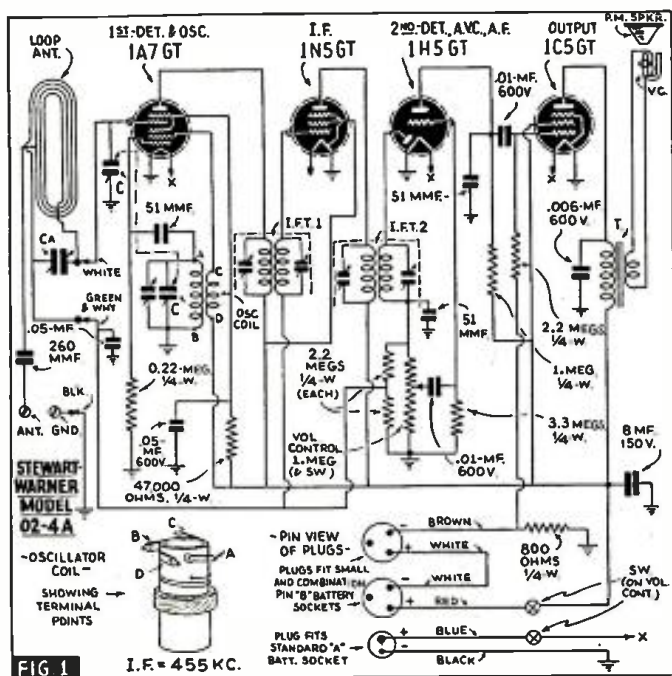



ficiently warmed-up to start delivering current to the circuit. The contacts activated by the relay change the arrangement of the filament wiring from parallel (for battery operation) to series (for power operation); and also switch the "B" power from batteries to the rectifier.

This action is automatic and is a good sales point since it eliminates the element of human forgetfulness. When plugged into the power line the set plays immediately, operating from its self-contained batteries. As soon as the rectifier has heated sufficiently a low "click" is heard indicating that the relay has changed the filament arrangement and the power source.

By far the largest group, for reasons best known to the manufacturers, employs the mechanical switching system. Some use a rotary switch for making the circuit changes. Others do it semi-automatically as follows: when reception from the light lines is desired the action of pulling out the electric plug from its receptacle in the receiver automatically makes the necessary circuit changes. However, unless one remembers to re-insert the power plug in its original position, reception will not be obtained from the batteries.

Of the 3rd method, that of floating the batteries across the output of the rectifier circuit, 2 variations are used. The 1st of these variations—1st put out by Automatic Radio Mfg. Co.—employs a series filament circuit both for battery and for line operation\*. The "A" battery naturally is 6 volts. When plugged into the power line, the set plays instantly, power being supplied by the self-contained batteries. However, as soon as the rectifier heats sufficiently it "takes over" the power load. Since the output of the rectifier is designed to be slightly higher in voltage than the "A"-battery supply it is claimed that the "A" battery "floats" across the line and is actually re-charged to a certain degree. The same conditions hold true for the "B" batteries.

The Majestic Radio and Television Corp., claiming that low line voltage may cause the batteries to discharge instead of re-charge, and that the batteries may be damaged through constant and excessive overcharging, puts out a portable receiver (models 5BD and 5BDR) which, although employing the general principles of this system, uses the 2nd variation, i.e., a method for controlling the amount of battery recharging.

The batteries are only recharged at the end of their life when they would have to be replaced if they were not recharged.

Therefore any additional life obtained through recharging is that much extra life gained. It is claimed that battery life can be extended from 25 to 40 per cent of normal life. This particular portable has 3 pushbuttons on its front panel, 1 for A.C.-D.C. operation, 1 for battery operation and 1 "off." Simultaneously pushing in all 3 buttons places the batteries on charge. (See schematic diagram, Fig. 3.)

All 3-way portable receivers employ the superheterodyne circuit of from 5 to 6 tubes. Here again (as with the receivers in the 1st classification) the 1st 3 tubes are the same, viz., 1A7GT, 1N5GT, and 1H5GT. Only the output and rectifier tubes seem to vary. The RCA receivers (models BP-55, BP-56, and BP-85) use a 1T5GT as output tube and 117Z6G as the rectifier. This latter tube, you will note by its number, has a 117-V. filament which eliminates the necessity of having either a ballast tube or a "hot" cord.

Audio power in the General Electric mod-



(\*) See "Radio Service Data Sheet No. 261," Radio-Craft, Sept., 1939.

# • RADIO DEVELOPMENTS •

## ONLY \$4.96 U. S. NAVY AIRPLANE-TYPE Microphone and Receiver

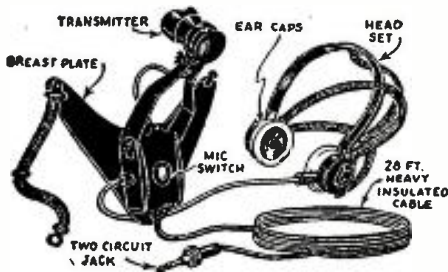

**THIS** Microphone and telephone headset outfit was built especially for the U.S. Navy Aviation Corps for Plane-to-Plane and Plane-to-Ground communication.

The Holtzer-Cabot Electric Company constructed the outfit to Government specifications and under rigid Navy Department supervision.

The outfit consists of a low-impedance carbon microphone (transmitter), securely fastened to a metal breast-plate, and a set of heavy-duty, low-impedance earphones. A specially constructed switch on the back of the breast-plate controls the microphone circuit. The earphones are U.S.N. Utah type, attached to adjustable headband. Twenty-eight feet of very heavy weather and waterproof conductor cable, terminating in a special brass plug, is furnished with this complete outfit. Current of not more than 10 volts should be used. A storage battery is the most satisfactory current supply. Talk in a natural tone of voice, when using the outfit, with the lips close to the mouthpiece. Shouting and loud talking should be avoided.

We understand that the U.S. Government paid more than \$40.00 for each of these outfits. We have bought the whole lot at a low price and are offering them, as long as the supply lasts, at \$4.96 each, complete as shown in illustration. The shipping weight is 9 lbs.

All merchandise in original packages—never used. Money-back guarantee.

All Shipments will be forwarded by Express Collect if not sufficient postage included.

**WELLWORTH TRADING CO.**  
1915 So. State St., Dept. RC-840, Chicago, Ill.



### SWINGS INTO ACTION

Primarily the aim of the Association is to return to the Distributor, the Dealer and the Serviceman the profits which are legitimately HIS! This can only be accomplished by raising the standards of ethics of merchandising within the Industry.

Names of Member Jobbers in your territory will be supplied if you will address the Executive Secretary of the Association.

**Office of the Executive Secretary**  
5 West 86th Street New York, N. Y.

el HB-412 portable is obtained from a 1T5GT on battery operation and the pentode section of the 117L7GT on A.C. or D.C. operation. The driving grids of the 2 tubes are in parallel. On battery operation the 117L7GT is dead, due to no filament voltage as is the case of the 1T5GT on A.C.-D.C. operation. A tapped primary output transformer is used to insure matching to the different load impedances of the 2 output tubes.

The Lafayette model CC-58A is a 6-tube, s-band portable. The extra tube is a type 1N5GT used as a 2nd I.F. When used on batteries, the output tube is a 3G5GT. On A.C.-D.C. operation, a type 70L7GT is used as a combined rectifier and output tube.

Majestic Radio and Television Corp. models 5BD and 5BDR use a 1D8GT as 2nd A.F. amplifier and output tube on battery operation (diode portion of this tube remains unused) and a 70L7GT as combined output and rectifier on line operation.

Briefly, the other output tubes in general use are the 1A5GT and the 1Q5GT; the other type of rectifier tube not already mentioned is the 35Z5GT.

A few of the portables, of which the Belmont models 507 and 513 (Series A) are representative, are housed in a decorative, polished-wood case which is especially appropriate in average homes. A weatherproof zipper-case is slipped over the set to protect it when it is desired to take it outdoors.

### PHONO-RADIO COMBINATIONS

Although not as popular as the 3-way receivers, the *phono combinations* are definitely forging ahead to increasingly larger sales each year. Inasmuch as the phono motors have to be of the A.C. noise-free (induction) type most of these combinations must necessarily confine their operation to the A.C. lines. However in one case, the General Electric model H-639 D.C., operation is also obtained on D.C. through the use of an inverter. The function of this inverter is simply to change the D.C. of the line to the A.C. necessary to operate the phono motor. The radio receiver portions of these combinations are 5-tube superheterodynes using the following complement of tubes: 1-12SA7 as oscillator and 1st-detector; 1-12SK7 as I.F. amplifier; 1-12SQ7 as 2nd-detector, A.V.C. and 1st A.F. amplifier; 1-35L6 as beam-power output; and 1-35Z5 as rectifier. All phono pickups are of the crystal variety.

### LOOP ANTENNAS

All portable receivers are equipped with a loop-type antenna attached to the inside of the cabinet. This type of antenna is directional so that by rotating the entire receiver (which rotates the antenna, too) the signal may be "beamed" and thus intensified. If a nearby broadcasting station interferes with other stations it is merely neces-

### REPRESENTATIVE GROUP OF 1940 PORTABLES

Make	Model No.	Power		S.W. No. of Band Tubes	Total Phono Voltage	"A"	Dynamic Speaker Electro-Dynamic	
		A.C.	D.C. Batt.				P.M.	Dynamic
Pilot Radio Corp.	T-1452	•	•	•	5	1.5	•	•
Sparks-Withington Co.	590-1	•	•	•	5	6	•	•
Crosley Radio Corp.	549	•	•	•	5	6	•	•
Belmont Radio Corp.	507 & 513 (Series A)	•	•	•	5	6	•	•
Lafayette	CC-58A	•	•	•	6	9	•	•
General Electric	HB-412	•	•	•	4	6	•	•
RCA	BP-55	•	•	•	5	6	•	•
	BP-56							
	BP-85							
Kadette Radio Corp.	L-41	•	•	•	5	•	•	•
Westinghouse	WR-475	•	•	•	5	•	•	•
Wells-Gardner	Series 6B7	•	•	•	6	9	•	•
Majestic Radio & Television	5BD & 5BDR	•	•	•	5	1.5	•	•
Stewart-Warner	02-4A1	•	•	•	4	1.5	•	•

\*2 shortwave bands

All these portable receivers incorporate automatic volume control, built-in loop antennas and broadcast-band reception. The Lafayette model CC-58A provides for headphone connection. It is interesting to note that none of these portables incorporates a stage of R.F. amplification ahead of the mixer.

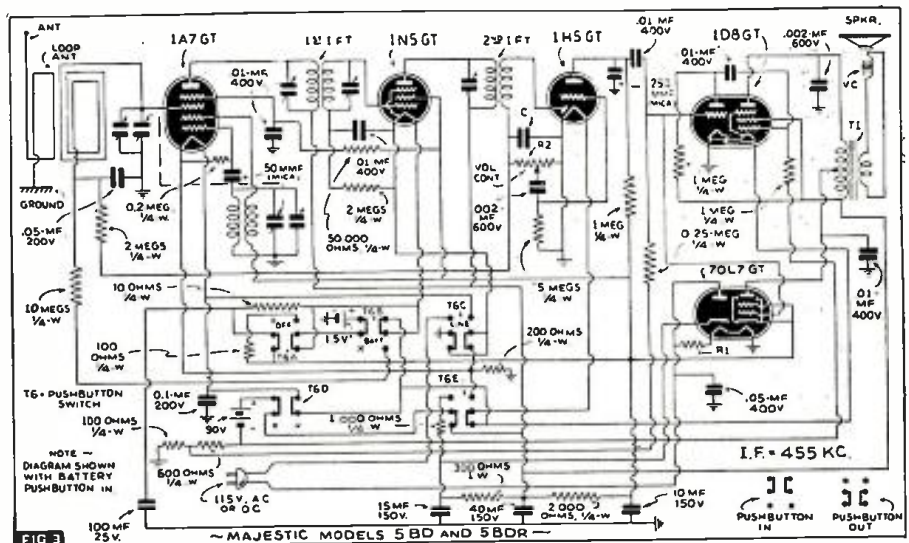

# • LATEST RADIO APPARATUS •

sary to rotate the receiver to a position which will produce *minimum* volume from the interfering station.

Ordinarily this built-in loop antenna is the only antenna required. However in remote locations the reception may be weak. Therefore provisions are generally made for attaching an outside antenna and ground. The external antenna and ground circuits are inductively coupled to the loop by means of a single turn of wire terminating in "A" and "G" terminals somewhere on the back or the bottom of the portables. For best results an outside antenna of ap-

proximately 50 to 75 ft. long (including the lead-in) is recommended.

The "Wavemagnet" (loop antenna) in Zenith portables is *removable*. This (patented) construction permits efficient reception in trains, planes, boats, autos, and steel-construction buildings. The loop antenna has handy *vacuum cups* for attachment to windows when used in these special locations. The necessity for aerial and ground connections is thereby eliminated.

Caution: It is always safe *not* to use a ground connection when the receiver is operated from either the A.C. or D.C. line.

## COMMUNICATIONS RECEIVER

The Hallicrafters  
2611 S. Indiana Ave., Chicago, Ill.



**T**he new Hallicrafters SX-25 "Super Defiant" is offered as a medium-price instrument despite array of new features. Among the features are 2 preselector stages, broad and sharp crystal filter circuits, temperature and line voltage compensation (which means freedom from tuning drift), frequency-calibrated band spread on ham bands from 80 to 100 meters, inclusive, continuous range of 538 kc. to 42 mc. in 2 bands, optional A.V.C., single-signal C.W. reception, direct-reading "S" meter, and others.

Set uses 12 tubes, including push-pull output, and claims an average sensitivity of 0.3-microvolt throughout tuning range. Provides for A.C. operation or for instant changeover to battery-vibrator operation for mobile or emergency work.

## "MICRO-TESTER" MULTI-RANGE AMMETER

Simpson Electric Co.  
5216 W. Kinzie St., Chicago, Ill.

**A** COMPACT A.C. multi-range ammeter, model 280, which consists of a current transformer and indicating instrument. It is pocket-size measuring only 2 1/4 x 5 1/4 x 1 1/4 ins.—weighs 20 ozs. Provides readings in any of 5 different ranges from fractions of an ampere up to 25 amperes. (Companion meters, to match, measure voltage and resistance; and compose a new line of "Micro-Testers".)

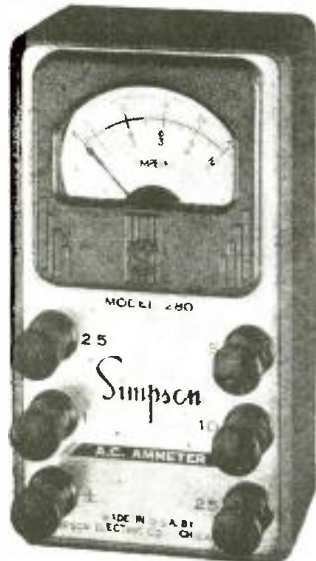

## HIGH C., LOW V. MIDGET ELECTROLYTICS

Aerovox Corp.  
New Bedford, Mass.



**N**EW line of midget can electrolytics for applications calling for very high capacity at very low voltages. The capacities range from 1,000 to 3,000 mf. with working voltages of 6, 12 and 15, D.C. The metal can is insulated.

## STANDARDIZED P.A. UNITS

Montgomery Ward  
Chicago, Ill.

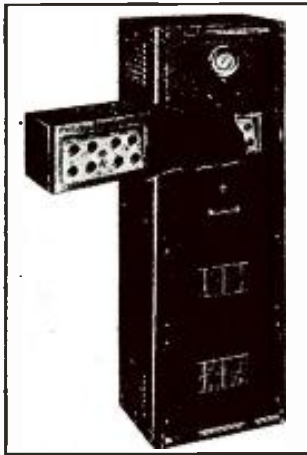

**T**HESE units have 4 individual mike channels and 2 phonograph inputs as well as separate, booster-type bass and treble controls. Four mike inputs use 4 input tubes with individual volume controls. One master phono volume control is used for 2 phono inputs; 2nd master control with provision for remote operation used to adjust overall volume of all channels.

This standardized preamplifier when attached to the company's 60- to 100-W. amplifier becomes an integral part of same. When a power output of more than 100 W. is wanted additional 100-W. amplifiers (up to 5, for 500-W. output) are connected to the preamplifier. The illustration shows a de luxe installation using a hi-fi radio tuner, automatic record changeover and 3-100 W. amplifier units.



DEALERS  
SERVICEMEN  
SOUND MEN  
RADIO BUILDERS  
AMATEURS

## Get this book of RADIO VALUES

Now!

SAVE ON  
EVERYTHING  
IN RADIO

FREE



60  
NEW  
SETS

1940 RADIO HITS! New "Camera" and standard Portables—new European reception models—new "Com-bats"—all types, all sizes, for every purpose. New plastic phono-radios, new Recorder-Radios, new auto radios—all at the very lowest prices—in this new FREE Catalog.

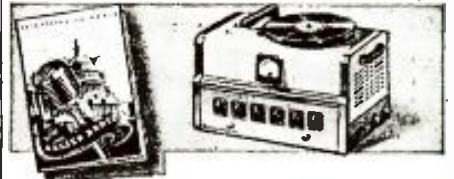

NEW  
SOUND  
SYSTEMS

18 new Public Address Systems—7 to 75 watts—for Electoneering, Orchestras, Churches, Schools, Rentals, etc. America's finest P.A. at startling low prices. Easy Time Payment Plan. Complete accessory listing, new recording equipment, etc.—all in this new value-packed book.



15,000  
RADIO  
PARTS

You'll find Everything in Radio in this new Catalog. Servicemen—see the new Test Equipment and full replacement parts listings. Amateurs—get a big surprise and the "low-down" on the new "Ham" receivers. And don't miss the special 8-page Bargain Section—there's nothing like it!



Dozens of brand-new exciting kits—new diagrams—Depend on ALLIED for information and advice. Send for Free Parts Lists to build any type of radio circuit. Consult ALLIED! See the splendid new Howard Amateur Communications Receivers (Model "435" illustrated). Get the exciting story of the new "Progressive Series"—a brand-new Amateur Receiver idea—there's never been anything like it before.

## ALLIED RADIO

833 W. JACKSON BLVD., DEPT. 2-F-0  
CHICAGO, ILLINOIS

Send me your FREE New 172 page Spring Catalog covering Everything in Radio!

Name .....

Address .....

City ..... State .....

SEND COUPON NOW!

# For Better Servicing - For Bigger Profits - USE GERNSBACK MANUALS AND BOOKS!

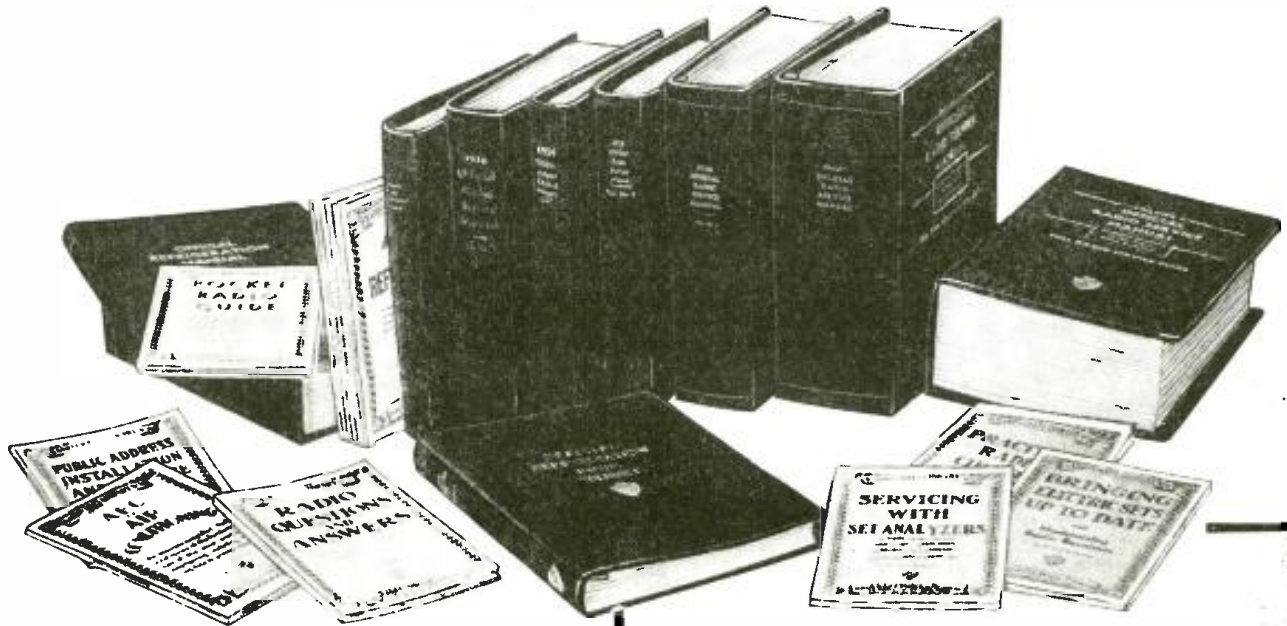

**S**INCE 1931 Servicemen have been buying more GERNSBACK OFFICIAL RADIO SERVICE MANUALS year after year. The authentic material, easily accessible diagrams and complete service data make them invaluable to dealers and radio Servicemen. *Without a Gernsback Service Manual at the repair job, there's time and profit lost.* Your service kit or laboratory is incomplete without all the GERNSBACK OFFICIAL RADIO SERVICE MANUALS. There are GERNSBACK MANUALS for servicing auto-radios, also refrigeration and air conditioning equipment.

### VOLUME 7 OFFICIAL RADIO SERVICE MANUAL

Over 1,800 Pages • Over 3,000 Illustrations • Stiff, Leatherette, Looseleaf Covers • Size 9 x 12 Inches • Net Weight 10½ lbs. **\$10.00**

### 1936 OFFICIAL RADIO SERVICE MANUAL

Over 1,200 Pages • Over 2,500 Illustrations • Stiff, Leatherette, Looseleaf Covers • Size 9 x 12 Inches • Net Weight 8 lbs. **\$7.00**

### 1935 OFFICIAL AUTO-RADIO SERVICE MANUAL

Over 240 Pages • Over 500 Illustrations • Flexible, Leatherette, Looseleaf Covers • Size 9 x 12 Inches • Net Weight 1¼ lbs. **\$2.50**

### 1934 OFFICIAL RADIO SERVICE MANUAL

Over 400 Pages • Over 2,000 Illustrations • Flexible, Leatherette, Looseleaf Covers • Size 9 x 12 Inches • Net Weight 2¼ lbs. **\$3.50**

### 1932 OFFICIAL RADIO SERVICE MANUAL

Over 1,000 Pages • Over 2,000 Illustrations • Flexible, Leatherette, Looseleaf Covers • Size 9 x 12 Inches • Net Weight 4½ lbs. **\$5.00**

### OFFICIAL REFRIGERATION SERVICE MANUAL

(Volume II)  
Over 352 Pages • Over 300 Illustrations • Flexible, Leatherette, Looseleaf Covers • Size 9 x 12 Inches • Net Weight 1¼ lbs. **\$5.00**

### OFFICIAL AIR CONDITIONING SERVICE MANUAL

Over 352 Pages • Over 600 Illustrations • Flexible, Leatherette, Looseleaf Covers • Size 9 x 12 Inches • Net Weight 2¼ lbs. **\$5.00**

To order these famous Manuals, see or write to your jobber or favorite mail order house. If more convenient, mail coupon directly to publishers.

**RADCRAFT PUBLICATIONS, Inc.**  
20 VESEY STREET NEW YORK, N. Y.

## RADIO-CRAFT LIBRARY SERIES

Get into the swing of reading instructive, authoritative books on technical subjects—radio, air conditioning and refrigeration. It's the easiest, quickest and most inexpensive way to improve your knowledge on these topics. In this series, popularly known as the RADIO-CRAFT LIBRARY SERIES, are all the titles necessary to your personal advancement. Only by careful study of these enlightening books, can you gain adequate experience in fields of radio, air conditioning and refrigeration. Each book is uniform. The volumes measure 6 x 9 inches—contain 64 pages, and have stiff, flexible covers. PRICE 50c PER BOOK. All books are sent to you postpaid.

### Here Are The Titles:

- |   |   |
|---|---|
| Book No. 2<br>MODERN VACUUM TUBES               | Book No. 16<br>PRACTICAL RADIO CIRCUITS             |
| Book No. 3<br>THE SUPERHETERODYNE BOOK          | Book No. 17<br>SERVICING WITH SET ANALYZERS         |
| Book No. 6<br>BRINGING ELECTRIC SETS UP-TO-DATE | Book No. 18<br>POINT-TO-POINT RESISTANCE ANALYSIS   |
| Book No. 9<br>AUTOMOBILE RADIO AND SERVICING    | Book No. 19<br>PRACTICAL RADIO KINKS AND SHORT CUTS |
| Book No. 10<br>HOME RECORDING AND ALL ABOUT IT  | Book No. 20<br>THE CATHODE-RAY OSCILLOSCOPE         |
| Book No. 13<br>ABC OF AIR CONDITIONING          | Book No. 21<br>BREAKING INTO RADIO SERVICING        |
| Book No. 14<br>POCKET RADIO GUIDE               | Book No. 22<br>NEW RADIO QUESTIONS AND ANSWERS      |
| Book No. 15<br>ABC OF REFRIGERATION             | Book No. 23<br>PRACTICAL PUBLIC ADDRESS             |

**EACH BOOK IN THIS SERIES—50c**

RADCRAFT PUBLICATIONS, Inc., 20 VESEY ST., NEW YORK, N. Y.

Gentlemen: Enclosed find my remittance of \$..... for which send me, POSTPAID, the Manuals or Books indicated below by a cross (x) in the panel.

- ( ) Volume 7 @ \$10.00      ( ) 1936 Manual @ \$7.00      ( ) 1934 Manual @ \$3.50  
( ) 1935 Auto-Manual @ \$2.50      ( ) 1932 Manual @ \$5.00  
( ) Refrigeration Manual (Vol. 2) @ \$5.00      ( ) Air Conditioning Manual @ \$5.00

RADIO-CRAFT LIBRARY SERIES @ 50c EACH

Circle book numbers wanted: 2 3 6 9 10 13 14 15 16 17 18 19 20 21 22 23

Name ..... Address .....

City ..... State .....

(Send remittance in form of check or money order; register your letter if you send cash or unused U. S. Postage Stamps.)

RC-640

# • LATEST RADIO APPARATUS •

## POLYSTYRENE CRYSTAL HOLDER

American Phenolic Corp.  
1250 W. Van Buren St., Chicago, Ill.

A NEW socket for crystal holders made of transparent, low-loss, non-hygroscopic polystyrene (Amphenol "912") permits full crystal output to be applied to the grid of the oscillator tube. Contacts are of phosphor-bronze, silver-plated to reduce contact resistance. Can be mounted either on top of chassis or from underneath with a single No. 6 screw.



## OBSOLESCENCE-PROOF TUBE TESTER

The Radiotechnic Laboratory  
1328 Sherman Ave., Evanston, Ill.



THE main feature of this model 120 tube tester is its PMT (permutation) switching system (for which patent has been applied). This system, the manufacturer claims, will enable the instrument to test every tube on the market today as well as any tube which may be subsequently developed. Besides testing every tube on the market today it also checks pilot lamps, Christmas tree bulbs, gaseous rectifiers, et al.; 3 D.C. ranges: 0-10 V., 0-100 V. and 0-1,000 V. are available for testing batteries and D.C. power supplies. Available in counter and portable models.

## PHONE TRANSCEIVER

Harvey Radio Labs., Inc.  
25 Thorndike St., Cambridge, Mass.

THIS instrument is a telephone transmitter-receiver designed particularly for private plane installations. Contains a 5-tube receiver operating on the aviation beacon bands. The transmitter operates on 31.05 megacycles. The unit, type IMP, is exceptionally small and compact.

## SMALLER "RED-CAPS"

Solar Mfg. Corp.  
Bayonne, N. J.

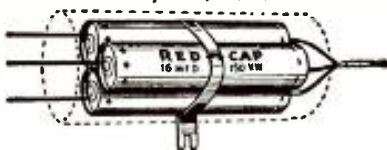

A LIST of only 12 ratings in this new series of units so made as to cover the majority of filter block repair requirements. Lengths are uniform but diameters are less than previous models. Several units strapped together occupy no more space than the original filter—the purpose being that Servicemen can make up their own filter blocks without the necessity of getting exact replacements. The Red-Caps are sealed in metal containers.

# ---"B"---line to profit!

Stock the "B" battery that revolutionized the portable radio industry—"Eveready" "MINI-MAX" 45 volt "B" battery—its light weight means heavy profits for you!



"Eveready" "MINI-MAX" means less weight ...less bulk...portable radios that are really portable *without sacrifice in service life. It gives twice the service life of any other "B" battery of equal size!*

Over 30 manufacturers have designed portable receivers around the "Eveready" "MINI-MAX" No. 482. Your customers will demand this mighty midget in the busy season ahead. Get your order in *today!*

## NATIONAL CARBON COMPANY, INC.

General Offices: New York, N. Y.  
Branches: Chicago and San Francisco  
Unit of Union Carbide and Carbon Corporation



The words "Eveready" and "Mini-Max" are registered trade-marks identifying products of National Carbon Company, Inc.

## "MULTIVOLT" RESISTORS

Ohmite Mfg. Co.  
4835 Flournoy St., Chicago, Ill.



MULTI-TAP vitreous enamel resistors especially suitable for cathode-modulation radio telephone circuits. Units of 50 W. rating are available in 10,000- and 25,000-ohm values, making it possible to secure the proper impedance match of the modulator to the filament or cathode circuit of the final R.F. amplifier. Each resistor has 10 equal-section taps.

## I-UNIT SOUND SYSTEM

Allied Radio Corp.  
833 W. Jackson Blvd., Chicago, Ill.



THE "Speechmaster" model A12255 is a portable 1-unit sound system with a lighted tilt-top reading table. The amplifier, speaker and microphone are all included in the single case. Features include 14 W. of usable power (also available in 7-W. size), inverse-feedback phono connection, separate microphone and phono volume controls in a mixer circuit, bass-treble tone control, uni-directional microphone. Dimensions of entire unit, 18 x 17 x 13 3/4 ins.

## SOMETHING NEW! JUST OUT

GET A COMPLETE SET OF THE SEVEN ESPECIALLY SELECTED UP-TO-DATE DESIGNS



## TECHNIFAX CONSTRUCTION PATTERN SERIES

## TREASURE LOCATORS BLUE PRINTS and INSTRUCTIONS

For Building the Following Treasure Finders and Prospecting Outfits

- Folder No. 1 The "Radiolector" Pilot.
- Folder No. 2 The "Harmonic Frequency" Locator.
- Folder No. 3 The "Beat-Note" Indicator.
- Folder No. 4 The "Radio-Balance" Surveyor.
- Folder No. 5 The "Variable Inductance" Monitor.
- Folder No. 6 The "Hughes Inductance-Balance" Explorer.
- Folder No. 7 The "Radiodyne" Prospector.

With any one of these systems you can construct instruments to locate buried treasures, metal war relics, mineral deposits, subterranean water veins, oil deposits, (under certain circumstances), buried gas and water pipes, lost objects, tools and treasures sunken in water, etc. Each set of blueprints and instructions enclosed in heavy envelope (8 1/2" x 12 1/2"). Blueprints 22" x 34"; eight-page illustrated 8 1/2" x 11" folder of instructions and con-

struction data ..... **50¢**  
Add 5¢ for postage  
The complete set of seven folders..... **\$3.00**  
(Sent postpaid)

## TECHNIFAX

1917 S. STATE ST. CHICAGO, ILL.

## PATENTS—TRADE MARKS

Booklet concerning Inventions & Patents  
Form "Evidence of Conception" with  
instructions for use and "Schedule of  
Government and Attorneys Fees"—Free

LANCASTER, ALLWINE & ROMMEL  
Registered Patent Attorneys  
436 Bowen Bldg. Washington, D. C.

# • LATEST RADIO APPARATUS •

## FLUORESCENT-LAMP RESISTORS

Clerostat Mfg. Co., Inc.  
285 N. Sixth St., Brooklyn, N. Y.

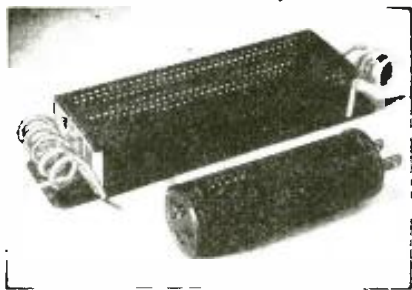

THESE are series resistors for inclusion in the power circuit of fluorescent lamps operated on D.C. Intended for use with G.E.-type D.C. reactors or their equivalents. Series FT resistors plug into the power circuit of a fluorescent desk lamp or other D.C.-operated lamp. Series GT resistors are designed to fit into standard fluorescent fixture channels. Resistors are available in 5 types to take care of 15 and 20 W. lamps on 120-V. lines, and 30 and 40 W. lamps on 240-V. lines.

## UNIVERSAL-PURPOSE METER

Radio City Products Co., Inc.  
88 Park Place, New York, N. Y.

AN all-purpose portable multimeter, known as model 411P Super-tester. Has full array of A.C. and D.C. voltage-measuring ranges up to

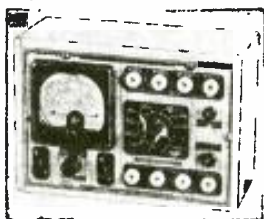

5,000 V.; A.C. and D.C. high current ranges up to 25 amperes; and, a D.C. low-current range permitting measurements down to 4 microamperes. These are in addition to the usual A.C. and D.C. milliampere; resistance (ohmmeter battery is self-contained), and decibel ranges. Its single meter is a square 3-in. type with 200-microampere movement which provides a voltage-measuring sensitivity of 5,000 ohms/volt. The instrument is housed in a solid walnut carrying case measuring 7 1/2 x 5 1/2 x 3 1/2 ins. and having a hinged, removable cover.

## MULTIMETER

Triumph Mfg. Co.  
4017 W. Lake St., Chicago, Ill.

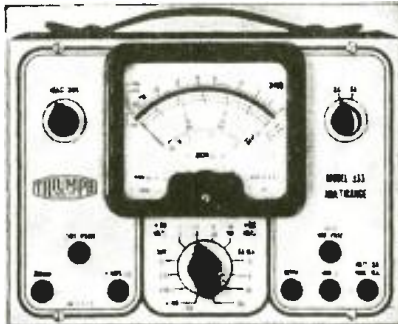

THIS new "Multi-Quantum-Meter" model 333, has a rotary switch for selecting 33 ranges, as follows: 0-3,000 V. A.C. and D.C. at 1,000 ohms/volt; resistance to 10 meg.; D.C. milliamperes 0-300; D.C. Amps. 0-15; decibels -20 to +64; mirror scale on 4 1/2-in. meter; 15-V. internal battery. Calibrated, wire-wound, 1 per cent resistors throughout. Pre-aged rectifier. Automatic overload

protection on resistance ranges. Specially-tapered "ohms adjust" control. Has D.C. isolating condenser on output ranges. Case is finished in black wrinkle. Ivory metal panel, with black, raised designations. Size, 9 x 6 1/2 x 4 ins.; weight, 6 lbs.

## PORTABLE ROTARY SANDER

Sterling Products Co.  
2457 Woodward Ave., Detroit, Mich.



KNOWN as the Gyro Sander this tool should prove a real money-maker to enterprising radio Servicemen and dealers who repair and re-finish cabinets as well as radio chassis. Cabinet refinishing can and does provide a lucrative income for many men in the service field.

The Gyro Sander weighs but 3 1/2 lbs. and is extremely simple to operate. Its base comfortably fits the hand and requires very little pressure applied to the work. Any make or type of abrasive paper may be used. Rubbing cloths can be similarly attached for final polishing work. Operates on 110 V. D.C. and/or 110 V. A.C. of 25-40-50-60 cycles.

# Mr. Serviceman:

## We're Proud of the R. S. A.!

### The Only National Organization of Servicemen

Servicemen, broadcasters, manufacturers, jobbers, trade associations and trade journals, all have contributed their share toward making the RSA the fine organization it is today.

RSA is doing everything possible to earn and keep this continued support from the whole industry by providing an outstanding program of activity—Year-Round Sales-Promotion to build Public Confidence, Technical Help for Members, Bulletins, and many other important business-aids are regular RSA features!

RSA needs the help of every good serviceman—so Join us now!



Let's Grow Together in 1940!



# RADIO SERVICEMEN OF AMERICA, Inc.

JOE MARTY, JR., EXECUTIVE SECRETARY  
304 S. DEARBORN STREET, CHICAGO, U.S.A.

MAIL THIS COUPON NOW!

RADIO SERVICEMEN OF AMERICA, INC.  
304 S. Dearborn St., Chicago, Ill.

Name .....

Address .....

City ..... State .....

I am interested in RSA Membership. Tell me about it.

I am enclosing \$4.00 for National dues and initiation. Covers dues up to Jan. 1, 1941.

(Does not include Local Chapter dues where Local Chapters are organized.)

RC-640

# • LATEST RADIO APPARATUS •

## "WIRELESS" PHONO OSCILLATOR

Bud Radio, Inc.  
5205 Cedar Ave., Cleveland, Ohio

THE No. WO-6 "wireless" phono oscillator is a compact, A.C.-D.C. unit intended to adapt standard record players for "wireless" (radio) operation up to about 75 ft. Its small size (4½ x 2½ x 2 ins. deep) permits it to be attached inside the case of most record players. The circuit uses only 1 tube but is claimed to be very stable.



reflection or feedback paths. A switch on front of the mike permits the choosing of any one of these 6 pick-up patterns at will.

## INTERCOMMUNICATION UNITS

Regal Amplifier Mfg. Corp.  
14 W. 17 St., New York, N. Y.



THE "Tokfone" 600-series units provide 2-way communication between any master station and any of 10 or less remote stations. It is possible with these units to have 5 simultaneous private conversations with no crosstalk. Patents have been applied for on these units. (Interphones are good items for Servicemen to boost.)

## FREQUENCY METER

Lampkin Labs.  
Bradenton, Fla.

TYPE 103 micrometer frequency meter is an inexpensive band-spread heterodyne type, A.C.- or D.C.-operated instrument, consisting of a ratio-coupled oscillator, an untuned detector and a rectifier-filter power supply. Designed for monitoring transmitters on any frequency up to 56 mc.



A calibration table shows the relation between fundamental frequency and dial reading. Measurements on local transmitters outside the fundamental range are readily made by means of harmonics or their combinations heard in the untuned detector. The fundamental frequency range averages from 2,300 to 2,700 kc. (2.3 to 2.7 mc.). Can be re-calibrated by zero-beat with WWV on 5, 10 or 20 mc.

## HOME RECORDING COMBINATIONS

Howard Radio Co.  
1731 Belmont Ave., Chicago, Ill.

THIS company has just announced 4 new phonograph combinations with home recording features. All instruments are in beautiful Hepplewhite Period cabinets with dual-section tilting tops. Two of the models include automatic phono record changers. A fader-mixer circuit makes it possible to sing or record comments with radio programs in the background.

## DIRECTION FINDERS FOR SMALL BOATS

Airplane & Marine Direction Finder Corp.  
Clearfield, Pa.

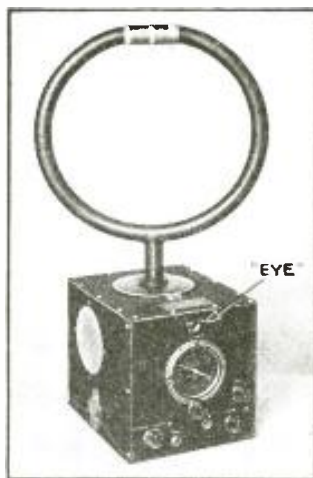

## AMPLIFIER FOUNDATION CHASSIS

Parmetal Products Corp.  
3262 49 St., Long Island City, N. Y.

THIS latest amplifier foundation chassis follows the latest trend in amplifier design and enables one to build up jobs similar to those used in commercial amplifiers. All parts are finished in slate gray ripple enamel, trimmed with red-stripped, chrome-finished moldings and handles. Front panel is removable and extends 3 ins. from the face of the screen cover. Chassis are supplied complete with bottom plates. Available in 3 chassis sizes, 10 x 12 x 12, 10 x 17 x 3, 13 x 17 x 3 ins. Screen covers are 6½ ins. high.



## 6-WAY CARDIOID MIKE

Western Electric Co.  
195 Broadway, New York, N. Y.

IN addition to non-directional, bi-directional and cardioid directivity patterns, this new model 639B mike gives 3 new pick-up patterns which reduce effects of reverberation to an even greater degree. It permits shifting the angle of minimum response to 150, 130, or 110 degrees, enabling the operator of a P.A. sound system to avoid particular

ILLUSTRATED is the streamlined, model I Direction Finder which is ideally suited for small boats and for airplanes. In addition to tuning to coastal and airplane beacon stations it also covers the broadcast band in its continuous frequency range of 200 to 1,500 kc. Incorporates tuning "eye" tube to facilitate taking bearings.

The entire unit weighs but 26 lbs. and is self-contained with speaker and dynamotor power supply; operates from boat's storage battery. The cabinet measures 8¼ ins. high, 8 ins. wide and 9¼ ins. deep. Also available with removable loop for mounting outside cabin.

## ELEMENTARY MATHEMATICS



EASY — SIMPLIFIED — PRACTICAL

HERE is a book for the business man, the technician and craftsman explaining and answering every operation and meaning with interpreting illustrations and examples. It is the key to a simple understanding of many perplexing problems in daily life. In clear, positive and definite language, the author popularizes and clarifies every subject and helps the reader to overcome any apparent difficulty in the study of mathematics.

A real home study-course in mathematics for the student or the man who wants to achieve proficiency or desires to brush-up on his knowledge.

Entire Chapter on Special Mathematics for the Radio Technician

### CONTENTS OF BOOK

- CHAPTER I. Arithmetic—Addition—Subtraction—Multiplication—Division.
- CHAPTER II. Factoring and Cancellation—Fractions—Decimals—Percentage—Ratio—and Proportion.
- CHAPTER III. The Metric System.
- CHAPTER IV. How to Measure Surfaces and Capacity (Geometry).
- CHAPTER V. Powers and Involvement—Roots and Evolution.
- CHAPTER VI. Mathematics for the Manual and Technical Craftsman—Thermometer conversions—Graphs or Curve Plotting—Logarithms—Use of the Slide Rule.
- CHAPTER VII. Special Mathematics for the Radio Technician.
- CHAPTER VIII. Commercial Calculations—Interests—Discounts—Short-Cut Arithmetic.
- CHAPTER IX. Weights and Measures—Useful Tables.

ONLY  
50c  
POSTPAID

"Practical Mathematics" can be carried readily in your pocket. Send Stamps, Cash or Money Order.

## TECHNIFAX

1917 S. State St. RC-640 Chicago, Ill.

## KADETTE

### 4 WAY PORTABLE

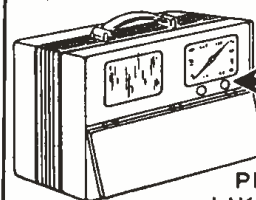

SWITCH TO CAR ANTENNA

AND GET PERFORMANCE LIKE A REGULAR AUTO-RADIO

A POWERFUL 6-TUBE SUPER AND ONLY KADETTE MODEL L46 4 WAY PORTABLE HAS THIS IMPORTANT FEATURE.

1. AC for Home
2. DC for Office
3. BATTERY for Sportsmen
4. AUTO—(special switch)

Complete with 250-hour Standard Batteries \$29.95

KADETTE RADIO CORPORATION  
ANN ARBOR, MICHIGAN

## FACTORY-TO-YOU SAVES YOU UP TO 50%

EASY TERMS



30 DAYS TRIAL

FOREIGN RECEPTION Other models from 5 to 17 Tubes, and up to 5 Wave Bands.

Write for FREE 1940 catalog, showing complete line. (User-agents make extra money!) See MIDWEST'S Answer to TRADE-INS!

PUT THIS NEW 14-TUBE CHASSIS IN YOUR PRESENT CABINET

19.95 COMPLETE

MIDWEST RADIO CORPORATION  
Dept. 12 G Cincinnati, Ohio

# • LATEST RADIO APPARATUS •

## DUAL MIDGET ELECTROLYTICS

Sprague Products Co.  
North Adams, Mass.



**A**DDED to the line known as "Atoms" are 3 dual-capacity midget dry electrolytic condensers with separate positive and negative leads. Recommended especially as replacements for auto-radio units. The new units are 20-20 mf., 150 V. (type TU-220, 1 x 2 1/2 ins. long); 16-16 mf., 250 V. (type TU-216, 1 x 2 1/2 ins. long); and 8-8 mf., 450 V. (type TU-88, 1 1/16 x 3 3/8 ins. long).

## HOME-TALKIE AMPLIFIER

Victor Animatograph Corp.  
Davenport, Iowa

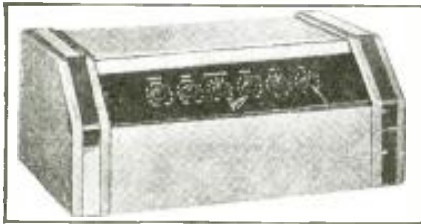

**D**ESIGNED for use in connection with Animatograph's 16-mm. motion picture projector, are the new types O and R amplifiers which may be used with equal suc-

cess in the reproduction of recordings, for public address work, etc. These amplifiers have a system of controls which permits a wide range of frequency reproduction.

## RADIO PHONOGRAPHS

Philco Radio & Television Corp.  
Tioga & C Sts., Philadelphia, Pa.

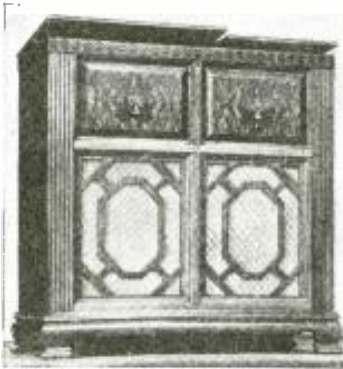

**M**ODEL 515 is one of 2 new radio-phonograph combinations put out by this company. It is fitted with a de luxe intermix record changer which plays a loading of 14-, 10- and 12-inch records intermixed to give an hour of uninterrupted music; the circuit is especially adapted to record reproduction. The radio portion features 8 tubes, including a 1232 television-type tube, built-in aerial, automatic bass compensation, electric push-button tuning, and 3 tuning ranges. Cabinet dimensions are 35 1/2 ins. high, 35 1/2 ins. wide, 18 ins. deep.

## "LITTLE NIPPER" SETS

RCA Manufacturing Co., Inc.  
Camden, N. J.



**I**LLUSTRATED is one (model 46 x 24) of the new additions to the "Little Nipper" series. Its features are electric pushbutton tuning, "Magic" (loop) antenna, P.M. dynamic speaker, automatic volume control, Underwriters approved, brilliant clock dial, American and foreign reception, 5-tube superhet. circuit. Its cabinet is of solid mahogany, top and sides of walnut and burl elm veneers. Measures 10 1/2 ins. high, 16 ins. wide, 7 9/32 ins. deep.

## STUDIO AMPLIFIER

Thordarson Elec. Mfg. Co.  
500 W. Huron St., Chicago, Ill.

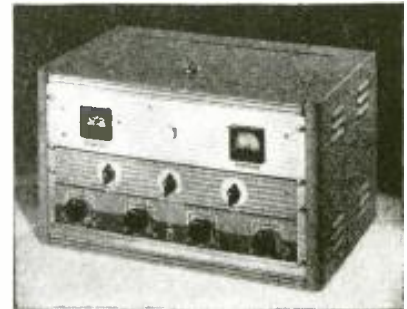

**K**KNOWN as the Tru-Fidelity Studio Amplifier (type T-30W10), this 10-tube instrument has the tone quality which makes it particularly suitable for broadcast stations, studios, expensive phono installations, etc. Its audio frequency equalizers provide an unlimited choice of audio frequency ranges. Available for rack mounting or in a gray cabinet.

Frequency response (equalizers normal), 30 to 15,000 c.p.s.  $\pm$  1 db.; bass control varies response from +10 to -22 db. at 80 cycles, while with treble control the range is +13 to -15 db. at 10,000 cycles. Hum, noise, etc., 70 db. below 10 W. (the rated power output, with the push-pull 2A3's, at "less than 2% distortion"). Has 3 inputs, with mixers and a master gain control, to meet all requirements.

## AMPLIFIER KITS

Kenyon Transformer Co.  
840 Barry St., New York, N. Y.

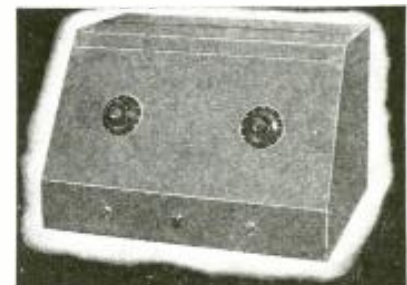

**A** NEW line of 3 amplifier kits. All 3 models using the "cath-o-drive" system of modulation, feature a peak limiter, and modern streamline cabinets. The "50" model



## Get This Electric Dry Shaver ABSOLUTELY FREE!

**JUST THINK OF IT**—you can get absolutely FREE, the useful DRY ELECTRIC SHAVER which is shown at the left. This ELECTRIC DRY SHAVER is sent to you by the publishers with a one-year subscription to RADIO-CRAFT.

### Here Are the Features of The ELECTRIC DRY SHAVER

Constructed of metal with attractive red bronze finish. Scientifically constructed to give a perfectly clean shave. 5-foot rubber insulated cord and plug. Constructed to last for many years.

Operates from 110-volt, 60-cycle A.C. electric line. Carries a two-year manufacturer's guarantee. A fine quality, self-sharpening toilet necessity.

Send your subscription to RADIO-CRAFT for One Year (12 issues) and receive absolutely FREE one of these remarkable Electric Dry Shavers. New subscribers are accepted or you may extend your present subscription another twelve months. Mail your remittance of \$2.00 (plus 25c for shipping charges on Shaver) to the publishers. (Canada and foreign \$2.75.) You will receive your DRY ELECTRIC SHAVER immediately by return mail. Use coupon below to enter your subscription.

**RADIO-CRAFT**

RADIO-CRAFT, 20 Vesey Street, New York, N. Y.

Gentlemen: Enclosed find my remittance of \$2.00 for which enter my subscription to RADIO-CRAFT for one year (12 issues). Send me immediately FREE, ELECTRIC DRY SHAVER (Canada and foreign \$2.75). In U. S. add only 25c additional to cover shipping charges on Shaver.

New Subscriber  Extend Present Subscription

Name .....

Address .....

City ..... State .....

(Send remittance by check, money order or unused U.S. Postage Stamps. ReRegister letter if you send cash or stamps.) RC-6-40

OPERATES ON  
110-VOLT, 60-CYCLE  
A.C. LINE

**WE SHIP ELECTRIC DRY  
SHAVER THE SAME DAY  
YOUR SUBSCRIPTION  
ORDER IS RECEIVED.**

**CLIP COUPON—  
AND MAIL!**



# • LATEST RADIO APPARATUS •

uses 5 tubes and has a conservatively rated output of 5 W. using class A. The "150" model uses 5 tubes, rated at 15 W. and operates in class AB. The "600" model uses 8 tubes, separate chassis for power supply, and is rated at 60 W. output.

## COMPACT CONDENSER DECADES

Cornell-Dubilier Electric Corp.  
South Plainfield, N. J.

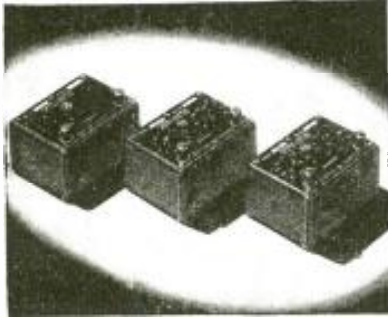

ILLUSTRATED is one of a series of new decade boxes for high precision work. Each box measures only 3 3/8 x 5 x 5 ins. but provides a wide variety of capacity standards. The CDA-5 unit for instance provides values of 100 mmf. to 0.011-mf. in steps of 100 mmf.—or a total of 100 different capacity combinations through the medium of its two 10-position switches. Each switch is directly calibrated in mf. and these values are claimed to be accurate within ± 5%. For utmost precision work, accompanying charts may be used.

## "STATIC MUFFLER"

Radiart Corp.  
Shaw Ave. at East 133 St., Cleveland, Ohio

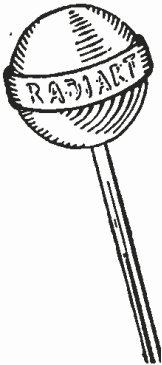

THIS "static muffler" Magic Ring, described by the manufacturer as a "Corona-discharge equalizer," is used on top of antenna rods. Something really new and different, it consists of a plastic pole of broad surface area encircled by a metal ring. The effect of the latter is to set up equal-potential zones for the steady dissipation of static electricity which ordinarily collects at the tip of the aerial rod. Gradual instead of abrupt discharge of this energy reduces the "crackle" due to sudden static discharges.

tip of the aerial rod. Gradual instead of abrupt discharge of this energy reduces the "crackle" due to sudden static discharges.

## Telly Accurate to 1-Millionth Second

IF television images are to remain in "frame," steady and with best detail, extremely accurate impulses must be transmitted to guide the movement of the spot of light which builds up the image seen on the receiving instrument. These "synchronizing" impulses must be almost perfectly timed to a precision usually needed only by astronomers. It is not uncommon to specify an accuracy of beginning one of the impulses of one 2-millionth of a second. In fact, an error in timing of 1 microsecond (1/1,000,000-second) would cause the image to shift about 1/8-in. when seen on a large Kinescope cathode-ray tube.

## HOME TALKING MACHINE

The Ampro Corp.  
2839 N. Western Ave., Chicago, Ill.

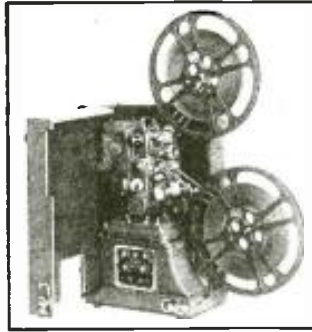

SOUND movie projector model XA is one new 1940 line being marketed. Specifications: 60 cycle A.C. motor without commutator, brushes or governor; 750-1,000 W. illumination; tone, projector volume, and microphone volume controls permit mixing of microphone or phonograph with sound from film; forced draft ventilation on amplifier; 2-in. F.1.85 lens; attached folding reel arms of 1,600-ft. capacity; single-case 8-in. speaker.

## COMMODORE RADIO

Allied Radio Corp.  
833 W. Jackson Blvd., Chicago, Ill.



THE Knight 8-tube Commode radio model TA-10773 is housed in a charming period design cabinet with fluted front doors. The receiver covers 2 bands from 5.7 to 18.3 mc., and from 540 to 1,600 kc. Other features include built-in "Air-Magnet" aerial, push-button tuning for 6 stations, large slide-rule dial, tuning eye, television connection, A.V.C., bass compensation, 5-W. output, large dynamic speaker. Operates from 110 V., 50-60 cycles A.C.

## ELECTRON MICROSCOPE

A MICROSCOPE which opens up whole new worlds which are invisible to light and shows promise of extending the boundaries of knowledge in the study of human disease and in other fields of research, has been developed in the RCA Radio Research Laboratories at Camden, N. J., under the supervision of Dr. Vladimir K. Zworykin. Optical microscopes cannot magnify above 1,500 diameters in ordinary light or about 2,500 in ultra-violet light, but the new electron microscope will magnify directly up to 25,000 diameters and by photo enlargement up to 100,000 diameters. The electron beam has a voltage of from 30,000 to 100,000. Magnetic fields focus the beam for the same service as glass lenses perform in optical microscopes.



## Extra Profits for Radio Men Selling Electric Humidifiers

IT doesn't take a salesman to sell this Humidifier. You can do it on a single demonstration. The unit talks for itself. This electric Fountain Humidifier is 14" in diameter and sprays into the air eight streams of water which rise 5" above fountain head and then fall back into the pond. The Humidifier is made of heavy spun aluminum (scratch-proof surface) and is available in five different attractive colors—Bronze, Chrome, Copper, Red and Green. No water connections are needed—merely plug into the 110-Volt, 60-Cycle A.C. line and turn the switch—no pipes, no rubber connections, no messy fittings. Complete evaporation does not damage the mechanism.

In winter, the Fountain Humidifier adds healthful moisture to the air, evaporating as much as a pint of water in 24 hours. In summer, it is a charming, useful attraction and provides the pleasant, trickling sounds of falling water which suggests comfort and coolness. A drop of perfume added to the water will diffuse any room odor. Operating cost is only a few cents monthly.

Price complete, ready to use, with 8 ft. silken cord and switch on base (F.O.B. N.Y.C.) shipping weight 9 lbs. **\$14.95**

Distributors, jobbers and dealers write for prices

### JOSEPH H. KRAUS COMPANY

123 Liberty Street New York, N. Y.

### JOSEPH H. KRAUS COMPANY

123 Liberty St., New York, N. Y.

Gentlemen: Enclosed you will find my remittance of \$14.95 for which ship me one ELECTRIC FOUNTAIN HUMIDIFIER (F. O. B. New York City).

Send me details for

- JOBBERS and DISTRIBUTORS  
 DEALERS and SERVICEMEN

Name .....

Address .....

City .....

State .....

(Remit by check or money order; register letter if you send cash) RC-640

## 1/30 H.P. UNIVERSAL G.E. MOTOR

Specifications: 1/30 H.P. Heavy Duty operates on either A.C. or D.C., 110 volts, 3200 R.P.M. with 5' cord and plug. Rheostat can be used to vary speed. Height 3 1/4". Length 3 3/4". Width 3". Shaft 1/4".



Can be used to drive Sewing Machines, Models, Buffing Lathe, Polishing Head, Drills, Grindstones, etc., same type motor furnished in 6 volt D.C. Less cord and plug, \$1.95.

MOTOR Universal 1/30 H.P. .... \$2.55

MOTOR 6 Volt D.C. .... \$1.95

Shipping weight, either style 3 lbs.

Money back guarantee. Send check or M.O.

Add 25c for special packing and mailing anywhere in U. S. A.

### WELLWORTH TRADING COMPANY

1915 SO. STATE ST., Dept. RC-640, Chicago, Ill.

# DATAPRINTS



TESLA-LOUDIN HI-FREQ. COILS

- 20c Ea. in order for 10 (Data and Drawings only.)
  - 36" Sp'k Tesla-Oudin Coil 40c (1 K.W. Exc. Trf. Data, included FREE!)
  - 8" Sp'k Tesla-Oudin Coil 40c (¼ K.W. Exc. Trf. Data, included FREE!)
  - 3" Sp'k Oudin; 110 Vt. "Kick Coil" type.....40c
  - 3" Sp'k Tesla Works on Ford Sp'k Coil .....40c
  - 1" Sp'k Violetta Hi-Freq. Coil.....40c
- Model Warships—Get List of Plans



Induction PIPE & ORE LOCATOR

- Induction Type, Data .....40c
- Radio Type .....40c

## More DATAPRINTS 40c each!

- |                                 |                             |
|---------------------------------|-----------------------------|
| 5 Meter Superhet.               | Electric Refrigerator       |
| ¼ Meter Tr. & Rec.              | Resistance Measuring Bridge |
| 20 A.C. Probs. & Ans.           | Weld. Transf. 2 K.W.        |
| 20 Telephone Hook-ups           | Rewinding Armatures         |
| 100 Mech. Movements             | String Galvanometer         |
| 20 Motor Hook-ups               | 20 Simple Bell Circuits     |
| Television Hook-up              | Steel Wire Recorder!        |
| 20 Elec. Party Tricks           | Water Wheels or Turbines    |
| Solenoids and Magnets—get list. | Photo Cell and Relay        |
| Fry Eggs on Ice!                | Ring 4 bells: 2 Wires       |
| Experimental Photo-Phone        | 20 Tesla Tricks             |
| Radio Control for Models        | Polarized Relay             |
| Diathermy Apparatus             | Induction Balance           |
| Indicator Organ                 |                             |

Special Prices: 4 prints \$1.00; 10 for \$2.00; Single, 40c each. Get New Catalog 100 A.

The DATAPRINT Co.

Lock Box 322C, Ramsey, N. J.

## Readers Please Note

RADIO-CRAFT has MOVED its New York General, Editorial and Advertising offices to NEW QUARTERS. Please address all correspondence to

**RADIO-CRAFT**  
20 VESEY STREET  
NEW YORK CITY, N. Y.

Visit your nearest newsdealer and buy a copy of

**SUPERWORLD COMICS**

A popular comic edited by HUGO GERNSBACK

"DO you have to have a license to transmit by radio if you can't be heard in any other State?"

Such is one inquiry in a day's mail received by the Federal Communications Commission. The answer to this particular question is simple: The courts have held that a radio signal is interstate in character and that the Communications Act applies to all stations which produce radio emissions intended for reception. It is an established engineering fact that in any use of radio the signals will at times have effects which extend beyond the borders of a State, or interfere with transmission to or reception from other States. Accordingly, any person building or operating a radio transmitter is required to obtain a license from the Commission.

Another mail "I.Q." involves permission to construct a private telegraph line from a boy's house to a friend's house. The Commission has no jurisdiction over such private circuits. Any legal requirements rest with the State or municipal authorities.

Still another writer complains about a local telephone service. The jurisdiction of the Commission is limited to the regulation of interstate and foreign communication by wire or radio. Authority over local exchange and intrastate toll service was, by the Communications Act, specifically exempted from the Commission's jurisdiction and reserved to the respective State regulatory bodies.

Another complaint relates to interference with radio reception by emissions of a local power company. Though the Commission has no authority in this matter, it is glad to refer the complaint to the company involved. Complainants are usually in position to furnish information of value in locating interference conditions.

Under the Communications Act, individual licenses for all types of radio services—broadcast, amateur, commercial, etc.—are restricted to citizens. Broadcast station licenses are denied corporations "of which any officer or director is an alien or of which more than 1/5 of the capital stock is owned of record or voted by aliens or their representatives."

Acts of Congress have repeatedly indicated a national policy against possible control of radio facilities by aliens. Accordingly, the Commission's regulations forbid location of an amateur station on premises controlled by an alien. This invites presentation of many problems, usually decided by the statement that, in view of its obvious purpose, the rule applies to an entire residence and is not avoided by nominal rental of a room from an alien parent to another member of the family who is a minor.

Another question that never stays answered is: "How much does it cost to build a commercial radio broadcast station?" The frank reply must dissuade some would-be operators. The minimum power considered capable of rendering appreciable service is 100 watts. The approximate cost to construct such a station is between \$5,000 and \$8,500.

Complaints about individual radio programs run the gamut from taking issue with an announcer's English and differing with a speaker's conclusions to objecting to advertising and protesting refusal of time on the air. In such cases the Commission has to advise that it has no power of censorship over programs, and that since the Act expressly provides that a radio broadcast station is not a common carrier the Commission cannot compel any station to accept a particular program or to allow someone's favorite performer or speaker to use its facilities. In many cases it refers complainants to the particular station or

network involved. Occasionally a complaint alleging unfair competitive practices is received and referred to the Federal Trade Commission.

However, certain things are definitely barred from the air by the Communications Act. Hence, cases which involve violation of the specific injunction against lotteries and obscene language are referred to prosecuting authorities for appropriate action. Also, the Commission can and does review the general public service rendered by stations in determining if renewal of license is in the public interest. The statute requires the Commission in acting upon renewals to consider the same factors as it must consider before granting a new application. In either case the service proposed to be rendered to the public is the dominant consideration.

Numerous letters erroneously attribute a broadcast "code" to Commission regulation. This is really a Code of Ethics adopted by the National Association of Broadcasters, and the Commission has no jurisdiction in the administration of its provisions. Adoption of the Code is not a substitute for compliance by a licensee with duties under its license and the Act. The Code represents the efforts of the broadcasters themselves to impose self-regulation in addition to the absolute requirements of the law.

In reply to a currently recurring inquiry, the Commission has to report that it is without authority to require a broadcast station to make frost warning announcements. On the telegraph side of its incoming mail desk, the Commission is in receipt of complaints that these carriers should now recognize "airmail" as one word, and charge accordingly.

Some persons have a mistaken notion that the Commission can recommend schools and publications, or find jobs for them in the broadcast industry. As for applications for positions with the Commission itself, with few exceptions the entire personnel is under Civil Service and its occasional vacancies are filled from those ranks.

A Purdin, Mo., letter inquires as to the cost of construction permit and license for a broadcast station, also for radio operator. The Commission makes no charge for these authorities. Likewise, the Commission advises a London, Ohio, inquirer that no Federal license is required to cover the ownership of radio receivers in the United States.

A Jerome, Ariz., writer asks the Commission to recommend a radio receiver. The Commission does not maintain facilities for the testing of radio receiving equipment and is not in a position to advise with respect to the relative merits of receivers of different manufacture.

Regarding Government station assignments, an inquirer is advised that the Commission merely assigns blocks of frequencies, as well as certain call letters, to the Government departments, and that these facilities are in turn allocated various activities at the discretion of the department having jurisdiction.

A New York corporation is advised that although vessels of Philippine registry fly the United States flag, they are registered in the Philippines, and their radio equipment is licensed by the Philippine authorities. Various sections of the Communications Act exclude the Commission from jurisdiction in those islands.

For the reason that the limited number of frequencies must be used in the public rather than private service, the Commission advises a farmer that it has never limited a channel to communication on private property, and notifies a battery corporation and a sport shop that it has not yet authorized any business to sew up a frequency for demonstrating radio equipment.

All the worthwhile  
Radio Trade News  
of the past Month—  
Digested for busy  
radio men.

# RADIO Trade Digest

A PLEDGE: — To  
print the important  
news of the radio  
industry; to review  
major news events;  
to help point a path  
to radio profits.

IMPORTANT HAPPENINGS OF THE MONTH IN THE RADIO INDUSTRY

No. 22

JUNE, 1940

No. 22

## AN OPEN LETTER

Mr. James L. Fly, Chairman  
Federal Communications Commission  
Washington, D. C.

My dear Mr. Fly:

The writer has been watching the progress of television in the United States since some time in 1926—the days when a 60-line picture was considered the last word in high definition. As he is still active in the field, he was extremely interested in (a) the Commission's brief approval of partial commercialization of television broadcasting; (b) the Commission's rapid change of heart on such authorization; and (c) your explanation, as delivered over the NBC and Mutual networks.

I wonder whether the Commission is aware that perhaps the public might be the best judge as to whether or not the public wishes to buy television receivers? The possible obsolescence of television receivers within a comparatively short time has been widely publicized even prior to the Commission's reversal of its original ruling. The receivers are by no means in a price class which would induce the impoverished to purchase them. A piece of apparatus which costs as much as a small automobile will, I am confident, be bought only by those who can afford major expenditures.

It has been my experience that this class of person, having enough intelligence to gather money, is able to judge reasonably well as to how best to spend it.

The problem of obsolescence, incidentally, is not necessarily a major one. I recently interviewed the Chief Engineer of a leading western television transmitter, who told me that the station had broadcast at 331 lines for a period, after which it shifted to the present so-called standard of 441 lines. Each owner of a television receiver found his apparatus "obsoleted"—yet was able to make minor alterations which did away with the temporary obsolescence and made it capable of receiving the 441-line images. The cost of such circuit changes was hardly prohibitive, being from \$2 to \$5, depending on the set.

It is my opinion that the Commission's reversal of its original ruling in the matter of television has worked tremendous harm upon that part of the public who own the some 2,500 television receivers now in operation in the metropolitan area. Such lookers-in yearn for the day when "big names" and elaborate presentations will reach the television screen. This highly desirable end can be attained only through the commercial sponsorship of television programs.

It is, of course, known that companies not utilizing the same circuits for transmission and reception as are employed by RCA, G.E. and

(Continued on following page)

## FCC REVERSAL IS TEMPORARY BLOW TO ALL TELLY PROGRESS

*Expensive Merchandising Campaigns Ruined, Public Distrust of Telly Increased, and Plans to Better Programs Stopped Dead*

### BOSS' BRAIN-CHILD

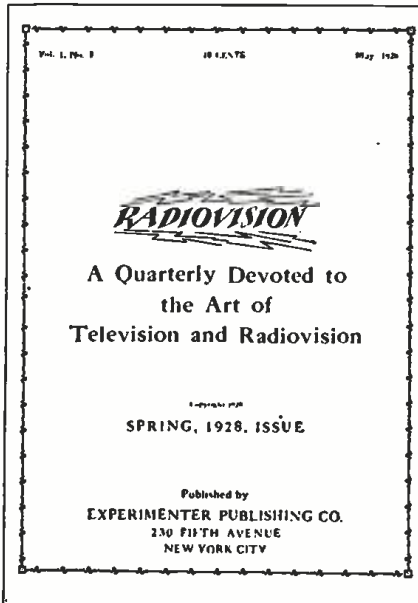

With announcement that telly was expanding, leading mfr. announced that art would be known as "Radiovision". Cover of pamphlet, reproduced above, shows that Hugo Gernsback, Editor of Radio-Craft, originated name "Radiovision" as early as May, 1928.

Biggest blow struck the radio industry in its history, in the opinion of many, was the FCC sabotage of television in mid-March.

A tentative green light had been given the industry for experimental telly commercials to begin Sept. 1. Immediately one large manufacturer made plans to merchandise 25,000 telly receivers, ranging in price from \$200 to \$400 during the coming year. Advance advertising copy showed thought toward minimizing obsolescence in that price adjustment was offered early purchasers of equip't, who had paid higher prices. Campaign got off to bang-up start with pg. copy in leading metropolitan newspapers.

No sooner had this copy appeared when FCC emitted anti-telly blast which gave entire industry kick in teeth. Immediate result was to call off ad campaign, kill incentive for bettering programs, and plant distrust of telly in public mind; also claimed was the canceling of plans to put over 5,000 persons to work in making and selling telly sets, and that much broadcast biz, too, had gone-with-the-FCC. Secondary result—and this is only a rumor—may be gov't investigation of FCC with clipping of that august body's claws, and trimming of its wings.

Independent industry sources hazily predict a new telly campaign providing liberal trade-in or next-to-free rebuilding of chassis if present sets obsolesce.

At press time, new FCC hearings on telly were being held.

## EXECS FETE NEW BABY



Co. execs above delightedly inspect first of the new SADA Majestic receivers to be produced. L. to R. are C. J. Hirsch, Chief Eng.; H. T. Byrne, Ass't Gen. Sales Mgr.; E. Fuchs, Cabinet Eng.; H. Norins, Designer; & W. B. E. Norins, Gen. Sales Dir. Gal is cardboard display. Famous line has been selling well in many centers throughout U.S., jobbers' and retailers' reports say.

## RCA TERRITORIAL REPS MEET



RCA territorial reps who will help parts distrib build bigger biz, were snapped during Camden visit. L. to R. E. C. Hughes, renewal tube sales; Fred Dobbs, Dallas rep.; F. J. Gallagher, Kansas City rep.; W. P. Laws, Atlanta; A. C. Nash, San Francisco; D. J. Finn, RCA-Victor Adv. Mgr.; L. W. Teegarden, Mgr. of Tube & Equip. Div.; W. H. Allen, New York; A. L. Saltzman, Dist. Sales Org.; C. V. Bradford, Boston; W. H. Autenreith, New York; John Allen, Tube & Equip. Adv. Mgr.; D. M. Branigan, Chicago rep.

THE LIGHT THAT FAILED



FOR THRILLS...EXCITEMENT...ACTION... Look to NBC TELEVISION! Here are some of its recent SPECTACLES... DRAMAS... "The Donovan Affair," "Treasure Island"...

The Radio Corporation of America Takes Another Vitally Important Step in Its 5 Point Plan to Provide

TELEVISION for the Home

Through New Low Prices on Television Receivers that save you up to \$205



EVER since its founding, twenty years ago, RCA has had one of the most brilliant and diverse programs of general television...

Table listing RCA television programs and their times, including 'The Laboratory Stage', 'The Laboratory Stage', 'The Laboratory Stage', etc.

For RCA receivers started the problem in the fall of 1939 when the television receiver was first put on the market...

1 The Laboratory Stage... The RCA Laboratory Stage... The RCA Laboratory Stage... The RCA Laboratory Stage...

2 Television Field Tests... From the start, RCA has demonstrated that television receivers are not mere toys...

3 Television Program Service... The possible solution... The possible solution... The possible solution...

4 Network Television Service... An apparent... An apparent... An apparent... An apparent...



Personal

NILES TRAMMELL, exec. v.-p. of N.B.C., is chairman of the radio broadcasting section of the 1940 campaign of the Greater N. Y. Fund. FRANK LYMAN, Jr., former treas., has succeeded J. B. Parker as pres. of Harvey Radio Labs., Cambridge, Mass.; J. S. LYMAN succeeds C. A. HARVEY, resigned, as v.-p.; and RALPH A. VACCA has been made chief eng.; N. R. HINCKLEY is now marine radio sales mgr.

FRED A. RAY, Bridgeport, is Eastern sales mgr., GEORGE S. PETERSON, central sales mgr., and HENRY A. CROSSLAND, Western sales mgr. of G.E. radio receivers in the new sales set-up.

Springville, N. Y., expects to save \$1,050 per yr. through having installed \$1,575 worth of Pyranol capacitors.

An anonymous memo states, "No. 3 girl is BARBARA JANE ('Amperite') RUTTENBERG, 7 lbs., 6 ozs., last month." Congratulations! WILLIAM J. FRASER takes over W. C. LEWIS' job as Western N. Y. sales rep. for Stromberg-Carlson as LEWIS advances in post of merchandising mgr.

WILLIAM T. WALLACE, ex. of Sears, Roebuck, is the new mgr. of Crosley Corp.'s radio div.

Forty-seven RCA engineers were honored by the National Ass'n of Manufacturers—or nearly 10% of the 500 awards which the Ass'n made. FRED N. ANIBAL has been made radio sales mgr. of Stromberg-Carlson.

ALLAN R. ROYLE, formerly of Elliott-Lewis Co., is now selling for Joseph E. Hornberger Co., S.-C. distrib. in Reading, Pa.

DR. RAY H. MANSON, succeeds the late GEORGE A. SCOVILLE, as v.-p. & gen. mgr. of Stromberg-Carlson; LEE MCCANNE is now sec'y & ass't gen. mgr.; EDWIN C. ROWORTH, treas., is new v.-p. in charge of finance; W. W. HETZEL succeeds him as treas.; and FRED C. YOUNG is new chief eng.

RALPH N. HARMON is head of the new engineering dept. of Westinghouse's radio div. The dept. is devoted to commercial design & production of radio apparatus.

WLADIMIR J. POLYDOROFF has won a \$100,000 suit against a large manufacturing co. (Johnson Labs., Inc.). One of the inventions covered in the suit is the use of the Polydoroff transformer core, said to have made midget sets possible. The case may be appealed.

ALBERT P. CRAIG, Jr., is director of the Westinghouse exhibit of the N. Y. World's Fair 1940.

Changes & New Addresses

Where to Reach Old and New Companies Radio-Craft and Radio and Television (incorporating Foto-Craft) Magazines have moved their editorial and advertising offices to 20 Vesey Street, N.Y.C., occupying the entire 10th floor.

GAROD RADIO CORP. now at 70 Washington St., Brooklyn, N. Y., says its new factory has 4 times the production facilities of its former quarters.

New STROMBERG-CARLSON distrib. are the BOND-RIDER-JACKSON CO., Charleston, W. Va., handling the line in that area, Western Ky. and Southeastern Ohio; COREVA CO., INC., York, Pa., selling counties around its headquarters; CONSOLIDATED MILLS CO., 2226 First Ave., N. Birmingham, Ala., covering its home State; UNITED ELECTRIC SERVICE, INC., 308 N. 3rd St., Monroe, La., serving northeast La.

New FARNSWORTH TEL. & RADIO CORP. distrib. are LEW BONN CO., Minneapolis, Minn., SPENCER AUTO ELECTRIC, INC., Tampa, Fla., and MAYFLOWER SALES CO., St. Louis, Mo. (succeeding Crest, Inc.).

RCA MFG. CO. has opened a plant at Bloomington, Ind., to specialize in "Nippers". The co. now has plants in Camden & Harrison, N. J.; Indianapolis & Bloomington, Ind.; and Hollywood, Calif.

RCA VICTOR TELEVISION

A SERVICE TO THE RADIO COMMUNITIES OF AMERICA

Sad relic above is advance proof of full-page telly ad which RCA Victor had scheduled for New York Times. RTD's telly observer has personally witnessed majority of shots shown; was looking forward—as was all N.Y.—to proposed future telecasts, including presidential campaigns, etc. Then came the deluge. FCC expressed belief that telly had not adhered to spirit of ruling. (See story on 1st page of RTD Section.)

AN OPEN LETTER (Continued from preceding page)

similar manufacturers, are eager that standards be not "frozen." They are correct. The writer can see no reason why both systems should not be permitted on the air, the set purchaser to be given a perfectly free choice as to what type of apparatus he prefers to buy.

The contrasts you pointed out between the field of television and the automotive industry were both interesting and true. When phonograph recording was changed from the old "hill and dale" type to the present method of side to side modulation, the early Edison machines were obsolete. Still no government body made any attempts to protect the phonograph industry.

In the amateur motion picture field, the American standardization of 8 and 16 millimeters for film widths has made it virtually impossible for the amateur motion picture photographer to obtain the 9 1/2 millimeter film which earlier motion picture cameras used.

In announcing a price reduction of its television receivers, one of the leading manufacturers offered to rebate the difference in price between its original models and the new figure to all

TIMELY TELLY TRENDS

United States Television Mfg. Co. is rumored planning a line of 14-in. telly receivers with a console and table model, each including the standard broadcast receiver. Company officers include J. B. Milliken, pres., Hamilton Hoge, v.-p., G. H. Hobson, treas., and Martin Morris, sec'y. F. A. Lindley is chief eng. & members of his staff include: G. Jacob & C. Alba, ex-RCA and R. Fisher, formerly Du Mont, as head of service dept.

Telly relay system to link Albany, Troy & Schenectady areas has been described by Dr. W. R. G. Baker.

purchasers of the older sets. With such a liberal policy established, it seems likely that the industry can be trusted to make liberal trade-in allowances if present models become obsolete or to modernize them at low cost should they fail to receive signals sent out by an improved system.

Sincerely yours, ROBERT EICHBERG, Editor, Radio Trade Digest

# AN EDITORIAL

By Artie Dee

After all the publicity on static-free radio, NBC has begun putting regular network programs on the telly channel from 7:00 to 10:00 P.M. nightly E.S.T. This apparently is in answer to the claims for F.M.'s advantages. Listeners with telly sets have reported these sound channels to be virtually free of all interference. Further, their extreme width permits true high fidelity reception. *But what does this mean to you?*

**Sell U.H.F. Converters** It means more money. You can make and sell U.H.F. amplitude-modulated converters for appreciably less than you can make F.M. converters. That means lower sales resistance.

With the public acutely conscious of static-free radio (particularly at this time of the year) you should be able to sell miniature low-cost conversion units together with the necessary antenna systems to enable radio listeners to hear broadcasts free from interference.

RTD, from reports that it has heard and from its own observations, believes that F.M. is very nice but that it will be hard for Servicemen and dealers to sell F.M. sets to persons who already have standard receiving equipment unless such equipment is defective or obsolete. Far easier will be the sale of a unit to cost not over \$10 to \$20 which will enable the listener to pick up the U.H.F. transmissions using the amplitude modulation system.

**Telly Sound Static-Free** RTD's own observations have revealed that the television sound channels are completely static-free within the transmitters' primary service area.

The first man in your locality to offer this static-free reception to the listener should cash in on it. Will he be you?

## WELL DESIGNED



Modern lines & handsome finish mark both the Radiobar & movie star shown above. The glamour gal is Alice Faye; the set is a combination phonoradio with drinkables in its upper story.

## \$'s & No.'s

**250,000 DOLLAR LOSS** incurred by Farnsworth Television & Radio Corp. of Ft. Wayne, Ind., for the 8 mos. of the co.'s fiscal year ended December 31, 1939. The co., in report to stockholders, is careful to mention that it entered the radio and television field several mos. after competing mfrs. Co.'s balance sheet at end of December 1939 was \$2,000,000, half in ready cash in banks.

**5,000,000 STEWART-WARNER RECEIVERS** in use in the United States, according to Mgr. L. L. Kelsey. Sales volume upped 300% in 1939 as compared to 1938. Figs. show, says Kelsey, that radio retailing is no longer seasonal but maintains even keel throughout the year.

**\$8,082,811 NET PROFIT** is record of RCA for 1939, after payment of all preferred dividends, equivalent to 35c per share on outstanding common stock—this according to the co.'s 20th annual report. Consolidated gross income was \$110,494,398, an increase of \$10,528,288 over 1938.

**DIVIDEND DECLARED BY G.E. OF 35c** a share for the first 1/4 of 1940, to stockholders of record on March 15th. This is 10c more per share for same period in 1939.

## DEMONSTRATES ANTENNA



Charles E. Gerhard, mgr. of Philco parts sales dept., turns on static-box to demonstrate efficiency of built-in Philco aerial (rotatable cylinder in cabinet). Inset is close-up of the demonstrator (arrow).



**Atlas Sound Corp.** is doubling present plant space in anticipation of P.A.'s biggest yr. . . . Persons with claims against **Coast-to-Coast Radio Corp.** should present them to **Joseph Neumann, N.Y.C.**, the assignee's lawyer. . . . **Jenkins Music Co.**, Tulsa, Okla., **Prentke Labs.** of Cleveland, O., took 1st and 2nd in **Stromberg-Carlson's** 45th anniversary prize window contest. . . . 10 **G.E.** officials toured 39 cities with the co.'s 8 new models plus promotion & financing plans.

**Zenith Radio** is going to put F.M. in their 4-band 1940 models. . . . Federal Telegraph Co., subsidiary of Mackay Radio & Telegraph Co., though unknown to most, is one of the nation's largest mfrs. of water-cooled transmitting & rectifying tubes—and sold \$1,500,000 worth of apparatus to the U. S. Gov't in '39. . . . 1940 will be a boom yr. in radio according to L. L. Kelsey, head of Stewart-Warner's radio div.

**Roy S. Johnson** and **Frank LaBianca** of Long Island City, took 3 of G.E.'s cabinet design awards—\$825 of the \$1,700 budget. . . . **Westinghouse** has formed a new engineering div. to specialize in commercial design & production of radio apparatus—**Ralph N. Harmon** will head it.

**Recordings** boosting **Rexall Stores'** 1c sales are being used by 250 stations; there are 4 records in the series & N.B.C. arranged them. . . . A couple of bright salesmen are taking old apparatus or farm produce as 10% trade-in on washing machines. You might try this on radio sales. . . . Period cabinets went big in a recent Detroit show, according to **Stromberg-Carlson** reps. . . . **Moto-Scoot** believes that Servicemen can profit by using scooters or scootered bicycles (low cost, low upkeep, fair speed, etc.)

Six new table models bring **RCA Victor's** 1941 line to 14 A.C.-D.C. models—all new Nippers have foreign wavebands. . . . Canadian radio dealers now report directly to the Gov't regarding sales rather than calling Servicemen to inspect buyer receiving licenses—and the Servicemen don't like it. . . . **N.Y.U. Law School** points out that libel and slander laws governing radio programs are being changed; liberalization is foreseen.

**Universal Microphone Co.** has adopted a letter W with a flash superimposed as its trade mark (*Wonder what's the connection?*) . . . Oregon College of Education has just installed that co.'s recorders & amplifiers. . . . A new type of resistor cable by G.E. is specially designed for connecting resistor banks where moisture & heat are prevalent.

**Hammond Instrument Co.** is pushing the **Novachord** with special transcription sent to 200 station execs. . . . **Farnsworth** announced that its television activities would be stepped up following the F.C.C. decision (?) permitting sponsored programs. Ah, this uncertain world! . . . G.E. engineering & sales reps. from all over the U.S. had a 4-day get-together in Schenectady; subjects stressed were television, F.M., and emergency-radio equip't.

**Wedemeyer Radio Co.** of Ann Arbor played host to 350 radio men at a radio show in which 15 mfrs. participated. . . . Somebody wrote to the F.C.C. asking them to bar all "Confucius Says" from the air; the F.C.C. turned it down—too bad. . . . **Philco** expects to have sold 4 million autoradios by now. . . . The co. also has 2 new phono-radios (one of their new auto-radios gets shortwave broadcasts—how about local ordinances against pick-up of police broadcasts).

## SALES HELPS

The 1940 Radiart display holds 6 popular-type aerials, has attractive printed panel displaying interesting features of line. Space is provided on the metal support for mounting the mfr.'s mirror-combination aerials.

**CROSLY HELPS BOY SCOUTS IN CINCI SHOW**

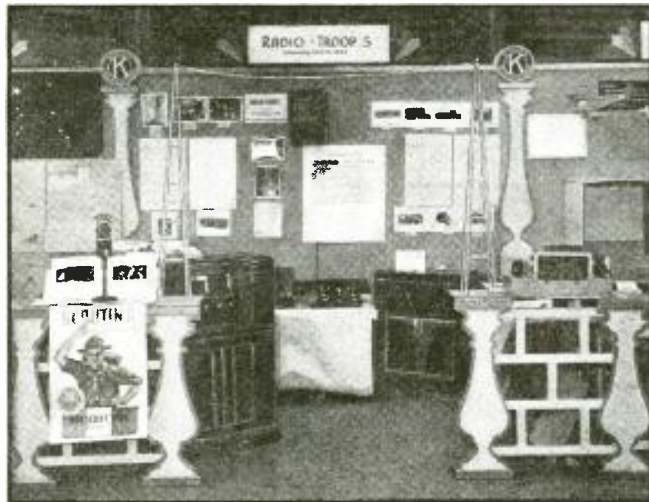

Radio Troop No. 5 of the Cincinnati Boy Scouts held a Merit Badge Exposition sponsored by Kiwanis Club. Their display was rounded out by radio equip't loaned by Crosley Corp. It is said that possibly 60,000 persons saw this publicity.

**\$alesman \$am \$ays:—**

*Data issued by U. S. Gov't. Far more detailed information is available from the Bureau of Foreign & Domestic Commerce, Washington, D.C. Publications to request are: World Radio Markets covering countries wanted & The Electrical & Radio World Trade News.*

**SPAIN**—800,000 sets in use by population of 25,000,000. Commerce still highly disorganized as result of Spanish Civil War. The market before the Civil War amounted to 100,000 sets annually of which 90,000 were imported. The demand is 80% for A.C. sets and 20% for A.C.-D.C. types. Practically no demand for straight D.C. and battery sets. Most important requirement at present is *low price*. Short- and medium-wave receivers are required; i.e., ranges from 10 to 50 and from 180 to 550 meters. All sets must be protected against the hot, humid climate. Prevailing electric service is 90% 50-cycle A.C., mostly in the 110- to 130-volt range.

**COLUMBIA**—110,000 sets in use by population of 8,700,000, of which only 20% are whites. Annual market is about 23,000 sets, with greatest demand being in the fourth-quarter of the year. 80% of the receivers sold are for 110-volt, 60-cycle A.C. operation. Types most in demand are allwave table models using 5 to 8 tubes.

**MANCHURIA**—200,000 sets in use by population of 30,000,000. No import permits are being granted for American receivers during the present hostilities.

**UNION OF SOUTH AFRICA**—350,000 sets in use by population of 10,000,000, comprising 2,000,000 Europeans, 7,000,000 natives, 800,000 Mulattoes and about 200,000 Asiatics. The effective buying population of

2,000,000 Europeans is spread over 475,000 square miles. Annual market (about 55,000 sets) is fairly steady throughout the year. The most popular sets are allwave table models of from 5 to 7 tubes.

**PERU**—40,000 sets in use by population of 6,500,000, of whom ½ to 1 million have sufficient income to bother with. These latter live in and around Lima. 10% of all set sales are phonograph combinations. Majority of sets are socket-power operated.

**RSA Bulletins**

There are now 35 R.S.A. chapters in the Guarantee Service Plan. These chapters also have cooperative arrangements with local broadcasting stations. R.S.A. is moving to include other chapters in the plan.

Application for a new Chapter has been received from Servicemen in the Milwaukee area.

Joe Marty, Jr., exec. sec'y of R.S.A., just back from a 7,000-mi. trip through the East and mid-West, reports Servicemen pepped-up over N.A.B.-R.S.A. cooperation and hopeful for better biz in '40.

**OFF THE PRESS**

**CATALOG.** The Turner Company, Cedar Rapids, Iowa. 8 pp. Complete line of microphones, stands and accessories.

**CIRCULAR.** Stromberg-Carlson Mfg. Co., Rochester, N. Y. Describes the complete frequency modulation radio line. Included are 3 labyrinth consoles, 1 labyrinth automatic radio-phono comb. and 1 table model. Folder also explains highlights of F.M. broadcasting.

**CATALOG.** J.F.D. Mfg. Co., Brooklyn, N. Y. 80 pp. A complete listing of dial-drive replacements and ballast tube replacements for all commercial receivers. Also lists a ballast tester and several types of antennas.

**CATALOG No. 3908.** (supplement) RCA Institutes, Inc., New York City. 4 pp. Contains outline of new aviation communications course.

**FOLDER.** Premo Products Corp., Chicago, Ill. Lists 5 different types of phono needles for recording and playback use. Also gives interesting treatise on the use of needles.

**REPLACEMENT MANUAL.** Clarostat Mfg. Co., Brooklyn, N. Y. 32 pp. An extensive up-to-the-minute compilation of plug-in resistor tube replacements. Gives all essential data connected with such replacements.

**CATALOG, F-40.** Atlas Sound Corp., Brooklyn, N. Y. Describes new 1940 line of loudspeakers including "marine" horns, parabolic baffles, chandelier baffles, projectors, microphone stands and accessories. Also included are P.M. driver units.

**SPRING-SUMMER CATALOG.** Allied Radio Corp., Chicago, Ill. 172 pp. Contains complete listings of all the latest radio equipment. 32 pages devoted to radio receivers of every description; 36 pages devoted to public address and accessories; large general section devoted to servicemen. For the amateurs, plenty of kits and stuff.

**ANNUAL REPORT.** RCA, New York City. 24 pp. The 20th annual report of the financial status of the entire RCA structure addressed to the stockholders of the corporation. Also reviews RCA operations for 1939 and 20 years of RCA progress from 1919 to 1939. Interesting reading even for non-stockholders.

**MAP OF EUROPE.** Stromberg-Carlson Telephone Mfg. Co., Rochester, N. Y. Aside from a large colored map of the European war zone, for the benefit of radio listeners who follow the war news, this large circular illustrates a large portion of the company's 1940 receiver line. Lists foreign shortwave stations and key American network stations broadcasting war news.

**CATALOG.** Thor Radio Co., Inc., New York City. 64 pp. Everything from soup to nuts—including some radio receivers.

**4-CITY TELEVISION RELAY BRINGS SHOWS TO HILLS**

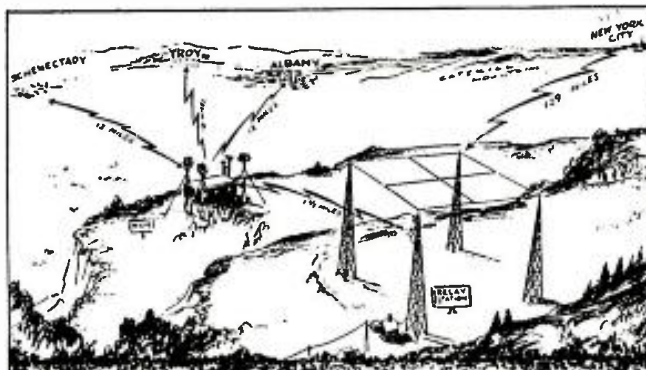

A relay station atop the Heiderberg Hills, 129 mi. from N. Y. C., is to spread big-city programs to Schenectady, Troy & Albany via G.E. station W2XB. Drawing at left shows the set-up by which 4 cities are to receive programs originating in a central studio. (But see story on 1st pg. of RTD Section.)

**HOBBIES**

**as a Money Maker**

Radio dealers can take a lesson from enterprising Moe Lager of Try-Mo Radio, N. Y. C. (now Try-Mo Hobbycraft & Supply Co.). Try-Mo has taken on the distributorship of any number of items listed in the hobby group and reports that in a very short time this business should equal the present volume that he has been doing on radios.

About a year ago, he took on bicycles and successfully established himself as a leading bicycle dealer.

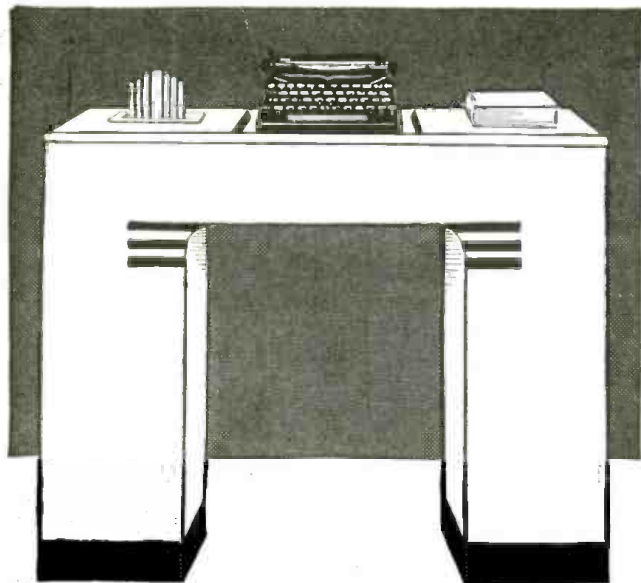

**THIS  
BEAUTIFUL DESK  
for only \$1.00 EXTRA**

**WITH ANY  
REMINGTON  
PORTABLE TYPEWRITER**

*The*  
**COMBINATION**  
FOR AS LITTLE AS  
**10¢ A DAY**

How easy it is to pay for this combination of desk and Remington Deluxe Noiseless Portable Typewriter! Just imagine, a small good will deposit with terms as low as 10c a day to get this combination at once! You will never miss 10c a day. Yet this small sum can actually make you immediately the possessor of this amazing office-at home combination. You assume no obligations by sending the coupon.

**THESE TWO EXTRA FOR YOU**

**LEARN TYPING FREE**

To help you even further, you get free with this special offer a 32-page booklet, prepared by experts, to teach you quickly how to typewrite by the touch method. When you buy a Noiseless you get this free Remington Rand gift that increases the pleasure of using your Remington Noiseless Deluxe Portable. Remember, the touch typing book is sent free while this offer holds.



**SPECIAL CARRYING CASE**

The Remington Deluxe Noiseless Portable is light in weight, easily carried about. With this offer Remington supplies a sturdy, beautiful carrying case which rivals in beauty and utility the most attractive luggage you can buy.



**SPECIFICATIONS**

ALL ESSENTIAL FEATURES of large standard office machines appear in the Noiseless Portable—standard 4-row keyboard; back spacer; margin stops and margin release; double shift key and shift lock; two color ribbon and automatic ribbon reverse; variable line spacer; paper fingers; makes as many as seven carbons; takes paper 9.5" wide; writes lines 8.2" wide. There are also extra features like the card writing attachment, black key cards and white letters, touch regulator, rubber cushioned feet. These make typing on a Remington Deluxe Noiseless Portable a distinct pleasure. Thousands of families now using the Remington Deluxe Noiseless Portable know from experience how wonderful it is!



**MAIL  
COUPON  
NOW!**

Remington Rand Inc., Dept. 189-6  
465 Washington St., Buffalo, N. Y.

Tell me, without obligation, how to get a Free Trial of a new Remington Deluxe Noiseless Portable, including Carrying Case and Free 32-page Typing Instruction Booklet on terms as low as 10c a day. Send Catalogue.

Name.....  
Address.....  
City.....State.....

**OPPORTUNITY AD-LETS**

Advertisements in this section cost 15 cents a word for each insertion. Name, address and initials must be included at the above rate. Cash should accompany all classified advertisements unless placed by an accredited advertising agency. No advertisement for less than ten words accepted. Ten percent discount for six issues, twenty percent for twelve issues. Objectionable or misleading advertisements not accepted. Advertisements for July, 1940, issue must reach us not later than May 7th.

Radio-Craft • 20 Vesey St. • New York, N. Y.

**AGENTS WANTED**

300% PROFIT SELLING GOLD LEAF LETTERS FOR store windows; Free samples. Metallic Company, 431 North Clark, Chicago.

**BOOKS AND MAGAZINES**

**ASSURE YOURSELF OF GREATER PROFITS BY** doing radio service jobs more quickly. Authentic service guides show you the way to locate and correct troubles in any radio receiver. Gernsback Official Radio Service Manuals show you how to complete more repair jobs in less time—how to earn more money by faster servicing. Read the advertisement which appears on Page 710 of this issue.

**WE HAVE A FEW HUNDRED RADIO ENCYCLOPEDIAS**, by S. Gernsback, second edition, originally sold at \$3.98. Book has 352 pages, weight 3 lbs., size 9 x 12 inches. Red morocco—keratol flexible binding. Send \$2.49 in stamps, cash or money order and book will be forwarded express collect. Technifax, 1915 So. State Street, Chicago, Illinois.

**DIATHERMY (SHORT-WAVE THERAPY) MACHINES**

**DIATHERMY, SHORT-WAVE THERAPY, AND** ultra short-wave therapy machines custom-built by radio engineer at considerable saving over commercial machines; 6 meters, 16 meters or any other frequency specified can be furnished. Machines substantially built with high patient-safety factor. 250-300 watts output. Neat professional appearance. Automatic safety time switches. All necessary pads and electrodes. For sale only to physicians, hospitals and sanitariums. Prices from \$195.00 to \$300.00. Not for sale to the general public. Write for further information giving your own specifications and requirements. Allan Stuart, 1015 Wilson Ave., Teaneck, N. J.

**EDUCATIONAL COURSES**

**USED CORRESPONDENCE COURSES AND EDUCATIONAL** books bought, sold, rented, exchanged, catalog free. V. W. Vernon, Henagar, Alabama.

**CORRESPONDENCE COURSES AND EDUCATIONAL** books, slightly used. Sold. Rented. Exchanged. All subjects. Satisfaction guaranteed. Cash paid for used courses. Complete details and bargain catalog FREE. Send name. Nelson Company, E-242 Manhattan Building, Chicago.

**PHONOGRAPH RECORDS**

**PHONOGRAPH RECORDS—TWELVE \$1.00.** Paramount, EA-358 East Market, Wilkes-Barre, Penna.

**RADIO**

**WE BUY AND SELL USED RADIO TESTING EQUIP-**ment. Time payments if desired. Harold Davis, Inc., Jackson, Miss.

**ANY RADIO DIAGRAM.** 25c. SPECIFY MANUFACTURER, model. Radio magazine free. Supreme Publications, 3727 West 13th, Chicago.

**WANTED—RADIO SETS IN GOOD CONDITION DAT-**ing prior to 1922. Also parts in use prior to 1918; state wants. R. Bernard, 40 Manning Ave., N. Plainfield, N. J.

**ATTENTION DEALERS, SELL WRIGHT SPEAKERS,** WARD-LEONARD relays, resistors, CONSOLIDATED VOLUME CONTROLS, SUPREME INSTRUMENTS, Illinois CONDENSERS, Gernsback Manuals, Sentinel Radios. Send for catalog. Anchor Radio Distributing, Dryden Rd., Ithaca, New York.

**HARD-TO-GET RADIO DIAGRAMS.** Try usual sources first. If you can't get them, try us. Price, 75c to \$1.50 if we succeed; no charge if we don't. You lose nothing! Send no money—write first giving fullest information. Enclose return-addressed, stamped envelope. We have helped many Servicemen, experimenters and radio fans. We may help you. Allan Stuart, 1015 Wilson Ave., Teaneck, N. J.

**WILL SWAP TEST EQUIPMENT, CAR-RADIO SET,** radio books, experimental receivers, camera—or what do you want—for IP-501 receiver, airplane-cloth speaker, magnetic detector, navy tuner, deForest Audion control box, W.E. 18-inch free-edge magnetic-type cone speaker, or what old apparatus have you? R. Bernard, 40 Manning Ave., N. Plainfield, N. J.

**STAMPS**

**THREE SCARCE SETS, NOW OBSOLETE.** 25c, WITH new customer. Gift: Box 211, Malden, Mass.

**TECHNICAL ART SERVICE**

**DRAFTING AND ART SERVICE—A COMPLETE** Service for the Industrial and Commercial Marketers. If your business or plant can't afford a designing or drafting staff, don't let this stop you from going ahead with that new product you intend marketing, or that catalog of mechanical or electrical items which needs fine detailed drawings and highly retouched photographs. Any mechanical, electrical or radio problem can be solved for you by our associated staff of designers, draftsmen and artists, and technical copywriters. Write for any additional information as to methods and price for this service. Tec-Art Drafting Service, 223 Charlotte Terrace, Roselle Park, N. J.

**FULL-WAVE TRANSFORMER-LESS RECTIFIER**

● I AM submitting herewith a power-pack system that I am using, in the hope that you can use it in your "Useful Kinks and Circuits" column. Maybe it would help some brother experimenter among your/our readers who has to build his "B"-supply himself, out of spare parts.

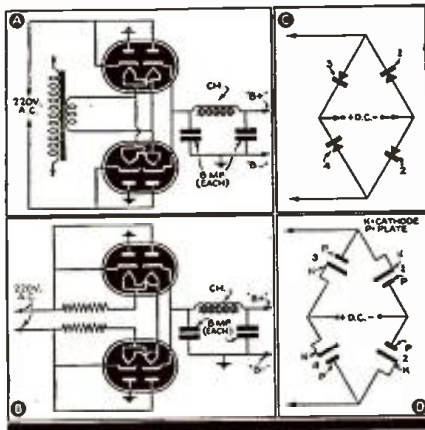

thus cause the rectifier tube to fail. The instantaneous surge voltages developed may be as high as 300 volts, and occur only if the set happens to be turned off on a particular part of the cycle.

The remedy is as simple as the surge action is complicated. Connect a 50-ohm, 1-watt resistor in series with the lead from the rectifier cathodes to the filter conden-

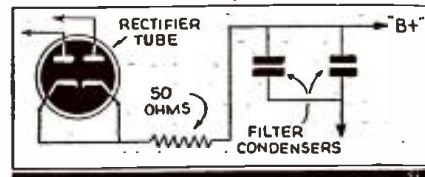

sers. This prevents a high surge from building up across the condensers since the charging current of the condensers causes a fairly high voltage drop across the resistor. It is recommended that such a resistor be installed in all A.C.-D.C. sets where condensers or rectifiers have failed prematurely.

SPOKANE RADIO Co., Service News.

**RACK FOR TEST INSTRUMENTS**

● I AM a regular reader of the *Radio-Craft* magazine and I always find it instructive, full of timely information about the radio

**IN NEW YORK**

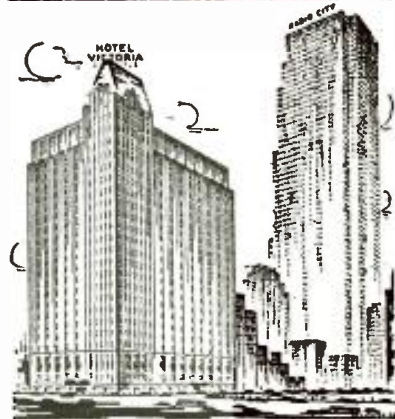

The pleasure of your New York visit can be marred or enhanced, depending upon the selection of your hotel.

IT'S WORTH THINKING ABOUT that The Victoria attracts the most discerning travelers...because discerning travelers are attracted to the new Victoria.

Every room with every modern convenience. From \$2.50 single, \$4 double.

Hotel AT RADIO CITY  
**VICTORIA**  
7th AVE. at 51st ST. NEW YORK  
RONALD A. BAKER, Manager

It will be noticed at Fig. A that I use a filament transformer; I call this a "transformerless full-wave rectifier," but I use the transformer just to keep it from being underfoot among my spare parts rather than because it is necessary. A line voltage dropping resistor to drop the line voltage to 50 volts for the filaments of the 25Z5's in series would do just as well and then it would be really a transformerless full-wave rectifier. (Fig. B.)

I wanted a "B"-power pack supply with sufficiently high voltage and current to operate a small phono-amplifier using 2-43's in push-pull at the last stage. This means in order to drive the 2-43's to their full power I would have to use 180 volts on the grid, and since the 2-43's were self-biased through a 270-ohm resistor in the cathode legs in parallel, I would need 200 volts of "B" supply.

Looking around in my junk-box, I found an old step-down transformer (220-25 volts), relic of an old battery charger. Not having any adequate power transformer on hand with a H.-V. secondary, I decided to use what I had on hand. The result is the accompanying diagram.

The circuit is not a voltage-doubling circuit. It simply utilizes the 220 volts A.C. house current that we have here, in a system that rectifies the current both ways just like the old familiar full-wave copper-oxide rectifier. The action is illustrated in Fig. C where the old full-wave copper-oxide action is illustrated and in Fig. D where the adaptation is made using 25Z5's for rectifiers.

Needless to say, the power gives me sufficient current and high enough voltage to drive the amplifier with its full output.

SUSANO A. VELAZQUEZ,  
Manila, Philippine Islands.

**A.C.-D.C. BUG IS CURABLE**

● THE tendency for filter condensers and rectifiers to fail prematurely in A.C.-D.C. sets is a common occurrence to most Servicemen. Even though the condenser and rectifier are not at fault, and normal line voltages are encountered, the trouble still persists in certain locations. An investigation disclosed the following information.

With certain line impedances, it has been found that extremely high surge voltages are developed across the filter condenser. As a result the condenser will puncture and



*Index to advertisers*

**PUBLIC ADDRESS EQUIPMENT**

Amperite Corporation ..... Back Cover  
 Amplifier Co. of America ..... 729, 731, 739  
 Arrow Sales Co. .... 729  
 Atlas Sound Corporation ..... 738  
 John Meck Industries ..... 731  
 Miles Reproducer Co. .... 738  
 RCA Manufacturing Co., Inc. .... 731  
 Thordarson Elec. Mfg. Co. .... 739  
 Utah Radio Products Co. .... 734  
 Wright, Inc. .... 738  
 Wright-DeCoster, Inc. .... 729

**PUBLISHERS**

Data Print Company ..... 760  
 National Plans Institute ..... 749  
 Radcraft Publications, Inc. .... 710, 754  
 Radio & Technical Pub. Co. .... 749  
 John F. Rider, Inc. .... 722  
 Superworld Comics ..... 760  
 Technifax ..... 755, 757

**RADIO PARTS**

Aerovox Corporation ..... 746  
 Dumont Elec. Co. .... 719  
 Hammarlund Mfg. Co. .... 746  
 Illinois Condenser Co. .... 746  
 International Resistance Co. .... 717  
 National Carbon Co. .... 755  
 Solar Mfg. Corp. .... 719

**RADIO SETS**

Kadette Radio Corp. .... 757  
 Meissner Mfg. Co. .... 709  
 Midwest Radio Corp. .... 757  
 E. H. Scott Radio Labs. .... 747

**RADIO SUPPLY HOUSES**

Allied Radio Corp. .... 753  
 Burstein-Applebee Co. .... 767  
 Hudson Specialty Co. .... 768  
 Lafayette Radio Corp. .... 767  
 Radolek Company ..... 767  
 Trymo Hobby Craft & Supply Co. .... 767  
 United Radio Company ..... 767  
 Wellworth Trading Co. .... 762, 759

**SCHOOLS**

Capital Radio Eng. Inst. .... 708  
 Lincoln Engineering School ..... 708  
 National Radio Institute ..... 705  
 National Schools ..... 706  
 New York YMCA Schools ..... 708  
 Radio Training Association ..... 708  
 RCA Institutes, Inc. .... 708  
 Sprayberry Academy of Radio ..... 707

**TEST EQUIPMENT**

Radio City Products Co. .... 728  
 Readrite Meter Works ..... 728  
 Superior Instruments Co. .... Inside Back Cover, 719  
 Triplett Elec. Inst. Co. .... 724

**TUBES**

HyGrade-Sylvania Corp. .... 746  
 National Union Radio Corp. .... 748

**MISCELLANEOUS**

Classified Section ..... 766  
 Joseph H. Kraus & Company ..... 759  
 Lancaster, Allwine & Rommel ..... 755  
 National Radio Parts Dis. Assoc. .... 752  
 Radio Servicemen of America, Inc. .... 756  
 Remington Rand, Inc. .... 765  
 Hotel Victoria ..... 766

(While every precaution is taken to insure accuracy, we cannot guarantee against the possibility of an occasional change or omission in the preparation of this index.)

field, and interesting. The page for "Useful Kinks and Circuits" interests me most. So I took this chance also of contributing a kink which I hope would be of help or use to other fellow radio-beginners and experimenters who have not yet a permanent rack for their portable testers.

In the illustration is shown how my tester's rack appears (it looks funny, though, for it resembles a dwarf's wooden bench). I constructed it in a few minutes' time out of a "Libby's Milk" box, which I obtained from a friendly grocer. It stands up high enough on my workbench so that, though it is behind the receiver I am servicing and if I may be sitting down while doing the job, I can easily glance at my tester without stretching my neck or bending over to see my tester's pointer. The rack appears a bit tilted backward to keep my tester from falling accidentally down before my face.

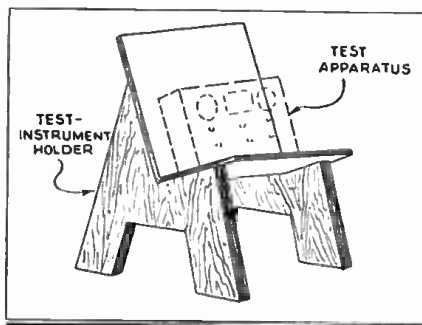

Anyone who contemplates constructing a similar one will have to find by himself the physical dimensions and the "angle of tilt" which suits him best. He may paint it in his own favorite color.

MANUEL MADRIDANO,  
 Manila, P. I.

**HOMEMADE MERCURY SWITCH CUTS RADIO WHEN 'PHONING**

● HAVE you ever wished for a mechanical robot that would shut off your radio set when the telephone is being used? Here is the simplest solution, a mercury switch that will short the aerial and ground of the radio receiver and cut off the program, when the phone is being used. (On some sets, tuned to strong locals, the signal may be only partially muted.)

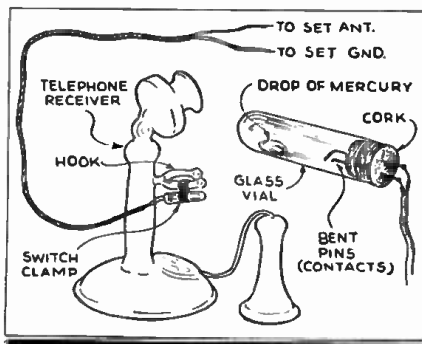

Find a small perfume vial with cork, 2 straight pins, and a drop of mercury. Push the pins into the cork, keeping the pins apart, bend the points downward until both almost touch the glass walls of the vial. Place mercury in tube and insert cork tightly. Run a wire from each of the pins along the wall to the radio set and connect one to the antenna and one to the ground.

Most any metal will make a clamp to hold the glass tube to the telephone hook. This switch may be used on all types of phones.

TERRELE SPENCER,  
 Wynne, Ark.

**FREE! VERY LATEST PROFIT GUIDE**  
*Everything in RADIO!*  
 at lowest prices

**COMPLETE SELECTIONS GUARANTEED QUALITY**  
**Faster Delivery**  
 Most complete stocks of Universal and Exact Duplicate Replacement and Repair Parts, Radio Sets, and Amateur Supplies.  
**P. A. EQUIPMENT**  
 Separate amplifiers or complete systems with any desired assortment of speakers, horns, baffles and microphones. Everything from 5 to 100 watts. Prices that save money for you.  
**ELECTRICAL APPLIANCES**  
 Extra profits for you! Standard Brand Electric Irons, Grills, Toasters, Percolators, Waffle Irons, Vacuum Cleaners, Clocks, Mixers, etc., at lowest prices.

**MAIL THIS COUPON TODAY**  
 The RADOLEK Co.  
 601 W. Randolph St., Chicago, Dept. C-42  
 Send the latest Radio Profit Guide FREE.  
 Name .....  
 Address ..... Dealer?.....  
 Experimenter?..... Serviceman?..... Amateur?.....

**EXPERIENCED RADIO MEN WILL**  
*Send it once!*  
**FREE New LAFAYETTE CATALOG**  
 Experience has taught men in radio that a new Lafayette catalog means news... buys... savings! Send for the Lafayette catalog—just published—and see for yourself. Move this guide to the best buys handy—buy everything you need from one source—save valuable time and money! Get your copy today. It's FREE.  
**LAFAYETTE RADIO**  
 Dept. 3F—100 Sixth Ave., New York, N. Y.

**IF IT'S RADIO**  
**ALL YOUR RADIO NEEDS**  
 Here in this one big book you will find everything you need in radio... sets, parts and supplies... public address systems... amateur equipment... testers and kits... your nationally known favorites at lowest possible prices. Write today for this big valuable catalog and save money.  
**PROMPT SERVICE**  
**FREE CATALOG**  
**BURSTEIN-APPLEBEE COMPANY**  
 1012-14 McGEE STREET, KANSAS CITY, MISSOURI

**WAKE UP Radio Dealers!**  
 Get a Hobby Dept. established in your store. \$25.00 starts you in business.  
 We are national distributors for many well known Hobby Crafts model airplanes, boats, motors, model railroads, etc. Write for our proposition.  
 See our Model Railroad on display.  
**TRYMO HOBBY CRAFT & SUPPLY CO.**  
 85 RC Cortlandt St. New York, N. Y.

**DON'T BUY—SAVE \$\$\$**  
**ON RADIO SETS — PARTS, TUBES, PHONOGRAPH RECORDS — UNTIL YOU HAVE SENT FOR OUR NEW GIANT MONEY-SAVING CATALOGUE.**  
**UNITED RADIO COMPANY,**  
 DEPT. X NEWARK, N. J.

# SUPER BARGAINS

Practically all of the attractive items listed here are brand new, others are reconditioned like new; but ALL are in PERFECT WORKING ORDER. In many cases, the parts alone total more than the price we are asking. 100% satisfaction guaranteed or your money refunded. ORDER FROM THIS PAGE. Use the convenient coupon below. Include sufficient extra remittance for parcel post charges, else order shipped express, collect. Any excess will be refunded. C.O.D. shipments require 20% deposit. If full remittance accompanies order, deduct 2% discount. Send money order, certified check, new U. S. stamps. No C.O.D. to foreign countries.

**ORDER TODAY LIMITED QUANTITIES PROMPT SHIPMENTS ASSURED**

## 24-HOUR ELECTRIC CLOCK MOVEMENT

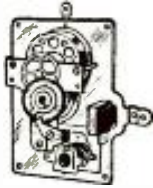

Made originally by the famous Waterbury Clock Company as part of an automatic defrosting timer for electric refrigerator. Has a powerful synchronous self-starting motor and complete clock movement. The handy experimenter can attach a calibrated dial and single pointer in order to make an accurate electric clock. If taken apart, its gears may be used for many experimental purposes and, in themselves, are worth more than the cost of the entire unit. The clock may be used only on the 110-20 volt 60 cycle A.C. line. One lubrication lasts practically a lifetime. Ship. wt. 3 lbs.

ITEM NO. 75  
YOUR PRICE ..... **95c**

## SUPER SPECIAL

### 3 1/2 R.P.M. SYNCHRONOUS MOTOR

110 Volt, 60 Cycle A.C. Only

There are 101 uses for a synchronous motor making only 3 1/2 revolutions per minute. Ideal for crowd-catching store-window displays, agitating film-developing tanks, as an electric winch on model motor boats, as detent motor in erector sets, etc. Built-in high-ratio step-down gears provide amazing amount of power. Made by Haydon Mfg. Co. of Waterbury. 2" in diameter x 2 1/4" x 1" thick overall. Ship. Wt. 2 lbs.



ITEM NO. 76  
YOUR PRICE ..... **\$1.95**

## A.C. "SQUIRREL CAGE" SYNCHRON. MOTOR



Self-starting shaded pole motor designed for radio chassis for Push Button Tuning. High speed, powerful. One lubrication lasts lifetime. Excellent for model railroad trains, small boats, humidifier water pumps, etc. 1/2" long shaft. 3/16" diameter. Complete with brass mounting posts. 2 1/4" x 2" x 2 1/4" overall. For 110 volts, 60 cycles, A.C. only. Ship. Wt. 4 lbs.

ITEM NO. 77  
YOUR PRICE ..... **\$1.35**

## MECHANICAL FLASHLIGHT

This battery-less flashlight generates its own power merely by pressing handle. Gives strong light whenever needed. Costs nothing to maintain. Amazing new miniature dynamo operates flashlight. Pocket size. 4 3/4" x 2" x 1". Ship. Wt. 2 lbs.



ITEM NO. 88  
YOUR PRICE ..... **\$2.25**

## MOTOR FOR ROTATING RADIO BEAM ANTENNA

One Revolution Per Minute



Built by Honeywell as a temperature regulator for coal fired furnaces but ideal for many other uses, especially for rotating beam antennas on the roof for directional receiving and reception of radio signals. Built-in commutator switching permits turning antenna from north-south to east-west direction from remote point. Constructed for hard use. Has double-end shafts geared down to about one revolution per minute. Ideal for window displays and other slow-moving mechanical motions. 110 volts, 60 cycles, A.C. only. 6 1/2" x 6 1/2" x 4 1/2". Ship. Wt. 10 lbs.

ITEM NO. 82  
YOUR PRICE ..... **\$5.95**

## AMAZING BLACK LIGHT!!

Powerful 300-Watt Ultra-Violet Bulb



The best and most practical source of ultra-violet light for general experimental and entertainment use. Makes all fluorescent substances brilliantly luminescent. No transformers of any kind needed. Fits any standard lamp socket. Made with special filter glass permitting only ultra-violet rays to come through. Brings out beautiful opalescent hues in various types of materials. Swell for amateur parties, plays, etc., to obtain unique lighting effects. Bulb only. Size of bulb. Ship. Wt. 1 lb.

ITEM NO. 87  
YOUR PRICE ..... **\$2.00**

## SUPER MAGNET

LIFTS MORE THAN 20 TIMES ITS OWN WEIGHT

LITTLE GIANT MAGNET. Lifts 5 lbs. easily. Weighs 4 oz. Made of ALNIO new high-magnetic steel. Complete with keeper. World's most powerful magnet ever made. The experimenter and hobbyist will find hundreds of excellent uses for this high quality permanent magnet. Measures 1 1/4" x 1 1/4". Ship. Wt. 3/4 lbs.



ITEM NO. 86  
YOUR PRICE ..... **\$1.00**

## EXTRA BARGAINS

IMMERSION TYPE WATER HEATER. 110 VOLTS A.C. or D.C. Excellent for aquariums, etc. Ship. Wt. 3/4 lb.

ITEM NO. 83  
YOUR PRICE ..... **35c**

6-VOLT A.C. MOTOR. Fine for door chimes, model electric trains, erector sets, etc. Ship. Wt. 3 lbs.

ITEM NO. 84  
YOUR PRICE ..... **\$1.95**

## G.E. INDUCTION DISC MOTOR FOR RECORDING PLAYBACK AND DISPLAY PURPOSES



Substantially constructed by General Electric, this ball-bearing motor is a high-quality phonograph unit. Its power and smooth-running make excellent home recording work. Its speed, governor-controlled, is variable both below and above 78 r.p.m. For 110 volts, 60 cycles, A.C. Solid less turntable and shaft. 7 1/2" diameter x 5 1/2" high. Ship. Wt. 14 lbs. Packed in Original Box.

ITEM NO. 81  
YOUR PRICE ..... **\$3.95**

## SEWING MACHINE MOTOR

For electrifying foot-treadle sewing machines and replacing burned-out motors on electrified machines. Powerful and high-speed; numerous other uses. Ideal as handy grinder-polisher motor. Small, compact, flat on two sides, requiring a minimum of space. Speed controllable by foot-pedal rheostat (available optionally for \$3.75). Its 3/4" diam. shaft is available with or without pulley (pulley 15c extra). Completely enclosed and dirt proof. Measures 3 1/4" x 5" x 3 1/4". Ship. Wt. 7 lbs.



ITEM NO. 79  
YOUR PRICE (motor only) ..... **\$3.75**

## OLD AUTO SETS FOR NEW CARS

• A GREAT many people purchase used auto-radios, 3 to 6 years old, and want them installed in late-model cars with metal tops. Such an installation, especially with a whip aerial, is seldom satisfactory.

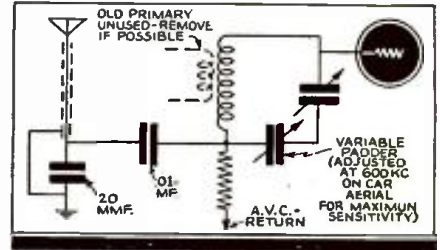

Rather than lose his initial investment, usually \$8 to \$15, he will gladly pay \$2 or \$3 to have the input of his set changed as shown in the diagram reproduced here.

I have changed several RCA's, G.E.'s, a Knight, etc., and find they operate very well on a hinge aerial.

HOWARD E. BADGER,  
Chariton, Ia.

## QUASI-ELECTRIC SOLDERING IRON

• FIRST, get the heating element from an electric heater and mount it (with a porcelain-base socket) on a board that is covered with some asbestos. Place this board at about an 85-degree angle and connect the heater element to the 110-V. main.

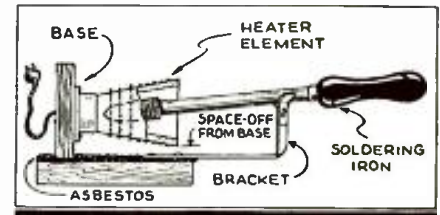

The fellow who uses this idea will have the next best thing to an electric iron, merely by carefully placing his ordinary, flame-heated iron into the open end of the heater unit.

J. BREWSTER WILLIAMS,  
Whitemarsh, Pa.

## MIKE HANDLE

• TO make an inexpensive microphone handle, take the handle from an old screwdriver or some kitchen utensil. Hunt around in the old junk-box for a phone plug with a 5/8-27 thread on the barrel and remove all the parts except the sleeve with

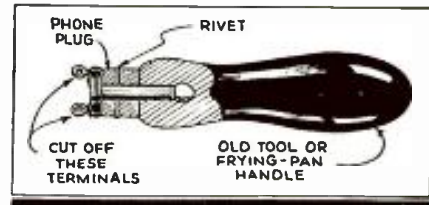

the threaded shoulder. Drive the sleeve into the end of the handle. Drill a 1/16-in. hole in the ferrule and sleeve and use a nail for a rivet, to prevent the threaded part from turning when screwing into the mike.

E. H. DISNEY,  
Lowry City, Mo.

## CORRECTION:—"Profits in Recording"

On pg. 665, of the May, 1940, issue of Radio-Craft, the captions for the Speak-O-Phone recording machine and the Wilcox-Gay recording machine were inadvertently interchanged. These are the 2 lower illustrations in the extreme-right-hand column:—sorry.

## HUDSON SPECIALTIES CO., 40-R West Broadway, N. Y. C.

WE HAVE NO CATALOG. IT'S EASY TO ORDER—CLIP COUPON—MAIL NOW ORDER FROM THIS PAGE

HUDSON SPECIALTIES CO., 40-R West Broadway, New York, N. Y. RC-640

I have circled below the numbers of the items I'm ordering. My full remittance of \$..... (include shipping charges) is enclosed.

OR my deposit of \$..... is enclosed (20% required), ship order C.O.D. for balance. (New U. S. stamps, check or money order accepted.)

Circle Item No. wanted: 75, 76, 77, 79, 81, 82, 83, 84, 86, 87, 88

Name ..... Address .....

City ..... State .....

Send remittance by check, stamps or money order; register letter if you send cash or stamps.

**THE NEW CHANNEL-ANALYZER**  
Follows The SIGNAL from Antenna to Speaker

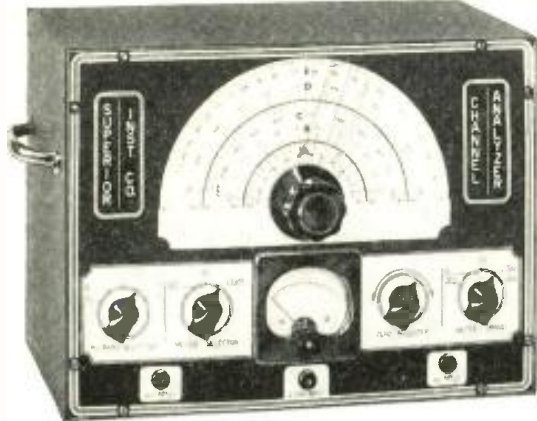

The well-established and authentic SIGNAL TRACING METHOD of locating the very circuit in which there is trouble, and the very component that causes the trouble, is now for the first time available at a price any radio serviceman can afford.

**The CHANNEL-ANALYZER will**

- ★ Follow signal from antenna to speaker through all stages of any receiver ever made.
- ★ Instantly track down exact cause of intermittent operation.
- ★ Measure both Automatic-Volume-Control and Automatic-Frequency-Control, voltages and circuits without appreciably loading the circuit, using built-in highly sensitive Vacuum-Tube Voltmeter.
- ★ Check exact gain of every individual stage in receiver.
- ★ Track down and locate cause of distortion in R.F., I.F., and A.F. amplifier.
- ★ Check exact operating voltage of each tube.
- ★ Locate leaky condensers and all high-resistance shorts, also show opens.
- ★ Measure exact frequencies, amount of drift and comparative output of oscillators in subcircuits.
- ★ Track down exact cause of noise.

The Superior Channel-Analyzer comes housed in shielded cabinet and features an attractive etched aluminum panel. Supplied complete with tubes, three specially engineered shielded input cables, each identified as to its purpose. Also full operating instructions. Size 13" x 10" x 6". Shipping weight 19 pounds. Only ...

**\$19<sup>75</sup>**

**THE NEW MODEL 1280 SET-TESTER**

Combines Models 1240 and 1250

A complete testing laboratory in one unit, the Model 1280 combines the Models 1250 Multitester and 1240 Tube Tester. (See specifications of each below.)

- ★ Instantaneous Snap Switches Reduce Actual Testing Time to Absolute Minimum.
- ★ Spare Socket and Filament Voltages Up to 120 Volts, Make the Model 1280 Obsolescence Proof.
- ★ Latest Design 4 1/2 D'Arsonval Type Meter.
- ★ Works on 90 to 125 Volts 60 Cycles A.C.



Even those servicemen who through past purchases know they can always get SUPER-VALUES from Superior, will be amazed and delighted when they read the specifications of this all-purpose instrument and then note the unbelievably low price. The Model 1280 features a 4 1/2" D'Arsonval type meter for easy reading of the various scales, and in line with our new policy of stressing appearance as well as serviceability in our new 1200 line of test equipment, our Model 1280 utilizes an aluminum etched panel, designed for beauty as well as ruggedness. The primary function of an instrument is, of course, to make measurements accurately and when designing test equipment this is our first thought. However, we also appreciate the important part the appearance of an instrument plays in the impression a serviceman makes on his customers, especially on home calls. We have, therefore, paid special attention to the outward design of all of our new instruments. For instance, the panel of this Model 1280 is made of heavy-gauge aluminum and etched by a radically new process which results in a beautiful, confidence inspiring appearance.

Model 1280 comes complete with test leads, tabular data and instructions. Shipping weight 18 pounds. Size 13" x 11" x 6 1/2". Our net price ..

**\$19<sup>95</sup>**

Portable cover \$1.00 additional

**THE NEW MODEL 1250 MULTITESTER**



**SLOPING PANEL FOR PRECISE RAPID SERVICING**

Etched aluminum panel

Specially designed electronic rectifier enables linear A.C. scale, high stability and little or no temperature drift.

Here is an opportunity to acquire a Multi-Service, Precision Engineered Instrument, for less than you would have to pay for an ordinary Volt-Ohm Milliammeter. Besides making the usual volt, resistance and current measurements (both A.C. and D.C.) this unit accurately measures the CAPACITIES of mica, paper and electrolytic condensers, INDUCTANCE of coils, chokes and transformers, DECIBEL gain or loss, of power amplifiers and public address systems, WATTS output of amplifiers, receivers, etc.

**SPECIFICATIONS**

Complete A.C. and D.C. Voltage and Current Ranges	High and Low Capacity Scales .0005 to 1 mfd. and .05 to 50 mfd.
D.C. Voltage:—0-15, 0-150, 0-750 volts	3 Decibel Ranges
A.C. Voltage:—0-15, 0-150, 0-750 volts	- 10 to +19, - 10 to +38, - 10 to +53
D.C. Current:—0-1, 0-15, 0-150, 0-750 ma.	
A.C. Current:—0-15, 0-150, 0-750 ma.	Inductance: 1 to 700 Henries
2 Resistance Ranges	Watts: Based on 6 mw. at O D.B. in 500 ohms .006000 to 600 Watts
0-500 ohms, 500-5 megohms	

Model 1250 works on 90-120 volts 60 cycles A.C. Comes complete with test leads, tabular charts and instructions. Shipping weight 9 lbs. Size 9 1/2" x 11" x 6 1/2". Our net price ....

**\$11<sup>85</sup>**

Portable cover \$1.00 additional

**THE NEW MODEL 1240 TUBE TESTER**



Instantaneous snap switches reduce actual testing time to absolute minimum.

Tests all tubes 1.4 to 117 volts.

Sockets for all tubes—No adapters.

Superior is proud to offer the newest and most practical tube tester ever designed. Unbelievably low in price—unbelievably high in performance.

- ★ Tests all tubes, 1.4 to 117 volts, including 4, 5, 6, 7, 7L, octals, loctals, Bantam Jr., Peanut, single ended, floating filament, Mercury Vapor Rectifiers, the new S series, in fact every tube destined to date.
- ★ Spare socket included on front panel for any future tubes.
- ★ Tests by the well-established emission method for tube quality, directly read on the GOOD ? BAD scale of the meter.
- ★ Jewel protected neon.
- ★ Tests shorts and leakages up to 2 megohms in all tubes.
- ★ Tests leakages and shorts in all elements AGAINST all elements in all tubes.
- ★ Tests BOTH plates in rectifiers.
- ★ Tests individual sections such as diodes, triodes, pentodes, etc., in multi-purpose tubes.
- ★ Latest type voltage regulator.
- ★ Features an attractive etched aluminum panel.
- ★ Works on 90 to 125 volts 60 cycles A.C.

Model 1240 comes complete with instructions and tabular data for every known type of receiving tube. Shipping weight 12 pounds. Size 6" x 7 1/2" x 10 3/4". Our Net Price.....

**\$11<sup>85</sup>**

Portable cover \$1.00 additional

**SUPERIOR INSTRUMENTS CO. 136 LIBERTY ST., DEPT. RC6 NEW YORK, N. Y.**

MAY 8 A.M.

# AMPERITE Announces the **BIGGEST ADVANCE** in the Dynamic since its Inception!



PRESSURE GRADIENT

**DYNAMIC**

- **UNI-DIRECTIONAL.** NEW SUPERIOR ELIPSOID PICKUP PATTERN
- **ELIMINATES FEEDBACK** TROUBLE BECAUSE IT HAS LOWEST FEEDBACK POINT OF ALL DIAPHRAGM TYPE MICROPHONES
- **FLAT RESPONSE.** FREE FROM ANNOYING PEAKS, GIVING STUDIO-QUALITY REPRODUCTION.



The P.G. diaphragm follows air particle velocity where amplitude is a GRADIENT of the PRESSURE. In ordinary dynamics amplitude is restricted from following air particle velocity.

The P.G. DYNAMIC is a radical improvement in this type of microphone. You can actually hear the difference. Case is designed according to modern acoustic principles. Rugged, not affected by temperature, altitude or humidity. HAS UNUSUALLY HIGH OUTPUT. —55 DB.

MODEL PGH (PGL 200 ohms). Excellent for high fidelity P.A. installations, broadcast studio, and professional recording. With switch, cable connector, 25' cable. Chrome finish. LIST \$32.00 (40-10000 C.P.S.)

MODEL PGAH (PGAL 200 ohms). For speech and music. 70-8000 C.P.S. Switch, cable connector, 12' cable. Chrome, LIST \$25.00

## COMBINATION VELOCITY-DYNAMIC ACHIEVED WITH ACOUSTIC COMPENSATOR



An exclusive Amperite feature: By moving up the Acoustic Compensator you change the AMPERITE VELOCITY to a DYNAMIC microphone without peaks. At the same time you reduce the back pick-up, making the microphone practically UNI-DIRECTIONAL.

WITH ACOUSTIC COMPENSATOR: MODEL RBHk: RBMk (200 ohms) with switch, cable connector.

Chrome, LIST \$42.00

RSHk: RBSk (200 ohms). Switch, cable connector, Acoustic Compensator.

Chrome or Gunmetal, LIST \$32.00

## AMPERITE KONTAK MIKE Puts Musical Instruments Across



So beautiful is the tone produced with the Kontak Mike, that it was used in the Philadelphia Symphony to amplify a mandolin solo. Gives excellent results with any amplifier, radio sets, and record players.

MODEL SKH (hi-imp) ..... LIST \$12.00

MODEL KKH, with hand volume control. LIST 18.00

Plug extra ..... List 1.50

FOOT PEDAL, for making beautiful crescendos ..... LIST 12.00

WRITE FOR FREE SALES AIDS

**AMPERITE** ©

561 BROADWAY, N. Y. U.S.A.

Specify **AMPERITE**

