

RADIO-CRAFT

HUGO GERNSBACK, *Editor*

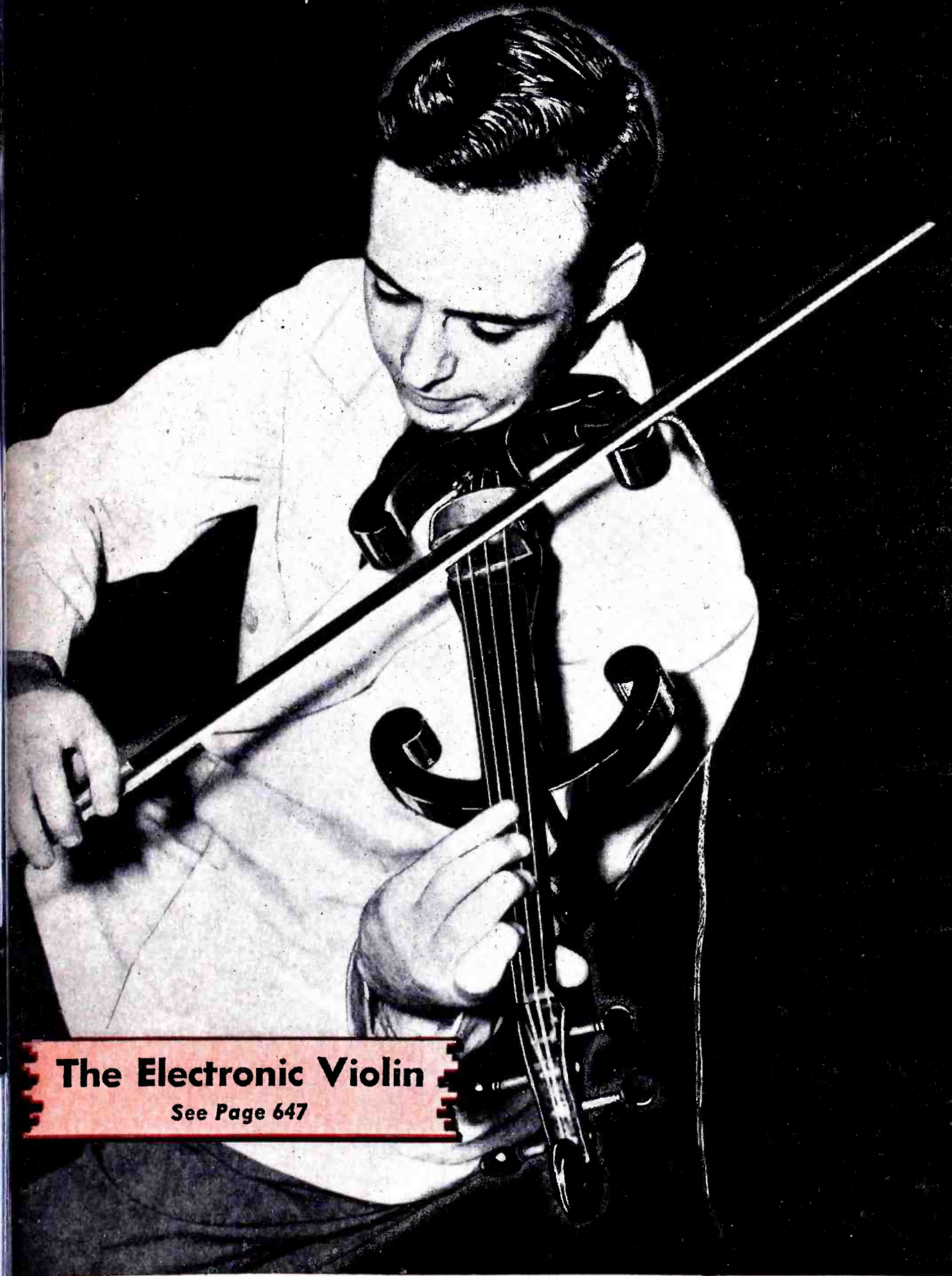

The Electronic Violin

See Page 647



FOR THE RECORD

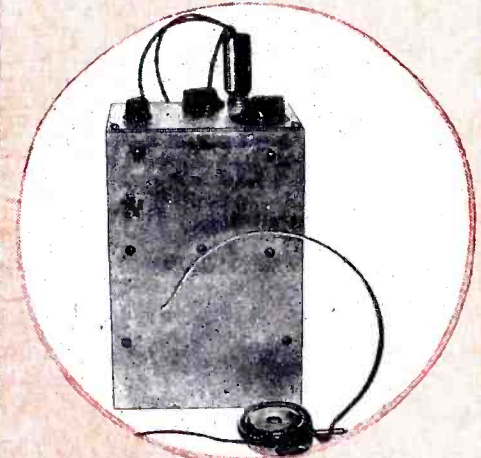

THE BASEBALL SPECIAL

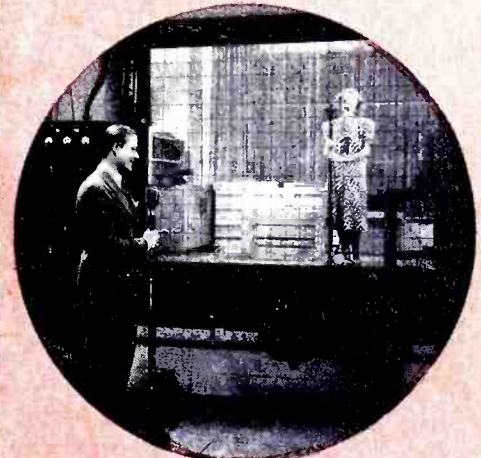

"TELEVISION SPY"

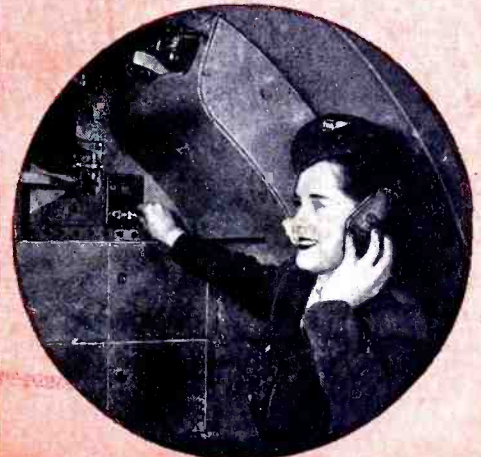

MUSIC IN THE AIR

MAY 40 RADIO'S GREATEST MAGAZINE

25c MODERN FREQUENCY MIXERS • COMBATING RADIO INTERFERENCE

60-WATT DIRECT-COUPLED AMPLIFIER • PROFITS IN RECORDING

U.S. AND CANADA

AMPERITE Announces the **BIGGEST ADVANCE**
in the Dynamic since its Inception!

P G
PRESSURE GRADIENT
DYNAMIC

- **UNI-DIRECTIONAL.** NEW SUPERIOR ELIPSOID PICKUP PATTERN
- **ELIMINATES FEEDBACK** TROUBLE BECAUSE IT HAS LOWEST FEEDBACK POINT OF ALL DIAPHRAGM TYPE MICROPHONES
- **FLAT RESPONSE.** FREE FROM ANNOYING PEAKS, GIVING STUDIO-QUALITY REPRODUCTION.

The P.G. diaphragm follows air particle velocity where amplitude is a GRADIENT of the PRESSURE. In ordinary dynamics amplitude is restricted from following air particle velocity.

The P.G. DYNAMIC is a radical improvement in this type of microphone. You can actually hear the difference. Case is designed according to modern acoustic principles. Rugged, not affected by temperature, altitude or humidity. HAS UNUSUALLY HIGH OUTPUT, -55 DB.

MODEL PGH (PGL, 200 ohms). Excellent for high fidelity P.A. installations, broadcast studio, and professional recording. With switch, cable connector, 25' cable. Chrome finish. LIST \$32.00 (40-10000 C.P.S.)

MODEL PGAH (PGAL, 200 ohms). For speech and music. 70-8000 C.P.S. Switch, cable connector, 12' cable. Chrome, LIST \$25.00

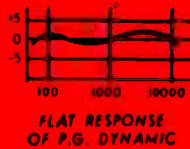

COMBINATION VELOCITY-DYNAMIC
ACHIEVED WITH
ACOUSTIC COMPENSATOR

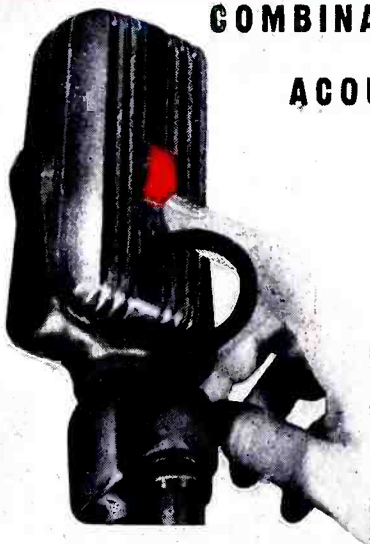

An exclusive Amperite feature: By moving up the Acoustic Compensator you change the AMPERITE VELOCITY to a DYNAMIC microphone without peaks. At the same time you reduce the back pick-up, making the microphone practically UNI-DIRECTIONAL.

WITH ACOUSTIC COMPENSATOR:
MODEL RBHk; RBMk (200 ohms) with switch, cable connector.

Chrome, LIST \$42.00

RSHk; RBSk (200 ohms). Switch, cable connector, Acoustic Compensator.

Chrome or Gunmetal. LIST \$32.00

AMPERITE KONTAK MIKE
Puts Musical Instruments Across

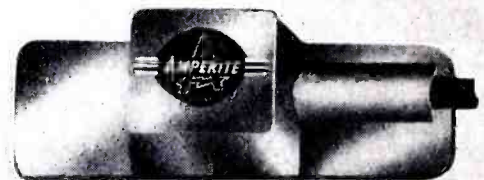

So beautiful is the tone produced with the Kontak Mike, that it was used in the Philadelphia Symphony to amplify a mandolin solo. Gives excellent results with any amplifier, radio sets, and record players.

- MODEL SKH (hi-imp) LIST \$12.00
- MODEL KKH, with hand volume control.. LIST 18.00
- Plug extra List 1.50
- FOOT PEDAL, for making beautiful crescendos LIST 12.00

WRITE FOR FREE SALES AIDS **AMPERITE Co.** 561 BROADWAY, N. Y. U. S. A.

Specify **AMPERITE**



**Men NOW in Radio
who Don't Think
they know it ALL
Read This**

You don't want to see younger, better-trained men push ahead of you I know. You don't want Radio's new technical developments to baffle you either, I am sure. You want to get ready to "cash in" on Television, too. I have helped many already in Radio to get ahead, to win promotions, to make more money. Read my message below.

**J. E. SMITH, President
NATIONAL RADIO INSTITUTE
Established 25 years**

He has directed the training of more men for Radio than anyone else—has helped men already in Radio to get ahead, and men not in Radio to get into Radio and win success.



**If You're NOT
Working in Radio Now
Read This**

Do you want to make more money? Do you want to cash in on your present interest in Radio and Television? Do you want a full-time job with good pay in one of Radio's many fascinating branches? Or do you want to make extra money in your spare time to boost your present income? If you want to do these things—you owe it to yourself to find out how I have trained hundreds of men for jobs in Radio. Read the facts below—and MAIL THE COUPON TODAY.

Make Me Prove I Can Train You at Home for RADIO and TELEVISION

Clip the coupon and mail it. I'm so certain I can train you at home in your spare time to be a Radio Technician that I will send you a sample lesson free. Examine it, read it, see how clear and easy it is to understand. See how my course is planned to help you get a good job in Radio, a young, growing field with a future. You don't need to give up your present job, or spend a lot of money to become a Radio Technician. I train you at home in your spare time.

MANY RADIO TECHNICIANS MAKE \$30, \$40, \$50 A WEEK

Radio broadcasting stations employ engineers, operators, technicians and pay well for trained men. Radio manufacturers employ testers, inspectors, foremen, servicemen in good-pay jobs with opportunities for advancement. Radio jobbers and dealers employ installation and servicemen. Many Radio Technicians open their own Radio sales and repair businesses and make \$30, \$40, \$50 a week. Others hold their regular jobs and make \$5 to \$10 a week fixing Radios in spare time. Automobile, police, aviation, commercial Radio; loudspeaker systems, electronic devices, are newer fields offering good opportunities to qualified men. And my course includes Television, which promises to open many good jobs soon.

Charles F. Helmut, 419 N. Mass. Ave., Atlantic City, N. J., writes: "I started Radio in the Marines. Later I took the N.R.I. Course. Now I am my own boss, and get jobs over others who were sure they had them. I owe plenty to N.R.I. Training." James E. Ryan, 1535 Slade St., Fall River, Mass., writes: "I was working in a garage when I enrolled with N.R.I. I am now Radio service manager for the M— Furniture Co. for their four stores."

MANY MAKE \$5 TO \$10 A WEEK EXTRA IN SPARE TIME WHILE LEARNING

The day you enroll, in addition to my regular course, I start sending you Extra Money Job Sheets which start showing you how to do actual Radio repair jobs. Throughout your Course I send plans and directions which have helped many make \$200 to \$500 a year in spare time while learning. I send special Radio equipment; show you how to conduct experiments, build circuits. This 50-50 training method makes learning at home interesting, fascinating, practical. I devote more than 10 Lesson Tests exclusively to Television, and Television fundamentals thoroughly in my Course.

I ALSO GIVE YOU THIS PROFESSIONAL SERVICING INSTRUMENT

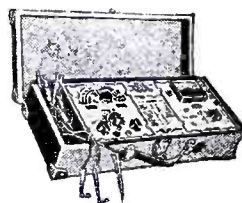

Here is the type of instrument Radio Technicians use—an All-Wave Set Servicing Instrument. It contains everything necessary to measure A.C. and D.C. voltages and current; to check resistances; adjust and align any set, old or new. It satisfies your needs for professional servicing after you graduate—can help you make extra money

fixing sets while learning.

GET SAMPLE LESSON AND 64-PAGE BOOK FREE—MAIL COUPON

Act today. Mail coupon now for Sample Lesson and 64-page Book. They're FREE. They point out Radio's spare time and full time opportunities and those coming in Television; tell about my course in Radio and Television; show many letters from men I trained, telling what they are doing and earning. Read my money back agreement. Find out what Radio offers you. Mail coupon in envelope or paste on penny postcard—NOW!

**J. E. SMITH, President
Dept. OEX, National Radio Institute
Washington, D. C.**

SAMPLE LESSON FREE

I want to prove that my Training gives practical, money-making information, is easy to understand—is what you need to master Radio. My sample lesson text, "Radio Receiver Troubles—Their Cause and Remedy" covers a long list of Radio receiver troubles in A.C., D.C., battery, universal, auto. T. R. F., superheterodyne, all-wave, and other types of sets. And a cross reference system gives you the probable cause and a quick way to locate and remedy these set troubles. A special section is devoted to receiver checkup, alignment, balancing, neutralizing and testing. Get this lesson FREE. No obligation. Just mail coupon.

GOOD FOR BOTH 64 PAGE BOOK FREE SAMPLE LESSON FREE

**J. E. SMITH, President
National Radio Institute Dept. OEX,
Washington, D. C.**

Dear Mr. Smith: Mail me FREE, without obligation, your Sample Lesson and 64-page book "Rich Rewards in Radio" which tells about Radio's spare time and full-time opportunities and explains your 50-50 method of training men at home to be Radio Technicians. No salesman will call. (Please write or print plainly.)

(Please Check)

I AM doing Radio work. I am NOT doing Radio work.

Name Age

Address

City State 14X1



RADIO-CRAFT

HUGO GERNSBACK, *Editor-in-Chief*

N. H. LESSEM
Associate Editor

THOS. D. PENTZ
Art Director

ROBERT EICHBERG
Trade Digest Editor

R. D. WASHBURNE, *Managing Editor*

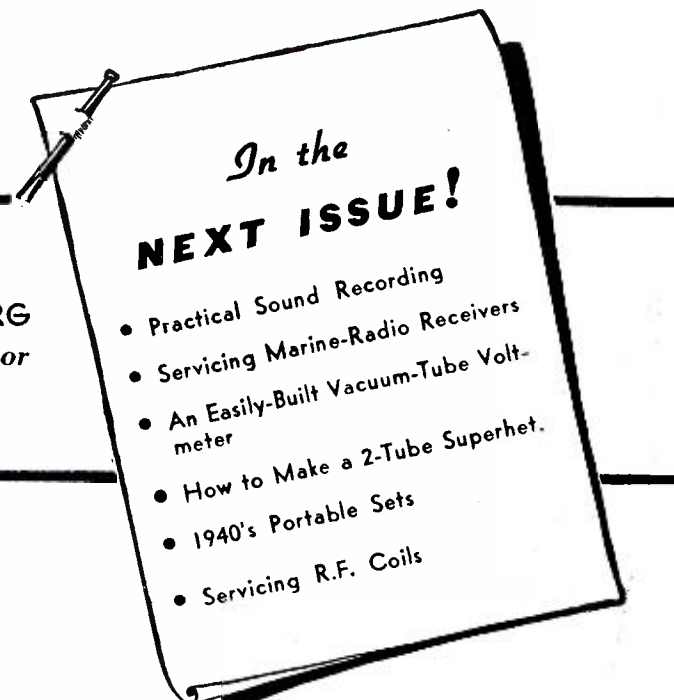

Contents MAY, 1940 Issue

VOLUME XI -- NUMBER 11

Mailbag	643
Editorial: A Serious Radio Menace..... Hugo Gernsback	645
The Radio Month in Review.....	646

SERVICING

Combating Radio Interference..... L. Blok	649
Adapters Are Good Money-Makers..... H. T. Ziegler	654
New Circuits in Modern Radio Receivers—No. 32 F. L. Sprayberry	656
Return Those Replaced Parts to Set-Owners!.....	657
Service Questions & Answers.....	658
Servicing "Orphans" and Private-Brand Sets— Part III (Conclusion)..... Charles R. Leutz	659
Frequency Conversion in Superheterodynes..... C. W. Palmer	679
RADIO SERVICE DATA SHEETS:	
No. 276—G.E. Model HB-412 "Carryabout".....	661
No. 277—RCA Victor Model M-60 Auto Radio (Chassis No. RC357K).....	663
Mathews Radio Service.....	662

SOUND

Profits in Recording..... Sam M. Harper	664
Sound Engineering—No. 5..... Conducted by A. C. Shaney	668
How One Sound Man Drums-Up Business..... W. L. Fuller, Jr.	670
Designing a 60-W. Direct-Coupled Beam-Power Amplifier..... A. C. Shaney	671
Case Histories of P.A. Sales—No. 8.....	674
The Latest Miniature Hearing-Aid Amplifier H. S. Manney and A. C. Hewitson, M.D., Ph.D.	676
Public Address Unit Builds Trade.....	678
4 Thumb-Size Pentodes for Hearing-Aids..... R. D. Washburne	682
Articles on Sound in Past Issues.....	687

ELECTRONICS

Frequency Conversion in Superheterodynes..... C. W. Palmer	679
4 Thumb-Size Pentodes for Hearing-Aids..... R. D. Washburne	682

ENGINEERING

Combating Radio Interference..... L. Blok	649
Frequency Conversion in Superheterodynes..... C. W. Palmer	679

EXPERIMENTERS

Adapters Are Good Money-Makers..... H. T. Ziegler	654
The "Baseball Special"—A 1-Tube Broadcast Receiver L. F. Rogers	684

RADIO DEVELOPMENTS

Pick-a-Back Radio Set.....	675
Radio-Sound Studio in College.....	686

CONSTRUCTION ARTICLES

Designing a 60-W. Direct-Coupled Beam-Power Amplifier..... A. C. Shaney	671
Case Histories of P.A. Sales—No. 8 (Construction of an Infinite Baffle and a P.A. Housing).....	674
The Latest Miniature Hearing-Aid Amplifier H. S. Manney and A. C. Hewitson, M.D., Ph.D.	676
The "Baseball Special"—A 1-Tube Broadcast Receiver L. F. Rogers	684

DEPARTMENTS

Mailbag	643
The Radio Month in Review.....	646
New Circuits in Modern Radio Receivers—No. 32 F. L. Sprayberry	656
Service Questions & Answers.....	658
RADIO SERVICE DATA SHEETS (See Servicing).....	661, 663
Sound Engineering—No. 5..... Conducted by A. C. Shaney	668
Case Histories of P.A. Sales—No. 8.....	674
Latest Radio Apparatus.....	688
Radio Trade Digest.....	695
Shop Notes—Kinks—Circuits.....	655, 699
Book Reviews.....	681, 702-4



STREAMLINED!

This is the second *streamlined* issue of *Radio-Craft*. How do you like it? The contents, scope of articles, monthly departments and features remain the same—but the manner in which these are laid out, the sequence in which they are presented, and the method of their continuity, have been so altered as to make the magazine easier and more convenient to read. All articles have been departmentalized. The practice of continuing a story from the front of the book to the rear has been entirely eliminated. Continuity of articles has been made smooth and uninterrupted.

Our thanks to those of our readers who have taken the time and bother to suggest various changes in *Radio-Craft's* physical make-up.



Published by Radcraft Publications, Inc. Publication office: 29 Worthington Street, Springfield, Mass. Editorial and Advertising Offices: 99 Hudson Street, New York City. Chicago Advertising Office: RADIO-CRAFT, 520 North Michigan Avenue, Chicago, Ill.

RADIO-CRAFT is published monthly, on the first of the month preceding that of date; subscription price is \$2.00 per year in U. S. and Canada. (In foreign countries, \$2.50 a year to cover additional postage.) Entered at the post office at Springfield as second-class matter under the act of March 3, 1879.



Foreign Agents:

London—Gorrings's American News Agency, 9A Green St., Leicester Square, W. C. 2, England.
Paris—Messageries Dawson, 4 Rue Faubourg, Poissonniere, France.
Melbourne—McGill's Agency, 179 Elizabeth St., Australia.
Dunedin—James Johnston, Ltd., New Zealand.



Text and illustrations of this magazine are copyright and must not be reproduced without permission of the copyright owners.



Copyright 1940 Radcraft Publications, Inc.

HARMONIC CONVERSION

Dear Editor:

I read with interest your article on "Harmonic Conversion" in the December, 1939, issue of *Radio-Craft*. As you no doubt realize, such a system seems to refute the accepted theory on harmonics. To give an example, using the sideband theory:

If we assume a fundamental frequency of 150 kc. and 1,000-cycle modulation, the frequencies transmitted will be 149, 150, and 151 kc. The 3rd-harmonic of these frequencies will be 447, 450, 453 kc. It will be seen that the 1,000-cycle modulation has also been multiplied by 3 and becomes 3,000 cycles. The same condition holds for the single-frequency theory of modulation, although it is more difficult to show.

Whether this is actually the case or not can easily be proved by modulating an R.F. signal with a single frequency and feeding it into the receiver, and then connecting the modulating signal to one set of plates of your oscilloscope, and the output of the receiver to the other set. The frequency relationship of the input and the output can then be determined by means of Lissajou's Figures. It would be interesting to note how much, if any, 3rd-harmonic is present, should the frequency prove to be the same. The theory on harmonics makes it almost impossible to believe that no 3rd-harmonics of the modulation on the fundamental are present; also that it is possible to cut off the modulation above 5 kc. in the fundamental amplifier, and still have an overall characteristic for the whole receiver which is flat to 15 kc. I would therefore appreciate hearing the results of the experiments which I have suggested, together with any mathematical theory which you may have formulated.

CHARLES CROSS,
Philadelphia, Pa.

Mr. Redcay answered as follows:

Dear Mr. Cross:

According to tests made on my oscilloscope some time ago on my harmonic conversion receiver, the phase relation between the input and output of the receiver are exactly the same. In other words the modulation envelope at the harmonic conversion tube output is directly proportional to the fundamental frequency.

The theory according to your letter should indicate that the modulation on the harmonic frequency, would be 3 times the modulation on the fundamental frequency. This is not so, because, the tuned circuits in the receiver are brought to resonance to the signal frequency and not the audio or modulation frequency.

According to the curves plotted in the Dec. issue of *Radio-Craft* the audio frequency in the tuner is not flat to 15,000 c.p.s. in the sharp position as you state in your letter, but rather, to 5,000 c.p.s. with a slight drop to 10,000 c.p.s. Due to the self-phasing characteristics of the tuner the higher frequencies are enriched.

P. WILSON REDCAY,
Sinking Spring, Pa.

THE "IRON-CORE 6" T.R.F. SET

Dear Editor:

The "Iron-Core 6" Broadcast Set described in October, 1939, *Radio-Craft* interested me very much for several reasons. Generally speaking, the possibilities of tuned-radio-frequency receivers are not fully appreciated by radio experimenters, not just for broadcast reception but also for a wide range of the higher frequencies.

Today, without at least 1 stage of straight T.R.F. amplification, the best superheterodyne circuit is useless for the broadcast

band. Any superheterodyne's performance is limited by the performance of the R.F. stage or stages. In that case, why bother with a superheterodyne circuit at all; why not simply add additional R.F. amplification and associated tuned circuits to secure the degree of selectivity, sensitivity and fidelity desired? *It can be done*, especially for the broadcast bands, very conveniently. As far as musical value is concerned, the T.R.F. set has something that is not found in superheterodyne.

Costly pianos and other musical instruments are not sold to real musicians on a basis of a performance chart. In any radio receiver, the real "musical value" can be more than that claimed or alleged by performance curves. In T.R.F. circuits it is possible to obtain this desirable "musical value" to an extent not generally appreciated.

Years ago, with nothing but sharp cut-off tubes available, it was quite a trick to produce a satisfactory T.R.F. set. The introduction of the type-58 tube around 1933, a tube with a remote cut-off, helped matters greatly. Even with the type -58 tube it was necessary to provide tuning for the antenna circuit and variable coupling between the antenna circuit and grid circuit of the 1st R.F. tube to prevent unreasonable cross-modulation. Hundreds of different transformer designs were tried in order to obtain a reasonable gain and degree of selectivity.

The "iron-core" R.F. transformers manufactured by Meissner, used with 6K7's or similar tubes, provide the basis for experimental T.R.F. sets with unlimited possibilities. The "Iron-Core 6" is designed for a reasonably compact space, but if the DX fan is willing to spread out a bit the sensitivity can be increased tremendously by building each R.F. stage in a separate shielding container. In case that sounds too complicated, added amplification to the above circuit can be obtained by adding de-couplers to the 6K7 screen-grids and R.F. plate-return circuits; also fitting the cathodes for a supplementary manual adjustment. A sketch is attached (see below—*Ed.*) showing these

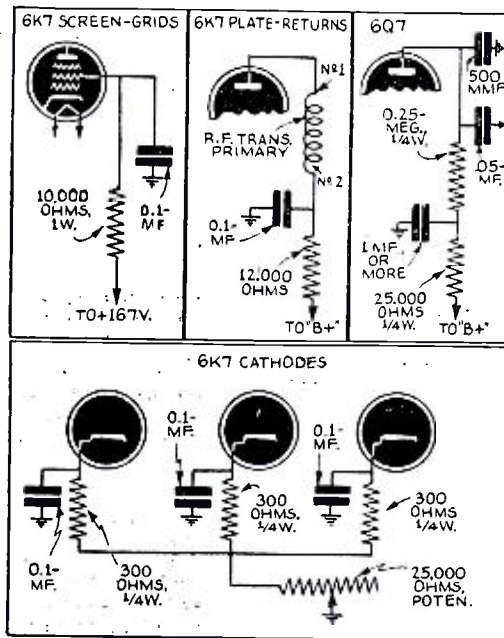

changes together with values, also including a de-coupler for the 1st audio stage.

CHARLES R. LEUTZ,
Glendale, L. I., N. Y.

WORLDLY IDEA!

Dear Editor:

I have an idea which will, I believe, boost your circulation, and also give your newsstand readers a break.

You could publish a coupon in each issue of the magazine, for a period of time, say 12 months. The premium, a really good-size

I'll Help YOU SMASH YOUR WAY To Bigger Income in RADIO AND TELEVISION

I Train You Quickly in Your Spare Hours . . . Right at Home

You Do Practical Experiments with Real Equipment

I offer you a new and altogether different type of practical training for a money-making career in Radio and Television. I teach you in a simplified, logical, understandable style . . . all about Television, Electronics, Facsimile Radio, Radio Set Repair and Installation. I GIVE YOU PERSONAL COACHING ALL THE WAY.

TRAINING PREPARES YOU FOR GOOD RADIO JOBS . . . at Excellent Pay

No matter if you desire to be YOUR OWN BOSS in your own business or hold down a good job in Radio, my training will give you the useful information and knowledge to win success. DON'T JUST WISH FOR MORE MONEY—START TRAINING FOR IT RIGHT NOW!

Read What This Student Says:

EARNED \$250 SINCE STARTING COURSE
"I have only completed one-third of the Sprayberry Course and I find it very interesting, which makes it easy to learn."
"By devoting several hours of my spare time daily to studying and servicing, I have made about \$250 gross since starting the Course." Earl W. Hostetter, R. No. 4, Lebanon, Pa.

YOU GET PROFESSIONAL TEST EQUIPMENT PLUS EXPERIMENTAL OUTFITS

Includes 146 RADIO PARTS for building a complete 5-tube Radio Receiver. **RADIO TOOLS:** ALL-WAVE, ALL-PURPOSE ANALYZER. Besides its invaluable use in experimental work, my Equipment will enable you to make spare-time profits while you're learning and can serve you in your own Service business later on. I give you DATA SHEETS on how to build popular Radio circuits. Also you receive BUSINESS BUILDERS which show you how to get and do spare-time, neighborhood Radio Service work.

NO PREVIOUS EXPERIENCE NEEDED

My Training starts right at the beginning of Radio and covers all essential subjects. It makes no difference what your education has been. I can fit you for an excellent paying job in Radio. Your success is my full responsibility. I know how to get Radio across so that you can understand it and remember it.

SERVICEMEN

I offer Advanced Training for those already in Radio. Get complete details in my FREE 52-page Book.

REMEMBER—THE SPRAYBERRY COURSE IS SOLD UNDER A MONEY-BACK AGREEMENT

RUSH THIS COUPON FREE for BIG FREE BOOK

DON'T DELAY! ACT NOW!

SPRAYBERRY ACADEMY OF RADIO
F. L. Sprayberry, Pres.
320-E University Place, N. W., Washington, D. C.
Please send me FREE copy of "HOW TO MAKE MONEY IN RADIO."

Name Age

Address

City State

Tear off this coupon, mail in envelope or paste on penny postcard. Servicemen—Check here

RADIO plus TELEVISION

-mastered by pre-tested Training

No matter where you are or what you do, National has a complete training plan for you—to fit your circumstances. National's plan is for those seeking immediate shop-training as well as for those who cannot give up present employment and income. Mail coupon for FREE literature.

NATIONAL SCHOOLS

NATIONAL SCHOOLS, Dept. RC-5
4600 So. Figueroa St., Los Angeles, Calif.

Please send free Literature and full details

NAME _____ AGE _____

ADDRESS _____

CITY _____ STATE _____



RADIO TECHNOLOGY



RCA Institutes offer an intensive course of high standard embracing all phases of Radio and Television. Practical training with modern equipment at New York and Chicago schools. Also specialized courses and Home Study Courses under "No obligation" plan. Catalog Dept. RC-40.

RCA INSTITUTES, Inc.

A Radio Corporation of America Service
75 Varick St., New York, 1154 Merchandise Mart., Chicago

Are You The Man For The Job?

ARE YOU prepared to take advantage of the opportunities that the new TELEVISION industry is creating? Train yourself now, for a better job, while you have an equal chance. Write for FREE ILLUSTRATED BOOKLET, "A Tested Plan for a Future in Radio & Television." CAPITOL RADIO ENGINEERING INSTITUTE, Dept. RC-5, 3224-16th St., N.W., Washington, D. C.

LE'S Correspondence Courses in RADIO and ELECTRICAL ENGINEERING

ELECTRICAL ENGINEERING Get good grasp of wide electrical field. Prepare yourself, at Low Cost, for secure future. Modern, simplified, you can understand quickly.
RADIO ENGINEERING Extra fine course in radio, publishes address, photo-electric work. Trains you to be super-service man, real vacuum tube technician. Exper. kits furnished. Diploma on completion. Tuition, \$25. either course. Deferred payment plan. Get copies of school catalogs, student magazines, complete details. SEND NOW!

FREE
LINCOLN ENGINEERING SCHOOL, Box 931-C17. LINCOLN, NEBR.

RADIO MATHEMATICS

Practical Book for Home Study

Complete training in useful radio mathematics. Explains and interconnects simplified arithmetic and algebra with real everyday radio problems. Covers in detail every phase of radio work. Size: 8 1/2" x 11". Special price, only 50c, postfree.

SUPREME PUBLICATIONS 3729 W. 13th St. Chicago, Ill.



SWINGS INTO ACTION

Primarily the aim of the Association is to return to the Distributor, the Dealer and the Serviceman the profits which are legitimately HIS! This can only be accomplished by raising the standards of ethics of merchandising within the Industry.

Names of Member Jobbers in your territory will be supplied if you will address the Executive Secretary of the Association.

Office of the Executive Secretary
5 West 86th Street New York, N. Y.

map of the North American continent, might be about 4 x 6 ft. Outline on it the various radio divisions, according to the Amateur Operators' Call Letters; and any other data that will be of interest to Shortwave DX-ers.

Or you might use a map of the entire World; and measuring about 10 x 12 ft.

A good, large-size map would I believe be very useful to everyone interested in radio. Maps of this type are rather expensive and hard to get, for so has been my experience.

You might print this letter in your next issue, and find out what your other readers think of the idea.

I have read your magazine for over a year now and have enjoyed every issue. I have kept each one and have quite a library now.

WM. M. BARBER,
Prince Albert,
Sask., Canada.

RE XMITTER ARTICLES— ... YES!

Dear Editor:

I was reading over with interest the Mailbag in the Feb. 1940 issue of *Radio-Craft*, of the pro and cons for wanting XMT'R articles in *Radio-Craft*.

Being a Serviceman for the past 12 years, I still look forward to your magazine and would enjoy seeing an xm't'r article occasionally.

I like very much your new department, edited by Mr. A. C. Shaney, on Sound Engineering. How about more dope on "electric eye" equipment, motion picture equipment, servicing "coin-operated" phonographs?

KENNETH BABB,
Decatur, Ill.

P.S. Can you refer me to a very good, light, compact hearing-aid for a deaf person? My mother is using one at present and claims she always hear two voices. Is this possible? What can be done to eliminate this?

Several commercial types of hearing aids have been described in recent issues of *Radio-Craft*; so, too, have been circuits for constructors. One of the more modern circuits is shown elsewhere in this issue, in the *Sound Engineering* department. An otologist probably is qualified to advise regarding the particular hearing affliction you mention; and, incidentally, is in best position to prescribe proper characteristics for a hearing aid.—Editor.

... NO!

Very soon I shall finish a course with National Radio Institute, Washington, D. C., and will be opening a repair shop of my own. Now, at present I live in a small town, and have been wondering if it would pay me to open my shop here.

Well, today I received my February issue of *Radio-Craft* and upon flipping the pages came to the article, "My Small-Town Service Shop" by Roy Powell. It was the answer to my prayer. It has given me courage and confidence to go ahead and open my own shop in my small town with a limited capital against an already established competitor. Thanks to Mr. Powell and your magazine!

Now being a comparatively new subscriber to *Radio-Craft* (this my 2nd issue) I have found that it answers my every need for a magazine that helps the radio Serviceman. But, upon turning to the Mailbag page and reading the "—Yes" letters—I begin to boil. And the madder I get the more determined I am to write to you and back up A. K. Gibson's letter under the "—No" and voice my opinion in saying that I hope that *Radio-Craft* will continue to cater to the

OPPORTUNITY AD-LETS

Advertisements in this section cost 15 cents a word for each insertion. Name, address and initials must be included at the above rate. Cash should accompany all classified advertisements unless placed by an accredited advertising agency. No advertisement for less than ten words accepted. Ten percent discount for six issues, twenty percent for twelve issues. Objectionable or misleading advertisements not accepted. Advertisements for June, 1940, issue must reach us not later than April 6th.

Radio-Craft • 99 Hudson St. • New York, N. Y.

AGENTS WANTED

300% PROFIT SELLING GOLD LEAF LETTERS FOR store windows; Free samples. Metallic Company, 451 North Clark, Chicago.

BOOKS AND MAGAZINES

ASSURE YOURSELF OF GREATER PROFITS BY doing radio service jobs more quickly. Authentic service guides show you the way to locate and correct troubles in any radio receiver. Gernsback Official Radio Service Manuals show you how to complete more repair jobs in less time—how to earn more money by faster servicing. Read the advertisement which appears on page 694 of this issue.

WE HAVE A FEW HUNDRED RADIO ENCYCLOPEDIAS, by S. Gernsback, second edition, originally sold at \$3.98. Book has 352 pages, weight 3 lbs., size 9 x 12 inches. Red morocco—keratol flexible binding. Send \$2.49 in stamps, cash or money order and book will be forwarded express collect. Technifax, 1915 So. State Street, Chicago, Illinois.

CAMERAS & SUPPLIES

BULK FILM: 100 FT. 8MM. \$.90; DOUBLE, \$1.60; 16 mm., \$1.20. Titles or pictures. Chemicals, outfits. Big catalogue for stamp. Hollywoodland Studios, South Gate, Calif.

DIATHERMY (SHORT-WAVE THERAPY) MACHINES

DIATHERMY, SHORT-WAVE THERAPY, AND ultra short-wave therapy machines custom-built by radio engineer at considerable saving over commercial machines; 6 meters, 16 meters or any other frequency specified can be furnished. Machines substantially built with high patient-safety factor. 250-300 watts output. Neat professional appearance. Automatic safety time switches. All necessary pads and electrodes. For sale only to physicians, hospitals and sanitariums. Prices from \$195.00 to \$300.00. Not for sale to the general public. Write for further information giving your own specifications and requirements. Allan Stuart, 1015 Wilson Ave., Teaneck, N. J.

EDUCATIONAL COURSES

USED CORRESPONDENCE COURSES AND EDUCATIONAL books bought, sold, rented, exchanged, catalog free. V. W. Vernon, Henagar, Alabama.

CORRESPONDENCE COURSES AND EDUCATIONAL books, slightly used. Sold, Rented, Exchanged. All subjects. Satisfaction guaranteed. Cash paid for used courses. Complete details and bargain catalog FREE. Send name. Nelson Company, E-242 Manhattan Building, Chicago.

PHONOGRAPH RECORDS

PHONOGRAPH RECORDS—TWELVE \$1.00. Paramount, E-358 East Market, Wilkes-Barre, Penna.

RADIO

WE BUY AND SELL USED RADIO TESTING EQUIPMENT. Time payments if desired. Harold Davis, Inc., Jackson, Miss.

ANY RADIO DIAGRAM, 25c. SPECIFY MANUFACTURER, model. Radio magazine free. Supreme Publications, 3727 West 13th, Chicago.

WANTED—RADIO SETS IN GOOD CONDITION DATING prior to 1922. Also parts in use prior to 1918; state wants. It. Bernard, 40 Manning Ave., N. Plainfield, N. J.

ATTENTION DEALERS: SELL ARCTURUS RADIO Tubes, good discounts. Write Anchor Distributing, Dryden Road, Ithaca, New York.

HARD-TO-GET RADIO DIAGRAMS. Try usual sources first. If you can't get them, try us. Price, 75c per diagram if you succeed; no charge if we don't. You lose nothing! Send no money—write first giving fullest information. Enclose return-addressed, stamped envelope. We have helped many Servicemen, experimenters and radio fans. We can help you. Allan Stuart, 1015 Wilson Ave., Teaneck, N. J.

STAMPS

THREE SCARCE SETS, NOW OBSOLETE, 25c, WITH new customer, gift: Box 211, Malden, Mass.

TECHNICAL ART SERVICE

DESIGN AND ART SERVICE FOR INDUSTRIAL Marketers. We solve your problems on: product and package design, industrial illustrations, technical drawings and diagrams, phantom, cutaway and explanatory drawings, layouts, lettering, photo retouching, displays, industrial cartoons, etc. Wash photos made from blueprints. We excel in airbrush and color work. Complete catalogs illustrated. 100% satisfaction guaranteed. Suggestions and estimates gladly furnished. Rapid delivery on mail orders. Tec-Art Drafting Service, 228 Charlotte Terrace, Roselle Park, N. J.

• MAILBAG •

Serviceman. We do need a magazine like *Radio-Craft*. Why don't you suggest to these "Yes" guys that they read "Radio & Television"?

And boy!, did I like your "Useful Kinks and Circuits!" In fact I like everything about *Radio-Craft*—as is.

ROGER W. MORSE,
Box 141,
Groveland, Fla.

... YES

Dear Editor:

In response to your recent request for information on types of articles the reader likes, I would like to go on record as wanting more small 2- and 3-tube receiver and transmitter construction articles. I would also like to see a short-wave broadcast station list appear in one of your issues in the near future.

GEORGE TAYLOR,
Poulsbo, Wash.

Station lists such as mentioned above appear regularly in *Radio & Television* (Incorporating *Foto-Craft*) magazine.—Editor

... NO!

Dear Editor:

I have been a regular reader of *Radio-Craft* for some years and have received much benefit from it in radio servicing. Your Radio Service Data Sheets have been a boon to me many times. To my knowledge, *Radio-Craft* is the only magazine filling the needs of the radio Serviceman.

I most strongly disapprove of Mr. E. G. and Mr. Diehl, Jr.'s, idea to turn *Radio-Craft* into an amateur's magazine. There are plenty of magazines dealing wholly in amateur and short-wave articles, so why ruin a good service magazine?

I join with Mr. Gibson in hoping that *Radio-Craft* will continue to cater to the Serviceman.

A. W. MILLION,
Española,
New Mexico.

... NO!

Dear Editor:

In regards to those transmitter articles, it would seem that many have spoken without thinking. There is really no necessity for argument on the subject. The publishers very thoughtfully provided a companion magazine to *Radio-Craft*, entitled variously *Short Wave Craft*, *Short Wave & Television*, *Radio, Television and Foto-Craft*, in which shortwave equipment designers may design to their heart's content!

Being by profession a Serviceman, and by nature an experimenter, *Radio-Craft* appeals to me as it is. For the same reason, I would be the last to suggest that *Short Wave Craft*, etc., get "up-to-date" and print special constructional articles on broadcast set testing equipment.

I don't believe *Radio-Craft* should encourage discussion on subjects or apparatus which is relatively foreign to this magazine. Thanks for the regular diet.

THOMAS C. RUMNEY,
Toronto 3, Ontario,
Canada

News Item:

A television "network" from New York City to the General Electric transmitter at Schenectady, New York, is expected to become an actuality this Fall, with the completion of relay stations on this route, according to *Motion Picture Herald* last month.

Now you can enjoy radio!

with the New Meissner

FREQUENCY MODULATION RECEPTOR

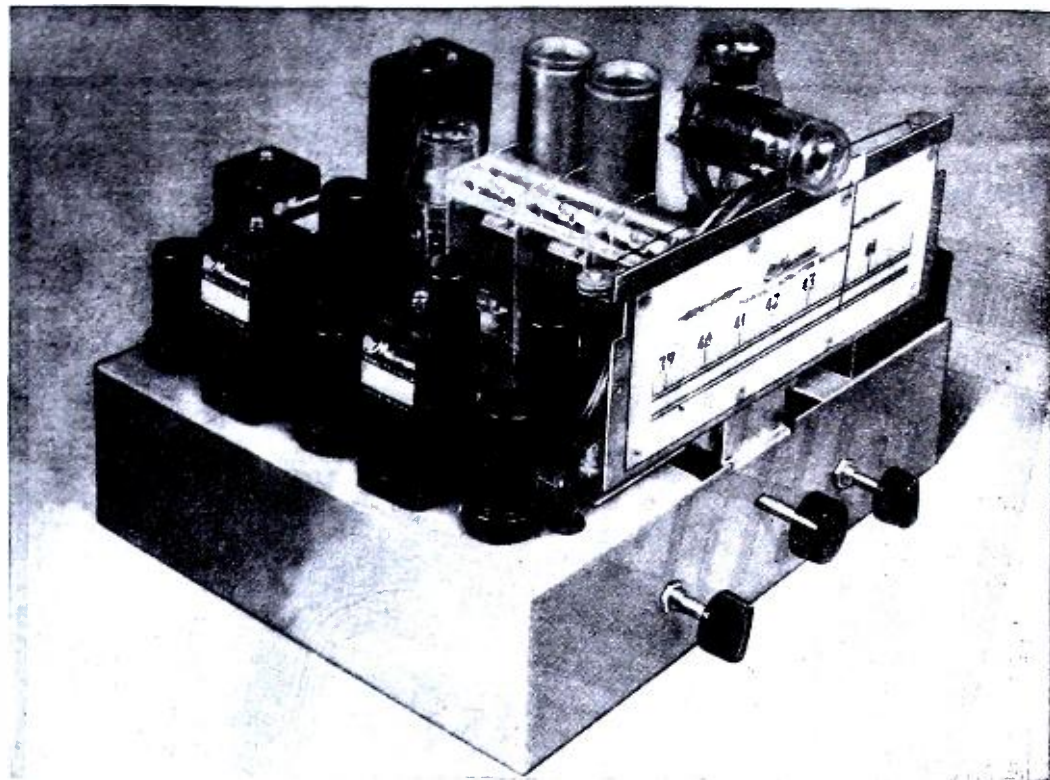

Biggest Achievement of the Decade!

The most outstanding development since the beginning of radio—staticless, interference-free reception is now a practical reality. Frequency Modulation has eliminated the biggest obstacle to real quality reception and now provides the only system capable of true High-Fidelity reproduction. Dozens of F-M stations are now operating—many more are under construction.

—And again Meissner is first with this ten-tube Receptor for Frequency Modulation! Use it as a "Tuner" with your present radio set or with any good external audio amplifier to begin immediately enjoying this amazing new method of reproduction! The Receptor is complete, except tubes, factory-wired and aligned—ready to operate. Just hook up the antenna, connect its output to the audio system and you're ready to go. Frequency range is 39 to 44 megacycles—vernier type dial with $7\frac{1}{4}$ " linear scale for easy, accurate tuning. Only two other controls—volume and tone. Fully self-powered with positive voltage regulation for maximum stability. Operates on 110-volts, 60 cycles.

The F-M Receptor chassis provides space and punchings for two additional tubes so that a high-fidelity audio system may be built right into the unit if desired, thus making it a complete twelve-tube receiver. Complete instructions and diagrams are furnished with each Receptor for the addition of the built-in audio system—a simple half-hour job for anyone. In order to complete the picture, Meissner has made available a specially designed, two-toned walnut console cabinet with large bass-reflex tone chamber,—a truly beautiful piece of furniture to house the complete F-M receiver.

See this remarkable unit at your Jobber's today or write at once for further details!

INSTRUCTION MANUAL

Get your copy of this big NEW 168-page book, "How to Build Radio Receivers". Contains added material on Frequency Modulation theory and design principles as well as complete instructions on the Receptor. See your Jobber or send 50c at once to the address below. Order it today!

COMPLETE CATALOG FREE

Meissner's entire line of receiver components and complete kits is described and illustrated in this big 48-page catalog. Over 600 items of vital interest to the serviceman and experimenter. Write for your free copy today. A postal card will do!

ADDRESS DEPT. C-5

 **Meissner** MT. CARMEL ILLINOIS
"A FAMOUS NAME FOR TWO DECADES"

Order your copy NOW—the only
P. A. HANDBOOK

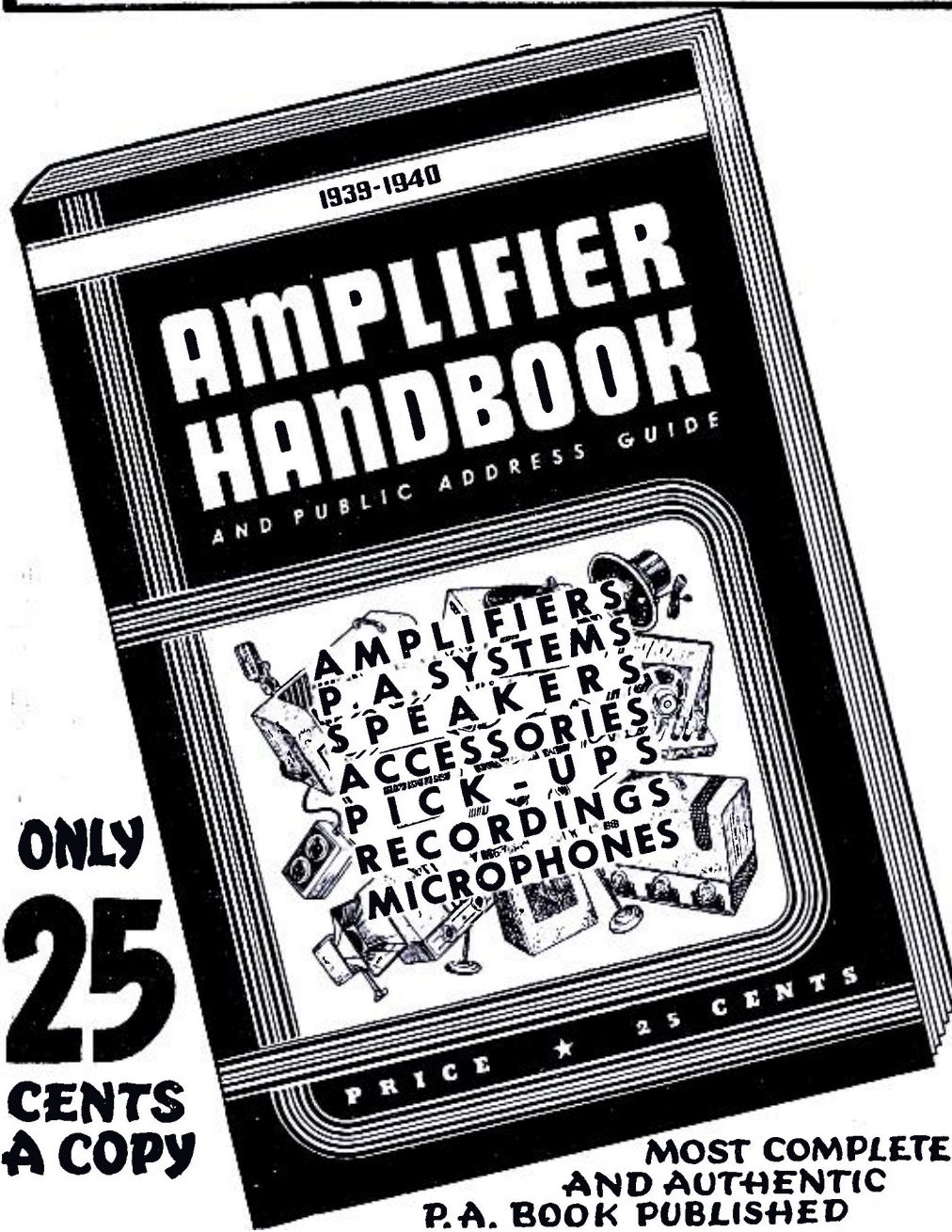

ONLY
25
 CENTS
 A COPY

**A Resume of the Contents of the
 AMPLIFIER HANDBOOK
 AND PUBLIC ADDRESS GUIDE**

PREFACE

INTRODUCTION

CHAPTER I—FUNDAMENTALS

Vacuum Tube as Amplifier—Ratings—Bels and Decibels—Harmonics—Distortion—Attenuation—Gain—Ohm's Law—Bridge Circuits—Rectification—Microphonics—Condensers—Resistors—Impedance—Phase—Resonance—Inductance—Frequency—Magnetism—Shielding.

CHAPTER II—VACUUM TUBES

Voltage Amplifiers—Power Amplifiers—Control and Indicator Tubes—Rectifiers—Ballast and Regulator.

CHAPTER III—CIRCUIT ANALYSIS

Inputs—Coupling—Degeneration (Inverse Feedback)—Frequency Compensation—Outputs—Push-Pull—Phase Inversion—Class A, A. B, B. A, etc.—Hum-Bucking—Automatic Gain Control—Spectrum Control—Time Delay—Tone Compensation—Voltage Dividers—Swinging Chokes—Beam Power—Push-Pull.

CHAPTER IV—MICROPHONES

Carbon—Condenser—Electrodynamical—Ribbon (Velocity)—Crystal—Lapel—Uni-directional (cardioid)—Electromagnetic—Transducers.

CHAPTER V—AMPLIFIERS AND PREAMPLIFIERS

A. C.—D. C.—A. C.—D. C. (120 V.)—A. C.—D. C. (6 V. D. C. - 120 V. A. C.)—Mobile—Portable—Multi-Channel—Biphonic—Preamplifiers—Monitors.

CHAPTER VI—LOUDSPEAKERS

Magnetic—Dynamic—P. M. Dynamic—Crystal—Horn Units.

CHAPTER VII—HORNS AND BAFFLES

Flat—Infinite—Octave Resonance—Exponential—Flares—Labyrinths—Perodynamic—Biphonic.

CHAPTER VIII—AMPLIFIER COMPONENTS

Resistors—Condensers—Transformers—Chokes—Fuses—Sockets—Chassis and Housings—Meters—Name Plates and Bezels—Terminals—Jacks and Plugs—Switches—Frequency Filters—Bias Cells—Tone and Volume (Attenuator) Controls—Pads—L, T, H, etc.

CHAPTER IX—POWER SUPPLIES

Power Lines—Batteries—Converters and Generators—Rectifier Tubes—Dry Rectifiers—Vibrators and Inverters—Bias Supplies—Field Exciters—Ballasts and Regulators.

CHAPTER X—ACCESSORIES

Coin Phonographs—P. A. Tuners.

CHAPTER XI—RECORDING AND PLAYBACK

Pickups—33-1/3 and 78 r.p.m. Turntables—Film, Disc and Wire—Recorders—Lateral and Vertical (hill-and-dale) Recording—High Fidelity Recording and Playback—Accessories.

CHAPTER XII—MATCHING AND MIXING

Input to Amplifier—Amplifier to Line—Line to Speakers—Pads—Attenuators—Matching Amplifiers—Booster Amplifiers.

CHAPTER XIII—ACOUSTICS

Absorption—Reverberation and Echo—Low-Level Distribution—High-Level Distribution.

CHAPTER XIV—SELLING SOUND

Ethics—Who are the prospects?—What are reasonable charges?—Sidelines—Accounting—Advertising and Publicity.

CHAPTER XV—SCHOOL SOUND SYSTEMS

CHAPTER XVI—CALL SYSTEMS

Railroads—Hotels—Restaurants.

CHAPTER XVII—INTERCOMMUNICATORS

Wire Type—Wired—Radio Type—Switchless—Multiple-Station.

CHAPTER XVIII—TALKIES

Soundheads—Amplifiers—Loudspeakers—Sound-on-Film—Sound-on-Disc—Home-Talkies—Commercial-Talkies.

CHAPTER XIX—HEARING AIDS

Tubeless—Tube Type.

CHAPTER XX—MISCELLANEOUS APPLICATIONS

CHAPTER XXI—FORMULAS AND TABLES

CHAPTER XXII—TEST EQUIPMENT

Multi-Meters—C.-R. Oscilloscope—A. F. Oscillators—Output (Level) Indicators—V. T. Voltmeters.

CHAPTER XXIII—INSTALLATION PROCEDURE

Placement of Equipment (Microphones, Amplifiers, Loudspeakers)—Use of Woofers and Tweeters—Wiring—Indoors and Outdoors—Portable and Mobile Set-Ups—Permanent Installations.

CHAPTER XXIV—SERVICING

THAT no book has yet been published which covers amplifiers and sound systems (also kindred systems) in one complete, authentic volume is almost unbelievable. Yet, it is a fact, there is no book in print which covers Public Address from A to Z. To bridge this wide-spread gap, RADIO-CRAFT will publish a complete, magnificent volume on Public Address of such magnitude—so complete and authoritative—that every man engaged in radio can have both a theoretical and practical knowledge of the function and operation of sound systems. The editorial pages are so filled with instruction and replete with illustrations that the volume fully justifies its title—1939-40 AMPLIFIER HANDBOOK AND PUBLIC ADDRESS GUIDE. This great HANDBOOK on Public Address should be read and studied by those who consistently build, service and sell sound equipment.

A MATCHLESS VOLUME

As complete as you would expect to find any engineering handbook—this is how the radio or P. A. man finds the AMPLIFIER HANDBOOK AND PUBLIC ADDRESS GUIDE. With essential technical data compiled from an exceptionally large number of sources, the volume covers nearly two hundred different subjects of Public Address.

THE CONTENTS

To actually show the scope and magnitude of the AMPLIFIER HANDBOOK AND PUBLIC ADDRESS GUIDE, an analysis of the contents is found at the right, showing the breakdown of the material featured within each particular section. A thorough reading of the contents shows the completeness of this book.

RADCRAFT PUBLICATIONS ■ 99 HUDSON STREET ■ NEW YORK, N. Y.

RADCRAFT PUBLICATIONS, INC. ★ 99 HUDSON STREET ★ NEW YORK, N. Y. RC-540
 Gentlemen: Enclosed find my remittance of 25c for which send me POSTPAID, one copy of your NEW—1939-40 AMPLIFIER HANDBOOK AND PUBLIC ADDRESS GUIDE.

Send me others, for friends, also POSTPAID @ 25c each.

Name Address

City State

Remit by check or money order; register letter if you send cash or unused U.S. Postage Stamps.

Order Your Copy NOW—
Clip Coupon and
Mail Today!

RADIO-CRAFT

"RADIO'S GREATEST MAGAZINE"

. . . . a pernicious type
of man-made interference
menaces all forms of radio
reception

A SERIOUS RADIO MENACE

By the Editor — HUGO GERNSBACK

MAN-MADE static is no longer a novel subject because it has been with us ever since the advent of radio. But it seems as soon as we eliminate one source of man-made interference, several new ones crop up in the place of the old ones.

Many sources of interference have been done away with completely, during the past few years, by the cooperation of various bodies with radio broadcasters as well as the radio industry. The Federal Communications Commission; the Radio Manufacturers Association; and in the East, the National Committee for the Prevention of Radio Interference (see editorial, "Man-made Static," October, 1936, issue of *Radio-Craft*), have done a great deal to clear the air of interference.

There is, however, a growing menace which so far has not been eliminated but, quite to the contrary, grows worse every year to the great annoyance of the radio industry, radio listeners and, more recently, to television receiver owners. I refer to *diathermy equipment* used by physicians, hospitals and even by individuals.

Now then, a diathermy machine (fever apparatus) is in reality a miniature broadcasting station. Inasmuch as it works on a wavelength between 6 and 10 meters, it raises havoc with all radio receivers that operate on these frequencies. This is particularly true at present of television receivers. All of these are seriously affected by diathermy machines. These machines not only affect and break up the television image, but also the audio or sound part, and therefore at one stroke ruin both audio and video reception of television. They even lay down a noise barrage capable of interfering with the new wide-band system of frequency modulation (which is the nearest approach we know of today to a static-free radio system).

There is nothing new about all this. Indeed, I went to great pains to give a complete analysis of this in my editorial "New Short-Wave Interference" in the May, 1936, issue of *Short Wave Craft*. Among other things I said:

"But, while these machines are curing one ill, they also give rise to thousands of others, namely, interference in the various radio bands! The machine may operate on one frequency, but as adjustments are made of the electrodes between which the patient is placed, the frequency changes. This is what makes for additional mischief. It can readily be seen why a number of machines of this type can raise untold havoc with radio sets all over the country, because shortwave transmissions of this type do not necessarily cause interference in the locality in which they operate, but can create a most powerful disturbance a thousand, or even 3,000, miles away."

I furthermore said that it was curious that the Federal Communications Commission did not take immediate steps to remedy the situation. I then stated as follows:

"Anyone operating such a machine should be required to operate it inside of an electrical shield, so that no radio waves could penetrate to the outside. This is a rather simple thing to do, and the only point is that it may prove somewhat inconvenient and make for additional expense. The electrical shield to which I refer is simply a room completely screened by means of a metal screen. This would have to include ceiling, flooring as well as doors and windows. This shield would have to be grounded. Then any machine operating in such a room would create no outside disturbance at all, and there

would, therefore, be no more interference from that particular machine. If too costly to build such a shield, it is even possible to have a collapsible portable shield which would inclose the machine and the patient; this would be a cage, measuring about 6 feet on each side and 6 feet high. Again, this cage would have to be grounded so that no waves should pass to the outside. There will, of course, be other solutions which might even be simpler, and which I am sure will be evolved before long."

It seems that the Federal Communications Commission recently stated that it had no power to regulate or control diathermy because such equipment does not come within the Radio Law. It is quite possible that the Commission is right and that legally nothing can be done to stop diathermy machines, as far as the present law is concerned, but there is no reason why the law cannot be amended if the nuisance keeps on growing, as it is bound to do.

Of course, I do not mean by all of this that doctors and particularly hospitals, requiring the use of these machines should stop using them. Nothing could be further from my mind, but as I have pointed out above, there are many ways of eliminating the nuisance if certain precautions are taken and if the necessary laws are passed to give the Federal Communications Commission authority to insist that installations of diathermy machines must be shielded so that no waves can be broadcast outside of the room in which such machines are placed.

Allen B. du Mont, well-known television engineer, recently pointed out that it may be necessary that diathermy equipment must sooner or later be forced to employ *crystal oscillator controls* so as to remain definitely within operating frequency bands. That is an excellent thought, if it can be made workable. The reason for my doubts is that diathermy, in order to be effective, has to use a number of frequencies, some of which might fall within the present video and audio channels. Mr. du Mont further suggests that it may be necessary to operate the more troublesome equipment within shielded cages (which I recommended 4 years ago). But he also makes the very practical suggestion that it is entirely feasible to obtain very thin metal foil which can be applied under wall-paper coverings, which foil, in conjunction with suitable window and door screening, could quite effectively and inexpensively shield such equipment and minimize radiation. I might add that metallic floor covering would have to be added as well, as many diathermy machines are located high up on the upper floors of hospitals, etc. Of course, line filters would have to be used in any case.

But, without an adequate law, it will be impossible to enforce users to shield their equipment. It is therefore up to the Radio Industry to introduce a bill for amendment of the present Radio Act to include diathermy machines, as well as any other instrumentality that may later be invented and which—not necessarily being used for communication purposes—still may raise havoc with radio reception. Incidentally, when such an amendment is drafted, it should be kept sufficiently broad to include ALL forms of man-made static, be they leaky insulators of power lines, electric flashing signs, electric railroads, ignition systems of automobiles and buses, oil burners, motors of all types, vacuum cleaners, hair dryers, etc., including such innocent-appearing appliances as electric heating pads, which frequently in the past have disturbed entire neighborhoods due to their thermostatic contacting devices.

• THE RADIO MONTH IN REVIEW •

The "radio news" paper for busy radio men. An illustrated digest of the important happenings of the month in every branch of the radio field.



ESKIMO FOLK MUSIC AND LORE RECORDED

Father Bernard J. Hubbard (at controls of RCA Victor recorder) records the speech of primitive Eskimos in the Alaskan wilderness on his latest expedition to the Arctic area which is his parish. The famed "Glacier Priest" last month brought back 100 invaluable records of vanishing native music, chants and folklore. The recorder and its portable electric power unit were transported more than 14,000 miles by rail, boat, truck, canoe and pack.

RADIO ABROAD

THE tendrils of Radio have become entangled in the mesh of war in Europe and in the Orient, and hence, war topics constituted most of the radio news from abroad, last month, as we shall now see . . . *Berlin*—German artillery silenced French loudspeakers on the Rhine border "because derogatory remarks about Adolf Hitler were broadcast." Apparently, the Nazis were being hoisted by their own petard, since they were the first to introduce this "old Spanish custom" to the Western Front. . . . *Paris*—The radio magazine, *L'Onde Electrique*—suspended "for the duration." . . . *Finland*—Finns on the Mannerheim line acquired one Russian in fair condition when he left his fellow travelers in response to loudspeaker appeals, by the Finns, on a "We have soup for you" platform. Russian leaders countered by ordering troops into dugouts beyond earshot. . . . *China*—From Chungking comes a report by the engineers of station XGOK that Japanese interference accounted for the interruption of a program being rebroadcast by WEA. It all started when Chang Po-ling, president of Nankai Univ., Tientsin, began to discuss the effect of Jap-American trade relations on the China situation. From Chungking also comes the report that the Chinese Govt. is planning a "radio war" on Japan with a station having world-wide coverage, and from which programs in 16 languages will be aired 24 hours a day.

SOUND

A NUMBER of the news items, last month, of interest to sound men, concerned the use of sound recordings. For example, watch for a big boost in the sale of Novochords (the 163-tube electronic piano described in a past issue of *Radio-Craft*), when the 200 double-faced 16-in. transcriptions, which Hammond Instrument Co. just completed, get into the hands of the broadcast stations to which

they were sent. Stations can skip the portions with sales patter when airing the free music. . . . Loudspeakers at many points throughout our fair land exuded wordage of and about "57 varieties" when 9,000 persons were tied into a nationwide "conference" hookup via telephone in celebration of the 70th anniversary of the H. J. Heinz Co. . . . According to *Variety*, a trick

which is making theatre people lots happier about radio is the success with which the "Pot O' Gold" program has been fed into the theatre sound system so that patrons could thus listen-in via P.A. for their telephone number. A lucky listener would be privileged to use the theatre manager's telephone to call the broadcast station and collect his \$1,000. . . . Newest technique in radio combines the "live" voice of a newspaper reporter, with recordings of actual on-the-scenes sounds (the roar of presses, Chinese sing-song, etc.) made at various institutions in the Archdiocese of New York, in acquiring material which is later worked into a Catholic Charities' "Visiting Mike" series being broadcast over station WMCA on Saturdays. . . . Entire programs running several months now come neatly packaged. Vogue Fine Cut Tobacco of Canada bought a set of 117 transcriptions, of 15-minute episodes, from NBC. . . . Largest single order for recorded programs in the history of the company was shipped by NBC to 666 broadcast stations in the U. S. The Orthacoustic discs, entitled "Uncle Sam Calling," explained the 1940 Census.

SHORT WAVES

FIGURES on the efficacy of police radio head the short-wave news this month. Cleveland credits 2-way radio and a zone patrol system as accounting for a good portion of the drop of 17.23 per cent in major crime in the city during 1939. . . . A British radio amateur called into war service had lost the address of a "pen-pal" he had met via ham radio. Members of the Providence (R. I.) Radio Assoc., cooperating with the American Radio Relay League, located the party, a "YL," in Woonsocket, R. I. Dan Cupid probably patted his telegraph key as Miss Marcelle Vanasse renewed old acquaintances.

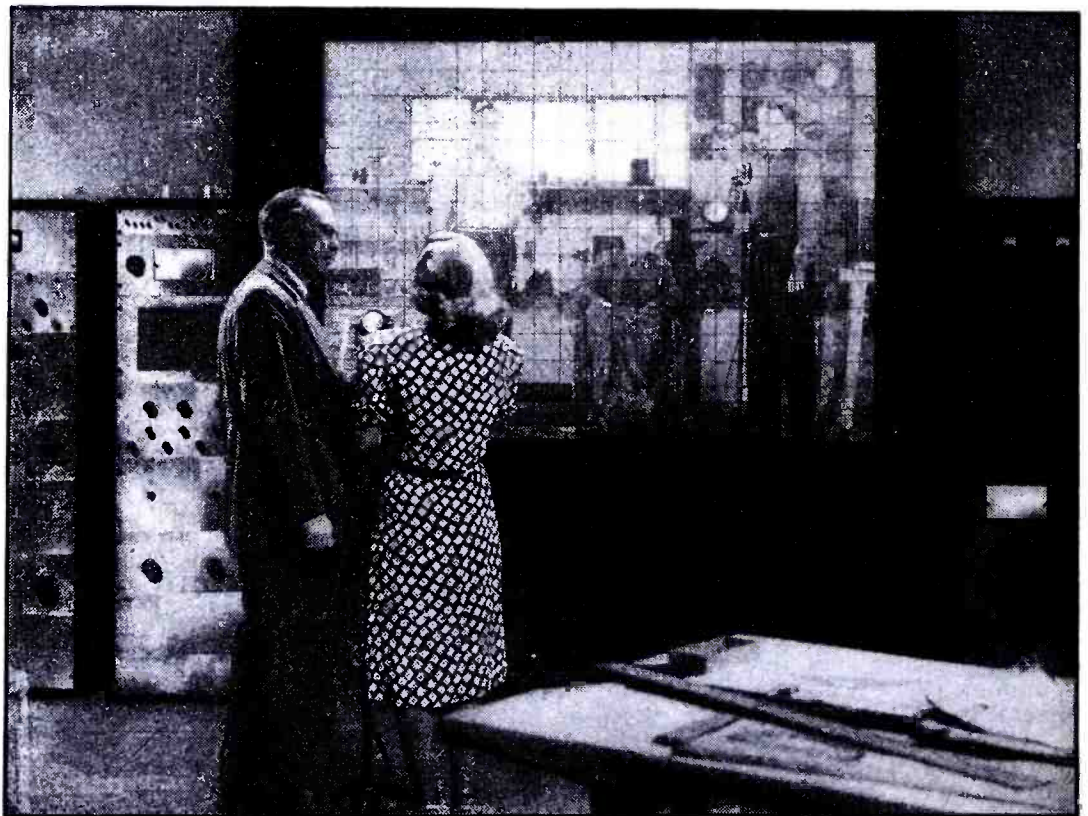

"TELEVISION SPY"

The development of long-range television of theatre screen size is the background of a new Paramount Pictures, Inc., film, and released last month, called "Television Spy." Brilliant young scientist Douglas Cameron (acted by William Henry) convinces his crusty old sponsor, James Llewellyn (William Collier, Sr.), that long-range television is within his grasp. Llewellyn orders him to perfect the instrument with the expectation of offering it to the U. S. Government gratis. Sweet young thing Reni Vonich (Dorothy Tree), foreign spy, steals Cameron's plans from the laboratory and dupes Llewellyn's ex-partner into constructing a television set from the plans, which she intends to sell to the enemies. Begins complications, etc. Maybe we ought to leave it to the Hollywood producers to develop television for us!



MUSIC IN THE AIR

The latest bit of comfort and entertainment to be added to the pleasure of the air traveler is *individual radio reception*—installed last month in all transport planes of Transcontinental and Western Air, Inc. Passengers can now listen to their favorite radio programs as well as to flight comments by the pilots. A (Motorola) master receiver (see diagram, right) in the rear

of the cabin is operated by the hostess and each passenger is provided with a tiny "Hushatone" crystal speaker (see photo, left) which can be held in the palm of the hand or fastened under the head-rest cover. The pilots can switch their mikes (see photo, center) into the plane's radio system at will. Use of the soapcake-size crystal "phone" helped produce a lightweight system.

TELEVISION

EXCEPTIONAL activity was evidenced in television last month with the West Coast contributing a goodly share. The Hollywood Television Artists & Writers Guild got off to a good start when T. C. Sawyer, production director of Thomas Lee's telly station W6XAO told the members that screen writers are better equipped for television than are radio writers, and pointing out that the former are accustomed to visualizing continuous action and preparing brief script. Guild director Geo. H. Seward is also pres. of the Hollywood Television Society, and also recently organized the Television Engineers of America, an educational and social group. . . . Professor Jos. T. Tykociner, working at Illinois University, has found that by bombarding a light-sensitive potassium photocell surface with atomic hydrogen and electrons in a high vacuum, a telly "eye" tube 10 to 50 times more sensitive than preceding types can be made. . . . The production manager of station KDKA, Mr. Chas. Urquhart, conducted a forum discussion of television before a congregation of 700 at Pittsburgh's First Baptist Church following a Sunday evening sermon by Rev. Bernard C. Clausen on "The World's Two Greatest Inventions—Printing Press and Television." Both the discussion and a telly set on display beneath the pulpit created exceptional interest. . . . Sally Rand "debuted" over the Don Lee System telly station W6XAO, but without her fans and bubbles. P.S.—She wore a tailored dress suit.

F.M.

HAPPENINGS in the sphere of Frequency Modulation, last month, included the formation of FM Broadcasters, Inc. One of the first pieces of press material released was a description of the 3 F.M. stations now operating in the metropolitan area, viz.: W2XMN (Major Armstrong's pioneer station), 42.8 mc.; W2XQR (F.M. outlet of WQXR), 43.4 mc.; and W2XOR (F.M. outlet of WOR), 43.4 mc. It was pointed out that the F.C.C. now has applications for 8 more F.M. stations to operate in the New York area. . . . Daily transmission is now

being undertaken by Zenith Radio Corp. to push F.M. programs out over Chicago. Columbia Broadcasting System programs are piped to the F.M. transmitter (connected to an antenna atop a 550 ft. building in the Loop district) over a special high-fidelity transmission line. . . . Station W2XOR is now radiating 1-kw. F.M. programs 18 hours daily. . . . The Feb. 15 issue of *Broadcasting* magazine contains an excellent analysis of the present status of frequency modulation. . . . A special hearing is to be held by the F.C.C. March 18 to determine the advisability of opening up 15 or more new channels. At present there are only 2 main channels assigned for frequency modulation operation. With 48 applications (up to mid-February) already made to the F.C.C. it has been found difficult to find accommodations in the present 2 bands for the many new members of this rapidly-growing family.

BROADCASTING

AMONG the many interesting items concerning Broadcasting which appeared in the press last month was the observation by the Radio Section of *Variety* that although there are over 700 licensed broadcast stations, and the F.C.C. daily turns down requests for construction permits because the areas are already well serviced, there are 113 towns not yet receiving adequate radio program service. Applications made from these areas would probably be given the "go ahead" sign in short order. . . . Montgomery Ward informed *Radio-Craft* last month that the Government of the Island of Jamaica has begun broadcasting once a week, from 5:30 to 6:30 P.M., E.S.T., on Fridays. Transmissions are being made with the cooperation of amateur radio station VP5PZ whose call they are using for these broadcasts. Reports on reception are requested and may be directed to Mr. John F. Grinan, Box 5, Kingston. Operation is on 4.8 mc. . . . A comic strip made the grade as suitable material for broadcast programs. Listen for the disc version of "Superman". . . . The job-securing air program, "Let's Go to Work," reported that radio engineers are included among the 202 persons who have been placed. What more fitting than that radio should be the medium which



ELECTRONIC VIOLIN (Cover Feature)

What appears to be the skeleton of a violin is actually an *electronic* violin. It has no sounding chamber, the vibrations of the strings being picked-up electrically and translated into corresponding electrical currents. The instrument is one of many in the Cracraft Electronic Orchestra which last month played at a Musicians' Fund benefit.

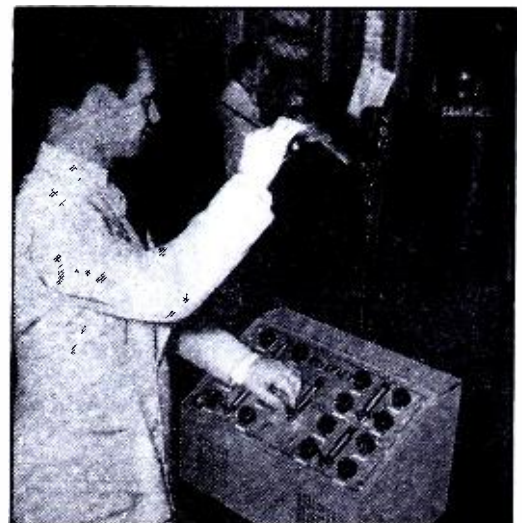

"ELECTRONIC" BAND LEADER

More important than the baton now is the control board of an electronic orchestra. Each electronic instrument in Cracraft's orchestra wires into it.

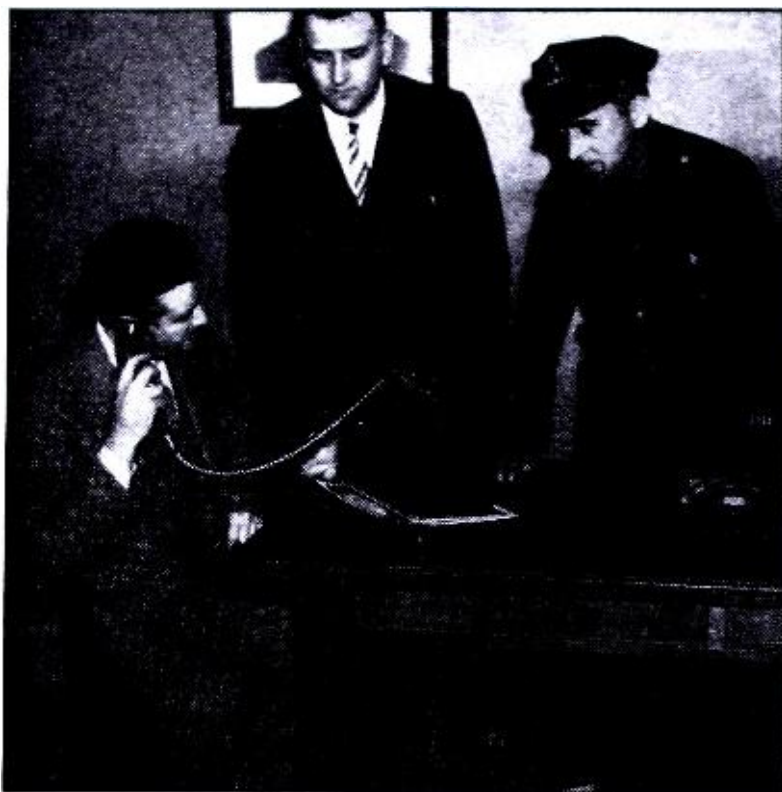

FOR THE RECORD

Police Chief Schepper of Decatur, Ill., in an effort to develop better manners and greater courtesy in the members of his traffic squad, last month introduced the radio "snooper" car. This car with a concealed portable recording device of the dictograph type toured the city, violating traffic regulations and collecting tickets and the conversations of the arresting officers. As shown in the photo on the cover a small mike was concealed above the driver's head with a wire leading to the trunk in which the recording apparatus was hidden. Later the recording was played back on the same machine in Chief Schepper's office—with what results we don't know! In the photo at left we see a playback of the recording shown on the cover.

(Photos—Decatur, Ill., *Herald Review*)

helps re-employ the men who have helped build it. . . . Excitement of listening to an "Americanism" mass meeting program broadcast from Madison Square Garden, N. Y., brought on a fatal heart attack to A. D. Phillips, 88, of Mount Vernon, N. Y. . . . How do you like the one this writer heard John Gambling reel out: "The temperature now is 7 o'clock"?

• • •
The Cracraft Electronic Orchestra which last month performed at Mrs. Astor's Musicians' Fund benefit at the Waldorf-Astoria in New York City, incorporated many changes over the orchestra described in the July, 1939 issue of *Radio-Craft*. In its newest version this electronic orchestra includes the following instruments: Novachord "Electone" piano, 4 electronic violins (see cover photo), 1 electronic cello, 1 electronic bass, electronic steel guitar, electronic Spanish guitar, electronic tympani unit, plus the addition of saxophones, clarinets, oboe, English horn, trombone and 2 trumpets. The brass and reed instruments are non-electronic but the 12 musicians "double" to the electronic instruments when the leader deems it necessary. (See photos, on pg. 647, showing one of the electronic violins and the control board through which it feeds an individual amplifier and speaker.)

TELEVISION GOES COMMERCIAL!

THE present state of flux of television does not warrant confining standards, but development of the industry does merit limited commercial operations in the near future, the Federal Communications Commission holds unanimously on the basis of its recent public hearing and subsequent study of the situation.

Accordingly, the Commission last month adopted the rules recommended by its Television Committee, with revisions including provision for limited commercial operations beginning Sept. 1.

The Commission declined, pending further study, to take any steps to crystallize the allocation of frequencies to television and other competing services. The channels already assigned to television remain unchanged pending consideration of testimony at the Commission's hearing, scheduled to begin March 18, on aural broadcasting on frequencies above 25,000 kilocycles. At this hearing Frequency Modulation will have its innings.

"That research should not halt and that scientific methods should not be frozen in the present state of the art is fairly to be deduced from the engineering testimony of representatives of the companies represented at the hearing," points out the Commission's report, adding: "Actual demonstrations to members of the Commission indicate the need for further improvement in the technical quality of television. The evidence before the Commission reveals a substantial possibility that the art may be on the threshold of significant advance. Research in fact does and should continue in significant phases of the field."

The Commission asserts that nothing said in the Report should "be construed as a lack of confidence in the future of television." It hails television as "a mighty achievement" and credits pioneers in the field with making "great advances." Continues the Commission (italics are ours—Ed.):

"We feel that potentially television is of tremendous value to the public generally. Even now, there is no reason apparent why those members of the public to whom regular television programs are available, who are conscious of the fluid state of the art,

and who are willing to assume the financial risks involved for the obvious benefits of current programs, should not acquire receivers.

"Nor is it suggested that television broadcasters should be barred from going forward in program production and sponsorship. The progress made by the industry is worthy of recognition, and the present state of the art renders appropriate the further steps permitted by the rules being established."

In general, the rules being issued are based substantially on the rules proposed by the Commission's Television Committee on November 15th last. Two classes of television stations are set up. Class 1 stations will carry forward technical investigations and may be assigned to more than 1 channel. Class 2 stations are designed to experiment in program production and technique and will operate on 1 channel only. Under proper showing, a license may incorporate provisions for both classes.

Beginning Sept. 1, Class 2 television stations may begin limited commercial operations under which advertising will be permitted in connection with programs the cost of which is borne by sponsors. The rules stress, however, that emphasis on the commercial aspects of the operation at the expense of program research is to be avoided.

In not attempting to impose standards at this time, the Commission recommends that the industry itself eschew such restrictions. The report explains:

"Enough has been said to indicate the present state of flux of television and the fact that its progress still continues. The issuance or acceptance of transmission standards by the Commission, especially in combination with the more extensive experimental program service which will in all probability develop under these rules, would have a tendency to stimulate activity on the part both of manufacturers and the public in the sale and purchase of receivers for home use. It is inescapable that this commercial activity inspired and then reinforced by the existence of Commission standards would cause an abatement of research. To a greater or less extent the art would tend to be frozen at that point.

"Even more important, nothing should be

done which will encourage a large public investment in receivers which, by reason of technical advances when ultimately introduced, may become obsolete in a relatively short time. The Commission has not overlooked the significant sums invested by pioneers in making possible our present knowledge of television, and it is not unsympathetic with their desire to recoup their investment in the process of bringing television's benefits to the public. It will be realized, however, that the loss to the public by premature purchase in a rapidly advancing field might in a relatively short period exceed many times the present total cost of research. Such an economic loss in the long run can rebound only to the harm of the industry. In view of the apparent proximity of improvement and of the resolution of disputed technical questions, these risks should not be taken. The Commission is, therefore, reserving the matter of issuing standards for consideration at some future time."

The Commission hopes that the members of the industry "will make every effort to obtain and maintain informal unanimity of opinion among themselves so that their now proven valuable assistance may be available to the Commission in serviceable form" when the time comes to consider standards. In this connection, the Commission suggests attention to marketing of receivers capable, insofar as consistent with reasonable cost, of receiving or of being adjusted to receive any reasonable change in methods of synchronization or changes in number of frames or lines which may be found to be practical and licensed in the future operation of Class 2 stations. Increased size of receiving set screens, it feels, is essential to widespread public acceptance of television. The Commission is also of the opinion that continued experiments in the staging and studio aspects of television performances are necessary.

(The above is a substantially verbatim reprint of F.C.C. release No. 39403. The Commission deserves a vote of thanks from all concerned for slashing redtape and issuing a permit for "commercialization" of television even though limiting it within the confines here outlined.—Editor)

COMBATING RADIO INTERFERENCE

In this article it is shown how radio interferences can be suppressed in the neighborhood of the source of interference, and how interferences can be prevented from entering the mains. The method is further discussed of combating radio interferences at the receiving set, and the article concludes with several practical examples of the removal of interferences. This article is reprinted from "Philips Technical Review," Vol. IV, No. 8, by courtesy of the publishers.

L. BLOK

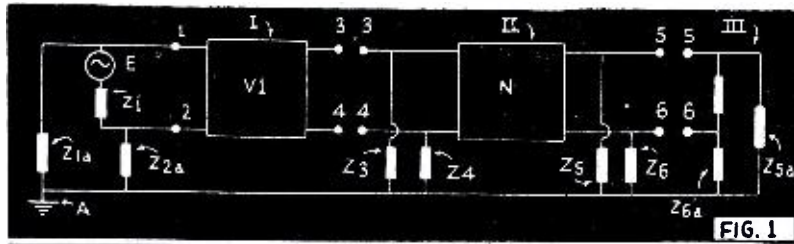

FIG. 1

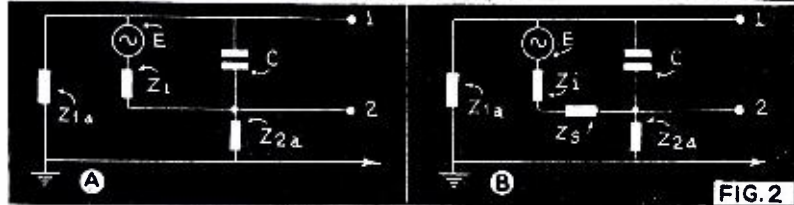

FIG. 2

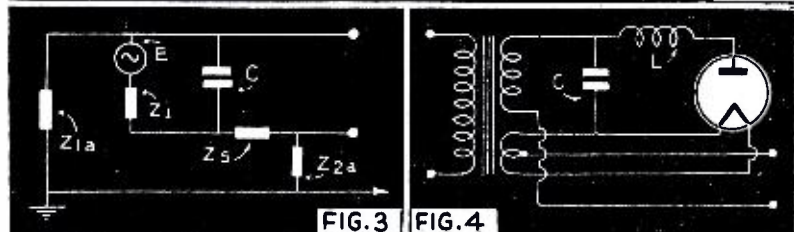

FIG. 3 FIG. 4

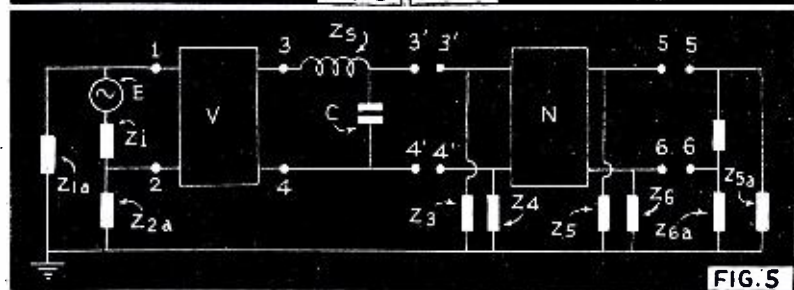

FIG. 5

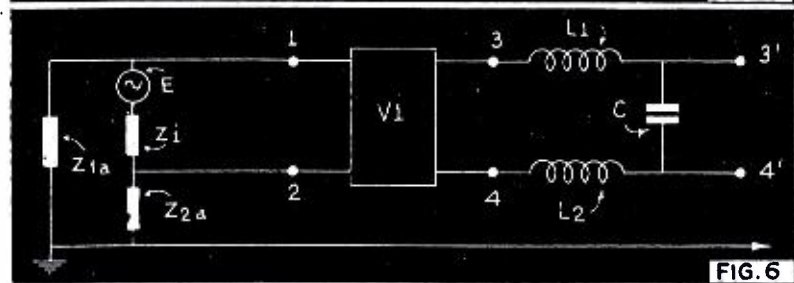

FIG. 6

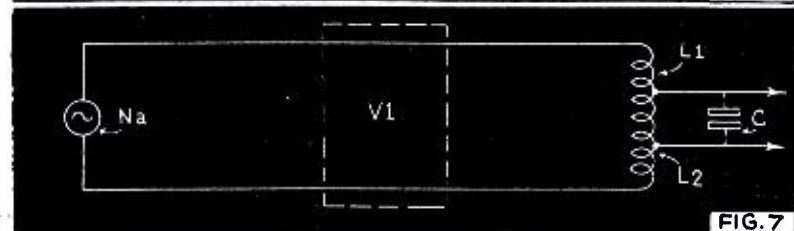

FIG. 7

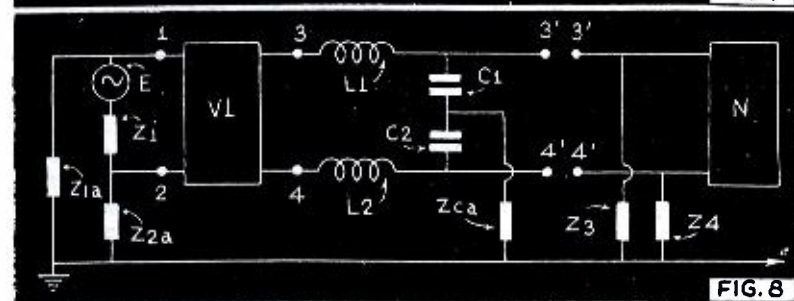

FIG. 8

INTERFERENCE which occurs in radio reception due to sudden changes of currents or voltages in electrical apparatus is usually communicated by this apparatus to the radio receiver by way of the light line. It is therefore of the greatest importance to make it impossible for the source of interference to infect the light line with an interference. How it is possible to prevent electrical apparatus connected with the light line (or "mains") from communicating disturbing interference voltage to the line will be discussed with reference to Fig. 1.¹

Fig. 1. Equivalent circuit of a source of interference. The source of interference voltage E with an internal impedance Z_i is situated between the terminals 1 and 2 of the quadrupole V_1 , through which it is connected with the input terminals 3 and 4 of the power line N , the output terminals of which, 5 and 6, are connected with the receiving set. Items $Z_{1a} \dots Z_6$ are ground impedances.

The interference voltage which an electrical apparatus can communicate to the light line is represented in this diagram by a randomly varying e.m.f. E in series with an internal impedance Z_i , both of which are connected through the terminals 1 and 2 by means of a general quadrupole V_1 with terminals 3 and 4 of the light line N . The latter again forms a quadrupole between grounded terminals 3 and 4, and receiving-set terminals 5 and 6. Furthermore different points of this circuit are grounded over the different impedances: $Z_{1a}, Z_{2a}, Z_3, Z_4, Z_5, Z_6, Z_{5a}, Z_{6a}$.

In the article cited in footnote (1) a discussion is also given of how the interference E can be divided into 2 components, namely the symmetrical E_s and the asymmetrical E_a .

For the symmetrical component the currents flow at all times in opposite directions in the 2 circuits 1, 3, 5 and 2, 4, 6, and are equal in value, while it produces no flow of current through ground.

For the asymmetrical component the currents always flow in the same direction at all points in the connections, while the ground here functions as return connection.

Since the 2 light-line connections usually lie close together and therefore have a large mutual capacity, the symmetrical interference voltage generally does not penetrate far into the line, and the interferences in radio receiving sets connected with the line are usually caused by the asymmetrical interference voltage.

Fig. 2. Suppression of interference is obtained by introducing a capacity C between the terminals 1 and 2 in the circuit of Fig. 1, when the internal impedance Z_i is not too low (A). Otherwise an impedance Z_s must be introduced in series with Z_i (B).

A simple method of removing interference, for the case where it is possible to make the provision in front of the input terminals 1 and 2 of the quadrupole V_1 , is represented in Fig. 2A. If the internal impedance Z_i of the interfering apparatus is not too low compared with E , a satisfactory suppression of the interference can be obtained by connecting a sufficiently large condenser C between the terminals of the source of interference. In some cases of which we shall give an example this condenser must not exceed a defined value.

In order to attain sufficient suppression of the interference with a condenser which is not too large, the internal impedance Z_i should be artificially increased by connecting an impedance Z_s (a resistance or a high-frequency choke coil, for instance) in series with it (Fig. 2B). By choosing suitable types of resistance or choke Z_s and condenser C , the interference voltage at the terminals 1 and 2 can be made much smaller than the interference voltage E produced by the electrical apparatus. With this connection there-

(1) The equivalent circuit of a source of interference connected with a receiving set by means of the light lines has already been derived in Philips Techn. Rev. 3, 235, 1938.

*Merely for purposes of discussion the source of interference, as for instance, certain types of electric motors (as in shavers, etc.), etc., is here considered to be an assembly—identified in the equivalent circuits as quadrupole V_1 —having 4 poles or terminals. The interference voltage, even though it originates within the mechanical confines of the assembly, is considered as being apart from the assembly and, for analysis, only electrically connected to it at assembly-input terminals 1 and 2. Thus, in the instance of certain electric shavers, "quadrupole V_1 " would represent not only the shaver as a whole but also its motor, but the interference voltage generated at the brushes of the motor would be, in Fig. 1 for example, E and Z_i shown external to the shaver-and-motor (quadrupole V_1). The shaver's motor leads which connect to the light line then become assembly-output terminals 3 and 4 on quadrupole V_1 .

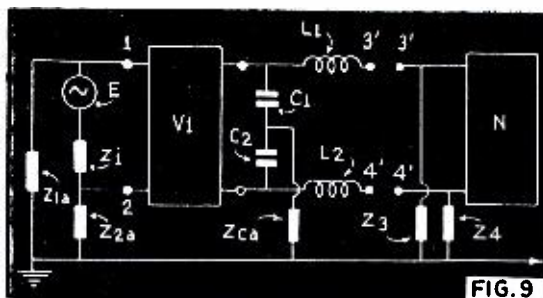

FIG. 9

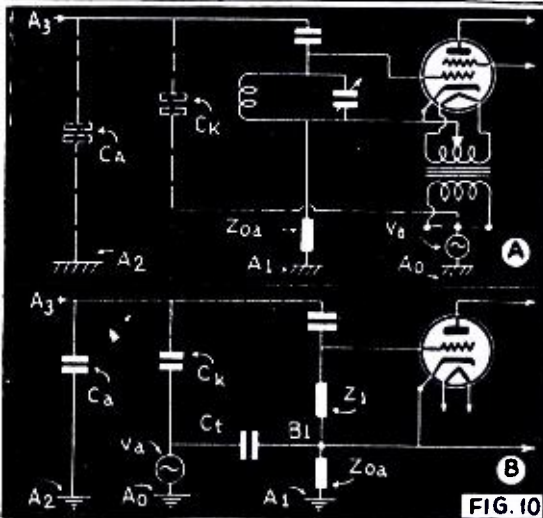

FIG. 10

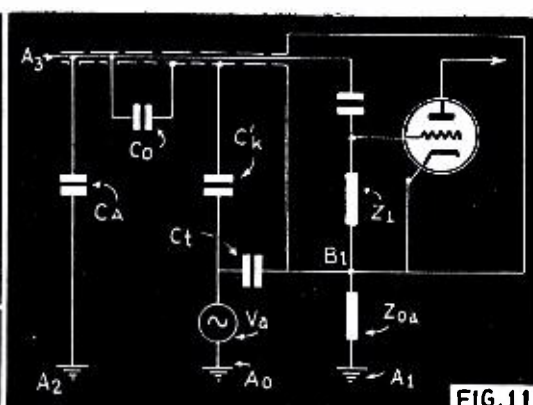

FIG. 11

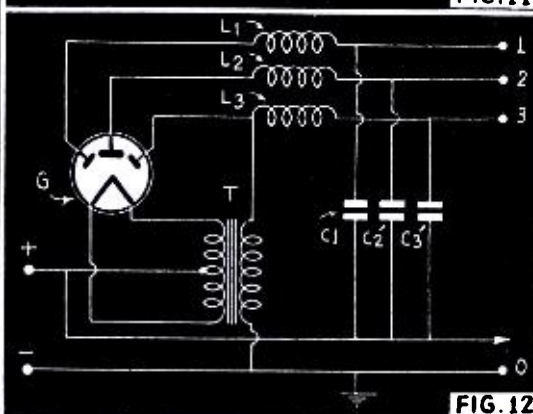

FIG. 12

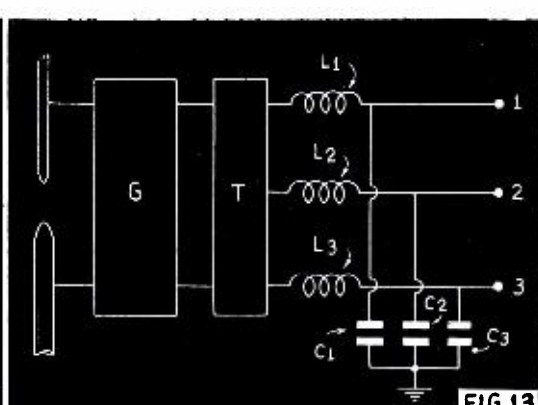

FIG. 13

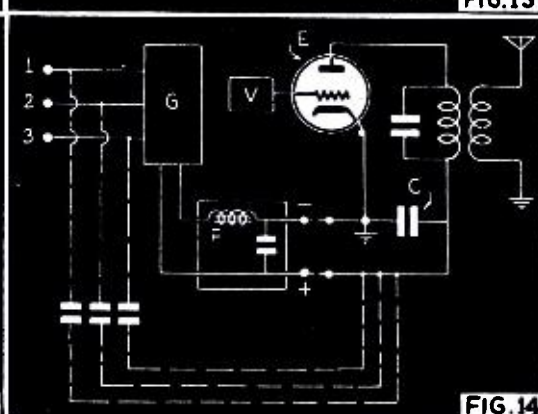

FIG. 14

fore the whole interference is thus "nipped in the bud."

Fig. 3. Behind the interference-suppressing condenser C, which together with Z_s forms a filter, another impedance Z_s has been inserted, which, together with the capacity of the quadrupole V₁, forms a 2nd filter between the terminals 1 and 2. The suppression of interference is thus actually achieved here by a double filter.

If a condenser and a choke coil must be used as above for the removal of interference, they can also be connected as indicated in Fig. 3, and the interference is removed directly at its source. The condenser C is now connected in parallel with the interference voltage E and the internal impedance Z_i. This is only permissible when Z_i is not too small. This connection can be successfully applied when the quadrupole V₁ has an impedance between the terminals 1 and 2 which is small compared with Z_s. It is then as if a double filter were introduced, namely Z_i with C, and Z_s with V₁.

For the suppression of interference from alternating-current sodium lamps the connection indicated in Fig. 2B is applied, as has already been mentioned (2). The element which is composed for this purpose from Z_s and C is a so-called asymmetric interference-suppressing filter, since a suitable choke coil or resistance is introduced into only 1 of the connections, as indicated in the diagram in Fig. 2B. For the correct functioning of such asymmetrical interference-suppressing filters it is necessary that they be introduced close to the source of interference.

Fig. 4. Suppression of interference from a rectifier obtained by introducing a self-inductance L in the anode connection and a condenser C between cathode and anode connection.

Some types of rectifiers can be rendered free of interference in the same way if desired. According to the diagram given in Fig. 4 a high-frequency choke coil is then introduced in each of the anode connections, while beyond the choke coil a condenser C is connected across to the cathode. Alternating- and direct-current light and power lines are both rendered free of interference in this way. In the application of the

scheme of Fig. 4, however, care must be taken in choosing C, as has been remarked by the discussion of Fig. 2. The reignition voltage V_D of a rectifier is considerably higher than its working voltage V_B, so that upon ignition a large e.m.f. V_D-V_B is suddenly released in the circuit between anode and cathode. If the condenser has been chosen too large, it causes large current surges of low frequency through the rectifier tube, which can considerably decrease its life. Especially in rectifiers which can be regulated by means of their grid voltage (3) V_D-V_B may be very large, and it is then advisable to avoid a condenser in the connection of Fig. 4, and cause suppression of the interference in some other way, and not directly behind the rectifier.

REDUCING INTERFERENCE NEAR ITS SOURCE

Fig. 5. Suppression of interference is obtained by introducing an element consisting of a condenser C and an impedance Z_s, directly behind the quadrupole V, which connects the source of interference with the light lines. This must be done when the source of interference E cannot itself be reached for the introduction of an interference-suppressing element in the way indicated in Fig. 2.

For practical reasons it is often impossible to reach the place where the interference voltage is generated. In the connections of Fig. 1 it is then only possible to introduce the interference suppressor behind the quadrupole V₁, for instance, between terminals 3 and 4 which form the output terminals of this quadrupole. If we introduce an asymmetrical interference-suppressing filter at that point, as indicated in Fig. 5, the condenser C between terminals 3' and 4' forms practically a short-circuit for high-frequency voltage. Such voltage does not then occur on the input terminals 3' and 4' of the light lines, but over the ground connections Z_{1a}, Z_{2a}, etc., a high-frequency interference voltage may very well reach the input terminals 5 and 6 of the receiving set with the connection 4'4 serving as return connection. In certain cases it is even possible that the interference is some-

what intensified at the receiving set by the introduction of such an asymmetrical interference-suppressing filter, since the asymmetry of the light lines is changed in such a way that the asymmetrical component of the interference voltage is thereby increased.

Fig. 6. The interference-suppressing element introduced behind the quadrupole V₁ is made symmetrical, so that there is a self-inductance (L₁ and L₂) in each of the connections. In this way the asymmetrical interference is satisfactorily suppressed.

If the symmetrical component of the interference voltage plays the main part, which occurs only seldom, removal of interference can of course always be achieved with the connection according to Fig. 5. If the ground impedances Z_{1a} and Z_{2a} are not large, it is advisable for the suppression of the asymmetrical component to divide the self-induction of the interference-suppressing element over the 2 connections, as indicated in Fig. 6. With such a connection the impedance of the circuit of the symmetrical interference voltage is not changed, but for the asymmetrical interference voltage, where the ground functions as return connection, the impedance is appreciably increased by the introduction of such a symmetrical interference-suppressing filter since 4,4' now also contains an impedance. The impedances L₁ and L₂ in the 2 connections need not be equal to each other in this arrangement, but both of them must be sufficiently large. In order to suppress the asymmetrical interference voltage adequately, they must moreover be large with respect to the impedance of the quadrupole V.

Fig. 7. Upon the use of a leakage transformer the sodium lamp Na is rendered free of interference without special precautions according to the principle of Fig. 6, by the leakage reactances L₁ and L₂ and the capacity C of the light line connections.

Fig. 8. The interference suppressor is made more symmetrical than in Fig. 6, since the condenser is divided into C₁ and C₂ whose point of connection is connected through Z_{ca} with ground.

In the case of sodium lamps fed through a leakage transformer, suppression of interference according to the scheme of Fig. 6

(2) Philips Techn. Rev. 1, 87, 1936.

(3) Cf.: Philips Techn. Rev. 1, 161, 1936.

is automatically obtained. As indicated by the broken line in Fig. 7, the capacity of the supply cable then functions as condenser C in the scheme of Fig. 6, while the leakage field of the leakage transformer plays the part of the choke coils L1 and L2 in that scheme. Since each of the connections of the supply cable possesses in addition an appreciable capacity with respect to the grounded covering of the cable, a suppression of interference is often obtained automatically with the leakage transformer according to a still better scheme, which is given in Fig. 8.

In this the condenser C is divided into C1 and C2 which are in series, while their point of connection is connected with ground. This ground connection naturally possesses an impedance which we have indicated in the figure as Zca. Only in the case where this ground impedance Zca is small with respect to the impedance Z3 and Z4 of the ground connections of the input terminals 3' and 4' of the light line, is it effective, because it then provides that the asymmetrical circuit is connected through itself with ground, so that the high-frequency current no longer penetrates into the net with disturbing intensity. The size of Zca depends upon the length of the ground connection, which is proportional to its self-induction, and it depends also especially upon the local character of the soil by which the transition resistance is determined.

If the impedance of the quadrupole V1 as well as Z3 and Z4 is not small, it is possible to omit the self-inductances, L1, L2, from the scheme of Fig. 8, and to obtain a good suppression of interference by introducing only the condensers C1 and C2 with their ground connection Zca. In such a manner a dynamo or motor with collector can be rendered free of interference, if, as is customary, each of the brushes is connected through a condenser with the grounded housing of the machine.

In general, by introducing 2 condensers C1 and C2 with their ground connection Zca, a satisfactory suppression of interference can be obtained. Two situations may, however, occur which make this impossible; namely when:

- (1) the ground impedance Zca cannot be made sufficiently small, or
- (2) the ground impedances Z3 and Z4 of the input terminals of the mains are themselves already low and an interference nevertheless occurs.

In the 1st case one may with much difficulty succeed in diminishing the ground resistance by a factor 2 or 3, for instance, but this is usually insufficient for a satisfactory suppression of interference.

In order to understand the situation in the 2nd case it is necessary to find out how the ground impedances Z3 and Z4 are constituted. Although they are given schematically as impedances concentrated in 1 point of the circuit, they are actually for the most part continuously-distributed stray capacities which depend upon the length of the cables which are included in the quadrupole N. The farther the radio receiver is from the source of interference the greater will be the effective stray capacity between the 2, so that the ground impedances Z3 and Z4 become smaller. This will in general result in the fact that receivers will suffer less from interference the farther they are from the source of interference. The 2nd case can therefore only occur when a very strong source of interference is still found to have a disturbing influence on a far-distant receiver. The asymmetrical interference current should then already have sufficient opportunity to flow off to ground over the small ground impedances Z3 and

Z4 without condensers C1 and C2 with their ground connection Zca being specially introduced for that purpose, and should therefore no longer be able to penetrate in disturbing intensity into the light line. For this, however, the interference voltage on the terminals 3 and 4 is found to be too high, nor is the scheme of Fig. 8 capable of improving the situation appreciably.

Fig. 9. The interference suppressor of Fig. 8 is connected in the opposite way, since the self-inductances L1 and L2 are introduced behind the condensers C1 and C2 in the light line connections. In this way we have actually again obtained a double filter as in Fig. 3. The output impedance of the quadrupole V1 together with C1 and C2 forms the 1st filter, while the self-inductances L1 and L2, together with the capacity between the input terminals 3' and 4' of the light line, form the 2nd filter.

In the 2 cases here described a connection according to Fig. 9 may give the desired result. In this arrangement the condensers C1 and C2 form a short-circuit for high frequencies between the 2 light line connections and ground, preceding the self-inductances L1 and L2 which serve to prevent the interference current from penetrating into the light line. We now have as it were the symmetrical, interference-suppressing filter of Fig. 8 connected in the opposite way, and this suppression of interference is particularly effective when the internal impedance of the quadrupole V1 is not too small. In that case one is actually concerned with a double filter: V1 forms the 1st filter together with C1 and C2; and L1 and L2 together with Z3 and Z4, form the 2nd filter.

INTERFERENCES AT THE RECEIVER

In the foregoing we have discussed how precautions can be taken in the more or less immediate neighborhood of the electrical apparatus in order to prevent its giving rise to interferences in radio reception. We shall now deal with the measures which may be taken in the neighborhood of the receiving set against radio interferences.

Fig. 10. Circuit of the input of a radio receiving set (A) with the corresponding equivalent circuit (B). The aerial A3 is loosely coupled with the tuned circuit represented by Z1. The aerial lead wire possesses stray capacities Ca toward ground (A2), and Ck toward the source of interference Va. The ground point B1 of the receiving set is connected with ground A1 over the ground impedance Z0a. The capacitive coupling of the source of interference Va with the supply side of the receiving set over the supply transformer is represented by Ct.

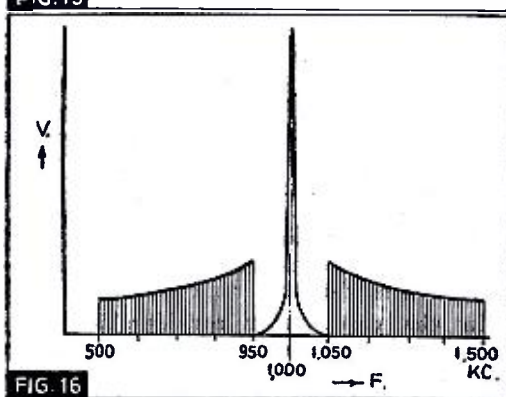
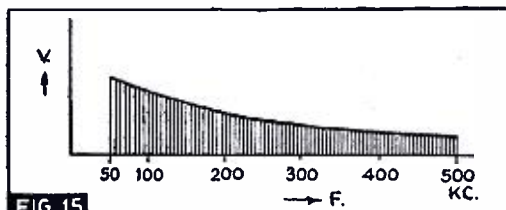

In Fig. 10 a diagram is given of the input of a radio receiving set, accompanied by an equivalent circuit (*). Those interferences which are capable of causing the occurrence of an appreciable interference between the cathode and the grid of the receiving tube, i.e., over Z1, in the equivalent circuit, will be disturbing for radio reception. We must keep in mind here that in the practical case of a good receiver care is taken that the capacitive coupling Ct between the primary and the secondary winding of the supply transformer is made sufficiently small, so that one need not in general fear that disturbing interference voltages will act across Z1 by way of the circuit Va, Ct, Z1, Ca, A2, A0. If this should be the case the impedance of this circuit can be increased by introducing a high-frequency choke coil in series with Ct, i.e., in the primary circuit of the supply transformer; the impedance of the primary is large with respect to that of Ct and also with respect to the ground impedance Z0a, so that the interference current still flowing through Ct can easily flow off to ground (A1) and only an extremely small fraction passes through Z1 and Ca to A2.

For the communication of interference voltages from the light line to the grid of the receiving tube the capacitive coupling Ck between the supply line and the lead-wire of the aerial A3 usually, however, plays the most important part. The interference voltage in this case acts on Z1 by way of the circuit Va, Ck, Z1, Z0a, A1, A0. By the use of special aerials, the interference current through this circuit may be kept low, but we shall not go into this point in this article. We shall here only discuss what can be achieved by shielding the lead of the aerial along a good part of its length.

Fig. 11. Interference suppression in the radio set of Fig. 10 by means of shielding the aerial (dotted line). This shielding is connected with the ground point B1 of the receiver which is connected with ground (A1) via Z0a. The shielding has a capacitive coupling C0 with the aerial connecting wire and Ck' with the source of interference Va. The latter can no longer, as in Fig. 10, cause an interference to penetrate into the receiving set by way of the aerial connection.

This shielding is obtained by the use of shielded cable, whose core, which serves as aerial lead, has only a low capacity with respect to the grounded metal covering. The capacity C0 in Fig. 11 is therefore small, so that the intensity of reception is not thereby decreased disturbingly. The grounding of the metal casing is done by connecting it with the ground point B1 of the receiver, as indicated in Fig. 11. As a result the interference voltage Va can now no longer cause an interference current to penetrate into the receiving set over the aerial input by means of a capacitive coupling (Ck in Fig. 10) between supply line and aerial input lead, because the coupling capacity (Ck' in Fig. 11) means only an increase of the capacity Ct of the transformer windings.

The only circuit over which an interference current can now pass through Z1 is: Va, Ct + Ck', Z1, Ca, A2, A0. Just as was noted in the discussion of the circuit over Ct and Z1 in Fig. 10, here also no disturbing interference currents will flow in the circuit of Ct + Ck' and Z1 in Fig. 11, if only the ground impedance Z0a can be made small enough with respect to the impedance of the capacity Ct + Ck'. Practically the interference current is then immediately conducted to ground (A1) through Z0a. The suppression of interference which can be

(* This circuit has already been given in Philips Techn. Rev. 3, 240, 1938.

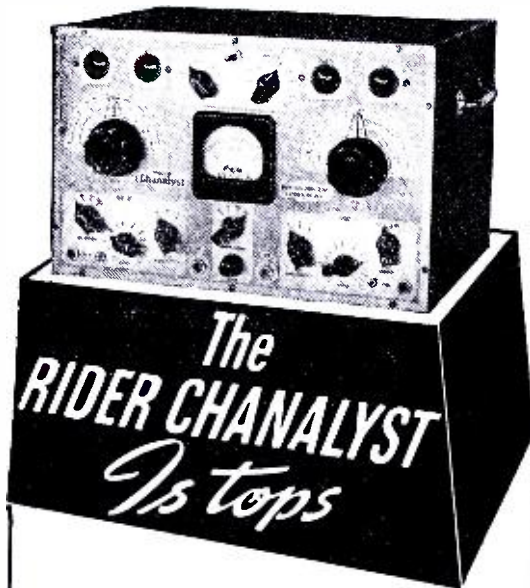

THE RIDER CHANALYST established signal tracing! It was the first instrument of its kind and still is the top instrument! Dollar for dollar the RCA Rider Chanalyst offers the most for the money.

The present-day RCA Rider Chanalyst is the result of years of development based on a wide range of receiver circuit knowledge, test equipment application, and country-wide contacts with the servicing fraternity. Every possible arrangement of meters, "eyes," and other type indicators was tried. The final version of the RCA Rider Chanalyst offers the greatest amount of utility and flexibility combined with built-in stability and freedom from complicated circuits at the lowest price.

For instance: Five separate channels are available *simultaneously*, permitting the isolation of intermittent troubles—the bane of your existence—in the shortest possible time. The RF-IF channel is a 3-stage tuned r-f amplifier—resonated vacuum tube voltmeter type—assuring adequate sensitivity and selectivity. A calibrated meter—automatically protected against normal overloads—is arranged to function in 4 channels at the option of the operator. The use of inertia-less "electronic eyes" as indicators affords the greatest speed of action for fast servicing since the "eye" provides an easily observed signal level permitting stage gains to be read directly from level control. The RCA Rider Chanalyst makes servicing more profitable for more than 3,000 progressive service men. Before you buy—ask the man who uses one!

RCA RIDER CHANALYST
\$10750

net. F. O. B. Camden, New Jersey
It will pay for itself by saving your time...
...upping your profits.

Over 335 million RCA Radio Tubes have been purchased by radio users... in tubes, as in parts and test equipment, it pays to go RCA All the Way.



Test Equipment

RCA Manufacturing Company, Inc., Camden, N. J.
A Service of the Radio Corporation of America

obtained with shielding is better, the smaller the ground impedance Z_{0a} compared with the impedance over the connection Z_1 , Ca, A2.

PRACTICAL EXAMPLES OF INTERFERENCE SUPPRESSION

We shall in conclusion deal with several examples of the way in which suppression of interference can be obtained in practical cases.

Fig. 12. Suppression of interference from a 3-phase rectifier G connected directly with the mains (1, 2, 3) by the self-inductances L1, L2, L3 and the condensers C1, C2, C3 according to the principle indicated in Figs. 2B and 4.

If the radio interferences are for example due to a 3-phase rectifier, whose anodes can easily be reached and do not carry too-heavy currents, so that a self-inductance can be included in the anode supply line close to each anode, the suppression of interference can be achieved on the principle indicated in Figs. 2B and 4 in the direct neighborhood of the source of interference. In the case of the circuit given in Fig. 12 the anode supply lines are connected with the zero point of the cathode through the condensers C1, C2, C3, directly outside of the self-inductances L1, L2, L3, so that the interference is then indeed "nipped in the bud" and has no chance of penetrating the light line. The condensers in this case are expressly connected with the cathode and not with ground, because in this way the interference current has not the slightest chance of penetrating into the direct-current mains. If C1, C2, C3 were grounded, the interference current circuit would have to be completed over the divided capacity between the + and - connections. If it is desired to ground C1, C2, C3, then the + and the - connections must be short-circuited for high-frequency with a condenser close to the rectifier.

Fig. 13. Suppression of the interference from a rectifier installation F with a transformer T according to the arrangement given in Fig. 8.

If one is concerned with a 3-phase rectifier for high power, whose anodes are in general not connected directly with the mains, but are fed via a transformer, the anode currents are too large, and the anodes are generally too difficult to reach to make it possible to introduce self-inductances in the supply lines close to the anodes. Such a case may for instance occur in the neighborhood of a movie theatre in which a rectifier fed by the 3-phase mains serves as source of energy for the carbon arc in the projector. In one such case where by means of measurements with a portable receiver it could be ascertained that in the neighborhood of the theatre the power line was infected with a disturbing radio interference, we were able to bring about an effective suppression of the interference by introducing self-inductances L1, L2, L3 in the supply of the transformer and connecting these lines immediately outside of the self-inductances to ground through condensers C1, C2, C3, as indicated in Fig. 13. Since in this case the interference was propagated by means of the mains, at some distance the asymmetrical interference voltage was the only disturbing factor, and the circuit of the asymmetrical interference voltage is closed by this arrangement directly behind the transformer as has already been explained with reference to Fig. 8.

In the case under consideration self-inductances of 0.2-millihy. were used which were wound as solenoids of 1 layer in thickness around a hollow core in order to pre-

vent the windings from possessing too high a capacity with respect to each other. If the capacity of the coil itself is too great it would be possible that the self-induction of the coil would be short-circuited for the high frequencies of the range which one wishes to render free of interference. The resonance frequency of the coil should be higher than the frequencies to be freed of interference.

If we may neglect further impedances, the series impedance in the supply line, for interference waves of 300 meters, i.e., 1 mc. is $\omega L = 2\pi \cdot 10^6 \cdot 2 \cdot 10^{-4} = 1,256$ ohms. Since condensers of 0.1-mf. were used, the impedance of the shunt on the supply line amounts to:

$$\frac{1}{\omega C} = \frac{10^{-6}}{2\pi} \cdot 10^7 = \frac{1}{0.628} \text{ ohms.} \quad \text{The}$$

division of voltage obtained by this arrangement reduces the interference voltage which penetrates into the mains, therefore, by a factor equal to $0.628 \cdot 1256 = 800$, which constitutes a satisfactory suppression of the interference. As a result of the unavoidable ground impedance, in practical cases the suppression factor will be smaller.

Fig. 14. Interference suppression in a radio transmitter. The 6-phase rectifier G connected with the power-line (1, 2, 3) supplies by means of the smoothing filter F the anode voltage for the final stage of the transmitter. The pre-stage V supplies the grid voltage for the end tube E. The connections of the supply mains are capacitatively coupled with the feed lines for the final stage, and along this connection intermediate and high-frequency interferences from the rectifier could enter the final stage. This is prevented by short-circuiting the feed line for high frequency close to the final stage with a condenser C.

An unusual case of radio interference was encountered in the case of a broadcasting transmitter (Fig. 14). The final stage was fed with a 6-phase rectifier G for a voltage of 20,000 V. and a power of 60 kw., which was provided with 6 gas-filled rectifier tubes. The supply is from the 3-phase mains (power line) of 380 volts and 50 cycles. Per second therefore each tube carries 50 current impulses, so that the total number of current impulses is 300 per sec.

The interference spectrum given by the rectifier has a fundamental frequency of 50 cycles, since the 6 rectifier tubes are not exactly alike and it continues up to several hundred thousand cycles. By the smoothing filter F the low-frequency part of the interference spectrum is indeed cut off, but the intermediate and high-frequency part penetrates through the transformer of the rectifier installation into the supply mains. The mains cables are capacitatively coupled (shown by dotted line in Fig. 14) with the supply lines of the final stage, and therefore generate interference voltage between cathode and anode of the final tube E. In this way the part of the interference spectrum which is not of low frequency enters the final stage where it is modulated on the carrier wave and thus it is transmitted by the aerial.

Fig. 15. Interference spectrum of the rectifier of Fig. 14. V., interference voltage; F., frequency.

If we now assume that the interference spectrum extends over a frequency range from 50 to 500 kc. (Fig. 15), after modulation on a carrier wave of 1,000 kc. (wavelength 300 meters) 2 sidebands occur: 500-950 kc. (600-316 meters) and 1,050-1,500 kc. (286-200 meters).

Fig. 16. The voltage V. in the aerial as a function of the frequency F. The carrier

•SERVICING•

wave is at 1,000 kc.; the audible sidebands occupy the range $1,000 \pm 4.5$ kc. so that the sidebands generated by the interference voltages (500-950 and 1,050-1,500 kc.) fall outside of this range.

Since the interference voltages are low, the voltage generated in the aerial by the normal sidebands will be much greater than the voltage in the sidebands generated by the interference, as is indicated in Fig. 16. At a great distance from the transmitter, therefore, this interference is not observable. If one listens to the transmitter in its immediate neighborhood, one will again fail to notice the interference, because the normal band-width to which a receiver is tuned is about 9 kc. and practically no interference occurs in the frequency range of $1,000 \pm 4.5$ kc. If, however, the receiver is tuned to the frequency ranges 500-950 kc. or 1,050-1,500 kc., the modulated interference band is then received. Since it contains 6×50 wave trains per sec., this modulation will be heard in the loudspeaker as a rattle. The radio reception of stations with carrier waves in the above-mentioned frequency ranges will then be seriously affected.

In this case a satisfactory suppression of interference is achieved by short-circuiting the supply lines of the final stage for high frequency close to the transmitting tube by means of a condenser C as indicated in Fig. 14.

This article has been reprinted with the permission of Philips Glowlamp Works, Ltd., (Eindhoven, Holland), publishers of the magazine in which it originally appeared.

This article will aid you to properly install high-fidelity radio receivers. Further merit to this story lies in its discussion of first principles in the elimination of interference—principles which now enter the problem of making interference-free television installations.—Editor

SERVICE PROBLEM

Jack Tenczar, Jewett City, Conn.

(Q.) I have a Majestic, model 130A chassis, on which I cannot obtain reception; plate voltage is obtainable only on the 45's; no plate voltage on any of the four 24's in the R.F. stages; the detector plate resistor, which measures 4,875 ohms, heats up greatly; and the filament resistor, which is 1.6 ohms, heats up also. The latter resistance is center-tapped, and only 1 side heats up. All resistors test OK; so do all the filter condensers and chokes. The filament voltage tests OK.

(A.) Lack of plate voltage on all but the output, type 45 tubes, in the Majestic 130 receiver, with the attendant circumstance of overheated 4,875-ohm section of the voltage divider, is due to a short-circuited 0.3-mf. R.F. plate bypass condenser, one section of a block.

The overheating of one side of the filament center-tap resistor is probably caused by grounding of one terminal of the dial light.

News Item:

Mapleton, Ohio, has a population of only 132 inhabitants, but the Mapleton, Ohio, made famous in "The American Way" has an actor population of almost 250, and this entire theatrical community daily has its nerves soothed by means of a public-address system connecting the stage with all dressing rooms and offices at the Center Theatre in New York. There is even a gossip column that goes over the P.A. system!

MOISTURE PROTECTION

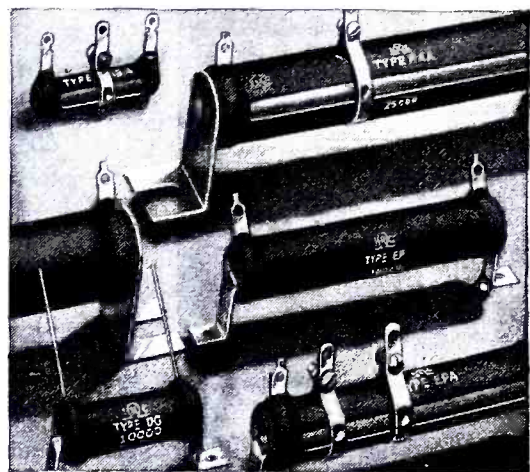

... THE FIRST REQUISITE OF A REALLY GOOD POWER RESISTOR

Irrespective of any other features, a power wire wound resistor is only as good as the protective coating which guards its windings from moisture and corrosive atmospheric conditions. Nothing else is so important. That is why IRC engineers spent so many years in perfecting the now famous IRC specially processed Cement Coatings. These Coatings are different—tougher—more durable. They excel in protection as proved by the toughest tests—the cycling tests of boiling hot and freezing cold salt immersion. They are the big reason why IRC Power Wire Wounds are specified for the most critical submarine, naval, airplane and industrial jobs. And they are the big reason why IRC's mean more for your money for any radio service or amateur need. They last longer.

All ranges in fixed and adjustable types from 10 to 200 watts. These and IRC Insulated Metallized Resistors, IRC Volume Controls, All-Metal Rheostats, etc., fully described in IRC Catalog 45—free on request.

Cement Coated POWER WIRE WOUND RESISTORS

INTERNATIONAL RESISTANCE COMPANY
401 N. BROAD STREET, PHILADELPHIA, PA.

BACK ISSUES OF RADIO-CRAFT

If you are in need of back issues of RADIO-CRAFT to complete your files, write to the publishers and advise them of your requirements. Many of the older issues are available and they can be obtained at special prices. Write, Back Number Dept., RADIO-CRAFT, 99 Hudson Street, New York, N. Y.



FREE!

HAMMARLUND NEW "40" RADIO CATALOG

The latest Hammarlund catalog with complete data, illustrations, drawings and curves on the entire Hammarlund line. Address Department RC-54 for your free copy.

HAMMARLUND MFG. CO., INC.
424-438 West 33rd Street, New York City

ADAPTERS ARE GOOD MONEY-MAKERS

Adapters sell to the consumer for \$1.00; parts cost the Serviceman about 30c. Not much profit there, only enough to pay you for wiring the adapter. But adapters sell radio "add-on" units!

H. T. ZIEGLER

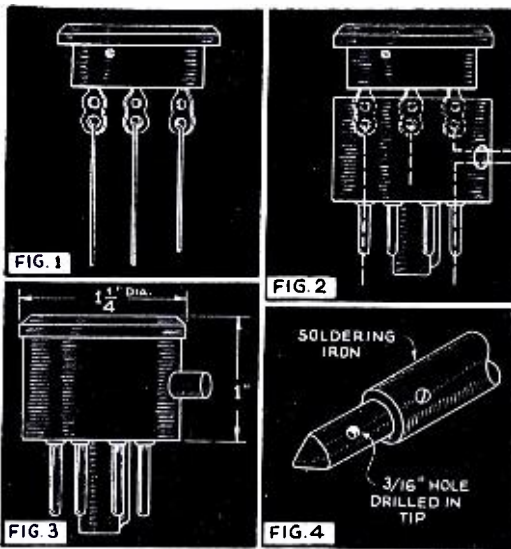

EVERY radio owner today is in the market for one or more of the following units so easily added to his set:

- (1) Headphones for the shortwave fan or hard-of-hearing person, and for those who like to stay up late.
- (2) Auxiliary speaker to be installed in some other room, especially in taverns, restaurants, clubs, etc.
- (3) Record Players. The sudden popularity of recordings has made everyone a prospect. If you can't sell your prospect a complete record player, look around his home for an old spring-winding Victrola and sell him a pickup.
- (4) Recorders. *This will probably be the main feature of radio sets for 1940!* There are now recording arms on the market (which can be used for playback also) selling to the Serviceman for as little as \$3.50, for recording on pregrooved and self-cutting discs. Magnetic types will operate from any radio receiver or amplifier having at least 3½ watts output. They record radio programs right off the air, or from microphones.
- (5) The person who likes to give parties is a push-over for a mike. Most people do not realize that the average radio set has a mighty fine audio amplifier, and will give ample volume when used with a magnetic or carbon mike.

This article will tell you how to wire adapters and connect appliances for each one of these requirements.

WIRING ADAPTERS

Referring to Fig. 1.—No. 20 bare, solid tinned wire should be used for the internal wiring of adapters. Leads should be about 2½ ins. long. Wrap leads around socket contact and solder. Correct contacts are easily determined because contact numbers are molded into the bakelite. It is usually safest to place thin spaghetti, ⅝-in. long, over each lead.

Referring to Fig. 2.—Feed wires down through prongs of base. Any external leads are fed out through side hole. (External wires should be No. 20 stranded, rubber

covered.) Pull down on leads which now protrude through prongs and push the socket into place.

Referring to Fig. 3.—Insert the side set screws before proceeding further. Clip the excess leads protruding through the prongs as close as possible to the prongs. Solder in an upside-down position. It is usually best for a beginner at this type of soldering to use acid-core solder. If there is any excess solder on prong sides, remove with a file.

Referring to Fig. 4.—A simple method of soldering adapter prongs (and plugs, too, when the leads feed through the prongs) is to drill a 3/16-in. hole in the soldering-iron tip; the hole, of course should not go clear through. Fill this small cup with solder, dipping into Ruby or acid, dip into molten solder and capillary action draws solder far up into the prong, assuring a neat, positive contact.

ADDING A PHONO PICKUP TO ANY RADIO SET

Any high-impedance pickup can be fed into any radio receiver, even the smallest midget set, and the volume will be as great or greater than the volume of radio reception. If a receiver has 2 audio stages, the pickup is fed into the 1st audio tube, except in "radios" having resistance-coupled amplifiers, where the pickup must be fed into the detector tube. If the radio set has but 1 A.F. stage, the pickup is fed into the detector. (In a superheterodyne, this is the 2nd-detector.) When a detector is the duodiode-triode type, the pickup is fed into the triode section of the tube. The pickup should always be fed into the control-grid. (This is G1 on tube charts.)

When the control-grid is at the top of the tube, the connection is very simple (see Fig. 5). No adapter is necessary. The center lead of the pickup's shielded cable is connected to the top cap of the tube; the shield of the cable is connected to the chassis. Of course, to play the phono, the lead from the radio circuit to the tube top cap must be broken. A S.P.D.T. switch may be used for this purpose. If a crystal pickup is used a 1-meg. resistor, R (¼-watt size), must be connected from the tube's top cap to the chassis. For magnetic pickups this resistor is unnecessary.

To determine the correct prong for any element, consult the tube chart of any tube

manufacturer. These charts are available from any radio jobber without charge.

The wiring diagram for the phono pickup adapter for tubes which have the control-grid fed through a prong is shown in Fig. 6. Fahnestock clips, which may easily be fastened to the side of the cabinet with small wood screws, can be used for connecting the pickup wires to the adapter. The adapter is wired straight through—1 of the adapter top to 1 on the adapter bottom; 2 goes to 2; etc. On the control-grid, however, a separate wire is soldered to the socket top and a separate wire to the adapter bottom. These wires should be No. 20 stranded, rubber covered. They are brought out the side hole of the adapter.

NOTE: If a magnetic pickup is used, resistor R in the diagram is not required. If a crystal pickup is used, the resistor is very necessary to complete the grid circuit to the ground. The resistor can be wired directly inside the adapter, shunting the 2 wires brought out the side hole. Value of the resistor is not important. It may be any size between 1 and 2 megohms. Use a ¼-watt resistor because of its small size. The phono pickup is then connected to the 2 wires coming from the side of the adapter. If a Phono-to-Radio switch is desired, a S.P.S.T. switch is hooked across the phono leads. All leads from the adapter to the switch, and from the switch to the phono pickup should be made of shielded wire. Ground the shield to the chassis. If 2 separate shielded wires are used, be sure and connect the shields.

Low-impedance pickups may be fed into the cathode of any detector tube, except in radio receivers which have resistance-coupled amplification. The adapter is wired straight through as for the grid adapter, but the cathode lead is broken and brought out the side. A S.P.S.T. switch is connected across the leads to switch from Phono to Radio.

ADDING A MIKE TO ANY RADIO SET OR AMPLIFIER

No great effort has ever been made to sell microphones to the public. The public will buy them if they are shown that good reproduction can be had from their radio-set audio amplifier.

Wiring the adapter is exactly the same as for the phono adapter. The mike is fed

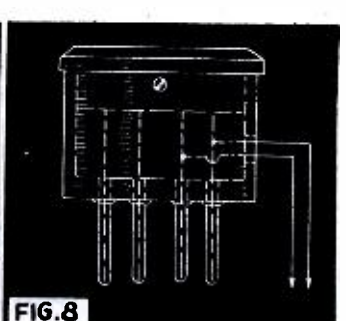
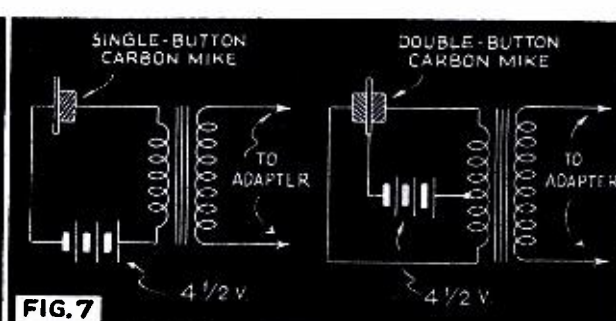
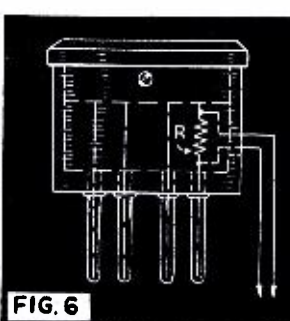
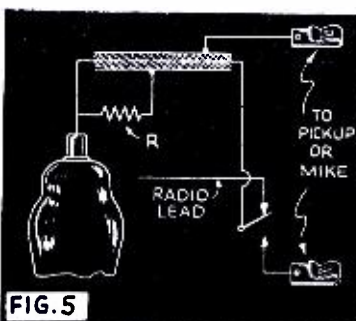

•SERVICING•

into the control-grid. All leads outside the adapter should be shielded. Switching is the same as for the phono pickup. Only high-gain, high-impedance mikes should be used. Low-impedance mikes require a matching transformer. Carbon mikes will have the highest gain, but a matching transformer and "C" battery are required as shown in Fig. 7. For any mike all leads, as for the phono pickups, should be shielded. A S.P.S.T. switch may be inserted in the same manner for switching from Mike to Phono. Low-impedance mikes can be fed into the cathode of the detector tube as described for low-impedance pickups.

ADDING HEADPHONES TO ANY RECEIVER

Headphones may be connected to the detector (2nd-detector in superhets), 1st A.F. stage, or the output stage. If there is a 1st audio stage it is usually best to connect the headphones at this point; if not, connect them to the output tube. Where the 1st audio tube is used, or a single output tube (not push-pull) the headphones are connected from plate to ground. A 0.5-mf. condenser (600 working volts) is inserted in 1 lead.

The adapter is wired as shown in Fig. 8. The adapter for headphones is wired straight through—1 to 1; 2 to 2; etc. The plate lead is not broken as the grid lead was for a phono adapter. It, too, has a lead from the socket top to the adapter bottom. In addition, a No. 20 stranded, rubber covered lead is connected to the plate of the socket top, and a similar lead is connected to a socket contact that goes to ground. For most octal tubes the No. 1 contact goes direct to the chassis. However, consult a tube chart to make sure.

If no tube element is connected to the ground, connect the return of the speaker to the cathode (K in tube diagrams). For connecting headphones to tubes without a cathode, and with no element connected to the ground, only 1 wire should be brought out from the adapter (the plate lead), and the other side of the headphones will be connected directly to the chassis externally.

High-impedance phones should be used, although 2,000- and 3,000-ohm headphones are suitable. When more than 1 pair of phones is desired, use the 3,000-ohm type and connect them in series.

A S.P.S.T. switch can be inserted in the plate lead to disconnect the headphones when they are not in use.

FOR PUSH-PULL OUTPUT—

—Two adapters are used, 1 under each tube. The adapters are wired straight

through, and a lead from each plate is brought out the side for connecting to the phones. A 0.5-mf. condenser (600 working volts) should be inserted in each line.

Headphones without speaker operation are used by the short-wave enthusiast to tune-in distant stations. Headphone and speaker reception simultaneously is important when there is a hard-of-hearing person in the home. This allows everyone to enjoy the radio receiver at the same time.

ADDING AN AUXILIARY SPEAKER

Every radio Serviceman has potential customers in his locality who would buy an auxiliary speaker if they realized how simple and inexpensive the installation is.

In the first place, use either a P.M. (permanent-magnet field) dynamic speaker, or a magnetic type. Installing 2 extra wires to energize the field of an electrodynamic speaker only adds to the cost and difficulty of the installation and is not recommended.

An additional speaker is connected in the same way as headphones, from the plate to the chassis. A 0.05-mf. condenser is inserted in the line to guard against the impedance of the speaker upsetting the radio circuit. A speaker with a 7,000-ohm voice coil should be used, although 2,000- and 3,000-ohm speakers may be employed. When 2 or more speakers are used they should be connected in series. Adapters for push-pull output tubes are the same as headphone adapters for this purpose.

ADDING A RECORDING UNIT

A recording unit may be connected to any radio receiver in the same manner as an auxiliary speaker: from plate to chassis where there is only 1 output tube, across the 2 plates in push-pull circuits. *No condenser should be inserted in the line for recording.*

Use either a high-impedance magnetic or crystal recorder, the light type which records on pregrooved or self-cutting recording discs. Results will be surprisingly good for such a low-cost installation. Recordings can be made from radio programs tuned-in by the radio receiver, or a mike can be connected as previously described to record home programs.

This article has been prepared from data supplied by courtesy of Allied Radio Corp.

(The author will answer any questions concerning adapters for testing tubes, and for adding units as described in this article. When your questions refer to a particular radio set, give make, model number, and tube line-up. Please enclose a stamped envelope return-addressed.)

PILOT-LIGHT FUSE

● THE little gadget sketched here has saved me quite a few sets of tubes in battery radio sets that had a short in the "B"-battery circuit going through the filaments (as it seems to mostly). The gadget is made from the socket out of an old "B"-battery and a "B"-battery plug. It is plugged into the 1st "B"-battery and the set plugged into it, thus the "B"-return

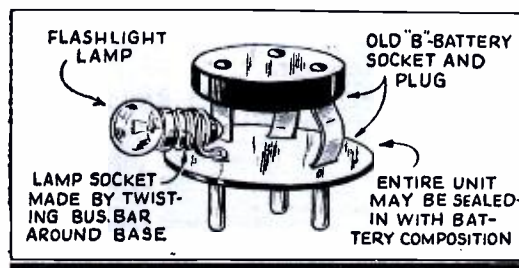

goes through the flashlight lamp. In case of a short the lamp burns out before anything can happen elsewhere. The lamp must

of course have a current rating less than the total filament drain of the tubes being protected. The lamp must be bypassed by a condenser; 2 mf. ordinarily is about the right value (to prevent motorboating).

ERIC BARSCHER, *Canora, Sask.*

KILLING "BIRDIES"

● WITH many smaller radio sets which lack a stage of R.F. amplification, "birdies", whistles and heterodyning are frequently unwanted visitors. These undesirable effects may be greatly reduced—sometimes totally eliminated—by putting a resistor of from 400 to 1,000 ohms across the aerial and ground posts. Much heterodyning is caused by distant stations feebly beating with a local. The shorting resistor "kills" this faint beat while only slightly reducing volume on regular stations. This trick has greatly helped me where nothing else worked.

FRED LIGHTGARN, *Wilmette, Ill.*

EXTRA PROFITS IN THESE 2 new RCP Extra-Value TEST INSTRUMENTS!

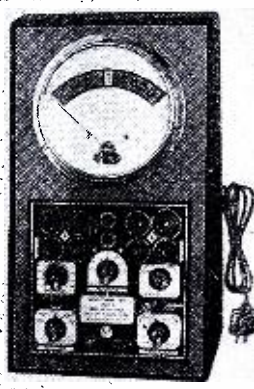

MODEL 308 SERIES D SALES PROMOTER TYPE TUBE TESTER

New from the ground up! Impressive new appearance . . . new advanced engineering features . . . new miniature tube tests . . . new economy of equipment . . . new low prices!

Sales Promoter. That's the type this new RCP 9-inch meter Tube Tester, Model 308 Series D, is. Tests all new miniature tubes, all ballast tubes. Noise and hum test for tubes showing otherwise "good." Sensitive neon tests for shorts and leaks. Spare sockets (miniature and large) for future tube developments. Checks pilot lights, headlights, miniature lights. Rapid, accurate. Line voltage indicator directly on meter. Individual check of sections of rectifiers and multi-purpose tubes. Bull's eye signal when tester is "ON." It's Tomorrow's Tube Checker TODAY! . . . amazingly versatile, handsomely finished, sensationally low-priced! Counter Type (Model 308, Series D) . . . \$25.95
Type (Model 308P, Series D) . . . \$28.85
Combination Portable-Counter Model 308, with 3" meter . . . \$16.95

MODEL 801M COMBINATION TUBE AND SET TESTER



Additional socket for miniature tubes . . . extra self-contained battery supply for ohmmeter range below 1 megohm. New features built on the basic advantages RCP owners have long enjoyed in Combination Model 801. Brilliant success from the start, now with sparkling new features added at no increase in cost. Model 801M represents the biggest test instrument value in the history of radio! It has every worthwhile modern feature . . . opens a whole new era in quality test instruments at a price within reach of all. It's something to see your nearest jobber about TODAY!

Model 801M Complete . . . \$27.95
Model 801MA (Combination tube tester and plug-in set analyzer) \$37.90

NEW FREE RCP Catalog just off the press. Get the quality test equipment with the low-price appeal. It's extra value for the money. Send at once for catalog No. 122.

RADIO CITY
PRODUCTS CO. INC.
88 PARK PLACE, N. Y. C.

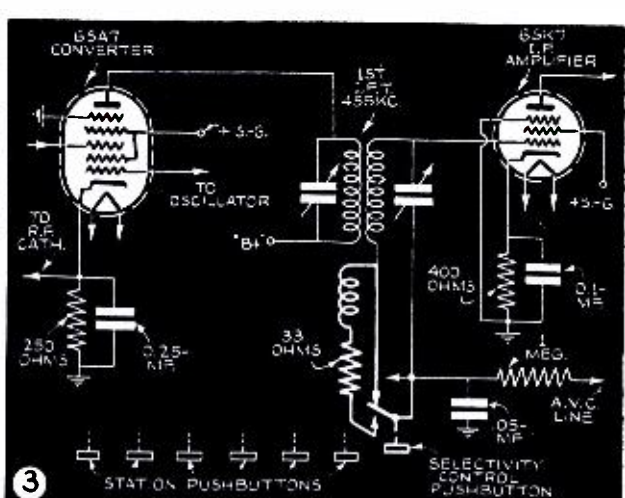
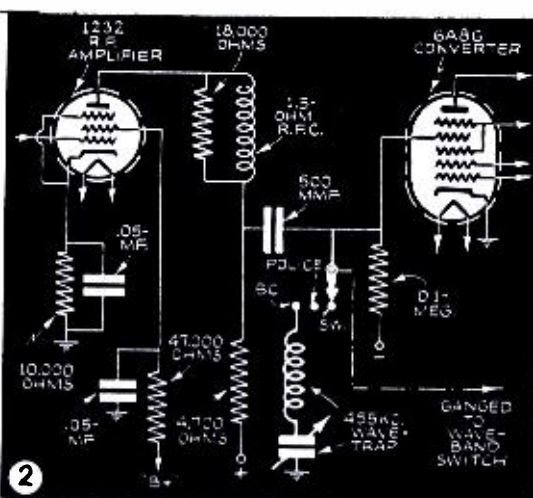
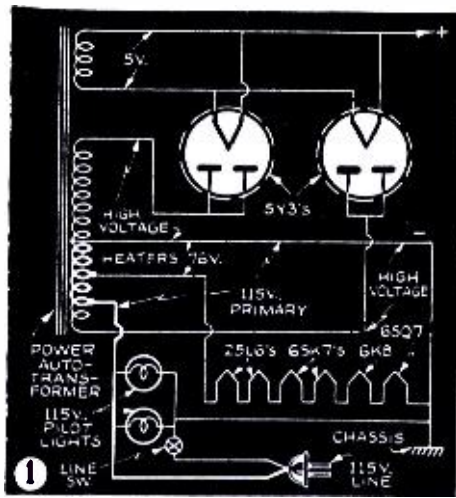

NEW CIRCUITS IN MODERN RADIO RECEIVERS

In this series, a well-known technician analyzes each new improvement in radio receiver circuits. A veritable compendium of modern radio engineering developments.

F. L. SPRAYBERRY

No. 32



(FIG. 1.) PRIMARY COMBINED WITH HIGH-VOLTAGE AND FILAMENT WINDING IN POWER AUTOTRANSFORMER

CROSLY MODELS 819 AND 1019.—The high-voltage center tap is connected to the chassis as will be seen in Fig. 1 and one side of the high-voltage winding is tapped for the line voltage input, and the 76-volt series filament circuit, for the entire set (except the rectifiers, in an autotransformer arrangement).

Through this construction the total number of turns on the power transformer is reduced nearly 1/3 and the transformer may be constructed with a shorter core length and a smaller "window" making it more efficient. By tapping the same section of the winding for series filament supply at the correct voltage a series resistor is not needed, thus preventing a considerable loss in power.

The fact that the chassis may not always be at ground potential has less importance than in earlier days when the chassis may have been more exposed to external contact. In this case the chassis must not be grounded.

(FIG. 2.) INTERSTAGE WAVETRAPH SWITCHES OUT OF CIRCUIT

ZENITH MODELS 8S443-51-63, 10S443-52-70-91-92 AND 11S474.—In the untuned coupler system used between the R.F. and converter stages where it cannot influence

other tuned circuits directly, the I.F. wavetrap is placed, in such a way that it is switched in use only for the broadcast band.

The I.F. wavetrap is of no importance in the high-frequency bands as these high frequencies are considerably out of range of the I.F. So as not to reduce the grid impedance more than necessary for high frequencies the wavetrap is switched out of the circuit for high frequencies. Although considerably off of resonance with these high frequencies, the wavetrap has distributed capacity enough to appreciably lower the input grid impedance of the converter tube. Its elimination from the circuit, when adjusted for high-frequency reception, thus improves high-frequency reception.

(FIG. 3.) SELECTIVITY CONTROLLED WITH PUSHBUTTON

STEWART-WARNER MODELS 01-8A AND 01-8B.—One in a group of 8 pushbuttons in this receiver is used to control the selectivity of one of the I.F. coupling transformers by changing the amount of its coupling and its secondary series resistance.

As will be seen by reference to Fig. 3, one pushbutton has been reserved for controlling the selectivity of the I.F. amplifier. Despite the fact that only one pushbutton at a time will remain depressed this is rather a nice arrangement. When the regular automatic tuning pushbuttons are in use local or powerful stations are being re-

ceived in which case additional selectivity is not desired for best fidelity. Also, when the phono-television pushbutton is in use the R.F. and I.F. stages are of course not in use. However, in the broadcast band or in any other band where extra-broad tuning must be sacrificed for selectivity for best receiving conditions the selectivity control button may be used.

Note especially as mentioned above, that the operation of the selectivity control is in no way affected by the position of the band switch, because it is connected to the I.F. circuit.

(FIG. 4.) EFFECTIVE USE OF DOUBLET RECEIVING ANTENNA ON 2 WIDELY DIFFERENT FREQUENCIES

GENERAL ELECTRIC MODEL HM-136.—As a tuned antenna for receiving wide-band frequency modulation signals this antenna functions as a tuned resonator, magnetically coupled to the input, but for broadcast and other frequencies it functions as a capacity antenna which is conductively coupled to various antenna coils in turn.

The very simple input circuit used with this receiver is shown in Fig. 4. The doublet coupling coil or primary (P) of T₁ is tapped at its electrical center which does not influence its operation as a doublet. Ultra-high frequencies at which the doublet is tuned, flow from one end of the coil to the other, being fed by opposite voltages at the

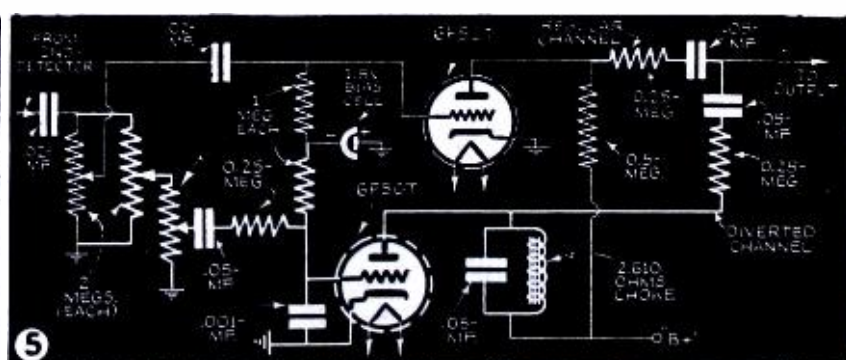
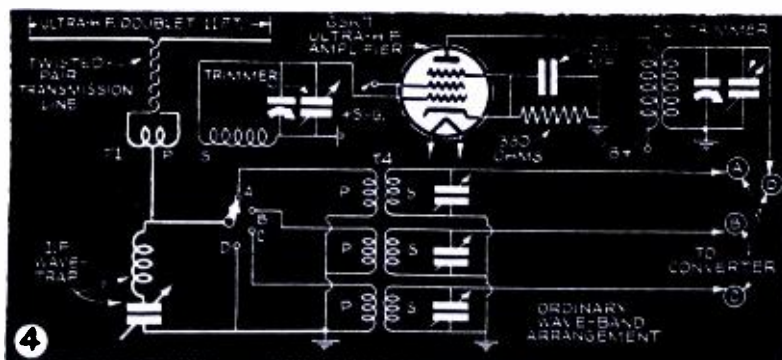

•SERVICING•

transmission line. There is essentially no ultra-high frequency voltage at the center-tap of the T_1 primary (P) and hence no tendency for these frequencies to enter the other circuits for the other bands.

For the broadcast and other usual bands, however, the antenna simply acts as a T-type antenna with a single lead-in. Signal currents flow at these lower frequencies simultaneously up and down in each lead of the transmission line and the effect of the primary of T_1 in this case is like a very low resistance, the inductive reactance being neutralized out of the circuit by equal and opposite currents in each half of the T_1 primary. This type of antenna may be used for simultaneous transmission, reception or both if desired, its discriminating action is so complete.

(FIG. 5.) DIVERTED-CHANNEL BASS AMPLIFIER

HOWARD MODELS 518 AND 520.—Two volume controls in parallel permit the regular voice channel to continue as usual and an auxiliary channel diverted from the regular channel to amplify bass frequencies so as to raise their volume higher than they would be found in the regular channel.

A separate 6F5GT triode makes use of a resistance-capacity grid input circuit which favors low frequencies and a plate load tuned to a very low audio frequency. As its circuit in Fig. 5 shows, its plate signal circuit is then coupled back into the normal audio channel by a means appropriate for audio mixing circuits.

Instead of losing high frequencies for bass reproduction as for the conventional tone control, this circuit makes no changes in them but may greatly boost the low frequencies producing a much more real tone effect.

RETURN THOSE REPLACED PARTS TO SET OWNERS

"THERE'S a lot of good business psychology in returning all replaced parts to set-owners," states Vic Mucher, who heads Clarostat sales and knows more than a thing or two about the service business.

"Successful auto repairmen are doing just that, and since these auto boys have many years on us when it comes to service psychology, we surely can't go wrong following in their footsteps.

"Remember, your public is always suspicious of service bills. So if you include an item for replaced parts, there's that lurking suspicion that some fancy gypping is going on. But if you include the replaced parts when you return the set, the customer is promptly disarmed on that score and perhaps on all scores.

"Take it home, Mr. Set-Owner, and throw it in the ashcan,' you can say, as you hand said customer some old part taken out of his set. 'We don't want old parts kicking around our shop. Too much danger of having them sneak into some set or assembly, by accident. You know, we use only brand new, fresh, up-to-the-minute components in our work.' What a good-will wallop you can pack in those few remarks!

"Then, too, this practice is mighty important from your side. It eliminates the temptation to use junk parts. Human nature being what it is, we all know that where there's a junk box around, there's going to be a lot of old stuff pressed into further service. And the breakdown of just one job, due to junk parts, can cost you many times the price of new parts. So why take needless chances! Why permit such temptation to be present?"

FOR COMPLETE DYNAMIC

Signal Tracing

Use Model 560 Vedolyzer With Model 561 Combination Oscillator

THE MODEL 561 is radio's most complete oscillator—a combination of 4 essential instruments which every well equipped serviceman should have. It provides (1) A.F. oscillator, 15 to 15,000 cycles. (2) R.F. oscillator. Variable amplitude or frequency modulated. (3) Carrier and modulation monitor. Vacuum tube circuit. A.F. and R.F. oscillators may be used separately or the variable audio oscillator used to modulate the R.F. Percentage of modulation read directly on meter. (4) Frequency modulator. Double image, positive self-synchronizing.

THE MODEL 560 is a basically different dynamic test instrument using a high frequency 3" scope; 3 stage, wide range, high gain, television, video, vertical amplifiers; multi-range, multi-function, push button controlled, vacuum tube A.C., D.C., ohm and megohmmeter; super-sensitive R.F. voltmeter; broadcast, I.F. and oscillator variable tuning section; push button controlled multi-probe input circuit. The Model 560 Vedolyzer used with the 561 Oscillator is radio's finest and most complete signal tracing set-up.



Or Use Model 562 Audolyzer with Model 561 Combination Oscillator

THE MODEL 562 is the simplest and most logical signal tracing and dynamic tester available. Servicemen everywhere are recommending its use because it will start "paying

off" an hour after it reaches your shop. It is not necessary to "take out" a few days and learn to operate your new instrument. One hour with the AUDOLYZER, a test oscillator, and a receiver and you can tear into those repair jobs you have pushed aside to rest for a while. The AUDOLYZER contains a five inch dynamic speaker for its primary indicating device; a meter to monitor RF, IF, AF, AVC, AFC, and D.C. voltages; a two stage tuned amplifier to check frequencies from 95 KC to 14.5 MC; a vernier and step attenuator to control signal level reaching speaker; a vacuum-tube voltmeter to check D.C. volts from 0 to 1000 volts in seven ranges; a single probe to be used in any type circuit; dual probes for intermittents.

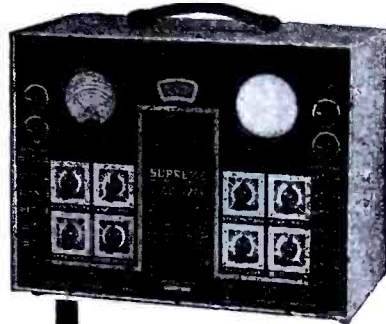

CHOOSE EITHER COMBINATION — YOU CAN'T GO WRONG!

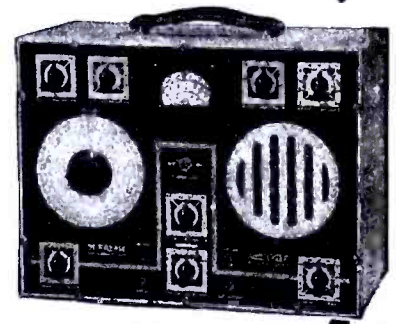

SUPREME 504 TUBE AND SET TESTER

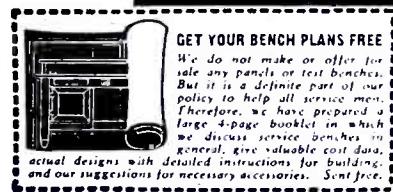

MODEL 504 is SUPREME's finest combination tube tester, set tester and condenser tester. All tubes correctly tested regardless of base terminations or filament voltages. 31 multimeter and resistance ranges available on last push button switch. Condenser settings included on roller chart for every capacity and working voltage. The Model 504 plus your signal tracing instruments and you have everything that a modern shop requires.

SUPREME INSTRUMENTS CORP. GREENWOOD, MISS., U. S. A.

Export Dept., Associated Exporters Co., 145 W. 45th St., New York City

Visit your nearest newsdealer and buy a copy of SUPERWORLD COMICS!

A popular comics edited by Hugo Gernsback.....

FREE "Get Acquainted" Offer

If you will send us the name of your jobber, we'll send YOU free and postpaid, by return mail, a genuine high-quality Illinois Tubular Paper Condenser. Dealers: Servicemen: accept this free offer by writing TO-DAY.

ILLINOIS CONDENSER CO., INC. 1160 N. Howe St. Chicago, Ill.

Save on Everything in Radio

NEW 1940 RADIO CATALOG AND PROFIT GUIDE Most complete line of latest radio sets, amplifiers, kits, tools and replacement parts. All leading brands at lowest prices. Fast Service. Guaranteed Quality.

The RADOLEK Company Dept. Y-41 601 W. Randolph St. Chicago SEND FOR YOUR COPY TODAY

FREE RADIO PROFIT GUIDE



TWO NEW INSTRUMENTS

AT RECORD-BREAKING LOW PRICES

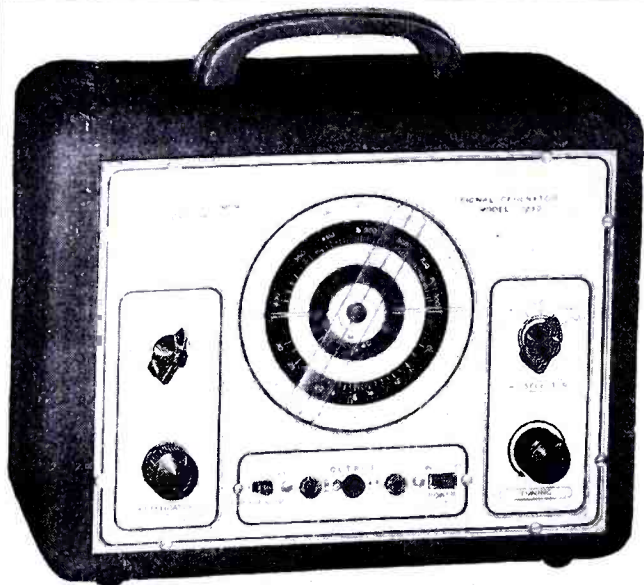

THE NEW MODEL 1230

SIGNAL GENERATOR with FIVE STEPS of SINE-WAVE AUDIO

SPECIFICATIONS

RADIO FREQUENCIES from 100 K.C. to 90 Megacycles in 7 bands by front panel switch manipulation. All direct reading and accurate to within 1% on I.F. and Broadcast bands, 2% on higher frequencies. The R.F. is obtainable separately or modulated by any one of the five Audio Frequencies.
AUDIO FREQUENCIES: 5 steps of SINE-WAVE audio 200, 400, 1000, 5000 and 7500 cycles WITH OUTPUT OF OVER 1 VOLT. Any one of the above frequencies obtainable separately for servicing P.A. hard-of-hearing aids, etc.
ATTENUATOR: Late design, full-range attenuator used for controlling either the pure R.F. or modulated R.F.

CIRCUIT: The Model 1230 employs an improved electron coupled oscillator circuit for the R.F. affording positive protection against frequency drift and a Hartley oscillator circuit for the A.F. section.
DIAL MANIPULATION: Large 5 1/2" dial etched directly on front panel, using a new mechanically perfected drive for perfect vernier control.
APPEARANCE: The front panel is etched by a recently perfected process which results in a life-long attractive finish and the instrument comes housed in a streamlined shielded cabinet.
CURRENT SOURCE: The Model 1230 operates on 90 to 130 Volts A.C. or D.C. any frequency.

The Model 1230 comes complete with tubes, shielded cables, molded carrying handle and instructions. Size 14" x 6" x 11". Shipping weight 15 pounds. Only

\$1285

THE NEW MODEL 1220

WORLD'S LOWEST PRICED

5000 OHMS PER VOLTER!!

Extremely valuable because of its high sensitivity, the Model 1220 is an all-purpose tester that permits resistance measurements up to 3 Megohms, with only a 3 V. self-contained flashlight battery and reads directly down to 0.2 ohm.

SPECIFICATIONS

- * 6 D.C. Voltage Ranges: 0-3-10-50-250-500-5,000 volts.
- * 3 A.C. Voltage Ranges: 0-15-150-1,500 volts.
- * 4 Resistance Ranges: 0-3000 ohms, with 15-ohm center, direct reading to 0.2 ohm; foregoing base range multiplied by 10, by 100 and by 1,000, to read up to 3 Meg. with self-contained 3 V. flashlight battery.
- * 4 D.C. Current Ranges: 0-200 microamperes; 0-2-20-200 milliamperes, using wire-wound shunts.
- * 3 Output Meter Ranges: Same as A.C. Voltage Ranges.
- * 3 Decibel Ranges: From -2 to +58 D.B., based on .006 watt in 500 ohms.
- * Uses full-sized 3" square 0-200 microammeter, with 2% accuracy and finely damped movement, contained in a handsomely designed, square molded Bakelite case.



Model 1220 comes complete with cover, self-contained battery, test leads and instructions. Only....

\$1045

SUPERIOR INSTRUMENTS COMPANY

136 Liberty Street

Dept. RC-5

New York, N.Y.

SERVICE Questions & Answers

NO CONTROL OF VOLUME

(158) S. F. Dunn, Versailles, Mo.

(Q.) Would like help on General Motors radio set model 120A, 8 tubes. This set was struck by lightning which ruined the antenna coil and volume control. Both replaced but cannot control volume unless I use only 1/2 of control, then will burst out loud once in a while. Owner said he could not control volume before lightning came in on set.

(A.) Poor control of volume was a common complaint with one version of the General Motors model 120 receivers. With those models employing 1 section of the dual volume control in the cathode circuit of the

R.F. tubes, a solution consisted of replacing the 1st R.F. type 24A tube with a variable-mu type 35 tube. Better control is effected by using type 35 tubes in 1st and 2nd R.F. stages.

CODE INTERFERENCE

(159) Carl D. Ettinger, Portland, Pa.

(Q.) I have a Philco model 38-12C on my bench for repairs. As you know, this set has but 1 band which is the broadcast, but it tunes-in code with the stations. The code is so annoying that the program cannot be heard. This is mostly at night between 800 and 1,500 kc.

I have had it back to my jobber; who is

supposed to have a cracker-jack factory repair man. He said there was nothing to do because it has no R.F. stage. I do not believe it for there are a lot of sets similar to this one which do not pick up code, and neither did this one when it was new. I want to make clear that it is not the same code on every station. The code signals that come in with different broadcast stations have different speeds and tones.

Some say if the antenna is shortened it will stop it. I did not try it for the set played on it for about 9 mos. and should play on the same length again (about 75 ft.).

I have checked tubes by meter and substitution, and they are all OK; have checked all condensers by substitution except electrolytics. Have tried to balance it out. Checked all resistors with ohmmeter after rebalancing the set. It works better now but is not OK yet. Can you help me out?

(A.) We compliment you upon the common sense you have displayed in reasoning that better performance might be reasonably expected from this set. However, the problem of code interference on receivers which do not employ an R.F. stage is not unusual. In some cases, aligning the I.F. transformers to some higher or lower frequency aids matters. We do suggest, though, the use of an I.F. wave trap. Connect this trap in series with the antenna and adjust for minimum response by feeding an I.F. signal of 470 kc. into trap circuit.

A.V.C. BLOCKS SIGNAL

(160) W. R. Wonsettler, Oil City, Pa.

(Q.) I have a Majestic model 60 in my shop which has the following defect: The A.V.C. blocks the passage of the signal through the I.F. stages. The setting of the volume control is very critical and must be adjusted every time a different station is tuned-in. The set refuses to take normal volume, only extremely close and powerful stations being received with any satisfaction. When set blocks, the tuning meter swings either maximum or minimum indicating a very low or very high C-bias on the controlled tubes. Plate current on these tubes must be adjusted to an exact value before signals can be heard.

The following checks have been made: All voltages are normal (1,000 ohms/volt meter) with the exception of the grid voltages on the 35/51's as mentioned above. All resistors in the A.V.C. section have been checked and those which deviated more than 10% were changed.

The two 0.35-mf. condensers in the A.V.C. filter circuit were checked by substitution. A new tube was tried in the A.V.C. stage. The quality of the tone from this receiver is good. No perceptible distortion is present. This condition may be a natural condition in this model but it hardly seems possible to me that a receiver in this condition could be sold.

(A.) Fading, erratic meter operation and weak reception on the Majestic 60 are due to leakage between porous cotton-covered leads, leaky 0.067-mf. R.F. and 1st-detector secondary-return bypass condensers, and porous 5,700-ohm (blue) carbon resistor.

Replace cotton-covered tuning condenser leads, control-grid leads, A.V.C. plate leads, R.F. and 1st-detector secondary-return leads, with good rubber-covered leads. Replace condensers mentioned with high-quality units, and carbon resistor with wire-wound unit.

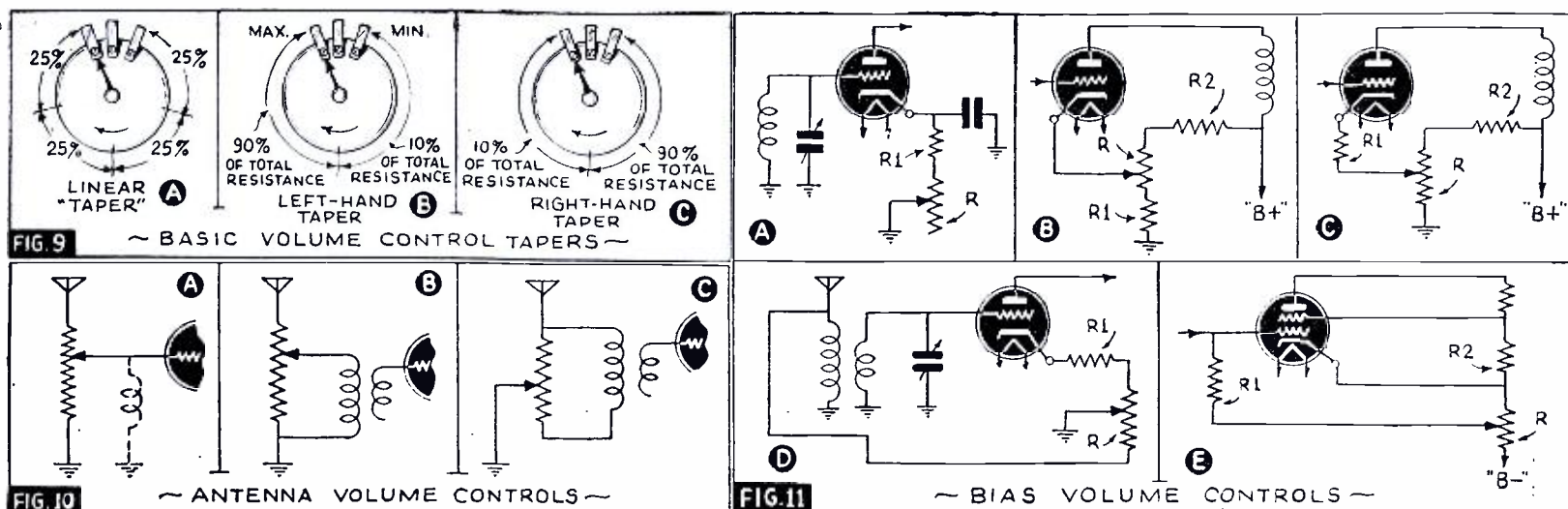

SERVICING "ORPHANS" AND PRIVATE-BRAND SETS

This article discusses the problem of restoring to proper working order any radio set for which there is no conveniently-available diagram. Not only test procedure for checking circuits but also probable characteristics of replacement units are described.

CHARLES R. LEUTZ

PART III (Conclusion)

THIS series, plus the series entitled "Emergency Servicing Without Meters" (*Radio-Craft*, August and October, 1939, and January, 1940), constitutes a useful reference which even experienced Servicemen may find worthwhile checking-over for ideas.

In this concluding Part III will be discussed the problems which arise in connection with the replacement of volume and tone controls, and the correction of circuit-oscillation after rewiring, in those "alley cat" radio sets, for which there never were any published diagrams, which every Serviceman encounters from time-to-time; and those other, better-parented sets which once rated well but which Time has obsolesced both as to style and service diagram.

Part I, in the March, 1940, issue of *Radio-Craft*, described basic circuits and how to recognize them no matter how well they may be disguised. Last month, in Part II, the procedure for checking-up on components in such sets was discussed in detail. Now let's go on from there.

MANUAL VOLUME CONTROLS

For standard sets, specifications for replacement volume controls are available both from the set manufacturer's service sheets and from the volume control manufacturer's catalogs. For odd sets, the matter of correct replacement values becomes a bit complicated. The defective unit can be measured to determine the taper and value originally used. However, if the set has been serviced before, there is a possibility that a volume control of incorrect specifications has been installed.

Accordingly in making volume control replacements, no mistake will be made if the new unit is selected to suit the tube and circuit requirements rather than simply inserting an identical substitute.

Outside of the overall physical size permissible, the correct shaft diameter and

length, the important considerations are, (1) type of resistance element, (2) maximum value and (3) the characteristic or taper. Wire-wound elements are generally used for values up to about 7,500 ohms and usually for bias control, antenna shunt (or a combination of both) and for voltage dividing applications. Carbon element controls are invariably used for service where a total resistance above 7,500 ohms is required.

The maximum value of resistance of a broken or burned-out control can be determined by measuring the value of resistance each side of the break and adding the 2 values.

TAPERS

The characteristic of any control can be determined by making resistance measurements of the control, from the rotating contact to either end terminal, for different angular positions of the control knob. For example if the measurements indicate equal resistance values, say 1,250 ohms at 25% rotation, 2,500 ohms at 50% rotation, 3,750 ohms at 75% rotation and 5,000 ohms at full rotation, the total resistance or maximum value is 5,000 ohms and the control has a linear characteristic (no taper) as per Fig. 9A.

Measurements indicating approximately 10% of the total resistance, for the first 50% of rotation (counterclockwise) and the balance of the total resistance concentrated in the second-half of rotation, points to a left-hand taper as per Fig. 9B. With the same rotation, but the above resistance values reversed, the taper is right-hand as per Fig. 9C. Variations of these basic characteristics exist, but one of the above 3 types will usually satisfactorily fill most replacement requirements.

R.F. & A.F. CONTROLS

Typical antenna volume controls, formerly used quite extensively, are shown in

Fig. 10, wherein a potentiometer is used as a signal voltage divider. The full antenna voltage or any part thereof can be fed to the 1st tube grid, depending upon the control adjustment. Values of 3,000 to 7,500 ohms and a linear characteristic are commonly used for this application in the rather old sets and may or may not be combined with bias control.

Variation of the cathode resistor value to obtain control of R.F. gain is used in numerous different circuits, all essentially identical.

Figure 11 shows bias volume controls, wherein R1 represents the minimum resistance to produce the minimum bias voltage permissible, R represents the adjustable cathode resistor to regulate the bias voltage and R2 is the bleeder resistor. In circuits using old-type tubes with a sharp cut-off, the variation from minimum bias for maximum gain to maximum bias for cut-off represents only a few volts and the available regulation is restricted. Accordingly in the older A.C. sets, a combined cathode-bias regulator and antenna potentiometer (or a dual unit) is usually found and gives combined attenuation of input signal and amplifier gain, as per Fig. 11D.

Modern remote cut-off (variable μ) tubes have a much higher control range and the R.F. gain can be regulated at the tubes without any antenna potentiometer. However, bleeder resistors (R2) are used extensively from either the "B" supply or screen-grid supply to, to hasten increasing the bias values.

The diagrams are shown for 1 tube but the same considerations hold true for 2 or more tubes in cascade having a common bias control and whether the tubes are triodes, tetrodes or pentodes.

Figure 11E is another variation of bias control, the grid-return connecting to the cathode resistor R, the latter being in series with the negative "B" line, the voltage drop across R and the amount of this drop used, providing the bias. This is also a common method of obtaining bias in battery sets.

Varying the screen-grid voltage to control R.F. tubes is practically obsolete but the circuit is shown in Fig. 12A. Likewise it is unusual to find broadcast receivers with controls to vary plate voltage, as shown in Fig. 12B. For the above applications the controls must be capable of carrying definite power with noiseless operation. Where control circuits of this type are found, it is well to change the circuit to a more modern method of regulation.

Figure 13A is a typical audio volume control, with the output from the preceding tube shunt-coupled to a potentiometer, the latter also acting as a grid resistor, and in addition must be considered as reflecting on the plate load of the preceding tube. The values may vary from 100,000 ohms (0.1-

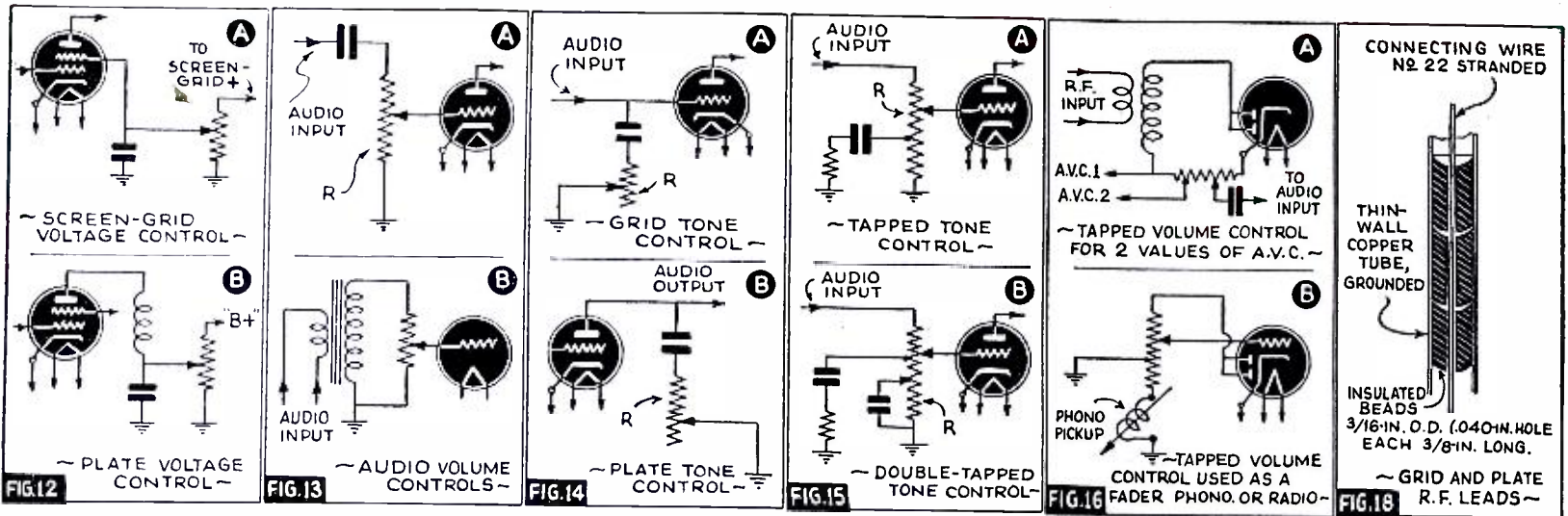

meg.) to 1 megohm, or more, depending upon the tube type. Figure 13B is the same audio control application, where R is shunt-connected across the secondary of an A.F. transformer or choke. For push-pull secondaries, resistor R becomes a twin or dual unit, controlled by 1 shaft. Depending upon the characteristics of the transformer, the value of control across the secondary winding will vary from 0.1-meg. to 0.5-meg., maximum. Figure 13B is also occasionally found arranged to control an R.F. circuit, in which case the values for R across a tuned circuit may vary from about 0.1-meg. to possibly 0.25-meg., maximum.

TONE CONTROLS

Most tone controls are simply a means to bypass or attenuate the higher audio frequencies, leaving the lower frequencies or bass apparently more prominent. This bypass control can be accomplished at the A.F. tube grid input per Fig. 14A, or at the plate circuit, per Fig. 14B. The grid-circuit method is preferred as there are no power considerations. Using the grid control circuit, the values of R may vary from 50,000 ohms to 1/2-megohm. For the plate-type control the value of R may be from 5,000 to 0.1-meg., maximum. The exact values depend entirely upon the total or degree of high-frequency attenuation required.

Tapped tone controls are in common use to hasten the high-frequency cut-off at 1 or more points on the control scale. Figure 15A shows the single-tapped type and Fig. 15B the double-tapped type; in the latter case, a very decided or abrupt attenuation of the high frequencies occurs upon passing the 2nd tap.

Tapped controls are also found in diode detector circuits to provide more than 1 value of A.V.C. as shown in Fig. 16A, and also used as a fader to change from phonograph to radio as per Fig. 16B.

In order to properly replace tapped resistors, one must be guided by careful measurements made on the defective unit to determine the total value, value of resistance at the taps and the taper, in some cases the taper may be left-hand on one side of the tap and right-hand on the opposite side of the tap!

R.F. WIRING

In relatively compact receivers, it is not unusual to find tests indicate poor sensitivity and gain due to inherent feedback coupling which has been inefficiently decreased. One common method to eliminate feedback is the excessive use of shielded braid R.F. plate and grid connecting leads. Ordinary R.F. shielded hookup wire has a very high capacity and when used for long grid leads may prevent proper alignment of the circuit with the trimmer provided.

Furthermore, due to the poor dielectric of the insulation the loss is always high and can increase to tremendous amounts with moisture absorption.

This common defect can be corrected by running all R.F. plate and grid leads as shown in Fig. 18, wherein the connecting lead is run through insulating beads which in turn are housed in a grounded copper tube. By using beads made of low-loss insulating material and also free from moisture absorption, for example Polystyrene or Amphenol No. 912B, a connecting lead is provided having low capacity, low loss and free from effects of humidity.

After having replaced ordinary shielded leads with efficient connectors, as described above, the gain and sensitivity are invariably substantially improved, in fact the receiver may now be unstable or actually oscillate in the R.F. stages. Such oscillations can be traced to coupling between stages using a common voltage supply. Isolation of this coupling will eliminate the feedback, preserve the high gain and restore stability.

FILTERS & DECOUPLERS

Figure 17 illustrates the method of applying the type of filters known as *decouplers*. The circuit under consideration may have 2 or 3 R.F. screen-grids connected together and served by a common bypass condenser. By providing each screen-grid with a filter resistor (R4, R5, of about 10,000 ohms each) and an individual bypass condenser (C5, C6, each about 0.1-mf.), the 2 (or 3) screen-grids are isolated. In compact sets, the R.F. plate-return leads of 2 or more R.F. stages may also be connected directly together to the power supply and bypassed by a common condenser. Filter resistors (R6, R7, about 10,000 ohms each) are inserted in these plate-return leads, together with separate bypass condensers (C3, C4, about 0.1-mf. each). Chokes may be used in place of resistors to avoid high D.C. voltage

loss. However in limited space, the use of chokes means a possibility of stray coupling between the chokes if they are not carefully shielded from each other.

In the applications described above, the bypass condensers form a low-impedance path for the R.F. to ground while the resistors offer a high-impedance path for the R.F. to the power supply. High-quality paper condensers must be used and for high-frequency applications low-loss mica condensers become necessary.

In the cathode circuit, the situation is a little different. If the cathode bias resistor is large, it offers impedance to R.F. signal currents and accordingly is bypassed by a condenser. Where 2 or more cathodes are connected directly together, it can be a source of common coupling between stages. This is best eliminated by using individual minimum-bias resistors (R1, R2) and separate cathode bypass condensers (C1, C2) as shown in Fig. 17.

Multiple audio-frequency stages can be isolated in the same manner, by a resistor and condenser (R9, about 5,000 ohms; C7, about 4 mf. or more) or by an iron-core choke and condenser Z and C7, respectively. In filtering A.F. circuits the bypass condensers need to be of sufficient size to offer a low-impedance path for the very lowest audio frequencies to be passed. Accordingly the condensers must be of relatively large size, 4 to 8 mf. or more, and of good quality.

This series of articles, together with the series on "Emergency Servicing Without Test Meters," which appeared in the August and October 1939 and the January 1940 issues of *Radio-Craft* form a valuable reference work for Servicemen in instances (which occur all too frequently) where either no diagram is available or suitable test instruments to check on various symptoms are not handy. We would appreciate hearing from Servicemen regarding future articles on similar topics. Any suggestions?

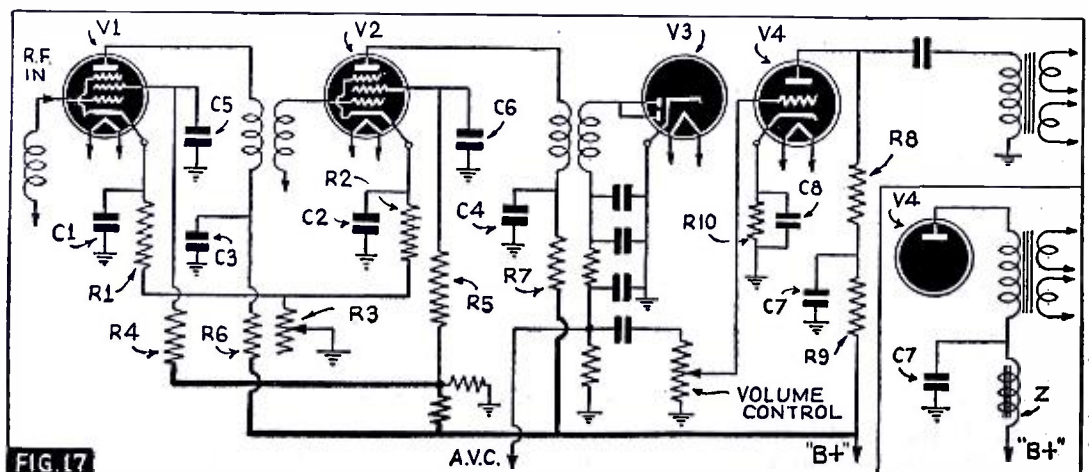

Radio Service Data Sheet

276

G. E. MODEL HB-412 "CARRYABOUT"

4-Tube Superhet.; A.C.-D.C. or Battery Operation; Built-In "Beam-a-Scope" Antenna; 4-In. Dynamic Speaker; Airplane Type Dial; A.V.C.; Tuning Range, 540 to 1,600 kc.; Power Output (max.), 2 W. on A.C. (using 117L7GT), 200 milliwatts on Batteries (using 1T5GT).

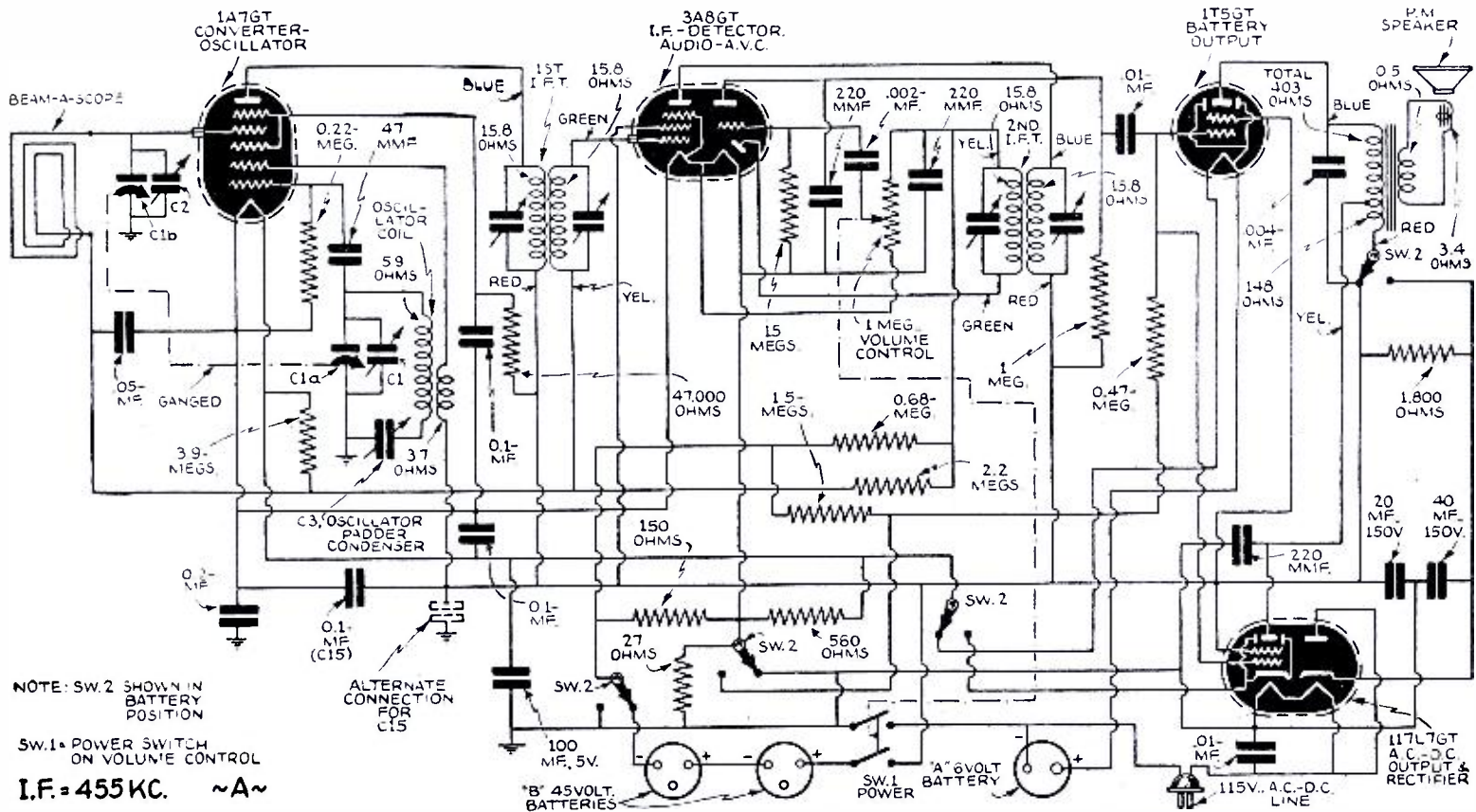

NOTE: SW.2 SHOWN IN BATTERY POSITION
SW.1 - POWER SWITCH ON VOLUME CONTROL
I.F. = 455 KC. ~A~

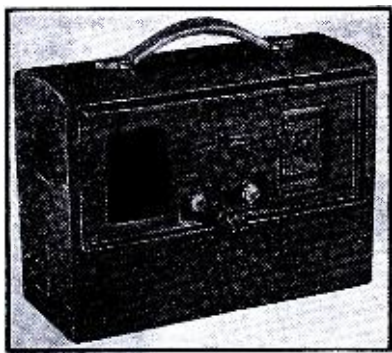
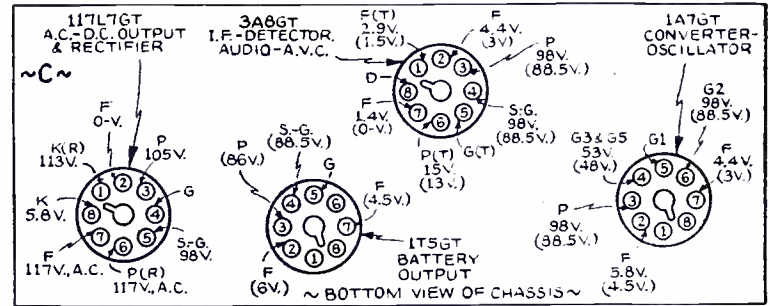
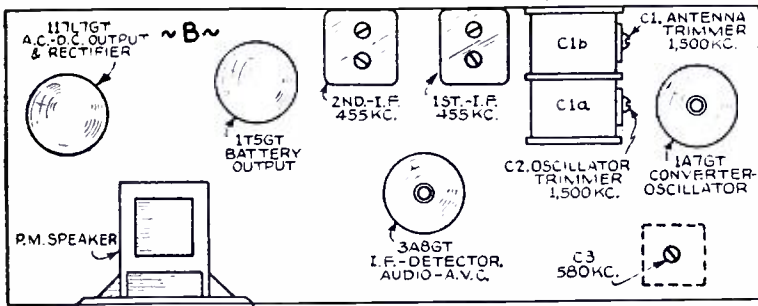

G. E. Model HB-412

Audio power output is obtained from the 1T5GT on battery operation, and from the pentode section of the 117L7GT on A.C. or D.C., 115-V. operation. The driving grids of the 2 tubes are in parallel. On battery operation the 117L7GT is "dead" due to no filament voltage, as is the case of the 1T5GT on A.C.-D.C., 115-V. operation. A tapped primary output transformer is used to insure matching to the different load impedances of the 2 output

tubes. If the receiver does not operate on low line voltage check 117L7GT for low plate current since its plate current energizes the 3A8GT and 1A7GT filaments; also check 1A7GT for low emission. Precaution:

Model HB-412 when used on an A.C. power supply will have one side of the chassis connected directly to the line. In order to prevent injury to alignment equipment or shock to the Serviceman, use an isolating transformer between the convenience outlet and the receiver power cord.

ALIGNMENT PROCEDURE

This receiver must be removed from the carrying case in order to perform the alignment. Special care must be exercised to place the batteries, Beam-a-Scope (loop antenna) and chassis in the same relative positions with respect to one another as these components occupied in the case; otherwise, alignment will not be satisfactory.

I.F. ALIGNMENT

With batteries, Beam-a-Scope and chassis in position for alignment as mentioned above, and using an isolating transformer if operating from an A.C. power source, set up and align as follows: Connect an output meter across the voice coil. Rotate the volume control to maximum. Set test oscillator to 455 kc. and apply signal to the control-grid of the 3A8GT tube through a 0.05-mf. condenser. Align the 2nd I.F. transformer trimmers. Next apply signal to the control-grid of the 1A7GT through the same 0.05-mf. condenser and align the 1st I.F. transformer trimmers. Retouch the 2nd I.F. transformer trimmers while applying signal to the 1A7GT tube. Do not remove the grid leads from the tubes when applying the oscillator signal and keep the test oscillator output as low as a readable meter reading will permit.

R.F. ALIGNMENT

Place a 1-turn coupling loop not closer than 6 inches from the receiver Beam-a-Scope. Apply a 1,500 kc. signal to the coupling loop. Set pointer to 1,500 kc. and align the oscillator trimmer (c1a). Peak (c1b) for maximum output. Change test signal to 580 kc. and with pointer in region of 580 kc. peak (c3) while rocking the gang condenser. Retrim at 1,500 kc.

The Beam-a-Scope leads should be dressed the same after the components are mounted in the cabinet as during alignment.

OPERATING VOLTAGES

Normal operating voltages are given in the above diagram. They are measured between the socket terminal indicated and chassis. Circled figures indicate values obtained when operating with a 6-V. "A" battery and a 90-V. "B" battery. Remaining voltages were obtained when operating on a 117-V. A.C. power supply. Readings greater than 50 are obtained on a 250-V./scale of a 1,000 ohms/volt meter.

CONCLUSIVE TESTING

That Builds Profits

MODEL 1213 TUBE TESTER

FOLDEX TUBE CHART!

A folding "card-index" system giving quick and complete tube data with the additional advantage of new tube supplements mailed free to registered users.



Only \$22.00 Complete

Model 1213 contains all sockets to check present-day tubes, including Loc-tals, Bantam Jr., and the new 1.4-volt Miniatures. Tests High Voltage series including 117Z6G; also gaseous recti-

fiers, Filament voltages in 20 steps from 1.1 to 110 volts. Neon shorts test and Ballast tube continuity test. Has RED•DOT Lifetime Guaranteed Instrument. Complete in Black Baked Enamel Suede Finish Case. Dealer Net Price, \$22.00

Write for Catalog! Section 165 Harmon Drive

THE TRIPLETT ELECTRICAL INSTRUMENT COMPANY
Bluffton, Ohio

Big Value . . . TUBE TESTER COMBINATION

ONLY
\$26.85
DEALER NET



With RED•DOT Lifetime Guaranteed Meter

Readrite
RANGER

MODEL
432-A-742

- Model 432-A-742 is a combination Tube Tester and Volt-Ohm-Milliammeter.
- Complete Volt-Ohm-Milliammeter, 16 Ranges
 - Sockets for All Tubes . . . Filament Voltages from 1.1 to 110—A Safeguard Against Obsolescence
 - Precision Indicating Instrument with Two Highest Quality Sapphire Jewel Bearings
 - Separate Line Control Meter
 - Neon Shorts Test
 - Approved RMA Circuit
 - Portable Black Leatherette Covered Case—Professional in Appearance. Etched Panel. Complete, less batteries . . . \$26.85 . . . Dealer Net Price.

Write for Catalog! Sec. 516 College Ave.

READRITE METER WORKS, Bluffton, Ohio

MATHEWS RADIO SERVICE

THE service shop picture (below) shows my idea of what a modern shop should look like. No effort was spared to make the panel as neat as possible. Even the aerial wires were wired into jacks on the lower panels next to the Service manuals. (*)

The 2 lower panels, extreme left and right, are duplicate for servicing 2 auto-radio sets at the same time. Two pairs of jacks—male and female—of the standard auto plug type are mounted in the lower portion of these panels. With this arrangement the lead connected to the auto set can be plugged in to either the negative or positive side of the circuit. The ground to the set is supplied by an accessory lead plugged into the opposite polarity. One of the meters is a 0-10 V. voltmeter; the other is a 0-10 A. ammeter. A heavy-duty storage battery is wired with No. 8 wire to each auto panel to supply the necessary 6 volts. The battery is automatically kept charged by a trickle charger.

The A.C. outlet, second from the left, is used for soldering irons. This outlet has a special provision for reducing the voltage on the iron when not in use. The A.C. outlet on the extreme right is wired to a Chanalyst wattmeter indicator so that the "wattage" of any set can be determined instantly by plugging into this socket.

The large, white toggle switch under the Chanalyst instrument is a 10-ampere throw-out switch. The entire bench A.C. supply goes through the switch. Whenever there is a short, such as a defective power transformer, all you have to do to restore power to the bench is to flip the switch.

LOUIS K. SANDOR,
Piqua, Ohio.

*See "Building an Amplifier to Test Amplifiers," Radio-Craft, March, 1940.

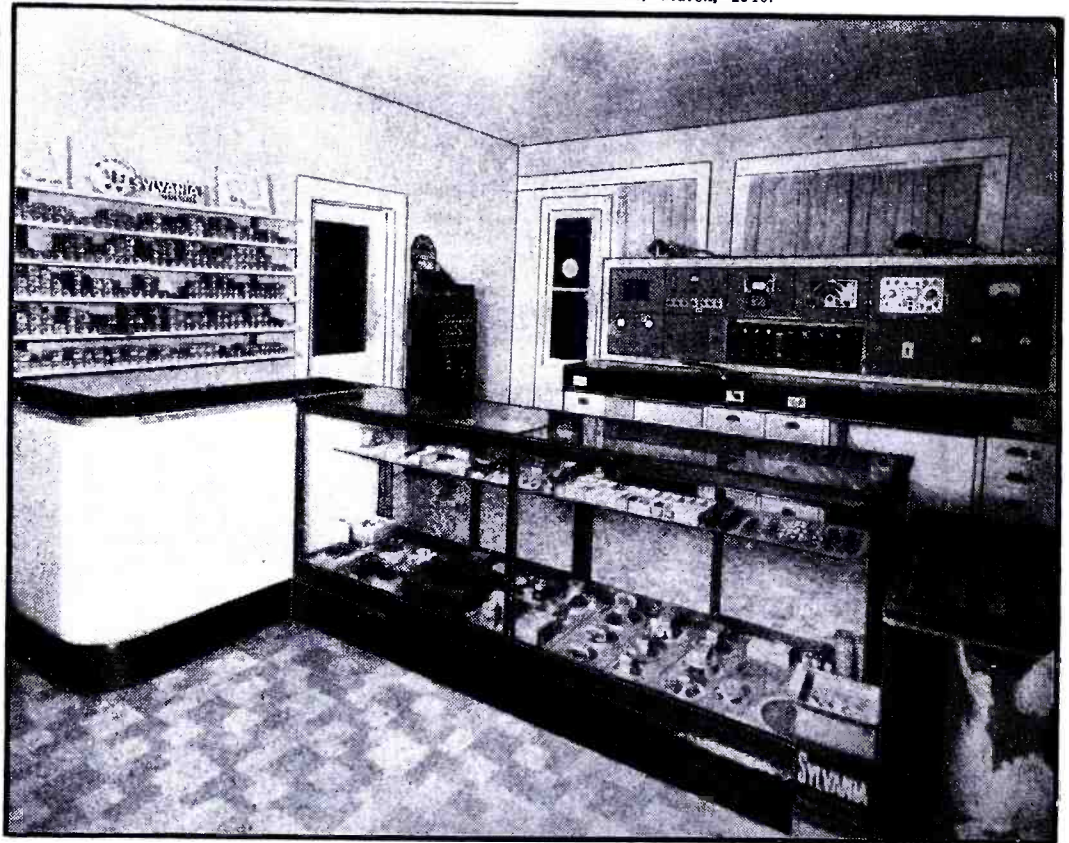

THE BUSINESS-LIKE SHOP OF MATHEWS RADIO SERVICE

(The test panel at right-center is shown close-up in March *Radio-Craft*, pg. 521. See story above, and data below, for the details.)

The bench was designed so that the 2 Servicemen could work on it at the same time with about the same efficiency. Each of the 10 unit panels on which the instruments are mounted are standard amateur panels, 14 x 19 ins., finished in gray crackle. The bench top is just 40 ins. from the floor. This may seem high to some people but we have found that the biggest advantage is that it gets the work closer to your eyes. This reduces eye strain considerably and gives you a better view of the wiring of the set. The top of the bench is 30 ins. from the front to the test panel and is 10 ft. long. It is covered with heavy black mottled linoleum. The bench is built 2 feet from the back wall so that all wires and instruments are easily accessible from the back. Our service shop goes under the name of Mathews Radio Service. John L. Mathews (W8TEI), and the writer (W8QNU) are partners.

RCA VICTOR MODEL M-60 AUTO RADIO (Chassis No. RC357K)

6-Tube Superhet.; Pushbutton Tuning; Automatic Volume Control; Antenna Noise-Filter; Battery Drain, 6.5 Amperes; Power Output (max.), 3.5 W.; Broadcast Band.

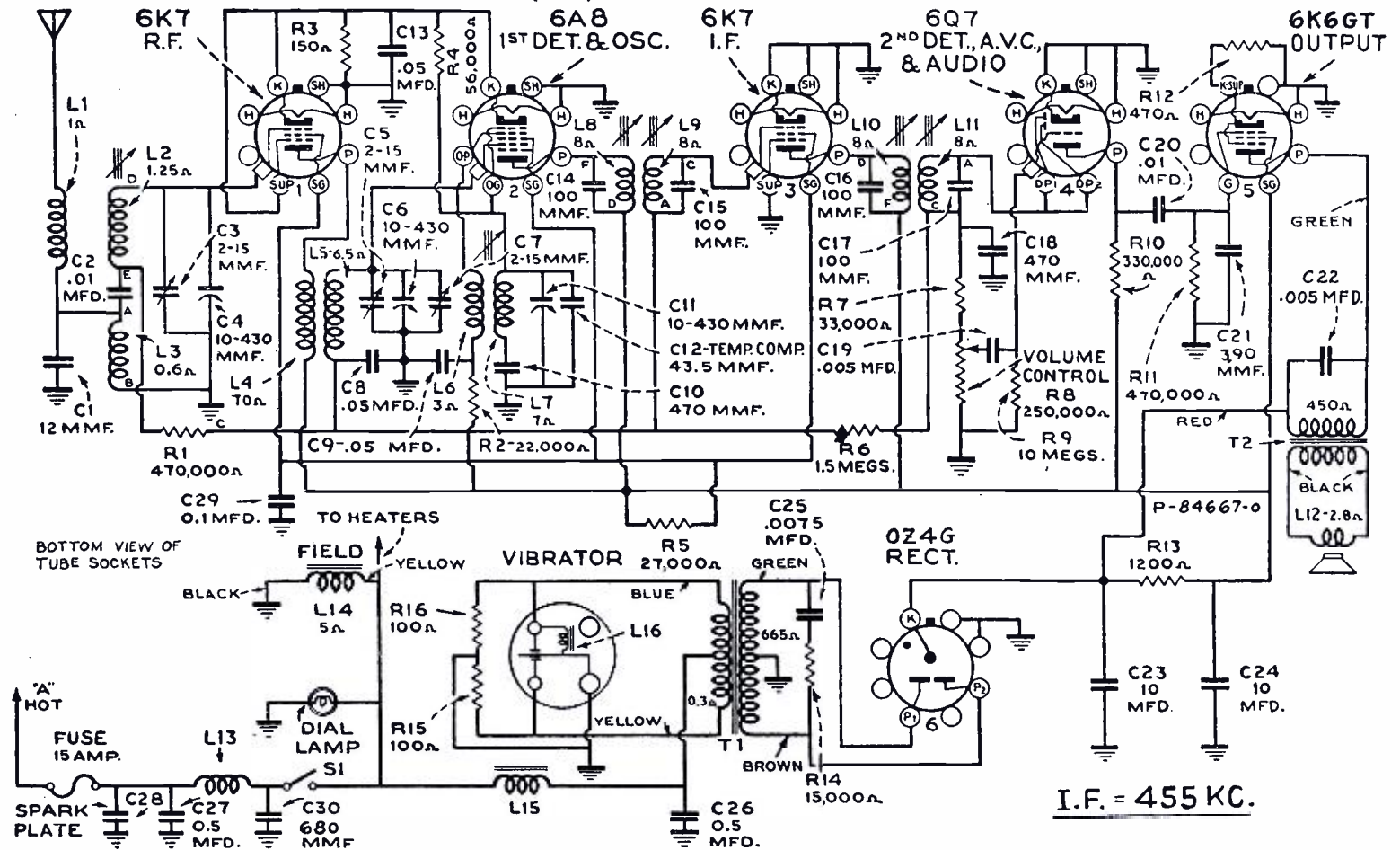

Fig. 1. Schematic circuit of RCA Victor model M-60 auto-radio.

Antenna Circuit. The antenna circuit is designed to work with an antenna having a total capacity including the shielded lead-in not to exceed 150 mmf. If an antenna having a larger capacity is to be used, it will be necessary to add a condenser in series with the lead from antenna to add a capacity of approx. 200 mmf. Where a "double under-the-running-board" type of antenna is to be used having a capacity of approx. 300 mmf. The insulated running board type having an approx. capacity of 550 mmf. will require a condenser of approx. 200 mmf. Cars using an insulated steel top of approx. 3,500 mmf. will require a series condenser of 150 mmf.

After installation, and with antenna connected, tune-in a weak station near 1,400 kc. and adjust compensator trimmer C3 for maximum signal output. This trimmer is accessible by prying-off the nameplate between the control knobs.

Antenna Filter. A filter is included in the antenna circuit. Being completely shielded, it prevents radiating ignition interference within the set. It also produces the possibility of picking up vibrator interference. The filter unit is mounted inside a steel shell which in turn is welded to the chassis. The shielded antenna lead-in makes contact with the filter unit within the steel shell and is held in place by a bayonet-type connector.

Alignment Procedure. Use an output meter across the speaker voice coil. A 1.8-volt reading indicates output of 1 watt. Volume control should be in full clockwise position.

IMPORTANT ALIGNMENT NOTES

* Make the generator connection to the receiver through a shielded lead-in having not more than 50 mmf. (0.0005-mf.) capacity with a male connector attached for connection to antenna socket. If a condenser has been added in series with the lead from antenna filter L1 to the antenna coil, as outlined under "Antenna Circuit," for reason of a high-capacity antenna, the Dummy Antenna should be the same value as the antenna itself.
* Readjust C3 after installation as outlined under "Antenna Circuit."

Each step of the alignment should be repeated in its original order for greater accuracy. Always keep the output from the generator at its lowest possible value, to prevent the A.V.C. action of the receiver from interfering with accurate alignment.

Alignment adjustment locations are shown on the top and bottom parts location views of chassis.
Only the dummy antenna indicated in the chart for any particular frequency should be used. Grid cap leads should remain in place during alignment.

Position of Dial Pointer	Generator Frequency	Dummy Antenna	Generator Connection	Adjustment Symbol	Circuit Adjusted
No Signal	455 kc.	0.001-mf.	6K7 I.F. Grid	L10, L11	2nd I.F. Trans.
550-750 kc.	455 kc.	0.001-mf.	6A8 Grid	L8, L9	1st I.F. Trans.
Rock Through 600 kc.	600 kc.	0.0001-mf.†	Ant. Lead	L7	Osc.
1,400 kc.**	1,400 kc.	0.0001-mf.†	Ant. Lead	C5	Det.
1,400 kc.**	1,400 kc.	0.0001-mf.†	Ant. Lead	C3	Ant.
Rock Through 600 kc.	600 kc.	0.0001-mf.†	Ant. Lead	L7	Osc.
1,400 kc.**	1,400 kc.	0.0001-mf.†	Ant. Lead	C5	Det.
1,400 kc.**	1,400 kc.	0.0001-mf.†	Ant. Lead	C3*	Ant.

OSCILLATOR CIRCUIT

A magnetite core is used to provide temperature stability. The conventional high-frequency trimmer has been replaced with a fixed temperature-compensating condenser, C12, which determines the high-frequency range. Since the inductance of L7 is adjustable, the conventional series trimmer has been replaced with a fixed condenser, C10. Unit C10 is a special condenser having zero temperature coefficient to provide for oscillator stability in the low-frequency range. Aligning the receiver for 600 kc. is accomplished by adjusting L7 to the antenna and detector circuits (gang condenser must be rocked while making this adjustment). The 1,400 kc. alignment is accomplished by adjusting the antenna and the detector trimmers, C3 and C5, to the oscillator.

SOCKET VOLTAGES

The normal operating voltages indicated in Fig. 3 were obtained with a 1,000 ohms/volt D.C. meter having ranges of 10, 50, 250 and 500 V. Each value should hold within ± 20 per cent. Storage battery voltage 6.3. Volume control set at minimum; no signal input.

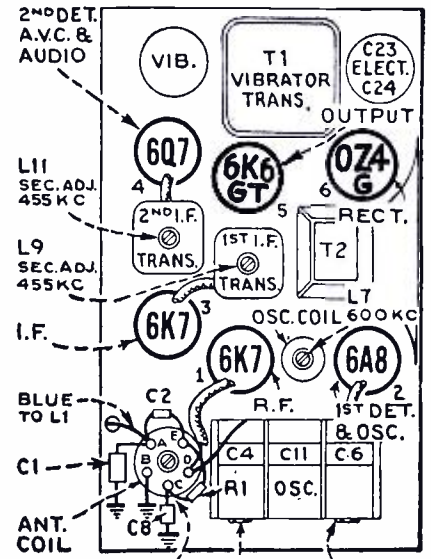

Fig. 2. Chassis layout and trimmer locations.

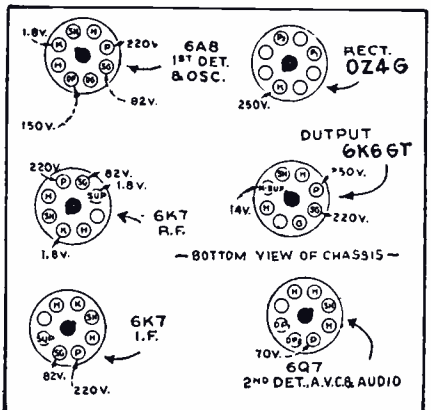

Fig. 3. Normal operating voltages.

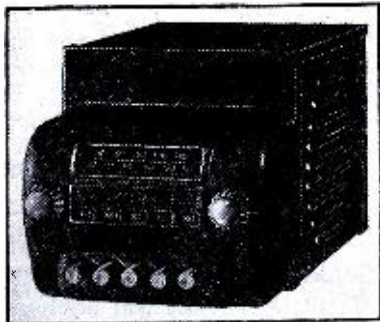

Fig. 4. RCA Victor model M-60.



Ozzie Nelson and his orchestra are shown making recordings of their musical arrangements. Hundreds of recorders are in use all over the country in similar capacities. Recording is "taking hold" very rapidly. So much so in fact, it is predicted that the 1941 line of phono-radio combinations will include home recording as an additional feature. Wideawake Servicemen and sound techni-

cians should get in on the ground floor of this new recording boom. The tabulation on the opposite page shows some of the more common uses to which recordings are put these days. Every community, small and large, must have some use for a recording machine—if these uses are pointed out to them by some well-qualified person—you, Mr. Serviceman and you, Mr. Sound Man.

PROFITS IN RECORDING

This article proceeds from the first step of analyzing local markets for setting-up an "instantaneous recording" enterprise, through the procedure of making contact with the many prospects for recording services, to the conclusion of obtaining and setting-up proper equipment for making sound-on-disc recordings. Elementary technicalities are discussed. The author is a manufacturers' representative.

SAM M. HARPER

TO the modern Serviceman looking around for ways and means to increase his store traffic and earnings, the writer heartily recommends the comparatively new art of *instantaneous recording*.

In the writer's travels as a sales engineer for several manufacturers of equipment selling to the service engineer through the radio parts jobber, he has been brought face to face with the fact that many times the Serviceman depending solely upon the revenue derived from radio servicing is totally unable to invest in capital goods and not being able to invest in capital equipment, to speed up his work and make his business venture profitable, he naturally suffers by a continued dwindling of incoming new business until all that he has left is virtually a store with a door and a counter. This state of affairs is appalling to the manufacturer, jobber and salesman, all of whom are vitally interested in the success and growth of the individual Serviceman-dealer whether he be in the large metropolitan center or smallest of the small towns.

Instantaneous recording as a business is sound and stable and has far greater chance of succeeding than any other type of venture that we know of. Portable equipment of excellent quality is now available from several manufacturers and no trouble should

be experienced in choosing the particular type of recorder that will satisfy your likes and pocketbook.

WHERE SELL RECORDING?

One of the first steps in setting up a recording enterprise is, of course, to make a thorough analysis of your local market. Such analysis should be based upon the amount of monthly business, repeat business, you can expect from the different types of prospects once you have become established.

With well-designed apparatus it is possible for anyone to make high-quality recordings to meet practically any purpose. See Table I. Recording music and radio programs broadcast on the foreign shortwave bands, addresses of famous speakers, sound accompaniment for home movies, personal messages and greetings are but a few of the many uses to which recording equipment can be put.

Teachers, actors, singers, dancers, public speakers and performers readily perfect their technique by means of records made during their performance or rehearsal. Instructors of music, speech, public speaking, etc., realize that better progress is made when the student is able to hear himself as others hear him, and are turning to record-

ings as the most practical method to use in developing students quickly and surely. Since hardly any of the teachers in this category are financially able to purchase their own equipment, they can readily be sold on your recording service. You should be able to anticipate at least one record per month per student when compiling your analysis of available business.

Prospects for recording are as numerous in the small towns as they are in the large metropolitan areas. The small-town dealer has, however, prospects for recordings that are not easily available to the large city dealer. Nearly every local community boasts of a "little theatre" movement. The people and organizations associated with such activities are enthusiasts and spare no expense to improve their performances. Approach the local director and convince him of what a convenience such recordings are in enabling him to learn how performers read their lines and to the performers themselves, enabling them to improve their diction.

CHARGES

A little thought will disclose many other prospects for recordings in your community but remember that the fee for recording is not the only element of profit. The studio

will bring many new faces into your store and develop many valuable prospects for other merchandise which you handle, in addition to complete portable recorders.

Prices for individual recordings may be graded from \$1 to \$5 according to the length of such recordings. The usual price charged by metropolitan studios is \$1 for a 6-inch recording and \$5 for a 12-in. recording. Rehearsal time is usually charged at from \$3 to \$4 per hour. Copies of originals can be supplied at prices varying from 75c for one side of a 6-in. record to \$3.50 for a 12-in. record.

Where copies are required, they can either be supplied by the so-called *dubbing* process; or, where the quantity is considerable, by means of *pressings*. Dubbing can be accomplished very well by any experienced operator who has a good phonograph with a steady motor. Dubbing of this nature can be done by wiring the phonograph pickup directly into the phono input of the recording amplifier.

It is rather simple to set up a studio in almost any dealer's store as a starter. The studio need not be over 8 x 12 ft. maximum. In this can be built the heavy benches on which to set the recorder. Monk's cloth can

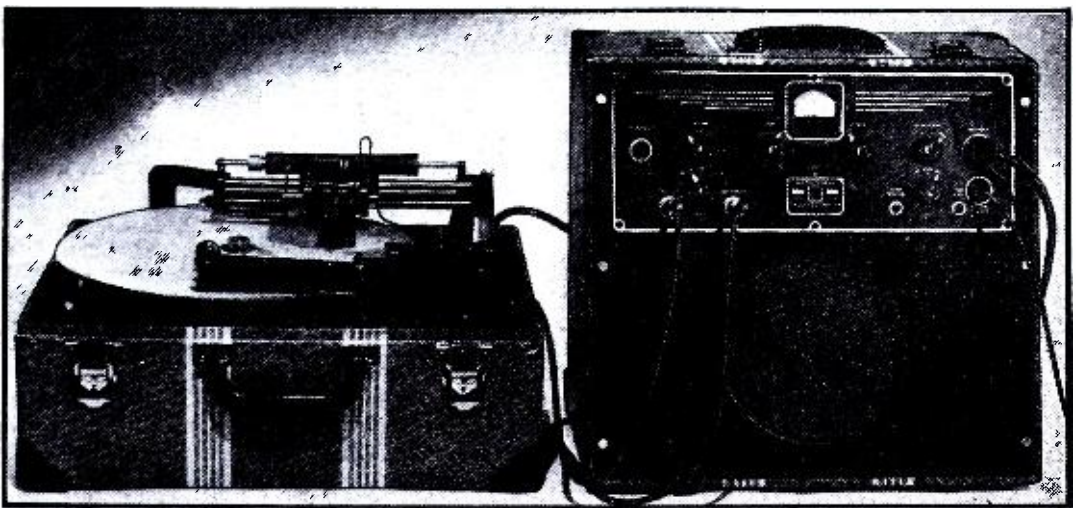

Fairchild model F-26-3 Portable Recorder and Amplifier. This 2-unit portable instrument records and plays-back at 2 speeds and cuts up to 16-in. transcriptions. Adjustable pitch permits cutting "inside out" or "outside in." The 12-W. amplifier is said to have flat frequency response from 40 to 10,000 cycles; push-pull design throughout each of its 4 high-gain stages results in low harmonic distortion and low hum level. Crystal cutter and pickup; 10-in. loudspeaker.

discs to use with his machine. It is not uncommon for established dealers and studios in the smallest towns to sell as many as 100 12-in. blank discs per month.

TABLE I—SOUND-ON-DISC PROSPECTS

Among the definite prospects for your recording services are:

LARGE STORES	Advertising sales with "personal" recordings.
SALES MANAGERS	Meetings all over the country may be addressed simultaneously.
CONFERENCE COMMITTEES	Recording important business conferences.
MINISTERS	Send sermons to small population areas in far-removed districts. Self-instruction.
HOMES	Children's voices, parties, amateur theatricals, musical programs. Converting home-movies into home-talkies. Making sound "veris" of ham-radio DX phone or code contacts.
SCHOOLS	Correcting defects in speech, etc. Making records of important speakers.
MUSIC LOVERS	To make recordings from radio set or other source of favorite selections.
LAWYERS	Recording depositions. Preparing and practicing for cases.
BROADCASTING STATIONS	Recording special programs and all broadcasts.
HOTELS	Recordings to guests as souvenirs.
ADVERTISING AGENCIES	Recording auditions. Sending advertising messages to prospects, etc.
POLICE DEPARTMENTS	Recording witnesses' stories, etc.
DETECTIVES	Recording descriptions of lost persons, witnesses, etc.
NIGHT CLUB MANAGERS	Fill-in records when orchestra absent. Souvenirs for guests.
TEACHERS AND STUDENTS OF VOICE, MUSIC, DRAMA	Teachers may point out strong points or defects in students' work.
THEATRES	Sound effects, etc.
MUSICIANS, VOCALISTS, INSTRUMENTALISTS	Applications for auditions. For self-criticism.
ACTORS	Recordings to send friends; to apply for parts in distant plays.
DOCTORS	Experimental work (as recording heart phenomena), etc.
VAUDEVILLE, CABARET AND CONCERT ARTISTS	Auditions, souvenirs, practice.

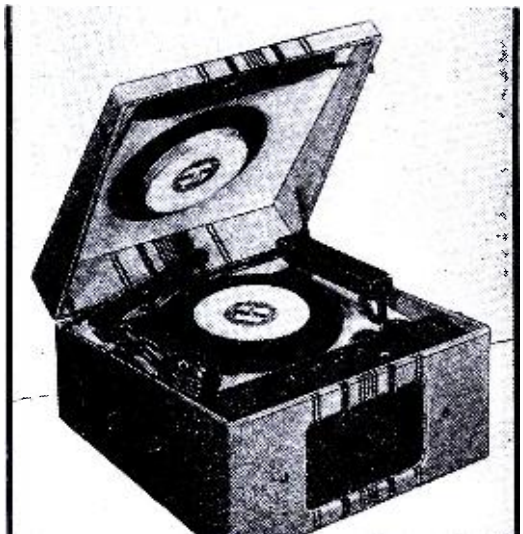

Here is the Speak-O-Phone model 1-52 Combination Instantaneous Recorder—Playback and Public Address Unit. Amplifier output is 4 W. Magnetic cutter and crystal pickup. A General Electric high-torque motor is utilized in this instrument. Turntable is heavy cast aluminum. An interesting Speak-O-Phone feature is the drive mechanism which is a tangent arm, positive-drive underneath assembly. Total weight, 34 lbs. Instrument is supplied complete with crystal microphone.



An "eye" tube is incorporated in the above-illustrated Wilcox-Gay "all crystal" model A-72 Recording instrument for indicating correct recording level. The eye tube has a circuit network which creates quick response and slow recovery so that the indications will not confuse the lay operator. The output of this instrument with minimum distortion is 3 W.; "its response characteristic on microphone recording is acceptable from 50 cycles to 7,000 cycles," the manufacturer states. Rotary switch selects positions as follows: recording, transcription, public address. Cutter, pickup, and microphone, all are crystal.

be used to drape the walls to improve acoustic qualities. The dealer setting up a studio has, in addition to his original recording business, the opportunity of developing prospects for completely portable recorders and good phono playback equipment. The sale of completely portable recorders can be a veritable gold mine when you bear in mind that the purchaser must buy blank

CHOOSING AND TESTING

In this matter the writer of course recommends the purchase of a completely portable recorder, all components pre-assembled in its case from the manufacturer. Lately, however, there has appeared on the market a series of component parts supplied by one manufacturer which have been designed to operate together. These parts can either be

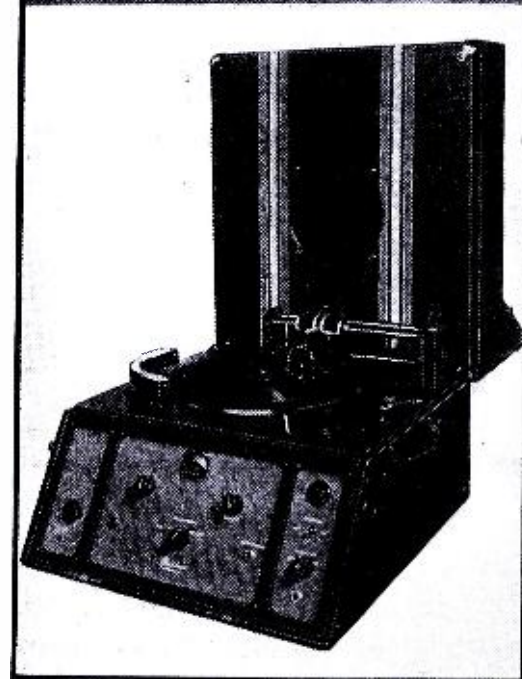

Top.—RCA Victor Portable model MI-12701 Recorder and Playback instrument. Of especial importance is a newly-developed cutter head "float stabilizer" which counteracts "flutter" due to microscopic variations in the texture of the lacquer on coated blanks. Magnetic cutter and crystal pickup; velocity microphone. Overall weight, 37½ lbs. Amplifier output, 3 W. Cuts "outside in" on 12-in. records, at 78 r.p.m. Meter V.I. A specially-designed motor assembly is said to assure freedom from "wows."

Bottom.—the Radiotone Portable model HR-11 Recorder and Phonograph. It includes a 3-position switch for recording, playback and public address. Rim drive, dual speed, (78 and 33 1/3 r.p.m.), lathe-type positive overhead lead screw, recording "outside in" on 12-in. discs. Magnetic cutter, crystal pickup, crystal microphone. Amplifier output is 5 W., and incorporates 1 low-gain stage for dubbing channel. Electronic eye for V.I. Cutter frequency range, 50 to 5,500 cycles. Overall weight, 50 lbs.

purchased pre-assembled or as individual units. The entire list is built around what is called a "basic mechanism," which in reality consists of the complete tracking mechanism, turntable, cutting arm and cutting head. For those persons now owning a good amplifier and accessories, this mechanism will permit the setting-up of professional equipment with a minimum of capital investment.

There has been but little radical change in recording equipment in the last few years. Major changes have centered around quieter gearing in the tracking system and refinements in the cutting heads used.

When the purchase of a completely portable recorder is contemplated, the purchaser should first make up his mind not to let the price angle influence him because price is usually the result of manufacturing costs and since manufacturing costs are more or less the result of production methods used, it can readily be seen that for any two

given manufacturers producing the same identical article the list price might fluctuate as much as \$50.

Therefore do not let the list price of the recorder influence you but rather note very carefully the performance of the unit under investigation. Particular attention should be paid to the following:

(1) Turntable should be machined, rim and top should be smooth. A table turning at rated speed may not introduce perceptible "wow" if wobble is under 1/64-in. Any wobble in the turntable or any variation in speed will result in unsteadiness of tone. This may not be noticeable in certain types of recording, such as "swing" music, but will result in unsatisfactory recordings of classical selections and piano solos. The turntable itself should be fairly heavy, but most important, it should, regardless of weight, have most of its weight concentrated in the rim in order to obtain maximum flywheel effect and thereby smooth-out vibrations and variations in speed. In this connection, check the turntable speed with a stroboscope and neon light.

(2) Amplifier gain should be sufficient to record normal speech with the speaker standing from 10 to 15 feet from the microphone, without having to turn the gain on full.

(3) Check gear and turntable rumble. This is important, for if there is too much rumble present it will be recorded, and will no doubt ruin recordings that are made at a low level. Rumble can be conclusively checked by recording your voice at the normal volume as indicated by the volume level meter supplied with the recorder, for a few revolutions of the turntable—then remove the microphone from the amplifier and finish cutting the record without any input. During this test the volume control setting should not be changed. When the record is cut, play it back and if there is any noise other than a slight amount of scratch (normal) the unit should be rejected as an unsuitable purchase if satisfactory performance is expected.

(4) Gear pattern can be checked the same way as rumble. After the record is cut, there should be only the clean-cut groove showing on the record. Any extraneous pattern showing on the record, as for example a spiral shadow superimposed on the grooves, is indicative of either poorly designed tracking mechanism or drive system, or that the unit has been badly adjusted.

78 OR 33 1/3 R.P.M.?

Practically all portable recorders now on the market are designed for operation at 78 r.p.m. Some machines using 16-in. turntables are equipped for dual operation (78 and 33 1/3 r.p.m.) but for the radio Serviceman just entering the recording field we definitely recommend the unit with a 12-in. turntable and single-speed operation. The higher initial cost of dual-speed 16-in. equipment in view of the demands which you will have for its use is not warranted.

Records cut at 78 r.p.m. are always started at the outside of the discs. Playing time is governed by not only the diameter of the record but by the number of lines per inch which are cut along its diameter. Good recording practice demands that there be no crowding of the cut, which tends to cause bulging of the cut when sounds of high amplitude are recorded, thus causing poor frequency response, double-talk, and ghosts. Most recorder manufacturers have set a top limit of 100 lines-per-inch for machines other than those that are to be used by radio stations, and the largest recording studios, which employ the finest recording engineers to operate the equipment. The

only thing in favor of recording at more lines per inch is a slight gain in playing time.

The fidelity of a recording system depends upon the frequency range and quality of the cutting head, the stability of the turntable and the type of discs used, because it is assumed that all other components of a recorder offered by a reliable manufacturer will in general be capable of giving more than satisfactory fidelity. In general the cutting head governs the frequency response of the system thus you should be sure to get complete specifications from the manufacturer showing the frequency response of the head. It is not enough to just know that a recording head records to—let's say, 5,000 c.p.s. The real and important information you need to have is: how far down in decibels is it at 5,000 c.p.s., and at all other limiting frequencies? In general there is little to be said in favor of one type of cutting head over another (crystal vs. magnetic), both types as they are manufactured today offer very high quality operation as far as frequency response and durability are concerned. The magnetic type is, however, of a more rugged makeup than the crystal type, and is not so apt to be damaged in everyday use.

TYPES OF DISCS

There are 2 major types of discs in common use today, namely: (1) cellulose coated (the most popular), and (2) aluminum.

The cellulose-coated disc is broken down into 2 divisions, (1) those having aluminum centers and (2) those having cardboard or fibre cores.

As far as frequency response and general all-round usefulness is concerned, the writer recommends that you use the cellulose-coated, aluminum-cored disc. Most recording studios, today, use the cellulose-coated record for making professional and semi-professional types of recordings. This type of record offers but little over the plain, highly-polished aluminum disc and has a much shorter life than does the aluminum. The cellulose-coated disc, while offering considerably quieter recordings and somewhat greater frequency response, suffers in comparison with the aluminum record because of the shorter life, aside from playback, due to the drying-out of the compound.



Duplex model A-16 Recorder and Playback instrument; provides for attachment for converting silent movies into home-talkies. A feature of this instrument is the use of a 2-speed gear drive which is said to permit piano recordings at 33 1/3 r.p.m. "absolutely free of wows." Magnetic cutter, crystal pickup. The wow-free operation of the driving mechanism is due to a unique arrangement of gears coupled directly to the turntable through an intermediate filter. The A-16 will cut 16-inch ungrooved blanks at 78 or 33 1/3 r.p.m. A flexible shaft, attached to an independent gear-train driven by the same motor, enables hand-crank 16-mm. movie cameras to be operated at either 16 or 24 frames per second for synchronized sound. A clutch disengages the camera drive when desirable.

There has been a great deal of interest expressed on the question of instantaneous-disc durability. In the uncut condition, all discs can be kept for quite a while. Some formulas have been found unchanged after 4 or 5 years. The others will keep very satisfactorily if the containing can is kept taped to keep out dust.

In the cut condition, the cellulose disc has 2 enemies—(1) dust, and (2) wear. Dust will raise the noise level of a cellulose record instantly. You should never use cellulose discs in a room with open windows or with dusty surroundings. A valuable disc should be stored in a cellophane envelope which is both dust-proof and free from lint. When playing-back cellulose discs, a shadowgraph needle, with a radius to fit the bottom of the groove, should be used. It is understandable, of course, that the lowest possible needle pressure should be used. This pressure should not be over 2 ounces.

Cacti, fibre or wooden needles should not be used on an acetate record because the coefficient of friction is very high and the disc will be ruined in a few playings.

Aluminum discs with highly-polished surfaces are considerably lower in cost than cellulose-coated discs (about 50% lower) and if they are properly recorded may have only slightly higher surface noise. Diamond-pointed "cutting" (indenting) needles are required for recording (indenting) on aluminum. This type of needle has an average "cutting" life of several hundred hours. Considerably heavier needle pressure is required to record on aluminum discs than is required on cellulose. The average weight necessary to record on aluminum is from 15 to 18 ounces.

Most present-day recorders have been designed with provisions for recording on the aluminum disc by means of adding extra weight to the cutting head. One company in particular has designed its cutting arm and cutting head so that it can be changed instantly to record on either cellulose or aluminum without any additional equipment being necessary. This is accomplished by means of a locking latch to make the cutting arm rigid, thus placing the entire weight of the cutting arm and cutting head in cutting position.

A point to bear in mind in favor of aluminum discs is that they are more durable and have a longer life in any climate than coated discs. For this reason, aluminum is preferable when recording the voices of children for preservation over a period of years or for ordinary school or student work. Non-metallic needles, such as thorn, cactus or fibre, must be used when playing-back aluminum discs. It is not recommended that the aluminum disc be used for professional recordings due to the somewhat higher noise level of the recording.

Summing up, the writer is of the opinion that recordings and the sale of recorders offer the Serviceman and dealer a greater opportunity of service to his community and at the same time far greater earnings for himself than any other addition he might make to his business.

The author of this article is Manufacturer's Representative for The Turner Co.

Technical details which space limitations precluded running this month will appear in a forthcoming issue of *Radio-Craft*, if readers express interest in such an article.

The recording equipment shown in the photograph on the 1st page of this story is a Presto model Y recorder - playback instrument. The loudspeaker, which is part of the model Y unit, is not shown in this photo.

* The term "cutting" is used here in its popular sense, for actually there is no shaving at the needle-point, but instead the sound impression is indented.

SOUND TIPS ABOUT THE SOUND THAT'S TOPS



IN THE MOVIES, he-men like the one above mean dollars to exhibitors. They have public acceptance.

RCA offers you public acceptance in the sound business. And any man using a product with this vital advantage is well on the way to new business every time he approaches a prospect.

The RCA trademark is known everywhere. In the minds of your prospects and customers it means high grade equipment at reasonable cost. It means research and engineering plus the world's most comprehensive experience in sound. It's another reason why it will pay you to recommend RCA Commercial Sound.

RCA Mfg. Co., Inc., Camden, N. J. • A Service of Radio Corp. of America

FOR FINER SOUND SYSTEM PERFORMANCE—USE RCA TUBES

A NEW BOOK ON PUBLIC ADDRESS
An important announcement about the greatest book on the subject of sound and allied subjects appears on Page 644 of this issue. **TURN TO THE ANNOUNCEMENT NOW!**

PERFECT REPRODUCTION FOR STUDIO OR HOME
RECORDING - PLAYBACK AMPLIFIERS

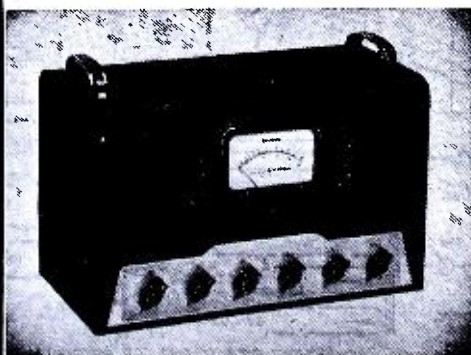

Designed by A. C. Shaney
YOU'LL WANT to know more about our entirely New Series of Professional Recording-Playback Amplifiers, because they offer features usually found only in the most expensive laboratory and studio equipment. Ideal for studio recordings or for the hobbyist who makes his own recordings.
FREE BOOKLET describes three economical, versatile recording-playback amplifiers.
Write or Wire Today for Complete Details and Unusually Attractive Prices.

AMPLIFIER CO. of AMERICA
17 WEST 20th STREET NEW YORK, N. Y.

SOUND ENGINEERING

*Free Design and Advisory Service
For Radio-Craft Subscribers*

Conducted by A. C. SHANEY

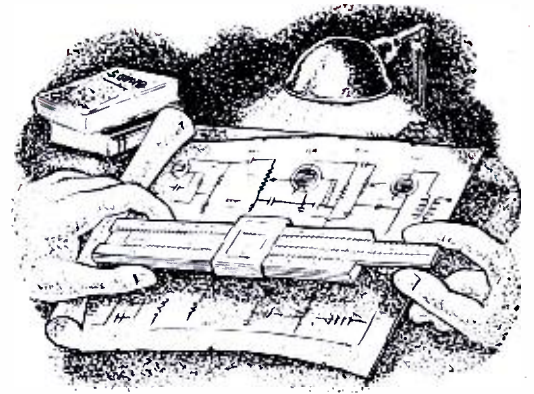

This department is being conducted for the benefit of RADIO-CRAFT subscribers. All design, engineering, or theoretical questions relative to P.A. installations, sound equipment, audio amplifier design, etc., will be answered in this section. (Note: when questions refer to circuit diagrams published in past issues of technical literature, the original, or a copy of the circuit should be supplied in order to facilitate reply.)

No. 5

XTAL MIKE PREAMPLIFIER

The Question . . .

I would like to have the circuit and the values of the various parts to be used in building a small portable preamplifier, to be energized by a crystal microphone and to feed into a 500-ohm line at approximately 90 db. gain and 2-5 watts power output. I would like to use a type 80 rectifier and type 57 tubes, resistance-coupled, all powered by 110-V., 60-cycle A.C. No volume or tone control need be provided, just an on-off switch.

P. W. BOGESS,
Sunbury, Pennsylvania

The Answer . . .

A circuit of a small portable preamplifier of the type you desire is illustrated in Fig. 1. You will note this is essentially a 3-stage job utilizing a 57 pentode for the 1st stage, a type 57 triode for the 2nd stage, a 6V6 pentode for the output stage, and a type 80 rectifier. The overall gain of this amplifier is approximately 90 db.

Although you did not request the inclusion of a volume control, this was added so as to make the preamplifier suitable for some of our other readers who may desire such a circuit variation. You of course can substitute a 1/2-megohm resistor in place of the 1/2-megohm volume control. I do not however, recommend the omission of the volume control, as its use will enable you to adjust the gain of the preamplifier to your required level and, at the same time, will prevent excessive tube noises, hum, and microphonics generated in the 1st stage from appearing in the output.

Your requirements of a 2-5 watt power output seems rather unusual for a preamplifier. I presume, however, that this unit has some special application, and I have therefore used a 6V6 output tube, which is capable of delivering 2 watts with 180 volts on the plate and screen-grid, or 4.2 watts with 250 volts on both the plate and screen-grid. If the latter condition is desired, the high-voltage secondary of the power transformer should be capable of delivering approximately 200 volts from each side of center-tap, under full load condition. On the other hand, if the former power is desired, the power transformer need only deliver 160 volts from each side of center-tap, under full load condition.

The circuit follows conventional design procedure with the exception of the use of 3 instead of 2 chokes. This precaution has been taken to insure low hum.

The output transformer should have a primary impedance of 5,000 ohms and a secondary impedance of 500 ohms. Its primary should be capable of carrying 50 ma.,

D.C. The power transformer should be equipped with a 5-volt 2-amp. rectifier filament secondary, 2.5-volt 2A. winding, as well as a 6.3-volt 1/2-amp. heater secondary for the output tube. Chokes Ch.1 should be 10 henries. Choke Ch.2 should be a 300-ohm, 30-henry unit. All resistors are of the 1/2-meg. type unless otherwise indicated.

The 1st stage 57 should be shielded in order to avoid hum pick-up. The only precaution to follow in constructing this unit is to prevent hum pick-up by the output transformer from either the power transformer or the filter chokes.

If a high-frequency cut-off is desired, it may be included, as indicated in the dotted portion of the diagram.

"WIRELESS" PICKUP

The Question . . .

I would like to have on 1 base, a power pack, a volume expander, a record-scratch suppression circuit, and an oscillator for a "wireless" pickup. Separate boost and suppression for low and high audio frequencies should be included, and the overall frequency response should be as good as feasible. This unit would be for use with a phonographic pickup, alternately for direct connection between the pickup and audio amplifier or remote reception by radio.

H. ORLO HOADLEY,
Rochester, N. Y.

The Answer . . .

Your particular problem has no practical or even feasible solution because of a number of interfering factors.

In the first place, high-fidelity performance can not be attained through conventional oscillator "wireless" pickup circuits, unless expensive components are employed. In the second place, the addition of either a volume expander or a scratch suppressor

to any old amplifier will rarely result in satisfactory performance.

As the operation of both the expander and scratch suppressor are closely linked to the design of the amplifier, I do not recommend that any such features be added as auxiliaries in existing amplifiers. A great deal of harm has unquestionably been done by many experimenters and technicians who have used expanders incorrectly.

A complete discussion on this phase of the subject will be found in the November, 1939 issue of *Radio-Craft*, pg. 302.

HI-FI PHONO AMPLIFIER

The Question . . .

Your new free consultation and design service is certainly great. I'm all for it.

I would like your recommendation on a high-fidelity phono amplifier for home use.

I had in mind the push-pull direct-coupled 10-watt amplifier as described in July, 1939, issue of *Radio-Craft*. If you do recommend this amplifier instead of some

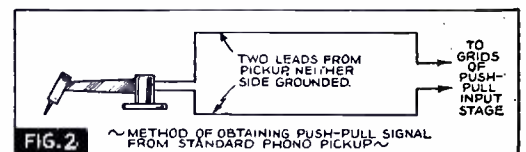

FIG. 2 ~ METHOD OF OBTAINING PUSH-PULL SIGNAL FROM STANDARD PHONO PICKUP ~

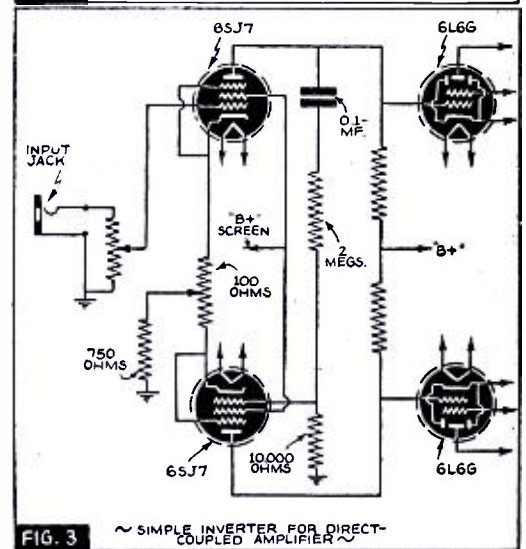

FIG. 3 ~ SIMPLE INVERTER FOR DIRECT-COUPLED AMPLIFIER ~

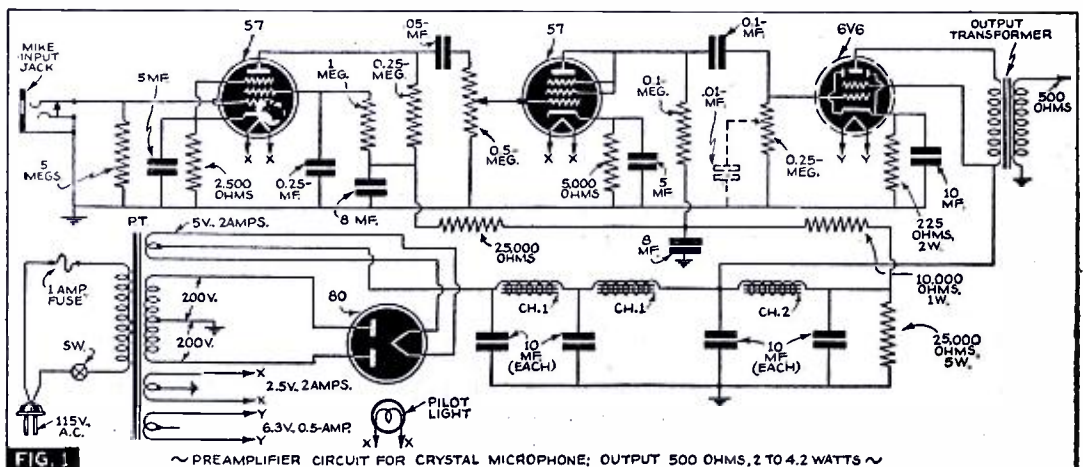

FIG. 1 ~ PREAMPLIFIER CIRCUIT FOR CRYSTAL MICROPHONE; OUTPUT 500 OHMS, 2 TO 4.2 WATTS ~

others, I would like further information as: How to obtain push-pull input signal (a diagram will help a great deal)? Is a special phono pickup necessary? How to couple the amplifier to a broadcast receiver replacing amplifier section? What moderate-priced phono pickup and loudspeaker would you recommend for use with the amplifier?

CHANG HA KIM,
Honolulu, Hawaii

The Answer . . .

The 10-Watt Direct-Coupled Amplifier described in the July, 1939, issue is admirably adapted for your purposes. You can further improve it by incorporating the hum-balancing feature used in the 30-Watt Direct-Coupled Amplifier which was described in the October, 1939, issue of *Radio-Craft*.

This slight change involves the use of a 100-ohm potentiometer in series with both cathodes of the input tubes. It will enable you to quickly balance any differences in plate current and, at the same time, cancel hum.

A push-pull signal can easily be obtained from any ordinary pickup, which does not have either of its terminals grounded. Figure 2 shows such a circuit arrangement. If one of the terminals of the pickup (crystal, magnetic or dynamic) should be grounded to the tone arm, it may, in many cases, be easily isolated and 2 leads brought out from the pickup instead of a single shielded cable. If the phono leads are run close to disturbing hum fields, they should both be shielded. A simple expedient of using a center-tapped network of resistors in the input circuit of the 10-Watt Direct-Coupled Amplifier, provides the equivalent of push-pull signal from any signal source (phono pickup, or microphone, etc.), which does not have either of its terminals grounded.

The amplifier can easily be coupled to a broadcast receiver by using a conventional inverter stage, which was described in the November, 1939, issue (see page 269).

An alternate circuit which does not add any gain nor require an additional tube, is given in Fig. 3. The 6SJ7's indicated therein, are the 2 input tubes of the 30-Watt Direct-Coupled Amplifier.

Any good phono pickup or loudspeaker may be used with the amplifier with excellent results. No special type or make is required. The only restrictions are that the phono pickup should preferably be of the high-impedance type. It may be either crystal or magnetic, depending upon your personal preference. The speaker should be of the permanent-magnet type and equipped with a voice coil of either 4, 8, or 16 ohms. It is imperative that the speaker be capable of handling the power developed by the amplifier, without overloading.

News Items:

Russia—Radio program listings received by *Radio-Craft* last month from Radio Centre, Moscow, include listings of 1/2-hour "television programs" at stated times over stations RV-43 (1,293 meters), and RV-49 (531 meters).

Some of the first words ever spoken over a phonograph, and other priceless records made during the lifetime of Thomas A. Edison, were aired in a 93rd birthday program over WMCA.

To circumvent the possibility of espionage work on ultra-shortwaves the Senate Appropriations Committee OK'd the suggestion of F.C. Commissioner Fly that a monitor station be built near Anchorage, Alaska, at a cost of about \$40,000.



FOR THE NEEDLE YOU NEED!

ask your supplier for

PERMO POINT

Phonograph Needles

Permo Products Corporation, for 11 years the leading manufacturer of needles for automatic phonographs, now makes available to you a complete line of long play quality needles for every use.



FOR RECORDING—Permo offers a new stylus equalling the cutting ability of sapphire. It cuts clean, quiet grooves, free from surface noises. Records entire frequency range with a minimum loss of high frequencies, due to special alloy tip. It is very rugged and will stand harder usage than any other cutting stylus available. Permo Metal Point gives longer life. MICROSPECIED for uniformity and packed in a special protective metal container.



FOR REPRODUCTION—the Fidelity Permo Point Needle is specially made for home record players and changers. It keeps surface noise at a minimum, and the Permo Metal point assures finest full range reproduction. Record wear is negligible due to the self-lubricating action of Permo Metal point. Will give 50 hours service on standard recordings. Long play for use in home, salon, sound distributing systems, schools, etc.



FOR TRANSCRIPTION—the new Transcription Permo Point Needle gives an even response over entire audio frequency range . . . is constant at over 10,000 cycles. Specially designed to transmit all frequencies useful in modern broadcasting and recording work. Fits standard record groove. Valuable in play-back and dubbing work. Permo Metal tip gives 35-50 hours service. Won't wear acetate, nitrate coated, commercial records—prolongs life with self-lubricating Permo Metal Point.



Microspected **TO INSURE**

PERFECT PERFORMANCE

Every Permo Point Needle sold is subjected to the rigid Permo MICROSECTION process before it leaves the Permo laboratories. This process is a positive check on the precious Permo Metal point for perfect uniformity and performance. The above and other Permo Point Needles for professional and home use are available at all leading suppliers.



PERMO PRODUCTS CORP.

6415 Ravenswood Ave.
Chicago, Illinois

Gentlemen:

Please send me your free booklet on Needles and Records, and full information on Permo Point Needles.

Name.....

Address.....

GET A REAL ELECTROPLATING KIT ABSOLUTELY FREE!

Complete details as to how it is possible to get a Real Electroplating Kit FREE, appear on Page 693 of this issue. TURN TO IT NOW!

DIRECT-COUPLED AMPLIFIERS



ENGINEERED BY
A. C. SHANEY

Write For Complete Details and Attractive Proposition

AMPLIFIER COMPANY of AMERICA

35-45 WEST 20TH STREET NEW YORK CITY, NEW YORK



WEBSTER PHONO-MOTOR

Self-starting, rim-driven, constant-speed (78RPM). Friction-drive is preferable wherever driving torques are low and quietness is all important, as in a phonograph. Motor with 9" felt covered turntable operates on 117 volt, 60 cycle only. Shipp. wt. 6 lbs. Price Each **\$2.69**

WE REQUIRE A 25% DEPOSIT WITH ORDER
Write For Our Latest Bargain Parts Bulletin
ARROW SALES COMPANY

Dept. RC-5
619 W. RANDOLPH ST. CHICAGO, ILL.

Save on Everything in Radio

NEW 1940 RADIO CATALOG AND PROFIT GUIDE
Most complete line of latest radio sets, amplifiers, kits, tools and replacement parts. All leading brands at lowest prices. Fast Service. Guaranteed Quality.

The **RADOLEK** Company
Dept. Y-41 601 W. Randolph St., Chicago

SEND FOR YOUR COPY TODAY

FREE RADIO PROFIT GUIDE



HOW ONE SOUND MAN DRUMS-UP BUSINESS

Or: A 2,900-Mile Trip that Paid for Itself!

W. L. FULLER, JR.

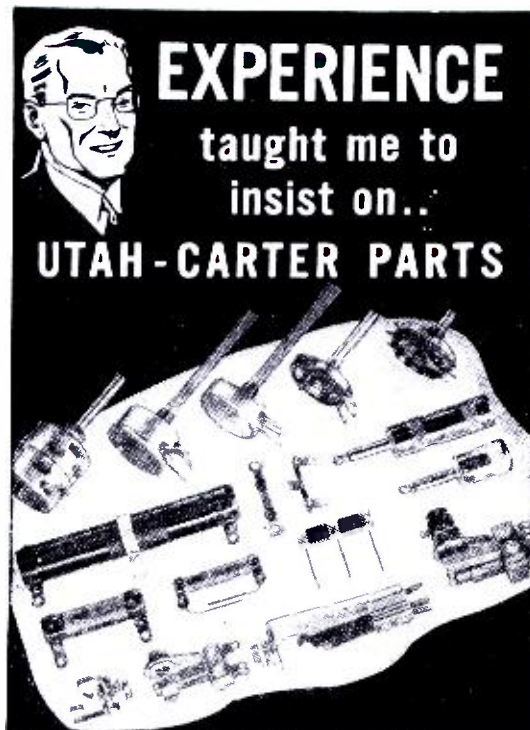

EXPERIENCE

taught me to
insist on...

UTAH-CARTER PARTS

● Hundreds of designers, builders and manufacturers have found that the use of Utah-Carter parts saves time and money—avoids unnecessary replacements. They know by experience that satisfactory performance is assured at every Utah-point in the circuit.

You, too, can have the benefit, with Utah-Carter parts, of more than a decade of experience in the development of resistance units; wire-wound and carbon type volume controls; switches; relays, etc. Utah engineering keeps abreast of all industry developments. And Utah precision manufacturing assures maximum dependability.

Utah-Carter parts are distributed nationally through carefully selected recognized parts jobbers and dealers. Look for the famous Utah trademark on the part or carton. If your supplier can't furnish Utah-Carter parts, write us direct. Utah Radio Products Company, 826 Orleans Street, Chicago, Ill. Canadian Sales Office: 414 Bay St., Toronto, Canada. Cable Address: Utaradio, Chicago.

**IT PAYS TO INSIST ON
THESE HIGH-VALUE
UTAH-CARTER PARTS**

VITREOUS ENAMEL
RESISTORS

VOLUME CONTROLS

Wire-Wound Type

Improved Carbon Type

POTENTIOMETERS

RHEOSTATS

PLUGS

"T" and "L" PADS

LONG and SHORT JACKS

IMPJACKS

JACK-SWITCHES

PUSH-BUTTON SWITCHES

PLUG-IN TYPE D. C. RELAYS



SPEAKERS • VIBRATORS • TRANSFORMERS

AFTER reading a lot of articles regarding experiences by sound men to the effect that sound trucks were passé, the writer tried to settle this point.

FINANCES

To finance an extended trip, I found the Lions Club of Virginia was very much interested in a novel representative at the Lions' International Convention held in Pittsburgh. I also found the Jackson County Apple Festival, Jackson, Ohio, and the Mason County Potato Festival at Point Pleasant, West Va., were interested in having their festivals advertised through the East.

What made this Good Will Tour so unique was the fact that the Jackson County Apple Festival gave me novel invitations—in the form of Apple Recipes, Wooden Nickels from the preceding year's Apple Festival, an invitation to compare apple lists (and possibly win a bushel of apples), and an invitation to visit the current Apple Festival—to present to the mayors or chiefs of police of principal Eastern cities. The Mason County Potato Festival sent 13 x 15 in. invitations to the mayors, on the front of which appeared a very beautiful and historic picture. One each of the invitations was delivered by me personally, to each of the mayors of the cities I will mention below, with the exception of the city of Philadelphia.

Of course, from these 3 mediums sufficient money was not derived but it did help somewhat to defray expenses.

P. A. "RIGHT OF WAY"

Before I started on this journey, I had to do a lot of preliminary work such as writing to the City Fathers of the towns through which I would pass to get an OK to operate my sound system in each particular city. As a result of this correspondence I had to change my itinerary several times.

The little towns of Clarksburg, W. Va., and Winchester, Va., would not grant me permission to operate even on a Good Will Tour. Neither would Washington, D. C., due to its police set-up; however, Major Brown, who is Superintendent of Police for the District of Columbia, wrote me a very nice letter of explanation. Neither would the City of New York permit us to use our sound equipment but later on in this article I will explain how we got around this.

The towns of Pittsburgh, Pa., Cumberland, Hagerstown, and Baltimore, Md., Grafton, West Va., Wilmington, Del., Philadelphia, Pa., Camden, Newark, and Trenton, N. J., were gracious enough to allow us to operate the sound equipment.

EN ROUTE

After receiving permission to operate in the cities mentioned, on July 17 I arrived in Pittsburgh for the Lions' International Convention. I was supposed to have been in the parade for the Virginia Lions. However, on the day set, it was postponed 4 different times due to inclement weather. I had to operate the truck through the city to announce the postponement of same each time. The next day it still continued to rain and the parade was postponed. (Eventually, the idea of a parade was abandoned.) That evening, however, I started on what ended up to be a 2,900-mile Good Will Tour!

I drove until I reached Hagerstown, Md., where I spent the night. The next morning I visited the Chief of Police and then drove to Baltimore, thence to Philadelphia, where I was treated most royally—that fine city certainly lived up to its name of the "Friendly City." The Mayor of Philadelphia being ill, I presented the invitation to the Superintendent of Police and then drove to Camden where I had a very pleasant visit at the RCA plant. I spent that night at Chester, Pa. The morning of the 21st, I drove into Newark, spending the night there. Bright and early the next morning I headed the truck for New York.

P. A. IN N. Y. C.

As the truck is equipped with electricity by means of a Pioneer Gen-E-Motor Red Top Light Plant, I do not have to be conservative of power. So with the power plant and sound equipment running full-blast, I drove to the entrance of the Holland Tube. En route we passed the time of day with a friendly motorcycle policeman and he asked me to "kid" the sergeant at the entrance of the Tube. This I did to the amazement of all the motorists and as the "Sarg" turned out to be an Irishman, he took the joke like one.

Never having driven a panel truck in a city the size of New York, I found the sound equipment came in very handy in securing directions. This was my method of getting around in the City of New York and it also got around the City Fathers, who stated that sound trucks could be used if they were not bothersome to anyone. As I only had the volume turned up enough to contact the policeman on the intersection, this naturally did not annoy anyone. I will state here there were a lot of surprised policemen in New York when a voice out of the air would ask how to get to Flushing Avenue, Brooklyn, and other New York points. I do think from the way New Yorkers gaped at the truck, that it was quite a novelty. I had a lot of pleasure in getting round New York as I believe I have the distinction of being the only sound, in fact any, truck to get across the Express Highway.

Eventually I got to a parking lot across from the entrance to the New York World's Fair, which was my ultimate destination. I can see one reason why the Fair did not prove as successful as was anticipated. We had invitations to deliver to Grover Whalen, and when I arrived to present them, our reception was anything but cordial. As I was extremely interested in the type of sound to be found at the World's Fair, I was somewhat disappointed with some of the installations. Of course, the sound at the Railroad Exhibit and the Trylon-Perisphere, G-E and RCA Exhibits, was unusually nice but the others did not impress me a great deal. Not having a "speedometer" (pedometer) on my feet, I do not know how many miles I traveled, but in the 3 days I spent at the Fair, I know plenty of miles were covered as I afterwards had fallen arches.

The return trip to Parkersburg, West Virginia, was uneventful but it settled one point in my mind, that sound trucks can be operated in practically all cities in the United States—providing the operators use discretion in their operation, also first securing permission.

Next summer I hope to go to Havana, Cuba, for the Lions.

DESIGNING A 60-WATT DIRECT-COUPLED BEAM-POWER AMPLIFIER

This novel amplifier employs a new push-pull Cathode Drive system to insure full power output with minimum distortion;—sequel to the popular 10- and 30-watt direct-coupled amplifiers previously described.

A. C. SHANEY

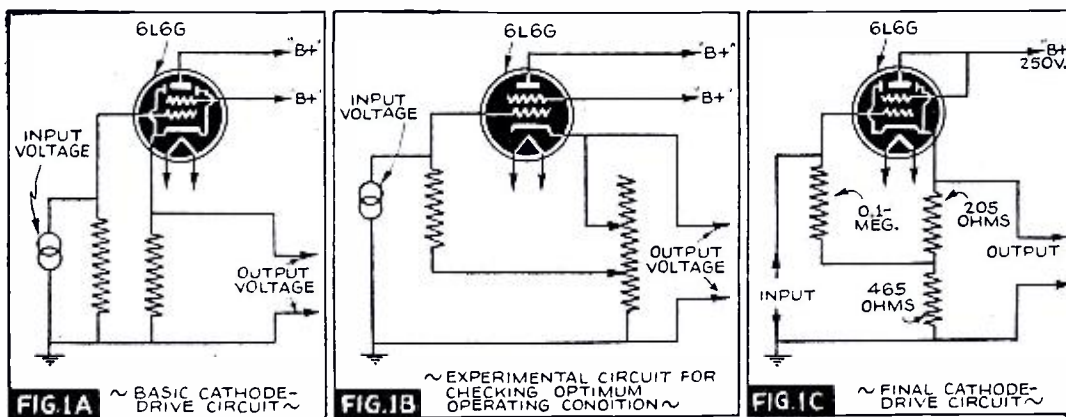

bypassed directly to the cathode; as a triode, the screen-grid and plate were tied together, and the same potential applied to both elements). The triode connections give best results for maximum signal power handling ability, best response and greatest stability. The final driver circuit adopted is shown in Fig. 1C. This circuit has the following characteristics:

- (NOTE: Screen-grid is tied to plate.)
- Plate Voltage—250 volts
- Plate Current—60 milliamperes
- Maximum Input r.m.s. Signal—28.5 volts
- Maximum Cathode r.m.s. Output Voltage—22 volts
- Cathode Potential from Ground—37½ volts
- Effective Bias—12 volts

This unconventional circuit provided an ideal solution to our driver problem. Its response was flat from D.C. to 20,000 cycles!

While the tube has no voltage amplification (in fact, it has a slight voltage loss), its gain in db. is dependent upon the impedance from which it works. If the input circuit is considered to be high impedance (100,000 ohms) it has a gain of 18.5 db. The following formulas show how to calculate the effective gain of the stage, based on the transformation of impedance, assuming the voltage remains constant:

$$G \text{ db.} = 10 \log \frac{Z_a}{Z_b}$$

where Z_a equals the impedance of the input circuit and Z_b the impedance of the output circuit.

If this cathode drive circuit is coupled to a preceding stage, having an output impedance of 100,000 ohms, we are effectively going from 100,000 ohms impedance to 670 ohms. This, according to our formula, gives us a gain of $10 \log \frac{100,000}{670} = 21.73$

The loss, however, incurred in the voltage step-down of 28.5 to 22 volts give us a corresponding loss in db., which is equal to

$$\text{Loss db.} = 20 \log \frac{E_1}{E_2} = 20 \log \frac{28.5}{22} = 2.8 \text{ db.}$$

Subtracting the 2.8 db. from the 21.73, we have an overall gain of 18.5 db. This gain,

THE excellent performance of the 10- and 30-Watt Direct-Coupled Amplifiers described in *Radio-Craft*, July, October, November and December 1939 issues, has led the writer to continue his direct-coupled development in 2 directions. One, towards the design of a high-gain direct-coupled preamplifier for cardiograph applications, which is being developed in our laboratories at the present time, and may shortly be described in *Radio-Craft*; and the other, towards the design of a high-power amplifier for all indoor and outdoor applications requiring good quality at high audio levels.

THE DEVELOPMENT OF THE DRIVER STAGE

An important limitation in the production of a high-power amplifier has centered about the *driver stage*; particularly, when the power output stage is operated in either class AB2 or class B. For maximum efficiency, minimum voltage requirements, and low cost, it was decided to employ 2 pairs of 6L6G's in the power output stage, each pair to terminate in its own output transformer. As approximately a 52-volt peak grid-to-grid voltage is required to drive these tubes to full power output, it was decided to carefully check all possible low-impedance driver circuits.

If the driver stage is to be directly coupled to the output stage, the use of transformers or any type of reactive coupling circuit is naturally impossible. A cathode-

drive type of circuit, Fig. 1A, suggested itself and was carefully laboratory checked for performance characteristics. With this type of circuit, the usual plate load is taken out of the plate circuit and placed into the un-bypassed cathode circuit. The value of the cathode load, however, is considerably lower than its corresponding plate load. The formula for determining the correct cathode load for any tube is as follows:

$$K1 = \frac{10^9}{G_m}$$

For a 6L6 operating under the 250-volt fixed-bias condition, this is equal to

$$K = \frac{10^9}{6,000} = 166 \text{ ohms}$$

It is to be noted that the normal plate load for this condition is 2,500 ohms. The 166-ohm corresponding cathode load results in an overall reduction of driver impedance in the order of 15 to 1. In setting this circuit up, however, it was found that only a limited signal could be handled by the tube. It was therefore decided to increase the cathode resistor without increasing the effective cathode bias. The revised circuit is shown in Fig. 1B.

The 2 variable adjustments provided by this circuit make it a comparatively simple matter to attain ideal operating conditions. The tube was checked as a triode and tetrode (as a tetrode, a variable resistor was inserted in the screen-grid circuit and

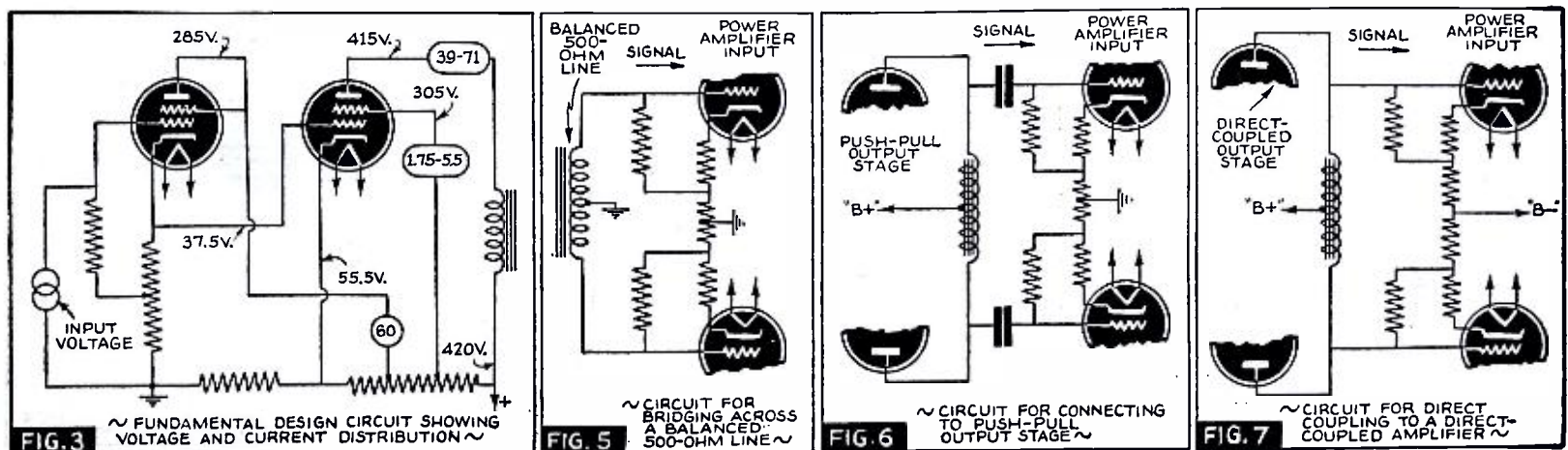

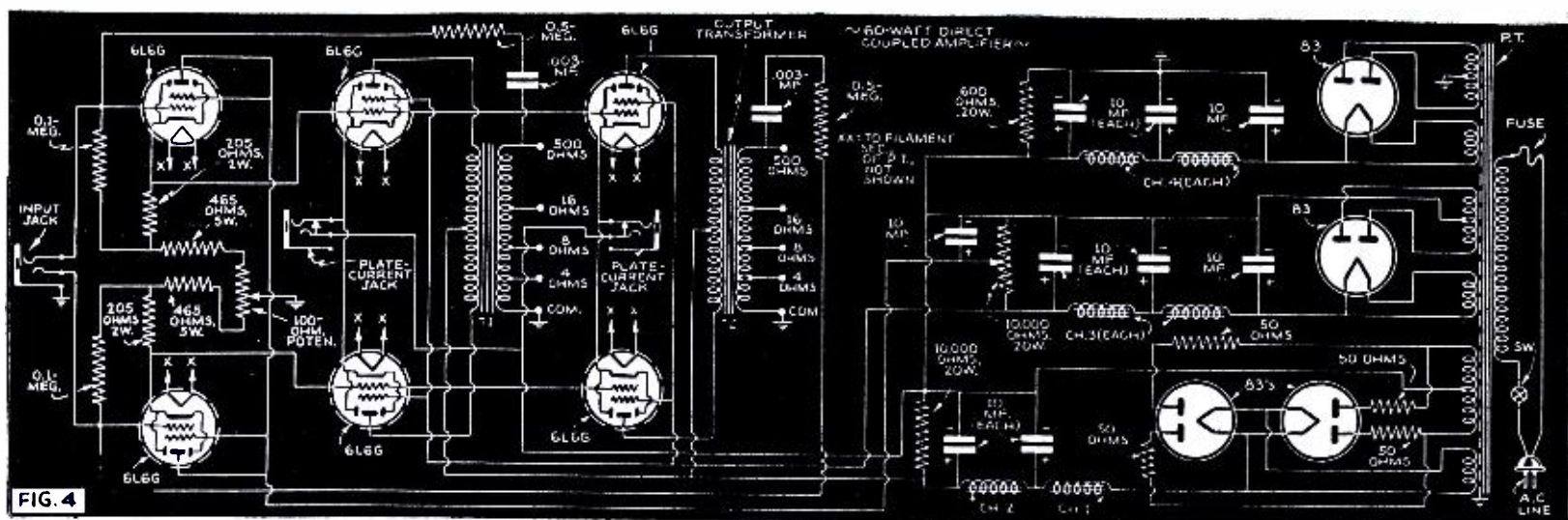

however, will be decreased, as the impedance of the input circuit is decreased, until we have approached 670 ohms, at which time, a loss of 2.8 db. is encountered, and greater losses are incurred if lower input impedances are used. In normal applications, however, a lower impedance will not be available unless a transformer is employed. As this would actually upset the advantages of our direct-coupled circuit we will assume our driver impedance will exceed 670 ohms. Therefore, some effective gain is always maintained in this circuit.

CATHODE DRIVE AND GRID POWER

Another great advantage of this type of driving circuit in comparison to conventional transformer coupling (aside from its excellent frequency response characteristic) is that an unlimited amount of power is available should the output stages draw grid current. Figure 2 shows a conventional transformer-coupled output circuit. When the peak grid potential (E_g) of this circuit exceeds the cathode bias (E_{kdc}), the grid becomes positive in relation to the cathode, and rectification occurs. This condition results in limiting the signal swing in one direction. This type of distorted waveform can easily be seen on an oscilloscope, as illustrated in Fig. 2B. This peak limiting effect introduces the most objectionable form of distortion in power output stages requiring grid current.

In our Cathode Drive circuit, however, this condition does not prevail, because a large amount of current is available to the grid of the output stage from the plate circuit of the driver stage, as illustrated in Fig. 2C. As the plate current of the driver stage is approximately 60 ma., and the input grid current is approximately 2 ma., it can readily be seen that the driven grid will not chop peaks until the driver supplies 55.5 r.m.s. volts to each grid. (Only 36.6 volts r.m.s. per grid is required for full power output.)

FUNDAMENTAL DESIGN CIRCUIT

The basic design circuit together with the required voltage distribution is illustrated in Fig. 3. All currents are indicated within circles. Those showing 2 values indicate the change from no signal to maximum signal. The output stage values are only 1/2 of the published currents for push-pull stages.

It is of prime importance that the cathode potential of the power output stage be maintained at 55.5 volts in order to provide an 18-volt bias for the output tubes. As fixed bias must be employed in the output stage, a separate supply is used to maintain this 55.5-volt potential. In order to minimize screen-grid distortion, a separate

power supply is likewise used for this portion of the amplifier circuit. As a pair of output tubes draw under maximum signal, approximately 142 milliamperes (4 tubes will draw 284 ma.), 2 type 83 rectifiers are used in the plate circuit supply. Adequate filtering is used in order to insure minimum hum.

FEATURE CIRCUITS

The Cathode Balancing Circuit.—No portion of this circuit (Fig. 4) is critical to voltage adjustments. Some driver tubes, however, may draw more current than its push-pull mate, and thereby apply a different bias to each of the output stage push-pull grids. A cathode balancing adjustment is therefore provided. This adjustment merely introduces more or less resistance in the input cathode circuit so as to adjust the D.C. bias.

Two jacks are provided on the rear of the amplifier for measuring the plate currents of each pair of output tubes. This circuit arrangement makes it easy to both rapidly check the condition of the power output tubes, and facilitate adjustment of the input stage should it be necessary.

The Feedback Circuit.—Because of the fact that 2 isolated output transformers are employed, each one of which has its common grounded, a special feedback circuit must be employed in order to provide out-of-phase voltage from each of the transformers to the correct push-pull output grids. This is accomplished by having each transformer contribute some of the feedback voltage. These transformers must be phased so that both feedback voltages are out-of-phase with the signal voltage. Otherwise, undesirable positive feedback will take place. The phasing of the output transformers is easily accomplished by reversing plate leads.

The feedback circuit, being of a frequency discriminating nature, compensates for any discrimination in the output transformer. Naturally, the limiting factor in the over-

all response of the amplifier is the output transformer. With a correctly-designed feedback circuit, its response can be made substantially flat from 20 to 20,000 cycles (± 1 db.).

High-Impedance Input Circuits.—Because of the no-grid-current high-impedance input circuit, this amplifier can be bridged across any balanced 500-ohm line (see Fig. 5); or through isolating condensers, across plate to plate of any push-pull amplifier (see Fig. 6). It may also be directly coupled to the output of the 10- or 30-Watt Direct-Coupled Amplifiers previously described, as illustrated in Fig. 7. Under normal conditions, both chassis will be at a different potential from each other, i.e., approximately 415 volts. In order to avoid this condition when direct-coupling is employed, the power amplifier may be wired so that the chassis itself does not become any part of the circuit. Insulating precautions will therefore not be necessary.

The amplifier has been designed to fill a need in the high power field wherein both quality and dependability are prime requisites. The amplifier is housed in a chassis measuring 17 1/2-in. long, 10-in. wide, 11 1/2-in. tall. It weighs approximately 45 lbs.

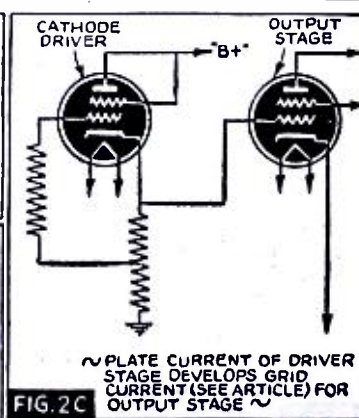
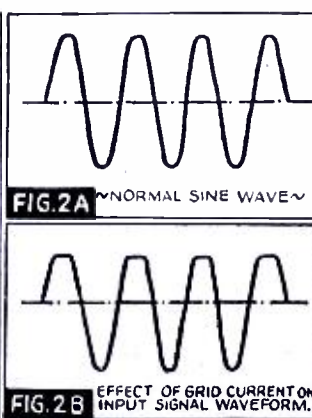
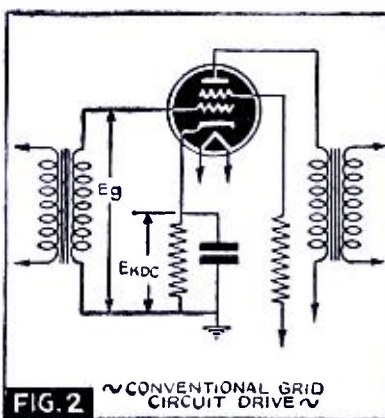
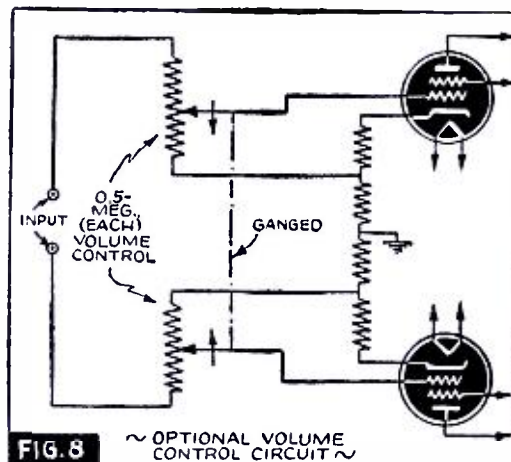

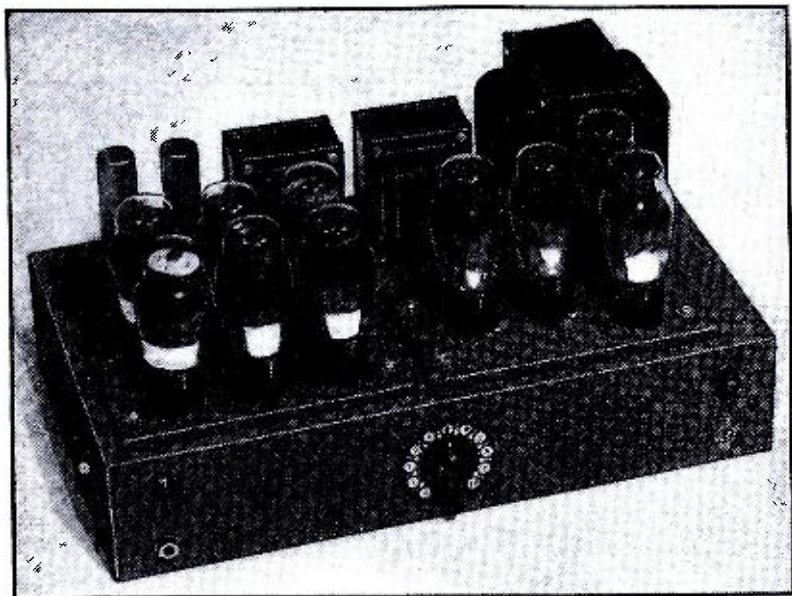

The completed 60-watt amplifier. It features *direct coupling*, between driver and output stage, employing *cathode driving* of the latter. At left are: pilot, and input jack; center: gain control; right: front-of-panel removable fuse, and off-on switch.

A. BRIDGING AMPLIFIER

As the amplifier has a high-impedance input circuit it may be bridged across any balanced 500-ohm or high-impedance line. As the actual input impedance is approximately 200,000 ohms from grid to grid, practically no signal loss will be encountered if as many as 10 of these amplifiers are connected across a low-impedance (500-ohm) balanced line. If a balanced line is not available, a single-stage inverter or a push-pull input transformer may be employed between the power amplifier and its driving amplifier.

180-WATT AMPLIFIER SYSTEM!

Where more than 60 watts of audio power is required any number of these direct-coupled power stages may be employed to provide any required amount of audio power. Naturally as each amplifier is rated at 60 W. only multiples of this power would be available. In other words, for a 180-W. amplifier it would be entirely feasible to use 3 power stages. Under this arrangement all input circuits would be connected in parallel. The output transformers could be connected either in parallel or they may each individually feed a couple of speakers.

It should be remembered that when 2 output transformers are connected in parallel

the effective output impedance is halved (or *subtractive*).

By ungrounding the common it is also feasible to connect the output in series. Under this arrangement the relative impedances become *additive*.

The important point to remember in connecting output transformers either in series or in parallel is that they must be properly phased. Otherwise the output of one transformer may tend to cancel the output of another. A simple check for correct phasing is to measure the output voltage before and after a pair of terminals is reversed. The higher voltage condition indicates correct phasing. When transformers are connected in parallel and found to be out-of-phase, the input of the amplifier may be reversed to correct this condition or the plate lead of the output push-pull stage may similarly be reversed.

By using either a 10- or 20-W. direct-coupled amplifier with a suitable built-in preamplifier stage, the over-all gain of the complete direct-coupled system would be approximately 120 db. (for the 60-W.-output unit; add about 5 db. gain for the 180-W. unit).

This article has been prepared from data supplied by courtesy of Amplifier Co. of America.

F.C.C. Contemplates Survey of Amateur Radio Service

A survey of amateur radio service was proposed last month by the F.C.C. Idea was to obtain additional information which would permit the Federal Communications Commission to meet any amateur problems due to neutrality, national defense and other emergencies, plus normal regulation. At the outbreak of the World War, in 1914, there were 2,137 radio amateurs in the U.S.; the World War of 1939-'40 sees 53,500 licensed amateur operators (and therefore licensed amateur transmitters). Latter figure includes roughly 300 hams in Hawaii, 200 in Alaska, 50 in Puerto Rico, and a scattered few in American Samoa, Wake Island, and Guam. Of this group, about 7,500 are members of the Naval Communication Reserve and Army Amateur Radio System. An interesting estimate is that probably not more than 15,000 amateurs are active in the U.S. during a given month.

The F.C.C. Commission's report states that the only transmitting code permitted amateurs is the International Morse Code; minimum speed requirement is 13 words per minute.

The only countries authorized under the Cairo and Inter-American agreements to engage in third-party international contact are the United States, Chile, Peru and Can-

ada. Latter has closed down "for the duration." Ham portables and portable-mobile units may be operated without licenses *but must be operated while in motion*.

"Portable-mobile stations are those which may conveniently be transferred to or from a mobile unit or from one unit to another, and ordinarily operate while the mobile unit is in motion," the Report continues.

"Monitoring stations of the Commission—which are located in Boston, Baltimore, Atlanta, Grand Island (Nebr.), Great Lakes (Ill.), Portland (Ore.), and San Pedro (Calif.)—observe the amateur bands daily. In addition, field inspectors listen to amateur operation. The amateurs, for their part, have established their own neutrality patrol during the period of the present emergency.

"This Government has long recognized the necessity of providing for the development of amateur radio, and has encouraged the use of such stations in many important fields of communication. Their wide distribution not only creates a most important resource in connection with regional disasters, but also contributes a great body of experimenters, making contributions to the radio art and serving as a valuable reserve for the national defense."

**EACH
'TOPS'
IN
Performance
Economically
Priced**

Other Models
up to \$150

Ask Your
Jobber for
CATALOG
Including
New Releases

Mailed Direct
on Request

Licensed
by
**ELECTRICAL
RESEARCH
PRODUCTS
COMPANY**
and
**THE BRUSH
DEVELOP-
MENT
COMPANY**

**AMERICAN
MICROPHONE
COMPANY**

1915 So. WESTERN AVENUE
LOS ANGELES, CALIFORNIA

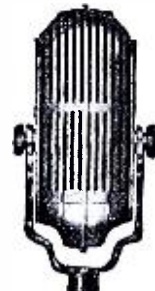

The NEW DOENUT Horn

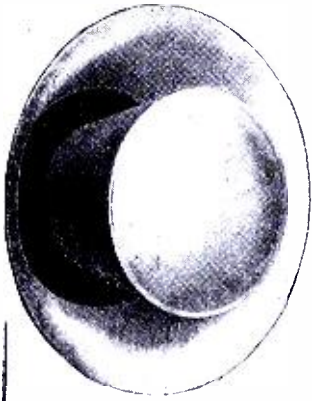

Provides
Wider
Angle
Coverage

Model
DX8B

An entirely new development in exponential horns which provides unique features never obtainable before.

- Spreads high frequencies over a wide angle.
- Weatherproof.
- Wide frequency range.
- No metallic sound.

Write for complete details

WRIGHT-DeCOSTER, Inc.

2251 University Ave., St. Paul, Minn.
Export Dept.: M. Simons & Son Co., New York
Cable Address: "Simontrice"

Canadian Representatives:
Wm. F. Kelly Co., 1207 Bay St., Toronto, Ontario
Taylor & Pearson, Ltd., Edmonton, Alberta

For
PROFESSIONAL USE

RECOTON

Playback
& Transcription
NEEDLES



STEEL
CUTTING
NEEDLES

Made to cut a smooth, quiet groove . . . of the finest steel, highly polished. Round and flat shank . . . for acetate. True-cutting, uniform, and absolutely dependable.

A New Transcription Needle

Designed and shadow-tested for home, studio, or professional work. Hi-fidelity. Endorsed by sound and music technicians.

Ask for full details

RECOTON Corporation

178 Prince St., New York

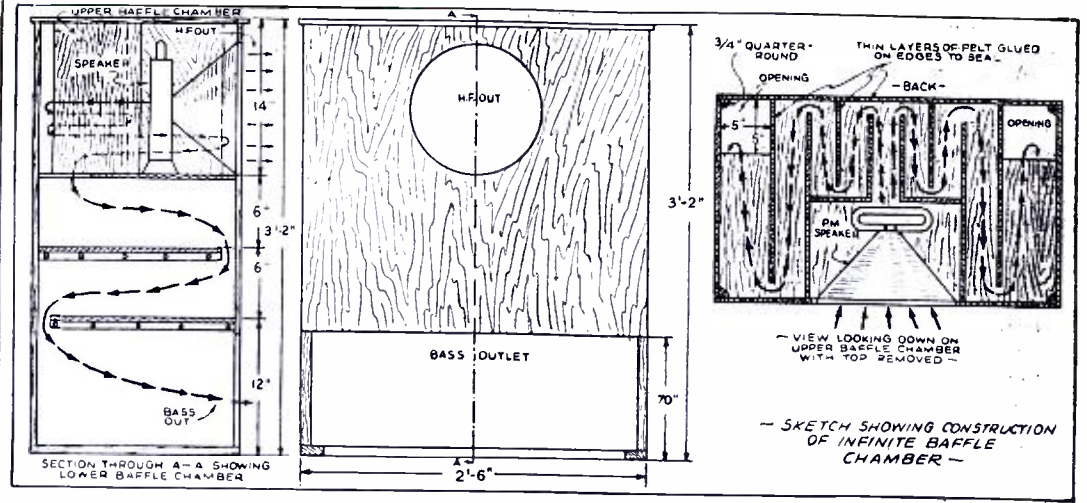

CASE HISTORIES OF P.A. SALES—NO. 8

● LAST year, the Suffolk County American Legion Convention was held at Lindenhurst, L. I. As part of the program, it was necessary for the Post to have an adequate Public Address system installed in the High School for the 2 days the Convention was in session.

Knowing this, I contacted the Post Commander and ascertained the date of the meeting, when the matter of the Public Address System would be taken up. I asked and received permission to attend the meeting with the understanding that I would answer all questions of a technical nature, regarding this particular sound installation. I was told that the sound system for the previous Convention had been rented for \$35 and that was the maximum they would expend. After endeavoring unsuccessfully to secure a better price, I accepted the job.

Knowing that my 12-watt amplifier didn't possess sufficient power, I spent \$25 of the \$35 for parts to build a booster amplifier, composed of 4 6L6G's in push-pull parallel. Parts used were Thordarson transformers and chokes, Aerovox condensers and Ohmite wire-wound resistors.

I had but 1 P.A. speaker, a Rola model G-12. Knowing that 2 speakers, at least, would be required to give sufficient coverage in the High School auditorium as well as to handle the load from the booster amplifier, another Rola G-12 was bought.

For the 1st Rola speaker, I built a ply-

wood cabinet and directional baffle (see sketch and snapshot). The 2nd Rola, I housed in an elaborate Infinite Baffle speaker cabinet. The excellent response secured

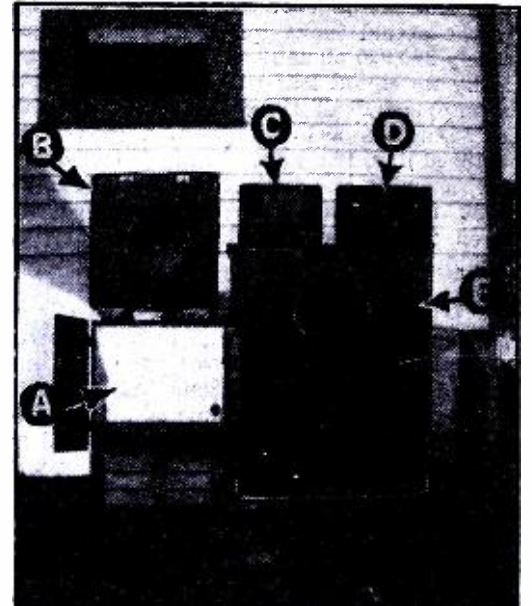

Snapshot showing all the equipment used for the installation except the directional baffle for use in front of the speaker case and the portable record player. The equipment shown is as follows: (A) the amplifier and carrying case; (B) booster amplifier; (C) small radio set; (D) infinite-baffle speaker cabinet.

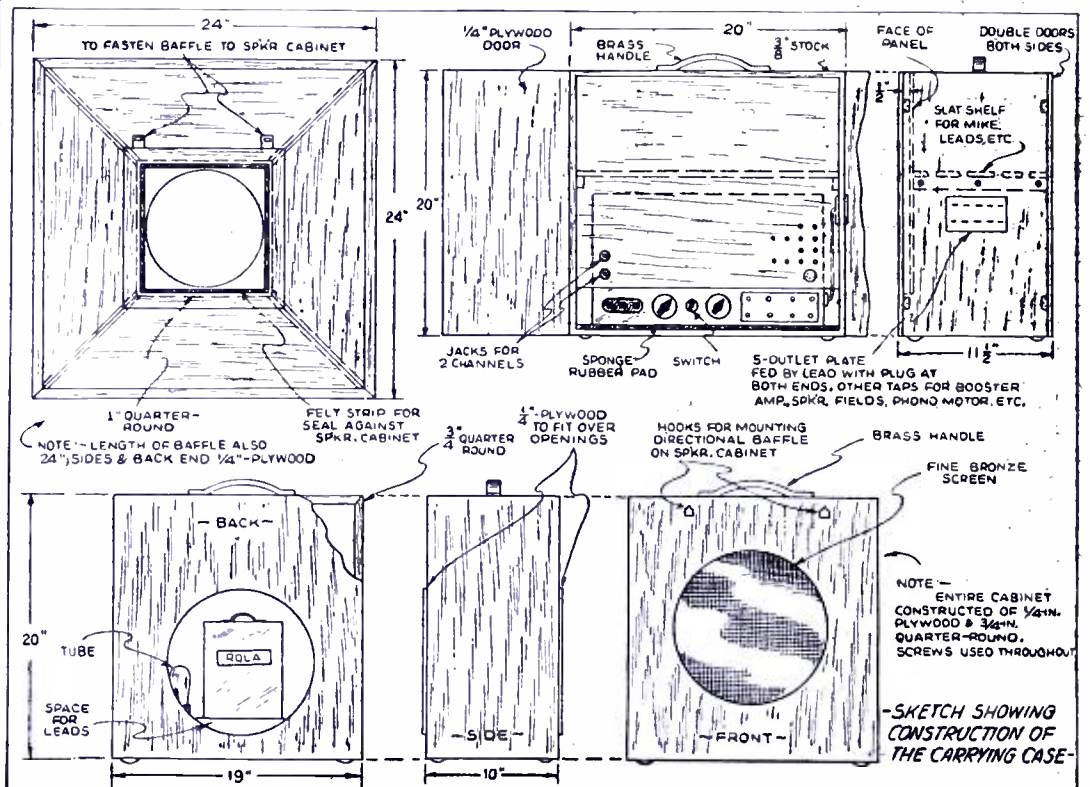

•SOUND•

more than compensated for time and expense expended.

A carrying case was made for the 127-A amplifier (see sketch and snapshot). (The directional baffle for front of speaker case and portable record player, are not shown in the snapshot.)

By connecting the speaker outlets of the 127-A amplifier with tip plugs, to the tip jacks on the front panel of the carrying case, outlets for 2 speakers of 8-ohms and 500-ohm impedance are made available. With the output of booster amplifier, connected to the panel through the speaker plug, there are outlets for the following impedances: 1 each, of 4 and 15 ohms; and 2 each of 8 and 500 ohms.

The small bakelite terminal strip, containing 3 screws for the coupling of input devices to the 2 channels, was extended to 2 large jacks on the panel of the carrying case so that input-device leads might be equipped with standard plugs for facilitating connection to the amplifier. Arrangements were also made to couple the 500-ohm line of the 2A5 amplifier to the booster.

The amplifier, booster, record player and records were placed just off-stage on a small table; microphone for speakers at center of stage; P.A. speakers, at each side of stage and directed at rear-center of auditorium.

Band records of a martial nature and songs, popular during the World War—such as "Advancing Colors"—were played before Convention sessions, during recess periods and at appropriate times.

From this installation, the advertising and publicity received, was the means of obtaining many other jobs.

LEROY PETERS, Lindenhurst, N. Y.

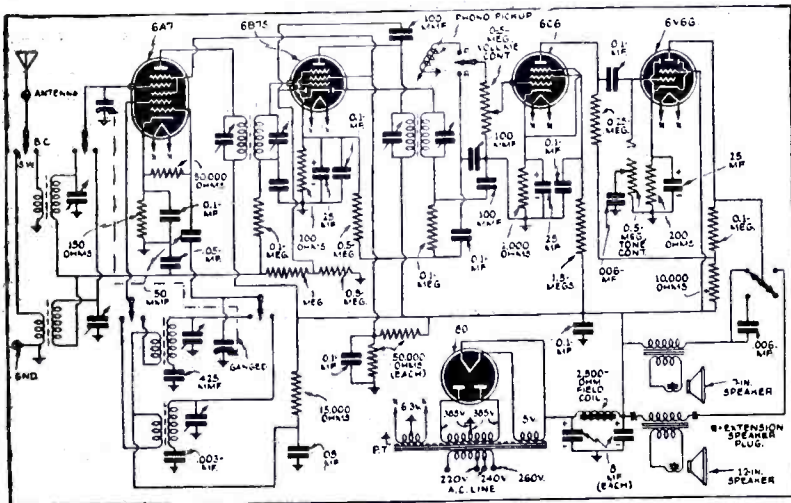
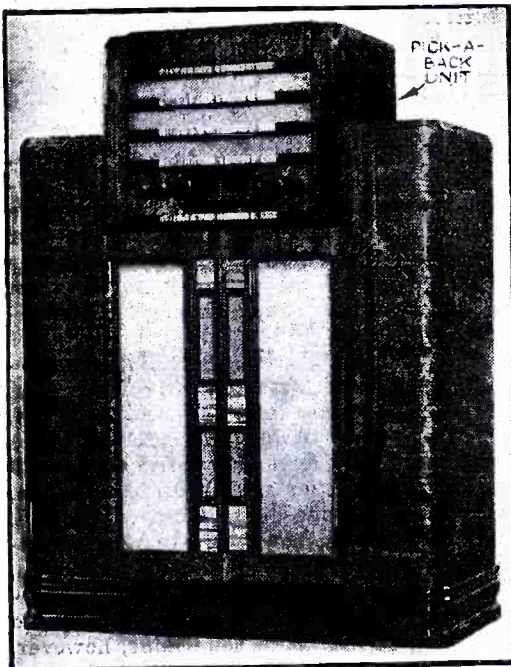

Stressing RELIABILITY—HUM SUPPRESSION and 20% OVERLOAD CAPACITY

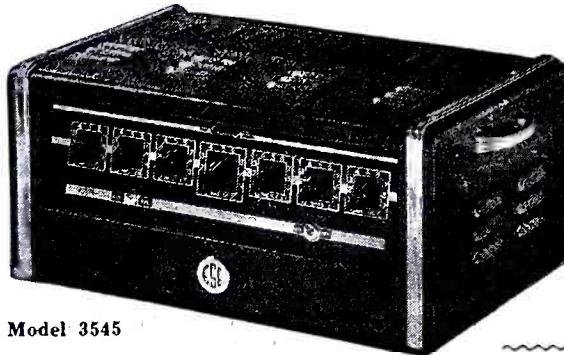

Model 3545

● Provides advanced engineering in volume compression and expansion circuits—hum suppressed to a new low level. Hear this new amplifier.

Be sure to enter the ERWOOD Slogan Contest. \$350.00 in merchandise. Write for free information.



JOHN ERWOOD, President

says, "Years of experience in the public address and sound equipment field, combined with careful workmanship, have resulted in a line of equipment that makes possible profitable sales."

The Sound Engineers' biggest problem—is stressed in all Erwood designs. Each item has been designed to insure sound satisfaction under various acoustic conditions and wide variations in power supply.

Send for Complete Catalogue

Erwood SOUND EQUIPMENT CO.

222 W. HURON ST.

CHICAGO, ILL.

Pick-a-Back Phono-Radio Set

The radio receiver here shown by photo and diagram has been introduced in Australia as the "Pick-a-Back" phono-receiver. It is so named because the top-center add-on unit is easily removable for placing at some point removed from the lower section (which houses a low-frequency speaker).

A condenser switched in series with the transformer on the 7-in. speaker in the upper cabinet restricts the reproduction of this speaker to frequencies above 300 cycles-per-second. The middle and low frequencies are then reproduced by the 12-in. speaker in the lower cabinet.

A very pleasing semi-stereophonic can be secured by placing the lower cabinet several feet from the upper one. The resulting spaciousness of reproduction simulates an orchestral arrangement in which the high-frequency musical instruments (brasses, etc.) are located at one side of the stage and the remaining, low-frequency instruments (drums, etc.) at the other.

UNIVERSITY HIGH POWERED INTERCOMMUNICATOR Booster SPEAKER

BOOSTS
SOUND
THREE
TIMES
HIGHER
THAN
CONE
SPEAKER

DOES
NOT
NEED
BOOSTER
AMPLIFIER

VERY
COMPACT

100%
WATER-
PROOF

NOT A
CONE
SPEAKER

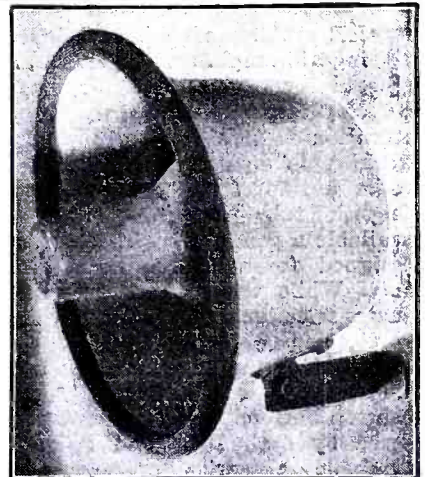

WRITE FOR CATALOGUE

UNIVERSITY LABORATORIES 195 CHRYSTIE STREET • NEW YORK CITY

NEW AUDIOGRAPH Sound Catalog

AUDIOGRAPH Sound Systems represent the latest in Sound Engineering and Design—a complete line plus pre-tested accessories.

NEW LOWER PRICES

Outstanding quality and performance at prices that help you meet any competition.

WRITE FOR FREE COPY

JOHN MECK INDUSTRIES
1313 W. Randolph St., Chicago, Ill.

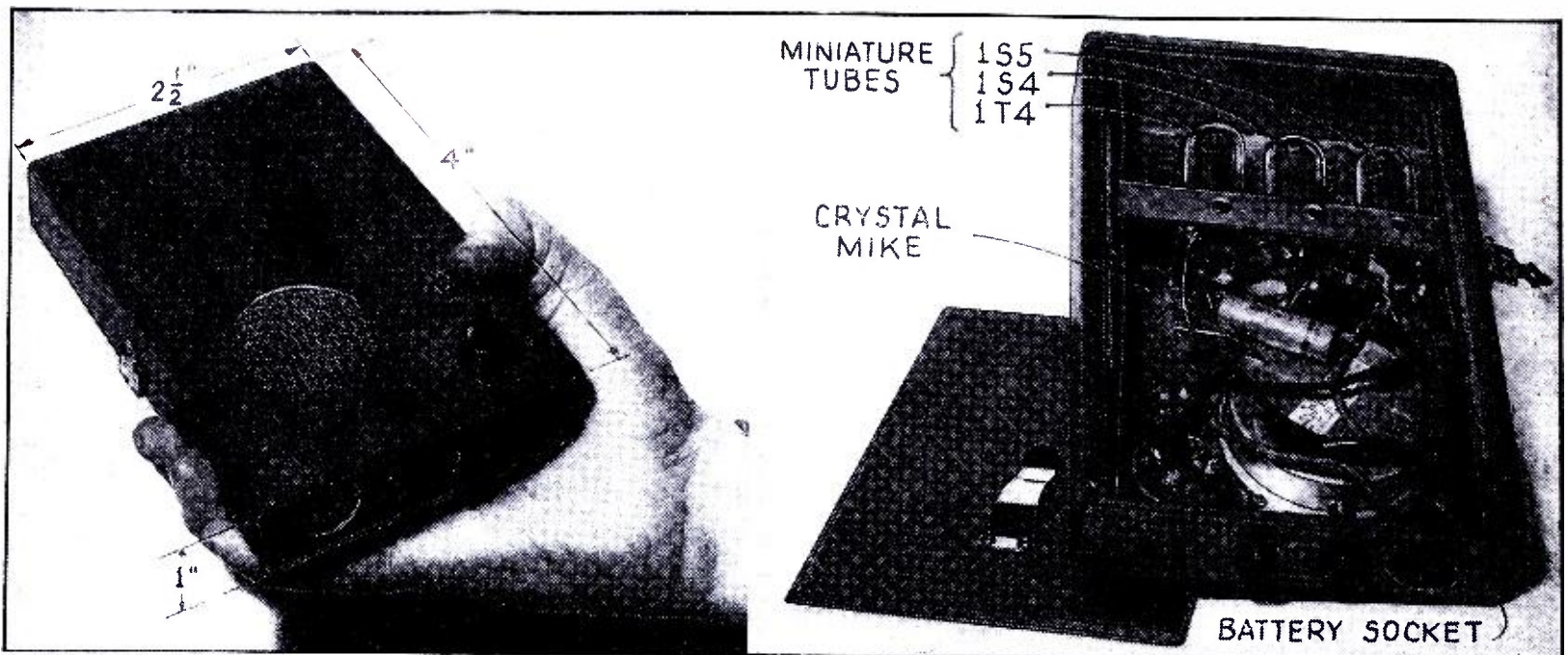

Compact, isn't it? Well, the authors point out how designers are able to achieve still greater compactness by using only 2 of the high-efficiency button-bottom tubes employed in this inexpensive, wearable hearing-aid!

Here's "inside information" on where and how to place the tubes, xtal microphone, socket for the battery power plug, etc. The cover slides in grooves in the case; a clip suspends the entire wearable unit out-of-sight.

THE LATEST MINIATURE HEARING-AID AMPLIFIER

Radio-Craft readers are given detailed design information for constructing a "wearable" hearing-aid amplifier utilizing the latest miniature-type tubes in an automatic audio volume control circuit.

H. S. MANNEY and A. C. HEWITSON, M.D., Ph.D.

THE problem of designing efficient hearing-aid amplifiers in general, and *wearable* types in particular, has undoubtedly received a considerable amount of attention from a small group of engineers working in this particular field. For some years a limited number of American and English tube manufacturers have made available a group of small tubes specifically designed for wearable hearing-aid amplifiers. While these tubes provided an adequate selection for all H.A. (hearing-aid) applications, their relatively high price kept them out of the experimental field.

Per the recent announcement, the new, "button bottom" miniature tubes (manufactured by both RCA and Sylvania) make available a series of economical tubes ideally adapted for the design of an efficient, lightweight and compact wearable H.A. amplifier.

DEAFNESS

Before delving into the design and special features of the amplifier proper, it might be advisable to briefly review the fundamental process of hearing.*

Deafness is the result of some pathological condition of the hearing mechanism. Fortunately, deafness does not usually manifest itself completely and suddenly. It usually is brought about slowly. In fact its development can be so slow that an individual may be unaware that he is gradually losing his sense of hearing until hearing tests (audiograms) are made. Deafness can be, for our purposes, broadly classified into

2 groups: (1) Conductive Deafness; (2) Nerve Deafness.

Conductive Deafness is characterized by the inability of the outer ear and its associated components to *conduct* the sound vibrations to the "inner ear." The most common pathological conditions producing this effect are: thickening and inflexibility of the tympanic membrane; and, immobility of the ossicles (hammer, anvil and stirrup). This inoperative or inefficient conducting path may be "jumped" out of the conducting circuit by *bone conduction*.

This takes place when solid sounding bodies are placed directly on the head, so that the vibrations in the bones of the head set the air in the "middle ear" and auditory canal in vibration. This, in turn, is communicated to the tympanic membrane, so that nerve stimulation arises from this as under normal circumstances. It is therefore natural to assume that if hard-of-hearing persons hear normally through the bones of the skull, the cause of deafness is not in the nervous part of the ear, but in the

external sound-conducting part of the apparatus. It should be borne in mind, however, that even under the most favorable conditions, conduction through the bones of the skull affords less favorable conditions for excitation of the auditory nerves than conduction of the sound through the auditory canal.

Nerve Deafness as has probably been surmised, involves a pathological condition of either the "labyrinthia," or auditory nerve, or both. Affections of the labyrinth are characterized by loss of low-frequency (20 to 64 cycles) response with air conduction, but a good response with bone conduction. High frequencies, however, are poorly perceived. Auditory nerve affections, though, while characterized by a good high-frequency response, are not receptive to voice frequencies. Both conditions, however, may not show a preference for bone conduction.

In a majority of cases, it will be found that deafness is caused by a mixture of varying degrees of both nerve and conduction affections. It can therefore be seen that the selection of the proper type of earpiece is not a matter of guesswork.

FREQUENCY-DISCRIMINATING DEAFNESS—Audiograms

Another predominant characteristic of all types of deafness is that it usually takes on a frequency-discriminating characteristic. In other words, the loss of hearing varies with frequency (in no predetermined manner). This particular characteristic may be dependent upon the type of deafness.

An *audiometer* is used to measure the loss of hearing throughout the audio spectrum.

AUTHOR'S NOTE: *This discussion is not intended to encourage radio dealers, Servicemen, or technicians to set themselves up as hearing-aid specialists, nor is it intended to promote the sale of hearing-aid equipment by unqualified persons. A qualified otologist should be consulted for audiometric measurements and proper fitting of a hearing-aid amplifier should its use be indicated. This article is presented only for its general educational and experimental value.*

*See *Radio-Craft*, May, 1936, page 649, "How Do We Hear?", Part I; and Part II in the June, 1936 issue, page 719.

This is accomplished by gradually increasing the level of sound at any given frequency until the threshold of hearing is reached. A calibrated attenuator indicates directly the amount of db. increase above normal that is required to reach this threshold of hearing. The reading is taken as the loss in db. at the frequency tested. It is obvious that an audiograph taken with an air conductor and bone conductor would quickly classify the type of deafness—and, at the same time, suggest the ideal type of frequency response for the microphone.

For ideal correction, the frequency response of the microphone, or microphone and amplifier, should exactly complement the measured hearing loss with whatever type of earpiece is finally selected. A wide variety of specially-designed crystal microphones have been developed for this particular type of selection. Where unusual degrees of compensation are required, the response of the amplifier may be varied to fit the conditions. It is therefore obvious that indiscriminate use of unfitted hearing-aid units, will not always provide ideal correction for individual hearing loss characteristics.

DEGREE OF DEAFNESS

Hearing-aids of any one particular type cannot be used for all degrees of deafness. It is obvious, that a person suffering from an average loss of 80 db. will require an entirely different type of hearing-aid amplifier than one having an average loss of only 25 db.

The United States Public Health Service recently classified degrees of deafness as follows:

- (1) *Stage 1.* Partial Deafness, unable to understand speech in a public place, such as a church, or theatre, or in a conference between 5 or 6 people.
- (2) *Stage 2.* Partial Deafness, unable to understand speech from a speaker 2 or 3 ft. away.
- (3) *Stage 3.* Partial Deafness, unable to understand speech from a telephone.
- (4) *Total Deafness,* unable to understand speech under any conditions.

Audiometric tests showed the following averages for normal and partially-deafened hearing losses of the various groups:

Group	Average Loss
Normal	5 db.
Group 1	25 "
" 2	45 "
" 3	65 "
" 4	85 "

THE AMPLIFIER

The amplifier to be described should adequately handle all of Groups 1 and 2, and some of Group 3. Where excessive hearing losses are involved, a more powerful hearing-aid amplifier should be used. (Such a non-wearable unit will be described in a future issue of *Radio-Craft* if sufficient interest is indicated by readers.)

Basically, the amplifier is composed of a 1T4 high-gain pentode preamplifier; a 1S5 pentode-diode, as a 2nd stage high-gain amplifier and rectifier for A.V.C. voltage; and, a 1S4 power amplifier pentode for the output stage. (See Fig. 1.)

Optimum values were selected for both plate and screen-grid loads of all tubes in order to adequately handle the signal levels encountered.

The gain of the 1T4 is made variable for A.V.C. purposes. It will be noted that the grid-return passes through a resistor-condenser time delay circuit fed by a diode rectifier from the output of the amplifier. Figure 1 shows the basic elements of the

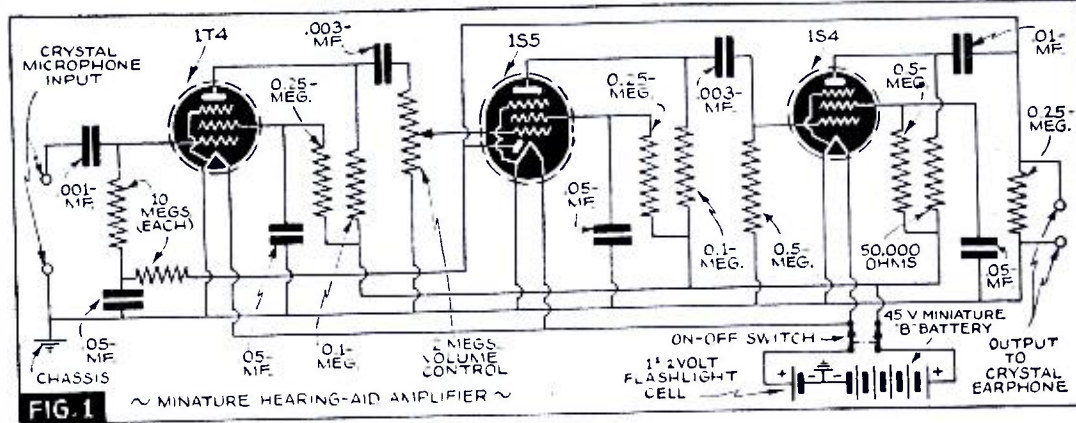

bias generating A.V.C. voltage. The output of the amplifier is fed back, through a 0.01-mf. coupling condenser, to the 2nd-stage diode. With this arrangement, instantaneous peak positive potentials are passed from diode to filament, and on to ground. The negative components of the output pile up across the 0.05-mf. condenser through the 10-meg. isolating resistor.

There are 2 time constants involved in this A.V.C. circuit; i. e., the "starting" time and the "releasing" time. The starting time is a function of the 10-meg. series resistor and 0.05-mf. condenser. If the resistor is made smaller the A.V.C. starting speed is increased. If the condenser is made larger, the speed is reduced. The releasing time is dependent upon the discharge path offered to the condenser. If the 1/4-meg. resistor across the output terminals were omitted from the circuit, the condenser would have no discharge path, excepting through the flow of grid current in the input tube and other minute leakage paths. Under these conditions, the release time would be very slow.

The size of the resistor connecting the diode to ground, determines the release speed. As the 1/4-meg. is increased, the release time is increased, and, conversely, if the 1/4-meg. is decreased, the release time is decreased. High-speed release time (the use of a very small resistor), however, produces a shunt effect across the output of the amplifier and may also become frequency discriminating because of the small coupling condenser employed in the output circuit. The time constant of the A.V.C. circuit has been adjusted to 1/8th of a second for starting and 1/2-second for release.

The amplifier is capable of maintaining a constant power output with wide variations in input signal level. (A change of signal level in the input circuit of 20 db. produces a change in the output of approximately 2 db.)

The manual volume control provides for individual gain adjustments and compensates for very wide variations in input signal level.

The output tube is designed to operate into a crystal earpiece. Should it be fed into a magnetic-type bone conductor or earpiece, the output circuit should be changed. An output transformer will be required to obtain efficient matching of the magnetic unit to the amplifier output.

All resistors, condensers, sockets, switch, interconnecting cable, and plugs, selected for this amplifier, have been particularly designed for miniature hearing-aid applications. Every precaution has been taken in the design of the amplifier to provide for continuous trouble-free performance under adverse operating conditions.

The amplifier tube filaments require a 1 1/2-volt drycell and draw approx. 200 ma., total. The plate supply requirement is 1.2 ma. at 45 volts. The overall dimensions of

the amplifier case are: 4 ins. long x 2 ins. wide x 1 in. deep. The overall dimensions of the battery case are: 5 3/8 ins. long x 3 3/8 ins. wide x 1 1/8 ins. deep.

SELECTION OF THE MICROPHONE

The input of the amplifier is designed to accommodate any type of crystal microphone. At the present time, there are approximately 5 different types available which have various types of frequency response. The selection of the correct microphone depends a great deal upon the compensating characteristics desired in the entire hearing-aid system. It should be remembered that when unusual compensation is desired, the response of the amplifier may be altered to augment the response of the microphone. Either high-frequency or low-frequency compensation may be incorporated in accordance with standard engineering practice. This phase of the subject has been completely covered in past issues of *Radio-Craft* but the authors will gladly answer all questions on hearing-aid amplifiers and their applications.

VARIATIONS OF STANDARD AMPLIFIERS

To meet unusual conditions the amplifier may be revised to provide either lower gain or higher power output. For lower-gain applications the 2nd stage 1S5 may be omitted. (Naturally, the A.V.C. circuit would also be eliminated.) The 1T4 input stage would then be directly coupled to the 1S4 output stage. This provides us with a 2-stage amplifier having an overall gain of approximately 65 db. It may be necessary however to employ a higher-level microphone.

For conditions requiring higher output levels, particularly where abnormal loss of hearing is encountered, it may be desirable to add an additional output stage. This would require the use of one more 1S4 output tube which can, for simplicity sake, be connected directly in parallel with the

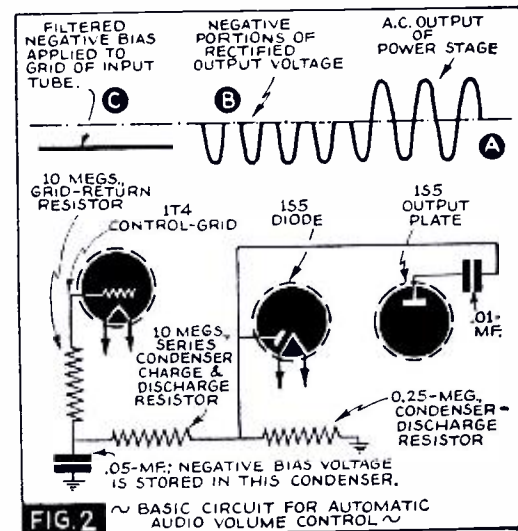

Tok Fone

REG. U.S. PAT. OFF.

SOLVES EVERY PROBLEM OF INTERCOMMUNICATION

TOKFONE makes the most complete line of intercommunication systems in the world. A system for every need from simple two-unit installations to 10-unit systems providing 5 simultaneous conversations. Standard systems for the specific needs of police, banks, restaurants, offices, factories, professional and home use. Also custom-designed systems. Let US solve your intercommunication problems for you! Prices, discounts, literature on request.

REGAL AMPLIFIER

Mfg. Corp., Dept. RC-5
14 W. 17th St.,
New York

1/30 H.P. UNIVERSAL G.E. MOTOR

Specifications: 1/30 H.P. Heavy Duty operates on either A.C. or D.C., 110 volts, 3200 R.P.M. with 5' cord and plug. Rheostat can be used to vary speed. Height 3 1/4", Length 3 3/4", Width 3", Shaft 1/4".



Can be used to drive Sewing Machines, Models, Buffing Lathe, Polishing Head, Drills, Grindstones, etc., same type motor furnished in 6 volt D.C. Less cord and plug, \$1.95.

MOTOR Universal 1/30 H.P. \$2.55
MOTOR 6 Volt D.C. \$1.95

Shipping weight, either style 3 lbs.

Money back guarantee. Send check or M.O.

Add 25c for special packing and mailing anywhere in U. S. A.

WELLWORTH TRADING COMPANY

1915 SO. STATE ST., Dept. RC-540, Chicago, Ill.

PATENTS—TRADE MARKS

Booklet concerning Inventions & Patents

Form "Evidence of Conception" with instructions for use and "Schedule of Government and Attorneys Fees"—Free

LANCASTER, ALLWINE & ROMMEL

Registered Patent Attorneys

136 Bowen Bldg. Washington, D. C.

RADIO FREE!

Parts—Accessories and Equipment

320 Pages

CATALOG

Showing & Describing Over 10,000 items

ZACK RADIO SUPPLY CO.

1426 Market Street, Dept. D-1, San Francisco, Cal.

A BIG SURPRISE IN STORE FOR YOU!

Be sure to read the announcement which appears on Page 690 of this issue . . . DO IT NOW!

FILMGRAPH VOICE AND MUSIC RECORDINGS

PERFECT SOUND on film recording can now be had with FILMGRAPH at only 25c per hour (this is cost of film only—no other expense). Permanent play-back. The only device capable of making lengthy recordings and play-back. Closing out several demonstrator models at special price. Complete 1940 line now ready.

MILES REPRODUCER CO., INC., Dept. RC,
812 Broadway New York City

present output stage. For more efficient coupling it might be advisable to employ a miniature-type output transformer. It should be borne in mind however that the crystal earpieces should not have more than 25 V. A.C. applied to them. A nominal value of 18 V. would provide a reasonable safety factor.

LIST OF PARTS

- One Amplifier Co. of America amplifier case;
- One Amplifier Co. of America battery case;
- One Amplifier Co. of America amplifier chassis;
- One Amplifier Co. of America interconnecting battery cable and plugs;
- One Amplifier Co. of America earpiece battery cable and plugs;

- One Brush crystal hearing-aid microphone;
- One Stackpole Carbon Co. switch, SS1;
- One Centralab sub-midget volume control, 1 meg.;
- Two I.R.C. resistors, 10 meg., 1/3-W.;
- Two I.R.C. resistors, 50,000 ohms, 1/3-W.;
- Three I.R.C. resistors, 0.25-meg., 1/3-W.;
- Two I.R.C. resistors, 0.1-meg., 1/3-W.;
- One I.R.C. resistor, 0.5-meg., 1/3-W.;
- One Solar condenser, 0.001-mf., 100 V.;
- Two Solar condensers, 0.003-mf., 100 V.;
- One Solar condenser, 0.01-mf., 100 V.;
- Four Solar condensers, 0.05-mf., 100 V.;
- One RCA or Sylvania 1T4 tube;
- One RCA or Sylvania 1S5 tube;
- One RCA or Sylvania 1S4 tube;
- Three Cinch 6-prong sockets, for the new RCA or Sylvania miniature tubes.



Here's Lester McAlister, Cedar Hill (Texas) tenor, and his hill-billy band. Such "home talent" as the youthful performer shown in photo at right has helped zoom Cedar Hill business.

PUBLIC ADDRESS UNIT BUILDS TRADE

USING a small public address unit, Lester McAlister has for the last 15 months entertained the home folks and drawn thousands of persons from the surrounding communities to his Saturday night "home talent" shows at Cedar Hill, Texas. McAlister is the owner of a grocery store in this little town of 600 population which is located 18 miles down the pavement from Dallas.

"Automobiles and good roads have doomed the business of many of the hamlets and villages in America," says McAlister. "No man can stay the hand of progress, he must keep in step. The small-town merchant usually sits by the side of his main street thoroughfare and watches his customers speed on their way to the cities to shop. To get people to stop in Cedar Hill was the reason for my purchase of a public address unit and the beginning of the home talent shows in August, 1938.

"My initial purchase consisted of a Silver-tone 30-watt amplifier, a Magnavox model No. 132 30-watt amplifier with 12-inch speaker, a Shure Bros. model R-5632 crystal microphone, and a record turntable. All of these articles were portable and cost approximately \$150.

"Our first show was on Saturday night in early August, 1938. Since that time, we have missed very few Saturday nights. When I first started, I told the people that with the coming of cold weather, which generally arrives in our part of Texas in November or early December, there would be no more shows."

With the coming of cold weather in 1938, McAlister stopped the shows as he had stated he would, but the crowds kept coming, so that now when the weather is bad the show is moved inside of his store.

"At first the show was given on an improvised stage in front of my store. As interest increased, I had to buy an additional speaker. This time, I bought a Magnavox 30-watt amplifier with a 12-inch

speaker mounted in steel baffles. This cost \$14.50. From a carnival company, I was able to get a collapsible stage, which helped.

"There has been no check on the number of persons attending these shows, but our top crowds have been estimated to be as many as 2,000 persons. We seldom have as small a crowd as 500."

McAlister uses his equipment, which is portable, to announce the plays on the local high school football field and it is strong enough to carry to all parts of the crowd. The speakers are mounted opposite the 50-yard line and sufficient electric cord is attached to the microphone to enable him to carry it from one 20-yard line to the other to follow the plays.

Inside the basketball gymnasium the speakers are mounted high in the rafters and turned into the crowd. In this manner the people absorb and diffuse the sound waves, otherwise the hardwood floor of the court reflects the sound until the whole building roars.

"Even with all the carrying around of the unit, I have not been 'out' anything since I bought the unit, with the exception of a few tubes and some additional cord," says Mr. McAlister.

"This unit has benefited me in 2 ways. First, when I opened up in Cedar Hill less than 2 years ago, I was practically unknown in the community. Now, I can truthfully say that I know as many persons in this section of Dallas County as some of the old timers. To one person I know, there are 10 who know me. Secondly, my sales are materially increased each week by the Saturday night crowd."

This has been a very profitable thing for all of the merchants of Cedar Hill, because without this entertainment most of the people of this section would get in their cars and go to Dallas to see the bright lights on Saturday night and while they were there they'd very likely buy their supplies for the next week.

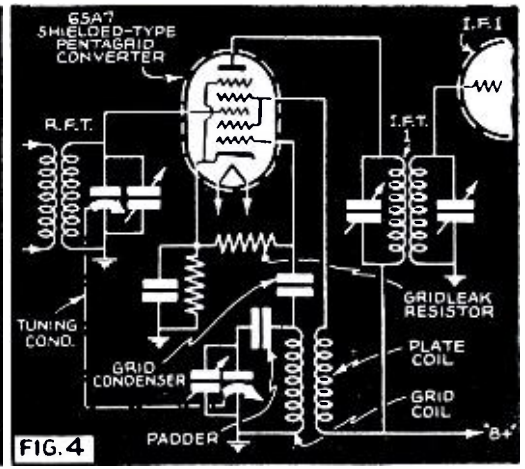
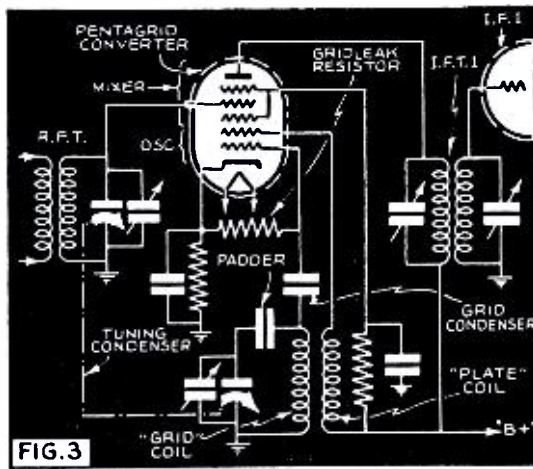
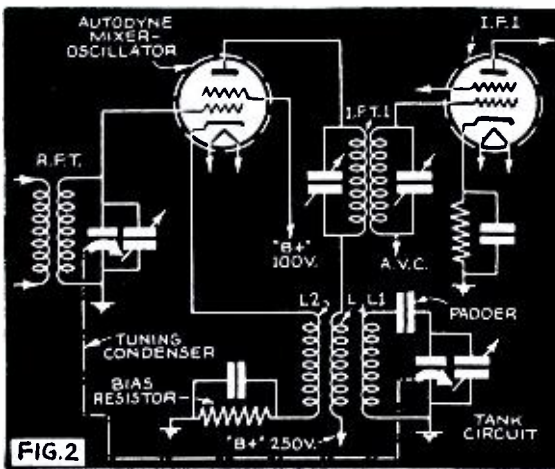

FREQUENCY CONVERSION IN SUPERHETERODYNES

A comprehensive article on the modern aspects of frequency converters in today's superheterodyne circuits. A short discourse on first principles introduces the more technical data. The writer is eminently qualified to discourse on this subject which is of vital importance to Servicemen and technicians.

C. W. PALMER

FREQUENCY changing or *conversion* in modern superheterodyne receivers has progressed through a complex series of stages from the first triode detector and oscillator arrangements with their separately-tuned condensers through the various stages of ultradyne, infradyne, dynatron, 2nd-harmonic, autodyne and many other such circuits, to 4 clearly defined arrangements.

There is little to be gained by an historic résumé of the various stages of development in frequency converters or "beat" circuits, but a general outline of how an intermediate frequency signal is made from a high-frequency signal and a locally generated oscillation may be of use to those who do not fully understand the principles of *superhet. operation.

The description will be followed by an explanation of the basic circuits and schemes used in up-to-date receivers. It is not possible to take into account every circuit in use, because there are too many, but fortunately practically all of them fall into one of 4 general classifications.

BEAT NOTES

The operation of a superheterodyne receiver depends on what are known as *beat notes* produced when 2 electrical voltages of somewhat different frequency are passed through a single reactive circuit.

Suppose for example, we refer to Fig. 1. This shows 2 alternating voltages (A and B) which are beat together to produce a 3rd alternating voltage, C. As the voltages in A and B start at the same instant and both increase in the same direction, the voltage of the beat is equal to the sum of the 2 voltages. As they gradually get out of step because of the difference in frequency, they no longer are additive but the resultant voltage is equal to the *difference* between the 2 (algebraic sum), the polarity being the same as the voltage that is greater at a particular instant. Thus, the resultant

*Superheterodyne or, speaking more technically, super-sonic heterodyne.

voltage, D, is gradually varying from a peak to a valley; and at a rate equal to the difference in time or frequency between the 2 original voltages.

Now, if one of the voltages under consideration is a radio signal being picked up, and a vacuum-tube oscillator is connected to the circuit carrying the radio signal and tuned to a frequency either slightly higher or lower in frequency than the radio signal, a lower or beat frequency will be produced. Because the radio signal is not constant in either frequency or voltage as is the signal A of Fig. 1, the beat produced is not a simple increase and decrease as C, but rather a complex wave having a number of different frequencies. Basically, however, the lower or *beat* frequency is present and by adjusting the voltage B, the frequency of C can be made to equal some previously-decided value to which amplifiers in the receiver (called *intermediate frequency amplifiers*) are tuned.

By varying the resonant frequency of both the signal circuit (tuning) and the

local oscillator circuit in step, signals on different frequencies can be picked up from the aerial and beat against the local oscillator to produce the same difference or intermediate frequency as before. Thus, the intermediate frequency amplifier can be tuned to a fixed frequency and all signals within the scope of the tuning arrangement in the signal circuit and the oscillator circuit can be beat to this same frequency.

Of course, one must not get the mistaken idea that there is nothing complicated about the superheterodyne receiver from the above simplified description of its operation. Actually there are many complex actions going on in the process of frequency conversion and since the signals received are of a complex wave shape, many peculiar effects can be obtained from poorly-constructed or -aligned circuits.

It is necessary, for example, to have sufficient selectivity in the input transformer to the intermediate frequency amplifier to prevent the series of undesired "beats," "harmonics" and "image" frequencies from passing through to the detector where they would cause howls, monkey-chatter or other forms of interference. It is necessary to have sufficient selectivity in the frequency converter or the amplifiers prior to this circuit to keep signals that are tuned to the frequency of the I.F. (intermediate frequency) amplifier from passing through and causing interference. It is necessary that the oscillator tune over a certain specified wave band so that at any and all points on the band, the difference between the input tuned circuits and the oscillator will be equal to the intermediate frequency. Otherwise no signals will be forthcoming; or unwanted beats or harmonics may be heard.

It can be seen that there is a lot of detail involved in the design, construction and repair of superhet. sets.

TRACKING

One of the most important things about the operation of modern single-dial receivers is the "tracking" of the oscillator. As

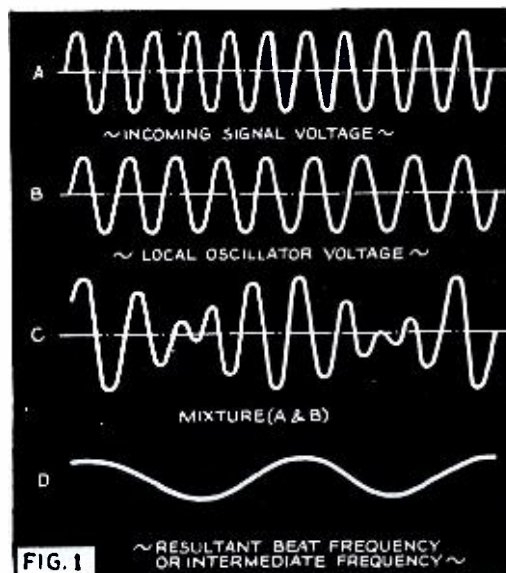

mentioned above, the oscillator must be tuned to a point higher or lower in frequency than the desired signals, by an amount equal to the intermediate frequency. The "higher" frequency setting is practically always chosen because of convenience in making oscillators tuned to these frequencies. It can be seen therefore that at any point on the dial the oscillator is tuned higher in frequency than the signals to be received.

For example if we are using 450 kilocycles in the I.F., for an incoming signal of 1,500 kc., the oscillator must be tuned to 450 plus 1,500 kc. or 1,950 kc., while this same oscillator for a signal at 550 kc. must be tuned to 1,000 kc. The variation of the oscillator is therefore from 1,950 to 1,000 kc. or a band of 950 kc. when the input circuit is tuned from 1,500 to 550 kc. (the broadcast band). The band width in both cases is 950 kc., but the oscillator is tuned to a higher frequency band which necessitates the use of a smaller change in the oscillator tuning capacity and a smaller inductance to cover the desired band between maximum and minimum on the tuning dial.

Two methods are used to permit the oscillator to cover this wave band. In some receivers the plates of the variable condenser section tuning the oscillator are shaped differently and less plates are used than in the other sections. This is called the *shaped-plate* method of tracking. The other more common method is to use an oscillator condenser identical to the other sections of the gang condenser and connect a fixed or semi-fixed condenser (known as a *padding* or *padding condenser*) in series with the oscillator condenser. The series condenser reduces the over-all capacity of the oscillator condenser and thus restricts the change in capacity. Then, with an oscillator coil of the right dimensions the oscillator can be made to "track" with the input or signal circuit.

We will not go into further discussion of the details of how the frequency converter works, but will proceed with an examination of some modern circuits used for the purpose. Lack of space prevents a more detailed account of the theory, which can be read in many text books. "The Super-heterodyne," *Radio-Craft Library Series* book No. 3, is a good reference work on this subject.

MODERN CIRCUITS

(1) *Autodyne*.—The first circuit of interest as found in modern manufactured radio receivers is called the "autodyne circuit" because the same tube elements are used as the *demodulator* or *1st-detector* and as the source of local oscillations. Figure 2 shows a simple form of autodyne (there are many variations of this basic circuit in use). This circuit in one form or another was used for almost all commercial superhet. receivers before the advent of special converter tubes.

The signals are fed into the grid of a type 36 or other R.F. pentode or tetrode tube from the aerial or preceding radio frequency amplifier through a tuned coil and condenser circuit. The plate of the tube contains the tuned I.F. transformer primary. A coil L is connected in series with this I.F. primary and is coupled to a coil L2 in the cathode lead of the tube. The coupling between coils L and L2 provides the link between input and output of the tube that permits oscillation. The resonance of the oscillator circuit is controlled by the coil L1 and the condenser C1 (called the *tank circuit*). The tuned I.F. transformer primary provides a low-impedance path for the oscillatory currents. This I.F. winding at the same time introduces a high im-

pedance to the flow of I.F. or difference-frequency signal voltages, thus developing a high I.F. voltage across the coil to feed on-through the I.F. amplifier. Note the fixed padding condenser in series with the oscillator tuning condenser to restrict its tuning range and permit tracking.

The autodyne circuit has several inherent disadvantages—especially in multi-band receivers—and is used mostly in single-band broadcast receivers. There is for instance the tendency to "pull in" on high frequencies caused by the coupling between signal and oscillator circuits making tuning unstable and difficult on high-frequency signals.

(2) *Pentagrid Converter*.—The 2nd frequency-converter method uses a special converter tube—as a contrast to the autodyne which employs a general-use R.F. pentode or tetrode tube. This special tube, known as a "pentagrid converter" has 2 sets of elements—an oscillator set and a frequency mixer set—combined in the 1 glass envelope (bulb). Figure 3 shows the arrangement of electrodes. It will be seen that the oscillator section is situated between the cathode and the control-grid of the screen-grid section. Coupling between the 2 sets of elements is therefore in the electron stream from cathode to grid as contrasted with the coupling coil used in the autodyne method.

The pentagrid converter is perhaps the most popular tube used for frequency conversion in superhet. receivers. Such tubes as the 6A7, 6A8, 6D8-G, 1A7, 1C7, 1D7, 1C6, 1D6 and 2A7 are in this category.

Grids Nos. 1 and 2 and the cathode connect to a feedback circuit and operate as a triode oscillator (the 2nd grid is the plate). The 2 grids and the cathode can also be considered as the composite or "virtual" cathode of the remaining elements of the tube, supplying an electron stream that varies at the oscillator frequency. This varying stream of electrons moving toward the plate of the tube is further varied or controlled by the signal voltage on grid No. 4. Thus the currents which reach the plate are a combination of oscillator and signal currents. Grids Nos. 3 and 5 are connected together and act as a screen-grid to shield No. 4 grid electrostatically from the other electrodes and also to accelerate or speed up the electrons toward the plate.

Pentagrid converters of this type are good frequency-converting tubes, developing conversion gains (transconductances) of 550 compared to about 350 or less for other types. They have the drawback of being more efficient on lower frequencies than on high frequencies and actually stop oscillating in the neighborhood of 7 meters. This is due to interaction between the elements which becomes more prevalent as the frequency is increased.

To minimize these effects, several of the newer pentagrid converters have a dif-

ferent internal construction. The 6SA7 and 1R5 are examples of this later design. In these tubes the first grid functions as the oscillator grid. Grid No. 2 is connected within the tube to grid No. 4. Grids Nos. 2 and 4 shield the signal grid No. 3 and at the same time combine to function as the oscillator plate (anode). Grid No. 5 operates as the suppressor-grid. Converter tubes of this type (see Fig. 4) are designed so that the space charge around the cathode is not affected by electrons from the signal grid. The result is a marked improvement on high frequencies and a reduction in the detuning action of automatic volume control systems in the receiver on the frequency of the oscillator.

(3) *Triode-Hexode Converter*.—The 3rd method of frequency conversion is known as the *triode-hexode* converter. This consists of having a special tube which is really 2 tubes in 1—a triode oscillator and a hexode signal section. Figure 5A shows the electrode arrangement (plan view) in this type of converter and Fig. 5B shows the accompanying circuit arrangement.

In Fig. 5A the cathode, the triode grid No. 1 and the triode plate form the local oscillator. The cathode, the hexode mixer grid (grid No. 1), the hexode screen-grid (grids Nos. 2 and 4) the hexode mixer grid (grid No. 3) and the plate, form the signal mixing circuit. The internal shields connect to the shell of the metal tube and act as the suppressor (grid) of the mixer (signal) section.

The action of the triode-hexode comprises the generation of local oscillations in the triode, the transference of these oscillations to the hexode grid No. 1 and the mixing of the local oscillations with the signal voltage in grid No. 3.

The 6K8 triode-hexode will oscillate on quite high frequencies; and oscillator shift due to interelement coupling is quite low. This tube is therefore good for allwave receivers. The conversion gain (transconductance) is about 350 compared to 550 for the pentagrid converter—but the greater stability off-sets the drop in efficiency on the lower frequencies.

(4) *Pentagrid Mixer*.—The 4th method of frequency conversion in use in modern receivers is called the *pentagrid mixer* method and is particularly advantageous for short-wave and ultra-shortwave receivers. It calls for the use of 2 tubes: a "pentagrid mixer" and an oscillator. The pentagrid mixer has 2 control-grids—the signal grid and the oscillator "injection" grid. It can be seen therefore that the variations in the plate current in the mixer tube are due to a combination of the oscillator voltage and the signal voltage.

An examination of Fig. 6 shows the electrode arrangement in the mixer and a typical oscillator circuit. The oscillator, of course will vary to suit individual designer's preferences. In the mixer tube, grids Nos.

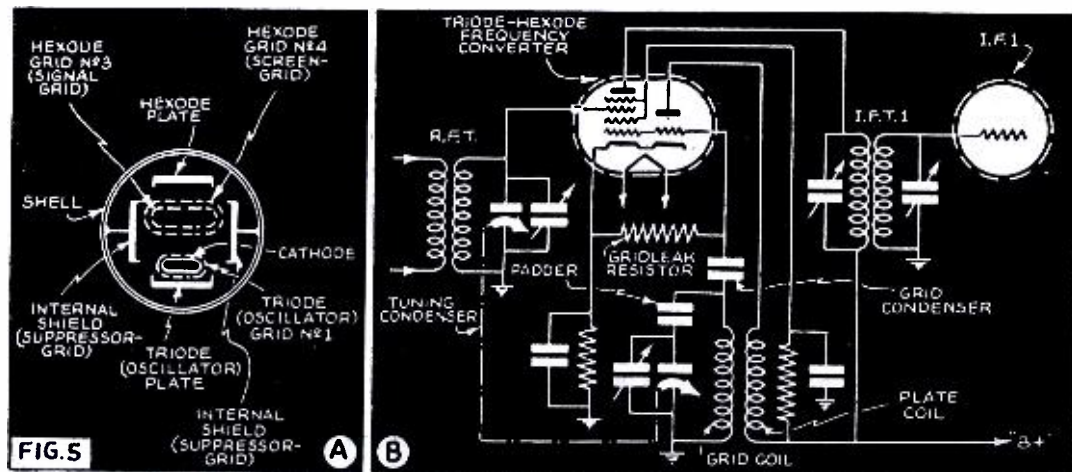

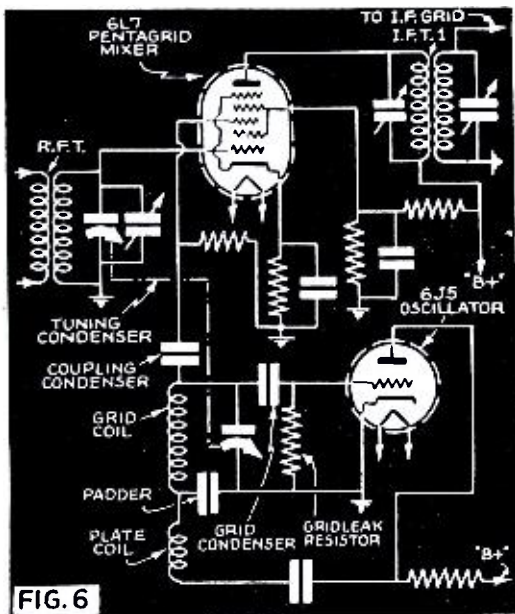

1 and 3 are control-grids, No. 1 for signal voltage and No. 3 for oscillator injection. Grid No. 1 has remote cut-off characteristics like the remote cut-off type of pentode 6K7, 6D6, 6SK7, etc. This grid may be controlled by automatic volume control systems in the receiver. The oscillator injection grid No. 3 is a sharp cut-off grid to increase the effect of small oscillator voltages on plate current. This is particularly useful on very high frequencies where oscillator voltage drops off. Grids Nos. 2 and 4 are connected together inside the tube—they act as the screen-grid and accelerate the electrons toward the plate. At the same time they shield grid No. 3 from the other electrodes. Grid No. 5 is connected internally to the cathode and operates as a suppressor.

The conversion transconductance of the 6L7 tube is 350 to 375 which compares favorably with the triode-hexode type in efficiency.

Similar circuits to Method 4 have been

used with R.F. pentode tubes in the mixer position. However, the introduction of the 6L7 and 6L7G tubes has made these circuits become obsolete because of the advantages in shielding and gain in the pentagrid mixer tube. The 6F7 tube has been used to some extent for such mixing, but the rather high degree of coupling between triode plate and pentode grids has made this tube a rather poor one on high frequencies.

As explained before, no attempt is made to cover all the circuits in use in up-to-date superhet. receivers. Four representative examples were chosen as they supply all the basic types in use. Minor variations in circuit design, values of parts, etc., will be found in the sets of different manufacturers—and the use of multi-band coils in allwave receivers will perhaps make it difficult to distinguish the various circuits. However, the type of tube will be a great aid in determining the system of frequency conversion.

For example, if a general-purpose pentode is used for both mixer and oscillator, the circuit is obviously a form of autodyne. If a pentagrid converter tube such as the 6A7, 6A8 or 6D8G is used the circuit is a pentagrid electron-coupled circuit while if the 6K8 or 12K8 is used the system is the 3rd type or triode-hexode method. The pentagrid-mixer circuits can be identified both by the use of the 6L7 or 6L7G tube and the fact that 2 separate tubes are used for mixing and generation of the local oscillations.

In summarizing, the underlying principles of all the systems of frequency conversion are the same—the circuits differ in the methods of coupling and other characteristics, but the I.F. signals in all cases are produced by beating an incoming signal voltage against a locally-generated R.F. voltage and removing undesired beats or images by the use of selective circuits that exclude them, passing only the desired beats on to the 2nd-detector and audio-frequency amplifier.

BOOK REVIEWS

HOW TO BUILD RADIO RECEIVERS (1940). Published by Meissner Mfg. Co. Size, 8½ x 11 ins., stiff paper cover, profusely illustrated, 168 pgs. Price, 50c.

In addition to all the constructional data on the entire line of Meissner kits, this new book includes circuits and complete information on many Meissner ready-wired units, such as the signal shifter, signal booster, crystal calibrator, etc. This book includes complete instructions on 28 different models, with 18 pgs. of television data. The book is fully illustrated with charts, radio formulas, schematic circuits and picture diagrams.

It is difficult to conceive of greater value in publications for the constructor than "How to Build Radio Receivers." This title, however, is a bit misleading; the index is too long to reprint but a few titles selected at random indicate the diversity of its contents:

How to Tell What Resistor to Use; Handy Radio Formulas; Radio Coils and Circuit Applications; Television in Theory and Practice; Pushbutton Converter; High-Fidelity Public Address Tuner; "Wireless" Phonograph Oscillator Adapter Unit; "Lamb" Noise Silencer Adapter Unit; 6-Volt Vibrator Power Supply Unit; Meissner "Analyst."

MANUAL OF RADIO SERVICING, Compiled by M. N. Beitman (1939). Published by Supreme Publications. Size, 5½ x 8½ ins., paper cover, illustrated, 21 pgs. Available gratis.

This recent book by Mr. M. N. Beitman is on "Ideas That Clicked." Short-cuts in servicing, information on resistance, condenser and transformer replacement, servicing procedure, and information for the sound specialist are included in this book.

MANUEL TECHNIQUE DE LA RADIO, by E. Aisberg, H. Gilloux and R. Soreau (1937). Published by Societe Des Editions Radio, Paris, France. Size, 4½ x 7 ins., paper cover, 270 illustrations, 224 pgs. Price, 23 francs.

Written in French, this book is mainly an analysis of receiver circuits with particular respect to the use of vacuum tubes. (A sort of French version of the Sprayberry department, "Circuits in Modern Radio Receivers," which appears regularly in Radio-Craft.)

LISTEN AND LEARN, by Frank Ernest Hill (1937). Published by American Association for Adult Education. Size, 5½ x 7¼ ins., stiff cover, 248 pgs. Price, \$1.25; free to members of the Association.

This book is a study of 15 years of adult education on the air. The first in a series of about 40 studies to be issued over a 5-year period by the American Association for Adult Education. It is briefly, a correlated report of the important facts about adult education by radio.

FOUNDATIONS OF WIRELESS, by A. L. M. Sowerby (2nd Edition, 1938). Published by Iliffe & Sons, Ltd., London, S.E.1, England. Size, 5 x 7½ ins., cloth cover, 158 illustrations, 272 pgs. Price, 4/11.

This text book is a technical analysis of the elements of radio receiver operation. Unlike most books on the A-B-C of radio, it offers a really worthwhile technical analysis of the elements of radio receiver operation presented in such simple, straightforward form that most beginners will have little difficulty in assimilating its contents.

Of special importance is the fact that the process of detection is treated in considerable length.

SPECIAL TUBES FOR SOUND RELEASED BY NATIONAL UNION

13 SOUND X/TRA TYPES AVAILABLE

Demonstrably Different!

The chief requirement for National Union's new SOUND X/TRA tube types is that they must be demonstrably better. In order to accomplish this outstanding performance in SOUND X/TRA types, modification in construction and details of engineering were incorporated. Emission limits are very high to insure exceptional uniformity, long life and adequate power handling capacity. Gas and grid current are held to exceptionally low limits to insure minimum distortion, uniformity and stability. Every tube is carefully tested for hum and microphonics and, where necessary, changes have been made in construction such as the use of special micas, extra rugged supports, double helix heaters, special insulation minimum hum, etc.

The thirteen SOUND X/TRA types now available cover the major percentage of replacement requirements. SOUND X/TRA types can be substituted in all cases for the same type of tube in the regular line. This means they can be used for special audio work in any amplifier, public address, inter-office system or other audio device where the identical type number is specified but where improved performance is desirable.

SOUND specialists have long hoped for extra quality tubes engineered specifically for the requirements of SOUND work . . . they're here now in National Union SOUND X/TRA types.

TYPES NOW READY:

SOUND X/TRA types available at this time are as follows:

5U4G	6L6G
5V4G	6L7G
5Y3G	6N7G
6C5G	6V6G
6F6G	6X5G
6J7G	83
6K6G	

Buy Them! Try Them!

Order Samples from
Your National Union Distributor

NATIONAL UNION RADIO CORP.
NEWARK, N. J.

4 THUMB-SIZE PENTODES FOR HEARING-AIDS

The pros and cons, and use, of a new line of thumb-size A.F. amplifier tubes especially suitable for wearable hearing-aids are discussed in this article.

R. D. WASHBURNE

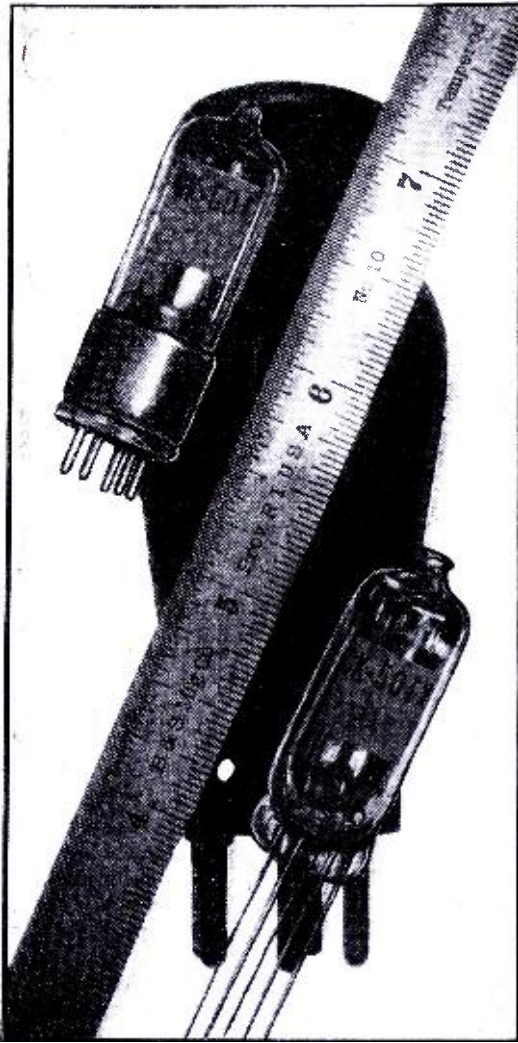

The thumb-size A.F. voltage and power amplifier tubes are available in based (upper-left) and tinned-lead types. Compare with ordinary 5-prong tube (silhouette background).

SMALLEST of the midget tubes so far to be announced is the new Raytheon all-pentode CK-500 series, for wearable hearing-aids, here illustrated in full life size; the tinned-lead type shown at lower-right in the photo is further identified with the letter X (see Table I).

The manufacturer of these 4 thumb-size pentodes is of the opinion that these tubes are the smallest in size and require the lowest battery drain of any tubes now available.

THE SPACE FACTOR

Miniature tubes previously described in *Radio-Craft* were neither as short (1 7/8 ins. complete with base) nor as slender (9/16-in. in dia., for the base type). The 1st dimension, in particular, represents a saving of about 1/4-in. in length and one which is important to many manufacturers of hearing-

aids in which space ordinarily is at a premium.

Too, many manufacturers of hearing-aids are willing to sacrifice a certain amount of gain and power output in order to be able to still further conserve space by using smaller, lower-voltage "A" and "B" power supplies. Thus it is possible to effect a saving in battery space requirements through the use of these Raytheon tubes which draw an "A" current of only 33 milliamperes and "B" current of not over 1.85 ma. (including screen-grid current) at max. rated filament and plate - S.-G. voltages.

Still further saving in space may be effected by operating 3 of these tubes in series on a 3-V. "A" supply thus reducing the "A" drain to roughly 20 milliamperes; using, at the same time, the minimum rating of plate voltage makes it possible to hold the total "B" drain to something under 0.5-ma. for the power tubes and roughly 0.35-ma. for the voltage tube.

Of course this means the available power output is greatly lessened but if a *head-telephone* or sensitive *earphone* is being used adequate operation perhaps may be obtained for many types of work.

If the output device is a *bone conductor* it probably will be necessary to utilize a type CK-503 tube as the output device and to operate it at full plate voltage. If a less-sensitive type of bone conductor is used it may be necessary to use 2 such tubes in parallel; or in push-pull preceded by a higher-gain voltage amplifier.

The low filament drain of these tubes makes it economical to use a flashlight cell as the "A" supply.

TUBE TYPES

Three types of output pentodes are available with different output characteristics and watts ratings as shown in the tabulation of tentative characteristics, Table I.

The CK-502 (and -X) is designed to properly match into a crystal earphone and yet afford a mutual conductance of 500 mmhos.

The 503 (and -X) has a mutual conductance rating of 600 mmhos but its low load

resistance renders it a more suitable match for bone conductors and magnetic air-conduction earphones.

The 504 like the 502 has a high plate impedance and affords excellent matching into a crystal earphone. It is the most economically-operating output tube of the 3 but it therefore has the lowest mutual conductance.

For driving these output tubes there is available a 4th pentode, which is a voltage amplifier, the CK-501 (and -X). This tube is a special pentode having "low microphonic design."

"C" BIAS

Although bias improves operation, as Table I shows, all the tubes will operate at low distortion with zero bias. If it is desired to apply a bias voltage to the tubes the writer wishes to call attention to the fact that the inclusion of a self-generating bias cell in this circuit will eliminate the necessity for using a drycell which in time would need replacement. In other circuits it may be found convenient to so wire the filaments and the grid leads as to derive grid-bias voltage in one or more circuits without recourse to a "C" cell.

All 4 tubes are available either with miniature bases, or tinned copper leads for direct soldering, as shown in the photograph. These tubes are identical except for the bases; hence the tinned-lead tubes are only 1 1/2 ins. long and 1/2-in. in dia. while the base tubes, although only 1 1/4 ins. long, because of the base are slightly larger around—or 9/16-in. in dia.

Unlike miniature tubes designed for radio receivers and which may be used with considerable success in hearing-aids, these new hearing-aid tubes on the other hand will not operate with any degree of efficiency in R.F. circuits; due to interelectrode capacities, for instance, the gain in R.F. circuits is much less than when equivalent types of tubes particularly designed for R.F. work are used.

Every hearing-aid manufacturer has his own idea of "ideal" circuits for use in hearing-aids and in fact may have a number of

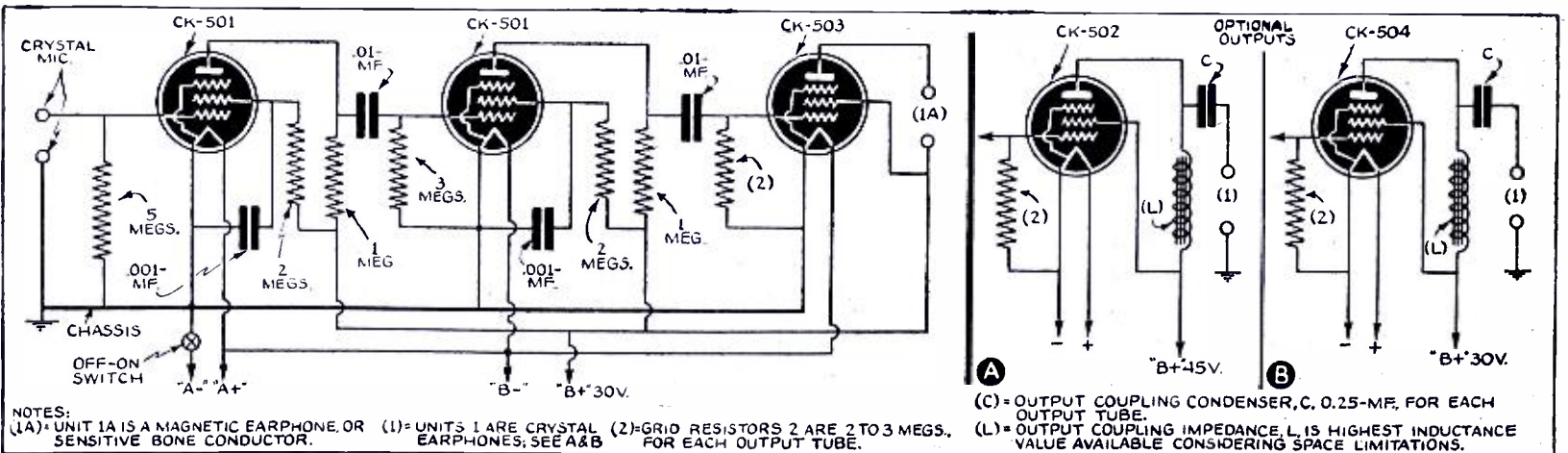
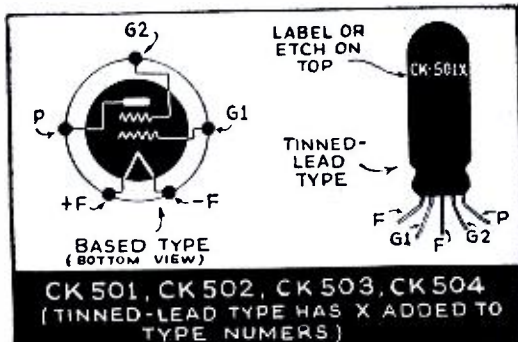

Fig. 1. Experimental, all-pentode hearing-aid circuit, and (A and B) optional output circuits, utilizing the new 500-series tubes. A single "A" cell is used.



circuits each with a different characteristic to suit a particular set of conditions. For example one circuit may incorporate automatic volume control (as is the case in a circuit shown elsewhere in this issue); or it may include any one of several types of tone controls, as for instance, the hearing-aid circuit shown in the Sound Engineering Department of the April, 1940, issue of *Radio-Craft*. For this reason the circuit reproduced here (Fig. 1) is merely representative of the use of these new hearing-aid tubes and is not necessarily the diagram of any previously-constructed or commercially-available hearing-aid.

It is for this reason that the 2 additional circuit details A and B are included to show optional arrangements of the output circuit to include either of the 2 remaining output pentodes for matching into various types of sound reproducers. We wish to here point out that a certain amount of experimentation probably will be necessary before optimum values of components are secured to suit individual requirements of amplifier overall voltage gain and power output with whatever filament and plate voltage it is desired to use.

As a further assistance to technicians, who may wish to apply these new tubes in experimental pocket-size A.F. amplifiers, references to a few articles published in past issues of *Radio-Craft* are given. (*) However the writer wishes to stress the fact that it is inadvisable to utilize such amplifiers as hearing-aids without first consulting a competent otologist to determine the type and extent of the hearing deficiency; and the requisite hearing-aid characteristics which might be prescribed.

Engineering data sheets are available from the manufacturer of these tubes and these include the curves of output and harmonic distortion as a function of load resistance and grid bias. Note that these tubes in the base type utilize a newly-developed base for which sockets have been made available by several parts manufacturers (including American Phenolic Corp.).

*"New High-Fidelity Hearing-Aids," "R.-C.," Oct. '39. "Build This Pocket-Size 3-Tube Hearing-Aid," "R.-C.," Nov. '38. "3-Tube Ultra-Compact Deaf-Aid," "R.-C.," Feb. '40.

TABLE I—IMPORTANT ELECTRICAL CHARACTERISTICS (CK-500, and -X, SERIES)
(With Min. and Max. Ratings)

	CK-501	CK-502	CK-503	CK-504
Based Construction	CK-501	CK-502	CK-503	CK-504
Tinned Lead Construction	CK-501X	CK-502X	CK-503X	CK-504X
FILAMENT				
TYPE	Pentode	Pentode	Pentode	Pentode
TYPICAL APPLICATION	Voltage Amp. Resistance or Impedance-Coupled Amp.	Output Amp. Crystal Phone Output Stage	Output Amp. Bone Conductor and Magnetic Phone Air-Conductor Output Stage	Output Amp. Crystal Phone Output Stage
FILAMENT	volts	1.25	1.25	1.25
FIL. CURRENT	ma.	33	33	33
		Tentative Operating Characteristics		
Plate	volts	30	45	30
Screen-grid	volts	30	45	30
Control-Grid	volts	0	-1.25	0
Plate Current	ma.	0.3	0.55	0.6
Screen-Grid Current	ma.	0.06	0.13	0.12
Mutual Conduct.	mmhos.	325	300	400
Plate Resistance	megs.	1.0	1.5	0.5
Load Resistance	ohms		60,000	80,000
Approx. Output	mlws.		3.5	11

THOUSANDS ARE PRAISING THIS
1940 SYLVANIA
TECHNICAL MANUAL

Send for your copy of this big "tube fact" book today

The 1940 Sylvania Technical Manual is bigger and better than ever with a new easy-to-use arrangement. It has 264 pages packed with vital tube information for servicemen, radio technicians, engineers and amateurs.

It gives you complete data and tube diagrams for 344 types of tubes all now listed in numerical-alphabetical order for quicker reference. Operating conditions, characteristics and circuit applications for Standard Glass tubes, "G" types, "GT" types, Loktal, Metal, Majestic and Special types. Full information, too, on Sylvania's complete line of Panel Lamps.

The new Manual also includes data on special tubes for particular applications in Television amplifiers, Cathode-Ray tubes, etc., with new circuit information and diagrams covering the latest type tubes.

Send the coupon below for your copy! This new edition is a bargain at only 35c.

SYLVANIA
Set-Tested Radio Tubes

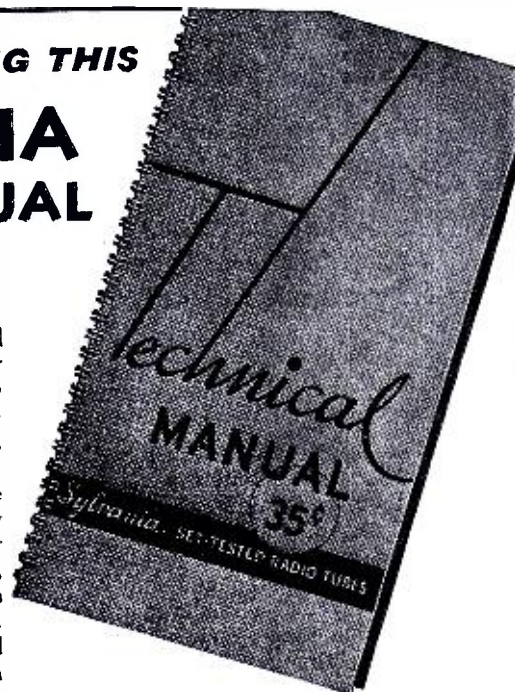

HYGRADE SYLVANIA CORPORATION RC50
Emporium, Pa.

Here is 35c. Please send me a copy of the bigger and better Sylvania Technical Manual.

Name

Address

City State

Serviceman Experimenter
 Dealer Amateur

SERVICING
R.F. COILS

Do you know how to properly match, replace and repair R.F. coils in radio receivers? Very little practical information on this topic has been published in radio magazines. Read the June issue of *Radio-Craft* for complete data on servicing procedure concerning all types of R.F. coils. . . . Reserve your June copy today!

RADIO COURSE \$1.95

GREATLY REDUCED
Amazing offer of latest \$39.00 R.T.I. radio course. Limited number of courses reprinted and reduced to \$1.95. Exactly the same as higher priced originals. Prepared for home-study; practical facts only; unusual bargain in radio education.

THOUSANDS OF GRADUATES
Men like you studied Radio Servicing for a short time and today are making good money in radio. Radio Technical Institute unique radio training will bring rich rewards to you. Pre-tested and approved by thousands. Prepared with the aid of 43 leading radio manufacturers. You can get ready inexpensively, quickly, easily, and in your spare time, for a good job in radio.

THREE COURSES IN ONE
You get three complete essential courses combined and streamlined: (1) Fundamentals of Radio and Electricity; (2) Practical Radio, and (3) Advanced Training. This is the training which will place you above average. From the very start you get this practical course for only \$1.95. A final test examination may be taken and diploma obtained.

COMPLETE IN ALL DETAILS
R.T.I. course will give you the radio training you need. The lessons are clear, interesting, easy to master and use. A. Gold, now a serviceman in Illinois, writes: "From the very start I learned about practical equipment and methods. . . . You too, can make spare-time money on radio repair jobs before you reach the 14th lesson."

M. N. Beltman, radio engineer, author, instructor in Chicago schools, says: "R.T.I. course will help you get into radio with the right training. Special \$1.95 price for complete course can be earned in an hour of radio servicing."

LATEST FACTS
The training is remarkably complete. Everything from simple radio facts to advanced radio problems. Many servicemen find R.T.I. course excellent for brush-up and study of modern servicing methods. Learn latest facts. Revised and reprinted in 1939. Hurry order to us today. Limited edition available at reduced \$1.95 price. You must be satisfied or your money is refunded promptly.

FREE EXAMINATION COUPON
SUPREME PUBLICATIONS, Agents
3727 West 13th St., Room 605, Chicago, Illinois
Ship complete R.T.I. Radio Course. I must be satisfied or I may get my money back immediately.
 I am enclosing \$1.95, full price. Send prepaid.
 Send C.O.D. I will pay mailman \$1.95 and a few cents postage.

NAME
Write address below and send this corner.

THE "BASEBALL SPECIAL"

A 1-Tube Broadcast Receiver

The article describes an easily-built portable battery receiver to take to the ball games this season . . . recommended to perennial bleacherites. The aerial?—a short wire.

L. F. ROGERS

If this be April can baseball be far behind? The answer—all too obvious—set the author a thinkin'. Being an avid baseball fan of the bleachers' type and somewhat of a radio experimenter he decided (alas) to combine the two to their mutual advantage. The result is illustrated here—a portable battery set to enable him to listen-in on the game he is watching!

A more decrepit-appearing set is hard to imagine; a better circuit easy to obtain, but this is the first thing that came to mind, and . . . what do they say about following that first impulse? Anyway it works fine business and serves the purpose very well. It's not meant to be a DXer (and it sure isn't); it merely gets the locals—those that broadcast the games. All in all, for a "throw-together" it's pretty good.

The original idea was to build it into a camera case hence its peculiar shape. It's still a good idea if we can swap a couple of old radio parts in the "junk box" for a camera case (can you take a hint?). However the case is not essential; the set will play in the nude. Just fasten the batteries to the chassis with a couple of elastic bands, throw the "works" into an old paper bag or into the great inside pocket of last

year's top coat, and trot off to the games. NOTE: In case your fellow bleacher blokes bother you to listen-in (and it's 10 to 1 they will) just hand them each a copy of this article and tell them to go build their own. So there!

Although a single tube is used the results obtained are equivalent to a 2-tuber plus. The new 1D8GT tube is a triple purpose diode, triode, pentode used as a combined regenerative detector and 1 stage of A.F. The diode section remains unconnected; the pentode section is the regenerative detector and the triode section is utilized as the audio stage.

In short, the circuit is an "old reliable" 2-tuber, applied to 1 tube—the new 3-in-1 drycell-type 1D8GT—at the suggestion of Mr. R. D. Washburne.

The circuit makes use of a standard high-gain midget-type antenna coil with the primary winding used for feedback. The amount of feedback (regeneration) is controlled by varying the screen-grid voltage of the detector section of the 1D8GT. An air-dielectric 35 mmf. variable condenser in series with the antenna lead controls the effective length of the antenna thus helping the selectivity of the set. When tuning-in the low-frequency broadcast stations this

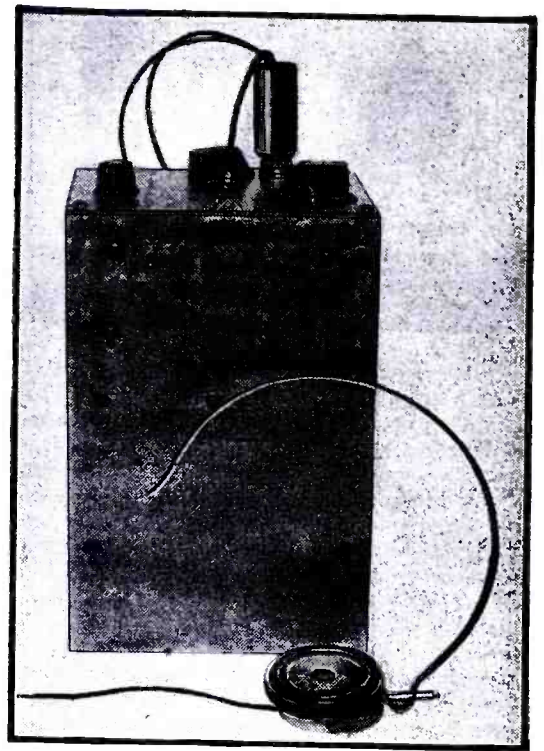

Pack this radio with your lunch next time you go to the ball game. It will help you digest the game better.

series condenser is not required at all. To eliminate it from the circuit automatically it is merely necessary to bend one of the outer plates of the rotor so that in the maximum-capacity position it makes contact with the adjacent stator plate, shorting itself out.

The batteries used are 2 "B's" totaling 67½ volts; and a 1½-volt "A" cell.

Concerning the placement of parts, the less said the better. Follow, if you wish, the author's layout as shown in the illustrations; or use your own judgment. How-

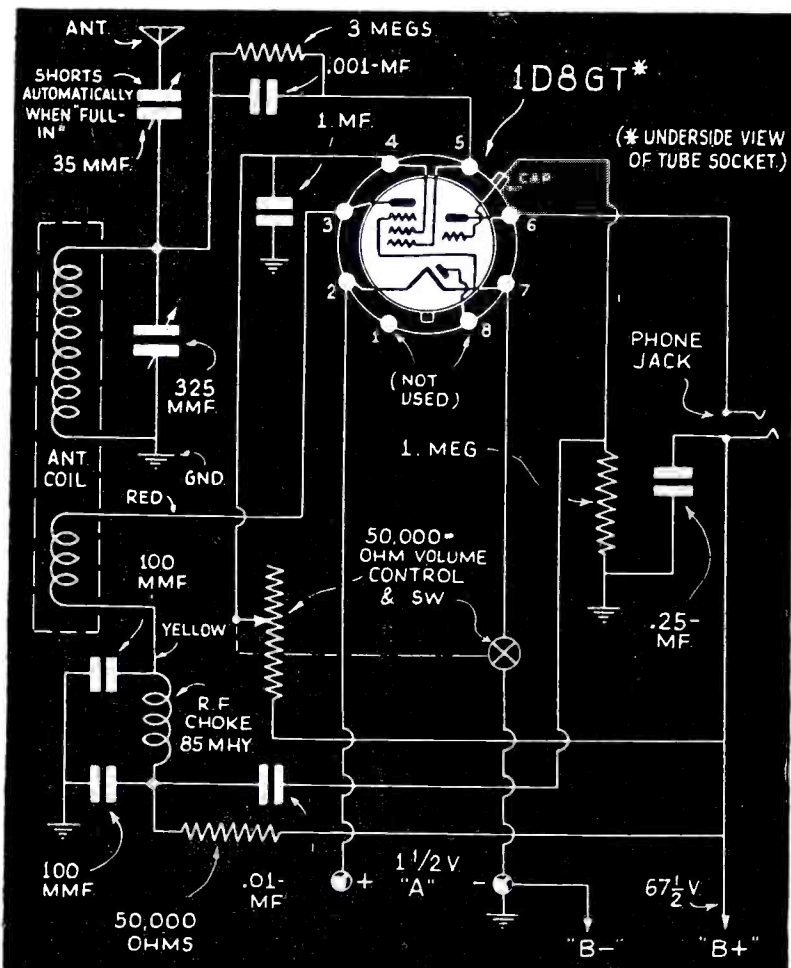

The 1D8GT does double duty; the pentode section is the regenerative detector and the triode section the audio amplifier. The diode section is not used.

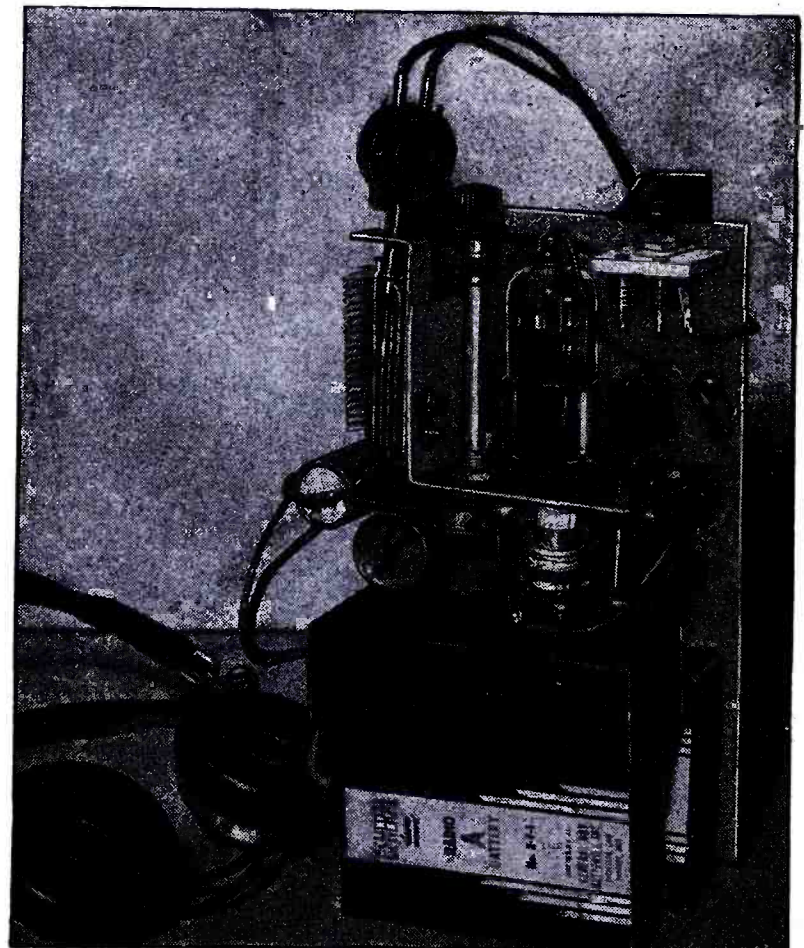

Neither the height of beauty nor the pinnacle of perfection—merely a good local-station getter. The tuning knob is behind the phone plug. The other knob is for the antenna trimmer condenser.

PROFITS ARE PILING UP

FOR DEALERS IN **HIGH LINE** DISTRICTS

SELLING GTC PORTA-POWER!

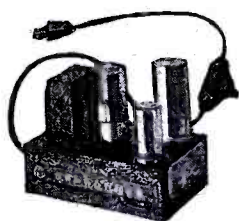
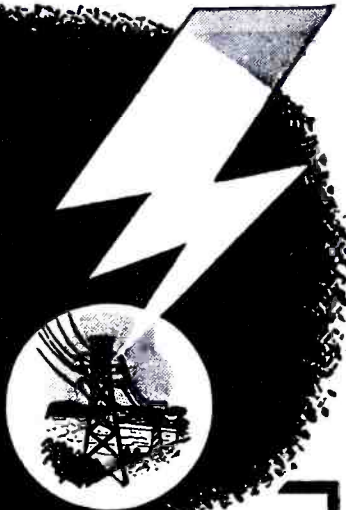

Model "L" Porta-Power supplies "A", "B", and "C" power to any 4- to 8-tube farm battery set using 2-volt tubes.

List **\$9.95**

NEW ... TWIN-POWERED MODEL "P" CONVERTS 98% OF ALL 6-VOLT BATTERY RADIOS TO ALL-ELECTRIC OPERATION

★ TWIN-POWER provides TWO sources of 6 volts each; a separate source to the vibrator and a separate source to the filaments. This eliminates vibrator disturbance and assures high fidelity performance. Operates on 105-125 volts, 50-60 cycle current.

Make big profits by selling Porta-Power, converting "traded-in" battery sets and using on your service bench.

Free literature and further information on request

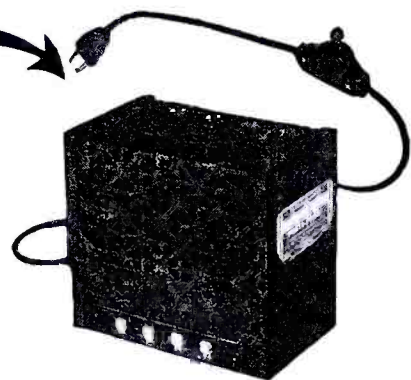

EASILY INSTALLED

Model "P" Porta-Power for 6-volt battery radios.

List **\$13.95**

GENERAL TRANSFORMER CORP.
1252 W. VAN BUREN STREET • CHICAGO, ILLINOIS

ever, keep the wiring as short as possible. Don't forget to place a small pan under the gridleak to catch the fine drippings or else the man in front of you might take a swing at you with his souvenir baseball bat.

Outside of the tube, coils and variable condensers you needn't follow the list of parts too carefully (tap the contents of the "junk box"); however the recommended parts will bring the described results (!).

Cheerio, and happy listenings.

LIST OF PARTS

- One RCA type 1D8GT tube;
- One Amphenol type S8 molded black-bakelite octal tube socket;
- One I.R.C. resistor, 3 megs., 1/4-W.;
- One I.R.C. resistor, 50,000 ohms, 1/2-W.;
- One I.R.C. resistor, 1 meg., 1/4-W.;
- One I.R.C. type P-102 midget volume (regeneration) control, 50,000 ohms; linear taper, with "on-off" switch;
- One Solar paper condenser, 0.25-mf.;
- One Solar paper condenser, 1 mf.;
- One Solar paper condenser, 0.02-mf.;
- Two Solar mica condensers, 100 mmf.;
- One Solar mica condenser, 0.001-mf.;
- One Meissner type 14-1496 (550 to 1,750 kc.) high-gain midget antenna coil for the standard broadcast band;
- One Aladdin type K-2500 R.F. choke, 25 millihy.;
- One Hammarlund variable condenser, 25 mmf. type HF-35;
- One Hammarlund variable condenser, 325 mmf. type MC-325-M;
- One set of General Dry Batteries, Inc., extra-small portable batteries: 1-1 1/2-V. "A"; 1-45-V. "B"; and, 1-22 1/2-V. "B";
- Miscellaneous items such as sheet aluminum, phone jack and plug, phones, wire, hardware, etc.

Feature Articles in MAY Radio & Television

Antenna Layout at de Luxe Amateur Station W2USA—New York World's Fair—Arthur H. Lynch, W2DKJ

Television Signal Booster—A 2-Stage Pre-amplifier—Ricardo Muniz, E.E.

How to Build the 3-Tube "Ocean Hopper" Receiver—Harry D. Hooton, W8KPX

Mobile 10-Meter Transmitter and Receiver—Part 2—Howard G. McEntee, W2FHP

International Radio Review—"World-Wide" Digest

Latest Television News and Pictures—World Short-Wave Station List—Question and Answer Box

FOTO-CRAFT Section

How to Take Sport Photos—Wm. C. Greene, Pres., N. Y. Press Photographers Assn.

"Speed Up Motion" with Still Cameras—Dr. E. Bade

Gadgets for Your Exposure Meter

A Course in Composition—Ricardo

Making a Split-Field Range Finder

Some Facts on Filters

Photo Hints and Kinks

SAVE MONEY
WITH THIS
FREE BOOK

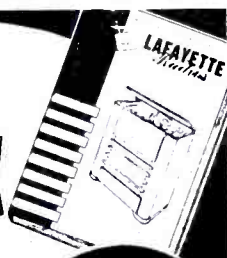

**RADIOS
PARTS-TOOLS
PUBLIC ADDRESS
"HAM" KITS
TUBES**

Sound specialist, serviceman, experimenter, ham—whatever you are, this book is your "baby"! A radio catalog so packed with values, it takes 120 newsy pages to describe 'em! Here, for quick easy reference, arranged so you can compare brands, is every possible radio part and tool. Plus a P.A. section presenting LAFAYETTE'S big complete line for '40. Everything priced low in this great guide to thrifty buying. Send for your FREE copy of Catalog 80 today. Just mail the coupon.

NEW YORK, N. Y.
100 SIXTH AVENUE
CHICAGO, ILL.
901 W. JACKSON BLVD.
ATLANTA, GA.
265 PEACHTREE STREET
BOSTON, MASS. • BRONX, N. Y.
NEWARK, N. J. • JAMAICA, L. I.

LAFAYETTE RADIO

LAFAYETTE RADIO • Dept. 3E, 100 SIXTH AVE., N. Y.
Rush FREE 1940 Lafayette Catalog No. 80

NAME.....
ADDRESS.....
CITY..... STATE.....

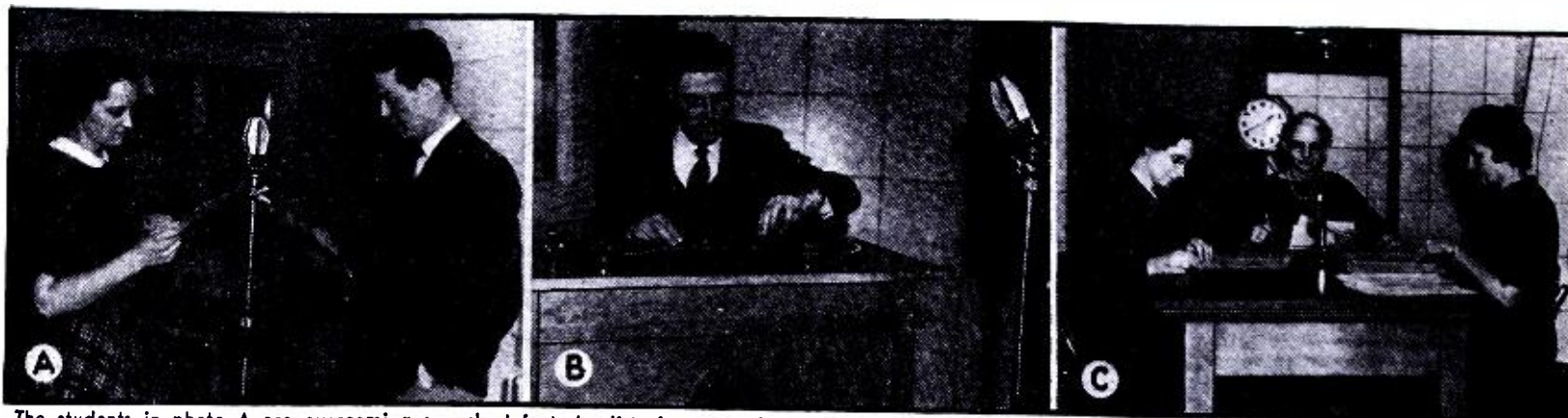

The students in photo A are overcoming speech defects by listening to their own voices via recordings. In photo B one of these recordings is shown being played-back by the student. The college itself does no actual broadcasting but feeds a variety of programs via telephone lines to nearby commercial stations

which carry them as regular features. "Food and Your Daily Living" is the title of one of these features which, Mrs. Gladys Cook (left to right), Dr. Helen S. Mitchell, and Miss May E. Foley, nutrition specialists at the college, are shown doing in photo C. Radio in education is increasing its horizon.

RADIO - SOUND STUDIO IN COLLEGE

Each day sees Radio's influence on education increase. This story is another milepost in that direction—a complete radio-and-sound studio in Massachusetts State College. The importance of sound recording is given special consideration in this new studio set-up, which is now pioneering in the use of sound equipment by colleges.

AMHERST, Jan. 20—A buzzer sounds. A light flashes red. We're on the air! This little drama signalized completion of a complete small-scale *broadcasting and recording studio* at Massachusetts State College last month after more than a year spent in planning and construction.

Designed to be of comprehensive use to students of speech, foreign language and music, as well as for radio work, the studio idea received its first practical impetus from a grant of \$800 made by the Carnegie Corporation more than a year ago.

Provisions of the grant limited expenditure to purchase of recording and broadcasting equipment. The student Senate, however, made a small grant which enabled the college to begin construction of a studio, 18 x 25 ft., in the tower of South College, administration building, and President Hugh P. Baker made available other funds for sound treatment and necessary accessories, and for a separate control room.

The studio will serve a multiplicity of interests, according to Francis C. Pray, chairman of the committee in charge of operation.

SOUND-ON-DISC

Students in corrective speech classes will record their voices at the beginning of each semester in order to hear their particular speech defects. At the end of the semester another recording will be made so that the student may hear his improvement.

Language students who have difficulty in pronunciation of foreign languages will make recordings so that they may have auditory proof of their errors. Recordings of masters of foreign language speech will also be played as models for these students.

These uses, according to Clyde W. Dow, speech specialist, are based on the fact that the individual never hears himself as others hear him. An opportunity to get an objective view of one's own voice will convince students of defects in many cases where they are inclined to believe the instructor is exaggerating. The recording is also an important factor in stimulating interest.

Student musical organizations will be recorded so that individual members of the

band or orchestra may hear themselves objectively in relation to the whole, a feat impossible while playing in the group.

BROADCASTING

In addition to the recording mechanism, the studio is equipped to originate broadcasts and send them, via telephone line, to commercial radio stations in the vicinity.* At present a weekly program on nutrition is offered by college specialists and broadcast over 4 stations of the Colonial Network. Other programs will be added until 3 broadcasts are put on the air each week.

The radio and recording facilities consist of a large main studio and a control room separated from it by a partition containing the usual double windows. Many aids to direct broadcasting have been provided, including a double-turntable sound-effects cabinet, 2 types of microphones, and provisions for remote pickups from various points on the campus. These facilities make possible presentation of radio programs requiring almost any combination of sound effects and special techniques.

So that undergraduates may make fullest use of the equipment, 2 students are being trained to operate the recording mechanism. Members of the staff of the Physics department are cooperating in operation of equipment during actual broadcasting.

FUTURE PLANS

Plans for extension of college radio programs to stations which cannot be reached economically via telephone lines include the possibility of making electrical transcriptions of programs and mailing these transcriptions to stations for use on sustaining spots throughout the week. The first of this transcription series, to be completed this week, will be a recorded performance of the college choir. Other musical organizations will be put on the air in this manner.

Other plans, as yet incomplete, may include recording of educational programs for use in schools, lending of the studio facilities to educational groups outside the college, and the possibility of a cooperative broadcast with Amherst College.

*See "Inter-College Wired-Radio Network," *Radio-Craft*, April 1940, for information on new developments in this direction.

In the college broadcasting program, adherence will be made to the principle laid down by President Baker that the College, as a State supported institution, is obligated to extend its influence in education throughout the state. To this end, all programs will be judged primarily upon their educational value to listeners.

The following, individual reports of instructors at "M.S.C." show in more detail why sound recording is so important a tool for educational institutions; and afford sound specialists valuable tips for use in approaching equivalent prospective users of recording equipment, i.e., music and language teachers, etc.

REPORTS

SOUND RECORDING IN SPEECH CORRECTION: Clyde W. Dow, Instructor in Speech.—We have just begun to use the recording apparatus, but the indications are that it will be particularly valuable for corrective work of certain types, especially articulatory disorders, and sound substitutions.

When an individual talks, even though he has a speech defect, his speech may sound all right—to him. *He does not hear himself as others hear him!*

Dr. Harold Ross states that one of his students on hearing her record said, "Why, I believe it sounds as though I had a lisp." "You have," replied the instructor. The recording apparatus is much more effective than the comment of any instructor, friend, or enemy, in pointing out to a student just how he speaks.

The corrective program for this type of speech disorder is based on 3 main attacks: (1) the speech defective must be made aware of his articulatory error; (2) he must learn the correct response through instructor and trial-error learning (this response involving auditory and kinesthetic association); and, (3) he must drill until the correct response becomes automatic and habitual.

The value of the recording apparatus in showing the defect to the student has been indicated. During the instruction, trial and error period, it is often helpful to record, and then play back, some of the correct and incorrect attempts, as the playback seems

RADIO DEVELOPMENTS

to help the student to acquire the correct sound pattern more easily. In the last phase of the training the recording serves largely the function of motivation. Speech defectives sometimes feel that all other people in the class or clinic are progressing more rapidly than they. A comparison of their first record with the present work is usually all that is needed.

Monotonous voices, continually repeated inflections, too-slow and too-rapid speaking, are most clearly indicated to the student by recordings.

These are a few of the ways in which the recording apparatus may be used in speech correction. After we have had an opportunity to experiment with the apparatus over a longer period of time, we shall probably find other uses for it in connection with speech correction.

SOUND RECORDING IN LANGUAGE STUDY; Stowell C. Goding, Assoc. Professor of French.—Research has proved conclusively that soon after 12 years of age the average child loses the ability to assimilate a foreign language naturally.

Further investigation has shown that even at college age oral facility is necessary to a complete mastery of a foreign tongue.

The missing link is now clearly indicated to be the inability of the adult to hear himself "as others hear him." The comparison of an individual recording with a master recording of the same selection is better than any amount of theoretical study or endless "practice," although both these latter are still needed.

SOUND RECORDING IN MUSIC STUDY; Doric Alviani, Instructor in Music.—The musical groups at the College, represented by the Men's and Women's Glee Clubs, choir, ensembles, and orchestra, plan to use the new radio apparatus for the making of records, and presenting radio programs. The former to improve their work, and make radio transcriptions, while the latter will endeavor to put into practice the elements of improvement gained from the records.

The use of this apparatus, in music, as a teacher device, is of enormous value. We have discovered that recordings made during rehearsals are beneficial.

The result and benefit is that the teacher or director may point out sections which need special care on the part of the performers. Another aid to the director is that during the playing of these recordings he may suggest corrections which will be more

clearly understood, whether that demand is for improved tone, clear enunciation, or emphasized rhythms.

As to actual programs, and public performances, the recordings—and the broadcasts—make the students aware that they must work as a group, careful of the slightest detail, and force themselves to perform well, in spite of mental or physical interference.

EQUIPMENT

The power output of the wired audio "broadcast" system is about 4 W., obtained from a pair of 6C5 tubes in pushpull.

The output power of the recording and playback amplifier is approximately 3W.

It has been found that the following equipment at present is adequate for all the requirements of wired-sound broadcasting, and of recording, at "M.S.C.":

- (1) Two microphone preamplifiers (1 is portable).
- (2) Control mixer panel. Three faders. Permits switching and adjustment of microphone and playback level.
- (3) Line amplifier. To feed program into telephone line for transmission to broadcasting station.
- (4) Monitor amplifier. Required to drive 2 high-quality loudspeakers. One for control room, and 1 for studio to permit playback of recordings into that room.
- (5) Two concert-type loudspeakers. Must be high-fidelity type to reproduce wide-range sound.
- (6) One turntable complete with broadcast-quality cutter head and playback arms. Dual speed, 33-1/3, and 78 r.p.m. Housed in cabinet for table-mounting in control room.
- (7) Recording amplifier (to drive turntable cutter head).
- (8) Sound-effects table. Must be complete with double turntables, individual fader controls, built-in amplifier and loudspeaker, and mounted on casters. For use in studio. Permits artists to hear sound-effects during plays.
- (9) Relay rack enclosed cabinet for mounting equipment, amplifiers, etc.
- (10) Microphones and accessories.

Radio-Craft is indebted to Mr. Francis C. Pray, Assistant Editor, College News Service, at "M.S.C.," for his cooperation in supplying the above information.

ARTICLES ON SOUND IN PAST ISSUES OF RADIO-CRAFT

1939

May

How to Build a High-Fidelity 5-Watt Versatile Amplifier

Intermodulation and Its Relation to Distortion Sound-on-Wire Tape!

An "Octave Resonance" Multiple Air-Column Baffle

Speaker Placement in Public Address Work

June

Build This Switchless 2-Way Interphone! Servicing Coin-Operated Phonographs (Part I of a multi-part article)

July

How to Design an Inexpensive All-Push-Pull Direct-Coupled 10-Watt Amplifier

Latest Circuit Features in Modern Public-Address Amplifiers (Part I of a 2-part article)

August

Obscure Sources of Hum in High-Gain Audio Amplifiers

Modernize Old Phonographs

September

Universal 32-Watt Neutralized-Feedback P.A. Amplifier

Case Histories of P.A. Sales (Prize winners in Radio-Craft's Public Address Contest; first of a series)

October

How to Design a Flexible All-Push-Pull Direct-Coupled 30-Watt Amplifier

November

How to Add 1 to 14 Modern Features to the All-Push-Pull 30-Watt Direct-Coupled Amplifier (Part I of a 3-part article on adding features)

Hints on "Portable Sound"

December

Wide-Range Loudspeaker—Designed for Reproducing Frequency-Modulated Programs

1940

January

"Wireless" Microphones for Professional P.A. Sound Engineering (First installment of a new department)

A "3-in-2" A.C.-D.C. Midget A.F. Amplifier How to Select and Place Sound Equipment (Part I of a multi-part article)

February

3-Tube Ultra-Compact Deaf-Aid

Scratch Filter Design

March

Build an Amplifier to Test Amplifiers! A.F. Amplifier Load-Matching Technique (Part I; Part II is scheduled for the June issue)

April

A Low-Cost Pushbutton Amplifier for Recording and Playback

The ABC of Db., VU, Mu, Va, Gm and Sm

(Due to lack of space only a limited number of articles in past issues of Radio-Craft on just the one topic of Sound are listed here.)



DEALERS
SERVICEMEN
SOUND MEN
RADIO BUILDERS
AMATEURS

Get this book of
RADIO VALUES
Now!
SAVE ON
EVERYTHING
IN RADIO
FREE

60
NEW
SETS

1940 RADIO HITS! New "Camera" and standard Portables—new European reception models—new "Compacts"—all types, all sizes, for every purpose. New plastic phono-radios, new Recorder-Radios, new auto radios—all at the very lowest prices—in this new FREE Catalog.

NEW
SOUND
SYSTEMS

18 new Public Address Systems—7 to 75 watts—for Electioneering, Orchestras, Churches, Schools, Rentals, etc. America's finest P.A. at startling low prices. Easy Time Payment Plan. Complete accessory listing, new recording equipment, etc.—all in this new value-packed book.

15,000
RADIO
PARTS

You'll find Everything in Radio in this new Catalog. Servicemen—see the new Test Equipment and full replacement parts listings. Amateurs—get a big surprise and the "low-down" on the new "Ham" receivers. And don't miss the special 8-page Bargain Section—there's nothing like it!

Dozens of brand-new exciting kits—new diagrams—depend on ALLIED for information and advice. Send for Free Parts Lists to build any type of radio circuit. Consult ALLIED!

See the splendid new Howard Amateur Communications Receivers (Model "435" illustrated). Get the exciting story of the new "Progressive Series"—a brand-new Amateur Receiver idea—there's never been anything like it before.

ALLIED RADIO

833 W. JACKSON BLVD., DEPT. 2-E-0
CHICAGO, ILLINOIS

Send me your FREE New 172 page Spring Catalog covering Everything in Radio!

Name

Address

City State

SEND COUPON NOW!

• LATEST RADIO APPARATUS •

PERCENT-O-METER

Triumph Mfg. Co.
4017 W. Lake St., Chicago, Ill.

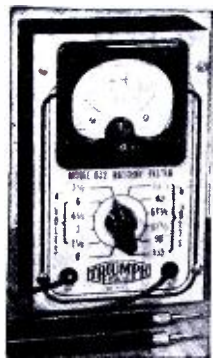

AN instrument designed to check all types of individual "A" and "B" dry batteries and battery packs *under current load conditions*. The 3-in. meter scale for the model 632 Percent-O-Meter is calibrated in per cent of new battery voltage showing "Replace—Useful Battery—New" areas. Rotary switch selects 11 ranges, viz., 1½, 3, 4½, 6, 7½, 22½, 45, 61½, 67½, 90 and 135 V. English-reading, it helps sell batteries by visualizing need for battery replacements.

22½, 45, 61½, 67½, 90 and 135 V. English-reading, it helps sell batteries by visualizing need for battery replacements.

SOCKET FOR TINY TUBES

American Phenolic Corp.
1250 W. Van Buren St.
Chicago, Ill.

THIS molded, "high-dielectric" bakelite socket measures only ½-in. in dia. and adds but 3/32 of an inch to the length of the new small-size hearing-aid tubes just released. Has low-noise contacts. A spring steel retainer holds the socket in place in the chassis. Especially suited to the hearing-aid tubes described in this issue.

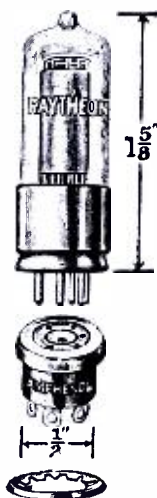

500-W. ADJUSTABLE LINK-COUPLING COILS

Bud Radio, Inc.
5205 Cedar Ave., Cleveland, Ohio

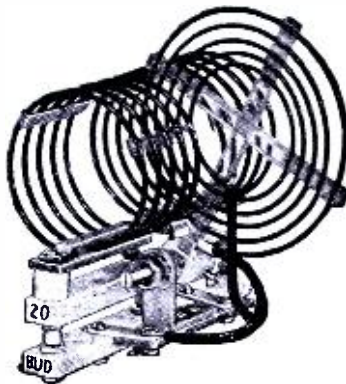

THIS series of "air-wound" 500-W. plug-in transmitter inductances has been designed to adjust antenna loading by varying the link coupling. The link is of a new spiral-wound design which enables one unit to be used for all bands and assures maximum coupling with the various diameters of coils used for the different bands.

FIXED-FREQUENCY TUNER

Aladdin Radio Industries, Inc.
466 W. Superior St., Chicago, Ill.

DESIGNED for police and aircraft receivers which are pre-tuned to certain frequencies, these drift-free units employ permeability tuning of the latest type. Antenna, R.F. and oscillator coils are mounted on a single base, measuring 1½ ins. high, 3½ ins. wide and 3¼ ins. deep. Mica trimmers originally used are being replaced by air trimmers. Range: 1,570 to 3,250 kc. (for 465 kc. I.F.).

FARM RADIO SET

RCA Manufacturing Co., Inc.
Camden, N. J.

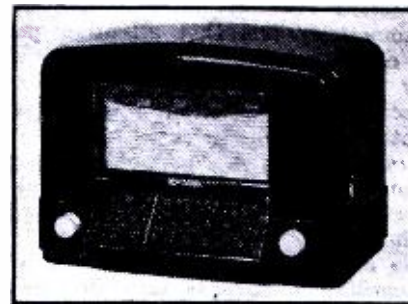

THE model 4QB is a 3-band receiver designed to be easily convertible to A.C. operation when the "high line" comes along. Housed in a modern streamline plastic cabinet with colorful full-vision dial. Power supply from one 1½-V. "A" cell and two 45-V. "B" batteries. The speaker is of the P.M. type. Chassis assembly, like "export" sets, is weatherproofed.

MASTER MULTITESTERS

Radio City Products Co., Inc.
88 Park Place, New York, N. Y.



ILLUSTRATED is one of a series of new, model 414 "Master Multitester" instruments. In addition to a wide range of voltage (to 5,000 V.), current (to 25 amperes) and resistance (to 15 megs.) measurements, 5 direct-reading capacity ranges (from 100

Mr. Serviceman:

RSA PUTS YOU ON THE AIR!

Listen In! Broadcasters are cooperating with R.S.A. to sell radio servicing to the American Public! Radio Listeners everywhere are learning that it *pays* to call an R.S.A. man! It means increased business and *more money* for R.S.A. members! And—this is only one of the big advantages of the R.S.A. Program! Year-Round Sales-Promotion to build Public Confidence, Technical Help for Members, Bulletins, and many other important business-aids are regular features in the R.S.A. program! Cash in on growing Public Acceptance of R.S.A.—Join Today!



Let's Grow Together in 1940!

RADIO SERVICEMEN OF AMERICA, Inc.

JOE MARTY, JR., EXECUTIVE SECRETARY
304 S. DEARBORN STREET, CHICAGO, U.S.A.

MAIL THIS COUPON NOW!

RADIO SERVICEMEN OF AMERICA, INC.
304 S. Dearborn St., Chicago, Ill.

Name

Address

City State

I am interested in RSA Membership. Tell me about it.

I am enclosing \$4.00 for National dues and initiation.

(Does not include Local Chapter dues where Local Chapters are organized.)

RC-540

• LATEST RADIO APPARATUS •

mmf. to 300 mf.) are included—a ratio of 3,000,000 to 1. Other features include 4½-, 7- and 9-in. meters in the different series; styles for bench, counter and rack mounting. Low-ohms scale reads 0.05-ohm; 2 ohms mid-scale. A unique system of A.V.C. measurements is claimed to excel the copper-oxide rectifier system in that it is not subject to frequency, temperature and waveform errors of the latter. Has instrument and double line fuses.

MULTI-IMPEDANCE MICROPHONE

The Turner Co.
Cedar Rapids, Iowa



THE model U-9 Multi-Flex dynamic microphone offers 4 different impedance outputs by incorporating a built-in universal matching transformer. These impedances are: 50, 200, 500 and 50,000 ohms. It eliminates the cost and annoyance of having duplicate microphones for various requirements. Pick-up is semi- or non-directional, as desired. Rugged and weatherproof. Frequency range, 40 to 9,000 cycles. Output level, -52 db.

Frequency range, 40 to 9,000 cycles. Output level, -52 db.

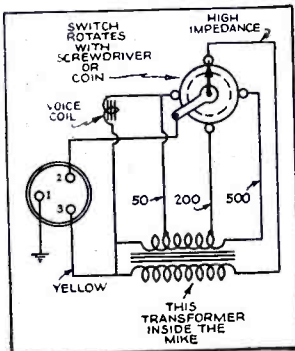

Diagram showing how the multi-impedance taps are obtained.

MARVEL GRINDER SHIELD

The Boyer-Campbell Co.
6540 Antoine St., Detroit, Mich.



A NEW and novel device for the protection of the eyes and face from flying particles when using grinding, turning and similar types of machines. The shield is made of a tough molded plastic material in the center of which are 2 large panes of removable glass, the lower one of the ordinary glass and the upper of the shatter-proof type. On each side of this transparent window is a countersunk electric bulb which focuses its light directly on the work. A pushbutton switch on top of the instrument turns the light on and off. Lamps are of the bayonet base type—resisting vibration. Magnifying lenses to replace the glass panes are available for work of close limits. This instrument is a highly desirable adjunct to the service shop since in addition to its use as a shield it can also be used as a bench light.

COMMUNICATIONS RECEIVER

RCA Manufacturing Co., Inc.
Camden, N. J.

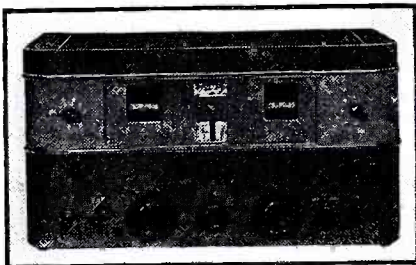

MODEL AR-77 communications receiver has a built-in power supply, variable selectivity crystal filter. Three features are outstanding, viz., polystyrene insulation, "stay put" tuning, and switch-controlled negative feedback. Other features include new type of calibration for the 2 illuminated tuning dials; band-spread calibrations extended to nearly the full rotation of the dial for 10-, 20-, 40-, and 80-meter amateur bands; selectivity variable in 6 steps; improved noise-limiter circuit; and so-on. Consumes 70 W. Metal cabinet measures 20½ ins. wide, 10½ ins. high, 11½ ins. deep.

25-W. AMPLIFIER

RCA Manufacturing Co., Inc.
Camden, N. J.

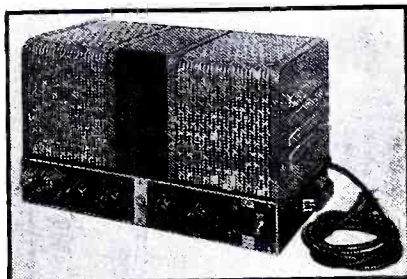

MODEL MI-12205 25-W. amplifier has provisions for mixing up to 4 microphones. New circuit improvements have reduced hum to an absolute minimum. Further, automatic bass compensation is employed for the reproduction of recorded music. Available for 105-125 V., 50-60 cycles A.C.; and, 110-220 V., 25-60 cycles A.C.

BATTERY TESTER

Simpson Electric Co.
5216 Kinzie St., Chicago, Ill.

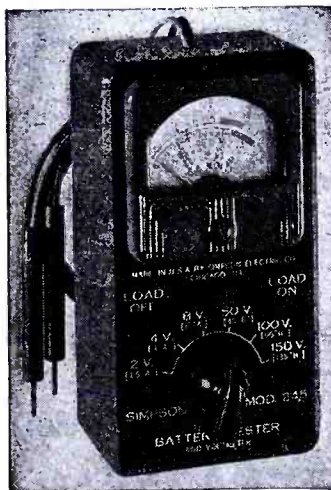

A NEW instrument for testing dry batteries under actual load; model 245. Six voltage ranges are provided covering the popular sizes of "A" and "B" batteries in use. For "A" batteries the ranges are 0-2-4-8 V.; for "B" batteries the ranges are 0-50-100-150 V. Meter sensitivity is 1,000 ohms/volt for each range. The less-common battery ratings of 4.5, 7.5, 22.5, and 67.5 V. are also indicated on the meter dial. With switch in Load Off position the meter is available for use as an ordinary meter.

RADIO made EASY

with Ghirardi's BIG
1-Volume Radio Training Course

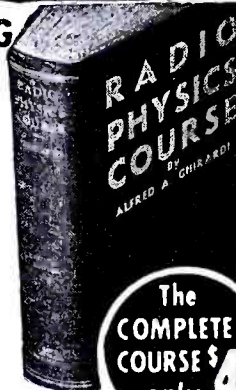

Fit yourself, at home in spare time, for a good-paying Radio job. Yes, you can do it—with Ghirardi to help you, as he has helped thousands of others who got their basic training in Radio from his world-famous Radio Physics Course. Because you see he has a genius for making it all vividly clear and easy to understand. You need no "background" to prepare you for this intensive course of technical training—not even a knowledge of mathematics. Ghirardi will "see you through" from elementary Electricity right through Radio, Sound, Television, Cathode-Ray Tubes, etc., etc. It's all explained here—complete—in one big handy \$4 volume.

USED BY U. S. ARMY

Yes, because of its excellence, Radio Physics Course has been given the rare honor of being selected as a training text for radio courses conducted by the U. S. Army and Navy. In fact, it's recommended and praised everywhere as "tops"—it's used by more radio schools and students than any other radio text in the world!

36 Volumes in 1—972 pp.—508 illus.
1. Radio Broadcasting System. 2. Sound. Speech. Music. 3. Electron Theory; Elec. Current. 4. Elec. Units; Ohm's Law; Resistance. 5. Elec. Circuits; Batteries. 6. Magnetism. 7. Electromagnetism. 8. Electromagnetic Induction. 9. Inductance. 10. Capacitance; Condensers. 11. A. C. Circuits. 12. Filters. 13. Measuring Instruments. 14. Radio Waves. 15. Broadcasting. 16. Receiving. 17. Vacuum Tube Principles. 18. Vacuum Tube Characteristics. 19. Vacuum Tube Construction. 20. Vacuum Tube Detector and Amplifier Action. 21. Radio Frequency Amplification. 22. "Superhets". 23. R.F. Amplifiers; Tuning Coils. 24. Audio Amplifiers. 25. Speakers. 26. Battery-Operated Receivers. 27. Power-Supply Units. 28. Elec. Receivers. 29. Automobile and Aircraft Radio. 30. Phono Pickups; Sound Systems. 31. Short-Wave. 32. Photoelectric Cells; Cathode-Ray Tubes. 33. Television. 34. Antennas and Grounds. 35. Testing; Servicing. 36. Sound Motion Pictures. . . . 856 Self-Review Questions! Send for this great book!

Test it 5 DAYS—OUR RISK—MAIL NOW!

RADIO & TECHNICAL PUBLISHING CO.,
45 Astor Place, New York, Dept. RC-50.
 Here is my \$4 (\$4.50 foreign). Send RADIO PHYSICS COURSE postpaid, with money-back guarantee.
NAME
ADDRESS
CITY STATE
 Send me free illustrated descriptive literature.

RADIOS—50% AND 10% OFF

of list price on new 1940 guaranteed GOLDENTONES in lots of six or more:

Model 1S1 Four Tube AC-DC Super	\$ 5.38
Model 8S2 Under Dash Car Set	8.98
Model 9S1 Radio Phono Combination	13.48
Model 3T3 8 Tube 2 Band AC-DC	11.23
Model 7W1 Portable (less batt.)	8.98

Send for free bargain catalog showing over 50 models and giving details of trial plan, agent's proposition and sample prices. No obligation.

GOLDENTONE RADIO CO., Dept. RC, Dearborn, Mich.

SERVICE MANUAL

427
DIAGRAMS OF MOST SERVICED RADIOS

4 OUT OF 5
CIRCUITS YOU NEED

COMPLETE
\$1.95
POSTPAID

DIAGRAMS YOU NEED

In one handy manual you have all the diagrams of the most often serviced radios today. Over 80% of all sets you service every day are included. These important, hint-giving, trouble-shooting circuits make your job easier, permit faster and better repairs.

HOW TO SAVE TIME

Circuit data, hints, information are time-savers and money-makers for you. Let this diagram manual be your guide to bigger profits and easier service work. Why work blind-folded when 4 out of 5 diagrams you will ever need are included in this new, low-priced manual. Compiled by M. Beltman, B.S., radio serviceman, author, teacher of Radio in Chicago schools.

LIMITED EDITION

Get your copy of this radioman's biggest time-saver. No need to spend money for bulky, space-wasting manuals. Only \$1.95 today, brings your copy of the handiest "on-the-job" handbook of useful diagrams. (Models 1926 to date.) Well printed, with illustrations, large size 8½ x 11 inches. Limited quantity at the special price. Rush order now.

FREE EXAMINATION COUPON

Supreme Publications
3727 West 13th Street
Chicago, Illinois
Ship complete Service Manual. I may return the manual for a full cash refund if I am not satisfied.
 I am enclosing \$1.95, send postpaid.
 Send C.O.D. I will pay postman \$1.95 and a few cents postage.
NAME
Write address below and send this corner.

★ ★ ★ **THREE STAR RADIO VALUE**

You receive valuable subscription to **RADIO-CRAFT**
PLUS A FREE COPY of 1940 Radio-Television Reference Annual

WITH our compliments, we want to send a copy of the 1940 RADIO-TELEVISION REFERENCE ANNUAL to you FREE, if you will simply take advantage of RADIO-CRAFT magazine's special subscription offer NOW. This offer is being made for a limited time only.

The 1940 RADIO-TELEVISION REFERENCE ANNUAL has 68 pages, large size 8½ x 11½, with over 170 illustrations. The contents of this book has never appeared before in handy book form. Its pages cover practically every branch of radio sound, public address, servicing, television, construction articles for advanced radio men and technicians, time and money-saving kinks, wrinkles, useful circuit information, "ham" transmitters and receivers, and a host of other data.

The Annuals have always been regarded as a standard reference work for every practical branch of radio operation and service. This 1940 edition ably sustains this reputation. Every radio man wants a copy of this valuable book. Just as this book will be of unquestionable value to you, so, too, will every monthly issue of RADIO-CRAFT. This magazine brings you big value every month. It keeps you intelligently informed about new developments in radio and television. You want the news, want it fully but concisely, want it first—that is why you should read RADIO-CRAFT regularly.

This very special offer is made for just one purpose—we want you as a regular subscriber. The Annual, whose contents appears at the right, is not sold, but a copy is FREE to you if you subscribe now.

SAME SIZE AS RADIO-CRAFT

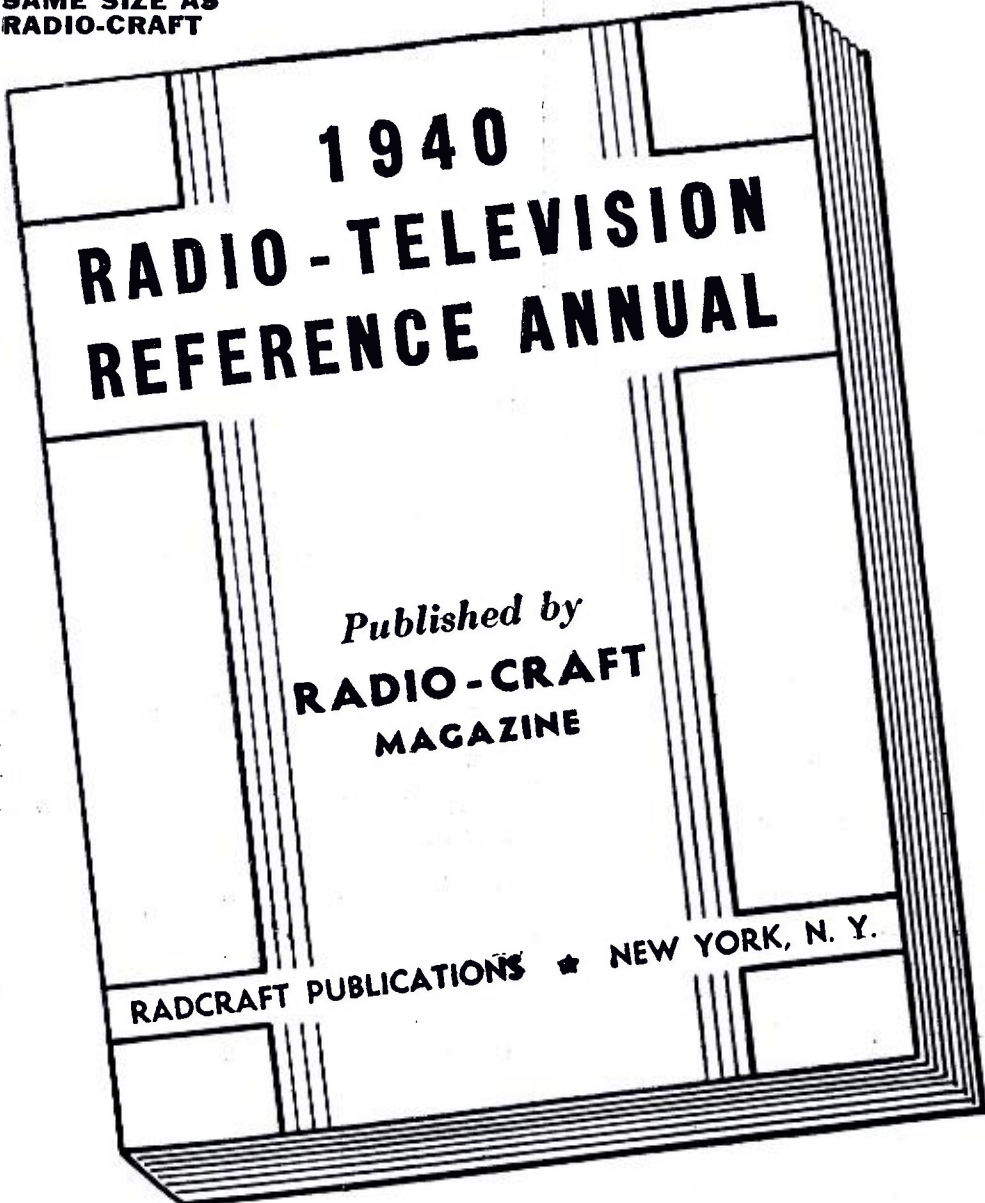

THIS COUPON BRINGS YOU THE ANNUAL

RADIO-CRAFT • 99 HUDSON STREET • NEW YORK, N. Y.

Gentlemen: Enclosed you will find One Dollar for which enter my subscription to RADIO-CRAFT Magazine for Eight Months. Send me **ABSOLUTELY FREE** and **POSTPAID**, my copy of 1940 RADIO-TELEVISION REFERENCE ANNUAL.

This is a new order Extend My Present Subscription

NAME ADDRESS

CITY STATE

DON'T DELAY — MAIL TODAY!

RC-540

Read the summary of contents in this FREE BOOK!

THE 1940 RADIO-TELEVISION REFERENCE ANNUAL contains a collection of the best and most important articles. Covering as they do nearly every branch of radio, they form a handy reference works. In addition, many time and labor-saving kinks, circuits and wrinkles, tried and tested by practicing Servicemen, experimenters and radio fans have been included. This book cannot be bought anywhere at any price. Yet it is yours by merely subscribing. Use the convenient coupon below.

BEGINNER'S SIMPLE INEXPENSIVE CONSTRUCTION ARTICLES

Beginner's Breadboard Special - a 1-Tube High-Gain, All-Wave Receiver—Wiring Pointers for Radio Beginners—A Watch Charm Size 1-Tube Set—Beginner's Simple Volt-Milliammeter—Making a 1-Tube Broadcast Loop Receiver—A.C.-D.C. Power Supply for Battery Portables—A 1-Tube Short-Waver with Band Coil Switching.

MORE ADVANCED SET CONSTRUCTION

The "High-Seas 4" Broadcast Lamp Radio—How to Build a 6-Tube 1.4-Volt Short-Wave Superhet for the "Ham" or Short-Wave Fan—Build the "Lunch Box 5" Super Set - a Broadcast Battery Portable—How to Build a Plug-Together 8 Tube Broadcast Set—The "5-in-4" All-Wave Radio for A.C. Operation—An Easily-Built 3-Tube Midget Broadcast Superheterodyne Receiver.

THE SERVICEMEN'S SECTION

Bass Tone Control—Simplified Variable Selectivity—Practical Servicing Pointers—Servicing Universal A.C.-D.C. Receivers—Killing the "Intermittent" Bug—A Service Shop A.C.-to-D.C. Power Supply—Sideline Money for Servicemen—Adding A.V.C. to any Screen-Grid T.R.F. Receiver—Iron Particles in Speaker Air Gap.

TEST INSTRUMENTS

A Useful Neon Lamp Tester—An Inexpensive Output Meter—Making Milliammeter Multipliers—Home-Made Frequency Modulator—The Busy Servicemen's V.T. Volt-Meter.

PUBLIC ADDRESS AND AMPLIFIERS

Build this Combination A.C.-D.C. Radio and Inter-Communicator—Speaker Placement in P.A. Work—The Design and Construction of an Inexpensive All-Push-Pull 10-Watt Amplifier—Obscure Sources of Hum in High-Gain Amplifiers—How to Build a High-Fidelity 5-Watt Versatile Amplifier.

"HAM" SECTION

Ultra-High Frequency Antennas—The Beginner's Low-Cost Xmitter-Modulator Meter—Phone Monitor—The Beginner's "Ham" Receiver—2½ Meter Acorn Transceiver.

TELEVISION

How to Build a 441 Line T.R.F. Television Receiver—Useful Notes on Television Antennas.

MISCELLANEOUS

Simple Photo-Cell Relay Set Up—Making a Burglar Alarm—How to Build A.C.-D.C. Capacity Relay—How to Make a Modern Radio Treasure Locator.

USEFUL KINKS, CIRCUITS AND WRINKLES

Making a Flexible Coupler—Two-Timing Chime—A Simple Portable Aerial—An Improvised Non-Slip Screw-Driver. NOTE: The book contains numerous other useful Kinks, Circuits and Wrinkles, not listed here.

(approximately)

45 ARTICLES

(approximately)

170 ILLUSTRATIONS

68 BIG PAGES

RADIO-CRAFT
99 HUDSON STREET
NEW YORK, N. Y.

• LATEST RADIO APPARATUS •

A new way to EXTRA PROFITS with PYRO PANTAGRAPH

Size of box: 12 1/2" x 8 1/2"

With this PYRO PANTAGRAPH turn leisure time into profitable hours. Make money a novel, easy way—"Burn Your Way to Extra Dollars with Pyro Pantagraph."

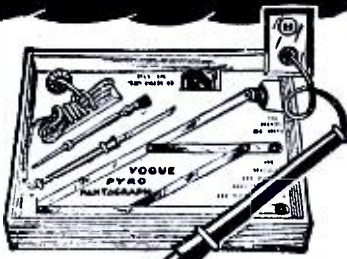

\$2.75

Shipping weight, 3 lbs.

This electrical outfit is especially designed for burning designs permanently on Leather, Wood, Cork, Gourds, Bakelite, etc. Simply plug the Pyro-electric pencil in any 110-volt AC or DC outlet and it is ready to be used. Plug and cord furnished as part of equipment. By the use of a special Pantagraph included in the outfit, any design may be reproduced either in original, reduced or enlarged form.

Outfit consists of: one Pyro-electric Pencil; one Pantagraph; three hardwood plaques; one bottle of Varnish; one Brush; one tracing tip and four-page instruction sheet.

Outfit will be forwarded by Express Collect if not sufficient postage included with your order.

WELLWORTH TRADING COMPANY

1915 S. State Street, Dept. RC-540, Chicago, Ill.

IN NEW YORK

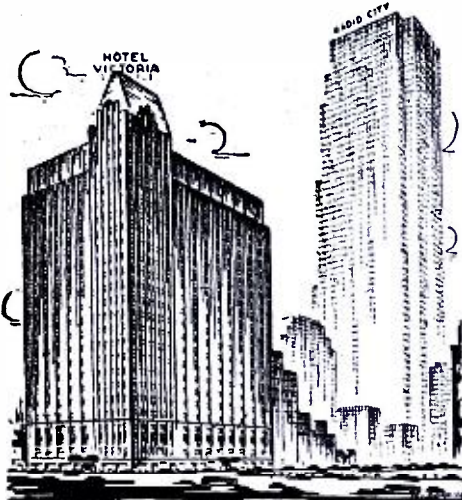

The pleasure of your New York visit can be marred or enhanced, depending upon the selection of your hotel.

IT'S WORTH THINKING ABOUT that The Victoria attracts the most discerning travelers...because discerning travelers are attracted to the new Victoria.

Every room with every modern convenience. From \$2.50 single, \$4 double.

Hotel AT RADIO CITY
VICTORIA

7th AVE. at 51st ST. NEW YORK
RONALD A. BAKER, Manager

RADICALLY-DESIGNED RADIO SET

Kadette Radio Corp.
200 Hill St., Ann Arbor, Mich.

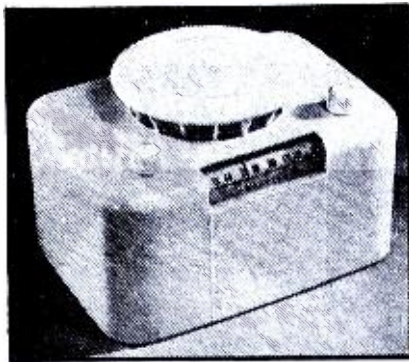

APPARENTLY the first plastic-cabinet radio receiver featuring all-directional sound diffusion. A turret projecting from the top of the cabinet radiates the sound in all directions. The Kadette "Topper" is a 5-tube midget superhet. of the A.C.-D.C. variety. A sketch (below) shows the rela-

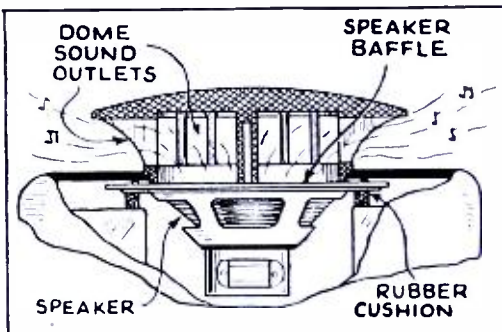

tionship of the speaker to the sound-diffusing turret. Uses 1-12SA7, 1-12SK7, 1-12SQ7, 1-35L6, and 1-35Z5. Loop antenna.

2-BAND MIDGET RECEIVER

Stewart-Warner Corp.
1826 Diversey Parkway, Chicago, Ill.

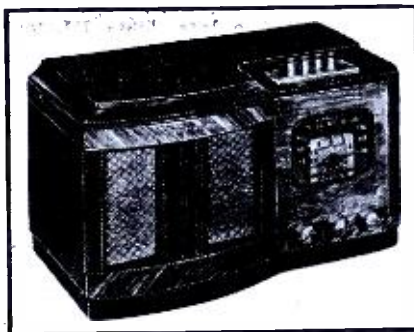

MODEL 07-5S2 is one of a new line of 1940 receivers. It is a 5-tube superhet. giving 7-tube performance and including 8 tuned circuits. Other features are A.V.C., 4-pushbutton tuner, 2 bands, tone control, phono switch; range, 540 to 1,725 kc. and 2,200 to 7,000 kc. Measures 8 ins. high, 14 1/2 ins. wide and 8 ins. deep.

COMMUNICATIONS RECEIVER

The Hallicrafters
2611 S. Indiana Ave., Chicago, Ill.



THE over-all range of this latest 12-tube model SX-17 Super Sky rider is from 540 kc. to 42 mc. in 4 bands. "More preselection, and more and better audio" is claimed for

DATAPRINTS



TESLA-LOUDIN HI-FREQ. COILS

20c Ea. in order for 10 (Data and Drawings only.)
36" Sp'k Tesla-Oudin Coil 40c (1 K.W. Exc. Trf. Data, included FREE!)
8" Sp'k Tesla-Oudin Coil 40c (1/4 K.W. Exc. Trf. Data, included FREE!)
3" Sp'k Oudin; 110 Vt. "Kick Coil" type.....40c
3" Sp'k Tesla Works on Ford Sp'k Coil40c
1" Sp'k Violetta Hi-Freq. Coil.....40c
Model Warships—Get List of Plans



Induction PIPE & ORE LOCATOR

Induction Type, Data40c
Radio Type40c

More DATAPRINTS 40c each!

5 Meter Superhet.
1/2 Meter Tr. & Rec. Bridge
20 A.C. Probs. & Ans. Weld. Transf. 2 K.W.
20 Telephone Hook-ups Rewinding Armatures
100 Mech. Movements String Galvanometer
20 Motor Hook-ups 20 Simple Bell Circuits
Television Hook-up Steel Wire Recorder
20 Elec. Party Tricks Electric Pipe Thawer
Solenoids and Magnets Water Wheels or Turbines
—get list.
Fry Eggs on Ice! Photo Cell and Relay
Experimental Photo- Ring 4 bells on 2
phone Wires
Radio Control for 20 Tesla Tricks
Models Polarized Relay
Diathermy Apparatus Induction Balance
Inductor Organ

Special Prices: 4 prints \$1.00; 10 for \$2.00; Single, 40c each. Get New Catalog 100 A.

The DATAPRINT Co.

Lock Box 322C, Ramsey, N. J.



ELEMENTARY MATHEMATICS

● EASY — SIMPLIFIED — PRACTICAL ●

HERE is a book for the business man, the technician and craftsman explaining and answering every operation and meaning with interpreting illustrations and examples.

It is the key to a simple understanding of many perplexing problems in daily life.

In clear, positive and definite language, the author popularizes and clarifies every subject and helps the reader to overcome any apparent difficulty in the study of mathematics.

A real home study-course in mathematics for the student or the man who wants to achieve proficiency or desires to brush-up on his knowledge.

Entire Chapter on Special Mathematics for the Radio Technician

CONTENTS OF BOOK

CHAPTER I. Arithmetic—Addition—Subtraction—Multiplication—Division
CHAPTER II. Factoring and Cancellation—Fractions—Decimals—Percentage—Ratio and Proportion.
CHAPTER III. The Metric System.
CHAPTER IV. How to Measure Surfaces and Capacity (Geometry).
CHAPTER V. Powers and Involutions—Roots and Evolution.
CHAPTER VI. Mathematics for the Manual and Technical Craftsman—Thermometer conversions—Graphs or Curve Plotting—Logarithms—Use of the Slide Rule.
CHAPTER VII. Special Mathematics for the Radio Technician.
CHAPTER VIII. Commercial Calculations—Interests—Discounts—Short Cut Arithmetic.
CHAPTER IX. Weights and Measures—Useful Tables.

"Practical Mathematics" can be carried readily in your pocket. Send Stamps, Cash or Money Order.

ONLY
50c
POSTPAID

TECHNIFAX

1917 S. STATE ST. RC-540 CHICAGO, ILL.

Save on Everything in Radio

NEW 1940 RADIO CATALOG AND PROFIT GUIDE
Most complete line of latest radio sets, amplifiers, kits, tools and replacement parts. All leading brands at lowest prices. Fast Service. Guaranteed Quality.

The RADOLEK Company
Dept. Y-41 601 W. Randolph St. Chicago
SEND FOR YOUR COPY TODAY

FREE RADIO PROFIT GUIDE



• LATEST RADIO APPARATUS •

the new receiver. Includes automatic noise-limiter. The set is sold complete with speaker, crystal and tubes, and at a comparatively low figure. Works on 110 V., 50-60 cycles A.C. May be adapted to use D.C.

25-W. MARINE RADIOPHONE

The Hallicrafters
2611 S. Indiana Ave., Chicago, Ill.

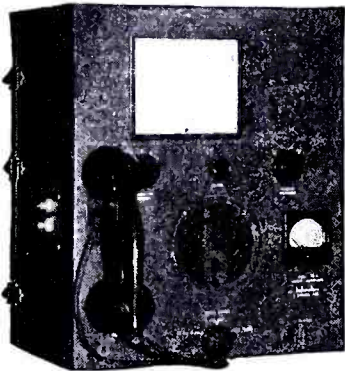

THIS extremely compact 25-W. marine radio telephone (*) is designed for use by anyone on small craft. Provides 2-way communication with other boats, land telephone and Coast Guard stations. Has 5 crystal-controlled transmitting frequencies instantly available by means of rotary switch. Five corresponding receiving frequencies plus an extra weather-report channel are available with equal convenience. Lifting handset from hook cuts off built-in

(*) See "Marine Radio Telephone Installation and Servicing," Radio-Craft, March 1940.

loudspeaker. All circuits are internally pre-tuned during installation. Both the transmitter and the 7-tube superhet. receiver are enclosed in a single, compact cabinet designed for bulkhead mounting. When docked, unit may be plugged into 110-V. A.C. line to conserve boat battery.

"1-PIECE" PARABOLIC

University Laboratories
195 Chrystie St., New York, N. Y.



FABRICATED entirely from 1 piece of metal this parabolic horn eliminates troubles such as water leakage and rattles which so often occur in the 2-piece parabolics. Other features include rubber tire rim, rubber tire cone speaker mounting, universal "U" mounting fork. Oversize rubber protected "breather."

FULL-RANGE SPEAKER

Jensen Radio Mfg. Co.
6601 S. Laramie Ave., Chicago, Ill.

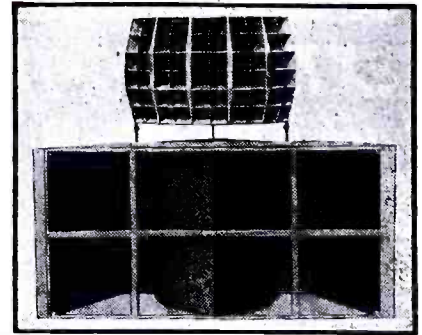

TYPE B full-range speaker system, illustrated, consists of a multicellular high-frequency horn utilizing 2 annular-diaphragm speaker units and a "folded"-type horn equipped with 2 low-frequency loudspeakers. Most of such equipment has been custom-built for special installations. This appears to be the first time that this type of high-fidelity speaker is being offered to the general sound trade as a standard item.

"TWIN-POWER" BATTERY ELIMINATOR

General Transformer Corp.
1250 W. Van Buren St., Chicago, Ill.



BY providing separate sources of power to the filaments and to the vibrator this model P "Twin-Power" battery eliminator provides 6-V. farm sets with noise-free performance from the "high lines." "Vibrator hash" which was the bug in practically all preceding types of battery eliminators is entirely absent here. Each source develops 6 V. at 1½ amps. for use on 105-125 V., 50-60 cycles A.C. Size, 3½ x 6½ x 5½ ins. high.

NEW-TYPE SOLDERING IRON

Dual Remote Control Co.
505 Guaranty Bldg., Detroit, Mich.

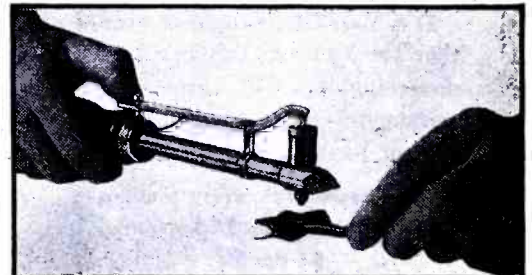

A NEW pushbutton arrangement on this "Ducon" 60-W. soldering iron permits the functions of both heating and applying solder to be done with one hand, leaving the other hand for holding the part to be soldered. The pushbutton is pressed to release a drop of the solder which is contained in a small reservoir immediately above. Priced moderately. It is a useful adjunct to the radio Serviceman's shop or the radio laboratory for general soldering work (How about tight squeezes, though?).



OPERATES ON
110-VOLT, 60-CYCLE
A.C. LINE

WE SHIP ELECTRIC DRY
SHAVER THE SAME DAY
YOUR SUBSCRIPTION
ORDER IS RECEIVED.

CLIP COUPON—
AND MAIL!

Get This Electric Dry Shaver ABSOLUTELY FREE!

JUST THINK OF IT—you can get absolutely FREE, the useful DRY ELECTRIC SHAVER which is shown at the left. This ELECTRIC DRY SHAVER is sent to you by the publishers with a one-year subscription to RADIO-CRAFT.

Here Are the Features of The ELECTRIC DRY SHAVER

Constructed of metal with attractive red bronze finish. Scientifically constructed to give a perfectly clean shave. 5-foot rubber insulated cord and plug. Constructed to last for many years.

Operates from 110-volt, 60-cycle A.C. electric line. Carries a two-year manufacturer's guarantee. A fine quality, self-sharpening toilet necessity.

Send your subscription to RADIO-CRAFT for One Year (12 issues) and receive absolutely FREE one of these remarkable Electric Dry Shavers. New subscribers are accepted or you may extend your present subscription another twelve months. Mail your remittance of \$2.00 (plus 25c for shipping charges on Shaver) to the publishers. (Canada and foreign \$2.75.) You will receive your DRY ELECTRIC SHAVER immediately by return mail. Use coupon below to enter your subscription.

RADIO-CRAFT

99 Hudson Street, New York, N. Y.

RADIO-CRAFT, 99 Hudson Street, New York, N. Y.

Gentlemen: Enclosed find my remittance of \$2.00 for which enter my subscription to RADIO-CRAFT for one year (12 Issues). Send me immediately FREE, ELECTRIC DRY SHAVER (Canada and foreign \$2.75). In U. S. add only 25c additional to cover shipping charges on Shaver.

New Subscriber Extend Present Subscription

Name

Address

City State

(Send remittance by check, money order or unused U.S. Postage Stamps. Register letter if you send cash or stamps.) RC-5-40

FREE- REAL ELECTROPLATING OUTFIT



**Now—
You Can ELECTROPLATE
EASILY WITH A BRUSH**

SOMETHING new for radio men—something which gives you the opportunity to make additional profits—or to improve your type of service. Here's an **ELECTROPLATING KIT** amazingly simple to operate—you just Electroplate with a Brush!

NOT A TOY!

Electroplate for profit, hundreds of things in the household—ashtrays, fixtures, water faucets, worn brackets, door knobs, musical instruments, jewelry and silverware and other articles. It's an indispensable piece of equipment—plate articles in hotels, apartments, office buildings, medical and dental offices, factories, schools, laboratories, etc. Exactly the same outfit (but larger) is used professionally by electricians, radio service men, automobile repair shops, etc. Requires one single dry cell 1½-volt battery to operate.

You can electroplate tarnished receiver parts, escutcheons, contacts, worn radio parts and accessories, and display chassis. Put this **REAL ELECTROPLATING KIT** to use immediately—make it the most useful article in your shop or laboratory. And, you can get it absolutely **FREE** (except for slight mailing cost).

Subscribe today to **RADIO-CRAFT** for One Year (12 issues) and receive absolutely **FREE** this **ELECTROPLATING KIT**. New subscribers are accepted or extend your present subscription twelve months. Mail remittance of \$2.00 (plus 10c for shipping charge on kit) to the publishers. (Canada and foreign \$2.85) You will receive your **FREE, REAL ELECTROPLATING OUTFIT** by return mail. Use coupon below to enter subscription.

RADIO-CRAFT

99 Hudson Street New York, N. Y.

RADIO-CRAFT RC-540
99 Hudson Street, New York, N. Y.

Gentlemen: Enclosed find my remittance of \$2.00 for which enter my subscription to **RADIO-CRAFT** for One Year (12 Issues). Send me **FREE, ELECTROPLATING OUTFIT** (Canada and foreign \$2.85). In U. S. add only 10c additional to cover shipping charges on kit.

New Subscriber Extend Present Subscription

Name

Address

City State

(Send remittance by check, money order or unused U. S. Postage stamps. Register letter if you send cash or stamps.)

PRESELECTOR

Howard Radio Co.
1731 Belmont Ave., Chicago, Ill.

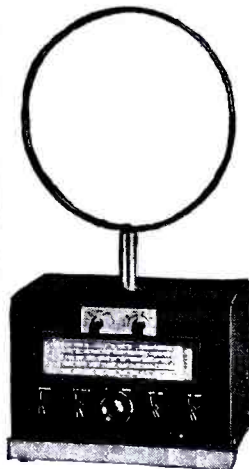

loop for direction

THE model 650 pre-selector consists of a completely self-contained 2-stage high-gain preamplifier with tuning range of 540 kc. to 43 mc. May be used to feed any type receiver or other radio apparatus. Input for standard antenna or rotating loops. Four loops are furnished for different frequencies. Compass scale at base of loop indicates direction of finding. Priced low.

2-BAND CONSOLE SUPERHET.

Allied Radio Corp.
833 W. Jackson Blvd., Chicago, Ill.

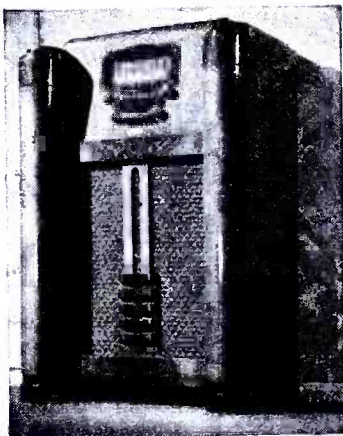

THE Knight "11" is a new 11-tube 2-band console superhet. featuring sloping dial panel and a modern 2-band chassis. Circuit features include A.V.C., 7 W. output, 12 pushbuttons (6 for tuning, 3 for tone control, 2 for on-off and 1 for television or phono); 12-in. dynamic speaker, built-in "Air Magnet" (loop) aerial with electrostatic shield, sliderule dial. Range, 5,650-18,100 kc. and 540-1,550 kc.

SPEAKER ENCLOSURES

Atlas Sound Corp.
1447 39 St., Brooklyn, N. Y.

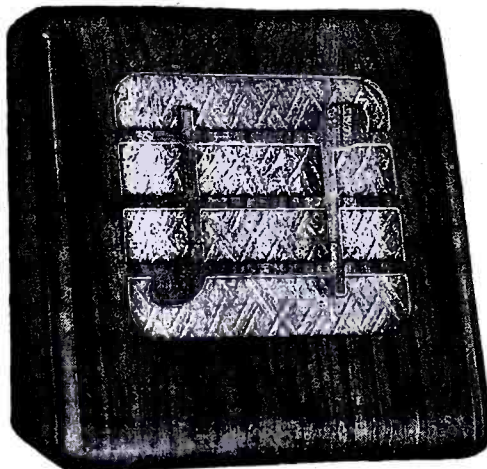

A NEW line of "Music Box" speaker enclosures designed for general P.A. applications and for use as an extension with coin-operated phonographs. Made of natural-grain walnut and supplied with attractive "Acousti-Cloth" grille. Available for 8- and 12-in. speakers.



TECHNIFAX CONSTRUCTION PATTERNS SERIES

TREASURE LOCATORS BLUE PRINTS and INSTRUCTIONS

For Building the Following Treasure Finders and Prospecting Outfits

- Folder No. 1. The "Radiolector" Pilot.
- Folder No. 2. The "Harmonic Frequency" Locator.
- Folder No. 3. The "Beat-Note" Indicator.
- Folder No. 4. The "Radio-Balance" Surveyor.
- Folder No. 5. The "Variable Inductance" Monitor.
- Folder No. 6. The "Hughes Inductance-Balance" Explorer.
- Folder No. 7. The "Radiodyne" Prospector.

With any one of these systems you can construct instruments to locate buried treasures, metal war relics, mineral deposits, subterranean water veins, oil deposits, buried gas and water pipes, lost objects, tools and treasures sunken in water, etc. Each set of blueprints and instructions enclosed in heavy envelope (9½" x 12½"). Blueprints, 22 x 34";

eight-page illustrated 8½ x 11" folder of **50¢** instructions and construction data. Add 15c for postage

The complete set of seven folders..... **\$3.00**
(Sent postpaid)

TECHNIFAX

1917 S. STATE ST. CHICAGO, ILL.

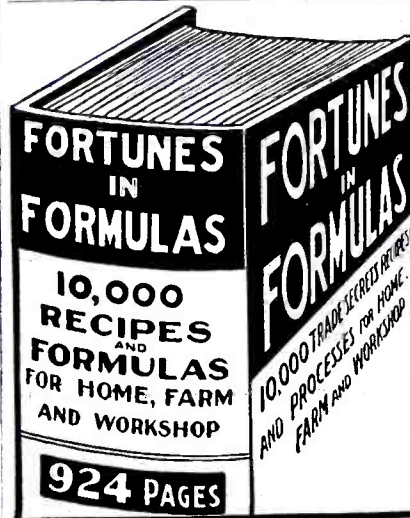

NOW!

The greatest and most important formula book in print. It contains over 10,000 trade secrets, recipes and processes for home, farm and workshop.

Check-full of money-making ideas for cosmetics, soaps, perfumes, antiseptics, water-proofing, photography, lacquer, paints, cements, preservatives, fumigants, insecticides, etc.

Book also contains following important chapters: Useful Workshop Laboratory Methods, fully illustrated, Complete Buyer's Guide, where to buy materials at wholesale prices; Measuring Made Easy; Latin Names of Drugs and Chemicals Translated into English. Completely indexed. In short, this is a **Wonder Book of Useful Knowledge!** Worth its weight in gold.

Book is up-to-date and has the newest methods—latest discoveries—countless thousands of ideas—which you will find useful. Remember—there are actually over 10,000 clearly described formulas, processes, recipes—**MANY NEVER BEFORE REVEALED.**

This huge book has **924 pages**, printed on good paper. Size is 8½" x 5½". Send for a copy of this veritable gold mine **TODAY**. You will never regret it. Remember, great fortunes are often made on formulas.

\$1.79 per copy, sent postpaid anywhere **\$1.79** in U. S. (Canada and foreign countries 25c extra for postage.) **POSTPAID** Send money order, check, unused U.S. stamps or cash. (Register all letters containing cash.)

NATIONAL PLANS INSTITUTE

246-R Fifth Avenue New York, N. Y.

Save on Everything in Radio

NEW 1940 RADIO CATALOG AND PROFIT GUIDE
Most complete line of latest radio sets, amplifiers, kits, tools and replacement parts. All leading brands at lowest prices. Fast Service. Guaranteed Quality.

The **RADOLEK** Company
Dept. Y-41 601 W. Randolph St., Chicago

SEND FOR YOUR COPY TODAY

FREE RADIO PROFIT GUIDE



For Better Servicing - For Bigger Profits - USE GERNSBACK MANUALS AND BOOKS!

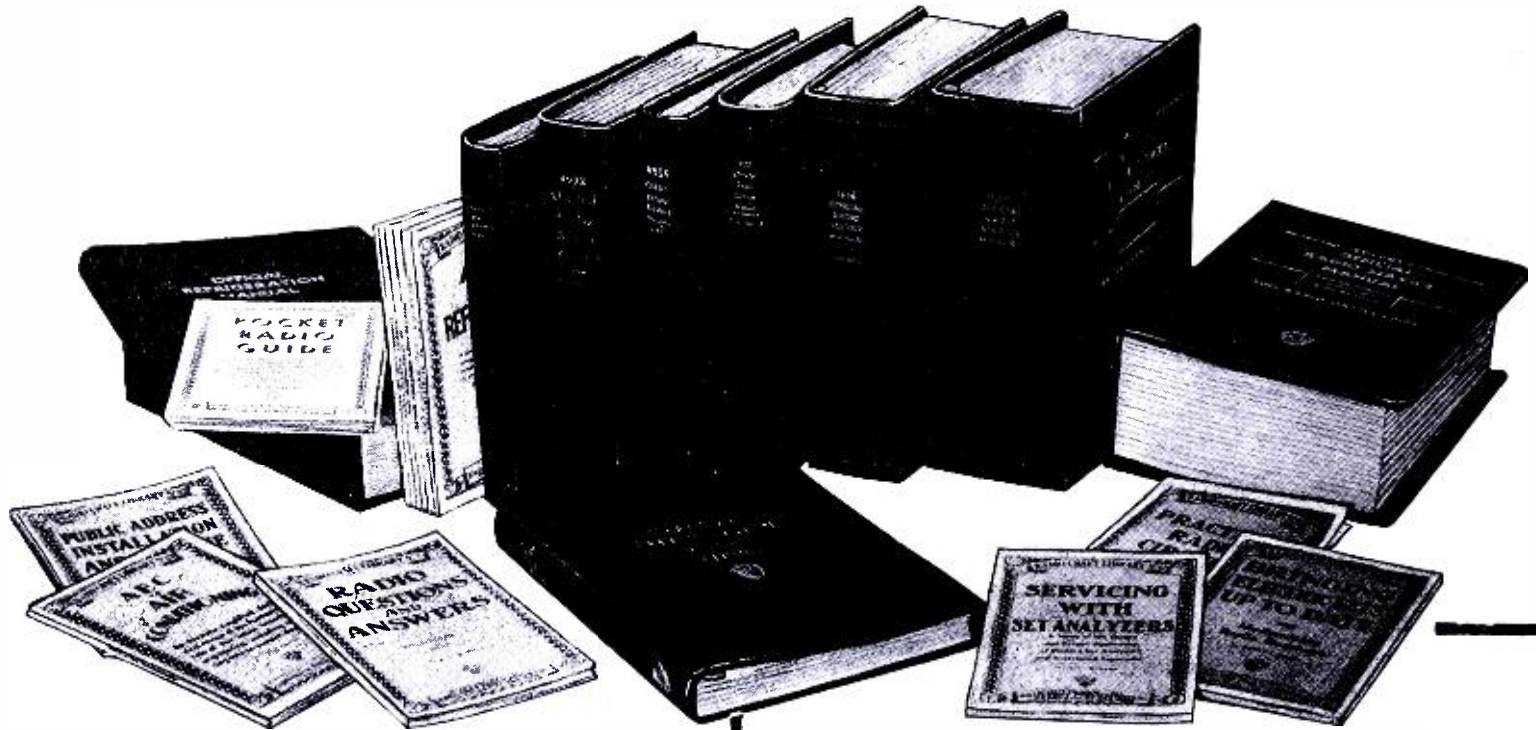

SINCE 1931 Servicemen have been buying more GERNSBACK OFFICIAL RADIO SERVICE MANUALS year after year. The authentic material, easily accessible diagrams and complete service data make them invaluable to dealers and radio Servicemen. *Without a Gernsback Service Manual at the repair job, there's time and profit lost.* Your service kit or laboratory is incomplete without all the GERNSBACK OFFICIAL RADIO SERVICE MANUALS. There are GERNSBACK MANUALS for servicing auto-radios, also refrigeration and air conditioning equipment.

VOLUME 7 OFFICIAL RADIO SERVICE MANUAL

Over 1,800 Pages • Over 3,000 Illustrations • Stiff, Leatherette, Looseleaf Covers • Size 9 x 12 Inches • Net Weight 10½ lbs. **\$10.00**

1936 OFFICIAL RADIO SERVICE MANUAL

Over 1,200 Pages • Over 2,500 Illustrations • Stiff, Leatherette, Looseleaf Covers • Size 9 x 12 Inches • Net Weight 8 lbs. **\$7.00**

1935 OFFICIAL AUTO-RADIO SERVICE MANUAL

Over 240 Pages • Over 500 Illustrations • Flexible, Leatherette, Looseleaf Covers • Size 9 x 12 Inches • Net Weight 1¾ lbs. **\$2.50**

1934 OFFICIAL RADIO SERVICE MANUAL

Over 400 Pages • Over 2,000 Illustrations • Flexible, Leatherette, Looseleaf Covers • Size 9 x 12 Inches • Net Weight 2¼ lbs. **\$3.50**

1932 OFFICIAL RADIO SERVICE MANUAL

Over 1,000 Pages • Over 2,000 Illustrations • Flexible, Leatherette, Looseleaf Covers. Size 9 x 12 Inches • Net Weight 4½ lbs. **\$5.00**

OFFICIAL REFRIGERATION SERVICE MANUAL

(Volume II)
Over 352 Pages • Over 300 Illustrations • Flexible, Leatherette, Looseleaf Covers. Size 9 x 12 Inches • Net Weight 1½ lbs. **\$5.00**

OFFICIAL AIR CONDITIONING SERVICE MANUAL

Over 352 Pages • Over 600 Illustrations • Flexible, Leatherette, Looseleaf Covers. Size 9 x 12 Inches • Net Weight 2¼ lbs. **\$5.00**

To order these famous Manuals, see or write to your jobber or favorite mail order house. If more convenient, mail coupon directly to publishers.

RADCRAFT PUBLICATIONS, Inc.
99 HUDSON STREET NEW YORK, N. Y.

Many New Books Have Been Added to RADIO-CRAFT LIBRARY SERIES

Get into the swing of reading instructive, authoritative books on technical subjects—radio, air conditioning and refrigeration. It's the easiest, quickest and most inexpensive way to improve your knowledge on these topics. In this series, popularly known as the RADIO-CRAFT LIBRARY SERIES, are all the titles necessary to your personal advancement. Only by careful study of these enlightening books, can you gain adequate experience in fields of radio, air conditioning and refrigeration. Each book is uniform. The volumes measure 6 x 9 inches—contain 64 pages, and have stiff, flexible covers. PRICE 50c PER BOOK. All books are sent to you postpaid.

Here Are The Titles:

Book No. 2 MODERN VACUUM TUBES	Book No. 18 POINT-TO-POINT RESISTANCE ANALYSIS
Book No. 6 BRINGING ELECTRIC SETS UP-TO-DATE	Book No. 19 PRACTICAL RADIO KINKS AND SHORT CUTS
Book No. 13 ABC OF AIR CONDITIONING	Book No. 20 THE CATHODE-RAY OSCILLOSCOPE
Book No. 14 POCKET RADIO GUIDE	Book No. 21 BREAKING INTO RADIO SERVICING
Book No. 15 ABC OF REFRIGERATION	Book No. 22 NEW RADIO QUESTIONS AND ANSWERS
Book No. 16 PRACTICAL RADIO CIRCUITS	Book No. 23 PRACTICAL PUBLIC ADDRESS
Book No. 17 SERVICING WITH SET ANALYZERS	

EACH BOOK IN THIS SERIES—50c

RADCRAFT PUBLICATIONS, Inc., 99 HUDSON ST., NEW YORK, N. Y.

Gentlemen: Enclosed find my remittance of \$..... for which send me, POSTPAID, the Manuals or Books indicated below by a cross (x) in the panel.

() Volume 7 @ \$10.00 () 1934 Manual @ \$3.50 () 1932 Manual @ \$5.00
() 1935 Auto-Manual @ \$2.50 () 1936 Manual @ \$7.00
() Refrigeration Manual (Vol. 2) @ \$5.00 () Air Conditioning Manual @ \$5.00

RADIO-CRAFT LIBRARY SERIES @ 50c EACH

Circle book numbers wanted: 2 6 13 14 15 16 17 18 19 20 21 22 23

Name Address

City State

(Send remittance in form of check or money order; register your letter if you send cash or unused U. S. Postage Stamps.)

RC-540

All the worthwhile
Radio Trade News
of the past Month—
Digested for busy
radio men.

RADIO Trade Digest

IMPORTANT HAPPENINGS OF THE MONTH IN THE RADIO INDUSTRY

A PLEDGE: — To
print the important
news of the radio
industry; to review
major news events;
to help point a path
to radio profits.

No. 21

MAY, 1940

No. 21

\$15,000 TELLY SHOWS FOR 8,000 VIEWERS

*Figures Cover First Eight
Months of Telecasting
During 1939*

Alfred H. Morton, NBC vice-pres. in charge of telly, has released figs. in a survey of the first 8 mos. of telecasting. Here are some of Mr. Morton's conclusions:

He estimates that about 2,000 sets are in use in and around N.Y.C. About 89.8% are in homes—the rest in theatres, hotels, etc. Figuring 4 to a family, about 8,000 persons look in nightly. Average number of sets in use (afternoon and evening) is 68.9%. Breakdown shows that 100% of audience sees 2 hrs. or more per week, and 87.1% sees 5-6 hrs. of shows weekly; 60% sees 7-8 hrs. weekly (which would be all evening shows and Sat. & Sun. matinees—*Editor*) and 21% sees all broadcasts.

Studio features, especially dramatic shows, are most popular with viewers; followed by outside special events, with feature films third. While these 3 averaged from good to excellent in listeners' reports, film shorts drifted in between fair and good.

Program schedules rose from little over 20 hrs. monthly in May to nearly 60 hrs. in Dec. During the 8 mos., 362 hrs. of shows were shown; 38.2% of the shows were live talent while films were 31.9% and special events were 29.9%.

Morton estimates that programs cost from \$10,000 to \$15,000 per wk. Important is the fact that 67 advertisers representing 16 industries presented 148 shows over telly. The monthly period of such "unsponsored" commercial shows rose nearly 100% from May to Dec.

COMMERCIAL TELLY BROADCASTING GETS GREEN LIGHT FOR SEPTEMBER

*Fall Programs May Be Sponsored;
New Low Prices May Boost
Telly Set Sales Too*

SALES CURVE FLATTENING

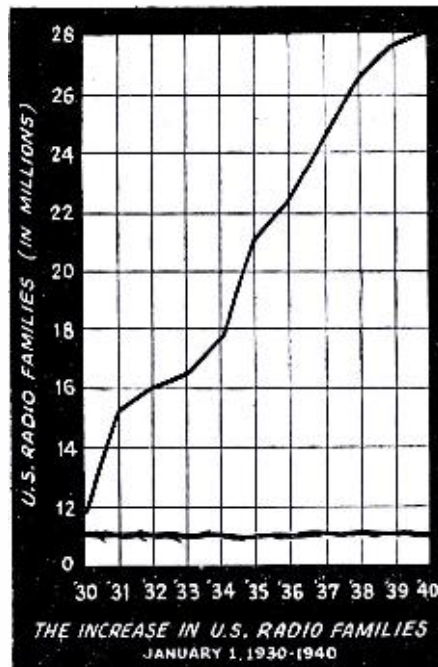

The graph above, reproduced from information supplied by the Columbia Broadcasting System, shows a less rapid increase in growth of number of U.S. radio families since 1938. Most rapid increases were from 1930 to '31 and 1934 to '35. Flattest curve is shown from 1939 to '40.

Television is getting the green light definitely this Fall when the FCC makes effective 2 types of stations. One of these might be called "technical experimental"; the other "program experimental." The latter will be permitted to sell time commercially. This, in the opinion of industry leaders, will result in program improvement and should aid in the sale of sets.

Another interesting development is seen in the inside story of the long-heralded price reduction in television receivers. One prominent manufacturer, it has been rumored, would drop the price of his 12-in. \$650 radio-television console to slightly under \$400. The fact is that this manufacturer is putting out a new and cheaper-model 12-in. set to sell for about that price. But this model will be without A.V.C. and will lack the D.C. restorer in the telly end, be minus the tuning indicator in the radio end and have other cost-saving omissions. (Note: D.C. restorer functions as automatic brilliance control; its absence may necessitate frequent manual readjustment of brilliance unless transmission technique is modified to counteract this.—*Editor*)

Nevertheless industry's opinion is lower prices plus better programs will result in telly taking a sharp upcurve with resultant profits to manufacturers, broadcasters, dealers and Servicemen.

MAKES MONEY BY SPENDING SOME

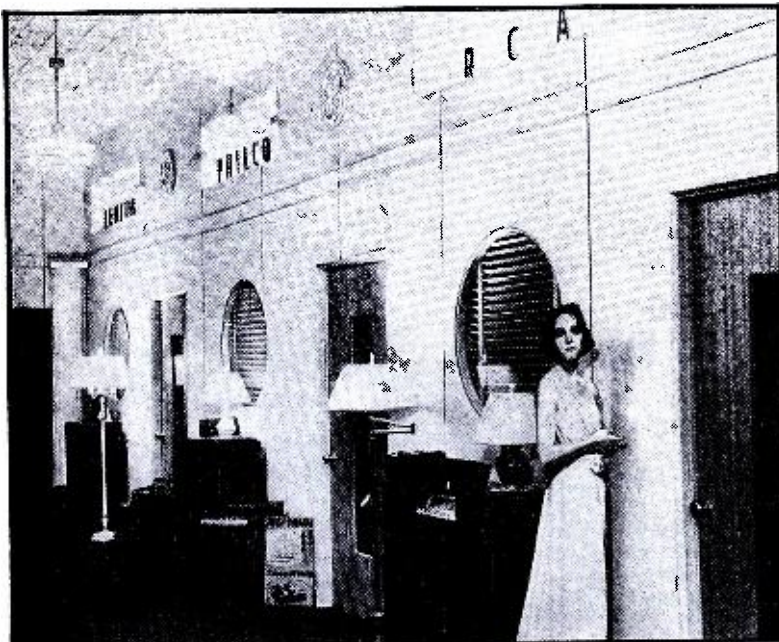

Jack Goodwin, Milwaukee radio, music and appliance dealer, had his store thoroughly streamlined. Within 1 yr. the modernization brought in enough more sales to pay for itself, and the heating bill alone has dropped 75%. Mr. Goodwin says he now sells as much merchandise in a week as he formerly sold in a month, and he needs keep his heat on only during business hrs. instead of 24 hrs. a day, as formerly.

MFRS. DISCUSS NEW LINES

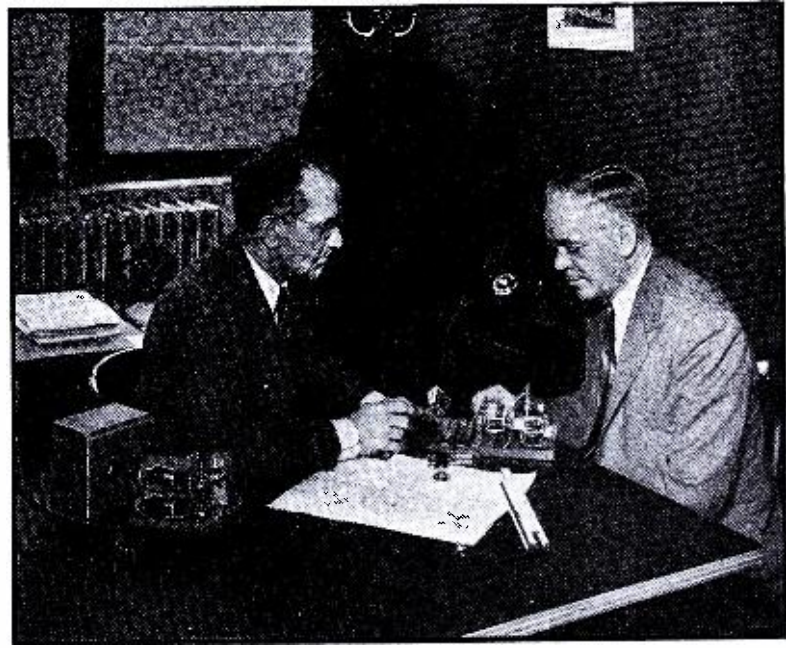

Leon Worner, left, pres. of Worner Products Corp., and Arthur Eidan, co.'s chief eng., are seen above discussing new lines of electronic apparatus. Scene is exec. office of co.'s new and enlarged factory at 1019 W. Lake St., Chicago. Move was necessitated, according to Mr. Worner, by increased business. Line includes many novel products which Worner distrib. predict will break biz records during current year.

THE COMMITTEE OF THE RADIO TECHNICIANS' GUILD OF NEW ENGLAND

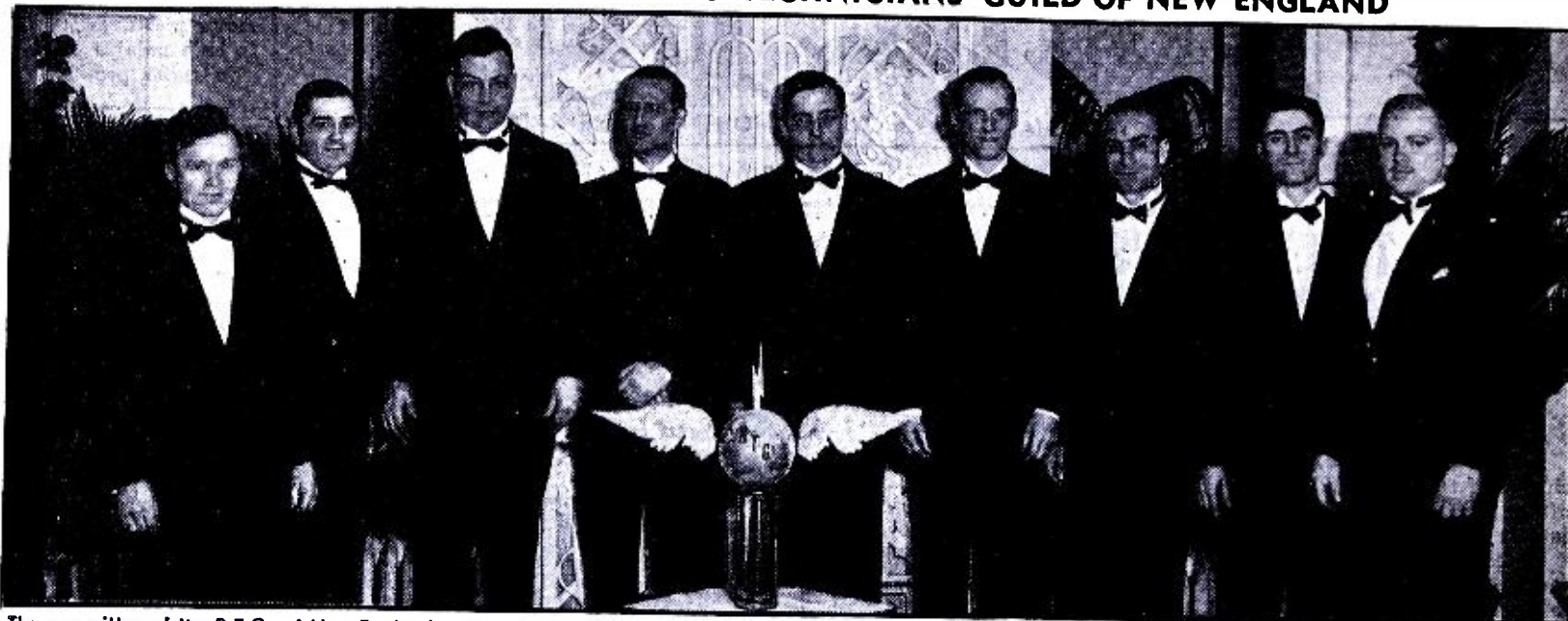

The committee of the R.T.G. of New England gathered at the Boston banquet to work out a plan for promoting a clearer and better understanding among Servicemen and for protecting the radio listener from unethical methods. Left to

right they are: G. Batt Staff Artist, J. R. Cabral Secy., W. F. Staples Librarian, E. J. Maginot Pres., A. C. W. Saunders Educational Dir., F. Kennes Treas., N. Baratta Asst. Treas., S. Di Russo, Chairman Trustees, E. Glynn, Vice Pres.

Personal

F. R. LACK, mgr. of the special products div. of *WESTERN ELECTRIC*, has been appointed to the board of directors of the *INSTITUTE OF RADIO ENGINEERS*.

JOHN H. BROWN has resigned as parts dept. mgr. of *H. C. NOLL CO.* to open his own firm, *ALL STATE DISTRIBUTING CO.* CARL KRUMREI, JR., succeeds to the managership.

JAMES R. FOUCH, pres. of *UNIVERSAL MICROPHONE CO.* underwent a major operation at the Hollywood Hosp.

JAMES L. FOUCH replaces E. E. GRIFFIN as vice-pres. & chief eng. of same co. ROBERT GRIFFIN, purchasing agent, has replaced S. E. SHAPIRO as head of recording sales & service in the Southwest for the co.

G. V. ROCKEY, v.p. & gen. sales mgr. of *MEISSNER MFG. CO.*, back from Western sales tour reports dealer enthusiasm.

IRVING FRISCH has replaced H. J. TAUBER as adv. mgr. of *RADIO WIRE TELEVISION, INC.*

W. A. WOLFF, adv. mgr. of *WESTERN ELECTRIC* and its subsidiary, *ERPI*, has been made information mgr. of both cos. He is succeeded by H. W. FORSTER, former information mgr.

FLINT HARDING of Minneapolis has been made *ARCTURUS* rep. in the Northwest. CHARLES R. POLLARD, JR. of Baltimore will take over Md. and Va.

HERMAN H. SMITH, formerly of *AMERICAN RADIO HARDWARE CO.*, is the new sales mgr. of the *J.F.D. MFG. CO.*

HAL BLAKESLEE, in charge of sales & merchandising of *ZENITH'S* parts & tubes div., back from a coast-to-coast dealer survey, reports his co.'s tube promotions as sensationally successful.

CARL LOHMAN-JANIK, former export chief of *THORDARSON*, has been appointed export mgr. of *KENYON TRANSFORMER CO.*

There are several changes at *HYGRADE SYLVANIA*: BERNARD J. ERSKINE has been made ass't to the v.p. as has ARTHUR L. MILK. ROBERT P. ALMY succeeds Mr. Milk as sales supervisor. E. T. REID has been given complete charge of the order dept. for *SYLVANIA* tubes.

\$'s & N^o. 's Dept.

\$183,721.86 NET PROFIT are the earnings of the Cornell-Dubilier Electric Corp. for the year ending Sept. 30, 1939. Equivalent to 69.3c per share on outstanding common stock of 264,640 shares.

12 OUT OF 16 "firsts" in the way of program material were polled to NBC Network by 89 radio editors, representing 140 newspapers—according to *Radio Daily*. New York *World-Telegram* poll gave NBC 11 out of 14 "firsts" as findings of 200 radio editors.

\$68,899 FOR NEW IDEAS adopted by the co. were given to G.E. employees during 1939—\$12,497 more than in 1938. Awards ranged from \$2.00 to a top of \$525.00. 26,901 suggestions were received (6,702 more than in 1938); 10,121 were adopted. \$1,000,000 have been thus paid during past 20 yrs., with awards sometimes as high as \$1,500.

CAB FIGURES SHOW CBS audience larger than NBC's and Mutual's from 6 to 11 P.M. (most competitive hours in radio). CAB means Cooperative Analysis of Broadcasting, i.e., the "Crossley report."

TUBE BUSINESS UPPEd, as Pacific northwest business showed largest increase in history during 1939, according to rep.

PATENT SUITS MAY LEAD TO AN INDEPENDENT RMA

About the most important outcome of the recent patent suits brought by RCA, G.E., and A.T.&T. against 5 small mfrs. is the effort by Bruce L. Campbell of N.Y. to organize an independent radio and television mfrs.' association to buck the biggies. One of their prime aims will be to break the "powerful radio patent monopoly" of the big cos. Campbell says that one leading mfr. does not now claim that more than 10% of most groups of patents acquired by it are used or useable.

A. S. Detsch, who predicts even better biz. for 1940 from this region.

\$4,405,208 GROSS NBC network income for Jan. 1940 is all-time high in co.'s history. Increase of 9.2% over Jan. 1939 and 2.9% over Dec. 1939.

\$83,000,000 GROSSED in 1939 by 3 major networks—more than \$10,000,000 over previous year. NBC Red and Blue facilities led with \$45,245,354 followed by CBS with \$34,539,665. Mutual grossed \$3,329,782. This data according to *Radio Daily*.

TELEVISION TRENDS

● Baird Television is planning to go ahead with the production of receivers for theatre use, projecting images on a 16 x 20 ft. screen.

● Farnsworth's mobile television unit is playing successful dates at dept. stores in the New England States.

● William H. Grimditch, v.-p. in charge of engineering at Philco, says gross injustice will be done to the public if present television standards are frozen. "Television is still in the research laboratory," he adds.

● At last reports, Allen du Mont was still objecting to the proposed standardization of television at 441 lines with 30 frames per second.

● A special telecast showed the new Bulova watch line to the co.'s salesmen. The broadcast, not publicly announced, lasted 50 mins.

● According to *Radio Daily*, a publication for broadcasters, television was the industry's most important news during the past yr.

● Reports are that low-cost relay stations will soon make television networks a reality.

● Scophony, Ltd., British telly mfrs., have devised new projection tube for large-screen images. Known as *Skiatron*, it was developed by Dr. A. H. Rosenthal, and employs the optical storage principle.

AN EDITORIAL

By Artie Dee

When "summer reception" troubles begin that's the time for you to put on a service sales drive.

Of course warm weather, sun spots, magnetic storms and all the other conventional annoyances mar reception, but most of the woes of the broadcast listener are due to the little bugs which creep into the best of sets. Such troubles go unnoticed during the winter months when signal strength is sufficient to override set noise and a good deal of local interference ("man-made static").

"Little Bugs!"

However when signal strength falls off the little peeps, wheezes and frying noises caused by set defects become more noticeable. The listener blames it on "Summer Static" and lets it go at that—but we know, don't we?

It's up to the Servicemen, both as individuals and a group, to educate the public to demand as good reception in summer as in winter, within reason.

Noisy volume or tone controls, poor contacts on variable condensers, misalignment of padders or trimmers, weak or noisy tubes—these and many other minor defects often result in interference which is wrongly attributed to "Summer Static". Modest advertising campaigns in local newspapers, with throw-aways, envelope-stuffers, dodgers, etc., will do much to educate the public as to the true reasons for impaired reception.

Why should you give a hoot about the public? Because they're your customers! More knowledge in their skulls means more profit in your pocket.

Make Summer your best season!

KITS FOR KIDS



Electronic kit which enables even a child to build many scientific instruments is new RCA seller. Kit comes in neat package providing everything necessary for construction of innumerable apparatus including simple radio set, home broadcasting equipment, code practice outfit, capacity-operated relay, etc. Scientific minded youngsters love it.



Stromberg-Carlson, G.E. and R.E.L. are making F.M. receivers commercially. Brown-ing & Meissner have kits on the market, & Zenith, Stewart-Warner, Pilot, Scott, National. Hammarlund & Hallicrafters have Major Armstrong's OK to manufacture sets. The FCC has over 50 applications in. About a dozen F.M. stations are on the air and more than \$1,500,000 have been spent on equipment and experimentation . . .

Farnsworth is readying a line of export receivers, covering from 13 to 550 meters. Power transformer has 6 primary taps to work on all voltages from 90 to 240 . . . Muzak has taken over the acc'ts of Wire Broadcasting . . . Bighearted Philco has sent a complete set of replacement tubes for the receiver used by the Pitcairn Islanders. The transmitter there has been off the air for over a year.

The complete sale in 8 days of receivers which had taken 2 mos. to produce is Emer-

son's enviable record; maybe it's a record for the industry, eh? . . . By the time this comes out WOR should be on the air with a 1 kw. F.M. transmitter . . . Didja know there are 1,500 or more exact duplicate volume controls in the Clarostat line? . . . Word is that Cath-Ray Electronic Labs. are planning a complete telly receiver to retail at \$100. Wanna bet?

Tubes used in Bell & Howell Filmo sound projectors will be pre-tested and bear the "B. & H." brand . . . There are 12 models in the new Stewart-Warner line . . . H. C. Noll Co., distrib. of Emerson radios and parts & supplies for various appliances, denied 2 rumors. They WILL continue the radio & refrigeration parts business; they are NOT financially backing anyone in another business under another name to take over the radio & refrigeration parts distribution.

A Novachord has been acquired by Time Abroad, Inc., electrical transcription studios . . . What ever happened to American Television Corp.? . . . Hygrade Sylvania Corp. sends out a circular letter "to dispel any possible belief" that RCA's "Preferred Tube Types Program" has won industry acceptance or acceptance by tube mfrs. as a group. The letter is quite a blast . . . Didja know that American Bosch has discontinued manufacturing radios? . . . Watch the new Broadcast Music Corp., ASCAP's new competitor! It begins licensing music on April 1 and has contracts assured for \$1,250,000 worth of business.

Eagle Elec. Mfg. Co., Inc., has just celebrated its 20th birthday . . . Kenyon Transformer Co. is out with a new series of Cath-O-Drive transformers, to cathode-modulate various types of transmitters . . . RCA announces enthusiastic reception of its preference list tube program to limit the number of models which dealers need stock.

AEROVOX PUSHES CHECKER

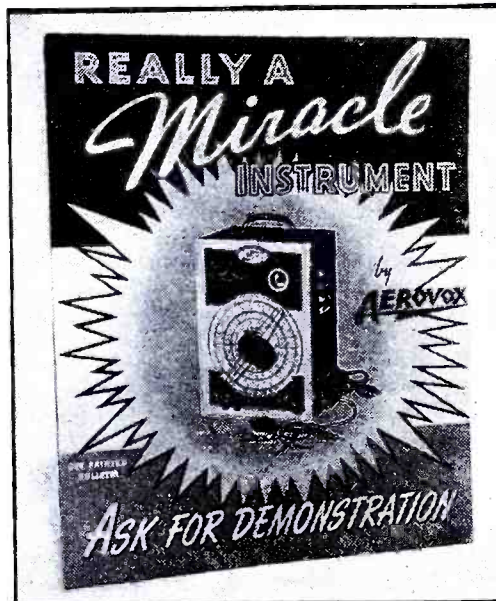

A red and black wall, counter, or window display features a large picture of the Aerovox L-C Checker and offers demonstration and circulars. Instrument checks inductance and capacity.

Changes & New Addresses

Where to Reach Old and New Companies

Sales Manager Jack Geartner of ARCTURUS RADIO TUBE CO., Newark, N. J., announced the appointment of the S & S Co. of Staunton, Va., as representatives covering the southeastern territory. This firm travels 4 men. Affiliated Co., S & S Company of Memphis, Tenn., is now covering the deep South.

RAYTHEON PRODUCTION CORP. have moved their West-coast warehouse and offices to new and larger quarters at 1045 Bryant St., San Francisco, Calif. Orders and adjustments will be handled from this address.

SHREE JYOTI ELECTRIC TRADING CO. of Bombay, India, have moved their offices and stores to Ravindra House, Kalbadevi Road, Bombay, 2.

WARD LEONARD ELECTRIC CO. announces change in address of their representative, Northwestern Agencies, to larger offices located at 2411 First Ave., Seattle, Wash.

TRANSDUCER LABS. directed by B. Isenberg, located at 42 West 48th Street, New York City, have assumed all manufacturing and experimental facilities of Transducer Corporation.

L. L. Kelsey, Radio Division Manager of STEWART-WARNER CORP., announces 7 new distributors as follows: Graybar Electric Co., Inc., Cincinnati, Ohio; Forston Distributing Co., Houston, Tex.; Appliance Merchandisers Co., Rockford, Ill.; Old Dominion, Inc., Toledo, Ohio; Ball Store Fixture Co., Dayton, Ohio; Royal-Eastern Electrical Supply Co., New York City; and Behrer-Nason Co., White Plains, N. Y.

NEW PATHS TO PROFITS



E. Foster Hammonds of Bryn Mawr, Pa., is one of country's most successful dealers in home recorders. Above, a customer plays & sings, while Hammonds cuts the wax on RCA Victor de luxe recorder in control room. Although the recorder has playback, separate phono is provided in studio which is built in rear of store's showroom.

LIVE SERVICEMAN KEEPS CUSTOMERS COMING WITH INEXPENSIVE REMINDERS

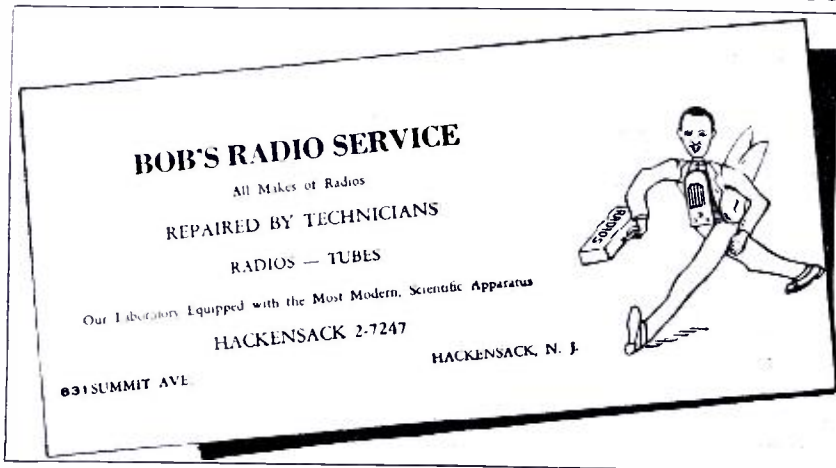

← The old reliable blotter carries this Serviceman's messenger to customers & prospects. His illustration conveys idea of speedy service.

Dollar special, including thorough test, is featured on one side of card at right, reverse of which logs local stations and repeats company name and phone.



OFF THE PRESS

CATALOG. United Transformer Corp., New York, N. Y. 64 pages. Complete listing of transformers for transmitters & receivers; filters, equalizers, etc. Replete with diagrams, curves & technical information.

CATALOG. Crowe Name Plate & Mfg. Co., Chicago, Ill. 1940 line of automobile remote controls & panels to match dashboards of all cars.

"IDEAS THAT CLICK." Supreme Publications, Chicago, Ill. 32 pp. Full of money-making ideas plus a listing of books helpful to Servicemen & technicians.

RECEIVING TUBE MANUAL. RCA Mfg. Co., Harrison, N. J. 224 pp. Complete characteristics, fundamental circuits & technical information on every type of RCA receiving tube. 41 pages devoted to theoretical discussion.

CATALOG. No. 102. Allied Radio Corp., Chicago, Ill. 36 pages. Devoted to amateur equipment. Lists receivers, transmitters, components for both.

BULLETIN KMF. Amperite Co., New York City. Shows interesting applications and diagrams of the Amperite "Kontak" mike in an electrified orchestra.

"ELECTROLYTIC CAPACITORS." Cornell-Dubilier Electric Corp., So. Plainfield, N. J. 300 pp. By Paul McKnight Deeley. First half devoted to comprehensive theoretical discussion of condensers; second half to practical applications, testing, limitations, industrial uses, etc.

CATALOG. Burstein-Applebee Co., Kansas City, Mo. 164 pages. Equipment for radio from A to Z is best description—plus miscellaneous items on electrical appliances, etc.

FOLDER. General Electric Co., Radio & Telly Dept., Schenectady, N. Y. Listing of high-vacuum air- and water-cooled radio transmitting tubes. Also includes mercury-vapor rectifier.

FOLDER. Same co. Describes new line of frequency-modulation transmitters.

CATALOG. Triplett Electrical Instrument Co., Bluffton, Ohio. 8 pp. Listing of new line of test equipment. Tube testers, analysis testers, volt-ohm-milliammeters, oscillators, oscilloscopes, etc.

SHEET. Same co. Describes inexpensive pocket-size battery tester.

BOOKLET. General Ceramics Co., Keasbey, N. J. 24 pp. Complete data on Steatite and Ultra-Steatite low-loss insulators, coil forms, etc., for ultra-high-frequency circuits.

FLYER. Radio Wire Television, Inc., New York, N. Y. 8 pp., tabloid size. Lists receivers, phono combinations, portables, recorders, interphones, radio components, etc.

SHEET. John Meck Industries, Chicago, Ill. 2 pp. Lists new line of "Audiograph" sound equipment, including speakers, mikes, record players, etc.

CATALOG. Littelfuse, Inc., Chicago, Ill. 10 pp. Fuses and holders for every conceivable radio use.

CATALOG. Central Scientific Co., Boston, Mass. Catalog No. J-136. 1,660 pages. Available to school, college and university, and industrial libraries, write on company letterhead. A practically complete cross-section of every piece of equipment and raw material for the laboratory worker in electronics, physics, chemistry, electricity.

FOLDER. Allen D. Cardwell Mfg. Corp., Brooklyn, N. Y. 4 pp. Describes model TA-240, 240-watt phone output R.F. amplifying kit.

CATALOG. Atlas Press Corp., Kalamazoo, Mich. 74 pp. A beautifully-illustrated book on precision lathes, and accessories, for laboratory and commercial use. Also describes variety of drill presses, shapers, arbor presses, etc.

DISPLAY SELLS MOTOROLAS



Three-dimensional "Mainliner" display makes demonstration of 5 new Motorola car radios possible. Special phono record on Motorola wireless record player also demonstrates this adjunct of line. Heavy consumer advertising backs up dealers.

Sales Helps and Deals

New Paths to More Business
(How Leading Mfrs. Help YOU
Make Money)

To help put over its new line of replacement vibrators **MEISSNER MFG. CO.** has prepared an attractive 3-color counter display which contains 6 fast-moving items & a powerful sales appeal. A limited number are being sold to Meissner jobbers on a special price plan which offers extra profits.

AEROVOX CORP.'S attractive new red & black display card ties in with extensive advertising on their L-C Checker & jacks up dealer sales. Swell for window or counter.

A new folding **Stock Boy** cabinet which accommodates 240 tubes is being offered by **HYGRADE SYLVANIA** to jobbers, dealers & Servicemen to help step-up sales. Inscribed prominently on the front panel is "Insist on Sylvania Set-Tested Radio Tubes." The new cabinet has 2 swinging compartments which, when open, provide accessible shelves measuring 60 ins. wide.

A **GENERAL ELECTRIC** metal display cabinet for its Mazda flashlight and radio panel lamps won a major award in the All-America Package Competition, sponsored by **Modern Packaging Magazine.**

Bulbs are inserted in several vertical slots in face of cabinet. Removable cards under the slots identify the bulbs by type, voltage and price. Batteries are placed along the top of the display, to help the customer recognize those used in his flashlight, so that clerk can select the right bulbs.

A painted flashlight and its white rays, on a yellow background, flash on and off to play up the GE sales message. A transformer is included in the display, for quick testing of bulbs. Batteries too can be tested.

• SHOP NOTES—KINKS—CIRCUITS •

VISUAL VOLUME INDICATOR

• HERE is a circuit diagram of a volume indicator. The potentiometer is used to set the indicator to peak at different outputs and may be calibrated in db. or watts.

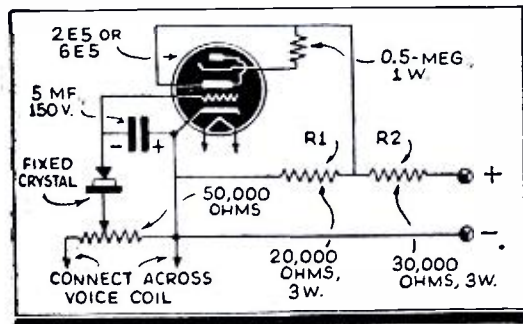

It may be found necessary to reverse the connections on the fixed crystal which is used as a rectifier. The supply voltages may be taken from the radio receiver or amplifier on which the device is to be used. A type 2E5 should be used if 2.5 V. is available and if 6.3 V. is available a 6E5 should be used. The regular high voltage of the amplifier may be used.

PETER WALTNER,
Los Angeles, Cal.

EMERGENCY 25Z5 REPLACEMENT

• WHEN working on A.C.-D.C. receivers, I have found that the most usual trouble is the 25Z5 tube blown out or not rectifying at all. When a new tube is not at hand, which is very common, I change the circuit and use a 43 tube in place of the 25Z5. As you know, this tube is cheaper and when used in this manner will stand very severe changes of current. Before using my circuit, I first tried it in my own receiver and after 6 hours of continuous use it was as efficient as before. Also many 43 tubes which do not work as A.F. amplifiers, will work in this circuit. The filament circuit is NOT changed.

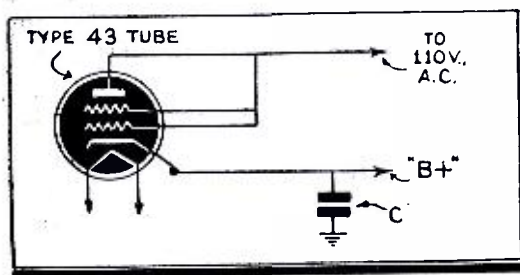

In your last copy, in this same section, a circuit appeared which induced me to write this letter. It was the Emergency Rectifier circuit.

JOSE A. FERNANDEZ,
Santurce, P. R.

ADDING A SLIDE-BACK SCALE TO YOUR OHMMETER

• SEVERAL years ago most volt-ohm-milliammeters were built to read 0-1,500 ohms on the Low-Ohms scale and were built around a 0-1 ma. meter. Today the 0-1,500-ohm scale is not sensitive enough to read the resistance values and few of us stop to figure how easily these instruments can be changed to read these lower values without interfering with the other functions of the tester. To prevent this attachment being left "On" and an attempt made to use the tester, possibly damaging the multiplier resistors or some other part, a pilot lamp has been built into the tester as warning that it is connected. Considering its value and its cost I believe it is well worth its cost.

A separate back-up or slide-back scale can be glued to the meter bezel or may be calibrated right on your present scale.

No accurate calibration can be given as it varies considerably with different types of meters but using Ohm's Law and a handful of low-resistance resistors no trouble should be encountered in doing the job.

If your instrument has a switching arrangement to read either 0-1 or 0-1.5 ma. D.C. to the tip-jacks, the attachment can be soldered to the back of these tip-jacks. If not, they should be attached directly to the meter terminals.

LIST OF PARTS

- Two 1.5-volt flashlight cells;
- One No. 48 2-volt, 0.06-A. panel light;
- One 1,000-ohm, 1 W. resistor;
- One 500-ohm wire-wound rheostat or potentiometer;
- One D.P.S.T. switch, either rotary or toggle;
- One 16-ohm resistor (can be made from an old 20-ohm C-T. resistor cut off to make the pilot lamp burn correctly);
- Two tip-jacks (to match the ones on your instrument);

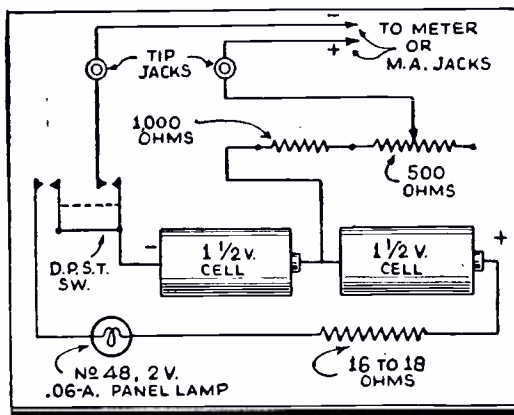

- One panel (the proper size and color to match the one on your instrument);
- One jeweled pilot-light bracket (miniature screw base);
- Hook-up wire, solder, screws, etc.

O. T. BOLICK,
Charlotte, N. C.

PRIVATE PHONE CIRCUIT

• HERE is a sketch of a private phone hookup which can easily be arranged by using various parts usually found in radio shops. The transformer used on each end is an output (speaker) transformer and the secondary is used as primary. The original primary used across the lines as secondary will not short-out the battery as it is of such high resistance that the low voltage will not be affected. Old dry-disc receivers with their transformers can be used

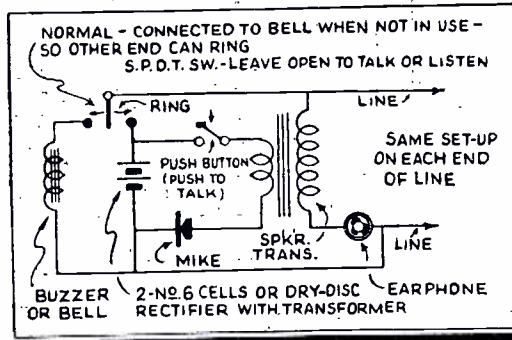

for battery if a very high capacity is used across them; but, 2 No. 6 drycells at each end will make for much clearer operation and it does work well. The mike can be a regular telephone or any carbon type.

HENRY E. BECKER,
Becker Radio Service,
Grand Ledge, Mich.

ONLY \$4.96 U. S. NAVY AIRPLANE-TYPE Microphone and Receiver

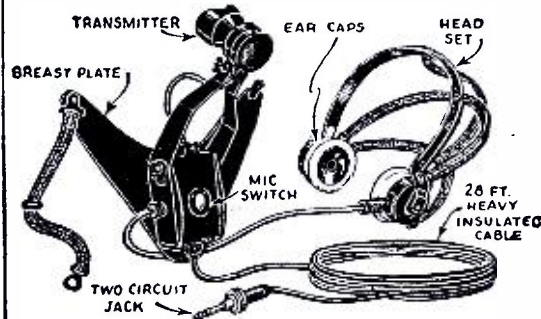

THIS Microphone and telephone headset outfit was built especially for the U.S. Navy Aviation Corps for Plane-to-Plane and Plane-to-Ground communication.

The Holtzer-Cabot Electric Company constructed the outfit to Government specifications and under rigid Navy Department supervision.

The outfit consists of a low-impedance carbon microphone (transmitter), securely fastened to a metal breast-plate, and a set of heavy-duty, low-impedance earphones. A specially constructed switch on the back of the breast-plate controls the microphone circuit. The earphones are U.S.N. Utah type, attached to adjustable headband. Twenty-eight feet of very heavy weather and waterproof conductor cable, terminating in a special brass plug, is furnished with this complete outfit. Current of not more than 10 volts should be used. A storage battery is the most satisfactory current supply. Talk in a natural tone of voice, when using the outfit, with the lips close to the mouthpiece. Shouting and loud talking should be avoided.

We understand that the U.S. Government paid more than \$40.00 for each of these outfits. We have bought the whole lot at a low price and are offering them, as long as the supply lasts, at \$4.96 each, complete as shown in illustration. The shipping weight is 9 lbs.

All merchandise in original packages—never used. Money-back guarantee.

All Shipments will be forwarded by Express Collect if not sufficient postage included.

WELLWORTH TRADING CO.
1915 So. State St., Dept. RC-540, Chicago, Ill.

IF IT'S RADIO

ALL YOUR RADIO NEEDS

Here in this one big book you will find everything you need in radio... sets, parts and supplies... public address systems... amateur equipment... testers and kits... your nationally known favorites at lowest possible prices. Write today for this big valuable catalog and save money.

PROMPT SERVICE

FREE CATALOG

BURSTEIN-APPLEBEE COMPANY
1012-14 McGEE STREET, KANSAS CITY, MISSOURI

Save on Everything in Radio

NEW 1940 RADIO CATALOG AND PROFIT GUIDE
Most complete line of latest Radio sets, amplifiers, kits, tools and replacement parts. All leading brands at lowest prices. Fast Service. Guaranteed Quality.

The **RADOLEK** Company
Dept. Y-41 601 W. Randolph St., Chicago

SEND FOR YOUR COPY TODAY

FREE RADIO PROFIT GUIDE

SUPER BARGAINS

Rockbottom Prices on New and Rebuilt Apparatus

Many of the attractive items listed here are brand new, others are reconditioned like new; but ALL are in PERFECT WORKING ORDER. In many cases, the component parts alone total more than the complete price we are asking. 100% satisfaction guaranteed or your money refunded.

ORDER FROM THIS PAGE. Use the convenient coupon below. Be sure to include sufficient extra remittance for parcel post charges, else order will be shipped express, charges collect. Any excess will be refunded. C.O.D. shipments require a 20% deposit. If full remittance accompanies order, deduct 2% discount. Send money order, certified check, new U. S. stamps. No C.O.D. to foreign countries.

ORDER TODAY LIMITED QUANTITIES PROMPT SHIPMENTS ASSURED

24-HOUR ELECTRIC TIME SWITCH

Complete with Built-in Holding Relay

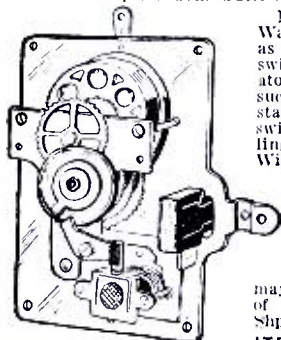

Made by the famous Waterbury Clock Company, as an automatic defrosting switch for electric refrigerators and still usable as such. Has synchronous self-starting clock motor and switch contacts for controlling any 1/3 H.P. motor. Will modernize any electric refrigerator by providing automatic defrosting. Merely plug refrigerator into clock outlet, and clock into 110 volt, 60 cycle A.C. line. Its maze of gears may be used for a variety of experimental purposes. Shp. Wt. 3 lbs.

ITEM NO. 75 **95c**

Your Price (as illustrated)

SUPER SPECIAL

3 1/2 R.P.M. SYNCHRONOUS MOTOR

110 Volt 60 Cycle A.C. only

There are 101 uses for a synchronous motor making only 3 1/2 revolutions per minute. Ideal for crowd-catching dynamic, store-window displays, agitating film-developing tanks, as an electric winch on model motor boats, as derrick motor in erector sets, etc., etc. Built-in high-ratio step-down gears provide amazing amount of power. Made by the well-known Haydon Mfg. Co. of Waterbury, Conn. Measures but 2" in diameter x 2 1/2" x 1" thick overall. Shp. wt. 2 lbs.



ITEM NO. 76 **\$1.95**

YOUR PRICE

A.G. "SQUIRREL CAGE" SYNCHRONOUS MOTOR

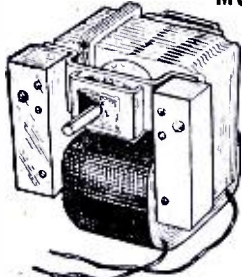

A self-starting shaded pole motor originally designed for use on radio chassis for Push Button Tuning. High speed and powerful. One lubrication lasts lifetime. Excellent for model railroad trains, small boats, humidifier water pumps and a host of other uses. Has 1/2" long shaft, 3 1/16" diameter. Complete with brass mounting posts. Measures 2 1/2" x 2" x 2 1/4" overall. For 110 volts, 60 cycles, A.C. only. Shp. wt. 4 lbs.

ITEM NO. 77 **\$1.35**

YOUR PRICE

SCOOP!

REPLACEMENT ELECTRIC CLOCK MOTOR

Complete with Rotor

STOP! Don't throw out your electric clock just because the field coil has burned out. Replace the entire motor quickly, economically with this new one, which fits 90% of all electric clocks. Where it does not fit, use the field winding only, on the old lamination. The result is the same; new life for the clock. For use on 110 volts, 60 cycles only. Measures 2" in diameter.

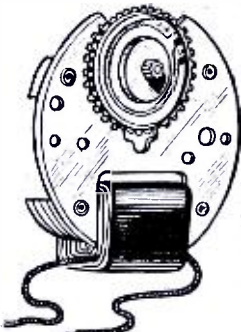

ITEM NO. 78 **49c**

YOUR PRICE

HUDSON SPECIALTIES CO. 40-R West Broadway, N. Y. C.

WE HAVE NO CATALOG. IT'S EASY TO ORDER—CLIP COUPON—MAIL NOW ORDER FROM THIS PAGE

HUDSON SPECIALTIES CO., 40-R West Broadway, New York, N. Y. RC-540

I have circled below the numbers of the items I'm ordering. My full remittance of \$..... (include shipping charges) is enclosed.

OR my deposit of \$..... is enclosed (20% required), ship order C.O.D. for balance. (New U.S. stamps, check or money order accepted.)

Circle Item No. wanted: 75, 76, 77, 78, 81, 82, 86, 87

Name Address

City State

Send remittance by check, stamps or money order; register letter if you send cash or stamps.

AMAZING!!

BLACK LIGHT

Powerful 300-Watt Ultra-Violet Bulb

The best and most practical source of ultra-violet light for general experimental and entertainment use. Makes all fluorescent substances brilliantly luminescent. No receivers or transformers of any kind are needed. Fits any standard lamp socket. Looks like ordinary light bulb except that it is made with special dark filter glass which permits nothing but ultra-violet rays to come through. Brings out beautiful opalescent hues in various types of materials—even non-fluorescent objects. Swell for amateur parties, plays, etc., to obtain unique lighting effects. Shp. Wt. 1 lb. Bulb only.



ITEM NO. 87 **\$2.00**

YOUR PRICE

SPECIAL

LITTLE GIANT MAGNET. Lifts 8 lbs. easily. Weighs 4 oz. Made of ALNICO new high-magnetic steel. Complete with keeper. Most powerful magnet ever made for size. Shp. Wt. 3/4 lbs.

ITEM NO. 86 **\$1.00**

YOUR PRICE

G.E. INDUCTION DISC MOTOR FOR RECORDING PLAYBACK AND DISPLAY PURPOSES

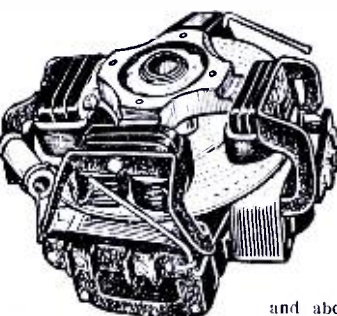

Substantially constructed to General Electric specifications, this ball-bearing motor was originally designed as a high-quality phonograph unit. Its power and smooth-running characteristics make it excellent for home recording work. Its speed, governor-controlled, is variable both below and above 78 r.p.m. Designed for use on 110 volts, 60 cycles, A.C. Sold less turn-table and shaft.

Overall dimensions are 7 1/2" diameter x 5 1/2" high. Shp. wt. 11 lbs. Packed in Original Box

ITEM NO. 81 **\$3.95**

YOUR PRICE

MOTOR FOR ROTATING RADIO BEAM ANTENNAS

One Revolution per Minute



Built by Honeywell as a temperature regulator for coal fired furnaces but ideal for many other uses, especially for rotating beam antennas on the roof for directional beaming and reception of radio signals. Built-in commutator switching permits turning antenna from north-south to east-west direction from a remote point. Substantially constructed for hard usage. Motor has double-ended shaft geared down to about one revolution per minute. Ideal for window displays and other slow-moving mechanical motions. 110 volts, 60 cycles, A.C. only. Overall size 6 1/2" x 6 1/2" x 4 1/2". Shp. Wt. 10 lbs.

ITEM NO. 82 **\$5.95**

YOUR PRICE

"WATER-GLASSING" STATION TABS

• AFTER replacing the tiny cardboard indicators in the pushbuttons of several of the newer radio sets several times I finally hit upon the stunt described below.

After placing the tiny cardboard with the station call letters on it in the slot, paint the cardboard with sodium-silicate solution (water-glass). Forget about the tiny celluloid strip that comes with some sets as these have been effective only in generating high-pressure profanity. They usually work out in about 3 days and leave the cardboard exposed. They also soon turn yellow and make the letters hard to see, especially when scratched by fingernails.

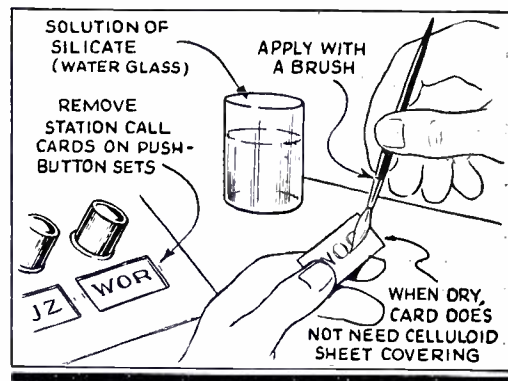

The water-glass solution is perfectly transparent and does not turn yellow. It acts as an adhesive and holds the indicator strips in place very nicely. It is applied in 1/10th the time needed to place the celluloid pieces in place. Twenty-five cents worth of sodium-silicate will be plenty for a year's supply.

R. M. HILTON,
Hilton's Radio Service,
Seattle, Wash.

LAMP BULBS AS RESISTORS

• ORDINARY lamps of the types commonly obtainable may be used to take the place of more expensive resistors. This is illustrated in the accompanying sketch, which shows the various uses to which the bulb idea may be put.

Of course, the resistance of the bulbs is not fixed, if the current through them should approximate that for which they were designed originally. That is, at first application of any voltage there will be a sudden rush of current, decreasing as the filament of the bulb warms up. When they are used as resistors of low-watts loading, the above condition will not be encountered.

EDISON SOCKET

TIP JACKS

LOW-RESISTANCE FIELD COIL

TO LAMP

USED AS REPLACEMENT FOR SPEAKER FIELD OF CHASSIS LESS OWN SPEAKER

120-VOLT LAMP	WATTS	OHMS
10	10	1,440
15	15	960
25	25	576
40	40	360
50	50	288
60	60	240
75	75	192
100	100	144

MIDGET RADIO SET

TO PWR. LINE

TO LAMP

USED AS REPLACEMENT FOR A.C.-D.C. LINE CORDS (EMERGENCY ONLY)

$R = E^2/W$

The resistances given in the table are for 120-volt lamps and this data is intended as only approximate. You must experiment to get just the right lamp for the particular application you wish.

WILLARD MOODY,
New York, N. Y.

Index to advertisers

MISCELLANEOUS

Classified Section	643-A
Lancaster, Allwine & Rommel	678
National Radio Parts Dis. Assoc.	643-A
Radio Servicemen of America, Inc.	688
Hotel Victoria	691

RADIO PARTS

Hammarlund Mfg. Company	653
Illinois Condenser Co.	657
International Resistance Co.	653
Solar Mfg. Company	651

PUBLIC ADDRESS EQUIPMENT

American Microphone Co.	673
Amperite Corporation	Back Cover
Amplifier Co. of America	667, 669
Erwood Sound Equipment Co.	675
John Meek Industries	675
Miles Reproducer Co.	678
Permo Products Corp.	669
RCA Manufacturing Co., Inc.	667
Recoton Corp.	674
University Laboratories	675
Utah Radio Products Company	670
Wright-DeCoster, Inc.	674

PUBLISHERS

Data Print Company	691
National Plans Institute	693
Radercraft Publications, Inc.	644, 690, 694
Radio & Technical Pub. Co.	689
Supreme Publications	643-A, 683, 689
Technifax	691, 693

RADIO SETS

Goldentone Radio Company	689
Meissner Mfg. Co.	643-B
E. H. Scott Radio Labs.	702

RADIO SUPPLY HOUSES

Allied Radio Corp.	687
Arrow Sales Company	669
Burstein-Applebee Company	699
Hudson Specialty Company	700
Lafayette Radio Corp.	685
Radolek Company	669, 691, 693, 699, 701
Wellworth Trading Company	678, 691, 699
Zack Radio Supply	678

SCHOOLS

Capitol Radio Engineering Institute	643-A
Lincoln Engineering School	643-A
National Radio Institute	641
National Schools	643-A
RCA Institutes, Inc.	643-A
Sprayberry Academy of Radio	643

TEST EQUIPMENT

Radio City Products Company	655
RCA Manufacturing Co.	652
Readrite Meter Works	662
Superior Instruments Company	658
Inside Back Cover	658
Supreme Instrument Corp.	657
Triplet Electrical Instrument Co.	662

TUBES

Hygrade Sylvania Corp.	683
National Union Radio Corp.	681
RCA Manufacturing Co.	Back Cover

(While every precaution is taken to insure accuracy, we cannot guarantee against the possibility of an occasional change or omission in the preparation of this index.)

ELECTRIC "SIGNAL CHASER"

AS regular readers of *Radio-Craft*, we sometime ago noticed J. C. Ravelle's signal tester in the February, 1939, issue and while pleased with the results we decided to electrify it. Mounted behind the service panel with 4 tip-jacks on the panel, it will be a useful addition to those shops which cannot afford the more elaborate "signal tracers." If a pronounced hum is heard, reverse the line plug.

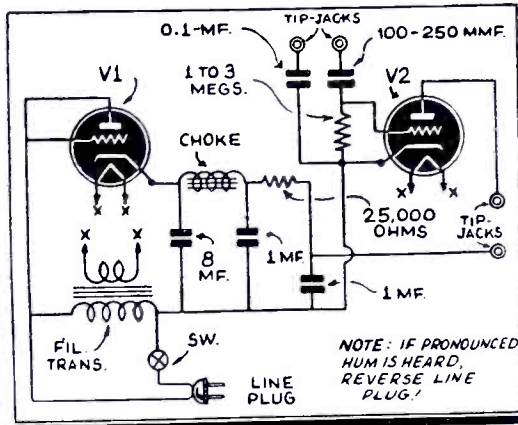

The circuit elements are described in more detail as follows:

V1, V2—any triode (27, 56, 37, 76, etc.); fil. trans.—2.5 V. or 6.3 V.; choke—midget filter or 1 winding of an A.F. transformer; 1—100 to 250 mmf. condenser; 1—25,000-ohm, 1-watt resistor; 1—0.1-mf. 300-V. paper condenser; 2—1 mf., 300 V. paper condensers; 1—8 mf. filter condenser; 1—3 meg. resistor.

CHARLES J. BOYLAN and TOM CLIFFORD,
Baltimore, Md.

COMBINED PICKUP, MICROPHONE AND SPEAKER

THE mechanical soundhead of the old phonograph is put to modern use by the addition of a magnet from a headphone, and a sound chamber. How these are added to the unit is clearly shown in the accompanying illustration.

When used as a phono pickup the mechanical vibrations of the sound lever induce electrical currents in the headphone magnet, the leads from which may go either to an amplifier or the audio amplifier section of a radio receiver. By reversing this process the output of a receiver can be fed to the leads of the magnet which in turn would cause the lever to vibrate and through the radio's connection to the diaphragm, produce sound. The sound is somewhat magnified by the sound chamber attached to the other side of the diaphragm.

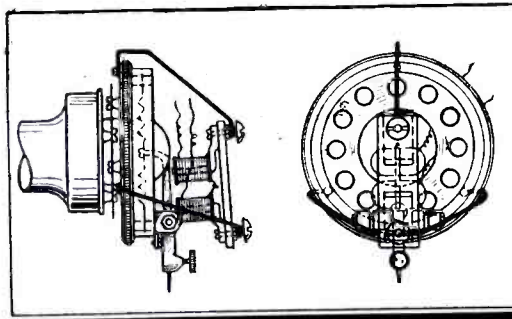

(Although it has not been tried, this device might be used for experimental home recording.) When used as a microphone one merely speaks into the sound chamber causing the diaphragm to vibrate—the vibrations being transmitted to the lever which in turn induces voltages in the electromagnet. The device works very well in all 3 applications mentioned.

N. BACRIA,
Bucharest, 6, Roumania.

Save Money!
With the
RADOLEK RADIO PROFIT GUIDE!



In the Radolek catalog you will find the MOST for your money! Lowest Prices! Best Quality! Biggest Values! Most Complete Stock! Fastest Service! Send for your FREE copy NOW!

OVER 15,000 REPAIR PARTS

The world's most complete stock of radio repair parts and exact duplicate replacements. All leading brands at lowest prices!

COMPLETE TUBE SELECTION

All types. RCA, Sylvania, Raytheon, Philco, etc. Includes Kellogg special Majestic and transmitting tubes. Complete selection.

NEWEST TEST INSTRUMENTS

The most complete line ever displayed in any catalog. All leading makes. Includes latest improved 1940 models at lowest prices.

GREATEST RADIO VALUES

A huge selection of money-saving set bargains! New Phono-Radio combinations. Automatic tuning sets. Beautiful cabinets. New "Ham" receivers and equipment.

EVERYTHING FOR AUTO RADIO

Complete new auto radio section. Includes vibrator replacement guide, new auto aerials, custom panel control plates for all autos.

COMPLETE P. A. SELECTION

New 1940 public address amplifiers from 5 to 100 watts. Complete P. A. Systems for permanent, mobile and portable use.

NEW ELECTRICAL APPLIANCES

Extra profits for you! Standard Brand Electric Irons, Stoves, Heaters, Percolators, Waffle Irons, Vacuum Cleaners, Trains, Clocks, Mixers, etc., at lowest prices!

FREE
Mail Coupon

The **RADOLEK Co.**

601 W. Randolph, Chicago, Dept. C41

Send the 1940 Radolek Radio Profit Guide FREE.

Name

Address
Serviceman? Dealer? Experimenter?

A MARVEL OF ADVANCED RADIO ENGINEERING

**THE NEW 1940
Custom Built
PHILHARMONIC**

By *Scott*

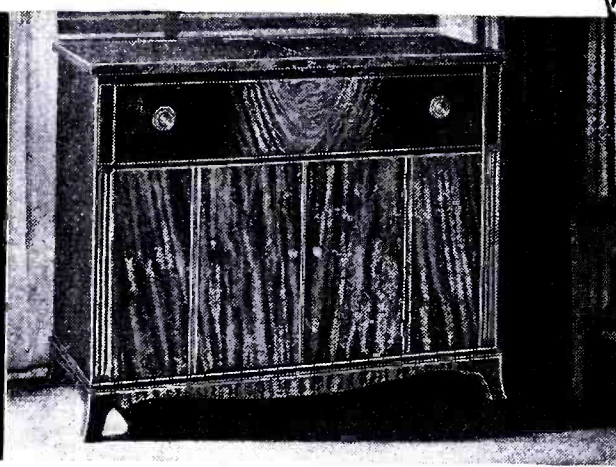

LONG acknowledged "the World's Finest Radio," the new 1940 custom built Scott rises to even greater heights of engineering development and performance. It is guaranteed to give you finer tone, clearer, quieter reproduction of broadcast or recorded music, higher fidelity, greater undistorted volume, wider long distance range—is laboratory built and tested with greater precision than any other radio receiver in the world, or your money will be refunded. A long and ever growing list of famous musicians (including Toscanini, Heifetz, Barbirolli) have honored the custom built Scott by choosing it above all others for personal use.

BUILT-TO-ORDER BY HIGHLY SKILLED TECHNICIANS

Skillful Scott technicians hand build these superb instruments from materials of finest quality, to the most exacting standards known to advanced radio engineering science. The result is an ability to perform that, to our knowledge, is more sensational than has ever been attained in radio or record reproduction. Yet the magnificent Scott can be yours for surprisingly little premium over many standard production instruments sold in retail stores.

EXCLUSIVE SCOTT DEVELOPMENTS

Many features available only in Scott receivers are developments of our own engineering laboratories. These are combined with the best general developments in advanced radio design. Here are a few of many desirable features: Record scratch suppressor • 6 noise reducing systems • undistorted Class A power output 40-60 watts • over-all fidelity 30 to 16,000 cycles • Continuously variable selectivity 2 to 16 KC • 6 wave bands 3.75 to 2,000 meters including ultra high frequencies.

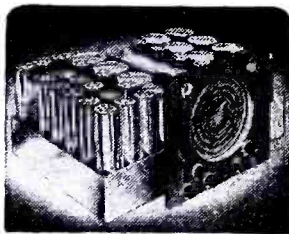

A FIVE YEAR GUARANTEE!

90 days is the standard guarantee adopted by the radio industry. The custom built Scott, however, is guaranteed for 5 YEARS! A full month allowed for home trial. Extended terms if desired (U.S.A. only). Sold only direct from our laboratories and studios. Get all amazing facts and details of savings you can make by ACTING NOW!

Special Offer :: Send for it NOW!

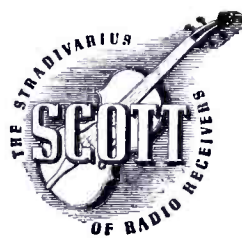

E. H. SCOTT RADIO LABORATORIES, INC.

4404 RAVENSWOOD AVENUE Dept. 24A40 CHICAGO, ILLINOIS
Send special offer, order blank, and all facts on new Scott Philharmonic, Phantom De Luxe, and Masterpiece models. Also send Scott Record Review. No obligation.

Name

Street

City State

STUDIOS: NEW YORK BUFFALO DETROIT CHICAGO LOS ANGELES

SERVICE MANUAL OF WIRING DIAGRAMS, compiled by M. N. Beitman (1940). Published by Supreme Publications. Size, 8½ x 11 ins., stiff paper cover. Price, \$1.95.

A new diagram manual last month was added to the branch of radio literature pioneered by the Gernsback "Official Radio Service Manuals" and the Rider "Perpetual Trouble Shooter Manuals."

The new manual, compiled by M. N. Beitman, totals 220 pages, plus index, and includes schematic circuits and in some cases service procedure on approximately 44 makes of sets.

It is important to note that this book is a compilation of the approximately 400 receiver models most frequently called for of the thousands of circuits which have appeared. In other words, if there is need for a circuit, the "odds" are that it has been included in this new manual.

THE OSCILLATOR AT WORK, by John F. Rider (1940). Published by John F. Rider Publisher, Inc. Size, 5½ x 8½ ins., cloth cover, profusely illustrated, 243 pgs. Price, \$1.50.

A basic element in superheterodyne broadcast receivers, television receivers, and servicing signal generators is the oscillator. The elementary oscillator circuits discussed in most text books have long been obsolesced and it is the more modern versions which are treated in great detail in John F. Rider's new book, "The Oscillator at Work." Elementary circuits are illustrated and described but merely to complete the presentation and to pave the way to an understanding of the more advanced circuits by student technicians.

Of outstanding importance is the fact that the entire book has been prepared primarily as a working reference for Servicemen. Hence it is of inestimable value to all practitioners.

This review would not be complete without paying special tribute to the 7-pg. bibliography which concludes the book.

A listing of its chapters illustrates the sequence of presentation: Oscillation; Complex Waves; How an Oscillator Works; Triode Oscillators; Electron-Coupled Oscillators; Ultra-Highfrequency Oscillators; Negative-Resistance Oscillators; Electromechanical Oscillators; Relaxation Oscillators; Modulation of Oscillators; Audio-Frequency Oscillators; Radio-Frequency Signal Sources; Testing and Servicing Test Oscillators; Receiver Checking with a Test Oscillator; Oscillators in Superheterodyne Receivers; Appendix.

TECHNIQUES OF RECORDING, by F. H. Goldsmith and V. G. Geisel (1939). Published by the Gamble Hinged Music Co. Size, 7 x 10½ ins., paper cover, 43 pgs., 16 illustrations. Price, \$1.25.

"The purposes of this book are manifold. To explain the 'why' of recorders; to create interest in recording and its applications; and, to furnish a source of information that heretofore has not been readily available, is our purpose. We have attempted to state facts briefly. When technical information promises to become too involved for the layman's easy understanding we suggest that he refer to texts on the particular subject concerned. If we succeed in doing no more than creating interest and furthering the study of any one of the many phases of recording, we have accomplished our purpose."

The above quotation from the author tells most of the story regarding "Techniques of Recording." We add: Clearly understandable illustrations make the text unusually understandable. Persons interested in disc recording are missing something if they do not read this book.

SERVICING SOUND EQUIPMENT, by James R. Cameron (4th Edition, 1940). Published by Cameron Publishing Co. Size, 5½ x 8 ins., cloth cover, profusely illustrated, 506 pgs. Price, \$7.50.

James R. Cameron, a well-known author of books for the projectionist, has completely revised his "Servicing Sound Equipment" in presenting the 4th Edition. This book is intended for those constructing, operating or servicing sound reproducing equipment—motion picture-radio-public address—as well as for those interested in the installation and servicing of television equipment.

The trouble-shooting charts, which over the past several years have met with such success, have all been revised and a great number of new charts added, several of these dealing with the installation and servicing of television equipment. Several new chapters have been added, dealing not only with actual servicing but also with the tools and instruments necessary for servicing.

THE VICTORY OF TELEVISION, by Philip Kerby (1939). Published by Harper & Bros. Size, 5½ x 8 ins., cloth cover, 120 pgs. Price, \$1.00.

The author of this book may not be well known to many readers of Radio-Craft, but Mr. Kerby has been very active in keeping the public informed of television activities. In "The Victory of Television" the author presents a non-technical approach in presenting a story for popular acceptance, as witness the following chapter titles: Early inventions; Television comes of age; Eye-view of modern television studio; Lighting, music, miscellaneous accessories; Television versus the theater, the cinema and radio; Sports and news broadcasts, political speeches, military maneuvers; Public service programs; Who pays?; Suggestions for solving the sponsor's problems; Whither television?; Appendices—(A) FCC Regulations, (B) Television Terms.

SIMPLIFIED FILTER DESIGN, by J. Ernest Smith (1939). Published by RCA Institutes Technical Press. Size, 8½ x 11 ins., heavy board covers, 64 pgs. Price, \$1.00.

A technician in the central office engineering laboratory of RCA Communications, Inc., here presents a short-cut method of solving problems of accurate filter design. Of inestimable value to practical design engineers, we wish to warn readers, however, that this book is not designed for the consumption of any but engineers.

Graphs enable accurate determination of composite-filter insertion loss without calculation; tables and charts permit insertion phase shift to be readily determined. If it is desired to use these filters between unequal impedances, an external network such as a transformer must be employed. Typical filter design illustrations are included to clarify the use of the graphs, formulas and tables.

"RCA Preferred Tube Program ... Best News in Years for Dealers and Service Men!"

...says *John F. Rider*

"It has been extremely difficult to keep track of the number of receiving tubes in recent years. It's a situation that's driven dealers wild and made servicing more difficult and more costly. The RCA idea to reduce tube types will ease this condition... fewer tube types in sets means a better replacement tube market and easier servicing. It should result in better service for customers... and more rapid turnover of service shop tube inventory. All in all it's a real constructive step in making the tube business more profitable and easier to operate."

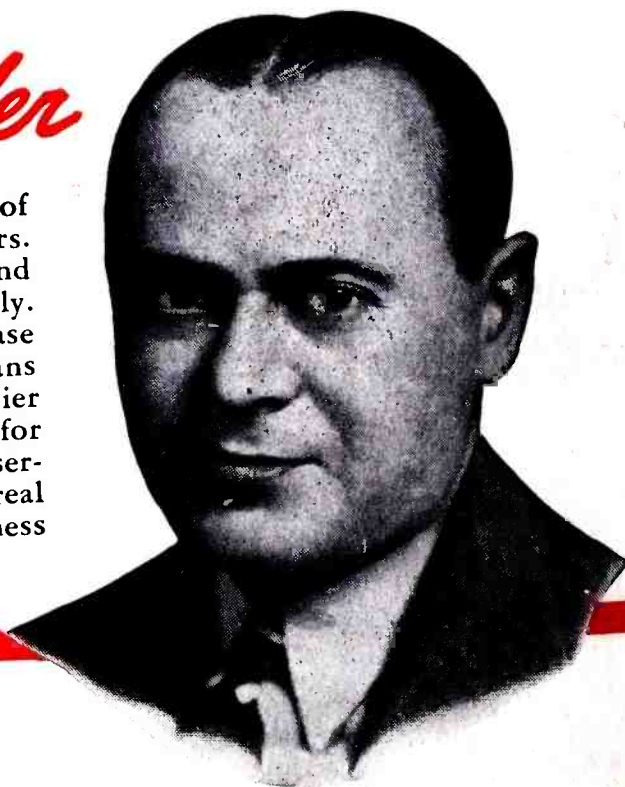

Less than one type in ten of the 470 types of radio receiver tubes now on the market is actually needed to design practically every type of radio receiver at the lowest ultimate cost. RCA has outlined a program of Preferred Type Tubes which cannot help but materially benefit every concern and individual associated with tube sales.

NOW JOHN RIDER speaks up for the RCA plan to reduce tube types! Every dealer knows John... every service man knows John... in fact the whole radio industry respects him

as the leading figure today in the service field.

John Rider voices the approval of thousands of dealers and service men. Prominent manufacturers are expressing the enthusiasm of the radio makers. And from distributors comes an overwhelming endorsement.

There's no doubt about it... the RCA Preferred Type Tubes Program means better times ahead for the whole industry. And you can count on RCA to make every effort to see that the full benefits of this program are realized for the industry as quickly as possible.



Radio Tubes

RCA Manufacturing Company, Inc., Camden, N. J. • A Service of the Radio Corporation of America