

RADIO-CRAFT

HUGO GERNSBACK, *Editor*



STENCILS BY FACS

See
Page 578

STREAMLINED!



FLAME="A-B" POWER!



SHOP BENCH A LA MODE



RADIO WAKENER

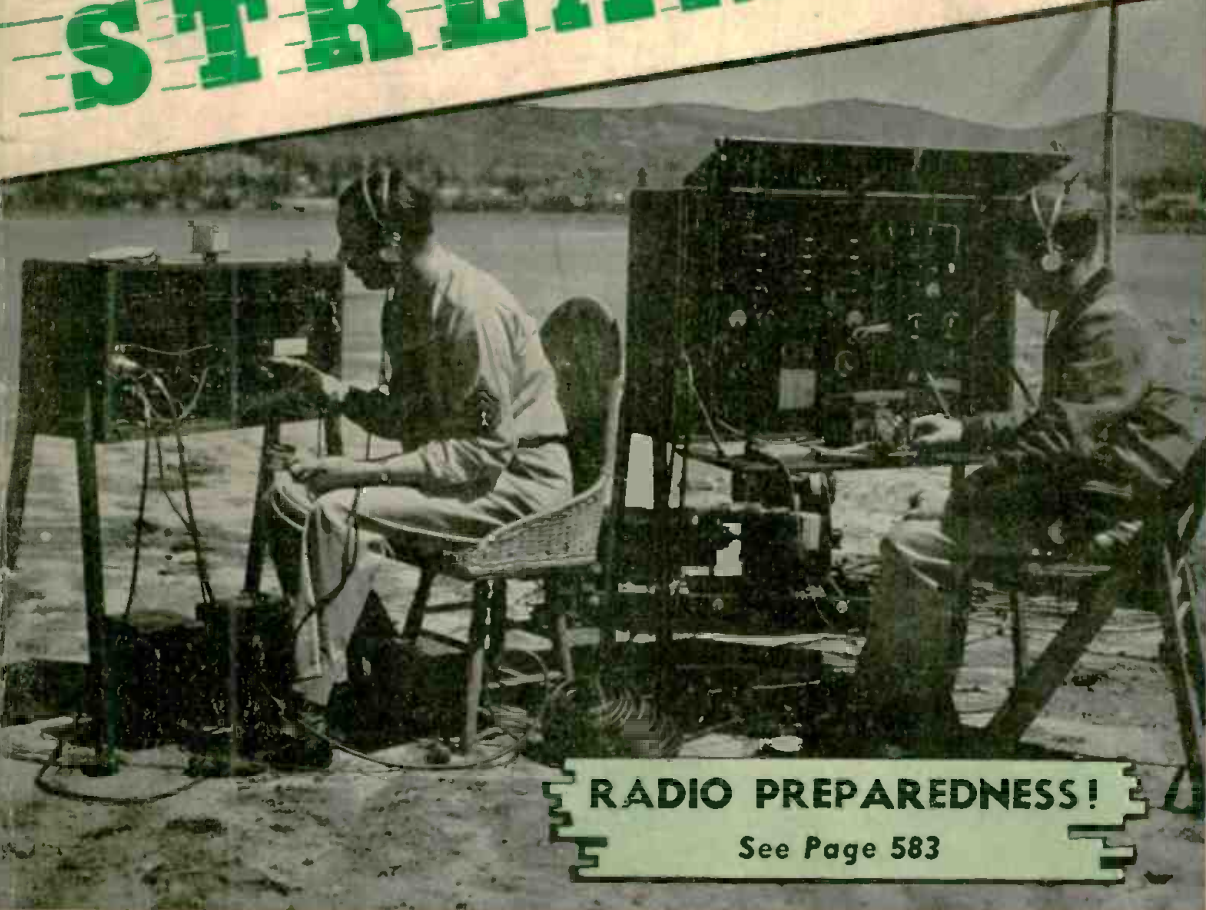

RADIO PREPAREDNESS!

See Page 583

APRIL 25c IN U.S. AND CANADA
RADIO'S GREATEST MAGAZINE
2-TUBE FARM SET • THE ABC OF Db., VU, Mu, Va, Gm, AND Sm
HIGH-FIDELITY RECORDING — PLAYBACK AMPLIFIER • NEW TUBES
www.americanradiohistory.com



THREE STAR RADIO VALUE

You receive valuable subscription to **RADIO-CRAFT**
PLUS A FREE COPY of 1940 Radio-Television Reference Annual

WITH our compliments, we want to send a copy of the 1940 RADIO-TELEVISION REFERENCE ANNUAL to you FREE. If you will simply take advantage of RADIO-CRAFT magazine's special subscription offer NOW. This offer is being made for a limited time only.

The 1940 RADIO-TELEVISION REFERENCE ANNUAL has 68 pages, large size 8 1/2 x 11 1/2, with over 170 illustrations. The contents of this book has never appeared before in handy book form. Its pages cover practically every branch of radio sound, public address, servicing, television, construction articles for advanced radio men and technicians, time and money-saving kinks, wrinkles, useful circuit information, "ham" transmitters and receivers, and a host of other data.

The Annuals have always been regarded as a standard reference work for every practical branch of radio operation and service. This 1940 edition ably sustains this reputation. Every radio man wants a copy of this valuable book. Just as this book will be of unquestionable value to you, so, too, will every monthly issue of RADIO-CRAFT. This magazine brings you big value every month. It keeps you intelligently informed about new developments in radio and television. You want the news, want it fully but concisely, want it first—that is why you should read RADIO-CRAFT regularly.

This very special offer is made for just one purpose—we want you as a regular subscriber. The Annual, whose contents appears at the right, is not sold, but a copy is FREE to you if you subscribe now.

**SAME SIZE AS
RADIO-CRAFT**

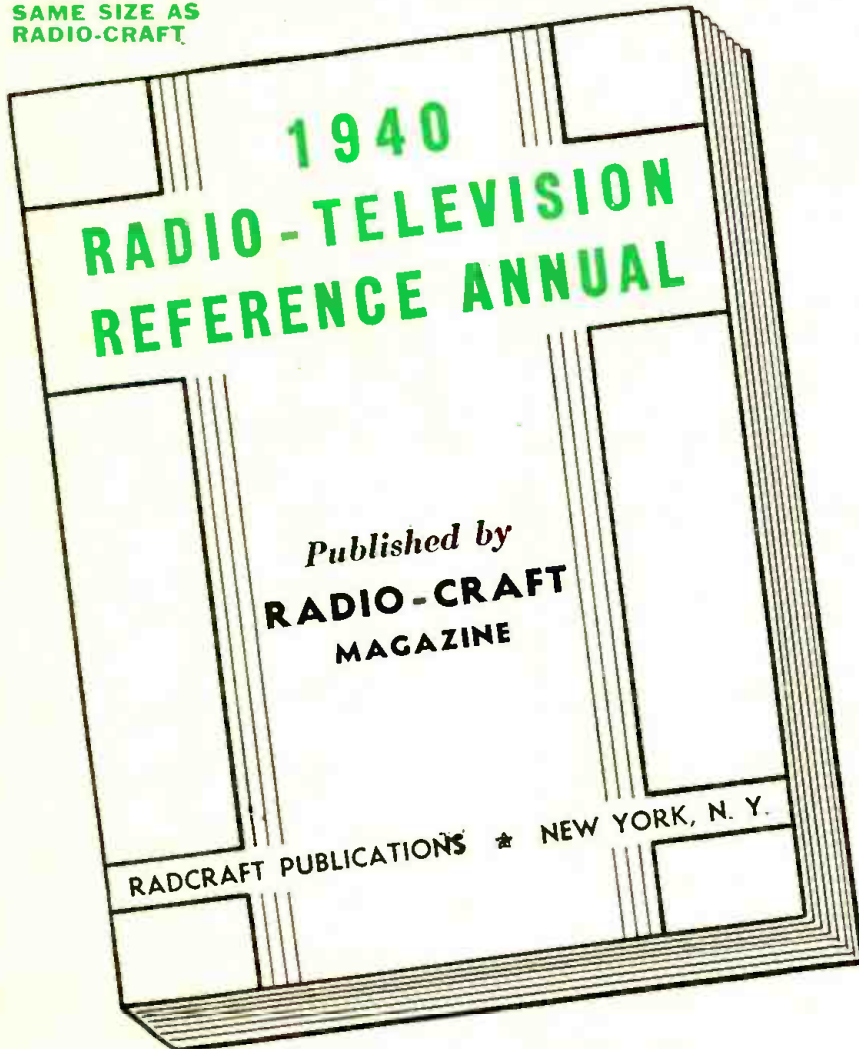

THIS COUPON BRINGS YOU THE ANNUAL

RADIO-CRAFT • 99 HUDSON STREET • NEW YORK, N. Y.

Gentlemen: Enclosed you will find One Dollar for which enter my subscription to RADIO-CRAFT Magazine for Eight Months. Send me **ABSOLUTELY FREE** and **POSTPAID**, my copy of 1940 RADIO-TELEVISION REFERENCE ANNUAL.

This is a new order Extend My Present Subscription

NAME ADDRESS

CITY STATE

DON'T DELAY — MAIL TODAY! RC-440

**Read the summary of contents
in this FREE BOOK!**

THE 1940 RADIO-TELEVISION REFERENCE ANNUAL contains a collection of the best and most important articles. Covering as they do nearly every branch of radio, they form a handy reference works. In addition, many time and labor-saving kinks, circuits and wrinkles, tried and tested by practicing Servicemen, experimenters and radio fans have been included. This book cannot be bought anywhere at any price. Yet it is yours by merely subscribing. Use the convenient coupon below.

BEGINNER'S SIMPLE INEXPENSIVE CONSTRUCTION ARTICLES

Beginner's Breadboard Special - a 1-Tube High-Gain All-Wave Receiver—Wiring Pointers for Radio Beginners—A Watch Charm Size 1-Tube Set—Beginner's Simple Volt-Millammeter—Making a 1-Tube Broadcast Loop Receiver—A.C.-D.C. Power Supply for Battery Portables—A 1-Tube Short-Waver with Band Coil Switching.

MORE ADVANCED SET CONSTRUCTION

The "High-Sea" 4" Broadcast Lamp Radio—How to Build a 6-Tube 1.4-Volt Short-Wave Superhet for the "Ham" or Short-Wave Fan—Build the "Lunch Box 5" Super Set - a Broadcast Battery Portable—How to Build a Plug-Together 8 Tube Broadcast Set—The "5-In-1" All-Wave Radio for A.C. Operation—An Easily-Built 3-Tube Midset Broadcast Superheterodyne Receiver.

THE SERVICEMEN'S SECTION

Bass Tone Control—Simplified Variable Selectivity—Practical Servicing Pointers—Servicing Universal A.C.-D.C. Receivers—Killing the "Intermittent" Bug—A Service Shop A.C. to D.C. Power Supply—Sideline Money for Servicemen—Adding A.V.C. to any Screen-Grid T.R.F. Receiver—Iron Particles in Speaker Air Gap.

TEST INSTRUMENTS

A Useful Neon Lamp Tester—An Inexpensive Output Meter—Making Millammeter Multipliers—Home-Made Frequency Modulator—The Busy Servicemen's V.T. Volt-Meter.

PUBLIC ADDRESS AND AMPLIFIERS

Build this Combination A.C.-D.C. Radio and Inter-Communicator—Speaker Placement in P.A. Work—The Design and Construction of an Inexpensive All-Push-Pull 10-Watt Amplifier—Obscure Sources of Hum in High-Gain Amplifiers—How to Build a High-Fidelity 5-Watt Versatile Amplifier.

"HAM" SECTION

Ultra-High Frequency Antennas—The Beginner's Low-Cost Xmitter—Modulator Meter—Phono Monitor—The Beginner's "Ham" Receiver—2 1/2 Meter Acorn Transceiver.

TELEVISION

How to Build a 441 Line T.R.F. Television Receiver—Useful Notes on Television Antennas.

MISCELLANEOUS

Simple Photo-Cell Relay Set Up—Making a Burglar Alarm—How to Build A.C.-D.C. Capacity Relay—How to Make a Modern Radio Treasure Locator.

USEFUL KINKS, CIRCUITS AND WRINKLES

Making a Flexible Coupler—Two-Timing Chime—A Simple Portable Aerial—An Improvised Non-Slip Screw-Driver. NOTE: The book contains numerous other useful Kinks, Circuits and Wrinkles, not listed here.

(approximately)

45 ARTICLES

(approximately)

170 ILLUSTRATIONS

68 BIG PAGES

**RADIO-CRAFT
99 HUDSON STREET
NEW YORK, N. Y.**



*I Jumped from \$18 a Week to \$50
-a Free Book started me toward this
GOOD PAY JOB IN RADIO*

*Here's
How it
Happened*
by S. J. E. NAME AND ADDRESS
SENT UPON REQUEST



"I had an \$18 a week job in a shoe factory. I'd probably be at it today if I hadn't read about the opportunities in Radio and started training at home for them."



"The training National Radio Institute gave me was so practical I was soon ready to make \$5 to \$10 a week in spare time servicing Radio sets."

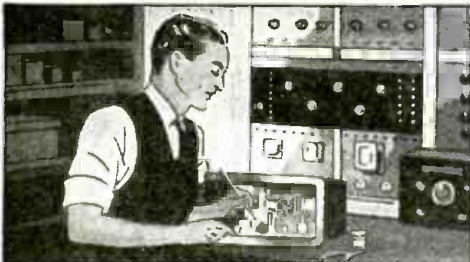

"When I finished training I accepted a job as serviceman with a Radio store. In three weeks I was made service manager at more than twice what I earned in the shoe factory."



"Eight months later N. R. I. Employment Department sent me to Station KWCR as a Radio operator. Now I am Radio Engineer at Station WSUL. I am also connected with Television Station W9XK."

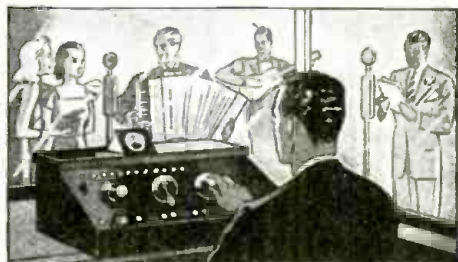

"N. R. I. Training took me out of a low-pay shoe factory job and put me into Radio at good pay. Radio is growing fast."

Find out today how I Train You at Home
to BE A RADIO TECHNICIAN



J. E. SMITH, President
National Radio Institute
Established 25 Years

Radio is a young, growing field with a future. It offers you many good pay spare time and full time job opportunities. And you don't have to give up your present job, go away from home, or spend a lot of money to become a Radio Technician. I train you right at home in your spare time.

Why Many Radio Technicians Make \$30, \$40, \$50 a Week

Radio broadcasting stations employ engineers, operators, technicians and pay well for trained men. Radio manufacturers employ testers, inspectors, foremen, servicemen in good-pay jobs with opportunities for advancement. Radio jobbers and dealers employ installation and service men. Many Radio Technicians open their own Radio sales and repair businesses and make \$30, \$40, \$50 a week. Others hold their regular jobs and make \$5 to \$10 a week fixing Radios in spare time. Automobile, police, aviation, commercial Radio; loud-speaker systems, electronic devices, are newer fields offering good opportuni-

ties to qualified men. And my Course includes Television, which promises to open many good jobs soon.

Many Make \$5 to \$10 a Week Extra in Spare Time While Learning

The day you enroll, in addition to my regular course, I start sending you Extra Money Job Sheets which start showing you how to do actual Radio repair jobs. Throughout your training I send plans and directions which have helped many make from \$200 to \$500 a year in spare time while learning.

I Also Give You This Professional Set Servicing Instrument



Here is the type of instrument Radio Technicians use—an All-Wave Set Servicing Instrument. It contains everything necessary to measure A.C. and D.C. voltages and current; to check re-

sistances; adjust and align any set, old or new. It satisfies your needs for professional servicing after you graduate—can help you make extra money fixing sets while learning.

Sample Lesson and 64-Page Book Free

Act today. Mail coupon now for sample Lesson "Radio Receiver Troubles—Their Cause and Remedy" and 64-page Book "Rich Rewards in Radio." They're FREE. They point out Radio's spare time and full time opportunities and those coming in Television; tell about my course in Radio and Television; show many letters from men I trained, telling what they are doing and earning. Read my money back agreement. Find out what Radio offers you. Mail coupon in envelope or paste on penny postcard—NOW.

J. E. SMITH, President
Dept. ODX, National Radio Institute
Washington, D. C.

**MAIL THIS NOW
Get 64 Page Book Free**

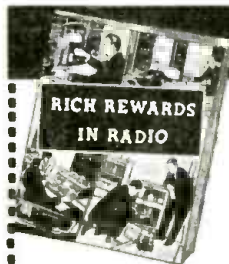

J. E. SMITH, President, Dept. ODX,
National Radio Institute
Washington, D. C.

Dear Mr. Smith: Mail me FREE, without obligation, your Sample Lesson and 64-page book "Rich Rewards in Radio" which tells about Radio's spare time and full-time opportunities and explains your 50-50 method of training men at home to be Radio Technicians. No salesman will call. (Please write or print plainly.)

Name AGE

Address

City State

14X1

A Tested Way to Better Pay

RADIO-CRAFT

HUGO GERNSBACK, *Editor-in-Chief*

N. H. LESSEM
Associate Editor

THOS. D. PENTZ
Art Director

ROBERT EICHBERG
Trade Digest Editor

R. D. WASHBURNE, *Managing Editor*

Contents APRIL, 1940 Issue VOLUME XI -- NUMBER 10

Mailbag	579
Editorial: Stabilizing the Radio Industry.....Hugo Gernsback	581
The Radio Month in Review	582

SERVICING

New Circuits in Modern Radio Receivers—No. 31F. L. Sprayberry	589
A.C. Power for Battery Portables	591
Servicing Questions & Answers	592
Servicing Puzzlers—No. 4 (Conclusion)	593
Servicing "Orphans" and Private-Brand Sets—Part IICharles R. Leutz	594
RADIO SERVICE DATA SHEETS:	
No. 274—Montgomery Ward & Co. "Airline" Models 93BR-420B, 93BR-421B, 93BR-423B, 93BR-424B, 93BR-431B	598
No. 275—Howard Models 308APC, 308C and 308TT	599
Dynamic Testing Simplifies Servicing	601
9 New Tubes	617

TEST INSTRUMENTS

Dynamic Testing Simplifies Servicing.....Harold Davis	601
---	-----

SOUND

A Low-Cost Pushbutton Amplifier for Recording and PlaybackA. C. Shaney and H. A. Fogel	604
Sound Engineering—No. 4.....Conducted by A. C. Shaney	609
Case Histories of P.A. Sales—No. 7.....	611
The ABC of Db., VU, Mu, Va, Gm and Sm.....H. S. Manney	615

TELEVISION

Converting a 5-Inch Telly Kit for Receiving a 9-Inch Image— Part III (Conclusion)	612
--	-----

ELECTRONICS

The ABC of Db., VU, Mu, Va, Gm and Sm.....H. S. Manney	615
9 New Tubes.....R. D. Washburne	617

RADIO DEVELOPMENTS

Radio Coordinates Emergency Power-Repair Service.....	620
Inter-College Wired-Radio Network.....N. H. Lessem	622
Stencil-Cutting by Facsimile	624
Flame Generates "A," "B" and "C" Power.....	625

EXPERIMENTERS

Serviceman Earns Extra Money Building 2-Tube Farm SetRoger Dickey	628
--	-----

CONSTRUCTION ARTICLES

Complete Construction Data on an Ultra-Modern Service Bench.....C. Rask Latimer	585
--	-----

In the NEXT ISSUE!

- The Elements of Sound-on-Disc Recording
- Camera-Case 1-Tube Portable
- How One Sound Man Drums Up Business
- How to Make a Hearing-Aid Using New Miniature Tubes
- Design of a 60-Watt Direct-Coupled Amplifier
- New Tubes

A Low-Cost Pushbutton Amplifier for Recording and PlaybackA. C. Shaney and H. A. Fogel	604
Converting a 5-Inch Telly Kit for Receiving a 9-Inch Image— Part III (Conclusion).....Charles Sicuranza	612
Serviceman Earns Extra Money Building 2-Tube Farm SetRoger Dickey	628

DEPARTMENTS

The Radio Month in Review.....	582
New Circuits in Modern Radio Receivers—No. 31F. L. Sprayberry	589
Servicing Questions and Answers.....	592
RADIO SERVICE DATA SHEETS:	
No. 274—Montgomery Ward & Co. "Airline" Models 93BR-420B, 93BR-421B, 93BR-423B, 93BR-424B, 93BR-431B	598
No. 275—Howard Models 308APC, 308C, 308TT	598
Sound Engineering—No. 4.....Conducted by A. C. Shaney	609
Case Histories of P.A. Sales—No. 7.....	611
Latest Radio Apparatus.....	629
Shop Notes—Kinks—Circuits.....	635
Radio Trade Digest.....	631



STREAMLINED!

You have in your hands the first issue of *streamlined Radio-Craft*. The contents, scope of articles, monthly departments and features remain the same—but the manner in which these are laid out, the sequence in which they are presented, and the method of their continuity, have been so altered as to make the magazine easier and more convenient to read. All articles have been departmentalized. The practice of continuing a story from the front of the book to the rear has (except in unavoidable instances) been entirely eliminated. Continuity of articles has been made smooth and uninterrupted. We hope that you will like the new *Radio-Craft*.

Our thanks to those of our readers who have taken the time and bother to suggest various changes in *Radio-Craft's* physical make-up.



Published by Radcraft Publications, Inc. Publication office: 29 Worthington Street, Springfield, Mass. Editorial and Advertising Offices: 99 Hudson Street, New York City, Chicago Advertising Office: RADIO-CRAFT, 520 North Michigan Avenue, Chicago, Ill.

RADIO-CRAFT is published monthly, on the first of the month preceding that of date; subscription price is \$2.00 per year in U. S. and Canada. (In foreign countries, \$2.50 a year to cover additional postage.) Entered at the post office at Springfield as second-class matter under the act of March 3, 1879.



Foreign Agents:

London—Gorrings's American News Agency, 9A Green St., Leicester Square, W. C. 2, England.
Paris—Messageries Dawson, 4 Rue Faubourg, Poissonniere, France.
Melbourne—McGill's Agency, 179 Elizabeth St., Australia.
Dunedin—James Johnston, Ltd., New Zealand.



Text and illustrations of this magazine are copyright and must not be reproduced without permission of the copyright owners.



Copyright 1940 Radcraft Publications, Inc.

•MAILBAG•

RE: ALLAN STUART TREASURE LOCATOR

Dear Editor:

● IN your Sept. 1939 edition you published a modern Radio Treasure Locator by Allan Stuart. I built this locator but cannot get any results from it.

I built the transmitter and tuned it to my radio set at 700 kc. which is WLW. Then I built the receiver and took the receiver and loop frame about 15 feet away from the transmitter and turned the transmitter on and tuned the receiver for loudest signal, then I mounted the transmitter and receiver on the carrying frame as shown in the magazine. When I turn on the transmitter and receiver the receiver picks up the signal.

I have tried putting the transmitter in various positions on the frame but cannot get all the noise out of the receiver, also when I walk between the handles with the earphones on, the noise gets louder, and I cannot tell any difference when I get over metal except when I get about a foot from a large piece of metal; it will then cut off and I cannot hear anything. I built the transmitter and receiver just as you said but I did not use the microammeter (which I did not think was necessary as I could go by the sound in the earphones). I would appreciate if you could send me any information regarding this trouble so I can get it straightened out.

ARTHUR G. RICKENBACKER,
Cameron, S. C.

This and several other letters were sent to Allan Stuart, resulting in the following communication:

Dear Editor:

● SINCE the gist of the complaints on the Treasure Locator seem to be mainly about instability, noise and poor meter deflection, I have made some changes in the original receiver circuit which should clear up these troubles. The transmitter remains unchanged.

These changes and additions are enumerated as follows:

- (1) Put a tube shield on all 3 tubes.
- (2) Line the inside walls and bottom of the receiver box with tin-foil. The edges of the tin-foil should touch the receiver panel, thus forming a shielded box.
- (3) The I.F. transformers are decoupled to prevent oscillation.
- (4) The receiver loop frame may be covered with tin-foil on all 4 sides leaving only the bottom edge exposed. This will help the "minimum tone" condition.
- (5) More complete control of sensitivity

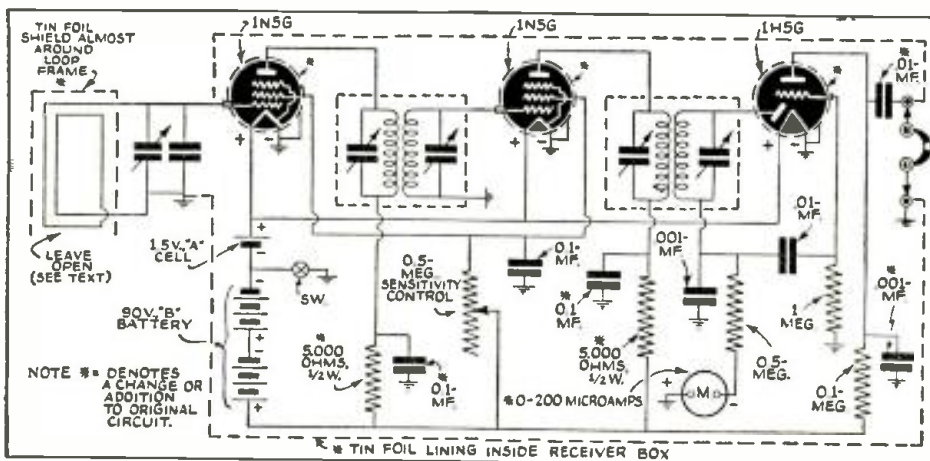

Diagram showing changes in original Treasure Locator Circuit.

is afforded by the change to a 0.5-megohm potentiometer in the screen-grid circuit.

(6) The microammeter has been changed to the ground end of the diode load resistor. In this position it indicates average carrier amplitude rather than the change in plate current caused by the modulated note. Thus when passing over barren ground the received carrier is weak, the diode current is nil and the meter reads zero. When the reflected wave is strong the diode current rises proportionately and the meter reads upwards according to the strength of the carrier, regardless of modulation.

(7) To prevent I.F. currents on the audio plate from getting out via the phones and causing overall regeneration, a mica condenser of 0.001-mf. is placed from plate to ground.

(8) To further isolate causes of feedback, the phone circuit is made "cold" at one end by grounding one tip-jack and blocking the D.C. through the phones with a 0.01-mf. condenser.

(9) It is important to note that the minus side of each filament be grounded. The plus side is then 1.5 volts positive with respect to its grid thus giving the grid a bias of -1.5 volts. If this is not done the receiver circuit may oscillate or block, as one complaint stated.

(10) Finally, when all these changes have been made, should these troubles persist it is advisable to remove one of the oscillator tubes from the transmitter. This will cut down the radiated power to one-half and make it easier to control the received wave.

The enclosed schematic (reproduced here —Editor) has been marked by asterisks to show each of the changes mentioned above.

ALLAN STUART.

EXPERIMENTAL ELECTRONIC ORGAN

Dear Editor:

Since my article (March, 1940 issue) was submitted, it has been found that curved vanes improve the blower. Description of an inexpensive wheel with curved vanes built by a friend, Allan Bertram, is enclosed. After performance of this blower, I consider it an error to advise anyone to build a straight-bladed one.

Material required to build this blower is as follows: 1 face plate for a wood-turning lathe (50 to 75c); 5 pieces of 3-ply wood, 9 ins. dia. (not necessarily absolutely circular); a 1-gal. oil can, approx. 7 ins. in dia.

The procedure is as follows: Drill, to start saw blade, and cut with coping saw 2 pieces of the 3-ply at the same time, with

I'LL SHOW YOU HOW TO MAKE REAL MONEY IN RADIO AND TELEVISION



New Practical HOME TRAINING fits you quickly

YOU GET PROFESSIONAL TEST EQUIPMENT plus EXPERIMENTAL OUTFITS!

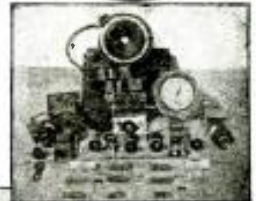

146 RADIO PARTS RADIO TOOLS All-Purpose, All-Wave ANALYZER



I'LL PROVE THAT YOU CAN HAVE

A GOOD JOB IN RADIO . . . OR A BUSINESS OF YOUR OWN

I offer you a new and altogether different type of practical Training for a money-making career in Radio and Television. No matter if you desire to BE YOUR OWN BOSS in your own business, or hold down a good job in Radio, my Personalized Training will give you the useful knowledge to win success.

EASY TO LEARN—EARN FROM THE START
YOU DO PRACTICAL EXPERIMENTS with real Radio Equipment with your own hands. Thus the principles of Radio become crystal-clear to you. The valuable spare-time BUSINESS BUILDERS I supply will show you how to put this knowledge to work in handling Profitable Radio service jobs while learning.

NO PREVIOUS EXPERIENCE NEEDED

It makes no difference what your education has been. My Training starts at the beginning of Radio, covers in a simple understandable style all essential subjects including Television, Electronics, Facsimile Radio, Radio Set Repair and Installation.

READ WHAT THIS STUDENT SAYS

Earned \$250. Since Starting Course
"I have only completed one third of the Sprayberry Course and I find it very interesting, which makes it easy to learn. By devoting several hours spare time daily to studying and servicing I have made about \$250 gross since starting the Course." Earl W. Hostetter, B. No. 4, Lebanon, Pa.

SERVICEMEN

I offer Advanced Training for those already in Radio. Get complete details in my FREE 52-page Book.

REMEMBER—THE SPRAYBERRY COURSE IS SOLD UNDER A MONEY-BACK AGREEMENT

RUSH THIS COUPON FREE for BIG FREE BOOK

DON'T DELAY! ACT NOW!

SPRAYBERRY ACADEMY OF RADIO
F. L. Sprayberry, Pres.
320-D University Place, N.W., Washington, D.C.
Please send me FREE copy of "HOW TO MAKE MONEY IN RADIO."

Name Ago

Address

City State

Tear off this coupon, mail in envelope or paste on penny postcard. Servicemen—Check here

EXPERIENCE ALONE DOES NOT ASSURE SUCCESS



● Experience PLUS Technical Training Prepares You for Advancement in **RADIO & TELEVISION ENGINEERING**

Years of experience on a routine job does not in itself prepare a man for a more advanced position. Radio, Facsimile, Television... are offering constant new opportunities through new developments. But, experience alone cannot qualify you for a job that demands ability based on specialization and modern training. The better job that you want must be earned in your spare time. Hundreds of men in every branch of the radio industry are improving their knowledge and jobs by training in their spare time. CREI home-study courses prepare you for a definite career by backing up your experience with modern technical training.

Write for Your Free Copy of "The CREI Tested Plan"

Please give Education and Present Position

CAPITOL RADIO Engineering Institute

Dept. RC-4, 3224-16th St. N. W., Washington, D. C.

RADIO plus TELEVISION -mastered by pre-tested Training

No matter where you are or what you do, National has a complete training plan for you—to fit your circumstances. National's plan is for those seeking immediate on-the-job training as well as for those who cannot give up present employment and income. Mail coupon for FREE literature.

NATIONAL SCHOOLS

NATIONAL SCHOOLS, Dept. RC-4
4000 So. Figueroa St., Los Angeles, Calif

Please send free literature and full details

NAME _____ AGE _____
ADDRESS _____
CITY _____ STATE _____

LES Correspondence Courses in RADIO and ELECTRICAL ENGINEERING

ELECTRICAL ENGINEERING Get good grasp of wide electrical field. Prepare yourself, at Low Cost, for secure future. Modern, simplified, you can understand quickly.

RADIO ENGINEERING Extra fine course in radio, public address, photo-electric work, train you to be super-service man, real vacuum tube technician. Exper. kits furnished. Diploma on completion. Tuition, \$25. either course. Deferred payment plan. Get copies of school catalogs, student magazines, complete details. **SEND NOW!**

FREE

LINCOLN ENGINEERING SCHOOL, Box 521-C16, LINCOLN, NEBR.

RADIO TECHNOLOGY

RCA Institutes offer an intensive course of high standards embracing all phases of Radio and Television. Practical training with modern equipment at New York and Chicago schools. Also specialized courses and Home Study Courses under "No obligation" plan. Catalog Dept. RC-40.

RCA INSTITUTES, Inc.
A Radio Corporation of America Service
75 Varick St., New York, 1154 Merchandise Mart., Chicago

RADIO DIAGRAMS

Any circuit diagram for all radio sets. To help you service radios. Specify manufacturer and model number. Only 25c each. Guarantee immediate shipment.

25c

SUPREME PUBLICATIONS 3729 W. 13th St. Chicago, Illinois

the natural curve of the can, beginning 1/4-in. from the circumference and finishing 1 1/2 ins. from the center. Use 8 blades, starting each cut on a radius containing the inner end of the preceding cut. Assemble as shown and glue, being sure both end pieces

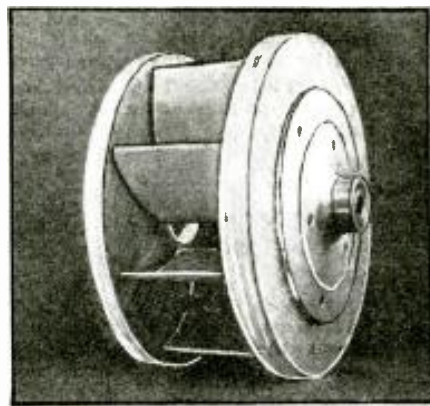
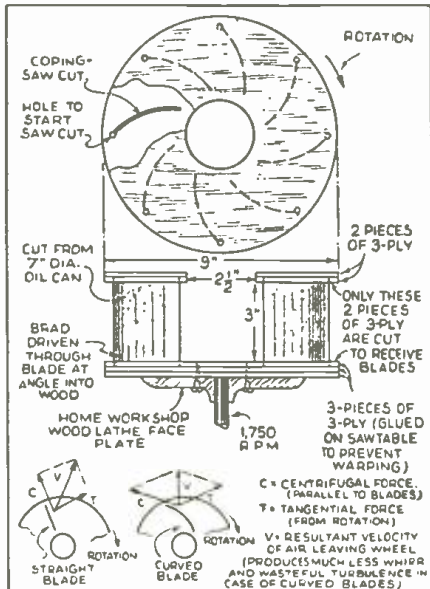

are the same distance apart all the way around, and leave clamped to a steel sawtable for 24 hrs. while drying, because no warping can be tolerated.

Mount on motor and turn true with chisel and turn out 2 1/2-in. hole. Perfect balance is very important. Mount face with hole about 1/8-in. from flat side of windchest (outboard) with hole of same diameter.

Incidentally, the following comments on the article itself may clear up one or two slight discrepancies which appeared. In Fig. 11, pg. 522, the piano is not visible. In Fig. 4 (facing page), a rear view of the console is shown. The Quebec (Can.) firm mentioned at the top of pg. 523 is Casavant Frères. Disadvantages 1 and 2, listed in the box on pg. 522, do not matter when this organ is combined with a simple electron-tube oscillator type which is very fast in attack and very auto-like in tone.

W. K. ALLAN,
Calgary, Alberta, Canada.

PRIZE WINNERS

Dear Editor:

I wish to thank you and Amperite Co. for the Microphone, 7th Prize awarded in the Third Section of your P.A. contest.

I have been a reader of your magazine since 1932, and have all of the copies on file for ready reference. I find this is important in keeping abreast with the latest

OPPORTUNITY AD-LETS

Advertisements in this section cost five cents a word for each insertion. Name, address and initials must be included at the above rate. Cash should accompany all classified advertisements unless placed by an accredited advertising agency. No advertisement for less than ten words accepted. Ten Percent discount for six issues, twenty percent for twelve issues. Objectionable or misleading advertisements not accepted. Advertisements for May, 1940, issue must reach us not later than March 6th.

Radio-Craft • 99 Hudson St. • New York, N. Y.

AGENTS WANTED

300% PROFIT SELLING GOLD LEAF LETTERS FOR store windows; Free samples. Metallic Company, 431 North Clark, Chicago.

BOOKS AND MAGAZINES

ASSURE YOURSELF OF GREATER PROFITS by doing radio service jobs more quickly. Authentic service guides show you the way to locate and correct troubles in any radio receiver. Gernsback Official Radio Service Manuals show you how to complete more repair jobs in less time—how to earn more money by faster servicing. Read the advertisement which appears on page 580 of this issue.

WE HAVE A FEW HUNDRED RADIO ENCYCLOPEDIAS, by S. Gernsback, second edition, originally sold at \$3.98. Book has 352 pages, weight 3 lbs., size 9 x 12 inches. Red morocco—keratol flexible binding. Send \$2.49 in stamps, cash or money order and book will be forwarded express collect. Technifax, 1915 So. State Street, Chicago, Illinois.

CAMERAS & SUPPLIES

BULK FILM: 100 FT. 8MM. \$9.00; DOUBLE, \$1.60; 16 mm., \$1.20. Titles or Pleures. Chemicals, outfits. Big catalogue for mamp. Hollywoodland Studios, South Gate, Calif.

DIATHERMY (SHORT-WAVE THERAPY) MACHINES

DIATHERMY, SHORT-WAVE THERAPY. AND ultra short-wave therapy machines custom-built by radio engineer at considerable saving over commercial machines; 6 meters, 16 meters or any other frequency specified can be furnished. Machines substantially built with high patient-safety factor. 250-300 watts output. Neat professional appearance. Automatic safety time switches. All necessary pads and electrodes. For sale only to physicians, hospitals and sanitariums. Prices from \$195.00 to \$300.00. Not for sale to the general public. Write for further information giving your own specifications and requirements. Allan Stuart, 1015 Wilson Ave., Teaneck, N. J.

EDUCATIONAL COURSES

USED CORRESPONDENCE COURSES AND EDUCATIONAL books bought, sold, rented, exchanged, catalog free. V. W. Vernon, Henagar, Alabama.

RADIO

RADIO KITS—\$3.95 UP, COMPLETE, SINGLE BAND: all-wave; 8-10 tubes. Save 50%. Parts catalog—FREE. McGee Radio, P-2055, K.C., Mo.

WE BUY AND SELL USED RADIO TESTING EQUIPMENT: Timely payments if desired. Harold Davis, Inc., Jackson, Miss.

ANY RADIO DIAGRAM, 25c. SPECIFY MANUFACTURER, model. Radio magazine free. Supreme Publications, 3727 West 13th, Chicago.

MONEY FROM DISCARDED RADIO TUBES! PARTICIPATE! C. M. Dentlinger, 2732 Whittier Avenue, Dayton, Ohio.

WISH TO EXCHANGE IDEAS WITH YOUNG SERVICEMAN. Electric Shop, Logan, Kansas.

ATTENTION DEALERS: SELL ARCTURUS RADIO Tubes, good discounts. Write Anchor Distributing, Dryden Road, Ithaca, New York.

ULTRA MODERN SERVICE CONSOLE, KNOCKED-DOWN kit of all parts cut to size also completely assembled. Details and prices on request. Millard P. Koopman, 363 "D" Street, South Boston, Mass.

HARD-TO-GET RADIO DIAGRAMS. Try usual sources first. If you can't get them, try us. Price, 75c per diagram if we succeed; no charge if we don't. You lose nothing! Send no money—write first giving fullest information. Enclose return-addressed, stamped envelope. We have helped many Servicemen, experimenters and radio fans. We can help you. Allan Stuart, 1015 Wilson Ave., Teaneck, N. J.

STAMPS

THREE SCARCE SETS, NOW OBSOLETE, 25c. WITH new customer, gift: Box 211, Malden, Mass.

TECHNICAL ART SERVICE

DESIGN AND ART SERVICE FOR INDUSTRIAL Marketers. We solve your problems on: product and package design, industrial illustrations, technical drawings and diagrams, phantom, cutaway and explanatory drawings, layouts, lettering, photo retouching, displays, industrial cartoons, etc. Wash photos made from blueprints. We excel in airbrush and color work. Complete catalogs illustrated. 100% satisfaction guaranteed. Suggestions and estimates gladly furnished. Rapid delivery on mail orders. Tec-Art Drafting Service, 223 Charlotte Terrace, Roselle Park, N. J.

• MAILBAG •

developments, mention of which you can always find in *Radio-Craft*.

The microphone is something I have always wanted, and am sure it will be appreciated in more ways than one.

So again I thank all of you who had part in the Contest and wish you all much success in life.

GEORGE REIGER,
Holidays Cove, W. Va.

Dear Editor:

I have just received the equipment from the Amplifier Company of America offered as 2nd Prize in the 3rd Section of your Public Address Contest. I had purposely delayed receiving same in accordance with agreement with the manufacturer.

I am writing at this time to take the opportunity of thanking you for the chance to win this equipment in your contest. The amplifier is an excellent "job."

Your magazine is excellent. I like the Service Data Sheets for the purpose of studying new hook-ups, etc. As an experimenter I should like to see an article or so on resistance-coupled amplifiers, phase inversion, for addition or rather substitution for amplifiers in older radio sets. There have been some hook-ups, etc., on that subject but I have not seen an article on anything like that within the past year.

WM. F. BRUENING,
Bronx, N. Y. C.

These comments—and commendations—are appreciated.—*Editor*.

RE XMITTER ARTICLES—
... NO!

Dear Editor:

I feel that I MUST put in my "two-bits" into this controversy about turning our good old *Radio-Craft* into a "ham" magazine.

I say NO! MOST EMPHATICALLY NO!

Because, there are several magazines already on the market that cater to the Ham fraternity. And their scope is broad enough to cover any and all needs of these fellows. Two of these are: **Radio & Television*, and *QST*. The first published by the same firm as *Radio-Craft*; and an excellent magazine for the beginner to the advanced Ham. The latter published for the Ham, EXCLUSIVELY.

'Way back in the years of the '20's, I began reading "R.-C." and have been a constant reader ever since. Because, as a Serviceman, I have gotten more usable material out of "R.-C." than ALL of the others collectively.

Also, I would like to here remind the editors of "R.-C." that away back in the '20's they, the editors, PROMISED us Servicemen that "R.-C." would be kept EXCLUSIVELY a Serviceman's magazine.

In view of this promise, and past policies of "R.-C.," I, for one shall cancel my subscription to "R.-C.," the FIRST time that I see any Ham gear data in it.

I am speaking from an unbiased viewpoint, inasmuch as I am also a Ham, with a 250-watt X-mitter under construction at the present time.

Please give us MORE constructional data on service equipment. Practically all of my quite flexible panel is constructed from articles found in "R.-C."

Now, for a beef. Please make all manufacturers of test equipment and receivers state the values of ALL component parts in their schematics. And NOT leave out one or two values just to keep us fellows from building us one like it.

FRANK MILLS,
Dependable Radio Service,
Great Falls, Mont.

**Radio & Television (Incorporating Photo-Craft)* is published by Popular Book Corp. *Radio-Craft* is published by Radcraft Corp.

THE BEST BUYS ARE MADE "FOR KEEPS"!



MODEL 774 CHECKMASTER

A tube checker with complete analyzer ranges! Tests high filament voltage tubes, ballast, miniatures, loctal and OZ4 tubes; provides noise, short and leakage tests; has spare socket, and spare tube compartment. Contains 23 circuit testing ranges for trouble-shooting. Compact, inexpensively priced!

MODEL 669 VACUUM TUBE VOLTMETER AND SIGNAL DETECTOR



Hear as well as measure the signal with this inexpensive instrument. Measures gain in video and sound amplifying channels—peak voltages in thyatron generators in oscillator circuits—grid potentials on cathode ray tubes—and other essential measurements in sound receivers.

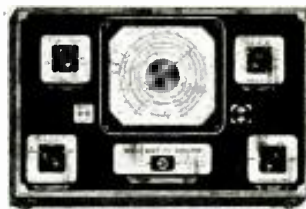

MODEL 776 OSCILLATOR

Hand calibrated dial (no trimmers or padders used). Uniform output level regardless of frequency. Constant signal free from drift or shift in frequency. Complete attenuation of signal on all bands.

POCKET SIZE DRY BATTERY TESTER

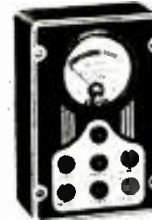

Inexpensive unit tests dry batteries under load. "Replace—Good" scale instantly shows when the battery is delivering sufficient potential for good reception. Pin jacks for following voltages: 1.5—4.5—6—7.5—45 and 90 volts.

Long life PLUS dependability
and versatility make
these WESTON'S Real Profit Builders!

"We buy WESTON Instruments and buy less often," says this successful serviceman. "Proper design and high quality materials and construction make them last for years, and stay dependable for their entire life. So by paying but little more, we save many dollars every year . . . hard-earned dollars which we otherwise would be forced to spend for rebuilding or for replacing obsolete equipment." * * * That's talking the serviceman's language! Lower instrument costs . . . better work . . . more profit at the end of each year.

If you, too, are anxious to cut instrument costs . . . and have the added advantage and satisfaction of working with quality instruments, you'll investigate WESTONS when you make your next buy. Remember, the difference in initial cost is negligible . . . but the saving over the years is decidedly worth while. Let us send all the facts now. Return the coupon below.

WESTON Radio Instruments

WESTON ELECTRICAL INSTRUMENT CORPORATION
599 Frelinghuysen Avenue, Newark, New Jersey
Send complete information on WESTON Radio Instruments.

Name..... Address.....
City..... State.....

For Better Servicing - For Bigger Profits— USE GERNSBACK MANUALS AND BOOKS!

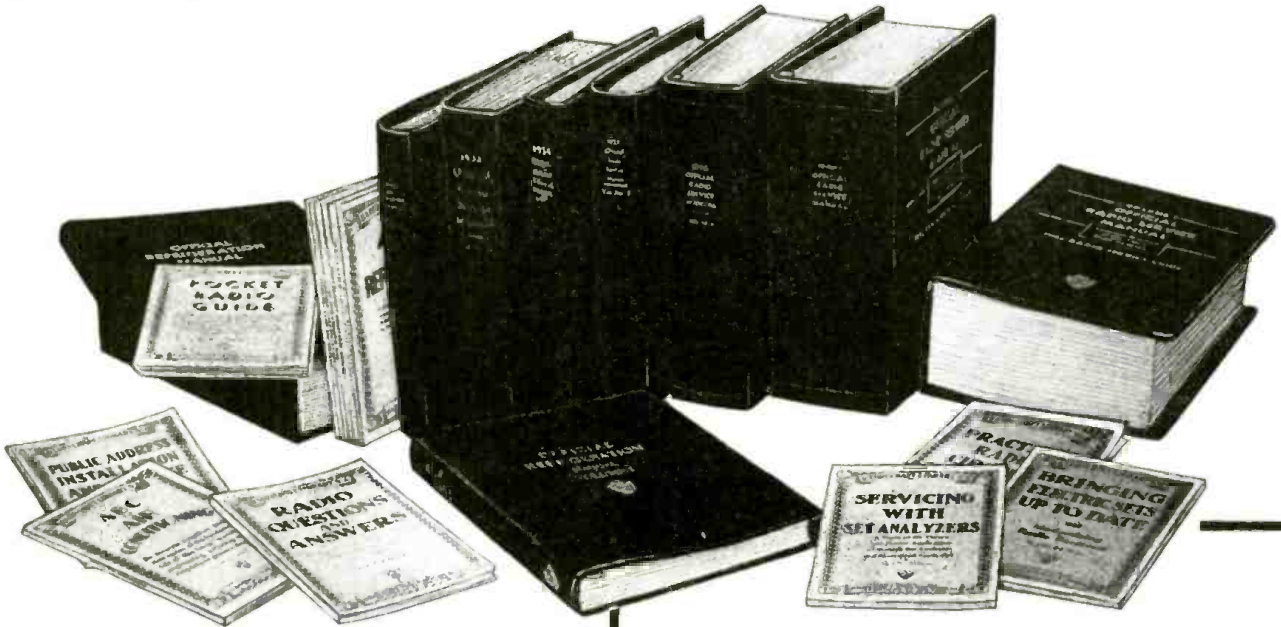

SINCE 1931 Servicemen have been buying more GERNSBACK OFFICIAL RADIO SERVICE MANUALS year after year. The authentic material, easily accessible diagrams and complete service data make them invaluable to dealers and radio Servicemen. *Without a Gernsback Service Manual at the repair job, there's time and profit lost.* Your service kit or laboratory is incomplete without all the GERNSBACK OFFICIAL RADIO SERVICE MANUALS. There are GERNSBACK MANUALS for servicing auto-radios, also refrigeration and air conditioning equipment.

VOLUME 7 OFFICIAL RADIO SERVICE MANUAL

Over 1,800 Pages • Over 3,000 Illustrations • Stiff, Leatherette, Looseleaf Covers • Size 9 x 12 Inches • Net Weight 10½ lbs. **\$10.00**

1936 OFFICIAL RADIO SERVICE MANUAL

Over 1,200 Pages • Over 2,500 Illustrations • Stiff, Leatherette, Looseleaf Covers • Size 9 x 12 Inches • Net Weight 8 lbs. **\$7.00**

1935 OFFICIAL AUTO-RADIO SERVICE MANUAL

Over 240 Pages • Over 500 Illustrations • Flexible, Leatherette, Looseleaf Covers • Size 9 x 12 Inches • Net Weight 1¾ lbs. **\$2.50**

1934 OFFICIAL RADIO SERVICE MANUAL

Over 400 Pages • Over 2,000 Illustrations • Flexible, Leatherette, Looseleaf Covers • Size 9 x 12 Inches • Net Weight 2¾ lbs. **\$3.50**

1932 OFFICIAL RADIO SERVICE MANUAL

Over 1,000 Pages • Over 2,000 Illustrations • Flexible, Leatherette, Looseleaf Covers • Size 9 x 12 Inches • Net Weight 4½ lbs. **\$5.00**

OFFICIAL REFRIGERATION SERVICE MANUAL

(Volume II)
Over 352 Pages • Over 300 Illustrations • Flexible, Leatherette, Looseleaf Covers • Size 9 x 12 Inches • Net Weight 1½ lbs. **\$5.00**

OFFICIAL AIR CONDITIONING SERVICE MANUAL

Over 352 Pages • Over 600 Illustrations • Flexible, Leatherette, Looseleaf Covers • Size 9 x 12 Inches • Net Weight 2¾ lbs. **\$5.00**

To order these famous Manuals, see or write to your jobber or favorite mail order house. If more convenient, mail coupon directly to publishers.

RADCRAFT PUBLICATIONS, Inc.
99 HUDSON STREET NEW YORK, N. Y.

Many New Books Have Been Added to RADIO-CRAFT LIBRARY SERIES

Get into the swing of reading instructive, authoritative books on technical subjects—radio, air conditioning and refrigeration. It's the easiest, quickest and most inexpensive way to improve your knowledge on these topics. In this series, popularly known as the RADIO-CRAFT LIBRARY SERIES, are all the titles necessary to your personal advancement. Only by careful study of these enlightening books, can you gain adequate experience in fields of radio, air conditioning and refrigeration. Each book is uniform. The volumes measure 6 x 9 inches—contain 64 pages, and have stiff, flexible covers. PRICE 50c PER BOOK. All books are sent to you postpaid.

Here Are The Titles:

Book No. 2 MODERN VACUUM TUBES	Book No. 18 POINT-TO-POINT RESISTANCE ANALYSIS
Book No. 6 BRINGING ELECTRIC SETS UP-TO-DATE	Book No. 19 PRACTICAL RADIO KINKS AND SHORT CUTS
Book No. 13 ABC OF AIR CONDITIONING	Book No. 20 THE CATHODE-RAY OSCILLOSCOPE
Book No. 14 POCKET RADIO GUIDE	Book No. 21 BREAKING INTO RADIO SERVICING
Book No. 15 ABC OF REFRIGERATION	Book No. 22 NEW RADIO QUESTIONS AND ANSWERS
Book No. 16 PRACTICAL RADIO CIRCUITS	Book No. 23 PRACTICAL PUBLIC ADDRESS
Book No. 17 SERVICING WITH SET ANALYZERS	

EACH BOOK IN THIS SERIES—50c

RADCRAFT PUBLICATIONS, Inc., 99 HUDSON ST., NEW YORK, N. Y.
Gentlemen: Enclosed find my remittance of \$..... for which send me, POSTPAID, the Manuals or Books Indicated below by a cross (x) in the panel.

() Volume 7 @ \$10.00 () 1934 Manual @ \$3.50 () 1932 Manual @ \$5.00
() 1935 Auto-Manual @ \$2.50 () 1936 Manual @ \$7.00
() Refrigeration Manual (Vol. 2) @ \$5.00 () Air Conditioning Manual @ \$5.00

RADIO-CRAFT LIBRARY SERIES @ 50c EACH

Circle book numbers wanted: 2 6 13 14 15 16 17 18 19 20 21 22 23

Name Address

City State

(Send remittance in form of check or money order; register your letter if you send cash or unused U. S. Postage Stamps.) RC-440

. . . . a leading radio manufacturer points the way back to reason

STABILIZING THE RADIO INDUSTRY

By the Editor — HUGO GERNSBACK

ON more than one occasion in the past the writer has referred to the chaotic conditions prevailing in the radio industry. In a number of previous editorials, he has had occasion to point out that the cut-price, cut-throat and dumping evils in the end undermine the radio industry and kill off many worthwhile radio concerns. Business today calls for constructive streamlining of the industry.

While over-production is a great evil, one of the other evils is over-styling and a huge over-supply of models and types of various items manufactured.

There are, of course, today far too many types of radio sets. One manufacturer will put out in one season a large array of various models and then end up the season by selling 95% of one model and 5% of all the others combined. It has not been unusual for a radio set manufacturer to put out as many as 40 different models, all in a single year.

This is destructive to the manufacturer himself and wholly uneconomical as well as wasteful. If instead of putting out 40 models he would put out 4 or 5, his profit at the end of the year would without a doubt be much greater.

To show how far this sort of thing can go, it is pointed out that the radio tube industry, for instance, announced no less than 470 radio tubes since the latter part of 1939. Of these 470 tubes, one manufacturer announced 263 different types. That meant, that this manufacturer not only had to manufacture this tremendous number of styles, but had to keep in stock all of the different types as well. This not only causes a vast outlay in capital, but ties up the manufacturing plant in having to produce all of these types, most of which, it has been found, were unnecessary.

A survey by the RCA Manufacturing Company showed that of the 470 radio tube types, 90 tube types actually accounted for 90% of the entire radio tube volume. Unbelievable as this seems, still more astonishing was the fact that these 90 types of radio tubes actually represented only 20 basic functions.

By analyzing these 90 tubes, it was furthermore found that this list could be cut down to only 36 tube types and that these 36 types could still take care of the normal needs of the radio industry without serious difficulty to any one.

In the past, new types of tubes have mushroomed so rapidly that it was impossible even for an expert to keep track of them. Most of the tubes—just as most of the different types of radio sets—all duplicated something in existence anyway, and the differences between existing styles became of a microscopical order.

It became the vogue that nearly every radio set designer wanted a tube with a special function so he could tell his jobbers and retailers that his set had the latest types of tubes. Yet these very tubes were really not new tubes at all but were already in existence in one way or another.

Someone had to be courageous enough to lead the industry out of this quagmire back to the solid land of sane reason, and the RCA Manufacturing Company is to be congratulated by all for its pioneering in doing away with ridiculous duplication which served no purpose except to befuddle everyone in the industry—the manufacturer, retailer, Serviceman and, finally, the consumer.

In cutting down the number of radio tubes from 470 to 36, that is, of course, not a final total but, as the RCA people

emphatically point out, the list will change from year to year. As new improvements are made, as new tube types really are needed, and where the art evolves new tubes, these then will replace the older types. Indeed, the list of 36 tubes might be expanded in one year and shortened in another, so as to keep abreast with the radio tube art.

It seems to us that *here we have an example that might well be emulated by the entire radio industry*, from the set manufacturers on down. Every manufacturer today, large and small, wastes most of his profit in duplication of types that are really unnecessary. Every maker of parts—be they tubes, condensers, coils and transformers, down to tuning knobs—can easily cut down his entire list of types and serve the radio industry and himself much better for doing so.

This is an age of streamlining and standardization. Furthermore, the radio industry is not the first to try out the experiment of cutting down on styles and types. Indeed, this process has been going on in other industries for a long time with benefits to the respective industries and to the public as well. It has been found that by cutting down on models and types, the savings in costs were so great that the remaining types could be merchandised at a lower price to the public, yet at the same time with greater profits to the manufacturer, due mainly to ensuing efficiency that took place in the plant and elsewhere.

Just to name a few, with astonishing figures that seem unbelievable:

General Cigar Company had a list of 150 types of different cigars. They cut this down to 6 and found that they were selling more with the smaller line.

A few years ago the Waldorf-Astoria Hotel in New York had no less than 30 types of glasses. This list was cut down to a mere 10 glasses with not a single complaint by anyone and a huge saving to the hotel.

Scott Paper Company a few years ago had as many as 2,000 types of paper towels. This list was cut down to only 3 types of paper towels and the company is more successful today than ever before.

One of the largest clockmakers in the country had 600 models of clocks. This list was cut down to 80 models, with no loss in business.

One of our leading shoe manufacturers had no less than 2,500 different types and styles of shoes. This huge list was cut down successfully to just about 100 models.

One of the leading incandescent lamp manufacturers had 80 types of lamps which were successfully cut down to 6, with an increase in business. The same industry cut down a list of 170 different lamp bases to a mere 6.

In the milk bottling industry, one of the large companies found that they had no less than 29 different model bottle caps. This was cut down successfully to 1 *single cap*—with no loss in revenue.

The hat industry, to cap the climax, had no less than 2,500 different types and models of hats several years ago. This has been reduced to 20 models to the satisfaction of every one.

From this it will be seen that standardization and cutting down in types really can be accomplished and the radio industry might well follow the example set by the largest radio tube manufacturing company in the country.

• THE RADIO MONTH IN REVIEW •

The "radio news" paper for busy radio men. An illustrated digest of the important happenings of the month in every branch of the radio field.

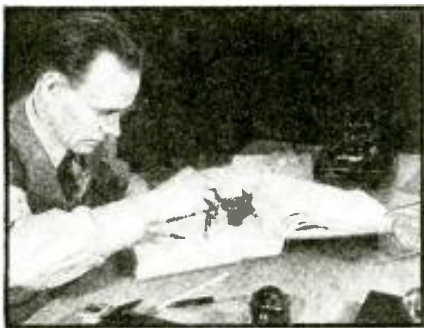

"ENGINEER AT WORK" . . .

. . . Seems to best describe this view of Philo T. Farnsworth, who at the age of 33 has to his credit more than 100 issued patents and approximately 80 patent applications, around a large number of which is based an entire television transmission and reception system bearing his name. His Horatio Alger-like rise is described in a 20-page booklet released last month by Farnsworth Television & Radio Corp., of which he is Director of Research.



HE SHOUTS HIMSELF AWAKE!

Have you ever overslept? So has H. William Richter, Jr., a Sophomore at Brown University (Providence, R. I.)! Unlike most of us, however, he did something about it, as shown here and on the cover. His phonoradio now clicks-on at the appointed time but plays Richter's own home-made recording to himself!; it starts off gently enough, but concludes with a bellow to "GET UP!!", that always works.

TELEVISION

LAST month, the nearly knock-down and drag-out 3-way fight between the F.C.C., the "freeze standards" boys, and the "don't freeze standards" boys, at Wash., D. C., wound up with Chairman James Lawrence Fly closing the public hearings (regarding the "rules recommended in the Second Report of the Television Committee" which the F.C.C. had adopted Dec. 22) before the Commission with the suggestion that a new committee be named to reconsider the R.M.A. Television Standards (which you may recall were kicked around quite a bit before the F.C.C. finally broke down and gave them a tumble) . . . Other bits of excitement, and otherwise, in the telly field last month

include the following: N.B.C. in televising a football game picked up a view of the broadcast booth—which gave WOR's chief engineer, J. R. Poppele, a chance to see whether his boys were doing their stuff in approved fashion. Maybe when WOR gets its telly outfit tuned-up it will return the compliment Columbia Broadcasting System's test telly programs—the sound portion of them—climbed right into the movie sound channel of Loew's 42nd St. Theatre and worked up a swell case of cine-televisitis, until a radio doctor diagnosed the case as pick-up via the light-line, and prescribed the remedy—a bypass condenser . . . Exciting and imagination-stirring stuff: "Fighting by Television," a reprint in *Science and Discovery* mag. for Feb. '40. Same issue has E. F. McDonald, Jr.'s (Zenith Radio Corp.). "Government Subsidy of Television?" . . . Test sales of RCA telly sets in Newburgh, N. Y., area, at cut prices reportedly netted 100 sales in under 1 mo. With N'burgh 1/35-th as large, it's figured N.Y.C. should rate better; in fact, everything else being equal, gross biz would be 3,500 sets—no . . . Says F.C.C.: "Only a few experimental television stations are

rendering service to not more than 1,000 receivers" (note that this was taken to refer only to Gotham). Says N.B.C. (A. H. Morton, vice-Pres.): "There are now 1,500 television sets in use in and around New York City." West-coast comment, via Don Lee System: "There are an estimated 600 television set owners in Southern California." An additional 1,000 telly receivers "were put on sale in Los Angeles by several manufacturing concerns" last month . . . Major Edwin H. Armstrong speaking: "When and if there is a television chain it will be done with frequency modulation. The technical principles are the same in television as in frequency modulation." Such F.M. sight-and-sound networks would eliminate the necessity for extensive wire-line facilities between regional telecasters.

BROADCASTING

SPACE does not permit mentioning all the interesting events that occurred last month on the wavelengths between 200 meters (or thereabouts), and 545 meters, but following are a few: WOR's new Novachord (Lurens Hammond's 163-tube electronic organ described in the April, 1939 issue of *Radio-Craft*) had gone haywire, Ted Steele discovered "when he sat down to play." Came nearly program time, but no music. What to do! In the nick of time (of course!), Steele spied an electrocuted mouse hiding-out in the tubes and stuff, removed it (uh, excuse, had it removed), when presto!, sweet music—and History had recorded the Electronic Pied Piper Mouse-trap! Station WPG (*Atlantic City*) went to timepiece-maker Arde Bulova for \$275,000 Sid Weiss, in *Radio Daily*, referred to "microgenic" voices. Nice coinage Excitement of listening to the "Americanism" mass meeting program broadcast from Madison Square Garden, N. Y., brought on a fatal heart attack to A. D. Phillips, 88, of Mount Vernon, N. Y. A WOR announcer prognosticated one Thursday (states WOR's press dept.): "Tonight, fair and cooler, followed by tomorrow and Saturday." The calendar shows he was right, the item concludes.

SHORT WAVES

WAVELENGTHS below 200 meters had their share of interesting happenings last month. Give a look: "I'm crashing; call police," was the substance of an interruption in a ham-radio conversation between Wilfred Stacey, at home, and O. R. Higgins, in his transmitter-equipped auto; both are Vancouver, Wash., radio amateurs. The urgent message from Higgins, as a second car passed a stop signal and headed for a crash with Higgins' car, brought police in a minute A *Radio-Craft* reader sent in a clipping from *The Millburn & Short Hills ITEX* which should point some sort of moral. It seems that the control switch in a 2-way radio-equipped car of the Millburn, N. J., police department accidentally turned the transmitter to "ON" during the "Aw, sister, have a heart, give a guy a kiss" unrehearsed sequence "somewhere in Millburn" that raised eyebrows at headquarters; in homes of S.-W. fans who may have been tuned-in; in other police cars; and, in Springfield police receivers. The fire-works are still going off around a certain cop's head! Poor radio reception by police and fire depts. of Fresno, Calif., ended when radio troubleshooter Bob Schuler directed removal of the millions of ants



"G.W.T.W." PREMIER TELEVIEWED

It is unfortunate that photography is not yet able to convey in a picture the mental impression of very satisfactory entertainment viewers derive from seeing a television image. A case in point is the insert-photo at left of Ann Rutherford and "Ben" Grauer, as seen on a television screen as these first-nighters attended the premiere of "Gone With the Wind" in New York City last month; viewed directly, the actual image much more closely equaled a motion picture of this couple. A second telly camera outside the Capitol Theatre televiewed the street scene as illuminated by high-power floodlights.

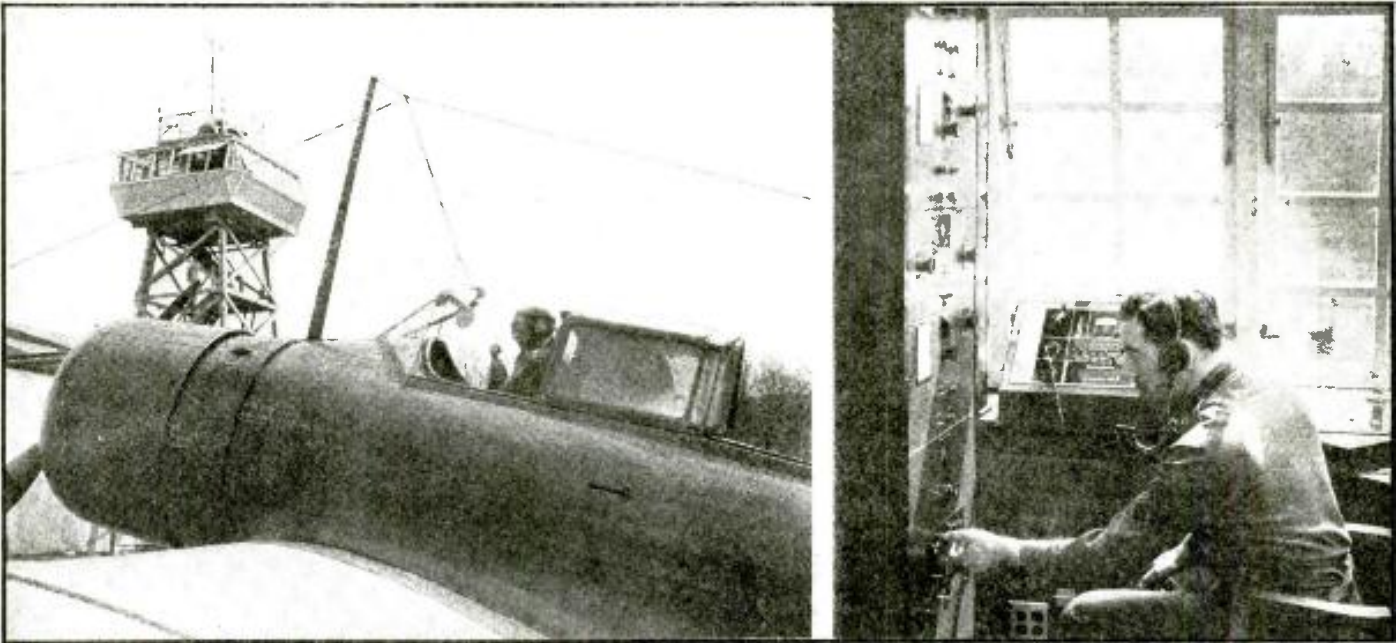

RADIO PREPAREDNESS IN THE UNITED STATES ARMY AIR CORPS (Cover Feature)

On the cover of this issue of *Radio-Craft*, and above, you see pictured a few of the many activities, and uses of radio facilities, of the U. S. Army Air Corps. Above are official photographs of, left, the exterior and, right, interior of the Radio Control Tower at Bolling Field, District of Columbia. Last month press notices disclosed that the Civil Aeronautics Authority air program calls for giving flying instructions to over 9,000 civilian students at over 400 colleges; this of course will include instruction in the elements of radio in

flying, landing, etc. The U. S. Army Corps it is expected will need at least 4,000 new, unmarried military pilots between the ages of 18 and 35 before the end of 1940 to help man the air armada of 5,500 airplanes which it is planned to have awing by that time. Want to enlist for 3 years? If you make the grade you're eligible for instruction at the Technical School at Chanute Field, Rantoul, Ill., or its branch Technical Schools at Scott Field and Lowry Field.

which had nested in the hollow mast, 333 ft. above ground, atop the Pacific Southwest bldg. ("Quick, Hank, that nationally-advertised insect exterminator!")

SOUND

LAST month saw continued advance in the development and use of sound equipment, to wit: Station WOR in presenting a year-end program, "1939 in Review," utilized recordings of the 10 outstanding special events of 1939 . . . "Some people get the idea that the right of free speech is coupled with the right to make noise," said New York's Mayor LaGuardia in discussing the quietus on sound trucks, etc., and continued, "There is a constitutional right of free speech but no constitutional compulsion to listen." . . . *Radio (in program form) is chickenfeed, at Wirtz Bros' poultry farm in Hunterdon Co., and helps boost laying by reducing interruptions, according to the Pennsylvania Farmer. A radio set in the feed room is wired to 4 loudspeakers in the 2-story, 8-pen chicken house. Operated all day, this "radio P.A." system establishes a "noise level" which makes laying hens less sensitive to hunters' gunshots, etc. "Audiographs" are newest thing. Stated Radio Daily, youthful Dallas, Tex., "autograph" hunters asked Eddie Dunn, WFAA highlight, to "say something" over the telephone—for spot home-recording by the "audioscript" hunters! . . . A simulated commercial air program, the work of radio students at Columbia University, was made into a transcription through cooperation of a sound-recording firm which supplied use of its studio and equipment. . . . "On the Air," read the studio light, but only the studio audience heard Benay Venuta, WOR-Mutual radio listeners hearing instead Senator Rob't A. Taft, to whom Benay had relinquished her air time; a sound recording of the Benay studio program, for which many tickets had been issued, however was aired a week later!*

RADIO ABROAD

LEND an ear to happenings in Europe, last month: *Berlin*—Large restaurants, says an A.P. item, use public address systems to inform patrons when menued items are "gone with the last customer." Curtailed staff of waiters couldn't find time to blue-pencil the menus. . . . *France*—*Bulletin de la Société Française Radio-Electrique*, Paris club paper, and *La Nature*, suspended "for the duration." . . . *Sweden*—A secret transmitter in northern Sweden is keeping Moscow informed of that country's troop

movements, Stockholm reported. . . . *Finland*—From Helsinki, via U.P., comes the report that Russians have resorted to a "war with word bullets" (see Feb. *Radio-Craft* cover feature). Loudspeakers verbally bombard Mannerheim line, urging Finns to surrender. Item No. 2: Russian planes silenced the Finn station at Lahti which long had been broadcasting in Russian; Leningrad listeners, caught in the act, reportedly were arrested.

F.C.C.

TELEVISION, Frequency Modulation and Facsimile continued their forward march last month as the following excerpts from the records of the Federal Communications Commission show.

Television.—W2XBT, Nat'l Broadcasting Co., Inc., N.Y.C.; was granted temporary OK to operate on 156-162 mc. . . . W2XAB, Columbia System, Inc., N.Y.C.; requested permission to operate on 42-56 mc. and 60-86 mc. . . . General Electric Co., Schenectady, N. Y.; applied for station at New Scotland, N.Y., on 156-162 mc., 10 watts . . . W2XB, General Electric Co., Albany, N. Y.; requested OK to operate on 66-72 mc. . . . W1XA, same Co., Bridgeport, Conn.; applied for reinstatement of construction permit for 60-86 mc., 175 W. visual and 100 W. aural . . . W9XG, Purdue Univ., West Lafayette, Ind.; applied for blessings on a 63-72 mc. channel, 3,000 W. visual and 750 W. aural . . . The Travelers Bdstg. Service Corp., Avon, Conn.; asked to go on the air with 1,000 W., 66 to 72 mc. (amended from 84-90 mc.) . . . W9XZV, Zenith Radio Corp., Chicago, Ill.; asked permission to switch from 42-56 mc. to 44-50 mc. . . . W3XAD, RCA Mfg. Co., N.Y.C.; station was granted temporary OK to operate on 282-294 mc. . . . WEJJ, National Bdstg. Co., Inc., N.Y.C.; received temporary OK to operate as relay broadcast station sound channel, on 30-40 mc., for experimental telly station W3XAD . . . National Bdstg. Co.



RUSS PARACHUTE RADIO!

Remember the "Bicycle-pedal Generator" illustrated and described in January *Radio-Craft*? (It's in daily use as a source of power for radio sets owned by settlers in the Australian bushland.) Well, the Russians rigged up something like it for supplying electricity to a portable radio set—and last month parachuted the whole works to a hideout in back of the Finnish lines! That was their finish! A Finn patrol, sent out to check up the source of enemy signals which a radio direction finder had spotted, found the parachute, the generator, one Russian merrily cranking away on the latter and getting nowhere fast, and a transmitter going full-blast as a second Russian radioed information concerning the Finnish positions.

• THE RADIO MONTH IN REVIEW •

requested OK to set up new telly station on 282-294 and 312-324 mc., 15 W. for visual and aural transmissions . . . *KDAL, R. B. Eaton, Des Moines, Ia.*; permission to set up a 100 W. (visual and aural) station was requested, on a 44-50 mc. channel . . . *WVXG, General Television Corp., Boston, Mass.*; applied for license renewal . . . *W2XBT, National Bdestg. Co., N.Y.C.*, portable station; granted OK to experiment on 156-162 mc. . . . *W6XDU, Don Lee Bdestg. System, Los Angeles, Cal.*, portable-mobile station; OK received to experiment on 318-330 mc.

Frequency Modulation.—*W2XAB, Camden, N.J.*: assigned channels 162-168, 210-216, and 264-270 mc., for frequency modulation . . . *WGN, Inc., Chicago, Ill.*; requested opportunity to locate an "F.M." station at 435 No. Michigan Ave., with 1,000 W. on 43.2 mc. . . . *James F. Hopkins, Inc., Detroit, Mich.*; requests air channel at 43.4 mc., 1 kw. . . . *The Moody Bible Inst. of Chicago, Chicago, Ill.*; OK asked for F.M. station at R.F.D. No. 1, Addison, Ill., with 1 kw. on 43 mc. . . . *WOKO, Inc., New Scotland, N.Y.*; New-station OK asked for, at this address, with 250 W. on 43.4 mc. . . . *Edwin H. Armstrong, North of Alpine, N.J.*; granted special temporary authority to push out 1 kw. on 43 mc., via a special station, to permit check-up of adjacent-channel interference with regular station W2XMN (40 kc. on 42.8 mc.) . . . *WVXG, The Yankee Network, Inc., Boston, Mass.*; granted extension of special temporary authority to test W1XOJ, 2 kw., 43 mc.

Faeximile.—*WHK, The United Bdestg. Co., Cleveland, Ohio*; granted OK to air pictures between 1 and 6 A.M., on 1,390 kc., with 1 kw. . . . *W8NE, ditto*; granted permit to use equipment of WRPM for pictures, with 50 to 100 watts . . . *WBEN, Inc., Buffalo, N. Y.*; applied for renewal of W8XA's license . . . *Sparks-Withington Co., East Ganson St., Jackson, Mich.*; license-renewal of W8XUF requested.

GENERAL

F.C. Commissioner Thad H. Brown last month recommended legislation to improve shipping's radio safeguards to life and property on the Great Lakes and coastal waters. Also the F.C.C. reported marine radio regulations now read 410 kc., in lieu of 500 kc., for the International distress and calling frequency in the Great Lakes region.



POLE STEALS AIR!

Staunch Polish patriot Louis Bielecki of Boston stormed into Fall River's WSAR, commandeered the mike at "gun point" and started a tirade "in the interests of Poland." The mike turned out to be "dead" (thanks to control operator), the gun turned out to be a wooden mallet held in the pocket, and the police turned out to futher Bielecki in. But Mr. B. had done his bit for the motherland, his conscience was relieved—so was his liberty.

TELEVISION

THE Television Ball telly broadcast illustrated in *Radio-Craft* last month was an experiment, according to Alfred H. Morton, N.B.C. television chief. Said Mr. Morton, "One of television's prime problems is studio space. Television lacks the sun-drenched California 'locations' and Hollywood movie 'lots' of fantastic proportions."

In tackling the Television Ball, he said ". . . we are figuratively bursting the walls of our present Radio City studios. The point we want, and expect to prove, is that *New York City, any city, is one huge television studio.*"

"Many programs must be televised under studio conditions even if not actually in the studio. In televising the Television Waltz, for instance, we have 8 couples gracefully whirling in one large circle. It would be impossible to pick that up in a crowded studio, and equally impossible to telecast it from an outdoor setting."

Co-operation last month solved the problem of interference between the television signals of Philco station W3XE in Philadelphia and Columbia Broadcasting System

station W2XAX in New York City.

The agreement, said to be the first time-sharing arrangement in television's short history, was necessitated by the fact that both stations operate on the same frequency band—Channel No. 2 (50 to 56 megacycles).

Philco engineers have been transmitting in Channel No. 2 to avoid any possibility of collision of signals from the transmitter of Station W2XBS, the National Broadcasting System television station atop the Empire State Building in New York, which operates in Channel No. 1 (44 to 50 megacycles). Signals from W2XBS are being received regularly in the Philadelphia area, particularly in that section of the area nearest New York City.

Effective at once, Philco will transmit television programs between midnight and noon daily, and on Wednesday, Friday and Sunday evenings after 6 p.m. The Columbia station will confine its television broadcasts to all other times.

Philco last month petitioned the Federal Communications Commission to change its proposed allocation of television channels so as to give Channel No. 2 to Philadelphia since New York City has been assigned to Channel No. 1.

Philco has been making television pictures experimentally for more than 10 years and for the last 2 years has served the Philadelphia area with television programs. A variety of programs including educational motion pictures, musical variety features, fashion shows and studio demonstrations of a scientific and educational nature, have been transmitted from the Philco station for experimental and entertainment purposes, it is said.

The 20-in. cathode-ray television tube shown on pg. 519 of the preceding issue of *Radio-Craft* is only one of the several new developments which Allen B. Du Mont Labs. last month demonstrated to representatives of the Federal Communications Commission, Radio Manufacturers Association, N.B.C., and C.B.S. networks, RCA, *Radio-Craft, Radio & Television* (which incorporates *Foto-Craft*), and representatives of other interested organizations.

For instance, it was shown that a new time-delay fluorescent screen for television C.-R. tubes makes it possible to demonstrate images of 15 complete interlaced frames per second without observable flicker!

It was further demonstrated that the present fidelity of 441 lines per image area, when enlarged to the 14½ x 11½ ins. (high) image area possible on the new 20-in. "onion" tube presents an unsuitable image—the lines become objectionably noticeable. When the same image (a movie film) was projected at 625 lines, the lines were not noticeable.

The present channel widths assigned for television are not wide enough for 625-line scanning, but as demonstrated in a 7-mile television transmission from the Du Mont 50-W. experimental transmitter W2XVT, when 625-line images are transmitted at only 15 complete (interlaced) images per second and received on a delayed-image screen, higher-fidelity transmission becomes possible *over present channel widths!* In other words the Du Mont long-persistence screen by cutting down on the repetitive rate releases frequency space which may be utilized for a finer scanning texture.

It was demonstrated that present receivers are capable of responding to the new signals in some cases without any changes except local adjustment of the controls; and in other cases, slight changes in the circuit components.

In the demonstrations a special Du Mont "trick receiver" instantly reproduced 441-line or 625-line images alike.

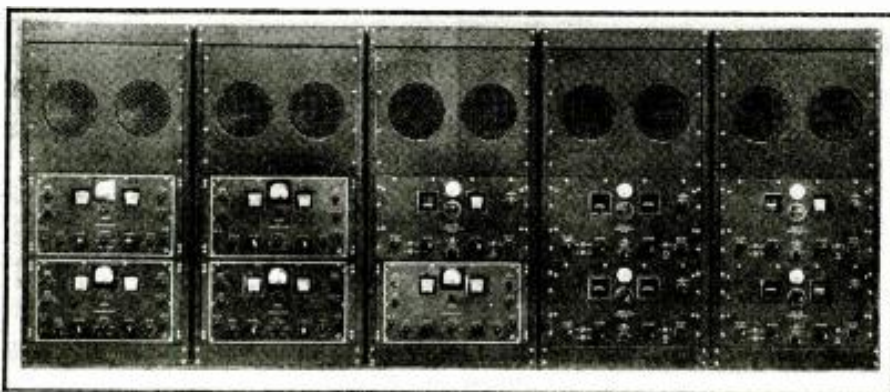

RADIO FOR LITTLE AMERICA

Hammarlund equipment is well represented at the Little America base of the Byrd Antarctic Expedition. The illustration above shows 5 receiving units, each composed of 2 receivers. In some dual units 2 "Super Pros" are used—in others 2 HQ-120X models, and in still others, 1 of each. In all, 15 Hammarlund receivers (9 Super-Pros and 6 HQ-120X's) are used. Double units are being used at base stations and on ships; individual sets in outpost stations and mobile units. The planes and Snow Cruiser are equipped with the HQ-120X's.

Except for airplane flights to South America, radio is the sole means of communication with the outside world. During the stay in the Antarctic, the expedition will employ amateur radio for handling the majority of personal traffic.

While numerous and valuable service test instruments have been introduced from time to time, there has been no definite trend toward any one, efficient test bench arrangement. The Console-type Control Unit, used rather extensively in connection with broadcast activities, however, lends itself admirably as a convenient, flexible and efficient design for test or service bench, as illustrated at left.

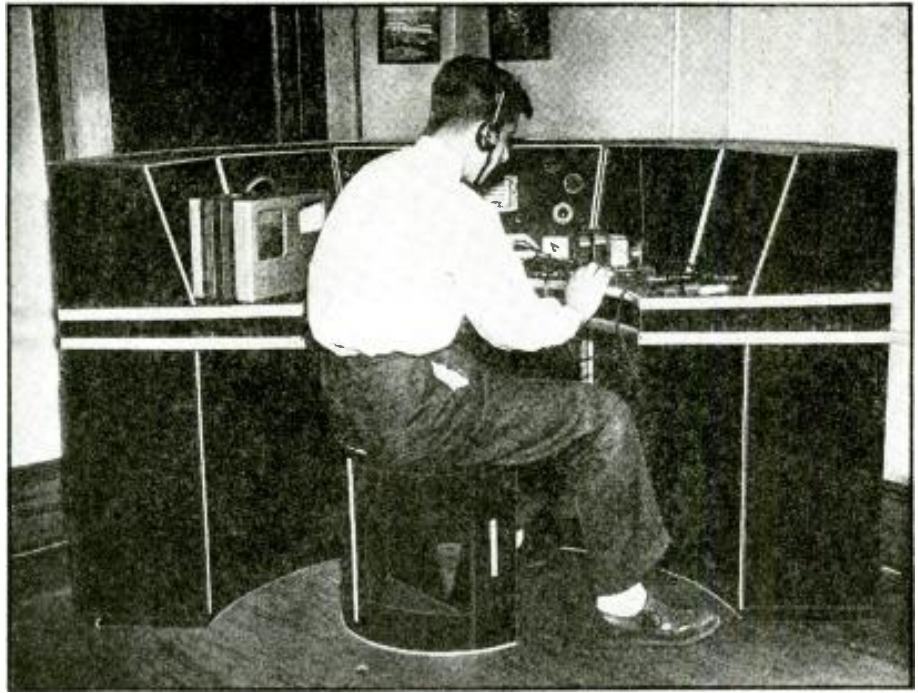

Complete Construction Data on an

ULTRA-MODERN SERVICE BENCH

C. RASK LATIMER

THE design to be described in this article is very flexible and can be constructed to suit individual requirements. First it is divided into 3 sections. One section is sufficient for a small service unit, 2 for a medium sized installation, and 3 units for a complete assembly. As the units are made up of plywood which can be purchased cut to size, the assembly is relatively simple and can be easily accomplished in a workmanship-like manner by any technician who can handle a hammer and screwdriver.

THE PLYWOOD PATTERNS

TABLE SECTIONS—Referring to Fig. 1, it will be noted that the following parts are cut to pattern, A (1 piece); B (1 piece); C (1 piece); D (8 pieces); E (1 piece); F (6 pieces) and G (3 pieces). The remaining pieces are all cut square and to exact size, but care must be taken to see that pieces I, J, L, M, O, P and Q are cut so they bend easily in the direction required, as 3-ply plywood bends much easier in one direction than the other. The upright supports are all made of ½-in., 5-ply plywood, the horizontal sections are made of ¼-in., 3-ply plywood, and the front and back covers (curved pieces) are made of 3/16-in., 3-ply stock. The material should be secured specified as Clear 1 Side and Sanded 2 Sides.

In cutting out the pieces to pattern, for example the 6 pieces of detail F, the 6 blanks 36 x 24 x ¼-in. should be fastened together temporarily with 2 nails, making a block 6 pieces thick. The pattern is then laid out on the top piece and all of them sawn at one time, insuring that they will be identical. If desired, the builder can have a

local cabinet maker run these pattern pieces through on a band-saw.

Figure 1E shows a cross-section of the construction, vertically, and gives a clear picture of the assembly. The 1st step is to complete the assembly in Fig. 1G, the table sections. Upon 1 piece F, the 3 spacers H are glued and nailed, 1 at each end and 1 in the center. Small pieces of scrap are used to make additional end-spacers as shown in the drawing. The other piece F is then glued and nailed in place. The front cover J, and rear cover I, can then be nailed and glued in place. That completes 1 table section and the remaining 2 table sections are of course assembled in the same manner.

The next assembly is per Fig. 1H. Upon a piece pattern G, 3 feet (pieces N) are glued and nailed into place, followed by the front covers P and back covers O. Three main uprights K are nailed and glued into place, also supported by supplementary triangular pieces made from scrap. The tops of the pieces K can then be joined to the table section, as shown in Fig. 1E, here again using pieces of scrap to strengthen the joint. The rear covers L can now be glued and nailed into place. The front covers J are left until last as they are removable to provide access to the lower compartments.

HOODS.—The center hood A is different from the left hood B and right hood C, but the latter 2 are identical. For convenience, the hoods should be readily removable. Accordingly it is suggested that the hoods be fastened to the table section through the use of small, brass angles and wood-screws. Each hood top, A, B and C, is supported by 3 uprights D at each end and

a center upright; also part D except for the center hood top requiring the special upright E. Before placing the back hood cover Q in place, the uprights D, and the one upright E, should be fastened to the table sections with the brass brackets and wood-screws mentioned above.

The back covers Q should be glued and nailed to the hood tops A, B and C, but the covers Q should not be glued or nailed to the table sections.

All the front and back covers are specified in the Bill of Material to their exact width but somewhat longer than the actual length, accordingly after covering the curved surfaces there will be a bit to trim in each case.

The front covers M should be set in place, neither glued nor nailed, but fastened in place with the moulding strips U, which in turn are fastened with the wood-screws V. After the covers M are fitted and trimmed to size they should be removed again for surface finishing.

FINISH

Fir plywood can be finished in any one of several accepted methods. One simple and economical finish can be obtained with a single coat of white undercoater pigmented to the desired tint or shade and thinned sufficiently so that the figure of the wood will show through. A 2nd coat of clear shellac or varnish will add to the durability of the finish and also add a deep lustre.

Another simple finish can be quickly obtained by using one of the standard, combined stain and wax-stain finishes which are available on the market under different trade names. The console can be

Every REPLACEMENT TYPE FOR Every RADIO NEED



CS STANDARD

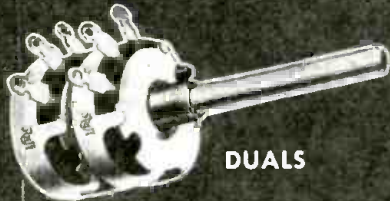

DUALS

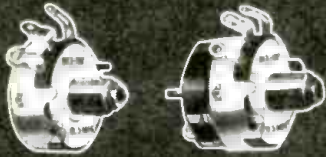

MIDGETS



SPECIAL STANDARD



SPECIAL SHAFTS FOR EVERY NEED



AUTO RADIO



WIRE WOUNDS



IRC SILENT SPIRAL CONNECTOR

Positive "clockspring" connection—no slide—no friction—no noise.

IRC 5-FINGER "KNEE ACTION" CONTACTOR

Amazingly uniform—permanently quiet.

IRC METALLIZED ELEMENT

Moisture-proof—durable—outstandingly smooth.

IRC COIL SPRING

Assures smooth rotation, prevents end play of shaft.

4 EXTRA FEATURES . . NO EXTRA COST!

Only in IRC Volume Controls do you get the exclusive features illustrated above—and an important thing to remember is that you get them at not one cent of extra cost. They mean more for your money. They are your assurance of the smoothest-acting volume controls you ever tried. They mean IRC Controls are quiet—and built to stay quiet.

Every one of these features is included in IRC Midget Controls as well as in the standard and special replacement types. One standard of quality only! Each and every IRC Control is made to the same high standard that has made them tops in performance and dependability throughout the world.



FREE! 1940 SUPPLEMENT TO THE IRC GUIDE IS OUT . . . Most complete, up-to-the-minute listing available. Covers control replacements for practically every receiver made since Edition No. 2 of the IRC Guide was issued. The new Supplement—and the Guide if you need it—free upon request from your jobber or direct from IRC.

INTERNATIONAL RESISTANCE COMPANY

401 North Broad Street, Philadelphia, Pa.
(In Canada, 187 Duchess Street, Toronto)

VOLUME CONTROLS

Makers of Resistance Units in More Types, More Shapes and More Sizes for More Applications Than Any Other Manufacturers in the World

Your looking at an overnight sensation!

RCP TUBE CHECKER



MODEL 308



NEVER before so dazzling an array of features in equipment priced so low! Years ahead in engineering, years ahead in design and years ahead in ownership cost. For just as with all RCP Equipment, the price of this tube checker is low—within reach of all.

IT'S A BUY! MODEL 308

As you can see once you check the features in RCP's improved Diaphragm Tube Checker. Tests all ballast tubes, all filaments and heaters up to full line voltage. Spare socket for future developments. Checks pilot and headlights. Neon test for shorts and leaks. Noise test checks only and "hum" tubes. Rapid, accurate test of every type tube. Line voltage indicator on meter. Individual check of sections of rectifiers and multi purpose tubes. Counter Type (Model 308)

\$16.95

Combination Portable-Counter Type (Model 308P) \$18.95.

IT'S A BEAUTY!

RCP POCKET MULTITESTER MODEL 413

IT TOOK RCP to design a pocket size instrument with all the sensitivity, ranges and features of the large expensive testers. 400 microamps, or 2500 ohms per volt. Fine Aineco magnet identical to that used in high-cost meters. 10 AC-DC voltage ranges 0-5000, 3 range ohmmeter 0-1 meg. DC microamps, 0-500; DC Milliamps, 0-1000; DC Amps, 0-10. In natural finish wood case.

Net \$12.90

Also available in model 413P solid wood nut, piano finish, hinged cover case.



IT'S A BARGAIN!

MODEL 445

RCP MULTITESTER AC-DC

Actually, the equivalent of 35 different instruments. 15 Aironval meter 2% accurate. DC volt-meter 0-5/10/250/1000/2500. DC Ammeter 0-10. AC voltmeter 0-10/100/500/1000. Three range ohmmeter 0-1 meg. Meter sensitivity 1 Milliamper or 1000 ohms per volt.

\$9.95

Send today for FREE Catalog No. 121



RADIO CITY
PRODUCTS CO. INC.
88 PARK PLACE, N. Y. C.

Take another look at this illustration. See how the Ultra-Modern Service Bench is built in 3 sections? For purposes of illustration these sections are here shown separated a few inches. Whether doors, shelves, etc., are added to the design is optional with builders to suit individual needs.

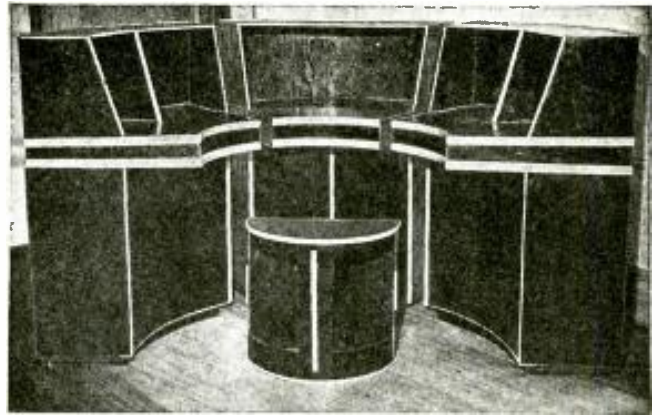

In some cases the lower compartments may not be used at all, in which case it is not necessary to have any holes through the table tops F. However, when leads are run from under the hood down to the lower compartment, it is of course necessary to cut through table top F and the corresponding lower half; this is readily accomplished with a wood bit, or for larger openings with an expansion bit or a keyhole saw.

As the instruments are mounted on a slanting panel, it is possible some such assemblies may be too long in depth to fit into the size compartment specified. That situation can usually be corrected by cutting a suitable recess in table top F, under the hood, as required. Where the console is to be built to receive a definite group of instruments, these dimensions should be checked beforehand as it may be necessary to increase the size of the hood compartment, or the table radius, or both.

Connections from 1 of the 3 sections to an adjacent section may be conveniently made through the use of male and female panel connectors or cable connectors. Where 2 or 3 sections are to be used permanently at one location, increased stability or rigidity is obtained by bolting the sections together, through pieces K at the ends.

OTHER USES

Aside from the use of these consoles as test-tables, they are equally suited to house a de luxe DX receiver, for a complete amateur transmitter and receiver, a laboratory test table (with hoods removed) or as a broadcasting transmitter, network or studio control point. Other applications would include use as an airport dispatching or sound system control switchboard.

The bottom compartments lend themselves to a wide variety of useful applications. The lower front panels may readily be hinged by also providing the inside of these panels with a shaped reinforcing piece, to keep these panels curved when open. The lower panels may also be made of one of several transparent plastic materials available, so the technician can see the various shelves which can be built into these lower sections. The shelves can be used for replacement parts, portable test instruments, wire, solder, tools and tubes.

One lower compartment can also be used for a shielded test loop, rigid or adjustable as required.

The console dimensions are such that the necessary size pieces are cut from stock plywood sheets with very little waste. However, there is some waste due principally to the curved pieces. The semi-circular stool illustrated was made up of scrap that developed during the work. Details of constructing this item are not given as it is not important and can be varied to suit individual taste.

BILL OF MATERIAL

Part	Quantity	Description
(A)	1	Hood top, cut to pattern, gross size 36x12x 1/4-in. 3-ply Ply-wood;
(B)	1	Hood top, cut to pattern, gross size 36x12x 1/4-in. 3-ply Ply-wood;
(C)	1	Hood top, cut to pattern, gross size 36x12x 1/4-in. 3-ply Ply-wood;
(D)	8	Hood Uprights cut to pattern, 1 1/2 x 1 1/4 x 1/2-in. 5-ply;
(E)	1	Hood Uprights, cut to pattern, gross size 14 7/8 x 1 1/4 x 1/2-in.
(F)	6	Table Sections, cut to pattern, gross size 36x24x 1/4-in. 3-ply;
(G)	3	Base Sections, cut to pattern, gross size 36x18x 1/4-in.;
(H)	9	Table Supports, 21x3 1/2 x 1/2-in. 5-ply;
*(I)	3	Table, Back Covers 39x3 1/2 x 3/16-in. 3-ply;
*(J)	3	Table, Front Covers 17x4 x 3/16-in.;
(K)	9	Main Uprights 24x12x 1/2-in. 5-ply;
*(L)	3	Upright, Back Covers 39x 24 1/2 x 3/16-in. 3-ply;
*(M)	3	Upright, Front Covers 30x 24 1/2 x 3/16-in.;
(N)	9	Base, Feet, 10x2x 1/2-in. 5-ply;
*(O)	3	Base, Back Covers 36x2x3/16-in. 3-ply;
*(P)	3	Base, Front Covers 34x2x3/16-in.;
*(Q)	3	Hood, Back Covers 39x12 1/4 x 3/16-in.;
(R)	6	Moulding**, 1x 1/4 x 17-ins. long;
(S)	6	Moulding**, 1/2 x 5/32, half-oval, 39 ins. long;
(T)	3	Moulding**, 1/2 x 5/32, half-oval, 39 ins. long;
(U)	9	Moulding**, 1/2 x 5/32, half-oval, 24 ins. long;
(V)	27	No. 4 nickel-plated brass oval-head wood-screws, 1/2-in. long, for (U);
(W)	1/2-Pint	Waterproof wood glue;
(X)		1/4-Lb. No. 18 Ga. wire brads 1-in. long; 1/2-lb. No. 18 Ga. wire brads 1/2-in. long;
(Y)	18	Brass Angles, 1x1-in. and 72 wood-screws, round-head No. 4 x 1/4-in. long, brass; Finish Material, as selected.

*Cut to bend easily the long length. All plywood is Douglas Fir Plywood. Scrap pieces saved and used to reinforce corner joints as required.

**Standard moulding in the above sizes and shapes comes available in several different styles, viz, Satin Aluminum or Metallic Colors, covering solid stock. Metal-covered wood moulding may be obtained in Satin or Bright Chrome Finish, or Stainless Steel.

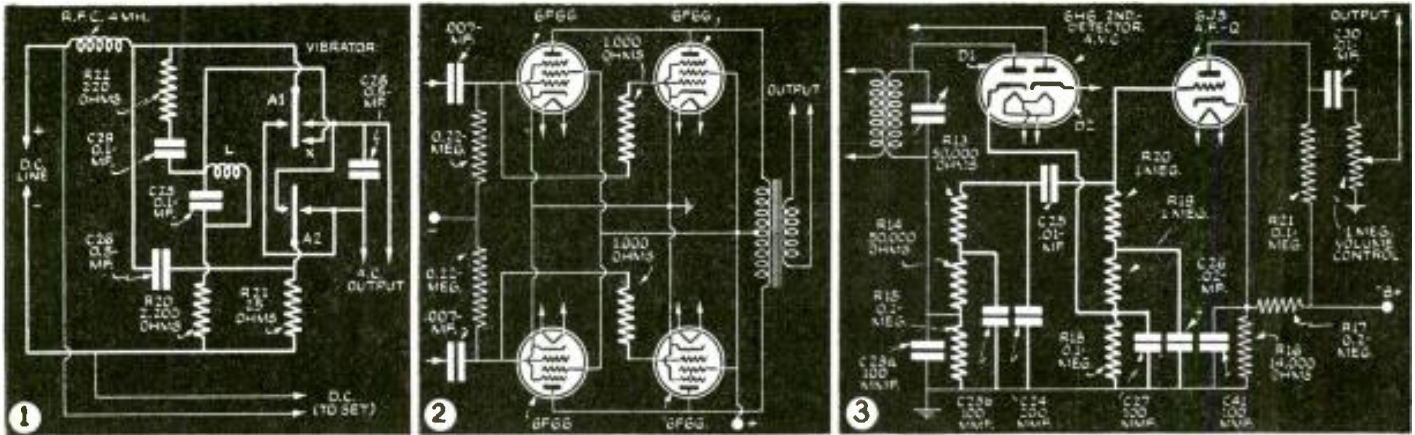

NEW CIRCUITS IN MODERN RADIO RECEIVERS



In this series, a well-known technician analyzes each new improvement in radio receiver circuits. A veritable compendium of modern radio engineering developments.

F. L. SPRAYBERRY

NUMBER 31

(FIG. 1) INVERTER FOR A.C. PHONOGRAPH OPERATION ON D.C. LINE

GENERAL ELECTRIC MODEL H-639 D.C.—Used with models intended for D.C. line operation, the A.C. phonograph motor is provided with an inverter, for changing D.C. to A.C.

As shown in Fig. 1 the inverter is simply a rapidly-operating polarity reversing switch. Like the synchronous automotive vibrator this unit has 2 mechanically-synchronous armatures, each connected to one side of the D.C. line. One is connected through an R.F. choke to reduce interference through current surges, while the other is connected through a low resistance (25 ohms) to introduce starting and loading regulation. Additional filtering is acquired by a 0.5 mf. condenser across the vibrator armatures.

Coil L furnishes magnetism for operation of the armatures, and is started by continuity through the odd contact X. Its operation is similar to that of any automotive vibrator. The line choke is 4 microhy.

Contact arcing is prevented by C29 and C26 in conjunction with resistors R22 and R21. These items also aid with C28 to improve the A.C. waveform.

(FIG. 2) COMPENSATING PARALLEL OPERATION WITH A SINGLE GRID-SUPPRESSOR

RCA MODEL K-130.—In one side of a push-pull circuit, where 2 tubes are operated in parallel, only 1 grid-suppressor is used, total, instead of 1 for each tube.

Since the value of the grid-suppressor lies in isolating the grids so that they may react individually to regulation, a single suppressor may be used between the parallel grids, 1 grid being excited directly. The 2 parallel circuits in push-pull are shown in Fig. 2. The excitation of each tube in the parallel groups is identical except for the differences imposed by regulation of the grids. As this action tends to be the same for each side of the circuit, the entire circuit is correctly balanced.

(FIG. 3) FIRST AUDIO STAGE ACTS AS "SELF-QUIET" CIRCUIT

GENERAL MOTORS CADILLAC MODEL C-8.—An unusual intercarrier noise suppressor circuit makes use of a graduated bias for the 1st audio amplifier stage, thus avoiding an additional Q tube with its more complex circuits. The operation may be derived from a study of Fig. 3.

The rectifier diode D1 of the 2nd-detector 6H6 is equally loaded in the plate and cathode circuits by resistors R15 and R18 respectively. With no incoming signal the 6J5 tube is biased at cut-off by means of the cathode network R16-R17 and the grid is at ground potential. This circuit is quiet.

An incoming signal will form equal D.C. drops across R15 and R18 but the audio modulation across R15 is not filtered; while that across R18 is filtered to near D.C. The drop across R18 is positive with respect to ground and its value is proportional to the carrier strength. Thus as a signal is detected the 6J5 grid is raised above cut-off bias in proportion to the carrier strength. The A.F. signal is coupled into the 6J5 grid through C25, and for any value of carrier, the circuit constants are chosen so that the A.F. peak can never exceed the D.C. across R18.

For low signals where curvature of the Eg-*I*p characteristic of the tube would tend toward distortion the total grid A.F. range is correspondingly small so that reproduction is essentially linear within good practical design. The volume control is placed at the 6J5 output.

(Concluded on next page)

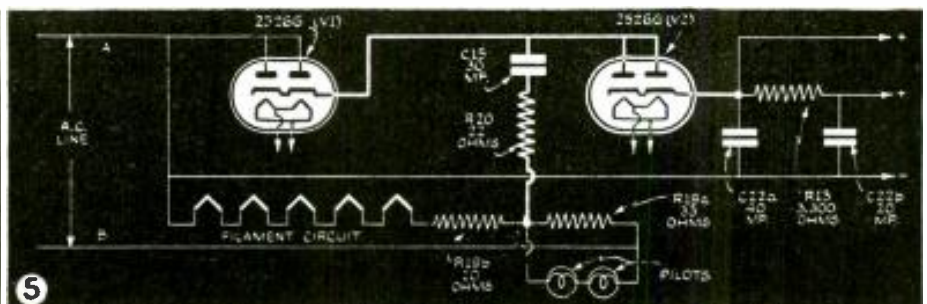
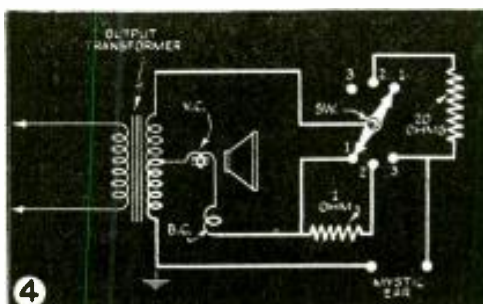

Here's the New Meissner ANALYST

IN KIT FORM

BUILD IT YOURSELF

SAVE HALF THE COST

COMPLETE KIT ONLY

\$60 Net

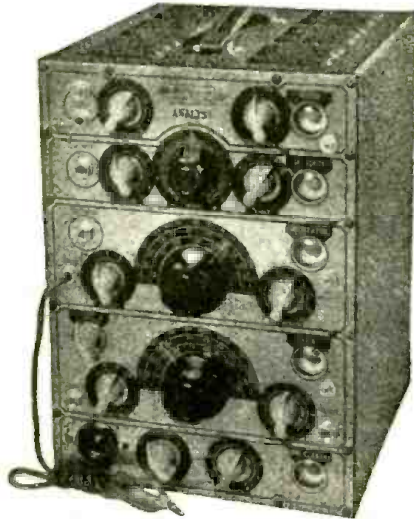

FIVE CHANNELS

AUDIO
50-50000 cycles

VOLTS
5-15-50-150-500

OSCILLATOR
0.6 to 15.0 MC

RF-IF
95 to 1700 KC

LINE CURRENT
0.1 to 3.0 Amp.

A Complete Service Lab in One Instrument

The same tried and proven circuits—the same dependable components—the same time and money saving performance—now offered in a new dress—a new panel finish and design that makes reading and operation even easier than ever.

It is unnecessary to repeat the numerous advantages of signal-testing over old-time servicing procedures. It is a proven fact, however, that every day you try to get along without this remarkable instrument is costing you money! It will eliminate the long hours fre-

quently spent in trying to locate some obscure fault and will make trouble location the simplest part of your work.

All measurements are made quickly, easily and accurately—during actual operation—without affecting the receiver circuits a bit. All channels of the receiver may be thoroughly tested—individually or simultaneously. A separate panel for every channel!

Don't delay! See the Meissner Analyst at your Jobber's today—or write for fully illustrated descriptive folder.

To obtain any of the literature below, check the items you want, clip the lower part of this ad, write your name and address in the margin and mail to the address below.

Get Your Copy Now!



A brand new 168-page book, full of live, interesting, up-to-the-minute radio constructional data and information. Contains complete diagrams and instructions for all the Meissner Kit Receivers as well as complete data on ready-wired units.

18-pages of latest Television data covering theory and practical application in plain language. See your Jobber at once or order your copy direct from factory. Only 50c net.

FREE DESCRIPTIVE FOLDER

Complete details of the Meissner Analyst, fully described and illustrated in a big four-page folder. Get your copy at once.

BIG FREE CATALOG

The big 1940 48-page catalog contains complete information, illustrations and prices on the entire Meissner line of high-grade kits and parts for the serviceman.

INSTRUCTION MANUAL

See description at left. Be sure to enclose 50c in cash, stamps or money order. Order yours today!

TIME PAYMENT PLAN

The Meissner Analyst and many other products may be purchased on easy monthly payment plan. Small carrying charge. See your jobber for details.

DEPT. C-4

(Continued from preceding page)

(FIG. 4) OUTPUT EQUIPPED FOR BONE-CONDUCTION "MYSTIC EAR" CONNECTION

FADA RADIO & ELECTRIC CO. MODEL S-46.—An output circuit and switching means are provided with this circuit for listening to the speaker as for the usual radio arrangement, the regular speaker in combination with a bone-conduction unit, or to the bone-conduction unit alone.

The 3 switch settings illustrated in Fig. 4 provide the listening conditions described above in their respective order. For the 1st switch position the top section of the output transformer supplies the voice coil in series with the switch contact and the hum neutralizing coil B-C.

The 2nd switch position places a 1-ohm resistor in series with the speaker voice coil circuit and connects the "Mystic Ear" circuit across the entire transformer secondary in series with 20 ohms resistance. The 1-ohm resistance reduces the total speaker load while the "Mystic Ear" circuit increases the load so that the same total as before is provided.

In the 3rd position of the switch the "Mystic Ear" alone is supplied from the entire secondary of the output transformer, the regular speaker circuit being broken.

(FIG. 5) UNUSUAL VOLTAGE-DOUBLING RECTIFIER CIRCUIT

GENERAL ELECTRIC MODELS H-736 AND H-708.—A power supply voltage-doubler in which the rectifier elements are in series in one side of the line is used in this receiver.

The circuit is given in Fig. 5. Its operation is as follows: When lead A of the line is positive with respect to B, condenser C15 is charged to the peak voltage across the line minus the drop across V1 (plate to cathode) occasioned by its load current; R20 protects tube V1 from current surges. Now as lead B of the line becomes positive with respect to A, V1 goes out of operation, and the lower (negative) plate of condenser C15 is elevated to a peak equal to the line voltage minus the drop across R19a and the pilot lamp. The sum of the voltage retained by C15 from the 1st half-cycle, and that added as just described, is applied to the plates of V2.

Features in APRIL

Radio & Television

Building a Cathode Modulator for the Ham Transmitter—Harry D. Hooton, W8KPX

2" C.-R. Tube Television Receiver

1-Tube Portable Works Loud-speaker—Robt. W. L. Marks

Network Television Demonstrated

Tips for the Short-Wave Radio Beginner—H. G. Cisin, M.E.

A Good Audio Amplifier for P.A. and Radio Tuner Use

Question Box

FOTOCRAFT Features:

How to Take Good Action Shots Better "Indoor" Photos



A.C. POWER FOR BATTERY PORTABLES

Rural electrification in all parts of the United States has created an unprecedented demand for the type of unit here described; Servicemen near the new "high lines" will find such low-price devices sell on demonstration. Plugged into any 115-volt light line, it delivers "A," "B" and "C" voltages for all battery-type portable and farm radio receivers (up to about 8-tube size).

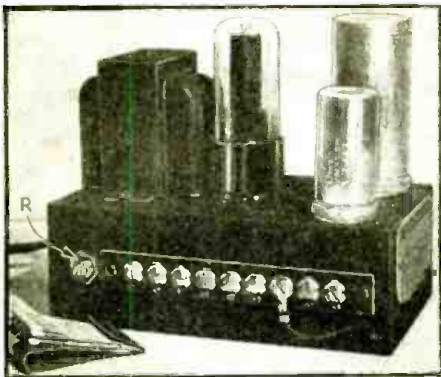

The G.T.C. model L Porta-Power unit. It measures 3 3/4 x 6 1/16 x 5 1/8 in. high.

“WHY a 'power pack'?" you ask? Well, battery set owners who have received electrification want it; and dealers need it for service and for demonstration purposes, and to electrify traded-in battery sets for re-sale. As a side-line item for Servicemen it's worth attention. Remember, every new HIGH LINE being run by the Rural Electrification Administration creates new and extensive markets for you.

For the purpose of discussion a representative type of power pack is here illustrated and described; the G.T.C. model L Porta-Power unit is shown. Its output is sufficient to replace batteries in 2-volt farm radio sets having 4 to 8 tubes, when connected to a 115-V. power line.

DESIGN

The "A" supply is obtained from a full-wave copper sulfide rectifier filtered by a condenser input filter. The filter consists of 3 condensers and 2 low-resistance chokes. A terminal voltage of 2 exists, with a load of 750 ma., increasing to 3.1 V. with a 420 ma. load.

The "B" supply employs a 5W4GT tube operated as a full-wave rectifier. The rectifier operates into a condenser-input filter of the conventional type. Four supply voltages, 67 1/2, 90, 112 1/2 and 135, obtained through the use of voltage divider resistors, are brought out to screw terminals. Through

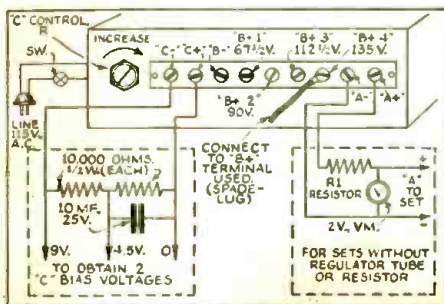

the use of external voltage divider resistors 45V. may be obtained.

The variable "C" bias supply is derived from the "minus" end of the plate supply. The potentiometer used for setting any desired voltage between -4 1/2 and -25 is a portion of the bleeder system.

The "A" and "B" circuits are not common to each other or to the metal container. This is necessary because of the different methods of biasing found in various receivers.

A number of factors are involved in the proper installation of such a power pack, as simple as it seems, and the practical elements of these factors will now be discussed.

INSTALLATION

LINE VOLTAGE.—If the line voltage is 125 to 130 volts, a 40-ohm, 4-watt (minimum rating) line regulating resistor (such as a Clarostat) should be plugged in between the receptacle and the power pack line plug. Failure to use such a resistor where high line voltages are encountered will materially reduce the life of the tubes in the radio set.

"A" SUPPLY.—First, determine the filament drain of the receiver to be electrified. If this is not given in the service manual of the set, it can be quickly determined by adding the current drains of the individual tubes and pilot lights found in the set. (See tube manuals for data.)

A few sets will be found which do not have regulating resistors or tubes to regulate the 2.5- to 3-volt supply to 2 volts for the filaments of the tubes. For these sets a resistor in series with the "A" plus lead as shown in Table I will be necessary.

TABLE I

(Values of 1/2-watt resistors required in series with "A+" lead where no ballast tube or resistor is wired into set. Filament current is in milliamperes.)

Fil. Ma.	Resistance (Ohms)	Fil. Ma.	Resistance (Ohms)
400	3.5	620	0.95
420	3.0	660	0.7
440	2.8	720	0.0
500	2.0	750	0.0
560	1.5		

A 4- or 2-ohm, 1/2-watt wire-wound resistor will be found convenient for this purpose. The exact value needed can be obtained by removing one of the end clips and re-clamping it on the resistor to give 2 volts on the filaments of the tubes. A 60 ohms/volt meter should be used in making this adjustment. For sets having filament drains of 720 to 750 ma., a jumper wire should be soldered across the terminals of the regulation tube or resistor.

"B" SUPPLY.—On sets where battery plugs are provided, remove these plugs and connect the leads to the respective "A," "B" and "C" terminals on the power unit. At the same time, shift the lead which is ordinarily connected to "B+4" to the "B+" terminal to be used. This need be done only where other than a 135-volt "B" source is needed.

This pack is designed with "B" voltages of 67.5, 90, 112.5 and 135 volts. The ratings of the various voltages are as follows:

- "B+1"—67.5 volts—4 ma.—when 90 volt tap is loaded
- "B+2"—90 volts—12 ma.
- "B+3"—112.5 volts—15 ma.
- "B+4"—135 volts—25 ma.

Other voltages may be obtained by using an external voltage divider resistor. The exact values of resistance depend on the current necessary from the tap.

"C" SUPPLY.—A variable "C"-bias supply of 4.5 to 22.5 volts is provided. This is to be adjusted to the desired voltage by turning the "C"-bias potentiometer with a screwdriver. A voltmeter having at least 10,000 ohms/volt resistance should be used in making this adjustment. Where 2 "C" voltages

Diagram G.T.C. model L A.C.-to-D.C. power supply unit. A dry-disc rectifier supplies the "A" voltages; and a tube rectifier delivers "B" and "C" voltages. The primary input is 28 watts. Condenser C is 10 mf., 25 V. Correct value for the high-voltage units is 20 mf., 250 V. (not 8 mf., 150 V.). The "A" chokes are each 40 mhy., 450 ma., 0.9-ohm; "B" choke, 3.5 hy., 35 ma., 200 ohms.

Important to Servicemen are the circuits at left which show solutions to installation problems.

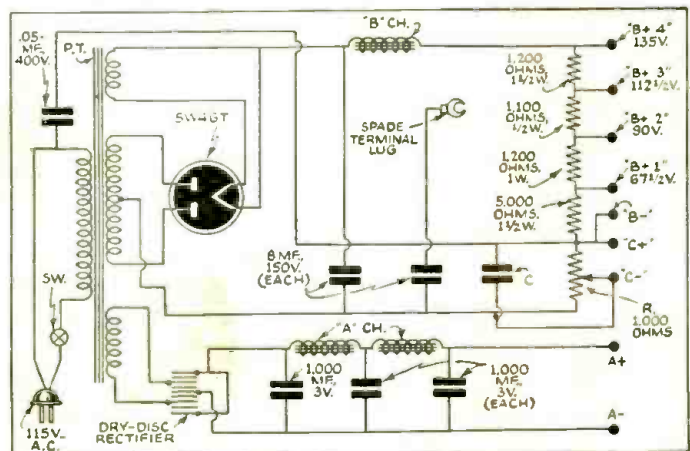

•SERVICING•

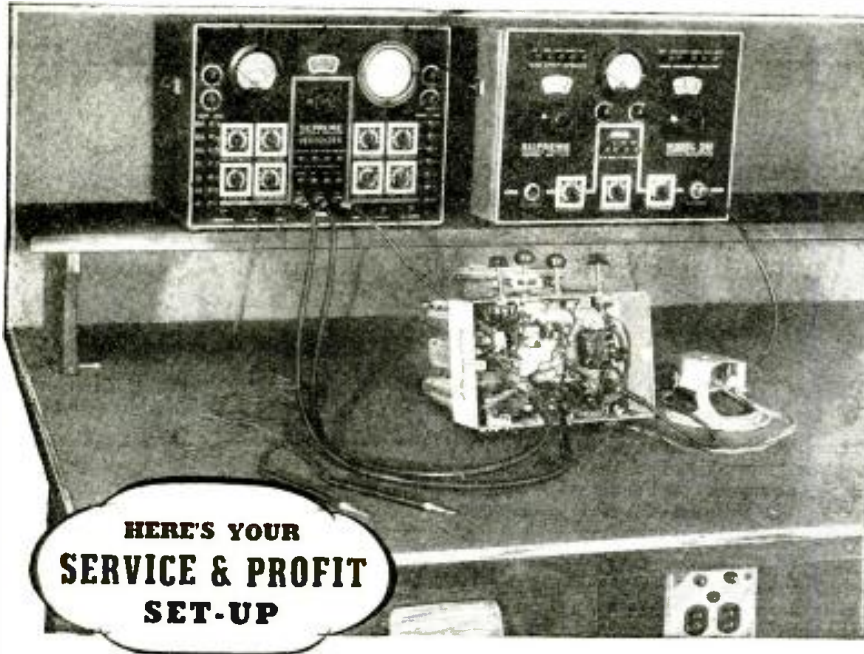

**HERE'S YOUR
SERVICE & PROFIT
SET-UP**

The test bench illustrated above is not an elaborate affair. It was built for about \$10.00 by a serviceman eight years ago and is still doing duty.

We like this test bench not only for the fine instruments shown, but because it's an ideal service set-up to get out the most work in the shortest and most convenient manner. It's neat, it's efficient, it's business-like and it's attractive—it's not a junk shop nor is it a store window mannequin. That's why it is a real work bench.

Please note that your instruments are solidly placed on a shelf about 9" above the table surface. As compared to a rack and panel or built-in job, this alone means that on only a 5' bench, you have saved over 1000 square inches of working space because the instruments require no working space at all. Add to this—the instrument probes come out at a natural "reach for" position—over your work, not behind it. And the instrument panels too—all indicators and controls in full view. No squat—no stoop—no squint. Give yourself a rest.

Do a better job, too, by using the modern and improved instruments now available. For the most complete and modern service shop imaginable only three instruments are required. On the left a Model 560 Vedolyzer is illustrated (a 562 Audolyzer could be substituted); on the right is one of the new 561 R. F. and A. F. Signal Generators. Open on the work bench or on the shelf above, or tucked away in the compartment below the

bench (not shown) there should be a 504 Set and Tube Tester instantly available for bench work or an urgent outside service call. This is the only instrument which need be portable. You could spend over a thousand dollars and still not have as complete an equipment set-up as these three instruments will give you. In only three instruments you have:

1. C. R. oscilloscope, 3" tube, standard controls all on front panel.
2. Three stage vertical amplifier, wide range video.
3. Vacuum tube voltmeter, 25 ranges A. C., D. C., R. F. volt and resistance.
4. Wave meter, 3 band.
5. Multi-input R. F., I. F. and A. F.
6. A. F. oscillator, 15 to 15,000 cycles.
7. R. F. oscillator, variable amplitude or frequency modulated.
8. Carrier meter, vacuum tube.
9. Modulation monitor, with vacuum tube voltmeter circuit.
10. Frequency modulator, double image, positive self-synchronizing.
11. Tube Tester, patented circuit which tests all present or future tubes regardless of tube base terminations or filaments.
12. Leakage tester, tests 7-ways for quality, "hot" or super-sensitive leakage, etc.
13. Condenser tester, tests all electrostatic condensers for leakage up to 20 megohms.
14. Electrolytic tester, accurately tests them all. Settings on tube roller chart and tested on "English Reading" scale.
15. Complete push button multimeter, 31 necessary ranges of A. C. and D. C. volts, micro-amperes and amperes, output ranges, ohms and megohms.

All of this and more in only three instruments; more additional ranges and functions than we can describe here. Write now for your free Test Bench booklet and get your perfect Service and Profit Set-up.



GET YOUR TEST BENCH PLANS FREE!

We do not make or offer for sale any panels or test benches. But it is a definite part of our policy to help all service men. Therefore, we have prepared a large 4-page booklet in which we discuss service benches in general, give valuable cost data, actual designs with detailed instructions for building, and our suggestions for necessary accessories. Send free.

we have prepared a large 4-page booklet in which we discuss service benches in general, give valuable cost data, actual designs with detailed instructions for building, and our suggestions for necessary accessories. Send free.

SUPREME

SUPREME INSTRUMENTS CORP.
GREENWOOD, MISSISSIPPI, U. S. A.

EXPORT DEPT. Associated Enterprises Co., 115 W. 4th Street, New York
Cable Address: LOPREN, N. Y.

A NEW BOOK ON PUBLIC ADDRESS

An important announcement about the greatest book on the subject of sound and allied subjects appears on Page 600 of this issue. **TURN TO THE ANNOUNCEMENT NOW!**



FREE!
**HAMMARLUND
NEW '40'
RADIO CATALOG**

The latest Hammarlund catalog with complete data, illustrations, drawings and curves on the entire Hammarlund line. Address Department RC-44 for your free copy.

HAMMARLUND MFG. CO., INC.
424-438 West 33rd Street, New York City

Keep Your Home or Shack ORDERLY! Bind your magazines in "JIFFY" Magazine Binders



Sturdily built and covered with black fabricoid. Has two stamped metal ends with 12 spring wire separators. Magazines can be inserted and removed in a jiffy. No fuss—no lost time—no labor.

- No. 1. 12 1/2" x 9 1/2", with 2-inch back for Radio-Craft, R. & T., Radio News, etc. — \$1.50
- No. 2. 10 1/2" x 7 1/2", with 3-inch back for QST, Radio, Popular Mechanics, etc. — \$1.25
- No. 3. 8 1/2" x 6 1/2", with 3 inch back for Reader's Digest, etc. — \$1.00

P.P. Prepaid in U.S. and Canada
Send for catalog containing full descriptions of many other interesting items.
GOLD SHIELD PRODUCTS
Dept. RC-440 350 Greenwich St. New York

are required, such as 9 and 4.5, the potentiometer is adjusted to 9 volts. Then connect two 10,000-ohm, 1/2-watt resistors, in series, across the "C" terminals. The common connection between the 10,000-ohm resistors is the 4.5-volt tap. It may be found necessary to bypass this "C" tap to "C+." The "C" adjusting knob should be left in the Zero position if no "C" bias is needed.

OPERATING DATA

In some sets it may be found that the bypass condenser from intermediate "B+" to Ground is old or of insufficient capacity to avoid oscillation. In such cases a 0.1-mf. or 0.25-mf., 200-volt condenser connected from the tap used to "B-" will remedy the difficulty.

The switch in the line cord of the power pack rather than the switch in the radio set should always be used for turning on or off. This will eliminate the possibility of leaving the power pack turned on with the radio receiver turned off. Install the power supply unit so that its terminals are not readily exposed to prying fingers. Reversing the power plug in the wall-receptacle may reduce hum.

This article has been prepared from data supplied by courtesy of General Transformer Corp.

**SERVICING
QUESTIONS & ANSWERS**

**SPEAKER HOWL—POOR
VOLUME CONTROL**

(153) Peter Valoscia, Mt. Kisco, N. Y.

(Q.) I have an RCA model 4 radio set that is giving a bit of trouble to straighten out. When switch is turned on there is a loud howl from speaker for about 15 seconds, then set starts to play; also this set has no control in volume, that is, it will play only when volume is at "high" position.

I have aligned the set several times, tried new tubes, installed new filter condensers, checked interstage transformer and also output transformer. Volume checks OK.

(A.) The condition is caused by regeneration. Suggest you check all bypass condensers and electrolytic bypass condensers. Do this by opening the condensers and using a known good one across the one opened.

Actually the condition is due to a rise in common resistance which is automatically adjusted when the tubes reach their operating temperature and stable point.

The volume control condition indicates that the condenser may be in this portion of the circuit if the volume control itself is OK. As we could not inspect the circuit we do not know if this is a cathode control or A.F. control in a diode A.V.C. circuit.

DISTORTION—RED-HOT GRID

(154) Vernon W. Presnell, Linair, N. C.

(Q.) I have in my shop for repair a General Electric model F77 radio receiver. This set when turned on makes a low, scratchy, crackling noise and the sound (music and voice) is barely audible; then after a half-minute the inner grid of the 41 power tube becomes red hot.

The tubes check OK in the tube tester, the resistors and condensers check OK also. When the plug from the speaker is pulled out the red brilliance of the grid in the 41 tube disappears. The speaker has strong field current. The 6U5 tuning eye tube shows that a signal comes through. What is the trouble and the remedy?

(Continued on page 614)

SERVICING PUZZLERS

Solved by the Use of Test Equipment

● **Defective Power Pack of Farm Radio Set.** A 6-volt vibrator-type power pack of a farm radio receiver was brought into the shop for service. Filter condensers checked satisfactorily, continuity was obtained through the power transformer and the vibrator would buzz. A test for high voltage was made across the secondary of the power transformer with a cheap A.C. voltmeter, and a "no voltage" reading was obtainable.

A test unit using a tube rectifier would allow a peak A.C. voltage reading with no current drain. Using this, a peak A.C. voltage could be read but the voltage was only 1/3 of normal. The vibrator, not of standard manufacture, was obsolete. Grasping the vibrator, I found that it could be speeded up, causing, of course, a rise in the voltage reading on the tube voltmeter. By readjusting this "orphan" vibrator, I was able to speed it up so that sufficient voltage was available. If I could not have secured the tube voltmeter having no current drain for this test, I would not have been able to observe the action of the defective vibrator.

P. M. OHLINGER

● **Several Circuits Inoperative.** A 16-tube Midwest receiver was received for a thorough check. Instruments were employed for checking over each condenser, resistor and coil for leakage, resistance, capacity, opens, etc. Each tube was double-checked, cold and hot. After replacing various leaky condensers and off-value resistors, and all operating voltages corrected, the set was accurately and completely rebalanced with signal generator and output meter.

J. HUBERT HOWE

● **Distortion of Audio Output.** Set requiring servicing was an Atwater Kent model 89. Distortion occurred at intervals of time as much as an hour apart. Testing with a Weston model 566, all voltages and currents seemed correct.

After repeated testing of all circuits to enable a reading to be taken during distortion, it was found that there was a rise in the plate current of the 1st audio tube, a type 27. The bias voltage across the cathode bias resistor was then observed during distortion while set was in operation. During normal operation voltage was correct but it disappeared when distortion occurred. This disappearance was accompanied by some fluctuation of the voltage. The cathode bypass condenser was suspected, and when cut out and replaced, the trouble was corrected.

CHARLES E. DIEHL

● **"Dead" Receiver.** A Majestic 15 brought in for service was gone over; after 2 condensers and 1 resistor were replaced, it still wouldn't play, except to get a local, faintly. Checking revealed the need for alignment. After the I.F. was peaked and the trimmers set with an oscillator, the receiver played, but a new trouble arose: A local station came in at 3 places on the dial!

Set was realigned, with no improvement. A new 24 tube was placed in the autodyne socket and, using a station signal as the test frequency, was realigned. The coil leads

No. 4 (Conclusion)

In the recent Weston Contest, in celebration of the 50th Anniversary of Weston Electrical Instrument Corporation, on "How Modern Test Equipment Helped Me Solve a Difficult Servicing Problem", many letters were submitted which have general interest as typical of today's servicing requirements. A concluding group of letters is presented here in the form of servicing notes which may prove of value in enabling the Serviceman to obtain the greatest possible usefulness from his test equipment.

were unsoldered, and the coils were tested for the correct resistance values, still with no improvement. Finally, a Weston service oscillator model 692 was employed for realignment. Two I.F. trimmers were found to be off about a quarter of a turn and the autodyne oscillator in the set was a mixup. The trimmers were all realigned correctly this time, and the trouble was cleared up.

WILLIAM G. ESLICK

● **Distortion, Accompanied by Low Sensitivity and Inferior Selectivity.** The receiver in for test was a Stromberg-Carlson model 145-L, and the difficulty happened to be unusual in its effect on the performance of the set. A modern signal generator was employed to feed a sine wave audio modulated input to the various stages in the circuit, the distortion being localized in the 6A8 mixer.

A modern volt-ohmmeter placed on its Low range disclosed a short between the primary and secondary of the R.F. transformer coupling the 6K7 plate and the mixer, a pentode grid, putting a positive bias on the tube so that it drew grid current and distorted. The short was found to be through the fishpaper insulation separating the windings, an ohmmeter check being used to facilitate the repair. A straight voltmeter analysis of the receiver circuit would have entailed considerably more time than the method described.

MORGAN AND DORNICK

● **Noise Between Stations and On Stations.** A dealer whose servicing I do had several G.E. receivers, model 81. They caused considerable trouble as a result of noise between stations and on stations.

All tubes tested good, and all voltages were correct. Turning my Weston model 301 Universal Meter to Ohms, I tested all transformers and coils. Then all condensers, which tested OK. All resistors were measured and checked with their color codes. All tubes were replaced, with the same result. Then, recalling that the resistors furnishing the bias for the 1st and 2nd I.F.

seemed low, I measured them again and found both to be 2,200 ohms. By raising the bias until reaching 200,000 ohms, the noise entirely disappeared without any apparent loss of selectivity.

W. A. McDOWELL

● **No Signal Obtainable.** A competitor-friend had trouble with a small 4-tube Philco 57 superhet. After making a few voltage tests with his old 1,000 ohms/volt meter, he had tried to align the I.F. trans. but could get no signal through. At my shop, we tried alignment with my oscillator, and got a signal through with the attenuator controls almost wide open, showing, of course, that the trimmers had been "monkeyed with" in an effort to locate the trouble. Undoubtedly his oscillator did not have enough output to get a start where the I.F. was so far out of balance.

As this radio set uses a 77 tube as oscillator and detector, I measured the cathode resistor which is critical, and a common cause of trouble in circuits of this design. The resistor had "raised" in value about 3,000 ohms above its code. His meter, due to scale arrangement, would not clearly show this rather large difference. The radio set now played.

As a routine test we always check the audio coupling condenser, as the slightest leakage affects the bias of the following tube and so, the tone. The condenser did actually show a leakage of 6 volts on our Weston 772, but on his meter no leakage could be measured. Replacing this condenser raised plate voltage about 20 volts and improved the tone. A recheck of the tubes showed a slight, hot-cathode leakage on one of the 77's when it was jarred. Although the radio receiver now played nicely and tubes all checked OK on his tester, I recommended replacement of this one tube as the radio set may become noisy or intermittent after several hours' heating.

ROBERT H. LEHFELDT

● **Intermittent Operation of Battery-Operated Set.** This receiver would suddenly drop in volume from normal to virtually nothing and then return to normal. Tubes were given a careful check on the Weston model 773. Good indication on all. Voltage check on all tubes and vibrator with the Weston model 772 Analyzer. Voltages all normal. After making these routine tests, I broke the diode leads to the 6T7G tube, which is used as diode-detector and audio amplifier and, using the 0-100 microamp. scale on the Model 772, began a diode-current test.

During all the above tests, the receiver had been operating normally. Suddenly, the volume dropped to a whisper. The reading, on the meter, of the diode current had dropped from 46 microamps, down to around 20 microamps. A 10-watt resistor mounted very close to the socket of the 6T7G was causing the spring contacts on one of the diode pins, the one used as detector, to spring away from the pin (due to the heat). Replacement with a new socket and moving the resistor away from the socket cured the trouble.

H. H. HARMON

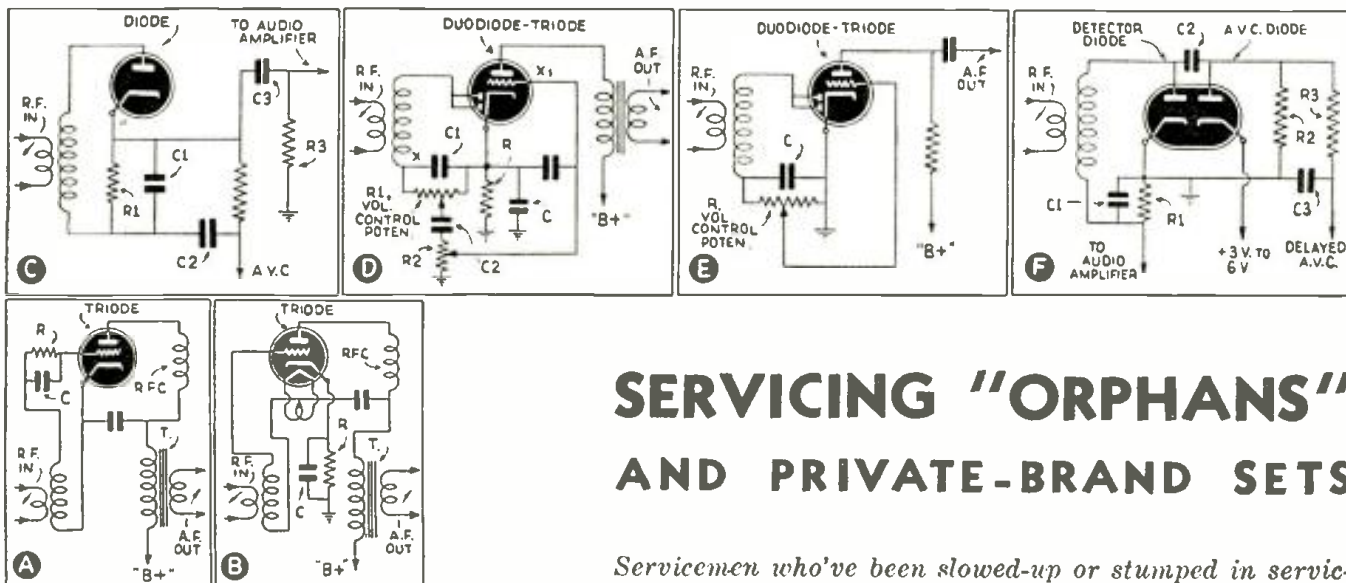

Fig. 7. Basic detection circuits. (A) Triode gridleak-and-condenser detector. (B) Triode grid-bias detector. (C) Diode detection and A.V.C. (D) Duplex duodiode-triode tube (detector, and A.F. amplifier). (E) Diode-biased detector, using duplex duodiode-triode. (F) Dual diode detector and delayed A.V.C.

SERVICING "ORPHANS" AND PRIVATE-BRAND SETS

Servicemen who've been slowed-up or stumped in servicing radio receivers for which no diagram was available will find Mr. Leutz's article well worth reading. Show it to your technical friends—they too may find it useful.

CHARLES R. LEUTZ

Part I

IN Part I, on the subject indicated in the above title, the discussion covered methods of checking the power supply and loudspeaker circuits. Knowing definitely that these 2 portions of the circuit are in order, greatly simplifies locating defects in other sections of the receiver.

In extreme cases the receiver involved may come into the shop without tubes and without marked sockets, or wrong type tubes may be found in one or more sockets. Accordingly, without a diagram, the Serviceman is not only called upon to find defects

but also to determine the proper tube complement.

DETERMINING TUBE COMPLEMENT

Measurement of the transformer filament winding will determine the series—2½-, 6.3-, 7-volt, etc. Absence of external shields for the R.F. tubes will ordinarily indicate metal tubes were originally used. The type and number of socket connections will be of further assistance in this direction. For example in examining a resistance-coupled audio amplifier stage, by checking the plate, grid and bias resistors used, against tube manual tables, one can determine if an ordinary triode or a hi-mu triode circuit is intended, for a 5-contact socket.

Possibly less than 50% of all Servicemen are completely equipped with modern test equipment. Accordingly in a discussion of this type, while the procedure calls for the use of test instruments, information is given covering satisfactory workable substitutes, therefore making the subject interesting to the largest possible number of readers. (*)

After having checked the power supply and speaker circuits, the balance of the set may be checked by starting at either the antenna or audio end. Preference is given to approaching the audio end first, because here again knowing the audio section is in order facilitates the remaining tests.

THE A.F. CHANNEL

Before subjecting the audio amplifier to signal tests, it is well to check the voltages appearing at each tube, that is the plate voltage, screen-grid voltage (if used), and bias voltage. Checking these values will also reveal any defective plate-coupling resistors, open transformer windings, shorted condensers, etc.

One of the easiest ways to test an audio frequency amplifier, or any one stage of same, is to apply an A.F. signal to the input and observe the resulting output. In the

absence of regular test instruments for this procedure, excellent results may be obtained by using an electrodynamic phonograph pickup and a *test record* as the audio signal source; and a pair of headphones for the output circuit, as per Fig. 5. This not only gives an indication of gain-per-stage, but by using high-grade wide-range phones, also gives a direct aural indication of quality and frequency coverage.

By connecting the phones directly across the phono pickup coil the direct response, for comparison, is obtained. This method is useful in testing 1 or 2 stages; where more amplification is present, the output should be observed at the loudspeaker. In testing an audio stage for quality and frequency coverage in this manner, the selection of the test record is very important. The recording should include musical instruments that jointly cover the entire musical scale. For example, vibraharp, bass violins and drums are excellent tests for the low frequencies; while flutes, piccolos, triangles and bells are excellent tests for the higher frequencies.

BASIC A.F. CIRCUITS

In using this *signal-test method* exclusively the technician may come to a stage giving distortion but also finding that all the electrical components appear to be in order. The trouble may be due to insertion of the wrong type tube and in this case a fair knowledge of the basic amplifier circuits and related tubes is valuable.

VOLTAGE AMPLIFIERS. Figure 3A is a standard triode resistance-coupled stage. Figure 3B is a similar amplifier but using an impedance plate load.

Figure 3C shows the standard transformer-coupled stage, the gain depending upon the tube used and transformer ratio: the frequency coverage depending upon the design of the transformer. It must be remembered that regardless of the fidelity obtained by preamplifiers which may be resistance-coupled, the overall fidelity is limited by the performance of either the driver transformer or output transformer,

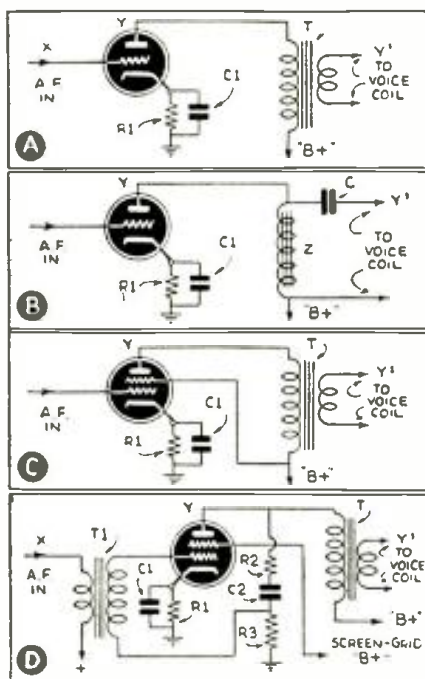
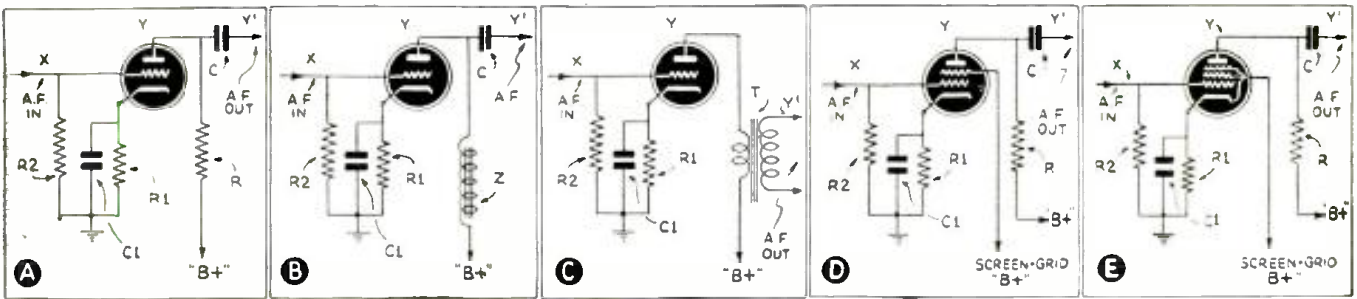

Fig. 4. Basic power amplifier circuits. (A) Triode output A.F. stage, transformer-coupled. (B) Triode output A.F. stage, impedance- (or resistance-) coupled. (C) Tetrode (beam power) output A.F. stage transformer-coupled. (D) Ditto, but with inverse audio feedback.

* See "Emergency Servicing Without Test Meters," Part I, Aug. 1939; Part II, Oct. 1939; Part III (conclusion), Jan. 1940.



accordingly for exceptional results these last 2 mentioned units should be of high-quality design.

Figure 3D shows a tetrode resistance-coupled amplifier; and Fig. 3E, a pentode resistance-coupled amplifier, the latter used for high gain-per-stage (with the sacrifice of possible distortion). All interstage audio amplifiers are primarily *voltage amplifiers*.

Audio stages can be quickly serviced by first determining that the associated resistors and condensers are of the proper value and in perfect condition; 2nd, determine that the proper tube is being used and that the rated cathode bias voltage, plate voltage and screen-grid voltage (if used) are being applied. A signal test can then be made and the grid and plate resistors changed to higher values for increased amplification, if required; or to lower values for reduced amplification, reduced distortion and greater stability.

Figure 3F shows the basic phase-inverter circuit. Signal balance on the grids of the push-pull output of the phase inverter circuit can be checked with a V-T.Vm., from points Y' to ground and Y'' to ground; these readings should be equal and the reading across Y' to Y'' should be double either of the single readings. Unless this condition is fulfilled, the voltages are not in phase.

At low frequencies the phase shift is usually very small, but the error may become great at high frequencies, therefore distortion may be introduced that will vary with frequency. Unequal capacities, grid to ground, will cause both unbalance of voltage and different phase positions for the grid voltage.

POWER AMPLIFIERS. Possible unbalance in the associated push-pull stage (see Fig. 6), can be checked by connecting the V-T.Vm. across the cathode bias resistor R1, but with C1 disconnected. With perfect balance, no A.C. voltage should appear. The phonograph pickup test is also applicable to any phase-inverter circuit.

The output amplifier stages must produce power, and accordingly, gain is usually a secondary consideration although some of the pentode output tubes do have a fairly high amplification factor.

Figure 4A shows the standard transformer-coupled output stage; Fig. 4B, the same circuit impedance-coupled, in both cases for a triode. Figure 4C is a pentode output stage transformer-coupled; and 4D, a beam power tube output stage, transformer-coupled and with inverse-feedback applied. For push-pull operation, the circuit may be considered as 2 circuits exactly the same as the one shown. All the above-mentioned amplifiers are shown self-biased. For fixed-bias, especially in the case of the larger tubes, the bias is taken from a separate small power supply.

A frequent complaint pertaining to resistance-coupled audio amplifiers is *motorboating*. It is invariably due to the use of excessively high grid leak or plate-load resistors and can be readily corrected by lowering the value of these units, otherwise the fault must be due to unstable plate "B" supply.

In most audio amplifier designs, a high value of cathode bias resistor bypass capacity is desirable but may be a source of increasing A.C. hum. Every effort should be made to eliminate the hum at its source and not sacrifice quality by reducing the bias resistor bypass value.

Figure 6 gives the points for aural test of a complete A.F. amplifier, overall, or for any 1 or 2 stages. The push-pull output stage, in its original condition, may be arranged for any one of the different classes of power audio amplification. By noting the value of the self-bias resistor, plate-load impedance, and driver transformer characteristics, and referring to a tube manual, the intended class of operation can be determined.

GAIN

The complete family of audio circuits is here given to bring out the similarity between the different variations. In absence of manufacturer's circuit specifications, reference should be made to a standard tube manual which will invariably give all the data required such as amplification factor, power output, proper bias values, plate load requirements, etc.

Generally speaking, it is well to remember that minimum gain, minimum distortion

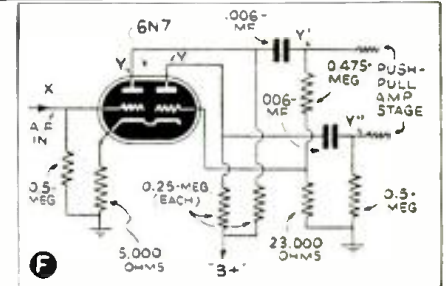

Fig. 3. Basic voltage amplifier circuits. (A) Triode resistance-coupled A.F. stage. (B) Triode impedance-coupled A.F. stage. (C) Triode transformer-coupled A.F. stage. (D) Tetrode resistance-coupled A.F. stage. (E) Pentode resistance-coupled A.F. stage. (F) Phase-inverter stage.

and maximum stability are obtained using low-gain triodes. Where more gain is essential per stage, a hi-mu triode may be substituted in resistance- or impedance-coupled circuits, and changing the associated resistors and condensers accordingly. If still more gain is required, and insertion of an extra stage is impractical, a pentode resistance-coupled or triode transformer-coupled circuit can be adopted to get the desired result. In a similar manner, if the existing arrangement gives excessive gain and distortion, a pentode stage can be changed down to a hi-mu, or a hi-mu changed down to a triode.

The radio technician should find audio amplifiers relatively easy to service. When a set comes in with 1 or 2 defective condensers an effort should be made to sell the customer on the idea of a complete new set of higher grade replacements. In a similar manner if the set-up uses cheap carbon resistors, it can be pointed out to the customer that the resistance value of carbon resistors varies with load and with temperature, and to insure permanent, stable operation the entire circuit should be changed to use higher-grade resistors with molded covering (so-called metallized resistors are one example). Provided the technician is a fair judge of music aurally, more reliance should be made on the "ear value" rather than on electrical measurements only. A "sour"

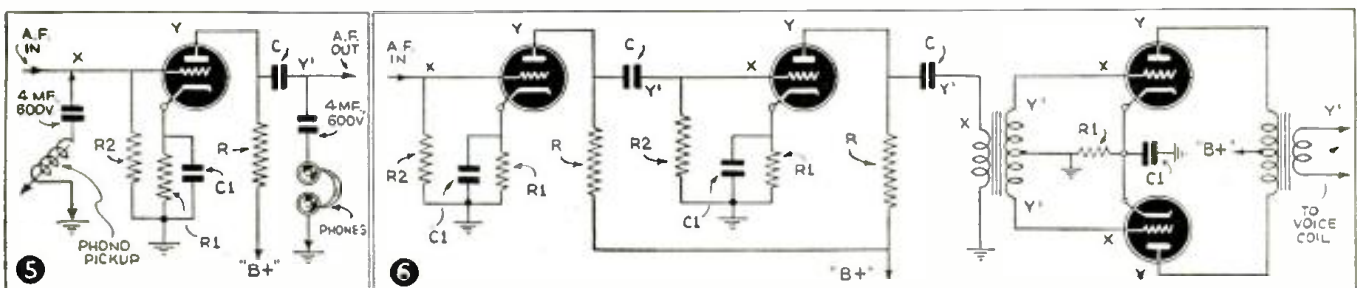

Fig. 5. Use of phono pickup for aural examination of A.F. amplifier stages. Fig. 6. Basic cascade (multi-stage) A.F. amplifier circuit with push-pull audio-output stage.

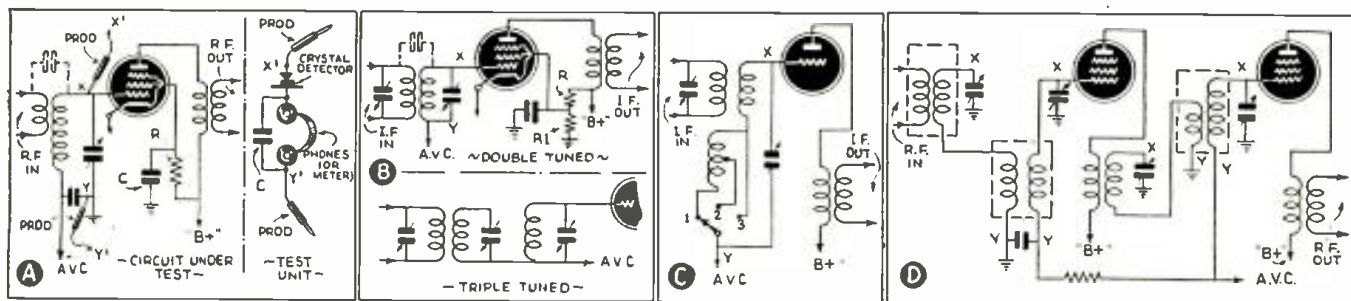

Fig. 8. Basic R.F. and I.F. circuits. (A) Basic R.F. pentode amplifier. (B) Basic I.F. amplifiers. (C) I.F. amplifier with adjustable transformer coupling. Position 1 = minimum selectivity; position 3 = maximum selectivity. (D) Bandpass T.R.F. amplifier.

audio amplifier is unacceptable even if accompanied by an impressive performance curve.

Referring again to the phono pickup test (or using a signal generator), the input is connected in each case from X to ground as per the family diagrams. The output indicator—phones or equivalent—is connected from Y to ground for the tube alone. Connecting the output indicator from Y' to ground brings condenser C into action, also the succeeding grid resistor, and the effect of these parts in-circuit is then noted. Under these conditions, necessary alterations may be made to the cathode bias resistor, the bias bypass, grid resistors, or plate load; or a change in type of tube, in accordance with proscribed values, or experimentally, to get the desired results.

DETECTOR CHANNEL—INCLUDING A.V.C.

Figure 7A shows the well-known *grid-leak-and-condenser detector circuit* which is usually found where high sensitivity is essential, for example in 1-, 2- or 3-tube sets. Maximum sensitivity and selectivity in the circuit are obtained by using a high value of grid leak, 2 megohms or more, but with a sacrifice of stability and audio quality. Stability and improved audio frequency response may be obtained by reducing the value of R, but at a sacrifice of selectivity. In this circuit there is no negative D.C. bias applied to the grid.

In Fig. 7B, the grid is biased practically to the cut-off point. In this diagram the bias is shown obtained from a cathode bias resistor, however it may also be obtained from a "C"-battery, a bias-cell or from a bleeder tap. This circuit has the advantage of amplifying the signal in addition to detection. Furthermore, this method does not draw current from the input circuit and does not lower the selectivity of the input circuit.

Typical diode detector circuits are shown in Figs. 7C, 7D and 7E. The diode method of detection (incidentally, invented in 1904), is subject to less distortion than most other systems, as the characteristics can be made fairly linear. However, diode detectors do not amplify the signal and furthermore as they draw current from the input circuit, a reduction in selectivity is inherent. The diode detector is widely used in spite of its disadvantage because of its 2 good features: (1) a linear characteristic; and, (2) ready adaptability to simple A.V.C. circuits.

The adjustments to these circuits are relatively simple, but steps should be taken to insure linearity and lowest possible distortion with high-percentage modulation. For standard diode tubes, such as the 6H6, the R.F. signal applied to the diode should be approximately 10 volts. The ratio of the A.C. impedance to the D.C. resistance of the diode circuit should be high. This means the grid-leak and A.V.C. filter resistors should be high as possible in the grid circuits of the R.F. and A.F. tube and the diode load resistor not excessive. An R.F. bypass condenser of too-high value across the load

resistor will cause both loss of gain, and distortion, at the higher audio frequencies.

DELAYED A.V.C. Some circuit designers prefer *delayed A.V.C.*; a typical circuit of this type is shown in Fig. 7F. The advantage of this method is that the receiver may respond to weak signals with maximum sensitivity. In this arrangement, one diode is used exclusively for detection, the other diode supplies delayed A.V.C.

The amount of delay depends upon the voltage of the cathode of the second diode circuit. With, say 3 volts applied to the cathode of the control diode, no current can flow until the signal strength increases sufficiently to cause more than 3 volts to be applied across the resistor R3. Accordingly the A.V.C. action is delayed until the signal strength attains a peak value of about 3 volts.

Performance of detectors should be checked and adjusted using a V.-T.Vm., and for sustained signal input, measuring the ratio of the rectified voltage across the diode load resistor to the R.F. voltage applied, from diode to cathode. With correct adjustment, the diode current should be directly proportional to the R.F. input voltage. Any variation in this proportion, upon changing the R.F. input voltage in value or frequency indicates that the detector circuit is improperly adjusted, and the associated capacities and resistors should be checked, altered or replaced as required.

Improper filtering of the R.F. from the grid of the triode or pentode associated with the diode will also cause distortion. This can be checked by using a V.-T.Vm. with a series condenser of 100 mmf. (.0001-mf.) in series with the grid lead of the V.-T.Vm. No R.F. voltage should appear between X and X', Fig. 7D; if found, additional shielding or filtering must be applied to eliminate all R.F. from the circuit.

When an A.V.C. receiver circuit "blocks", determine first if the A.V.C. is actually working: if an A.V.C. tube is used, check the tube. The A.V.C. motorboating means a defective tube, defective load resistor or defective or no bypass capacity. Another source of R.F. motorboating is usually due to oscillator instability and is best corrected by the addition of a voltage regulating tube to the "B" circuit.

R.F. AND I.F. CHANNELS

A simple and quick method of testing R.F. circuits, at either direct (signal) or intermediate frequencies is shown in Fig. 8A. The device consists of a pair of phones, a crystal rectifier and a bypass condenser (not critical—about 0.005-mf.). A microammeter may be used in place of the phones for visual observation.

The input signal may be obtained from a signal generator (modulated) or a received signal. The prod leads are applied to points X and Y. Testing the secondary of the antenna coupler is the equivalent of a simple crystal receiver. Testing at the output of the mixer tube (with oscillator tube removed) covers the 1st R.F. and 1st-de-

tor. In any case the test covers preceding tubes, from the point where the test is made.

Figure 8A is the conventional R.F. circuit used for either the antenna input or for direct R.F. amplification. For the broadcast band the coupler or transformer is usually of high-impedance, inductive-coupled type; and for the high-frequency bands, usually low-impedance, inductive-coupled. Quite often a small amount of capacity coupling is combined with the inductive coupling (indicated by dotted lines) and this capacity may be found within or external to the transformer case.

Figure 8B shows a standard I.F. stage as double-tuned and also for triple-tuned; and the latter may be designed for either band-pass or for peak selectivity. Figure 8C is a double-tuned I.F. unit with the desirable feature of *adjustable selectivity*, permitting a setting for high fidelity under conditions where extreme selectivity is not required (no adjacent-channel interference prevailing).

Figure 8D shows a direct (signal-frequency) radio-frequency amplifier with band-pass tuning circuits, a system that will become more and more common with the demand for high-fidelity reception.

Screen-grid voltage for R.F. amplifiers is usually obtained in either of 2 methods, a series resistor from the main "B"-plus (Fig. 8A) or from the main or an auxiliary voltage divider (Fig. 8B).

When available, a V.-T.Vm. should be used to check the gain of the R.F. and I.F. amplifiers.

The response of I.F. transformers or their proper peak value can readily be determined by a V.-T.Vm. and varying the input frequency.

ALIGNMENT

There is nothing complicated in servicing R.F. stages. First-hand, the individual components can be checked; the average cathode bias, screen-grid and plate voltages used for various tubes are then found in the tube manuals. Having checked the components, voltages and the tubes, the remaining step is alignment which can be accomplished using a signal generator or received signals.

Poor intermediate frequency selectivity, if no improvement is made by correct alignment, can be improved by inserting triple-tuned I.F. transformers in place of the universal double-tuned type.

Poor image-frequency conditions can be improved by inserting a band-pass 1st R.F. stage (Fig. 8D), adjusted for a sharp peak, in place of the usual single inductive coupler.

Improvement of overall audio response (assuming the audio amplifier is true) can be secured by replacing standard I.F. transformers with improved I.F. units having the modern feature of adjustable coupling as per Fig. 8C.

Unstable operation or oscillation in R.F. amplifiers may invariably be traced to defective or insufficient bypass capacity

•SERVICING•

around cathode bias resistors, to screen-grids or plate-returns.

OSCILLATORS—VOLTAGE DIVIDERS—MANUAL CONTROLS

The principal oscillator circuits were described in Part I. By connecting a V.-T.Vm. (through a 100 mmf. mica condenser) to the plate of the oscillator circuit under test, the oscillator output voltage can be checked over the tuning scale for each band. The output voltage should drop off gradually as the tuning pointer is moved toward the low-frequency end of each band. The voltage should not drop off abruptly or to zero under any circumstances. Abnormally low voltage for any point on any band indicates either insufficient oscillator grid-plate coupling or defective padding condensers.

The discussion so far has covered all essential parts of receiver circuits with the exception of *voltage dividers* and *manual controls*.

The checking and adjustment or replacement of voltage dividers requires an accurate working knowledge of Ohm's law as related to multiple circuits. In regard to volume and tone controls, some technicians go to a lot of expense to secure the exact factory unit specified. This is not always necessary as there are several reliable replacement lines wherein a satisfactory unit can be conveniently obtained. In the case of a variable cathode bias type of volume control, care must simply be taken that the maximum value is not too large, otherwise all the effective action will be confined to a small portion of the pointer rotation. In the case of audio volume controls, use of high maximum values means the connected grid is practically floating free and very sensitive to hum pick-up.

STABILITY

In general service practice, electrical and mechanical *stability tests* are often neglected. With the set in operation, the chassis should be jarred vigorously and the panel rocked, to bring out any loose or imperfectly soldered joints. The electrical stability is checked by tuning-in one of the major broadcast stations having a constant carrier and beating against this with a stable oscillator. With the beat note constant, the R.F. gain control should be moved quickly from minimum to maximum. With perfect stability there should be little change in the beat note under this test.

The Serviceman who finds it necessary to make repeated reference to wiring diagrams during repairs, will find it advantageous to memorize the basic family circuits given in this article, so that they can be instantly pictured or drawn. It will be then found during the examination of strange sets that the function of the different tubes and associated parts is usually instantly apparent, little trick variations will then be no obstacle.

The Conclusion, Part III, will include the additional servicing information which space does not permit running here.

RADIO SAMARITAN

True story: After Mrs. Edrie Hoffman left New York for West Palm Beach, Florida, her husband was stricken with a fatal heart attack. Mrs. Hoffman's car was not radio-equipped but radio caught up with her 800 miles away. At the request of the Nassau County (L. I.) Police, WOR broadcast a call for Mrs. Hoffman in the hope that a gas-station attendant might hear the broadcast, and spot the car. But it was a motorist, who had heard the announcement over his car-radio set, who recognized Mrs. Hoffman's car at Savannah, Georgia.

• SEE OUR FULL PAGE AD ON INSIDE BACK COVER OF THIS ISSUE •

THE NEW MODEL 1230

Signal Generator

WITH FIVE STEPS OF SINE-WAVE AUDIO

"I can't see how you do it at that price!" That one sentence states the consensus of opinion of the top-flight radio experts who examined and checked this new instrument, but you needn't be an expert to appreciate the amazing value we are offering in this new, most-advanced Signal Generator. Designed for appearance by one of the foremost instrument designers and engineered by a Radio Engineer who has specialized in frequency measuring devices for the past fifteen years, the Model 1230 is our bid for all of the 1940 Signal Generator business.



SPECIFICATIONS:

RADIO FREQUENCIES
From 100 K.C. to 80 Megacycles in 7 bands by front panel switch manipulation. All direct reading and accurate to within 1% on I.F. and Broadcast bands, 2% on higher frequencies. The R.F. is obtainable separately or modulated by any one of the five Audio Frequencies.

AUDIO FREQUENCIES
5 steps of SINE-WAVE audio 200, 400, 1000, 5000 and 7500 cycles WITH OUTPUT OF OVER 1 VOLT. Any one of the above frequencies obtainable separately for servicing P.A., hand-of-hearing aids, etc.

ATTENUATION
Late design, full-range attenuator used for controlling either the pure R.F. or modulated R.F.

The Model 1230 comes complete with tubes, shielded cables, moulded carrying handle and instructions. Size 14" x 6" x 11". Shipping weight 15 pounds. Our net price

CIRCUIT
The Model 1230 employs an improved electron coupled oscillator circuit for the R.F., affording positive protection against frequency drift and a Hartley oscillator circuit for the A.F. section.

DIAL MANIPULATION
Large 5 1/2" dial etched directly on front panel, using a new mechanically perfected drive for perfect vernier control.

APPEARANCE
The front panel is etched by a recently perfected process which results in a life-long attractive finish and the instrument comes housed in a streamlined shielded cabinet.

CURRENT SOURCE
The Model 1230 operates on 90 to 130 volts A.C. or D.C., any frequency.

\$12.85

SUPERIOR INSTRUMENTS CO.,

136 LIBERTY STREET, DEPT. RC 4, NEW YORK, N. Y.

• SEE OUR FULL PAGE AD ON INSIDE BACK COVER OF THIS ISSUE •



SWINGS INTO ACTION

Primarily the aim of the Association is to return to the Distributor, the Dealer and the Serviceman the profits which are legitimately HIS! This can only be accomplished by raising the standards of ethics of merchandising within the Industry.

Names of Member Jobbers in your territory will be supplied if you will address the Executive Secretary of the Association.

OFFICE OF THE EXECUTIVE SECRETARY

5 West 86th Street

New York, N. Y.

PATENTS—TRADE MARKS

Booklet concerning Inventions & Patents

Form "Evidence of Conception" with instructions for use and "Schedule of Government and Attorneys Fees"—Free

LANCASTER, ALLWINE & ROMMEL

Registered Patent Attorneys

436 Bowen Bldg. Washington, D. C.

Save on Everything in Radio

NEW 1940 RADIO CATALOG AND PROFIT GUIDE

Most complete line of latest radio sets, amplifiers, kits, tools and replacement parts. All leading brands at lowest prices. Fast Service. Guaranteed Quality.

The RADOLEK Company

Dept. Y-40 601 W. Randolph St., Chicago

SEND FOR YOUR COPY TODAY

FREE RADIO PROFIT GUIDE



MONTGOMERY WARD "AIRLINE" MODELS 93BR-420B, 93BR-421B, 93BR-423B, 93BR-424B, 93BR-431B

4-Tube Superhet.; Broadcast Band (range 540 to 1,720 kc.); Permeability Tuning Throughout (no tuning condensers!) Built-in Plate Antenna; 115-V. A.C.-D.C. Operation; A.V.C.; Power Output, 800 Milliwatts; 4-in. P.M. Dynamic Speaker.

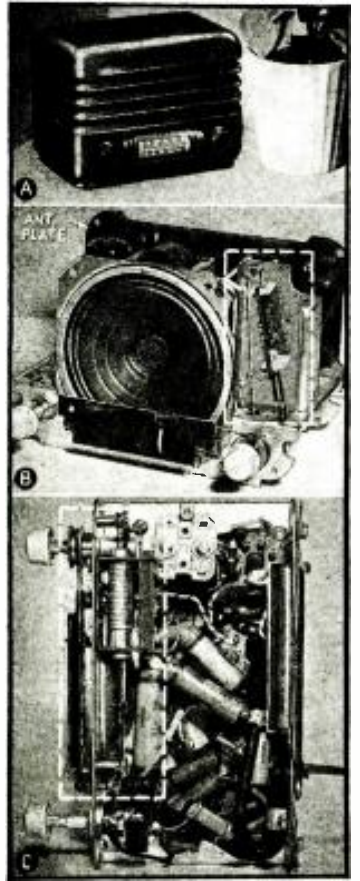
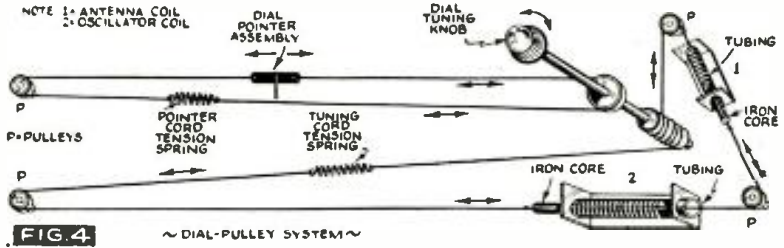
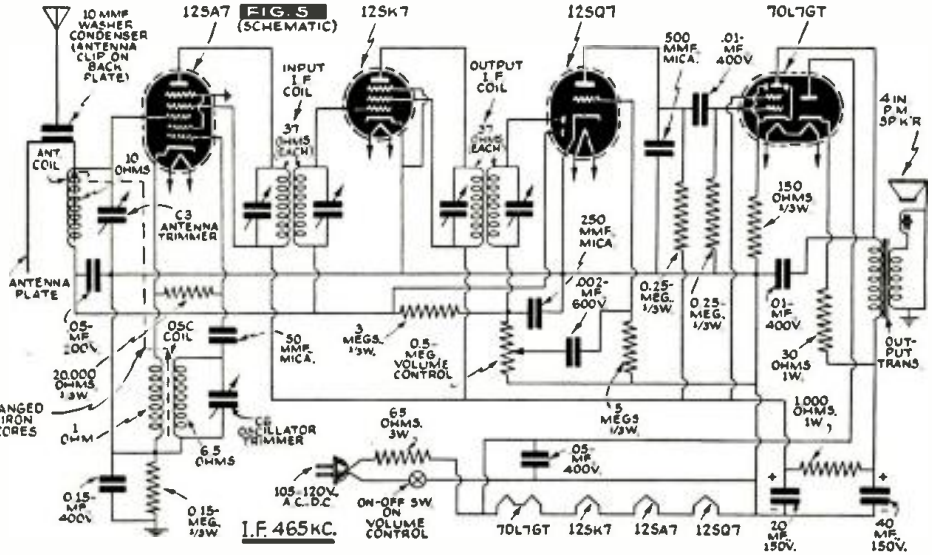
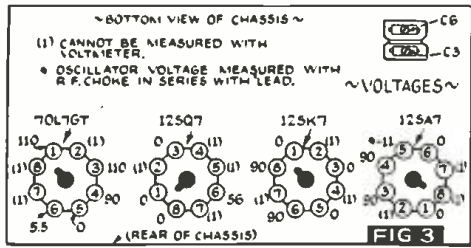
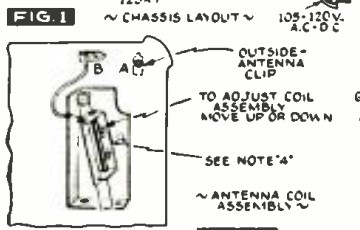
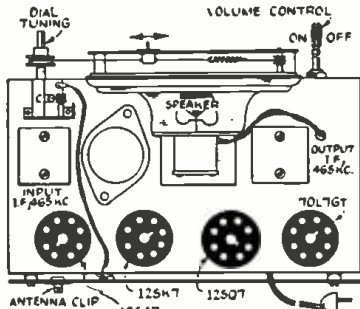

Four tubes are used, 3 of them multi-purpose. These are: a 12SA7 as a combination oscillator and 1st-detector; a 12SK7 as an I.F. amplifier; a 12SQ7 as a combination automatic volume control detector and signal 2nd-detector, and A.F. amplifier; and, a 70L7GT combination rectifier and A.F. output tube.

The tuning system is unconventional. Usual tuned circuits use fixed-inductance coils which are tuned by a variable condenser. In this radio set the condensers are fixed and the inductance of the coils is varied by moving iron-dust cores within the coil forms. The size and shape of the coils and the permeability of the iron cores have been designed to cover a tuning range from 540 to 1,720 kc. with very low tracking errors between antenna and oscillator tuned circuits.

Provision for an external aerial is made by a Fahnestock clip attached to the antenna plate and insulated from it. The small inherent capacity between the clip and the plate furnishes the coupling necessary, and at the same time permits the use of any size aerial without excessively detuning the antenna circuit. A ground is not required. Photo A shows the receiver in its cabinet. Photo B shows the chassis, with emphasis on the inductive antenna tuner; (the vertical antenna plate is slightly directional). Photo C, an underchassis shot, shows in particular the inductively-tuned oscillator coil.

SERVICE NOTES:

Voltages taken from different points of circuit to chassis are measured with volume control at minimum, all tubes in their sockets and speaker connected, with a voltmeter having a resistance of 1,000 ohms/volt. Voltages, shown on chart (Fig. 3), are measured with 117 volt A.C. or D.C. line.

Excessive hum, stuttering, low volume and a reduction in all D. C. voltages is usually caused by a shorted electrolytic condenser; open bypass condensers frequently cause oscillation and distorted tone. The plastic-type case is closed at back by the metal-plate capacity antenna(*).

ALIGNMENT

Use for aligning: an accurately calibrated all-wave signal generator; output indicating meter; non-metallic screwdriver; dummy antennas—0.1-mf. and 200 mmf. For proper alignment, chassis must be removed from cabinet.

Volume control—Maximum all adjustments. Connect "B-" of radio chassis to ground post of signal generator through 0.1-mf. condenser. Connect generator to set through dummy antenna. Output meter shunts pri. of output transformer. Allow chassis and signal generator to "heat up" for several minutes.

Aligning Procedure: All adjustments are for max. output. I.F. Circuits (cores all out)—Adjust trimmers atop Output coil, Fig. 1, at 465 kc. fed through 0.1-mf. dummy ant. connected to B, Fig. 2; ditto, Input coil. R.F. Circuits—Trim C6, Fig. 3, at 1,720 kc. fed through 0.1-mf. to B, Fig. 2; cores all out. Trim C3 at 1,720 fed through 200 mmf. to A, Fig. 2; cores ditto; see Note A. Next, turn dial to 1,400 kc., feed 1,400 kc. through 200 mmf. to A, Fig. 2, and adjust ant. coil up or down. Finally, trim C3 at 1,720 kc. with dial at 1,720 kc.; check for tracking (see Note B).

Note A.—Move coil assembly very slowly by hand or by pivoting a screwdriver blade between hole and coil-form gear teeth. Note B.—After tracking ant. coil at 1,400 kc. re-check C3 at 1,720 kc. Coil is not in track if change in C3 is considerable; hence, readjustment ant. coil position at 1,400 kc. Repeat until C3 remains unchanged at 1,720 kc.

*See "Making a 4-tube 'Permeability Portable' ", Radio-Craft, Sept. 1939.

Radio Service Data Sheet

HOWARD MODELS 308APC, 308C AND 308TT

8-Tube Superhet.; A.C. Operation; Built-In Loop Antenna (for Broadcast Band Only); 2 Bands (540 to 1,700 kc., and 5.5 to 18 mc.); Power Consumption, 70 W.; Power Output (max.), 7.5 W.; Automatic Volume Control; Mechanical (4-Button) Pushbutton Tuning; 12-In. Electrodynamic Speaker; Visual Tuning Eye.

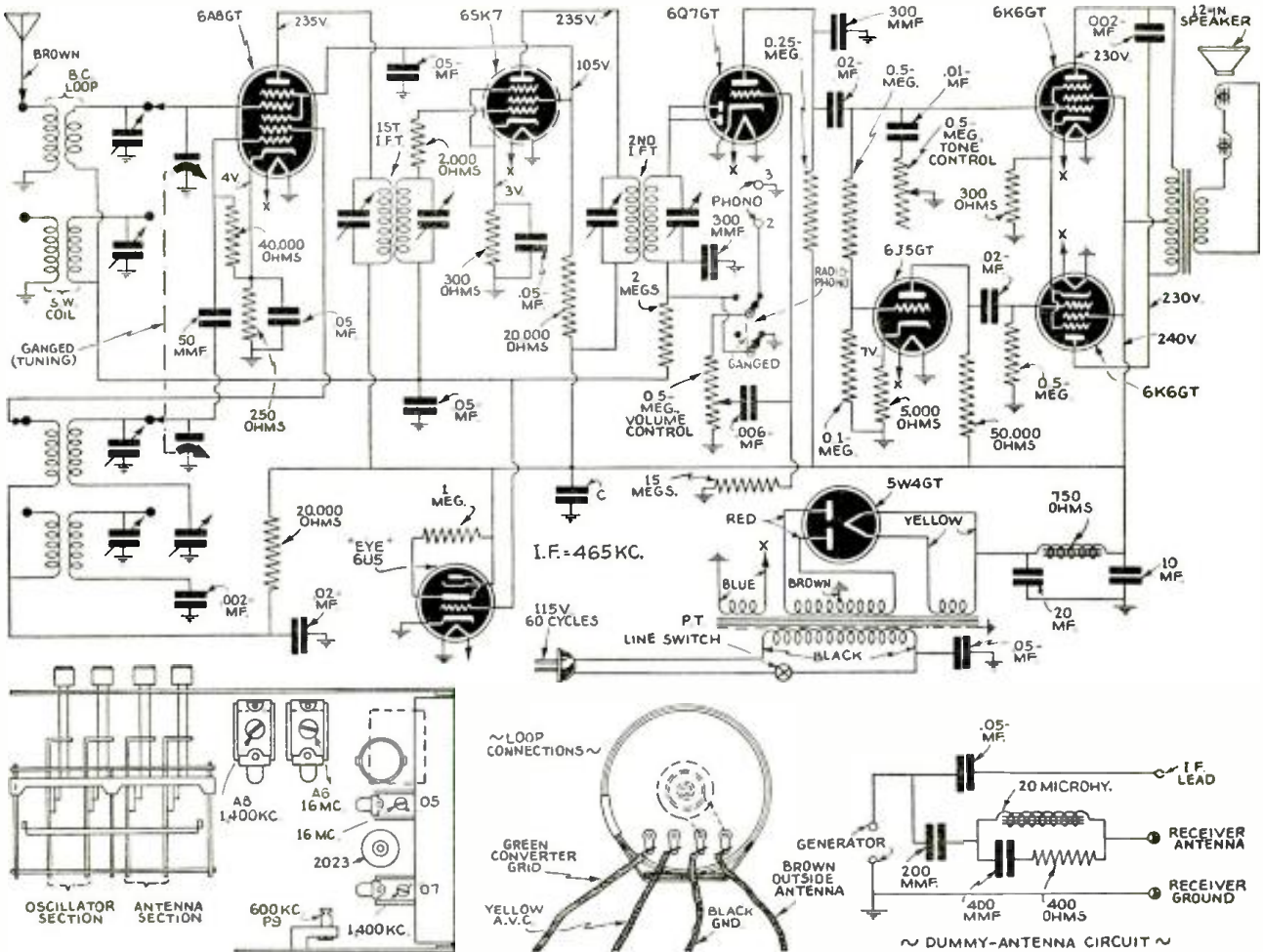

Schematic diagram, trimmer locations, loop antenna connections and dummy antenna circuit (for Alignment purposes) of the Howard 308 series chassis.

OPERATING VOLTAGES

All necessary operating voltages to properly service this receiver are given in the schematic diagram above. These measurements were taken with a 1,000-ohms/volt meter from the points indicated, to ground, the line voltage being at 117 V., A.C. The voltage drop across the 750-ohm speaker field is 75 V.

ALIGNMENT PROCEDURE

Each step of the alignment procedure below should be repeated in the given order several times, for greater accuracy. Keep the output from the signal generator low. The I.F. trimmers are reached through the 2 holes on the top of each I.F. can. The test signal should be injected into the receiver through the dummy antenna circuit shown in the diagram above. This circuit is recommended since it is usable for any frequency range. The grid cap should remain in place during alignment.

(1) With the band switch in broadcast position set the tuning condenser to minimum capacity and apply a 465 kc. signal through the dummy antenna to the grid of the 6A8 tube. Adjust the I.F. trimmers in order, starting from the 6Q7GT, for maximum response.

(2) Set the band switch to Shortwave position, the tuning dial to 16 mc., and apply a 16-megacycle signal through the dummy antenna circuit to the brown antenna lead. Adjust trimmers O5 and A6 in the given order for maximum response. When aligning the shortwave band, do not adjust to the image frequency. For example, if the adjustment is correctly made at 21 mc., then a weaker image will be heard at 21,000 kc. less 930 kc., or about 20,070 kc. on the dial. Make certain that the dial pointer is correctly positioned on its cord by turning the tuning condenser to maximum capacity and adjusting the pointer so that it is exactly on the last line above 540.

(3) Set band switch to Broadcast position, dial pointer to 1,400 kc., and introduce a 1,400-kc. signal through the dummy antenna circuit to the brown antenna lead. Adjust trimmers O7 and A8, in the order given, for maximum response.

(4) With band switch in Broadcast position, set dial pointer to 600 kc. and apply a 600-kc. signal through dummy antenna circuit

to brown antenna lead, and adjust trimmers P9 for maximum response. When adjusting this trimmer, move the tuning knob back and forth, and adjust the trimmer, until the peak of greatest response is obtained.

SETTING UP THE PUSHBUTTONS

(1) Leave the set turned on at least 15 minutes before making settings.

(2) Decide upon the 6 stations that you want to tune-in automatically.

It is preferable to set the lower frequency stations, starting with the button on the right. (3) Tune-in the station with the regular tuning knob, making certain the station is EXACTLY IN TUNE, then with the fingers, loosen the pushbutton with a twist to the left of about 1/2-turn; now push the button ALL THE WAY IN.

(4) Carefully release button, and tighten it with a twist to the right.

(5) Repeat above procedure for the other 3 buttons for 3 other stations, and insert station letter tab in position for each button.

The pushbuttons will only operate correctly when they are operated with a firm, quick thrust, keeping finger on button until dial pointer comes to a stop.



Howard model 308TT (note sloping panel).

Order your copy NOW—the only
P. A. HANDBOOK



ONLY
25
CENTS
A COPY

**MOST COMPLETE
AND AUTHENTIC
P. A. BOOK PUBLISHED**

THAT no book has yet been published which covers amplifiers and sound systems (also kindred systems) in one complete, authentic volume is almost unbelievable. Yet, it is a fact, there is no book in print which covers Public Address from A to Z. To bridge this wide-spread gap, RADIO-CRAFT will publish a complete, magnificent volume on Public Address of such magnitude—so complete and authoritative—that every man engaged in radio can have both a theoretical and practical knowledge of the function and operation of sound systems. The editorial pages are so filled with instruction and remedial illustrations that the volume fully justifies its title—1939-40 AMPLIFIER HANDBOOK AND PUBLIC ADDRESS GUIDE. This great HANDBOOK on Public Address should be read and studied by those who consistently build, service and sell sound equipment.

As complete as you would expect to find any engineering handbook—this is how the radio or P. A. man finds the AMPLIFIER HANDBOOK AND PUBLIC ADDRESS GUIDE. With essential technical data compiled from an exceptionally large number of sources, the volume covers nearly two hundred different subjects coordinating every conceivable branch or sub-division of Public Address.

To actually show the scope and magnitude of the AMPLIFIER HANDBOOK AND PUBLIC ADDRESS GUIDE, an analysis of the contents is found at the right, showing the breakdown of the material featured within each particular section. A thorough reading of the contents shows the completeness of this book.

A MATCHLESS VOLUME

THE CONTENTS

**A Resume of the Contents of the
AMPLIFIER HANDBOOK
AND PUBLIC ADDRESS GUIDE**

PREFACE

INTRODUCTION

CHAPTER I—FUNDAMENTALS

Vacuum Tube as Amplifier—Ratings—Bels and Decibels—Harmonics—Distortion—Attenuation—Gain—Ohm's Law—Bridge Circuits—Rectification—Microphonics—Condensers—Resistors—Impedance—Phase—Resonance—Inductance—Frequency—Magnetism—Shielding.

CHAPTER II—VACUUM TUBES

Voltage Amplifiers—Power Amplifiers—Control and Indicator Tubes—Rectifiers—Ballast and Regulator.

CHAPTER III—CIRCUIT ANALYSIS

Inputs—Coupling—Degeneration (Inverse Feedback)—Frequency Compensation—Outputs—Push-Pull—Phase Inversion—Class A, A-B, B, A₁, etc.—Hum-Bucking—Automatic Gain Control—Spectrum Control—Time-Delay—Tone Compensation—Voltage Dividers—Singing Chokes—Beam Power—Push-Pull.

CHAPTER IV—MICROPHONES

Carbon—Condenser—Electrodynamo—Ribbon (Velocity)—Crystal—Lapel—Uni-directional (cardioid)—Electromagnetic—Transducers.

CHAPTER V—AMPLIFIERS AND PREAMPLIFIERS

A. C.—D. C.—A. C.—D. C. (120 V.)—A. C.—D. C. (6 V. D. C.—120 V. A. C.)—Mobile—Portable—Multi-Channel—Biphonic—Preamplifiers—Monitors.

CHAPTER VI—LOUDSPEAKERS

Magnetic—Dynamic—P. M. Dynamic—Crystal—Horn Units.

CHAPTER VII—HORNS AND BAFFLES

Flat—Infinite—Octave Resonance—Exponential—Flares—Labyrinths—Eridynamic—Biphonic.

CHAPTER VIII—AMPLIFIER COMPONENTS

Resistors—Condensers—Transformers—Chokes—Fuses—Sockets—Chassis and Housings—Meters—Name Plates and Bezels—Terminals—Jacks and Plugs—Switches—Frequency Filters—Bias Cells—Tune and Volume (Attenuator) Controls—Pads—L. T. H. etc.

CHAPTER IX—POWER SUPPLIES

Power Lines—Batteries—Converters and Generators—Rectifier Tubes—Dry Rectifiers—Vibrators and Inverters—Bias Supplies—Field Exciters—Ballasts and Regulators.

CHAPTER X—ACCESSORIES

Gain Phonographs—P. A. Tuners.

CHAPTER XI—RECORDING AND PLAYBACK

Pickups—33-1/3 and 78 r.p.m. Turntables—Film, Disc and Wire—Recorders—Lateral and Vertical (hill-and-dale) Recording—High Fidelity Recording and Playback—Accessories.

CHAPTER XII—MATCHING AND MIXING

Input to Amplifier—Amplifier to Line—Line to Speakers—Pads—Attenuators—Matching Amplifiers—Booster Amplifiers.

CHAPTER XIII—ACOUSTICS

Absorption—Reverberation and Echo—Low-Level Distribution—High-Level Distribution.

CHAPTER XIV—SELLING SOUND

Ethics—Who are the prospects?—What are reasonable charges?—Sidelines—Accounting—Advertising and Publicity.

CHAPTER XV—SCHOOL SOUND SYSTEMS

CHAPTER XVI—CALL SYSTEMS

Railroads—Hotels—Restaurants.

CHAPTER XVII—INTERCOMMUNICATORS

Wire Type—Wired-Radio Type—Switchless—Multiple-Station.

CHAPTER XVIII—TALKIES

Soundheads—Amplifiers—Loudspeakers—Sound-on-Film—Sound-on-Disc—Home-Talkies—Commercial-Talkies.

CHAPTER XIX—HEARING AIDS

Tubless—Tube Type.

CHAPTER XX—MISCELLANEOUS APPLICATIONS

CHAPTER XXI—FORMULAS AND TABLES

CHAPTER XXII—TEST EQUIPMENT

Multi-Meters—C.-R. Oscilloscope—A.F. Oscillators—Output (Level) Indicators—V.T. Voltmeters.

CHAPTER XXIII—INSTALLATION PROCEDURE

Placement of Equipment (Microphones, Amplifiers, Loudspeakers)—Use of Woofers and Tweeters—Wiring—Indoors and Outdoors—Portable and Mobile Set-Ups—Permanent Installations.

CHAPTER XXIV—SERVICING

RADCRAFT PUBLICATIONS ■ 99 HUDSON STREET ■ NEW YORK, N. Y.

RADCRAFT PUBLICATIONS, INC. ★ 99 HUDSON STREET ★ NEW YORK, N. Y. RC-440
Gentlemen: Enclosed find my remittance of 25c for which send me POSTPAID, one copy of your NEW—
1939-40 AMPLIFIER HANDBOOK AND PUBLIC ADDRESS GUIDE.

Send me others, for friends, also POSTPAID @ 25c each.

Name Address

City State

Remit by check or money order; register letter
if you send cash or unused U.S. Postage Stamps.

Order Your Copy NOW—

*Clip Coupon and
Mail Today!*

DYNAMIC TESTING SIMPLIFIES SERVICING

In view of the continued interest of Servicemen, in the logical and effective servicing procedure known generally as "dynamic analysis," it is felt that the following description of a new test instrument for this use will be of interest to many readers of Radio-Craft. This article is also an exceptionally fine reference to procedure in Dynamic Testing.

HAROLD DAVIS

THE Dynamic Tester, being the only real development in the radio testing field, is an instrument the Serviceman should give careful consideration before he brands it as just another gadget.

The dynamic tester is new—in principle as well as appearance, and it is strange indeed that an instrument so simple had to make its advent in a day when complicated video circuits are the main topic of discussion. There is not a thing in the dynamic tester that could not have been given the Serviceman a decade ago, yet this new instrument is so powerful it gives him complete mastery over a radio circuit.

Dynamic testing means checking the radio set under actual operating conditions. It is concerned with the signal itself, and not with the condition that should make the signal correct and just as often doesn't. When the signal becomes affected by a defective condition, the dynamic tester permits the operator to put his finger on the defective circuit. It also permits him to eliminate those circuits which are not defective, thereby narrowing down the search.

TYPES

There are 2 general types of dynamic testers on the market: (1) those of the multi-channel variety which use the electronic eye for signal indicators; and (2) those of the single-channel, 1-probe type which have a built-in loudspeaker to permit constant monitoring of the signal, or "listening-in" at any point in the circuit. (Both types have been illustrated and described, and their uses analyzed in past issues of *Radio-Craft*.—*Editor*)

Because it was the privilege of the writer to help develop the Rimco Dynalyzer, it is around this instrument that this article is being written.

In designing the Dynalyzer, it was with the idea of producing an instrument with which the Serviceman could make every desired check on a radio receiver, using 1 instrument, 1 probe, and without jumping test leads around and throwing a multitude of switches.

The Dynalyzer consists of a 2-stage, high-gain, R.F. amplifier, having a tuning range of R.F. from 95 kc. to 15 mc., which is used to amplify R.F. signals and for use as a frequency meter. This is followed by a diode detector and a 2-stage audio amplifier driving a dynamic speaker. It has a no-current electronic voltmeter whose input resistance is never less than 10 meg.; and an ohmmeter which reads up to 10 meg. in 4 scales.

The meter is so designed that it may be thrown into the circuit to indicate R.F. or A.F. signal strength, or used individually with the probe or a pair of test leads. So much for the actual equipment. Now let's see how best to use it.

SIGNAL TRACING

To trace a signal through a superheterodyne, it is only necessary that the operator know the functions of the various tubes and their base socket connections.

R.F. and I.F.—Tune-in a station or a signal generator on the radio set under test and place the R.F. probe (which contains a small condenser) on the antenna post of the set. Tune-in the tester and observe volume. Jump the probe to the grid of the



The author is here shown using the Rimco Dynalyzer (this is the instrument in the photo to which the test cord is connected).

converter tube (1st-detector) or the grid of the R.F. tube should the set have an R.F. stage. The signal should increase considerably in volume if the set is of common design. If a decided loss in signal volume is found, the circuit is defective or out of tune.

Without attempting to realign the set, as yet, next jump the probe to the plate of the R.F. or converter tube as the case may be. If an R.F. stage is used the gain through the tube should drive the meter off-scale on the 5-volt range. (Don't worry about the meter. It will stand 100 times overload.) If the tube is a converter, it will be necessary to tune the dynamic tester to the intermediate frequency of the set to get the gain, because it is in this tube that the frequency is converted to the I.F.

setting. A signal at the signal (station) frequency will be available, but it will be weak because the circuit is tuned to the I.F.

Comparing the reading on the plate of the converter to the reading at the grid of the I.F. tube gives the condition of the I.F. transformer. A slight loss here is not uncommon, but a decided loss indicates a defective circuit or misalignment.

Gain through the I.F. tube may be had by comparing the plate to the grid reading; it should be approximately the same as the R.F. or converter. A weak tube or defective circuit is easily identified after a little experience.

The last R.F. point is the 2nd-detector, usually a diode. The signal here should be approximately the same strength as at the plate of the I.F. tube. Decided loss would be caused by the same things previously mentioned. At the diode, 2 things happen.

(1) The R.F. component or carrier, is filtered out and becomes A.V.C., to be applied to grids of R.F. and I.F. tubes. This is done through a network of high-value resistors and low-value condensers. This action may be checked by measuring along this network with the electronic meter.

(2) The 2nd thing that happens is that the audio component is separated and fed onto the grid of the 1st audio tube. To continue tracing the signal, the dynamic tester must be set to receive audio signals. On the Dynalyzer this is accomplished by throwing a single switch. To make the meter indicate AUDIO requires the throwing of a 2nd switch.

A.F.—The audio signal may be traced through the volume control to the grid of the 1st audio tube. The increase in signal strength through the 1st audio stage is sufficient to require using the 25-volt range.

The loss or gain between the plate of the 1st audio tube and the grid of the output tube depends on the type of coupling. If resistance-capacity coupling is used there will be no gain. If transformer coupling, there will be a gain depending on the ratio of the transformer. However, watch out for drivers in class B outputs. Drivers are step-down transformers and will show a loss even though they are normal.

The gain through the output tube or tubes will be slightly less than through the 1st audio, due to the amplification factor of the tube, and across the output transformer there will be a decided loss due to the difference in impedance between the plate winding and the voice coil winding.

(Continued on following page)

YOU ASKED FOR
QUALITY at a PRICE

Here it is!

Readrite
RANGER

Model
432-A



Only \$17.85 Net

- RED • DOT Lifetime Guaranteed Triplet Meter
- Sockets for All Tubes Including new 1.4-volt Miniaturs
- Filament Voltages from 1.1 to 110—A Safeguard Against Obsolescence
- Precision Indicating Instrument with Two Highest Quality Sapphire Jewel Bearings
- Separate Line Control Meter
- Neon Shorts Test
- Etched Panel of outstanding NEW Design
- Approved RMA Circuit

TODAY'S outstanding tube tester value—a guaranteed quality portable tester at a price you can afford to pay. Checks Loctals, Single Ends, Bantam Jr., the 1.4 volt miniaturs, Gameous Rectifier, Ballast, the High Voltage Series (including 11726G) and others recently announced. Direct Reading GOOD-BAD meter scale. Positively will not deactivate 1.4 volt or other type tubes.

WRITE FOR CATALOG
SECTION 416 COLLEGE AVENUE

READRITE METER WORKS, Bluffton, Ohio

FACTORY-TO-YOU SAVES YOU UP TO 50%

EASY TERMS



PUT THIS NEW
14-TUBE
CHASSIS IN YOUR PRESENT CABINET
\$19.95
COMPLETE

30 DAYS TRIAL FOREIGN RECEPTION Other models from 5 to 17 Tubes, and up to 5 Wave Bands.

Write for FREE 1940 catalog, showing complete line. (User-agents make extra money!) See MIDWEST'S Answer to TRADE-IN!

MIDWEST RADIO CORPORATION
Dept. 12-F Cincinnati, Ohio

GREATEST SLIDE RULE VALUES!



10 inch enameled slide rule, made of kiln dried genuine mahogany wood, has auxiliary removable magnifier with pins to fit (cursor) runner. This rule has inch, millimeter, sine, log and tangent scales. Packed in individual carrying case. This rule is equal in performance to a \$10.00 rule. Our special price, P.P. prepaid anywhere... **\$1.00**

8 inch slide rule in case with 36 page illustrated Book of Instructions & Examples. Parcel Post Prepaid **40c**

GOLD SHIELD PRODUCTS

Dept. RC-3-40 350 Greenwich St., New York

RADIOS SAVE UP TO 50%



REAL DIRECT-FACTORY PRICES! Over 50 models to choose from at wholesale prices. AC-DC models \$4.98 up. Portable sets \$5.98 up. Car sets \$9.98 up. Console sets \$12.98 up. Samples at 50% off list. Quantity discounts given. Send for FREE 1940 bargain catalog giving details of FREE trial and agent's proposition and discounts. No obligation, write today. **GOLDTONE RADIO CO., DEPT. RC, DEARBORN, MICH.**

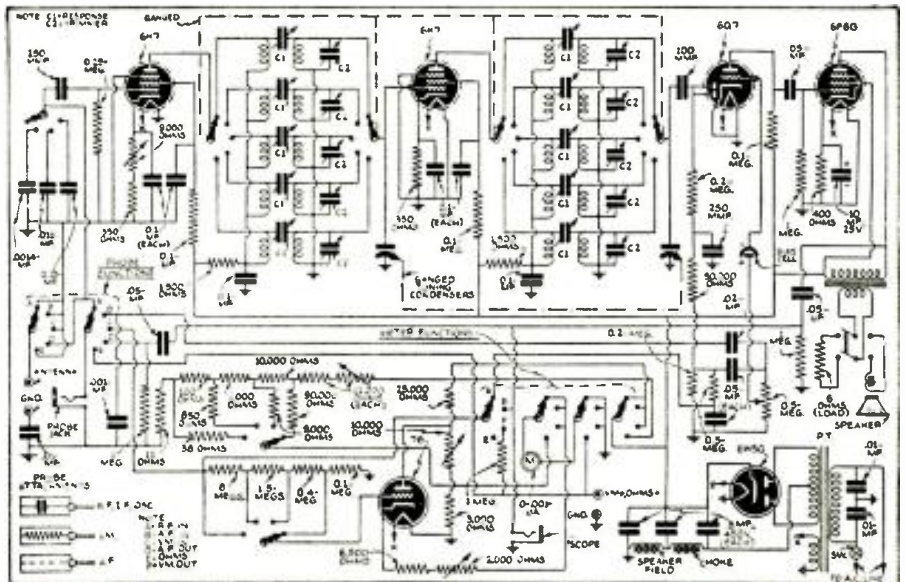

The interesting features in the Rimco "Dynalyzer" described in the accompanying article are here diagrammed.

(Continued from preceding page)

CHECKING ALIGNMENT

While the dynamic tester may be used to align a radio receiver using a station for a signal, it is of far more service as an out-of-alignment detector.

To check alignment, tune-in a station on the high-frequency end of the band (around 1,400 kc.). Add to this frequency the frequency of the I.F. (1,400 kc. plus 460 kc., for example) and set the tester at this frequency (in this case, 1,860 kc.). This should be the oscillator frequency when the set is tuned to 1,400 kc. To check this, place the R.F. probe on or near the oscillator tuning condenser. If the oscillator signal is off-resonance, it will not peak at this point, but instead, will tune to resonance at some other point on the tester dial. Peaking is indicated by the meter in the "R.F." position. Nothing will be heard in the tester speaker because the oscillator signal is unmodulated at this point.

To check alignment of the R.F. circuit, place the R.F. probe of the tester on the R.F. plate, or in case of no R.F. stage, the converter plate. If retuning the set increases the signal in the tester, the alignment is not correct. A slight variation here may be tolerated, but appreciable variation means that the set needs realignment. Disregard the signal in the speaker of the radio set when making this test, as the signal will disappear completely, of course, as the set is retuned.

To check I.F. alignment, place the R.F. probe on the plate of the I.F. tube and tune tester to maximum signal, which should be somewhere near the I.F. of the radio receiver. Next jump the probe to the diode, or to the plate of the 2nd I.F. tube. If the 2 I.F.'s do not peak exactly on the same frequency, the I.F.'s need re-aligning.

ALIGNMENT

To make adjustments to the R.F. and oscillator circuits, place the R.F. probe on the plate of the converter tube. Short the oscillator section of the tuning condenser (which stops oscillator), and tune the tester to the frequency of the station or signal being received. This must be a station near the alignment frequency specified by the manufacturer (usually, around 1,400 kc.). Adjust the antenna and R.F. trimmers for maximum intensity in the tester. The electronic meter, thrown to the "R.F." position, will serve perfectly as an output meter.

After the R.F. adjustments have been made, remove the short from the oscillator, and adjust the oscillator high-frequency trimmer to maximum signal in the tester with the tester set at the I.F.

Now tune set to a station or signal around 600 kc. and adjust the low-frequency padder in the same manner. Rocking the condenser gang will not be necessary. For careful alignment, repeat the procedure.

Adjustments to the I.F. circuits may be made by leaving the tester tuned to the I.F. and jumping the probe to the last I.F. point (usually, the diode). It will not be necessary to make actual contact at this point because the signal is now strong enough to be picked-up in the tester with the probe clipped to an insulated wire in the circuit. This is called "loosely coupling" to the circuit and its advantage is that it does not detune the I.F. With the tester coupled in this manner, adjust the trimmers to maximum reading on the meter, remembering to always use minimum signal into the radio set being aligned.

FINDING TRIMMERS

The dynamic tester is very useful in finding trimmers when alignment data is not available. To do this, tune-in a station or signal around 1,400 kc. Set the tester on the same frequency, and touch the R.F. probe to the various trimmers until the signal is found. The R.F. signals will be heard on the R.F. trimmers. As all the R.F. trimmers are adjusted to the same frequency, in most sets, it is not necessary to distinguish them; however in case of R.F. stages the various trimmers can be identified by their signal level. (The 2nd R.F. stage will be louder than the 1st, etc.)

Oscillator trimmers are easily found. Add to the frequency of the signal being received on the radio set the I.F. of the receiver. Tune the tester to this frequency, and watch the meter for indication. (Nothing will be heard in the tester speaker, as previously explained.) Usually the low-frequency padder will indicate less signal than the trimmer when the set is tuned to 1,400 kc., or thereabout.

Trimmers for the shortwave bands may be located similarly by using signals in the respective bands, but misleading harmonics must be watched-out for.

INTERMITTENTS

Intermittent operation is the bugaboo of radio servicing, yet with the dynamic tester,

•TEST INSTRUMENTS•

even this condition is simplified.

Intermittents can be quickly localized to either the R.F. or A.F. end by tying the R.F. probe into the radio set at the last R.F. point. (Usually, the diode of the 2nd detector.) Monitor both the speaker in the radio and the one in the tester. An interruption in the radio speaker that does not affect the tester, means that the trouble is in the audio section. Interruption to both means that the signal is being affected in the R.F. end as well as the audio. The electronic voltmeter may be tied into the high-voltage line to see if the interruption affects the voltage.

After the trouble has been localized to either the A.F. or R.F. end, the tester may be moved, 1 stage at a time until the defective stage is located.

MAKING ESTIMATES

The dynamic tester enables the Serviceman to give quicker and more accurate estimates. If there is more than one defect in a radio receiver, it is not necessary for him to repair one thing before he can find another. Cases where the oscillator, one of the I.F.'s, the 2nd-detector and the output transformer were out of commission have been found without making any temporary repairs. Servicemen are constantly getting into trouble by making estimates which do not include some unforeseen defect.

The Rimco Dynalyzer has a feature which permits a station to be tuned-in on the tester, and the audio output then fed out through the probe. This A.F. signal may be fed into the radio set under test at the 1st audio stage, and the entire A.F. end of the set tested within a single operation.

Intermediate frequencies may be checked by feeding an I.F. signal into the set and picking it off at any point with the tester.

ELIMINATE "CLIPPING"

With a little head work, the Serviceman can locate many defective parts without the usual clipping-out and resoldering into circuit. Bypass condensers are in a radio set for 2 purposes: (1) to pass A.C. and (2) to block D.C. Resistors are used to drop voltages and furnish return paths. The electronic voltmeter, because it draws absolutely no current from the circuit, may be used to a big advantage to analyze these conditions. Direct-current drops across defective condensers point out these defects. The amount of voltage dropped across certain resistors will often lead the Serviceman to the defective part.

FOR HAM RIGS

The dynamic tester is a handy gadget to have around the ham rig. Percentage of modulation and field strength measurements may be made with it. It will provide a very efficient means of neutralizing, and it is a good frequency meter and monitor.

As in servicing receivers, it may be used to trace signal failure and out-of-tune transmitter conditions. Standing waves on the lead-in and antenna may be observed, and distortion localized. On the Dynalyzer a plug has been provided for connecting an oscilloscope. This permits the operator to look at the waveform at any point. The electronic meter ranges may be extended to read high voltages.

This article has been prepared from data supplied by courtesy of Harold Davis, Inc.

Story of Radio Broadcasting

CBS BOOKLET. 32 pp. Titled "The Magic of Radio Transmission." Gives a clear, highly interesting and instructive picture of modern radio broadcasting—a la the CBS pattern. Includes information on trans-Atlantic shortwave news pick-ups, etc. Don't miss it.

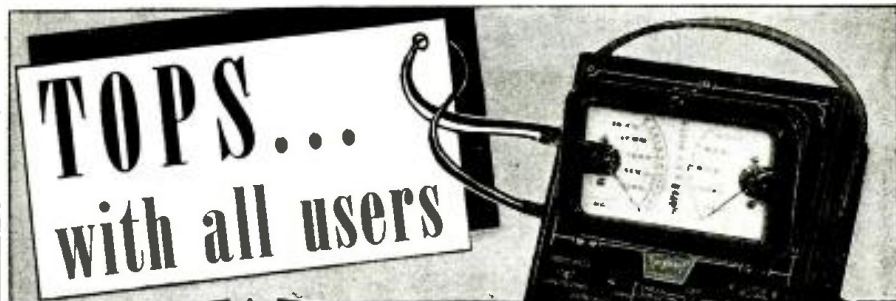

TRIPLETT VOLT-OHM- MILLIAMMETER

WITH RED • DOT LIFETIME
GUARANTEED INSTRUMENTS

Model 1200-A has separate AC and DC instruments in tilting twin case, accuracy of each within 2%. This exclusive Trip-lett feature permits adjustment of twin instrument to angle in direct alignment with reader's line of vision. AC-DC Volts 0-10-50-250-500-1000; DC MA 0-1-10-50-250; low ohms, 1/2-500; 1500 ohms; 1 1/2 and 3 megohms. Has two RED•DOT Lifetime Guaranteed Instruments. . . . Sturdy metal case with black suede enamel finish. Etched panel is silver and red on back.

Write for Catalog . . . Section 164, Harmon Drive

TRIPLETT ELECTRICAL INSTRUMENT CO.
Bluffton, Ohio

Model 1200-A

Only \$23.84 DEALER NET.

NEW 1940 BATTERY TESTER

Model 696 speedily checks all dry batteries under proper loads. Eleven loads from 1 1/2 to 125 available by selector switch control. . . . This tester is the first to provide a GOOD sector for all dry batteries in common use. . . . Model 696 also can be used as a 1000 ohms per volt Voltmeter with nine DC ranges: 4 3 10 25 50 75 100-150 volts. Net Price \$7.84



DATAPRINTS



TESLA-ODUIN HI-FREQ. COILS
20c Ea. in order for 10 (Data and Drawings only.)
36" Sp'k Tesla-Oudin Coil 40c (1 K.W. Exc. Trf. Data, included FREE!)
8" Sp'k Tesla-Oudin Coil 40c (1/4 K.W. Exc. Trf. Data, included FREE!)
3" Sp'k Oudin; 110 Vt. "Kick Coil" type. . . . 40c
3" Sp'k Tesla Works on Ford Sp'k Coil 40c
1" Sp'k Violetta Hi-Freq. Coil 40c
Model Warships—Get List of Plans



Induction PIPE & ORE LOCATOR

Induction Type, Data 40c
Gallo Type 40c

More DATAPRINTS 40c each!

5 Meter Superhet.	Resistance Measuring Bridge
1 1/2 Meter Tr. & Rec.	Weld. Transf. 2 K.W.
20 A.C. Probs. & Ans.	Re-winding Armatures
20 Telephone Hook-ups	String Galvanometer
100 Mech. Movements	20 Simple Bell Circuits
20 Motor Hook-ups	Steel Wire Recorder!
Television Hook-up	Electric Pipe Thawer
20 Elec. Party Tricks	Water Wheels or Turbines
Solenoids and Magnets—get list.	Photo Cell and Relay
Fry Eggs on Ice!	Ring 4 bells on 2 Wires
Experimental Photophone	20 Tesla Tricks
Radio Control for Models	Polarized Relay
Diathermy Apparatus	Induction Balance
Inductor Organ	

Special Prices: 4 prints \$1.00; 10 for \$2.00; Single, 40c each. Get New Catalog 100 A.

The DATAPRINT Co.
Lock Box 322C, Ramsey, N. J.

Size of box: 12 1/2" x 8 1/2"

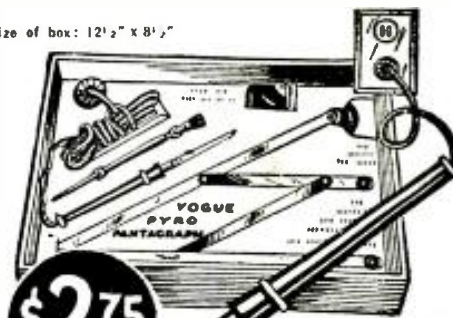

\$2.75

Shipping Wt. 3 lbs.

VOGUE
**Pyro
Pantagraph**

With this PYRO PANTAGRAPH turn leisure time into profitable hours. Make money a novel, easy way—"Burn Your Way to Extra Dollars with Pyro Pantagraph."

This electrical outfit is especially designed for burning designs permanently on Leather, Wood, Cork, Gourd, Bakelite, etc. Simply plug the Pyro-electric pencil in any 110-volt AC or DC outlet and it is ready to be used. Plug and cord furnished as part of equipment. By the use of a special Pantagraph included in the outfit, any design may be reproduced either in original, reduced or enlarged form. Outfit consists of: one Pyro-electric Pencil; one Pantagraph; three hardwood plaques; one bottle of Varnish; one Brush; one tracing tip and four-page instruction sheet.

Outfit will be forwarded by Express Collect if not sufficient postage included with your order.

WELLWORTH TRADING COMPANY
1915 S. State Street, Dept. RC-440, Chicago, Ill.



Fig. 1. The front-view photo of the completed hi-fi recording-playback sound amplifier, showing the cover in place; the various controls are identified as follows: pushbuttons (at left of the decibel meter, top to bottom)—Playback, Dialogue Filter, Record; (right) 0 Db., +20 Db., +30 Db. Bottom row of controls (left to right)—Mikes Nos. 1 & 2, Playback, Master Gain, H.F. & L.F. Controls.



The amplifier rear view, above, shows the tubes mounted on an anti-microphonic base. Unit includes the following features: Variable high and low inverse frequency compensation with concentric constant-current inverse feedback inverter; humless push-pull beam power output; dialogue filter; low-level, noiseless, non-frequency discriminating gain controls (adapted for remote control).

A LOW-COST PUSHBUTTON AMPLIFIER

For Recording and Playback



We suggest that you read the group of questions on the facing page before continuing with the article (below). This high-fidelity sound amplifier, in addition to incorporating many features never before presented in a professional-type unit, also provides for playback of either constant-amplitude or constant-velocity records. A complete educational description of design principles, involved in engineering a high-quality amplifier for recordists, is given here.

portance, invariably leads to a specific design. The order of tabulation, however, is dependent upon the ultimate application. For our immediate purpose, it was decided to head the list with cost and let all other factors become of secondary importance. As the actual selling price is of prime importance in design considerations, it was decided to limit this to \$35, plus \$12 for a choice of a calibrated and compensated DB., or VU meter with any

THE problem of economically producing a really good recording and playback amplifier has undoubtedly intrigued many professional design engineers and recording technicians. With the present-day high development of engineering skill and manufacturing technique, it is possible to build into a recording amplifier any exaggerated characteristic. Such an accomplishment, as a matter of fact, is not nearly so difficult as the designing of a unit in which there is a well-balanced relation between response, flexibility, quietness, fidelity, dependability, power output, size, weight, and cost.

Tabulating these characteristics, in the order of their im-

A. C. SHANEY and H. A. FOGEL

3 selectable ranges. Now let's analyze this objective still further.

FEATURES

With a selling price of \$35 in mind, it was decided to incorporate the following features:

- (1) Overall Gain: 110 db.
- (2) Playback Gain: 80 db.
- (3) Hum Level: 70 db. below recording level
- (4) Two Independent Microphone Input Channels (with

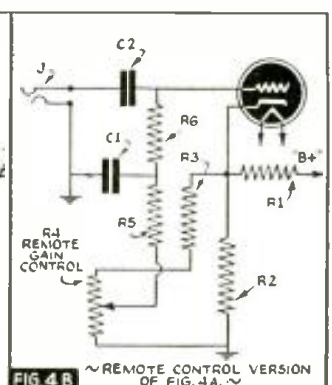
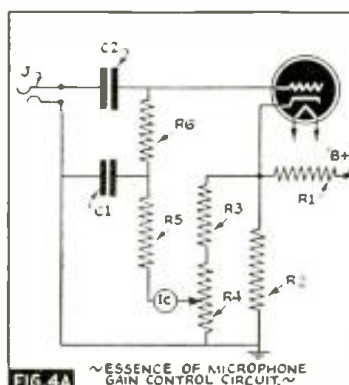
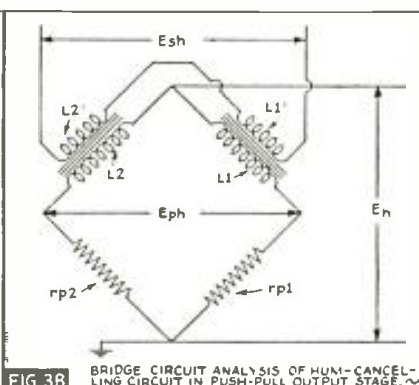
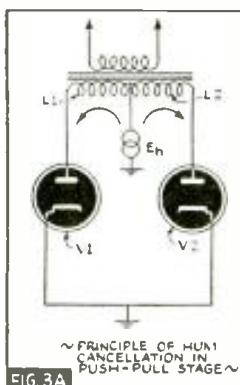

Circuit details. In Fig. 3B, the reference letters are: Eh, filter hum; Eph, hum in pri.; Esh, hum in sec.; L1, inductance 1/2 output; L2, ditto; L1', 1/2 sec. output; L2', ditto; rp1, static plate resistance, V1; rp2, ditto, V2.

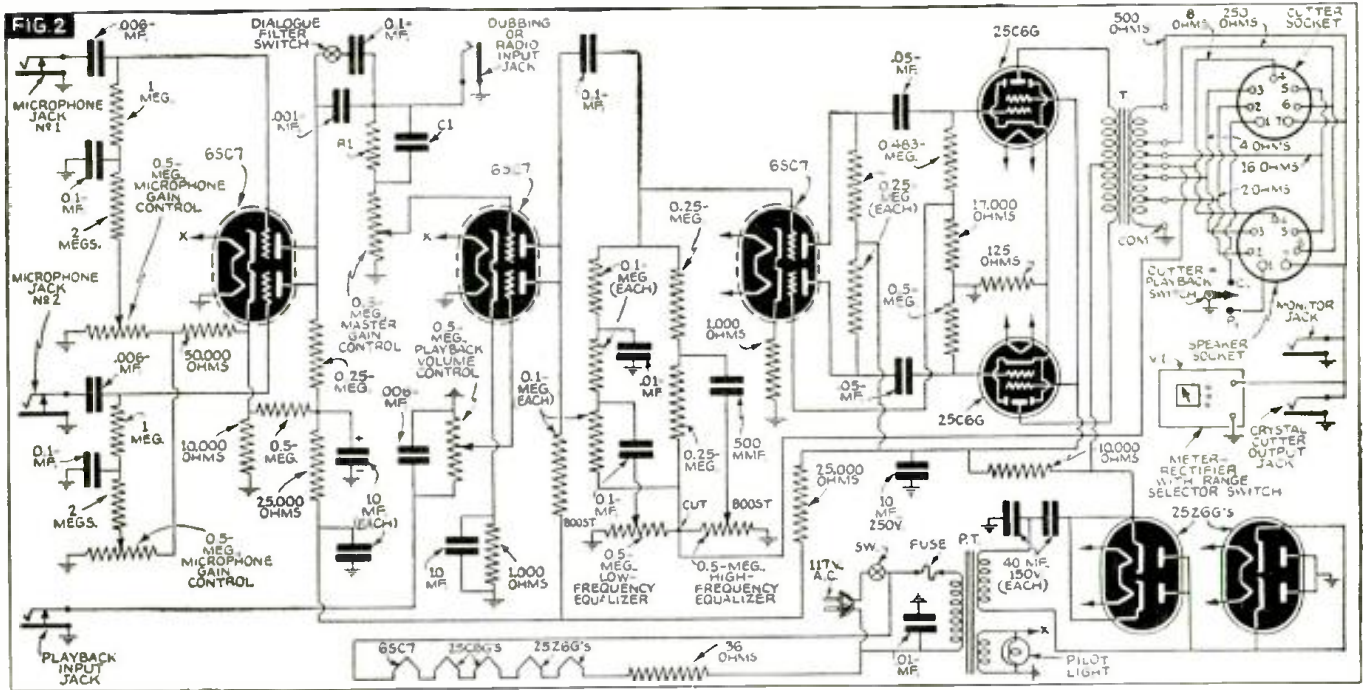

- (1) separate gain control)
- (5) Dubbing or Radio Input Channel
- (6) Separate Playback Channel (with individual gain control)
- (7) Master Volume Control
- (8) Independent High-Frequency Accentuation and Attenuation
- (9) Independent Low-Frequency Boost and Cut Control
- (10) Electronic Mixing Facilities
- (11) Dialogue Filter
- (12) Optional Remote Control of Microphone Gain Controls
- (13) 7-Watt Playback Level (3% Harmonics)
- (14) Push-Pull Beam Power Output
- (15) 2-Watt Recording Level (0.75% Harmonics)
- (16) Universal Magnetic or Crystal Cutter Output Impedance Terminals
- (17) Universal Speaker Terminals (4/8/16 250/500 ohms)
- (18) Monitoring Jack (for headphones or bridging amplifier)
- (19) Pushbutton Changeover from Record to Playback
- (20) Peak Power Output 10 Watts (6% Harmonics)
- (21) Voltage-Doubling Power Supply
- (22) Power Line Isolating Transformer

- (23) Frequency-Compensated VI Meter (optionally calibrated in VU or DB., and with triple-range pushbutton selection)
- (24) Economical Power Consumption
- (25) Light Weight
- (26) Compact and Portable

CAN YOU ANSWER THESE QUESTIONS?

Author's Suggestion: Write your answers before reading the text, but after studying the complete circuit diagram of Fig. 2. Credit yourself with 6.7% for each correct answer, and check your ratings against the following average tabulation.

100%	Design Engineer
93%	Field Engineer
86%	Assistant Engineer
79%	Studios Factory Wireman
60%	Studios Serviceman
40%	Average Serviceman
20%	Average Dealer, Technical Hobbyist
None	Non-Technical Enthusiast

- (1) Why is it possible to have less hum in this amplifier than one of standard design employing conventional brute force filter circuit? (Note extreme simplicity of filter circuit and total absence of chokes!)
- (2) Explain the operating principles of the independent low- and high-frequency "boost" and "cut" control circuits.
- (3) Why can this amplifier be used for recording or playing back constant-amplitude and constant-velocity records?
- (4) Name 3 design factors (aside from cost) which determine the size of the voltage-doubling filter condensers.
- (5) Why is the impedance of the secondary of the power transformer of prime importance in the design of the rectifier circuit?
- (6) Give 2 good reasons for using a 36-ohm resistor in series with some of the heaters. (Note all of the heater voltages add up to 118 volts and could have been connected directly across the line.)
- (7) Why was the center-tap omitted from the 6-volt winding?
- (8) What precautions have been taken to prevent rectifier failure?
- (9) What precautions have been taken to prevent filter condenser failure?
- (10) What is meant by the "ballistic characteristics of the VI meter"?
- (11) What are the 2 functions of the 0.006-mf. condenser across the playback volume control?
- (12) How would you select the proper size fuse for the amplifier?
- (13) Give at least 3 advantages of the microphone gain-control circuit.
- (14) What portion of the circuit compensates for the distributed capacity of the wiring and the input capacity of mixer and voltage-amplifier tubes?
- (15) Why are the microphone gain-controls admirably adapted for remote control applications?

THE FINISHED MODEL

The research, design and test data required to span the gap between the listing of the desired features and the production of the final laboratory-approved and field-tested amplifier, fills more than 100 pages with calculations, tabulations and test data. (Ed. note: Engineering research and design procedure may be covered in a future issue if interest in this phase of the development work is exhibited by readers.)

The final design, however, is illustrated pictorially in Fig. 1 and schematically diagrammed in Fig. 2. From a casual observation of this diagram, one may easily be led to believe that conventional design is prevalent throughout. A closer examination, however, will undoubtedly reveal a number of interesting and original circuit and design features.

CIRCUIT FEATURES

LOW HUM LEVEL

(A.1) The following information answers question No. 1 in the numerical listing at left.

Everybody agrees that one of the prime requisites of a good recording or playback amplifier is low hum level. With identical power supply filters, a push-pull output

WE APOLOGIZE!

To you, and our many friends and customers, who have found us tardy in shipping amplifier orders, we apologize.

Frankly, we've been snowed under by the unanticipated response to our exclusive amplifier refinements and developments.

Because our brilliant staff of design engineers, headed by A. C. Shaney, insists that every amplifier be individually custom built, no high speed mass production or testing methods are employed in our factory and laboratory. To assure performance in accordance with our high laboratory standards, time is taken for the individual assembling, wiring, inspection and testing of each amplifier.

Naturally, an unexpected deluge of orders may cause a temporary production gap, resulting in delivery delays.

We believe that all customers are entitled

to the same rapid service, whether they are our large clients such as Western Electric Company, Electrical Research Products, Inc., Johns Manville, Columbia Recording Co., Decca Records, Inc., C. G. Conn, Ltd., International Projector Corp., Federal Recorder Co., Sonotone Co., or our smaller accounts.

Therefore, by doubling the size of our staff we have inaugurated a new rapid delivery policy which guarantees shipment of standard amplifiers within 3 days, special amplifiers within 14 days, special power and audio transformers within 7 days, electronic equipment within 20 days, A.C. line voltage regulators within 14 days, regulated D.C. power supplies within 14 days, filter networks within 10 days, and special amplifier equipment requiring research, within 30 to 60 days, depending on complexity of the problem.

AMPLIFIER CO. of AMERICA
17-45 WEST 20th ST. NEW YORK, N. Y.



OPERATES ON
 110-VOLT, 60-CYCLE
 A.C. LINE

WE SHIP ELECTRIC DRY
 SHAVER THE SAME DAY
 YOUR SUBSCRIPTION
 ORDER IS RECEIVED.

Get This Electric Dry Shaver
ABSOLUTELY FREE!

JUST THINK OF IT—you can get absolutely FREE, the useful DRY ELECTRIC SHAVER which is shown at the left. This ELECTRIC DRY SHAVER is sent to you by the publishers with a one-year subscription to RADIO-CRAFT.

Here Are the Features of the ELECTRIC DRY SHAVER

Constructed of metal with attractive red bronze finish. Scientifically constructed to give a perfectly clean shave. 5-foot rubber insulated cord and plug. Constructed to last for many years.

Operates from 110-volt, 60-cycle A.C. electric line. Carries a two-year manufacturer's guarantee. A fine quality, self-sharpening toilet necessity.

Send your subscription to RADIO-CRAFT for One Year (12 issues) and receive absolutely FREE one of these remarkable Electric Dry Shavers. New subscribers are accepted or you may extend your present subscription another twelve months. Mail your remittance of \$2.00 (plus 25c for shipping charges on Shaver) to the publishers. (Canada and foreign \$2.75.) You will receive your DRY ELECTRIC SHAVER immediately by return mail. Use coupon below to enter your subscription.

RADIO-CRAFT

89 Hudson Street, New York, N. Y.

RADIO-CRAFT, 89 Hudson Street, New York, N. Y.

Gentlemen: Enclosed find my remittance of \$2.00 for which enter my subscription to RADIO-CRAFT for one year (12 issues). Send me immediately FREE, ELECTRIC DRY SHAVER (Canada and foreign \$2.75). In U. S. add only 25c additional to cover shipping charges on Shaver.

New Subscriber Extend Present Subscription

Name

Address

City State

(Send remittance by check, money order or unused U.S. Postage Stamps. Register letter if you send cash or stamps.) RC-4-40

CLIP COUPON—
 AND MAIL!

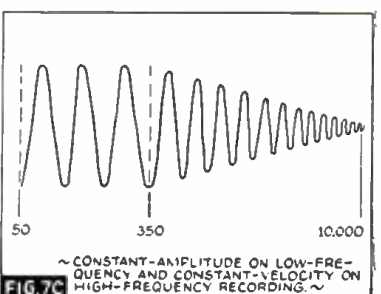
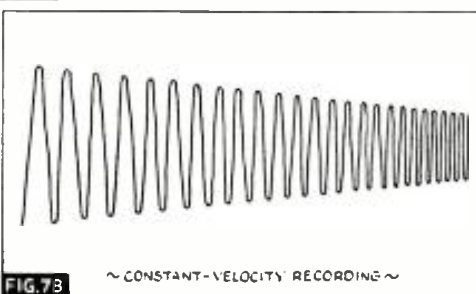
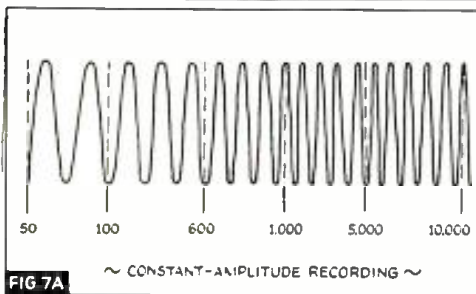

stage produces much less hum than a single-ended stage. As a matter of fact, any hum originating in the power supply should be cancelled in the output transformer. The principle behind such cancellation is illustrated in Fig. 3A. An instantaneous hum potential E_h is impressed through the primary of the output transformer L1, L2 to the plates of V1, V2. As the hum potentials are flowing in opposite directions, they create opposing flux in the iron core and cancel. Figure 3B shows a bridge circuit analysis of this common phenomenon. This circuit is the same as Fig. 3A. No matter how large the filter hum may be, no voltage will develop across E_{ph} as long as the bridge is balanced. In practice, it is difficult to perfectly balance this bridge unless unusual precautions are taken in the design of the output transformer and selection of output tubes having identical plate resistances. In the final circuit, it was found that the residual hum was introduced in the inverter circuit. To eliminate this source of trouble, this hum was amplified and fed back 180° out of phase to affect complete cancellation.

Careful output transformer design and 20 db. of hum-voltage feedback actually resulted in lower hum than that encountered in conventional (and expensive) recording amplifiers employing brute-force filter circuits!

DUAL MICROPHONE AND GAIN CONTROL CIRCUIT

(A.13, A.15.)

The problem of providing an economical, noiseless, low-level, electronic mixing, and non-frequency-discriminating gain control has received a considerable amount of attention from many engineers. The circuit finally employed proved to be a good practical solution. Its principle of operation depends upon changing the gain of the high- μ triode by increasing or decreasing its bias within predetermined limits.

Referring to Fig. 4A, it will be noted that a fixed bias is applied to the cathode (k) through the voltage-dividing network R1, R2. This bias is made high enough so as to considerably reduce the stage gain. An auxiliary voltage-dividing network, R3, R4, is placed across the bias voltage. As R4 is varied, the bias is increased or decreased to respectively increase or decrease the amplification factor of the tube. Limiting resistor R3 prevents zero bias. The grid current (Ic) would normally produce disturbing variations in contact potential of R4. The resistance-capacity filter network R5, C1, effectively bypasses any such variations. In fact, if the time constant of R5, C1 is large enough, it will bypass any hum potentials picked up by its associated wiring.

As practically no current flows through the center-arm circuit, the control may be placed at a point remote from the amplifier at any distance, and remote control attained without the use of shielded cable or hum pick-up. Since the control is not in the signal circuit proper it has no frequency discriminating characteristics whatsoever. By utilizing a twin-triode tube, and tying

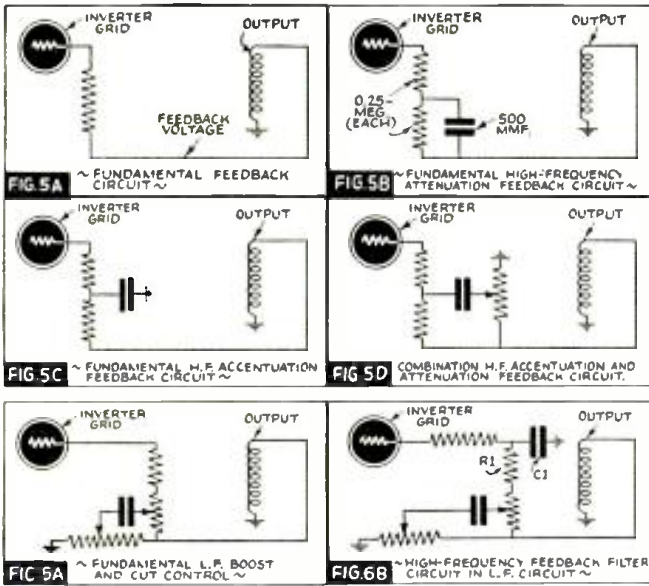

In the group, at left, of related diagrams—a circuit "family"—are shown the circuit variations by means of which various arrangements for feedback produce changes in frequency response. While there may be a strong tendency by experimenters to construct this amplifier of junkbox parts, it is strongly recommended that the special output and power transformers be employed. (To avoid undue electrostatic and electromagnetic hum pick-up, precautions should be taken in wiring the input circuit.)



both plates together, electronic mixing is attained.

RADIO OR DUBBING INPUT
(A.14.)

An auxiliary input feeding to the master volume control provides input facilities for radio, dubbing, or additional phono input. A high-frequency compensating network composed of R1 (50,000 ohms), and C1 (100 μmf.), provides a high-frequency boosting network to compensate for high-frequency losses due to stray wiring capacities shunting the input and output, and the capacities of the preamplifier and voltage-amplifier tubes.

PLAYBACK CHANNEL
(A.11.)

It is assumed that a crystal pickup will be employed for playback purposes. As is well known, the low-frequency response of the crystal pickup is determined by the shunt resistor across it. Since it was considered undesirable to employ an exceedingly-high-value control, it was found necessary to use a 0.006-mf. condenser across the 1/2-meg. potentiometer finally selected. This condenser does *not*, as is popularly supposed, cut high frequencies; instead, it lowers the overall output level and, at the same time, brings up the low-frequency response. This circuit phenomenon is characteristic of all crystal pickups, because they exhibit condenser-like properties. (The average crystal pickup may be considered equivalent to a 0.001-mf. condenser.)

THE FREQUENCY-COMPENSATING NETWORK
(A.2.)

To understand the principle of operation of this particular circuit, it is first necessary to briefly review the fundamentals of feedback frequency compensation.

Figure 5A shows the fundamental feedback circuit. As there are no frequency discriminating networks involved, all frequencies are fed back equally, and a fixed amount of degeneration is always present. If, however, the frequency-compensating network is introduced so as to increase the amount of feedback for some predetermined frequency, the gain at this frequency will decrease because degeneration has been increased. This ultimately results in frequency attenuation. Similarly, if the feedback is decreased for any predetermined frequency, the overall gain of the amplifier is increased at this frequency, resulting in frequency accentuation.

Figure 5B shows attenuation of high fre-

quencies by bypassing resistor R2 with a small condenser.

Figure 5C shows accentuation of high frequencies by cutting off the high-frequency feedback from the grid-return circuit. By introducing an additional potentiometer which enables a gradual transition from the circuit of 5B to 5C, and vice-versa, as illustrated in Fig. 5D, we have an independent high-frequency accentuation and attenuation control.

The low-frequency boost and cut control operates in a similar manner, as illustrated in Fig. 6A, with the exception that a higher-capacity condenser and slightly different value of network resistors are employed. As the low-frequency circuit, in its basic form, will affect the high frequencies, it is necessary to insert an additional filter, R1, C1, which is illustrated in Fig. 6B. By combining the circuits of Figs. 5D and 6B, we have our independent high- and low-frequency accentuation and attenuation circuits. Note that the high-frequency branch (the resistor network only) always passes a constant amount of all frequencies below 1,000 cycles. This provides for the desired hum-cancelling feedback circuit.

CONSTANT-AMPLITUDE AND CONSTANT-VELOCITY RECORDING AND PLAYBACK
(A.3.)

In *constant-amplitude* recording, a constant sound pressure for all frequencies at the microphone will cut all frequencies at the same amplitude, as basically illustrated in Fig. 7A. This characteristic is predominant in crystal cutting heads.

In *constant velocity* recording, a constant sound pressure for all frequencies produces the same cutting needle speed. Thus, of necessity, the higher frequencies exhibit a decreased amplitude, and conversely, the low frequencies produce an increase of amplitude, to provide a constant amplitude 7B. This characteristic is predominant in magnetic cutting heads. Naturally, this latter method necessitates excessive room between grooves for the lower frequencies, and it therefore becomes necessary to decrease record playing time.

As this is a decided disadvantage the *lower frequencies, from 350 cycles down, are usually cut at a constant amplitude, as illustrated in Fig. 7C.*

In recording technique, it is either necessary to compensate the cutting head or the amplitude, to provide a constant amplitude below 350 cycles. It is also desirable to accentuate the high frequencies so that a close approximation of constant-amplitude

WHY THE DEMAND FOR UTAH SPEAKERS IS GREATER THAN EVER BEFORE

The *balanced line* of Utah Speakers has won a continually increasing preference from every branch of the radio and sound equipment industries. It is a preference earned by time-proven dependability, uniformity and consistent high quality.

Utah engineering keeps abreast of the developments and improvements in both industries. Ruggedness, adequate power handling capacity and outstanding tone quality are built-in characteristics of service-free Utah speakers.

Wherever you use speakers, you can use Utah speakers with assurance of satisfactory performance. Utah engineers will gladly help you solve your speaker problems.



UTAH RADIO PRODUCTS COMPANY

826 Orleans St., Chicago, Ill.

Canadian Sales Office:

414 Bay St., Toronto, Canada

Cable Address: Utaradio, Chicago

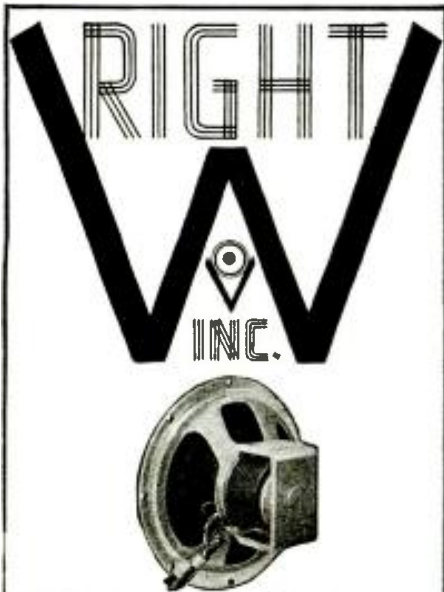

WRIGHT
Verified
SPEAKERS
CREATE
CONFIDENCE

Catalogue mailed on request
WRIGHT, Inc.
2233 University Ave., St. Paul, Minn.

Simplest WAY TO REPLACE **BALLASTS**

4 STANDARD TYPES of Amperite Regulators replace over 200 types of ACDC Ballast Tubes now in use. . . . Has patented automatic starting resistor.
List \$1.00

WRITE FOR REPLACEMENT CHART "S"
Amperite Co. 561 Broadway, N. Y. C.

AMPERITE

DIRECT-COUPLED AMPLIFIERS

Absolute Fidelity

ENGINEERED BY **A. C. SHANEY**

Write For Complete Details and Attractive Proposition

AMPLIFIER COMPANY of AMERICA
3145 WEST 10TH STREET NEW YORK CITY NEW YORK

WEBSTER
PHONO-MOTOR

Self-starting, rim-driven, constant-speed (78RPM). Friction-drive is preferable wherever driving torques are low and quietness is all important, as in a phonograph. Motor with 9" felt covered turntable operates on 117 volt, 60 cycle only. Shipp. wt. 6 lbs. Price Each **\$2.69**

WE REQUIRE A 25% DEPOSIT WITH ORDER
Write For Our Latest Bargain Parts Bulletin
ARROW SALES COMPANY
618 W. RANDOLPH ST. CHICAGO, ILL.

recording is attained for the higher frequencies. This condition increases the signal-to-noise ratio and effectively reduces surface noises. During playback, the high frequencies can be attenuated without affecting the high-frequency balance.

It is therefore apparent that when a crystal cutting head is employed, which records with constant amplitude, the frequency-compensating network should be adjusted for flat response, unless it is desired to compensate for any irregularities in the microphone or associated circuit. On the other hand, it is desirable to provide overall attenuation of the low frequencies when using a magnetic cutting head. As most of these cutters have a naturally low-frequency-attenuating characteristic, it is sometimes desirable to slightly boost the lows in order to compensate for any excessive losses incurred in the head itself.

It can therefore be seen, that the type of compensation circuit provided, enables recording or playback of both constant-velocity and constant-amplitude recordings.

THE DIALOGUE FILTER

The *dialogue filter* provides for an additional low-frequency cut. This circuit becomes effective at the turn-over frequency of 350 cycles. It is beneficial for the crisp reproduction of voice, but should not be used while recording musical selections.

THE VOLTAGE-DOUBLING POWER SUPPLY AND POWER LINE ISOLATING TRANSFORMER (A.4, A.5, A.7, A.8, A.9, A.12.)

No doubt, many technicians will be surprised at the power supply circuit employed. The rectifier tube, type 25Z5 (which is a prototype of the 25Z6G) has undoubtedly received unfavorable criticism in the service field because of improper application. This condition, upon investigation, was found to be caused mainly by excessive peak plate currents. This in turn was caused by feeding the power line directly into the rectifier tubes. As no appreciable impedance was present, excessive condenser-charging currents continually overloaded the tube, until breakdown occurred. Subsequently, series limiting resistors were recommended to keep charging currents within a safe value.

It was found, by further investigation, that an *isolating transformer* produced 3 desired effects:

- (1) Isolated the chassis proper from the power line and avoided any undue shocks.
- (2) Kept the line currents out of the chassis and considerably reduced hum pickup.
- (3) The introduction of a correctly-designed transformer furthermore provided the necessary impedance within the filter circuit so as to always keep the charging currents well within the maximum limits prescribed by tube manufacturers.

Furthermore, an amplifier designed with such an isolating transformer, will meet with both the American and Canadian Underwriters Laboratories requirements.

The choice and size of voltage-doubling filter condensers is affected by:

- (1) The desired filtering action required;
- (2) Peak safe charging current of the rectifiers;
- (3) Working voltage of the condensers, and;
- (4) The safe current per mf.

By carefully coordinating these limiting factors, it was found that a 40-mf., 150-volt condenser provided the ideal solution. It was found, that approximately 110 volts were applied across each of the 40 mf. condensers, thereby providing a safety factor of 36.5%. Furthermore, the peak voltage under any condition of operation never ex-

ceeded 150 volts, a safety factor of 50%.

While the selection of the proper fuse normally receives no unusual consideration, it was decided to check possible causes of failure within the amplifier to see what effect they had on primary current. The following checks were made:

TEST	PRI. CURRENT
Short-circuit of secondary	2.5 amperes
Short within rectifier tube	1.6 amperes
Short from "B+" to ground	1.6 amperes

As the peak short-circuit current is 2.5 amperes, it was decided to use a fuse which would open at 1.6 amperes. A fuse rated at 1 amp. serves this purpose.

THE HEATER CIRCUIT (A.6.)

Although the total voltage requirement of the series heaters adds up to 118.9 volts, it was found to be undesirable to apply these heaters directly across the line, for the following reasons:

(1) To reduce hum, the voltage amplifier and inverter 6SC7 could not be taken off ground potential. This immediately suggested the use of a separate 6-volt filament winding within the isolating transformer.

(2) When using series heaters directly across the line, a considerable amount of instantaneous current flows when the heater circuit is cold. This excessive current tends to eject the heater from its supporting medium. Furthermore, the rapid change in temperature sometimes causes opens within the heater circuit, and tends to produce heater-to-cathode shorts. A series limiting resistor of 32 ohms will not only make up the required difference in voltage, but also act as a ballast resistor.

Under actual tests, it was found that the 6SC7 provided less hum with one of its heater terminals grounded, than when a conventional center-tap method was used.

THE OPTIONAL-SCALE FREQUENCY-COMPENSATED VI METER (A.10.)

During the transitional period required for universally adopting the standard VU nomenclature, meters are being supplied with a choice of calibration in db. or VU.

In using a VI (volume indicating) meter for recording purposes, it is of prime importance that the ballistic characteristics of the meter be taken into consideration. If a meter is too slow-acting, over-cutting may take place before compensation can be affected, whereas if a meter is too fast-acting, it produces annoying eye fatigue. The new accepted standard for meter ballistic characteristics is such that the sudden application of a single frequency voltage of such value as to give a steady-state rating of 0 VU (or 100 mark), will cause the pointer to over-swing by 1% to 1½% (0.1- to 0.15-VU). The pointer speed should be such that under the same condition, a deflection of 99% of the steady-state value is reached 0.3-second after the sudden application of the single frequency voltage. Needless to say, the meter should be compensated for frequency, and should not exceed ± 0.1-db. of the 1,000 c.p.s. value over a frequency range from 35 to 10,000 cycles.

The overall power consumption of this amplifier is approximately 0.7-amp. Its overall size is 14 ins. long x 8½ ins. high x 7 ins. deep. Total weight is approx. 15 lbs.

The writers will be pleased to answer any questions relative to this versatile Recording and Playback Amplifier if a stamped and addressed envelope is enclosed. Simply address inquiries care of *Radio-Craft*.

This article has been prepared from data supplied by courtesy of *Amplifier Company of America*.

SOUND ENGINEERING

*Free Design and Advisory Service
For Radio-Craft Subscribers*

Conducted by A. C. SHANEY

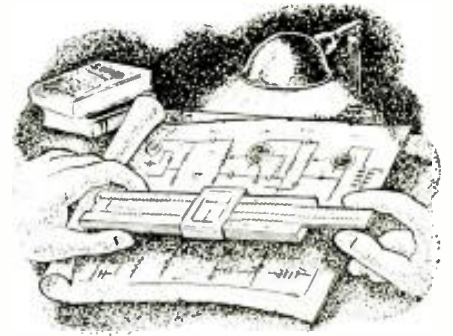

This department is being conducted for the benefit of RADIO-CRAFT subscribers. All design, engineering, or theoretical questions relative to P.A. installations, sound equipment, audio amplifier design, etc., will be answered in this section. (Note: when questions refer to circuit diagrams published in past issues of technical literature, the original, or a copy of the circuit should be supplied in order to facilitate reply.)

No. 4

The Question . . .

I have been reading with interest your articles in *Radio-Craft*, and in considering the many things that can be done with amplifiers, I thought of another function that might be incorporated, and which I believe would help considerably in reducing feedback in P.A. work.

It occurred to me that if it were possible to prevent the microphone from picking up any sound at all until the sound reached a predetermined level of intensity, there would be little or no feedback. For the sound coming from the original source would be much stronger than the feedback from the speakers and therefore only the original would be amplified. In other words, it would operate like Q.A.V.C. on a radio set. That is, unless someone were actually speaking or playing into the microphone, the system would be absolutely dead regardless of the volume control setting.

I have neither the engineering ability nor the laboratory facilities to work this idea out, so I am submitting it to you for your consideration. The cutoff level could undoubtedly be made variable and would be independent of the master volume control. It would also have the advantage of preventing embarrassing "under the breath" remarks from getting into the P.A. system as so often happens.

Hoping that my idea will prove worthwhile, I am anxious to learn what results

you get should you decide to work it out and give it a trial.

PAUL F. FERRY,
Glenfield, Pa.

The Answer . . .

The problem of feedback has always received a considerable amount of attention from all design engineers. As you know, feedback usually occurs only when a signal actually emanates from the loudspeaker, and gets back into the microphone.

With your contemplated arrangement, the system would be dead during the no-, or low-signal-level periods. During this time, however, feedback does not start. With your arrangement, as the signal level increases, the normal gain of the amplifier would be restored. Therefore, under normal conditions of operation, feedback would exist.

The quiet automatic volume control or Q.A.V.C. principle, as used in radio sets, consequently can not be applied to P.A. work.

There are 2 possible plans which eliminate feedback. One is to decrease the gain of the amplifier as the output level rises above a predetermined feedback threshold level. This method of attack, together with the design considerations of a suitable amplifier, was completely described in the July, 1936 issue of *Radio-Craft*, page 22. This amplifier circuit, Fig. 1, has proved to be

admirably adapted for suppression of feedback.

Another method of attack would be to use an auxiliary microphone placed somewhere near the loudspeaker, and connected to the input of the amplifier out-of-phase with the microphone used for voice pick-up. If feedback should develop, the feedback howl picked up by both microphones would cancel out and the only signal remaining would be that picked up by the voice microphone. We have done a considerable amount of work on this type of feedback suppression, and intend to completely describe it in a forthcoming issue of *Radio-Craft*.

HEARING-AID WITH 1½-V. LOCTAL TUBES

The Question . . .

I have in the past designed and built various hearing-aids for customers and would like to have your advisory service on one which I propose to build.

I wish to build a battery-operated hearing-aid using the 1½-volt tubes with a 45-volt "B" supply (preferably, to cut down the weight). Three stages will be required for the proper amplification since a crystal microphone will be used.

I wish to incorporate a transformer and switching facilities in the input also, so the amplifier will be readily shifted to the telephone line. On the output I will use a featherweight headphone. The D.C. resistance is 2,000 ohms. I notice your schematic of a preamplifier in January *Radio-Craft*, on page 403, of which 1 channel could be adapted for this purpose. Bias

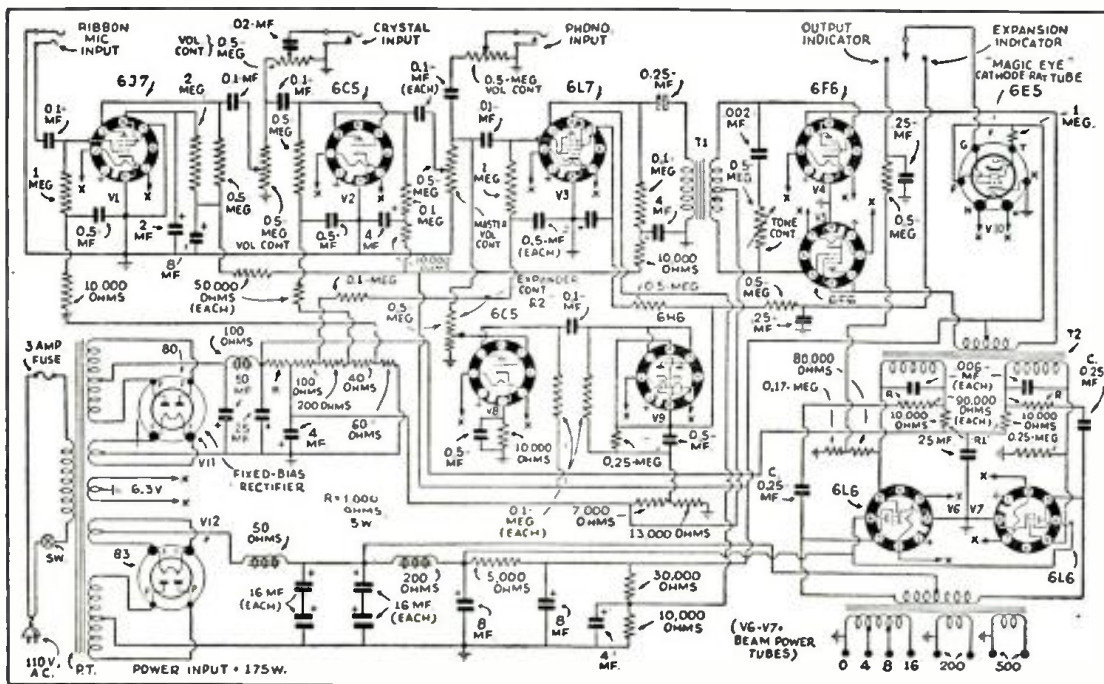

Circuit Diagram of An Anti-Howl Amplifier Described In The July, 1936 issue of *Radio-Craft*. The value and rating of resistor R in the voltage divider is given here (it was not given in the original presentation).

Do You Want PRICE Plus Quality?

Wright-DeCoster gives you replacement speakers of unquestionable quality at prices that will surprise you.



Write for full particulars

WRIGHT-DECOSTER, Inc.

2251 University Ave., St. Paul, Minn.
Export Dept.: M. Simons & Sons Co., New York
Cable Address: "Simonsrice"

Canadian Representatives:

Wm. F. Kelly Co., 1207 Bay St., Toronto, Ontario
Taylor & Pearson, Ltd., Edmonton, Alberta



UNIVERSAL "PRECISION"

Low priced sensitive recording head. Gives clear, clean recordings with ample "highs." Stays put. No adjustments needed at any time. Mounts quickly and easily on any machine. 15 ohms. 2 watts input. Full range of frequencies. If your dealer cannot supply you, write direct.

LIST
\$22.50

Catalogs now ready

UNIVERSAL MICROPHONE CO., LTD.
424 Warren Lane Inglewood, Calif.

NEW AUDIOGRAPH Sound Catalog

AUDIOGRAPH Sound Systems represent the latest in Sound Engineering and Design—a complete line plus pre-tested accessories.

NEW LOWER PRICES
Outstanding quality and performance at prices that help you meet any competition.

WRITE FOR FREE COPY
JOHN MECK INDUSTRIES
1313 W. Randolph St., Chicago, Ill.

BE SURE TO READ THE ANNOUNCEMENT WHICH APPEARS ON THE INSIDE FRONT COVER OF THIS ISSUE.

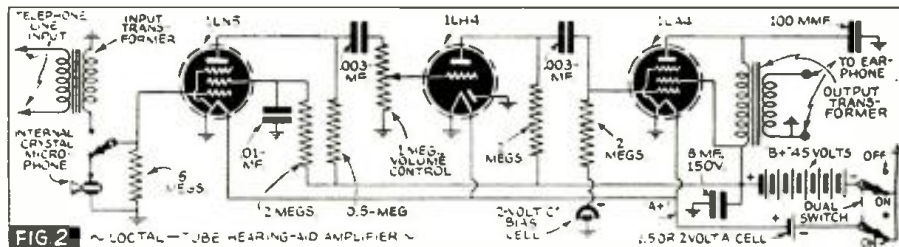

FIG 2 ~ LOCAL-TUBE HEARING-AID AMPLIFIER ~

cells could be used in place of the "C" and components changed for the 45-volt supply.

However, I have found that tubes such as types 75 and 1H5G seem more adapted for hearing-aids by using the triode section and ignoring the diodes. I have noted that some new, miniature, 1½-volt tubes are coming on the market and of course would contribute to compactness and performance, provided they would be fully as good a tube as the present 1½-volt types.

I have built an amplifier using the English XPD and XVS series of midget tubes, described in *Radio-Craft*, and incorporating automatic audio volume control and found it very unsatisfactory, so if the standard 1½-volt tubes will be any better it would be best to design it with them or the small local equivalents of the 1H5G could be used (that is, the 1LH4).

I had in mind the use of an electric 1½-volt power pack to substitute for the batteries when he is using it in his office. My customer is an attorney and will use this in his office on the 110-volt current and use the battery when the amplifier is used as a portable such as in the court room.

The size need not be such that it is "wearable" but can be approximately 5½ x 6 x 3½ inches, in size.

I would like to have you draw up a good, reliable circuit, giving component capacities and resistances, and I can design the layout and constructional details.

M. C. TURNER,
Precision Radio Service,
Langdon, North Dakota.

The Answer . . .

The type of amplifier you desire is schematically shown in Fig. 2. You will note that the input has the desired switching facility for switching from the internal crystal microphone to an external telephone

line. The transformer employed, for best results, should be of the high-fidelity "miniature" series and may be obtained from any transformer manufacturer. Its input impedance should be approximately 500 ohms and its secondary impedance approximately 50,000 ohms.

If the unit is to be placed in the vicinity of A.C. fields, it will be desirable to have this transformer adequately shielded to avoid external hum pick-up.

In order to attain maximum efficiency, an output transformer is employed to couple the output of the amplifier to the headphone you intend to use. The primary impedance of the transformer should be approximately 25,000 ohms, and the secondary should match the impedance of your phone. This transformer should be capable of handling 100 milliwatts without core saturation. It can likewise be obtained from any transformer manufacturer.

As size is not of importance, I have taken every precaution to insure both reliability and high-fidelity performance. You can easily replace the "A" and "B" batteries with one of the many commercial power supplies being offered.

You should have no difficulty in housing the entire hearing-aid in the dimensions you gave.

The new miniature-type 1½-volt tubes would contribute greatly to compactness. A complete story covering a "wearable" hearing-aid amplifier utilizing these tubes is scheduled to appear in a forthcoming issue of *Radio-Craft*.

About 2 years ago, the author of this department heard a hearing-aid amplifier which was designed and manufactured in England. This unit utilized XPD and XVS tubes and employed A.V.C. It performed remarkably well, and we therefore believe that the unit you built may have had some circuit error or defective component.

ITALIAN TELEVISION RECEIVER



Last month *Radio-Craft* received from Allocchio Bacchini & Co. (Milan) these illustrations of the newest in Italian television equipment. The compact arrangement evident in the exterior view is explained by reference to the interior photo at right. The arrangement of the coils for magnetic deflection eliminates astigmatism.

CASE HISTORIES OF P.A.
SALES—NO. 7

(Winner of 6th Prize in Section I of Radio-Craft's P.A. Contest in 1939.)

● I WILL endeavor in this letter to explain as briefly as possible a P.A. installation which I made recently at the Federal Shipbuilding Company, located in Kearney, N. J., for the launching of a U. S. Destroyer.

To start with, the job was one of those last-minute requests; having 2 other jobs at the time I had only a 20-W. amplifier on hand. Knowing that I would be called upon to handle some 3,000 to 5,000 people, I would have to take every precaution to obtain results. I assembled my equipment in my car and proceeded to the job.

The launching was to be at 10 A.M. and I arrived there at 8:30 A.M. I proceeded to look over the job. First to see if A.C. current was available, which it was. I will try to picture for you the launching set-up as I looked it over. The ship to be launched stood in between 2 other ships, one on each side, which were about 50 ft. apart. The sponsors' stand rose up about 20 ft. from the bottom of the ways. There was a seating capacity for about 800 people around the bottom of the sponsors' platform, which was of course of temporary construction.

I then started to mount my speakers, using three 12-in. speakers with aluminum dome baffles. I did not have to throw the sound out a great distance as the people would be all gathered around the ship. Placing one speaker in the center and one on each side, I tried the arrangement out, using a phono hand recording, until I felt that I had proper coverage.

In making P.A. installations I always carry along an A.C. voltmeter to check line voltage, and when I checked same, I found I had only about 90 V. Knowing that the amplifier would be called upon for peak performance I used a step-up transformer which I have hooked-up with several taps. I then could keep the line voltage to a proper point.

The only microphone available was a velocity mike: as there was a fairly high wind blowing I tested it for a proper location. I might also add that I have had very good results with the above mike for outside work, although plenty of my friends have had trouble.

The speakers were hooked up to a 500-ohm line and were checked to make sure they were in phase.

I furnished recorded band music for about a half-hour before the dedication and also after the dedication; everyone seemed quite satisfied with the results. I experienced little difficulty with echo and feedback with the short dome baffles I was using. A list of the names and make of the equipment follows.

Speakers—Utah 12-in. P.M. dynamic

Amplifier—Lafayette 20-W.

Microphone—Amperite velocity

Dome Baffles—Atlas Sound Corp.

Phono—Lafayette crystal

P.S. I was told that other sound installations had been made there, using larger amplifiers and speakers, but that they had been troubled with echo (due, probably, to the use of an excessive power, or to the speaker set-up). I had no trouble with the above set-up.

WILLIAM ROBINSON,
Hill Radio Sales & Service,
Belleville, N. J.

SUBSCRIBE NOW!—

and thus make sure you get May Radio-Craft "hot off the press." It will be worth making sure you receive it early!

SOUND TIPS ABOUT THE SOUND THAT'S TOPS



THE performance ratings on a great many sound products are often as unreliable as wildcats.

It will pay you to recommend RCA Commercial Sound because you can rely on RCA ratings. Every RCA rating may be proved by test. That means you can use RCA Sound products with confi-

dence in their ability to give first class performance. And nothing else helps so much to make a man successful as *customer satisfaction*.

Remember—RCA has had more experience in sound amplification than any other company in the business. You do a more profitable business—with RCA Commercial Sound!

RCA Mfg. Co., Inc., Camden, N. J. • A Service of Radio Corp. of America

FOR FINER SOUND SYSTEM PERFORMANCE—USE RCA TUBES

GET A REAL ELECTRIC DRY SHAVER ABSOLUTELY FREE

Complete details as to how it is possible to get a Real Electric Dry Shaver FREE, appear on Page 606 of this issue. TURN TO IT NOW!

**PERFECT REPRODUCTION FOR STUDIO OR HOME
RECORDING-PLAYBACK AMPLIFIERS**

Designed by A. C. Shaney

YOU'LL WANT to know more about our entirely New

Series of Professional Recording-Playback Amplifiers, because they offer features usually found only in the most expensive laboratory and studio equipment.

Ideal for studio recordings or for the hobbyist who makes his own recordings.

FREE BOOKLET describes three economical, versatile recording-playback amplifiers.

Write or Wire Today for Complete Details and Unusually Attractive Prices.

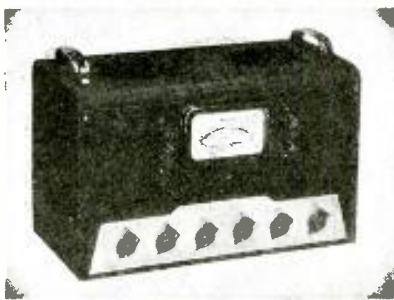

AMPLIFIER CO. OF AMERICA

17 WEST 20th STREET NEW YORK, N. Y.

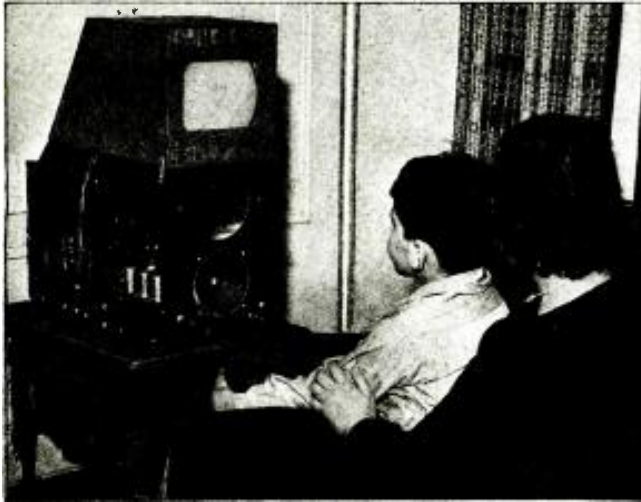

Complete plans for building the basic "5-inch" Meissner television kit, around which the conversion procedure was later developed, appeared as Part I in the November, 1939, issue of Radio-Craft. Part II, in the March, 1940, issue, described the entire mechanical and electrical sequence for utilizing a 9-inch Kinescope. Here, in Part III, aligning information and final check-up details are given. The result is a large-screen (even a 12-inch C.-R. tube may be used!!), 441-line teleceiver experimenters may build at much less cost than a set originally designed for large-screen images.

Converting a 5-inch Telly Kit

FOR RECEIVING A 9-INCH IMAGE

CHARLES SICURANZA

Part III (Conclusion)

In last month's issue we gave details on the construction of the 4 add-on units. In the course of the experimental work, it was found necessary to revise certain portions of the original circuit to conform with the new conditions.

Those readers who bought the earliest kits found that the circuit called for a 6F6 video output with *shunt* peaking, while later kits used an 1852 video output with *series* peaking. In each case the circuit constants were based on a video response flat to nearly 3 mc. This was changed in our case to series and shunt peaking, *flat* to 4 mc. The data required in the making of the 2 peaking coils is given in Fig. 22.

These coils should be fastened to the safety wall on the main chassis, as close as practical to the video output socket, taking care that no other parts or wiring come nearer than 1/2-in. to either coil.

In outlying districts where the signal level is poor, you may find that the passing auto traffic disrupts image synchronism to an annoying extent. This is because the sync. separator input was purposely adjusted to give a feeble pulse. When ignition interference over-rides this pulse, "tearing" of the image and loss of synchronism result. The sync. pulse may be strengthened by removing the 2-meg. resistor in the cathode circuit of the image detector, replacing it with a 1-meg. resistor, leaving the 4,000-ohm resistor in series with it as before. This procedure should be attempted only when absolutely necessary, however.

PRELIMINARIES

Assuming that the 4 units are completed, and have been double checked for possible errors, place the deflecting yoke over the stem of the Kinescope as far forward as it will go. The yoke terminal lugs should face to the rear. Now put the yoke plug in its socket and see that the

6-prong Kinescope socket is slipped on to the base pins of this C.-R. tube. The high-voltage lead ending in the bakelite cup is slipped over the metal cup on the side wall of the image tube.

Every tube should be in its place, **having first made certain that every tube is in good condition.**

An important point—the tubes with which the image I.F. channel was aligned should be numbered, and thereafter never switched around without good reason, as this may seriously alter the original response curve.

Another important point: never operate the set with the yoke disconnected from its socket as the result will be a blown 6L6 and a burned spot on the screen of the Kinescope.

GET SET!—

Now we are almost ready to plug the set into the line. First, turn the Brightness control to its Minimum position; then set the Focus control at its midway point; next set the Contrast control at about halfway-on; and finally, set the Vertical and Horizontal Amplitude controls at their center marks.

Standing in front of the set, at your left-hand side are the 7 controls for the sweep system. The 2 positioning controls are placed one above the other, the upper one moves the raster up or down while the lower one moves the raster from left to right. Once these controls are properly set they may not need readjustment for months.

Around the corner from the positioning controls we have 5 controls in a row—the first one (nearest your hand) is the *vertical speed* control. This control and the one after it, the Vertical Amplitude control, both function exactly the same as before. The 4th and 5th knobs are, respectively, Horizontal Amplitude, and Speed—these 2

controls also work the same as before.

The 3rd knob, however, is a new addition to the family and is called the Vertical Linearity control. The function of this control is to enable the operator to adjust the spacing between the lines of the raster evenly from top to bottom. Its function is affected by the Vertical Amplitude control and also to some extent by the Vertical Positioning control. In general, once the linearity control is correctly set, preferably on the test pattern, it will seldom require readjustment.

Note that the 2 most used controls, namely the Vertical and Horizontal Speed are placed 1st and last, respectively, in the row. Thus you can easily memorize their location and avoid upsetting the other controls.

READY!—

With all this in mind, plug the set into an A.C. receptacle that is really handy, so that you will be able to yank the plug out instantly if something should go wrong.

GO!!

If everything is working properly, you snap the power switch to ON, and this is what will happen:

1. After a few seconds you will hear a faint, shrill note emanating from the Horizontal sweep circuit—this is normal.

2. As the Kinescope warms up you will see a narrow white line expanding vertically from top to bottom. This line denotes the Vertical sweep is working and because of the smaller tubes, gets into action a few seconds sooner than the Horizontal sweep. The vertical line is extinguished in a few seconds because as you remember, the Brightness control was set at minimum and since this control is in the cathode of the Kinescope (which is warming up) the electron beam is soon cut off by the current

flowing through the Brightness control. Under normal conditions this current amounts to 1/2-milliamper.

3. You should hear a slight hum from the speaker, if you are standing within 2 feet of the cone. A loud hum signifies heavy overload.

4. Advance the brightness control slowly up to the medium bright level. *Note carefully that if only a single vertical line or a single horizontal line or, worst of all, only a bright spot is visible—yank the plug immediately and start looking for trouble in the "sweeps."* Normally however, you will see a rectangular raster.

5. With the contrast control set at minimum, no signal will reach the Kinescope grid, consequently no sync. pulses or noise voltages reach the sweeps. They are running free; and the scanning lines horizontally should be clean and straight, from top to bottom. When the contrast control is turned full on, all kinds of noise voltages trip the sweeps at odd moments causing the raster to take on a ragged appearance at the edges.

6. If a signal is on the air, adjust the horizontal and vertical speed; then adjust the height and width of the image to fill the mask opening; and finally, center the image properly. Last but not least the linearity control should be adjusted so that the vertical wedges in the inner circle of the test pattern are of equal length. It is rather difficult to make this adjustment correctly on subject matter in motion.

A final point to remember is not to use too much contrast as it is easily possible to overload the video output tube—resulting in a "washed-out" image; or, in case the sync. separator is over-driven, a ragged double image.

7. It may happen that the reading matter on the screen of the Kinescope is reversed. If so, transpose the 2 Horizontal leads at the deflecting yoke. If the image is upside down, rotate the deflecting yoke 180 degrees until the image is straight side up. For mirror viewing you must intentionally reverse the reading matter (at the yoke) so that the mirror reflection reads straight.

To keep the yoke snug up against the bell of the C-R. tube, simply wrap a narrow strip of ordinary writing paper around the stem of the tube and then slide the yoke over the paper, up to the bell. From the foregoing it can be seen that the operation of the set is practically the same as before the conversion.

SERVICING

Now let us shift over to the gloomy side of the picture and see how many things can go wrong with a telly set. As the writer pointed out in a previous article, a *telly set "gone wrong" practically tells you where and what ails it, quite often unmistakably!*

We will enumerate below some of the troubles which actually occurred from time to time over a period of 4 months. Strangely enough these troubles always occurred when the set was first turned on. In other words the set had been working perfectly when switched off and whatever defect was about to happen was helped along by the high "surge" voltages at the start of operation.

1. The high-voltage power supply (7,000 V.) once arced intermittently from the rectifier socket to the shell of the power transformer. Besides sparking, sizzling and sputtering, the raster on the Kinescope waxed and waned both in size and brightness. Should the high-voltage supply fail gradually you will see that the raster gets smaller and dimmer in proportion to the extent of

The photos at left (see facing page) and right show the ex-5-inch telly kit as revised, at comparatively low cost, to operate larger viewing tubes. The photo at left shows the 9-inch Kinescope in place; "the missus" and a small member of the author's family get real pleasure out of the tele-show.

Photo at right shows a 12-inch cathode-ray receiving tube, in its protective "overcoat," used experimentally to prove that the converted kit-set is well able to drive even this large size of C-R. tube!

BE SURE, when working on this television receiver, to observe the instructions given on pg. 555 of the preceding issue under the heading "SAFETY FIRST!"

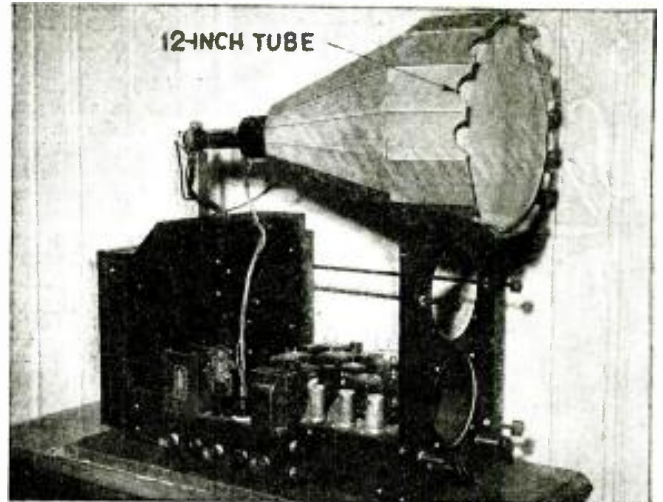

the failure of the supply. Look first to the 2X2 rectifier; then check the 2 filter condensers for leakage; and finally, check the voltage divider resistors for breakdown.

2. Failure of the medium-high-voltage supply (1,700 V.) will be evidenced by complete loss of focus and some loss in brightness. Check for trouble in the same way as before.

3. Failure of the low-voltage supply is evidenced immediately by the absence of the raster and the presence of the single bright spot. Note that this same trouble can be caused by leaving the yoke disconnected or by failure of the "B" supply to the sweeps (only). Check the circuit in the usual way, for shorts, opens and defective tubes.

4. If the screen is blank (no spot, nor raster) and the Brightness control has no effect over its full range, only 2 things can be wrong; either there is no high voltage (7,000 V.) or the Kinescope cathode circuit is open.

Connect, momentarily, a 500,000-ohm carbon resistor from chassis to the cathode prong of the Kinescope socket. If the screen lights up instantly then the trouble is definitely in the cathode circuit. If, on the other hand the screen does not light up, the trouble is just as definitely in the high-voltage supply.

5. Another form of trouble associated with the Brightness control is evidenced by inability to darken the screen of the Kinescope. Three causes were found for this trouble: (1) leaky or shorted 1-mf. condenser from Kinescope cathode to ground; (2) burned and shorted Brightness control; and, (3) leakage from grid to cathode within the Kinescope. Almost the same effect can also be had by removing the video output tube from its socket.

6. When the sound program comes through OK but with no image reception, look for open screen-grid, cathode, or plate resistors, in the image I.F. channel. This is likely to happen whenever one of the 1852 image tubes "goes sour," as these tubes draw as much as 50 ma. when they short.

7. If the sync. separator tube or circuit should go bad the result will be a succession of drifting images both vertically and horizontally. No amount of knob twiddling will bring the image into sync. Almost the same action occurs when reception is extremely weak, but in this case the drifting images will be speckled with noise voltages.

8. Complete or partial failure of either sweep is self-evident by noting the size and

appearance of the raster. Always check the tubes first, the yoke windings next and the remaining components last.

TESTING VIDEO RESPONSE

The instruments required for testing the video response are the usual shop oscillator and vacuum-tube voltmeter (with known input capacity). The V.-T.Vm. is connected through a blocking condenser of 0.1-mf. to the Kinescope grid, and chassis. Start the frequency run at the lowest possible frequency (about 50 to 100 kc., in most generators). With a known input of 0.1-volt of unmodulated R.F. on the video output tube grid, measure the output voltage between Kinescope grid, and chassis. Note reading (and frequency) on paper. Now feed 0.1-volt at 500 kc. to the video grid, and again note output on paper.

Continue this procedure from here on, in steps of 500 kc. and each at 0.1-volt, until a frequency of 5 mc. is reached. The voltage output readings should be within 5% from 50 kc. up to 4 mc., at which starting point the voltage readings should become higher, denoting a resonant rise is occurring in the peaking circuits. This is a normal action for this type of circuit.

We could not list in the above space, all the possible troubles that might crop up, but the writer will be only too glad to render any possible assistance to those readers who run into some unusual trouble. Just state your problem clearly and address it to the writer in care of *Radio-Craft*.

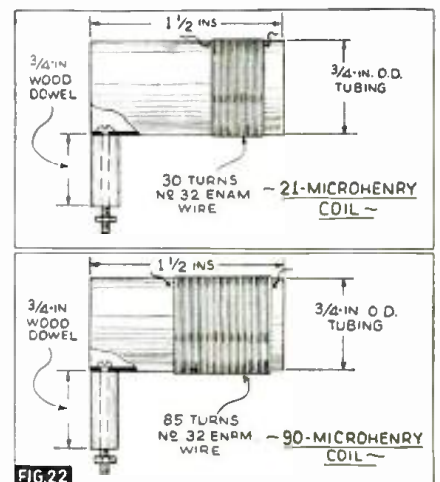

3 MONEY SAVING

"Sylvania Helps"

THAT HELP YOU SELL

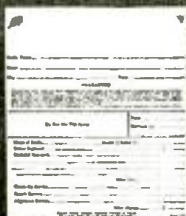

YOUR NAME AND ADDRESS IMPRINTED ON ALL FORMS

1. Save time and money and get more business through Sylvania's latest service helps. You'll want the Three-in-One Service Form that combines your invoice, guarantee, job record card and a promotional follow-up card for mailing.

2. Many servicemen and dealers use Sylvania's Job Record Card and find it's the handiest way to keep things straight. This new form combines your job record, a record for the customer and a guarantee.

3. Sylvania's "Guarantee Package" is a business getter. It provides you with a "selling guarantee" and repair recommendation form all in one. There's a customer guarantee form and a large one for your shop.

You can order as few as 100 of any of these Sylvania helps all imprinted with your name—at bargain prices. Send the coupon—today—for samples of these money savers.

HYGRADE SYLVANIA CORP. RC-10 Emporium, Pa.

Please rush free samples and prices of your

- 3-in-1 Form
- Job Record Card
- "Guarantee Package"

Name

Address

City State

SERVICING QUESTIONS & ANSWERS

(Continued from page 592)

(A.) We believe you will find the trouble to be an open primary winding (or shorting) of the output transformer or a shorted condenser which is usually connected from plate to chassis for high-frequency bypass.

Either condition will cause the symptoms indicated although the former condition is indicated by the scratchy, crackling noise and very low audible signals.

DISTORTION, HUM, INSENSITIVITY

(155) Paul Meyers, Malden, Mass.

(Q.) A model 1955 Silvertone runs all right on a small aerial; on a long one, distortion and hum result. This set will not pick up distant stations on small aerial, but on a long one very loud signals are obtained. Have tested condensers and resistors but no luck; shortwaves come in very good.

(A.) Assuming that all tubes are good, we believe that you will find the trouble to be principally misalignment; and possible variation in the component values of the A.V.C. system. Recheck all condensers and series resistors in the A.V.C. system which supply grid voltage to the R.F. and I.F. amplifier tubes.

Realign the receiver very carefully, repeating the process 2 or 3 times, and it is believed the condition will be overcome.

The receiver is very sensitive and it will be necessary to use a very low intensity alignment signal in order not to cause operation of the A.V.C. section which will hamper correct alignment.

2ND-HARMONIC DISTORTION

(157) V. W. Straub, New Cumberland, Pa.

(Q.) Have in service at the present time an audio speech amplifier employing for the power stage a pair of 42's in push-pull hooked as triodes, with another 42 as driver also connected as a triode. For the voltage stage am employing as input a pair of 6C6's feeding into a pair of 76's; all are resistance coupled and are connected in straight audio.

Have received excellent frequency response with no objectionable peaks from the above circuit; however, have also received quite an objectionable amount of 2nd-harmonic distortion which has proved beyond a doubt to be originating in the power stage. Is it possible to use an inverse feedback connection to cancel-out this distortion?

I might say here that I have been reading *Radio-Craft* for several years and believe it is truly one of the few good magazines for keeping abreast of late developments in the electronic field.

(A.) To introduce inverse feedback into the amplifier described in your letter would involve a good deal of cut and try operations. With a copy of the schematic diagram and all values, we would be better equipped to aid you. (Thanks for your kind comment re. "R-C.")

You state that the distortion experienced is caused by the output stage, but do not indicate the symptoms which have led to this conclusion. Although the best procedure is to determine which portion or component in the power stage is producing the distortion, feedback may be introduced to relieve the condition. A simple method to accomplish this is to connect a 50,000- to 250,000-ohm carbon resistor from one output power tube plate to driver plate. The correct value of resistance, and which output tube plate, must be determined by trial.

FREE- REAL ELECTROPLATING OUTFIT



Now—

You Can ELECTROPLATE EASILY WITH A BRUSH

SOMETHING new for radio men—something which gives you the opportunity to make additional profits—or to improve your type of service. Here's an ELECTROPLATING KIT amazingly simple to operate—you just Electroplate with a Brush!

NOT A TOY!

Electroplate for profit, hundreds of things in the household—schrays, fixtures, water faucets, worn brackets, door knobs, musical instruments, jewelry and silverware and other articles. It's an indispensable piece of equipment—plate articles in hotels, apartments, office buildings, medical and dental offices, factories, schools, laboratories, etc. Exactly the same outfit (but larger) is used professionally by electricians, radio service men, automobile repair shops, etc. Requires one single dry cell 1½-volt battery to operate.

You can electroplate tarnished receiver parts, earphones, contacts, worn radio parts and accessories, and display chassis. Put this REAL ELECTROPLATING KIT to use immediately—make it the most useful article in your shop or laboratory. And you can get it absolutely FREE (except for slight mailing cost).

Subscribe today to RADIO-CRAFT for One Year (12 issues) and receive absolutely FREE this ELECTROPLATING KIT. New subscribers are accepted or extend your present subscription twelve months. Mail remittance of \$2.00 (plus 10c for shipping charge on kit) to the publishers. (Canada and foreign \$2.85). You will receive your FREE, REAL ELECTROPLATING OUTFIT by return mail. Use coupon below to enter subscription.

RADIO-CRAFT

99 Hudson Street New York, N. Y.

RADIO-CRAFT RC-440

99 Hudson Street, New York, N. Y.

Gentlemen: Enclosed find my remittance of \$2.00 for which enter my subscription to RADIO-CRAFT for One Year (12 issues). Send me FREE ELECTROPLATING OUTFIT (Canada and foreign \$2.85). In U. S. add only 10c additional to cover shipping charges on kit.

New Subscriber Extend Present Subscription

Name

Address

City State

(Send remittance by check, money order or unused U. S. postage stamps. Register letter if you send cash or stamps.)

THE ABC OF Db., VU, Mu, Va, Gm, and Sm

Here is a concise explanation and inter-relation of fundamental terms usually confused by radio and by sound technicians.

H. S. MANNEY

A CLEAR understanding of the dynamic characteristics of vacuum tubes and their relation to each other, as well as to units of gain and volume, will necessitate a brief review of their academic definitions.

AMPLIFICATION FACTOR or (μ) **MU**, is defined as the ratio of change in plate voltage to a change in control-electrode voltage in the opposite direction, under the condition that the plate current remains unchanged.

For example, if the plate voltage (E_p) of a given triode is made 50 volts more positive and its grid bias (E_g) is made 5 volts more negative, in order to hold the plate current constant, the amplification factor μ is equal to the change in plate voltage (50) divided by the change in grid voltage (5) or 10. When expressed mathematically, this relation becomes

$$\mu = \frac{E_p}{E_g} \quad (1)$$

The symbol E_p should not be confused with E_b . The former is the change in plate voltage, while the latter is the average or quiescent value of plate voltage. Likewise, the symbol E_g should not be confused with E_c . Here, too, the former is the change in grid voltage while the latter is the average or quiescent value of grid voltage.

MUTUAL CONDUCTANCE (OR, **TRANSCONDUCTANCE**). The real meaning of *mutual conductance* (G_m) has undoubtedly floored more students of radio than any other term, with the possible exception of decibels. (Every science seems to have 1 or 2 apparently difficult, but really simple terms, which require a real basic understanding before complete mastery is attained.)

While it is true that mutual conductance is a group of 2 big-sounding words, the basic meaning of each is really very simple. "Mutual" has a number of meanings, including, proceeding from 2 or more together, common to 2 or more combined (when thought of in terms of tube structure, this would apply to elements as grid-plate, or grid-plate, screen-grid and suppressor-grid). Mutual also may mean reciprocally given and received, interchanged, as mutual assistance, mutual resistance, mutual conductance.

"Conductance," in our application, means to act as a conveyor or transmitter of current. It really is the opposite of *resistance* which is opposed to the conveyance or transmission of current. In Ohm's law,

$$R = \frac{E}{I} \quad (2)$$

the resistance is measured in ohms (named after the German physicist George Simon Ohm). The reciprocal of resistance, however, is conductance and if the term

$\frac{E}{I}$ is inverted to $\frac{I}{E}$, we have a unit of

conductance which for want of a better

term, is called *mho* (ohm, spelled backwards). If we let the symbol S stand for conductance, we have

$$S = \frac{I}{E} \quad (3)$$

If, for example, a circuit passes 2 amperes and develops a drop of 10 volts, we say its

resistance is $\frac{10}{2}$ or 5 ohms. We could also

say its conductance is $\frac{2}{10}$ or 0.2-mho, or

200,000 micromhos. When 2 or more tube elements are involved in calculations of re-

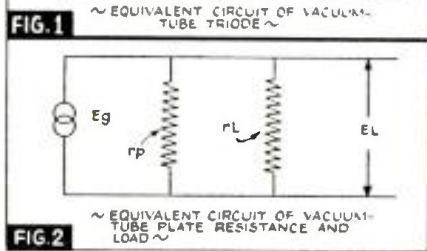
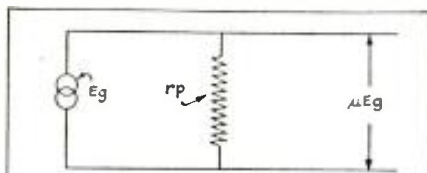

sistance or conductance the end result is known as mutual resistance or mutual conductance, respectively.

To more fully understand mutual conductance (G_m) or *transconductance*, it will be necessary to define the plate resistance (r_p) of a tube, i.e., the resistance of the path between cathode and plate to the flow of alternating current. Precisely, it is the ratio of a small change in plate voltage to the corresponding change in plate current, expressed in ohms. This follows the form of our very familiar Ohm's law:

$$r_p = \frac{E_p}{I_p} \quad (4)$$

Thus, for example, if a change of 100 microamperes is produced by a plate voltage variation of 20 volts, the plate resistance is equal to the change of plate voltage (20) divided by the change of plate current expressed in amperes (0.0001) or

$$\frac{20}{0.0001} = 20,000 \text{ ohms}$$

In formula 4, the symbol I_p should not be confused with I_b . The former represents the change in plate current, while the latter is the average or quiescent value of plate current. Mutual conductance (G_m) or more specifically grid-plate transconductance (S_m) is a factor which combines in one term the amplification factor and the plate resistance, and is the ratio of the 1st to the 2nd.

$$S_m = \frac{\mu}{r_p} \quad (5)$$

Substituting for μ and r_p from (1) and (4)

$$S_m = \frac{\frac{E_p}{E_g}}{\frac{E_p}{I_p}} = \frac{E_p}{E_g} \times \frac{I_p}{E_p} = \frac{I_p}{E_g} \quad (6)$$

It will be noted that equation (6) is identical to equation (3) with the exception that I_p refers to change in plate current while E_g refers to change in grid voltage. Because 2 elements are involved (plate and grid) the conductance is mutual.

Mutual conductance, therefore, can easily be understood to mean the ratio of a small change in plate current (I_p) to the small change in the control-grid voltage (E_g) producing it, under the condition that all other tube element voltages remain unchanged. For example, if a grid-voltage change of 5 volts causes a plate-current change of 10 milliamperes (0.01-amp.) with all other voltages constant, the mutual conductance is 0.01 divided by 5 or 0.002-mho or 2,000 micromhos. If formula (6) is reverted back to the form of Ohm's law, we will evolve an expression for mutual resistance

$$R_m = \frac{E_g}{I_p} \quad (7)$$

VOLTAGE AMPLIFICATION (V_a) is the ratio of the voltage variation (E_L) produced across a load resistor R_L to the change of input grid voltage.

$$V_a = \frac{E_L}{E_g} \quad (8)$$

Thus, if a 5-volt change in grid voltage produces a 50-volt change across the load resistor or *impedance*, the voltage amplification is 50 divided by 5, or 10.

It will be noted that equation (8) closely resembles equation (1). Amplification factor (μ) however, should not be confused with voltage amplification (V_a), because the former deals with E_p (change in plate voltage across load). Here E_L , of course, is the useful voltage developed by amplifiers, as it is this varying voltage which is ultimately applied across the output load.

As E_L is not always known, it becomes necessary to use other formulas for calculating voltage amplification, which involve either amplification factor or mutual conductance, or one or the other (or both), as usually given under tube characteristics.

The derivations of the following formulas clearly show the precise relation between voltage amplification, mutual conductance and amplification factor.

Figure 1 shows the graphic representation of a tube wherein the voltage developed

across the internal plate resistance of the tube r_p is equal to the product of the amplification factor and grid voltage E_g . Under such a condition (no shunting of plate load) the voltage amplification (V_A) equals the amplification factor (μ). When a plate load (r_L) is applied to the tube, it effectively shunts the internal plate resistance of the tube (see Fig. 2) so that the shunt resistance (r_s) or impedance of r_p and r_L is equal to

$$r_s = \frac{r_p \times r_L}{r_p + r_L} \quad (9)$$

The voltage variation E_L is, according to Ohm's law, the product of the plate current variations and the resistance, which may be expressed

$$E_L = I_p \left(\frac{r_p \times r_L}{r_p + r_L} \right) \quad (10)$$

Substituting (10) in equation 8, we have

$$V_A = \left(\frac{I_p}{E_g} \right) \left(\frac{r_p \times r_L}{r_p + r_L} \right)$$

Substituting (6) in the above equation we have

$$V_A = S_m \frac{r_p \times r_L}{r_p + r_L} \quad (11)$$

Knowing the transconductance, plate resistance and plate load, the voltage amplification can easily be calculated. For example, if a 6F5 is used under the 250-volt condition, its transconductance is 1,500 micromhos (or 0.0015-mho), and its plate resistance 66,000 ohms. Assuming a plate load of 50,000 ohms, its voltage amplification would be

$$V_A = 0.0015 \left(\frac{66,000 \times 50,000}{66,000 + 50,000} \right) = \text{approx } 43$$

If the transconductance is not known, the voltage amplification can be calculated from the amplification factor. The desired formula is evolved as follows:

Rewriting equation (4),

$$E_p = I_p \times r_p$$

Substituting E_p for $I_p \times r_p$ in equation 10, we have

$$E_L = \frac{E_p \times r_L}{r_p + r_L} \quad (12)$$

Substituting for E_L in equation (8), we have

$$V_A = \frac{E_p}{E_g} \times \frac{r_L}{r_p + r_L}$$

as $\frac{E_p}{E_g} = \mu$ we finally get

$$V_A = \mu \frac{r_L}{r_p + r_L} \quad (13)$$

If we check our previous illustration and recalculate our voltage amplification, based on an amplification factor of 100, we have

$$V_A = 100 \left(\frac{50,000}{66,000 + 50,000} \right) = \text{approx } 43$$

The relation between mutual conductance, transconductance, voltage amplification, and amplification factor is thus clearly defined.

An examination of formulas Nos. 11 and 13, indicate that voltage amplification may be calculated from either the transconductance or amplification factor, and it might appear superfluous for tube manufacturers to give both characteristics. Furthermore, from equation (5), it becomes relatively simple to solve for either

one, if the other and the plate resistance are known. As tube companies have agreed to shorten the length of data, which keeps getting longer and longer, you may expect either the transconductance (mutual conductance) or amplification factor omitted from tube characteristics.

GAIN is merely another term for expressing voltage amplification. When the gain of a circuit is given as 20, it means that it has a voltage amplification of 20.

DECIBEL (Db.). When gain is given in decibels, it is proportional to 20 times the logarithm of the voltage amplification.

This logarithmic function is used because it more nearly coincides with the sensation characteristics of the ear. As the voltage amplification is a ratio of voltage gain in db. (G db.),

$$G \text{ db.} = 20 \log_{10} V_A \quad (14)$$

Thus, a circuit having a voltage amplification of 43, has a gain in db. of

$$G \text{ db.} = 20 \log_{10} 43 = 20(1.6335) = 32.67 \text{ db.}$$

In our discussion of the decibel thus far, we have considered it as a ratio of voltage. It may, of course also be applied in calculations involving ratios of current, resistance, impedance, and power. Unfortunately, decibel has also been applied as an absolute measurement of power based upon a "standardized" level.

As this "standardized" power level is not universal (various groups working in different fields of sound measurement have accepted different standards, i.e., 1, 6, 10, 12½ or 50 milliwatts in a 500- or 600-ohm line), considerable confusion has resulted. To further add to this confusion, the term decibel is applied to both "power ratios" and "absolute" powers. It has therefore been arbitrarily decided (by the Bell Telephone Laboratories, Columbia Broadcasting System and the National Broadcasting Company) to adopt the volume unit as an absolute measure standard of power.

VOLUME UNIT (VU). This new standard of reference levels is a steady state of 1 milliwatt across a 600-ohm line.

In order to avoid the cumbersome terms of "db. above zero volume level", it has been proposed to designate the new levels as so many VU, which is numerically equal to the number of db. above this new reference level.

By comparison with the most popular reference level used in sound work (6 milliwatts in a 500-ohm line), this new reference level is 7.782 db. lower. The relation between the two may be found from

Power Decrease =

$$- \left(10 \log \frac{P_1}{P_2} \right) = - \left(10 \log \frac{.006}{.001} \right) = -10 (.7782) = -7.782 \text{ db.}$$

According to the old reference level + 30 db. equalled 6 watts. With the new standard + 30VU equals 1 watt (which is 7.782 VU below 6 watts!).

In expressing voltage gain in decibels, it is important that the impedance be taken into consideration. Formula No. 14 assumes equal impedance in both input and output circuits. If the impedance varies, a correction must be made. Additional formulas and their derivations may be discussed in *Radio-Craft*, if readers so desire.

AMPLIFICATION FACTOR

$$\mu = \frac{E_p}{E_g}$$

Where:

μ = Amplification factor
 E_p = Change in plate voltage
 E_g = Change in grid voltage

PLATE RESISTANCE

$$r_p = \frac{E_p}{I_p}$$

Where:

r_p = plate resistance
 E_p = Change in plate voltage
 I_p = Change in plate current

GRID-PLATE TRANSCONDUCTANCE

$$S_m = \frac{\mu}{r_p}$$

Where:

S_m = grid-plate transconductance
 μ = amplification factor
 r_p = plate resistance

Also:

$$S_m = \frac{I_p}{E_g}$$

Where:

I_p = Change in plate current
 E_g = Change in grid voltage

VOLTAGE AMPLIFICATION

$$V_A = \frac{E_L}{E_g}$$

Where:

V_A = Voltage amplification
 E_L = Voltage change across load
 E_g = Change in grid voltage

Also:

$$V_A = S_m \frac{r_p \times r_L}{r_p + r_L}$$

Where:

S_m = grid-plate transconductance
 r_p = plate resistance
 r_L = plate load

Also:

$$V_A = \mu \frac{r_L}{r_p + r_L}$$

Where:

μ = amplification factor
 r_L = plate load
 r_p = plate resistance

GAIN (Expressed in decibels)

$$G \text{ db.} = 20 \log_{10} V_A$$

Where:

$G \text{ db.}$ = gain in decibels
 V_A = voltage amplification

POWER LEVEL

(expressed in volume units)

$$VU = \text{db.} - 7.782$$

Where:

VU = power level expressed in volume units
 db. = power level expressed in decibels

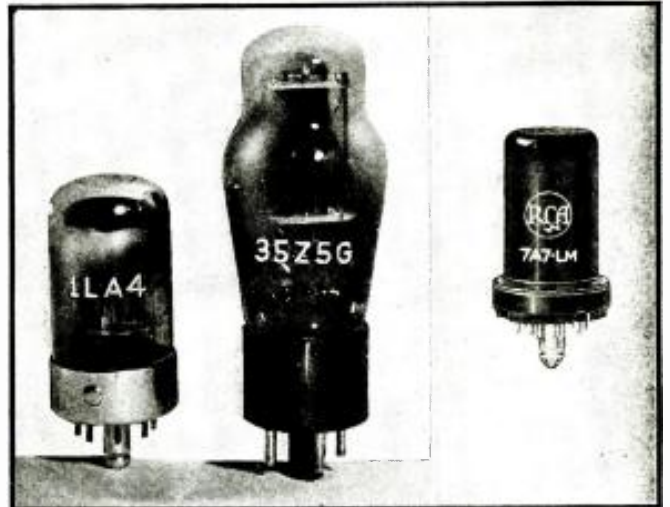
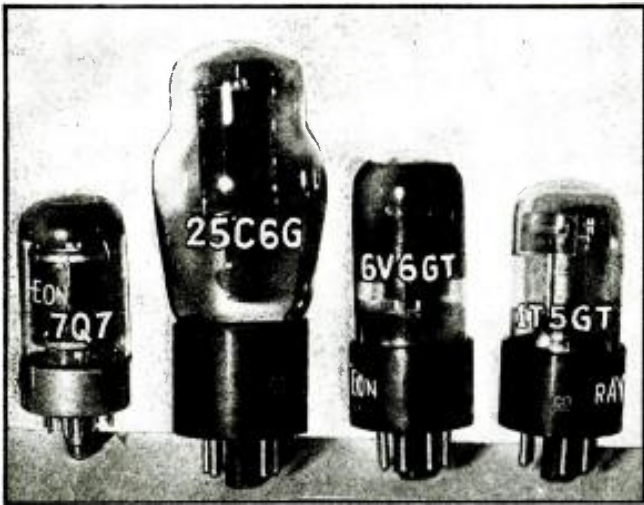

9 NEW TUBES

LAST month RCA Mfg. Co., Radiotron Division, proposed that the Radio Tube Industry take itself by the hand and carve a path, through the matted brush of rapidly pyramiding tube types having interlocking and duplicated functions, to a highway of standardization. The story is given briefly in recently-published material.

New tubes are described here, of course, but also mention is made of RCA's new Preference List which snips tube demands from about 450 types to a culled group of 36. The new tubes illustrated and described include mostly receiving types.

R. D. WASHBURNE

HOW TO STANDARDIZE?

It is generally agreed that *standardization* is one of the **VITAL NEEDS** of the Radio Tube Industry. How is this to be accomplished when the radio industry has announced 470 receiving tube types (of which RCA has announced 263 types)?

A study of the 470 types revealed that approximately 90 tube types account for 90% of the entire radio tube volume. A further study revealed that these 90 types represent only 20 basic functions. Starting with these it was found that a Preference List of 36 types adequately covered every function for any type of receiving set circuit, be it A.C., A.C.-D.C., Drycell ("battery"), or Auto-Radio.

From this selected group of tubes practically any type of radio set may be designed to have the lowest ultimate cost for a given performance.

The tubes culled for the Preferred List are indicated below. The reasons for their selection may be given in a forthcoming issue of *Radio-Craft* if it is felt that there is sufficient reader interest.

PREFERRED LIST OF TUBE TYPES

Metal		Glass		GT & G	
6.3 V.	12.6 V.	Octal (6.3-50V.)	(1.4 V.)		G
6H6	2A3	6J5GT	1A7GT	5U4G	
6J7	6U5/6G5	6K6GT	1G4G	5Y3G	
6AB7		6V6GT	1H5GT	6B8G	

6SA7	12SA7	35L6GT	1N5GT	6F6G
6SC7	12SC7	35Z5GT	3Q5GT	6N7G
6SF5		50L6GT		6R7G
6SJ7	12SJ7			6X5G
6SK7	12SK7			
6SQ7	12SQ7			
	12C8			

This Preference List should be regarded as a dynamic rather than a static list, subject to change in accordance with technical and commercial developments. Its purpose is to help the design engineer.

Now for the new tubes here illustrated. First let us list these tubes and see how they stack up as to services.

- 7E7—Duodiode—Pentode (similar in appearance to the 7Q7)
- 7Q7—Heptode Pentagrid Converter
- 25C6G—Beam Power Amplifier
- 6V6GT—Beam Power Amplifier
- 1T5GT—Beam Power Amplifier
- 7C7—Non-Variable Mu Pentode
- 1LA4—Power Output Pentode
- 35Z5G—Half-Wave Rectifier
- 7A7LM—Variable-Mu Pentode

These tubes are described individually in the following descriptions. Characteristics data for all of these tubes are given at the conclusion of the general descriptions.

DESCRIPTIONS

7E7 Duodiode • Variable-Mu Pentode
This glass-envelope pentode-type amplifier is designed for use as a combined diode

detector, A.V.C. rectifier and high-frequency or audio-frequency amplifier in radio receivers. Base is loctal. *Raytheon.*

7Q7 Heptode Pentagrid Converter

The glass-envelope 7Q7 is designed for use as a combined oscillator and mixer in super-heterodyne receivers, especially those of the all-wave type. The oscillator section is designed to operate in a Hartley circuit with the cathode connected to a tap on the oscillator coil. The 7Q7 can also be used as a separately-excited mixer. Base is loctal. *Raytheon.*

25C6G Beam Power Amplifier

This heater-type tube is designed for use in the output stage of radio receivers. Glass envelope. Base is 8-pin octal. *Raytheon.*

6V6GT Beam Power Amplifier

The 6V6GT is a heater-type beam tube intended for use in the output stage of radio receivers. Glass bulb. Base is octal. *Raytheon.*

1T5GT Beam Power Amplifier

This filament-type beam tube is designed for use in the output stage of radio receivers operating from a low-voltage drycell or dry-cell-battery filament supply. Glass envelope, octal base. *Raytheon.*

7C7 Non-Variable Mu Pentode

The heater-type 7C7 is a glass-bulb type of amplifier, with locking base, intended for use as a detector or high-frequency amplifier in radio receivers. Loctal base. Similar in appearance to 7Q7. *Raytheon.*

1LA4 Power Output Pentode

A loctal base is used on the 1LA4. This power output pentode is designed especially for use in low-drain battery-operated receivers. This tube is extremely economical

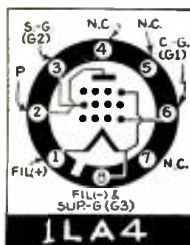
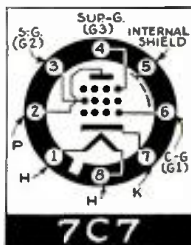
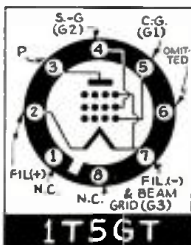
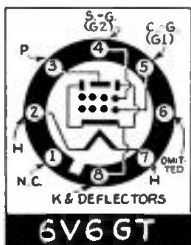
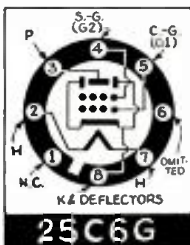
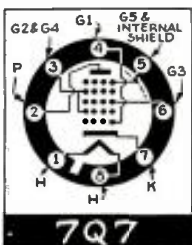
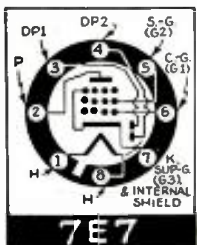



... thousands of Radio Service Dealers get the test equipment they need FREE from NATIONAL UNION ... WHY DON'T YOU?

WRITE FOR DETAILS NATIONAL UNION RADIO CORP. NEWARK, N. J.

RADIO COURSE \$1.95

GREATLY REDUCED

Amazing offer of latest \$39.00 R.T.I. radio course. Limited number of courses reprinted and reduced to \$1.95. Exactly the same as higher priced originals. Prepared for home-study; practical facts only; unusual bargain in radio education.

THOUSANDS OF GRADUATES

Men like you studied Radio Servicing for a short time and today are making good money in radio. Radio Technical Institute, unique radio training will bring rich rewards to you. Pre-tested and approved by thousands. Prepared with the aid of 47 leading radio manufacturers. You can get really inexpensively, quickly, easily, and in your spare time for a good job in radio.

THREE COURSES IN ONE

You get three complete essential courses combined and streamlined: (1) Fundamentals of Radio and Electricity; (2) Practical Radio; and (3) Advanced Training. This is the training which will place you above average radio men—and you get the practical course for only \$1.95. A final test examination may be taken and diploma obtained.



COMPLETE IN ALL DETAILS

R.T.I. course will give you the radio training you need. The lessons are clear, interesting, easy to master and use. A. Gold, now a serviceman in Illinois, writes: "From the very start I learned about practical equipment and methods. . . . You too, can make spare-time money on radio repair jobs before you reach the 14th lesson."



M. N. Beltman, radio engineer, author, instructor in Chicago schools, says: "R.T.I. course will help you get into radio with the right training. Special \$1.95 price for complete course can be earned in an hour of radio servicing."

LATEST FACTS

The training is remarkably complete. Everything from simple radio facts to advanced radio problems. Many servicemen find R.T.I. course excellent for brush-up and study of modern servicing methods. Learn latest facts. Revised and reprinted in 1939. Hurry your order to us today. Limited edition available at reduced \$1.95 price. You must be satisfied or your money is refunded promptly.

Guarantee

Your money back if you are not satisfied. References: Dun & Bradstreet or any magazine publisher.

FREE EXAMINATION COUPON

SUPREME PUBLICATIONS, Agents
3727 West 13th St., Room 505, Chicago, Illinois
Ship complete R.T.I. Radio Course. I must be satisfied or I may get my money back immediately.
 I am enclosing \$1.95, full price. Send prepaid.
 Send C.O.D. I will pay mailman \$1.95 and a few cents postage.

NAME _____
Write address below and send this corner.

to operate because the "A" and "B" current drains are unusually low. *Sylvania*.

35Z5G High-Vacuum Half-Wave Rectifier
Here is a tube designed for use in A.C.-D.C. and D.C. line operated receivers. The 35-volt heater is tapped to permit operation of a *Sylvania* type S40 or S47 panel lamp across pins 2 and 3. Conventional half-wave rectifier circuits are applicable.

A peak limiting resistor of at least 25 ohms must be used in series with the plate; and a surge-limiting resistor should be placed in series with the heaters of the other tubes in the heater circuit. Glass bulb. Octal base. *Sylvania*.

7A7LM Variable-Mu Pentode

This tube is a metal type of triple-grid (pentode) variable-mu (or "super-control") amplifier. It has a loctal base. *RCA Radio-tron*.

CHARACTERISTICS

Tentative Characteristics Data

7E7 Typical Amplifier Operation—Class A— Pentode Section		
Heater voltage	6.3	volts
Heater current	0.3	amp.
Plate voltage	250	volts
Screen-grid voltage	100	volts
Control-grid bias	-3	volts
Suppressor-grid voltage	0	volts
Plate resistance (approx.)	0.7	megohm
Transconductance	1,300	mmhos
Plate current	7.5	ma.
Screen-grid current	1.6	ma.
Control-grid bias (approx.)	-42.5	volts
Transconductance	-2	mmhos

Diode Section

The 2 diode units are independent of each other and of the pentode section except for the common cathode.

Direct Interelectrode Capacities— Pentode Section†

G1 to P (grid to plate), 0.005 max. mmf.; G1 to all other electrodes except P (input electrode), 4.6 mmf.; P to all other electrodes except G1 (output electrodes), 9.5 mmf.

† With standard tube shield connected to cathode.

25C6G

Typical Amplifier Operation—Class A1		
Heater voltage	25	25 volts
Heater current	0.8	0.8 amp.
Plate voltage	135	200 volts
Screen-grid voltage	135	135 volts
Control-grid voltage	-13.5	-14 volts
Peak A.F. signal voltage	13.5	14 volts
Transconductance	7,000	7,100 mmhos

Plate resistance (approx.)	9,300	18,300	ohms
Zero-signal plate current	58	61	ma.
Zero-signal S.-G. current	3.5	2.2	ma.
Maximum-sig. plate current	60	66	ma.
Maximum-sig. S.-G. current	11.5	9.0	ma.
Load resistance	2,000	2,600	ohms
Total harmonic distortion	19	10	per cent
Power output	3.6	6.0	watts

1T3GT

Typical Amplifier Operation—Class A1		
Filament voltage	1.4	D.C. volts
Filament current	0.05	amp.
Plate voltage	90	volts
Screen-grid voltage	90	volts
Control-grid bias	-6	volts
Transconductance	1,150	mmhos
Plate current	6.5	ma.
S.-G. current	1.4	ma.
Load resistance	14,000	ohms
Total harmonic distortion	7.5	per cent
Power output	170*	milliwatts

* E signal—4.3 volts r.m.s.

7C7

Typical Amplifier—Class A Conditions		
Heater voltage	6.3	6.3 volts
Heater current	0.15	0.15 amp.
Plate voltage	100	250 volts
Screen-grid voltage	100	100 volts
Control-grid bias	-3	-3 volts
Suppressor-grid voltage	0	0 volts
Plate resistance (approx.)	1.2	2 megohms
Transconductance	1,225	1,300 mmhos
Plate current	1.8	2.0 ma.
S.-G. current	0.4	0.5 ma.

Direct Interelectrode Capacities†: G1 to P (grid to plate), 0.007 max. mmf.; G1 to all other electrodes except P (input electrode), 5.5 mmf.; P to all other electrodes except G1 (output electrode), 6.5 mmf.

† With standard tube shield connected to cathode.

35Z5G

Operating Conditions and Characteristics (Condenser Input)		
Heater voltage (pins 2 and 7, entire heater)	35.0	volts
Heater current (entire heater)	0.150	ampere
Panel lamp section (pins 2 & 3)	7.5	volts
A.C. plate voltage (r.m.s.)	125	volts max.
D.C. output*	50	ma. max.
D.C. output**	100	ma. max.
Max. peak inverse voltage allowable	700	volts
Max. peak plate current allowable	600	ma.
Series plate resistor	25	ohms min.
Tube voltage drop at 200 ma.**	21	volts

* With rectified plate current through the panel lamp section of the heater shunted by a 6.3 volt, 0.150-ampere panel lamp (*Sylvania* Panel Lamp S40 or S47).

** Panel lamp not connected.

7Q7

Typical Frequency Converter Operation

Self-Excitation**		Separate Excitation		
Heater voltage	6.3	6.3	6.3	volts
Heater current	0.3	0.3	0.3	amp.
Plate voltage	100	250	100	250 volts
G2 & G4 voltage	100	100	100	100 volts
G3 (control-grid) bias	0	0	-2	-2 volts
Shield and G5 voltage	0	0	0	0 volts
G1 resistor	20,000	20,000	20,000	20,000 ohms
Plate resistance (approx.)	0.5	0.8	0.5	0.8 megohm
Conversion transconductance	425	450	425	450 mmhos
Plate current	3.2	3.4	3.2	3.4 ma.
G2 and G4 current	0.8	0.8	0.8	0.8 ma.
G1 current	0.5	0.5	0.5	0.5 ma.
G3 bias (approx.)	-35	-35	-35	-35 volts

(For conversion transconductance—5 mmhos)

The transconductance between G1 and G2 and G4 tied to plate (not oscillating) is approx. 4,500 mmhos under the following conditions: 0 volts on G1, G3, G5 and shield; 100 volts on G2 and G4 and plate.

Direct Interelectrode Capacities†: G3 to all other electrodes & base shell (R.F. input), 9.5 mmf.; P to all other electrodes & base shell (mixer output), 9.0 mmf.; G1 to all other electrodes & base shell, 7.0 mmf.; G3 to P, 0.10 max. mmf.; G1 to G3, 0.15 max. mmf.; G1 to P, 0.06 max. mmf.; G1 to all other electrodes & base shell except K, 4.8 mmf.; G1 to K, 2.2 mmf.; K to all other electrodes & base shell except G1, 5.0 mmf.

** Characteristics values are approx. only and are shown for a Hartley circuit with a feedback of approx. 2 V. Peak in the cathode circuit.

† With standard tube shield connected to base shell.

6V6GT

Typical Amplifier Operation—Class A1*

Heater voltage	6.3	6.3	6.3	volts
Heater current	0.45	0.45	0.45	amp.
Plate voltage	180	250	315	volts
Screen-grid voltage	180	250	275	volts
Control-grid bias	-8.5	-12.5	-13	volts
Plate resistance (approx.)	58,000	52,000	77,000	ohms
Transconductance	3,700	4,100	3,750	mmhos
No-signal plate current	29	45	34	ma.
No-signal S.-G. current	3	4.5	2.2	ma.
Max.-signal peak voltage	8.5	12.5	13	volts
Max.-signal plate current	30	47	35	ma.
Max.-signal S.-G. current	4	7	6	ma.
Load resistance	5,500	5,000	8,500	ohms
Total harmonic distortion	8	8	12	per cent
Power output	2.0	4.5	5.5	watts

* Two tubes in push-pull class A1 deliver 10 watts (250 V., plate; -15 V., C.G., with 5% total harmonic distortion).

1LA4

Operating Conditions and Characteristics		
Filament voltage D.C.	1.4	volts
Filament current	0.060	ampere
Plate voltage	85	90 volts max.
S.-G. voltage	85	90 volts max.
C.-G. voltage (neg. fil. return, pin 8)	-4.5	-4.5 volts
Plate current	3.5	4.0 ma.
Screen current	0.7	0.8 ma.
Plate resistance	0.3	0.3 megohm
Mutual conductance	800	850 mmhos
Amplification factor	240	255
Load resistance	25,000	25,000 ohms
Power output	106	115 milliwatts
Total harmonic distortion	10	7 per cent

7A7LM

Amplifier—Class A1

Operating Conditions and Characteristics		
Heater voltage	±6.3	volts
Heater current	0.3	amp.
Plate voltage	250 max.*	volts
B.-G. voltage	100 max.**	volts
C.-G. voltage	-3 min.**	volts
Sup.-G.	Connected to cathode at socket	
Plate resistance	0.8	megohm
Transconductance	2,000	micromhos
C.-G. bias for transconductance of 10 micromhos	-35	volts
Plate current	8.6	ma.
B.-G. current	2	ma.

* Design maximum for 117-volt line.
 ** Design minimum for 117-volt line.
 † In circuits where the cathode is not directly connected to the heater, the potential difference between heater and cathode should be kept as low as possible.

Direct Interelectrode Capacities: °Grid to plate, 0.005 max. mmf.; input, 6 mmf.; output, 7 mmf.

* With shell connected to cathode.

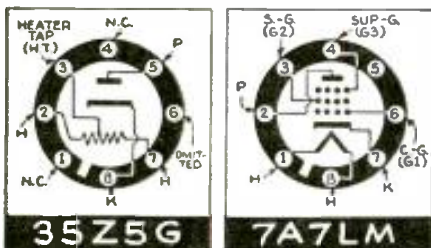

SERVICING QUESTION

VOLUME TROUBLE

H. H. Wonder, Radio Operator and Instructor, C.C.C. Camp, Somis, Calif.

(Q.) I have a Majestic table model 50 which I have had considerable trouble with. Whenever a light switch is turned on anywhere in the house the volume will go so low that you can't hear the set play; when this happens there is a "pop!" and the volume goes down. Then when another switch is turned on it will come on again; or if one snaps the radio switch on and off a couple of times it will come on again; or I can turn more volume on and it will be all right until a switch is snapped on somewhere then it will be too loud again. Have checked filter condensers and they seem to be OK. Voltages seem to be OK. In fact it works good except for this one fault. Is there any way to fix this receiver without too much expense?

(Will say in conclusion that we have all of your publications in our library and like them very much.)

(A.) There are two R.F. bypass condenser blocks in the Majestic model 50 receiver which produce the annoying condition described. These blocks each contain three 0.15-mf. condensers, which bypass plate screen and cathode circuits. Check each unit by substitution to locate the faulty condenser. Perhaps the quickest solution to the problem is to remove both bypass blocks and employ six 0.1-mf. tubular condensers instead.

(Thank you for your commendatory, concluding paragraph.)



SEND FOR
 WARDS NEW
 SOUND SYSTEM
 CATALOG

Shows how to select the correct Sound Equipment—How to get the best results—How much you can save and many other important facts—
MAIL COUPON!

THE MOST UNUSUAL SOUND EQUIPMENT BOOK EVER PUBLISHED . . .

It shows how simple and easy it is for anyone to select sound equipment exactly suited for any particular need. Whether for music or speech, for indoors or outdoors, for a small hall or a large auditorium, nothing is overlooked in this exceptional new catalog. Everything is so plainly illustrated that anyone, even without experience or technical knowledge, can easily make the selection and set it up.

But more than that! You get sound equipment without an equal. It's the product of quality builders of sound systems . . . concerns like Hallicrafters and Lyon & Healy, working under specifications of WARD Sound Engineers. You take no chances. For you get a

15-day trial and a Money-Back Guarantee on every WARD Sound System. Convenient time payments if you wish. You save money, too. WARD'S economical direct-selling methods save you up to half, or even more, on comparable quality and performance.

This new catalog is not yet off the press, but so that you can have your copy with the least possible delay, we urge you to send your name NOW. Requests will be filled in the order received. Don't Wait! Mail coupon for your FREE copy NOW!

FREE! The most unusual Sound System Catalog ever published. Mail Coupon for your copy.

MONTGOMERY WARD

9 GREAT MAIL ORDER HOUSES—OVER 600 RETAIL STORES

MONTGOMERY-WARD & CO.,
 DEPT. RZ-36 CHICAGO, ILL.

Please reserve a copy of your new Sound Catalog, and RUSH it to me FREE as soon as it is off the press.

Name

Address

City State



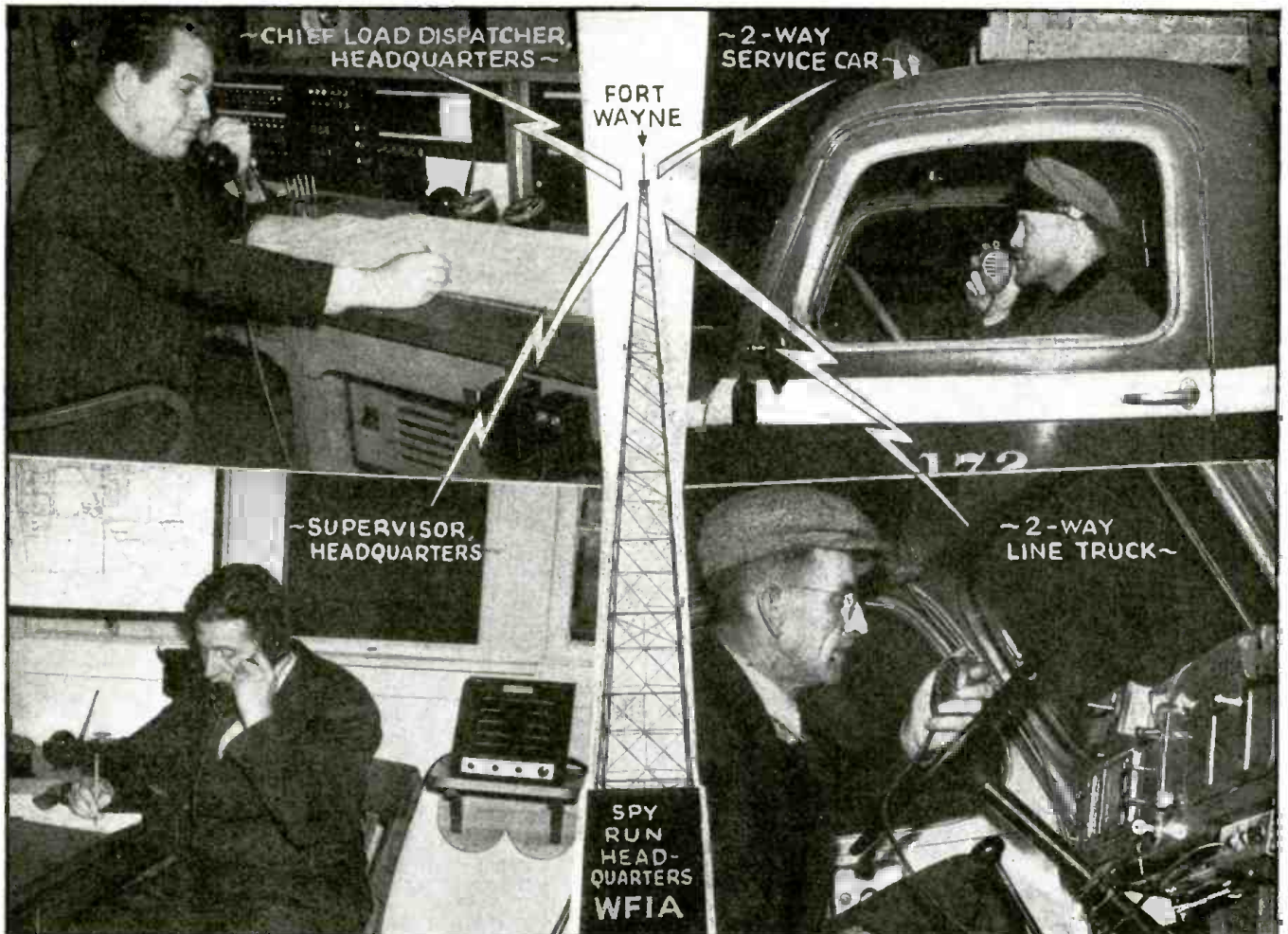

RADIO COORDINATES

Emergency Power-Repair Service

ELECTRIC, gas and water utilities supplying light and power are utilizing radio to insure as nearly uninterrupted service as possible under every conceivable condition. Many of these organizations are employing emergency radio systems to maintain constant contact with field mobile repair forces in emergencies. One such organization is the Indiana Service Corporation, one of the first utility companies in the mid-West to install a shortwave 2-way radio system to handle trouble dispatches when no other means of contact is available.

Regular operation of the 2-way emergency radio equipment at the company's power plant, with headquarters on Spy Run Ave., Fort Wayne, Ind., was authorized last month. This will enable dispatchers to flash orders to Servicemen in their cars, within a radius of about 18 miles (at present) from the plant, only when emergency service is needed in Fort Wayne and surrounding territory. The company's repairmen will receive orders by radio during emergencies, such as occasioned by storms and fires, and to restore electric service.

The company's radio-equipped trucks and cars will handle such cases where wires or lines are down, resulting in

The special communications service only recently extended to the public utilities by the Federal Communications Commission, has just been put in operation by Indiana Service Corporation, one of the first of 12 electric utilities to take advantage of this development. Details of this new emergency radio system—which will help promote public safety and minimize hazards to life and property—were released to Radio-Craft last month.

hazards to the public, and to maintain essential public service at hospitals, theatres, industrial plants, department stores and other places of public assembly. To restore such services in the least time is vital.

In the illustration reproduced at the head of this article is shown Chief Load Dispatcher George A. Grimm directing line unit in field from main transmitting and receiving station at Spy Run Headquarters. James R. Edwards (lower-left), Supervisor, Customer Service, directs service cars in cases of emergency from this Headquarters. Frank Firestone, in the photo at upper-right, is receiving instructions to proceed to a scene of emergency involving wires down. Below, Crew Foreman Howard Shelley talks from cab of line-truck, equipped with receiving and sending apparatus, in field.

The system at present includes one 25-watt transmission-line patrol truck and 2 service cars operating on the 2-way radio hook-up, and 1 repair-service car with 1-way radio service.

The line trucks and service cars, equipped with radio, have microphones located on the instrument panels. Equipped

RADIO DEVELOPMENTS

with a cord about 3 feet long, each mike can be unhooked from the dash and held in the hand while in use.

A switch on the microphone changes the equipment from listening to talking. Volume and other controls are mounted on the dash, and the speaker under the dash, similar to the arrangement of a common automobile radio receiver.

The Headquarters station has been assigned call letters WFIA. Operation is on 39.86 mc.; power output, 50 watts.

Extensive tests of the radio equipment were made by the company during the past two months before the FCC issued a special broadcasting permit to the utility.

TRIAL BY FIRE!

Already, this emergency radio system has been put to use! Recently, an exceptionally strong wind caused limbs of trees to be blown across some of the company's wires, tearing them down. Servicemen were dispatched to these locations by radio to protect the public from accidentally coming into contact with the fallen wires and to clear up the damage so that service could be restored.

In another case Servicemen were dispatched to the scene of a fire where pole lines were destroyed. Electric service was quickly restored by repairmen using the radio-equipped service cars.

BROADCASTING NEWS ITEMS

WHEN Victor Lindlahr recently moved into a new office, his first talk on his thrice-weekly program over WOR from the new location was nearly stymied because of the poor acoustics of the room. A technician saved the day by commandeering all the overcoats he could find and hanging them about the walls.

Nearly a dozen microphones and a special 12-channel mixing device were used last Xmas to broadcast midnight Mass at St. Patrick's Cathedral over WOR.

Vernon D. Boyd, last mechanic of the 3rd Byrd Antarctic Expedition to the South Pole, recently pointed out that when the 2nd Byrd expedition worked in the polar camp a few miles from the South Pole, the presence of ice made it impossible to secure a ground in the ordinary sense of the word.

A 340-ft. counterpoise, however, stretched on the ice in an inverted-V served as a combination aerial and ground, and permitted reception up to 12,000 miles.

Radio has drawn heavily on Hollywood for broadcasting talent, but last month the tables were turned when Kay Kyser's C.B.S. air program, "That's Right, You're Wrong" became an RKO-Radio talkie starring Kay Kyser, et al.

Six youths caught selling tickets to the Major Bowes Amateur Hour program last month received suspended sentences and in one case a fine in a N.Y.C. court.

An ingenious (N.Y.C.) Bronzite attempted to solve the program of a neighbor's noisy radio set, by arranging with the telephone company to have the neighbor's phone number called every 5 minutes between the hours of 8 and 10, on the premise that answering the telephone would necessitate turning down the volume of the radio set.

JUST OUT! ALLIED'S Spring CATALOG

EVERYTHING New IN RADIO!

FREE ALLIED RADIO Spring & Summer 1940

"Everybody in Radio will want this new 172-page ALLIED Catalog—it's tops in its field, take it from me . . ."

"Whether it's Parts, P.A., Test Equipment, or Radio Sets—you'll find everything you need in this book—all at lowest prices!"

MORE THAN 60 NEW SETS

There are some real Radio "Hits" in ALLIED'S new Spring Catalog. See the new "Camera" Portables—the new European reception table models—the plastic Phone Radios—new all-purpose "Compacts"—new Auto Radios—all types, all sizes—for every use and purpose. Only ALLIED'S 1940 Spring Catalog offers this complete radio selection!

NEW PUBLIC ADDRESS SYSTEMS

18 new Public Address Systems—6 to 70 watts—for Electioneering, Orchestras, Schools, Churches, rental work, etc. America's finest Sound Systems at startling low prices. New exclusive features—new P.A. applications. Complete accessory listings, new recording equipment, etc. Also P.A.'s easiest Time Payment Plan! See it all!

NEW KITS • HAM SETS • TESTERS

Servicemen—see all the new Test Equipment—new service gadgets, etc. Amateurs—get the "low-down" on new Amateur Receivers and A BIG EXTRA SURPRISE. Builders—there are dozens of brand new exciting kits—easy to build—low in price. You'll find Everything in Radio—more than 15,000 quality Radio items—in ALLIED'S great Spring Catalog.

"Doing business at the old stand for more than 17 years—sticking to our business—Radio and Radio only—that's the way we explain our reputation and our continued success as Radio Supply Headquarters. . ."

ALLIED Radio CORPORATION

Send for **FREE** Catalog!

ALLIED RADIO CORP.
833 W. Jackson Blvd., Dept. 2-D-0
Chicago, Illinois

RUSH me your FREE New Spring Catalog.

Name

Address

City State

BACK ISSUES OF RADIO-CRAFT If you are in need of back issues of RADIO-CRAFT to complete your files, other issues are available and they can be obtained at special prices. Write, Back Number Dept., RADIO-CRAFT, 99 Hudson Street, New York, N. Y.

IF ITS RADIO

1940 Complete Edition No. 56

Burstein-Applebee Co.

ALL YOUR RADIO NEEDS

Here in this one big book you will find everything you need in radio . . . sets, parts and supplies . . . public address systems . . . amateur equipment . . . testers and kits . . . your nationally known favorites at lowest possible prices. Write today for this big valuable catalog and save money.

PROMPT SERVICE

FREE CATALOG

BURSTEIN-APPLEBEE COMPANY

1012-14 McGEE STREET, KANSAS CITY, MISSOURI

A BIG SURPRISE IN STORE FOR YOU!

Be sure to read the announcement which appears on Page 600 of this issue . . . DO IT NOW!

Save on Everything in Radio

NEW 1940 RADIO CATALOG AND PROFIT GUIDE

Most complete line of latest radio sets, amplifiers, kits, tools and replacement parts. All leading brands at lowest prices. Fast Service. Guaranteed Quality.

The **RADOLEK** Company
Dept. Y-40 601 W. Randolph St., Chicago

SEND FOR YOUR COPY TODAY

FREE RADIO PROFIT GUIDE

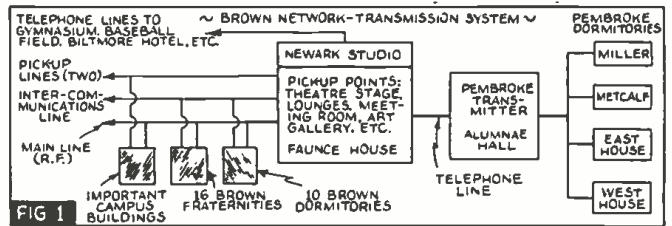

▲ Transmission lines on the Brown campus carry studio and remote programs, and serve network intercommunications.

◀ A 1-act play going over the Brown Network. The students are: (left to right) Howard B. Lyman '42, Victor J. Hillery '41, Helen E. Starrett, '40; George A. Stuckert '42, Barbara P. Allen, Pembroke '40; and Helen N. Thomas, Pembroke '40.

INTER-COLLEGE WIRED-RADIO NETWORK

A 2-WAY interphone started Brown U. student Abraham on a chain of thought which concluded last month in plans for an intercollegiate wired-radio "broadcasting" network!

This project — which has earned for these New England college students the distinction of being the first in the United States to institute an intercollege wired-radio system—calls for linking Brown, Dartmouth, M.I.T. and Wesleyan together over a leased wire system so that each college can broadcast to the other. At least 10 other colleges and universities it is expected will soon join this System, and others are being invited to hook-in.

It will not only provide entertainment for listeners, and experience for radio-minded students handling the technical details, but it will promote "friendly contacts" between the institutions taking part, the sponsors believe. Operation at present is on 570 kc.

STUDENT WIRED-RADIO

The network idea grew from Brown U.'s complete student-owned and -operated intramural system, conceived by George Abraham '40, Chairman of the board of the Brown Network, during his freshman year and originating from a simple 2-way communication hook-up with a friend in his dormitory.

Today the Brown Network is a major extra-curricular organization, with elaborate sound-proof studios and a central control room in Faunce House; 30 stations in dormitories and fraternity houses where programs can originate; and, a 3-board staff of 75 members at Brown and Pembroke College in charge of programs, advertising and technical arrangements, for its estimated daily audience of 2,000 listeners.

Technically the network is a wired-radio-frequency system, broadcasting on a 570-kilocycle band. Programs are carried over 30,000 feet of wire strung through steam tunnels into dormitories and fraternity houses, but the power used is so small that broadcasts can be heard only on radio sets within a few feet of the transmission lines. *The network accordingly needs no license.*

PROGRAMS

What sort of material do you suppose would be included in such a "school" program? Well, let us see. Let's take for example the program which appeared in an issue of the *Brown Daily Herald*, last month; we reproduce it, at right, just as it appeared.

In fact, daily programs are just as varied as those heard over commercial stations.

The network has a portable unit which is used in relaying dinghy races, campus interviews, athletic contests, and other outside events to the central control room.

An extensive intercollegiate wired-radio "broadcasting" system, first of its kind in the country, and now in the course of development at Brown University, is here described. The system, which first is to tie-in Brown, Dartmouth, Massachusetts Institute of Technology, and Wesleyan as a nucleus, soon will include 15 colleges!

N. H. LESSEM

A faculty advisory board is cooperating with the network in expanding its activities. Following in general a program pattern already tried out, the network will broadcast not only all available campus events, but will map out an extensive series of musical, dramatic and feature entertainment originating under the network's own auspices. *Much of the expense*

involved will be written off through advertising contracts—an innovation begun successfully a year ago.

The 2 block diagrams indicate the essentials of the "broadcasting" system, and the important equipment in the studio in Faunce House.

TRANSMISSION SYSTEM

FIG. 1.—As Fig. 1 indicates, all of the transmissions are performed by means of wires. "To points on the campus, we have run our own wires," says David Borst, in describing this system to *Radio-Craft*; these are a fine, single conductor when used for carrying audio signals, or twisted pair when used for the transmission of radio-frequency signals. To more remote points, and connecting the Pembroke facilities, rented telephone lines are used. Of course, no attempt is made to send radio signals over telephone wires.

The lines on the Brown campus are used for 3 distinct types of service:

- (1) To carry the radio signals which compose the programs.
- (2) To bring in signals from the 2 portable amplifiers so that important lectures, concerts, and interview programs may be obtained, and
- (3) For intercommunication among members of the Network who have microphones attached to their radio sets and who are connected to this separate line.

NETWORK STUDIO

FIG. 2.—The studio diagram, Fig. 2, may appear a bit complicated because Brown has incorporated a number of refinements which are not essential to broadcasting, but which aid materially in putting out good programs.

All the equipment is housed in a 2-bay relay rack and is mounted on standard panels. All signals entering the studio or leaving the studio over lines pass through the 2 line panels which are equipped with rows of jacks so that many different circuits may be put up quickly by means of patch cords. All the signals comprising the program pass through the 8-channel program mixer and master gain control, from there they are sent to the proper amplifiers and transmitters as indicated.

In addition to the main program a 2nd program may be rehearsed over the Re-

BROWN NETWORK
570 On Your Dial

AFTERNOON PROGRAM

4:00—Discs with Avery
4:30—Movie Reviews by Loretta Curran and Bill Clark
4:45—Midweek Special
5:00—Town Hall This Afternoon
5:30—Pembroke at the Turntables
6:00—Sign Off

EVENING PROGRAM

8:00—Battle of Wits
8:30—Brown - Harvard Varsity Basketball Game
10:00—News
10:15—Music We Like
10:30—Sign Off

hearsal Board, or it may be used to test a future program; furthermore, communication with people on the interdormitory line may be had over the proper amplifier.

The studio speaker may be set to reproduce signals from any line, or signals on the Rehearsal Board, as well as the main program. Cue signals consisting of the program at that time may be sent over the lines to remote points from which a program is about to originate by throwing switches on the program mixer. Also on the mixer is a volume indicating meter, which augments the earphones on the R.F. monitor in helping to keep the program at the proper level.

OPERATION

All of the panels are provided with circuit-opening jacks so that any panel may be disconnected from its present service and used elsewhere by means of patch cords. The operator sits in front of the program mixer which is mounted on a slanting panel. He faces the studio, and on his left is the relay rack bay, and on his right the 2 phonograph turntables and pickups. Microphone outlets are provided in convenient places around the room.

If need be, 1 man can run an entire program, but usually there are 2 men on deck, and sometimes 3. If a program outside of the studio is expected, additional men are required to operate the portable equipment.

Planning a program requires the work of men on the 3 boards of the network. A member of the Program Board plans the programs, sees that the script is written, and provides the announcers; a member of the Technical Board provides the switch-board operators and additional operators for the portable unit service; and a member of the Business Board provides the advertising copy if the program is sponsored.

Colleges and Universities contemplating tying-in to the Brown Network may still be in doubt as to just what technical complications they might be letting themselves in for. To these institutions the following additional technical information is directed in proof that neither undue complexity nor any considerable expense are involved.

ESSENTIAL EQUIPMENT

The initial equipment which is necessary to put out a variety of broadcasts is surprisingly small in amount. The most essential part is the small radio transmitter. Also needed are 2 phonograph turntables and pickups, one or more good quality microphones, and an amplifier capable of supplying the needed gain.

Provision to monitor the signals in the studio is desirable, and if programs from outside of the studio are contemplated a means of amplifying signals coming into the studio over a line must be devised. Remote broadcasts require additional amplifiers and mikes which are to be used on the broadcast location. In time this equipment will be added-to, but these additions will not be needed at first.

Two transmission methods are possible. It is possible either to send radio signals from one transmitter over a line and couple this line to the top-floor heating pipes of the buildings to be covered, or to send audio signals over a line and have a small transmitter modulated by these signals located in, and coupled to, every building to be covered.

In case there is a group of buildings at some distance from the studios a combination of the 2 methods may be used. Audio would be sent from the studio to one building in the group, and R.F. from a transmitter located there to the other buildings

The equipment shown in this drawing is operated as follows: Key switches: (6 gain controls are placed on right, 1 switch per control): up—to Rehearsal Board, center—off, down—to master gain. Two gain controls on left (2 switches per control, each terminating in plug on lines panels): up—cue signals on line, middle—communication on line, telephone headset, or intercommunications amplifier, down—to master gain (switches on mike channels cut studio's speaker when down).

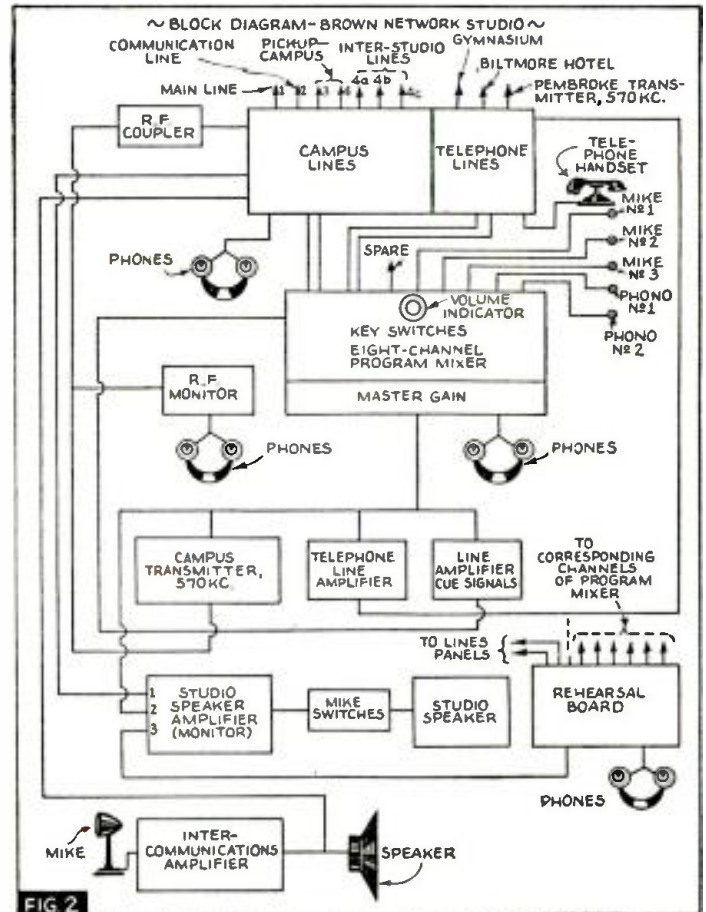

in the group. Local campus conditions will suggest the best arrangement to be used.

LINES FOR WIRED-RADIO

Various types of lines may be used, and each has its advantages. By far the least expensive is a single conductor with ground-return. This line works very well for audio circuits when run either between roof tops or underground in a tunnel, but R.F. signals should not be sent over this type of line if it is strung in the open.

Lines in the open should be made of fine wire, about No. 22 A.W.G., and the spans should be of bronze; while copper wire should be used if it is to be tacked along woodwork. Underground lines should be well insulated. Double-conductor twisted-pair lines are the best to employ for both R.F. and A.F., and for R.F. are imperative if the line is to be in the open for any length. Coupling devices to this line are more expensive, and the wire will cost at least a cent a foot. However, such a line is much more efficient, radiates less, and is more permanent than the single-conductor type.

Finally, *telephone lines* may be rented between buildings. They have 2 conductors, and are only for audio frequencies. Don't overlook the possibility of sending both A.F. and R.F. over the same line. This is especially easy with the first type.

Audio signals may be coupled to the single-strand lines by means of a 0.1-mf. condenser or an A.F. transformer, one end of the winding being grounded. Signals at R.F. may be coupled through a 250 mmf. condenser or a tuned circuit. Transformer coupling must be employed for both R.F. and A.F. on the twisted-pair line, the turns-ratio of the transformer depending upon the impedance of the line. A tuned secondary for the R.F. transformer is necessary.

It has been found excellent practice to couple the R.F. from either type of line to the radiator heating system someplace near

the top of the building to be covered, through the 250 mmf. condenser or R.F. transformer mentioned.

SOURCE OF SUPPLY

Most of the equipment needed in the studios is available from radio mailorder houses, and is described briefly as follows:

The transmitter may be one of the many types of small phonograph oscillators on the market. Next, an amplifier with several controls is recommended. For mikes, any inexpensive model would do. A reasonably-priced pickup and turntables are next on the list.

No great audio power is needed to modulate the oscillator recommended, therefore a connection should be made to the grid or plate of the driver tube in the amplifier and the signal from there fed to the oscillator. Since the amplifier may not work without a loudspeaker (for field inductance) this speaker may be used for the studio monitor. Arrange some way to turn it off when the mikes are on!

The A.F. output of the final tubes of the amplifier may also be sent over a line to cue an incoming program over that line. This is a good way to tell the operator at the remote position to "go ahead."

Inquiries regarding the Brown Network may be addressed to the University or to *Radio-Craft*.

This intercollegiate wired-radio network may well forecast a nation-wide development of far-reaching importance. However this is not the only interest which attaches to this article on the newest application of wired-radio. For this article also includes complete directions for setting up a wired-radio intercommunication or broadcasting system. Such systems may be used for point-to-point communication in schools, factories, large business organizations, etc. Need we say more to wide-awake Service and sound men?—*Editor*

STENCIL-CUTTING BY FACSIMILE

Thousands of legible reproductions of facsimile pictures are now possible, immediately upon receiving the picture by radio or wire and without further processing, as described in the article here presented for the first time in any radio magazine. Station WOR's Chief Engineer, J. R. Poppele, recently witnessed the new system in operation at Lehigh University.

*GEORGE KLINGAMAN



Professor H. C. Knutson closely examines the stencil and backing sheet as it emerges from the recorder. Joseph A. Waldschmitt is an interested observer.

DURING the past year the Department of Electrical Engineering of Lehigh University has been cooperating with station WOR in a study of facsimile reception. This work at Lehigh University is under the direction of Henry C. Knutson, Associate Professor of Electrical Engineering. In the course of these experiments it has been found possible to cut mimeograph stencils directly on the facsimile recorder! By this means an almost unlimited number of copies can be made of any facsimile reception.

WHY MAKE COPIES?

Facsimile stencil cutting might be used for the rapid reproduction of any material

*Packard Research Fellow. In cooperation with J. A. Waldschmitt, Packard Research Fellow, and Eric Weiss, Gotshall Scholar, all of Lehigh University.

sent out of which many copies are desired at the receiving end. Weather maps, line drawings, or any kind of printed matter lend themselves perfectly to this treatment.

This process should prove of particular value in the educational field. As an illustration, mimeographed copies of the facsimile-cut stencil of the static characteristics of new vacuum tubes were used in the Communication classes at Lehigh University.

SANS MIMEO

For this work a standard RCA facsimile recorder has been used. Ordinarily, reproduction in this recorder is accomplished by passing carbon paper and white paper between a vibrating printing bar and a rotating helical wire. The bar, whose vibrations are controlled by the received signal, presses the carbon paper against the white paper which rests on the helical wire. This produces an element of the picture, the density of which is thus governed by the input signal.

The helical wire is in the form of a single-turn helix mounted on a cylinder which rotates at 75 r.p.m. When the printing bar is deflected downwards by a signal, the rotation of the cylinder causes the single intersection of the helical wire with the printing bar to move laterally across the page at a constant speed. When this point of intersection reaches one side of the paper another point starts at the opposite side. Vertical scanning is accomplished by advancing the white paper at a constant speed of 3 feet per hour. The drawing illustrates the relation between printing bar, helix, and papers.

STENCILING

Since printing in this system is accomplished by *pressure action* it is possible to

cut stencils without any modification of the recorder.

To cut mimeograph stencils, the carbon paper and the white paper are removed from the machine. The mimeograph stencil without the heavy paper backing is fed into the recorder in place of the white paper. A thin piece of tissue paper (regularly furnished with the stencil) is fed in below the stencil to prevent the wax from the stencil gumming the helix. Several stencils with tissues are joined together and "leaders" of white paper attached to both ends for a full night's reception. The action of the printing bar striking the stencil cuts it directly according to the transmitted pattern.

CONCLUSION

The mimeographed reproductions of type and line drawings obtained by this method are practically as good as the original printings from the machine. Photographs lose their grey gradations, the reproductions being similar to those obtained from cuts made without the use of a half-tone screen.

One of the photos shows Professor Knutson inspecting a stencil as it emerges from the facsimile recorder. He is holding the stencil in his left hand and the tissue paper backing in his right hand. The receiver chassis has been removed from the recorder cabinet and stands to the right.

The authors wish to express their thanks to Mr. J. R. Poppele, Chief Engineer and Mr. C. Singer, Station Engineer, both of Station WOR, for their cooperation in these experiments.

Radio-Craft wishes to thank Mr. Dale H. Gramley, University News Editor, for his cooperation in making this story available.

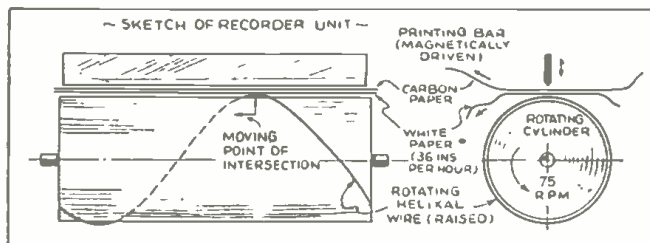

▲ This sketch shows the simplicity of the RCA system for obtaining thousands of copies of any facsy picture the radio waves may waft onto the stencil. Samples of copies made from such mimeo stencils and sent to *Radio-Craft*, last month, speak volumes for the excellence of the work which Lehigh's new system makes possible. Unfortunately, and like all stencil prints, they are not conveniently reproducible as magazine illustrations.

← Recorder mechanism, with printing bar lifted to show inserted stencil and backing paper. At right is the receiver chassis removed from the cabinet. (Test units constitute the background.)

FLAME GENERATES "A," "B" and "C" POWER

Although the principle of generating voltage by heating the junction of dissimilar metals is over 100 years old, only modern developments in metallurgy and chemistry have made practicable the English power supply unit here described. With illuminating gas as the source of power, and without the use of any moving parts, it delivers "A" voltage to any battery-type radio set; with the addition of a converter, "B" and "C" voltages are made available. Its design is analyzed.

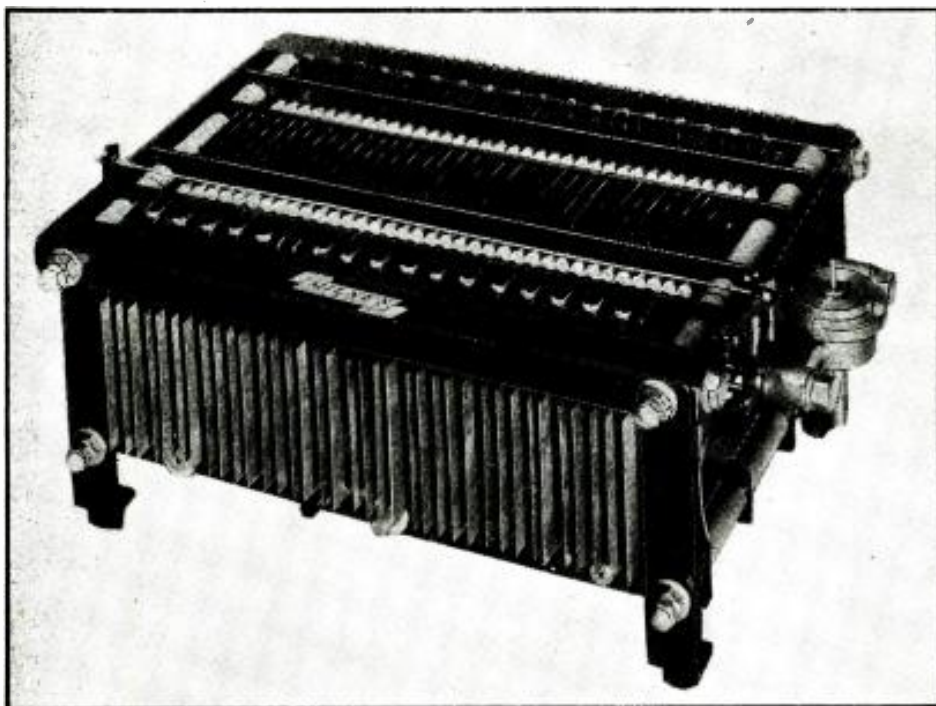

The Milnes converter-type Thermoelectric Generator is here shown with cover removed. It weighs 20 lbs., measures 12½ x 11 x 7 ins. high, and in American money would be priced at about \$20. It delivers 1 ampere at 2 V. as "A" supply; and 2 amperes at 2 V. to a converter, the output of which is 10 to 15 ma. at 120 V. for "B" supply; "C" is via a voltage divider. Cost to operate, only 2/3-cent per hour!

BACK in 1932 *Radio-Craft* published a *description of the work of Dr. Otto Herman in developing the "Thermotron," a device which delivered a 2-V. supply from the current developed in a thermopile heated by a Bunsen burner. It was not until some 7 years later however that a really successful device was developed here, and **described in *Radio-Craft*, for efficiently converting such low voltages to obtain adequate "B" voltage for operating farm and portable battery-type radio sets. ("C" voltage was obtained from self-energizing bias cells.)

In such thermocouple devices the heat of a gas flame is converted into electricity; much as, by way of corollary, in gas-operated refrigerators the heat of a gas flame is converted into cold.

NECESSITY — INVENTION

So much for the practical accomplishments of American technicians in this direction. Now let us go overseas—to Bingley, Yorkshire, England—where the cost of radio sets and the tax on their use have placed much greater pressure on manufacturers to develop radio receivers which will operate in the most convenient and economical

manner. A practical result of this necessity is the Milnes Thermoelectric Generator here illustrated.

It is available in 3 models. The 1st model generates 2 V. at 2 A. (or 4 watts) and is designed to "float" (be connected) across a 2-V. storage cell.

The 2nd model (illustrated) has an output of 6.4 W. and was designed especially for operation in conjunction with a full-wave self-rectifying vibrator type of converter to which it delivers 2 A. at 2 V.; at the same time it delivers 1 A. at 2 V. as "A" supply for a battery radio set. The output of the converter is 10 to 15 milliamperes at 120 V. as "B" supply.

The 3rd model, for heavy duty, delivers 1 A. at 6 V. and is designed to charge a special, 150 V. Nickel-Cadmium storage battery equipped with a switch which connects 2-V. series-wired cells in series-parallel for charging.

The Converter, used in conjunction with the 2nd model of Thermoelectric Generator to obtain complete battery-free operation of battery-type radio sets, is a self-rectifying device consisting of a vibrating reed and 2 sets of contacts.

The 2-volt D.C. supply from the Thermoelectric Generator is made into an A.C. supply by 1 set of contacts; the resulting alter-

nating current is then transformed to the required high voltage and the other pair of contacts rectifies this. A choke and condenser do the necessary filtering. This idea is at least 10 years old, states Milnes's secretary, Mr. W. Grosert, but of course now it has been greatly perfected.

FLAME RADIO POWER!

The principle of the thermopile, briefly, is that the application of heat to a joint of 2 special metallic alloys actually produces an electric current without the use of mechanism or moving parts of any kind. Any desired current or voltage can be obtained by increasing, respectively, the size or the number of junctions or thermocouples.

Tiny gas-jets, heating these special alloy thermocouples provide ample, unvarying electricity as long as the gas is burning.

The Milnes Thermoelectric Generator, in particular, obtains its power from the domestic lighting gas supply. Connection can be made by regular pipe fittings or by means of gas-hose. Within 1 minute of lighting the gas jets the generator develops full power.

The current supply can be regulated by means of a governor attached to the gas intake. This governor is equipped with an automatic "cut-off" so that if the gas is turned off at the supply and turned on again without the burners being lighted, gas cannot escape. The burners themselves are specially designed so that they cannot blow out except under extreme conditions.

The Generator is fitted with 2 burner pipes, the pressure of gas to these being maintained by the governor. No 2 city gas supplies are quite alike and, therefore, the governor (at right end, in photo) must be adjusted for each supply.

(The 2 units designed for charging batteries are also equipped with *thermostatic cutouts* so that the batteries cannot be discharged back into the Thermoelectric Generator if the gas is turned off.)

So much for the generalities; for the more serious-minded readers of *Radio-Craft* however, who want to know the "Why?" of things, the following detailed analysis is presented. True, it's elementary, but if details bore you, just skip it, we won't mind. First items for our verbal microscopy are . . .

THE BURNERS

The burner pipes are just plain pipes now fitted with porcelain burner tips with air intakes and a large number of small jet holes along their length. The gas has to pass through small bores just behind the air intakes and these must be made exactly alike so that each pipe receives exactly the same amount of gas. It is a delicate job to get a perfect balance.

The burner holes have to be graduated; the holes at the far ends of the pipes being about double the size. The reason for this

(*A Thermocouple 'A' Unit," *Radio-Craft*, July 1932.)
(**How to Make a "B" Batteryless Receiver," *Radio-Craft*, August 1939.)

RADIO DEVELOPMENTS

is that the air and gas entering are cold, but as this mixture travels along the pipes it gradually heats up to the temperature of the pipes and thus expands. A bigger size of hole is necessary at the far end of the pipe to allow for the greater volume of the gas. The size of holes is also a job for very careful adjustment.

COMPOSITION OF GASES

House lighting or "city" gas ordinarily consists of about 50% hydrogen, 30% Marsh Gas (called this as it is produced by rotting vegetation; the correct name is Methane), carbon monoxide 12%, and various other gases 6%.

Various gases may be used for this Generator besides city gas, the most convenient being Butane which can easily be procured, inexpensively, as a liquid in cylinders.

By compressing it to 22½ lbs. per square inch we get it into liquid form and as much as 200 cubic feet of the gas may be contained in a cylinder of less than 2 cubic feet capacity. The liquid readily turns back into gas as the pressure is reduced.

Butane gas has about 5 times the calorific value as compared with city gas, but owing to the resultant hotter flame it is actually 8 or 10 times better. One may, on the other hand have a gas of high calorific value which gives a very-low-temperature flame and which would not be as suitable for our purpose. Our heated parts must be maintained at 400°C. which is a fairly high temperature. Water boils at 100°C. and a low-temperature flame would be just as suitable for boiling water as a hotter one, but calorific value is not the only point to be considered when high temperatures are required.

Before going further we will explain somewhat in detail what a thermocouple is and what are its uses.

THERMOCOUPLE

The thermocouple was discovered by Seebeck in the year 1822. (There are 2 other phenomena, namely the Peltier and the Thomson Effects with which we do not propose to deal at the moment.)

Seebeck found that if a piece of metal were heated at one end and kept cool at the other end an electric potential was evident.

Now supposing we take a piece of wire and bend it into a V, then connect a galvanometer to the 2 ends of the wire, we find on heating the wire at the apex that no deflection is shown by the galvanometer, but supposing we use 2 different kinds of metal for our V, and join them at the apex, we shall at once note that ordinarily a current is now being generated (unless perhaps lead is used).

We cannot give the reason for the phenomenon, but it has been found that some metals when heated at one end produce a positive potential and sometimes a negative potential. Actually, the potential is not created at the hot joint, but is created between the hot and cold ends of the heated metal, and a difference in heat potential therefore produces an electric potential.

It is only possible to electrically test a piece of metal by completing the circuit, which means that we obtain the result of the difference between 2 different metals, in other words we must have a joint consisting of 2 metals to obtain any results.

If possible, we should choose our 2 metals so that one has a negative polarity and the other a positive polarity, so that the 2 potentials can be added.

Take a joint for instance as Fig. 1. The electrons are tending to travel in the same direction, towards the hot joint and all we obtain is the difference of the 2 potentials, that is 10 millivolts (measured on meter G).

In Fig. 2, the potentials are in opposite directions so that now we have the added

result of each of the metals, or 30 millivolts.

As an instance of this, suppose a man is pushing a cart in one direction and a boy is pushing against him in the opposite direction, the cart will move only slowly but if the boy begins to pull the cart in the same direction as the man is pushing it, the cart really begins to move.

It does not matter how the joint is fastened, the wires can merely be twisted together, welded or brazed; or we can interpose a 3rd wire as shown in Fig. 3. So long as A-B is kept at a uniform heat along its length the results are the same. If, however, A is hotter than B we shall have to take A-B into consideration. We have now 2 joints, C-A-B and A-B-D instead of 1, and our total result will depend on the difference or addition of each result, depending on which way the electrons are tending to travel in each piece of metal.

Thermocouples have in the past been used chiefly for the measurement of temperature.

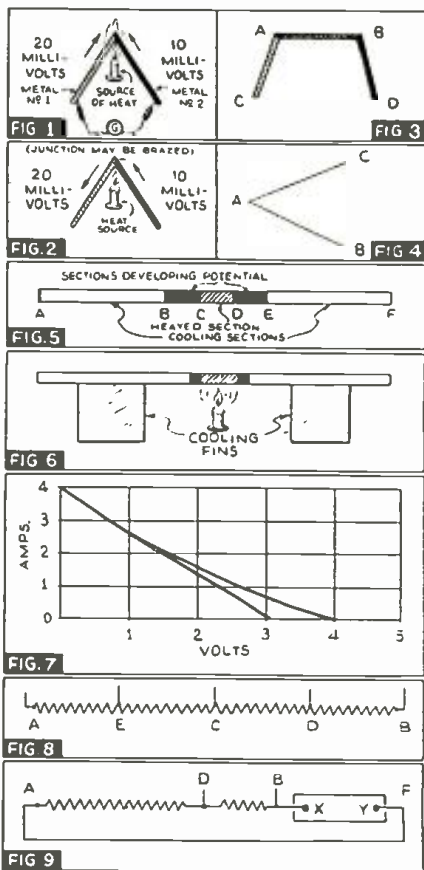

The various figures shown above detail the mechanical and electrical principles involved in the thermocouple, and the Milnes thermopile. Figure 4 is used to aid analysis of Fig. 9. In Fig. 7 is a graph which illustrates the watts output of the Milnes Thermoelectric Generator.

Temperatures over 400°C. cannot be measured by the ordinary thermometer, and a thermocouple provides a most reliable and accurate substitute. It is necessary, however, to use an expensive, 1st-class galvanometer in the circuit. For reading temperatures of 1,000°C., platinum and iridium-platinum wires are usually used. These give a very low potential, about 10 millivolts, but with an accurate high-resistance meter this low potential is no real disadvantage.

For lower temperatures iron and constantan wires can be used. Constantan is an alloy consisting of about 50 parts copper and 50 parts nickel.

Again, for temperatures under 200°C. bismuth and antimony may be used; these give a much higher reading.

Coming back to the Milnes Thermocouple we will consider Fig. 5 (Figure 4 will be discussed later.). Our potential has to be developed between B-C and D-E. The heater C-D is kept at about the same heat throughout its length and A-B and E-F are therefore disposing of the heat as quickly as possible. It is as well to make these of silver or copper as no other metals except gold come anywhere near the heat conducting ability.

Now we go a stage further as per Fig. 6. Our thermoelectric metals have been reduced in length to about 1/16-in. but so long as we can keep the hot sides of each element hot and the cold sides cold by means of the cooling bars and fins, results are the same; in fact, they are bettered, for by reducing the length of the elements we have reduced resistance.

Voltage-generating couples such as these can be joined in series just like cells to form a battery; or, for that matter, in parallel.

VOLTAGE OUTPUT

The difficulty with thermocouples is low voltage and to get an adequate working voltage means at least 40 couples. Although our couples each may have quite a low resistance, when we multiply this 40 times and add to this 160 surface contacts, the resistance can be considerable. If we had no resistance, we should be able to obtain an efficiency of 100%—that is, all the heat would be turned into electricity—but unless we had some resistance to heat, we could not maintain a hot joint, all the heat would leak away as soon as it was applied; and as heat resistance and electric resistance follow one another very closely it appears essential that the couples have a certain amount of resistance. Our ideal would be a couple which had practically no resistance to an electric current while presenting a high resistance to heat but this seems impossible of attainment.

It is a scientific fact which can be readily proved that to obtain the greatest efficiency from any electrical apparatus the external load should be equal to the internal resistance.

We will plot a graph of the Milnes 4-watt Generator. The open-circuit voltage is 4. Now with a certain load we obtain a current reading of 2 amperes and the voltage at the Generator terminals has now dropped to 2 volts. With a current of 1 amp. we find the voltage is 3; and conversely, a current of 3 amps. pulls the voltage down to 1 volt.

CURRENT OUTPUT

If we discard all exterior resistance, so far as is practically possible (The ammeter must have some resistance or it would not operate.) we find that our voltage has dropped to practically nothing and our ammeter shows 4 amps. Why do we get this result? It is because of internal resistance in the Generator.

It is impossible with this particular example to take a higher current than 4 amps. and this high current is of no use as we have no potential at our terminals. All the power is being absorbed in the Generator itself (in overcoming the internal resistance of the Generator) and simply goes back to heat. The graph, Fig. 7, shows a typical curve for the thermoelectric generator, and other electrical apparatus for supplying D.C. will follow very closely. Storage batteries, of course, are an exception as chemical conditions have to be considered here.

Our graph shows that 2 amps. at 2 volts is the greatest power output, which is 4 watts.

What, therefore, is the internal resistance of this particular generator? At no-volts at the terminals we have a current of 4 amps. The open-circuit E.M.F. is 4 volts. To pass a current of 4 amps. at 4 volts, according to

RADIO DEVELOPMENTS

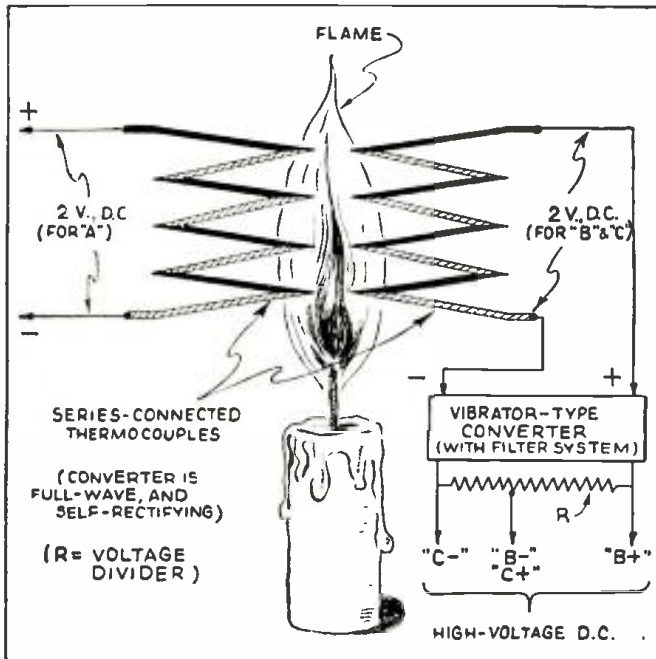

Radio-Craft has prepared the illustration at left to illustrate the principle involved in the thermopile and in particular its application in the Milnes Thermoelectric Generator. Note that the Milnes unit shown photographically on the first page of this article is divided into approximately 1/3 and 2/3 sections, the larger section supplying current to the converter (for "B" and "C" voltages), and the smaller supplying "A" current for the tube filaments. In this commercial unit 3 separate "B" terminals are provided (as shown elsewhere in schematic form) and each of these taps is thoroughly decoupled to eliminate all possibility of motorboating.

Ohm's law we find we need a resistance of 1 ohm. So by simply putting a dead short on the apparatus we are able to ascertain the approximate internal resistance.

A better way of testing for internal resistance, in fact the best we know and the easiest, is to use a resistance of known value which on being connected across the terminals of the apparatus drops the voltage to half open-circuit voltage, or even if it drops the voltage by 1/4 we shall be able to get a very accurate result. Suppose our resistance drops the terminal voltage to exactly half we know, immediately without any calculation, the internal resistance—it is the same as our known resistance.

To explain more fully, we will take a length of resistance wire and connect this to a battery, a larger one for preference, with a low internal resistance so that it does not affect results. We pass a current through this, not concerning ourselves at the moment what current is flowing, and we take the E.M.F. at A-B, Fig. 8, which for example is 4 volts.

Now if we apply our voltmeter between A and C we find we get half the E.M.F.; similarly between C and B.

If we divide the wire into quarters we have 1 volt shown in each quarter section.

The voltage of D-B will be 1/3 of A-D and the resistance of D-B will be 1/3 of A-D.

Suppose we now wish to take the internal resistance of a battery we will regard this internal resistance as separate and the battery having no resistance. See Fig. 9.

Let X-Y be the battery and D-B its internal resistance. We place our voltmeter across D and F, the 2 terminals of the battery. We cannot put the voltmeter across B-F as D-B is actually inside the battery. Suppose we get a reading of 4 volts. Now if we connect our exterior circuit A-D we shall note a voltage drop across D-F. If the E.M.F. is now 3 volts it shows that 1 volt is to be accounted for inside the battery D-F and the exterior resistance A-D will be accounting for 3 volts. Therefore A-D must have a resistance of 3 times that of the battery.

It is quite easy to find exactly the resistance of A-D. Connect an ammeter in the circuit. Suppose we have 24 amps. flowing and an E.M.F. of 3 volts across A-D, ac-

ording to Ohm's law we have a resistance of 3/24ths equals 1/8-ohm and as this resistance A-D is found to be 3 times that of D-B the resistance of the battery is

$$\frac{1}{8} \times \frac{1}{3} = \frac{1}{24} \text{ ohm}$$

Now in the case of a thermocouple we find that internal resistance is due to at least 3 causes. We have the normal resistance of the wires at ordinary temperature. We have an added resistance due to the heated ends (all metals increase in resistance to electric current on being heated; carbon which is not a metal decreases in resistance). We may have in some cases contact resistance.

It is quite easy to ascertain if this contact resistance is present by first of all testing the resistance across B-C and then doubling the length of A-B and A-C, as shown in Fig. 4. If we find a proportionate doubling of resistance we can deduce there is no contact resistance, but if the resistance is found to be very little more, then contact resistance must account for most of the total.

EFFICIENCY

Previous attempts with thermopiles have failed through corrosion or, if the metals have been welded together, through fracture (the latter due to the different coefficient of expansion of each of the metals). In the Milnes unit, silver in the alloy elements (in porcelain sleeves) ensures against corrosion; when heated, the elements are slightly plastic, therefore maintaining good bedding with the heating and cooling rods. Platinum faces on the heating bars, and ends of rhodium plating on the cooling bars, prevents oxidation until a perfect bed has been established.

An efficiency of 1 W. per cu. ft. of gas per hour is obtained; put another way, and taking the domestic gas-rate in New York City as an example, the 6.4-watt unit here illustrated would supply "A," "B" and "C" power for 1 hour, to a radio set, at a cost of only two-thirds of a cent per hour!

This article has been prepared from data supplied by courtesy of Milnes Electrical Engineering Co.

SO MANY BIG PAY JOBS

BEGIN WITH THIS FREE BOOK!

Earn money in spare time... be your own boss in a profitable business... enjoy an absorbing hobby. *Whatever your ambition*—added income, big pay job or relaxation after hours, this **FREE BOOK** will get you started. *And enable you to buy the finest, nationally advertised radios, radio parts and accessories, Sound Systems and equipment at remarkably low prices!*

HUNDREDS HAVE PROFITED!

Here's a buying guide so comprehensive, so complete, so up-to-date you can order everything you need—at home. And save on everything you buy! Take advantage of this **FREE** offer. Hundreds have done it, and taken a new lease on life. Our twenty years of experience is your guarantee of dependable merchandise and complete satisfaction. Our staff of trained technicians stands ready to furnish you with helpful information and advice. *Why not send for our FREE catalog today? See what's in it for you. Simply tear out coupon and mail NOW!*

NEW YORK, N. Y.
100 SIXTH AVENUE
CHICAGO, ILL.
901 W. JACKSON BLVD.
ATLANTA, GA.
245 PEACHTREE STREET
BOSTON, MASS. • BROOKLYN, N. Y.
NEWARK, N. J. • JAMAICA, L. I.

LAFAYETTE RADIO

LAFAYETTE RADIO • Dept. 3D, 100 SIXTH AVE., N. Y.
Rush **FREE** 1940 Lafayette Catalog No. 80

NAME.....
ADDRESS.....
CITY..... STATE.....

NOW ONLY 10c

NEW 1940 EDITION

68 PAGES

MAIL ORDER PLANS TESTED MONEY MAKERS BUSINESS SECRETS SUCCESS SCHEMES

300 WAYS TO MAKE MONEY

In "CASH IN" you get ALL the real money-makers — dozens of profitable tested mail order plans, confidential business secrets, dozens of practical tested formulas, successful tested schemes—actual experiences of men who have started on a shoestring—with less than \$10 capital. Money-Back Guarantee.

"CASH IN" contains only tested ideas covering every type of full-or spare-time enterprise—it's a "masterpiece" in business ventures.

10 CENTS per copy. Sent **POSTPAID** anywhere upon receipt of 10 cents U.S. stamps or coin.

NATIONAL PLANS INSTITUTE
246-R FIFTH AVENUE NEW YORK, N. Y.

QUALITY ABOVE ALL

SOLAR CAPACITORS

Write for Catalog
SOLAR MFG. CORP.
BAYONNE, N. J.

Save on Everything in Radio

NEW 1940 RADIO CATALOG AND PROFIT GUIDE
Most complete line of latest radio sets, amplifiers, kits, tools and replacement parts. All leading brands at lowest prices. Fast Service. Guaranteed Quality.

The RADOLEK Company
Dept. Y-40 601 W. Randolph St., Chicago

SEND FOR YOUR COPY TODAY

FREE RADIO PROFIT GUIDE

Serviceman Earns Extra Money Building

2-TUBE FARM SET

A radio Serviceman in Grand Prairie, Texas, has found that the new 1N5GT and 1D8GT battery tubes make possible an economical and sensitive loud-speaker set that's easy to build. This tuned-radio-frequency Farm Set is virtually a "4 tubes in 2" receiver since the 1D8GT is a combined diode-pentode with each section being put to efficient use.

Serviceman Roger Dickey writes:

SINCE 1933 I have been in the radio service business and have read *Radio-Craft* during most of that time. A number of interesting articles have appeared from time to time showing clever, new circuits, designed to work with new-type tubes.

FARMER JONES'S SET

Frequently I have requests from farmer customers of mine for a battery radio set that is smaller and more economical to operate than the commercial sets available. We have in this vicinity some 7 or 8 local radio stations which make it possible to use a small T.R.F. (tuned-radio-frequency) receiver about as well as a superheterodyne. In fact the T.R.F. receiver works better as there is less interference from the powerful locals. Working along the lines of a small and economical T.R.F. battery receiver I have designed one which has performance far better than anticipated.

The set uses 2 of the new battery bantams—a 1N5GT and 1D8GT. It is unbelievable that 2 tubes can work so well, but thanks are due to the engineers who designed the 1D8GT. They did a swell job. This tube, combining a diode plate, a triode amplifier and a pentode output amplifier all in one GT bulb, is a peach for small sets with low battery drain.

FEATURES

The set is extremely sensitive, has volume to spare, excellent tone—even better than some \$25 commercial battery sets with which it was compared. It has automatic volume control; this allows the use of an audio gain control, instead of an antenna control, thus giving very smooth volume control. The A.V.C. circuit works perfectly, preventing any overloading on powerful 50,000-watt stations only 10 miles distant. It draws 0.15-ampere from a 1.5-volt "A" cell, and 6.5 milliamperes from the "B" batteries. This economy of operation is beyond any farmer's dream.

The highest-grade iron-core antenna and R.F. coils were used, which adds greatly to the performance of the receiver.

The 1D8GT tube is supposed to be operated with 9 volts bias on the control-grid of the pentode section. I obtained a bias of about 7.5 volts by using the voltage drop across a 1,000-ohm

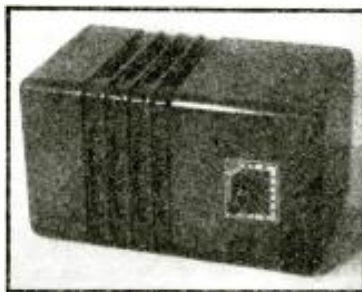

resistor connected between "B-" and ground. This works best with a plate voltage of 82.5 volts. Greater output can be obtained by using a separate "C" battery for bias and the full 90 volts on the plate and screen-grid; however, so little difference in performance was noticed that the simple battery connections were deemed more desirable.

A 4-inch P.M. dynamic speaker was used, and housed in a small walnut cabinet. Care was taken to mount the speaker on the cabinet and not on the chassis as the filament is so small in these tubes that vibrations from the speaker may cause the tubes to seem microphonic by the vibration of the filament.

Care was used in the placing of parts and coils so as to have as short leads as possible to prevent any coupling between the circuits.

Under actual test all the local stations were received with plenty of volume with a short wire for an antenna. At night using an outside antenna WGN, WMAQ, WLW, WSM and a number of other distant stations were well received. The selectivity is good enough to pick up WGN at 720 kc. without any interference from WFAA on 800 kc. operating on 50,000 watts with the transmitter only 10 miles away.

This receiver is economical to construct because of the simple circuit and the few parts required.

LIST OF PARTS

- One Meissner iron-core antenna transformer, L1;
- One Meissner R.F. transformer, L2;
- One Meissner 2-gang tuning condenser, 365 mmf., to match the above coils, C1, C2;
- One Quam 4-in. P.M. dynamic speaker, with output transformer having 10,000-ohm primary impedance;
- One Centralab 1-meg. volume control, midrot type, with attached power switch;
- One RCA type 1N5GT tube;
- One RCA type 1D8GT tube;
- Two octal wafer sockets;
- One 1.R.C. resistor, 0.1-meg., 1/4-W.;
- Three 1.R.C. resistors, 1 meg., 1/4-W.;
- One 1.R.C. resistor, 0.25-meg., 1/4-W.;
- One 1.R.C. resistor, 0.5-meg., 1/4-W.;
- One 1.R.C. resistor, 15 mega., 1/4-W.;
- One 1.R.C. resistor, 1,000 ohms., 1/2-W.;
- One Cornell-Dubilier electrolytic condenser, 10 mf., 25 V.;
- Four Cornell-Dubilier condensers, 0.05-mf., 200 V.;
- Two Cornell-Dubilier mica condensers, 100 mmf.;
- One Cornell-Dubilier condenser, 0.005-mf., 200 V.;
- One cabinet, 5 1/4 x 5 1/2 x 9 1/4 ins. long (overall).

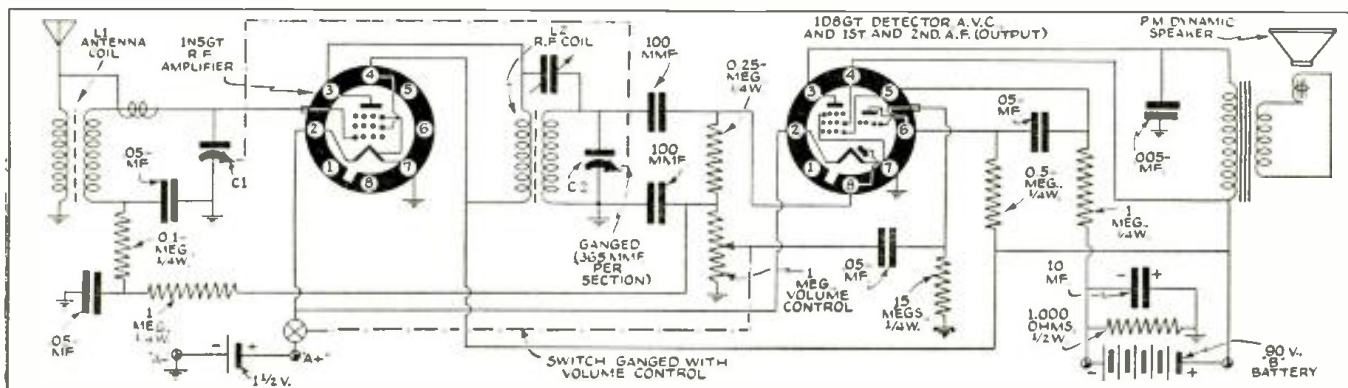

Diagram of the sensitive, selective and loudspeaker-volume 2-Tube Farm Set using the new low-drain 1.4-volt tubes.

•LATEST RADIO APPARATUS•

JUMBO VOLT-OHM-MILLIAMMETER

The Hickok Electrical Instrument Co.
10514 Dupont Ave., Cleveland, Ohio



ITS main feature is the display, 9 1/4-inch rectangular meter. Its ranges are as follows: A.C. and D.C. Volts, 0/10/50/250/-500/2,500; D.C. microamperes, 0/500—especially handy for sensitive measurements; D.C. milliamperes, 0/5/50/500; ohms, 0.05/30 (8 ohms mid-scale), 0.5/10,000 (150 ohms mid-scale), 50/1 megohm (15,000 ohms mid-scale), and 500/10 megohms (150,000 ohms mid-scale); decibels, -10 to +15, 29, 43. Output, 0/10 50/250 500/2,500. This range incorporates a blocking condenser.

PORTABLE METER

The Triplett Electrical Instrument Co.
Bluffton, Ohio

AN entirely new line of 7-in. portable meters having a 6-in. mirror scale and knife-edge pointer. Accuracy claimed is within 1 per cent, and 1/2-per cent for many ranges. Available in microammeters, milliammeters, ammeters, voltmeters, millivoltmeters, thermoammeters—in multiple or single ranges. Case measures 11x9x4 ins. Cover detachable.

NEW VU METER

General Electric Co.
Schenectady, N. Y.

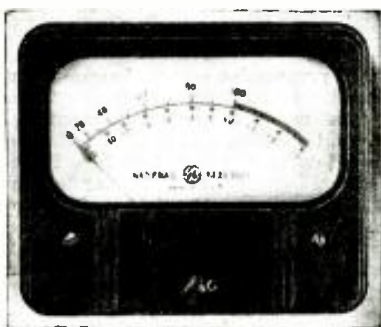

VU is a new unit of measurement of volume level. It is numerically equal to the number of decibels above or below the reference level of 1 milliwatt in a load of 600 ohms. The instrument is essentially a low-range rectifier-type r.m.s. voltmeter with a built-in copper-oxide rectifier. It is housed in a molded black case—special colors available.

"SIGNALYST"

RCA Manufacturing Co., Inc.
Camden, N. J.

A HIGH-EFFICIENCY signal generator for servicing. Good for aligning I.F. and R.F. circuits in all-wave broadcast receivers, for television overall tests when modulated by square waves or composite image signals. Has fundamental frequency range of 100 kc. to 120 mc. on 10 bands. Its accuracy is claimed to be within $\pm 1\%$ scale calibration. Its 3-color dial has scale length of 90 ins. Output is available at the end of the coaxial cable. Measures 14 ins. long, 8 ins. deep, 9 3/4 ins. high.

SERVICING SIDELINE

Kisco Co., Inc.
39th & Chouteau St., St. Louis, Mo.

THE "nu-pep" air circulator is a modern successor to the electric fan. It is a complete ventilator unit operating on a new principle of cooling and air circulation. Forces air upward in all directions.

NEW ANTENNA KIT

Stromberg-Carlson Telephone Mfg. Co.
Rochester, N. Y.

ACCORDING to the manufacturer, this antenna is for "picking up frequency modulation and television signals, as well as standard, shortwave, and other ultra-short-wave broadcast signals . . . "picks up radio waves with super-sensitivity, automatically adjusting itself to the tuning range in use." It is a doublet with a low-loss matched impedance transmission line.

PORTABLE RECORDING AND PLAYBACK OUTFIT

Bell Sound Systems, Inc.
1183 Essex Ave., Columbus, Ohio

KNOWN as the Record-O-Fone, this compact instrument attaches to any radio receiver and permits both transcription and recording of all types of programs on discs. Two models are available, one for recording of radio programs only, the other incorporating an oscillator for microphone recording. Either may be hooked up to any radio set for 110 V. A.C. only.

REPLACEMENT CONDENSERS

Cornell-Dubilier Electric Corp.
South Plainfield, N. J.



A NEW-TYPE dry-electrolytic replacement condenser features low cost and quick replacement. Available in single, dual, triple and quadruple units—38 different varieties ranging from single 8, 12, 18 and 24 mf. condensers with ratings of 250, 350 and 450 V., to multiple units of various sizes. Enclosed in cylindrical cardboard containers with insulated, color-coded leads.

(See page 630 for additional items)

HAVE YOU TRIED... National Union CONDENSERS

FEATURES

HIGH BREAKDOWN VOLTAGE—

Uniformly aged and tested considerably above their rated operating voltages.

UNIFORMITY—

Double checked to insure reliability and uniformity of characteristics.

CAPACITY—

Very close tolerances result in extreme uniformity and freedom from replacement difficulties.

LOW LEAKAGE—

Remember N.U.'s check-test of every condenser insures uniformly low leakage and good leakage recovery. Excessive leakage causes more service difficulty than any other type of condenser trouble. Just compare.

POWER FACTOR—

The life and performance of electrolytic condensers are determined to a considerable extent by the power factor. Compare the low power factor of National Union condensers with other leading makes.

SEND FOR CATALOG.

Can be applied to all National Union Tube Deals

ASK YOUR JOBBER OR WRITE
NATIONAL UNION RADIO CORP.
NEWARK, N. J.

GET A REAL ELECTROPLATING KIT ABSOLUTELY FREE!

Complete details as to how it is possible to get a Real Electroplating Kit FREE, appear on Page 614 of this issue. TURN TO IT NOW!

SERVICE MANUAL

427
DIAGRAMS
OF MOST
SERVICED
RADIOS

DIAGRAMS YOU NEED

In one handy manual you have all the diagrams of the most often serviced radios today. Over 80% of all sets you service every day are included. These important, hint-giving, trouble-shooting circuits make your job easier, permit faster and better repairs.

4 OUT OF 5
CIRCUITS
YOU
NEED

HOW TO SAVE TIME

Circuit data, hints, information are time-savers and money-makers for you. Let this diagram manual be your guide to bigger profits and easier service work. Why work blind-folded when 4 out of 5 diagrams you will ever need are included in this new, low-priced manual, compiled by M. Bellman, B.S. radio serviceman, author, teacher of Radio in Chicago schools.

COMPLETE
\$1.95
POSTPAID

LIMITED EDITION

Get your copy of this radio man's biggest time-saver. No need to spend money for bulky, space-wasting manuals. Only \$1.95 to-day brings your copy of the handiest "on-the-job" handbook of useful diagrams. (Models 1926 to date.) Well printed, with illustrations, large size 8 1/2 x 11 inches. Limited quantity at the special price. Rush order now.

FREE EXAMINATION COUPON

Supreme Publications
3727 West 13th Street
Chicago, Illinois

Ship complete Service Manual. I may return the manual for a full cash refund if I am not satisfied.
 I am enclosing \$1.95, send postpaid.
 Send C.O.D. I will pay postman \$1.95 and a few cents postage.

NAME _____
Write address below and send this corner. _____

SUPER BARGAINS

Rockbottom Prices on New and Rebuilt Apparatus

Many of the attractive items listed here are brand new, others are reconditioned like new; but ALL are in PERFECT WORKING ORDER. In many cases, the component parts alone total more than the complete price we are asking. 100% satisfaction guaranteed or your money refunded.

ORDER FROM THIS PAGE. Use the convenient coupon below. Be sure to include sufficient extra remittance for parcel post charges, else order will be shipped express, charges collect. Any excess will be refunded. C.O.D. shipments require a 20% deposit. If full remittance accompanies order, deduct 2% discount. Send money order, certified check, new U. S. stamps. No C.O.D. to foreign countries.

ORDER TODAY LIMITED QUANTITIES PROMPT SHIPMENTS ASSURED

24-HOUR ELECTRIC TIME SWITCH

Complete with Built-in Holding Relay

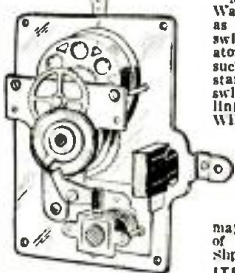

Made by the famous Waterbury Clock Company, as an automatic defrosting switch for electric refrigerators and still usable as such. Has synchronous self-starting clock motor, and switch contacts for controlling any 1/3 H.P. motor. Will modernize any electric refrigerator by providing automatic defrosting. Merely plug refrigerator into clock outlet; and clock into 110 volt, 60 cycle A.C. line. Its maze of gears may be used for a variety of experimental purposes. Shp. Wt. 3 lbs.

ITEM NO. 75 **95c**

Your Price (as illustrated)

SUPER SPECIAL

3 1/2 R.P.M. SYNCHRONOUS MOTOR

There are 101 uses for a synchronous motor making only 3 1/2 revolutions per minute. Ideal for crowd-catching dynamic, store-window displays, agitating film-developing tanks, as an electric winch on model motor boats, as derrick motor in erector sets, etc., etc. Built-in high-ratio step-down gears provide amazing amount of power. Made by the well-known Haydon Mfg. Co. of Waterbury, Conn. Measures but 2" in diameter x 2 1/2" x 1" thick overall. Shp. wt. 2 lbs.



ITEM NO. 76 **\$1.95**

Your Price

A.C. "SQUIRREL CAGE" SYNCHRONOUS MOTOR



A self-starting shaded pole motor originally designed for use on radio chassis for Push Button Tuning. High speed and powerful. One lubrication lasts lifetime. Excellent for model railroad trains, small boats, humidifier water pumps and a host of other uses. Has 1/2" long shaft, 3/16" diameter. Complete with brass mounting posts. Measures 2 1/2" x 2" x 2 1/4" overall. For 110 volts, 60 cycles, A.C. only. Shp. wt. 4 lbs.

ITEM NO. 77 **\$1.35**

Your Price

SCOOP!

REPLACEMENT ELECTRIC CLOCK MOTOR

Complete with Rotor

STOP! Don't throw out your electric clock just because the field coil has burned out. Replace the entire motor quickly, economically with this new one, which fits 90% of all electric clocks here it does not fit, use the field winding only, on the old lamination. The result is the same; new life for the clock. For use on 110 volts 60 cycles only. Measures 2" in diameter. ITEM NO. 78 **49c**



HUDSON SPECIALTIES CO. 40-R West Broadway, N. Y. C.

WE HAVE NO CATALOG. IT'S EASY TO ORDER—CLIP COUPON—MAIL NOW ORDER FROM THIS PAGE

HUDSON SPECIALTIES CO., 40-R West Broadway, New York, N. Y. RC-440

I have circled below the numbers of the items I'm ordering. My full remittance of \$..... (include shipping charges) is enclosed.

OR my deposit of \$..... is enclosed (20% required), ship order C.O.D. for balance. (New U.S. stamps, check or money order.)

Circle Item No. wanted: 75, 76, 77, 78, 81, 82, 86, 87

Name Address

City State

Send remittance by check, stamps or money order; register letter if you send cash or stamps.

AMAZING!! BLACK LIGHT

Powerful 300-Watt Ultra-Violet Bulb

The best and most practical source of ultra-violet light for general experimental and entertainment use. Makes all fluorescent substances brilliantly luminescent. No receivers or transformers of any kind are needed. Fits any standard lamp socket. Looks like ordinary light bulb except that it is made with special dark filter glass which permits nothing but ultra-violet rays to come through. Brings out beautiful opalescent hues in various types of materials—even non-fluorescent objects. Swell for amateur parlors, plays, etc. to obtain unique lighting effects. Shp. Wt. 1 lb. Bulb only. ITEM NO. 87 **\$2.00**



YOUR PRICE

SPECIAL

LITTLE GIANT MAGNET. Lifts 8 lbs. easily. Weighs 4 oz. Made of ALNICO new high-magnetic steel. Complete with keeper. Most powerful magnet ever made for size. Shp. Wt. 3/4 lbs. ITEM NO. 86 **\$1.00**

YOUR PRICE

G.E. INDUCTION DISC MOTOR FOR RECORDING PLAYBACK AND DISPLAY PURPOSES

Substantially constructed to General Electric specifications, this ball-bearing motor was originally designed as a high-quality phonograph unit. Its power and smooth-running characteristics make it excellent for home recording work. Its speed, governor-controlled, is variable both below and above 78 r.p.m. Designed for use on 110 volts, 60 cycles, A.C. Sold less turn-table and shaft. Overall dimensions are 7 1/2" diameter x 5 1/2" high. Shp. wt. 14 lbs. Packed in Original Box. ITEM NO. 81 **\$3.95**

YOUR PRICE

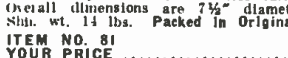

MOTOR FOR ROTATING RADIO BEAM ANTENNAS

One Revolution per Minute



Built by Honeywell as a temperature regulator for coal fired furnaces but ideal for many other uses, especially for rotating beam antennas on the roof for directional beaming and reception of radio signals. Built-in commutator switching permits turning antenna from north-south to east-west direction from a remote point. Substantially constructed for hard usage. Motor has double-ended shafts geared down to about one revolution per minute. Ideal for window displays and other slow-moving mechanical motions. 110 volts, 60 cycles, A.C. only. Overall size 6 1/2" x 6 1/2" x 4 1/2". Shp. Wt. 10 lbs. ITEM NO. 82 **\$5.95**

YOUR PRICE

(Continued from preceding page)

METER-SHUNTING MICA CONDENSERS

Aerovox Corp.
New Bedford, Mass.



THESE condensers are provided with handy meter mounting brackets and R.F. shunting of meter windings. Long slots in the brackets permit attachment to the terminals of any of the standard panel-mounting meters.

SYNCHRONOUS TURNTABLE

Universal Microphone Co.
Inglewood, Calif.

A 100 per cent synchronous motor and turntable for recording and playback work capable of 2-speed operation,—78 and 33 1/3 r.p.m. The assembly is complete with aluminum plate ready to mount on the control desk or panel. Designed especially for radio stations and recording studios.

TAPPED "CORDOHM" HAS PILOT RESISTOR

Ohmite Mfg. Co.
4835 Flournoy St., Chicago, Ill.



FOR voltage-dropping resistors and ordinary line cord. Has a 3-conductor cable which furnishes 110 V. for the tube plate, plus a reduced voltage for the filaments; and, in addition, has a 4th conductor to supply pilot light voltage. Available in a range of values for 4 or 5 tube, 110-V. A.C.-D.C. sets.

COMMUNICATIONS RECEIVER

Howard Radio Co.
1731 Belmont Ave., Chicago, Ill.

THIS progressive series of communications receivers comprises a 2-stage preselector, 10-tube receiver, frequency monitor, and external speaker. The entire layout may be started with a small investment for the receiver. Later the receiver may be converted to a 7-, 9-, or 10-tube set. This enables the purchaser to obtain a better receiver when he is able to do so, and without any loss from trade-ins. A nifty set-up indeed.

28-W. AMPLIFIER

Erwood Sound Equipment Co.
224 W. Huron St., Chicago, Ill.

THE model 3428 amplifier is rated at 28 W., with less than 5 per cent distortion. Has provisions for 2 microphones and 1 phono input; 2 frequency characteristic controls; and a variable output impedance. Provisions are made for the remote control of volume. (See page 637 for additional items)

All the worthwhile
Radio Trade News
of the past Month—
Digested for busy
radio men.

RADIO Trade Digest

A PLEDGE: — To
print the important
news of the radio
industry; to review
major news events;
to help point a path
to radio profits.

IMPORTANT HAPPENINGS OF THE MONTH IN THE RADIO INDUSTRY

No. 20

APRIL, 1940

No. 20

RMA TELLY STANDARDS NO BAR TO PROGRESS

*\$5 Total Cost to Change 330-Line
Telly Set to 441 Lines,
Including Service*

Much good worry is being wasted over possible obsolescence of present RMA telly standards (441 lines, 30 frames). In an interview with RTD, Harry Lubcke, chief engineer of Thomas S. Lee station, W6XAO, Los Angeles, disclosed cost of receiver conversion when that station changed from 330- to 441-line standard. Exclusive of time, cost was between \$1 and \$2. He estimated that Serviceman could make conversion at a profit for \$5 fee.

While this makes the proposed FCC "freezing" of television at present standards unimportant, Mr. Lubcke says, "I do not think that anybody would regret such freezing for a moderate period, for it might give the industry the go-ahead signal which it has been awaiting. Perhaps another spark needed to set off television is limited or complete commercialization. This should result in program improvement, for sponsors are eager to make use of this new advertising medium. Several, indeed, have already approached us with offers of sponsorship."

At present, Don Lee is on the air about 10½ hrs. a week, now, about 4 of which are "live" talent, the rest being educational or entertainment films.

1939 ACCLAIMED GREATEST RADIO YEAR IN HISTORY OF INDUSTRY

*Year-End Statements Optimistic About
1940, Including Television*

There seems to be no shadow of doubt that the year just ended was the greatest in the entire history of the radio industry. Year-end statements from many manufacturers, large and small, bear this out. General Electric did \$360,748,386 worth of business.

Clarostat "added several hundred thousand dollars" business on its books. Westinghouse sold 100% more radios than preceding year; and so it goes. Employment has risen in the entire radio industry, which is paying higher wages to workers, musicians, artists and performers. Radio gives employment to 400,000 people in the United States; has an annual payroll in excess of \$5,000,000—this from the year-end statement of David Sarnoff. In the broadcasting field, NBC announces a gross client expenditure for 1939 of \$45,244,354—an increase of 9.1% over the preceding year.

1939 was an important year from the standpoint of radio developments, too. The first public service of television programs was introduced. Direct radio communication circuits have been established with 51 countries. The quality of telly images broadcast by NBC has improved in brilliance and clarity and was picked-up experimentally in air lines. A new Iconoscope called the "Orthicon" has been successfully tested. New, lightweight portable Telly field equipment was demonstrated to the F.C.C. commissioners.

1940 will doubtless see demonstrations of improved projection of large-screen tele-
(Continued on page 634)

PRETTY PACKAGE SELLS GOODS



Handsomest package of current season is that of RCA Victor's long-life needle. Molded plastic case adds quality touch to make item ready seller at dollar price. Needle good for 1,000 records. Though package resembles ice cube, this one shouldn't freeze on your counters.

NEW CO. HANDLING CINAUDAGRAPH



Still operating in the established plant at Stamford, Conn., a new co. headed by I. A. Mitchell & S. L. Baraf (r. to l.) of United Transformer Co. is handling the manufacture and sale of Cinaudagraph loudspeakers. Known as United Telitone Corp., the organization continues with unchanged personnel.

P. L. JENSEN JOINS UTAH



Peter L. Jensen (left), one of best-known men in speaker industry, is shown above being welcomed into Utah Radio Products Co. by G. Hamilton Beasley, Pres. Utah has been in the speaker biz for 18 yrs., while Jensen is also known as pioneer in this field. The organization is undergoing enlargement.

MFRS.' REPS. WHO TOOK PART IN 3-DAY ALLIED RADIO SHOW



Allied Radio Corp. ran 3-day radio show in Chi. with features such as recording studios, electric-eye robot, model service shop in action, etc. Picture above shows, l. to r., Bert Heuvelman, Triplatt Instruments; "Bunk" Hill, Supreme Mfg. Co.; Paul Botteroff, Trimm Radio; Walter Weiss, Hickok Electrical Instruments; Unidentified (who is it?); A. Cumming, Burgess Battery; H. Goldsmith, Waken and Whipple; Harold Bergren, Astatic Microphone Labs.; L. L. Worner, Worner Prods.; Larry Chambers, National Co.; Royal Stemm, Sr., Audak; Garrett Davis, P. R. Mallory; Dan Von Jeneff, Televiso; William Atkins, Meissner Mfg.; Ralph Haines, Raytheon Mfg.; William Bishop, Taylor Tubes; Jack Albert, Shure Bros.; Ray Hutmacher, Utah Radio.

Personal

HANS MANNHEIMS has succeeded ROBT E. KIESER (whose ass't he formerly was) as mgr. of the foreign sales dept. of the INT'L RESISTANCE Co.

STANLEY H. MANSON is now in active charge of sales for STROMBERG-CARLSON's Kansas City branch. WILLIAM C. LEWIS has taken over Mr. Manson's former duties as sales rep. in the Western N. Y. area while Manson fills the hole left by KENNETH GILLESPIE, gone to manage the appliance dept. of the JENKINS MUSIC Co. (complicated, eh?).

RAYMOND C. COSGROVE, long with WESTINGHOUSE, is a v.-p. of the CROSBLEY CORP.

T. T. SULLIVAN, sec'y-treas. & v.-p. of STEWART-WARNER, has resigned from the first 2 offices due to ill health, & other interests. He continues as v.-p. & dir. E. H. FARRELL, controller, has been elected treas., & LYNN H. WILLIAMS, JR., ass't sec'y, has been elected sec'y.

MILTON B. SLEEPER, former export mgr. of PILOT RADIO CORP. & later press agent for ANDREA RADIO CORP., is back as nat'l jobber sub-mgr. for PILOT.

DR. RALPH L. POWER, adv. mgr. of UNIVERSAL MICROPHONE Co., has never had his picture in any magazine. So here it is, folks—gaze on it & be happy. He has been in radio since 1922 & with UNIVERSAL since 1929.

LARRY E. GUBB, pres. of PHILCO, foresees revolutionary improvements for television in '40.

P. C. SANDRETTO, sup't of UNITED AIRLINES radio lab., has been elected pres. of the Radio Engineers Club of Chicago, succeeding H. B. CANNON, chief eng. of WELLS-GARDNER.

PETER L. JENSEN, former pres. of JENSEN RADIO MFG. Co., has become a v.-p. of UTAH RADIO PRODUCTS Co.

NATIONAL CABRON Co.'s sales, advertising & promotion staffs have been reorganized, and now: R. P. BERGAN, former ass't to J. M. Spangler, gen. sales mgr., and H. M. WARREN, former adv. mgr., are new ass't sales mgrs. J. M. MELDARM, member of adv. staff for the last 2 yrs., has been made mgr. of the new advertising & sales promotion div. A. H. HOUSMAN & H. A. MACMULLEN, of the advertising & sales promotion, are now ass't mgrs. of that div.



TIMELY TELEVISION TRENDS

Watch for big doings at FCC on television. Insiders are hopeful that new art will take quick spurt if regulations are loosened—and whispers are that they may be soon.

Engineers of San Francisco's KFRC have surveyed 3 sites for a television station, license for which has been granted. Bets are that roof of KFRC-Don Lee bldg. will be chosen.

Du Mont Labs. demonstrated high-definition television using 625 lines to produce

11½ x 14 in. images on 20-in. tube. Also shown at demonstration was high-persistence screen, making lower frame frequencies possible. RTD observer expressed enthusiasm for demonstration but commented on what he considered excessive curvature of the screen and remarked that tube that size must have such curvature to support 2-ton atmospheric pressure on end of tube.

Some mos. ago RTD wagered that telly commercials would be broadcast. Within predicted period a shoe co. was paying a Broadway columnist to mention their product during series of interviews; cigarette-lighter co. had presented revue featuring close-ups and descriptions of its product; book publisher was giving illustrated lectures on his latest volume; other well-known books were being close-upped and blurred as contest awards; a flour was being touted in cooking broadcast with package close-ups, etc.

BIZ OPPS—CASH IN

Here are 2 opportunities for mfrs. & distributors to make sales. Be first in the field—and get those profits.

Joseph W. Marnitz writes "I am in the market for a 500-ohm-line cutting-head and plain ungrooved records, also suitable needles for cutting and reproducing. Please have firms who market such equipment write to me." Mr. Marnitz can be addressed at 30 Essilen St., Sunnyside, Pretoria, S. Africa.

Enterprise Radio Co. writes, "The writer has been branch mgr. for Messrs. Pilot Radio & Tube Co., S.A. (Pty.) Ltd., East London, importers of Pilot Radio ex U.S.A. and Pye Radio ex England. We now wish to import on our own account a reliable and well-constructed American set. Our requirements will probably amount to 20 sets per month, providing we can get the right type of goods. One of the essentials is a big, attractive and easily read dial, and cabinets should be of good appearance. On account of the S. African Customs restrictions we do not wish to import anything bigger than 7 tubes, which figure must include the 'eye' or cathode-ray tuning beam. We do not wish to deal through any intermediate firm, but would rather deal direct with the factory."

This firm may be addressed at 8, North St., East London, South Africa.

Facts Facts

A complete 3-story building, more than 20,000 ft. of floor space, has just been acquired by Finch. This new factory is located at 4th & Virginia Sts. in Passaic, N. J. In addition to this building the Finch organization is now operating an experimental plant at Bendix, N. J., developing the use of facsimile for commercial, military and naval aviation. Their latest facsimile machine is said to produce 2, 3, 4 or 5 column newspaper print matter at the rate of 22 sq. ins. per minute.

Changes & New Addresses

Where to Reach Old and New Companies

GAROD RADIO CORP. has moved to 70 Washington St., Bklyn, N. Y. Three times the size of the present plant the new quarters will be equipped to produce radio & television receivers.

CHARLES MICHELSON ELECTRICAL TRANSCRIPTIONS AND SPEEDY-Q SOUND EFFECTS have moved to 67 W. 44 St., N.Y.C. These offices are Eastern hq. for Earnshaw Radio Productions, Speedy-Q Sound Effect Record Co., Porto-Playback Co., Walter Biddick Co., & several West Coast transcription firms.

AN EDITORIAL

By Artie Dee

While elections will not take place until Fall, the aspirants are extremely active trying to build up sufficiently large followings so that they may gain the coveted nominations to municipal, county, state & federal offices. No aspirant for office can be elected unless he is first nominated—and the boys are bending every effort to win nominations. It is your opportunity to sell them the equipment they need.

Every man or woman who wishes a career in politics must address large crowds loudly and often. You can sell them the apparatus which will enable them to do so most effectively and with the least expenditure of energy. The sound truck complete with microphone, amplifier, power system, playback & speakers has become an integral part of the American political picture.

If aspirants for office cannot afford to buy such equipment, they must rent it; if they cannot afford to rent it, they had best forget their aspirations. You are in business to make money; you can make money by selling or renting the equipment which all such aspirants need.

Watch your local newspaper for the names of individuals who are aspiring to office. Contact them with your very best sales talk. Also visit local party hq. and political clubs; you have a selling job to do with the leaders. If they already have equipment you may be able to sell them a job of repairing or modernizing it. If they tell you you're too early—to come back in a month—go back in 3 weeks.

But if you're early they won't say, "Sorry, but we've just placed our order," thus making you still sorrier. Be early—don't be sorry.

Be early—don't be sorry.

SET IS SHOWN, TOO



Shown right, above, is Farnsworth's model BC-102, one of the line's leaders which has 3 bands from 1.6 to 18.1 mc. and 540 to 1,600 kc., pushbutton tuning, built-in aerial, A.V.C., bass compensation, continuously-variable tone control, 12-in. speaker fed with 10 W. by 10-tube super. Telly sound, or phono, input terminals provided. Model, left, defies description.

\$'s & No.'s

18% MORE RADIOS sold by Stromberg-Carlson in 1939 and 49% more dealers chose its line than in 1938 according to sales mgr. Lloyd Spencer.

100% MORE RADIOS sold by Westinghouse in 1939 than in 1938. This includes sets in all categories and sales in every type of market.

\$190,000 SAVED BY G.E. employes when contributions to the additional group life insurance plan were suspended during November and December. This is equivalent to 16 2/3 per cent of the yearly contribution rate.

1939 BEST YEAR YET for Clarostat Mfg. Co. "Several hundred dollars more" on its books in 1939 according to sales mgr. Vic Mucher. He attributes it to the war situation, improved American trade and employment.

ORDERS FOR \$112,166,535 received by G.E. during the 4th quarter of 1939 compared to \$63,419,265 for same period year before—increase of 77%. Total 1939 orders were \$360,748,386; for 1938, \$252,176,223—upped 43%.

TROPIC AIR TESTS SETS

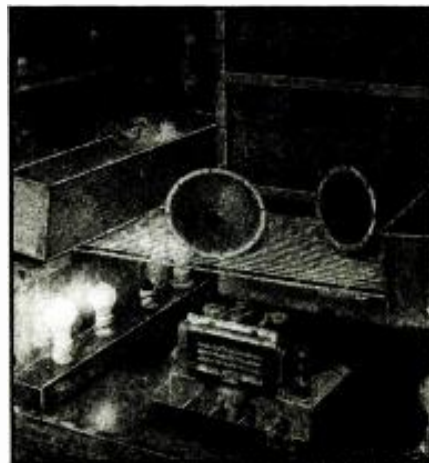

G.E. apparatus is proven in a room which duplicates weather conditions more adverse than any encountered this side of you-know-where. Heavy humidity at high temperature is maintained for periods which alternate with cooling periods that precipitate the moisture onto all parts of the equip't undergoing tropic torture test. That's why G.E. can feel sure its products will stand up under trying conditions.



DeJur-Amaco's photo accessories have been going so well that a nat'l DeJur Camera Club has been organized with headquarters at Shelton, Conn. . . . D'ja know that there are tropics in Bridgeport, Conn.? 'S a fact—G.E. has a test room where temperatures range from 85 to 110 degrees and humidity up to 100% for testing sets to be sold in S.A. See pic on this pg. . . . The reorganized Airplane & Marine Direction Finder Corp. now at Clearfield, Pa. is specializing in direction finders & communication equip't for the Army, Navy, Coast Guard & other U.S. gov't depts. McMurdo Silver is gen. mgr. & Wm. F. Diehl, dir. of eng. & mfg. . . .

Flash!! Radio, which many thought neglected at the 1939 N. Y. World's Fair, will be featured in '40. Plans are to increase shortwave & commercial broadcasts & to have a whale of a telly set-up.

It's a G.E. H-116 receiver that was used 24 hrs. per day to report the War of Words on the Western Front for station WPIC: Heiges Bros. radio lab. of Sharon, Pa., were responsible . . . 4 of 8 new Stromberg-Carlson receivers have F.M. bands . . . Eicor, Inc., has a new line of dynamotors for aircraft, police, marine, ham & other radio work . . . FCC has given W. G. H. Finch permission to operate his 1,000-W. 42.18 mc. station W2XWF on freq. mod. as well as amp. mod. Finch's Telecommunications Co. has licensed a 7-station Cuban net to use his facsy patents . . . NBC added 20 stations to its Red and Blue nets in 1939, making a total of 181—in 1928 there were only 18 . . . G.E. has announced a new VU volume level indicator to meet the specifications of the major networks; it's a low-range rectifier type r.m.s. voltmeter . . . Novachord music is being featured in a broadcast series to advertise gas.

Philco tube structure has been simplified & prices correspondingly revised . . . Universal Microphone Co. has added 2 new lead screws for recording to its line. . . . New patent agreements link RCA, G.E. & Westinghouse—and watch for new Westinghouse tubes, now . . . 'Twas a Merry Xmas for Sylvania employes—3,700 of them got 1

week's pay (up to \$25) from Santy. . . . As of Jan. the Mutual chain had 125 links . . . NBC's Red network (which now has 15 50-kw. stations) won 7 out of 10 firsts on the C.A.B. & Hooper reports & 12 out of 18 on the Cleveland Plain-Dealer poll.

Admiral Dick E. Byrd saw new G.E. sets before the distrib did—he had to take them on his boat before the Show . . . 2 console & 2 table models have been added to the Farnsworth line . . . 1,200 Emerson employes shared \$50,000 in a pre-Christmas bonus . . . The Clyde (Int'l Business Machines) J. Fitches point with pride to their new daughter, Anne Marie . . . Sideline: An attractive mounting for radio programs to set by the set has been invented by H. H. McNash, who's looking for distrib.

Sales Helps and Deals

New Paths to More Business

STEWART-WARNER campus radios are being awarded mid-West food retailers to boost sales of Paul Schulze Biscuit Co. products. One coupon is packed in each store box of Schulze cookies—25 coupons get the set. There are about 30,000 dealers eligible in the deal.

A crystal-clear rectangular block of transparent plastic is the package for the new RCA VICTOR long-life phono needle. Needle costs about a dollar & plays 1,000 records or more. These facts, plus prettiest package yet, should help them sell. (See pic, pg 631.)

SET PRICE HITS RECORD LOW

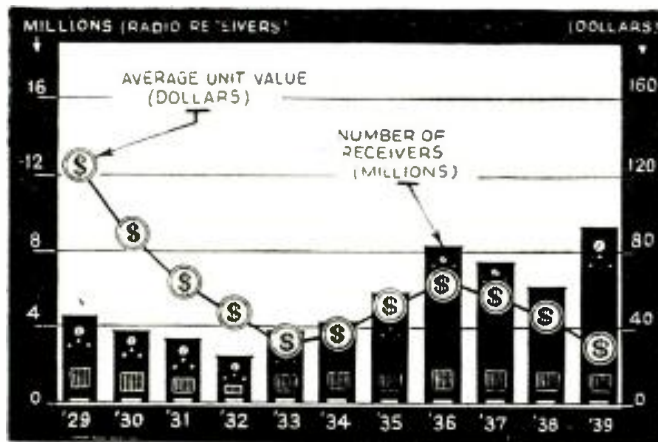

Recent survey reveals \$30 as average price for radio sets in 1939, with close to 10 million sets sold! Runner-up year was '33 when average price was \$35, but with less than 4 million set sales. Highest-price year was 1929 with average set price at \$125, and slightly more than 4 million sets sold. In 1940... aw, you guess!

Salesman Sam Says:—

Data issued by U. S. Govt. Far more detailed information is available from the Bureau of Foreign & Domestic Commerce, Washington, D.C. Publications to request are: World Radio Markets covering countries wanted & The Electrical & Radio World Trade News.

BELGIUM—1,120,400 sets in use by population of 8,400,000. Difficult for American sets to compete with domestic sets because of high tariff on complete imported sets. Low tariff on parts.

PHILIPPINE ISLANDS—About 35,000 sets in use by a population of 16,000,000 of which major portion is Malayan. American and European number only 14,000. Principal demand for sets is in October, November and December. Majority of sets are A.C. table models covering 150 to 22,000 kc. Half the sets in use are 5-tubers; remainder vary from 6 to 20. Very high humidity plays havoc with cabinets and components unless tropic-proofed. 97% of radio tubes are American.

FRENCH GUINEA—No estimate available as to number of sets in use by the 2,000,000 population; probably small. Late 1940 will find a substantial market here for cheap sets when the present project for development of a network of local broadcasting stations for the retransmission of European programs is realized. All selling of mfgd. goods is through trading companies with hq. in Europe.

SENEGAL—Practically same conditions as for French Guinea except slightly less population.

BRITISH INDIA—About 100,000 sets are in use by 383,000,000 population. The market is about 25,000 sets per year—expected to

1939 Acclaimed Greatest Radio Year in History of Industry

(Continued from page 631)

vision images, theatre size. More important, 1940 will see definite moves towards a telly network, using frequencies of 500 megacycles and upwards.

"Looking ahead," says David Sarnoff, "I believe that 1940 will be a year of even greater importance than the year just ending." Interest in the international situation and in the presidential elections should boom radio.

continue for about 2 years despite the war. Three set types are recommended; a local receiver of 3 or 4 tubes, an "ALL-INDIA" receiver of 5 to 6 tubes covering 19 to 100 and 200 to 550 meters, and an all-wave set for foreign reception having 6 to 12 tubes. (Climate varies between extremes of high humidity and dryness; cabinets and components must be weatherproofed. Both battery and socket-powered sets are good sellers.

TANGANYIKA—Extremely limited demand for sets from population of 5,000,000. Electric service where available, is nominally 240 volts at 50 cycles, with fluctuations between 220 and 260 volts. Battery sets used in majority of locations.

How to Sell More Telly Sets!

A novel promotional set-up for selling telly kits has been established by the Poe Television Co., 1129 Sixth Ave., New York City. Anyone who buys a television kit from the company has the privilege of building it in the company's laboratory and under the supervision of its technicians, at no extra charge. To make things even more interesting, tournaments and competitions are held among the builders with various prizes awarded for speed and excellence of construction. Sol Sanford Poselle, the originator and owner, reports outstanding success. Time generally required to assemble the set is 15-20 hrs. The laboratories are open from 10 A.M. to 10 P.M. and buyers include many women. Frequent demonstrations of good telly programs, with salesmen freely circulating among the audience, help a lot towards getting business. Every telly set and kit on the market has its place in the Poe showrooms. Other dealers might take their cue from this set-up and start something similar in their local territory.

OFF THE PRESS

SERVICE GUIDE. Thordarson Electric Mfg. Co., Chicago, Ill. 23 pp. New replacement transformer encyclopedia and service guide. Lists proper replacement for power transformer, 1st filter choke, 2nd filter choke, 1st audio transformer, 2nd audio transformer and output transformer, in all manufactured sets. Available free.

CATALOG. Burgess Battery Co., Freeport, Ill. Lists flashlights, lanterns, flashlight batteries, hearing-aid batteries, ignition & telephone batteries, radio batteries, Mazda lamps and special-purpose batteries.

FOLDER. Radio Wire Television, Inc., New York, N. Y. For band leaders; pointing out advantages enjoyed by bands which own their own sound equipment. Describes special coordinated sound system for use in such work.

CATALOG. James Vibrapowr Co., Inc., Chicago, Ill. 12 pp. Complete list of replacement vibrators for home & auto sets. 2, 4, 6, and 12 V. vibrator units available.

CATALOG. South Bend Lathe Works, South Bend, Ind. 48 pp. Beautifully illustrated descriptions of complete new line of 9-in. workshop, back-gear, screw-cutting lathes & attachments; 24 different models are shown. Write for free copy, attention Technical Service Dept.

FOLDER. Transducer Corp., New York City. Complete technical information, graphs & diagrams of "Co-X" Concentric Cable for low-loss transmission.

CIRCULAR. Stromberg-Carlson Telephone Mfg. Co., Rochester, N. Y. Lists complete current line of receivers. Gives data on frequency modulation & television. Also lists antenna kit, "Wave Wizard" & head-phone kit.

FOLDER. East Coast Phonograph Distributors, New York City. Describes the Seeburg MULTI-RAY-O-LITE RIFLE RANGE, a photoelectric device in which a rifle shoots a ray of light at a PE-cell target.

SHEET. Finch Telecommunications, Inc., New York City. Describes latest Finch compact facsimile unit for receiving & sending printed matter, pictures, maps, etc.

BOOKLET. Allen B. Du Mont Labs., Passaic, N. J. 8 pp. A technical study of phase displacement in electrical circuits from linearly-expanded Lissajous figures Dec. '39-Jan. '40 issue.

REPORT. Federal Communications Commission, Washington, D. C., 246 pp. A complete statistical report for the fiscal yr. ended June 30, 1939 covering every conceivable branch of the radio industry. Replete with graphs, charts, maps, tables, etc. Fifth Annual Report of the FCC.

SHEET. Warner Photoelectric Products, Chicago, Ill. Describes line of photoelectric relays, light sources, complete systems & accessories.

SERVICE BULLETINS. Wilcox-Gay Corp., Charlotte, Mich. Available to distributors, dealers & Servicemen. Aside from usual service data, they include discussions pertaining to the function of the equipment employed—especially that used on the "Recordio," a radio-phono home-recording combination.

•SHOP NOTES—KINKS—CIRCUITS•

Contributions to this department if published are subject to payment at space rates after publication. Illustrations should be on separate paper; pencil sketches will be accepted. Text should be triple-spaced (preferably typed); descriptions should be concise. Only contributions accompanied by postage, or stamped and return-addressed postcard or envelope, can be acknowledged (or returned, if rejected).

If you have a "pet" idea, perhaps one which "tops" any you've seen here, submit it to RADIO-CRAFT. If it's published you have it for future reference in convenient form—in addition to receiving payment.

ANTI-HUM KINK FOR A.C.-D.C. SETS

● WHEN all other methods fail to take ripple fuzz out of an A.C.-D.C. receiver, especially when it is being operated on 25 cycles, try the stunt illustrated here. Make sure the rectifier, in its half-wave circuit,

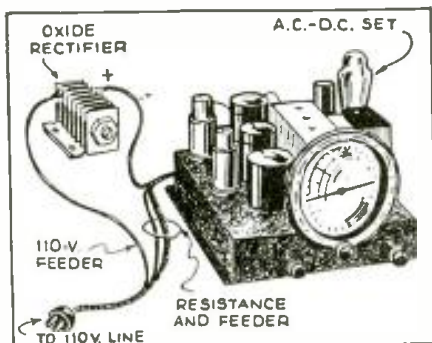

is properly connected as to polarity; rectifier gets "just warm." An old dry-disc rectifier from a trickle charger, connected as shown, will usually eliminate about 90% of the difficulty.

E. PETTY,
Toronto, Ont., Canada.

HOW TO TEST COLD-CATHODE RECTIFIERS

● THE problem of testing cold-cathode rectifiers first arose with the advent of the Raytheon types BH- and BR- tubes. Subsequently the type 0Z4 was brought out for

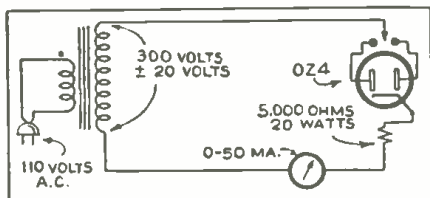

car-radio sets and resulted in the development of the simple test circuit reproduced here. A good tube will read 24-ma. per plate; reject it at 18 ma.

"WESTON POINTER,"
Weston Electrical Inst. Co.

COMpletely PORTABLE

IDEAL FOR SOUND TRUCKS

1940 ELECTIONS

Will Make You Money With Silvertone P. A. Equipment

One of the most interesting political campaigns of all time is getting under way. Huge sums will be spent by candidates and parties to get their messages to the people. Conventions, meetings, rallies, banquets, sound trucks—all this means more Public Address system sales and greater profits from rentals and service. Sound equipment will have the biggest boom in its history.

Are you prepared to cash in on this enormous business? Let Silvertone Public Address equipment help you, with its wide selection of systems, its greater values and its amazingly low prices.



SEND FOR THIS FREE CATALOG!

Just address Sears Personal Service Department and ask for Catalog RC8132A. Send to our nearest Mail Order House. They are located in Chicago, Philadelphia, Boston, Kansas City, Minneapolis, Atlanta, Memphis, Dallas, Los Angeles and Seattle.

SEARS, ROEBUCK AND CO.

ONE WATCH AND YOUR PIPE STAYS LIT

NO SOGGY HEEL

NO BITE

NO RELIGHT

NO BREAK-IN

Briar Hill - the Ideal PIPE

The Pipe that Really STAYS LIT

\$1.50

Why buy "just another pipe." Get the one that makes all others obsolete. Here's real pipe satisfaction—it's making pipe smokers of thousands who "couldn't smoke a pipe." Save 30% to 50% of your tobacco—burns it all. Smokes cool, dry and velvety. Genuine imported Briar—unsurpassed at twice the price. Stoker pushes tobacco UP and **KEEPS IT LIT**. Send for FULL SIZE PIPE CATALOG. It's FREE. GIVE Briar Hills for gifts—get one for yourself. You'll like it.

YOUR OWN PIPE can be fitted with a BRIAR HILL STOKER. Put a ONE DOLLAR BILL with your pipe BOWL and mail to us. (Pack it well—do not mail the stem).

See our complete line ad in December Popular Science and Esquire.

BRIAR HILL CORP., MILLERSBURG, OHIO

BRIAR HILL CORP. Millersburg, Ohio

Enclosed is \$..... Send Briar Hill "Pioneer" Stoker pipes checked at left. Enclosed is \$1.00 and my favorite pipe. Please "fix it so it will stay lit." Send Briar Hill Chart of full size illustrations.

NAME

ADDRESS

CITY and STATE

BE SURE TO CHECK YOUR CHOICE

MEN...GO MODERN WITH YOUR SHAVING!

You can get a useful ELECTRIC SHAVER absolutely FREE! Simply turn to page 606 of this issue and read the advertisement which tells how to get your shaver and a subscription to RADIO-CRAFT.

Save on Everything in Radio

Most complete line of latest radio sets, amplifiers, kits, tools and replacement parts. All leading brands at lowest prices. Post Service. Guaranteed Quality.

The RADOLEK Company
Dept. Y-40 601 W. Randolph St., Chicago

SEND FOR YOUR COPY TODAY

FREE RADIO PROFIT GUIDE

Westinghouse Power Generator

Manufactured for U. S. Signal Corps
200 Watt. 110 V. AC

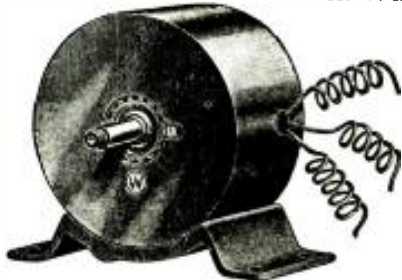

A. C. ELECTRICAL POWER

from a Windmill, from available Waterpower, from your Automobile, from your Motorcycle, from your Bicycle, Foot-pedal or Handcrank (for transportable Radio Transmitters, Strong Floodlights, Advertising Signs); do you want to operate AC Radio sets from 32 V. DC farm light systems; operate two generators in series to get 200 V. AC; obtain two phase and three phase AC, etc., etc.

There Are Over 25 Applications Some of which are:

A.C. Dynamo lighting from eight to ten 20 Watt 110 Volt lamps. Short Wave Transmitter supplying 110 Volts AC for operating "Ham" transmitter. Operating 110 V. Radio Receiver in DC districts. Motor Generator. Public Address Systems. Electric Sirens on motor boats, yachts, etc. Camp Lighting. Short Wave artificial "fever" apparatus. Television. Pelton Waterwheel for lighting or other purposes. Airplane: for lighting strong searchlights or electric signs. Laboratory work, etc., etc. $\frac{1}{4}$ to $\frac{1}{2}$ H.P. needed to run generator.

BLUE-PRINT 22 x 28 in. and Four-Page
8 1/2 x 12 in. INSTRUCTION SHEETS
FREE with Generator.

Generator, as described, including Blue-print and instructions. **\$7.90**

Send \$2.00 deposit, balance C.O.D.
Shipping weight 18 lbs.

MONEY-BACK GUARANTEE

WELLWORTH TRADING COMPANY
1915 SO. STATE ST., Dept. RC-440, Chicago, Ill.

EASY — SIMPLIFIED, — PRACTICAL ELEMENTARY MATHEMATICS

HERE is a book for the business man, the technician and craftsman explaining and answering every operation and meaning with interpreting illustrations and examples. It is the key to a simple understanding of many perplexing problems in daily life.

In clear, positive and definite language, the author popularizes and clarifies every subject and helps the reader to overcome any apparent difficulty in the study of mathematics.

A real home study-course in mathematics for the student or the man who wants to achieve proficiency or desires to brush-up on his knowledge.

Entire Chapter on Special Mathematics for the Radio Technician

SEND TODAY FOR YOUR COPY OF THIS INDISPENSABLE BOOK. "PRACTICAL MATHEMATICS" CAN BE CARRIED READILY IN YOUR POCKET.

CONTENTS OF BOOK

- CHAPTER I. Arithmetic—Addition—Subtraction—Multiplication—Division.
- CHAPTER II. Factoring and Cancellation—Fractions—Decimals—Percentage—Ratio—and Proportion.
- CHAPTER III. The Metric System.
- CHAPTER IV. How to Measure Surfaces and Capacity (Geometry).
- CHAPTER V. Powers and Involutions—Roots and Evolution.
- CHAPTER VI. Mathematics for the Manual and Technical Craftsman—Thermometer conversions—Graphs or Curve Plotting—Logarithms—Use of the Slide Rule.
- CHAPTER VII. Special Mathematics for the Radio Technician.
- CHAPTER VIII. Commercial Calculations—Interests—Discounts—Short Cut Arithmetic.
- CHAPTER IX. Weights and Measures—Useful Tables.

ONLY **50c** POSTPAID

Stamps, Cash or Money Order.

TECHNIFAX

1917 S. State St. RC-440 Chicago, Ill.

A NEW BOOK FOR YOU!

If you will turn to the important announcement which appears on the Inside Front Cover of this issue, you will see how easy it is to get a copy of the FREE BOOK, "1940 RADIO-TELEVISION REFERENCE ANNUAL". This handy book, the same size as RADIO-CRAFT, is sent to those who subscribe to RADIO-CRAFT.

TIRE COVERS AS SPEAKER COVERS

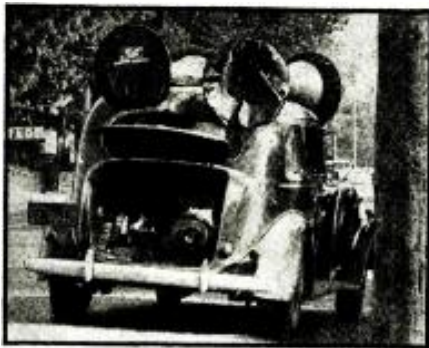

● ORDINARY automobile spare-tire covers were put to a novel use by a California radio dealer. He found them to be just the right size and shape to fit over the end of the loudspeakers used in his public address system, protecting them from the rain, snow, etc., when not in use.

(It is sometimes possible to obtain such covers at less cost if an auto dealer's name is allowed to remain in plain view on the cover; however, if the need for cash is not so pressing, the radio man can use plain covers, or even paint-on his own name and publicity copy.—Editor)

NESTOR BARRETT,
San Jose, Calif.

CONDENSER-PLATE DRAWER-PULLS

● SURE, this is a simple idea, but so was the hairpin. Anyway, the writer was glad when he hit upon the idea of drilling and

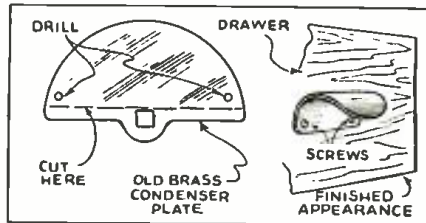

bending some discarded variable condenser plates, as illustrated, to form drawer handles. Cost—\$0.00.

F. E. T. PRATT
Sattley,
Birmingham, 8,
England.

HOME-MADE MULTI-IMPEDANCE OUTPUT TRANSFORMER

● HERE'S how I obtained results equal to several expensive output transformers I recently bought! The voice coil winding suits most dynamic speakers.

Obtain an audio transformer from the junk box, strip outer insulation off coil, and space will be found to wind a voice-coil secondary of 50 turns of No. 26 D.S.C. wire over the existing coil.

From sketch shown, use: (1) pri. or sec.

WIEN BRIDGE "BIRDIES" FILTER

● HERE'S a circuit that clips out any audio frequency to which it is tuned. Introduced by Raymond W. Woodward, W1EOA, in *QST* magazine (Sept. 1939), as the "Hetrofil," it subsequently became available as a kit. Interposed between headphones and the output of any radio set, it permits annoying

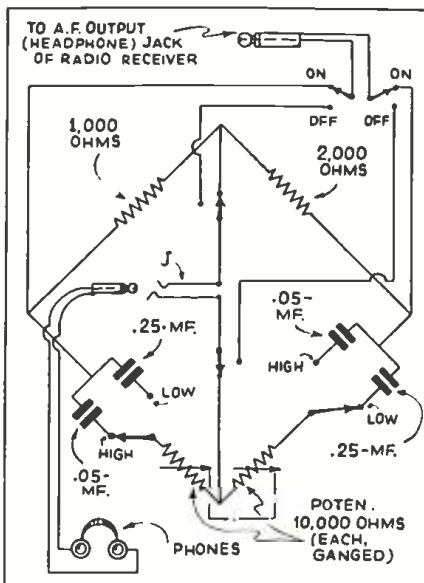

"birdies" to be eliminated (phased-out) during C.W. and phone reception; in fact, gives T.R.F. receivers the advantage in this respect ordinarily afforded only in superhets. with I.F.-circuit quartz crystals.

"SRC HAM NEWS,"
Spokane Radio Co., Inc.

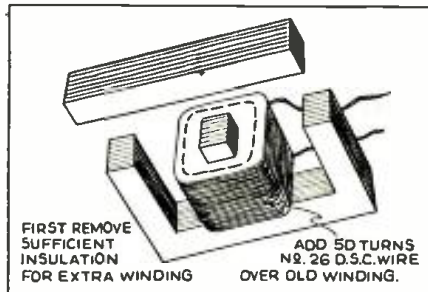

windings for pentodes such as 2A5 or 42; (2) pri. and sec. in parallel for power tubes, 45 or 2A3. Note: phase-out pri. and sec. to ensure against bucking one winding with other before paralleling them. The above combinations give 3 impedances; i.e., (1) primary winding, (2) secondary winding, and (3) pri. and sec. in parallel. The impedance varies with the ratio of transformer used.

JOHN E. RYAN,
Mowbray, Capetown,
South Africa.

CAN-OPENER RADIO TOOL

● HERE is an emergency tool that has helped me many times. This tool is the lowly can opener. It will cut aluminum 1/16-in. thick or thin sheet brass, copper and iron without spoiling the blade. If a stiff guide is held along the line of cutting a fairly straight line may be cut.

The opener cuts rapidly and should only be used in work not requiring an even cut or smooth unmarred surface.

By means of the can opener I have saved myself many hours' work since it can get into some corners shears cannot.

JOSEPH ERDELL,
New York, N. Y.

LATEST RADIO APPARATUS

See pages 629 and 630 for other items
PORTABLE RADIO ELIMINATOR
 Electro Products Labs.
 549 W. Randolph St., Chicago, Ill.



AN "A"- and "B"-battery eliminator for portable and home receivers, using 1.4 V. tubes. Accommodates 4-, 5- and 6-tube sets, and provides 90 V. of "B". Works on 115 V., 50-60 cycles A.C., and accommodates all plugs or connectors.

CONSOLE GRAND RECEIVER HAS 2 LOOP ANTENNAS!

Radio Wire Television, Inc.
 100 Sixth Ave., New York, N. Y.



KNOWN as model BB-11, this Console Grand employs 11 tubes and covers 3 bands; 13.7-42.8 meters, 42.8-137 and 173.5-568 meters. Has 2 built-in loop antennas—one for the longer waves and one for the short waves. Other features include push-button tuning for 6 stations, large slide-rule dial with inset tuning eye, 4-position tone

control, interstation noise elimination circuit, 12-in. electrodynamic speaker. Cabinet is grained burl walnut, 40½ x 28 x 14½ ins. deep. Operating from 110-120 V., 50-60 cycle line.

MINIATURE TROUBLE TRACER

Radio City Products Co., Inc.
 88 Park Place, New York, N. Y.



MEASURING but 6 x 3 x 2½ ins. and weighing but 28 ozs. this miniature instrument combines the functions of an all-purpose meter with those of a trouble tracer. Has 16 ranges, used in connection with a 0-1 ma. d'Arsonval meter with an accuracy of plus or minus 2 per cent. The ranges of this model 456 instrument are: A.C. volts, 0-5, 50 500/1,000; D.C. volts, 0-5 50/500/1,000; D.C. milliamperes, 0-1, 10; ohms, 0-5,000/500,000; decibels, -12 to +8 8 to 28 28 to 48 34 to 54.

WIRE-WOUND "KOOLOHM" RESISTORS HAVE HEAT TELL-TALE PAINT-DOT!

Sprague Products Co.
 North Adams, Mass.



A SPECIAL insulation around wires of these resistors quickly radiates any generated heat. The units may be overloaded to bright red heat and yet not be damaged. Interleaved windings permit a guaranteed accuracy of 5 per cent or better. Each unit has a "teledot wattage indicator" which automatically indicates by change of color when the resistor is running beyond its rated watts power. When overload is removed, the "teledot" returns to its original red color!

SERVICING PUZZLERS

● Intermittent and Gradual Insensitivity. An RCA R-21 receiver was subject to intermittent and gradual insensitivity, which could be solved for a time by turning the set on and off. All tubes, all voltages and all resistances checked correctly. There was no appreciable hum, noise, scratch or hiss. While watching, an 8 mf. electrolytic condenser was placed across the 40,000-ohm resistor in the cathode return of the A.V.C. tube. The trouble was cured temporarily, but it furnished a clue to the trouble.

After examining the schematic of the set a tap in the filter reactor was found to be in series with the resistor in the cathode-return of the A.V.C. tube. This choke was checked with a tube indicator type V.T.-VM. When the set heated after playing awhile a major part of the reactor was shorted out. On examination it was found that the choke wires crossed and the enamel insulation had broken down. The heat caused expansion and contact causing the trouble in the receiver.

Edmund McD. Bendheim

○ Bad 60-Cycle Hum and Intermittent Operation. An RCA T 6-5, 6-volt house set, powered with a synchronous vibrator. The set uses five 2-volt tubes and one 6.3-volt tube wired in series, parallel with resistors to even filament drain and voltage. A visual examination revealed that although all filters had been renewed, everything was as it should be. A voltage check showed all "B" voltages to be exact but the "A" voltage on the 30 driver and 49 final audio tubes to be off, the 30 having about 3.2 volts and one 49 having only 1.2 volts. These two tubes are wired in series with a 16.5-ohm resistor with two 16.5-ohm resistors to ground to compensate for the difference in drain on the 30 tube. Disconnecting these resistors we found the one 16.5 ohms to ground OK but the other reading 50 ohms. Replacement cured the bad hum.

A check of the oscillator primary coil showed an intermittent opening at the juncture of the S.W. plate coils, which caused the intermittent-operation complaint.

Newton J. Baird

Save Money! With the **RADOLEK RADIO PROFIT GUIDE!**



In the Radolek catalog you will find the MOST for your money! Lowest Prices! Best Quality! Biggest Values! Most Complete Stock! Fastest Service! Send for your FREE copy NOW!

OVER 15,000 REPAIR PARTS

The world's most complete stock of radio repair parts and exact duplicate replacements. All leading brands at lowest prices!



COMPLETE TUBE SELECTION

All types, RCA, Sylvania, Raytheon, Philco, etc. Includes Kellogg, special Majestic and transmitting tubes. Complete selection.



NEWEST TEST INSTRUMENTS

The most complete line ever displayed in any catalog. All leading makes. Includes latest improved 1940 models at lowest prices.



GREATEST RADIO VALUES

A huge selection of money-saving set bargains! New Phono-Radio combinations. Automatic tuning sets. Beautiful cabinets. New "Ham" receivers and equipment.



EVERYTHING FOR AUTO RADIO

Complete new auto radio section. Includes vibrator replacement guide, new auto aerials, custom Panel control plates for all autos.



COMPLETE P. A. SELECTION

New 1940 public address amplifiers from 5 to 100 watts. Complete P. A. Systems for permanent, mobile and portable use.



NEW ELECTRICAL APPLIANCES

Extra profits for you! Standard Brand Electric Irons, Stoves, Heaters, Percolators, Waffle Irons, Vacuum Cleaners, Trains, Clocks, Mixers, etc., at lowest prices!



The RADOLEK Co.

601 W. Randolph, Chicago, Dept. C40

Send the 1940 Radolek Radio Profit Guide FREE.

Name

Address

Service man? Dealer? Experimenter?

RADIO IN THE 1940 CENSUS

FROM the days of Marconi and de Forest to the present era of television, facsimile and high-frequency transmission, the dramatic story of the Radio Industry can be traced through the reports of the United States Census Bureau, which in 1940 brings its record up to date with new Censuses of Business and Manufactures.

Starting in January, every factory, store and repair shop in the radio field will receive from a Census enumerator a schedule of questions covering operations for the year 1939. Basic facts obtained will be tabulated and published by late summer or early fall of 1940, with special industry reports to be issued later.

The Census reports on past trends furnishes radio men with the raw material out of which future plans must be shaped. The coming Census of Manufactures, for example, will show production by number and value of portable radio receivers during 1939, the first year for which this item is being listed. Other new products which will be enumerated include facsimile sets

and transmitters, remote control units, automatic tuners, shortwave radio sets, and new types of transmitting tubes.

TELEVISION CENSUS!

Reports on production of all standard items will be continued, and the first complete figures on television kits, sets and transmitters are expected. The 1937 Census of Manufactures called for these data, but television production was in such an experimental stage only 2 years ago that satisfactory reporting was impossible.

In addition, the Census Bureau will report the number of American homes equipped with radio sets, on the basis of an inquiry of the Housing Census, the first ever conducted, which starts in April, 1940.

All figures given to the Census Bureau are confidential, and cannot be used for taxation, investigation or regulation. To avoid disclosure of facts about individual establishments, they are combined when published into totals for states, counties and large cities, by kinds of business.

Index to advertisers

BROADCASTING

Radio Corporation of America... Back Cover

MAIL ORDER HOUSES

Allied Radio Corp.....621
Arrow Sales Company.....608
Burstein-Applebee Company.....621
Gold Shield Products Company.....592, 602
Hudson Specialty Company.....630
Radio Wire Television, Inc.....627
Radolek Company.....597, 621, 627, 635, 637
Sears, Roebuck Company.....635
Montgomery Ward & Co.....619
Wellworth Trading Company.....603, 636

MISCELLANEOUS

Briar Hill Corp.....635
Classified Section.....579-A
Lancaster, Allwine & Rommel.....597
National Radio Parts Dis. Assoc.....597

RADIO PARTS

Hammarlund Mfk. Company.....592
International Resistance Company.....587
Solar Mfk. Company.....627

PUBLIC ADDRESS EQUIPMENT

Amperite Corporation.....608
Amplifier Co. of America.....606, 608, 611
John Meck Industries.....610
RCA Manufacturing Co., Inc.....611
Universal Microphone Co., Ltd.....610
Utah Radio Products Company.....607
Wright, Inc.....608
Wright-DeCoster, Inc.....610

PUBLISHERS

Data Print Company.....603
National Plans Institute.....627
Radercraft Publications, Inc.....580, 600
Radio & Technical Pub. Co.....638
Supreme Publications.....579-A, 618, 629
Technifax.....636

RADIO SETS

Goldentone Radio Company.....602
Midwest Radio Corp.....602

SCHOOLS

Capitol Radio Engineering Institute....579-A
Lincoln Engineering School.....579-A
National Radio Institute.....577
National Schools.....579-A
RCA Institutes, Inc.....579-A
Sprayberry Academy of Radio.....579

TEST EQUIPMENT

Meissner Mfk. Company.....590
Radio City Products Company.....588
Readrite Meter Works.....602
Superior Instruments Company
Inside Back Cover, 597
Supreme Instruments Corp.....592
Triplet Electrical Instrument Co.....603
Weston Electrical Instrument Corp.....579-B

TUBES

Hygrade Sylvania Corp.....614
National Union Radio Corp.....618, 629

(While every precaution is taken to insure accuracy, we cannot guarantee against the possibility of an occasional change or omission in the preparation of this index.)

INFORMATION You've BEEN LOOKING FOR!
SERVICE MEN! RETAILERS! STUDENTS!

GET ALL 3,313 "CASE HISTORIES"

Smart service men are using Ghirardi's complete, world-famous collection of 3,313 receiver "Case Histories" because it shows them how to find the common troubles to which each set is most subject, and gives step-by-step directions for fixing them quickly. Saves much trouble-shooting and testing time! Yes, they're in his Radio Trouble-Shooter's Handbook!

TEST INSTRUMENT DATA

Modern Radio Servicing gives you a 420-page section (a whole book in itself!) about servicing instruments—the theory behind them—how to use them properly—how to select those most useful for your own service work with descriptions and wiring diagrams of all types of equipment on the market. Construction data, too. And in the Handbook you'll find a useful up-to-date Directory of test equipment manufacturers.

Easy Now to Crack the Tough Ones

Now you'll know just what you're doing! Get right to the bottom of your servicing jobs at once—with Ghirardi's 3 big books for service men: Modern Radio Servicing for servicing all types of radio sets and Radio Trouble-Shooter's Handbook for fast reference data. Stop guessing, mister! Stop wasting time! Keep these two books on your bench—use them every day!

UP WITH THE PROFITS Cut Down Service Time!

Ghirardi's servicing books are proved time-savers and profit-makers! Put them to work in your shop—get the combined experience of the country's leading servicing organizations packed into 3 handy books for service men. Use the latest "Factory Methods" for making quick repairs with maximum efficiency (in Modern Radio Servicing). Use the 3,313 receiver "Case Histories" in the Handbook to save trouble-shooting time. And that's but a small fraction of what these 3 books will do for you!

LEARN RADIO AT HOME—QUICKLY!

Now, in spare time you can get your practical training from the man who has been called "The World's Greatest Teacher of Radio", the man who has given thousands of students their start in various branches of the profitable career of Radio—with the easiest, quickest and most thorough home-study course in Radio. No previous training necessary—no math. So simple—clear and inexpensive you will wonder how it is possible! Just imagine—

A \$50.00 Training Course Complete for Only \$4

Yes, Ghirardi's Radio Physics Course is the equivalent of 36 different radio books bound together in one huge, easy-to-use, profusely illustrated self-instruction book of nearly 1,000 pages. Besides the fundamentals of Radio you also get Electric Supply, Sound, Television, Cathode-Ray, Tubes, etc. The biggest bargain in radio education!

Used by U. S. Army

It's used by more schools and students all over the world than any other radio text ever published. Even the U. S. Army and Navy use it in their radio training courses!

Your Chance!

Here's your opportunity to get started on preparing for a good-paying radio job. And it's all yours for only \$4 complete! This may be your Big Chance—grab it now!



ALFRED A. GHIRARDI AND HIS

3 GREAT Radio BOOKS

RADIO TROUBLE-SHOOTER'S HANDBOOK • Case Histories—Trouble Symptoms and Remedies for 3,313 sets, compiled from actual Service Records—a world's record for quantity and authority! • Auto-Radio—Gear Ratios and Dial Directions of Tuning Controls; Installation and Car-Ignition Systems Data; Interference Elim.; Elect. Wiring Diagrams for cars; etc. • Other Data—Over 100 more pages, including quick Trouble-Shooting Charts; Servicing Home Recorders; Servicing Intercomunicators; Trade Directories; Charts and Tables on Tubes, Filters, Transformers, etc. • \$18 Pp.—134 illus.—Standard Manual Size (8 1/2 x 11)—Fabrikoid-bound—\$3.00.

MODERN RADIO SERVICING • Test Equipment—420 pages of Theory, Descriptions, Diagrams of all Commercial Instruments, How They Work, Control Data, etc. • Trouble-Shooting—254 pages of short-cut methods for tracking down all types of different set troubles. • Repairing—184 pages of advanced "Factory Methods" for Superhet Alignment, Interference Elim., Repairing of Receiver Parts, etc. • Special Problems—442 pages on Auto-Radio Installation and Servicing; Servicing All-Wave Sets, Hi-Fi Fidelity Sets, AVC and QAVC, Selling and Advertising, etc. • 1300 Pp.—708 illus. 720 Review Questions—\$4.00.

RADIO PHYSICS COURSE • 1. Radio Broadcasting System. 2. Sound, Speech, Music. 3. Electron Theory; Elec. Current. 4. Elec. Units; Ohm's Law; Resistance. 5. Elec. Circuits; Batteries. 6. Magnetism. 7. Electro-magnetism. 8. Electro-magnetic Induction. 9. Inductance. 10. Capacitance; Condensers. 11. A.C. Circuits. 12. Filters. 13. Measuring Instruments. 14. Radio Waves. 15. Broadcasting. 16. Receiving. 17. Vacuum Tube Principles. 18. Vacuum Tube Characteristics. 19. Vacuum Tube Construction. 20. Vacuum Tube Detector and Amplifier Action. 21. Radio Frequency Amplification. 22. Superhets. 23. R.F. Amplifiers; Tuning Coils. 24. Audio Amplifiers. 25. Speakers. 26. Battery Operated Receivers. 27. Power-Supply Units. 28. Elec. Receivers. 29. Automobile and Aircraft Radio. 30. Phone Pick-ups; Sound Systems. 31. Short-Wave. 32. Photoelectric Cells; Cathode-Ray Tubes. 33. Television. 34. Antennas and Grounds. 35. Testing; Servicing. 36. Sound. • 572 Pp.—508 illus. • \$56 Self-Review Questions—\$4.00.

USE THEM 5 DAYS

Send for any or all of these books today. Keep them 5 days to look over at your leisure. Then if not fully satisfied, return them in good condition and we will refund your money at once. You can't lose!

FREE CIRCULARS!

Descriptive illustrated circulars are available—FREE! Send for them!

SPECIAL COMBINATION OFFER **\$6.50** **FOR BOTH SERVICING BOOKS IF PURCHASED TOGETHER**

ORDER NOW before prices GO UP!

NAME
ADDRESS
CITY STATE
Please send me FREE illustrated descriptive literature.

RADIO & TECHNICAL PUBL. CO.
45 Astor Place, N.Y., Dept. RC-40

Enclosed find payment for, and print to me postpaid with 5-Day Money-Back Guarantee:

- MODERN RADIO SERVICING at \$4. (\$4.50 foreign)
- RADIO TROUBLE-SHOOTER'S HANDBOOK at \$3. (\$3.50 foreign)
- Both Servicing & Radio Physics Books at \$6.50. (Self-Review Course at \$4. (\$4.50 ext. Comb. Price (\$7 for.) foreign)

THE NEW CHANNEL-ANALYZER

Follows The SIGNAL from Antenna to Speaker

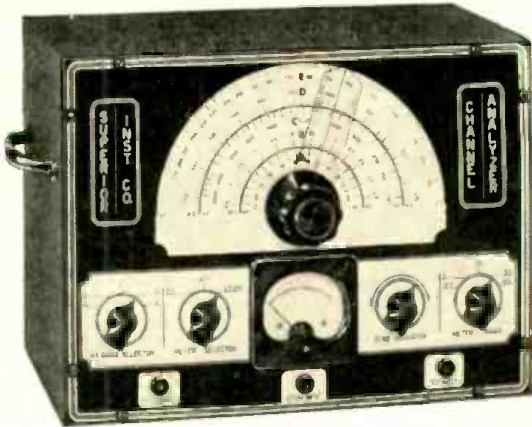

The well-established and authentic SIGNAL TRACING METHOD of locating the very circuit in which there is trouble, and the very component that causes the trouble, is now for the first time available at a price any radio serviceman can afford.

The CHANNEL-ANALYZER will

- ★ Follow signal from antenna to speaker through all stages of any receiver ever made.
 - ★ Instantly track down exact cause of intermittent operation.
 - ★ Measure both Automatic Volume-Control and Automatic-Frequency-Control, voltages and circuits without appreciably loading the circuit, using built-in highly sensitive Vacuum-Tube Voltmeter.
 - ★ Check exact gain of every individual stage in receiver.
 - ★ Track down and locate cause of distortion in R.F., I.F., and A.F. amplifier.
 - ★ Check exact operating voltage of each tube.
 - ★ Locate leaky condensers and all high-resistance shorts, also show opens.
 - ★ Measure exact frequencies, amount of drift and comparative output of oscillators in superhets.
 - ★ Track down exact cause of noise.
- The Superior Channel-Analyzer comes housed in shielded cabinet and features an attractive etched aluminum panel. Supplied complete with tubes, three specially engineered shielded input cables, each identified as to its purpose. Also full operating instructions. Size 13" x 10" x 6". Shipping weight 19 pounds. Only

\$19⁷⁵

THE NEW MODEL 1280 SET-TESTER

Combines Models 1240 and 1250

A complete testing laboratory in one unit, the Model 1280 combines the Models 1250 Multitester and 1240 Tube Tester. (See specifications of each below.)

- ★ Instantaneous Snap Switches Reduce Actual Testing Time to Absolute Minimum.
- ★ Spare Socket and Filament Voltages Up to 120 Volts, Make the Model 1280 Obsolescence Proof.
- ★ Latest Design 4 1/2 D'Arsonval Type Meter.
- ★ Works on 90 to 125 Volts 60 Cycles A.C.



Even those servicemen who through past purchases know they can always get SUPER-VALUES from Superior, will be amazed and delighted when they read the specifications of this all-purpose instrument and then note the unbelievably low price. The Model 1280 features a 4 1/2" D'Arsonval type meter for easy reading of the various scales, and in line with our new policy of stressing appearance as well as serviceability in our new 1280 line of test equipment, our Model 1280 utilizes an aluminum etched panel, designed for beauty as well as ruggedness. The primary function of an instrument is, of course, to make measurements accurately and when designing test equipment this is our first thought. However, we also appreciate the important part the appearance of an instrument plays in the impression a serviceman makes on his customers, especially on home calls. We have, therefore, paid special attention to the outward design of all of our new instruments. For instance, the panel of this Model 1280 is made of heavy-gauge aluminum and etched by a radically new process which results in a beautiful, confidence inspiring appearance.

Model 1280 comes complete with test leads, tabular data and instructions. Shipping weight 18 pounds. Size 13" x 11" x 6 1/2". Our net price ..

\$19⁹⁵

Portable cover \$1.00 additional

THE NEW MODEL 1250 MULTITESTER

SLOPING PANEL FOR PRECISE RAPID SERVICING



Etched aluminum panel

Specially designed electronic rectifier enables linear A.C. scale, high stability and little or no temperature drift.

Here is an opportunity to acquire a Multi-Service, Precision Engineered Instrument, for less than you would have to pay for an ordinary Volt-Ohm Milliammeter. Besides making the usual volt, resistance and current measurements (both A.C. and D.C.) this unit accurately measures the CAPACITIES of mica, paper and electrolytic condensers, INDUCTANCE of coils, chokes and transformers, DECIBEL gain or loss, of power amplifiers and public address systems, WATTS output of amplifiers, receivers, etc.

SPECIFICATIONS

Complete A.C. and D.C. Voltage and Current Ranges	High and Low Capacity Scales .0005 to 1 mfd. and .05 to 50 mfd.
D.C. Voltage:—0-15, 0-150, 0-750 volts	3 Decibel Ranges
A.C. Voltage:—0-15, 0-150, 0-750 volts	- 10 to +19, - 10 to +38, - 10 to +53
D.C. Current:—0-1, 0-15, 0-150, 0-750 ma.	
A.C. Current:—0-15, 0-150, 0-750 ma.	Inductance: 1 to 700 Henries
2 Resistance Ranges 0-500 ohms, 500-5 megohms	Watts: Based on 6 mw. at O D.B. in 500 ohms .005000 to 600 Watts

Model 1250 works on 90-120 volts 60 cycles A.C. Comes complete with test leads, tabular charts and instructions. Shipping weight 9 lbs. Size 9 1/2" x 11" x 6 1/2". Our net price ..

\$11⁸⁵

Portable cover \$1.00 additional

THE NEW MODEL 1240 TUBE TESTER

Instantaneous snap switches reduce actual testing time to absolute minimum.

Tests all tubes 1.4 to 117 volts.

Sockets for all tubes— No adapters.



Superior is proud to offer the newest and most practical tube tester ever designed. Unbelievably low in price—unbelievably high in performance.

- ★ Tests all tubes, 1.4 to 117 volts, including 4, 5, 6, 7, 7L, octals, loctals, Bantam Jr., Peanut, single ended, floating filament, Mercury Vapor Rectifiers, the new S series, in fact every tube designed to date.
- ★ Spare socket included on front panel for any future tubes.
- ★ Tests by the well-established emission method for tube quality, directly read on the GOOD ? BAD scale of the meter.
- ★ Jewel protected neon.
- ★ Tests shorts and leakages up to 2 megohms in all tubes.
- ★ Tests leakages and shorts in all elements AGAINST all elements in all tubes.
- ★ Tests BOTH plates in rectifiers.
- ★ Tests individual sections such as diodes, triodes, pentodes, etc., in multi-purpose tubes.
- ★ Latest type voltage regulator.
- ★ Features an attractive etched aluminum panel.
- ★ Works on 90 to 125 volts 60 cycles A.C.

Model 1240 comes complete with instructions and tabular data for every known type of receiving tube. Shipping weight 12 pounds. Size 6" x 7 1/2" x 10 1/4". Our Net Price ..

\$11⁸⁵

Portable cover \$1.00 additional

SUPERIOR INSTRUMENTS CO.

136 LIBERTY ST., DEPT. RC4
NEW YORK, N. Y.

... AND TO THE PEOPLE!



Carved now in marble in America's most noble memorial, are the immortal words of the Gettysburg Address. Few even among those gathered on the battlefield heard them as they were spoken. Days, weeks, and even months and years were consumed before the speech traveled to all parts of the world. Radio would have winged it *to the people* instantly.

A Service the Family of RCA Might Have Rendered

THE Family of RCA has kept a good many dates with history. As we shape our plans for presenting all sides of the issues of democracy *to the people* in this election year, we recall one date with history we wish we could have kept. It was before our time.

Just suppose there could have been an NBC microphone before the speakers at Gettysburg! Then the greatest words ever spoken by an American would have received an instantaneous world-wide hearing. Out over the two major National Broadcasting Company networks! Across the world via R.C.A. Communications, the radio message service of the Radio Corporation of America! To ships at sea through the radio services of Radiomarine!

The assembled crowd on the battlefield would hear each word clearly, impressively, thanks to a sound system developed in RCA Laboratories and built

by the RCA Manufacturing Company. Listeners everywhere would hear a lifelike reproduction of the speech on RCA Victor radios. And motion picture audiences would listen to the address recreated by the RCA Photophone Magic Voice of the Screen.

Record lovers would, of course, turn to Victor for a higher fidelity recording of the American masterpiece. And the Gettysburg Address would be relived time and time again on RCA Victrolas.

You may be sure that the members of the Family of RCA will continue to dedicate themselves to their responsibilities *to the people*. Whatever radio can do will be done to further the cause of government "*of the people, by the people, for the people.*"

Trademarks "RCA Victor," "Victor," "RCA Victrola" Reg. U. S. Pat. Off. by RCA Manufacturing Company, Inc.



Radio Corporation of America

RADIO CITY, N. Y.

RCA Manufacturing Co., Inc.
Radiomarine Corp. of America

National Broadcasting Company
R.C.A. Communications, Inc.

RCA Laboratories
RCA Institutes, Inc.