



RADIO'S LIVEST MAGAZINE

# Radio-Craft

Special  
Electronics  
Number

April  
25 Cents  
Canada 30c



HUGO GERNSBACK Editor

AN ELECTRONIC  
"PARTY" TREASURE HUNT  
See Page 586



The "Dynamic-Coupled" Tube — 20 Uses of P.E. Cells — Home Electronics  
Electronic Music — Cathode Ray Tubes — Making an A. C. - D. C. Voltmeter

# Magic? No! Tests --- Thousands of them!

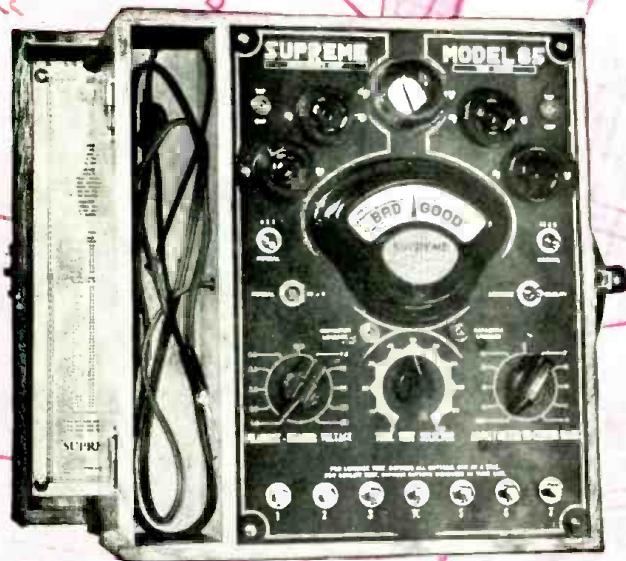

Supreme Neonized Tube Tester available from your jobber at dealers net cash wholesale price **\$39.95**  
Also in modernistic walnut upright counter model.

● The Why and Wherefore of the unfailing, outstanding accuracy of Supreme 85 Neonized Tube Tester is now available in complete bulletin form. It takes you behind the scenes in the laboratory with Supreme engineers. You see test after test . . . thousands of them . . . back of every reading and analysis of the 85. Now radio technicians can give not only the most complete, positive testing of every type of tube . . . if equipped with a Supreme 85 . . . but also know the reason why for every reading. Write for this free bulletin "TESTS - THOUSANDS OF THEM!"

● **Supreme Instruments Corporation, Greenwood, Miss., U. S. A.** ●  
Export Dept., Associated Exporters Co., 1457 Broadway, New York City

# OPPORTUNITIES are many for the Radio Trained Man

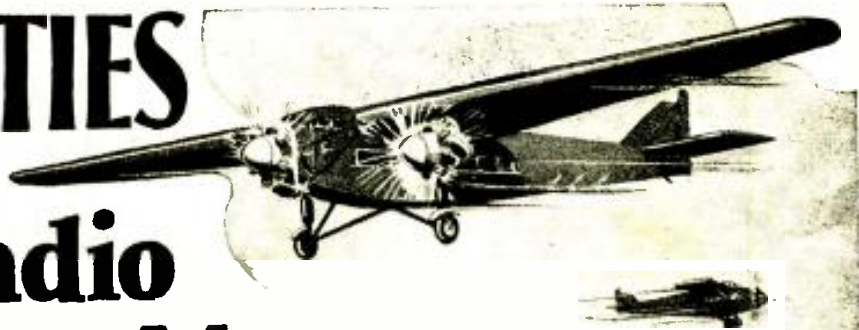

Don't be an untrained man. Let me show you how to get your start in Radio—the fastest growing, livest money-making game on earth.

**Jobs Leading to Salaries of \$35 a Week and Up**

Prepare for jobs as Designer, Inspector and Tester—as Radio Salesman and in Service and Installation Work—or for work in a Broadcasting Station—as Wireless Operator on a Ship or Airplane, or in Talking Picture or Sound Work—HUNDREDS OF OPPORTUNITIES for a real future in Radio!

## Ten Weeks of Shop Training Pay Your Tuition After Graduation

We don't teach by book study. We train you on a great outlay of Radio, Television and Sound equipment—on scores of modern Radio Receivers, huge Broadcasting equipment, Television apparatus, Talking Picture and Sound Reproduction equipment, Code Practice equipment, etc. You don't need advanced education or previous experience. We give you—RIGHT HERE IN THE COYNE SHOPS—the actual practice and experience you'll need for your start in this great field. And because we cut out all useless theory and only give that which is necessary you get a practical training in 10 weeks.

## TELEVISION and TALKING PICTURES

And Television is already here! Soon there'll be a demand for THOUSANDS of TELEVISION EXPERTS! The man who learns Television now can have a great future in this great new field. Get in on the ground-floor of this amazing new Radio development! Come to COYNE and learn Television as it should be learned on Television equipment. Talking Picture and Public Address Systems offer opportunities to the Trained Radio Man. Here is a great new Radio field just beginning to grow! Prepare NOW for these wonderful opportunities! Learn Radio Sound Work at COYNE on actual Talking Picture and Sound Reproduction equipment.

### PAY FOR YOUR TRAINING After You Graduate

I am making an offer that no other school has dared to do. I mean exactly what I say. You can get a complete training by the world's oldest and largest Practical Radio School and I'll finance your Tuition. You won't have to start paying me back in small, monthly payments until 2 months after your required training period is over. I consider the fellow who is ambitious enough to want to get ahead by taking my Training, worthy of my help. MAIL THE COUPON BELOW, and you can prove to me that you are willing to spend just TEN WEEKS in the Coyne Training Shops Learning RADIO. Then, I'll tell you how I finance your Tuition—give you your complete Training and let you pay me back later.

I've got enough confidence in ambitious fellows and in my methods to give them the training they need and let them pay me back after they have completed their training.

### ELECTRIC REFRIGERATION AIR CONDITIONING

To assure your thorough preparation for a prosperous future, I include—at no extra cost—a course in Electric Refrigeration and Air Conditioning, taught you by personal instruction and actual work on latest-type equipment.

### ALL PRACTICAL WORK At COYNE in Chicago

ALL ACTUAL, PRACTICAL WORK. You build radio sets, install and service them. You actually operate great Broadcasting equipment. You construct Television Receiving Sets and actually transmit your own Television programs over our Television equip-

ment. You work on real Talking Picture machines and Sound equipment. You learn Wireless Operating on Actual Code Practice apparatus. We don't waste time on useless theory. We give you the practical training you'll need—in 10 short, pleasant weeks.

### MANY EARN WHILE LEARNING

You get Free Employment Service for Life. And don't let lack of money stop you—my plan makes it possible to get Coyne training with very little money. Many of our students make all or a good part of their living expenses while going to school and if you should need this help just write to me. Coyne is 36 years old. Coyne Training is tested—proved beyond all doubt. You can find out everything absolutely free. Just mail coupon for my big free book!

H. C. Lewis, Pres. RADIO DIVISION Founded 1899

## Coyne Electrical School

500 S. Paulina St., Dept. 45-8H, Chicago, Ill.

Mail Coupon Today for All the Facts

H. C. LEWIS, President  
Radio Division, Coyne Electrical School  
500 S. Paulina St., Dept. 45-8H, Chicago, Ill.

Dear Mr. Lewis:—Send me your Big Free Radio Book, and all details of your Special Offer, including Electric Refrigeration, Air Conditioning courses and your "Pay After Graduation" offer.

Name \_\_\_\_\_  
Address \_\_\_\_\_  
City \_\_\_\_\_ State \_\_\_\_\_

Please Say That You Saw It in RADIO-CRAFT



# CONTENTS OF THE APRIL, 1935, ISSUE

Volume VI

Number 10

Editorial: The Electronic Art.....	Hugo Gernsback	581
The Radio Month in Review.....		582
Electronics Radio Pictorial.....		584
An Electronic "Party" Treasure Hunt.....	J. H. Renkens	586
Twenty Ways to Use the "Electric Eye".....	C. W. Palmer	588
A Modern Picture of Television, Part I.....	Wilhelm E. Schrage	589
The New 6B5 Dynamic-Coupled A.F. Tube.....	Clifford E. Denton	590
New National Wirephoto Service.....	Gideon Seymour	591
The Meaning of "Electron".....		592
International Radio Review.....		593
Fundamental Facts About Cathode-Ray Tubes.....	E. B. Patterson	594
Home Electronics.....		595
Short-Cuts in Radio.....		596
How to Make a Grid-Glow Tube Control Unit.....	Charles D. Savage	597
Build This 5-Tube All-Star "Junior," Part II.....		598
The Listening Post for All-Wave DX-ers.....	C. A. Morrison	599
An Easily-Built "Theremin".....	E. L. Deeter	600
The Latest Electronic Organ.....	Edward E. Kassel	600
How to Read Graphs and Charts in Radio Work, Part I.....	W. Eglit	601
The Latest Radio Devices.....		602
A Low Cost A.C.-D.C. Vacuum Tube Voltmeter.....	S. W. Lichtman	603
Make This Variable-Tone Code Practice Set.....	H. Leroy Flesh	603
Operating Notes.....		604
Replacement Status of the New Tubes, Part II.....	H. M. Neustadt	605
How to Make a "I-Tube" Battery-type Superhetero- dyne.....	R. D. Washburne and N. H. Lessem	606
The Known Frequency Spectrums.....	John J. Glauber	607
An Electronic and P.A. Amplifier.....	Charles R. Shaw	608
New I-Tube All-Wave Battery Set.....	W. Green	609
A 10 to 600 Meter 3-Tube A.C.-D.C. Kit Set.....	L. J. Miles	609
New Tubes vs. Old.....	Austin C. Lescarbours	610
ORSMAs Members' Forum.....		611
RADIO-CRAFT'S Information Bureau.....		612
<b>RADIO SERVICE DATA SHEETS:</b>		
No. 135—American-Bosch Model 376 5-Tube Air- cell Battery—Model Superheterodyne.....		613
No. 136—Stewart-Warner Model R-123 4-Tube Superheterodyne; Sparton Model 81-A "Coun- try Home" 5-Tube Dual-Wave Battery Superhet		614

HUGO GERNSBACK, Editor-in-Chief  
C. W. PALMER Associate Editor  
J. H. RENKENS Associate Editor  
R. D. WASHBURNE, Technical Editor

## FEATURING PUBLIC ADDRESS IN OUR NEXT ISSUE

Public address has attained not only national prominence but also is rapidly surging to the fore in other countries. In the next issue of RADIO-CRAFT we are going to inform our readers of some of the happenings in the P.A. field, abroad. Then, we'll go over domestic happenings in our own backyard—something about fidelity in phonograph records—the "infinite baffle"—a new electronic-music instrument by that dean in the field, Captain Ranger—an easily-built 100-watt amplifier—and many other interesting items.

Then, there will be the usual departments you look for each month—the DX Listening Post that keeps you and your customers posted on what DX stations to listen for and when—Operating Notes for the Service Man—instructional articles for the beginner in radio—and descriptions of new developments by the commercial labs.

Don't miss the PUBLIC ADDRESS NUMBER of RADIO-CRAFT—and tell your friends to look for it!

RADIO-CRAFT is published monthly, on the fifth of the month preceding that of date; its subscription price is \$2.50 per year. (In Canada and foreign countries, \$3.00 a year to cover additional postage.) Entered at the post office at Mount Morris, Ill., as second-class matter under the act of March 3, 1879.

Text and illustrations of this magazine are copyright and must not be reproduced without permission of the copyright owners. We are also agents for WONDER STORIES and EVERYDAY SCIENCE AND MECHANICS. Subscription to these magazines may be taken in combination with RADIO-CRAFT at reduced Club rates. Write for information.

Copyright 1935. Continental Publications, Inc.

HUGO GERNSBACK, President I. S. MANHEIMER, Secretary

Published by Continental Publications, Inc. Publication office: 404 N. Wesley Ave., Mount Morris, Illinois. Editorial and Advertising Office: 99 Hudson Street, New York City. Chicago Advertising Office: L. F. McClure, 919 North Michigan Avenue, Chicago, Ill. Western Advertising Office: Loyd B. Chappell, 511 So. Alexandria St., Los Angeles, Calif.

London Agent:

Hachette & Cie., 3 La Belle Sauvage, Ludgate Hill, E.C. 4

Paris Agent: Hachette & Cie., Australian Agent: McGills Agency  
111 Rue Reamur 179 Elizabeth St., Melbourne

# Learn at Home to Make More Money



**Here's Proof**



Broadcasting Stations employ managers, engineers, operators, installation and maintenance men for jobs paying up to \$5,000 a year.

## I'll train You Quickly for Radio's GOOD spare time and full time Jobs . . .

**Mail Coupon for FREE Information**

Why slave your life away in a no-future job? Why skimp, why scrape, trying to pay your bills? I'll train you quickly for the live-wire field—the field with a future—RADIO. \$40 \$60, \$75 a week—that's what many Radio Experts make. \$5, \$10, \$15 a week extra money—that's what many of my students make in their spare time shortly after enrolling. My free

book tells you about Radio's spare time and full time opportunities—about my tested training—about my students and graduates—what they are doing and making. Get this book. Be a Radio Expert. The Radio field is big enough to absorb many more properly trained men.

### Many Radio Experts Make \$40, \$60, \$75 a Week

Spare time and full time Radio Service installing, Operating, Maintaining Broadcast, Aviation Radio, Commercial Ship and Television stations, a Radio service business of your own—I'll train you for these and other good jobs in the manufacture, sale and service of Radio and Television apparatus. My FREE book tells you about the many money-making opportunities in Radio. Get a copy—mail coupon today.

### Save—learn at home in your spare time

You don't have to leave home and spend \$500 to \$1,000 to study Radio. I'll train you quickly and inexpensively right in your own home and in your spare time for a good Radio job. You don't need a high school or college education. Many of my successful graduates didn't even finish grade school. My practical 50-50 method of training—half with lessons, half with Radio equipment—gives you broad practical experience—makes learning at home easy, fascinating, practical and rapid.

### Many make \$5, \$10, \$15 a week extra in spare time while learning

My book shows how my special training, instruction material, plans, ideas, and my twenty years' experience training men for Radio careers has helped many students make \$200 to \$1,000 a year quickly in their spare time. My Course is famous as "the one that pays for itself."

### Your money back if not satisfied

I'm so sure you will be satisfied with my training that I agree in writing to refund every penny of your money if you are not entirely satisfied with my Lesson and Instruction Service when you finish.

### Find out what Radio offers you

Act today. Mail the coupon. My 64-page book will be sent free to any ambitious fellow over 15 years of age. It tells about Radio's opportunities—explains the eighteen star features of my Course—shows letters of what others are doing and making. There is no obligation. Mail the coupon in an envelope, or paste it on a 1c post card.

**J. E. SMITH, President  
National Radio Institute**

**Department 5DX, Washington, D. C.**

### FREE: Radio Servicing Tips

Let me PROVE that my Course is clear, easy to understand and fascinating to study. Send the coupon for a free lesson, "Trouble Shooting in D.C., A.C., and Battery Sets." This interesting lesson gives 132 ways to correct common Radio troubles. I am willing to send this book to prove that you too can master Radio—just as thousands of other fellows have done. Many of them, without even a grammar school education, and no Radio or technical experience, have become Radio experts and now earn two or three times their former pay. Mail the coupon now.



**"Made \$6,000 in 2 Years"**

"Soon after the depression started, I found myself without a job, but I was well protected with N.R.I. training. I swung right to full time Radio Servicing and I have made over \$6,000 in a little over two years."  
—W.M. SPARTIVENT, Sparty Radio Service, 93 Broadway, Newark, N. J.



**"Made \$17 in One Night"**

"Who says there's a depression? I have made more money in Radio than ever before. I am busy day and night. Last night I made \$17. Last week \$45. I had a tough struggle at first but you fellows helped me back in the race and kept me going."  
—WILLIAM J. MARK, Creighton Mine, Ont., Canada.



**"\$500 a Year in Spare Time"**

"Although doing spare time Radio work only, I have averaged about \$700 a year extra in addition to my regular income. Full time Radio work would net me many times that amount."  
—HOW. H. FAWCETT, Slough Rd., Ladner, B. C., Canada.



**"Good Position, Good Pay"**

"I am Chief Operator at Radio Station WSMK. This is a good position with good pay. I have advanced in Radio right along. I recommend N. R. I. to anyone who wants to be successful in Radio."  
—JOHN HADJIK, JR., 21 Gerard Ave., Southern Hills, Dayton, Ohio.



**Some Other Jobs N.R.I. Trains Men For**

- Broadcast Engineer.
- Operator in Broadcast Station.
- Aircraft Radio Operator.
- Operator of Airway Beacons.
- Government Radio Operator.
- Ship Operator.
- Serviceman on Loud Speaker systems
- Installation Engineer on Loud Speaker Systems.
- Sales Manager for Retail Stores.
- Service Manager for Retail Stores.
- Auto Radio Installation and Serviceman.
- Television Broadcast Operator.
- Television Engineer.
- Set Servicing Expert.

**MAIL THIS for FREE 64 page book**

Please Say That You Saw It in RADIO-CRAFT

Dear Mr. Smith: Without obligation, send me the Service Manual and your free book at home in spare time and tell me other Radio opportunities, and how I can train for them.

NAME.....

ADDRESS.....

CITY.....

STATE.....

AGF

# Radio Men!

**GOOD BOOKS WHICH HELP  
MAKE RADIO WORK MORE PROFITABLE**

Presented on this page are books of the RADIO-CRAFT LIBRARY SERIES—a most complete and authentic set of volumes treating individually, important divisions of radio. Each book has been designed to give radio men the opportunity to specialize in one or more of the popular branches of the industry. You will find them a real help in your work and they will contribute to your money earning capacity. Read these books during your spare time at home.

The authors of these books are well-known to everyone. Each is an expert radio man; an authority on the subject—each is thoroughly familiar with the field which he represents.

This is the first real opportunity that you have ever had to build a library of radio books that are authentic. **MOST OF THE BOOKS HAVE BEEN RECENTLY REVISED AND REWRITTEN TO KEEP THEM UP TO THE MINUTE.** Mail coupon below for your books.

**Book No. 1**  
**Radio Set Analyzers**  
And How To Use Them  
By L. VAN DER MEL

With Full Instructions and Observations of Set Analyzers, Tube Checkers, Oscillators, etc. (Just revised.)

**Book No. 2**  
**Modern Vacuum Tubes**  
And How They Work  
By ROBERT HERTZBERG

With complete Technical Data on All Standard and Many Special Tubes. (Just revised.)

**Book No. 3**  
**The Superheterodyne Book**

All About Superheterodynes  
By CLYDE FITCH  
How They Work, How to Build and How to Service Them.

**Book No. 4**  
**Modern Radio Hook-Ups**  
The Best Radio Circuits  
By R. D. WASHBURNE

A Complete Compendium of the Most Important Experimental and Custom-built Receivers.

**Book No. 5**  
**How to Become a Radio Service Man**  
By LOUIS MARTIN

How to get started in the business of servicing radios and how to make money in this field.

**Book No. 6**  
**Bringing Electric Sets Up to Date**  
By CLIFFORD E. DENTON

With Pentodes, Multi-Mus, Dynamic Speakers—Complete Information How to Modernize A. C., D. C. and Battery Operated Receivers.

**Book No. 7**  
**Radio Kinks and Wrinkles**  
By C. W. PALMER

For Service Men and Experimenters  
A Complete Compendium on the Latest Radio Short-Cuts and Money Savers—These Kinks Are Great Time-Savers.

**Book No. 8**  
**Radio Questions and Answers**  
By R. D. WASHBURNE

A Selection of the Most Important of 5,000 Questions Submitted by Radio Men During the Course of One Year—They Are All Answered by a Technical Expert.

**Book No. 9**  
**Automobile Radio and Servicing**  
By LOUIS MARTIN

A Complete Treatise on the Subject Covering All Phases from Installing to Servicing and Maintenance. A Book That is Greatly Needed Today. (Just Revised.)

**Book No. 10**  
**Home Recording and All About It**  
By GEORGE J. SALIBA

A Complete Treatise on Instantaneous Recordings, Microphones, Recorders, Amplifiers, Commercial Machines, Servicing, etc.

**Book No. 11**  
**Point-to-Point Resistance Measurements**

By CLIFFORD E. DENTON  
The Modern Method of Servicing Radio Receivers—A Book Which Radio Service Men Have Referred to More Than Any Other.

**Book No. 12**  
**Public Address Installation and Service**  
By J. T. BERNSELY

Modern Methods of Servicing and Installing Public Address Equipment.

**Big Discount To You**

In order to make it possible for everyone to buy these books, the fifty (50) cent price has been made uniform for all volumes. You can buy these books separately, but you should take advantage of our special offer:

**When Five (5) Books Or More Are Ordered Deduct 20% From Your Remittance**

Simply fill in the coupon at left, and mail it to us together with your remittance. Checks, stamps or money orders accepted.

**Here are the subjects covered--**

- Set Analyzers
- Tubes
- Superheterodyne Circuits
- Radio Hook-ups
- Servicing Business
- Modernizing Electric Sets
- Kinks and Wrinkles
- Questions and Answers
- Auto-Radio Servicing
- Home Recording
- Resistance Measurements
- Public Address

**All Books Uniform** Volumes are all uniform size, 6 x 9 inches, and contain on an average of 50 to 120 illustrations. Each book is printed on fine paper and no expense has been spared to make it an outstanding value.



**CLIP—MAIL THIS COUPON TODAY!**

GERNSBACK PUBLICATIONS, INC., 99 Hudson Street, New York, N. Y.

I have circled below the numbers of books in the RADIO-CRAFT LIBRARY SERIES which you are to send me, and have deducted 20% for ordering five (5) books or more. I have included my remittance in full, at the price of 50c each, when less than five books are ordered.

The amount of my remittance is.....(Stamps, checks or money orders accepted.)

Circle numbers wanted: 1 2 3 4 5 6 7 8 9 10 11 12

Name ..... Address .....

City ..... State ..... RC-335

Please Say That You Saw It in RADIO-CRAFT



"Takes the Resistance out of Radio"

Editorial Offices: 99 Hudson St., New York, N.Y.

HUGO GERNSBACK, Editor

Vol. VI., No. 10, April, 1935

# THE ELECTRONIC ART

An Editorial by HUGO GERNSBACK

**T**HE electronic art encompasses that branch of radio and allied radio branches which has to do with the motion of electrons in certain electrical devices, such as vacuum tubes.

The radio tube, for instance, is a device which is electronically operated. It functions by the motion of the electrons between the different plates and grids in the interior of the radio tube. But radio tubes are not the only electronic devices. There is a formidable array of devices and instrumentalities in use today which is making the electronic art a big business—one that is growing by leaps and bounds, with a magnificent future before it.

Besides the radio receiving tubes, we have, of course, the transmitting tubes, power tubes for various purposes, rectifier tubes, and tubes with such high sounding names as Thyatron—grid-controlled rectifiers; Phanotron and Kenotron—high-potential rectifiers; Plotron—oscillators; Magnetron and Axiotron—magnetically-controlled oscillators; Ignitron—mercury-pool controlled rectifiers; Kathetrons—grid-controlled mercury-vapor rectifiers; Cathautograph—cathode-ray pencil; etc.

In addition to this, there are, of course, X-ray tubes, of various types, all electron-operated. Then we have the long, tubular glowing lamp, known as the illuminating neon-type tubes, although many of the newer ones contain other gasses besides neon. Not every colored tube which you see today uses neon; those which give off the red-pinkish light still use neon but others, such as those which give green and blue and yellow, use other gases and metals. Thus, a brilliant yellow illuminating tube is made by using the volatile metal *sodium*; the green illumination is made with *mercury vapor*; blue is made by means of *cadmium*, another volatile metal; while a mixture of vapors of mercury, zinc and cadmium gives a light much like daylight.

The operation of all these tubes, no matter what gas used, is, of course, by means of the ubiquitous electrons.

But the tube which the public associates, perhaps more than anything else, with the electronic art is the photoelectric cell. This electronic device, commonly called the "electric eye," has found hundreds of new uses and the proverbial surface has, as yet, not been scratched. Photoelectric cells are used today for opening doors automatically by intercepting a light beam; they are used even to assort beans, as well as grade different shades of cigars; and the photoelectric cell does this much better than the human eye because it is unfailing and it never tires. Photoelectric cells are used to level off elevators, so they stop exactly at the proper floor height; they turn on street lights at sundown and turn them off at sunrise; they accurately count people in the street, or automobiles in underriver tunnels. They operate garage doors by the light from the automobile headlight; they are one of the most important adjuncts to television in transmitting the light impulses from the televised subject; they check drinking water on shipboard for the presence of oil or sediment; protect the operators of

shearing and punching machines in factories; check the humidity of air in a room; align the printing on toothpaste tubes with the "seal" at the bottom; inspect jigsaw puzzles in manufacture; verify the timing of automobiles or runners in competitive races; control automatic machines for making paper bags; record the time of flight of shells from large guns at proving grounds; save electric bills in large industrial plants by correct control of illumination; measure the sand and cement in mixing mortar; measure the acidity or alkalinity of chemicals and, last but not least, permit blind people to "see." An entire book could be written as to the application of the wonderful photoelectric cell itself, and many new and far-reaching uses will be found for it in years to come.

Closely allied with photoelectric cells are such devices as light-sensitive selenium cells and copper-oxide cells. The latter has particularly found a fine field of new endeavor in measuring (by means of an attached meter) the illuminating power of reading lamps, so that the engineer can tell whether your eyes are being strained by a particular type of illumination.

The latter device operates somewhat differently from other electronic devices in that the light falling upon the cell, itself, gives rise to the release of an electronic stream. In other words, the light ray falling upon the cells transmutes the light energy into electric energy inside of the cell—as the result of electron motion, of course.

Dr. Colin G. Fink of Columbia recently declared that photo-cells of this type, producing electricity equivalent to 75 per cent of the solar energy, are not beyond the realms of possibility, though at present they are only a fraction of 1 per cent effective. Considering that there is an equivalent of 150 watts of power in a square foot of sunlight, a roof on your house made of such a photoelectric material would convert, in one short hour, sufficient electricity to supply all your needs for a week.

This research has led many engineers into still another field of electronic devices, and that is the "cold electronic tube." Today, the overwhelmingly larger percentage of electronic devices are dependent upon the radiation of their electrons from a hot wire (filament) or cathode, the temperature rise in which releases the electrons. Without such a hot wire or a hot cathode, the device would not function. But all the time we are getting closer to the new cold electronic tube, where no hot electrode, no hot wire, no hot surface, is used, and where the entire electronic emission is dependent upon the electrical current which, in a number of ways, tears out the electrons from a cold cathode or cold wire. So far, such devices have not been highly successful, and we still must use our heating or "A" power in order to get the energetic electronic flow; but the time will come when all electronic devices will be of the cold-tube variety, and the efficiency of such electronic devices will no doubt be far higher than those with the hot cathodes or hot wires in use today.

# THE RADIO MONTH



An experimental set-up of the inverter used in the new power distribution system.

## NEW DEVELOPMENT IN POWER DISTRIBUTION

**E**LECTRONIC tubes have made possible a new highly efficient method of sending electric power over great distances—without the tremendous losses heretofore encountered in such projects. This fact was made known last month in a paper read before the members of the A.I.E.E.—and is the work of Dr. C. H. Willis of Princeton University, and B. D. Bedford and A. C. Sprague of the G.E. Co.

The new system depends on the use of gigantic thyatron and phanotron tubes—half as large as a man—and is briefly dependent on the conversion of high potential alternating currents into direct currents of the same potential, which are transmitted over high voltage power lines, and then the efficient re-conversion of these extremely high “constant currents” into low voltage alternating or direct currents.

The paper read before the A.I.E.E. stated that power losses of 1 to 2 per cent were encountered in these conversions. With such highly efficient distributing systems, huge power plants, such as the Tennessee Valley, Boulder Dam, etc., will be able to supply their power to wide areas in the country—and because of the size of these plants, the power cost will be extremely economical. The importance of this development, cannot be over-estimated.

In addition to great economy in distribution, there are other advantages—complete regulation of power flow is always realized—short circuits cause a drop in power instead of a concentration of flow as with present methods.



The appearance of the Hewlett sun motor which uses four selenium photo-cells.

## RAYS OF LIGHT OPERATE NEW MOTOR

**A**NOTHER step forward in the search for machines which can harness the natural energy received from the sun was demonstrated last month by an eminent scientist—Dr. C. W. Hewlett.

Dr. Hewlett's model which utilized unusually sensitive light-sensitive cells of the selenium type, derived sufficient energy from sunlight or even artificial light to run a small motor.

Four of the selenium cells, connected together, operated a motor rated at four ten-millionths of a horsepower. The speed with which the motor turned depended on the amount of light—direct sunlight turned it about 400 revolutions per minute but even a sky light on a cloudy day was sufficient to turn the motor rapidly.

No practical applications for the sun-driven motor have been undertaken, for its size of four ten-millionths of a horsepower, which might be likened to one flea-power or less—is too low to be of immediate practical value.

It has been pointed out, though, that “each square foot of sunshine continuously delivers energy equivalent to 150 watts of electrical power—enough solar energy falls on the average automobile to drive it at speeds up to the legal limit. More solar power is delivered to the decks of the average steamer than the total power of her engines.”

Dr. Colin G. Fink of Columbia University recently declared that photo-cells producing electricity equivalent to 75 per cent of the incident solar energy are not beyond the realms of possibility—though the present efficiency is a fraction of 1 per cent.

The little sun motor made by Dr. Hewlett has no practical value, according to its constructor—but it is probably the forerunner of really practical types.

## PROFESSOR LECTURES CLASS FROM HOME

**T**HE dream of every pedagogue to sit comfortably at home and deliver lectures to a classroom, without having to face the yawns of inattentive students, became a reality last month when Dr. C. C. Clark of New York University introduced the use of ultra-short-wave transceivers to his class in science.

Dr. Clark, chairman of the school's science department, seated in his home at 10 Sheridan Square, about a quarter of a mile from the “School of Commerce,” delivered lectures and answered questions for more than a week, without once having to attend class.

The means whereby this was accomplished was the use of two transceivers or combination transmitters and receivers which operated on ultra-high-frequency waves. One of the transceivers was set up in the Doctor's home and the other, with a suitable amplifier was installed in the classroom. These ultra-high frequencies, it will be remembered, do not carry over long distances, but are ideal for spans up to 20 miles.

The Professor was so closely in touch with the students during these experiments and so familiar with his students that he even enjoyed the fun of admonishing—“You two in the back of the room—sit up and pay attention.”

This practical experiment immediately suggests other uses for which the transceivers might be applied. For instance, they could be used for communication between the school principal and any of the classrooms, thus eliminating the lines and public address equipment otherwise required.

The professor can now sit comfortably at home and lecture his classes.





# IN REVIEW

Radio is now such a vast and diversified art it becomes necessary to make a general survey of important monthly developments. RADIO-CRAFT analyzes these developments and presents a review of those items which interest all.

## RADIO BUSINESS IN 1934

**I**N THIS, the beginning of the fifteenth year of broadcasting, it is interesting to look back over the past twelve months and note the financial condition as reported last month by Dun and Bradstreet, Inc.

In addition to the continual encouraging reports during the first six months, an abrupt increase in sales took place when the new all-wave models were displayed early in the fall. In comparison with the totals for the corresponding period in 1933, no losses were reported in any part of the country, while increases ranging from 25 to 100 per cent were recorded. The less expensive sets were bought freely, but the proportion was not as large as it was last season, because of the decided shift to the higher-priced all-wave sets.

The report of Dun and Bradstreet indicates that the sales averaged 40 per cent higher than the comparative period in 1933—an encouraging report, indeed! The results are shown in the graph here.

But the advances reported in set sales are nothing compared to the startling figures reported for the radio broadcasting network business.

In October, the highest sales in broadcasting history were reached at \$4,527,000, a gain of 59 per cent over the 1933 comparative figures and 49.1 per cent higher than October, 1932. For 10 months of 1934, the sales amounted to 33.8 per cent higher than the 1933 comparative figures and 2.2 per cent in excess of the 1932 total, which was the previous all-time high level.

Let us hope that these encouraging reports continue to pile up!

Some of the encouraging figures reported for the year just past—1934.

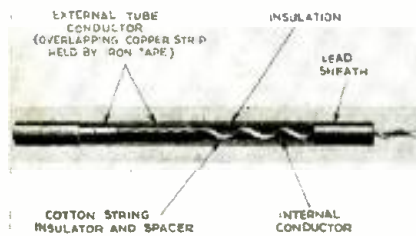
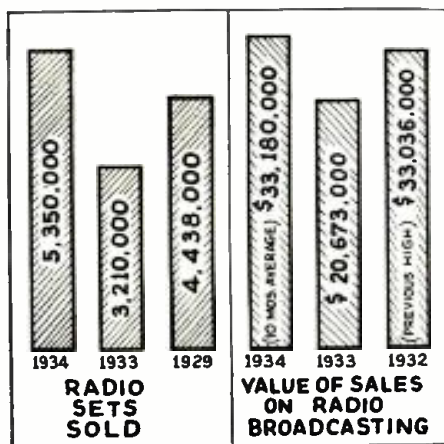

A section of the new coaxial conductor showing the inner wire and copper tube.

## NEW-TYPE CABLE AIDS TELEVISION

**A** NEW type of electrical transmission line which will provide a television channel (signal) "giving size and clarity for vision hitherto unknown," was announced last month by the Bell Telephone Laboratories. The wire and associated apparatus, it was reported last month "permit the extension of frequency band widths of the order of 1,000,000 cycles or more to be transmitted over long distances."

While existing telephone lines can be worked at frequencies up to the tens of thousands of cycles, the new cable multiplies that capacity by a hundred times. In addition to being useful for the development of television, this new type cable can be applied to telephone work and will carry 200 long-distance telephone conversations simultaneously over a single pair of conductors—by the use of "carrier current" methods. The latter make use of vacuum tube amplifiers and filters so that each conversation covers only a narrow band of frequencies—thus with a million cycle band available, 200 bands each 5,000 cycles wide can be accommodated.

The "coaxial conductor," as the new wire is called, consists of a central solid copper wire insulated by cotton string wound spirally around it. Next comes the outer conductor which is formed of overlapping copper strips held in place with a binding of iron tape. The whole structure is then protected from the weather by a lead sheath.

Thus, a wire within a wire is formed which utilizes what is known as the "skin effect," namely that high frequency currents like to travel on the outside of a wire. In the new conductor, the high frequencies travel on the outside "skin" of the inner wire and on the inside "skin" of the hollow tube surrounding it.



The new 1000 watt transmitter of the New Jersey state police—W3XCW.

## POLICE RADIO OPERATES CONTINUOUSLY

**S**OMETHING new in police radio broadcasting was started last month, with the inauguration of the new 1000 watt station of the New Jersey State Police—W3XCW.

This station operates continuously from 8 a.m. to 4 a.m., giving the time every fifteen minutes and relaying teletype telephone messages received at the police headquarters to six state police cars and a radio equipped motorcycle. The teletype messages are interrupted whenever special instructions are to be given to a particular car.

The receivers in the six cars and the motorcycle are fixed-tuned to 1610 kc. and are operated at all times.

By keeping the transmitter operating continuously, in this manner it is expected that the radio service to the squad cars will be greatly increased. Important instructions can be given to any car at any time without delay, and the teletype descriptions of missing persons, stolen goods, etc., keep the patrolling cars always "on their toes" and instructed as to late happenings, etc.

The situation in this installation is somewhat different from the usual police installation, in that the cars are scattered over quite a few miles of territory and they do not report, except by private telephone, for days at a time each car having a certain portion of road and territory to cover.

# ELECTRONICS RADIO PICTORIAL

Here are five views of an experimental "engine-to-caboose" radio telephone, recently installed and operated on a freight train. It might be construed at first thought to be a distinct novelty, but such is not the case at all. It has been an ever-present problem, since the first freight train took to the rails, to secure instant and continuous communication between the engineer and the conductor, 50 to a 100 cars behind. Now, using a very practical ultra-short-wave (about 8 meters) "transceiver" at each end, it is easy to maintain constant communication. Each unit is very compact, and readily portable, as can be seen in the view at left. At upper right is shown the rod antenna system installed on a caboose roof. Lower right shows the hand microphone and loudspeaker secured to the caboose wall. The center view shows the receiver unit, also in the caboose, out of the way. At lower left is the engine antenna system, installed on top of the tender.

Westinghouse photo.

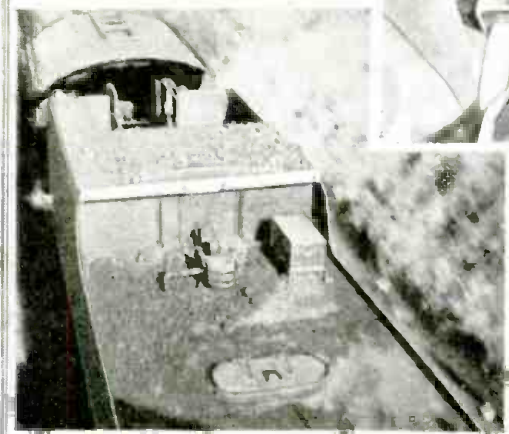
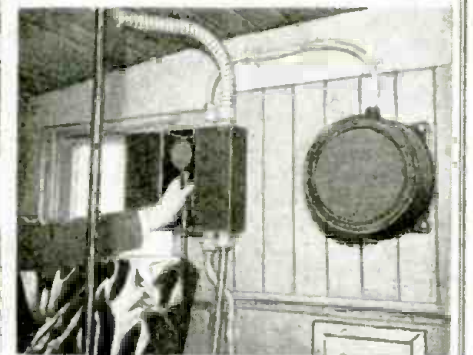
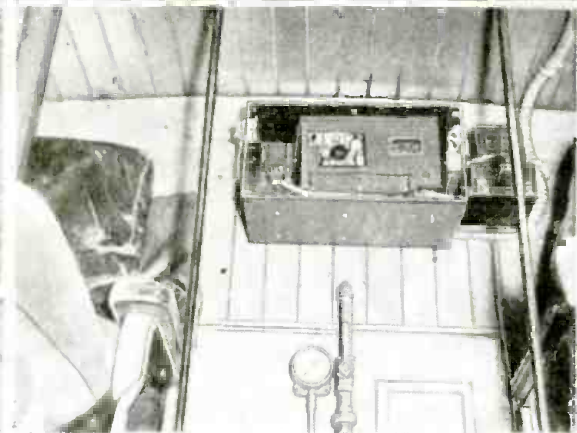

At right is a demonstration tube built to very large dimensions and with a plate coated with a material which becomes luminous when bombarded by electrons. In this way it is possible to see the action in the tube as the grid potential is varied. The action of a "microphonic" tube is also readily seen, such as the variation of luminous areas due to vibrating filament strands.

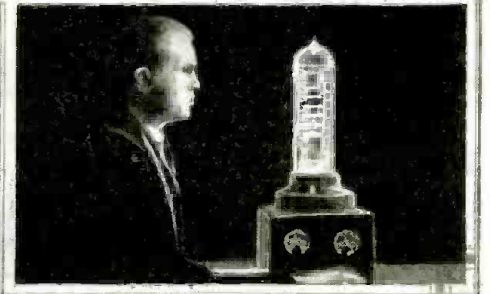

Operating mechanism of the "Robot." A turntable at top supplies the talk while synchronized-motion relays occupy space below.

This complicated "Robot" smokes cigarettes, turns his head from side to side, shakes hands, picks up objects and talks and sings. A photoelectric cell in each eye (remote-controlled) helps.

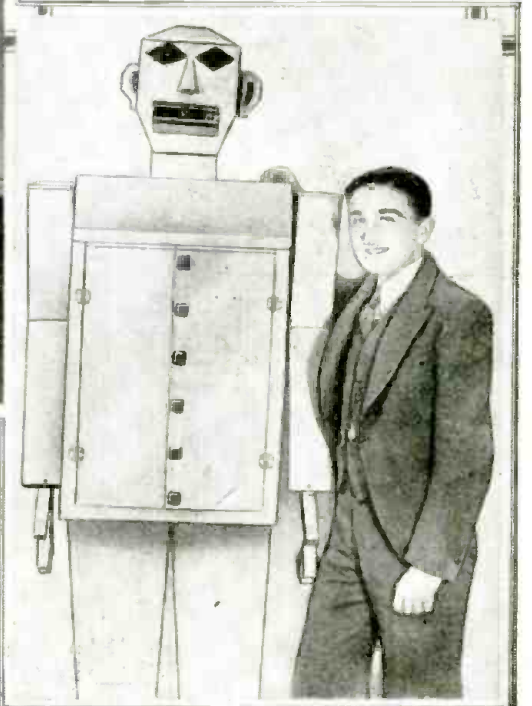
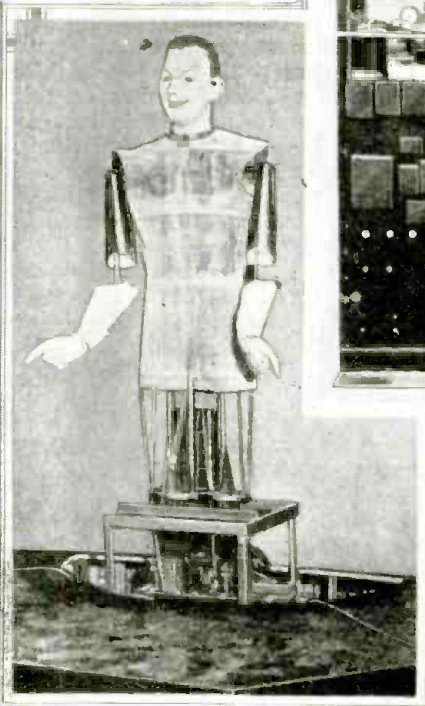

Mechanical men, or "Robots" as they are termed, always attract much attention at fairs and conventions. This one, above and left, is unusual in that his face is mobile (his mouth moves and expressions change in synchronization with his speech). He was designed and built for advertising purposes, and always draws a crowd and gets a hand when he talks, in Fred Allen's best manner, of the wonderful benefits to be derived from using a well-known brand of relief medicine and a tooth paste! Through a few simple mechanical levers and a system of relays, he points over his shoulders, contorts his face in a very life-like manner. These views, together with that shown at right, serve to indicate the great variety of forms these interesting automata can assume.

Photos courtesy Andrews & Reullo



In the window of an enterprising New York radio dealer is this interesting device. Passersby are invited to try to stop the wheel on a lucky number. The wheel stops when closely approached by the hand. A metal plate inside the window is connected in a grid-glow tube circuit. The two grids form a balanced bridge. When a hand approaches the plate it changes capacity of one side of the bridge, and a relay opens the wheel motor circuit. When the hand is removed the wheel resumes rotation.  
Photo courtesy Blan, The Radio Man, Inc.

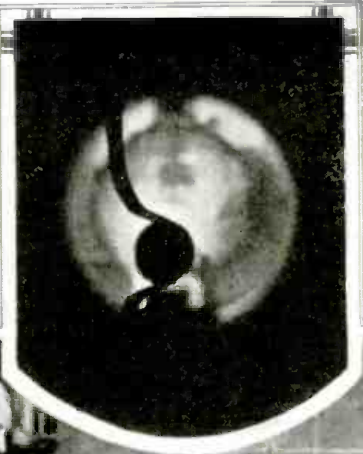

This view was made from an actual photograph of the action of an "ignitron" tube, making a ball, traveling at four miles a minute appear to stand still and pose for its picture! The ball is shown at the instant of breaking a fine wire, concealed in a rubber tube. The time of exposure is about one millionth of a second.

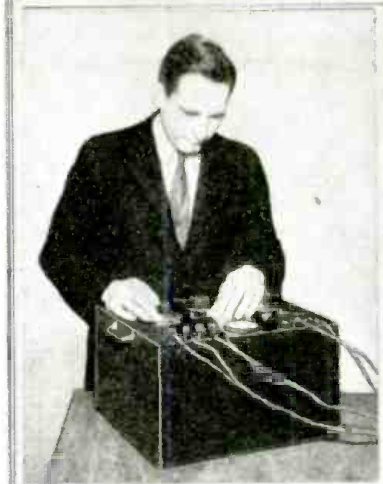

While the automatically opening and closing doors separating the two vast rooms in Pennsylvania Station, N.Y.C., are now a familiar sight to New York's commuters, there are many who look and wonder what it is all about. This view shows how it is done. As a person passes the beam of light (dotted line), he interrupts it, causing the photo-cell in one of the posts to operate a relay, which in turn causes the door operating mechanism to open the door.

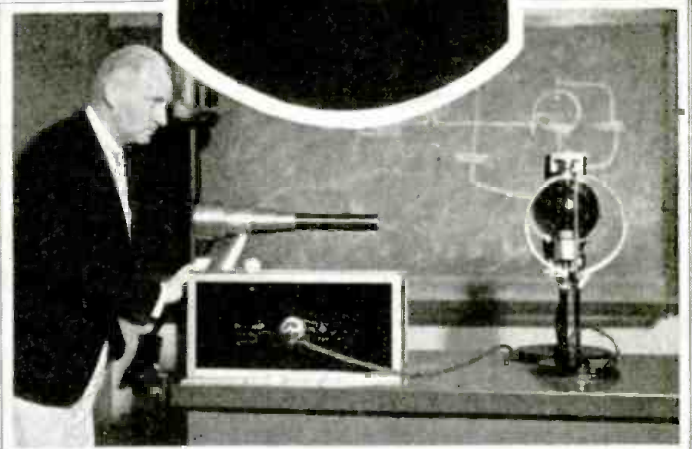

This is the actual setup of apparatus used to obtain the striking picture above. It illustrates the manner in which the new ignitron tube, which discharges 1,000 amperes in one-millionth of a second, operates. Recently a large audience was able to see, apparently standing still, a ball shot out of a cannon and traveling at a speed of four miles a minute. The ball while it was moving through a distance of one inch broke a wire in front of the electron tube in about ten-thousandth of a second. The broken wire sent a condenser discharge through the tube, which then flashed brilliantly for a millionth of a second, during which time the ball moved only about a one-hundredth of an inch, or was practically standing still!  
The almost incredible speed at which this new tube goes into action, and the simplicity of the entire setup open a new era in the observation of rapidly moving objects.  
Westinghouse photos.

A unique photoelectric tube use—that of judging paper quality with a P.E. cell. The more light reflected from book-paper, the better the paper!

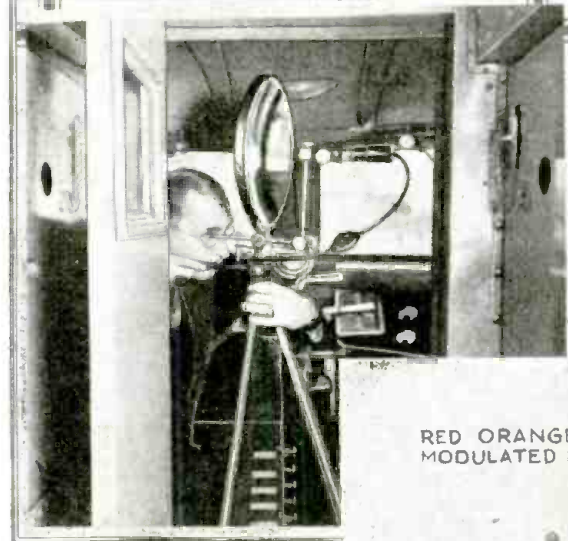
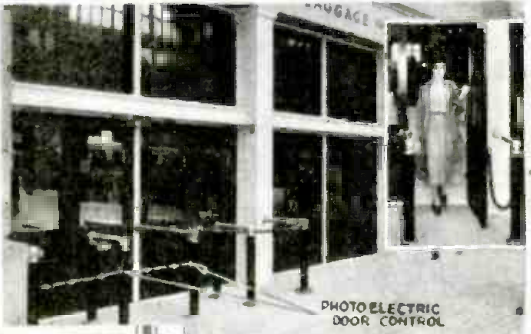

Two close-up views showing how transmitting (left) and receiving stations are operated in conducting conversations over a beam of light in broad daytime! A microphone aboard the train modulates a light beam from the train's headlight. The receiving end picks up the light on a photo-cell and converts the energy into sound again by means of amplifiers and a loud-speaker.

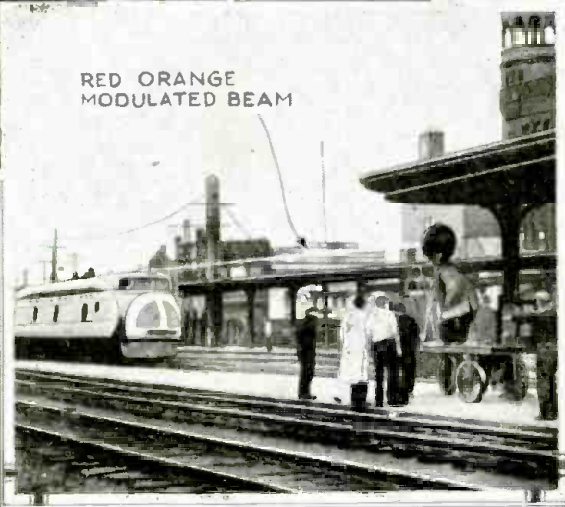
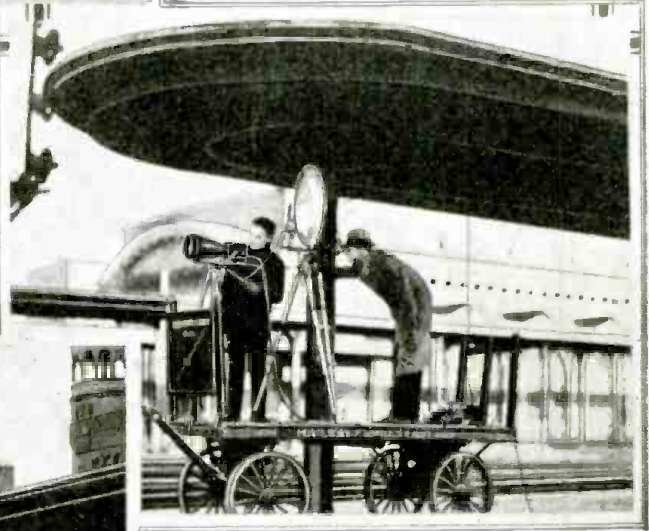

When the new Union Pacific six-car streamlined passenger train visited Schenectady recently it had a headlight that talked. On the platform of the station stood a handtruck, on which was a tripod-mounted concave mirror, and in back of that a loudspeaker system. The train rounded a curve in approaching the station and, in full daylight, the orange-red beam of a headlight could be seen. The operator on the train aimed the beam of his projector at the mirror; and then, while the train pulled into the station and stopped, persons aboard the train were able to talk, over the beam of light, to those on the platform. The train

was stopped briefly at the station and was then backed to a siding, to remain a few hours while thousands of people were given an opportunity to inspect it. While the train was being backed to the siding, the light-beam conversation was continued. The special headlight had been installed while the train was in Albany the previous night, and persons on the platform were unaware of what was being done until a voice was heard over the loudspeaker. He explained the talking light and invited the public to inspect the train while it was at Schenectady.  
Aboard the train the voices were converted by the microphone into electrical energy. This was used to modify the light of the neon lamp in the "headlight." At the focus of the concave mirror of the receiving equipment was a photoelectric tube which converted the modulated light into electrical energy. This was fed to an amplifier and then to the loudspeaker system.  
General Electric photos.

# AN ELECTRONIC

## A NOTE TO ALL SERVICE MEN—

Every day new ways are found for the wide-awake Service Man to capitalize his knowledge of the fundamentals of radio. One of the most lucrative and profitable of the fields in which the radio Service Man is a "king pin," and which is particularly rich in possibilities, is that of ELECTRONICS. For this reason RADIO-CRAFT has developed a novel means of bringing to the attention of radio men an application of electronics which will appeal to the non-technical person. The electronic "party" treasure hunt (as distinguished from the more serious methods of actual metal-location described in past issues of RADIO-CRAFT) offers to the far-sighted technician an opportunity to stage an entertaining demonstration of the possibilities of electronics in the home. By thus sugar-coating the technique of electronic applications it is possible to interest a great number of people, group by group, who otherwise would never realize just what the Service Man can do for them. YOU, MR. SERVICE MAN, as a member of a great, fast-growing organization, ARE IN DUTY BOUND to do your share toward promoting interest in those fields to which your technical abilities are perfectly adapted. Plan today to stage an electronic treasure hunt!

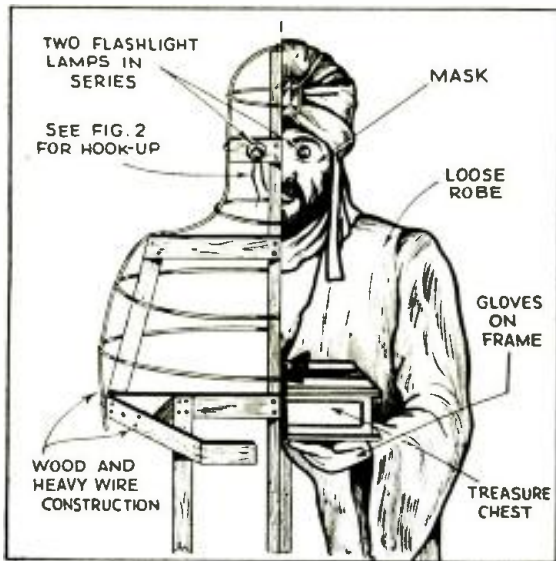

Fig. 3. Details of figure in the closet.

**W**HATEVER your experiences have been with "treasure hunts," we have something entirely different in store for you in this "electronic" variety. Whether you are a radio technician or an uninitiated novice—whether you know anything about photo-cells or not, makes not the slightest difference. All that is required to "go to town" on this idea is an elementary idea of electrical circuits. Since you are reading RADIO-CRAFT, it is a pretty safe bet that you have the required knowledge. So—let's get going on a 1935 edition of a search for treasure, minus the long voyages, yard-arm hangings and murders, but *plus* all of the thrills and plenty of excitement!

The only theory you will get in this article is right here in a single sentence. A beam of light striking a photo-cell in a darkened room causes a relay to close circuits. There you are. If you want the theory and technical knowledge of electronics, this issue of RADIO-CRAFT is full of it (see pages 588 and 592). We're on a treasure hunt, so let's get down to business. The idea is this: Hidden around a room are half a dozen photo-cell tubes of the simplest type, costing about a dollar each.

Guests at the party, who should be masked and costumed for a treasure hunt, are armed with flashlights. They go looking for the treasure. The room is dark. After greeting your guests, you disappear to the control room. Just as every show has its stage manager, this one has too, and you are elected. Then the fun begins. From your vantage point you control the circuits with simple switches, leaving the treasure switch open until you want it to be found. In the meantime a beam of light "finds" one of the photo-cells. Immediately a loud alarm bell begins to ring, or the lights flash on and off, or an auto horn blasts out from the family

piano—well, you get it! Of course you are not limited to just six effects. Use as many or as few as you like. The more varied the thrills, the better. You can shoot off guns, operate sirens, and do countless other stunts. Your own pocketbook and ingenuity and available time are the controlling factors.

### EQUIPMENT NEEDED

The parts necessary for this setup (assuming that you will follow the layout as shown here) are few in number and not at all costly. They can be obtained from any good radio supply house. First you need the six photo-cells. They are of the photo-emissive (selenium) type, the ones most generally used for commercial purposes. The cheapest ones are plenty good enough for this "hunt." Since good relays are pretty expensive, by means of switches you can get fine results using only one relay to work the whole business. The cost varies considerably, but about \$3.50 is average. If you can get hold of the bell-ringing mechanism from a telephone box, it will be just the thing for a good relay. Next comes a simple 1-stage amplifier, used to build up the feeble current from the photo-cell to a value to operate the relay. A 90 V. "B" battery, a 6 V. storage battery, some light bulbs, wire, etc., complete the list.

### CONSTRUCTING A SENSITIVE RELAY

Making a good relay is a rather painstaking job, but if you want to do it, Fig. 4 gives the details. Wrap the core with a layer of friction tape before mounting coils. Coils must fit snugly. Mounting the armature is an important part of the work. Make sure it is clean and wraps closely but not tightly around the mounting screw. The contact

Fig. 1. This is a typical layout for the "treasure hunt" party. The photo-cells and all wiring should be hidden.

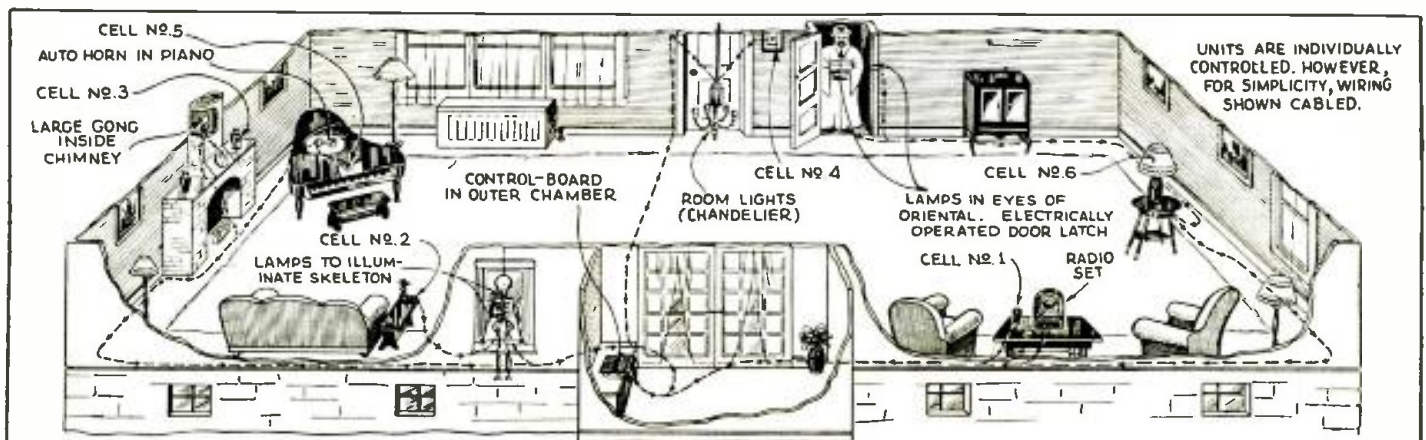



# TWENTY WAYS TO USE THE "ELECTRIC EYE"

One of the most interesting fields for experiment—by the radio fan—is the use and application of photoelectric cells.

C. W. PALMER

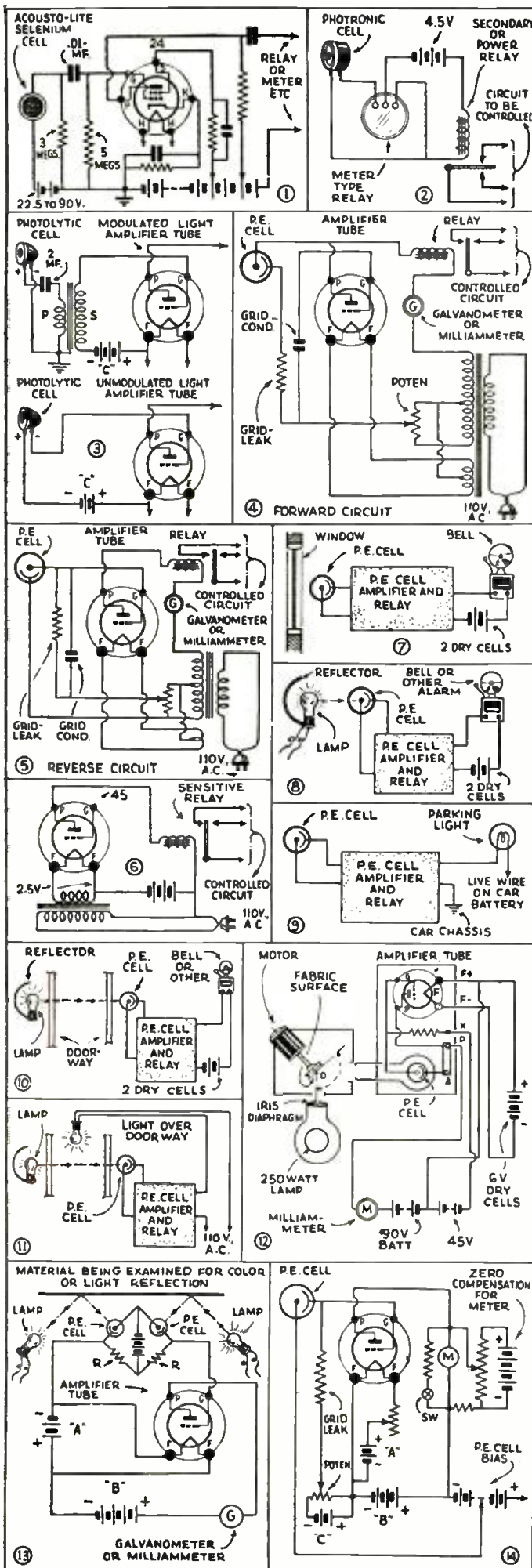

THE PHOTOELECTRIC effect was discovered in 1889 by Hallwachs—who found that crystals of fluorite not only became electrically charged by heat but also by exposure to sunlight or to the light of an electric arc, both of which are rich in ultra-violet light. It has been scientifically demonstrated that every material is electricaly sensitive to light—conductors and insulators alike all emit electrons when exposed to a suitable source of light. Some materials exhibit marked photo-sensitive effects, while others are notably insensitive.

There are many practical uses in everyday life for photoelectric cells (the devices which operate by means of photoelectric effects). In industry they are used for counting, sorting, regulating artificial lighting, protecting workers, and many other such tasks—in the home they are applied to opening doors, turning on lights, announcing guests, smoke and fire alarms, burglar alarms, etc.

Photoelectric cells may be divided into five general classes:

The selenium cell—or photo-conductive cell which is perhaps the oldest practical photo-cell. The fact has been known since 1851 that the resistance of selenium decreases when light falls upon it—though the effect was not understood or applied until about 1890.

Photo-voltaic cells—or light batteries as they are sometimes called. They are of the wet type having electrodes in a suitable liquid. They produce their own voltage when light falls on them.

The photoelectric tube—which consists of an alkaline covered cathode and an anode enclosed in a glass or quartz bulb and either evacuated or filled with an inert gas. By means of a "B" battery a current is caused to flow from cathode to anode and this current is controlled by the amount of light impinged on the cathode.

Semiconducting layers of cuprous oxide similar to the rectifiers used in radio work form the fourth type. This type resembles the dry battery in that it produces a current when illuminated.

Still another type consists of a flat metal plate with a suitably sensitized surface which becomes a generator of electricity when exposed to light. This type is known as the photronic cell.

The last two types are generators, in that they convert light into electricity directly, without an intermediate source of current.

## HOW THEY ARE USED

The photo-sensitive cell—whichever type is chosen—may operate a sensitive magnetic relay and so accomplish electrical or mechanical tasks controlled by a source of light. Some types produce current differences sufficient to actuate the relays directly, while others require amplifiers to increase the change in current sufficiently to operate practical relays. (With sufficiently sensitive relays, any type could work directly—but the relays would be too costly and too delicate for practical use.)

(Continued on page 622)

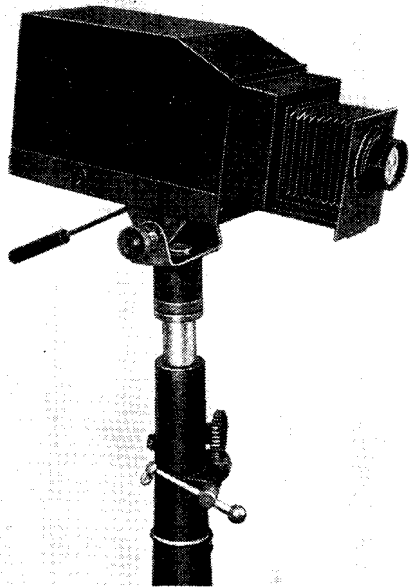

An outdoor television camera made by Farnsworth.

# A MODERN PICTURE OF TELEVISION

This survey of the television situation today is written by a technician well versed in the subject. In 1929, Mr. Schrage wrote a book on television and he has had an opportunity to see the progress on both sides of the Atlantic.

WILHELM E. SCHRAGE

PART I

**S**EVEN YEARS AGO a famous European television expert told the author during a visit to his vast laboratory filled to the last corner with expensive television devices: "Television in its principles is well known since Paul Nipkow applied in 1884 for his famous television patent, and thus founded the basis of the television technique of today. We are now looking back upon an evolution of about 50 years, and it should not be taken as exaggeration if I say television is only a question of six or eight months. In case some difficulties so far unknown should occur, it will not be more than a year before television will be in general use."

Since then a great many other well-known experts have called television a device "just around the corner," and if the public, disappointed by statements of this kind, has some doubt about the possibilities of television, nobody will be surprised. In the meantime we have been informed by statements of rather more pessimistic tendency that television is more than only a technical question, because it is also a financial problem, and involves a great many

program difficulties. The history of other great inventions, however, has shown that limitations of this kind could not prevent an important technical improvement being put into use sooner or later, and the following consideration about the ripeness of television will show that a little more optimism should be employed instead of the tremendous pessimism found today.

## IS TELEVISION AROUND THE CORNER?

There is no doubt that the progress of television technique during the past three years has been much greater than during the entire previous time. We should forget about "foolish statements" made by experts in this field and should pay attention to the fact that approximately more than 5 million dollars have been spent in this country and abroad for television experiments; quite a large sum of money which never would have been spent for an invention considered only as a kind of technical toy!

The number of television systems around the globe—today, in a pretty ripe state of construction—can be counted as 10 without danger of using superlatives. But only a few of them have a chance to be put to work. This, of course, will sound hard in the ears of the investors and inventors who spent a fortune for the progress of television. However, this sharp cut is necessary if difficulties are to be avoided in putting different systems to work. A television receiver useful only for one

particular station is taboo because the television enthusiast must have the alternative of switching over to another transmitter if desired. It is, therefore, not worth while to talk about television being around the corner until a so-called "unit" television receiver is created, useful for all of the television stations to be erected.

## WE NEED COOPERATION BETWEEN THE DIFFERENT PATENT HOLDERS!

There are 20 television stations in this country now in use, and the main reason that 99 per cent of the radio listeners know nothing about them can easily be explained by the fact that at least 18 of the 20 stations are using different transmission methods! This trouble is not limited only to the U.S. The well-known English magazine, *WIRELESS WORLD*, in an editorial in the December 28 issue of last year, emphasized this dark point in the progress of television, and called attention to the fact that the only way to improve the condition for a general use of television is cooperation between the various patent holders. The magazine states further: "... the rival companies should get together and adopt a joint licensing scheme for manufacturers of television receiving sets."

In Germany they have been farsighted, and made a start in this respect a few years ago by founding the so-called "Fernseh A.G.," a company created by cooperation of a few im-

*(Continued on page 628)*

A German television receiver manufactured by "TEKADE."

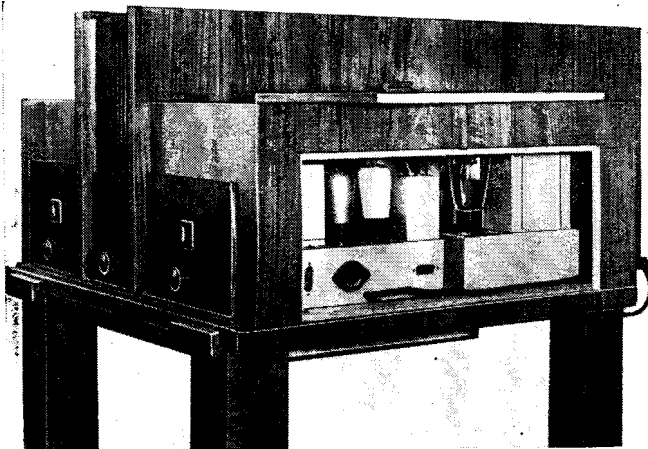

An American television studio connected with W6XAH.

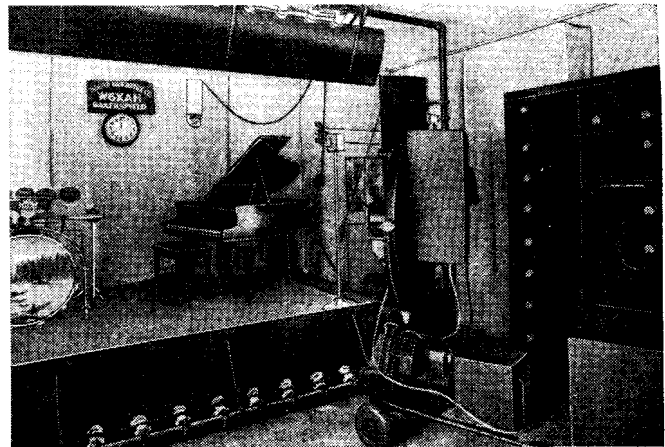

# THE NEW 6B5 DYNAMIC-COUPLED A. F. TUBE

First published data on a new tube which promises to be a favorite among radio technicians. This advance information gives a complete and authentic description of the electronic newcomer.

CLIFFORD E. DENTON

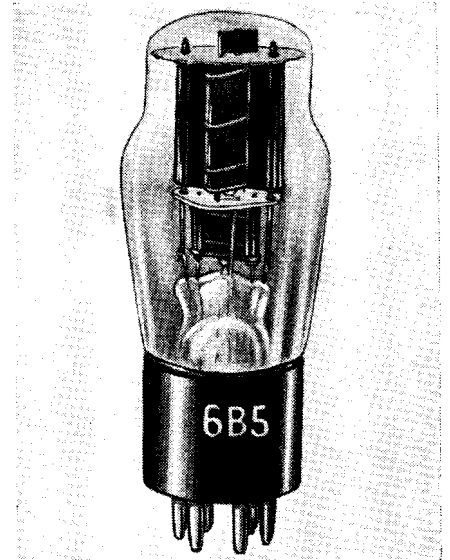

Fig. A  
The appearance of the dynamic-coupled tube.

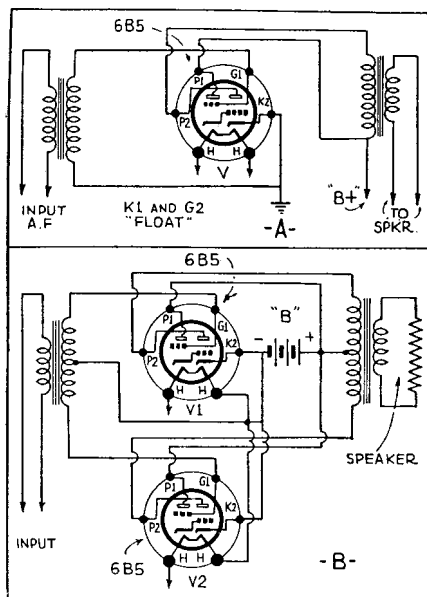

Fig. 1—single and push-pull circuits.

**H**IGH-POWER output with high-power sensitivity is much to be desired in an audio tube in this day and age. Composite tubes with a dozen elements scattered helter-skelter, but connected according to Hoyle, have gone a long way toward saving space in the R.F. and I.F. end of a receiver, and it is with a feeling of equilibrium that the writer presents herewith advance information, with authentic characteristics, of what promises to be one of the most widely used tubes in the audio-amplifier field.

This new offspring is not one of those "shots in the arm" that appear one morning and disappear the next; it has been long in the making and will remain long in the using. Just mull over these figures: power output, 4 watts with one, and over 10 watts with two in push-pull; harmonic distortion (total), less than 5 per cent; strictly class A, and no grid-bias resistor or bias condenser of any sort, concealed or otherwise; the overload point seems

to be the safe heating of the *grid*; filament voltage, 6.3; heater current, .8-ampere. See the curves for plate voltage and plate current.

## THE TUBE IN PERSON

The tube is pictured in Fig. A and the schematic circuit in Fig. 1A. There seems little difference in external appearance between this tube and most others in use, but the circuit tells the story. The tube is divided into two sections, the first designated by the subscript 1 and the second designated by the subscript 2. The input section, No. 1, receives the signal, and the out-

(Continued on page 618)

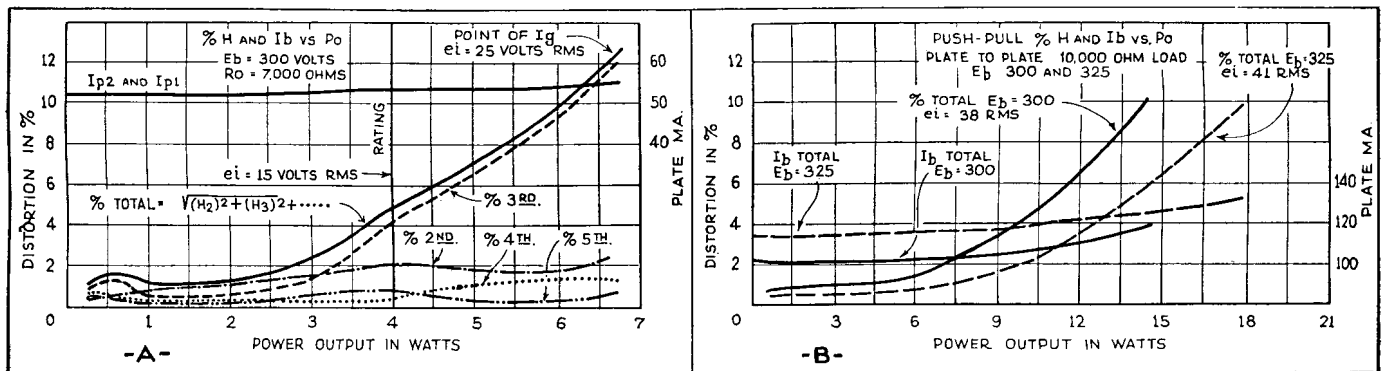
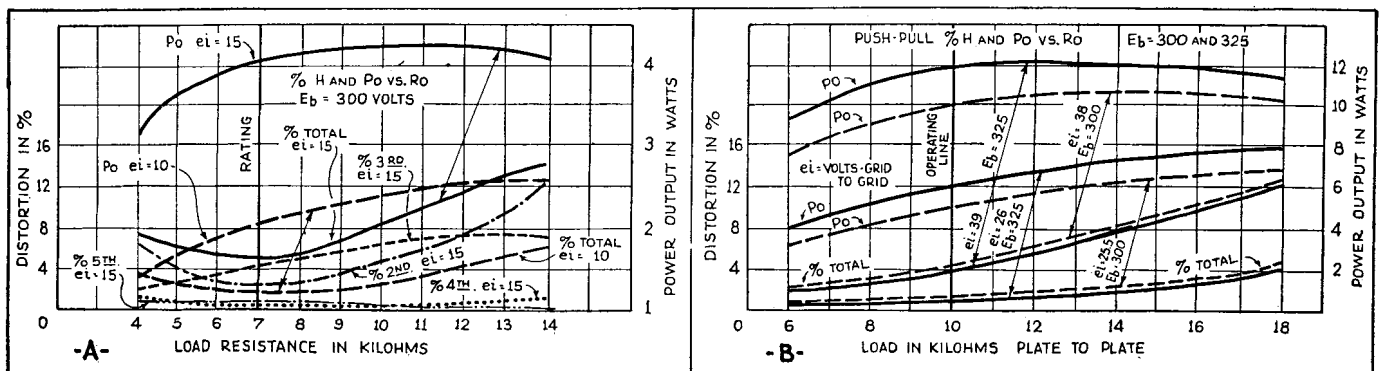
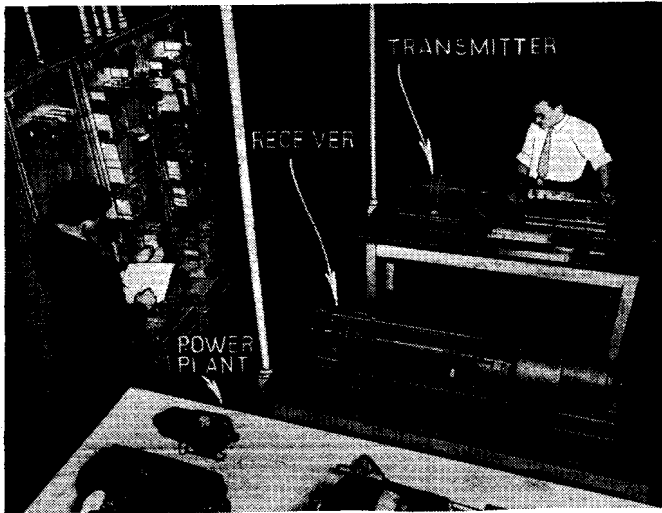

Fig. 3, above  
The per cent distortion and plate current values as the power output is varied—single and push-pull.

Fig. 4, below  
The power output and distortion values as the load impedance is varied—single and push-pull.







One of 24 stations of the nation-wide wirephoto service.

# NEW NATIONAL WIREPHOTO SERVICE

Forty-eight of the leading newspapers in the United States are now supplied with news photographs over land lines almost as soon as the news itself can reach them. Here is one more commercial application of electronics which promises to become a "national institution."

GIDEON SEYMOUR

**O**BSTACLES of time and distance which have compelled news photos to trail hours and days behind the news was overcome or reduced when the newspapers inaugurated a few weeks ago, a wirephoto service bringing to them from 24 cities throughout the country, at the same speed as news, the events of the day in pictures over a 10,000-mile leased-wire system.

A president addresses Congress, and accompanying the text of his message will be a picture of the scene in the national House of Representatives transmitted with all the perfection and detail of the original print.

An inter-sectional football game in Los Angeles excites the fans of the nation, and an action picture of the winning touchdown appears in the papers beside the final score.

A malefactor is found guilty by a Kansas City court, and riding the wires beside the account of his conviction is a picture of him as he listens to the verdict.

America wins a yacht race in Long Island Sound and a picture of the finish helps the sport writers convey to readers, 3,000 miles away, the graphic story of the last long mile.

A hurricane sweeps Cuba, and views of devastation travel by wire abreast of the news dispatches, to describe what

words cannot.

A boxing title changes hands in a Chicago ring, and topping the round-by-round account of the bout is a picture of the knockout blow.

## THE NETWORK

Linking in the new newspaper service the cameraman on the spot and the picture in the newspapers is the wirephoto network stretching from Boston to San Francisco, from Miami to Los Angeles, from Minneapolis to Dallas. Costly and highly technical equipment, adjusted to measurements too fine for the naked eye to see, must be disciplined to follow up and down the continent the swift and unpredictable finger of the day's news.

The wirephoto day begins, in each of the 24 equipment rooms over the country, with the pressing of a button which starts a power plant. The equipment room occupies 240 square feet of floor space in which, in addition to the power plant, are sending and receiving machines for pictures and a "bay" or switchboard for each. The "bay" contains a talking circuit with loudspeaker over which any point in the network may talk to the others. The function of the power plant is to furnish an absolutely constant source of voltage to the sending and receiving machines, for

no commercial source of electricity is steady enough. It consists of special generators, regulators and storage batteries. The generators are the sources of power; the storage batteries and regulators keep the generators steady.

The operator, having started his power plant, adjusts the sensitive machinery by meter readings and tunes the light valve mechanism of the receiving machine, making the tension on a little ribbon vibrate at a natural frequency of 1,200 cycles per second. This operation takes five minutes or less.

## SETTING THE SCHEDULE

Then the control station in the New York office of The Associated Press, which maintains and operates the wirephoto system for the 48 newspapers of the United States cooperating in its use, opens the talking circuit. All points report that they are ready, and each reports what pictures it has for sending.

Detroit may have a picture of a serious fire, New York some photographs of celebrities just arrived by ship or an important news photograph from Europe, St. Louis a view of an airplane crash, and Miami, by the morn-

*(Continued on page 629)*

Here are the 24 cities equipped with wirephoto stations which serve 48 newspapers.

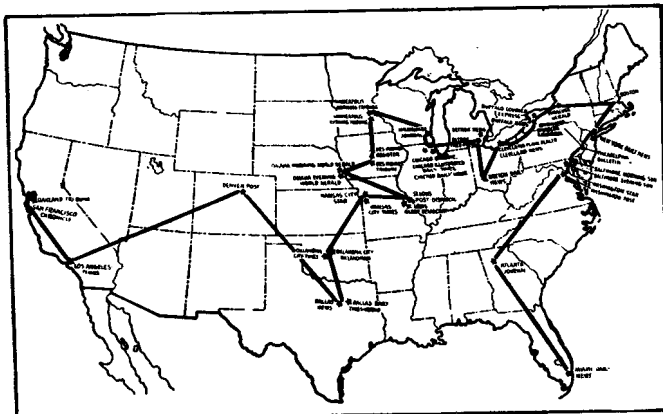

The perfection of the photographic copies sent over the wires is evident from the unretouched sample below. The left photo is the original; on the right is the copy. The printing screen limits the comparison.

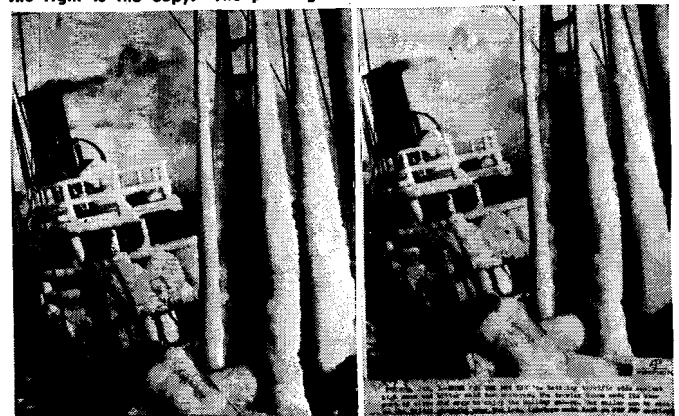



# INTERNATIONAL RADIO REVIEW

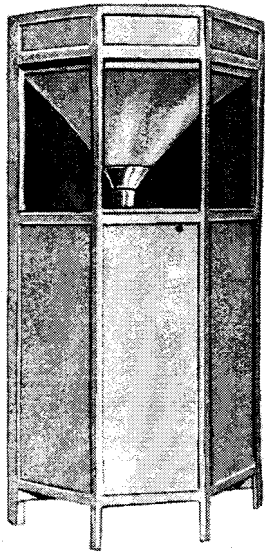

Fig. A  
The "corner-type" exponential horn.

## NEW REPRODUCER DEVELOPMENTS

THE demand for high-fidelity equipment has not been limited to the U.S.; its effects are found also in foreign publications.

In line with the developments of new amplifiers and receivers, several new reproducers have made their appearance. One of these which appeared in *WIRELESS WORLD* magazine, is shown in Fig. A and consists of a horn-type unit which is designed to fit into a corner. By this means, the walls form an extension of the exponential curve taken by the sides of the horn. The dimensions have further been reduced by the judicious use of reflectors and the low frequencies which might be attenuated by the restricted dimensions of the horn are strengthened by a special "bass chamber" with an outlet in the floor of the cabinet. This speaker has the characteristics of a straight horn four times its volume. It is applicable

EACH month there are received at the offices of RADIO-CRAFT hundreds of daily, weekly and monthly magazines originating from all over the world.

SINCE the cost of subscribing to each of these would be prohibitive for most radio men, we have arranged with technical translators to prepare for our readers reviews of all the really important, new developments illustrated and described each month in these publications.

NOTE that the only available information is that which is published; the experimenter must adapt the ideas to whatever equipment he has on hand.

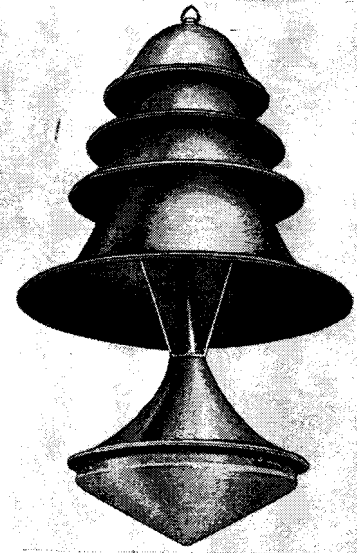

Fig. B  
A combination reproducer and light.

particularly to public address installations.

The second reproducer is made particularly for permanent installation in halls and similar places, where there is need for overhead lights as well as sound distribution. The unit is shown in Fig. B; it was described in a recent issue of *BASTELBRIEFE DER DRAHTLOSEN*.

It is evident from the view of this reproducer just how it is made—with its multiplicity of sound deflectors and the electric light below.

Because of the special design of the drive unit in this reproducer, a flat frequency characteristic of 50 to 15,000 cycles is claimed for it. Three models are made having output ratings of 2, 8 and 20 watts.

these instruments have been described in magazines, both in the U.S. and abroad.

A new organ depending on electronic tubes was recently described in *FUNK TECHNISCHE MONATSHEFTE*, a magazine published in Berlin, Germany.

This instrument, shown in Fig. C depends on the use of neon glow tubes for the generation of the tones. These tubes are arranged in oscillatory circuits tuned to the desired frequency and feeding into a bank of condenser-type reproducers which produce the actual tones.

By the use of frequency control circuits, the harmonics of the fundamental tones produced by the glow-tube oscillators may be varied to change the "overtones" or quality of the notes. By this means, the organ can be made to imitate many different instruments. The tone quality is controlled by "stops"

(Continued on page 615)

## A NEW ELECTRONIC ORGAN

ELECTRONICS has been applied to the development of musical instruments and several different types of

Fig. C, below  
The glow-tube electronic organ.

Fig. D, right  
The "visible current" radio set.

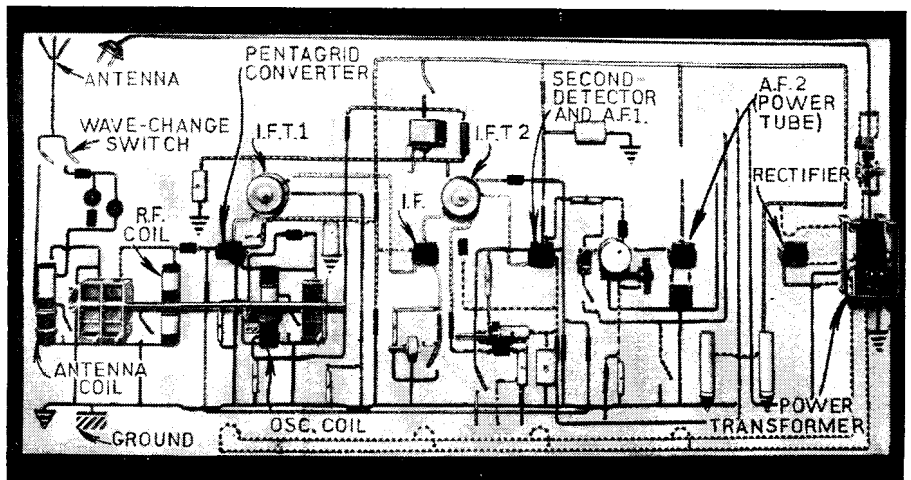
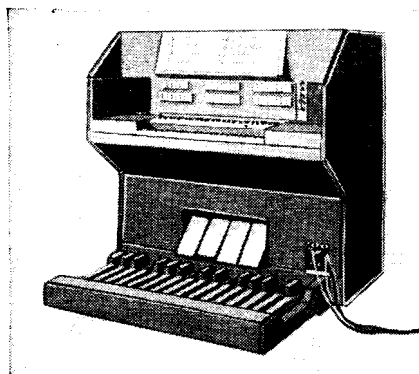

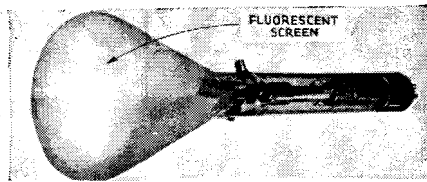

E. B. PATTERSON\*

PART I

Left, cathode-ray tubes visualize waveforms.

# Fundamental Facts About CATHODE-RAY TUBES

**T**HE cathode-ray tube is an instrument which has as its moving part a stream of electrons. The stream may be considered as a flexible wire in which current is flowing. In the cathode-ray oscilloscope, the ray is deflected by electric or magnetic fields and its travel is observed on the "fluorescent" (glowing) screen at the end of the tube; in the oscillograph, this image on the screen is recorded (usually, on photographic film). Both instruments are of great value in all branches of engineering work, wherever alternating electrical currents are involved.

## A 19TH CENTURY DEVELOPMENT

The cathode-ray tube has been known for many years and Professor F. Braun is credited with first applying the tube for measurement purposes—about 1897. In the same year of Braun's early experiment, Sir J. J. Thomson showed the rays were deflected by electrostatic and electromagnetic fields; further, the direction of deflection proved the particles in the rays were negatively charged.

The latter part of the 19th century thus was a banner period in that it saw the birth of commercial radio, the determination of the value of the electron charge, and the birth of the cathode-ray tube and its cousin, the Fleming "valve" (tube)!

\*Engineer, RCA Mfg. Co., Inc., Victor Div.

## THE ELECTRON BEAM A "WEIGHTLESS POINTER"

Now, the mass of an electron, being electrical and due only to the charge which it carries, is of very low order compared to the moving parts of a Dudell galvanometer with its mirror and strips, or a fibre of the Einthoven instrument. Consequently, the cathode-ray oscilloscope, utilizing this electron-beam as a "weightless pointer" having practically no inertia, has been hailed by technicians as an instrument especially suitable for use at the higher frequencies (where former oscilloscopes were useless); further, the development of new, inexpensive cathode-ray tubes has greatly accelerated interest in the application of this type of equipment. Service Men, and in fact technicians in every walk of engineering, are rapidly realizing the usefulness and increasing low cost of this tool.

The cathode-ray tube is extremely useful in frequency determination and phase relations; Lissajous' discovery in the field of sound, some years before the advent of cathode-ray tubes, is useful in this connection.

## LISSAJOUS' FIGURES

Jules Antoine Lissajous showed an exact relation between the vibratory motions of two sounding bodies. The equipment in his classical experiment  
(Continued on page 639)

Fig. 2, right  
Phase relations and the results obtained with multiples of frequency with respect to sine-wave voltages are illustrated. These waveforms should be carefully noted as being the most common.

Fig. 1, below  
A mechanical oscilloscope, as contrasted with the cathode-ray instrument illustrated and described in (succeeding) Part II.

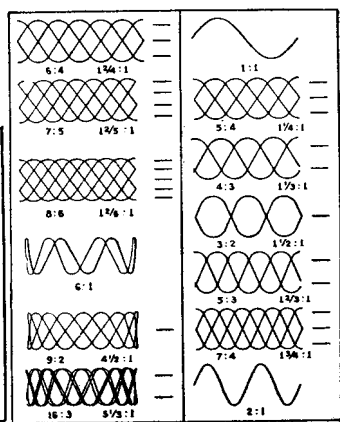
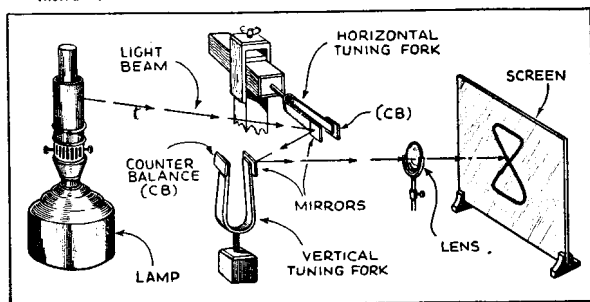

There are 5 major methods of operating that useful radio tool, the "cathode-ray tube"; and these methods subdivide into at least 32 different, important applications. The author tells "how" and "why" these operations are made possible.

## TABLE I

### APPLICATIONS OF THE CATHODE-RAY OSCILLOSCOPE

- (1) Oscilloscope and power supply but without amplifier or sweep circuit.
  - a. Modulation Meter trapezoidal pattern.
  - b. Polarity and Amplitude in D.C. circuits.
  - c. Frequency Comparison Meter.
  - d. Phase Indicator and Amplitude in A.C. circuits.
  - e. High-Voltage Peak Voltmeter for low and high frequencies.
  - f. Bridge Balance Indicator for phase and amplitude.
  - g. Speaker Impedance Characteristic Measurement.
  - h. Synchronization of Alternator phase and amplitude.
- (2) Oscilloscope and power supply with amplifier but without sweep circuit.
  - a. Peak Voltmeter and Ammeter amplifier with as wide a frequency range as practical.
- (3) Oscilloscope and power supply with amplifier and linear sweep circuit.
  - a. Waveform and distortion studies.
  - b. Receiver Test Equipment indicating stage gain output and distortion.
  - c. Detector Performance Tests.
  - d. Study of Static and Stray Electric Noise.
  - e. Monitoring in a Radio Station.
  - f. Study Voice and Music Waveforms in conjunction with a microphone.
- (4) Oscilloscope and power supply with linear sweep circuit but no amplifier.
  - a. Check on Code Signals.
  - b. Waveform studies on Alternators, Transformers, Generators, and Rectifiers.
  - c. Study of dynamic characteristics of circuit breakers and fuses.
- (5) Special Equipment in conjunction with oscilloscope assemblies outlined above.
  - a. Resonance Curve Tracer—use case (1) with extra equipment.
  - b. Audio Frequency Response Tracer or Sound Prism—use case (1) with extra equipment.
  - c. Frequency Comparison Meter with standard frequency source enclosed—use case (1) with standard frequency oscillator.
  - d. Electrocardiograph—use case (1) with extra equipment.
  - e. Vibration and Noise Apparatus—use case (3) with extra equipment.
  - f. Pressure Measuring Apparatus with Piezo Crystal—use case (4) with extra equipment.
  - g. Ignition Test Indicator—use case (4) and extra equipment.
  - h. Power Factor of Dielectrics—use case (1) with extra apparatus.
  - i. Magnetic Hysteresis Indicator—use case (1) with extra equipment.
  - j. Trace Vacuum Tube Characteristics—use case (1) with extra equipment.
  - k. Check Tube Noise—use case (1) with extra equipment.
  - l. Chemical Analysis by Dielectric or Resistance Properties—use case (1) with extra equipment.
  - m. Circuits for locating ore deposits, locating concealed weapons on persons, etc.—use case (2) as balance indicator on extra bridge circuit equipment.
  - n. Radio Beam Direction Indicating as used in navigation or airplane landing—use case (2) with extra equipment.

# HOME ELECTRONICS

Modern Scientific advances tend more and more to make life easier and more enjoyable. In this article, a description is given of the residence of a well-known radio authority who has made a hobby of applying electronic devices to his home life. Some of these applications are easily duplicated—they will be fine fun for the experimenter and a profitable source of income for the professional. Most of these examples use the PE. cell.



(Photos, except Fig. C, McGraw-Hill.)  
Fig. A, PE. cell switches lights.

**T**HE MODERN home is an ideal place to experiment with applications of electronic devices. The better known devices are the garage-door opener and a photo-cell-controlled lighting system which turns the house lights on when dusk approaches. But these by no means exhaust the possibilities of light-controlled equipment. This was made plain recently in an amazing "electric home" where even the weather is controlled electrically to suit the likings of occupants in each room! Dr. Orestes H. Caldwell, former Federal Radio Commissioner and well-known radio authority, has his estate near New York hooked up with many ingenious gadgets. There will be no kidnapping in that home. As soon as a prowler attempts to enter a window, he interrupts a beam of light. The result is immediate. A loud gong rings, the window is illuminated by a photo-flash bulb, and a camera takes the startled chap's picture!

At dusk an "electric eye" turns on the all-night lights of the estate and illuminates an outdoor clock on the garage. At dawn it just as surely puts the lights out, Fig. A.

A very novel idea is shown in Fig. B. With the radio set playing soft music, the hearer is apt to feel like dozing.

With this set-up, as soon as he nods his head, the radio set obligingly shuts off, preventing shocks to the nervous system if a loud program should take the place of slumber music.

Those habitual "foulers" in bowling are reminded of their fault by the PE. cell arrangement shown in Fig. C. When a foot slides over the line, it interrupts a beam of light, causing a bell to ring or a red light to flash.

PE. cells are admirably suited to the tired and lazy folks. If you feel too "tired" to turn your drinking water on, just rig up the device in Fig. E. As you bend your head, the shadow turns on the valve. When your thirst is quenched and you stand erect, the water flow stops. Ho-hum!

Of more practical use is the garage-door opening mechanism. It may be operated in two ways. The simplest method is shown in Figs. D and F. The headlights of your car operate the PE. cell opening mechanism. A safer way is the use of a short-wave radio transmitter mounted in the car. A receiver tuned to the same frequency picks up your signal when you approach and the door opens.

If you don't like to jump out of bed on a cold morning (who does?) to close your window, let the first rays of  
(Continued on page 627)



Fig. B  
"Doz-o-Dyne" shuts off radio set when listener dozes.

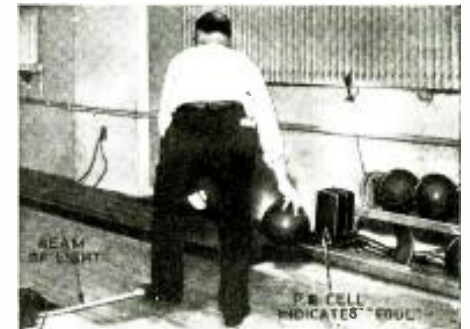

© International News Photos Inc.  
Fig. C  
PE. cell indicates bowling "foul."

Fig. D, below  
Cleverly concealed PE. cell lights up grounds.



Fig. E  
PE. cell provides automatic drinking service.



Fig. F  
Garage-door opening mechanism, PE. cell operated.

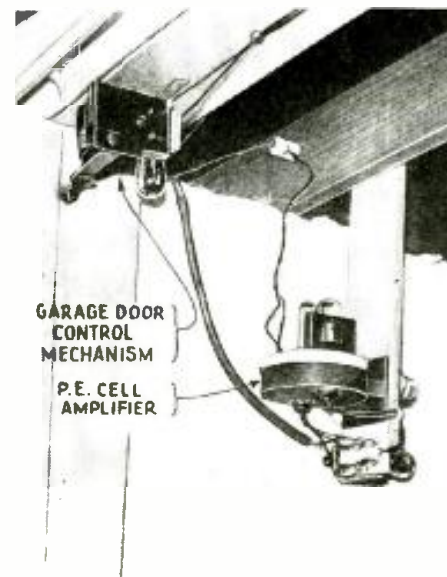

# SHORT-CUTS IN RADIO

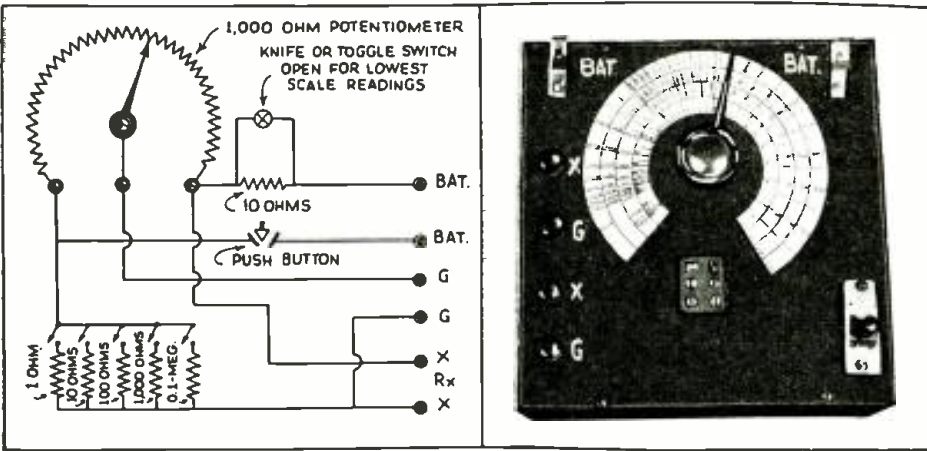

The circuit of the resistance bridge—and a view of the device.

## FIRST PRIZE

**B**EING in need of a reasonably accurate instrument for measuring resistances, I worked out the simple bridge arrangement shown. It consists of a 1000-ohm wire-wound potentiometer, five fixed resistances and 6 binding posts.

After connecting the parts up as shown in the diagram, connect the points G-G to some current indicating device such as a galvanometer, 0-1 milliammeter or voltmeter. A 1½ volt dry cell serves well for all resistances up to 10,000 ohms. It is wise, however, to insert a series resistor in the battery circuit when used with the one ohm resistance. For the higher ranges from 10,000 ohms to 1 meg., a higher voltage source is needed. A 4½ volt "C" battery works nicely if the indicating instrument is sensitive.

The instrument is calibrated by borrowing from a high-school physics lab-

One of the 2-in-1 coils ready for use.

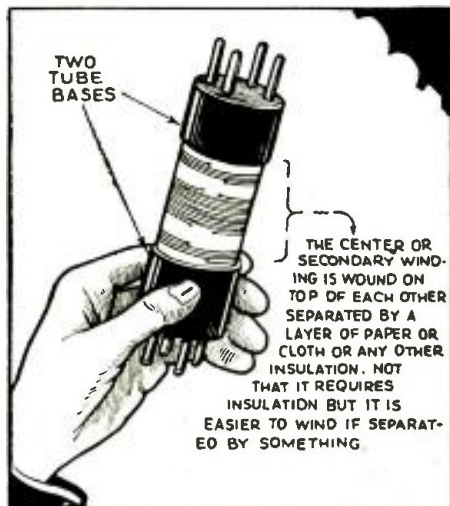

oratory a resistance box—or by reference to precision resistors (those guaranteed accurate within 2 per cent).

Attach the standard resistance to X-X and adjust the potentiometer until meter reads zero.

H. C. POULSON

## SECOND PRIZE

**H**ERE is a kink for the short-wave fan. By using the construction shown in the sketch, the cost of a set of coils will be saved and instead of the usual 4 coils to cover the short waves, only two will be needed.

The coil form is made by winding thin cardboard to fit tightly into the tube socket—which supplies the connection prongs for plug-in purposes. One of these sockets at each end of the cardboard makes a rigid winding form and if the coil is made sufficiently long two sets of windings may be placed on the same form and connected to opposite ends. Thus one coil covers two wave-bands.

The coils containing two windings and four prong sockets, for simple regenerative sets may be made about 4 in. long to accommodate the two sets of windings. The coils containing three windings and six prong sockets should be 5 ins. long to accommodate the extra wire.

When the coils have been wound they should be soldered to the tube base prongs and then cemented into the bases to make the assembly rigid.

J. O. FRIED

## THIRD PRIZE

**T**HE RADIO experimenter who has need for space-wound coils will find this scheme particularly effective.

Wind resistance wire on the coil form along with a size of enamel covered

FIRST PRIZE . . . . . \$10.00  
SECOND PRIZE . . . . . 5.00  
THIRD PRIZE . . . . . 2.50

## Honorable Mention

**EXPERIMENTERS:** Three cash prizes will be awarded for the best "short-cuts" — time- and money-saving ideas—submitted by readers of **RADIO-CRAFT**; Honorable mention will be given for all other published items concerning radio and its allied fields.

Send us your "kinks" right away.

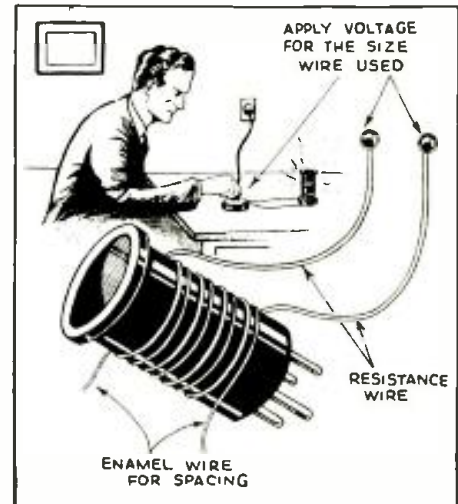

Cutting grooves in coil forms.

copper wire of a size correct to supply the desired spacing between turns. Secure the ends of both wires and then apply sufficient voltage to the resistance wire to make it glow red. Then disconnect and remove the wires.

If a hard rubber or fibre form is used, the hot resistance wire will have burned a groove into the form which can be used conveniently to space out the wire on R.F. tuning coils, chokes, etc. This method will not work with ceramic forms which cannot be burned by the hot wire.

NORMAN CURL

(Continued on page 622)

A coil winder from an egg beater.

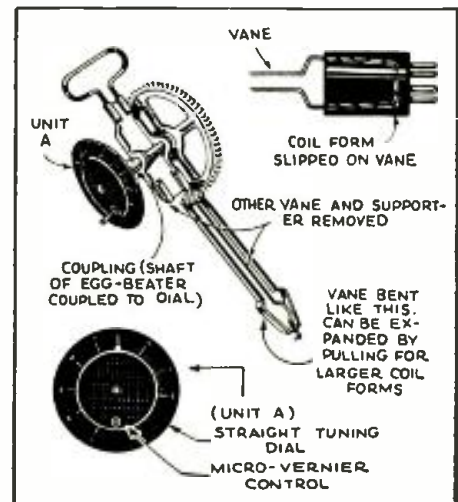

# HOW TO MAKE A GRID-GLOW TUBE CONTROL UNIT

The grid-glow tube is finding innumerable uses in industrial work—because of its flexibility as a relay for counting, sorting and protective applications. The electronics experimenter will find in this tube a wide field for experiments which are not only interesting but may be highly profitable.

CHARLES D. SAVAGE

**T**HE thyatron and the grid-glow tube are growing in industrial importance and the alert radio man will find them useful tools. If he will build a control unit of the type pictured, he will find his experiments greatly facilitated and at the same time he will gain some experience with phase-shifting circuits, such as are now being used in cathode-ray television. This unit is built around a Westinghouse type KU-610 "power" grid-glow tube (neon filled) but it can also be used with thyratons with perhaps a change in filament voltage.

When the jack switch S1 is thrown to the right, the unit operates as a grid-controlled rectifier, supplying D.C. power from the 110-volt line. With the switch thrown to the left, the elements of the tube are brought out to separate terminals for any desired experiment,—such as obtaining a time axis in oscillograph work, as a D.C. to A.C. "inverter," as a sensitive relay-tube, etc. The experimenter will find many other uses as he becomes familiar with it.

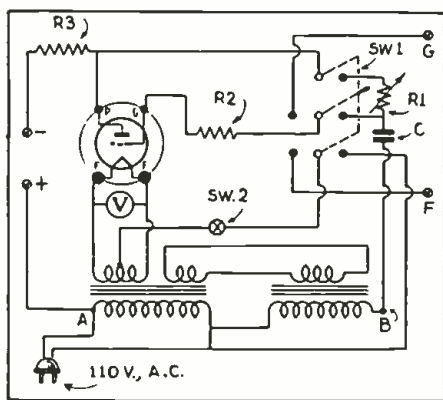
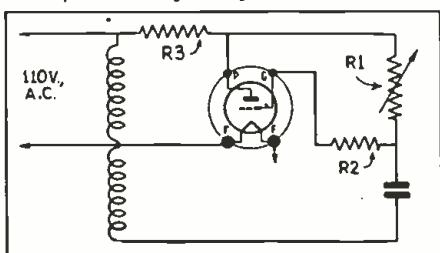

Fig. 2, below  
The phase shifting arrangement of the device.



## THE CONTROL UNIT CIRCUIT

The complete circuit appears in Fig. 1, but Fig. 2 shows the phase-shifting feature more clearly. Unlike ordinary radio practice, the grid voltage remains fixed in magnitude, but its phase angle varies over a range of nearly 180 degrees. As R1 is decreased, the grid voltage swings into phase with the plate voltage. The plate current picks up earlier in the cycle and the average plate current increases. Thus the rectified current delivered from the 110-volt A.C. line can be varied smoothly and efficiently. A small direct current motor could be connected to the binding posts at the left and its speed accurately controlled by R1. Incidentally, the protective lamp R3 can be dimmed or brightened in exactly the same way as the most modern theater lighting systems.

The 110 volts needed for the grid circuit could be obtained from an auxiliary winding on the filament transformer. If the transformer has no such winding, but does have an extra



5 or 7.5 volt winding, connect this to the low voltage side of a bell-ringing transformer. The 110 volts induced in the primary of the latter transformer is added to the line voltage to give a total of 220 volts between points A and B. This was the scheme adopted by the writer and shown in Fig. 1.

R1, the phase control, is a carbon rheostat having a range of 100 ohms to several megohms. A 100,000 ohm resistor, R2, protects the grid from excessive current and a 40-watt lamp, R3, does the same for the plate circuit. The condenser is rated at 0.5-mf, at 500 volts. While not absolutely necessary, the filament voltmeter gives a useful check, as all gas-filled tubes are critical as to filament voltage. For the same reason, switch S2 controls only the plate circuit and the filament is kept hot as long as the unit is connected to the 110-volt supply.

## HOW IT OPERATES

When used as a grid-controlled rectifier, the output of the device may be filtered and used around the laboratory or test-bench as a source of variable D.C. The unit is extremely versatile, and as a guide to experimenters, the following suggestions are offered:

The grid-glow tube has the peculiar property of not passing any current until the plate voltage exceeds a critical value determined by the grid bias. Hence, a grid current of the order of microamperes can control a D.C. plate current of 0.4-A., giving an extremely sensitive relay effect. The tiny grid currents required are readily passed by small capacities or high resistances.

In cathode-ray sweep circuits a condenser is charged at constant current through a suitably biased pentode. The voltage across the condenser (and across the oscillograph deflecting plates to which it is connected) rises linearly until it reaches the critical voltage of the grid-glow tube. The latter then breaks down, discharges the condenser, and the cycle is repeated.

Since a condenser discharge through the neon gas produces a brilliant orange-red light, the tube may be used in stroboscopic work. An alternating

(Continued on page 630)

Fig. 1, left  
The complete circuit of the grid-glow control unit with the change-over switch which makes it so flexible for experimental work.

Fig. 2, below  
The side view of the unit, ready for operation—note the tube and lamp.



# BUILD THIS 5-TUBE ALL-STAR "JUNIOR" PART II

We continue here the construction of this interesting A.C. powered kit set—for the all-wave radio enthusiast. Blueprints and full-size layouts may be obtained by addressing an inquiry to RADIO-CRAFT.

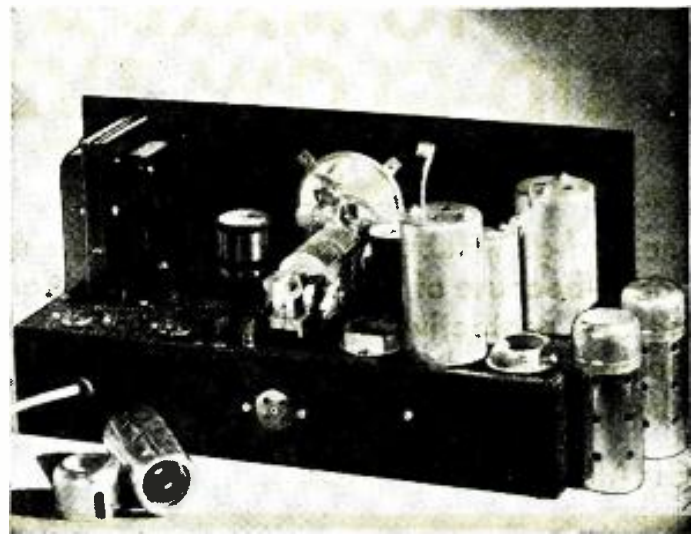

**T**HE FIRST operation in the construction of the All-Star "Junior" is to mount the wafer sockets on the sub-base in the positions indicated in the layout view. When mounting the sockets for the 6A7, 6F7, and the 77 tubes, the shield bases should be fastened with the same bolts which hold the wafer sockets for those tubes. The 6-32 3/8-in. bolts are suitable for mounting these sockets. Lock washers should be used between the nut and the under side of the wafer socket. While mounting these sockets observe on the layouts (Figs. 2 and 3) which show the under side of the sockets, those which have soldering lugs. These soldering lugs should be installed at the same time the sockets are installed. The volume control and the speaker socket are the only pieces which may be mounted on the sides of the subbase at this time. Install the I.F. transformers so that the lead from the top is close to the tube to which it connects. Solder grid clips to the wires which connect to the tops of the tubes. Keep these leads short.

Fig. 1—The top side of the chassis layout.

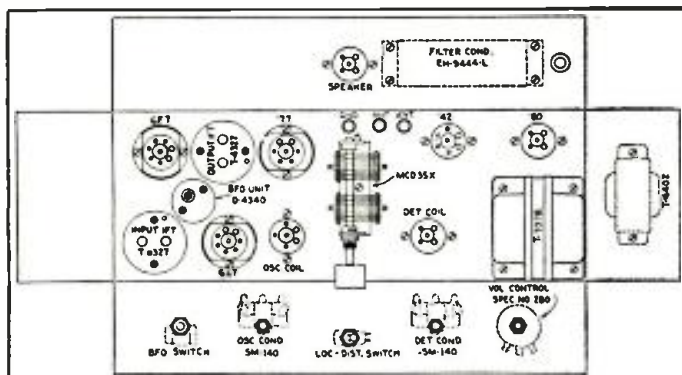
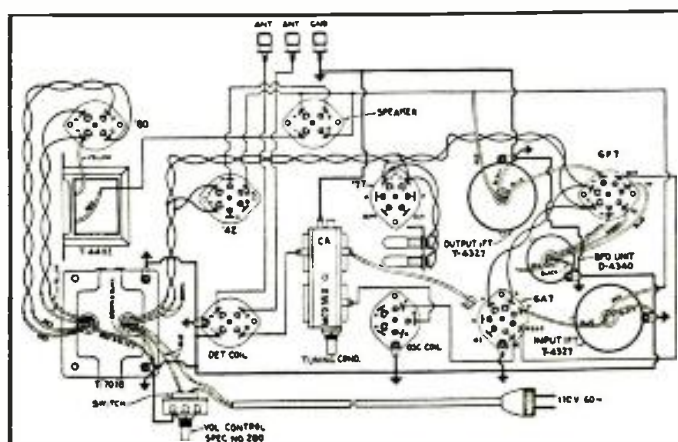

Fig. 2—The beginning of the wiring—pictorially. The twisted filament wires are first, followed by the other connections shown—the wiring is finished according to fig. 3 at the right.



Mount the dial on the dual condenser before fastening the one bolt which holds the dual condenser in place.

The twisted leads which supply the filament voltages to the tubes and the plate circuits of the type 80 tube constitute the first wiring which should be installed. (Fig. 2.) The twisted leads which connect to the dual pilot lights need not be connected until the dial is installed after the rest of the wiring is complete. Exercise care in selecting the correct colored leads from the power transformer so as to avoid any possibility of burning out the tubes or equipment. The tools you will need are a good electric soldering iron with a supply of rosin core solder, a screwdriver, and a pair of short-nose wire cutting pliers. If you have any difficulty distinguishing color, secure assistance when selecting the proper colored wires from the transformer. The ground wire which appears in the layout may be run immediately after the filament wiring, and should be one continuous length.

At this time the choke coil should be mounted as shown in Fig. 1. The colored wires from the I.F. transformers and the BFO unit should be connected at this time. The red wire from the BFO unit will not be connected until later.

In making connections to the two antenna binding posts use fiber washers to insulate these posts from the metal chassis. The ground binding post should have a lock washer and be tightened sufficiently to assure good electrical contact with the metal subbase. Sandpaper the base wherever connections are made to the metal. The flexible rubber-covered power cord should be threaded through the hole on the back of the base and looped in a knot to prevent it from pulling out. The junction of one lead of the power cord with a blue wire from the transformer should be covered with tape. A serving of tape around the wire

(Continued on page 634)

Fig. 3—The remainder of the under-chassis wiring.

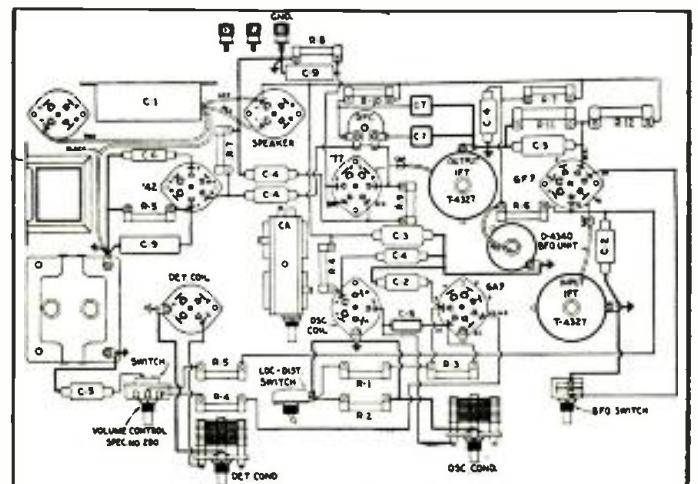





Studio of the 120kw. station at Warsaw, Poland.

# THE LISTENING POST FOR ALL-WAVE DX-ERS

This page is devoted to the radio enthusiast who is solely interested in world-wide reception and facts that will aid him in obtaining the ne plus ultra in radio results.

C. A. MORRISON

## DX-ers' Award

Here's the winner of the current award in the DX contest for All-wave DX-ers—Mr. H. S. Bradley of Hamilton, New York. DX-ers here is your chance to win a valuable prize by submitting your 10 best "veri's." See rules in January, 1935, RADIO-CRAFT.

**S**INCE starting this series of DX articles, we have taken up in consecutive order, "General Rules to Observe in DX-ing," "The Importance of a Good Log Book," and "Securing and Displaying Verifications." In this issue we propose to give you some very practical, and helpful pointers on *choosing a receiver for DX-ing*.

No one receiver, even the most expensive custom-built receiver, incorporates every desirable feature, and often a very cheap receiver will incorporate at least *one* unique feature that makes it deserving of attention. As the popular priced receiver does not include everything, we must choose (from the standpoint of practicability) a receiver which incorporates the most important DX features, in that price class which we feel able to pay. We suggest that all blatant and ballyhoo advertising be "taken with a grain of salt," as certain highly publicized features are nothing more than glorified names for

The International station at Shanghai—jointly owned by the U.S. and China. Note the peculiar construction of the towers.

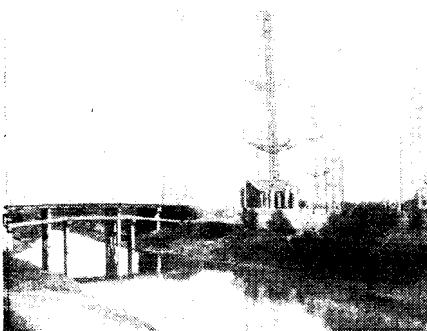

common receiver functions.

*Here are the questions you need to be primarily concerned with:* (1) *Is the receiver all-wave, covering all useful channels from 22,000-kc. down to 540-kc. or is it in reality a short- and long-wave set covering only a small part of the short-wave spectrum?* No one today should consider buying anything but an all-wave receiver, since fairly good all-wave receivers may now be had at very reasonable figures and a set, for broadcast band use only, will soon be as out of date as a "horse and buggy on Broadway."

(2) *How selective is the receiver?* A receiver cannot be too sharp in tuning, for the "dyed-in-the-wool" DX-er. A model superheterodyne should give better than 10-kc. selectivity over the whole broadcast band. Does the set bring in a distant station clear and sharp, with no station splash, between two powerful locals? This is absolutely essential for DX-ing. Much DX reception is even sharper than this, as Cubans, Mexicans, and Europeans work on split frequencies, only 5-kc. or less from a local station. With good conditions of reception, split frequency tuning will reward the DX-er with many rare catches. In some of the more expensive receivers *crystals* are incorporated which make 5 kc. tuning easy. These crystals may be switched out for better tone quality. Will the receiver give you adequate selectivity on the 49 meter band? If the receiver is sharp in tuning on these crowded channels such stations as YV2RC, CJRO, VE9GW, or IRA should be brought in without perceptible interference. There is no excuse for poor selectivity today as even a cheap set if carefully designed will be selective enough for the ordinary DX-er.

(3) *What degree of usable sensitivity does the receiver possess?* We are not particularly interested in the highly advertised claim of fractional microvolt sensitivity unless this also means a high ratio of signal strength to noise. Nearly every all-wave receiver at the present time is too noisy, part of which is due to inherent receiver noises, and part of which is local electrical interference. Correctly designed antennas will do much toward reducing the latter type of noise. As I write this article, I am listening to GSE, Daventry, England. I have two

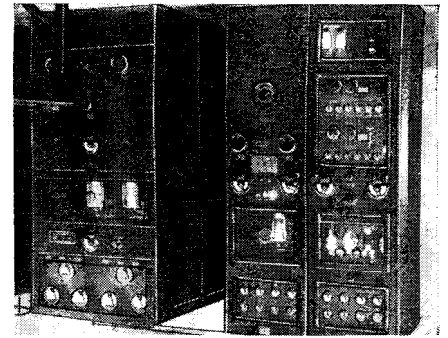

The world's highest transmitter—station CP4, of Radio Illimani at La Paz, Bolivia. It is 12,000 ft. above sea level.

all-wave receivers on test. One is a highly complicated, and technical commercial set embodying all of the supposed gadgets that improve reception. The other is the common stock factory production model of a well-known manufacturer, and has only six tubes. As I turn from one to the other I can detect little difference in the signal strength, although the commercial job is more intelligible on account of the tone pitch which is very high. (When DX-ing your tone control should always be turned to its highest pitch, as weak carriers are more easily distinguished with the tone control in this position.)

(4) *Is the receiver equipped with some device to denote when a signal is tuned to exact resonance?* This may take the form of a beat oscillator, a tuning meter, or a neon glow indicator of some sort. Although some DX-ers still prefer the delicate swish-swish of a carrier heard by the ear alone to any of these mechanical devices, personally I have found these devices are a definite aid in working a weak signal in to its maximum strength, and in locating new stations that might be lost in noise, and thus inaudible to the ears as a carrier wave.

(5) *Is the receiver equipped for headphone operation, or may they be installed without disturbing the balance of the circuits in the receiver?* Many DX-ers still prefer headphones for working with weak signals, or for using their receiver in the wee hours of the morning without disturbing less enthusiastic members of the family. If this is an important factor in your con-

(Continued on page 633)

# AN EASILY-BUILT "THEREMIN"

Electronic musical instruments have been a source of enjoyment to many experimenters—here is one that is simple to make; yet, it has the features of more complicated units.

E. L. DEETER

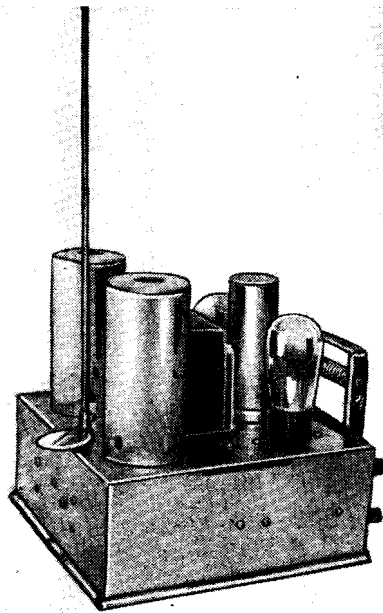

The appearance of the home-built Theremin which will afford the experimenter many hours of enjoyment in making it and learning to play it.

The circuit of the Theremin showing coil connections and power supply circuit.

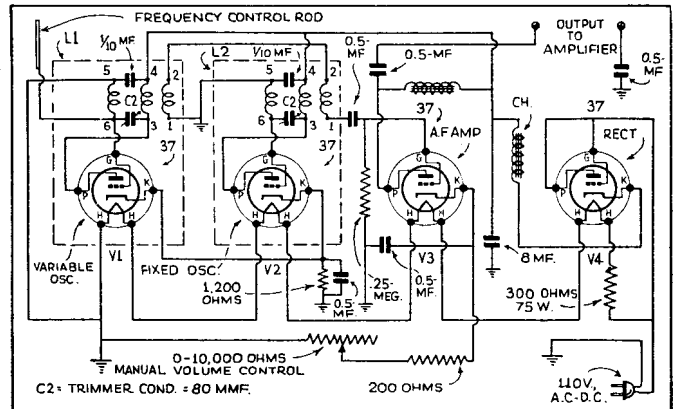

IN EVERY field of art and industry we constantly find new developments, involving new principles to replace the old or to improve the present ones.

For the past fifty years there have been very few appearances of new ideas in the field of musical instruments. Outstanding among these few newcomers are the electrical instruments of the Theremin type utilizing oscillating circuits of electronic tubes.

Professor Theremin made use of two oscillating circuits, one beating against the other, to produce audible

tones covering in a continuous manner the entire musical scale. Of special interest is his space-controlled instrument wherein the capacity of the hand is utilized to produce changes in one of the oscillating circuits. Bringing the hand closer to an antenna rod (*Continued on page 617*)

# THE LATEST ELECTRONIC ORGAN

An advanced type of electronic musical instrument—developed by Ivan Eremeeff—a noted Russian physicist. It is based on photoelectric tubes—and is more flexible in "tone quality" than the standard pipe organ consoles.

EDWARD E. KASSEL

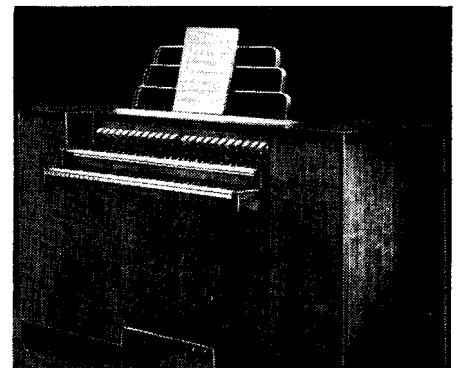

The Eremeeff organ in its complete form.

THE LATEST Eremeeff electronic organ, shown in the accompanying photographs, was invented, designed, and built by Ivan Eremeeff, Russian physicist and craftsman, in the Eremeeff-Stokowski Electronic Musical Laboratories established by the WCAU Broadcasting Station in Philadelphia. This modern instrument has two manuals, twelve interdependent stops for each manual, a volume control pedal, and a tremolo pedal which can also be adjusted by the small knob seen below the keyboards.

This instrument is entirely A.C. operated, without the use of rectifiers, having an outlet for 110 volts A.C. and a three-way wire lead to an amplifier and loudspeakers. The modernistic console is of compact size in order that it may be moved easily through standard-size doors.

The lower manual is provided with stops for combining harmonics and sub-harmonics to the fundamental tones, and the upper manual is provided with stops for combining fractions of the harmonics and sub-harmonics to the fundamental tones, in accordance with the Eremeeff-Helmholtz methods of tone synthesis, which have been described previously in the November, 1932, and August, 1934 issues of RADIO-CRAFT.

(Continued on page 621)

A simplified circuit of the organ. The methods of obtaining tremolo and "piano" like tones are illustrated. Twelve photo-electric tubes and nine hundred auto lamps make up the tone "generator."

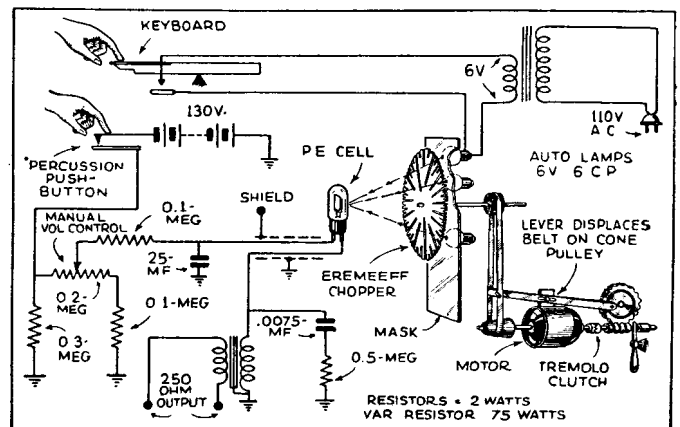

# HOW TO READ GRAPHS and CHARTS IN RADIO WORK

Are you frightened by the appearance of a graph in reading a radio book or magazine? If so, this clear explanation of the mechanics of graph making will assist you materially.

W. EGLIT

PART I

**T**HE RADIO experimenter, when reading articles pertaining to his hobby, is frequently confronted with graphs that illustrate the electrical performances that are discussed in the text. All too often the reader shies at these charts and skips by them without studying them, consequently losing much of the value of the article because of his poorly grounded fears of a very simple method of representing facts. The purpose of this article is, therefore, to aid such a reader in acquiring an understanding of the full significance of the graphs that he is likely to meet in future articles.

The commonest form of graph is of the rectilinear type. It is built upon a frame of two reference lines, or coordinate axes, which in Fig. 1 are X'X and YY', intersecting in a zero point, O, called the origin. These lines are at right angles to each other and the vertical line, YY', is called the axis of ordinates, while X'X, the horizontal line, is called the axis of abscissas. If you prefer, you may simply call them the Y axis and the X axis, respectively; or you may dismiss these names from your memory altogether and just retain what they imply. OY determines positive values or distances measured vertically from the zero line X'X, and the higher a point lies above X'X, the greater its positive value. OY' likewise determines the extent of the negative values of points lying below X'X. Points lying on the graph sheet to the right of YY' are positive when measured horizontally from YY' and the further from this axis, the greater the value. Similarly, points lying to the left are negative, that is, at least as far as horizontal measurement is concerned.

## THE FOUR QUADRANTS

The graph sheet is divided by the coordinate axes into four quadrants, labeled I, II, III, and IV in Fig. 1. In the first quadrant the Y or vertical values and the X or horizontal values of any point lying in that quadrant are both positive. In the second quadrant the Y value is positive and the X is negative; in the third quadrant the X and Y values are both negative; and in

the fourth quadrant X is positive and Y is negative. For example: the Y value of point A is plus 2 and the X value is plus 3; for point B, Y = plus 3 and X = minus 3; for point C, X = minus 1 and Y = minus 1; and for point D, X = plus 4 and Y = minus 4. Since the majority of electrical graphs occur in the first quadrant, we shall give this type of graph the most of our consideration.

Figure 2 illustrates a graph of this type, where OY and OX are the coordinate axes or reference lines, representing amperes and volts respectively, zero voltage and zero current occurring at the origin, O. It is seen that lines are drawn parallel to the axes at equal distances apart. Each of these lines represents a particular value, the horizontal ones for current and the vertical ones for voltage. It is seen that every fifth line is drawn heavier in order to make the chart easier to read. For instance, at intervals of 50 volts and at intervals of one ampere the lines are heavier than for intermediate values. We notice that as we start from the origin and read along the X axis (carrying the voltage scale) we count five lines to the line marked 50 volts; therefore, since an interval of five lines represents 50 volts an interval of one line represents 10 volts. Likewise, each horizontal line measured from the origin

(Continued on page 620)

Fig. 3  
An increasing value—of more than uniform rate—compare this with Fig. 2.

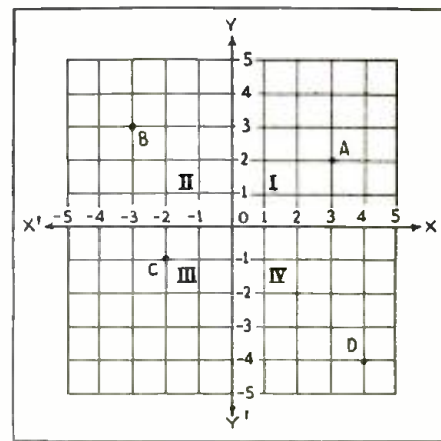
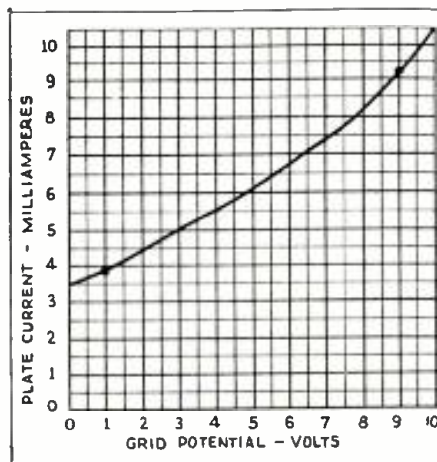

Fig. 1—A graph of the rectilinear type.

Fig. 2, below  
A graph in the first quadrant showing a uniformly increasing value of current and voltage.

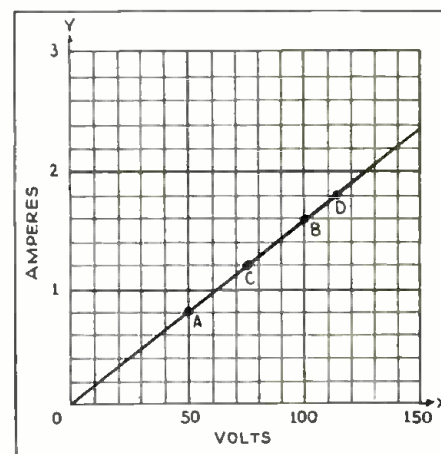

Fig. 4, below  
An extension of Fig. 3; the line extends into the second and third quadrants.

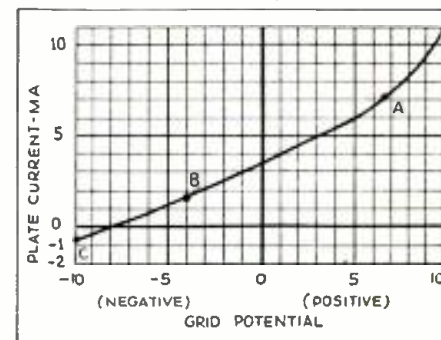
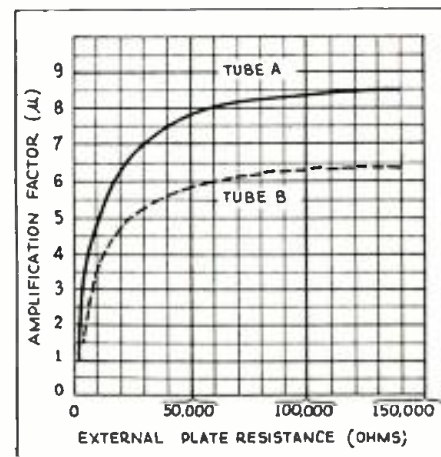
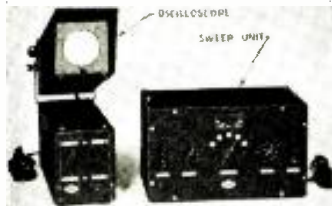

Fig. 5, below  
The amplification characteristics of two tubes plotted against plate resistance.



# THE LATEST RADIO EQUIPMENT



Cathode-ray oscilloscope. (674)

## CATHODE-RAY OSCILLOSCOPE AND SWEEP UNIT (674)

(The Clough-Brengle Co.)

THIS cathode-ray equipment is new in mechanical development—yet it employs a proven type of cathode-ray equipment and sweep-unit type tube, is a fully standardized, portable, and suited for field-service work, as well as production and laboratory use.

Brilliance is sufficient to allow photographic records when desired. Furnished complete in crackle-finished metal housing, dimensions 11½x6½x16½ ins.



Portable "crystal" P.A. system. (675)

## TWO PORTABLE P.A. OUTFITS (675)

ANNOUNCEMENT has been made of two compact, portable P.A. systems using crystal microphones. The smaller model is designed to feed 3.5 W. to the dynamic speaker mounted in front of case. The larger unit (7.5 W. output) can handle as many as 6 permanent magnet speakers.



New rectifier-filter unit. (676)

## NEW RECTIFIER-FILTER UNITS (676)

RECTIFIERS are devices for changing A.C. to D.C. with no moving parts. They consist of transformers, rectifying elements, choke coils, and condensers. Rectifiers are designed for operation from an A.C. power circuit and, by appropriate design of the transformers and rectifying elements, can be made to deliver D.C. at almost any combination of voltage and current. Both copper-oxide and bulb rectifiers are employed depending upon the rating.



Adjustable pickup-recorder. (677)

## ADJUSTABLE PICKUP-RECORDER (677)

(Universal Microphone Co.)

THIS latest combination pickup and recorder is so assembled that pressure can be decreased to a featherweight on the needle groove; minimizing groove and needle wear. As a recording cutting head, it matches all standard line-to-line mixers, tube-to-line and line-to-line transformers. The arm is long enough to play up to 16-in. records.



Variable-field dynamic speaker. (678)

## A VARIABLE-FIELD DYNAMIC REPRODUCER (678)

(The Radolek Company)

SOMETHING new on the market is a special 6¼-in. electro-dynamic speaker with a multi-tapped field winding having a total resistance of 11,000 ohms with an 8-point tap-selector switch adapting the speaker voice coil to any power tube circuit or to any output transformer secondary. The speaker and transformers are contained in a fabricoid-covered portable carrying case. 12x12x6 ins.



A new 8-in. dynamic speaker. (680)

## NEW TUBES FOR CATHODE-RAY APPARATUS (679)

(RCA Mfg. Company, Radiotron Division)

### CATHODE-RAY TUBES

NEWCOMERS to the list of tubes—The 907 and 908 are of the hot-cathode, high-vacuum, electrostatic type, and employ a fluorescent viewing-screen material especially suited for recording on moving film and for rotating-mirror timing methods. The 907 has a 5-in. diameter screen, while the 908 has a 3-in. diameter screen.

### HIGH-VOLTAGE RECTIFIER

The 879 is a high-vacuum, half-wave rectifier tube of the hot-cathode type for use in suitable rectifying devices to supply the D.C. voltage requirements of cathode-ray tubes.

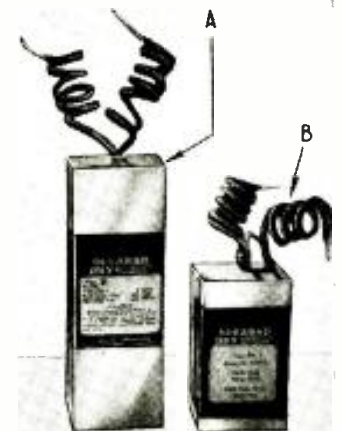

Smallest electrolytic condensers. (681)

## A NEW 8-IN. DYNAMIC SPEAKER (680)

ASPECIALLY designed reproducer, built to supply the need for a good, dependable unit, selling for a low price. It is an excellent replacement unit for many types of sets.

## ULTRA-COMPACT REPLACEMENT ELECTROLYTICS (681)

(The Aerovox Corp.)

THESE units (B) are the most compact electrolytics yet offered. Each section is enclosed in two wax-impregnated cardboard boxes. The unit remains positively dry, free from leakage, seepage or corrosion. One type is rated at 525 V. surge peak, 450 V. D.C. working. The other is rated at 600 V. surge peak, 475 V. D.C. working. Both types are offered in single and dual capacities.



An improved 7-scale dial. (682)

Three new tubes for cathode-ray apparatus. (679)

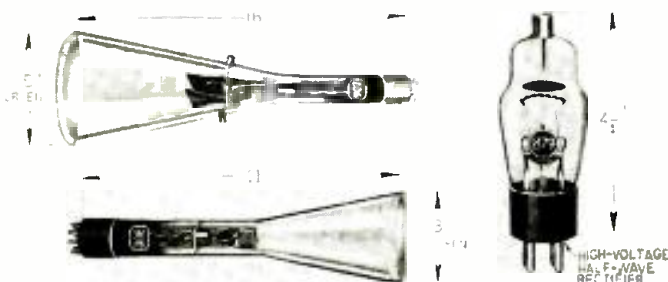

## AN IMPROVED DIAL (682)

THIS new model eliminates vernier at the opposite end of pointer of old model. Open vision pointer permits fast location on any of the 7 scales. This is just the dial for oscillators, short- and all-wave receivers. Outside diameter is 3¼ ins. Ratio is 6½ to 1.

(Continued on page 631)



New "dry-cell batteries." (683)

Name of manufacturer of any device will be sent on receipt of a self-addressed, stamped envelope. Kindly give (number) in description under picture.

# A LOW-COST A. C.-D. C. VACUUM TUBE VOLTMETER

Here is a unit which is made from parts found in most radio "junk boxes"—it has many uses in the shop and lab.

SAMUEL W. LICHTMAN

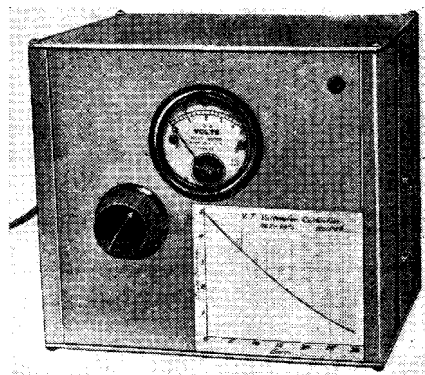

**A**N INVALUABLE addition to any experimenter's laboratory, is a vacuum-tube voltmeter. This is an instrument which many have desired to possess, yet have been deprived of owning, because of the costly, delicate meters and elaborate apparatus required in one as dictated by most of the available circuit requirements and by the high cost of upkeep of such an instrument due to the

use of batteries for supply purposes.

To surmount both of these difficulties, yet to produce an instrument of sufficient precision to meet most of the experimenters' requirements, the following circuit has been developed. In this, low cost and simplicity of operation and construction have been the dominating factors considered in its design.

Since most D.C. meters available to the experimenter are usually of the insensitive type, having a range in the order of 20 ma. for full scale deflection, such a meter was employed in the circuit.

In order to obtain high-power sensitivity, as is necessary because of the use of such a high-range plate milliammeter, a 12A5 tube was selected, due to its high transconductance and also to its low filament current consumption; which enabled the selection of a convenient filament divider resistance and in addition the losses in this divider were minimized. The divider employed,  $R_3$ , was a 35 W. standard mazda lamp. Condensers  $C_2$  and  $C_3$  comprised the sections of a dual 8 mf. electrolytic condenser, while  $C_1$  was a 1 mf.

(Continued on page 625)

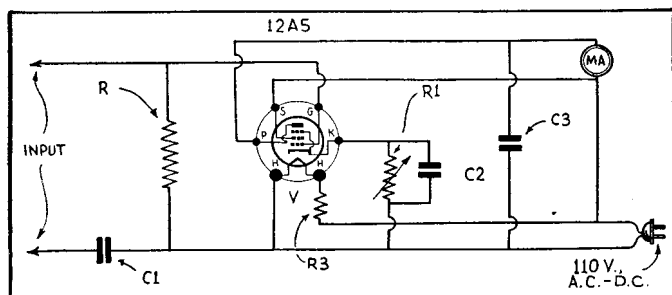
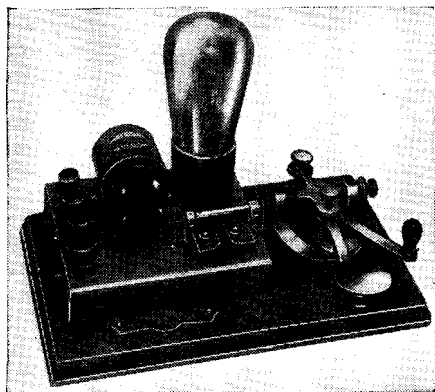

Fig. 1. The circuit of the A.C.-D.C. V.T. voltmeter.



## MAKE THIS VARIABLE-TONE CODE PRACTICE SET

The secret ambition of most radio fans is to own and operate an amateur radio transmitter—but learning the code stumps many of them. A practice set of many uses.

H. LEROY FLESH

**T**HIS CODE practice oscillator is designed for the beginner or even the licensed ham. It can be made into a very compact job, having a variable tone which can be controlled by the variable grid resistor. If one likes to copy a high-pitched note it can be so adjusted; or a low tone can be obtained or any pleasing tone the operator wishes to copy.

If one doesn't have a variable grid-leak, the tone can be varied by using a variable grid condenser instead of a fixed condenser. In this case a fixed grid-leak should be used, ranging anywhere from three to ten megohms. The variable condenser should be about 250 mmf. maximum.

Either one of these arrangements can be used depending on what parts the

builder has or if he wants a compact job.

This all-A.C. oscillator was designed for beginners unable to buy expensive batteries. One can purchase an old "B" box at a reasonable price and filament transformers can also be obtained very cheaply, or if one has a small receiver the "A" and "B" supply can be tapped from its powerpack.

The oscillator in the picture is made on a 3½-in. x 4-in. aluminum pan ¾-in. deep. The binding posts on the end are for power-supply taps. The two small ones are for the filament supply, and the two large ones for the positive and negative "B" supply. The audio transformer is of the midget type with a ratio of one-to-five, but almost any old transformer will work. The vari-

able grid-leak has a range varying from ¼ to 10 megohms and the grid  
(Continued on page 619)

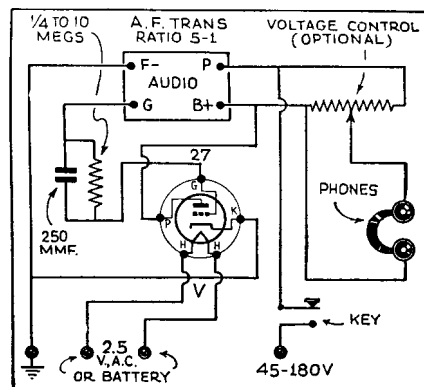

# THE ANALYSIS OF RADIO RECEIVER SYMPTOMS

## OPERATING NOTES

### WHAT THIS DEPARTMENT IS FOR

It is conducted especially for the professional Service Man. In it will be found the most unusual troubles encountered in radio service work, written in a practical manner, by Service Men for you.

Have you, as a professional man, encountered any unusual or interesting Service Kinks that may help your fellow workers? If so, let us have them. They will be paid for, upon publication, at regular space rates.

### PHILCO 16, 17, 17X

A GREAT number of variable condenser gangs of the type used in Philco radio sets go so tight after some months' use that they are difficult to turn for station selection. This is due to the strong wire springs at the ends of the condenser gang frame cutting into the shaft. It would appear that a new condenser gang would be the only remedy. However, not only can a repair be made quickly but also it will improve the mechanical construction. The method of repair is as follows:

First, remove the rotor section of the condenser gang and sandpaper the roughened parts, then, replace. Discard the two end wire springs which are the ones where the wear takes place. Procure a flat spring about 3 ins. long and about 3/16-in. wide (See Fig. 1). This can be obtained from a discarded butcher's saw blade or hacksaw blade, by cutting lengthwise

Fig. 1

Here is how one Service Man solved the problem of preventing "sticking" condenser shafts in Philco sets.

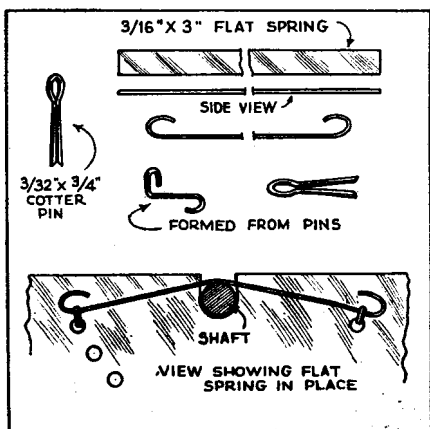

from the back with a tinner's snips. Hold each end of the springs in a flame until the ends can be curved over, as in the drawing. Open out cotter pins and cut and shape as shown in the drawing. Slip the newly formed pins over the ends of springs and place springs in position; the flat side of spring bears against shaft. One end is fastened with cotter key permanently and other end is hooked in hole that gives proper pressure on shaft. This is a quick solution of a perplexing problem and makes a better job as the flat spring will not cut into the shaft like the wire does. Of course, a phosphor bronze spring would make a better contact; however, you still have the center wire for that, and with the flat springs we have never experienced any trouble in lack of contact. Note: After cutting a spring from a blade, smooth any rough edges with a file or emery wheel.

GEO. A. AUBLE, JR.

### MAJESTIC MODELS 60, 70, 80

AN EFFECTIVE method of increasing the sensitivity and volume of the above models is to place a 250 mmf. mica condenser between the contact-arm of the 10,000 ohm volume control and the low end of the variable R.F. coil in the first R.F. stage. This will have the effect of bypassing some signal directly to the coil without affecting the action of the volume control.

Various condensers were used at this point in the circuit (see Fig. 2), ranging from .01 mf. to 100 mmf., but best results were obtained with a mica-insulated condenser of 250 mmf. Incidentally, noise was reduced consid-

Fig. 2

A single 250 mmf. condenser improves Majestic volume.

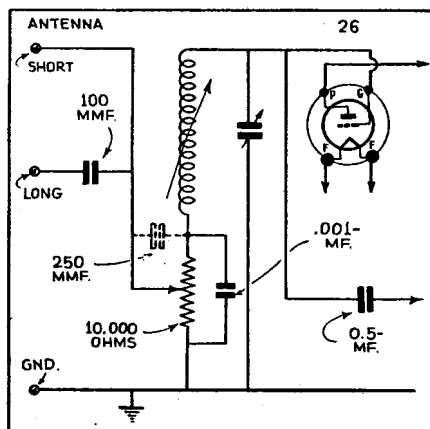

### DEFECTIVE TUBES—

Are not to be considered as the subject for an Operating Note. It is assumed that all Service Men test tubes when making a service call. Their experiences on the subject of testing tubes, unless most unusual, are not of sufficient interest to other Service Men. Operating Notes should be confined to those faults which are characteristic of, and repeatedly occur in connection with a particular model of radio receiver.

erably. In the case of a particularly dirty volume control, a once-over with chamois cloth on the contact-arm wiper and shaft will work wonders.

BERNARD SUNSHINE

### AUDIOLA 30-B

ONE 24 tube was burned out in an Audiola 30-B and the customer mentioned the fact that he was never able to get the volume low enough on powerful local stations without detuning, or turning the local-distance switch to local. The volume control was noisy, too, and so I recommended adapting the receiver to type 35 tubes. I pointed out that the cost would be very little extra, since they had to buy a new volume control and one new 24 anyway.

(Continued on page 632)

Fig. 3

Correcting defective volume control and adapting Audiola to 35's (A,B). Locating defective speaker field in Zenith 410 (C).

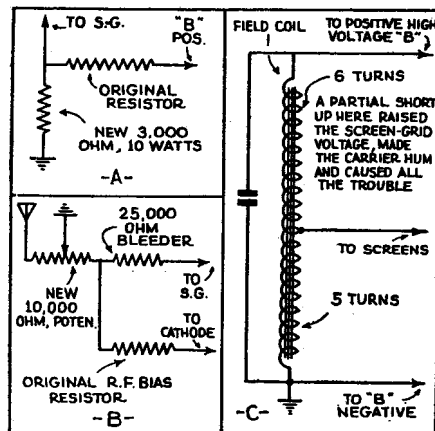



# REPLACEMENT STATUS OF THE NEW TUBES

The beginner in radio who has been stumped by the numerous tubes now available will find this article an invaluable aid in learning just how they are intended to be used.

H. M. NEUSTADT\*

PART II

IT WAS stated in these columns last month that trying to use new type tubes in sets designed for earlier types can cause a lot of trouble and usually produce results of doubtful benefit. Nevertheless tube changes are often attempted because it is desired, for instance, to increase the audio output of a set, or to change an A.C. set for operation on a D.C. power supply. In the following discussion of these tube changes, a description of the difficulties involved may serve to caution those who think that the changes are usually simple, and the information given may be helpful to those with sufficient knowledge and experience to have a fair chance of success in making changeovers.

It should be noted that when the new type takes a different socket than the tube for which it is substituted, an adapter may be used in A.F. stages but this is unsatisfactory in an R.F. or I.F. stage. The losses and capacity introduced by the adapter usually spoil the set's tuning, and the elevation of the tube above the chassis makes tube shielding difficult.

## SUBSTITUTIONS AMONG THE 2.5 VOLT TUBES

### Voltage Amplifiers

**24A by 57** Socket Differences: 24A and 35 have 5-pin base; 57 and 58 have 6. These substitutions are often attempted because the new tubes have a higher  $\mu$ . But if any increased gain is realized, feedback through the power supply, and electrostatic coupling between the tube's plate and the grid circuit can both become troublesome. This necessitates more R.F. filtering and the addition of tube shields. The difference in shape of the grid-plate characteristic curve sometimes means that a change in the A.V.C. system and the taper of the volume control is necessary. Grid bias usually must be changed. The difference in inter-electrode capacity may mean that the tuning condensers have to be realigned. In I.F. stages, the higher plate resistance of the new tubes puts less loading on the transformers, so looser coupling may be required.

**27 by 56** Socket Differences: None. In R.F. and detector stages this substitution requires tube shielding and additional R.F. filtering if any increase in gain is to be realized. In detector stages no other change is necessary. In R.F. and A.F. stages with fixed bias, the bias should be made less negative; if a cathode bias resistor is used it need not be changed.

### Power Amplifiers

**45 by 2A3** Socket Differences: None. In a single-ended stage the control-grid bias should be changed and an output transformer with a smaller step-down ratio should be used. In self-biased push-pull circuits, 2A3s can sometimes be substituted without any changes. In all cases, the set's power supply must be able to deliver the extra

plate and filament power drawn by the 2A3s. This last should be given consideration before the tube change is tried; otherwise the change may cause a burned-out filter choke or power transformer!

**45 by 47** Socket Differences: 45 has 4-pin base; 47 has 5. This substitution requires an output transformer with more step-down ratio. In order to suppress the shrill tones which are characteristic of the output of an improperly installed pentode it may be necessary to add a filter network to the output. (A .03-mf. condenser and A 10,000 ohm resistor in series, and connected from plate to chassis, is one inexpensive expedient that may be tried.—Editor)

**45 by 46 or 59** Socket Differences: 45 has 4-pin base; 46 has 5; 59 has 7. This substitution can be made if the new tubes are connected as triodes. The output of the 59 is more hum-free than that of the 45 be-

(Continued on page 639)

## CHARACTERISTICS OF NEW AND OLD TYPES AT TYPICAL OPERATING VOLTAGES

TABLE III  
VOLTAGE AMPLIFIERS  
2.5 Volt Types

Tube Type	Amplification Factor	Plate Resis. Megs.	Grid Bias Volts	Grid to Plate Plate muf.	Input muf.	Output muf.
24A	630	0.6	-3	0.007	5.3	10.5
57	1,500+	1.5+	-3	0.007	5.0	6.5
35	420	0.4	-3	0.007	5.3	10.5
58	1,280	0.8	-3	0.007	4.7	6.5
		Ohms				
27	9	9,250	-21	3.3	3.1	2.3
56	13.8	9,500	-13.5	3.2	3.2	2.2

6.3 Volt Types

Tube Type	Amplification Factor	Plate Resis. Megs.	Grid Bias Volts	Grid to Plate Plate muf.	Input muf.	Output muf.
77	1,500	1.5	-3	0.007	4.7	11.0
6C6	1,500+	1.5+	-3	0.010	5.0	6.5
39/44	1,050	1.0	-3	0.007	3.5	10.0
78	1,160	0.8	-3	0.007	4.5	11.0
6D6	1,280	0.8	-3	0.010	4.7	6.5
		Ohms				
37	9.2	8400	-18	2.0	3.5	2.9
76	13.8	9500	-13.5	2.8	3.5	2.5

TABLE IV  
POWER AMPLIFIERS—SINGLE TUBE CLASS A  
2.5 Volt Types

Tube Type	Power Output Watts	Grid Bias Volts	Plate Current Ma.	Plate Load Ohms	Output Trans. Ratio*
45	1.6	-50	34	3900	20:1
2A3	3.5	-45	60	2500	16:1
47	2.7	-16.5	31	7000	27:1
46	1.25	-33	22	6400	25:1
59 (t)	1.25	-28	26	5000	22:1
47	2.7	-16.5	31	7000	27:1
2A5 (p)	3.0	-16.5	34	7000	27:1
59 (p)	3.0	-18	35	6000	25:1

6.3 Volt Types

38	2.5	-25	22	10000	32:1
41	3.4	-18	32	7600	28:1
42 (p)	3.0	-16.5	34	7000	27:1

(\*)—Step-down ratio of output transformer for 10 ohm voice-coil load.  
(t)—Triode. (p)—Pentode.

\*RCA Manufacturing Corp., Radiotron Division.





# THE KNOWN FREQUENCY SPECTRUMS

In this fast-moving age we are prone to use the tools available to us, with no regard for their principles of operation—we glibly refer to "light rays," "heat rays," "radio waves," etc., without much realization of their relative status. The author interestingly clarifies the subject.

JOHN J. GLAUBER\*

**A**LMOST daily we either hear or speak about radio waves, light rays, heat rays, and sound waves. It is frequently asked if some relationship exists between these waves or rays, seemingly so different in their effects. To some extent a similarity exists. First, all are of a wave motion.

## THE AUDIBLE SPECTRUM

Second, radio waves, light rays and heat rays all require an ether medium for transportation. Sound waves require a material substance such as air or a liquid or solid matter for transportation. Sound waves may be thought of as alternate condensation and rarefaction of material conducting the sound; that is, it is a series of pressures. Sound waves travel much slower than do waves of radio, light, or heat. The latter waves travel at a speed of about 186,000 miles or 300,000,000 meters per second. Sound waves travel through air, at normal temperature and pressure, at about one-fifth mile or 335 meters per second.

## THE ETHER SPECTRUM

The sound waves form what is known as the audible spectrum because they affect our aural senses, while the radio, heat, and light waves form the electric wave or ether spectrum. Figure 1A is

a chart showing the ether spectrum, beginning at the left with the long radio waves to the short cosmic rays at the right. Included between these extremes are the infra-red radiations, the visible radiations, the ultra-violet radiations, the Roentgen or X-rays and the gamma rays. These are all similar as to their speed and the medium transporting them. Their only difference lies in their frequency or wavelength, those of lowest frequency (the radio waves) having the longest wavelengths and those of highest frequency (the cosmic rays) having the shortest wavelength.

## METERS AND ANGSTROM UNITS

A 1,000,000 cycle (1.000 kilocycle) radio wave has a wavelength of 300 meters. If we imagine a wave motion such as is produced on the surface of a pool of water, the distance measured from the crest of one wave to the next crest would, in the case of our radio, measure 300 meters. The average length of visible light which, as we can see from the chart, are by no means the shortest waves, have a wavelength of .00000033-meter (violet) to .00000081-meter (red). Because of the awkwardness of such figures, the "Angstrom unit" is used when these minute waves

\*Chief Eng. Arceturus Radio Tube Co.

(Continued on page 636)

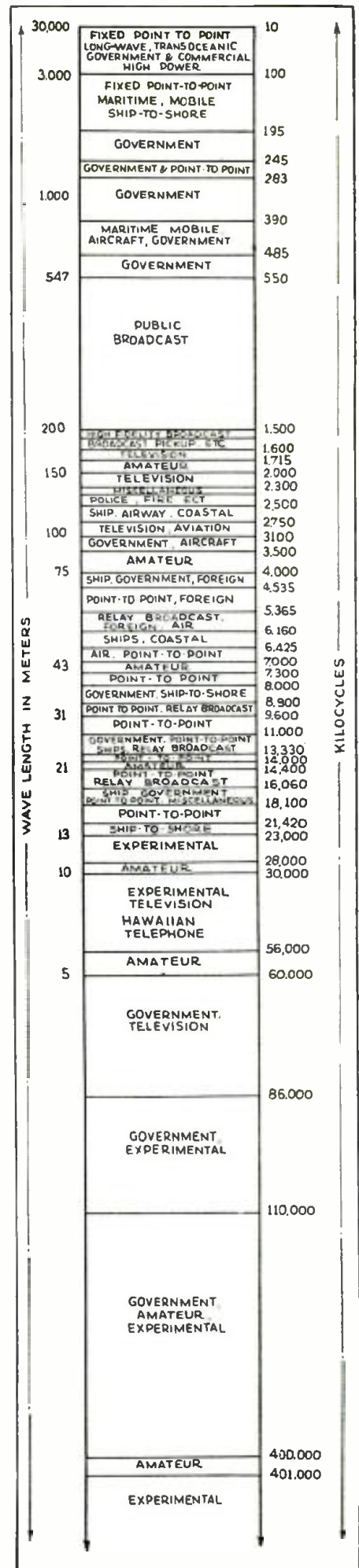
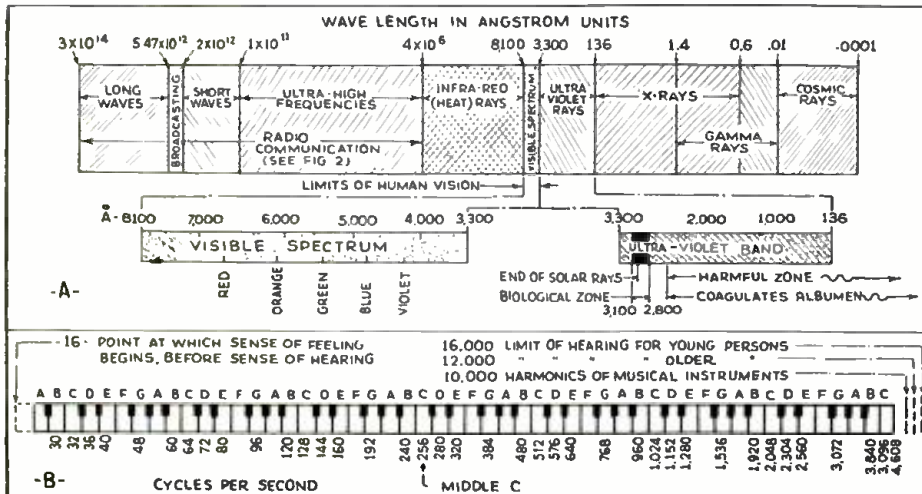

Fig. 1, below  
Frequency spectrums in air and ether.

Fig. 2, right  
"Radio" portion of ether spectrum.



# AN ELECTRONIC AND P. A. AMPLIFIER

A new amplifier with many departures in design, making it suitable for a wide variety of P.A. and electronic applications.

CHARLES R. SHAW\*

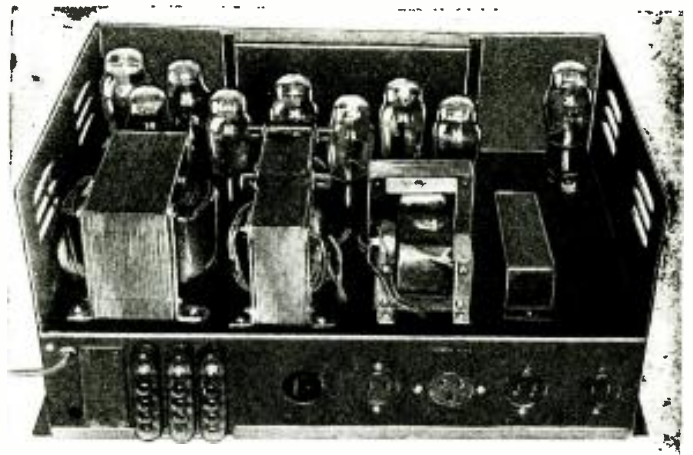

IN DESIGNING a combined electronic and public address amplifier our first assumption was that the typical experienced buyer of amplifiers has passed the stage of purchasing amplifiers merely for the restricted amplifying properties of the unit itself. Although it is true that it was the original purpose of all audio amplifiers to build up weak audio signals, and as all of them do this, amplifiers and particularly general utility amplifiers are no longer bought entirely from this standpoint. Public address men now consider details of gain, power output, operating economy, frequency response, operating power, input impedances, number of channels, class of output stage, mixing and fading facilities, type of interstage coupling, bias circuits, speaker field supply, frequency control, simplicity of installation and operation, plus innumerable details which one

might say are more or less insignificant within themselves, but when taken collectively, might mean the difference between a poor and profitable investment—particularly when an amplifier is bought with the idea of using it for three, four, or five years, or even longer.

Considering the fact that amplifiers are (or can be) used in practically every phase of industrial, commercial, recreational, and political activity, one wonders why the technicians engaged in renting, selling and installing amplifier systems have not long before demanded a truly versatile device, suitable for all practical applications designed and built to compete with other amplifiers which are definitely restricted to one or, at the most, two uses.

To meet the demand for such an amplifier of surprising versatility, the laboratories of a well-known manufacturer have developed a combined electronic and P.A. amplifier, Fig. A. A study

of Fig. 1 will disclose the following interesting design details; the device is essentially composed of a dual channel amplifier powered and biased by a common high voltage and low voltage supply system. Each of these clear channels combine a high gain pre-amplifier (for use with ribbon (velocity), condenser, dynamic, crystal microphones, low-level phono, pickups, and photocells for sound-on-film work), a voltage amplifier, a phase inverter, a class A fixed bias output stage with universal output impedances, complete mixing and fading controls, selective high and low gain universal input circuit, high and low frequency cut-off tone control, as well as innumerable optional electronic features too numerous to mention in this brief resumé but which will be subsequently enumerated.

## WHAT IT CAN DO

Besides serving all of the prosaic  
(Continued on page 623)

\*Design Engineer, Columbia Sound Co., Inc.

Fig. 1. The circuit of the electronic amplifier including the 6 V. and 110 V. power supplies.

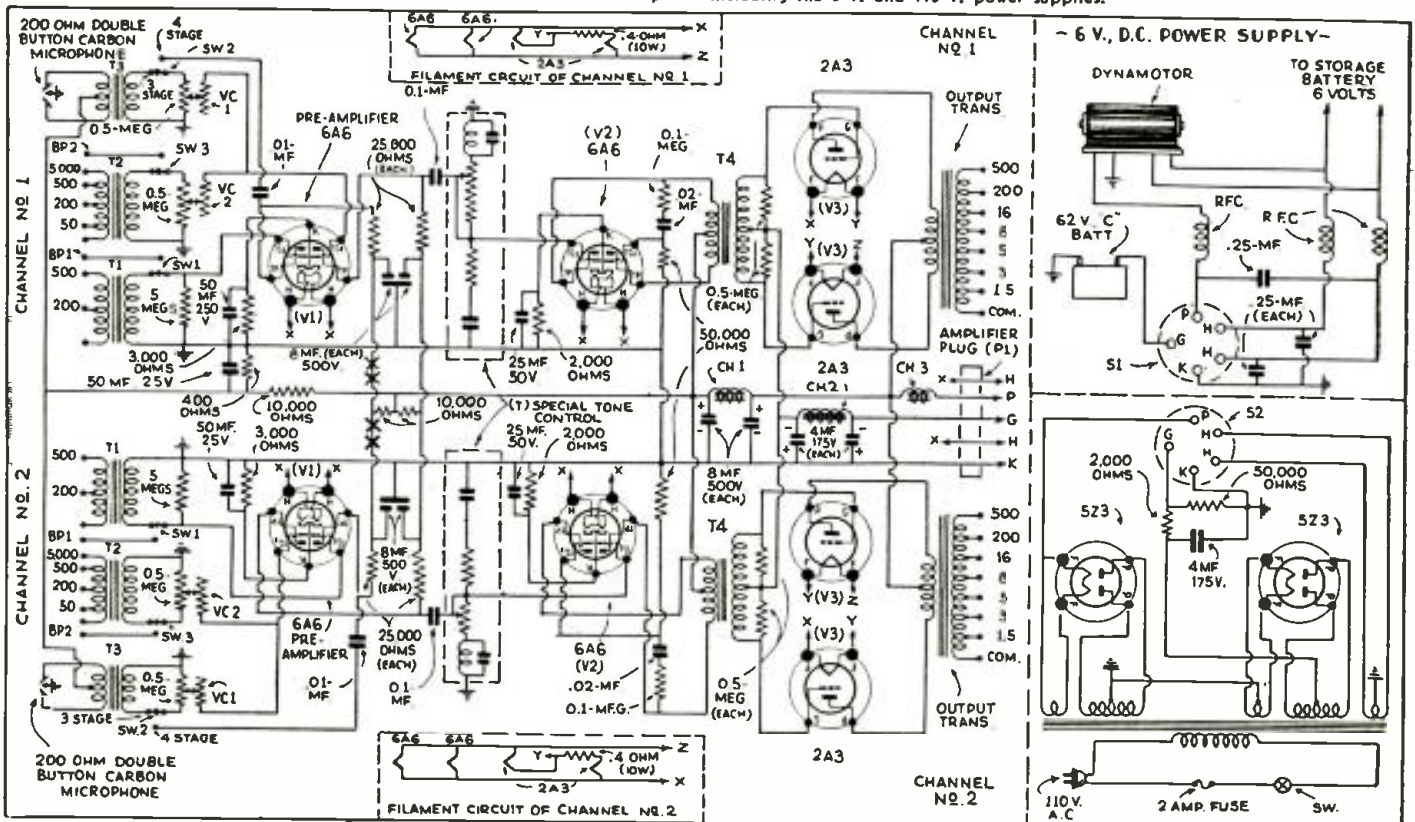



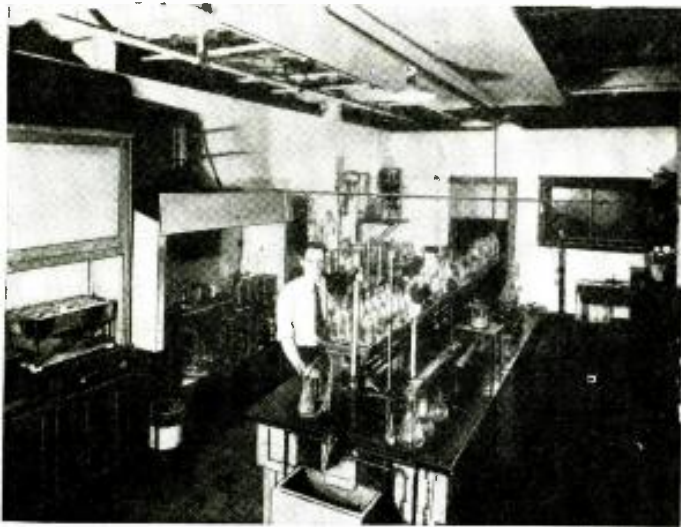

# NEW TUBES VS. OLD

While few new tube models of startling interest have been announced recently, the tube development laboratories have been hard at work modernizing the older types—to keep abreast of the later methods of manufacture. Thus all tubes, even the oldest types have been improved tremendously both in operation and working life.

AUSTIN C. LESCARBOURA

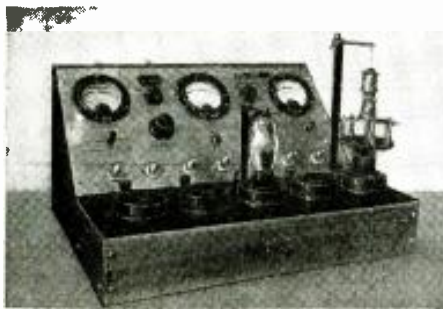

An elaborate "third-degree" test for tubes which indicates any defects or weaknesses. Neon glow tubes indicate the conditions in addition to the usual meters.



These vibrators give tubes as much shaking in a few minutes as they receive in thousands of miles of use in auto radio sets. Any rattles or poor welds soon show up.

Filament and heater wire is critically examined before being accepted for radio tubes; its diameter is checked—its composition is examined microscopically for structural features.

Photos—II Grade Sylvania Corp.



FOR CERTAIN reasons best known to themselves, tube manufacturers select an exceptionally obvious bushel basket under which to hide the blazing light of their research, engineering development, and production achievements. In their advertising and sales messages they usually resort to meaningless generalities and empty superlatives. Because they fail to announce the specific merits of their wares, therefore, a disinterested observer may be pardoned for stepping forward and telling the behind-the-scenes story solely with the reader's interest in mind.

To begin with, tube appearances mean little or nothing. The best tube and the poorest tube look pretty much alike. Even momentary performance in any given circuit may fail to reveal superior design, production and inspection; for it is a fact that poor tubes frequently excel in just one particular, usually to the extent of being unbalanced or useless for normal and general functions. But in all-round practice, over a protracted service life, inherent quality is bound to tell its own story. And that story can be anticipated, perhaps, by taking a peek in the research laboratories and manufacturing plants where tubes are conceived and brought into being.

Really a surprising amount of research and engineering development is lavished on certain brands of radio tubes. Some manufacturers maintain extensive development sections, for while general types may be set by one

or two leaders, other manufacturers have pretty much their own ideas as to how to attain the standard characteristics. Engineering staffs of several dozen men are by no means unusual. One tube manufacturer, for example—and not the leader of the industry, either—has over 150 graduate engineers constantly at work on research, design and production problems. The day of sitting on the door step of the leader and waiting for ideas to copy, Chinese-like, has passed.

## MECHANICAL IMPROVEMENTS

The rapidly expanded variety of tube types absorbed the major efforts of engineers during 1931, 1932 and 1933. The record shows that the growing multiplicity began in 1931, with 10 new types, followed by 32 types in 1932 and 15 in 1933. The enormous amount of detail work represented in designing, tooling and putting into production so many new types can hardly be appreciated outside tube manufacturing circles. By 1934, however, with upwards of 80 standard types to choose from, the radio industry no doubt is well taken care of in the matter of tube variety. New types have been coming along more sparingly. So engineers seemingly have had a breathing spell, but beneath the calm they have been hard at work on numerous refinements and improvements well worth the telling.

It is in innumerable details, rather than in anything startling, that radio

(Continued on page 626)

Testing tubes for microphonic sounds at different frequencies and amplitudes—generated by the A.F. oscillator.

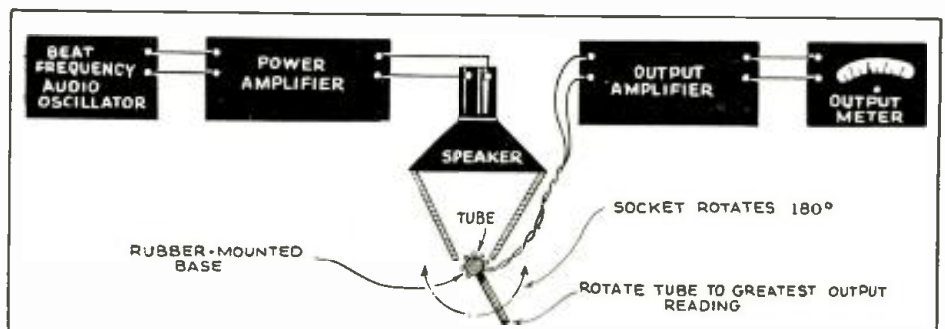

# OFFICIAL RADIO SERVICE MEN'S ASSOCIATION, INC.

## MEMBERS' FORUM

This department is devoted to members and those interested in the Official Radio Service Men's Association. It is the medium for exchanging ideas, kinks, gossip and notes of interest to those who comprise the membership.

### CANADIAN RADIO NEWS

RADIO-CRAFT, ORSMA Dept.:

Just a few lines to let you know of the latest "doings" in Canadian radio sets. There is no use to mention the new Victor, G. E., or Westinghouse, because you have them down there, also Stewart-Warner with its Magic Dial, but up here we have the largest radio firm in the British Empire, namely The Canadian Radio Corporation which is a group consisting of DeForest-Crosley and Rogers-Majestic. (It must not be forgotten that Mr. E. S. Rogers gave us the first batteryless radio set by perfection of the A. C. filament tube.)

The tubes manufactured by the Canadian Radio Corporation are of the lead-shielded type; two new tubes are as follows:

(1) A full-wave rectifier and an output power pentode of 1.8 W. in one envelope.

(2) A combined high-mu triode and output power pentode, of 2.3 to 3 W. I will now give you a short description of these tubes because there is not much data available on them as yet, but I believe that if anyone will write directly to the company at Toronto they can obtain the characteristics.

Tube 1: full-wave rectifier; output power pentode; 1.8 W.; lead-shielded; 6.3 filament; 7 prong base; numbered 89RS last year but changed to 6G7, also, tube is improved in regulation.

This tube used with a 6A7 and a 6F7 makes a very efficient and compact radio set.

Tube 2: High-mu triode, output power pentode, 2.3 to

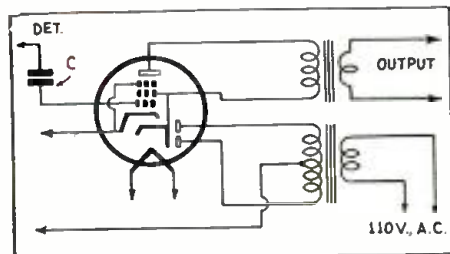

A Canadian tube, the 6G7, combines a power pentode with a full-wave rectifier—it makes a fine 3-tube superhet.



One Service Man uses this method of identifying replacement parts put into a set—it avoids misunderstandings.



The service bench of Mr. Verson, in Havana, Cuba. It is constructed entirely of maghogany.

3 W.; lead-shielded; 6.3 filament; number 6H7.

At the present time no further data is available, but this tube is being used along with 3 others in a 7-tube, 18-60 m., 550-1,500 kc. receiver and it sure does its stuff.

As a radio Service Man for 7 years and a reader of your magazine for nearly the same number of years I have seen very few letters from Canadian radio men; also, very few schematics of the lesser known Canadian-made sets. There is no need of publishing schematics of well-known makes because their service data is available to every Service Man who can make himself known to the radio trade. Many radio Service Men, radio technicians, radio experimenters, etc., when they write to a radio manufacturer for service data do not give the reason for doing so, their experience in the radio field, etc.

If your Canadian readers have trouble in this line of radio work I will be glad to help them out. I can also give them the address of a place where they may obtain any schematic of radio receivers made in Canada at a moderate cost; in some cases the cost is nothing compared to the headaches one gets upon working on an old set with no service data.

I will be obliged, however, to have them enclose a stamped envelope for a reply.

ROBERT ROGERS

### IDENTIFYING REPLACEMENT PARTS

RADIO-CRAFT, ORSMA Dept.:

I practice the following kink (Continued on page 619)

# RADIO-CRAFT'S INFORMATION BUREAU

## CONDENSERS IN SERIES FOR HIGH VOLTAGES

(318) Mr. C. R. Delehanty, Indianapolis, Ind. (Q.) Recently, having an urgent need for several high-voltage electrolytic condensers (900 V.) and being unable to obtain same, I thought of connecting several 500 V. units in series. To play safe, I used three 8 mf. condensers rated at 500 V. each. I found they worked perfectly in a filter circuit. Is this practice recommended for general service work?

(A.) With condensers of the same make and capacity and the same voltage rating, you are safe in using such an arrangement. However, don't be too free in coupling units of different ratings in such circuits. By way of example, if a 5 mf. condenser were put in series with a 2½ mf. unit, and the arrangement subjected to 900 V., the smaller condenser would be forced to take 600 V., as against only 300 V. for the 5 mf. This is true and provable by reference charts showing the effect of condenser reactance upon applied voltage. While such hookups will work satisfactorily (assuming the leakage to be the same for each unit), following the above precaution, they should be followed only when units of prescribed voltage rating are not obtainable. Always use standard condensers when available.

## CATHODE-RAY OSCILLOSCOPE USES

(319) Mr. Joshua Colbin, Lucerne, Pa.

(Q.) I have read about cathode-ray oscillographs (or, more correctly, oscilloscopes). Just what are they used for, and how do they compare with the "standard" mirror type?

(A.) The cathode-ray instrument is particularly suited to high-frequency work, due to the practical absence of inertia of a cathode-beam, compared to the high inertia at high frequencies

of the moving elements of string or mirror types. Thus the upper limit of the cathode type is about 200,000 kc. (You may recall that mirror types become inoperative above 10 kc.) Since the cathode-ray oscilloscope operates quite as well at low frequencies, and since it is sturdy in construction, it is more and more becoming the general handy-man in the laboratory. Mention is made here of a few uses for the instrument.

"In Fig. Q319-B is sketched a means for measuring the percentage of modulation of a radio-frequency oscillator. The modulated radio-frequency voltage under observation is impressed across the two vertical deflecting plates of a cathode-ray "oscillograph." Across the horizontal plates is impressed a voltage of the modulating-oscillator frequency. For the sake of simplicity, the schematic is drawn with the same audio-frequency source modulating the radio-frequency oscillator and deflecting the beam horizontally. The amplitude of oscillation of the radio-frequency oscillator varies at the same rate that the spot is swept back and forth across the screen by the audio-frequency current. Therefore, there results a trapezoidal pattern on the screen which has a maximum amplitude proportional to the peak of the radio-frequency wave and a minimum proportional to its lowest amplitude. The actual degree of modulation can then be determined by comparing the two amplitudes with a pair of dividers. A perfectly modulated oscillator will show an almost perfect trapezoidal pattern. The cathode-ray oscillograph makes an excellent peak voltmeter or ammeter.

"This oscillograph is excellent for aligning receivers. In the example shown in Fig. Q319A the tuned circuits of the receiver are slightly out of line, which accounts for the double hump in the output resonance curve. By the observation of the pattern during the adjustment of the alignment condensers, the set can be brought into adjustment with considerable speed. The

(Continued on page 638)

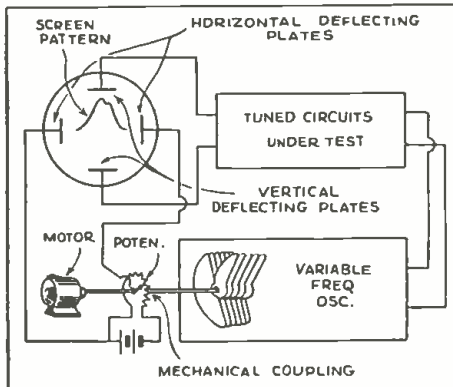

Fig. Q. 319 A, above  
Oscillograph testing receiver alignment.

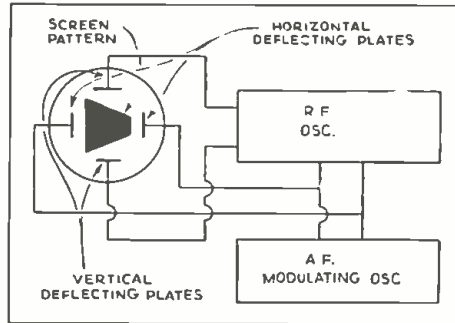
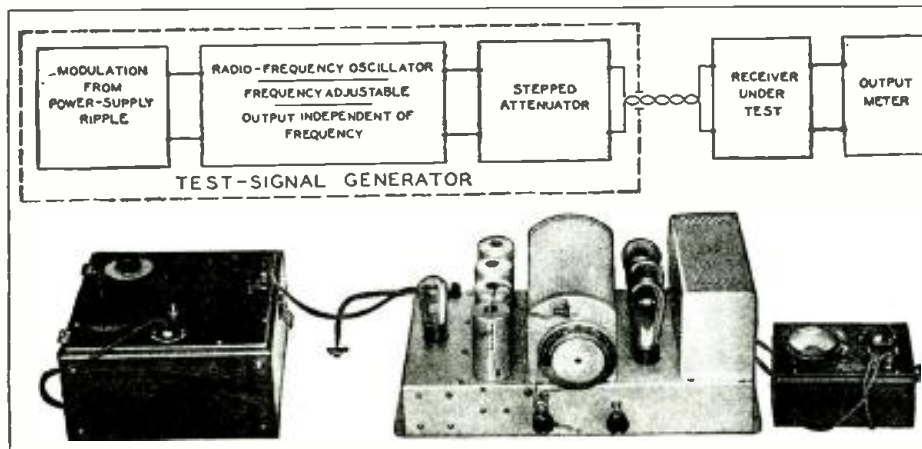

Fig. Q. 319 B, above  
Testing transmitter modulation with oscilloscope.

Fig. Q.319 C, below  
Set-up for testing receiver circuits.



## SPECIAL NOTICE

Those questions which are found to represent the greatest general interest will be published here, to the extent that space permits. (At least 5 weeks must elapse between the receipt of a question and the appearance of its answer here.) Mark such inquiries, "For Publication."

Replies, magazines, etc., cannot be sent C.O.D. Back issues of RADIO-CRAFT prior to December, 1932, are available at 50c per copy; except the following issues: 7/29, 2, 3, 4, 6, 7, 9 and 11/30; 5, 8 and 9/31; and 10/32, which are out of print. Succeeding issues are still available at the regular price of 25c per copy.

Inquiries to be answered by mail MUST be accompanied by 25c (stamps) for each separate question; answers are subject to subsequent publication if considered of exceptional interest.

Furnish sufficient information (in reference to magazine articles, be sure to mention issue, page, title, author and figure numbers), and draw a careful diagram (on separate paper) when needed to explain your meaning; use only one side of the paper. List each question. Be SURE to sign your name AND address.

Enclose only a STAMPED and self-addressed envelope for names and addresses of manufacturers; or, in connection with correspondence concerning corrections to articles, as this information is gratis.

Individual designs can be furnished at an additional service charge. The fee may be secured by addressing the inquiry to the SPECIAL SERVICE department, and furnishing COMPLETE specifications of desired information and available data.

## ELECTRONIC TUBE ARTICLES IN RADIO-CRAFT—FEBRUARY, 1933 TO FEBRUARY, 1935

Article	Issue	Page
50-Year-Old Edison Lamp Used in Receiver (Actually used to re-broadcast WJZ program)	Feb. 1933	463
The A. C. Meterless Tube Tester (Includes complete tube table)	Feb. 1933	472
Controlling Fidelity with the 58 Tube (Practical means of tone control)	Feb. 1933	476
Quasi-Optical Home Experiments (Interesting uses of photo-cells)	Feb. 1933	504
Electronic Music (Editorial by Mr. Hugo Gernsback)	Mar. 1933	521
The Trautonium: A New Musical Instrument (A how-to-build-it article on a distinctly novel device)	Mar. 1933	523
And Now—The Filamentless Tube (An arc-electrode type with interesting possibilities)	Mar. 1933	528
Tube Reference Index (Filament voltages, socket connections and purposes of all tubes to date)	Mar. 1933	533
A Survey of the Vacuum-Tube Voltmeter Field (Detailed construction article)	Mar. 1933	544
Home Experiments (More data on light-sensitive cells)	Mar. 1933	563
Here are the New Tubes! (Data on the 2A3, 5Z3, 2A5, 75, 12Z3, 23Z5 and 84)	Apr. 1933	586
More Information on the Trautonium	Apr. 1933	590
The Radiolight "Talking Beam" (Communication by means of light beams)	Apr. 1933	592
New Tube Data (Complete specifications for types 2A6, 2A7, 6B7, 6A7 and 6F7)	July 1933	12
Building an A.C. Operated V.T. Voltmeter (Complete constructional and technical data. Range 1-300 V.)	July 1933	30
A New English All-Metal Tube (Eliminates 95% of glass commonly used)	Aug. 1933	75
New Tube Data (Characteristics of types 12A5, 1-V, and 53)	Aug. 1933	78
And Now—The Electric Violin (Skeleton frame; electromagnetic pickup; surprising tone)	Aug. 1933	85
Constructing the Dependable Model 303 Tube Tester (Complete constructional data)	Aug. 1933	86
The New Radio Garage Door Opener (Short-wave car transmitter signals robot mechanism inside of garage!)	Sept. 1933	138
The 2B6—A Duplex Triode (Refinement of the triple twin tube)	Sept. 1933	142
The Design Principles of an All-Purpose Tester (Technical, practical article by a chief engineer)	Sept. 1933	148
New Adapters for Modernizing Radio Equipment (Schematic circuits of 22 new adapters)	Sept. 1933	152

(Continued on page 638)

AMERICAN-BOSCH MODEL 376 5-TUBE AIRCELL-OPERATED 540 TO 1,600 K.C. SUPER-HET.

(376 BT, table model; 376 S, console model; 376 F, console model. Incorporates magnetic reproducer, A.V.C., tone control, interference wavetrap.)



Above, Exterior of the table-model set. Extreme right, battery arrangement.

Although generally referred to as an "air-cell" receiver, this set, which is supplied without batteries, may use any of the following three types of "A" supply.

- (1) Dry-cell pack: a ballast tube (No. 107042) is provided with the receiver to accommodate the voltage drop of the dry cell pack which varies from slightly over 3 v. for a fresh battery to less than 2 v. for a battery near the end of its useful life.
- (2) Storage battery operation: when using a single cell of storage battery whose terminal voltage is 2 volts, it is important that the ballast tube be replaced by an accessory which serves to short-circuit the ballast tube socket terminal. (Such an accessory will be supplied as service part No. 108015.) Greater satisfaction will result when using the new low-discharge type of battery which has been specifically developed for radio receiver use.
- (3) Aircell operation: the aircell, unlike the dry-cell pack, does not vary greatly in terminal voltage during its useful life, and while the ballast tube may be used, it does not allow the total life of the aircell to be realized because its use results in low filament voltage. (Service accessory No. 108014 which consists of a low-value fixed resistor should be used to replace the ballast tube when using the aircell.)

(Replace the Ed. 1 polarized electrolytic condenser, if used, with an Ed. 2 nonpolarized unit. This tends to prevent damage due to an incorrect battery connection.)

(Replace the Ed. 1 polarized electrolytic condenser, if used, with an Ed. 2 nonpolarized unit. This tends to prevent damage due to an incorrect battery connection.)

The following grid bias voltages are measured to chassis, from A or B as indicated on the schematic circuit, using a 1,000-ohm-per-volt meter; plate and screen-grid measurements are made on a 250 V. scale.

Tube Type	Plate Volts	S.-G. Volts	C.-G. Volts	Chassis To
V1	135	140	15	A
V2	135	12	25	B
V3	140	70	2.5	B
V4	140	70	2.5	B
V5	145	70	2.5	B

I.F. Aligning Procedure

The first step is to align the I.F. at 456 kc., connecting a high-quality service oscillator through .25-mf. to the control-grid cap of V3, with volume full on, tone control in bass position, and antenna and ground leads connected together. Use a sensitive output meter of high sensitivity and a resistance of at least 4,000 ohms, connected across the windings of the magnetic reproducer. Adjust condensers 4 and 5 to maximum output; then connect the service oscillator to the control-grid of V1 and adjust condensers 8 and 9 to maximum output.



Aligning Wavetrap (Direct Signal, 456 kc.)

An adjustable wavetrap is provided in series with the antenna circuit to prevent interference due to direct transmission of telegraphic signals at the I.F. of 456 kc.

- (1) With the service oscillator remaining at 456 kc., connect oscillator leads to the antenna and ground terminals through a 200 mmf. antenna condenser.
- (2) Set the dial scale to 540 kc., and adjust the service oscillator output to obtain full-scale reading on the output meter.
- (3) Adjust the wavetrap trimmer 14 until a null or minimum reading of the output meter is obtained.

Aligning Oscillator and R.F.

- (1) Connect the service oscillator to the control-grid of V1 and set the service oscillator for an output of 1,500 kc.
- (2) Set the dial scale to the maximum mark beyond the 540 kc. calibration point when the gang condenser is entirely closed.
- (3) Set the dial at 1,500 kc. and adjust condenser 11 to maximum output.
- (4) Connect the service oscillator to the antenna through a 200 mmf. fixed condenser and, with the scale still set at 1,500 kc., adjust condensers 11 and 12 to max. output.
- (5) The padding condenser is next adjusted. Set the scale and service oscillator to 600 kc. and adjust condenser 13 simultaneously, then change this adjustment and the station selector of the chassis for maximum output.

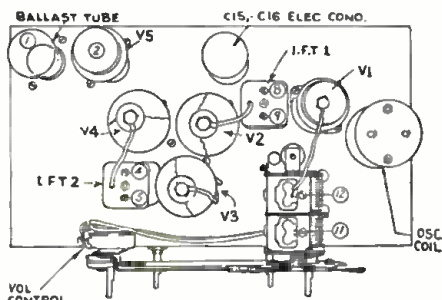

Above, locations of trimmers.

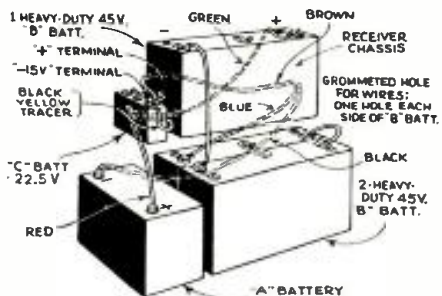

Above, the connections to the batteries.

Below, circuit of aircell superhet.

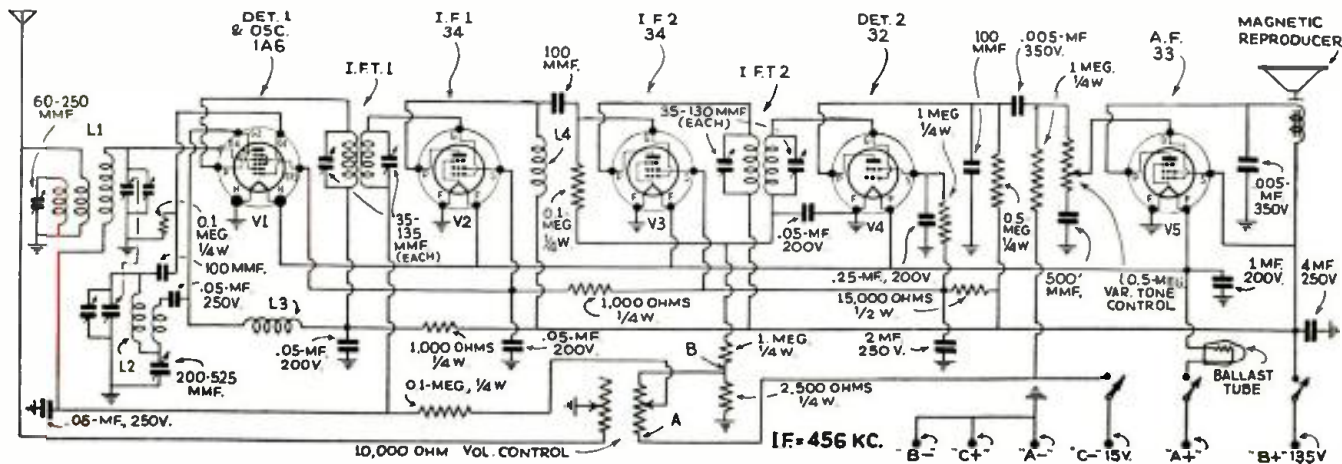





(Continued from page 593)

above the manual.

This electronic organ is a product of the Heinrich-Hertz Institute of Berlin.

### "VISIBLE CURRENT" RADIO MODEL

THE average man who looks at the under side of a radio chassis gets the impression of a jumbled mass of wires and parts which is confusing and possibly mystifying. As a means of clearing up these mysteries, the Marconiphone Company, Ltd., of England has made a most ingenious model of a five-tube radio receiver.

As shown in the illustration, Fig. D it is made bread-board style, with the parts mounted on a panel, "connected" by glass tubes, in which bubbles of differently colored liquids flow.

By means of the colored bubbles in the glass tubes, the current is seen entering vacuum tubes, leaving transformers and passing through resistances. In the case of the latter, the effect of resistance is produced by a change in the size of the bubbles.

This interesting model made by the Marconiphone Co. was demonstrated at a recent radio show, in England.

### THE RAILWAY BROADCASTER

VICTORIA, the smallest and most densely populated state in Australia, is credited with having the first commercial broadcasting station on wheels in the world.

This station, 3YB, is installed in a specially equipped railway car and travels from place to place over the 5,000 miles of railroad tracks in Victoria.

The nature of the mobile station, according to WIRELESS WEEKLY, permits a unique service to advertisers. The listening public is told why they should buy and where to buy locally, the advertised product. Radio set owners look forward to the periodical visits of the station which have been made for three years, as they know from experience that they will receive radio entertainment of the best, without the annoyance of fading, static and distortion encountered in receiving the regular stations which are many miles away.



Fig. E, above. View of transmitter.

Fig. F, below. The railway "studio."



# PROFITABLE SERVICING DEMANDS AN *Accurate* ALL-WAVE OSCILLATOR

*Here it is*

**All-Wave!**  
Complete Receiver Frequency Coverage

**Basic!**  
Frequency Band Depends Only on Plug-In Coil

**Stray Field!**  
Below ½ Microvolt at all Frequencies

**Output!**  
1 to 100,000 Microvolts

**Triple Shielded Attenuator**

**Independent Modulation Circuit—Constant Percentage**

**High Impedance Input for External Modulation**

**Individually Designed Coils for Each Band**

**Constant Impedance 200 Ohm Output Circuit!**

Here's the complete solution to your oscillator problem! Weston supplies it in the new Model 692 . . . an oscillator designed to do a precision aligning job on radio receivers.

Model 692 is not limited to the present frequency bands for frequency ranges can be added at any time.

A few of the outstanding features of this all-wave precision oscillator are shown above. Study them carefully . . . and make your own comparisons. Then, send for the descriptive bulletin which contains all the facts on the oscillator you have been waiting for . . . one that will enable you to give complete customer satisfaction on every aligning job. Mail the coupon today . . . Weston Electrical Instrument Corporation, 599 Frelinghuysen Avenue, Newark, N. J.

## WESTON *Radio Instruments*



Weston Electrical Instrument Corporation  
599 Frelinghuysen Avenue  
Newark, New Jersey.

Send for Bulletin on Model 692 All-Wave Oscillator.

Name \_\_\_\_\_

Address \_\_\_\_\_

City \_\_\_\_\_ State \_\_\_\_\_

Please Say That You Saw It in RADIO-CRAFT

*An Event of  
IMPORTANCE*



See Page 619

**ALLIED RADIO**  
CORPORATION  
833 W. JACKSON BLDG., CHICAGO, ILL.

**AN AUTO RADIO FOR \$17.95  
COMPLETE WITH REMOTE  
CONTROL & TUBES**

Sell auto radios . . . an opportunity for you to make real profit and . . . make it quick. Last year the demand for auto radios was greater than the supply. This season is going to be bigger than last year.

Sell auto radios which . . . are not sold in stores. In so doing you will not be forced to meet price slashing competition. You can secure a good, fair profit for yourself . . . a fair price for installing, and in so doing make yourself the profit you deserve. Let us tell you about our \$17.95 auto radio, complete with tubes, speaker and remote control . . . a value which you will recognize as just what you need.

Can you afford to pass by the auto radio? Today they are so easily installed, and if designed and made right . . . they are almost service free. You will not only please your customer, but . . . make them boosters for you if . . . you sell and install for them an auto radio which will deliver satisfaction.

Our reputation of 14 years' successful radio manufacturing is behind this and every other model of our radios. Over 7900 radio service men have been selling our radios for many years. If we can please them . . . we can please you.

You'll also want to know all about our new five tube broadcast and short wave \$19.95 model, which . . . does get Europe and with an ease of tuning that the public demands.

Remember this . . . our line is complete in electric, auto, and battery radios. Don't overlook the new type battery radios which require no "B" batteries . . . this is the radio which has revived the battery radio business. We can also furnish you with 6, 7, 10 and 12 tube AC chassis, with speaker and tubes to install in your customers' cabinet. We supply a new wood panel . . . match the wood, color and finish of your customers' cabinet.

Don't fail to write for our illustrated literature on radios which are . . . made for sale exclusively by radio service men . . . the radio which makes you a real profit . . . the radio on which the retail price is never slashed. Write today.

**J. MATHESON BELL, INC.**  
308 W. Randolph St., Dept. A, Chicago

*If you are interested in servicing electric refrigerators, write Gernsback Publications, Inc., 99 Hudson St., New York, N. Y., for circulars on the Official Refrigerator Service Manual.*

# TECHNICIANS' DATA SERVICE

JOSEPH  
CALCATERRA

DIRECTOR

The literature listed in this department contains a wealth of very useful information.

A special arrangement between RADIO-CRAFT magazine and the publishers of this literature, which permits bulk mailings to interested RADIO-CRAFT readers, eliminates the trouble and expense of writing to each individual organization represented in this department.

To obtain any of the material listed in this department, simply draw a circle around each booklet number in the coupon, corresponding to the numbers of the items you would like to have, fill in the coupon and mail it to RADIO-CRAFT Technicians' Data Service.

2. **HAMMARLUND 1935 CATALOG.** Contains 12 pages of specifications, illustrations and prices on the new line of Hammarlund variable, midjet, band-spread and adjustable condensers; trimming and padding condensers; R.F. and I.F. transformers, coils and coil forms; sockets, shields, chokes and miscellaneous parts for ultra-short-wave, short-wave and broadcast reception and transmission.

3. **HOW TO GET A HAMMARLUND 1935 SHORT-WAVE MANUAL.** A circular containing a list of contents, excerpts and illustrations from the new 16-page Hammarlund Short-Wave Manual, together with instructions on how to obtain a copy of it, containing construction details, wiring diagrams and lists of parts of 12 of the most popular short-wave receivers of the year.

4. **THE "COMET PRO" SHORT-WAVE SUPER-HETERODYNES.** Describes the outstanding features of the standard and crystal-type Hammarlund "Comet Pro" short-wave superheterodynes

designed to meet the exacting demands of professional operators and advanced amateurs for a 15 to 250 meter code and phone receiver, but which can be adapted by anyone for laboratory, newspaper, police, airport and steamship use.

5. **ELECTRAD 1935 VOLUME CONTROL AND RESISTOR CATALOG.** Contains 12 pages of data on Electrad standard and replacement volume controls. Truvolt adjustable resistors, vitreous wire-wound fixed and adjustable resistors and voltage dividers, precision wire-wound non-inductive resistors, center-tapped filament resistors, high-quality attenuators, power (50- and 150-watt) rheostats and other Electrad resistor specialties.

6. **AMPERITE LINE-VOLTAGE CONTROL.** Characteristics and uses of the Amperite voltage regulator and chart showing the correct Amperite recommended by set manufacturers for their receivers.

25. **LYNCH NOISE-REDUCING ANTENNA SYSTEMS.** Complete descriptions and instructions issued by Arthur H. Lynch, Inc., for making all kinds of antennas for broadcast and short wave reception, with a special supplement covering Ham Antenna Design for transmitting as well as receiving on all the amateur bands, including the ultra-high frequencies.

26. **LYNCH AUTO RADIO ANTENNAS, FILTERS AND NOISE SUPPRESSORS.** This folder describes a complete line of Lynch antennas, filters and ignition noise suppressors designed for auto radio installations. The antenna system is of the under-the-car type for easy installation. It includes data on Hi-Gain matched-impedance transmission lines which make the under-car antenna highly desirable for use with the new "Turret-top" cars.

28. **LYNCH SUPER-FILTASTATS FOR AUTO RADIO INSTALLATIONS.** Describes and illustrates, with instructions for using, the new Lynch Super-Filtastats which do away with the need for suppressors in auto radio installations, giving better performance in operation for both the car and the radio set.

34. **SERVICE MAN'S 1935 ELECTRAD REPLACEMENT VOLUME CONTROL GUIDE.** A 52-page vest-pocket size booklet containing a revised, enlarged and complete list, in alphabetical order, of all old and new receivers showing model number, value of control in ohms and a recommended Electrad control for replacement purposes. Contains specifications and volume-control circuits for over 2,000 receiver models.

57. **HOW TO BUILD A HIGH-QUALITY AMPERITE CONDENSER OR RIBBON MICROPHONE.** A circular which describes the Amperite microphone kits with which it is possible to build, easily and quickly, high-quality condenser and ribbon microphones.

65. **SUPREME 1935 LINE OF TESTING INSTRUMENTS.** A 20-page catalog which gives complete information on the entire Supreme line of testing instruments, including the new 5-in. Supreme fan-shape meter, the new Model 333 De Luxe and low-priced analyzers, the improved Model 85 tube tester, the Model 61 oscillator and the Model 180 precision multi-wave signal generator.

66. **A SUPREME A.C.-D.C. TESTER WHICH CAN BE BUILT AT HOME AT LOW COST.** Gives complete information about the Supreme 5-in. fan-shape meter, rectifier and resistor kit for the home construction of an inexpensive A.C.-D.C. tester.

67. **PRACTICAL MECHANICS OF RADIO SERVICE.** Information, including cost, features and outline of lessons of the Frank L. Sprayberry course in Radio Servicing, and list of Sprayberry Data Sheets for modernizing obsolete test equipment and receivers.

68. **HOW TO MODERNIZE THE SUPREME 400-B.** This is Data Sheet No. 4 of the Frank L. Sprayberry series of data sheets on how to modernize obsolete test equipment and receivers.

69. **CASE RECORDS OF BROADCAST RECEIVER REPAIRS.** Gives plan, contents and price of the Capitol Radio Research Laboratories' loose-leaf case records of 1,500 service jobs showing how actual troubles were corrected. Serves as a guide in correcting troubles in all types of receivers and power-supply units.

(Continued on page 637)

**Radio-Craft Technicians' Data Service**

99 Hudson Street,  
New York City, N.Y. RC-435

Please send to me, without charge or obligation, the catalogs, booklets, etc., the numbers of which I have circled below.

2	3	4	5	6	25	26
27	34	57	65	66	67	68
69	70	72	73			

My connection in radio is checked off below:

- Service Man operating own business.
- Service Man for manufacturer.
- Service Man for jobber.
- Service Man for dealer.
- Service Man for servicing organization.
- Dealer.
- Jobber.
- Experimenter.
- Professional Set Builder.
- Amateur Set Builder.
- Licensed Amateur.
- Station Operator.
- Radio Engineer.
- Laboratory Technician.
- Public Address Worker.
- Manufacturer's Executive.
- Student.
- 

I am a:

- Subscriber
- Newsstand reader.

I buy approximately \$..... of radio material a month. (Please answer this question without exaggeration or not at all.)

(Please print name and address)

Name.....

Address.....

City..... State .....

Avoid delay. The catalogs and booklets listed are now in stock and will be sent promptly as long as the supply lasts. Only the items listed are available. To avoid disappointment, please make your selection now from the current issue of RADIO-CRAFT and mail the coupon without delay.

## AN EASILY BUILT "THEREMIN"

(Continued from page 600)

raises the pitch of the audible note until it finally runs so high as to be inaudible. Removing the hand lowers the pitch to the bottom of the scale, where the tone cuts off and the instrument becomes silent.

Use is made of the other hand in a like manner to control the volume of the notes produced by varying the distance between the hand and another rod or ring.

Because of their cost these instruments have not achieved the popularity they deserve. However the radio experimenter need not let the price interfere with his desire to own a Therman, for he can, at low cost, construct one himself.

Herein is described a Music Box built for use in conjunction with a public address amplifier. Although designed with this use in mind it will do quite well when coupled to the audio end of a good radio, having ample audio amplification.

Because of its complications the capacity volume control is not incorporated in this model. Instead a manual volume control is used as in some of the earlier models of the original Therman instruments. This volume control is held in the operator's hand or attached to the side of the instrument.

In building instruments containing oscillating circuits it is important to provide good shielding if stability is to be expected.

The oscillator coils are Remler, type 620, used in the early superheterodyne sets. (Any superheterodyne oscillator coils having a "coupling coil"—or any good three-circuit tuners can be used with equal success.—Ed.) These coils contain two windings on the main form and one on the inner movable form. Shellac the windings on the main form and after they are dry remove ten turns of wire from the outer side of each of the two windings. Follow this procedure with each of the two coils. Also cut off the control shaft flush with the mounting plate on each coil as it will not be necessary to rotate these coils. They are used as pick-up and mixer coils in the circuit.

Impedance coupling is used in the audio circuit of the output tube. The choke is the primary of an audio transformer. Likewise the primary of an audio transformer is used as a choke in the power filter circuit.

The operating rod is a piece of heavy wire about two feet in length. It fits into an insulated pin-jack in the chassis. A small plate is seen fastened to the rod just above the chassis and is rotated to secure final adjustment of the instrument.

With the plug in and the resistance cut out on the volume control, adjust the trimmers until a squeal is heard. Set carefully until the squeal runs the scale and disappears at the low end. It may be necessary to make use of the plate on the antenna rod, which should be turned out away from the chassis to start.

Now as the hand approaches within about a foot of the rod, the oscillating circuit to which the rod is attached will be thrown off balance by the capacity of the hand and a low audible sound will be produced, increasing its pitch as the hand is brought nearer.

With the output properly coupled to an amplifier system: a little practice (more or less) and we have the latest in music.

Fig. B.—Bottom view of the unique electro-musical instrument, showing distribution of parts. Note the "bias" coil layout.

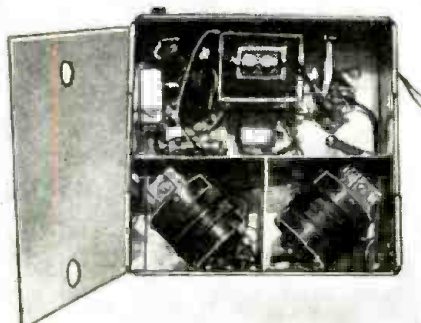

# Variable I.F. COUPLING

provides **SELECTIVITY** or **FIDELITY**, as you choose

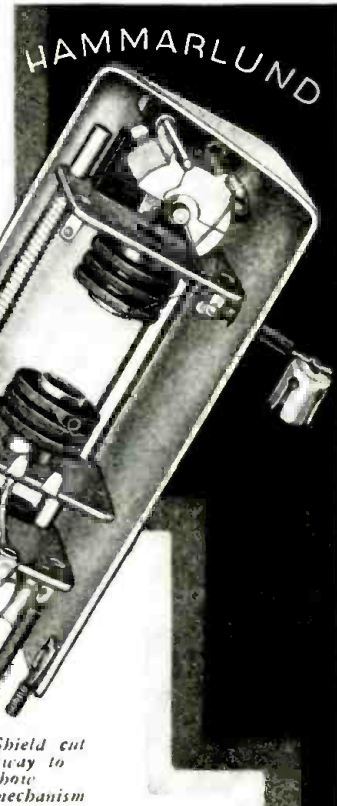
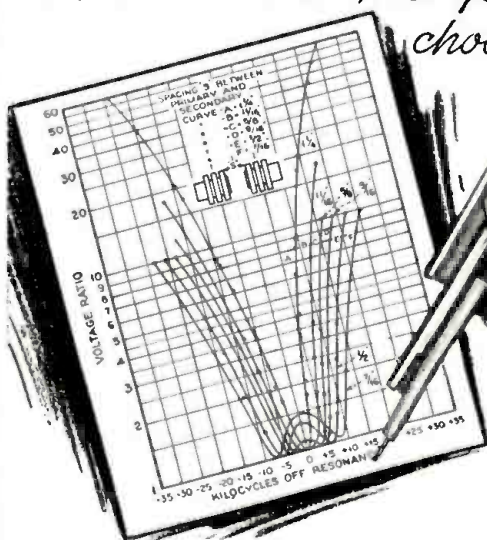

**N**OW, the greatest single improvement in receiver flexibility in recent years.

**CONTINUOUSLY VARIABLE SELECTIVITY**, from a needle-sharp peak to the flat top required for fidelity—without affecting tuning.

The transformer, basically, is the time-tested Hammarlund I.F.T. design, with new triple-type, pie-wound Litz coils and air-dielectric condensers. Plus the startling feature of *continuously variable coupling between the coils*.

Adjustment of coupling in each transformer may be fixed at any point, or continuously varied by panel-control, either individually or ganged in groups, according to selectivity desired.

The diagram shows the variable selectivity characteristics of a single transformer only.

Designed primarily for use in the new COMET Super-"PRO" Receiver, soon to be announced, these transformers may easily be adapted to other superheterodynes.

Code No. VT-465 (465 kc.). List price, \$5.50 each, less 40% to experimenters.

Canadian Office:  
41 West Ave. North,  
Hamilton, Ontario



HAMMARLUND MANUFACTURING CO.,  
423-438 W. 33rd St., New York  
—Check here for details of new Variable-Coupling I.F. Transformer.  
—Check here for 1935 General Catalog.

Name \_\_\_\_\_  
Address \_\_\_\_\_

RC-4

Please Say That You Saw It in RADIO-CRAFT

# Professional Service Instruments

## All-Wave R. F. Oscillator



Approved by Grunow, Sparton, Wells-Gardner, Zenith, Audiola, Motorola, Arvin, etc., for servicing latest all-wave high gain receivers. Output continuously variable from 50 k.c. to 30 mc. (5000 to 10 meters). Each instrument hand calibrated and supplied with calibration chart accurate to 1/2% at no extra cost. Now two types: Model UC is A.C.-D.C. line operated, and Model OD is battery operated. Not to servicemen, complete with tubes.....\$29.94

## A New Service Instrument —The Vacuum-Tube Voltmeter

Check r.f. stage gain accurately. Match coils. The most sensitive measuring instrument ever designed for portable use. Accurate down to 1/10 V. Has resistance of 10 megohms and thus can be used to measure circuit voltage, m.p. readable with ordinary voltmeter. Write for new booklet describing these and many other important service and engineering tests that leading set manufacturers recommend be made with the Vacuum-Tube Voltmeter. At last an instrument that enables you to measure all troublesome receiver circuits.



## New C-B Amplifiers

Rendall Clough, world famous amplifier designer, has just completed design of an entirely different line of sound amplifiers. Have built-in pre-amplifiers for crystal mikes, fixed C-bias. Each unit shipped with laboratory certified output curve. Write for pre-announcement information, or ask your C-B jobber.

Write for FREE Bulletin

The CLOUGH-BRENGLE Co.  
1130 W. Austin Ave., Chicago, U.S.A.

# Ken-Rad Radio Tubes

DEPENDABLE LONG LIFE

Ken-Rad Radio Tubes are made to give clear, dependable reception. They satisfy customers and build good will for dealers. Write for full information.

THE KEN-RAD CORP., Inc., Owensboro, Ky.  
Division of The Ken-Rad Tube and Lamp Corp.  
Also Mfrs. of Ken-Rad Incandescent Electric Lamps

# RESISTOR SPECIALISTS

Featuring:

- QUIET VOLUME CONTROLS, built on an entirely NEW principle.
- VITREOUS RESISTORS
- TRUVOLT RESISTORS
- POWER RHEOSTATS

Write Dept. RC-4 for 1935 Catalog

175 Varick St., New York, N.Y.  
**ELECTRAD**

## THE NEW 6B5 DYNAMIC-COUPLED A.F. TUBE

(Continued from page 590)

put section, No. 2, feeds it, duly amplified, to the speaker.

The secondary of an audio transformer feeds the rectified signal to G1 and K2; the cathode of the input section connects only to G2. The input plate, P1, connects directly to "B plus," and the output plate, P2, feeds the "soup" to the usual output-transformer primary. The first thing that strikes the eye is the apparent lack of bias on the input grid; the second thing that stirs the imagination is the load (or apparent lack of it) of the first tube; and the third effect is, "Well, what about it?" But to complete the story, the input section is built below the output section as may be seen by the photograph, Fig. A and the sketch, Fig. 6, with a common heater and separate cathodes, so that the signal starts from the bottom and works its way up—in intensity as well as in physical level!

### THEORY OF OPERATION

With no signal impressed on the grid of the tube, plate current flows from the "B plus" to the input plate P1 to K1, to the output grid G2, through the grid-cathode resistance of the output section to ground, the inevitable stopping point for all signals. The voltage drop across the plate-cathode of the input section is, therefore, the "B" voltage minus the voltage drop from G2 to K2, which in this tube is about 15 volts; the remainder is good plate voltage for the input section.

The first important conclusion, therefore, is that the cathode of the output section is negative with respect to the grid G2 (or the grid of the output section is positive with respect to its cathode) by the amount of the voltage drop from this grid to cathode—15 volts. The sweeping conclusion, therefore, is that the input grid is negative with respect to its cathode by this same voltage—15 volts, the normal bias on this tube. The simple circuit of Fig. 2 will clear this up, since the resistances take the place of the apparent "space" inside the tube. This, I believe, will clear up that little matter of bias.

Now let us apply a signal to the grid of the input section. The grid becomes positive and negative alternately because of this signal and raises and lowers the plate current of the input section. This varying plate current (the signal, no less) must flow through the G2-K2 resistance, and so the voltage drop from G2-K2 varies, which, in turn, varies the plate current of the output section, and the signal flows out of the faucet—the speaker—by the usual route. Thus, the same grid-cathode resistance that acts as a grid-bias resistance also acts as the plate load of the input section, and no coupling transformers, resistors or condensers are needed.

But the usual grid-bias resistor in a single-tube amplifier has a bypass condenser across it, and ours has none. The reason is simple: if a bypass were connected from G2 to K2, we would bypass our signal, just as if a big condenser were connected from plate to cathode of any tube. Without a bypass condenser, the first grid is affected by the fluctuations in plate current—the more positive the signal the more negative the bias—degeneration, in other words.

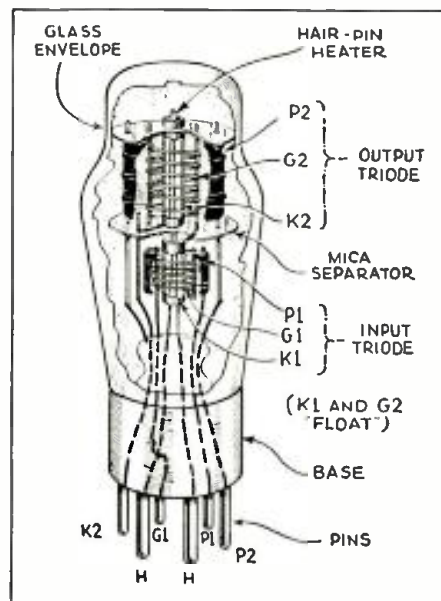

Fig. 6. Cut-away view, showing 6B5 construction.

True, degeneration does take place; but the point is that it is not harmful in this tube, because in order for degeneration to take place the G2-K2 voltage must be high, and increase with signal. But it is precisely this same voltage that actuates the output section, so that regardless of the amount of degeneration the first tube receives, the final signal is unaffected. The degeneration has another advantage—the first grid, G1, can never go positive, because the greater the signal, the greater the plate current, the greater the voltage drop from G2 to K2, and the more the negative bias applied to the input grid. It is this G2-K2 bias that is the signal applied to the input of the No. 2 section, as previously explained. So you see, it's ring around the rosy: the more signal, the more bias and the more output. Why worry about degeneration?

Another way of looking at the theory of the tube is that the output grid section requires power, all of which is supplied by the input tube. So long as this input tube can supply power enough to keep the G2 section satisfied, all is well.

### SOME CURVES

And now some curves for you technical boys. Figure 3A shows the per cent distortion and plate current as the power output is varied with the plate voltage at 300 volts. Note that at 5 per cent distortion, 4 watts can be obtained with an input signal of 15 volts r.m.s. The dotted curves merely show the per cent 2nd, 3rd, 4th, and 5th harmonics.

Figure 4A shows the power output and per cent distortion with 300 volts on the plate for different values of load impedance. Note that with 5 per cent distortion, over 4 watts are obtained with a load impedance of 7,000 ohms.

Fig. 5. "Family" of curves—the plate characteristics of the new 6B5.

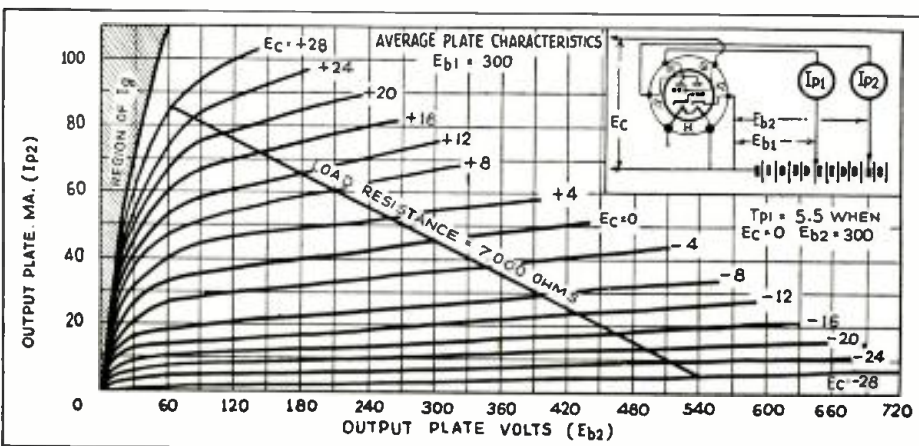

Please Say That You Saw It in RADIO-CRAFT

# Announcing the Spring & Summer Edition of RADIO'S LEADING CATALOG

A new ALLIED RADIO Catalog is on the press—not a meager supplement—but a full-size, meaty, complete book about Everything in Radio for Everyone in Radio. It's the kind of Value and Profit Guide for which ALLIED is famous. You need this new Catalog if you build, sell, service or operate radio equipment. Reserve your FREE copy immediately.

*What Will the new Allied Catalog Show in Sets?*

Everything: Short Wave, Dual Wave, All-Wave models—new Auto Radios—all types of electric, battery, and 32 Volt receivers. Prices are low, too.

*What About the Set Builder?*

He'll be in his element with more than a dozen great new kits to choose from. He'll find parts at lowest prices for building any radio circuit.

*Why Will the Amateur Want this New Book?*

Because it is complete in its listing of all the leading Amateur lines. It shows everything for Short Wave Transmitting and Receiving.

*Will There Be a Special Short Wave Section?*

Yes. With interests for everybody. There will be new receivers, transmitters, and parts for "DX" fans, Experimenters, Amateurs, and Set-Builders.

*What About the Serviceman?*

The new ALLIED Catalog will answer every Service need with the latest test equipment, and with thousands of parts priced for Servicemen's profits.

*Will There Be Anything New in Public Address?*

Yes, absolutely the most advanced Sound Equipment built today—portable, mobile and permanent—an amazing selection to fill every Public Address need.

## ALLIED RADIO CORPORATION

833 JACKSON BLVD., Dept. D1, CHICAGO, ILL.

Gentlemen: You may reserve my FREE copy of the new Spring and Summer ALLIED Catalog.

Name \_\_\_\_\_

Address \_\_\_\_\_

**RESERVE YOUR COPY NOW!**

Maximum output power is obtained with a load impedance of about 10,000 or 11,000 ohms, but the distortion is high. One set of curves is for an input signal of 10 volts and the other for a signal of 15 volts. Those diagonal lines with arrowheads on both ends merely tell you which curves correspond.

### PUSH-PULL CIRCUITS

Figure 1B shows the connections for a push-pull circuit and Fig. 3B the distortion curves for two values of plate voltage, 300 and 325 volts, as marked. The total plate current is also shown on this as well as on other curves. For about 10 watts output, a signal of 38 volts r.m.s. (between outside terminals of the push-pull transformer) are required. For the same distortion, we can get about 13 watts output with 325 volts on the plate.

Figure 4B is a nice bunch of curves which give the power output and per cent distortion for the push-pull connection with 300 and 325 volts on the plate. The arrows tell you what curves correspond. Note that a plate-to-plate resistance of 10,000 ohms has been officially selected by the designers of the tube as the best value for 5 per cent distortion, just like 7,000 ohms was selected as the optimum value for a single tube.

And Fig. 5 is our good old reliable plate voltage—plate-current family with which we are so familiar. A 7,000-ohm load line is drawn, terminating at about 550 volts. Thus, when the

plate current is about 50 ma., the plate voltage is about 300 volts, one of the rated values.

### USING THE TUBE

The base pin connections are as shown in Fig. 1A and B. When you finally dope the thing out, you will find that this tube can replace the type 41 or 42, without any socket changes, merely by short-circuiting the grid-bias resistor normally used with the 41 or 42. Just short this resistor and slip in the 6L5—and watch that speaker hop off the table!

### CONCLUSION

The power sensitivity is high, as in a pentode, and this tube will give class B power with class A quality. The design of the power unit is not critical, since, as shown in the curves, the plate current remains practically constant from no load to full load. You don't have to worry about low-resistance chokes or saturated cores. And you can dispense with one audio stage in that new receiver of yours and still hold up the volume.

code from a receiver; there is always static or interference and it is too inconsistent to make any real headway in code speed.

### ORSMA MEMBERS' FORUM

(Continued from page 611)

when I install new parts in a set. I show the customer the replacement part installed in his set. I then take a fine lettering brush and run a red stripe on the part, at the same time calling the customer's attention to it and giving a 90-day guarantee.

Should anything else go wrong after service and the customer complains that I did a poor job, I call his attention to the fact that the part with the red stripe is still good. This prevents the customer from demanding free service or telling the neighbors that I am a "gyp."

I find that this method of procedure prevents much trouble and helps to maintain the prestige I have built up over years of effort.

W. J. RYAN

### MAKE THIS VARIABLE-TONE CODE PRACTICE SET

(Continued from page 603)

condenser has a capacity of about 250 mmf. The tube used is a type 27. (Note—A 27 with poor filament emission will operate much more satisfactorily than a new tube, so any old tube will do that isn't shorted.) This oscillator will give a pure D.C. signal.

This rig was designed through necessity of being unable to use batteries for a regular D.C. set and it has enabled the author to increase his code speed considerably. The would-be amateur probably knows what a job it is to learn to copy

### A CAREFULLY PLANNED SERVICE BENCH

RADIO-CRAFT, ORSMA Dept.:

While making a trip around the United States with the view of improving my studies in radio and also acquiring new equipment for my shop in Havana, Cuba, I wish to take this opportunity to send you a photo of my service bench.

It consists principally of one set analyzer; one tube tester; one service oscillator; one grid-dip oscillator and signal generator; and one power pack for different voltages, as well as speakers, condenser-resistance box, etc. All drawers are different in size and are divided in sections to have all replacement parts handy.

REINALDO D. VERNON

Fig. 2.  
Grid-bias resistor detail circuit.

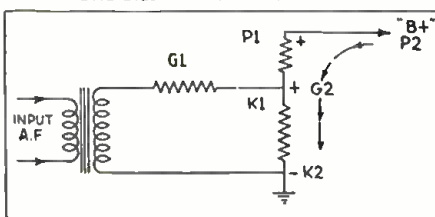

Please Say That You Saw It in RADIO-CRAFT

# THEN THEY CAME TO SPRAYBERRY!



"I WANT TO SAY that the Sprayberry Course is the finest I have ever seen. It contains more information than many other courses combined." A. WALMSLEY, Vancouver, B. C.

The list of Sprayberry students includes literally hundreds of servicemen who have first taken ordinary radio courses. And that is as it should be—for here alone can the forward-looking serviceman obtain sound ADVANCED training at a price so low he can't afford to miss it. For Sprayberry's Practical Mechanics of Radio Service will save you money—and it will help you make greater profits in a dozen different ways. It won't cost a cent to get the facts which may introduce you to the one thing needed to insure your business future.



"I AM A GRADUATE of three other home study schools—yet can truthfully say it was worthwhile in every sense to have taken your course." HORACE W. HART, Yonkers, N.Y.



"I HAVE TAKEN several radio courses, but none which have compared with yours. Sprayberry's is the best I have ever seen!" LLOYD HENDERSON, Grinnell, Iowa.

**NEWS FLASH!** Our three new and complete lessons on the use of the Cathode Ray Tube at principling low price asked for the entire course!

**F.L. SPRAYBERRY** 2548 University Place, N. W., Washington, D. C.

Send me the dope—free! Also tell how I can get the NEW SERIES of Sprayberry Data Sheets at no extra cost.

Name .....

Address .....

**SPRAYBERRY'S PRACTICAL MECHANICS OF RADIO SERVICE**



**FOR Service Men Amateurs and Experimenters Paper - Mica Oil Electrolytic**

Backed by twenty-five years of scientific research and quality production. One billion since 1910. Available at all leading suppliers. Use a C.D. the next time.

**CORNELL-DUBILIER CORPORATION**  
4347 BRONX BOULEVARD  
NEW YORK

**BEGIN MAKING MONEY** in Public Address with **COLUMBIA SOUND AMPLIFIERS**. Write for FREE Catalogue. **COLUMBIA SOUND CO., INC.**, 135 LIBERTY ST., NEW YORK, N. Y.

# HOW TO READ GRAPHS AND CHARTS IN RADIO WORK

(Continued from page 601)

along the Y axis (carrying the current scale) represents two tenths of an ampere, since there are five such lines to one ampere.

The curve plotted in this system of coordinates represents the currents flowing in a certain resistance for different voltages, or vice versa. If we wish to find what current flows through this resistance at 50 volts we find the point A on the curve where the 50-volt line cuts the curve and then read horizontally from this point to the current scale and find that it is 0.8-ampere. In like manner where the voltage is 100 the current is read from point B as 1.6 amperes.

## PRACTICAL APPLICATIONS

Suppose now, that the voltage is 75 and we wish to find the current. The procedure is first to find where the 75-volt line crosses the curve. Since this line is not drawn, we must imagine it to lie midway between the 70-volt line and the 80-volt line, and then we find that it cuts the curve at C, which apparently lies on the 1.2-ampere line. Again, let us find the current when the voltage is 112.5. We must imagine the voltage line to lie one quarter of the distance between 110 and 120, because  $112.5 - 110 = 2.5$ , which is one quarter of 10, the voltage between adjacent lines. Thus from D we read the current as 1.8 amperes.

We may obviously reverse the process and use the graph for finding what voltage drops correspond to various known currents. We find the point on the curve where it is cut by the known current line and project downward from this point and read the desired value on the voltage scale.

This graph, incidentally, gives us an additional bit of information, namely, the resistance of the circuit from which the curve was derived. Take any point on the curve, say A, where the voltage is 50 and the current is 0.8, and by applying Ohm's law the resistance will be found to be 62.5 ohms.

## AN IMPORTANT APPLICATION

Curves not only indicate what values of one kind exist for different values of another kind, as does the foregoing, but also indicate rates of change of increase or decrease. Figure 3 is an example of this. It shows how the plate current of a certain three element vacuum tube varies as we add a positive bias on the grid. We see that the slope of the curve becomes greater, as it progresses away from the origin. In Fig. 2, because the curve was a straight line, the slope was uniform and the Y values increased at a uniform rate; but here we have more than that—we have a greater rate of plate current increase as we increase the grid voltage. Let us check on this and see what increase in current we have at either end of the curve for an increase of one volt of grid potential. When we increase the grid voltage from zero to 1.0 the plate current increases from 3.5 ma. to 4.0 ma.—an increase of 0.5-milliampere. However, when we increase the grid voltage from 9 to 10 the current increase is from 9.15 ma. to 10.5 ma., an increase of 1.35, which is more than two and a half times the increase at the beginning of the curve.

It might be desired to know what happens to the plate current when we put negative bias voltages on the grid. Figure 4 is an extension of the curve in Fig. 3 and it is seen that the curve runs from the first quadrant into the second and third quadrants, the zero current line and the zero voltage line being the coordinate axes (represented in Fig. 1 as X'X and Y'Y). Point A lies in the first quadrant where the grid voltage is +6.5 and the plate current is +7.1 ma.; point B is in the second quadrant where there is a negative grid bias of -4.0 volts and a plate current of +1.7 ma.; and point C lies in the third quadrant where the grid potential is -10 and the plate current is -0.7, the minus sign before the plate current value indicating that the direction of current flow in the plate circuit has reversed. A potential of 100 volts was maintained on the plate in deriving this curve.

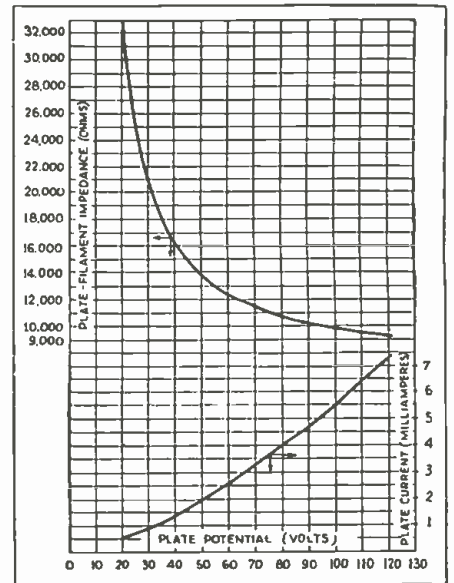

Fig. 6.—Plate voltage-current curve.

It may be observed that the scales for Figs. 3 and 4 are different. In Fig. 3 there are two divisions per volt and per milliampere, while in Fig. 4 there is one division to each one of these units. Compare the first quadrant of Fig. 4 with Fig. 3.

## THE RATE OF CHANGE

We have seen that the change of slope of a curve denotes the rate of change of increase (or decrease, if the slope is down hill) of the particular phenomenon represented in graph form. These sound like so many idle words but a knowledge of rate of change can often be of practical use to us. Figure 5 will bear out the value of this kind of information. The curve labeled "Tube A" is the graph of the amplification factor of the tube we have been considering versus external plate-circuit resistance. We wish a tube to operate on as high an amplification factor as practicable; hence according to the curve we would use a high resistance in the plate circuit. We can see that 20,000 ohms is much better for our purpose than 10,000 ohms, the amplification factor (ratio of output to input) being increased by 1.4. When it comes to a choice between resistances of 110,000 ohms and 120,000 ohms, again a difference of 10,000 ohms, the final result would make little difference, as the amplification factor is increased by only about 0.05. It is also evident that there is no advantage whatever in having an external plate resistance higher than 130,000 ohms, for here the curve has practically leveled out. In fact half that value gives almost as much amplification.

There are times when two or more similar curves are plotted on the same coordinate sheet. They are generally distinguished by appropriate labeling or by being drawn with different types

Fig. 7.—A polar graph.

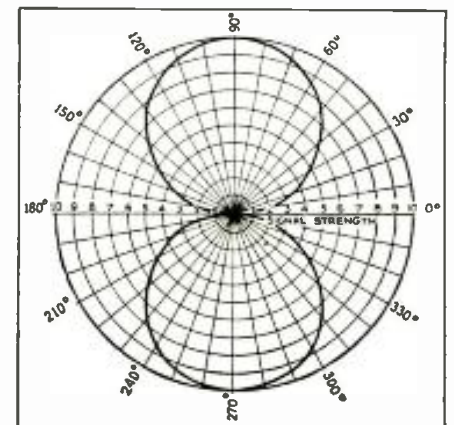

Please Say That You Saw It in RADIO-CRAFT

of lines, as illustrated in Fig. 5. Here they employ the same scales and are particularly useful for making comparisons of the two tubes.

There are other occasions when we come across a pair of curves of associated concepts plotted to three scales on the same chart. Figure 6 is of this class and in such instances one scale is common to both curves and the directions of the small arrows on the individual curves show which scales apply to them. The arrows, though they often appear on such curves, are not always necessary, for the curves and their scales may be identified by their general locations on the graph sheet. It will also be noted in this illustration that the plate-filament impedance scale is not extended down to the origin because no values near the origin are plotted. Incidentally the origins for these curves are not coincident, for although the Y axes coincide, the X axes do not.

**THE POLAR COORDINATE GRAPH**

Finally, in this brief treatment, there is the polar coordinate graph which the experimenter in all probability encounters at some time or other. For some obscure reason a great deal of mystery has been attached to this system of graph plotting, when it is, as a matter of fact, no more complicated than the rectilinear system. It is used where rotation is involved and is illustrated by Fig. 7, which is a graph for signal strength in a loop antenna as it is turned through a complete revolution. The radial lines signify the angles through which the loop is trained and the distances from the center of the chart, as measured by the concentric circles, represent signal strength, 10 being considered as full strength. Here we have taken the zero angle as that in which the plane of the loop is in the direction of wave propagation. As the loop is rotated the signal strength increases until it reaches a maximum at 90 degrees, after which it decreases to zero at 180 degrees. Further rotation again increases the signal strength until it is again at a maximum at 270 degrees and finally back to zero strength at 360 degrees which corresponds to zero degrees, the starting point.

It will be observed that changing the loop direction from 0 degrees to 5 degrees causes a considerable change in signal strength, whereas changing the loop direction from 90 degrees to 95 degrees makes only a slight difference in strength. In other words, the loop is sharper in the vicinity of the angle for minimum signal strength than it is around the maximum.

In closing, a few words of warning may be issued to the prospective graph maker. If in plotting a chart from a set of data, the points lie in a more or less scattered fashion, as shown by the small circles in Fig. 8, do not attempt to connect them as has been done by the broken line, but instead draw a smooth curve through them, as has been done with the solid line. Of course, if the matter plotted is of such a nature that it has no intermediate states between the points plotted, as would be a weekly graph for the closing prices of a certain stock, the points would be connected with a series of straight lines. When points cannot be connected with a fair curve it generally means that the data was not of sufficient accuracy and if a smooth curve were drawn through their averages, as it were, it would be a reasonably good representation of the actual facts of the case; provided, of course, that the points are not too widely scattered.

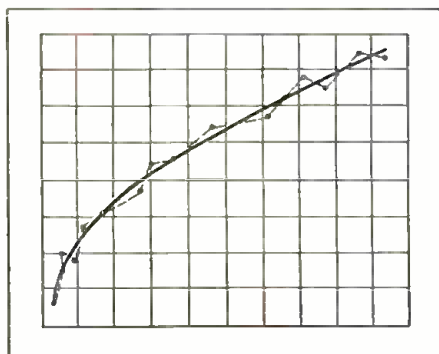

Fig. 8.—Right (solid) and wrong (dotted) methods.

**THE LATEST ELECTRONIC ORGAN**

(Continued from page 600)

The small push-button which can be seen at the right of the lower manual frame is provided for producing staccato effects or percussion tones, similar to those of a piano. By means of this device, the tonal effects of bells can be produced, as well as the tones produced by the picking and strumming of string instruments. The tones may be sustained as long as desired, with and without tremolo. The tremolo operates purely on a slight fluctuation in pitch, as in a violin. Inside of the instrument, supported by a special panel board, are twelve rotating Eremeeff-type light choppers, which are driven by a single endless belt from a single synchronous induction repulsion motor. For each light chopper, there are seventy-five ordinary automobile lamps, making a total of nine hundred lamps connecting with different circuits to the keyboards and stops.

Twelve parallel-connected photoelectric cells are in the line to the preamplifying coupling as shown in the accompanying simplified diagram, which shows in general the operation of the Eremeeff electronic organ. Raw A.C. is used for keying light from the lamps to the photoelectric cells! When the clutch is engaged with the motor shaft, shown in the diagram, the speed of the light choppers is slightly varied for producing tremolo. When a key in the manuals is depressed, a corresponding lamp is lit, and the light beam from the filament is thrown through the rotating light chopper onto the photoelectric cell which cooperates with that particular light chopper for producing the corresponding musical tone of the frequency produced by the row of apertures in the light chopper.

When the percussion push-button is depressed, a sudden rush of polarizing current for the photoelectric cells produces the effect of cracking or striking, similar to the tones produced by striking a piano key. When the percussion push-button is released, the key in the manual continues to produce the tone at a low intensity, although the polarizing current is disconnected, thus producing diminishing effects.

The tones produced by this instrument are so powerful that their force is felt by a listener who is standing even a good distance from the loudspeakers. The fundamental tones are not merely uninteresting pure tones, as in most electronic musical instruments which the writer has heard, but each tone is already rich and round, even before the additional partials are annexed. Of course, each added partial can be adjusted in volume, for which each stop is provided with a small knob, which can be seen in the photograph just below each stop, for increasing and decreasing the current feeding each lamp. Due to the short time duration of usage of each lamp, the percentage of burned out lamps is so small as to be negligible.

The volume control pedal is connected to a potentiometer which is connected after the pre-amplifying coupling. When typical organ pedals for bass tones are required, these are attached to the organ in the form of a small platform containing them, on which the entire instrument is set, and a contact bar of the pedals is connected to the organ with the aid of a multi-plug.

The electronic organ never goes out of tune, since the tuning depends on the revolutions of the light choppers, and the tuning is mathematically perfect. The response of the keys is instantaneous, and the writer has witnessed the playing, and has questioned reputable organists who stated that the organ responds quicker than any of the latest pipe organs with electrical actions, since in a pipe organ there is still a time lag in the pipes for building up air pressure.

A recording and transcription turntable, operating from the same synchronous induction repulsion motor which is used in the instrument, will be added, as will also the use of the amplification system and the loudspeakers, so that other music can be played synchronously, with the organ music as accompaniment.

Plans are in preparation with engineers and noted organists of Philadelphia for broadcasting this electronic organ over a network of stations all over the United States and abroad in the near future, so that readers can enjoy listening to it.

Please Say That You Saw It in RADIO-CRAFT

**34,000 SERVICE MEN HAVE SENT FOR THIS BOOK**

GET YOUR COPY FOR 10c

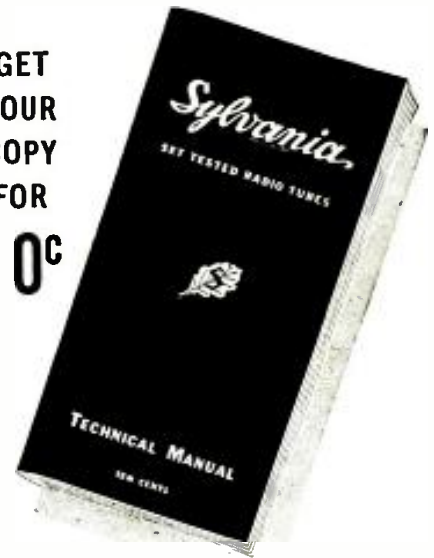

Take the guess work out of tube application! You can if you will send 10c for a copy of the newest Sylvania Service help . . . a handy pocket manual with 104 pages crammed full of useful information that not only helps you recognize tube and set troubles, but how to solve these problems.

Description of over 90 types of tubes, including types 15, 18, 25S, 46B1, 25Y5 and 182 B . . . 150 cuts and diagrams . . . complete data no radio man can afford to be without are in this new booklet.

You'll find it so valuable you wouldn't take \$10 for it . . . and yet it's yours for only 10c in stamps. Send coupon today for your copy.

HYGRADE SYLVANIA CORPORATION  
Emporium, Pennsylvania

Makers of  
SYLVANIA TUBES  
HYGRADE LAMPS  
ELECTRONIC PRODUCTS  
© H. S. Corp., 1935

Factories  
ST. MARY'S, PA.  
EMPORIUM, PA.  
SALEM, MASS.  
CLIFTON, N. J.



**10c- TECHNICAL MANUAL-10c**

Hygrade Sylvania Corporation,  
Emporium, Pennsylvania. (B-21)  
Please send me the new Sylvania Technical Manual.  
I enclose 10 cents in stamps.

Name .....

Address .....

City ..... State.....

## Dual-Section



### COMPACT ELECTROLYTICS

Ultra-Compact Hi-Farad Electrolytics . . . four leads instead of three, providing two negatives and two positives . . . for more applications and greater flexibility. Also mounting flanges.

In 4-4, 4-8 and 8-8 mfd. units.

Individual sections . . . not concentrically-wound dual sections.

Heavily wax-impregnated cardboard case with mounting flanges.

Flexible rubber-covered leads, color-coded for polarity.

**FREE DATA**—New 1935 Catalog is yours for the asking. Also sample copy of Research Worker. Ask your nearest jobber about the Aerovox line of condensers and resistors.



### CONDENSERS

77 Washington St. : : Brooklyn, N. Y.

SEND FOR THIS

# FREE CATALOG

Check full of BARGAINS in RADIO SETS, Long and Short Wave Apparatus, Servicemen's Repair and Replacement Parts, Electrical Appliances and hundreds of miscellaneous specials at TREMENDOUS SAVINGS.

Get this big new Bargain Book. It's absolutely FREE without obligation—just send us your Name and Address on a post card

WRITE FOR YOUR COPY NOW.

**JUST OFF THE PRESS**

RADIO CIRCULAR CO., INC.  
225 RC VARICK ST., NEW YORK

## Stop Guessing!

Radio service is easy when you know just where to look for the troubles. And, the securing of profitable fees for the repairs makes the work still more attractive. A CHUCKER eliminates guess-work in "What Is Wrong and What to Charge." This trouble localizer, with a really profitable repair-price schedule included, enables radio men to localize any trouble in any radio, quickly, right in the field, without dismantling the radio. It looks official, and permits you easily to convince set-owners that you are not guessing at either the trouble or the price of the repair job. Your competitor makes good money by using a CHUCKER!

Send \$1.00 NOW for yours, postpaid.

**FREED'S RADIO CO.**

Publishing Division R

5053 Baltimore Ave. Philadelphia, Pa.

For quality products and best values—patronize advertisers in RADIO-CRAFT.

## TWENTY WAYS TO USE THE "ELECTRIC EYE"

(Continued from page 588)

The circuit in Fig. 1 shows how a selenium cell is connected to an amplifier tube. This type of cell can actuate a relay directly and, in fact, it is usually used in this way. The device shown is a rather specialized use of the cell for indicating the intensity of light—such as the light in a room. It is used (practically) for regulating the amount of artificial light used. The circuit may also be applied to other control applications where unusual sensitivity is needed.

The circuit in Fig. 2 illustrates the normal way of connecting up a photronic cell to other equipment. Fig. 3 shows two ways of connecting the photolytic cell (this is a photo-voltaic cell) where uninterrupted light is used to actuate it and also when a modulated light—such as that found in talking movies—is the controlling means.

The circuits in Figs. 4 and 5 are practical ways of connecting gas-filled or "hard" photo-tubes. Fig. 4 is known as a "forward" circuit in that when the tube is dark, a minimum plate current flows and the relay is inoperative. Then when light falls on the cell, plate current of the amplifier increases and actuates the relay. Fig. 5 is a "reverse" circuit in which maximum plate current flows when the cell is dark and a decrease occurs when the cell is illuminated. Thus the relay opens when light falls on the cell. The contacts on the relay may be selected to open or close the circuit for either forward or reverse arrangements.

It is interesting to note that A.C. is applied to both the photo-tube and amplifier—as both act as rectifiers.

Certain radio tubes exhibit marked photo-electric effects and may be used by the experimenter in this field with fine success. We refer particularly to the type 45 with the common "black-plate." The grid is left floating—by cutting off the grid prong, as shown in Fig. 6 and the plate is connected in series with a battery to the relay or an amplifier tube. A tube should be chosen which is clear at the top so that light can reach the plate easily.

### HOW TO USE THE PHOTO-CELLS

There are numerous interesting experiments that can be performed with photo-cells connected in the ways described. For example, Fig. 7 shows how a bell or alarm can be sounded by the rising sun in the morning. By reversing the relay contacts, a lamp or light can be turned on when the sun sets. Fig. 8 shows how a practical burglar alarm is made up. In this application, of course, it is preferred to use an ultra-violet or infra-red ray which is not visible to the human eye but will actuate the PE. cell. An arclight or a strong spotlight with a sheet of thin hard-rubber over the front is fine for this "invisible light" (sometimes called "black" light).

The arrangement in Fig. 9 shows how a parking light can be turned on a parked car either by the headlights of another approaching car or by the setting sun. For the former use, the photo-sensitive cell should be mounted low on the car—in the direct path of the beam of an approaching vehicle. Two are needed—one for the front and one for the back.

The applications in Figs. 10 and 11 show how visitors can be announced and welcomed by PE. cells. The arrangement in Fig. 10 shows a spot of light across the doorway which is interrupted by the visitor thus ringing the door bell automatically. The one in Fig. 11 automatically turns on a light over the door when anyone approaches it.

### COMMERCIAL APPLICATIONS

The circuits in Figs. 12 and 15 show some interesting industrial applications of the photo-cell which show the methods used and are thus of interest to the experimenter who may apply them to his own needs.

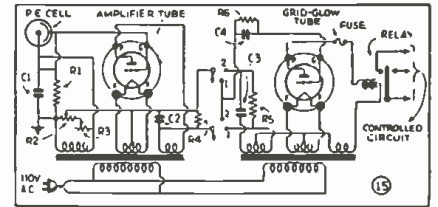

Fig. 15

Control circuit using a grid-glow tube. Use this connection for past actions.

Figure 12 is a method of testing the lustre of fabrics by revolving them very fast in the path of a light beam and registering the reflected light impinged on a PE. cell. A sample of the cloth is secured to the disc on the motor. Fig. 13 shows how two cells are employed for comparing colors or light intensities. The cells are connected as two arms of a wheatstone bridge and any difference in the light recorded by the cells causes an unbalance to occur between the cells which is recorded on the milliammeter. Different colors reflect differently. This arrangement is also used for examining paper on rolls for breaks or thin spots, etc., and for many other applications.

The set-up in Fig. 14 is a practical device for measuring light intensity. This is applied to the control of light in industrial plants—to the examination of translucent objects and to similar commercial uses. One of these devices can be applied to photography as an experimental "exposure" meter. A battery is connected with a suitable high variable resistance to oppose the plate current from the "B" battery, so that the milliammeter reads zero when the cell is dark.

For certain specialized tasks, the speed of operation is an essential factor. Ordinary circuits such as those given above are not quick enough in action to serve the purpose. Such applications as the control of hot steel to respond to the radiant energy of the bars—to the control of package wrapping machines to insure the correct register and the printed matter on the wrapper, and for aligning properly the end crimp on tooth paste tubes with the printed matter on the tube—require unusual sensitivity and greater speed than normal. The circuit in Fig. 15 shows a commercial unit which has the necessary speed. The PE. cell actuates an amplifier of the triode type and this in turn triggers a grid-glow relay tube into action.

The applications and methods presented here are by no means a complete summary of the possible uses for PE. cells. Such a survey would require a complete volume to cover, in even a sketchy manner. However, a few of the most interesting applications for the experimenter and radio enthusiast are outlined. They may help those who are interested to apply these interesting devices to their own particular needs. The values of voltage and resistors, etc., required for the experimental circuits (Figs. 1 to 6 inclusive) are not at all critical but depend upon the sensitivity needed. A little trial and error will soon show the correct values for the particular tube and experiment undertaken.

If this brief article results in stimulating interest in electronic devices, the author will feel genuinely gratified.

## SHORT CUTS IN RADIO

(Continued from page 596)

### HONORABLE MENTION

**AN EGG BEATER** and a micro-vernier dial form the basis of an effective, inexpensive coil winder and counter for the experimenter.

One of the vanes of the egg beater is removed by cutting the vane support at the upper part. The remaining vane is bent to a "V" shape.

Then the vernier dial is secured to the beater support and coupled to the shaft with a suitable coupling. A coil can now be slipped on the V-shaped vane and the winding can be started by turning the crank. The beater should be secured in a vise or clamped to the bench. The vernier dial serves as a counter.

WILLIAM TOTH.

Please Say That You Saw It in RADIO-CRAFT



## AN ELECTRONIC AND P.A. AMPLIFIER

(Continued from page 608)

duties of a conventional amplifier, this twin channel unit can actually be used for reproducing sound in true auditory perspective either in two, three, or four dimensions. (See RADIO-CRAFT issues for January, 1935, page 407 and February, 1935, page 481 for fundamentals of fourth dimensional sound systems.) Naturally, for the recreation of sound in four dimensions, two of these units will be required so as to provide the four clear channels necessitated by such a system.

Another interesting application of the two-channel amplifier, is the simultaneous amplification of both television and sound signals, a condition which ordinarily requires two separate receivers. Any ingenious experimenter can build a two-channel radio frequency amplifier to couple to this unit so that television images and accompanying sound are received together under high-fidelity conditions.

Additional interesting radio applications are discussed in the latter portion of this article. Because of its wide variety of electronic applications this amplifier is admirably suited for academic instruction in all schools and colleges. Practically every natural phenomena and scientific law can be measured, studied, and recorded with this amplifier and suitable accessory equipment. Of course, the amplifier can be used for every public address application that can possibly arise (within limits of its power output, maximum of 40 watts.)

A number of unusual features incorporated into this amplifier include:

1. *Combination high and low frequency cut-off control (T)* which is capable of introducing desirable frequency discrimination at either the upper or lower portions of the audio frequency spectrum, so that compound sounds may be simultaneously studied (or viewed on an oscilloscope) while these sounds are passed through both channels and subjected to predetermined frequency attenuation. For public address applications, this control may be used to cut off extraneously induced 60-cycle hum without seriously affecting the reproduction of speech. When undesirable acoustic feedback takes place at some resonant frequency, the control can be adjusted to suppress this particular frequency and so permit a velocity microphone to be operated in close proximity to its associated loudspeaker.

2. *Transformer-coupled phase inverter* which provides for a push-pull interstage coupling transformer to be connected between the second 6A6 (combined voltage amplifier and phase inverter) and the pure class A push-pull fixed bias output stage.

3. *Universal power operation.* To make this amplifier suitable for field use (where 110 volt A.C. power lines are not available) it has been designed for optional operation from a 6-volt storage battery.

4. *Two-program amplifier.* By virtue of its two distinct and clear channels it is possible to use the amplifier system for the amplification of two different phenomena or programs. It is particularly adapted for centralized radio program distribution wherein two separated programs are individually amplified and distributed to appropriate outlets within the various rooms of a hotel, hospital, school, etc., for ultimate program selection by auditors. One of the channels may also be used for some predetermined program distribution while the "spare" channel is used for special announcements, emergency instructions, etc. The two clear channels are of particular value in the study of feeble transient phenomena in relation to some other conditions which must be simultaneously amplified but separately photographed, recorded or otherwise observed. By interposing two suitable relays, in the plate circuits of the input sections (marked xx, in both channels) these relays may be made to operate any device either when some synchronized phenomena take place (connect relay contacts in series) or entirely independent of each other (connect operating contacts of relays in parallel).

### ELECTRICAL CIRCUIT

A brief study of the input circuit will disclose the following interesting circuit details:

1. Low-level high impedance input devices as crystal microphones, or pickups, photo-cells, etc., are connected to the high impedance tap

BP1 connected to switch SW1. By snapping SW2 to the 4-stage position, the full gain of the amplifier is made available. Ribbon (velocity), condenser or dynamic microphones are coupled into the first 6A6 tube through transformer T1 which may be coupled to either 200 or 500 ohm lines. Under these operating conditions, the "L" pad control (VC1) attenuates all low-level input signals, but does so only after these signals have been pre-amplified in one section of the 6A6 pre-amplifier.

2. High-level input devices or dynamic or magnetic phono, pickups, radio tuners, etc., are coupled into the *second stage* of the amplifier through transformer T3, or high impedance tap (BP2) by virtue of the selection switch SW3. Under these circuit conditions, the "L" pad (VC2) acts as the attenuator control for these high-level input signals while VC1 continues to modify the volume intensity of the low-level inputs, so that "mixing" and "fading" facilities are made available between these two input signal sources.

A 200 ohm double-button carbon microphone may also be coupled into the second stage of the amplifier through transformer T2 by setting switch SW2 to the 3-stage position. With this arrangement, the "L" pad VC1 (independently) controls the output level of carbon microphone.

The push-pull output stage of each channel utilizes a fixed bias class A circuit capable of delivering 15 watts with 2 per cent total harmonic distortion, and 20 watts with 5 per cent harmonic content. The total power output of both channels is 30 to 40 watts depending upon the permissible harmonic content. Under ordinary conditions, a 5 per cent harmonic content is permissible and unnoticeable.

It will be noted that the power supply circuit is composed of two separate voltage supplies utilizing two 5Z3 rectifiers. One of these circuits furnishes plate voltages for all tubes and optional dynamic speaker field supply, photo-cell "B" voltage, etc., while the other 5Z3 supplies a constant bias of 62 volts to the grids of all 2A3's. It is of utmost importance to utilize two rectifiers made by the same manufacturer so that they both heat up at the same time, and avoid the detrimental condition of applying plate voltage before the bias voltage is established.

### ELECTRONIC AND PUBLIC ADDRESS APPLICATIONS

We could fill volumes simply by listing all of the practical applications for which this amplifier is suited. To conserve space, we will merely mention a few of its most popular applications. It should be borne in mind, however, that for some uses, special auxiliary equipment such as sensitive relays, cathode ray oscilloscopes, photo-cells, etc., are necessary.

In the field of sound alone, the amplifier is particularly suited for call system and inter-office communication, listening in to two rooms at the same time, detecting leaks in water and oil mains, comparing and adjusting timepieces against a standard clock, study and comparison of echoes, operating automatic "announcers," "demonstrators," "salesmen," inspecting and detecting surface irregularities, talking signs and clocks, aeronautical and mobile advertising, superstethoscopes for listening to faint heart sounds.

With the aid of a photoelectric cell many light-controlled functions can be performed by suitable devices connected to a relay inserted in the plate circuit of the first 6A6 tube. A few of the more popular uses include sound-on-film recording and pickup, illumination control, automatic door openers, automatic elevator stops, smoke detectors, color matchers, automatic counters, and a host of other inspecting, and protective applications.

With a cathode ray oscilloscope connected to the output circuit the minutest transient voltages and currents may be studied or photographed.

In the public address field this amplifier is particularly suitable for all types of installations, rentals, and applications which heretofore required separate amplifiers: for storage battery operation or 110 volt A.C. operation; for high-fidelity reproduction; for medium and high power output; for indoor, outdoor, mobile, aeronautical, marine, and portable work; for ribbon, crystal, dynamic, condenser, inductor and carbon microphones; for high and medium gain; for radio tuners photo-cells, and phono, pickups.

The author will be pleased to answer any questions relative to the construction or application of this amplifier. RADIO-CRAFT.

Announcing  
**TRIPLITT**

VOLT - OHM - MILLIAMMETER

**IN KIT FORM!**



No. 1200

**S**ERVICE men who want to build their own equipment, or who want to use instruments that can be made to fit special space and installation requirements, will be particularly interested in Triplitt No. 1200 Volt - Ohm - Milliammeter. Now, it is available in kit form, and is designed for use with built-in job equipment.

Every necessary item is included in this kit —and all assembly details have been carefully worked out. All you need is soldering iron and a pair of pliers. The complete kit includes these units:

Triplitt Twin Meter, net	\$10.33
Special Triplitt Selector Switch, net	1.67
Shunt Board for 1-10-50-250 milliamperes readings: 1500 ohms and 1.5 megohms, net	2.33
Resistor board for 10-50-250-500-1000 DC volts and 50-250-500-1000 AC volts and current limiting resistors for 1500 ohms and 1.5 and 3 megohms, net	4.83
.5 MFD Condenser for output measurements, net	.33
Rheostat Assembly, consisting of 65-6000-9000 ohm resistors for ohmmeter zero adjustments, net	1.67
Set of blue prints and instructions, net	.67
Hook up wire, net	.33
No. 32 Triplitt test leads, net	.50

### SEE YOUR JOBBER

See this complete kit at your jobber's. Total price, complete kit, net to dealers. \$16.67

**THE TRIPLITT ELECTRICAL INSTRUMENT COMPANY**  
124 Main Street Bluffton, Ohio, U. S. A.

Please Say That You Saw It in RADIO-CRAFT

**Build this NEW Low-priced ALL-STAR JR**  
 ★ ALL-WAVE Superheterodyne ★



**WORLD-WIDE Reception 10-550m**

It's a receiver that's popular in your country! Seems as though everyone wants one! That's because it's a giant in performance despite its low cost. Even a novice can build the ALL-STAR JR.—and what a thrill you'll get when it reaches out and brings in world wide stations. Buy the complete kit of parts from Radio Headquarters for only \$26.19 (less tubes and speaker), or if you prefer, send \$2.25 for the Foundation Kit so that you can start building at once. You can buy the balance of parts as needed. FICKLE, Dept. Radio, Dept. 13 and Catalogs.

**BUY FROM S.W. HEADQUARTERS**

Thousands of Hams, Amateurs and Experimenters from the Atlantic to the Pacific look to us for every latest development in Short Wave. They know that because we have the world's largest stock we can always render faster, more dependable service. Last, but not least, they know that they can always save money here because we list everything at LOWEST WHOLESALE PRICES!

**FREE!** Our great new 136 page catalog—50¢—which lists thousands of Bargains at latest, lowest wholesale prices. This catalog brings you right up to date. You NEED it! Features hundreds of timely items most in demand in Spring and Summer! Get your FREE copy at once by addressing Dept. C-45.

**WHOLESALE RADIO SERVICE Co.**  
 NEW YORK, N.Y.—100 Sixth Avenue  
 ATLANTA, GA. 430 W. Peachtree St. NEWARK, N.J. 219 Canal Ave.

**COMPLETE PARTS IN STOCK FOR THE**



Write for Free Diagram and Parts List  
**Radio Electric Service Co.**  
 N. E. Corner of 3145 N. Broad St. 811 Federal St.  
 7th & Arch Sts., Philadelphia Camden,  
 Philadelphia, Pa. Pa. N. J.

**Official "ALL-STAR" Cabinet Fits ALL-STAR JUNIOR or SENIOR!**

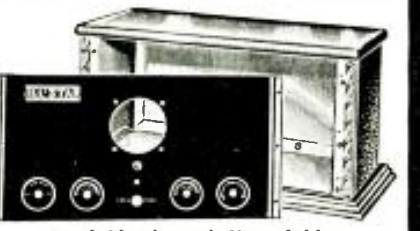

Available through Your Jobber  
**Crowe Name Plate and Mfg. Co.**  
 1748 Grace St., Chicago, Ill.

**HAVE YOU A RADIO-CRAFT INDEX?**  
 By subjects, issues and authors, the July 1929 to June 1932 issues of RADIO-CRAFT are indexed and cross-indexed, in a publication you may obtain for only 25c. You may send stamps or coin for this amount to the publishers of this magazine for your copy. Its use will save you time and money!

**THE MEANING OF "ELECTRON"**

(Continued from page 592)

and pass to other electrodes called anodes. The four methods of getting electrons out of metals, which are commonly useful at this time are:

- (1) the electrical field;
  - (2) thermal agitation;
  - (3) electron bombardment;
  - (4) photoelectric emission.
- (1) The first method (Fig. 1A) consists of putting on the surface of the metal an intense electric field, in the right direction to pull out the electrons.
- (2) The next method (Fig. 1B) is that of heating the metal sufficiently, thus raising the thermal agitation velocity to such an extent that a few of the electrons have sufficient velocity to break through the surface tension.
- (3) The third method (Fig. 1C) "splashes" out some of the electrons near the surface; by bombarding the surface of a metal with high-speed electrons, it is possible to knock out of the surface several electrons for every collision. This phenomenon goes by the name of "secondary emission."

(4) The fourth method (Fig. 1D) utilizes the energy of a light beam to pull electrons through the surface of the metal; certain of the metals yield electrons copiously when intensely illuminated by light of proper frequency. This action is called "photoelectric emission."

The use of a third electrode called the grid enables the flow of electrons to be controlled by varying the potential between it and the anode or cathode. One of the very important features of the grid is its ability to provide amplification. If the tube is evacuated certain performance is obtained. If the tube is filled by certain gases a somewhat different performance is secured. Additional electrodes are sometimes put into tubes by which the performance is still further modified.

In the passage of electrons through a gas collisions occur between the electrons and gas molecules and by virtue of their momenta electrons on the molecules may be knocked loose and thus exhibit a positive charge, or slow moving electrons may attach themselves to a gas molecule causing it to become negatively charged. In an electric field, ions and electrons are attracted and accelerated toward the electrode of opposite polarity to their charge. Gas ions as well as electrons may produce ionization by collision. With sufficiently intense fields, depending especially on the temperature, pressure, and type of gas, the ionization becomes so intense that the gas breaks down into a conducting state. Such a condition exists in arcs, sparks, neon sign tubes, and grid-glow tubes.

As the gas pressure is reduced, the gas is first more easily ionized, but finally as very low pressures are reached the gas molecules are so far apart that collisions are rare. No vacuum tube has been completely evacuated, but when the electrons can travel on the average a great distance compared to the dimensions of the electrodes it is classed as high vacuum.

**CONDUCTORS AND INSULATORS**

In certain of the elements, notably the metals, it appears that the atom does not hold all its electrons in rigid control; one of the outer electrons seems to be free to leave the atom and move around in the outer molecular space at will. If there is an electric potential gradient in the material, these free electrons will, of course, move against it (their charge being negative), and this progressive motion of these free electrons constitutes an ordinary conduction current; the material is styled a conductor.

If a conductor is positively charged, some electrons have been removed from it; and if it is negatively charged, some extra electrons have been supplied to it.

In other substances it seems that the internal molecular forces bind all the electrons firmly in place, making it impossible for an electron to leave its molecule and move along through the material. If a voltage gradient is impressed upon such material there can be

no progressive motion of electrons and hence no conduction current. Such materials are called *insulators*.

There is no sharp demarcation between conductors and insulators. There are some materials having thousands of times as much resistance as copper, the most widely used material for carrying current, yet these high-resistance materials are styled *conductors*.

Also it must be remembered that the finest insulators (as e.g., glass) become fairly good conductors when sufficiently heated. The increased violence of atomic collisions which accompanies high temperature makes it easier for the normally tightly-bound electrons of the insulator to break loose from the atom and become free. They can act the same as the normally free electrons of ordinary conductors.

No experiment has yet been performed which shows how many free electrons there are in a metal; there are indirect proofs that there may be one free electron for every 10 or 20 atoms; others indicate that there may be nearly as many free electrons as there are atoms.

The atoms of a metal are reasonably well fixed in space with respect to the rest of the atoms of which the material is composed. This is, of course, in contradistinction to the atoms of a gas, each of which is free to bounce where chance takes it. The free electrons of a metal, however, seem to act like a gas; they are free to move about in the material, wherever collision, or other action, may urge them. Thus the metal is an aggregate of atoms, each of which is reasonably well fixed in position with respect to the others, and in between these atoms is an electron gas, the individual particles of which are free to migrate throughout the substance of the metal.

Electrons in a magnetic field are acted on only when in motion, and in a direction perpendicular to the magnetic field. This action is made use of in some specialized vacuum tubes.

The space charge in the region of the cathode is caused by the field which the electrons themselves produce and which interacts with the field due to the electrodes. This space charge retards the flow of electrons from the cathode in all tubes, but is neutralized by positive ions in grid-glow tubes.

(Credit is given to Westinghouse Electric and Manufacturing Co., Inc.—The Literary Digest—John Wiley and Sons, Inc.—and RCA Manufacturing Co., Inc., for the information contained in this article.—Ed.)

\*The American Standards Assoc. definitions of electrons, protons and ions are: An *electron* is the natural, elementary quantity of negative electricity; a *proton* is the natural, elementary quantity of positive electricity. An *ion* is an electrified portion of matter of subatomic, atomic, or molecular dimensions.

**BUILD IT YOURSELF**  
 ★ BUILD YOUR OWN ★  
**ALL-STAR JR**  
 ★ ALL-WAVE Superheterodyne ★  
**COMPLETE PARTS In Stock**  
 Write for Free Diagram and Parts List  
 Send for Big 1935 Catalog  
**M & H Sporting Goods Co.**  
 512 Market St., Phila.

★ **FREE Parts List—Schematic** ★  
 ★ BUILD YOUR OWN ★  
**ALL-STAR JR**  
 ★ ALL-WAVE Superheterodyne ★  
**TRY-MORADIO CO., INC.**  
 85-C Cortlandt St., N. Y. C.  
 179-C Greenwich St., N. Y. C.  
 NOTE! Write for full Particulars about FREE membership to the Try-Mo Money-Saving Club. ★

Please Say That You Saw It in RADIO-CRAFT

# A LOW COST A.C.-D.C. VACUUM TUBE VOLTMETER

(Continued from page 608)

paper condenser. Resistor R was a 100,000-ohm and R<sub>1</sub> a 600-ohm, 1/4-W. rheostat. This completes the equipment, all of which is either in the possession of or is readily accessible to any radio experimenter. Using the above circuit constants a range of 0-30 volts (effective) will be obtained.

While the set-up is operative on either 110 volts A.C. or D.C., calibration of the instrument on A.C. is rendered invalid on D.C. as evident by the following considerations:

With a sinusoidal voltage wave impressed upon the power input terminals, the resultant plate current pulses will be as indicated in Fig. 2A. Assuming these to be half sine waves, their average value will be  $I_{AVE.A.C.} = \frac{I_m}{\pi}$  where  $I_m = F(\sqrt{2}E_{eff})$ . With D.C. impressed,  $E_{eff} = E_{D.C.}$  and  $I_{AVE.D.C.} = F(E_{D.C.})$ . From these relations it follows at once that  $\frac{I_{AVE.D.C.}}{I_{AVE.A.C.}} = \frac{\sqrt{2}}{\pi}$ . Therefore, the voltage range of the instrument is approximately  $\frac{\pi}{\sqrt{2}}$  times as great on an A.C. as it is on a D.C. power supply.

In setting the instrument up for calibration and for use, R<sub>1</sub> is adjusted for full scale deflection of (M.A.) This places the operating point of the tube in the region of plate voltage saturation, resulting in a decrease of plate current with the application of a grid E.M.F. instead of the inverse, as found in the usual type of V.T. voltmeter. This is made evident by inspection of Fig. 2B.

The advantages of selecting this operating point in preference to the customary one—taken near the region of plate-current cut-off—are:

1. Elimination of a plate current neutralizing device yet retaining the full sensitivity and utilizing the entire range of the plate milliammeter.
2. Simplicity of adjustment to the operating position.
3. Variational plate conductance very high just below region of saturation resulting in high-power sensitivity for this adjustment.

## CALIBRATING THE INSTRUMENT

The V.T. voltmeter may be conveniently calibrated by comparison with a standard A.C. voltmeter, using 60-cycle current for the grid excitation. In order to avoid reverse reading of the plate milliammeter in this connection, however, the phase of the grid-exciting E.M.F. should be opposite to that of the power-supply source. This may be done by connecting these leads in the manner which results in a decrease of plate current instead of an increase upon their application to the voltmeter.

The versatility and uses of the V.T. voltmeter are so well-known and are so numerous that no attempt shall be made to delve into this subject in any great detail. However, one example shall be given which may be considered as typical of the uses of such an instrument. This shall pertain to the determination of the constants of an A.F. transformer under no-load conditions by a means which, in the writer's estimation, is not generally well known to the average experimenter.

## DETERMINATION OF PRIMARY AND SECONDARY INDUCTANCES,

### L<sub>p</sub> AND L<sub>s</sub>:

This measurement consists of impressing an E.M.F. E<sub>0</sub> across either the transformer primary or secondary, in series with a resistor R as indicated in Fig 2C. R is selected so that it has a resistance value much greater than the winding under measurement. The voltage appearing across the transformer coil (E<sub>1</sub>) and the voltage impressed (E<sub>0</sub>), are now measured with the V.T. voltmeter. The inductance value of the transformer section is then given by—

$$(1) L \text{ (henries)} = \frac{R}{2\pi f \sqrt{\left(\frac{E_0}{E_1}\right)^2 - 1}}$$

when  $R \gg r_l(\text{coil})$

## DETERMINATION OF COUPLING COEFFICIENT (k):

For this measurement the same set-up is used as in the above, only in this case the primary inductance is determined by applying formula (1), first with the secondary open and secondly with the secondary short-circuited. Denoting the former value by L<sub>oc</sub> and the latter by L<sub>sc</sub>, (k) can be determined by substitution of these into the formula—

$$(2) k = \sqrt{1 - \frac{L_{sc}}{L_{oc}}}$$

From this information the leakage reactances are readily determined by the following: Primary leakage reactance = L<sub>p</sub> (1-k); secondary leakage reactance = L<sub>s</sub> (1-k).

The above example is typical of the uses to which a V.T. voltmeter may be applied. If a development of the formulas is desired, the writer shall be pleased to furnish such information upon request.

## BACK NUMBERS OF RADIO-CRAFT

Back issues of RADIO-CRAFT prior to December, 1932, are available at 50c per copy; except the following issues: 7/29; 1, 2, 3, 4, 6, 7, 9 and 11/30; 5, 8 and 9/31; and 7 '33, which are out of print. Succeeding issues are still available at the regular price of 25c per copy.

Please Say That You Saw It in RADIO-CRAFT

for World-Wide Reception  
10 to 550 meters  
or 30 m. c. to 545 k. c.

Easy to build—splendid performance

Sponsored by 11 Prominent Radio Parts Manufacturers: Belden, Cornell-Dubilier, Crowe, Electrad, Erie, Hammarlund, Meissner, Oak, Ohmite, Oxford and Thorderson . . .

### Sensational Design!

A truly professional communication receiver that can be readily assembled without the use of special tools or test equipment. A soldering iron, screw-driver, and pliers are all you need to build the ALL-STAR JUNIOR.



CONTINUOUS BAND SPREAD—over the entire tuning range makes possible the separation of hundreds of stations that are jammed together at a single spot on the ordinary receiver dial.

BEAT-NOTE OSCILLATOR—using the new 6F7 tube, brings in DX carrier waves inaudible on any other short wave receiver.

SUPERHETERODYNE CIRCUIT—Five tubes in the latest design; does the work of 7 tubes!

PRE-ADJUSTED I. F. COILS—Tuned at the factory to 370 k.c. No adjustment required.

ALL ELECTRIC—For 110-120 volt, 60 cycle, standard A. C. house current.

STANDARD PARTS—Ask your radio dealer or jobber for the ALL-STAR JUNIOR Foundation Unit that includes drilled sub and front panels, enlarged drawings of wiring and pictorial diagrams, three step assembly, and all instructions. Start with the Foundation Unit. Buy the remaining parts as you need them. For further information send for the

FREE  
Circuit Diagram  
and Parts List!

ALL STAR HEADQUARTERS  
360 N. Michigan Ave., Chicago, Ill.

Name \_\_\_\_\_  
Address \_\_\_\_\_

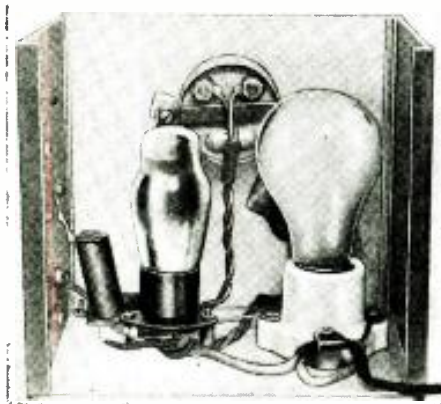

Above, inside view of V.T. meter.

Fig. 2, below. Wave analysis; measurement.

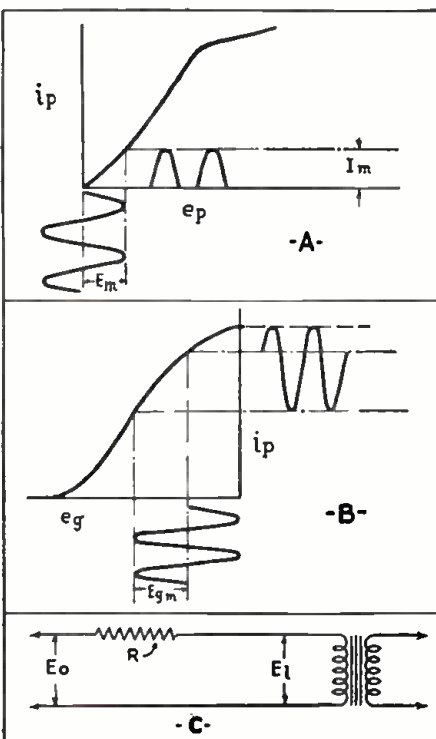



## Short Wave Speaker

Model S.W. 4830  
(formerly No. S.W. 429)

You will not have to switch over to head phones in order to bring in weak signals when using an S.W. 4830.

Those noticeable back ground noises will be reduced to a minimum and there will be no annoying hum.

The A.C. switch on the front panel enables the operator to turn off the field current when quiet night reception is desired.

Copies of interesting reports written by well-known short wave operators will gladly be furnished.

There is a Wright-DeCoster Dynamic Type Speaker of the correct size with a universal transformer for replacement in any type or size of radio.

Write for complete catalog, dealers' discounts and name of our nearest Distributor.

You will find the Wright-DeCoster Distributor anxious to cooperate with you in every way possible.

### WRIGHT-DeCOSTER, Inc.

2251 University Ave. St. Paul, Minn.  
Export Dept.: M. SIMON and SON CO.,  
25 Warren St., New York  
Cable Address: SIMONTRICE, New York

## NEW TUBES VS. OLD

(Continued from page 610)

tubes have been improved upon. First and foremost are the mechanical details. We can readily recall tubes of not so long ago that had to be carefully packed for shipment. It is a far cry from those tubes to those of today shipped in set sockets, instantly ready for use. The rapid rise of the auto radio set has also been responsible for sturdier tubes, particularly in the matter of eliminating looseness which, while perhaps unnoticed in the home receiver, would certainly show up big in the jiggled auto radio.

The most obvious refinement is the dome-shaped bulb generally introduced in 1931. Providing a rigid means of support at top of tube mount, by means of a snug-fitting mica washer or spacer, it has brought remarkable rigidity to tubes, sadly in need of this additional bracing. Crooked mounts are now a rarity. But it has also brought in its wake a multiplicity of mechanical problems.

In the first place, the dome section is not perfectly round. Tube designers therefore have made use of saw-toothed spacers, sometimes round, sometimes cruciform, sometimes something else. Large and small teeth have been used, as well as combinations. Yet loose fits have developed due to imperfect contact at the very beginning or the breaking of the thin mica teeth. Buyers, growing more and more critical of rugged radio tubes, hold a tube to their ear, strike it violently with open palm, and listen intently for the slightest rattle upon which to base a rejection.

Tube engineers have worked hard on dome-bulb rattles. Some time ago the mica pad was introduced—tiny mica members mounted perpendicular to the plane of and attached to the usual top spacer, or mounted on the metal cage, in either case bending and pressing against dome sides in a snug manner. Practically all refined tubes now have the dome pads or an even more recent refinement in the form of resilient spring clips. The latter are simply springy bits of wire mounted on mica spacer or metal cage and pressing against the dome sides. Wire clips insure a positive and lasting snug fit.

meter. Present mechanical design is more suggestive of good structural engineering. Materials are more carefully selected. To cap the climax, tubes are sometimes employed deliberately as microphones and subjected to the full blast of a loudspeaker running the full gamut of audio frequencies. Thus any tendency towards microphonism or rattles in the tube is soon detected for any given audio frequency. The loudspeaker is fed by a beat-frequency audio oscillator and power amplifier. The tested tube is connected with an output amplifier and output meter for precise quantitative measurements. Plate or grids in the tube, together with cathode, serve virtually as a condenser microphone.

Tubes are also "taken for a ride." A device which is really an adaptation of the well-known beauty massage vibrator, receives a tube to be tested for looseness or weaknesses. The motor drive may be speeded up to any vibration frequency. Held in a conventional socket, the tube may be tested from time to time and any looseness or weakness immediately detected. Or the tube may have a suitable potential impressed between different elements, and connected with amplifier and loudspeaker, to detect imperfect contacts or faulty insulation. Much the same scheme is sometimes employed to detect lint or foreign matter present in a tube because of careless production. With high potential applied to elements, the jiggled lint is attracted to those elements. Its presence becomes known as it lights to incandescence with the passage of 20 or 30 milliamperes.

## ELECTRICAL ADVANCES

Electrically, too, important refinements are being scored. Such activities center largely about the emitter, whether filament or heater cathode. In the former type, no end of improvement has taken place during the past few years. From tungsten to thoriated tungsten and then to oxide-coated filaments, chemist, metallurgist and engineer have worked together for better characteristics. In oxide-coated filaments, important improvements have been made by way of new alloys permitting heavier conductors for greater rigidity and minimum microphonism, as well as better emitters providing copious emission at minimum operating temperature. Troublesome types, such as the 22 battery-operated screen-grid amplifier and the 99 detector-amplifier, have been redesigned with new oxide-coated filaments in place of original, tricky, thoriated-tungsten filament, and made practical.

Meanwhile, corresponding advances have been made in heater cathodes. The short life and uncertainty of the early 27 type are history. Almost no end of materials and constructions have been tried in mounting the heater filament inside the cathode sleeve. The intense heat disposed of most materials originally tried. The unequal rate of expansion and contraction between ceramic and tungsten wire resulted in undue wear and tear. Chemical reactions accounted for many breakdowns. The partial conduction of some insulating materials caused leakage and corresponding noise between filament and cathode sleeve. Hum troubles were experienced.

Today the heater cathode is a perfected thing in the better brands of tubes. Here again, there is considerable divergence of opinion. Several manufacturers employ as many different methods of attaining the perfected heater cathode. Some still use a ceramic insulator to support the heater filament and isolate it from the surrounding metallic cathode sleeve. Others coat the heater filament with a suitable ceramic. There are hair-pin filaments, straight filaments, M-shaped filaments, reverse spiral filaments and even folded-ribbon filaments. The sum total is reliable performance and long life for most cathode-type or indirect-heater tubes.

Heating time, once held up as the main desideratum, is no longer a talking point for engineers to shoot at. A study of the heating time of a number of representative types and brands indicates no particular attempt to run a race on this score. Take the 36 type, for example. One manufacturer scores 9.88 seconds, another 20.40, and another 8.00. Type 58 shows up at 17.70 and 21.10 seconds. The 24 type scores 15.50 and 16.50 for two different brands. The 2A7 type scores 17.35 and 19.75. We don't seem to have those split-second performances which made advertising copy a few years back when 45 seconds to over one minute was by no means unusual, and 7 seconds was something to shout about.

## MICROPHONIC EFFECTS

Mechanical looseness is closely affiliated with microphonic troubles. What with powerful dynamic speakers mounted close to high-gain tubes, the slightest displacement of tube elements is apt to serve as a most effective microphone, causing marked distortion in rendition. Our British friends some two years ago decided that much of the microphonism was caused by vibrating filaments in certain types. They therefore introduced additional anchor hooks whereby to apply tension on hair-pin filaments between usual top hook and bottom terminals. In some American tubes the same idea is now to be found. Ceramic-coated or insulated tension hooks, welded to the grid, pull the legs of the hair-pin filament outwardly, thus applying tension necessary to eliminate undue vibration and microphonism. The idea sounds simple, but engineers have tried heavy-hook tension and light-hook tension, heavy and light filament coatings, ribbon filaments and circular filaments, in evolving the proper structure.

## NEW TESTING METHODS

Vibration has been fought in many directions. Tube construction today is much heavier than a while ago. Support rods are of greater dia-

Tube characteristic comparisons instantly checked.



Please Say That You Saw It in RADIO-CRAFT

### SHORT-WAVE SET BUILDERS NEED THIS BOOK

Every experimenter who has ever tried to build a short wave set knows by experience, the difference between a good and a poor receiver is usually found in the short wave coils. Often you have to hunt through magazines, books, etc., to find the information you require. The present book has been gotten up to obviate these difficulties.

In this book you find every possible bit of information on coil winding. Only the most modern "dope" has been published. Illustrations galore, giving not only full instructions on how to wind coils, but dimensions, sizes of wire, curves, how to slot them, by means of which any coil for any particular short wave set can be figured in advance, as to number of turns, size of wire, spacing, etc. There has never been such data published in such easy accessible form as this.

Send your remittance of 25c in cash or unused U. S. Postage Stamps for your copy of the SHORT WAVE COIL BOOK. Sent to you prepaid.

RADIO PUBLICATIONS, 101C Hudson St., New York, N. Y.



**WET AND DRY ELECTROLYTIC PAPER AND MICA CONDENSERS**

RECOGNIZED FOR SUPERIOR QUALITY IN ALL CLIMATES THE WORLD OVER

ASK FOR CATALOG OF EXTREMELY COMPACT TYPES HANDY FOR SERVICE

**BEST BY TEST!**

SOLD BY LEADING JOBBERS EVERYWHERE

SOLAR MFG. CORP. 599 BROADWAY NEW YORK

**SERVICEMEN ATTENTION!**

We remodel your old analyzer—factory experts. Write in for quotations.

**SPECIAL!** Weston 301 0-1 mil meter, volt, MA, ohms scale, net \$6.00

8 mfd. 550 volt peak cardboard dry electrolytics, very compact, net \$3.25

**SUPREME INSTRUMENTS IN STOCK FOR IMMEDIATE DELIVERY**

**UNCLE DAVE'S RADIO SHACK**

356 Broadway Albany, New York Phone 4-5746

**THE CHEMIST HAS HIS SAY**

The chemistry of tubes has become a prime consideration. Leading tube manufacturers now have impressive chemical laboratories and staffs for the purpose of testing, selecting and passing upon different ingredients that enter into tubes. These chemists get down to the smallest details, for production failures are often difficult to fathom, because of their minute causes. In one tube plant, for instance, chemists have worked out a means of coating mica spacers with a lacquer which evaporates during bombardment just prior to the sealing-off operation. The lacquer protects the mica proper from perspiration and oils that might be deposited by fingers of girl operators. Prior to this innovation, finished tubes might test noisy, because of leakage due to moisture or oil deposits on mica spacers.

**PENNY-SPLITTING ECONOMIES**

While tube manufacturers have made tremendous gains in tube refinements, they have at the same time met a steadily declining price level. Compare the \$1.50 list price of say the O1A type in 1928 with its present 60 cents; the \$4.25 for the 80 as against 70 cents today; the \$4.00 for the 27 as against 70 cents today. Here you have pretty much the story of most tube prices. Improving quality while reducing costs has meant production economies of all sorts. Tube costs today get down to fractions of a penny. Short-cuts and daring innovations are the order of the day.

For instance: a leading tube manufacturer studied his costs on hydrogen gas bought in steel tanks and coming from quite a distance. His chemists suggested buying liquid ammonia instead, because there would be more hydrogen available in ammonia tanks for given freight charges. Of course, an elaborate device called a "dissociator," was necessary—a machine for breaking down the ammonia compound so as to release the desired hydrogen. The elaborate equipment is installed today to feed the hydrogen furnaces, and the manufacturer is saving still another fraction of a penny on each tube. But fractions of pennies mount into real money when multiplied by tens of thousands of tubes each working day.

Or in the matter of tube bases. Most manufacturers buy them complete, with prongs molded in place. One manufacturer in his penny-splitting adventures found that a saving could be effected by using plain bakelite bases and then riveting the prongs in place by means of ingenious automatic machines.

Savings are particularly evident in the parts end of tube production. While smaller tube manufacturers buy most of their components, leaders are fabricating their own almost entirely. Some mighty ingenious machines knock out complete parts, such as plates and grids, at minimum labor cost.

In the final analysis, however, good tubes get down to matters of sound engineering and chemistry, rigid inspection of materials and components, conscientious production with good labor and best obtainable automatic machinery, and thorough testing of finished product. No matter how carefully tubes may be designed and produced, it is unavoidable that some will not be good. Uncompromising tests on finished products are essential to good tubes. And here enters the conscience of the manufacturer, for tube rejects mean shrinkage in production output and rising costs. A high pile of broken glass behind a large tube plant is generally the hallmark of a good producer, for only the quality producer dares scrap a liberal proportion of his output, particularly on newer types, in order to attain rigid characteristics.

There is definite salvage value in that junk pile, but not in the material sense. Outside of bakelite bases, there is nothing of tangible value. But far beyond tangible recovery are the engineering lessons that go to reduce future shrinkage. In leading plants tube shrinkage is critically studied. Remarkable devices have been developed for studying tube failures and drawing conclusions for future designs and production practices. Also in routine testing equipment. Some manufacturers have developed their own equipment. Small neon lamps which flicker on and off, in addition to usual meters, now serve to detect tube flaws which might get by unnoticed with test equipment of only a year or two ago.

And the account of refinement and improvement might go on and on. But the editor now

calls a halt to this dissertation because of space limitations. Suffice it to state, in conclusion, that whatever progress has been made of late in radio sets, corresponding progress is to be found in many radio tubes fresh from the factories, as distinguished from bargain-price tubes that are as shy as a spinster when the conversation turns to birthdays.

**HOME ELECTRONICS**

*(Continued from page 595)*

The sun close your window for you. When it becomes light, a cell supplies the relay mechanism, and if you like to wake with the sun, it will ring your alarm for you at the same time. Likewise, when you retire at night, why risk a draft while opening your window? Just wave your hand from the bed, and presto, the window opens. You can even go so far as to vary the amount of opening by several waves of your hand. The sky is the limit!

Getting back to automobiles, did you ever get a ticket because you forgot to turn on your parking lights? Dr. Caldwell prevents this tragedy by the simple expedient shown in Fig. G. When daylight gives way to dusk, the little PE cell obligingly lights the lights. If you leave your car out all night, the same cell turns them off at daylight.

A PE cell, placed at a crossroad approach, will operate traffic warnings to prevent crossing accidents, Fig. H. The car's headlights operate a PE cell controlled timing device which keeps the warning light on red until the approaching car has had time to pass the crossing.

We could go on and on until you could finally be automatically matching the colors of socks and ties, controlling coffee and toast by their color, letting the cat in and out automatically, and dozens of other stunts. But these suggestions should serve to show that electronics in the home is the answer to many prayers.



Fig. G.—PE cell turns on parking light.

Fig. H.—PE cell prevents crossing accidents. (© Wide World)



**NATIONAL UNION**  
—gives to  
**SERVICE MEN**  
**THIS BOOK TO**  
**HELP THEM SELL**  
—Radio Service

**EXTRA!** An Oscillograph has been added to the list of free shop equipment available with National Union tube purchases. Get details! Remember testers, analyzers and manuals are also still available.



● CONTENTS ●

- Direct Mail
- Circularizing
- Newspaper Advertising
- Window Displays
- Business Forms
- Broadcasting
- Canvassing
- Special Selling Plans

*Get your copy and tie up with National Union for better business!*

National Union Radio Corporation of N. Y.  
400 Madison Ave., New York, N. Y. RC-435

Send me a copy of "Merchandising Radio Service under 'The Sign of Efficiency'."

Name.....  
Street.....  
City.....State.....

Please Say That You Saw It in RADIO-CRAFT

# BUILD YOUR OWN SHALLCROSS UNIVERSAL TESTER

For \$41.50 Complete



**VOLTS**  
A.C.-D.C.  
5-25-100-250-  
1000 ohms  
per volt

**MILLI-  
AMPERES**  
D.C.  
1-10-100-1000

**CAPACITY**  
.001-10 Mfd.  
Paper or  
electrolytic  
condensers

**INDUCT-  
ANCE**  
1-10,000 Henrys

5-5,000,000 ohms D.C. Resistance

Send 6c in stamps for the new Bulletin No. 611-P containing the complete wiring diagram and operating instructions for this modern serviceman's instrument.

**SHALLCROSS MFG. COMPANY**

Electrical Measuring Instruments  
and Accurate Resistors

700 MAC DADE BOULEVARD  
COLLINGDALE, PA.

## ONE OF THE SUPREME FIDELITY AMPLIFIERS

Model DE250  
30 Watts

**\$36.50**

Less  
Tubes

7 other models



Uses 2-57, 2-56, 2-250  
& 2-281

Triple Push Pull Class "AAA." Tapped Inputs and Outputs for Mike, Phono and Speakers. Master Gain and Tone Control. Mike Current Supply. Mike-Phono switch. No external transformers necessary.

Send for copy of our Public Address Sales Manual and General Catalog.



**WHOLESALE MERCHANDISERS INC.**  
626 Broadway, Dept. C, New York, N.Y.

## SPEAKER REPAIR KITS

**SERVICEMEN  
AND DEALERS**

These Kits contain everything necessary for the efficient repair of speaker. All kits backed by Multiplex Guarantee of Quality.

You can't afford to be without it.

EXCLUSIVE TERRITORY  
OPEN FOR JOBBERS

**MULTIPLEX RADIO SERVICE, INC.**  
88 4th Avenue Brooklyn, N. Y.

Send for this  
**FREE**

Attractive  
Folder



## FREE COLORED SHORT WAVE

Double MAP (Send 10c postage, etc.)

**FACTORY PRICES**

Short-Wave-All-Wave-Kits

Free Catalog B

**Radio City Labs, Suite 1222**  
30 Rockefeller Plaza, New York, N.Y.

## A MODERN PICTURE OF TELEVISION

(Continued from page 589)

portant patent holders. There are, of course, other companies in Germany outside of this agreement, but the fact that the German government helped this company by placing huge orders with it, and further that the government erected the first 10 kw. ultra-short-wave television transmitter in the world, and adopted the 180 line transmission system, has given the television technique in Germany the uniformity which is necessary to obtain real progress in television. No wonder that Germany is today the country with the greatest progress in television technique. While other countries discuss the question: "Shall we have television in the near future?"—the Berlin television station has been working on a regular schedule for months.

Despite the fact that the satisfaction in television reception is determined among other things by the number of lines into which the picture has been cut during transmission, no agreement could be settled until now about the number of lines to be used uniformly by all television stations in the United States. On the other hand, much work has been done during the last few years to find the right number of lines necessary for a satisfying television transmission, and we now know exactly how many lines are necessary to reproduce an acceptable television image. The results of the various experiments made in this country by E. W. Engstrom (RCA) and in Germany by R. Thun (German Post Office) are given in Table I.

TABLE I

No. of Lines	Classification by E. W. Engstrom	Classification by R. Thun
60	entirely inadequate	8.8 per cent
120	hardly passable	51.0 per cent
180	minimum acceptable	84.0 per cent*
240	satisfactory	97.0 per cent
360	excellent	99.5 per cent
480	equivalent of practical condition	100 per cent

(\*Quality of home movies.)

This table shows that 240 lines are satisfactory according to Engstrom and promises an image natural to 97 per cent according to Thun. But it seems to be advisable to choose the 180-line television transmission, not only because it may be sufficient to have only a picture quality comparable to the image of a home movie, but also because the transmission and amplifier technique of today is not sufficiently well developed to start at once with more than 180 lines.

## SOUND QUALITY VS. TELEVISION IMAGE

We know that the broadcast reproduction with an average radio receiver in use today (frequency range from 150 to 4,500 cycles), is natural only to about 65 per cent. Tests made by well-known experts have shown that the performance of a modern high-fidelity receiver (50 to 7,500 cycle—the latest in radio improvements) can be marked as natural only to 90 per cent. If we have been satisfied for 14 years with sound fidelity of 65 per cent, an image fidelity of 84 per cent should be acceptable.

There are, of course, a great many people who will not be satisfied with the decision to use a 180-line image. It might, therefore, be worth while to indicate what a transmission of 180 lines involves in respect to amplifiers and transmitters. It had been said often that a 180-line image is equal to 40,000 picture elements. The experiments of movie technique show that a change of 24 pictures per second is necessary to obtain a "motion" not fatiguing to the eye. This means that we obtain by a 180-line transmission, a picture frequency of about 500,000 cycles (500 kc.). The rules of transmitter technique indicate that for the reproduction of a high-class sound or television reproduction a transmitter is necessary which radiates two sidebands. Therefore, we need for television a communication band of about 1,000,000 cycles (1,000 kc.) a band 100 times as broad as used by broadcasting transmitters. With this fact in mind, it seems advisable to work a few years with a television system natural only to 84 per cent, because a 240-line television picture (natural to 97 per cent), necessitates a frequency band of 2,000,000 cycles (2,000 kc.).

(This most interesting discussion will be concluded in a forthcoming issue.—Editor)

## NEW "I-TUBE" ALL-WAVE BATTERY SET

(Continued from page 609)

the regeneration control. A double-pole switch is used. One turns off the filament current, the other disconnects the "B" battery, thus removing all battery drain when the set is not used.

## COIL WINDING DATA

The coils are wound on small 4-prong forms, 1 1/2 in. diameter and 1 1/4 in. long. Coils A, B, and C are wound with No. 25 D.S.C. wire, and coil D with No. 30 D.S.C. wire. The bottom winding is put on first and connected to the two heavy prongs, and then the top winding to the two thin prongs. Turns: A—2 3/4-7 3/4; B—6 3/4-7 3/4; C—17 3/4-8 3/4; D—38 3/4-11 3/4.

Accessories needed are a type 19 tube, a pair of sensitive phones, and an antenna. The antenna may be an ordinary single wire antenna, high and clear of near-by buildings, trees, etc., about 35 to 75 feet long. It should be well insulated so that there will be no possibility of the antenna wire or lead-in grounding at any point. Batteries needed are but two dry cells and two 45 volt "B" batteries.

## LIST OF PARTS

- One 6-prong socket, 19;
- One 4-prong socket;
- One 50,000 ohm potentiometer, with D.P.S.T. switch;
- One Harrison dial drive;
- One Harrison dial scale;
- One variable condenser, 140 mmf.;
- Two 200 mmf. condensers;
- One 5 megohm resistor;
- One .01 mf. condenser;
- One 10,000 ohm resistor;
- One .1 mf. condenser;
- One 1 megohm resistor;
- Three knobs;
- One 100 mmf. antenna coupling condenser;
- One speaker jack;
- One extruded washer;
- Two knurled nuts.



Underside (above) and rear (below) views of the I-tube all-wave battery set.

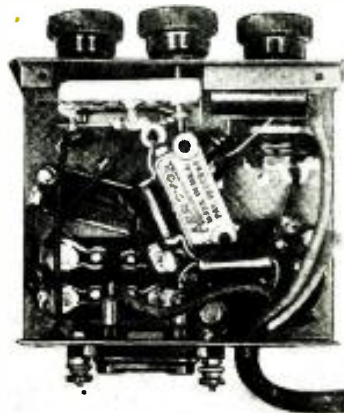

Please Say That You Saw It in RADIO-CRAFT

## NEW NATIONAL WIREPHOTO SERVICE

(Continued from page 591)

ing plane from South America, a picture of yesterday's flood damage in Panama. The control station knows of other pictures which will be coming along as the day's events unfold, but meanwhile it schedules the order of sending for those awaiting transmission. New York, it decides, will send the European picture; Detroit, St. Louis and Miami will follow in order with theirs.

Before New York begins to send a picture it transmits for a few seconds, onto the line and into each receiving station, an amount of power corresponding to the lightest and darkest parts of the picture. Each point adjusts its power to the receiving equipment at the proper value for those two limits, knowing that the receiving machine, when adjusted to receive the two extremes of light and darkness in the print, will handle normally all the intervening shades.

All this has taken less than ten minutes, or has been accomplished in two or three minutes if an important picture was ready to send. Then the signal from the bay of the sending station—three interruptions of power—tells every point to press the button on its receiving equipment, operating the relays which prepare the circuits to start. A few seconds later a smaller button is pressed on the sending machine, starting in the same instant every receiving machine along the line.

A cylinder on the receiving machine at every station, 17 in. long and 12 ins. in circumference, has been loaded with a negative upon which can be received a picture of any dimensions up to 11 x 17 in. (the size of half a newspaper page). The negative is fastened around the cylinder and enclosed in a light-proof container.

This negative is then exposed to light from a lamp focused through an aperture .01-in. wide, which opens little or much according to the strength of the current caused by the picture on the sending machine. Where the portion of the incoming picture is very black the aperture which admits light to the negative is nearly closed; where very white, the aperture is almost open.

At the end of the picture the receiving machine automatically cuts off. The cylinder is lifted off and taken to a darkroom a step away, where the light-proof container is unlatched and the negative removed and developed. If the picture transmitted was of maximum size, reception took 17 minutes.

Development of the negative takes 5 more.

As soon as New York has sent its picture, Detroit becomes the sending station to transmit its fire photo. As soon as the operators in the other 23 cities have lifted the cylinders with the exposed negatives off their receiving machines, they put on another loaded cylinder.

But perhaps before Detroit begins to send, Cleveland comes in on the talking circuit and schedules two strike pictures of prime news value, taken a few minutes before. If the editor in charge at the control station decides that these are of greater news importance than the pictures awaiting transmission at Detroit, St. Louis and Miami, he may tell Cleveland to send its photos at once, and direct the other stations to follow it.

Thus through the day and night the schedules constantly change. Fresh pictures are available as the world wags, and the control station constantly rearranges the order of sending in accordance with the breaking of the news, putting this photo ahead, holding that back, bringing to the entire country the day's news in pictures in order of interest.

As the news day reaches its peak this becomes a more exacting task, but while the pressure increases the machines are rolling steadily, in perfect synchronism, delivering the pictures while the chattering automatic printers close at hand deliver the news.

On important and continuing stories there come every few hours fresher and later pictures, keeping abreast of the news, so that pictures which were news in the forenoon may have been superseded at mid-afternoon by subsequent shots showing developments which occurred in the meantime.

For 16 hours a day, on normal days, the wire-photo machines will function, delivering in that time enough pictures—60 odd at a mini-

mum—to enable newspaper editors to choose those which most appeal to their readers.

If big news is breaking, and important picture news is on tap outside the regular hours of operation, the wirephoto service can be kept functioning, or set into motion at a moment's notice, to meet any emergency. For like any loyal reporter it knows no hours and asks no let-up when a big story is running.

### THE TECHNICAL ASPECTS

Those whose hobby is electricity will delight in studying the advanced science of telephotography represented in the wirephoto service.

A positive print wrapped around the sending machine cylinder is scanned in strips .01-in. wide by means of a light beam focused first on a light valve aperture similar in all respects to the light valves used in sound picture work. The light valve chops the beam at a frequency of 2,400 cycles, passing a pulsating beam which is turned through 90 degrees to focus sharply on the surface of the picture. The light beam travels horizontally at an inch a minute. The cylinder, rotating at 100 revolutions a minute, is approximately 12 in. in diameter, thus giving a scanning area speed of more than 11 sq. in. a minute. Since the light reflected from the picture surface is proportional to the tone density of the surface, the pulsating beam is thereby modulated with the tone values of the picture before reflection to a photo-cell of the gas-filled cesium-oxide-on-silver type.

The optical system is made up of a condenser lens to focus the beam on the light valve aperture and an objective for focusing the pulsating beam onto the picture surface. Turning through 90 degrees is accomplished with a small stainless steel mirror, and parabolic surfaces also of stainless steel gather reflected light from the picture for passage to the photo-cell.

The light valve itself is an aperture .01-in. square with two parallel duralumin ribbons, .006-in. wide and .0005-in. thick, partially covering it and connected at one end to form a loop. A magnetic field at right angles to the plane of the ribbons, furnished by two permanent magnets, and a 2,400-cycle current through the ribbons furnishes the shutter action. As the ribbons vibrate on their inward swing the aperture is closed, and on their outward swing the aperture is opened.

Due to the small quantity of light that strikes the photo-cell cathode, its output is extremely low, and a 3-tube dry-cell amplifier having a gain of 77 db. is used to step up the power to a usable quantity for use on the network. Proper filters eliminate possible extraneous frequencies, and equalizers to eliminate frequency distortion are inserted following the high-gain amplifier.

A single-tube amplifier, having variable attenuators, furnishes the regulation necessary just before passing the power to the line.

The normal maximum line power is one milliwatt. That value represents maximum reflected light to the photo-cell, or the maximum high-light of the positive print. The minimum output is adjusted to 14 db. below maximum, the proper value being attained by inserting an adjustable mirror in the path of the light beam before it strikes the picture surface and cutting into the beam just a sufficient amount to send directly to the photo-cell the minimum light required to get the 14-db. contrast between the maximum and minimum representing respectively the lightest and darkest tones in the picture.

On the network, the overall gain is kept constant by automatic regulators which remain inoperative during the transmission of a picture. They do their work during the intervals between transmissions, compensating for progressive atmospheric and other conditions that must be contended with on a 10,000-mile network of wire.

### THE RECEIVER

At the receiving stations the incoming power is regulated by a variable output amplifier similar to that in the sending circuit, after which it is sent through a full-wave rectifier and filters which eliminate the 2,400-cycle carrier, leaving the fluctuating direct current representing the modulation or the actual tone variation of the picture. This varying direct current is used to operate a duralumin ribbon shutter on the light valve of the receiving machine to vary the exposure of a negative, enclosed in a light-proof container on which the picture is received.

## MAKE MORE CALLS and BIGGER PROFITS

with New  
**READRITE**  
*Point to Point*  
**TESTER**  
• No. 720 •



HERE is the tester that every serviceman needs for properly servicing radio receivers. The new Readrite No. 720 Tester enables you to make more calls per day at less cost per call—and make bigger profits because of its speed, its accuracy and its dependability.

The new No. 720 unit operates *faster . . . more efficiently* and with *less manipulation*. It tests all resistances, continuities, voltages, current and capacities from the set socket by the reliable point-to-point method. And it is built to withstand severe field service.

Two highly developed Vane-type AC and DC meters are incorporated into this new tester. They are simple in design and dependably accurate. The DC scales are 15, 150, 300 and 600 volts, 15-150 milliamperes. AC scales 10, 25, 150 and 750 volts.

### Your Jobber Can Supply You . . .

With the Readrite No. 720 Tester at Dealer's net price of only \$15.00. Write direct for literature to

**READRITE METER WORKS**  
144 College Ave. Bluffton, Ohio

### MAIL COUPON FOR CATALOG

Readrite Meter Works  
144 College Avenue. Bluffton, Ohio.

Send me catalog on Readrite No. 720 Tester and folder proving Readrite leadership.

Name.....

Address.....

City..... State.....

Please Say That You Saw It in RADIO-CRAFT

**THE FULTONE "DUETTE"**

**TWO-IN-ONE ALL-WAVE SET 2-Lbs COMPLETE**

A compact All-Wave (15 to 200 meter coils free with kit) receiver using the newest "Twin" tubes!

Battery model using type 19 tube as described in this issue. Easy construction kit including all necessary parts, metal chassis and cabinet, and simple instructions **\$375**



All Electric AC-DC model uses the new 12A7 tube. Completely self-contained—no plug in! See feature descriptions on page 538 and 573 of March Radio Craft. Complete Kit **\$4.45**  
 Tube—050, 200-625 meter broadcast band coils **\$1.25**  
**SPECIAL COMBINATION OFFER!** Kit, tube, and B. C. coils—Add \$1.80 to kit price! Kit wired and tested—\$1.25 extra. Send for FREE Literature!

**HARRISON RADIO CO., 142 LIBERTY ST.,**

**THE NEW FULTONE V**

**FIVE-IN-THREE SET**

Sensitive—powerful—world-wide reception—all electric—full five tube performance—compact—speaker or headphone operation—easy to operate—easy to build! A receiver you will be proud of! Complete kit, including all necessary parts, crystal finished metal chassis with all holes, and complete, easily followed instructions. **\$745**  
 Set of 5-Volt Tubes—\$2.00. Metal cabinet—\$1.25  
 Special loud speaker—\$1.45. 200-625 meter coils—\$1.25

**SPECIAL COMBINATION OFFER**  
 Complete kit, speaker cabinet, tubes, and broadcast band coils—**\$12.75**  
 Kits wired and tested—\$1.00. Deposit required. At your dealer or order direct.

**Dept. R4, NEW YORK, N. Y.**



ondary of a transformer whose primary is connected in the plate circuit. This forms the simplest type of single tube "inverter" or device for changing D.C. to A.C.

Other applications of the grid-controlled rectifier are appearing almost daily,—spot welding control, time delay relays, cable testing, voltage regulation, theater and highway lighting, and many others. With this control unit you can test these ideas for yourself, and develop new ones of your own.

**LIST OF PARTS**

One General Transformer filament transformer giving 2.5 volts, 7 amp. and 5 volts, 1 amp. (If Thyratron FG-17 is used filament requirements are 2.5 volts, 5 amp.);

One bell ringing transformer with 6-8 volt secondary;

One Acrovox 0.5-mf. 400 volt condenser (paper type), C1;

One 1RC high resistance carbon rheostat, R1;

One IRC 100,000 ohm 2 watt. carbon resistor, R2;

One 40-watt, or smaller, 110-volt lamp (Note: use of carbon filament lamp will reduce current surges in the plate circuit), R3;

One D.P.D.T. jack switch, with neutral position, SW1;

One S.P.S.T. toggle switch, SW2;

One Radio City AC voltmeter, 0-3 volts (optional), V;

Four binding posts;

One grid-glow tube socket;

One porcelain lamp receptacle.

**A 10 TO 600 METER 3-TUBE A.C.-D.C. KIT SET**

(Continued from page 609)

amplifier stage. Resistance coupling is again employed to the second stage which uses the type 76 tube. A type 1V tube functions as a half-wave rectifier, and the filaments of all tubes are connected in series in the usual A.C.-D.C. arrangement. The result is a screen-grid regenerative detector, two stage audio frequency amplifier, rectifier and complete built-in power supply. No external power pack or batteries are necessary.

Unit C1 is an antenna series condenser having a capacity range of about 6-70 mmf. Gridleak-condenser detection is used, values of 5 meg. and 100 mmf. respectively, being satisfactory. The large value of gridleak results in a high level of sensitivity. Feedback occurs between the coils L1 and L2 both of which are wound upon the same form. Regeneration is controlled by means of the potentiometer R2 which varies the screen-grid voltage of the 6F7 tube.

The plate resistance of the RF pentode section of the 6F7 is quite high, hence it is necessary to use a large value of plate resistor in order to take full advantage of the high gain possibilities of this type of tube. A value in the neighborhood of 12-megohms is satisfactory.

This receiver has given unusually good results both on the short-wave and broadcast bands. Foreign stations come in with excellent headphone volume. The volume on many of the near-by broadcast stations is ample for a good magnetic loudspeaker.

Under-chassis view of 10-600 meter receiver.

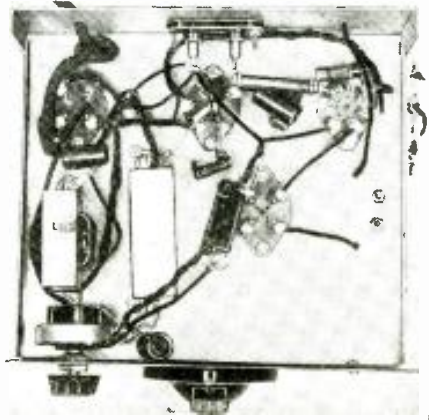

**WHEN CHOOSING A RADIO SCHOOL**

RCA Institutes, with its reputation established by 25 years service, is an institution recognized as an important factor in the radio industry. Whether elementary radio principles or advanced subjects, sound applications or practical radio engineering, RCA Institutes is prepared to give you the instruction you need.

**RESIDENT SCHOOLS NEW YORK AND CHICAGO** with modern standard equipment

**EXTENSION COURSES FOR HOME STUDY** under convenient "no obligation" plan. Illustrated Catalog on Request.

**R. C. A. INSTITUTES, Inc.** Dept. RT-35  
 75 Varick St., New York—1154 Merchandise Mart, Chicago

**WANTED!**

Jobs—Mail Order Houses and Representatives in all Territories

**TWO FAST MOVERS**



Free Edge Cone and Voice Coil Assemblies And Field-Coils for All Dynamic Speakers  
 We also Manufacture Various Types of Magnetic Speakers

We can Supply and Remedy Your Speaker Needs. **Speaker Mfrs. Since 1921**

**LEOTONE RADIO CO., 63 Dey St., New York, N. Y.**

**Servicemen, Dealers and Hams JUST OUT!**

Write for your **FREE** copy!

**AIREX CATALOG**

Contains thousands of bargains such as—8 mfd. 600 volt electrolytic condensers, price 23c; carbon pigtail resistors 3c each; four tube radio chassis with tubes and speaker \$6.75; all-wave, 12 to 2,000 meter, super-heterodyne kit with all coils and switch, etc., complete \$9.40—and many more too numerous to mention.

**THE AIREX CO., INC.**

60 Dey Street New York, N. Y.

**AGENTS WANTED!**

**MOTION PICTURE SOUND**

Most fascinating field awaits live Radio Service Men—quick, sure profits  
**ASK FOR FREE CATALOGS**  
**S.O.S. CORPORATION**

1600 Broadway New York, N. Y.  
 Cable Address: "Sosound" New York

**GOOD NEWS ABOUT THE 1935 OFFICIAL RADIO SERVICE MANUAL**—this new volume is now ready for delivery. Turn to the announcement on page 634 of this issue, and read full particulars about this excellent book.

The principle of operation of the receiving light valve is similar to that of the sending light valve except that only one ribbon is used. It is caused to move by the fluctuating direct current representing the tone variations in the picture, and not by a constant frequency. This ribbon is tuned to the rather high natural frequency of 1,200 cycles, and suitably damped so that all movement of it is forced vibration caused by the incoming picture signal. In this ribbon circuit is a tuned equalizer which prevents unwanted or transient vibrations.

By varying the side motion of the receiving light valve ribbon, the opening through which the light reaches the film is varied proportionately, thus obtaining film exposure in exact proportion to the original tone values of the print on the sending machine. This light beam is adjustable in width, so that the exposure lines may be made to merge and be practically invisible on the finished print.

**SCANNING AND POWER SUPPLY**

The scanning of the negative is exactly at the same rate as the scanning of the print by the sending machine, the cylinders rotating at the same speed and the beam moving horizontally at the same rate.

Constant rotational speed for all motors within extremely small limits is obtained in a rather unusual manner. A controlled oscillating circuit, maintained by a tuning fork kept at constant temperature, furnishes 300-cycle power. Part of the power in this circuit is used in connection with an overloaded tube and filters, to supply the 2,400-cycle carrier for the sending light valve. Part of the power is fed to the grid of a 2-tube phase detector. Mounted on the same shaft as the cylinder driving motor is a 300-cycle inductor generator which feeds the plates of the phase detector. The tubes act as a full-wave rectifier to control the output of other tubes which furnish current for the driving motors, which are separately excited, 300-cycle synchronous units.

The output of the tubes furnishing power to the motors is dependent upon the phase relationship of the 300 cycles from fork and inductor generator. By suitable circuits the speed of the driving motors is thus kept at 100 revolutions per minute within one part in 300,000. The fork is sealed in a container, the temperature of which is kept constant by a tube-controlled thermostat.

A constant power source is obtained from small generators suitably filtered with electrolytic condensers and storage batteries.

**HOW TO MAKE A GRID-GLOW TUBE CONTROL UNIT**

(Continued from page 597)

voltage on the grid will flash the tube at the same frequency, and if these flashes are synchronized with rapidly turning machinery, the latter will appear to be stationary or nearly so, and its action may be analyzed.

If a condenser discharge through the tube be controlled by a feed-back to the grid, the plate current will pulsate at a regular frequency. These pulsations will induce A.C. in the sec-

Please Say That You Saw It in RADIO-CRAFT



# THE LATEST RADIO EQUIPMENT

(Continued from page 602)

## NEW "DRY-CELL BATTERIES" (683) (Burgess Battery Co.)

RECOGNIZING the desirability of producing batteries in which the electrical capacity is confined to small space and reduced weight, the engineers of a well-known battery manufacturer have developed a new type of 1½-volt battery, known to the "trade" as the Little Six.

This battery is a combination of dry units of the size known as "F" cells, carefully manufactured and selected for maximum uniformity. Four of these cells are used—they are connected in parallel.

The rated voltage of the battery is, consequently, only 1.5 volts! The rated capacity is 40 watt hours—i.e., under typical conditions of discharge, for which the battery is designed, the Little Six will deliver 40 ampere hours of service at an average potential of one volt. It is, therefore, the electrical equivalent of the standard No. 6 cell, though it is 30 per cent smaller and 40 per cent lighter than the latter!

The new batteries may be used wherever No. 6 cells are called for and, because they are smaller, lighter, leakproof and because they maintain a higher average working voltage as shown by the typical discharge curve illustrated on the graph on this page, Figure 1, they will, without doubt, find extensive use in portable radio receivers, broadcasting equipment, telephone and telegraph lines, inter-office communication systems, railroad speeders, electric clocks, alarm devices and the myriad of other applications calling for dry cells.

It is interesting to consider that it is technically correct to call this new battery a "battery," as it is not a single "cell" like the No. 6, but actually comprises four individual cells in one small, neat container.

Little Six compares to "Standard" No. 6

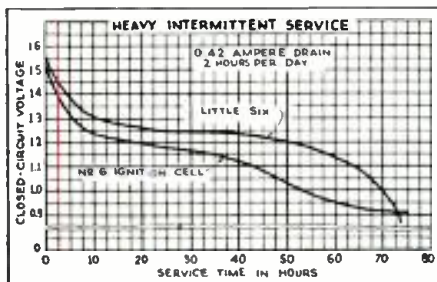

## MERCURY



Above, New Mercury Six Switch, No. 684

Below, adjustable Resistor Mounting, No. 685

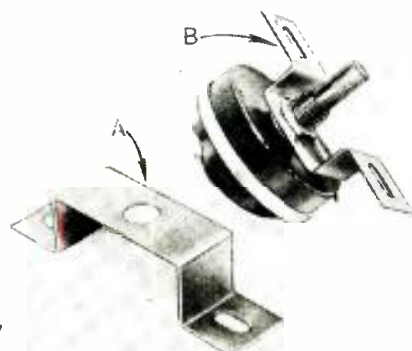

As a companion to the Little Six, a 6-volt battery—being, in effect, four of the above batteries in series—has been introduced, also. This unit is provided with a metal container like previous 6-volt ignition batteries.

## MERCURY SWITCHES FOR AUTOMATIC CONTROL (684)

FOR many forms of automatic control, switches of the mercury tilting type are unexcelled. This line of switches (including as standard, items rated from 200 W. to 4,000 W.) offers wide choice of types. Inert gases sealed within the tubes, stifle the arc instantly. There is entire absence of oxidation and corrosion. The switches operate silently and require no attention after original installation.

## ADJUSTABLE MOUNTING BRACKETS (685)

TWO useful brackets for mounting potentiometers, volume controls and other small parts, are available. They have two features of especial merit. The mounting holes and foot-holes are slotted, to compensate for panel-hole variations. The metal of which they are made, while stiff, can be bent to compensate for different depth measurements of shafts. It would seem that a collection of these items ought to be real handy for every Service Man and experimenter.

## CHUCKKER CONTEST AWARD

Freed's Radio Co., Philadelphia, Pa., recently concluded a contest among service men. Of the many answers received from all parts of the country, Paul G. Freed decided that the answer from Mr. J. N. Cole, Rutherford, Tennessee, deserved the prize. The idea, of course, was to sell more "Chuckkers," and nobody can object to that ambition. The Chuckker (RADIO-CRAFT, August, 1934, page 103) is a first-rate tool for service men. The prize was a Weston Tube Checker.

## Now—a high-powered—



## Radio Engineering Library

—especially selected by radio specialists of McGraw-Hill publications

—to give most complete, dependable coverage of facts needed by all whose fields are grounded on radio fundamentals

—available at a special price and terms.

These books cover circuit phenomena, tube theory, networks, measurements, and other subjects—give specialized treatment of all fields of practical design and application. They are books of recognized position in the literature—books you will refer to and be referred to often. If you are a practical designer, researcher or engineer in any field based on radio, you want these books for the help they give in hundreds of problems throughout the whole field of radio engineering.

5 volumes, 2981 pages, 2000 illustrations

1. Everitt's COMMUNICATION ENGINEERING
2. Terman's RADIO ENGINEERING
3. Chaffee's THEORY OF THERMIONIC VACUUM TUBES
4. Hund's HIGH FREQUENCY MEASUREMENTS
5. Henney's RADIO ENGINEERING HANDBOOK

10 days' examination. Special price. Monthly payments, \$26.00 worth of books cost you only \$23.50 under this offer. Add these standard works to your library now; pay small monthly installments, while you use the books.

### SEND THIS ON-APPROVAL COUPON

McGraw-Hill Book Co., Inc.  
330 W. 42nd St., New York, N. Y.

Send me Radio Engineering Library, 5 vols., for 10 days' examination on approval. In 10 days I will send \$25.00, plus few cents postage, and \$3.00 monthly till \$23.50 is paid, or return books postpaid. (We pay postage on orders accompanied by remittance of first installment.)

Name.....  
Address.....  
City and State.....  
Position.....  
Company..... RC-4-35

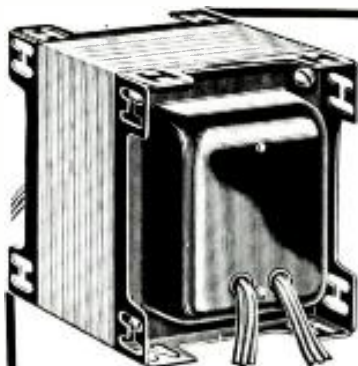

## PATENT CLAIMS ALLOWED!

...that protect distributors and their service engineer customers in the full profit to which they are entitled—placing the radio servicing profession on a staple basis.

*Free for the Asking!*

2114 models of radios which you can immediately service with one of only five (5) "Multi-Tap" Power Transformers.

General Transformer Corporation  
504 S. Throop St., Chicago, Ill.

## "Multi-Tap"

TRADE MARK

## POWER TRANSFORMERS! STOCK OF ONLY FIVE (5)

POWER Transformers provide immediate renewal of original performance in case of trouble in the transformer—the heart of the radio—in any of more than 95% of all receivers, whether "orphaned" or current models.

## ANNOUNCED in July, 1933

Now the leading Radio Engineers pronounce these universally adaptable power units the most practicable transformers for replacement purposes on all makes of sets since 1927—and for the future.

### MAIL THIS TODAY

General Transformer Corporation,  
504 S. Throop St., Chicago, Ill.

Send me without charge a copy of "Multi-Tap" Guide with name of nearest distributor.

Name.....  
Address.....  
City..... State.....

Please Say That You Saw It in RADIO-CRAFT

**JUST OFF THE PRESS!**



**SEND For Your Free Copy Today**

We have **MOVED** to considerably **LARGER QUARTERS** to give you **FASTER SERVICE!**

We now occupy over **FOUR times MORE SPACE.**

File-1 with Latest Design Portable, Mobile and Rack and Panel, Public Address Amplifiers, Short-Wave and All-Wave Receivers and Converters, Inter-Office Call Systems, Test Equipment Replacement Parts, Kits, Tubes, and Accessories—All at unbeatable Rock Bottom Prices!

**WE ARE HEADQUARTERS FOR PUBLIC ADDRESS SYSTEMS**

**Buy Direct from the Manufacturer and Pay Only One Profit**

**COAST-TO-COAST RADIO CORP.**  
559-W SIXTH AVE., NEW YORK, N.Y., U.S.A.



**THE ALL-ELECTRIC ALL-WAVE RECEIVER**

A completely electrified SW receiver capable of world-wide reception. Uses special circuit for 6F7 (2 tubes in 1 bulb), 76, and 1V tubes resulting in 4 tube performance. Operates entirely on 110 volt ac or dc house lighting system. Coils for 10-200 meters and instructions included. Beautiful black crackle finish metal chassis & panel. **FOREIGN RECEPTION GUARANTEED.**

Kit ..... \$5.95 Arcturus tubes ..... \$2.25  
Wired & tested ..... 1.25 Broadcast coils ..... .95  
Metal Cabinet \$1.00

\$1.00 Deposit on COD Orders. Prompt Shipment.  
**EILEEN RADIO LABORATORIES, Dept. RC4,**  
136 Liberty St. New York, N.Y.

**RUN YOUR A.C. RADIO by DIRECT CURRENT**

Operates AC Radios, amplifiers, transmitters, etc. from 6.32 or 110 DC. Sent on trial.

**KATO ENGINEERING CO.**  
Mankato, Minn. U. S. A.  
AC generators \$16.00. Light plants \$99.00.

**BUILD IT YOURSELF**

You can build this Trailer with ordinary tools easily from our step-by-step constructional sheets and large sized blueprints. Finest designed Trailer in existence, sleeps 4. Toilet, Shower, Electric Lights, etc. Save 75% of the cost by building it yourself. Send 25c for plans photo, illustrations and details.

**THE PLAN SHOP, 910 Palmolive Bldg. Chicago, Ill.**

**1935 RADIO CATALOG**

*Free Book*

All models: AC-DC midgers; dual and world wide all wave; fam. bat. tor; and car—at factory prices! Write for 24-page Bargain Catalog and 30-DAY TRIAL plan. Prices from \$9.95 UP.

**AGENTS WRITE!**

**GOLDENTONE RADIO CO.,**  
128 Oakman Bldg., Detroit, Mich.

**SEXOLOGY**

The Magazine of Sex Science. Foremost educational sex magazine. Sex secrets in plain English. Instructive and enlightening—not a salacious book—contains no offensive matter. Know thyself! All articles written by doctors. Each issue contains 26 important sex articles; 68 pages, numerous illustrations. Our doctors answer your sex questions FREE. Send 15c for sample or \$1.00 for 8 months subscription. **SEXOLOGY, 95R Hudson Street, New York City.**

**New CRYSTAL MICROPHONES**

Now at Your Jobber (Licensed Under "Brush" Patents)

**SHURE BROTHERS COMPANY**  
*Microphone Headquarters*

215 WEST HURON ST. CHICAGO, U. S. A.

**HOW TO MAKE A "I-TUBE" BATTERY-TYPE SUPERHETERODYNE**

(Continued from page 606)

or the primary of an A.F. transformer (for matching into a stage or two of A.F. amplification).

The 6F7 is, as the code number signifies, a 6 V. tube. It may be operated from a 6 V. battery, as shown in the photographic illustration, or the filament ("heater") circuit may be powered from a 110 V. A.C. source by means of a step-down transformer. In the latter case, instead of using batteries for the "B" supply, a "B" eliminator could be used. However, the small "B" requirements of this set are best met with a battery supply, we believe.

Oh yes, by the way! The method used to secure first-detector regeneration without appreciably affecting the tuning, or causing sufficient radiation to affect a sensitive receiver a short distance away, is worth mentioning. Perhaps the circuit has appeared elsewhere, but we credit Scott-Taggart with the "screen-grid regeneration" used in this set; it is this connection (see RADIO-CRAFT, February, 1935, International Radio Review department, page 469), in essence, with which Johnny S.T. climaxes, in his new "S.T.600" receiver, 20 years of radio designing! This form of regeneration results in much more stable feedback than can be obtained with plate-circuit regeneration.

The second-detector regeneration takes place at a fixed frequency (the I.F.), and consequently is quite stable.

Coil T is made by winding about 55 turns of No. 36 enameled wire on a form 11/16-in. in dia. Slip the wire off the form, cover with a single layer of adhesive or friction tape, and prepare to drop the coil inside, and about halfway down the length of L1. With headphones temporarily placed in the pentode-plate circuit, place T on top of L1 and note whether regeneration can be obtained at some point in the tuning range; if the characteristic hiss is not obtained, "flop" (turnover) coil T. Having secured regeneration, with R1 set for maximum regeneration, gently push T down toward its final position (horizontal with the baseboard) in the center of L1.

**LIST OF PARTS**

- One RCA, Ken-Rad or Sylvania type 6F7 multi-purpose tube;
- One Gen-Win 456 kc. 1-tube superhet. coil kit;
- One Hammarlund, 2-gang variable condenser, with trimmers, C1-C2-C;
- Two Hammarlund padding condensers, 140 mmf. (each), C3; (A single unit of twice this capacity may be used.);
- One Cornell-Dubilier fixed condenser, 500 mmf., C6;
- One Bud fixed condenser, 0.1-mf., C7;
- Two Radio Trading Co. fixed condensers (with grid-leak mountings), 250 mmf., C8, C9;
- One Aerovox fixed condenser, 100 mmf., C10;
- One Aerovox fixed condenser, .001-mf., C11;
- One Tube Deutschmann fixed condenser, 2 mf. (paper), C12;
- One CRL or Electrad volume-control potentiometer, 50,000 ohms, R1;
- One CRL or Electrad volume-control potentiometer, 0.1-meg., R2;
- Two Radio Trading Co. plunger-type grid-leaks, 0-20 megs., R3, R4;
- One Hammarlund R.F. choke, R.F.C.;
- Eight fahnestock clips (GROUND is not shown in the photo; ground connects to "B-");
- One 6-volt "A" supply;
- Two small 45-volt "B" batteries (at least one battery tapped at 22½ V.);
- Three knobs (for C1-C2-C, R1 and R2);
- One pair headphones, Blan Radio Man. Inc.
- One wooden baseboard, 16x11½x¾-in.

**OPERATING NOTES (From page 604)**

So I made the change as shown in the diagram, Fig. 3, A and B. A 10,000 ohm potentiometer was substituted for the old volume control; a fixed screen-grid voltage was put on the screen by substituting a wire-wound resistor for the old volume control; a bleeder was hooked to one end of the volume control and the aerial to the other. When new 35's were placed in the R.F. sockets, the thing worked perfectly. **JIM KIRK**

**SPECIAL—**  
This Month Only for  
**ORSMA**  
MEMBERS

THE OFFICIAL RADIO SERVICE MEN'S ASSOCIATION has arranged to supply a number of "Service Men's essentials" for its members and associate members only.

These essentials are priced at cost, plus a small additional fee which is the only source of income that the Association has. No one obtains any profit or benefit, except the Association itself. Whatever profit accrues, is reinvested for the furtherance and enlargement of the Association.

By using the letterheads, billheads, etc., you present the business-like appearance to your customers. In addition, the Association has made arrangements with most of the prominent manufacturers to allow special discounts to members, providing ORSMA letterheads are used when ordering.



**ORSMA LETTERHEADS**

These letterheads, shown above, are furnished with your name, address and telephone number, printed on excellent paper. They are sold in lots of 100 or multiple thereof, with a distinct saving for single orders of 1,000 or more. **Per 100, 60c; per 1000, \$3.00.**



**ORSMA ENVELOPES**

These are furnished to match the letterheads, printed with your name and address and sent at the Association. They go hand in hand with the letterheads and are usually ordered in the same quantity. **Per 100, 60c; per 1000, \$3.00.**

Write for complete details about membership in the OFFICIAL RADIO SERVICE MEN'S ASSOCIATION. State whether you prefer Full Membership or Associate Membership.

OFFICIAL RADIO SERVICE MEN'S ASSOCIATION  
99 Hudson Street, New York, N. Y.

Please send me the following RADIO SERVICE MEN'S ESSENTIALS which I have selected from this advertisement. My remittance for \$ . . . is enclosed. Send remittance in form of check or money order. Register letter if it contains cash, currency or unused U. S. Postage Stamps.

Name ..... ORSMA No. ....  
Address ..... City and State.....

Please Say That You Saw It in RADIO-CRAFT

# Many Auto-Radios Installed Last Summer Now Need Servicing!

Auto-radios installed during the past six months usually need some minor adjustment—new tubes, new suppressors or other parts. Perhaps the job will even be more difficult—then you'll find how needy the Auto-Radio Service Manual is to repair the job quickly.

**\$2.50**  
LIST



To everyone who now purchases the OFFICIAL AUTO-RADIO SERVICE MANUAL, this big 48-page Supplement is issued FREE. Practically all of the latest sets, together with servicing information will be found in these new pages. The new Supplement does not increase the cost of the book to you, but gives you an Auto-Radio Service Manual that is right up-to-the-minute with service notes.

### Good Money in Servicing Auto-Radios

If you are overlooking servicing auto radios, you're missing a great deal of business. The auto-radio business had its greatest boom last summer when thousands of sets were sold. By now many of these same sets require servicing and with hundreds of them right in your own community, you can build up a good auto-radio servicing business. In a short time you can easily add 25% profit or more to your regular servicing business.

#### List of sets covered in the Manual

- |                               |                                 |
|-------------------------------|---------------------------------|
| Acme Radio Mfg. Co.           | P. R. Malloy & Co.              |
| Allied Radio Corp.            | Melhorn Radio Mfg. Co.          |
| Atwater Kent Mfg. Co.         | Montgomery Ward & Co.           |
| Audlola Radio Co.             | National Co., Inc.              |
| Autocrat Radio Company        | Nobilit-Sparks Int., Inc.       |
| Automatic Radio Mfg. Co.      | Philco Radio & Tel. Corp.       |
| Carter Generator Corp.        | Pierce-Alto, Inc.               |
| Century Radio Prods. Co.      | Premier Electric Co.            |
| Chevrolet Motor Company       | Radio Chassis, Inc.             |
| Consolidated Industries, Ltd. | RCA-Victor Co., Inc.            |
| Crosley Radio Corp.           | Sentinel Radio Corp.            |
| Deleo Appliance Corp.         | Sparks-Wilmington Corp.         |
| Detrola Radio Corp.           | Stewart Radio & Tel. Corp.      |
| Emerson Electric Mfg. Co.     | Stewart-Warner Corp.            |
| Fada Radio & Elec. Corp.      | Stromberg-Carlson Tel. Mfg. Co. |
| Federated Purchaser, Inc.     | Transformer Corp. of Am.        |
| Ford-Majestic                 | United Amer. Bosch Corp.        |
| Franklin Radio Corp.          | United Motors Service           |
| Galvin Mfg. Corp.             | U. S. Radio & Tel. Corp.        |
| General Electric Co.          | Utah Radio Prods. Co.           |
| General Motors Corp.          | Wells-Gardner Company           |
| A. H. Grebe & Co.             | Wholesale Radio Serv. Co.       |
| Grigsby-Grunow Co.            | Rudolph Wurlitzer Mfg. Co.      |
| Chas. Hoodwin Company         | Zenith Radio Corp.              |
| International Radio Corp.     |                                 |

**Over 200 Pages**  
**Over 500 Illustrations**  
**9 x 12 Inches**  
**Flexible, Loose-Leaf Cover**

### MAIL THIS COUPON TODAY!

GERNSBACK PUBLICATIONS, INC. RC-4-35  
99 Hudson Street, New York, N. Y.  
Enclosed you will find my remittance of \$2.50 for which please send me One Copy of the OFFICIAL AUTO-RADIO SERVICE MANUAL, with FREE 48-page Supplement. Send remittance in check or money order. Register letter if it contains cash or currency. WE PAY POSTAGE.

Name .....

Address .....

City ..... State .....

## THE LISTENING POST

(Continued from page 599)

sideration of a DX receiver, by all means find out if it is practical to install headphones in the particular model you have under consideration.

(6) *Is the main tuning dial so calibrated that you can depend upon finding a station at, or close to its stated frequency?* This is a most essential feature and it is indeed surprising to note how many receivers run off as much as 1000 kc., or even more at some place on the dial. See that the receiver you buy is at least reasonably accurate throughout the scale.

(7) *Does the receiver provide for the use of the doublet, or double-doublet type of antenna?* These two types of antennas have been found, as a result of numerous tests, to be most nearly adapted for all-wave reception. The superior results that will be obtained from a good antenna cannot be overestimated.

(8) *Does the receiver have a smooth, and well-graduated tone-control?* A tone control should be incorporated that will give you a deep mellow tone when turned to the base pitch position, a natural realistic tone when turned to about middle position, and a high grade of voice intelligibility when turned to high pitch position.

Although the receiver you finally select may not have all of these features, at least the main ones should be incorporated, so that you may be assured of not only full value for your money, but that you may have a receiver that will be suitable for DX work, and at the same time one which will also still be practical for ordinary home program enjoyment.

### WHAT TO LISTEN FOR DURING MARCH-APRIL

#### Broadcast Band

March is the best time of the year, as a rule, to log and enjoy reception from stations in the Southern Hemisphere, especially those from Australia and New Zealand. We prophesy that this March will bring the greatest period of successful reception yet from the stations "down and under." This will be partly due to the more powerful stations now in operation in these countries, and to a certain extent due to the ever-increasing perfection of receiving sets. More knowledge is now available also on just how, and when, to tune in these stations.

Reception of European stations will practically be over until next fall, except in Maine, Nova Scotia, and Newfoundland where the season sometimes lasts for a full month longer.

South American stations will be good over the whole continent of North America during March, and should provide mighty good hunting. Some of the larger South American stations are in fact so well heard now that they at times completely blot out U.S. stations on the same channel. This is partially due to the increase to super-power of a number of our Argentine friends.

Reception of Japanese and Chinese stations will continue good on the Pacific coast throughout March.

April will mark the decline of all broadcast band signals, although I have known April to yield a number of excellent DX-ing nights. Spring rains, however, with the attendant spring static will be upon us, and this is a signal for most DX-ers to close the broadcast band log for the season, and turn their attention to the higher frequencies (short waves) which will be getting better, and better as "Old Sol" climbs higher and higher in the sky.

### SPECIAL BROADCAST FROM XGOD, CHINA

In an unusual and interesting dispatch from radio station XGOD of Hangchow, China, Mr. E. Pan, chief engineer of the station writes that XGOD will arrange some special programs for North American radio listeners on March 15 and March 16, from 4:30 to 6:30 a.m. C.S.T. on each day. In his own inimitable language Mr. Pan states: "And expect very much to hear from you as soon as the programs have been transmitted." Reports should be addressed to radio station XGOD, Telephone Administration, Chekiang Provincial Government, Hangchow, China. XGOD broadcasts on a frequency of



## Lady-Call Constable Centralab!

By cracky . . . he'll soon put a stop to that noisy "picket fence" attenuation. If your radio acts up, Madam, call a good serviceman . . . he'll change that noisy wire-wound control to a smooth as silk CENTRALAB Radiohm that will forever banish "picket fence" reception.

Note to servicemen: A mere handful of CENTRALAB RADIOHMS will service practically any radio that is still worth fixing. Employs the smooth, non-rubbing contact in both high and low resistance values. Furnished with fixed minimum external resistor at no extra cost.

THE NEW PATENTED RADIOHM



RADIOHMS SUPPRESSORS RESISTORS SOUND PROJECTION CONTROLS

**Centralab**  
Division of Globe Union Mfg. Co., Milwaukee

## Train for ELECTRICITY IN 12 WEEKS AT COYNE

The great Coyne Shops in Chicago have a world-wide reputation for training men here in Chicago in this big-pay field in only 12 weeks. Then they get behind you to help you to success by giving you lifetime employment service. By my new plan YOU can take advantage of their wonderful method of learning-by-doing NOW—no need to lose time and money while you strive and save to raise the necessary tuition.

### I WILL FINANCE YOUR TRAINING

You can get your training first—then I'll give you over a year to pay me back in small monthly payments starting 60 days after your required Training Period is over. If you will write to me at once I will send you complete details of this sensational new plan, together with the BIG FREE Illustrated Book telling all about COYNE and how many earn while learning and the training you can get there without book study or useless theory.



A. E. Quinn

### SEND NOW FOR FULL DETAILS!

Mr. H. C. Lewis, President.  
Dept. 45-78, 500 S. Paulina St., Chicago, Ill.  
Tell me how you will finance my training at COYNE and send me the BIG FREE Illustrated book on ELECTRICITY.

NAME .....

ADDRESS .....

CITY ..... STATE .....

Please Say That You Saw It in RADIO-CRAFT



**NOW READY!**

NO other radio book is comparable to the new 1935 OFFICIAL RADIO SERVICE MANUAL. In contents, in style of printing, in grade of paper, in illustrations, there has never been published such a comprehensive volume.

The 1935 Manual contains over a thousand pages—yet it is only 1 1/4 inches thick because it is printed on a special Bible stock which is an exceptionally good stock, yet one of the thinnest and most durable papers. This 1935 Manual is the most authentic and elaborate service guide ever used in the radio industry. Service Men and dealers who use this 1935 Manual are astonished by finding in it such a wealth of profitable service information which has never been published before.

**Contents of the 1935 Manual**

Over 1,000 pages full of diagrams and essential information of manufactured receivers—only data of real use in servicing is included. This new Manual is really portable since it will be extremely thin and light as well. ● Volume V continues where the preceding manual left off. ● Many circuits of old sets are included. ● Service Men know every set has certain weak points which are really the cause of trouble. Wherever the information could be obtained, these weaknesses with their cures are printed right with the circuits. This is an entirely new and valuable addition to the Manual. ● All the latest receivers are included—all-wave sets, short-wave sets, auto-radio sets, midjet and cigar-box sets, etc., as well as P.A. amplifiers and equipment, and commercial servicing instruments. ● The cumulative index is even more complete than before; including cross-reference to sets sold under different names and type numbers. ● Volume V includes resistance data; socket layouts; I.F. data; and voltage data. ● Tube data on latest tubes. ● Free question and answer service—as included in our last three manuals.

**OVER 1,000 PAGES**

Over 3,000 Illustrations. Flexible, loose-leaf leatherette covers. Size 9x12"—yet only 1 1/4" thick

**GERNSBACK PUBLICATIONS, Inc.**  
99 Hudson Street New York, N. Y.

**MAIL COUPON TODAY!**

**SET SERVICING**  
Service information found in the 1935 Manual covers all types of radio receivers. The material is extremely valuable to Dealers and Service Men. On many diagrams appear voltage readings of tubes, socket connections, transformer data, alignment details, and other service notes.

**PUBLIC ADDRESS**  
The pages on P. A. Installation will be helpful to Service Men and P. A. specialists. Such prominent features as class A and B amplifiers—single and dual channel systems—attenuators, and mixer—superpower stages—transformers and other commercial devices for P. A. work are included.

**ALL-WAVE RECEIVERS**  
Information relative to short-wave receivers have found their way into the 1935 Manual. For these standard manufactured sets, wherever possible, complete alignment details for all wave bands are included in addition to the service material listed for other sets.

**AUTO-RADIO RECEIVERS**  
All available service information on new auto-radio sets has been included. From this data alone Service Men could derive sufficient knowledge to venture in a specialty field—that of servicing only auto-radios.

**GERNSBACK PUBLICATIONS Inc., 99 Hudson St., New York, N. Y.**

Enclosed find my remittance of \$7.00 for which send me, POSTAGE PREPAID, One Copy of the 1935 OFFICIAL RADIO SERVICE MANUAL. [Send remittance by check or money order; or register letter if it contains cash, currency or unused U.S. Postage stamps.]

NAME .....

ADDRESS .....

CITY ..... STATE ..... RC-4-35

960 kc., with a power of 1000 watts. XGOD has been reported by a number of listeners on the Pacific coast recently.

**MYSTERY SOLVED**

For some weeks listeners on the Pacific coast have been mystified by a new and apparently powerful broadcasting station on about 560 kc. This station has now been definitely established as the new government super-power 100 kw. broadcast station located at Hsingking, Manchukuo.

**LIST OF BROADCASTING STATIONS OPERATED IN**

**BUENOS AIRES**

Call	Name of Station	Wavelength	KC.	KW.
LS10	Radio America	308.5	590	2.87
LS3	Radio Mayo	476.2	630	5.07
LS4	Radio Portena	447.8	670	5.09
LS1	Radio Municipal	422.5	710	5.
LR10	Radio Cultura	379.7	790	11.05
LR5	Radio Excelsior	361.4	830	30.
LR6	Radio La Nacion	341.8	870	39.
LR2	Radio Argentina	329.7	910	9.62
LR3	Radio Belgrano	315.8	950	13.9
LR4	Radio Splendid	303.	990	15.96
LR9	Radio Fenix	291.3	1030	3.88
LR1	Radio El Mundo (New Station)	280	1070	
LS5	Radio Rivadavia	270.3	1110	5.06
LR8	Radio Paris	260.9	1150	3.54
LS2	Radio Prieto	252.1	1190	30.
LS8	Radio Stentor	243.9	1230	15.46
LS9	Radio La Vos del Aire	236.2	1270	3.
LS6	Radio del Pueblo	222.2	1350	4.

NOTE: I take especial pleasure in presenting this list through the courtesy of Mr. Alberto Dougall, owner of Radio Excelsior, Station LR5, Buenos Aires. It is an absolutely accurate and authentic list of Buenos Aires broadcasting stations corrected to the date of writing. This is the first list to give the increased power of LR6, the station which is causing such interference with WENR in the evenings.—Ed.

**BUILD THIS 5-TUBE ALL-STAR "JUNIOR"**

(Continued from page 598)

where it comes through the chassis will prevent wear on the wire at this point.

You are now ready for Fig. 3. A systematic method to complete this portion of the wiring is to install all of the condensers (except C1, which mounts last), and then the resistors.

Tube voltages and connections for All-Star, Jr.

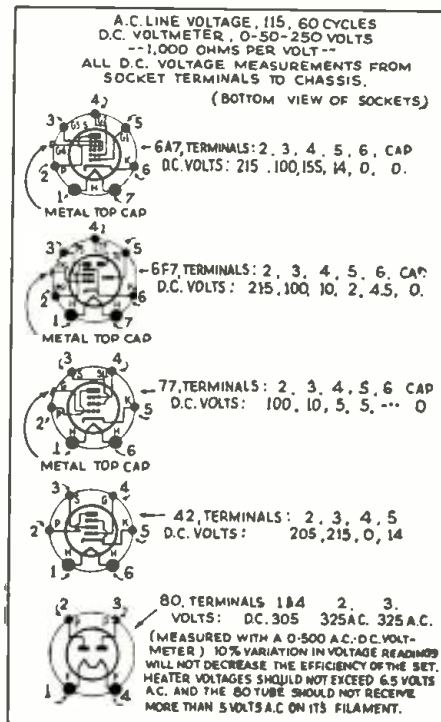

**HIGH SEAS**

**ADVENTURES MAGAZINE**

For April

A COMPLETE NOVEL

"Outlaw of the Sea"

By DR. GEORGE S. KING

A Thrilling Story of the African Slave Trade

Also Short Stories by Bill Adams, P. H. MacArthur, Warren F. Carleton, etc.

A GERNSBACK PUBLICATION

15c The Copy—On All Newsstands



**Stirring Stories of Future Science**

Here, each month, you can revel in the wonders of science and imagination through masterful tales by the world's leading authors of science-fiction. Besides many thrilling stories in each issue, you will find several interesting departments, including "Science Questions and Answers" and "The Science Fiction League"—the voice of a world-wide organization.

SPECIAL OFFER (in U.S.A. only)—One year for \$2.00. Send check or money order.

WONDER STORIES

99R Hudson St. New York, N. Y.

A GERNSBACK PUBLICATION

Please Say That You Saw It in RADIO-CRAFT

A MAGAZINE WHICH NEEDS  
NO INTRODUCTION  
TO SHORT-WAVE FANS

## SHORT WAVE CRAFT

This popular monthly magazine, **SHORT WAVE CRAFT**, contains everything you want to know about Short Waves. The wonders of world-wide short-wave reception are clearly described and illustrated. Latest practical information for radio fans, experimenters and "hams" will be found. Tells you how to build short-wave receivers and transmitters; construct sets of one and two tubes or as many as seven, eight or more. Tells best foreign stations to log and when to tune them—includes newest and best circuits of the time. **SHORT WAVE CRAFT** is edited by Hugo Gernsback.

**NEW FEATURE RECENTLY ADDED**—To the short wave fan who has logged and obtained verification of the largest number of short-wave stations from all over the world during one month, will be awarded a magnificent 24" silver trophy.

### Special This Month Only!

For the month of March only, we offer readers of this magazine the opportunity to read radio's greatest short-wave magazine at a special saving. The regular subscription price is \$2.50 per year. You can now get **SHORT WAVE CRAFT** for the next

**8 MONTHS FOR \$1.00**



4-Color Cover  
Over 200 illustrations  
9x12 inches in size

**25c** The Copy  
ON ALL  
NEWSSTANDS

Send remittance by check, money order or U.S. Postage Stamps. Register letter if it contains cash or currency.

**SHORT WAVE CRAFT**  
99R Hudson St. New York, N. Y.

## AIR CONDITIONING

is America's Next Great Industry

THE idea of electricians, radio service men and other mechanically inclined men servicing Air Conditioning and Refrigeration Units is self-evident and the thought has occurred to some untold thousands ever since air conditioning equipment has been installed in public auditoriums, theatres, studios, department stores, office buildings and manufacturing plants. The tremendously broad possibilities in this new industry are bound to give employment and success to men far-sighted enough to see its advancement and development.

### Well-known Engineer Edits Manual

The **OFFICIAL AIR CONDITIONING SERVICE MANUAL** is edited by L. K. Wright, an expert and a leading authority on air conditioning and refrigeration. In this Air Conditioning Service Manual nearly every page is illustrated; every modern installation and individual part carefully explained; diagrams furnished of all known equipment; special care given to the servicing and installation end. The tools needed are illustrated and explained; there are plenty of charts and page after page of service data.

### CONTENTS IN BRIEF

History of Air Conditioning; Fundamental Laws; Methods of Refrigeration; Elector System of Refrigeration; Compression System of Refrigeration; Refrigerants; Lubricating Oils; Liquid Throttle Devices; Servicing Expansion and Float Valves; Servicing Refrigerating Systems; Control Devices; Thermodynamics of Air Conditioning; Weather in the United States; The Field of Air Conditioning; Insulating Materials; Heat Transmission Through Walls; Complete Air Conditioning Systems; Estimating Requirements for the Home, Small Store, Restaurant; Layout of Duct Systems; Starting Up a System; Operating and Servicing Air Conditioning Systems; Air Filtration, Ventilating and Noise Eliminating Devices; Portable Electric Humidifiers and Room Coolers; Automatic Humidifiers; Air Conditioning Units for Radiator Systems and Warm Air Systems; Central Conditioning Units, etc.



352 Pages  
600 Illustrations  
9x12 Inches

Flexible, Loose-Leaf  
Leatherette Cover

**\$5.00** A COPY

(Send remittance by check, money order or unused U.S. Stamps. Register letter if it contains stamps or currency.)

**GERNSBACK PUBLICATIONS, INC.**  
99R Hudson Street New York, N. Y.

## READERS

### Free Post Cards May Be Had Upon Request

They will make it easy for you to answer any of the ads. which appear in **RADIO-CRAFT**, and without cutting any valuable articles or data which you may wish to save.

Many times manufacturers request you to "clip the coupon" when answering their ads. Often this means destroying part of an article on the reverse page you may need later for reference. *Save your RADIO-CRAFT issues complete.* If you should ever want to see bound volumes, or certain copies of **RADIO-CRAFT**, the resale value of *uncut* issues is very much higher than that of mutilated ones. Furthermore, some numbers are already out of print, and the earlier ones cost 50 cents apiece. So send for a supply of these free post cards and use them in answering all **RADIO-CRAFT** advertisers.

## AN ELECTRONIC "PARTY" TREASURE HUNT

(Continued from page 587)

shows the closet effect. Immediately before the door opens the room is dark, except for the roaming flashlights. Then the photo-flash lamp blinds every one and the treasure is exposed. Much depends upon the effect you create, so fix it up well! Details of the figure are shown in Fig. 3. Here again you can use your originality. Flashlight bulbs, painted red, project from the eyes.

The door latch shouldn't prove difficult. Follow the kink in Fig. 5. The solenoid to operate the plunger is made as follows: Get a 1/4-in. carriage bolt and cut it to 4 ins. in length. Slot one end for 1/2-in. and drill a 3/8-in. hole through the slot. Cut the latch in the shape shown in Fig. 5 and secure the bolt to it loosely with a cotter pin.

The coil is wound on a 3/8-in. form, 4 ins. long. Use round wooden or fibre end pieces 1 1/2 ins. in diameter. Wind on 600 turns (in layers) of No. 20 enameled wire. The door hook is the kind used to hold up curtain rods.

A skeleton or skull painted on a piece of white cloth, mounted on a wooden frame outside a window and illuminated by two or more 3 V. lamps gives a startling effect when seen from a dark room.

## THE CONTROL ROOM

You will want to share in the fun, so the room selected for the party must have a window opening into another room, or better yet, a glass door. The room next to the party room is where you make your headquarters. Of course it must be completely dark, with curtains on your side (and locked!). Set up your table with the relay, switches, amplifier, and batteries in a convenient position. A hole in the curtain or peeping through the drapes affords means of seeing what is going on. If you want to add an additional control you can use a cheap microphone to the family radio receiver's audio system and broadcast ghost effects into the party room. It adds one more thrill!

## RUNNING THE WIRING

The main point to remember in wiring up the job is to conceal every wire and device as completely as possible. Under no circumstances must it look like an electrical laboratory! (See Fig. 1.) Use fine wire for the photo-cell wiring, (No. 30 is large enough) and run it behind mouldings, under carpets—any way to keep it out of sight.

The switches may be manipulated in any combination you desire. Of course switch No. 3 can be used at any time to operate the devices selected by Switch No. 2, without using the photo-cells. This makes a highly flexible arrangement with a large number of combinations. Practice until you know just how every part works—and you are ready for the party!



Known  
by the  
Company They Keep

In case you haven't already noticed it, we want to call your attention to an important fact you can readily verify: *Sprague Condensers are featured by more of the better parts jobbers than any other make of condensers.*

Jobbers of this type know quality—and feature it accordingly. Even though they may carry other makes of condensers, chances are ten to one they'll recommend Sprague's to the man who wants the best. Ask your jobber and see! **SPRAGUE PRODUCTS CO.**, North Adams, Mass.

**SPRAGUE CONDENSERS**  
MADE RIGHT **SPRAGUE GOO LINE** PRICED RIGHT

## Now, The New 403-A DEPENDABLE "RCP" MULTITESTER is

Only \$13.95

Complete and  
GUARANTEED  
FOR LIFE

Against Defective  
Materials and  
Construction

KIT, \$10.65



YOU can't go wrong on this superior instrument. It is guaranteed for life against defective materials and construction. Compactly designed for use with the new 501 "RCP" Analyzer Unit, or will bring your old analyzer up-to-date. 2,000 ohms per volt. PARALLEL meter, accurate within 2 per cent. 3-range 0-2,000,000 ohmmeter; 4-range 0-5-50-250-750 voltmeter; 0-500 microammeter. Equipment includes self-contained batteries and set of fine illuminated prods. Write for data.

## 15 Assorted Bakelite INDICATOR KNOBS - - \$1.00

High-grade molded, black Bakelite. Recessed to fit over lock nuts. Easy access to set screws. All fit 3/8" shaft. Assortment includes: Three 2 1/2" dia. and Six 1 1/2" dia. Bar Knobs. Two 7/8" dia. and Four 1 1/2" dia. Round Knobs. All 11 mailed postpaid for \$1.00 bill or money-order.

\$1.00  
for 15  
Knobs  
Postpaid



**RADIO CITY PRODUCTS CO.**  
Dept. RC-4, 28-30 W. Broadway, New York

Please Say That You Saw It in **RADIO-CRAFT**

# Modern Testing Instruments that give Accurate Measurements, Longer Service and are Lower-Priced

**DEPENDABLE ANALYZER MODEL 5414**

A new efficient analyzer unit combining many prominent features:—2000 ohm per volt sensitivity—Self contained 3 range ohmmeter—NO external batteries required—Eliminates referring to charts and fussing with connecting plugs—Protection against obsolescence—Entire metering system is independent of circuit switching—Free Reference Point testing—Instantly makes all Point to Point measurements between ANY TWO POINTS.

Model No. 5413 Analyzer—Ohmmeter: 0-2000; 0-200,000; and 0-2,000,000—Voltmeter: 0-5; 0-50; 0-250 and 0-750—Microammeter: 0-500—Milliammeter: 0-50—2000 ohms per volt; 3 1/4" meter; 2% accuracy.

**COMPLETE, ready to operate. \$24.95 NET**  
**KIT \$21.50**

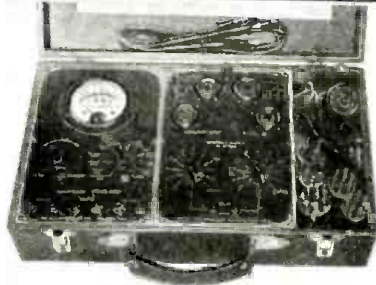

Model No. 5414—Same as above with additional Milliammeter: Ranges 0-50; 0-250. Bakelite case; meter 3 1/4"; 2% accuracy. All shunts and multipliers individually calibrated to within 2%. Model 5414, COMPLETE, ready to operate. \$28.95  
**KIT \$24.50**



## DEPENDABLE MULTITESTER MODEL 403-A

Service men and dealers highly praised the Model 403 Multitester—and it deserved praise. But the new improved Model 403-A "DEPENDABLE" MULTITESTER insures even greater satisfaction at less cost. Embodying every feature of the former model. No. 403-A is more compact, having been designed as a companion instrument to the new Model 501 ANALYZER UNIT described below.

2,000 ohms per volt. Accuracy within 2 per cent in D'ARSONVAL type moving coil meter. 3-range 0-2,000,000 ohmmeter; 4-range 0-5-50-250-750 voltmeter; 0-500 microammeter.

**COMPLETE, ready to operate. \$13.95 NET**  
**KIT \$10.65**

## DEPENDABLE TUBE TESTER MODEL 304

Accuracy is essential in tube testers. Adaptability for all present and future needs is valuable. Convenience and good looks are desirable. But high price isn't necessary.

The new Radio City "DEPENDABLE" Tube Tester provides all of these features at the lowest cost. And their reputation with service men and dealers is unsurpassed. Complete units, ready to operate, or money-saving kits.

The only tube tester showing leakages above one-million ohms. Neon-light indicator. "Good-Bad" meter. Tests all today's tubes and provides for 50% increase. One-button operation. Etched metal panel. Leatherette case. Counter and

**\$19.95**

**515.65 KIT**

Ready to Operate



**We Issue No Catalog** All orders are F.O.B. New York. Term: A deposit of 20% is required with every order. Balance may be paid on delivery. DEDUCT 2% IF FULL AMOUNT IS SENT.

## GREN PARK COMPANY

101 Hudson St.

Dept. RC

New York, N. Y.

## THE KNOWN FREQUENCY SPECTRUMS

(Continued from page 607)

are discussed. One Angstrom unit is equal to .000000001 or 10<sup>-10</sup> meter. In Angstrom units the wavelength of violet light would be 3,300 units. The wavelength of yellow light which is in the center of the visible spectrum is 5,900 Angstrom units or about 1/100 the diameter of the average human hair.

## THE INVISIBLE SPECTRUM

If we proceed to wavelengths shorter than 3,300 Angstrom units we advance into the invisible ultra-violet region and if we proceed in the opposite direction we advance into the invisible infra-red region. Included in the latter region are the heat rays such as those radiated by the sun, or other hot bodies. The radiations of light and heat are similar. (Conclusive evidence of this similarity is furnished by the fact that heat radiations obey the same laws of reflection, refraction, polarization, and interference as light radiations.) The apparent difference merely arises in the different manner in which they affect our senses.

## INFRA-RED RAYS

When a solid object, such as a horseshoe, is heated, it glows at first with a dull red heat, then as it gets hotter it becomes bright orange, and then yellow. The act of heating it up causes it to emit radiations, and the hotter it becomes, the shorter are the emitted waves. We may say that, as an object gets hotter, its radiation moves along the spectrum in the direction of shorter and shorter waves. We do not begin to see the object by its own light until its radiation has passed into the visible part of the spectrum, but long before this stage is reached, it is giving out radiation in the infra-red part of the spectrum. Our skins, but not our eyes, are sensitive to this radiation. If we hold our hand near a hot horseshoe, we shall feel its radiation long before it can be seen. Ordinary photographic plates are not affected either by infra-red or by red light. For this reason red light can be used in a photographic dark room without damaging the sensitized plates.

Although the human eye cannot detect waves outside of the visible spectrum, the presence of ultra-violet and infra-red radiations can be easily detected by means of photographic plates. Ordinary photographic plates are sensitive to ultra-violet radiations but not to infra-red. Photographic plates with special emulsions are sensitive to infra-red radiations. If an ordinary electric flatiron is stood on its end and heated in a dark room by means of the electric current passing through the iron, no form of radiation from the flat surface of the iron is visible to the eye. But if a camera equipped with a special photographic plate is focused on the flatiron and exposed to the infra-red radiations, a negative of the flatiron is obtained. (A soldering iron produces a similar effect.)

## ULTRA-VIOLET RAYS AND OTHER "SUPER-VISUAL" FREQUENCIES

If one color of light is half the wavelength of another, the light having the shorter wavelength is said to be an octave higher in pitch. Violet light is just half the wavelength of red light so it is said that violet light is an octave higher in pitch. The human eye can see all that lies within only one octave.

However, scientists have found means of studying as many as 64 octaves. About 10 octaves above the octave of visible light, the X-rays are found. Light substances are more transparent to these than dense substances, so that when an object containing both light and dense substances is subjected to these X-rays the denser substances cast deeper shadows than the lighter ones. Because of this property a surgeon can use these rays to photograph bones through flesh.

Above these radiations come the gamma rays which are emitted by radium, and finally, 32 octaves above the octave of visible light, come

## Know Thyself!

Well Illustrated

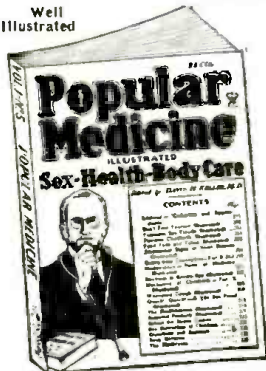

This new monthly magazine is also your own doctor. WHAT AILS YOU? POPULAR MEDICINE tells and helps you thoroughly. Written for you by doctors. Non-technical yet authoritative for all laymen. Many anatomical illustrations.

Special Offer!

8 Months \$1 for 1

Send 25c for sample copy POPULAR MEDICINE

97R Hudson St., New York, N. Y.

On All Newsstands

# PIRATE STORIES

For May

A COMPLETE BOOK-LENGTH NOVEL

"Galleons of Death"

By NELS LEROY JORGENSEN

A Swift-Moving Story of the Caribbees. Also Short Stories by J. Allan Dunn, Norman White, Jr., Jack Covington and Others. A True Story by Frederick J. Hood

A GERNSBACK PUBLICATION

15c The Copy—On All Newsstands

Please Say That You Saw It in RADIO-CRAFT

# It's NOW

EVERYDAY SCIENCE AND MECHANICS is the most scientific — technical — mechanical — constructional magazine in the field. Up-to-the-minute with news flashes of scientific events. Dozens of constructional articles and many popular experiments. Ideas from which you can make things to sell.

10¢



**A HOST OF INTERESTING SUBJECTS COVERED:**  
 —Woodworking —Photography —  
 Magic —Patents and Inventions—  
 Book Reviews —Metal-working—  
 Chemistry —Engineering —Mi-  
 croscopy—Electrical Experiments—  
 Household Hints—Astronomy  
 —Prize Contests—and other  
 subjects.

Get your copy today!  
 On all newsstands

10¢ the copy

Over 150 Illustrations

## Most Amazing TYPEWRITER BARGAIN

10 DAY  
 FREE TRIAL  
 OFFER

EVER  
 OFFERED



NEW  
 REMINGTON  
 PORTABLE only

10¢  
 A DAY

FIRST TIME! Remington's new purchase plan now lets you buy a genuine latest model Remington Portable No. 5 direct from the factory for only 10¢ a day. Not used or rebuilt. Not incomplete. A beautiful brand new remanufactured Remington Portable. Standard 4-row keyboard, standard width carriage, margin release on keyboard, back spacer, automatic ribbon reverse; every essential feature found in standard typewriters.

With your machine we send you free a 19-page course in typewriting. Teaches touch system quickly, easily. Soon you dash off letters quicker than with pen and ink. You also get a handsome, sturdy carrying case free.

FREE  
 Typewriting  
 Course

**BIG PRICE REDUCTION**

The amazing low price and easy terms now make it possible for you to buy this genuine complete Remington Portable for only 10¢ a day. But we cannot guarantee present prices long. Higher wage scales, rising cost of materials, everything points to higher prices. So we say, "Act now," while our liberal offer still holds good!

FREE  
 Carrying  
 Case

**You Don't Risk One Cent**



Try this typewriter in your home or office on our 10-day FREE TRIAL OFFER. Then, if you do not agree that it is the finest portable at any price, return it at our expense. You don't even risk shipping charges. Don't wait. Mail coupon now. It's the best chance you've ever had to own so complete a machine for so little money. So act NOW!

### CLIP COUPON NOW

Remington Rand Inc., Dept. 189-4  
 205 E. 42nd St., New York, N.Y.

Please tell me how I can buy a new Remington Portable typewriter for only 10¢ a day. Also enclose your new catalog.

Name \_\_\_\_\_  
 Address \_\_\_\_\_  
 City \_\_\_\_\_ State \_\_\_\_\_

certain of the constituents of cosmic rays, possessing such an extraordinary penetrating power that they can pass through many feet of lead and have been detected 800 feet below the surface of Lake Constance (Switzerland).

### "SUB-VISUAL" FREQUENCIES AND RADIO WAVES

Proceeding from the infra-red radiations in the other direction, we advance to the ultra-short radio waves of a fraction of a centimeter (one centimeter=0.3937 in.) wavelength. Still proceeding we enter the region of the so-called "short waves," then the broadcasting waves, and then the long waves used for government and transoceanic communication. The ultra-short waves can be directed, reflected, and polarized like light waves. The long waves follow the curvature of the earth's surface while the short waves radiate skyward and are reflected back to earth by an ionized gas layer far above the earth (about 70 miles), known as the Kennelly-Heaviside Layer. For convenience the ether spectrum has been enlarged, Fig. 2, to show the positions of the various services in the radio portion of the spectrum.

Returning to the audible spectrum, shown as Fig. 1B, the ear is capable of hearing sounds ranging from about 16 to approximately 20,000 frequencies or vibrations per second. Some of us only hear up to 12,000 vibrations per second. Thus the middle C string of a piano vibrates 256 times per second but in addition to this "fundamental" or "note" also vibrates at higher frequencies or overtones which give the sound the distinguishing characteristic—the "timbre"—associated with a piano. The piano includes a little over 7 octaves, the lowest note having about 26 vibrations or cycles per second and the highest note 4,096 cycles. Each note contains the fundamental and many harmonic overtones. Harmonies at least as high as the 8th, that is 8 times the fundamental frequency, play an important part in determining the tone of a piano. The seventh harmonic, which produces a rough and discordant tone, is carefully eliminated by hammers, covered with felt and placed at strategic places along the wire, which strike the wire and prevent it from vibrating at the unwanted frequency. (It is the harmonics that produce the characteristic tone of the piano and differentiate it from a harp or violin.)

The difference in human voices also is due to a difference in the range of fundamental notes, and the tone as determined by the number and proportionate strength of the overtones produced. The average male voice has a fundamental of 128 cycles per second and the average female voice 256 cycles per second; (the overtones, however, extend to nearly the end of the audio spectrum).

Not so many years ago, large gaps existed in the frequency spectrum but the advancement of science has now made the spectrum continuous. Nevertheless, there is still an opportunity to advance beyond the mystifying cosmic rays.

### TECHNICIANS' DATA SERVICE

(Continued from page 616)

70. DATA SHEET ON BUILDING AN ANALYZER ADAPTER. Compiled by the Capitol Radio Research Laboratories to show Service Men how any analyzer may be brought up to date; or how to build a complete, modern analyzer out of spare parts and the use of only a multimeter.

72. HALLICRAFTERS' SKYRIDER SHORT-WAVE RECEIVERS. Descriptions of the Skyrider tuned R. F. and Super Skyrider superheterodyne short-wave receivers designed and built by Hallcrafters, Inc. Features: range of 13 to 200 meters (with broadcast or 10-meter band optional), automatic wave-change switch, continuous band-spread, built-in monitor, speaker and power supply (or batteries), high-fidelity audio, and other refinements.

73. HETRO HOME AND AUTO-RADIO RECEIVERS AND ACCESSORIES. A folder containing descriptions, illustrations, list and net prices of the Hetro Electrical Industries, line of console, phono-radio and table-model home radio receivers, auto-radio sets, phonograph automatic record changers and motors, antenna systems and D.C. converters.

PORTABLE SOUND SYSTEMS  
 ELECTRO DYNAMIC UNITS  
 CARBON MICROPHONES  
 AMPLIFIERS  
 4, 5 & 6 FT. ALL ALUMINUM TRUMPETS  
 FIELD EXCITERS  
 AIR COLUMN HORNS  
 LOW AND HIGH FREQUENCY UNITS FOR WIDE RANGE THEATRE USE



ACCEPT OUR  
 5 Day  
 FREE  
 TRIAL

You can try any Toledo P.A. Equipment you need 5 days under any and all conditions absolutely without cost or obligation. Accept this challenge to duplicate Toledo's amazing performance and absolute dependability at any price. Write for folder giving complete details of free trial offer, prices and descriptions of Toledo's sensational, advanced 1935 equipment.

TOLEDO SOUND EQUIPMENT LABORATORIES  
 Formerly Bud Speaker Co.  
 1147 JACKSON STREET • TOLEDO, OHIO, U.S.A.

### SERVICEMEN!

Step Ahead of the rank and file—



with "CASE RECORDS of BROADCAST RECEIVER REPAIRS"

- ADD 10,000 Hours to your experience!
- ELIMINATE GUESSWORK IN YOUR SERVICING!
- DON'T PUZZLE YOUR PROFITS AWAY!

\$4.75

Each CASE RECORD tells all details for anti-factory repair. SUPPLEMENTED QUARTERLY FREE for 1 Year. 108 receiver makes . . . 3,000 models.

. . . the FASTEST Technique known to the Professional!

First Supplement NOW READY!

Send cash now and receive 1st Supplement with "CASE RECORDS" and our DATA SHEET on "BUILDING AN ANALYZER ADAPTER" also.

Refund on return of Manual within 10 days.

CAPITOL RADIO RESEARCH LABORATORIES, INC.  
 1503 21st Street, N.W. H. K. Bradford, President  
 Washington, D.C.

### CATHODE-RAY Testing and Analysis

A new booklet now on the press, written by Kendall Clough. Has over 50 illustrations. Tells how to test and service amplifiers, transmitters, and filter systems with Cathode-Ray Equipment. You must have a copy to be up to date. Ask your jobber, or write today.

Send 25c for your copy

The CLOUGH-BREngle CO.  
 1136 W. Austin Ave. Chicago, U.S.A.

Please Say That You Saw It in RADIO-CRAFT

# WELLWORTH TRADING COMPANY CHICAGO

560 W. WASHINGTON BLVD.

## Electrical PORTABLE SPRAYER Outfit

**\$27<sup>50</sup>**  
COMPLETE

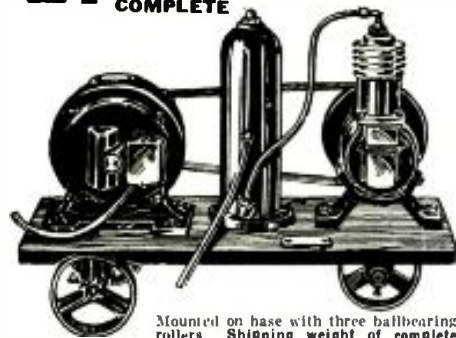

Mounted on base with three ballbearing rollers. Shipping weight of complete outfit, 55 lbs.



Internal Mix Spray Gun Supplied with the Portable Electric Sprayer.

This is the outfit for all-around spraying work wherever current is available. You can spray paint, varnish, dyes, enamel, lacquer, insecticides, etc., with it. Simply insert plug into electric socket and this marvelous machine is ready.

Outfit equipped complete with Internal Mix Spray Gun, with quart aluminum cup, round or fan spray, 1/4 H.P. heavy duty motor, 110-volt, 60-cycle AC, air filter, Kellogg Air-cooled Compressor, 1 1/2 x 1 1/4, 15 feet of hose, cord and plug.

**Price of Complete Outfit with Gun, \$27.50**

Internal Mix Spray Gun alone.....	\$ 7.50
Filter Tank alone.....	4.25
Kellogg Air-cooled compressor alone.....	7.50
Price of complete outfit without motor.....	20.00

**WELLWORTH TRADING CO.**  
560 West Washington Blvd., Chicago, Ill. **RC-435**

I enclose \$..... for which please send me the following:

Name..... Address.....  
City..... State.....

## WESTINGHOUSE POWER GENERATOR

Manufactured for U. S. Signal Corps

### SPECIFICATIONS:

**HOUSING**—Aluminum (Diameter 6 1/4 in. Length—5 1/4 in.)  
**SHAFT**—2 3/16 in. (driving end) Diameter 1 9/16 in. (the end is threaded for a distance of 1/2 in.)  
**BASE**—Cast Iron (Length—7 1/4 in. Height 1 9/16 in. Width 4 3/4 in.)  
**OUTPUT**—200 Watt 110 volts AC (speed 4500 R.P.M.)  
**STATORS**—Two pairs (two North and two South)  
**ROTOR**—12 tooth inductor.  
Built-in commutator.  
Rotor turns in ballbearings.



ups and installing explanations. We also include a set of four replacement carbon brushes.

**FREE** With each Generator we supply a set of diagram-blue prints and instructions showing twenty-five different uses, technical information, electrical hook-

**There Are Over 25 Applications**  
Some of which are:

A.C. Dynamo lighting from eight to ten 20 Watt 110 Volts lamps.  
Short Wave Transmitter supplying 110 Volts AC for operating "Ham" transmitter.  
Operating 110 V. AC 60 Cycle Radio Receiver in DC districts.  
Public Address Systems.  
Camp Lighting, etc., etc.  
Furthermore the following uses are explained:  
How to obtain electrical power: from a Windmill, Waterpower, Automobile, Motorcycle, Bicycle, Footpedals or Handcrank; how to operate AC Radio sets from 32 V. DC farm light systems, etc., etc.

## COMBINATION WOOD and METAL CUTTING LATHE



**Only \$6<sup>95</sup>**  
less chuck

\$3.50 extra for chuck (4 jawed, 3 in.)

65c extra for 5" woodworking "T" rest  
LENGTH: 20 in. WIDTH OF BASE: 4 in. HEIGHT OVERALL: 9 in.  
WEIGHT: 24 lbs. SPEED: Two-step pulley. FINISH: Baked on GRAY ENAMEL. COMPLETE with Compound Slide rest.

Slide rest having swivel base and tool holder. Large oversize bronze bearings. Accurately planned bed, machined face plate, hollow spindle, 5 in. swing.  
Standard Morse tapers; 13 in. between centers. Shipping weight: 26 lbs.

Generator, as described, including four replacement carbon brushes, blue-print and instructions.....  
**\$7<sup>90</sup>**  
Shipping weight 18 lbs.  
(Replacement carbon brushes bought separate \$1.50 per set of four. Set of instructions bought separate \$1.00.)

## ORDER FROM THIS PAGE

SINCE WE DO NOT PUBLISH ANY CATALOG

Remit by check or money order for full amount of each item—shipped by express collect. If no money for P.P. enclosed. No C.O.D. Money refunded if not satisfied.

All Merchandise Offered in This Ad is Absolutely New and Unused

## ELECTRONIC TUBE ARTICLES IN RADIO-CRAFT, FEBRUARY, 1933, TO MARCH, 1935

(Continued from page 612)

Article	Issue	Page
A Valuable Resistor-Condenser Chart ("Reciprocal chart" which simplifies calculations).....	Sept. 1933	164
And Now—The "Shoe-Button" Tube (A practical tube only 1/2-in high).....	Oct. 1933	205
How to Make the Beginner's Pianatron (Complete how-to-make-it instructions for workable instrument).....	Jan. 1934	404
Making A Diode Multimeter (Practical vacuum-tube volt-milliammeter).....	Jan. 1934	412
How the Sounds of Birds are Recorded on Film and Disc.....	Feb. 1934	462
An Introduction to Radio Dynamics (Interesting to all experimenters).....	Feb. 1934	472
A "Neon-Type" Electro-Musical "Trombone" (Another Unique Musical Instrument).....	Mar. 1934	525
Facts About Dynatron Operation (Part I of an informative series).....	Mar. 1934	535
How to Make an Inexpensive "Talkies" Sound Head.....	Mar. 1934	538
Facts About Dynatron Operation (Part II, conclusion).....	Apr. 1934	598
Save Your Old Tube Tester (Complete data for modernizing the old one).....	Apr. 1934	602
The "Polytone" (An entirely different electronic musical instrument).....	May 1934	657
"Telephotophone" (More about "light beam" transmission).....	May 1934	663
Soundhead Optical Systems (Their adjustment and care).....	May 1934	664
Applications of the 25Z5 Voltage Doubling Tube.....	May 1934	666
RADIO CRAFT Table of Bias Resistor Values (A handy chart for all Service Men).....	May 1934	670
Radio Device Guides the Blind (Another photoelectric cell use).....	July 1934	12
The Radio Pen (Facsimile reproducer for home or office).....	July 1934	13
A Radio-Controlled Boat (Actual construction of model boat).....	July 1934	18

Article	Issue	Page
A "Syntronic" Organ (New photo-cell instrument with amazing possibilities).....	Aug. 1934	77
The PE. Cell (Explanations of characteristics and adaptations).....	Aug. 1934	86
Radio Telemechanics (An editorial by Mr. Hugo Gernsback).....	Sept. 1934	133
Talk and Hear Over a Light Beam (Still another PE. cell application).....	Sept. 1934	140
How to Make a "Grid-Dip" Oscillator (To complete Service Man's test equipment).....	Sept. 1934	154
The Marinibalite—A Musical Instrument Utilizing Photo-cells (A light-controlled novelty for stage work).....	Oct. 1934	204
Uses of a Neon-Tube Condenser Analyzer (Tube indication of leakages and shorts).....	Oct. 1934	214
How to Use the New Tubes (Smoothing out the wrinkles in tube selection).....	Oct. 1934	217
A Compact Tube Tester (Complete in every detail).....	Oct. 1934	220
Midret Tube and Set Tester (Complete facilities for all tubes and point-to-point testing).....	Oct. 1934	223
A Service Man's All-Wave Oscillator (Generates fundamentals from 100 to 21,000 kc.).....	Nov. 1934	282
Latest in Television (A new idea completely portrayed).....	Dec. 1934	330
3 New Tubes (Acorn (ultra-short-wave); improved 80; 6A6).....	Dec. 1934	343
A Real "How-to-Build" Service Man's All-Wave Oscillator (Build your own 110 V. A.C.-D.C. job).....	Jan. 1935	416
The Radio Set of 1950 (Mr. Gernsback in a startling forecast).....	Feb. 1935	458
WLW's "Electric Eye" Lighting Protector (Most unique photo-cell application).....	Feb. 1935	471
Modern Theory of Electronics—Part I.....	March 1935	524
Replacement Status of the New Tubes.....	March 1935	525
How to Read Diagrams.....	March 1935	526

## V.T. VOLTMETERS IN RADIO-CRAFT

Article	Issue	Page
Vacuum-Tube Multi-meter (versatile instrument, measuring voltage, current, resistance, inductance and amplification).....	July 1930	13

## RADIO-CRAFT'S INFORMATION BUREAU

(Continued from page 612)

tuning condenser of the oscillator and the potentiometer, which determines the horizontal deflection of the pattern, is kept continuously in rotation by a small motor. The rate of rotation is adjusted so that the trace repeats itself eight or ten times a second, thus providing a continuous indication of the resonance curve of the high-frequency amplifier.

"Frequency comparisons are a particularly useful application of cathode-ray tubes. In comparing two frequencies by the zero-beat method, listening to them with a pair of phones, the observer may be handicapped by two difficulties.

"(1) The two oscillators, unless well isolated, may have a tendency to lock into step over a fairly wide frequency range if working into a common detector.

"(2) Beats lower than about 20 cycles per second cannot be heard. Two equal frequencies impressed respectively on the vertical and horizontal plates will result in a stationary elliptical pattern. The mutual conductance between these pairs of plates is practically nil, thus the locking-in tendency is very slight. Any motion of the pattern at all is immediately apparent so that the comparison at zero frequency difference is readily accomplished."

Text in quotation marks, courtesy The General Radio Experimenter.

Please Say That You Saw It in RADIO-CRAFT



**CLASSIFIED ADVERTISEMENTS**

Advertisements in this section are inserted at the cost of twelve cents per word for each insertion—name, initials and address each count as one word. Cash should accompany all classified advertisements unless placed by a recognized advertising agency. No less than ten words are accepted. Advertising for the May, 1935, issue should be received not later than March 5.

**A.C. GENERATORS**

**TWENTY PRACTICAL AND LOW COST CHANGES** converting Ford, Dodge, or Chevrolet generators into new generators and motors 100-500 watt capacity, direct or alternating current, with six to 400 volts for radio operation, power, light, or welding. Also instructions for rewinding armatures; 350 definitions of electrical terms, etc. All in new, revised book with simplified instructions and illustrations. Endorsed by thousands. Only \$1.00 postpaid, Auto Power—110—S. Hoyne Ave., Chicago.

**AUTO SUPPLIES**

**FORD OWNERS—OVERHEAD VALVE SPEED UNITS,** Winfield carburetors, camshafts. Dual-ratio axle for V-8's. Dime secures sample Speedway Racing Magazine, catalog speed books, crash helmets, English racing, stock motor-cycles, accessories. CLYMER, 410 W. Pico, Los Angeles, California.

**ELECTRICAL SUPPLIES**

**INSULATION, WIRE, VARNISHES, SUPPLIES, ETC.** Send 3c stamp for bulletin. Auto Power, 410 S. Hoyne Ave., Chicago.

**PATENT ATTORNEYS**

**PATENTS—REASONABLE TERMS. BOOK AND ADVISE** free. L. F. Randolph, Dent. 562, Washington, D.C. **PATENTING INVENTIONS IN MY SPECIALTY** through 28 years; Sterling Dink, Registered Patent Attorney 7280, 620 F. Washington, D.C. (Free Booklet-R).

**RADIO**

**NEW LONG DISTANCE CRYSTAL RECEIVER. BLUE-** print, 17 others, 25c coin. Particulars free. Modern Radiolabs, 151-14 Liberty, San Francisco, Calif.

**RADIO INSTRUCTION**

**RADIO SERVICING—RESIDENCE COURSE, 6** months, modern methods, new courses, special work on service equipment and superheterodyne servicing; instruction on public address systems, photo cell and cathode ray tubes included. Other courses obtainable: Radio Engineering—9 months; Marine Radio—6 months; Morse telegraphy—6 months. School est. 1871. All expenses low. Catalog free. DODGE'S INSTITUTE, Tenth Street, Valparaiso, Ind.

**ARMY-NAVY GIVES FREE RADIO OPERATORS'** training for service on ships, aircraft. Salary, expenses paid. Information pamphlet, how to apply, 20c. Continental, Box 341K, Indianapolis, Ind.

**UNDERGROUND TREASURES**

**TREASURE SEEKERS—MAKE YOUR OWN GOLD** finders. Learn facts about mineral localities, experimental outfits, etc. E. Dudenhoff, 111 E. 24th St., New York City.



**There's plenty of SERVICING MATERIAL in the 1934 Manual!**

Radio Service Men and others engaged in various branches of radio know the importance of the GERNSBACK Manuals, and how much they depend on them for reliable information. Whether for public address work, receiver diagrams or tube information, the material needed is certain to be found in one of the volumes of the OFFICIAL RADIO SERVICE MANUAL.

**Contents of the 1934 Manual in Brief**

Diagrams and service notes, more complete than ever before in any manual. Voltage readings for practically all sets, as an aid in checking tubes and wiring. All values of I.F. transformers used in superheterodynes, with the manufacturers' own suggestions as to correct balancing. A complete compilation of radio tube data, covering both old and new types. A complete list of American broadcast stations, with their frequencies in kilocycles; extremely useful in calibrating test oscillators and receivers. Free question and answer service. No theory; only service information in quickly accessible form. A handy, easily-consulted master index making it easy to find almost anything pertaining to service problems, instantly. This index includes all the diagrams published in all the previous GERNSBACK manuals, as well as the 1934 diagrams. A big convenience and time saver.

**400 PAGES**  
**Over 2,000 Illustrations**  
**9 x 12 Inches**

**Flexible Looseleaf Leatherette Cover**  
Send remittance of \$3.50 by check, money order or unused U. S. Postage Stamps. Register letter if it contains cash or stamps. MANUAL SENT POSTAGE PREPAID.

**GERNSBACK PUBLICATIONS, Inc.**  
99 Hudson Street, New York, N. Y.

**REPLACEMENT STATUS OF THE NEW TUBES**

(Continued from page 605)

cause of the 59's heater cathode. However, the 59 as a triode cannot handle as much power as the 45. The 46 triode also has less output than the 45 and, not having a heater cathode, does not make a good replacement.

Socket Differences: 47 has 5-pin base; 2A5 has 6; 59 has 7. These new tubes give more power output and, since they have heater cathodes, less hum. The 59, of course, must be connected as a pentode.

**SUBSTITUTIONS AMONG THE 6.3 VOLT TYPES**

**Voltage Amplifiers**

77 by 6C6; Socket Differences: 77 and 6C6  
39/44 or 78 have same socket; 39/44 has 5-pin  
by 6D6 base; 78 has 6; 6D6 has 6-pin base.

These substitutions are much like the 24A-by-57 and 35-by-58 replacements in the 2.5-volt class, and the circuit changes which may be necessary are again rather extensive. If any increase in amplification is obtained, it will probably be necessary to shield the tube individually and to improve the R.F. filter system in order to suppress feedback. For the same reasons as mentioned in the previous case, it may be necessary to change the volume control, A.V.C. system, grid bias, tuning alignment, and I.F. transformer coupling.

Socket Differences: None. The factors involved in this change are practically the same as those mentioned in connection with the 27-by-56 replacement. In addition, the difference in grid-plate capacity means a change in neutralization when substituting in R.F. stages.

**Power Amplifiers**

38 or 41 Socket Differences: 38 has 5-pin  
by 42 base; 41 has 6; 42 has 6. In both these substitutions an output transformer with a lower turns ratio should be used. The 42 of course is to be connected as a pentode.

The substitution of new tubes for early types of battery tubes, and also for other and miscellaneous types (12V., 25V., 30V., etc.) will next be discussed.

**FUNDAMENTAL FACTS ABOUT CATHODE-RAY TUBES**

(Continued from page 594)

consisted of two tuning forks, a beam of light and a screen, as shown in Fig. 1.

The two forks are so placed that one vibrates in a vertical plane and the other in a horizontal plane. The beam of light received on one mirror, attached to a fork, is reflected to the other mirror, on the other fork, and then reflected once more to a point on the screen. When the first fork vibrates alone, the point on the screen is lengthened out to a vertical line. The second fork lengths the point to a horizontal line. When both forks vibrate the point describes a curve.

In essentially the same manner Lissajous figures are obtained with the cathode-ray tube, although the electron beam replaces the light source and is deflected by electrostatic and electromagnetic fields instead of the actual mechanical motion as in the case of the tuning forks.

The relation of sine-wave voltages (in an oscilloscope circuit these voltages would be applied to each set of deflecting plates of the cathode-ray tube) is shown in Fig. 2. The various phase relations are illustrated, as well as the results obtained with multiples of frequency. (It would be a good plan to memorize these figures.)

A convenient method when observing such cyclic phenomena employs a sweep circuit which can be adjusted easily in frequency.

The applications of the cathode-ray tube are numerous, and only a partial list is given in Table I.

(This data, and the accompanying illustrations, are published by courtesy of BROADCAST News, a house organ of RCA Mfg. Co., Inc., Victor Div.—Editor)

**Train Now for New RADIO Opportunities**



**Get Into a Line Where There's Action—Every Day—And a Payday Every Week—You Be the Boss!**

**Analyzer & Resistance Tester—Latest Design—YOURS Without Extra Cost**

Right now while hundreds are looking for work where there isn't any, the radio service field can use trained men. With the proper training and the necessary equipment, you can enter this field and make a comfortable living. We include with our course this modern set analyzer and trouble shooter without any extra charge. This piece of equipment has proved to be a valuable help to our members. After a brief period of training, you can take the set analyzer out on service calls and really compete with "old timers." We show you how to wire short-wave receivers—analyze and repair all types of radio sets—and many other profitable jobs can be yours. Teaching you this interesting work is our business and we have provided ourselves with every facility to help you learn quickly yet thoroughly. If you possess average intelligence and the desire to make real progress on your own merits, you will be interested.

**ACT NOW—MAIL COUPON**

Start this very minute! Send for full details of our plan and free booklet that explains how easily you can now cash in on radio quickly. Don't put it off! Write today. **SEND NOW!**

**RADIO TRAINING ASSN. of AMERICA**  
Dept. RC-54, 4513 Ravenswood Ave., Chicago, Ill.  
Gentlemen: Send me details of your Enrollment Plan and information on how to learn to make real money in radio quick.

Name.....  
Address.....  
City.....State.....

**7-POINT MIKE= NO FEEDBACK with speakers full blast**

"I set it up in the booth, and with the gain wide open I was able to completely eliminate feedback by turning the microphone at right angles to the monitor speaker." Thus writes the engineer of a large theatre (name on request). He continues, "The mike has plenty of gain. The quality, sensitivity, and directional effect are better than any other mike I have ever tested or heard." Order from your wholesaler. Or write for Bulletin 73C.



AMPERITE Corporation  
501 BROADWAY NEW YORK

**AMPERITE VELOCITY MICROPHONE**

**BUILD YOUR OWN SHORT WAVE RECEIVER**  
Here's the World's Easiest to Build

You get 5 tube performance with this great little set. Get foreign stations easily! Loud speaker operation. Set and power pack all in one. Other I.C.A. kits from 1.5 tubes listing from \$9.95 to \$31.75 complete, look-up and schematic diagrams with each. Ask your jobber!

**DISCOUNT** of 40% allowed when purchased through your mail order house or jobber. If he cannot supply you, write us direct. Insist on I.C.A. for Reliability!

**The MASCOT "3"**  
\*105-130 V., 50-60 cycles  
\*5 Tube Performance  
\*List Price only \$22.50



**INSULINE CORP. OF AMERICA**  
23-25 Park Place, Dept. C-4, New York, N. Y.

Please Say That You Saw It in RADIO-CRAFT

# SWEEPING CLOSE-OUT SALE

## = CLEARING ALL SHELVES =



PRICES LESS THAN  
**40¢**  
ON THE DOLLAR

### OF NEW STANDARD OVER-STOCKED RADIO AND SHORT-WAVE PARTS

Tremendous bargains, every one of them! All these items represent standard radio merchandise which we have discontinued cataloging. There is only a definite quantity of each item on sale. When they are gone no more can be had.

Act fast to take advantage of this amazing sale! We reserve the right to refund your money in the event any item you've ordered has become depleted. You can find most items listed in our various catalogs under identical catalog numbers. Immediate shipment can be made on all this merchandise. All goods guaranteed perfect.

#### Short-Wave, B'Cast Receivers, Amplifiers

No. 3000 Wright DeCoster 7-Tube 2-volt Farm Sets. Requires 6-30's and 1-31 for operation. Less tubes and batteries. Your price... \$8.00

No. 35 Baird Universal Short-Wave & Television Receiver, complete with coils. Requires 3-24's, 2-27's, 1-45 and a RH rectifier for operation. Your price, less tubes... \$14.95

No. 1614 Air-King 3-Tube Superhet S.W. Converter. Requires 3-27's for operation. Works with all receivers. Your price, less tubes... \$3.50

No. 1617 A.C. Short-Wave Converter, with built-in filament transformer. Requires 3-27 tubes for operation. Works with all sets. Your price, less tubes... \$4.00

No. 224-5-Tube DeLuxe Short Wave Receivers. Air-plane dial, plug-in coils, less tubes. Requires 2-58's, 1-58, 1-59, 1-80 for operation. Handsome black cracked finish cabinet. Your price, less tubes \$17.50

No. 7353 3-Tube 2-Volt Battery Short Wave Receiver. Complete with metal crystalline cabinet, including coil. Requires 2-30's and 1-31 for operation. Less tubes and batteries. Your price... \$7.70

No. 46 20-Watt Class "B" Amplifier Kits. 110 volts, 60 cycles. A.C. Requires 1-57, 1-46's and 82 rectifier for operation. Input to grid of 57; output 4000 ohms. Instructions included. Less tubes. Your price \$20.00

#### Tubes at "Give-Away" Prices

All these tubes are new, unused and boxed. WD12-38c; 201A-20c; 12A-20c; 20-44c; 20-18c; 35-33c; 40-40c; 71A-20c; 47-55c; 50-75c; 51-55c; 55-66c; 81-55c; 91 Triple Twin 50c; 93 Triple Twin-50c; ZHF (equivalent to 201A, excellent oscillator)-12c.

#### Tremendous Bargains in Microphones

(All Standard 100 ohm per button units.) No. F Faraday 2-Button Carbon Mikes. (Chromium Plated. YOUR PRICE... \$3.60

No. 8 Lifetime 2-Button Carbon Mikes. (Chromium Plated. YOUR PRICE... \$3.75

No. 22M Shure Bros. Professional 2-Button Carbon Mikes. YOUR PRICE... \$11.00

No. 11M Shure Bros. Professional 2-Button Hand Mikes. YOUR PRICE... \$7.25

No. 99B Shure Bros. Radio Modulator Public Address Converter. Converts any radio into Public Address System. YOUR PRICE... \$18.25

No. 1655 Single Button Lapel Microphone. Easily concealed. YOUR PRICE... \$1.30

No. 1654 Complete Microphone Input Stages including Single Button Midcut Mike, less battery. YOUR PRICE... \$4.80

No. 401 Professional Connectophones, Consists of Single Button Mike in cabinet with call button and single headphone. For intercommunication work. YOUR PRICE... \$4.80

No. 1562 Complete Microphone Impedance-matching Input stages for single button microphones. YOUR PRICE... \$2.65

No. 2352 Microphone Mounting Rings. YOUR PRICE... \$1.30

No. 88A Lifetime Microphone Table Stands. YOUR PRICE... \$1.50

No. 7270 U.S. Signal Corps Interphone Box for intercommunication work. YOUR PRICE... \$8.00

#### All Types of Condensers

**Electrolytics in Metal Cans**  
1 mf. rated at 300 volt-25c; triple 8 mf. section units 500 volts-\$1.05; double 8 mf. section units 500 volts-80c; single 8 mf. units, 500 volts-48c.

#### Electrolytics in Cardboard Boxes

Triple 8 mf. section units 500 volts-85c; single 8 mf. units 500 volts-35c; single 6 mf. units 500 volts-32c; single 4 mf. units 500 volts-30c; single 2 mf. units 500 volt-25c; single 25 mf. units at 50 volts 31c.

#### Duplicate Replacement Condenser Blocks

The following condenser block units are all available at the amazing price of only \$1.30 each. They are exact duplicates for the following receivers. Fada 35; Stewart Warner 930; Philco 87; Kolster K43; Brantdes B15; All American Lyric 90; Brunswick 14; Arphophone 45; Zenith E5; Fada KA60; Apex 42; Majestic 9011; Majestic 11; Kolster K24; Freed Eisenan NR80; RCA60; Steinlitz 70A; Atwater Kent 37. Your Price \$1.30 each.

#### Replacement Power Transformers

for the following receivers. Fada RA; Kolster 5517; Edison R1-Plate; Apex 8A; Kolster C6; General Electric 100MA; Majestic 7RP6-Plate; RCA 41; Fada 12. YOUR PRICE-ANY TRANSFORMER-\$1.75 EACH.

#### Audio Transformers and Filter Chokes

All type audio transformers... 40c each  
30-Henry Filter Chokes rated at 30 and 60 mls... 50c each  
Double 30-Henry Filter Chokes rated at 40 mls per section... 65c each

**TERMS:** Order directly from this "ad" and save money. 100% satisfaction guaranteed. All prices net, no further discounts allowed. No orders less than \$3.00. For C.O.D. orders send 20% remittance; balance C.O.D. Priority of shipment given to cash orders. **ACT NOW. FREE CATALOG** send 5c (coin or new U.S. stamps) for postage. Book by return mail.

**Radio Trading Co., 97 Hudson St., New York City**

### CRYSTAL RIBBON PRE-AMPLIFIER 70 D.B. GAIN - HUMLESS A.C. OPERATION



#### Modernize Your P. A. System

With this new RADOLEK All-Electric Pre-Amplifier. Builds up the gain so that the new latest style Crystal, Ribbon, or Dynamic mikes can be used with any standard two or three stage amplifier.

Entirely self contained—Operates from 115 volt, 60 cycle A. C. No batteries used. Input, impedance 5 megohms, grid to ground. Output, impedance 200, 400, 500, ohm or high "Z". Overall gain: 70 Db. (Practically humless!) Frequency Response: 40 to 9000 cycles. Standard input and output 4 and 5 hole sockets. Uses standard tubes: 80, 75, 77 as a triode! Fully shielded to prevent inductive hum pickup. Smooth silent volume control and power switch. Ruby Pilot Light and Twin-Choke, 26 Mfd. Filter. Compact size, only 14"x4 3/4"x8" high.

Price, Complete with tubes . . . . \$33.00

Standard Dealer Discounts Apply

FREE, 24 PAGE CRYSTAL-AMPLIFIER BOOK INCLUDING, "HOW TO MAKE MONEY ON P. A."

Secure Greater Radio Profits! Send for your copy of the 1935 Radio Profit Guide! Use your letterhead or card.

**The Radolek Co.**

590 West Randolph Street  
Chicago, Illinois

#### Index to Advertisers

<b>A</b>	<b>N</b>
Aerovox Corporation..... 622	National Radio Institute..... 579
Airex Company..... 630	National Union Radio Cor..... 627
Allied Radio Corp..... 616, 619	
Amperite Corporation..... 639	<b>P</b>
	The Plan Shop..... 632
<b>B</b>	Popular Book Corp..... 635
J. Mathewson Bell..... 616	Popular Medicine..... 636
Belden Mfg. Company..... 625	
	<b>R</b>
<b>C</b>	Radio Circular Company..... 622
Capitol Radio Research Labs..... 637	Radio City Laboratories..... 628
Central Radio Laboratories..... 633	Radio City Products Company..... 635
Classified Section..... 639	Radio Electric Service Company..... 624
Clough-Brengle Company..... 618, 637	Radio Publications..... 626
Coast-to-Coast Radio Corp..... 632	Radio Trading Company..... 640
Columbia Sound Systems, Inc..... 620	Radio Training Association..... 639
Cornell-Dubilier Corp..... 620, 625	Radolek Company..... 640
Coyne Electrical School..... 577, 633	Raytheon Production Corp..... Back Cover
Crowe Name Plate & Mfg. Co..... 624, 625	RCA Institutes, Inc..... 630
	Reudrite Meter Works..... 629
<b>E</b>	Remington Rand, Inc..... 637
Eilen Radio Laboratories..... 632	
Electrad, Inc..... 618, 625	<b>S</b>
Erie Can Company..... 625	S. O. S. Corporation..... 630
	Sexology Magazine..... 632
<b>F</b>	Shallcross Mfg. Co..... 628
Freed Radio Company..... 622	Shure Brothers Company..... 632
	Solar Mfg. Company..... 626
<b>G</b>	F. L. Sprayberry..... Inside Back Cover, 620
General Transformer Corp..... 631	Sprague Products Company..... 635
Goklentine Radio Company..... 632	Supreme Instruments Corp.....
Grenpark Company..... 636	..... Inside Front Cover
	<b>T</b>
<b>H</b>	Toledo Sound Equipment Labs..... 637
Hammarlund Mfg. Company..... 617, 625	Triplet Elec. Instrument Co..... 623
Harrison Radio Company..... 630	Try-Mo Radio Co., Inc..... 624
Hygrade-Sylvania Corp..... 621	
	<b>U</b>
<b>I</b>	Uncle Dave's Radio Shack..... 626
Insuline Corp. of America..... 639	
	<b>W</b>
<b>K</b>	Wellworth Trading Company..... 638
Kato Engineering Company..... 632	Weston Elec. Instrument Corp..... 615
Ken-Rad Corporation..... 618	Wholesale Merchandisers, Inc..... 628
	Wholesale Radio Service Co., Inc..... 624
<b>L</b>	Wright-DeCoster, Inc..... 626
Leotone Radio Company..... 630	(While every precaution is taken to insure accuracy, we cannot guarantee against the possibility of an occasional change or omission in the preparation of this index.)
<b>Mc</b>	
McGraw-Hill Book Company..... 631	
<b>M</b>	
M & H Sporting Goods Co..... 624	
Meissner Mfg. Co..... 625	
Multiplex Radio Service..... 628	

Please See That You Saw It in RADIO-CRAFT

# SPRAYBERRY

Announces

*New Help for Servicemen!* . . . **THE MOST SENSATIONAL SERVICE MANUAL IN YEARS**



F. L. SPRAYBERRY needs no introduction to thousands of servicemen throughout the world—men who owe much of their success to his advanced service training course or who have found practical help of enduring value in his numerous magazine articles. For years Mr. Sprayberry has concentrated his efforts on sound, advanced training for men already in the service business. No fluff, fancy bindings or meaningless theory—just practical aid presented in a practical way and at a price within easy reach of every forward-looking serviceman who can benefit from it.

## ANOTHER BOOKLET

**FREE!** In sending in the accompanying coupon with your order for "VOLTAGE TABLES" be sure and ask for our free booklet describing SPRAYBERRY'S ADVANCED MECHANICS OF RADIO SERVICE—the most helpful, lowest priced advanced study course for servicemen—one which has paved the way for more efficient work and better profits for servicemen in every state of the United States and Canada. NOT a course for beginners, but one designed exclusively for the aggressive serviceman who is looking for ways and means of forging ahead. It will cost nothing for you to investigate.

**GUARANTEE:** Like all Sprayberry publications, "VOLTAGE TABLES FOR BROADCAST RECEIVERS" is sold under a strict money-back guarantee. If, within three days, you are not more than pleased you can return it for full credit less only the postage. Nothing could be fairer!

# VOLTAGE TABLES

## FOR BROADCAST RECEIVERS

**N**OW, in ONE convenient volume you can get essential information to enable you to service radio receivers quickly and accurately. No more guesswork as to voltages—no more lost time in searching for proper voltage information in scattered sources. Never before has any service manual offered the help available in Sprayberry's "VOLTAGE TABLES" in such handy form and at such low cost.

"Voltage Tables" has in excess of 250 pages containing more than 1500 complete voltage tables on radio broadcast receivers made in the United States and Canada from 1927 up to the present date. Obtained direct from manufacturers service information, these have been TRIPLE-CHECKED for accuracy. They include the normal voltage values for each tube element of a set, thus reducing the work of servicing to the simplest possible form. With this book you know *exactly* what voltage should be measured at each socket—you can go to the *root* of the trouble in short order. New voltage tables will be issued from time to time so that your book may always be up-to-date.

Book is 8½ x 11" and so compact you can carry it in your service kit. Lies open on bench. Durable fabric cover. Six large, easy-to-read voltage tables to a page. *Completely cross-indexed—you can find any desired table in an instant.*

## ALSO - A TREATISE ON VOLTAGE ANALYSIS

In addition to more than 1500 Voltage Tables, this new Sprayberry volume contains in a separate section a complete treatise on voltage analysis. Here you learn step by step how to interpret voltage tables in terms of normal and abnormal operation—what to look for, etc.

**ONLY 5000 COPIES OF THIS FIRST EDITION AVAILABLE GET YOURS While They Last**

The first print order for Sprayberry's "VOLTAGE TABLES FOR BROADCAST RECEIVERS" calls for *only* 5000 copies. According to present plans, it will be several months before another edition is printed. Thus, to insure receiving yours promptly we earnestly suggest that you order at once, on the attached coupon. You can't lose!

**ONLY \$2**

**While the Edition Lasts**  
Never before in your service career have you had an opportunity to invest \$2 to such good advantage.

**250 PAGES - 1500 TABLES**  
A COMPLETE MANUAL IN ITSELF!

FAIRBANKS - MORSE

TUBE TYPE	SOCKET	B-V	P-V	SO-V	CO-V	A-V	SP-V	HT-V	P-P-V
606	1RF	6.15	225	100			17	27	
606	2RF	6.15	225	100					
6A7	1D0	6.25	235	100					
606	2F	6.15	235	100			17.5	27	4.5
6B7	2D	6.15	35	3C			17.5	27	5.5
6E	AF	6.15	225	235	1				
80	A		13C						235

A greatly reduced illustration of a specimen Voltage Table. Six of these are printed to a page in large, easily read type.

## USE THIS COUPON—TODAY!

**F. L. SPRAYBERRY** 2548 University Pl., N. W., WASHINGTON, D. C.

Enclosed find  check or  money order for \$2 for which please rush me postpaid a copy of your new service manual VOLTAGE TABLES FOR BROADCAST RECEIVERS containing 250 pages and more than 1500 voltage tables, etc.

Please send without charge a copy of your booklet describing "SPRAYBERRY'S PRACTICAL MECHANICS OF RADIO SERVICE."

Name .....

Complete Address .....

RC-4-35

**YOU MUST BE SATISFIED . . . SOLD UNDER OUR MONEY-BACK GUARANTEE**



# Factory Sealed!

## TO GUARANTEE LABORATORY QUALITY

More than 95 minute pieces of wire, metal and chemicals are processed with microscopic accuracy into the assemblage of a Raytheon Tube.

4-Pillar support anchors these elements rigidly and gives Raytheon Tubes a matchless sturdiness and makes them outstanding favorites, particularly where dependability and long life are vital factors. Now Raytheon Tubes are packed in "Factory Sealed" Cartons.

Sold by good radio dealers. Recommended and used by reputable service men everywhere.

**Dealers Note:** New 1935 displays are ready — use the coupon.

**Service Men Note:** 1935 Tube Characteristic Chart now available—use the coupon.



**TO TEST**  
Do not break corners. Push tube downward in box.

**RAYTHEON PRODUCTION CORPORATION**  
30 E. 48 St. New York    55 Chapel St. Newton, Mass.    445 Lake Shore Dr. Chicago    555 Howard St. San Francisco

**RAYTHEON**  
TRADE-MARK  
**4-PILLAR RADIO TUBES**

RAYTHEON PRODUCTION CORP.,  
Dept. E-4, 30 E. 48th St., New York, N.Y.

Please send  1935 Display Material  1935 Tube Chart

Name \_\_\_\_\_

Address \_\_\_\_\_

Dealer: ( ) ( ) \_\_\_\_\_ Service Man: ( ) ( ) \_\_\_\_\_