

Proceedings of The Radio Club of America

Volume 37 No. 3

FALL, 1961



Founded 1909

THE ANATOMY OF AN ELECTRONIC TYPewriter

BY

WALTER HLADKY, PROJECT ENGINEER

SHEPARD LABORATORIES, SUMMIT, N.J.

THE RADIO CLUB OF AMERICA, INC.

11 West 42nd Street ★ ★ ★ New York City

FOUNDED 1909 NEW YORK, U.S.A.

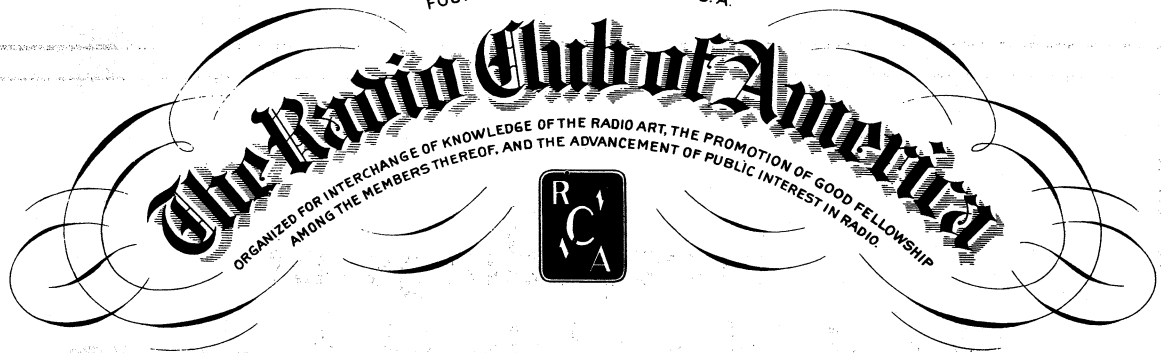

11 West 42nd Street, New York City

Telephone — LOnacre 5-6622

Officers for 1961

President

R. H. McMann, Jr.

Vice President

George Washington, Jr.

Corresponding Secretary

James Morelock

Treasurer

Joseph J. Stantley

Recording Secretary

Albert F. Toth

Directors

Ernest V. Amy
Ralph R. Batcher
John H. Bose
George E. Burghard
Frank A. Gunther
Samuel N. Harmatuk

Harry W. Houck
Walter A. Knoop
Lloyd Jacquet
Jerry B. Minter
Alexander Proudfit
Frank H. Shepard, Jr.

Committee Chairmen - 1961

Affiliations

Walter Knoop

Manuscript

George Washington, Jr.

Armstrong Memorial

George E. Burghard

Medals

Harry W. Houck

Budget

Joseph J. Stantley

Membership

Robert Finlay

Banquet & Entertainment

Albert F. Toth

Papers & Meetings

Samuel N. Harmatuk

Legal Counsellor

George E. Burghard

Publications

Ralph R. Batcher

Publicity

Lloyd Jacquet

PROCEEDINGS OF THE RADIO CLUB OF AMERICA

PUBLICATION BOARD

Editorial Director

Ralph R. Batcher

Production Manager

James Morelock

Advertising Manager

Lloyd Jacquet

Papers Procurement

George Washington, Jr.

PROCEEDINGS OF THE RADIO CLUB OF AMERICA

THE ANATOMY OF AN ELECTRONIC TYPER

by

Walter Hladky, * Project Engineer

Shepard Laboratories, Summit, N. J.

The Shepard Electronic high-speed typer, a companion unit to the high-speed computer, prints the information processed and delivered by the computer. The high-speed electronic typer appeared in 1950, just several years after the appearance of the practical, economical, and generally usable computer. The first successful typer was of the impact variety although at the outset, leading authorities feared that impact typers would never attain the very high speeds needed by this computer, because of their inherent mechanical limitations. However, these limitations were found to be less severe than as first thought.

static latent image is made visible by means of powered ink permanently fixed by heat. In the magnetic technique, the magnetic latent image is made visible by exposure to a ferromagnetic powder attracted to the magnetized portions of the paper and fixed by heat. In the photographic technique, micro film photographs are taken of characters displayed on a cathode ray tube which has a persistence of several microseconds.

Being unable to match the speed of the computer is not a drawback, because of the successful use of a "Time Buffer" which can record the computer output at high speeds and deliver it later at lower speeds suitable to the typer.

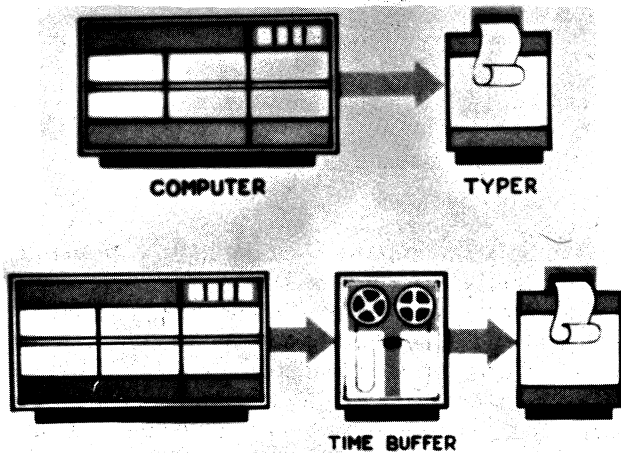

Figure 1. The Computer-Typer System

Now after eleven years the impact typer is considered a practical machine, comparing favorably with other printing techniques developed meanwhile. These other techniques, which are all non-mechanical, include electrostatic printing, magnetic printing, and photographic printing.

In the electrostatic technique, a controlled source of electricity forms small charged areas on the surface of a coated paper and the electro-

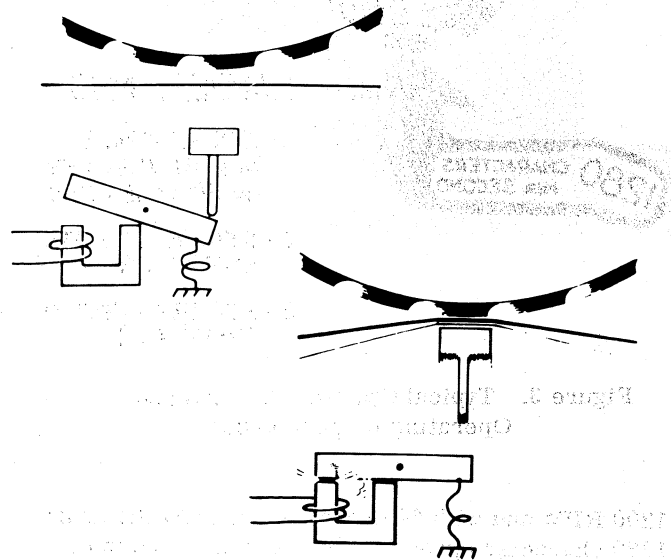

Figure 2. Mechanical and Electro-Mechanical Section of the Typewriter

The mechanical and electromechanical parts of an impact-type mechanical typer include a character drum, a hammer, and an armature-solenoid assembly.

*Engineer-Designer, Shepard Laboratories; Member, Radio Club of America

The character drum consists of a group of type wheels mounted and keyed on a continuously revolving shaft. Each wheel contains 64 type characters equally spaced around its periphery, and it is so mounted with respect to the other wheels that similar characters are placed side by side along the longitudinal axis of the drum. Although the characters can be placed in any order of sequence around the wheel, the Shepard Typers usually have the characters arranged in their natural order.

The conversion of electric energy into kinetic energy takes place in the armature-solenoid assembly. Impact is provided by the hammer. Despite the fact that the Typer operates with mechanical motion it can be made amazingly fast. High speeds are attained because the moving parts have small mass (3 grams), move only short distances (1/16-inch), and are driven with considerable force (5 horsepower). At an operating speed of



Figure 3. Typical Operating Speeds and Operating Requirements

1200 RPM and with 64 characters around the drum, 1280 characters pass the face of a print hammer each second.

The practical requirements for the typer parts to fulfill are:

- (1) The hammer must strike a character once per revolution of the drum, or 20 different characters per second (when printing at a rate of 20 lines per second).

- (2) The hammer must strike a selected character.
- (3) It must hit the characters full face each time.
- (4) Finally, it must hit the paper and ribbon with sufficient impact to make a worthwhile print without leaving a noticeable smear.

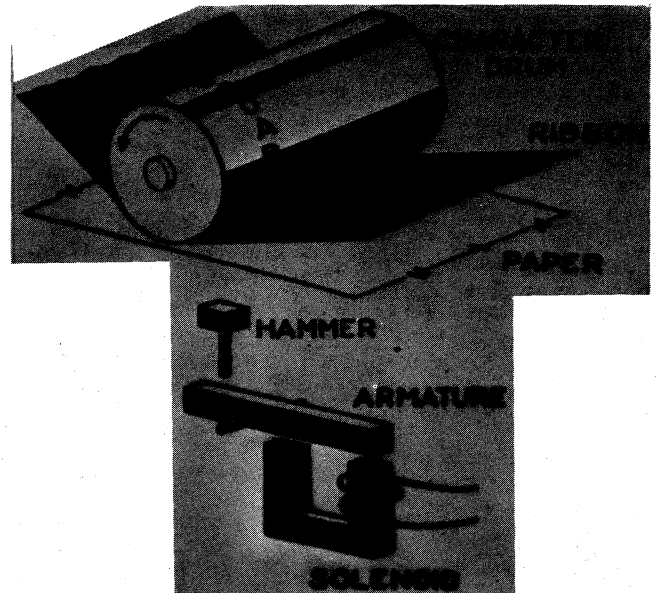

Figure 4. Armature-Hammer Action

In the initial state, the hammer is at rest and the armature is in an open position. Upon receiving an electric current of sufficient intensity, the solenoid attracts the armature which impels the hammer swiftly toward the character drum. The hammer is permitted free flight for a short distance before it reaches the character drum. At the proper instant, the hammer hits its mark, leaves an imprint on the paper, and rebounds. By virtue of the compression wave which travels through the hammer after impact and the subsequent tension wave, the hammer first dwells against the paper for 50 microseconds then rebounds abruptly, leaving a negligible smear, which actually has a sharp edge that appears to be a part of the intended print and consequently is unnoticeable.

The dwell depends upon the construction of the hammer and is independent of the hammer velocity. Since the hammer has a specific velocity (i. e. kinetic energy) as it travels toward the drum, the

time-pressure curve of the hammer bearing against the drum is only secondarily affected by the thickness of the paper and ribbon combined.

This means that the printing pressure is constant, correct, and independent of whether printing is being done on one copy or several copies. When many copies are printed, energy is absorbed by the paper, the carbon, and the ribbon. Consequently the rebound velocity is reduced but the pressure-time curve is substantially the same as for the case in which a single copy is printed.

Since the time-pressure curve of the hammer is an inherent with its physical characteristics, it is not subject to adjustment and hence can never get out of adjustment. The time and pressure are finite so that no destructive wear, fatigue, or deterioration of the parts will occur even after billions of operations. Shepard typers have averaged over 1/2 million lines a day for periods of many years without detectable signs of deterioration in any of the eighty Shepard typers now in service. Not one hammer or print wheel has ever had to be replaced because of wear.

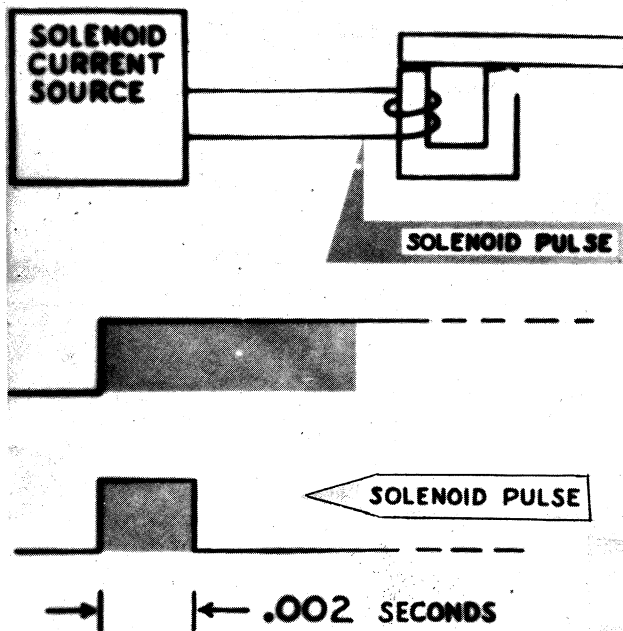

Figure 5. Solenoid Current Waveforms

An electric current of sufficient intensity to cause the solenoid assembly to impel the hammer with necessary momentum is supplied by a simple high-power electronic amplifier stage. Once the

armature hits the stop and the hammer is in free flight there is no further need to supply additional power to the solenoid. It would be wasted as heat, therefore it is cut off after a short duration. On the other hand, if the power is cut off too soon, the hammer will not receive sufficient drive. Thus, this motivating power is timed accurately.

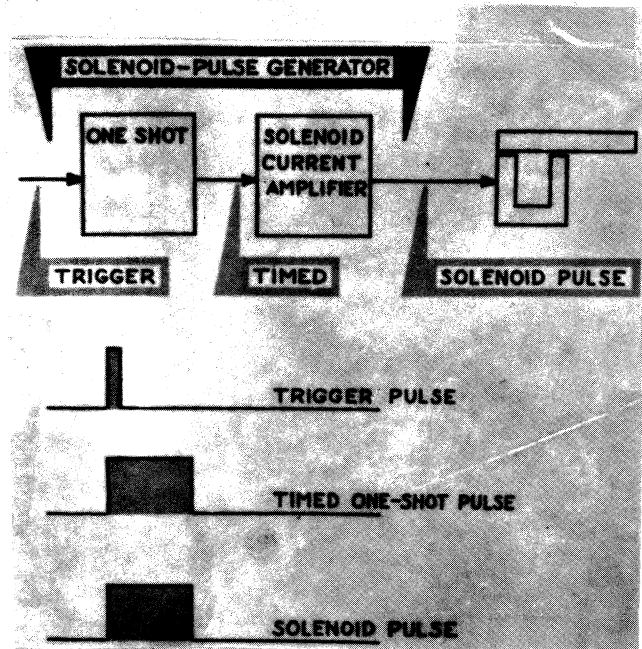

Figure 6. Solenoid-Pulse Generator

Timing is accomplished by an electronic one-shot pulse generator (multivibrator) which supplies a precisely timed pulse to drive the current amplifier stage. These two stages are combined into one circuit called the "Solenoid Pulse Generator". A short "Trigger" pulse is supplied precisely timed so that the previously inactive hammer will strike the character desired -- and hit it full face.

Since the characters travel at 180 inches per second, "Timing" is the first major task for the electronics. Since there are 64 possible character choices, "Character Selection" is a second major task for the electronics. And in order to accomplish character selection the third task is to give "Identity" to the signals used for printing. These three tasks are fulfilled by two separate sections of the electronic system: The Synchronization Section and the Decoder Section.

The Synchronization Section generates both the accurately-timed pulses that assure full face

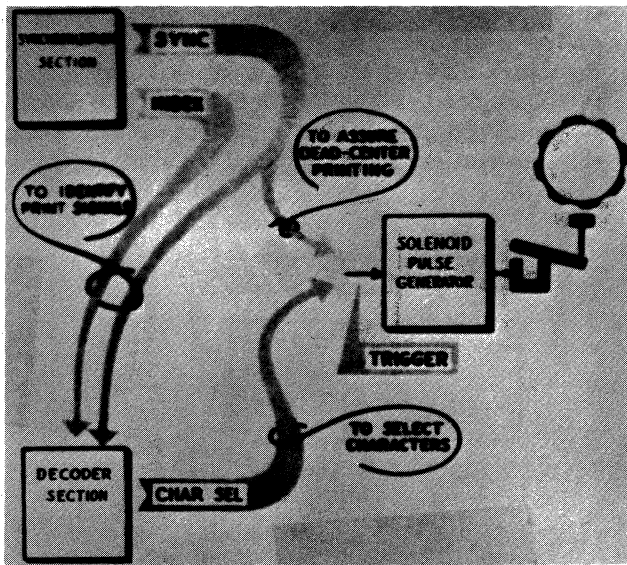

Figure 7. Major Electronic Sections

printing and the indexing pulse that is used for identifying the print signals. Since the characters are in constant motion, a definite spatial-time relationship must exist between the position of the characters and the delivery time of the trigger pulses. The "synchronization" signals are generated as follows:

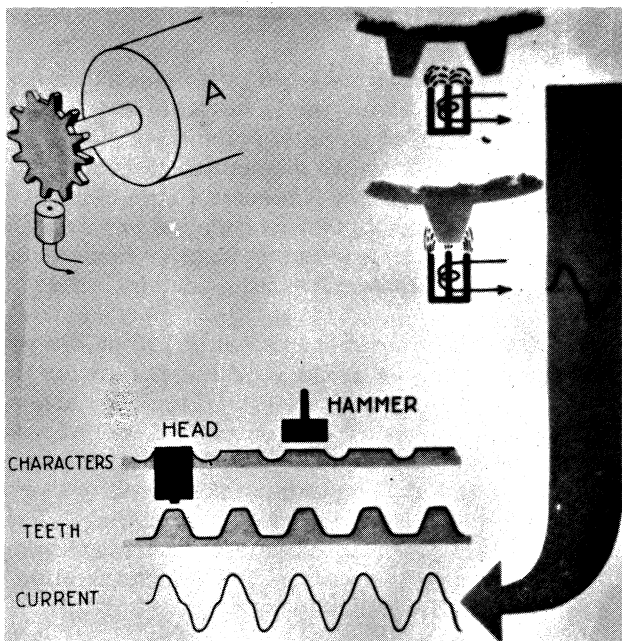

Figure 8. Sync Signal Source

The first step is clocking the characters as they approach the print position. Of the many ways by which this can be accomplished, the Shepard Typers employ a steel timing gear and a reluctance-type magnetic pickup head arranged to generate signals by virtue of magnetic flux changes. The gear contains as many teeth as there are characters, and each tooth corresponds in position to a character. At times when the magnetic field is undisturbed, the head does not deliver a signal. Each time a tooth passes the head, the magnetic field is disturbed and a signal current is developed. As the gear rotates, the current waves are delivered in synchronization with the characters passing the hammer.

Although their timing is proper, these signals are too small to trigger the solenoid-pulse generator, and they are not properly shaped, they contain noise created by the impact shocks transmitted from the drum to the gear, and they contain phase distortion due to mechanical imperfections in the gear.

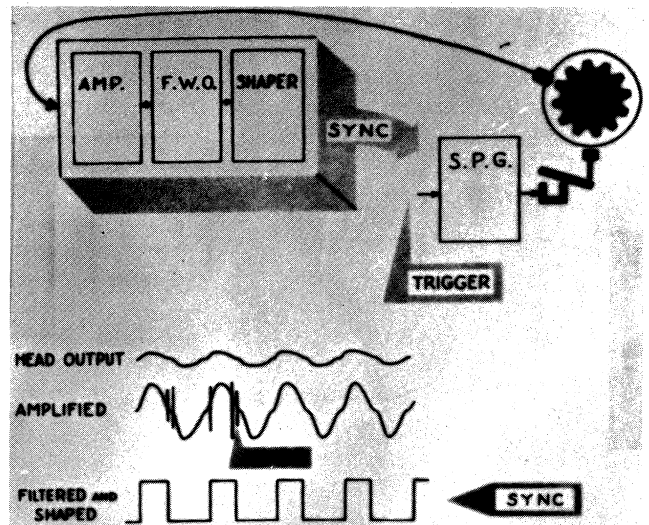

Figure 9. Sync-Pulse Generation Process

To be useable they are first amplified, then by means of a flywheel oscillator they are filtered of extraneous noise and cleared of phase distortion, and finally shaped into sharp rectangular pulses suitable for triggering.

These signals now have proper shape and timing, but since they are supplied in a continuous, unbroken train they have no identification with respect to the print station. Therefore an electronic circuit relates each pulse with a character type.

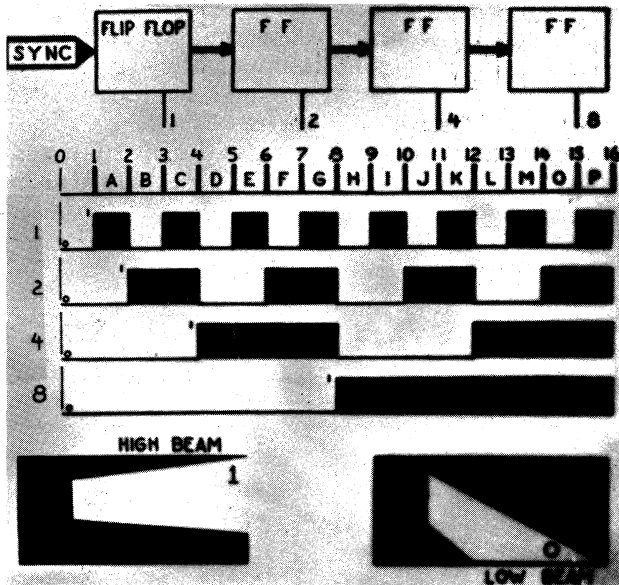

Figure 10. Index-Pulse Source

This identification originates at the same timing gear and pickup head that generates the sync pulses: A tooth related to a specific key character is removed from the gear. Thus a gap appears in the train of teeth and in the amplified pickup pulses. As the sync signals progress through the flywheel oscillator, the oscillator inserts the missing pulse by flywheel action; consequently, a gap does not appear in the sync signals -- they remain in a continuous unbroken train. An "Index" pulse is formed at the gap by passing the amplified pickup pulses through a discriminator. This is illustrated in the waveforms of Figure 10. After leaving the amplifier stage, the pickup signals are clipped, formed into rectangular pulses by a shaper circuit, integrated, and finally passed on to a discriminator stage. The sawtooth pulse associated with the gap extends much lower than any of the others. The discriminator detects this extended pulse, and its amplitude drops below a fixed bias level and generates the Index pulse required for sync signal identification.

The first character that appears in print position after the occurrence of the Index pulse is the first of the series of characters to pass the hammer in sequence. If this first character happens to be an "A" then the first sync pulse appearing after the index pulse will be related to that "A". The prospective trigger pulses now have accuracy, form, and identity. Now, it is only a matter of selecting a specific pulse to print a specific character. This task is carried out by the "Decoder" section.

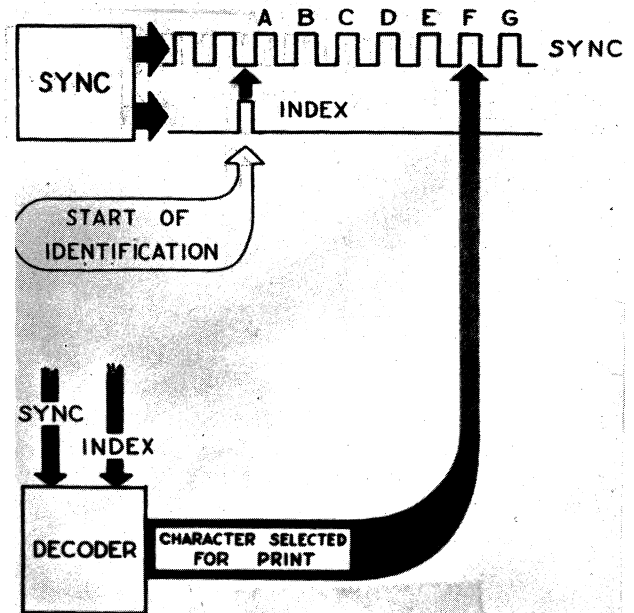

Figure 11. Identification System

Fundamentally, all that needs to be done is to count the sync pulses as they occur in sequence, and to select the one associated with the desired character to be printed for the trigger pulse. The essential circuit in the decoder is a counter. A binary counter suits the purpose excellently.

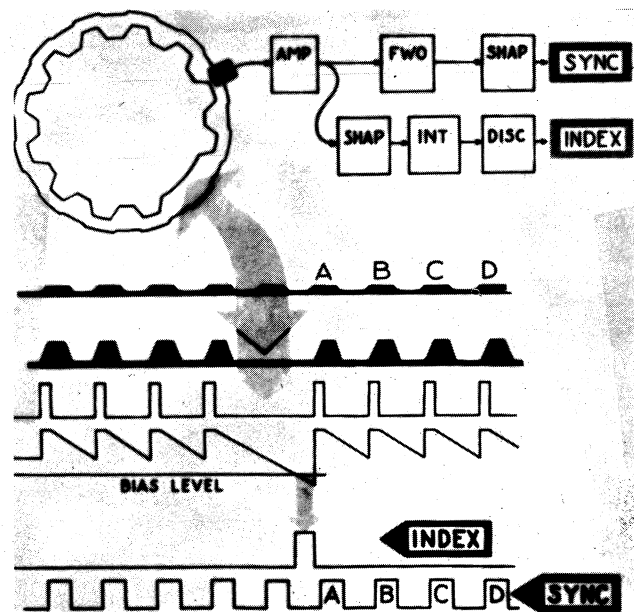

Figure 12. Binary-Counter Output Wave Forms

A binary counter consists of a number of identical circuits connected in tandem, as illustrated. Each block shown in Figure 12 is a flip-flop, an electronic equivalent of a mechanical toggle. Each time a flip-flop is served with a pulse it transfers from one to the other of its two possible states, just as the headlights of an automobile transfers from high-to-low or low-to-high beam with each successive tap upon the floor switch.

The first flip-flop receives the sync pulse in a continuous, unbroken train, and transfers with each pulse. The second flip-flop is driven by pulses delivered from the first flip-flop each time the latter flip-flop transfers from high-to-low. Consequently, the second flip-flop transfers once for each two transfers of the first flip-flop. By arranging the subsequent stages similarly, the flip-flops operate as depicted by the chart of Figure 12. A study of the chart will reveal that the combination of states beneath any character is unlike any other combination. For instance, the code for F is 0-1-1-0, the only such code on the chart.

Being driven by an endless train of incoming sync pulses, the counter counts constantly continuously. The counter shown in Figure 12 counts up to sixteen then starts all over again. A five stage counter will reach 32 counts then repeat, whereas a six stage will reach 64 counts and repeat.

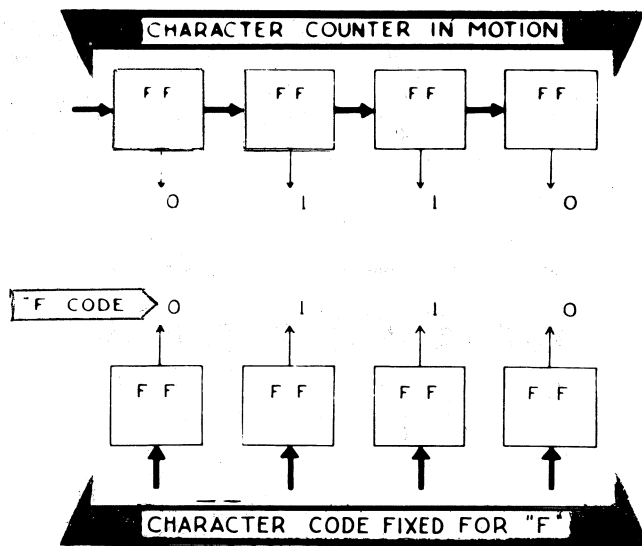

Figure 13. Character-Code Flip-Flops

Identification is accomplished by a second group of identical flip-flops isolated from each other but which can be individually set into either a "0" or "1" state and remain fixed that way until changed by external signals. For the purpose of illustrating the development of a character-selection signal, the flip-flops are shown arbitrarily set into an "F" code 0-1-1-0. It is only a matter of matching these fixed signals with the counter chain signals to select a specific pulse.

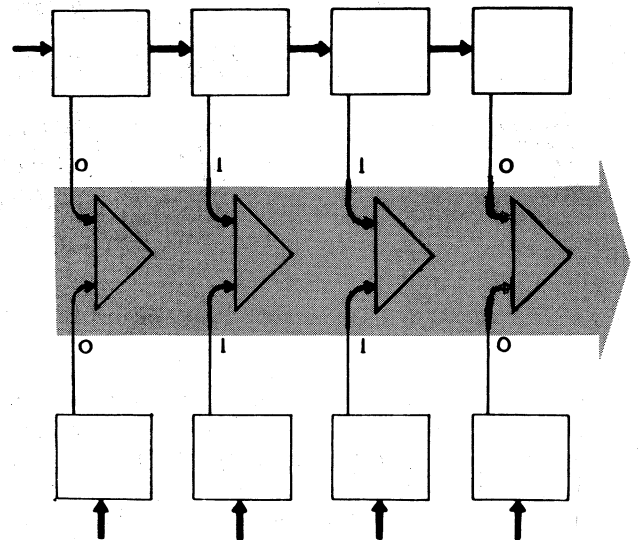

Figure 14. Matching Gates (Coincidence Stage)

Matching is accomplished by a group of matching gates: When similar signal levels are applied to its two inputs it will deliver an output signal. A complete set of matching gates arranged as an AND gate circuit is called the "Coincidence Stage". Although it is not shown in Figure 14, the index pulse is supplied to each and all of the counter flip-flops simultaneously to set them into the initial "0" state at the beginning of the count.

After the appearance of the index pulse, the counter delivers its signals in successive combinations and when the one that matches the combination held by the "code" flip-flops is reached coincidence occurs and a "character selection" pulse is generated. Figure 16 shows where the "character code" signals enter the system. These code signals originate at the computer and are supplied by either the computer directly, or indirectly through the time buffer.

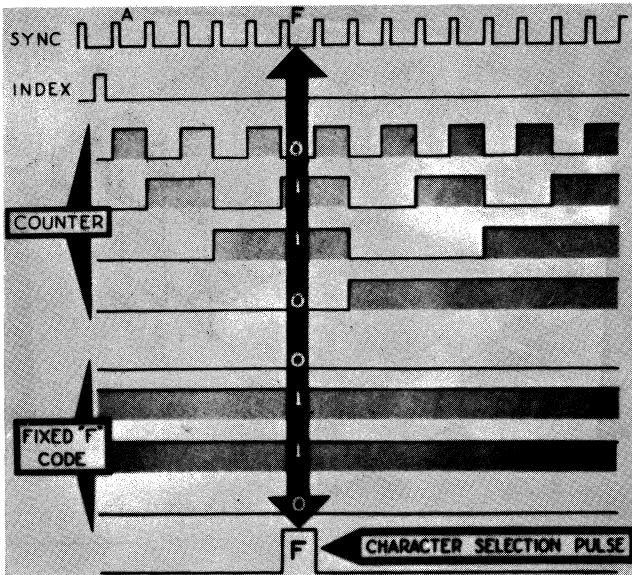

Figure 15. Generation of Character Selection Pulse

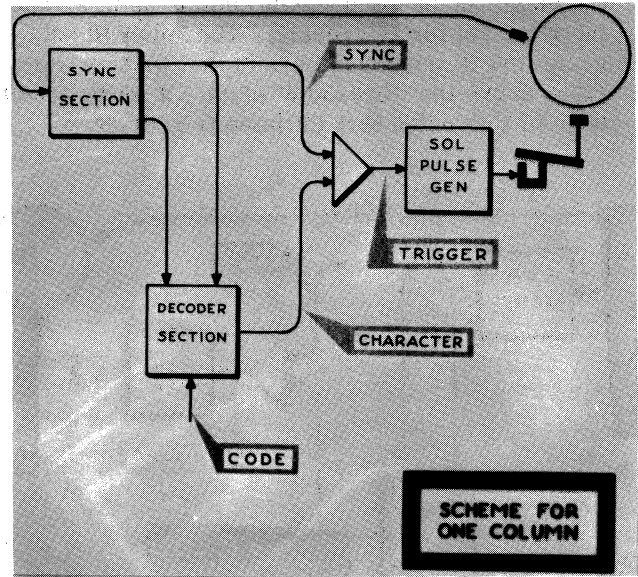

Figure 17. Gate at Which Sync Pulse and Character Pulse Combine to Form Trigger Pulse

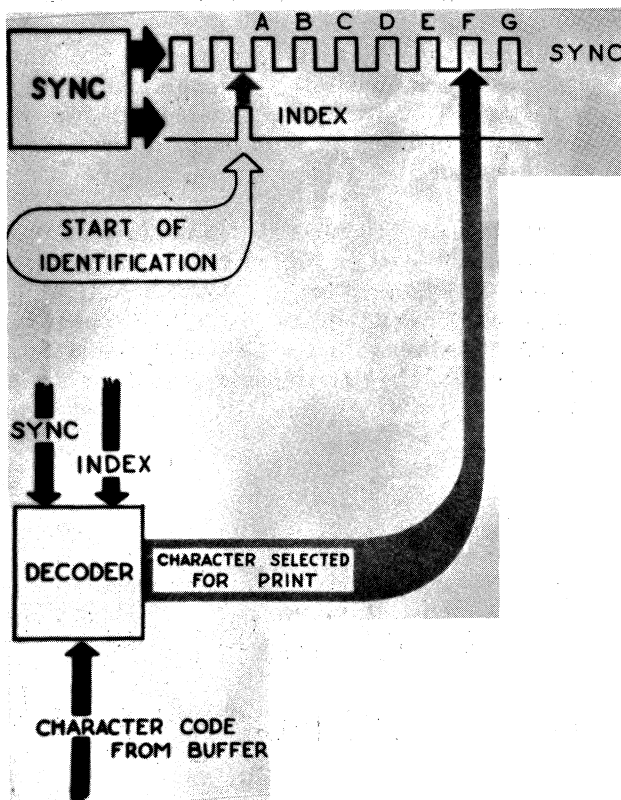

Figure 16. Character Code Entry

The signal resulting from combining the synchronization signal and the character-selection signal in a gate is the ideal "Trigger" pulse. It fulfills all the requirements for driving the solenoid-pulse generator, having the proper shape, timing accuracy, and identification.

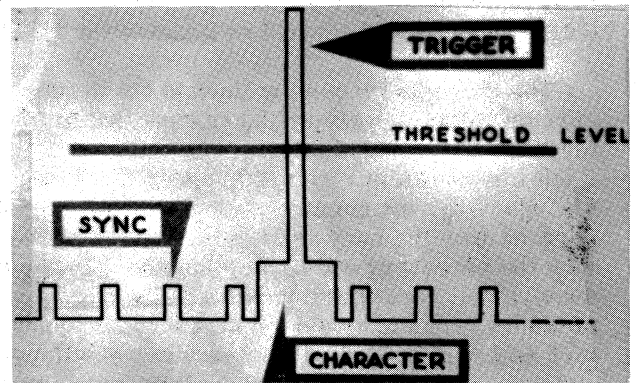

Figure 18. Trigger Pulse Formation Method

The waveform of figure 18 shows how the sync pulses and the character-selection pulse combine in the gate to form the trigger pulse. The character-selection pulse provides a pedestal

upon which the sync signal (which occurs during the existence of the pedestal) builds up to an effective level for triggering. The solenoid pulse generator is triggered by only that portion which rises above the "threshold" level. It is the leading edge of this pulse that initiates triggering.

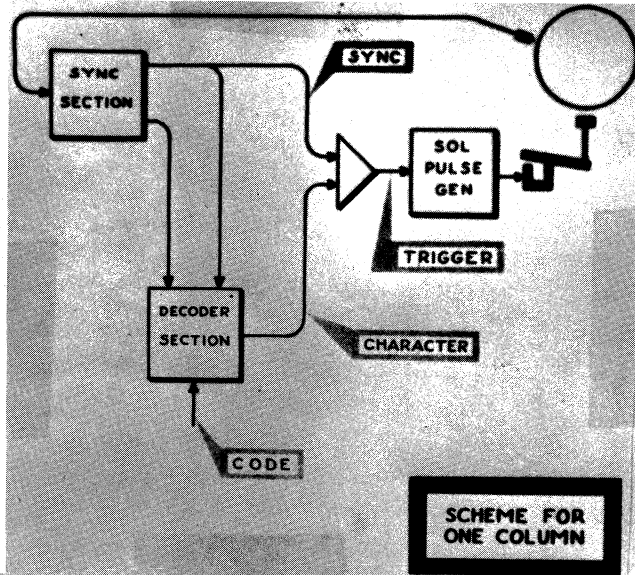

Figure 19. System Scheme for One Column

With the circuitry as described this far, the system is able to print a selected character in one print column. Figure 20 shows the typical distribution of signals to several columns of the typer.

The individual incoming lines to the decoder carries voltage levels in binary code that are held for the time required to print one complete line. Each line shown in Figure 20 represents 4, 5, or 6 conductors, the number of conductors being dependent upon the number of bits required to provide the necessary code. For instance, four conductors will permit sixteen different combinations of binary codes to reach the decoder; five conductors will supply thirty-two binary combinations; and six conductors will furnish sixty-four binary combinations.

The chart in the lower, right corner of Figure 20 shows the sequence in which the trigger pulses appear in three typical columns of the printer. If there had been a need to print an "F" in other columns, such as, columns 9, 17, 31, etc., those F's would have been printed simultaneously with the "F" appearing in the column shown in figure

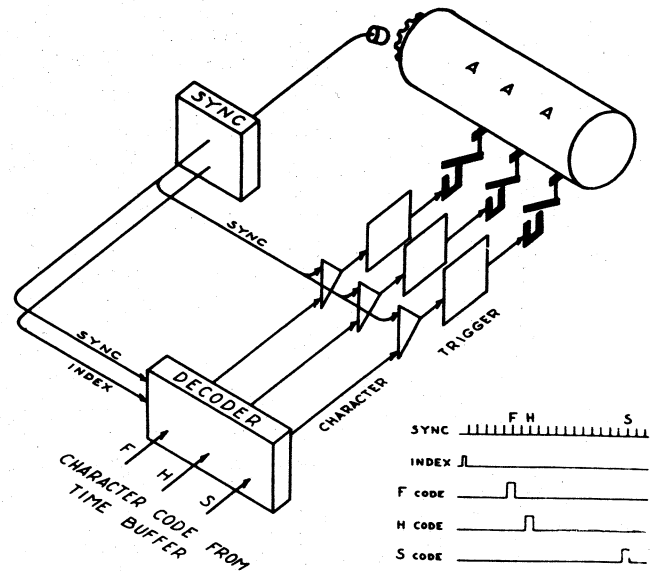

Figure 20. Typical System Scheme For Three Columns

20. In other words, all similar characters print out simultaneously in their respective columns.

After all the characters around the drum have passed the print position, one cycle of operation is partially finished. The remainder of the cycle involves the advancement of paper to the next print position.

As the system stands at this point, it is free-wheeling and printing occurs continuously without a stop. Unless printing is stopped briefly while the paper is in motion, print-out will appear in the space between lines. Therefore, printing must be controlled and co-ordinated with paper movement.

FIRST LINE THIS IS A SAMPLE
 SECOND LINE OF PRINT MADE
 THIRD LINE ON MOVING PAPER

Figure 21. Print Sample on Moving Paper

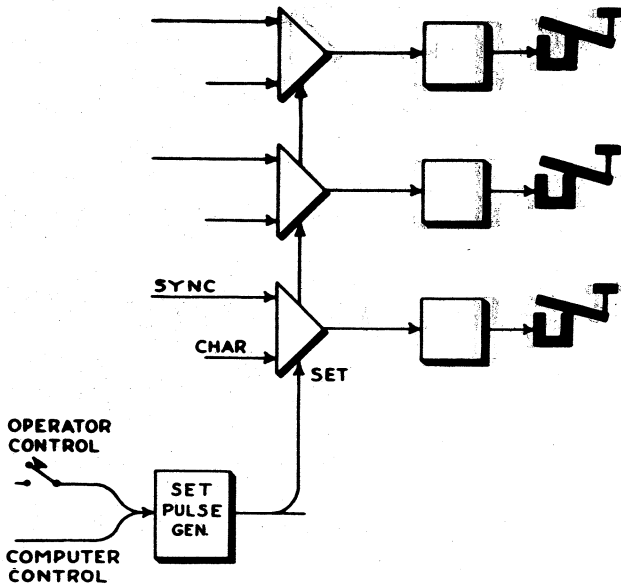

Figure 22. Print Control Scheme

The gate at which the trigger pulse is formed is the most logical and convenient place to control printing. This gate shown in Figure 22 is so arranged that it will not deliver a trigger pulse unless it is "set" to do so. Once it has been set, however, it will then pass the first trigger pulse that comes along. This gate is also arranged so that it will "reset" itself, much like a fired rifle uncocks, when the trigger pulse has been delivered. The gate can be set at any random time, either manually by an operator, or automatically by the computer or buffer.

Upon delivering the trigger pulse, the gate resets and does not deliver another trigger pulse until it is again "set". The next set pulse can be held back while the paper is being advanced and the incoming character codes are being changed. At the instant an operator presses the push button or the computer or buffer supplies a signal, a "Set Pulse Generator" delivers a "Set" pulse to all column gates simultaneously. Then as soon as all the individual gates receive their "character-selection" pulse, respective trigger pulses are delivered and specific characters are printed for the line.

The typer is now ready for the paper-advance operation, which is accomplished by means of a solenoid assembly, similar to that used for im-

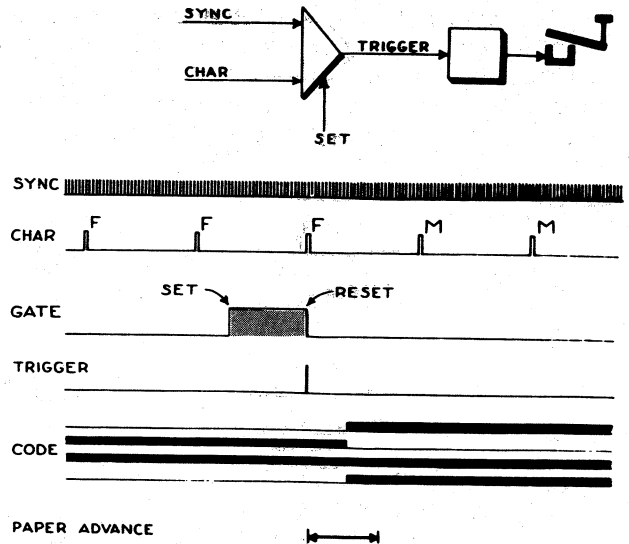

Figure 23. Typical Distribution of Set Pulse

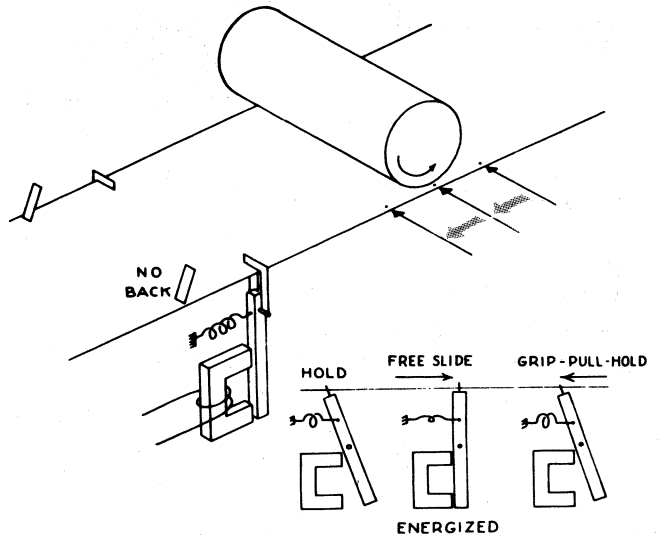

Figure 24. Paper-Advancing Mechanism

pulling the hammer, with the addition of a pinch mechanism mounted on the end of the armature as shown in figure 24. The pinch mechanism grips the paper firmly as it tends to move in one direction with respect to the paper and slides freely over the paper while moving in the opposite direction. The paper is up spaced in short, swift advances.

This solenoid, like the hammer solenoids, is also energized by a solenoid pulse generator. And this generator is also actuated by a trigger pulse, in this case, called the "Paper Advance" trigger pulse. This trigger is brought about by a com-

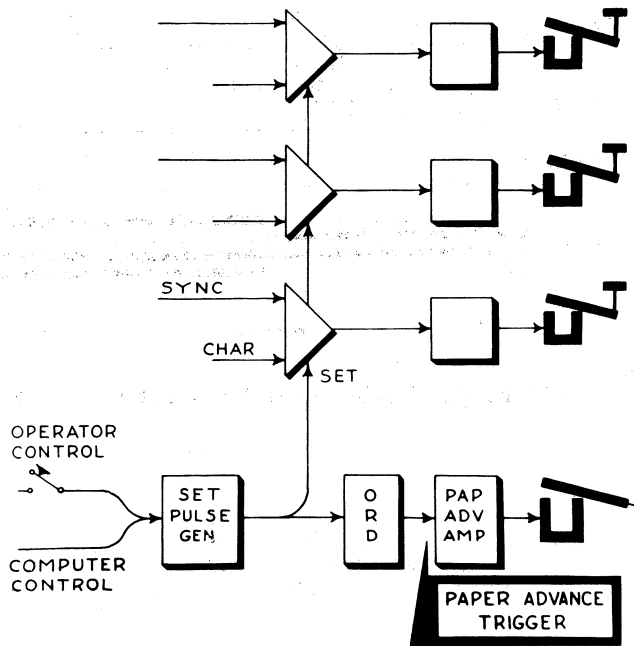

Figure 25. Paper-Advance Circuitry

pletely different scheme than is used for the print trigger. The "set" pulse which sets the hammer-trigger gates is simultaneously supplied to a "one-revolution delay" stage (ORD). The purpose of this stage is to deliver a pulse precisely one-revolution time later after it receives the actuating "set" pulse.

Thus, the paper-advance solenoid pulse generator doesn't receive a trigger pulse until one-revolution time after the gates received their set pulse. Consequently, the paper is not moved until all the characters have had their opportunity to be considered for print.

The chart in figure 26 shows several sequences of signals and operation of the typer. For logical purposes the "Control" signal discussed previously will now be appropriately called the "Print then Paper Advance" signal, and the "set" signal will now be called the "Okay to Print" signal.

To illustrate the timing relationship between various signals and operations, the chart was pur-

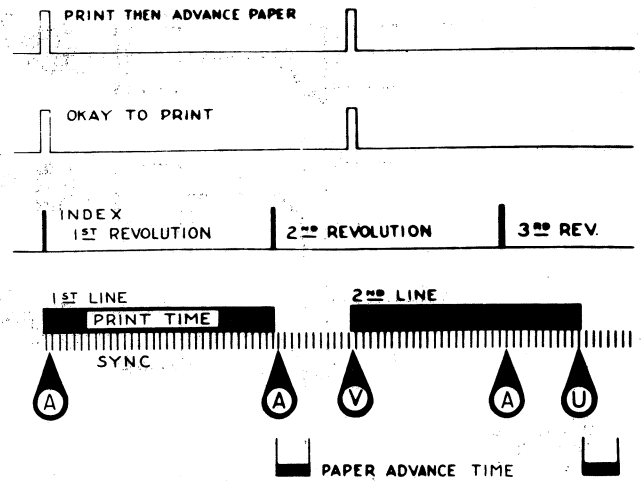

Figure 26. Typical Typer-Operation Sequences

posedly arranged to show the index pulse occurring simultaneously with the appearance of the first "Okay to Print" pulse.

As the character drum rotates, and the characters appear in print position, each character is considered at least once for printing starting in this case with the "A". As illustrated in the chart, printing ceases just before the A comes around for the second appearance. Paper is moved immediately after the last character around the drum has been considered for printing. Printing of the second line does not start until the paper is at rest.

As shown in the chart, the second "Print then Advance Paper" pulse arrives by the time the second revolution has progressed to the "V" character. Actually, printing can begin at any character that appears immediately after paper becomes motionless.

Notice that the second line was printed partially in the second revolution and partially in the third revolution.

In this chart, the timing is based on a 64-character font. The characters include the twenty-six alphabets, ten numerals, and twenty-eight symbols such as ? / ! . , # \$ * () - & etc.

Printing across a whole line takes place in the same "Print Time" interval regardless of whether there are 10 columns or 190 columns in the typer. This is so because, as mentioned before, all similar characters are lined along the longitudinal

axis and when the A character is in print position the A will print out simultaneously in all columns calling for an A; this might be in columns 1, 17, 33, 77, etc.

A typer arranged to print only ten numeric characters has a correspondingly shorter "Print Time"

consequently, its printing rate is considerably faster.

A standard 120-column Shepard typer, operating at a 1200 R. P. M. drum speed, delivers 2400 characters or 480 five-letter words per second (1,000,000 words in approximately 35 minutes).

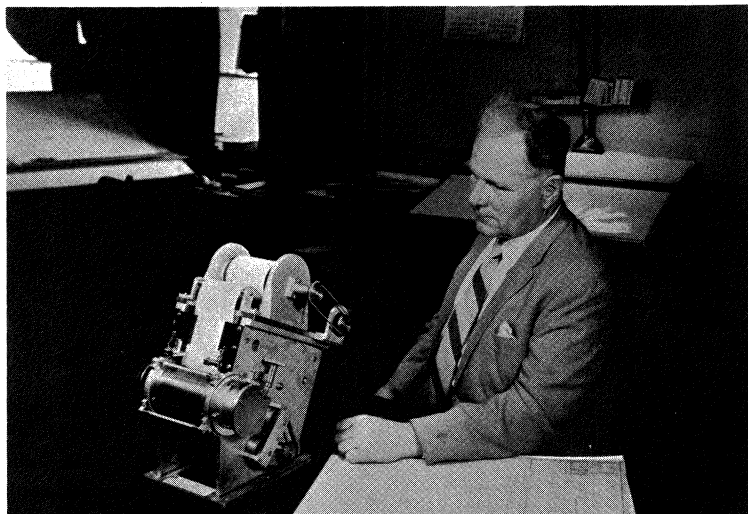

President F. H. Shepard, Jr. of Shepard Laboratories, Inc., Summit, N. J., views his new Shepard Minityper, which he developed for the U. S. Navy's POLARIS Project.

Not too long ago, all sizeable merchandizing houses employed a staff of clerks whose duties were to process all sorts of business information concerning purchases, sales, receipts, inventories, just to mention a few. These clerks, acting on specific instructions, performed detailed work winding up the day's work with numerous tabulations, summaries, or records of the business activity. Whatever their output was, such as statements, order lists, inventory tabulations, commissions, these were all prepared in a directly useable form for analysis or study by other personnel.

Today, these clerks could be replaced by high speed computers, which are programmed with instructions to carry out the same work done by the clerks but in much greater volume and in much less time. But the computer does not deliver its work in a directly useable form for analysis and study by interested personnel. It is up to the "printer" to convert the computer's information into that useable form. An extremely ingenious and relatively inexpensive printer for such work is described here. Routine clerical

work such as payrolls, statements, running records of inventory, order lists, ad infinitum, are being handled presently by such a computer-printer team, and many more new functions are being added daily. This printer is quite universal and can be tied in with numerous types of computer systems.

Examples:

One Shepard printer is handling the inventory work for the 7th Army in Europe. Another is processing the spare parts inventory for all naval aircraft all over the world for the Bureau of Aeronautics, two others keep a running inventory of spare parts for motorized vehicles for the U. S. Army for all depots all over the world. These units have been in service for 6 years averaging one-half million lines per day per printer. Other printers are turning out renewal policies, premium notices, and statements for the New York Life Insurance Company, Travelers Insurance Company, etc. All Polaris submarines are equipped with Shepard Typers & Decoders that are used as output for their NAVDAC computer.

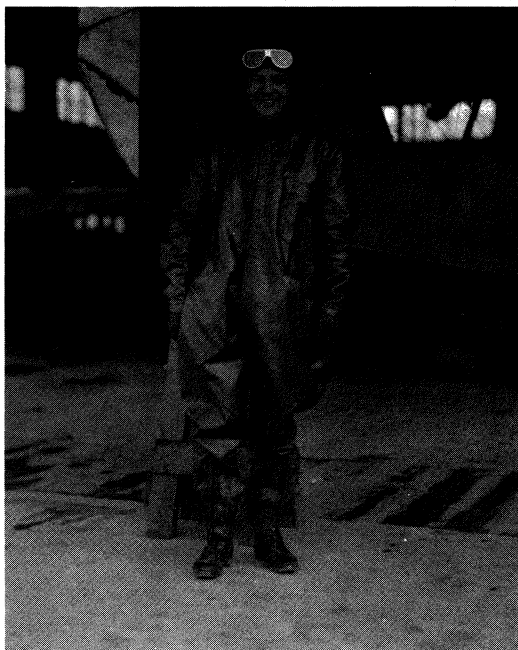

Harry Sadenwater at NC Hanger, Far Rockaway before Transatlantic Flight, 1919

With deep sorrow and regrets we record here the death of our esteemed member and fellow, Harry Sadenwater who suffered a heart attack on August 29, 1961. Harry, who was a mainstay in the old guard of the Radio Club, became a member in 1913. In the years that followed he served as Director in 1916 and intermittently from 1922 to date. He was elected President in 1931 and acted as corresponding Secretary from 1946 to 1947. In addition, he served on many committees with distinction, outstandingly as chairman of the year book committee which post he held for several years. His services as toast-master at the annual banquets are well remembered. His last appearance was at the Golden Jubilee Dinner when he acted as master of ceremonies pinch hitting for Frank Gunther who was taken ill at the last minute. It was Harry's charm, eloquence and understanding that were primarily responsible for the success of this affair.

His radio career began in his teens, when in 1908 he became an amateur radio operator, using the call letters "S W" from his home in the Bronx. His later calls were WSEPZ, 2PZ, and last W2YI. After training at Columbia University, Mechanics Institute and Union College, in addition to the

University of Pennsylvania, he became a ship radio operator for the Marconi Wireless and Telegraph Co. Ltd. in 1912. Other ventures in the radio field were duties as radio instructor at the East Side YMCA, 1913 to 1914, until he became an assistant radio inspector of the port of New York for the U. S. Department of Commerce from 1914 to 1917.

A pioneer in both the radio and aviation fields, Harry has been honored with a place in aviation's Hall of Fame. While serving in the U. S. Navy in World War 1, he was part of the crew that pioneered the way for the first transatlantic flight in May, 1919. As radio officer Lt. (JG) Sadenwater's duties on the historic flight included sending SOS signals when his plane the NC1 went down in the Atlantic off the Azores during a storm. The Spanning of the Atlantic at that time was comparable in stature to the first flights into space of these times. Harry and fellow crew members received the Navy Cross, were named Knights of the Tower and Sword (one of Portugal's highest awards), and other honors including those from the American Flying Club and Glenn Curtiss Aviator and builder of the NC seaplanes. Many mementos of this feat are part of a permanent exhibit at the Smithsonian Institute in Washington. In that same year Harry also contributed one of radio's firsts, when he made a long distance air to ground wireless telephone call from a navy seaplane.

After the war he began a long career in the radio industry. From 1920 to 1929 he joined the General Electric Company as a radio engineer. During this period he was in charge of technical operation of the company's broadcasting stations as well as the construction and initial operation of some of its western stations. Later he went with Radio Corporation of America's Camden Division in the engineering sales field. From 1941 and thru the years of World War II he served at RCA Laboratories in Princeton, N. J. His post war connection was with RCA Victor as sales manager of engineering production, until 1948, when he joined Radio Engineering Laboratories in Long Island City, New York as New York City technical sales representative. In 1956 he joined the sales and marketing departments centered at the main REL Plant.

His many associations and memberships include: Director and past President of the Radio Club of America, Director of the Veteran Wireless Operators Association and recipient of the Marconi Memorial Scroll of Honor - 1934, Director and founding member of the Armstrong Memorial Research Foundation.

He is survived by his wife, Grace, and a son, Paul, to whom we express our sincerest sympathy.

Harry's great love was the Radio Club and where it was concerned no job was too small or too large for him. He was always available and gave of himself fully and willingly. His wonderfully contagious

smile and genial personality endeared him to all who knew him and will always live in the hearts of his many "Wireless" friends everywhere.

A Salute to Pioneer Radioman

HARRY SADENWATER (1894 - 1961)

by

Captain Pierre Boucheron, USNR - Ret.

I first met Harry in 1912 when he came aboard the nondescript tramp steamer "Camaguey" of the old Ward Line at its East River, New York pier. This was my first proud job as a "sparks" and Harry was checking the efficiency, if any, of the emergency 10-inch spark coil transmitter that the United Wireless Telegraph Company had hurriedly installed in the wireless shack topside to meet the new Law of 1912.

Harry was dubious about the installation, a true "lashup" as the Navy boys would say, because the Edison nickel-iron storage batteries (for light weight) abaft the shack were not too secure for sea-going. (He was so right, as the "light weight" batteries washed overboard a week later in a heavy sea.) Now, Harry could have held up the ship, due to sail in an hour, and insist on a complete re-installation, but on my urgent promise to anchor the battery box more securely, he okayed the rig, and Harry remained a life-long friend of mine thereafter. He could have been very officious and stuffy about this but although competent in his duties always, he could also be a "regular guy".

Later, I saw Harry many times when in 1914 he became one of the early government Radio Inspector for the New York area.

When World War I came in 1917 and Harry and I went Navy, he as a lieutenant (J. G.) and I as a lowly warrant "radio gunner", U. S. N. R. F. (thereafter dubbed by the scoffers "you shall never reach France"), we were stationed together as instructors in the Electrical School of the Brooklyn Navy Yard. When I finally made Ensign, at Harry's prompting and considerable assistance, he was the first to help "wet down" my single gold stripe, along with other pioneers of the day, Ernie Amy, Frank Kin, George Eltz, George Burghard and Charlie Horn, and with a kind of sincere admiration that might well have been reserved, on his part, for a pro-

motion to the rank of Rear-Admiral.

Lieutenant Harry Sadenwater distinguished himself later as one of the intrepid crew of naval aviators that manned the NC-1 planes, in 1919, on their historic flight over the Atlantic. In those early days of trans-Atlantic flying, it was even money that these sea-planes would ditch at the slightest mechanical failure and it took a lot of savvy and guts to keep them airborne. His ship made it and he received the U. S. Navy's highest award for bravery, the Navy Cross.

Over the years, I used to urge Harry to wear the coveted Navy Cross rosette on his coat lapel button hole, but modest and ever unassuming, he wasn't that kind of a hero.

Then came the long span of years when we were both associated with a certain large radio company, he as an extremely able salesman of highly technical equipment and me as a press agent, today a much more respectable profession now called "public relations". Why Harry should have been "retired" a couple of years before this otherwise generous company inaugurated an equally generous pension plan that Harry missed out on is neither here nor there.

We would meet again many times later at I. R. E. and other trade conventions and meetings of the Radio Club of America, with Harry ever the gracious greeter and host in his last connection with another electronics concern that truly appreciated his special skill as a master salesman and top-flight representative - as well as a regular guy.

I salute you, Harry Sadenwater, true friend of many radio pioneers over a span of some fifty years, and with the sincere hope that we shall meet again in the Great Beyond!

EDITORIAL

SCIENCE SAFARIS

Members of the Radio Club are in a very unusual position - they can become active in many fields not necessarily related to their day-time work. And also, some of the earlier members, now retired, are adept at many practices that would provide many interesting improvements in some of the diversified problems in quite different activities.

Our anniversary issue shows many important advancements resulting solely from the pursuit of radio principles as a hobby. Looking back, the various ideas, experiments and measurements carried out throughout the last half century were not always based on precise theories and known effects, but they all provided useful, and to many of us, remunerative pastimes. We approached this matter in the editorial of the "Summer, 1960" issue and will expand it further now.

The grouping of kindred spirits in this and other clubs to permit discussions, experiments and even arguments turned up many new approaches and sometimes new fields of experimentation. While there was only one main field of interest to hobbyists fifty years ago, there are now hundreds. Most of these stem from studying the "variations of the unexpected" resulting from our tests. Many of our wider excursions from the beaten paths were followed later by commercialization.

We wish now to call attention to some of the new fields that await the attention of technically (electronically) trained experimenters. In some of these fields the basic principles are almost as vague as were those "of this wireless business" some decades ago. We all know that some of these scientific curiosities may gain notable progress if attacked by electronically trained minds. In many of them one will have to work out his own techniques, equipments and measurements. Why not tackle one of these?

What manner of subjects are we talking about?

Some of these might be cited, but only to draw out other ideas from you members.

Better means for measuring athletic effort in terms of muscular reaction, fatigue, expended energy

Smell and taste, measurements relating to, Any unusual measurement

The age of materials

Improved lie detector

Better methods for studying and identifying stamps

Improved medical instruments

Blood counting device

Sleep-study

Ultrasonics used as communication over wires

Non-linear devices, -- and applications

Home magic by electronics -- or otherwise

Pinpoint Photography

Underwater Photography

Crystal cutting, and growing

Simple computers for ordinary problems

Transistor applications (and there are thousands)

Most of the projects do not take a fortune to pursue, using native ingenuity such as was displayed by Club members during the past years. Pioneering times are just beginning in these and similar scientific curiosities. We invite your comments and hope to receive reports on current hobbies of a technical nature. It is the best way of expanding the Proceedings, both as to size and frequency of publication. Needless to say, space will be made available in these columns to comments from anyone who has already started something of interest, whether or not they may wish to enlist efforts of others in the project; or whether you know of other ideas in different fields that would seem to be of interest. Such projects in any stage of completeness can be written up informally, in the form of letters to the Club; or in a more detailed form as a Proceedings article. However if there is no response the matter will be dropped. What have you to say?

R. R. B.

**LETTER TO THE SECRETARY
AND COMMENTS**

The following letter dated June 14, 1961 was received by the Secretary of the Club from Paul G. Watson, Commander U.S.N.R. Ret., 27 Price Street, West Chester, Pa.

The Officers and Directors concur in the motives of Mr. Watson, and know that a considerable amount of historical material exists among our members at other locations. Comments on this matter are invited concerning practical plans whereby such material could be catalogued, or even collected and displayed ultimately within our abilities and means.

"I am in receipt today of the 'Winter 1960-61' issue of the 'Proceeding' of the Club, and found therein one particular item which is of great interest to me i. e. Coggeshall's discourse on radio history.

I have for the past 35 to 40 years been collecting mounting in cases, and documenting such old, unusual and otherwise interesting specimens of electron tubes as I am able to get. While I have been successful, so far as an individual goes, in a field of this sort, I am very well aware of my limitations, that my collection covers only a small portion of the whole field. I mention this collection by way of an introduction to the main purpose of this letter.

It was my good fortune to work many years ago with some of those who we then (in the 1920's) considered 'old timers', Charlie Cooper, C. D. Guthrie, Bob Sharples, and others of that same period who had wonderful colorful descriptions of the real beginnings of things in radio. From these people it seems to me that one of the greatest sources of revelation of these real early days could be found in a review of some of the court proceedings involving such things as the 'high frequency' spark suit, the attempt of the Marconi interest to prove that the three element (or otherwise) tube was electrostatic, and so on. I have one of the Marconi tubes made for evidence in the last named item.

Many names, Fessenden, Slaby-Arco, Poulsen, and others which played major parts in radio communi-

cation years back are totally unknown to the modern electronic specialist, or in radio communications. Just as 'Quad' type antennas were 'discovered' in recent years, by the amateur fraternity, the fact that Telefunken used them at Nauen, Germany in 1912 or 1913 is a completely unknown fact, unless you look in 'Zenneck' of 40 years ago.

Much was controversial in those early days, however, if people from each of the many sides involved in these technical and legal discussions could be found, or papers involved in these litigations could be 'borrowed' from court records and copied, the discussions and the copied documents would most certainly be of a most interesting nature. Published without editing, they would show, if nothing else, why 'radio' progressed slowly in its first decade, or so.

In concluding this, I will mention just one experience of my own, concerning the 'controversial' nature of things in radio and 'electronics' in the past. In November 1954 the writer published an article covering a portion of the tube collection, and made some general statements concerning the origin of the three element tube. Within a week of the release of this magazine I was favored with a visit by a very well known and firmly established electronic expert whose purpose was to set me 'straight' on some of my statements in the article, fifty years after they happened. He came from the 'other side' of a long controversy.

Let's do something about this if it is physically (and financially) possible before all the participants are dead."

CLUB NOTES

WILLIAM DUBILIER, well-known radio pioneer inventor, manufacturer, and long-time Club member, now retired and living in Palm Beach, is still active in the inventing business, and is acting as consultant to the management of organizations he once controlled. Patent applications have been made recently by Bill on certain equipment production techniques that have great possibilities, according to the Palm Beach Post for January 23rd, 1961, which carried a half-page story about our fellow member.

Laboratory Standards

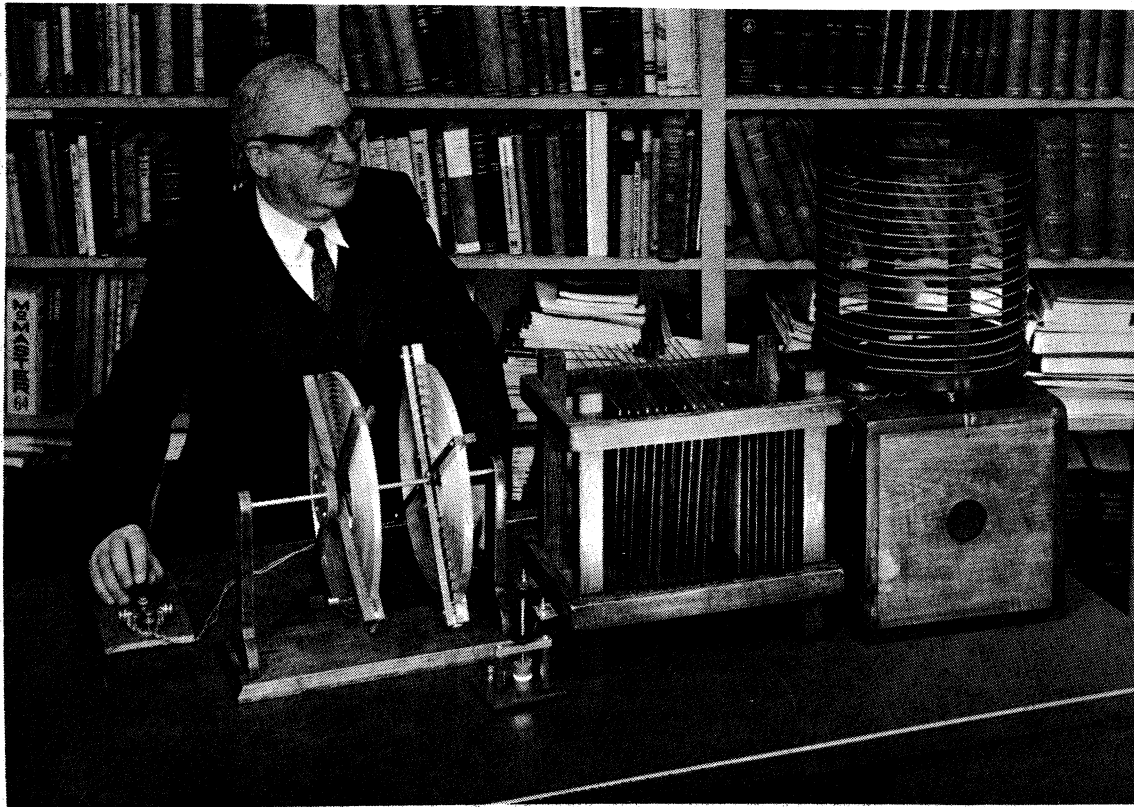

Harry W. Houck at key of his original 1909 Spark Transmitter

HIS MORE THAN 50 YEARS

of Radio Experience Stands Behind
MEASUREMENTS INSTRUMENTS

Standard Signal Generators
Pulse Generators
FM Signal Generators
Square Wave Generators
Vacuum Tube Voltmeters
Television & FM Test Equipment

U.H.F. Field Strength Meters
L-C-R Bridges
Crystal Calibrators
Megacycle Meters
Megohm Meters
Frequency Measuring Equipment

WRITE FOR BULLETIN

Laboratory Standards 

MEASUREMENTS

A McGraw-Edison Division
BOONTON, NEW JERSEY

FORM 215-A

SAME HIGH ACCURACY OVER ENTIRE LOGARITHMIC VOLTAGE SCALE

BALLANTINE ELECTRONIC VOLTMETERS

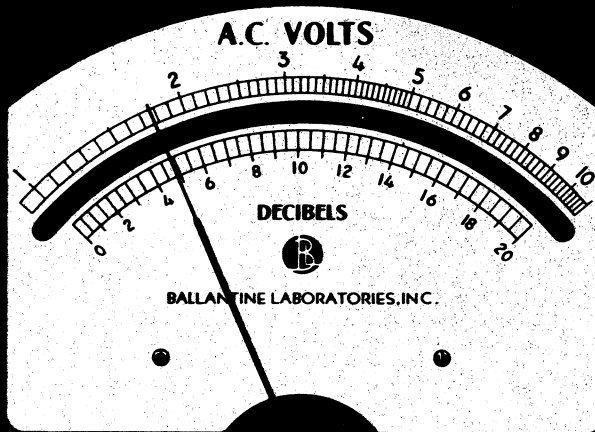

AC/DC Calibrators, Capacitance Meter, AF Amplifiers, DC/AC Inverters, AC/DC Converters, and Accessories to extend Voltage Range from 10 Microvolts to 28,000 Volts. Laboratory Standards for Voltages to 1,000 MC.

Available in Cabinet and Rack Models. Prices F.O.B. Boonton, N. J., subject to change without notice.

ELECTRONIC VOLTMETERS

MODEL	FREQUENCY RANGE	VOLTAGE RANGE	INPUT IMPEDANCE	ACCURACY	PRICE
300	10 cps-150 kc	1 mV-100 V	0.5 MΩ shunted by 30 pF	2%	\$220
300D	10 cps-250 kc	1 mV-1000 V	2 MΩ shunted by 15 to 25 pF	2%	\$255
300E	30 cps-100 kc	300 μV-300 V	2 MΩ shunted by 20 to 30 pF	2%	\$260
300G	10 cps-250 kc	1 mV-1000 V	2 MΩ shunted by 10 to 25 pF	1% 20 cps-20 kc, 1 mV-250 V; 2% elsewhere	\$315
302C Battery Operated	2 cps-150 kc	100 μV-1000 V	2 MΩ shunted by 10 to 25 pF	3% 5 cps-100 kc; 5% elsewhere	\$255
305A Peak Reading	5 cps-500 kc, sine waves. Pulses 0.5 μs up, and 5 pps up	1 mV-1000 V Peak or Peak-to-Peak	2 MΩ shunted by 5 to 15 pF	2% sine waves, 20 cps-200 kc; 4% elsewhere; 3% pulses above 3 μs and 100 pps; up to 5% elsewhere	\$415
310A	10 cps-2 Mc; 5 cps-4 Mc as a null detector	100 μV-100 V (Down to 40 μV as null detector)	2 MΩ shunted by 9 to 19 pF	3% 15 cps-1 Mc; 5% elsewhere	\$250
314 Wide Band	15 cps-6 Mc	1 mV-1000 V (100 μV-1 mV without probe)	11 MΩ shunted by 8 pF with probe, or 1 MΩ shunted by 25 pF without probe	3% 15 cps-3 Mc; 5% elsewhere	\$300
316 Infrasonic	0.05 cps-30 kc; 0.01 cps with corrections supplied	0.02 V-200 V Peak-to-Peak	10 MΩ shunted by 17 to 40 pF	3%	\$330
317 Wide Band	10 cps-11 Mc	300 μV-300 V	10 MΩ shunted by 7 pF with probe; 2 MΩ shunted by 11 to 24 pF without probe	2% 20 cps-2 Mc 4% 10 cps-6 Mc 6% 10 cps-11 Mc	\$495 with probe
320 True RMS	5 cps-500 kc	100 μV-320 V	10 MΩ shunted by 8 to 18 pF	3% 15 cps-150 kc; 5% elsewhere	\$445
350 True RMS	50 cps-20 kc	0.1 V-1199.9 V	2 MΩ shunted by 15 to 45 pF	¼% 0.1 V-300 V, 100 cps-10 kc; ½% outside these limits	\$720

ELECTRONIC TEST EQUIPMENT

DECADE AMPLIFIER

Model 220C

Battery-operated amplifier, 10x or 100x; 10 cps-150 kc; 5 MΩ input; 2% accuracy. \$115

CALIBRATOR, Precision dc and ac

Model 420

Provides precise output, rms, peak-to-peak, or dc, from 0-10 V; accuracy ¼% with cal. chart. \$365

CAPACITANCE METER, Direct-reading

Model 520

Direct-reading of capacitance 0.01 pF to 12 μF; accuracy 2% above 0.1 pF. \$335

INVERTER, Sensitive dc to ac

Model 700

Inverts dc as low as 10 μV and up to 100 V, to ac to be measured on any of VTVM's listed. \$365

CONVERTER, Linear ac to dc

Model 710

Converts ac to dc linearly over each decade, 1 mV-1000 V; 30 cps-250 kc; accuracy ¼% 50 cps-10 kc, ½% 30 cps-50 kc, 1% above 50 kc. \$450

LABORATORY STANDARDS

A-T VOLTMETER

Model 390

10 Mc to 1000 Mc; as laboratory standard for high voltage. NBS calibration not included in price. \$2,250

H-F TRANSFER VOLTMETER

Model 393

25 cps to 30 Mc; a transfer device for accurate measurement of voltages or calibration of voltmeters; each probe covers 2 to 1 voltage range, 1 V to 50 V. \$550 inc. one probe (\$100 for each add. probe)

MICROPOTENTIOMETER

Model 440

0 to 900 Mc; as laboratory standard for 40 μV to 0.33 V. NBS calibration not included in price. Price includes one resistor-thermocouple combination. \$250

Write for brochure giving many more details

— Since 1932 —



BALLANTINE LABORATORIES, Inc.

Boonton, New Jersey

Phone: DEerfield 4-1432 TWX: BONTN 831



Links in free world early warning systems can be filled overnight with van-mounted REL tropo radio equipments.

Flyable anywhere... then in 24 hours on the air

Wherever reliable, long-range radio communication is needed, REL tropospheric scatter equipment can now be available with spectacular speed. ■ A full 10 kw station, complete with antenna and generating facilities, is installed in three vans and two small trailers for air transportation. Erection and interconnection at the site takes as few as 24 hours. REL designed and built all the AN/FRC-39(v) transmitting and receiving equipment in all these AN/MRC-85 systems to Air Force specifications, under subcontract to Page Communications Engineers. ■ Performance equals that of the permanently installed REL tropo equipment which stretches most of the way around the free world. ■ Your specialized radio problems deserve the imagination and experience of REL.



Radio Engineering Laboratories, Inc. Dept G · 29-01 Borden Ave · Long Island City 1, N.Y.

A subsidiary of Dynamics Corporation of America • Create careers at REL with a few exceptional engineers. Address résumés to James Kelly, Personnel Director.