

RADIO BROADCAST



CONTENTS

What Are the Season's Kits
Locating and Remedying Interference
Distinguishing Between Good and Bad Quality
Radio Picture Reception for the Experimenter
A Directory of Manufactured Receivers
A Survey of the A·C·Tubes

35 Cents

Doubleday, Page & Company
Garden City, New York

Sept. 1927

Cunningham RADIO TUBES

*Since 1915—
Standard For All Sets*

are built in one of the
greatest radio research
laboratories the world
has ever known —

Every process and material used in their manu-
facture has been developed in or passed the
exacting tests of this world-renowned research
organization. That is the secret of the in-built
quality of Cunningham Radio Tubes.

A hidden yet ever-present integrity, twelve years
of constant striving for a better and still better
product, and always the ideal of "Quality-First"
—these combine to create value, an assurance
of trouble-free radio reception.

There is a special purpose Cunningham Radio
Tube for every radio and power supply use.
Consult your radio dealer. He will tell you the
best combination of Cunningham Radio Tubes
to use for your particular set.

E. T. CUNNINGHAM, Inc.

New York ~ Chicago ~ San Francisco

**CUNNINGHAM
RADIO
TUBES**

FAIS

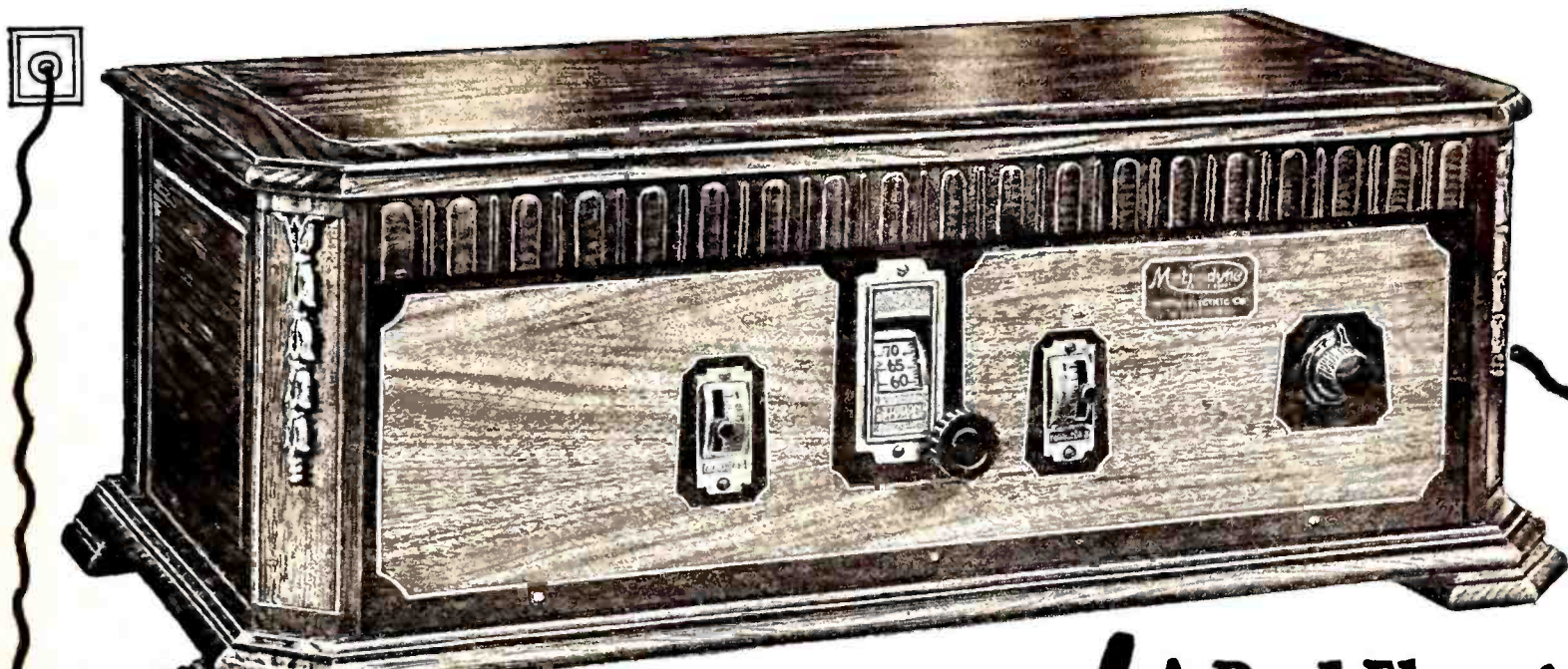

30 Days Free Trial

Now! A Real Electric Radio Set

Three Year Guarantee
 Shipped direct from our factory at rock bottom prices—cost less than most battery sets

No Batteries, Chargers or Eliminators
 No Acids; No Liquids—Plug In—Press Button—“Tune In”

Metrodyne
ALL ELECTRIC RADIO

7 Tubes—Single Dial Set

100% Electric Radio

At last! The radio you've dreamed about! If you have electricity in your home you can now really enjoy coast to coast radio reception without the care, bother and muss of batteries, chargers, eliminators, etc. The Metrodyne All Electric is a real, genuine batteryless radio set. Simply insert the plug in the socket, press the switch button and “tune in.” You could not possibly buy a better radio set than the Metrodyne All Electric, no matter what price you paid.

**BEAUTY—EFFICIENCY
 DEPENDABILITY**

The Metrodyne All Electric Radio is a 7 tube, single dial set. Only the highest quality low loss parts are used throughout. Solid walnut cabinet, beautiful two-tone effect, with handsome gilt metal trimmings. Size of cabinet, 28 inches long, 13 inches deep, 10 inches high. Has electrically lighted dial so that you can log stations in the dark. Only one dial to tune in all stations. Excellent tone qualities—wonderful volume—very selective.

Costs Less Than Most Battery Sets

Do not confuse the Metrodyne electric radio with ordinary light socket sets, because the Metrodyne is truly an all electric radio—consumes less than 2c worth of power a day. Comes to you direct from the factory. Its low cost brings it down to the price of an ordinary battery set. We are so confident that you will be delighted with this wonderful, easy-to-operate batteryless radio that we offer to ship it to your home for thirty days' free trial—you to be the judge.

Mail This Coupon

We are one of the pioneers of radio. The success of Metrodyne sets is due to our liberal 30 days' free trial offer, which gives you the opportunity of trying before buying. Thousands of Metrodynes have been bought on our liberal free trial basis—**WRITE TODAY!**

METRO ELECTRIC COMPANY
 2165 N. California Ave., Dept. 606
 Chicago, Illinois

Gentlemen:
 Send me full particulars about Metrodyne All Electric Radio and your thirty days' free trial offer.

Name _____
 Address _____
 If you are interested in AGENTS' proposition place an "X" in the square

MAIL COUPON NOW!

**AGENTS! DEALERS!
 BIG PROFITS!**

Make big money taking orders for Metrodynes. All or part time. Metrodyne All Electric Radios are in a class by themselves. Unequaled for quality, performance and price. Demonstrate at home and take orders. Lowest wholesale prices. Your demonstrating set on 30 days' free trial. Mail coupon below for details.



Gorgeous Console Electric Radio

Here is the Metrodyne All Electric Console Radio—a gorgeous, genuine walnut cabinet, in a beautiful two-tone finish. Has a built-in genuine Metro-Cone large size speaker. Brings in programs with great volume, reproducing the entire range from the lowest to the highest notes with remarkable clearness and distinction. All metal parts are finished in old gold. Wonderful electric radio, in a cabinet that will beautify the appearance of any home.

METRO ELECTRIC COMPANY

2165 N. California Ave. Dept. 606 Chicago, Illinois

Still the Standard of Excellence in Audio Transformers



The AmerTran DeLuxe
for 1st and 2nd Stages \$10.00 each

MONTH after month, and on into years, speeds the development of new radio units. Yet to-day the AmerTran DeLuxe is still the measure used to judge transformer quality. Time has taken no toll of the AmerTran DeLuxe. Rather, it has broadened its acceptance as the faithful amplifier of natural quality.

Research and test laboratories—some of the best known in the country—use the AmerTran DeLuxe as it comes nearest in their opinion to perfection in this type of apparatus. Structural ruggedness has made the AmerTran DeLuxe stand up in the climate of Central America. It has proved itself under all conditions. With the proper tubes and loud speaker, and clear signals from the detector tube, these transformers will produce the truest quality with most volume.

American Transformer Co.

178 Emmet Street

Newark, N. J.

"Transformer Builders for Over 26 Years"

Other AmerTran Radio Products

Type PF52 Power Transformer
Type PF281 Power Transformer for
Filament plate supply with new
tubes.

Type H-67 Filament Heating Trans-
former
AmerTran Resistor Type 400
AmerChokes Types 854, 709 and 418

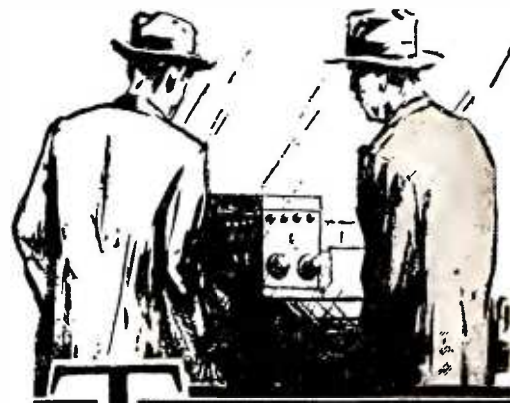

There's the 'B'
for Your Set"
\$28⁵⁰

with Raytheon B H Tube

IF YOUR SET has five tubes or five and a Power tube, you can now get a Sterling Raytheon-equipped "B" for it at \$28.50—why spend more? Think of it! For less than \$30 you can get rid of "B" batteries once and forever and in their place be sure of full-powered Sterling-filtered "B" current right from the light socket.

Sterling Model RT-81 has an output at 35 mills of 135 volts. Detector and Medium voltages are each adjustable and the high tap takes care of the Power tube on most sets. This assures plenty of voltage and exact power regulation for your particular set. RT-81 is no larger than one dry "B" battery, and fits right into the console cabinet or into Radiolas 25 & 28.



RT-81

Another Popular Sterling Model for Larger Sets, R-98 "B-C" Power Unit

A "Universal" "B-C" model for high class sets. Output at 35 mills, is 180 volts. Has four "B" terminals, two of which are independently variable. All four voltages are variable through primary control. Variable High "C" voltage. On and Off switch. Uses Raytheon B or B H Tube. List price; without Tube, \$33.50.

Sterling

"B" POWER UNITS

THE STERLING MFG. CO.
2831 Prospect Avenue - Cleveland, Ohio



Designer of Broadcast Station WEMC



Tours Europe On Inspection Trip.

How Would You Like to Have John Fetzer's Job?

Would you like to tour Europe, inspecting broadcast stations? You would? My friend John Fetzer DID! Maybe you'd like to hold a fine job as Chief Engineer of a widely-known American broadcast station? That's what John Fetzer is right now—Chief Engineer of Station W E M C, "The Radio Lighthouse," located at Berrien Springs, Mich. Read his interesting letter at the right.

Will YOU Take a Better Job—More Money?

If I offered you a job like John Fetzer's at \$100 or \$150 a week, would you take it?

If I told you that to get this job you would have to do a little studying, say half an hour a day for a few months, would you do that too?

You bet you would. You probably even think I'm foolish to ask you such questions. But, as a matter of fact, you today have such an opportunity in the same place John Fetzer found his—in the brand-new, growing Radio Industry.

Plenty of Plums Still Left On The Tree

We've just barely scratched the surface in the Radio business. There are plenty more opportunities just as good as the one John Fetzer gasped.

You'll have to do some studying before you can hold down one of the good jobs—only well-trained men are wanted,

But that part isn't hard—lots of men without a grade school education have done it. And it only takes a comparatively

short time, studying about half an hour a day. You can keep right on with your present job, and learn in the quiet of your own home.

Get My Big Free Book

300,000 new openings have been created by the swift growth of the Radio business in the past few years. During the same years I have helped thousands of men to take advantage of opportunities like these.

John Fetzer, whose picture you see above, is only one man among these thousands I've helped. Lots of the others didn't climb as high as Fetzer, but there are some, too, who have gone higher.

I'm ready to help you, too, if you are looking for a better job and more money. The good jobs in Radio pay from \$50 all the way up to \$250 a week. And the accomplishment of television, trans-Atlantic Radio telephony, the other new inventions constantly being made, all point to even greater things for the future. If you're ambitious and dissatisfied with your job or your future, let me help you share in the Rich Rewards of Radio.

Mail the coupon below for my big free book about Radio, its opportunities, and how I train you, quickly and easily in your spare time at home, to take advantage of them. No previous experience needed. You learn by doing, with six big outfits of practical experimental material I send you at no extra cost. Mail coupon now for book. Address J. E. Smith, President, National Radio Institute, Washington, D. C.

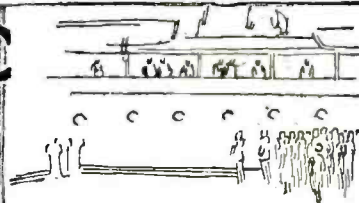

Dear Mr. Smith:

I went to Europe at the expense of my station, WEMC, to learn the best methods used there and bring them back for my station. I found about 20 stations in the British Isles, mostly used to relay programs from 2LO. They were very kind to me at 2LO—their equip-



ment is about like that of our own good stations. French stations, I found, don't compare with the British. There are 6 important stations in France. Eiffel Tower is the best known. I visited Holland, Belgium and Switzerland, and got a real thrill from seeing the big station at



Nauen, Germany. On my return I designed and built the new high

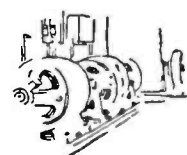

power station for WEMC, using best features of what I had

seen. Our first program was reported in 40 States. Your training is the way to lasting success in Radio.



John C. Fetzer



J. E. SMITH, President of the National Radio Institute, Washington, D. C., has directed the training of more men for the Radio profession than any other educator. The National Radio Institute is the oldest and largest Radio home-study school in the world.

Originators of Radio Home Study Training

HERE'S THE SAME COUPON THAT FETZER CLIPPED

This Book FREE!

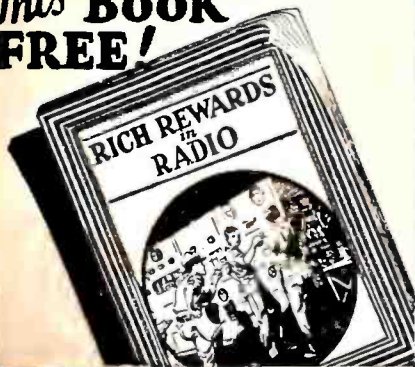

C O U P O N

J. E. Smith, President,
National Radio Institute,
Dept., , Washington, D. C.

Dear Mr. Smith; Kindly send me your free book "Rich Rewards in Radio," and all information about your practical, home-study Radio training. I understand this places me under no obligation.

Name

Address

Town State

RADIO BROADCAST

WILLIS KINGSLEY WING, Editor

SEPTEMBER, 1927

KEITH HENNEY
Director of the Laboratory

EDGAR H. FELIX
Contributing Editor

Vol. XI, No. 5

CONTENTS

Cover Design	From a Design by Harvey Hopkins Dunn	
Frontispiece	A Method of Speedy Radio Transmission	262
A Discovery that Newton Missed	James Stokley	263
The March of Radio	An Editorial Interpretation	266
Radio Needs No Yearly Models Will Telephotography Be the Experimenters' Next Field? A Prosperous Radio Year Forecast Discovering Ore Deposits by Radio	Broadcasters in New York Organize Judge Davis Resigns Where Are the Listener Organizations? The Month in Radio	
Piezo-Electric Crystals	M. Thornton Dow	271
Home Constructing Transformers and Chokes for Power Supply Devices	Homer S. Davis	274
Pictures by Radio		279
Building the Laboratory "Super"	Ernest R. Pfaff	280
We Need Better Radio Salesmen	Carl Dreher	283
<i>Drawing by Franklyn F. Stratford</i>		
"Strays" from the Laboratory		284
<i>A Survey of the A. C. Tubes</i>		
The Listener's Point of View	John Wallace	286
Why Not Try the Short Waves?	Keith Henney	290
As the Broadcaster Sees It	Carl Dreher	293
Causes of Poor Tone Quality	Edgar H. Felix	296
New Receiver Offerings for the Fall	The Laboratory Staff	298
Suppressing Radio Interference	A. T. Lawton	299
Three-Element A. C. Vacuum Tubes	B. F. Miessner	302
"Radio Broadcast's" Laboratory Information Sheets		308
No. 121. The Hertz Antenna	No. 125. The Morse Code.	
No. 122. Testing Radio Receivers	No. 126. Condenser Reactance.	
No. 123. Characteristics of the 171 Type Tube.	No. 127. Condenser Reactance Table.	
No. 124. Curves of the 171 Type Tube.	No. 128. B Power Units.	
Manufacturers' Booklets Available		314
"Radio Broadcast's" Directory of Manufactured Receivers		316
What Kit Shall I Buy?		324
A Key to Recent Radio Articles	E. G. Shalkhauser	326

AMONG OTHER THINGS. . .

SOME may look with critical eye at the leading article this month which delves into the subject of ultra-violet, infra-red, and X-rays, for they may think that field a bit removed from radio. But in these days of scientific advance, many fields of experiment which have heretofore been widely separated, are becoming more closely associated, and anything, therefore, having to do with the generation of short electrical waves, is of interest to those who dabble in radio. James Stokley, who contributes this story on ultra short waves, is on the staff of Science Service, that interesting and important Washington organization devoted to telling the public more about science.

OF OUR other authors, M. Thornton Dow, the writer of the article on the remarkable piezo-electric crystal, is at Cruft Laboratory, Harvard University. Homer Davis, whose calculation charts have appeared in RADIO BROADCAST before, is a graduate engineer and a resident of Memphis, Tennessee. Ernest R. Pfaff, who describes the interesting super-heterodyne which may be made with the Jeweller's Time amplifier, is a radio denizen of Chicago and a frequent contributor to the radio press. B. F. Miessner, the author of the Radio Club of America paper on the a. c. tube, is chief engineer of the Garod Corporation and has had an extensive and varied radio experience. In early radio days, he was associated with John Hays Hammond, conducting radio and other experiments. A. T. Lawton, author of the series on eliminating man-made radio interference, is a Canadian, living in Ottawa. He has been associated with the interference-prevention work now being done in the Dominion.

THE short-waves, long the almost exclusive playground and workshop of the amateurs and commercial and military services, are now beginning to harbor broadcast programs. Some of our own American stations are broadcasting their programs on two waves—the standard broadcasting wave and a short wave. This experiment, long exclusively conducted by WGY and KDKA, is now being shared by several others. There are stations abroad, too, providing voice and music on these bands. The article in this issue by Keith Henney tells something of the traffic in these lesser-known bands.

THE subject of transmission of photographs by radio—wrongly termed television by many, for it is in fact, radio-telephotography—is receiving increased attention, and for the readers of RADIO BROADCAST we have arranged to publish an exclusive series of articles. These stories will describe a practical and inexpensive system which can be attached to any good radio receiver. By its use good pictures will result, as experiments, conducted in RADIO BROADCAST Laboratory over a period of more than three years, have shown. An introductory article appears in this number and others will soon follow.

THE Directory of Manufactured Receivers, which appeared in our August number for the first time, appears in a slightly revised form in this number. The present form is much easier to use. We call especial attention to the fact that the Service Department of RADIO BROADCAST will furnish much more detailed information on any or all of the receivers listed if the coupon on page 328 is filled out and sent to us.

—WILLIS KINGSLEY WING.

<p>Doubleday, Page & Co. MAGAZINES</p> <p>COUNTRY LIFE WORLD'S WORK GARDEN & HOME BUILDER RADIO BROADCAST SHORT STORIES EDUCATIONAL REVIEW LE PETIT JOURNAL LE ECO FRONTIER STORIES WEST</p>	<p>Doubleday, Page & Co. BOOK SHOPS (Books of all Publishers)</p> <p>LORD & TAYLOR BOOK SHOP PENNSYLVANIA TERMINAL (2 Shops) NEW YORK: { GRAND CENTRAL TERMINAL 38 WALL ST. and 526 LEXINGTON AVE. 848 MADISON AVE. and 166 WEST 32ND ST. ST. LOUIS: 223 N. 8TH ST. and 4914 MARYLAND AVE. KANSAS CITY: 920 GRAND AVE. and 206 W. 47TH ST. CLEVELAND: HIGBEE CO. SPRINGFIELD, MASS.: MEEKINS, PACKARD & WHEAT</p>	<p>Doubleday, Page & Co. OFFICES</p> <p>GARDEN CITY, N. Y. NEW YORK: 285 MADISON AVENUE BOSTON: PARK SQUARE BUILDING CHICAGO: PEOPLES GAS BUILDING SANTA BARBARA, CAL. LONDON: WM. HEINEMANN LTD. TORONTO: OXFORD UNIVERSITY PRESS</p>	<p>Doubleday, Page & Co. OFFICERS</p> <p>F. N. DOUBLEDAY, President NELSON DOUBLEDAY, Vice-President S. A. EVERITT, Vice-President RUSSELL DOUBLEDAY, Secretary JOHN J. HESSIAN, Treasurer LILLIAN A. COMSTOCK, Asst. Secretary L. J. McNAUGHTON, Asst. Treasurer</p>
--	---	--	---

DOUBLEDAY, PAGE & COMPANY, Garden City, New York

Copyright, 1927, in the United States, Newfoundland, Great Britain, Canada, and other countries by Doubleday, Page & Company. All rights reserved.
TERMS: \$4.00 a year; single copies 35 cents.

KINGSTON



PRICES

Type 2, for 110-120 Volt AC 50 or 60 Cycle Current, \$35.00.

For receiving sets having not more than eight tubes and not having type UX171 power tube or equivalent.

Type 2A, for 110-120 Volt AC 50 or 60 Cycle Current, \$42.50.

For all sets using type UX171 power tube or equivalent and for all large sets having nine or more tubes.

Type 2C, for 110-120 Volt AC 25, 30 or 40 cycle current, \$47.50.

Prices include type BH Raytheon tube.

For Perfect Reception

THE KINGSTON B CURRENT SUPPLY UNIT insures everything Radio has to give—rich, full tone, clearness, perfect reception always! This unit met last year with unprecedented success, and this year it will attain a new high record in sales and satisfaction. Make the Kingston the leader of your fall and winter business.

KOKOMO ELECTRIC CO.
KOKOMO, INDIANA

WHAT THE KINGSTON IS

THE KINGSTON will maintain the radio set always at its perfection peak. It contains no acid or solution, operates without vibration or noise and will not heat. There are provided three different voltage terminals, each adjustable over a wide range, making possible any desired voltage from 5 to 200. A fourth variable voltage may be easily had, if desired, by connecting a separate variable resistor to one of the terminals. The primary or main current supply is controlled by a rheostat making it possible to reduce the current entering the unit to the amount actually required for any individual set, thus protecting the set against overload.

For an additional \$2.50 an automatic control switch is furnished by which the Unit is switched on or off when switch on the radio set panel is turned.

Handsomely finished in satin black. Size; 9 inches long, $5\frac{1}{4}$ inches wide, $8\frac{1}{4}$ inches high. The Raytheon 85 milliamper type BH tube is used as rectifier. Fully guaranteed.

sent by Wireless Facsimile
Telegraphy

HIGH SPEED WIRELESS TELEGRAPHY INTERNATIONAL CONTROL ORGANISATION

THE quarter of a century which has witnessed the development of commercial wireless telegraphy, the sending of the first tentative signals to the establishment of high speed telegraph services to all parts of the world has been a period of incessant progress.

Every year has brought some fresh invention to increase the speed of signalling or to improve methods of working, but a stage has now been reached when certain basic principles have been established and can be incorporated in standard practice. Two of the most important of these are the ascendency of continuous wave wireless telegraphy by means of valve transmission, and the distant control of the transmitting and receiving stations from a central office.

These modern methods are to be seen at their highest state of efficiency in the group of Marconi stations comprising Radio House, Ongar, Brentwood, and Carnarvon, from which high-speed commercial services are conducted with France, Switzerland, Spain, Canada, and the United States of America.

The wireless stations at Ongar and Brentwood are situated in Essex, some 20 miles from London, but full control is centred at Radio House, Wilson Street, in the City, the relaying of signals from the land lines to the wireless transmitters at Ongar transmitting station, and from the wireless receivers to the land lines at Brentwood receiving station being entirely automatic. The transmitting plant at Carnarvon used for communication to the United States is also controlled automatically from Radio House, and the signals from the United States are received at Brentwood and relayed automatically to Radio House.

March 12/1927

A METHOD OF SPEEDY RADIO TRANSMISSION

Radio telegraph messages, using the present system, when sent must be translated into the code, and at the receiving station, must be decoded and copied. A method has been developed by J. M. Wright of the British Marconi Company for facsimile transmission which eliminates the translation into the code altogether. The sample in the illustration above was transmitted in 100 seconds

RADIO BROADCAST

VOLUME XI



NUMBER 5

SEPTEMBER, 1927

A Discovery That Newton Missed

*Something About Waves of One Trillion Kilocycles Frequency—
Ritter's Discovery of Ultra-Violet and Herschel's of Infra-Red Rays
—The Uses of Ultra-Violet Rays for Their Health Giving Properties*

By JAMES STOKLEY

Science Service

ABOUT two and a half centuries ago Sir Isaac Newton performed an experiment. During his life, this greatest scientist of his day and one of the greatest of all time, performed many experiments, but from this one in particular there came many far-reaching results. From it, more or less directly, came much of our knowledge of radio, of X-rays, the radiations of radium, and of the composition of the most distant stars, obtained by spectrum analysis.

Just what did Newton do? It so happens that we have a very complete account in his own words, left in one of his books, which bore the title of: *Opticks: or, a Treatise of the Reflexions, Refractions, Inflexions, and Colors of Light*. The first edition, of this great work, now very rare, was published in 1704, and on page 18 we read:

THE LIGHT OF THE SUN CONSISTS OF RAYS DIFFERENTLY REFRACTIBLE

The Proof by Experiments

In a very dark chamber at a round hole about one third part of an inch broad made in the shut of a window I placed a glass prism, whereby the beam of the sun's light which came in at that hole might be refracted upwards toward the opposite wall of the chamber, and there form a colored image of the sun. The axis of the prism (that is, the line passing through the middle of the prism from one end of it to the other end

parallel to the edge of the refracting angle) was, in this and the following experiments, perpendicular to the incident rays. . . . I let the refracted light fall perpendicularly upon a sheet of white paper at the opposite wall of the chamber, and observed the figure and dimensions of the solar image formed on the paper by that light. This image was oblong and not oval, but terminated with two rectilinear and parallel sides, and two semicircular ends. . . . This image, or spectrum, was coloured, being red at its least refracted end, and violet at its most refracted end, and yellow, green, and blue in the intermediate spaces.

This experiment of Newton's is a very easy one to repeat, for all you need is a prism. If you have one of the kind that used to hang from chandeliers in mid-Victorian homes, it will serve the purpose admirably.

But there was one important thing that

Newton missed. So far as he could detect, the spectrum began at the violet end and ended at the red, which, together with the colors in between, constituted the complete composition of sunlight. That was because he was human, and had only his sense of sight to guide him. Actually the spectrum that he saw was only a small part of the complete spectrum of sunlight and an infinitesimally small part of the total range of radiation that is now known. The complete spectrum ranges from the longest radio waves and the still longer waves of alternating electric currents, down to the X-rays, and the penetrating radiation recently investigated by Professor Millikan. According to a well-known physicist, Dr. M. Luckiesh, if the visible part of the spectrum were one foot in length, approximately the length that Newton saw it, the spectrum of the total range of radiation would be several million miles long!

When you go to the seashore, and sit on the beach to get tanned by the sunshine, or when you take a snapshot of some member of the family, you demonstrate the presence of one kind of rays that the eye cannot perceive, for many of the chemical effects of sunlight, including that on the skin, and on the photographic film, are due to ultra-violet rays, consisting of waves which are a little

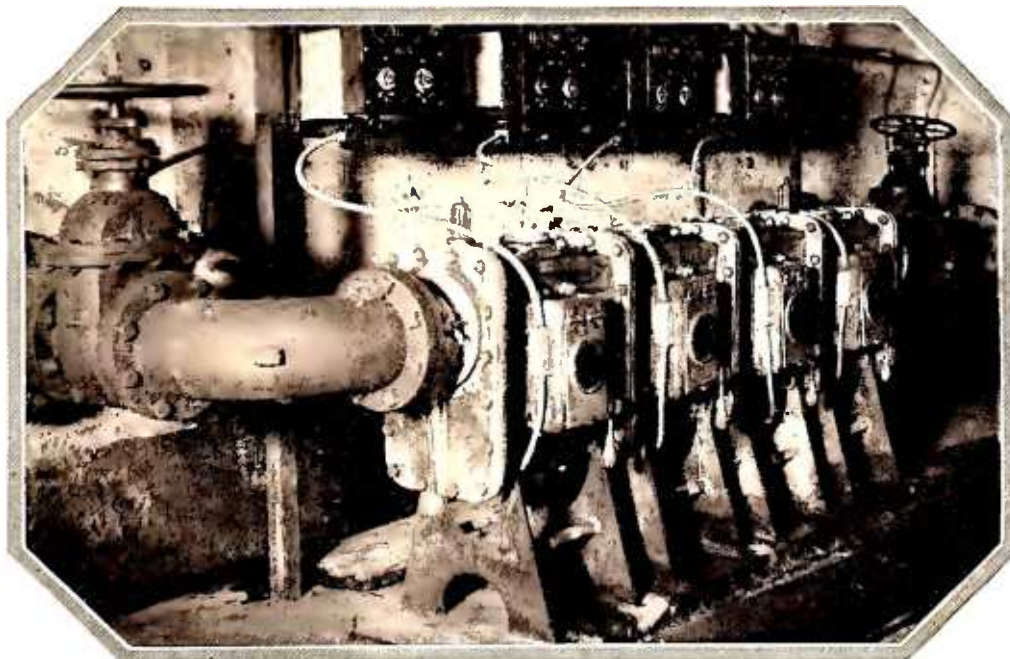

ONE OF THE USES OF ULTRA-VIOLET RAYS

Quartz tube mercury vapor lamps in use as sterilizers for the water supply of a small city. The ultra-violet rays prevent thriving of germs in the water



LOOK AT THIS PHOTOGRAPH

A steel surface photographed through a microscope with blue light. Ultra-violet rays would have given a much clearer picture

too short, and vibrate a little too rapidly, to be apparent to the eye.

As radio fans who are familiar with the modern system of designating stations by frequency rather than wavelength are aware, the average broadcasting frequency is in the neighborhood of 1000 kilocycles, which means that the complete vibration which produces the wave occurs 1,000,000 times a second. But the longest of the visible rays, those in the deepest red that the eye can see, have a frequency of 375,000,000,000 kilocycles. The violet rays at the other end of the spectrum vibrate about twice as rapidly, and the ultra-violet rays are between these and those vibrating with a frequency of 24,000,000,000,000 kilocycles!

But Newton, as we have seen, did not know of these invisible radiations. It was not many years after the publication of his *Opticks*, however, that some of their effects were noticed, for in 1727 a German physician, Johann Heinrich Schulze, happened to mix some chalk with nitric acid in which had been dissolved a little silver. At the time, he happened to be standing near a

window, and he noticed that where the light fell on the mixture it became dark. The silver had dissolved in the nitric acid forming silver nitrate, and this must have reacted with some of the impurities in the chalk, such as ordinary salt, or sodium chloride, to produce silver chloride, which is one of the chief constituents of modern photographic materials.

However, Schulze also missed the discovery of ultra-violet radiation, for he only tried daylight on his silver chloride mixture. Half a century later, in 1777, its discovery was missed by a still narrower margin. This was by the famous Swedish chemist, Carl Wilhelm Scheele, who in 1774 had discovered the gas chlorine, and, three years before that, another gas—fluorine. Unlike Schulze, who accidentally came across the effect when he was trying to do something else, Scheele was studying the chemical action of light, and he exposed a surface coated with silver chloride to the spectrum obtained from sunlight with a prism.

What must have happened was that the silver chloride under the red and yellow part of the spectrum was not darkened at all, while that under the violet and the part where no color was visible beyond the violet, were darkened most. The experiment is one that is easily repeated; a piece of photographic printing paper may be used as the silver chloride surface.

But Scheele didn't notice this. Probably he was working in a room that was not entirely dark, except for the spectrum, and so the silver chloride was partly darkened all over due to the white light in the room. Anyhow, it remained for a German physicist, named Ritter, to discover that the invisible extension of the solar spectrum, beyond the violet, produced a greater effect on the silver chloride than did the violet itself, and so he discovered the ultra-violet rays, in 1801. Curiously enough, it was at almost the same time that the extension of the spectrum in the other direction, beyond the red, was discovered; the year before, the great English astronomer,



—AND NOW, THIS ONE

The same steel surface photographed with ultra-violet light, and a magnification of 1600 diameters. Notice the great amount of detail that can be seen in this picture as compared with the blue light photograph

Sir William Herschel, discovered the infra-red rays.

In the century following the discovery of the invisible rays, there came many discoveries, such as that of methods by which these rays could be produced artificially. The most copious source of ultra-violet rays known is, of course, the sun itself. On a clear summer day we get great quantities of them, with possibly even painful results if we are at the seashore, lying on the beach. But in winter, even when the sun is shining, it may be low in the sky, and the smoke and dust in the atmosphere may effectually keep most of these rays away from us.

As we shall see a little later, ultra-violet rays are important in keeping people healthy, and in curing various diseases. For this reason, as well as for the accommodation of the physicist who wishes to study the rays in his laboratory, an artificial source is important. The ordinary carbon arc light, particularly if operated at a high voltage, perhaps 120 (which is high for an arc light), is rich in these invisible rays;

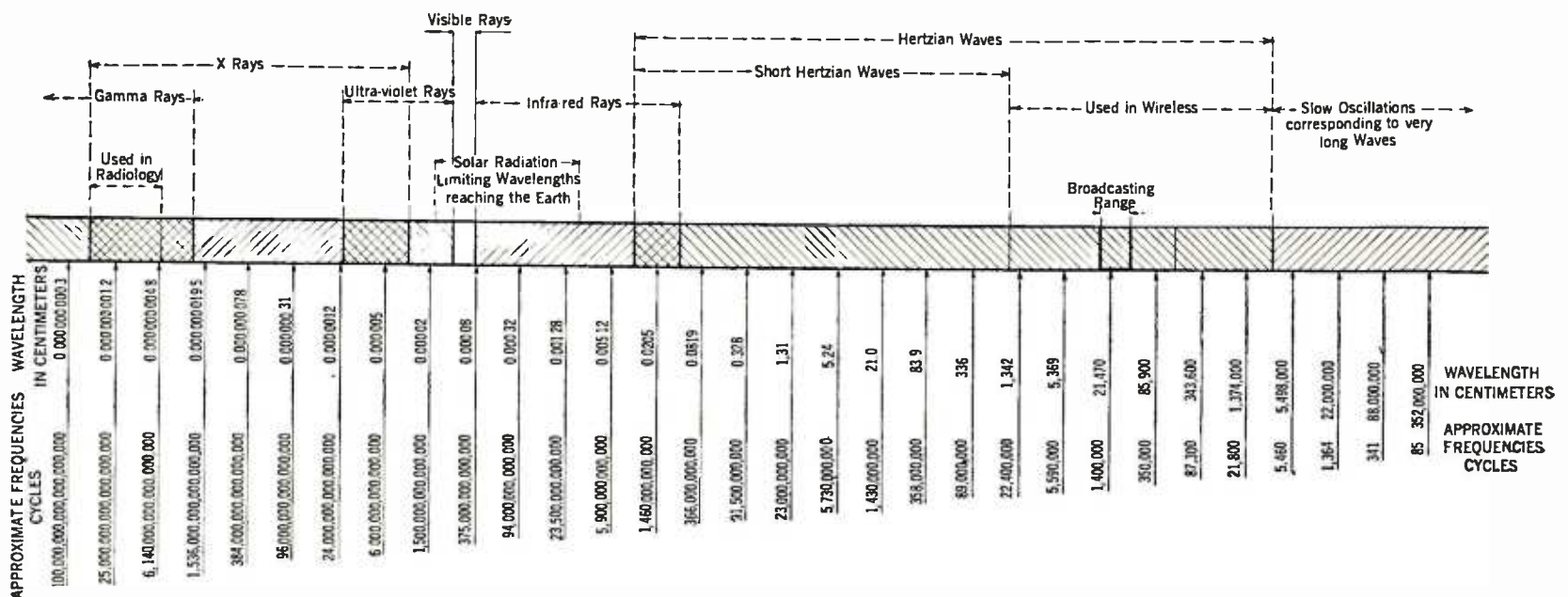

HOW THE FREQUENCY SPECTRUM IS DIVIDED

The spectrum of radiation, from X-rays to alternating-current waves. The penetrating rays, studied by Millikan, would extend from the left end of the diagram. Naturally, this diagram is not to scale, for if it were, and the short visible part a foot in length, the entire scale would be many millions of miles long

even larger quantities result if we substitute rods of iron for the carbons. When the iron arc is used in laboratories, it is necessary to protect the eyes from its light. Many a physicist making experiments with the iron arc has got as nice a case of sunburn as if he had been at the seashore.

Other metals can be used instead of iron and even more copious quantities of ultra-violet light result, for example, if the electrodes are of silicon. In this case the visible light is reduced nearly to a minimum, and the output of the lamp is almost entirely invisible light. But mercury, or quicksilver, is most commonly used, particularly in the form of the mercury vapor lamp, where an electric discharge is made in an atmosphere of the vapor of mercury instead of air.

As mercury vapor is a gas, it is necessary to completely enclose such a lamp in a transparent tube. Glass, of course, is often used, and the glass-tube mercury vapor lamp is a common light source in photographic and movie studios, as well as in many factories, because it is a very efficient illuminating device. The incandescent gas mantle takes the equivalent of about nine watts of electric power to produce one candle power, the tungsten filament electric lamp about a watt, and the ordinary arc lamp about nine-tenths of a watt; but the glass tube mercury vapor lamp produces the same amount of light with about two-thirds of a watt. Of course the purple color of the light, and the lack of red rays, gives the skin a ghastly pallor, but the light is not harmful to the eyes and is said to be pleasant to work under after one gets used to it.

Such a light doesn't give off much ultra-violet radiation, because these rays are absorbed by glass, but by making the tube of quartz, large amounts of ultra-violet radiation are emitted, and then the lamp gives one candle power for every quarter of a watt. This is the most convenient source of the rays, and is the one now most generally used in laboratories and hospitals. Such lamps are often used for sterilizing water and various food products as the action of ultra-violet light is fatal to many germs. A common use is in swimming pools, for the same water can be filtered and purified by passing it and re-passing it through apparatus which exposes it to ultra-violet rays. The water in a pool so equipped can really be kept purer than if it were emptied and refilled daily.

ULTRA-VIOLET RAYS IN PHOTOGRAPHY

BECAUSE the ultra-violet rays are so short they have an important application in photography of minute objects through the microscope. In modern optical factories it is possible to make lenses for microscopes which will theoretically magnify almost without limit. Actually, such lenses are limited, because a structure must be as large as a wave of light is long in order to reflect it.

If you toss a tennis ball against a wall it bounces back, but if you throw it against a spider web it passes right through. This is because the mass of the wall compared

with the ball is very great, but that of the spider web is very small. The case is somewhat analogous to light. The object that reflects it must compare favorably in size with the length of one of the waves.

Since the waves of ultra-violet light are shorter than those of visible light, structures that are too small to be seen under the microscope with ordinary illumination may be seen, or rather photographed, in the ultra-violet ray. It was with a method such as this that the English biologist, Gye, with the assistance of the expert microscopist, J. E. Barnard, was able to make photographs through the microscope of the germs which caused cancer in chickens, and which were beyond the limits of the ordinary microscopic methods. In metallurgical laboratories, ultra-violet microscopic apparatus is used in photographing steel and other metals. As glass stops most of the ultra-violet rays, such a microscope must use lenses made of quartz.

Since ultra-violet light may be used so advantageously in photomicrography, a natural idea is that of using X-rays, the waves of which are much shorter than the ultra-violet. If X rays could be used, structures could be photographed a thousand times smaller than with the visual rays, instead of, perhaps, half the size, as with the ultra-violet. But though X-rays can be deflected through crystals, they can't be focussed, like light, by means of a lens; so X-ray photomicrography is one of the yet unsolved riddles that are so numerous in science.

One of the most important uses of ultra-violet light is its effect on the body. We hear a great deal nowadays about vitamins, those mysterious substances in food about which so little is known, but that are so necessary if we are to keep healthy. One of these vitamins prevents a disease which in some localities is very common among children, namely, rickets. Few people realize just how common this ailment is, but Dr. Alfred Hess, a prominent New York specialist on children's diseases, has estimated that seventy-five per cent. of the children in New York City have at one time or another had at least a mild case of rickets.

However, though there are not many diseases for which the medical profession knows any practically sure-fire remedies, rickets is one of them, for it may be cured with either cod liver oil, which is rich in the anti-rachitic vitamin, or with treatment by ultra-violet light.

The ways of the vitamins, like the "heathen Chinees," are peculiar. But rickets is a disease of the bones, due to lack of salts of calcium, especially calcium phosphate, and the action of the anti-rachitic vitamin seems to be to hasten the deposition of calcium. Cod liver oil normally contains the vitamin, and so it can be used as a cure. Other oils, like cottonseed oil, or foods such as milk or flour, do not ordinarily contain it, but if they are exposed to ultra-violet light the vitamin seems to be formed, for then the anti-rachitic powers are bestowed on them.

Then also, by exposing the child afflicted to the disease to the beneficial rays of the sun, or of the quartz tube mercury vapor lamp, the calcium deposition is also hastened and the disease relieved. Since egg shells consist largely of calcium, exposure of chickens to ultra-violet light hastens egg laying in the same way that it prevents or cures rickets in children. Such eggs also have anti-rachitic powers, so we may expect to see "eggs from sun-kissed hens" a common article in our markets of the future!

In order that the ultra-violet rays may reach the body, it is necessary that they have an unobstructed path to the skin. Glass stops the rays, so that a sun bath indoors behind ordinary windows is of little value. Windows made of quartz, which can now be fused and made into a variety of shapes, including large windows, will let the rays through. Several kinds of glass have recently appeared on the market which are much less expensive than quartz, but still let the beneficial rays through in large quantity. Ordinary clothing also is opaque to the rays, so that at a sanitarium such as that of Dr. Rollier, in Switzerland, the patients, both children and older people, spend most of their time outdoors with a minimum of clothing. However, the so-called "artificial silk" or rayon, which is so much used, for hosiery and other articles of apparel, is partly transparent to the rays. We can conform with all the standards of modesty, and still get the ultra-violet rays.

Unlike X-rays, ultra-violet rays are not very penetrating. They do not go very deep into the body, but reach only the outer skin, and it has been a puzzle how they have their effect on the bones. Doctor Hess has suggested an explanation which fits in pretty well with the observed facts.

There is a substance known to the chemists as cholesterol, which is found in practically every living animal, especially the skin and brain, a similar substance, phytosterol, being found in plants. Doctor Hess has found that when cholesterol is placed under ultra-violet rays, it achieves the power of preventing rickets, so he believes that this same process takes place in the skin when exposed to ultra-violet light. The radiated cholesterol is then carried by the blood to other parts of the body. To confirm this idea, Doctor Hess took pieces of animals' skins and fed them to rats, as their main article of diet. When the skin had been exposed to ultra-violet rays, the rats remained healthy but another group that were fed with skin that had not been radiated soon developed rickets.

So another step has been made in understanding how these rays work on the body. Beginning over two centuries ago with Newton, continuing with Ritter's discovery of the rays, our knowledge of them has gradually advanced. Though their medical uses are important, they are not the only applications, and the physicist constantly makes use of them. Just what part these rays play in the daily life of the physicist we shall see in a subsequent article.

The March of Radio

News and Interpretation of Current Radio Events

Radio Needs No Yearly Models

THE success of the June Chicago Trade Show establishes that function as an annual custom. It gives the manufacturers opportunity to introduce their wares to the trade so that, when the Radio World's Fair in New York and the other fall shows take place, distribution of the new models will be an accomplished fact. The 1927 Trade Show was marked principally by advances in the alternating-current tube sets, deriving their A, B, and C potentials direct from the power mains. Last season might have been styled single-control year; this season marks the beginning of a general market for the a.c. set.

We do feel, however, that the yearly model business cannot long continue to be an advantage to the radio industry. One of the best ways to establish the summer slump as a permanent institution is to promise new and revolutionary changes each fall. Naturally, the public will stop buying about January 1 to await the year's developments. Yearly models are justified if, each year, advances are made of such significance that all the products of the preceding years are justifiably obsolete and the public adopts the custom of scrapping their radio sets every year or two. But the radio ship is approaching a more even keel. Refinement is already replacing revolution in improvement. The purchase of a radio receiver is becoming a four- or five-, and perhaps even a ten-year investment. Consequently, it is of advantage, both to the owner and the manufacturer, to work toward constant refinement and improvement, embodying developments in production as soon as they are perfected rather than annually disrupting the market by "yearly models."

It took the automobile industry twenty years to learn the fallacy of the yearly model plan and we hope that the radio industry will be quick to perceive the hazards and pitfalls of that system. Let us put a stop to the yearly model plan

lest it bring us that millstone of the automobile industry—the used model business. A radio receiver does not seriously depreciate in use and hence a used receiver business, the inevitable by-product of the yearly model plan, is of advantage neither to the dealer nor to the set owner.

Will Telephotography Be the Experimenters' Next Field?

A PHOTOGRAPH received by radio in your own home! That is a reward worth working for! We have been watching the efforts of many experimenters in telephotography, hoping to

bring a new and alluring field of activity to the home constructor. Essentially, the spirit of the set builder is that of the conqueror who faces and overcomes mechanical and electrical difficulties. When broadcasting first began, the man who built his own receiver was regarded as a sort of wizard among his friends. And indeed, considering the difficulties under which he then labored, he was worthy of that title.

But set building has lost a little of its glamour. It is still, by a wide margin, the most satisfying hobby for one with a flair for electrical experiment. At first, it had, as an additional incentive, the fact that

the home-built set was much better and cheaper than anything that could be bought on the market. Competition and technical development, however, have brought such great improvements in the manufactured set, both from the standpoint of price and performance, that the home constructor finds his economic advantage and his pride of achievement both measurably diminished. He must content himself with the fascination of building as his return for the time and money he puts into set making.

And now comes telephotography! Will it be the experimenter's next hobby? It offers a pride of accomplishment which will again make the home constructor a genius among his fellows. And, as for economy, it is impossible to buy telephotographic apparatus; hence, only the home constructor can now possess a telephoto receiver.

In other pages of this issue, we discuss a system of phototelegraphy which seems, from the home constructor's standpoint, to be the most promising development in telephotography. It does not enable the experimenter to secure *perfect* pictures, but it has the great and outstanding advantage of simplicity and low cost. When we are satisfied—and from every indication, it is a matter of weeks

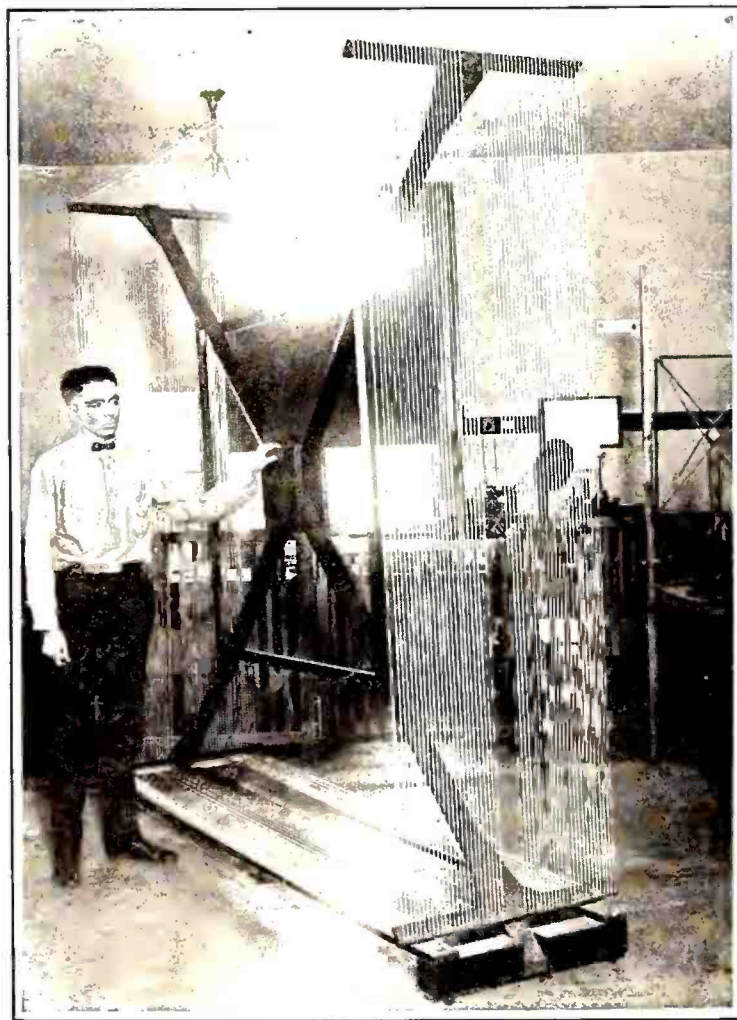

LOOPS THEY USE IN WASHINGTON

Morris S. Strock of the Bureau of Standards radio laboratory with one of the large coil antennas used in experimental work at the Bureau. This coil is employed in receiving long-wave European radio telegraph stations



been provided with the receiving set which it desires. High quality of reproduction, tuning reduced to the manipulation of a single calibrated control, and maintenance troubles virtually eliminated, have made radio attractive to millions who, in the past, felt faint at the thought of a hydrometer. That terror of the housewife, three dials which must be turned in the correct ratio to bring in a station, is a bugaboo of the past.

Prosperity to the radio industry and a vastly increased

number of listeners mean not only an aggressive and prosperous industry but, much more than that, the establishment of broadcasting in a healthy and wholesome condition. When the ether is cleared so that every station on the air can be received clearly and without interference, throughout its service range, and the number of listeners doubles and triples, the increased income of broadcasting stations will justify tremendously improved programs. Consequently, every owner of a receiving set profits as the art advances. Broadcasting will enjoy a re-awakening of such proportions that any home without a radio will soon be regarded as an object of sympathy and commiseration.

and months rather than years—that the apparatus will give the experimenter a pleasing and satisfactory field in which to exercise his ingenuity and to secure results commensurate with the effort and expense involved, we will describe the new apparatus with full constructional details. From present estimates, the cost of a complete set of parts will be in the neighborhood of seventy-five or a hundred dollars. No special transmitting apparatus will be required to put photographs on the air because the picture is embodied in an audio-signal which modulates the carrier, as do the speech currents of the studio microphone. Consequently, the only equipment needed by broadcasting stations to put pictures on the air, is a phonograph and a phonograph record of a picture transmission.



RADIO ABOARD PACIFIC LINERS

The Panama-Pacific Line, has installed long- and short-wave broadcast receivers with power loud speakers located at various points on the ship. The view at the upper left shows one of the 104 loud speakers on deck and the other view shows a public room in which is an electric radio-phonograph — part of the entertainment system

Discovering Ore Deposits By Radio

ALTHOUGH many devices have been announced, alleged to discover the presence of metallic ore under the ground by magnetic or electromagnetic means, until quite recently very little practical use has been made of them. When ground currents of radio frequency are transmitted from one point to another, the strength of the received impulse is dependent upon the power of the transmitter, the sensitivity of the receiver, the distance, and the conductivity of the soil. The presence of metallic ores exhibits itself by an unusually strong signal for the transmitting power and distance involved. However, no means has yet been developed for identifying the kind of metal involved so that the principal value of such observations has been rather the elimination of unpromising ground than the identification

Our editorial in June regarding the relation of the set constructor to the set buyer, has aroused a great deal of comment, both from home constructors and from leaders in the industry. Many of our readers have written us in approval of the statement that the parts manufacturer must offer new fields to conquer for the set constructor—new designs and new ideas. We believe the trend is toward new fields and toward improved and economically justifiable combinations of parts for broadcast receiver building. The latter will always interest the home builder, but telephotography, short- and long-wave radio, laboratory experiments and measurements, and ingenious methods of installation, will command ever increasing attention.

A Prosperous Radio Year Forecast

THE fourteen thousand radio manufacturers and dealers who attended the Trade Show were uniformly optimistic. The radio receiver has emerged from a puny complexity to a magnificent simplicity. That large element of the general public which has been awaiting the perfection of radio and the elimination of all maintenance problems has at last



BEAM SERVICE FROM ENGLAND TO AUSTRALIA IS OPEN

After long tests, the Marconi short-wave beam transmitter has been turned over to the British Post Office. Reliable two-way communication at the rate of 200 words per minute has been established for some time. The antenna system shown is so arranged, that, according to the time of day, the beam signals are sent to Australia either by the eastward route (left of illustration), or the antenna at the right is used in which case the signals are sent to Australia in the direction of America. Beam service between England and Canada has been in operation since October, 1926, and announcement of the New York-London beam service is expected shortly. Engineers of the Radio Corporation and the British Marconi Company are understood to be at work with tests and developmental work now

of valuable mineral ores. Recent experiments with portable seismographs, however, have been used with some success in locating salt domes and oil domes in the Southwest. A charge of dynamite is set off and the different sound vibrations are recorded by the seismograph. The relative rate of sound transmission has been used in locating ore bodies.

Sulphide ore bodies are good conductors of electricity and hence act like antennas. The radio waves set up in these subterranean antennas create an oscillating current of electricity. These re-radiated waves, however, are so feeble they cannot easily be detected.

In prospecting, a specially designed transmitter is set up in the immediate neighborhood to be prospected. A wavelength is used which will most easily penetrate the earth. The ore body receives strong radio waves from the near-by transmitting station and therefore re-radiates a fairly strong wave. The latter is picked up by a loop receiving outfit stationed close by.

The loop receiver is capable of being rotated around a horizontal and a vertical axis. Telephone receivers are connected with the apparatus and, as the loop is rotated, the position of maximum and minimum sound in the telephone receivers is determined and the instrument readings are recorded. The direction and location of the ore body can then be computed from these readings.

In practical prospecting, when there is an indication of an underground conductor, such as an ore body, and it is desired to make the information as definite as possible, a large number of readings are taken at intervals of twenty-five to fifty feet across the suspected axis of the ore body, and for a distance along the axis as far as it is

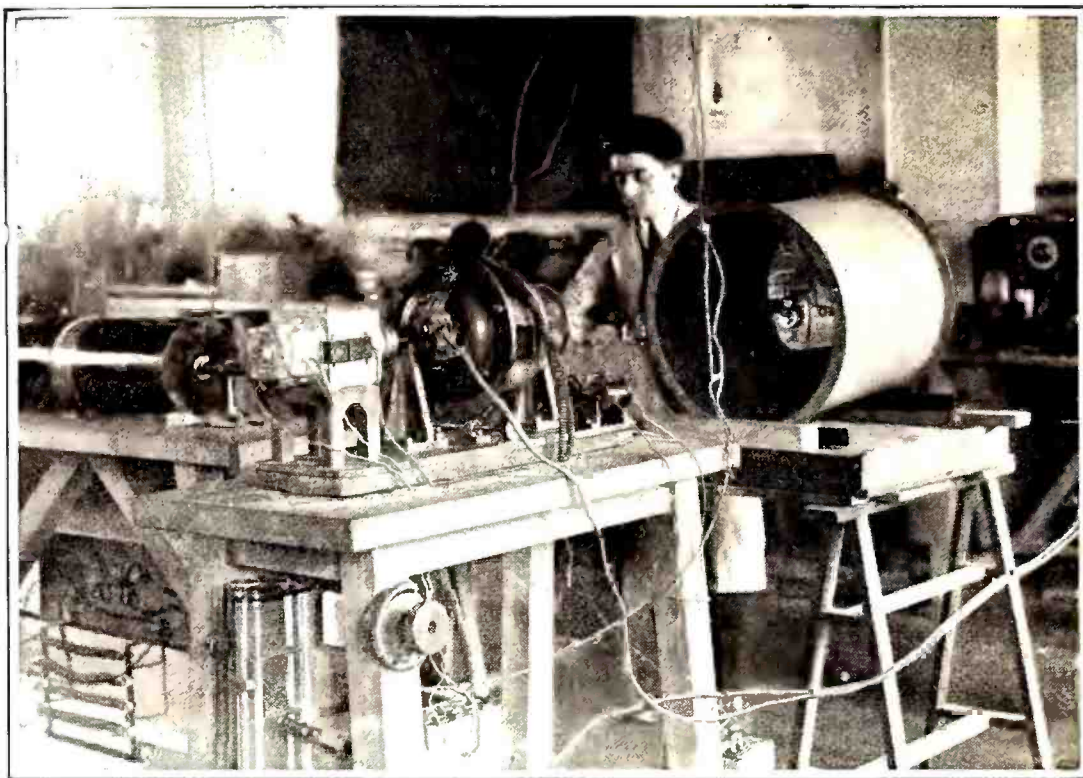

SOME OF THE BELIN TELEVISION APPARATUS

The Belin system of television is not radically dissimilar from other systems. In this illustration, a beam of light is reflected from the arc lamp at the left, reflected by a pair of oscillating mirrors, one to send the beam in a horizontal motion, the other for vertical motion. The mirrors (behind the dynamo and the large cogged wheel) throw the beam across the image to be transmitted and on to a photo-electric cell in the large cylinder. These varying light impulses then operate a transmitter

desired to investigate. These readings are then correlated on paper and cross sections made. The location of the ore body shows up quite plainly on such cross sections.

Broadcasters in New York Organize

WE HAD the pleasure of attending one of the early meetings of the New York Broadcast Owners' Association and observing the altruistic attitude of some of the small protesting broad-

casters. It was announced in the press that thirty-three New York stations had combined to offer a united protest to the Federal Radio Commission because they had been compelled to split time and to go on the higher frequencies. The meeting was called to organize these thirty-three into a powerful association to present a united protest. Seventeen, as we recall it, attended and, of these, only seven agreed on roll call to protest. Some of these first insisted upon a promise that the constitutionality of the Radio Act would not be questioned but that the committee would confine itself to attempting to seek a better frequency and less division of time for the stations involved. We understand that, after the meeting, one or two additional stations joined.

When we read of the glorious speeches made before the Commission as to the service rendered the public by these stations, it was interesting to recall that the owners had to say regarding their service to the public at their own little meeting. Not once was the matter of serving the public mentioned. The only thing that they whined about was that they could not hope to make as much money out of advertisers if they could not broadcast whenever they pleased. Apparently, the lack of audience has not discouraged these stations, possibly because their sales representatives have succeeded in inducing advertisers to use their facilities in spite of a well nigh non-existent audience. And, when we say advertisers, we do not mean goodwill broadcasters, but broadcasters of the direct advertising which is characteristic of this sort of station.



IN THE CAPTAIN'S SUITE ABOARD THE "LEVIATHAN"

Captain Herbert Hartley uses his own radio receiver in his moments of leisure from his duties. European and American stations are heard with ease at all times during the transatlantic passage. The receiver is displayed among autographed photographs of President Coolidge, General Pershing, Secretary of the Navy Wilbur, and Sir Thomas Lipton

Judge Davis Resigns

JUDGE STEPHEN B. DAVIS announced his resignation from the Department of Commerce after four years of praiseworthy service as administrative supervisor of the Bureau of Navigation, Bureau of Fisheries, Steamboat Inspection Service, Patent Office, and Coast and Geodetic Survey. His service to the Department of Commerce will, however, be most widely remembered by the public for his direction of broadcasting matters. Judge Davis' new book, *The Law of Radio Communication*, recently published, is the only volume on the subject available and discusses the legal phases of radio control with complete competence and thoroughness.

Where Are the Listener Organizations?

ONE of our readers, Mr. R. L. Hitchcock of Detroit, Michigan, suggests that RADIO BROADCAST start an association of listeners among its readers and offers also to pay annual dues of one or two dollars. We had hoped that our recent editorial on this subject would bring out some strength in existing listener organizations but, aside from a few letters from indignant executive secretaries immediately following it, there have been no signs of activity. Considering that, at the moment, the very foundations of broadcasting are threatened by the effort of a few inferior pirate stations to set aside the Radio Act, certainly, if the listener organizations had the slightest voice or influence, there should be some manifestation of activity at this time. While we are pleased at this suggestion as expression of confidence on the part of our readers, we would certainly rather see an independent outside organization formed. Only if the demand were insistent and widespread, would we consider any such task. Why do not some of the existing organizations get busy? We would be glad to help any meritorious listener group to the best of our ability.

The Month In Radio

UNPOPULAR BROADCASTING STATIONS

THE Federal Radio Commission has been haled into court and application for an injunction to set aside its powers has been made. At present the action is pending. We are very doubtful that an injunction will be granted but, if it ever is, the result will be nothing less than a catastrophe to the radio industry. It will interest the protesting stations that 11.2 per cent. of the listeners who responded to our questionnaire, which appeared in the May issue, demanded the elimination of WJAZ because it started the radio chaos last season by tying up the regulatory power. Seven times as many listeners demanded its elimination as considered it a favorite local or out-of-town station.

"If the report is true," writes one of these in a letter accompanying his questionnaire, "that WJAZ has been assigned a desirable wavelength, then the radio public has been not only insulted,



© Underwood and Underwood
DR. LOUIS COHEN

Washington, D. C.

Consulting Radio Engineer. A special statement prepared for RADIO BROADCAST:

"Standardization may be very desirable from an economic and commercial standpoint, but if the standardization process sets in prematurely it may be a serious handicap to the further growth and development of an art. The radio broadcasting art illustrates this. We have come to regard the broadcast frequency band, 500 to 1500 kc., as being more or less fixed, and all broadcasting is confined to channels within this band of frequencies. The extension of the frequency range to, say, 2000 kc., which would greatly increase the number of channels for broadcasting, is being opposed on the ground that the receivers have been standardized to cover only the present limited range, which was done at a time when it was considered very difficult to design a commercial receiver suitable for the higher frequencies. Engineering development, however, has since progressed to a point where it is entirely feasible to build a receiver suitable for the higher frequencies as well as the lower frequencies, but because of the standardization which has set in altogether too early in the art, we are reluctant to take advantage of the new developments which would benefit the entire art."

but outraged, as this is the station that brought us the whole mess of trouble and should be made to take the leavings, if any."

This is the tenor of many written complaints which we have received, which indicate the permanent unpopularity which accrues to any station or organization which destroys the public's radio entertainment. If any other station again succeeds with a similar move, it will incur the violent hatred of the radio audience, regardless of any noise about martyrdom which it may make. Station WJAZ was not the most unpopular station in the United States, KFNF being the winner of our unpopularity contest. One hundred and four out of each 500 answering our questionnaire demanded the elimination of that station. This is almost 100 per cent. of those

within its range. Actually one listener in 500 called KFNF a sixth local favorite and three named it as an out of town favorite. The public knows what stations it likes to listen to, even if the broadcasters and their commercial sponsors do not.

HAZELTINE PATENTS SUSTAINED

FEDERAL JUDGE GROVER N. MOSKOWITZ handed down a decision recently in the Hazeltine-Grebe suit, favorable to the former. The defense was based largely on the grounds that prior inventions displaced those of Professor Hazeltine and that his original patent, filed shortly after he had left the employ of the Navy in radio work, contained a clause permitting the general use of his invention. An accounting of the profits received by the defendant during the period of the alleged infringement was ordered.

R. C. A. VS. HAZELTINE PATENTS

A DECISION favorable to the Radio Corporation of America, which sued the Twentieth Century Corporation for selling radio receivers in violation of the Hartley and Rice patents, was handed down in the Circuit Court of Appeals, to which it had been brought from a district court. This decision is of the utmost importance and should be studied closely by every manufacturer in the field. It establishes the relation of the R. C. A. patents to those held by the neutrodyne group. As we understand it, the patent establishes the basic nature of Hartley and Rice's work in preventing the generation of oscillatory currents through neutralization methods and that the Hazeltine inventions are, in effect, a practical and improved method of utilizing the Rice and Hartley inventions. Since the Hazeltine method of neutralization is a simple and effective one, we would not be surprised if many manufacturers find it desirable to secure licenses under both the R. C. A. patents and the Hazeltine patents. License under the R. C. A. patents does not necessarily imply, under this decision, freedom from suit for infringement under the Hazeltine patents.

The patent situation is too complex to be accurately summed up briefly. It is clear, however, that stability in the radio industry would be fostered if it were made convenient for set manufacturers to obtain blanket licenses at a sufficiently low rate to permit them to utilize all the necessary inventions in the field. If Hazeltine licenses are valuable, and it appears under the recent decision that they are, some form of combination license ought to be worked out. Manufacturers ought to be free to develop the radio art, designing, building, and selling better receiving sets, rather than squandering time in conferences with patent lawyers.

NEW R. C. A. LICENSEES

ADDITIONAL licensees under the R. C. A. patents are the powerful Crosley Radio Corporation, the Splitdorf Company, the F. A. D. Andrea Company, the Charles Freshman Company, and the Freed Eisemann Company. By the time this appears in print, there will be many others. The Crosley contract is said to provide for a seven and a half per cent. royalty and the statement is made that more than half a million dollars has already been paid to the R. C. A. by the Crosley Corporation and an additional three quarters of a million by other concerns.

SAN SALVADOR boasts of a broadcasting station, installed in its national theater, with the call letters AQN. It broadcasts three evenings a week on 482 meters, 625 kilocycles

UNFINISHED BUSINESS FOR RADIO

IN HIS address before the Radio Manufacturers' Association, assembled at the Chicago Trade Show, Federal Radio Commissioner Orestes H. Caldwell pointed out that, in six years of broadcasting, the radio industry had succeeded in placing radio equipment in but one fourth of the twenty-two million homes of the United States. Considering that there are eighteen million pleasure automobiles, sixteen million wired homes, sixteen million telephones, and eleven million phonographs, the radio industry has a lot of unfinished business ahead of it. The 1927-1928 season will see a marked change in the ratio of radio to non-radio homes.

SHORT-WAVE TELEPHONES FOR FREIGHT TRAINS

THE General Electric Company recently demonstrated its short-wave radio telephone equipment designed for use on long freight trains for communication between engineer and conductor. Although the train was a mile and a quarter long, not the slightest unreliability was observed, the signals being loud and clear under all conditions. Up to this time, it has been necessary for the conductor to use the emergency brake to stop the train or to rely on whistles or flare lights which often fail because of bends in the tracks or poor weather conditions.

WE HAVE before us the souvenir booklet sent by the National Carbon Company to those who write in comment on its Eveready Hour programs. It is a twenty-page booklet, neatly bound, and nicely printed, with an absorbing intimate story of the famous people and the regular artists with Eveready Hour. The character of printed matter sent out by the important commercial broadcasters is of sufficient merit and deserves wider circulation than it now enjoys. Listeners who have not tried the experiment of commenting on the better programs have a pleasant surprise in store for them.

CONGRESSMAN EMMANUEL CELLER, who is very expert in getting large publicity out of small matters, again calls attention to the abuses of radio censorship. Some of the cases cited by him in a story in the *New York Sunday World* are such outrages as the refusal of KOA to broadcast an inflammatory address by De Valera, a pacifist address by Mrs. Mary H. Ford, an address by a Smith College professor, criticising the policy of the Government in its Near East diplomacy, and various similar matters. When one considers what proportion of audiences of millions are interested in the opinions of the persons named, no serious injustices have been done. Since there is a limit to the time which can be devoted by the larger stations to expressions of private opinions, this so-called censorship must be exercised. Stations have been moderately intelligent in their discriminations and the attempt to make this a burning question, considering the insignificance of the cases cited, is either a publicity stunt or a marked failure to appreciate how liberal the broadcasting stations have been with their facilities.

LISTENERS all over the country report a marked improvement in receiving conditions as a result of the allocations made effective June 15. Many individual cases of interference are noted and the Commission is doing its best to adjust them by shifting station assignments. But until there is a radical reduction in the number of stations, or time splitting is more widely practiced, the ether will never be entirely cleared. The Radio Commission has done extraordinarily well with its problem. Had any one

predicted at the Washington hearings last spring that it would eliminate practically no stations, there would have been few ready to say that the Commission could effect any material improvement in broadcasting conditions. That it has done so, under the conditions, shows that the President appointed a committee of ingenious and hardworking men who have taken upon themselves the most difficult method of solving a well nigh impossible problem.

SENATOR EDWARDS of New Jersey has formulated a verbose protest about the Federal Radio Commission's treatment of station WAAT, which a few listeners in its immediate vicinity may be familiar with. The Commission, fortunately, has turned a deaf ear to strictly political pressure and has based its ratings of stations upon expressions of broadcast listeners. Under the circumstances, WAAT has not fared badly. RADIO BROADCAST readers, in their 452 listings of favorite local New York stations, give five votes to WAAT, approximately one per cent.

DR. L. W. AUSTIN, physicist of the Radio Transmission Research Laboratory of the United States Bureau of Standards, was awarded the 1927 medal of honor by the Institute of Radio Engineers. This is the highest recognition which the radio engineering fraternity can offer its fellows.

THE Ninth Radio District, with Chicago as its headquarters, boasts of 233 active broadcasting stations out of a grand total of 694 now on the air. This is approximately 34 per cent. of the stations. Chicago may pride itself on being the noisiest place on earth.

THE French inter-colonial radio service has been extended to equatorial Africa by the opening of a radio telegraph station at Brazzaville. The system consists of a station at Banako, West Africa; Tananarivo, Madagascar; Saigon, Indo-China; Bihouti, Somaliland; and the new station in western Africa. Owners of long-wave receivers now have some new marks to shoot for.

FAILURE to obtain a receiving license in Greece, as required by the Director of Greek Telegraphs, Telephones and Posts, may result in twelve months' imprisonment and a fine of 100,000 drachmas. Licenses are somewhat less expensive.

THE meeting of the stockholders of the Marconi Wireless Telegraph Company, held in London recently, was a stormy scene, well attended by hundreds of stockholders. The company has undergone a drastic financial reorganization, including such measures as a reduction of nearly 46½ per cent. in its total outstanding stock. These courageous steps, coupled with the economy and extensions of short-wave beam telegraphy, may quite conceivably make future stockholders' meetings much happier affairs.

FIELD strength measurements made in the Eighth Radio District by Radio Supervisor S. W. Edwards have revealed the now oft-confirmed fact that location is of as great importance as antenna power in determining the service area of a broadcasting station. The most serious factor which prevents equal radiation in all directions from a radio antenna is the shadow effect of large surrounding masses of both conducting and non-conducting materials. As the cost of transmitting installations goes up, port-

able transmitters will be used to determine the characteristics of any transmitting point before a station is erected. It appears that irregularities in transmission characteristics, due to location, can be analyzed with a portable low-power transmitter and that great increase of power does not change the general nature of shading effects. It is not unusual to find that a broadcasting station of considerable power may serve only fifty or seventy-five miles in one direction, but is easily heard four or five hundred in another.

A TELEPHOTOGRAPHIC radio line (erroneously called television transmission by wireless in the Department of Commerce's Trade Commissioner's report) has been placed in operation between Vienna and Berlin, the time required for transmission being only twenty seconds, considerably faster than any commercial system we know of on this side of the Atlantic.

THE Hydrographic Office of the Navy Department, in collaboration with various other branches of the Navy, has announced further results in their study of weather forecasting methods, based on observation of the strength and direction of static through loop receivers. The study has indicated that the use of new devices which have been developed, to measure static intensity in standard units, will make it possible to plot the highs and lows of static in the same way that we now plot barometric pressures. Static intensity is said to bear a definite relation to barometric pressure, thus offering a valuable aid to reliable weather forecasting.

THE Bakelite Corporation of New York has succeeded in inducing the Tariff Commission to recommend to the President that the importation of certain forms of synthetic, phenolic resin be no longer permitted. Apparently this material made it impossible for the complainants to exercise their rights under certain of their patents, because the material could be used in violation thereof without difficulty.

COMMERCIAL beam wireless service between Great Britain and Australia was recently begun at rates lower than the existing cable rates.

PRESIDENT COOLIDGE has appointed the personnel of the United States delegation to the International Radio Telegraph Conference, to be held in Washington during October. This body, in spite of its name, which was adopted before radio telephony had been invented, will discuss broadcasting problems. The members of the American delegation are Herbert Hoover, Secretary of Commerce; Senator James E. Watson of Indiana; Senator Ellison D. Smith of South Carolina; Representative Wallace H. White, Jr., of Lewiston, Maine; William R. Castle, Jr., Assistant Secretary of State; Alternate, William R. Vallance, Assistant Solicitor of the Department of State; Maj. Gen. Charles M. Saltzman, Chief Signal Officer, U. S. A.; Capt. Thomas T. Craven, Director of Naval Communications, U. S. N.; W. D. Terrell, Chief of Radio Division, Department of Commerce; Owen D. Young, Chairman of the Board of Directors, General Electric Company; Alternate, Samuel Reber, Colonel, U. S. A., retired; John J. Carty, Chief Engineer, American Telephone and Telegraph Company; Stephen Davis, former Solicitor, Department of Commerce; John Beaver White, Electrical Engineer, and John Hays Hammond, Jr.

Piezo-Electric Crystals



VARIOUS KINDS OF MOUNTINGS FOR PIEZO-ELECTRIC CRYSTALS
The mounting at the extreme left holds a spherical crystal

A Simple Explanation of the Theory Involved in Quartz Crystal Applications—Their Use for Precision Calibration of Wavemeters

By M. THORNTON DOW

CONSIDERING the very large number of radio sets in use to-day, it is not surprising that there exists a national irritation over the uninvited and exasperating whistlings which intrude at many inopportune moments during otherwise enjoyable radio programs. Though the whistling has been dignified by the descriptive term "heterodyning," under any name it must be universally unpopular.

Very often, however, the phenomenon of heterodyning is a most useful one to scientists and in the laboratory. For instance, the information obtainable by this means makes it possible to find with precision the number of times per second piezo-electric crystals oscillate when excited electrically. Among the crystals illustrated in an article entitled "Piezo-Electric Crystals" in RADIO BROADCAST for January, 1927, was one which vibrates at the strikingly high rate of 6,000,000 times per second. It is quite usual for interested persons to ask the question: "How do you know that the crystal oscillates with a frequency of 6,000,000 times per second?" A truthful but uninformative answer is: "The whistles tell us." How these whistles are made to divulge these secrets of the crystal is somewhat briefly described in what follows.

As pointed out in the previous article, a single quartz crystal, or some other piezo-electric crystal, can be used with a vacuum-tube circuit to act as an oscillator giving any one of two or three (or more) principal frequencies which hold remarkably constant; and when an oscillator, either an electric or crystal-electric one, is operating at some one principal frequency, called the fundamental, there are usually simultaneously available in effect numerous other frequencies which are whole number multiples of the fundamental. These other frequencies are often spoken of as "the harmonics" but in order to specify them clearly it is best to assign to each frequency a number which, if multiplied by the frequency of the fundamental, gives the frequency of the harmonic. On this basis the fundamental is harmonic number one; twice the fundamental frequency is harmonic number two; and so on. If, then, the fundamental, the predominant frequency of the oscillations, is known, the simple multiplication by a whole number gives the frequency of any chosen harmonic. In the case of a crystal oscillator it is easy to see that, since the fundamental frequency is very nearly constant, all the harmonic frequencies are likewise just as constant.



WITHIN A CRYSTAL OSCILLATOR
When compared with the wiring of many radio sets this looks simple indeed

With these facts in mind, we can rightly inquire what they have to do with the whistling notes originating at times in radio circuits. A familiar fact is that whistling notes, called beat notes, are heard in any oscillating tube circuit whenever its frequency (a harmonic or fundamental) differs by an audible amount (that is, within the range of audible frequencies) from some fundamental or harmonic frequency of another oscillating tube circuit which is near enough to the first for the requisite transfer of energy. Although each tube itself may be producing oscillations which are inaudible, yet the interaction between the two circuits results in a beat note which may be adjusted to an audible frequency.

To illustrate the facts noted, we may consider a crystal-controlled circuit giving a fundamental inaudible frequency of 100,000 cycles per second set up, as in the diagrams of Fig. 1, in the vicinity of an oscillator having variable frequency. In a telephone receiver in one of the plate circuits we should hear a beat note of 1000 oscillations per second when the variable oscillator had been adjusted to give 101,000 cycles per second. Thus, the frequency difference between the two inaudible frequencies was made audible, in the form of a beat note.

By further adjusting the variable oscillator toward 100,000 cycles per second the beat note can be decreased in frequency until it is so low as to become inaudible, under which conditions we may be certain that the variable frequency is within, say, 50 cycles or less of 100,000 cycles per second. To decrease the variable frequency further, to 99,000 cycles per second, would again

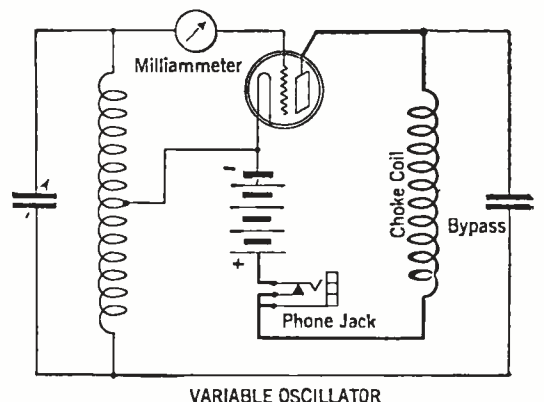
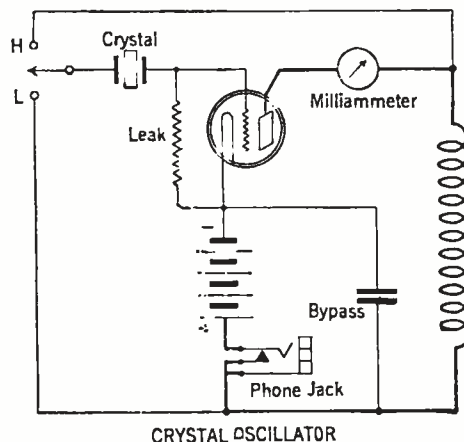

FIG. 1

bring in a beat note of 1000 cycles per second. The width of the region of inaudible (subaudible) beats just passed through is determined by the limitations of the human ear and of the apparatus used. In most cases a beat note below about 50 cycles per second would not be heard. In practice it is possible to approximate closely to *zero beat* (that condition existing when the two notes are of exactly equal frequency and no beat note is heard) by setting the dial at the middle of the silent region which is confined, often narrowly, between the two regions of clearly audible beats whose frequencies decrease as the inaudible band is approached from either side. Examine Fig. 2.

If the occasion demands, it is possible to actually make the *zero beat* frequency audibly evident by employing a third oscillator to give an auxiliary constant audible beat note whose intensity varies except when the variable frequency oscillator gives zero beat with the first oscillator.

All that has been said above regarding frequencies is true of every frequency, whether fundamental or harmonic, having the requisite amount of energy; when we hear a beat note, therefore, we are not at once certain which pair of frequencies from the two harmonic systems of the oscillators is producing the beats. We can be certain, however, that the audible beat frequency is the difference in frequency between some harmonic of one oscillator and some harmonic of the other oscillator, and, by methods described in part farther on, we can determine the respective harmonic numbers in question. The important thing to remember is that the audible beat note is used to indicate a very definite relation between frequencies which in themselves may be far above the range which is audible.

These indicators bridge the gap between such frequencies as fall above a few thousand cycles per second, which by any stretch of the imagination could not be measured by simple mechanical means, and those frequencies in the few hundred cycles per second class which are readily measured by mechanical-photographic means. An adaptation of the familiar telephone receiver, for example, makes it possible to photograph oscillations of a few hundred, or say for instance, a thousand cycles per second. It is a familiar fact that the metal diaphragm just back of the hole in the ear piece of the telephone receiver can be made to vibrate audibly at this frequency. If the vibratory motion of the diaphragm were made to operate a small mirror suitably, a spot of light reflected from the mirror would be deflected with a vibratory motion. A photographic record could be made by the spot of light, simultaneously with a similar record from the motion of the pendulum of an accurately regulated clock, upon a moving photographic film. The resulting print would look like the illustration of Fig. 3. The time represented by the distance between any two lines made by the swinging pendulum could be read from the clock. The number

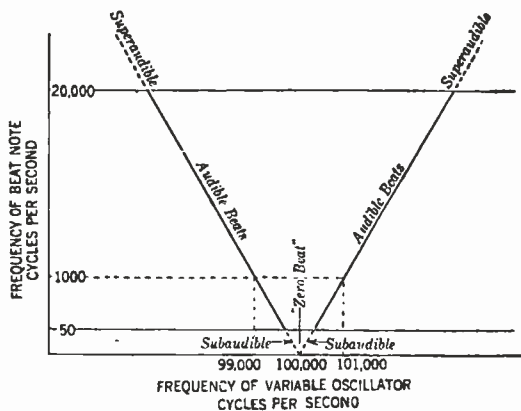

FIG. 2

of oscillations of the mirror within the boundaries set by any two time-lines can be counted, just as the number of box-cars between the locomotive and caboose of a long freight train can be counted. The number of oscillations per second can then be computed from the information so obtained.

CALIBRATING CRYSTALS

TO PUT the facts outlined in the preceding paragraphs to work to tell us the frequency of piezo-electric or other electric oscillating circuits, a series of oscillators are set up as suggested

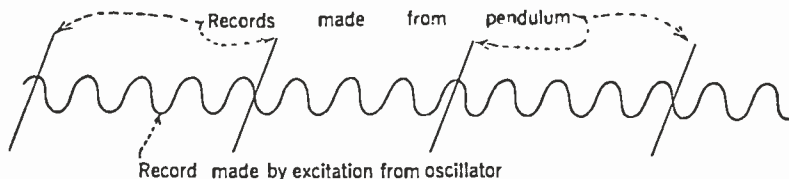

FIG. 3

by Fig. 4. Suppose that "A" is the crystal oscillator which we had suspected of giving oscillations of frequency in the neighborhood of 6,000,000 cycles per second. "D" is a variable low-frequency oscillator which can be photographically calibrated as above described. "B" and "C" are two other variable oscillators. The fundamental frequency of "B" may be adjusted until its harmonic number 10 gives zero beat with the fundamental of "A"; harmonic 20 of oscillator "C" may be similarly set against the fundamental of "B"; harmonic 30 of oscillator "D" may be set to equal the fundamental of "C." Under these conditions we now know that the fundamental frequency of "A" is $10 \times 20 \times 30 = 6000$ times the fundamental frequency of "D." If a photograph of "D" shows its frequency to be 1019.8 cycles per second it is safe to believe that the frequency of A is $6000 \times 1019.8 = 6,118,800$ cycles per second, which would certainly justify the nickname "six-million cycle crystal." Thus we can measure extremely high frequencies by first measuring in an electro-mechanical way a much lower frequency which has some simple and definite relation, as indicated by beat notes, to the very high frequency.

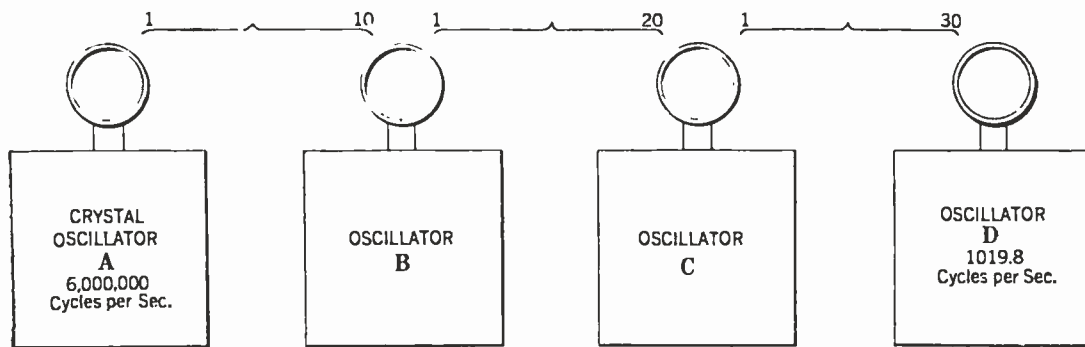

FIG. 4

For an instructive and very interesting article which describes unusual results of some recent experiments of Professor Wood of Johns Hopkins University with piezo-electric crystals, readers would do well to read "A New Magic," by Frank Thone, in the *Century Magazine*, for February, 1927. A scientific report on methods of using the piezo-electric crystal for precision wavemeter calibration was published in 1923 by Prof. G. W. Pierce of Harvard University in the *Proceedings of the American Academy of Arts and Sciences*. Since that time frequency meters covering the range from more than 150 million cycles per second down to audible frequencies have been built and crystal-calibrated at Cruft Laboratory, Harvard. Another paper by Professor Pierce on the measurement of the velocity of sound at high frequencies, published in October, 1925, by the American Academy of Arts and Sciences, includes a detailed description of some of the methods noted here for calibrating crystals and for using them in precision work.

When once a crystal has in the above manner been calibrated it is a standard against which other instruments for measuring frequency may be checked by methods much simpler in procedure but which in many instances again make use of the whistle of beat notes. Other crystals, by chance or by careful cutting, giving beats with the standard, may be precisely calibrated in short order. The case, however, of precision wavemeter calibrations against a standard crystal is typical of what may be done with, and represents one of the earlier laboratory uses for, the piezo-electric crystal; methods for such work developed in the university laboratory a few years ago have now become common and are regarded as standard practice.

CALIBRATING WAVEMETERS

A WAVEMETER is essentially an instrument for measuring frequency and therefore may better be called a frequency meter. Consisting merely of a coil connected to a condenser, the latter usually variable, a wavemeter gives a marked response at each setting of the condenser to a particular frequency. The response takes the form of a very rapid increase in the current circulating in the wavemeter when the condenser setting is adjusted toward a value at which the wavemeter is in tune to the frequency of the oscillator inducing the current. The evidence of the response may be given by a current meter built into the wavemeter, by a meter in a circuit of the oscillator to which the wavemeter is being tuned, or by other means.

Although for many wavemeters calculation will give the approximate range of frequency, or wavelength, covered by the scale of the instrument, only an experimental comparison against frequencies already known can give a dependable calibration. The frequencies for comparison may be determined by using another wavemeter which has already been standardized, but in any case the frequencies must at one time or another have been measured by some such methods as described for the case of the crystal. Because the frequency of the piezo-electric oscillator depends almost wholly upon the physical dimensions of the crystal, it is especially well adapted for meeting the requirements of a standard of frequency. So, ultimately, if our needs demand frequent measurement of frequency with high accuracy we shall find it necessary to calibrate a wavemeter against a piezo-electric crystal. The wavemeter is the instrument of greater utility in radio work in general, while the crystal is the more highly dependable as a standard of frequency. In

this particular connection then, what is usually needed is not an original determination of unknown frequencies but, rather, the *corrections* applicable to frequencies already known approximately. The fact that corrections to a calibration, which through frequent use has come to be held somewhat in doubt, are about to be carried out, greatly simplifies the experimental procedure and is justified as an illustrative case because it is so common in practice.

The procedure may be most briefly indicated by recollecting two facts before mentioned: A variable electric oscillator can be adjusted to give subaudible, or zero, beat note when in proximity to a piezo-electric crystal oscillator; a wavemeter (having the required range) can be adjusted to respond to the fundamental frequency of the electric oscillator. Thus, through the intermediary of the variable oscillator, the wavemeter calibration can be compared against the crystal frequencies. Suppose that there are 40 harmonics developed in the crystal circuits and 40 harmonics also developed in the variable oscillator circuits, then there are $40 \times 40 = 1600$ different settings of the variable oscillator which will give subaudible, or zero, beat notes, since each harmonic of the latter may in turn be adjusted by beats to equal in frequency each one of the 40 harmonics of the crystal oscillator. There is, therefore, the possibility of obtaining 1600 different settings on the scale of the wavemeter, each setting representing a definite frequency related to the fundamental standardized frequency of the crystal. There may be more than, or less than, 40 harmonics available from each circuit; for any given case there usually are more than enough for a satisfactory calibration.

And now, in deciding upon which pair of harmonics is in each case fixing the setting, we utilize to the fullest extent the old calibration of the wavemeter which we are correcting. We note, furthermore, whether at each setting the beat note obtained is strong, medium, or weak in intensity, for as a general rule the smaller the number specifying the harmonic involved the more intense is the beat note response, and this information aids in identifying the harmonics. To illustrate we shall assume that a standard crystal fundamental frequency is 100,000 cycles per second and that for a setting of a frequency meter, when tuned to an oscillator which had been set against the crystal by the beat method, the older calibration reads 134,670 cycles; this reading is presumably in error by some small amount, since it is taken from the previous calibration now being corrected. The question is, "what is the *correct* reading?" In the course of the experimental work we had noted that by comparison with beats obtained on the average this beat note had been among the louder ones. This leads us to suspect that the harmonic numbers associated with the case were rather small. Proceeding blindly we might calculate that:

$$101 \times 100,000 = 75 \times 134,667 \text{ (Very nearly)}$$

which indicates that if the variable oscillator fundamental were 134,667 cycles per second then its 75th harmonic equalled in frequency the 101st harmonic of the crystal. But when we note:

$$4 \times 100,000 = 3 \times 133,333 \text{ (Very nearly)}$$

we can feel safer in believing that the auxiliary oscillator stood not at 134,670 cycles per second as indicated on the doubted calibration of the frequency meter, but at 133,333 cycles since, in this case, harmonics 3 and 4 would have been used as against harmonics 75 and 101 in the other computation; this recognizes the spirit of our memorandum which showed that the beat note was among the louder ones observed. The old calibration was, then, at this point, in error by 1340 cycles in a total of 133,333, an error of

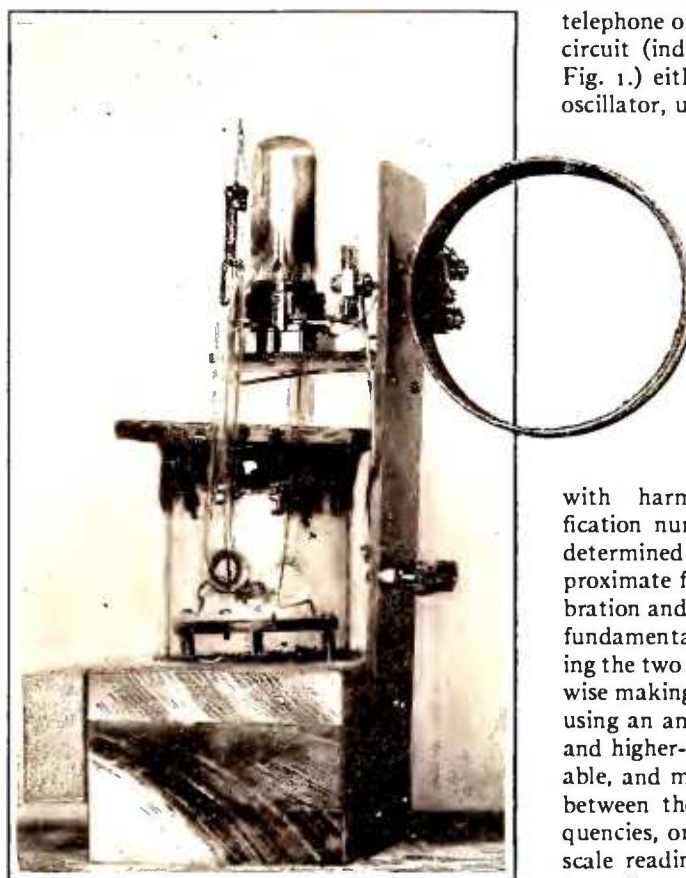

A PRECISION CRYSTAL OSCILLATOR
This instrument is being used at Cruft Laboratory, Harvard, and is making possible some very accurate measurements

telephone or amplifier is connected into the plate circuit (indicated as possible in the diagram of Fig. 1.) either of the crystal or of the auxiliary oscillator, usually but not necessarily in the circuit having the lower fundamental. To begin with, settings of the variable oscillator giving only loud beat notes are chosen throughout the range of the wavemeter; to suppress the weaker responses the distance between the crystal oscillator and the variable oscillator is, for the time being, reasonably increased, or the coils of the two oscillators may be oriented to give the same result. Since these loud responses are surely associated

with harmonics having the lower identification numbers, the correct frequency can be determined without ambiguity from the approximate frequency taken from the earlier calibration and from calculation based on the known fundamental frequency of the crystal. By placing the two oscillators closer together or by otherwise making the coupling closer and, possibly, by using an amplifier to the telephones, the weaker and higher-numbered harmonics are made available, and more data are taken to fill in the gaps between those at first recorded. When the frequencies, or wavelengths, are plotted against the scale readings of the wavemeter, some orderly smooth curve should result. Points much in error become evident at once and the correct assignment of harmonic numbers for these points is now easily made.

A little experience soon dispels the bewilderment which the novice usually feels at the beginning. It soon teaches him the difference between the lively well-behaved whistle of the beat notes which hold the key to all the data of the experiment, and the liquid transitory chirps which speak of the crystal's willingness to oscillate in other ways but which are useful only under other circumstances. He learns that to place the variable oscillator too near the crystal oscillator, or the wavemeter too near the variable, causes undue reactions in the circuits, evidenced by their meters, and is, so far as practicable, to be avoided. A lesson or two makes it an easy matter to pick out many harmonics as individualities, their characteristics of mark being tied up with their intensity and breadth of audible band. A harmonic of small index, in addition to its marked intensity, results in a more leisurely "running of the scale" when the beat note is tuned-in and out by the dial of the auxiliary oscillator.

nearly one per cent., which past experience, we will say, has shown to be not unreasonable.

Having looked at an illustrative example of an isolated calibration point let us get a better view of actual experimental procedure, tie in a few odds and ends of useful information, and thus better understand how the process of calibrating a wavemeter against a piezo-electric crystal may be methodically carried out with a minimum of difficulty from doubtful points which arise for the novice, and even for the expert, at times.

A photograph on this page was taken in a college laboratory. It shows a typical arrangement of apparatus for students' use in the calibration of a wavemeter by means of a crystal. A crystal is chosen which gives as one of its *fundamental* frequencies a frequency not too near the range covered by the wavemeter; the

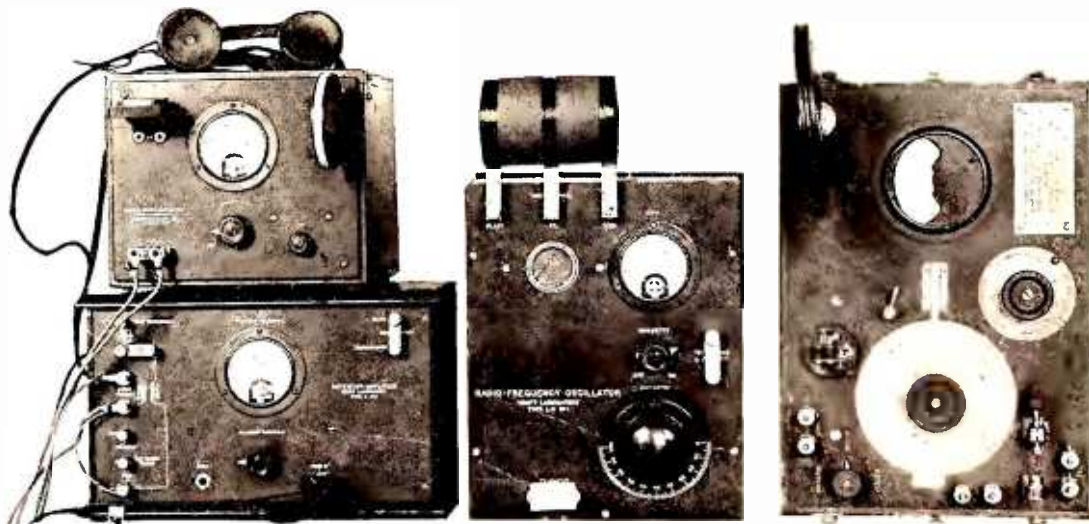

A TYPICAL SET-UP

Apparatus in a students' laboratory for calibrating a wavemeter by means of a crystal. On the left is the crystal oscillator, on top of the amplifier cabinet. In the center of the photograph is the auxiliary oscillator. The wavemeter to be calibrated stands at the right

Home-Constructing Transformers and Chokes for Power-Supply Devices

How the Number of Turns, Dimension of Core, Gauge of Wire, Etc., May Be Determined Without Resorting to Complicated Mathematical Calculations

By HOMER S. DAVIS

WITH steady improvements being made in the perfection of socket power-supply devices, there is hardly any doubt that they will eventually be even more widely used than at present. The building of these power devices offers an interesting field to the home constructor, resulting in a demand not only for data on the complete assemblies, but also for information about the actual design and construction of the individual units in these devices. In this article, dealing with power transformers and iron-core choke coils, the mathematical complexities of design are reduced to simple arithmetic by means of the calculation charts, and practical information is at the same time offered about the more common methods of construction.

The power transformer is an alternating-current device for changing electric power at one voltage to electric power at another voltage. It consists of two coils of wire wound upon a magnetic core. The winding which receives electric power from the source is called the primary winding, and the winding which delivers electric power to the load is called the secondary winding, the function of the core being to transmit the electric energy from the primary to the secondary, through the medium of magnetic energy. The voltage available at the secondary terminals depends upon the ratio of turns in the two windings. That is to say, if the secondary has, for instance, twice as many turns as the primary, the secondary voltage will be twice as great as that impressed upon the primary; conversely, if the secondary has half as many turns as the primary, its voltage will be only half as great. If the transformer serves to increase the voltage, it is called a step-up transformer; if to decrease the voltage, a step-down transformer.

A small part of the power put into the transformer is used up in overcoming the losses. The copper losses are due to the resistance of the windings, and may be reduced by choosing wire of reasonably ample size. Other losses are due to hysteresis and eddy currents in the core, and may be reduced by the proper choice of flux density, and by using a laminated core of sheets of silicon steel. The power consumed in overcoming these losses is dissipated in the form of heat, so that when the transformer is put under load, the core and windings will slowly warm up to some steady value above room temperature. Although it is possible to design transformers to operate at comparatively cool temperatures, a certain amount of heating is permissible, and transformers that run warmer can be built somewhat cheaper and made more compact. The temperature rise, however, should not be so great as to damage the insulation.

When the transformer is put under full load the voltage across the secondary terminals will drop a small amount. This is what is referred to as voltage regulation, and is expressed by the percentage

of ratio of the ratio of this drop in voltage to the original, or no-load, voltage. Good regulation in a transformer is desirable, and depends upon the resistance of the windings and the leakage of magnetic energy between them. The magnetic leakage may be reduced by arranging the transformer as compactly as possible with the winding adjacent and close to the core, by keeping the path around the core as short as possible, and by making good neat joints in the core. As will be shown later, it is possible to use either a large core with relatively few turns of wire, or a small core with many turns. For good regulation, the larger core with fewer turns is preferable.

In general there are two types of transformers, differing chiefly in the arrangement of their cores. One is known as the shell type, the other, the core type; both are shown in Fig. 1. The core type is the simpler of the two to construct, and is the one considered in this article.

Turning now to the design, the fundamental formula for the transformer is:

$$E = 4.44 \frac{BANF}{10^8} \quad (1)$$

where E is the supply voltage, B the flux density in lines per square inch of core area, A the net area of a cross section through one leg of the core, N the number of turns in the primary winding, and F the frequency of the supply voltage. To avoid the labor of solving formulas such as this, the calculation charts accompanying this article have been prepared, the above formula being represented by Chart III. Flux density is the measure of magnetic energy used in the core to link the primary and secondary coils. Its magnitude depends upon the material used in the core, and for the silicon sheet steel commonly used it is taken as 60,000 lines per square inch. This value was used in the right hand scale, Chart III.

Information as to the supply voltage and frequency may be obtained from the local electric light company. With these values known, and the flux density assumed, it can be seen from formula (1) that it is possible to use either a large core with few turns, or a small core with many turns. To establish a working ratio, the number of turns may be figured from the following formula, corresponding to Chart II:

$$\text{Turns per volt} = \frac{C}{\sqrt{\text{Watts Output}}} \quad (2)$$

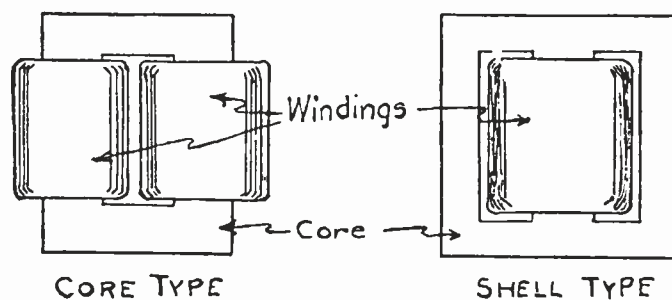

FIG. 1

where C is a constant, the value of which may be so chosen as to give any desired proportion between core and copper. The number of turns in any coil is then the product of the turns per volt and the voltage of that coil. In order to obtain better regulation, and also because wire, especially in the smaller sizes, is much more expensive than core material, the transformer with a larger core and fewer turns is preferable. A value of 35 for C will give a good ratio from the home constructor's standpoint and has been used in Chart II. If for any reason the reader wishes to use a different ratio, the new value of turns per volt must be figured from formula (2) and then employed in Chart II to find the total turns in each winding. The larger the value of C used, the greater the ratio of copper to iron, and vice versa.

PROCEDURE IN TRANSFORMER DESIGN

BEFORE taking up the solution of a typical example, it is advisable to have in mind a general idea of the proper procedure to follow. The first step is to ascertain the output rating, or secondary voltage and current, as required by the apparatus to which the transformer is connected. Then the power output in watts is the product of the voltage and the current in amperes, and may for convenience be obtained from Chart I. If there is more than one secondary winding, the total output, of course, is the sum of them all. The number of secondary turns to give the required voltage may be figured by multiplying the turns per volt, from formula (2) by the secondary voltage, or it may be obtained from Chart II. About five per cent. more turns should actually be used on the secondary, to compensate the voltage drop under full load due to losses and regulation. The number of turns required for the primary winding is then found from Chart II in the same manner.

The next thing to be determined is the size of the core. The cross section area may be obtained from formula (1) or from Chart III. The net area is usually assumed to be about 90 per cent. of the gross area, to allow for oxide coating or other insulation between the core laminations. The use of a square core is advisable, to facilitate the winding of the coils as well as the general construction.

The subsequent step is to choose a size of wire for each winding large enough to carry the current without objectionable heating. It is customary in figuring wire sizes to use a unit of area called the circular mil, which is the area of a wire one thousandth of an inch in diameter. For steady loads, (continuous over a period of hours), 1500 circular mils of area should be provided for each ampere of current; if the load is intermittent (in use over short periods of time), this may be reduced to 1000 circular mils per ampere. The current-carrying capacities of the different sizes of wire have been set down

TRANSFORMERS 25 TO 1500 WATTS

POWER

URNS

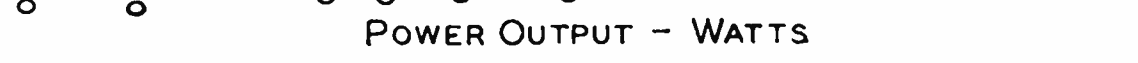
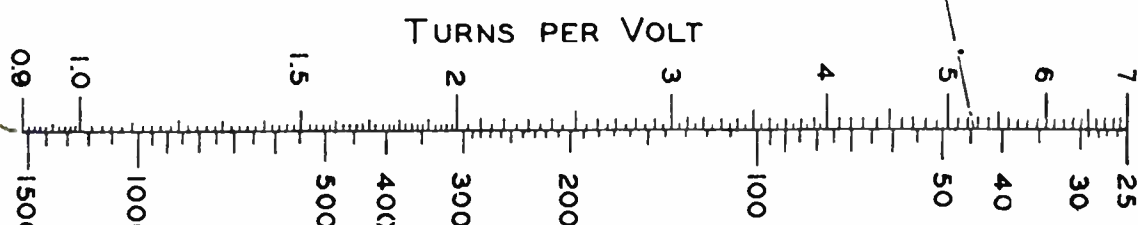
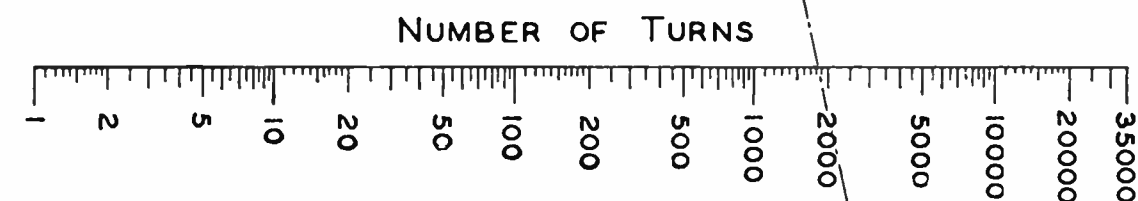
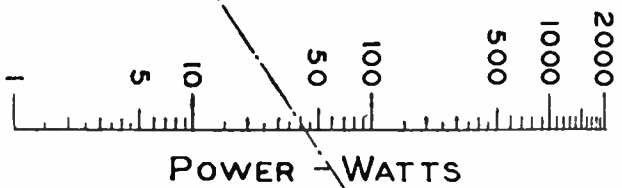
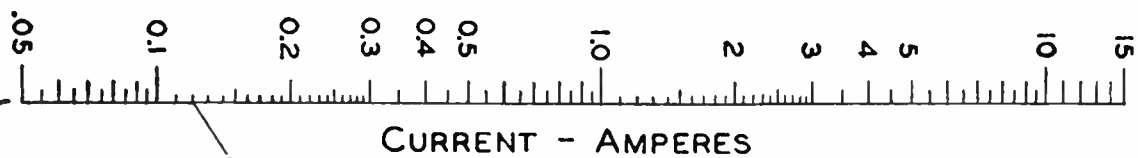

CHART I

CHART II

TRANSFORMERS

CORE
SILICON STEEL

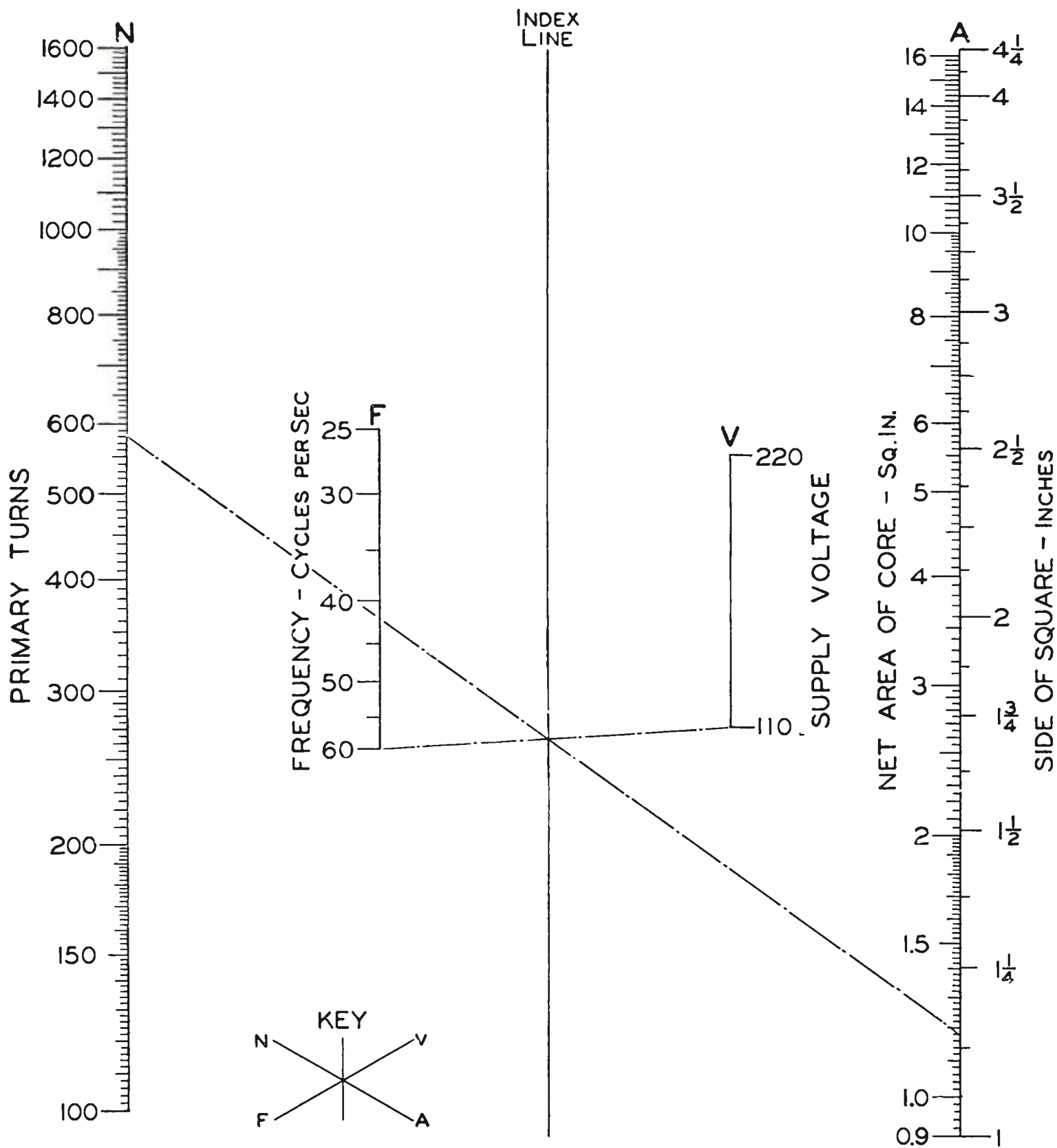

CHART III

in the copper wire table accompanying this article. The secondary current having been previously determined, the correct size of wire may be found by referring to the second or third column of this table. The primary current may be obtained from the primary, or input, power, which exceeds the output power by an amount sufficient to overcome the transformer losses. The percentage ratio of output to input is the measure of efficiency of the transformer. Home constructed transformers of about 1500 watts rating may be as high as 95 per cent. efficient, decreasing to about 90 per cent. at 100 watts, and then probably dropping to about 80 per cent. at 50 watts, or even lower for smaller sizes. To find the primary current, therefore, first divide the power output by the probable efficiency, which gives the power input; the primary current is then equal to this input power divided by the supply voltage, or it may be found by means of Chart I. The proper size of wire for the primary may now be obtained from the table.

All that remains is to design a core of required cross section, with an opening or window in it large enough to contain the windings. This is most readily done by making a full size pencil drawing of the transformer, similar to Fig. 2. (on this page). After drawing in one leg of the transformer, choose a tentative width for the windings and from the wire table, "turns per linear inch" columns, figure how many turns per layer may be wound in the primary coil. Either double cotton-covered wire or single cotton-covered enameled wire may be used. Except in the smaller sizes, the use of plain enameled wire in transformers is not advisable, and then only is it permissible when a layer of paper is placed between each layer of wire. Enameled wire has the added disadvantage that it cannot be shellaced in place. The number of layers is then found by dividing the total number of turns by the number of turns per layer. From this the depth of the winding may be estimated, allowing for any insulating paper between layers, if used. The primary coil may now be put on the drawing, leaving at least an eighth of an inch for insulation between it and the core. The depth of the secondary winding may be found in the same manner, using the same width as the primary. In placing the secondary on the drawing, allow about a quarter of an inch between it and the primary winding, to take care of insulation and discrepancies in actual construction; or if it is planned to wind it directly over the primary on the same leg of the core, allow for about an eighth of an inch of insulation between them. Then draw in the rest of the core, allowing about a quarter of an inch clearance between it and the ends of the windings.

It can be readily seen from such a drawing whether the transformer is well proportioned from the standpoint of good voltage regulation. If it looks like either A or B in Fig 3, assume a different value for the width of the windings and try another layout. A little care and judgment here will be well repaid in final results.

The solution of a typical example

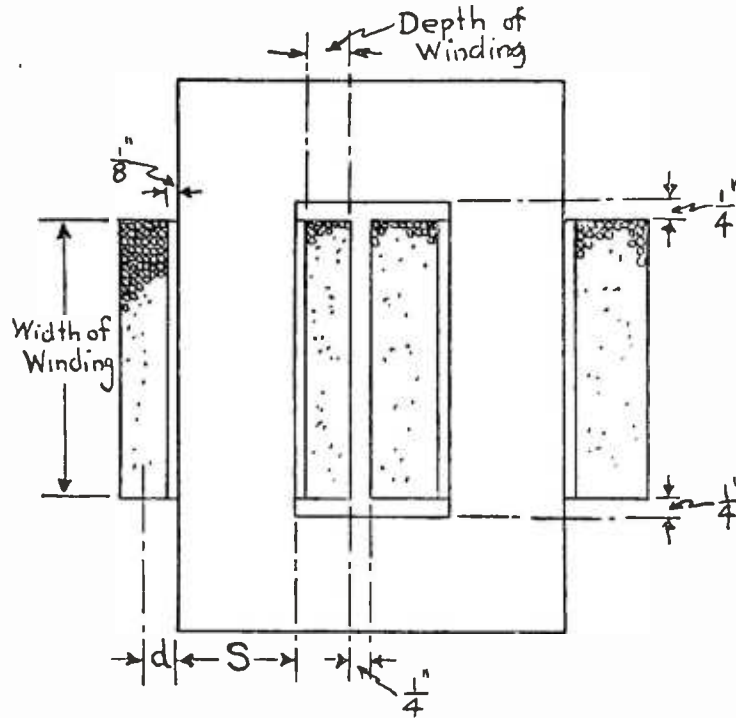

FIG. 2

will better illustrate the use of the calculation charts. Suppose a transformer to operate from a power supply of 110 volts and 60 cycles, is to be designed for use in a plate supply unit employing a Raytheon type BH rectifier. A secondary voltage of 350 is required by this tube; its capacity is 85 milliamperes of direct current, but it is safer to design the transformer to handle about 120 milliamperes (0.12 amperes) of alternating current to allow for that bypassed by the filtering system. If a power amplifier stage is to be included, a filament winding delivering 0.5 amperes at 5 volts will be required for, say, a UX-112 (CX-312) or UX-171 (CX-371) type tube.

The power output of the high-voltage winding is found from Chart I by drawing a straight line from 0.12 on the current scale to 350 on the voltage scale, which will be found to cross the middle

scale at 42 watts. The power output of the low-voltage winding is similarly found to be 2.5 watts. The sum of these gives 44.5 watts as the power output of the transformer. The number of turns to put on each winding is found from Chart II. For the 350-volt winding, draw a line from 350 on the voltage scale to 44.5 on the power output scale, intersecting the third scale at 1850 turns. Five per cent. more turns should be added to take care of the voltage drop due to regulation, making 1940 turns for the 350-volt winding under full load. Since the Raytheon tube is a full-wave rectifier, two 350-volt windings, or one 700-volt winding (3880 turns) with a center tap, will be required. Using the chart in the same manner for the filament winding gives 26 turns, and adding about five per cent. makes 27 turns. Similarly, the primary will be found to require 580 turns; the allowance for regulation is not used here of course, as the voltage of the supply mains is fairly steady and independent of the transformer.

With the number of turns for each winding determined, the next step is to find the size of core cross section from Chart III. The four scales of this chart are to be used as shown in the key; that is, the inner or frequency and voltage scales are always connected together, and likewise the outer two scales are always used together. With a power supply of 110 volts and 60 cycles, a line is drawn between these two points. Through the point at which this line intersects the index line, draw a second line from 580 on the primary turns scale until it meets the core area scale. This shows that a core having a net cross section area of 1.18 square inches is required; the nearest size is 1 1/4" square.

In determining the size of wire for the secondary, it is noted that each 350-volt winding delivers current only half the time, and therefore a wire of half the area might be used. However, the resistance of the winding would thereby be doubled, introducing a detrimental effect upon the voltage regulation, and for this reason it would be better to compromise on a larger size. With a secondary current of 0.12 amperes, choose a size of wire to carry, say, 0.10 amperes, which, at 1500 circular mils per ampere, requires a No. 28 wire as shown by the wire table. For the filament winding delivering 0.5 amperes, No. 21 wire would be satisfactory.

Before the size of wire for the primary can be found, the primary current must be known. Assuming an efficiency of 75 per cent. for this size of transformer, the power input to the primary will be 44.5 divided by 0.75, or about 60 watts. The current is then found from Chart I by drawing a line from 110 on the voltage scale through 60 on the power scale until it meets the current scale, at 0.54 amperes. From the table, No. 21 wire is required for the primary.

The rest of the design consists in laying out the full size drawing of the transformer as described earlier. This layout being completed, it is often desirable before ordering the material, to estimate the weights of wire and core steel required.

COPPER WIRE TABLE									
SIZE B & S	CURRENT CAPACITY AMPERES		RES. PER 1000 FT. OHMS	TURNS PER LINEAR INCH			WEIGHT—LBS. PER 1000 FT.		
	1000 C. M. PER AMP.	1500 C. M. PER AMP.		D. C. C.	S. C. E.	ENAM.	D. C. C.	S. C. E.	ENAM.
8	16.5	11.0	.628	7.1	7.3	7.7	51.2	51.2	50.6
9	13.1	8.7	.792	7.8	8.1	8.6	40.6	40.6	40.2
10	10.4	6.9	1.00	8.8	9.0	9.6	32.2	32.2	31.8
11	8.2	5.5	1.26	9.8	10	11	25.6	25.6	25.2
12	6.5	4.4	1.59	11	11	12	20.4	20.4	20.0
13	5.2	3.5	2.00	12	12	13	16.2	16.2	15.9
14	4.1	2.7	2.52	14	14	15	12.9	12.9	12.6
15	3.3	2.2	3.18	15	16	17	10.3	10.2	10.0
16	2.6	1.7	4.02	17	18	19	8.21	8.14	7.93
17	2.0	1.4	5.06	18	20	21	6.54	6.47	6.28
18	1.6	1.1	6.38	20	22	24	5.24	5.14	4.98
19	1.3	.86	8.05	22	24	27	4.22	4.00	3.96
20	1.0	.68	10.2	24	27	30	3.37	3.26	3.14
21	.80	.53	12.8	28	30	34	2.68	2.60	2.49
22	.64	.43	16.1	30	33	38	2.17	2.07	1.97
23	.51	.34	20.4	33	36	42	1.73	1.66	1.56
24	.40	.27	25.7	36	40	47	1.40	1.33	1.22
25	.32	.21	32.4	38	44	53	1.13	1.06	.988
26	.25	.17	40.8	42	48	59	.914	.849	.784
27	.20	.13	51.5	45	52	66	.756	.678	.622
28	.16	.11	64.9	48	57	74	.608	.543	.494
29	.13	.084	81.8	52	62	82	.489	.433	.392
30	.10	.067	103	56	67	92	.396	.346	.310
31	.080	.053	130	60	73	103	.326	.281	.246
32	.063	.042	164	63	79	116	.270	.228	.196
33	.050	.033	207	66	86	130	.227	.185	.155
34	.040	.026	261	70	92	145	.193	.150	.123
35	.032	.021	329	73	99	164	.160	.123	.098
36	.025	.017	415	77	105	182	.136	.101	.078
37	.020	.013	523	80	113	206	.120	.084	.062
38	.016	.010	660	84	120	235	.105	.071	.049
39	.012	.008	832	90	128	261	.094	.061	.039
40	.010	.007	1050	95	136	290	.084	.053	.031

The weight of each size of copper wire is approximated by first finding the total length of wire in each winding. The mean or average length of a single turn may be found from Chart IV. Here the left-hand scale represents the width of the square side of the core, shown as "S" in Fig. 2, while the right-hand scale is the distance from the edge of the core out to the center layer of the winding in question, as "d" in Fig. 2. To use the chart it is necessary merely to measure these two distances on the full-size drawing of the transformer, locate each of these values on their respective scales on the chart, and draw a line between these two points; the point at which this line crosses the center scale is the average length of a turn in feet. For instance, if a $1\frac{1}{8}$ "-core has a 2000-turn winding, the center layer of which is $\frac{1}{8}$ " out from the core, a line drawn between these two figures on the chart will intersect the center scale at 0.505 feet, the average length of a turn. Multiplying this value by the total number of turns, 2000, gives 1010 feet as the length of wire in the winding. The weight of the wire may be found from one of the last three columns of the copper wire table; the length of wire in feet divided by 1000 and multiplied by the weight per thousand feet gives the total weight.

The weight of the core is obtained by subtracting the area of the window in square inches from the gross area of the core as it appears on the drawing, multiplying by the depth, and then

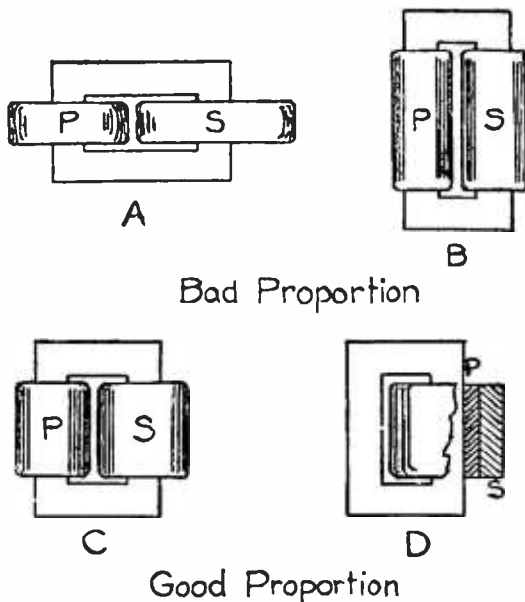

FIG. 3

multiplying this result by the factor 0.28, which gives the weight in pounds. For example, suppose a 1" core measures 3" by 4" along its outside edges. The window will then measure 1" by 2", with an area of 2 square inches. Subtracting this from the gross area of 12 square inches leaves 10 square inches of net area. Multiplying

this by the depth, 1", gives 10 cubic inches as the volume of the core. The volume multiplied by 0.28 gives 2.8 pounds as the weight of the core. If the number of laminations is desired, it may be calculated by dividing the depth of the core by the thickness of a single sheet, which is usually 0.014 inches. The shape to cut the laminations will be discussed later.

As a final operation it may be desirable to check the resistance of each winding to make sure it is not excessive. Knowing the length of wire and looking up the resistance per thousand feet in the wire table, the total resistance is a matter of simple arithmetic. The voltage drop under full load due to resistance (exclusive of flux leakage, etc.) is then the product of the resistance and the current.

Summarizing, the general procedure to follow in designing a transformer may be outlined as follows:

- (1.) Characteristics of secondary windings, *i. e.*, voltage, current and power.
- (2.) Total number of turns in each winding.
- (3.) Size of core cross section.
- (4.) Wire sizes.
- (5.) Physical dimensions from full-size drawing.
- (6.) Amounts of wire and core material.

The next and final article will take up the actual construction of the transformers, and the fundamentals of choke coil design will also be discussed in detail.

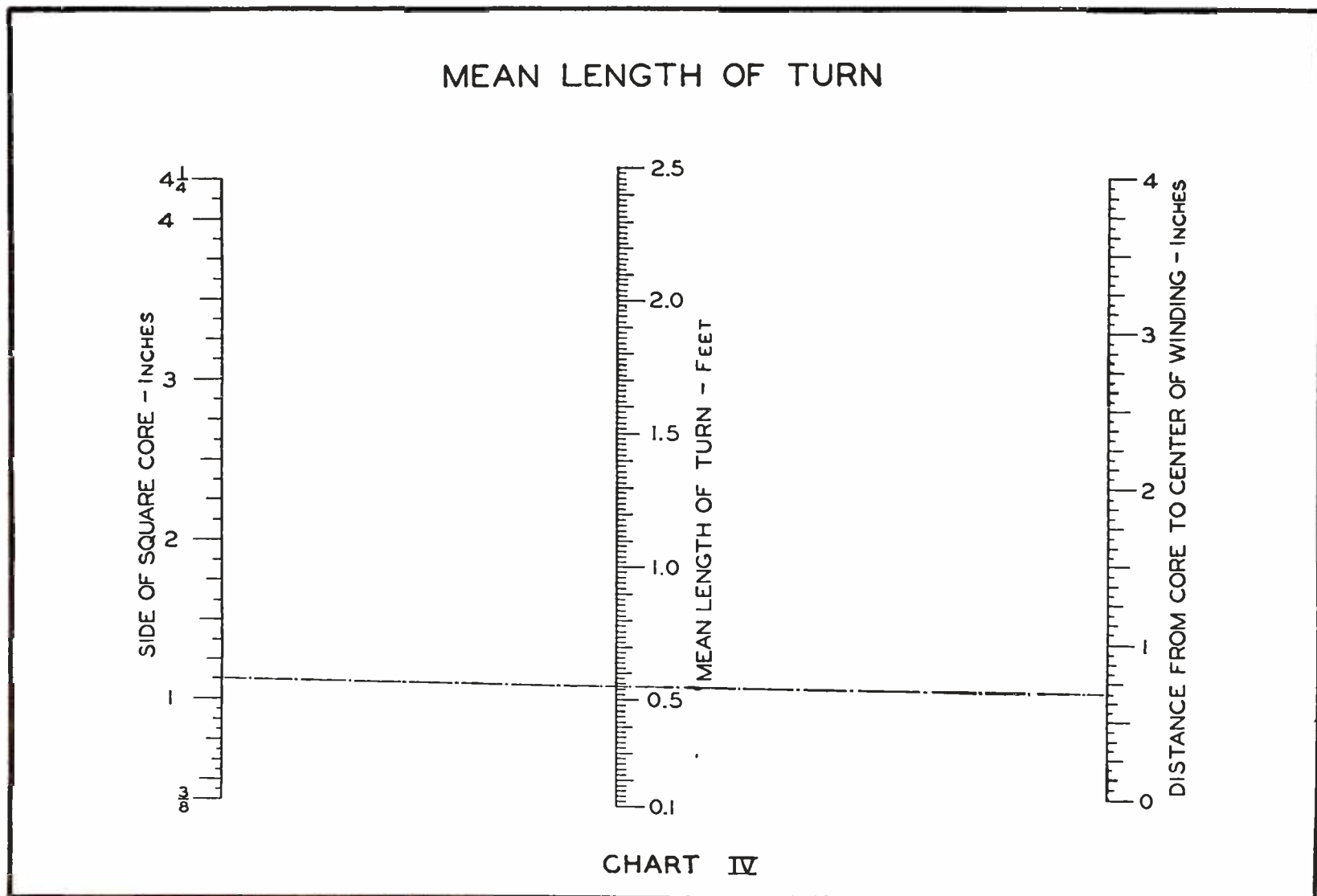
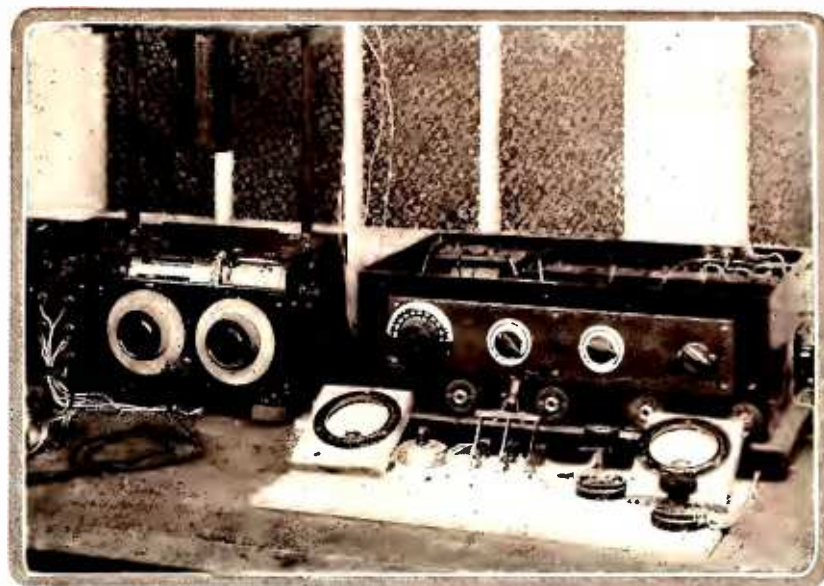
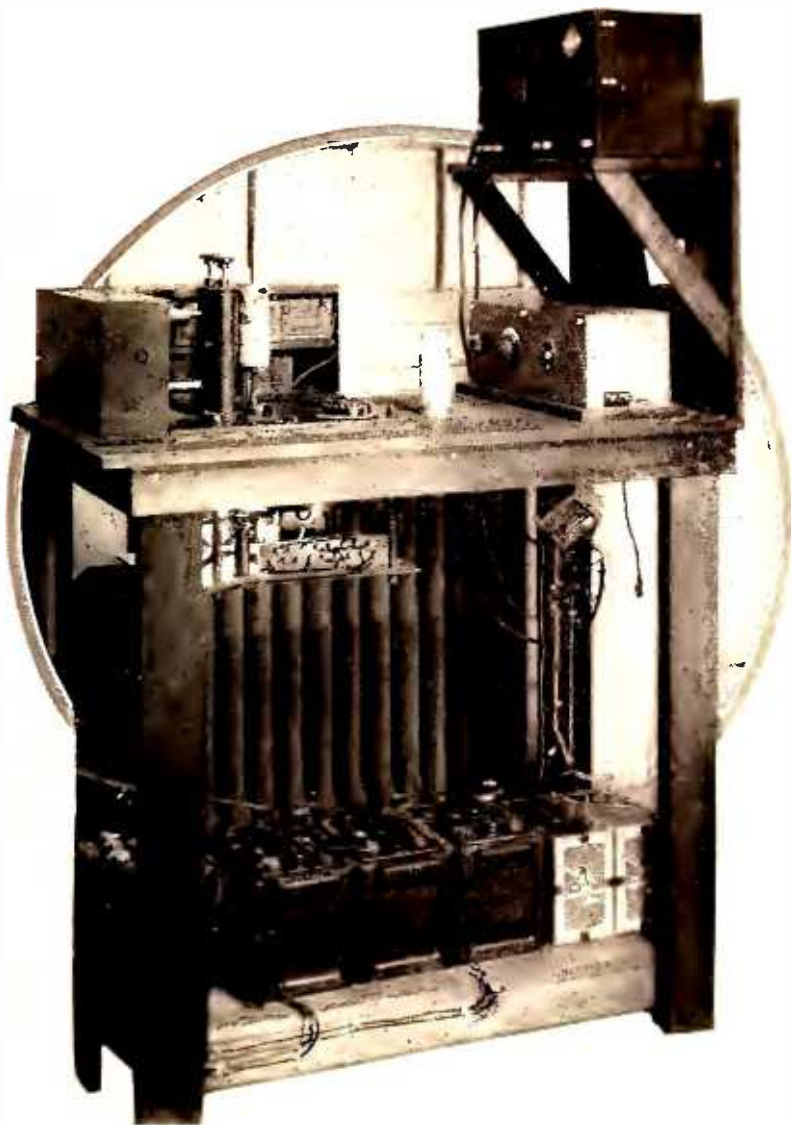

CHART IV



RADIO BROADCAST Photographs

RADIO PICTURE EQUIPMENT IN THE LABORATORY

These two photographs give some idea of the compactness of the radio photograph equipment which has been in the course of development in the RADIO BROADCAST for some time. Left, the transmitter, above, the receiver

Pictures by Radio

What Radio Broadcast Laboratory Is Doing to Aid the Home Constructor to Develop Phototelegraphy

DURING the years of 1924 and 1925 two demonstrations of phototelegraphy were given, one by radio and the other by wire. These were milestones in the progress of the art of transmitting pictures to distant points by electricity. The first demonstration, making use of the system developed by R. H. Ranger of the Radio Corporation of America, was given on December 2nd, 1924, when pictures were transmitted from New York to London utilizing a mechanism with which the picture is produced by means of a pen making ink marks on paper. In 1925, a second system, developed in the Bell Telephone Laboratories, was demonstrated, and the system was adapted to use to full advantage the facilities of the Bell system. It made use of photo-electric cells which are sensitive to light and which are capable of controlling electric currents in accordance with the strength of the light impressed on the cell. The Bell system is similar in many ways to the Korn system with which, in 1907, some very good pictures were transmitted from Paris to London.

A great deal of valuable, and not too technical, information on picture transmission is given in a book recently published by the D. Van Nostrand Company, entitled *Wireless Pictures and Television*, and in this book will be found fairly complete descriptions of both the RCA and Bell Laboratory systems. The author is Mr. T. Thorne Baker, himself a scientist who has been actively interested in phototelegraphy, and anyone interested in the subject will find the book well worth reading.

Most of the press accounts describing the Ranger and Bell Laboratory demonstrations have made some reference to the possibility that perhaps, at some later date, means will become available to the general public of receiving, via radio, photographs of important public

events, news items, etc., as well as ordinary broadcasting. In order for such a use to become common it is, of course, essential that the system used be simple to operate and fairly cheap in first cost and upkeep. How soon can such a development of picture transmission be expected?

IS AMATEUR PICTURE RECEPTION NEAR?

READERS of RADIO BROADCAST will be interested to know that during the last four years or so experimental work has been going on in the Laboratory on a system of picture transmission which has the essential characteristics of simplicity and low cost that make it especially well adapted for use by amateurs and home-constructors. No technical knowledge is required in order to use the system and it is hardly more difficult to operate than the tricky squealing radio receiver of four years ago. Photographs on this page show the picture transmitting and receiving apparatus in use in the Laboratory.

The system used in RADIO BROADCAST Laboratory has been developed to the point where good pictures can be transmitted by either wire or radio. To transmit a picture 4" x 5" requires about two minutes. The picture is received on a piece of ordinary photographic paper which is finally developed like an ordinary photographic print. There is more "kick" in producing a picture which has been received by radio in your own home than there ever was in "pulling in" the Coast at 2 A. M.

It is quite possible that picture transmission by radio will follow, to a certain extent, the same course that radio followed only a comparatively few years ago when it first became popular. The first picture receivers will probably be home constructed and the home-constructor will, at the beginning, take an important part in stimulating

the rapid development of picture transmission. The first users of picture receivers will be the same persons who, when radio first started, constituted the larger part of the radio audience.

The problem in picture transmission with which the Laboratory is concerned at present, is the development of apparatus easily constructed and operated at home. The various parts must be manufactured and made generally available so that their assembly into a complete unit will not be difficult. RADIO BROADCAST is making extensive arrangements to present workable plans to the home constructor, and the latter may expect reasonably soon to see a most interesting series of articles in this magazine which will open this new and fascinating field to him. Complete constructional information will aid the experimenter to start work with no delay. The pictures will be transmitted by broadcasting stations and will be received on a small unit which can be attached to any efficient radio receiver. The number of experiments that can be made with a small picture transmitter costing not more than \$100.00 is practically unlimited.

The amateur experimenter has long looked to the transmitting of photographs by radio with envious eyes. Up to the present, experiments of this sort have been confined to luxurious laboratories bristling with engineers and a wealth of apparatus. But now it will shortly be possible to assemble a picture receiver which will not cost much more than \$100.00, attach it to a good broadcast receiver, and jump into what will soon be an enthralling hobby. In the meantime we invite correspondence from our readers who have already given thought to this new field of experiment or who have perhaps done some experimenting on their own in picture transmission.

An Eight-Tube Receiver Which Is Remarkably Sensitive, Has Knife-Like Selectivity, and Is Simple to Construct

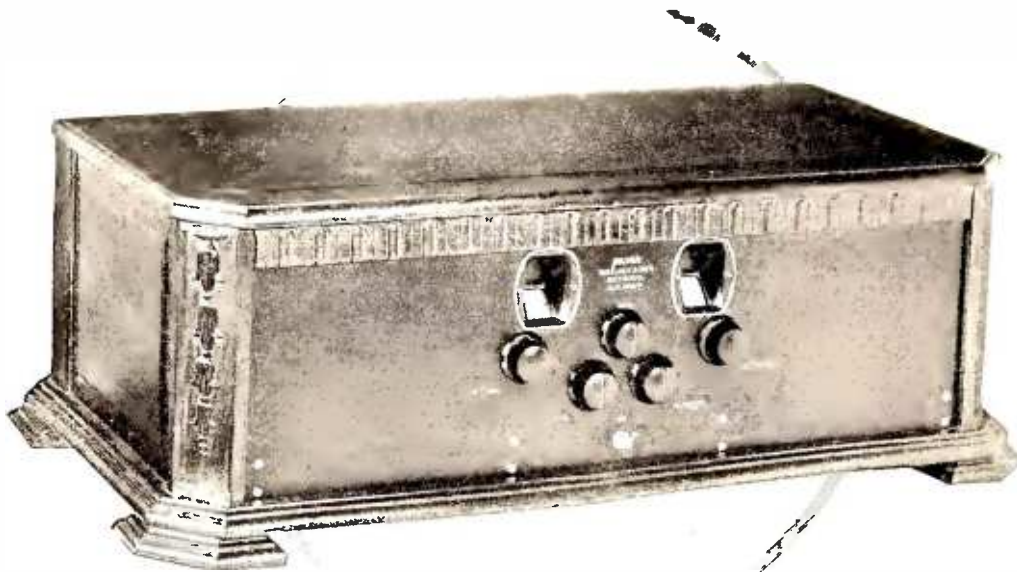

The Intermediate Frequency Used, 112 Kilocycles, Is Unusual but Has Considerable Advantages

THE LABORATORY "SUPER" AS IT LOOKS AFTER COMPLETION
Compactness is one of the features of this exceptionally efficient eight-tube super-heterodyne. Many five or six tube receivers require just as large a cabinet

Building the Laboratory "Super"

By ERNEST R. PFAFF

WHEN McMurdo Silver described a super-heterodyne receiver in the January, 1925, RADIO BROADCAST, it represented about as satisfactory a receiver of that type as could then be built. In the intervening two and one-half years, many thousands of these receivers have been constructed, and while the design was not blessed by an absolute freedom from the vicissitudes that often attend the building of radio sets at home, many builders have reported truly remarkable reception records, while as far as is known, practically all have enjoyed quite satisfactory results. In the meantime, many experiments have been carried on in an endeavor to improve the original receiver, and a new model

has finally been developed which, judging from comparative tests, bids fair to eclipse the very best performance of the original circuit. In the design of the latest improved model, described herewith, cognizance has been taken of the engineering advances made since the development of the first circuit, as well as of the many helpful comments and suggestions of the builders of the original receiver.

The improved Laboratory model super-heterodyne employs eight tubes in a comparatively conventional arrangement—a first detector, an oscillator, three long-wave (intermediate) amplifiers, a second detector, and two audio stages. The first detector circuit is very similar

to the conventional short-wave regenerative circuits now so popular. The circuit is regenerative, a small 75-mmfd. midget condenser controlling regeneration, while a 0.00035-mfd. condenser does the tuning. The coil system consists of a conventional Silver-Marshall plug-in coil, so connected that both regeneration and tuning condensers are at ground potential, with consequent total absence of hand-capacity effect. No provision is made to use a loop, as it has been found that, for extreme selectivity, the use of an antenna, the coupling to which is variable, provides for greater flexibility than a loop.

The oscillator circuit is very similar to that of the first detector, and offers few unusual points

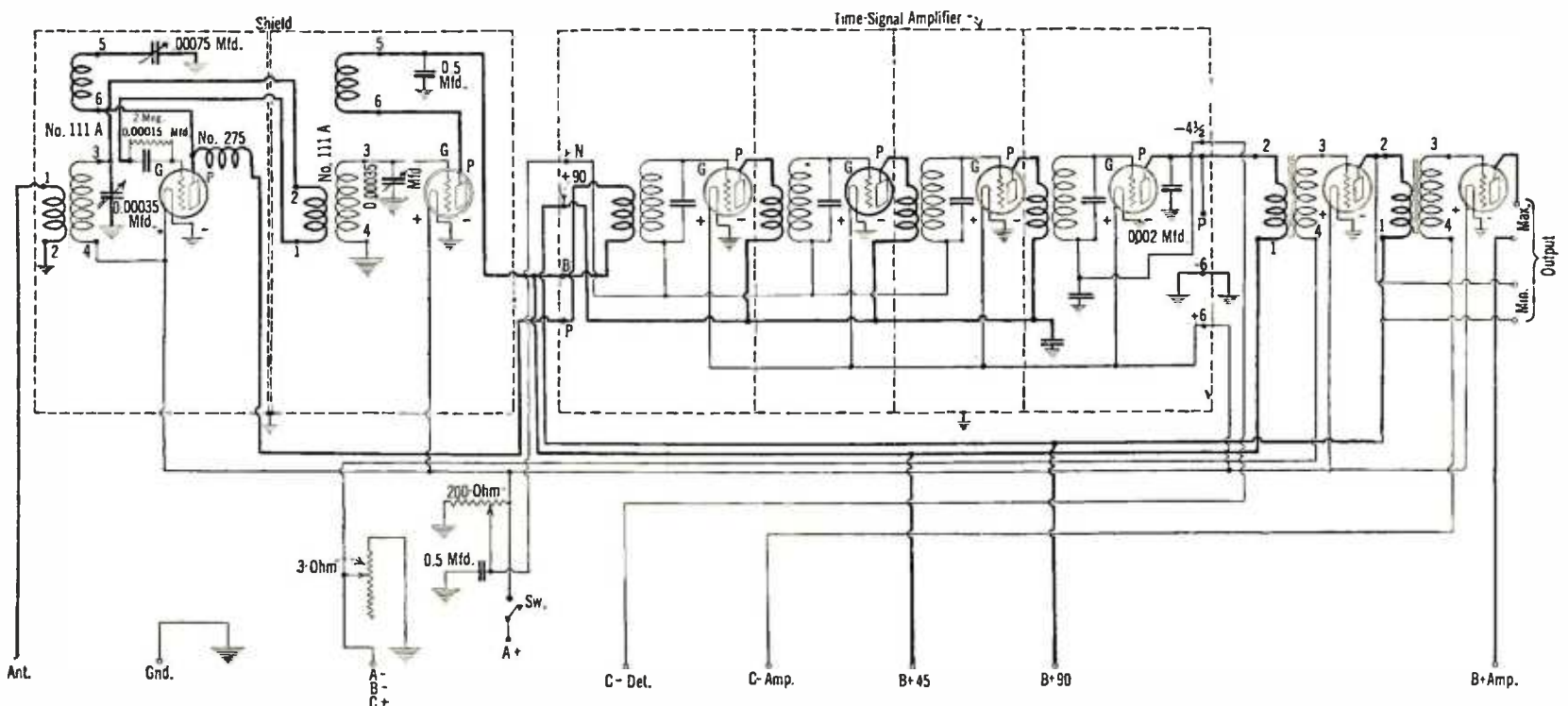

THE CIRCUIT DIAGRAM OF THE EIGHT-TUBE SUPER-HETERODYNE

other than that it is grid-tuned with a 350-mmfd. condenser and there is complete absence of hand-capacity effect. Its output at different wavelengths is sufficiently constant for practical requirements, as is its calibration, while the coupling to the first detector is variable.

The long-wave, or intermediate, amplifier is possibly the most unique and interesting part of the receiver, for it is a completely shielded assembled unit, or catacomb. The copper can 15 inches long, 5 inches wide, and 3 inches deep, contains four individual stage compartments, each holding an r. f. transformer and its attendant tuning capacity, a tube socket, and the necessary wiring and bypass condensers. Three r. f. stages and a detector are employed, and the whole unit is tuned to exactly 112 kilocycles. The reason for the selection of this intermediate frequency is that very satisfactory low-resistance air-core tuned r. f. transformers may be built for operation there.

Another reason for the selection of the odd 112-kilocycle amplifier frequency is because of decreased interference possibilities. Normally, in a super employing, say, a 50-kilocycle intermediate frequency, two stations 50 kilocycles away will heterodyne each other and be received without the use of the local oscillator at all, selectivity being dependent upon the selectivity of the antenna tuner and the local coil pick-up. As the intermediate frequency is increased, this possibility decreases, since it is far easier for an antenna tuner to discriminate between stations 112 kilocycles apart than between powerful locals 30, 50, or even 60 kilocycles apart. Further, powerful stations are generally spaced on even 10-kilocycle separations, so that the odd 112-kilocycle frequency is a greater aid to selectivity.

Coil pick-up is, of course, absent in the shielded amplifier, and wiring pick-up is almost negligible since all wiring is very close to the grounded metal panel or chassis. Complete shielding of the first detector and oscillator sections prevents pick-up of strong local stations on the coil systems themselves, though in receivers to be operated in the country, or in non-congested broadcasting centers, these two shields might be omitted.

The audio amplifier offers no unusual points except one of very great value in an ultra-selective receiver. This is the 5000-cycle cut-off, or fall-off in amplification, which occurs in this amplifier. Normally, frequencies above 5000

cycles do not contribute to realism of reproduction, according to no less an authority than the Bell Telephone Laboratories, while in the range above 5000 cycles lie practically all parasitic amplifier noises, atmospheric disturbances, and the only too prevalent heterodyne squeals. These the 5000 cycle cut-off tends to decrease very markedly, and almost entirely eliminate.

The amplification possibilities of the receiver are interesting, as compared to, say, a good bridge-balanced or neutralized eight-tube r. f. receiver. Such an r. f. set would employ, perhaps, four r. f. stages, a detector, and three audio stages, and would cost from \$250 to \$1000. The probable r. f. gain at best would be 10 per stage (including the detector for simplicity), while the assumption of three impedance-coupled audio stages would allow 8 per stage as an average audio gain with a 112 output tube. Thus, the overall voltage amplification would be about $10^5 \times 8^3$, or 51,200,000 times amplification for a weak signal. In the Laboratory Super, it is safe to assume a voltage amplification of, say, 25 times for the first detection and frequency conversion. The overall amplification of the intermediate amplifier is problematical, but the normal computed, and actual, gain of an r. f. stage such as is used in the Laboratory Super is about 20. Thus four tubes (three amplifiers, and a detector, coupled by four similar tuned circuits), might conservatively be counted on for a total gain of 10 to the fourth power. The audio gain is about 20 per stage or 20^3 overall, so the total gain may be assumed to be $25 \times 10^4 \times 20^3$, or 100,000,000.

These figures seem borne out in practice, for the Laboratory Super will bring in on the loud speaker signals inaudible on a good seven-tube shielded and neutralized r. f. receiver. The selectivity appears sufficient to allow reception of out-of-town stations 10 kilocycles away from locals in Chicago, and, in fact, is so great as to allow the reception of a frequency band only three to four kilocycles wide if desired.

The wavelength range of the receiver with standard coils is from 30 to 3000 meters (10,000 to 100 kc.). Regular broadcast range coils cover the range of 200 to 550 meters (1500 to 545 kc.), but it can be seen that the receiver is adapted to any class of broadcast reception by virtue of its wavelength flexibility.

The assembly of the Laboratory Super is very simple if the standard parts recom-

mended for its construction are procured. The completely pierced and decorated steel panel and chassis can be obtained as a standard foundation unit which reduces the whole assembly operation simply to one of mounting parts with a screw driver, machine screws, and nuts. If preferred, a bakelite or wood chassis might be employed with slight alterations in design, but the change is not recommended unless the receiver is to be located well away from powerful broadcasting stations, since the steel chassis and panel contribute materially to the wiring shielding of the receiver. The whole construction is very simple and the one big bugaboo of super construction—uncertainty as to long-wave-transformer matching and operation under varying conditions of home assembly—is totally eliminated. The assembled intermediate amplifier recommended, known as the 440 "Jewelers' Time Signal Amplifier," is a laboratory-calibrated amplifier, the operation of which will not vary appreciably even with the widest variation of standard tube characteristics to be encountered in practice. The original Laboratory Super was constructed with the following parts:

1—Van Doorn Panel and Chassis Unit, with Hardware	\$ 8.50
1—Carter 0.00015-Mfd. Grid Condenser, with Clips	50
1—Carter M-200 Potentiometer	75
2—Carter 0.5-Mfd. Condensers	1 80
1—Silver-Marshall 275 R. F. Choke	90
1—Silver-Marshall 342 0.000075-Mfd. Regeneration Condenser	1 50
1—Carter 3-Ohm Rheostat	50
1—Carter Battery Switch	50
4—Carter No. 10 Tipjacks	40
1—Polymet 2-Megohm Leak	25
2—Silver-Marshall 220 Audio Transformers	16.00
4—Silver-Marshall 511 Tube Sockets	2 00
2—Silver-Marshall 805 Vernier Drum Dials	6.00
1—Silver-Marshall 440 Time-Signal (Intermediate) Amplifier	35 00
2—Silver-Marshall 515 Coil Sockets	2 00
2—Silver-Marshall 111A Coils	5 00
9—X-L Binding Posts	1 35
2—Silver-Marshall 320 0.00035-Mfd. Variable Condensers	6 50
Total	\$89.45

(If shielded oscillator and first detector are desired, add \$4.00 for two Silver-Marshall 631 stage shields)

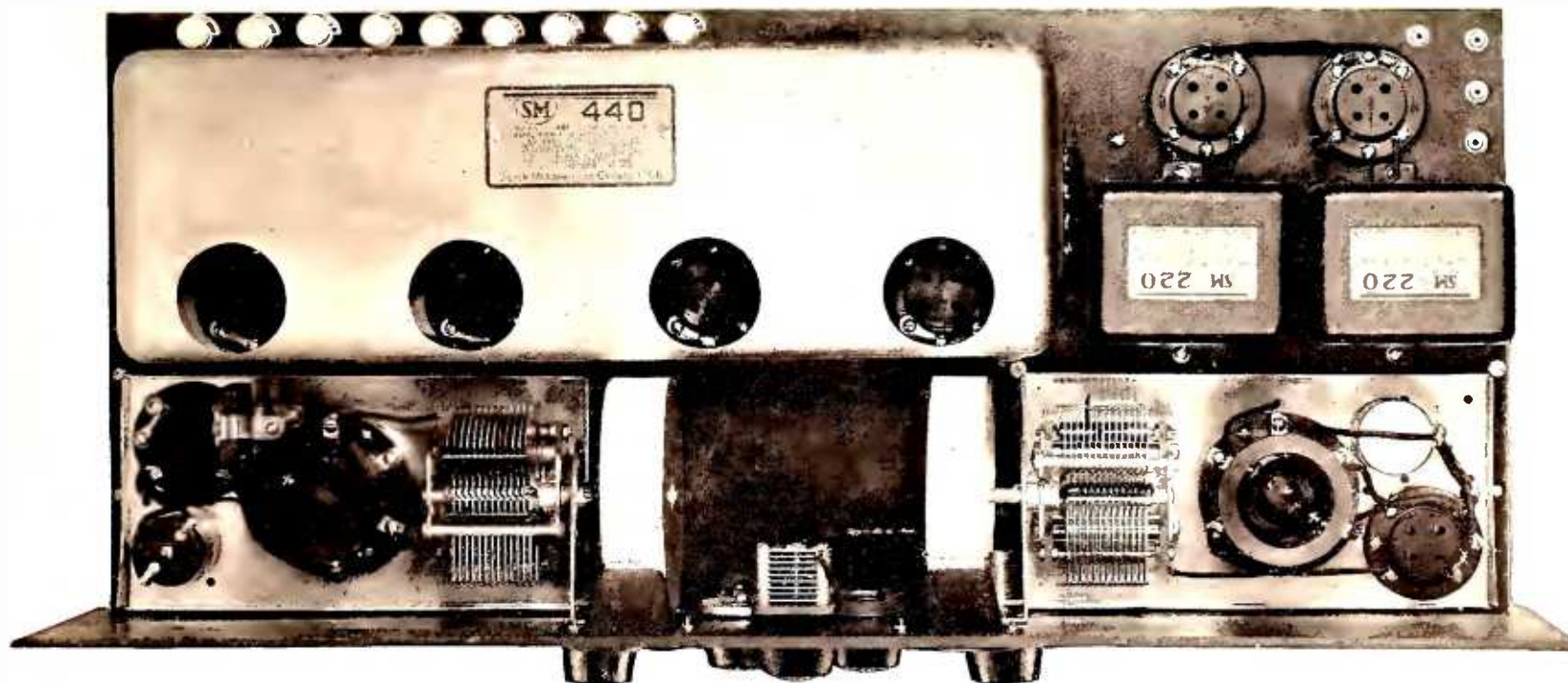

METAL PANEL AND CHASSIS ARE SPECIFIED ALTHOUGH THEY ARE OF BAKELITE IN THIS PHOTOGRAPH

The assembly of the set may be accomplished very easily if the following suggestions are carefully watched.

Upon the chassis should be mounted the detector and oscillator assemblies—inside the stage shield pans if shields are to be used. The end mounting screw of each 511 tube socket is used to join the A minus to the chassis, so a lug should be placed under the screw head, to be soldered to the F minus socket terminal, and the under side of the chassis scraped bright for good contact with the fastening nut. One terminal of the 0.00015-mfd grid condenser should be bent at right angles and fastened directly under the "G" terminal screws. The single long screw holds the 275 choke coil in the detector stage assembly.

The binding posts should be mounted in the nine holes at the rear of the chassis using the insulating washers to positively insulate them from the chassis. The "Ground" post grounds to the metal chassis, and the fastening screw of this post holds one end of the second 0.5-mfd. condenser tightly to the chassis, while the free end must be bent up clear and free of the metal chassis. The four tipjacks mount, using insulating washers, at the right rear of the chassis.

The intermediate amplifier mounts with four 8-32 screws, the chassis being scraped bright for good contact with the screws (the A minus connection is made to the amplifier through the contact between the amplifier shield and chassis). The two audio-amplifier tube sockets mount using their rear fastening screws to connect the F minus posts to the chassis.

All possible wiring should be done on the chassis before proceeding further, leaving free the wire ends that will connect to the instruments on the front panel, and to the two audio transformers, as, if they were put on first, it would be impossible to make the three connections to the right end of the intermediate amplifier.

The potentiometer should be mounted as shown, using insulating washers to thoroughly insulate its frame from the panel. The rheostat and the midget condenser are similarly mounted, except that care is taken to make good contact between them and the panel.

The drive mechanisms of the dials should be dropped into the bracket bearings intended for them, the shafts pushed through the holes in the front panel, and the two brackets bolted to the panel, using the screws provided. One variable condenser fastens to either bracket, using the shaft mounting nut provided. A drum should be slipped over each condenser shaft, with set screw loosened, and pushed up until the drum scale edge is just ready to enter the crack in the

drive mechanism shaft. With a knife blade this crack should be widened to receive the drum scale edge, and the drum pushed well up on the condenser shaft. The scale should then be adjusted to read 100 degrees against the indicator points in the panel windows, when the condenser plates are entirely disengaged, upon which the set screw in the drum dial hub should be tightened on the condenser shaft. With the knobs fastened on the drive shafts, the condenser dials should rotate if the knobs are turned.

The connections to the condensers, rheostat, and potentiometer should be made before fastening the panel to the chassis. After they have been put in, machine screws and nuts serve to hold panel and chassis together. The "On-Off" switch mounts in the one remaining panel hole, with insulating washers to thoroughly insulate it from panel and chassis (it may previously have been connected in circuit, and allowed to hang on the wiring until ready to be mounted).

TESTING AND OPERATING

BEFORE actually hooking up the set for test, or before cabling and lacing the under chassis wiring, the set should be carefully checked. The A battery alone should be connected, a single tube inserted in any socket, and the "On-Off" switch and the rheostat turned on. The tube should light in any and all sockets, with brilliancy slightly varied by rheostat adjustment. The A plus wire should be successively connected to the plus 45, plus 90, plus Amp., minus 4½, and minus Amp. binding posts. If the wiring is correct, the tube will light with the A battery connected only to the proper posts. The remaining batteries should be connected. A B socket-power device may be used, but only a good model employing a glow tube voltage regulator, such as the one described by Howard E. Rhodes in the June RADIO BROADCAST.

To operate the set, all tubes should be inserted, except the first detector tube. A CX-371 (UX-171) goes in the right rear socket; a CX-340 (UX-240) in the adjacent rear socket. The rest of the tubes are CX-301-A's (UX-201-A's). With the "On-Off" switch on, the rheostat should be turned to within ⅓ inch to ¼ inch of the full right position. If the potentiometer ("Gain" knob) is turned to the right, a "plunk" will be heard at some point. This can be detected by varying the oscillator drum, which should cause a number of shrill whistles to be heard. The "Gain" knob should always be operated just to the left of the "plunk" point, *i. e.*, to the right of which squeals were heard when the "Oscillator" dial was varied. The receiver is least sensitive when the "Gain" knob is at the left, and most sensitive

when the "Gain" knob is just to the left of the "plunk" point.

The first detector tube should be inserted and the midget condenser set all out. The antenna coil rotor should be set at 45 degrees, and the oscillator rotor should be all in. A small antenna, 30 to 60 feet long, should be used, or even a larger one if the set is not too close to powerful local stations. Stations may be tuned-in using the two drum adjustments only. Weak stations may be intensified by turning up the "Regeneration" condenser on the front panel. This condenser functions similarly to the "Gain" knob, in that, as it is turned to the right to interleave the plates, signal strength on weak stations will increase up to the point where the first detector oscillates, and the signal turns into a squeal. Adjusting the midget condenser will react slightly on the setting of the "Antenna" drum.

Tuning operations for weak out-of-town stations are as follows: With the rheostat to within ⅓ inch to ¼ inch of the extreme right position (adjusted to give 5 volts to the filaments of all tubes), the "Gain" knob should be turned to the right until it is just below the "plunk" or oscillating point for the intermediate amplifier. This adjustment is independent of the wavelength of any signal being received. The two drum dials should then be varied to tune-in stations. In order to cover the entire broadcast band, the "Antenna" dial should be varied in steps of one degree at a time, and for each one-degree step the "Oscillator" should be varied over a range of 15 degrees above and below the "Antenna" dial setting. Once a weak station is heard, it may be strengthened by turning the midget condenser farther in and resetting the "Antenna" dial slightly. Each station should be tuned-in at one point on the "Antenna" dial and at either one or two points on the "Oscillator" dial. If stations are heard at two or more points on the "Antenna" and "Oscillator" dial, it is not the fault of the receiver, but is probably due to re-radiation of the transmitted signal from local steel structures, etc., which energy, while very weak, may nevertheless be picked up by the Laboratory Super and amplified as it would be on no other receiver. It is just this sensitivity that accounts for the set's remarkable long-distance performance.

The position of the antenna coil rotor should generally be at about 45 degrees. With a small antenna, it may work best all in; with a large antenna, it should be at nearly right angles. The sharpness of tuning of the antenna dial depends upon the setting of this rotor, as well as that of the midget condenser. The oscillator rotor should be adjusted once on a very weak signal at about 300 to 350 meters, and, once set for maximum volume, may be left alone.

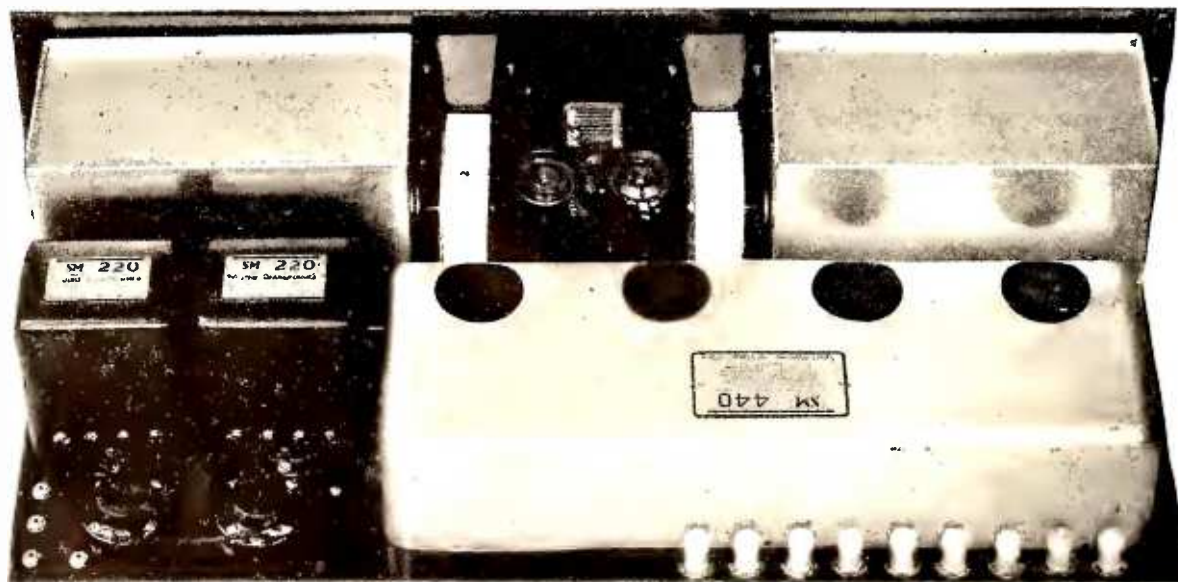

A BEHIND-THE-PANEL VIEW

In this photograph the Laboratory Super has been completely wired and is now ready for connection to the necessary source of A, B, and C power

We Need Better Radio Salesmen

The Sheep and the Goats of the Radio Sales Fraternity—The Goats Need Better Preparation for their Job Which is Not a Simple One

By CARL DREHER

Drawing by Franklyn F. Stratford

I KNOW little about the mystic process of selling radio equipment to the ultimate user, and disclaim, at the beginning of this discussion, any idea of instructing experts in the merchandising art. My experience has all been in other directions. By these modest words, I hope to avoid harsh looks and nasty expressions from the commercial gentlemen on whom my sustenance depends, although, happily, theirs depends equally on me. With all this ignorance, occasionally I do venture into a radio store in order to purchase some trifle which I am unable to cadge lawfully from the company whose payroll I adorn. On these pilgrimages I have occasionally made observations of possible interest to radio men engaged in trying to earn money.

Some of the most insufferable little jackanapes ever expelled from high school are behind the counters of radio stores, and there are also many decent, sober, competent fellows, the two types being found, often, five feet apart. The latter make money for the stores in which they serve, and, I hope, for themselves. As for the former, I should be sorry to hear that any of them starved, but, abstractly, it would seem to me a highly salutary social phenomenon. That they are not an asset to the businesses which afford them shelter is a foregone conclusion. Furthermore, their lives are in danger. I do not speak of myself, my homicidal impulses being mild outside of family circles, but imagine an ex-president of the Institute of Radio Engineers, for example, entering one of the radio emporiums on Cortlandt Street in the dizzy metropolis, to buy a grid leak, and being patronized by some beardless youth who was playing marbles on the Brooklyn lots two years ago. Such things happen, and is it not conceivable that some worthy pioneer, taking the law into his hands, will reach behind the counter, carry off one of these lightweights, and, declining the polite offers of the porters at the foot of Liberty Street, plunge his struggling burden into the waters of the Hudson?

The development of these radio counter boys and sales clerks is not hard to visualize. The process starts with a young fellow of high school graduation age, no worse and no better than thousands of others, faced with the necessity of earning his living. He has built a few receiving sets, and, as his education has not trained him for anything in particular, and the sets work part of the time, he decides that radio must be his forte. Through an advertisement or otherwise he secures a job in a radio store of the sort which sells everything from rubber overcoats designed to cure vacuum tubes of the notion that they are microphones, to \$600 phonograph-radio combinations in Louis XV cabinets. His responsibilities and authority are ill defined, the

principal idea being that he is to do whatever he is told and act as a door-mat for the rest of the staff. He unloads thousands of loud speakers from trucks, crates and uncrates sets, hunts through mountains of excelsior for missing parts, and sweeps out the store. In time he learns something about the business and is promoted to an assistant sales clerk in charge of the binding post counter. He now faces the public. And now something happens to him, inwardly.

All day long people come in and ask him questions. Our hero doesn't know much, but it is clear that lots of people know even less, about radio, at any rate. Some of the questions are sensible, and some are idiotic, but all must be answered. This is what happens when a horde of people of every grade of intelligence and aptitude invade a highly technical field. The clerk answers the questions fired at him as well as he can. When he does not know the answer, he bluffs. This vice of pretence he shares with much larger carnivora, even up to the presidents of corporations, sometimes, and high officers of government on land and sea. When he bluffs, he is rarely caught, because, as we remarked,

his clients know even less than he does, and no stenographer takes down his words. The more he gets away with it, the better he thinks he is. By the time he gets to be a full fledged retail

salesman, with shiny current supply sets, amplifying transformers containing a pound of iron, and variometers colored like a pair of pajamas, loading down the shelves behind him, he feels like the Oracle of Delphi. And like the priestess who intoned her prophecies above the cavern of noxious vapors, he is mainly a fraud.

For, when you come down to it, this business of selling radio is intricate enough, and as yet there is little systematic preparation for the job. When the job is well done, it is merely the result of a fortunate accident. There are some qualified, resourceful men selling radio parts and sets here and there—the fortuitous combination of opportunity, experience, and aptitude. When a customer enters, not knowing what he wants except that he doesn't wish to pay much for it, they cross-examine him skillfully and give him what he needs, within the limits of his expenditure, carefully explaining what he is not getting before he leaves the store. Encountering an experienced radio man, they secure what he asks for without loss of time, perhaps dropping a deft suggestion which, very likely, it will be profitable for him to listen to.

The job being complicated, and the results, under present conditions, decidedly haphazard, why should not more attention be given to this problem? A well-known chain of barber shops advertises the claim that its tonsorial employees are trained in a school which it maintains, that they may become adept in the superior technique of the establishment. I presume that the course is a brief one, that few of the professors on the faculty have Heidelberg Ph. D.'s, and that the whole advertisement is ninety per-cent wind. Even so, my observation has been that the barbers afore-mentioned are decidedly better than the average run, that they wash their hands at the proper time, cut hair neatly, and do not take the skin with the beard. If it profits a barber establishment to select and train its operating personnel with some care, should not the same principle apply to a far more technical business like radio? There is money in radio, too, and there might be more if we looked out for these little things. We should discard, also, several freight-train loads of the current bunk about salesmanship. A good salesman is primarily one who knows his goods, senses accurately the needs of his clients, and has the normal energy and social qualifications required in any other business. To the devil with personal magnetism, hypnotism, the psychological approach, and the whole bag of tricks, if he only knows that a high impedance speaker will work across a low impedance output, but not vice versa, and that a paper grid leak will not carry fifty milliamperes. There are plenty of ex-commercial operators and zealous amateurs who can do good work as radio salesmen, although they know nothing about salesmanship. Some of them, praise be, are already in the retail establishments of the industry, and the proprietors would do well to get in more of them before the next season sends them into the bankruptcy courts

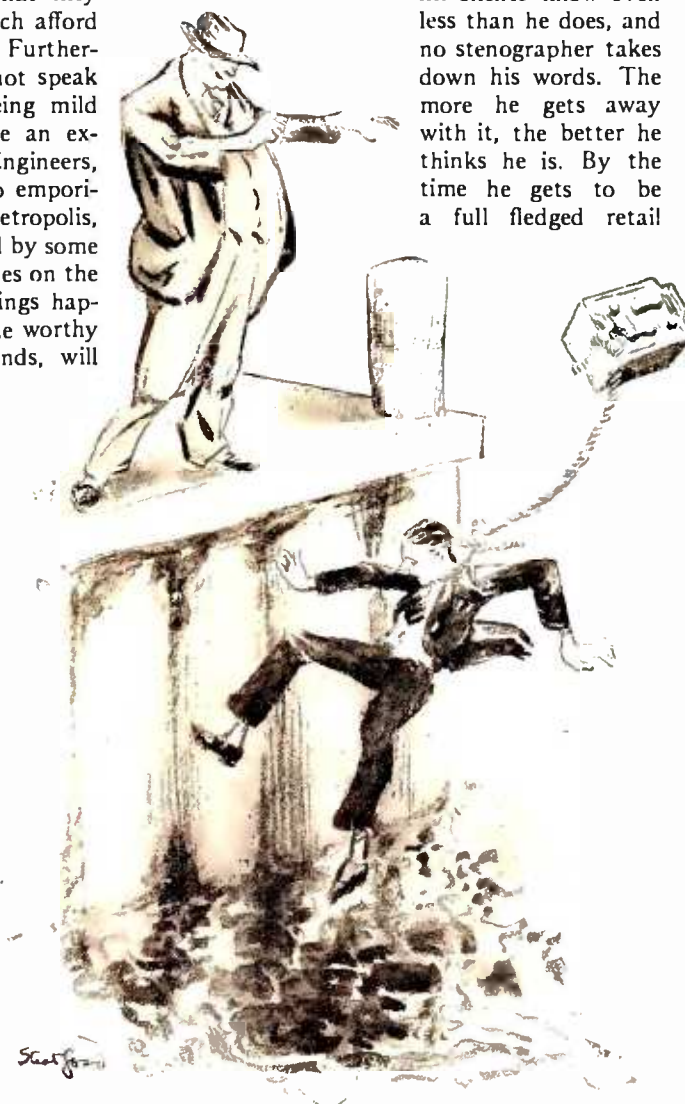

"PLUNGE HIS STRUGGLING BURDEN INTO THE WATERS"

The New A. C. Tube

UNCERTAINTY regarding the constants of the new a.c. tubes reigns supreme, as a glance at the table on this page will show. While it has been impossible to secure all makes of tubes designed to operate from raw a.c., those measured in the Laboratory are representative at least, and should give the reader something to think about. Whether or not he is to throw away his batteries and present set of tubes is for him to decide, but if the tubes are good and his battery still possesses its appropriate lead plates and sulphuric acid, he need be in no hurry to make changes.

The a.c. tube has not sprung up overnight. It has been the dream of engineers for a long time and, in the case of the McCullough tube, has been in actual production for several years. It is difficult to understand why there should be any general concern about the situation now that it is possible to choose between a.c. tubes that operate on 1 volt and consume 2 amperes and those that require a voltage of 15 at 0.35 amperes, but there is always something akin to hysteria in the radio business when anyone makes a suggestion that is more or less new.

The a.c. tubes are of two kinds, those that have filaments in the usual sense, and those that have heaters which operate from a.c. and which, in turn, heat a cathode which supplies the electron stream which the radio set actually makes use of. The first a.c. tube in this country was the McCullough tube, which is a heater type requiring a voltage of 3 and a heater current of one ampere. Others tested in the Laboratory in recent weeks are made by Marathon (Northern Manufacturing Company), Sovereign (of Chicago), and of course the Cunningham. It has been impossible up to the time this is written to get R. C. A. a. c. tubes into the Laboratory. The data given here on the c-326 and c-327 (taken from early tubes sent to the Laboratory) will probably not be far from the final design which, according to the Cunningham Company, has not as yet been reached.

The heater type of tube, of which the McCullough is the forerunner, is not new to the industry. The stout filament type, which has been associated with the name of Mr. B. F. Miessner (although others had worked on the tube prior to Mr. Miessner's papers delivered before the Radio Club of America) is newer and works on different principles. It has a true filament, very heavy and rugged, heated by a lot of current at a low voltage. Readers interested in the theory underlying this tube, which is the result of a nice piece of research on Mr. Miessner's part, will do well to read his articles in RADIO BROADCAST for February and March, 1927, and a paper in this issue.

It does not seem possible to use the latter type of tube as a detector of the familiar grid leak and condenser type. For this reason the R. C. A. and Cunningham recommend that the 227 (c-327) or heater type be used as a detector for all other positions. There is no reason why the heater tube

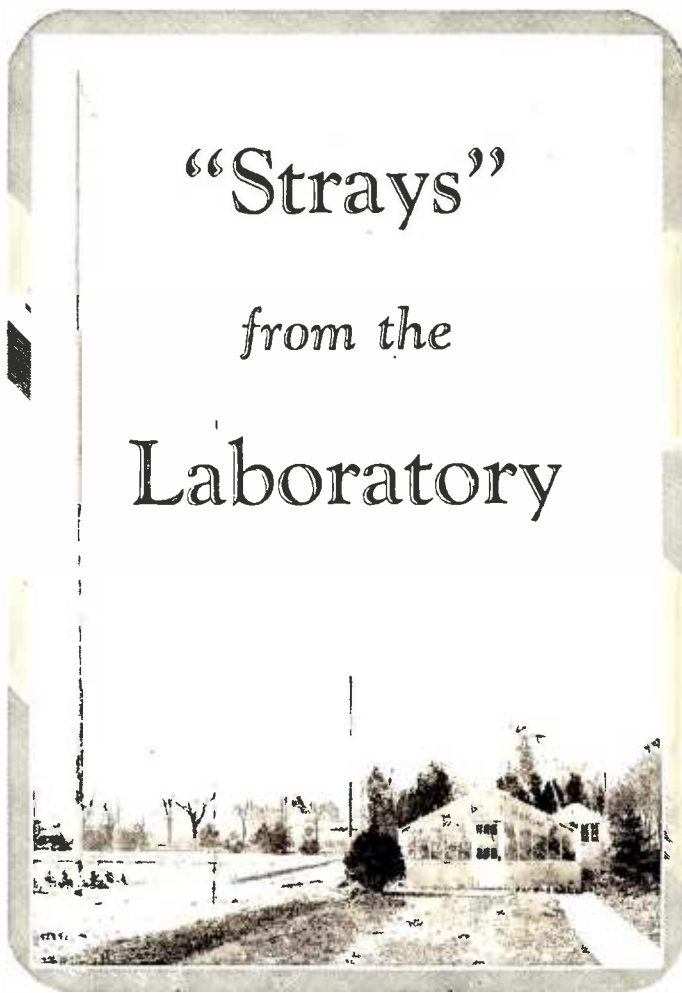

**“Strays”
from the
Laboratory**

cannot be used throughout the set; indeed, receivers utilizing the McCullough tube have been used this way for some time. The rugged filament type may be used with a C-battery detector.

A cursory perusal of the data given here shows that the average constants of these new tubes are better than the average d.c. tube designed for the same purpose. For example, the table gives the average plate impedance and amplification factor of the familiar 201-A (C 301-A) type. It is possible with either the heater or rugged filament type to build much better tubes than this table indicates is now being done. Such tubes have been designed to have characteristics as near to those of the d.c. tubes now used as possible. It is futile for a tube manufacturer to

build a tube that has half the impedance of present tubes, if only one or two set manufacturers have gumption enough to build a set around them. On the other hand, gradually changing tubes toward those with greater gain and gradually altering the design of radio-frequency transformers to go with them, will ultimately bring about receivers which are more selective and which have greater gain per tube.

Some of these a.c. tubes are noisy while others from the same allotment and with practically the same electrical characteristics are quiet. It seems imperative that a.c. tubes must be highly exhausted. Hum is kept at a minimum by biasing the heater with respect to the cathode, as indicated in Fig. 1. The biasing voltage is not always the same. Some receivers, particularly those with high-quality amplifiers (going down below 60 cycles and using high-quality loud speakers), will hum if a transformer carrying 60-cycle current is anywhere near them. The solution at times is to change the relative positions of the cores of the audio transformers, or chokes, and that of the power transformer. An electrostatic shield, properly grounded, between primary and secondary of a power transformer, is also of considerable aid in stubborn cases of 60-cycle hum.

Some manufacturers of a.c. tubes have been ambitious enough to put out a whole series of a.c. tubes, adding to the general purpose tubes those with high amplification factors, and power tubes. The Van Horne Company lists no less than eight tubes designed for straight a.c. operation or for series filament connection. The Marathon list is made up of general-purpose tubes, high-mu tubes, and power tubes. The Arcturus line includes detector, general purpose and power tubes.

It is unfortunate that all of these tubes require different values of filament, or heater, current and voltage. This puts a big burden on the manufacturers of transformers, and upon those who like to construct their receivers at home. For example, the Cunningham heater tube utilizes 1.75 amperes at 2.5 volts, while the rugged filament type demands a voltage of 1.5 and a current of 1.05 amperes. The Arcturus type,

on the other hand, uses a voltage of 15, which can be conveniently supplied by toy transformers stocked by practically every electrical dealer.

From several engineers who have been responsible for the development of these tubes, comes the suggestion that high values of C bias are desirable from the standpoint of hum, and from others comes the report that at high frequencies, the heater type is subject to some strange vagaries. It seems that the resistance of certain mechanical parts that go into the construction of these tubes decreases at high frequencies, which naturally will cut down the overall gain of a tube. It seems to be true, too, that some trouble is had at times with the vacuum when the oxide coated low-voltage filament is used. Perhaps this explains why some tubes, for no apparent reason, are noisy.

The Arcturus tube is unusual.

A. C. TUBES								
Heater Type								
NAME	E_f	I_f	E_p	E_g	I_p	μ	R_p	G_m
c-327	2.5	1.75	90	-4.5	4.2	8.0	9200	940
McCullough	3.0	1.0	90	-4.5	4.2	8.6	9400	870
Sovereign	3.0	1.5	90	-4.5	4.6	8.5	9100	935
Marathon 608	5.5	1.0	90	-4.5	4.2	7.3	9500	775
Marathon 615	5.5	1.0	90	-1.0	3.2	12.0	19000	635
Marathon 630	5.5	1.0	90	-1.0	1.1	28.0	40000	680
Marathon 605	5.5	1.0	135	-12.5	14.0	4.5	4400	1000
Arcturus	15.0	0.35	90	-4.5	3.1	10.5	12150	870
Filament Type								
c-326	1.5	1.05	90	-4.5	5.0	8.5	8300	1030
Armor A. C.								
100	1.0	2.0	90	-4.5	3.8	7.8	11200	600
Van Horne	1.0	2.0	90	-4.5	4.0	9.5	10000	980
CX-301-A								
(UX 201-A)	5.0	0.25	90	-4.5	2.0	8.0	12000	675

E_f = Filament Volts
 I_f = Filament Current
 E_p = Plate Volts
 E_g = Grid Volts
 I_p = Plate Current
 μ = Amplification Constant
 R_p = Plate Impedance
 G_m = Mutual Conductance

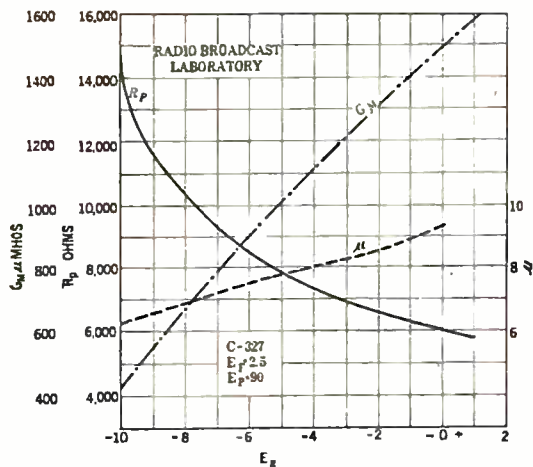

IMPORTANT CONSTANTS OF THE C-327 (ABOVE) AND C-326 (BELOW) PLOTTED AGAINST GRID VOLTAGE

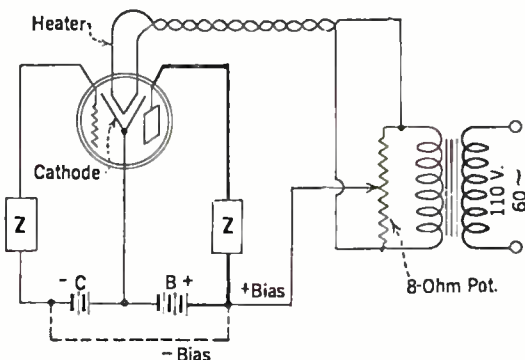
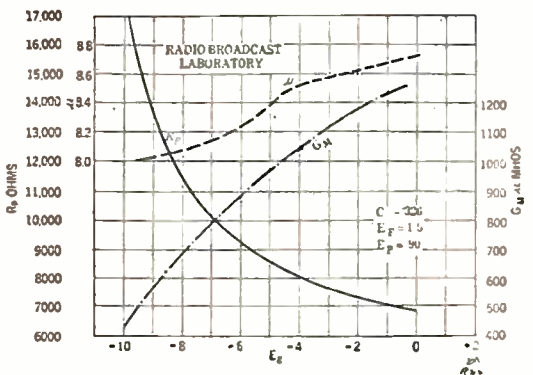
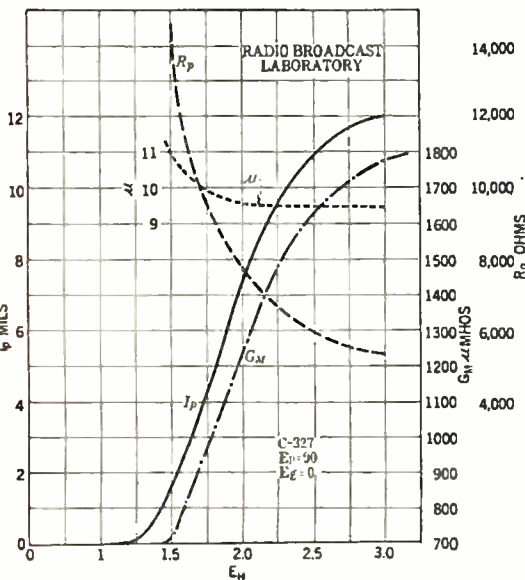
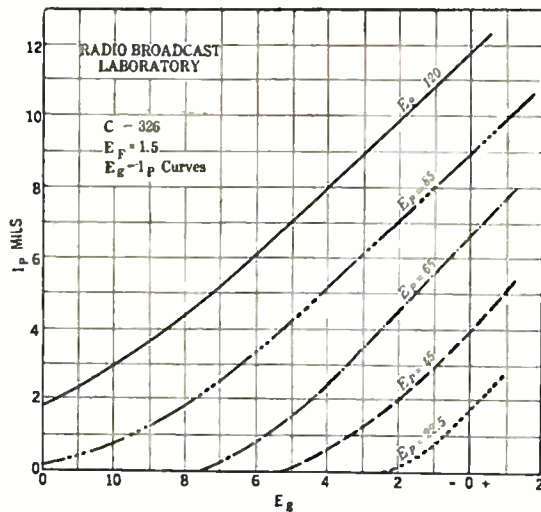

FIG. 1



HOW THE CONSTANTS OF C-327 VARY WITH HEATER VOLTAGE



Eg- I_p CURVES FOR C-326 (ABOVE) AND MARATHON HIGH-MU TUBE (BELOW)

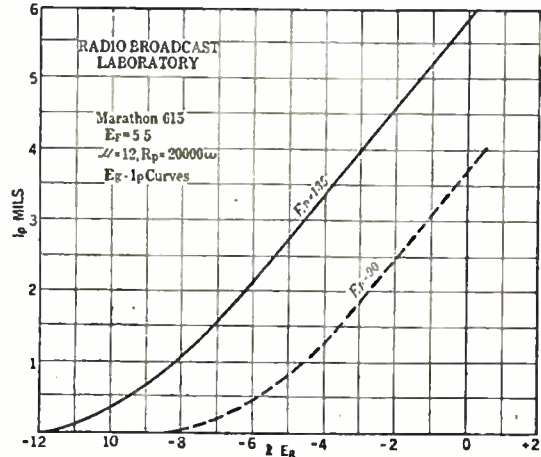

It is a heater type, the heater current being about 0.35 amperes at 15 volts. The heater is a rather heavy carbon filament which at the top is electrically connected to the cathode. This makes it possible to use a standard four-prong base—an obvious advantage which other heater tubes do not possess. The R. C. A. and Cunningham heater tubes require a special five-prong base, while the others, of which the McCullough is the prototype, have two heater terminals at the top of the tube, or at the side, to which are attached the a.c. terminals.

We noted at the Chicago Radio Trade Show that 35 per cent. of

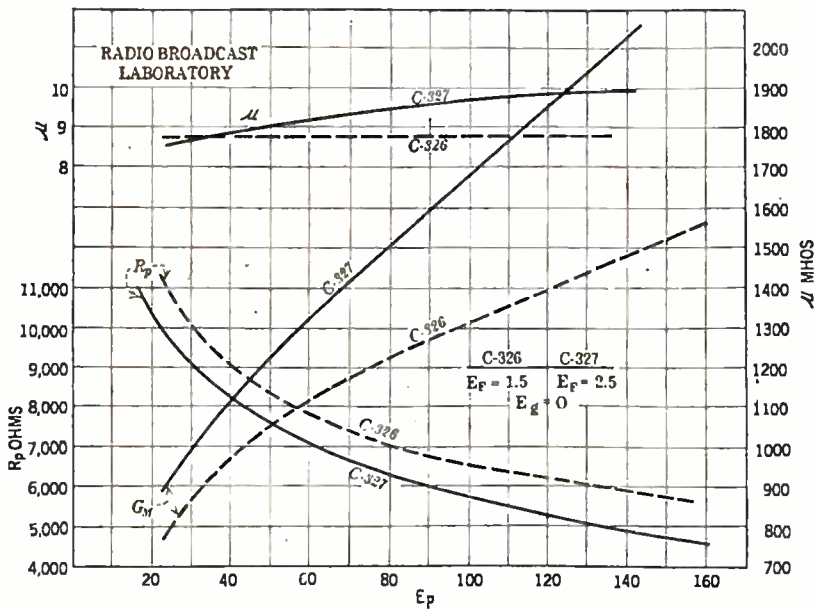

CONSTANTS OF C-326 AND C-327 AS RELATED TO PLATE VOLTAGE

the receivers shown were a.c. operated. Not many of these sets used a.c. tubes, but used some other method of eliminating hum when using standard d.c. tubes.

All in all, the a.c. tube is something to watch. It is still in the development stage, and the work of many tube engineers and chemists will be involved before the final answer is ready. The a.c. tube is not destined to supplant the present type of tube we all use in the next six months or in any other period so short. As soon as the Laboratory gets more data on the operation of the new tubes, they will be made available.

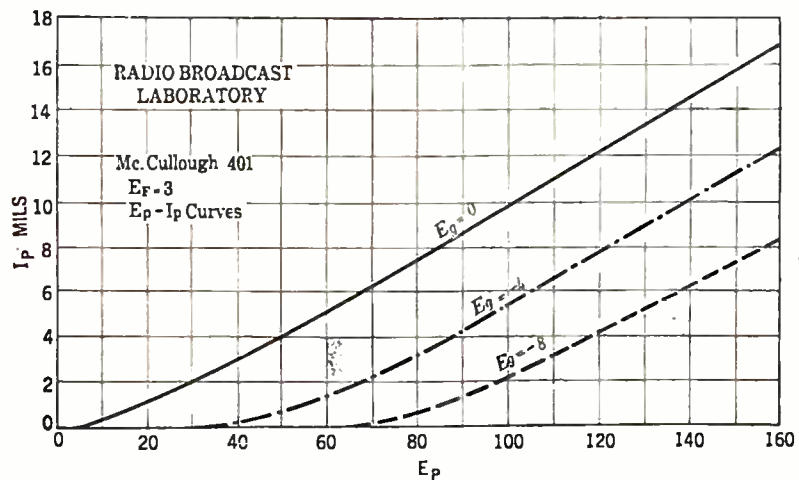

Ep- I_p CURVES OF MCCULLOUGH A. C. TUBE

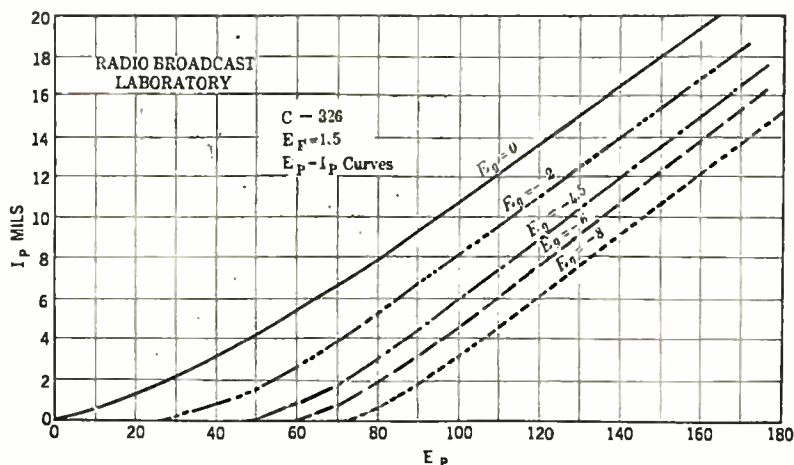

Ep- I_p CURVES FOR C-326

THE LISTENERS' POINT OF VIEW

Conducted by John Wallace

Should We Name Our Broadcasting Stations?

THE following bulletin was recently sent to all station owners by the National Association of Broadcasters:

On many occasions during the past few months, during informal discussions among our members, and occasionally during official hearings, the question of continuing the designation of a station by announcement of its call letters over the air has attracted keen interest.

The use of combinations of letters to designate a radio station originated properly in "point to point" communication some years back, and as a natural outgrowth of this, with the advent of broadcasting stations this type of designation has been continued. It was never specifically designed for *radiophone* broadcasting stations.

It is a well-known fact that due to the phonetic similarity of many letters in the alphabet (for example, B may sound like D, E, P or T) the average owner of a radio receiving set makes many mistakes in identifying the station he has tuned, which in turn causes the credit due that station to be entirely misplaced.

At this point, those who favor abolishing call letters immediately advance the argument that the sole reason for a station existing is to create personality for itself, and immediately draw the analogy between the station and a boat or a yacht. For official records, the Government designates all vessels under a license form, as, for instance, KX-100. However, immediately, regardless of whether it is a pleasure or commercial craft, its owner christens it with an appropriate name which lends personality to the ship, and the license designation of letters and numbers is never given further consideration except in connection with the license to operate.

From this analogy, the proponents of the idea ask, "Why is not an announcement, such as 'The Mayflower, Cincinnati' of more value to the station and easier to identify than the announcement 'This is Station WØØR'?" The first is at once suggestive of a personality and entirely distinguishable while the latter is negative and easily confused.

The opponents of such an idea point out that hundreds of thousands of dollars have been spent, in many instances building up the prestige of a certain combination of letters, which in some cases correspond to the trade slogan of the owner of a station. Undoubtedly such stations would be slow to consider favorably the idea of relinquishing their call letters.

However, the discussions have been so frequent and active by both sides, that it is with the thought of determining what the real consensus of opinion is that your vote is asked on the enclosed ballot.

We tremble. We hold our breath. We pace about apprehensively our pockets loaded with horse shoes. Suppose they decide to do it! What manner of mon-

strous monikers may we not have to listen to! We think the suggestion a highly indecent and immoral one—like giving small, and notably reckless boys, shining, loaded revolvers to play with. Needless to say the broadcasters will jump at the idea; tacking names on things is their meat. What grand and glorious, resplendent and superlative station names may we not expect. Give a look what the gents did back in the days when they were coining slogans for their stations:

"Kall For Dependable Magnolene"
"Where The Sun Shines Every Day"
"Stephens College Where Friendliness is Broadcast Daily"
"Kant Fool Us Long Horns."
"The Best Little Station"
"The World's Largest Grease Spot"
"Kum To Hot Springs"
"We Sell Goods Cheaper"
"Where Cheer Awaits U"
"Where Harrisburg Broadcasts Gladness"
"One of Indiana's Most Beautiful Little Cities, And The Home Of The First Automobile"
"Watch Mercer Attain Zenith"

"We Are Never Tired"
"Sunshine Center of America"
"Known For Neighborly Folks"
"Keep Folks Quoting The Bible"

Names like the suggested one, "Mayflower," wouldn't be so bad, but there'll never be enough of them for seven hundred stations. Arrived at the second hundred, there will be a terrible struggle to create some appropriate and unduplicated collection of syllables. Moreover we, the poor listeners, will have to do all the dirty work of memorizing the new names, and it was only at the cost of much travail that we got the multitude of call letters finally straight in our mind. Also we shall have to junk our receiving set cabinets and install new ones with three-foot dials whereon to inscribe the new and lengthy appellations.

We submit that letters, or even numbers, are quite as easy to memorize in large quantities as names. Imagine what a boon it would have been if Mr. Pullman had only started off in the dim ages, by christening his sleeping cars with call letters. Have you ever returned from the observation platform at a late hour and attempted to crawl into lower twelve in "Grassmere" or "Graymere," only to discover, amidst much feminine shrieking, that you really belonged in lower twelve in "Grassbeer"?

If names must be used, let us, f'revvns sakes, have some system about it. Let all the stations in Georgia be lovely ladies, and those in Mississippi, flowers; those in New York, drinks and those west of the Rockies, kitchen utensils, and so forth. Thus would we have an entertaining and easily catalogued roll call of such stations as: "Gertrude," "Josie," "Maizie," "Clarabelle"—"Hyacinth," "Petunia," "Erysipelas," "Plastodolphus"—"Old Crow," "Tom and Jerry," "Benedictine," "Kummel"—"Rolling Pin," "Potato Masher," "Egg Beater," etc.

But we quite disagree with the main contention that call letters can have no personality. To us they have always seemed very vivid personalities. What matter the fact that the personalities of the letters, as we interpret them, seldom correspond with the personality of the station mentioned.

WEEI, for instance, is a thin, squeaky sort of a name. It has a long skinny nose which is rather red and which it blows at intervals. It is querulous and complaining and takes its tea rather weak.

KDKA, on the other hand, is a robust, high pressure name. It is six feet two, bulging with muscles and wears red, sweaty underwear. It is



AT WJAX, JACKSONVILLE

Isaac Wessell of the Jacksonville Little Symphony Orchestra—broadcast by WJAX—and his old faithful bass fiddle. The press agent claims that it is over two hundred years old and has been repaired in Budapest, Leipsig, New York, Boston, and other places, and that it has been cracked so often that there is hardly a sound spot on the instrument

the dynamic type, bubbling over with energy and talks with explosive loudness. Likes to squeeze little boys' wrists till they squeal.

WEAF is a sanctimonious assembly of letters. It is tall and gaunt and affects loosely flapping black garments. Its cheeks are sunken, its mouth inexpressibly sad, and it wears horn rimmed glasses over a pair of weak watery blue eyes. Delights in eighteen-carat Baptist Camp Meetings.

wjz is a high sounding and celestial name. It wears purple robes and quite a high crown. Is preceded by two pages blowing trumpets and is followed by a procession of High Priests chanting its praises. Expects the populace to bend its knee before it and occasionally smites one down. Has a large Roman nose.

CNRO is an ugly, snarling name; woc is bland, honest and open faced, belongs to the Rotary Club; wbbm is a nasty, nagging name, drums on the table with its finger tips while playing bridge; kfoo is boorish and stupid, given to belching at the dinner table and so on, and so forth, through the list. wham is breezy—a calliope-like individual. wgy is a deep-voiced soul with a sombrero and an educated voice.

Where Broadcasting Reigns Supreme

THE making known of great national events, while they are actually taking place is, after all, radio's unique contribution, and the one field in which it reigns supreme without competition from phonographs, theaters, churches, or newspapers.

And it is greatly to radio's credit that it does this job so thoroughly and well. As an example of a national broadcast well done, may we be permitted to hearken back as far as last Memorial Day? The official ceremonies at the Arlington National Cemetery, as broadcast by the N. B. C. chain, we listened to from start to finish and found not only interesting but entertaining. The ceremony began with an overture by the United States Marine Band, then a "Call to Order" by Major General John L. Clem. Following a soprano solo, the "Star-Spangled Banner," accompanied by the Marine Band, the original order establishing Memorial Day was read. Then two more musical interludes: the solo "Out of the Night, a Bugle Blew," accompanied by buglers, an enormously effective and dramatic work for such an occasion, and the "Battle Hymn of the Republic" sung by the Imperial Male Quartet. Then the *piece de resistance* President Coolidge's address, which, agree with him or not, was an expert piece of speech construction. The program was concluded with the reading of an original "poem" by Clagett Proctor, which was bad verse and the only stupid moment of the entire ceremony, and a brief address by Commander-in-Chief Means of the United Spanish War Veterans. Each different feature of this varied program, the voices of the speakers, the distant notes of the bugles, the ensemble singing of the quartette, the vocal solos and the massed volume of the Marine Band, was "picked up" in perfect style and broadcast with such clarity that the radio listeners must have heard the program more effectively even than those actually present at Arlington.

The broadcasting of the hullabaloo incidental to Lindbergh's arrival was likewise thoroughly done—perhaps in spots too thoroughly for the



MRS. ANNETTE R. BUSHMAN, PROGRAM DIRECTOR, WEAF

interest of this particular listener. For instance at the banquet tendered Lindbergh in New York. We would have been quite content had all the speeches of eulogy been omitted and only that of the flyer broadcast. Never have we heard worse blah sprung at a banquet, and sprung by such eminent leaders, divines and statesmen! The supposedly tongue-tied airplane mechanic gave a valuable, though doubtless unheeded, lesson in public speaking to the much touted, so-called orators who shared his platform. But the nation as a whole was interested in every and any detail of the flyer's reception and credit must be given to the National Broadcasting Company for slipping up on no smallest part. The N. B. C. established a number of new records in covering the event:

Miles of Wire Line Used—14,000.
Number of Engineers Involved—350.

Pick-up Points—Washington, 5; New York, 7.
Number of Stations—50.
Estimated Audience—35,000,000.
Number of "Radio Reporters"—Washington, 4; New York, 6.
Longest Continuous Program Devoted to One Subject—11½ hours.

SUNDAY NIGHTS AT WPG

WPG is offering a series of Sunday night concerts during the summer from the Steel Pier. Operatic arias, duets and concert selections make up the programs which are arranged by Jules Falk. Among the artists scheduled for the series are: Julia Clausen, mezzo-soprano; Marie Sundelius, soprano; John Uppman, baritone; Berta Levina, contralto; Doris Doe, contralto; Arthur Kraft, lyric tenor; Elsa Alsen, soprano; Julian Oliver, tenor; Edwin Swain, baritone; Marie Tiffany, soprano and Paul Althouse, tenor.

NOVELTY THAT IS GENUINE

A COMMENDABLE move on the part of wbal was the arranging of a program of "first-time" numbers—meaning selections that had never previously been heard over the air. Two of the numbers "Air de Ballet" and "An Irish Tune" were contributed by Gustav Klemm, wbal's program supervisor who is also a composer. Other selections were "Carioca" and "Batuque," Brazilian tangos by Ernesto Nazareth, "Indian Summer" by Sturkow-Ryder and "Barn Dance" by James Rogers. The recital was given by Sol Sax, pianist, during one of the wbal Staff Concerts which are on the air Wednesday evenings from 9 to 10 o'clock Eastern Standard Time.

NEW PROGRAM MATERIAL

H. V. KALTENBORN, whose editorial discussions of the outstanding happenings of the week constitute perhaps the best "one man show" of all radio's offerings, is to resume his talks from wor on October 10. We are informed

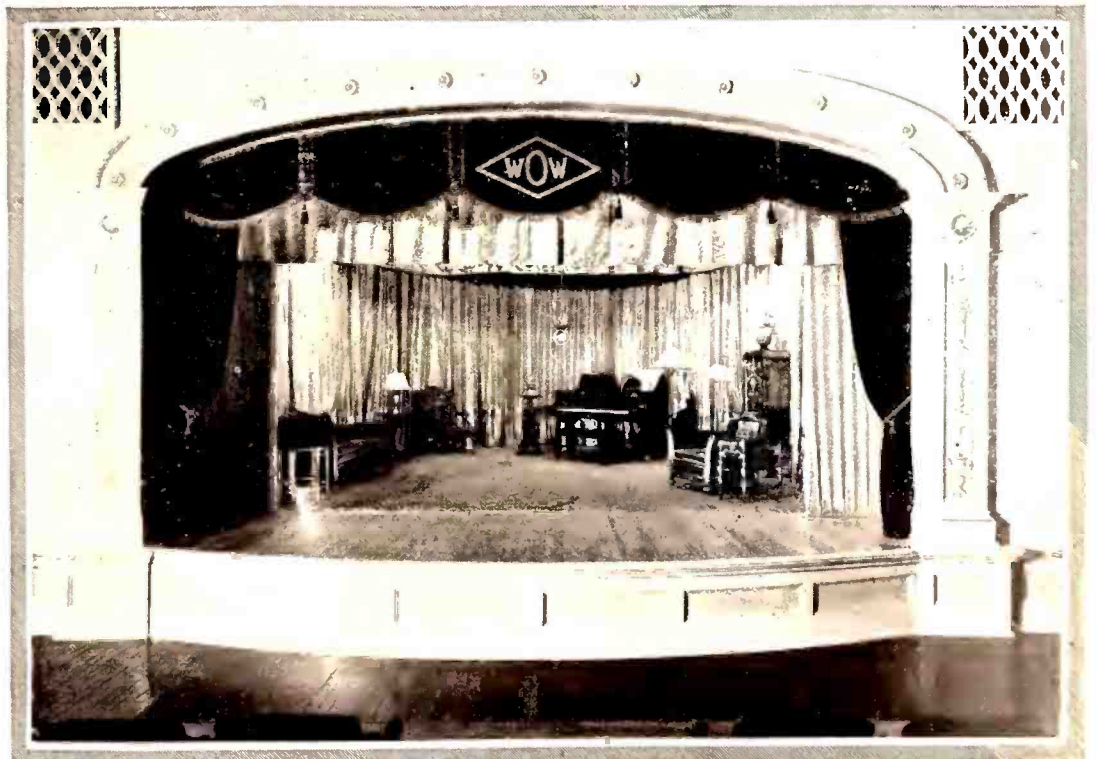

THE CRYSTAL STAGE STUDIO OF WOW

Many of the broadcasting stations have made use of this method of accommodating studio visitors without confusion or danger of interference with the program. The stage is insulated from the auditorium by plate glass across the entire stage. Visitors hear the artists via loudspeakers placed behind the grills at the upper left and right

that he is at present in the Far East making a study of the Chinese revolution. He is to visit the important centers in South China and North China and will also visit the Philippines to study problems associated with colonial administration and the independence movement. On his return journey he will travel overland through Manchuria and Korea to get first hand information concerning Japanese colonization and penetration and will spend some weeks in Japan before sailing home.

HURRAH FOR THE A. S. C. A. P.

A MOVEMENT has been started (may it get farther than the ten preceding starts!) by the American Society of Composers, Authors and Publishers to prevent the too frequent broadcasting of popular compositions, according to E. C. Mills, representative of the Association. It is contended that experience has proved beyond a doubt that the excessive broadcasting of a composition quickly destroys its market in published and recorded forms.

"It is not at all unusual to hear a number in popular demand broadcast in any particular area from six to a dozen times in an evening," says Mr. Mills. "Long before the public has had opportunity to purchase the rolls and phonograph records, or the music in sheet form, the composition has been 'blasted to death' and the public is weary of even hearing it.

"No composition should be rendered more than once in an evening in the same form. If played by one orchestra it should not be included in the program of another; sung once during an evening, it should not be sung again. From the broadcaster's viewpoint, as well as for the welfare of the composition and its owner, the public appetite should not be surfeited.

"It looks very much as though it were going to be necessary for program directors to exercise the same sort of jurisdiction over their programs as managers of vaudeville theatres do. In the theatres it is the custom to prohibit more than one rendition of the same composition in any program. The rule is that whatever act first rehearses a certain song at the beginning of the engagement shall have the right to use that composition during the appearance at that theatre.

"If it happens that other acts have the same song in their routine, they are required to substitute something else. If this were not done in vaudeville, patrons would in many cases hear the same song two or three times during the course of a show."

GOOD STUFF IN CHICAGO

IF YOU are anywhere near Chicago the best thing available during the daytime in that neck of the woods is the noon musical period furnished by WGN—almost a full two hours of instrumental music of a caliber quite as good as most of the expensive evening programs. From 12:40 to 1:00 P. M. a luncheon concert by the Drake Concert Ensemble and the Blackstone String Quintet; 1 to 2 P. M. Lyon and Healy artist recital; 2 to 2:30 a luncheon concert. And frequently the succeeding half hour, 2:30 to 3 which is



THE "COOKIES"

Lucile and Nell Cook, who have been heard in harmony over WEAJ, New York, and WEBH, WJJD, Chicago



MARIE HILL OF KTCL, SEATTLE

A Cadillac roadster, equipped with a portable broadcasting set is used by Miss Marie Hill, studio hostess at KTCL in conducting what is known as "Juniata's Shopping Tour," a feature of the daily woman's hour program from this station.



AN ARTISTS' BUREAU AT WLW

WLW, following a practice already in efficient operation at several broadcasting stations, has organized an "Artists' Bureau," an agency for managing the outside bookings of artists appearing regularly on its programs. In the photograph are Emil Heerman, concert master of the Cincinnati Symphony Orchestra, Lydia Dozier, soprano, and Powel Crosley.

turned over to staff soloists, is equally pleasant.

Another Chicago daytime feature that comes as a welcome relief from the unending recipe and household hints lectures is the Overture Hour, WMAQ, 10 to 11 A. M. A varied program, made up according to the expressed wishes of the listeners, is played by the Whitney Trio. We have taken occasion to praise this trio before, while their playing can not yet be called inspired or resplendent with subtle nuances they are at least thoroughly routined and play with a coordination surprisingly good for such a young organization.

THUMB NAIL REVIEWS

WHO—The "Automatic Adjutors," on an advertiser's program, doing some pretty fair harmony singing with fine pianissimo effects. The tenor soloist did as good a job by "Three For Jack" as we have yet heard by radio. It is a surprising fact that songs of the ilk of "Three For Jack" are so seldom heard in radio programs; songs, if you are not familiar with this particular piece, which rely for their effect largely upon the words. Perhaps it is because so few solists can sing them effectively. They require an intelligence astute enough to fully grasp the meaning of, and properly interpret, the verse without at the same time so neglecting the music as to relapse into mere *recitative*. Of course "On the Road to Mandalay" and its sister song are given plenty of airings, but there is a host of other "speaking-songs" that are never heard. They are generally light in mood, sometimes quite funny, and mostly designed for male voices. We offer, gratis, the suggestion that a complete program be arranged of these songs and turned over to a capable singer. We venture to guess that it would be popular.

WLBW—Somebody playing classics on the piano in acceptable style. A premature fading out prevents further record.

WJAY—One of those so called "nut" hours. A reading of original poems by the announcers involved, which was not so hot. Some piano work which was a lot better. And some comics which coaxed an occasional grin. Professor Bumguesser, burlesquing the radio seers, of which we had an epidemic recently, undertook to give answers to the various problems perplexing his listeners, along the lines of: *Q.* ". . . should I have the family wash in the back yard? Signed, "Puzzled Housewife." *A.* "No, the neighbors might fall out the windows." and *Q.* "Should I allow my boss to help me get the mail out or should I stick the stamps on myself?" *A.* "They will be much more effective on the letters."

WGBS—Morry Leaf, the "Eskimo Ukist" and "Bad-Time Story-Man" burlesquing the gwan-to-bed programs and singing some swell original ditties.

WHT—"Al and Pat" on the "Your Hour" (Announcer Pat Barnes and Organ-



AT 3 LO, MELBOURNE, AUSTRALIA

This young woman is not giving a lecture on tooth paste, but has just concluded a recital of "Songs at the Piano." She is Lee White and is, we are told, very popular with Australian audiences

ist Al Carney—we had their names backwards last time we mentioned them—beg pardon!) Between the two of them they put on the complete graduating exercises of a "deestrick school," the unctuous trustee, the quavering voiced teacher, and the smart pupils. We recommend them to you. Humorists of the old, ever-reliable, school.

KFAB—A station operated by an automobile dealer. We sat through a long and tedious direct advertising talk just to see how far they would go with it. They went plenty far enough, a full fifteen minutes was devoted to a long winded discussion on why the car they sold was equipped with cast iron pistons. The main issue seemed to be whether or not wear and tear on the piston was more disadvantageous than wear and tear on the cylinder. Long arguments pro and con were duly considered and the proper and predetermined conclusions reached. Aside from the effrontery in offering such a bald piece of advertising at all, the discussion was of such a technical nature that it could not conceivably have interested anybody less than an automotive engineer. What average motor car buyer gives a whoop, we ask you, whether his car has cast iron pistons or not? And how many other listeners besides myself—who is paid to do so—lasted out the boring dissertation?

WCFL—"The Two Peppers" delivering some not bad close harmony and some very high-powered self accompanying, and solo work, on the guitar and banjo.

WEBH—The Indiana Male Quartet singing a good novelty song having to do with Whispering Sweet Whispers.

WJZ—A first rate concert now being broadcast every Sunday evening at 9:30 Eastern Daylight Saving Time. A studio orchestra consisting of eighteen instrumental soloists in woodwinds, strings and brass, under the direction of Hugo Mariani. The first program, typical of the ones following, was made up of the lighter and most popular compositions of Goldmark, Strauss, Massenet, Wagner, Schubert, Chaminade, Tschai-kowsky, Herbert, and Saint-Saens.

WMCA—Art Gillham, singer of sentimental ballads, par excellence, accompanying himself on the piano.

WOR—A good instrumental ensemble and an unusual one: a trio made up of harp, violin and flute. Called the French Trio and under direction of Mme. Savitskaya.

COMMUNICATIONS

WE QUOTE a couple of paragraphs from a long and interesting letter from G. W. Ferens of New Zealand.

The class of programme transmitted is, in a small way, similar to those broadcast by your well-known stations. You are probably aware that the receiving conditions in New Zealand are considered by experts to be the finest in the world due to our geographical position. For instance, a receiver that is not capable of consistent reception of Australian broadcasts every night of the week over a distance of 1400 to 2000 miles is no good whatsoever in this country. A powerful receiver has no trouble at this time of the year in bringing in Pacific coast Stations and even Chicago. In fact, I have many a time listened to KFON at Long Beach on the loud speaker for two hours and heard it as well as a listener in the Middle West would receive that station. In passing, I would like to mention that KFON is the best American broadcasting station heard in this part of the country.

I trust that you will now understand how acceptable the information in your columns is to readers here, when we can, in many cases actually hear the stations and artists of which we read about. In particular the photographs of the artists and the general description of programs are very interesting and it gives one quite a thrill to hear an artist or an orchestra who, through your columns, one considers an old acquaintance

ASHTABULA, OHIO.

SIR:

Re: Sunday Broadcasting, July issue, you have ably covered a subject that has been too long and too much ignored by anyone actively interested in radio programs . . . Church services have a legitimate place in broadcasting but they are not enjoyable to the exclusion of everything



D. R. P. COATS

Former program director and announcer at CKY, has taken charge of a new station erected by a manufacturer at Moose Jaw, Saskatchewan. CJRM

else, and neither are the heavy, slow musical features and hymns.

A. K.

WASHINGTON, D. C.

SIR:

On the Eveready hour the substitute manager one evening put on the 1812 Overture and then: "After the tumultuous emotions of this great work we will soothe ourselves back to normal by a soprano and tenor duet" and put on the grand seduction scene from Samson et Delilah. What dye mean "normal"?

E. S. S.

LOS ANGELES, CALIFORNIA.

SIR:

The announcer at KFON has just informed his listeners that the orchestra would next play, "Folies Bergères," but, now for the big laugh, he announced it as "Foley's Brassiers," in the approved and generally accepted American pronunciation.

I. W. H.



AT WSM, NASHVILLE

The Andrew Jackson Hotel Trio, Vivian Olson, cellist; Marguerite Shannon, pianist, and Clair Harper, violinist, broadcasting daily through wsm

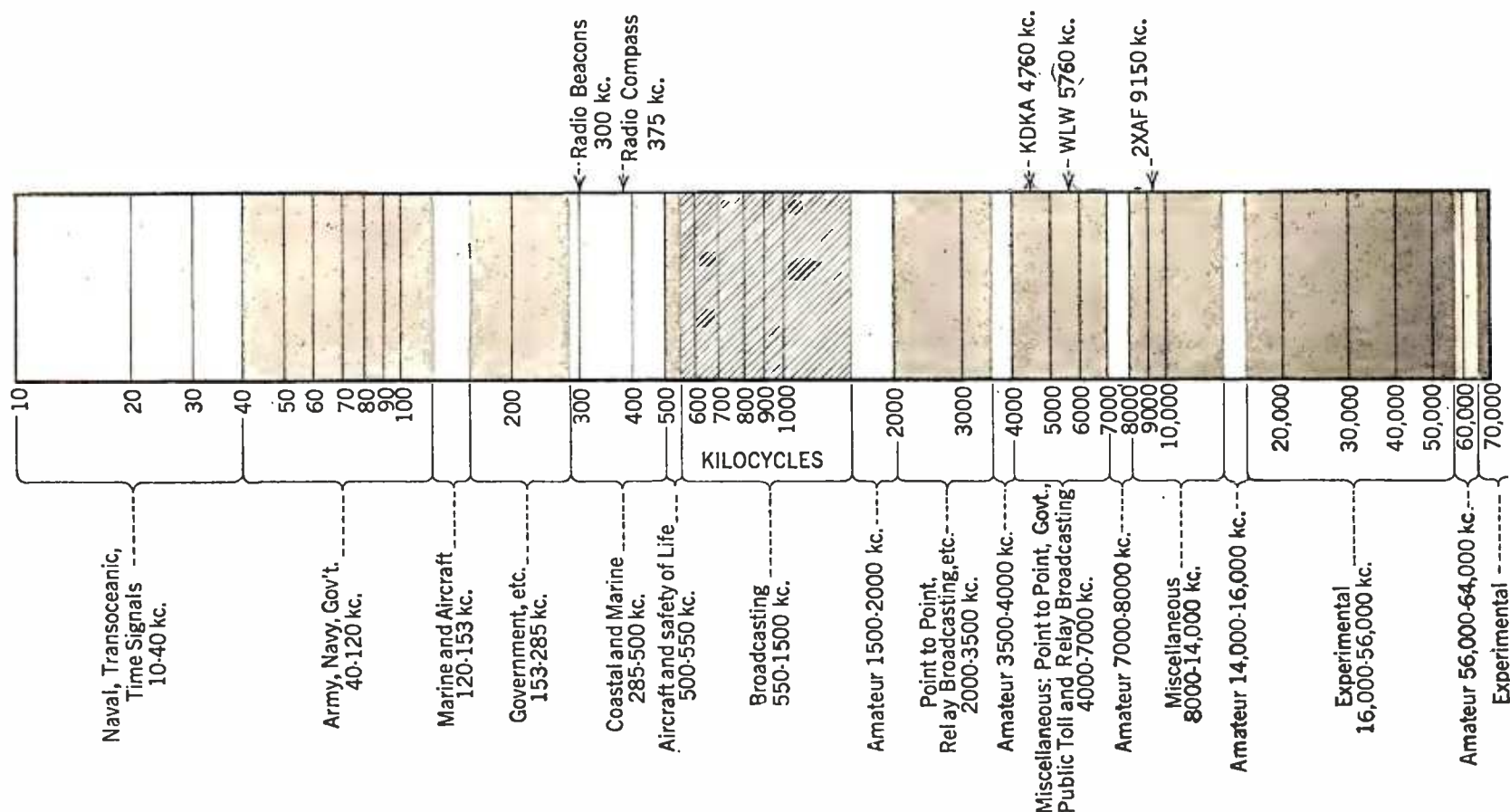

FROM TEN TO SEVENTY-THOUSAND KILOCYCLES

This diagram shows very clearly how the frequency spectrum between these two widely separated points is divided, and a very good idea of the comparative width of the band set aside for broadcasting may be had

Why Not Try the Short Waves?

In Which the Appetite of the Broadcast Listener Is Whetted—A Receiver for Exploring the Nether Regions of the Wavelength Spectrum, Where a Real Taste of Internationalism Is Possible

By KEITH HENNEY

Director of the Laboratory

OUT of a total number of frequencies available for radio communication amounting to some 60 million, the broadcasting band occupies only one million—a very small band indeed. What goes on in the other bands has been, until recently, a closed book to the vast majority of listeners because of the language used there—the International Morse code. Now, however, there are at least three American broadcasting stations using voice and music to modulate waves in these vast open spaces outside of our familiar broadcasting band, so that adventuring into the other 59 million frequencies is not too devoid of interest.

For many months the General Electric Company has put programs into the ether experimentally on a wavelength of 32.79 (9150 kc.) meters, and the 63-meter (4760 kc.) signals of the Westinghouse station KDKA are already too well known to need introduction. Recently WLW at Cincinnati has been using a band at 52 meters (5750 kc.) for rebroadcasting their regular programs and, according to reports, a 30-meter (9900-kc.) station operated in Eindhoven, Holland, can be heard during the early evening hours in the United States. Also, as this is being written (July) a station near Quebec is testing on approximately 32 meters (9380 kc.) and signing cs.

Here are five landmarks for which anyone equipped with a short-wave set can go seeking. Fortunately, it is possible to build a receiver for the high frequencies in a very simple manner

indeed, and with removable coils one can cover the entire range from below about ten meters (30,000 kc.) to something beyond the broadcasting band, thereby opening up a vast expanse of receiving territory unfamiliar to the average listener, and filled with interesting goings-on.

The usual short-wave receiver uses only two tubes since headphone reception is the rule. The first tube is a detector, which may be made to oscillate, or not, as the operator desires, and the second tube is used in a transformer-coupled amplifier. If loud speaker signals are desired it is only necessary to provide an additional stage, preferably equipped with a power tube.

The illustration forming the heading of this article shows the part of the spectrum that broadcasting utilizes and also gives an idea of the many services which take place in the other parts of this spectrum. Above the broadcasting frequencies come the many-tongued bands filled with amateur transmitters. In the United States, for example, there are several sections in which amateurs may operate, that immediately above our broadcasting section (or below if we think in meters), then another at 3750 kilocycles, or 80 meters, one at 7500 kilocycles or 40 meters, and still others at 15,000 and 60,000 kilocycles, or 20 and 5 meters respectively.

Communications take place on these higher frequency bands that would be considered miraculous on lower frequencies. For example, on February 20th, 1927, the following stations were heard at 2 EJ, one of the stations operated by RADIO BROADCAST LABORATORY, on or below the so-called 40-meter (7500-kc.) band:

FREQUENCIES AVAILABLE FOR AMATEUR USE

AMATEURS in the United States operate in bands set aside for their use as shown in the table below. Other interesting services carried on the high frequencies are given in the box on page 291:

METERS	KILOCYCLES	WIDTH Kc.
0.7477-0.7496	401,000-400,000	1000
4.06 -5.35	64,000-56,000	8000
18.7 -21.4	16,000-14,000	2000
37.5 -42.8	8000-7000	1000
75.0 -85.7	4000-3500	500
150.0 -200.0	2000-1500	500

EST	STATION	LOCATION
3:35 P. M.	NL 4 X	West Indies
	G 5 XY	England
3:50 "	FO A 3 B	South Africa
3:55 "	G 5 XY	England
4:00 "	EK 4 UAH	Germany
4:07 "	OA 5 WH	Australia
4:20 "	F 8 1 B	France
6:25 "	SB 1 AR	Brazil
6:35 "	NQ 5 AZ	Cuba

Thus, in a space of one hour and a half, it was

COIL No.	WAVE-LENGTH RANGE METERS	KILOCYCLE RANGE	SECONDARY, L ₂				TICKLER, L ₃		
			TOTAL TURNS	LENGTH OF WINDING INCHES	SIZE WIRE	INSULATION	TOTAL TURNS	SIZE WIRE	INSULATION
1	15-28	19,990-10 710	3	5	18	Enamel	2*	26	d.s.c.
2	30-52	9994-5766	8	3 1/2	18	Enamel	4*	26	d.s.c.
3	57 1/2-111	5260-2701	19	3 9/16	18	Enamel	6*	26	d.s.c.
4	119-228	2399-1199	40	1 3/8	22	d.s.c.	15*	26	d.s.c.
5	235-550	1276-545	81	1 1/2*	26	d.s.c.	21*	26	d.s.c.

*Close wound.

Note: Tuning condenser is 100 mmfd. Primary, L₁, consists of 10 turns, wound in a space of 9-32nds inch, of No. 22 cotton-covered wire, and is 2 3/4 inches in diameter. Secondary is 3 inches in diameter.

possible to listen-in on the whole world. At another time 8Z 11B, a Brazilian Amateur, was heard talking to GMD, the Dyott Expedition. It would be possible to go on indefinitely with stories of long distances covered and interesting experiences, but the preceding paragraphs should give the uninitiated some idea of what can be expected in the short-wave provinces.

Kits of short-wave coils, condensers, etc., are now available from several manufacturers, and with these, receivers may be constructed. All of these receivers will radiate and can disturb near-by listeners, but with loose coupling to the antenna and an additional audio stage if neces-

sary to make up for the decrease in signal strength, this radiation is reduced to a minimum.

In actual practice, the detector is on the point of oscillating when voice or music is being received, and when code signals are copied the detector is actually oscillating, but is near the point where oscillations are liable to cease. In these conditions the detector is most sensitive.

Attention is called to the two articles by Frank C. Jones, 6 AJF, on non-radiating short-wave receivers. Mr. Jones has made a substantial contribution toward the ideal receiver and the set described by him in RADIO BROADCAST in May, 1927, approaches very closely to a truly non-radiating receiver.

Each of the coils designed for the short-wave kits differs from the others, Silver-Marshall using a form similar to broadcast coils, Aero Products using spaced windings on slotted forms, REL supplying the familiar basketweave style, and those of Gross or Hammarlund consisting of spaced windings on a celluloid form.

WINDING THE COILS

FOR the experimenter who likes to make his own, the following description of coils similar to the Aero inductances will be helpful. The number of turns for the various frequency bands to be covered is given in the table on this page.

An insulating tubing three inches in diameter can be used without introducing much loss. The tickler coil is, in each case, 2 3/4 inches in diameter and is made self-supporting by using collodion or some other binder. This coil is placed inside the secondary at a position near the grounded end of the coil and need not have a great deal of mechanical strength as it is protected by the secondary. The same primary is used for every coil and should be fastened on a hinge which makes it possible to vary the coupling as desired. This coil is made self supporting, is wound without spacing, and a binder is used to keep it in shape. It is wound with ten turns of No. 22 double silk-covered wire. The primary may be mounted on the sub-panel of the receiver. It will be found, in operation, that the setting of the coupling need not be changed very often and once adjusted properly may be left in a fixed position. Secondary coils Nos. 1, 2, and 3 are wound with No. 18 enameled wire spaced approximately the diameter of the wire. Secondary coil No. 4 is space wound with No. 22 double silk-covered wire, the dimensions of the coil being 1 1/2 inches by three inches. Coil No. 5, which covers the broadcast band, is wound with No. 26 double silk-covered wire and is not spaced. The coils are mounted on flat strips of bakelite, and four connections are brought out from each coil in the form of pins, mounted on the bakelite strips. The pins are designed to fit into corresponding slots in the sub-panel mounting. Three pins are spaced at one end of the bakelite strip with a fourth apart from the others, making it impossible to plug the coils in the wrong way. Almost any type of plug system having four contacts may be used. Suggestions have been made from time to time for using an old base of a vacuum tube and a tube socket for this purpose. If such a device is used care should be exercised to see that too much capacity is not introduced, otherwise the wavelength ranges will be considerably affected.

This covers the mechanical details of the coils. It is not necessary to go into details of the wiring of the receiver shown in Fig. 1 as most of our readers are familiar with this part of set building. It is important, however, especially in short-wave work, to make the grid lead very short and to keep all wires rigidly fixed in their respective positions. The actual order of wiring is not mandatory but it is suggested that the filament wires be completed first.

The circuit used for the several kits on the market is fundamentally the same. That used in the Aero kit is shown in Fig. 1. The Radio Engineering Laboratories kit consists of a complete set of parts, including panel, wire, transformer, coils, etc., and lists at \$36. Silver-

HOW THE HIGHER FREQUENCIES ARE ALLOCATED

AN IDEA of what goes on in the higher frequency bands may be gleaned from the following table, which shows how the various frequencies were divided up by the Fourth National Radio Conference:

KILOCYCLES	METERS	SERVICE
500-550	600-545	Aircraft and fixed safety of life stations.
550-1500	545-200	Broadcasting only.
1500-2000	200-150	Amateur only.
2000-2250	150-133	Point to point.
2250-2300	133-130	Aircraft only.
2300-2750	130-109	Mobile and Government mobile only.
2750-2850	109-105	Relay Broadcasting only.
2850-3500	105-85.7	Public toll service, Government mobile, and point-to-point communication by electric power supply utilities, and point-to-point and multiple-address message service by press organizations, only.
3500-4000	85.7-75.0	Amateur, Army mobile, naval aircraft, and naval vessels working aircraft, only.
4000-4525	75.0-66.3	Public toll service, mobile, Government point to point, and point-to-point public utilities.
4525-5000	66.3-60.0	Relay broadcasting only.
5000-5500	60.0-54.5	Public toll service only.
5500-5700	54.5-52.6	Relay broadcasting only.
5700-7000	52.6-42.8	Point to point only.
7000-8000	42.8-37.5	Amateur and Army mobile only.
8000-9050	37.5-33.1	Public toll service, mobile, Government point to point, and point-to-point public utilities.
9050-10,000	33.1-30.0	Relay broadcasting only.
10,000-11,000	30.0-27.3	Public toll service only.
11,000-11,400	27.3-26.3	Relay broadcasting only.
11,400-14,000	26.3-21.4	Public service, mobile, and Government point to point.
14,000-16,000	21.4-18.7	Amateur only.
16,000-18,100	18.7-16.6	Public toll service, mobile and Government point to point.
18,100-56,000	16.6-5.35	Experimental.
56,000-64,000	5.35-4.69	Amateur.
64,000-400,000	4.69-0.7496	Experimental.
400,000-401,000	0.7496-0.7477	Amateur.

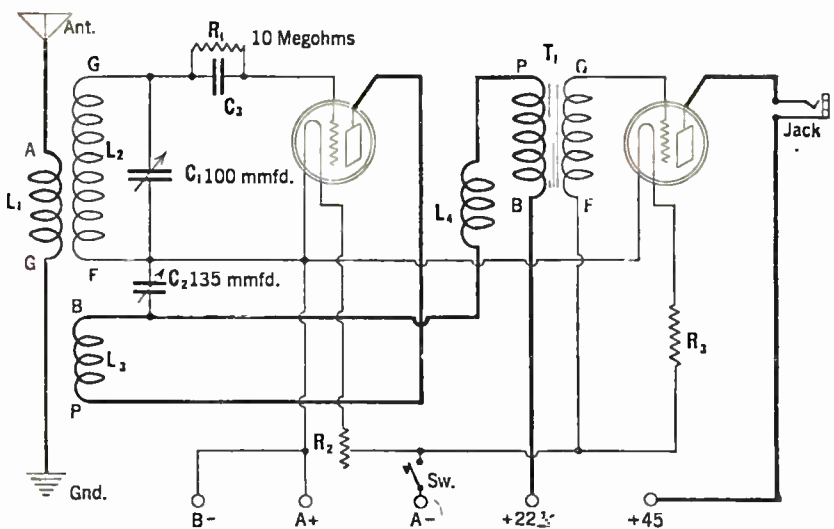
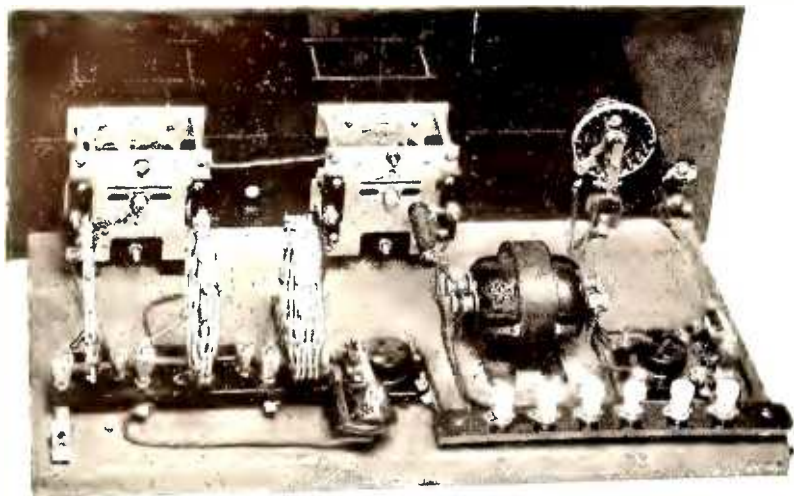

FIG. 1

The circuit diagram of the Aero short-wave receiver



RADIO BROADCAST Photograph

MADE IN THE LABORATORY

The short-wave receiver here shown employs REL coils, National condensers, X-L binding posts, etc. The circuit is basically the same as that shown in Fig. 1

Marshall's kit includes coils, coil socket, and three condensers and lists at \$23.00. Other kits of coils are sold by the Aero Products Company as indicated on the list of parts in this article, and that sold by J. Gross which lists at \$27.90. Aero also stocks a short-wave drilled and engraved foundation unit listing at \$5.75.

THE ANTENNA

THE antenna used with these receivers may be of practically any type, long or short. A long outside antenna will naturally give the better results, though the coupling between the primary and secondary coil will have to be reduced or perhaps a series condenser inserted in the lead-in, if it is found that the set refuses to oscillate over a certain band. This is probably due to absorption by the antenna. A little experimenting with the coupling or perhaps changing the antenna length or position will usually remedy this.

Another point which is important in making a set of this character oscillate evenly over the entire band is the grid leak. For best results a high-resistance leak should be used, say of 6-10 megohms. The detector tube should go in and out of oscillation easily when the regeneration condenser is varied. As seen from the circuit diagram the set may be grounded on the negative return (dotted lines) or not, according to which connection gives the better results. A little time spent in becoming familiar with the adjustments of the set will tend to insure better results and at the same time preclude unnecessary disappointments.

The variable condenser used for tuning the set illustrated in Fig. 1 is one of 100 micro-microfarad (0.0001-mfd.) capacity. While this condenser does not quite cover the entire bands it does

spread out the available bands and makes tuning much easier. If it is desired to cover every wavelength over the full range a small shunt condenser may be placed across the main condenser and be operated with a switch. A straight frequency-line condenser is used for tuning. The regeneration control condenser may be of any type as this control is not at all critical.

A list of parts for this Aero receiver, shown

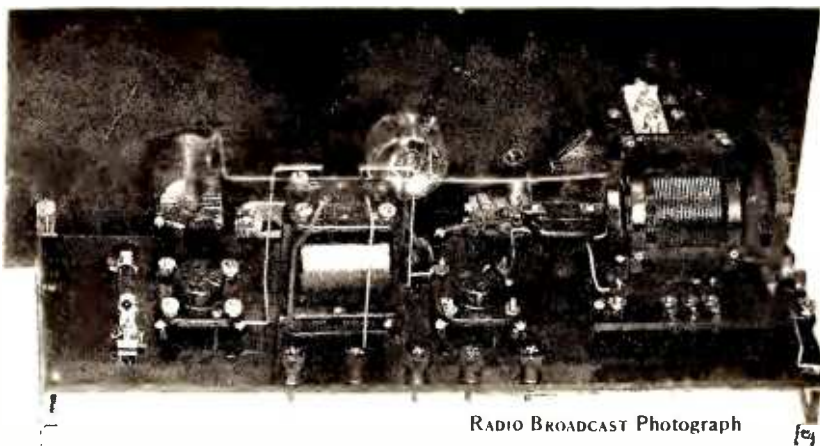

RADIO BROADCAST Photograph

THE RECEIVER DESCRIBED IN THIS ARTICLE

The parts list and panel layout for this particular receiver are given on this page while the circuit diagram appears as Fig. 1, on page 291

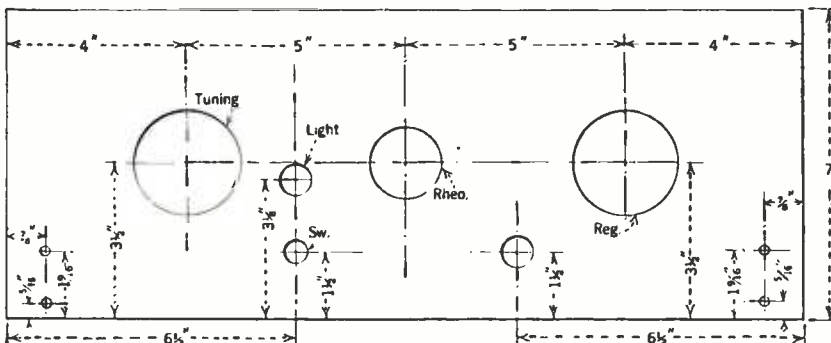

PANEL LAYOUT OF THE SHORT-WAVE RECEIVER

diagrammatically in Fig. 1, made in the Laboratory, and used at 2 GY, is given below, and panel and sub-panel layouts are shown in Figs. 2 and 3.

LIST OF PARTS

L ₁ , L ₂ , L ₃ —Short-Wave Kit Consisting of Coils Nos. 1, 2, and 3 with Primary and Plug-In Mounting, Aero Products Company (15-111m.)	\$12.50
L ₄ —Coils Nos. 4 and 5, Aero Products Company (119-550 m.)	8.00
L ₅ —Silver-Marshall Short-Wave Choke	.60
C ₁ —Hammarlund Variable Condenser, 100 Mmfd.	4.25
C ₂ —Precise Variable Condenser, 135 Mmfd.	2.00
C ₃ —Sangamo 0.0001-Mfd. Grid Condenser with Mounting	.40
R ₁ —Grid Leak, 10 Megohms	.50
R ₂ —Frost 20-Ohm Rheostat	.50
R ₃ —Amperite and Mounting, 1-A	1.10
T ₁ —Samson 6:1 Audio Transformer	5.00
Two Benjamin Spring Sockets	1.50
Yaxley Single-Circuit Jack	.50
Yaxley Combination Switch and Pilot Light	.75
Two Benjamin Brackets	.70
Five Eby Binding Posts	.75
Two Karas Vernier Dials	7.00
Radion Hard Rubber Panel 7 x 18 x 1/16 Inches	2.50
Radion Hard Rubber Sub-Panel 5 x 16 1/2 x 1/16 Inches	1.65
Wire, Screws, Etc.	.50
TOTAL	\$50.70

ACCESSORIES NEEDED

- 2 CX-301-A Type Tubes
- 1 45-Volt B Battery
- Pair of Phones
- Antenna and Ground Connections

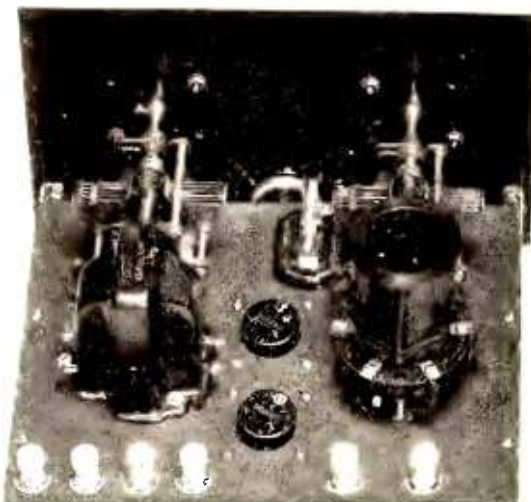

RADIO BROADCAST Photograph

ANOTHER SHORT-WAVE RECEIVER

Silver-Marshall parts form the basis of this efficient and compact receiver

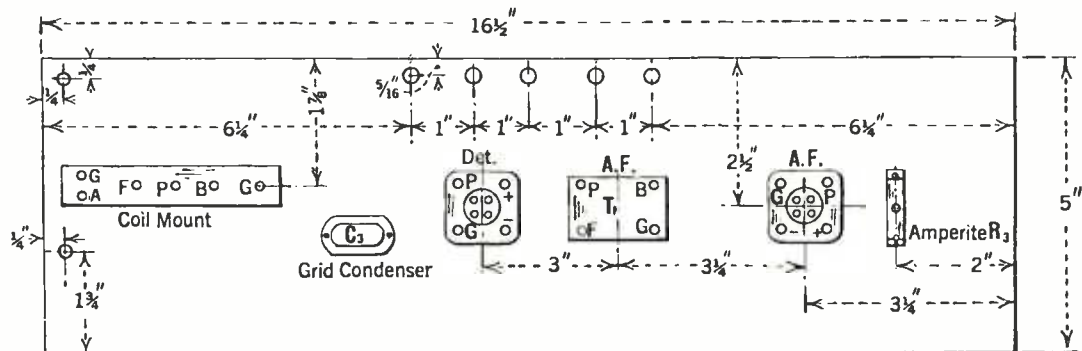

A SUB-PANEL LAYOUT OF THE RECEIVER

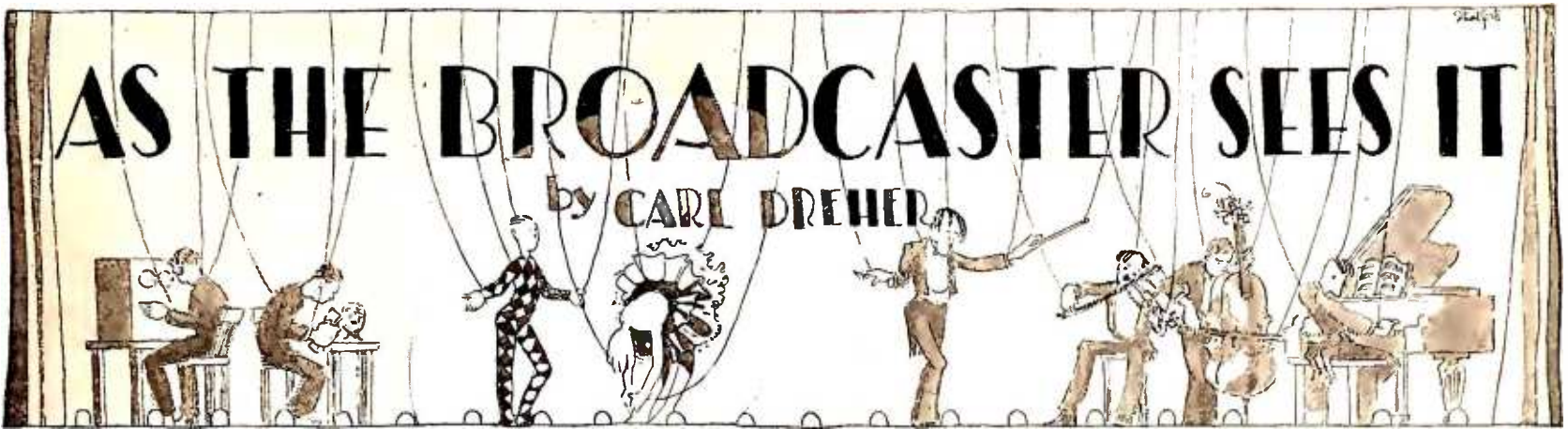

Drawings by Franklyn F. Stratford

Design And Operation Of Broadcasting Stations

17. Attenuation Pads

THE instrument known as a "pad" among broadcasters is usually a simple resistive network used to cut down signal level by a definite amount. It may be adjustable, but more frequently various sizes are supplied with the terminals led to jack strips so that a loss of, say, ten, twenty, or forty TU may be introduced at will. A general and sufficiently exhaustive treatment of passive networks in general may be found in Chapters VIII and XI of *Transmission Circuits for Telephonic Communication*, by K. S. Johnson. (D. Van Nostrand Co.) The most thorough work on the subject of artificial lines is no doubt *Artificial Electric Lines*, by A. E. Kennelly, Sc. D. (McGraw-Hill Book Company). Being by Doctor Kennelly, this book leaves little to be said on the subject; the reader must be warned, at the same time, that the mode of approach is through hyperbolic geometry and the calculus, quite in the Heaviside and Steinmetz tradition. Here we shall present only a restricted, elementary, practical treatment of one aspect of the subject, for the benefit of those of the boys who have not gone to M. I. T., but manage to broadcast anyway.

Fig. 1 shows a typical pad of the "H" form. With the resistances shown this network will introduce a loss of 20 transmission units, while presenting an impedance of 500 ohms in either direction. It might be used in the output of an amplifier terminated in a transformer with a 500-ohm secondary, between this secondary and a line, in order to keep the current in the line within allowable cross-talk limits, or for a similar purpose. Fig. 2 illustrates a line which will lose something a little less than 40 TU, but at

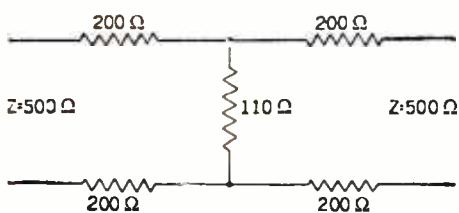

Fig. 1

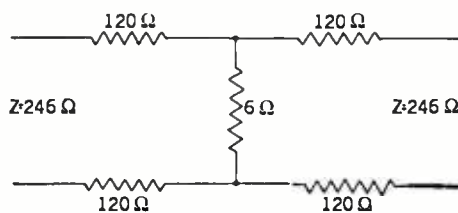

Fig. 2

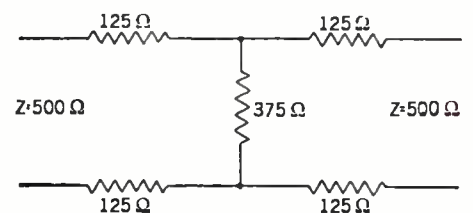

Fig. 3



"THE READER MUST BE WARNED"

a lower impedance—about 246 ohms, forwards and backwards. It will be noticed that the sum of the two side resistances and the shunt member gives the approximate impedance presented by the network, when the resistance of the shunt member is low compared to the rest of the arti-

cial line on the other side and the apparatus tied thereto. This qualification must not be neglected, for, as in the 10-TU pad shown in Fig. 3, the impedance may be 500 ohms in each direction, while the sum of the three members of the network proper is 125 plus 125 plus 375, equalling 625. However, the 375-ohm shunt member is paralleled by 750 ohms (125 plus 125 plus the 500 ohms of the actual line) which brings the resultant down to 250 ohms, and 125 plus 125 plus 250 equals 500.

In Figs. 1, 2, and 3 we have shown H-shaped artificial lines of various sizes, and with the same impedance looking in either direction. This type of line exhibits complete symmetry, the resistance being the same on each side of the pair, and the impedance the same on each side of the cross-member. Except for the consideration of bilateral symmetry, any such H-network may be replaced by a T-network with three members instead of five. For example, take the 10-TU H circuit of Fig. 3. This may be replaced, if perfect symmetry is not required, by the T circuit of Fig. 4. The only change is in the shifting of one 125-ohm resistance to the same side as the other, leaving no series resistance on one side and collecting 250 ohms on the other. The ohmic relations are unaffected. A different effect is secured when the network is unsymmetrical about the cross member. Then the impedance looking backwards and forwards is changed. To illustrate: take the 40-mile pad of Fig. 2, presenting some 240 ohms at both terminals. Assume that it has become necessary to match a 500-ohm circuit on the right. The network might then be modified as shown in Fig. 5. Toward the left the impedance remains sensibly unchanged, but toward the right the impedance is now approx-

imately 500 ohms. This network would match a 200-ohm output to a 500-ohm input. At the same time, of course, the attenuation of the pad has been changed. The magnitude of the change may readily be calculated, but instead of taking this network as an example we shall outline in a more general way the simple theory involved. All that is required is an acquaintance with Ohm's Law.

Fig. 6 shows a network of the H-type, with series resistances x_1 and x_2 and shunt resistance y . The impedance on either side of this network is Z . In the calculation we shall also use the quantity r , which represents the resistance of the shunt combination formed by y paralleled by $x_2 + Z + x_1$. E_1 is the voltage across the input of the network, E_y the voltage across the shunt member y , E_2 the output voltage of the device. The current in the left-hand rectangle is i_1 , that in the right-hand rectangle is i_2 . With these

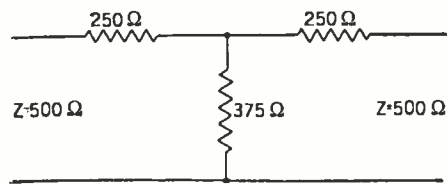

Fig. 4

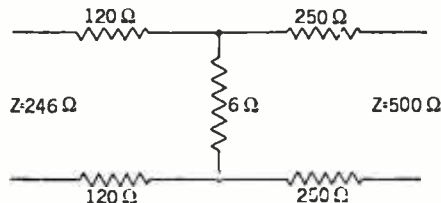

Fig. 5

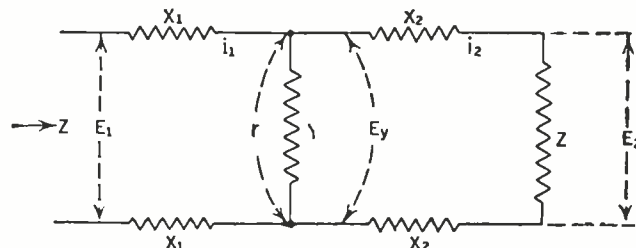

Fig. 6

We may now apply the last two formulas to the artificial line of Fig. 3, which was stated to be of 10-TU size. Substituting $x = 125$, $y = 375$, and $Z = 500$ in (14), we find

$$r = \frac{(375)(250 + 500)}{250 + 500 + 375} = \frac{(375)(750)}{1125} = 250$$

This value ($r = 250$) being substituted in (13) with the other numerical data, we have

$$L = 20 \log_{10} \frac{(500 + 250)(250 + 250)}{(500)(250)} = 20 \log_{10} 3 = 20(0.477) = 9.54 \text{ TU}$$

This answer is sufficiently close to the actual attenuation of the pad for all practical purposes, and the formulæ derived in the discussion above may be used in calculating the constants of

casting about for the proper etiquette under the circumstances, my two friends, having settled the inevitable dispute as to who should have the privilege of paying for the ride, joined me, and together we entered, through a second door, the main body of the church. It was quite light, in contrast to the gloom of many church auditoriums, and empty, save for us and one fair penitent who knelt before the altar at the far end.

I need not tell my readers that it is the in-violate custom of all good broadcasters in the technical end of the business, on entering a hall of any kind, to clap their hands, whistle, yell, sing, and stamp on the floor in a learned manner, in order to test the acoustics of the enclosed space. The eyes of Mr. Hanson and myself rolled upward toward the groined ceiling of the church, and both of us felt the impulse to clap our hands, at least, but we stood as still as the statues of the saints confronting us on every

symbols we may carry out a sufficiently accurate calculation.

First we may write

$$E_1 - 2x_1 i_1 = E_y \tag{1}$$

$$E_y - 2x_2 i_2 = E_2 \tag{2}$$

$$E_1 - 2x_1 i_1 - 2x_2 i_2 = E_2 \tag{3}$$

$$E_1 - 2x_1 i_1 = E_2 + 2x_2 i_2 \tag{4}$$

Also $i_1 = \frac{E_1}{2x_1 + r}$ (5)

And $i_2 = \frac{E_2}{Z}$ (6)

Substituting (5) and (6) in (4), we obtain

$$E_1 \left(1 - \frac{2x_1 E_1}{2x_1 + r} \right) = E_2 \left(1 + \frac{2x_2 E_2}{Z} \right) \tag{7}$$

$$\text{Or } E_1 \left(1 - \frac{2x_1}{2x_1 + r} \right) = E_2 \left(1 + \frac{2x_2}{Z} \right) \tag{8}$$

$$\text{Simplifying } \frac{E_1}{E_2} = \frac{(Z + 2x_2)(r + 2x_1)}{Zr} \tag{9}$$

The value of r is found readily on the principle that the resultant conductivity (the reciprocal of resistance) of paths in parallel equals the sum of the individual conductivities:

$$\frac{1}{r} = \frac{1}{y} + \frac{1}{2x_2 + Z} \tag{10}$$

Clearing of fractions

$$\text{Whence } r = \frac{y(2x_2 + Z)}{2x_2 + Z + y} = \frac{r(2x_2 + Z) + r(y)}{2x_2 + Z + y} \tag{11}$$

By definition, the TU loss of the network is given by

$$L = 20 \log_{10} \frac{E_1}{E_2}$$

(See this department in RADIO BROADCAST for September and October, 1926, for a discussion of the meaning of the telephonic "Transmission Unit.")

Hence, from (9) above

$$L = 20 \log_{10} \frac{(Z + 2x_2)(r + 2x_1)}{Zr} \tag{12}$$

From (11) and (12) we may calculate the loss introduced by any H-network where the impedance is unchanged from input to output. In the usual practical case, where in addition $x_1 = x_2 = x$, (12) becomes

$$\text{And } L = 20 \log_{10} \frac{(Z + 2x)(r + 2x)}{Zr} \tag{13}$$

$$r = \frac{y(2x + Z)}{2x + Z + y} \tag{14}$$

other networks of the same type. The simplest procedure is usually to draw up a network for the required purpose on the basis of previous experience, make a calculation of the TU drop corresponding thereto, modify the constants as indicated by the result of the calculation, and by successive changes and calculations to approach the desired value. With a little experience a very few operations will be found sufficient.

Broadcasters In Church

WHILE ago my distinguished colleague, O. B. Hanson, who presides over the engineering destinies of the National Broadcasting Company, a prominent architect of New York, and I, were engaged in argument concerning the merits and demerits of various commercial sound-absorbing materials. Harassed by the fireproofing zealots of the Building Department, who care little about the yearning of a broadcaster for acoustically flat studios, we sat sweating amid sample slabs of expensive special plasters and nondescript compounds, which we glared at through magnifying glasses, scratched with pencils, and chewed with our teeth. Finally, having exhausted our learning without reaching a conclusion, we leaped into a taxicab and sped to a point on First Avenue where, we had been informed, there stood a church whose domed ceiling had been treated with one of the materials in which we were interested, so that we might see and hear the virtues of this substance for ourselves.

Leaving my companions to pay the taxi driver, I approached the door of the edifice, which, I noted, was of the Catholic denomination. The door was open, and, removing my hat, I stepped into a sort of lobby, in which votive lights were burning. It was only at this point that I realized the incongruity of our errand with the primary purpose of the building. We had come neither for prayer, meditation, nor the confession of our sins, but to test the acoustics of an auditorium, a deed in itself neither good nor bad, but certainly not of a religious character. While I was

side. We twitched and opened our mouths, but no sounds came forth. Such an inhibition is astounding in men who have been broadcasting as long as we have. The architect seemed to suffer less. Architects are concerned with the building of houses, rather than with the noises generated in them after completion.

"Now that we are here," I whispered, hunching my shoulders fearfully at the lady kneeling with her back to us, "how shall we proceed? What noise can we make without damning our selves, if it has not been done already? What shall we do?"

"Don't you know any monsignors or high church dignitaries who might furnish us with a dispensation to make a racket in this church?" mumbled Mr. Hanson, wiping the perspiration from his brow with his hat.

"I do not move in those circles," I answered regretfully. "Once, at a reception on Pearl Street, I was introduced to a rabbi, but I left him to talk to a pretty girl. How about you?"

"I am an Episcopalian," confessed Mr. Hanson, in a tragic whisper.

"Cough!" the architectural gentlemen suddenly ejaculated, voicelessly. I flashed him a grateful look, and emitted several genteel but loud reverberations from the region of my diaphragm. Emboldened by the echoes, Mr. Hanson snapped his fingers under his coat, skilfully varying the pitch. I continued to cough and whoop. After about half a minute the lady at the altar crossed herself and rose, perhaps to send for an ambulance. If so, she has certainly increased her chances of ascending to heaven, because she neglected her own salvation to aid a fellow being. But it was equally possible that she was going to call the sacristan, so the three of us turned and fled. We slowed down on the next block and my colleague Hanson addressed me.

"I have spent a bad ten minutes," he said. "I'm never going into a church with you again. Knowing your record, I was afraid you would start to yell and howl as you do up at Carnegie Hall in order to impress the ushers, with the result that we would have been thrown out

on our ears into First Avenue and clubbed by all the cops in the parish. Our social reputation would have been ruined if we had had to go to jail with you. Finally, I must say that you cough in a disgusting manner."

But I was unable to answer. I was still coughing.

That SOS Question Once More

THE behavior, actual and ideal, of broadcasters when an sos call is on the air, constitutes a question of perennial interest which has been discussed a number of times in this department, and will no doubt bob up again at intervals. Mr. Ray Newby of San Jose, California, wrote us about it some time ago, and his view is worth noting. Mr. Newby says:

I wish to take exception to the suggested complete shutdown of broadcasting stations in the vicinity of distressed vessels, and to take sides with the critic mentioned, who was in favor of a station coming on the air at intervals during sos shutdowns with its call letters and the reason for its silence.

The article in contradiction to this practice was well taken, but there are two sides to all questions. As an ex-ship operator, broadcast, etc., allow me to present mine.

With present-day commercial receivers there is no possibility of a broadcast station interfering with ship traffic carried on at 600 meters and above, and as to the 300-meter wave for ships, I think this is automatically eliminated.

Now for the main reason: Did it ever occur to you that the ship operators also listen to broadcast programs? Well, that is the case, even though the Chief Operator says that one ear must be on the stand-by wave (600 meters) at all times while the vessel is at sea. Now, if an operator's favorite broadcast station reminded him at intervals that there was an sos on the air, no doubt he would get both ears working where they were supposed to be, and possibly be of some assistance to the sos'er.

I claim from experience that this is entirely possible, and it is also probable that some one-operator oil boat, or perhaps a private yacht, might be within a stone's throw of the ship in trouble.

Mr. Newby takes a practical view of the matter, and what he says is pertinent enough. It is unfortunately true that some marine operators, standing their watches at sea, neglect their immeasurably important duty in order to listen to jazz on the higher kilocycle channels. I can understand why they do it, and I might be tempted myself if I were standing midnight-to-eight watches again—but that stunt is going to put one of the boys into jail yet. Mr. Newby's argument recognizes, and in some slight measure tolerates, this practice. I doubt whether it is wise to condone what amounts to criminal negligence, even to this degree. The great majority of ship radio operators are wholly reliable; they would as soon think of leaving their marine listening channels to hear some entertainment as they would push ahead of women and children into the life boats on a sinking vessel. The relatively few men who neglect their stand-by function on 600 meters are controlled to some extent, also, by the necessity of making a log entry every fifteen minutes.

The point regarding the one-operator boats and private yachts not required to stand a regular radio watch, seems to me well-taken. In the case of yachts carrying only a broadcast receiver it would seem, however, that little good would be accomplished even if it became known, through a broadcast station's announcement, that an sos was abroad. In the absence of a telegraph operator the people on the yachts would have no idea where the ship in distress was

to be found. The chance of succor from this quarter is hardly great enough to justify permitting powerful broadcast stations on the higher wavelengths to make lengthy announcements giving the location of the vessel in trouble, when these communications might interfere with the radio telegraph stations in direct charge of the situation. Furthermore, in actual practice stations below 360 meters, or well inland, generally do not shut down at all for sos calls, leaving only a fraction of the broadcast stations for possible utility in these situations.

My view has been right along that a careful study should be made of the possibility of interference by broadcast stations with distress signals, that those entertainment transmitters which may conceivably interfere should shut down and not let out another note beyond a bare sos sign-off formula till the clear signal is given by the radio telegraph station in charge, and that where there is no possibility of interference, broadcasting should be permitted to continue without interruption.

With more general high power broadcasting, however, another consideration arises. A powerful radio telegraph coastal station may have about five kilowatts in the antenna. A few of the broadcasters, existing and projected, possess ten times that energy. When an sos is heard, these stentorian voices become silent. Yet it is conceivable that under conditions of heavy static and a distress call far out at sea those fifty kilowatts might come in handy. It might be practicable to arrange some of the very high powered broadcasting stations so that they could be controlled telegraphically, in case of need, from the nearest Naval District Communication Office, the wavelength being shifted, by an automatic wave-changer, to 600 meters. The main item of expense would be the telegraph line. If the handling of sos signals were facilitated in even a small percentage of cases, it would be money well spent.

Blame It on Radio

UNDER this caption we have repeatedly reprinted denunciations of radio broadcasting, which has been blamed for every thing but prohibition and the World War, and would be blamed for those little annoyances as well if they had not antedated it. One of the most persistent of these eruptions of scapegoat psychology is the notion that broadcasting, or wireless communication in general, is responsible for heavy rainfall and floods. Only recently a noted French statesman is reported to have issued a discourse on this subject, suggesting solemnly that the excessive amount of broadcasting in Europe caused the Seine to overflow its banks. A domestic specimen follows below:

SUGGESTS RADIO INTERFERENCE CAUSED SOUTHERN FLOODS

Special to the New York Times
WASHINGTON, May 7.—The Federal Radio Commission has received a letter from a man in Hurricane, W. Va., suggesting that radio interference may be responsible for the present floods. He wrote:

"In view of the excessive downpour of rain and the havoc wrought by floods and the inability of dirt farmers to plow or plant lately, might it not be possible that 'high-wattage' from the many broadcasting stations is so magnetizing the ether, similar to lightning descending to earth, producing magnetic disturbances and rain?"

"There surely is some cause. If broadcasting were suspended for ten days or two weeks in America we might find the culprit or nolle the indictment."

Toward the close of the World War there was a summer during which a great deal of rain fell. There resulted great suffering among summer hotel proprietors and the managers of carnivals, fairs, medicine shows, and the like. The

organ of the latter, the *Billboard*, printed an advertisement, or remarked in one of its departments—I don't remember which—that the unusual amount of rainfall must be caused by the firing of the heavy guns in France. The bankrupt concessionaires were advised to go into the umbrella business. Exactly how the detonation of the guns, which could not even be heard a few hundred miles away—and it takes doggone few dynes per square centimeter to make an audible sound, and a dyne, withal, is a pitifully small force, such as might be exerted by a section of a human hair less than an inch long—just how that sort of disturbance was to cause rain to fall . . . but why labor the point? Schiller said all there was to be said when he declared, "Against stupidity the gods themselves fight in vain." And if there is any field in which superstition is rampant, it is the perennial topic of the weather, in its relation to the other phenomena of the universe. After all, radio only gets a little tar from that stick. Ignorant people have always feared the "powers of the air."

As for the suggestion of the gentleman from Hurricane, W. Va., I announce myself in favor of it, although not for the reason he mentions. I could use a two weeks' vacation very nicely almost any time.

Correction On The Gamma Rays

MR. S. WHITTEN of Berkeley, California, justly takes us to task in the following letter:

Please refer to the center column of Page 107 of your June, 1927 issue, in which the wavelength of the gamma rays of radium is given as about 200 Angstroms.

A few years ago some bright gentlemen got a lot of credit for measuring X-rays as long as 15 Angstroms, and Millikan measured ultra-violet rays as short as 400 Angstroms. So I'm afraid someone misinformed you and dropped you in a dark and lonesome part of the spectrum. Therapeutic X-rays are around one Angstrom and gamma rays are one-tenth to one-twentieth as long. (See Page 96 of the *Bell Technical Journal*, January, 1927, for a fine discussion).

I like your department and wouldn't be as rude as this, but we radio bugs are "powerful ignorant" about some things and I hate to see it spread.

I'm glad to see that Mr. Stratford uses log-log slide rules in his pictures. Few of us can use them any other way.

The article in the *Bell System Technical Journal* to which Mr. Whitten refers is by Dr. Karl K. Darrow, on "Contemporary Advances in Physics—XII. Radioactivity," and, curiously enough, it was lying on my desk when I perpetrated the lamentable bull now dragged into the light. Doctor Darrow remarks:

The gamma-rays are spread out into a spectrum, and sometimes lines are discernible in the spectrum; but the line of shortest wavelength thus far measured (so far as I know) is at 0.052 Angstrom units or 52 X-units, and there are certainly many others at much shorter wavelengths which the crystal spectroscopy does not diffract far enough outward to be located.

As for Mr. Franklyn Stratford, whose name has adventitiously entered the discussion, let it be known that by vocation he is an engineer, engaged, furthermore, in the active practice of the telephone and telegraph arts. The sketches with which he has amused the readers and the author of "As the Broadcaster Sees It" for, now, over two years, are merely one of his relaxations from TU calculations and struggles with quadruplex balances.

The Causes of Poor Tone Quality

How to Systematize the Search for and Remedy the Causes of Distortion in Radio Receivers

By EDGAR H. FELIX

THE radio listener may, with the aid of modern amplifiers and reproducers, secure tonal quality which is little short of perfect. Advances made this last twelvemonth have lifted radio reception from near-mediocrity to such a standard that it is possible to reproduce music difficult to distinguish from the original. The full force of this statement, however, cannot be realized unless one has opportunity, over a period of hours, to compare a last year's receiver with the best kind of modern equipment. For this purpose, switches must be installed so that one may change from an inferior amplifier system to a modern one without the loss of an instant. After such a test, there are few listeners who would be content with anything less than the best reception attainable.

In general, distortion arises either from improper operation and adjustment of the receiving set and its associated equipment, or from imperfect design of parts in the set itself. When improper operation or adjustment is the cause the trouble may lie almost anywhere in the radio receiver. Given a high-grade amplifier system and a loud speaker adequate to handle the output of the receiver, distortion may yet exist because of failure to work within the power or voltage limitations of one or more parts of the receiver. The most frequent cause of curable distortion is overloading of vacuum tubes.

Any judgment formed must be based only upon the reproduction of high-grade broadcasting stations. Not more than ten per cent. of the broadcasting stations on the air exercise sufficient care in the placing of their artists before the microphone, in the adjustment of the input amplifier, and in determining the percentage of modulation, to be classed as being fit to listen to by the owner of a really high-grade receiving set capable of true reproduction.

Overloading may arise in almost any part of the radio receiver. Briefly, it is manifested by blurred, ringing, or harsh effects, particularly noticeable on loud signals. A receiver so overloaded but otherwise satisfactory, gives high-grade reproduction when tuned to nearby stations which deliver a strong signal providing the volume is so adjusted that the music is only quietly and softly heard. Under those conditions, a good receiver gives adequate amplification of low, middle, and high registers, meeting all the requirements constituting good quality. Yet, when volume is increased, displeasing distortion may occur. Oftentimes, this kind of overloading may be corrected by adjustments.

DISTORTION ARISING IN THE R. F. AMPLIFIER

THE first point of distortion which we will consider is that occurring in the radio-frequency amplifier. Distortion in this part of the receiver is not always due to too powerful a signal but frequently to the influence of regeneration. It may be present, therefore, even though the signal itself is weak. Appreciable regeneration in the radio-frequency amplifier is fatal to good quality because it cuts off the high frequencies and causes the lower frequencies to be drummy and ringing.

No matter what the circuit used, good quality cannot be expected if the radio-frequency amplification is mainly regenerative. With the

most modern receivers, sensitiveness and volume may be controlled by a means of varying the gain in the radio-frequency amplifier. With such receivers, it is not difficult to determine if distortion is due to overworking of the radio-frequency amplifier.

Tune to the most powerful nearby station, and then weaken the signal to moderate volume, at the same time observe the quality carefully. Now tune-in a station at a moderate distance which is delivering considerably less energy than the first station. For instance, if the first station is a 500-watter, twenty-five miles distant, pick a second station of equal power forty or fifty miles away. Then, by adjustment of the radio-frequency amplifier control, bring the volume of the second station up to the same point of moderate volume as the first. Provided the quality of



READERS of RADIO BROADCAST have made so many requests for specific information as to A and B power devices, tubes, single-control sets, and the various other subjects treated in this series of practical articles on how to select and judge the quality and performance of manufactured products, that we have arranged to make it more convenient to take advantage of the information which we can make available.

If you are interested in learning of manufactured products, embodying the features of high-grade tone quality, mentioned in this article, and the one which preceded it, address the Service Department, RADIO BROADCAST, Garden City, New York, and the necessary information will be sent to you. Preferably use one of the two forms below in wording your letter or postal:

(1.) I desire to convert my receiver into one giving the best tone quality. Please send me information as to suitable apparatus which will accomplish this purpose.

(2.) I desire information as to manufactured receiving sets which give the high-grade tone quality described in the series of articles on that subject in the July, August, and September issues of RADIO BROADCAST.—THE EDITOR.



transmission of both stations is equal, there will be a marked falling off of quality with the more distant station because of the regenerative influence. An additional stage of radio-frequency amplification, or limiting reception to only nearby stations, is the cure for this condition.

It must not be assumed that absence of a regeneration control implies that no regeneration occurs in the receiver. If stations, particularly distant ones, fall into tune with a hiss and give good quality only when tuned-in exactly, but distort badly if de-tuned slightly, the regenerative effect is likely to be present. The result is that the "highs" are lost and the "lows" are drummy and throaty.

One source of regeneration, both in the audio and radio amplifier, arises from inadequate bypassing and failure to keep the radio and audio signals out of the plate potential leads. This may be caused by magnetic coupling between transformers or by conductive coupling in the power supply leads. The latter difficulty is obviated by the use of choke coils in the plate supply leads and adequate bypass condensers to shunt the radio- and audio-frequency currents.

This precaution of adequate choking and bypassing is usually neglected in home-built receivers.

The high-grade manufactured receiver of 1927 employs three and four stages of fully shielded radio-frequency amplification. Its range is likely to be little more than that of the home constructor's receiver with one stage of radio frequency and a regenerative detector. It may deliver but little more signal to the detector than does the delicate receiver of the home constructor. The principal advantage of the four-stage r. f. receiver is not greater efficiency, but the fact that every element in it has a capacity far in excess of that which it is called upon to exert. Under all conditions it operates far below the overloading point. Similarly, a small four-cylinder automobile covers the ground just as rapidly and carries just as many passengers as a powerful straight-eight. The latter's reserve power, however, gives a smooth, gliding power, impossible with the small, four-cylinder car. Reserve capacity, in the case of a radio receiver, means a realistic tone with all the necessary volume variations between soft and loud to portray the varying feeling of musical compositions.

OVERCOMING DETECTOR OVERLOADING

THERE is a different form of overloading possible with high-gain radio-frequency amplifiers when too powerful a signal is offered to the detector tube. For example, home-made super-heterodyne receivers, equipped with a volume control only in the audio system (particularly if fed by an outside antenna) may overload the detector because too powerful a voltage is delivered to the grid of this tube. When the radio-frequency system is equipped with a volume control, usually through a filament rheostat in the first stage, no trouble is encountered from this source because it is possible to keep the volume below the point where the detector or audio stages overload. In absence of this well nigh essential control, reduce the signal input by considerably shortening the antenna. If a long antenna is considered necessary for distance work, install both a long and a short one, employing the latter for enjoying nearby stations.

Two stages of radio-frequency amplification, so neutralized that there is no regenerative amplification, require a fair sized antenna to produce a good signal, even from nearby stations. Three tuned stages of radio-frequency amplification work satisfactorily with a small, indoor antenna, while four stages pick up sufficient signal to work from a loop.

The use of a C-battery detector in preference to a grid leak and condenser, somewhat increases the handling capacity of the detector tube and reduces the danger of overloading, due to excessive radio-frequency energy. The best results are attained if the audio amplifier system is sufficiently good to give normal loud speaker volume when the detector signal, as heard in the phones connected in the detector circuit, is so weak as to be practically inaudible. Under those conditions, reception from a good station is characterized not only by absence of noticeable distortion but by great variations in volume following those existing in the original music.

When, however, the signal heard in the detector circuit with a pair of phones is comfortably loud, it is quite likely that at least the second stage of audio-frequency will be overloaded, unless a tube capable of handling considerable power and with correct plate and grid voltages is used.

The recommended C-battery voltages must invariably be used if overloading is not to be experienced even in the first stage, a precaution frequently neglected.

The same principle applies to power tubes. Generally speaking, the higher the amplification factor, the smaller the variation in grid voltage which may be impressed upon it without overloading. For example, the 112 (cx-312) type gives higher amplification than the 171 (cx-371) both of which, incidentally, may employ the same plate voltage. If powerful signals from nearby stations overload a 112 (cx-312) tube, the substitution of a 171, using proper grid biasing voltage, will very probably overcome overloading.

The output stage, to give a comfortably loud signal in a good sized living room, must employ a 371, a 310 tube, or perhaps, two 112 tubes in parallel. The 120 tube is of sufficient power to give satisfactory music only in a small room, unless used in connection with an amplifier which neglects the lower tones. When such semi-power tubes, rather than power tubes, are used, it is simply a matter of operating the set at low volume to attain good quality.

It is not often realized that the improvement of the audio-frequency system of a receiver by the substitution, for example, of three stages of resistance coupling for two poor transformers, or by the use of the highest grade of transformers now available in preference to a pair of low or medium priced transformers, means that the power handling capacity of the audio system, tubes and reproducer, may be easily exceeded. If, by this process of renovation, the lowest frequency amplified is brought from 200 down to 125 cycles, the voltage swings in the audio system may increase fivefold as a result. The hum from a poor-filtered power supply is now easily audible. The output tube and the reproducer, which might have been satisfactory under the old conditions, may overload considerably when better transformers are installed. By substituting, for the 120, a 371 or 310 output tube, satisfactory reproduction of low tones is secured. It must be said here that no receiver employing a 201-A type tube as the second audio amplifier is capable of quality reproduction. It is bound to overload and distort.

Quality of reproduction requires that every link in the chain—radio-frequency amplifier, detector, audio-frequency transformers, tubes in the audio stages, and reproducer—be adequate to do its work. Improvement of any one part of the receiver may simply uncover other weaknesses.

REPRODUCER PROBLEMS

A POOR loud speaker usually fails to reproduce a wide scale of frequencies, missing either "lows" or "highs." When a 171 or a 210 (Cunningham 371 or 310) tube is used, an output transformer, or choke and condenser, should be employed so that the direct-current component of the plate current does not pass through the loud speaker winding. This is absolutely essential. The coupling device must be carefully engineered. Listeners still using the old diaphragm type of speaker with the short narrow necked horn need not expect good reproduction because such a horn cannot release the lower tones properly. Cones of small diameter give good reproduction of the high tones but are incapable of setting up the lows. Again we must realize that distortion in the radio-frequency amplifier, or

that overloading the detector, audio stages, or loud speaker, is fatal to true reproduction and is best cured by strengthening the weak link or maintaining the receiver at gentle volume.

One of the most difficult causes of distortion for the receiving set owner to analyze for himself is the kind which creeps upon him gradually. When the receiving set is first installed, it may give amazingly good reproduction but quality may fall off so gradually that this deterioration does not attract the attention of the listener. This often occurs because the voltage of the power supply falls or amplifier tubes lose their emission or A batteries run down. With socket B power supply, gradual deterioration of the rectifier tube may bring this trouble. B batteries used too long bring about the same result. Amplifier tubes themselves are often used unconsciously long after their emission has fallen below the point where they carry the low tones without distortion.

RESONANCE PEAKS AND THEIR CONTROL

DISTORTION is sometimes of the resonant variety, that is, confined to a particular frequency rather than spread over a wide range. This is particularly true of horn type loud speakers or poor transformer-coupled audio amplifiers. When the loud speaker is on top of the cabinet, it frequently causes the cabinet to be vibrated mechanically and that, in turn, causes the tube elements themselves to vibrate, producing distortion due to mechanical resonance of tubes, etc. If the loud speaker is moved twenty feet away from the set, the mechanical energy of the sound wave imparted to the tubes is reduced to a minute fraction.

Microphonic tubes usually have a characteristic ringing sound fairly familiar to the listener, and moving the loud speaker some distance from the set often prevents a continuous "sing" produced by mechanical resonance. Sometimes this cure is inconvenient to apply and less troublesome means may be successful. First try changing the tubes about in different sockets, giving particular attention to the detector tube.

Tap each tube lightly and see which one causes the most ringing noise. Frequently the microphonic tube may be identified in this way. Exchange that tube with each of the other stages until the trouble is minimized. With dry cell tubes, it often pays to wrap a cloth around the detector tube or, better yet, to use one of the weighted arrangements or vibration dampers made for the purpose.

A convenient expedient is to hang the reproducer from the moulding so that it is mechanically free and clear of wooden floors and furniture. Plaster walls do not transmit the frequencies to which cabinets resonate nearly as readily as do tables and floors.

Super-sensitive detector tubes often introduce the resonance type of distortion and this effect may frequently be minimized by burning the filament rather brilliantly.

Those who read the article in last month's RADIO BROADCAST on quality of reproduction should have no difficulty in detecting the absence of either "highs" or "lows." Whatever the kind of amplifier the home constructor likes, transformer, resistance, impedance, or combinations thereof, it is entirely possible to secure relatively perfect reproduction. A loss of a broad band of frequencies, if no regenerative or resonant effects are present, almost invariably points to an incapable reproducer or the use of coupling devices which give a filtering effect.

The experimenter who takes pride in the manipulation of a delicate, efficient, and sensitive receiving set is most likely to neglect tonal reproduction. Experiment is usually concerned with problems of efficiency—getting the greatest distance, the best possible selectivity, or the highest gain with the minimum number of tubes. The attainment of these objectives is in opposition to securing true tonal quality. More than half of those answering a recent questionnaire maintain two or more sets, one for experimental and long-distance purposes and a receiver for local high-grade reception which meets, or attempts to meet, the modern standards of good tone quality.



RADIO BROADCAST Photograph

CONCOMITANTS OF GOOD QUALITY

The use of power tubes, together with good reproducers, is essential if good quality signals of adequate volume are desired. The photograph shows a baffleboard "Peerless" cone and a Western Electric cone, together with a 171 type power tube

New Receiver Offerings for the Fall

What the Radio Industry Has in Store for the Set Builder—Advance Information about the Hammarlund-Roberts, LC 28, Silver-Marshall Line, Infradyne, Aero Products Kit, Loftin-White, Strobodine, and Others

By THE LABORATORY STAFF

DRUM tuning controls, complete shielding, and high-gain radio-frequency amplifiers will be the predominant trend in kit receivers available to home constructors this fall. All of the new kits also provide for the use of power tubes in the output stage so that good quality can be obtained, and in many cases it is possible to operate the receiver either from batteries or from alternating current, using, in the latter case, a.c. tubes or special rectifier tubes with the filaments of the tubes in the receiver connected in series. Many modern kit receivers are the equal in every respect of much more expensive manufactured sets in the same class, and because of the many kits to be available this coming season, the home constructor will have a wide choice of different types and will doubtless find some one kit which meets his own needs particularly well.

One of the most popular kit receivers of 1927 was the Hammarlund-Roberts "Hi-Q," so it is interesting to note that a new Hi-Q receiver has been developed for the fall. This new "Hi-Q" receiver will contain three stages of tuned radio-frequency amplification, using automatic coupling variation between the primaries and secondaries of the radio-frequency transformers. All of the radio-frequency stages will be carefully neutralized by the Roberts method and the receiver will be completely shielded by the use of a Van Doorn metal sub-panel and heavy aluminum interstage shields. The set has been designed so that most of the wiring may be done beneath the sub-panel, and the final appearance of the receiver is thereby improved. The tuning of this new "Hi-Q" receiver is accomplished by a unique drum control which has not the slightest amount of backlash and which is illuminated by means of a small flashlight bulb placed above the indicator. The drum is actually in two sections, each section controlling two of the variable condensers. Radio-frequency choke coils and bypass condensers are used in each radio-frequency stage and likewise in the plate circuit of the detector tube, so as to prevent coupling in the power supply. The audio amplifier will consist of a two stage transformer-coupled unit with an output filter in the plate circuit of the power tube.

The LC28, which will be featured by *Popular Radio* during the fall, will contain three completely shielded radio-frequency stages so designed that they cannot oscillate. The receiver will be tuned by two drum controls one controlling the antenna circuit and the other controlling a gang condenser which tunes the other two stages. The radio-frequency amplifier and detector have been designed as a single unit which will be described in *Popular Radio* in a preliminary article. Later articles will then tell how to use this high-gain radio-frequency amplifier with several different audio amplifying systems. The set will be engineered so that it can be operated from batteries or from a.c., using alternating current tubes in the latter case. An unusual feature about the receiver is that it is laid out in such a manner that very short leads are pos-

sible and the complete wiring can be done with slightly less than five feet of wire. Also, the receiver will be so designed that it will give satisfactory operation using no outside antenna but merely a very short indoor antenna, or the ground system may also be used as part of the antenna system.

The Silver-Marshall Company will place before home constructors three kits, including an improved design of the shielded six, which proved so popular last year. The receiver will be tuned by means of a new type drum control and will be designed to operate on either a.c. or d.c. Silver-Marshall will also market in kit form a four-tube receiver designed for a.c. or d.c. operation. The third Silver-Marshall unit presents essentials for a super-heterodyne, a description of which appears elsewhere in this issue of *RADIO BROADCAST*.

Many improvements are evident in the new 1928 model of the Infradyne receiver which was featured by *Radio* during the season of 1927. The new model will be tuned by two large drum dials and there will be two supplementary controls, one for adjusting the volume and the other for adjusting the sensitivity. A special filament switch is used and wired so that in one position all the filaments are turned off and when in the center position the filaments of the radio-frequency, audio-frequency and detector tubes are lighted while the tubes in the special Infradyne amplifier are automatically cut out. When the filament switch is in the third position all the tubes are lighted and the complete receiver is in operation. A single turn of this switch therefore makes available a five-tube single-control tuned radio-frequency receiver for those who desire extreme simplicity, or a ten-tube Infradyne offering high sensitivity and selectivity. The audio amplifier will be a two-stage transformer coupled affair with an output transformer. The receiver is so designed that very little wiring need be done above the sub-panel.

Aero Products, Incorporated, have done considerable work on a new seven-tube receiver to be put out in kit form and which will contain three stages of tuned radio-frequency and three stages of resistance-coupled audio-frequency amplification. This receiver will be somewhat unique in that no shielding will be used, the new Aero coils having been designed so that they are rather long in comparison with their diameter, this causing their magnetic fields to be quite closely confined; as a result, it is possible to make up a high-gain radio-frequency amplifier without the use of shielding. The set will measure about 22 inches long and it is understood that it will be engineered for a.c. operation.

The Loftin-White receiver, after enjoying a popular year in 1927, will be slightly redesigned and placed among the kits available in the fall. Very few details regarding the receiver are available but it is understood that the receiver will very likely be an a.c. model with single control and shielding.

Super-heterodyne fans will find much interest in the new Strobodine, an eight-tube set using a new type of frequency changer which causes the

circuit to function very much like a super-regenerative receiver. In practical operation it will be found possible to receive a station at only one point on the dial, a feature in which this receiver is different from many other super-heterodynes, in which stations can always be picked up at two adjacent points. The new Strobodine will contain one stage of radio-frequency and three stages of intermediate-frequency amplification and a two-stage transformer-coupled audio amplifier with a choke condenser combination in the output of the power tube. The tuning will be controlled by two main dials but there will also be several supplementary controls consisting of one potentiometer, three rheostats, and a volume control. The radio frequency stage and first detector stage will be operated by a single dial and the oscillator will be operated by the other main dial. The receiver will be carefully shielded with three individual stage shields.

Incidentally, we might mention here that an article is at present being prepared by the laboratory staff describing the various super-heterodyne kits now being sold. This article will shortly appear and should prove very interesting because it will be crammed full of valuable dope on many super-heterodyne receivers.

The Arthur H. Lynch Company has designed a unique unit which should prove to be unusually popular because of its adaptability to many different circuits. Briefly, the unit which they have developed consists of five tube sockets mounted on a bakelite panel measuring about 6" x 12". Four of the sockets are arranged along the rear part of this small sub-panel and one socket is placed in the center toward the front. There is on the sub-panel, besides the sockets, three resistance-coupled amplifier stages which are wired into the circuit when the assembly is purchased. We therefore have a unit consisting of a complete resistance-coupled amplifier, a socket for a detector tube, and a fifth socket in the front part of the panel for a radio-frequency tube. The home-constructor may then use any r. f. and detector circuit which he prefers and will find space on either side of the r. f. tube socket for the placement of the necessary coils and condensers. The unit may be used as part of a receiver with a 14" or 18" front panel.

Besides the kits which we have mentioned above, there will be several others on which no detailed information was available at the time this article was written. The Karas Electric Company is working on two kits which will incorporate the "quamatic" system, featuring automatic coupling variation. The Bruno Radio Corporation and the Grimes Radio Engineering Company are also designing new kit receivers for the fall but no information concerning their characteristics is available. It is also likely that a new Browning-Drake receiver will be designed. The Radio Receptor Company, Incorporated, will continue to sell the kit which they manufactured last year, which consists of three stages of tuned radio-frequency amplification, a stage of reflexed audio, and two straight audio stages.

Suppressing Radio Interference

Practical Hints on How Radio Interference May be Minimized With Actual Data on How It Has Been Accomplished in Numerous Cases

By A. T. LAWTON

NOTWITHSTANDING the fact that we have really good broadcasting stations and radio receivers of high quality, a surprising number of broadcast listeners are deprived of normal reception because of local outside interference. This interference may take the form of harsh nondescript noises, so-called "static," crashing, buzzing, clicking noises, etc., which either mutilate the program or blot it out altogether.

Almost any piece of electrical apparatus is a potential source of disturbance to the radio receiver. Wherever an electric spark is formed, waves of high-frequency electrical energy are sent out. They are identical (though untuned and uncontrolled) with those emitted from the broadcasting station. Consequently, they are picked up by the radio installation and amplified in the same manner as radio music or speech. There are two different methods of suppressing the interference due to sparking electrical apparatus. One is to eliminate the spark by discarding the apparatus or by placing it in a condition so the spark will not occur. The other is to confine the electrical waves set up by the apparatus to a very small area and thus prevent interference to reception of radio programs. The following paragraphs, and other articles of this series which will appear in RADIO BROADCAST from time to time, will give definite data on the various causes of interference and, in most cases, the solution of the problem. These data were collected over a period of two and one-half years, during which a 6000-mile patrol with a radio-equipped car was made, taking in the combined interference of more than one hundred and thirty-two towns and cities.

OIL BURNING FURNACES

THE problem of interference from the oil-burning furnace is a most important one today and will be discussed first. Certain types of oil-burning furnaces will interfere with reception one block or more distant. At close range they will probably put the set out of business for whatever period the electrical ignition system is functioning.

We say "certain types" of burners because there are many types on the market, and no two seem to act alike, especially when suppressive measures are being considered. Any oil-burning furnace which has its ignition system covered in several enclosures of metal and has all its associated wiring run in conduits, will cause a minimum of interference. This is a condition obtaining only occasionally; the majority of furnaces cause a lot of radio noise.

The fact that the ignition of some furnaces

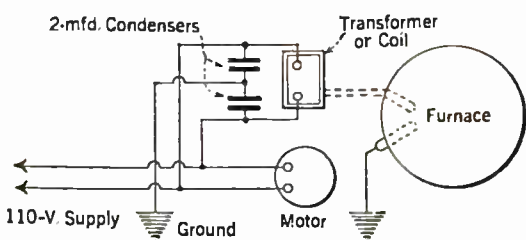

FIG. 1

RADIO BROADCAST published some of the first articles which appeared in the technical press dealing with the reduction of man-made or "artificial" interference. These were written by A. F. Van Dyck of the Radio Corporation of America and appeared in this magazine for April, May, and July, 1924. This article, the first of a pretentious series, includes some of the material covered by Mr. Van Dyck, and also a large amount of additional definite information of immeasurable practical value to the man faced by an interference problem in his own locality. Every conceivable source of interference is noted in these articles. The treatment is intensely practical, for Mr. Lawton has crystallized here the results of his work for two and one half years in more than 132 cities.

—THE EDITOR

operates only for ten seconds each time the furnace starts does not help matters. Eight such installations were recently investigated in less than one block on the same street. Being of the thermostat control type, they started up and stopped at frequent and irregular intervals. The combined interference made reception in the whole district unsatisfactory. Three other furnaces in the same town were fitted with continuous type ignition system, *i. e.*, the spark coil operated for fifteen minutes or more at a time

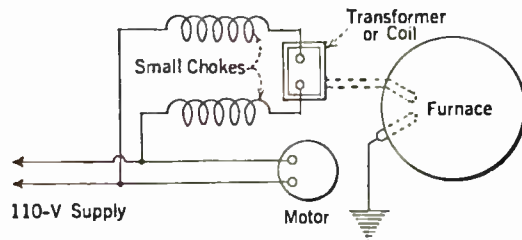

FIG. 2

and did not shut off automatically after lighting the gas. This type is a bad offender.

In considering methods of interference elimination it should be noted that two types of ignition coil are in general use. The first, an ordinary spark coil with vibrating contact, and the second, a straight 100 to 1 ratio transformer giving 11,000 volts on the secondary and operating directly off the 110-volt supply. The former creates much more disturbance than the latter.

While interference from the motor on the oil

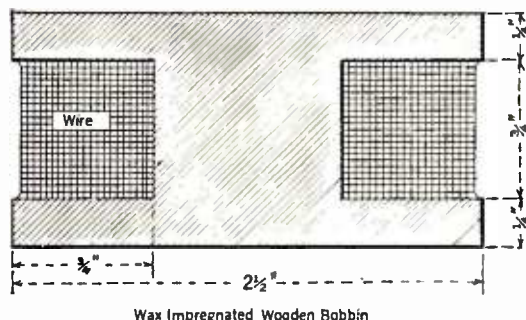

FIG. 3

burner is possible, in most cases the major disturbance is confined to the high-tension spark. For this reason it is usual, when installing apparatus to eliminate the radio interference, to concentrate on the spark coil, or transformer circuit, rather than on the main 110-volt supply lines.

The first and most promising method is to bridge the transformer primary with two 2-mfd. condensers connected in series, with the mid-point grounded. The interference from five furnaces has been entirely eliminated by this arrangement, shown diagrammatically in Fig. 1. Thermostats, control wires, etc., have been omitted in this diagram for the sake of simplicity. The following points should be noted:

- (1) Connection of the condensers is made as close to the coil as possible.
- (2) Keep the ground wire short; if it is abnormally long, elimination of the interference is not complete.
- (3) Two 500-volt condensers are used (costing about \$2.00 each). We are dealing with a 110-volt circuit but the surge causing radio noise may be many times this voltage—sufficient to puncture a low voltage condenser.
- (4) The capacity of the condensers should be at least 2 microfarads each. One-half or one-microfarad condensers are not usually effective.
- (5) Ground connection to the furnace itself may prove more effective than direct connection to, say, a water pipe.

Another method is shown in Fig. 2, where small choke coils are substituted for condensers. The current in the coil primary circuit varies from one ampere to two and one-quarter amperes according to the type of manufacture, and in winding the choke coils, wire of sufficient size to carry this current without heating must be used. For intermittent service, No. 18 d. c. c. wire may be employed; for the continuous electrical ignition type it might be as well to use No. 16 d. c. c. since, in a narrow coil wound ten or twelve layers deep, the radiating surface is small.

Approximately one hundred and thirty turns are required on a wooden bobbin of the measurements given in Fig. 3. No particular effort need be made to have this winding done neatly in regular layer fashion, as jumble winding is usually just as effective as straight winding.

Taken by itself, while not usually as effective as the condenser method, the choke coil method becomes an important factor in obstinate cases. Several furnaces failed to respond to either of the foregoing arrangements but all interference caused by them was successfully obliterated by a combination of the two, as shown in Fig. 4.

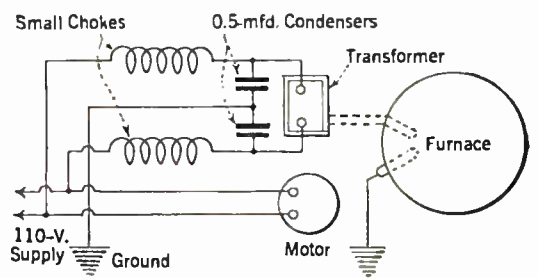

FIG. 4

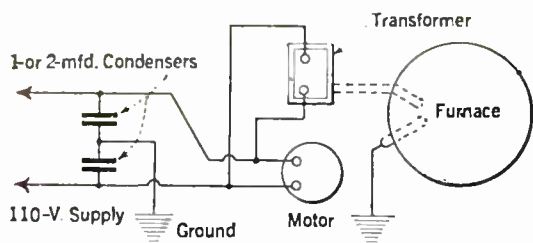

FIG. 5

It will be noted that 0.5-mfd. condensers are used instead of the two-microfarad capacity type. Care should be taken to see that the condensers are attached to those leads of the choke coils which are connected to the spark coil or transformer. Attaching them to the opposite, or supply line, end, is of practically no value.

One might imagine that this "surge trap," incorporating as it does, the merits of two methods, would be an all-round more efficient eliminator. As a matter of fact it is not necessarily so. Certain furnaces which respond to the choke coil method again become noisy when condensers are attached, and the only sure check is to try each method individually.

We now come to those cases where interference is caused by the furnace motor as well as by the ignition spark. In this instance, we apply the above methods to the main supply lines with condenser and choke values altered.

Fig. 5 shows an arrangement which has proved successful on several furnaces fitted with the straight transformer coil. This circuit is electrically the same as that given in Fig. 1, the difference being that the condensers are connected close up to the motor instead of near to the transformer. This condenser method did not work in every case, however, as two furnace installations were found in which the addition of the condensers only increased the trouble.

Choke coils wired as shown in Fig. 6 and of the specifications shown in Fig. 7, entirely eliminated the interference from these two offenders; adding condensers brought all the trouble back again, so these latter were dispensed with.

Fig. 8 shows a method which may be applied to the main supply lines, No. 12 wire chokes being used. This method has been found necessary in certain cases.

Practically all furnace motors operating on 110-volt circuits draw a current of 5 amperes. Allowing 2 amperes for spark coil consumption we have a total current of 7 amperes to handle. On first consideration No. 12 wire may seem unnecessarily large but when the necessary reduction in current-carrying capacity is made for layer depth in winding and proper heat radiation it will be seen that only normal precautions are taken to ensure a reasonable factor of safety.

Tests carried out with single-layer coils, *i. e.*, 100 turns of wire wound in a single layer along a tube $3\frac{1}{2}$ inches in diameter, were not conclusive. Complications rendered the findings void and the dimensions of the completed surge trap were such as to make its use objectionable.

The data on bank wound coils, as applied to furnaces, are also incomplete though some tests have been carried out with satisfactory results. For intermittent current under 8 amperes, however, little can be gained by substituting banked coils for jumble winding unless it can be determined that, in the former, a smaller quantity of wire can be used with equal results.

PLACING THE COILS CORRECTLY

BEFORE going any further we should stress a point, the importance of which is often overlooked. Let us suppose that you have eliminated the trouble by one of the choke coil methods, say Fig. 6. In this case you have deliberately or un-

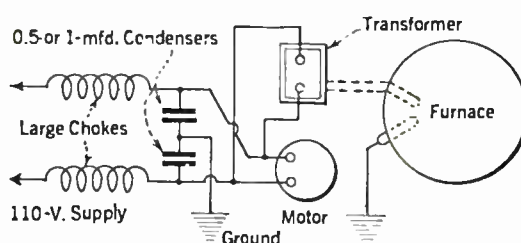

FIG. 6

consciously made the right connections and placed the proper coil faces together. For the sake of compactness it is usual to install these chokes one on top of the other in a standard metal outlet box, and by simply turning one coil over we may bring back the interference sixty per cent. or more although the connections remain unchanged.

Contradictory results in actual practice indicate that so far as furnace installations are concerned no specific method of connection will suit all cases, so if interference elimination is not complete on first trial, then lay the two flat coils face to face and turn the top one over. If this does not produce the desired result reverse the leads of one coil only and repeat the turning test.

You are not so likely to run into this trouble if the inside lead of one coil and the outside lead of the other be connected to the furnace and the two free ends to the 110-volt supply line, but if two inside leads are connected to the furnace and the two outside leads to the line, or vice versa, and both coils are wound in the same direction, then the "turning" test may be necessary.

The reason for this little complication, which, by the way, has caused some investigators to abandon their experiments on the brink of success, is that in one setting the flux of one coil "helps" that of the other, but when the top coil is turned over, both are, as electrical men say, "bucking" or opposing. Just whether they should "help" or "buck" is a question more likely to be settled by the individual furnace than by any other authority. Different installations give different results, but in all cases one or other of the settings proves effective.

Paradoxical as it may seem, all this care and attention to coil positions, etc., proved unnecessary in three instances; the furnace interference in these three cases was reduced to zero when coils were installed in the lines, regardless of the manner of connection or relation of one coil to the other. This is quite in keeping, however, with the whims and vagaries of radio interference.

Perhaps we should condition the statement made a little while ago that "in all cases, one or other of the settings proves effective." This is literally true so far as the ignition systems under discussion are concerned, but in the course of extended patrol one occasionally meets the old belt driven magneto type ignition. Some day it may yield, but so far, all efforts to eliminate its interference have failed. The best method we can suggest now is to take it out and substitute a transformer with surge traps.

High tension leads on modern type furnaces are comparatively short and do not need any particular attention, but on older types, where

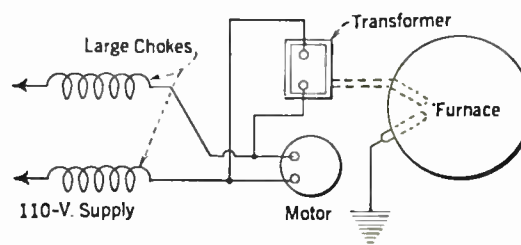
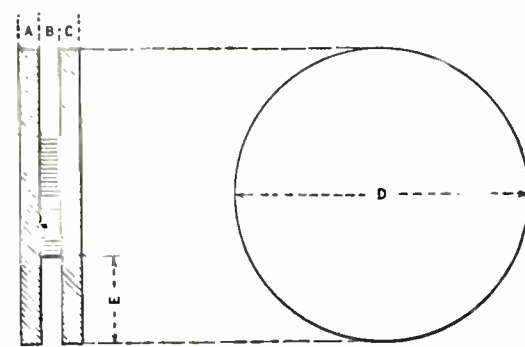

FIG. 8



110 Turns No. 12 D.C.C. Wire on Wax Impregnated Hardwood Bobbin. Winding Groove $\frac{1}{8}$ " wide, $2\frac{1}{2}$ " deep; A, B, C, $\frac{1}{2}$ " each; E, $2\frac{1}{4}$ " D, $7\frac{1}{4}$ ".

FIG. 7

the lead to the spark plug is two or three feet long, it may be necessary to run a metal pipe, of say, one inch diameter, over this to shield it, first of all running a piece of rubber hose over the high tension lead. The latter precaution is taken not altogether for the sake of insulation but to increase the distance from the wire itself to the metal shield so that there is less probability of foundering the spark energy. In most cases grounding this shield increases its efficiency as an eliminator.

Oil burning furnaces, as a rule, are hooked up to the electric supply lines by an ordinary cable and bayonet plug-receptacle fitting. If for any reason the circuit is opened here in the course of making tests the plug and receptacle should be carefully marked so that the plug is inserted the same way in the receptacle each time it is replaced.

Remembering that one side of this line is grounded and "dead" and the other side very much alive, you will appreciate the desirability of guarding against the introduction of unnecessary complications. As a test, however, there is no objection to reversing this plug during experimental work to find out if, in conjunction with the surge traps, a reversal of the supply leads has any beneficial effect.

The first thing to do when setting out to clear up some determined source of interference is to talk the matter over with some man in the electrical business, preferably one conversant with radio, and get an estimate of the cost of making up the necessary filter coils. If you do not care to stand the whole expense personally, interview the furnace owner and ascertain if he is willing to meet you half way. In a good many instances you will find that the owner, once he is made aware of the disturbance unconsciously created, will gladly shoulder the whole or part of the expense.

A more equitable apportionment of the costs, however, is desirable; we must remember that the neighbor is just as much entitled to run his furnace as we are to run our radio receivers. In a recent instance, twelve radio fans in the immediate vicinity of an offending furnace were approached on the question of furnishing the necessary interference elimination apparatus and all but two agreed to a division of costs. The installation came to six dollars; for sixty cents each they rid themselves of an aggravating interference that spoiled winter evening reception for a previous three years.

ELECTRO-MEDICAL THERAPEUTIC APPARATUS

BBROADCAST listeners living in the vicinity of a hospital are quite familiar with the class of interference generated by high-tension electro-medical treatment machines. Even the humble violet ray for home treatments can spoil reception over a radius which will include a large number of residences.

Larger machines, as used by medical men, can

be distinctly heard a distance of eight city blocks, and in the near vicinity radio interference is extremely heavy. When this is multiplied by the number of machines in every city, it becomes obvious that the total interference from this source alone is serious.

Details and particulars of the various types in common use would serve no useful purpose. Ninety per cent. reduction of interference caused by one of the small machines was obtained by inserting 100-turn banked choke coils of No. 16 d.c.c. wire in each line near the machine, and bridging the circuit with condensers. This large percentage of reduction was not evident in the same building, only forty per cent. reduction being noted here, but in the neighboring residences, only a short distance away, practically all the noise had disappeared. A second machine, closely resembling this one but of greater power, failed to respond sufficiently to this treatment to warrant the expense of installing a surge trap.

So far as the larger apparatus is concerned we have experimented with every known surge trap connected at the machine, where preventative measures usually are most effective, and without exception, all proved useless.

The reason is obvious. If, while walking in a room where one of these machines is being operated, you place your hand near a radiator or lamp fixture or any piece of metal, grounded or ungrounded, sparks will pass from your body to the metal, and vice versa. The whole atmosphere is charged with electricity as also is the water piping, gas piping, metal fixtures, etc. And by the same token the electric lighting wires are charged, all the more because they are directly connected to the offending apparatus, and interfering surges set up are carried out over the distribution system.

It is hardly possible to clear up this interference to the satisfaction of broadcast listeners in the immediate vicinity, say within 100 feet, but it can be stopped from radiating very far beyond, an actual case on record proving this conclusively.

The necessary choke coils in this case are connected, not at the machine, but in the residence main supply lines, preferably at the meter. No condensers are used. Condensers in any combination, in the particular case referred to, brought all the interference back after it had been cleared up with choke coils alone.

Coils for the purpose should be bank wound, three layers deep, and should consist of 150 turns of d.c.c. copper wire on a 3½-inch tube of insulating material. See Fig. 9.

It must be remembered that these coils are required to handle the house load, not merely the current drawn by the therapeutic machine, and the size of wire used will be governed by this. It will probably be No. 8 or 10, B. & S. gauge.

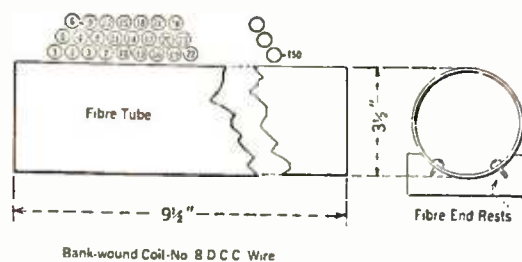

FIG. 9

Allowance is not made for electric cooking ranges or fireplace coils as these are usually on a separate circuit. If their associated wiring runs close by the lighting mains, however, it is desirable to separate them or else introduce additional heavy coils.

This interference reaches near-by listeners in two ways; first, by radiation from the surges set up in the city distribution wires, and second, by direct radiation from the source.

Preventive measures already described take care of the first channel; direct radiation can only be reduced by shielding the offending apparatus with a metal screen. More interference comes from the high-tension flexible cables than from the coil or vibrator itself, so that shielding of the vibrator proper has no beneficial effect.

We find too that any amount of metal screening in close proximity to the equipment interferes with free use of its various parts by the operator, and the only satisfactory way to get around this problem of direct radiation is to shield the entire room with a metal screen, an expensive arrangement but one which is more or less common in up-to-date hospitals where X-ray machines are in daily use.

X-RAY EQUIPMENT

THERE is a marked difference between the sound characteristics of X-ray interference and that propagated by the apparatus just discussed. High-frequency treatment machines give rise to an indefinite "mushy" noise—more or less of a blanketing interference—while that from the X-ray is more in the nature of a hard buzzing.

Where a rotary synchronous rectifier is used you can safely count on the installation setting up violent interference. In fact, it constitutes a good, healthy wireless transmitter and interferes, to a greater or lesser extent, all over a small town. In addition to the spark disturbance several cases are on record where the motor driving this rectifier caused enough trouble to bother reception within a radius of 300 feet.

From theory, we should say that choke coils inserted in the main supply at the house meter would reduce the total radiation though it is questionable if complete elimination can be se-

cured. Preventive measures taken on the machine itself gave unsatisfactory results.

So far as our experience goes, we have never yet gotten any trouble from the X-ray tube itself. Also, two complete installations were checked while operating on full power without any interference being noted. These installations used tube rectifiers instead of rotary synchronous rectifiers.

Possibly old or defective tube rectifiers might give rise to some trouble but no definite case appears on record and the substitution of tubes for the rotary rectifier seems to be the best solution of this problem.

Since the change over from rotary synchronous to tube rectification involves considerable expense, it is our policy to place the situation frankly—and courteously—before the medical men using such equipment, and with very few exceptions all have agreed to refrain from using the apparatus during the evening broadcast hours, or at least, limit its operation to urgent cases which cannot be left over.

DENTAL MOTORS

THERE is every probability of your getting fairly loud radio interference if your radio set is being operated in the vicinity of a dental office.

The motor commonly used is of the universal type, which may be operated off direct or alternating current. It runs so smoothly and silently that sometimes with the naked ear it is difficult to tell whether the machine is running or not, while at the same time radio sets for four or five houses either side of its location experience a high pitched buzzing interference.

Fig. 10 shows three methods of clearing up this trouble; No. 1 does not always prove effective; No. 3 is only required in obstinate cases; and No. 2 will usually do the trick.

A little removable plate at the base of the engine stand gives access to the motor supply leads, and makes a convenient point at which to cut in with surge traps. Water piping runs up the centre of this column also, facilitating good ground connections.

Remember that the coil in (b) Fig. 10, must be inserted in the live side of the line, not the grounded side. The live side is easily found with an ordinary incandescent lamp and socket. One lamp lead is attached to a water pipe or other convenient ground and the free lead touched on the two motor mains in turn; the lamp lights only when touched on the live wire.

Little consideration need be given the second motor usually found in dental offices; we refer to the lathe or "working" motor. Its interference as a rule is negligible and its periods of operation are short.

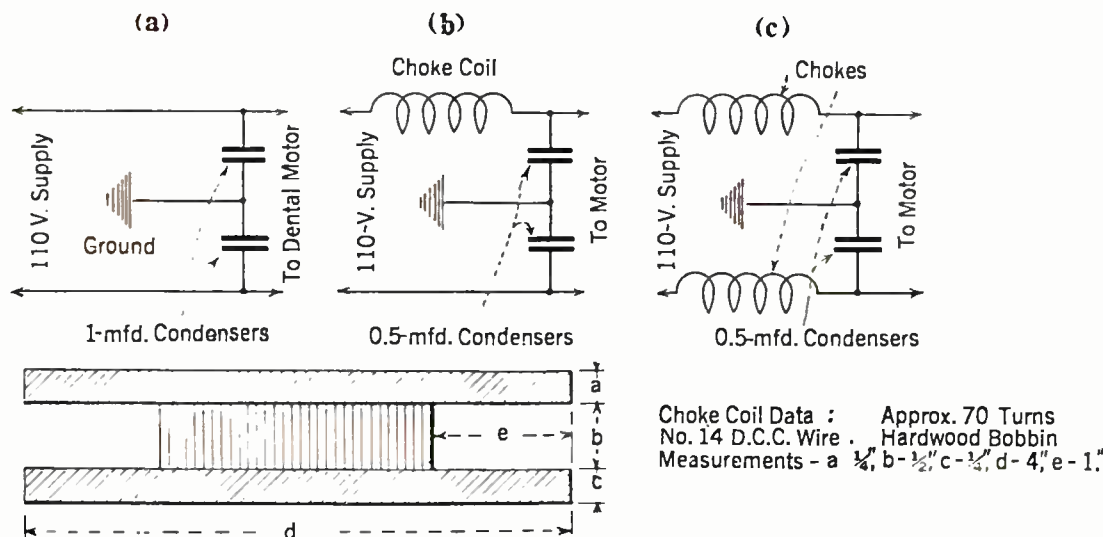

FIG. 10

Choke Coil Data : Approx. 70 Turns
 No. 14 D.C.C. Wire . . . Hardwood Bobbin
 Measurements - a ¼", b ½", c ¾", d - 4", e - 1."

The Three-Element A. C. Vacuum Tube



A Paper Delivered Before the Radio Club of America Which Discusses the Theory Underlying A. C. Operation of Vacuum Tubes



By BENJAMIN F. MIESSNER

Chief Engineer, Garod Corporation

IN A RECENT paper delivered before the Radio Club of America by the author, and printed in the February and March, 1927, issues of RADIO BROADCAST, it was shown that two principal causes for hum are present within tubes of the ordinary types when their filaments are heated with alternating current. One of these is due to the fluctuations of filament temperature with fluctuations of the energizing current, and the other is due to the effect of the positive leg of the filament acting as a plate electrode of periodically varying potential. It was further pointed out and demonstrated that at least one of the commercially available standard receiving tubes, when subjected to the proper operating conditions, would function normally as an amplifier without the introduction of an objectionable amount of disturbing hum. A commercial broadcast receiver, the Garod Model EA, which has a. c. excitation of all filaments except the detector (this latter has a 100 type tube heated by the combined plate current of all tubes), was demonstrated. Control of the two types of hum resulted in the neutralization of one by the other within the tube itself. Numerous curves were shown, which indicate the relation of the hum amplitude to the operating voltages on most of the standard types of receiving tubes. It was also pointed out in the latter paper that the author's experiments with special tubes had demonstrated the possibility of accentuating the desirable characteristics of standard tubes by a tube of new design, which could be used not only in the amplifier stages, but in the detector stage as well, which requires hum elimination of an extremely high order because of the large amount of amplification behind it in the receiver.

The purpose of the present paper is to amplify some points in the previous discussion, which time did not then permit, and more particularly to describe the a. c. tube, which was discussed briefly and which is now being made available through commercial channels, for use as a detector as well as a radio or audio amplifier.

In the author's researches on a. c. filament excitation, it was found that there are three distinct cases, requiring separate analysis and discussion, depending upon the use of the tube so operated. In audio-frequency amplifiers, with which the hum measurements of the first paper were principally concerned, we have one set of conditions. Another set of conditions obtains when the tube is used as a radio-frequency amplifier; and a third, and considerably more complicated set of conditions, are presented when the tube is used as a detector. Here

both the radio and audio effects are present in the same tube, and some very interesting actions have been observed.

HUM IN AUDIO-FREQUENCY AMPLIFIER TUBES

AS BEFORE stated, the previous paper dealt principally with the hum in audio-frequency amplifier circuits. It was shown that the temperature type of hum resulted from the changes in temperature of the filament due to the variable heating current flowing through it. It was shown further, that the degree of the temperature variation is due to what was termed "thermal inertia" of the filament, this "thermal inertia" being dependent upon the ratio of heat storage capacity of the filament, to its heat dissipating ability. The heat storage capacity depends upon the volume or cubical contents of the filament as well as upon its heat absorbing ability, which is called specific heat. This storage capacity may be likened to the electrical storage capacity of a condenser wherein the area of its electrodes compares with the volume of the filament, and its dielectric constant compares with the specific heat of the filament. The capacity in either case is proportional to the product of the two factors. It was shown that the amount of this temperature hum was greatest with thin low-heat capacity filaments, such as those used in the 100 type of tube, and smallest in the heaviest filaments, such as those used in the 112 type of tube. It was shown further, that the amount of temperature variation depended not alone upon the ratio of surface or radiating area to the mass of the filament, but also upon the actual operating temperature of the filament itself. The radiation losses for heat are proportional approximately to the fourth power of the temperature, and inasmuch as these radiation losses are the chief ones to be reckoned with as lowering the filament temper-

ature during periods of small or no current, it is seen that very low temperatures greatly facilitate temperature stability.

The temperature stability of such a filament, with a pulsating heat input occasioned by its alternating heating current, and with a heat output or load consisting chiefly of radiation losses, and partly of conduction losses, depends, as above stated, upon the ratio of its heat storage capacity to its heat dissipating ability. The former has already been defined, and the latter depends upon the operating temperature and the radiating or surface area, neglecting the conduction losses through lead wires. Obviously our problem, in securing high stability, is to obtain a high ratio of storage capacity to dissipating ability.

One method of accomplishing this is to use a filament of round cross-section. This form is to be preferred because the ratio of volume, or storage capacity, to surface, or dissipating ability, is greatest. The strip form of filament so common in the oxide-coated types, decreases this ratio, and is therefore to be avoided, unless increased area is necessary for other reasons.

Another method of increasing this ratio is to use a filament of large diameter. Since the volume is proportional to the second power of the radius, while the surface area is proportional to its first power only, it is seen that the ratio of volume to area of the filament increases rapidly with increasing diameter, and as large a diameter as possible, consistent with other considerations, is to be desired.

A third method, as before noted, consists in reducing the operating temperature to as low a value as possible consistent with other considerations so that the heat dissipation rate of the filament is low. Remembering that the radiation losses are proportional to the fourth power of the temperature, it will be seen that merely

cutting the operating temperature in half, as by going from a thoriated tungsten to an oxide platinum filament, may permit of a very great decrease in radiation losses and a correspondingly greater temperature stability.

The temperature stability of an a. c. energized filament may be understood better perhaps by comparing it with the voltage stability across a condenser fed from a rectifier and feeding a load resistance. In both cases we have a pulsating input and a more or less steady output of energy. If the output load is small, the energy level of temperature or voltage remains steady. If the load be large, there will be a large decrease in energy level during periods of little or no input, and consequent great instability.

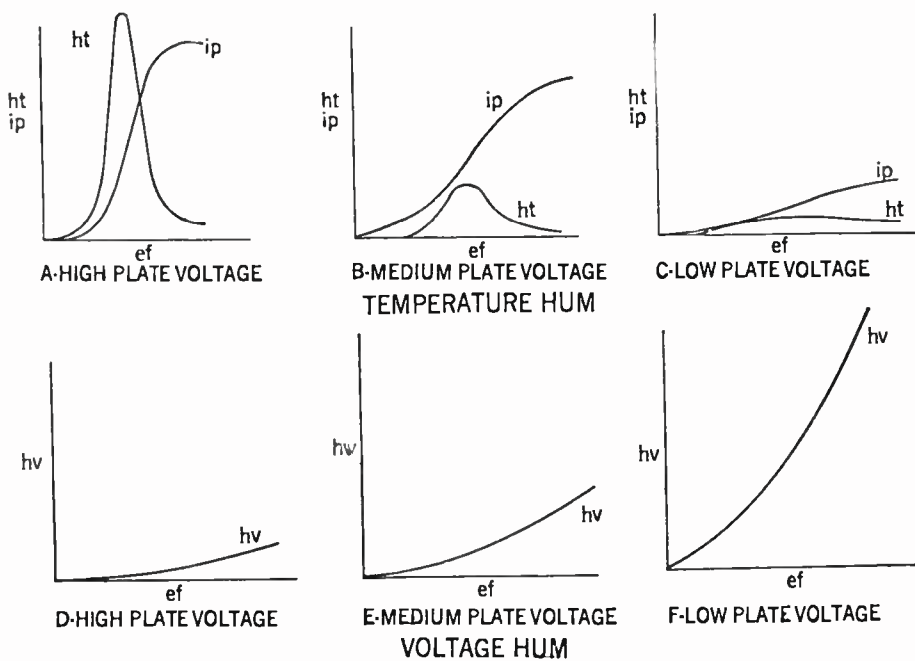

FIG. 1

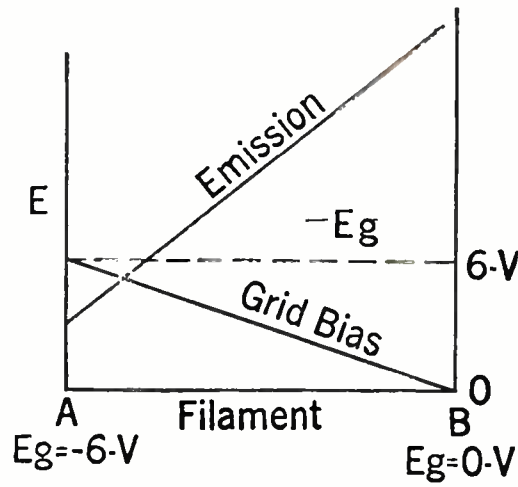
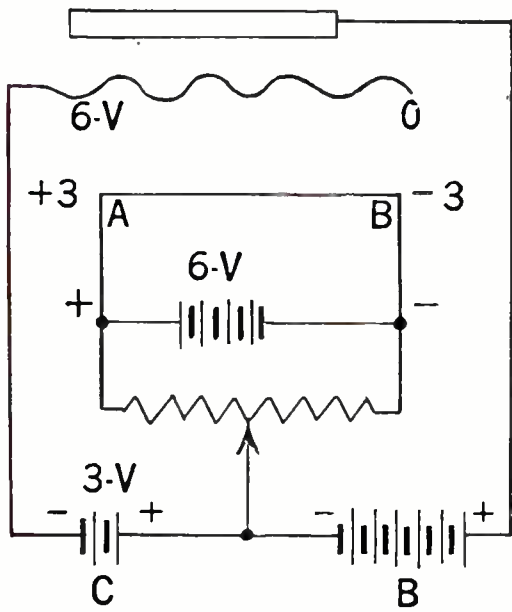

FIG. 2

To summarize then, the method of securing high temperature stability is to use a filament of round cross section, large diameter low temperature, and high specific heat.

The curves presented in the former paper show that the temperature type of hum is at its maximum value at the point of greatest steepness of the filament-voltage plate-current curve of any given tube. That is to say, if a static plate-current curve be plotted with variable filament voltages, the greatest amount of plate current variation will be obtained for a given amount of filament voltage variation at the steepest point in such a curve, and it follows that under dynamic conditions, where the filament current is constantly changing at a high rate, such as by the action of a 60-cycle impressed voltage, the greatest amount of temperature fluctuation would be obtained at a filament voltage corresponding to the steepest point of the plate current curve.

The curves show also that at high plate voltages, where the plate current curve is steepest, the temperature type of hum is greatest, and at low plate voltages, where the plate current curve is comparatively flat, the temperature hum is low or has entirely disappeared. This is shown by the typical curves of Fig. 1.

In curve "A," for a plate voltage that is high compared to the filament voltage, a high temperature peak is produced, due to the steep plate current curve. In "B," where the plate voltage is reduced and the plate current curve is thereby flattened, the temperature peak is much reduced. In "C," where the plate voltage is low and the plate current curve is relatively very flat, the temperature hum has almost completely disappeared. In "D" is shown the low-voltage type of hum produced when the plate voltage is high compared with the filament voltage. In "E," where the plate voltage is reduced, the hum has considerably increased, while in "F," where the plate voltage is very low, the voltage hum has become very high.

These curves represent the general relationship between the two types of hum and the plate voltage with a tube of any given type. With a fixed plate voltage and differing filament voltages the same general results will be obtained, as the ratio of plate to filament voltage is the factor determining the degree of the voltage type hum. This is explained by the fact that there are within the tube two electrodes of positive potential and competing with each other for the emission of the filament. With an a. c. filament voltage of, say, five volts, and a d. c.

plate voltage, say, 135 volts, the plate electrode, by reason of its over-powering attraction for the electrons, attracts to itself most of the emission, while the positive filament end with its small voltage gets only a small part of the emission. When, however, the plate voltage is reduced to a low value, such as twenty-five volts, the five-volt potential of the filament becomes relatively important and it now takes a much greater proportion of the emission than it did under the high-voltage plate condition.

It should be remembered here that the attraction of the plate electrode is considerably modified by the presence of the intervening negatively charged grid, and that no such intervening grid is present between the positive side of the filament and the negative side, and this further contributes to the effectiveness of the positive filament end as a contender with the plate for the electron emission.

As a result of these various studies, the previous paper pointed out that the temperature type of hum could be reduced by increasing the ratio of mass to radiating surface of the filament and by lowering the temperature, and that the voltage hum could be decreased by reducing the filament voltage to a low value and by separating the filament ends as far as possible, that is, by use of a filament of the straight type. Another method is to so construct the grid of the tube, that it surrounds the two filament sides in a V-

type filament and thereby shields the emitting negative side from the attracting positive side, by virtue of its relatively high negative bias.

The latter paper also discussed the variation of emission from the two sides of the filament and explained that the negative leg was considered to be responsible for the chief part of the emission, at least during those portions of the applied a. c. cycle where the voltage was high. In addition to the reasons given for this non-uniform emission, there is another simple explanation which leaves no doubt on this point. This has been proposed by the author's assistant, Mr. Charles T. Jacobs.

Consider a filament excited by a six-volt battery; its associated grid and plate circuits are returned to the mid-point of a potentiometer connected across the battery and filament, as shown in Fig. 2. The grid is biased negatively by a three-volt battery. An examination of this circuit discloses that the negative bias with respect to the negative end of the filament is zero, while the bias with respect to the positive end of the filament is six volts. It is seen that in the case of the negative end of the filament, the C-battery voltage is exactly neutralized by the oppositely poled voltage of one half the A battery. However, for the positive end, one half the A battery voltage is added to the negative bias, producing an overall bias between the grid and the most positive end of the filament of six volts. At the mid-point of the filament, the A voltage neither adds nor subtracts, so that the voltage of the grid with respect to this point is that of the C battery, or negative 3 volts. We can conceive, therefore, that the emission of the positive end of the filament compared to that of the negative end must be very small, because of the much greater negative bias on the grid with respect to the positive end, and that the emission will vary uniformly from one end to the other. The conditions here may be understood by reference to the graphs showing the distribution of emission over the filament as shown in this diagram. If "A" is the positive end of the filament, three volts positive with respect to the mid-point, and "B" is the negative end of the filament, three volts negative with respect to the mid-point, then the potential difference between the grid and "B" is zero volts. The accompanying graph shows in general the distribution of emission over the filament from "A" to "B," being lowest at "A" and highest at "B."

If now the polarity be reversed, as shown in Fig. 3, we see that the distribution of emission is

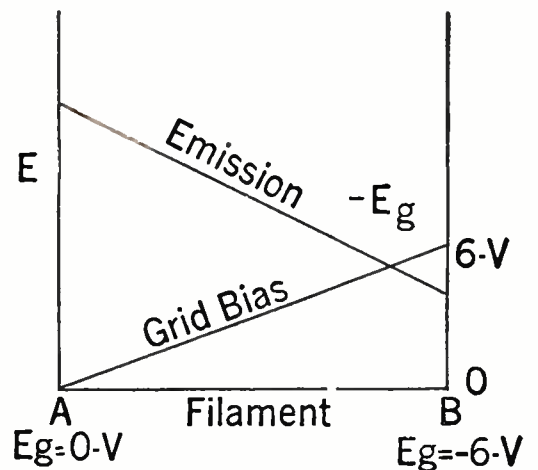
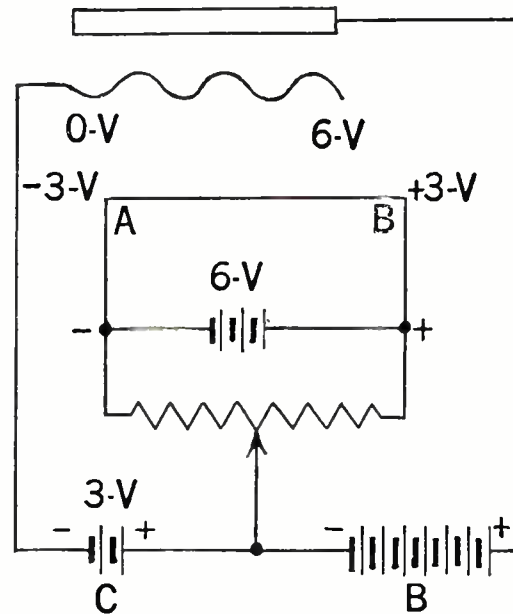

FIG. 3

the same but reversed with respect to the filament ends. In the third case, shown in Fig. 4, wherein the filament supply voltage passes through the zero point, shown by the omission of the battery, the whole filament will be at a uniform potential difference with respect to the grid, and equal to the voltage of the C battery or three volts. The emission of the filament in this case will have an amplitude equal to the mean value of the amplitude over the filament as a whole, as shown in either Fig. 2 or Fig. 3.

If now, we exchange for the six-volt battery a source of alternating current, such as a transformer secondary, having a peak voltage of six and, for sake of simplicity, a sinusoidal waveform of 60 cycles frequency, we have a continuously changing condition wherein at some instances we have one or the opposite set of polarities on the filament with varying voltage, and at other instances, we have no voltage whatsoever, that is, when the applied voltage passes through the zero point in its cycle. The action under these circumstances is considerably more complex than in the steady state given by the battery, and can best be expressed by graphs showing the separate effects, their phase relations, and the net result of all of them.

In Fig. 5, this a.c. filament excitation substituted for the A battery is shown, together with graphs indicating the nature of the emission variation to the plate with respect to the two

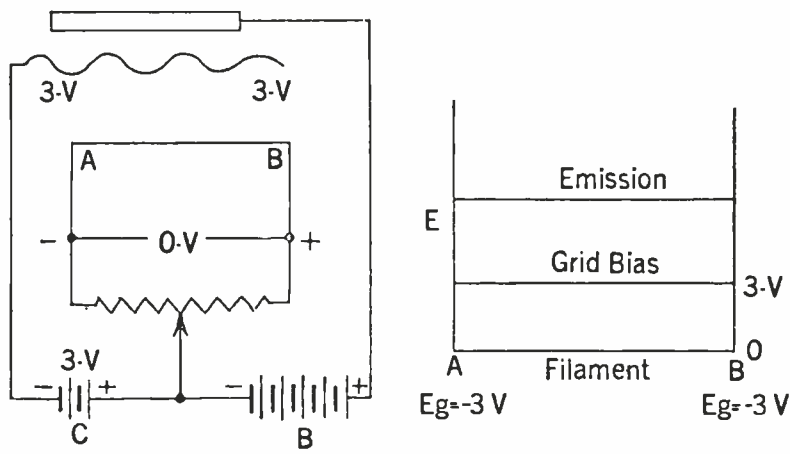

FIG. 4

filament ends. With a peak filament voltage of six, a mid-point grid return, and a C bias of 3 volts, as indicated, both ends of the filament, "A"-"B," will vary from zero to six volts with respect to the grid, during a cycle of the filament voltage. Graph No. 1 shows the filament voltage; graph No. 2, shows the variation in emission from "A;" and graph No. 3, shows the corresponding variation from "B." Graph No. 4, which is a straight line, represents the sum of "A" and "B," and shows the total plate current under this condition to be constant, neglecting the slight effect of the B return and any slight departure from symmetry in the geometry of the filament, grid, and plate at the two ends of the filament. Returning now to Fig. 4, we can make this quite clear. If the emission and grid bias lines be given an oscillatory rotating motion

in opposite directions, each about its point of mean amplitude, it is obvious that the total emission is always constant

If, now, the grid and plate return be made at some point off the central point of the potentiometer, it can be shown that the emission will no longer undulate symmetrically about the center point and therefore remain constant, so that the two effects will be unbalanced, and a 60-cycle variation of plate current will result. In Fig. 6, the dynamic conditions with a.c. on the filament and the potentiometer slider displaced somewhat from the center, are shown. Here again Graph No. 1 represents the exciting voltage across the

ends of the filament; No. 2, the emission from one end of the filament; No. 3, the emission from the other end of the filament; and No. 4, the sum of curves Nos. 2 and 3, which is a 60-cycle variation. It will be explained later how this 60-cycle grid voltage can be made to counteract a 60-cycle ripple in the plate voltage.

These curves and this analysis are, of course, based upon the assumption that the tube is operating as a proper amplifier, with the normal negative grid bias coinciding approximately with the center of the straight line portion of the grid-voltage plate-current curve of the tube. The action in the case of a detector acting as a plate rectifier is different from that of the amplifier as above explained, and will be discussed at length later in this paper, the latter half of which will appear soon in RADIO BROADCAST.

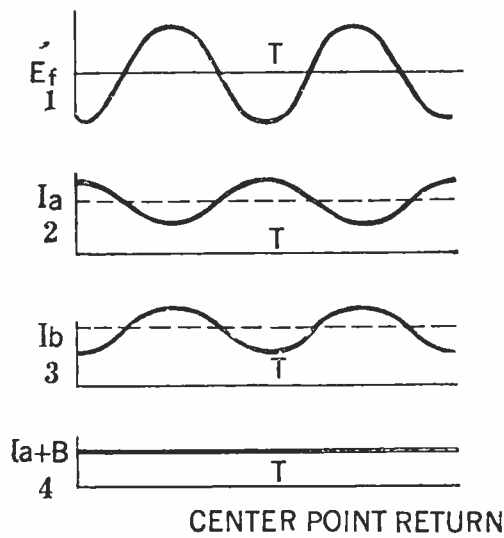

FIG. 5

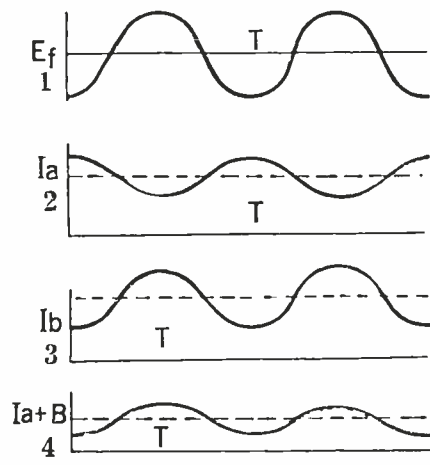
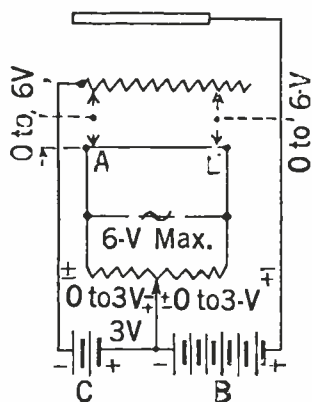
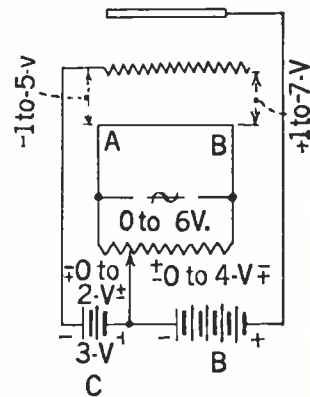
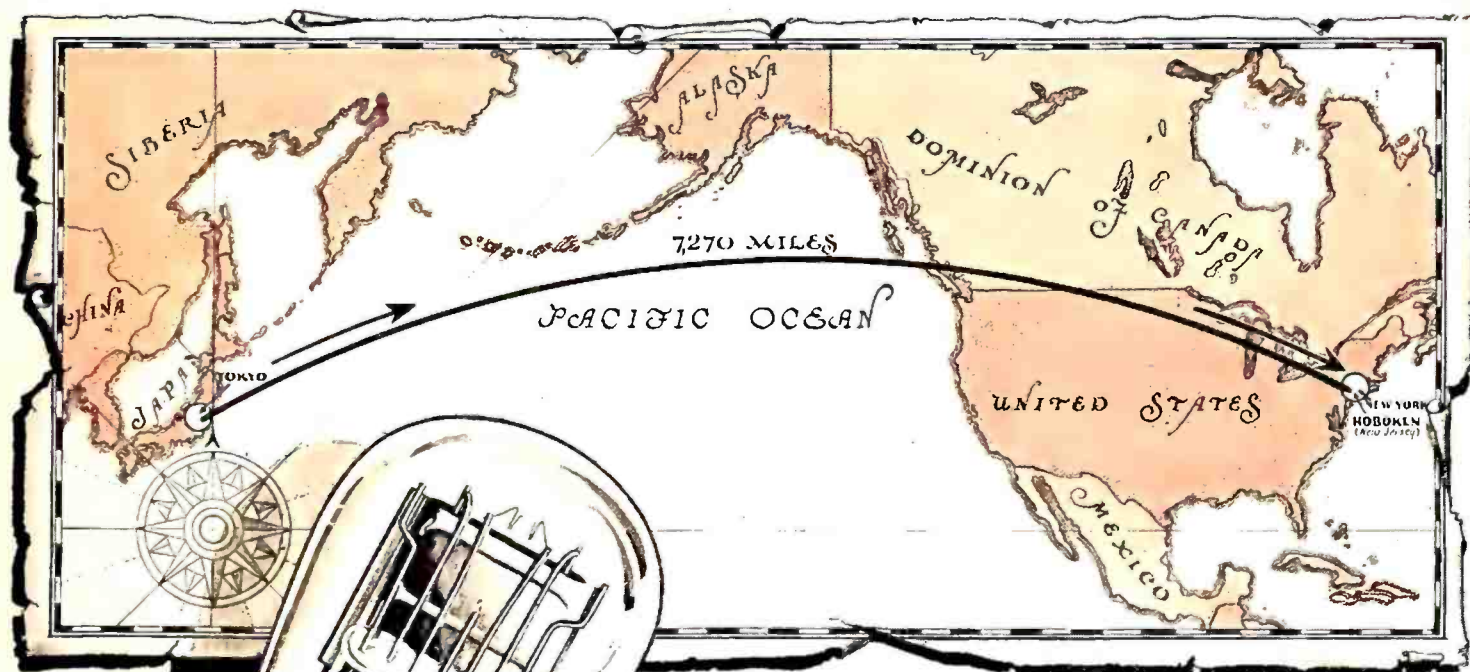

FIG. 6



RADIO BROADCAST is the official publication of the Radio Club of America, through whose courtesy the foregoing paper has been printed here. RADIO BROADCAST does not, of course, assume responsibility for controversial statements made by authors of these papers. Other Radio Club papers will appear in subsequent numbers of this magazine



A World's Record!

Tokyo, Japan to Hoboken, N. J. with ZETKA Clear-Glass Tubes

East Meets West in 7270 Mile Radio Hop

ON April 15, 1927, Arthur Wald of Hoboken, New Jersey, made a new World's Record for DX reception—7270 air miles . . . Station JOAK of Japan—the longest distance bridged in radio history, according to the New York Evening Telegram.

Zetka Clear-Glass Tubes—five Z-201-A's and one Z-112 Power Tube—brought in this monumental achievement, across the Pacific Ocean, across the entire United States—proving once again the unparalleled distance-volume characteristics of these finer, clear-glass tubes.

The new ZP-201-A all-socket Power Tube is another great Zetka achievement. A power tube that goes into every socket, without re-wiring—that gives greater volume, greater distance, purer tone—yet consumes less "A" Battery current—that lasts longer and increases in efficiency with service—that brings radio to its highest point of efficiency.

Every tube is serial numbered and guaranteed—and the price is as much an achievement as the tube itself—only \$2.50 each. Hear them today, at your dealer's.

"I RECOMMEND the use of Zetka Tubes to any one who is deeply enough interested in radio to want the best equipment it is possible to secure.

"Zetka tubes have given me infinitely more power, greater distance, better tone qualities, and a complete freedom from microphonic noises, way beyond any other tubes I have ever used."

Arthur Wald

*There is a Zetka Clear-Glass Tube for every radio purpose
--each one an outstanding achievement*



ZETKA LABORATORIES, Inc.

73 Winthrop St., Newark, New Jersey

Superior Tone Quality plus Artistic Appearance

IMPROVEMENT in reproduction is the outstanding radio achievement of the past year. Engineering methods developed for radio have given a new lease on life to the phonograph industry.

The audible range of radio receivers and phonographs has been greatly extended by the intelligent application of sound engineering fundamentals gleaned from research in the electrical and acoustical field.

Radio and Phonograph engineers have recognized in Lata Balsa — the marvelous, tropical wood with no inherent acoustic resonance points—the ideal diaphragm, and have begun to apply it to sound reproducers of more than ordinary excellence. Lata Balsa is rapidly gaining favor in both fields.

A good loud speaker must be fed by a good audio amplifier. Radio engineers agree that there is no means of providing tone fidelity to compare with resistance coupling.

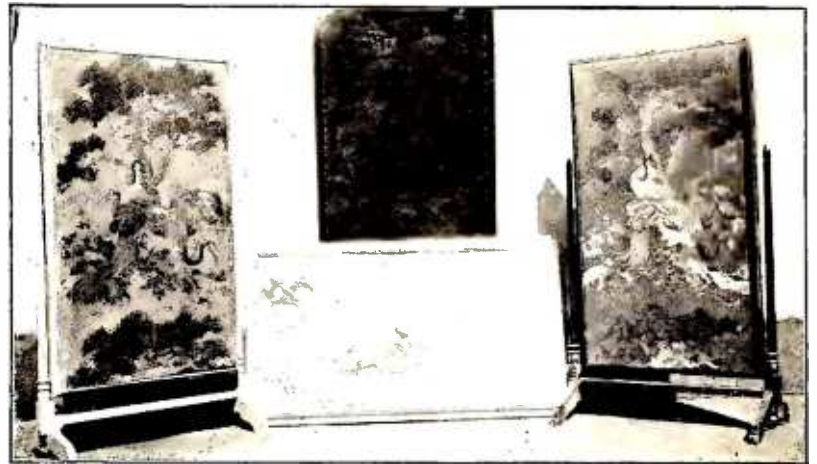

The complete Lata Balsa Reproducer Kit which you may assemble in a few minutes into a wonderful reproducer of tone quality and an artistic piece of furniture—

13" x 24", \$8.00 21" x 36", \$10.00

Lata Balsa Balanced Armature Reproducer Unit designed especially for use with Lata Balsa Reproducer Unit...\$8.00

Resistance coupling and its manifold applications have been the work of the Engineering Department of Arthur H. Lynch, Inc., for a long period. In their search for a reproducer which would demonstrate its superiority in a conclusive manner they have made exhaustive tests on the Lata Balsa Reproducer and find the combination to be ideal.

Musicians, Music Lovers and Acoustic Experts agree with them. Artists and artistically inclined housewives recognize in the decorated Lata Balsa Reproducer, which may be made into a firescreen or wall decoration, a relief from the unsightly appearance of the old fashioned "loud speaker."

These scientific wonders are now available to every man and woman at but slight cost. They are easy to apply to any receiver either old or new.



Everything necessary for the building of a modern three-stage resistance coupled amplifier. \$9.00

JOBBER AND DEALERS

We have a most attractive proposition on these rapidly moving lines. A word from you will bring full details.

RETURN THIS COUPON—

ARTHUR H. LYNCH, Inc.
General Motors Building
1775 Broadway
NEW YORK CITY

Sole Sales Representatives

ARTHUR H. LYNCH, Inc.
General Motors Bldg., 1775 Broadway
At 57th Street, New York City
Gentlemen:
Please send me the items checked, for which I enclose my money order or cash.

Lata Balsa Reproducer Kit, 13 x 24.....	\$8.00
" " " " 21 x 36.....	10.00
" " " " Unit.....	8.00
Lynch Resistance-Coupled Amplifier Kit.....	9.00

Name.....
Address.....
City-State.....

**BALSA WOOD
REPRODUCER, Corp.**
331 Madison Avenue
NEW YORK CITY

New

THORDARSON
POWER TRANSFORMERS



130 M. A. FULL WAVE RECTIFIER

Here is a power unit that will satisfy the ever increasing demand for improved quality of reception. A split secondary 550 volts either side of center, makes possible full wave rectification, using two 216-B or two 281 tubes. Current capacity, 130 milliamperes. The low voltage secondary, 7½ volts, will supply two UX-210 power tubes, enabling the use of push-pull amplification in last audio stage. The Double Choke Unit 2099 is designed for this power unit. Contains two individual chokes of 30 henries, 130 milli-amperes capacity each.

T-2098 Transformer, 4½" x 5¼" x 5¾"
List Price, \$20.00

T-2099, Choke Unit
3¼" x 4⅞" x 5⅝"
high

List Price
\$14.00

Realistic tone quality, that elusive but much talked of characteristic of radio reception— can be obtained only through the use of apparatus of the finest materials and workmanship. For years Thordarson transformers have been the choice of many discriminating manufacturers of quality receiving sets. Follow the lead of the leaders. If you enjoy good music specify Thordarson transformers



POWER PUSH-PULL TRANSFORMER and CHOKE

Quality reproduction that cannot be obtained with straight audio amplification, is made possible through the Thordarson power push-pull combination. This arrangement is designed for use with power tubes only and has sufficient capacity for all tubes up to and including the UX-210. Makes an ideal power amplifier when used with power supply unit T-2098.

Input transformer couples stage of straight audio to stage of push-pull. Output choke is center-tapped with 30 henries on either side of center tap. Dimensions of both transformer and choke, 2½" x 2½" x 3" high.

Input Transformer T-2408

List Price, \$8.00

Output Choke T-2420

List Price
\$8.00



A. C. TUBE FILAMENT SUPPLY

The new R. C. A. and Cunningham A. C. filament tubes will be very popular with the home constructor this season. The Thordarson Transformer T-2445 is designed especially for these tubes. Three separate filament windings are provided.

Sec. No. 1, 1½ volts, will supply six UX-226 amplifier tubes.

Sec. No. 2, 2½ volts, will supply two UX-227 detector tubes.

Sec. No. 3, 5 volts, will supply two 5 volt power tubes.

In addition to the above, this transformer is equipped with a receptacle for the B-supply input plug. Supplied with six-foot cord and separable plug for attachment to the light circuit. Transformer in compound filled, crackle-finished case. Dimensions — 2¾" x 5¾" x 4¾".

A. C. Tube Supply, T-2445

List Price, \$10.00

THORDARSON ELECTRIC MANUFACTURING CO.
Transformer Specialists Since 1895
WORLD'S OLDEST AND LARGEST EXCLUSIVE TRANSFORMER MAKERS
Huron and Kingsbury Streets — Chicago, Ill. U.S.A.

THORDARSON ELECTRIC MFG. CO.
500 W. Huron St., Chicago, Ill.
Gentlemen:
Please send me your booklets describing your new power supply transformers.

Name.....
Address.....
City..... State.....

(3562-J)

Modernize Your Radio



Improvements will bring you a new standard of convenience and comfort in radio entertainment.



Switching Rheostat

Serves as a filament switch and rheostat in one. Construction same as famous Air-Cooled Rheostat—gives correct voltage range and carrying capacity; feeds current slowly and evenly through use of large number of turns of special non-rusting, resistance wire. Resistance unit suspended in air to permit ventilation.

Furnished in sizes from 2 to 100 ohms \$1.75



Pup Jacks

Easy to mount on front, sub or rear panels. The ideal Jack for Loud Speaker connections and for use as binding post, for connecting Battery Leads, Ground, Antenna, etc. Mount in $\frac{5}{16}$ " panel hole.

Per Pair.....25c



Convenience Outlets

To give you greater joy with your radio, with less muss and fuss with its accessories, these Radio Convenience Outlets permit the wiring of the home so that batteries are out of sight, a loud speaker can be placed in any room, and the aerial and ground can be tapped like your regular electric convenience outlets. Do away with unsightly lead-in wires and set connections. Avoid damage to the building and acid stains on floors or furnishings. Outlet plates made single or in gangs. Fit any standard switch box or may be attached directly to plaster laths or studding.

No. 135—Radio Convenience Outlet for Loud Speaker and Head Phones.....\$1.00

No. 136—Radio Convenience Outlet for Aerial and Ground.....\$1.00

No. 137—Radio Convenience Outlet with Plug for Battery Connections.....\$2.50

Yaxley also makes Air-Cooled Rheostats, Automatic Power Controls, Cable Connector Devices, Potentiometers, Jacks, Jack Switches, Special Switches, Phone Plugs, Midget Jacks and Plugs, Pilot and Panel Lights, Pilot Light Switches, Name Plates, etc.

Write for new illustrated and descriptive price sheet
At your dealer's. If he cannot supply you, send his name with your order to

YAXLEY MFG. CO.
Dept. B—9 So. Clinton Street
CHICAGO, ILL.

The Radio Broadcast LABORATORY INFORMATION SHEETS

THE RADIO BROADCAST Laboratory Information Sheets are a regular feature of this magazine and have appeared since our June, 1926, issue. They cover a wide range of information of value to the experimenter and to the technical radio man. It is not our purpose always to include new information but to present concise and accurate facts in the most convenient form. The sheets are arranged so that they may be cut from the magazine and preserved for constant reference, and we suggest that each sheet be cut out with a razor blade and pasted on 4" x 6" filing cards, or in a notebook. The cards should be arranged in numerical order. An index appears twice a year dealing with the sheets published during that year. The first index appeared on sheets Nos. 47 and 48, in November, 1926. Last month an index to all sheets appearing since that time was printed.

The June, October, November, and December, 1926, issues are out of print. A complete set of Sheets, Nos. 1 to 88, can be secured from the Circulation Department, Doubleday, Page & Company, Garden City, New York, for \$1.00. Some readers have asked what provision is made to rectify possible errors in these Sheets. In the unfortunate event that any such errors do appear, a new Laboratory Sheet with the old number will appear.

—THE EDITOR.

No. 121

RADIO BROADCAST Laboratory Information Sheet September, 1927

The Hertz Antenna

CHARACTERISTICS

ONE of the commonest antenna systems used by amateurs for transmitting purposes is the Hertz system. This antenna, in its simplest form, consists of two straight wires located diametrically opposite each other as indicated in the drawing on the accompanying curve. The length of the two wires bears a definite relation to the fundamental wavelength at which the antenna system will tune and this relation is indicated by the curve, which is reprinted from *QST* of May, 1926. The relation between the length of the antenna system and the fundamental wavelength is a constant; the length L is equal to the wavelength divided by a constant, 1.3.

It is possible to obtain radiation on any wavelength by using different lengths of antenna and counterpoise. Suppose we wish to transmit on 40 meters (7500 kc.) and the antenna system is to be operated on the fundamental wavelength. Then from the curve the length of the antenna "A" would be 31 feet and the length of the counterpoise "B" would also be 31 feet. It would also be possible to transmit on 40 meters using the third harmonic of the antenna, in which case the antenna would be of such a size as to have a fundamental wavelength equal to 40 times 3 or 120 meters. If supplied with energy at a frequency corresponding to 40 meters,

however, the antenna would radiate energy at this frequency very efficiently even though its natural wavelength is 120. If such a system of transmission were to be used, the length of the antenna and the counterpoise would each be 93 feet.

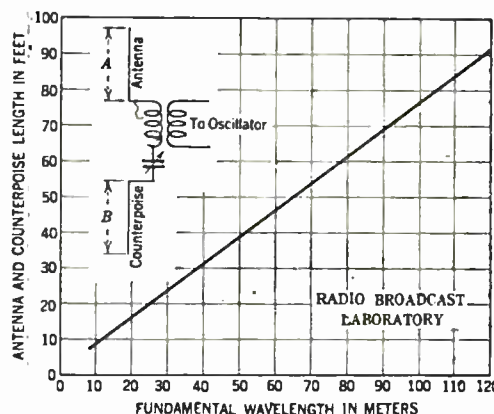

No. 122

RADIO BROADCAST Laboratory Information Sheet September, 1927

Testing Radio Receivers

FEATURES TO CONSIDER

IT IS obviously of distinct advantage to test radio receivers in accordance with some standardized test procedure so that the results obtained from different receivers can be readily compared. If such a method is used the manufacturer will be able to have before him information which will tell him definitely just how his product compares with those of other manufacturers and also the buyer of a receiver will have certain definite data upon which to base his decision in buying a receiver. Considerable information on methods of testing radio receiving sets is given in the Technologic Paper of the Bureau of Standards, No. 256. In this paper it is suggested that the following tests be made on a receiver:

- (A) Frequency range.
- (B) Vibration test, which determines how well the set has been constructed mechanically and whether it will be able to withstand the ordinary shocks obtained in transportation.
- (C) Sensitivity.
- (D) Selectivity.

These tests are especially effective in indicating how well the set has been engineered from an electrical standpoint. A test should also be made of fidelity, to determine how well the receiver is capable of reproducing voice and music.

From the standpoint of the average user these tests are not conclusive because he is interested in

other things besides the electrical efficiency of the receiver or its fidelity of reproduction. In a laboratory test one receiver might show up much better than another in regard to sensitivity and selectivity but the good results might only be obtained with very accurate adjustments. Obviously, a single-control receiver lacking somewhat in sensitivity and selectivity in comparison with another receiver might actually give somewhat better results when operated by an ordinary buyer with little knowledge of the circuit. As is stated in the paper mentioned above, it is really very difficult to judge the performance of any particular receiving set on the basis of any one trial of its operation, largely due to the widely different types of receivers and conditions under which they are best operated. The skill of the operator very largely determines the degree of satisfaction that will be obtained from any given receiver. In practice it will very likely be found best to just make available to the prospective purchaser some figures of merit indicating the sensitivity, selectivity, and fidelity and then to let him determine for himself whether the receiver in his hands gives satisfactory results.

Many letters are received from readers requesting comparisons between different receivers but to give conclusive information of this sort is impossible. The choice of the receiver which one finally purchases after trying out many sets is governed by many factors on which no laboratory measurements can be made.



S-M IS READY— For A. C. Tubes or Any New Developments!

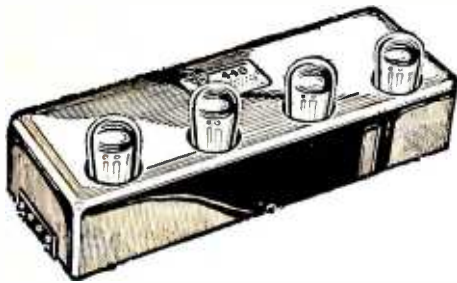

THE 440 time signal amplifier is a fully assembled three stage, 112 K. C., long wave amplifier-detector catacomb. It consists of three air-core low-resistance tuned R. F. stages and detector, with all necessary by-pass condensers, etc., mounted in a copper and brass catacomb, providing individual stage and over-all shielding.

Each 440 amplifier is accurately matched in the S-M laboratories to exactly 112 K. C., and every amplifier is guaranteed to within one-half of one percent. The selectivity of the 440 is tremendous—it may be made 10 K. C., or even 5 K. C., at will, while the sensitivity is guaranteed greater than that of any amplifier that might be built of individual parts. Price \$35.00.



The fall season finds S-M 220 audio and 221 output transformers still the acknowledged leaders in the high-quality transformer field. And they are accorded the sincerest form of flattery—imitation—for this year other manufacturers, profiting by their phenomenal success copy the 220 characteristics, introduced by S-M a year ago—5000 cycle cut-off, rising low frequency characteristics, and plenty of iron and copper to make a good job.

But S-M audio transformers stand supreme as the finest available—the only types ever backed by a guarantee of BETTER reproduction or your money back. That's the S-M guarantee—and the return average is less than one in every 4000 sold—3999 satisfied customers out of every 4000. 220 Audio Transformer, price \$8.00. 221 Output Transformer, \$7.50.



The S-M Unipacs, introduced this June, have taken the country by storm. Everywhere, builders are realizing what true distortionless reproduction really is—for the larger Unipacs (power amplifiers and ABC power supplies) can deliver from 5 to 300 times more—and purer signals—than any standard receiver amplifier, which they replace. Prices range from \$62.00 to \$93.25 for wired and unwired models.

The new 1927 model Improved Shielded six has all the points that made the original the most popular high-priced TRF kit ever offered. The new "Six" has greatly improved selectivity—so great that will allow 10 to 20 K.C. separation of local and distance stations. The volume has been increased. The tone quality of the new 630 is just as fine as last year's model—GUARANTEED UNCONDITIONALLY to be equal or superior to any other set, regardless of price.



The new 630 can be built for battery, eliminator, or complete A. C. operation. The A. C. model is absolutely batteryless, and uses the 652A, ABC power supply. (Any 1926 Shielded six can easily be brought up to date, or adapted for complete A. C. operation.) No matter what developments come, the 630 will always be one of the finest of sets, amply satisfying the most discriminating of fans. Price \$95.00.

The S-M 652A unit is the famous 652 "Reservoir B" supply, developed into a complete ABC power supply. Thus, with a 652A kit at \$36.50, plus as many A. C. tubes as your set needs, you make it entirely A. C. operated, with all batteries eliminated. Or any new set you are building can dispense with batteries if you use the 652A. Or if you want to change over your present B eliminator, new S-M ABC power transformers are available.



We can't tell you the whole story of new S-M developments, so if you'll just fill in the coupon, and mail it with 10c to cover postage, we'll send you free more up-to-the-minute advance radio information than you could buy in a text book.

Silver-Marshall, Inc.

838 West Jackson Blvd. Chicago, U. S. A.

SILVER-MARSHALL, Inc.
838 West Jackson Blvd., Chicago, U. S. A.

Please send me information on new S-M developments, for which I enclose 10c.

Name.....

Address.....

ASK . . ANY . . RADIO . . ENGINEER



The Crowning Adventure of Burgess Radio Batteries

They Flew Over the North Pole with Byrd

ON May 9, history was made . . . American history . . . World history . . . undying history.

Lieut. Commander Byrd, in his fearless 1500-mile flight across the top of the world, adds another thrilling triumph to the long, proud list of American achievements.

Radio went along, for radio has become vital to the lives and success of explorers and adventurers. Burgess Batteries went along, sharing the fate—sharing the hardships and the glory of Commander Byrd, the Detroit Arctic Expedition, and Capt. Donald MacMillan.

It is eminently significant that in these glorious triumphs of American courage and American equipment where the test of men and their tools was the test of the survival of the fittest, that the standard products of the Burgess Battery Company were selected, used and "carried on" under extreme and unprecedented conditions.

BURGESS BATTERY COMPANY
GENERAL SALES OFFICES: CHICAGO
Canadian Factories and Offices:
Niagara Falls and Winnipeg

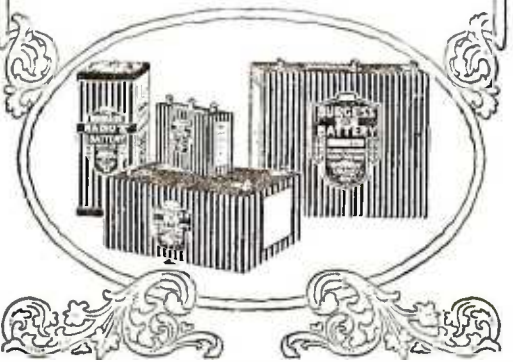

BURGESS

RADIO BATTERIES

No. 123

RADIO BROADCAST Laboratory Information Sheet September, 1927

Characteristics of 171 Type Tube

STATIC AND DYNAMIC

ON LABORATORY Sheet No. 124 are given several curves for the 171 tube. It will be noted that one curve is marked static and another dynamic. The dynamic characteristic is, as its name implies, a curve indicating how the tube will function under actual operating conditions. The static characteristic curve, although valuable in giving an idea of the general characteristics of a tube, gives no indication at all of the tube's actual performance. Under actual operating conditions a tube always operates with a certain load in its plate circuit and consequently a curve taken to indicate the tube's performance should be made with some load in the plate circuit. The curve marked "dynamic" was taken when the tube had 4000 ohms resistance in its plate circuit. The difference between the static and the dynamic curves is considerable.

The curves were taken with 180 volts on the plate and 40.5 volts on the grid. In order that an amplifier may give good quality, its plate-current grid-voltage characteristic must be straight from zero grid vol-

tage to twice the d. c. voltage on the grid. The static characteristic, although straight from 40.5 volts to zero volts, is very curved at voltages greater than 40.5. It might be judged from this curve that the tube's performance would be very poor. However, if a dynamic characteristic is taken, we find that the characteristic remains straight from zero grid voltage down to about 85 volts and consequently the tube would actually give good results.

The other curves on Sheet No. 124 are dynamic characteristics taken with different resistances in the plate circuit. Curve No. 1 was made with 1000 ohms resistance, No. 2 with 2000 ohms, and No. 3 with 8000 ohms. It will be noticed that as the resistances increase the straight portion of the curve becomes greater and greater. The curves all cross at about 40 volts because this grid voltage represents the initial d. c. potential placed on the grid and the curves are made by increasing and decreasing the grid voltage about this average value. It is necessary in taking the curves to adjust the plate voltage each time so that with the different resistances the same plate current is obtained at 40.5 volts on the grid.

No. 124

RADIO BROADCAST Laboratory Information Sheet September, 1927

Curves of the 171 Type Tube

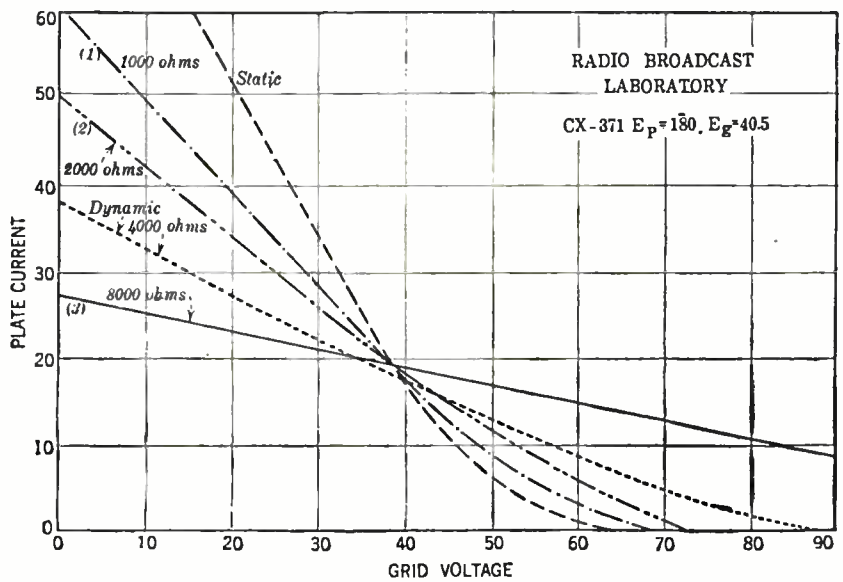

No. 125

RADIO BROADCAST Laboratory Information Sheet September, 1927

The Morse Code

A	• —	Ä (German)	• • • • •	Period	• • • • •
B	• • • • •	Å (German)	• • • • •	Semicolon	• • • • •
C	• — • —	Á or À	• • • • •	Comma	• • • • •
D	• — • •	Spanish-Scandinavian	• • • • •	Colon	• • • • •
E	• • •	CH (German-Spanish)	• • • • •	Interrogation	• • • • •
F	• • • • •	(È French)	• • • • •	Exclamation Point	• • • • •
G	• — • —	(Ñ Spanish)	• • • • •	Apostrophe	• • • • •
H	• • • • •	Ö (German)	• • • • •	Hyphen	• • • • •
I	• •	Ü (German)	• • • • •	Bar indicating fraction	• • • • •
J	• • • • •	1	• • • • •	Parenthesis	• • • • •
K	• — • •	2	• • • • •	Inverted Comma	• • • • •
L	• • • • •	3	• • • • •	Underline	• • • • •
M	• — • —	4	• • • • •	Double dash	• • • • •
N	• — •	5	• • • • •	Distress Call	• • • • •
O	• — • —	6	• • • • •	Attention call to precede every transmission	• • • • •
P	• • • • •	7	• • • • •	General inquiry call	• • • • •
Q	• — • •	8	• • • • •	From (de)	• • • • •
R	• • • • •	9	• • • • •	Invitation to transmit (go ahead)	• • • • •
S	• • •	0	• • • • •	Warning-high power	• • • • •
T	• —			Question (please repeat after _____) interrupting long messages	• • • • •
U	• • •			Wait	• • • • •
V	• • • • •			Break (double dash)	• • • • •
W	• • • • •			Understand	• • • • •
X	• — • •			Error	• • • • •
Y	• — • •			Received (O.K.)	• • • • •
Z	• — • •			Position report (to precede all position messages)	• • • • •
				End of message (cross)	• • • • •
				Transmission finished (end of work)	• • • • •

For the Best in Short Wave Reception

Build the

AERO SHORT WAVE RECEIVER

Described in this issue of Radio Broadcast

This kit is the basis of the Aero Short Wave Receiver, described in this issue.

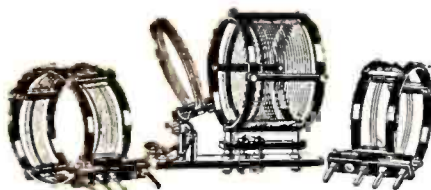

Experts and amateurs everywhere have found that this Aero Kit improves any circuit.

AERO LOW WAVE TUNER KIT
Code No. L. W. T. 125 Price \$12.50

Everyone interested in short wave reception should read about the Aero Short Wave Receiver described elsewhere in this issue of Radio Broadcast. This superlative set insures the very best in short wave reception.

Always the prime favorite of experts and amateurs insistent upon extraordinary short wave performance, the Aero Short Wave Receiver for this season has been made even better than ever. Greater volume, finer selectivity, better tone quality and flexibility to a degree never before thought possible have been embodied in the new Aero Low Wave Tuner Kit, around which this Aero Short Wave Receiver is built, so that the set has a gapless range (when used with INT. coils No. 0, 4, and 5) of 13 to 725 meters!

The performance of this Aero Receiver is so flawless, so satisfactory in every way, that it has been selected as standard equipment by the University of Michigan's Expedition to Greenland (1926-1927-1928) and by the MacMillan Arctic Expedition. No greater proof of its efficiency could be offered than by its selection for these important tasks.

The Aero Low Wave Tuner Kit, illustrated above, is completely interchangeable. The kit itself includes three coils and base mounting, covering U. S. bands 20, 30 and 80 meters. You can increase or decrease the range by securing the Aero Interchangeable Coils described below. All coils fit the same base and use the same condensers.

New AERO INTERCHANGEABLE COILS

INT. NO. 0



Range 13 to 29.4 meters. This is the most efficient inductance for this low band. Code number INT. No. 0. Price \$4.00

INT. NO. 4

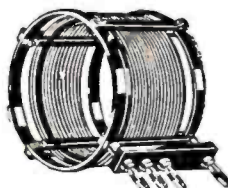

Range 125 to 250 meters. Fits same base supplied with low wave tuner kit. Code number INT. No. 4. Price \$4.00

INT. NO. 5

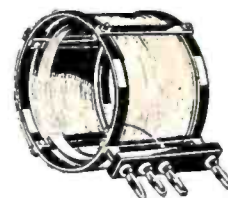

Normal range 235 to 550 meters. However, by using .0001 Sangamo fixed condenser across the rotor and stator of the .00014 variable condenser, the maximum wave band of this coil is increased to 725 meters. This gives you coverage of the following bands: Airplane to Airplane, Land to Airplane, Ship to Shore (Great Lakes), Ship to Shore (Atlantic and Pacific oceans), Code number INT. No. 5. Price \$4.00

NEW AERO CHOKE COILS

The new Aero Choke 60 has a uniform choking action over a wide range of wave lengths. It eliminates so-called "holes" in the tuning range and is exceptionally efficient in every respect. Price \$1.50

The Aero Choke 248 is an unusually efficient transmitter choke. It presents a high impedance over the usual amateur wave lengths and handles transmitters up to 100 watts. Price \$1.50

We Can Furnish Foundation Unit for this Set

We have made arrangements to furnish complete foundation units for the Aero Short Wave Receiver, completely drilled and engraved on Westinghouse Micarta, at a price of \$5.75 each. This fully finished panel greatly simplifies the construction of the Aero Short Wave Receiver and is a great convenience for the home set builder. A detailed blueprint and wiring diagram for this circuit is included with every foundation unit.

Plan for DX Records NOW

Order any of these Aero Coils direct from us if your dealer doesn't happen to have them. Be sure to specify code numbers when ordering

AERO PRODUCTS, Inc., 1772 Wilson Ave., Chicago
Dept. 109

It will pay you to investigate the new Aero Amateur Transmitter Coils and improved Aero Universal Coil, designed for broadcast band usage. These coils are supplied in complete kits for the improved Aero-Dyne Six, the Aero Seven, the Aero Four and other popular circuits. Write for interesting descriptive literature on these and other new Aero products.

LOBOY MODEL
\$160 (without tubes)



MAGNAVOX

Power Cone Speaker
(Dynamic)

Now—a speaker to match the finest set

Improved quality of reception is the keynote of the new sets and tubes. Magnavox matches the finest with its new power speaker. Built on electro-dynamic principles under patents controlled exclusively and made famous by Magnavox.

All the music in ALL its natural beauty is possible only with this type speaker. Even extreme upper and lower register fundamental notes can come through with complete fidelity. Volume ranges from pianissimo to fortissimo without the slightest distortion.

Uses one 216B and one 210 type tube. For connection with alternating house current, doing away with B batteries and B eliminators. Works directly from light socket.

Magnavox Electro-dynamic speaker unit only, type R4, for 6 volts 1/2 ampere field winding \$45.00.

Type R5, unit only, for use in Electric phonograph 100 volt 40 milliamperere field winding \$45.00.

Type R50, unit only, as used in Loby Speaker complete with amplifier and eliminator \$110.00.

Warwick Model Cone

Permanent magnet type handles power tube volume without distortion \$27.50.

Type M7 Self contained, complete permanent magnet cone, unit only, 8 3/4" diameter \$12.50.

If you don't know a Magnavox dealer, write us.



THE MAGNAVOX CO.

Oakland, California

1315 So. Michigan Ave.

Chicago

No. 126

RADIO BROADCAST Laboratory Information Sheet **September, 1927**

Condenser Reactance

HOW IT IS CALCULATED

IF A condenser is connected in series with an a. c. ammeter to a source of alternating current, a certain amount of current will flow in the circuit, depending upon the size of the condenser and the frequency of the current. If the voltage of the source is divided by the current, the quotient will be the "reactance" of the condenser in ohms. For example, if the frequency of the current being supplied by the source of potential was 60 cycles and the voltage was 110 volts and the size of the condenser was 1 mfd. we would find that 0.412 amperes of current would flow through the circuit. Then 110 volts divided by 0.412 gives 2666, which is the reactance in ohms at 60 cycles of a 1 mfd. condenser. The reactance of a condenser depends upon its size and upon the frequency of the current. It can be calculated by means of the following formula:

$$\text{Reactance} = \frac{10^8}{6.28 FC}$$

Where F is the frequency in cycles per second and C is the capacity of the condenser in microfarads.

In many calculations it is necessary to know the reactance of a particular condenser at some frequency, and for this reason, on Laboratory Sheet No. 127, is given a table of condenser reactances for capacities between 0.001 and 10 mfd. at frequencies from 60 to 1,000,000 cycles. From the formula given herewith it is evident that the reactance of a condenser is inversely proportional to the capacity of the condenser and inversely proportional to the frequency. Doubling the size of the condenser therefore gives half the reactance, and doubling the frequency of the current also halves the reactance of the condenser. Remembering these two facts it is a simple matter to calculate mentally the reactance of almost any capacity not given in the table on Laboratory Sheet No. 127. For example, a 3-mfd. condenser at 100 cycles has 1/3 of the reactance of a 1 mfd. condenser at 100 cycles. Since the reactance of the latter size at 100 cycles is 1600, then the reactance of a 3-mfd. condenser must be 1600 divided by 3, or 533 1/3 ohms. A 0.001-mfd. condenser at 1,000,000 cycles has a reactance of 160 ohms. A 0.0001-mfd. condenser at this frequency therefore has a reactance of 1600 ohms and a 0.01-mfd. condenser likewise has a reactance of 16 ohms.

No. 127

RADIO BROADCAST Laboratory Information Sheet **September, 1927**

Condenser Reactance

CONDENSER CAPACITY IN MFDS.	REACTANCE IN OHMS AT VARIOUS FREQUENCIES							
	60	100	250	500	1000	10,000	100,000	1,000,000
0.001	2666000	1600000	640000	320000	160000	16000	1600	160
0.005	533200	320000	128000	64000	32000	3200	320	32
0.01	266600	160000	64000	32000	16000	1600	160	16
0.1	26660	16000	6400	3200	1600	160	16	1.6
0.5	5332	3200	1280	640	320	32	3.2	.32
1.0	2666	1600	640	320	160	16	1.6	0.16
2.0	1333	800	320	160	80	8	0.8	0.08
4.0	666	400	160	80	40	4	0.4	0.04
8.0	333	200	80	40	20	2	0.2	0.02
10.0	267	160	64	32	16	1.6	0.16	0.016

This table shows how the reactance of various capacities varies with different frequencies. The reactance of a condenser varies inversely with its capacity and with the frequency. See Laboratory Sheet No. 126

No. 128

RADIO BROADCAST Laboratory Information Sheet **September, 1927**

B Power Units

DESIRABLE CHARACTERISTICS

A B-POWER unit is essentially a device to supply plate voltage to a radio receiver but such a unit has several characteristics besides the ability to supply proper voltages that are important in determining how satisfactorily it will operate. Modern batteries for the plate supply of a receiver can hardly be improved on. Their voltage is constant, they are perfectly quiet in operation, and leave little to be desired as a source of plate potential. The expense of operating a multi-tube receiver using power tubes from batteries is considerable, however, but a B power unit, properly designed, affords an excellent source of high plate potential at moderate cost.

What are the desirable characteristics of such a unit? It must first of all be capable of supplying the proper voltages to a receiver. Either insufficient or excessive voltage will adversely affect the operation of a receiver in many cases and it is therefore essential that some care be taken to make certain that the voltages being supplied are correct.

The power unit must deliver those voltages with a minimum of a. c. hum. Low hum output is only obtained with a properly designed transformer and filter system. The various filter chokes should be shielded so that magnetic coupling between them will not be possible and it is also necessary that some means be used to electrostatically shield the high-

voltage secondary windings from the primary winding to prevent any line noise from the power mains getting into the filter system, and making the output of the unit noisy. This shielding between the primary and secondary may be accomplished by means of a grounded copper shield between the primary and secondary windings or the shielding may be accomplished quite effectively by placing the filament winding, supplying the power tube, between the primary and high-voltage windings. The filament winding, being at ground potential, therefore acts as a very effective shield. A noisy plate supply unit generally indicates the lack of proper magnetic shielding, or improper filtering.

A third desirable characteristic of a power unit is good regulation, which determines how much the output voltage will change with changes in the amount of current being supplied by the unit. A particular plate supply device might give exactly 90 volts at the 90-volt tap with a load of 10 mA. If, however, the regulation was poor and your receiver only required 4 mA. from the 90-volt tap, the actual voltage at this tap might rise as high as 130 volts; if the unit had good regulation the voltage would not be more than 98 at a load of 4 mA. Power units with poor regulation frequently cause receivers to "motor boat" or distort the signal in some other way, and good regulation, i. e., small variation of output voltage with output load, is therefore a very desirable characteristic.

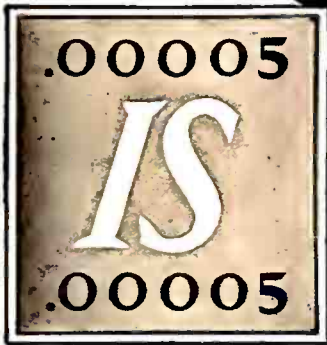

Permanently when Sangamo Mica Condensers are used.

Condenser accuracy is not only measured by factory tests of value—it is determined by permanence after heat of soldering, work box knocks, and a year or more of service under all atmospheric conditions!

Sangamo condensers are accurately rated (within 10 per cent of marked value) and of greater importance—they stay accurate. A solid sheathing of pressure-molded bakelite makes that certain.

SANGAMO ELECTRIC COMPANY
Springfield, Illinois

SANGAMO

MICA CONDENSERS

Hoyle

B ELIMINATOR VOLTMETER



A new sensitive voltmeter, for regular dealers' service work as well as for laboratory and precision measurements. Resistance 1,000 ohms per volt. Provided with two scales—0-100 volts and 0-500 volts, covering the entire range of ordinary B-Eliminator and Power-Amplifier work.

PRICES

HOYT Standard B-Eliminator Voltmeter, 0-100 and 0-500 volts, \$28.00.

Supplied on special order with additional scale, either: 0-10 volts or 0-100 ma. at \$32.50.

Send for price list B-9

BURTON-ROGERS CO.

Sole Selling Agents

Boston

Massachusetts

The Improved SHIELDED LABORATORY Receiver

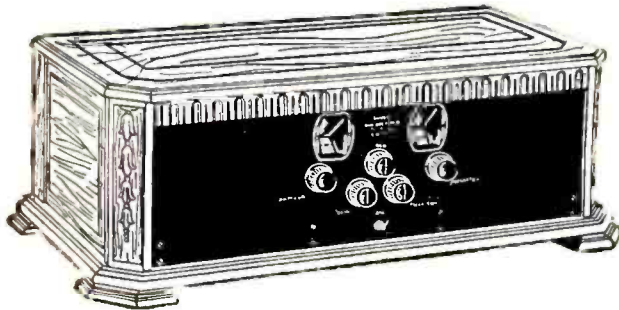

FROM the Setbuilders Supply Co. you can get all parts for the new Laboratory Receiver, each and every item most carefully inspected and checked, and with a guarantee that your set, assembled from these parts, will give you results you've never had before on any set. You can also buy tubes, batteries, cabinets and loud speakers specially approved and tested for the Laboratory Super by McMurdo Silver and Ernest R. Pfaff.

It goes without saying that you want to own the Laboratory Receiver, just as you want the best of anything. And the Laboratory Receiver is the best, for it has features that you won't find in the most expensive factory set you could buy. Take its selectivity for instance—it will tune in out of town stations through local interference that paralyzes ordinary sets. It's so sensitive it brings in these same stations with tremendous punch—when other sets don't even get through.

Then, its appearance is in the three to five hundred dollar class, though you're not handicapped by a factory cabinet—you can put your set in any cabinet or console that suits your taste.

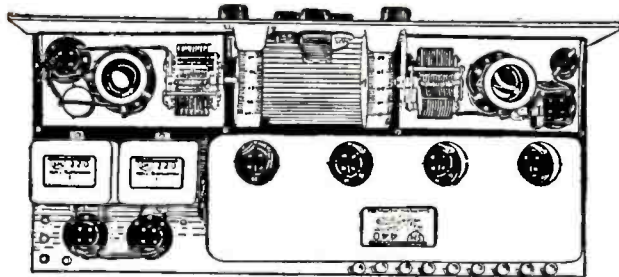

Tested and Guaranteed Parts Exactly as Specified for the Laboratory Receiver

1 Van Doorn panel and chassis, pierced, with hardware	\$8.50
1 Carter .00015 condenser with leak clips50
1 Carter M-200 potentiometer75
2 Carter No. 105, 1/2 mfd. condensers @.90 ...	1.80
1 Carter 3 ohm rheostat50
1 Carter battery Switch50
4 Carter No. 10 tipjacks @ .10.....	.40
1 Polymet 2 megohm leak25
2 S-M 220 audio transformers @ 8.00.....	16.00
4 S-M 511 tube sockets @ .50	2.00
2 S-M 805 vernier drum dials @ 3.00	6.00
1 S-M 275 RF choke90
1 S-M 342 condenser	1.50
1 S-M 440 time signal amplified, 112 K.C.....	35.00
2 S-M 515 coil sockets @ 1.00	2.00
2 S-M 111A coils @ 2.50	5.00
9 X-L binding posts @ .15	1.35
2 S-M 320 .00035 condensers @ 3.25	6.50
	<hr/> \$89.45

GUARANTEE

The Setbuilders Supply Company unconditionally guarantees the performance of any receiver built from the parts listed above to be superior to that of any other eight-tube receiver.

SETBUILDERS SUPPLY CO.

502-E South Peoria St., Chicago, U. S. A.

FACTS

Sensitivity: The Laboratory Receiver, in direct comparative tests, will bring in with loud speaker volume stations barely audible upon seven and eight tube shielded neotrodynes. Compared to other super-heterodynes, it will give greater volume, and generally bring in more stations, than any other eight or nine tube sets.

Selectivity: Located in Chicago, the Laboratory Receiver will allow reception of out-of-town stations within 7 to 10 kilocycles of powerful locals. In comparative tests, it will give greater selectivity than any eight or nine tube super that can be built from standard parts. In fact, the set is so selective that it will take a week's careful combing of the broadcast band to log all stations within range!

Range: On short waves below 200 meters, the range is unlimited—5,000 to 12,000 miles reception is not at all unusual. In the 200 to 550 meter broadcast band, the range is 1,000 to 10,000 miles, but is guaranteed equal to or greater than that of any other receiver. Between 500 and 3,000 meters, the range is guaranteed greater than that of any other receiver. **Volume:** It can only be stated that the volume of the Laboratory Receiver is equal to that of any standard receiver, and is guaranteed equal or greater than that of any eight to ten tube set.

Wavelength Range: 30 to 3,000 meters with standard interchangeable plug-in coil.

Amplification: The first detector and oscillator give a voltage amplification of 25; the long wave and second detector 10,000 (10 x 10 x 10 x 10 for four tubes); and the audio amplifier, 400 (20 x 20 for two stages). The over-all amplification is thus seen to be 100,000,000—about 80 times that of average eight tube super-heterodynes; about twice that of the best eight tube neotrodynes, and 20 times that of average seven tube shielded neotrodynes. The one hundred million amplification figure for the Laboratory Receiver is without extremely critical adjustment—critically adjusted for a very weak station, it will go up to a billion times or more!

**This Brings
All the
Details!**

Please send me all data on the Laboratory Receiver for which I enclose 10c.

TRIMM Headsets

For

Short-Wave Receivers



Dr. Donald B. MacMillan

used Trimm Headsets in his last three expeditions to the Arctic regions in the ship Bowdoin. Here, isolated from the rest of the world, with no chance to make repairs, Dr. MacMillan depended on Trimm 'phones, maintaining unprecedented communication over tremendous distances.

Short-Wave Radio

is growing in interest. The new conquests, the big promise of the future are definitely tied up with these experiments. At least three American stations are broadcasting short-wave voice and music. The most progressive of the amateurs are constructing short-wave sets. And their experiences are writing a chapter of modern miracles.

Trimm Head 'Phones

are the choice of the leading amateurs and expert radio men. The Trimm Professional leads the line.



Trimm Professional Headsets at \$5.50

The Trimm Dependable at \$4.00 is the best low-priced headset on the market. At a price but little higher than that of a cheap, inefficient headset, you may buy this real quality instrument.

At all Radio Dealers
or write to us direct



Manufacturers' Booklets

A Varied List of Books Pertaining to Radio and Allied Subjects Obtainable Free With the Accompanying Coupon

READERS may obtain any of the booklets listed below by using the coupon printed on page 322. Order by number only.

1. FILAMENT CONTROL—Problems of filament supply, voltage regulation, and effect on various circuits. RADIALL COMPANY.
2. HARD RUBBER PANELS—Characteristics and properties of hard rubber as used in radio, with suggestions on how to "work" it. B. F. GOODRICH RUBBER COMPANY.
3. TRANSFORMERS—A booklet giving data on input and output transformers. PACENT ELECTRIC COMPANY.
4. RESISTANCE-COUPLED AMPLIFIERS—A general discussion of resistance coupling with curves and circuit diagrams. COLE RADIO MANUFACTURING COMPANY.
5. CARBORUNDUM IN RADIO—A book giving pertinent data on the crystal as used for detection, with hook-ups, and a section giving information on the use of resistors. THE CARBORUNDUM COMPANY.
6. B-ELIMINATOR CONSTRUCTION—Constructional data on how to build. AMERICAN ELECTRIC COMPANY.
7. TRANSFORMER AND CHOKE-COUPLED AMPLIFICATION—Circuit diagrams and discussion. ALL-AMERICAN RADIO CORPORATION.
8. RESISTANCE UNITS—A data sheet of resistance units and their application. WARD-LEONARD ELECTRIC COMPANY.
9. VOLUME CONTROL—A leaflet showing circuits for distortionless control of volume. CENTRAL RADIO LABORATORIES.
10. VARIABLE RESISTANCE—As used in various circuits. CENTRAL RADIO LABORATORIES.
11. RESISTANCE COUPLING—Resistors and their application to audio amplification, with circuit diagrams. DEJUR PRODUCTS COMPANY.
12. DISTORTION AND WHAT CAUSES IT—Hook-ups of resistance-coupled amplifiers with standard circuits. ALLEN-BRADLEY COMPANY.
13. B-ELIMINATOR AND POWER AMPLIFIER—Instructions for assembly and operation using Raytheon tube. GENERAL RADIO COMPANY.
- 13a. B-ELIMINATOR AND POWER AMPLIFIER—Instructions for assembly and operation using an R. C. A. rectifier. GENERAL RADIO COMPANY.
16. VARIABLE CONDENSERS—A description of the functions and characteristics of variable condensers with curves and specifications for their application to complete receivers. ALLEN D. CARDWELL MANUFACTURING COMPANY.
17. BAKELITE—A description of various uses of bakelite in radio, its manufacture, and its properties. BAKELITE CORPORATION.
19. POWER SUPPLY—A discussion on power supply with particular reference to lamp-socket operation. Theory and constructional data for building power supply devices. ACME APPARATUS COMPANY.
20. AUDIO AMPLIFICATION—A booklet containing data on audio amplification together with hints for the constructor. ALL AMERICAN RADIO CORPORATION.
21. HIGH-FREQUENCY DRIVER AND SHORT-WAVE WAVE-METER—Constructional data and application. BURGESS BATTERY COMPANY.
46. AUDIO-FREQUENCY CHOKES—A pamphlet showing positions in the circuit where audio-frequency chokes may be used. SAMSON ELECTRIC COMPANY.
47. RADIO-FREQUENCY CHOKES—Circuit diagrams illustrating the use of chokes to keep out radio-frequency currents from definite points. SAMSON ELECTRIC COMPANY.
48. TRANSFORMER AND IMPEDANCE DATA—Tables giving the mechanical and electrical characteristics of transformers and impedances, together with a short description of their use in the circuit. SAMSON ELECTRIC COMPANY.
49. BYPASS CONDENSERS—A description of the manufacture of bypass and filter condensers. LESLIE F. MUTER COMPANY.
50. AUDIO MANUAL—Fifty questions which are often asked regarding audio amplification, and their answers. AMERTRAN SALES COMPANY, INCORPORATED.
51. SHORT-WAVE RECEIVER—Constructional data on a receiver which, by the substitution of various coils, may be made to tune from a frequency of 16,660 kc. (18 meters) to 1090 kc. (150 meters). SILVER-MARSHALL, INCORPORATED.
52. AUDIO QUALITY—A booklet dealing with audio-frequency amplification of various kinds and the application to well-known circuits. SILVER-MARSHALL, INCORPORATED.
56. VARIABLE CONDENSERS—A bulletin giving an analysis of various condensers together with their characteristics. GENERAL RADIO COMPANY.
57. FILTER DATA—Facts about the filtering of direct current supplied by means of motor-generator outfits used with transmitters. ELECTRIC SPECIALTY COMPANY.
59. RESISTANCE COUPLING—A booklet giving some general information on the subject of radio and the application of resistors to a circuit. DAVEN RADIO CORPORATION.
60. RESISTORS—A pamphlet giving some technical data on resistors which are capable of dissipating considerable energy; also data on the ordinary resistors used in resistance-coupled amplification. THE CRESCENT RADIO SUPPLY COMPANY.
62. RADIO-FREQUENCY AMPLIFICATION—Constructional details of a five-tube receiver using a special design of radio-frequency transformer. CAMFIELD RADIO MFG. COMPANY.
63. FIVE-TUBE RECEIVER—Constructional data on building a receiver. AFRO PRODUCTS, INCORPORATED.
64. AMPLIFICATION WITHOUT DISTORTION—Data and curves illustrating the use of various methods of amplification. ACME APPARATUS COMPANY.
66. SUPER-HETERODYNE—Constructional details of a seven-tube set. G. C. EVANS COMPANY.
70. IMPROVING THE AUDIO AMPLIFIER—Data on the characteristics of audio transformers, with a circuit diagram showing where chokes, resistors, and condensers can be used. AMERICAN TRANSFORMER COMPANY.
72. PLATE SUPPLY SYSTEM—A wiring diagram and layout plan for a plate supply system to be used with a power amplifier. Complete directions for wiring are given. AMERTRAN SALES COMPANY.
80. FIVE-TUBE RECEIVER—Data are given for the construction of a five-tube tuned radio-frequency receiver. Complete instructions, list of parts, circuit diagram, and template are given. ALL-AMERICAN RADIO CORPORATION.
81. BETTER TUNING—A booklet giving much general information on the subject of radio reception with specific illustrations. Primarily for the non-technical home constructor. BREMER-TULLY MANUFACTURING COMPANY.
82. SIX-TUBE RECEIVER—A booklet containing photographs, instructions, and diagrams for building a six-tube shielded receiver. SILVER-MARSHALL, INCORPORATED.
83. SOCKET POWER DEVICE—A list of parts, diagrams, and templates for the construction and assembly of socket power devices. JEFFERSON ELECTRIC MANUFACTURING COMPANY.
84. FIVE-TUBE EQUAMATIC—Panel layout, circuit diagrams, and instructions for building a five-tube receiver, together with data on the operation of tuned radio-frequency transformers of special design. KARAS ELECTRIC COMPANY.
85. FILTER—Data on a high-capacity electrolytic condenser used in filter circuits in connection with A socket power supply units, are given in a pamphlet. THE ABOX COMPANY.
86. SHORT-WAVE RECEIVER—A booklet containing data on a short-wave receiver as constructed for experimental purposes. THE ALLEN D. CARDWELL MANUFACTURING CORPORATION.
88. SUPER-HETERODYNE CONSTRUCTION—A booklet giving full instructions, together with a blue print and necessary data, for building an eight-tube receiver. THE GEORGE W. WALKER COMPANY.
89. SHORT-WAVE TRANSMITTER—Data and blue prints are given on the construction of a short-wave transmitter, together with operating instructions, methods of keying, and other pertinent data. RADIO ENGINEERING LABORATORIES.
90. IMPEDANCE AMPLIFICATION—The theory and practice of a special type of dual-impedance audio amplification are given. ALDEN MANUFACTURING COMPANY.
93. B-SOCKET POWER—A booklet giving constructional details of a socket-power device using either the BH or 313 type rectifier. NATIONAL COMPANY, INCORPORATED.
94. POWER AMPLIFIER—Constructional data and wiring diagrams of a power amplifier combined with a B-supply unit are given. NATIONAL COMPANY, INCORPORATED.
100. A, B, AND C SOCKET-POWER SUPPLY—A booklet giving data on the construction and operation of a socket-power supply using the new high-current rectifier tube. THE Q. R. S. MUSIC COMPANY.
101. USING CHOKES—A folder with circuit diagrams of the more popular circuits showing where choke coils may be placed to produce better results. SAMSON ELECTRIC COMPANY.

ACCESSORIES

22. A PRIMER OF ELECTRICITY—Fundamentals of electricity with special reference to the application of dry cells to radio and other uses. Constructional data on buzzers, automatic switches, alarms, etc. NATIONAL CARBON COMPANY.
23. AUTOMATIC RELAY CONNECTIONS—A data sheet showing how a relay may be used to control A and B circuits. YAXLEY MANUFACTURING COMPANY.
25. ELECTROLYTIC RECTIFIER—Technical data on a new type of rectifier with operating curves. KODEL RADIO CORPORATION.
26. DRY CELLS FOR TRANSMITTERS—Actual tests given, well illustrated with curves showing exactly what may be expected of this type of B power. BURGESS BATTERY COMPANY.
27. DRY-CELL BATTERY CAPACITIES FOR RADIO TRANSMITTERS—Characteristic curves and data on discharge tests. BURGESS BATTERY COMPANY.
28. B BATTERY LIFE—Battery life curves with general curves on tube characteristics. BURGESS BATTERY COMPANY.
29. HOW TO MAKE YOUR SET WORK BETTER—A non-technical discussion of general radio subjects with hints on how reception may be bettered by using the right tubes. UNITED RADIO AND ELECTRIC CORPORATION.
30. TUBE CHARACTERISTICS—A data sheet giving constants of tubes. C. E. MANUFACTURING COMPANY.
31. FUNCTIONS OF THE LOUD SPEAKER—A short, non-technical general article on loud speakers. AMPLION CORPORATION OF AMERICA.
32. METERS FOR RADIO—A catalogue of meters used in radio, with connecting diagrams. BURTON-ROGERS COMPANY.
33. SWITCHBOARD AND PORTABLE METERS—A booklet giving dimensions, specifications, and shunts used with various meters. BURTON-ROGERS COMPANY.
34. COST OF B BATTERIES—An interesting discussion of the relative merits of various sources of B supply. HARTFORD BATTERY MANUFACTURING COMPANY.
35. STORAGE BATTERY OPERATION—An illustrated booklet on the care and operation of the storage battery. GENERAL LEAD BATTERIES COMPANY.
36. CHARGING A AND B BATTERIES—Various ways of connecting up batteries for charging purposes. WESTINGHOUSE UNION BATTERY COMPANY.
37. CHOOSING THE RIGHT RADIO BATTERY—Advice on what dry cell battery to use; their application to radio, with wiring diagrams. NATIONAL CARBON COMPANY.
53. TUBE REACTIVATOR—Information on the care of vacuum tubes, with notes on how and when they should be reactivated. THE STERLING MANUFACTURING COMPANY.
54. ARRESTERS—Mechanical details and principles of the vacuum type of arrester. NATIONAL ELECTRIC SPECIALTY COMPANY.
55. CAPACITY CONNECTOR—Description of a new device for connecting up the various parts of a receiving set, and at the same time providing bypass condensers between the leads. KUR7-KASCH COMPANY.

(Continued on page 322)

**NATIONAL
RADIO CHARGERS**



2½ ampere Charger. Employs one Raytheon "A" Rectifier. Complete with cord and plug, rubber-covered battery leads and terminals.

Price \$11.50

NATIONAL Radio Chargers use the new RAYTHEON "A" dry rectifier cartridge. They are light, compact and use very little electric current. Made to recognized NATIONAL standards.



NATIONAL Duo Range Chargers, 2½ or 5 amperes. Complete with fuses, tell-tale lamp, cord, black rubber-covered leads and battery clips and two Raytheon "A's"

Price \$19.00

**NATIONAL
RADIO PRODUCTS**

Send for Pamphlet B-9

NATIONAL CO., Inc., Malden, Mass.
W. A. Ready, President

New!

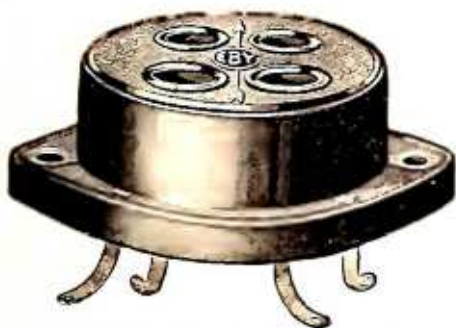

and *Much Better!*

The prongs are completely enclosed and *can't* spread. No more socket trouble to shoot!

After all, a socket's only job is to provide a perfect contact. The Eby three point wiping spring contact is the most scientifically perfect type known.

Easy to mount above or below Bakelite, Wood, or Metal.

Specified in Hammarlund Roberts Hi-Q6 and other popular circuits.

List Price 40c

THE H. H. EBY MFG. CO.

INCORPORATED

4710 Stenton Ave.

Phila., Pa.

Makers of Eby Binding Posts

TIME

*to think about
your set!*

AUTUMN is coming—World's Series games, Davis Cup matches, football, even a heavy-weight championship to be decided.

But will your set be ready? Most sets lose their vitality through summer idleness, taking on a general fatigue which affects batteries, tubes, and circuits alike. Your set is probably no exception.

It may have a "swinging open-circuit," improper voltage "balance" between B and C batteries, or some other electrical defect. Can you locate these troubles and correct them?

Your set deserves an electrical inspection with



WESTON

Model 519

Radio

Set Tester

1000

ohms

per volt

Consult a Reliable Dealer—One who maintains a service department equipped to make the required tests at your home. Make certain that his service man employs the instrument shown above. You can then be assured that your set will receive a thorough "conditioning"—circuits adjusted, tubes and batteries replaced where necessary—and all with laboratory accuracy.

Then with your set in complete order you should install a small Weston instrument to *maintain* the efficiency of your set.

There are several models available. Your dealer will advise you which one to use for your set. Ask for Circular J.

**WESTON ELECTRICAL
INSTRUMENT CORPORATION**

179 Weston Avenue, Newark, N. J.



STANDARD THE WORLD OVER

WESTON

Pioneers since 1888



"RADIO BROADCAST'S" DIRECTORY OF MANUFACTURED RECEIVERS

☐ A coupon will be found on page 328. All readers who desire additional information on the receivers listed below need only

insert the proper numbers in the coupon, mail it to the Service Department of RADIO BROADCAST, and full details will be sent.

KEY TO TUBE ABBREVIATIONS

99—60-mA. filament (dry cell)
01A—Storage battery 0.25 amps. filament
12—Power tube (Storage battery)
71—Power tube (Storage battery)
16B—Half-wave rectifier tube
Hmu—High-Mu tube for resistance-coupled audio
20—Power tube (dry cell)
10—Power Tube (Storage battery)
00A—Special detector
13—Full-wave rectifier tube
26—Low-voltage high-current a. c. tubes
27—Heater type a. c. tube

DIRECT CURRENT RECEIVERS

NO. 424. COLONIAL 26

Six tubes; 2 t. r. f. (01-A), detector (12), 2 transformer audio (01-A and 71). Balanced t. r. f. One to three dials. Volume control: antenna switch and potentiometer across first audio. Watts required: 120. Console size: 34 x 38 x 18 inches. Headphone connections. The filaments are connected in a series parallel arrangement. Price \$250 including power unit.

NO. 425. SUPERPOWER

Five tubes: All 01-A tubes. Multiplex circuit. Two dials. Volume control: resistance in r. f. plate. Watts required: 30. Antenna: loop or outside. Cabinet sizes: table, 27 x 10 x 9 inches; console, 28 x 50 x 21. Prices: table, \$135 including power unit; console, \$390 including power unit and loud speaker.

A. C. OPERATED RECEIVERS

NO. 508. ALL-AMERICAN 77, 88, AND 99

Six tubes; 3 t. r. f. (26), detector (27), 2 transformer audio (26 and 71). Rice neutralized t. r. f. Single drum tuning. Volume control: potentiometer in r. f. plate. Cabinet sizes: No. 77, 21 x 10 x 8 inches; No. 88 Hiboy, 25 x 38 x 18 inches; No. 99 console, 27½ x 43 x 20 inches. Shielded. Output device. The filaments are supplied by means of three small transformers. The plate supply employs a gas-filled rectifier tube. Volt-meter in a. c. supply line. Prices: No. 77, \$150, including power unit; No. 88, \$210 including power unit; No. 99, \$285 including power unit and loud speaker.

NO. 509. ALL-AMERICAN "DUET"; "SEXTET"

Six tubes; 2 t. r. f. (99), detector (99), 3 transformer audio (99 and 12). Rice neutralized t. r. f. Two dials. Volume control: resistance in r. f. plate. Cabinet sizes: "Duet," 23 x 56 x 16½ inches; "Sextet," 22½ x 13½ x 15½ inches. Shielded. Output device. The 99 filaments are connected in series and supplied with rectified a. c., while 12 is supplied with raw a. c. The plate and filament supply uses gaseous rectifier tubes. Milliammeter on power unit. Prices: "Duet," \$160 including power unit; "Sextet," \$220 including power unit and loud speaker.

NO. 511. ALL-AMERICAN 80, 90, AND 115

Five tubes; 2 t. r. f. (99), detector (99), 2 transformer audio (99 and 12). Rice neutralized t. r. f. Two dials. Volume control: resistance in r. f. plate. Cabinet sizes: No. 80, 23½ x 12½ x 15 inches; No. 90, 37½ x 12 x 12½ inches; No. 115 Hiboy, 24 x 41 x 15 inches. Coils individually shielded. Output device. See No. 509 for power supply. Prices: No. 80, \$135 including power unit; No. 90, \$145 including power unit and compartment; No. 115, \$170 including power unit, compartment, and loud speaker.

NO. 510. ALL-AMERICAN 7

Seven tubes; 3 t. r. f. (26), 1 untuned r. f. (26), detector (27), 2 transformer audio (26 and 71). Rice neutralized t. r. f. One drum. Volume control: resistance in r. f. plate. Cabinet sizes: "Sovereign" console, 30½ x 60½ x 19 inches; "Lorraine" Hiboy, 25½ x 53½ x 17½ inches; "Forte" cabinet, 25½ x 13½ x 17½ inches. For filament and plate supply: See No. 508. Prices: "Sovereign" \$460; "Lorraine" \$360; "Forte" \$270. All prices include power unit. First two include loud speaker.

NO. 403. ARGUS 250B

Six tubes; 2 t. r. f. (99), 1 untuned r. f. (99), detector (99), 2 transformer audio (99 and 12). Stabilized with grid resistances. Two dials. Volume control: resistance across 1st audio. Watts required: 100. Cabinet size: 35½ x 14½ x 10½ inches. Output device. The 99 filaments are connected in series and supplied with rectified a. c., while the 12 is run on raw a. c. The power unit requires two 16-B rectifier tubes. Milliammeter included in d. c. supply. Price \$250.00 including self-contained power unit. Other models: No. 125, \$125.00; console model, \$375.00.

NO. 401. AMRAD AC9

Six tubes; 3 t. r. f. (99), detector (99), 2 transformer (99 and 12). Neutrodyne. Two dials. Volume control: resistance across 1st audio. Watts consumed: 50. Cabinet size: 27 x 9 x 11½ inches. The 99 filaments are connected in series and supplied with rectified a. c., while the 12 is run on raw a. c. The power unit, requiring two 16-B rectifiers, is separate and supplies A, B, and C current. Price \$142 including power unit.

NO. 402. AMRAD AC5

Five tubes. Same as No. 401 except one less r. f. stage. Price \$125 including power unit.

NO. 484. BOSWORTH, B5

Five tubes; 2 t. r. f. (26), detector (99), 2 transformer audio (special a. c. tubes). T. r. f. circuit. Two dials. Volume control: potentiometer. Cabinet size: 23 x 7 x 8 inches. Output device included. Price \$175.

NO. 406. CLEARSTONE 110

Five tubes; 2 t. r. f., detector, 2 transformer audio. All tubes a. c. heater type. One or two dials. Volume control: resistance in r. f. plate. Watts consumed: 40. Cabinet size: varies. The plate supply is built in the receiver and requires one rectifier tube. Filament supply through step down transformers. Prices range from \$175 to \$375 which includes 5 a. c. tubes and one rectifier tube.

NO. 407. COLONIAL 25

Six tubes; 2 t. r. f. (01-A), detector (99), 2 resistance audio (99), 1 transformer audio (10). Balanced t. r. f. circuit. One or three dials. Volume control: Antenna switch and potentiometer on 1st audio. Watts consumed: 100. Console size: 34 x 38 x 18 inches. Output device. All tube filaments are operated on a. c. except the detector which is supplied with rectified a. c. from the plate supply. The rectifier employs two 16-B tubes. Price \$250 including built-in plate and filament supply.

NO. 507. CROSLY 602 BANDBOX

Six tubes; 3 t. r. f. (26), detector (27), 2 transformer audio (26 and 71). Balanced t. r. f. circuit. One dial. Cabinet size: 17½ x 5½ x 7½ inches. The heaters for the a. c. tubes and the 71 filament are supplied by small transformers available to operate either on 50 or 60 cycles. The plate current is supplied by means of rectifier tube. Price \$65 for set alone, power unit \$60.

NO. 408. DAY-FAN "DE LUXE"

Six tubes; 3 t. r. f., detector, 2 transformer audio. All 01-A tubes. One dial. Volume control: potentiometer across r. f. tubes. Watts consumed: 300. Console size: 30 x 40 x 20 inches. The filaments are connected in series and supplied with d. c. from a motor-generator set which also supplies B and C current. Output device. Price \$350 including power unit.

NO. 409. DAYCRAFT 5

Five tubes; 2 t. r. f., detector, 2 transformer audio. All a. c. heater tubes. Reflexed t. r. f. One dial. Volume control: potentiometers in r. f. plate and 1st audio. Watts consumed: 135. Console size: 34 x 36 x 14 inches. Output device. The heaters are supplied by means of a small transformer. A built-in rectifier supplies B and C voltages. Price \$170, less tubes. The following have one more r. f. stage and are not reflexed: Daycraft 6, \$195; Dayrole 6, \$235; Dayfan 6, \$110. All prices less tubes.

NO. 469. FREED-EISEMANN NR11

Six tubes; 3 t. r. f. (01-A), detector (01-A), 2 transformer audio (01-A and 71). Neutrodyne. One dial. Volume control: potentiometer. Watts consumed: 150. Cabinet size: 19½ x 10 x 10½ inches. Shielded. Output device. A special power unit is included employing a rectifier tube. Price \$225 including NR-411 power unit.

NO. 487. FRESHMAN 7F-AC

Six tubes; 3 t. r. f. (26), detector (27), 2 transformer audio (26 and 71). Equaphase circuit. One dial. Volume control: potentiometer across 1st audio. Console size: 24½ x 41½ x 15 inches. Output device. The filaments and heaters are all supplied by means of small transformers. The plate supply requires one 13 rectifier tube. Price \$160 including tubes.

NO. 411. HERBERT LECTRO 120

Five tubes; 2 t. r. f. (99), detector (99), 2 transformer audio (99 and 71). Three dials. Volume control: rheostat in primary of a. c. transformer. Watts required: 45. Cabinet size: 32 x 10 x 12 inches. The 99 filaments are connected in series, supplied with rectified a. c., while the 71 is run on raw a. c. The power unit uses a Q. R. S. rectifier tube. Price \$120.

NO. 412. HERBERT LECTRO 200

Six tubes; 2 t. r. f. (99), detector (99), 1 transformer audio (99), 1 push-pull audio (71). One dial. Volume control: rheostat in primary of a. c. transformer. Watts consumed: 60. Cabinet size: 20 x 12 x 12 inches. Filaments connected same as above. Completely shielded. Output device. Price \$200.

NO. 410. LARCOFLEX 73

Seven tubes; 4 t. r. f. (01-A), detector (01-A), 2 transformer audio (01-A and 71). T. r. f. circuit. One dial. Volume control: resistance in r. f. plate. Console size 30 x 42 x 20 inches. Completely shielded. Built-in A, B and C supply. Price \$215.

NO. 490. MOHAWK

Six tubes; 2 t. r. f., detector, 2 transformer audio. All tubes a. c. heater type except 71 in last stage. One dial. Volume control: rheostat on r. f. Watts consumed: 40. Panel size: 12½ x 8½ inches. Output device. The heaters for the a. c. tubes and the 71 filament are supplied by small transformers. The plate supply is of the built-in type using a rectifier tube. Prices range from \$65 to \$245.

NO. 413. MARTI

Six tubes; 2 t. r. f., detector, 3 resistance audio. All tubes a. c. heater type. Two dials. Volume control: resistance in r. f. plate. Watts consumed: 38. Panel size 7 x 21 inches. The built-in plate supply employs one 16-B rectifier. The filaments are supplied by a small transformer. Prices: table, \$235 including tubes and rectifier; console, \$275 including tubes and rectifier; console, \$325 including tubes, rectifier, and loud speaker.

NO. 416. NASSAU POWER

Six tubes; 2 t. r. f. (99) detector (99), 3 audio (99 and 10). Two dials. Volume control: resistance in r. f. plate circuit. Bridge circuit. Cabinet size: 28 x 45 x 18 inches. The 99 filaments are connected in series and supplied with rectified a. c., while the 10 is supplied with raw a. c. The power unit requires one 16-B tube. Output device. Milliammeter on the front panel indicates filament current.

NO. 417. RADIOLA 28

Eight tubes; 2 detectors (99) 1 oscillator (99), 2 transformer audio (99 and 10), 3 intermediate frequency (99). Super-heterodyne. One dial. Volume control: potentiometer on intermediate stages. Console size: 26½ x 63 x 17 inches. The 99 filaments are connected in series and supplied with rectified a. c., while the 10 tube is supplied with raw a. c. The power unit requires two 216-B's, one 874, and one 876, the latter two being regulator tubes. Loop operated. Shielded. Output device. Price \$540 including all tubes and No. 104 loud speaker. Model 28 also sold without the power units and loud speaker.

NO. 418. SUPERPOWER A. C.

Five tubes; "Multiplex" circuit using 01-A tubes. Two dials. Volume control: resistance in r. f. plate. Console size: 28 x 50 x 21 inches. Antenna: loop or outside. The filaments of the 01-A tubes are supplied with rectified a. c. The rectifier employs two tungar tubes. Price \$390 including loud speaker and power unit. Cabinet size: 27 x 10 x 9 inches and lists for \$180 including power unit.

NO. 420. SIMPLEX B

Six tubes; 3 t. r. f., detector, 2 transformer audio. All tubes a. c. heater type. One dial. Volume control resistance in r. f. plate. Headphone connection. Console size: 34 x 36 x 14 inches. The heaters are supplied by means of a small a. c. transformer, the B and C voltage being obtained from a built-in plate supply unit. Price \$250, complete.

NO. 421. SOVEREIGN 238

Seven tubes of the a. c. heater type. Balanced t. r. f. Two dials. Volume control: resistance across 2nd audio. Watts consumed: 45. Console size: 37 x 52 x 15 inches. The heaters are supplied by a small a. c. transformer, while the plate is supplied by means of rectified a. c. using a gaseous type rectifier. Price \$325, including power unit and tubes.

NO. 422. SUPERVOX, JR. AND SR.

Four tubes; 1 t. r. f., detector, 2 transformer audio. All tubes a. c. heater type except last which is a 71. One dial. Volume controls: antenna coupler and resistance in r. f. plate. Watts required: 40. Console size: 28 x 30 x 16 inches. Shielded detector. Output device. The heaters are supplied by a small transformer while the 71 filament is supplied with a. c. Price \$275 complete. The SupervoX Sr. has one more stage of t. r. f., has two dials, requires 60 watts, is completely shielded and has output device. Price \$450, complete.

NO. 488. U-FLEX 5

Four tubes; 2 t. r. f., crystal detector, 2 transformer audio. Reflexed. Three dials. Volume control: resistance in r. f. plate. Cabinet size: 28 x 9 x 9½ inches. A 01-A is used as a rectifier for the plate supply. Headphone connection. Price, \$125.00

BATTERY OPERATED RECEIVERS

NO. 512. ALL-AMERICAN 44, 45, AND 66

Six tubes; 3 t. r. f. (01-A, detector) 01-A, 2 transformer audio (01-A and 71). Rice neutralized t. r. f. Drum control. Volume control: rheostat in r. f. Cabinet sizes: No. 44, 21 x 10 x 8 inches; No. 55, 25 x 38 x 18 inches; No. 66, 27½ x 43 x 20 inches. C-battery connections. Battery cable. Antenna: 75 to 125 feet. Prices: No. 44, \$70; No. 55, \$125 including loud speaker; No. 66, \$200 including loud speaker.

NO. 428. AMERICAN C6

Five tubes; 2 t. r. f., detector, 2 transformer audio. All 01-A tubes. Semi balanced t. r. f. Three dials. Plate current 15 mA. Volume control: potentiometer. Cabinet sizes: table, 20 x 8½ x 10 inches; console, 36 x 40 x 17 inches. Partially shielded. Battery cable. C-battery connections. Antenna: 125 feet. Prices: table, \$30; console, \$65 including loud speaker.

NO. 433. ARBORPHONE

Five tubes; 2 t. r. f., detector, 2 transformer audio. All 01-A tubes. Two dials. Plate current: 16 mA. Volume control: rheostat in r. f. and resistance in r. f. plate. C-battery connections. Binding posts. Antenna: taps for various lengths. Cabinet size: 24 x 9 x 10½ inches. Price: \$65.

Better Results from POWER CIRCUITS

Centralab Power Rheostat

HERE are the new Centralab units designed especially for use in socket power circuits to carry continuously and unusually heavy current for their size, providing smooth acting control under all conditions.

Centralab Power Rheostat is warp-proof, heat-proof, permitting continuous operation at temperatures of 482° F. and beyond. Resistance wire is wound on metal core, asbestos insulated. Core expands with wire, insuring smooth action. Narrow resistance strips give small resistance jumps per turn, further insurance of even regulation. Compact 2" diameter, 1" behind panel. Ohms—500, 250, 150, 50, 15, 6, 3, 2, .5—price \$1.25.



POWER Centralab Potentiometer

This new unit is identical with the Power Rheostat except for an additional terminal, and is especially suited to obtain variable voltages for detector tube and variable "C" bias in socket power circuits. 15, 150, 250 ohms, \$1.50; 2,000, \$1.75; 5,000, \$2.00.

4th TERMINAL Centralab Potentiometer

With an added semi-variable contact arm, this new potentiometer is identical to the above units. The 4th terminal is adjustable behind panel to any resistance value. 175 ohm unit gives 2 variable voltages in ABC power circuits. 250 ohms is used with the new Raytheon ABC. The 2,000 is used for "C" bias in such circuits as AmerTran Power Pack. Two 6,000 ohm units in series across output of a "B" eliminator gives best possible voltage regulation. 175, 250 ohms, \$2; 2,000, 3,000, 5,000, \$2.25.

At your dealer's, or C.O.D. Send for new ABC power circuits and circuits for improved "B" power control.

Central Radio Laboratories
22 Keefe Ave., Milwaukee, Wis.

Centralab

BETWEEN 80 and 5000 Cycles is the effective range of Radio Reproduction



Type 285 Transformers

The type 285 transformers are available in two ratios as follows:

Type 285-H 1 to 6
Type 285-D 1 to 3

Price \$6⁰⁰ each



Type 387-A

The function of the Speaker Filter is to protect the speaker windings from the direct current while allowing an unimpeded flow of alternating frequency current. This reduces the amount of distortion and prolongs the life of the speaker. Such a device should always be used especially between a power tube in the last audio stage and the speaker.

Price \$6⁰⁰

In buying parts for an audio amplifier it should be borne in mind that no better tone quality can be reproduced than is radiated from the broadcasting station or than can be sustained by the loudspeaker regardless of what method of coupling may be used.

The frequency range of the better broadcasting stations is about 80 to 5000 cycles; the frequency range of the better loudspeaker is about 80 to 7000 cycles; thus making the effective range of radio reproduction between 80 and 5000 cycles. This represents approximately the full orchestral and vocal range.

The logical amplifying device to use in covering the effective range of radio reproduction, then, is the one which will amplify uniformly all frequencies between 80 and 5000 cycles, with the greatest gain per stage and lowest operating cost. Such a device is a properly designed audio frequency amplifying transformer.

While other methods of coupling may have a more uniform frequency curve over a wider range than a transformer, there is much to be said in favor of using good transformers because of the greater gain in amplification per stage and the lower operating cost.

The General Radio Type 285 Transformers are designed to have a high inductance value, but with lower capacity. This combination sustains both the upper and lower ends of the amplification curve to the same degree as the middle portion and is accomplished by using a larger core of a very high quality of selected steel and proper adjustment of coil turns.

When you overhaul your old receiver or build your new one why not assure yourself of good tone quality with plenty of volume at moderate cost by using a pair of General Radio Type 285 transformers?

Have you thought of operating your set entirely from the light socket by using the new A. C. tubes and a plate supply unit?

Write for our circular showing how to rewire the filament circuits of a standard four tube set to use the new A. C. tubes.

GENERAL RADIO COMPANY
Cambridge Massachusetts

GENERAL RADIO
PARTS AND ACCESSORIES

NO. 431. AUDIOLA 6

Six tubes; 3 t.r.f. (01-A), detector (00-A), 2 transformer audio (01-A and 71). Drum control. Plate current: 20 mA. Volume control: resistance in r.f. plate. Stage shielding. Battery cable. C-battery connection. Antenna: 50 to 100 feet. Cabinet size: 28½ x 11 x 14½ inches. Price not established.

NO. 432. AUDIOLA 8

Eight tubes; 4 t.r.f. (01-A), detector (00-A), 1 transformer audio (01-A), push-pull audio (12 or 71). Bridge balanced t.r.f. Drum control. Volume control: resistance in r.f. plate. Stage shielding. Battery cable. C-battery connections. Antenna: 10 to 100 feet. Cabinet size: 28½ x 11 x 149 inches. Price not established.

NO. 485. BOSWORTH B6

Five tubes; 2 t.r.f. (01-A), detector (01-A), 2 transformer audio (01-A and 71). Two dials. Volume control: variable grid resistances. Battery cable. C-battery connections. Antenna: 25 feet or longer. Cabinet size 15 x 7 x 8 inches. Price \$75.

NO. 513. COUNTERPHASE SIX

Six tubes; 3 t.r.f. (01-A), detector (00-A), 2 transformer audio (01-A and 12). Counterphase t.r.f. Two dials. Plate current: 32 mA. Volume control: rheostat on 2nd and 3rd r.f. Coils shielded. Battery cable. C-battery connections. Antenna: 75 to 100 feet. Console size: 18½ x 40½ x 15½ inches. Prices: Model 35, table, \$110; Model 37, console, \$175.

NO. 514. COUNTERPHASE EIGHT

Eight tubes; 4 t.r.f. (01-A), detector (00-A), 2 transformer audio (01-A and 12). Counterphase t.r.f. One dial. Plate current: 40 mA. Volume control: rheostat in 1st r.f. Copper stage shielding. Battery cable. C-battery connections. Antenna: 75 to 100 feet. Cabinet size: 30 x 12½ x 16 inches. Prices: Model 12, table, \$225; Model 16, console, \$335; Model 18, console, \$365.

NO. 506. CROSLY 601 BANDBOX

Six tubes; 3 t.r.f., detector, 2 transformer audio. All 01-A tubes. Balanced. t.r.f. One dial. Plate current: 40 mA. Volume control: rheostat in r.f. Shielded. Battery cable. C-battery connections. Antenna: 75 to 150 feet. Cabinet size: 17½ x 5½ x 7½. Price, \$55.

NO. 462. CUSTOM BUILT 7 AND 9

Seven tubes; 5-01A, 1-00A, 1-71. T.r.f. circuit. Two dials. Plate current: 40 mA. Volume control: special. Binding posts. C-battery connections. Output device. Antenna: 100 feet. Built-in A and B supply. Panel: 7 x 21. Price \$275 completely equipped. The Custom Built 9 has 9 tubes with built-in speaker and loop. Price \$375 completely equipped.

NO. 477. DAVEN BASS NOTE

Six tubes; 2 t.r.f. (01-A), detector (HMu), 3 resistance audio (HMu and power). Two dials. Plate current: 17 mA. Volume control: potentiometer. Battery cable. C-battery connections. Antenna: 50 to 100 feet. Cabinet size: 23½ x 12 x 16 inches. Price \$150.

NO. 434. DAY-FAN 6

Six tubes; 3 t.r.f. (01-A), detector (01-A), 2 transformer audio (01-A and 12 or 71). One dial. Plate current: 12 to 15 mA. Volume control: rheostat on r.f. Shielded. Battery cable, C-battery connections. Output device. Antenna: 50 to 120 feet. Cabinet sizes: Daycraft 6, 32 x 30 x 34 inches; Day-Fan Jr., 15 x 7 x 7. Prices: Day-Fan 6, \$110; Daycraft 6, \$145 including loud speaker; Day-Fan Jr. not available.

NO. 435. DAY-FAN 7

Seven tubes; 3 t.r.f. (01-A), detector (01-A), 1 resistance audio (01-A), 2 transformer audio (01-A and 12 or 71). Plate current: 15 mA. Antenna: outside. Same as No. 434. Price \$115.

NO. 497. EXCELL GRAND

Five tubes; 2 t.r.f., detector, 2 transformer audio. All 99 tubes. Na-Ald drum control. Plate current: 15 mA. Volume control: rheostat in r.f. Binding posts. C-battery connections. Headphone connection. Antenna: 75 feet. Cabinet size: 21 x 16 x 14 inches. Price \$100, including loud speaker.

NO. 503. FADA SPECIAL

Six tubes; 3 t.r.f. (01-A), detector (01-A), 2 transformer audio (01-A and 71). Neutrodyne. Two drum control. Plate current: 20 to 24 mA. Volume control: rheostat on r.f. Coils shielded. Battery cable. C-battery connections. Headphone connection. Antenna: outdoor. Cabinet size: 20½ x 13½ x 10½ inches. Price \$95.

NO. 504. FADA 7

Seven tubes; 4 t.r.f. (01-A), detector (01-A), 2 transformer audio (01-A and 71). Neutrodyne. Two drum control. Plate current: 43 mA. Volume control: rheostat on r.f. Completely shielded. Battery cable. C-battery connections. Headphone connections. Output device. Antenna: outdoor or loop. Cabinet sizes: table, 25½ x 13½ x 11½ inches; console, 29 x 50 x 17 inches. Prices: table, \$185; console, \$285.

NO. 436. FEDERAL

Five tubes; 2 t.r.f. (01-A), detector (01-A), 2 transformer audio (01-A and 12 or 71). Balanced t.r.f. One dial. Plate current: 20.7 mA. Volume control: rheostat on r.f. Shielded. Battery cable. C-battery connections. Antenna: loop. Made in 6 models. Price varies from \$250 to \$1000 including loop.

NO. 505. FADA 8

Eight tubes. Same as No. 504 except for one extra stage of audio and different cabinet. Prices: table, \$300; console, \$400.

NO. 437. FERGUSON 10A

Seven tubes; 3 t.r.f. (01-A), detector (01-A), 3 audio (01-A and 12 or 71). One dial. Plate current: 18 to 25 mA. Volume control: rheostat on two r.f. Shielded. Battery cable. C-battery connections. Antenna: 100 feet. Cabinet size: 21½ x 12 x 15 inches. Price \$150.

NO. 438. FERGUSON 14

Ten tubes; 3 untuned r.f., 3 t. r.f. (01-A), detector (01-A), 3 audio (01-A and 12 or 71). Special balanced t.r.f. One dial. Plate current: 30 to 35 mA. Volume control: rheostat in three r.f. Shielded. Battery cable, C-battery connections. Antenna: loop. Cabinet size: 24 x 12 x 16 inches. Price \$235, including loop.

NO. 439. FERGUSON 12

Six tubes; 2 t.r.f. (01-A), detector (01-A), 1 transformer audio (01-A), 2 resistance audio (01-A and 12 or 71). Two dials. Plate current: 18 to 25 mA. Volume control: rheostat on two r.f. Partially shielded. Battery cable. C-battery connections. Antenna: 100 feet. Cabinet size: 22½ x 10 x 12 inches. Price \$85. Console \$145 including loud speaker.

NO. 440. FREED-EISEMANN NR-8, NR-9, AND NR-66

Six tubes; 3 t.r.f. (01-A), detector (01-A), 2 transformer audio (01-A and 71). Neutrodyne. NR-8, two dials; others one dial. Plate current: 30 mA. Volume control: rheostat on r.f. NR-8 and 9: chassis type shielding. NR-66, individual stage shielding. Battery cable. C-battery connections. Antenna: 100 feet. Cabinet sizes: NR-8 and 9, 19½ x 10 x 10½ inches; NR-66 20 x 10½ x 12 inches. Prices: NR-8, \$90; NR-9, \$100; NR-66, \$125.

NO. 441. FREED-EISEMANN NR-77

Seven tubes; 4 t.r.f. (01-A), detector (01-A), 2 transformer audio (01-A and 71). Neutrodyne. One dial. Plate current: 35 mA. Volume control: rheostat on r.f. Shielding. Battery cable. C-battery connections. Antenna: outside or loop. Cabinet size: 23 x 10½ x 13 inches. Price \$175.

NO. 442. FREED-EISEMANN 800 AND 850

Eight tubes; 4 t.r.f. (01-A), detector (01-A), 1 transformer (01-A), 1 parallel audio (01-A or 71). Neutrodyne. One dial. Plate current: 35 mA. Volume control: rheostat on r.f. Shielded. Battery cable. C-battery connections. Output: two tubes in parallel or one power tube may be used. Antenna: outside or loop. Cabinet sizes: No. 800, 34 x 15½ x 13½ inches; No. 850, 36 x 65½ x 17½. Prices not available.

NO. 443. GREBE CR18 (SHORT-WAVE)

Two tubes; detector, 1 transformer audio. All 01-A tubes. Three-circuit regenerative. Two dials. Plate current: 8 mA. Volume control: rheostat on detector and regeneration. Headphone connection. Binding posts. Wavelength range: 8 to 210 meters. Antenna: 100 feet. Cabinet size: 16 x 7 x 7½ inches. Price \$100 including set of coils.

NO. 444. GREBE MU-1

Five tubes; 2 t.r.f. (01-A), detector (01-A), 2 transformer audio (01-A and 12 or 71). Balanced t.r.f. One, two, or three dials (operate singly or together). Plate current: 30 mA. Volume control: rheostat on r.f. Binocular coils. Binding posts. C-battery connections. Antenna: 125 feet. Cabinet size: 22½ x 9½ x 13 inches. Prices range from \$95 to \$320.

NO. 445. HARMONIC R AND S

Four tubes; 1 t.r.f., detector, 2 transformer audio. All 01-A tubes. S type has three resistance audio and 5 tubes. Regenerative detector and t.r.f. Three dials. Volume control: rheostat on r.f. Binding posts. C-battery connections. Headphone connection. Antenna: 100 feet. Cabinet size: 26 x 9 x 9 inches. Prices: R, \$75; S, \$100.

NO. 426. HOMER

Seven tubes; 4 t.r.f. (01-A), detector (01-A or 00A); 2 audio (01-A and 12 or 71). One knob tuning control. Volume control: rotor control in antenna circuit. Plate current: 22 to 25 mA. "Technidyne" circuit. Completely enclosed in aluminum box. Battery cable. C-battery connections. Cabinet size, 8½ x 19½ x 9½ inches. Chassis size, 6½ x 17 x 8 inches. Prices: Chassis only, \$80. Table cabinet, \$95.

NO. 502. KENNEDY ROYAL 7. CONSOLETTA

Seven tubes; 4 t.r.f. (01-A), detector (00-A), 2 transformer audio (01-A and 71). One dial. Plate current: 42 mA. Volume control: rheostat on two r.f. Special r.f. coils. Battery cable. C-battery connections. Headphone connection. Antenna: outside or loop. Console size: 36½ x 35½ x 19 inches. Price \$220.

NO. 498. KING "CRUSADER"

Six tubes; 2 t.r.f. (01-A), detector (00-A), 3 transformer audio (01-A and 71). Balanced t.r.f. One dial. Plate current: 20 mA. Volume control: rheostat on r.f. Coils shielded. Battery cable. C-battery connections. Antenna: outside. Panel: 11 x 7 inches. Price, \$115.

NO. 499. KING "COMMANDER"

Six tubes; 3 t.r.f. (01-A), detector (00-A), 2 transformer audio (01-A and 71). Balanced t.r.f. One dial. Plate current: 25 mA. Volume control: rheostat on r.f. Completely shielded. Battery cable. C-battery connections. Antenna: loop. Panel size: 12 x 8 inches. Price \$220 including loop.

NO. 429. KING COLE VII AND VIII

Seven tubes; 3 t.r.f., detector, 1 resistance audio, 2 transformer audio. All 01-A tubes. Model VIII has one more stage t.r.f. (eight tubes). Model VII, two dials. Model VIII, one dial. Plate current: 15 to 50 mA. Volume control: primary shunt in r.f. Steel shielding. Battery cable and binding posts. C-battery connections. Output devices on some consoles. Antenna: 10 to 100 feet. Cabinet size: varies. Prices: Model VII, \$80 to \$160; Model VIII, \$100 to \$300.

NO. 500. KING "BARONET" AND "VIKING"

Six tubes; 2 t.r.f. (01-A), detector (00-A), 3 transformer audio (01-A and 71). Balanced t.r.f. One dial. Plate current: 19 mA. Volume control: rheostat in r.f. Battery cable. C-battery connections. Antenna: outside. Panel size: 18 x 7 inches. Prices: "Baronet," \$70; "Viking," \$140 including loud speaker.

NO. 501. KING "CHEVALIER"

Six tubes. Same as No. 500. Coils completely shielded. Panel size: 11 x 7 inches. Price, \$210 including loud speaker.

NO. 447. LEUTZ "TRANSOCEANIC" AND "SILVER GHOST"

Nine tubes; 4 t.r.f. (01-A), detector (00-A), 1 transformer audio (01-A) 3 resistance audio (HMu and 71 or 10). Grid resistance in t.r.f. Wavelength range: 35 to 3600 meters. One to five dials. Plate current: 20 to 40 mA. Volume control: special. Shielded. Binding posts. C-battery connections. Voltmeter. Output device. Antenna: outside or loop. Cabinet sizes: "Transoceanic," 27 x 8½ x 13½ inches; "Silver Ghost," 72 x 12 x 20 inches. Prices: "Transoceanic," \$150; Other not available.

NO. 489. MOHAWK

Six tubes; 2 t.r.f. (01-A), detector (00-A), 3 audio (01-A and 71). One dial. Plate current: 40 mA. Volume control: rheostat on r.f. Battery cable. C-battery connections. Output device. Antenna: 60 feet. Panel size: 12½ x 8½ inches. Prices range from \$65 to \$245.

NO. 449. NORBERT "MIDGET"

One multivalve tube; detector, 2 transformer audio. Two dials. Plate current: 3 mA. Volume control: rheostat. Binding posts. C-battery connections. Headphone connection. Antenna: 75 to 150 feet. Cabinet size: 12 x 8 x 9 inches. Price \$12 including multivalve.

NO. 450. NORBERT 2

Two tubes; 1 t.r.f., detector, 2 transformer audio. One multi-valve tube and one 01-A. Two dials. Plate current: 8 mA. Volume control: special. Battery cable. Headphone connection. C-battery connections. Antenna: 50 to 100 feet. Cabinet size: 20 x 7 x 5½ inches. Price \$40.50 including multivalve and 01-A tube.

NO. 451. NORCO 66

Six tubes; 2 t.r.f. (01-A), detector (01-A), 3 impedance audio (01-A and 71). Drum control. Plate current: 20 mA. Volume control: modulator on audio. Shielded. Battery cable. C-battery connections. Output device. Antenna: 70 to 90 feet. Cabinet size: 18½ x 8½ x 13½ inches. Price \$130. Price of console, \$250 including loud speaker.

NO. 452. ORIOLE 90

Five tubes; 2 t.r.f., detector, 2 transformer audio. All 01-A tubes. "Trinum" circuit. Two dials. Plate current: 18 mA. Volume control: rheostat on r. f. Battery cable. C-battery connections. Antenna: 50 to 100 feet. Cabinet size: 25½ x 11½ x 12½ inches. Price \$85. Another model has 8 tubes, one dial, and is shielded. Price \$185.

NO. 454. PARAMOUNT V AND VI

Five and six tubes. All 01-A t.r.f. circuit. Binding posts. C-battery connections. Antenna: 100 feet. Panel size: 26 x 7 inches. Prices: V, \$65; VI, \$75

NO. 453. PARAGON

Six tubes; 2 t.r.f. (01-A), detector (01-A), 3 double impedance audio (01-A and 71). One dial. Plate current: 40 mA. Volume control: resistance in r.f. plate. Shielded. Battery cable. C-battery connections. Output device. Antenna: 100 feet. Console size: 20 x 46 x 17 inches. Price not determined.

NO. 475. PENN C-6

Six tubes; 2 t.r.f. (01-A), detector (00-A), 3 traphonic audio (01-A). Phasatrol. One dial. Plate current: 15 mA. Volume control: potentiometer. Binding posts. C-battery connections. Antenna: 75 feet. Cabinet size: 24 x 10 x 15 inches. Prices range from \$95 to \$165. A console model having three dials and five tubes sells for \$150.

NO. 480. PFANSTIEHL 30 AND 302

Six tubes; 3 t.r.f. (01-A), detector (01-2A), transformer audio (01-A and 71). One dial. Plate current: 26 to 32 mA. Volume control: resistance in r.f. plate. Shielded. Battery cable. C-battery connections. Antenna: outside. Panel size: 17½ x 8½ inches. Prices: No. 30 cabinet, \$99.50; No. 302 console, \$165 including loud speaker.

NO. 455. PREMIER 6-IN-LINE

Six tubes; 3 t.r.f. (01-A), detector (00-A), 2 transformer audio (01-A and 12). One or two dials. Plate current: 16 to 18 mA. Volume control: rheostat in r.f. Battery cable. C-battery connections. Antenna: 100 feet or loop. Cabinet size: 25 x 45 x 16 inches. Prices range from \$60 to \$150.



Power Transformers and Chokes

—insist on Dongan

It's a 'power year'—for the buying public and the manufacturer. To the designer of sets it resolves itself into a matter of the proper selection of type and design.

One thing you can be certain of—for all types of A C and Rectifier Tubes, Dongan Power Parts (transformers and chokes) are standard. In fact Dongan laboratories helped to develop several of the leading types. Whatever you prefer you can secure Dongan Power Parts designed for that particular type.

Send your specifications—or problems—to our engineering department. For experimental work or quantity production Dongan is in a position to cooperate with you on all approved types of Transformers and Chokes—now.



Power Transformer
No. 3591

Used with 350-400 m.a. rectifier tubes, making a thoroughly satisfactory and practical ABC eliminator. Specify make of tube you will use. \$15 list.

Choke
No. 3584

Used together with above transformer and 350-400 m. a. rectifier tubes. \$15 list.



Fans

Set Builders—You can secure immediate delivery on the Power Parts shown here—see your dealer or send check or money order to factory direct. Also write for information on Transformers for the new A C Filament Tubes.

DONGAN ELECTRIC MFG. CO.
2991-3001 Franklin St., Detroit, Michigan

TRANSFORMERS of MERIT for FIFTEEN YEARS

Dubilier

The Pioneer

A history of the Dubilier organization takes us back to the very conception of wireless telegraphy. Then, practically every Dubilier device was a "special order" built for experimenters whose names are now famous. Today, these same electrical and radio engineers turn instinctively to Dubilier for either standard articles of manufacture or laboratory models for their research. This keeping step with the industry has given Dubilier a merited reputation for condensers which are way above the average in ruggedness, safety factor and long life.

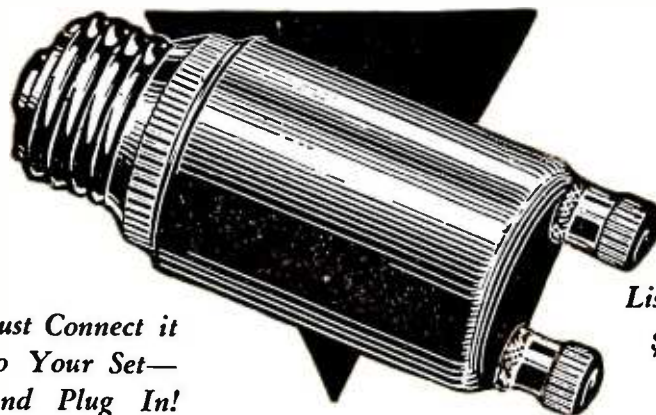

Just Connect it to Your Set—and Plug In!

List Price
\$1.50

Why Bother With Outdoor Aerials?



Present-day broadcasting and modern receivers don't require them. A Dubilier Light Socket Aerial and a few feet of cord will give you a highly efficient antenna and do away with lead-in wires, insulators, faulty connections and lightning arresters. The device consumes absolutely no current and needs no attention whatever. Works on any cycle, A.C. or D.C. Sold on a 5-day money-back basis.

Price \$1.50



The Approved Condenser Blocks for Radio Power-Units

Dubilier condenser blocks for Raytheon and other leading circuits are rugged in construction, and have the unusually high factor of safety of better than five to one—insuring the longest condenser life obtainable. Your dealer will gladly supply you with the right Dubilier Block Condenser for the right purpose.

A New Dubilier MICADON Moulded in Bakelite

Here's the famous Dubilier *Micadon* in its modern shape and new case of rich Bakelite. Compact, handsome and efficient. Terminals adapted to screwed or soldered connections. Your dealer has them in all capacities.

Prices 40c to 80c



The Noiseless Dubilier Metaleak

A tubular grid leak you can bank on for accurate resistance value and noiseless operation. Your dealer has them in all values from 20,000 ohms to 5 megohms.

Prices, 50c and 75c

Dubilier Condenser Corporation

4377 Bronx Blvd., New York

NO. 481. PFANSTIEHL 32 AND 322

Seven tubes; 3 t.r.f. (01-A), detector (01-A), 3 audio (01-A and 71). One dial. Plate current: 23 to 32 mA. Volume control: resistance in r. f. plate. Shielded. Battery cable. C-battery connections. Output device. Antenna: outside. Panel: $17\frac{1}{2} \times 8\frac{1}{2}$ inches. Prices: No. 32 cabinet, \$135; No. 322 console, \$225 including loud speaker.

NO. 473. PRMCO 105 AND 110

Six tubes; 2 t.r.f., detector, 2 transformer audio, 1 resistance audio. All 01-A tubes. Volume control: rheostat on r.f. Battery cables. Headphone connection. Antenna: 100 feet. Panel size: 18×7 inches. Price No. 105, \$45. The No. 110 has C-battery connections, shielding, and drum tuning control. Price \$80.

NO. 456. RADIOLA 20

Five tubes; 2 t.r.f. (99), detector (99), 2 transformer audio (99 and 20). Balanced t.r.f. and regenerative detector. Two dials. Volume control: regenerative. Shielded. C-battery connections. Headphone connections. Antenna: 75 to 150 feet. Cabinet size: $19\frac{1}{2} \times 11\frac{1}{2} \times 16$ inches. Price \$115 including all tubes.

NO. 457. RADIOLA 25

Six tubes; oscillator (99), 2 detectors (99), 3 intermediate r.f. (99), 2 transformer audio (99 and 20). Drum control. Super-heterodyne with two reflexed stages. Volume control: potentiometer on intermediate grids. Shielded. C-battery connections. Headphone connection. Antenna: loop. Cabinet size: $28 \times 37 \times 19$ inches. Price \$165 with tubes and loop. Can be operated on a. c. with special attachments.

NO. 458. RADIOLA 28

Eight tubes; oscillator (99), 2 detectors (99), 3 intermediate r.f. (99), 2 transformer audio (99 and 20). Super-heterodyne. Drum control. Volume control same as model 25. Shielded. C-battery connections. Headphone connection. Antenna: loop. Console size $26\frac{1}{2} \times 63 \times 17$ inches. Price \$260 with tubes and loop. Can be operated on a. c. with special attachments.

NO. 493. SONORA F

Seven tubes; 4 t.r.f. (01-A), detector (00-A), 2 transformer audio (01-A and 71). Special balanced t.r.f. Two dials. Plate current: 45 mA. Volume control: rheostat in r.f. Shielded. Battery cable. C-battery connections. Output device. Antenna: loop. Console size: $32 \times 45\frac{1}{2} \times 17$ inches. Prices range from \$350 to \$450 including loop and loud speaker.

NO. 494. SONORA E

Six tubes; 3 t.r.f. (01-A), detector (00-A), 2 transformer audio (01-A and 71). Special balanced t.r.f. Two dials. Plate current: 35 to 40 mA. Volume control: rheostat on r.f. Shielded. Battery cable. C-battery connections. Antenna: outside. Cabinet size: varies. Prices: table, \$110; semi-console, \$140; console, \$240 including loud speaker.

NO. 495. SONORA D

Same as No. 494 except arrangement of tubes; 2 t.r.f., detector, 3 audio. Prices: table, \$125; standard console, \$185; "DeLuxe" console, \$225.

NO. 482. STEWART-WARNER 705 AND 710

Six tubes; 3 t.r.f., detector, 2 transformer audio. All 01-A tubes. Balanced t.r.f. Two dials. Plate current: 10 to 25 mA. Volume control: resistance in r.f. plate. Shielded. Battery cable. C-battery connections. Antenna: 80 feet. Cabinet sizes: No. 705 table, $26\frac{1}{2} \times 11\frac{1}{2} \times 13\frac{1}{2}$ inches; No. 710 console, $29\frac{1}{2} \times 42 \times 17\frac{1}{2}$ inches. Tentative prices: No. 705, \$115; No. 710 \$265 including loud speaker.

NO. 483. STEWART-WARNER 525 AND 520

Same as No. 482 except no shielding. Cabinet sizes: No. 525 table, $19\frac{1}{2} \times 10 \times 11\frac{1}{2}$ inches; No. 520 console, $22\frac{1}{2} \times 40 \times 14\frac{1}{2}$ inches. Tentative prices: No. 525, \$75; No. 520, \$117.50 including loud speaker.

NO. 459. STROMBERG-CARLSON 501 AND 502

Five tubes; 2 t.r.f. (01-A), detector (00-A), 2 transformer audio (01-A and 71). Neutrodyne. Two dials. Plate current: 25 to 35 mA. Volume control: rheostat on 1st r.f. Shielded. Battery cable. C-battery connections. Headphone connections. Output device. Panel voltmeter. Antenna: 60 to 100 feet. Cabinet sizes: No. 501, $25\frac{1}{2} \times 13 \times 14$ inches; No. 502, $28\frac{1}{2} \times 50\frac{1}{2} \times 16\frac{1}{2}$ inches. Prices: No. 501, \$180; No. 502, \$290.

NO. 460. STROMBERG-CARLSON 601 AND 602

Six tubes. Same as No. 549 except for extra t.r.f. stage. Cabinet sizes: No. 601, $27\frac{1}{2} \times 16\frac{1}{2} \times 14\frac{1}{2}$ inches; No. 602, $28\frac{1}{2} \times 51\frac{1}{2} \times 19\frac{1}{2}$ inches. Prices: No. 601, \$225; No. 602, \$330.

NO. 461. SUN

Five tubes; 2 t.r.f., detector, 2 transformer audio. All 01-A tubes. Two dials. Volume control: resistance in r.f. plate. Binding posts. Antenna: 100 feet. Cabinet size: $23 \times 10 \times 10$ inches. Price, \$80.

NO. 491. SUPERFLEX A4

Four tubes; 1 t.r.f., detector, 2 transformer audio. All 01-A tubes. Special circuit. One dial. Plate current 10 to 15 mA. Volume control: capacity. Battery cable. C-battery connections. Headphone connection. Antenna: outside. Cabinet sizes: table, $24 \times 10 \times 9\frac{1}{2}$ inches; console, $25 \times 44 \times 14$ inches. Prices: table, \$80; console, \$139.50.

NO. 486. VALLEY 71

Seven tubes; 4 t.r.f. (01-A), detector (01-A), 2 transformer audio (01-A and 71). One dial. Plate current: 35 mA. Volume control: rheostat on r.f. Partially shielded. Battery cable. C-battery connections. Headphone connection. Antenna: 50 to 100 feet. Cabinet size: $27 \times 6 \times 7$ inches. Price \$95.

NO. 471. VOLOTONE XX

Five tubes; 1 t.r.f. (01-A), detector (00-A), 3 resistance audio (HMU and 71). Balanced t.r.f. Two dials. Plate current: 18 mA. Volume control: rheostat on r.f. Battery cable. C-battery connections. Output device. Antenna: 100 feet. Cabinet size: $20\frac{1}{2} \times 8 \times 12$ inches. Price \$50.

NO. 472. VOLOTONE VIII

Six tubes. Same as No. 471 with following exceptions: 2 t.r.f. stages. Three dials. Plate current: 20 mA. Cabinet size: $26\frac{1}{2} \times 8 \times 12$ inches. Price \$140.

NO. 464. WRIGHT VII

Seven tubes; 3 t.r.f. (99), detector (99), 3 impedance audio (99 and 20). Na-Aid audio amplifier. Two dials. Plate current: 17 mA. Volume control: resistance in r.f. plate. Battery cable. C-battery connections. Output device. Panel voltmeter. Antenna: 80 feet. Cabinet size: $25 \times 15 \times 17\frac{1}{2}$ inches. Price \$160.

NO. 478. ZIMPHONIC 6

Six tubes; 2 t.r.f. (01-A), detector (00-A), 3 audio (01-A and 12). One dial. Regeneration and t.r.f. Plate current: 22 to 24 mA. Volume control: resistance in r.f. plate. Coils shielded. Battery cable. C-battery connections. Headphone connection. Antenna: 75 to 100 feet. Panel size: 21×7 inches. Prices: table \$90; console, \$125.

NO. 479. ZIMPHONIC 7

Seven tubes; Same as No. 478 except for one more stage t.r.f. Completely shielded. Console size: $20 \times 40 \times 15$ inches. Prices: table, \$140; console, \$175.

RADIO ACCESSORIES
at WHOLESALE

Radio Sets, "B" Eliminators, Chargers, Tubes, Kits, Parts—everything new in Radio at lowest wholesale prices. Thousands of nationally advertised bargains. All listed and illustrated in my Big New Catalog and FREE Call Book.

132 Pages of valuable Radio information—trouble finding, set building—Radio knowledge of all kinds. Write today. HARRY SCHWARTZBERG PRES.

AMERICAN AUTO & RADIO MFG. CO.
Dept. 124 American Radio Bldg.
Kansas City, Missouri

FREE BIG BARGAIN CATALOG

Make any Good Receiver **BETTER**

AX

CC TUBES

C. E. MFG. CO.
Inc.
Providence
R.I.

For Neat Appearance

ELECTRAD
Certified Lead-In

Grounded circuits on wet window sills—unsightly porcelain tubes or holes in walls or window sash—these can be avoided by using the Electrad Lead-In.

Built to Electrad's quality standard! Bends any shape permitting you to lock windows upon it. One piece copper strip heavily tinned, with three-ply waterproof installation full 10 inches long.

Insist on the Electrad Lead-In and have the best. Price 40c.

Write for descriptive circular
At your dealer's or write
Dept. 61
175 Varick St., New York, N. Y.

ELECTRAD

Write today
for your copy of
"Copper Shielding for Radio"

This new book shows how to improve the reception of your set. There is no charge.

Copper shielding means greater selectivity and sensitivity.

COPPER & BRASS
RESEARCH ASSOCIATION
25 Broadway, New York

Great Sensitivity

Made with our exclusive, superior feature—the TELEVOCAL SUPPORT—Televocal Quality Tubes won't short and are non-microphonic. Manufactured, tested and balanced by technical experts, they combine sensitivity with high amplification. Insist on Televocal—the quality tube that's guaranteed.

If your dealer cannot supply you, write us giving his name.

Televocal Tubes are made in all Standard Types



TELEVOCAL CORP'N
Televocal Building

Dept. B, 588 12th St., West New York, N. J.

TELEVOCAL QUALITY TUBES

General Electric Battery Chargers

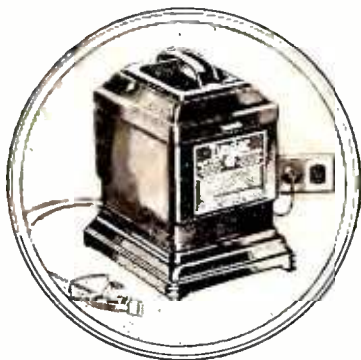

\$10

\$14

\$24

KEEP your radio set ready—at all times—for all the good things that come over.

Just clip a Tungar [the name of the General Electric battery charger] to your batteries at night, leave it as you would the light in the hall in the morning the batteries are pepped up and ready for active duty.

Your dealer can help you. Ask him to show you the popular 2-ampere Tungar that charges both "A" and "B" radio batteries. *It has a binding post for a trickle charge.* Charges auto batteries, too.

New Prices (East of the Rockies)

- 2-ampere Tungar . now \$14
- 5-ampere Tungar . now \$24
- G-E Trickle Charger now \$10

Tungar causes no radio interference. It cannot blow out tubes.

An overnight charge costs a dime.

It is a G-E product developed in the Research Laboratories of General Electric.

The 2 or 5 ampere Tungars charge 2, 4, and 6 volt "A" batteries, 24 to 96 volt "B" batteries in series; and auto batteries, too. No extra attachments needed.

Merchandise Department
General Electric Company
Bridgeport, Connecticut



Tungar

REG. U.S. PAT. OFF.

BATTERY CHARGER

Tungar—a registered trademark—is found only on the genuine. Look for it on the name plate.

GENERAL ELECTRIC

Permanent Accuracy!

AEROVOX Fixed Mica Condensers stay accurate because they are moulded in genuine Bakelite and are sealed and protected against possible injury, moisture or chemical action.

A special process in the manufacture of the condenser element enables us to manufacture and guarantee them to be within 10% of their marked rating.

AEROVOX

70 Washington St., Brooklyn, N. Y.

Why not subscribe to *Radio Broadcast*? By the year only \$4.00; or two years, \$6.00, saving \$2.40. Send direct to Doubleday, Page & Company, Garden City, New York.

Learn the Code at Home With the Omnigraph



Morse and Wireless—taught at home in half usual time and at trifling cost. Omnigraph Automatic Transmitter will send, on Sounder or Buzzer, unlimited messages, any speed, just as expert operator would. Adopted by U. S. Govt. and used by leading Universities, Colleges, Technical and

Telegraph Schools throughout U. S. Send 6c for Catalog.
OMNIGRAPH MFG. CO., 13K, Hudson St., New York



FREE

Money-saving prices—discounts that show you a real profit! All popular kits—new A C tubes and transformers—Parts for any circuit—power audio equipment—short wave supplies—all in our big new 1928 Catalog. Write for it today.

Dan-Ashe Radio Co.

202 North 10th St. ST. LOUIS, MO.

U. J. HERRMAN
G. CLAYTON IRWIN, Jr.

RADIO MANUFACTURERS SHOW ASSOCIATION
Presents

The World's Two
Largest Radio
Expositions

**FOURTH ANNUAL
RADIO
WORLDS FAIR**
MADISON
SQUARE GARDEN
NEW YORK CITY
SEPT. 19-24
INCLUSIVE

**SIXTH ANNUAL
CHICAGO
RADIO SHOW**
COLISEUM
CHICAGO
OCT. 10-15
INCLUSIVE

OFFICIAL SHOW
RMA
RADIO MANUFACTURERS ASSOCIATION

The exhibits of new inventions and developments in radio receivers, parts and accessories will be of great interest to all amateurs, professionals and radio fans. You will also meet radio's most popular entertainers and announcers. Among the many new innovations will be "The Theatre of Wonders," a storehouse of magical and practical inventions you can't afford to miss. Special business sessions for the trade. Radio shows open daily from 1:00 P. M. until 11:00 P. M. Monday to Saturday inclusive.

NATIONAL RADIO DAY, SEPTEMBER 21

- 68. CHEMICAL RECTIFIER—Details of assembly, with wiring diagrams, showing how to use a chemical rectifier for charging batteries. CLEVELAND ENGINEERING LABORATORIES COMPANY.
- 69. VACUUM TUBES—A booklet giving the characteristics of the various tube types with a short description of where they may be used in the circuit. RADIO CORPORATION OF AMERICA.
- 77. TUBES—A booklet for the beginner who is interested in vacuum tubes. A non-technical consideration of the various elements in the tube as well as their position in the receiver. CLEARTRON VACUUM TUBE COMPANY.
- 87. TUBE TESTER—A complete description of how to build and how to operate a tube tester. BURTON-ROGERS COMPANY.
- 91. VACUUM TUBES—A booklet giving the characteristics and uses of various types of tubes. This booklet may be obtained in English, Spanish, or Portuguese. DEFORREST RADIO COMPANY.
- 92. RESISTORS FOR A. C. OPERATED RECEIVERS—A booklet giving circuit suggestions for building a. c. operated receivers, together with a diagram of the circuit used with the new 400-millampere rectifier tube. CARTER RADIO COMPANY.
- 97. HIGH-RESISTANCE VOLTMETERS—A folder giving information on how to use a high-resistance voltmeter, special consideration being given the voltage measurement of socket-power devices. WESTINGHOUSE ELECTRIC & MANUFACTURING COMPANY.
- 102. RADIO POWER BULLETINS—Circuit diagrams, theory constants, and trouble-shooting hints for units employing the BH or B rectifier tubes. RAYTHEON MANUFACTURING COMPANY.

MISCELLANEOUS

- 38. LOG SHEET—A list of broadcasting stations with columns for marking down dial settings. U. S. L. RADIO, INCORPORATED.
- 41. BABY RADIO TRANSMITTER OF 9XH-9EK—Description and circuit diagrams of dry-cell operated transmitter. BURGESS BATTERY COMPANY.
- 42. ARCTIC RADIO EQUIPMENT—Description and circuit details of short-wave receiver and transmitter used in Arctic exploration. BURGESS BATTERY COMPANY.
- 43. SHORT-WAVE RECEIVER OF 9XH-9EK—Complete directions for assembly and operation of the receiver. BURGESS BATTERY COMPANY.
- 44. ALUMINUM FOR RADIO—A booklet containing much radio information with hook-ups of basic circuits, with inductance-capacity tables and other pertinent data. ALUMINUM COMPANY OF AMERICA.
- 45. SHIELDING—A discussion of the application of shielding in radio circuits with special data on aluminum shields. ALUMINUM COMPANY OF AMERICA.
- 58. HOW TO SELECT A RECEIVER—A commonsense booklet describing what a radio set is, and what you should expect from it, in language that any one can understand. DAY-FAN ELECTRIC COMPANY.
- 67. WEATHER FOR RADIO—A very interesting booklet on the relationship between weather and radio reception, with maps and data on forecasting the probable results. TAYLOR INSTRUMENT COMPANIES.
- 73. RADIO SIMPLIFIED—A non-technical booklet giving pertinent data on various radio subjects. Of especial interest to the beginner and set owner. CROSLY RADIO CORPORATION.
- 74. THE EXPERIMENTER—A monthly publication which gives technical facts, valuable tables, and pertinent information on various radio subjects. Interesting to the experimenter and to the technical radio man. GENERAL RADIO COMPANY.
- 75. FOR THE LISTENER—General suggestions for the selecting, and the care of radio receivers. VALLEY ELECTRIC COMPANY.
- 76. RADIO INSTRUMENTS—A description of various meters used in radio and electrical circuits together with a short discussion of their uses. JEWELL ELECTRICAL INSTRUMENT COMPANY.
- 78. ELECTRICAL TROUBLES—A pamphlet describing the use of electrical testing instruments in automotive work combined with a description of the cadmium test for storage batteries. Of interest to the owner of storage batteries. BURTON ROGERS COMPANY.
- 95. RESISTANCE DATA—Successive bulletins regarding the use of resistors in various parts of the radio circuit. INTERNATIONAL RESISTANCE COMPANY.
- 96. VACUUM TUBE TESTING—A booklet giving pertinent data on how to test vacuum tubes with special reference to a tube testing unit. JEWELL ELECTRICAL INSTRUMENT COMPANY.
- 98. COPPER SHIELDING—A booklet giving information on the use of shielding in radio receivers, with notes and diagrams showing how it may be applied practically. Of special interest to the home constructor. THE COPPER AND BRASS RESEARCH ASSOCIATION.
- 99. RADIO CONVENIENCE OUTLETS—A folder giving diagrams and specifications for installing loud speakers in various locations at some distance from the receiving set. YAXLEY MANUFACTURING COMPANY.

CORWICO

Radio's Best Wire
"From The Ground Up"

"Corwico" is the wire used by Mr. John Hartley, holder of the world's international set building championship. "Corwico" wire is also specified by the leading set manufacturers and hundreds of professional set builders. For all around efficient service and for meeting the requirements of high-class workmanship "Corwico" radio wire has no equal.

"BRAIDITE" A New Hook-Up Wire

To make a soldered connection, it is not necessary, with Braidite to strip back the insulation. The braid is simply pushed back while the soldering is done and then replaced, thus forming the neatest possible connection. Made in red, yellow, green, brown and black.

"Corwico" Radio Wires
Antenna Wire (Solid, Stranded and Braided), Complete Aerial Kits, Magnet Wire, Battery Cable, Bus Bar Wire, Hook-Up Wire, Lead-In Wire, Annunciator Wire, Loop Aerial Wire, Litz Wire, Flexible Wire.

"Corwico" Radio Wires are sold by all leading dealers. Write for free booklet on radio wires and their uses.

CORNISH WIRE COMPANY
30 Church Street New York City

USE THIS BOOKLET COUPON

RADIO BROADCAST SERVICE DEPARTMENT
RADIO BROADCAST, Garden City, N. Y.
Please send me (at no expense) the following booklets indicated by numbers in the published list:

.....

.....

.....

Name.....

Address..... (Name) (Street)

..... (City) (State)

ORDER BY NUMBER ONLY

This coupon must accompany every request. RB 927



Volume
With
Clarity

DOUBLE ENJOYMENT

From Any Set With

Burns

LOUD SPEAKER

Why sacrifice the excellent reproducing qualities of a set by the use of an inferior speaker. With a BURNS it is possible to reproduce with amazing exactness every note of music and inflection of voice that the set can pick up. A trial will convince.

AT YOUR DEALER'S OR WRITE DIRECT

American Electric Company, Inc.

State and 64th Sts. Chicago, U. S. A.

Ask About BURNS B-Eliminator

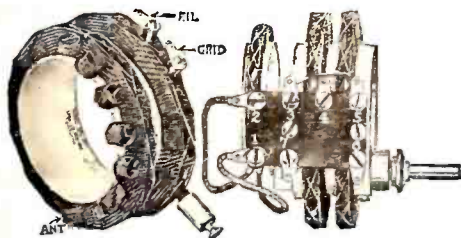

Sickles Coil Set No. 18A for Roberts Circuit

SICKLES Diamond-Weave Coils

THE new Sickles Shielded Tuned Radio Transformer prevents both outside and local interference. It is remarkably compact, sharp tuning, sturdy.

Sickles Diamond-weave coils have established an enviable reputation for low distributed capacity, low dielectric losses, and large range of frequency with small variable capacity.

The ideal coil for the Naald Localized Control Tuning Unit and for the Tru-phonic Catacomb Assembly.

There are Sickles Diamond Weave Coils for all Leading Circuits.

The F. W. Sickles Co.
132 Union Street
SPRINGFIELD, MASS.

COIL PRICES

- No. 30 Shielded Transformer... \$2.00 each
- No. 24 Browning-Drake 7.50 Set
- No. 18A Roberts Circuit 8.00 "
- No. 25 Aristocrat Circuit 8.00 "



Two New Quality Products by the makers of the famous Hammarlund Condensers

The New
Hammarlund R. F. Choke

MODERN engineering practice has proved the value of R. F. chokes for confining radio-frequency currents to their proper channels, thus preventing unbalanced circuits and consequent distortion. This is a quality idea, ideally exemplified in the use of the new style Hammarlund Choke. Made in two sizes: 85 and 250 millihenries, effective over the entire broadcast and amateur wave-band.

Wherever radio is known throughout the world, Hammarlund's reputation for precision quality is recognized. No other introduction is required for these two worthy new members of the Hammarlund radio family.

Write for Literature

HAMMARLUND MANUFACTURING CO.

424-438 W. 33rd Street, New York

An Improved
"Hammarlund Jr."

THE famous Hammarlund Midget Condenser has been simplified. The new "Hammarlund Jr." has all essential features of the former model—soldered brass plates, aluminum frame, one-hole or baseboard mounting. Knob included. In addition, it is equipped with a rotor lock which fixes the rotor in any position—an important advantage when used for neutralizing. Four sizes.

For Better Radio
Hammarlund
PRECISION
PRODUCTS



The Best in Radio Programs

The first to review programs, RADIO BROADCAST has maintained its interesting department of news and comment about broadcasters and their programs in "The Listeners' Point of View." A regular and lively department, conducted by John Wallace from his "listening-post" in Illinois.



5 TUBE RADIO ONLY \$19.98

It's a wonder for power and selectivity. Famous ARL circuit. Coast to coast reception! Finely built of selected, tested parts. Thousands now in use. FREE Log and Call Book and New 132-p. Catalog with thousands of nationally advertised bargains. Latest in radio at big savings. Write for Free copy.

AMERICAN AUTO & RADIO MFG. CO.
HARRY SCHWARTZBERG, PRES.
Dept. 121 American Radio Bldg., Kansas City, Mo.

AMERICAN RADIO BARGAINS

Magnaformer

Set Builders, be first—send Now for the NEW Magnaformer 9-8 Hook-up. The Commander-in-Chief of 1028 Circuits. Now being featured in the Radio Magazines. The very last word in Receivers. Two years ahead of field in Design and Performance. Amazing tone quality. A fiend for distance. Double amplification each R. F. stage. A world of volume. No interference. Its equal has never been achieved. A beautiful looking job. Easy to build. Just the set to build for yourself or for others. Full size circuit blue prints and NOVEL wiring diagram, complete wiring instructions and detailed story of development and accomplishments of Magnaformer, the perfect Long Wave Transformer sent at once for 10 cents. SEND NOW. Be first.

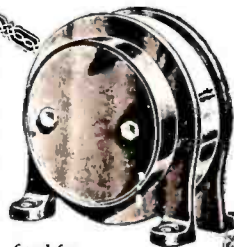

RADIART LABORATORIES COMPANY
19 S. La Salle Street Dept. 56 Chicago

MAIL COUPON NOW
Radiart Lab. Co., 19 S. La Salle St., Dept. 56, Chicago.
Enclosed find 10c for which please send me blueprints and data as advertised.

Name

Address

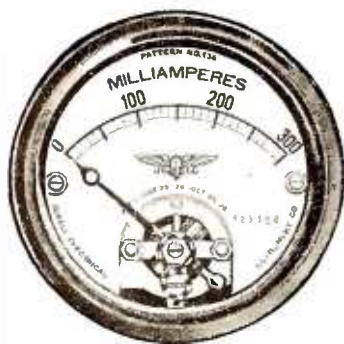

Pattern No.
135
Milliammeter

Use A Milliammeter

A sensitive milliammeter in series with the plates for indicating the current in these circuits and the power of the tubes or in the grid circuit for showing the grid current flowing, is the best means of observing the operating condition of a radio set.

The Jewell Pattern No. 135 milliammeter is a 2-inch round moving coil instrument for the set owner that will indicate the conditions given above, and will make an attractive addition to any set. Used in connection with the Jewell Pattern No. 135-B Voltmeter, which is the same size and appearance, it tells at a glance just when the filament voltage is at the proper value to give maximum set efficiency.

Write for Radio Instrument Catalog No. 15-C

Jewell Electrical Instrument Co.

1650 Walnut Street, Chicago

"27 Years Making Good Instruments"

RADIO PRODUCTS



manufactured under the BRUNO trade mark have been produced by the same management for over five years. The story of BRUNO quality is best told in the results obtained from BRUNO Parts.

BRUNO Coils, Brackets, Kits, Uni-tunes, Condensers & Light Switches can be had at your Dealer or direct from us. Our NEW 36 page booklet thoroughly explains our line.

Send 25 cents for your copy

BRUNO RADIO CORPORATION

Long Island City

New York

Now is the time to subscribe for **RADIO BROADCAST**

Through your dealer or direct, by the year only \$4.00

DOUBLEDAY, PAGE & CO.

GARDEN CITY, NEW YORK

BUILD the most POPULAR Kit Set!

The Official BROWNING-DRAKE

BROWNING-DRAKE, during the summer of 1924, gained an unprecedented popularity that has never waned because the Browning-Drake developments are based on the solid rock of scientific research. Browning-Drake sells more than twice as many parts as those designed for other kits. Prof. Browning and Dr. Drake designed the Official Kit Set to take care of modern broadcasting conditions. This set is dependable and it is unsurpassed for all around performance. Get your parts TO-DAY and BUILD the most popular kit set . . . the Official **BROWNING-DRAKE**.

DEALERS: Write for information on the parts for the Official Kit Set and the Browning-Drake line of factory-built receivers.

BROWNING-DRAKE CORPORATION
CAMBRIDGE - - - MASS.

BROWNING-DRAKE RADIO

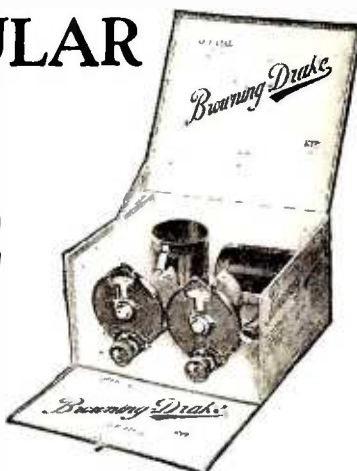

What Kit Shall I Buy?

THE list of kits herewith is printed as an extension of the scope of the Service Department of RADIO BROADCAST. It is our purpose to list here the technical data about kits on which information is available. In some cases, the kit can be purchased from your dealer complete; in others, the descriptive booklet is supplied for a small charge and the parts can be purchased as the buyer likes. The Service Department will not undertake to handle cash remittances for parts, but when the coupon on page 326 is filled out, all the information requested will be forwarded.

201. **SC FOUR-TUBE RECEIVER**—Single control. One stage of tuned radio frequency, regenerative detector, and two stages of transformer-coupled audio amplification. Regeneration control is accomplished by means of a variable resistor across the tickler coil. Standard parts; cost approximately \$58.85.

202. **SC-11 FIVE-TUBE RECEIVER**—Two stages of tuned radio frequency, detector, and two stages of transformer-coupled audio. Two tuning controls. Volume control consists of potentiometer grid bias on r.f. tubes. Standard parts cost approximately \$60.35.

203. **"HI-Q" KIT**—A five-tube tuned radio-frequency set having two radio stages, a detector, and two transformer-coupled audio stages. A special method of coupling in the r.f. stages tends to make the amplification more nearly equal over the entire band. Price \$63.05 without cabinet.

204. **R. G. S. KIT**—A four-tube inverse reflex circuit, having the equivalent of two tuned radio-frequency stages, detector, and three audio stages. Two controls. Price \$69.70 without cabinet.

205. **PIERCE AIRO KIT**—A six-tube single-dial receiver; two stages of radio-frequency amplification, detector, and three stages of resistance-coupled audio. Volume control accomplished by variation of filament brilliancy of r.f. tubes or by adjusting compensating condensers. Complete chassis assembled but not wired costs \$42.50.

206. **H & H-T. R. F. ASSEMBLY**—A five-tube set; three tuning dials, two steps of radio frequency, detector, and 2 transformer-coupled audio stages. Complete except for base-board, panel, screws, wires, and accessories. Price \$35.00.

207. **PREMIER FIVE-TUBE ENSEMBLE**—Two stages of tuned radio frequency, detector, and two steps of transformer-coupled audio. Three dials. Parts assembled but not wired. Price complete, except for cabinet, \$35.00.

208. **"QUADRAFORMER VI"**—A six-tube set with two tuning controls. Two stages of tuned radio frequency using specially designed shielded coils, a detector, one stage of transformer-coupled audio, and two stages of resistance-coupled audio. Gain control by means of tapped primaries on the r.f. transformers. Essential kit consists of three shielded double-range "Quadraformer" coils, a selectivity control, and an "Ampitrol," price \$17.50. Complete parts \$70.15.

209. **GEN-RAL FIVE-TUBE SET**—Two stages of tuned radio frequency, detector, and two transformer-coupled audio stages. Volume is controlled by a resistor in the plate circuit of the r.f. tubes. Uses a special r.f. coil ("Duo-Former") with figure eight winding. Parts mounted but not wired, price \$37.50.

210. **BREMER-TULLY POWER-SIX**—A six-tube, dual-control set; three stages of neutralized tuned radio frequency, detector, and two transformer-coupled audio stages. Resistances in the grid circuit together with a phase shifting arrangement are used to prevent oscillation. Volume control accomplished by variation of B potential on r.f. tube. Essential kit consists of four r.f. transformers, two dual condensers, three small condensers, three choke coils, one 500,000-ohm resistor, three 1500-ohm resistors, and a set of color charts and diagrams. Price \$41.50.

211. **BRUNO DRUM CONTROL RECEIVERS**—How to apply a drum tuning unit to such circuits as the three-tube regenerative receiver, four-tube Browning-Drake, five-tube Diamond-of-the-Air, and the "Grand" 6.

212. **INFRA DYNE AMPLIFIER**—A three-tube intermediate-frequency amplifier for the super-heterodyne and other special receivers, tuned to 3490 kc. (86 meters). Price \$25.00.

213. **RADIO BROADCAST "LAB" RECEIVER**—A four-tube dual-control receiver with one stage of Rice neutralized tuned-radio frequency, regenerative detector (capacity controlled), and two stages of transformer-coupled audio. Approximate price, \$78.15.

214. **LC-27**—A five-tube set with two stages of tuned-radio frequency, a detector, and two stages of transformer-coupled audio. Special coils and special means of neutralizing are employed. Output device. Price \$85.20 without cabinet.

215. **LOFTIN-WHITE**—A five-tube set with two stages of radio frequency, especially designed to give equal amplification at all frequencies, a detector, and two stages of transformer-coupled audio. Two controls. Output device. Price \$85.10.

216. **K.H.-27**—A six-tube receiver with two stages of neutralized tuned radio frequency, a detector, three stages of choke-coupled audio, and an output device. Two controls. Price \$86.00 without cabinet.

217. **AERO SHORT-WAVE KIT**—Three plug-in coils designed to operate with a regenerative detector circuit and having a frequency range of from 19,990 to 2306 kc. (15 to 130 meters). Coils and plug only, price \$12.50.

218. **DIAMOND-OF-THE-AIR**—A five-tube set having one stage of tuned-radio frequency, a regenerative detector, one stage of transformer-coupled audio, and two stages of resistance-coupled audio. Volume control through regeneration. Two tuning dials.

219. **NORDEN-HAUCK SUPER 10**—Ten tubes; five stages of tuned radio frequency, detector, and four stages of choke-and transformer-coupled audio frequency. Two controls. Price \$291.40.



CLAROSTAT

The hand on the throttle—

Just as an engine can be no more useful than its throttle, so with the radio power unit and its controls. But the CLAROSTAT is an electrical throttle—positive settings, tremendous resistance range in several turns of knob, silent operation, ample capacity, fool proof, reliable and long life.

What's more, there's a CLAROSTAT for every purpose—from the tiny volume control for receivers to the giant power type for A-B-C power units. That's why you find CLAROSTATS in all good radio equipment.

Whether you are a manufacturer, jobber, dealer, set builder or listener-in, write for your facts on CLAROSTATS.

AMERICAN MECHANICAL LABS. Inc.
285 N. 6th St. Brooklyn, N. Y.

The CLAROSTAT is being imitated. For your protection look for the name stamped on the shell.



6 TUBE RADIO

ONE DIAL *Only \$32.50*

Latest advanced circuit. All steel chassis totally shielded. Balanced parts of best quality. Marvelous power and selectivity. Gets the long range stations as clear as a bell. One dial single control. An unsurpassed value—just one of our many mighty bargains.

FREE Log and Call Book and Big New Catalog—just off the press. Full of Radio Bargains. Send for your free copy now!

American Auto & Radio Mfg. Co.
HARRY SCHWARTZBERG, Pres.
Dept. 122 American Radio Bldg., Kansas City, Mo.

CARTER

New and Complete Line
Molded Mica Condensers
By-Pass, Filter & Buffer Condensers

Not affected by climatic or temperature changes. Guaranteed to be and constantly to remain within 10% of rated capacity. These condensers as well as Carter Jacks, Rheostats, Potentiometers and Switches are specified in the New Improved Laboratory Super described in this issue. Any dealer can supply.

In Canada: Carter Radio Co., Ltd., Toronto



The Outstanding Radio Power Units

What does it mean to you that over fifty leading manufacturers of light socket power units submitted their designs to the Raytheon research laboratories for approval and right to use Raytheon long life rectifying tubes? Just this—that Raytheon's technical personnel and unusual scientific facilities in conjunction with the use of the Raytheon rectifier are invaluable aids in the making of a *reliable* radio power unit. Look over the Raytheon-approved devices. They are the outstanding radio power units by reason of their highly dependable performance. Today, over 700,000 receivers are performing at the height of their efficiency by being powered with Raytheon-approved light socket power units. Your dealer can show you a Raytheon-equipped unit exactly suited to the needs of your receiver.

RAYTHEON MANUFACTURING CO.
Cambridge, Massachusetts



When you see this green Seal of Approval on a power unit you know that it is a Raytheon-approved unit and can buy it with full confidence in the integrity of its makers and the performance of the device.

Raytheon

THE HEART OF RELIABLE RADIO POWER

BIG RADIO CATALOG

From the "Big, Friendly Radio House"

NEW 1928 Book offers finest, newest well-known sets; parts, eliminators, accessories at lowest prices. Set-builders, dealers, agents—WRITE for this CATALOG!

Western Radio Mfg. Co.

134 West Lake Street
CHICAGO, ILL.

For the Latest and Best in Radio Get the New Miller-Welles 1928 Catalog—FREE

SILVER SUPER KIT

As described in this issue, ready for immediate shipment. Kits on all popular receivers in stock. This new book contains the complete lines of such well-known manufacturers as Tyrman Electric Corp., Camfield, Silver-Marshall, Karas, Carter, Aero Coil, etc. Dealers and professional set builders will receive this new book free and without obligation, upon request. Write today!

MILLER-WELLES CO.
18-B W. Kinzie St. Chicago, Illinois

ACME



Flexible Celatsite Wire

A cable of fine, tinned copper wires with non-inflammable Celatsite insulation. Ideal for sub-panel or point-to-point wiring. Strips easily, solders readily. Nine beautiful colors; sold only in 25 ft. coils, in cartons colored to match contents.

Acme Celatsite Wire

Tinned copper bus bar hook-up wire with non-inflammable Celatsite insulation, in 9 beautiful colors. Strips easily, solders readily, won't crack at bends. Sizes 14, 16, 18, 19; 30 inch lengths.



Spaghetti Tubing

Oil, moisture, acid proof; highly dielectric — used by leading engineers. Nine colors, for wire sizes 12 to 18; 30 inch lengths. (We also make tinned bus bar, round and square, in 2 and 2½ ft. lengths.)

Stranded Enameled Antenna

Best outdoor antenna you can buy. Seven strands of enameled copper wire. Presents maximum surface for reception, resists corrosion; this greatly improves the signal. Outside diameters equal to sizes 14 and 16. (We also offer solid and stranded bare, and stranded tinned antenna.)

Loop Antenna Wire

Sixty strands of No. 38 bare copper wire for flexibility, 5 strands of No. 36 phosphor bronze to prevent stretching. Green or brown silk covering; best loop wire possible to make.

Battery Cable

A rayon-covered cable of 5, 6, 7, 8 or 9 vari-colored Flexible Celatsite wires for connecting batteries or eliminator to set. Plainly tabbed; easy to connect. Gives set an orderly appearance.



Send for folder THE ACME WIRE CO., Dept. B New Haven, Conn.

ACME WIRE

MAKES BETTER RADIO

WHAT KIT SHALL I BUY (Continued)

220. BROWNING-DRAKE—Five tubes; one stage tuned radio frequency (Rice neutralization), regenerative detector (tickler control), three stages of audio (special combination of resistance- and impedance-coupled audio). Two controls.

221. LR4 ULTRADYNE—Nine-tube super-heterodyne; one stage of tuned radio frequency, one modulator, one oscillator, three intermediate-frequency stages, detector, and two transformer-coupled audio stages.

222. GREIFF MULTIPLEX—Four tubes (equivalent to six tubes); one stage of tuned radio frequency, one stage of transformer-coupled radio frequency, crystal detector, two stages of transformer-coupled audio, and one stage of impedance-coupled audio. Two controls. Price complete parts, \$50.00.

223. PHONOGRAPH AMPLIFIER—A five-tube amplifier device having an oscillator, a detector, one stage of transformer-coupled audio, and two stages of impedance-coupled audio. The phonograph signal is made to modulate the oscillator in much the same manner as an incoming signal from an antenna.

USE THIS COUPON FOR KITS

RADIO BROADCAST SERVICE DEPARTMENT
Garden City, New York.

Please send me information about the following kits indicated by number:

.....

.....

.....

Name

Address

(Number) (Street)

(City) (State)

ORDER BY NUMBER ONLY. This coupon must accompany each order.

RB027

A KEY TO RECENT RADIO ARTICLES

By E. G. SHALKHAUSER

THIS is the twenty-second installment of references to articles which have appeared recently in various radio periodicals. Each separate reference should be cut out and pasted on 4" x 6" cards for filing, or pasted in a scrap book either alphabetically or numerically. An outline of the Dewey Decimal System (employed here) appeared last in the January RADIO BROADCAST.

R343.7. ALTERNATING-CURRENT SUPPLY. SOCKET-POWER. RADIO BROADCAST, May, 1927. Pp. 43-45. B-Battery. "Perfecting the B Socket-Power Device," H. E. Rhodes. The various parts of a good B socket-power device are discussed. The causes of "motor-boating" in these devices, and its possible elimination, are outlined, circuit diagrams and graphs of the operation of a typical B socket power unit being given.

R201.6. MEASUREMENTS WITH HIGH-FREQUENCY BRIDGE. RADIO BROADCAST, May, 1927. Pp. 46-50. "Methods of Measuring Tube Characteristics," K. Henney. The writer discusses tube constants, their characteristics, and the bridge circuits used in obtaining these data. The various bridges used to measure amplification factor, plate impedance, mutual conductance, input conductance, and power output, are shown, and experimental data of a variety of tubes on the market are given.

R131. CHARACTERISTIC CURVES; GENERAL PROPERTIES. RADIO, April, 1927. Pp. 26-28. "A High-Mu Tube At Work," J. E. Anderson. Here is presented a discussion on the effect of grid bias for various plate voltages when using high-mu tubes and resistance coupling. With the circuit arrangement shown and the curves obtained, the writer presents a detailed analysis of the curves and states why a negative bias is necessary.

R384.1. WAVEMETERS. RADIO, April, 1927. Pp. 29-ff. "How to Calibrate a Wavemeter," C. T. Burke. Methods used in obtaining fundamental standards of frequency with the aid of quartz crystals and a series of coupled oscillators are outlined. How this standard may be used in calibrating other wavemeter circuits, methods of checking, calibration of frequencies above the fundamental, etc., are other topics discussed by the author.

Now You can build the kind of a radio you have always wanted

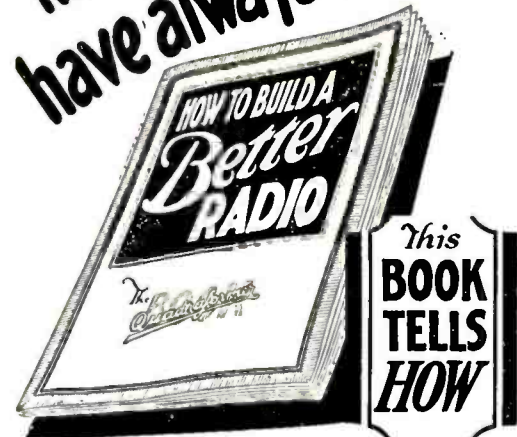

This BOOK TELLS HOW

No matter whether you want to improve a set you now have or build a new one — get this book first. Tells how to build the latest one, two and three dial receivers — 5 to 7 tubes.

10¢ PREPAID

GEARHART-SCHLUETER, Fresno, Cal.

RADIO WHOLESALE

Write for my Big 1928 Radio Catalog — just off the press. Thousands of marvelous bargains in nationally advertised goods. All the LATEST IN RADIOS and equipment. Lowest wholesale prices.

It's a regular encyclopedia on Radio. All about trouble finding. **FREE Log and Call Book** and Catalog. Get your copy today. Send postcard now!

American Auto & Radio Mfg. Co.
HARRY SCHWARTZBERG, PRES.
Dept. 123 American Radio Bldg., Kansas City, Mo. 3

DEALERS NEW 1928 CATALOG

Use Power tubes for good quality at full volume

Simply adapt to your set with Connectorals



For UX 171 and UX 112 Tubes, Na-Ald 112 Connectorals are recommended for maximum volume with storage battery sets. These tubes will deliver without distortion several times the volume of the regular 201A. Price \$1.50

For UX 120 Tubes in UV 201A sockets, the Na-Ald No. 120 Connectorald should be used. To convert a storage battery set to dry batteries with ample loud speaker volume, use a UX 120 tube in the last audio stage with the 120 Connectorald and UX 199 tubes with 419X Adapters in the other sockets. Price \$1.25.

For the UX 120 Tube in UV 199 sockets, ample loud speaker volume without distortion is obtainable from any set equipped for UV 199 tubes by means of the UX 120 or equivalent tube with the Na-Ald No. 920 Connectorald. The tube is raised slightly, but provides for its use in most sets with limited headroom. Price \$1.25.

For UX 120 tubes in the UV 199 sockets of the Radiola Superheterodyne Semi-Portable, and Radiola Super VIII. These excellent Superheterodynes will deliver ample volume for loud speaker operation when equipped with the UX 120 used with the Na-Ald No. 420 Connectorald. Price \$1.25.

ALDEN MANUFACTURING CO. Dept. B-29 Springfield, Mass.

FROST-RADIO

APPARATUS
EXCLUSIVELY
SPECIFIED
For the
MAGNAFORMER
9-8

The following FROST-RADIO parts are *exclusively* specified for the Magnaformer 9-8, "Commander-in-Chief of the Air":

- 1 No. S-1810 De Luxe 10-ohm Bakelite Combination Rheostat and Battery Switch, gold arrow knob.
- 1 No. 1824 De Luxe 400-ohm Bakelite Potentiometer, gold arrow knob.
- 1 No. 1810 De Luxe 10-ohm Bakelite Rheostat, gold arrow knob.
- 1 No. 1830 De Luxe 30-ohm Bakelite Rheostat, gold arrow knob.
- 4 No. 253 Frost-Radio Cord Tip jacks

Your dealer can supply you with these parts for your Magnaformer. Secure them from him today

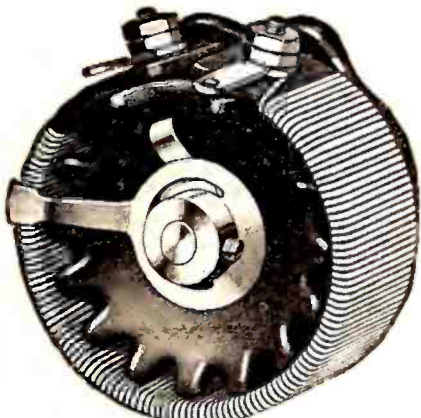

FROST-RADIO

No. 1824 De Luxe 400-ohm Potentiometer, \$1.25



FROST-RADIO

No. 253 Cord Tip Jack

The handy cord tip jack with the spring clutch. 2 pairs used in the Magnaformer. Per pair, 30c.



FROST-RADIO

NEW FROST-RADIO De Luxe Gem Rheostat

The neatest, most compact rheostats made. 6 to 30 ohms; plain type, 75c; with switch \$1.00. Also 200 and 400 ohm potentiometer, \$1.00.

HERBERT H. FROST, Inc.

Main Offices and Factory
ELKHART, IND.

- Chicago
- Philadelphia
- Washington, D. C.
- New York
- Los Angeles
- St. Paul
- Boston
- Pittsburgh
- New Orleans
- Buenos Aires, Argentina

Goodrich



Radio Panels

Black, Mahogany and Walnut. Standard thickness 3-16" and 1/4". High softening point prevents warping.

Low free sulphur content prevents discoloration.

Machine easier and are better electrically than any other material in common use.

Your radio dealer has them or will get them for you—if not, write to us and we will see that you are supplied.

Also hard rubber for coils, spaghetti tubing and miscellaneous rubber items for radio manufacturers.

Radio Sales Division

The B. F. Goodrich Rubber Company
Established 1870 Akron, Ohio

BIG NEW CATALOG FOR RADIO BUILDERS
FREE My big 1928 Radio Catalog, Call Book and Trouble Finder. 132 pages about Radio. Chock full of newest circuits—kits, transmitter parts, short wave outfits, eliminators and speakers. Thousands of bargains at lowest wholesale prices. A regular Radio Encyclopedia—Free. Write today.
American Auto & Radio Mfg. Co.
HARRY SCHWARTZBERG, PRES.
Dept. 125 American Radio Bldg., Kansas City, Mo.

LATEST RADIO CIRCUITS

Independent Radio Corporation

Manufacturers of

Precision Radio Apparatus

1516 Summer Street Philadelphia

This is a good time to subscribe for
RADIO BROADCAST
Through your dealer or direct, by the year only \$4.00

BUILD THIS 3 Ft. CONE



THE famous "Enseo" cone with the decorated cone and the new unit, fully covered by patents, can be assembled by anybody in less than an hour. No soldering. Perfect reproduction of every tone broadcast.

ALL PARTS—\$10.00
Kit with Wall Frame, \$11.00

Six types illustrated and fully described in instruction book. Ask your dealer or we will ship direct—Money-back guarantee, of course.

ENGINEERS' SERVICE COMPANY
25 Church Street, New York
73 Cornhill, Boston
28 E. Jackson Blvd., Chicago

Bradleystat

PERFECT FILAMENT CONTROL

For noiseless, smooth filament control and maximum range, ask your dealer for the Bradleystat. This well-known

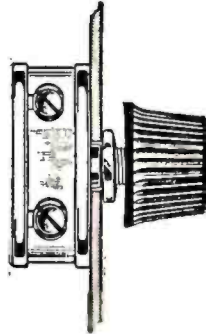

graphite disc rheostat can be used for ALL TUBES, without change of connections. The bakelite knob is removable, if desired. The one-hole

mounting makes the Bradleystat easy to install.

Bradleyleak

THE PERFECT GRID LEAK

With a range from 1/4 to 10 megohms, the Bradleyleak offers a variation of adjustment that adapts it to any

tube or any circuit. A small grid-condenser can be attached direct to its terminals. One-hole mounting.

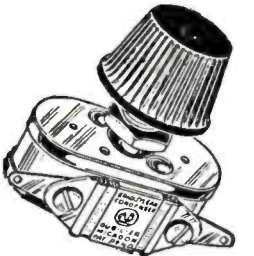

Bradley-Amplifier

Resistance-Coupled

PERFECT AUDIO AMPLIFIER

For perfect tone quality, use resistance coupling, and for convenience and reliability, ask your dealer for a Bradley-Amplifier. Ready to install in your radio set.



Mail this coupon to

ALLEN-BRADLEY CO.
278 Greenfield Ave., Milwaukee, Wis.

Please send me your folders on Allen-Bradley radio devices, including the Bradley-Amplifier.

Name

Address



Kept Cool—

Like An Air-Cooled Engine!

TRUVOLT

An All Wire Variable Power Resistor

Truvolt, a wire variable high resistance of special mechanical construction, is air-cooled on the same principle as Lindbergh's transatlantic motor. This results in a greater radiation area and adapts it especially for B-Eliminators and power devices.

1. Made entirely of wire; permanently accurate; long life.
2. Permits potentiometer control; positive metallic contact at all times.
3. Nichrome wire resistance—very low temperature coefficient. Wound on an asbestos-covered enamel core.

Type	Ohms Resistance	Milliamperes Current
T-5	0 to 500	224
T-10	0 to 1,000	158
T-20	0 to 2,000	112
T-50	0 to 5,000	71
T-100	0 to 10,000	50
T-200	0 to 20,000	35
T-250	0 to 25,000	32
T-500	0 to 50,000	22.5

Eight stock types with resistances up to 50,000 ohms. All rated at 25 watts. List \$3.50 each.

Write for free resistance booklet

"This Is An Eliminator Year"

Dept. 14
175 Varick Street
New York

ELECTRAD

R270. SIGNAL INTENSITY MEASUREMENTS. SIGNAL INTENSITY. *Radio News*, April, 1927. Pp. 1220-ff. "A New Field for Experimentation," J. F. Rider. This article describes a layout of apparatus which may be used to record the intensity of carrier waves of different stations broadcasting, in order to obtain data for the analysis of transmission problems and fading. The apparatus needed is listed; it consists of a receiver, equipped with meters, and an oscillator for purposes of receiver calibration. The method of plotting signal strength curves, and particulars on the proper operation of the set, are given.

R132.3. RESISTANCE COUPLING. COUPLING, RESISTANCE. *Radio News*, April, 1927. Pp. 1250-ff. "Does Resistance Coupling Give Best Quality?" S. Harris.

The disadvantages, as compared to the advantages, of resistance-coupled amplifier circuits, are given. Two main disadvantages are said to be the presence of the blocking condenser, which reduces amplification at the lower frequencies, and the low amplification per stage as compared to transformer coupling. The effects of these disadvantages are discussed, and remedies are suggested.

R144. HIGH-FREQUENCY RESISTANCE. RESISTANCE. *Physical Review*, Jan., 1927. Pp. 165-173. *High-Frequency.* "The Resistance of Copper Wires at Very High Frequencies," W. M. Roberts.

At frequencies of the order of 107 cycles, the distributed capacity of single loops of wire are said to cause sufficient unequal current distribution in the loop to account for large apparent discrepancies between observed and calculated resistances. For a given frequency, more uniform current distribution is gained by decreasing the size of the loop and simultaneously increasing the capacity of the tuning condenser. Curves are plotted with ratio of observed to calculated resistance as ordinate and condenser setting as abscissa. For all curves taken, the ratio fell well below 1.45 and was still decreasing as far as data were taken. The presence of oxide on copper wire is said to have no appreciable effect on the resistance.

R376.3. LOUD-SPEAKING REPRODUCERS. LOUD-SPEAKERS. *RADIO BROADCAST*, April, 1927. Pp. 587-590. "A Fundamental Analysis of Loud Speakers," J. F. Nielsen.

The quality of radio broadcast programs when reproduced depends in part on the loud speaker. The nature of the signal which is to be reproduced determines entirely the method of loud-speaker construction. A study concerning facts of speech and musical tones and harmonics is, therefore, presented. The desirable characteristics of loud speakers and the mechanism that is to reproduce these characteristics is taken up in a mathematical discussion under the following: (1) The motor element, which converts the electrical impulses into corresponding mechanical vibrations; (2) the coupling system, which transmits the mechanical vibrations from motor to diaphragm; (3) the diaphragm or loading device, which radiates the mechanical vibrations into the air as waves of sound. Distortion is said to result from saturation of armature and pole faces, and from iron losses.

R113.5. METEOROLOGY. METEOROLOGY. *Popular Radio*, April, 1927. Pp. 327-ff. *Earth Blankets.* "The Three Blankets Around the Earth," E. E. Free.

The writer presents information relative to the nature of space surrounding the earth. Three layers of gases are said to be found varying in height and having different temperatures. The lower layer or blanket, about seven miles high, contains mixed gases and varies considerably in temperature. The middle layer, about 80 degrees below zero Fahrenheit, is about 25 miles in height. The upper layer, about 400 to 600 miles high, is supposed to have a temperature of about 80 degrees above zero Fahrenheit. This latter is said to serve as the protecting blanket, surrounding the earth, against the many meteors which would otherwise destroy everything on the surface. It also serves as the reflecting layer for many radio waves, being commonly called the Heaviside Layer. It is ionized by the ultraviolet rays from the sun. In it the aurora is said to be displayed. Above this layer, space at a temperature of 460 degrees below zero is supposed to exist.

R412. RADIO TELEPHONE SYSTEMS. TELEPHONY. *Radio News*, March 1927. Pp. 1086-ff. *Trans-Atlantic.* "Hello, London! 'Are You There, New York?'" G. C. B. Rowe.

The apparatus and the single side-band transmitter system as used in the new transatlantic radio telephone station are described. The principle of single side-band transmission, with its partial secrecy and saving of "watts per mile," is based on the heterodyne method of frequency amplification.

Most from Your Tubes



GOOD tubes are little better than poor tubes without Amperite. Utmost performance and longest life requires the perfect automatic filament control of each individual tube, afforded only by Amperite. Insist on this variable filament resistance—and look for the name. Eliminates hand rheostats. Simplifies wiring.

Radial Book—FREE
Explains fully Amperite principle and operation. Gives season's best Hook-Ups and Construction Data. Send for it today to Dept. RB-9.

Radial Co., 50 Franklin St., New York
Price \$1.10 mounted (U.S.A.)
Sold Everywhere

AMPERITE
REG. U.S. PAT. OFF.
The "SELF-ADJUSTING" Rheostat

RADIO PANELS
BAKELITE—HARD RUBBER
Cut, drilled and engraved to order. Send rough sketch for estimate. Our complete Catalog on Panels, Tubes and Rods—all of genuine Bakelite or Hard Rubber—mailed on request.
STARRETT MFG. CO.
521 S. Green Street Chicago, Ill.

Electrostatic condensers for all purposes
Faradon
WIRELESS SPECIALTY APPARATUS COMPANY
Jamaica Plain Boston, Mass.

RADIO FANS, a one-year's subscription to Radio Broadcast will cost you four dollars, two years six dollars. Consider this expenditure as being a necessary investment on your part for the future development of your own knowledge of Radio.



U. S. Patent, Oct. 12, 1926
Add the new Balkite Combination to your radio set now—with your "A" battery it supplies all radio power automatically from the light socket.

Ask your radio dealer
FANSTEEL PRODUCTS CO., INC.
North Chicago, Ill.

USE THIS COUPON FOR COMPLETE SETS
RADIO BROADCAST SERVICE DEPARTMENT
RADIO BROADCAST, Garden City, New York.
Please send me information about the following manufactured receivers indicated by number:

.....
.....
.....
Name

Address (Number) (Street)

(City) (State)

ORDER BY NUMBER ONLY
This coupon must accompany each order. RB 927

Like A Long Arm!

Tune out a poor program and bring in a good one—without leaving your easy chair. Only tuning unit of its kind.



Easily attached to any single dial receiver with removable dial by removing old dial and attaching Remote Control adapter plate.

Mechanical Model....\$18.00
Electrical Model..... 60.00

Write for illustrated descriptive circular

ALGONQUIN ELECTRIC CO.
245 Fifth Ave., New York City

ELKAY
TRADE MARK REG
TUBE EQUALIZER

INSTEAD OF RHEOSTATS

Permits instant change from one combination of tubes to another without rewiring. Simply insert Equalizers to match the different voltages. Self-adjusting. Made for all tubes. Unmounted, 50c. mounted 75c.

Elkay Suppressors, made in same form, suppress regeneration and thus annihilate the squeals. Unmounted, 75c; mounted, \$1.00.

Langbein-Kaufman Radio Co.
(Dept. B)
62 Franklin St., New Haven, Conn.

R U ONE?

Co-operative membership in E I A RADIO is establishing an honest, industrious man in each locality in a successful radio industry of his own. Young married men preferred. Apply by letter, giving the name of your county, to

EQUITABLE INDUSTRIES ASS'N, RADIO DIV.
350-B Broadway, New York

BROADCASTING FROM THE INSIDE

EVERY month in RADIO BROADCAST appears the departments "As the Broadcaster Sees It," written by Carl Dreher, one of the best known broadcast engineers in the country. Alive with humor, news, apt and searching comment, Mr. Dreher's writing, have become one of the most popular features of radio writing anywhere. Are you reading it? Subscribe by the year and make sure of not missing a single issue. Mail your check for \$4.00 to Subscription Department, Doubleday, Page & Co., Garden City, N. Y.

\$75 A WEEK

BUILDING RADIO SETS

In Your Spare Time

Join the Radio Association of America. Learn how to build and repair sets. The Association will train you—start you out in business, if you wish. Be the radio "doctor" of your community. \$3 an hour upwards easily made.

Earns \$500 in Spare Time

"I have at last found myself", writes Lyle Follick, Lansing, Mich. "I have already made over \$500." Werner Eichler, Rochester, N. Y., "... have made over \$50 a week in my spare time." Our members are starting radio stores, increasing their salaries, securing better positions, passing radio operator examinations, earning big money in spare time.

Join Association Now

Are you interested in Radio for pleasure or profit? Join now because we have a Special Plan whereby your membership need not cost you a cent. Only limited number of these memberships acceptable. Write now for details—before it is too late.

Mail this Coupon—

Radio Association of America,
Dept. R. B. J., 4513 Ravenswood Ave., Chicago

Send me details of your special Radio Association Membership Plan.

Name.....

Address.....

City.....State.....

There is a Vitrohm Radio Resistor for EVERY power unit

More than 90 standard Vitrohm Resistors and Rheostats cover the resistance need of every socket power circuit now on the market.

Resistance is the heart of power circuits. Make sure of quiet, permanent, and unfailing service by insisting on Vitrohms for radio.

Vitrohm Resistors and Rheostats are guaranteed unconditionally for continuous-duty in any circuit where they operate within their watts dissipation rating—Vitrohm Resistors have the highest continuous-duty rating without resistance change of any resistor.

New Vitrohms

The list below of new resistors and rheostats is partial. A full description of new Vitrohms for Radio is available without charge. Send for it.

RAYTHEON 350 M. A. UNITS
Vitrohm Resistor 507-70 \$7.50
Vitrohm Rheostat 507-59 5.50

QRS 400 M. A. CIRCUITS
Vitrohm Resistor 507-62 \$7.50
Vitrohm Rheostat 507-59 5.50

SILVER-MARSHALL UNITS
Vitrohm Resistor S-M 653 \$2.50
Vitrohm Resistor S-M 655 2.50
Vitrohm Resistor S-M 657 5.00

THORDARSON POWER PACKS
Vitrohm Resistor for R-171 \$2.15
Vitrohm Resistor for R-210 2.65
Vitrohm Resistor for R-210 4.90
with UX874 Regulator Tube

The Adjustat

A new Vitrohm Rheostat, dissipating 20 watts, having 15 steps of resistance. The Adjustat is priced at \$3.00.

11 types are available in the following resistances and current capacities:

507-79, 1 ohm, 4 amp.—507-71, 2 ohms, 3 amp.—507-72, 6 ohms, 1.5 amp.—507-73, 20 ohms, 1.0 amp.—507-74, 30 ohms, 0.75 amp.—507-80 50 ohms, 650 m.a.—507-81, 600 ohms, 180 m.a.—507-75, 1000 ohms, 125 m.a.—507-76, 2250 ohms, 90 m.a.—507-77, 10,000 ohms, 40 m.a.—507-78, 25,000 ohms, 10 m. a.



WARD LEONARD
ELECTRIC COMPANY
MOUNT VERNON, N. Y.

B BLOCKS **TOBE** TINY TUBES

CONDENSERS—RESISTORS

Specified—Used—Universally

TOBE DEUTSCHMANN CO. Cambridge, Mass.

Write quick FOR HARRY ALTER'S

New Wholesale RADIO BOOK

"Minute-Man" shipping service means quicker turnover for radio dealers—bigger business and more profits without increasing your capital investment.

Everything in RADIO at BED-ROCK PRICES

made possible by cash buying and cash selling. If it is used in radio and is a reputable product, we have it. Send now for catalog.

Note: We sell radio retailers only

The Harry Alter Co.
1750 Michigan Avenue CHICAGO



When the
Greatest
Show in
History thrills
the World

....You're there with a Crosley



\$35



\$85

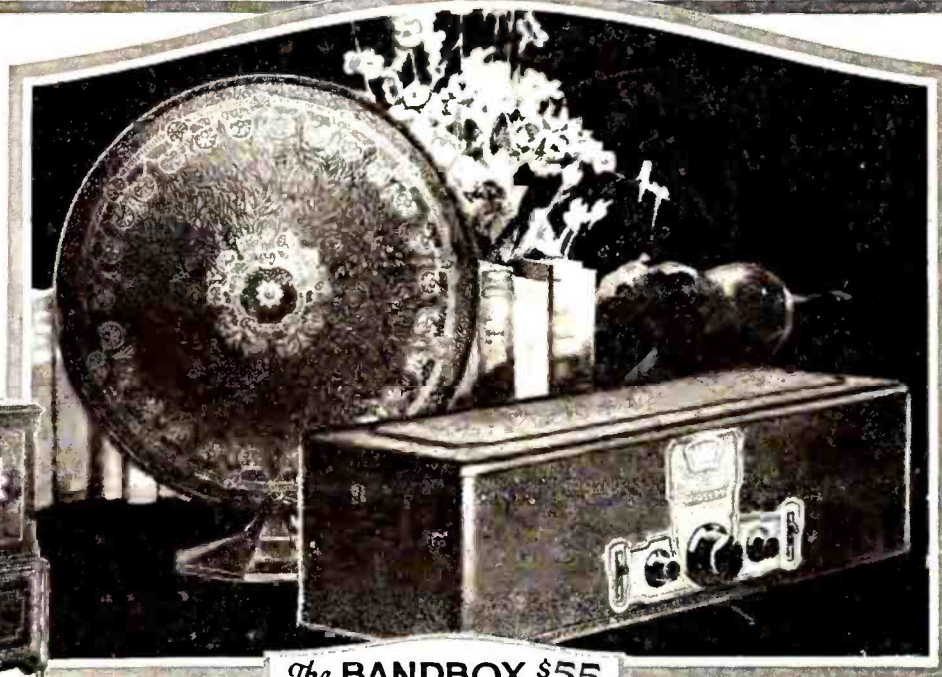

The BANDBOX \$55
A 6 tube Receiver
Brown frosted Crystalline finish—
Bronze Escutcheon.



\$65

These approved cabinets have been selected by Powell Crosley, Jr., as ideal consoles, acoustically and mechanically, for the installation of the Crosley "BAND-BOX." Genuine Musicones built in Crosley dealers secure them from their jobbers through

H. T. ROBERTS CO.,
914 S. Michigan Ave.,
Chicago, Ill.
Sales Agents for Approved
Console Factories:

SHOWERS BROTHERS
COMPANY
THE WOLF MFG.
INDUSTRIES

A tremendous Crosley radio achievement for 1927-28

RECENT court decisions which clarified the radio patent situation have paved the way for still greater Crosley triumphs. Now—completely available to Crosley—and amplifying Crosley supremacy in the fullest measure, are the enormous resources, great discoveries and ideas embodied in patents of

- 1—The Crosley Radio Corporation.
- 2—The Radio Corp. of America.
- 3—The Westinghouse Co.
- 4—The General Electric Co.
- 5—The American Telephone & Telegraph Co.
- 6—The Hazeltine Corporation.
- 7—The Latour Corporation.

under which Crosley is now licensed to manufacture.

Here are the seven big things which represent radio's greatest advancement, brought together by Crosley and combined with the experience, mass production method and leadership of the Crosley organization. No wonder a waiting radio world pronounces the "Bandbox" at the unprecedented price of \$55, Crosley's paramount achievement.

The Bandbox is Shielded

Radio coils are surrounded by magnetic fields similar in every respect to the magnetic field around the earth that moves the needle of a compass but around radio coils these fields make nuisances of themselves by feeding back on each other. Heretofore it has been customary to make inefficient coils with inefficient fields to prevent such feeding back. The Crosley Bandbox incorporates copper shields around each coil to prevent such feeding back. The coils consequently can be made and are very much more efficient. The amplification of the receiver is, therefore, much higher—the sensitivity is greatly increased. Condensers are also completely shielded from each other in separate metal compartments. Hitherto, only high priced sets have enjoyed this super radio advantage.

There Is No Oscillation

The Bandbox employs completely balanced or neutralized radio frequency stages to prevent oscillation, instead of the common form of lossy method. More costly, to be sure, but extremely necessary in achieving such results as are obtained by this marvel of radio reception.

For Sharpness—The Acuminators

"Bandbox" acuminators enable "fishers" for distant stations to bring them in loud and clear. As powerful telescopes magnify distant scenes, acuminators increase the volume of far-away-signals so they seem like local programs.

Volume Control

This is another big "Bandbox" feature which permits full brass band power for those who want their dance notes strong and loud. For others, it cuts volume down to a soft and gentle murmur, without distortion.

Illuminated Dial

A Master Station Selector has an illuminated dial for easy reading in shadowy corners. A single knob permits full tuning for ordinary reception of local, nearby and super-powered stations.

Installation Simplified

A woven cable, containing vari-colored rubber covered leads makes installation and hook-up easy for the veriest novice. No waiting for the radio service man, should the batteries be changed.

Easily Adapted to Consoles

Simply remove screws in escutcheon and in base of set. Lift off metal case. Chassis now stands ready for installation in console cabinet. Opening in console cabinet permits control shafts to protrude. Escutcheon screws in place and—Presto! the console radio is complete.

For A. C. Operation

a special Bandbox is available at \$65, wired especially for use with



IMPROVED MUSICONES
Although Musicones improve the reception of any radio set, they are perfect affinities in finish, beauty and reproductive effectiveness for Crosley Radios. A new model built in the form of a Colonial Tilt-Table with brown mahogany finish, stands 3 feet high. Price \$27.50.

16-inch Super Musicone (As pictured with Bandbox) \$12.75

12-inch Ultra Musicone \$9.75

the Crosley Power Converter at \$60. This special Bandbox utilizes the new R.C.A. AC tubes which have made the operation of radio receivers direct from house current so simple, efficient and dependable. The first three tubes employed in the AC model are UX 226. These go into the radio frequency sockets. The detector tube is UY 227, with indirectly heated emitter. Another UX 226 is used in the first audio stage. Raw AC current heats the filament of all UX 226 tubes. Power tube UX 171 is in the last audio socket. This makes the "dog houses" rumble sonorously and the bass drums deeply boom.

The Power Converter

The power converter which smooths the alternating current is a marvel of engineering ingenuity. Only half the size of an ordinary "A" storage battery, it supplies the required A, B and C currents, without hum. Finished in brown frosted crystalline. There are models for 25 and 60 cycle current. A snap switch shuts down the set and power converter completely.

Price of Power Converter—\$60

You owe it to yourself to see the "Bandbox" and listen to its remarkable performance. If you cannot easily locate the nearest Crosley dealer, his name and address will be supplied on request. Write Dept. 20.

CROSLEY RADIO

Crosley Radio is licensed only for Radio Amateur, Experimental and Broadcast Reception.

Crosley recommends the use of one UX171 power tube, or which are furnished at stan Bandbox. While Radiotron gives a superior performance



of five 201-A Radiotrons and Cunningham equivalents, dard tube prices, with each UX171 is 180-volt tube, it for 135-volt "B" batteries.

The Crosley Radio Corporation

Powell Crosley Jr., Pres.
Cincinnati, Ohio

Prices slightly higher west of Rocky Mountains

Your "B" Battery Eliminator
will give you better service with

Q · R · S

(Trade Mark Registered)

**Gaseous
Rectifier Tubes**

ARE BETTER

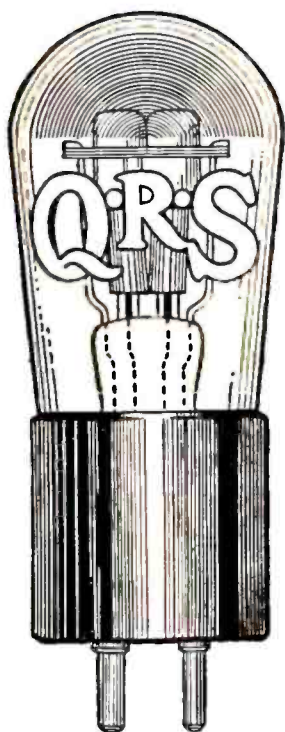

60 Milliamperes - \$4.50
85 Milliamperes - 4.50
400 Milliamperes - 7.00

Ask for Catalog of full line of Standard Tubes.

Guaranteed

The standing of the Q·R·S Company, manufacturers of quality merchandise for over a quarter of a century, establishes your safety.

Orders placed by the leading Eliminator Manufacturers for this season's delivery, approximating Four Million Dollars' worth of Q·R·S Rectifier Tubes, establishes the approval of Radio Engineers. Ask any good dealer.

THE Q·R·S COMPANY

MUSIC

Manufacturers

Executive Offices: 306 S. Wabash Ave., Chicago

Factories: Chicago—New York—San Francisco—Toronto, Canada—Sydney, Australia—Utrecht, Holland

Established 1900. References—Dun, Bradstreet, or any bank anywhere

**30
DAYS
FREE
TRIAL**

7 Tube Set

Single Dial Radio

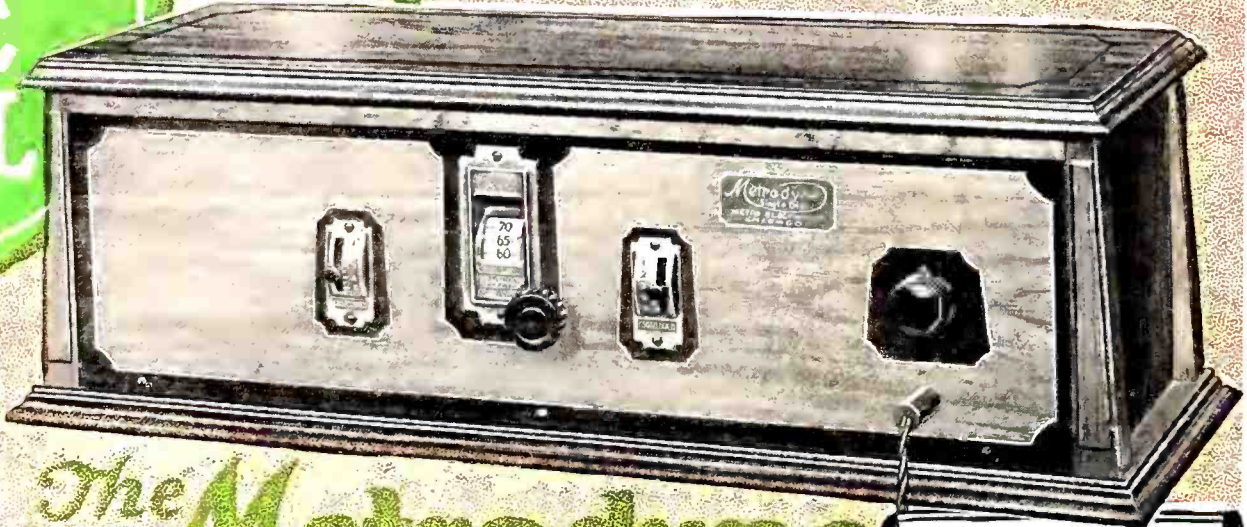

The Metrodyne
ONLY ONE DIAL TO TUNE

RETAIL PRICE
\$75⁰⁰
Completely Assembled
Big Discounts to
Agents and Dealers

**Metrodyne
Radio Sets**
Are Equipped
For
**BATTERY or
ELECTRIC**
operation

Wonderful offer direct from the factory! The world's greatest radio! A perfect working, single dial control, 7 tube receiver! And just to prove our claims, we will ship it to your home for 30 days' free trial. Test it under all conditions. Test it for distance, volume and tonal quality—and if you are not convinced that it is the best single dial set you ever heard, return it to the factory. We don't want your money unless you are completely satisfied.

Three Year Guarantee

**BIG PROFITS
TO AGENTS AND DEALERS**
Our Agents and Dealers make big money selling Metrodyne Sets. You can work all or part time. Demonstrate the superiority of Metrodynes right in your home. Metrodyne Radios have no competition. Lowest wholesale prices. Demonstrating set on 30 days' free trial. Greatest money-making opportunity. Send coupon, a letter or a postal for our agent's proposition.

Metrodyne Super-Seven Radio

A single dial control, 7 tube, tuned radio frequency set. Tested and approved by Popular Science Institute of Standards, Popular Radio Laboratory, Radio News Laboratory and by America's leading Radio Engineers. Designed and built by radio experts. Only the highest quality low loss parts are used. Magnificent, two-tone walnut cabinet with beautiful, gilt metal trimmings. Very newest 1928 model, embodying all the latest refinements.

Easiest set to operate. Only one small knob tunes in all stations. The dial is electrically lighted so that you can log stations in the dark. The volume control regulates the reception from a faint whisper to thunderous volume, 1,000 to 3,000 miles on loud speaker! The Metrodyne Super-Seven is a beautiful and efficient receiver, and we are so sure that you will be delighted with it, that we make this liberal 30 days' free trial offer. You to be the judge.



30 Days Free Trial—3 Year Guarantee
Metrodyne Super-Six

Another triumph in radio. Here's the new 1928 model Metrodyne 6 tube, two dial, long distance tuned radio frequency receiving set. Approved by leading radio engineers of America. Highest grade low loss parts, completely assembled in a beautiful walnut cabinet. Easy to operate. Dials easily logged. Tune in your favorite station on same dial readings every time—no guessing.

Mr. Howard, of Chicago, said: "While five Chicago broadcasting stations were on the air I tuned in seventeen out-of-town stations, including New York and San Francisco, on my loud speaker horn, very loud and clear, as though they were all in Chicago."
We are one of the pioneers of radio. The success of Metrodyne sets is due to our liberal 30 days' free trial offer, which gives you the opportunity of trying before buying. Thousands of Metrodynes have been bought on our liberal free trial basis.

**6
Tube Set**
\$48⁵⁰
RETAIL PRICE
Completely
Assembled

**MAIL THIS
COUPON**
or send a postal or letter. Get our proposition before buying a radio. Deal direct with manufacturer—**SAVE MONEY—WRITE NOW!**

MAIL COUPON BELOW

Let us send you proof of Metrodyne quality—our 30 days' free trial offer and 3 year guarantee

Mrs. Wm. Leffingwell, Westfield, N. J., writes: "The Metrodyne Radio I bought of you is a 'wow'! This is as good as any \$225 machine I have ever seen."

N. M. Greene, Maywood, Ill., writes: "My time is up and the Metrodyne works fine. I got Havana, Cuba, Oakland, Calif., Denver, Colo., Toronto, Canada, all on the loud speaker."

J. W. Woods, Leadville, Colo., writes: "Received the 7-tube Metrodyne in fine condition. Had it up and working same day received. Was soon listening to Los Angeles, San Diego, Oakland and other California points; also St. Louis, Kansas City and other east and south stations—all coming in fine. Am more than pleased. Sure enjoying it."

We will send you hundreds of similar letters from owners who acclaim the Metrodyne as the greatest radio set in the world. A postal, letter or the coupon brings complete information, testimonials, wholesale prices, and our liberal 30 days' free trial offer.

METRO ELECTRIC COMPANY
2161-71 N. California Ave., Dept. 16
Chicago, Illinois

Gentlemen:
Send me full particulars about Metrodyne 6 tube and 7 tube sets and your 30 days' free trial offer.

Name _____
Address _____

If you are interested in AGENT'S proposition, place an "X" in the square

METRO ELECTRIC COMPANY
2161-71 N. California Ave. • Dept. 16 • Chicago, Illinois