

First Published Details of New Standards for Radio Parts

APR. 1925 **RADIO** 35 CENTS
BROADCAST

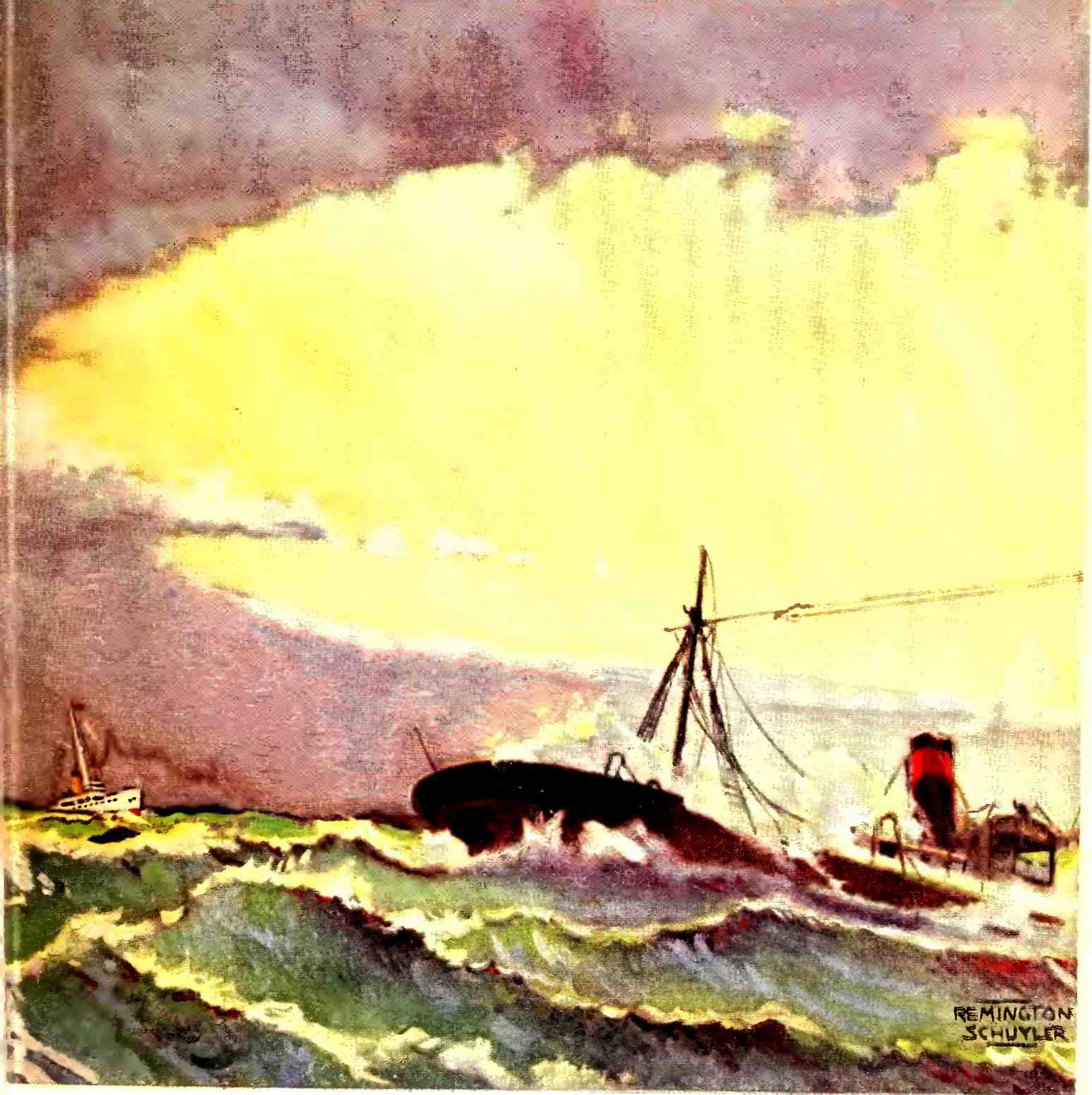

New Experiments with the Roberts Knockout Set

516 "As the Broadcaster Sees It"

What Radio Equipment Does the Public Favor?

PUBLISHED BY DUBLEDAY, PAGE & COMPANY

GARDEN CITY, NEW YORK



It's the Latest Dance Hit!

Roll Up the Rugs

Sway to the pulsating lilt of your favorite Metropolitan Orchestra.

Dance in unison with ten thousand other gliding couples. Tap the limitless Ether for the Rhythmic Harmony that awaits your tuning-in.

Cunningham Radio Tubes give that bell-like clearness, that perfect re-creation of tone which you must have for the utmost in radio enjoyment.

Since 1915 - Standard for all sets

**Types C301A, C299, C300, C11, C12
In the Orange and Blue Carton**

Price \$3.00 Each



Cunningham ★ **RADIO TUBES**

Home Office:
182 Second St.,
SAN FRANCISCO

A. J. Cunningham Inc.

CHICAGO
NEW YORK

Patent Notice: Cunningham tubes are covered by patents dated 2-18-08, 2-18-12, 12-30-13, 10-23-17, 10-23-17, and others issued and pending.

★ Tested and approved by RADIO BROADCAST ★

*Specify
Belden*

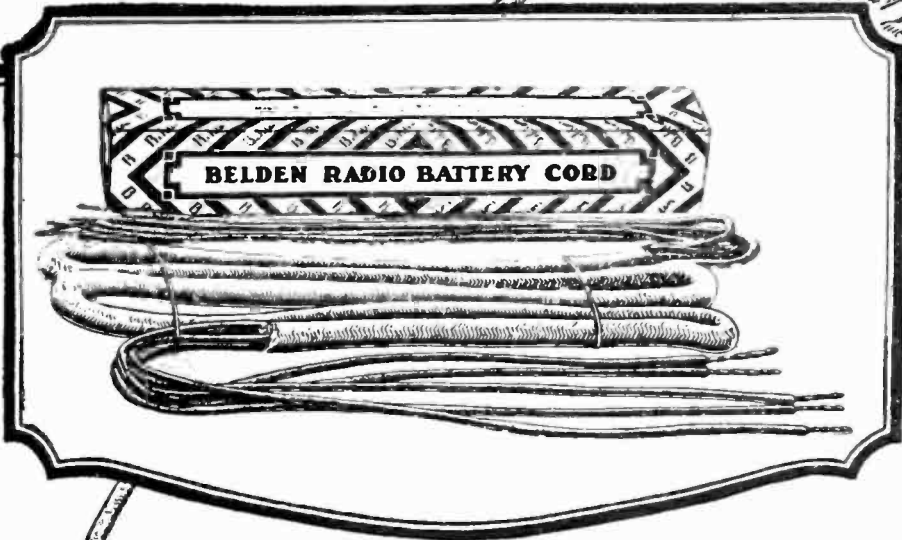
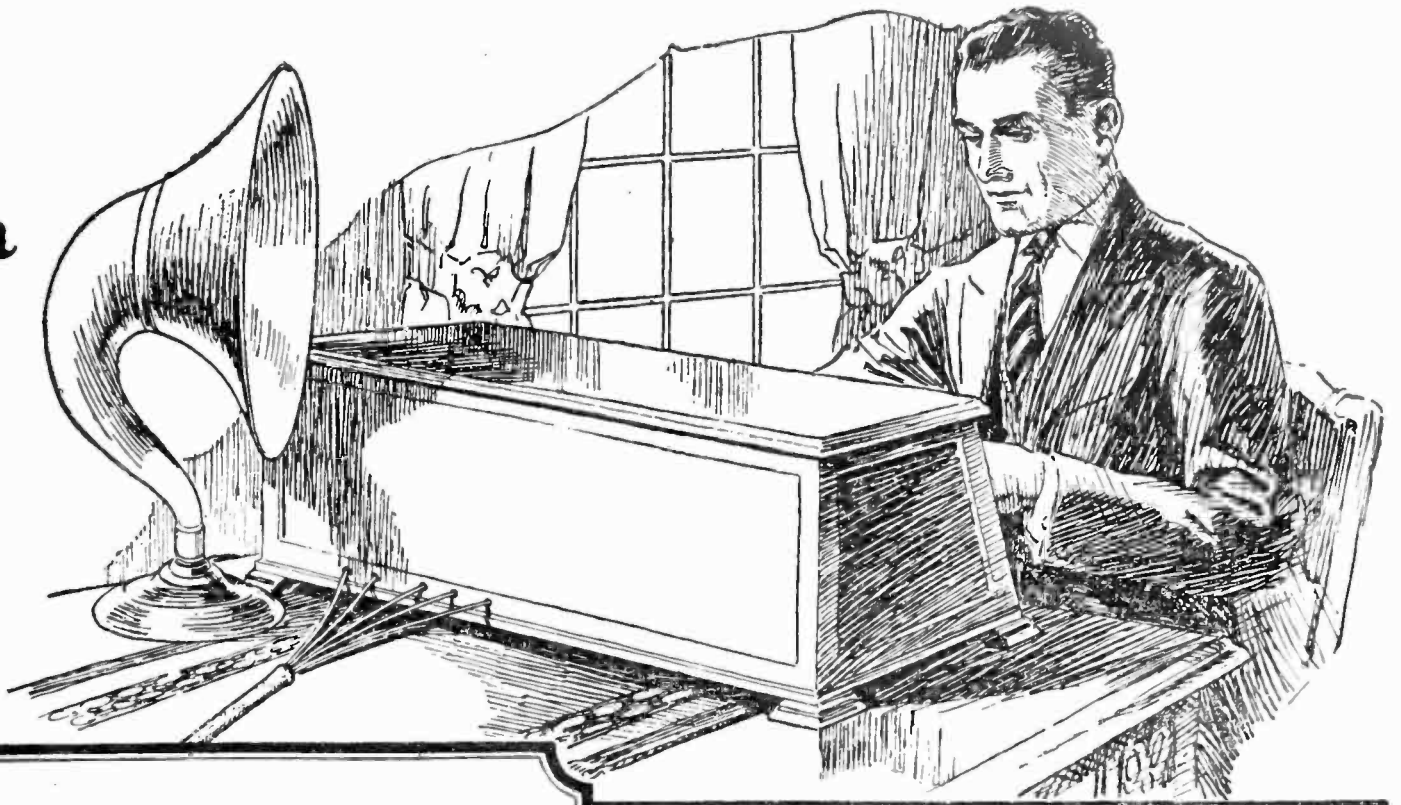

Make Your Set Safe for Tubes and Batteries

Improves Appearance of Set

The Belden Radio Battery Cord contains five flexible, rubber-covered conductors, each marked plainly with a colored tracer. Two conductors are No. 16, for the A-battery circuit, and three are No. 18 for the B-battery circuit. All conductors are enclosed in a glazed brown braid that resists wear and protects the conductors. The ends are soldered, and can be used with any type of terminal. Does away with all messy, dangerous battery wiring.

Just one accidental short circuit among the battery wires, that lead to your set, can burn out all the tubes or ruin the batteries. That is why the experienced radio fan does not trust to a mess of connecting wires, between the set and the batteries, but uses a sturdy, neat battery cord in their place.

Loose connections and poor joints are responsible for much noise in the receiver, and a good battery cord eliminates much of this trouble. The circuits are easily traced and B-battery taps can be changed without danger of wrong connections. Try a Belden Radio Battery Cord before you burn out your tubes. It is inexpensive insurance against trouble. Get one, today!

Free Booklet
Send for it
Now!

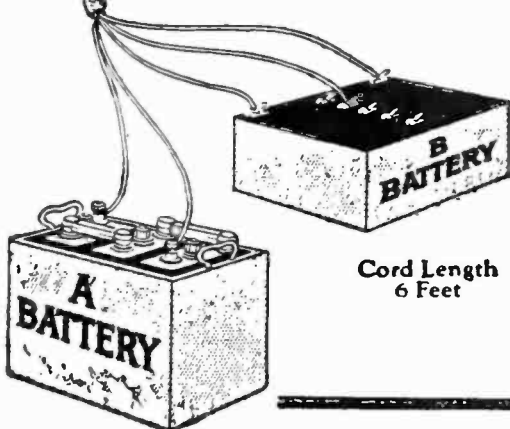

Belden
Manufacturing Company
2312A So. Western Ave.
CHICAGO, U. S. A.
*Manufacturers of Electrical Wire
Products Since 1902*

Belden Manufacturing Company
2312A So. Western Ave., Chicago

Please send me "Helpful Hints for Radio Fans," describing all Belden Radio Products

Name _____

Address _____

★ Tested and approved by RADIO BROADCAST ★

Thompson Tone--

a quality of naturalness never before attained in radio reception

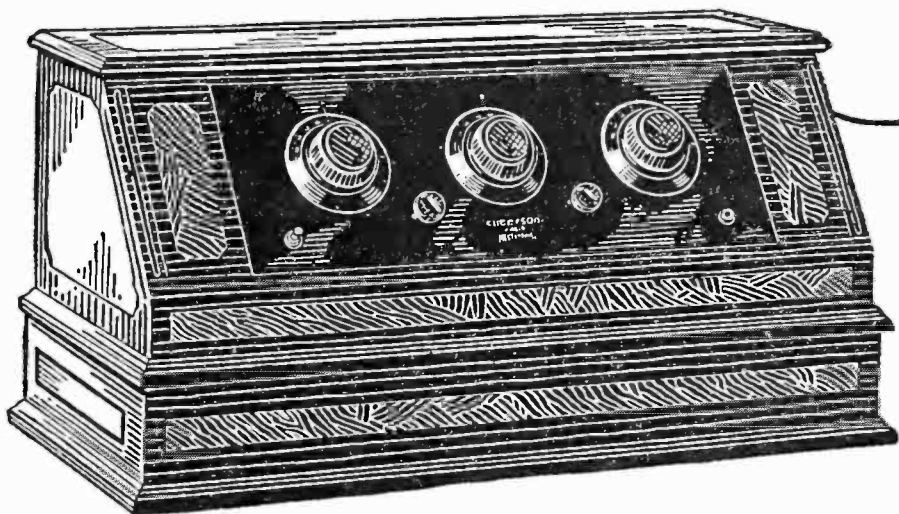

THE THOMPSON CONCERT GRAND The Only 6-Tube Neutrodyne

IMAGINE a Radio Receiver so capable as to fill a Concert Hall seating 1,500 people, and the quality of tone so natural as to carry no suggestion of mechanical or electrical reproduction!

The Thompson Concert Grand (Model S-70) is seldom used at full power; yet when the occasion requires, it will fill a Ball Room, Concert Hall, or other large gathering place, with speech or music, and at no sacrifice of tonal quality. In fact it provides a quality of tone never before attained in radio reception.

The reason for the remarkable performance is due to the use of exclusive Thompson audio transformers. Three stages of audio amplification without

distortion is a distinct achievement in radio engineering.

Eminent radio authorities have acknowledged the Concert Grand Model as the latest and most important achievement in the development of Home Radio Receiving sets.

The beautiful two-tone mahogany finished cabinet, with sloping panel and special compartment for all dry batteries is an outstanding example of the cabinet maker's art. Equipped for either dry or storage battery operation. The Thompson Concert Grand (Model S-70) is \$180 without accessories.

For fifteen years the Armies, Navies and big Commercial Companies of the world have used radio apparatus produced by the Thompson Organization. This experience pre-eminently places it in position to supply the best for Home Radio Purposes.

THOMPSON



RADIO NEUTRODYNE

Various Models
\$125 to \$180

Embodying Exclusive
and Important
Features.

West of Rocky
Mountains, \$130 to \$185

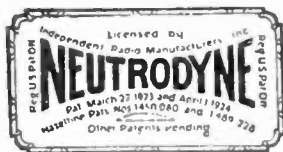

On request, an interesting booklet will be forwarded

R. E. THOMPSON MANUFACTURING COMPANY
30 CHURCH STREET, NEW YORK, N. Y.



A creation that reaches the highest pinnacle of TONE REPRODUCTION the

THOMPSON SPEAKER

THE Thompson Speaker was designed by famous engineers with wide experience in acoustics and sound reproduction.

It has the most natural tone of any speaker on the market today—and a greater capacity for volume.

An efficient speaker is necessary in combination with a radio receiving set to secure desirable results. Any good receiving set is limited if a first-class speaker is not used.

Many people, unfortunately, not realizing the importance of owning a first-class radio speaker, are sacrificing the richness and sweetness of tone through the use of an inferior speaker, whose only appeal rests in its low price.

The Thompson Speaker has seven unusual features which combine to make tone reproduction beautifully satisfying in its Trueness and Fidelity to every musical pitch and tone.

The Thompson Speaker is the only speaker—within its price range—that can function efficiently on sets using five or more tubes.

Regardless of price or type, a Thompson Speaker will improve the tonal reproduction of your receiving set.

NOW ONLY \$28

West of Rocky Mountains \$30

★ Tested and approved by RADIO BROADCAST ★

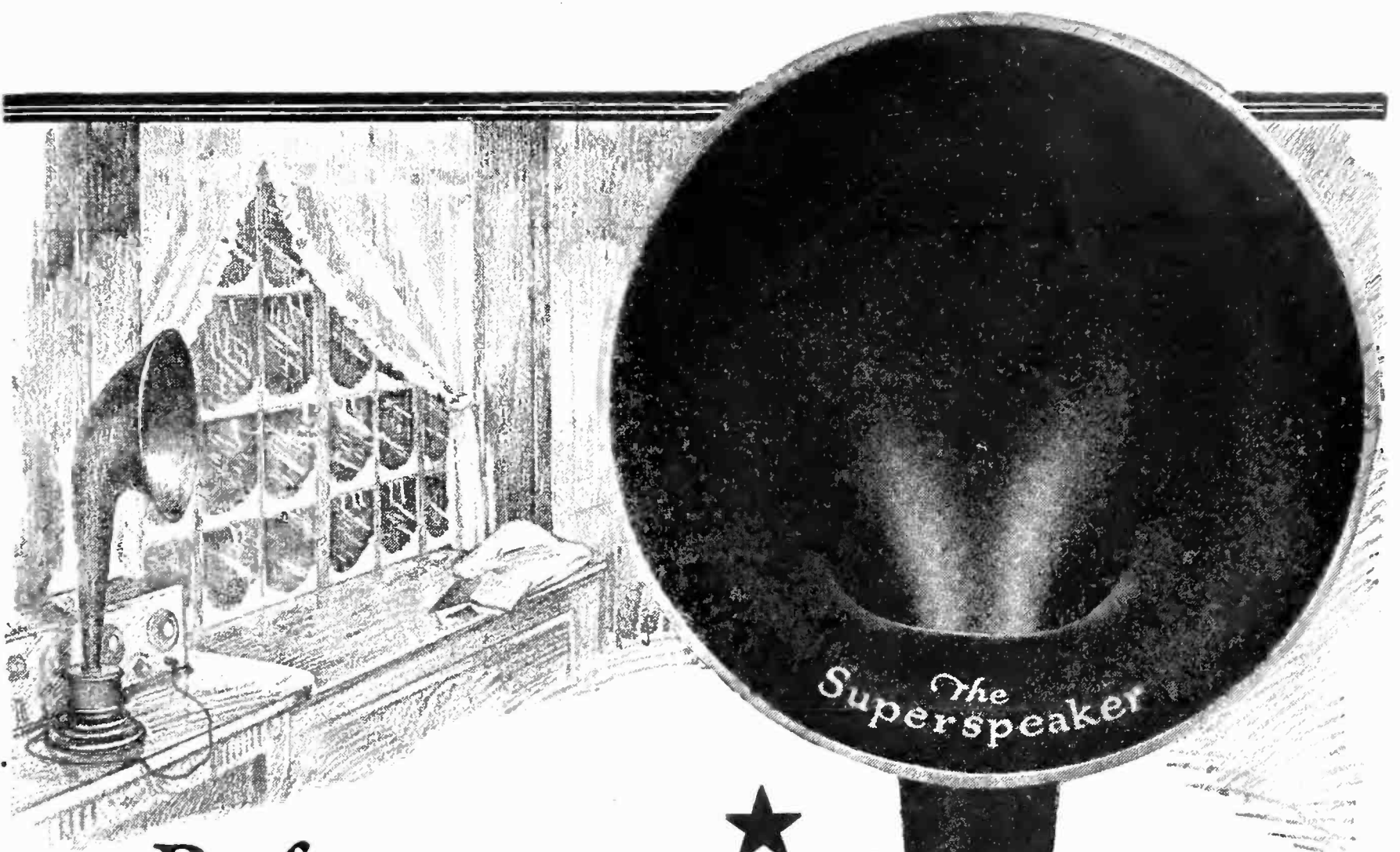

Performance

Through the calm, moon-lit silence of the mid-winter night, your Jewett Superspeaker will increase amazingly your ability to reach out and bring in messages you would hear otherwise only through your headset.

But stormy weather is Superspeaker weather too. January blizzards and the hot humidity of July will both find your Superspeaker reproducing faithfully, roundly and without distortion, the sound vibrations brought to it by your Radio Set.

This uniformity of performance is possible only because of the Superspeaker's exclusive, patented air-gap adjustment.

With this adjustment you can increase or lessen Superspeaker volume, and can balance accurately the result of any climatic change.

Ensure uniform, year-round Superspeaker performance by the one and only possible method—The Superspeaker itself.

Throat straight as an organ pipe—No crooks or turns to impart bugle effect—Size ample to reproduce band and orchestral music—A big, glossy, substantial, non-vibrating instrument, built complete by musical instrument people who know their business. Sold by leading, established merchants everywhere.

The JEWETT RADIO & PHONOGRAPH CO.
5672 DIXIE HIGHWAY PONTIAC, MICHIGAN



"THERE IS NO SUBSTITUTE FOR THE BEST"

Superspeaker

Trademark Registered

★ Tested and approved by RADIO BROADCAST ★

It Charges
-any size
-all makes



The new Tungar will keep your storage batteries up—fully charged all the time. It charges radio "A" batteries of 2, 4, or 6 volts. Radio "B" batteries of 24 to 96 volts. And auto batteries, too.

It makes no disturbing noise—is simple—charges while you sleep. Just clip the Tungar to the battery, plug it in on the house current and leave it overnight to charge. A Tungar at home means clearer tone—full volume—your set at its very best all the time for all that's on the air.



The Tungar is a G-E product, developed in the great Research Laboratories of General Electric.

The New Model Tungar charges Radio A and B batteries, and auto batteries. Two ampere size (East of the Rockies) \$18.00

The Tungar is also available in five ampere size, design unchanged (East of the Rockies) \$28.00

60 cycles—110 volts



Tungar

REG. U.S.

PAT. OFF.

BATTERY CHARGER

Tungar—a registered trademark—is found only on the genuine. Look for it on the name plate.

Merchandise Department

General Electric Company, Bridgeport, Connecticut

GENERAL ELECTRIC

★ Tested and approved by RADIO BROADCAST ★

Great News for SUPER- HETERODYNE OWNERS:

1. Enjoy absolutely interchangeable tubes
2. Get your signals much louder
3. End microphonic noises in your set
4. Use the same tubes indefinitely
5. Operate on 6 volt storage A Battery

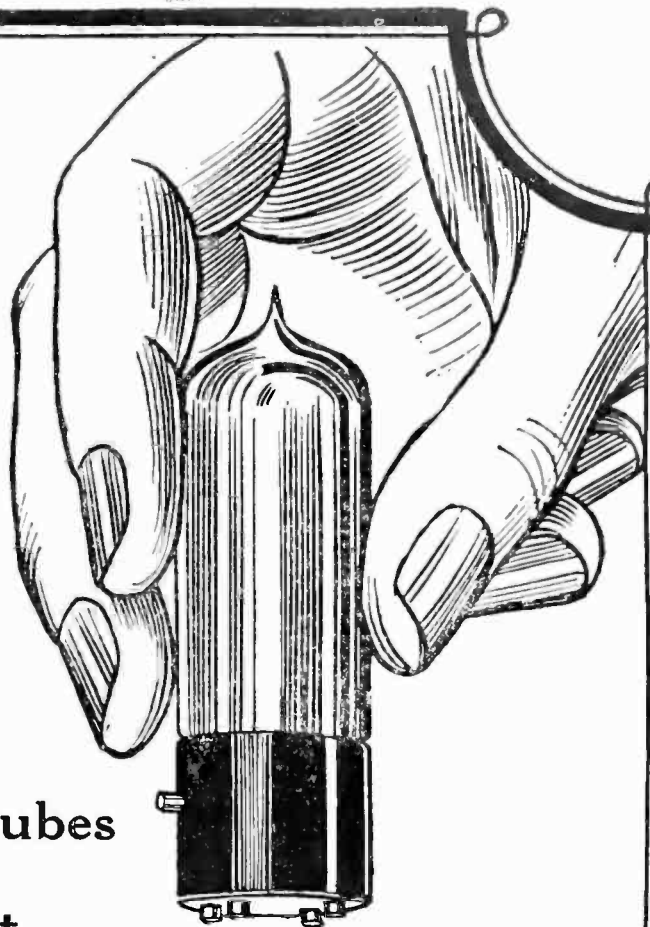

The new TRUE BLUE POWER-PLUS Super-Heterodyne Tubes are not merely improved small socket tubes. They are big tubes refined to take small space. Their plates and grids have four times the area of any tube of like size or shape. Their filaments are twice as long with double electron emitting surface, and will stand normal use for indefinite period.

Despite large internal proportions TRUE BLUE POWER-PLUS Super-Heterodyne Tubes draw much less A Battery am-

perage than standard socket amplifiers and only half as much B battery amperage as other small socket tubes.

Ask your radio dealer for a demonstration of TRUE BLUE POWER-PLUS TUBES or write us. We will see that you are supplied and also send you literature on TRUE BLUE TUBES.

TRUE BLUE
STANDARD
RADIO TUBES
for Standard
Sockets \$6.

TRUE BLUE
POWER-PLUS
SUPER-
HETERODYNE
RADIO TUBES
\$5.00

BRIGHTSON LABORATORIES, Inc.

Executive Offices and Demonstration Salon,
Northwest Corner Waldorf-Astoria Hotel,
16 West 34th St., New York, N. Y.

Wholesale and Retail

Write any one of these distributors. He will direct you to a nearby dealer.

Wm. C. Oakes, 832 Park Square Bldg., Boston, Mass.

R. G. Newland, Glenbrook, Conn.

Trilling & Montague, 49 N. Seventh St., Philadelphia, Pa.

Yahr & Lange, 207 E. Water St., Milwaukee, Wis.

Yahr & Lange, 28-31 Gratoit Ave., Detroit, Mich.

Magneto & Machinery Co., 1035 Cathedral St., Baltimore, Md.

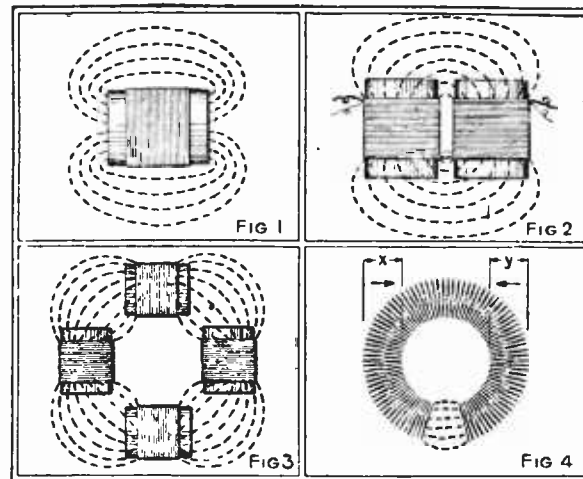
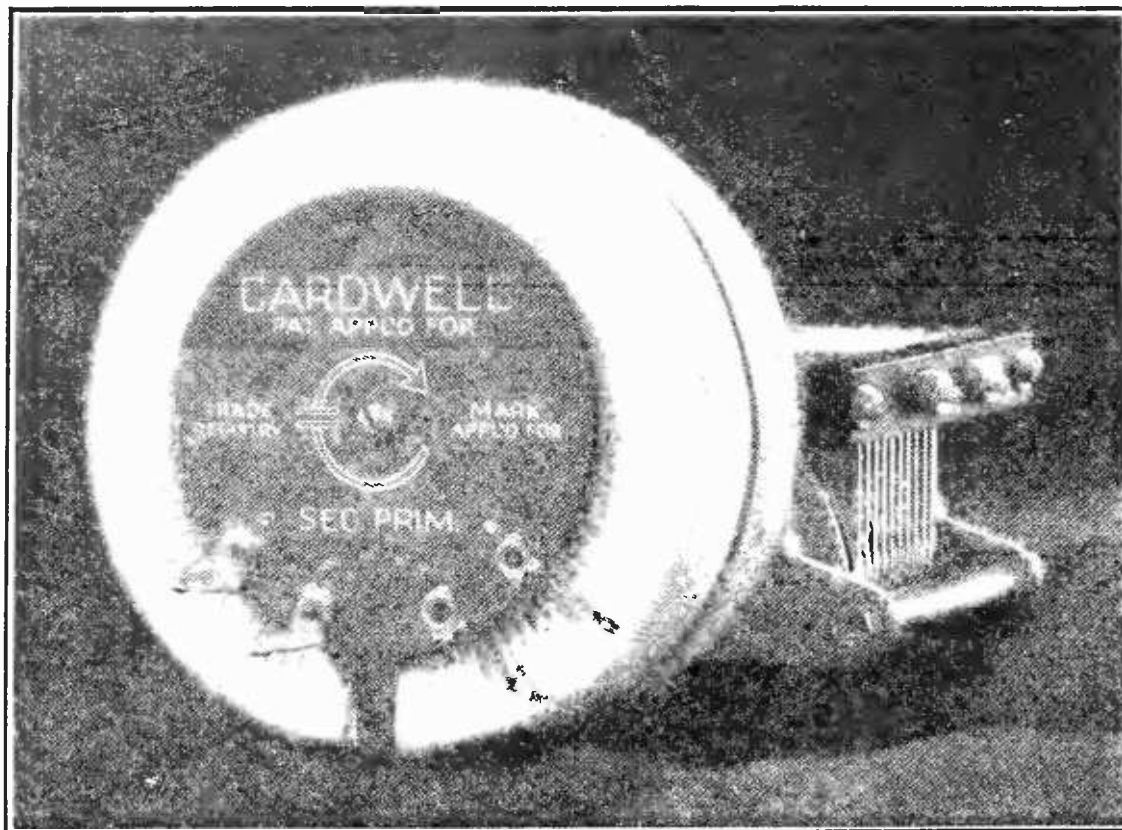

General Theory of the Toro-Tran

Figure 1 shows how the field of the ordinary coil extends into space and increases losses due to stray field. Figure 2 shows a "double series" winding, which restricts the field somewhat. Figure 3 shows a "four series" winding and the field almost enclosed. In Figure 4 (the Toro-Tran) the field is entirely enclosed and the losses due to stray fields are eliminated.

Note that a stray signal passing through the coil at "X"—not introduced from the aerial or the tube—is balanced out at "Y" by the reversed polarity of the winding. This rejects undesirable signals, while the concentrated internal field builds up the tuned signal. Hence maximum distance and selectivity.

—and now the TORO-TRAN!

CARDWELL, whose pioneer "low-loss" condenser established new standards of radio efficiency, is now introducing the Toro-Tran*—the ideal *balanced* coupling inductance for all radio frequency work.

*TRADE MARK
Registry applied for

The Toro-Tran eliminates signal energy picked up by ordinary coils from nearby stations. It eliminates magnetic feed-back in multi-stage radio frequency circuits, thus removing the most active factor in causing howling and distortion, and thereby increasing selectivity and distance. It rejects almost entirely the interference effects caused by electrical power

machinery, elevators, door-bells, arc stations, etc.

The Toro-Tran winding confines the field to the inside of the coil, a small area, and thus avoids one of the greatest causes of loss known to radio receivers—that of stray magnetic fields, which result in the absorption of signal energy and reduce the efficiency of the receiver tremendously.

Note these unusual advantages in assembly and operation

1. Compactness. The coils do not require spacing or angular mounting. They occupy less space than your condensers.
2. Permit exact nullification for tube and stray capacity without guesswork or tedious testing.
3. Closed magnetic field eliminates magnetic feed-back in tuned radio frequency amplifiers.

4. Low distributed capacity, due to air spacing of each winding and to low voltage-drop per turn of small diameter wire.

5. Maximum coupling and high ratio of voltage increase due to concentrated field with zero leakage.

6. Absence of all supporting insulation in the field of the coil. This is one of

the greatest loss factors in the ordinary circuit and is not remedied by "skeleton" or so-called "low-loss" windings.

7. Ease of neutralizing oscillation due to tube capacity by means of rotating control, which anyone can "balance."

8. Low capacity between primary and secondary, affording maximum transfer of energy to succeeding grid circuit.

The Toro-Tran has a lower "circuit resistance" (i.e., effective resistance as assembled in a set and not as isolated in the laboratory for theoretical measurements) than any inter-stage tuned transformer made and has a correspondingly higher amplification factor, its ratio exceeding ten.

To appreciate the many remarkable advantages of the Toro-Tran, write for our two free booklets: "The Torodyne Circuit" and "The Most Interesting Radio Frequency Transformer Ever Invented."

Toro-Trans are ready to mount in any tuned radio frequency circuit. Replace your ordinary coils

with Toro-Trans. You will be astonished with the results. Most .00035 mfd. variable condensers will tune them, but by using Cardwell Condensers you get maximum efficiency.

Order from your dealer or direct

CARDWELL TORO-TRAN WITH BALANCING POTENTIODON.....	\$ 4.00
Cardwell .00035 Condenser for tuning.....	4.75
Cardwell .00035 Vernier Condenser.....	6.25
Cardwell .00035 Dual Condenser (two-in-one).....	8.00
Cardwell .00035 Triple Condenser (three-in-one)....	12.00
Cardwell Audio-Trans (compound audio transformers)	10.00

The Allen D. Cardwell Manufacturing Corp.

81 Prospect Street, Brooklyn, N. Y.

★ Tested and approved by RADIO BROADCAST ★

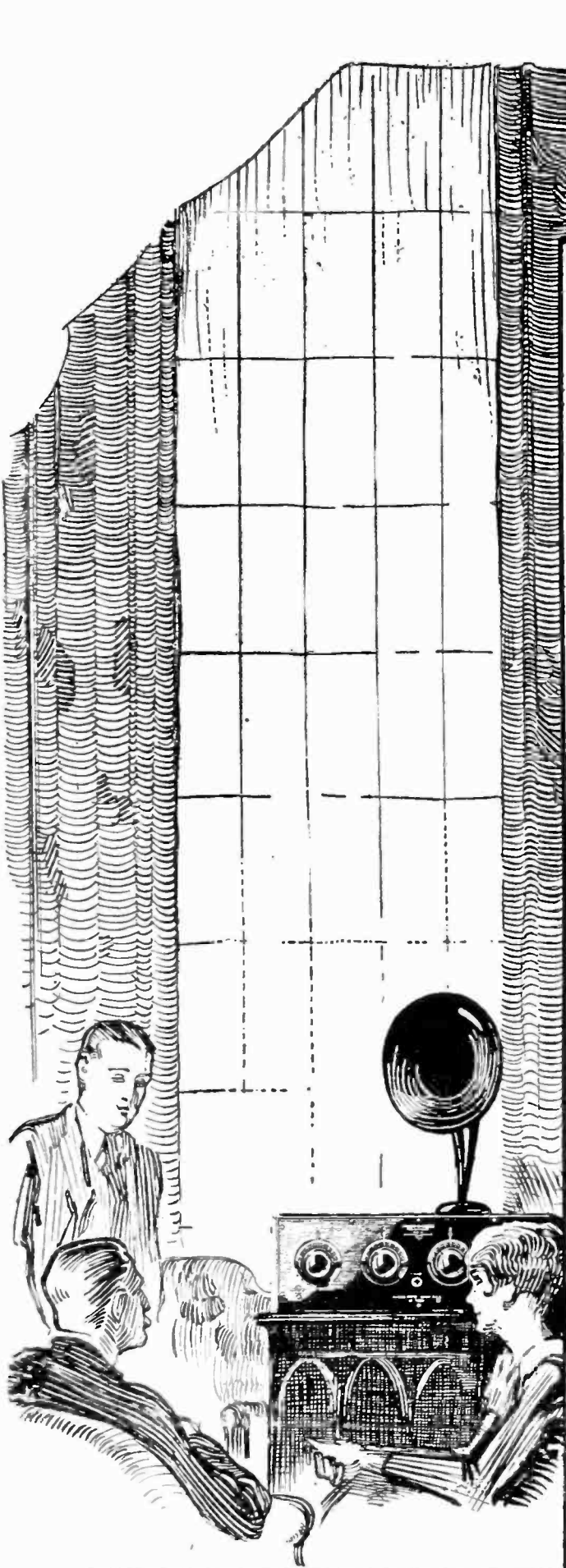

Compare the Value!

COMPARE the MARV-O-DYNE point for point with any other receiving set. Consider the performance and the appearance and the units—consider those things and you'll wonder how such a set can be sold for only \$98.

What other receiving set costing \$150 or more uses Haig and Haig Straitline condensers? MARV-O-DYNE does because they reduce losses and facilitate station finding. What other receiver incorporates a genuine Weston meter, which has a special provision for measuring "B" battery voltage? MARV-O-DYNE has chosen this recognized standard as part of its Fil-a-meter.

And speaking of the Fil-a-meter—that in itself is an exclusive MARV-O-DYNE feature. The Fil-a-meter alone should make you choose the MARV-O-DYNE. What this device saves in tube and battery costs by keeping the tubes at the proper operating point is obvious.

\$ 98

MARV-O-DYNE has so many outstanding points of superiority that you owe it to yourself to go to the nearest dealer to inspect it. Write us for literature.

AMBER MANUFACTURING CORP.
115 W. Broadway New York City



MARV O DYNE
The set with the Fil-a-meter!

★ Tested and approved by RADIO BROADCAST ★

Easy to Charge and Easy to Keep Charged

with the WILLARD "B" BATTERY
CHARGING OUTFIT

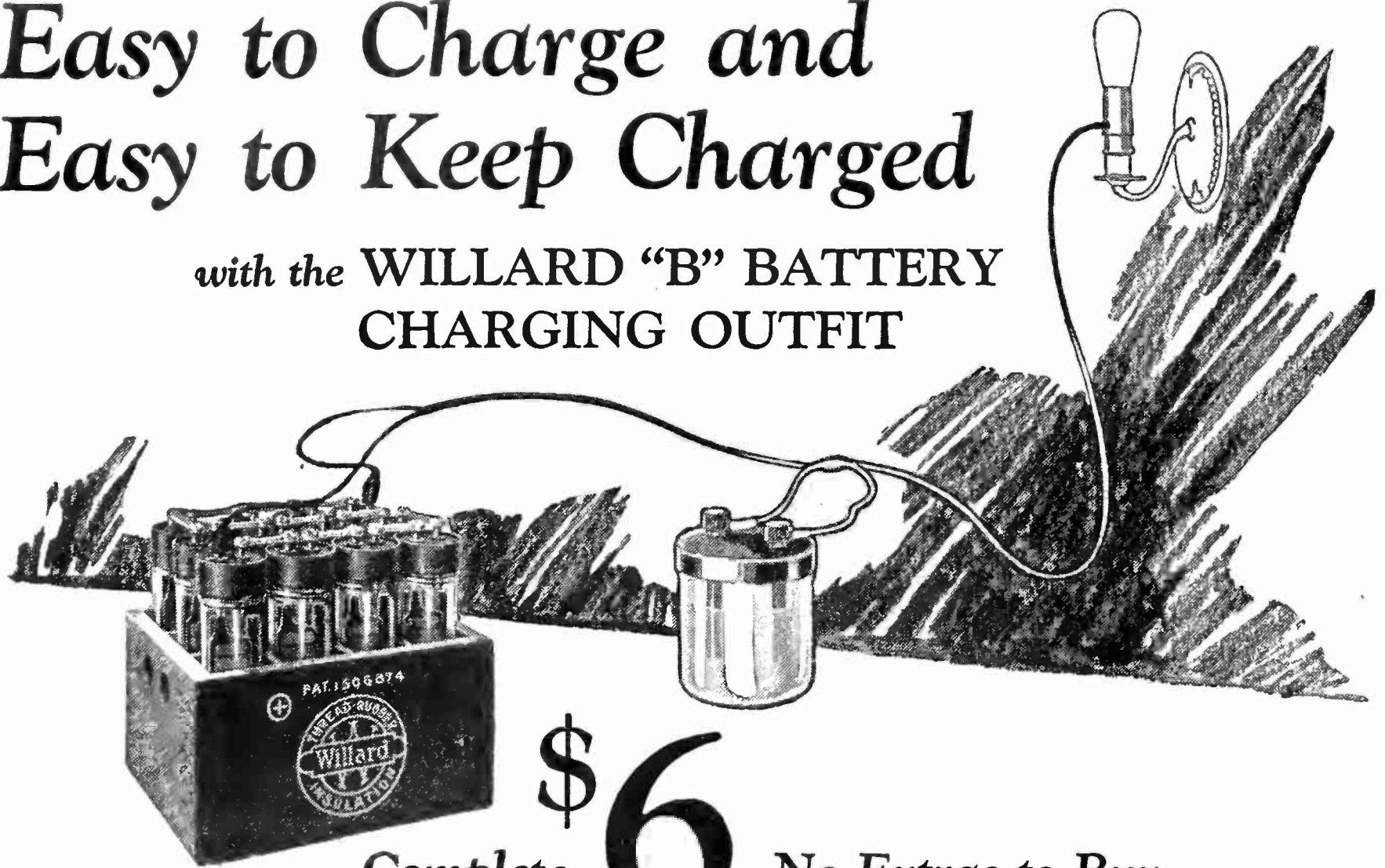

Complete **\$6** No Extras to Buy

It's as easy to recharge a Willard "B" Battery as it is to change a tube.

The new Willard "B" Battery Charging Outfit comes complete. No extras to buy. Simply screw

the plug into your light socket, clip the charger terminals to the battery and charging starts immediately. Charges both 24 and 48-volt units. Cannot injure the battery.

WILLARD RADIO BATTERIES



FOR SALE AT ALL WILLARD SERVICE STATIONS AND
RADIO DEALERS

Current that is the same strength all the time is what you need for better radio reception.

Only a battery that is rechargeable can produce this type of current.

That is one reason why 185 broadcasting

stations use Willards. Other reasons are freedom from noise, economy, and the better all 'round results they get with Willards.

Why buy "B" batteries more than once when Willards last for years, and can be recharged so easily.

FOR BETTER RADIO RECEPTION, USE STORAGE BATTERIES

★ Tested and approved by RADIO BROADCAST ★

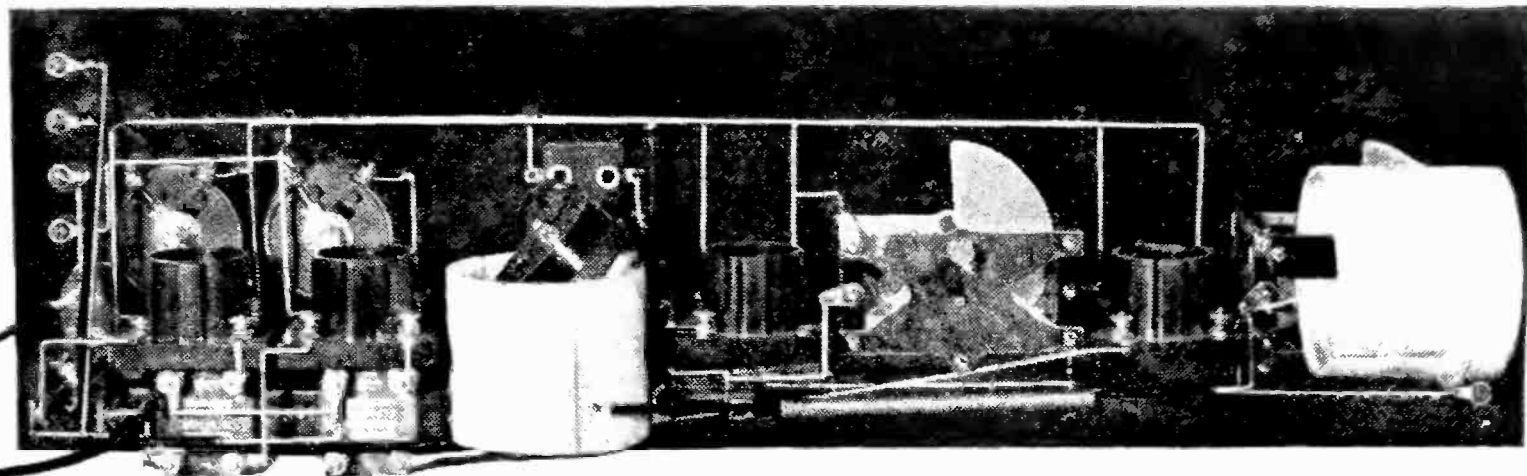

The Silver

Four-Tube Receiver

Arthur H. Lynch commented editorially on this receiver as described by Mr. Silver in the March RADIO BROADCAST as follows:

"The receiver produces results, for those in our laboratory on test, quite came up to the promises made by the author."

And the promise was—Super-heterodyne results on four tubes. Selectivity superior to any receiver but a super—volume to spare on stations up to 2000 miles distant—tone quality to satisfy the most discriminating ear.

A Chicago physician's experience is typical. He assembled the set in three hours—hooked it up at four o'clock in the afternoon, and in daylight logged twenty-seven stations from coast to coast on his loudspeaker. In a week he logged more than one hundred stations. And he was a green operator. That record was made in spite of interference from a dozen powerful broadcasting stations.

Read about the Silver Four-tube Receiver in the March Radio Broadcast—find out for yourself why it is the finest four-tube set that novice or engineer can build—yet the simplest. Build one and see for yourself how sound engineering design and low-loss inductances have produced the most satisfactory four-tube receiver yet developed.

McMURDO SILVER'S BOOK ON THE FOUR-TUBE RECEIVER

This book will be invaluable—will interest you intensely whether you build the set or not. In addition to photographs and diagrams it contains valuable data on low-loss inductances. Price 25c

DEALERS—Because of its remarkable results and low cost, both in initial expense and upkeep, there is a tremendous market to-day for such a receiver as Mr. Silver's Knockout. Apply to your jobber at once and cash in on a product that is well advertised and backed by the leading radio journals.



Silver-Marshall, inc.

RADIO EQUIPMENT

103 So. Wabash Avenue

CHICAGO

★ Tested and approved by RADIO BROADCAST ★

Its Curve is on the Gag

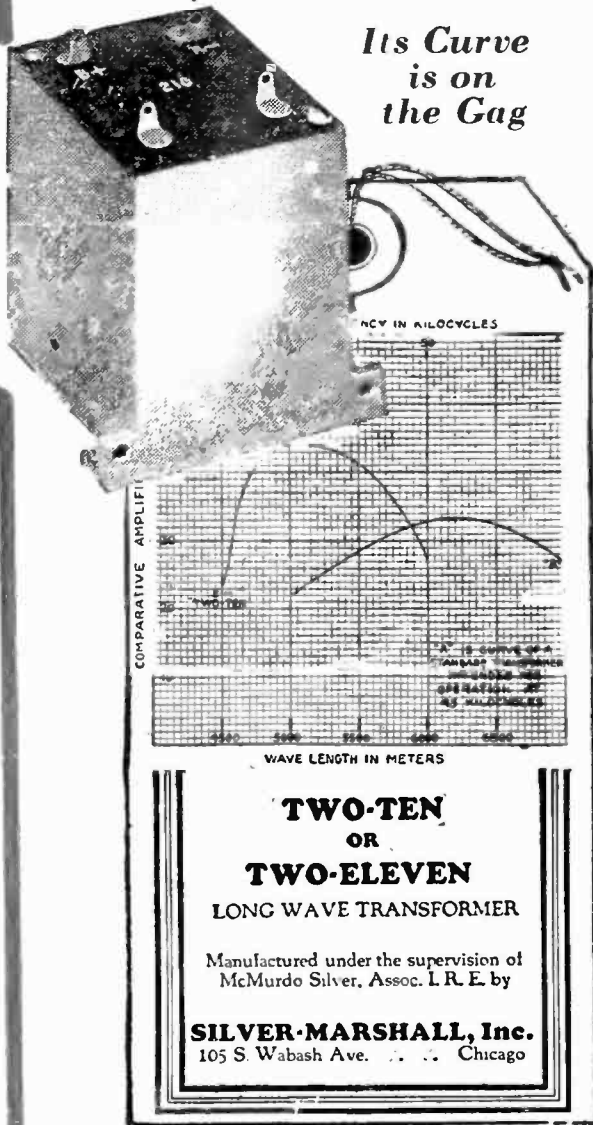

COMPARATIVE AMPLIFICATION

FREQUENCY IN KILOCYCLES

WAVE LENGTH IN METERS

TWO-TEN OR TWO-ELEVEN
LONG WAVE TRANSFORMER

Manufactured under the supervision of
McMurdo Silver, Assoc. I.R.E. by

SILVER-MARSHALL, Inc.
105 S. Wabash Ave. Chicago



SILVER-MARSHALL products need no introduction, for they are known and used wherever results are the ultimate end in view.

BEHIND each item stands years of research work, months of practical testing, and behind everything else, sound, thorough engineering design.

THAT'S why you will find engineers who use the best and editors who must recommend the best, using and recommending S-M products wholeheartedly—unreservedly.

THAT'S why you will find them in England, France, Germany, Austria, Italy, South America, Alaska, Japan, China.

THAT'S why you will find the advanced jobbers and dealers handling them.

THAT'S why your friends use them.

THAT'S why you will do so—eventually.

DEALERS—Apply to your jobber for this line of business getters. In demand by all discriminating fans, they insure rapid turnover and big profits.

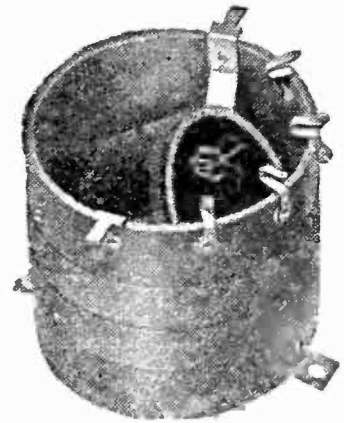

101a Coupling Unit

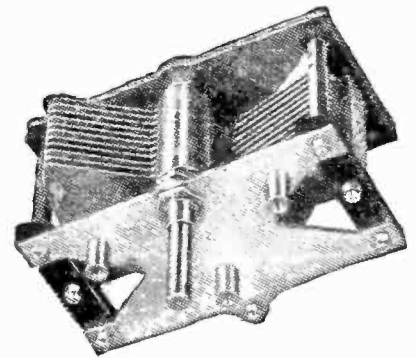

301a Condenser

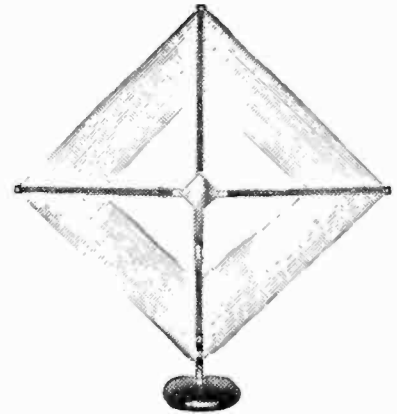

601 Loop

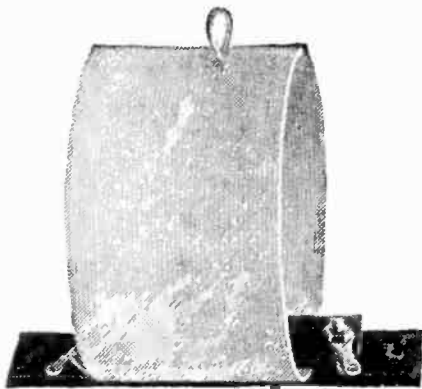

205 Antenna Coil

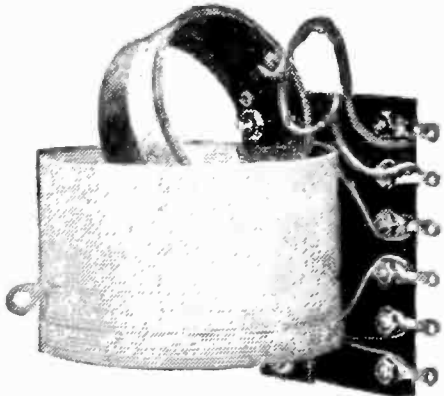

105 Coupler

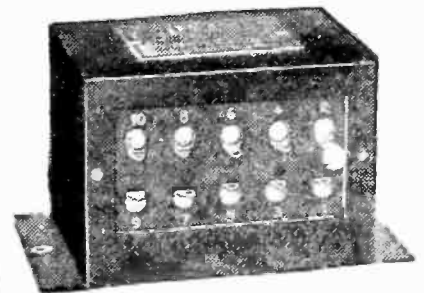

401b Transformer Unit



Silver-Marshall, Inc.
RADIO EQUIPMENT

103 So. Wabash Avenue

CHICAGO

★ Tested and approved by RADIO BROADCAST ★



PORTABLE MODEL SUPER

An All Year Round Receiver

Whether the portable is operated in a luxurious home, or in the north woods, it will perform consistently, regularly, pulling in distant stations on the speaker with surprising volume.

With it Captain Irwin brought in both coasts, Canada and Mexico every night on his trip across the continent—right in the covered wagon itself—on his loud-speaker.

A New York builder brought in Oakland, California, every evening for two consecutive weeks—during the summer—just 2800 loud-speaker-miles on seven dry cell tubes and an 18 inch loop.

Every feature of the laboratory model is present in this design—the same efficient regenerative detector, unequaled long-wave amplifier, powerful audio circuit. Nothing has been sacrificed, but due to a special compact arrangement, the whole set with seven UV199 tubes and dry “A,” “B” and “C” batteries fits in a standard 7" x 7" x 18" cabinet.

DISTORTIONLESS AUDIO AMPLIFIER

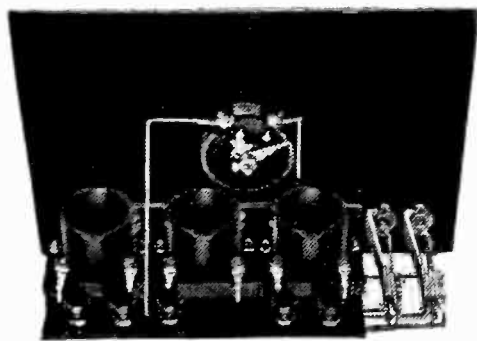

For the cost of a good two-stage, transformer-coupled amplifier, you can build a truly distortionless three stage amplifier, giving greater volume with lower battery expense.

Because of the carefully worked-out design of this unit, it gives greater volume than other resistance coupled amplifiers, because each condenser and resistance used is properly proportioned for the circuit it is to work in.

The unit may be built on a 7" x 10" panel, or it may be assembled and placed in any set, for it takes up less room than the average two-tube transformer amplifier.

Silver-Marshall, inc. ★

RADIO EQUIPMENT

103 South Wabash Ave.

Chicago

★ Tested and approved by RADIO BROADCAST ★

Approved!

Arthur H. Lynch, Editor of *Radio Broadcast*; Volney D. Hurd, Editor of the *Christian Science Monitor*; Milton B. Sleeper, Editor of *Radio Engineering*; E. H. Smith, Editor of *Radio Age*; Charles E. Erbstein, Editor of *On The Air*; Iverson C. Wells, Editor of *Everybody's Radio*; Frank D. Pearne, Editor of the *Chicago Herald & Examiner*; R. E. Hughes, Editor of the *Drovers Journal*; G. M. Best, Technical Editor of *Radio*; L. M. Cockaday, Technical Editor of *Popular Radio*.

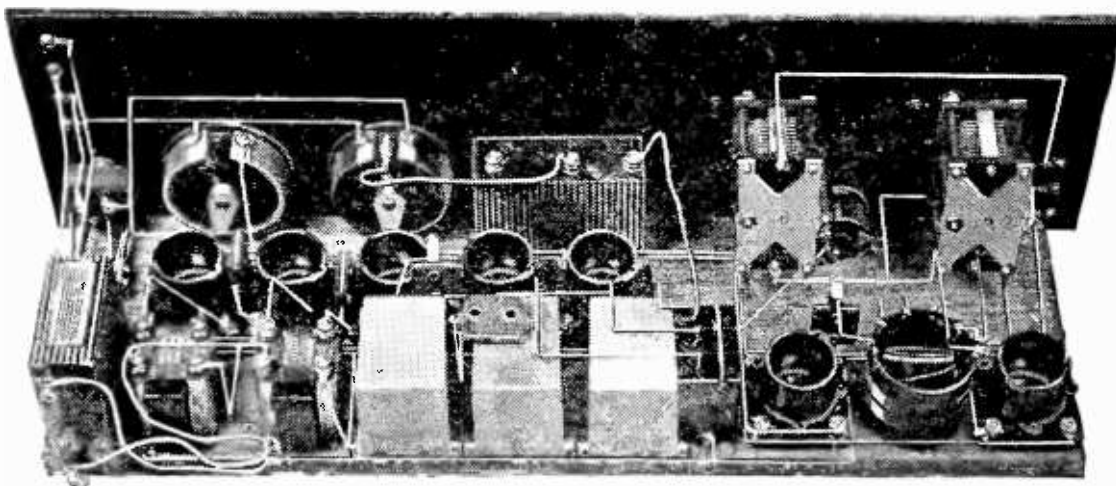

Laboratory Model Super

3000 Loud Speaker Miles On a Small Loop

ALL over the country you will find Silver Supers bringing in stations one, two and three thousand miles distant with amazing regularity—so consistently that their builders regard such results as commonplace.

You will find sets in Chicago listening to the entire country—not on silent nights—but on every night. In Los Angeles Silver Supers are pulling in New York, Schenectady, Pittsburgh; and in New York they are bringing in the West Coast—and Europe, through the local stations. Editors, engineers and builders praise them for the sheer outstanding excellence of their performance.

Why? Because their design is correct—their sensitivity is assured by a regenerative first detector and an intermediate amplifier never equalled for efficiency. Selectivity is so great as to be uncanny, and tone quality is almost unbelievable.

Using seven dry-cell or storage battery tubes, Silver Supers consistently outperform other eight and nine tube sets.

That's why the men and magazines listed at the top of this page have approved them—just because in design and results they're "right."

Exactly as thousands have built these sets, so can you with but a screw-driver, pliers and soldering-iron.

A list of specified parts will be found on an adjacent page. Every item is the product of a manufacturer noted for high-grade precision parts. Each item is absolutely guaranteed not only by the manufacturer but by Silver-Marshall and all of their distributors and dealers. Circulars will be sent upon request with descriptions and price lists.

Silver-Marshall, inc. ★

RADIO EQUIPMENT

103 South Wabash Ave.

Chicago

★ Tested and approved by RADIO BROADCAST ★

McMurdo Silver says:

“I use and recommend Thordarson Transformers because of their extreme uniformity as well as the fact that they give the best amplification—with less distortion—than any other transformers on the market.”

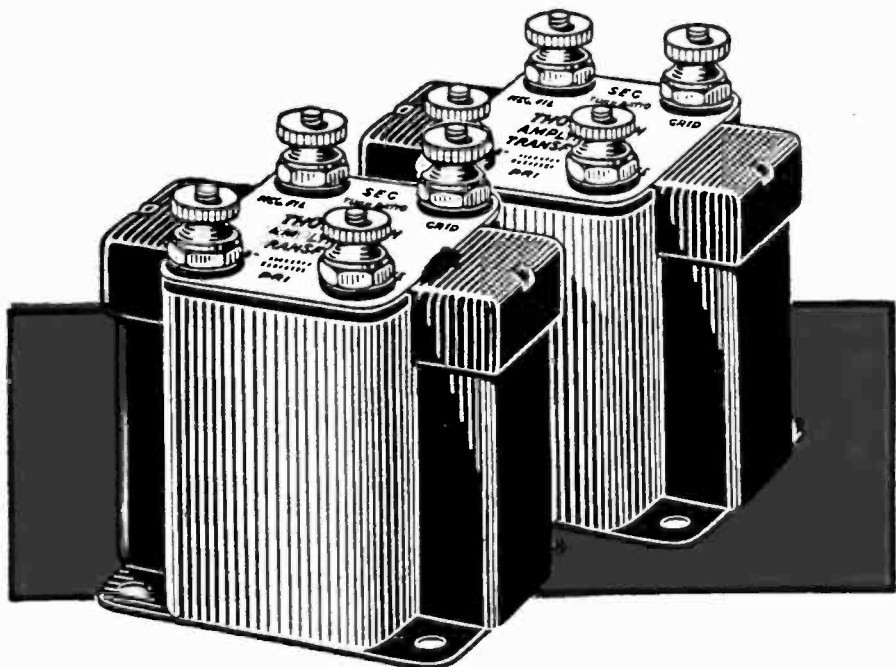

SILVER-MARSHALL
have standardized on Thordarsons. So have

ZENITH
KENNEDY
RADIODYNE
THERMIODYNE
ULTRADYNE
MURDOCK
AZARKA
Pfanstiehl
MICHIGAN

Follow the Lead
of the Leaders!
Build or replace with Thordarsons

One reason that leading builders of fine sets use *more* Thordarsons than all competitive transformers combined is because EVERY Thordarson amplifies *evenly* over the *entire* musical scale.

Thordarsons run absolutely uniform; always “match up” perfectly.

And why shouldn't they? Aren't they made by the world's oldest and largest exclusive transformer makers—transformer specialists for thirty years!

For the finest amplification to be had at any cost, follow the lead of the leaders—build or replace with Thordarsons. Sold the world over.

Deresnadyne
MALONE LEMON
MASTER RADIO
ROYAL
Howard
Pathe
HARTMAN
AUDIOLA
EAGLE
GLOBE AND
MANY OTHERS ★

Unconditionally Guaranteed

THORDARSON
Super
AMPLIFYING TRANSFORMERS
Standard on the majority of quality sets

TYPES AND PRICES

Thordarson “Super” Audio Frequency Transformers are now to be had in three ratios: 2-1, \$5; 3½-1, \$4; 6-1, \$4.50. Thordarson Power Amplifying Transformers are \$13 the pair. Thordarson Interstage Power Amplifying Transformer, \$8. Write for latest hook-up bulletins—free!

THORDARSON ELECTRIC MANUFACTURING CO.
Transformer specialists since 1895
WORLD'S OLDEST AND LARGEST EXCLUSIVE TRANSFORMER MAKERS
Chicago, U.S.A.

★ Tested and approved by RADIO BROADCAST ★

DISTRIBUTORS

for all



SILVER MARSHALL, Inc.

Products

Including:-

	<i>Each</i>
Silver 210 and 211 Long Wave Transformers..	\$ 8.00
Silver Coupling Unit 150 to 600 meters.....	2.50
Silver 50 Kilocycle Transformer Unit—Type 401.....	14.00
Silver Tapped Loop....	6.50
Silver Low Loss Coupler—Type 105.....	5.00
Silver Low Loss Antenna Coil—Type 205	2.50
Silver .0005 Low Loss Condensers--Type 301	4.50
Complete set of parts for the Silver Super using "210" and "211" Transformers — using parts specified by McMurdo Silver.....	\$73.90

WIND YOUR OWN
INDUCTANCE!

THE
SEE-ESS
COIL WINDER

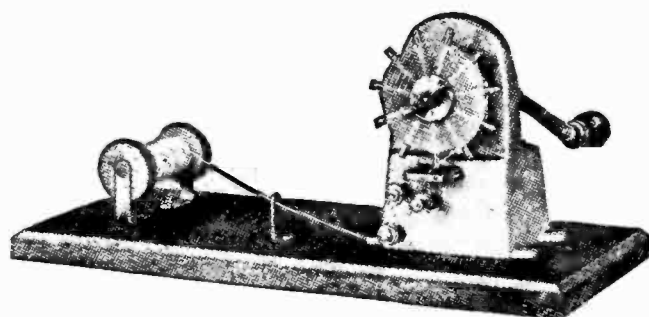

List Price Only \$10.00

Winds low loss inductance coils
for any circuit.

Jobbers write

WIRELESS ELECTRIC ©

Sole National Distributors

Mail orders filled. Dealers write.

WIRELESS ELECTRIC ©

204-206 Stanwix Street
Pittsburgh, Pa.

★ Tested and approved by RADIO BROADCAST ★

I Will buy for You!

A shopping service conducted for the convenience of Radio Broadcast readers

Avail yourself of the services of an expert buyer in the great radio markets of New York City and Philadelphia.

I will act as your personal representative in these markets without charge to you for my services and will buy any radio equipment mentioned in Radio Broadcast at its Regular Price plus only parcel post and insurance charges. I will buy for you the parts YOU want.



McMurdo Silver
Asso. I. R. E.

Silver Products



McMurdo Silver, Assoc. I. R. E., is perhaps one of the greatest authorities to-day on radio. His circuits (the Silver Portable, the Silver Laboratory Super, and the "Knock-Out" Four-Tube Silver Receiver) have all been described in Radio Broadcast.

Of Silver's Portable, Mr. Lynch says in part: "Mr. Silver came on from Chicago to show his receiver to us. He assembled and wired one

tory in two hours, hooked it up, and it worked right off the bat—which is no mean feat for a super-heterodyne. It is an excellent receiver."

In commenting on the laboratory model of Mr. Silver's Super, Mr. Lynch says: "Experienced constructors, and those not so experienced will readily appreciate that this 'super' is well worth the time necessary to build it."

The editorial comment on the "Knock-Out" Four-Tube Silver Receiver was: "The receiver produces results, for those in our laboratory on test, quite came up to the promises made by the author." This receiver consistently gives Coast to Coast day light reception right through the locals from Chicago.

I can buy for you and make immediate shipment of the Silver Super, the Silver Portable, and the "Knock-Out" Four-Tube Silver Receiver. These receivers are exactly as described by McMurdo Silver in Radio Broadcast magazine and are the receivers that have caused so much enthusiastic comment from thousands of builders both in America and abroad.

	Parts	Accessories
Silver Portable Super	*\$57.65	\$39.65
Silver Laboratory Super	* 63.60	43.15
Silver Four-Tube "Knock-Out"	43.50	30.65

**If two intermediate transformers, type 210, and one output transformer, type 211, are used instead of Silver R. F. Transformer, No. 401, add \$10.00 to these lists.*

These prices include a complete list of parts and booklet of instructions written by Mr. Silver, personally. These receivers are thoroughly described in plain language by Mr. Silver. Every Fan who means to build a Super or a "Knock-Out" Four-Tube Silver receiver should have one. They are elaborately illustrated with photographs, diagrams, and detail drawings. Price, \$0.50

I Specialize in these Circuits:

These receivers are composed of only highest grade apparatus.

Before building your receiver, consult me, FIRST. I will do your complete shopping for you on any circuit.

**"Knock-out" Two-Tube Roberts	\$31.00
**"Knock-Out" Three-Tube Roberts	44.00
**"Knock-Out" Four-Tube Roberts	53.00
*Two-Tube Rasla	36.00
*Three-Tube Rasla	43.00
*Four-Tube Rasla	50.00

**All orders cover complete set of parts and a comprehensive and thoroughly illustrated construction booklet.*

You can depend on me to get you reliable radio apparatus, and to make quick delivery. Your correspondence and inquiries will be given my personal attention and will be answered promptly.

Your ORDER is carefully packed and delivered to your door. You may remit with order or pay your postman.

E. M. CLARKE CO.

1523 Chestnut Street

Philadelphia Pa.

★ Tested and approved by RADIO BROADCAST ★



A rheostat is built for every tube

Silver Has Endorsed



It is significant to the Radio enthusiast that McMurdo Silver, Assoc. I. R. E. of Silver-Marshall, Chicago, one of the best known Super and Radio authorities in America, has chosen United Scientific Laboratory Rheostats and Potentiometers for the Laboratory model of his Silver-Super and for his "Knock-Out" Four Tube Silver Receiver.

This endorsement came to United Scientific Laboratory Products only after Mr. Silver had personally conducted in his laboratories the most rigid and exacting tests known to radio science.

This is the reason and but one of the instances of the trend among the real authorities to the United Scientific Laboratory Products. United Scientific Laboratory Parts are found to-day in practically all quality Receivers and home-constructed sets.

All United Scientific Laboratory Products are unconditionally guaranteed for one year

The United Scientific Laboratory rheostat and potentiometer are built of the highest grade resistance wire—a type of wire that will carry the current without over-heating. The winding is carefully set in grooves thereby obviating any possibility of loosening.

The contact arms are constructed of phosphor bronze and are adjustable and renewable. The shaft may be adjusted to any panel thickness.

The Knob and Base are of genuine bakelite.

The resistance element is held firmly in place by a wedge.

The contact arm is fixed. This feature eliminates the customary adjusting when shaft is removed for mounting.



Potentiometer is built for every circuit

The United Scientific Laboratory Rheostat and Potentiometers are both one whole mount jobs

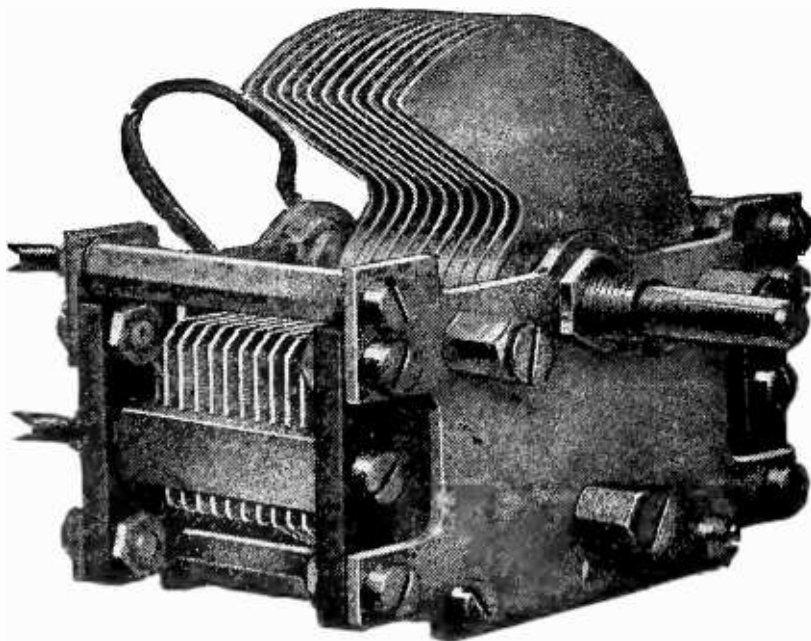

Prices range from \$1.15 to \$1.70 for potentiometers and from \$.90 to \$1.30 for rheostats.

United Scientific Laboratory Condensers are Precision Instruments

Rigid frame. Straight line capacity. Pig-tail connection. Hard rubber detectors. Stator plates automatically wedged. Adjustable bearing.



A condenser has been carefully and efficiently designed for every radio purpose

From \$2.50 up

Jobbers and dealers write for our lists

United Scientific Laboratories, Inc.

92 East 10th St.

New York City

★ Tested and approved by RADIO BROADCAST ★

The Answer!

T OWER Scientific Head Sets	Brandes Table Talkers Head Phones	Accurate Dials Daven Products	A.C. Dayton XL-5 Sets and Kits	U LTRADYNE MARCO PRODUCTS	M ODERN TRANSFORMERS
R AULAND ALL AMERICAN Transformers	Jefferson Thordarson Transformers	D.T.W. GERMAN LOOPS	Burgess and Bright Star Batteries	APCO Rectodyne B Battery Eliminator	O PERADIO Receiving Sets
I MPROVED Jacks and Switches	MARVO DYNE SET EBY POSTS	T. & M FOR SILVER SUPER PARTS THE DETERMINING FACTOR TO-DAY! Governing the success and expansion of the average retail radio store is the <i>Strength of the distributor behind your orders</i> Our 1925 Catalogue is a valuable guide to every dealer— IT IS FREE FOR THE ASKING		F RESHMAN SETS & KITS	N ATIONAL Air phone Receiving Sets
V OOPIAIALS Paramount Mathieser Duo-Spiral	Heath continental Condensers			Hammerlund Condensers Talking Tape	T HOROLA Loud Speaker Phonograph Units
L OPEZ Low Loss Tuners	A DAPTO CONSOLE CABINETS			Dubilier Condensers Super-Ducons and Products	A CME Condensers Transformers Pot. Rhea.
I NSULATORS Fieron Brach Sensory	Gray Chargeable B Batteries			Shamrock-Harkness Reflex Kits Tuners and Products	G RIMES Receiving Sets
N A-ALD Dials Sockets Adapters	Home Chargers and Kodet Sets	R ASLA REFLEX PARTS	U NCLE SAM Low Loss Tuners		
G ENERAL RADIO Condenser Rheostats etc.	Pacent Jacks Rheostats Sockets etc.	Western Electric Speakers Head-Sets Phonograph Units	Bradleystats Bradleyohms	R ADION PANELS ETC	R LA Transformers Detectats etc.

Trilling & Montague

49 North 7th Street, Philadelphia ★ "Grow With Us"



★ Tested and approved by RADIO BROADCAST ★

SILVER MARSHALL and 92 Other Manufacturers

use and recommend **CARTER** Radio Products

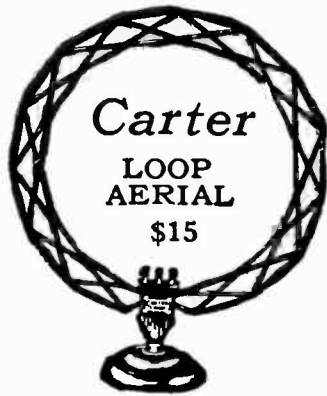

Longer Distance, Greater Volume and far more Selectivity

The "just as good as" and the "just the same as" are not Genuine Carter, and will not give Carter results. Silver Marshall and the other 92 know—they've tried and found out for you.

Insist on the Genuine Carter

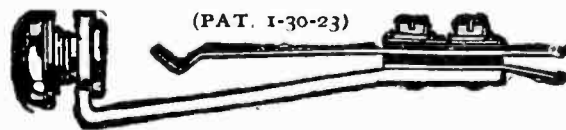

CARTER JACKS

require no spacer washers to mount. A type for every circuit. Standard equipment on the better sets.

OFFICES IN PRINCIPAL CITIES

In Canada: Carter Radio Co., Ltd.

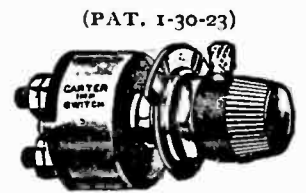

CARTER "IMP" Battery Switches, 65c

The smallest, the most compact. Complete with "Off and On" name plate, pointer and knob.



Any Dealer Can Supply

Model N. Cap. 1.8 to 20 MMF.

Price \$1.00



For positive balance in Neutrodyne and all other tuned radio frequency sets.

For Greater Distance, Volume, Clarity, Easier Tuning and Greater Stability

Use X-L Vario Densers

Specified by Silver-Marshall.

Endorsed by Radio Broadcast.

Tested and Approved by G. M. Wilcox, Prof. of Physics, Armour Institute of Technology

MR. WILCOX says:

"The range of adjustment of these condensers is sufficient to allow the value of grid capacity best suited for a particular tube or circuit to be obtained easily. Compact, well made desirable accessory for high grade radio equipment."

X-L RADIO LABORATORIES
2424-26 Lincoln Ave., Chicago

If your dealer cannot supply you write direct. Dealers solicited

For correct grid condenser values, Superheterodyne filter and intermediate frequency balance, and reflex balance.

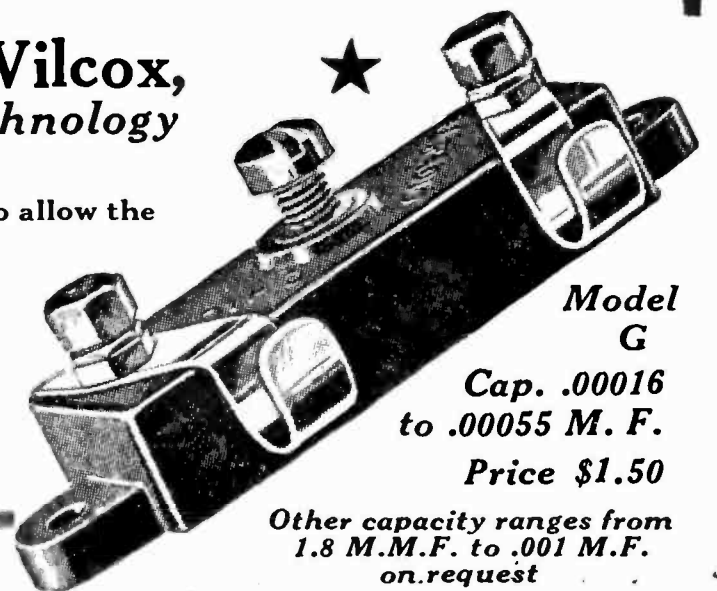

Model G

Cap. .00016 to .00055 M. F.

Price \$1.50

Other capacity ranges from 1.8 M.M.F. to .001 M.F. on request

★ Tested and approved by RADIO BROADCAST ★

The Radio Supply Company

of Los Angeles



Parts for Silver Sets



Listed below are all the parts used and recommended for the famous Silver Sets. Each part is exactly as specified by Mr. Silver. Each item is guaranteed to be mechanically and electrically "right."

The Radio Supply Company carries a complete stock of authorized S-M parts, ready for immediate shipment, as well as large stocks of the products of America's foremost manufacturers of radio equipment.

Parts for Laboratory Super

	Price ea.
2 Silver .0005 Low Loss Condensers No. 301	\$4.50
2 4" Moulded Dials—Tapered Knobs	1.00
1 United Scientific 6 Ohm Rheostat	1.00
1 United Scientific 200 Ohm Potentiometer	1.50
7 Insulated Top Binding Posts	.05
1 Carter 102A Jack	.80
1 Carter 101 Jack	.70
2 Silver 210 Charted Transformers	8.00
1 Silver 211 Charted Transformer and Condenser	8.00
1 Silver Coupler No. 101B	2.50
7 Benjamin Spring Sockets (199 or 201A)	1.00
2 Thordarson 3½:1 Audio Transformer	4.00
1 Carter On-off Switch	.60
3 .5 MFD By-pass Condensers	.90
2 .00025 Mica Condensers with Leak Clips	.45
2 .002 Mica Condensers	.40
1 .000045 Balancing Condensers	1.50
1 5 Meg Ohm Grid Leak	.50
1 1 Meg Ohm Grid Leak	.50
1 7 x 24 x ⅜" Bakelite Panel, Drilled, Grained and Engraved	7.00
(Specify with or without meter hole.)	
7 x 23 x ½" Oak Base Board, Bus-Bar, Spaghetti, Screws, Nuts, Solder, Lugs	1.50

Silver Portable Super

	Price ea.
2 Silver .0005 Low Loss Condensers No. 301	\$ 4.50
2 4" Moulded Dials—Tapered Knobs	1.00
1 United Scientific 6 Ohm Rheostat	1.00
1 United Scientific 200 Ohm Potentiometer	1.50
3 Insulated Top Binding Posts	.05
1 Carter 102A Jack	.80
1 Carter 101 Jack	.70
1 Silver R. F. Transformer Unit No. 401B	14.00
1 Silver Coupler No. 101B	2.50
2 Silver 199-Sockets	.50
2 Thordarson 3½:1 Audio Transformer	4.00
1 Silver 5-Gang Panel Mounting 199 Socket No. 501	3.00
2 .5 MFD By-pass Condensers	.90
2 .00025 Mica Condensers with Leak Clips	.45
2 .002 Mica Condensers	.40
1 .0075 Mica Condensers	.75
1 .000045 Balancing Condensers	1.50
1 5 Meg Ohm Grid Leak	.50
1 2 Meg Ohm Grid Leak	.50
1 7 x 18 x ⅜" Bakelite Panel, Drilled, Grained and Engraved	6.00
7 x 4½ x ½" Oak Base Board, Bus-Bar, Spaghetti, Screws, Nuts, Solder, Flexible Lead Wire	1.25

Distortionless Amplifier

	Price ea.
1 United Scientific 6 Ohm Rheostat	\$1.00
5 Insulated Top Binding Posts	.05
1 Carter 102A Jack	.80
1 Carter 101 Jack	.70
3 Hoosick Falls Panel Mounting Sockets	.60
1 Carter On-Off Switch	.60
4 .0075 Mica Condensers	.75
1 ½ Meg Grid Leak	.50
2 ¼ Meg Grid Leak	.50
3 ⅓ Meg Grid Leak	.50
6 Grid Leak Clips	.20
1 7 x 10 x ⅜" Bakelite Panel, Drilled, Grained and Engraved	3.00
1 7 x 2½ x ⅜" Bakelite Panel, Drilled, Grained and Engraved	1.00
Bus-Bar, Spaghetti, Screws, Nuts, Solder, Lugs	1.00

4 Tube Receiver

	Price ea.
2 Silver .0005 Low Loss Condensers No. 301	\$4.50
3 4" Moulded Dials—Tapered Knobs	1.00
1 United Scientific 6 Ohm Rheostat	1.00
6 Insulated Top Binding Posts	.05
1 Carter 102A Jack	.80
1 Carter 101 Jack	.70
1 Silver Low Loss Coupler No. 105	5.00
1 Silver Low Loss Antenna Coil No. 205	2.50
4 Hoosick Falls Panel Mounting Sockets	.60
2 Thordarson 3½:1 Audio Transformer	4.00
1 Carter On-Off Switch	.60
1 XL Variodenser	1.00
1 .00025 Mica Condenser with Leak Clips	.45
1 .002 Mica Condenser	.40
1 .0075 Mica Condenser	.75
1 2 Meg Grid Leak	.50
1 7 x 24 x ⅜" Bakelite Panel, Drilled, Grained and Engraved	7.00
Bus-Bar, Spaghetti, Screws, Nuts, Solder, Lugs, etc.	1.00

Dealers:—Here is your opportunity to cash in on the demand for S-M products. Get behind the equipment that has been approved by countless editors, engineers, magazines and newspapers. Take advantage of a line that your market demands—that sells itself upon merit and performance. Send for circulars and our price-list on all standard merchandise.

THE RADIO SUPPLY CO.

920 SOUTH BROADWAY

Los Angeles, California

Silver Products Offer Big Possibilities to Dealers!

The inventions and discoveries of McMurdó Silver, Assoc., I. R. E. of Silver-Marshall, Inc., Chicago offer extraordinary possibilities for sales to Dealers.

The Silver Portable, the Silver-Super, and the Four Tube Silver receivers have been introduced nationally through the editorial columns of Radio Broadcast magazine. These receivers are nationally and locally advertised and have caused a tremendous amount of the most commendatory and enthusiastic comment from every section of America.

Wide awake dealers everywhere are tying into these products to worthwhile advantage. New York and New England dealers will be promptly supplied through the 20th Century Radio Corp. Establish relations with us at once. Our lines are diversified; it is our pride to give prompt and helpful service. The Silver and our other lines will make sales for you.

Quality Products & Helpful Service & Prompt Delivery

A
Amperites
Apco Chargers
Apex Products

B
Bates Radio Index
Baker Cabinets
Benjamin Sockets
Black Beauty Speakers
Bright Star Batteries
Bristol Loud Speakers

C
Cardwell Condensers
Como Duplex Transformers
Cook Loops

E
Eagle Chargers
Electrad
Exide Batteries
EZ Toon Dials
Eby Binding Posts

F
Filkostats

G
Garod Products

H
Hammarlund Condensers
Hoyt Meters

J
Jewell Instruments

K
Karas Transformers
K. K. Dials

N
Nazely Folding Loops
National Dials

P

R

S
Silver-Marshall Products

T

U

W

Y

Build Your Own B battery Eliminator
Build it with Mayolian Units

The Mayolian B battery Eliminator is a practical, guaranteed B battery Eliminator that is simple to construct, that is inexpensive to operate, and that is highly efficient. The Mayolian can be assembled and working in 45 or 50 minutes. To construct the Mayolian B battery Eliminator requires only:

1 Mayolian Input Transformer Type No. 601	\$ 8.00
1 Mayolian Filter Unit Type No. 602	21.00
2 Standard Sockets	
1 Resistance	

Nothing else is required to build the Mayolian

1. The Mayolian operates on either A. C. or D. C. with equal efficiency.
2. The Mayolian delivers 120 Volts on the amplifier when A. C. is employed.
3. The Mayolian has a Detector Variation of from 0 to 80 Volts.
4. The Mayolian employs either 200 or 201-A tubes as detectors with equal efficiency.
5. The Mayolian delivers 50 milliamperes.
6. Your tubes cannot be burned out when a Mayolian B battery Eliminator is used.
7. The Mayolian is a new filter circuit that chokes the hum out of both sides of the line.
8. The Mayolian may be assembled in your Cabinet. It requires no more space than your B batteries.

Write for Mr. Mayo's descriptive and construction booklet. Dealers write for merchandising plan.

Easy to Construct & Practical
Efficient & Economical

SAVE THIS FOR REFERENCE

20TH Century
102 Flatbush Ave.,



Radio Corp.
Brooklyn, N. Y.

Combines distance, selectivity, power, deep full tone, beauty and simplicity!

Looks like—and performs like—a \$200 radio set

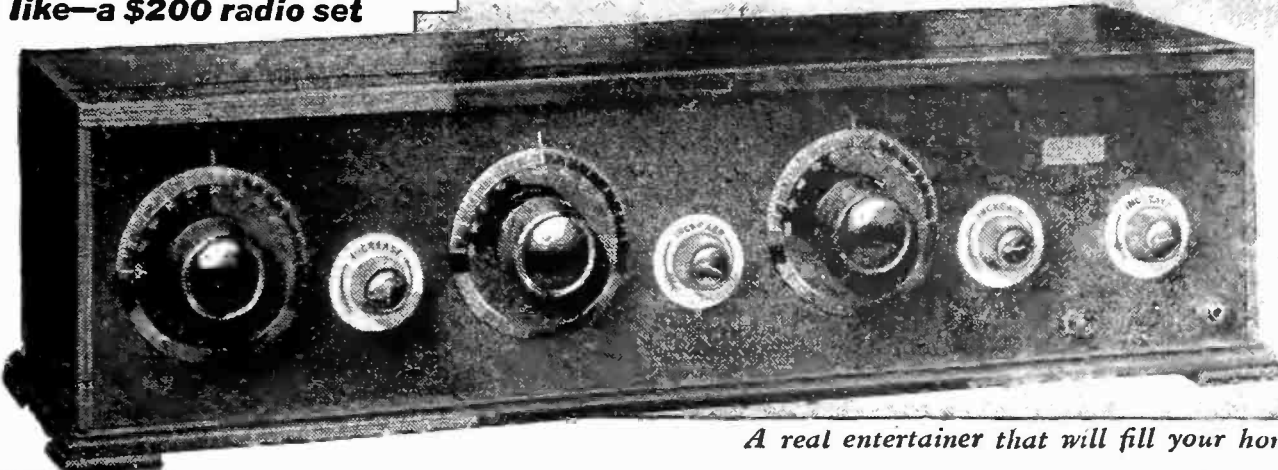

BUILT TO GIVE LOUD SPEAKER ENTERTAINMENT FROM STATIONS THOUSANDS OF MILES DISTANT WHILE LOCAL STATIONS ARE BROADCASTING

A real entertainer that will fill your home with friends!

MIRACO RADIO GETS 'EM COAST TO COAST

West Virginia Hears Australia
Got 2-XB Wellington, Australia, plain last night at 12:45 A. M.

Indiana Hears England
During the International Test, was successful in bringing in 2-LO, London, also Manchester, England, on my Miraco.—H. R. Royer, Servia, Ind.

Iowa Hears Coast to Coast
Using Miraco, I get 'em all from coast to coast. Also picked up London, England.—E. O. Wachter, Hammond, Ind.

Ohio Hears 104 Stations
Miraco very successful, having gotten 104 stations so far, California to New York, Canada to Texas. Also heard piano solo Nov. 24th from Wales.—H. S. Owen, Columbus, Ohio.

Wisconsin Hears France
Have received over 60 stations with the Miraco, San Francisco to New York City—also Sheffield, England and Paris, France.—Carl H. Dettmann, Waukesha, Wis.

Illinois Hears Cal. to N. Y.
Miraco works fine. I have Los Angeles, Cal., and several New York stations on my list.—W. W. Worrell, Carthage, Ill.

Texas Hears All Over U. S.
I have heard stations all over the United States and Havana, Cuba. Think Miraco as good as can be bought.—Thos. Peyton, Parker, Texas.

Pennsylvania Hears Germany
During International Radio Test we received Germany. Also San Juan, Porto Rico.—F. G. Kaminsky, Mildred, Pa.

South Dakota Hears Coast to Coast
Received Miraco a few days ago and it is a wonder. Have heard from Coast to Coast.—Dewey Grabinski, Rockham, South Dakota.

New York Hears California
Miraco received O. K. and am well pleased with results. Concert from Oakland, Cal., came in clear—and it's a long way from New York to California.—E. M. Davis, Waverly, N. Y.

The Marvelous **MIRACO Ultra 5** - costs only \$75

Send for free bulletins and **SPECIAL OFFER** today!

[FIVE TUBE OUTFIT IN BEAUTIFUL SOLID MAHOGANY CASE]

Completely built, thoroughly tested and factory guaranteed by one of America's oldest and most reliable manufacturers of quality sets! Years of experience and quantity production explain its almost incredible price. Users say that friends who see and hear it are amazed that it sells for less than \$150 or \$200. Radio experts, who know good construction and quality parts, are equally astonished. You, too, will be delighted, thrilled, amazed with your big five-tube Miraco Ultra 5 in its beautiful hand-rubbed solid mahogany cabinet!

Imagine getting all this for \$75—a beautiful sweet toned "coast to coast

loud speaker" set, composed of finest parts, equipped with the latest improvements, refinements and features found on costliest sets. An instrument approved by radio's highest authorities! A set anyone can connect and operate. Even beginners learn quickly to cut through the "locals," get distant stations loud and clear, log stations and return to them at will. (Full directions with each set.) It is non-radiating, non-distorting, non-howling. Has cut-out switch—and a first stage phone jack for tuning—on Bakelite panel. All wiring concealed under Bakelite sub-base. Works on storage battery or dry cells. Literature describes other newest features.

Other Miraco Long Distance Sets \$14³⁵_{up}



Miraco Model R justly deserves its title, "Radio's finest low priced quality receiver." One tube acts as a tuned radio frequency amplifier and detector combined. A great distance getter. Easy to operate and log. Covers all wave lengths 150 to 625 meters. Like all Miraco sets, it operates on a storage battery or dry cells. Never such value before at only \$14.35. Send coupon today!



This wonderful new Miraco Model R-3 is the three-tube, long distance, loud speaker set that has created such a sensation. Easy to tune and log. Covers wave lengths 150 to 625 meters. Detector acts also as a tuned radio frequency amplifier. 2 stages audio frequency amplification. Has no equal for simplicity, volume, range or clearness at anywhere near its price of \$29.50. Use coupon!

All the Proof you want is waiting for You!

Reports from the many users in every state prove Miraco Tuned Radio Frequency Receivers—at rock bottom prices—have efficiency of sets costing up to three times as much. Remember that Miraco Sets are the product of a long established, reputable manufacturer—pioneer builders of sets. Send for further evidence that they are Radio's finest moderately priced receivers. All Miraco sets bear the endorsement of radio's highest authorities. Mail coupon now for latest bulletins, SPECIAL OFFER and plenty of additional testimony from users leaving no doubt that "Miraco Radio Gets 'em Coast to Coast."

Dealers! Jobbers!

Write for the new Miraco proposition. **Agents!**

The wonderful tone, volume and distance-getting ability of Miraco Sets makes them easy to sell. Send coupon for proposition; good territory open.

Send coupon for free bulletins or order direct from this ad

MIDWEST RADIO CORPORATION
Pioneer Builders of Sets, 406-2 E. Eighth St., Cincinnati, O.
Send free literature, SPECIAL OFFER and all particulars regarding Miraco Sets. () Jobber () Dealer () Agent () User

NAME.....
ADDRESS.....

★ Tested and approved by RADIO BROADCAST ★

Here's a peculiar fact about radio insulation

MATERIAL that is satisfactory for general electrical use often gives poor results in radio-frequency service. Experience has shown that best results come with the use of material and apparatus designed especially for radio's peculiar demands. This is particularly true of insulating material.

Radion is a special material, developed to order by our engineers to meet the needs of radio. For radio frequency insulation its characteristics

are highest, as shown by authoritative laboratory tests.

The use of the most efficient insulation material is important not only for panels, but also for dials, sockets, knobs, binding post panels, rotors, stators, spaghetti tubes, etc. In all these there is a Radion product of the right type and size for your set. Radion is also used by leading set manufacturers who appreciate the superiority of "the supreme insulation."



Radion Dials help to keep down losses

RADION DIALS match Radion Panels perfectly and make the ideal mounting for your set. In design, quality and high-finish these Dials are exceptional. They are moulded with knob and dial plate in one piece with strong metal insert. Condensers and other radio instruments equipped with Radion dials show lower losses than those operated with dials of other materials. All standard sizes.

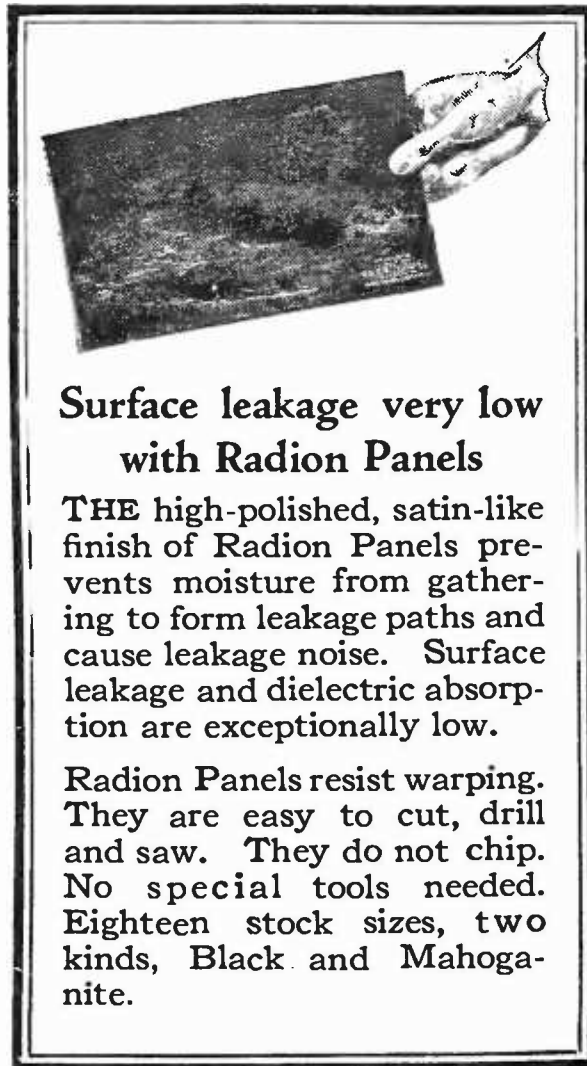

Surface leakage very low with Radion Panels

THE high-polished, satin-like finish of Radion Panels prevents moisture from gathering to form leakage paths and cause leakage noise. Surface leakage and dielectric absorption are exceptionally low.

Radion Panels resist warping. They are easy to cut, drill and saw. They do not chip. No special tools needed. Eighteen stock sizes, two kinds, Black and Mahogany.



Radion Sockets eliminate capacity effects

THE utmost protection against leaks and losses is provided by Sockets made of Radion—V-T Socket, Improved Type. Threaded metal bushings moulded in the socket insure positive contact between terminal points. The Radion collar with strong bayonet lock eliminates the capacity effects that occur when metal collars are used.

AMERICAN HARD RUBBER COMPANY, Dept. C4, 11 Mercer St., New York City

Chicago Office: Conway Building.

Pacific Coast Agent: Goodyear Rubber Co., San Francisco—Portland

Mail coupon for Booklet, "Building Your Own Set"

RADION ★

The Supreme Insulation

MADE TO ORDER FOR RADIO PURPOSES EXCLUSIVELY

AMERICAN HARD RUBBER COMPANY
Dept. C4, 11 Mercer St., New York City

Please send me your new booklet, "Building Your Own Set," giving wiring diagrams, front and rear views, showing a new set with slanting panel, sets with the new Radion built-in horn, lists of parts and directions for building the most popular circuits.

I enclose 10 cents.

Name.....
Address.....

★ Tested and approved by RADIO BROADCAST ★



Volume and Newport Are Synonymous!

In the country place or in the town home, Newport volume is more than sufficient for all needs.

You may prefer to sit quietly watching the nimble shadows from the cozy grate fire and listen to some especially beautiful solo or to some restful ballade. Then it is that you want your Newport toned down to almost a whisper. How it seems to enter into your moods! How responsive it is to your wishes!

A few friends come in for a chat of an evening. The Newport is switched on. Comes tantalizingly, dance music from any one of the excellent Metropolitan orchestras. The chairs are pushed back. A delightful evening's entertainment has been furnished without any difficulty or uncertainty).

You experience definite satisfaction in having a Newport. It performs reliably on all occasions.

*The Newport is a Good Receiver
Built in a Piece of Fine Furniture*

★ *Newport Radio Corp.*
1250 West 54th Street,
New York City



★ Tested and approved by RADIO BROADCAST ★

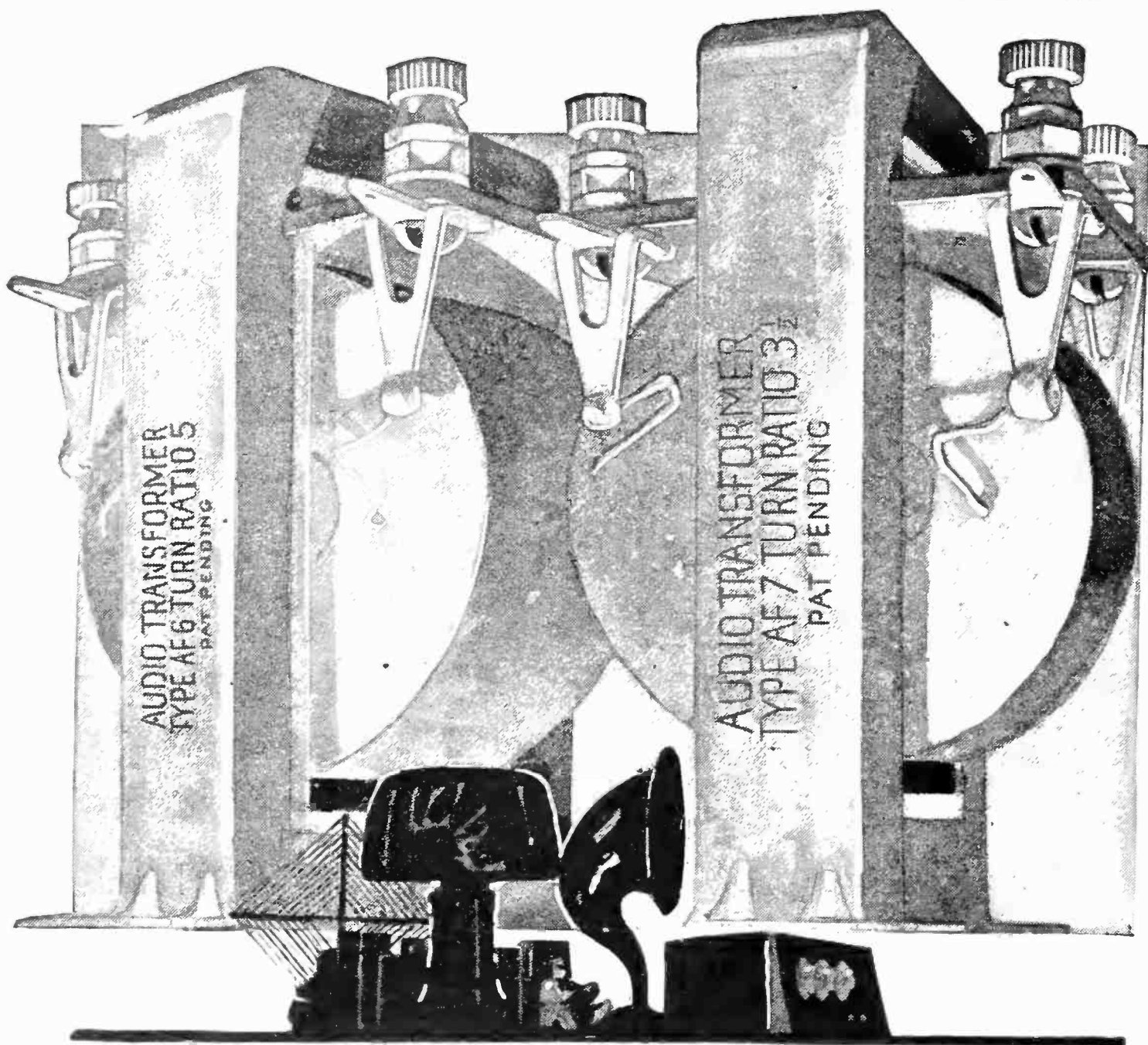

★ POWER

WHEN it comes to making a loudspeaker deliver the goods, there's nothing like a pair of AmerTrans.

Built to operate by the pair, they secure from two stages all you could possibly hope for in audio amplification.

Look for a pair of AmerTrans in the set you buy—use them in the sets you build. Learn just what the famous Amer-Tran “kick” means—and then get a loudspeaker to take it.

AmerTran is made in two types, one quality—
A F 6 — ratio 5: 1 and A F 7 — ratio 3½: 1.

Buy them by the pair!

AMERICAN TRANSFORMER COMPANY

181 EMMET STREET, NEWARK, N. J.

“Transformer builders for over twenty-four years”

Price either model \$7.00
At your dealers.

Send for leaflet giving useful
amplifier information.

AMERTRAN
TRADE MARK REG. U.S. PAT. OFF.

*A New
System
of Radio
Reception—*

Francis R. Hoyt, inventor of the Hoyt System of Signal Augmentation has specified AmerTran for use in this new system. We have a limited number of Blue Printed copies of Mr. Hoyt's original laboratory notes on this new system of radio reception, together with nine circuit sketches, which will be sent free to you upon receipt of this coupon and 4 cents for postage.

NAME

ADDRESS

★ Tested and approved by RADIO BROADCAST ★

BT Condensers Go with Fleet

F. H. Schnell to Accompany Navy in Maneuvers

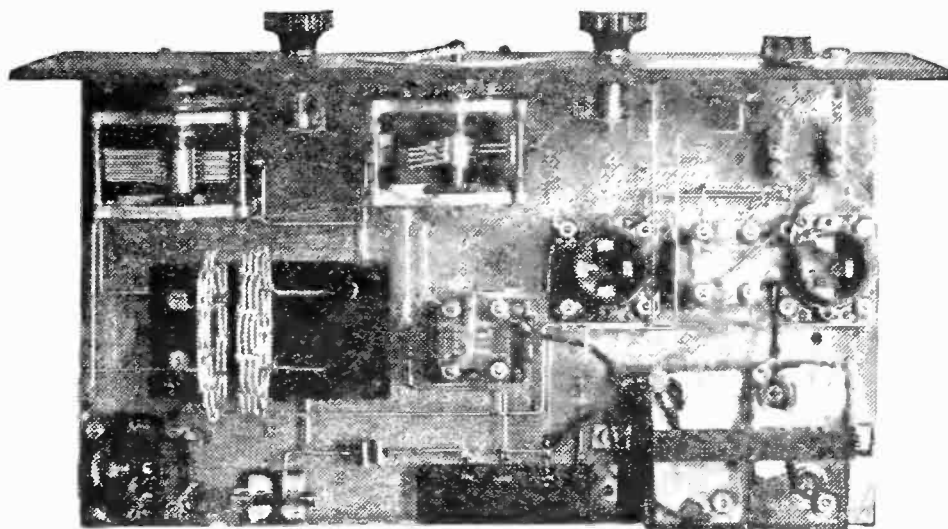

Schnell's Short Wave Tuner-Set
with Bremer-Tully Condensers

F. H. Schnell, Traffic Mgr. of the American Radio Relay League, is to accompany the Pacific Fleet in its forthcoming battle practice in Hawaiian waters. With him goes his short-wave Tuner-set for Navy-Amateur experimental tests. In this receiver he uses B-T Type L Condensers.

Choice of Experts

The enormous frequencies at low wave lengths,—25,000,000 per second at 12-meters, for example,—compared with 834,000 at 360, demands the utmost of condensers. Mr. Schnell chose B-T's.

The B-T Tuner will be found in such stations as those of Kruse, Technical Editor of Q S T; Clayton, Information Service Mgr.; and Budlong, Current Service Editor of the League.

A Leading Technical Editor Says:

"Have been testing various tuners,—everything we could get on the market, and I want to go on record that the B-T Type "B" ran circles around the whole bunch. Tests were all made in one evening, and the only changes made were one tuner for another."

"Best reception was KGO on an indoor cage antenna with the B-T, and best with any other was WGN, Chicago, with an outside antenna, 200 ft. For a motto for B-T, I suggest, "Ask the man who owns one."

The B-T Nameless

The 5-tube "Nameless" will be found in America's finest homes. It can be built and tested step-by-step. Write for information on this greatest of B-T achievements. It is described in "Better Tuning."

"Better Tuning" a 48-page booklet of diagrams, hook-ups and advice will help anyone get better results on all circuits. The 7th edition is ready. If your dealer doesn't carry a stock, send 10c for postpaid copy. "Better-Tuning" is packed with each B-T Tuner.

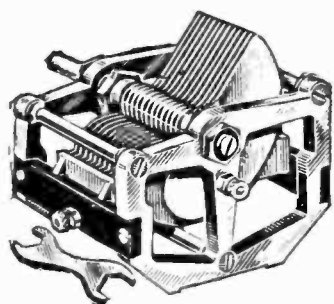

B-T Lifetime Condensers

Type	Capacity	Price
L-7	125 M.M.F.	\$4.25
L-13	250 M.M.F.	4.50
L-23	500 M.M.F.	5.00
L-35	750 M.M.F.	6.50



BREMER-TULLY MFG. COMPANY
534 S. Canal Street Chicago, Ill.

★ Tested and approved by RADIO BROADCAST ★

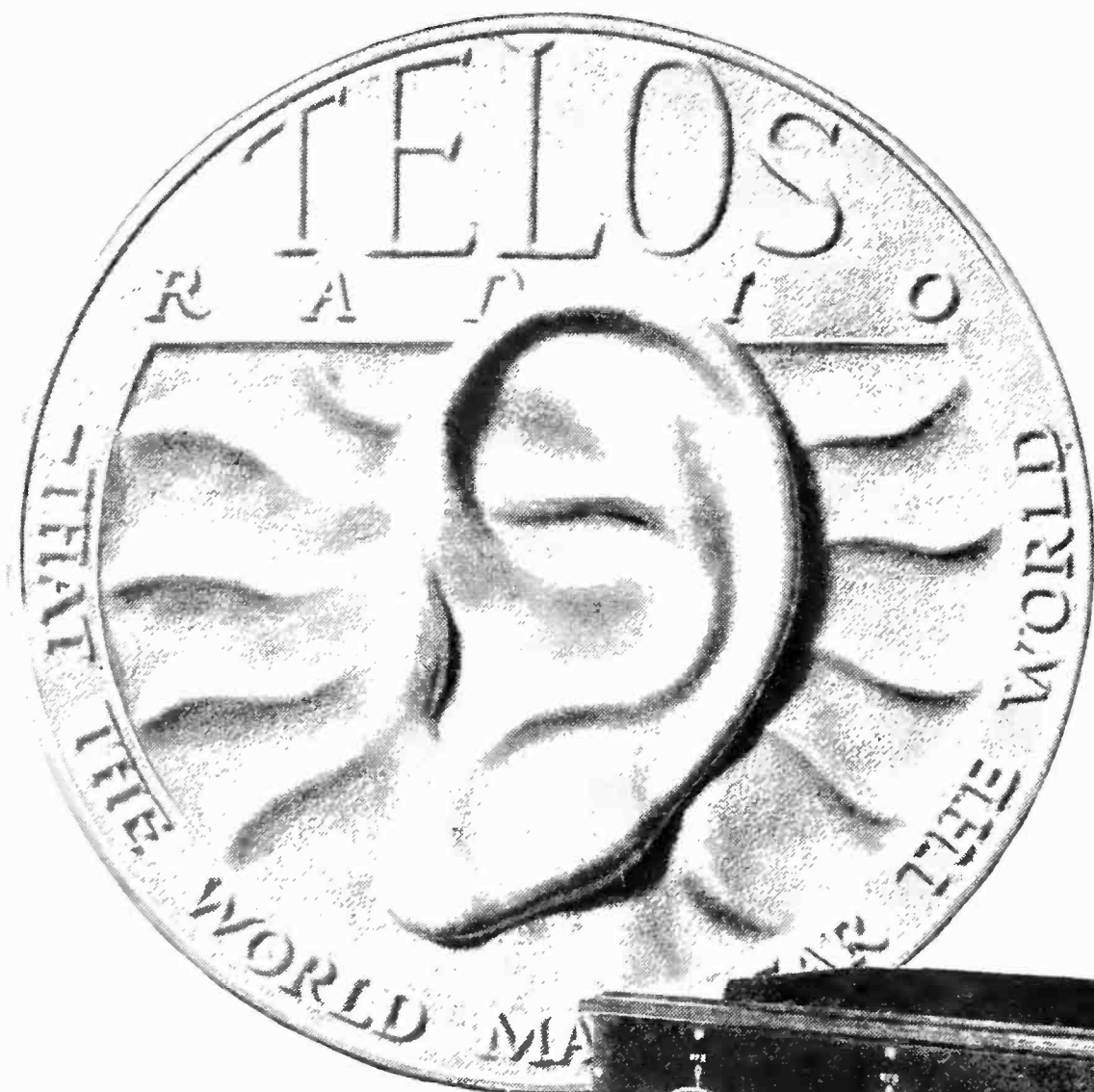

**Build a
Telos—
and
hear
the
world!**

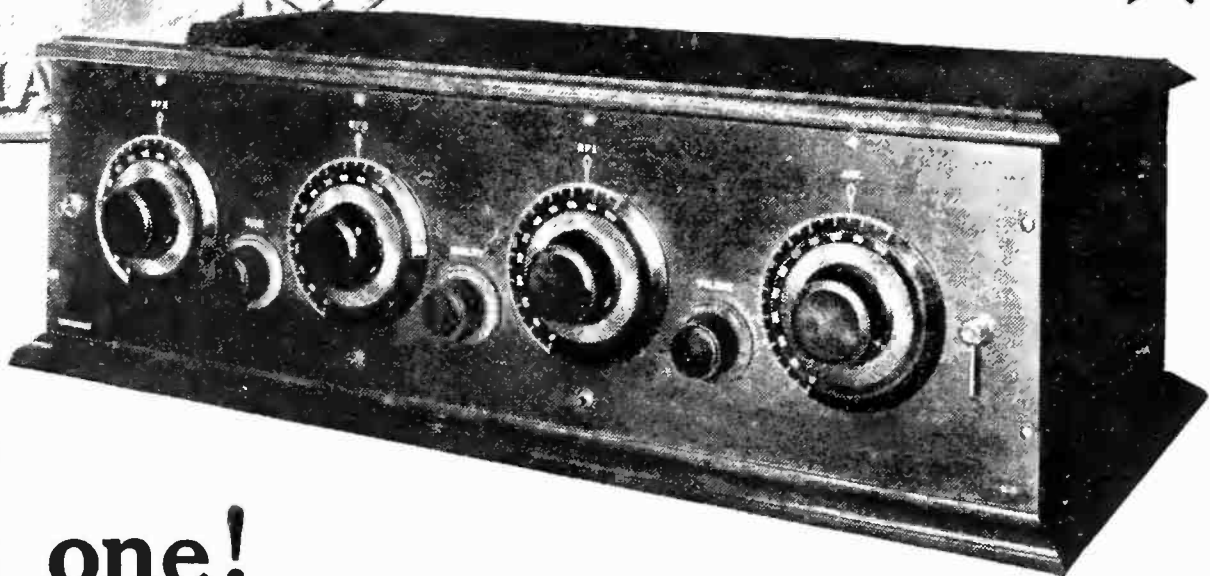

Four dials— that tune as one!

WITH the "Uni-control" lever *down*—all four dials tune together. Turn any one dial and the whole set responds.

Then, if you want ultra-fine tuning, turn the "Uni-control" lever *up*—and each dial tunes independently!

Telomonic III is the only set that combines single control simplicity of tuning, with multi-control opportunity for ultra-precise results on distance!

And Telomonic III is the only set in which three stages of tuned R. F. are made entirely practical. It is the only 6 or 7 tube set that runs entirely on dry cell tubes—with the plate current consumption of an ordinary 3 tube set.

You can't buy a Telomonic III—you must build it yourself—with the new Telos Kit. And the amazing variety this Kit offers is fully explained in our handsomely illustrated booklet, "The KIT of a Thousand Possibilities." Use the coupon now for your copy.

DANZIGER-JONES, Inc.
25 Waverly Place Dept. B New York

DANZIGER-JONES, Inc.
25 Waverly Place, Dept. B,
New York, N. Y.

Send me at once your profusely illustrated folder—
"The Kit of a Thousand Possibilities"—free!

Name

Address

★ Tested and approved by RADIO BROADCAST ★

Another Famous TOWER

Tower's Scientific LOUD-SPEAKER

\$8.50



It had to be the **BEST**

We could have manufactured a loud speaker two years ago, but we wouldn't! We have waited — studying, planning, continually striving for perfection and now at last! WE HAVE IT — In the new TOWER'S LOUD SPEAKER. Surely a Wonderful TOWER Triumph.

The many features include, magnets that lift 2 lbs. 10 oz.; diaphragm of specially constructed material, perfect non-vibrating fibre horn, finished in beautiful golden bronze 10" bell.

TOWER'S phones are tested by Government Licensed Radio Operators. Weight only 8 1/4 oz. On sale at all good dealers from coast to coast.



THE TOWER MFG. CORPORATION
98 BROOKLINE AVE Dept. I BOSTON, MASS.

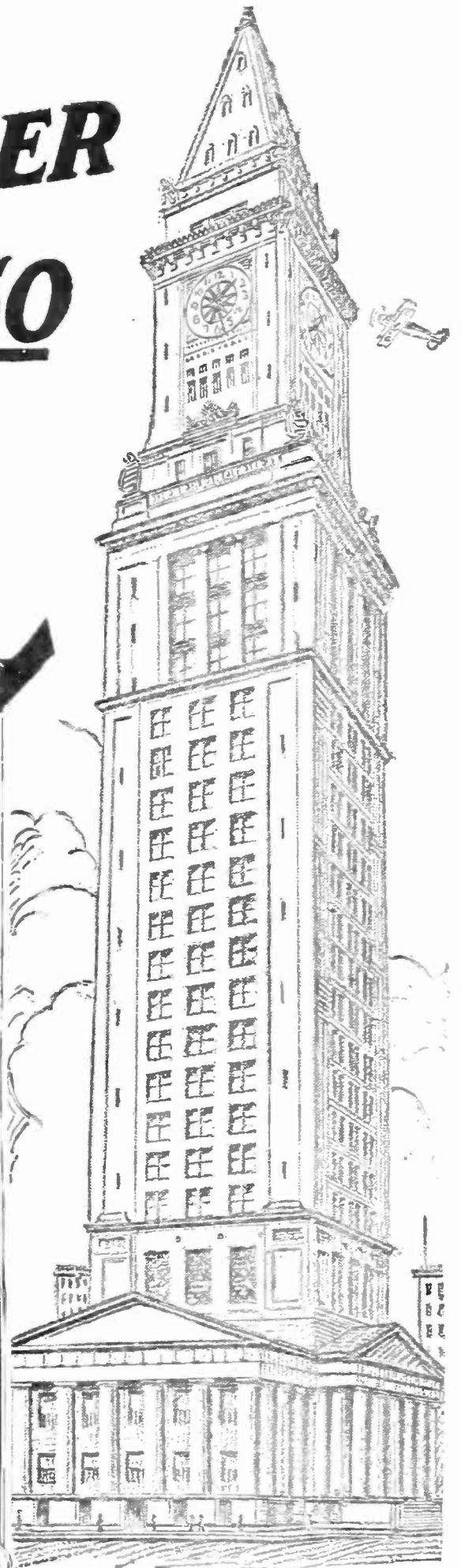

The U. S. Custom House Tower at Boston is 500 feet high and is situated in the business district overlooking Boston Harbor. It is the tallest Government building in America.

Worlds Greatest Loud Speaker Value

★ Tested and approved by RADIO BROADCAST ★

Radio Broadcast

ARTHUR H. LYNCH, EDITOR

APRIL, 1925

COVER - - - - -	<i>From a Painting by Remington Schuyler</i>	
STANDARD COLOR CORD CHART - - - - -	<i>Frontispiece</i>	
HOW RADIO IS BEING STANDARDIZED - - - - -	<i>G. Y. Allen</i>	1035
CAN WE SOLVE THE BROADCAST RIDDLE? - - - - -	<i>Zeb Bouck</i>	1040
HOW TO WRITE A RADIO PLAY - - - - -	<i>Mildred Weinberger</i>	1045
THE LISTENERS' POINT OF VIEW - - - - -	<i>Jennie Irene Mix</i>	1050
THE PHYSICS OF SOUND - - - - -	<i>B. F. Miessner</i>	1057
THE MARCH OF RADIO - - - - -	<i>J. H. Morecroft</i>	1062
THE MAN WHO KNEW ALL ABOUT RADIO - - - - -	<i>William H. Cary, Jr.</i>	1072
PROGRESSIVE EXPERIMENT WITH THE ROBERTS CIRCUIT - - - - -	<i>Keith Henney</i>	1078
AS THE BROADCASTER SEES IT - - - - -	<i>Carl Dreber</i>	1085
IN THE R. B. LAB - - - - -		1092
Some Notes on the Second-Harmonic Super A Radio Power Panel A Handy Capacity Bridge The C Battery and Resistance Coupling		
NEW BROADCASTING WAVELENGTHS - - - - -		1098
RADIO FREQUENCY AMPLIFICATION AND HOW TO MEASURE IT - - - - -	<i>Harry Diamond</i>	1099
DO YOU KNOW OF A BETTER RECEIVER? - - - - -	<i>Arthur H. Lynch</i>	1104
AT SEA IN A HURRICANE - - - - -	<i>John L. Eddy, Jr.</i>	1106
BENEFICENT RESULTS OF BROADCASTING - - - - -		1111
ESSENTIAL RADIO ACCESSORIES - - - - -	<i>Walter Van B. Roberts</i>	1112
WHAT RADIO EQUIPMENT DOES THE AMATEUR USE? - - - - -	<i>Harold S. Fraine</i>	1115
"NOW, I HAVE FOUND . . ." - - - - -		1121
THE GRID - - - - -		1123
Use of Meters in Receiving Circuits The Neutralization of Neutrodynes How to Prepare Panels Notes on the Roberts Circuit How to Use Storage Batteries The Use of Wave Traps		
NEW EQUIPMENT - - - - -		1130
AMONG OUR AUTHORS - - - - -		1132

Copyright, 1925, in the United States, Newfoundland, Great Britain, Canada, and other countries by Doubleday, Page & Co.
All rights reserved. TERMS: \$4.00 a year; single copies 35 cents.

F. N. DOUBLEDAY, *President*
ARTHUR W. PAGE, *Vice-President*

NELSON DOUBLEDAY, *Vice-President*
RUSSELL DOUBLEDAY, *Secretary*

S. A. EVERITT, *Treasurer*
JOHN J. HESSIAN, *Ass't. Treasurer*

<p><i>Doubleday, Page & Co.</i> MAGAZINES</p> <p>WORLD'S WORK COUNTRY LIFE GARDEN MAGAZINE & HOME BUILDER RADIO BROADCAST SHORT STORIES EDUCATIONAL REVIEW LE PETIT JOURNAL EL ECO THE FRONTIER</p>	<p><i>Doubleday, Page & Co.</i> BOOK SHOPS</p> <p>NEW YORK: LORD & TAYLOR BOOK SHOP PENNSYLVANIA TERMINAL ARCADE LONG ISLAND TERMINAL ARCADE AND 38 WALL ST. ST. LOUIS: 223 NORTH 8TH STREET 4914 MARYLAND AVENUE KANSAS CITY: 920 GRAND AVENUE TOLEDO: LASALLE & KOCH CLEVELAND: HIGBEE CO. NEWARK: 34 PARK PLACE SPRINGFIELD, MASS.: MEEKINS, PACKARD & WHEAT</p>	<p><i>Doubleday, Page & Co.</i> OFFICES</p> <p>GARDEN CITY, NEW YORK NEW YORK: 120 WEST 32ND STREET BOSTON: PARK SQUARE BUILDING CHICAGO: PEOPLES GAS BUILDING SANTA BARBARA, CALIFORNIA LONDON: WM. HEINEMANN, LTD. TORONTO: OXFORD UNIVERSITY PRESS</p>
--	--	--

EVEREADY HOUR
EVERY TUESDAY AT 9 P. M.
(Eastern Standard Time)

For real radio enjoyment, tune in the
 "Eveready Group." Broadcast through
 stations

WEAF	New York	WFI	Philadelphia
WJAR	Providence	WCAE	Pittsburgh
WEEI	Boston	WGR	Buffalo

*Dry "B" Batteries
 are an economical,
 dependable and
 convenient source
 of plate
 current!*

Satisfaction Reliability Economy

You need three things in radio "B" Batteries—
 satisfaction, reliability and economy. You get
 them all in Eveready "B" Batteries. Satisfac-
 tion, because they produce all the current needed
 by your tubes, giving you the maximum results
 of which your set is capable. Reliability, because
 you can depend on them to work at full power.
 Economy, because they long maintain their
 strength, and because they are low in price.

Advances in the art of battery manufacture
 make Evereadys last longer than ever. You
 actually get much longer service for your money.

There is an Eveready Radio Battery for every
 radio use.

Buy Eveready Batteries.

Manufactured and guaranteed by

NATIONAL CARBON COMPANY, INC.
 New York San Francisco
 Canadian National Carbon Co., Limited, Toronto, Ontario

EVEREADY Radio Batteries

—they last longer

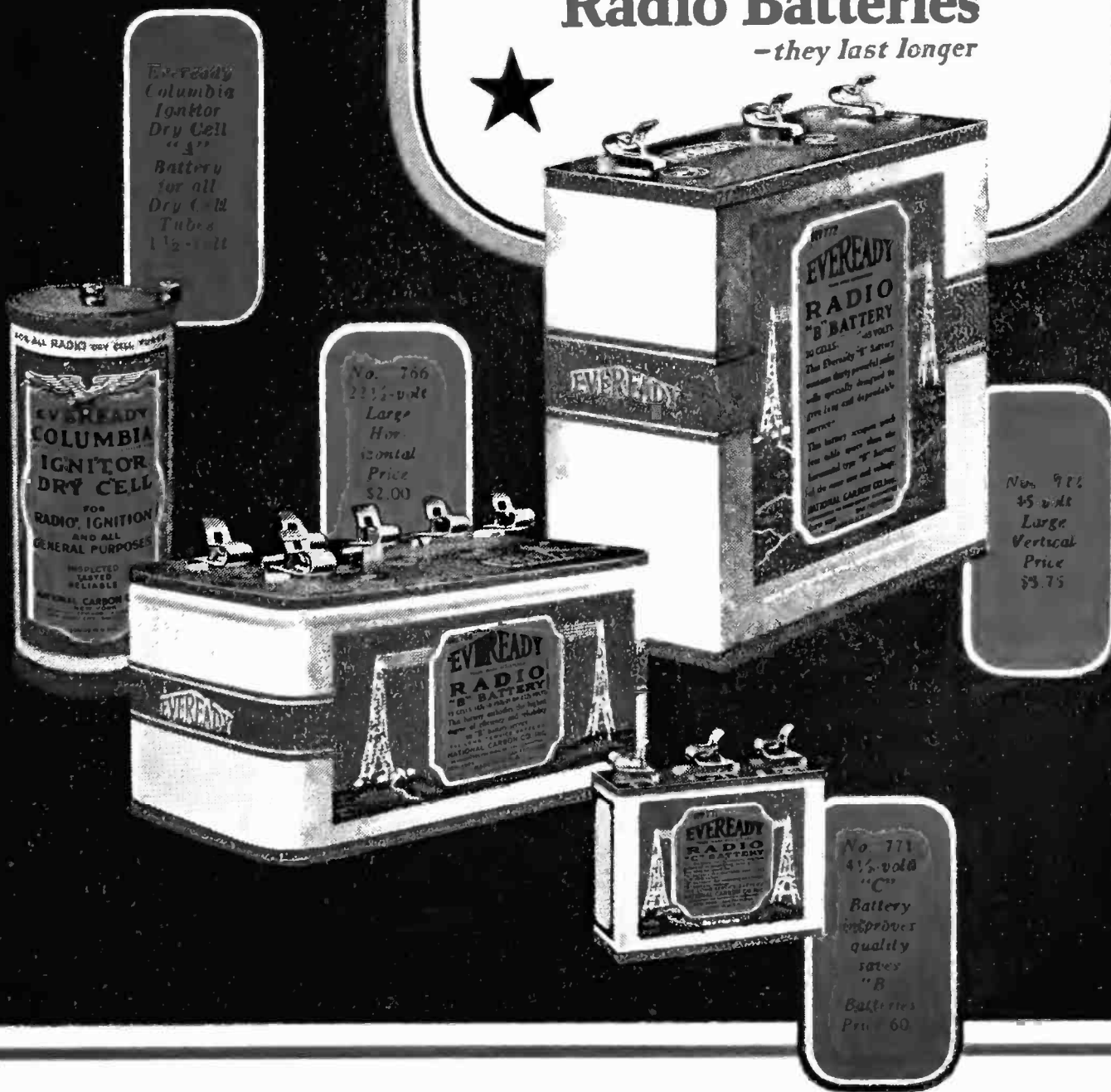

*Eveready
 Columbia
 Ignitor
 Dry Cell
 "A"
 Battery
 for all
 Dry Cell
 Tubes
 1 1/2 - 1.11*

*No. 766
 2 1/2 - volt
 Large
 Horizontal
 Price
 \$2.00*

*No. 972
 4 1/2 - volt
 Large
 Vertical
 Price
 \$3.75*

*No. 771
 4 1/2 - volt
 "C"
 Battery
 improves
 quality
 sets
 "B"
 Batteries
 Price .60*





★ Tested and approved by RADIO BROADCAST ★

Standard Color Designations for Cords Used for Outside Connections in Radio Receivers

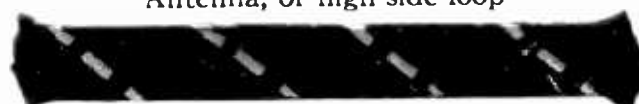
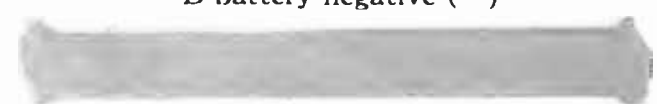
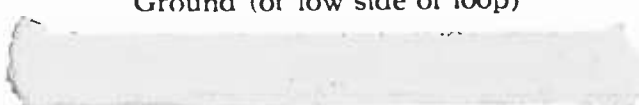
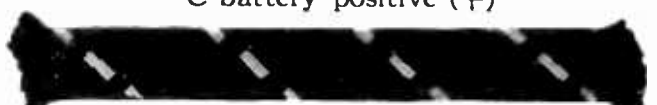
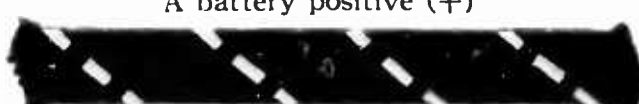
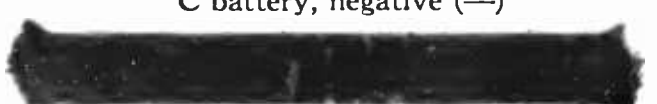
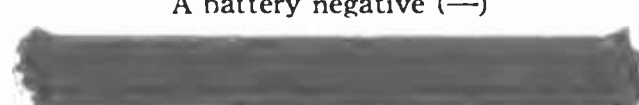
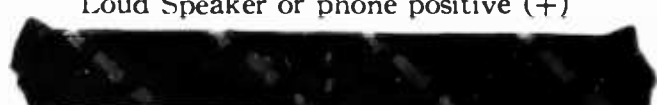
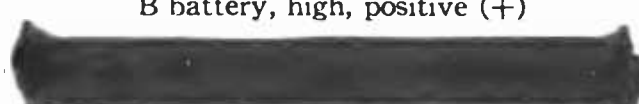

As Adopted by

The Associated Manufacturers of Electrical Supplies

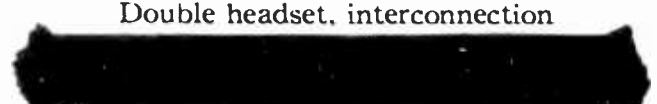
SIMPLE CORD COLOR COMBINATIONS

	
BLUE Antenna, or high side loop	BLACK, RED TRACER B battery negative (—)
	
BLACK, BLUE TRACER Ground (or low side of loop)	GREEN C battery positive (+)
	
YELLOW A battery positive (+)	BLACK, GREEN TRACER C battery, negative (—)
	
BLACK, YELLOW TRACER A battery negative (—)	BROWN Loud Speaker or phone positive (+)
	
RED B battery, high, positive (+)	BLACK, BROWN TRACER Loud speaker or phone negative (—)
	
DARK RED B battery intermediate positive (+)	BROWN, WHITE TRACER Double headset, interconnection
	
MAROON B battery, detector positive (+)	BLACK Battery Jumpers

COLOR DESIGNATIONS OF CONDUCTORS COMMON TO MORE THAN ONE CIRCUIT (Solid color is chosen to represent most positive lead)

	
RED, BROWN TRACER B battery, high side (+) Loud speaker, low side	YELLOW, RED TRACER B battery negative (—) A battery positive (+)
	
GREEN, YELLOW TRACER A battery negative (—) C battery positive (+)	

RADIO BROADCAST presents for the first time in any magazine the colors to be used in dyeing the braid used in the cord. Solid colors are to be used to designate the high or positive side of a circuit. Tracer colors are to be used to designate the low or negative side. The shade designations, in parentheses, are the same as those specified in the Standard Color Card of America, 6th edition, published by the Textile Color Card Association of the United States, Inc., 50 West 42nd Street, New York.

The general scheme is: { BLUE FOR THE ANTENNA CIRCUIT (Bluebird S-6065)
RED FOR B BATTERY (Geranium S-2035)
MAROON FOR B BATTERY (Magenta S-7285)
YELLOW FOR FILAMENT CIRCUIT (Orange S-3005)
GREEN FOR C BATTERY (Emerald S-5005)
BROWN FOR TELEPHONE CIRCUIT (Gold Brown S-3285)

In using these designations, always be guided by the point to which the flexible cord is attached, not where it leads to. For instance, a cord connecting the positive side of the B battery to the high side of the loud speaker jack should be marked red.

MAR 23 1925

RADIO BROADCAST

Vol. 6, No. 6



April, 1925

How Radio Is Being Standardized

Order for the Radio Chaos—Facts About a Progressive Step Taken by the Associated Manufacturers of Electrical Supplies Involving Batteries, Connecting Cords, Plugs, and Jacks

By G. Y. ALLEN

STANDARDIZATION in nature is universal. It is essential to the existence of the universe and to the existence of life in all forms. If the law of mutual attraction of worlds should change one iota, their present orderly movement would degenerate into hopeless chaos. With the laws of nature so firmly standardized, it is not strange that man in applying these laws should find that standardization is essential.

Standardization of a new art must go hand in hand with its development. If standardization is projected too far ahead of development it tends to hinder and choke such development because it is impossible to look far enough into the future to an-

ticipate all phases of the development. On the other hand, lack of standardization is likewise a drawback.

The development of the air brake for railroads illustrates how

standardization may seriously handicap the development of an industry through the impossibility of looking far enough into the future. The diameter of the train pipe for the operation of the air brake was decided upon long before the advent of the long freight train of to-day. For the short and comparatively light train, the size determined upon was adequate. When long, heavy trains came to be the rule, however, a larger size pipe was found to be desirable, but owing to the standard that had been set and due to the investment in rol-

"I desire heartily to endorse the plan that you have outlined to me for having printed a chart in colors showing the standard color markings for radio receiver cords, as adopted by the Standards Committee of the Associated Manufacturers of Electrical Supplies. The widespread adoption of such a color code will be a great step forward in radio manufacture and will also be of substantial benefit to the broadcast listener in connecting up a receiver as well as to the repair man who is servicing the set.

"I feel that the Committee is indebted to Doubleday, Page & Company for their kind offer to cooperate in preparing this chart, and I am sure that the publicity obtained through their magazine, RADIO BROADCAST, will be a very valuable factor in making the adopted standards widely used, thus resulting in simplifying the manufacture, installation, and maintenance of radio receivers."

—ALFRED N. GOLDSMITH, *Chief Broadcast Engineer, Radio Corporation of America.*

ling stock using the smaller size pipe, a larger diameter pipe could not be adopted. The industry was delayed several years and vast sums of money were expended to compensate for the handicap imposed by the short-sighted standardization. Standardization thus must be farsighted and must progress with the development of the art if it is to assist instead of hinder normal development.

Standardization of radio receiving sets may be subdivided into the following classes:

Terminology.
Physical dimensions.
Constructional details.
Features involving operation.

Terminology is the language of an art and it is essential that new terms be accurately defined so that no one can misunderstand them. Frequently names are given to devices at the time they are invented which are unfortunate and which are either totally inadequate or totally misleading. The word "tickler," for instance, was given to the plate coil of a regenerative receiver by some Navy engineers shortly after the regenerative circuit was invented. No serious thought was expended in picking out a suitable name, but early investigators simply used the word colloquially, and, as is almost always the case, the name stuck in spite of frequent efforts to substitute some more suitable word.

WHAT TERMS SHALL WE USE?

IT IS thus evident that new terms incident to development in a new art should be suitable for the purpose and must mean one thing only. This does not mean that only one word must be used to name any part. It is well known that every flower has in addition to its common name a botanical name, and so devices in the radio art may have two names, if that seems desirable. For instance, the term "feed back control" may be changed to "amplification control," when the receiver is de-

signed to be handled by the novice, providing that this term is consistently used in this way and is not used to describe any other part of the device.

The standardization of physical dimensions in a new art may be of two kinds; namely, specific and general.

Specific dimensions for radio apparatus must be standardized for such devices as are generally termed accessories. This includes tele-

phone plugs and jacks, vacuum tubes, dry batteries, etc. Specific dimensions are the most difficult features of standardization of a new art. It is next to impossible for any one to stand at the threshold of development and foresee all of the possibilities of new devices, yet such standardization is essential to the progress of the art. Very seldom are the early standards permanent, and the general procedure is to adopt the most obvious standard, changing it as necessary, using adapters to accommodate the old standard to the new practice until the old has

Another Sign of Progress

Radio has changed in definite cycles since the time that the last word in wireless communication was a curious appearing device in a glass tube called a coherer. Although the industry has not nearly so much in common with the automobile industry as many Wise Ones would have us believe, a similar period of standardization in radio is coming and Mr. Allen's article analyzes the situation very sanely and helpfully, we think. The Associated Manufacturers of Electrical Supplies, Radio Section, in their meeting at Atlantic City in June, 1924, canvassed the entire situation and decided that radio was sufficiently developed so that certain necessary elements could be safely standardized, with vast benefits to all concerned. The Radio Corporation of America group has already adopted the color cord standards, as have many of the neutrodyne manufacturers. Standard batteries, plugs, and jacks are already available according to the specifications of the Standards Committee, of which Mr. Allen is a member.—THE EDITOR.

been completely superseded. This involves inconvenience and expense, of course; but greater expense would surely be involved through not having the courage to change standards when changes are obviously necessary.

Standard sizes for dry batteries are governed principally by the minimum size that will give a satisfactory life. The battery manufacturer determines the sizes. The manufacturer of the self-contained radio receiver must make his equipment to accommodate the batteries offered.

The general physical dimensions of radio receivers are determined partly by whatever sizes conveniently fit into the modern home and partly from the style of furniture prevailing. Cabinet receivers, complete with stand, are on the market in both upright and pedestal types. Table or console models are also popular.

Cabinet radio receivers designed to be supported on a table have their proportions, of course, determined by the proportions of available tables. Fig. 1 illustrates one of the vertical self-contained sets complete with a stand, and other cabinet receivers are suitable for mounting on a gate-leg table.

WHY CONSTRUCTIONAL DETAILS SHOULD BE STANDARDIZED

THE standardization of constructional details is important both from the standpoint of the manufacturer and the user. The use of a universal type of connector for flexible cord terminals, for instance, is desirable to the manufacturer because all manufacturers can purchase these parts in large quantities from the same outside manufacturers with corresponding reduction in price.

The user prefers such a type of terminal because he can connect such a terminal to any type of battery. Likewise the standardization of markings is a great step forward in reducing ambiguity and confusion particularly in sets that are sold, ready to be assembled.

By the standardization of features involving operation is meant the arrangement of knobs, binding posts, tubes, etc. In the cabinet set, it further means the arrangement of batteries and especially battery connections.

Except for the work done by the Bureau of

Steam Engineering of the U. S. Navy, the first real step in standardization was taken during the past year by the Radio Section of the Associated Manufacturers of Electrical Supplies. An immeasurable amount of credit is due this organization for the courage and foresight that has been shown and equal credit is due the manufacturer members for the unselfish way in which they have subscribed to the standards of the Association. True, only a start has been made, but even in the past short year, the work that has been accomplished will have far-reaching effect both for the manufacturer and the user of radio receivers.

One of the outstanding results of the year's work that is of particular interest to the user is the standardization of color markings for cord connections to radio receivers. With the modern trend toward the convenient flexible cords for connections to batteries instead of the older type binding posts, some automatic method of insuring correct connections even if the instruction book be lost becomes essential. The colors adopted by the Association are shown on the color plate on page 1034.

RADIO CORDS ARE TO BE STANDARD

A STUDY of the chart will disclose the fact that a very definite plan has been followed which is almost self-explanatory.

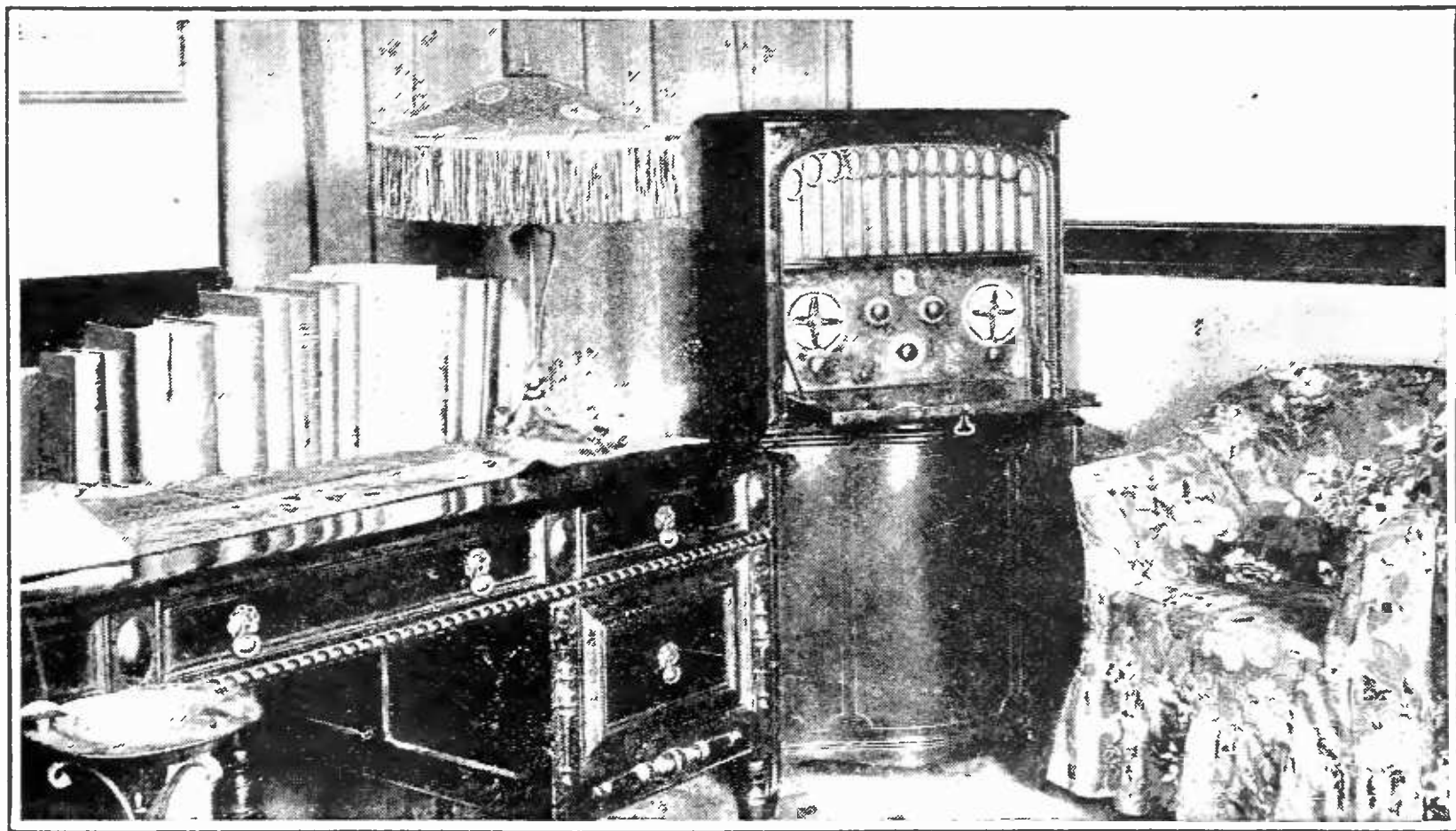

FIG. 1

A standard receiver of a popular type. The batteries, antenna, etc., are all contained in the cabinet. In order for set manufacturers and battery manufacturers to supply parts which will fit into any receiver of similar type, standardization of supplies is essential

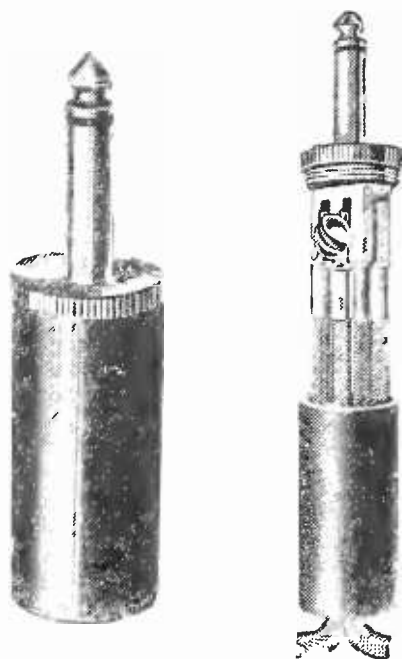

FIG. 2

A type of plug made according to the specifications of the Standards Committee of the Associated Manufacturers of Electrical Supplies. The plan of the Committee is that any plug sold will fit into any jack available. With very few exceptions these standards have already been put in force by manufacturers of these parts

Blue is used to designate the antenna circuit, due to the fact that the antenna is always associated with height and the blue sky. Yellow is used for the filament circuit to suggest the color at which the filaments operate. Bright red was used to designate the highest positive B battery potential, this being conventional electrical engineering practice. Maroon, a less bright red, is used to designate one of the lower voltage positive leads. Black is used for ground and in all places where another color is now required.

These colors are solid colors. In the case of the low side (negative) of circuits, a tracer of the proper color to designate the circuit is used instead of a solid color. Thus, the negative side of the filament circuit uses a black cord with a yellow tracer.

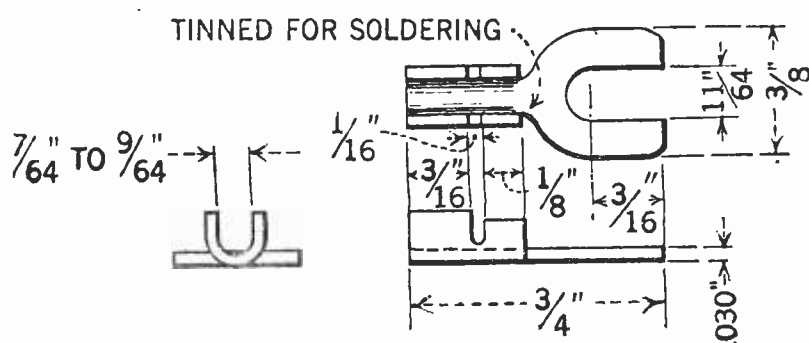

FIG. 3
The standard lug

Where one cord does double duty, such as when the negative B battery cord also serves as the negative A battery cord, the cotton covering is red with a yellow tracer.

While these color designations are primarily intended for connections to factory-made sets, there is nothing to prevent the builder of home-made sets adopting such a color scheme for internal wiring. Every constructor will at once recognize the value of standard color cords in connecting receivers he builds. Hours of time can be saved. As soon as these color markings are published, colored spaghetti and covered bus wire will undoubtedly make its appearance. The circuits of a set built in this way will be infinitely easier to trace than if the set was wired using wire of all one color.

Some of the specific dimension standards are of general interest. The terminal lug shown in Fig. 3 has been adopted for battery connections by the Association. This terminal will fit the standard thumb-screw battery post and will also fit any of the spring battery terminals. Any one who has attempted to connect B batteries with spring connectors to some of the terminals on the market will appreciate the value of such a standardized lug.

The dimensions of telephone plugs and jacks have been standardized so that any make of plug will fit any make of jack. These standardized sizes are shown in Fig. 4.

STANDARD B BATTERIES

B-BATTERY dimensions have been standardized and the size of battery for different current drains has been specified. The following designating letters refer to batteries using the individual standard size cells shown:

DESIGNATION	INDIVIDUAL CELL DIMENSIONS
A	$\frac{5}{8}$ X $1\frac{7}{8}$
B	$\frac{3}{4}$ X $2\frac{1}{8}$
C	$1\frac{1}{16}$ X $1\frac{13}{16}$
D	$1\frac{1}{4}$ X $2\frac{1}{4}$
E	$1\frac{1}{4}$ X $2\frac{7}{8}$
F	$1\frac{1}{4}$ X $3\frac{7}{16}$

In addition to these letter designations, the letter H is used to indicate the horizontal type of radio battery and V to indicate vertical type of battery.

The complete designating data for a battery also includes the number of cells. Thus the Eveready battery No. 766 and Burgess No. 2156 will be known as H-15-D, meaning a horizontal battery of 15 D size cells.

The Radio Apparatus Section of the Associated Manufacturers of Electrical Supplies has specified that for portable sets the B or C size cells are to be used. For non-portable

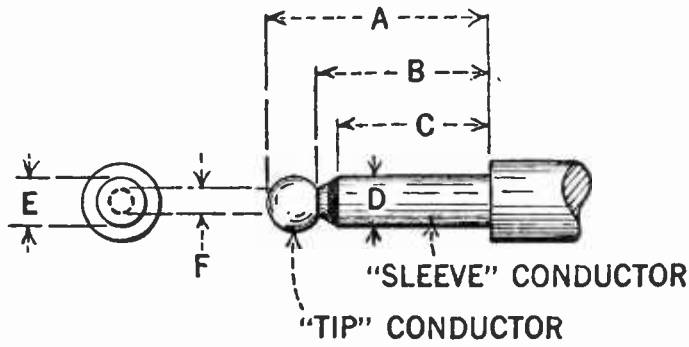

DIMENSION	MINIMUM	TOLERANCE	MAXIMUM
A	1.179"	.020"	1.199"
B	-	-	.959"
C	-	-	.863"
D	.248"	.002"	.250"
E	.243"	.002"	.245"
F	3/16"		

FIG. 4

The standard plug for radio use and the complete specifications of the Standards Committee of the A. M. E. S.

receivers the D size cells are to be used for current drains not exceeding 15 milliamperes and for the highest current drains, the F size cell is to be used.

In addition to these specific standard dimensions, the Section has adopted standards of practice for manufacturers which will make for improved quality of apparatus and for greater convenience in handling. For instance, it has been decided that the sleeve of the telephone plug shall in every case be made positive. This is an important feature for loud speakers used outside the receiver, as some types of loud speakers are particularly sensitive to the direction of current flowing to the B battery.

American Society of Mechanical Engineers standard screws have been adopted, which will facilitate repairs and knob-markings have been standardized. The diameters of shafts on which knobs are used have been definitely

specified. The maximum and minimum impedance of loud speaker and telephone receivers are stated. Electrical tests have been planned and many other standards have been laid down by the Section which will operate to increase the convenience of operating standardized receivers, and will, furthermore, make for a better and cheaper product that can be more easily maintained at a decreased cost.

While it is true that much yet remains to be done in the standardization of radio receivers, it is felt that a very decided start has been made and there is no doubt but that as the art progresses, standardization by reputable manufacturers, through their representative organization, the Associated Manufacturers of Electrical Supplies, will continue to keep abreast of the times which will eventually result in vast benefits to the user.

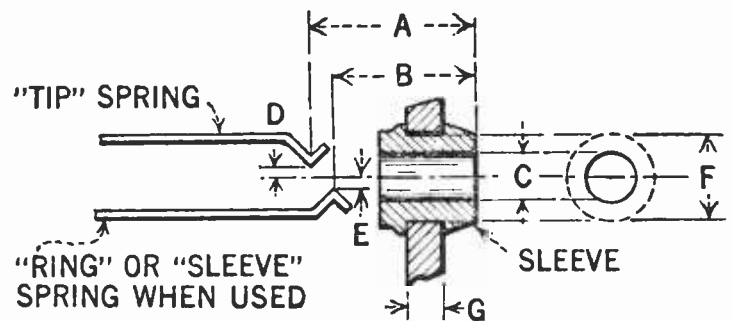

DIMENSION	MINIMUM	TOLERANCE	MAXIMUM
A	1.000 "	.040 "	1.040 "
B	.770 "	.020 "	.790 "
C	.2515"	.0015"	.2530"
D	.020 "	.010 "	.030 "
E	.030 "	.010 "	.040 "
F	-	-	.450 "
G	1/8 "	-	1/4 "

FIG. 5

Specifications and dimensions for the standard jack

NEW TRENDS IN BROADCASTING

THERE is a definitely new departure lately manifest in broadcasting programs which has appeared in the form of the so-called "Hours." Some of these have been devoted entirely to music, others are partly musical and partly dramatic, and so on. How this development came about and how these programs are planned are described in one of James C. Young's interesting articles which will be a feature of an early number of RADIO BROADCAST. The broadcast listener who is interested in seeing the manufacture of a program from the very real "inside" will enjoy Mr. Young's story.

Can We Solve the Broadcast Riddle?

A Consideration of the Prize Plans in RADIO BROADCAST'S \$500 Contest—Is the Winning Plan Feasible?—Some Thoughts on the Economics of Broadcasting

BY ZEH BOUCK

THERE were about eight hundred plans submitted in the recent contest conducted by RADIO BROADCAST in which a prize of \$500 was offered for the best answer to the question: "Who Is to Pay for Broadcasting—and How?" It was my pleasure, as one of the judges, to read over all the plans which were considered. It was very gratifying to find so representative a portion of the radio audience exhibiting a sincere interest in the economics of broadcasting. The variety of the solutions showed that considerable intelligent thought had been devoted to the problem.

All of the ideas possess workable possibilities and in many cases the ingenuity of the plan compensates for the absence of more practical qualities. Among the especially ingenious schemes were two based on the possibility of capitalizing the necessity for printed radio programs. One idea was to syndicate these programs to the daily press throughout the country at a nominal rate which nevertheless would agglomerate into a respectable sum. The second arrangement advocates the printing of radio programs as an individual publication, prohibiting, through copyright, any duplication in the press. Radio listeners would therefore be compelled to pay for their programs, buying them on the news stands or through subscriptions. A bit of interesting and relevant

text might be worked into the programs. It will not be surprising if, to-morrow, we find this scheme oiling the cogs of radio's economic machinery.

Another idea was that the Government license all receiving sets. This system is working in several European countries. But regardless of its success across the water, which

is wide open to doubt, it could only fail here. Fundamentally no government is capable of supervising a highly technical utility (as Professor Pupin has observed), and the idea is too autocratic to be palatable to Yankee tastes. For the same reasons, a third suggestion of complete government control, with taxation in proportion to the ability of the set to receive distance, must be abandoned.

Another ingenious idea provides for a gigantic drive, concentrated into a period of thirty days in which voluntary contributions would be solicited from rich and poor enthusiasts. The resulting sum, high up in million-dollar optimism, would form a trust fund which should support wireless broadcasting for the rest of its days. Aside from making up, in part, to posterity for the ills we are bequeathing it, little else recommends this idea.

In these plans, and many more, we find the main idea.

The essence of the whole contest is that ultimately the listeners must pay for their

"Admission Free"

A certain acute sense of what is "good business" in Americans makes them particularly curious about the future of broadcasting, because it seems to be coming to their studies and their living rooms night after night with no charge attached. Obviously, broadcasting has a definite invisible "means of support," but there is very general uncertainty among those who have given the subject thought whether this situation is ethically right. Zeh Bouck was one of the judges in the recent contest conducted by this magazine to find the best suggested solution for the "Who's to Pay" problem. In this article, the author reviews the main points of the other submitted plans which were considered and adds many conclusions of his own which throw not a little light on the subject. The last word has certainly not been said on this subject, but the only way to get nearer the real solution is to discuss all angles of the problem thoroughly.—THE EDITOR.

aërial pleasures, and that such a payment is not only fair and just, but will add tremendously to the pleasurable possibilities of radio.

THE WINNING PLAN

AS TO the manner in which this happy situation is to be achieved, the winning plan of Mr. Kellogg is probably the most enlightening. Certainly, did it not possess considerable merit it would not have won. Thus, if we strip from it a few superficial incompatibilities, we should have a creditable backbone—well integrated and sturdy vertibræ—capable of sustaining the weight of problems associated with its materialization. This, indeed, we shall find, and also that the idea has not dawned solely upon Mr. Kellogg, but upon other minds more intimately associated with radio.

The plan, in brief, (RADIO BROADCAST for March, page 863) advocates a federal stamp tax on crystals and tubes, with revenues distributed to the various broadcasting stations by the Government.

WHY NOT EXTEND THE TAX?

OUR first doubt, in order of mention, is the limitation of Mr. Kellogg's tax. If the tax is confined only to crystals and tubes it will boost the prices of these commodities, particularly of tubes, far above their present high levels. Mr. Kellogg recommends a two-dollar tax on vacuum tubes. Simple addition then determines the ultimate price of vacuum tubes at five dollars each. This would undoubtedly discourage the use of multi-tube receivers, with an automatic reduction in revenue to those concerned with revenue, and perhaps seriously hamper the progress of popular wireless. Moreover, this system does not place the burden of taxation where it belongs. In almost all of the suggested plans, too much emphasis has been given to the specious desirability of taxing in proportion to the amusement or benefits derived from the purchased material. Enjoyment is entirely relative and individual, and varies in no arbitrary ratio to the amount of money spent upon it. It is probable that

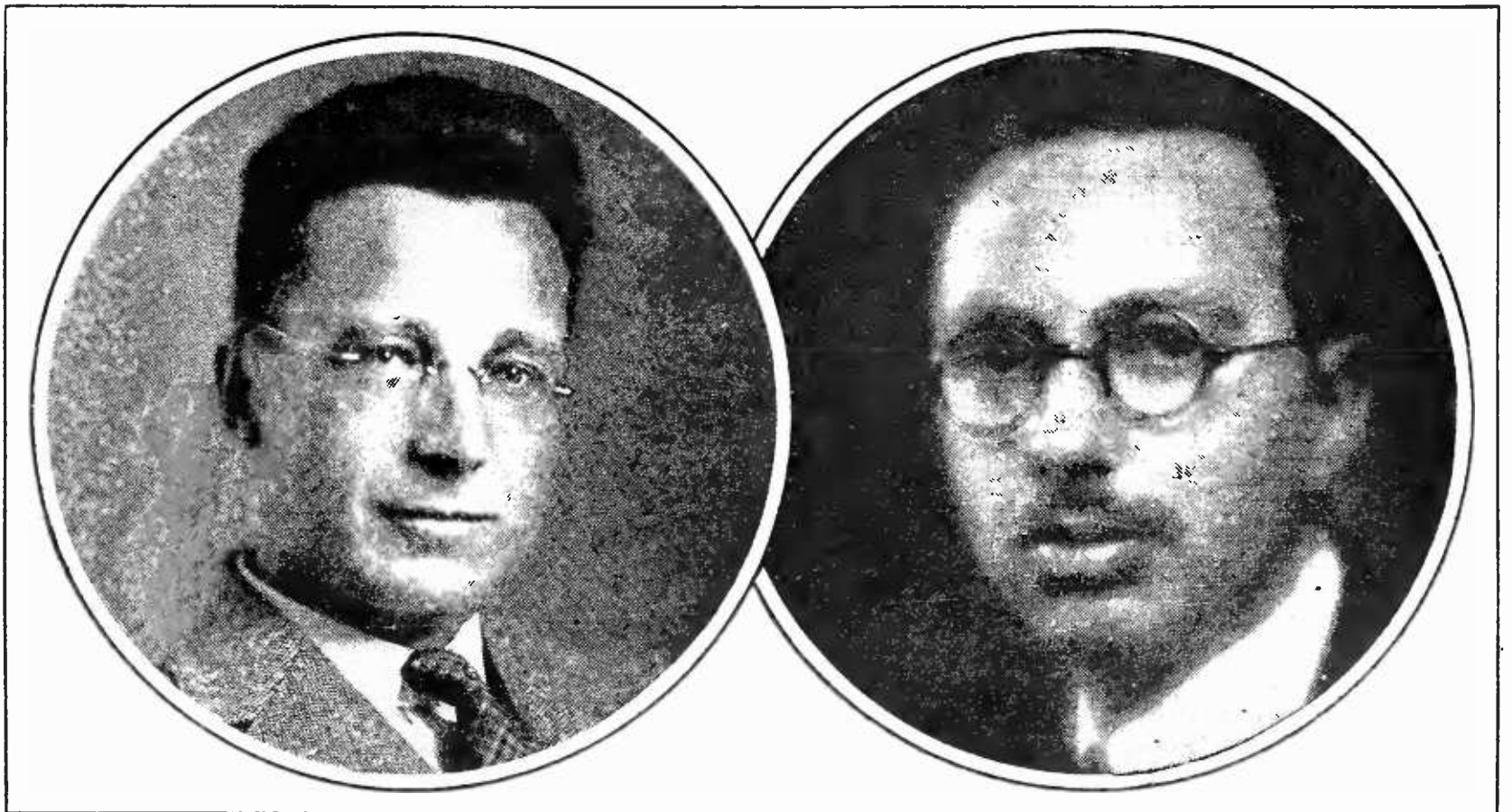

SIMILAR OPINIONS

Are held by Professor J. H. Morecroft, left, past president of the Institute of Radio Engineers and author of *The Principles of Radio Communication*, and John V. L. Hogan also a past president of the I. R. E. and a consulting radio engineer. Mr. Hogan wrote *The Outline of Radio*. Says Professor Morecroft about the prize-winning plan: "I do not see how a fund collected from the taxing measure can be equitably distributed. I dislike the idea of the Government getting into the game because of its well-known and frequently proved inefficiency and blighting effect in attempting to carry on a technical enterprise. Let us keep broadcasting as far as possible out of Government hands." And Mr. Hogan wrote: "I see no real objection to a voluntary tax on tubes and crystals, but I feel that the real difficulty would lie in distributing the funds so raised. I do not believe the Government would be willing to accept the responsibility for such distribution, and, even were it willing, I feel quite strongly that governmental supervision of the program treasury would not please either the radio listeners or the radio industry"

the impecunious fellow in the hall bedroom derives more amusement and utility from his three-tube set, than does the millionaire listening in occasionally on his thousand-dollar installation.

A tax limited to tubes and crystals would impose an equal rate upon the purchaser of a five-hundred-dollar console and the chap who has scraped together sixty dollars for a simply made five-tube receiver.

To levy an ad valorem duty on all parts and complete sets is obviously a more equitable system of taxation. This would slash the necessary tax to a fraction of the sixty-six and two thirds per cent. addition recommended by Mr. Kellogg on tubes, and would impose itself *in a proportion closely commensurate with the buyer's ability to afford it.* It has been estimated that radio of the tomorrow, no farther ahead, perhaps than 1926, can be adequately supported by a one per cent. tax on all equipment. The millionaire will then pay \$505.00 for his sumptuous receiver, while the less pretentious five-tube set will retail for \$60.00.

A sliding scale might be desirable, the rate of tax increasing with the value of the apparatus somewhat after the manner of our present income tax arrangements. Thus the suggested rate might apply to all goods under fifty dollars, two per cent. between fifty and one hundred dollars, three per cent. between one hundred and two hundred dollars, and so on.

Our first change then, in Mr. Kellogg's plan, would be to extend a reduced tax to all goods intimately associated with radio, the stamps to be applied to the manufactured article at the final factory. The imposition of such a duty is quite as simple a matter as the limited stamp act proposed in the winning plan.

GOVERNMENTAL CONTROL

A GAIN we must make objection to the governmental finger in the pie. Mr. Kellogg, in his plan, argues that this is most desirable in the following manner:

What Authorities Think . . .

HERBERT HOOVER, Secretary of Commerce: "I do not believe that your prize-winning plan is feasible under conditions as they exist in this country, however well it may work elsewhere."

MICHAEL PUPIN, Engineer, Educator, and Inventor: "Railroads, telegraphy, telephony, radio broadcasting . . . are certainly public utilities. . . . All of these public utilities are full of complex technical problems which cannot and never were intended to be handled by any government."

PAUL B. KLUGH, Executive Chairman, National Association of Broadcasters: "A Government tax would be obnoxious. For obvious reasons, voluntary contributions offer only an unfair solution. The rain would fall equally on the just and unjust. This leaves the possibility of a non-federal stamp tax, which seems to hold most promise of satisfaction for all parties concerned."

"The tremendous value to the Government of continuously having broadcasting stations under its control to crystallize and direct public opinion cannot be over-emphasized." This possibility about which Mr. Kellogg is so enthusiastic is the very thing that should be avoided as far as possible, and it is a consideration of even greater importance than federal incompetency in handling technical matters. It is the writer's opinion that the educational possibilities of radio broadcasting are the most potent of all known systems of teaching. This is because it insinuates itself to you in your home, in your receptive leisure moments. It teaches, insidiously, unfelt and pleasantly, which is how things truly learned are always learned. To place wireless under a more strict governmental supervision would be to hamper a great educator. The idea is comparable, but more iniquitous, with placing every school in the United States under direct Federal supervision.

The Government must never be permitted to direct and mold public opinion. On the contrary, *public opinion should mold and direct the government.* This is not socialism, anarchy, or Bolshevism. It is merely progress, and well-developed democracy if you will. The Government is already capable of protecting itself to a legitimate extent through its licensing of stations and the powerful cancellation prerogative. Anything more than this would tend to atrophy original thought in almost every branch of art and science, perhaps culminating in an odious censorship comparable to that we are told now exists in Russia.

THE ALTERNATIVE

IF WE eliminate governmental control what may we substitute for it? The only logical thing that comes to mind is an organization composed of broadcasters and manufacturers who will impose and collect a stamp tax (the simplest form of excise), and distribute the funds in an equitable manner. The only

argument in favor of a government-controlled air is the desirable central authority of a federal act. The facilities such an act would confer for enforcing whatever tax measure the legislature should deem wise and fit, would greatly simplify the whole matter. But it should not be difficult for a highly representative organization to develop executive powers, quite comparable (if not actually greater), than to those of national authority. The organization must necessarily be a representative one, and the manufacturers affiliated with it—the soundest and most reputable in the country—would need only decline to deal with such retailers who handle bootleg or unstamped apparatus to bring them around. To obviate partiality and the possibility of corruption, the committee in charge of collection and appropriation would be composed largely of commercially disinterested individuals such as J. P. Morgan, Robert W. De Forest, George Gordon Battle, or many others who might be willing and qualified to serve.

Perhaps Mr. Kellogg, who characterized such an arrangement as “inconceivable,” will be inclined to alter his opinion upon the above analysis. Its practicability is such that it suggested itself to the National Association of Broadcasters, an organization closely comparable to that we have outlined, and of which Paul B. Klugh is Executive Chairman. The Committee On Paid Programs, authorized by this organization, evolved a system almost identically similar to that suggested above. The feasibility of this proposal is emphasized by the general satisfaction it would give.

The public would receive better service, the best possible programs with the additional

satisfaction of a direct deal between the listener and the artist.

The artist would be satisfied for obvious reasons.

The broadcaster certainly would not complain, for his expenses would not only be reduced, but in many cases his station turned into a profitable proposition.

THE DISTRIBUTION PROBLEM

RADIO, were this suggestion adopted, would become still more popular, with an appreciable and welcome benefit to the manufacturers, jobbers, retailers, and all concerned.

The equitable distribution of the collected funds is the real and acknowledged rub. The sands which must necessarily support the foundation of any radio economic system are to-day shifting, if not actually sliding. The permanence and desirability of radio advertising have not been established. Radio advertising rates have not as yet adjusted themselves, as they must, to a sum commensurate with the value of the publicity, nor has the

amount of advertising permissible in a single program been determined upon. The hundreds of stations, small and large, whose economic status, is doubtful, plus many other factors, lend their weight to the general lack of equilibrium of the radio industry.

Radio is in a chaotic halfway stage. It is *not* in its infancy, but it is only in the early process of development. Super-power, the interlinking of stations and other experiments are just emerging from mental and engineering laboratories, and all these inchoate developments, these budding possibilities, must vitally affect the mechanics of paying for broadcasting.



FRANK REICHMANN

Of Chicago. He is a well-known radio manufacturer and engineer and was one of the judges in the contest recently conducted by this magazine

ARE WE READY?

PAUL B. KLUGH, in reference to the activity of his own organization, has described the movement as premature. I believe he is right. For the present, I think it is better to let things ride along as they are. To work these excellent plans into a more mandatory proposition, to make a law of this plan and endeavor to apply it, would be forcing the issue. Such a procedure is rarely wise or successful. To be successful and permanent—a proposition must *force itself* upon the situation as a necessity, whether or not far-sighted individuals appreciated the desirability many years before.

Herbert Hoover has said, "If we are once agreed that broadcasting really has a mission [who doubts it?] it follows that it must and will work out its own financial basis." Exactly so. And in concluding we desire to point out that, in all probability, the resulting scheme of things will be closely similar to the plans proposed to-day.

The taste of the fan is rapidly being educated. His innate desire for what is good is being gratified, and he has learned to expect the best in programs which have been stead-

ily improving. Retrogradation is inconceivable. All large broadcasters indubitably will continue to improve their programs. The increased expenses concurrent with this consistent improvement can only be met by the broadcasting manufacturers, through an increase in the selling price of their products: complete sets, tubes, loud speakers, storage batteries, etc., or by a refusal to lower prices when it could be otherwise possible for them to do so. Other radio manufacturers who do not support broadcasting stations—a grand and glorious host of comparatively small corporations—will therefore be able to undersell the larger companies. It will be then (or perhaps before the situation becomes acute) that these great organizations will be forced to protect their own interests, either by confederating among themselves, or, as would be more palatable to the public, lending their coöperative support to some recognized non-commercial radio body. In this, the reader will recognize the principal recommendation discussed in these pages. A stamp tax imposed by such a federation seems the least complex method of adjusting a very difficult and involved situation so that it may be within the boundaries of fair competition.

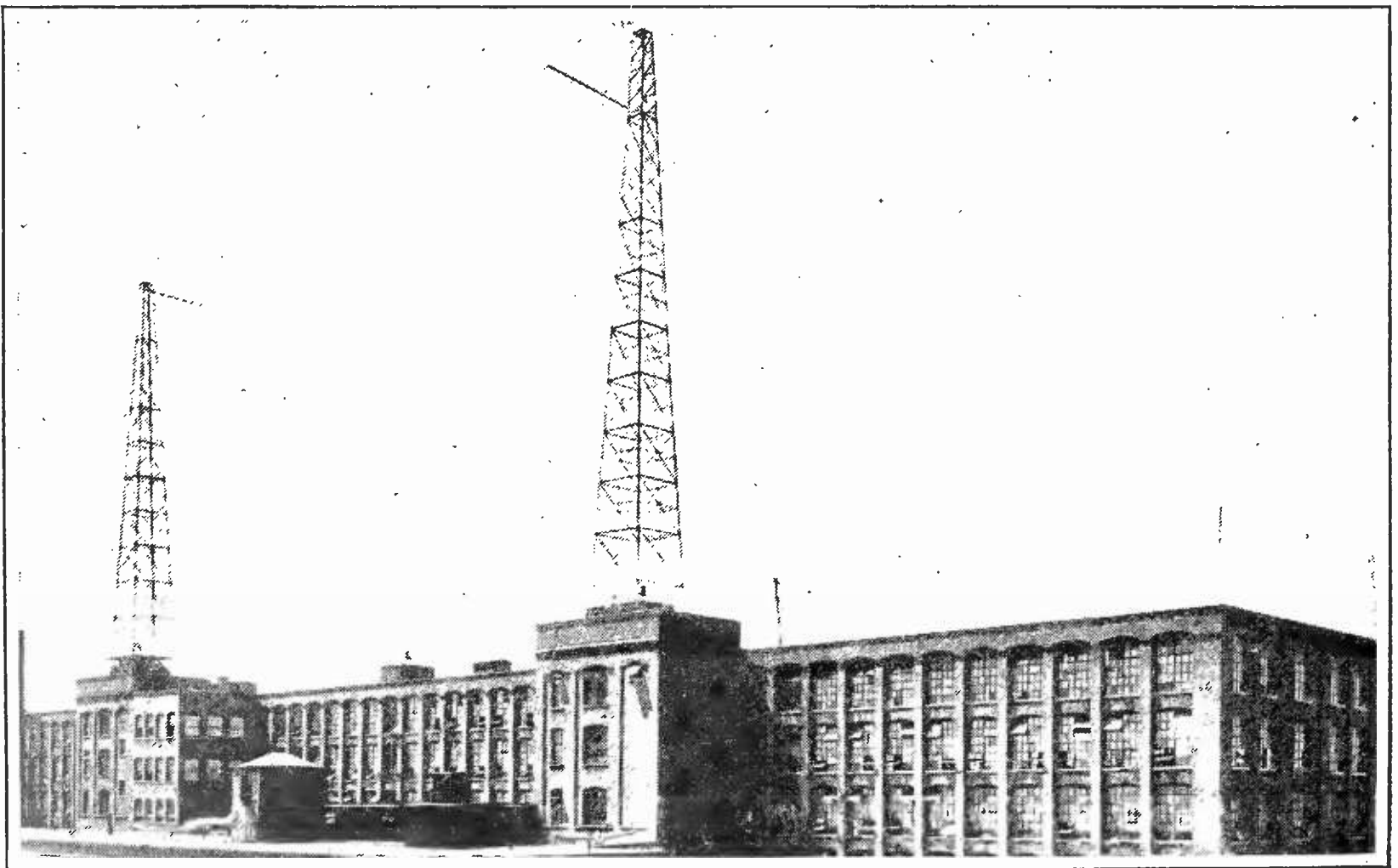

THE TOWERS OF WBZ

At Springfield, Massachusetts. This is one of the stations heard abroad during the recent Radio Broadcast International Tests

How to Write a Radio Play

by MILDRED WEINBERGER



A "RADIO PLAY"—what is it? Simply a play, comedy, tragedy, or what not, written directly for broadcasting. Its definition thus depends wholly on

its purpose. A play which is primarily a radio play may, of course, be perfectly adaptable for presentation on the boards, the so-called "legitimate" theatre, inasmuch as the differences between these two are not such as to make them mutually exclusive. It is the special play written for the microphone and received on radio sets in a multitude of homes, that we are going to discuss.

The question naturally arises, why should there be a special radio play? Legitimate plays have been broadcast before now, some of them with marked success. It is true that the

number of plays open to choice for broadcasting is necessarily limited, and the whole number of plays large. Only certain types of play are effective when so given, and only certain

plays are sufficiently free of copyright and other strictures, to be available. The whole question of broadcasting plays, which is agitating some of our theatre managers at present, might be answered by keeping the two fields largely separate. Thus a play which is running on Broadway may not, be broadcast, if the manager considers that his seat sale would be jeopardized. The program department of a radio station would not even be tempted to request to broadcast the play if there were plenty of other material to choose from. But the radio audience *does* like plays.

Statistics Show

That one person out of every six has written a play at some time in his life. The statistics don't have much to say about the number of these plays actually produced, however. And since radio drama has lately been included on an increasing number of programs from an increasing number of stations, it is perfectly obvious that the plays must come from somewhere. There is no question about the fact that a lot of budding radio-play talent is hiding its light under various rural and municipal bushels. It is possible that a number of Ambitious Ones have even submitted radio plays to program directors before now—certainly they did in a contest held last year by a large eastern station. Mildred Weinberger has set down here a lot of information about radio plays and how they should be written which should be of great help to the budding playwright and of interest to those of the radio audience who listen to radio plays. Radio program managers might be interested in developing good radio plays for their programs and a contest or two would probably draw forth some very good work.—THE EDITOR.

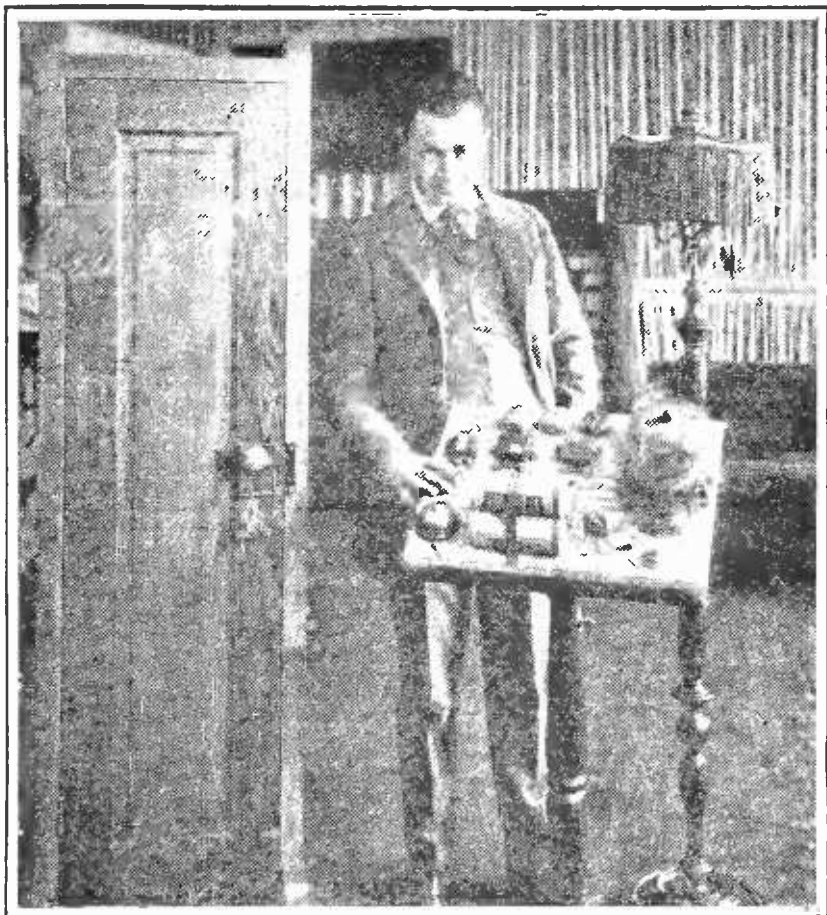

A FEW PROPERTIES FOR THE RADIO DRAMA

A portable door which can be opened and shut to indicate entrances and exits of characters. The bells on the stand give any effect from that of an ambulance to the thin chime of a clock. Edward H. Smith, director of the WGY players at Schenectady is shown in the photograph

To write a play for broadcasting one must remember that your play "gets over" through the ear alone. There will be no costumes, settings, make-up, or properties to assist in putting it across. Simple settings, costumes, and properties can be described by the radio announcer. Many interruptions of the action of the play, for interpolated directions, weaken its effect. Therefore, we have a list of things to do, and another of things *not* to do in writing a play for radio broadcasting.

WHAT TO DO

WHAT are the *positive* requirements to make our radio play effective? First, keep the cast simple. Have only a *few* characters, so that your audience will not forget them and be confused as to which one is speaking. Then, when you name your people, use names which are clear in sound. Remember how some names are easy to get over the telephone, and others have to be repeated five or six times before you understand who is speaking. If you are blessed with one of those difficult names, and call up a department store, or telephone a telegram, you will know all about that! Your patience is gone before the matter is even comprehended at the other end. So call your people by names which come

clearly to the ear. Then, too, each name must be distinct from every other one. "Sue," and "Prue," would not be a good choice for two women characters in the same play. When you can *see* who is speaking there is no doubt in the matter, but our radio audience can distinguish only by its ears. A crowd is never useful in a broadcast play, unless you wish merely an effect of confusion. If the idea is to represent a background of conversation, it can be done very well, with perhaps two voices, those of important characters, coming out of it. One must be careful not to risk confusion in the lines of important characters. If three or more people try to talk at once even at very close intervals, so as to give an effect of eagerness, excitement, or what not, the author of a radio play runs a strong chance of merely blurring the speeches. In a radio play, the speech and the speaker should at all times be easily recognized by the sounds going out.

It might be helpful, also, to use the name of the character addressed, more often than necessary in a stage play. For example. Joe and Harry meet

JOE. Well, Harry, how's the boy?

HARRY. First rate, Joe. How's the world treating you?

JOE. Oh, so so. I've had a pretty raw deal from Mamie. Did you hear?

HARRY. Why no, Joe. That's too bad—

The hearer is never in doubt about which radio character is speaking. Of course, the actors in a radio play will be selected principally for their voices, so that the voice of each



THE KISS—BY RADIO

The personal touch, it is obvious, is quite lacking. The scene was snapped in the studio of KGO, at Oakland, California

character is recognized as distinct from every other one. But it never hurts to make assurance doubly sure. Without the use of the eye some of us are surprisingly helpless. Have you ever noticed how comparatively few people can recognize which of their friends is talking over the telephone?

GOOD WORDS FOR RADIO

THEN there is the question of the actual words of your speeches. Use simple and direct English. Make the speeches short enough to be comprehended at one hearing.

Do not use dialect which is often difficult to follow, even where the speaker is visible, and over the telephone it is very confusing. That means eliminate the humorous Irish brogue, the colored mammy, the Scotch, and various other tempting type parts. Also, it is better judgment and better taste not to use slang, or the curtailed and often grossly incorrect English of the "pedestrian." Good English can be learned through the theatre, as many Settlement dramatic organizations will affirm. The radio program is especially effective in this field because it comes so directly into the home, and because it has so many young lis-

teners, many of whom like to be in style with the latest colloquialisms, at the expense of a real knowledge of their own language.

When it comes to the story of the play, give enough in the actual words of your speeches so that the physical activity of the characters is clear. If one man were trying to get something from another, for instance, he might say, "Give that to me, or I will tear it from you." The answer is, "Over my dead body!" A third voice cries—a woman's—"Don't fight! Oh, you are hurting him!" The first man exclaims, "I have it." Now we know what has taken place, without seeing a thing. There can, of course, be simple sounds, put in by the "property man," such as the shutting of a door, a pistol shot, a bell ringing, the thump of a falling body. The simplest and clearest of these actions can be explained by words in a radio play without being redundant. In general, words must take the place of what would be pantomime in a stage play. This leads to an interesting development—the use of the soliloquy, which has been out of date in the legitimate drama for several decades.

The soliloquy must represent in the radio play what an actor is feeling, where he

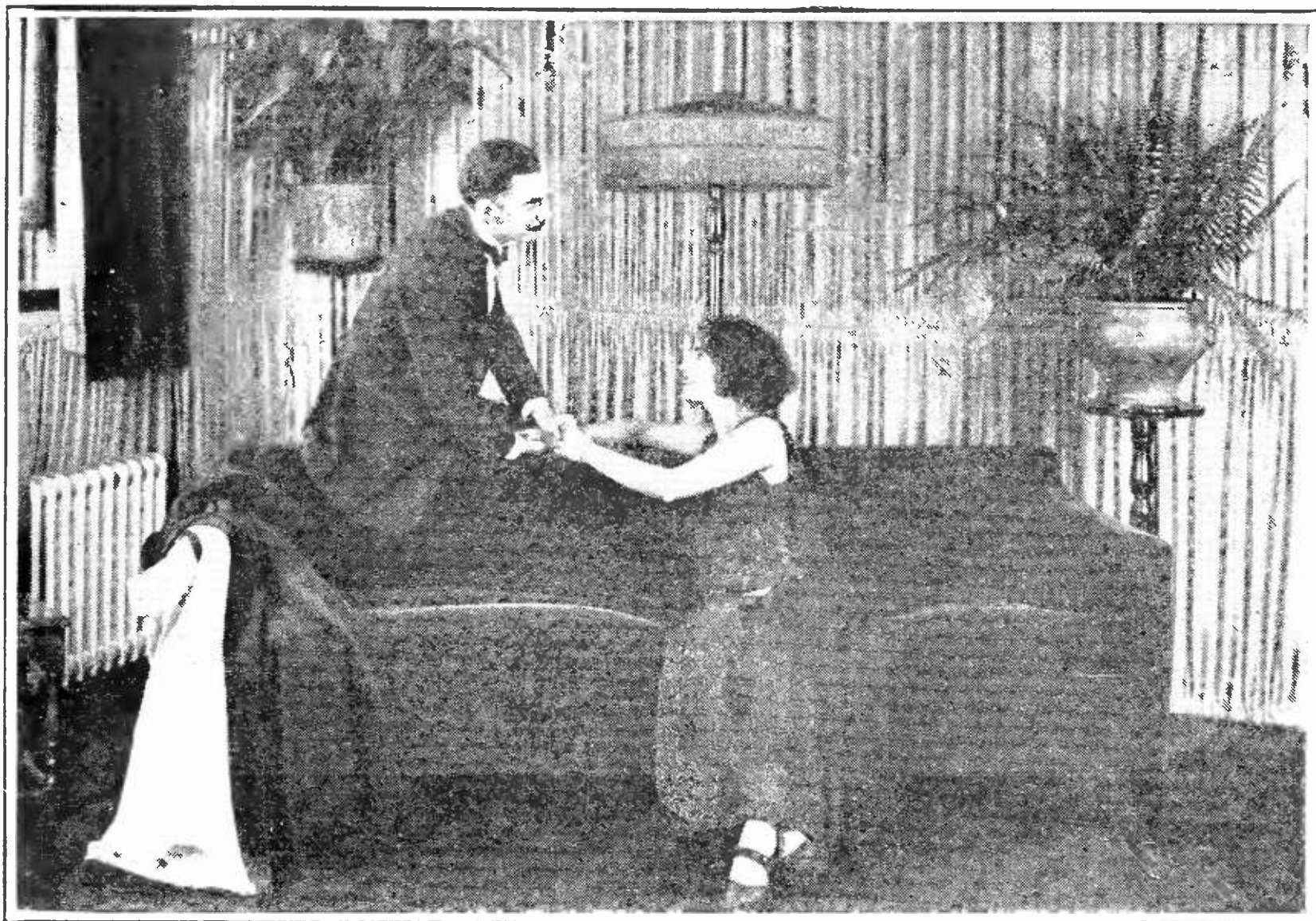

CONTRAST

This photograph shows how a love scene would be enacted on the stage and the cut which forms the heading of this article shows how a love scene was broadcast recently from WGY. There, the two outside players are involved and the actors in the center are awaiting their cues

could show this to his audience by the working of his face, his hands, his general movements, if our eyes could see him. Still we are out of patience with the long soliloquy, which is merely a stilted recitation. When a man talks to himself, it should therefore be natural, natural in the play and in the character. People who are much alone often do talk to themselves. Under the stress of emotion any one may exclaim aloud, and so the cases multiply. But the soliloquy in the radio play must serve a double purpose. It must continue the action, audibly, while any character is "on the stage" alone. We must hear what he is doing.

It would seem besides all this, as though the radio play especially ought to be kept at a constant pitch of emotion—that is, the characters should be highly involved, emotionally, as much of the time as possible. There is something very effective in the quiet spaces of a stage play, filled with color, light, dramatic pauses, when our eyes are taken with the picture and our interest held. But not so in the broadcast play. We cannot see. This fact cannot be too much emphasized, because it is at the root of the whole difference between the radio play and any other sort. Our interest has but one medium to sustain it here. If we are bored, we retune the radio set and pick

up some other station. The radio playwright can only hold his audience by sustaining constantly the movement, the emotion, of the story in the play. And all of this has to go into the speeches—the words of the actors.

RADIO PLAYS SHOULD BE SHORT

IT IS advisable to make the radio play short and so avoid tiring the audience. This opens delightful fields for the playwright. Try to interest a Broadway manager in a play which runs less than two hours! Try to make him consider even a two-act play! Yet here in the broadcasting of plays, we are free. Why not write that two-act play which has been bothering you this long while, and try it on the radio? There are many delightful situations which naturally fall into just this division of time or place, but, unfortunately, we know they will have no Broadway market in the two-act form. So we try to fatten them, and spread them, and pull them out of proportion, much to our own grief, and theirs. Another delightful prospect is that of freedom in the choice of setting. The most fantastic, the most extravagant set that the imagination can devise, is nothing to the disadvantage of your play. All you have to do is describe it—in words—and the announcer in the radio station will read them and create the scene. There

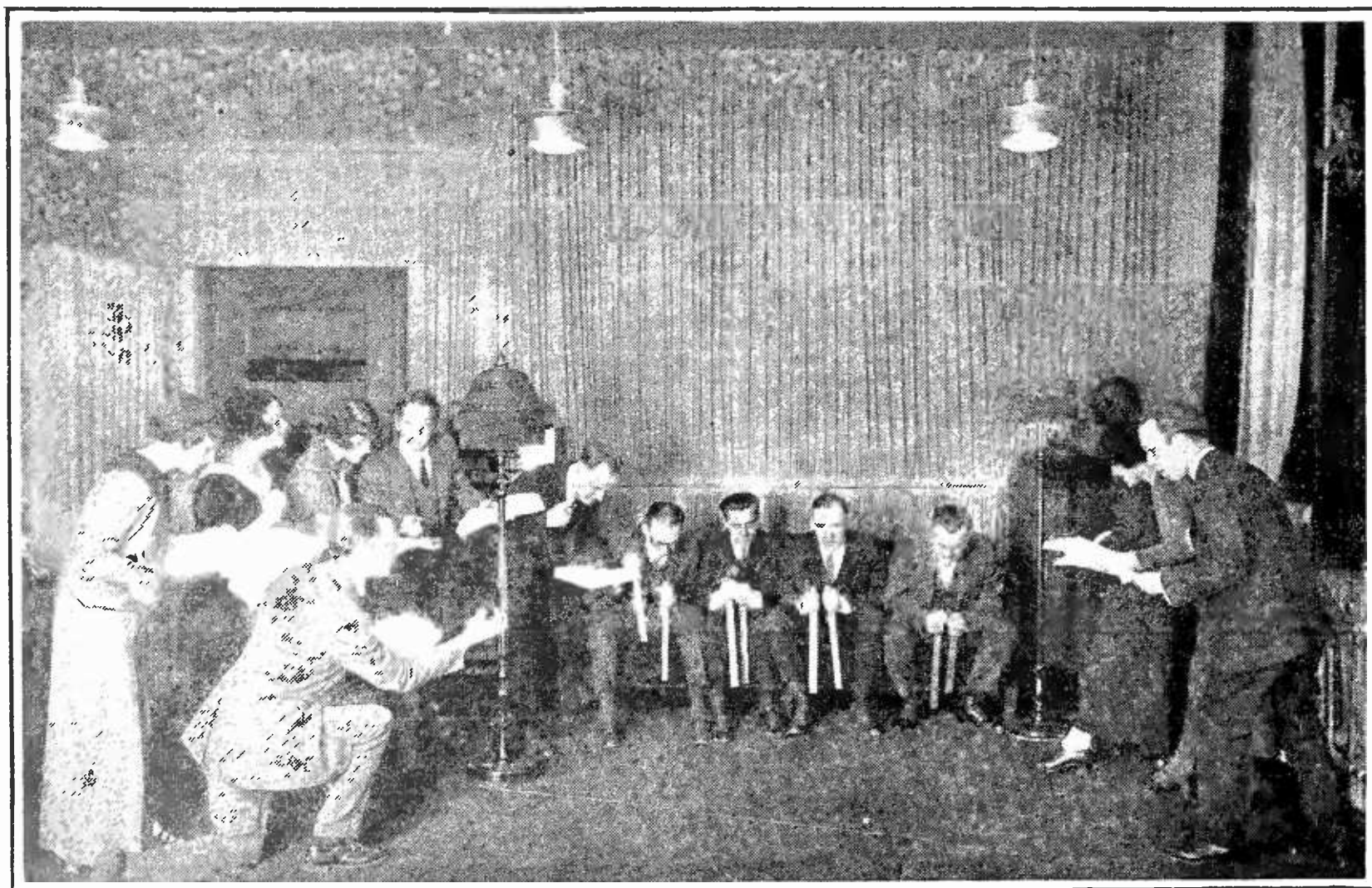

"THE COUNTRY FAIR"

In the process of broadcasting in the studio of WGY. The four on the divan are really horses, ready to race. In recent months, radio plays have become increasingly popular in almost every section of the country



“PIERRE OF THE PLAINS”

A melodrama, recently produced at WGY. One of the prime essentials of this new art is that the number of characters be few, and their speeches informative and direct. The radio drama has no limitations as to place, for it is just as easy to hold one act in Central America and the next in Iceland as it is to have both before a log fire in a London Club

should then be a field, here, for many a good play which offers obstacles to a Broadway production.

THE STAGE VS. THE BROADCASTING STUDIO

THE apparent rivalry between the stage play and radio broadcasting seems, on these grounds, not so formidable. As a matter of fact, many a play which is scoring a great success in the theatre would not be good, at all, sent out from a radio station. Take “What Price Glory,” a most stirring experience on the regular stage. What would the second act be, if we could only *hear* it? Take away the dugout, the dim light, the make-up of the men and you have a series of disjointed recitations, with all that grim significance gone. And the last act wouldn’t be there at all. But how tremendously it *is* there, at the Plymouth Theatre! Conversely, however, the fact that a play is effective on a radio program does not prohibit its stage success. Perhaps it has never had a hearing, and what better hearing could it possibly have than this, to be broadcast far and wide?

It should be very possible to rewrite many plays, originally intended for stage production so that they will suit the peculiar demands of broadcasting very well. It has been suggested that a moving picture scenario offers greater possibilities, but this does not seem likely. The moving picture appeals to the eye almost as exclusively as the radio play reaches the ear. It is written in terms of pantomime, which is the very thing impossible to represent over a studio microphone. Its story is based on physical action, and the possibility of effective visual drama. The radio play must make its pictures audible. Everything needful to the furtherance of the story must be told in the lines. Thus only slight changes or additions to an existing stage play might make it a good radio vehicle, while rewriting the story of a movie would mean writing a whole new play.

Why, in any case, borrow from preëxisting fields, when new horizons open? Why not create a body of dramatic literature primarily intended for this specific purpose, the radio play?

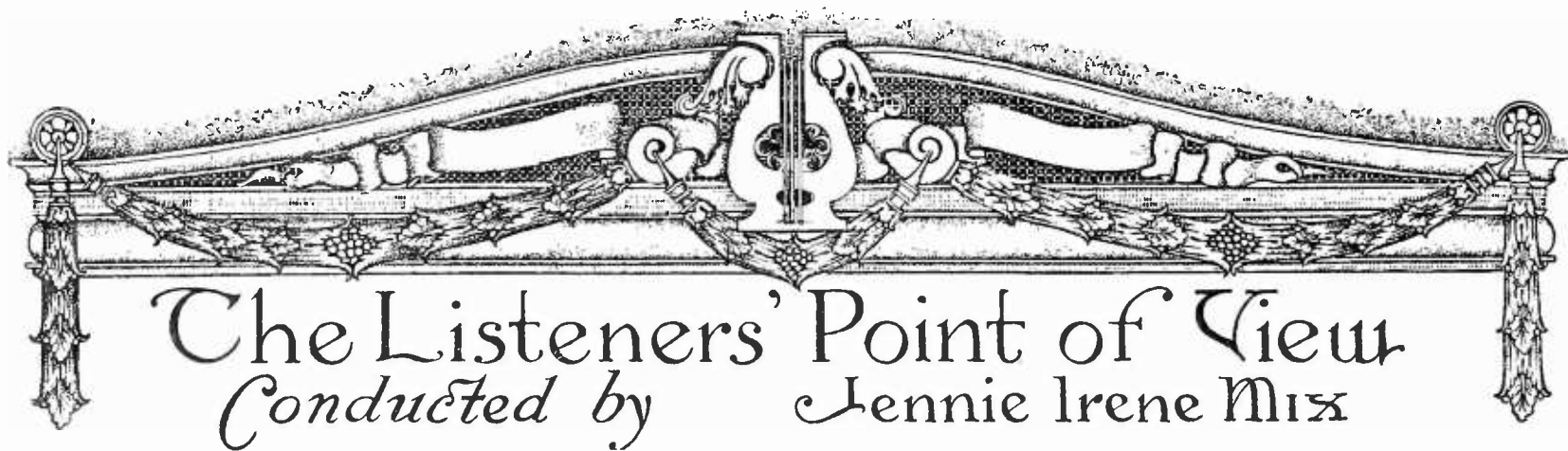

The Listeners' Point of View

Conducted by Jennie Irene Mix

Opinions About the Jazz Age in Radio

OF LATE some of the saxophone specialists and some of the leaders of jazz orchestras heard over the radio have risen up in wrath, and in letters couched in unmistakable terms, have accused the conductor of this department of trying to put all the jazz players in the country out of their jobs, and especially to condemn every saxophone player to eternal obscurity.

It has been interesting to receive these letters. Adverse criticism as well as laudatory criticism can be a tonic. But to be a tonic it must strike with truth at the core of the subject criticised. In this, every letter so far received protesting against this department's attitude toward the broadcasting of jazz, has failed to make its point. For every letter has brought the accusation that we have unremittedly condemned, wholesale, all jazz and all jazz players.

Now, first let it be said that the conductor of this department does not especially enjoy jazz. If it is so-called "artistic jazz" about all you get out of it is to listen to distortions of the masterpieces of music, the great operatic arias, the immortal songs. If it is the sort of jazz that plays the latest popular hits it is pretty nearly unspeakable, in our opinion.

Although not an admirer of any sort of jazz, it would be far from consistent or fair for us to make a sweeping condemnation of this form of music. By certain jazz specialists it has been raised to what is, of its kind, an art. If it is the sort of art you enjoy, it is your full right to hear as much of it as you desire. If you don't enjoy it, yours is the privilege to say so.

Here is a list of the jazz orchestras that have received "Honorable Mention" in this

department since it opened in April, 1924. In every instance a photograph of the organization mentioned was published.

Vincent Lopez and his Hotel Pennsylvania Orchestra.

Harvey Marburger and his Keith Vaudeville Entertainers, Café L'Aiglon, Philadelphia.

The Campus Serenaders of the Rensselaer Polytechnic School, Troy, New York.

Perry & Russell, "Two-Man Singing Orchestra."

Paul Specht's Hotel Alamac Orchestra, New York.

Also was published a photograph of William Menzer and his "Musical Saw." We confess that the Musical Saw has a weird and haunting fascination for us. And as for the steel guitars, they stand high, in our regard, as radio entertainers. Have you noticed what good music you hear when they are programmed? They produce music played, generally, with fine taste. Indeed, there are precious few violinists heard over the radio who can come within sight of these guitar players in musical taste or technical achievement.

It is not against legitimate jazz or any of the musical features that cannot be ranked as "classical" and yet are good, that this department is fighting. What we are out to kill completely and forever is the sort of broadcasting described in masterly fashion by Dr. R. S. Miner of Erie, Pennsylvania, who, writes, in a letter recently received from him, after uttering a hearty Amen to all that has been said in this department against radio programs:

Night after night, when I get home after a hard, long day, I don't feel like tuning-in and tuning-out half a dozen stations, each of which inquires in squally, squeaky, uncanny, "saxofool" wails, "What's Become of Sally?" Who, of all the millions of musi-

cians and musically inclined listeners-in in the world ever cares a hang where that fool Sally is or anything else about her except to regret that hers was not a still-birth! Or who's going to "Follow the Swallow" to find "Where's My Sweetie Hiding?" And "Red Hot Mama" is such a beautifully endearing term to screech into the ear of one whose tenderest memories are those of "Mother"!

I have tuned-in the same station several times each evening, only to hear that someone has just wired or phoned a request for another repetition of one of these soulless assemblages of noise which had already been "played" several times the same evening.

The radio audience certainly is *not* composed wholly of morons. There are, perhaps, as large a number of those who appreciate music as there are persons whose musical appreciation wallows in the depths of the muck and mire, and it is an outrage that stations which are trying to broadcast music must realize that their efforts come to naught because some near high-powered station persists in profaning the very air with their senseless confusion. . . . I am expressing the feelings of a host of radio enthusiasts among my friends when I say what I have said.

Dr. Miner does not by a word exaggerate the condition that prevails, a few stations excepted, all over the country from about 10 P. M. to 2 A. M.

Where does the fault lie? Well, all will agree that the programs from a broadcasting

station cannot rise higher than the intelligence of the program director.

The remedy? It can be found only in the owners of broadcasting stations. When they see to it that their stations are run intelligently we shall have programs that can command our respect, but not until then.

It is the public that must make the owners of broadcasting stations see that they are playing a losing game. And this can be done only by putting up a loud and never-ending protest against present conditions. Judging from the letters that come to this department this protest will soon gain such momentum and volume as to cause a sudden and devastating explosion somewhere.

Interesting Sidelights on the Flonzaley Quartet

WHEN the Flonzaley Quartet broadcast from station WEAJ in the third of the Victor Talking Machine radio programs, no doubt many said:

"Isn't it simply fine that this great string quartet can be heard by thousands of people in the small cities and towns? I don't suppose they can appreciate them on a first hearing, but then, they can buy records of the numbers they hear to-night."



THE STUDIO OF KOA, AT DENVER

A group of artists broadcasting from the main studio of the new station of the General Electric Company, KOA, at Denver. A pity the performers couldn't be seen as well as heard!



THE FLONZALEY QUARTET

From left to right, Adolfo Betti, first violin; Alfred Pochon, second violin; Iwan d'Archambeau, violoncello; Félicien d'Archambeau, viola

Now, the truth is, that the Flonzaley Quartet, the most idealistic and artistic players of chamber music in the world, are known and loved all over this country. Season after season they have toured far and wide, returning each year to towns of no more than a few thousand inhabitants, who feel that unless they hear these players each year a big gap remains in their music season. Nor are they satisfied with anything but the best programs the Flonzaleys have to give. Said one of the members of the quartet to the present writer not so very long ago:

"We look forward to our engagements in these smaller towns as among the keenest pleasures of a season. The people are delightful and charming to meet and they possess unusually good musical taste."

It took a good many years for the Flonzaleys to build up a clientele all over the country because they never make a single concession to popular demands. Now they are booked solid from fall to spring every year. Not a member of the quartet ever accepts any engagement for an appearance as soloist or in

any other capacity. They play only as an ensemble. This is that they may retain the perfect unity in their playing that would be impossible if they indulged in individual work.

Having appeared in more than four hundred American cities and towns, the Flonzaleys on that evening of their first broadcasting experience were heard by tens upon tens of thousands far distant from New York, not as strangers, but as friends.

Did Ethel Leginska Seek Publicity?

WHEN Ethel Leginska's concert with the New York Symphony orchestra was broadcast from WEAJ it aroused special interest because it was the first time a woman had conducted an entire orchestral concert in this country. Miss Leginska is known both as pianist and composer, with a *flair* for the extremely modern in the latter medium. Then she displayed this ambition to prove that she could also be a conductor, a perfectly legitimate ambition indulged in by various famous men pianists.

Her disappearance, recently, while the audience waited for her to give a piano recital at Carnegie Hall failed of the dramatic effect which we assume was intended. Genuine artists are not temperamental. They are about the sanest people in the world. Were it otherwise they would not have the poise to appear before the public repeatedly and give masterly interpretations of the musical masterpieces.

Novaes an Excellent Feature of One Brunswick Program

THAT was a happy thought on the part of the Brunswick Phonograph Company to have Mme. Guiomar Novaes play a Brazilian program for her initial radio appearance made through wjz and wgy and other stations. Novaes is not only the greatest woman pianist, next to Carreno, who has come to us from South America, but she is one of the foremost women pianists from any country now before the public. Radio assuredly has its moments of uplift when such an artist can be heard by a vast audience. Novaes has toured this country many times since she first came here as a shy young girl still in her 'teens.



ETHEL LEGINSKA

Who recently mysteriously disappeared and was later found. She is the only woman ever to conduct a Symphony Concert. It was heard through WEAJ



BROADCASTING STUDIO OF THE "BROOKLYN DAILY EAGLE"

Which is operated in connection with station WAJG, at Richmond Hill, New York City. H. V. Kaltenborn, associate editor of the *Eagle*, is here seen before the microphone about to broadcast one of his noted "Current Topics Talks," formerly one of the biggest features at WEAJ, and now a regular feature of the *Eagle* programs. Also in the picture are George Currie, chief announcer at the studio (at the left), and at the right, Elmer M. Applegit, radio editor of the *Eagle*

Newspaper Radio Programs Are Incomplete

COMPLAINTS are constantly coming to this department regarding the failure of the radio programs published in the newspapers to make clear what kind of performances can be heard from certain stations at certain hours. These complaints are frequently accompanied by outlines of suggestions whereby this condition that so hampers the listener-in may be remedied. But

none of them has been especially practical. It will take a long time to solve this difficulty.

At present, the newspapers in printing these programs are throwing away space that, in its prodigality, astonishes one. What does an entire page in the Sunday New York *Times* cost if bought for advertising purposes? Something prodigious, you may rest assured. Yet, there you see it, each week, filled up with radio programs most of which, so far as giving the reader any real enlightenment of what he may hear during the week, might just as well never have been printed.

We will lift two of these programs bodily, and let you see for yourself. Here is one headed WCAE, Pittsburgh. The questions in parentheses are, of course, our own.

- 6.30 P. M. William Penn Orchestra
- 7.30 P. M. Bedtime Story
- 7.45 P. M. Address (What about? Turnip growing or tax regulation? Or art?)
- 8.30 P. M. Concert (What kind?)
- 9.00 P. M. Gypsy String Ensemble (That explains itself.)
- 10.00 P. M. Concert (What kind?)
- 11.00 P. M. Orchestra: songs. (Is this a jazz concert or a concert of legitimate music?)

Follows a WGY program; we refrain from comment:

- 2.00 P. M. Music; talk, Mrs. E. P. Pressy
- 6.00 P. M. News. Market reports
- 6.30 P. M. Dinner music
- 7.45 P. M. "Income Tax," J. F. Zoller; A. O. Coggeshall, tenor.
- 8.00 P. M. John Leather, baritone; talk.
- 10.00 P. M. Same as WJZ,

Do not let it be understood that we are laying the blame for this weekly printing of useless bunk on the heads of the radio editors.

That is, not wholly. With the full advance programs they receive they could do much better with the leading stations than is now the case. The larger stations send out full programs, giving every number in detail, weeks in advance. But with the majority of the stations the situation is, we grant, almost hopeless.

This is a big subject. One of these days we are going to have a good deal to say about it. But the time is not yet ripe.



MME. GUIOMAR NOVAES
Brazilian pianist, recently heard
from WJZ, WGY, WRC, and KDKA

recitals recently given from that station by Francis Macmillen, concert violinist, brought in more mail and from a more discriminating and interested group of listeners, than any one event in the history of the station. Mr. Macmillen presented the same kind of programs he gives at his regular recitals on tour, with no concession whatever to "popular" taste. Yet there are hundreds of program directors who are still unconvinced that the radio public cares for anything but rattle-clap music.

Are All Telegrams to Radio Stations Laudatory?

BROADCASTING directors are not prone to read to their listeners-in during a program the derogatory comments that come to them by wire or telephone. Here is such a comment that a man writes us

FROM station KSD, St. Louis, comes the good news that the

he sent to a well-known station that was tearing the air to tatters with jazz.

"Discharge your orchestra and install a small air compressor attached to several tin fish horns. It would be more economical, louder, and the musical effect would be the same."

Cross Word Puzzles vs. "Music Memory" Contests

IT HAS been said that the cross word puzzle has drawn thousands of owners of radio sets from the loud speaker to the dictionary. But we would put up quite a good-sized bet that, during the evenings of the "Brunswick Music Memory Contests" the cross word puzzle gave way in interest to the musical puzzle involved in this contest. Artists that the listeners were assured were well known, and many of world fame, sang or played with no introductory remarks to give any indication who they were or what compositions were being performed. But the names of some of the artists to be heard were published in advance, but no indication given as to when they would appear. The Brunswick company arranged a schedule of awards totalling five thousand dollars for those guessing correctly the largest number of names both of artists and compositions. That would mean some guessing, and done without a dictionary, too! At this writing the winners had not been announced.

Where Announcers Are Perfect

STATION wcco vouches for the absolute truth of this story. Their chief announcer, wishing to improve the carrying power and quality of his voice, went to a voice specialist in Minneapolis. He already knew something of the subject, but wanted to

become as proficient in his announcing as possible.

The voice specialist dealt with him with weary patience for some lessons, and then, one day, exclaimed:

"See here! The best way for you to learn voice control is to hear perfect tone production every day. I advise you to listen to that new announcer at wcco. I don't know his name. But he has all the qualities it seems impossible for you to learn."

Unpardonable Conflict in Good Programs

THE excellent Brunswick broadcasting program featuring their "Music Memory" contest, and the "Eveready Hour," both of which have come to be ac-



MISS MIRIAM STEEP

Star of the Washington Square College Players, is being heard in a series of radio dramas through station wjz



MISS MARY HOWARD

Soprano, of San Antonio, Texas, who is in New York studying singing, is here seen broadcasting the song, "Texas" through station WEAJ in honor of "Ma" Ferguson's inauguration that was then taking place. Special amplifiers made it possible for the audience at Austin to hear the song clearly

cepted and eagerly awaited features of Eastern radio programs, were scheduled for the identical time on Tuesday night, February 10. Assuming that the radio audience is kindly disposed toward both programs, it is obvious that they cannot listen to both at the same time.

Good showmanship is more and more coming to play in the arrangement of radio programs and there is no doubt that in particular, the programs of these two organizations are as near the ultimately desirable radio entertainment as anything we now have in this country. It is hard to understand just how those responsible for the radio programs of these two companies failed to discover that there was a conflict in time. One assumes that the conflict is unintentional. If it is by direct design, there is absolutely no excuse for it.

Europe for Good Programs, America for Good Performances

A STUDY of the programs put on at the station of the *Compagnie Française de Radiophonie* as they are received week by week, shows that these programs are much superior in quality to those given in this country. And they are much better compiled. Classical music is not mixed with popular music, any more than it is in any regular concert programs. But regarding the

quality of the performances, witness an enlightening communication of Eleanor McLellan, New York voice teacher who has recently returned from a number of months in Europe. She says, in part:

I made something of a study of radio programs while in Europe, and listened-in twice in Paris and once in Switzerland. The programs, so far as quality of selections is concerned, are far superior to ours, which seem to be growing worse every day. But in the quality of the performances, the programs are decidedly inferior to ours, especially the singing. Our cheapest vaudeville houses demand better voices and singing than I heard when I listened-in over there, and yet they were supposed to be artists who were broadcasting. They were simply terrible. For that matter, the singing was equally bad in the public performances I heard. This degeneration of the singing art seems to have come to Europe since the war, at any rate since I was last there. Our supposed second-class artists are so much better than the best they have over there now that they simply cannot be compared. Of course, these defects show up with merciless truth over the radio. In a nutshell, I would put it, Europe for good radio programs, America for good radio performances.

DR. W. M. CLARK, of Indio, California, writing regarding the stupidity of reading telegrams during a radio program asks: "What would the audience at a theatre think to have the hero of the play make the announcement between the acts: 'Mr. Blank, who is sitting in the gallery, has just sent down word that he can hear every word of the play distinctly.'"



JOSIAH ZURO

Conductor of the Sunday Symphony Society, whose concerts have been broadcast every alternate Sunday from wjz. Mr. Zuro is also an operatic conductor of far more than average ability

The Physics of Sound

The Nature of Sound—How It Is Produced,
How It Travels and Its Importance to Radio

By B. F. MIESSNER

COMMUNICATION, since the first days of man and beast, has been the one great instinctive force responsible for the increasing pace of progress through the ages. From the grunts of our primeval ancestors to the radio of to-day, the progress of mankind has followed the progress of communication.

There seems to be some definite relation between the facilities for disseminating ideas and the development of civilization. Certainly, the spreading of news is vital to the progress of humanity.

The South Sea Islander, with only smoke clouds or tom-toms with which to spread his news, is still in the uncivilized barbarous state of our own progenitors thousands of years ago. And why? Principally because the knowledge and ideas of other peoples the world over has not been carried to him. He has stood still because he has been isolated.

The highest type of communication yet developed is radio. Everywhere, instantly, it spreads its mystic, sound-bearing force and man progresses faster than ever before.

In radio as in so many other forms of communication, it is sound we broadcast and sound we receive, and so it is toward sound itself that we direct our attention, the better to understand and more highly to develop the usefulness of radio.

SOUND IS BOTH PHYSICAL AND PSYCHOLOGICAL

SOUND is the sensation produced by the action of vibrations of matter upon the hearing organs of living beings, and is therefore a physico-psychological phenom-

enon. The old catch question of the physics teacher:

“Does a falling tree in a forest make a noise if no one is present to hear it,” can be answered “No”, because sound is only the auditory effect of the forces we call sound waves. Generally, however, the word “sound” refers to the sound waves or vibrations themselves rather than to the sensations they produce, and because this usage is so general it will be adhered to in these discussions on sound and radio.

SOUND PRODUCED BY
VIBRATION

THAT sound is produced by rapid movement of matter can easily be demonstrated. A piano string when struck appears blurred and wider than before, and the vibration can be felt with the finger; the vibrations of a phonograph or loud speaker diaphragm can also be felt; a vibrating tuning fork

provided with a sharp point and drawn over a smoked or waxed surface will trace its vibrations visibly. We need only clap our hands, force air through our vocal cords, or tap our pencil upon the table to show that the rapid movement of matter generates sounds. If we view a phonograph record through a magnifying glass and see for ourselves how the needle is vibrated by the wavy-lined groove in which it rests, we can understand that vibrating bodies set up vibrations of the air surrounding them which we hear as sound. When it is desired to produce sound of considerable magnitude and the vibrating body itself has only a relatively small area of contact with the air, an auxiliary body of large area and responsive to the vibrations of the smaller body is connected to it. By this expedient a small

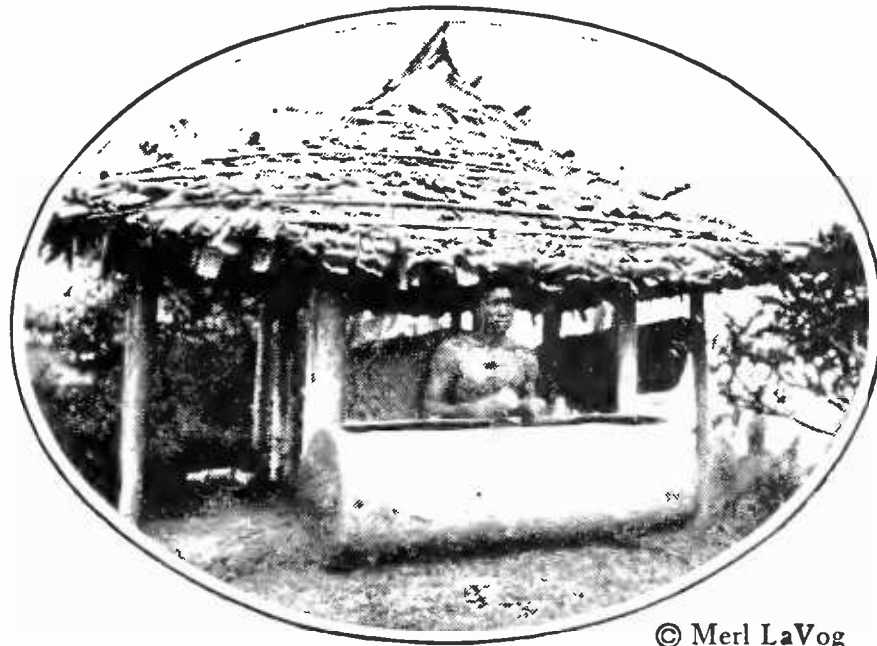

© Merl LaVog

FIG. 1

South Sea broadcasting is simple and effective but limited in range and restricted to code signals

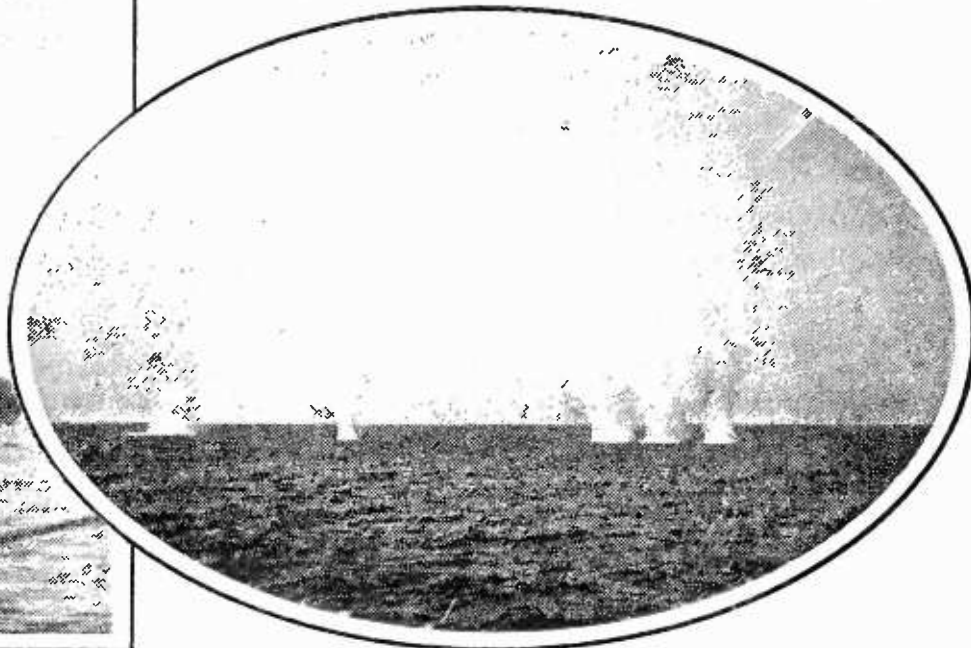
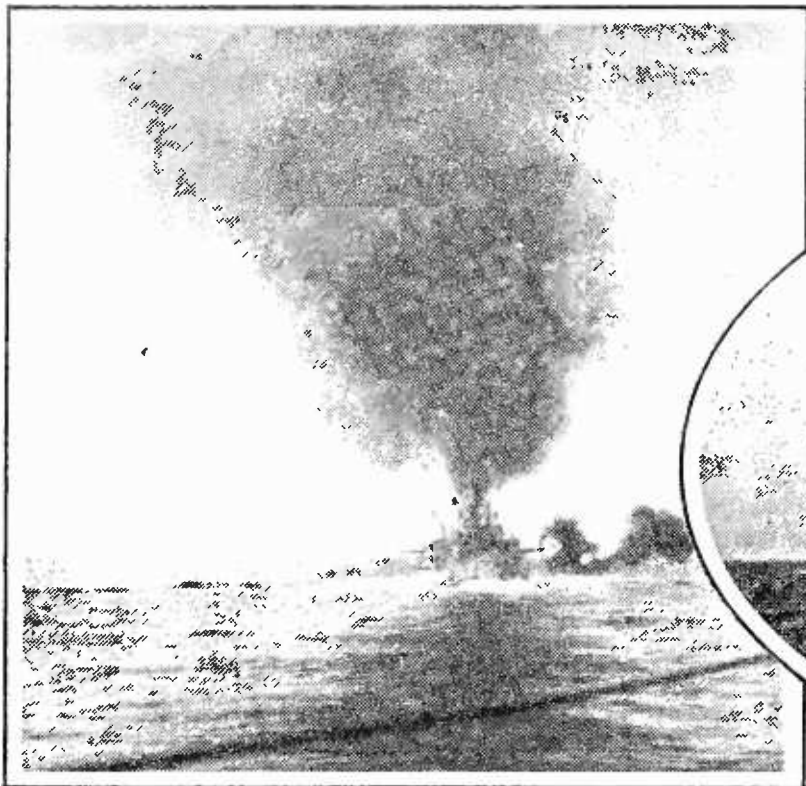

of it, we actually hear the crunching sounds of crushing food between our teeth, conveyed directly to the auditory nerves in the ear

FIG. 2

Naval target practise demonstrates very well the varying velocities of light and sound. The light, smoke, etc., from the gun muzzle is seen long before the sound of the detonation is heard

body vibrating with great force but unable to get a grip on the air, is able to transfer a large part of the energy of its vibration to the air, which appears as sound energy. The sound board of the piano, the belly and back of the violin, the drum heads in percussion instruments, the diaphragms of phonographs and telephones, the air columns of amplifying horns and wind instruments, are concrete examples of this principle common in everyday life.

THE NATURE OF SOUND

THE vibrations or movements of bodies in contact with the air thus impart some of their energy to it which appears in a form which we hear as sound, and which we call sound waves. Like light and heat and radio, sound is a form of energy capable of acting through space. While the former are vibrations of an omnipresent substance called the ether, and travel with least resistance through empty space, sound waves require some actual physical substance, such as solid, liquid, or gas, for their generation and propagation. This can easily be demonstrated by suspending a vibrating electric bell in a bell jar and pumping out the air.

While sound is ordinarily thought of as existing only in the air, most of us are familiar with sounds in other substances to some extent. All of us who swim have surely heard the sounds of clapping stones made by a comrade under water as we submerge our head. Many of us, too, have listened to the approach of a train miles away with ear to the steel rail of its track. While most of us are unconscious

through the bones of the head from the teeth.

THE VELOCITY OF SOUND

UNLIKE the waves of light or radio in the ether, which travel at the amazing speed of 186,000 miles per second, sound is a relatively slow moving force. Who has not seen the flash of a distant gun, of a stroke of lightning, or the rush of steam from a whistle and heard its sound come pealing in some seconds later? The light and sound are produced at the same instant, but the light travels so fast that its visual effect is practically instantaneous; the sound is relatively very slow, taking roughly five seconds to the mile for it to reach the listener.

The distance of any object which produces sound and some visible effect simultaneously, such as those above mentioned, may easily be determined by counting the seconds elapsing between the sight and the sound and allowing eleven hundred feet of distance for each second so counted. Three different degrees of velocity are most wonderfully illustrated in naval target practice to those aboard the target towing ship. The demonstration is particularly beautiful at night. As the battleship six miles away lets go a salvo; we see first the bright yellow flash of the powder explosion as the projectile rushes out of the gun muzzle on its journey to the search-lighted target a few hundred feet behind our ship. If the shells are provided with luminous tracers, we see the comet-like shell coming on at a tremendous pace, for about ten seconds. Then almost

simultaneously we see the huge geyser-like splash of the shell impact with the water near the target, and hear the roar of the splash and the crack of the atmospheric bowwave of the shell. Then, last of all, twenty seconds or so later, comes the deep booming roar of the sound.

THE SPEED OF SOUND VARIES WITH SUBSTANCE CONDUCTING IT

THE speed of sound depends chiefly on the nature and condition of the substance in which it occurs. In air it changes slightly with the temperature, and also somewhat with the intensity of the sound itself. It increases slightly with both temperature and intensity. In air at thirty-two degrees Fahrenheit, its speed is 1090 feet per second. In salt water at the same temperature it is about 4770 feet per second, and in steel it increases to the relatively rapid rate of 16,400 feet per second.

An extremely effective method of measuring ocean depths is now used in oceanography. A powerful sound is generated in the water by a vibrating diaphragm several feet in diameter energized by several kilowatts of electromagnetic energy. This sound travels to the bottom of the ocean and is there reflected or "echoed" back to the sending ship, where a submerged microphone receives it. Measuring instruments record the elapsed time between the transmitted toot and its received echo, and the whole distance to the bottom and back is the product of this time in seconds and the velocity of the sound in the water. The actual depth is obviously only half of this distance.

When we speak of waves we think of a disturbance or movement of some kind imparted at one end of a series of particles and transmitted to the other end by a progressive transfer of movement through the series. Thus a row of billiard balls struck sharply at one end will transmit the impact successively through the series without appreciable movement and the last ball will fly away. A very long coiled spring, if pushed or pulled suddenly so as to compress or elongate it, will carry a wave of compression or elongation from one turn of the coil to the next toward the farther end, which gradually becomes weaker and finally dies out. A long rope suspended at one end and suddenly jerked at the other will transmit a distinctly visible wave pulse to the suspended end.

HOW WATER WAVES ARE PRODUCED

PERHAPS the most familiar example of wave motion is that set up in a water surface by a falling stone. Here the stone in

entering the water pushes it aside, thus forming a small crater-like rise in water level about it, and as it sinks, a depression in the water above it. The high portion, because of the presence of the stone, can only move outward in its tendency to equalize the water level. The depression left by the stone in sinking also is a center of disturbed equilibrium, and the tendency there is to move upward. As the water there moves upward it acquires momentum which causes the central portion to rise higher than the normal level, so that now a distinct peak forms where the depression was before. Again this peak drops down, forms another smaller depression, rises to form another smaller peak, and so on. Thus the falling stone has created a center of dis-

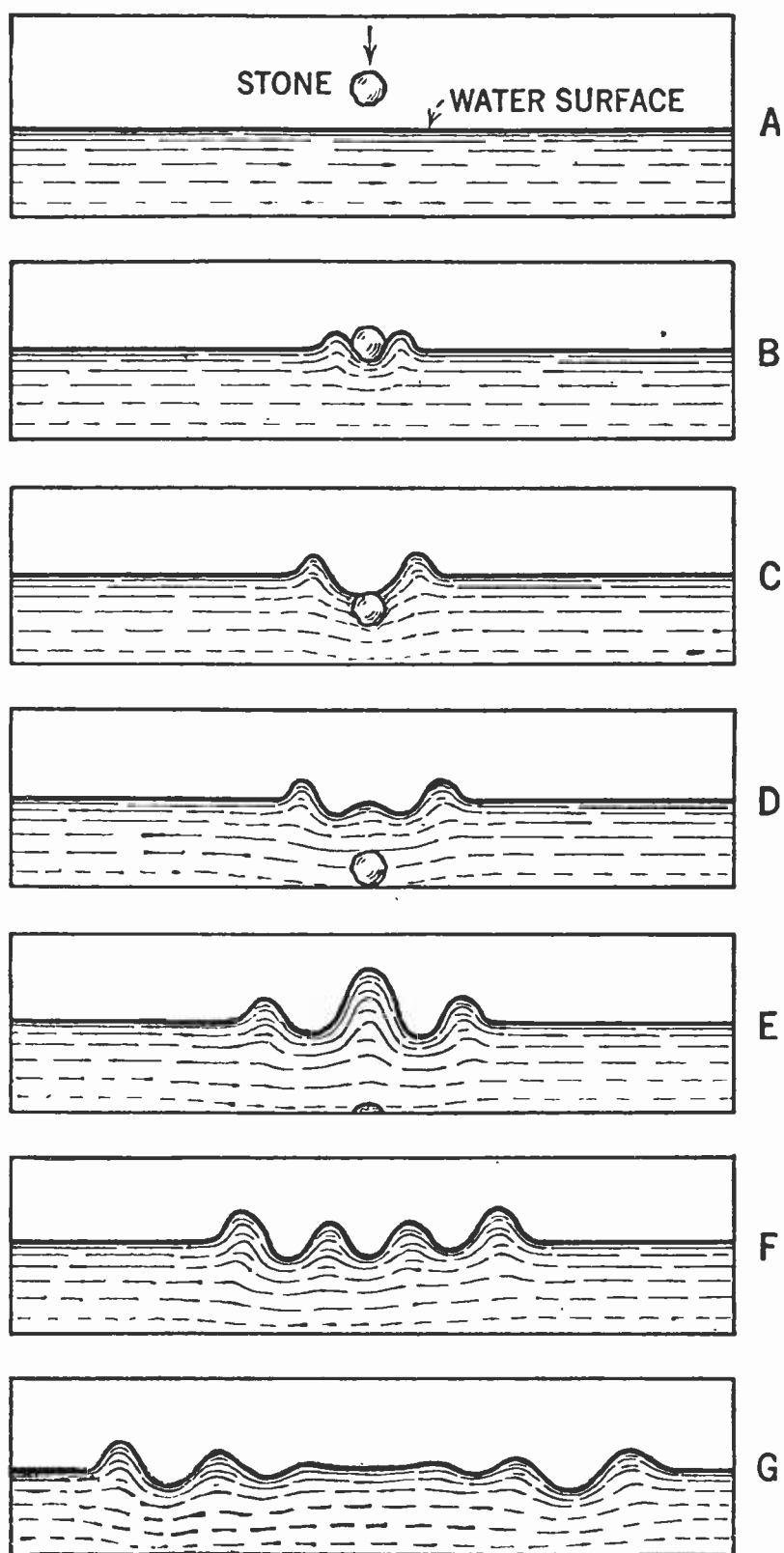

FIG. 3

How waves are produced when a stone is thrown into quiet water

turbance in the water surface which changes from high to low in a regular fashion and sets up a series of several circular waves with gradually diminishing force. While the particles of the water merely move up and down, the wave advances outward in widening circles. Slow motion pictures of divers in aquatic sports show these effects very clearly.

The size of the waves depends largely on the size of the stone, and their force upon the velocity and weight of the stone. If the stone is large, a longer time is required for the raised water at its edge to flow back and fill up the depression than if the stone is small, and so the speed of the up and down vibration of the water particles is slower; that is, the frequency of the up and down vibrations of the water is less. For the same reason the distance between two successive crests, or wavelength, is longer. Incidentally the splash of the stone creates a hemispherical sound wave whose pitch is lower the larger the stone.

WATER WAVE EXPERIMENTS

MANY very interesting experiments with water waves can be made at home in the bath tub. Like the old philosopher, Archimedes, who discovered the laws of buoyancy while in his daily bath, so can we discover for ourselves some of the principal laws of acoustics by experiment with water waves. If the rays from the bath room light fall on the bottom of the tub through the water, and if drops of water from a slightly open faucet take the place of falling stones, the waves may be observed as shadows moving over the bottom of the tub. Reflection or echoing from flat

surfaces may be visualized very clearly. Likewise the focussing effect of the curves at the corners of the tub may be seen with ease. Further, the bending of the waves around objects of different size, shadows produced by fairly large obstacles. In fact nearly all the laws of acoustics may thus be demonstrated most simply. Numerous photographs of water waves will be included in later installments of this series.

ATMOSPHERIC WAVES LIKE WATER WAVES

WE CAN produce waves in the atmosphere in much the same manner that we produce waves on water. The normal pressure of the atmosphere caused by the gravitational attraction for its gas particles, is 14.7 pounds per square inch at sea level. At higher elevations this pressure decreases, and at lower levels it increases. This normal pressure corresponds to the normal pressure of water at some point in a tank, or to the normal level of its surface. Just as there is a tendency to equalize any change in this normal level produced at any point within it, so there is the same tendency in the atmosphere, or in fact in any gas, to equalize any variations in its pressure however produced. If we suddenly change this pressure at some point, a center of disturbance is created from which sound waves will radiate in all directions. Thus, by suddenly breaking an electric light bulb containing no air, we introduce a center of practically zero pressure. The surrounding air at comparatively high pressure, rushes into this void in its tendency to equalize the pressure. The air particles surrounding these also move

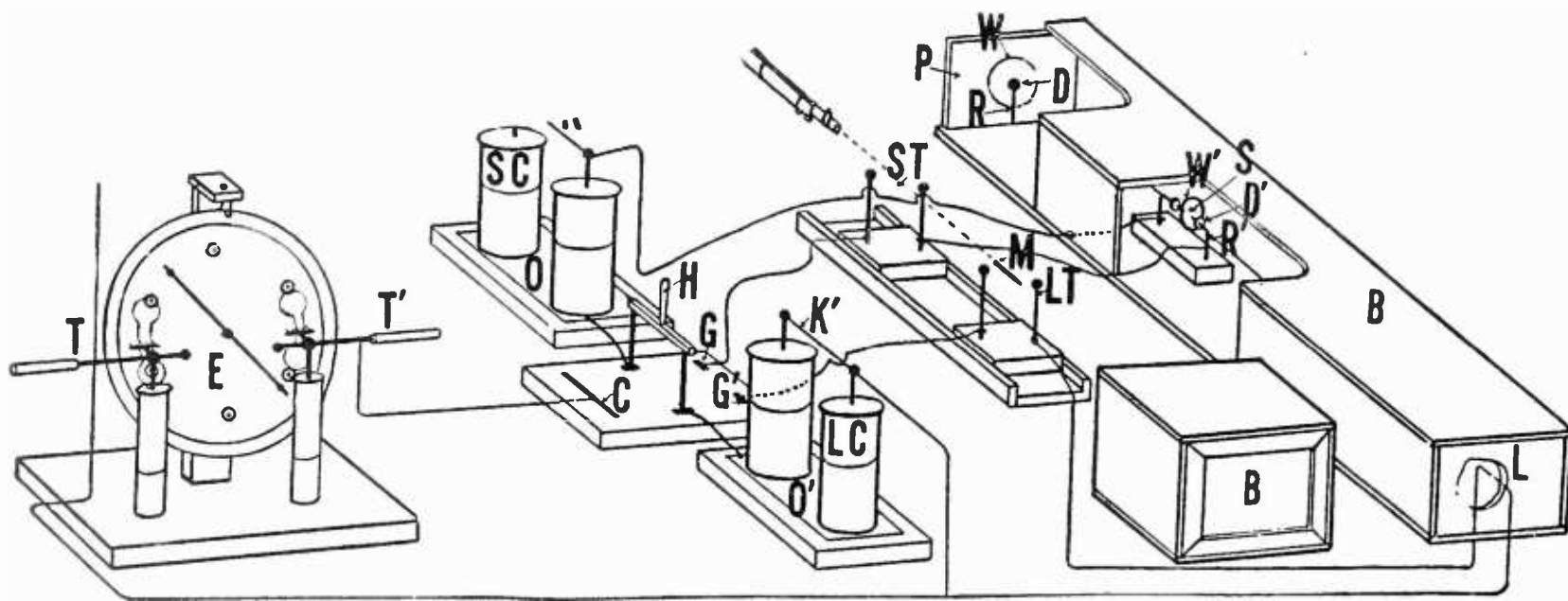
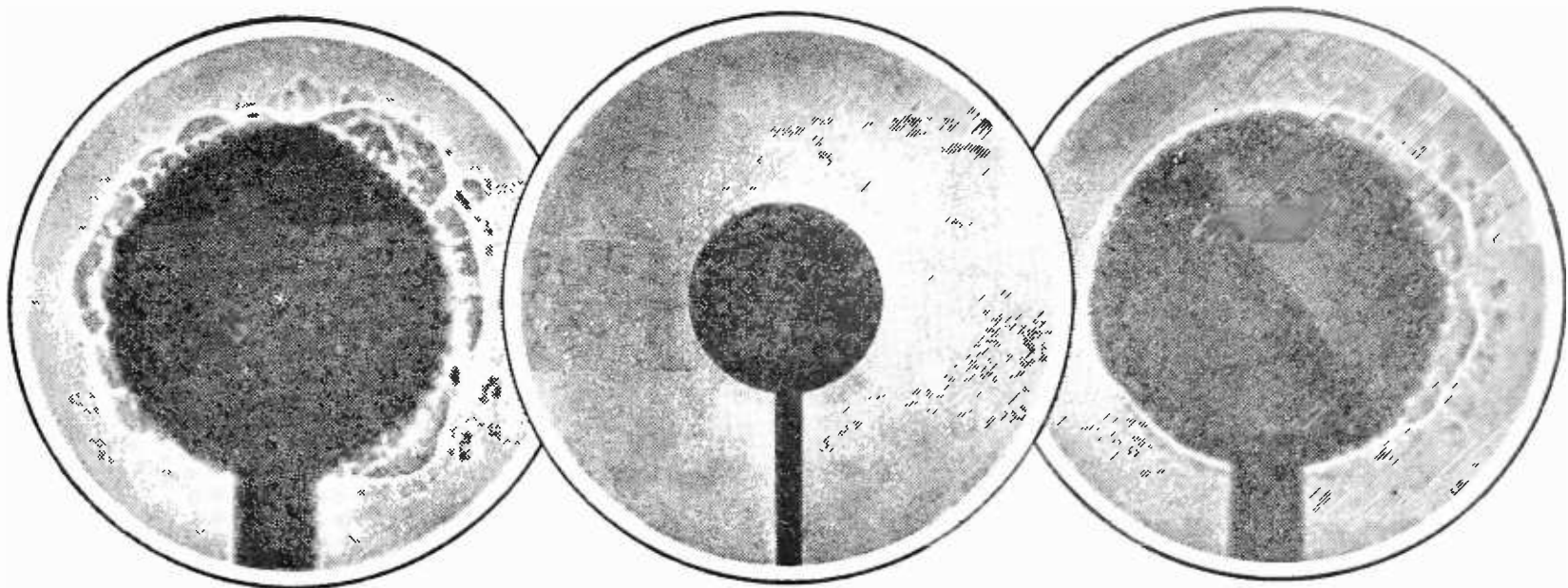

FIG 4.

A diagram of the apparatus used by Professor Foley to visualize sound waves. E, the electric machine, charges a battery of leyden jars for the sound spark S, and another for the illuminating spark L. Trigger gaps ST and LT, connected in series with these two circuits, are shortened when a high velocity bullet is shot through them, whereupon the sound and illuminating sparks are passed in rapid succession. The time interval between the two sparks is determined by varying the distance between the two trigger gaps



Courtesy Riverbank Laboratories, Geneva, Illinois

FIG 5.

The photograph in the center shows the circular shadow of the spherical wave produced by an electric spark behind the central disk. The photograph on the right shows the reflection or "echoing" of a spark sound at the surface of a hard body. In the first photograph, the absorption of a spark sound by a pad of soft felt is very clear. All these photographs were taken by the device diagrammed in Fig. 4

inward to fill the partial void left by them, and so a wave of reduced pressure moves outward in all directions, forming a spherical shell of reduced pressure which expands like a toy balloon as it moves away from its center.

As in the case of the water waves, the air, in rushing into the vacuous space, gathers momentum as it goes, and instead of just filling up the space to normal pressure it goes past the normal and actually increases the pressure. In returning it again passes the mark on the low side, and so on. A short series of waves of alternate low and high pressure are thereby set up, the outermost one of which is a reduced pressure shell or "rarefaction." It will be noted here that while the water particles moved in a direction at right angles to the direction of motion of the wave, the air particles in sound waves move back and forth along the lines of motion of the wave itself. The particles in the rarefaction are moving opposite to the direction of wave advancement, those in the compression in the same direction.

The process above described may be reversed by the sudden introduction of a high pressure center instead of the low one just described. The firing of a gun introduces such a center. In this case the high temperature gases rush out of the gun muzzle behind the projectile, forming a wave of compression, following by one of rarefaction, etc. In this case, because of the great length of the gun barrel, considerable time is consumed in emptying and filling the gun barrel in the pressure equalizing process and the pitch charac-

ter of the sound is lowered accordingly. As a matter of fact the nature of the sound changes with the size and length of the gun barrel because of this fact. Short barrels produce sharp, piercing sounds having high pitched characteristics; long, large bore barrels produce low, booming sounds of low pitched character.

SOUND WAVE PHOTOGRAPHY

A VERY beautiful method of visualizing certain kinds of sound waves has been perfected by Professor Arthur L. Foley, of Indiana University. He generates a sound pulse of very short duration and of high intensity by a powerful, instantaneous, electric spark. The wave so produced is allowed to spread outward to the desired point, when a second spark is produced whose light, in its path to a photographic plate, passes through the sound wave of the first. The variations in density of the air in the sound wave cause a refraction of the light from the illuminating spark, that produces a shadow of the wave on the plate, and therefore a picture of the wave itself. The beauty of this method may be appreciated when one considers that the interval between the first and second sparks, and therefore the point at which it is desired to picture the wave, may be controlled to within one hundred thousandth of a second.

Many obscure phenomena of sound have been investigated in this manner and much has been learned. The accompanying figures show the arrangement of his apparatus and several photographs of sound waves made with it.

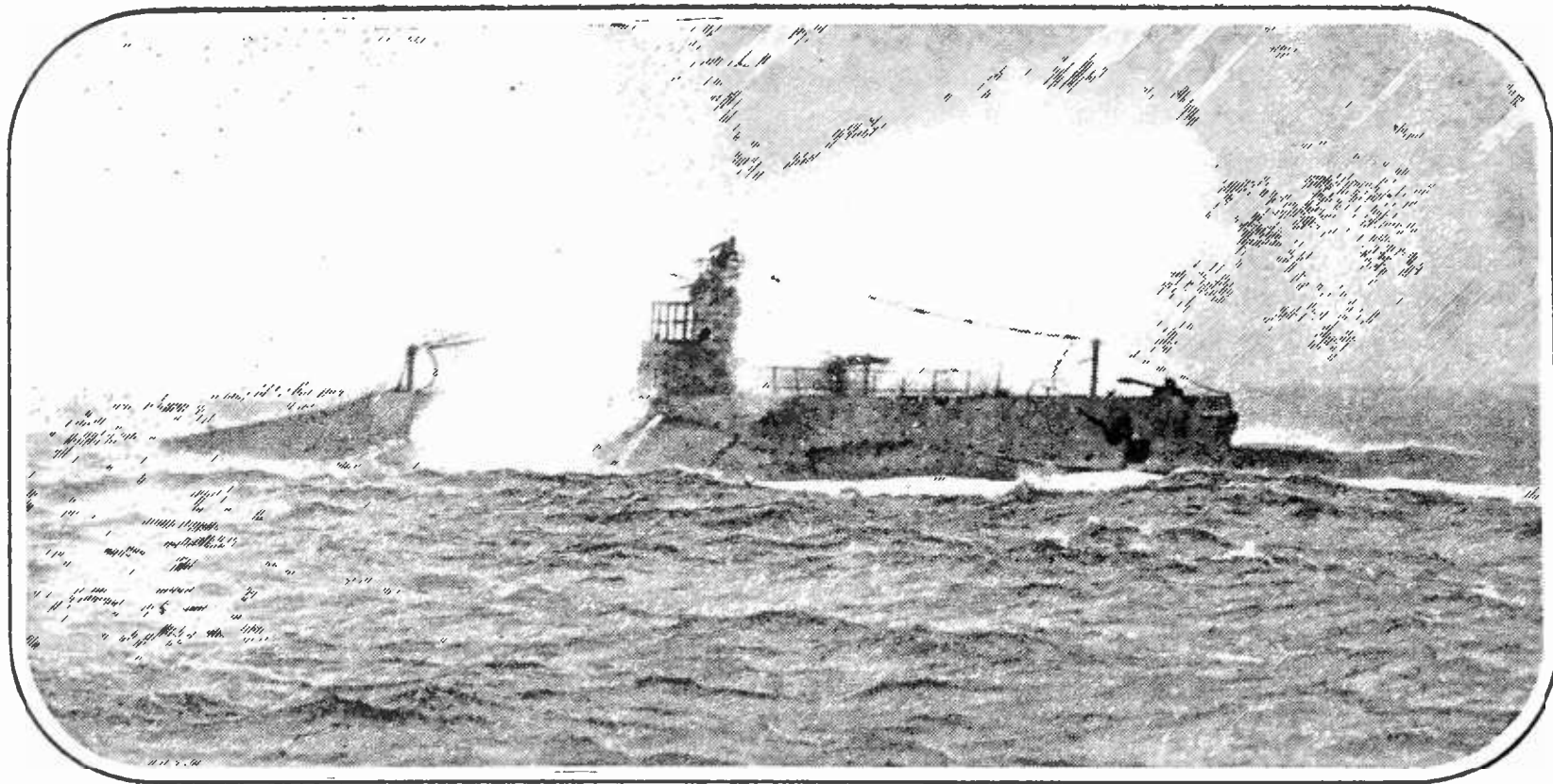

WHEN RADIO AIDED

The S-19 recently grounded on a reef, near Cape Cod. The sos from the ship brought them help during one of the worst storms of the winter. It was snowing, and the wind was high but the radio warning brought the Coast Guard from near Nauset Beach, Massachusetts.

THE MARCH OF RADIO

By

J. J. Morecroft
Past President, Institute of Radio Engineers

Fearless Statement of Fact Is Not Illegal

AN EXTREMELY important decision was reached on January, 30, 1925, by a jury sitting in the Federal Court of Judge Garvin in Brooklyn. The case involved the publishers of RADIO BROADCAST, who were sued for libel by the originator of the "Kaufman Circuit," a peculiar type of regenerative circuit which was generally brought to the broadcast listeners' attention during the last two years. The circuit was, in our opinion, a hodge-podge arrangement of various coils and condensers and it was characterized as in no real sense "new" in an excellent article by Mr. Zeh Bouck appearing in RADIO BROADCAST for March, 1924, entitled, "The Truth About Trick Circuits." Naturally after the appearance of unfavorable criticism in such an unbiased

medium as RADIO BROADCAST always endeavors to be, sales of parts for the so-called Kaufman Circuit fell off, whereupon Mr. Kaufman claimed that his personal character had been harmed to such an extent that he was legally entitled to damages.

The jury, after a very brief review of the evidence, decided that no libel had been shown, thus vindicating once more the cause of truth-telling. Had the case been decided differently, a great harm would have been done to the average broadcast listener. There are always people who are continually getting up new circuit arrangements and marketing them at a profit to any who have heeded the extravagant and unwarranted claims made for them. Many times the average radio enthusiast is not able to judge of the accuracy of the claims put

forth and finds that he has been deceived only after investigation of the worthless material.

It has been and will be the aim of RADIO BROADCAST fearlessly to criticize and expose all such impositions upon the radio public. If, after our careful analysis and truthful exposure of a circuit or device the "Inventor" suffers loss of caste (as Mr. Kaufman claimed was his plight), he can then blame only his own unfortunate ignorance.

Telling the unpleasant truth about a radio set certainly is not libel, and it is a sound rule, not necessarily confined to the radio field that one should not permit one's name to be too intimately connected with a development or event which won't stand up under honest criticism.

This Radio and the Stage Nonsense

STAGE-FRIGHT is an ailment which is likely to attack nervous performers, the performer being supposedly on a stage of some kind. Managers are, of course, worried about their *protégés* suffering from such attacks, as their earnings generally suffer. But now we have the interesting spectacle of stage-fright among the managers themselves. They seem to be on the point of nervous breakdown because of the relentless attacks they think that radio is making upon box-office receipts. Receipts are falling off at a tremendous rate, they say, because people prefer to sit at home and get their enjoyment by radio at no cost and no inconvenience. Rainy nights and dirty taxis cannot bother the radio listener.

It is extremely questionable that radio has had any such effect on the public's patronage of the stage. To offset the panicky statements from some of the stricken managers, we quote from a recent letter of Mr.

William H. Priess, a well-known radio engineer and executive:

Broadcast entertainers are in two principal classes: those whose main income is derived from the sale of seats in theaters and concert halls and those whose main income is derived from the sale of talking-machine records.

Both classes benefit directly when their members broadcast. The sale of seats for their entertainments and the sale of their records is enormously stimulated. Their income increases greatly. Their managers and employers will realize this in a very short time and will make them see it too.

It would seem that those theatrical folk of reasonably broad vision have already seen the truth of this assertion. The broadcasting

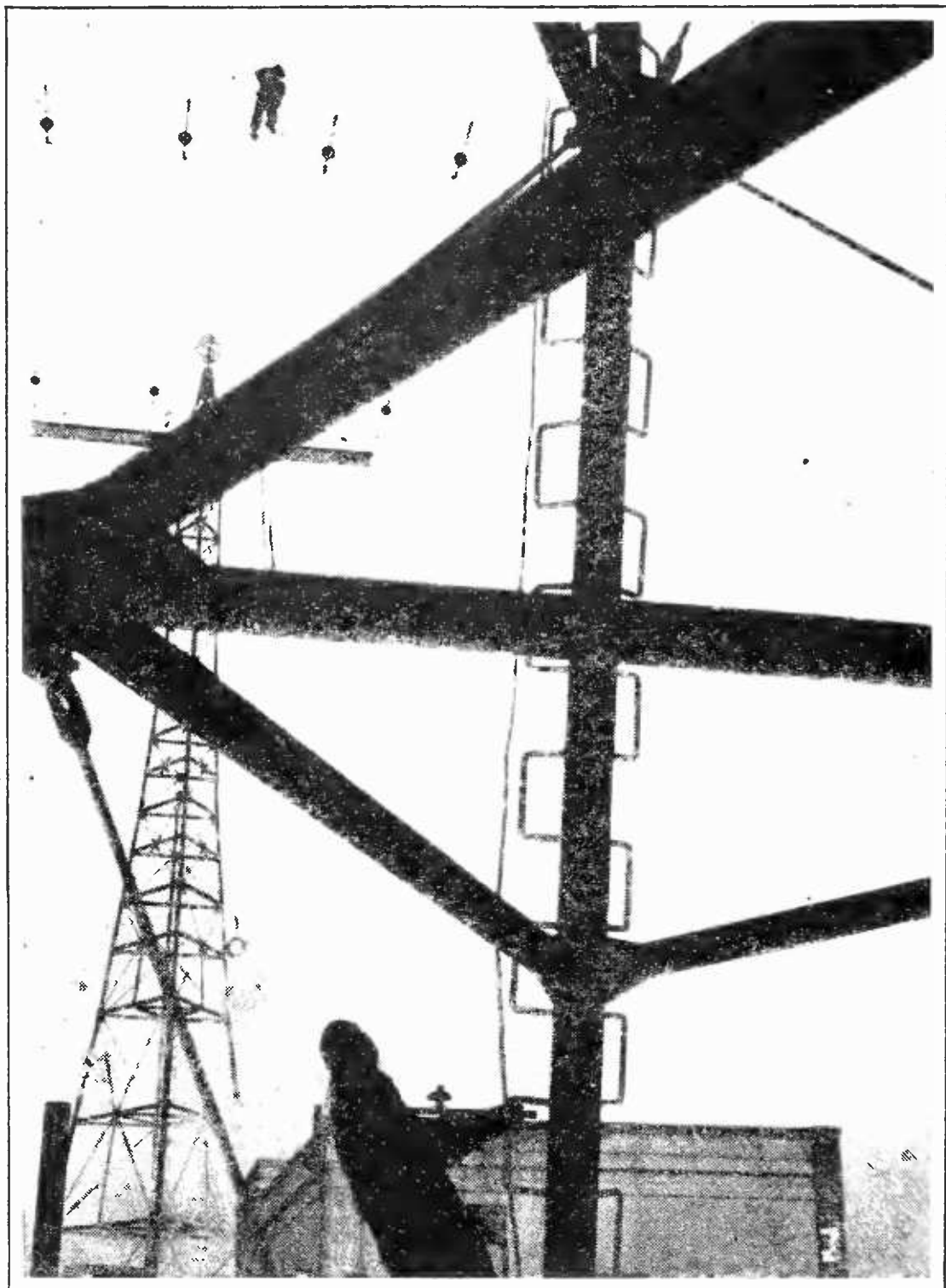

REPAIRING A BROADCAST STATION ANTENNA

New lead-in wires are being put in place at WJZ-WJY, New York. The rigger is suspended by a cable midway between the two masts which rise 100 feet above the 20-story building on which they are installed. The square house between the towers is the apparatus room for the twin stations, the control room and studio being on the sixth floor.

by Brunswick and Victor artists is being done in no eleemosynary vein. The managers of the artists concerned and the talking-machine manufacturers have determined that it is good business. But many of the managers (the less important generally) hold that radio is making real inroads on their fields. In the words of one of them—"The theater, the radio, and the disc are engaged in a battle from which one may not survive. Let Equity (the actors' guild) provide in its contract that an actor may not take part in a process which may prove his own destruction."

Some of the managers rather disparage radio as a competitor of the stage. Lee Shubert, for example, says: "Just at present radio is new and the public may stay at home for a while listening-in, but the novelty will wear off and they'll return to the theater. Radio cannot keep people from the theater because it cannot broadcast personalities and situations."

It may well be that the stage has recently fallen into disrepute with many of the theatergoers, as some of the managers seem to think the box-office receipts indicate, but if so it is more likely that the pernicious practices in

which the managers themselves indulge may have something to do with the public's contempt. A short time ago we tried to get some front seats for one of the revues. The box office sold no seats farther front than the twelfth row, we were informed. They sold all the best seats through the agencies according to the dictum of the presiding genius at the theatre's box office. Inquiry at the agencies disclosed that not only did they not have third row seats but they would not take an order for such as the best they could engage to deliver were sixth row seats. Where the best seats were disposed of they pretended not to know. In fact, at two of the agencies they showed considerable rancor that such an exorbitant request should be made! One can only conclude that the best seats are disposed of at a considerable advance over the advertised price to scalpers and curb speculators, and it is only by dealing with this undesirable class of vendors that one can buy the best theater tickets. It seems very likely that if the theater is gaining disrepute, it is pernicious practice of this sort rather than radio competition that is bringing it about.

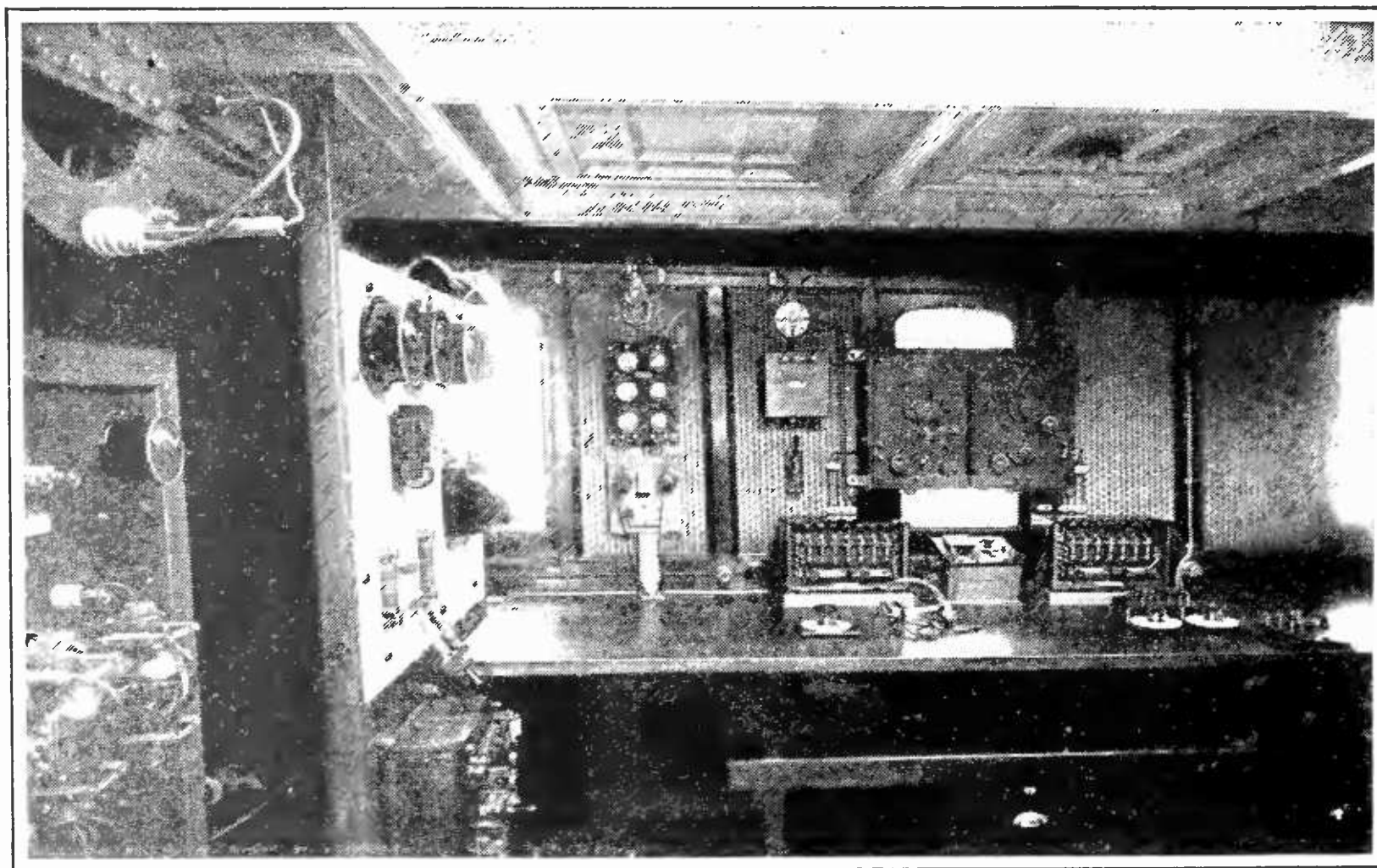

©Underwood & Underwood

THE RADIO ROOM OF MARCONI'S YACHT

The *Elettra*. Equipment of almost every sort is here, including receiving apparatus for very long and very short waves. Signor Marconi has lately been conducting experiments with short waves and found that on those from 100 to 32 meters, the daylight absorption decreased rapidly with the shorter waves. It was also found that reflectors at the transmitting station, using very short waves, increased the strength of the received signal and diminished fading

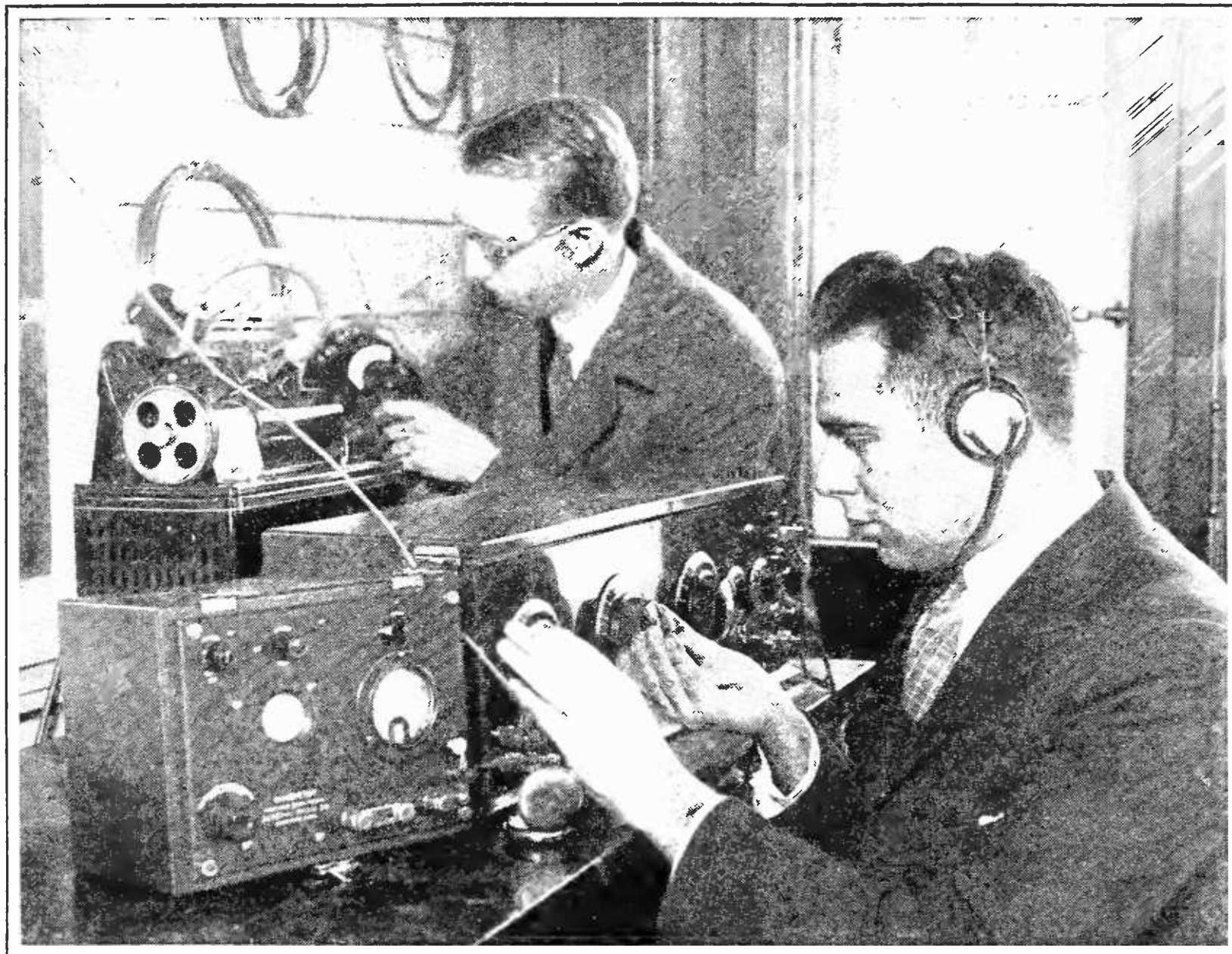

RECORDING RADIO SIGNALS

During the total eclipse of the sun in the RADIO BROADCAST laboratory at Garden City. Signals were received from WGY, WBZ, and other stations. The photograph shows John B. Brennan (right) and Keith Henney (left), both of the laboratory staff with one of the receivers used in the measurements. The dictaphone at Mr. Henney's left was connected to a loud speaker unit attached to the receiver and continuous records made of the signals of various broadcasters before, after, and during the eclipse. Effects noted in the accompanying editorial were observed

What the Sun's Eclipse Proved About Radio

IF ANYONE had expected to find great and sudden changes in radio transmission during the recent total eclipse of the sun, he was doomed to disappointment. It had been confidently predicted, and not without some foundation, that, in the path of total eclipse, radio transmission would greatly improve during the time the moon intercepted the sun's rays. We do know that night transmission is better than that during daytime, and as it might well be expected that the moon would act as a complete shield against the sun's active rays, improved transmission during the eclipse seemed sure.

As a matter of fact no such thing was observed at all. Many skilled observers, having carefully planned their work and apparatus days in advance, submitted reports which in

several cases are almost unbelievably opposite to each other. From Schenectady to New York the radio waves had to pass completely through the hundred or so miles of shadow. One observer in New York noticed that WGY became very steady, with no fading at all during the eclipse, and two others report that WGY disappeared completely during the eclipse!

Further to upset our ideas, the short wave station at Schenectady was well received in New York both before and after the eclipse, but during the period of totality disappeared altogether. And while this was happening in New York the short wave from Schenectady was not received at all during the observations in Ithaca, only 150 miles away by G. W. Pickard, one of the ablest experimenters in radio to-day. He reported that the short wave station of Schenectady could not even be heard in Ithaca, much more measured.

So we have at our disposal these facts. Radio transmission at night is much better than during the day. Short wave stations in Schenectady and Pittsburgh have been heard halfway round the world. During the eclipse, which we have assumed was night time for radio, the short waves traveled in the direction of movement of the moon's shadow less than 150 miles. In a direction across the shadow's path, they traveled reasonably well both before and after the eclipse, but during the eclipse they completely disappeared. And while these contradictory effects are being noted directly in and around the moon's shadow, listeners hundreds and thousands of miles away from the path of total eclipse reported a wonderful gain in signal strength!

And not to have any one spot of the entire field of possible happenings uncovered, engineers at Riverhead, Long Island, listening to Schenectady's short wave, reported no change whatever in the signal strength, although the

sending and receiving stations were on opposite sides of the shadow band!

The vagaries of radio transmission are apparently more inexplicable than before the moon cut off the sun's light. This is much more satisfactory than might be supposed, however, because when we know all the secrets of radio, its fascination for thousands of devotees will have disappeared. We knew that there was still much to be learned about radio and the eclipse showed us that there was even more than we had supposed.

Too Many Bootleg Radio Tubes Are Being Sold

AS A result of the investigation of poor tubes being marketed in New York City, Joseph Haberman was found to have been guilty of fraud and misrepresentation and was recently sentenced to three months in the workhouse. He had been buying tubes from a New Jersey manufacturer and putting them up in cartons marked "Radio Corporation of America." The District Attorney who represented the state in the prosecution vouched for the statement that 10,000 spurious tubes were being sold each day in America.

New Amateur Regulations

THE Department of Commerce has just issued new regulations for amateur transmitting stations. Every amateur operator should secure a copy of these new rules and adjust his transmitter accordingly. Amateurs are given plenty of wave bands to work in, but these bands are so well defined that the average amateur will have to measure his emitted wave much better than he has in the past. From 4.69 meters to 5.35, from 18.7 to 21.4, from 37.5 to 42.8, from 75 to 85.7, and from 150 to 200 meters are assigned to his use. There will have to

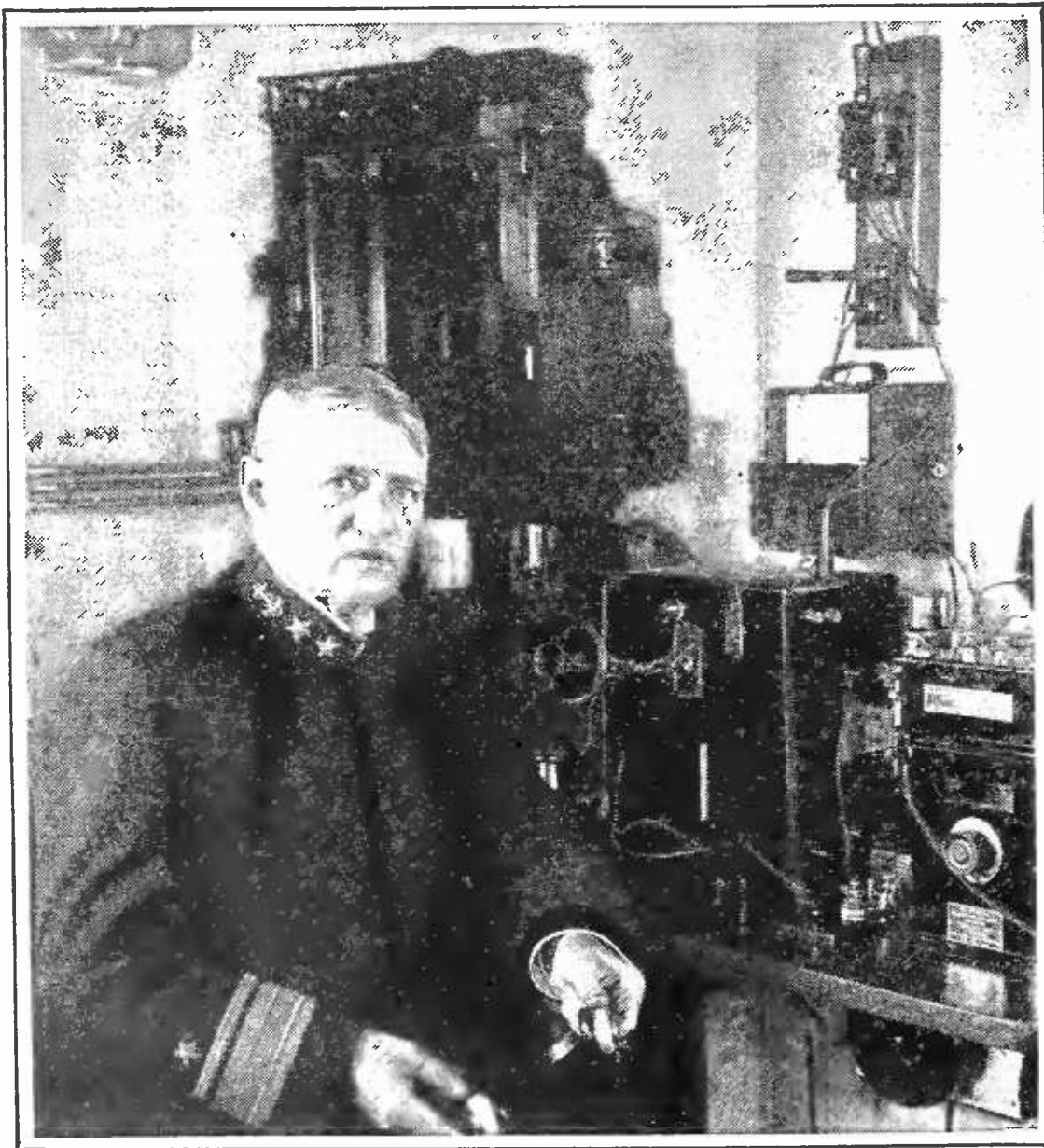

© Underwood & Underwood

RADIO TELEPHONY IN THE NAVY—1907

This photograph was taken aboard the flagship *Connecticut* with the late Rear Admiral Robley D. Evans seated in the wireless room in front of the De Forest wireless telephone which was the latest achievement at that time. The transmitting range was quite limited since the power was only fifty watts. The radio telephone was then used merely for inter-fleet communication

be quite a bit of wavemeter calibration carried out before the average amateur can avail himself of the privileges allowed in these new regulations.

There are two sections in the regulation which will interest the broadcast listener. On spark transmitters, we learn that:

Amateur spark transmitters produce considerable interference and consequently are responsible for many complaints. Amateur owners of such transmitters should abandon their use as early as possible and adopt a system producing less interference. Until such change is made they will be permitted in the wave band between 170 and 180 meters and should have a decrement not exceeding .1.

There are two "shoulds" in this regulation that would serve much better if interpreted as "musts." Under the heading "Quiet Hours" we read "amateur stations when using wavelengths between 150 and 200 meters are required to observe a silent period from 8 to 10.30 P. M. daily.

Stations which have been using between 105 and 110 meters under temporary permit must now move into one of the above specified bands because the 105-110 meter band is now given over to other uses.

What Radio Power Supply Apparatus Should Be

AS LONG as the alternating current filament tube is withheld from the market, the one great improvement in radio which we warmly endorse and encourage, is apparatus which will take power from a lighting socket and run the ordinary vacuum tube set. The idea of using dry cells for all modern radio receivers is somewhat absurd in some respects when viewed from the engineer's standpoint. Dry cells certainly have

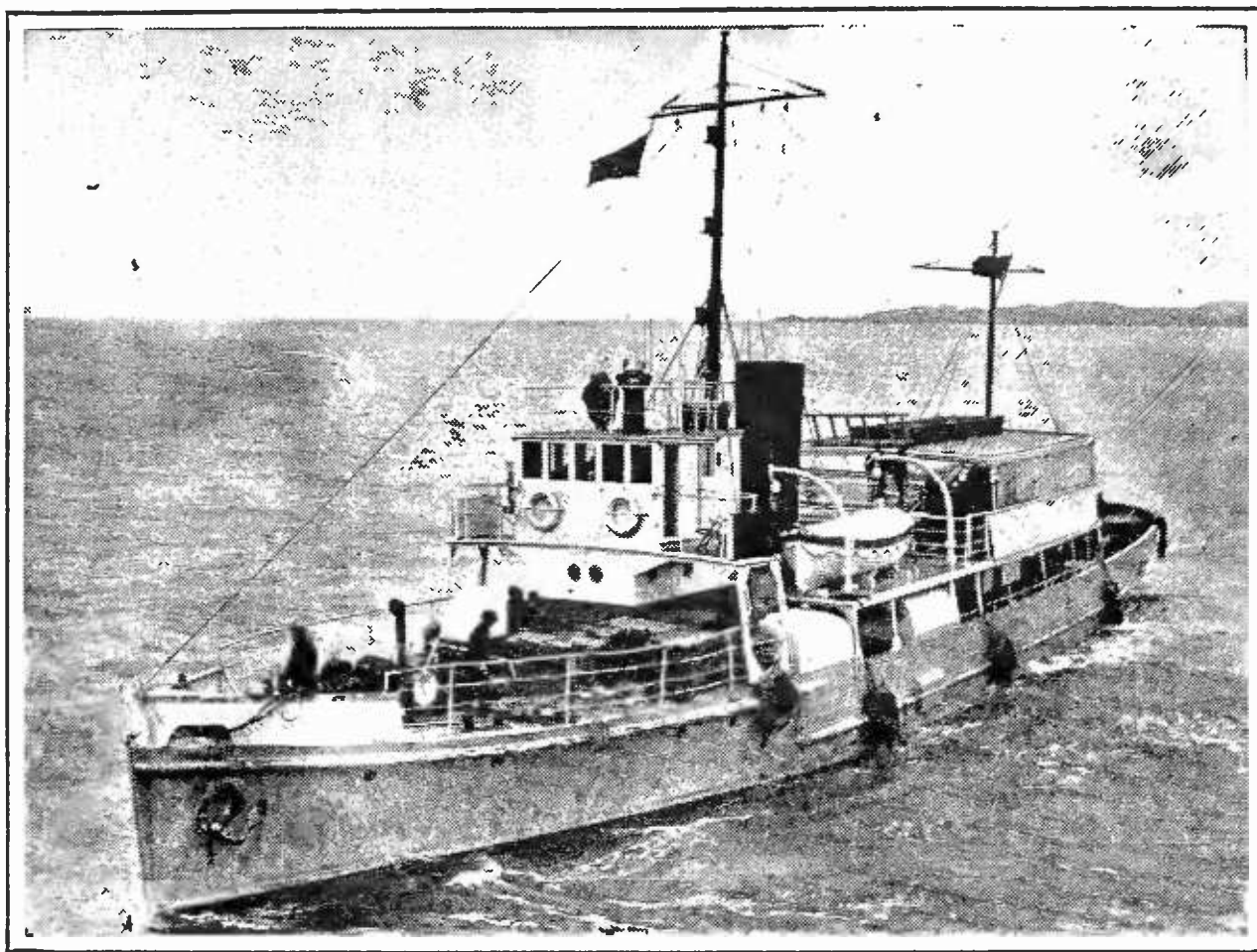

THE TENDER "HAMILTON"

Which ferries passengers from the port of St. George, Bermuda, to liners making it as a port of call. The seaworthy little ship has its radio equipment which is of considerable value in maintaining communication between ship and ship, and ship and shore

a special radio application which they should meet, and so has the power apparatus.

The power supply apparatus at present available employs some kind of rectifying cells or tubes, combined with electrical filters to eliminate hum from the receiving set. This type of power supply apparatus is connected to the house lighting circuit. Enough power can be drawn from the house mains so that a fire could be caused by improperly designed equipment. It is most necessary that the radio outfits be made satisfactory from the fire risk standpoint. The flimsy construction of many radio receivers now being sold will not suffice if the set is connected to a power supply device, and the sooner the manufacturers of these devices gets this firmly into his designer's head the better it will be for the art. If these rectifying outfits are designed so that they will pass the fire underwriters' inspection, they will meet great favor.

Receiving Short Broadcast Waves

PERHAPS some of our readers are trying to pick up broadcast programs sent out over the short wave (less than 100 meters) channels. If so, they are probably disappointed by the quality of the received signal. There is a rapid period of waxing and waning in the short wave channels, as we have men-

tioned before, which has the effect of making the received speech or music of peculiar quality. The companies which are using these short wave channels for rebroadcasting have to use a special method of picking up the signal to eliminate this fading effect. Either two or more antennas, at different points, or a very long antenna are used at the receiving station. Either method is unsuitable for the average broadcast listener.

New Religious Broadcasters

THE Episcopalians and Baptists have been foremost in broadcasting religious services, or so it appears to one who listens-in. In addition in New York we have besides some church services, the services of the Federation of Churches and those of the United Synagogue of America.

The Roman Catholics have now entered the radio fold by having a station installed at the Church of the Paulist Fathers in New York. Instruction in the faith of the Roman Catholic Church will be sent out regularly over the channel of WPL, their call letters.

Not to be completely outdone, the Luther-

ans have installed a station at Concordia Seminary, St. Louis. This station, KFUS, will be used to bring the Lutheran view of Christianity to the attention of those who care to tune-in on its channel.

In addition to these stations, about eight or ten others are regularly operated by religious organizations in various parts of the country.

A Halt to Progress

IF OUR understanding is correct, the newest type of loud speaker introduced in the radio market is to be withdrawn. The paper cone speaker, as it is generally called, designed and produced by the Western Electric Company, was the achievement of skilled engineers combining and improving previously known telephone and loud speaker parts. It accomplished reproduction of music and speech extremely well—in fact, it gave a more natural quality than any other speaker we have heard.

Many people who obtained these 540-AW reproducers were quite evidently disappointed in them, judging from comments made by

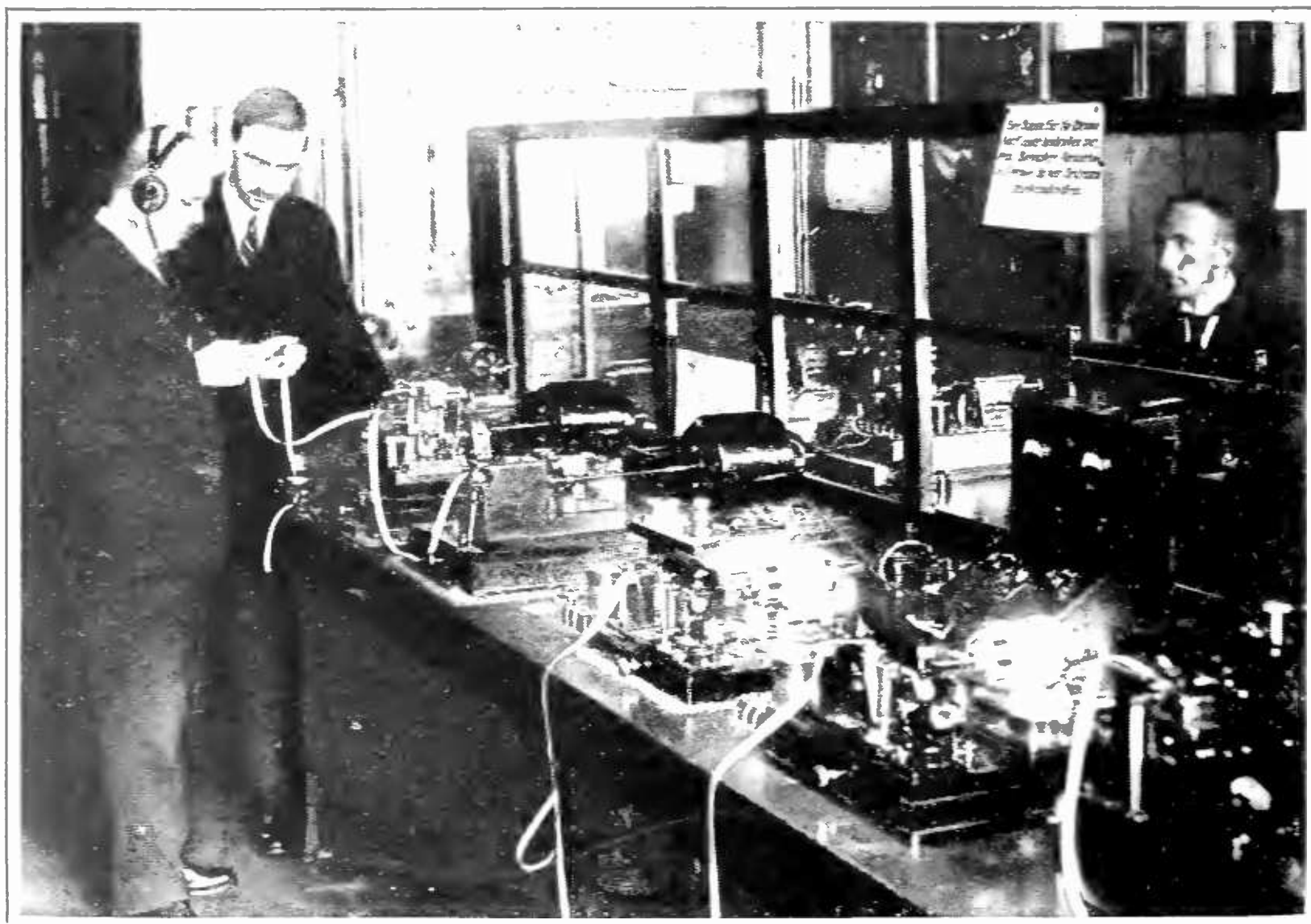

RAPID FIRE RADIO

Transatlantic radio messages being received in Germany, direct from Rocky Point, Long Island. The automatic machines in the photograph receive the dots and dashes at high speed and print them on the paper tape from which they are later decoded by operators

dealers and some of the users. Criticism of the quality of these reproducers, however, was not based on real fact. These paper cones give off notes which the other speakers do not reproduce. Well-balanced orchestras produce many low notes which give character and depth to their renditions, but these notes do not appear in the ordinary radio reproduction. Neither the horn type loud speaker nor the audio-frequency amplifier will pass these low-frequency notes along. The paper cone would give them off very well provided the proper current was supplied to it by the audio-frequency amplifier. Practically none of the available amplifiers are designed so that this is done. Because of this defect in the radio circuit, the paper speaker often disappointed its enthusiastic purchasers who had expected much improvement in their radio music.

We now hear that the paper cone speaker is to be withdrawn from the market because its manufacture and sale violate some kind of an agreement between the American Telephone and Telegraph Company and the Radio Corporation. We sincerely hope that if this proves to be true the Radio Corporation will busy itself in putting out loud speakers equal in quality to those now being suppressed. The radio public wants and is entitled to have the best speaker that science affords, irrespective of agreements of any sort.

About a year has passed since our last inquiry received reproof from the Radio Corporation officials. We venture to ask again, where is the alternating current filament tube? The public is still turning in tremendous revenues to the battery manufacturer by using dry cell tubes in five to ten tube receivers. One of our friends tells us, for instance, that his receiver uses up a set of filament batteries each week! When those who have authority in this matter can see their way clear to marketing the lamp socket tube they will receive hearty praise from the radio public. With power from the lighting company, good audio-frequency transformers, best quality loud speakers, and freedom from squealing receivers, radio really becomes a pleasure. Therefore we regret, if it is true, that the backward

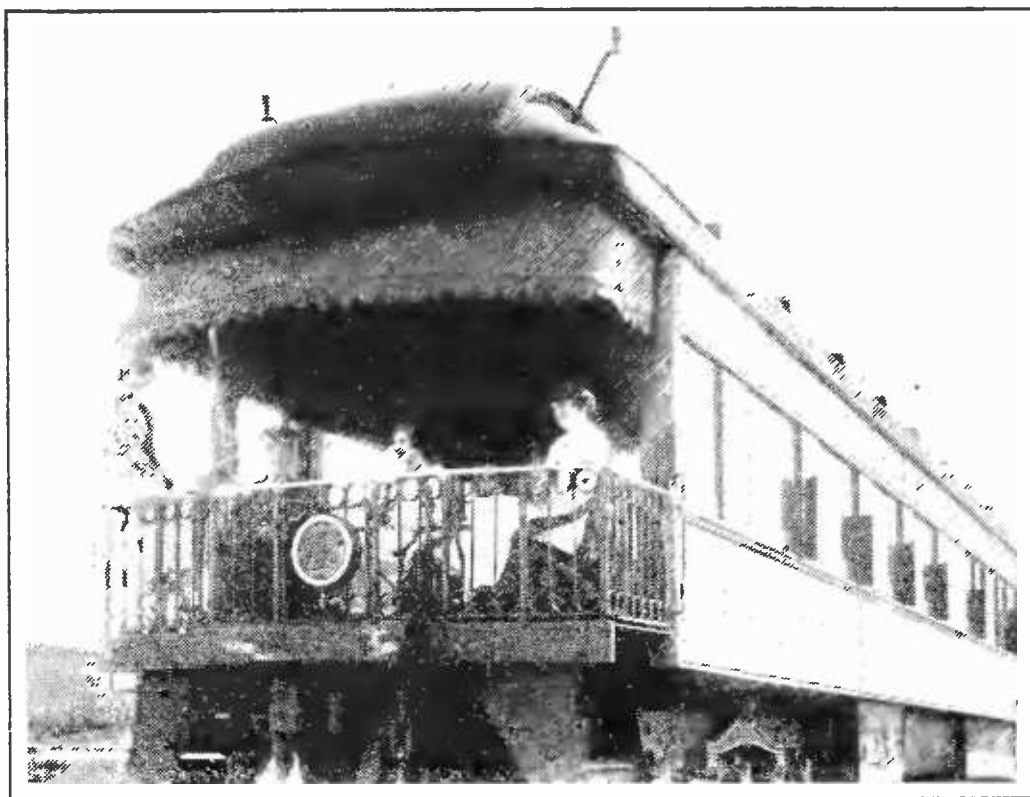

THE FINAL LUXURY

Passengers on express transcontinental trains can now listen to broadcasting as they while away the hours. The photograph shows passengers on a Canadian National Railways train and the antenna which brings them their broadcast programs. The first transmitting to and from a moving train was done by the Delaware, Lackawanna and Western Railroad about ten years ago, but was largely to determine the advisability of dispatching trains by radio. An entire chain of broadcasting stations has lately been set up in Canada by the Canadian National Railways

step has been taken in the suppression of the 540-AW speaker.

The March of Science

RADIO is a part, even if a comparatively small one, of the vast field of general science, so that we must be interested in the advance of science as a whole if we would appreciate the advancement of our own small portion. The eclipse of the sun brought forth in the *New York Times* an editorial on science exceptional in treatment and language, which we think worth while passing along.

SCIENCE AND LIFE

Perhaps few stop to reflect about the attitude of millions of people toward the eclipse of the sun, and to ask themselves what it is that has made this differ so wonderfully from the mental state of those human beings whom such a natural phenomenon used to fill with superstitious fears. It is one of the beneficent works of science. An attribute of true science is the power of prediction. That has been exemplified in a way which all can understand in the case of the eclipse. Its beginning, duration, and ending have all been minutely forecast. Everybody has implicit confidence in the accuracy of these conclusions of astronomical mathematics. Going behind technicalities, what is it that has been done for the world, in this particular, except to give it the truth, to furnish a complete explanation of a



WILLIAM H. EASTON

New York; Westinghouse Electric & Manufacturing Company

"Short-wave rebroadcasting can provide us with a world-wide system of intercommunication, but the question will immediately arise 'What good will it be if you cannot understand what it says?' The answer is that a universal language will be adopted which all can understand.

There has been a great deal of discussion on this point, especially by those who have gone to infinite labor to invent or learn some artificial speech, such as Volapuk, Esperanto, or Ido.

It seems to me that the weight of probability lies with the adoption of some living language, and that, furthermore, the chances are that English will be adopted for this purpose."

natural event? Knowing in advance the thing that will occur, accepting the reasons given for its occurrence, people face with curiosity and keen interest, but without a particle of dread, what in other ages and other climes would have stricken terror to the hearts of great multitudes.

The whole is a good illustration of what science has done, or is endeavoring to do, in a thousand other fields touching upon human life. It is forever in quest of the truth. It seeks to ascertain and to make known to the common intelligence the why and the wherefore of many things that have been regarded as impenetrable mysteries. With every conquest, it not merely enlightens the minds of men, but gives them more confidence, more calmness in the face of the unknown, and banishes haunting fears that have long afflicted mankind. We speak with propriety of the blessings of applied science, but we ought not to forget the great boon which theoretical science has been to the human race. When we note and read to-day of the temporary veiling of the sun in full accord with the scientific prophecy, we should be moved to give a grateful

thought to the vast revolution in man's outlook upon the universe which has been wrought by scientific workers in unnumbered laboratories and experiment stations. They had added immensely not only to the safeguards and comforts of life, but to its dignity, its intellectual satisfactions, its assurance that the process of the suns will go on majestically. The endless and sublime search for knowledge which has marked the strivings of star-eyed science has lifted the minds of men to a level where they can feel secure and affirm that it would be a shame to stand in God's creation and doubt truth's sufficiency.

Interesting Things Interestingly Said

HERBERT HOOVER (Washington; Secretary of Commerce). "The greatest development of broadcasting during the past year has not been in the application of new methods of transmission or reception, important as improvements in these lines have been. It is rather in the change of public attitude. Listeners are becoming more and more appreciative of the real service of radio and increasingly critical both as to the character of the matter furnished them and as to the efficiency with which it reaches them. . . . There is a growing realization on the part of the broadcasters of the public responsibilities they assume in conducting an agency so greatly affecting the cultural progress of our people and the innovations of which we hear so much, national programs, short-wave rebroadcasting, increased power, and wired radio . . . —all are based entirely upon the necessity for meeting the growing popular requirement of better service."

FRANKLIN P. ADAMS (New York; in the *New York World*, "The Conning Tower"). "If the theatres are afraid that the average theatrical patron is going to stay at home to hear the radio version of "The Sunshine of Your Smile," or songs to that effect, they are greater cowards than we thought; which is no faint praise. One solution of the Radio Menace problem might be More and Better Plays."

H. I. PHILLIPS (New York; in "The Sun Dial," *New York Sun*). "Now the radio owes its popularity to the fact that no speculator can touch it, and that you can begin listening with \$11 in your pocket and still have the \$11 when it is all over. Then if you find you are in on a bad entertainment, you can switch yourself right out of it without the assistance of check boys and taxi drivers. It is this take it or leave it principle that is the chief lure of radio, and if the theatre men want to crowd it any they've got to find some way for a man in a theatre to tune himself out of a bum show without any trouble or added expense.

"The show business will never rival the radio for

popularity until it becomes possible for a patron to press a button or twist a knob and immediately turn a very bad actress into eight Hawaiian ukelele players or convert a painful actor into somebody like Lopez or Whiteman."

GUGLIELMO MARCONI (London). "Recent tests from England to the United States, Canada, Brazil, Argentina, Australia, India, and South Africa, using only fifteen kilowatts power indicate the possibility of installing low-power systems capable of day and night commercial radio services to all parts of the globe. For ordinary efficient communication between fixed places or between particular countries, I think the logical thing to do if possible at both points with a view to secrecy and economy is to concentrate all the radiated energy into direct beams. It may be necessary in the near future to regulate by international legislation the use of short waves and to safeguard them from preventable interference."

H. V. KALTENBORN (Brooklyn; Associate Editor, Brooklyn Daily Eagle). "Radio cooperates rather than competes with newspapers and magazines. It supplements in a remarkable and delightful way the former means for filling leisure hours. Radio is not a suitable medium for direct advertising. . . . The radio advertiser has no chance to catch the eye. His only appeal is to the ear. . . . Nor can radio, with its limited appeal to a single sense, compete with the many-sided appeal of the speaking stage. . . . The great future of radio broadcasting lies in the field of education. Education comes more easily through the ear than through the eye. There is scarcely a subject taught in a great university which could not be taught over the air, but not at the same time that it is taught in a classroom. It is a mistake to suppose that the best results in radio work can be obtained by making it a by-product. Radio requires its own technique."

EDWARD H. JEWETT (Detroit; President, Jewett Phonograph & Radio Company). "In my opinion, the public should not be made to pay the cost of broadcasting. I doubt very much if it would be desirable to have them pay, any more than they are now called on to pay the entire cost of the newspapers and magazines they read. Advertising carries the load there and it is my belief that advertising should carry the load in making up the expenses of broadcasting. Radio as an advertising medium is a sort of halfway station between the newspaper and the billboard. The message of any advertiser on the air must be limited to a selling message such as a billboard seeks to put across. There will probably develop a school of broadcast



DR. ALFRED N. GOLDSMITH

New York; Chief Broadcast Engineer,
Radio Corporation of America

"High-power (in broadcasting stations) is an experiment, and we must move cautiously. . . . I believe that if the higher-powered station is located judiciously, that is, in sparsely settled localities outside the city, it will provide just as good reception for the city folk and at the same time, give the farmers out in Iowa, Indiana, and other agricultural sections a chance to see what radio really can do.

"If the receiving set is really selective, practically no difficulty will be experienced in tuning-out the super-power station, that is, if you are ten or twenty miles away from it. Of course if you are close, a three-circuit set and perhaps a wave-trap may be necessary to tune it out, if it can be accomplished then.

"Super-power is simply a matter of increasing the signal strength over the strength of the static. It stands to reason that if the static and the signal have the same strength, you are going to hear nothing but a lot of weird noises. If the signal strength is increased, you can shorten your antenna, thus reducing the static, while at the same time, the signal will come in with equal or greater force."

advertising which will make advertising messages as attractive as there are to-day in newspapers and magazines."

JOHN GOLDEN (New York; theatrical producer). "If bicycles, automobiles and radio keep people away from the theatre, so does love-making, and where would we all be if we stopped that? It is just as sensible to blame the cross word puzzle as an influence unfavorable to drama. If the theatre cannot withstand the radio, or any other influence, it deserves to die."

I SHOT a joke into the air,
It fell to earth I know not where;
But when I'd sown my meagre chaff,
I listened close, nor heard a laugh,
And felt that pang which all must know
Who've jested through the radio. —Life.

The Man Who Knew All About Radio

BY WILLIAM H. CARY, JR.

Drawings by George C. Williamson

THEY sat in the living-room, looking at Brainley Nutmeg's new receiving set—Brainley, his wife, her father and mother, and eleven-year old Junior. It seemed to be all set, but no receiving.

"I do hope it will be going by the time Jack and Jean Mabie arrive," said Mrs. Nutmeg. "They're waiting to see how ours works before they buy a radio of their own."

"So am I," said Mr. Muscadier, with a twinkle in his eye.

"My crystal set upstairs has it all over this one, so far," boasted Junior, tactlessly.

Brainley seemed to sweat under the burden of these last two remarks.

"Well, I'm hanged if I know what's wrong," he said. "I've connected up everything just the way it says in the instructions. All the parts seem to be here—I don't know where I'd connect any more if I had them."

He glared at the silent cabinet as if trying to determine what kind of punishment to administer to it. But he realized, on this very first evening of his radio experience, that a receiving set can't be disciplined like a child. It's a lot wiser than you are: you can't bluff it. Punishment only makes it more stubborn and unmanageable. Junk! New, shiny junk, with excelsior-particles still clinging to it. The big receiving set sat on a table in the corner as if it were a god upon a pedestal, with cartons, wrapping paper, and excelsior spread about on the floor, like offerings.

"Well, I'll go over it with the diagram again, and see if I can find the trouble. If not, I guess we're out of luck to-night."

"It will be a disappointment for those friends of yours who are coming," said Grandma Muscadier.

"Who, the Mabies? That's not half of it. I saw James Grunt at lunch to-day and got talking about the new set, and sort of had to ask him to stop in, too."

"Oh Brainley! You didn't!" This from his wife.

"Sorry but I did."

"Oh dear!—he's so—so impatient and sort of superior."

"Well, perhaps he won't know anything about radio."

"I'm sure he won't."

Mrs. Nutmeg said they shouldn't have asked *anyone* to come, the very first evening.

"The very first fifty, you mean," replied Brainley, with his head in the receiving cabinet.

At this point, the doorbell rang, and Junior bounced out into the hall to let in the two Mabies and Mr. Grunt.

"Hello, Nutmegs!" came Jack Mabie's hearty voice. "Well, Brainley, they tell me there's music in the air."

"I guess there is," replied Brainley, with an effort to be cheery. "So far I haven't been able to draw any of it out."

"Jean and I expect to get one like it—if it seems to be a good one."

"I advise you to wait."

"But it's an expensive critter, with those four lights and a big horn and batteries and all that. It *must* be good."

"Good as the day it was born—no more, no less."

With this off his chest, Brainley felt better, and greeted Mr. Grunt with a perverse, almost savage gaiety.

The talk was, of course, on radio. For the first five minutes every one was so busy giving each other their ideas and secondhand experiences that it didn't matter whether the new apparatus was working or not. Mr. Grunt, a slightly bald little bachelor with a cock-sure manner, sat himself down next to Mr. and Mrs. Muscadier.

"I THINK it's awfully nice looking," Mrs. Mabie was saying to her husband and the Nutmegs, as they stood gazing at the set. "See how nicely the cabinet is made. Jack, we must have a mahogany one like this. How well it blends with the other furniture in the room."

"Yes, in harmonious silence like the bookcase, apparently," observed Jack. "I wish I could help you out, Brainley, but I don't know the first thing about this radio game."

"As if I did."

"Well—you at least have the advantage of having read the directions."

"Call that an advantage, do you? Wait till you've read 'em!"

"Wait'll I take off my coat and roll up my sleeves, too. We might as well both look like electricians, anyway."

Then Brainley handed him the little sheet labeled: "Instructions: Assembly and Operation."

"What'll we do first—blow 'Assembly'?" said Jack, briskly.

"Yes. You begin at the top and read out loud what it says; I'll accompany you on this double-barreled steam-calliope."

Brainley picked up his screw-driver and pliers, and the two men bent over the set like surgeons over an appendicitis case.

It was Mr. Grunt who made things uncomfortable, a few minutes later, by remarking:

"Well, Brainley, how about a little concert?"

And to make things worse, Junior called downstairs from his room that he was getting the local station "swell" on his crystal set.

"It's easy to see where the electrical genius lies in this family," observed Mr. Grunt. "I'm going up to see Junior's machine."

He went; and although it relieved Brainley considerably, it didn't put voice into his newly acquired receiver.

"I give it up," he said finally. "We'll have to get somebody from the radio store to come round to-morrow."

WE MIGHT call up the Flashes next door," suggested Mrs. Nutmeg.

"Mrs. Flash told me yesterday that they've had a radio for three months and it works like a charm. Perhaps her husband could tell us what is the matter. She said he knows all about radio."

"All about it like Mr. Grunt?" murmured Brainley. "I think one expert like that is enough in the house at one time."

"Still," said Jack Mabie, "if this Flash fellow has had a set working like a charm for three months, he might be able to make this one work like *something*, for three minutes."

Mrs. Muscadier called to Mrs. Nutmeg: "I'm afraid your father and I shall have to go, my dear. Perhaps we shall be able to hear it another night."

Brainley was filled with chagrin. Poor parents-in-law! They had sat there listening to James Grunt's half-baked opinions, waiting for the new apparatus to speak, all without complaint or meddlesome suggestion. He hastened to apologize. If they could wait just a few minutes longer, he'd get Mr. Flash right over, and maybe he'd find some simple thing wrong which could be remedied in a minute. He'd call him right up.

The Muscadiers decided that they'd wait a bit, then, and see.

Over the telephone, Brainley described to Mr. Flash the symptoms of the sick receiver. They knew each other only by sight, but Brainley's flattering request for aid, and Mr. Flash's obliging response that he'd be right over, seemed to unite them immediately by the bonds of friendship. When the doorbell rang a minute later, Brainley and his wife both went out into the hall to greet their neighbor, with a welcome that was almost shouted.

"Come *right* in!" said Mrs. Nutmeg, heartily. She introduced him as "Mr. Flash—a real radio expert."

That was an unfortunate introduction to live up to, and it rather knocked the pins from under Mr. Flash—they would expect him to make a few passes in the air and produce music. He was an earnest little man of about thirty-five, who seemed to make up in his pathetic eagerness to please what he lacked in a sense of humor. His only electrical experience before he bought his own set, had been the repairing on an occasional bell circuit. Once, when he had spent half of a Saturday afternoon under his dining-room table and in



"IT SEEMED TO BE ALL SET, BUT NO RECEIVING"

the pantry, trying to determine why the buzzer wouldn't work, and had finally thought of exchanging the old dry cells for new ones, and had done it—with amazing and complete success—his wife and some of her women friends had marveled, and had called him “awfully clever at that kind of thing.” And when he had done a similar trick with his radio set, and even remedied a couple of more serious ills such as replacing a burnt-out tube, he began to believe they were right. At any rate, the Nutmegs and their guests would think he was “awfully clever at that kind of thing” unless he proved himself otherwise; and he saw no reason to hasten a show-down. Besides, he had plenty of confidence that he could do the job. It wasn't as if he didn't know a rheostat from a loop antenna; he had picked up a lot in three months. So he walked over to the table and looked at the Nutmegs' receiver. It wasn't at all like his: it had twice as many tubes and half again as many dials.

However, most sets are essentially the same. He looked at Brainley and Jack in their shirt-sleeves. “May I?” he asked of Mrs. Nutmeg.

“Oh, of course! Here, let me take your coat.”

Off came Mr. Flash's coat and up went his sleeves. Then he planted himself in front of the set with Brainley on one side of him and Jack Mabie on the other, and the others giving him their undivided and confident attention in the background.

WE MIGHT as well begin at the beginning and go right through,” he said briskly, for once in his life feeling the thrill of being master of a situation. “Antenna's all right, I suppose? Well insulated? Not touching the side of the house? Between 75 and 150 feet long? Hmm!” He looked at the knife switch on the window-sill, to which Brainley had dutifully connected the lead-in and ground, as per directions. “That seems to be as it should. Now the ground—hmm!—radiator—ground clamp. Tight? Yes. Now the B battery.”

Here *was* talent! Everyone perked up considerably, filled with admiration and with renewed hope of having some music after all. Mr. Flash had the air of a doctor who says: “Pulse, normal; temperature, normal. . . .”

“Have you a B-battery voltmeter?”

Brainley was sorry to say that he didn't know what one looked like.

“Well, never mind; they're new batteries, aren't they?”

“Yes. Brand new.”

“Hmm! A-battery? Newly charged?”

“I think so. It came from the store with the rest of the stuff.”

The radio expert twirled a nut off one of the A-battery binding posts in the rear of the set, losing the nut on the floor. He touched the end of the wire to the other post of the battery. Spat! Spat! All kinds of fireworks. “Juice there,” he said calmly. His audience looked on in rapture.

“Are you sure the polarity's right?”

“The what?”

Mr. Flash descended to a term more intelligible to the uninitiated. “Are you sure that the wire going to the plus A on the set is attached to the positive, and not the negative side of the battery?”

“I think so. The directions said the positive dingus generally had a swipe of red paint on it.”

“Sometimes the battery people make a mistake,” said Mr. Flash, indulging in this flight of fancy so as to pave the way for a spectacular effect that suddenly occurred to him. “Now if we only had a potato—a raw potato—we could easily tell.”

“A raw potato?”

Mr. Flash seemed to be rapidly becoming inebriated with the wine of rapt attention that everyone was giving him. “Yes. You put the terminals into it, and a black ring appears around the positive one.”

Magic! Mrs. Nutmeg started out to the kitchen to get a potato.

But Mr. Flash had spoken before he had thought. He wasn't sure whether it was the positive or the negative terminal which discolored the potato. “Never mind!” he called. “There's an easier way. We'll consider the red positive, and if the set doesn't work that way we'll reverse the connections.”

All the others, even Grandma Muscadier, looked disappointed that they weren't to be shown what happens to the potato. Brainley resolved to try the experiment himself, sometime, when nobody was around.

NOW the vacuum tubes,” went on the monarch-of-all-he-surveyed. He wagged the rheostats back and forth. “All four of them light. Now for the connections.”

Jack Mabie picked up the direction sheet which had fallen to the floor, and offered it to him. But he declined it, gently. “I think I can trace out the wiring just as well without it, thanks.”

Extraordinary! The others looked at him



“THE MORE THEY LOOKED, THE MORE THEIR WONDER GREW
THAT ONE SMALL HEAD COULD CARRY ALL HE KNEW”

with even increased admiration. Brainley thought of the only two verses of poetry he remembered out of all he had read in school:

The more they looked, the more their wonder grew,
That one small head could carry all he knew.

And so the examination progressed, until all possibilities of bad or broken connections, and other troubles, had been disposed of. But still the set didn't speak a word. They reversed the A-battery connection. Nothing doing. They put it back the way it was. This was all gradually becoming a bit tiresome. The audience was not quite so breathless with interest, their eyes weren't glued quite so tightly as at first, upon the Last Straw.

“The trouble with a radio set,” said Mr. Flash, finally; “is that one little defect puts the whole machine out of business.”

“I guess we'd better give it up for to-night,” said Brainley.

Mr. Flash shook his head in bewilderment. “It's beyond me,” he confessed, in a tone that implied it was probably beyond any one else, too. “Everything's all ready: if we could only put our finger on the trouble, we ought to get a signal that could be heard out on the street.”

MAYBE the tubes don't make good contacts in the sockets,” suggested Junior, who had appeared at one side of the table from nowhere in particular.

Mr. Flash was the only one who bothered to reply to this. “No, it can't be that,” he said gently.

But Junior was not to be squelched so easily. “Well,” he asserted stoutly, “maybe there's a grid contact or a plate contact that's bent so far down in the socket that it doesn't touch the prong on the end of the tube. That was what Joe Brown and I found was wrong with his set, last week.”

His father was impatient. “No no—can't you see they all light?”

“*They would anyway*, if the filament prongs made contact.”

A strained silence followed this announcement. *Would they or wouldn't they?* Brainley didn't know. Mr. Flash hurriedly said, with the air of one who is being polite to the child of the house:

“Well, we can soon see whether the tube contacts are at fault.”

Action again! He took out all the tubes and fished around in the first socket with the tip of the screw-driver. There was a sputter, and he jerked his hand out as if a bee had stung it.

“What's that? What's the matter?” asked Brainley.

“Juice from the A battery,” replied Mr. Flash, as calmly as he could. And he undid one of the connections at the A battery.

“I can't get under these contacts with a



"BECAUSE . . . MR. GRUNT IS SITTING UP IN MY ROOM . . . LISTENING TO THE PRIZE FIGHT"

screw-driver. I wonder if I could have a hair-pin?"

Mrs. Mabie said she hadn't been able to offer any advice, but that she could at least supply the hair-pin. She did, and Mr. Flash began hooking it under each one of the prongs, bending it up a little way.

"First a potato, now a hair-pin," murmured Mrs. Nutmeg to Mrs. Mabie. "They'll be asking us for a china egg next."

After a while, Mr. Flash gave back the hair-pin, somewhat the worse for wear, and replaced the tubes.

"Funny," said Brainley, leaning wearily over the cabinet. "Now the tubes don't even light. I thought we had been holding our own at least, but it seems as if we're going backwards."

"No, you forget the A-battery connection," said Mr. Flash, remembering it himself just in time to make the remark. Brainley bent down, attached the A-battery wire—and a blast of music filled the room! It was some woman singing.

"There it is!"

"Oh, good!"

"Good for you, Mr. Flash!" cried the

women, coming up from the background to join the group round the set.

"Hooray!" yelled Junior.

Brainley was all smiles. "Now to tune in just a bit better," he said. He stepped round more in front of the set, pushing Junior out of the way. In a few seconds the singer's voice was coming in as clear as could be.

Junior seemed to be somewhat disheartened at the treatment he had received, but Jack Mabie clapped him on the shoulder and gave him a sly wink that sent his spirits soaring again.

Then everybody sat down and listened to the singing. At the end of the piece, the announcer gave his call letters. It was a place some distance away. "What do you know about that? 150 miles right off the bat," exclaimed Brainley. They sat still and listened to the next selection. And the next. Marvelous thing, the radio! However, that woman hadn't much of a voice. . . .

Mrs. Mabie was scanning the evening paper. She didn't yet know how to turn directly to the page where the radio programs are, but she finally found them.

"You know—there's a prize fight on to-

night. Why, it's being broadcast by the station right in the city!"

"Yes, it's Kid McDuggin versus Bullethead Jones . . ." began Junior; but he was interrupted by cries of "Oh, do let's try and get it!" "That will be a lot better than the woman singing!" etc., from the others.

Mr. Flash and Brainley rose to the occasion, tuned out the 150-mile woman, and searched for the local station. But they didn't seem to strike the right combination, even with Mr. Flash turning the dials at the right of the panel while Brainley turned those at the left. They did get all kinds of shrieks and groans, however; at which Mrs. Nutmeg put her hands over her ears and said: "Brainley! For mercy sakes—stop those awful noises!"

Brainley stopped, and let Mr. Flash have

all the knobs to himself. Soon a man's voice was heard, faintly.

"Bring him in! Bring him in!" called the others excitedly, as if advising an angler how to play a fish.

Mr. Flash brought him in. It was the announcer at the same 150-mile station, declaring that Miss Spairus was done for the evening.

"My goodness!" exclaimed Mrs. Nutmeg. "Junior, it's eleven o'clock. You ought to have been in bed long ago. Say good night to everyone, dear, and run along up. You can listen to the radio any night, now that it is working."

"But I *can't* go to bed yet", said Junior, earnestly.

"You can't? Why not?"

"Because—Mr. Grunt is up there sitting on my bed, listening to the prize fight."

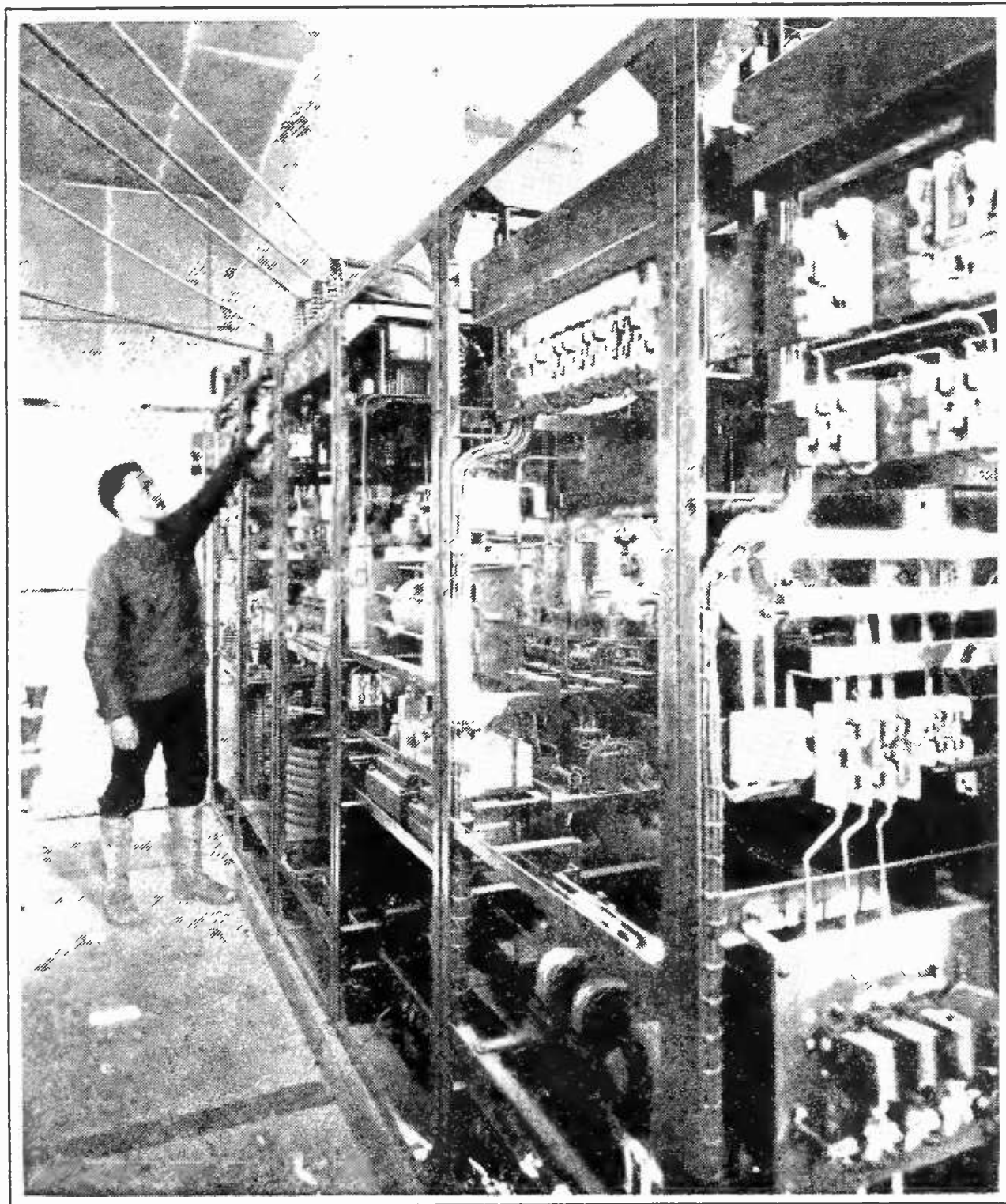

WHAT A FIVE THOUSAND WATT BROADCASTING STATION LOOKS LIKE

From the unromantic side. The operator is shown behind the apparatus panel of the new WLW station at Harrison, Ohio, about twenty-five miles from Cincinnati where the studio is located. Operators in the Cincinnati studio control the station which is located far enough outside the city limits so that the powerful waves of the station will not mar the reception of the local enthusiasts

Progressive Experiment with the Roberts Circuit

By KEITH HENNEY

THIS well-written and extremely enlightening article by Mr. Henney is distinctly not a construction article. The author is a new member of the technical staff of RADIO BROADCAST and has made one of his subjects for experiment in our laboratory, the Roberts circuit. We feel that there is room for a great deal of legitimate and productive experiment with this circuit, which has, as great numbers of radio folk will tell you, very large possibilities. Here Mr. Henney has carefully outlined the technical basis for his suggested experiments and shown why the changes he thinks desirable can be made. Those who have not yet built a Roberts Knockout receiver can do so and make the alterations recommended and those who already have one of them operating will unquestionably be interested in this line of technical thought. The author would be interested to hear from readers who follow in some of the paths here suggested.—THE EDITOR.

TO THOSE who enjoy radio for what it brings from the outer world, the "Knockout" series of receivers employing the Roberts circuit has much to offer. These may be built according to predetermined dimensions and specifications with the certainty that each one will work, or can be made to work. Building a receiver from the various articles about the Roberts circuit is like, let us say, making a cake according to an old established recipe.

On the other hand, there are many inquisitive mortals who enjoy radio *per se*, who like to build, and raze, and then rebuild. For these,

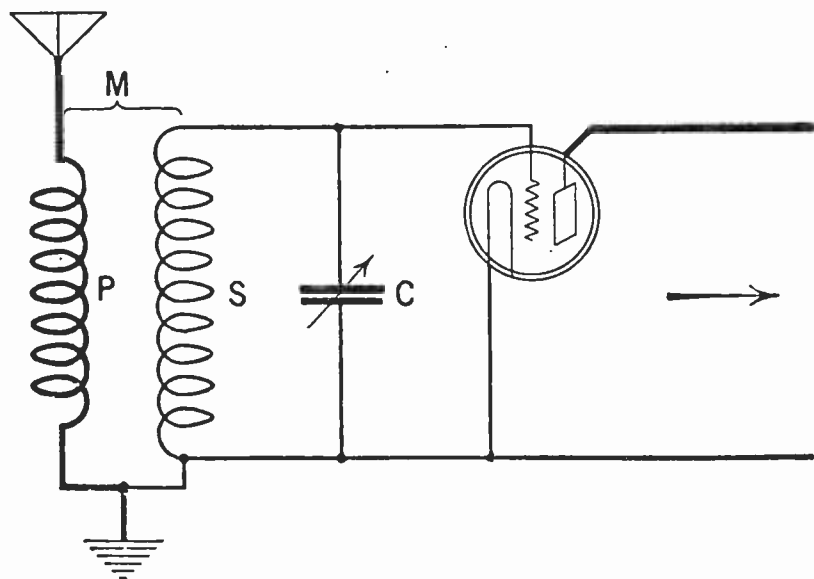

FIG. 1

The antenna-radio frequency amplifier circuit. The four variable elements in this circuit, the antenna coil, P, the secondary coil, S, the coupling, M, between these coils, and the secondary condenser C, are intimately connected with the operation of the receiver

the Roberts circuit has many avenues along which one might find something new.

The several Knockout receivers have been thoroughly described in RADIO BROADCAST and it is not for those who enjoy the completed receiver that this article is written. Rather, it is for those adventurous souls who would like to disprove the statement that there is nothing new under the sun.

Now to experiment efficiently is to experiment with some definite object in view; it is not to tear into the midst of things in the vain hope that somewhere along the line of destruction something interesting may turn up. One might forgive a surgeon who advised the removal of tonsils when one had a sore throat, but if he stumbled around and wanted to carve an appendix or the left middle finger for the same cause, it would be another matter.

The anatomy of the Roberts circuit should be well understood before the actual business of dissection and remodeling is begun. In general, the various sets of the Roberts Knockout series and the circuit upon which they are built is but one of several types of combined radio-frequency amplifiers and regenerative detectors. The Cutting and Washington Teledyne was one of the first commercial examples of this efficient combination. The High Mu receiver described by G. H. Browning in RADIO BROADCAST for December, 1924, was another method of doing about the same thing. All of these combine two prominent patented ideas, that of regeneration

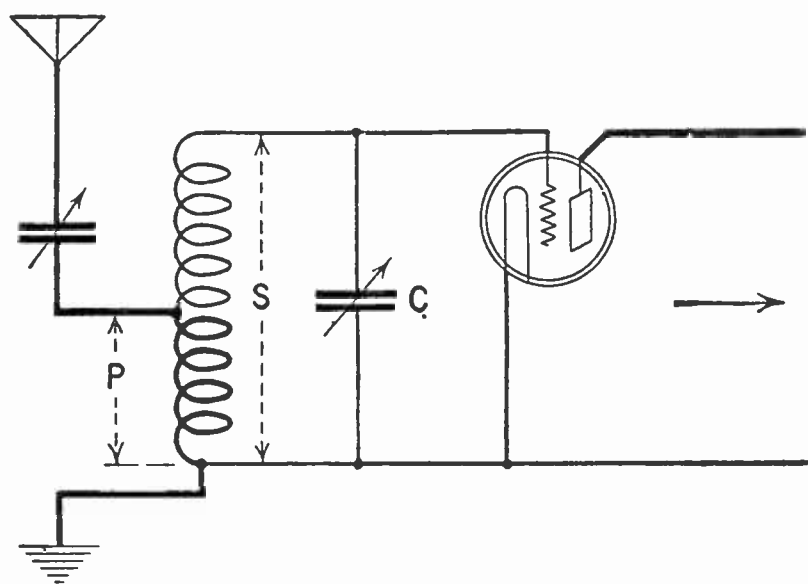

FIG. 2

The series condenser method of connecting the antenna to the amplifier. Once the proper place to tap the coil and the size of the condenser are found, the tuning will be practically independent of the antenna and will be very sharp

and that of neutralization of capacity feedback between the circuits.

The only excuse for these suggested experiments with the Knockout Roberts circuit is to make it better—if possible. There are two points of attack: the amplifier and the detector. Tuning may be made sharper and signals may be made stronger. Both of these are worthy improvements. Another improvement would be a simplification of the tuning; the elimination of the taps and the antenna coil.

THE RADIO FREQUENCY AMPLIFIER

BEGINNING with the amplifier, then, let us see what it consists of and where we might find a point of attack. Fig. 1 shows the conventional arrangement of coils, condenser, and tube. Evidently there are four variable factors:

1. Primary or antenna coil, P.
2. Coupling of primary and secondary coils, M.
3. Secondary or grid coil, S.
4. Secondary tuning condenser, C.

Now the size of the secondary coil and its tuning condenser are intimately related to the wavelengths to be received. We may increase the number of turns on the coil and decrease the number of plates on the condenser, or vice versa. When we increase factor 3 (in the list above), we must decrease factor 4. One has the certainty, however, that better results will always be obtained with the largest practical coil and the smallest practical condenser. The use of a small condenser is advisable because of the fact that a variable capacity has a high resistance near the low end of its scale.

Any one of the orthodox fifteen or seventeen

plate condensers of the "low-loss" variety, that is, a condenser of about .00035 microfarads capacity, will cover the broadcasting wavelength range nicely provided the coil used with it is made properly.

The size of wire and the method of winding are variables also, but until more is known definitely about the importance of these variables it is safe to leave them out of consideration. It has been demonstrated that it is unwise to go to extremes in the matter of size of wire, say larger than No. 18 or smaller than No. 28. At the present time it seems that any of the methods of winding are effective, say the single layer coil, the spider web or the basket weave. The main thing is to see that there are no short circuited turns, and to avoid all forms of "stickem," except an occasional dab of collodion.

The size of the antenna coil and its coupling to the secondary control the sharpness of tuning of this amplifier circuit, and to some extent govern the strength of signals. If the coil is too close or too large, the high resistance of the antenna will be reflected into the grid circuit and will make tuning broad. If the coils are too far apart not enough voltage will be impressed from the antenna circuit and signals will not be as strong as they might be.

A solution to this matter seems to lie in an arrangement attributed to the English circuit wizard, Scott-Taggart. The method is illustrated in Fig. 2 and is quite simple. Instead of using a distinct coil and feeding in the voltage by electromagnetic coupling, the voltage is introduced directly into the secondary circuit by means of a small series condenser. One of the small vernier types, external to the average condenser itself, will

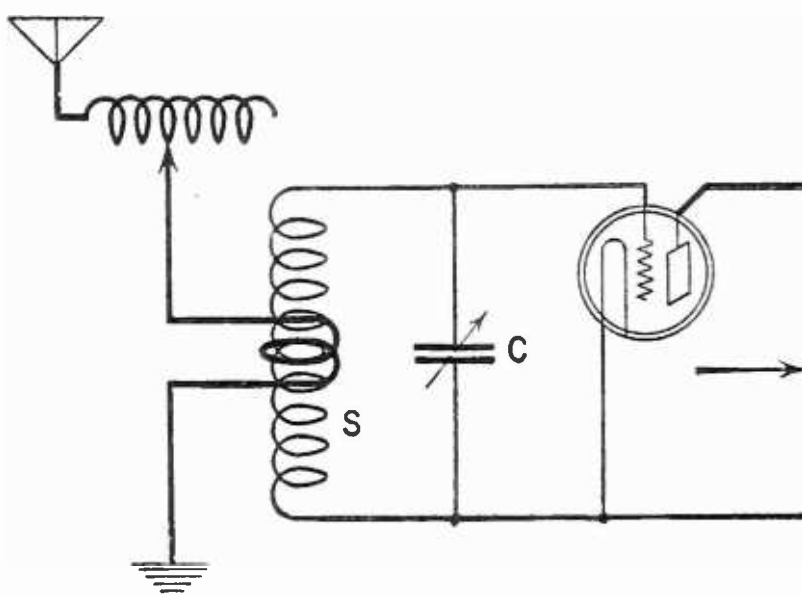

FIG. 3

The series inductance method of tuning the antenna circuit. For each wavelength there is a particular tap and value of the secondary tuning condenser that will give maximum volume and selectivity

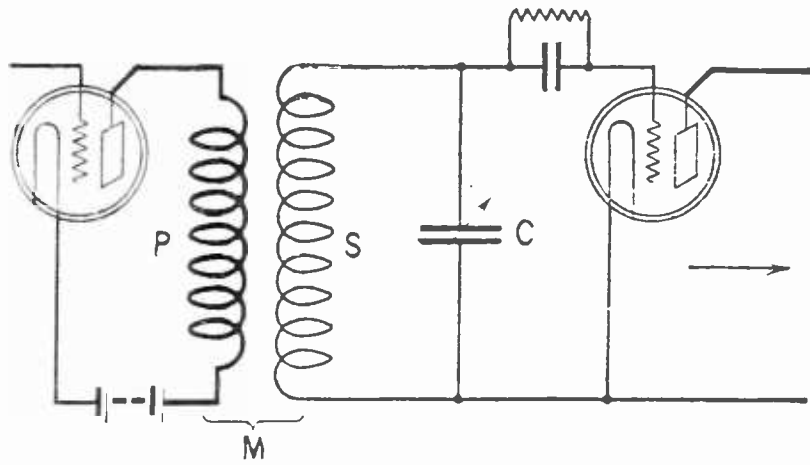

FIG. 4

The radio-frequency transformer. Here again are four variables. Instead of an antenna coil as in Fig. 1 three is a plate coil which serves the same purpose—that of transferring the voltage from one part of the circuit to another. The coupling, M , must be close if the longer wavelength stations are to be heard

do very well, and if one wishes, a fixed condenser, say of .0001 mfd. may be used, and the coil then tapped at two or three places.

The antenna-ground circuit in this case is completed by attaching the ground to the bottom of the coil. If too many turns are included in this antenna circuit, tuning will be broad, but with the proper juggling, a position will be found where the tuning is practically independent of antenna size, and the other taps may be discarded.

Another method is shown in Fig. 3 but is open to the objection that an additional tuning control is necessary. The plate in Fig. 9 shows this arrangement. The antenna coil is tapped but its adjustment is not critical.

For simplicity, the series condenser method seems best. It eliminates one coil and the taps of the Roberts Knockout receivers, and makes the tuning of the amplifier sharper without decreasing the strength of signals. In fact, separating the antenna from the grid circuit by this isolating condenser tends to decrease the resistance of this circuit so that stronger signals frequently result.

THE RADIO FREQUENCY TRANSFORMER

TACKLING the radio-frequency transformer is like experimenting with dynamite. Something is bound to happen, but when or what are unknowns.

In this case the same variables exist. Fig. 4 shows the simplified diagram of this transformer.

Here again the size of the secondary coil and its condenser are controlled by the wavelengths to be received, and the condenser should not be larger than necessary. If the two tuning condensers of the set are alike it is

always possible to adjust the number of turns on the coils so that the dials will read alike for any particular station.

The primary may vary from one turn to as many as one wishes but with various results. The usual commercial neutrodyne uses about ten turns or less, which are scarcely enough to get full gain out of the amplifier. Five-tube sets which are not manufactured under Hazeltine licenses use fewer turns on the primary so that there is little danger of the amplifier oscillating.

The effect of varying the ratio between the primary and secondary turns is not so obvious as it may seem. In low frequency circuits, the voltage across the secondary of a transformer depends directly on the turn ratio, but this is not the case in high frequency circuits. Because of this there is no reason in trying for a high "step-up" by cutting down the primary and increasing the secondary turns.

Too few turns will not transfer enough voltage from the plate circuit, especially at the longer wavelengths. Too many turns distort the amplifier characteristic so that the low wavelength stations are slighted. And without complicated laboratory equipment the experimenter is not able to find the correct ratio of turns except by cut and try. The best ratio is the one that brings in stations about the middle of the broadcasting range loudest, say those around 360 meters.

In the Knockout spider web coils the primary has 22 turns. In the High Mu receiver there are 26 turns—both being at least twice the number on most commercial neutrodyne. With many turns in the plate circuit of the amplifier tube the tendency toward oscillation is greater, and more care must be exercised in arranging the apparatus to eliminate feed-

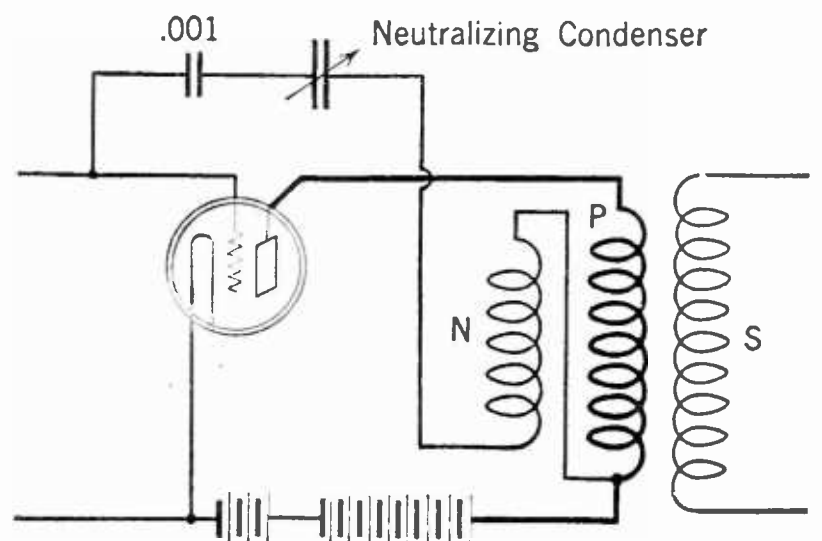

FIG. 5

A method of protecting tubes in case the neutralizing condenser becomes shorted. The additional condenser may be of any size provided it is larger than the neutralizing capacity

back. On the other hand, the amplifier with 20 turns in the plate circuit will perform better as an amplifier once it is properly neutralized, and the long wavelength stations will receive their amplification.

The matter of coupling between the two coils of the radio-frequency transformer is important, and the inability of many receivers to pick up the longer wave stations lies in neglect of this important point. To get maximum voltage transfer, maximum coupling must exist between primary and secondary. This coupling must be electromagnetic, and electrostatic coupling must be reduced to a minimum. The High Mu receiver already mentioned employs an interesting method of eliminating capacity coupling, and to some extent the receiver illustrated here does the same.

The primary is a typical Knockout affair—two wires simultaneously wound into a compact coil. It has recently been found that greater ease in neutralizing will be obtained if the two wires are twisted together before winding. This may be done by placing two ends of the wires in a vise or some other support and twisting the wires together by means of a small hand drill.

The secondary should be as close to the primary as possible but without actual overlapping of wires, which has the effect of short-

ing several of the secondary turns with resultant broadness of tuning. Loosening the coupling between the coils is often useful in eliminating unwanted signals, but to get maximum voltage from the amplifier to the detector the two windings would be close together. Fig. 10 shows one method of making the coupling variable.

NEUTRALIZING METHODS

THE neutralizing condenser must be somewhat larger than the ordinary and care must be taken that it does not "short" for that would place the B battery voltage across the filaments. One method of preventing loss of tubes from this cause is shown in Fig. 5. A large condenser, say .001 mfd., is placed in series with the neutralizing condenser.

Since the Knockout is a reflex arrangement, the usual method of balancing out the capacity feed back with the amplifier tube unlighted is impossible. One method is to listen with the phones in the amplifier as usual and to tune the two circuits to the same wavelength. If the amplifier is any good at all it will oscillate, a phenomenon that is easily recognized. Then the neutralizing condenser may be adjusted until oscillations cease. It will be found that the adjustment is somewhat critical and increasing the capacity beyond the required point will cause the amplifier to oscillate

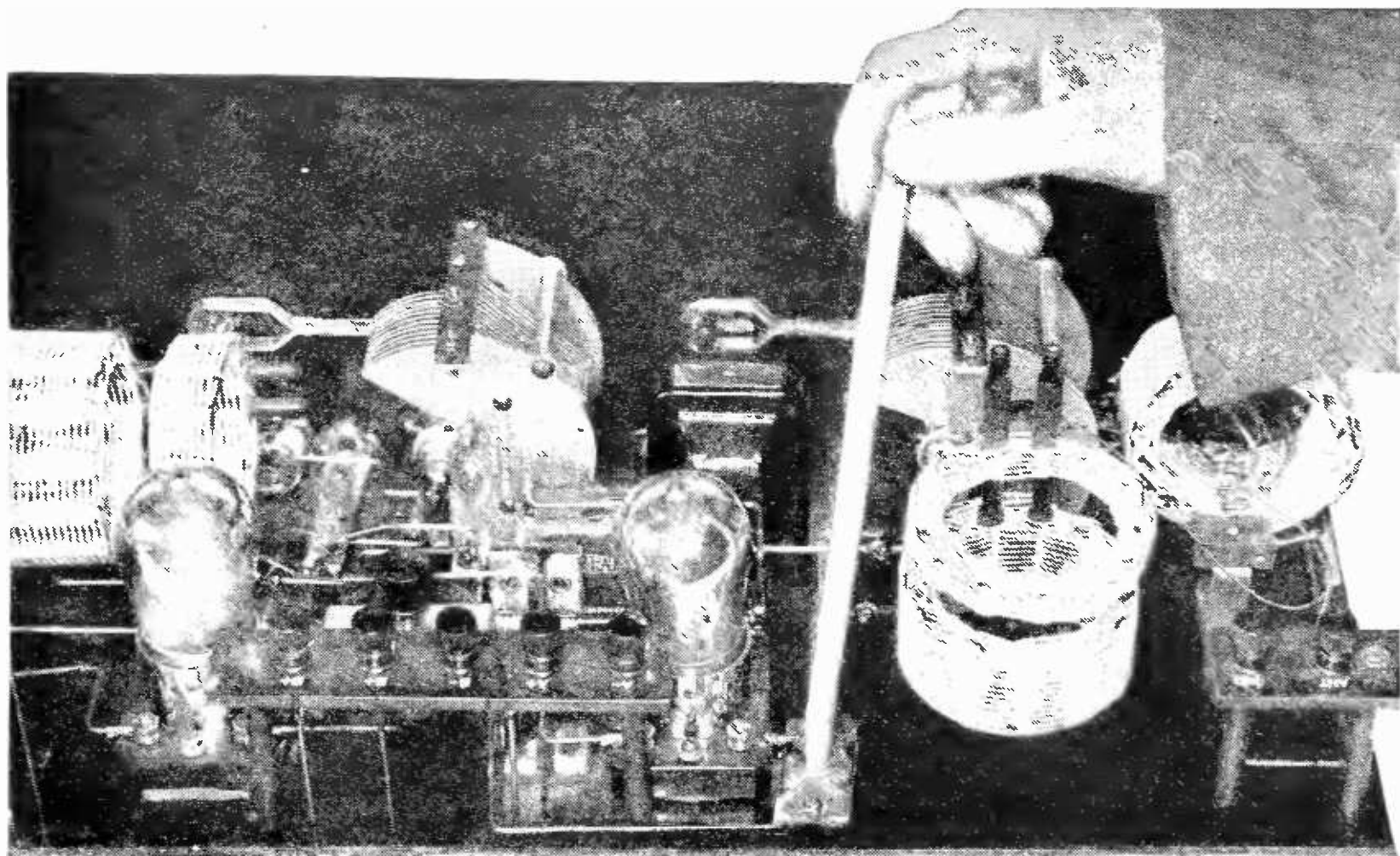

FIG. 6

A photograph of a convenient neutralizing condenser which may be adjusted as the photograph shows, so that the operator's hand does not come near enough to cause bad capacity effects

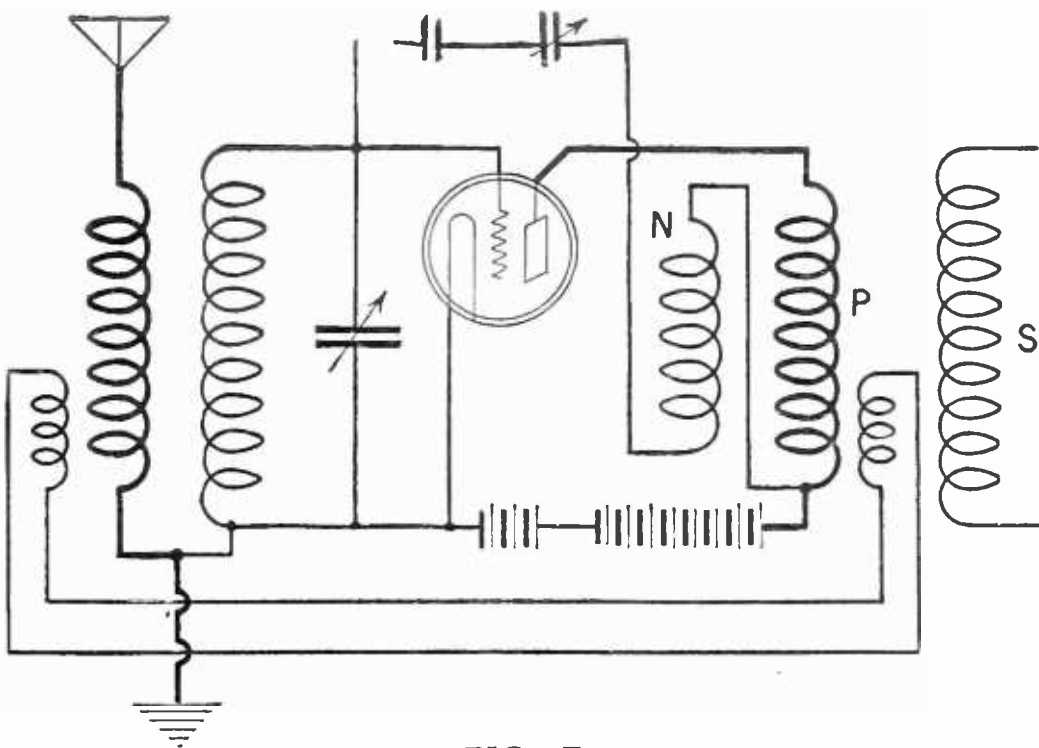

FIG. 7

A stunt for the "DX" seeker. The sizes of the coils that convey some voltage from the antenna directly to the detector and the coupling to their respective circuits must be determined by experiment. Interesting results have been obtained in preliminary trials of this scheme

again which results in effect, in a miniature Hartley circuit. In this method the tickler should be shorted, or at least turned to minimum coupling with the secondary so that the detector circuit does not oscillate.

Another method is actually to make the detector oscillate, and to tune to some carrier wave. Then the neutralizing condenser may be adjusted until the carrier wave does not change in pitch when the amplifier tuning condenser is varied.

A particularly useful neutralizing condenser is shown in Fig. 6. This may be adjusted with a stick whittled into the shape of a screw driver, eliminating the bad capacity effect of bringing the hand near the condenser itself.

THE SECONDARY WINDING

THE secondary winding should always be as large as possible with the condenser that is used. For the experimenter who winds his own coils, the correct number may be found by putting on too many to begin with. Then the longest wavelength station that is to be received is tuned in, and the coil reduced in size, one turn at a time until the station is tuned near the top of the condenser scale.

The end of the winding near the primary goes to the filament and the other to the grid. With some tubes it is better to connect the coil to the negative filament lead instead of the more usual connection to the positive. The proper polarity may best be determined by experiment.

A SUGGESTION WITH POSSIBILITIES

FOR the dyed-in-the-wool experimenter, a new scheme has been suggested for boosting signal strength. Fig. 7 illustrates

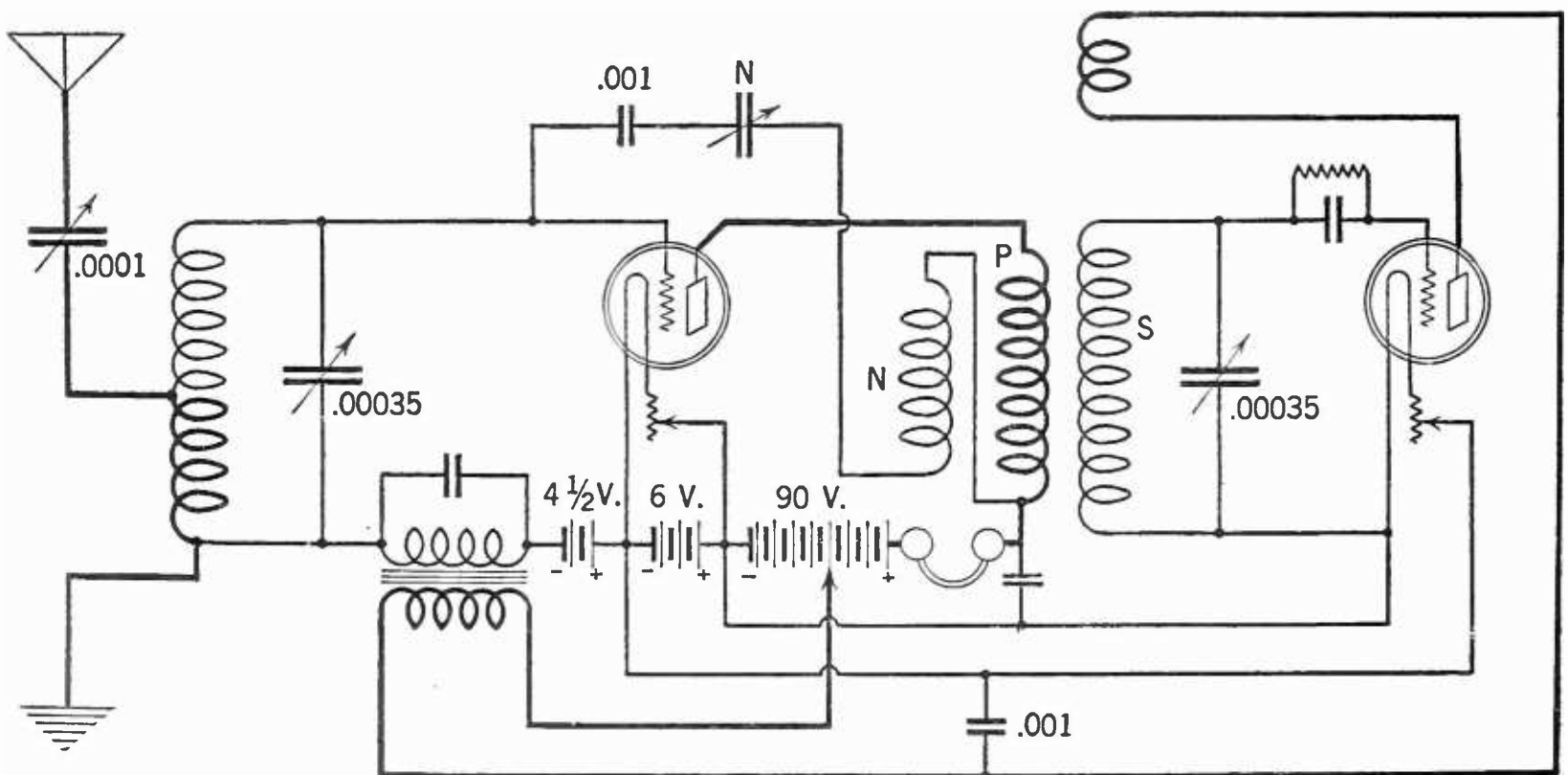

FIG. 8

The complete Roberts circuit. If condensers of other capacity than the .00035 mfd. shown here are used, corresponding changes will have to be made in the secondary coils. The fixed condenser across the phones in the amplifier should be about .001 mfd. and that across the secondary of the reflexed transformer as small as possible

this stunt in symbolic manner. A few turns from the antenna are placed near the primary of the radio frequency coil, with the object of feeding some of the antenna voltage directly into the detector circuit. In preliminary experiments on this modification in the RADIO BROADCAST Laboratory, some interesting results were obtained, but definite information as to the proper number of turns and coupling is not yet ready.

BY-PASS CONDENSERS

IN ALL reflex circuits the by-pass condensers are important items. Across the primary of the audio frequency transformer is a condenser to pass the radio frequencies around this high impedance coil. Unless this condenser is large enough, the detector circuit will not oscillate. On the other hand the condenser must not be too large or some of the high audio frequencies, say those of the piccolo or higher violin harmonics, will not be heard. This statement applies to all condensers that are used around audio-frequency transformers. The muffled tones that are often heard are due to oversize condensers.

The condenser across the secondary as shown in Fig. 8 should be as small as possible, for a small capacity here has the same effect as a large one across the primary. The experimenter should begin with the smallest condenser available, as say, .0001 mfd. and increase its value slowly until full gain is secured from the amplifier.

Another scheme that may be used is to use a grid leak across the secondary instead of a condenser. Its value is best determined by trial.

OTHER VARIABLE ELEMENTS IN THIS CIRCUIT

THE photograph in Fig. 9 shows the use of a variable grid leak—The Fil-Ko-Leak—that is very useful. This has any value up to and including 6 megohms, a range that is practical for any of the tubes now obtainable. For some tubes the value is quite critical and the simplicity of obtaining the required resistance appeals at once to the experimenter and the one who wants to adjust his receiver to the top notch of efficiency, and to leave it there.

In the original Roberts Knockout receiver, a voltage of 45 was recommended for the detector, a value which gives the maximum signal strength with average tubes. Tubes, however, are not all alike—would that they were!—and what is sauce for the goose is not always sauce for the gander. Too much B battery on the detector makes the tickler function irregularly and the detector too difficult to control. Too little B battery and the detector circuit refuses to oscillate at all. The correct value may lie anywhere between 16½ volts to above 45. The only approved method of discovering that elusive value is by experiment.

Connecting the negative B battery lead to the negative A battery gives a reduction of approximately 6 volts (with storage battery tubes) in the voltage to the detector, and is one method of adjusting this variable.

The photograph in Fig. 9 shows a set in which all the variables are present. The antenna coupling to the amplifier, the primary and secondary of the radio frequency transformer, the grid leak of the detector, the

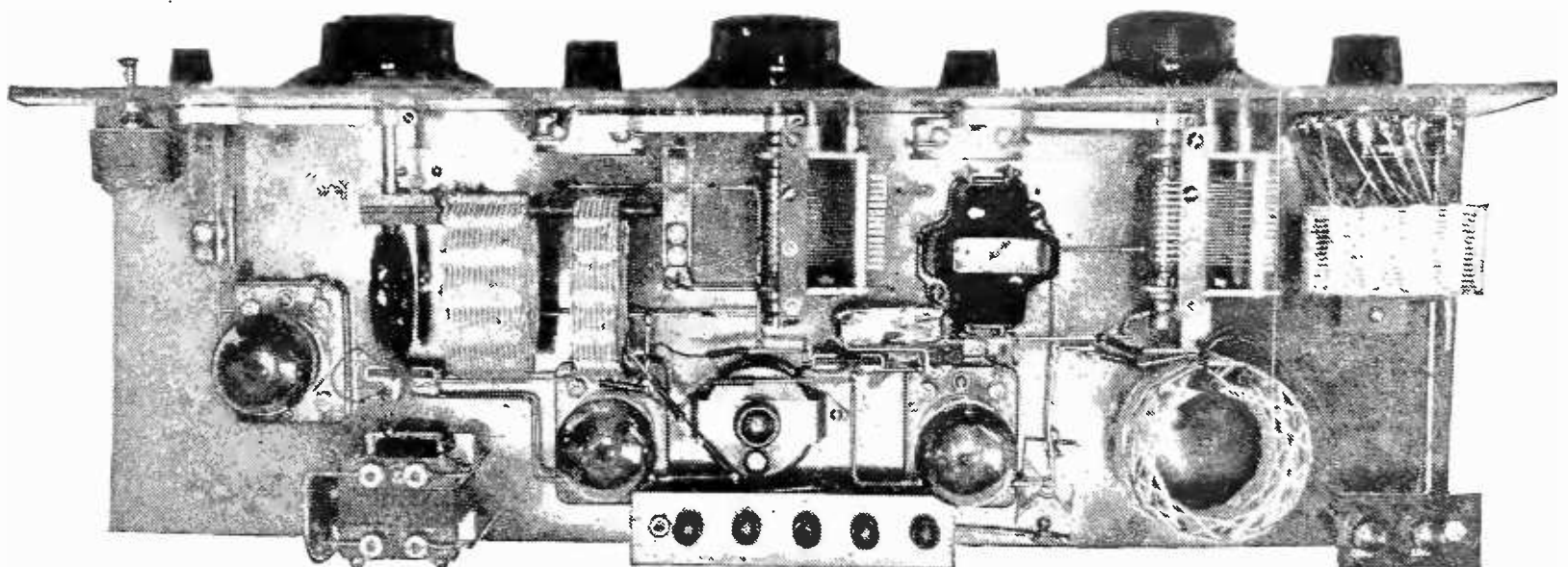

FIG. 9

A photograph of a receiver that is a veritable experimenter's paradise—everything is variable. The method of changing the coupling between the antenna coil and the amplifier as well as the series inductance method of tuning the antenna circuit is shown here. A variable grid leak may be seen near the binding posts. In this case the value was 2 megohms. The variable resistance was calibrated and was remarkably accurate for an instrument of its small size

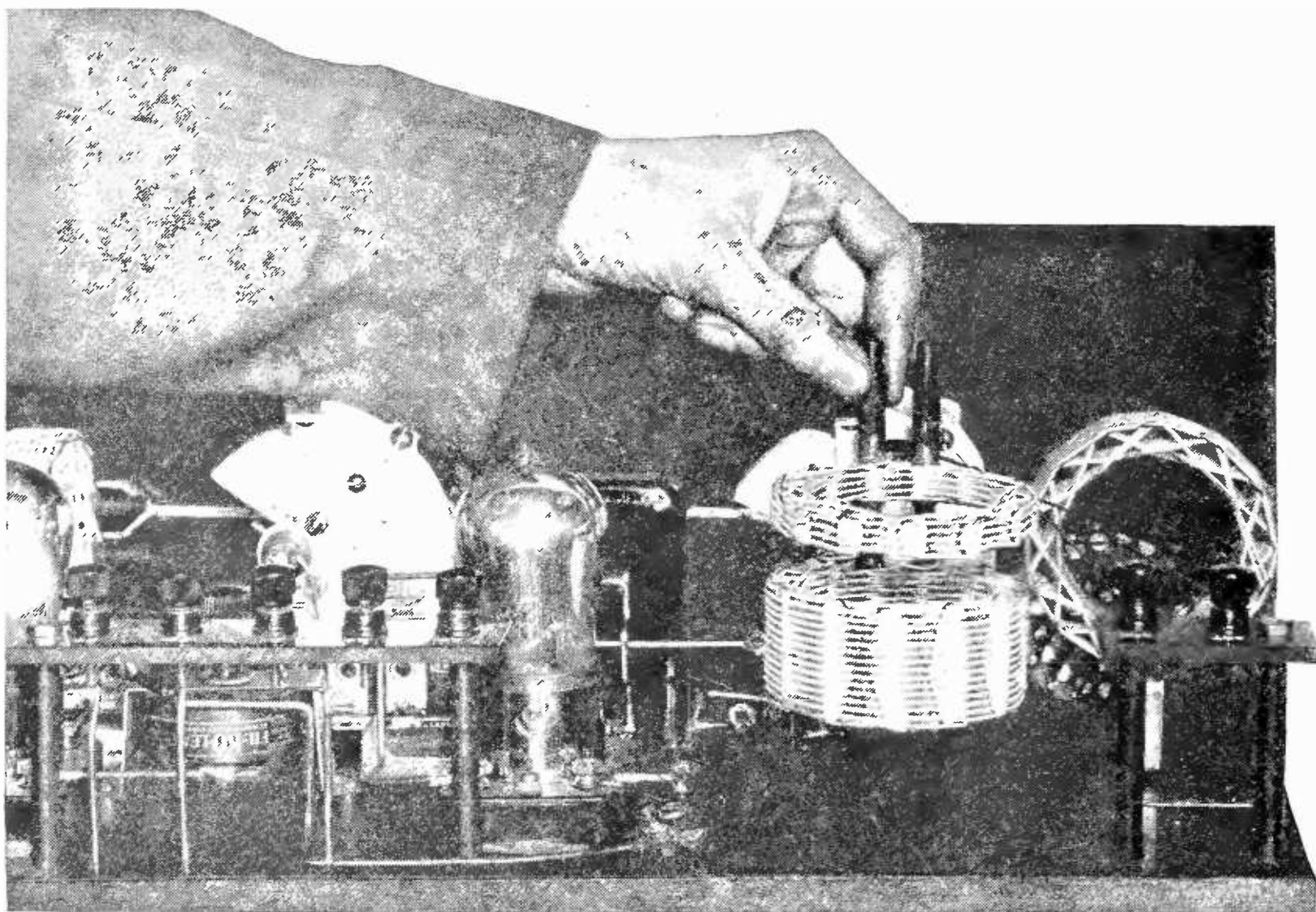

FIG. 10

The variable coupling between the primary and secondary of the antenna coupling coil is interesting to the experimenter. For selectivity the coupling should be loose, but when longer wavelength stations are received the two coils should be as close together as possible

neutralizing condenser—all are variable, a rather complicated state of affairs but one in which the experimentally inclined may be sure of getting the maximum results at all times.

There is another variable factor that has been discussed in recent radio articles, and that is the effect B battery voltage has on the radio frequency amplifier. The point has been raised that there is no use in placing full 90 volts on the tube of this amplifier, since there is no necessity for power amplification here but only for voltage step-up. The idea is that with decreased plate voltage, the current drain from the B batteries would be correspondingly decreased, which tends toward greater economy.

Unfortunately another point enters here that the uninitiated does not seem to know. We refer to vacuum tube operation and the mathematics of radio-frequency amplifiers. The facts are these: The voltage amplification produced by this tube depends inversely upon the plate impedance of the tube. The impedance in turn depends inversely upon the plate voltage.

In other words, the greater the plate voltage, the lower the plate impedance, and the greater

will be the amplification. The drain from the B batteries may be kept down to the proper limits by the judicious use of C batteries. The fact that the Roberts Knockout is a reflex circuit in which audio frequency currents are also flowing in the plate circuit of the first tube makes even more important the matter of proper B and C voltages on this tube.

It is a distinct advantage in the Knockout receiver to use as high plate voltages as possible and at the same time to keep down the B battery drain by means of C batteries. Ninety volts is none too much to use on the amplifiers, even 125 may be used provided the proper care is taken. As much C battery as possible should be employed consistent with good quality and good volume. It will be found that the C battery is very important, better signals always being secured when this voltage is correctly adjusted.

Standard apparatus was used throughout this receiver. The first transformer is a General Radio No. 285 and the second, a No. 65A Federal. The condensers are Gardner and Hepburn. The coils are "Supercoils" made by the Perfection Radio Manufacturing Company.

As the Broadcaster Sees It

By CARL DREHER

Drawings by Franklyn Stratford

Should Broadcasters Serve Local or Distant Listeners?

ONE of our readers, Mr. A. R. Cochran of Chester, Pennsylvania, complains of the difficulty encountered by distance hunters when they come across a station which does not announce its call letters at frequent intervals. The receiver being painstakingly tuned to the distant signal, the listener waits breathlessly for the end of a number, only to have the music start again without any announcement to give him the information he seeks. In DX fishing, the listener's time is limited: he cannot linger too long on any one wavelength if he is to grind out an imposing aggregate mileage to brag about on the 7.32 the next morning. Furthermore, he runs the risk of fidgeting through a number of selections, and then losing the announcement if the transmitting station happens to be down in a trough at that moment, and the signal drops below the omnipresent background of squeals, static, and induction. At bottom, the listener-for-distance is a person who gambles on fluctuations of signal strength against noise—and the noise is always present if one amplifies enough. Naturally, therefore, this class of listener feels aggrieved when the broadcaster does not cooperate with him by frequent emission of his call letters. He wants more. As every user of the telephone knows, some of the letters of the alphabet, like C, B, and D, are easily confused. The vowel component is the same in each case, and the consonant is apt to be lost in the shuffle. Mr. Cochran accordingly revives the proposal to assign names to the

letters, a procedure which has found successful application in various methods of code signaling. "wGY" would be announced as "Watch George Yoke." "Watch Boy Able Pup," it is pointed out, could not be confused with "Watch Pup Able Boy," as readily as WPAB may be read for WPAB.

This is all very logical, but immediately the question arises: Is it the purpose of a broadcasting station merely to distribute its call letters far and wide, or is it its object to give a program service, and if both these demands must be met simultaneously, to what extent shall one be subordinated to the other? As soon as we look at the question from this angle, the existence of two opposing bodies of opinion becomes apparent. One school looks at broadcasting as a game or competition in which one tries to beat out the elements and one's fellow listeners. The other party looks at broadcasting as a source of entertainment and instruction. It is my opinion that the future belongs to the party of the second part. However, let us proceed to a discussion of the question from both sides.

What does the DX hound get out of his hobby? First, the thrill of annihilating distance, in a certain sense. There is a kind of

Olympian triumph in listening to sounds coming from the other side of the continent. Secondly, there is the zest of competition. Not everyone can get distant stations. Here we have the I-can-take-any-hill-on-high psychology. In early youth, it's "My big brother can lick your big brother." But it is quite human at any age, and not

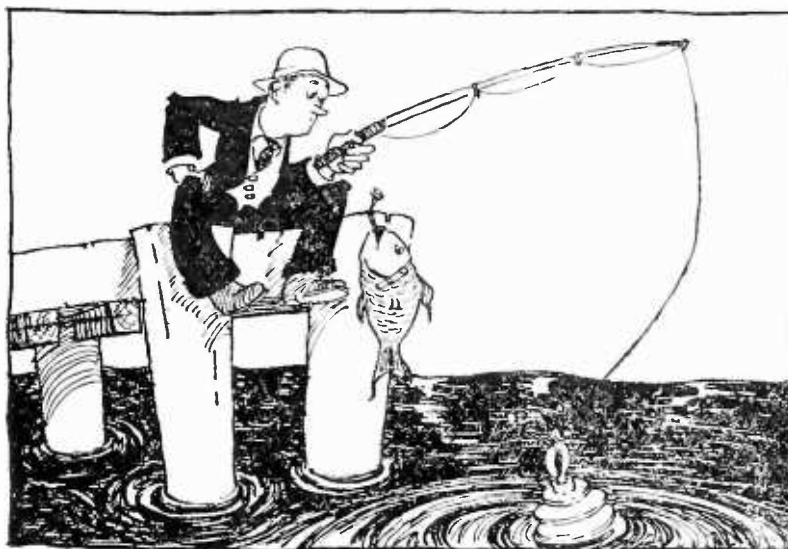

fishing' for radio distance

everyone can shoot tigers in India, or climb Mt. McKinley, or explore the polar regions. Such epic feats require space and money, and who will begrudge the denizens of city apartment houses, possessing none too much of either, getting what throb they can out of their radio sets? Thirdly, if one builds one's own set, or studies the operation of receivers, whether factory- or home-made, there is an element of technological education. There may be other factors besides these three and their corollaries, but I believe that most of the impulses behind the DX game may be classified as above.

To a disinterested witness, DX fishing seems about the same sort of thing as the feat of a graduate student at Columbia in writing six hundred words on the back of a postage stamp. It wasn't useful. It wasn't salubrious. It didn't make old Henry Barnard lean over the ramparts of heaven to applaud the scholarly achievement of this student of his university. The words that were written may have been worth reading, but one would go to a book to read them, not to a postage stamp. All one can say for the feat is that it amused that particular young man, that it quickened the sense of living in him. That is about all that one can say about DX reception. Perhaps that is a good deal. At the worst, *De gustibus non est disputandum*, or, in other words, Let everyone go to—Ahem—in his own way.

That is all there is to be said from a personal standpoint, but something may be said in the interest of the program directors. I am an engineer, not a program man, but I know enough of the problems of these harassed pioneers, whose work will probably be appreciated at its worth when they are dead, to give what I am sure would be their reaction to the proposal to use code words in place of letters. The letters themselves have no program value, but at least they are meaningless and innocuous. In the show business—and broadcasting is a branch of the show business, let it never be forgotten—it is only a short step from the sublime to the ridiculous. Nor does one like to risk annoying the audience by any conspicuous repetition of the commonplace. "Watch George Yoke," dinned too often into the ears of the Schenectady populace, might cause distressing reactions. It would not be a very fitting termination for the "Marche Slav." It would not be a romantic interlude between dances with a beautiful girl. If I had anything to do with running off WGY's program I should boggle at "Watch George

Yoke," and take my chances with the wrath of the listeners in Lower California.

Is it at all certain that call letters or arbitrary designations will continue to be used for identification of broadcasting stations? Are not these symbols a vestigial left-over from the purely telegraph days of radio? Would one assign call letters to the Odéon of Paris, or to Covent Gardens, or to the Metropolitan Opera? The day will come when broadcasting stations—some of them, at any rate—will be on this artistic level, and, as a matter of course, their programs will be heard all over the world. Then where will be the thrill of hearing distant stations? When everyone can do it, there will be no fun in it. There will be no more use for call letters when radio arrives at that stage than there would be for tree-blazes in a city park.

Furthermore, the urge to hear and be heard over thousands of miles leads to a frame of mind at least indirectly opposed to sound program considerations. As this article is written, a St. Louis station announces that on a certain day it is going to broadcast continuously for eighteen hours, in the expectation of being heard all over the world. Have they made certain that they are going to have something to say which should be heard all over the world? Eighteen hours is a long stretch. How much of the eighteen-hour output is going to be worth hearing? Would it not be just as well to have an automatic machine sending, "The quick brown fox jumped over the lazy dog," and signing the call letters every four seconds? Best of all, why not go the whole hog, simply repeat the call letters interminably, and let it go at that?

In building up this *reductio ad absurdum*, and in presenting the various aspects of this question as they appear to me, I have no desire to be dogmatic. I do not assume the powers of an arbiter for 500-odd broadcasters and heaven knows how many million listeners. Has anyone else something to contribute to the symposium?

How Many Radio Receivers Are There?

UNDER the direction of Borough President Connolly, a radio canvass was recently made in Queens, New York City, and a total of 34,994 receiving sets was found. Queens has a population of 470,000. Assuming that the canvass was accurately carried out, it would appear that in this locality there is one radio set to about 13.5

of population. With this figure as a starting point some approximations may be made as to the actual number of radio receivers in use in the United States.

Queens is a part of New York City, but, next to Richmond, it is the most sparsely settled of the five boroughs. The density of population is about 4,343 to the square mile. Richmond has 2,050 to the square mile; the Bronx, 17,900; Kings, 28,500; New York County (Manhattan) averages no less than 103,900 to the square mile. These figures are from the 1920 census. The great variation in the degree of urbanization and the density of population, even within the borders of New York City, is quite apparent.

If we assume that the inhabitants of other parts of New York City have gone in for radio to the same extent as those of Queens (one set to 13.5 persons), then, the population of New York City being about 5,623,500, there must be some 420,000 receivers within the city limits—say 450,000 to allow for the increase in population since 1920. Taking the population of the metropolitan district, comprising New York City, Westchester County in New York State, and most of seven adjacent counties in New Jersey, as about 8,000,000, there must be some 600,000 sets in this district.

On the basis of 100,000,000 as the population of the United States, half of the population being classified as urban, at the rate of one set to 14 persons, this section of the citizenry has absorbed some 3,500,000 receivers. In the remaining rural portion probably the percentage of receivers to the population is not over a quarter of the ratio disclosed in the Queens census. This would amount to 900,000 sets in rural territory, or a total of 4,400,000 for the entire country. This figure agrees fairly well with the conjectural totals of 3,500,000 to 5,000,000 receivers in the United States which have been offered by various estimators.

The writer is just enough of a statistician to insist that his results are not accurate to better than 25 per cent. high or low. Those who are booming radio will add the 25 per cent. and those very vocal gentlemen who insist that radio is ruining the theater, the varnished pretzel industry, etc., have the privilege of subtracting 25 per cent. if it will make them feel better.

If a radio census could be carried out in several rural counties a more accurate estimate of the number of radio sets in the country would be possible. The weakness of the

above estimates lies in the fact that they are based on a ratio obtained in one urban locality. The average density of population in New York State is only about 220 per mile, or about one twentieth of the density in Queens. In Nassau County on Long Island the figure is 460 per mile, while in Hamilton County it is 2.3 per mile, which is close to the figure of 1.0 per square mile taken as frontier population in political economy. If reliable figures on the number of radio sets in representative counties like Erie, Ulster, and Suffolk could be obtained, a reasonably accurate total for New York State could be calculated, and this might be adapted to other states.

“Pioneer’s” Static

THE New York *Herald-Tribune* runs a daily column of radio criticism, “Last Night on the Radio,” by “Pioneer.” Recently the first “Pioneer” departed, not, we are happy to say, from the earth, but merely from the lists of broadcasting comment, where he had engaged in many a scuffle and knock-down-drag-out fight. In making a respectful bow to his successor, and wishing her all the luck in the world in a profession where one needs it, heaven knows, we must say a word about Pioneer II’s use of the word “static.”

In the issue of December 31, 1924, it was stated that “the shrill wail of static intruded upon speeches and songs.” We have heard static crash, bang, grind, click, and growl, but never, in our hearing, has the monster wailed. We thought immediately of oscillating receivers. On January 12, 1925, Pioneer spoke of atmospheric disturbances which “sent shrieks of static to mar the patient voices of the singers.” Finally, on January 15th it became clear that to Pioneer “static” meant any interference, artificial or natural, with clear transmission, for she referred to a musi-

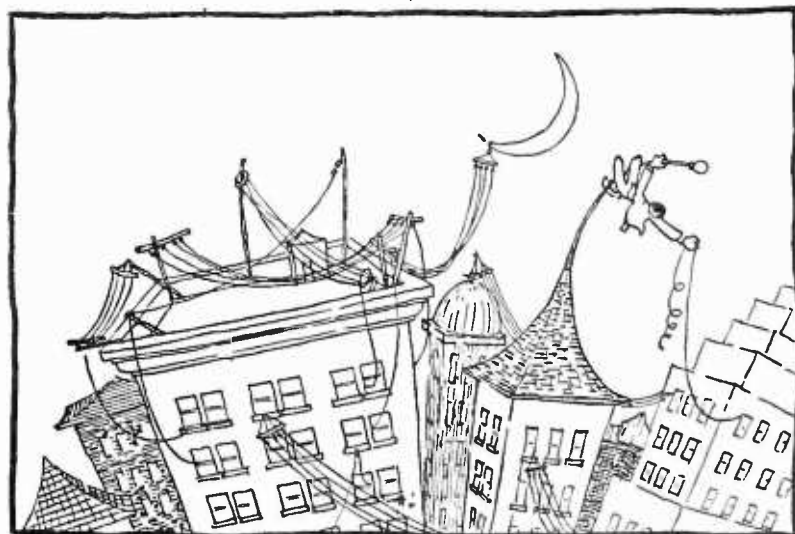

one radio for every 13½ citizens

cal feature "transmitted to that slight whistling accompaniment of static which we have noticed of late from——." Incidental comments were "overwhelmed in the rush of static noises." "This defect in transmission is due," we were told, "to some malady of the . . . microphone . . ."

"Static," in orthodox engineering terminology, is applied only to disturbances arising from electrostatic charges accumulating on a receiving antenna. "Strays" is the proper name for other natural disturbances with reception, generally originating in local or distant lightning. However, both static and strays are loosely grouped under the single term "static." This word is never properly applied to man-made disturbances. It was so used in a series excellent articles in RADIO BROADCAST on inductive disturbances by Mr. A. F. Van Dyck, but purely as a figure of speech. "Heterodyning," "squealing," "howling," "induction," "line noise," "cross-talk," "crossfire," "oscillation," "commutator ripple," "tube hiss," are a few of the names applied to various forms of artificial disturbance. To the expert, every little noise has a meaning of its own.

It is quite possible that technical radio terminology will diverge from the popular lingo much as in medicine and other fields. The man in the street talks of his "breast-bone," where the physician uses "sternum"; he speaks of an "ear-inflammation" where the professional medical man refers to "acute otitis media." As often as not the popular term means the same as the more esoteric technical expression; frequently, however, the latter has the advantage in definiteness and accuracy. The technical nomenclature is valuable, in another respect, it enables the technician to feel superior to the layman, and to write articles like this one.

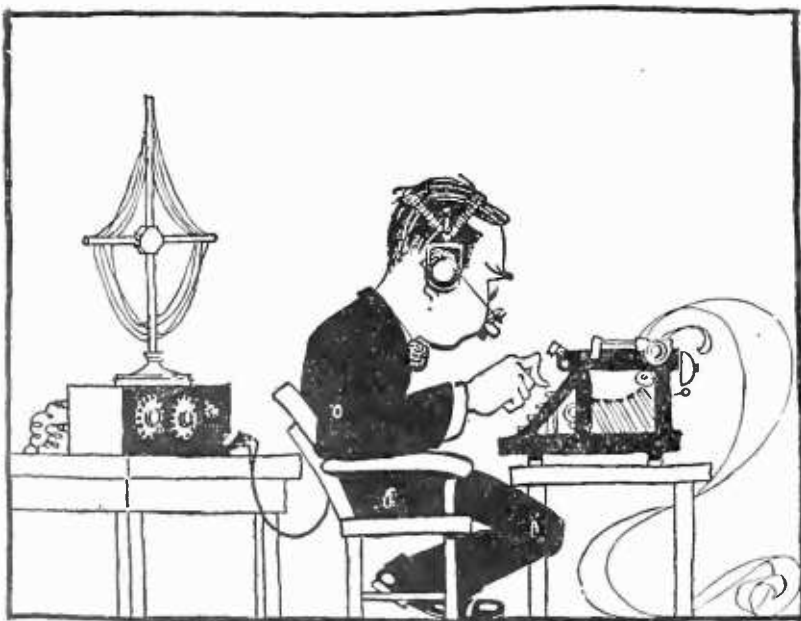

the radio critics are here to stay

Molly and the Paint

OUR estimable neighbor, Miss Mix, in "The Listeners' Point of View" for February, cites a WGY program in which a waltz, "Take a Look at Molly," is followed by a lecture on "The Metallography of Paint," after which appears the fox trot, "Jealous." Miss Mix then inquires whether anyone but the compiler of this program knows why a talk was put in such a place; she suggests, furthermore, that the compiler himself may not know.

In the course of our scientific investigations we have on many occasions found it necessary to inspect the lips, cheeks, and eyebrows of beautiful girls at close range. None of them was named Molly. All of them, if we may set it down without betraying confidences, enhanced their loveliness with various daubs and pigments. May it not be that the WGY program wrestler, looking at some Mary or Minnie or Molly in the office, had his mind driven, by an irresistible and logical association of ideas, to the subject of paint?

More Data on the Differentiation of Broadcasting Stations

THE New York *Times* of January 15th carries a news item stating that the Paulist Fathers are installing a 500-watt broadcasting station at their headquarters on 59th Street, the programs to include concerts by the Paulist Choristers, lectures by well-known Catholics, both clergymen and laymen, and instruction in the principles of the Roman Catholic church. Of course this is not the first broadcasting station to be operated by a religious organization, WQAO of the Calvary Baptist Church, and WBBR of the People's Pulpit Association being local predecessors in this field. The new station, whose call letters are to be WPL, is perhaps the first major broadcasting venture of the Catholic church in this country: the evangelical creeds, in general, have been less conservative.

Religious broadcasters are existing examples of specialization in radio program material. In the nature of the case they are limited to serious music and discussions. Jazz and humor have no place on their programs. Their object is to edify, not to amuse. At present practically all the New York stations, even the distinctively jazzy Let's-go-boys type, carry some sermonic or sacred material. In time, perhaps, this class of broadcasting will be taken over largely by specialists.

An SOS Log

IN OUR previous disquisition on the subject of "Broadcasting and the sos" we made the statement that the inland broadcasters, under the present system, do not pay much attention to sos calls on the high seas. We now present in substantiation our log of January 1, 1925, taken in New York City. We did not listen on wavelengths below 450 meters. The deleted entries represent radio telegraph traffic which we are not at liberty to divulge.

January 1, 1925.

- 12.30 A.M. QRT SOS NAH New York broadcasters go off air.
- 12.32 WHO Des Moines, Iowa, broadcasting. 522.3 meters.
- 12.33 _____
- 12.42 wcx Detroit, Mich., 516 meters. Broadcasting jazz—"Follow the Swallow," etc.
- 12.44 woc Davenport, Iowa. "What'll I Do?" and other dance numbers. 498 meters.
- 12.45 _____
- 12.47 KYW Chicago, 535.4 meters. Someone broadcasting request messages and smart patter. Says it's 10 minutes to 12.
- 12.49 _____
- 12.50 _____
- 12.56 WCAE Pittsburgh. Dance music Silver-town orchestra from New York by wire. 462 meters.
- 12.58 _____
- 12.59 _____
- 1.00 _____
- 1.01 Chimes on about 500 meters. Apparently Davenport. Then puts out noise and general merriment in studio.
- 1.05 As above (1.01) signs. Yes, it's woc.
- 1.09 wcx Detroit *Free Press* still on dance music from Book-Cadillac Hotel.
- 1.11 _____
- 1.14 woc on studio program. _____ Tenor, "Land of the Sky-Blue Water."
- 1.19 _____ woc lets a little wire talk go out changing to field pick-up.
- 1.30 sos not yet clear. Off watch.
All above reception was on super-heterodyne and loud speaker.

How Can Broadcast Operators Be Trained?

AS FAR as we know, there is no established school for broadcast radio operators in the United States. Schools for telegraph operators, both wire and radio, exist in sufficient number to meet the demand. But if a young man wants to be-



the making of a radio program

come a technical broadcaster, his only chance at the present time is to get into the employ of some station and to learn the business there. And, as the public becomes more critical and the broadcasters more careful, that chance, at least in the larger cities, is likely to become a slim one.

The source of supply for broadcast operators, up to this time, has been largely from the radio telegraph field, both commercial and amateur. Sea-going operators who had become tired of the briny deep got jobs on shore running broadcasting stations. Some of them, with a good ear for music and an interest in acoustics, added to that part of the technological foundation which is the same for radio telegraphy and telephony, turned out very well. Others with less aptitude for the new field got in and stayed in because the station owners knew even less than they did. Still others made blunders so egregious that they were discharged and became garage mechanics or salesmen. The more talented candidates likewise made blunders, of course, but they did not make the same mistake twice. Also, they had their troubles on the air at a time when the public was less critical.

This fact is not appreciated by some marine radio operators who turn their eyes toward broadcasting. They do not realize that many of the things which they know will have no direct application in a broadcasting station, that there are many problems in such a station with which they have had no contact, and that considerable adaptability and intelligence may be required to close up the gaps. There was a time—it ended about a decade ago—when a radio man was a radio man, and knew, or thought he knew, everything in the art. He was ready to build or handle any type of transmitter or receiver of any power. Nowadays, there are transmitter specialists and re-

ceiver specialists, high power men, low power men, and innumerable narrower divisions. A radio man may be an expert in loud speakers, or in super-heterodyne receivers, or in broadcasting microphones. The body of knowledge and technology which he shares in common with all radio men is no longer all-important; it is only the foundation of a structure of specialized knowledge, and it is the latter which has great economic importance. Broadcasting is one of these divisions. To try to get a job in a broadcasting station on the strength of one's experience in marine radio is somewhat like approaching a Mason for fraternal aid on the strength of the fact that one is a member of the Elks.

A considerable number of technical broadcasters have been recruited from the wire telephone field. These men approached broadcasting from a totally different direction than the radio telegraph people. Broadcasting may be summed up as radio plus acoustics. The difference between a tube set used for telegraphy and the same transmitter used for telephony is one in modulation. Up to the modulation circuits they are the same. In fact, the same transmitter is sometimes used for both purposes by the aid of change-over switches with the proper circuits. The telephone experts knew a good deal more about the acoustical features than most of the radio men. The latter were proficient in getting their waves out on the air and in picking them up, but they were familiar only with relatively simple forms of modulation. The elaborate and exacting modes of impressing the carrier with which they had to deal when broadcasting became the vogue, made some of them feel like brick-layers confronted by a problem in interior decorating.

One possible source of supply for broadcasting technicians, which has scarcely been touched, is the phonograph recording laboratory. The phonograph interests have been faced for many years by acoustic problems similar to those now encountered by the broadcasters, and some of the gramophone recording experts would be an asset to many a broadcasting station. Some really brilliant broadcast performances have in fact been turned out by the operators of a New York station working together with phonograph recording specialists in the latter's laboratories. For a number of reasons, however, there has been little actual interchange of workers between the two fields. The principal reason is that in the case of the phonograph man the first term in the equation, "radio plus

acoustics equals broadcasting," is missing, and at the present time, employers in the broadcasting field insist on the first and get what they can in the second. A broadcast technician is expected to know, first, how to run a radio transmitter and the associated amplifiers—the business of tuning, getting maximum radiation, standing a 600-meter watch, oiling generators and grinding down brushes, shooting trouble, and the like; in the second category he must balance up orchestras, detect blasting and all forms of distortion, and act, in short, as a musical critic and adjustor. In time, perhaps, the two functions may become differentiated. One class of operator will tend to the machinery, while the other class of technician will be concerned solely with the music. There is already some tendency in this direction in those stations where the power plant is separated from the studios and control room.

Judging by the inquiries received by a professional broadcaster, many young men are desirous of entering this new field, embracing its romance, and enduring its agonies. For such, a few words of advice may be of interest.

As to general temperament, one requires calmness unmingled with over-confidence. Calmness is essential because broadcasting is a branch of the show business which places even more reliance on machinery than does the theater; it is at best a nervous game, and if the players add to the tension by injecting an excess of temperament at every opportunity, explosions will be too violent and frequent for the successful running of the station. At the same time, on the technical end, a certain controlled apprehensiveness is in order. One must never trust the equipment; at times when one is not on the air one must always be looking for things that may go wrong when the amperes are in the antenna and the multitude is twirling its knobs. "Be not anxious for the morrow, for the morrow will be anxious for itself," is an injunction sadly inapplicable to the broadcaster.

A high school education, or its equivalent in general schooling, is essential. Broadcasting is a business in which one meets many highly cultivated and well-informed people. Good diction, a vocabulary of decent size, and polite deportment, are not qualities to sway the stars from their courses, but they are very useful in such a business as broadcasting: therein, of course, broadcasting is not unique.

General radio experience, as has been said, is necessary at the present time, and will probably always be eminently desirable. Ama-

teur experience is good, professional work is better. A knowledge of physics and of ordinary electrical practice is essential. Acoustics, theoretical and practical, must be studied. Alternating current theory is as important in radio broadcasting as in wireless telegraphy. The influence of inductance and capacitance on currents of various audible frequencies is one of the fundamental problems of broadcasting. Telephone practice is of obvious interest to the broadcaster, since all the larger stations reach out for a considerable part of their program material with wire lines.

While some excellent textbooks have been written on the subject of wireless telephony, a handbook on broadcasting remains a work for the future. However, the subject has been partly covered in its technical aspects by various engineering papers, the study of which forms a good preparation for actual work in the field. This bibliography is as follows:

- CASPER. Telephone Transformers (Section on *Frequency Requirements*) *Journal A. I. E. E.*, March, 1924. Page 197.
- MARTIN and FLETCHER. High Quality Transmission and Reproduction of Speech and Music. *Journal A. I. E. E.*, March, 1924. Page 230.
- JONES. The Nature of Language. *Journal A. I. E. E.*, April, 1924. Page 321.
- HITCHCOCK. Applications of Long Distance Telephony on the Pacific Coast. *Journal A. I. E. E.*, Dec., 1923. Page 1264.
- OSBORNE. Telephone Transmission Over Long Distances. *Journal A. I. E. E.*, Oct., 1923. Page 1051.
- JONES. Discussion on Thomas. A Diaphragmless Microphone. *Journal A. I. E. E.*, Sept., 1923, Page 979.
- ARNOLD and ESPENSCHIED. Transatlantic Radio Telephony. *Journal A. I. E. E.*, Aug., 1923. Page 347.
- GREEN and MAXFIELD. Public Address System. *Journal A. I. E. E.*, April, 1923. Page 347.
- MARTIN and CLARK. Use of Public Address Systems with Telephone Lines. *Journal A. I. E. E.*, April, 1923. Page 359.
- WEINBERGER. Broadcast Transmitting Stations of the Radio Corporation of America. *Proc. I. R. E.*, Dec., 1924. Page 748.

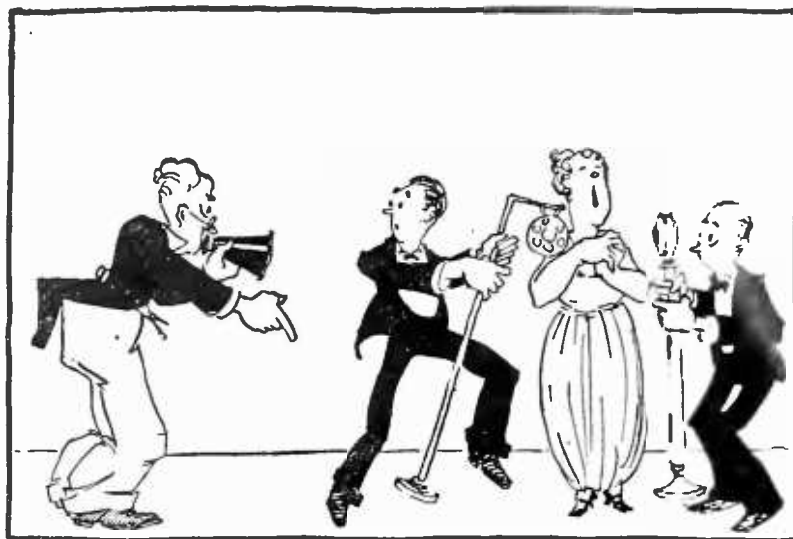

the training of a broadcaster

- NELSON. Transmitting Equipment for Radio Telephone Broadcasting. *Proc. I. R. E.*, Oct., 1924. Page 553.
- LITTLE. KDKA, the Radio Telephone Broadcasting Station of the Westinghouse Electric and Manufacturing Company, East Pittsburgh, Pa. *Proc. I. R. E.*, June, 1924. Page 255.
- BAKER. Commercial Radio Tube Transmitters. *Proc. I. R. E.*, Dec., 1923. Page 601.
- BAKER. Description of the General Electric Company's Broadcasting Station at Schenectady, N. Y. *Proc. I. R. E.*, Aug., 1923. Page 339.
- NICHOLS and ESPENSCHIED. Radio Extension of the Telephone System to Ships at Sea. *Proc. I. R. E.*, June, 1923. Page 193.
- ESPENSCHIED. Applications to Radio of Wire Transmission Engineering. *Proc. I. R. E.*, Oct., 1922. Page 344.
- SABINE. *Collected Papers on Acoustics*. Harvard University Press.
- MILLER. *The Science of Musical Sounds*. Mac-Millan.

Some valuable papers are also to be found in the semi-technical periodicals, and the above is by no means a complete summary of the important literature. However, any aspirant who digests all the information in these articles is well on his way to becoming a qualified technical broadcaster. It pains me, in fact, to make public the observation that there are many chief technicians and subordinate operators of metropolitan broadcasting stations who have not read them at all.

EACH month, Mr. Dreher's articles will deal with important and interesting phases of radio broadcasting, discussed particularly from the point of view of the broadcaster. Some of the topics he discusses are highly controversial, and readers who feel, either through their official positions or general knowledge, that they have something definite to contribute on these matters can communicate with the author through RADIO BROADCAST.



SOME NOTES ON THE SECOND-HARMONIC SUPER

THE many fans who are experimenting with the second-harmonic superheterodyne receiver described by Allan T. Hanscom in RADIO BROADCAST for November, 1924, will be interested in the further developments that more recent experiments have brought out.

Neutralization or balancing of the first tube is greatly facilitated by the use of a small variable condenser, such as the Chelton Midget, instead of the fixed capacity. This miniature condenser has a capacity of .000045 mfd., and is connected at N in diagram Fig. 1.

The difficulty with the common type of neutralizing condenser is that the capacity is not large enough for use in this circuit. Also, by mounting the small variable condenser on the panel, a certain amount of controlled regeneration may be obtained which builds up the signal strength remarkably on weak stations.

Certain makes of loop antennas require different values of neutralizing capacity, and practically all loops are easily balanced by slight variations of this condenser.

The operator will find that there is one value of neutralizing capacity that will give stability over the entire tuning range of the set, with the single exception of when the oscillator is tuned to a frequency the same as that of the loop. Since the range of the os-

cillator is from 400 to 1200 meters, and the range of the loop from 200 to 600 meters, this can only occur when the oscillator condenser reads close to zero—a combination that is never effected during actual reception.

Because of the effect of the intermediate frequency secondary

shunted across the loop, a variable tuning condenser which has a capacity of .0005 mfd. is scarcely large enough to reach the highest wavelengths. Some manufacturers' condensers fall noticeably short of their maximum rating. If experiment proves that the receiver will not re-

spond to wavelengths such as that employed by WEAf it will be necessary to add turns (one or two) to the loop. Likewise, the oscillator condenser may exhibit similar evidences of too low a capacity.—ALLAN T. HANSCOM.

In the R. B. Lab This Month

—Some notes on the second-harmonic superheterodyne.

—A radio power panel for the home constructor.

—How to build and use a capacity bridge for important laboratory testing.

—The theory of resistance coupling in audio frequency amplifiers and how to use the C battery in such circuits.

A RADIO POWER PANEL

FIGURES 2 and 3 show an accessory that will pay for itself many times over wherever it is installed by the radio enthusiast who "builds his own." Detailed consideration will disclose many advantages not apparent at first glance.

The radio fan who builds his own sets usually finds it desirable to test new circuits or parts from time to time, since he tries to keep his receiver as modern and efficient as possible.

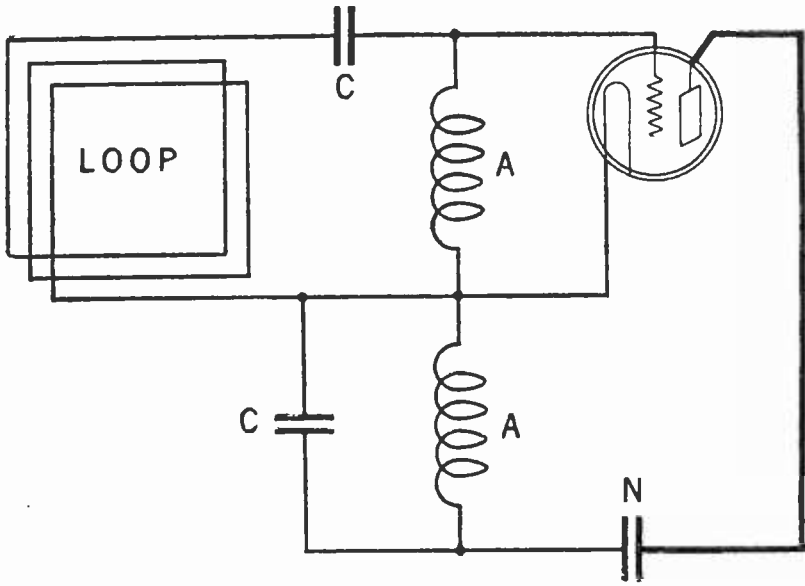

FIG. 1

The loop circuit of the Second Harmonic Superheterodyne.—“N” is the neutralizing condenser

Only too often, with A, B, and C batteries, and their numerous leads, scattered all over a table, or on the floor under or near the bench, such testing periods not only become a strain on the nerves of the operator, but are a source of actual danger to batteries and tubes. The constant tracing of wires and altering of connections, to determine proper leads and correct voltage, proves quite an inconvenience, while the accidental touching of wires often injures batteries or burns out one or more tubes. The price of one tube, even the cheapest bootleg variety, will more than pay for the materials used in constructing a power control panel.

Although the panel illustrated was installed in the back of the phonograph which contains the receiver and batteries used by the constructor who suggested this arrangement, it would have proved equally useful mounted on the top or side of an ordinary box which would protect the batteries and connections.

Enclosing all batteries and labeling the terminals make repeated tracing of connections unnecessary. The labeled terminals, and short flexible leads with lugs on each end, which connect the panel to the receiver, greatly reduce the possibility of accidental connections due to confusion or a wire slipping from its terminal and falling against another terminal. The triple-pole switch and the spring brass piece at its left, acts as a double-pole single-throw filament cut-off switch and a single-pole double-throw antenna switch which connects the antenna to the set when the filaments are connected, and connects the antenna direct to the ground wire when the switch is opened just enough to break the filament circuit. The switch arm and points left of the triple-pole switch permits instant regulation of C battery voltage from 0 to 6 volts. The center set of switch points effects the regulation of amplifier plate voltage from 1 to 8 batteries. (The extraordinary number of taps permit the adding of extra B batteries

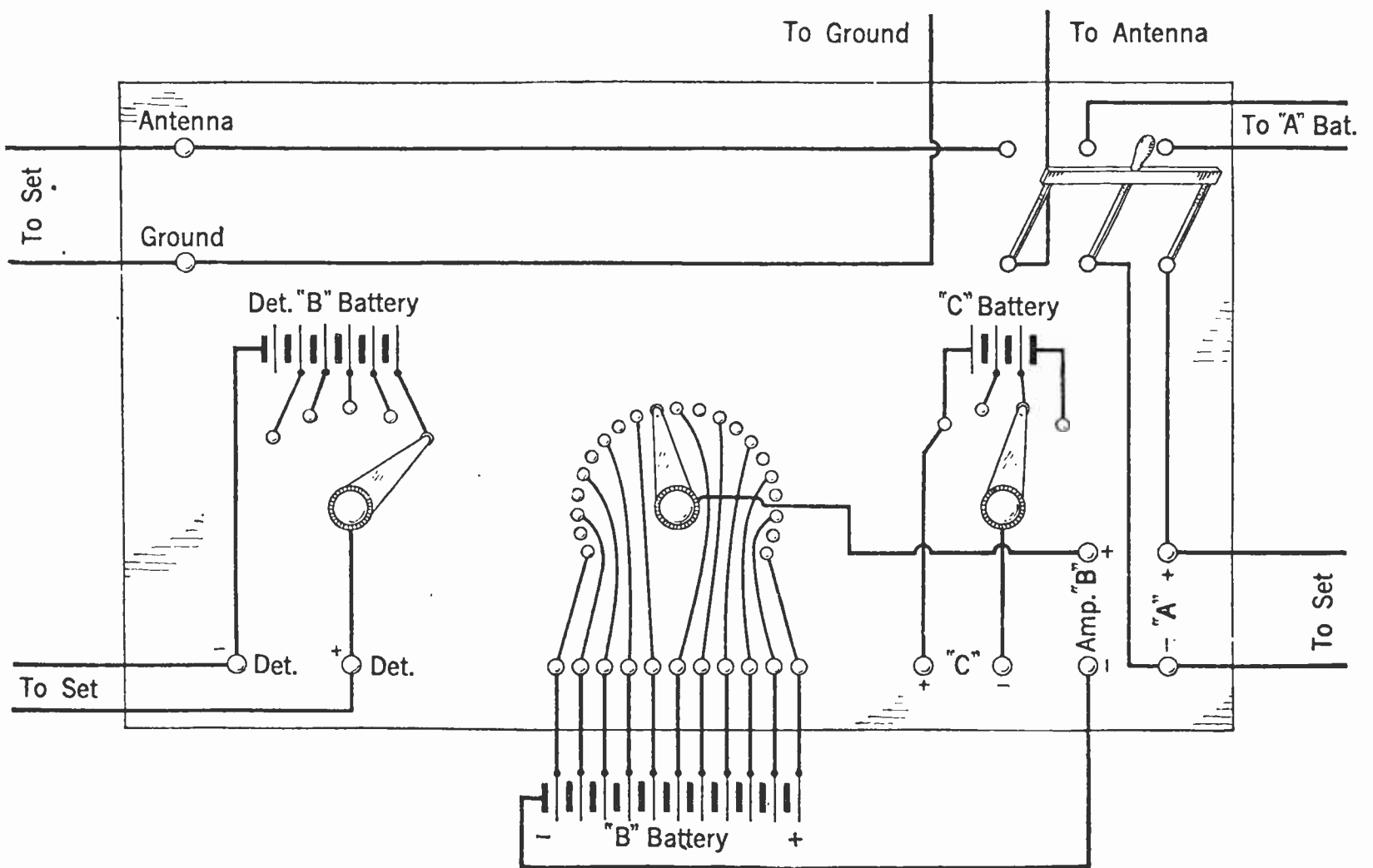

FIG. 2

Schematic connections of the radio power panel. Additional taps for special voltages may be added in any of the circuits

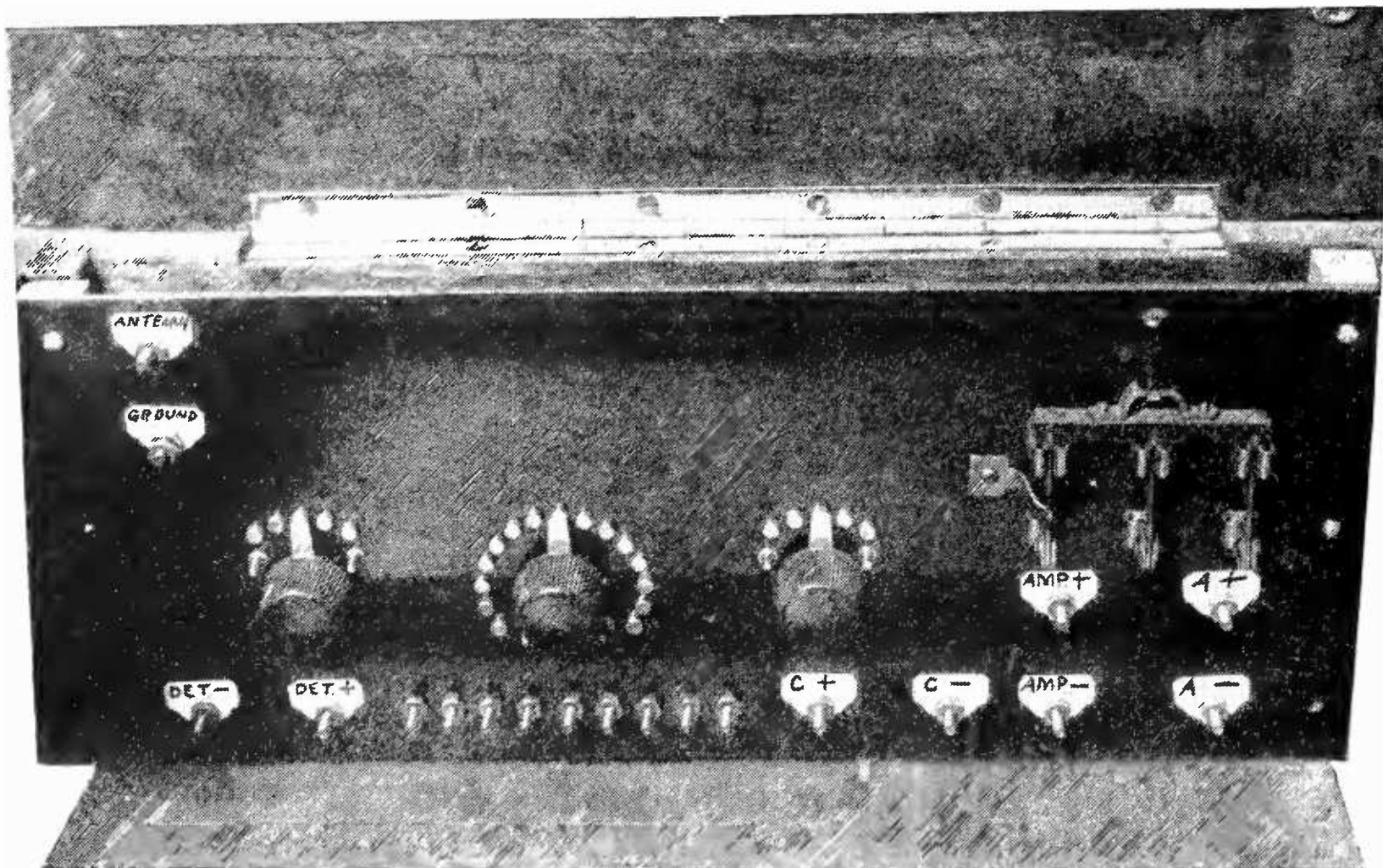

FIG. 3

This power control panel facilitates the testing of receivers and is a most useful addition to any laboratory

as the voltage drops off in use, while the alternating "dead" points prevent a 22-volt "short" every time the switch arm moves from one battery terminal to the next.) The nine screws just below the points permit the convenient testing of individual batteries for voltage or noise, and for "shorting out" any defective B battery which may be removed from the circuit at a later and more convenient time. The set of points at the left permit instant regulation of detector plate voltage from 16 to 22 volts.

It will be noted that none of the circuits are connected behind the panel, which permits any desired interconnection of circuits within the receiver itself.

The builder of the panel shown, who does considerable experimenting, and sometimes tests out equipment for others, has found that next to his A storage battery and battery charger, the power-control panel is the most useful piece of radio equipment he owns.

—GLENN McWILLIAMS

A HANDY CAPACITY BRIDGE

SEVERAL suggestions have been received by this department, evidencing an interest in an easily constructed capacity bridge for general test or checking work.

Figs. 4 and 5 illustrate an instrument of this character that was built up in the laboratory one afternoon, and which has proved itself of considerable value in routine work, such as checking and determining the capacities of small fixed condensers, and testing them for break-down or faulty insulation.

The circuit as shown in Fig. 4 and Fig. 5 is a photographic illustration of the ensemble mounted baseboard fashion. The parts used in this instrument are one telephone jack, four Fahnestock clips, one 50,000 ohm resistor (Daven) and mounting, one Bradleyohm (No. 10), two condenser clip mountings (Daven) and one variable condenser .001 mfd. maximum capacity. This last may be of the usual air type (the best form) or a Dubilier Variodon. It should have a straight line capacity characteristic, i. e., the capacity changes should be proportional to the dial settings. If 180 degrees gives .001 mfd., 90 degrees should be close to .0005 mfd.

The connections in Fig. 4 are almost self explanatory. R_1 is the Bradleyohm; R_2 is the fixed 50,000 ohm resistance; C_1 is the variable condenser and C_x is the unknown capacity which is clipped into the convenient mounting. The extra mounting is shunted across the variable condenser, so that its effective capacity can be increased by

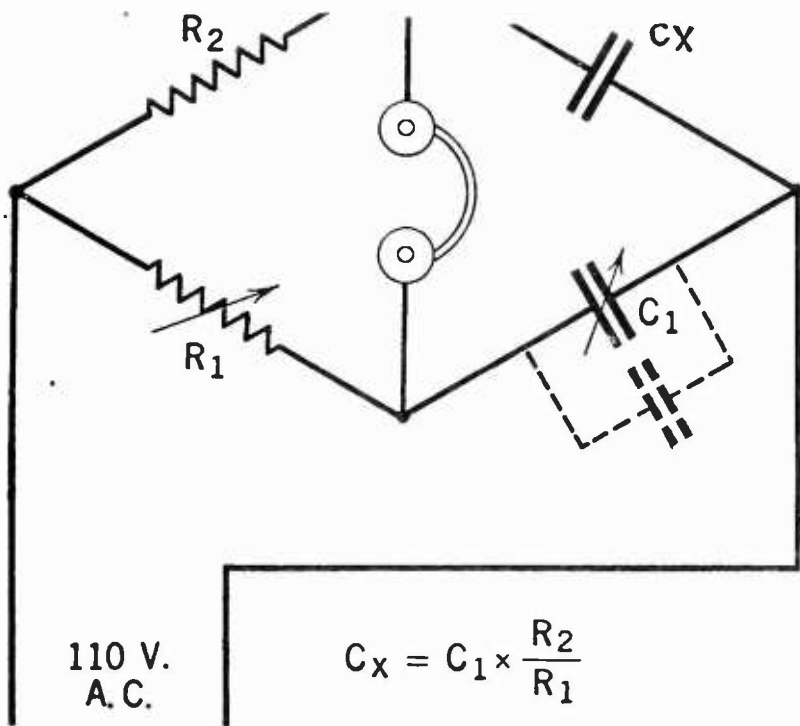

FIG. 4

The connections of the simple capacity bridge. The telephone receivers are most conveniently plugged into a jack

clipping in fixed condensers of reliably known values.

The phones and 110-volt A. C. lines are connected as indicated. The operation of the bridge is possible in two ways. The more simple and easily understandable is as follows:

R_x should be set at the same resistance as R_2 . This can be determined with a milliammeter, voltmeter and a B battery. Resistance in ohms is always equal to volts divided by current. This desired setting can also be arrived at by placing a condenser of .001 mfd. capacity in the "X" clip and turning C_x to maximum, that is the same .001 mfd. capacity. R_x is now adjusted until no alternating current hum is heard in the telephone receivers. At this adjustment the bridge will be "balanced," and R_x will equal R_2 . To

check an unknown capacity this procedure is reversed. The doubtful condenser is clipped into the "X" mounting and the capacity of C_x is varied until no sound is heard in the receivers. At this point, the unknown capacity will be equal to C_x .

The second method, while a little more complex, is preferable where convenient, and makes possible measurements of C_x , within reasonable limits, without adding capacities in shunt of C_x . In this case C_2 is generally turned to its highest setting, and R_x adjusted for no response in the phones. The resistance of R_x should be measured at this setting. The capacity of C_x can then be determined from the equation

$$C_x = \frac{R_2}{R_x} \times C_1$$

If, for example, R_2 has a resistance of 50,000 ohms, C_x is set at .001 mfd., and the resistance of R_x is found to be 25,000 ohms at the full adjustment, substituting in the above equation will determine the capacity of C_x as .002 mfd.

A leaky condenser will indicate only a reduction in hum, noticeably different from the almost absolute silence of a perfect condenser. A shorted capacity will give an increased hum that is constant regardless of adjustments.

THE C BATTERY AND RESISTANCE COUPLING

DUE to the meager justification for resistance-coupled audio amplification prior to the advent of radio telephonic broadcasting, its treatment in radio publications and the popular text books has been scant

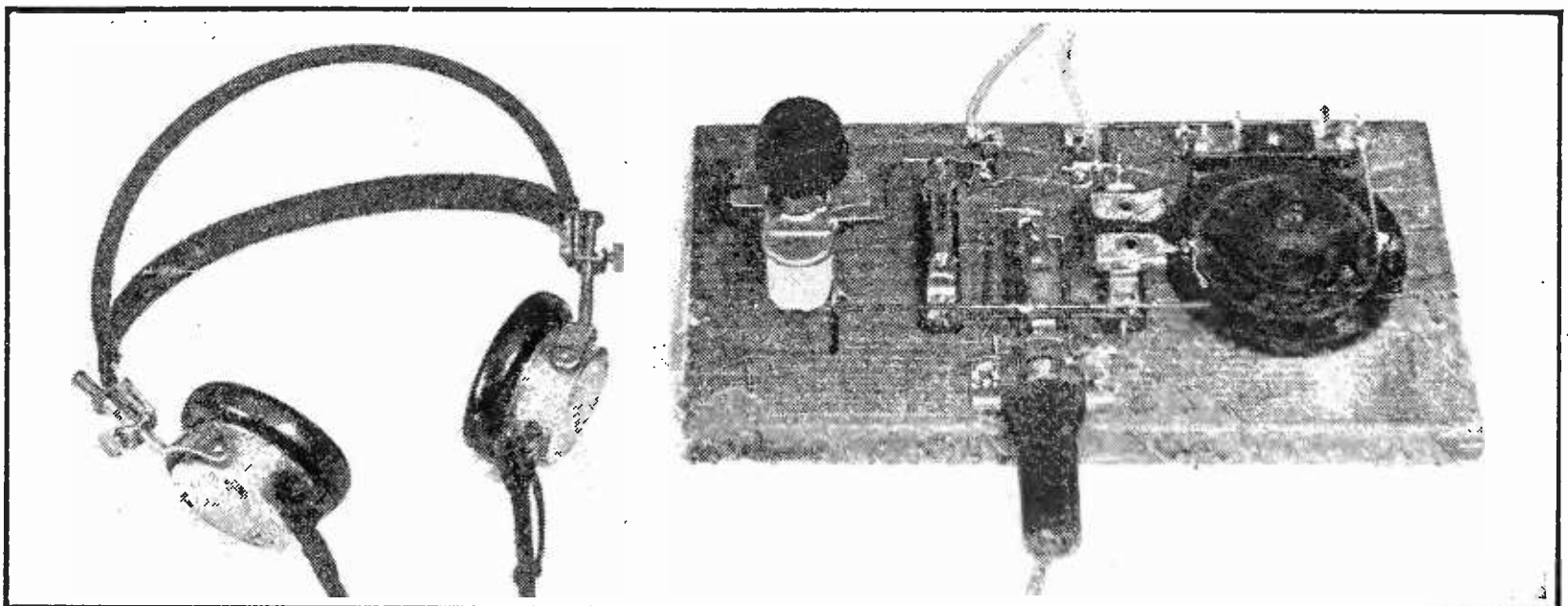

FIG. 5

This capacity bridge is quickly built and the more serious enthusiast will find it most useful

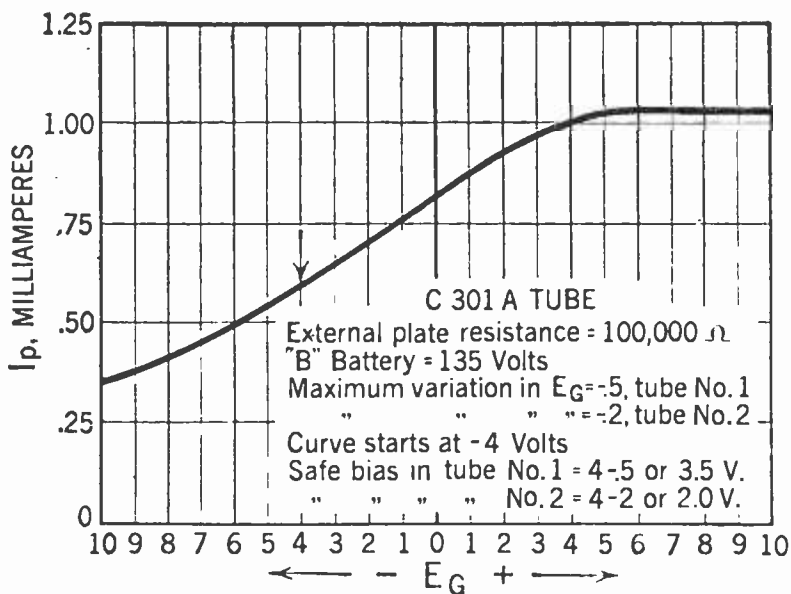

FIG. 6

The dynamic curve of a C-301-A tube taken under the conditions mentioned on the chart

and inadequate. Since resistance-coupled intensification was popularized by RADIO BROADCAST magazine as an amplifier ideally suited to the requirements of the broadcast enthusiast, many additional articles, in a variety of publications, have endeavored to throw light on the subject. However, due to the general lack of understanding, these write-ups have been of little avail. With few exceptions they have ignored the unique characteristics of resistance coupling, and have borrowed too freely from transformer-coupled phenomena in the attempt to make clear the functioning of the resistance-coupled system.

The most prevalent error has been the recommendation of a bias of similar proportions to that employed in transformer-coupled intensification. This ignores a fundamental difference between the actions of these two amplifiers. A transformer-coupled amplifier (in a vast majority of cases) modulates up while a resistance-coupled amplifier modulates down. That is, signal variation in a transformer-coupled amplifier places a plus potential of varying strength on the grid of the succeeding tubes causing the plate currents to increase, while a similar variation in a resistance-coupled intensifier, places minus potentials on the amplifying grids, causing the currents to decrease. The effect in a transformer-coupled amplifier is the placing of a positive bias on the grids, varying with the speech or music; while that in a resistance-coupled set is just the opposite. It was in appreciation of this, the significance of which will be explained shortly, that RADIO BROADCAST has not, in its past articles on resistance coupling, advised the use of a negative bias.

Figs. 6 and 7 are the "dynamic" curves of

two vacuum tubes, a Cunningham C-301-A and a Western Electric 216-A respectively. "Dynamic" refers to curves taken under conditions closely similar to those under which the tubes are to be operated. In the case of the C-301-A this means measurements were taken with a 100,000-ohm coupling resistance in the plate circuit. The winding of the loud speaker was included in the plate circuit of the power tube. These conditions are practically those indicated in the circuit, Fig. 8, in which the first two tubes are C-301-A's (or similar tubes) and the last tube, outputting to the speaker, is the WE-216-A.

The figures along the base of the curve, or abscissa, indicate the grid potential in plus or minus volts, and the vertical figures the plate current corresponding to different grid voltages. It will be observed that as the grid potential becomes positive, the current rises, and vice versa. Toward the upper and lower extremes of the characteristic curve, the line, which is quite straight immediately on both sides of the zero grid potential, bends. In other words, continued variations of the grid potential, in the same direction, no longer cause so great changes in the plate current. (The upper bend, being off the chart, is not shown in the 216-A curve.) Thus, if signals are so intense that they carry the grid potential down to the curve or bend, the plate current changes cease to vary in proportion to the signal fluctuations. The plate current changes, however, are responsible for the audio output, or the amplified impulse passed on to the next stage. Thus, if the curve portion of the characteristic is touched, the audio output will no longer vary exactly with the

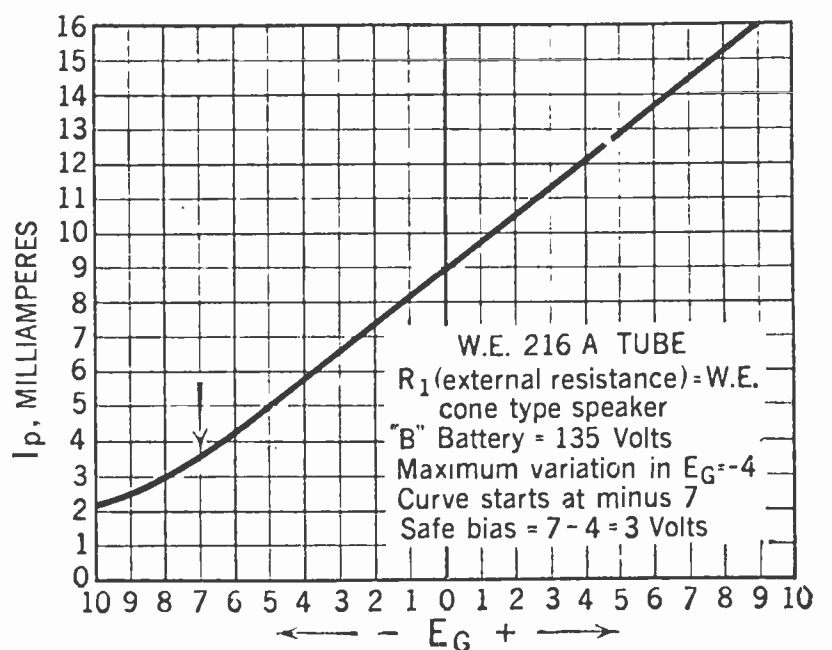

FIG. 7

A similar curve of a Western Electric 216-A power tube. These curves greatly facilitate the analysis of the action of an amplifying bulb

original signal. A single familiar word describing this condition is "distortion."

We may, therefore, write down, as the first law to be observed in distortionless amplification: The signal variation must be confined to the straight portion of the characteristic curve. It will be observed that the straight line begins to curve at minus 4 and minus 7 volts respectively in the Cunningham and Western Electric tubes.

There is another precept of distortionless intensification and that is that the grid must never become positive. All variations must be between zero and where the lines begin to curve, on the minus side. This rule which must be obeyed to the letter in transformer coupling, is less strict in the case of resistance-coupled amplifiers.

Therefore, in a transformer-coupled amplifier, which tends to move up the curve, a bias may be used to keep the top of the maximum impulse below the zero line. For instance, a negative bias, in the case of Fig. 7, of seven volts may be applied to the grid, and the upward impulses will all vary along the straight line. However, in the case of resistance-coupled amplification, with a similar bias, the slightest movement *down* would necessarily fall on the straight portion of the curve, with resulting distortion. (In some cases of extreme bias with a resistance-coupled amplifier, modulation will turn, somewhere on the curve, and begin to climb. This is equally bad, for it indicates a double space current change for a single grid impulse — i.e., the generation of harmonics.)

HOW MUCH BIAS IS PERMISSIBLE?

THE amount of C battery bias in a resistance-coupled amplifier is simply determined, merely by subtracting the amount of maximum minus grid signal variation from the permissible bias, or the point where the curve commences. If the curve is straight to minus seven volts, and the maximum grid variation is minus four volts, it is evidently possible to place an additional bias of three volts without causing distortion, by means of a C battery. This is exactly the case with the 216-A tube according to measurements

made in this laboratory with a plate battery of 135 volts.

It will be observed that in the case of the first two tubes, which are the same as far as the curve is concerned, the line breaks at about minus four volts. This, of course, precludes the possibility of a large bias. Indeed, consideration of the very many curves made in this laboratory, which indicate a much earlier break (at minus one or two volts) with what bulbs were available, a C battery bias is not recommended in these stages. As the plate current consumption in these tubes is very low, about one milliamperere with 100,000-ohm plate resistors and a 135-volt B battery, the bias is not necessary from the standpoint of economy. It is therefore suggested that the bias, on the first two tubes of a three-stage amplifier, be secured from the drop across the filament and rheostat. This will be well within the safe limit, with a margin for poor tubes.

The recommended circuit for a three-step resistance-coupled amplifier is shown in Fig. 8. The first two tubes receive their bias in the manner suggested, while a three volt C battery is included in the grid circuit of the last or "open" tube. The usual values of C and R are given on the diagram. Tests and curves made in THE R. B. LAB indicate that this diagram holds good for practically all storage battery tubes. With dry cell tubes, the C battery should be reduced to one and one half volts.

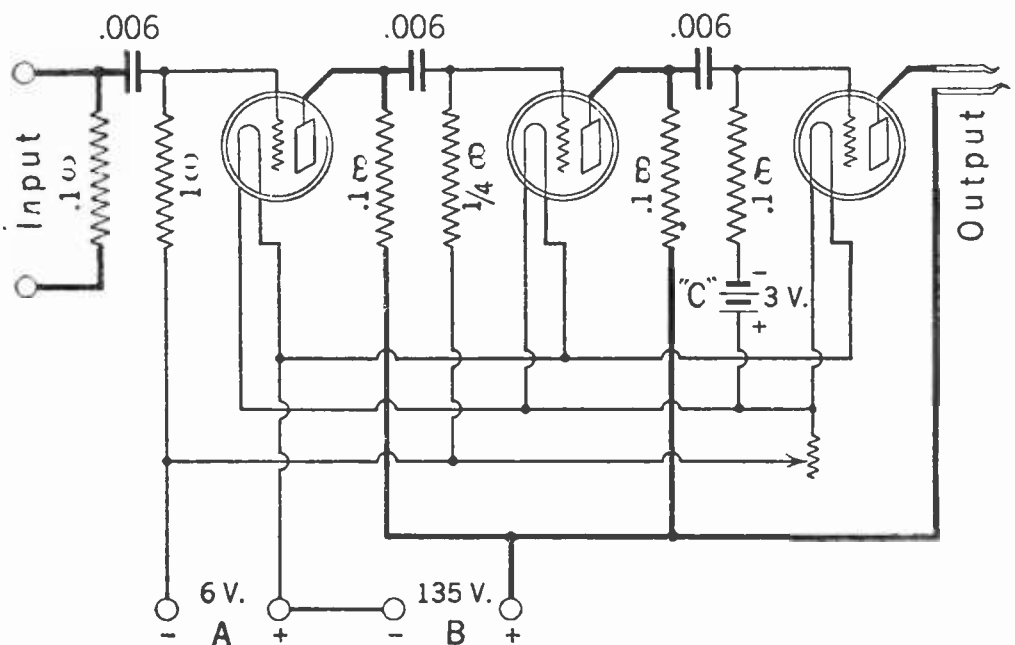

FIG. 8

The ideal connections for a resistance-coupled amplifier. This diagram is arrived at after a careful consideration of the resistance coupled amplification characteristics of standard tubes

New Broadcasting Wavelengths

FOR some time, the radio service of the Department of Commerce has been engaged in reallocating the wavelengths of many of the broadcasting stations in the Class B group. Stations of this class are those with power of at least 500 watts and especially efficient equipment. It is understood that the purpose of this readjustment is to make room for the many new applications for Class B licenses. Finer shades of differentiation between the stations now licensed has been tried. It is probable that if these allotments do not prove satisfactory, still other alterations may be made, though it is likely that the further changes, if made, will not be very great.

Among the changes made are KDKA from 326 to 309, WGY from 380 to 379.5, WIP from 509 to 508.2, WOO from 509 to 508.2, WDAR from 395 to 394.5 meters.

To station WMH at Cincinnati was allocated two wavelengths, 325.9 during the month when it divides time with station WSAI and 422.3 during the month, when it shares broadcasting time with station WLW, also of Cincinnati.

Wavelengths in meters, call letters, and locations announced by the Department are as follows:

WAVE LENGTH	CALL LETTERS	LOCATION
280.2	WNAC	Boston
282.8	WOAN	Lawrenceburg, Tenn.
285.5	WREO	Lansing, Mich.
285.5	WEMC	Berrien Springs
285.5	WKAR	East Lansing, Mich.
288.3	KFKX	Hastings, Neb.
293.9	WEAO	Columbus, Ohio
293.9	WBAV	Columbus, Ohio
296.9	KFRU	Bristow, Okla.
299.8	WPG	Atlantic City, N. J.
302.8	WTAS	Elgin, Ill.
302.8	WJJD	Mooseheart, Ill.
305.9	WJAR	Providence, R. I.
309.1	KDKA	East Pittsburgh, Pa.
315.6	WAHG	New York
315.6	WGBS	New York
315.6	KFDM	Beaumont, Tex.
319.0	WGR	Buffalo, N. Y.
322.4	KOA	Denver, Col.
325.9	WMH	Cincinnati, Ohio
325.9	WSAI	Cincinnati, Ohio
333.1	WBZ	Springfield, Mass.

336.9	WSAC	Clemson College, S. C.
336.9	KFMX	Northfield, Minn.
336.9	WCAL	Northfield, Minn.
340.7	WKAQ	San Juan, Porto Rico
340.7	KSAC	Manhattan, Kan.
344.6	WLS	Chicago, Ill.
344.6	WCBD	Zion, Ill.
348.6	KOB	State College, N. M.
348.6	WTIC	Hartford, Conn.
352.7	WWJ	Detroit, Mich.
352.7	WJAD	Waco, Tex.
361.2	WHN	New York
365.6	WHB	Kansas City, Mo.
365.6	WDAF	Kansas City, Mo.
370.2	WEBH	Chicago, Ill.
370.2	WGN	Chicago, Ill.
374.8	KTHS	Hot Springs, Ark.
379.5	WGY	Schenectady, N. Y.
379.5	WHAZ	Troy, N. Y.
384.4	WMBF	Miami Beach, Fla.
389.4	WTAM	Cleveland, Ohio
389.4	WEAR	Cleveland, Ohio
394.5	WFI	Philadelphia, Pa.
394.5	WDAR	Philadelphia, Pa.
394.5	WOAI	San Antonio, Texas
399.8	WHAS	Louisville, Ky.
405.2	WOR	Newark, N. J.
405.2	WJY	New York
416.4	WCCO	Minneapolis, Minn.
422.3	WLW	Cincinnati, Ohio
422.3	WMH	Cincinnati, Ohio
428.3	WSB	Atlanta, Ga.
434.5	NAA	Arlington, Va.
440.9	WDWF	Cranston, R. I.
440.9	WOS	Jefferson City, Mo.
447.5	WQJ	Chicago, Ill.
447.5	WMAQ	Chicago, Ill.
454.3	WJZ	New York
461.3	WCAE	Pittsburgh, Pa.
468.5	WCAP	Washington, D. C.
468.5	WRC	Washington, D. C.
475.9	WEEI	Boston, Mass.
475.9	WBAP	Forth Worth, Tex.
475.9	WFAA	Dallas, Tex.
483.6	WHAA	Iowa City, Iowa
483.6	WOC	Davenport, Iowa
491.5	WEAF	New York
499.7	WMC	Memphis, Tenn.
508.2	WOO	Philadelphia
508.2	WIP	Philadelphia
516.9	WCX	Detroit
526.0	WNYC	New York
526.0	WHO	Des Moines, Iowa
526.0	WOAW	Omaha, Neb.
535.4	KYW	Chicago, Ill.
535.4	WHA	Madison, Wis.
545.1	KSD	St. Louis, Mo.
545.1	KFUO	St. Louis, Mo.

Radio-Frequency Amplification and How to Measure It

A Clear Theoretical Discussion—Circuits to Measure Amplification—Proper Design of Coupling Devices

By HARRY DIAMOND

Department of Electrical Engineering, Lehigh University

IN THIS paper, the interested technical reader will find radio-frequency amplification most thoroughly discussed from the theoretical side with some very helpful diagrams and curves. Mr. Diamond attempts theoretically to show that for radio-frequency coupling, a choke coil having a natural wavelength equal to the signal to be received is better than a coil tuned by a condenser to the desired wavelength, and other important facts about coupling-coil design.

Much credit for the experimental work and circuits used in this article is due to H. T. Friis and G. A. Jensen, engineers of the Western Electric Company from whose paper "High Frequency Amplifiers" (which appeared in the *Bell System Technical Journal* for April, 1924) much of this material is taken.—THE EDITOR.

A RADIO amplifier is a device which makes possible the reception of very weak incoming signals by increasing or amplifying their strength. It must therefore be a kind of trigger which, whenever actuated by the extremely small signal voltages of the antenna, releases from a local energy source an amount of energy much greater than that actuating the antenna.

The vacuum tube is admirably fitted for such action. The grid constitutes the trigger device and the plate supply battery the local energy source. The small signal voltage variations impressed upon the grid or input circuit of the tube are reproduced on a much larger scale in the plate or output circuit, the amount by which the signals are amplified being known as the amplification factor of the tube. The actual voltage variations passed on to the next tube, however, depend not only upon this factor, but also upon the value of the impedance in the plate circuit which serves to couple the amplifier tube with the next tube.

Amplifiers are therefore classified according to the nature of this coupling impedance being known as resistance-coupled, inductance-coupled (tuned or untuned), or transformer-coupled amplifiers. (See Figs. 1, 2, and 3.)

It should be noted that amplification may take place either before or after detection. In the first case this requires the use of a radio-

frequency amplifier, and the second an audio-frequency amplifier. The advantage of using the former depends chiefly upon the nature of static interference. It is well known that this type of interference sets up voltage variations in the antenna well within the audible frequency range. If we use a radio-frequency amplifier, then, the radio-frequency signal voltages are amplified while the voltages due to static interference remain unamplified (theoretically). On the other hand, an audio-frequency amplifier amplifies not only the rectified signal voltages but also those due to the atmospheric disturbances.

Unfortunately, however, the design of an economical radio-frequency amplifier which will work efficiently on the shorter wavelengths used in broadcasting, is a very difficult matter. The advantages gained in reducing the effect of "static interference" are often lost due to the distortion introduced by the amplifier.

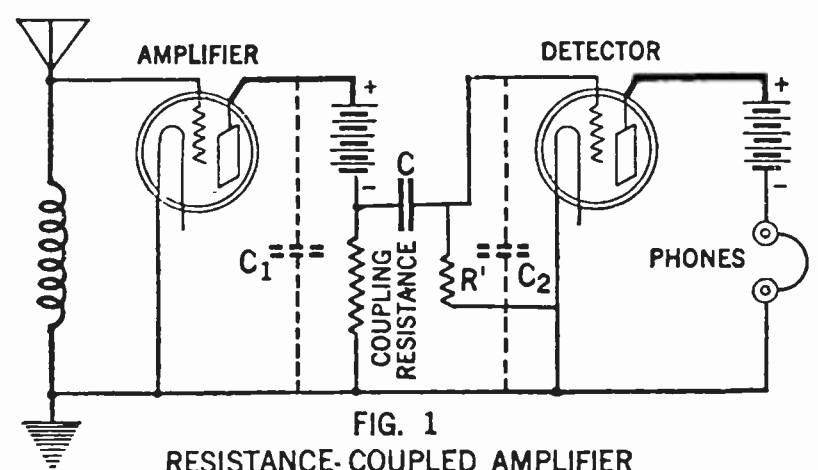

Again, at radio frequencies, the plate to filament capacity of the amplifying tube (c_1 in Figs. 1, 2, 3) constitutes a low impedance placed in parallel with the primary of the coupling impedance, while the grid to filament capacity of the next tube (c_2 , Figs. 1, 2, 3) constitutes a low impedance placed in parallel with the secondary of the coupling impedance. The net effect is to reduce the magnitude of the voltage variations passed on from one tube to the other, thus reducing the amount of amplification.

Other serious problems of design arise, depending on the type of amplifier. We shall here mention some of the problems common to each type and then describe a hook-up devised by engineers of the Western Electric Company, whereby the exact characteristics of each amplifier may be obtained, under actual operating conditions. With the aid of this method of test, it becomes possible to design an amplifier which will give a maximum of amplification with a minimum of distortion.

The term "distortion" as used here is intended to indicate that the amplification is not constant but varies with the frequency whether it be radio or audio.

RESISTANCE-COUPLED AMPLIFIERS

RESISTANCE varies but little with the frequency, being very nearly the same for direct currents, for alternating currents of audio-frequencies and for those of radio-frequencies. The value of the coupling resistance being then independent of the frequency of the signal note, all signals are equally amplified and little or no distortion is introduced.

However, the very fact that the coupling resistance offers the same opposition to the flow of direct current that it does to alternating currents constitutes one of the disadvantages of this type of amplifier. Much higher B battery voltages are made necessary, since the net plate voltage available equals the battery voltage *minus* the voltage drop caused

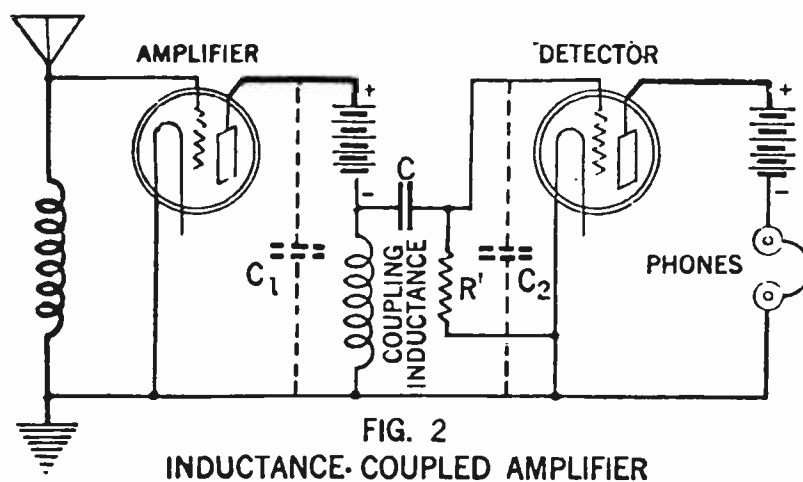
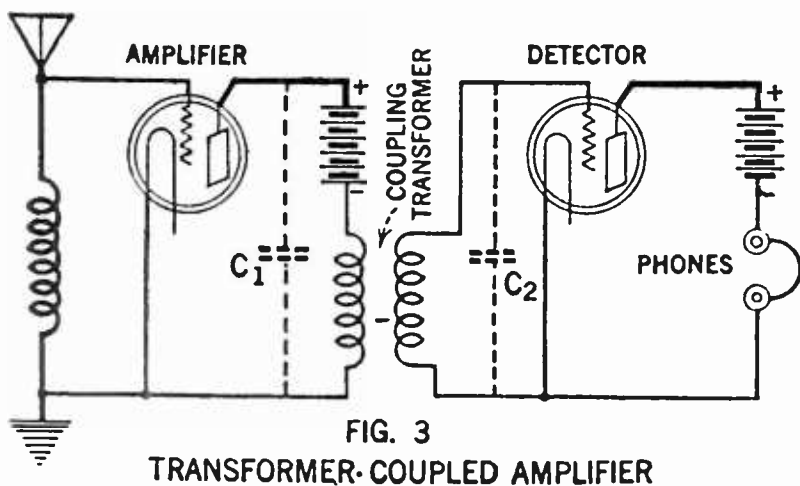

by the direct current flowing through the coupling resistance.

Furthermore, the maximum amplification theoretically possible with this amplifier is equal to but one half the amplification factor of the tube used. More tubes are therefore necessary for the same increase in signal strength. The cost of upkeep is also greater because the B batteries must be of higher voltages, as explained, must supply energy for more tubes, and must also compensate for considerable energy loss in the coupling resistances.

INDUCTANCE-AND TRANSFORMER-COUPLED AMPLIFIERS

THE main advantage of both the inductively coupled and the transformer-coupled amplifiers is that the inductive impedance placed in the plate circuit of the amplifying tube offers a very low resistance to direct currents and a very high impedance to high frequency currents. The plate supply battery furnishing the direct current in the plate circuit may then be of but slightly higher voltage than the rated voltage of the tube, since the voltage drop in the resistance is very small. Another advantage is that nearly the full amplification property of the tube may be utilized, which reduces the total number of tubes necessary. Either the inductance-coupled or the transformer-coupled amplifier can therefore be used in a relatively inexpensive circuit.

An important disadvantage common to both amplifiers, however, is that signal notes of frequencies near the resonant frequency of the coupling impedance are very well amplified, while those of much lower or much higher frequencies are very poorly amplified. Consequently, considerable distortion is introduced. This disadvantage often offsets any advantage in cost or increase of amplification. An obvious solution lies in using a coupling inductance or transformer whose resonant frequency is at least twice the frequency of the incoming

signals. The design of such a circuit requires the greatest care. In order to make a thorough study of the best possible hook up, a dependable method of measurement under actual operating conditions is necessary.

Such a method of measurement has been developed in the Bell System Laboratories and has proven very successful. Fig. 4 shows the circuit diagram of the apparatus used. The input apparatus is shown at the left. An oscillator (or generator of high-frequency currents having a range of from 400-1500 kilocycles [200-750 meters], is connected in series with a potentiometer and a sensitive thermo-couple ammeter (or a hot-wire milli-ammeter with a 1-m.a. scale) used for measuring the value of the very small current flowing in the circuit. This current, I , flowing through the resistance R_4 of the potentiometer causes a potential difference between the terminals of this resistance equal to IR_4 . This potential difference is then impressed between the grid and filament of the amplifying tube, A_1 . Obviously by varying the value of either the current I or the resistance R_4 , the potential difference impressed upon the input circuit of the tube may be varied.

The output potential difference of the amplifier stage is measured by means of the tube voltmeter B. This is merely a vacuum tube whose variations of plate currents for different values of alternating grid voltages are known. A given *change* in the plate current, as recorded by the plate ammeter, signifies then that an alternating voltage of definite value has been impressed upon the grid circuit.

THE C BATTERY

THE purpose of the C battery shown is to make the grid negative and thus limit the value of the direct-current flowing in the plate circuit. With this current reduced, it is possible to adjust the balancing device shown so that the plate ammeter will read zero when

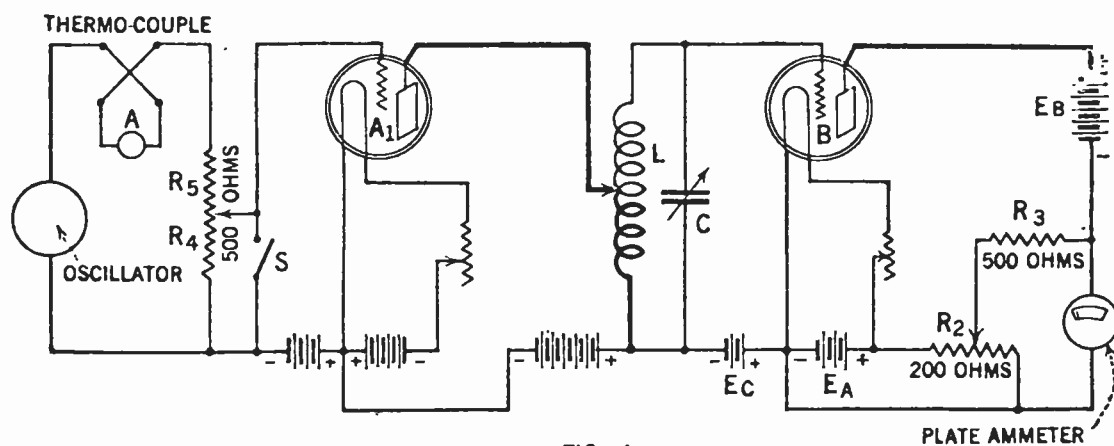

FIG. 4
METHOD OF MEASUREMENT OF TUNED AMPLIFIER

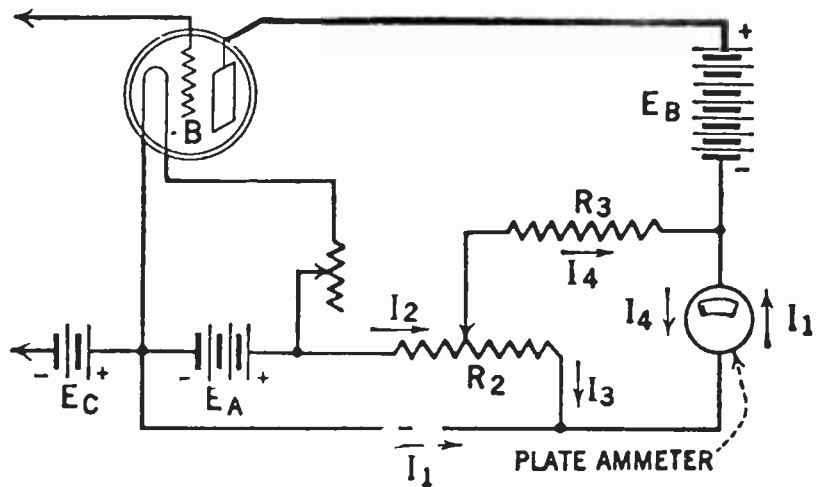

FIG. 5
DETAILS OF BALANCING ARRANGEMENT

there is no input to the grid. With this arrangement, the entire scale of the plate ammeter is in use, thus increasing the accuracy of the readings taken. Also, the measured voltage may be obtained from a single reading instead of from the difference of two readings.

The action of the balancing device may be understood from the portion of Fig. 4 to the right of the tuned amplifier, reproduced in Fig. 5. Consider the case when there is no input to the grid circuit of the voltmeter tube B. Under normal conditions, there is then a direct current in the plate circuit of a magnitude depending on the value of the B and C batteries. The direction of this current is shown by the arrow I_1 . With the balancing arrangement as shown, the filament battery sets up a secondary current, I_2 , which divides into I_3 and I_4 . It is seen that I_4 is in a direction opposite to I_1 . If the value of R_2 and R_3 is properly adjusted, I_4 may be made equal to I_1 . The plate ammeter will then read zero.

Now, when an alternating voltage is impressed between the grid and filament of the voltmeter tube, an alternating current will be superimposed upon the direct current I_1 . The value of I_4 will, however, remain constant. The plate ammeter therefore records directly the value of the alternating plate current. The voltage impressed upon the grid can then be found from established curves.

It is necessary first to calibrate the tube voltmeter. This is done by disconnecting it from the amplifier and connecting it directly across the potentiometer R_4-R_5 . R_4 is then adjusted to some definite value, say 500 ohms and the current through it adjusted to say

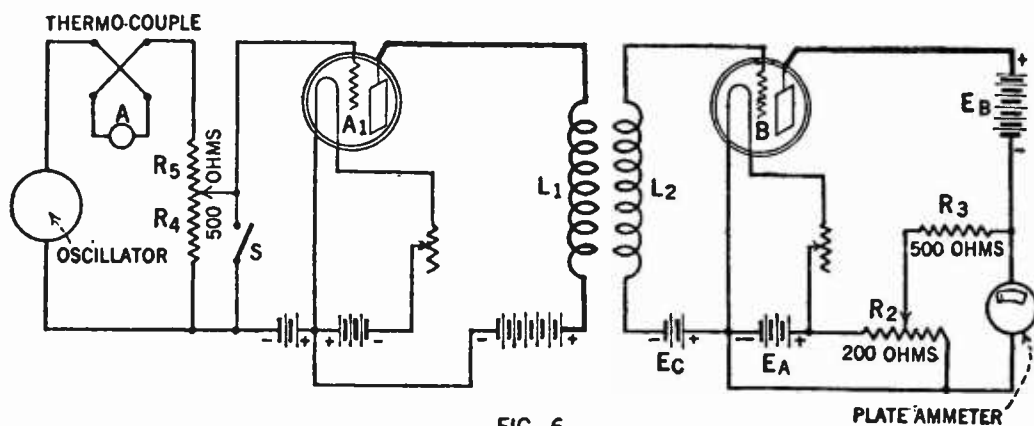

FIG. 6
METHOD OF MEASUREMENT OF TRANSFORMER-COUPLED AMPLIFIER

one milliamper. A resultant voltage of 0.5 volt is thus impressed upon the grid circuit of the tube and the corresponding change in plate current recorded.

The tube voltmeter is then replaced in its normal place in the circuit and the resistance R_4 reconnected to the input of the amplifier. Keeping the value of the current through R_4 constant at one milliamper, the resistance R_4 is reduced until the change in the tube voltmeter plate current is the same as before. The voltage impressed upon the grid of the amplifier is then the new value of R_4 times 0.001 ampere (1 milliamper). The voltage put into the grid of the voltmeter tube, which is also the output voltage of the amplifier is still 0.5 volt since the change in the voltmeter tube plate current is the same. The amplification factor of the stage is then equal to $\frac{.5}{.001R_4}$. If R_4 was reduced to, say 50 ohms, the amplification factor is equal to 10.

In the circuit as described, considerable precaution has been taken to make certain that no energy passes into the amplifier circuit except that which may be measured by the voltage drop across the resistance R_4 . The undesirable "pick-up" energy may be due to coupling to some stray source of energy. An excellent test for the presence of this "pick-up" is the closing of the switch "S" placed at the input of the amplifier. With this switch closed there should be no input to the tube voltmeter. The ammeter in the plate circuit of the tube voltmeter should read zero.

With the measuring apparatus here described, the resistance R_4 can be reduced to 1 ohm, the results obtained still being dependable. This means that an input voltage to the amplifier as low as 0.001 volt or 1 millivolt can be obtained. If the maximum input voltage to the tube voltmeter is limited to 0.5 volt, the maximum amplification that can be measured is then 500. For amplification factors above 500, the same apparatus can still be used by means of an indirect method.

It should be noted that the resistance R_4 must be absolutely independent of the frequency. Otherwise, the tube would be incorrect for all frequencies except for the one at which it was calibrated.

USES FOR THIS MEASURING APPARATUS

THE uses to which the measuring apparatus here described can be put are numerous. For example, Fig. 4 shows a tuned amplifier being tested. Keeping the magnitude and frequency of the oscillator current constant, the circuit may be tuned to resonance by means of the variable condenser C. The lead from the plate of the amplifier tube A_1 to the coil is then moved along the coil until a point is reached which gives the maximum reading of the ammeter in the plate circuit of the tube voltmeter. (The amplifier must, of course, be retuned for each point tried.) This is the point of maximum amplification.

The best step-up for a certain frequency being now established, we may measure the amplification for different frequencies and thus obtain the frequency range possible with this amplifier. Results may show that the frequency range is so narrow that considerable distortion would be introduced by the use of this amplifier. Since the frequency range for a given amplifier decreases as its amplification increases, it may therefore be advisable to increase our frequency range at the expense of the amplification by varying the step-up.

TESTING A TRANSFORMER-COUPLED AMPLIFIER

FIGURE 6 shows the hook-up for testing a transformer-coupled amplifier. The connections are the same as for testing the tuned amplifier with the exception, of course, of the details for the amplifiers.

Referring to Fig. 7, curve A shows the variation of amplification with frequency for a tuned amplifier for the step-up which gives the maximum amplification. The coil used consists of a single layer solenoid closely wound with 61 turns of No. 28 solid wire, and having an inductance of 200 micro-henries. The tuning condenser was set for 95.0 micro-microfarads.

B is a similar curve for a choke coil amplifier, (tuning condenser omitted) for the condition of maximum amplification. This coil consists of 173 turns of No. 28 solid wire, wound in

the same manner as the first coil, and having an inductance of 1630 micro-henries. It will at once be noted that while there is little choice between the tuned amplifier and the choke coil amplifier with respect to frequency width, there is a considerable difference in the amplification obtained, the choke coil giving nearly twice the amplification of the tuned circuit. However, it is to be remembered the choke coil amplifies at the resonant or peak frequency.

In general, the highest amplification is obtained when the inductance is as large as possible for the frequency in question, that is, for the smallest possible value of the tuning condenser. With choke coils, the value of the tuning condenser is, of course, zero. The distributed capacity of the coil must, however, be considered. To get a high amplification,

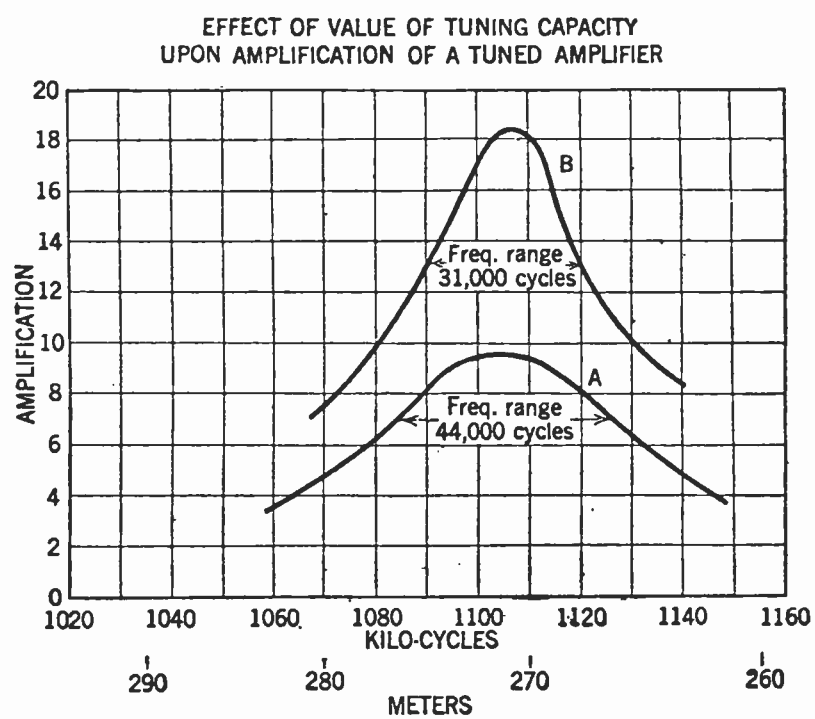

FIG. 7

small coils made of fine, solid wire and with large inductance and small distributive capacity should be used, rather than large coils made of stranded wire and with smaller inductance but larger distributive capacity. In practice, it is not important to go to extremes to reduce the distributed capacity by one or two micro-micro-farads, since the coil is always shunted by the tube capacities, which are of the order of 10 micro-micro-farads, and the distributive capacity of the coil here used was only 3.5 micro-micro-farads.

CHOOSING A PROPER TURN RATIO

FIGURE 8 shows the effect of the ratio of turns on the amplification and the frequency range obtained with a choke coil amplifier. Curve A is for a step-up ratio of 1:5, 34 turns being connected between the plate and filament of the amplifying tube and

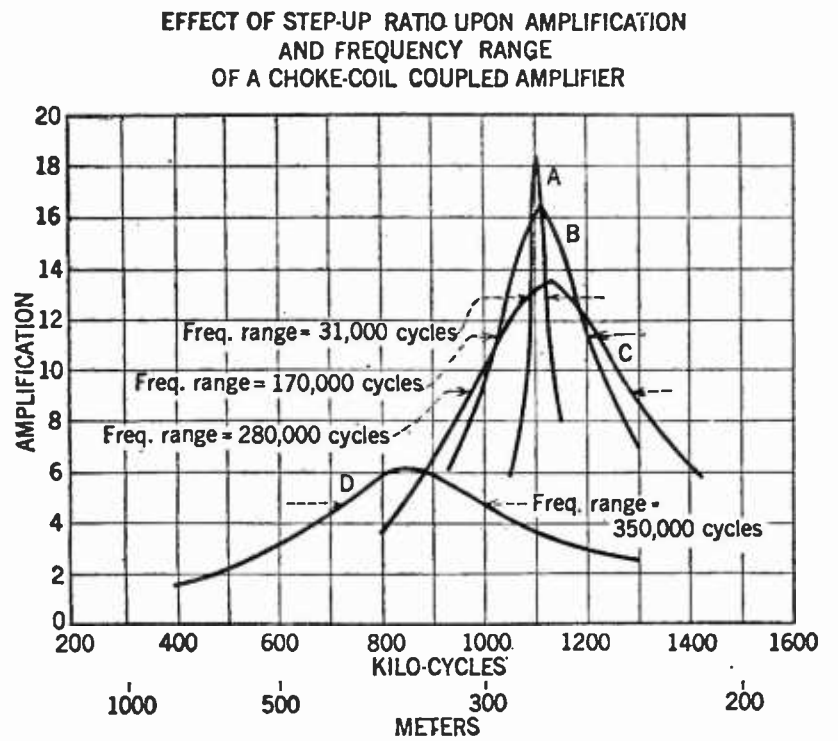

FIG. 8

the entire 173 turns across the grid and filament of the voltmeter tube. Similarly, curves B, C, and D are for step up ratios of 1:3, 1:2, and 1:1, respectively. As noted above, the choice of the proper ratio of turns is largely a compromise between the magnitude of the amplification and the width of the frequency band. For the particular choke coil here considered, a step-up ratio of 1:2 (curve C seems to be the best from both points of view). While giving an amplification considerably greater than for the 1:1 ratio, the frequency range obtainable is not very much less. A step-up ratio somewhere between 1:1 and 1:2 might give even better results.

Fig. 9 shows the amplification curve for a loosely coupled transformer, having two similar pancake coils, 2 inches in diameter, wound with 210 turns of No. 28 solid wire. The distance between the coils is equal to $\frac{3}{8}$ inch. By actual measurement at low frequencies, the inductance of each coil was found to be 2100 micro-henries and the mutual inductance 950 m. h.

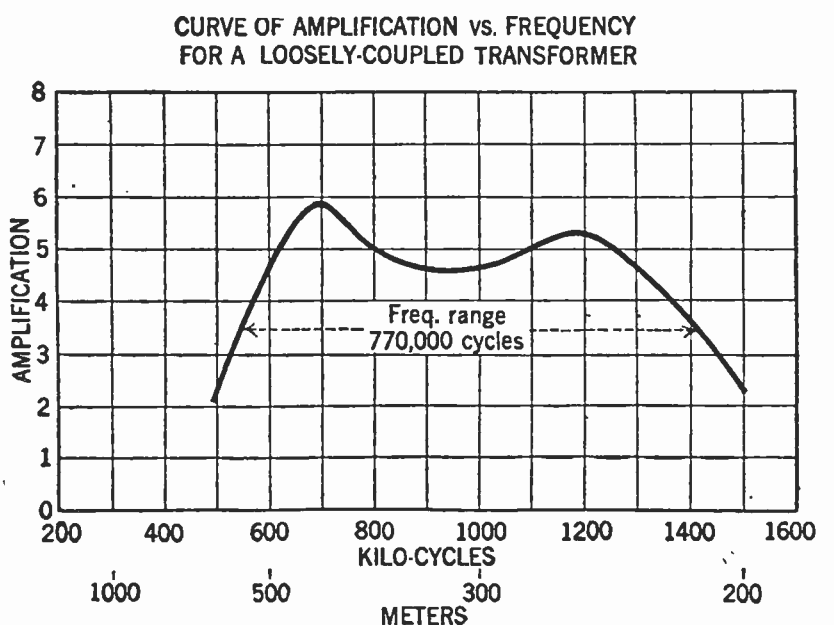

FIG. 9

Do You Know of a Better Receiver for Home Construction?

We Believe RADIO BROADCAST'S Four-Tube Knockout Is the Best and Will Pay \$100 for Description of a Better One

BY ARTHUR H. LYNCH

RADIO BROADCAST, from its first number, has been endeavoring to provide its readers with the most reliable radio information it is possible to obtain. In no section of the magazine is this more evident than in the description of various receivers for home construction. We have refrained from publishing descriptions of receivers just because they were new; they had to be *better* than information previously published.

And now, after considerable experience with the two- and four-tube Roberts Knockout receivers, we believe them to be better for home construction than any other receivers employing the same number of tubes ever described in any periodical. We want our readers to have the best it is possible for a very rapidly expanding art to produce and to this end we are at work, in three different laboratories, attempting to produce something better than the design which Walter Van B. Roberts gave us.

You will find, from reading Keith Henney's article on page 1078 of this magazine, that we have done a great deal of experimenting in our efforts to improve and simplify the fundamental circuit. Frankly, we have not improved the circuit, but we have found that the receivers employing the circuit may be improved by paying particular attention to the parts used in its building. Frankly, too, this improvement, though very much worth while, is not at all revolutionary.

Coils, transformers, condensers, sockets, resistances of all kinds, and parts of almost every kind have had their day in court and though there is a difference in the performance, when all the parts employed are good, the difference is very slight and in most cases it is negligible.

WHERE CAN A BETTER RECEIVER BE FOUND?

WE HAVE hunted high and low for something better. We have carefully experimented with many other receivers—in fact, nearly every night for the past six months

several members of our staff have hunted very diligently right up to the wee hours of dawn. We have come to know circuits by their middle names and all this work has been in vain so far as finding a new circuit worthy of the name is concerned.

As we said at the outset, we are making every effort to provide readers of RADIO BROADCAST with the most reliable information on valuable changes in receiver design. For this reason we are calling upon our readers to assist us in a task which, up to now, has brought us but little information not already well known. In a nutshell our proposition is this: We want you to assist us in locating a receiver design better than the two- and four-tube Knockouts.

Do you know of a better receiver? If so, you will not even have to write an article describing it or supply us with diagrams or other illustrations to win the prize which we are offering. If you are convinced that you have a better type of receiver, send us a set all made up according to your design. If it meets with the approval of our laboratory staff, we will mail a check for \$100 to you, provided, of course, that you will permit us to describe the receiver in RADIO BROADCAST and other publications under our control.

On the other hand, if, after the receiver has met with our approval, we can have an article describing it by you, we will pay generously for it, particularly if accompanied by suitable diagrams and illustrations.

Below we outline the problems more specifically and suggest that before submitting a receiver for test you test it against a four-tube Knockout receiver yourself. This will save time for you and for us.

SPECIFICATIONS OF THE DESIRED RECEIVER

THE receiver we are looking for must meet the qualifications outlined below:

1. The receiver must not radiate.
2. It may employ four tubes (or less if you think four are unnecessary).

3. It must be extremely selective.
4. It must be made of parts which may be had from dealers in at least ten large cities.
5. It must be capable of operation with both dry cell and storage battery tubes.
6. It must be capable of proper operation with tubes operated at their normal filament voltage.
7. It must be built to permit the transfer of tubes from one socket to another without materially changing the results obtained.
8. It must produce good quality, without blasting or rattling cone-type speaker.
9. It must be capable of satisfactory performance with several makes of parts designed for similar use.
10. It must not require critical grid condenser or grid-leak adjustment.
11. It must have no more than three tuning controls.
12. It must permit the use of voltage up to 120 on the audio amplifier tubes (though less may be used if desired.)
13. The plate current consumption of the four tubes (measured at normal filament voltage) must be less than 10 milliamperes, when storage battery tubes are used.
14. It must be capable of exceptional long-distance reception, with volume sufficient to fill a good-sized living room.
15. It must be simple to operate.
16. It must be free from hand capacity.
17. No shielding is to be used.
18. It must be capable of loud speaker operation on two tubes.

HOW THE TEST WILL BE MADE

AT LEAST three judges will be employed who will be capable of passing on the over-all quality of the receiver.

The test will be made on the following points:

- Volume on local stations
- Tone quality on local stations
- Selectivity, judged by ability to cut out locals and bring in distant stations

The receivers to be tested will use an identical set of batteries and antenna and ground equipment, provided with a switching arrangement by which first one receiver then the other may be put in use.

The test of volume on local stations will be the last, and immediately following it, without any adjustments being made, the judges will measure the filament voltage and plate current of both receivers and satisfy themselves of the comparative merits of each with particular regard to the items covered in the specifications. They will allot five points in favor of the receiver showing up better in each of these particulars.

Five points will be allowed the receiver producing greater volume (provided specification 6 is abided by).

Five points will be allowed for better tone quality.

Five points will be allowed for selectivity.

This offer is made to the advocates of receivers for home construction only. Those of standard manufac-

ture are not to be considered. Manufacturers may later want to establish a similar method of proving the all-around utility of their products. We have no desire to compete with them.

If a receiver is found, which proves better than our four-tube Knockout, it will be worth a lot to us to be able to present the design to our readers, which is what we will do if some one can show us such a receiver.

IMPROVEMENTS in radio circuits from the point of view of genuine technical advances come from the engineer and the research man, who are aided by the resources of their technical training and knowledge. Very few real technical advances have been made by the comparatively untrained amateur experimenter in radio, no matter how extensive his experience. And when the amateur increases his knowledge and technical experience to a great degree, he then becomes a professional. The editors believe that fundamental new discoveries in the radio art will come from the research laboratory, but there is always the possibility that some private investigator may chance on an improvement in construction and design that will prove revolutionary. We know that great numbers of radio enthusiasts are constantly experimenting and it is quite reasonable to expect that some of them may chance on a discovery with decided possibilities. RADIO BROADCAST wants to find that discovery and wants to turn it to the benefit of those who build radio receivers in the home workshop. The prize contest which is announced in the accompanying article is open to everyone. It should be remembered by all those who wish to compete that the improvement must be of unquestioned value, for nothing else will be considered.

A HURRICANE AT SEA

Afloat on an Oil Tank—A Thrilling Chapter
From the Life of a Marine Radio Man

By JOHN L. EDDY, Jr.

THE new radio operator was hungry. A vessel alongside the next dock had parted her moorings and swung around to ram its neighbor. In short, a squall was blowing in the Erie Basin, Brooklyn—where the *Elisha Walker* lay, cleared for Mexico and ready to sail any minute—five o'clock dinner was being served aft, across two hundred feet of deck, and the new wireless operator wasn't going to get himself wet! In fact he remembers exclaiming to himself fervently "Thank the Lord, we aren't out at sea in this!"

That, as I say, was a squall, as such may be had off the Brooklyn Flats.

A few weeks later the *Arabic* battled for her life; the *Nordfarer* lost her bridge—and her skipper—who happened to be at duty on this bridge; the *Delaware Sun* stood by a foundered schooner; a man was blown bodily from the flying bridge of the *Cerro Ebano*; and so on down the line. For forty minutes the *Elisha Walker* was in the actual storm center of the hurricane, and, well—the wireless operator got wet!

There is little pointedly thrilling in the life of the single operator carried by cargo vessels in ordinary times of fair weather and usual routine. He turns out in the morning when his inclinations dictate, which is anywhere from five o'clock to noon. If he has copied

press from the high-power, long-wave stations at Washington, Cape Cod, or Colon, perhaps he types up a wireless newspaper for the captain and the different messrooms. Then he may pick up a weather bulletin. Often, however, he does not do so much in the way of work as to start up his motor-generator during the entire course of morning and afternoon. His life is one of long lazy days, of sun-swept seas, of skies only less blue than the mazarine waves they dome, and nights made up of tropic stars and the gentle swish of ocean against the on-going hull of the ship.

But such idyllic weather as this did not last forever with the *Elisha Walker*. No indeed!

At seven-thirty in the evening of the twenty-fifth of August last I unsuspectingly went on watch after a doze of intermission of several hours. It was the wireless telegraph which first gave us an idea of what we were in for.

I put on the phones. The receptor was tuned to the usual ship's wavelength, 600 meters. A ship was sending out a report of its local weather conditions. First came the latitude and longitude, which I recognized as indicating a point some sixty miles south of us. (We were then nearing Cape Hatteras.) "Wind force eleven." Twelve is as high as the wind force code goes! Next came "Mountainous seas." The ship with which the first was communicating answered in a whistling

note slightly fainter than the first ship. Her latitude showed her to be some thirty miles south of the first. The operator spelled out the intriguing reply, "Conditions here same as yours, only wind is terrific." The great hurricane which had lain off to the east had looped around and was running to the north and northeast. However favorable our local weather conditions might be a few short hours' run to the south of us the seas were "mountainous", the wind "terrific."

A copy of these intercepted messages I took up to the skipper.

"SEAS MOUNTAINOUS;
WIND TERRIFIC"

AT EIGHT o'clock the first mate came off watch and I went in to play the usual evening game of chess with him. Said he at once, "You scared the dickens out of the Old Man, Sparks." I did not understand until the mate added, "He came up on the bridge with those messages you gave him. When he called me he was stuttering; when he handed me the messages he could hardly talk." This was Captain Prager's last trip after half a century of sailing the seas.

As the mate finished speaking, there came a grand crash on the deck overhead, the whole great frame of the vessel quivered and moaned, and down through a ventilator shaft in the middle of the ceiling of the mate's cabin poured a deluge of salt water. The mate seized a pail from a corner and held it up to intercept the flow.

When the chess game was over I went again to the radio to see what the wild ether waves might be whispering during a sure-enough hurricane.

But by this time wind and waves had worked themselves up to a rampant fury, and before putting on the phones it was necessary to "make fast" such movable objects as typewriter, table, and pails, to keep them from skating about the cabin.

I donned the phones, and had heard a

medley of loud and faint buzzes, when, in a trice—everything was dead silent! The antenna carried away! In a raging hurricane and out of touch with ships and shore! With a great shuddering lurch of the vessel and a tremendous sobbing crash that rose above the wowl of the wind, several thousand tons of water struck the deck outside. At the same instant the radio signals broke in again as strong, and as reassuring, as ever. This

happened more than once. The simple-enough explanation was that the waves were coming in a mass clean across the waist of the ship, wrapping the lower end of the lead-in wires in a solid bank of salt water, which naturally grounded the antenna to the ship's hull and the ocean, and so completely killed all signals.

Towards one o'clock the ether grew quiet; there was little to be heard but two or three ships exchanging weather bulletins, an operator who had missed the United States Navy

stations' weather broadcast requesting it from one who had copied it, a Dutchman with weird-sounding spark calling a coastal station a thousand miles away, the ceaseless crackle of atmospherics. I was sleepy, very sleepy. I decided to turn in.

But in this pleasant ambition I was sadly disappointed. How such a quantity of water as I discovered contrived to get into my bunk must remain a mystery!

"PRETTY THICK"

DISCOURAGED thus, I turned again to the radio. The *Munargo*, with tiresome repetitions necessitated by the heavy static, was handling traffic with the station at East Moriches, Long Island. This out of the way and the air clear again, the English-speaking operator on the Danish steamship *Nordfarer* called me and asked how the weather was with us. I gave him a detailed report, adding the words "Pretty t-h-i-c-k," with the dots and

Those Dots and Dashes

Which come through the loud speaker of many a broadcast listener's set on nights sometimes stormy and sometimes clear are often freighted with more meaning than their calm spacing indicates. Those new to radio are too prone to think that "radio" refers solely to broadcasting. But there is more to radio than that. Ship and land stations throughout the world are day and night carrying on their business by means of the same medium that brings entertainment to so many of us. Much of this radio telegraph traffic is workaday and routine, but when the emergency arises, radio is there to meet it. There are few radio men—"Sparks" as they are invariably called—who can not spin a yarn or two of radio and the sea well worth the hearing. Mr. Eddy's story gives an interesting and a true picture of an experience which is certainly not unknown to the marine radio operator.—THE EDITOR.

dashes dragged out for emphasis. At this two other ships put in the universal radio signal for a laugh—four dots and two dots—and the Dane returned a snappy “Thick, did U sa?!!!” The exclamation marks were emphasized. He followed them with a “Ditto here, OM.” (OM: radio for “old man”.)

Late the next day it was that this same operator called me with a long “service mes-

sage” telling of their bridge being taken away at midnight by the wind, and the skipper along with the bridge. The operator wanted to know how to go about getting a radio compass-bearing for his ship, which was now without navigating charts and had been without a “sight” on the sun for the past five days. They had no idea of their position. When the operator had been talking to me the night before,

his captain had been drowned more than an hour, but so mighty was the storm that the operator was as yet unaware of the disaster it had worked to his own ship.

Finally I took off the phones, put the A batteries on charge, and curled up on the narrow settee, still mysteriously dry, with my feet hanging over. I took care to brace myself in such a way that despite the violent movement of the ship I could remain on the settee without particular effort and without wobbling too much for sleep. The wind was screeching, groaning, bellowing, like some vast giant in alternate agonies of pain and rage. Already half asleep, I flattered myself that I had been listening-in on such stuff as the broadcast listeners about their snug hearths ashore could never hear.

I dozed off and slept while the *Elisha Walker*, some two score

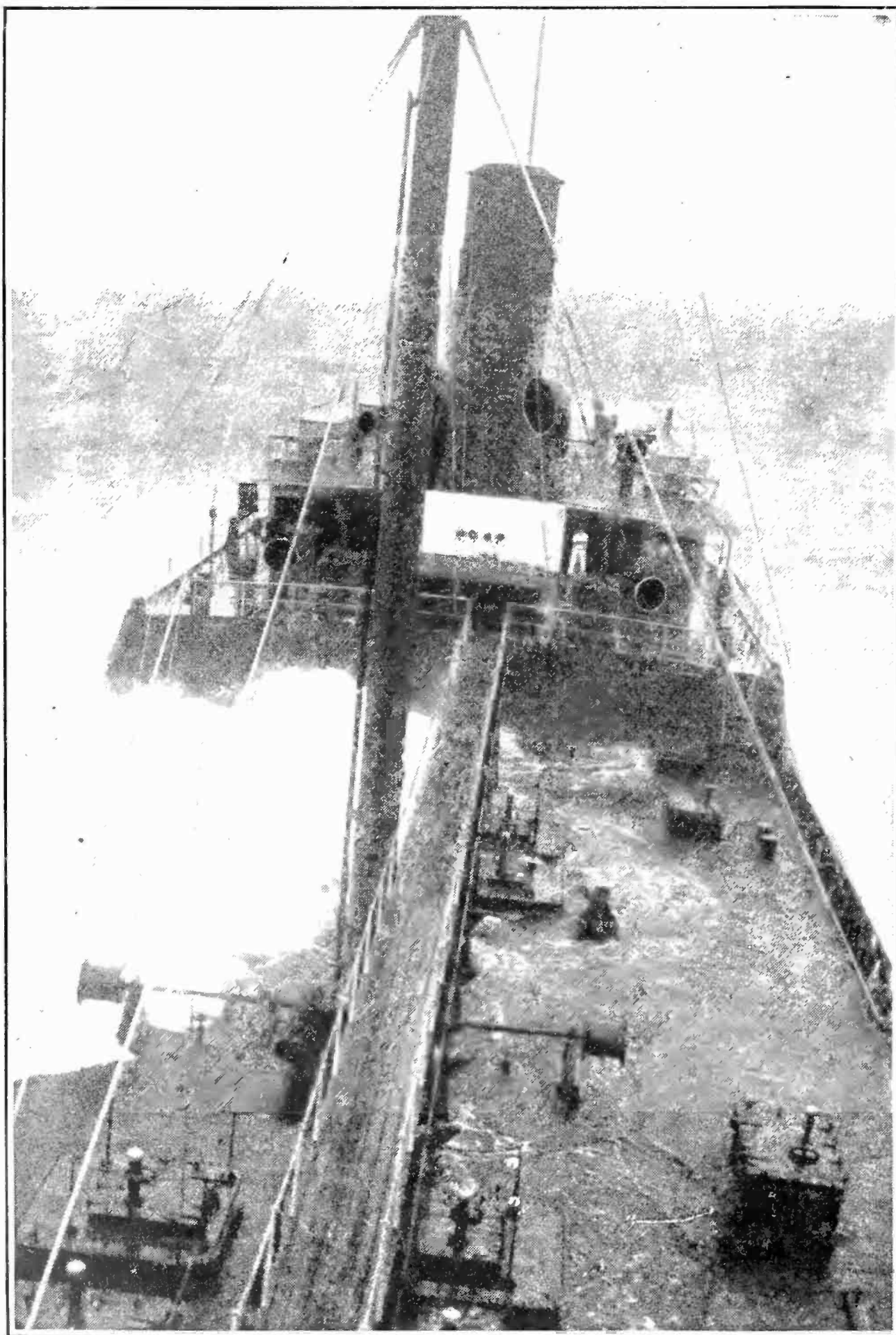

“THE HURRICANE HAD SUBSIDED . . .

And the sun was shining through scudding clouds.” The radio cabin of the ship was located at this end of the flying bridge, which is the narrow passageway in the center of the photograph

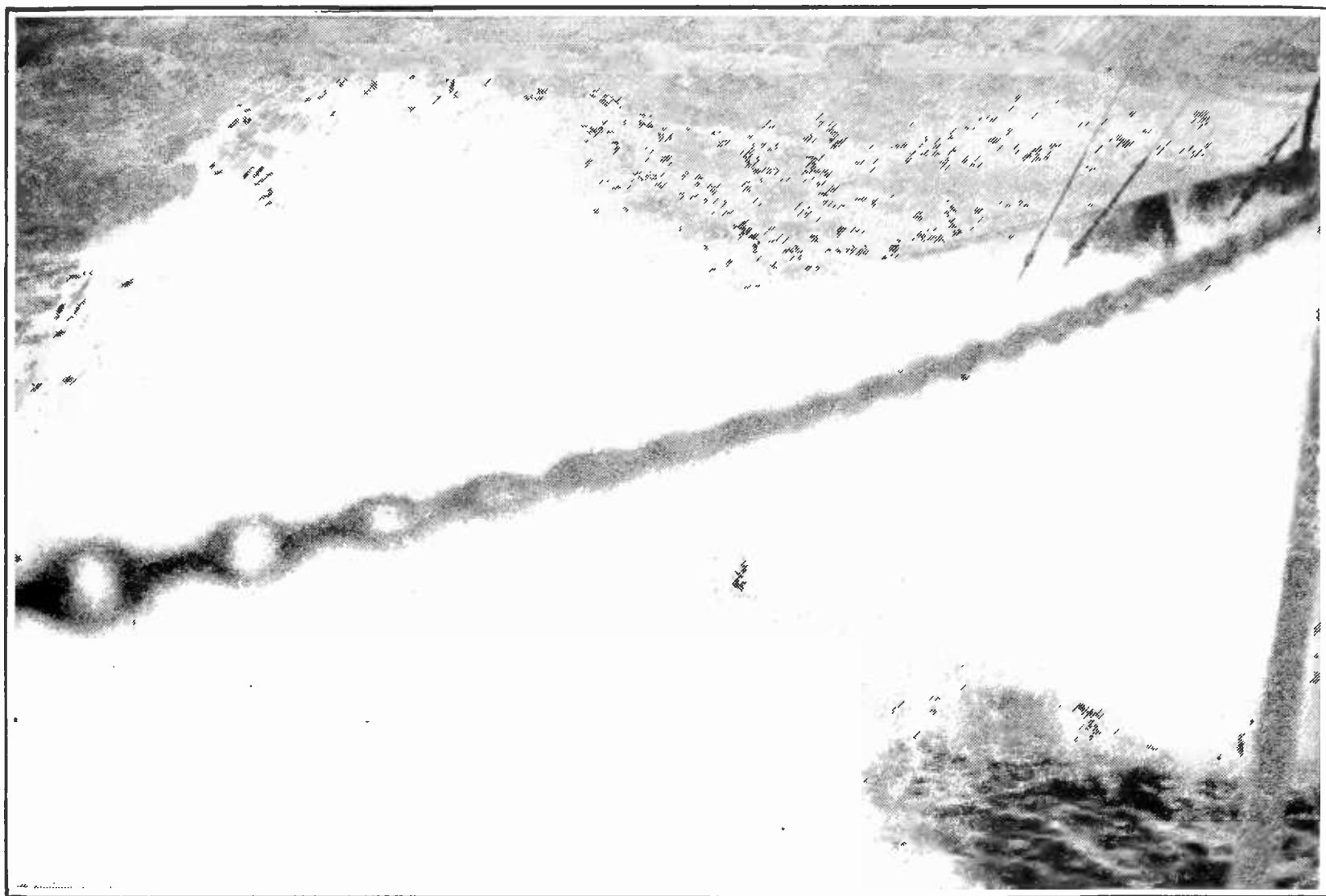

THE SEA AND THE SHIP

Amateur photography is a bit dangerous aboard ship during a hurricane and this view was taken by the operator of the *Elisha Walker* after the storm had abated enough so that the radio cabin door could be opened. The chain is the hand-chain of the fore-and-aft bridge. Just above it, the ship's rail is discernible through the flying water

miles off Cape Hatteras, passed through the very center of the hurricane.

THE CENTER OF THE HURRICANE

WHEN I awoke at five-thirty, the impenetrable shrieking blackness of the night before was the least bit less black with the rising of a sun somewhere in heavens far, far off and above the howling watery inferno in which we still weltered. We were passing out of the nearly breeze-less area at the widening center of the cyclonic storm and into the very worst part of it again. Government meteorological observers have estimated the wind velocity at this part of a hurricane to be as high as two hundred miles per hour. At any rate, it blows hard. The barometer, usually about thirty-something, and reported by the press as down to 29.42 and the lowest recorded in four years, read on the bridge of the *Elisha Walker* 28.65! There was a feeling in one's ears as when climbing a mountain—a hollow sort of pressure distending the ear drums.

Gigantic seas hid the ship, often flying over the top side of the antenna, making it im-

possible to discern the after lights and funnel from the bridge, even occasionally hiding the foremast from the view of those on duty in the wheel house. To walk down a narrow alleyway was an acrobatic stunt, and the excessive exercise gained in a little such walking impressed itself on arms and back and thighs with a soreness which lasted several days.

After half a cup of strong coffee in the pantry I returned to the radio cabin. The naval station at Norfolk, Virginia, was "coming in" extraordinarily loud. I talked with their operator for a minute, then started for the bridge with the idea that the offer of a radio compass-bearing might not be unwelcome, for only an unreliable approximation of the ship's position could be reached by dead reckoning in such weather, and of course no observation of the sun had been possible in the past few days.

No words could possibly describe the terrific, the awful, composition of sound and movement which struck one coming up the steps into the chart house of the *Elisha Walker* in the early morning of the twenty-sixth of August. As a comparison I see a small box-

like room, gained by a flight of stairs, the walls lined with small black-paned windows, a dim light focused over a broad chart on a high table at one side, the whole chamber jumping and rushing through a violently convoluted path. Just beyond the thin walls a thousand demented devils are making a frenzied onslaught against every square inch of outer surface. That the thousand devils are nothing more than the rapid movement of thin air is merely inconceivable; but it is so. Ask the lookout on the weather side of the bridge if it be not so. He had his very trousers stripped from his legs by the hand of this unseen giant.

After a shouted conversation with the captain, I returned to the radio, only to find that in the interim a sea, finding the transmitter, had drenched the inductances and put it out of commission. Attempting to clean the salt water from between the numberless turns of shiny copper ribbon availed only to get the operator a fall and a bloody contusion on the hip. Until the seas went down—to the extent of no longer keeping the transmitter under a continual shower—all efforts were futile. The *Elisha Walker* was out of communication with other vessels and with the shore; the ship's position could not be ascertained.

THE STORM ABATES

IN A few more hours we saw that the storm was perceptibly abating; but the wind was still blowing at a velocity in the neighborhood

of one hundred miles an hour, and great seas were still sweeping across the ship to mingle again with the ocean on the lee side. From seven-thirty to eight, breakfast was being served aft; so with the second mate's oil skin, sou' wester, and hip boots I fared forth to cross the flying bridge. It was no mere blow in New York Harbor now, but the fury of a mighty storm on the high seas that one bucked as one fought one's way down the narrow bridge which leads from amidships to the poop deck of an oil tanker. "Fought" is a suitable word, for it was as if ten men, grasping every part of body and clothing, were wrenching loose your grip on the hand chains to toss you over the side to Father Neptune.

In spite of this zestful prelude, my breakfast appetite, I confess, was not of the heartiest; though I made up for it a few hours later. By then the gale had subsided to a strong wind, the sun was shining through scudding clouds and mist sufficiently to permit an observation. A day or two later, with a life boat stove in, two-inch planking blown away, most of a large metal speaking tubing carried away, and the rest bent to fantastic shapes, the *Elisha Walker* steamed in the early forenoon sun up Ambrose Channel and into the port of New York.

As sang Chief Engineer R. C. Waite in his seafaring barytone,

"Oh, it ain't gonna rain no mo', no mo';
It ain't gonna rain no mo'!"

HOW TO CONSTRUCT A RADIO-FREQUENCY AMPLIFIER

WILL be the subject of an excellent construction article which will appear in an early number of RADIO BROADCAST. A tuned radio-frequency amplifier to meet the requirements of present-day broadcast reception ought to contain inherent neutralization or some means, either mechanical or electrical, to balance the circuit and prevent radiation. The circuit to be described employs two stages of amplification and the famous Roberts method of neutralizing.

The Beneficent Results of Broadcasting

SOME few weeks ago, the amiable Mr. Frank Sullivan, a special feature writer and well-known wit of the New York *World* paid a visit to the microphone of station WGBS in New York. Seldom has the clear cold light of reason been so thrown on individual reactions on the "Great Experience"—which, six years ago perhaps was the War, or facing the minister with one's bride. But now, we fear, the "Great Experience" is broadcasting. An experience it is, too, and perhaps more of an experience for the listener than the performer. Very shortly after appearing, Mr. Sullivan recovered enough to write the following testimonial for broadcasting which was printed in Heywood Broun's column "It Seems to Me" in the New York *World* (copyright, 1925, by that paper):

"I have a message for you from Mr. Eduard Lippe and Mr. Thurston Macauley, two of the most estimable gentlemen who ever made my lot an easy one at station WGBS last Tuesday night," he writes. "They want you to come and broadcast from their station. Take my tip, by all means do it. I did for the first time last Tuesday night, and since broadcasting I have been a different man.

"Before broadcasting, I had that achy, tired feeling all the time. I didn't want to get up in the morning. It was an effort to drag myself to work. I had spots before my eyes, spots on my vest, vertigo, malaria, pyorrhea, mitral insufficiency, endocarditis, acne, dipsomania, Argyll Robertson pupil, acute arnica, alopecia, migraine, megrims, and paronychia. To-day all I have is spots on my vest, and I feel I owe it all to that wonderfully tonic experience of broadcasting.

"You will be frightened before you go on. I walked around the block at Gimbel's four times before I had the abdomen to go up and face the music. But, as I told my dear radio audience, I comforted myself with the assurance that by no possible means yet known to science could they throw anything at me.

"Dr. Paul Sifton, radio editor of the *World*, was a great help. He advised a good sleep in the afternoon preceding the ordeal, so I

slept carefully all day Tuesday. I rose at 6 and breakfasted lightly on a steak, with a few lamb chops by way of vegetable, and a sirloin of beef for dessert. I took no stimulants whatever with the exception of three or four cups of coffee with brandy in them. It is best to avoid too much stimulant on such occasions.

"Then I put on a good heavy sweater and a rubber suit and ran from 105th Street to West Fourth and Perry. Whose place should be at that point but the dry cleaning establishment of my old friend, Sir Lucius O'Connor, whom John Masefield had the honor of working for as a barkeep in the old days, when Sir Lucius kept a dry cleaning establishment on Sixth Avenue. Several hours later, having worked up a perspiration, I had a good rub-down and massage, and then Dr. Sifton, after applying the stethoscope to Mr. Macauley and Mr. Lippe, said he thought I was fit to take the air.

"I was frightfully nervous, I can tell you. My heart was bumping like a Broadway surface car going over the crosstown tracks at Times Square. Dr. Sifton administered a hypodermic and gave me Marsh's test for arsenic. I felt better. Mr. Lippe asked me if I thought I could go ahead with it. I said 'Damn the torpedoes. A Sullivan never retreated from a microphone yet.'

"Dr. Sifton gave me the Shick test then, and I sat down. Immediately I had faced that modest little disc, so fraught with mystic, hidden possibilities, and visioned that vast invisible audience outside, something stirred within me and a mighty surge of emotion swept over me. I want to tell you, Broun, that at that moment I was proud of America, and proud to be an American.

"From that moment on I was sure of myself. I had all the calm of a man whose tooth is being extracted. Mr. Lippe said, 'It's all right, I don't think anybody is listening. Go ahead.' So I did.

"I had a splendid time, and I do want you to have the experience. WGBS has had 103 letters lauding my speech. If they haven't got the letters, then I must have forgotten to put stamps on them."

Essential Radio Accessories

A Brief Discussion of Radio Components of Great Importance in Receivers—Constructional Ideals and How They Are Attained—A Bibliography of Radio References

WHAT MAKES THE WHEELS GO 'ROUND: XII

BY WALTER VAN B. ROBERTS

IN THIS last installment of Mr. Roberts' excellent series of explanatory technical articles, the reader will find nothing that is new or revolutionary. He will find, however, a splendidly clear treatment of important radio fundamentals put in simple and direct fashion. And, too, many radio experimenters who have come in the art with broadcasting, but who want really to increase their technical reading, will do well to observe the bibliography recommended by the writer on page 1114.—THE EDITOR.

IT IS easy enough to stick a megaphone on to a receiver that produces a loud signal. Most loud speakers are merely refinements of this idea. The horn concentrates the sound somewhat in one direction and the tapered column of air that fits up against the small receiver diaphragm at the small end and swells gradually out to join the open air at the flared end, supplies something for the diaphragm to work against. It makes the diaphragm set more air in motion, just as if a bigger diaphragm were used, thus increasing the volume of sound produced. But inasmuch as the best receivers are only about two per cent. efficient (that is, of 100 units of electric energy entering them only about 2 leave in the form of sound energy), only small efficiencies are likely to be obtained even when horns are coupled to the diaphragm. It is interesting to note at this point that the great sensitivity of the human ear tends to make up for the inefficiency with which energy is converted from mechanical to acoustic by means of vibrating bodies. In ordinary speech only about one erg (the erg is the physicist's unit of energy) per second is converted into sound energy. How little this is can be seen from the following calculation: reckoning that the average human being talks the equivalent of two hours steady talking per day, and that the average population of the United States since the Revolution is forty million, and that power is worth two cents per kilowatt hour, then from the energy point of view all the talking that has been done in the history of our country is only worth \$8.59.

86. THE IDEAL LOUD SPEAKER

IN ADDITION to the low efficiency of the conventional loud speaker, there is more or less distortion introduced in this method of making radio signals audible by the horn. An excellent method of overcoming this is by the use of two or three separate horns, each with its own diaphragm. In the case where three are used, for example, one is a very long horn that responds well to low tones, the second is an ordinary sized loud speaker responding fairly well over the middle range, and the third is a very small horn giving the very high pitched notes. The three horns, all working at once, combine to give a satisfactory uniform response over the whole audible range. The three horns, of course, are combined in a single box. The long horn can be coiled to save space if necessary.

Another type of loud speaker avoids such distortion as is due to the horn by using no horn at all. This type of speaker usually, but not necessarily, has a large, light, stiff paper cone for a diaphragm, and this alone is sufficient to give it a good "grip" on the air. At present only a few commercial types of loud speakers give any sort of an approach to the goal of quality, which is to have all frequencies transmitted from speaker to listener with equal efficiency. (It would seem that this goal could be easiest attained by letting the faults of one part of the apparatus cancel those of another part. For instance, if an audio amplifier favors the lower frequencies and the loud speaker gives the loudest response at the

higher frequencies, then the combination of these two units would offer a nearly uniform response over the entire range. But then parts would not be interchangeable, so the endeavor at present is to make each unit, independently of the others, possess a "flat" characteristic, that is, to handle the whole necessary range of frequencies with equal efficiency.) The average amateur can build himself an amplifier that will operate a cheap loud speaker with passable quality and enough volume for a small quiet room, but if he wishes enough volume for a large audience, together with the best quality of music and "articulation" (intelligibility), he should buy or build a first class push-pull amplifier which can be used with a loud speaker unit, or amplifier using power tubes and use it to feed a high quality loud speaker such as those described above.

87. DRY CELLS FOR A BATTERIES

WHEN only a watt or less is required to heat the filaments of all the tubes of a receiving set, it is often simplest to use the standard six inch dry cell. The voltage of a dry cell is between $1\frac{1}{2}$ and 1 volt according to its condition. To get the most, in the long run, out of such a cell, not more than about $\frac{1}{4}$ ampere should be allowed to flow through it. Hence we should not figure on obtaining more power (volts times amperes) than about $\frac{1}{4}$ watt per cell. Thus a single tube requiring an ampere at five volts (five watts) for its filament would require about 20 dry cells to run it for any length of time. On the other hand, the Radiotron UV-199 tube needs only .18 watt (60 milamperes at three volts) for its filament. Two dry cells in series, or, better, three in series with a controlling rheostat, would take care of three such tubes easily. The WD-11 or WD-12 tube runs on $\frac{1}{4}$ ampere at 1.1 volts. It is obviously designed to run on a single dry cell.

88. RADIO TUBES

THE tendency in tube design seems to be toward very small tubes (requiring very little filament battery energy) for handling small amounts of alternating current power. At first the filaments of vacuum tubes were made mostly of tungsten, a metal which gives off a good emission of electrons only when very hot, and the tungsten filament still in use in the Radiotron UV-200 "soft" detector tube requires five watts to heat it. The Western Electric Company reduced the power required for their filaments by making them of platinum

coated with oxides of barium and strontium which give a good emission of electrons at a dull red heat. The WD-11 and WD-12 tubes of the Radio Corporation of America have filaments of the same type. The next step came with the discovery that if a little thorium oxide is mixed with the tungsten of a filament, upon operating the filament, pure thorium works its way out of the filament and coats its surface, as a result of which plenty of emission can be had with the filament running much cooler than when the surface is tungsten. If one of these thoriated filament tubes is run at more than the rated voltage with the idea of increasing the emission, the thorium surface is likely to boil off and then the filament will be no better than plain tungsten until the thorium surface is renewed by letting the filament run a while at rated voltage with the plate battery disconnected. The Radiotron 201-A is a tube having this type of filament and takes $\frac{1}{4}$ ampere at 5 volts and while it is a good detector and amplifier of weak currents, its advantage over the 199 is chiefly its ability to handle larger amounts of power, such as for a loud speaker. The Radiotron 199 also uses a thoriated filament but takes only .06 ampere at 3 volts, or only .18 watt. Its grid and plate are so small that the resulting reduction in grid-plate capacity makes it less apt to oscillate in radio-frequency amplifiers.

The next advance was the discovery that by special means caesium could be made to coat tungsten filaments. And caesium gives a good emission at the lowest temperature of any material known.

It is probable that before very long the tubes for radio frequency amplification and detection will be as small as one's little finger and many of them will be run on a few dry cells, and, last but not least, quantity production should bring the price down to a fraction of what we now pay.

89. DESIGN OF GOOD ACCESSORIES

A VARIABLE condenser that makes horrible noises due to short circuits or bad contacts with the rotating part, or is hard to turn, or that isn't balanced so as to "stay put," or that does not have the same capacity every time it is turned to the same setting, or that has lost motion or looseness in the knob, or that hasn't some satisfactory means for very fine adjustment, is enough to take all the pleasure out of a radio set. For a while, very few really good condensers were available to the radio public. Now, there are a

considerable number available of good construction. It doesn't pay to save money on the tuning condenser.

90. SOCKETS

ANOTHER point where trouble is likely to occur is in the tube sockets. The springs that make contact should be long, and made of several laminations so that they won't be permanently bent by pushing the tube into the socket. Poor contacts in tube sockets cause a lot of "unexplained" noises. The socket should also be made of a good insulating

material. Hard rubber, porcelain, pyrex glass, and bakelite are good but many of the fibrous and moulded materials are not.

91. CONTACTS

GOOD contacts throughout a set are essential. All contacts should be soldered, or else a good clean wire clamped firmly by a binding post or Fahnstock clip. Poor contacts are responsible for so much of the trouble that arises in receiving sets that it is worth while to guard against them with what might seem unnecessary care.

BIBLIOGRAPHY

1. H. J. van der Bijl, "*The Thermionic Vacuum Tube.*"
 2. R. A. Heising, "Modulation in Radio Telephony." *Proc. I. R. E.* Aug., 1921.
R. V. L. Hartley, "Relations of Carrier and Side Bands in Radio Transmission." *Proc. I. R. E.* Feb., 1923.
 3. H. D. Arnold and Lloyd Espenschied, "Transatlantic Radio Telephony." *Journal of the American Institute of Electrical Engineers*, Aug., 1923.
 4. S. E. Anderson, "Vacuum Tube Amplification." "*Q. S. T.*" Jan., 1923.
 5. R. A. Heising, "The Audion Oscillator." *Proc. A. I. E. E.* April and May, 1920.
 6. L. A. Hazletine, "Tuned Radio Frequency Amplification with Neutralization of Capacity Coupling." *Q. S. T.* April, 1923.
 7. Principles of Radio Transmission and Reception with Antenna and Coil Aerials, J. H. Dellinger. *Proc. A. I. E. E.* Oct., 1919.
 8. Lloyd Espenschied, "The Application to Radio of Wire Transmission Engineering." *Proc. I. R. E.* Oct., 1922.
 9. *Q. S. T.* Aug. and Sept., 1923.
 10. *Science*, Dec. 22, 1922, Supplement.
 11. Irving Langmuir and K. H. Kingdon, "Thermionic Effects Caused by Alkali Vapors in Vacuum Tubes." *Science*, Jan. 12, 1923.
 12. E. H. Armstrong, "Some Recent Developments of Regenerative Circuits." *Proc. I. R. E.* Aug., 1922.
 13. E. H. Armstrong, "A New System of Short Wave Amplification." *Proc. I. R. E.*, Feb., 1921.
 14. Otto J. Zobel, "Theory and Design of Uniform and Composite Electric Wave Filters." *The Bell System Technical Journal*, Jan., 1923.
 15. W. van B. Roberts, "A Single Tube Loop Set in a Brief Case." *RADIO BROADCAST*, May, 1923.
- Also, for general discussion of modulation, demodulation, and filters, see E. H. Colpitts and O. B. Blackwell, "Carrier Current Telephony and Telegraphy." *Proc. A. I. E. E.*, 1921.

What Radio Equipment Does the American Fan Use?

An Analysis of the Apparatus Used by Listeners Who Heard Europe in the International Radio Broadcast Test

By HAROLD S. FRAINE

WE ASKED a deep-dyed radio fan what he thought the recent International Radio Broadcast Test had proved to him.

He grinned. "Well," he rejoined, "it proved that there are a lot of fatheads like me who sit up all hours for the privilege of discovering that if he owns a radio set in New York one can hear a radiating rodeo rider as far away as Denver."

The Test did prove this in a sense. We found beyond doubt, that the million squealers who tantalized their dials during this time are the chief obstacle to distance reception. The tests led one to think that multi-tube sets are no more likely of success in distance angling than expensive tackle is the paraphernalia of success for a man who angles for fish.

It proved that the successful ten-tube sets strung end to end wouldn't reach to first base. It proved that Willie's one-tube set was ten times as effective as the multi-tube sets, and this is immense encouragement to the Willies until you examine the numbers of them, and discover where they live.

There are at least as many one-tube sets, as for instance, seven-tube outfits. And when one remembers that the multi-tube sets are

preponderantly owned in big towns where the money to buy them is more plentiful, where folks stay home less because of the big town's amusements, and where the lust for entertainment is overwhelmingly greater than the lust for distance; if one remember these things, one wonders if Willie deserves the distinguished service medal after all.

Naturally, having sponsored the International Broadcast Test and invested a great many thousands of dollars to insure their success, RADIO BROADCAST wanted to know something about those who achieved the note-worthy end of hearing Europe. We wondered where they lived, what circuits they used, how many tubes were used in their sets, whether they had a long or short antenna, high or low, or a loop, whether DX was picked up with phones, or whether the loud speaker brought it out enough for all to hear, whether they used dry or wet batteries.

The Facts in the Case

At various times in recent radio history—and all radio history is really "recent"—various agencies have collected statistics about the radio public. But most of these surveys, perhaps made for a particular purpose, were necessarily limited in their scope. Mr. Fraine, a member of RADIO BROADCAST staff, has examined the interesting questionnaires returned to the magazine from thousands of radio listeners in every part of this country and others, who reported hearing foreign broadcasters during the International Radio Broadcast Tests of last November and December. It is not incorrect to assume that those who returned their answers represent a very fair cross-section of the American radio public. We can judge from what they say what kind of radio equipment is most popular, and if we be of an analytical turn of mind, we might make a very fair prediction of the trend of radio. Are home-built or complete, purchased receivers more popular? Do listeners favor storage or dry cells? The author has tried carefully to draw reasonable conclusions about these, and many other, interesting points.

—THE EDITORS.

The first job was to sort out the answers to these questions as they came to us in the mail, and if you were ever in the unenviable position of having to write down in a few hasty sentences the result of the answers to over forty-six thousand questions, you know that takes a little longer than from yesterday

to to-day. That is why this article is in the April RADIO BROADCAST and not January.

MANUFACTURED VS. HOME-BUILT SETS

WHAT is the percentage of manufactured compared to home-built sets?" This question was put to a prominent radio retailer. He leaned back and thought a moment and said:

"I can't answer that question for the whole country, but I do know this. Two years ago, about 85 per cent. of our business was selling parts and only about 15 per cent. of our sales were complete sets. To-day just the reverse is true, and fully 85 per cent. of our business is in the sale of complete sets."

We got a very difficult picture from the questionnaire which reached a very representative part of the radio public. The answers showed that a majority of radio fans still "roll their own"—fifty-five per cent. to be exact. There was every sort and kind of radio mixture you could conceive of and while the table of percentages we made shows

only five different essential hook-ups, this number could be multiplied by a hundred and still you wouldn't have all the various "dynes" and "flexes." Some of you will say: "I might as well call my set one of these, as to say all birds are chickens." But in the last analysis, you will find that these classifications are about as good as any:—super-heterodyne, neutrodyne, stabilized radio frequency, reflex, and regenerative, and the greatest of these, as you will see by the table, is regenerative!

The typical regenerative circuit, after all we have said in the columns, must be closely associated in your mind with the radiating bloopers, and our fine argument against regenerative squealers is clean out—out with a knockout blow—down for the count of ten! But not so hasty! Practically every one of these people came right out flat footed and said "no radiation, in the antenna circuit" "extra neutralized tube in the antenna circuit," or something to that general effect. Which goes to prove that a large number of regenerative circuit owners at least know what they are up against, and that there is a fortune for the man who can invent some simple attachment preventing regenerative circuit radiation. In this connection, the new attachment, invented by Mr. Roy A. Weagant, Chief Engineer of the De Forest Company, may prove of great benefit to regenerative set users. The argument regarding the proper use of the regenerative sets seems to have generated more heat than light.

The super-heterodyne, neutrodyne, and the various kinds of reflex circuits divided honors nearly equally among the home built sets, employing not essentially regenerative circuits. There are more than three times as many regeneratives as any of these others. And this means absolutely nothing except that the cost of good home-made receivers, just as with good manufactured receivers, plays a big part in the number that are in circulation.

ANTENNA—LONG OR SHORT? HIGH OR LOW?

OUT on the wide expanses of the ocean on sailing ships in fair weather and calm, sailors rig a sail away up on the main mast which they call a "cloud-breaker" or "sky-sail." Its purpose is to pick up any vagrant air current which might help to carry the ship along. But the good ship really depends for its headway upon its broad sails of modest height. In the same way

INTERNATIONAL RADIO TESTS—1924

Name.....
 Location.....
 Will you accept appointment as official listener in next year's tests?.....
 Type Receiver.....
 If factory made, what kind?.....
 If home-made, what important parts?.....
 Number of Tubes..... Kind of Tubes.....
 Antenna or Loop..Length of Antenna..Height...
 A Battery. Wet.....Dry.....Make.....
 B Battery. Wet.....Dry.....Make.....
 Battery Eliminator?.....What kind?.....
 Any special equipment not covered above.....

 What was source of worst interference?.....

 Next worse source.....

 Did you use head-phone or loud speaker?.....
 Make of Phone.....Make of Speaker.....
 Names of radio enthusiasts having efficient apparatus and who can be recommended by you as official listeners.

*Return to RADIO BROADCAST,
 Garden City, New York.*

THE QUESTIONNAIRE

Which was sent to all listeners who reported hearing foreign broadcasts. The information which the answers brought gave a set of facts about radio users which had never been definitely known before

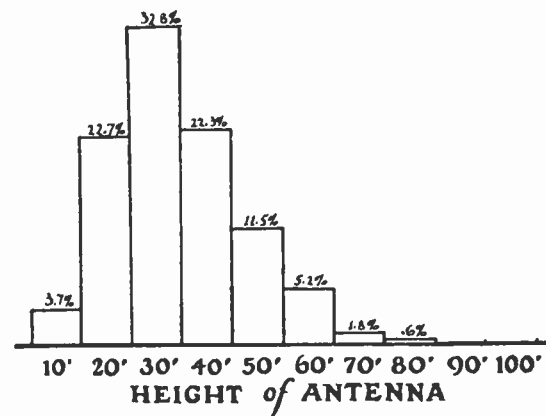
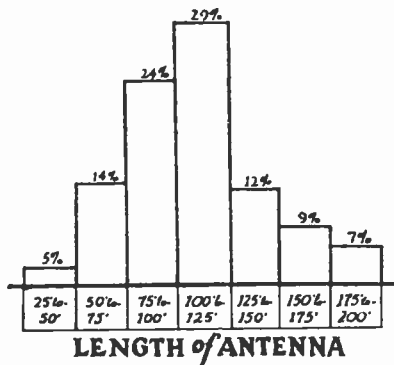
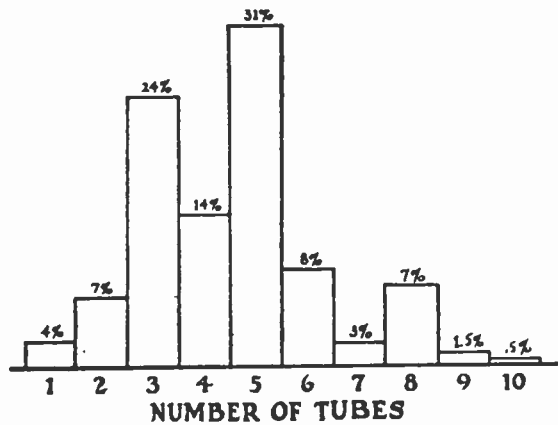

TYPES OF HOME-MADE HOOK-UPS USED IN TESTS

<i>Super-Hetrodyne</i>	16.23%
<i>Neutrodyne</i>	13.84%
<i>Radio Frequency</i>	5.01%
<i>Reflex</i>	15.38%
<i>Regenerative</i>	49.54%
	<hr/> 100.00%

SOURCE of WORST INTERFERENCE

<i>Radiating Receivers</i>	50.7%
<i>Spark Stations (Code)</i>	18.5%
<i>Static</i>	13.5%
<i>Fading</i>	5.3%
<i>Other Stations</i>	5.3%
<i>Man-made Static</i>	5.2%
<i>No Interference*</i>	1.5%
	<hr/> 100%

TABLE I

Showing graphically the results of answers to the questionnaire on page 1116. The tabulation shows that of the group answering, 45 per cent. used manufactured sets and 55 per cent. were home made. It roughly classifies the types of circuits used in the home made receiver, source of worst interference, average length and height of antenna and the number of tubes used

radio fans, looking for unusual results, sometimes can afford antennas stuck high in the air, which may pick up stray radio impulses, but the most dependable average good results, it would appear, are obtained from antenna of moderate height and length.

As you will see from the diagrams, the most popular antenna is from 100 to 125 feet long and about 30 feet above the ground. A surprisingly large percentage use an elevation of only 10 feet, and much shorter lengths.

Einstein has secured a good deal of publicity from what is popularly known as the Law of Relativity, which, in our modest understanding, means that anything you think is true, isn't true absolutely, except as it relates to something else that is true. You finish where you started, and then begin all over again!

So with antennas. Anything you think is true about them, isn't true except as it relates to the unavoidable conditions where your particular antenna is located. It is natural to expect that in cities where there is every sort of interference underneath the ground, on the ground, and in the buildings, a high antenna, as far away as possible from the disturbing elements, will be most effective. In the country, where one is far from all disturbances, great heights are apparently not so desirable.

Even these conclusions are relative, for high

antennas may collect static and more remote disturbances; long antennas with their inevitable lengthy lead-ins, cut down the selectivity of the receiver. In general these statistics show that for good results from antennas it is not necessary to put them in the clouds.

ANTENNA VS. LOOPS

ONE big quarter slice of pie in the statistics is given to the loop. Think of it! Twenty-four out of every hundred of these people didn't do any tree climbing or roof walking whatever.

"Oh," you say, "but all these people used big and expensive receivers."

Well, let us see. The table showing approximately the "Types of Home-Made Hookups" shows that only 16.23 per cent. were super-heterodynes. And of these super-heterodynes, 44 per cent. use a loop, another 19 per cent. use a loop loosely coupled with an antenna, while 37 per cent. used an antenna exclusively. Really, the users of both loop and antenna should be classed with the antenna users, giving a total of 56 per cent. operating their super-heterodynes on an antenna, against 44 per cent. operating on a loop.

In addition to the super-heterodyne hookup, among the loop users were listeners with neutrodyne, tuned radio-frequency sets and reflex sets. Conspicuous among the loop



TABLE II

The proportion of the use of outside antennas to the use of loops

users were those who employed one of the special types of reflex. It was a five-tube set.

PHONES VS. LOUD SPEAKERS

IT HAS been said that a large majority of radio owners now use only a loud speaker both for tuning and for constant reception. Our analysis, however, shows quite the contrary. For distance work 54.4 per cent. use only the phones, an additional 29 per cent. use both the phones and the loud speaker, while only 17.6 per cent. use the loud speaker alone. Adding those who use the phones exclusively and those who use both the loud speaker and the phones, we have a total of 82.4 per cent. of set owners who have phones on hand. It may be that in the future we will use only the loud speaker, but, for the present, phones appear to be holding their own. There are still, apparently, large numbers of people who need a good loud speaker.

WET VS. DRY BATTERIES

CONSIDERING the difficulties of charging and the occasional inconvenience of wet batteries, naturally there is a great temptation for many radio folk to use dry cells. One often hears it said that the use of dry cell sets is much on the increase. We have been wondering about this, and so have you, but not until the answers to these questions came to us did we have the lightest inkling of more than a general idea of the real truth. Table III shows clearly the true situation. Here

at last we have some knowledge beyond the mere fact that the fewer tubes one uses the less battery required.

AN HONEST RADIO FAN

WE THINK this investigation has discovered for you the most honest radio fan in America. His name is William Samuel Dycus and he lives in Moundsville, West Virginia. He stated in answer to the question, "What was your worst source of interference?" His worst source of interference was "distance." A truth which all of us felt, but lacked the candor to admit. While we admire his honesty and admit there is much truth in his statement, neither you nor I would say that distance is truly the real handicap to radio receiving to-day.

The table which is an analysis of the "worst source of interference" shows that practically half give first place to radiating receivers. Other sources play only a small part in the total, while only a few people stated they had no interference whatever.

By the way, you will wonder where the people live who are thus blessed with no interference. Doubtless not on Long Island, or anywhere close to large cities. On Long Island, if the thousands of bloopers were not enough, the code which covers the whole area like a blanket furnishes the rest of the interference. People who live in that area, and there are not a few of them, deserve especial credit to have heard Europe.

Conditions in the cities are in no way comparable with conditions in the smaller towns and in the country. And yet our successful listeners were limited to no special location. There were hundreds within the city limits of New York who heard. The rural sections were represented in almost exact ratio to their population.

Here, however, is a letter from as far West as Indianapolis which speaks more eloquently than any words we could use—with reservations, because naturally we do not admit that the International Tests were 90 per cent. bunk! Anyway, here is the letter:

RADIO BROADCAST,
Garden City, L. I.

GENTLEMEN:

Your secret is out! You disguised it well, but the truth of it has become so obvious during the last few days that there is no further need of secrecy.

Transatlantic Test? Ninety per cent. bunk. Demonstration of the curse of squealing receivers? Ninety per cent. perfect!

We have had several foreign stations on a Radiola super-heterodyne with a directional loop, but at the announcing of the station the squeals have invariably increased until no other sound can be distinguished. I enjoy RADIO BROADCAST as much as I detest "radio broadcast's" evening hour of babel. I understand now how super-power alone can eliminate the squealers. Your demonstration has been a great success, and you have many supporters of your campaign against squealers from this district. Success to you!

Yours truly
THOMAS B. NOBLE, Jr.,

We are glad the Tests have served for this incidental good effect.

Perhaps there is some hope in the remarks by Dr. J. H. Dellinger, Chief of the Radio Laboratory of the United States Bureau of Standards, in a survey on Interference released recently by the Department of Commerce:—

The various causes of interference divide into two great classes—natural and man-made. Progress is being steadily made against both of these enemies. As to the natural interference, there will always be a certain residuum of atmospheric disturbances and fading which will necessarily limit the distance from any broadcasting station at which reliable satisfactory reception will be possible. The various kinds of man-made interference, on the other hand, are curable and are of local character; it can be expected that more and more localities will be freed from the various types of this pest.

Increase of knowledge and of practical applications characterize all phases of radio. We are coming to have a picture of the machinery by which the waves are propagated. Remarkable discoveries are being made in the behavior and potentialities of the waves of hitherto unknown frequencies. We are learning to direct the waves in a desired direction. The battle against interference is being won in spite of enormous increase in the use of radio.

AN ENGLISHMAN TUNES-IN

AFTER looking over the letters, which came to us by the basketful from people in all parts of the United States, it was something of a shock to come across one mailed by Arthur Oswald Millne, "Homefleet," Northdown Way, Margate, Kent, England. He heard several of the American stations on a receiver which he called a

"1-V-2 Tuned H F Plug and Transformer L F."

Which translated from Continental radio "lingo" into ordinary "Yankee" means one stage tuned radio-frequency, detector, and two stages of transformer-coupled audio frequency.

"H F" in England means, high frequency

or radio frequency "valve" designates a detector, and transformer L F" signifies transformer low frequency or audio frequency.

In answer to the question on whether or not he used a battery eliminator, he said:

"What on earth is a battery eliminator?"

"Do you mean a rheostat?"

Power from the lighting circuit seems not yet to have appealed to the Englishmen.

THE IDEAL RADIO EQUIPMENT

IF WE could take a composite photograph of good radio sets along with their equipment, where we found them all over the country, and somehow visualize for you the kind that was most successful, this picture would be most valuable for every reader of these pages. In a sense the tables shown here do exactly that. They paint for you a picture taken from actual facts. For that reason we believe they are worthy of careful study.

Taking them one by one they form a very useful basis for comparison with the equipment you now use, or suggest the right thing to buy.

First comes the number of tubes used in successful sets (Table I). You will see that the number most frequently occurring is five. You might have guessed that, without having seen these percentages; but would you guess the next most popular number of tubes is—three?

Your ideal set, it would appear, will have either five or three tubes.

This would be very convincing and pleasing, in a way, if true. At least one question about radio would be solved forever, and you

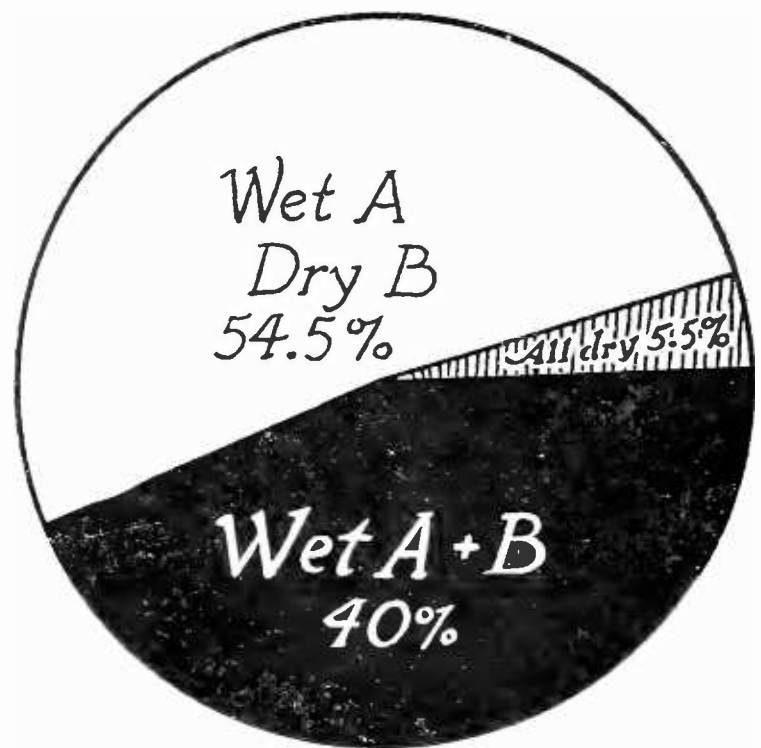

TABLE III

How the current for the radio receiver is supplied by the average user

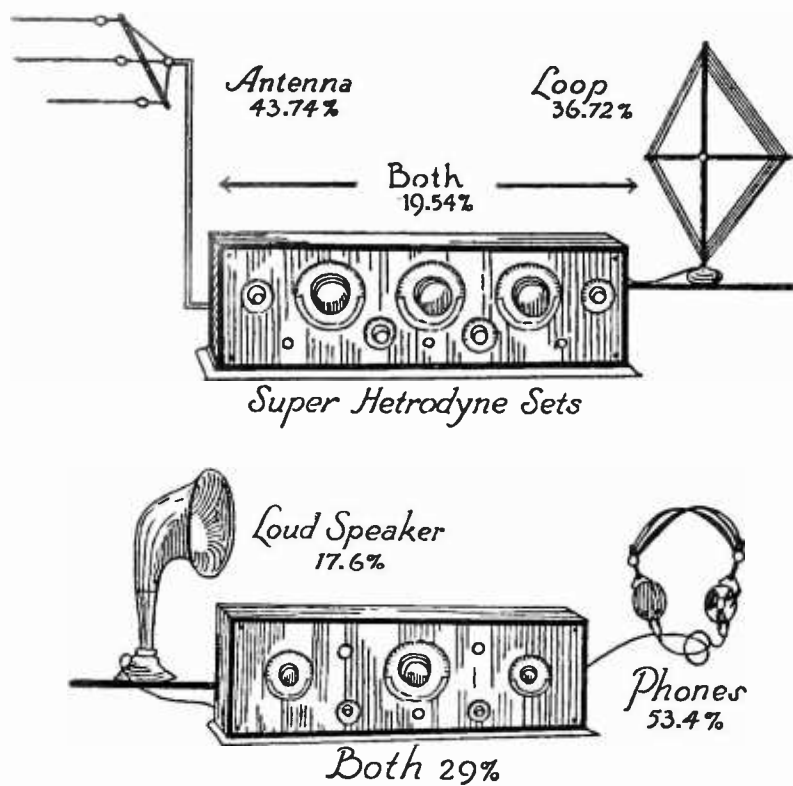

TABLE IV

The top illustration shows how the users of super-heterodynes in the RADIO BROADCAST survey got their energy from the ether. An unfortunately large percentage used an antenna directly connected to their "super." The lower drawing shows how the users of all types of receivers got their signals. Twenty-nine per cent. used both loud speaker and phones and 17.6 per cent. used the loud speaker alone. These figures, it is true, apply chiefly to reception during the International Test

could sleep peacefully to-night, knowing that your five- or three-tube creation is the set sublime. Herein lie the limitations of an investigation of this kind. Just because a large number of people are successful with a certain number of tubes does not prove that these same people would have gone wrong with a different number of tubes. You cannot prove that all cats have ten tails, because no cat has nine tails, and a cat has one more tail than no cat. Mr. Henry Ford does not necessarily make the best car for all uses because he makes more!

The purpose of these analyses is to suggest rather than to prove. In no place are the limitations of mere figures more clearly shown than in Table I, which shows the kind of hook-ups home radio builders use. Nevertheless the percentages are highly significant as an index to the kind of hook-up in use to-day.

But to return to our ideal set (with reservations), you see from Table I that you have a little better chance of owning a distance-getter if you make your set than if you buy it complete. Here again, on second thought, you will see that if you would rather buy than build, all you have to do is to be careful and purchase the right kind of set. There are more and more good ones being made every day. There is no table showing the comparative ratings of the various manufactured sets used. To outline them would be like trying to itemize the accomplishments of the automobiles of the United States. This book would not hold the complete record, and rather than work an injustice upon set manufacturers we are obliged to leave this interesting part of the story untold.

Our ideal set has one chance in four of using a loop, and if it uses an antenna, there will not be much over a hundred feet of it all told, and it will be from twenty to forty feet off the ground (Table I). It will probably use wet A and dry B batteries, or both units wet, but it has a healthy little chance of being good with all dry cells (Table III).

For "Radio Golf," as Secretary Hoover calls DX, we will surely need a pair of phones (Table IV). And if we own a super-heterodyne, we will have better chances for distance with an antenna outside, although the neighbors may rightly object. The secret being out, we can well conclude by considering the main causes of interference (Table I), which is radiating receivers—those birdies and cat-calls and squawks in the menagerie of din.

THE material appearing in this magazine is fully protected by copyright, and editors of periodicals are advised that unauthorized publication of circuit diagrams, technical descriptions, and parts or the whole of articles, without due permission and credit, is an infraction of the law. Those who wish to reprint material appearing in these pages are asked to communicate with the editor.

“NOW, I HAVE FOUND . . .”

A Department Where Readers Can Exchange Ideas and Suggestions of Value to the Radio Constructor and Operator

FOR a long time, RADIO BROADCAST has felt the need of an outlet for the many excellent ideas dealing with various features of radio construction which reach our office. With this issue, we begin the department of good ideas from our readers, and invite the coöperation of all those who are interested.

If you have an idea about a valuable and useful new circuit, some new device, a construction or operating suggestion, we should like to have it. Payment of from two to ten dollars will be made for every idea accepted. The descriptions should be limited to three hundred words and typewritten. Accompanying sketches, drawings, and circuit diagrams should be as plain as possible.

We do not want simple, obvious suggestions. Material to be acceptable for this department must offer something of definite value to the constructor. Mere novelty is not desired. Address your manuscripts to this department, RADIO BROADCAST, Garden City, New York.—THE EDITOR.

A TESTER FOR CIRCUIT CONTINUITY

I HAVE assembled a very simple test outfit made up from odds and ends around the work shop which helps considerably in determining whether purchased parts and laboratory odds and ends are defective or not. It has also been found useful in testing out radio sets for continuity of circuit, testing fixed and variable condensers for short circuits, jacks and sockets for loose connections, and transformers for short circuits, open circuits, and ground. This test unit consists of a 25-watt lamp inserted in one side of the 110-volt line to which are connected two awls. The test leads are of flexible wire. Two fuse sockets and fuses are inserted one in each side of the line at its input. The circuit diagram is shown in Fig. 1.

The lamp flashes when a circuit is closed indicating that the circuit of the unit tested is continuous. In testing audio transformers, the awl points are touched to the primary posts and if the secondary side is momentarily short circuited, a spark discharge may be observed at its terminals.—F. E. MADDUX, Roanoke, Virginia.

HEAD SET PLUG MADE FROM BROKEN AUTO BULB

SMALL plugs for plugging in radio headsets are indispensable where radio receiver or loud speakers are to be used in different rooms in the house. They can be made for little or nothing, from the bases of burned-out automobile lamps.

To make the plug, the glass bulb must be

broken away close to the top edge of the ferule and the remains of the filament removed from the ends of their coarse wire terminals. Then the latter should be spread about $\frac{1}{2}$ inch apart and thoroughly cleaned to make them bright.

The ends of the wires composing a length of twisted lamp cord are then cleaned and soldered to the two filament terminals. In doing this, care should be exercised not to use too much solder, otherwise there is apt to be a short circuit between the terminals.

Then the terminals are again pressed together so they are nearly parallel. Hot sealing wax is poured between and around them so they are thoroughly covered and imbedded in a solid insulation which completed the plug shown in Fig. 2.

This plug could then be inserted in an auto-

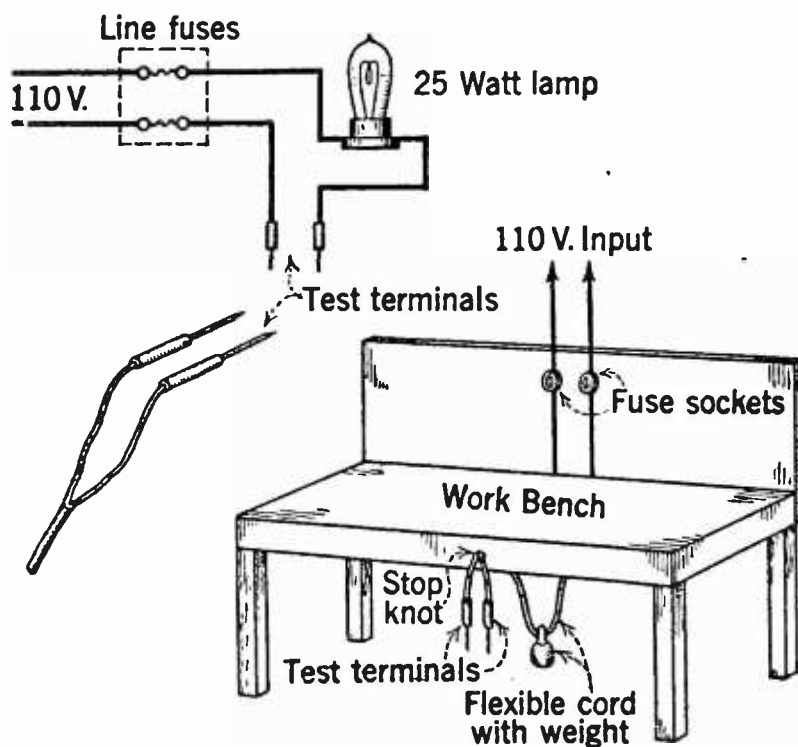

FIG. 1

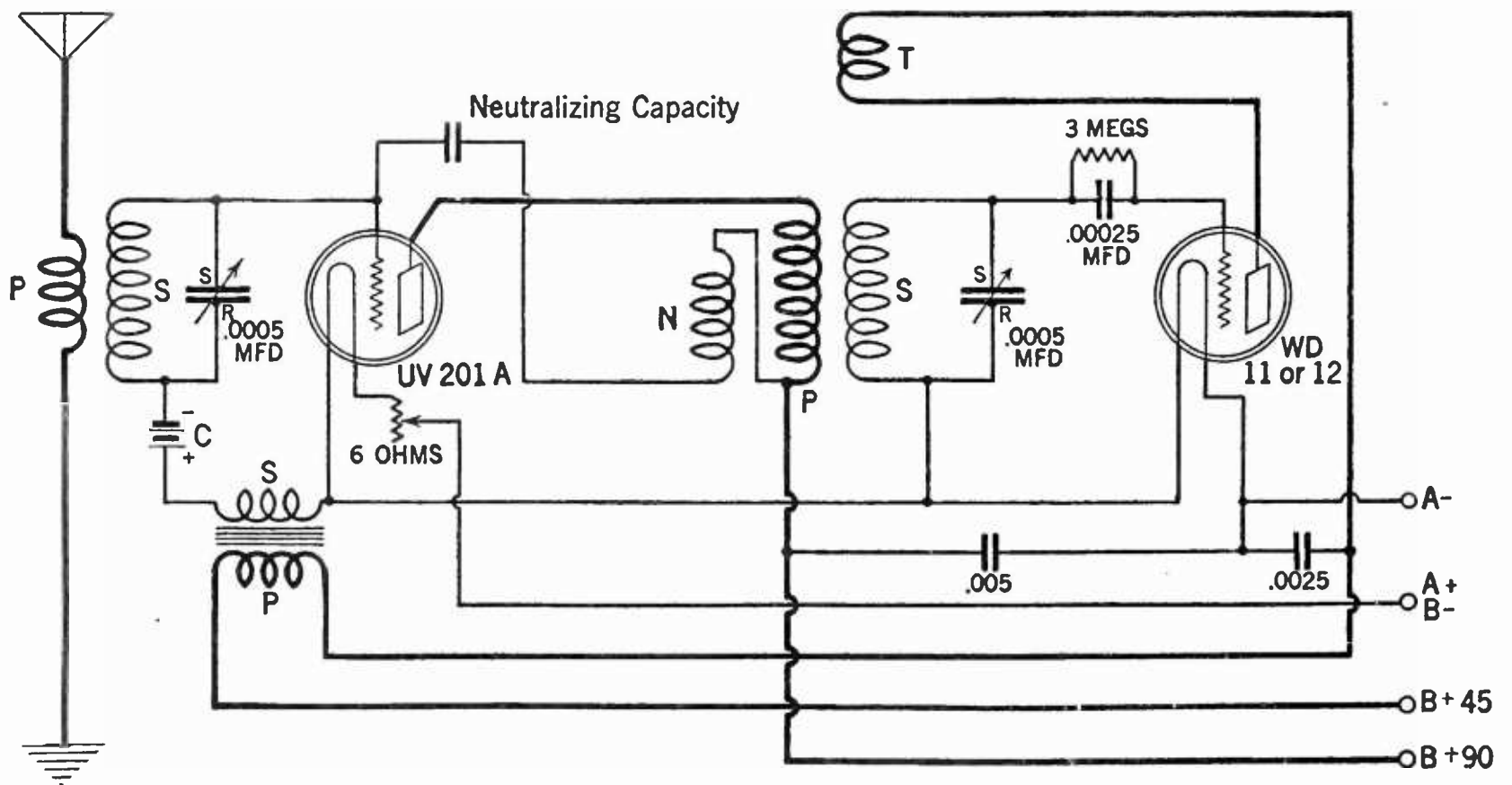

FIG. 3

mobile dash socket placed in a convenient place in the wall. Radio concerts can then be enjoyed just as well as though one were sitting near the receiver.—L. R. ROBBINS, Harwich, Mass.

THE WD-11 IN THE ROBERTS CIRCUIT

THE WD-11 or WD-12 as detector with the 201-A as amplifier is my first choice of tubes for the Roberts circuit. These tubes take the same current and can therefore be used with the filaments in series. This method uses the whole battery voltage usefully in the tubes, reduces the current con-

sumption about 20 per cent. below the 201-A-199 combination (which is quite an item when using dry cells) and in my opinion, based on the operation of a number of sets, is quite as satisfactory.

It also reduces first cost by eliminating the high resistance necessary with the 199 tube, the only resistance used being a six-ohm rheostat, which is not really necessary. However, I have found that most tubes will work as well or better, a little below rated voltage rather than above. With this combination it is impossible to overheat the filaments, giving the tubes a longer life.

This combination is much more stable in the four-tube set than when a 201-A is used as a detector and seems to me to give as good range and volume as when the larger tubes are used throughout. Care should be taken to use bus wire for the filament leads and not less than No. 14 wire for the A battery leads which should be as short as possible as there is no voltage to spare for line loss.

The diagram Fig. 3 shows the slight modification of the Roberts circuit necessary. Observe the changes in the filament circuit, the WD-11 grid return, and the return for the .005 mfd. bypass condenser.—HARDING GOW, East Sound, Washington.

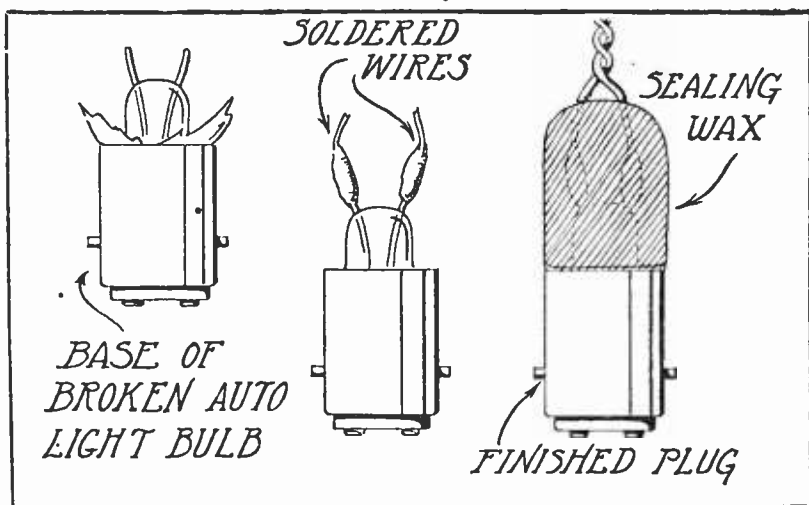

FIG. 2



WHEN YOU WRITE THE GRID

Don't fail to enclose a stamped, self-addressed envelope with your inquiry if you expect a personal reply.

Don't be impatient if you do not receive an immediate answer. Every letter is answered in the order of its receipt. Do not send a second letter asking about the first.

Look over your files of RADIO BROADCAST before asking a question which might have been covered in a previous issue.

Don't ask for a comparison between manufactured apparatus. The addresses of manufacturers of articles used in the construction of apparatus described in RADIO BROADCAST will be given on request.

Don't include questions on subscription orders or inquiries to other departments of Doubleday, Page & Co. Address a separate inquiry to The Grid.

Don't send us a fee for answering your questions. The Grid Department is maintained for the aid and convenience of readers of RADIO BROADCAST and there is no charge for the service.

QUERIES ANSWERED

OF WHAT USE ARE METERS IN A RADIO RECEIVING CIRCUIT?

H. B.—Saginaw, Michigan.

HOW ARE NEUTRODYNES NEUTRALIZED?

L. N. C.—Toledo, Ohio.

HOW ARE PANELS PREPARED?

I. M.—Philadelphia, Pennsylvania.

CAN YOU REFER ME TO ANY PREVIOUS PUBLISHED

METERS AND THEIR USES

THE inclusion of voltmeters and ammeters in a radio circuit is desirable but not always possible because of their cost. Meters offer a definite check on the condition and operating efficiency of the batteries used with radio receivers. Those who can afford these luxuries may well make this addition to their equipment.

A plate milliammeter with a full scale range of 0 to 100 milliamperes such as the Weston type 301 is admirably suited for the purpose of determining the rate of current flow in the B battery circuit. In other words, the amount of current the entire set is drawing in milliamperes may be determined.

NOTES AND COMMENTS ON THE ROBERTS CIRCUIT?

C. C.—Chicago, Illinois.

BRIEFLY, WHAT SHOULD I DO TO KEEP MY STORAGE BATTERY IN TOP-NOTCH ORDER TO INSURE PERFECT SERVICE?

J. A. T.—San Diego, California.

WILL YOU TELL ME WHAT WAVE TRAPS ARE, HOW THEY ARE USED AND WHAT ARE THE CIRCUITS?

A. L. T.—Norfolk, Virginia.

A correct reading of the voltage of the B battery is also desirable so as to determine the state of its life. When a battery drops in voltage below two thirds of its rated voltage it is ready to be junked. B batteries whose voltage is low mean weak, distorted signals.

The use of these two meters is clear when the following explanation is considered.

B batteries have a certain period of life. As in the case of the storage battery as described in last months' GRID, this life is rated in ampere-hours, only in B batteries the rating is a fraction of the larger filament batteries and is rated in milliamper hours. Explained, this means that a certain amount of current in milliamperes may be withdrawn from

the battery over a certain period. Applying values, a 4500 milliampere hour B battery may theoretically be discharged at the rate of 45 milliamperes for 100 hours. As this discharge takes place and the capacity of the battery is reduced, the voltage also decreases.

The use of the voltmeter and milliammeter is quite evident in determining this condition.

Some may wish to mount the meters permanently on the panel of their receiver.

In the case of the voltmeter this may well be a double reading scale covering both filament and plate voltages. By means of a double-pole double-throw switch, this voltmeter may be thrown from one circuit to the other. Excepting for momentary B battery tests the voltmeter should be thrown over to the filament side. See Fig. 1.

The milliammeter may be inserted in series with the negative lead of the B battery line. In this position it will register the total detector and amplifier tube drain.

However, for the true experimenter, this plan is not economical or entirely efficient since, on the building of other circuits it will necessitate the tearing out of these meters from the previous circuit.

A better way is to mount these meters on a special panel with the necessary clip leads attached. Then temporary tests may be made with any circuit. See Fig. 2.

The use of a voltmeter in a super-heterodyne, either of the manufactured or home-made type deserves special notice not related to the above discussion. Tubes have a definite voltage rating, specified by the manufacturer. For the good of the tube it is well not to exceed this rating. A voltmeter is the surest check-up.

NEUTRALIZING SYSTEMS

THE selection of a system for obtaining neutralization in a tuned radio-frequency amplifier depends largely upon the circuit employed. To qualify this statement—a circuit embodying a reflex system could not be neutralized by the standard neutrodyne method because in removing the tubes, one at a time, the audio frequency circuit would be broken, which would prevent the audio signal from being heard in the phones.

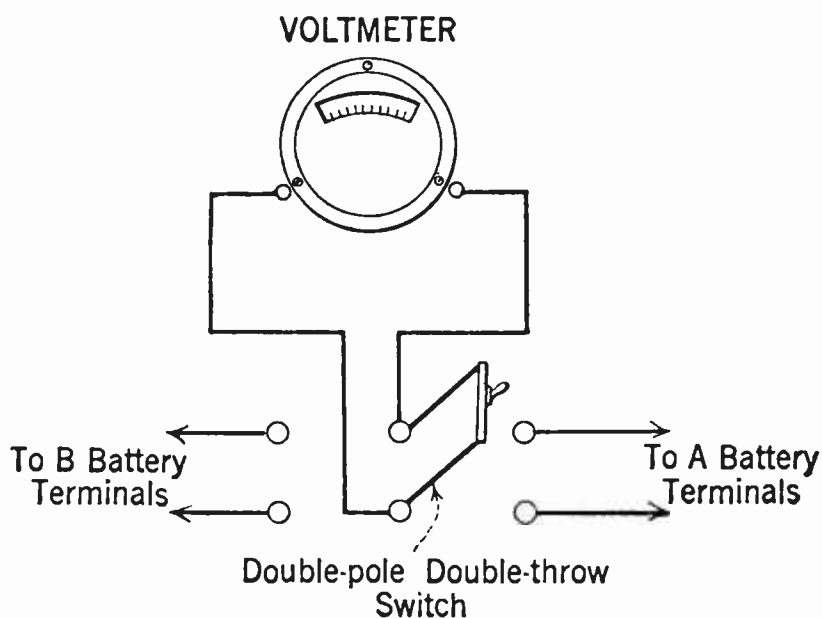

FIG. 1

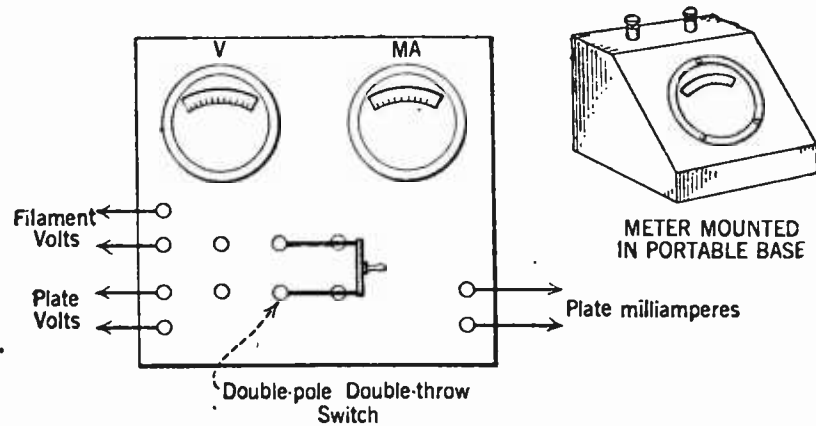

FIG. 2

Therefore for systems consisting in part of a reflex feature another is necessary. It is assumed that neutralizing condensers of a sort are employed, and no dependence placed upon inherent neutralization as the result of the various placements of the parts used.

The Roberts system of squeal neutralization as explained in the January, 1925, issue of RADIO BROADCAST will apply here.

For receivers of the standard r. f. type it will not be out of order to repeat the explanation of neutralization as recommended by the neutrodyne manufacturers.

First, tune-in a station to maximum signal strength. If possible tune-in a distant station as the neutralizing effect will be more manifest to the operator.

Then, remove the first tube, insulate one of the filament prongs with a slip of paper or spaghetti tubing so that it will not make contact with the filament socket blade, and replace it in the socket.

It will be noted that the signal will come in somewhat faintly. Carefully retune so that the signal will attain its loudest point, taking into consideration that it will not be as loud as before, because the tube is not functioning.

Now, with the aid of a rubber tipped pencil or other insulated object slowly slide the neutralizing tubing, or if it is a variable plate condenser, revolve it, until the signal vanishes. In some instances this condition may not be reached but at least the signal will decrease noticeably.

When this point has been reached, the insulation at the filament terminal may be removed and the operation repeated for the next tube.

HOW TO PREPARE PANELS FOR ASSEMBLY

IT MAY be said that in a majority of descriptive articles covering the construction of a receiver or other radio device, the preparation of the panel is lightly dismissed with the brief explanation that "the holes should be drilled according to the panel layout." In justice to this very important item, the few pointers that govern the proper preparation of a panel are described here.

To begin with, satisfactory tools are an essential not to be disregarded. A light hammer, dividers, center punch, scriber, square, and six-inch scale are entirely sufficient for the average work shop.

Wherever possible, dimensions given on panel layouts should be transferred to the back of the panel.



Goodrich
Radio Panel



Write for our free booklet on

RUBBER
for more perfect
RADIO
RECEPTION

It is filled with valuable hints to radio enthusiasts.



In building your set specify the following

GOODRICH
RADIO PANELS

highly polished — hold their luster. Supplied in black or mahogany; easily worked with same tools as wood or metals. Guaranteed against excessive warpage.

GOODRICH V. T.
SOCKETS

Only socket made where tube can be inserted and fastened or unfastened and removed without turning tube in socket. Locks automatically. Prevents tube breakage. Contacts automatically wiped when tube is inserted.

GOODRICH VARIOMETERS—UNWOUND
RADIOPHONE EAR CUSHIONS

SPAGHETTI TUBING
BATTERY MATS

Cut down that dielectric loss

Science has proved that rubber is best electrically — its dielectric loss is smallest of all known panel materials — but there are many different kinds of so-called rubber. Play safe and insist on Goodrich.

We are specialists in rubber. We manufacture every conceivable rubber product, from great conveyor belts and automobile tires to rubber bands. There are fifty-five years of experience behind us. Quality is ever our first consideration.

Goodrich Rubber Radio Products are made particularly for the service they are called upon to meet — developed after long experiment and research.

Use them — for better reception, maximum selectivity and widest possible range.

Listen in on the Silvertown Cord Orchestra

Every Tuesday and every other Thursday from 10 to 11 P. M. (Eastern Standard Time.) The greatest dance orchestra on the air. Tune in on the following stations:

WEAF, New York; WJAR, Providence; WFI, Philadelphia; WCAE, Pittsburgh; WGR, Buffalo, WEEL, Boston; WWJ, Detroit; and 9 to 10 P. M. (Central Standard Time), Stations WCCO, St. Paul-Minneapolis; WOC, Davenport.

THE B. F. GOODRICH RUBBER COMPANY
Established 1870 Akron, Ohio

Goodrich

★ *Rubber* **RADIO PRODUCTS**

★ Tested and approved by RADIC BROADCAST ★

The front panel side should be selected for its freedom from blemishes and other marks although if it is to be grained there is no preference as to which is to be front or back.

With the square and scribe, lay off the dimensions making light scratch lines. At the intersections make the centerpunch marks. Don't cant the centerpunch, otherwise the mark may become off center.

In drilling the panel place the front side down against the top of the bench and clamp in position firmly. Then, with a small drill, drill out all the holes. After this is finished, the holes may be re-drilled to their correct size. Be sure to hold the drill in as perpendicular a position as possible. If it is desired that the drill not penetrate into the bench, then a board larger than the panel should be placed under it.

In graining a panel use a fine sandpaper or No. 00 emery cloth.

Rub up and down the length of the panel keeping the motion parallel with the panel edges.

When the desired appearance has been obtained the bakelite dust may be removed and a finish produced by rubbing the panel with an oiled cloth.

NOTES AND REFERENCES ON THE ROBERTS CIRCUIT

AS IS to be expected when a circuit like the Roberts spreads like wildfire, the many deviations from the original construction and "just that personal touch" have had accompanying them the innumerable troubles that befall any radio circuit.

A glance at the fundamental circuit Fig. 3 and the theoretical action depicted in Fig. 4 will at once appraise one of the fact that there are three main features of which it is comprised. And each one has its possibilities of bringing to the finished sets its own peculiar troubles. Intelligent tests may be conducted to determine its locality and causes.

The January, 1925, GRID briefly outlined the several places where trouble might be met.

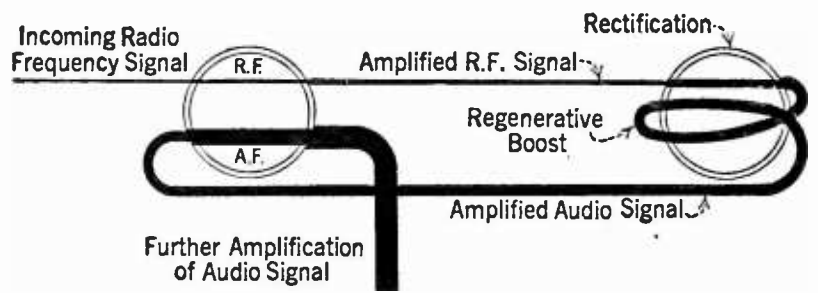

FIG. 4

The heart of the circuit is the two tuner units. Special care should be taken before assembly, to see that there are no open or short circuits in these coils.

Very often reversing the connections to the secondaries make the circuit function as should.

In the matter of reflexing the audio transformer should not be located too near the antenna coil unit. The coil units themselves should not be placed too near together and in all cases should be at right angles to each other.

Additional information on the Roberts circuit has appeared in the following pages of RADIO BROADCAST.

April	1924	Page 456
May	"	" 73
July	"	" 272
August	"	" 308
September	"	" 379-426-438
October	"	" 490
November	"	" 112
December	"	" 267
January	1925	" 511-524
February	"	" 711-721-746
March	"	" 875-909-930-931-939

CARE OF STORAGE BATTERIES

IT IS certainly true that you'll get out of a battery no more than you put into it.

A battery that is neglected lasts but a short while and in this day and age of radio modernity the time has not come when it is possible for us utterly to disregard battery expense.

Lead is subject to oxidation. Copper is subject to attack by sulphuric acid. In a battery, the terminals are of lead, and often after charging there is an excess of sulphuric acid covering the top of the battery jar due to spraying. Now, putting two and two together, the copper wire connecting cable will not always make perfect contact with the lead post due to the film of oxide on it. Also once the connection is on the post the acid causes corrosion which manifests itself in a light green slime covering the post and connector.

To insure a proper contact to the post it is well to scrape away the surface so that the

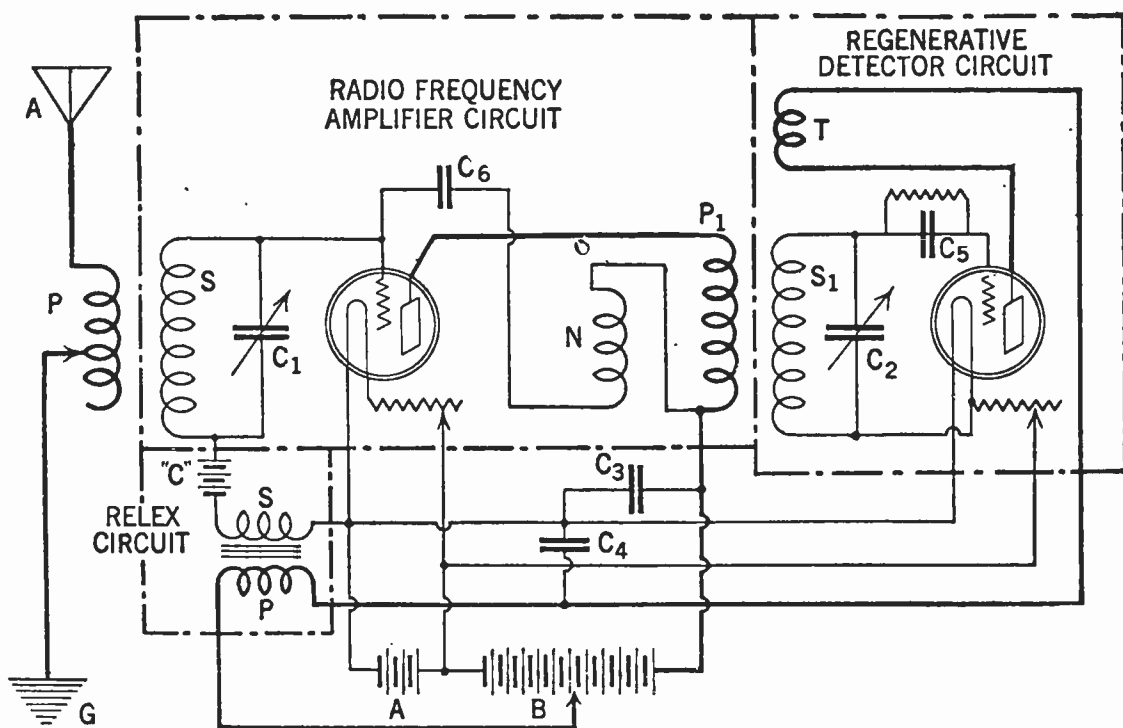
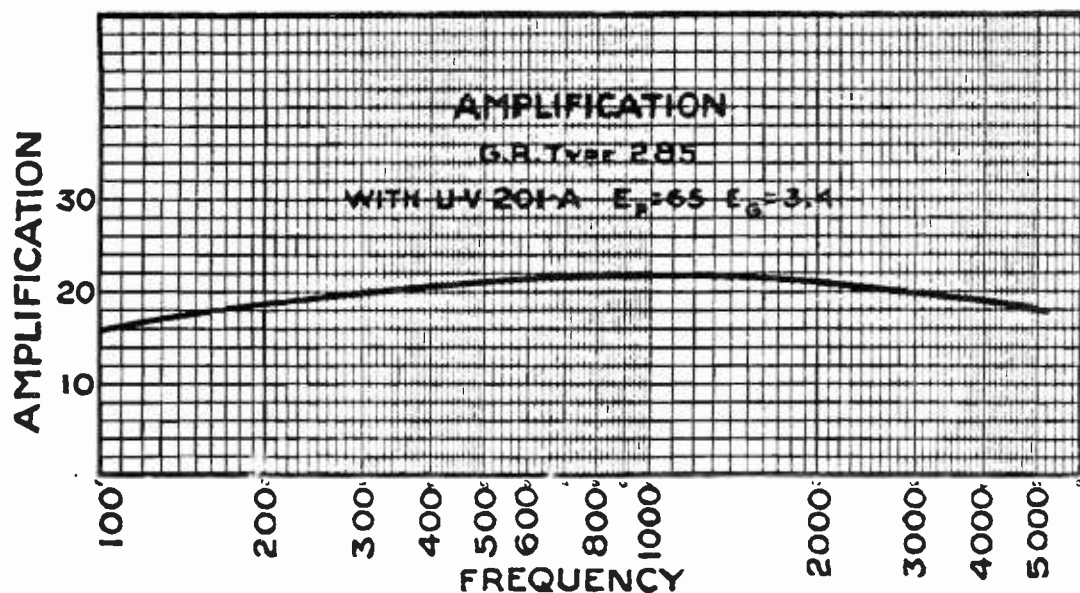

FIG. 3

The Outstanding Features of the Outstanding Transformer

*Amplification Curve
of the Type 285 Audio Transformer*



The NEW Price \$7 GENERAL RADIO

Type 285 Audio Transformer

*Higher Amplification over
the entire Audio Range.*

THE marked superiority of the Type 285 Transformer is evident by its high and uniform amplification over the entire audio range. High amplification is attained by a turns ratio of 6:1. Ordinarily such a high ratio would lower the primary impedance and distort the lower notes, while the higher notes would be muffled or lost entirely by the effect of distributed capacity.

To offset these tendencies the core of the Type 285 Transformer is made of specially selected steel of high permeability, and the turns of the primary and secondary coils are increased to give a higher impedance and turns ratio. Consequently both ends of the curve are sustained, so that greater volume with better tone quality is the result.

*More Natural Reproduction
of Speech and Music.*

TONES of high and low pitch, whether instrumental or vocal, in combination or individually, are reproduced with a clarity that pleases the most critical radio listener.

So great is the amplification produced by the Type 285 Transformer that one stage using a Type 285 gives a volume that is approximately equivalent to that produced by two stages using any average transformers. Seldom is more than one Type 285 necessary to produce good loud-speaker volume with a quality of tone never before realized in radio reception.

If you want the best there is in transformer design, the General Radio Type 285 should be your choice.

For Sale at all Leading Radio Stores

GENERAL RADIO CO.
Cambridge, Mass.



★ Tested and approved by RADIO BROADCAST ★

bright lead shows itself. To prevent corrosion often this cleaning process is applied: coat the post and connection liberally with ordinary vaseline.

Wipe the case and top of the jars dry of excess acid.

Keep the level of the solution one quarter of an inch above the plates.

Add distilled water when necessary but never add acid.

Do not bump the battery. Broken jar-units will result in a drop in capacity and voltage.

Keep the battery in a dry place. Once the wooden case becomes water soaked it is easy for the acid to attack and rot it.

Never short-circuit the battery to determine whether or not it's charged. Use a hydrometer.

In charging a storage battery do not charge it or discharge it at a higher rate than that specified on its nameplate.

The leads from the battery to the receiver should be strong and preferably of the double twisted lamp-cord type.

WAVE TRAPS AND HOW TO USE THEM

A WAVE trap is a remedy for poor tuning characteristics of a receiver. It is a cure but not a preventative.

However, the characteristics of many receivers are such that wave traps are really essential.

Briefly, a wave trap consists of a coil and variable condenser having the property to be tuned to or select a certain wavelength setting which it is desired to exclude from the receiver.

Usually a wave trap is required where the receiver

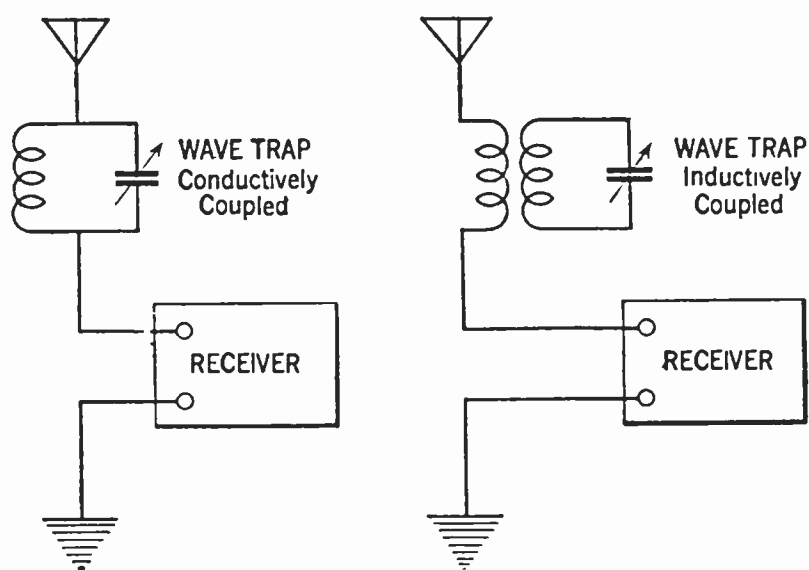

FIG. 5

tunes broadly permitting the reception of two or more signals simultaneously. The wave trap performs the functions of eliminating from the receiver circuit the undesired signal. The circuit is not unlike that of an ordinary receiver, the coil and condenser in parallel tune to the same wavelength range as the receiver.

Wave traps may be made according to several types as outlined in the circuit diagrams in Fig. 5, which also shows their proper connection.

The method of operation is as follows. The trap is tuned to the undesired interfering station, then the receiver is tuned to that station from which it is desired to receive.

HOW TO FIND RECEIVER TROUBLE

IN last month's GRID were listed three definite divisions where receiver trouble might arise.

The continuing four, listed below, are especially applicable to reflex receivers employing a crystal for rectification. Special attention must be paid to the selection of a crystal of merit, as this unit is really the heart of the circuit.

While, as has been said before, this information is especially intended for reflex trouble-shooting, much of it may be applied to a methodic trouble-detection system in many other types of receivers.

1.—General suggestions

A—Keep grid and plate wires separated and at right angles to each other.

B—Turn audio-frequency transformers so that their cores are at right angles to each other.

C—Separate tuning units so as to prevent reaction between them.

For reflex circuits employing crystal rectification the following notes may be observed.

2.—Howling

Be sure that the negative side of the A battery is grounded. When this is not done, howling or humming occurs. Howling is also produced by reversed leads to the primary of the audio frequency reflex transformer, and lack of use of suitable bypass condensers across transformer secondaries when amplifiers are used.

3.—Crystals

Upon crystals really depends the successful operation of the receiver. Poor crystals will cause squealing, lack of volume, improper reflex action, partial rectification in the first tube, and broad tuning. About nine tenths of all the trouble in the reflex circuit can be attributed to a poor crystal. Get a good crystal!

4.—Selectivity

As stated above, poor crystals sometimes cause broad tuning. Then, too, location, nearness to local stations, etc., greatly effect sharp tuning. Several remedies for overcoming this fault are as follows: 1. Rewind the primary of the antenna coupler so that this circuit may be tuned to the incoming wave. 2. Construct a counterpoise of several wires either underneath the antenna near the ground, or, if your location is in a city, erect it in the basement of your house. A counterpoise consists of several wires, very similar to an ordinary antenna and well insulated. The counterpoise is used instead of a ground.

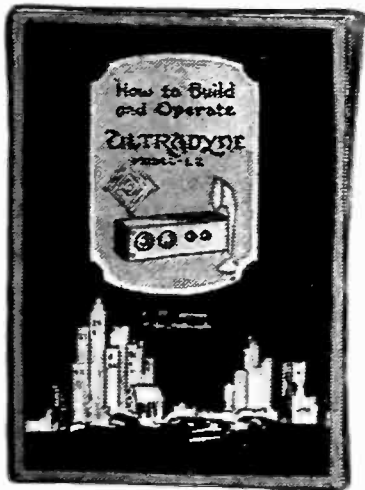

How to Build and Operate the Ultradyne

32-page illustrated book giving the latest authentic information on drilling, wiring, assembling and tuning the Model L-2 Ultradyne Receiver 50c

The Ultradyne Kit

Consists of 1 Low Loss Tuning Coil, 1 Special Low Loss Coupler, 1 Type "A" Ultraformer, 3 Type "B" Ultraformers, 4 Matched Fixed Condensers.

To protect the public, Mr. Lacault's personal monogram seal (R. E. L.) is placed on all genuine Ultraformers. All ultraformers are guaranteed so long as this seal remains unbroken \$30.00

Heard Europe on a Home Built Ultradyne Model L-2

Arthur Bender, 116 East 2nd Street, Covington, Ky., had no trouble picking up European stations last week on his eight tube Ultradyne which he constructed himself.

—Cincinnati-Enquirer, Nov. 30, 1924.

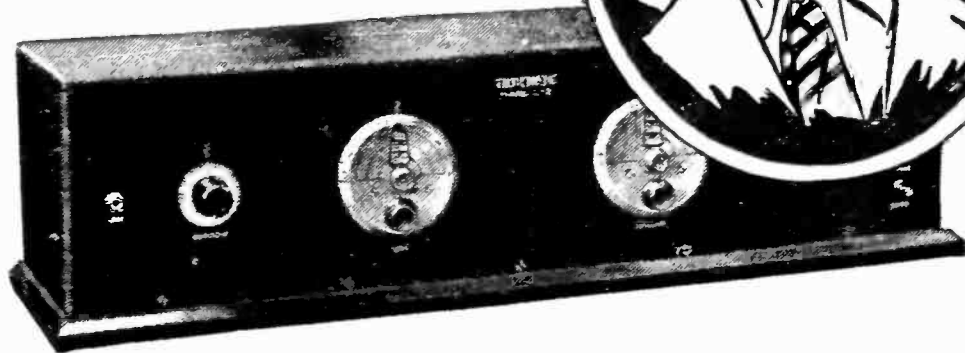

Thousands have built it!

LIKE Mr. Bender, thousands have successfully built the Model L-2 Ultradyne and claim it the most wonderful receiver they have ever known for great distance on the Loud Speaker.

In no other receiver is found the "Modulation System" of radio reception—an outstanding radio engineering development by R. E. Lacault, E. E., A. M. I. R. E., Chief Engineer of this Company and formerly Radio Research Engineer with the French Signal Corps Research Laboratories.

With the application of regeneration to the "Modulation System" the Ultradyne is capable of detecting the faintest broadcast signal, regenerating and making it audible on the loud speaker.

In addition, the Ultradyne is the most selective receiver known. Regardless of close similarity in wave length, it selects any station within range—brings in broadcasting clearly, distinctly, faithfully.

The Model L-2 Ultradyne will do everything better than any super-radio operating under the same conditions.

Write for descriptive circular

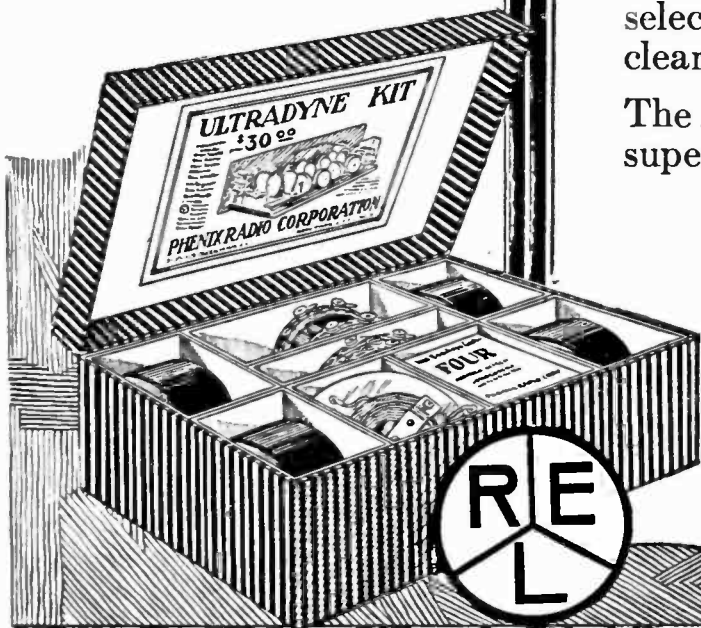

ULTRADYNE



MODEL L-2

PHENIX RADIO CORPORATION

5-7 Beekman Street
New York

★ Tested and approved by RADIO BROADCAST ★

New Equipment

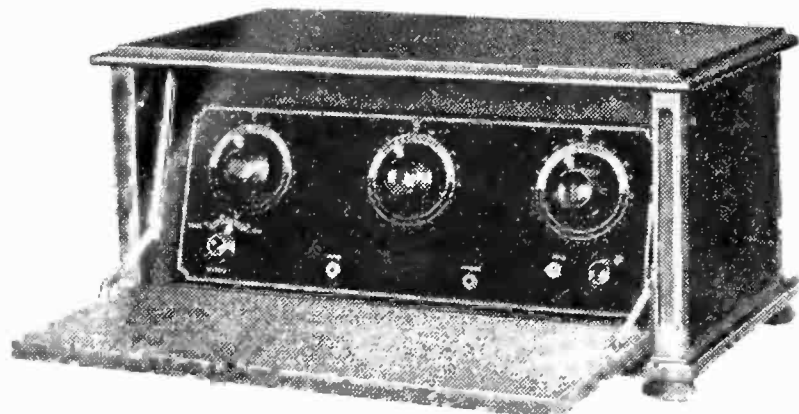

DAYOLA RECEIVER

A radio frequency receiver with good quality reproduction. It is enclosed in a cabinet of fine workmanship with a drop front, making it possible entirely to close the set when not in operation. Made by the Dayton Fan & Motor Co., Dayton, Ohio

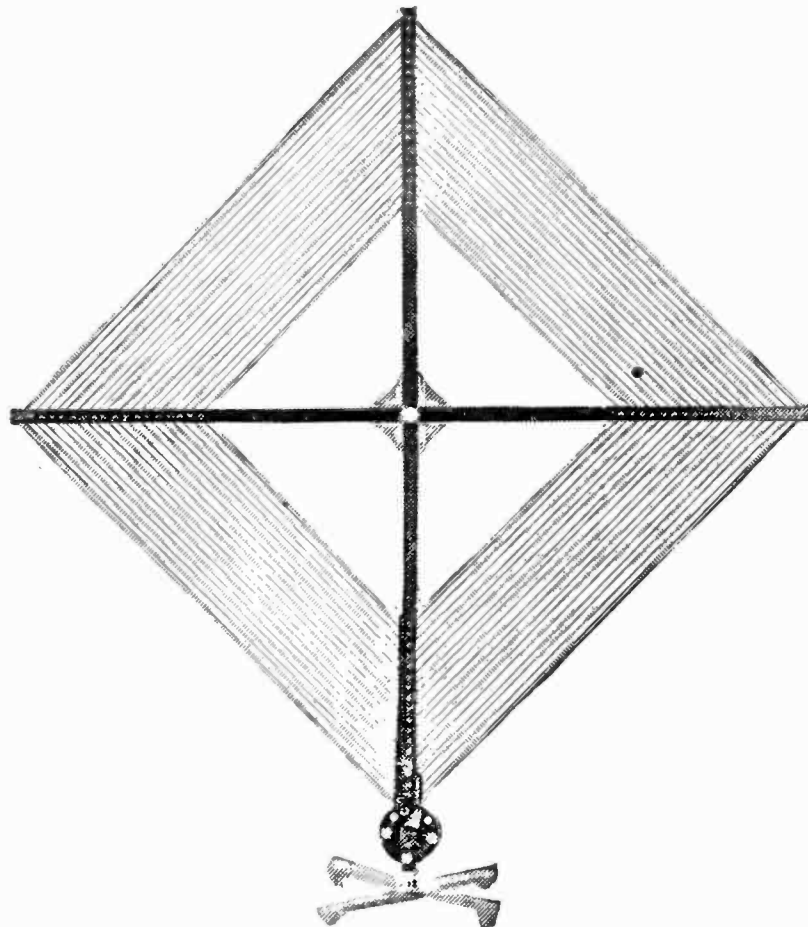

LINCOLN LOOP AERIAL

The super-heterodyne receiver depends on the loop for signal pick-up. It is, therefore, very necessary that this function be accomplished efficiently. The loop illustrated here is of commendable construction and design. The tap off switch near the cast base allows variation of wavelength range. Made by the Lincoln Radio Corp., 224 No. Wells St., Chicago, Illinois



PYREX SOCKET

The base is of pyrex glass and the brass shell takes the tube base. The prong contacts are extended to allow direct soldered connections. Made by the Garod Corporation, 120 Pacific St., Newark, New Jersey



JEWETT MICRO-DIAL

The Micro-Dial, unlike some devices for micrometrical tuning, fits readily into virtually any set. It requires no special mounting to put it into operation and is not cumbersome. Made by the Jewett Radio & Phonograph Co., 5680 Twelfth St., Detroit, Michigan

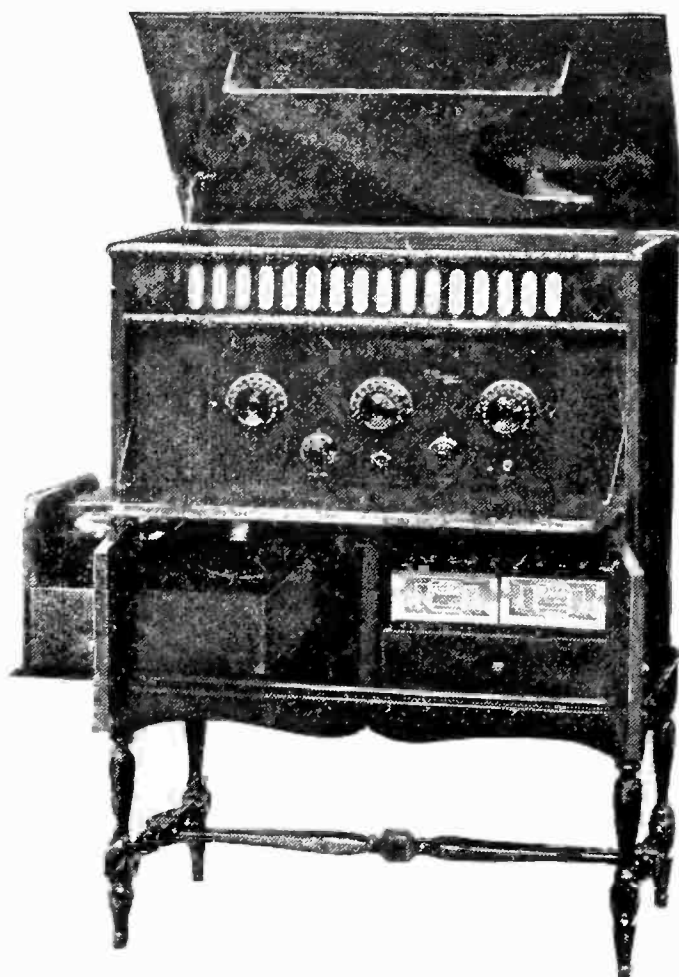

THE ADAPTO RADIO CABINET

Is complete in detail as well as being a handsome piece of furniture. It will take any panel size up to 10½" high and 31½" long and combines loud speaker, easily accessible battery compartments, and a drawer for small items. Made by the L. R. Donehue Lumber Company, New Albany, Indiana

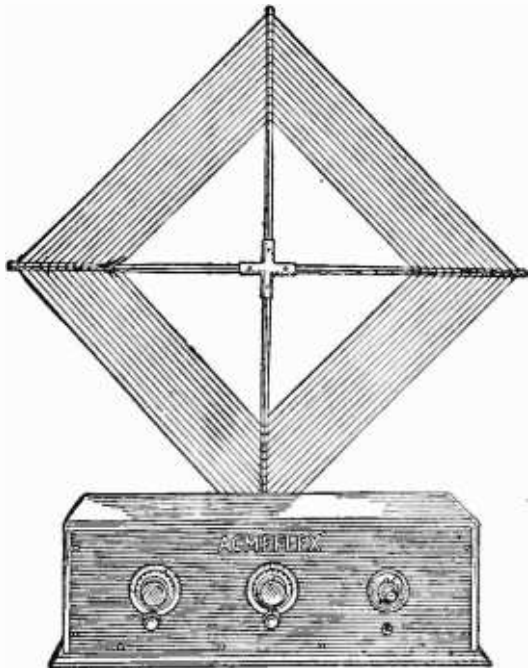

A set anyone can put together and enjoy all-the-year-'round radio.

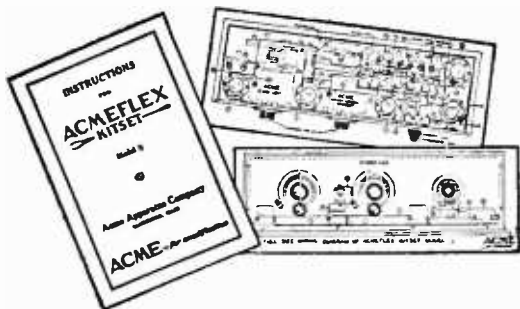

Directions given so simply that anyone can follow them

ABOVE are illustrated the circular of printed instructions and the life-size diagrams of the wiring, which are packed with each Model "S" Kitset. Step by step the making of the set is described in clear, simple language—just simple operations which anyone can easily follow.

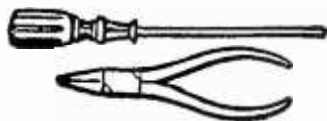

Only two tools required—a screw driver and pliers—and they are included in the kit.

Enthusiastic praise from Model "S" user From New York City:

"Well, I believe we had every jerk-water station in the U. S. Stations I never heard of before. At 11:45 P. M. I pulled in KFI (Los Angeles, Calif.) on the loudspeaker. At 12:15 A. M. KGO (Oakland, Calif.). I went back and picked up KFI three times. My home is located in what is considered one of the worst sections for radio. The skyline of New York is directly opposite me. I am on the harbor, a mile from the Navy Yard, and have three bridges with electric trains to bother me, but with it all I got the coast. Forgot to mention that two locals were on—WHN and WJZ; some selectivity."

ACME
~ for amplification

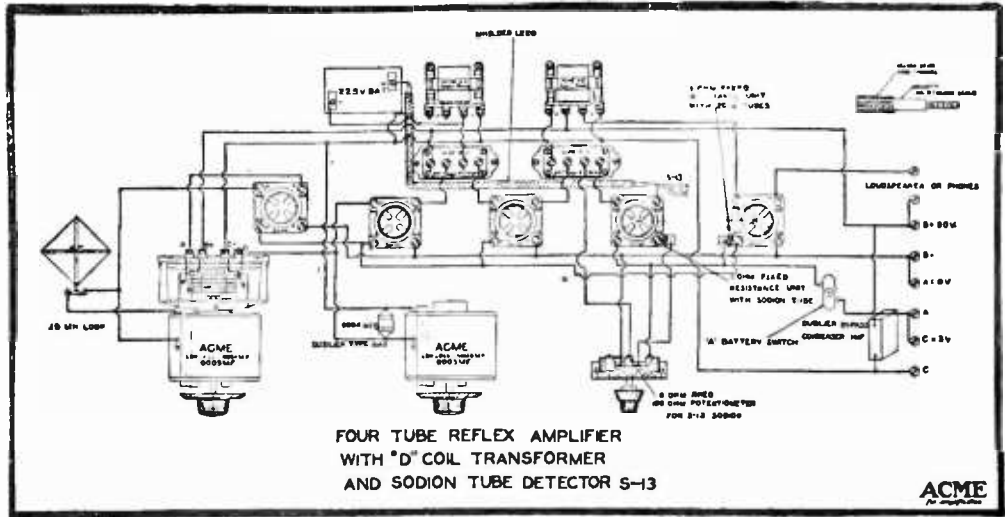

This is the new Model "S" Acmeflex Kitset

IN THE above wiring diagram special attention is called to the D-Coil radio frequency tuning unit and the vacuum tube detector, giving the famous Acme Reflex (trade mark) still greater distance, greater selectivity and better reception.

We can save you about \$60.00 on this \$150.00 radio

IF YOU bought this set completely assembled it would cost you \$150. But by putting it together yourself you can buy it for only \$80, plus cabinet, saving about \$60. We could make it for less but it wouldn't give results.

Acme Engineers have done all the engineering for you and have written clear, simple directions which show you, step by step, how to put the set together. Many have done it in three hours, and found it fascinating fun. Even if you know nothing about radio you can put it together. All the parts are in the kitset, even the loop. No antenna to erect. Even a screwdriver and pair of pliers,

the only tools you need, are included. No soldering to do. The panel is all drilled for you. The only accessories to buy are tubes, batteries, loudspeaker and cabinet. If you don't want to put it together yourself, there are amateurs and dealers glad to do it for you.

And your finished set is the famous Acme Reflex (trade mark) now wonderfully improved in distance, selectivity and reception. It will pull in more stations, louder and clearer, than any other set using the same number of tubes (five). Only one tuning dial—easy to tune. Send coupon today for complete information.

Note these features of Model "S" Acmeflex Kitset

- Complete directions given for putting set together.
- No antenna to erect.
- No technical knowledge or workshop required.
- Only two tools and they are in the Kit.
- No soldering to do.
- Only one tuning dial.
- Excellent reproduction.
- Greater distance, sensitivity and selectivity.
- Non-radiating—won't bother your neighbor.
- Saves you about \$60.00.



ACME APPARATUS COMPANY

Dept. F 3

Cambridge, Mass.

Pioneer Radio and Transformer Engineers and Manufacturers

ACME APPARATUS CO., Dept. F3, Cambridge, Mass.

Send complete information about the new Model "S" Acmeflex Kitset to

Name.....

Street.....

City.....State.....

Among Our Authors

GY. ALLEN is too modest to send us his photograph for this page. We last recall seeing his picture in a group of Westinghouse engineers who were working under his direction in experimenting with radio reception in 1924 in the Hudson-Manhattan vehicular tunnel. Mr. Allen, who is engineer assistant to the manager of the radio division of the Westinghouse Company, says that he has lately become convinced that his interest in radio dates from the time that he was old enough to talk.

ZEH BOUCK at this writing had deserted his New York laboratory and forsaken radio and all its works for a vacation in Ber-



ZEH BOUCK

muda, which, as he says, is the nearest thing to a desert island he can find. We suggested a New York traffic tower as the latest thing in solitude, but he turned that down because he was afraid that somebody might mistake one for a mast

and string an antenna on it. His article in this number of the magazine deals with a subject that we all feel is highly important.

MY ACTIVITIES in radio," writes Mildred Weinberger, "have been largely vicarious, for I married radio." Her husband is Julius Weinberger, a research engineer for the Radio Corporation of America in charge of broadcasting station design. The scope of her article may be better understood when we know that Mrs. Weinberger's hobbies and recreations "have been tied up closely with plays: writing and producing them. I have acted and often been the general handy man who makes something out of nothing", she writes.

B. F. MIESSNER, who is contributing a series of articles on sound and its relation to radio, is probably known to some readers by his book *Radio Dynamics* which was brought out by Van Nostrand, as well as for his invention of the Electric Dog which is more

scientifically known as Automatic Heliotropic Machine.

KEITH HENNEY is a new member of the technical staff of RADIO BROADCAST and recently completed three years of research under Dr. E..L. Chaffee at Cruft Radio Laboratories, Harvard University.

HARRY DIAMOND has been "in radio" since his undergraduate days at Massachusetts Institute of Technology. "Radio," says he, "has always been my hobby since the days of the spark gap (I often feel that some do not know that those days are over). My present position allows me considerable chance for radio research, but I have not as yet succeeded revolutionizing the art." Mr. Diamond is an instructor in Electrical Engineering at Lehigh University.

JOHN EDDY got his first thrill as a school boy in London at the time of the *Titanic* disaster. "Then I wound a coil on a two-by-four and tried to copy time signals from the Eiffel Tower," he writes. "I operated amateur stations 2AKN, 3FS, 2JE, and finally 8NI at Ithaca, New York. At fourteen, I held a commercial operator's license. During the summer vacations from school and college, I have enjoyed trips taken as radio operator to Cuba and Gulf of Mexico ports and to the



MILDRED WEINBERGER

West Coast. I can't decide whether radio has cursed my life or blessed it."

HAROLD S. FRAINE is a member of the advertising staff of RADIO BROADCAST and spends most of his time tracing scents in the radio forests of New York City. He has a wide acquaintance among those who manu-

facture and sell things radio. His work in the International Radio Broadcast Tests has made him a popular person indeed, for he has many valuable facts about the radio likes and dislikes of the American public now at his figurative finger tips.

A. C. Type 800 — \$47.50
(60 cycles—110 volts)

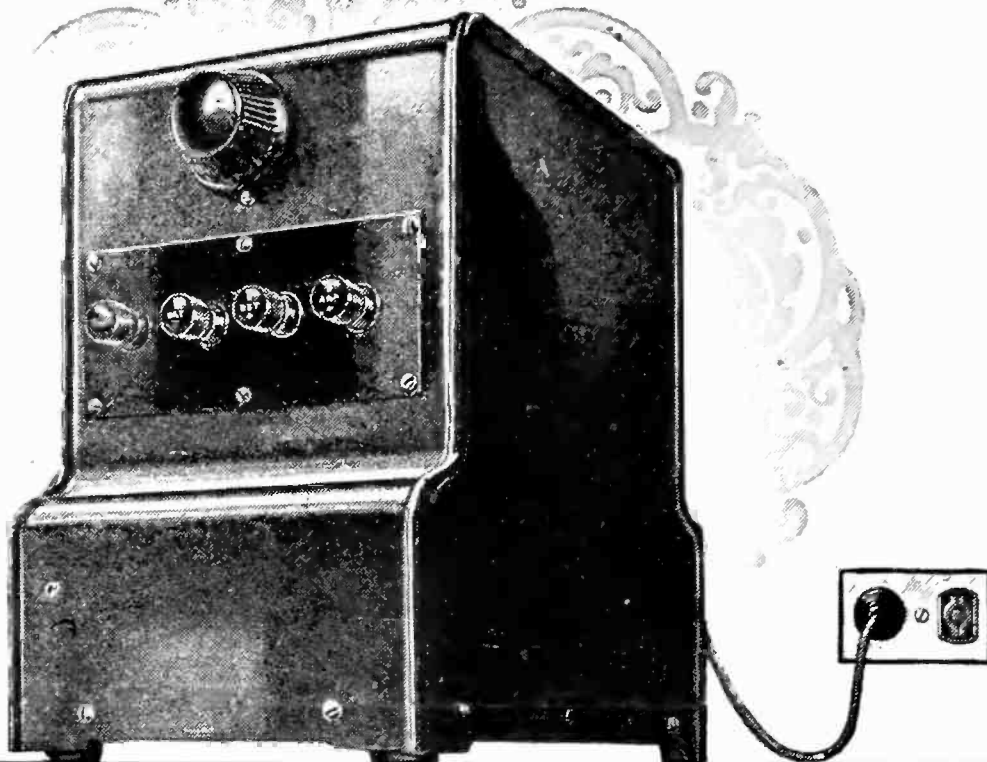

Super-Ducon

For better reception
everywhere—and always!

Right in your electric light wires lies all the current you need to keep your radio set at the peak of efficiency.

A Super-Ducon, plugged in, delivers a steady current of just the right voltage—always constant—always silent.

It takes the place of “B” batteries. Less trouble—lower upkeep—and better radio reception *always*—with a Dubilier Super-Ducon.



Tested and listed by the National Board of Fire Underwriters

Dubilier

CONDENSER AND RADIO CORPORATION

★ Tested and approved by RADIO BROADCAST ★

Low Loss **“Supercoils”** **Fully Adjustable**
For All Circuits

“RADIO BROADCAST’S ‘KNOCKOUT’ ”
 Walter Van B. Roberts’ Circuit

Combining Radio Frequency, Regeneration and Reflex.

Endorsed by Mr. Arthur H. Lynch, Editor, Radio Broadcast.

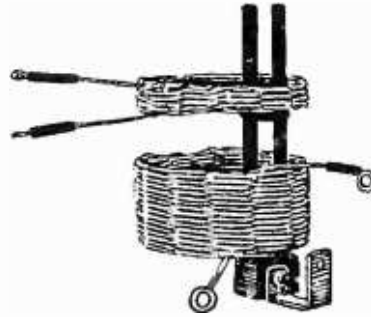
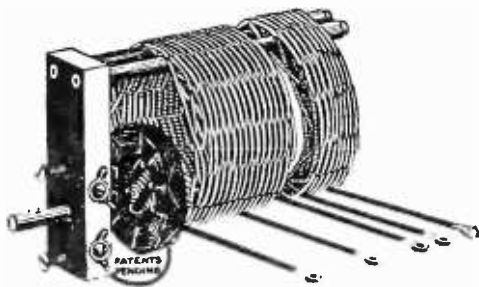

Basket weave windings. Large duplex insulated wire. Adjustable couplings. Minimum dielectric.

Per Set, 5 coils in 2 mountings, \$8.00

Send 3-2c stamps for Low-Loss Bulletins and Easy to Read Hook-ups.

At your Dealers or Direct plus Parcel Post

PERFECTION RADIO MFG. CO.

Office 319-1520 Chestnut St.

Philadelphia, U. S. A.



RUDYARD KIPLING’S
INCLUSIVE VERSE: 1885-1918

This volume is the finest treasure of verse of the last three decades. Here are the songs that have been sung the world 'round, the quotations that have inspired untold thousands, the poems that are the great heritage of the English speaking people, and the charm, “which, like the *Arabian Nights*, has enchanted men of all nations.” It is truly a book that should be in every home.

Printed on Oxford Bible Paper. At all bookstores, cloth, \$6.50. Leather, \$8.50.

DOUBLEDAY, PAGE & CO.

★ Tested and approved by RADIO BROADCAST ★

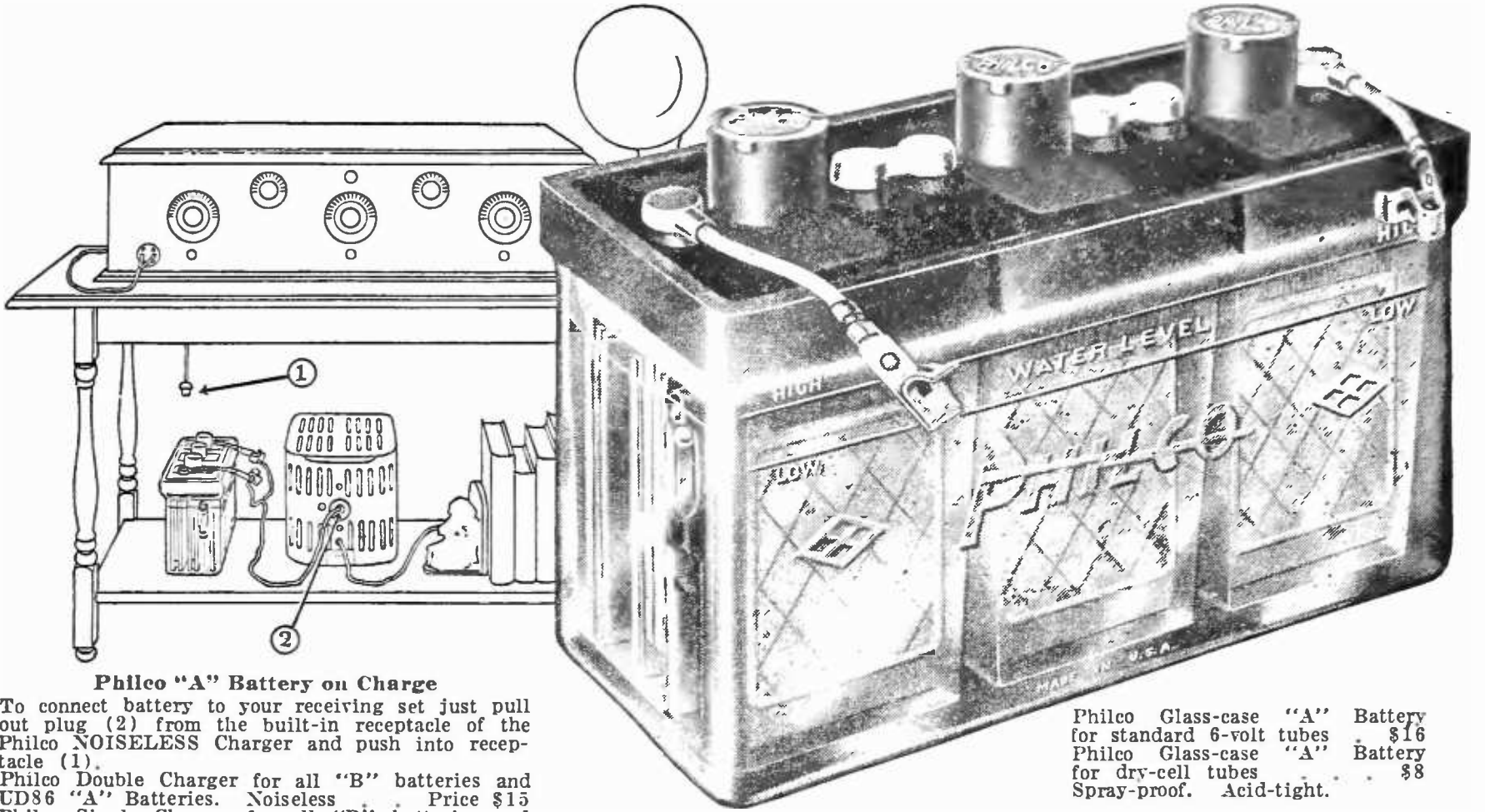

Philco "A" Battery on Charge

To connect battery to your receiving set just pull out plug (2) from the built-in receptacle of the Philco NOISELESS Charger and push into receptacle (1).
 Philco Double Charger for all "B" batteries and UD86 "A" Batteries. Noiseless. Price \$15
 Philco Single Charger for all "B" batteries and UD44 "A" Batteries. Noiseless. Price \$9.75
 Charger Prices include plugs and receptacles.

Philco Glass-case "A" Battery for standard 6-volt tubes \$16
 Philco Glass-case "A" Battery for dry-cell tubes \$8
 Spray-proof. Acid-tight.

Recharge in your living room without changing a wire!

Recharging a Philco Radio Battery with a Philco NOISELESS Charger means merely pulling a plug from your radio socket and pushing it into the charger socket. No changing wires. No moving the battery.

Philco Radio Batteries—both "A" and "B"—have other big advantages that make storage battery operation easy, convenient and economical.

They are assembled in attractive acid-tight, spill-proof glass cases—or in wood cases finished in beautiful Adam-brown mahogany. The glass case types have exclusive built-in Charge Indicators that tell you at a glance how far the battery is charged or discharged. Wood-case types are supplied with Philco Charge Testers, mounted in the filler caps, at \$1 extra.

No matter how expensive your radio set—whether it has one tube or many tubes—you must have the steady voltage and strong non-rippling current of a good STORAGE BATTERY for the best results.

Philco Radio Batteries deliver strong, non-rippling current *without hum, roar or buzz*. You can buy them from your nearest Philco Service Station, Radio or Music Dealer.

Philadelphia Storage Battery Company, Philadelphia

PHILCO DYNAMIC RADIO BATTERIES

JOBBERs and DEALERs—Philco has brought radio batteries out of the cellar and put them in the living room. Our new Radio Manual tells how. Fill out coupon below and we will mail you a copy.

Name

Street..... City.....

State..... Jobber Dealer

★ Tested and approved by RADIO BROADCAST ★

BURGESS BATTERIES

Contribute to
a Radio Miracle



President Coolidge



H. R. H. The Prince of Wales



The transmitter that sent photos by radio from London to New York. Batteries for energizing the tubes are shown in the lower shelves of the cabinet.

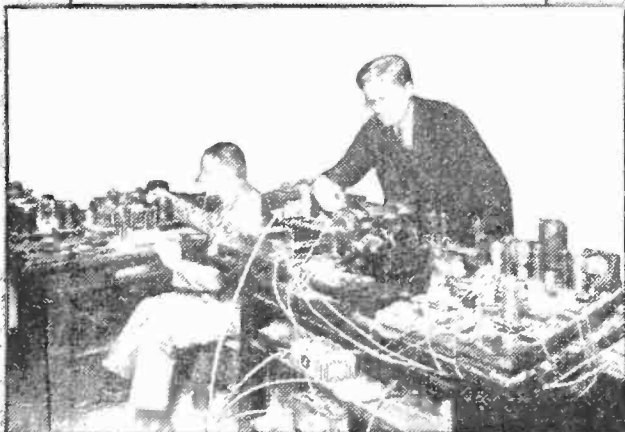

General view obtained through courtesy of the Radio Corporation of America. Captain Richard Ranger of the R. C. A., inventor of the apparatus, is seen placing film upon drum of transmitter. U & U Photos

THAT Burgess Radio Batteries were chosen for this inspiring achievement is a pleasing indication of the confidence placed in them by experienced radio engineers.

★ Ask Any Radio Engineer

BURGESS BATTERY COMPANY
Engineers DRY BATTERIES Manufacturers
Flashlight - Radio - Ignition - Telephone
General Sales Office: Harris Trust Bldg., Chicago
Laboratories and Works: Madison, Wisc.
In Canada: Niagara Falls and Winnipeg

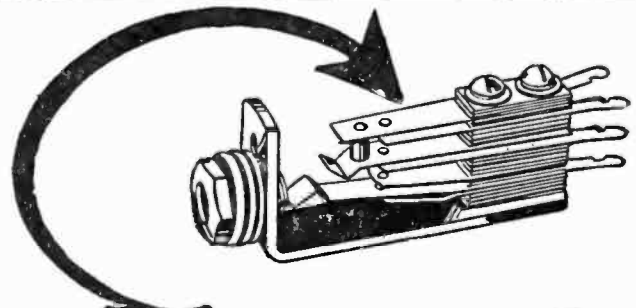

The spring's the thing!

Don't underestimate the importance of good jacks.

Don't buy jacks because they're cheap.

Over 25 leading set manufacturers use only Pacent Jacks. They have that most important essential—*fine springs* that keep the tension constant and the contact perfect.

Write for catalog of complete Pacent Line

PACENT ELECTRIC COMPANY, Inc.
91 Seventh Avenue, New York City

Washington
Minneapolis
Boston
San Francisco
Chicago
Birmingham

Pacent
RADIO ESSENTIALS

Philadelphia
St. Louis
Buffalo
Jacksonville
Detroit

Canadian Licensees: R. H. White Radio Co., Hamilton, Ont

"DON'T IMPROVISE - PACENTIZE"

*wonderful
startling!*

The NEW UNCLE SAM MASTER TUNING COIL

THE COIL WITHOUT LOSSES

- 1—Wound on moulded hard rubber.
- 2—Increases volume 50% to 180%, also selectivity, over old type.
- 3—Eliminates all adhesives.
- 4—Has a one hole mount and thin gold-plated compensating spring contacts.

FREE! Ask your dealer or send us four cents in stamps for wiring diagrams of circuits in which this remarkable coil can be used.

UNCLE SAM ELECTRIC CO.
219 E. Sixth St. Plainfield, N. J.

★ Tested and approved by RADIO BROADCAST ★

Now That You Get
"Distance"—How
About Quality?

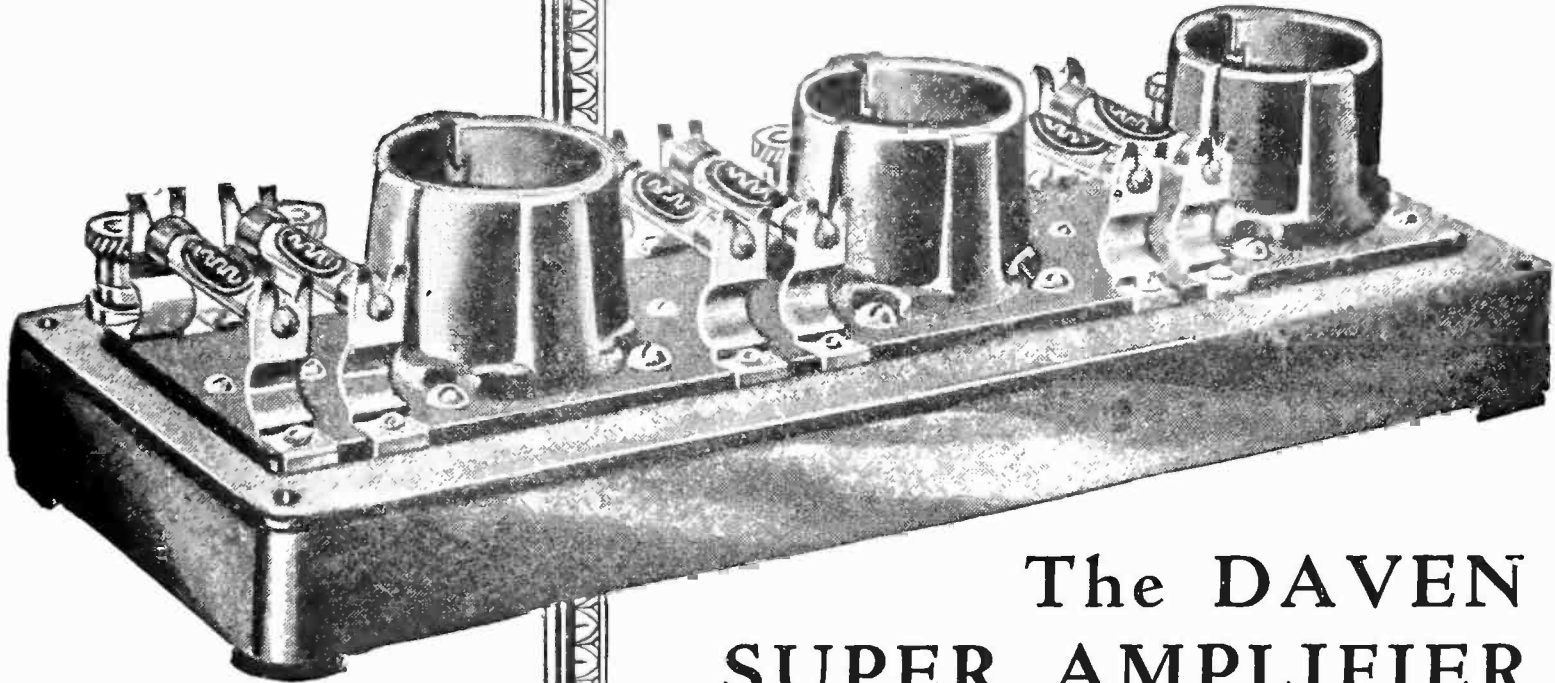

The DAVEN SUPER AMPLIFIER

To the Home Set Builder the *Daven Resistance Coupled* Amplifier will be found the most ideal. It simplifies the construction of his receiver, which, when completed, will reproduce the broadcasted concerts with a faithfulness not obtainable with any other method of amplification.

Let your next amplifier be Resistance Coupled, for this is the only method of audio amplification whereby high and low tones are amplified alike, therefore distortionless.



Your Dealer can supply you with the Daven Super Amplifier—Sold Everywhere.

DAVEN RADIO CORP.

"Resistor Specialists"

Newark

New Jersey

Obtain from your Dealer, the "Resistor Manual," our complete handbook on Resistance Coupled Amplification. Price 25c. If your Dealer cannot supply you, we will send one direct, postpaid, 35c.

DAVEN RADIO

THE ARISTOCRAT OF AMPLIFIERS

★ Tested and approved by RADIO BROADCAST ★

When
the phone
rings

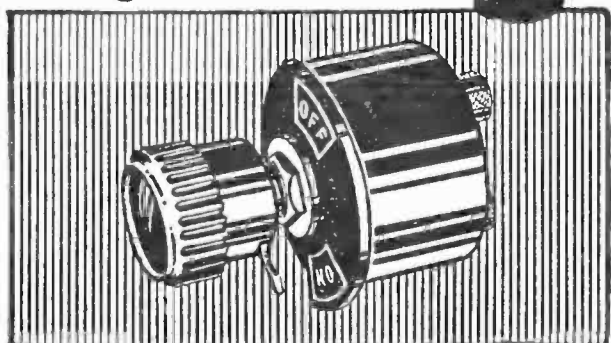

Snap ~
AND ALL IS SILENT
Snap again ~
AND THE PROGRAM
CONTINUES ~
without retuning

No modern set lacks the convenience of a MAR-CO filament battery throw switch. Its definite on and off positions make it far superior to any pull switch. Saves tubes and batteries—you don't forget to turn them off! Saves annoying interruptions when you only want to stop reception for a minute!

★
**Make your set
convenient with a
MAR-CO**



**ON AND OFF
BATTERY
SWITCH \$1.00**

—and when you need a variable condenser, get one you know will cut down leaks—a MAR-CO! Handsomely finished, individual tension adjustment, a precision instrument throughout!

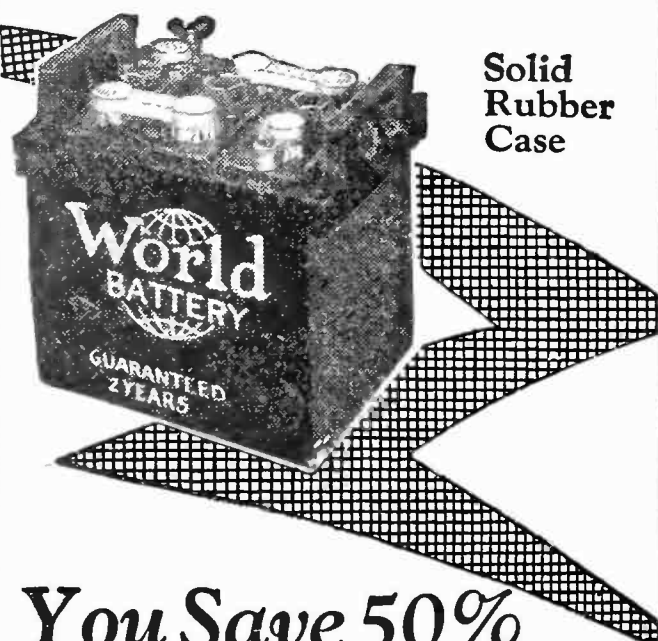

You Save 50%

World 6-Volt Storage Batteries are famous for their guaranteed quality and service. Backed by years of Successful Manufacture and Thousands of Satisfied Users. You save 50% and get a

**2-Year Guarantee Bond
In Writing**

World Battery owners "tell their friends." That's our best proof of performance. Send your order in today.

RADIO BATTERIES	
6-Volt, 100-Amperes	\$12.25
6-Volt, 120-Amperes	14.25
6-Volt, 140-Amperes	15.00
AUTO BATTERIES	
6-Volt, 11-Plate	\$12.25
6-Volt, 13-Plate	14.25
12-Volt, 7-Plate	17.00

SEND NO MONEY

Just state battery wanted and we will ship day order is received, by Express C. O. D., subject to your examination on arrival.

Extra Offer: 5% discount for cash in full with order. Buy now and get a guaranteed battery at 50% saving to you.

WORLD BATTERY COMPANY
1219 S. Wabash Ave., Dept. 24 Chicago, Ill.

World

Approved and
Listed as
Standard by
Leading
Authorities

including Radio
News Labora-
tories, Popular
Science Insti-
tute of Stand-
ards, Popular
Radio Labora-
tories, Radio
Broadcast Lab-
oratories and
Lefax, Inc.

**Solid Rubber
Container**

Now Standard
equipment on all
World Storage
Batteries. No
more leakage or
breakage of jars
or rotting of box.

The FRENCH BINDERS

An artistic binding will make a rare gift for your best friend—your book.

Country Life Press—Garden City, N. Y.

**Keep your Radio set
Clean!**

You must have a NODUST to keep your set working its best! Each stroke of a NODUST forces a blast of compressed air into all the hard-to-get-at places and cleans out every speck of dust and dirt in a jiffy.

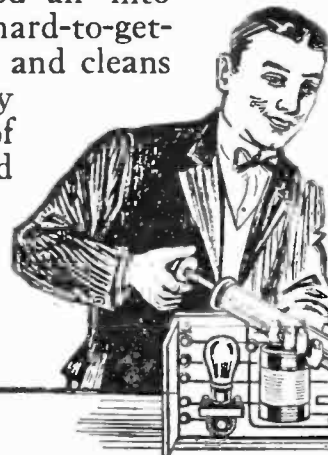

If your dealer has not received his NODUSTS yet, we will send you one on receipt of \$1.00. Satisfaction guaranteed.

PEIFFER & CO.
86 Liberty Street
Newark, N. J.

★ Tested and approved by RADIO BROADCAST ★

The Maker's Name A Public Promise

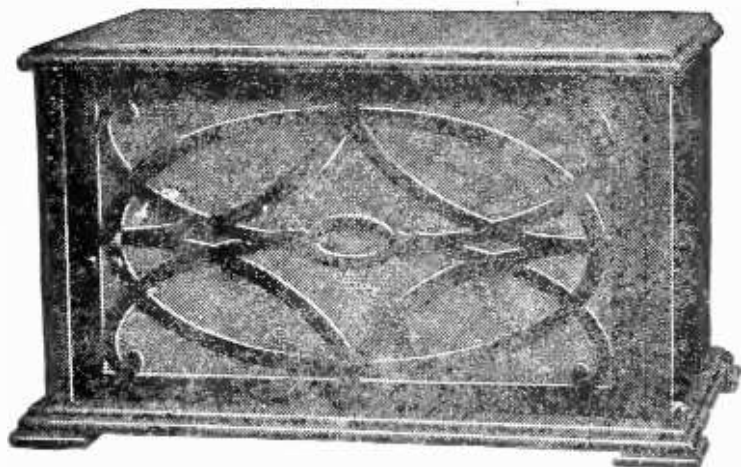

Model "C" Cabinet Type \$30.00
Beautifully finished mahogany. Size 17 x 10 x 10 1/4"

"BRISTOL" on the new Bristol's Loud Speakers indicates established responsibility and safeguards the buyer who knows the name.

Technical engineers know that for 36 years The Bristol Company has made for the great plants of America highly accurate and sensitive Recording

Instruments, and that they are fully qualified to make loud speakers of great excellence. They know that Bristol experience, scientific knowledge and honest purpose, must be this loud speaker's full inheritance.

There are five loud speakers, but all alike in those essentials which give true quality to the reproduction of voice or instrumental music. The "Voice" is not a mere phone unit but an electromagnetic device, and the horns of non-metallic material with long sound chambers allow free and full vibration. Prices, \$12.50 to \$30.00. If not at your dealer's, send for Bulletin AH-3022.



Model "S"
Audiophone
\$25.00

Horn 14 1/2" diameter.
Velvet mat finish of
bronze and gold.
Classic base

THE BRISTOL COMPANY
Waterbury Connecticut



BRISTOL TRADE MARK AUDIOPHONE REG. U.S. PAT. OFFICE Loud Speaker



★ Tested and approved by RADIO BROADCAST ★

For Better Radio
Hammarlund
 PRECISION
CONDENSER

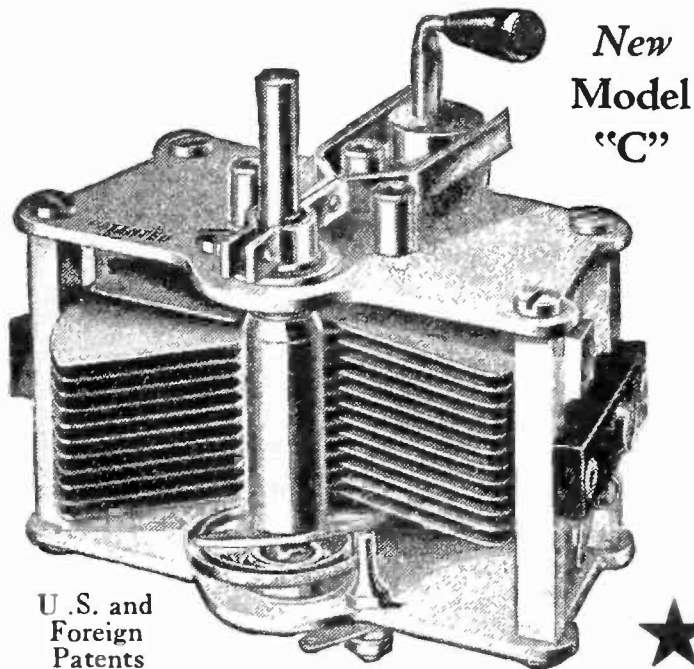

New Model "C"

U.S. and Foreign Patents

THE more you know about the technical requirements of radio, the more you appreciate the technical refinements of the Hammarlund New Model "C" Condenser.

It is an instrument of laboratory precision sold at a popular price by the better radio dealers. All capacities; plain and vernier.

HAMMARLUND MANUFACTURING CO.
 424-438 West 33rd Street, New York

9 points of superiority

- | | |
|--|--|
| <p>1—Soldered brass plates, chemically treated against corrosion; perfect alignment.</p> <p>2—Stator plates specially shaped for easy tuning of low waves.</p> <p>3—Adjustable ball-bearing rotor shaft, grounded through metal end-plates.</p> <p>4—Soldered clock spring pigtail, with automatic stop.</p> | <p>5—Minimum dielectric; losses too small to be measured.</p> <p>6—Rugged, compact construction; cannot warp.</p> <p>7—Micrometer cam-vernier moves all plates; knob or lever control; no backlash.</p> <p>8—Takes any size dial.</p> <p>9—The product of 14 years' experience, making precision instruments.</p> |
|--|--|

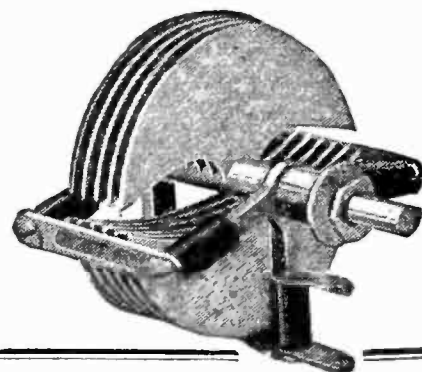
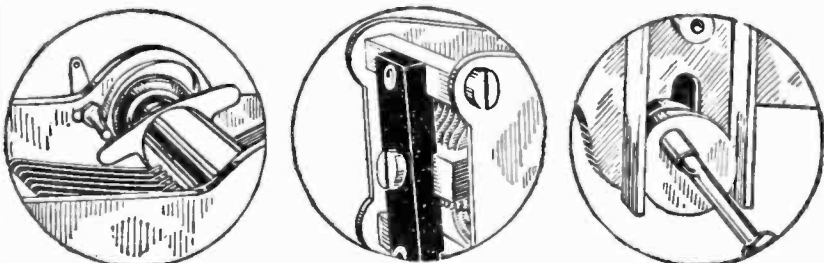

"Good Condenser Design"

What makes a good condenser? Send for this free folder and post yourself on to-day's requirements. This article is full of meat. It makes plain all the electrical as well as the mechanical qualities of a good condenser.

If you are planning to build a receiving set or to bring your present one up to date, go to your dealer and ask to see the new

Premier "CROFOOT" Variable Condenser

"CROFOOT" has all the necessary electrical and mechanical features. It is a real low loss instrument. It has the lowest minimum capacity yet attained—.000005 M. F. and the greatest tuning ratio—1 to 74. Made entirely of brass and hard rubber giving remarkably low skin resistance and low insulation leakage. Semi-straight line plate construction. All plates soldered; a feature identified by the "red stripe." A sturdy, smooth acting, compact, and graceful instrument. Mounts with one hole. Ratios 1 to 19, 1 to 42, 1 to 53 and 1 to 74. Price from \$2.75 to \$3.75. Vernier attachment with dial 75 cents additional.

FREE Hook-Up Diagrams

Ask your dealer for a complete set of Premier diagrams covering all types of hook ups. If he cannot supply them send his name and receive a set with bulletin.

PREMIER ELECTRIC CO.
 3812 Ravenswood Ave. Chicago

PREMIER
Quality Radio Parts

"No library complete without Kipling complete"

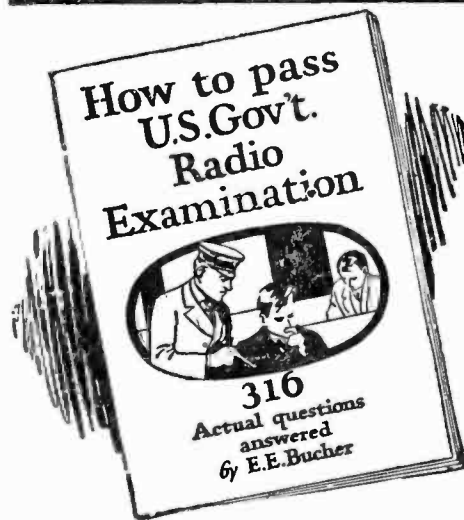

50c

PASS the U. S. Government Commercial or Amateur Radio License examination. This book will help you do it. Send fifty cents in stamps or coin for your copy—postage prepaid to any point in the U. S., Canada or Mexico.

RADIO INSTITUTE OF AMERICA
 328 Broadway New York City

★ Tested and approved by RADIO BROADCAST ★

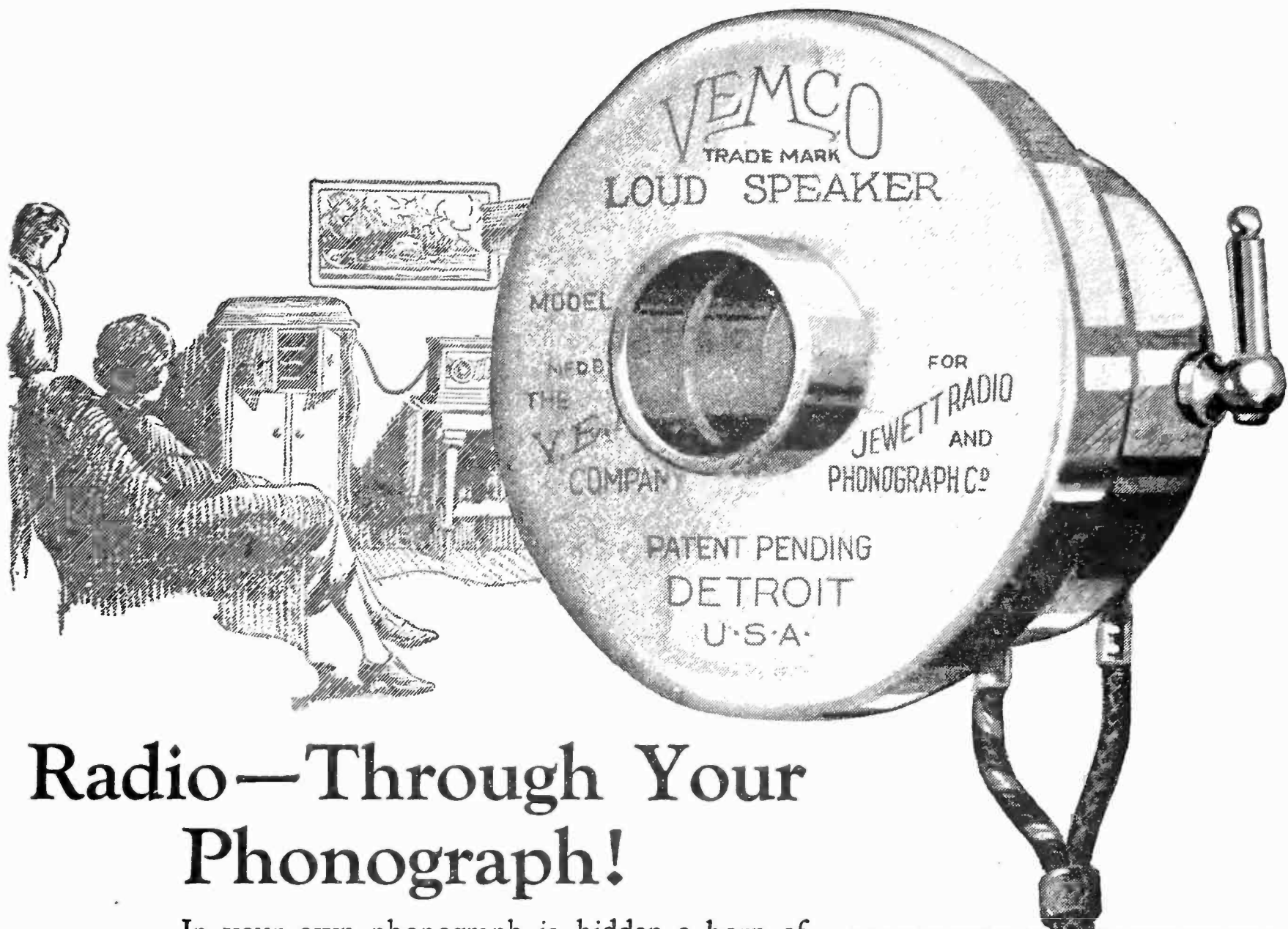

Radio—Through Your Phonograph!

In your own phonograph is hidden a horn of proved acoustical merit.



With a Jewett Vemco Unit, this horn can provide excellent Radio reproduction—reproduction so loud, so clear, and so accurate as to rival that of the best phonograph record you have ever heard.

But be sure that the Reproducer is a Vemco! That is the secret of accuracy, volume and tone.

No tools, no changes—Slips easily on or off the tone arm of a Victrola—We supply simple adapters for other phonographs. Volume control develops distant broadcasting to amazing strength. Above cuts show actual size. The same reproducer used in the famous Jewett Super-speaker. Price \$12; West of the Rockies, \$12.50. Adapter, when needed, slight addition. At your dealers or use the coupon.

"THERE IS NO SUBSTITUTE FOR THE BEST"

JEWETT RADIO & PHONOGRAPH CO.
5672 DIXIE HIGHWAY PONTIAC, MICHIGAN

SEND NO MONEY—
Just Fill In The Blanks!

Jewett Radio & Phonograph Co.
5672 Dixie Highway, Pontiac, Mich.

My dealer is not yet supplied so please send me, carrying charges prepaid, a Vemco Unit with adapter if needed. I will pay the postman. My Phonograph is a

_____ (make)

_____ (Name)

_____ (Address)

The Jewett Vemco Unit

★ Tested and approved by RADIO BROADCAST ★

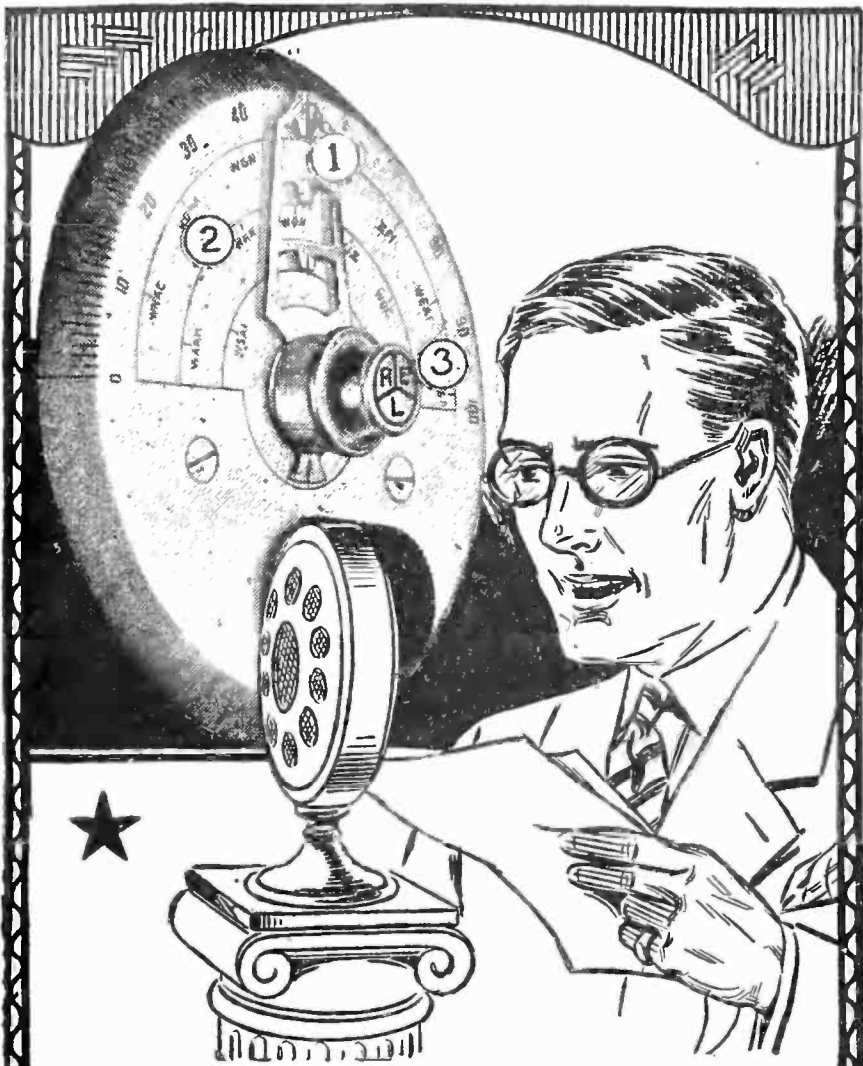

**Don't Wait
—for the Announcer!**

- 1. This alignment is the gauge for penciled station records.
- 2. Penciled records easily erased from silvered dial.
- 3. Takes standard condenser shaft lengths—easy to mount. Gear Ratio 20-1.



Designed by R. E. Lacault, E.E., A.M. I.R.E., inventor of the famous Ultra-dyne circuit. This monogram seal R. E.L. is your assurance of Lacault design.

\$2.50

Made by the Hammarlund Mfg. Co. your assurance of quality and dependability — produced solely for the Phenix Radio Corporation. At your dealer, otherwise send purchase price and you will be supplied postpaid.

Once you have marked your favorite stations on the Ultra-Vernier silvered dial, all you need is your radio program.

Make your evening's selection. Forget wavelengths. Don't fumble or guess. The Ultra-Vernier indicator points instantly to the preferred station and tunes it in with infinite precision.

Single control operates vernier for hair splitting adjustment and governs station indicator. For unprecedented tuning ease, replace your old dials with Ultra-Verniers—to-day.

Write for descriptive folder

**ULTRA-VERNIER
TUNING CONTROL**

PHENIX RADIO CORPORATION

5-7 Beekman Street
New York City



**\$1.50
now
for the Ideal
Radio Rheostat**

The old story of big demand and quantity production making for price reduction has worked out for the Marshall-stat, the ideal radio rheostat. Its new price is \$1.50 now.

For your money you get the smoothest accurate adjustment rheostat on the market. It gives vernier precision throughout its entire range from 100 to 0.2 ohms. Yet there is only one adjustment to make—only one dial to turn.

In addition, it is compact (illustration above full size), requires only one hole in panel, and can be used with any tube or combination of tubes.

You can't go wrong with the Marshall-stat.

MARSHALL ELECTRIC CO.,
3233 Locust Boul. St. Louis, Mo.

Get the Marshall-stat at radio dealers everywhere. Write us for descriptive literature.



**HERCULES ★
AERIAL MAST**

20 Ft. Mast.....	\$10
40 Ft. Mast.....	25
60 Ft. Mast.....	45

All steel construction. Complete with guy wires and masthead pulley. We pay the freight.
S. W. HULL & CO., Dept. F-5
2048 E. 79th St. Cleveland, O.

Write for Literature and FREE Blueprint

ALL SHOT That's the common expression of dry cell "B" batteries. Purchase the economy way and enjoy clearer reception, and greater volume. Put together an everlasting "HAWLEY" rechargeable "B" storage battery. Nickel-iron alkaline type. No former experience or soldering necessary. Put up in both assembled and knock-down types. The knock-down units contain all actual material for building battery and are put up in 90 volts at \$8.95; 100 volts at \$9.95; 120 volts at \$11.60; 135 volts at \$12.75; 150 volts at \$13.90; 200 volts at \$17.50. Guaranteed for 2 years with a 30 day trial offer of complete satisfaction or return of your money without any ifs nor ands. Complete sample cell 35c prepaid. 8 page illustrated folder of instructions showing simple putting together, making charger and charging free with all orders. Complete manufactured "B" battery charger \$2.75. Order direct or write for my literature, guarantee, and testimonials. Same day shipments. Address

B. F. SMITH 31 Washington Ave. Danbury, Conn.



YOU ARE PLANNING to build a radio receiver and you want to know what kind to make. Shall it be a one-tube reflex, or a four-tube ultra-sensitive tuned and neutralized radio-frequency receiver using regeneration and push-pull amplification? The book which will satisfy the needs of every radio constructor, RADIO BROADCAST'S KNOCK-OUT RECEIVERS, contains instructions on how to build these—in fact it tells how to make eight separate receivers.

EVERY PURSE and every desire is satisfied in the collection of receivers described in this book. Each one of the receivers was developed through the coöperation of RADIO BROADCAST, and thousands of radio enthusiasts all over the country have built these sets with the greatest of satisfaction.

THERE IS NO BETTER group of receivers from which to pick the type to build than those contained in RADIO BROADCAST'S KNOCK-OUT RECEIVERS because they have been designed by experts to fit the need of the broadcast listener. All of them can be built from standard parts.

COMPLETE INFORMATION is contained in the book (which has one hundred pages), for building these receivers, but no blue prints can be sold with it. Well known radio authors like Walter Van B. Roberts, Zeh Bouck, Kenneth Harkness, John B. Brennan, and others have written the descriptions. This book is now being printed and deliveries will be made from March 15th, 1925. It will be sent prepaid on receipt of \$1.00.

DOUBLEDAY, PAGE & COMPANY,
GARDEN CITY, NEW YORK

Please find enclosed \$1.00 for RADIO BROADCAST'S KNOCK-OUT RECEIVERS to be sent to

_____ NAME

RBM

_____ ADDRESS

*Heard 70 Stations
Between 8 and 11 P.M.*

JOHN F. Davidson, Rutherford, N. J., writes: "Following is a list of 70 stations I heard in two weeks on my Resas Tone-A-Dyne Receiver between 8:00 and 11:00 P. M. All of these stations were received while New York stations were broadcasting, yet there was no interference."

Included in this list are stations in Montreal, Ottawa, Nebraska and Georgia.

Some record! Yet no better than you should be able to do under similar conditions.

The Resas Tone-A-Dyne has such a high degree of selectivity that you can tune right through locals. If you paid twice the price you could not expect better results than you can get with a 5-tube Resas Tone-A-Dyne Receiver.

The cabinet is Mahogany, handsomely finished, 26½" x 8½" x 9½".

In everything except price, it's a \$150.00 set. It is fully guaranteed for one year.

Write for our interesting booklet

RESAS, Inc. ★

112 Chambers St. New York, N. Y.

Dealers: Write for name of distributor in your territory and our special proposition.

RESAS \$78
Tone-A-Dyne

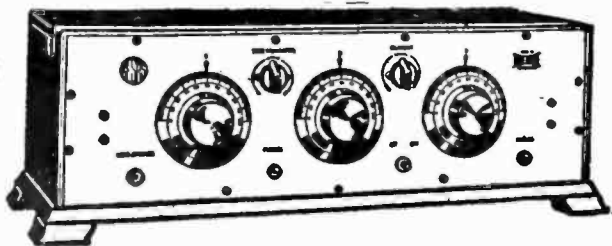

Apex Super 5

This highly efficient tuned radio frequency receiver is the most advanced in design and construction. It is an instrument that meets every critical expectation of the seasoned radio enthusiast.

Buy the Apex Super 5. You will have a radio receiver that brings in distant stations clear and distinct. Select the station you desire in your log-book, turn the marvelous Apex Vernier Dials to that number, and there you are—perfect reception. No greater selectivity can be had than is easily obtained with the Apex Super Five.

Housed in a highly finished walnut cabinet, complete with Jones Multi-plug Battery Cable. All settings highly gold plated. Sells for \$95 complete excepting accessories.

At All Good Dealers
Apex Elec. Mfg. Co. ★
1410 W. 59th St.
Dept. 404
Chicago

on
the
dot

The Andrews ★
Deresnadyne

RADIO RECEIVING SET

combines tone quality and selectivity with distance and volume. De Luxe Model \$165 without accessories. Write for literature.
ANDREWS RADIO CO. 327 S. La Salle St., Chicago

HEATH ★

CONDENSERS

For Real Radio Reception

Write for Literature

HEATH RADIO & ELECTRIC MFG. CO.
206 First St., Newark, N. J.

★ Tested and approved by RADIO BROADCAST ★

Avoid Fire and Loss Install an Electrad Lead-In

Absolutely safe—made in accordance with specifications of the National Board of Fire Underwriters. 3,000 volt tested.

Fahnestock clips. Soldered connections. And the most convenient form of lead-in imaginable. No unsightly porcelain tubes. No damaging holes in window frame or sash.

Electrad Lead-Ins are made of flat, pliable, insulated metal that will bend into any shape. Fits under closed, locked windows. Price, 40c.

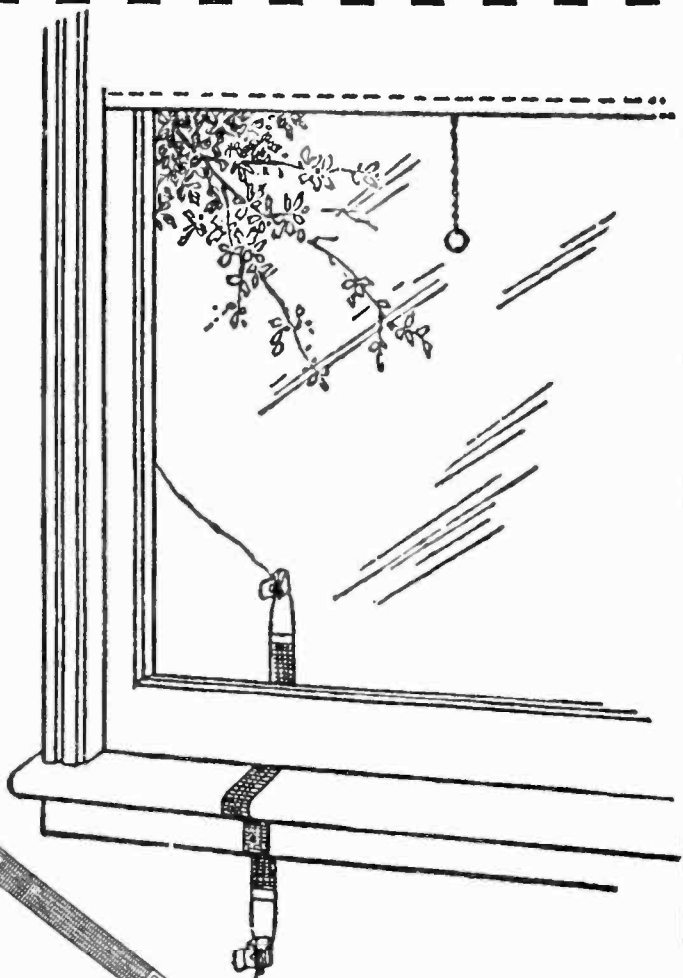

Electrad Guaranteed Parts Make Any Set Better

Variohms, Audiohms, Rheostats, Audio Transformers, Grid Leaks—a complete line of parts, every one fully guaranteed. Foremost radio engineers have developed Electrad parts and to-day supervise their manufacture.

And under that supervision each individual part is scrutinized—the slightest imperfection, and the part is instantly thrown away—destroyed.

Nobody has ever bought an Electrad “second.” Every part is perfect and guaranteed so.

Save yourself time, money, and disappointment by insisting upon “Electrad.” For sale at nearly all good radio dealers.

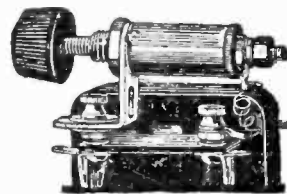

Use the Audiohm for clarity. Put one across the secondary of your transformer. Easily attached by anyone. Once set, it's permanent. Price, with adjustable bracket, \$1.50.

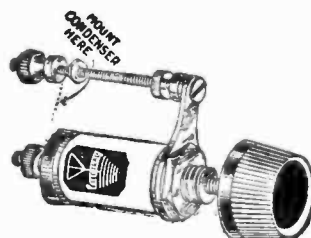

Electrad Variohm: A variable grid leak that will give exactly the correct grid resistance. Any resistance from $\frac{1}{4}$ to 30 megohms.; gives that last hair's breadth tuning that adds so much to enjoyment of radio. Price \$1.25 for panel mount, \$1.50 for base mount.

ELECTRAD

INCORPORATED

428 Broadway, New York City



★ Tested and approved by RADIO BROADCAST ★

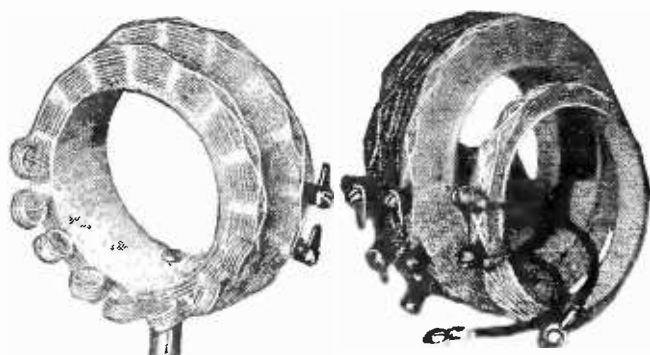

Coils for Roberts Circuit No. 18
Price \$8.00 a set

SICKLES

DIAMOND-WEAVE COILS

Patented Aug. 21, 1923

For Craig, Roberts and Hoyt Circuits

Sickles Coils were chosen by Albert G. Craig in designing his remarkable new Reflex Receiver using the new Sodian detector, and are specified by him for this circuit in the February issue of Popular Radio. This coil set, No. 20, is priced at \$4.50.

For the very popular Roberts Circuit the Sickles Coil Set No. 18 (\$8.00) is standard equipment. Unit No. 1 has primary and secondary coils. Unit No. 2 has primary, secondary, neutralizing coil and tickler. Broad variation in coupling adjustments is provided for. Tickler is provided with 180 degree dial control.

Coils for the Hoyt Circuit at \$10.00 a set, for the Knockout Reflex Circuit at \$4.00 a pair, the Tuned Radio Frequency coil at \$2.00 each and the Acme Reflex circuit at \$4.50 a set are among the standard Sickles coils. We manufacture special coils also for manufacturers' requirements.

An entirely new system of Radio Reception

Sickles Diamond Weave Coils have been specified for use in the Hoyt System of Signal Augmentation, by the inventor, Francis R. Hoyt. We have a limited number of blue printed copies of Mr. Hoyt's original laboratory notes on this new system of radio reception, together with nine circuit sketches, which will be sent free to you upon receipt of this coupon and four cents for postage.

The F. W. Sickles Co.
335 Worthington St., Springfield, Mass.
Please send information of Hoyt System.

Name

Address

Send for descriptive catalogue



The F. W. Sickles Co.

335 Worthington Street
SPRINGFIELD, MASS.

BRANSTON RADIO

Save \$75. to \$200.

Build Your Own Reflexed Super Heterodyne



Get Maximum Selectivity, "Local" Volume on distant stations, Wonderful Tone

Use Branston Kit No. R-199

Contains 8 matched super transformers, tested and guaranteed. Make 7 tubes do the work of 10. \$35.00. **Branston Accessory Kit No. R-199-A** contains panel, base, and correct jacks, condensers, rheostats, switch, (assembled) and sockets, square bus bar, spaghetti, grid leaks, etc., to complete the set. \$50.00. (Be sure to state whether you intend using 199 or 201-A tubes.)

Your dealer has Branston Kits or can get them for you. If not, write us direct.

CHAS. A. BRANSTON, Inc.
813 Main St. Buffalo, N. Y.

Manufacturers of Branston Violet Ray High Frequency Generators

In Canada—Chas. A. Branston, Ltd., Toronto, Ont.

ODD FISH

Being a Collection of London Residents described and drawn by

STACY AUMONIER
and
GEORGE BELCHER

Price, \$2.00

Doubleday, Page & Co., Garden City, New York

The Famous BEL-CANTO LOUD SPEAKERS

Our new cabinet speaker finished in mahogany of solid wood, with patented flexible reed tone arm. List \$17.50

10" Bell, 22" High, \$10

15" Bell, (Goose Neck) 29" High, \$15

If Your Dealer Cannot Supply You, Write Us and We Will Advise Where to Purchase One.

BEL-CANTO RADIO & TEL. EQUIP. CO., Inc.
872 Broadway, N. Y. C. Tel. Stuy. 1921

★ Tested and approved by RADIO BROADCAST ★

You will never know the thrills
of radio until you own a

FRESHMAN MASTERPIECE



The Greatest Value ever
Offered in a Radio Receiving Set
5 tube tuned radio frequency

embodying the 5 big features
demanded in a perfect receiver.

- ☑ Built of only the finest low loss material in a beautiful mahogany cabinet (or soft-toned leatherite);
- ☑ It brings in far distant stations,
- ☑ Night after night at the same points on the dials,
- ☑ With real loudspeaker volume,
- ☑ And full throated, true to life tone.

★ Be sure the serial number is riveted on the sub-panel. It is your protection and guarantee.

Chas. Freshman Co. Inc.
Radio Receivers and Parts
FRESHMAN BUILDING
240-248 WEST 40TH ST.-NEW YORK, N.Y.

\$ **60**

At all
dealers

★ Tested and approved by RADIO BROADCAST ★

Absolutely Essential for Sensitive Sets

Geared
80 to 1

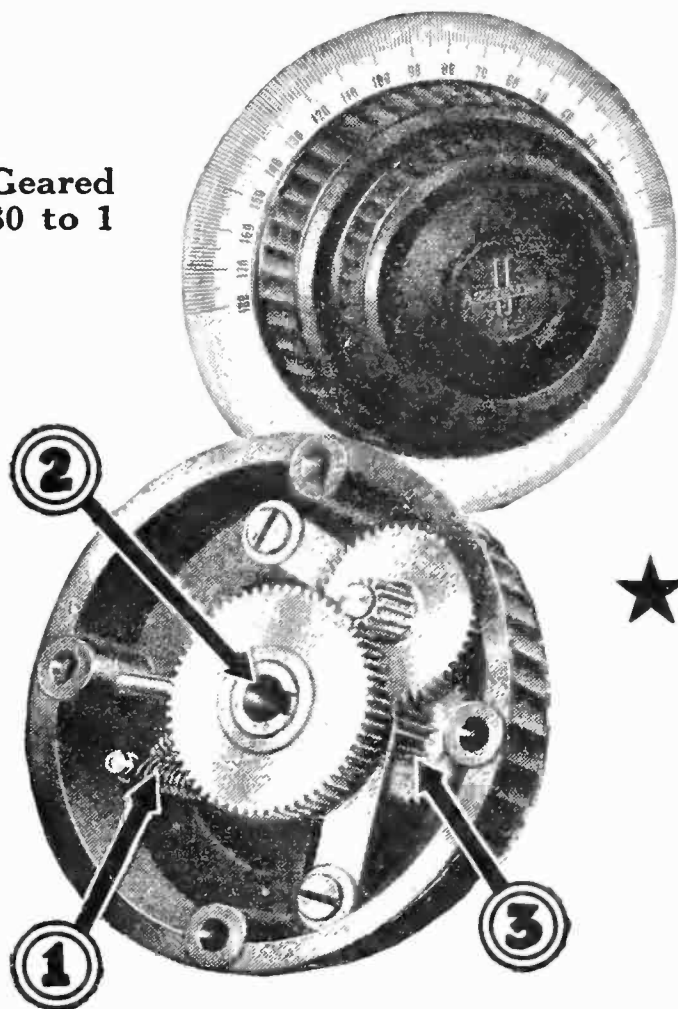

ACCURATUNE FEATURES

1.—**No Back Lash**—A new principle takes up all lost motion and back lash and produces a very smooth operating instrument.

2.—**Long center bushing eliminates all dial wobble** and takes all standard condenser shafts. Permits dial mounting flush with panel. No cutting of condenser shafts.

3.—**Gear mesh** and alignment perfected to the same degree of accuracy as the mechanism of a watch. Ratio 80-1.

You can change from ordinary dials to Accuratune Micrometer Controls in an instant, no set alterations necessary. More efficient than built-in verniers—a revelation in fine tuning.

At your dealers. Otherwise send purchase price (\$3.50) and you will be supplied postpaid.

Write for descriptive circular

MYDAR RADIO COMPANY
9-D Campbell St. Newark, N. J.

Canadian Representative: Radio Ltd., Montreal

English Representative:

G. E. Marbaix, 27 Anning St., London, E. C. 2

ACCURATUNE
REGISTERED GEARED 80 to 1 U.S. PAT. OFF.
MICROMETER CONTROLS

You Are Missing a Seven
Day Treat if You Are Not
Getting Every Issue of

RADIO WORLD

*The First Illustrated
National Radio Weekly*

Finely printed on good paper, with plenty of illustrations, both technical and human interest.

Every issue contains information telling you how to take care of your radio troubles.

RADIO WORLD is the great Superdyne authority, and its original articles and illustrations have attracted much attention, and have been copied all over the world.

RADIO WORLD does not, however, restrict its space only to the Superdyne, but pays attention in type and diagrams to all the other worthwhile circuits.

A splendid Question and Answer Dept. that everybody can understand and use to advantage.

Some of America's greatest radio authorities write regularly for Radio World.

*\$6.00 per year (52 numbers), \$3.00 six months,
\$1.50 three months.*

SPECIAL To Radio Broadcast Readers

Send \$1.00 for trial subscription of 8 issues, and the paper will be sent to you post paid starting with the current issue.

Or send us \$6.00, and mention this advertisement, and we will enter your subscription for a full year of Radio World, 52 numbers, and a full year of Radio Broadcast—12 numbers.

This offer is good until April 30, 1925.

RADIO WORLD
1493 Broadway New York

★ Tested and approved by RADIO BROADCAST ★

KESTER *Radio* SOLDER (Rosin Core)

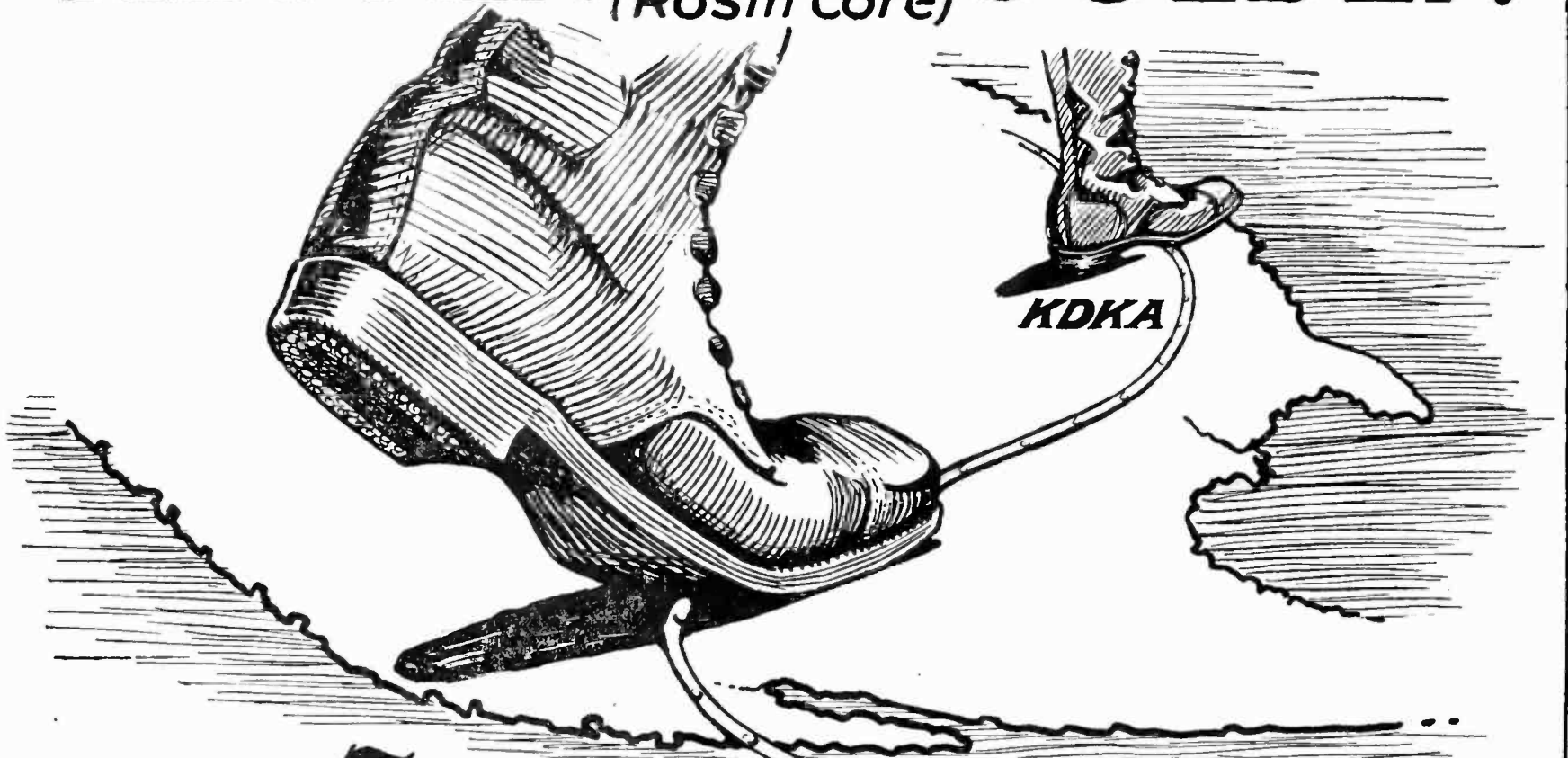

Puts 7 League Boots on Your Radio

—For example I had a 3 tube Reflex set and never got any farther east than Salt Lake. I got this solder from you and re-wired the entire set. I was surprised very much when Chicago and Mexico City came in on loud speaker a few evenings later, KDKA Pittsburg, came in and has been received once since that time so you see I am well prepared to tell what this solder will do.

*One of many letters
out Dill*



★

IF YOUR DEALER CANNOT SUPPLY YOU

Chicago Solder Company
4222 Wrightwood Ave., Chicago, Ill.
Gentlemen: Send me one can Kester Radio Solder, for which I enclose 25c in stamps.
(Postpaid anywhere in U. S. A.)

Name.....
Address.....
City..... State.....
Dealer.....

★ Tested and approved by RADIO BROADCAST ★



100%
Tone!

Magic Radio Clearness

with this new principle horn
—the Kellogg

Symphony Reproducer

Brings in the marvels of the air exactly as broadcast.

Embodies a new principle—the result of years of experiment by our experts.

Made by the 28-year-old Kellogg Switchboard & Supply Company—specialists in the transmission of sound.

Improves any set it's used on.

Hear it to-day

To-day, hear the Kellogg Symphony. Do not buy any lesser horn until you have heard it. It will increase the value of your set 100% in musical quality—in pleasure to your family and yourself. Any dealer will gladly demonstrate the Symphony for you. Hear it—to-day!

**KELLOGG SWITCHBOARD
& SUPPLY CO.**

★ Chicago Illinois

Kellogg Symphony Reproducer



**No Back
Panel Fussing**

Genuine
Bakelite
Throughout

DeJUR RHEOSTATS

ONE HOLE MOUNT ★

The one hole mount, one of the many exclusive features of the DeJur, makes it the easiest of all rheostats to mount, and when mounted it sets fixed and rigid. No screws to get loose, no back panel fussing. Compare the DeJur. You will readily recognize its difference and superiority. Guaranteed absolutely. Any part replaced at any time.

Sold by all dealers

**DeJUR
PRODUCTS Co.**

LAFAYETTE & BROOME STS.
NEW YORK



PATENTS APPLIED FOR

ARROW BATTERY SLASHES Prices TO

Prices Smashed!
Quality Not Sacrificed **CONSUMERS**

Here is real battery quality, guaranteed to you, at prices that will astound the entire battery-buying public. Order direct from factory. Put the Dealer's Profit in your own pocket. You actually save much more than half, and so that you can be convinced of true quality and performance, we give a **Written Two-Year Guarantee**

Here is your protection! No need to take a chance. Our battery is right—and the price is the lowest ever made. Convince yourself. Read the prices!

- Special 2-Volt Radio Storage Battery, \$3.75
- Special 4-Volt Radio Storage Battery, 6.00
- 6-Volt, 60 Amp. Radio Storage Battery, 7.00
- 6-Volt, 80 Amp. Radio Storage Battery, 8.00
- 6-Volt, 100 Amp. Radio Storage Battery, 9.50
- 6-Volt, 120 Amp. Radio Storage Battery, 11.50
- 6-Volt, 140 Amp. Radio Storage Battery, 13.00

We ask for no deposit. Simply send name and address and style wanted. Battery will be shipped the day we receive your order Express C. O. D., subject to your examination on arrival. Our guarantee accompanies each battery. We allow 5% discount for cash in full with order. You cannot lose! Act quick. Send your order today—NOW.

Arrow Battery Co.
1215 South Wabash Ave.
Dept. 10 Chicago, Ill.



★ Tested and approved by RADIO BROADCAST ★

Haynes-Griffin

RADIO SERVICE, Inc.

41 West 43rd St., N. Y. City

250 W. 49th St.,
New York

MAIL ORDER DEPARTMENTS

111 So. Clark St.,
Chicago

Ready Now! All parts for The New Haynes De Luxe Super-Heterodyne



A. J. HAYNES
Designer of the Haynes
De Luxe Super-Heterodyne

All the advances in design of the past year—all the best and most worthwhile improvements you have been waiting for are incorporated in the new Haynes De Luxe Super-Heterodyne. Mr. Haynes' new set represents the last word in super-heterodyne construction for the man who builds his own.

A New Degree of Sensitivity

A special type of tuned radio frequency amplification, used ahead of the straight super-heterodyne circuit, gives a new and remarkable degree of sensitivity, with distance range limited only by location and atmospheric conditions.

Many other new and important features.

Send for complete information on the new Haynes De Luxe Super-Heterodyne. It will be sent at once, without charge or obligation of any kind. Use the coupon below.

DEALERS: For name of jobber nearest you, write to Tested Radio Products, Inc., 244 W. 49th Street, New York City.

Reprints of Mr. Haynes' Original Article

Exactly as it appeared in February "Radio" mailed FREE upon request.

Complete description of the new De Luxe Super-Heterodyne.

Use the coupon below.

The Famous Haynes-Griffin Tube Matching Service

What It Does

Measures the mutual conductance of the tube, the most accurate and conclusive of all tube measurements.

Matches tubes to the same output per stage, insuring perfectly balanced tubes in multi-tube sets.

A new and special circuit employing seven meters assures perfect tube balance in super-heterodynes, neutrodynes, and other multi-tube sets. It permits you to secure the tube best suited for the particular purpose you intend to use it.

There is no charge for this service. Simply remit our regular price of \$3.00 for each tube ordered. Specify type of set, number of tubes, and position tubes are to occupy in your set. Also specify whether you want Radiotron or Cunningham tubes.

HAYNES-
GRIFFIN
RADIO
SERVICE, Inc.
250 W. 49th St.
New York City
111 So. Clark St.
Chicago

Send me reprint of Mr. Haynes' article on the De Luxe Super, with complete information and prices.

HAYNES-GRIFFIN RADIO SERVICE, Inc. ★

Mail Order Departments

250 W. 49th St., N. Y.

111 S. Clark St., Chicago

Name.....

Address.....

★ Tested and approved by RADIO BROADCAST ★

Transformer Results

Correct loud speaker performance depends almost entirely upon transformer design. Jefferson Transformers provide full, rich, smooth amplification. They furnish the loud speaker with the proper energy and assure the greatest possible volume consistent with purity of tone.

Even amplification over the entire musical range; perfect reproduction of the voice and instrument—these are some of the reasons why radio authorities and music lovers the world over recognize Jefferson superiority.

Designed by a concern which has specialized for more than 20 years in the manufacture of high grade transformers of every description. Jefferson Transformers meet the most exacting demands of every circuit. Give your circuit a treat—install Jeffersons.

Jefferson Electric Mfg. Co.
501 S. Green St., Chicago, Ill.

Manufacturers of:

Bell Ringing Transformers
Sign Lighting Transformers
Toy Transformers
Heavy Duty Signal Transformers
Auto Transformers
High Voltage Transformers
Welding Transformers
Automobile Ignition Coils
Jump Spark and Make and Break Coils
Testing Instruments
Gas Furnace and Oil Burner
Transformers and Ignition Equipment

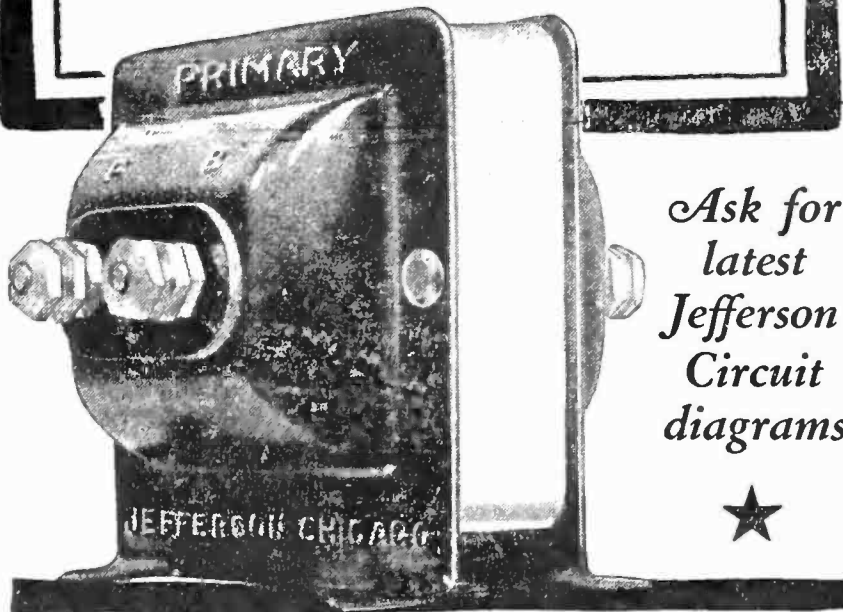

Ask for
latest
Jefferson
Circuit
diagrams



Building Better Service into RADIO PARTS

Aside from recognized radio uses in which no other metals can be substituted, COPPER and its alloys help you to make good radio sets *better* sets.

For instance, binding posts are superior posts, and battery nuts give best service and satisfaction when made of dependable free-cutting BRASS rod. *And—*



their speedier production makes labor costs lower.

COPPER & BRASS
RESEARCH ASSOCIATION

25 Broadway - - New York

for super-fine tuning

MAJOR TUNER does the trick! Selectivity? Lots of it—so much in fact that a fraction of a point movement of the condenser dial is enough to tune out one station and bring in another.

MAJOR TUNER is the most advanced form of Low-Loss three circuit tuner. It is packed with complete picture wiring diagram and full instructions. Your dealer will supply you!

BEL-TONE RADIO CO.

161 Jamaica Ave., Brooklyn, N. Y.



\$4

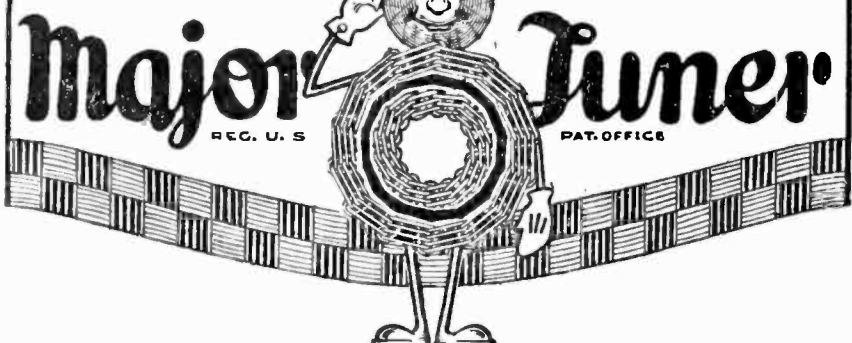

★ Tested and approved by RADIO BROADCAST ★



“HELLO, BILL, HOW’S BUSINESS?”

Tom was a friend of Bill. And Bill was a friend of Tom. Both were radio dealers. They met one day returning from the Business Men’s Tuesday Luncheon. Says Tom:

“Hello, Bill, how’s business?” “Rotten,” growled Bill. “I can’t get any deliveries from my wholesaler.”

“Who is your wholesaler?” asked Tom. “The Blank people,” came the answer.

“Now, old man,” Tom put in, “listen to what I tell you. You connect up with that HOMMEL organization—just as I do.

“If you are a HOMMEL Dealer you’ll get your deliveries even if no one else is. And co-operation! Why say, they sent me a couple of consumer inquiries—they always refer inquiries to their dealers—that brought me a sale of \$200. and another one of \$400. That’s gospel truth, Bill.

“Get their Encyclopedia of Radio Apparatus-266-B. That describes their complete line.” Bill followed Tom’s advice—and stopped worrying about “rotten” deliveries and business.

DISTRIBUTORS FOR
Radio Corporation of America



Westinghouse General Electric
Baldwin Brandes Burgess
Cardwell Crosley
Cutler-Hammer
Dubilier Fada Freed-Eisemann
Freshman Frost
General Radio Grebe
Haynes-Griffin Magnavox
Remler Rhamstine
U. S. Tool Western Electric
And other
leading manufacturers

WHOLESALE

EXCLUSIVELY

LUDWIG HOMMEL & CO

929 PENN AVENUE



PITTSBURGH, PA.

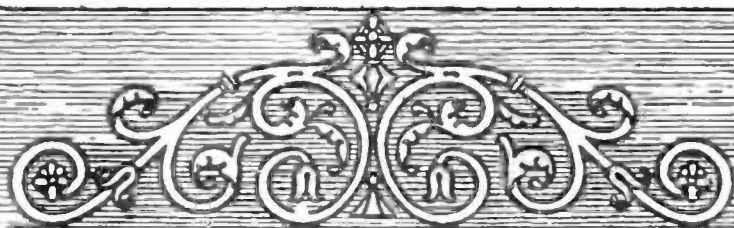

MEMBER
RMA

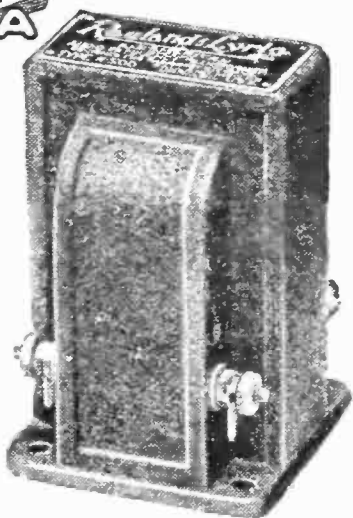

Radio Music for the Critical

Music lovers especially delight in Rauland-Lyric. Used in all audio amplifying stages of a radio receiver, it reproduces with fidelity those elusive refinements of tone quality which, to the trained ear, mean artistic excellence.

Rauland-Lyric is a laboratory grade audio transformer designed especially for music lovers. The price is nine dollars. Descriptive circular with amplification curve will be mailed on request. All-American Radio Corporation, 2652 Coyne St., Chicago.



The Choice of Noted Music Critics



Now you can UNDERSTAND RADIO!

Know all about it—build and repair sets—explain the vacuum tube—operate a transmitter—be a radio expert!



**514 PAGES
100,000
SOLD**

Compiled by
**HARRY F. HART
E.E.**

Formerly with the
Western Electric
Co., and U. S.
Army Instructor
of Radio.
Technically
Edited by
F. H. DOANE

More than 100,000 radio fans rely on this I. C. S. Radio Handbook to take the mystery out of radio. A wonderful value at \$1. Hundreds of illustrations and diagrams explain everything so you can get the most out of whatever receiver you build or buy.

It contains: Electrical terms and circuits, antennas, batteries, generators and motors, electron (vacuum) tubes, most receiving hook-ups, radio and audio frequency amplification, broadcast and commercial transmitters and receivers, wave meters, super-regeneration, codes, license rules. Many other features.

A practical book. Written by experienced radio engineers in language that you can understand. Something useful on every page of its 514 pages. A book that will save you many times its small cost.

Just mail the coupon with a dollar bill and your name and address, and we will send you this 514-page I. C. S. Radio Handbook by return mail. Note the other good books listed below and the low prices.

INTERNATIONAL CORRESPONDENCE SCHOOLS
Box 8297-D, Scranton, Penna.

I enclose \$....., for which send me, post-paid, the Handbooks marked X, at \$1 each. It is understood that if I am not entirely satisfied I may return them within five days and you will refund my money.

RADIO HANDBOOK, \$1

- Automobile Handbook - - - - - \$1
- Electrical Handbook - - - - - \$1
- Chemistry Handbook - - - - - \$1
- Pharmacy Handbook - - - - - \$1
- Traffic Handbook - - - - - \$1
- Building Trades Handbook - - - - - \$1
- Machine Shop Handbook - - - - - \$1
- Salesman's Handbook - - - - - \$1
- Advertising Handbook - - - - - \$1
- Bookkeeper's Handbook - - - - - \$1
- Civil Engineer's Handbook - - - - - \$1
- Steam Engineer's Handbook - - - - - \$1

Name.....

Address.....

Enclose \$1.50 for each book if you want the Leatheroid binding. All of the above books can be had in this binding except the Traffic Handbook and the Building Trades Handbook.

★ Tested and approved by RADIO BROADCAST ★

RATHBUN

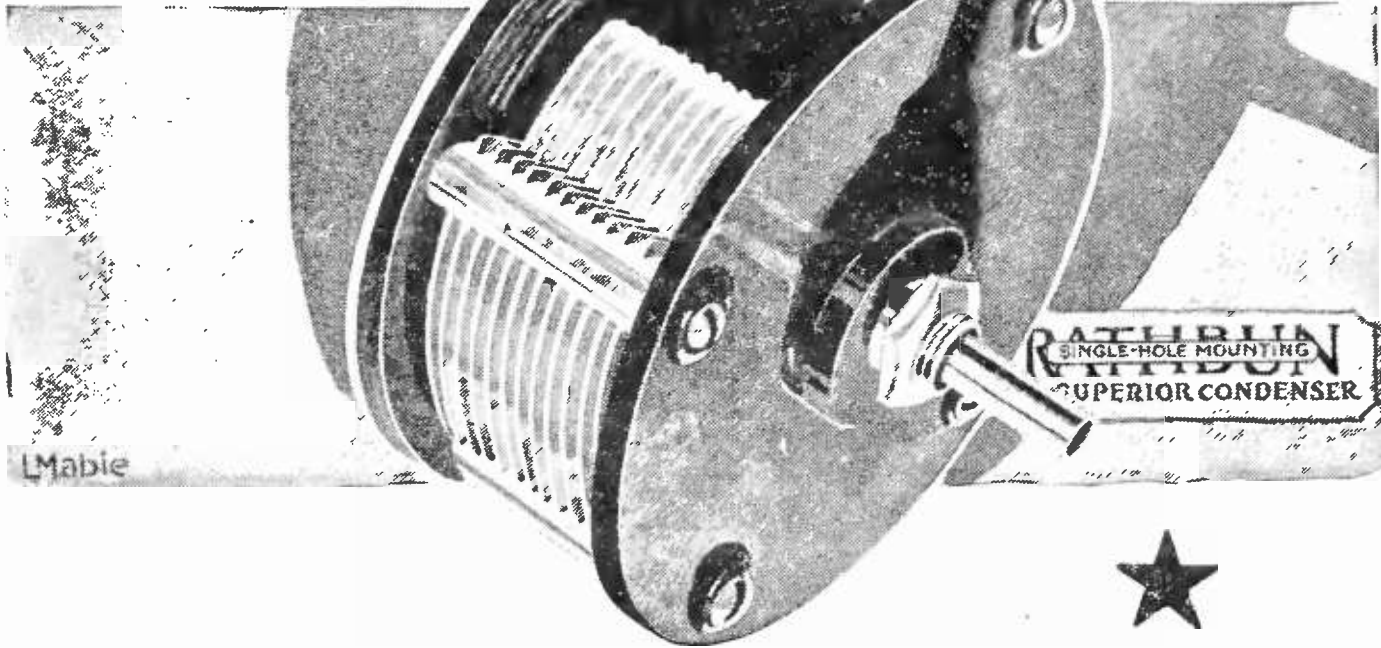

Just A Real Good Condenser!

A MONG the extravagant and oftentimes misleading claims made for so-called "low-loss" condensers, the Rathbun stands out as just a real good job—at a fair price.

Rathbun Condensers are guaranteed electrically and mechanically perfect—they are as well made, as skill, the best materials and the honest desire to give full value can make them. In actual results you will find them the equal of any other condenser—at any price. There is no need to pay more.

Insist on Rathbuns—they are good condensers. Try them in the next set you build—the single-hole mounting is a real convenience. And bear this in mind—if you can get longer distance, sharper tuning, better quality or more volume with any other condenser on the market today, return ours, and your money will be immediately refunded.

Don't be fooled by "low-loss" bunk. Insist on end plates of genuine moulded Bakelite.

We have prepared a little booklet giving in detail the story of so called "low-loss" condensers, including a tabulation of the losses, accurately measured, in over fifty standard condensers. You will find it interesting and instructive and it's free for the asking.

An Entirely New System of Radio Reception

Rathbun Single Hole Mounting Superior Condensers have been specified for use in the *Hoyt System of Signal Augmentation*, by the inventor *Francis R. Hoyt*. We have a limited number of Blue Printed copies of Mr. Hoyt's original laboratory notes on this new system of radio reception, together with nine circuit sketches, which will be sent free to you upon receipt of this coupon and 4 cents for postage.

NAME _____

ADDRESS _____

RATHBUN MANUFACTURING COMPANY, INC.
JAMESTOWN, NEW YORK

Honest **CONDENSERS**

★ Tested and approved by RADIO BROADCAST ★

GENUINE!

2 and 4-TUBE KITS

FOR THE ROBERTS "KNOCK-OUT" SET

You can now obtain the same parts and panel layout used by Mr. Roberts from the Laboratory in which the first commercial Roberts set was constructed.

A NEW SYSTEM of wiring makes this kit simplicity itself to build; ALL BINDING POSTS ARE MARKED WITH COLORED TAGS,—You merely connect all tags of the same color. Blue prints are packed with each set.

THIS KIT COMES TO YOU MOUNTED IN A BEAUTIFUL MAHOGANY FINISHED CABINET. ALL NECESSARY TOOLS, INCLUDING ELECTRIC SOLDERING IRON, PACKED WITH KIT.

2-Tube Kit, \$55.00

4-Tube Kit, \$75.00



Kits shipped C. O. D.

MAIL OR WIRE DEPT. C-S

NASSAU RADIO CORP.

80 NASSAU STREET
PRINCETON, NEW JERSEY



-the Panel SUPER FINE

No other material known possesses the many combined advantages for radio paneling as does Dilecto. It has every endorsement of dealer and manufacturer, because it is practically indestructible.

The Continental Fibre Co.
Factory: Newark, Delaware

NEW YORK, Woolworth Bldg.
CHICAGO, Wrigley Building
PITTSBURGH, Farmers Bank Building
SAN FRANCISCO, 75 Fremont St.
LOS ANGELES, 307 S. Hill St.
SEATTLE, 1041 Sixth Ave., So.

★
Look for the
Red
Stripe

Offices and agents throughout
the world

Dilecto



NOW \$3.50 C.O.D.

Direct from factory to you

THE RABAT SENIOR 4200 MIL. AMPS. CAPACITY

FOR A LIMITED TIME ONLY

You can purchase for \$3.50 a 12 cell 24 volt RABAT SENIOR battery. Saving \$6.10 through direct buying. The Jobber and Dealers profit now is yours. 24 cell 48 volt size \$7.00.

Rabat Senior Batteries

are neat, powerful, noiseless and will harmonize with any Radio Set. Separate cells and patented rubber cork prevent current leakage and clear glass tubes give vision of the condition of battery. Heavy duty plates 3-16" x 1" x 2 1/4" with staggered ribbed grid form the backbone of this sturdy battery. Shipped completely charged ready for instant use. And you can save \$6.10 by ordering now.

RABAT JUNIOR BATTERY \$2.15 c. o. d.
(12 CELLS 24 VOLTS 1200 M. A. CAPACITY)

Incomparable in price and performance. Designed to satisfactorily operate sets equipped with 3 tubes or less. Constructed of the same high grade materials as used in our Senior battery. Shipped dry, uncharged. Order today and save \$1.81.

Rabat batteries can be recharged at home at a very low cost.

Rabat Super-Charger \$3.00 c. o. d.

Is specially designed to satisfactorily recharge any make of storage "B" battery. Shipped complete ready to use, including lamp socket, attachment plug and cord. You save \$1.80 by ordering direct.

SEND NO MONEY

But write us today, advising quantity and type wanted. After examining and approving these wonderful batteries then pay the Expressmar the small C.O.D. charges.

The Rabat guarantee is back of all our products. DON'T WAIT ORDER TODAY and save the middleman's profit.

THE RADIO RABAT COMPANY
1757 St. Clair Avenue, Cleveland, Ohio

★ Tested and approved by RADIO BROADCAST ★

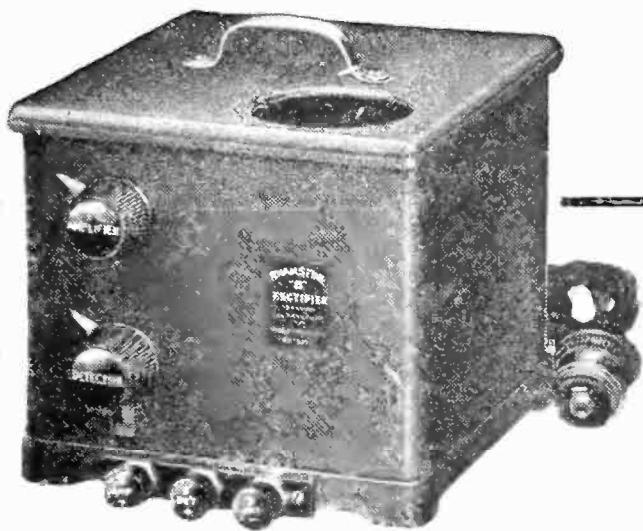

RHAMSTINE★

“B” RECTIFIER

Better than “B” Batteries

Only \$25

10 Advantages

- Low initial cost.
- Operating cost $\frac{1}{3}$ cent per hour.
- No hum or distortion.
- Operates on any set.
- No acid.
- Cannot burn out tubes.
- Perfect reception on local and DX stations.
- Simple to operate.
- Perfect control of detector and amplifier voltage.
- Small, compact and attractive in appearance.

Perfect control of “B” voltage to detector and amplifier tubes; elimination of snap and crackle due to chemical action in battery; a uniform, steady, never varying source of power—these are some of the reasons that make the Rhamstine* “B” RECTIFIER better than “B” batteries.

The “B” RECTIFIER plugs into any electric light socket of 110 to 120 volts, 60 cycle A. C. and rectifies it into direct current. Detector voltage may be varied from 0 to 50; amplifier voltage from 0 to 110. Operates efficiently on *any* tube set. Uses ordinary amplifier tube. It is so constructed that it cannot possibly burn out either the tubes in the “B” RECTIFIER or in your set. Has no hum—no acid.

Skillfully designed and made with finest parts obtainable to give years of steady, unflinching service. Transformer coils are of the latest, most approved type, accurately machine wound. Only select imported parts are used in the filter circuit to eliminate hum and assure a high degree of efficiency. It is small and compact—6 inches square—and has an attractive crystalline finish.

SEND NO MONEY

TAKE NO RISK

Use the “B” RECTIFIER on your own set, under any and all conditions. If it does not do everything claimed for it—yes, and a good deal more—if you are not entirely satisfied with it in every respect—return it and Rhamstine* will gladly refund your payment. This is the same hard and fast guarantee—the Rhamstine* guarantee—under which thousands of NEEDLEPHONES have been sold. Mail the coupon to-day—right now, before you forget!

J. THOS. RHAMSTINE★

Detroit, Michigan

PHILADELPHIA
1220 Vine Street

CHICAGO
218 S. Wabash Ave.

NEW YORK CITY
652 Broadway

Dealers Note

The Rhamstine* “B” RECTIFIER is the lowest priced, most efficient source of “B” current on the market. Write for dealer proposition before some one else gets it.

Mail this
Coupon
To-day

J. THOMAS RHAMSTINE*
506 E. Woodbridge St., Detroit, Mich.

Send me your “B” RECTIFIER by express C. O. D. subject to inspection, at \$25. It is distinctly understood that if I am not entirely satisfied, I will return it within 5 days and receive a refund of the full purchase price.

Name.....

Address

★ Tested and approved by RADIO BROADCAST ★

SUPPORTENA

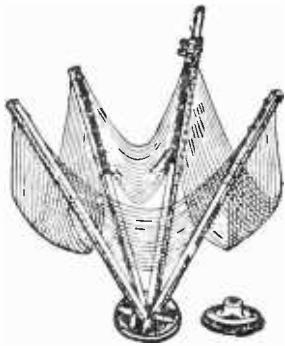
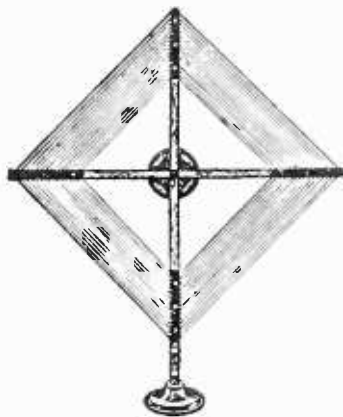

The final word in
FOLDING LOOPS

The Slider permits Tapping
at every one of the
16 Turns!!

\$9.00



Patent Applied for

ANY TUBE SET NOW MADE PORTABLE

Twelve different hookups showing how to use it, with
different types of receivers.



Perfected by Radio's Master Loop Craftsmen.

571 HUDSON ST. J. NAZELEY CO. NEW YORK

**For Push-Pull
Take No Chances!
Use "Como Duplex"**

The World's standard for Push-Pull amplification. Como Duplex Transformers are being specified continually by practically all leading Radio Editors and Authors of Radio subjects. This is because they know that the user will get results. Why not take their advice?

The new form of assembly takes up less room in your set.

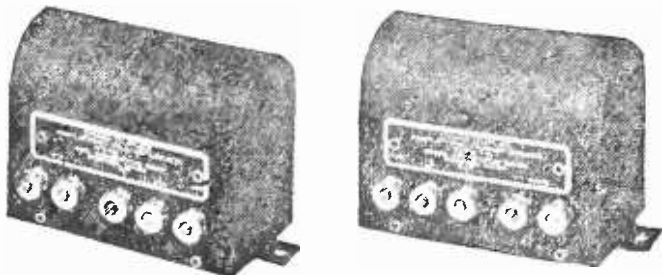

Price \$12.50 per pair

COMO APPARATUS CORPORATION
Manchester New Hampshire



— THE LAMBSKIN LIBRARY —
95 cents per volume
Doubleday, Page & Co. Garden City, New York

Burns The Perfect Reproducer

Tone loud and pleasing
Handsome material and design
Black—\$22.50 Shell—\$25.00

AMERICAN ELECTRIC COMPANY
State & 64th Sts. Chicago



At your dealer
50c



LOCK Your Set!

with this compact
—noiseless—shock-
proof and easily in-
stalled BATTERY
SWITCH.



WALBERT LOCK SWITCH



WALBERT MFG. CO., CHICAGO

★ Tested and approved by RADIO BROADCAST ★

DUPLEX CONDENSERS

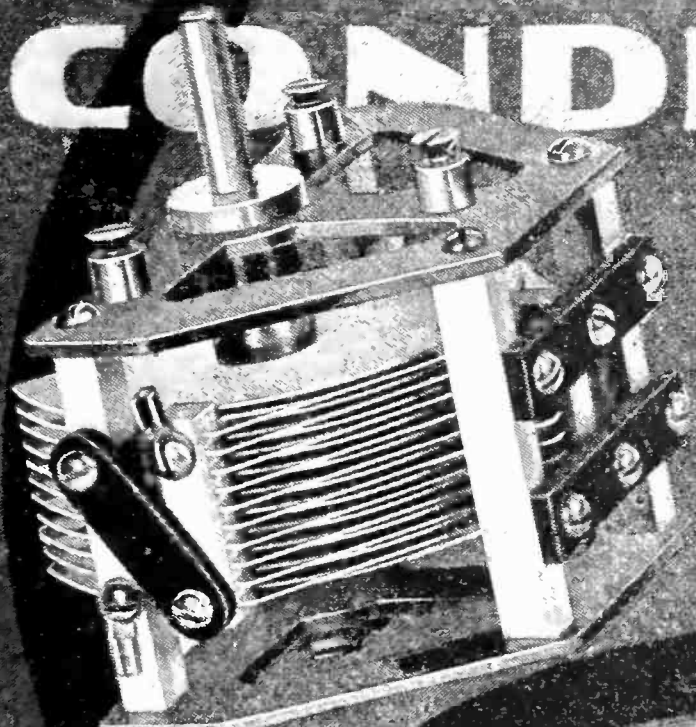

**DUPLEX
STANDARD**

★
The Accepted Standard

DUPLEX Standard Condensers (Series FR) have attained a generally recognized supremacy. They are especially designed to conform to Bureau of Standards specifications for lowest losses and best electrical characteristics. Bearings are brass on bronze, with automatic take-up at both ends. Four heavy metal posts further insure perfect alignment. Plain and vernier models both are unconditionally guaranteed to give absolute satisfaction.

A DUPLEX KIT of Matched Condensers Affords Uniform Dial Settings



The discriminating parts buyer will appreciate this latest DUPLEX innovation! *Matched Condensers*—packed three in a kit—specially tested and guaranteed! Uniform dial readings and simplified logging are possible only with DUPLEX Matched Condensers in tuned Radio frequency, Neutrodyne, and similar circuits. Don't just buy three condensers—insist on DUPLEX Matched Kits! Instructive literature sent on request.

Duplex Condenser & Radio Corp., 50 Flatbush Avenue Extension, Brooklyn, N.Y.

Best At The Price

DUPLEX Junior Condensers (Series DR) will give you the same satisfactory service that you get from other, higher-priced condensers. True, they are not quite so fine an instrument as is the DUPLEX Standard—but they are better than any other condensers at the same price. *DUPLEX Junior Condensers*, plain or vernier models, are particularly suitable for use in portable sets as they are extremely small and are light in weight.

**DUPLEX
JUNIOR**

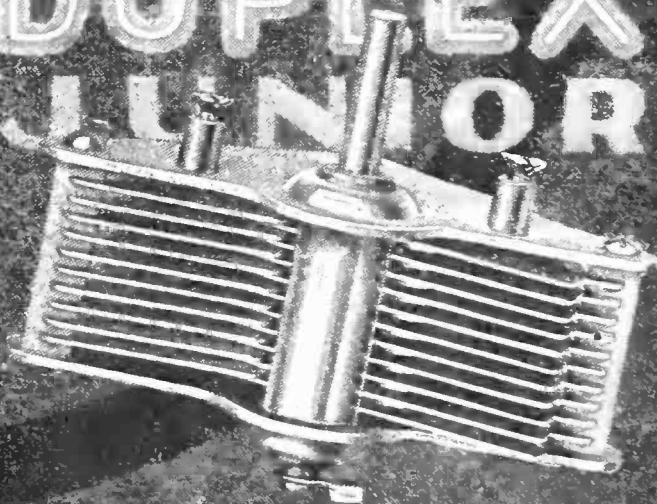

★ Tested and approved by RADIO BROADCAST ★

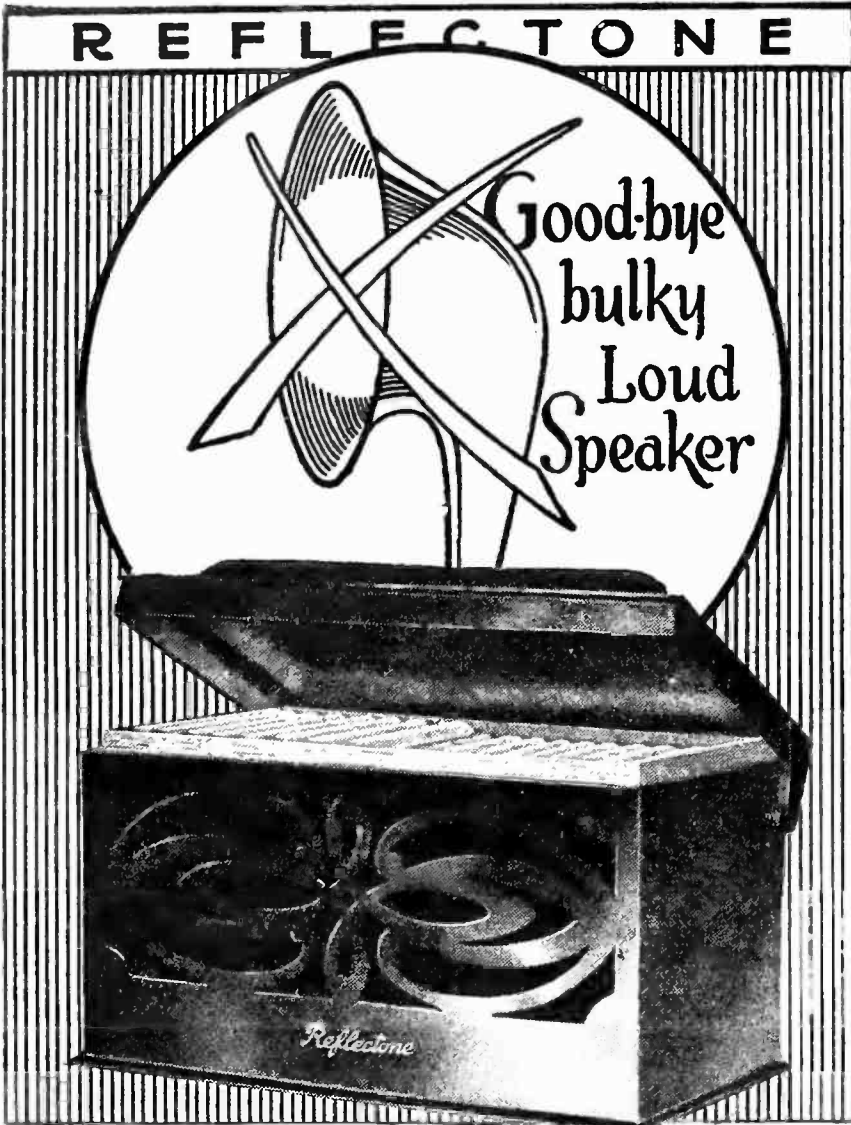

Reflectone

"only 4½ inches high"
Cigarette Box Amplifier

GIVES clear, full, natural reception of anything on the air . . . and offers an added convenience—a cigarette box! Place this amplifier—remarkable, small and attractive—on the smoking stand, in your library, anywhere, as an ornament . . . then tune in!

By a new scientific development, tone is reflected from one tonal chamber of Model "C" Reflectone to another. Vibration is neutralized, the faintest sound reflected—no note is added, none destroyed.

\$12⁰⁰



The Midget Loud Speaker
With the Giant Voice

At your dealers, otherwise send purchase price and you will be supplied postpaid. Write for descriptive circular.

RICE & HOCHSTER

132 Washington Place

New York City

NO REFLEX COMPLETE
WITHOUT CELERUNDUM COMPLETE



DE-TEX-IT

Complete \$1.25

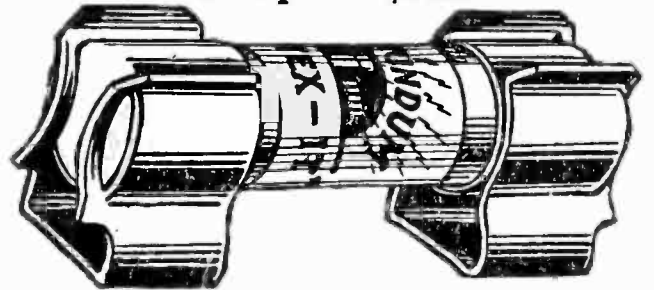

A low loss positive contact
Fixed Detector

Requires no adjustment. Cat whisker troubles eliminated. Will not burn out.

Best for Reflex
Power-Tone-Volume

Jobbers write for samples and discount

Celerundum Radio Products Co.
70-78 Woodbine Street, Wollaston, Mass.

JUDGMENT OF THE STORM

By Roy Mason

A novel written from the photoplay of Ethel Styles Middleton which has been produced by the Palmer Photoplay Corporation. \$1.50.

Doubleday, Page & Co., Garden City, N. Y.

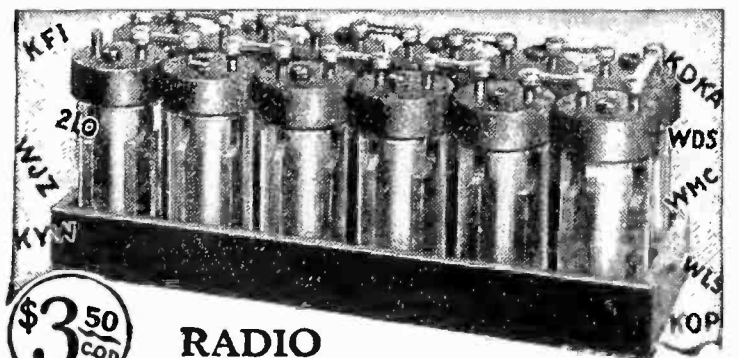

\$3⁵⁰
24 Cells

RADIO Storage "B" Battery

12 Cells 24 Volts **Lasts Indefinitely—Pays for Itself**

Economy and performance unheard of before. Recharged at a negligible cost. Approved and listed as Standard by leading Radio Authorities, including Pop. Radio Laboratories, Pop. Sci. Inst. Standards, Radio News Lab., Lefax, Inc. and other important institutions. Equipped with *Solid Rubber Case*, an insurance against acid and leakage. Extra heavy glass jars. Heavy rugged plates. Order yours today!

SEND NO MONEY Just state number of batteries wanted and we will ship day order is received. **Extra Offer:** 4 batteries in series (96 volts), \$13. Pay expressman after examining batteries. 5 per cent discount for cash with order. Mail your order now!

WORLD BATTERY COMPANY

1219 So. Wabash Ave., Dept. 78, Chicago, Ill.

Makers of the Famous World Radio "A" Storage Battery
Prices: 6-volt, 100 Amp. \$12.50; 120 Amp. \$14.50; 140 Amp. \$16.00.
All equipped with Solid Rubber Base.

World FOR **RADIO**
STORAGE BATTERIES



KDKA - WFAF - WGN - WJS - KHJ - KGO - KFAF - WJY - KOP

★ Tested and approved by RADIO BROADCAST ★

MARWOL

BABY GRAND
FIVE TUBE TUNED RADIO FREQUENCY

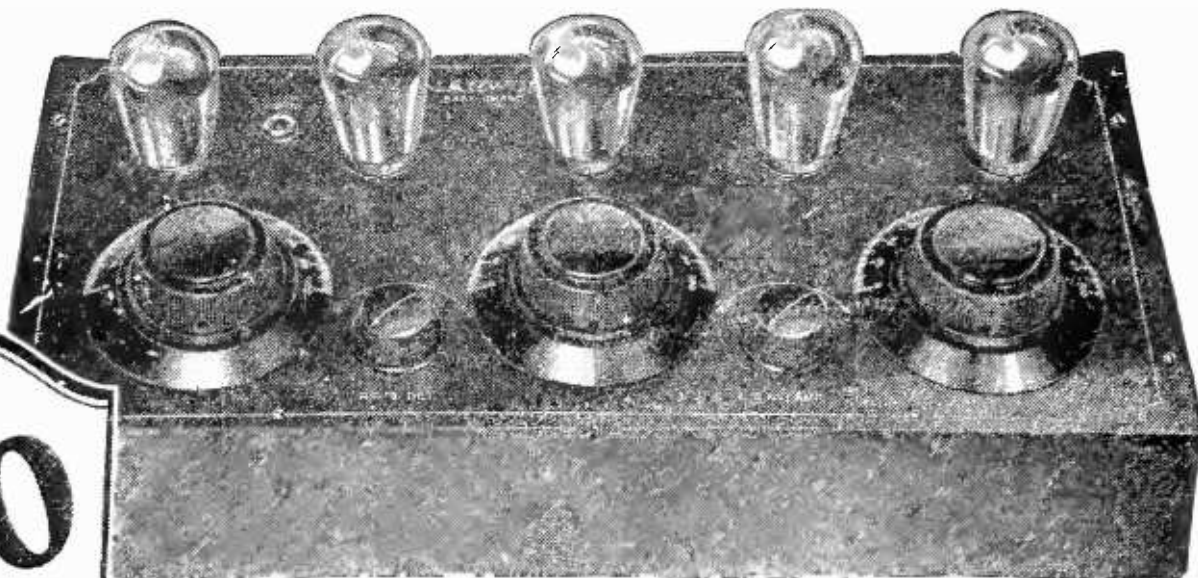

\$40

At Last—

A Guaranteed Set Price Beyond Comparison

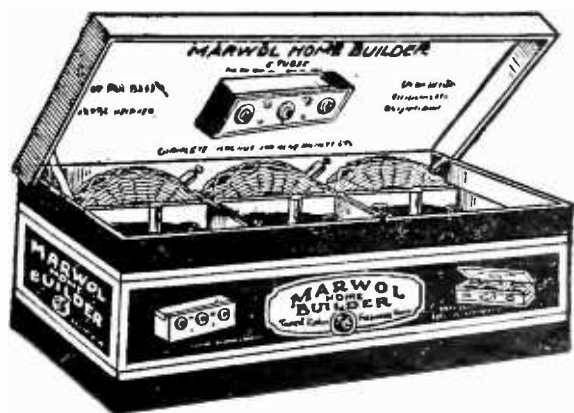

Marwol Home Builder

includes three condensers, three radio frequency coils, complete layout of front panel, sub panels and wiring diagram,

\$15.00

The remarkable success of the Marwol Circuit as incorporated in the Marwol Model A-1 is so great that it has made possible a Baby Grand Marwol. This identical famous circuit is now available in a different unique design—a great departure from the conventional model—at considerably lower cost!

The Marwol Baby Grand is a 5-Tube Tuned Radio Frequency Receiver which differs from the original Marwol only in design! Offers the same remarkable selectivity and range, with ease of operation, that makes the Marwol to-day's best radio buy for the money!

Write for descriptive folder. At your dealers—otherwise send purchase price and you will be supplied postpaid.

MARWOL RADIO CORP.

85-G Mercer Street

New York

DOLLAR FOR DOLLAR RADIO VALUE

★ Tested and approved by RADIO BROADCAST ★

Morrison

Loud Speaker Unit

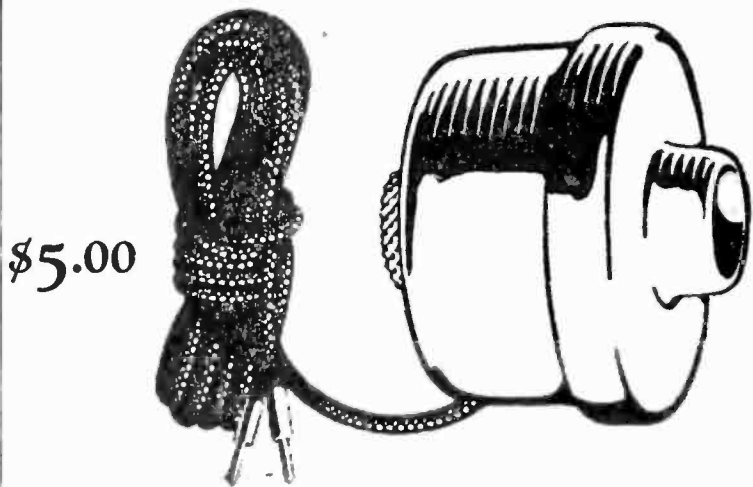

\$5.00

Volume - Tone

The Best in Radio

Every set reaches its maximum performance when it reproduces through a Morrison Unit. Volume on long distance work and the Marvelous Morrison tone quality are unmatched. Thousands of Morrison owners from coast to coast know this.

Of all the elements in radio receiving there is one you can be certain of—buy a Morrison and you've got the best reproducing unit you can buy. Use it indefinitely—it's built to stand long service.

Morrison is an adjustable unit.

Ask for our booklet on Loud Speaker Facts ★

On sale at all good radio and phonograph dealers.

Mail orders shipped promptly from factory.

Morrison Laboratories, Inc.

347 E. Jefferson Ave. Detroit, Mich.

BROWNLIE VERNIER DETECTOR

PATENT PENDING

FOR REFLEX OR CRYSTAL SETS

Best Reflex Crystal Detector

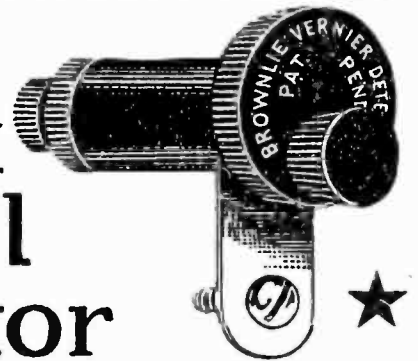

Says the **Acme Apparatus Co.**

No longer does the whisker scratch the crystal, or is the sensitiveness killed by heavy spring pressure—the Vernier Regulator takes care of that. It will surprise you to know how sensitive Crystal Detectors are when correctly made.

For Panel or Base Mounting including Crystal. Guaranteed **\$2.00**

At your dealers, otherwise send purchase price and you will be supplied postpaid.

ROLAND BROWNLIE & COMPANY
20-24 Saunders Street Medford, Mass.

"EAGLE" All-Metal Radio Towers ★

Adjustable to fit any Type of Roof

Get better reception with a good outside Aerial. Long distance sets, including ships at sea use the best possible Aerial. Eagle Radio Towers are handsome and sturdy. We ship on a money back guarantee. Ask your dealer or write us for literature.

J. R. BURRELL COMPANY
714 Cambridge Avenue, Dept. 16, Milwaukee, Wis.

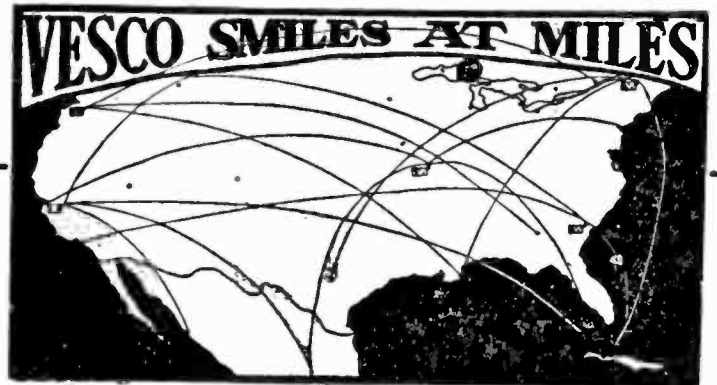

ON ONE TUBE

BIG FREE BOOKLET tells the story. California users of **CROSS COUNTRY CIRCUIT** hear Atlantic Coast. Canada, Cuba, Mexico, and Hawaii. Atlantic Coast users hear England to California. Our new plan makes this set easiest and cheapest to build. One hour puts in operation. One tuning control. No soldering. Any Novice can do it. **BIG BOOKLET FREE** or complete instructions for 25c stamps or coin.
VESCO RADIO CO. Box RB-117 Oakland, California

★ Tested and approved by RADIO BROADCAST ★



Everyone Interested in RADIO Should Write for this FREE Radio Book

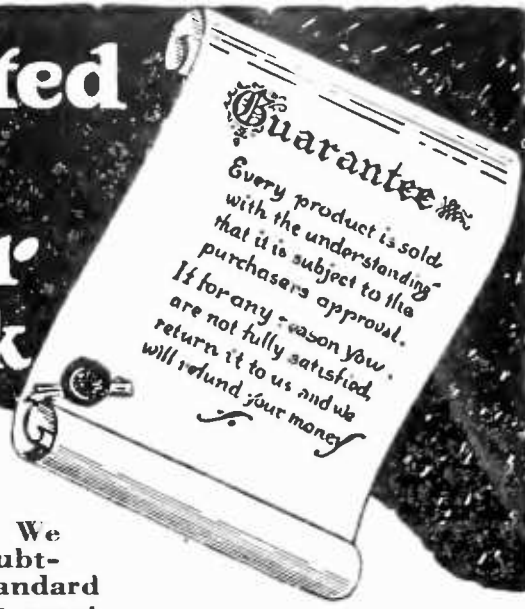

EVERY article sold by "WRS" must measure up to the highest standard of quality before it is offered to our customers. We

Guarantee every piece of radio equipment we sell. We have carefully avoided untried radio goods of doubtful merit; and the parts included in our kits are standard and known as strictly high grade. By purchasing in great

quantities direct from the manufacturer we are able to quote you prices

which mean a great saving over the usual cost of parts for good radio sets. Large stocks are carried at all times and we give you our usual PROMPT TWENTY-FOUR HOUR SERVICE on all orders for knock-down sets and parts.

Roberts New 6-Tube Receiver

With Resistance Coupled Amplification

Cockaday (8-Tube) Super-Heterodyne Reflex Receiver

- | | |
|--|--|
| 1 General Instrument .00051 mfd. NO LOSS with Insulantite Insulation | 2 Daven Resistors .25 meg-ohm (250,000 ohm) |
| 1 General Instrument .001 mfd. NO LOSS with Insulantite Insulation | 2 New York Mica Condensers .0001 mfd. |
| 1 Haynes Griffin input Transformer (new type) | 4 New York Mica Condensers .006 mfd. |
| 3 Haynes Griffin Intermediate Transformers (new type) | 1 New York Mica Condenser .00025 mfd. with grid leak mounts |
| 1 Precision Autodyne Coupler | 1 Duratran Radio Frequency Transformer |
| 1 Karas Harmonik Audio Frequency Transformer | 1 Walbert "A" Battery Switch |
| 1 Amplex Grid-denser | 7 Eby Marked Binding Posts |
| 1 Benjamin Cleartone Socket | 1 7 x 24 drilled and engraved Bakelite mirror-finished panel |
| 7 Federal Sockets No. 16 | 1 Mahogany Baseboard |
| 1 Pacent Double Circuit Jack | 1 Drilled binding post panel |
| 1 Pacent Single Circuit Jack | 1 Box assorted screws, nuts, washers, lugs, etc. |
| 2 NA-ALD 4 inch Dial | 40 feet of extra heavy No. 12 tinned bus bar wire |
| 1 Amsco Rheostat 2 ohm | 1 Set of angle brackets for mounting post panel |
| 1 Amsco Rheostat 400 ohm | 1 Special Cockaday bracket for mounting Amplex gridenser |
| 2 Daven Resisto-Coupler Mounts | 1 Set of three Popular Radio blue-prints covering complete constructional details for building this receiver |
| 1 Daven Grid Leak Mounting | |
| 2 Daven Resistors .5 meg-ohm (500,000 ohm) | |
| 1 Daven Resistor .5 meg-ohm | |
| 1 Daven Resistor .005 megohm (5,000 ohm) | |

OUR KIT PRICE, POSTPAID, \$65.00

Cockaday 8-Tube Super-Het built in beautiful piano hinged mahogany cabinet of the parts as listed above—guaranteed to be wired in accordance with Mr. Cockaday's specifications. Postpaid, \$99.50

FREE

80 page Catalogue just off the press. Dozens of sets and hundreds of parts described.

Quick Shipment

Goods subject to examination before acceptance if desired. We pay transportation to any P. O. or Shipping point in U. S. No money in advance unless you prefer to send with order. Letters answered quickly and intelligently. Radio questions answered free. Send Money Order or Pay Postman.

Complete Parts for Roberts 6-Tube Set Exactly as Specified by Radio Broadcast.

- | | |
|--|---|
| 2 Cardwell or General Instrument low loss condensers .0005 | 2 Daven resistors .05 |
| 6 Federal standard sockets | 1 Daven resistor .0005 |
| 1 Amertran 5:1 ratio Transformer | 1 Mica fixed condenser .0025 mfd. |
| 3 Federal single filament control jacks | 2 Mica fixed condensers .00025 mfd. |
| 3 Eztoon 4 in. vernier dials | 1 Neutralizing condenser |
| 1 Set of Nazeley or Sickle coils low loss | 1 Bakelite mirror polished, drilled, and eng. panel 7 x 27 x 3-16 |
| 4 General radio rheostats | 1 mahogany stained baseboard |
| 1 General Radio Switch and points | 2 special bakelite drilled binding post panels |
| 4 Daven resisto coupler mountings | 4 special brass brackets for mounting post panels |
| 4 Mica fixed condensers .012 mfd. | 40 Feet of extra heavy tinned bus bar |
| 1 Mica fixed condenser 1. mfd. | 8 Initialed Eby binding posts |
| 4 Daven resistors .1 | 1 Box of all necessary screws, nuts, washers, lugs, etc. |
| 1 Daven resistor .5 | |
| 1 Daven resistor .25 | |

Complete Kit, Price Postpaid \$65.00

If desired with 0-50 Weston Milliampere Meter \$7.50 extra

Roberts 4-Tube Knock-Down Set \$42.50

For complete List of Parts see our other "ad" in this issue

5-Tube Neutrodyne Set with Genuine Fada Neutroformers and Complete High Grade Parts \$39.50

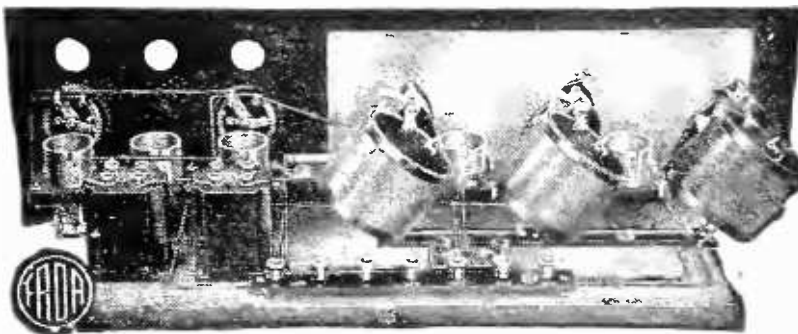

- | | |
|--|---|
| 1 Fada Neutrodyne kit, consisting of 3 Fada New Type neutroformers mounted on a new type Fada Low Loss condenser | 1 Amsco 20 ohm rheostat |
| 2 Fada Neutrodons | 2 Jefferson shielded audio transformers |
| 1 7x26 drilled and Engraved panel | 1 Baseboard |
| 1 Baseboard | 1 Metal shield |
| 3 4 in. Fada type dials (bakelite) | 30 ft. of tinned bus bar wire |
| 1 Pacent double filament control jack | 1 Dubilier .00025 mica grid condenser |
| 1 Pacent single circuit filament control jack | 1 Tubular certified grid leak |
| 2 Single "WRS" Bakelite double contact panel mounting socket | 1 drilled and engraved bakelite terminal block |
| 1 Triple "WRS" Bakelite double contact panel mounting socket | 7 Fada binding posts |
| 1 Amsco 6 ohm rheostat | 1 Dubilier by-pass condenser |
| | 1 Box of assorted screws, lugs, terminals, etc. |
| | 1 Fada book of instructions and schematic blue prints |

OUR KIT PRICE, POSTPAID, \$39.50

This Receiver built in solid mahogany cabinet, completely wired ready for use without tubes or batteries

POSTPAID, \$62.50

WHOLESALE RADIO SERVICE CO., Dept. R. B., 9 Church St., N. Y. C.

★ Tested and approved by RADIO BROADCAST ★

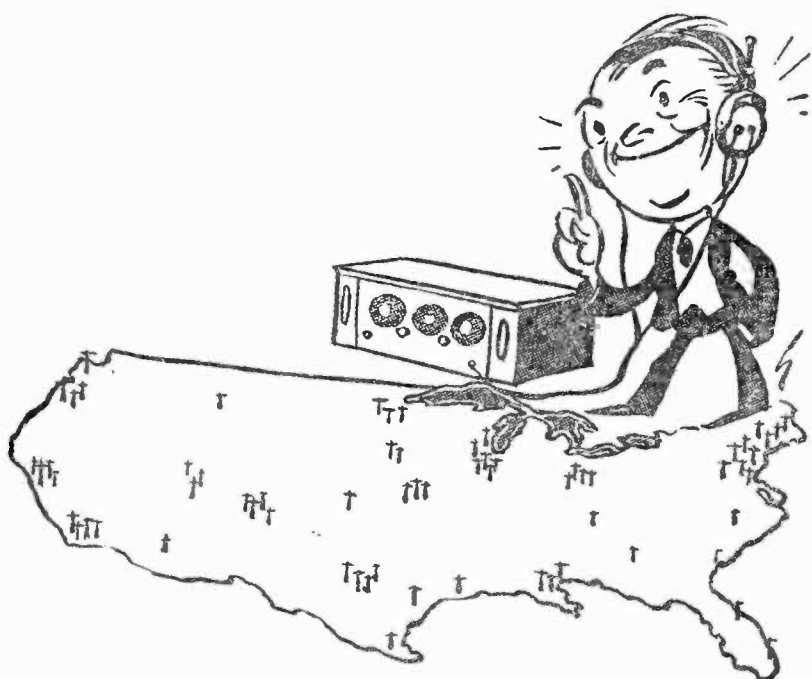

We've Mapped the Air for Radio Explorers!

Get your copy of this great new map to-day

TWIST the dials until you catch a faint hum. Nurse it carefully until it becomes a murmur of distant music. Then a moment of silence.

"This is station KFAF, Denver,"—and you add another station to your list.

But how far away was it? What sort of country did the message flash over? You want to visualize your exploit and mark it for future reference.

You can—with the New Collier Radio Map of the United States and Canada. It's beautifully printed in three colors. Every station is clearly marked and the time zones outlined.

Instantly you can tell how many miles away a station is. Cut out the scale of miles provided and paste it on cardboard. Put a pin through one end at the point where you are located. Swing the other end across the country until you reach the station you are after.

Here are some more points worth noting:

1. If you use a directional aerial, you can pick out any station you want to get on the map, and point the loop towards the exact point where the station is located.
2. Around the map there is an alphabetical list of all stations which also gives the name of the operator of each. If you miss the letters given by an announcer, you often catch the name of the operator of a station which can then be located by referring to the index.
3. The map outlines the boundaries of the radio districts, identifying them by number. This will be a help in locating amateur stations.

There's a lot of satisfaction in radio exploring with this great new map. And it costs only a quarter. Get your copy at your news stand, bookstore, or radio dealer's *to-night*. Or just mail 25c in coin or stamps with your name and address to us direct.

P. F. COLLIER & SON CO.
Dept. R. M., 250 Park Ave., New York City

ACH TUNING INSTRUMENT Using Expensive WORM GEAR

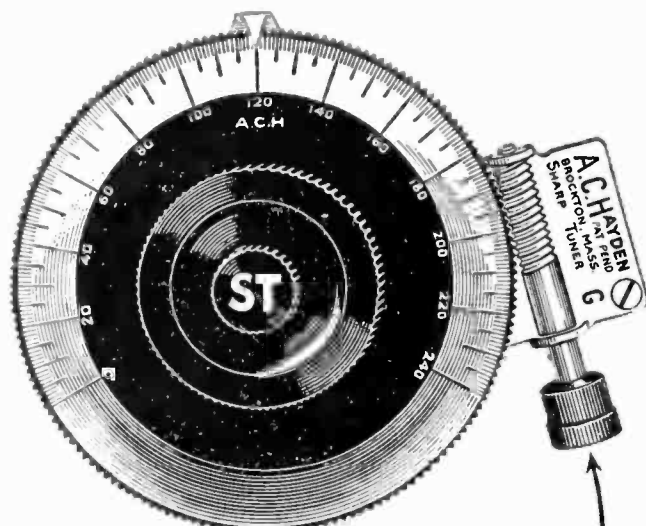

Why the A.C.H. is different

3 in. DIAL → A.C.H. → 156-t0-1

4 in. DIAL → A.C.H. → 215-t0-1

Price 3-inch size.....\$2.50 Price 4-inch size.....\$5.00
Regular fitting 5/16 shaft. 1/4 and 3/16.....5c each extra

The expensive worm gear is a type of gear in a class by itself. Ask for the

WORM GEAR

A new way to spell
SELECTIVITY—WORM GEAR

A WORM GEAR HAS NO SUBSTITUTE OR OTHER NAME

Mail orders—prepaid U.S. A.—if not at dealers

A. C. HAYDEN RADIO & RESEARCH CO.
BROCKTON, MASS., U. S. A.

Let the non-directional

Thor Speaker Lamp

[Patents Pending]

bring in your Radio programs and furnish light at the same time. Many models—many styles—parchment or any color silk shades.

Table lamp models \$35.

At your dealers—or delivered.

★ **THOR Radio Division**
of the Golden Gate Brass Manufacturing Co.
1239-1243 Sutter St., San Francisco, Cal. (125)

The TWIN-AUD



consists of *two audio transformers* combined in *one unit*. Intercoupling howls and squeals are entirely eliminated. Maximum volume and clearer reproduction result from its two stages of **BALANCED** audio amplification.

List Price \$9.50

AT ALL GOOD DEALERS

PEERLESS RADIO CORPORATION
Newton Lower Falls Boston, Mass.

For Those New Low Wave Lengths

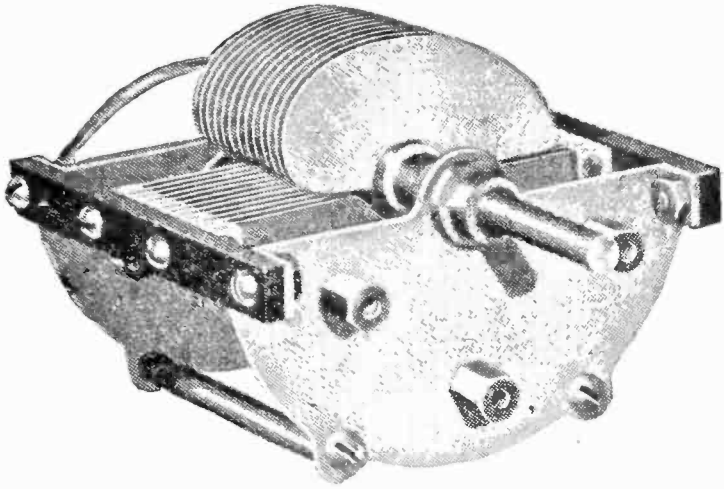

"The most difficult problem in radio regulation and development is the distribution of wave length use so as to prevent interference between stations. There are in all eighty-six different wave lengths available if we keep the stations ten kilocycles apart and stagger the assignment of wave lengths geographically so as to prevent overlap in the area of effective reception."

Herbert Hoover

THE NEW ~~CONTINENTAL~~ SEPARATOR

is all that its name implies—a condenser that successfully separates stations whose wave lengths differ only a fraction of a meter. With the increase of broadcasting stations and the adoption of narrower wave bands, old type condensers cannot possibly give efficient reception.

Mr. Arthur Lynch recommends Continental Condensers for efficient results on Radio Broadcast's Knock-out Circuit

LIST PRICES

Plate	Capacity	Price
13	.00025	\$4.50
18	.00035	4.75
25	.0005	5.00
45	.001	6.00

Continental JUNIOR Vernier Condenser

11 Plate .000022 Capacity, \$1.50 individually

With Separator \$1.00 more. All capacities are exact

Official tests show the Continental to have the following characteristics:

at 1,000,000 cycles—Resistance .8 ohm—Phase angle 12 min. (Large Eastern Univ. Lab. Test.)
When tested at 1,000 cycles and converted, losses are less than .1 ohm (Radio News Test)

If your dealer cannot supply you—Write us direct

GARDINER & HEPBURN, Inc.

Sales Dept., 611 Widener Bldg., Philadelphia, Pa.

Two condensers for the price of one!

Continental Separator and Continental Junior are sold together for a price which is no more than you would pay for any individual low loss Condenser. Complete connections and instructions are furnished.

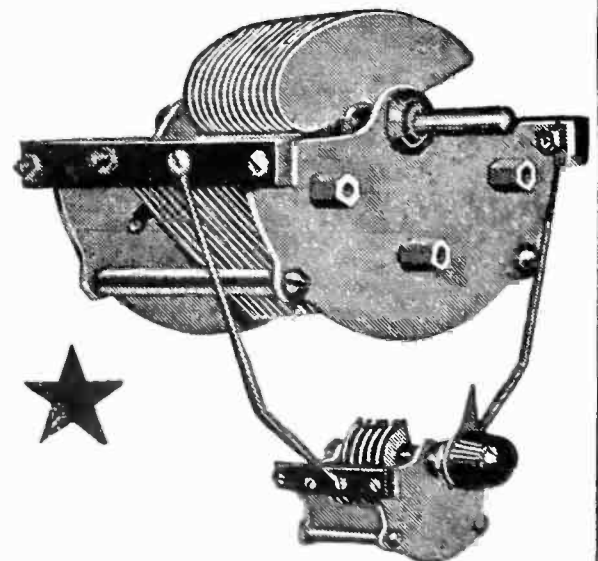

★ Tested and approved by RADIO BROADCAST ★

THE SUPERUNIT

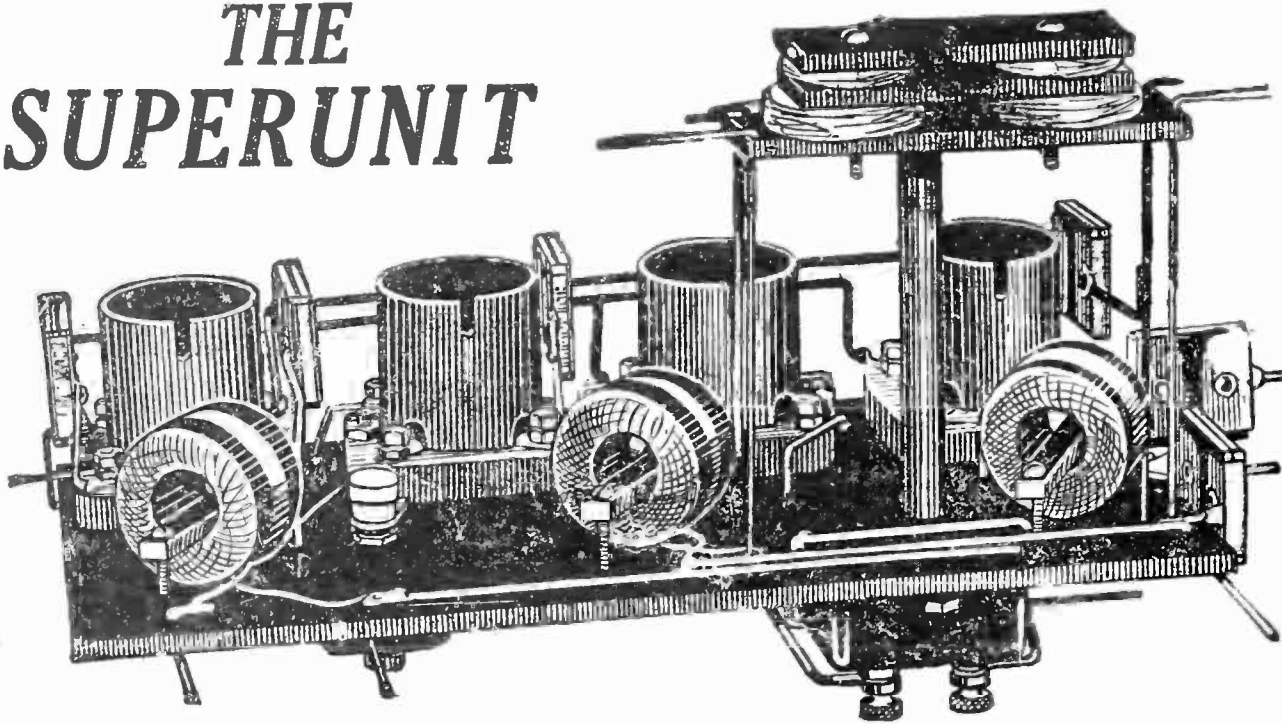

Type A for Standard Base Tubes \$37.50.
 Type B for 199 tubes \$37.50
 All the parts, including the "SUPERUNIT," to construct a 6 tube set, with drilled panel and base and complete instructions \$75.00.

Why not use some of those extra parts which you have? With the "SUPERUNIT" you can build a 6 tube Superheterodyne and the only other parts required are tuning condensers, rheostats and one or two stages of audio frequency. The set has ample volume on a loop and is ideal for reception during the coming static season.



ALLAN T. HANSCOM

WOONSOCKET,
RHODE ISLAND

The most distant stations are heard

With Myers Tubes you can get virtually every station on this continent and elsewhere. England, France, Cuba, Hawaii, Porto Rico, Japan are being heard daily with one, two or three Myers Tubes.

They are noise free—locate stations easily—clear reception—and are interchangeable. Each Myers Tube passes 49 separate and individual tests. Each is actually tested for reception.

Three types for dry and storage batteries. All ready to mount. At your dealer's or sent postpaid for.....

\$4

251 Craig Street, Montreal 10

Myers Tubes

Practically Unbreakable

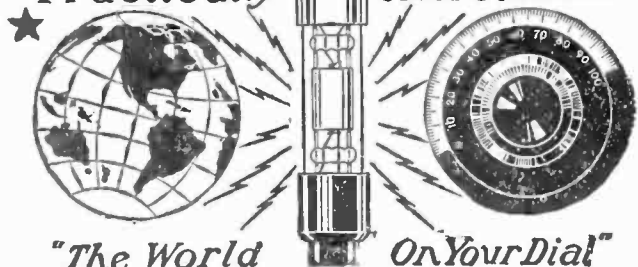

"The World On Your Dial"

Write for descriptive circular

PATENTS Secured Trade Marks Registered Radio Inventions A Specialty Write Us

MASON, FENWICK & LAWRENCE
 Patent and Trade Mark Lawyers
 Washington, D. C., New York, Chicago
ESTABLISHED OVER 60 YEARS

References: National Confectioners' Association, Chicago
 National Canners' Association, Washington, D. C. Life Savers Inc., Port Chester, N. Y. Bon Ami Co. and U. S. Cigar Co., New York City. Hershey Chocolate Co., Hershey, Pa. Stephen F. Whitman & Son, Philadelphia, Pa., and many others



JEWELL No. 55

Is a flush mounting panel instrument with a self contained multiple switch whereby double and triple reading can be obtained with but the one instrument.

Ideal for keeping check on "A" and "B" battery voltages from panel of your set.

Send for our 15-A Catalogue.

Order from Dealer

Jewell Electrical Instrument Co.
 1650 Walnut St. - Chicago

★ Tested and approved by RADIO BROADCAST ★

IT IS SO EASY TO BUILD WITH INSULINE

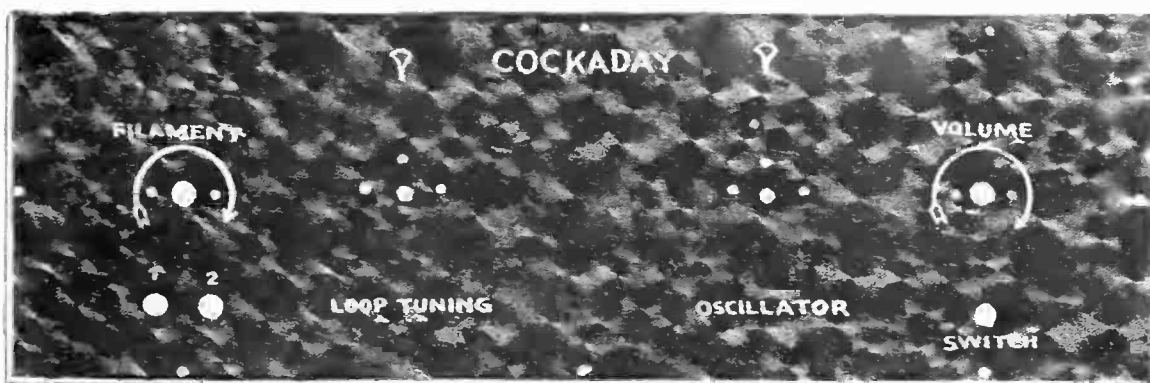

Ready
Drilled
and
Engraved
Panels
for
All Popular
Circuits

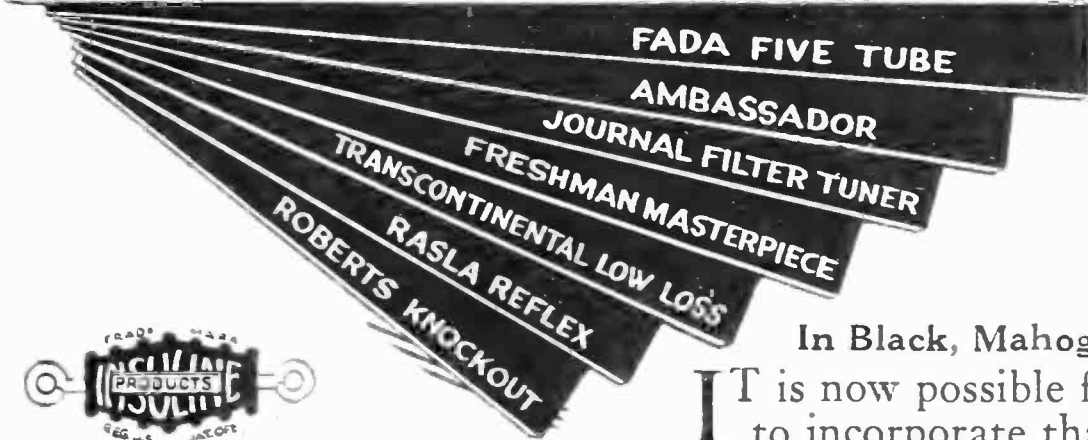

FANS Are Earning Real Money

Many radio fans are cashing in on their radio knowledge by building sets for people in their community.

We are preparing a new booklet showing how you can turn your spare time into real money by becoming a professional set builder in your community.

Send us your dealer's name and address together with your own, and we shall be pleased to mail you a copy of this booklet when it is ready.

In Black, Mahogany and Frieze Finish

IT is now possible for every radio set builder to incorporate that factory finished appearance in every one of his home made sets.

In answer to an insistent demand for a good looking panel that will fit in with amateur made products we prepared a complete line of ready drilled and engraved panels for most popular circuits in demand to-day. These panels are finished with the same factory precision and neatness that is usually found in extremely high priced factory made sets.

Insuline ready drilled and engraved panels are extremely low in price compared to drilling and engraving your own product, and it would never have that finished appearance. Insuline is stocked in standard sizes and also cut to order. Send for our complete list of Insuline drilled and engraved panels and save money.

Largest plant in the country for drilling and engraving to customer's specifications on large or small orders.



RADIO PANEL and PARTS CORP.

(INSULATING COMPANY OF AMERICA)

59 Warren Street

Insuline Bldg.

New York City

Western Division

Insulating Company of America
Madison, Wisconsin

538 So. Dearborn Street, Chicago, Ill.

Sales Representative for Ohio and Mich.

F. A. Krue, Jr.
333 State Street,
Detroit, Michigan

For Pennsylvania

Paragon Electric Sales Co.
134 No. 7th Street
Philadelphia, Pa.

★ Tested and approved by RADIO BROADCAST ★



★
The
Successful
Link

DULCE-TONE is the only unit which perfectly adapts the original "balance" of the talking machine's reproducer to radio.

Large volume sales by dealers everywhere *prove Dulce-Tone's success.*

Retail Price \$10.00
(In Canada \$14.00)

The
Teagle Company
1125 Oregon Avenue
Cleveland, Ohio

Canadian Distributor:
The Otto Higel Co., Ltd.,
Toronto.

Dulce-Tone

The
Quiet NILES

Battery Charger

Costs Less Per Charge
A vibrator charger built on a new principle. Takes less time and costs less to operate—because it converts 72% of current into battery charge. Charging rate (8 to 10 amp.) automatically controlled. Model A for 6-volt batteries, \$19.00; Model AB for 6-volt and 24-volt batteries \$21.00. West of Rockies, \$1 extra. ★
Ask Any Radio Dealer
NILES MANUFACTURING CO.
Dept. 84 Ypsilanti, Mich.

**GILFILLAN NEUTRODYNE
SETS — KITS — PARTS**

Made in our three Radio factories with years of Radio experience behind them.
Send for Literature
GILFILLAN BROS. INC. ★
1815 W. 16th St., Los Angeles, Calif.
KANSAS CITY NEW YORK
2525 W. Penn Way 225 W. 57th St.

★

**FROST-RADIO
MUSSETTE**

Phonograph Attachment
CONVERTS your present phonograph into loud speaker. Pure, clear tone, and faithful reproduction of voice and music insured. Order from your dealer.

Frost Radio
List price, complete with cord as shown... **\$5.50**

MEMBER
RMA

HERBERT H. FROST, Inc.
314-324 WEST SUPERIOR STREET, CHICAGO
NEW YORK CITY CLEVELAND KANSAS CITY LOS ANGELES

★ Tested and approved by RADIO BROADCAST ★

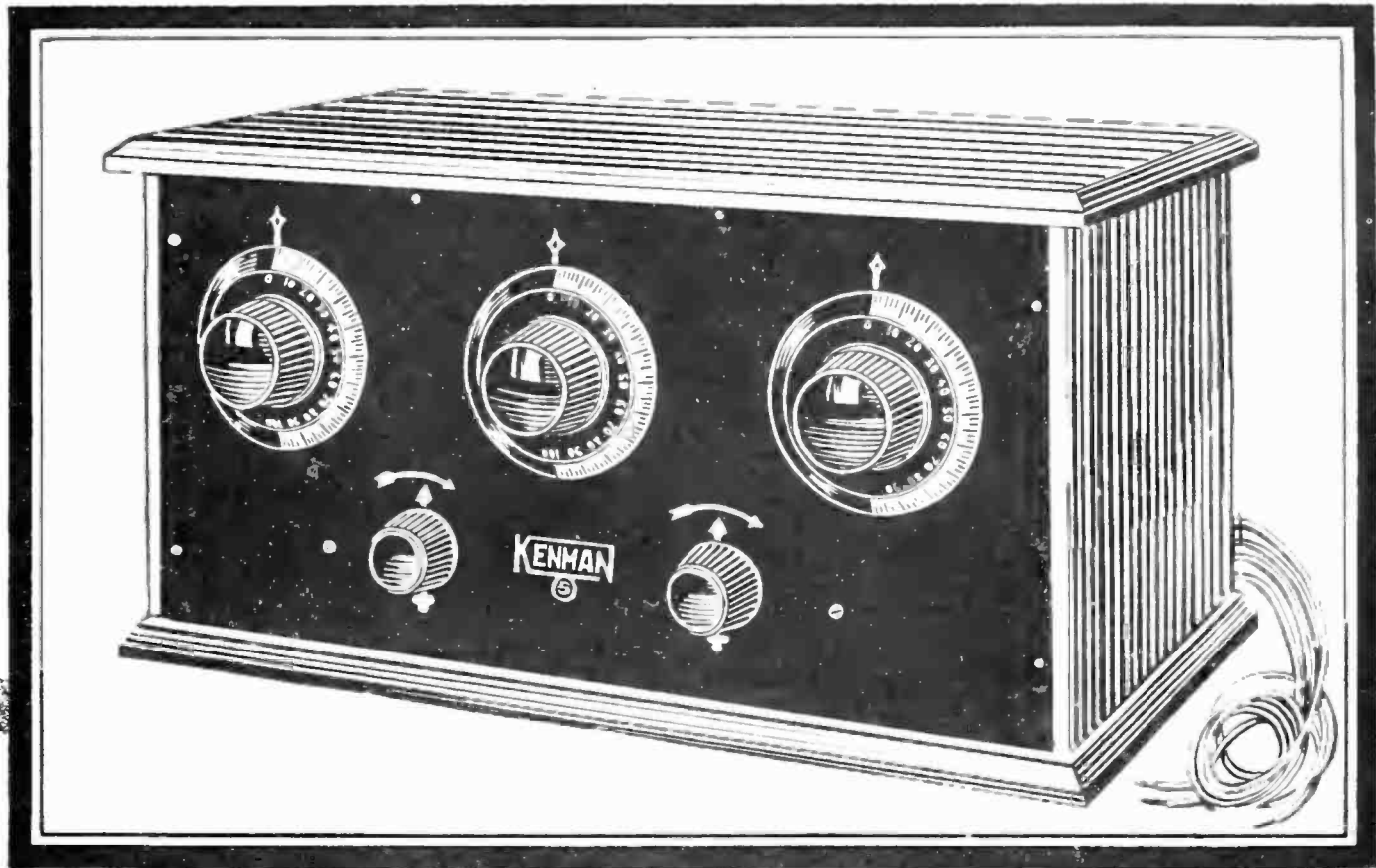

KENMAN

5

THE 1925 Wonder Receiver—a five tube set with two stages of radio frequency, detector and two stages of audio. The KENMAN 5 is very selective in its operation and very sensitive to incoming signals. It tunes on all wave bands from about 220 to 550 meters and logs perfectly.

DISTANCE with VOLUME plus CLARITY are the other outstanding features of the KENMAN 5. No trouble whatever should be experienced in separating local high-power broadcasting stations. Distant stations come in with volume and clarity.

DISTRIBUTORS AND DEALERS
Write or wire for particulars

Manufactured by the

KENMAN ELECTRIC CO., Inc.
454 Merrick Road Lynbrook, Long Island, N. Y.



★ Tested and approved by RADIO BROADCAST ★

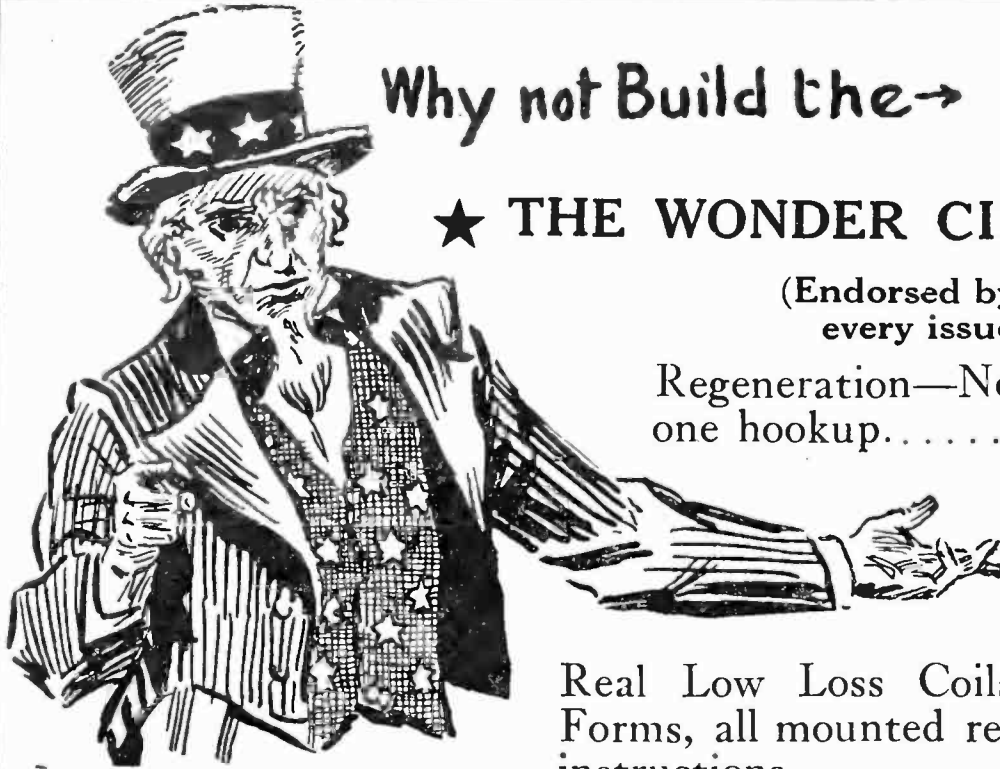

Why not Build the →

ROBERTS

(Trade Mark)

★ THE WONDER CIRCUIT OF THE YEAR

(Endorsed by Radio Broadcast in every issue since April, 1924)

Regeneration—Neutralization—Reflex combined in one hookup.....\$8.00

Easy to build with the genuine **NAZELEY ROBERTS UNITS**

Real Low Loss Coils, wound on Celoron Bakelite Forms, all mounted ready for installation, with building instructions.

The only coils officially approved by **Walter Van B. Roberts, E. E., Ph.D.**

Complete kits 2 tube \$53. with Portena Loop \$60.
4 tube 70. " " " 77.

571 Hudson St.

J. NAZELEY

New York

Sole Manufacturer

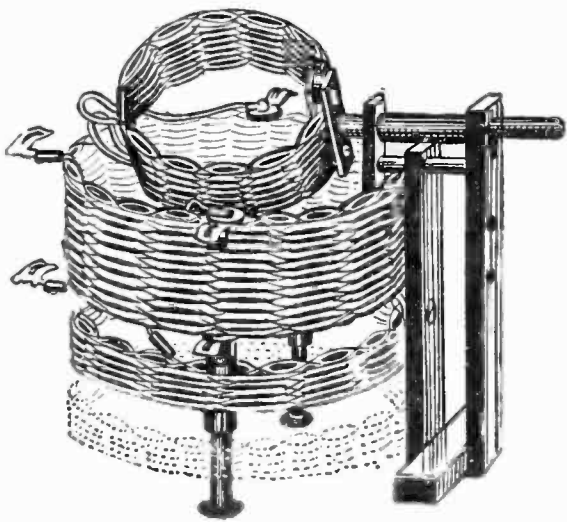
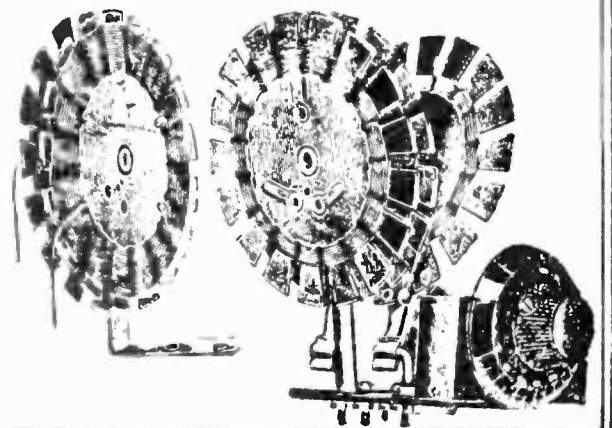

Reg. U. S. Patent Office

For Sensitivity—
Selectivity—
Distance

Transcontinental Low Loss Tuner

You love to labor—then make the most of it. To just build a radio set is not sufficient—the receiver you labor on should be the best.

Many radio fans using the Transcontinental Low Loss Tuner report having heard European Stations during the International Test Week. These remarkable 3-circuit tuners can be purchased at any good Radio Store.

List Price, \$7.00

Jobbers and distributors wanted

TRANSCONTINENTAL SALES CO.

241 Market St.

Newark, N. J.

★ PYRATEK

TRADE

MARK

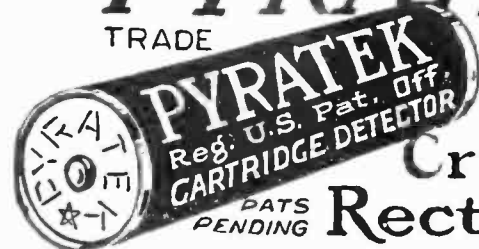

FIXED Crystal Rectifier

Guaranteed to give utmost sensitive reception with absolute stability. Especially designed for REFLEX work.

Used by

SLEEPER RADIO CORP. (Monotrol Sets)
DAVID GRIMES, INC. (Inverse Duplex Sets)
RADIO RECEPTOR CO., INC. (Multiflex Sets)

Tested and recommended for the "Knock-out" Reflex by Radio Broadcast" Laboratory.

WITH MOUNTING CLIPS \$1.25

At your dealers or sent direct upon receipt of purchase price
THE ERISMAN LABORATORIES. 3785 Broadway, New York, N. Y., Dept. C



Protects Radio Tubes

You can protect tubes against destruction from short circuits for a few cents by installing the "Gem" Radio Fuse. Then when there's a "short," the fuse blows and the tubes aren't injured. Easily installed.

Sent postpaid for 60c with fuse block for attaching, if not at your dealers. Write for booklet.

CHICAGO FUSE MFG. CO.

1505 West 15th St., Chicago, Illinois

"GEM" RADIO FUSE

★ Tested and approved by RADIO BROADCAST ★

PYREX

INSULATORS



**A STITCH IN TIME
SAVES NINE**

AN hour to change your antenna insulators and install PYREX will save many hours of poor reception.

At all Good Dealers

★ **PRICE 45c EACH**

CORNING GLASS WORKS
Industrial Division

CORNING **NEW YORK**

CARTER New Loop AERIAL



Gives you what you really need

FOR More Volume. Greater Distance. More Selectivity.

Due to the electrical advantages gained by the elimination of frame. Only 18" in diameter.

Any dealer can supply.

★ *In Canada: Carter Radio Co., Limited, Toronto*

Carter Radio Co.
1806 REPUBLIC BUILDING
CHICAGO

DeForest License

Honeycomb Coils



**Back and Front
Panel Mountings
Plain or Geared—
Genuine Bakelite**

The Universal all-wave inductance—accepted as standard in regard to superior construction and electrical units of measurement. Ask your

“Old Timer” radio friend why sets using honeycomb coils are better; they give closer tuning, greater selectivity and range. No dead end losses, easy to operate. 16 sizes, mounted and unmounted. Interchangeable with all mountings. Be sure the set you buy or build has them.

Send 25c for Super Heterodyne, Radio Frequency and Honeycomb coil Circuits and Complete Catalogue. ★

Chas. A. Branston, Inc., Dept. 7, 815 Main St., Buffalo, N.Y.
In Canada—Chas. A. Branston, Ltd., Toronto

LEESONA

REG. U.S. PAT. OFF.

WINDING MACHINES

for
**AUDIO FREQUENCY
TRANSFORMER
COILS**



FOR the manufacturer of transformers of quality, the No. 97 Universal winder should prove of more than ordinary interest. Users of this machine are obtaining highly efficient paper-insulated windings of extreme accuracy and durability. The same ingenious controls featured in our other coil winders are incorporated in this machine, enabling unskilled operators to maintain a high rate of production. Glin or yellow varnished papers are injected between the wire layers at high speed during the winding process, the paper being cut to length automatically, without interruption to production. Exact gearing takes care of possible variations in the diameter of wire, insuring against cross-overs due to faulty material, and thus reducing to an absolute minimum the possibility of rejected windings. The service that has characterized all our products is always available to users of this machine. Catalogue and prices on application.

UNIVERSAL WINDING COMPANY

*Manufacturers of coil winding equipment
covering practically every phase of
the electrical industry*

<p>MAIN OFFICE: 95 South Street Boston, Mass.</p>	<p>PLANT OFFICE: P. O. Box 1513 Providence, R. I.</p>
--	--

★ Tested and approved by RADIO BROADCAST ★

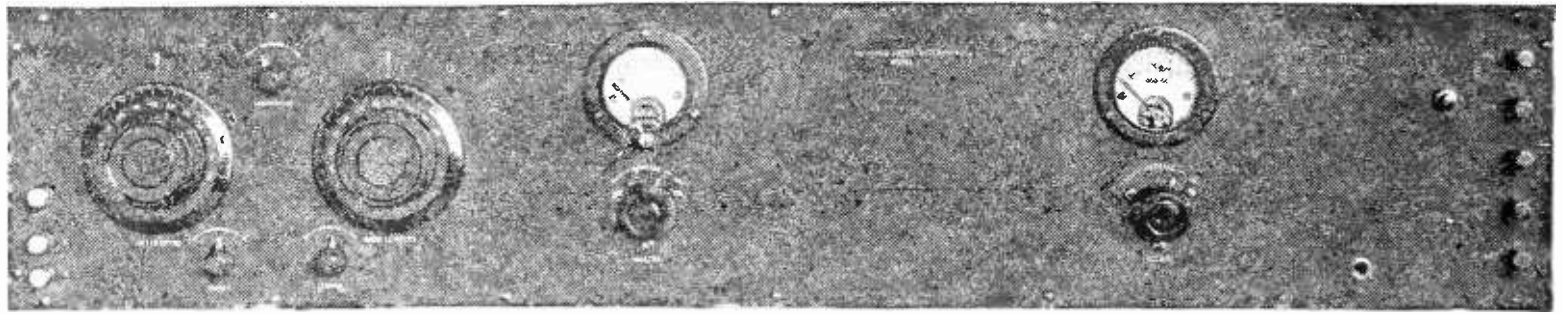

For any Circuit

Prompt shipment can be made on tested, standard apparatus of the following manufacture:

- | | |
|-------------------|-----------|
| E. I. S., Inc. | |
| General Radio | |
| Ultradyn | Willard |
| Sangamo Electric | |
| Benjamin Electric | |
| Allen Cardwell | |
| Dubilier | Formica |
| Weston | Magnavox |
| Jewell | Amer Tram |
| Western Electric | |
| Radio Corporation | |
| Music Master | Acme |
| Cutler Hammer | Frost |
| Federal | Kellogg |

Pressley Circuit

as described in Popular Radio. We furnish parts as specified.

Pliodyne

6 tubes—two stages tuned radio frequency detector and three stages audio frequency amplification, the famous Golden Leutz model—Completely constructed.

Price, without accessories . . . **\$60**

Super-Heterodyne C-7

Model C-7, the Long Distance Concert Receiver
With a Telephone Range of 3,000 Miles

NONE of the so-called new "circuits" or modifications of standards approach the C-7 in efficiency—for long range, for high audibility, for selectivity. Experimenters' Information Service design. *Seven tubes give the result of ten* because this model allows signals to be regenerated and heterodyned through radio frequency amplifier.

E. I. S. Model . . . All material we furnish is endorsed and recommended by the designers.

Using the finest apparatus and building to Naval standards, Model C-7 has a telephone range of 3,000 miles.

Norden-Hauck Price List Saves You Money

Free Information—Write for descriptive matter and price list. Our service is as near as your mail box.

Full Stock on Hand—We carry complete stocks of laboratory tested apparatus for immediate shipment.

NORDEN, HAUCK, INC. Engineers . Office and Laboratories
1617 Chestnut St., Philadelphia

Daniel Boone: Wilderness Scout, — by Stewart Edward White

An out-of-doors story for fathers and sons

At bookstores, \$1.75

Doubleday, Page & Co.



Harkness Counterflex Kit

List Price \$39.50

The new 3-tube Harkness Counterflex circuit is called the "Knock-out of Knock-outs!" This 3-tube circuit is better than the average 5-tube circuit—not just theoretically better, but *actually* better.

Dealers and Jobbers

This is a real opportunity for you to make money on the increasing demand for Counterflex Kits. Get started now and watch your business grow with the spreading popularity of this new Knock-out Harkness circuit.

KENNETH HARKNESS RADIO CORPORATION
727 Frelinghuysen Avenue Newark, New Jersey

★ Tested and approved by RADIO BROADCAST ★

THE Summit TOROIDAL

RADIO FREQUENCY TRANSFORMER

used in exactly the same manner as the open radio frequency coils—they are self balanced and self neutralized. They have no stray fields nor leakages, nor can they feed back, thus assuring the radio set builder of correct operation without howling or squealing.

One builder using these Transformers in the Summit circuit received 54 stations in two nights, traveling West to Denver and south to Mexico City. This circuit with instructions for building enclosed with each set of transformers.

List Price (Set of 3 mated units)
\$10.00

Distributors and Jobbers
Wanted

**SUMMIT RADIO
MFG. CO., Inc.**

Dept. 21 481 Broad St.
Newark, N. J.

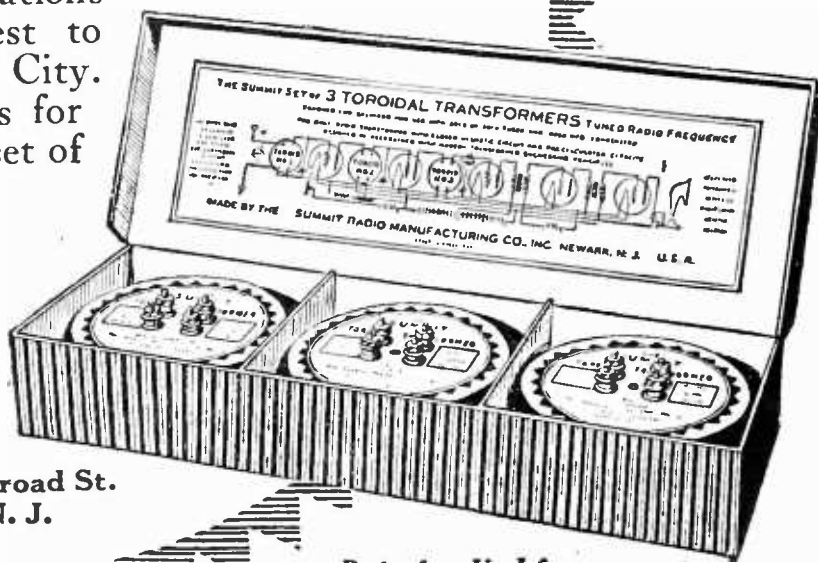

Pat. Applied for

THE SILENT FRANCE MULTI-DUTY SUPER-CHARGER

NO BULBS--NO ACIDS!

No Sticking or Sparking Contacts

A new application of the push-pull principle eliminates all the old drawbacks of battery charging. UP TO 120 VOLTS OF "B" BATTERY CAN BE CHARGED IN SERIES. No fuss or trouble, just connect the charger clips to the battery terminals and turn on the current. Simple—Speedy and Efficient. The France Super Charger also charges 2, 4, 6 or 8 volt radio or auto batteries at a 5 to 7 ampere rate, tapering as the battery is charged.

Price of Super-Charger, \$22.00; West of the Rockies, \$23.00; Canadian prices furnished on request. Write to-day for complete information on this highest attainment in battery charging.

DEALERS AND JOBBERS: Write to-day for sales proposition and literature.

The France Mfg. Co.
10327 Berea Road
Cleveland Ohio

Stock carried at convenient points throughout the United States and Canada.

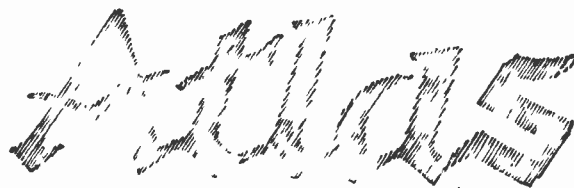

TRADE MARK

**RADIO REPRODUCTION
Gives the Best That's in Your Set**

- Tone-Quality.
- Clarity of reproduction.
- Sensitivity to signals.
- Harmonizer adjustment.
- Ample volume.

★ *ATLAS products are guaranteed.*

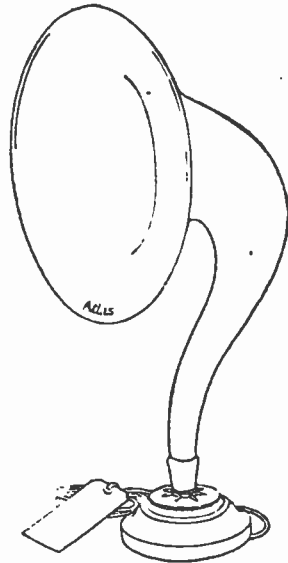

MULTIPLE ELECTRIC PRODUCTS CO., Inc.
365 Ogden St., Newark, N. J.
New York Philadelphia
Boston Baltimore Detroit
Pittsburgh Chicago
St. Louis San Francisco
Marconi Wireless Telegraph Co.
of Canada, Ltd.
Sole Canadian Distributors

★ Tested and approved by RADIO BROADCAST ★

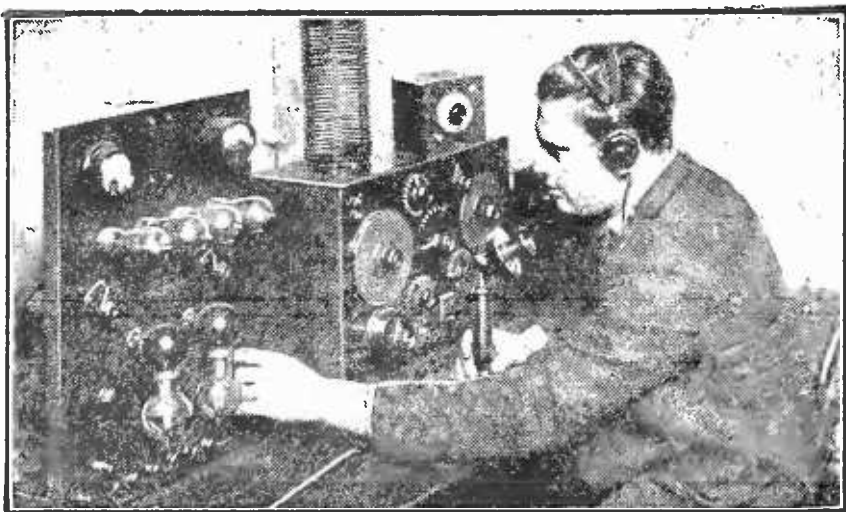

More Money For You in RADIO

THE amazing expansion of radio has opened up hundreds of wonderful new positions on land and sea. Big salaries, fascinating, easy work, short hours, and a wonderful future are offered to ambitious men who get into Radio now.

Take advantage of these wonderful opportunities to step into a big paying position in this great new field. You can stay at home and work up to a position paying up to \$10,000 a year, or Radio offers you an opportunity to travel and see the world, with all expenses paid, and a fine salary besides. One of our recent graduates, Emmett Welch of Peculiar, Mo., secured a position one week after graduating, paying a salary of \$300 a month. Hundreds of others report equal success.

Easy to Learn Radio at Home

Thousands of Certified Radio-tricians are wanted to design Radio sets; to make new Radio improvements, to manufacture Radio equipment and to install it; to maintain and operate great broadcasting stations and home Radio sets; to repair and sell radio apparatus; to go into business for themselves; to operate aboard ship and at land stations.

You can easily and quickly qualify in your spare time at home through the help of the National Radio Institute—first school to teach radio successfully by mail, established 1914. No previous experience or training needed. Prominent Radio experts will help you in every problem, giving you personal attention. You learn by actually doing, as we furnish free with course circuits and parts for building latest receiving sets, making the work thoroughly practical. You learn quickly and easily—right at home.

This is an absolutely complete course which qualifies you for the real "big pay jobs" in Radio and our big employment department helps you get one.

Send for FREE BOOK

No other field to-day offers such great opportunities as Radio. Take your choice of the many wonderful openings everywhere. Prepare now to step into the most interesting and best paid profession to-day. Read about the opportunities open now—the different kinds of work—the salaries paid. Write to-day for the 32-page book that tells how America's Pioneer Radio correspondence school (government recognized) can teach you to become a Certified Radio-trician in your spare time, and also Special Offer to those who act at once. Mail the coupon or write a letter NOW.

National Radio Institute, Dept. 31FB, Washington, D. C.

NATIONAL RADIO INSTITUTE, Dept. 31FB,
Washington, D. C.

Without obligation send me your book, "Rich Rewards in Radio," which tells all about the opportunities in Radio, how spare time study at home will qualify me quickly as a Certified Radio-trician so I can get one of the splendid positions, and how your Employment Service helps me to secure a big pay job. *Please write plainly.*

Name Age.....
Street
City State.....

BLUEBIRD RADIO TUBES

Distinctly New



AND EFFICIENT, satisfying every radio fan's wish in performance and price. Our direct sales plan enables us to sell at this low figure. "Bluebird" assures increased range and undistorted volume.

- Type 200—5 Volts, 1 Ampere Detector Tube.
- Type 201A—5 Volts, .25 Ampere Amplifier and Detector.
- Type 299—3-4 Volts, .06 Ampere Amplifier and Detector.
- Type 299A—3-4 Volts, .06 Ampere with Standard Base Amplifier and Detector.
- Type 12—1½ Volts, .25 Ampere Platinum Filament Amplifier and Detector.

All Standard Types \$2.00

TYPE 402 5 WATT TRANSMITTERS . . \$3.00

EVERY TUBE GUARANTEED to work in Radio Frequency. Especially adapted for Neutrodyne, Reflex and Super-Heterodyne Sets.

Shipped Parcel Post C. O. D.
When Ordering Mention Type

BLUEBIRD TUBE CO.

200 Broadway Dept. B New York City

Listen to **REASON**
Before You Buy!

Wood is sensitive to a wider band of sound frequencies than any other substance—and, the denser the wood, the more sound variations it will reproduce.

MADERA Die Cast Wood CLEAR SPEAKERS

are made of compressed wood—much denser than any natural wood. That's why a MADERA is natural in tone; why it misses none of the notes in a musical selection, nor any of the sound variations in the human voice.

Don't be satisfied with less than a MADERA. If your dealer is not supplied, order direct.

COMPRESSED WOOD CORP.
Formerly Am. Art Mache Co.
357 W. Austin Ave. Chicago

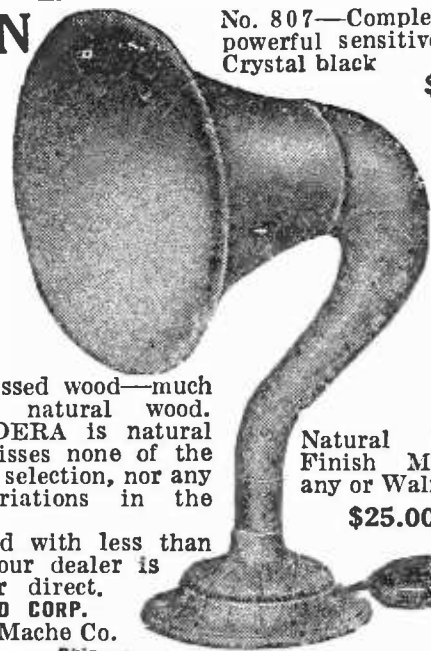

No. 807—Complete with powerful sensitive unit. Crystal black

\$20.00

Natural Wood Finish Mahogany or Walnut

\$25.00

Profit By Your Meteorological Observations

THE editor of TYCOS-Rochester, a meteorological journal published by Taylor Instrument Companies, Rochester, N. Y. seeks to review manuscripts based on observations of atmospheric phenomena, its effect on radio reception, with a view to publication in above magazine. Prevailing space rates paid promptly on acceptance. All material reviewed promptly. Addressed to the personal attention of F. M. Herrick, Editor Tycos-Rochester, Taylor Instrument Companies, Rochester, N. Y.



Best of all!
NO ELECTRICAL
EXPERT NEEDED

TO OPERATE
THE NEW

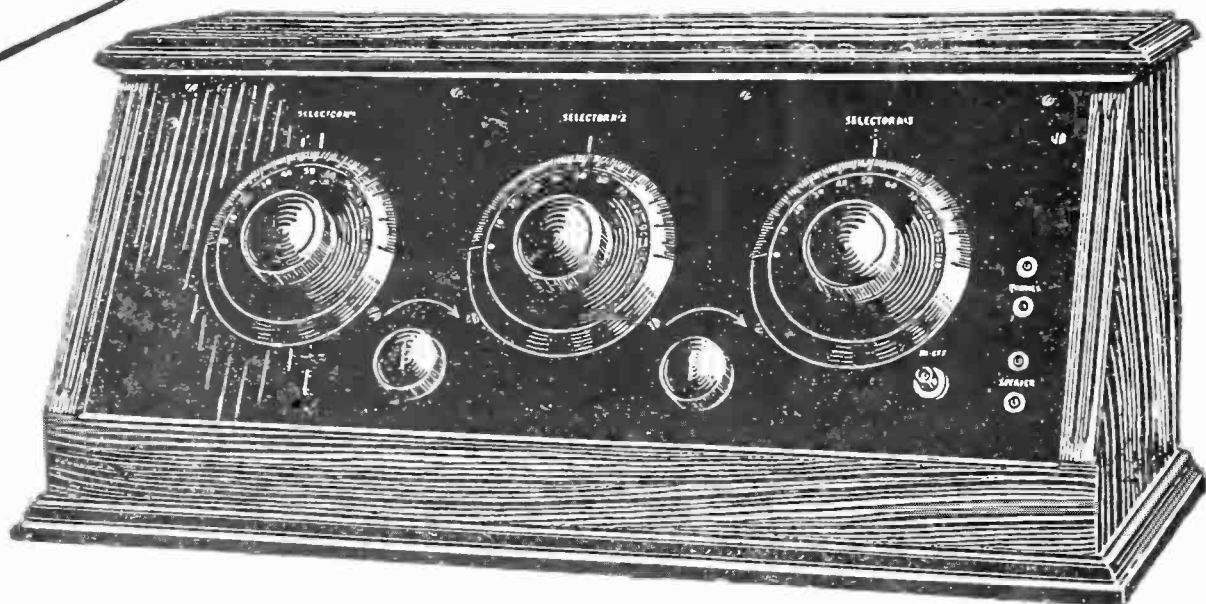

CHELSEA

SUPER-FIVE

5 TUBE RECEIVER \$50.⁰⁰

West of the Rocky Mountains \$60.00

The demand for the New CHELSEA Super Five has taxed manufacturing facilities. If you have any difficulty in obtaining this new model, write us and we will aid you to obtain immediately the New CHELSEA Super Five.

The name CHELSEA is synonymous with GOOD RADIO, maintaining always a rigid standard of supreme quality. CHELSEA manufacturers have succeeded in embodying in the new SUPER FIVE—all the extraordinary receiving principles of the highest priced sets. Made by one of the oldest radio manufacturers, the New CHELSEA in its mahogany finished cabinet with Bakelite panel, is a most remarkable set to own.



On sale at all good dealers—Catalog sent on request

CHELSEA RADIO COMPANY
179 SPRUCE STREET ~ CHELSEA, MASS.

Chicago St. Louis Seattle Denver Los Angeles San Francisco Cleveland

★ Tested and approved by RADIO BROADCAST ★

EARN

\$3,000 to \$10,000 a Year as Radio Expert

Enter fast growing radio field, thousands of big pay jobs waiting for you. U. S. Gov't., Steamships, R. R's., Corporations eagerly seek Radio trained men. Advancement rapid, earn from \$3,000 to \$9,000 yearly.

Pleasant Home Study In

RADIO



A. G. MOHAUPT

Prepare for Big Pay in Spare Time

My reputation as Radio Engineer and instructor insures you complete, speedy success, at home in spare time; **earn while you learn.** I make you expert in radio designing, building, repairing and operating and teach you only practical "inside" dope.

You quickly complete my course and a few pleasant hours prepare you to step into Big Pay. No experience required.



FREE
1000 Mile
Radio Outfit

This set, when completed, has a range of over 1000 miles. I give it free with my course. I give you practical training by having you work on this set. The knowledge you gain is not mere book knowledge but is usable, practical experience.

When you have finished my course, you can sell this set at a price that will pay the cost of the course. For a short time only, by my special plan, I will give a tube radio set in handsome cabinet to men, absolutely **FREE**. Send at once for my **FREE** wonder-book of inside Radio "dope." Act quickly.



MAIL COUPON

A. G. MOHAUPT, Radio Engineer,
Radio Association of America,
4513 Ravenswood Ave., Dept. B-4 Chicago

Please send me details of your Home Study Course—also your Free "Radio Facts" and information on how I can get a **FREE** 1000-mile Radio Set.

Name.....

Address.....

City..... State.....

fits any Grid Leak mounting

FRESHMAN PLUNGER TYPE VARIABLE GRID LEAK
was designed especially for the non-technical set owner who can replace in an instant the fixed grid leak with this new, efficient cartridge type Variable Grid Leak, without requiring the change of a single wire.

At your dealer or by mail postpaid. Write for free catalogue.



65c
240-248 W.
40th St., New York

A Steady Increasing Income For YOUR Spare Time

Are you willing to spend a few of your extra hours to provide for more of the better things of life—now; and at the same time build an ever-increasing income to safeguard your future?

The work will be pleasant, and dignified, and profitable; and you will not need a cent of money to start. We furnish all supplies. It will not interfere with your present occupation, regardless of what those duties are.

Please do not make any inquiries if you are not in earnest.

Doubleday, Page & Co., Garden City, N. Y.
Desk 7



By W. B. MAXWELL: *The Day's Journey*

"The novel is a masterpiece of comradeship on the highest level." *Boston Herald.* (\$2.00)

Doubleday, Page & Co.

AMBASSADOR Low Loss Products



Master Tuning Coil Perfectly Balanced Head Phone Low Loss Condenser

High grade, standard radio products that will increase the efficiency of any set and add to the satisfaction of the user. Ambassador Low Loss Products have long been the choice of particular fans. See them—compare them, and you will choose them too.

At all good dealers. Write for **FREE** diagrams of circuits in which Ambassador products can be used.

AMBASSADOR SALES COMPANY
108 Greenwich St., New York
326 W. Madison St., Chicago



★ Tested and approved by RADIO BROADCAST ★



NATIONAL DIALS

Radio experts as well as thousands of delighted users praise NATIONAL Dials for their velvety smoothness and for precise tuning.

NATIONALS are the dials with the

“Perfect Radio Touch”

PRICES, 4", \$2.50; 3 $\frac{3}{8}$ ", \$2.25

NATIONAL COMPANY, Incorporated
110 Brookline Street, Cambridge, Mass.

Sole Licensees for the Manufacture of the National Regenaformer under the Browning-Drake patents.



★ Tested and approved by RADIO BROADCAST ★

**RADIOLA III—FREE
with course**

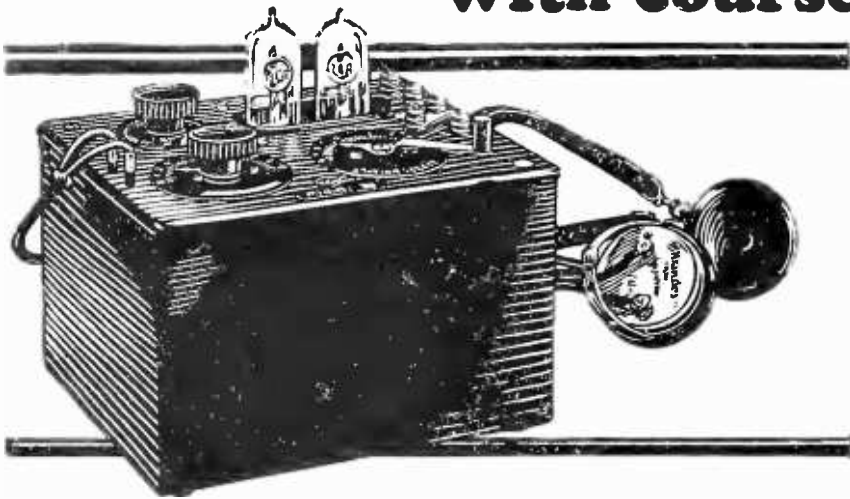

**A Life Career
for YOU in RADIO**

Thousands have won success in radio. Right now our graduates are voyaging to foreign ports as radio operators—ships' officers—with good pay—and no expense for rations and quarters. And hundreds of them are holding high salaried positions on land.

You, too, can earn big pay—and visit strange lands—or win success in radio right in this country! A few months of interesting study at home on the special Home Study Course of the Radio Institute of America and you can secure your Government Commercial Radio License—and your first radio job.

**RADIOLA III—FREE
with course**

The course is a new one, completely revised. New text-books. Radiola III with two tubes and Brandes headset and other exceptionally high grade apparatus free with course. Experts correct and grade your papers and answer all your questions. The most comprehensive and up-to-date radio instruction obtainable anywhere.

Don't delay. Fill out the coupon and send it today for our new booklet.

Radio Institute of America
(Formerly Marconi Institute)
Established in 1909
328 Broadway, New York City

RADIO INSTITUTE OF AMERICA
328 Broadway, New York City

Please send me full information about your Home Study Course of radio instruction.

- I am interested in the complete course including code instruction.
- I am interested in the technical course without code instruction.

Name.....

Address.....

**EASTERN
Pickle Bottle Coils**

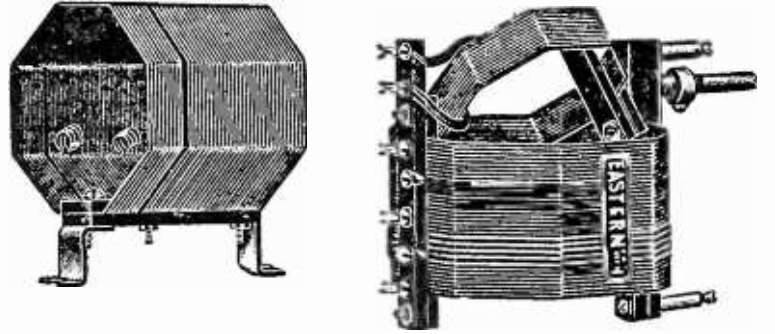

are creating a sensation in New York for the 4 tube Knock-out ROBERTS circuit. Endorsed by RADIO BROADCAST!

Fans have been waiting for simple to operate and efficient coils for the ROBERTS circuit, and after exhaustive experiment, we have produced a set of coils which we absolutely guarantee for maximum results in this wonder circuit.

You may now construct your ROBERTS set with the assurance that you will have the best 4 tube set that it is possible to build, for in using EASTERN PICKLE BOTTLE COILS, you are taking advantage of Radio Engineering's greatest advance in LOW LOSS coil design.

PRICE \$8.50 per set

At your dealers or direct, postpaid



EASTERN COIL CORP.

22 Warren St.

Dept. R. B.

New York

*The Standard
of the World*



The base-type

Freshman Variable Grid Leak

is the standard for those who build their own sets. It is the most compact and being entirely sealed it always remains unaffected by any climatic conditions.

Complete with either .00025 or .0005 Freshman Condenser— **\$1.00**
without condenser—.75

At your dealer's, otherwise send purchase price and you will be supplied postpaid

★ Chas. Freshman Company, Inc.
240 W. 40th St., New York

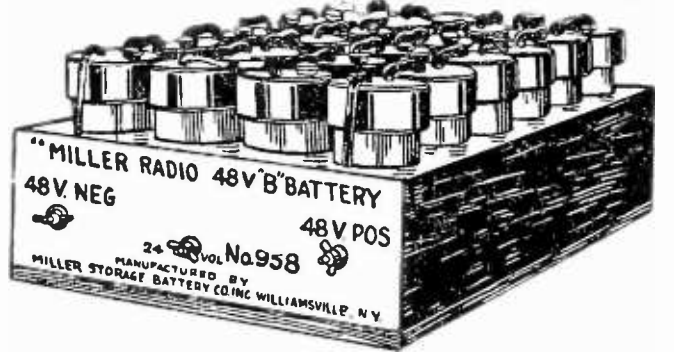

"Miller" Radio "B" Storage Batteries

ELIMINATE THE DISAGREEABLE NOISES CAUSED BY INEFFICIENT BATTERIES

24 V. "B" Storage \$9.00 48 V. "B" Storage \$17.00

MILLER STORAGE BATTERY CO., INC.
Williamsville New York

★ Tested and approved by RADIO BROADCAST ★

Prest-O-Lite

RADIO CHART

Voltage of Tubes	No. of Tubes	Type of Tubes (see foot-note)	Total Rated Ampere Drain	Recommended Prest-O-Lite "A" Batteries		
				Order by following Types	Days between Chargings	
5-Volt Tubes C-300 and UV-200 are interchangeable C-301A, DV-2 and UV-201A are interchangeable	1	UV-200	1	69 WHR OR 67 WHR	22 16	
	2	UV-201A	1/2	67 WHR	33	
	2	1 UV-200 1 UV-201A	1 1/4	611 WHR OR 69 WHR	22 17	
	3	UV-201A	3/4	69 WHR OR 67 WHR	29 22	
	3	1 UV-200 2 UV-201A	1 1/2	611 RHR OR 69 WHR	21 14	
	4	UV-201A	1	69 WHR OR 67 WHR	22 16	
	4	1 UV-200 3 UV-201A	1 3/4	613 RHR OR 611 WHR	22 15	
	5	UV-201A	1 1/4	611 WHR OR 69 WHR	22 17	
	5	1 UV-200 4 UV-201A	2	613 RHR OR 611 WHR	19 13	
	6	UV-201A	1 1/2	611 RHR OR 69 WHR	21 14	
	8	UV-201A	2	69 KPR OR 67 KPR	21 15	
	For sets using current at a rate higher than 2 amperes.			2 1/4	69 KRL OR 67 KPR	22 13
				2 1/2	69 KRL OR 69 KPR	19 16

Copyright, 1929
The Prest-O-Lite Co., Inc.

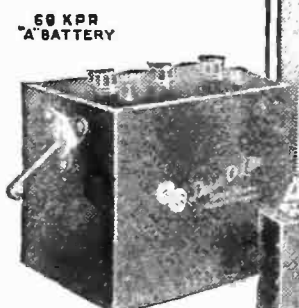

23 MRR TWIN 'A' BATTERY

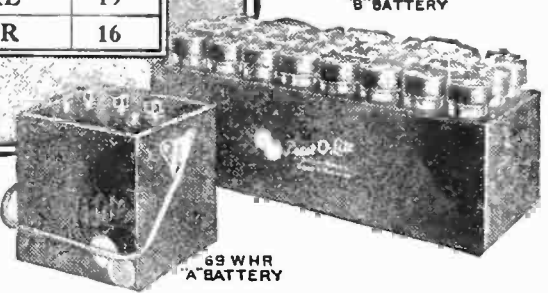

How to select batteries that run your set for weeks without recharging

Why select storage batteries by guesswork and risk getting one that requires charging every few days? Let the Prest-O-Lite Radio Chart guarantee you batteries that fit your set—and bring fine reception without too frequent recharging.

The above section of the master chart covers "A" Batteries for all 5-volt sets. It recommends two sizes for each set, depending upon the days of service you wish between chargings (based on the average use of your set of three hours a day). The larger capacity battery will be found more desirable unless facilities for frequent and easy recharging are provided. See the complete chart at your dealer's for data on "B" Batteries and also "A" Batteries for low voltage tubes.

In every detail—special structure plates, highly porous separators and superior internal design—these batteries are made to get the best out of your set. To supply the unvarying current essential to fine tuning, efficient operation and clear reception.

Prest-O-Lite Batteries offer you truly remarkable savings. Though standard in every respect, they are priced as low as \$4.75 and up. They last for years and are all easily rechargeable. See them at your dealer's or write us at Indianapolis, Ind., for our booklet "How to fit a storage battery to your set—and how to charge it."

THE PREST-O-LITE CO., Inc.
INDIANAPOLIS, IND.
New York San Francisco
In Canada: Prest-O-Lite Company of Canada, Ltd.
Toronto, Ont.



★ Tested and approved by RADIO BROADCAST ★



**For clearest reception
your socket must have
these three features**

1. *Low loss.* Laboratory tests proved that of 13 best known makes, Na-Ald Sockets were the *only* ones having losses lower than a good low loss condenser.
2. *Low capacity.* The same test showed that Na-Ald has lowest capacity of any socket. This is very important for short wave length reception.
3. *Positive side-scraping* contact (not just side pressure) that cleans corrosion from tube terminals. Only Na-Ald Sockets have this essential feature.

Use Na-Ald Sockets in the set you build or buy, if not already installed by the manufacturer. DeLuxe 75c; others 35c and 50c. Write for free booklet of tested circuits and facts about laboratory test.

ALDEN MANUFACTURING COMPANY
Also Makers of the Famous Na-Ald Dials
Dept. B-5 Springfield, Mass.

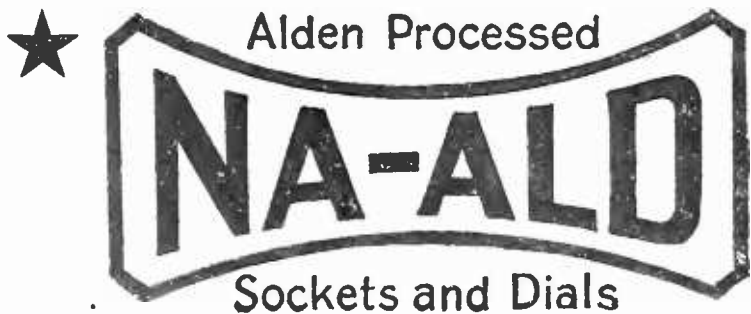

1/3 of 1%!

More Than Matched

COMPLETE KIT OF SIX COILS —

VICTOREEN V-QUALITY-N

\$37.00 SET OF FOUR BLUE PRINTS INCLUDED

The Super Heterodyne Transformer which contains a Condenser. Adjusted and sealed at the factory. Sold under a money back guarantee. Descriptive literature on request.

Complete Set of 4 Blue Prints \$1.00

VICTOREEN RADIO INC.
6534 Carnegie Ave. Cleveland, Ohio

FAHNESTOCK CLIPS

The Perfect Radio Connectors—Are Used



★ *Reg. U. S. Patent Office*

By manufacturers of standard sets and parts and makers of wet Battery, and exclusive on Eveready Dry Batteries. Their Sure Patented Grip is recognized universally by enthusiastic users.

FAHNESTOCK ELECTRIC CO. Long Island City

Now

EBY BINDING POSTS

are

—In 25 Different Markings

★ **15¢**

★ Tested and approved by RADIO BROADCAST ★

NEW YORK PRECISION MICA FIXED CONDENSER

Adds the real undistorted true tone quality to your receiver

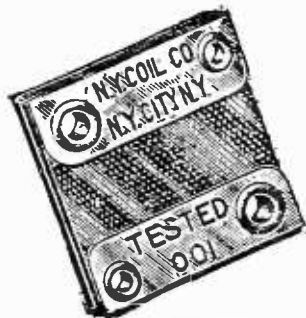

TYPE A.

MORE UNIFORM CAPACITY and superior construction improves selectivity and distant reception with marked freedom from noise. Endorsed by leading radio engineers, and standard equipment with most discriminating manufacturers—yet they cost no more than the ordinary products.

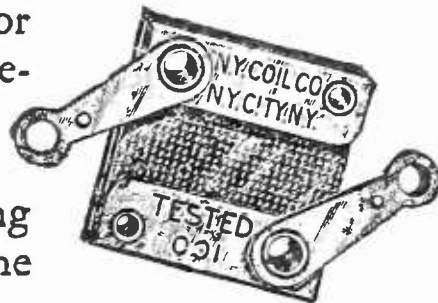

TYPE B.

ATTENTION SET MANUFACTURERS

OUR SPECIAL "SELECTOR" VARIABLE CONDENSER WITH SELF-BALANCED COIL ATTACHED is the equipment you have been waiting for—at a price you can afford to pay.

OUR GROUNDED ROTOR CONDENSER is superlative in low loss construction—no other manufacturer incorporates so many actual improvements.

NOTE THE REDUCED PRICES

.0005 (23 plate) without VERNIER, \$4.00; 17 plate, \$3.75; GEARED VERNIER attachment, \$1.50.

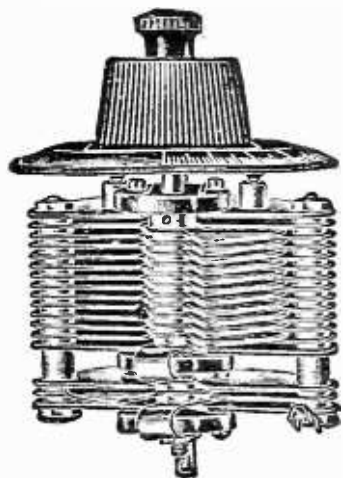
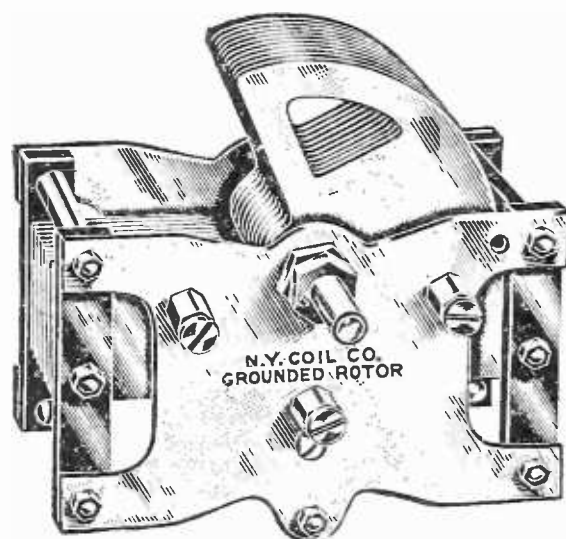

OUR STANDARD VARIABLE CONDENSERS are universally recognized for their efficiency, workmanship, DX reception and sharp tuning qualities. They equal many others selling at *double our price*—made possible by large production.

Price, without Vernier or dial—17 plate, \$1.80; 23 plate, \$2.00; 43 plate, \$3.00. Price with Vernier, including dial and knob, 23 plate, \$3.50; 43 plate \$4.50.

NEW YORK COIL COMPANY

338 Pearl Street, New York City, N. Y. ★

PACIFIC COAST—MARSHANK SALES CO., 926 Insurance Exchange Building, Los Angeles, Calif., also San Francisco, Portland.

★ Tested and approved by RADIO BROADCAST ★

Why it is Better

"MASTER of Every Note in the Orchestral Range" is the proven claim of the Federal No. 65 Audio Frequency Transformer! Volume without distortion is the basis for the beauty of Federal Tone.

From its oversize locking nuts to its heavy brass mounting feet the Federal No. 65 Transformer incorporates the same engineering skill that has made Federal the recognized leader in electrical communication apparatus since 1890.

Insist upon Federal parts for your "pet" hook-up. There are over 130 standard parts bearing the Federal iron-clad performance guarantee.

Federal Telephone and Manufacturing Corp.

Buffalo, N. Y.

Boston New York Philadelphia Pittsburgh
Chicago San Francisco Bridgeburg, Canada



Federal

Standard RADIO Products

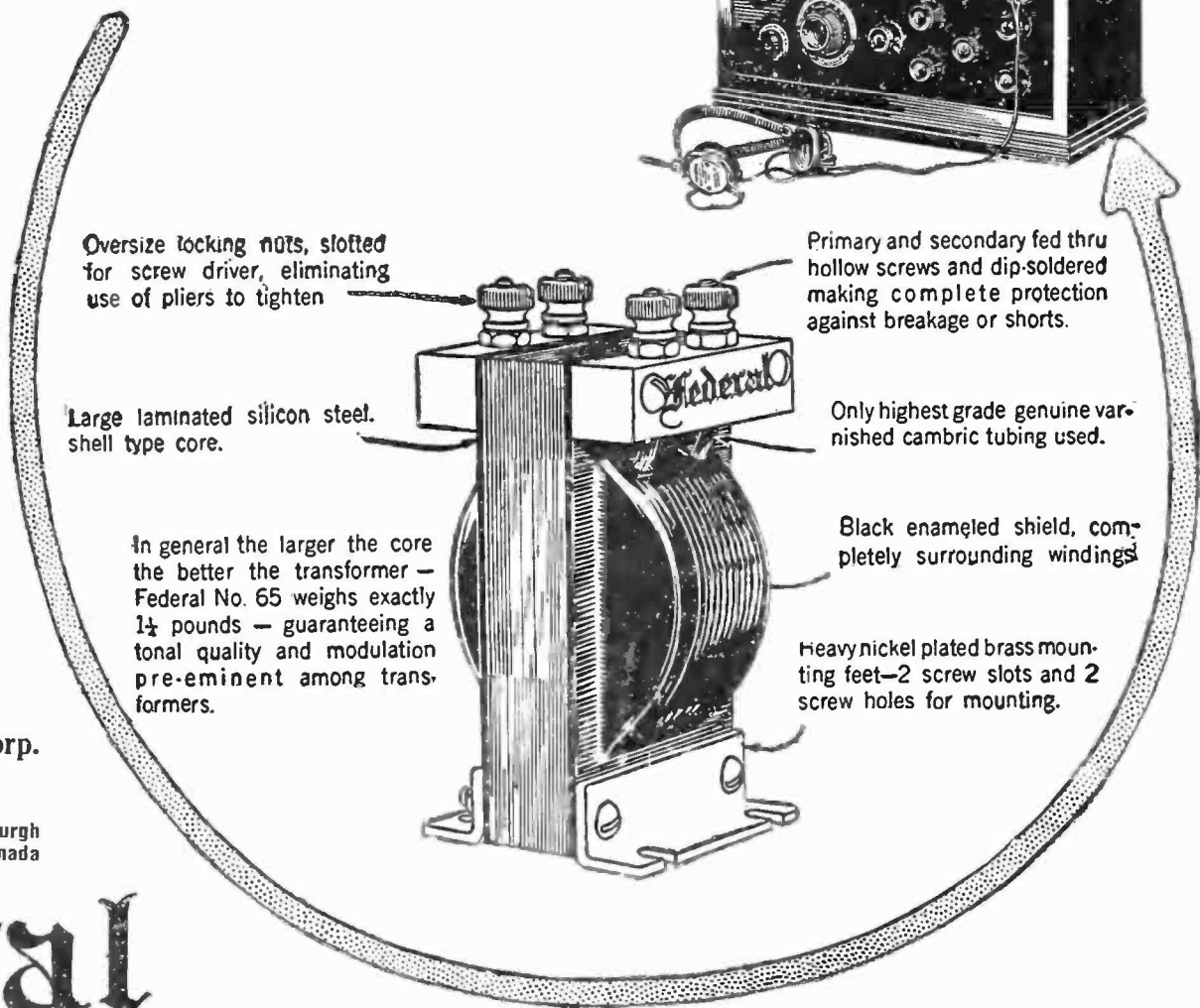
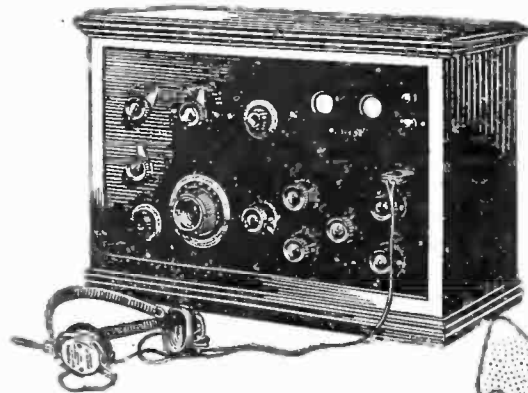

Oversize locking nuts, slotted for screw driver, eliminating use of pliers to tighten

Large laminated silicon steel shell type core.

In general the larger the core the better the transformer — Federal No. 65 weighs exactly 1½ pounds — guaranteeing a tonal quality and modulation pre-eminent among transformers.

Primary and secondary fed thru hollow screws and dip-soldered making complete protection against breakage or shorts.

Only highest grade genuine varnished cambric tubing used.

Black enameled shield, completely surrounding windings

Heavy nickel plated brass mounting feet—2 screw slots and 2 screw holes for mounting.

Crescent Lavite Resistances Absolutely Non-Inductive

12,000
48,000
50,000
100,000 } Ohms



List \$1.50

Special resistance to order. When better resistances are made Crescent will make them. CRESCENT RADIO SUPPLY CO., 5 LIBERTY ST., JAMAICA, N. Y.

Waiting in the Wilderness

by ENOS A. MILLS

Adventures close to nature in the Rocky Mountains, with pleasant by-paths into the realms of animal lore. A book no one could help enjoying. Illustrated from 19 beautiful photographs. Net, \$2.50.

DOUBLEDAY, PAGE & CO. GARDEN CITY, N. Y.

LEARN THE CODE AT HOME with the OMNIGRAPH

"Just Listen—The Omnigraph will do the teaching"

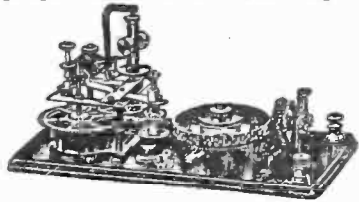

THE OMNIGRAPH Automatic Transmitter will teach you both the Wireless and Morse Codes—right in your own home—quickly, easily and inexpensively. Connected with Buzzer, Buzzer and Phone or to Sounder, it will send you unlimited messages at any speed, from 5 to 50 words a minute.

THE OMNIGRAPH is not an experiment. For more than 15 years, it has been sold all over the world with a money back guarantee. The OMNIGRAPH is used by several Depts. of the U. S. Govt.—in fact, the Dept. of Commerce uses the OMNIGRAPH to test all applicants applying for a Radio license. The OMNIGRAPH has been successfully adopted by the leading Universities, Colleges and Radio Schools.

Send for FREE Catalogue describing three models. DO IT TO-DAY.

THE OMNIGRAPH MFG. CO., 16K Hudson St., New York City

If you own a Radio Phone set and don't know the code—you are missing most of the fun

The HIGH QUALITY — LOW PRICE CLARITRON \$2.30 TUBE BY MAIL

FOR BRILLIANCE OF TONE, SHARP VOLUME, MORE PEP—USE CLARITRONS

The Highest Obtainable Quality at the Lowest Obtainable Price. Our price is low because we cut out the jobber-wholesaler's profit—which is YOUR saving.

All types, including our 501A, for 6 volt storage batteries; our 499 for 4½ volt dry cell batteries; and our 112, for 1½ volt dry cell batteries.

ALL MADE WITH BASES OF PURE BAKELITE—for superior efficiency
WE GUARANTEE COMPLETE SATISFACTION

From your dealers, or direct by mail, C. O. D. or prepaid on receipt of express or postal money-order. WE PAY POSTAGE. \$2.30 all types. DEALERS WRITE!!

SUPERIOR RADIO COMPANY, Dept. 202
176 Shephard Ave. Newark, N. J.

Type 499 Detector and amplifier 3-4 volts For dry cell batteries 0.06 Amp.

Type 501A Detector and Amplifier 5-6 volts For storage batteries 0.25 Amp.

★ Tested and approved by RADIO BROADCAST ★



MEMBER
RMA

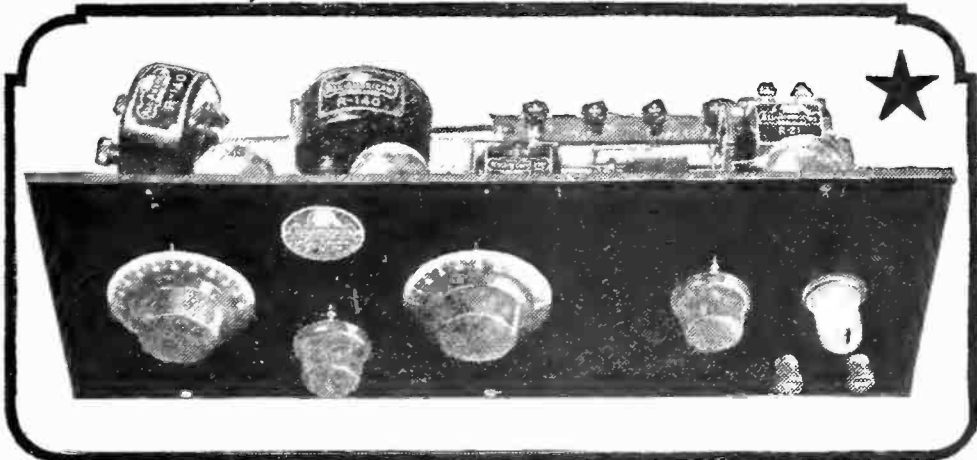

Now You Can Afford — a modern precision-made set which "cuts through"

Ⓒ Tuned radio frequency for distance and selectivity, reflex for economy, the unequalled loudspeaker tone quality and volume which comes with ALL-AMERICAN precision manufacture—all are present in this *non-radiating* three-tube receiver. Ⓒ And, owing to the economy of "wiring it yourself," ALL-AMAX SENIOR costs less than a finished one-tube set of equally high quality. Price \$42.

The RADIO KEY BOOK is a radio education in itself. Send ten cents, coin or stamps, for your copy.

ALL-AMERICAN RADIO CORP
PIONEERS IN THE INDUSTRY

2652 Coyne Street

Chicago

ALL-AMERICAN

Largest Selling Transformers in the World

ALL-AMERICAN Guaranteed Radio Products

Standard Audio Transformers
3 to 1 Ratio, type R-12... \$4.50
5 to 1 Ratio, type R-21... 4.75
10 to 1 Ratio, type R-13... 4.75

Power Amplifying Transformers
(Push-Pull)

Input type R-30... \$6.00
Output type R-31... 6.00

Rauland-Lyric

A laboratory grade audio transformer for music lovers. R-500... \$9.00

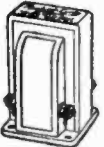

Universal Coupler

Antenna coupler or tuned r. f. transformer. R-140... \$4.00

Self-Tuned

R. F. Transformer
Wound to suit the tube. R-199 \$5.00. R-201A \$5.00



Long Wave Transformer
(Intermediate Frequency)

(15-75 kc.) R-110... \$6.00

10,000 Meter (30 kc.)
Transformer

Tuned type (filter or input). R-120... \$6.00



Radio Frequency Coupler

(Oscillator Coupler). R-130 \$5.00

Super-Fine Parts

Consisting of three R-110's, one R-120 and one R-130... \$26.00

The
ALL-AMAX
Sets

This shows how they come to you — mounted complete on panel and base-board, with full photographic wiring instructions.

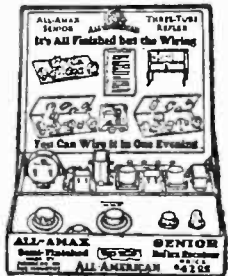

All-Amax Junior

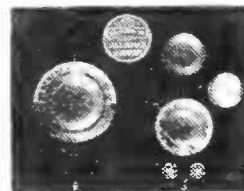

A one-tube reflex set that brings in the locals on the loudspeaker, with wonderfully clear tone quality, or tunes them out and gets real distance. *Non-Radiating.*
Price \$22.00

★ Tested and approved by RADIO BROADCAST ★

RADJO LOW LOSS PRODUCTS!

★ RADJO Low Loss Tuner



Install a Radjo Low Loss Tuner in your old tube set and you will increase its EFFICIENCY and SELECTIVITY to a surprising degree. Wound by the Lorenz type of winding. Single, Double or Three Circuit Tuner. **\$5.50**

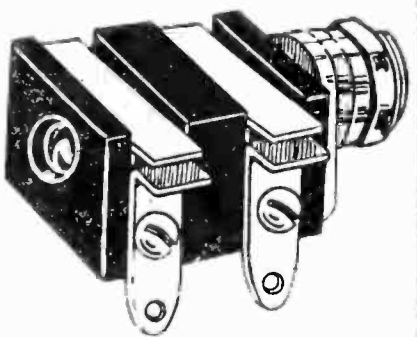

RADJO Anti-Capacity Jacks & Switches

Minimum of electrical capacity, wiping contact rugged and compact. The Radjo is one-third the size of other jacks and fits any standard plug. It assures minimum **70c to \$1.00** resistance.

RADJO Low Loss Radio Frequency Transformer

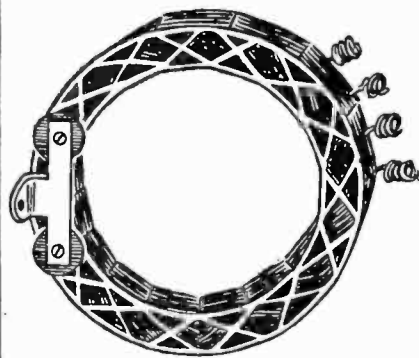

No dielectric absorption losses. Minimum distributed capacity gives increased clarity, volume and selectivity. For use in Tuned Radio Frequency Neutrodyne and Reflex **\$2.00** circuits.

FREE! You owe it to yourself and your set to learn about Radjo Low Loss Products. Send today for interesting Literature. It's free. Dealers and Distributors Wanted—Write for Proposition.

ELECTRIC CITY NOVELTY & M'F'G. COMPANY
Licensed Manufacturers Schenectady, N. Y.



**NO AERIAL
NO LOOP**

INCREASES
SELECTIVITY
IMPROVES
RECEPTION



ONE DOLLAR
BUYS

THE
Antennaphone
REPLACES
THE AERIAL

NOT ATTACHED TO,
BUT MERELY
PLACED UNDER
THE TELEPHONE

COMPLETE
WITH IN-
SULATED
WIRE, PRICE

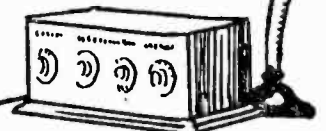

The Antennaphone will prove a still bigger seller this Spring and Summer because it reduces static interference and danger of lightning. No lightning arrester is necessary.

Easy to install. Works perfectly with any receiver. Satisfaction guaranteed or money will be refunded.

ON SALE AT YOUR DEALERS or sent by mail upon receipt of one dollar.
ANTENNAPHONE CO., 90 West St., New York City, N. Y.

RADIO KIT CATALOG

Something New!

Contains illustrations, descriptions and prices of a large number of unequalled Radio Receivers of one-tube and up, which you or anyone can build in from one to several hours by the use of our new system which makes assembling easy.

**No Solder — No Bare Wires!
No Poor Connections!
No Dissatisfaction!
No Loss of Time!**

Use only common pliers and screwdriver, with our flexible, insulated, eyeletted connecting wire in place of the old-style bus bar and solder. Our new, improved blueprints and simple instructions in each Kit. Catalog also offers Kits of complete parts for many of the popular and efficient advertised Receivers. We give you altogether a much better choice than anyone else in the United States. We have just what you want.

Liberal Terms and Conditions

No money in advance—goods sent on approval—we pay transportation charges—satisfaction guaranteed or money back.

Get Your Own Kit Without Money

You can do it! Our free Catalog tells all about our easy plan.

Start in Business for Yourself

and make sets for your friends and neighbors—full or part time. We show you how to get orders and make big profit.

RADIO SPECIALTY COMPANY,
Kit Dept., D676, 25 W. Broadway, New York

The present management issued the first radio mail order catalogue in the world, in 1904.

THESE BLUEPRINTS AND 16-PAGE INSTRUCTION BOOKLET

Help You to Make
the Receiver of
the Year

**A
Dollar
and the
attached
coupon
brings to
you com-
plete constructional
details with full-**

sized blueprints for building this cracker-jack receiver.

- ☐ It compares very favorably with any good super-heterodyne.
- ☐ RADIO BROADCAST'S pattern blueprints and sixteen-page instruction booklet make it easy for you to construct this receiver.
- ☐ This circuit combines tuned radio-frequency amplification, push-pull audio-frequency amplification, neutralization, reflexing, regeneration, ease of tuning, super-selectivity, and distortionless loud speaker volume.

DEALERS! We have a most attractive proposition for you. Will you let us aid you in selling stock parts for this Receiver? Make sales that stay sold.

What the set has done

During Radio Broadcast's International Tests the following stations were tuned-in with sufficient volume for a loud speaker, using the Radio Broadcast Knock-out Four-Tube Receiver.

PTT—Madrid, Spain
 2BD—Aberdeen, Scotland
 5NO—Newcastle England
 2EH—Edinburgh, Scotland
 2LO—London, England
 5IT—Birmingham, England

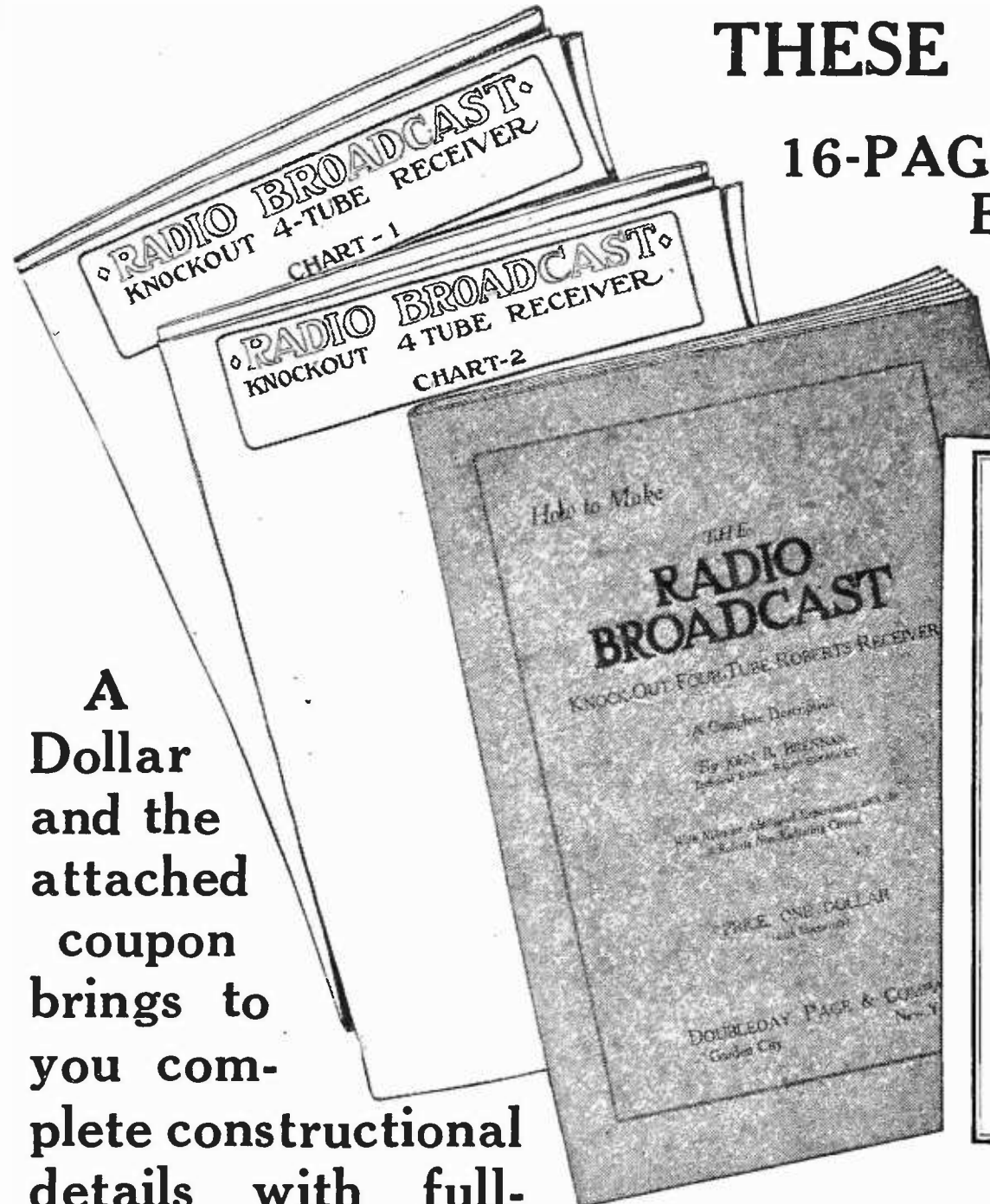

Doubleday, Page & Co.
Garden City, New York

Enclosed find my dollar for the Blue Prints and sixteen-page Instruction Book for building RADIO BROADCAST'S Four-Tube Knock-out. It is understood that my dollar will be returned if the material sent me does not come up to my expectations.

Name.....
 Address.....

RB-A

BARKELEW

Lightning Arresters

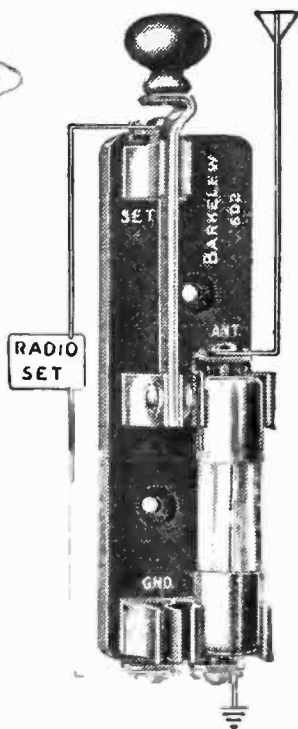

LIGHTNING ARRESTER SWITCH
No. 602 Price \$3.00

OUR No. 602 Lightning Arrester Switch is universally recognized as the only device on the market which combines on one base all those functions essential for maximum protection.

The Vacuum tube arrester is permanently in the circuit from antenna to ground, ready to "spill" any overcharge. With the switch blade the antenna may be disconnected from the radio set and thrown directly on ground.

It meets not only the requirements but also the additional recommendations of the National Electric Code.

Our No. 606 Vacuum Tube Lightning Arrester is less expensive but it meets all the actual requirements of the National Electric Code.

Both are Approved by the Underwriters' Laboratories.

See our Radio Catalog No. 32 at your Dealer.
If he hasn't his copy, we have one for him.



The Barkeley Electric Mfg., Co.
Middletown, Ohio, U. S. A.

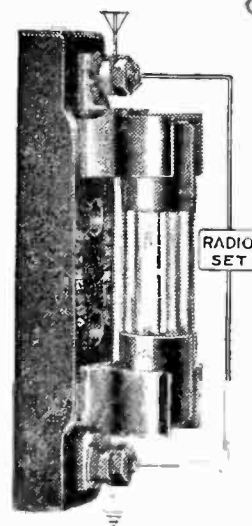

LIGHTNING ARRESTER
Vacuum Tube Type
No. 606 Price \$1.50

NEW YORK, 157 Chambers St.
BOSTON, 31 Bedford St.
WASHINGTON, D. C. Mills Bldg.

CHICAGO, 15 S. Clinton St.
DENVER, Denham Bldg.
MINNEAPOLIS, 1017 Lumber Exchange
TORONTO, Geo. B. Archdeacon, No. 7 Crang Ave.

SEATTLE, 1014 Sixth Ave. S.
SAN FRANCISCO, 75 Fremont St.
LOS ANGELES, 443 S. San Pedro St.



WHOLESALE RADIO SERVICE COMPANY

9 Church St. N.Y.C.
Dept. R. B.

The "W. R. S" Ultradyne Kit is the only complete kit. It is the result of the cooperation of the manufacturer of all its parts used in the Ultradyne circuit, R. E. Lacault, the designer of this famous circuit, and our own research engineers.

W. R. S. Knockdown Kits contain everything for building the circuit. Everything is included down to the last screw, nut and wire. Packed in sealed cartons that eliminate all difficulty and doubt for the purchase and assembly of proper materials.

Ultradyne Model L-2 Phenix Ultradyne Kit as follows

- 1 Special Low Loss 180 degree Sensitizing Coupler with Copper shield
- 1 Oscillator Coupler Low Loss
- 1 Antenna Low Loss Tuning Coil
- 4 Ultraformers. New improved long wave radio frequency transformer
- 4 Phenix matched transformers
- 2 Hammarlund .0005 new type Low Loss Cond.
- 2 Ultra vernier dials. New type
- 1 Accuratune control for coupler
- 8 Na-ald De Luxe sockets
- 1 Pacent Potentiometer
- 8 Amperites
- 2 Pacent Double Circuit Jacks
- 1 Pacent double Filament Control jack
- 1 Cutler-Hammer switch
- 2 Thordarson Audio transformers
- 1 Variable Grid Leak
- 7 Eby Binding Posts
- 2 Bakelite Binding post mountings
- 1 Dubilier .0005 with Grid leak mounts
- 4 Dubilier .00025 Mica Cond.
- 2 Dubilier .001 Mica Cond.
- 1 Dubilier .005 Mica Cond.
- 1 7x30 Bakelite Drilled and Engraved Panel
- 1 7x30 mahogany baseboard
- 1 Ultradyne book of instructions and blue prints
- 1 Box of assorted screws, lugs, nuts
- 40 feet of tinned bus wire

Our Kit. Price Postpaid, \$73.50

Complete parts for the "Knock-Out" 4-Tube Roberts Receiver

- 1 7x21 Drilled and Engraved Panel
- 1 Baseboard
- 1 Set of Roberts, Nazeley, or Sickles Coils
- 2 Mignon Low Loss grounded rotor Condensers .0005 Capacity
- 1 Dubilier .00025 Grid Condenser with grid leak mounts
- 1 Daven or Electrad 2 meg. leak
- 1 Dubilier Mica Condenser. 0025 mfd.
- 1 Dubilier Mica Condenser .005 mfd.
- 1 Fada type Neutralizing Cond.
- 3 Pacent 20 ohm rheostats
- 4 Bestone Double contact spring sockets
- 2 Como or Modern push-pull transformers
- 1 All American 5-1 ratio Audio transformer
- 1 Fada type Inductance switch
- 1 Doz. switch points and stops
- 3 Univernier New type Dials
- 1 Drilled and Engraved Binding post panel
- 7 Unmovable binding posts
- 1 Pacent Closed Circuit Jack
- 1 Pacent Open Circuit Jack
- 1 Eveready C Battery
- 8 Feet of high Grade Cambric tubing
- 1 Box of assorted screws, nuts, washers, lugs, etc.
- 30 Feet of tinned bus wire
- 1 Set of Radio Broadcast blue prints and book of instructions

Our Kit, Price postpaid, \$42.50

The Rasla Four-Tube Reflex Receiver

- 1 7x24 drilled and engraved panel
- 1 Baseboard
- 1 Rasla Radio Frequency Tuner
- 1 General Instrument .00029 mfd., No Loss with Isolantite insulation
- 1 Rasla Radio Frequency Transformer
- 1 Rasla Fixed Crystal Detector
- 1 Modern 10-1 Audio Transformer
- 1 Modern Low Ratio Transformer
- 1 Rasla Balancing Condenser
- 1 Filament Control Switch
- 4 Double Contact Spring Sockets
- 2 Pacent Double Circuit Jacks
- 1 Single Circuit Jack
- 1 4 in. Bakelite Dial.
- 1 Drilled binding post panel
- 9 unmovable Binding Posts
- 1 C Battery
- 1 Modern Push-pull Transformer No. 112
- 1 Modern Push-pull Transformer No. 113
- 1 Dubilier .0005 mfd. Mica Cond.
- 1 Dubilier .006 mfd. Mica Cond.
- 1 Dubilier .005 mfd. Mica Cond.
- 1 Dubilier .00025 mfd. Mica Cond.
- 1 Box of assorted screws, nuts, washers, lugs, etc.
- 1 Set of angle brackets for mounting post panel
- 30 ft. of Bus Wire
- 1 set of complete blue prints and instructions

Our Kit, Price Postpaid, \$44.50

SEE OUR FULL PAGE "AD" IN THIS ISSUE OF RADIO BROADCAST

★ Tested and approved by RADIO BROADCAST ★

8 improvements
at **ONE** stroke

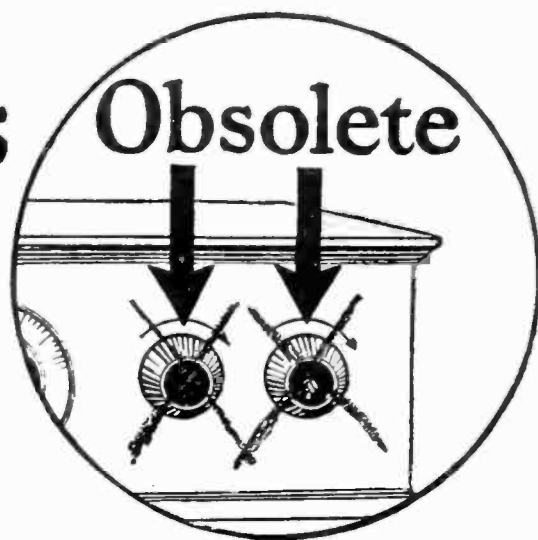

The Self-Adjusting Rheostat

1. Eliminates hand rheostats—simplifying control and giving compactness.
2. Simplifies wiring.
3. Prolongs life of tubes from 2 to 3 times.
4. No moving parts—therefore no grinding noises.
5. Permits use of any type of tubes or combination of tubes.
6. No filament meters necessary.
7. Brings the most out of each individual tube—automatically—no guessing.
8. Makes perfect tube operation absolutely fool proof.

AMPERITE takes the place of a good hand rheostat, a delicate meter and an expert operator. Operates on the thermo-electric principle. Automatically changes in resistance as the "A" battery voltage changes. Mounts conveniently inside the set. No knobs to turn. Nothing to get out of order. Approved by every prominent laboratory. Standard equipment in such sets as Somerset, Ultradyne, Marshall, Pfansteihl, Kilbourne & Clark, Ambassador, Penn-C, Cockaday and numerous others. Fully guaranteed.

Price \$1.10 Everywhere

Write for
FREE
Hook-Ups



RADIAL COMPANY

Dept. R.'B.-5

50 Franklin St., New York

AMPERITE

REG. U.S. PAT. OFF.

"means right amperes"

★ Tested and approved by RADIO BROADCAST ★

INDEX OF ADVERTISERS

IN THIS ISSUE

A

Acme Apparatus Co., The.....1131
 Alden Mfg. Co.....1180
 Allen Bradley Co.....1190
 Ambassador Sales Co.....1176
 Amber Mfg. Co.....1023
 American Electric Co.....1158
 American Hard Rubber Co.....1026
 American Transformer Co.....1023
 Andrews Radio Co.....1144
 Antennaphone Co., The.....1184
 Apex Electric Co.....1144
 Arrow Battery Co.....1150

B

Barkeley Elec. Mfg. Co.....1186
 Bel-Canto Mfg. Co.....1146
 Bel-Tone Radio Co.....1152
 Belden Mfg. Co.....1017
 Bluebird Tube Co.....1174
 Branston Co., Charles A.....1146-1171
 Bremer-Tully Mfg. Co.....1029
 Brightson Laboratories.....1021
 Bristol Company.....1139
 Brownlie & Company, Roland.....1162
 Burgess Battery Co.....1136
 Burrell Co., J. R.....1162

C

Cardwell Mfg. Co., Allen D.....1022
 Carter Radio Co.....1024J, 1171
 Celerundum Products, The.....1160
 Chelsea Radio Co.....1175
 Chicago Fuse Co.....1170
 Chicago Solder Co.....1149
 Clarke Co., E. M.....1024G
 Collier & Son, P. F.....1164
 Como Apparatus Co., The.....1158
 Compressed Wood Corp.....1174
 Continental Fibre Co., The.....1156
 Copper & Brass Research Ass'n.....1152
 Corning Glass Co.....1171
 Crescent Radio Supply Co.....1182
 Crosley Radio Corp.....Back Cover
 Cunningham, E. T.....Second Cover

D

Danziger Jones Co.....1030
 Daven Radio Co.....1137
 De Jur Products Co.....1150
 Doubleday, Page & Co.....1143, 1185
 Dubilier Condenser & Radio Corp.....1133
 Duplex Engine Governor Co.....1159

E

Eastern Coil Corp.....1178
 Eby Mfg. Co., The H. H.....1180
 Electrad, Inc.....1145
 Electric City Novelty & Mfg. Co.....1184
 Electrical Research Lab.....1189
 Erisman Laboratories, The.....1170

F

Fahnestock Electric Co.....1180
 Federal Tel. & Elect. Co.....1182
 France Mfg. Co.....1173
 Freshman Co., Charles.....1147, 1176, 1178
 Frost Inc., Herbert H.....1168

G

Gardiner & Hepburn Co.....1165
 General Electric Co.....1020
 General Radio Co.....1127
 Gilfillan Bros.....1168
 Goodrich Rubber Co.....1125

H

Hammarlund Mfg. Co.....1140
 Hanscom, Allan T.....1166
 Harkness Radio Corp., Kenneth.....1172
 Hayden Radio & Research Co., A. C.....1164
 Haynes Griffin Radio Service Inc.....1151
 Heath Radio.....1144
 Hommel Co., Ludwig.....1153
 Hull & Co., S. W.....1142

I

International Corres. Schools.....1154

J

Jefferson Electric Mfg. Co.....1152
 Jewell Elect. Inst. Co.....1166
 Jewett Radio & Phonograph Co.....1019, 1141

K

Kellogg Switchboard & Supply Co.....1150
 Kenman Electric Co.....1169

M

Marshall Elect. Co.....1142
 Martin Copeland Co.....1138
 Marwol Radio Co.....1161
 Mason Fenwick & Lawrence.....1166
 Midwest Radio Co.....1025
 Miller Storage Battery Co.....1178
 Morrison Laboratories.....1162
 Multiple Electric Products Co.....1173
 Myder Radio Co.....1148
 Myers Co. Limited, E. B.....1166

N

National Carbon Co.....1033
 National Company.....1177
 National Radio Inst.....1174
 Nazely Co., J.....1158, 1170
 Newport Radio Inc.....1027
 New York Coil Co.....1181
 Niles Manufacturing Co., The.....1168
 Nordon Hauck & Co.....1172

O

Omnigraph Mfg. Co., The.....1182

P

Pacent Electric Co.....1136
 Peerless Radio Corp.....1164
 Peiffer & Co.....1138
 Perfection Radio Mfg. Co.....1134
 Phenix Radio Corp.....1129, 1142
 Philco Batteries.....1135
 Premier Elect. Co.....1140
 Prest-O-Lite Co., Inc.....1179

R

Radiall Co.....1187
 Radio Association of America.....1176
 Radio Corp. of America.....Third Cover
 Radio Inst. of America.....1140, 1178
 Radio Panel & Parts Corp.....1167
 Radio Rabat Co.....1156
 Radio Shop, The (Nassau Radio Co.).....1156
 Radio Specialty Co.....1184
 Radio Supply Co., The.....1024K
 Radio World.....1148
 Rathbun Electric Co.....1155
 Rauland Mfg. Co.....1154, 1183
 Resas, Inc.....1144
 Rhamstine, J. Thos.....1157
 Rice & Hochster.....1160

S

Sickles Co., F. W.....1146
 Silver-Marshall Inc.
 1024A, 1024B, 1024C, 1024D
 Smith, B. H.....1142
 Summit Radio Corp.....1173
 Superior Radio Co.....1182

T

Taylor Instrument Co.....1174
 Teagle Company, The.....1168
 Thompson Mfg. Co., R. E.....1018
 Thordarson Elec. Mfg. Co.....1024E
 Thor Radio Department.....1164
 Tower Mfg. Co.....1031
 Transcontinental Sales Co.....1170
 Trilling & Montague.....1024I
 Twentieth Century Radio Corp.....1024L

U

Uncle Sam Electric Co.....1136
 United Scientific Lab. Inc.....1024H
 Universal Winding Co.....1171

V

Vesco Radio Co.....1162
 Victoreen Radio Inc.....1180

W

Walbert Mfg. Co.....1158
 Wholesale Radio Service.....1163, 1186
 Willard Storage Battery Co.....1024
 Wireless Electric Co.....1024F
 World Battery Co. ("B" Battery).....1160
 World Battery Co. ("A" Battery).....1138

X

X-L Radio Laboratories.....1024J

CIR-KIT



More Power per Tube brings Greater Radio—Economically

Triple power is the basis of Erla Supereflex records. Tubes, as used in Supereflex, simultaneously amplify received radio frequency currents, reflexed radio and reflexed audio frequency currents. So 1-tube Supereflex rivals the power of conventional 3-tube circuits. And 3-tube Supereflex readily outclasses the ordinary five! Only such power can give you the thrill of Supereflex distance and volume; always with Erla crystal-pure tone—and with uncanny selectivity that gets what you want when you want it.



SEE ERLA RECEIVERS

Inherent Erla advantages in power, tone and selectivity are now available in beautiful complete Erla receivers. Retail prices range from \$67.50 to \$225. Both price and performance place Erla receivers among the sensations of radio history.

This finer radio is brought within the reach of all by Erla Supereflex *CIR-KIT*, the factory-sealed carton of genuine Erla apparatus for building Supereflex yourself. Anyone can follow the *CIR-KIT* assembly plan to perfection, using only screwdriver and pliers, without the risk of drilling or soldering.

Pride of workmanship, extreme economy, priceless radio performance, are yours in Erla Supereflex *CIR-KIT*. Select your model at the Erla store. 1 to 5 tubes, antenna and loop types.

ELECTRICAL RESEARCH LABORATORIES
Department B, 2500 Cottage Grove Avenue, Chicago

ERLA

★ Tested and approved by RADIO BROADCAST ★



Selectivity?

—Use Allen-Bradley Parts

The experienced radio fan has learned the value of guaranteed parts in his set. He knows that Allen-Bradley Radio Devices, such as the Bradleystat, Bradleyleak, Bradleyohm, Bradleydenser, etc., provide noiseless control. He incorporates them into his set for maximum selectivity, and he is not disappointed. The stepless, noiseless adjustment eliminates the harsh noises produced by inferior devices. Any Allen-Bradley dealer will gladly show you why Allen-Bradley Radio Devices increase selectivity. Stop in, today.

An Exceptional Condenser

Like all Allen-Bradley Radio Devices, the Bradleydenser offers high efficiency and sharp tuning. Brass plates, soldered at all joints, and a new type of bearing insure low resistance and low losses. It is pronounced "a fine job" by radio engineers. If you want to see "an exceptional condenser," ask the Allen Bradley dealer.



Allen-Bradley Co.

Electric Controlling Apparatus

278 GREENFIELD AVE. MILWAUKEE, WIS.

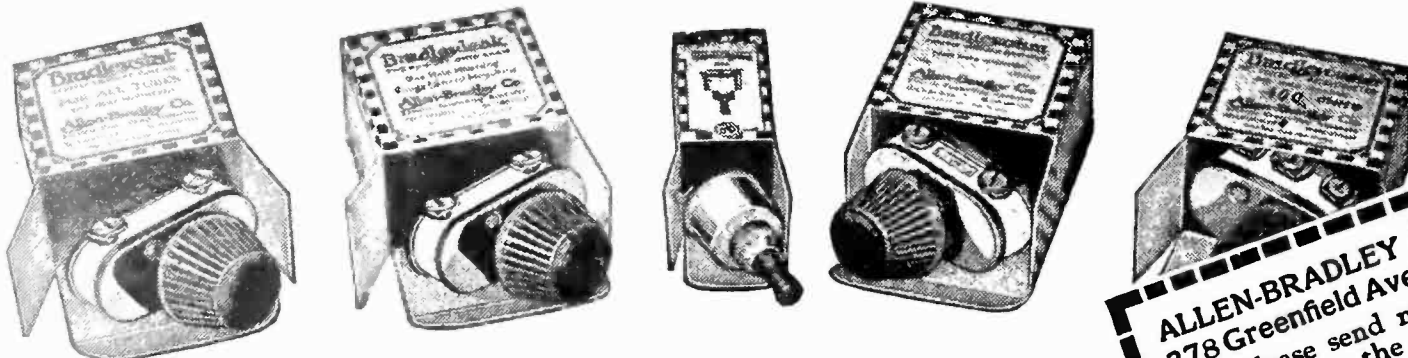

The Bradleystat, Bradleyleak, Bradleyswitch, Bradleyohm, and Bradleymeter are sold by all leading radio dealers and jobbers. They are known the world over for compactness, "one hole" mounting, and marvelous control. The superior finish will delight you.

MAIL THE COUPON

ALLEN-BRADLEY CO.,
278 Greenfield Ave., Milwaukee, Wis.
Please send me your descriptive literature on the Allen-Bradley line.

Name

Address

★ Tested and approved by RADIO BROADCAST ★

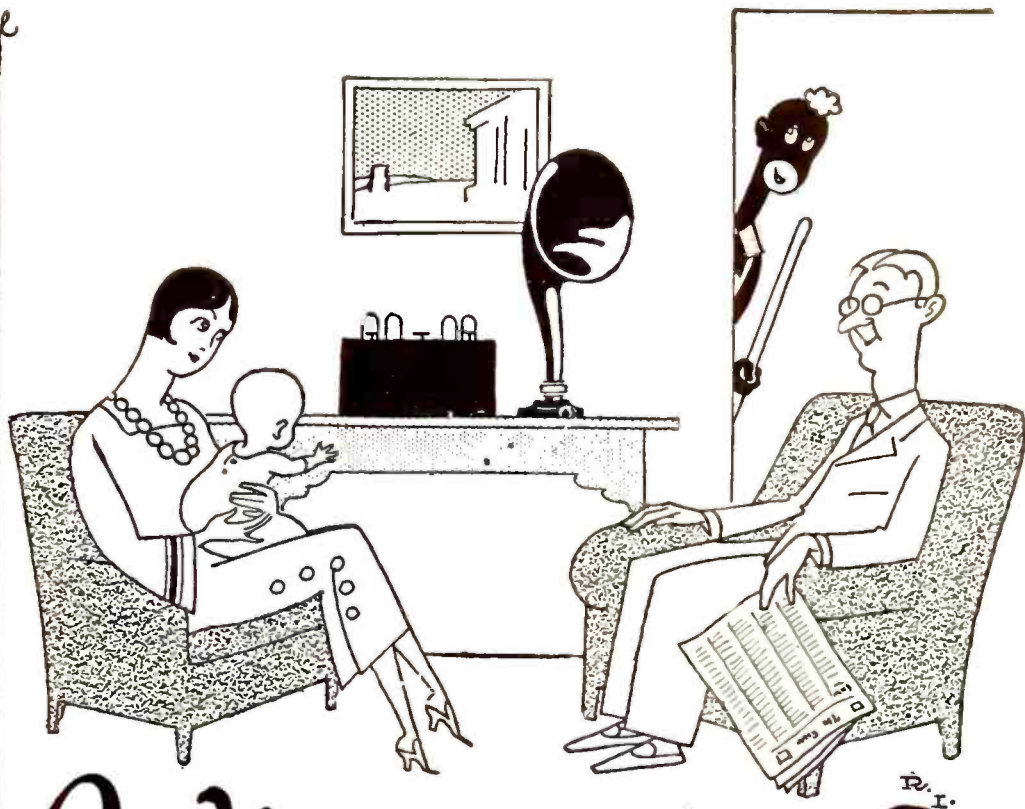

Where the fun comes in

Listening to real music—listening to clear, undistorted voice—getting what you want when you want it. That's where the fun comes in, in radio.

The tubes cannot do the whole job. But other good parts are of little avail without the *best tubes*. Everybody knows this, and most people do ask for RADIOTRONS by name, and watch to see that they get what they ask for. For the very best reception your set can give—no matter what type of tube you need—look for the Radiotron name, and the RCA mark.

Radio Corporation of America



233 Broadway
New York

Sales Offices:
10 So. La Salle St.
Chicago, Ill.

28 Geary St.
San Francisco, Cal.



WD-11
WD-12
UV-199
UV-200
UV-201-A

Radiotrons with these model numbers are genuine only when they bear the name Radiotron and the RCA mark.



This symbol of quality is your protection

Radiotron

REG. U.S. PAT. OFF.

★ Tested and approved by RADIO BROADCAST ★

THE NEW CROSLLEY 52-SPECIAL

\$35

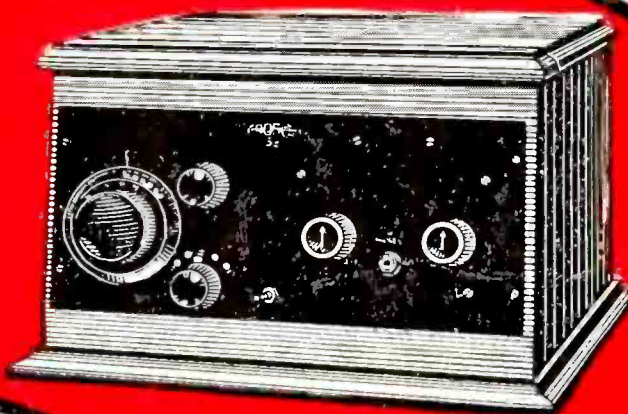

*Similar to
the well-known
Crosley 52 at \$30
in handsome large
cabinet with
Sloping Panel*

THE tremendous demand for the Crosley three tube 52 has encouraged us to offer this circuit in a new attractive cabinet with sloping panel, the Crosley 52 Special. This Cabinet is large enough to hold all dry cell batteries. It thus becomes self contained, a beautiful piece of furniture which can take its place in the living rooms of the most discriminating. The sloping panel makes operation easier and greatly adds to the appearance of the set.

Of course, the popular Crosley 52 will be continued. It has given uniformly satisfactory loud speaker service in all parts of the country. Continual coast to coast reception and even foreign stations on the loud speaker have been frequently reported. You can purchase a Crosley 52 or 52 Special from most any good dealer. All Crosley Radios are licensed under Armstrong Regenerative U. S. Patent 1,113,149. Write for Catalogue.

Prices quoted are without accessories

Prices West of Rockies—add 10%



THE CROSLLEY RADIO CORPORATION

420 Sassafras Street,

Powel Crosley, Jr., President

Cincinnati, Ohio

Crosley owns and operates Broadcasting Station WLW

★ Tested and approved by RADIO BROADCAST ★

THE COUNTRY LIFE PRESS, GARDEN CITY, NEW YORK

U619