

OCT. 1924 **RADIO** 25 CENTS
BROADCAST

Making
a Dry-Cell
Super-
Heterodyne

Another
Knock-out
Four-tube
Set

ASK THE PILOT
for details of
THE SETS
contained in this
LABORATORY

**RADIO
BROADCAST
COVERED WAGON**

REMINGTON
SCHUYLER

DOUBLEDAY PAGE & CO.

Garden City, N. Y.

Cunningham

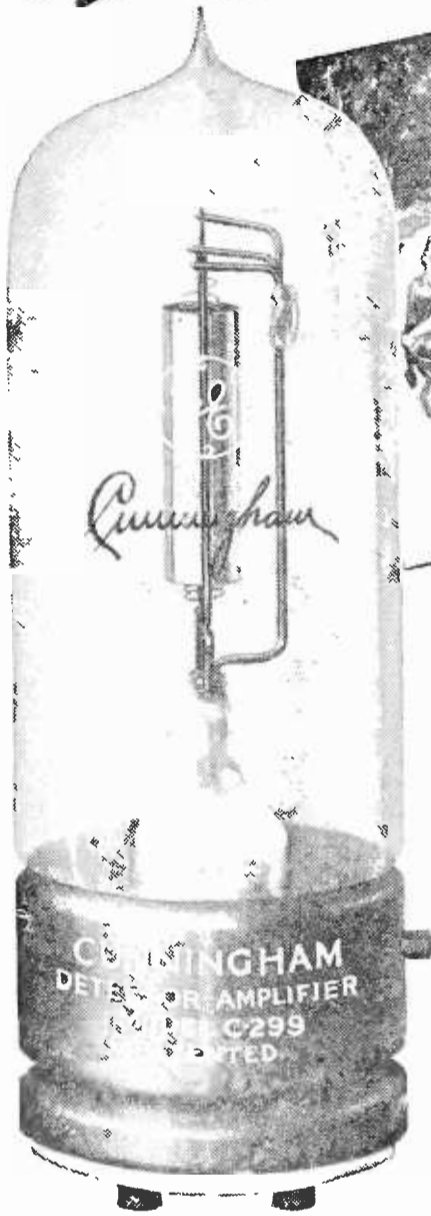

RADIO TUBES

Bring World Events to Far-Distant Vacation Lands

BACK-COUNTRY isolation melts into world contact as you tune in on music, drama, and the final battles of the Presidential Campaign.

Make your camp, your cottage, your yacht the center of hospitality and entertainment.

Perfected Radio will do it, and Perfected Radio means the use of Cunningham Radio Tubes. The Cunningham dry battery detector and amplifier tube, type C-299, makes it possible for you to treble your vacation pleasure by use of a portable receiving set. The special filament in this tube, using a current so low that it may receive its supply from standard No. 6 dry batteries or even from ordinary flashlight batteries, makes possible this far-reaching application of Radio.

The receiving set you now have can be readily adjusted to use this tube and be a source of use and pleasure on your vacation trip. Your dealer can give you useful suggestions for the purchase or construction of a highly efficient portable set.

CUNNINGHAM TUBE PRICES

C-301A—5 Volts $\frac{1}{4}$ Ampere filament	\$4.00
C-299—3 Volts .06 amp. Dry Battery Det. and Amp.	\$4.00
C-300—5 Volts Gas Content Detector	\$4.00
C-11—1.1 Volts .25 amp. Dry Battery Det. and Amp. Special Base	\$4.00
C-12—Similar to C-11 with standard base	\$4.00

PATENT NOTICE

Cunningham tubes are covered by patents dated 2-18-08, 2-18-12, 12-30-13, 10-23-17, 10-23-17, and others issued and pending. Licensed only for amateur, experimental and entertainment use in radio communication.

Any other use will be an infringement.

DATA BOOK

Cunningham 40-page Data Book fully explaining care and operation of Radio Tubes now available by sending 10c in stamps to San Francisco office.

Branch
Chicago

E. J. Cunningham Inc.

Branch
New York

182 Second Street, San Francisco



★
**APPROVED
THE WORLD!
OVER!**

Approved by magazines and newspapers the world over, including Radio News, Radio Broadcast, Popular Radio, Radio, New York Sun-Globe, and everywhere else wherever subjected to tests.

— and recognized as the
World's Greatest Headset Value

**TOWER'S
Scientific**
*Perfect
Tone
mates*
**\$
NOW
2.95**

Only because we are the **LARGEST EXCLUSIVE MANUFACTURERS** of Headsets in the country are we able to produce the **TOWER'S SCIENTIFIC** at the low price of **\$2.95.**

Every Set of Tower's Scientifics are tested and approved by licensed radio operators.

TOWER'S Scientific, lightest of all in weight, offers higher resistance, with elimination of distortion.

Longer cord (full 5 feet). Every set covered with our money-back guarantee. Our \$200,000 company stands squarely back of each headset.

Production over one million double headsets for this season. Fourteen days' production, if placed in cartons, one on top of the other, would reach a mile into the sky.

THE TOWER MFG. CORP.
98 I Brookline Ave., Boston, Mass.



★ Tested and approved by RADIO BROADCAST ★

Radio Broadcast

ARTHUR H. LYNCH, EDITOR

OCTOBER, 1924

COVER - - - - -	<i>From a Painting by Remington Schuyler</i>	
RADIO—WITH DR. LEE DEFOREST - - - - -	<i>Frontispiece</i>	
MEET J. ANDREW WHITE, THE MOST FAMOUS ANNOUNCER IN RADIO		
	<i>Myra May</i>	447
IS RADIO MAKING AMERICA MUSICAL? - - - - -	<i>Charles Orchard, Jr.</i>	454
HOW TO BUILD A PORTABLE SEVEN-TUBE SUPER-HETERODYNE		
	<i>McMurdo Silver</i>	456
THE MARCH OF RADIO - - - - -	<i>J. H. Morecroft</i>	470
THE CASE AGAINST THE RADIATING RECEIVER - - - - -	<i>Willis K. Wing</i>	478
THE LISTENERS' POINT OF VIEW - - - - -	<i>Jennie Irene Mix</i>	483
EFFICIENCY PLUS - - - - -	<i>Zeb Bouck</i>	490
W H B - - - - -	<i>R. Ernest Dupuy</i>	498
IN THE R. B. LAB - - - - -		506
Designing Small Transformers		
An Adapter for Peanut Tubes		
Winding and Counting Multi-Layer Coils		
An Impromptu Rectifier		
Ammeters for Pulsating Charging Currents		
Building Your Own Lab		
Helpful Hints on Building and Operating		
LISTENING-IN ON THE WORLD - - - - -	<i>Willis K. Wing</i>	512
OSCILLATIONS AND THE VACUUM TUBE - - - - -	<i>Walter Van B. Roberts</i>	513
WHAT OUR READERS WRITE US - - - - -		517
THE GRID - - - - -		519
What Are the Government Radio License Requirements?		
How Can I Reflex My Aeriola, Sr. Set?		
What Are the Specifications for the UV-1716 Transformer?		
Explain the Reverse Feed Back in the Superdyne Set.		
How May a Storage Battery Be Charged from a 32-Volt Line?		
What Are the Particulars of the Heavy Duty B Battery?		
Neutrodyne Noises		
THE PROGRESS OF THE COVERED WAGON - - - - -		524
ADDITIONAL BROADCASTING STATIONS IN THE UNITED STATES - - - - -		524
NEW EQUIPMENT - - - - -		526
AMONG OUR AUTHORS - - - - -		528

Copyright, 1924, in the United States, Newfoundland, Great Britain, and other countries by Doubleday, Page & Co. All rights reserved. TERMS: \$3.00 a year; single copies 25 cents.

F. N. DOUBLEDAY, *President* NELSON DOUBLEDAY, *Vice-President* S. A. EVERITT, *Treasurer*
 ARTHUR W. PAGE, *Vice-President* RUSSELL DOUBLEDAY, *Secretary* JOHN J. HESSIAN, *Ass't. Treasurer*

Doubleday, Page & Co. MAGAZINES WORLD'S WORK COUNTRY LIFE GARDEN MAGAZINE & HOME BUILDER RADIO BROADCAST SHORT STORIES EDUCATIONAL REVIEW LE PETIT JOURNAL EL ECO THE FRONTIER	Doubleday, Page & Co. BOOK SHOPS NEW YORK: LORD & TAYLOR BOOK SHOP PENNSYLVANIA TERMINAL ARCADE LONG ISLAND TERMINAL ARCADE 38 WALL ST. AND 5 LIBERTY ST. ST. LOUIS: 223 NORTH 8TH STREET 4914 MARYLAND AVENUE KANSAS CITY: 920 GRAND AVENUE TOLEDO: LASALLE & KOCH CLEVELAND: HIGBEE CO. NEWARK: 34 PARK PLACE	Doubleday, Page & Co. OFFICES GARDEN CITY, NEW YORK NEW YORK: 120 WEST 32ND STREET BOSTON: TREMONT BUILDING CHICAGO: PEOPLES GAS BUILDING SANTA BARBARA, CALIFORNIA LONDON: WM. HEINEMANN CO. TORONTO: OXFORD UNIVERSITY PRESS
--	--	--

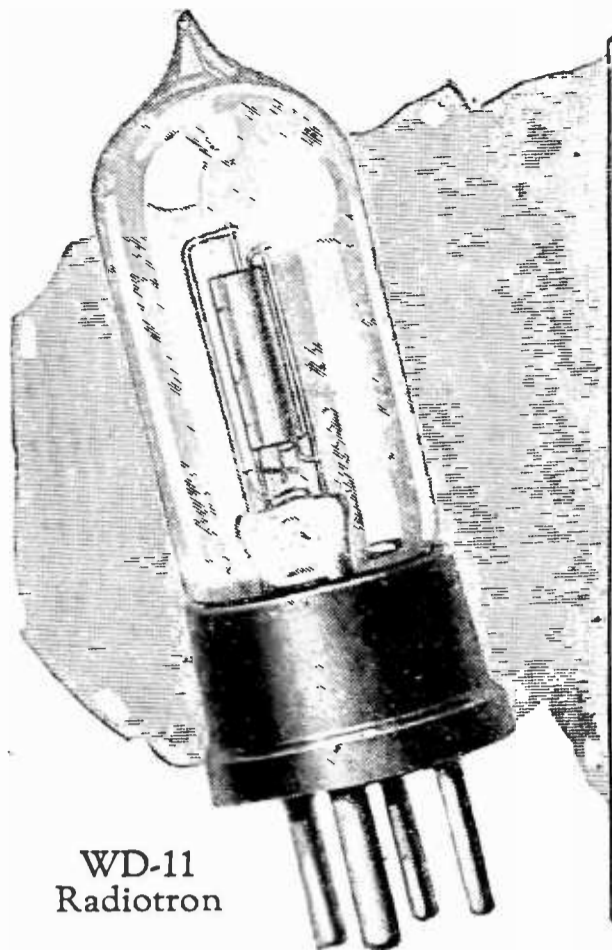

WD-11
Radiotron



Don't Buy *Just Tubes!*



*This symbol of
quality is your
protection*

It isn't a genuine WD-11
unless it's a Radiotron.

It isn't a genuine WD-12
unless it's a Radiotron.

It isn't a genuine UV-199
unless it's a Radiotron.

It isn't a genuine UV-200
unless it's a Radiotron.

It isn't a genuine UV-201-a
unless it's a Radiotron.

If you go into a reliable store and ask for a vacuum tube, you will probably get a genuine Radiotron, because most reputable dealers carry nothing else. And most buyers mean "Radiotron" when they say "tube." But the wise man says "Radiotron." And he takes the precaution to look for the name on the base, and the RCA mark on the glass. Those names have a history of invention, research and development back of them that has resulted in the production of the finest tubes possible to-day. And they have a history of *best performance* right within every fan's experience. That's why knowing fans buy by the name: Radiotron.

Radio Corporation of America

Sales Offices: Suite No. 310

233 Broadway, New York

10 So. La Salle St., Chicago, Ill.

433 California St., San Francisco, Cal.



Radiotron

REG. U. S. PAT. OFF.

★ Tested and approved by RADIO BROADCAST ★

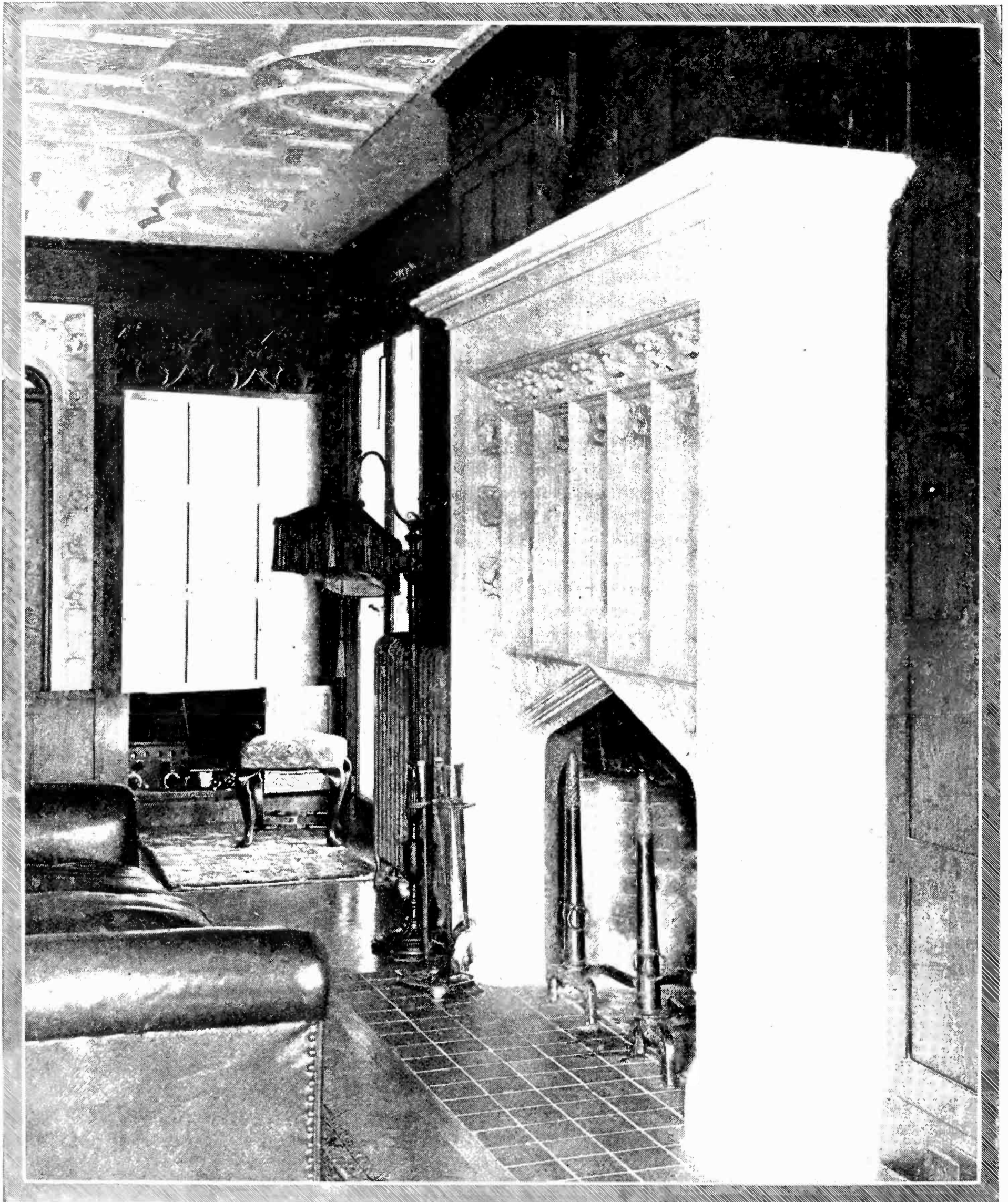

—Roger B. Whitman, *Staff Photographer*

RADIO—WITH DR. LEE DE FOREST

In his home at Spuyten Duyvil, New York. Dr. De Forest, whose patent on the audion three-element tube dates back to the early days of wireless, is one of the pioneers in the art. A four-tube reflex receiver is installed in the panel at the left in the photograph. The panel doors are opened to show the receiver and loud speaker, which is about five feet high. The broadcast programs come through the grill near the ceiling

SEP 25 '24

RADIO BROADCAST

Vol. 5, No. 6



October, 1924

Meet J. Andrew White, the Most Famous Announcer in Radio

The Man Who Calmly Announces Knock-Out Blows When Fifty Thousand People are Too Excited to Think—How the First Fight—Dempsey-Carpentier—was Broadcast

BY MYRA MAY

SEVERAL years ago, a worried young business executive sat in his office and considered his hard lot. Business was rotten, the slump of 1921 had hit the sales of every concern but had been particularly hard on the few existing radio companies. The worried young business executive, Major J. Andrew White, lit a cigarette and idly picked up the morning newspaper. His eye was immediately attracted to an account of the forthcoming Dempsey-Carpentier fight. It was the topic of conversation everywhere. As Major White read the preliminary story of the bout, he had a sudden idea. Nightly for months, he had been experimenting with radio telephone reception from the three low power pioneers which were droning "one, two, three, four" and grinding out scraps of

phonograph music. He had speculated often on the possibilities of introducing radio telephony to the nation at large—but an important event was needed for that introduction.

"This whole country has become interested in the Dempsey-Carpentier fight," Major White reasoned. "Now why can't my radio be tied up with it? Why can't I send this fight broadcast?"



MAJOR WHITE AT THE MICROPHONE

There were only about one thousand objections to this brilliant idea. Few dreamed the broadcasting was possible. Even if they did, they knew that July, a month of bad static, would be a dangerous month to experiment on a large scale. Everyone who thought of it at all, felt that the limited day-range of wireless was so small that the signals would not travel far enough to make broadcasting then worth while. And no

one would put up the money to try out his quixotic scheme. At least \$15,000 was necessary to build the high towers and install a station at Boyle's Thirty Acres in New Jersey, where the fight was to take place.

BROADCASTING: A CRAZY IDEA

“YOU'RE crazy,” Major White's friends told him. His enemies said the same thing behind his back. Nevertheless, entirely on his own initiative, he began to work out plans for transmitting the fight round by round to skilled receiving operators—mostly amateurs—throughout the country.

At this time, Major White was acting-president of the National Amateur Wireless Association. To pick up the Dempsey-Carpentier encounter, he selected certain members of the association, perhaps two hundred and fifty in all, who would secure halls or theatres, hook up their sets, install loud speakers and give the crowds the chance of hearing the fight direct from the ringside.

“When I approached the Radio Corporation of America for an appropriation for my ‘foolhardy plan’, no one was particularly anxious to be identified with my scheme, much less to contribute to it. But there was one man, David Sarnoff, who was willing to give me a chance. Through his influence, the company gave me \$1500 for my gamble,” Major White confides. “With that precious fifteen hundred, I started on a career of frenzied finance. You've heard of that farmer who made two blades of grass grow where one grew before? Well, his work was child's play next to mine; my simple little task was to make \$15,000 grow where \$1500 had grown.

“In reconnoitering Boyle's Thirty Acres for the best place to build my station, I saw the radio towers of the Lackawanna Railroad reared high over the surrounding country. In a flash, I saw my station. I finally secured permission from the railroad company to use their towers on July the second.

“My next difficulty was that I had no transmitter. But such a little detail did not worry me. In casting around among the electric companies, I located a continuous wave ship transmitter at the General Electric Laboratory in Schenectady. Then I hunted up a kind friend who owned a tug and he promised to bring the General Electric set down the river to Hoboken.

“Just about this time when everything seemed to be going nicely, some of our amateur opera-

tors got ‘stage fright’; the number diminished steadily and out of two hundred and fifty prospective agents, our loyal band had shrunk to about ninety. The day of the fight was only about ten days off. I had been working night and day since April, getting everything in readiness. Associated with me, were four men who devoted as much time to my ‘foolhardy plan’ as I did, chief among them was J. O. Smith, now

of the sales force of the Radio Corporation.

“Interest in the broadcasting of the fight had at last been awakened. Our office force was swamped with telephone calls, and a steady stream of telegrams. We were still in doubt as to whether we would even get the space for our transmitter, but we proceeded along the supposition that we would. Fortunately about a week before the fight, the railroad company turned over to us the end of a hallway in a railroad yard building and there we installed our improvised station.

PUTTING DEMPSEY AND CARPENTIER ON THE AIR

OUR amateur receiving operators were scattered in different cities from Maine to Washington (D.C.) and as far West as Pittsburgh. These men showed fine courage; they took large assembly halls and secured loud speakers. At that time, phonograph horns were our most up-to-date loud speakers. Smith and I worked after office hours until about two or three in the morning, testing our set. Announcements were sent to our opera-

“1—2—3—4 . . .

Sometimes they wish it were more,” do the thousands and thousands of radio listeners all over the country who have heard Mr. White broadcast one or all of the great sporting events where he has presided, calm voiced and observing, over the receptive microphone. Mr. White has been active in radio since 1911. During most of that time, he was editor of the Wireless Age, and an officer of the Wireless Press, Inc., a subsidiary of the Radio Corporation of America. He was the chief announcer for the Radio Corporation group of stations, of the Democratic National Convention in New York, and is in great demand as announcer whenever there is a sporting or other event of national prominence to be broadcast.—THE EDITOR.

tors to be in readiness for the tests and then to telegraph us what they heard. The results were discouraging. Their return messages told us of the few scattered words that had been audible and indicated that our fight broadcasting would be equally unsatisfactory. But things couldn't continue this way, our luck must change! It did. Our set began to work the night before the fight.

"Smith and I were worn out from lack of sleep and worry over the event. It had seemed that every imaginable objection had been put in our path. The eleventh hour, however, brought the final objection that threatened to ruin our whole project and send it into failure. The American Telephone and Telegraph Company refused to allow us to connect our radio set to a land wire from Boyle's Thirty Acres to Hoboken where our station was located. That was too much. This was the end, I thought. Then I took fresh courage. I couldn't back down at the last minute and disappoint the operators who were counting on my support. After some frantic scrambling around, I at last secured a high speed telegrapher.

"We arranged that I was to describe the fight from the ringside, blow by blow; my telegrapher was to take it down on the typewriter and give it to Smith to repeat into the radio transmitter at Hoboken. Our operators throughout the country, would then receive from the Hoboken station and give the account to the crowds, through the loud speakers.

A GONG MOVED THE RINGSIDE TO HOBOKEN

AT THE last minute, in a very pessimistic frame of mind, I decided to put a gong in our Hoboken station. 'At least the gong will be audible and the operators will know when a round ends and another begins,' I

thought. I was placed next to the press box, right at the ringside. Putting up my equipment, I proceeded to describe the preliminary bouts and the big fight round by round. It was a boiling hot day, the hottest day in history, I think, and I was right out in the glare, with the sun beating mercilessly on me for more than four hours. My throat was hot and dusty my voice was tired, but I talked on and on, giving minute details of each blow. I had no

time to ask my Hoboken station whether they were getting the fight clearly, I simply droned on and on, trusting to luck that the transmission was distinct.

"At length came Carpentier's knockout. 1-2-3-4-5-6-7-8-9-10. With a terrific bang, the four hundred telegraph operators at the ringside, flashed the news to their home papers. Simultaneously, every sport writer at the field frantically phoned his office the news that Dempsey retained his title. Our current was nearly used up. I calmly

described the knockout and then remarked 'Dempsey is still champion of the world.' Tired but satisfied with my afternoon's work, I tried to communicate with my Hoboken station to get a check-up on the audibility of the transmission. The line was dead!

"There I was. For four hours, I had talked steadily under that hot sun, in the fight arena dust, giving the best that was in me. And now when I tried to find out the results of my work, the line was dead. I had visions of having spent the afternoon in vain, of having worked night and day from April to July and then having my whole 'foolhardy plan' come to nothing, of having to face my cynical friends with their 'I told you so's', of having to admit that I was licked and of having to break the unpleasant news to the Radio Corporation that Mr. Sarnoff had lost his gamble.



JACK DEMPSEY AND MAJOR WHITE

The champion is being initiated into the mysteries of radio at his training camp before his fight with Carpentier which Major White announced—the first fight ever to be broadcast

"Utterly discouraged, I tried once more. After several minutes' wait—and it seemed hours—an answer finally came back from the Hoboken station.

"What', I demanded breathlessly, 'was the last thing you heard?'

DEMPSEY IS STILL CHAMPION OF THE WORLD

THOROUGHLY casual, the telegraph operator replied, 'Dempsey is still champion of the world.'

"My whole afternoon's description had been heard. I had won the gamble!

"Then came a stream of telegrams and more than four thousand letters. The receiving operators were wildly enthusiastic; they had heard everything. Functioning indifferently well, the loud speakers had brought the blow-by-blow account clearly to the auditoriums. The crowds who heard the radio descriptions knew the outcome sooner than those who had depended on any other means of communica-

The Vision of Better Americanism that Sports Broadcasting Has Given to Me

By J. ANDREW WHITE

(Written especially for RADIO BROADCAST)

I AM often asked why I specialize in sports.

The answer is—I don't.

The Democratic Convention is a notable exception, and I good-time myself occasionally by directing informal programs of the midnight frolic variety.

But the descriptive broadcasting I do for the sport classics is of a distinctive character, and that makes these events linger longer in the minds of listeners.

Incidentally, that goes two ways. The pleasantest recollections of radio I hold, too, center upon reporting athletic conflict, not so much because of enjoyment of the thrill of combat—I really don't get much pleasure out of viewing the events themselves, the work is hard and the concentration a terrific strain—but because of the sense that something has been accomplished when it's all over.

It means a whole lot more than entertaining the public. Opinion is moulded, and with it, character, and even spiritual betterment, along with the physical.

Sounds funny to deal with sport broadcasting that way, but let me show you—

This morning's mail, for instance, held two letters which particularly caught my attention.

One bears the signature of a nationally known banker, and his message to me is, that he used my fight description of the night before as an object lesson for his twelve-year-old son—to impress upon him how in dealing with the public one must be uncompromisingly conscientious and that this was an example of observance of the most rigid standards of impartiality and lack of prejudice.

The other letter was written by the head of the greatest industrial enterprise in America. It is just a note of congratulation and approbation, but there is much to be read between the lines.

Now I don't know either of these men, probably never will meet them. But when an industrial giant who controls a billion dollar business takes time out of a busy life to listen to my description of a sporting event and is impressed sufficiently by it to write me in complimentary vein, certainly it is a fair assumption that he will turn a sympathetic ear to any proposals for athletic recreation among his thousands of employes. And that is good for industry and humanity.

As for the banker-father who used the sport broadcasting to impress upon his son the principles of square dealing and integrity, that certainly needs no comment.

See what I mean? I could multiply these examples a hundred times. Entertainment of course is the primary object of tying-up radio to sporting events, but it can be seen from these two instances that the thing goes much deeper. Never in the wildest flights of imagination could I have anticipated, at the inaugural of broadcasting, the tremendous power for good which radio has become in this field alone.

My correspondence is filled with letters from old folks and those of gentle nature—a high percentage of them women, and there are many clergymen, too—but the letters I like best are from the youngsters. I feel that I have done something when I arouse their enthusiasm over sports, for I am just old enough to have escaped the current conception of jazz, petting and hip flasks as requisites to recreation, and young enough to appreciate the greater joys we found in the cultivation of athletic skill and how the girls of my time shared these views with us and found plenty of vent for their enthusiasms.

Mature people enjoy a thrill—to younger ones excitement is a necessity. And somehow I can't get over the idea that those thrills which accompany a contest for athletic supremacy are the real ones, after all. If radio reawakens that idea, and I am instrumental in putting over the revival in interest—well, that is a big enough broadcasting mission for me.

tion. The first time radio had been used for news, it had justified itself.

"Several days later, I met Tex Rickard, who had promoted the fight.

"I've been wanting to see you,' Tex began, 'I understand your description of the fight was the sensation of the afternoon. They tell me even the gong was audible.'

"Considering that the gong had been right in the Hoboken station, I was much amused that he should have commented on it."

Major White is always experimenting with something new. He is an explorer at heart. He loves adventure. He likes the thick of the fight. A picturesque figure he is, who even in this mundane, placid world, manages to inject thrills and hair-breadth escapes.

His escapes began 'way back in his 'teens. Most young boys climb trees and play baseball and get their thrills vicariously from their reading. They are always following the dauntless hero of a "series" who goes to the North Pole to drape an American flag over his discovery, or who fights lions in Africa, or something fierce in the Wild West, or who seizes the telegraph when the ship is sinking, sends out a s o s which saves the lives of the passengers and crew. But Andrew White had scant time for reading about rescues; he made them.

AN OFTEN-HEARD-OF, SELDOM-MET NEW YORKER

HE IS one of those often-heard-of but seldom-met real New Yorkers. Born and bred in the Metropolis, he has spent most of his life in Manhattan. In spite of the charge that big town boys can not enjoy the youthful pleasures that the country lads have, Andrew White managed to crowd every variety of sport into his childhood. He was an expert swimmer. During the summer at Long Beach, Long Island, he helped the volunteer life corps. It was not until he was twenty that he had his first narrow escape.

"As I patrolled the beach," he relates, "I noticed six people swimming out toward a dangerous section of the ocean bed. At this point about three hundred yards from shore, the ground sloped abruptly; there was a strong surf and an undertow powerful enough to drag a hapless swimmer out to sea. I hallooed to the people to warn them, but they only saw me wave and did not hear my message so they supposed I was simply sending a friendly greeting. They waved back and swam lazily toward the danger zone.

"I plunged into the water and when I was near the little group, shouted my warning. Four of them immediately turned back; the other two, a man and a girl were winded. They were being swept steadily out to sea. I had not brought the life rope or a belt with me. I was not equipped to cope with drowning persons. Nevertheless I made a grab at the girl. Turning hysterical in this perilous moment, she threw her arms around my neck, nearly choking me and dragging us both down. When we came

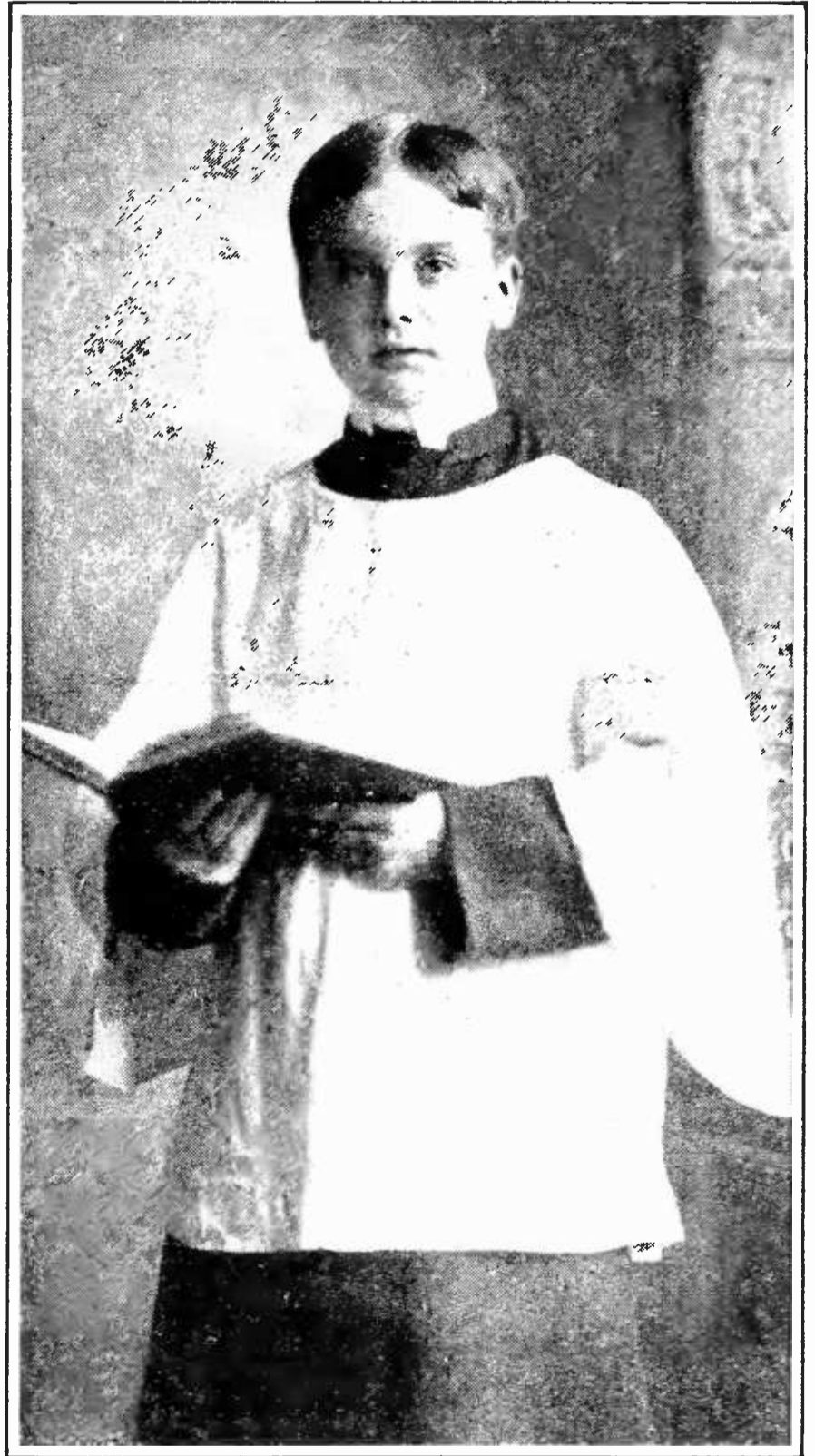

A CHOIR BOY

Was Andrew White in the days of his youth

up again, I ungallantly shook her until she was limp and then slung her over my shoulder. Thus impeded, I battled the surf and undertow as I slowly swam in. Her companion, a big man of about two hundred pounds, swam beside us. The water, never very calm, was

particularly rough that day and with a great effort, I pushed forward. To add to my difficulties, the girl over my shoulder fainted and her dead weight was an additional burden.

"We had gone perhaps fifty yards when the big man suddenly gasped, 'I'm all in'. By this time, one of my assistants who had seen our plight, had hooked his belt to the life line and was swimming toward us. I shifted the girl over to one shoulder, then I hoisted the big man onto the other. I swam a few yards until I was exhausted; then we all went down together. After a few seconds, I would again adjust my pack and the three of us would drift ahead. My assistant was swimming steadily closer. The huge holiday crowd on the beach, watched our little drama with breathless interest.

"Suddenly just within about one hundred yards of shore, I had the doubtful pleasure of seeing my assistant wave a distress signal, turn back and swim in. It seemed to me that for hours, I struggled through the undertow and surf, fighting my way every inch. Repeatedly when I was exhausted, the three of us would go down together; then, struggling to the surface, we would progress a little further. All the while the big crowd on the beach watched us as dispassionately as though they were witnessing an exciting moving picture.

"I have no idea how long I wrestled with the surf, but at a moment when I was thoroughly exhausted and felt that I could go no farther, the amateur life guards swam out with the rope. At last, help was in sight. With the man and woman clinging to my shoulders, I grabbed the rope and scores of people on the beach began pulling us in. Their enthusiasm overbalanced their judgment, for so vigorously did they pull, that they sent us to the bottom. I would struggle to the top and just as I was about to breathe, the crowd would give another mighty heave and down I would go to the bottom again. The man was exhausted and the woman had fainted. Four times, I worked my way to the top only to sink to the bottom. Finally I left the man and girl safely clinging to the rope, while I made for shore. I had ceased to have any feeling; numb, I swam on, when out of the crowd on the shore, a young man in flannels jumped into the water and swam out to help me. I found out later that he was Tom Thorp, the famous Columbia football player.

"As I staggered to shore, I had only one ambition—rest. My legs seemed to have

turned to jelly, they no longer functioned, and wearily I lay on the sand. Then someone brought me the bad news that no one knew how to resuscitate the girl I had rescued. I spent the next quarter hour bringing this girl back to life. When she was once more conscious, she threw her arms around my neck and kissed me. Can you imagine anything more embarrassing to a young man of twenty than to be kissed right in sight of thousands of visitors swarming on a beach?"

AUTOMOBILES, MINING, AND RADIO

WHEN Major White completed school, he started work in an automobile factory. He was helping build Vanderbilt Cup racers. Next to the draughting board where the designs for the engines were made, White had a cot. Day and night, he slaved over his blue prints and when he was too weary to work more, he slept a few hours. The young automobile engineer hoped to establish his reputation by the wonders this racer would accomplish. He had devoted all his energy, all his enthusiasm to building this engine; he had sacrificed his rest, his recreation, but he was content. He was confident that the racer would win the cup.

On the morning of the race, Major White was feverish with excitement. His engine was going to win the race and establish him as a master builder. The automobile was proudly driven out to the speedway and then the unexpected happened! A loud noise. Three cylinders blew out. That afternoon, Major White, haggard from lack of sleep, saw another automobile race on to victory while his car, the repository of so much work and so many youthful ambitions, lay abandoned in a ditch.

"I was disappointed but not discouraged," he says. "The very next year, I was on the job, determined this time to design a winning engine. We can't expect a lucky break the very first time and after a defeat it is up to us, to show twice as much spirit, added to the experience our failure has brought us."

Several years later, we find Major White selling mining machinery. He is still injecting thrills and hair-breadth escapes into his life. Let him tell you about his fall down a mine shaft in Arizona.

"I was examining a safety device on a bucket for hoisting ore out of the mine," he narrates. "The hoist force had all knocked off for lunch and only a group of curious Mexicans were gathered around the entrance to the mine.

My Spanish was sketchy yet when I got into the bucket, I flattered myself that I had told a Mexican laborer very correctly and distinctly that I wanted to see how the catch worked. Evidently my Spanish was not up to specifications for the Mexican misunderstand. Releasing the winch drum, he sent me hurtling down the mine shaft. Down and down that endless shaft I fell. Strangely enough, I was very calm.

“What an odd way for a man to end his life,’ I thought. And I philosophized over life’s vagaries. ‘There may be an obituary paragraph back in a New York paper,’ I decided. I wondered who would tell my mother. I recall that I shrugged my shoulders and murmured, ‘Well, goodbye, old world.’

“Then the bucket stopped. It dropped into a pool of very dirty, black mine water. That water undoubtedly, saved my life. Very much shaken and a little bruised, I cautiously crept out of the bucket. Up top, hubbub reigned. The Mexican, frightened at what he had done rushed for help. The mine foreman believed that I lay dead at the bottom of the mine. Nevertheless a relief expedition was organized and came down to collect my remains. I was chilled from lying in the water but very much alive, which considerably surprised the relief workers.”

Attracted by the new science of wireless, Major White had been studying the subject. He believed that it was the coming electrical marvel and wrote some articles, amplifying his opinion. These came to the notice of the British Marconi Company. When one of their representatives, Mr. Godfrey Isaacs, brother of Lord Reading, came to the United States, he felt the need of institutional publicity and arranged that Major White should enter the employ of radio to convince the world of wireless’ limitless possibilities. Since 1911, the major has been associated with the radio world.

While he was vice-president of a Radio Corporation subsidiary—The Wireless Press,



NEAR A MINE-SHAFT

In Arizona, where Major White had at least one exciting experience

Inc.—he conceived the plan for the first broadcasting, as we know it, that was ever attempted. His success with the Dempsey-Carpentier fight convinced the big electrical companies that radio broadcasting was the coming means of communication. They decided to build permanent stations with regular program schedules.

In the fall of that same year (1921) Major White, meanwhile, again experimented with the wonderful new broadcasting. He fitted up a station at the Electrical Show and transmitted a series of concerts and the World Series being played at the Polo Grounds. Since that time, he has been a necessary adjunct to sports. A big prize fight, a World Series, a football game is not complete without Major White to describe the event in his own delightful style. The father of practical radio broadcasting, he is still its most prominent relative.

THE STORY OF A GREAT SUCCESS

IS that of Powel Crosley, who in several short years has made his name one to conjure with among the many manufacturers of things radio. Myra May has written an interesting story about this interesting man, which will appear in an early number of this magazine.

Is Radio Making America Musical?

Good Music is Heard Near and Far—How a Bloodless Revolution is Occuring in Musical Taste and Appreciation

BY CHARLES ORCHARD, JR.

WHY has Europe more musical appreciation than America?" Time and again we hear this query—the answer is simple.

Musicians are not made by a few years of study, but are created only by generations of intimate association with good music. For generations, Europeans have been intimately accustomed to the best of music—in homes, the schools, in the churches and the theatres. Even in the smaller towns there are excellent bands and orchestras, choral societies, and even operatic organizations—organizations which are supported in only the larger cities in America. The European hears on all sides good music intelligently played—he is fairly steeped in it.

Heretofore, Americans, except those living in the larger cities, have been denied the privilege of hearing the best in music performed by accomplished musicians because worthwhile productions cost an enormous amount. Thousands of earnest students of music and music lovers in small towns and rural districts have never had an opportunity of enjoying the advantages to be had in the large cities.

There are traveling organizations which perform some of the better class of musical works; and many of the foremost artists appear as soloists in many of the very small towns—but these appearance are few and far between, and they fail utterly to reach the rank and file. Unfortunately, it is this element that must be reached and converted before America can equal the musical attainments of Europe.

For years musical educators have been striving toward this end; but because of the inaccessibility of those most needful of assistance, no marked progress has been made.

It is a theory of long standing; for ages people have contended that, if music is available without physical and mental effort and exertion, children will refuse to practise the technical exercises so necessary to a finished performance on a musical instrument. It has

been contended that the comparison of a child's accomplishments with those of a finished musician are so discouraging that the child should never be allowed to hear a virtuoso play. I remember that, when I had studied the piano for about four years, I was very anxious to go to one of John Powell's recitals. My father laughed at the idea. "Why, boy," he cried, "you'll be so discouraged that you'll never touch a piano again." But I went, and I learned that there was something in playing a piano other than merely striking the right key with the right finger at the right time. There were sensations to be aroused, stories to be told, pictures to be painted—and, executed in the subtle language of tones, they were much more appealing than in the more obvious language of the story-teller or the painter. I learned that pleasing sounds were merely a means and not an end in music. Music took on an entirely different aspect; and I went to work with far more interest and intelligence.

BROADCASTING CAN BRING THE BEST TO YOUR
FIRESIDE

TO-DAY, by means of radio, symphony orchestras, operas, oratorios, vocal recitals, and performances on all the solo instruments are accessible to those in even the most remote rural districts. Broadcasting stations scattered over the entire continent nightly offer much of the best in music in all its forms, performed, in general, by very good musicians.

There is no longer any reason why there should be a drought of musical knowledge and appreciation in America since radio has developed into its present state. Such artists as Anna Case, Freda Hempel, Fritz Kreisler, Claudia Muzio, Mary Garden, Mengelberg, Friedman, Zimbalist, and many others, have used radio as a means of promulgating their art, recognizing the unusual opportunities offered by this vehicle. The well known lecture-recitals of Walter Damrosch on the Beethoven symphonies have been given, by

means of radio, to thousands of interested listeners, who otherwise would probably never have had that privilege. Instructions in vocal and instrumental music even, have been given over the radio.

Theodore Thomas, one of the most potent forces in musical development in America, has said, "Popular music is familiar music." America's wholesale lack of interest in good music is due primarily to its astonishing lack of familiarity with good music. And radio, by making good music familiar, will do more to popularize good music and make America a truly musical nation than any other known means.

WHERE RADIO HELPS CHILDREN

BY A musical America I do not mean a nation of performers on musical instruments, but rather a nation of music lovers who have an intelligent understanding and appreciation of good music. There are already far too many Helens and Sams who merely hammer away on a piano, saw on a violin, or blow through a cornet; possibly with mechanical proficiency, but usually quite without musical understanding. It would be far better to have a child understand and appreciate good music, under-

stand the subtle language of tones and feel the emotions they delineated, than to have him perform on some musical instrument in an

uncomprehending, unintelligent manner. Let that child hear good music, surround him with good music everywhere he goes—in the home, and in the schools and churches. If there is latent musical ability within him, it will surely manifest itself. At least, by close and constant association with good music, eventually there will be developed within the child a love, apprecia-

tion, and understanding of good music which otherwise would never have existed.

As an educational force, radio stands pre-eminent, for it offers to all a simple, inexpensive, and thorough means of accomplishing this end. Radio sets may be had at a price that makes them prohibitive to none; they bring the music of the world into the most inaccessible rural districts and to your very fireside; and offer a constant source of benefit and pleasure.

For the parent who wishes to leave his child a worthwhile legacy; a love and appreciation of good music, let him buy a radio-receiving set, allow his child free use of it, and he will be well repaid in the development of that child's interest in and appreciation of good music.

"Theodore Thomas, one of the most potent forces in musical development in America, has said, 'Popular music is familiar music.' America's wholesale lack of interest in good music is due primarily to its astonishing lack of familiarity with good music. And radio, by making good music familiar, will do more to popularize good music and make America a truly musical nation than any other known means."

AN exceptionally interesting article by Walter Van B. Roberts will appear in an early number of RADIO BROADCAST, which no radio constructor should miss.

How to Build a Portable Seven-Tube Super-Heterodyne

A Real Super, of Perfected Design, Using UV-199's and Dry Cells, is Decidedly Portable, and of Simplified Construction so that the Average Builder Can Make It

BY McMURDO SILVER

FOR many months, we have waited for a truly portable super-heterodyne that we considered practical. Many designs have been offered to us, and refused. This article, which we believe, is the most complete one on the super-heterodyne ever published in any radio periodical, describes a receiver which we have compared with a mighty good five-tube radio frequency receiver using an outdoor antenna. The "super" described below proved more satisfactory in every way except volume from near by stations. Mr. Silver came on from Chicago to show his receiver to us. He assembled and wired one in our laboratory in two hours, hooked it up, and it worked right off the bat—which is no mean feat for a super-heterodyne. It is an excellent receiver.—THE EDITOR.

THE problem of reducing a standard super-heterodyne receiver to portable form without sacrificing selectivity, sensitivity, or quality of reproduction and at the same time without producing a receiver which could only be built in a laboratory, has occupied the writer for some months. In this article is described the final

a permanent installation. The set had to be laid out so that no gymnastic feats would be involved in wiring or assembling it, and after assembly the average builder must be saved from entering into a correspondence course with the editor to find out how to make it work or to find out why certain things had been overlooked. These last conditions automatically eliminated reflexing, which at best is not to be recommended, and small assemblies involving specially made parts. Few builders are machinists and engineers combined. Therefore, standard parts were used throughout, with the smallest

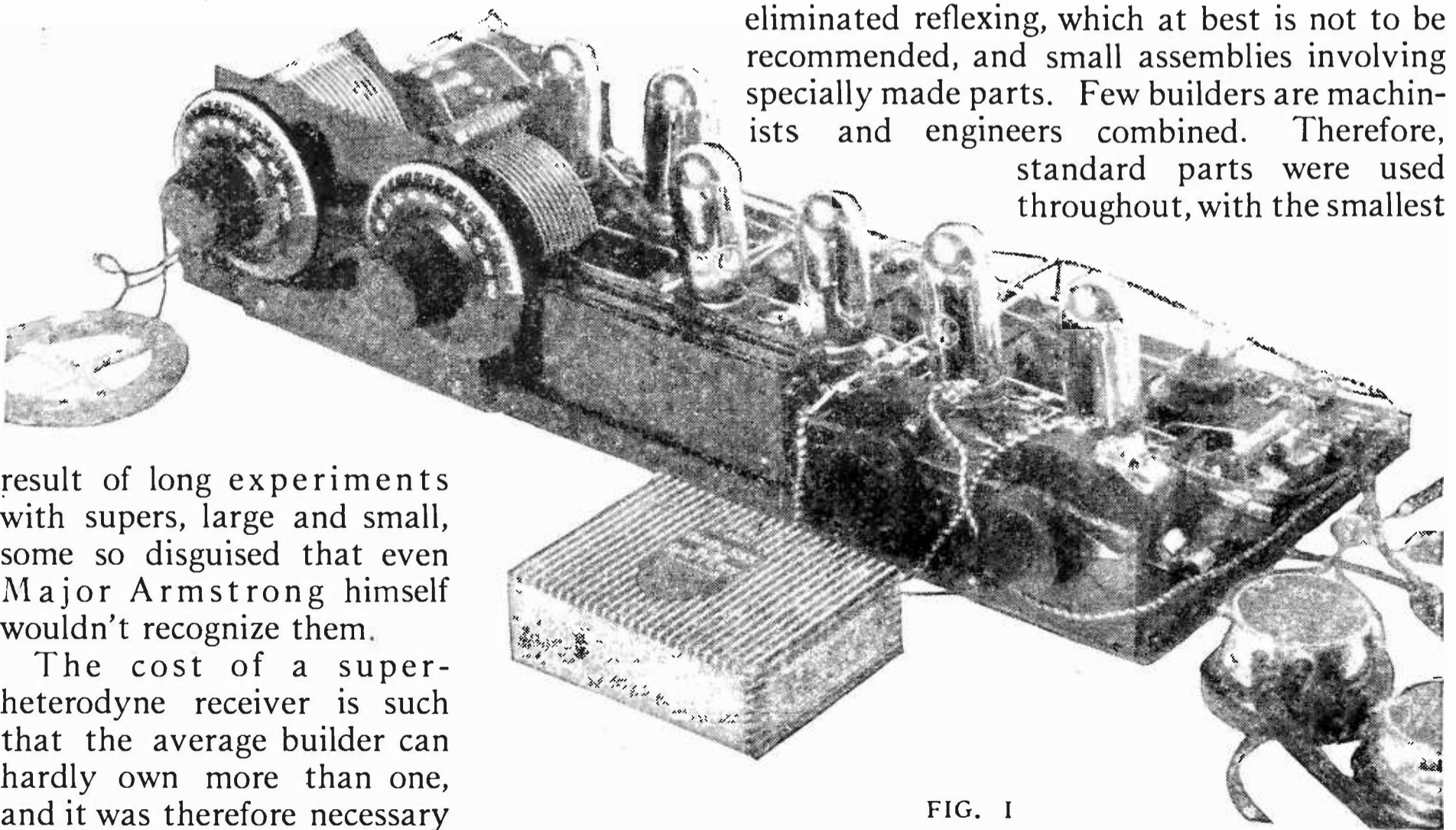

result of long experiments with supers, large and small, some so disguised that even Major Armstrong himself wouldn't recognize them.

The cost of a super-heterodyne receiver is such that the average builder can hardly own more than one, and it was therefore necessary in designing a set to provide one which would give results equal to a large outfit when used in

FIG. 1

One of the early models in Mr. Silver's series of super-heterodynes using air-core transformers, which were later abandoned. This experimental method of assembly is excellent for testing circuits, since no large panels are wasted on the first trial

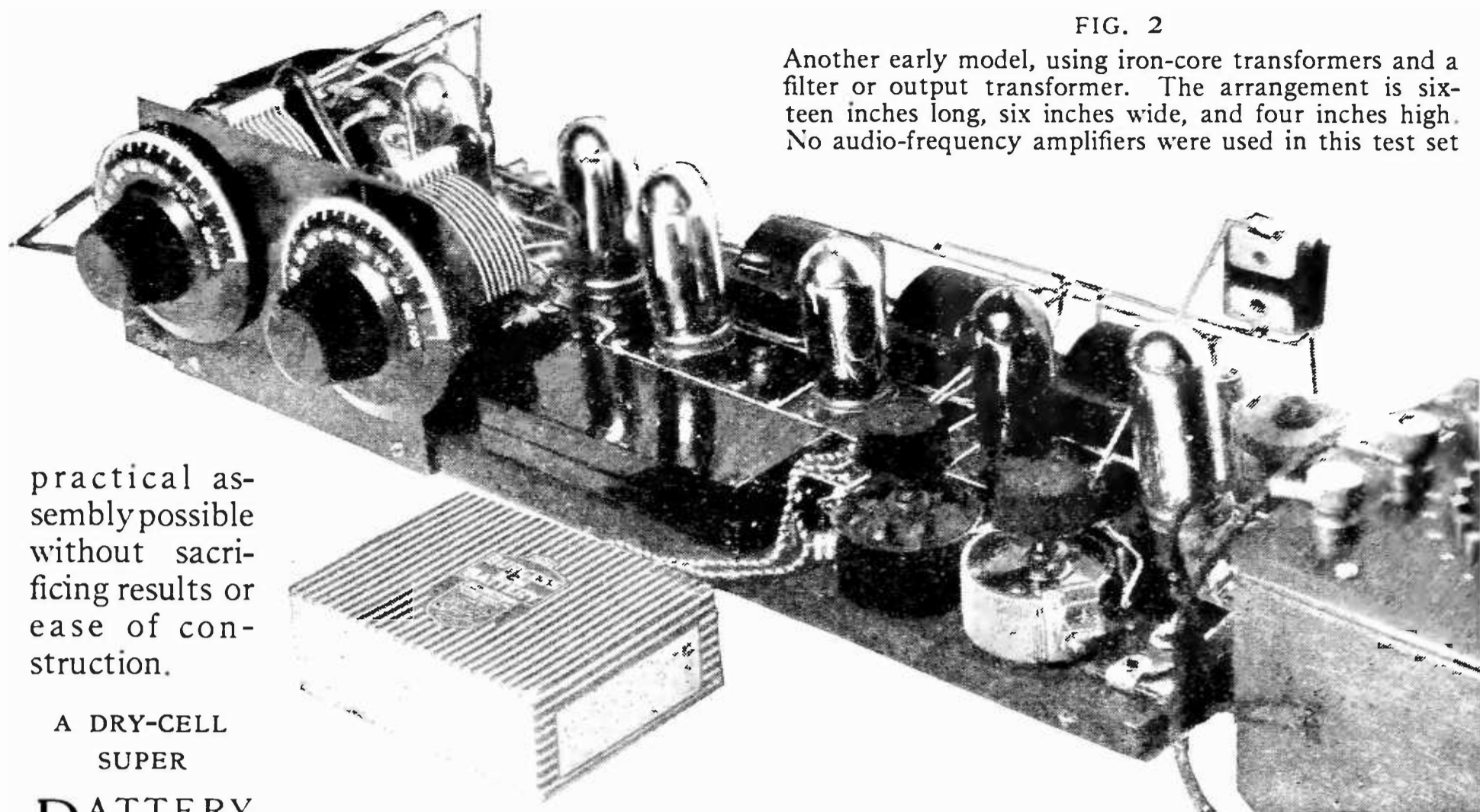

FIG. 2

Another early model, using iron-core transformers and a filter or output transformer. The arrangement is sixteen inches long, six inches wide, and four inches high. No audio-frequency amplifiers were used in this test set

practical assembly possible without sacrificing results or ease of construction.

A DRY-CELL SUPER

BATTERY

size and

current consumption were of very great importance, and to some extent determined the size of the set. It was possible, by the use of 199 tubes and an ultra-efficient circuit to decrease the B battery current consumption to approximately sixteen milliamperes, as against the average forty milliamperes for an eight-tube 201-A set. This increased the battery life, and permitted the use of four of the small size 22½-volt batteries together with three dry cells for the filaments, which were placed directly behind the set in its cabinet.

In a set of this type, the efficiency must be as high as possible, and the possibilities of trouble very remote. Reflexing being out of the question, it was necessary to use a standard circuit. That circuit was so improved that fewer tubes could be made to do the work of the eight generally considered necessary. These tubes had to operate from dry cells, which meant that a real step ahead had to be made to get approximately the same results out of seven 199's that had been previously obtained from seven or eight 201-A's.

WHY IRON-CORE TRANSFORMERS ARE USED

THE development of the portable was started with air-core transformers in the intermediate amplifier operating at between two and three thousand meters. These were later abandoned, since it was found that even when the most carefully matched set of trans-

formers was used in a specially built circuit, there was variation which rendered the amplifier insensitive, broad in tuning and generally unsatisfactory. In the few cases where it was possible, with specially designed and tuned transformers, to get the amplifier to operate at only one peak instead of the usual two or three, the amplification obtained was only slightly superior to that obtained with iron-core transformers operating at about six thousand meters.

This slight gain, so hard to realize dependably, was not worth while when the lack of stability of the air-core amplifier, especially when used with 199's, was considered. The battery consumption of the air-core amplifier was from 50 to 70 per cent. higher than with the iron-core amplifier, due to the use of a positive grid bias obtained by a potentiometer across the A battery. This positive bias was rendered necessary in order to stabilize the circuit, and is necessary with all practical air-core transformers now made. Its use is contrary to best operating practice, and is unnecessary with iron-core transformers. In the set herein described, a negative C battery of from 1½ to 3 or even 4½ volts is used in conjunction with a potentiometer.

WHY THE POTENTIOMETER HAS BEEN RETAINED

THE potentiometer is not an unmitigated evil, as often pictured, and when used with a C battery to get a fine voltage adjustment,

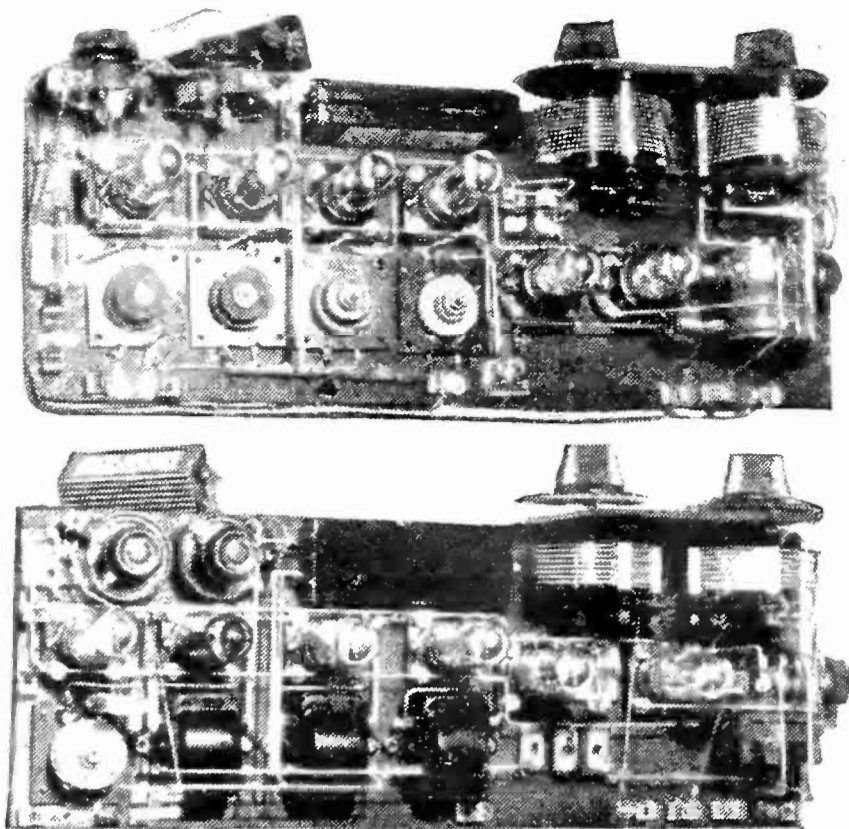

FIG. 3

Two experimental set-ups. Notice the two C batteries, one being used even with the air core transformers, which were especially designed and matched

permits adjusting the amplifier to its most sensitive condition. Often builders do not use the potentiometer in order to eliminate one control. Omitting it is like omitting the tickler control on a regenerative set—a large percentage of amplification is thrown away for simplicity of control; a fixed tickler adjustment is substantially the same thing. Never do we

see a circuit using a fixed tickler, unless it is a freak, yet often where a C battery is used in a radio-frequency amplifier, no potentiometer is included.

HOW THE STANDARD "SUPER" CIRCUIT WAS IMPROVED

IN IMPROVING a standard circuit, two things of major importance were done. The first detector circuit was made regenerative, which gave considerable increase in amplification, as well as sharpening up the loop-tuning condenser. The Rice split-loop method was used, which proved most satisfactory for this type of set. The next step was to improve the amplifier. After considerable experiment, an R.F. transformer unit was developed which eliminated practically all possibility of trouble, and gave amplification with two intermediate stages equal to that which had previously been obtained with three stages. The sensitivity of the set was such that it would still go down to the noise level in nine out of ten locations, and the absence of the third stage eliminated a tube and its battery drain, saved some space, simplified the construction of the set, and, most important, cut out a good deal of noise previously experienced with three-stage amplifiers.

The desirable amplifier is one that will go down to the lowest seasonal noise-level, and

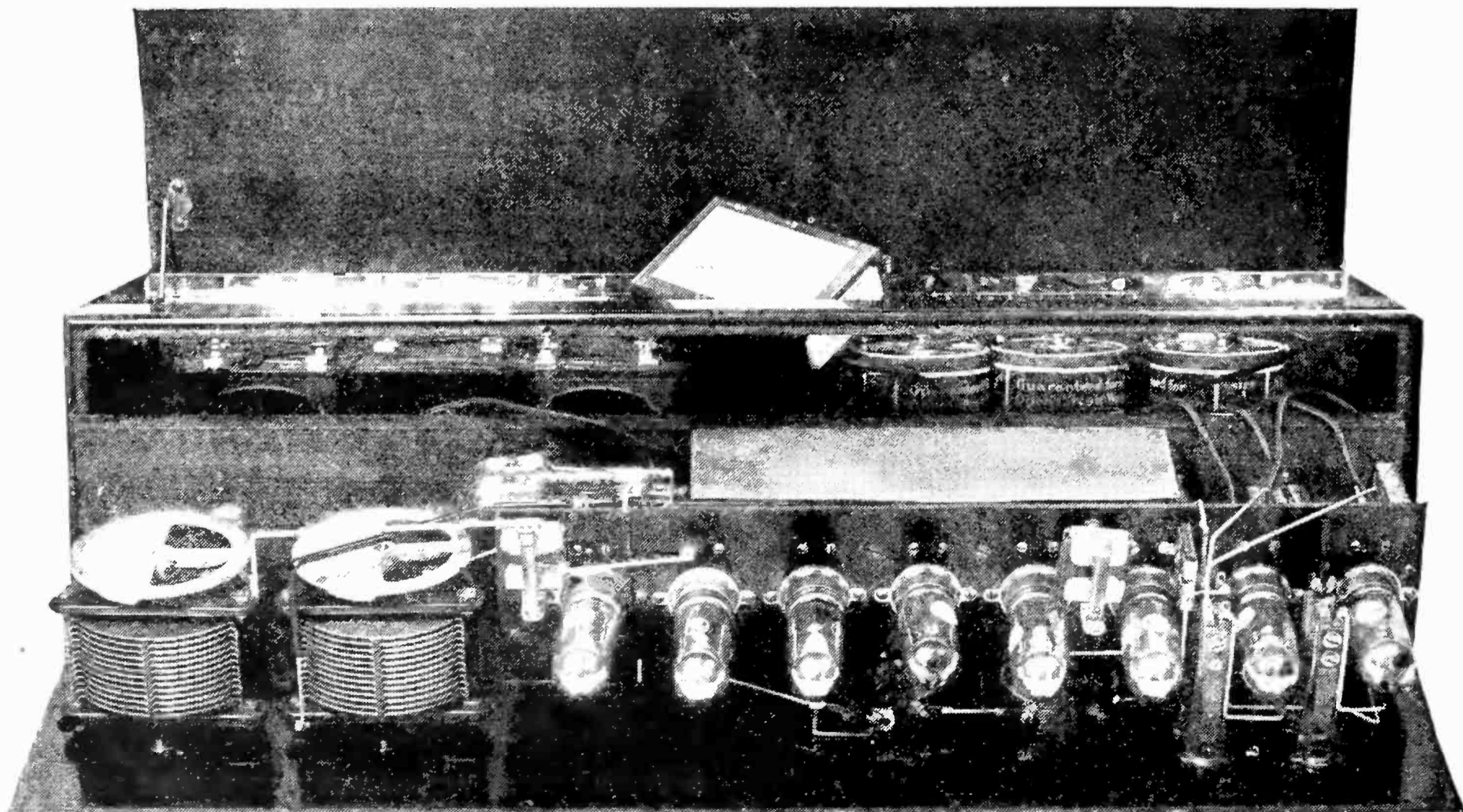

FIG. 4

An eight-tube portable super-heterodyne using iron core transformers sealed in a can below the eight-gang socket. Tests proved the third radio tube to be unnecessary

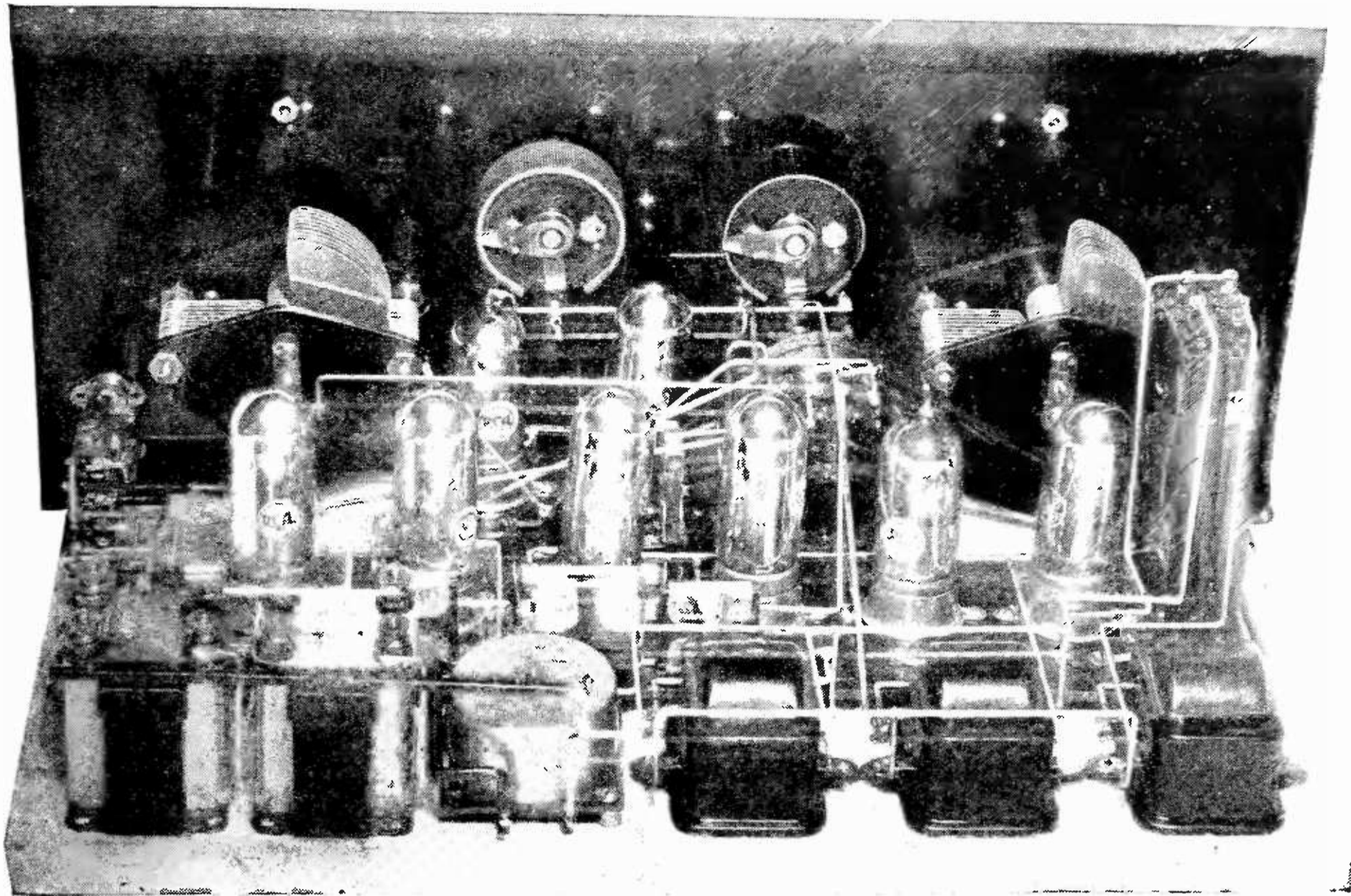

FIG. 5

Rear view of the sixteen-inch super. The wiring of this set is too complicated for general construction. A far simpler and just as effective assembly is described in the text of this article

amplify any signal as loud as, or louder than the noise. Extra amplification will only bring out more noise, and can not possibly bring out a weaker station, for it is bound to be drowned out in the atmospheric rumble, which is louder than it. This is the real limiting factor in distance reception and receiver sensitivity. The two-stage amplifier got down as low as was desirable. Why use more tubes?

Grid condensers and leaks were used on both rectifier tubes, as they were found somewhat preferable to C batteries, from the standpoints of sensitivity, ease of assembly and current-consumption, despite general belief to the contrary.

DESIGN OF THE AUDIO AMPLIFIER

CAREFUL consideration was given to the audio amplifier, and the Jefferson No. 41 audio transformer was chosen for its remarkable curve, the extremely good reproduction obtained with it, and its generally satisfactory operating characteristics.

The seven tubes in the set surely "do their stuff" to use a popular expression, for

coast-to-coast reception is quite common with the set during the summer months in Chicago, in many cases with loud-speaker volume. Its selectivity is such that when located three hundred feet from WGN's antenna, in a Ford car, WGN could be entirely eliminated with a six-degree oscillator-dial movement, and any other Chicago stations, and several within a fifty-mile radius, brought in with sufficient volume to be heard above traffic noise at seven in the evening. The same thing happened near WEBH and WMAQ, so the results were not at all freaky. Five miles away from local stations, they could be eliminated with a four-degree oscillator-dial movement, and a five- to ten-degree loop-dial movement. Two stations in the same direction, each about fifteen miles away, operating at 283 and 286 meters were tuned in, with a dead spot between them where neither could be heard. These results bore out the writer's belief that two stages of intermediate amplification were sufficient, for the results were almost up to those of an eight-tube 201-A set, and better on distance in every respect than a standard five-tube neutrodyne using five

201-A tubes and a 150-foot antenna. When it is realized that the super used an 18-inch loop and seven 199's, the full significance of these results will be appreciated.

Photographs are given showing several types of supers built, the first using air-core transformers, later abandoned for fifty kilocycle iron-core types in conjunction with a special filter. The final model, shown in Figs. 8, 12 and 13, is entirely contained in a standard 7 x 18 cabinet, with all parts mounted on the panel or on two small sub-bases. All batteries are placed behind the set, in the same cabinet, or if a permanent installation is to be made, leads may be brought out to larger type B's and six A's in series-parallel, or a small storage battery. The only additional equipment needed, aside from the tubes and batteries, is a loop with a center-tap and a pair of phones or a loud speaker. Following is a list of material needed, which should cost about \$55.00, without the cabinet.

- 2 .0005 low-loss condensers, such as Cardwell, Duplex, General Radio, New York Coil Co., or Silver
- 2 3" or 4" dials, preferably moulded (vernier types may be used if desired)
- 1 Allen-Bradley, Howard, or Pacent six- or seven-ohm rheostat
- 1 Howard or similar 150- to 400- ohm potentiometer
- 3 Binding posts, insulated type
- 1 Carter three-spring No. 102A jack, or similar
- 1 Carter one-spring No. 101 jack or similar
- 1 Carter on-off switch or similar, if desired (not shown in set.)
- 1 Silver RF transformer unit (specifications for substitution in this article)
- 1 Silver oscillator coupler (can be constructed—see text)
- 2 General Radio, Silver, or Benjamin, Na-ald 199 sockets
- 2 Jefferson No. 41 audio transformers
- 1 Silver five-gang 199 socket, or five single General Radio, Silver, or similar sockets
- 2 .5 Mfd. bypass condensers, large type preferably
- 2 .00025 Micadons, Daven, Meuter, or New York Coil Co., mica condensers with leak clips
 - 2 .002 Micadons, Daven, Meuter, or New York Coil Co., mica condensers
 - 1 .005 Micadon or similar mica condenser
 - 1 Chelton midget or similar .000025 mfd. condenser
- Any low-loss small vernier type may be used
- 1 3- to 5- megohm grid leak, good quality
- 1 1- to 2- megohm grid leak, good quality
- 1 7 x 18 x $\frac{3}{16}$ Bakelite or Condensite panel
- 1 7 x 18 cabinet
- wire, spaghetti, screws,

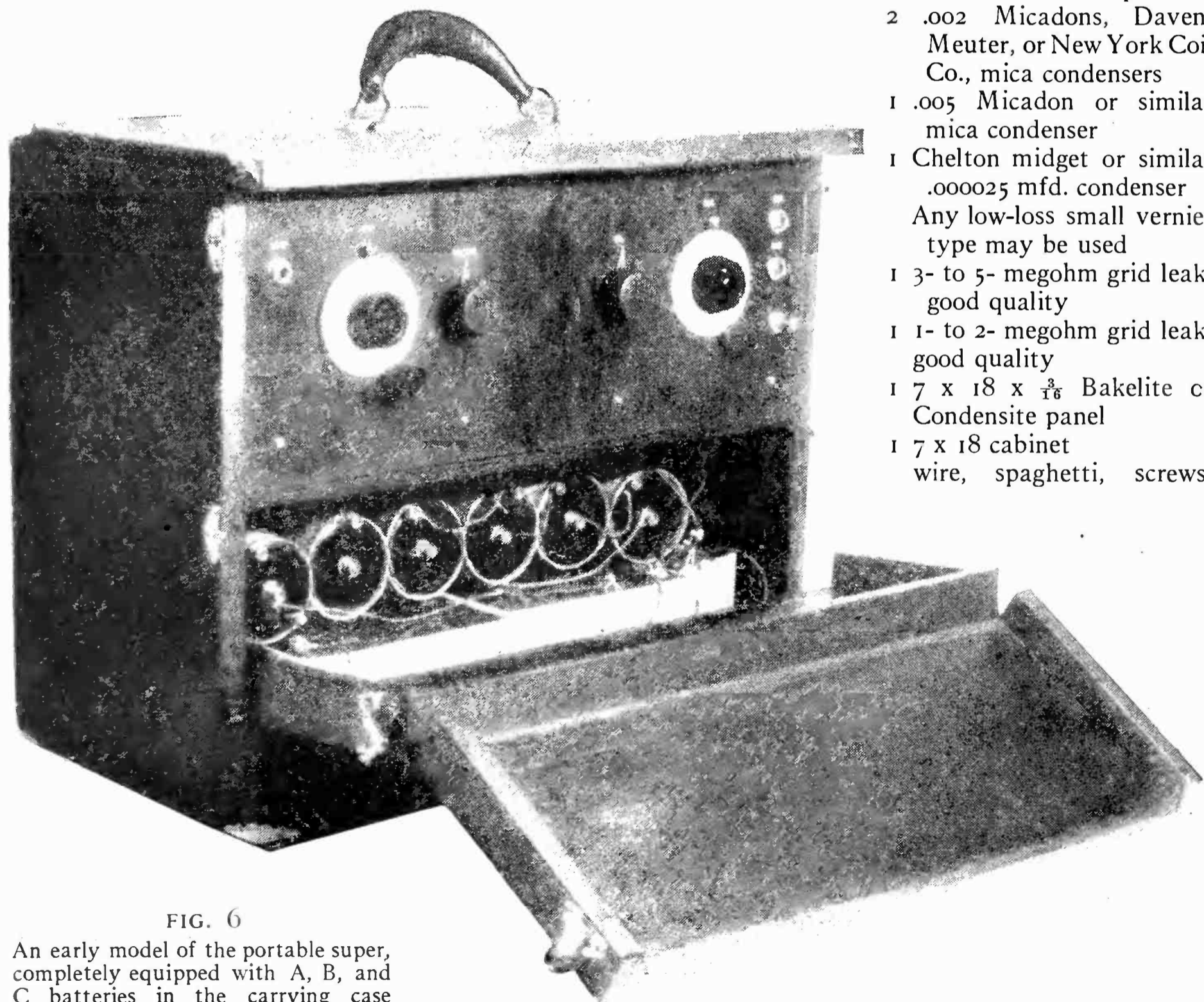

FIG. 6

An early model of the portable super, completely equipped with A, B, and C batteries in the carrying case

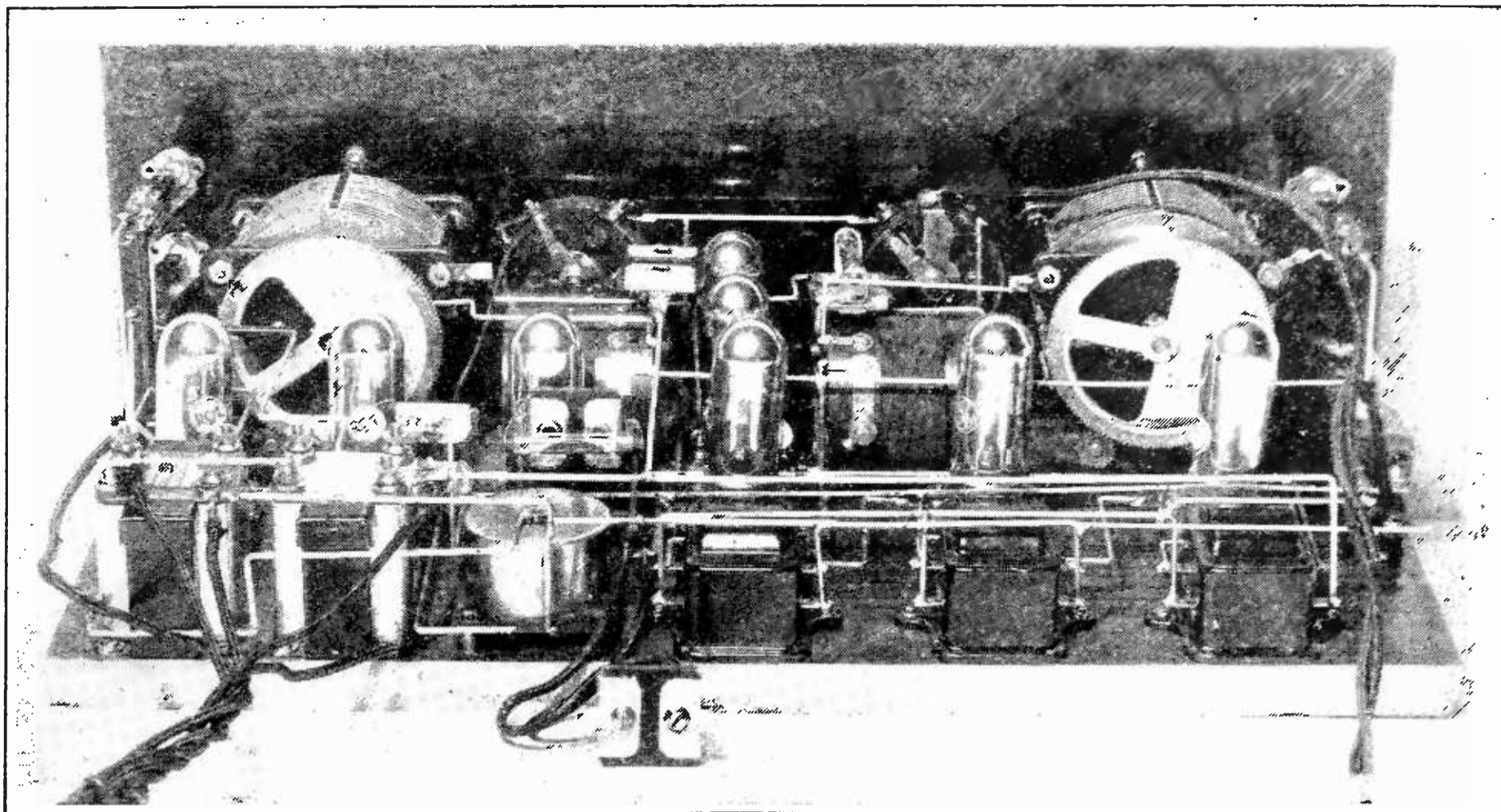

FIG. 7

Rear view of the set shown in Fig. 6. Notice the method of construction and how the flexible battery leads are fastened to the set wiring

solder flat lugs, flexible lead wire and baseboard $7 \times 4\frac{1}{4} \times \frac{1}{2}$

Tools needed: 1 pair side-cutting pliers, 1 screwdriver, hand-drill with drills, 1 soldering-iron with rosin core solder

It is advisable not to deviate from the rather flexible material list given above, as all the material is of first-class manufacture and was chosen carefully. Small parts, such as sockets, jacks, rheostat and potentiometer may be substituted, although trouble may be encountered fitting other parts into the available space, aside from the question of results.

HOW TO BUILD THE OSCILLATOR COUPLER

THE oscillator coupler may be made by winding two sections separated $\frac{1}{16}$ inch apart on a $2\frac{1}{4}$ -inch bakelite or condensite tube, each section containing twenty-eight turns of No. 28 D.S.C. wire. The rotor coil, shown in Fig. 9 as L₁, consists of twenty turns of the same wire on a $1\frac{1}{2}$ -inch tube, rotatable within the stator tube carrying coils L₂ and L₃. The range of this oscillator, with a .0005 mfd. condenser is about 150 to 550 meters—more than sufficient for broadcast reception.

The transformer unit may be replaced by two General Radio, Acme, All American or other types of iron-core, long-wave RF transformers and a filter. The results ob-

tained will not be as satisfactory, the assembly and wiring more complicated, and a filter will be necessary.

SUBSTITUTING OTHER PARTS IN THE I. F. AMPLIFIER AND FILTER

SUCH a filter may be made by turning out a wood form $1\frac{1}{2}$ inches in diameter. Three slots $\frac{1}{4}$ -inch wide and $\frac{9}{16}$ -inch deep are turned in the form, each separated by a $\frac{1}{8}$ -inch wall of wood. In the two outside slots are placed 1,600 turns each of No. 36 single-silk enameled wire, connected in series aiding. The center slot is wound with 800 turns of the same wire, and when shunted by a .003 mfd. condenser will tune the transformer to about 30 kilocycles. The outside coils are the secondary, and the inside the primary. This substitution is not recommended, and is mentioned merely for those who want to experiment with equipment they already possess.

HOW TO GO ABOUT THE CONSTRUCTION

THE construction of the set may now be started by laying out the panel with a rule and scribe following the dimensions of Fig. 10. The dimensions are correct, but the drawing is not to scale. Mounting holes are indicated for Silver low-loss condensers and Howard rheostat and potentiometer. If different equip-

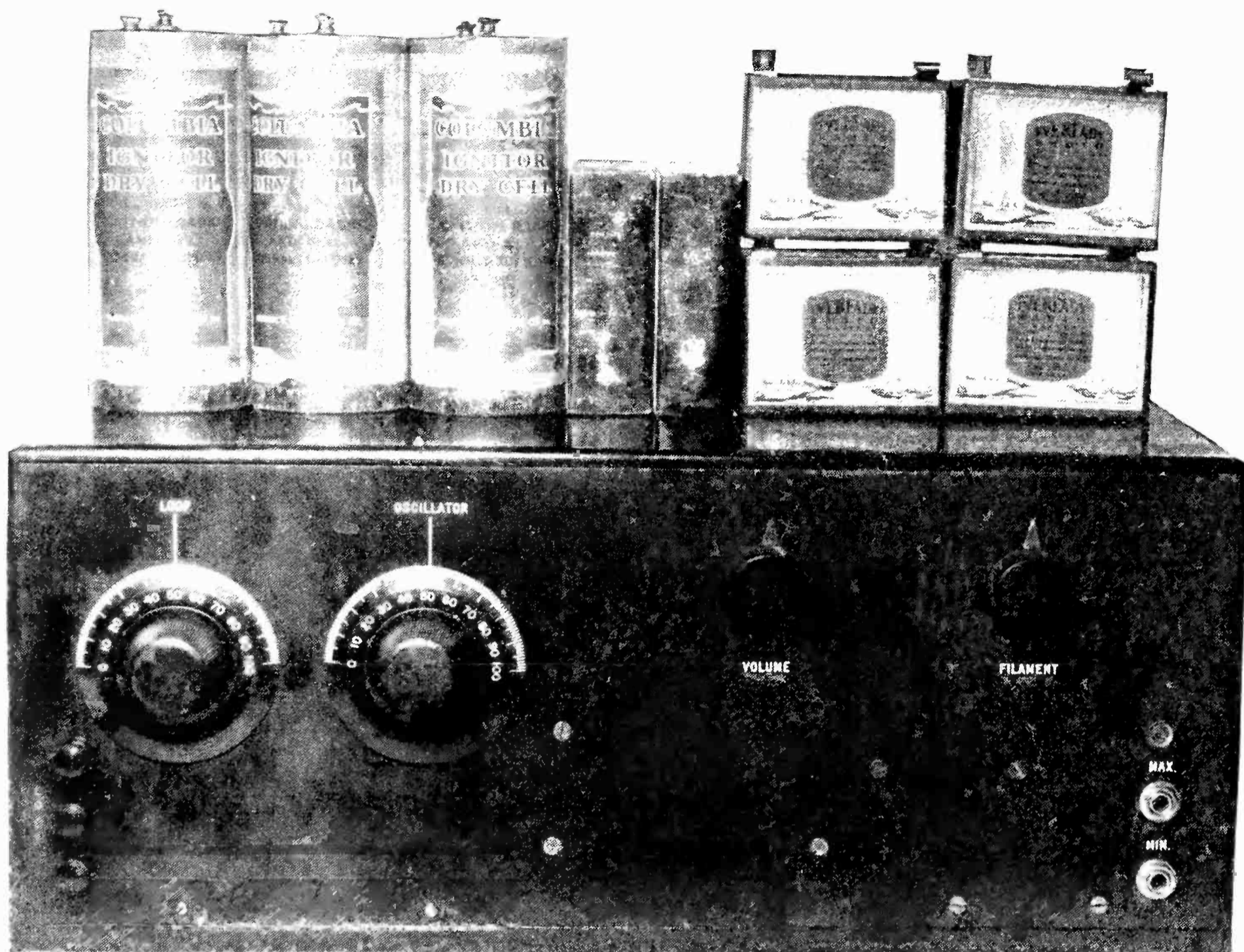

FIG. 8

The final design of the seven-tube portable super-heterodyne. The panel is quite simple and free from a multiplicity of dials. The A, B, and C batteries are placed on top of the cabinet to show just how they fit in the case when inserted

ment is used, the shaft-hole locations should remain the same, with screw holes located from the templates supplied with the parts by the manufacturers. The two holes for the gang-socket marked "X" on the drawing will have to be relocated on a line $3\frac{1}{2}$ inches down from the top, if single sockets on a wood support are used here. The support would be $\frac{1}{2}$ inch thick, 9 inches long, and no wider than necessary to accommodate the sockets. The panel should be grained with fine sand-paper and oil and cleaned with alcohol, if desired.

The baseboard may be laid out in accordance with Fig. 10-A, although it is best arranged by fastening it to the panel with the condensers on and fitting the coupler and two sockets on it for best position—then screwing them down. All wood screw holes should be started with a No. 45 drill, and No. 4 or No. 5 screws used, $\frac{3}{4}$ -inch length being satisfactory throughout. Size $\frac{6}{32}$ machine screws and nuts are used,

either flat or round head, about $\frac{3}{4}$ -inch long to fasten the parts to the panel and lugs to the condensers, etc.

A WISE PRECAUTION

BEFORE mounting any parts, all screws, nuts, etc., should be inspected and tightened, and socket-springs bent up. Lugs should be put on binding posts and tinned. All filament terminal lugs on one side of the gang-socket should be joined together, the lugs on the opposite side also being joined together by bus wire. The base-board with its coupler, by-pass condensers and sockets mounted, should be placed in position, then the gang-socket, followed by the transformer can, audio transformers, binding-posts, jacks, rheostat and potentiometer and filament switch if desired. All wiring that can be done should now be put in place, tinning the wire before endeavoring to make a joint. No soldering

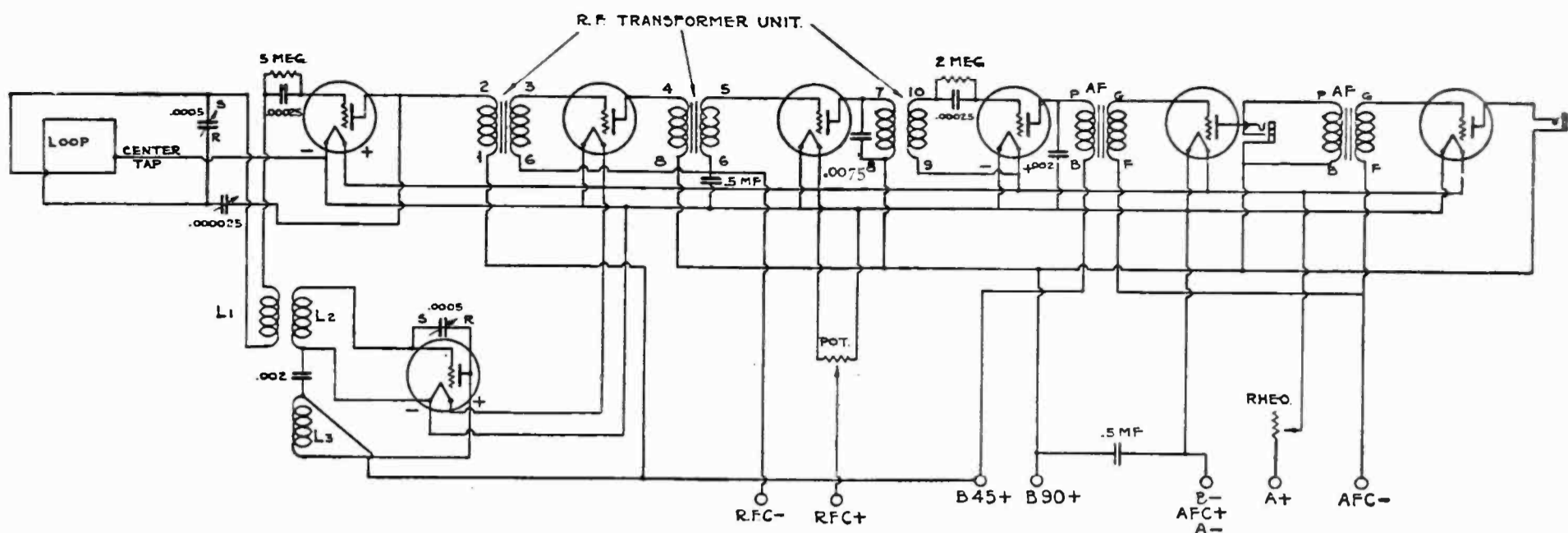

FIG. 9

Circuit diagram of the seven-tube portable super. Note the split loop and center tap as well as the regeneration employed in the first detector tube

paste should be necessary if a well tinned iron is used, and remember that a pound of solder does not make a good joint, if it isn't hot and the joint clean. All mica condensers have lugs fastened to them with machine screws, and are fastened on the wiring, which makes short leads possible, and permits easy assembly. The wiring is strong enough to support the condensers easily. The Chelton midget condenser is fastened to the rotary plate section of the right hand, or loop condenser, with two lugs soldered together. The support is sufficiently strong for all ordinary use.

In the photographs of the set, the engraving over the two condensers is reversed—the left-hand one is the oscillator condenser, and the right-hand the loop condenser. In the photo showing the unwired set, the Chelton dial has been placed on the wrong condenser, but in the view of the wired set it is correctly located.

A WORD ABOUT WIRING

NO BATTERY binding posts are provided, in accordance with the present trend of design. Battery leads, soldered directly to the wiring, are used. This simplifies wiring, and

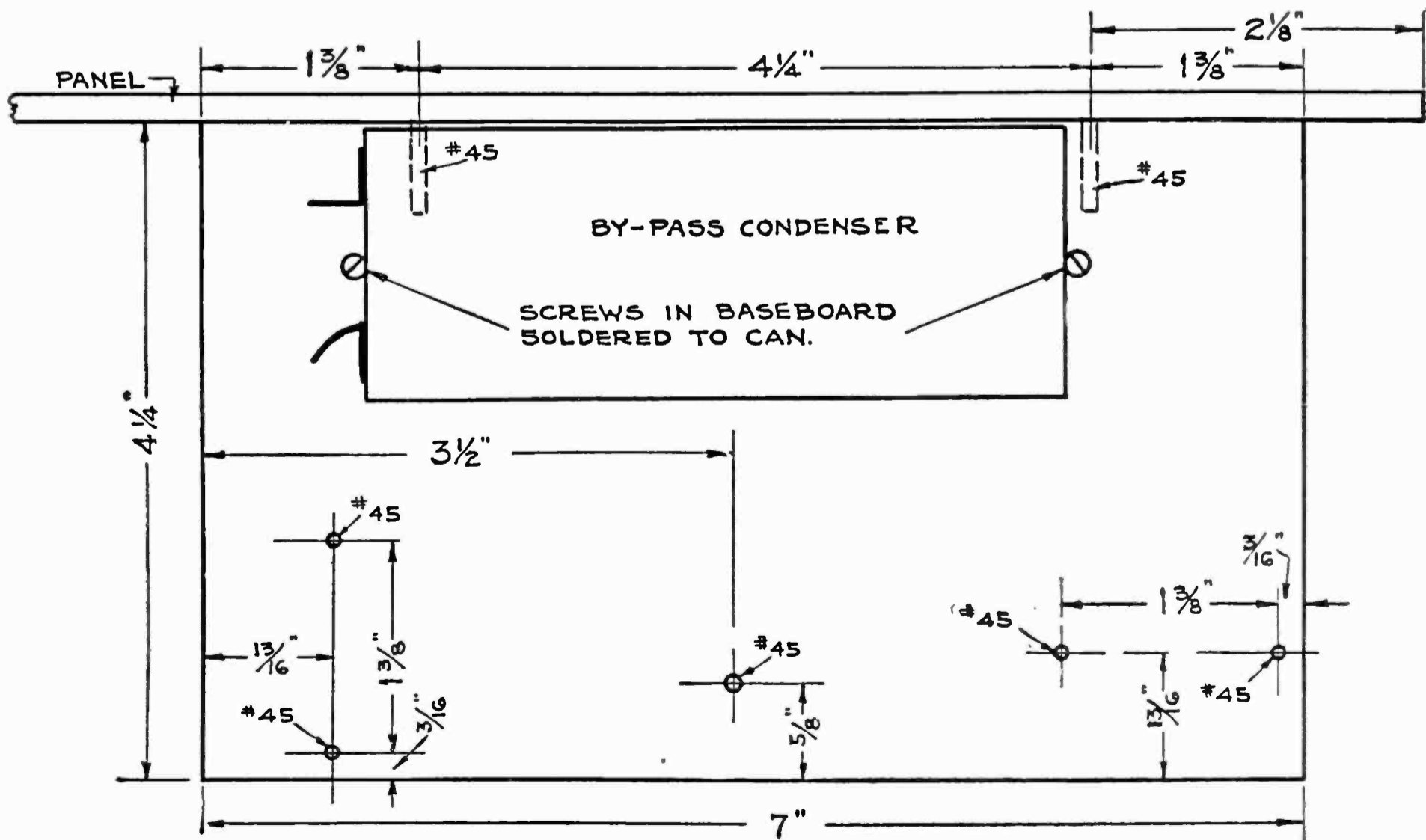

FIG. 10-A

Layout for the baseboard

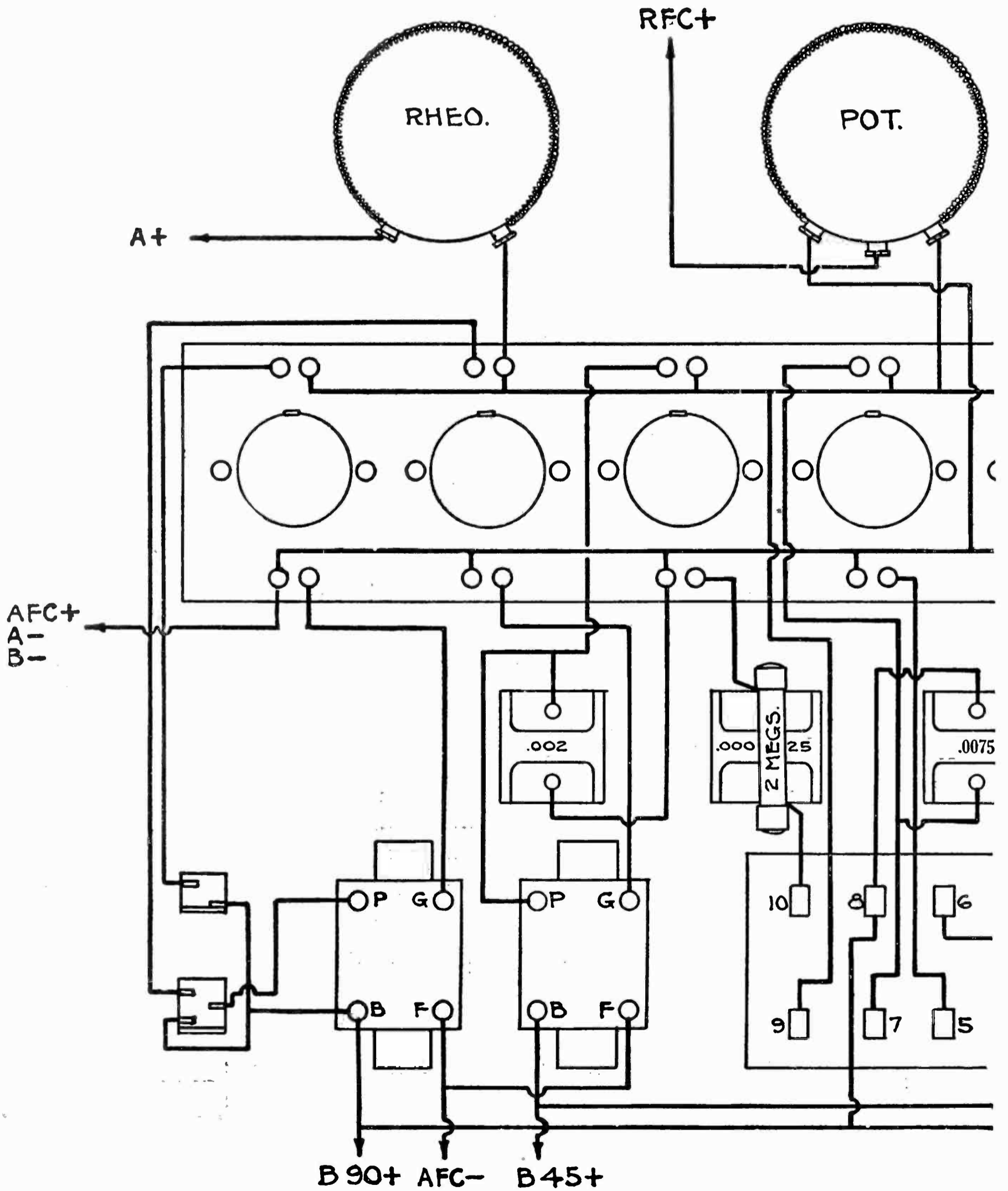
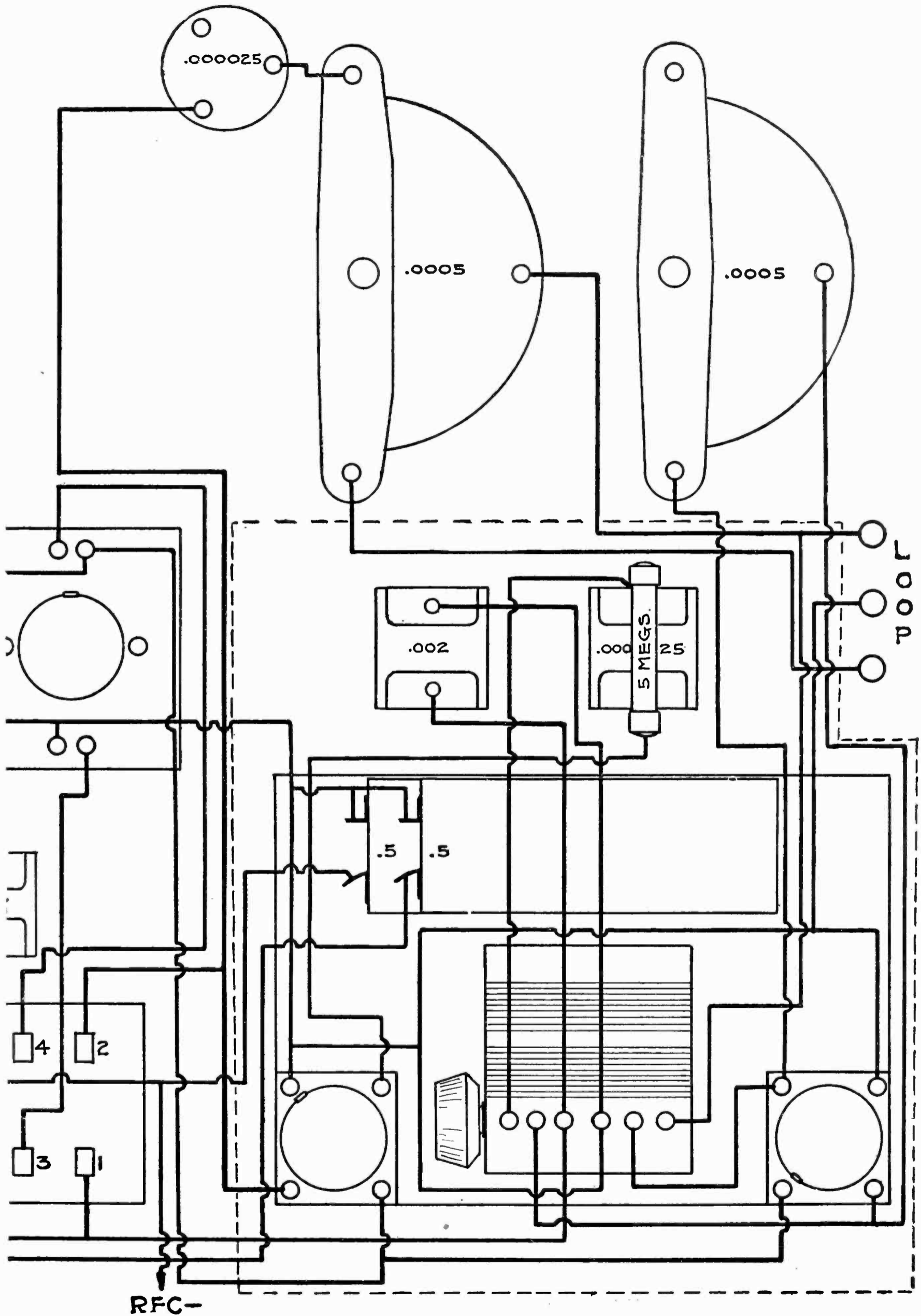

FIG.—
Complete layout for the portable super-heterodyne. In duplicating this—



—10

—set, it is advisable for the constructor to follow the drawing carefully

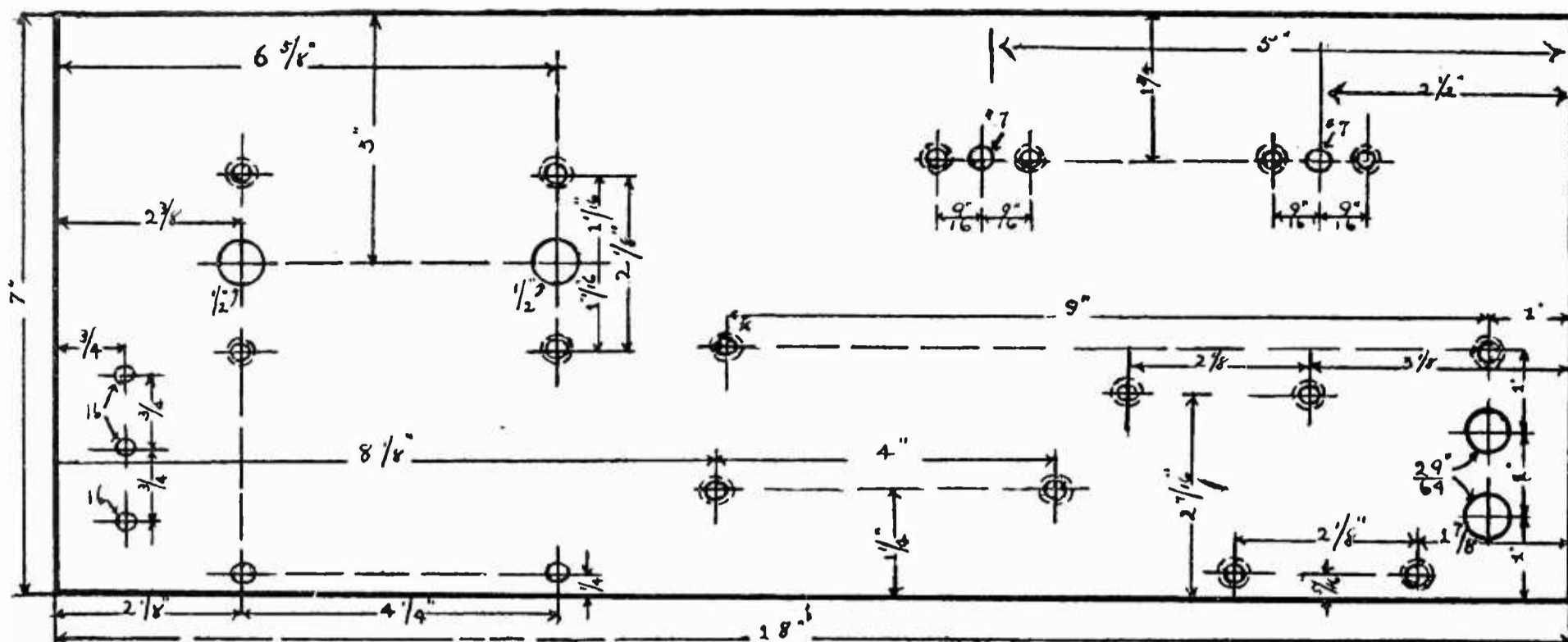

FIG. 11

Dimensions for the panel. The dimensions are given for the apparatus which was used by Mr. Silver, and but very minor changes will have to be made by those constructors who uses other and similar makes of parts

eliminates posts, which are generally unnecessary, since when once connected, the batteries are seldom changed. If desired, posts may be located on the panel, or on a sub panel, but are not recommended. The battery leads, of flexible lamp cord, about three to four feet long, are soldered to the wiring where it terminates in instrument binding posts, in order to relieve the wiring of any direct strain. This is shown in the view of the wired set. These leads may be tagged and braided together if desired, and should be long enough to connect with permanent batteries outside the set when used in a permanent or semi-permanent installation.

The set may be wired with bus-bar, or No. 18 or No. 20 magnet wire in spaghetti. If bus-bar is used, as little spaghetti as possible should be used and all wiring run as direct as possible. In wiring a set, it is best to start by putting in the filament lines, then following with the grid and plate leads, and the balance of the wiring, bearing in mind that all inaccessible connections should be made before the balance of the set wiring covers it. If desired, and it is somewhat of a help to do so, the variable condensers may be left off the panel until as much wiring as possible has been done without them.

THE LOOP

AFTER the set has been wired, the batteries and loop, described below, should be connected to it.

The loop may be any standard type now

on the market, the small folding type being recommended for portable use. With any standard loop, a tap must be taken at approximately the center. This tap may be one turn either side of the center, but should be no farther out. If the loop is to be built, it may consist of 18 turns of wire on a 24-inch form, either spiral winding, or squirrel-cage type. If made larger, it may consist of 14 turns on a 30-inch form, spaced $\frac{1}{4}$ -inch between turns for best results. The wire used may be standard loop wire, or No. 18 lamp cord, or even solid wire, No. 18, or larger being preferable. If a spiral loop is used, the outside end should go to the binding post on the set leading to the fixed plates of the loop condenser and the oscillator coupling coil. The center tap goes to the binding post connected to the negative filament line, and the other end to the post connected to the rotary plates of the loop condenser and the Chelton midget condenser.

THE BATTERIES

THE batteries required are four small $22\frac{1}{2}$ -volt B's, two $4\frac{1}{2}$ -volt C's, although only from $1\frac{1}{2}$ to 3 volts are used from one, and three standard dry cells. If a permanent installation is to be made, four large $22\frac{1}{2}$ - or two large 45-volt B batteries should be used, with six dry cells in series-parallel. These batteries should be connected to the set, and when the 90-volt plus lead is connected, assuming all other connections to be made, a slight spark should be noticed, indicating that the bypass condensers are charging up. This is entirely

correct, but any other sparking noticed will be due to short circuits in the set.

TESTING THE COMPLETED SET

THE set is now ready for test. A single tube should be inserted in the audio socket at the right hand end of the set, and the rheostat just turned on. The phone plug being inserted, a slight click should be heard as it goes into the last jack. If the grid post of the socket is touched, a slight click will also be heard. The second detector and first audio tube should now be inserted in their sockets and the rheostat adjustment left unchanged. A click or squeal should be heard when the grid terminals of these tubes, or their sockets, are touched. The two RF tubes may now be inserted, and the potentiometer moved from its positive to its negative end, with $1\frac{1}{2}$ volts C battery on the RF tubes. A scraping noise should be heard as the arm is moved over the resistance sector, which becomes slightly louder as the negative end is reached. If the grid terminals of the RF sockets are touched, a squeal or click as before should be heard.

The oscillator tube, at the left end, and the first detector should now be inserted in their sockets. All seven tubes are now in place. The oscillator coupler should be set full in, the Chelton midget, or balancing condenser all out, and the five-megohm leak put in the clips of the first condenser, the two-megohm leak being in the second detector grid condenser clips.

The loop condenser should be set at about twenty or thirty degrees, and the oscillator condenser adjusted. At some point a sharp click should be heard, indicating that the oscillator is in resonance with the loop circuit. At this point no signal can be heard, but if an outdoor antenna is used, the set is radiating slightly. This click adjustment is the only setting of the set where radiation is likely to occur, and it is practically negligible, especially on a loop.

An oscillator adjustment about five to ten degrees either side of this click is proper for a given loop condenser setting, and is where a station can be heard. These two points, one either side of the click, will hold over the entire wavelength range of the set, which is from about 200 to 600 meters. This means that each station may be heard at two oscillator adjustments, which is often a convenience, as if interference is noticed on one point, the other may be resorted to.

This click may be reduced in strength, or eliminated, by loosening the oscillator coupling. This should be done on a very weak signal, resetting both loop, oscillator, and possibly balancing condensers for each adjustment of the oscillator coupler. The coupling should be as loose as possible for good signal strength, and when once adjusted, should be left permanently set, as any change in its setting throws off the loop and oscillator condenser logging for stations heard.

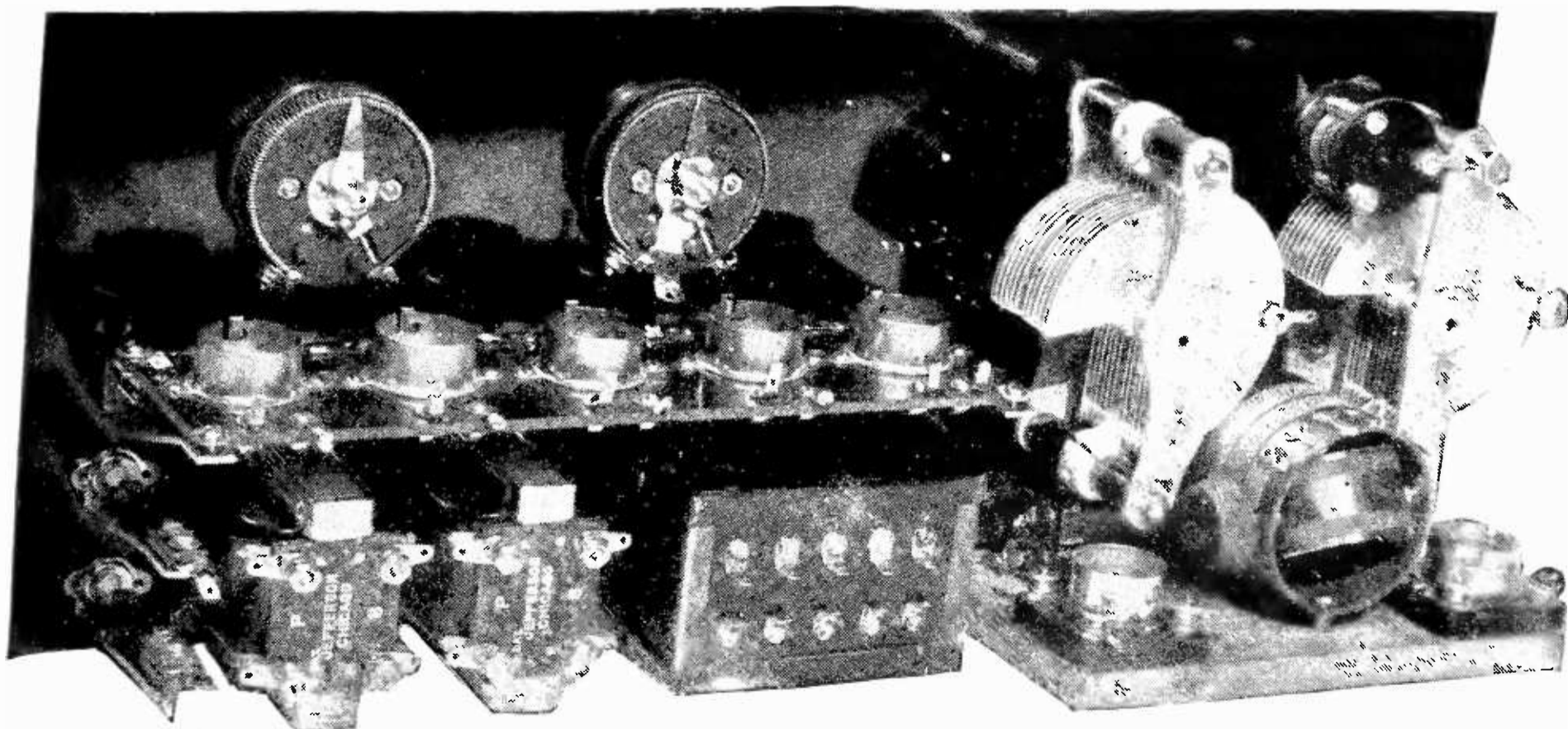

FIG. 12

Rear view of the seven-tube set unwired. This clearly shows how the parts are mounted. The small balancing condenser is shown located on the right hand or oscillator condenser, whereas it should be on the left hand or loop condenser. The .5 mfd. bypass condensers are placed beneath the two tuning condensers.

After a weak station has been heard, the potentiometer arm should be moved from the positive to the negative end. The signal will increase in strength until the amplifier goes into oscillation with a thud or until it squeals. If the amplifier is oscillating, signals will be heard as a squeal, as on a regenerative set, although the same is true if the balancing condenser is set too far in. If the signal is strongest at the negative end, increase the RF C battery to 3 volts, and adjust the potentiometer for best signals.

The balancing condenser should now be adjusted. A weak station is tuned-in on the oscillator and loop dials, and the balancing condenser increased slightly, resetting the oscillator and loop condensers for each change. The limit of capacity that may be used here is when the first tube begins to oscillate, indicated by the signal changing to a squeal or the entire set squealing. This condenser, once set at the highest value possible without rendering the set unstable, should be left set, as it, like the oscillator coupling, reacts on the tuning control calibration.

MORE TIPS ON OPERATION

IN OPERATING the set, always endeavor to use the same rheostat setting—about half to two-thirds on, with $4\frac{1}{2}$ volts, or three dry-cells in series. The potentiometer should be used to control the volume of the received signal, loud-speaker volume being obtained in the second jack, sometimes in the first, with head-phone volume from the first jack. No detector jack was incorporated, as the volume control (potentiometer) will take care of any reduction necessary, and the wiring was simplified by leaving it out.

POSSIBLE TROUBLES AND HOW TO REMEDY THEM

Broad Tuning

DUE to too tight oscillator coupling, improper setting of balancing condenser, potentiometer too far positive, defective grid condensers, or improper tuning condenser connected across can terminals Nos. 7 and 8. Check in order given. The output tuning condenser must be quite accurate, and if the set tunes broadly, it should be adjusted by adding .0005 mfd. condensers in parallel with it, starting with a value .002 mfd. less than recommended, and adding them until maximum signal strength and selectivity are obtained.

Hand capacity effect

This may be overcome by grounding the negative filament lead (center tap of loop) and checking all bypass condensers. Bypass condensers must not be omitted as they are very important.

Squealing

If squealing occurs in radio stages, it indicates improper filament rheostat and potentiometer adjustment and possibly improper balancing condenser adjustment. Defective tubes in radio stages may cause squealing. If the same trouble is found in the audio stages it may be overcome by switching tubes, or reversing the leads to primaries of audio transformers. Connecting .00025 mfd. condensers across audio secondaries and grounding the RF transformer unit can and audio transformer mounting brackets to the negative filament line will help. Audio amplifier squealing should not be experienced, however.

Noise

Noise may be due to defective tubes, batteries, condensers, or wiring. To locate, remove tubes one at a time beginning at left end of set until noise stops, which will indicate in which tube circuit it is. Check connections, tubes, contact of socket springs, rheostat arm, and batteries. Batteries should not be below 80 per cent. of rated voltage. Defective leaks may cause noise or blocking of entire set.

Tubes

Tubes should be shifted in the set for best operating positions. Microphonic noises are generally due to the second detector and audio amplifier tubes. Shifting them should overcome this type of noise. The most critical tubes in set in order are: first RF stage, second RF stage, oscillator, first detector, second detector and audio amplifiers.

Preliminary Testing Circuit

The split-loop circuit may be left out in the first tests if desired, by connecting one end of the loop to the grid or top binding post on the panel as usual, short-circuiting the lower two posts which then run to the other end of the loop, and ignoring the center tap on the loop. This gives a standard non-regenerative detector circuit, and its use will be helpful where it is found difficult to tune the set at first due to its

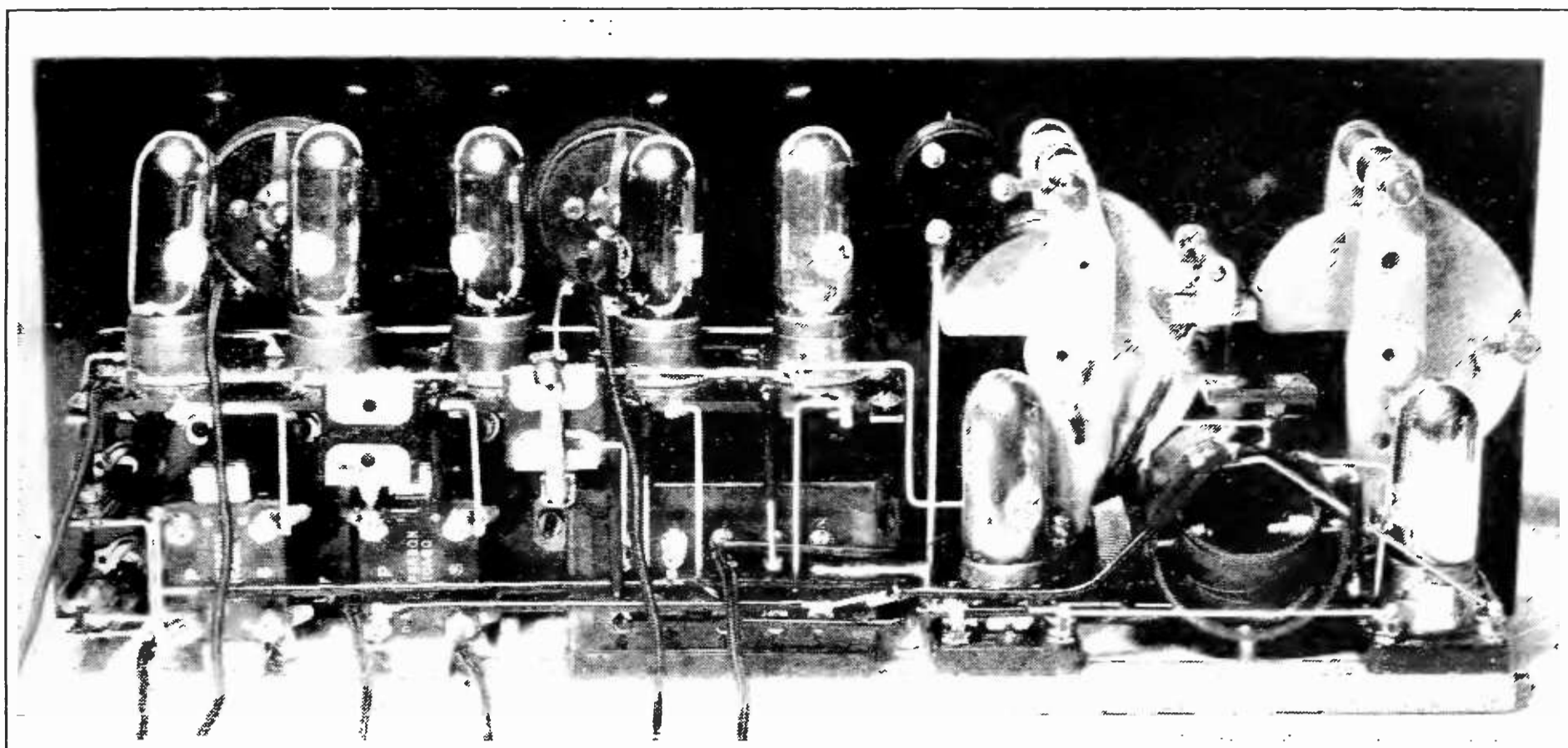

FIG. 13

Rear view of the final set, completely wired, with all tubes in place. Note how the mica condensers are hung on the wiring. The simplicity of this wiring and its accessibility is one of the strongest recommendations for this receiver. It is not advisable to copy the exact wiring as shown in this photograph, for it is preferable to follow that shown in Figs. 9 or 11. Keep the leads as short as possible. In this particular wiring job, six lengths of bus bar and one of spaghetti were used

exceptional selectivity. This type of connection will render the loop tuning condenser quite broad, and will help in locating stations which may not be heard because of the selectivity of the split loop circuit, which would cause the operator to pass over them when unfamiliar with the tuning of the set.

Filament Voltmeter

This is a very desirable addition to the set, since its use permits setting the tubes at the proper operating voltage each time the set is operated, and eliminates the possibility of damaging the tubes by overloading their

filaments. Any standard type of meter may be put on the panel in the space between the loop condenser dial and the potentiometer. A better way would be to put in an open circuit jack connected directly across the filament leads of the gang-socket, into which a voltmeter connected to a plug and cord could be plugged. This arrangement would not tie up the meter in one set, but would leave it free to be plugged into as many sets so arranged as the builder might wish. It is of course unnecessary to say that 199 tubes should never be operated with over three volts across their filaments, and they need not be when the set is operating properly.

THE material appearing in this magazine is fully protected by copyright, and editors of periodicals are advised that unauthorized publication of circuit diagrams, technical descriptions, and parts or the whole of articles, without due permission and credit, is an infraction of the law. Those who wish to reprint material appearing in these pages are asked to communicate with the editor.

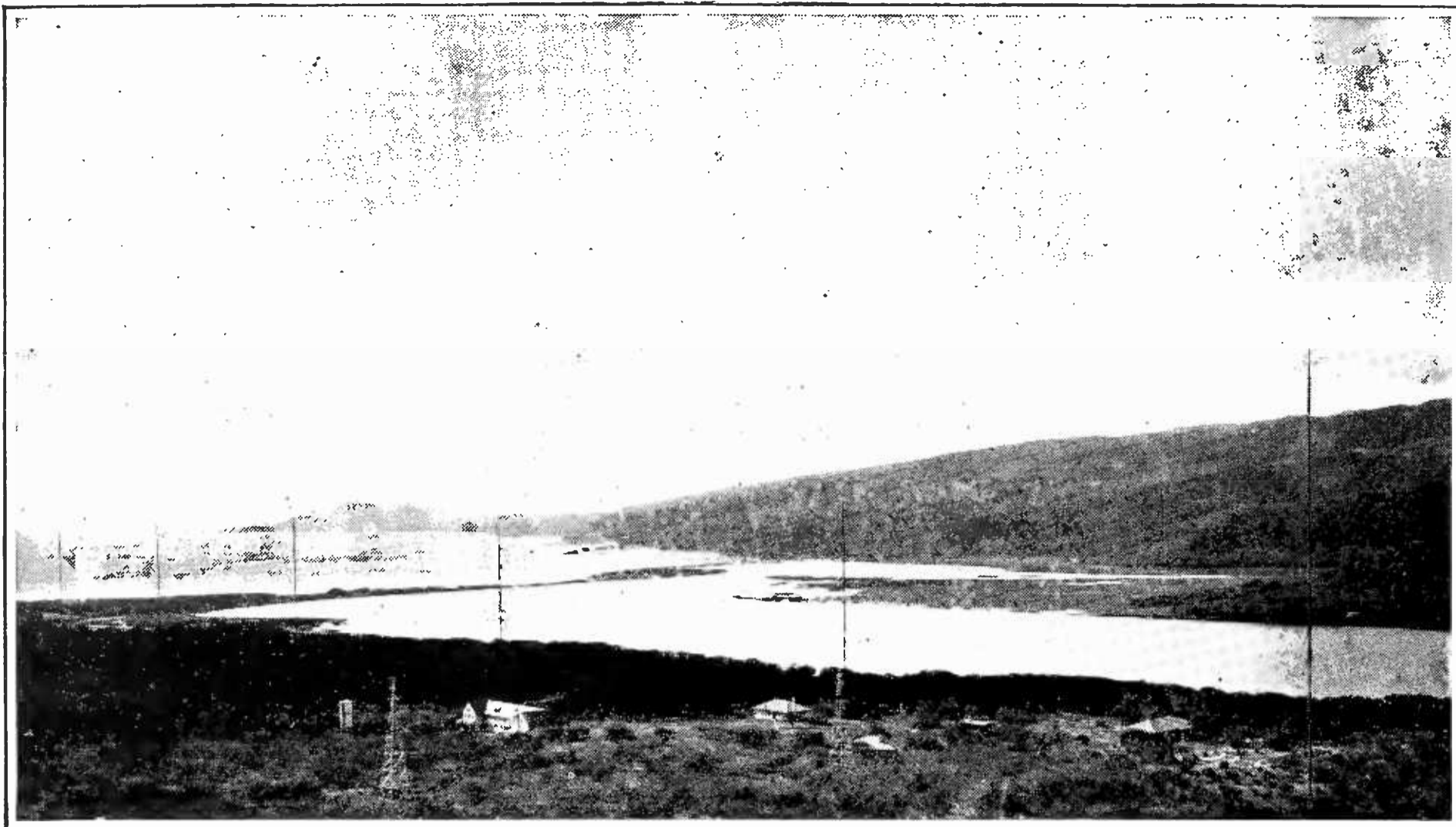

ON THE ISLAND OF OAHU, HAWAII

Is the transpacific radio receiving station of the Radio Corporation of America. The photograph was taken from the dead volcano crater at Koko Head. Sixty per cent. of the transpacific message traffic is said to be handled by radio

THE MARCH OF RADIO

BY *J. J. Morecroft*
President, Institute of Radio Engineers

Who Will Pay for the Campaign Broadcasting?

THE Bell Company's intention gradually to build up a group of high-class broadcasting stations, all modulated from one microphone when the occasion warrants, is gradually being worked out. On special occasions, large parts of the company's country-wide network of wires has been tied up for broadcasting control, but the arrangement has been temporary only. The connection between WEAJ and WCAP is of course a practically permanent installation, and now we hear that six stations, WEAJ, WCAP, WJAR, WGR, WCAE, and WGN, are to be tied together in a semi-permanent net-

work. It may be only a matter of a year or so before this company will have available a nation-wide service for those who have something worthwhile saying, and money enough to rent the broadcasting system.

A very large investment is tied up in such a wire and broadcasting chain. The stockholders have a right to a reasonable return on their money on this investment. Therefore the question of cost of broadcasting must necessarily be met in some fashion by those using it. How are the political campaigns to be carried on by radio? These radio campaigns sound logical and reasonable in so far as conserving

the candidates' strength is concerned, but who is going to foot the bill? Someone is going to find out that it costs money, a lot of it, for the privilege of addressing a million or more listeners. The telephone company cannot afford to give the service for less than cost, and the cost will be pretty high, if the present ambitious plans of some campaigners are carried out.

One thing is sure; when a campaign manager has paid \$10,000 or more for the use of the radio channel for an hour he is going to be careful who uses up his time—the days of the cheap ranter and phrase maker are over. For such a costly channel the manager will have to select men with brains who can present their arguments clearly and forcefully. Radio will probably do much good in improving the quality of pre-election oratory, and so give the people a better understanding of what the political issues really are.

We Need a Government Department of Communications

SECRETARY HOOVER is planning to call a general radio conference in Washington sometime in September, according to a press despatch. Representatives from every branch of the radio industry will be invited to the conference and it is hoped that some of the complications about wavelengths and interference which now exist will be straightened out.

We wonder whether this conference can accomplish any more than have its predecessors, which was not very much. Can conferences of this kind satisfactorily solve the radio problems as they arise? Radio conferences are always being held somewhere nowadays; one

is about to begin in Europe, and one has just ended in Mexico City.

It is really a question whether or not some extra government bureau is not necessary which would take care of government interests in the entire communication field. Shouldn't there be some office in Washington where all activities of this kind are centralized, headed by a man who knows communications? Wouldn't a communications portfolio, or at least a separate division in the Department of Commerce, headed by an Assistant Secretary, (who should know the economic side of com-



AND IN BERLIN—

Street vendors are selling radio apparatus. Using the loop at the top of the wagon, receivers can be demonstrated under actual operating conditions. The natives appear interested

munication) do more good and develop a more consistent policy than these conferences, which will apparently be called annually? The trouble with these conferences is that they lack continuity and of necessity have very little connection with the preceding ones.

New Privileges for the Radio Amateur

THE radio service of the Department of Commerce made an announcement recently which should be of great importance to radio experimenting in the United States. Official ruling was made that four new wave bands could be used by amateur operators. Wavelengths between 75 and 80 meters, 40 and 43 meters, 20 and 22 meters, and 4 to 5 meters may be used. This means that an amateur may use any or all of these waves, providing his application has been approved by his local Supervisor of Radio. It was further arranged that amateurs who use this new group of wave frequencies do not have to conform to the present quiet hours for the protection of the broadcast listeners, since it will not be possible for them to create any interference. Special amateur stations will

not hereafter use wavelengths above 200 meters, the Department has ordered, but they may use a special band between 105 and 110 meters.

This new ruling of the Department seems to show that the able officials of the American Radio Relay League, that active and representative amateur association, have been successful in securing the intelligent coöperation of the Government. The quiet hours which have been enforced on the amateur have undoubtedly greatly limited his legitimate activities and this ruling will open a new field for experiment on short waves where experiment is now most interesting and most productive. There are now some 15,500 licensed amateur transmitting stations in the United States. With a good proportion of these carrying on daily tests in short wave transmission it is entirely reasonable to expect that some productive results will follow.

Observers of radio progress during the last ten or twelve years are quite unanimous in agreeing that amateurs, in America particularly, have done much for the art. Their contributions have been in the improvement of apparatus, in training many operators who are



—Roger B. Whitman, Staff Photographer

A FIVE-FOOT LOUD SPEAKER CONCEALED

In the wall at the home of Dr. Lee De Forest at Spuyten Duyvil, New York. The soft travertine-stone walls, broken by the grill near the ceiling, give no hint of a radio set. Music seems actually to float in the room when the set is in use, giving a totally different effect than the usual one of positive impact when an average loud speaker is used in an average room

now working and improving radio for the Government and for many commercial companies. Trained amateurs are to be found operating and managing broadcasting stations, and in many, many parts of the country selling, explaining, maintaining, and repairing broadcast receivers. It is only because there was a force of well trained amateurs upon which to



THE S.S. "BOSTON"

Immediately after her recent collision with the S.S. *Swift Arrow*, in a thick fog off Point Judith. The *Boston* of the Eastern Steamship Company, a ship newly placed in commission, was bound for New York with a full passenger list. Radio in this disaster again proved its value in the rapid and efficient summoning of aid

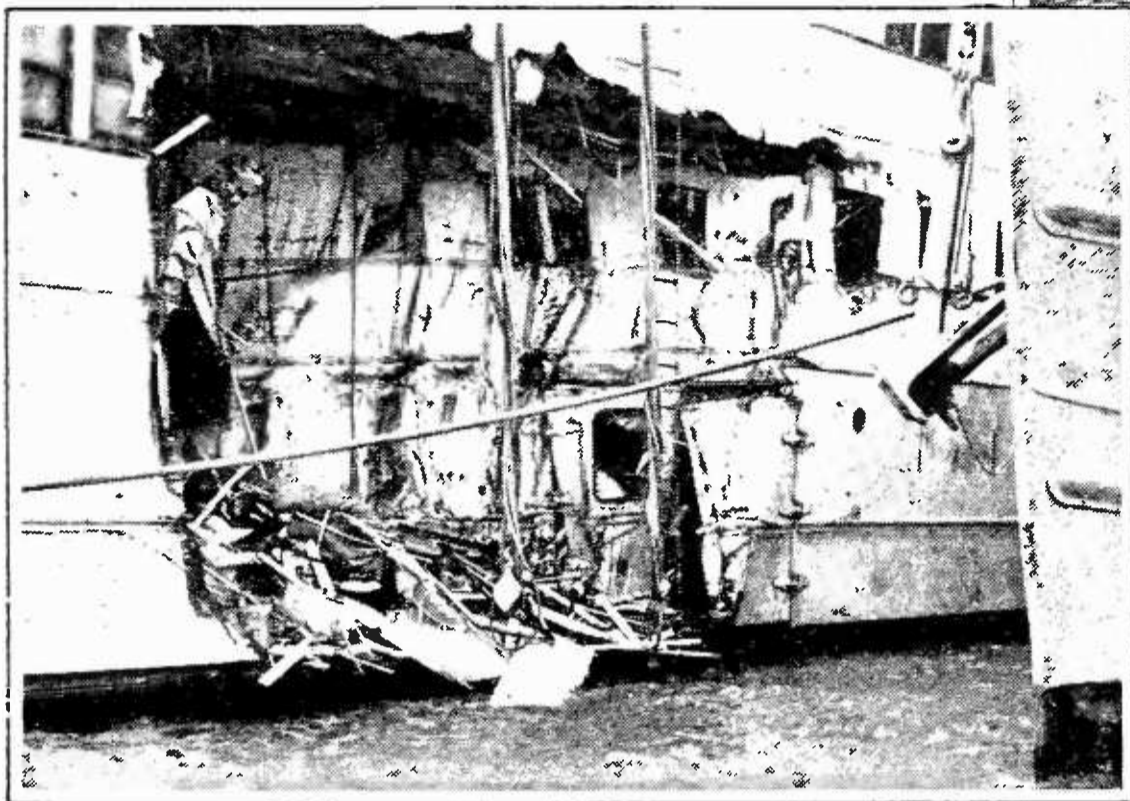

By process of elimination, the trouble was generally located in the tubes which, although purchased in cartons marked Radio Corporation of America, were not manufactured by that company. The bootlegger

draw that so many good radio shops have come into being in the last few busy radio years.

In the field of short wave transmission, the American amateur has almost been a pioneer. Who knows but that the great interest the amateur has shown is not pretty directly allied with the trend of present broadcast and code transmission on those wavelengths, both in this country and abroad?

It is good to see that the present disposition of the Government is, as it has been during the last twelve years, to allow the American amateur freedom and liberty of experiment. It is a typical American policy, and the experience of the last decade has shown that policy eminently to be justified.

Tube Bootlegger Caught

JUDGING from recent information, radio tubes bought from bootleggers are no more reliable than certain other goods purchased from those in a similar relation to the law. A newspaper account tells that most of the broadcast listeners in a certain district reported more or less trouble with their sets, sets which should have given no trouble at all.

dealer was located and summoned to court and he will undoubtedly suffer the law's penalty, as he should.

We believe that if these tubes were sold at a reasonable price, there would be no incentive to engage in this illegal traffic. The Radio Corporation, on August 5, announced a reduction in price of all tubes to four dollars. Probably much greater reduction is necessary before the tube bootleggers' business will become sufficiently unremunerative that his tubes are no longer to be had.

The Dry Cell B Battery and its Cost

BECAUSE the major item of expense in the operation of radio receivers has been the cost of B batteries, we all welcome the reductions in list prices recently announced by National Carbon Company, Inc., the manufacturers of Eveready batteries. B energy was never so inexpensive or reliable as it is to-day. That this is so is due in great part to the ability of the dry battery makers.

So rapidly did the demand grow for B batteries that only the best-equipped organizations could hope to keep up with it. That they have done so, and not only preserved the high quality

of their product but improved it, is little short of marvelous. That the largest of them now finds it possible to pass on to the user a large share of the saving of quantity production is, as the announcer says, "Worthy of much applause from the radio audience."

In addition to all this, dry battery research has been continued energetically, and those of us who have multi-tube sets now can buy special heavy duty dry batteries that are as economical under heavy current drains as were the smaller batteries on sets using less tubes. What tremendous economies the vast growth of radio have made possible may be guessed from the fact that the new Eveready heavy duty 45-volt battery actually can be purchased for less than the previous cost of the customary large 45-volt battery.

With the different sizes of B batteries now in the market, or more accurately with B batteries of different size cells—small, medium, large, and extra large—and with sets whose current drains vary all the way from 1 to 30 milliamperes or more, the time has come when it is necessary to fit the battery to the set in order to obtain the maximum of economy and satisfaction. Having chosen the right size dry B



THE RADIO BANK

Combining a crystal receiver and a small coin bank, all in a space three and a half inches in diameter. The lower half of the device is a detachable bank which can be taken to the bank offices for opening. It is distributed by the Harris Trust and Savings Bank of Chicago

battery of reputable manufacture, the user has a mighty efficient and economical source of electrical energy. For many of them it is the only possible one.

The Inventor of Bakelite Honored in His Native Land

MANY have probably wondered where the name of Bakelite came from; they merely know the material as a very useful radio product, but not why it is called Bakelite.

Dr. L. H. Baekeland of Yonkers, New York, (the same town that claims Armstrong), President of the American Chemical Society, who invented Velox paper many years ago, and after performing that very useful task succeeded in producing this "material of a thousand uses." Bakelite therefore is named after its inventor, who has just received from King Albert of Belgium (of which country Baekeland is a native), the honor of being made Commander of the Order of Leopold.

Help Eliminate the Whistle

WE HAVE a bulletin from the Department of Commerce regarding the whistling beat notes heard in receiving sets, asking the assistance of the listening public in locating their cause. If one's own set is oscillating, of course whistles will occur

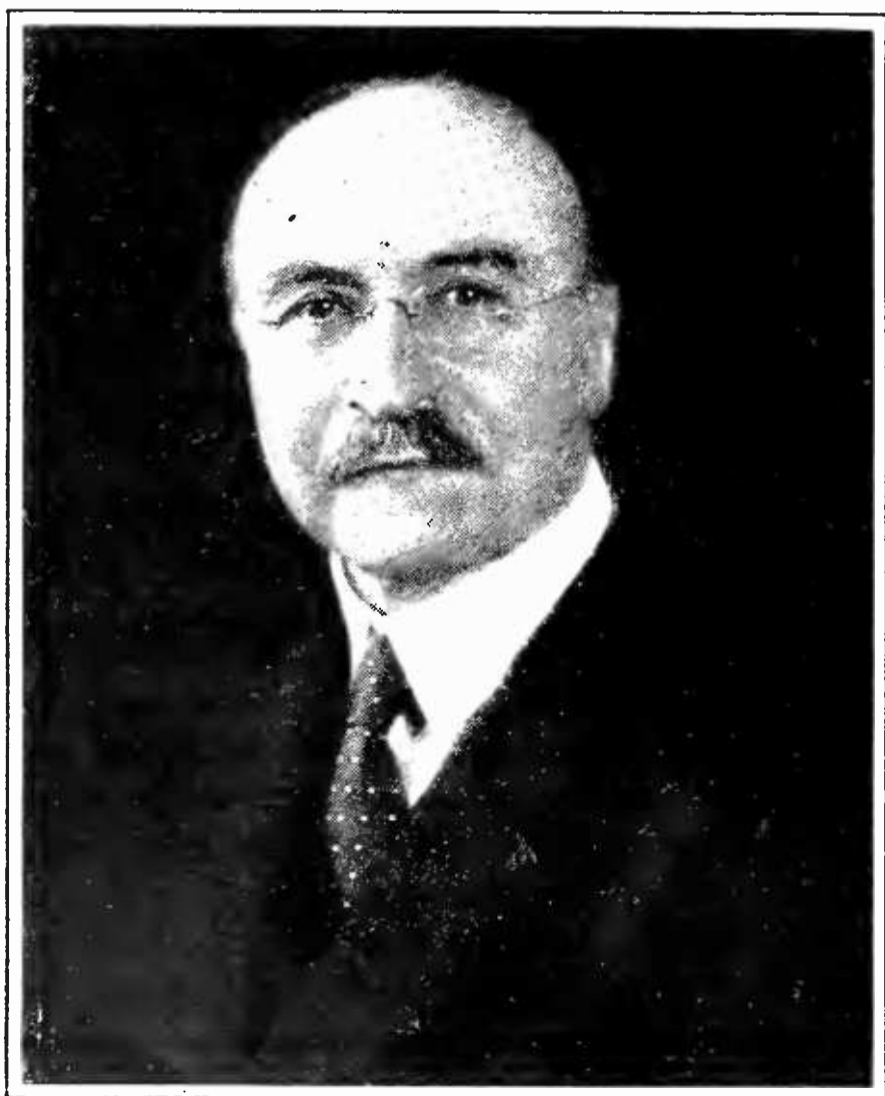

© Underwood & Underwood

DR. L. H. BAEKELAND

Of Yonkers, New York. Dr. Baekeland, president of the American Chemical Society, produced bakelite so generally used in radio work. He was recently decorated with the Order of Leopold by King Albert of Belgium

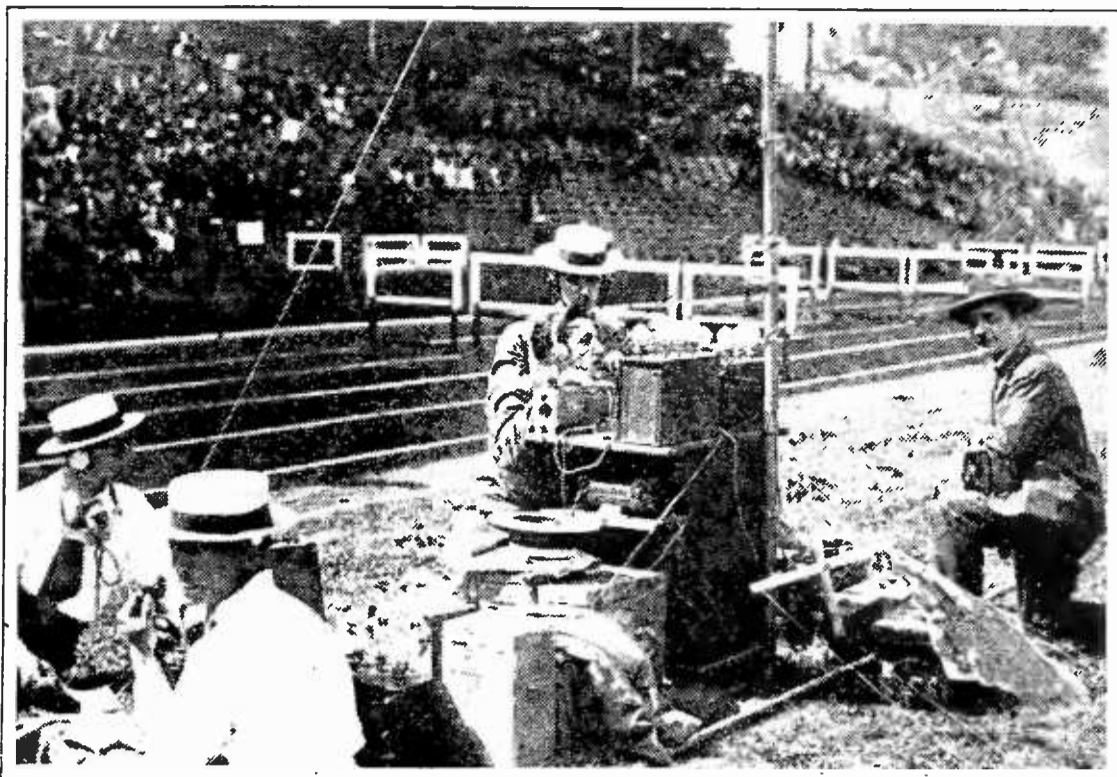

BROADCASTING THE OLYMPIC GAMES

At the Colombes Stadium, near Paris. . . Four years ago, at the last Olympiad, radio broadcasting had just begun in this country, and there was no broadcasting at all on the Continent

every time the set is tuned to a station; there is no trouble here with the radio transmitter, it is in one's own receiver. But whistles are heard when a set is not oscillating, whistles, whose pitch does not change as one's condenser setting is changed. These whistles are due to something outside of the receiving set.

One's neighbor may have an oscillating receiver which is sending out energy at nearly the same frequency as the station to which we are listening. That will cause a whistle. Such a whistle does not stay fixed in pitch very long, as the man with an oscillating receiver is just the kind that is continually changing his adjustments. Possibly two neighbors have oscillating receivers and each is trying to "get" the other, thinking it is a distant station. It's amusing sometimes to note the patience with which each of them waits for the other to say what distant station he is!

A third source of whistling is that caused by two bona fide transmitting stations sending on frequencies sufficiently close together to give an audible beat note. This note stays constant in pitch as long as the stations are operating. This is the condition which the Department wants to remedy. If the various stations are on their assigned fre-

quencies it should not occur. Any one having definite knowledge of the occurrence of such beat notes is asked to advise the nearest government Radio Supervisor that steps may be taken to put an end to it.

Good Work Well Done

MANY radio societies and associations are coming into being daily, some good and some bad. Few of them can be of any real service to the radio public. It is with pleasure then that we note the first bulletin of the American Radio Association, a nation-wide organization of listeners-in, which is really functioning. Alfred M. Caddell, the secretary of the American Radio Association is the active spirit behind this organization.

This association pledges itself to support any movement for the betterment of broadcasting. The Association will further movements which while not perhaps contributing directly to the good of the isolated listener-in, are movements which he should not hesitate to support.

Among activities of this kind which the

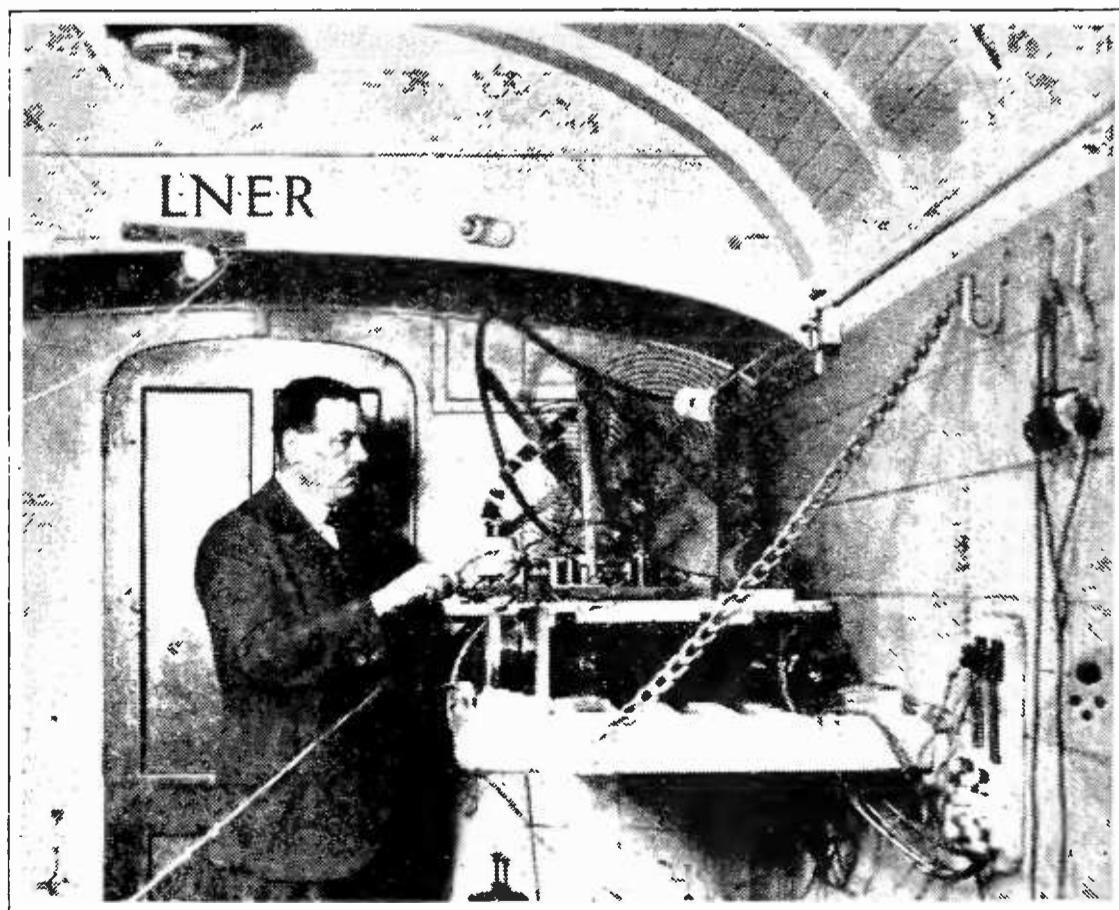

RADIO COACH 6 ZZ

Attached to the Scottish Express from London on the London and North-eastern Railway. Tests in receiving broadcast and amateur signals were made by members of the Radio Society of Great Britain. Several receivers and a transmitter on a wavelength of 185 meters were used, all operating on the inside antenna shown in the photograph. Signals were copied from 6 ZZ 270 miles away



©Harris and Ewing

ROBERT M. LAFOLLETTE

United States Senator from Wisconsin

"This is the first national political campaign in which radio has played its part as a medium of public information. In millions of homes, the proceedings of the two old party conventions were heard as plainly as in the convention halls. Throughout the campaign, more people will catch the voices of various candidates and their spokesmen than have ever before been heard from the platform in American history.

"The consequences of this great stride toward giving the people a first hand knowledge of political debate can hardly be estimated. Undoubtedly, it will serve to minimize misrepresentation in the news columns of the press. The most reactionary newspapers will fear to twist facts which thousands of its readers receive directly by radio."

A.R.A. has inaugurated is that to furnish radio sets to the blind, a movement which has the hearty coöperation of the American Foundation for the Blind. Helen Keller, who recently requested sets for the blind children of New York in furtherance of a scheme fathered by the Lions Club, is going to help the A.R.A.'s radio-for-the-blind movement. This is something well worth while doing.

The A.R.A. has also been active in coördinating the efforts of radio listeners and electric power companies to clear up interference problems in so far as they originate from lighting lines. It has given its hearty support to Roxie's campaign for the disabled soldier sets, and is now starting a campaign to maintain the broadcast channels free from advertising propaganda put forth in the guise of entertainment. It is well worth while to give your support to an association of this kind, for every one of its activities are directed toward the improvement of the radio broadcasting situation.

Another Milestone in Radio Progress

WHEN announcement was recently made from Chicago that E. T. Flewelling of that city had received an English station using merely a loop and a single-tube receiver, there was much interest in radio circles. When an experimenter receives signals with so little apparatus over so great a distance as that, everyone will agree that an extraordinary radio feat has been accomplished. RADIO BROADCAST congratulates Mr. Flewelling on his remarkable work.

This reception is an interesting and informative example of the work now going on in short waves. Intelligent and active experimenters in most parts of the world are busy finding out just what can be done in this interesting field. Most of these tests are taking place between England, France, and America. Broadcast listeners who cannot tune down to waves below 150 meters have not the slightest conception of the experimental activity in that almost untried band.

When Hertz first sent a wireless signal in his experiments in 1887, he used a small transmitting loop radiating very short waves. It is worth observing that now, practically all of the revolutionary radio work is being done on short waves. So the radio cycle moves.

Answering the editor's letter of inquiry about his experiments, Mr. Flewelling wrote:

It is well known in theory and fact that super-regeneration possesses the unique advantage of amplifying even more than inversely as the square of the incoming wave. This means that our amplification at 100 meters, or 10 meters is really tremendous.

I believe that we are going to enter a new era of radio that will combine such things as short waves, super-regeneration, and better design of apparatus.

We cannot help then coming closer to other nations, and I think that this increase in long distance reception between experimenters in various nations will do much toward a praiseworthy and desirable exchange of international thought.

Mr. Flewelling who is a designing radio engineer, is also an American amateur of the best type, and an active member of the American Radio Relay League.

"From what I know of radio," he said, "I believe that the developments now under way in several countries are such as to make one fairly gasp about the future."

Well, workers like Mr. Flewelling are helping bring the future to the present.

Interesting Things Interesting People Say

S. R. HELMS (Monroe, North Carolina; writing to station WGY): "I am one patient that a doctor prescribed a radio outfit for, and it was the greatest prescription he ever made. It has done me more good than specialists and sanatoriums. I sincerely wish that every shut-in could have a radio set."

JOHN V. L. HOGAN (New York City; consulting radio engineer; speaking of a radio vote taken among listeners to his talks at WEAf): "A tabulation of the returns from more than 5,000 listeners, as to the source of the radio interference they encountered in their receivers was:

First place:

Spark	39	per cent.
Whistles	31.4	per cent.
Cross talks	29.6	per cent.

Second place:

Whistles	43	per cent.
Spark	37	per cent.
Cross talk	20	per cent.

Third place:

Cross talk	60	per cent.
Whistles	22.5	per cent.
Spark	17.5	per cent.

This summary came from the reports of listeners from practically the entire Eastern half of the United States."

W. D. TERRELL (Washington; Chief Supervisor of Radio, Department of Commerce): "The day is not far off when there will not be the slightest excuse for two vessels colliding at sea. Fog, the age-old terror of the mariner, need no longer be feared. With the help of the radio compass and ability to pick up either shore radio compass stations, or other vessels, the modern ship can keep true to her course through the densest fog as well as in clear weather. It is the most wonderful aid to those who go down to the sea in ships since the invention of the mariner's compass itself."

B. G. HUBBELL (Buffalo; President, Federal Telephone and Telegraph Company): "In my opinion, Democracy can live only through the most exacting publicity and clear understanding of the country's necessities. There must be general accord. Already, there are signs of the breaking down of our form of government, largely because of this lack of understanding, and I believe that this new radio science was projected into the world's necessities



©Harris and Ewing

JAMES W. WADSWORTH, JR.

—United States Senator from New York—

"Broadcasting the proceedings of the Senate is hardly practicable. . . . The spontaneity of debate would be ruined by the installation of a broadcasting device. Consideration would be paid only to the political effects of what would be said on a given subject. Substance would yield to expediency. Our aim must be to limit the activities of the Government here at Washington and get more interest among the people in their community life and government. Radio is a great thing. It has done much for us already, and in the future will do much more as its processes and equipments are perfected. I do not think broadcasting the proceedings of the Senate will contribute anything toward a better understanding of what is going on"

particularly to furnish an economic and easy method in overcoming this growing lack of political faith. In the present campaign, the Republican candidate will be listened to by Democratic voters and vice versa. A very general and fair minded exchange of political thought will be possible without the heat of political passion. I believe that radio, the greatest of all scientific developments, was brought forth largely to furnish the means of preserving our political structures through easy methods of wide and easy distribution of political knowledge.

NEAL O'HARA (New York City; humorous writer, in the New York *Evening World*, apropos of the new New York Municipal broadcasting station WNYC): "That broadcasting plant comes under the municipal head of unnecessary noises. It will be in charge of a City Static-Stician . . . Mayor Hylan gave his constituents Civic Virtue. Now he will give them static violence. . . ."

The Case Against the Radiating Receiver

Some Interesting Statements by Those Prominent in Radio About a Serious Menace to Receiving—Why Sentiment is so Strong Against the Radiator—What the Future is Likely to Be

BY WILLIS K. WING

MY RECEIVER will bring in almost nothing but a grand assortment of squeals, howls, groanings, and all manner of other sounds not of this world. What is the matter?" A certain radio enthusiast asked us this question not so very long ago. And there are enough radio fans who are daily encountering the same trouble that it is decidedly worth while discovering what is the matter. "Is the trouble with me, or is the trouble with the set, or what?" he went on to ask. "Sometimes I can get programs beautifully complete and unspoiled, and then suddenly, these unearthly noises begin, and there seems no possible way to get rid of them. Is it all static?"

Radio is a God-given science, and at times involves apparently God-given interference which everyone is powerless to control. Static is more than a name to most radio listeners. "I'll tell you one thing," remarked our voluble radio friend, "if all these unearthly squeals, howls, groanings, etc., are static and can't be stopped, I am going to quit radio until God takes the static away."

Well, we told him that all that "squealed" or "scratched" wasn't necessarily static. We told him that practically all the interference he was complaining about came from thoughtless or unknowing radio neighbors. Then he was interested. His "What, when, where, how?" engulfed us. We told him the trouble was caused by oscillating or radiating receivers. That was a new idea to him.

While everyone grants that radio receivers are not now in their final stage of development, most of them in present use will bring in broadcast programs in good style. But let us qualify that a bit. There is one type which has been with us since the very inception of broadcasting, now nearly four years ago, that is responsible for much of this radio unpleasantness. And that receiver is the single-circuit regenerative receiver.

It isn't that the single-circuit set isn't a good receiver. It is, as a matter of fact, quite sensitive, and has been known to bring in much distance, but its general use has gotten us radio folk into all sorts of trouble. In the main, the single-circuit set, operated by the Jones, the Browns, the Smiths, and the Whites, in every city and town in this country, has brought us to a point where the radio life isn't very liveable for any of us.

The Joneses are interfering with the Smiths, and the Browns with the Whites and no one is really enjoying it. There was a recurrent sentence in "The Tavern" which played on Broadway not so long ago. "What's all the shootin' fer?" Substitute "blooping" for "shootin'", and this same question could well be asked about the present radio situation. Can't something be done about it?

What has been done? What is the situation, technically? What, indeed, can be done? And, most important of all, what is likely to be done?

FOUR YEARS OF THE SINGLE-CIRCUIT

AMERICA was the pioneer in broadcasting. And like all pioneers, she has made her mistakes. When the public, realizing that it could hear voices out of the air by installing a receiver, started to buy radio apparatus, there wasn't a radio manufacturer in the country prepared for the business that flooded him. Back in 1920, when broadcasting began, the simplest and most sensitive receiver then in use was the Armstrong single-circuit regenerative receiver. It was cheap, comparatively easy to operate, and sensitive. So, naturally enough, great quantities of this type of receiving set were made and sold.

Most people then owned either a crystal set whose range was not more than 25 or 50 miles, or they owned one of these single-circuit things (although some three-circuit regeneratives were in use). But this single-circuit affair, by its

construction and connection, is an excellent little transmitting set. The purchaser, who innocently thought he was buying merely a receiver, found out—indeed he was soon told—that his was a sending as well as a receiving set.

Paul F. Godley, one of the best-known radio amateurs, testifying at the Department of Commerce hearing on radio telegraphy, called at Washington for the purpose of decreasing radio interference, in February, 1922, said:

The single-circuit receiver requires the adjustment of but one control, and on that account can be operated by a four-year-old child, or the two-year-old for that matter—and these companies (manufacturing this type of set) feel that we are in the two-year-old class. The more complicated receiver requires the adjustment of three or four controls (and that is not difficult to get on to) to the end that one may provide himself far better results in selectivity than with the simpler type. . . .

It is possible with one of these sets to telegraph 25 or 30 miles with ease. Obviously, if you are going to cover the country with receivers of this type, particularly along the Atlantic seaboard, you are going to have a terrible "mess." In Newark, that exists now. One goes to listen to broadcast programs and one encounters this vast number of "canary birds" that was mentioned in this hearing yesterday. And the thing is only starting.

I should like to call the attention of the Technical Committee for consideration some sort of legislation or regulation which would make it impossible for any one to sell or promote receivers which eventually might nullify the benefits to be obtained from broadcast programs.

ARMSTRONG SPEAKS OUT IN MEETING

LET us see what the inventor of the regenerative circuit himself has to say on this moot question of radiation from receivers. Edwin H. Armstrong, in whose name the regenerative patent is issued, said at the Washington hearings on the White Radio Bill (H. R. 7357) held in March, 1924.

I want to bring to the attention of this Committee a technical matter, one relating to interference, which, in my estimation, is just as serious for the future of radio as any question of monopoly which has been considered. I mean the radiation from regenerative receivers.

I might as well identify myself as the inventor of the circuit which causes this interference. That circuit, on the other hand, has created radio broadcasting. It is the basis of radio broadcasting, and is used in every such transmitting station in the country, and in about 80 per cent. of the receiving stations.

Does the Golden Rule Apply—in Radio?

A lot of folk are finding out that human nature is, after all, only human nature. They have found that the squealing, single-circuit receiver "owned and operated" by the neighbor across the street can cause them quite as much mental anguish as Willie Jones's saxophone next door did, in the days before radio became a household word. Well, some of the neighbors are being good fellows about it, and discarding their oscillating receivers, or making them over so they don't oscillate. And some are growling to themselves, "Aw, what difference does it make?" Mr. Armstrong, to take one of the most prominent in radio, seems to think it makes a good deal of difference, as this article by Mr. Wing brings out. The cure for the situation is really in public opinion, and when sentiment grows strong enough there won't be a radiating receiver to be found anywhere outside the museums.—THE EDITOR.

The particular merit of the receiver is that it enables you to build very cheaply a sensitive and selective receiver, but it has one bad property. Technically speaking, it is this: just as you approach the most sensitive adjustment, the receiver begins to oscillate, becomes a miniature transmitter, and it sends out signals which interfere with every other receiver within a radius of a few hundred yards.

In the early days of broadcasting that was not serious; the receiving stations were too far apart; but at the present time, where you have dozens of antennas on the same roof (we have that situation right along in New York City),

broadcast reception from any distance is becoming impossible. It's getting worse every day.

Now I have no hesitation whatever in saying if you let this thing go on for another year, nobody will hear anything. What you have got to do in some way, is to prevent the increase of these sets. I do not think there is anything you can do with the sets already out. There is no remedy you can propose that will be practicable. But if you stop adding to the number of these sets, and provide the new ones with mufflers—and by mufflers I mean something very similar to the muffler you put on an automobile to stop the noise of the exhaust—you will stop and prevent this radiation. If you do that, then the sets which are out will gradually disappear, just as the automobiles of five years ago disappeared. The newer models of sets will be in demand because they will be more selective, and sensitive, and these radiating sets will gradually die out.

The manufacturers of radio apparatus would be

very glad to put these mufflers on, but they can't do it as long as the other fellow who is competing with them does not put them on, because then the other fellow would undersell him.

At this point in the hearings, Representative White, of Maine said, "Mr. Armstrong, in that connection, I do not suppose there is a mail that comes to me which does not contain complaints against these regenerative sets. I suspect that is true of all the members of the House who have any correspondence relating to radio."

Every owner of a radio set—and who, indeed, is there who doesn't own one?—knows how widespread complaints are about the radiating receiver. That point is one that requires no emphasis. Last November, when the editors of this magazine conducted the transatlantic broadcasting tests with England, they found in reading the hundreds and hundreds of letters which poured into the office, how widespread was the curse of this oscillating set. When the American broadcasters were quiet, to let American listeners hear the English stations, the air was made positively hideous by the squeals of the little single-circuiters, searching up and down the scale for the English voices. Those tests provided a highly dramatic proof to the great body of American listeners that the single-circuit sets had to go. Just when 2LO, or 2ZY or 5NO, to list some of the English stations which were best heard on this side, were about to be tuned-in, the whole show would be broken up by the noise of some nearby single-circuit set. More work was then out of the question. This report came, without variation, from hundreds. The editors wanted to prove to the radio nation how serious the menace of the radiating receiver was, and there are few who listened then who did not agree.

Let us pile up a bit more evidence—evidence from authority as the logicians say—before

we come to remedies, and a forecast of the future.

PILING UP THE EVIDENCE

MR. ARMSTRONG had told the House Committee, sitting on the radio bill, that if a "muffler tube" were included ahead of these radiating sets, there would be no radiating, and no further trouble. He meant, of course, that a radio-frequency transformer and amplifier tube should be connected to the antenna circuit, ahead of the regenerative detector. He estimated the cost at about \$10 per set.

Mr. Clay S. Briggs, of the Committee, asked Mr. Armstrong if he did not think that the public was vitally interested in buying and using apparatus which will not radiate, and that, therefore, the company which made apparatus not subject to that criticism would be able to sell it to the exclusion of the firm which made the radiating sets.

Mr. Armstrong replied that he did not think that was exactly the case. And he added that "It

only takes one man in a group of a hundred to spoil the whole business for everybody. That is where the difficulty is. If ninety-nine fellows say 'Well, I will expend the extra money and not interfere with my neighbors', one fellow can spoil it all by getting the cheaper (radiating) set. I am afraid you are up against the human element. When you have whistling interference, there is no enjoyment for anybody."

Mr. Briggs then remarked, "Of course I can appreciate that clear reception is desired by everybody, but I have known people who have sat down to listen-in on high priced sets, some of them running up as high as \$150. I have heard all sorts of groanings, whistlings, and moanings, and they told me one of the reasons for it is, the more powerful set they get, the more they reach out."

"Let me correct a false impression here," Mr.

The Radiating Receiver

"It is possible with one of these sets to telegraph 25 or 30 miles with ease. Obviously, if you are going to cover the country with receivers of this type, particularly along the Atlantic seaboard, you are going to have a terrible "mess." In Newark, that exists now. One goes to listen to broadcast programs and one encounters a vast number of 'canary birds.' And the thing is only starting. I should like to suggest some sort of legislation, or regulation, which would make it impossible for any one to sell or promote receivers which might eventually nullify the benefits to be obtained from broadcast programs."—PAUL F. GODLEY, of the *American Radio Relay League*.

Armstrong answered, "The mere fact that a man has spent a thousand dollars for a receiving set is not going to prevent a fellow who has spent \$25 for one of these radiating receivers from putting him out of business. There is no amount of money you can invest in a receiving set which will insure you against this interference. It is a physical impossibility to guard against that."

The bewildered radio enthusiast must be asking himself by this time, "Well, what is to be done?" What, indeed, is to be done? Several solutions, besides those indicated in the quotations made above were made in the February, 1922, hearings, and in the hearings of March, 1924.

It was suggested that the Government institute a licensing system which should list and license every receiver, prohibiting the radiating type. This has been done in England with what seem to be excellent results. The Government now has the power to license transmitting stations, and

it was argued that since the single-circuit regenerator was a transmitter, the Government's course was clear. That, however, has not yet been done.

ATTITUDE OF THE RADIO CORPORATION

MR. DAVID SARNOFF, Vice-President and General Manager of the Radio Corporation of America made a suggestion which attempted to solve the difficulty in another way. Mr. Sarnoff's statement is especially interesting, because it indicates the policy of his very large and very powerful organization. For a number of years, it should be recalled, the Radio Corporation sold several types of inexpensive receivers which radiated very decidedly.

" . . . with Major Armstrong's suggestions, looking to the avoidance of unnecessary radiation in the air which interferes with the listening public, I am in accord. Aside from this, however, I believe it undesirable, in so

rapidly developing and changing an art as radio, to prescribe the "kinds of instruments" which may be used in a radio station.

"The elimination of radiating receivers is regarded as desirable, and the Radio Corporation is sympathetic toward this end. If legislation in radio is to ensue, we favor a clause therein reading substantially as follows:

That on and after June 30, 1925, it shall be unlawful to manufacture or sell a radiating receiver (a radiating receiver is defined as one which produces audible interference with reception by others in close proximity):

That two years thereafter, or June 30, 1927, it shall be unlawful to use a radiating receiver as above defined, for broadcast reception.

The Position of the Radio Corporation

"The elimination of radiating receivers is regarded as desirable, and the Radio Corporation of America is sympathetic toward that end. . . . I think that when a receiver radiates into the air, it is a transmitter, and therefore . . . (the Government) has a right to license it.—DAVID SARNOFF, *Vice-President and General Manager Radio Corporation of America.*

Taking up the question of licensing receivers, Mr. Sarnoff said, "I think that when a receiver radiates into the air, it is a transmitter, and therefore you (the Government) have a right to license it."

Mr. Stephen B. Davis, solicitor for the Department of Commerce, then told the Committee that he thought the prohibition Mr. Sarnoff suggested "would be a prohibition against

any receiving set which emitted electrical energy in such a way as to interfere with interstate commerce. I am not trying to give the exact wording, but I think Congress could control the use from that standpoint, and quite as effectively as to control the manufacture."

How is this very real problem going to be solved? H. R. 7357 did not pass at the last session of Congress, but the next Congress may quite possibly pass a measure which will legislate the interfering receiver out of existence. What is the owner of a radiating receiver to do with the set he already has? And what, and most important, perhaps, is the prospect for the present radio listener, and for the prospective radio listener?

AN IMMEDIATE REMEDY

THE technical staff of a reliable radio store should be able to show the owner of a radiating receiver how to reconstruct it by the addition of a radio-frequency muffling tube,

which will effectively prevent radiation. If this appeal is not successful, the technical staff of RADIO BROADCAST will give the information by mail. Much information, indeed, has already appeared in these pages. Other radio magazines will doubtless aid, as well.

The prospective purchaser should be certain the set he purchases does not radiate. It is a small matter to get reliable technical advice on this score. The inveterate constructor should build no sets which radiate. The most casual glance at the circuit to be built will satisfy him on this score. As a kind of parenthetical remark, no receivers which radiate are described or illustrated in RADIO BROADCAST pages.

For the layman, be it said that the tide is turning. The realization is growing that single-circuit sets are not desirable. Multi-tube receivers, using sensitive, non-radiating circuits, are becoming increasingly popular. The one-tube reflex set has answered the radio prayers of many who could afford only an inexpensive receiver, but still wanted a sensitive one which does not radiate. The force of guided public opinion is growing stronger constantly and no one who has given much thought to the subject has any doubts that the "blooper" is gradually going out. But that does not mean the campaign should be relaxed. If it is relaxed, stern measures may be taken. If the Government is forced to step in with a licensing scheme for all receivers, as has been suggested from more than one source, the radio listener would undoubtedly lose much of his freedom. And the freedom of radio has been one of its greatest charms.

There can be no better conclusion to this

discussion of the radiating receiver than direct quotation of Mr. David Sarnoff's remarks at the Washington radio hearing last March. He said:

. I think the manufacturers will, sooner or later, for their own self-protection, recognize that it is important to bring out a Golden Rule receiver, which does not do anything to your neighbor, which

you would not have your neighbor do to you, that is, a non-radiating type of receiver. But in this business, as in other lines of business, there are irresponsible manufacturers, there are irresponsible people, whose concern for the art extends merely to knocking but never contributing anything, and they are going to be making these radiating types of receiver so long as they make money in doing it.

I do not know, and I am not certain in my mind that it is necessary to write a definite provision in a bill about it; it may be a matter of regulation by the Department of Commerce. But I should even go so far as to say that, if the properly constituted authorities of the Government having to do with radio

would give this subject sympathetic consideration, and state to the public that a radiating receiver is a transmitter, and therefore subject to license, that they would rapidly disappear.

Let's hope they will!

Meanwhile this interference goeth merrily on. Mr. Smith still swears because he gets a sqawk or a squeal, which may come from Mr. White, just across the street. And Mr. Smith himself may be doing some interfering on his own account and not know it. The condition is less humorous and far worse than that fabled one where the bootleggers were so thick they were selling to each other.

But after all, it is a matter of good radio citizenship.

What Major Armstrong Thinks

"The radiation from regenerative receivers . . . is just as serious for the future of radio . . . as any question of monopoly. I have no hesitation whatever in saying that if you let this thing go on for another year, nobody will hear anything. What you have got to do in some way is to prevent the increase of these sets. . . . It only takes one man in a group of a hundred to spoil the whole business for everybody. That is where the difficulty is. If ninety-nine fellows say 'Well, I will expend the extra money and not interfere with my neighbors,' one fellow can spoil it by getting the cheaper (radiating) set. I am afraid you are up against the human element. When you have whistling interference there is no enjoyment for anybody."—EDWIN H. ARMSTRONG, *Inventor of the Regenerative Circuit*.



How Valuable is Radio Publicity?

WHETHER any one whose work is adaptable to radio performance should broadcast this work free of charge is a question that will be the subject of lively controversy as long as broadcast directors refuse to pay for this service. The position having previously been taken in this department that, as every laborer is worthy of his hire, those who broadcast should be paid provided they have an established professional standing, it would seem upon first thought that exception could not be taken to the attitude of Heywood Broun of the *New York World* when, in his daily column in that paper, he recently expressed indignation that any one should so far forget his commercial value as to dispense talents free in this fashion. But the advisability of broadcast directors depending on free talent for the presentation of their programs, and the advisability of any one possessed of artistic self-respect agreeing to sing or play or lecture, as the case may be, for nothing, are two distinct questions. Mr. Broun, it would seem, was dealing with the latter one.

Dr. Sigmund Spaeth, one of the most authoritative and constructive living writers and lecturers on music, has taken issue with Mr. Broun on his position in this matter, and he speaks from experience as he has for some time been lecturing on music through station work, at Newark. He states:

The artist who "has the goods," who requires only a hearing to convince a huge public that further

hearings are well worth while, and, what is more important, deserving of financial reward, such an artist need not hesitate to broadcast freely and confidently, with an assurance of an ever increasing demand for personal appearances.

In my own case, the radio has been helpful in bringing before the average American citizen the title of my new book, *Common Sense of Music*, and that is just the sort of person I want to reach. I am not trying to reach the musicians and established music-lovers of the country, for they are taking very good care of themselves. The radio audience represents brand new material, full of interest and curiosity, and I am convinced that thousands of these listeners will eventually have *The Common Sense of Music* in their libraries. In fact, a great many of the letters which I receive contain direct orders for the book, which is something that might appeal even to Mr. Broun. In addition, there are frequent requests for popular talks on music in various clubs, schools, and colleges, even occasionally in a private home, and such engagements, naturally, imply the payment of my regular fee. It is impossible to give one's entire message over the radio, if that message is at all worth while, and all that is necessary is the confidence that a part of the message will create the desire to hear the whole.

Dr. Spaeth seems to have made out a pretty good case for himself by frankly stating that if he chooses to use the radio as a means of publicity it is in no way beneath his dignity to do so.

Mr. Broun, in his writings, has proved himself to be fair-minded, with a healthy outlook on life. He is a critic who does not himself resent criticism, genial and constructive. He

will surely not object to being asked why, if he so resents any one dispensing his talents free, he should have allowed complimentary copies of his two books to be sent to newspapers and magazines all over the country in order that he might obtain notices of the books in these publications—in other words, free publicity. Assuredly this was “dispensing his talents freely.”

What is the difference, then, between this sort of publicity and that employed by Dr. Spaeth when he uses the radio? What is the difference between giving to the public samples of one's writings through newspaper quotations made from a free copy of the book, and through a personal talk over the radio which is given free of charge?

Having spent many years behind the scenes of this country's musical life, the present writer can say with emphasis that any artist, no matter how great, who uses the radio for publicity purposes is employing a more dignified means to this end than the large proportion of the means employed constantly along less obvious lines. It is more dignified to keep yourself in the minds of the public through occasional free presentations of your work than through paying a press agent to concoct sensational stories about your personal tastes or habits of life.

Public Men Need Broadcasting

THE people of integrity who are heard over the radio do not claim that they are broadcasting for their health, or from altruistic purposes. They state frankly, as does Dr. Spaeth, that they want the publicity. And, as long as the radio offers opportunity for free publicity, then all power to those who take advantage of it! They are not only enjoying a big opportunity, but they are playing the game with the cards on the table. Those who say they do not need such publicity are simply bandying words. Every one who depends on public patronage needs publicity unceasingly.

All of this, as we have said, has nothing to do with the question as to whether or not the broadcast directors should ask people to broadcast for nothing. We have taken an unequivocal stand on this question by asserting that the people of professional standing who give performances over the radio should be paid for their services. And we are convinced that as soon as the broadcast directors have had sufficient experience in putting forth programs they will begin to change their policy in this respect. As it is, they have met and solved

tremendous technical problems that, a few years ago, were undreamed of, and it can scarcely be expected that during the short period broadcasting has been in operation they could solve their program problems with equal ability. Any one who listens in night after night soon comes to the conclusion that this problem will be solved by the listeners rather than by the directors.

But as long as the present system exists, it is a wise man or woman who, needing publicity, takes the opportunity, as does Dr. Spaeth, to get it through the radio.

When Debussy Was Introduced to the Radio Audience

ONE can scarcely estimate the value of such a broadcast feature as the half-hour program on “Claude Debussy and His Music,” given at station WGY by Vladimir Karapetoff, of Cornell University. It is interesting to observe that Mr. Karapetoff is Professor of Electrical Engineering at that institution. Even those who during this program may have been somewhat confused by trying with so brief an opportunity to understand something of this French composer's individual style, must have listened with interest and, it is hoped, with a desire to hear more about the man and his music.

Some of us can scarcely uphold Mr. Karapetoff's attempt to give, in his analysis of the compositions played, a specific meaning to



—Morris Rosenfeld, New York

WINIFRED T. BARR

Miss Barr is frequently heard through WEAJ.
She is the official pianist at this station



—Hiller, Pasadena

YVONNE FARR

Really an alias, as her name before she left her parental Philadelphia home was Edna Hudson. Her friends still call her that, but the public knows her only by her stage name. She prefers stage life to society life and is here seen as she appeared in the prologue to the motion picture version of "The White Sister." She was recently heard over the radio at station WIP, Philadelphia

the various themes or episodes or phrases. Debussy was the first of the musical impressionists, portraying tone moods instead of definite scenes. His "Cathedral in the Mist" is not supposed to portray an actual cathedral, but rather to inspire in the listener the mood

that would come to a sensitive spirit by seeing a cathedral through the mist. "What the West Wind Saw," which was another of Mr. Karapetoff's selections, while having a more easily sensed contour than the majority of Debussy's works, can still be interpreted from



HILDA
RAMON AND
CHARLES
BRYDEN

Among the musical programs heard from WEAf during the last few months, the joint recitals of Miss Ramon, mezzo-soprano, and Mr. Charles Bryden, lyric tenor, have proved a popular feature with discriminating listeners

as many points of view as there are listeners to hear it.

An impression existed for a time that Debussy invented the whole-tone scale which is so prevalent in his music, whereas in fact he became interested in this musical mode while in Russia, where it seems to have originated in that country's folk songs. But it was Debussy who brought it to the recognition of the musical world. With this scale, he produced the mystic intangible effects which soon placed him as the first great master of musical impressionism. This composer has as yet had no competitive successor. The whole-tone scale, let it be explained, is simply a scale without semitones—made up simply of whole tones.

Even the brief glimpse of Debussy's genius given through Mr. Karapetoff's well-executed program at WGY must have aroused curiosity as to this composer among many who hitherto had known little if anything of him. And once you are curious about a subject you are in a fair way to learn something about it on your own initiative. Debussy was first brought to the general public's attention in this country when Oscar Hammerstein produced in New York his opera "Pelleas and Melisande" at the Manhattan Opera House, with Mary Garden in the rôle of Melisande.

The Philharmonic and the Goldman Band of New York Are Popular

AS A feature of eager interest in the locality in which the conductor of this department is at present sojourning—Toledo, Ohio—the concerts of the New York

Philharmonic Orchestra at the Lewisohn Stadium, and of Goldman's Band at Central Park in New York, and broadcast frequently by WJZ and WGY, came second only to the interest excited by the proceedings of the Democratic convention. And that, so far as the success of a musical broadcasting feature is concerned, is, in the vernacular, "going some."

Whenever the telephone rang on the day one of these concerts was to be broadcast the present writer knew some one was about to ask, "Would it be convenient for me to drop in tonight and hear the Philharmonic (or Goldman's Band)?" Until the capacity of the seating space available was exhausted the answer was always, "Yes. Delighted."

And, wonder of wonders, even on the hottest nights the music was heard, sometimes with even greater clarity, so far as strings and wood wind were concerned, than if one had been seated, listening at the concert. But, alas, for that aggravating daylight saving time! Eight-thirty in New York is seven-thirty in Ohio, and seven-thirty in Ohio during July and August is too light for good radio reception from such a distance. But after it became dusk—what joy!

Real Artists from the Virgin Islands

WHEN listening to the first broadcast performance ever given by the Navy Band of the Virgin Islands, we made a note on a handy writing pad, "Very smooth playing. Not quite as much zip as the American bands, but a good deal more sentiment."

We were not cognizant at the time that the Virgin Islands are inhabited mostly by the

colored race, and we are still a bit hazy about just where they are situated. But there is no haziness in the impression made by that band, and we know now that the members, who are all colored men, were true to their race when they showed somewhat less aggressiveness and more sentiment in their playing than do American bandsmen. Their performance at station WCAP immediately followed their serenading of President Coolidge on the White House lawn. We hope the President enjoyed their performance as much as did those who later heard them over the radio.

What Do Broadcasters Know of Adverse Opinion?

AMONG the expressions of opinion received on a recent editorial in this department relative to broadcast speakers and announcers in general and women in particular, comes one from Dorothy Doane Haynes of Winfield, Kansas, from whose letter we are moved to quote some paragraphs, omitting, in charity, the names of those people or

stations who are hit hard. Here are some of Mrs. Haynes's comments:

There are people who have stood out in past programs to such an extent that they are not easily forgotten. Some of them were women. And, of course, some were pleasant and others were not. Among the pet peeves Mr. Haynes and I have is — of station —. When we feel like throwing things, we listen to her. And when her horribly affected voice comes over the air, we feel like throwing the whole thing out of the window. We listen, then both say, "Yah! Yah! Yah!" and hunt something else quick.

Then there is that — man who has begun to say, "Radiocasting." Of all the silly words! It reminds me of a piece of machinery. . . . Of the speakers, it is a rule that if they are talking about W. C. T. U. their voices are unpleasant. I have never yet heard a W. C. T. U. woman who was pleasant to listen to.

Preachers are generally too sanctimonious sounding. I wonder why they do it. They sound so pained, and yet resigned to the awful wickedness of the world. . . . I always like to hear Mrs. Poehler of WLAG. Her lovely voice no doubt has its explanation in her vocal training. It is a pleasure to listen to her talks. And the Story Lady at KDKA



ONONDAGA INDIANS

As they looked when broadcasting a war dance in the studio of WGY, Schenectady. Those who listened-in had no difficulty, provided they possessed a fragment of imagination, in visualizing the scene, for the whoops of the dancers and the drum beats were highly realistic—real "Injun" stuff

(I hope she is there again next winter), and the one at WFAA, Mary Tooney, and the announcer at WFAA. Too many of the men announcers try to be funny, as the one at —. He would be good if he would cut out the slapstick. Graham McNamee is a splendid announcer. And so is the one at KHJ. Can't you just hear him? This is K-H-J — Los Angeles — California.

Oh, there are heaps of pleasant voices that come to us both speaking and singing, and I for one have never thought that the men, as a rule, were more delightful to listen to than the women. There are good and bad of both.

Copious quotations have been made from this letter not only because it is entertaining and discriminating, but also because when opinions are expressed with no idea of their reaching the persons discussed, their value is augmented. We have a rather fixed idea that letters sent to broadcast stations are mostly of a complimentary character. Those who would criticize unfavorably seldom trouble to write. They say, "Yah! Yah! Yah!" and "hunt something else quick." So we look upon Mrs. Haynes's derogatory comments as of even greater value than the praise, although that is of no small value.



—Thomas Coke Knight, New York

ALICE WILLIAMSON

the "A. M." of the "C. N. and A. M. Williamson," two names long since famous among people who have enjoyed the writings of these joint authors. Since the death of Mr. Williamson at their home near London, Mrs. Williamson has "carried on" alone. She is now in this country and a short time ago delighted many of her admirers with a radio address given through station wjz

THE announcer who informed his listening world that the "Gavotte" by John Sebastian Bach, about to be played, had been dedicated by Mr. Bach to Mr. So-and-So of



HOWARD I. MILHOLLAND

Or, "H. M." as he is known over the radio. Mr. Milholland is studio director and chief announcer at station KGO, Oakland, California

Vermont, had his dates somewhat mixed, as John Sebastian Bach died in 1750.

IF THINGS keep on as they are going it will not be long before "The Star Spangled Banner" will be known as the National Requiem. Not a day passes without its being heard over the radio, slow-paced, wishy-washy, sickly, sentimental, drooling. That is saying—well—a typewriter full. But let it stand. And, like all truths, it can stand alone.

Is there no one—band conductor, orchestra conductor, singer—who can send this song out over the radio with at least some vestige of stirring vitality? As it is now played, one is tempted to shout back, "Yes! We have no star spangled banners to-day!"

WHAT could be more fitting than to send, via air mail, an advance announcement of a program to be heard on the air? This was the progressive course adopted by station KGO, at Oakland, California, and one recipient of the program can vouch for the strange sensation, half thrill, half wonder, with which it was received more than two thousand miles from its starting point.



—Boice, Troy, New York

THE CAMPUS SERENADERS

The personnel of this dance orchestra is drawn from students of the Rensselaer Polytechnic Institute at Troy, N. Y. Their monthly programs, given through the Institute's broadcasting station, WHAZ, have been heard in every state in the Union, every province of Canada, from Alaska to Panama, from Hawaii to Bermuda and in New Zealand. According to the director of WHAZ, these players have received more than 10,000 letters of appreciation. A tribute well deserved, as you will agree if you have heard them

A NUMBER of inquiries have also been received asking who is Igor Stravinsky, two of whose compositions were played at the New York Philharmonic Stadium concerts referred to elsewhere in this department. To describe this Russian in a sentence one might say that if any one can take from Richard Strauss the honor of being the greatest living composer, that person is Igor Stravinsky. In his methods he is the most extreme of iconoclasts; in his mastery of orchestra, supreme; in imagination, superbly gifted. People have been known to leave a concert hall during a performance of one of his works, dismayed and offended by such amazing discords, such unexampled freedom of utterance. But the history of music shows that the discords of yesterday are the harmonies of to-day. The Boston Symphony Orchestra created a profound sensation last winter in Boston and New York through the first presentation in this country of Stravinsky's "Sacre du Printemps." Mr. Stravinsky will make his first American visit

next winter and is already booked to conduct many of our leading symphony orchestras.

THIS stupendous human miracle, in its quiet suggestiveness of the majesty of God's power in the creation of man, awakens feelings I cannot describe, and which are too holy for expression by any language of this world."

According to the *Atlantic Monthly*, George E. Waring, Jr., of New York, wrote thus to his wife regarding the latest stupendous achievement of man. The radio? No, for the year was 1858. He referred to the then just completed Atlantic cable. What would he write about broadcasting were he living to-day?

THE 999th inquiry, "Are you any relation to Donald Mix, radio operator of the McMillan expedition?" arrived by mail some days ago. Until we know for sure that we are not, we have decided to claim relationship to this gloriously adventurous radio expert. It gives one such a feeling of adventurous prestige.

Efficiency Plus

The Roberts Knock-Out Set With Resistance-Coupled Amplification

By ZEH BOUCK

EFFICIENCY in the criterion of the broadcast fan is quite removed from abstruse theoretical considerations, and is expressed in the most simple arithmetic as "results per dollar."

Perhaps I might say, a little more technically, results per tube, which is much the same thing. From the point of view of the enthusiast, and even by the more abstract calculations of the engineer, the radio frequency-regeneration-reflex Roberts circuit is the most efficient receiving system employing more than one tube.

Radio-frequency amplification has been introduced into all modern and efficient receivers. No truly high class receiver, as determined by the advanced standards of to-day, can be designed that does not incorporate one or more stages of such amplification. Within certain limits, radio-frequency amplification is more effective than audio intensification, because the output of a detector tube varies approximately as the square of the applied input voltage. A little reflection will demonstrate the advantage which R. F. amplification takes of this squaring. For instance: If we have a signal coming down the antenna with an intensity of 2, and amplify it ten times through one stage of R. F. (10×2) the output of the detector immediately following will be 400. However, if such a signal is first detected (with an audio output of 4) and then amplified (10×4) our final achievement will represent a total amplification of only twenty times.

Tuned radio-frequency amplification, such as is employed in the circuit we are discussing, is far more effective than untuned systems for the same reason that a receiver tuned to a distant transmitter will give a greater response to signals from that station than an untuned or poorly tuned receiver. Thus in the Roberts set we have carried the picked-up radio signal through the first tube with probably the highest practical efficiency.

This efficiency is maintained throughout the detector circuit by regeneration, which in effect is a form of radio-frequency amplification. Regeneration has the additional function of reducing the apparent resistance in the detecting circuit, compensating for inefficiencies and resistances often found in inexpert design and construction. (However, the writer desires to emphasize that this phenomenon of negative resistance is only an "effect," and, contrary to a somewhat prevalent belief, it does not actually eliminate the grid re-

Do You Believe in Resistance-Coupled Amplification?

Mr. Bouck has applied an excellent resistance-coupled amplifier to the Roberts Two-Tube Knock-Out circuit with splendid results. This article continues the practical experiment and research of this author in the inviting realm of the RADIO BROADCAST Knock-Out series. The article, like most of those of Mr. Bouck's, is really two articles. The first part consists of an able discussion of the technical "why and how" of what the circuit is and does, and the second part is a clear presentation of how to do it. Walter Van B. Roberts himself described his extraordinary circuit in this magazine for April and May. In July, J. E. Roberts described the Roberts circuit with an additional stage of audio, and Mr. Bouck told how to use the arrangement for short-wave reception. In September, J. B. Brennan's article told how to build the Roberts circuit with a push-pull amplifier.—
THE EDITOR.

sistance, nor permit the builder to omit the usual precautions and radio finesse. The output of the detector remains inversely proportional to the resistance of the circuit. In other words, reducing the resistance of the system by using large size wires, perfectly soldered joints, and eliminating metals and dielectrics from the electro-magnetic and electro-static fields, will still increase the signal strength even when regeneration is employed.) This apparent reduction of resistance results in greater signal intensity and increased selectivity. These

phenomena are very interesting and merit the student's serious attention. For an admirable non-technical discussion of their operation, the reader is referred to *The Outline of Radio*, by John V. L. Hogan.

Lastly, the signal so efficiently maintained and strengthened, is reflexed through the first amplifying tube as one stage of audio-frequency amplification. An additional tube and its expenses are thus eliminated and, in consideration of our opening paragraph, a very decided jump in efficiency is achieved.

The output of this two-tube receiver, arrived at with so close an approach to engineering ideals, is capable of operating a loud speaker on signals from fairly distant stations. The volume, however, is somewhat limited for concert and dance purposes. This is partly due to the inadvisability of overloading the first tube which does the double duty of radio- and audio-frequency amplifier. The possibilities of the Roberts receiver may be multiplied, making it ideal for almost every purpose, by the addition of an external audio-frequency amplifier, operated by the output of the reflexed stage.

The author has devoted considerable research to the capabilities of the resistance-coupled amplifier, and the unequalled quality of reproduction and the genuine economy of first cost and maintenance suggest this system as the logical continuation. Likewise, in designing the receiver I am describing in this article, I have endeavored to incorporate vari-

ous mechanical refinements that are equally justified by the excellence and over-all efficiency of the set.

THE FUNDAMENTAL CIRCUIT

THE fundamental circuit of the Roberts receiver plus two stages of resistance coupled amplification is shown in Fig. 1. This primary arrangement permits a number of variations according to the desires and originality of the individual experimenter. Filament control jacks for inter-stage reception, ballast resistances, and other mechanical facilities can be added to the circuit or dispensed with according to individual desire.

T₁ and T₂ are radio-frequency couplers. These coils can be purchased, and the experimenter is advised to avail himself of the manufactured inductances rather than attempt the winding of them. However, if desired, the coils may be wound according to the following directions:

The pasteboard or similar winding forms should have an odd number, about 17 spokes, and a first-turn-diameter of 2¼ inches. Both secondaries, S, are wound with 44 turns of No. 20 or 22 wire. The secondaries are wound "over three under three." When wiring, the outer or upper lead of S in T₁, and the inner lead of the secondary of T₂ connect to their respective grids.

The primary, P, of T₁ has forty turns of about No. 22 wire, wound over one under one. The primary is tapped at the 2nd, 3rd, 5th,

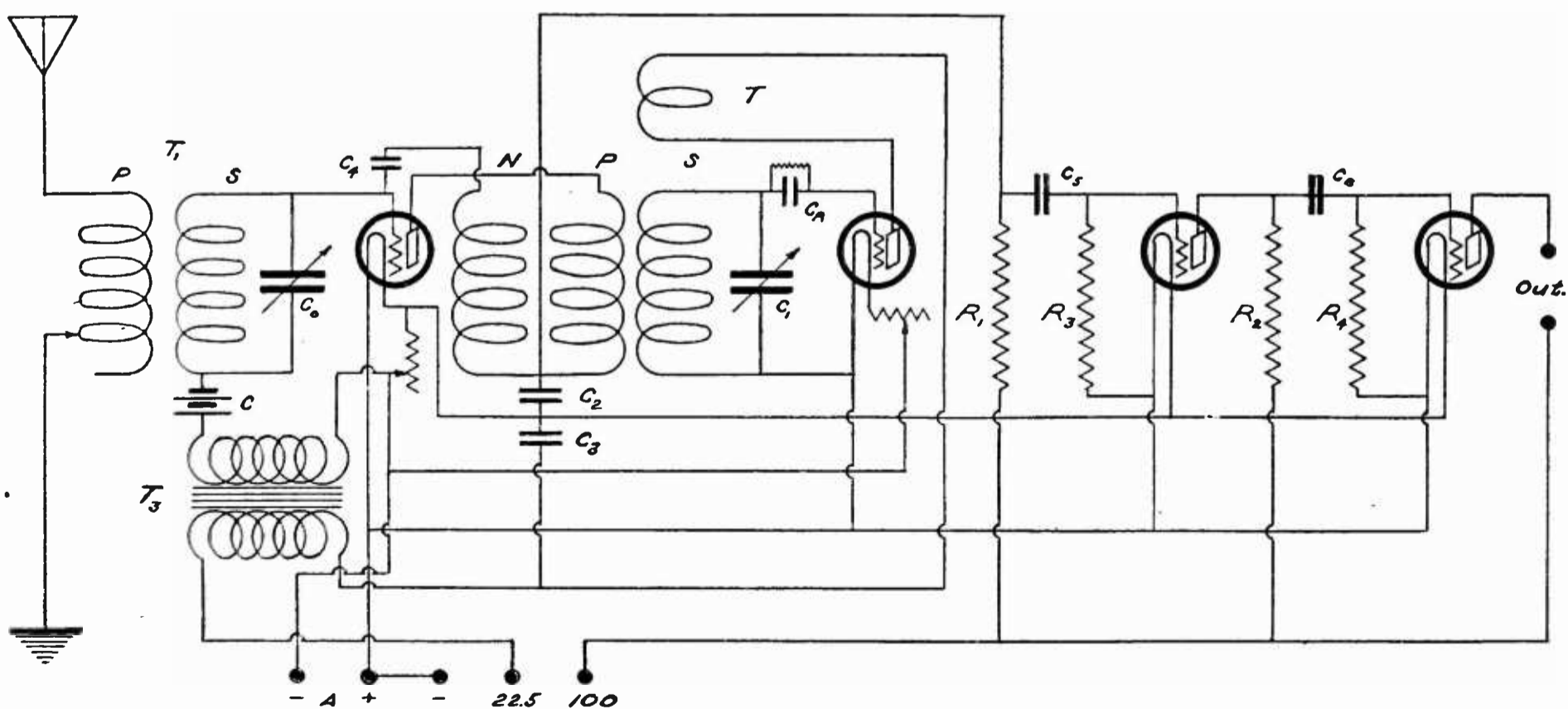

FIG. 1

The fundamental circuit. This is the starting point for readers who desire to express their own originality in the choice and arrangement of filament control jacks, etc.

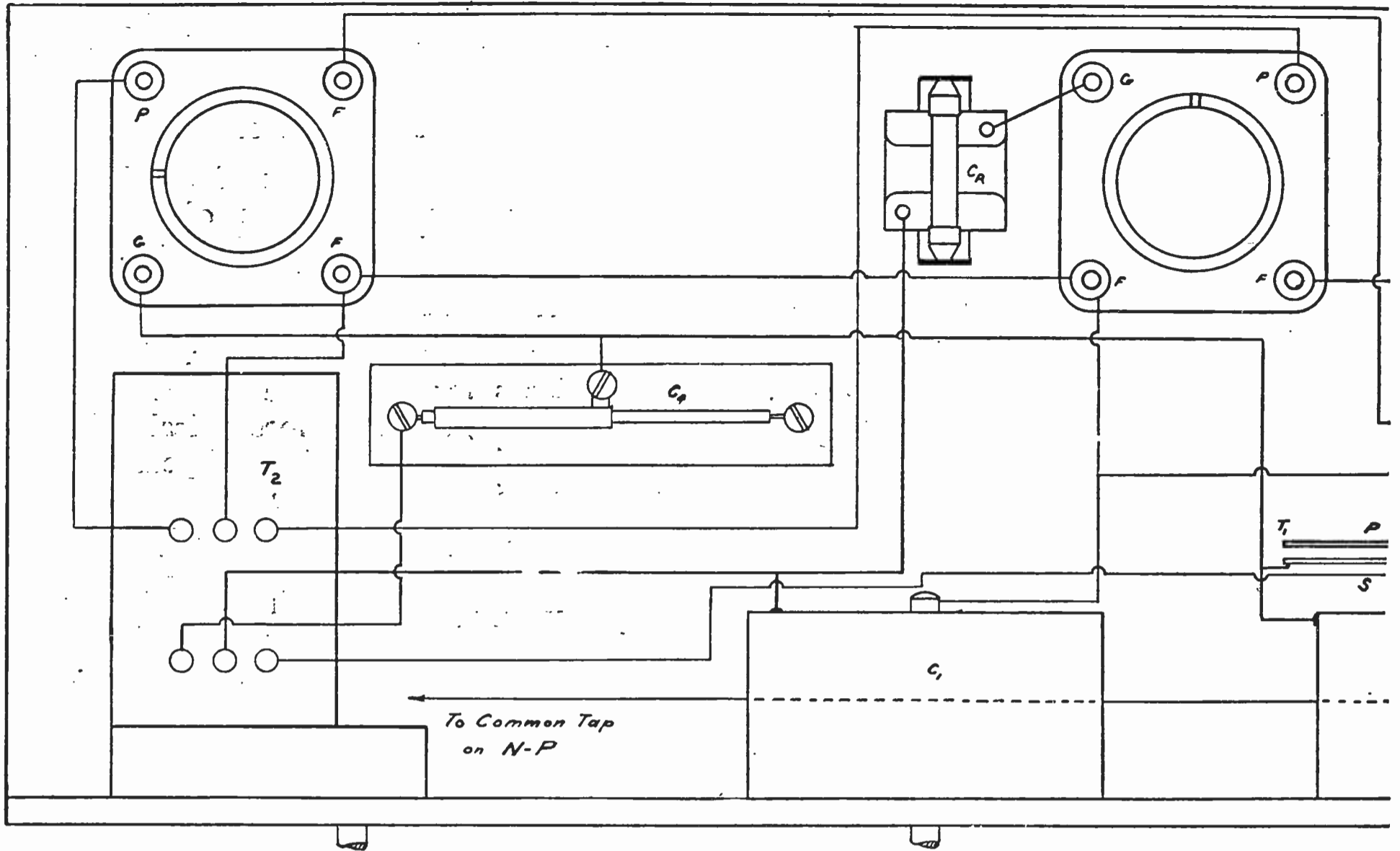

FIG.—
The specific circuit employed by Mr. Bouck. Filaments and ampli—
the tube at the extreme left, is the amplifier and the next one—

10th, 20th, 30th and 40th turns, the ground leading to the switch arm.

Coils N and P, of T₂, are wound with 20 turns of No. 26 wire in the following manner: The two wires of sufficient length, or run from separate spools, are wound simultaneously over one under one, to the required number of turns. This will result in two separate coils very closely coupled to one another. The *end* of one coil is connected to the *beginning* of the other, this common terminal running through the coupling resistance, R₁, to the plus B battery. The remaining two terminals are led, indiscriminately, one to condenser C₄, and one to the plate of the first tube. P functions as the primary of the radio-frequency transformer, and N is the stabilizing winding that makes possible the highly efficient radio-frequency amplifier.

Coil T is the tickler by which regeneration is effected and controlled. This inductance consists of from eleven to twenty turns of No. 26 wire. The correct winding is best determined by experiment. The circuit regenerates properly when it is possible to control regeneration and oscillation over the full tuning range. The author uses a tickler of fifteen turns. It

may be necessary (a fifty-fifty chance) to reverse the connections to the tickler.

The relative position of the tickler and S of T₂ represents the only variable coupling. In both T₁ and T₂ the primaries and secondaries are mounted concentrically and permanently separated one half inch.

T₃ is an audio-frequency amplifying transformer connected according to the initialed terminals. C is a bias battery, negative through to the grid, of from 1½ to 6 volts. This bias potential should be varied and perhaps reversed during the stabilization experiments on the first tube.

C₀ and C₁ are .0005 mfd. variable condensers. It is important that they be of a reliable make, capable of attaining this maximum capacity. In wiring, the stationary plates of the condensers should be connected to the grids of the tubes.

C₂ and C₃ are bypass condensers of about .002 mfd. capacities. For the best control of regeneration, and for the stabilization of the first tube, it may be advisable to experiment with these fixed capacities.

C₄ is the neutralizing condenser. This is easily made by winding bare wire over two

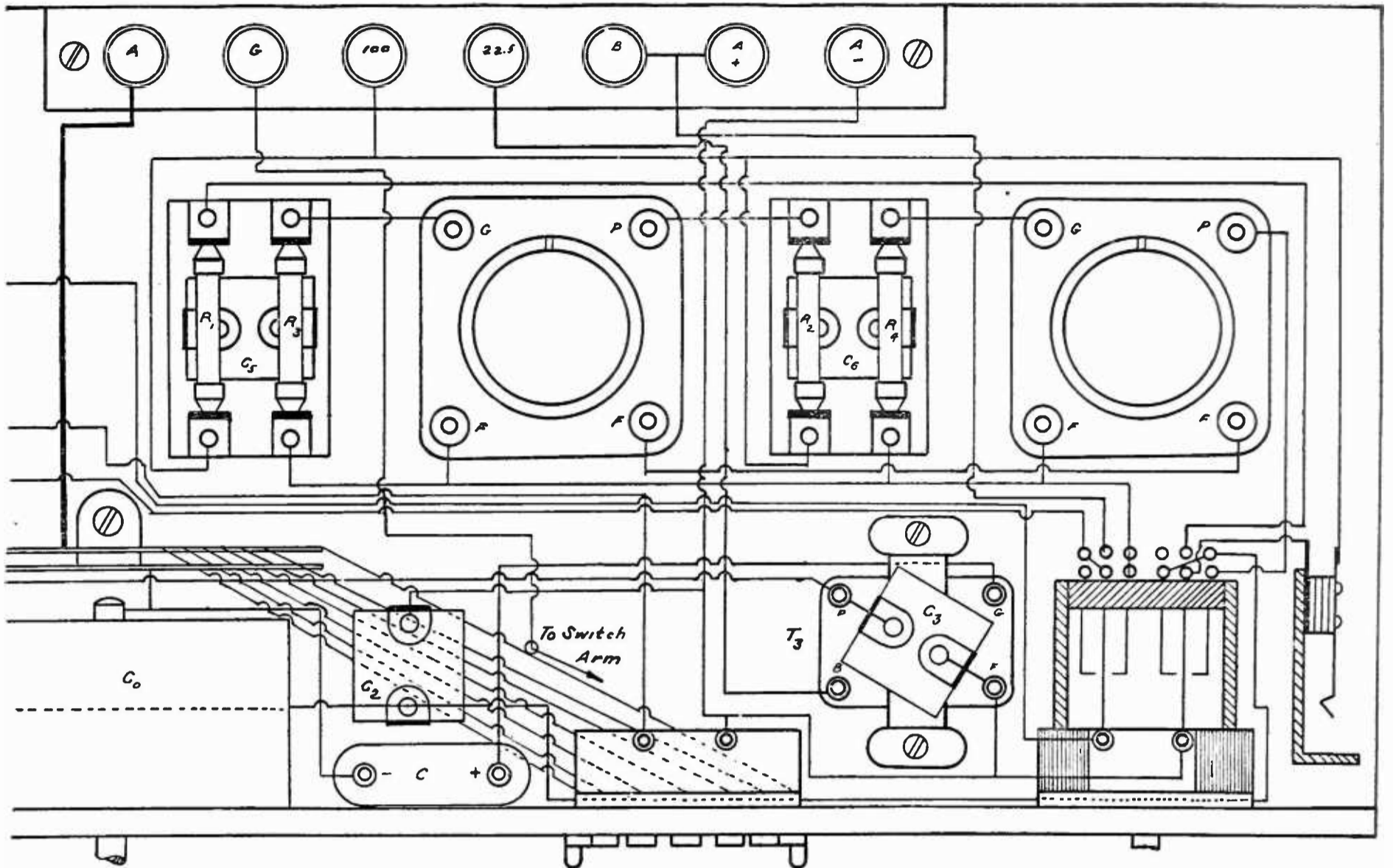

—2

—cation are controlled by the anti-capacity switch S. In this drawing, —is the detector, which is the only change from the photographs

inches of spaghetti tubing, slipping the winding on a bit of bus bar wire left projecting from the grid terminal on the amplifying socket. By adjusting the tube farther on and off the bus bar, the capacity is varied until the tube is properly stabilized—i. e., does not oscillate regardless of condenser C_0 settings and the magnitude of incoming signals.

C_5 and C_6 are the isolating (or coupling, if you prefer) condensers of the resistance-coupled amplifier, having capacities of .006 mfd.

CR is the grid condenser and shunt grid leak, generally having respective values of .00025 mfd. and 2,000,000 ohms. Again experimentation with other values may improve the regeneration control.

R_1 and R_2 are the coupling resistors of 100,000 ohms each. R_3 and R_4 are grid leaks having respective resistances of 250,000 ohms and 50,000 ohms.

The usual open circuit jack is employed for plugging in the output.

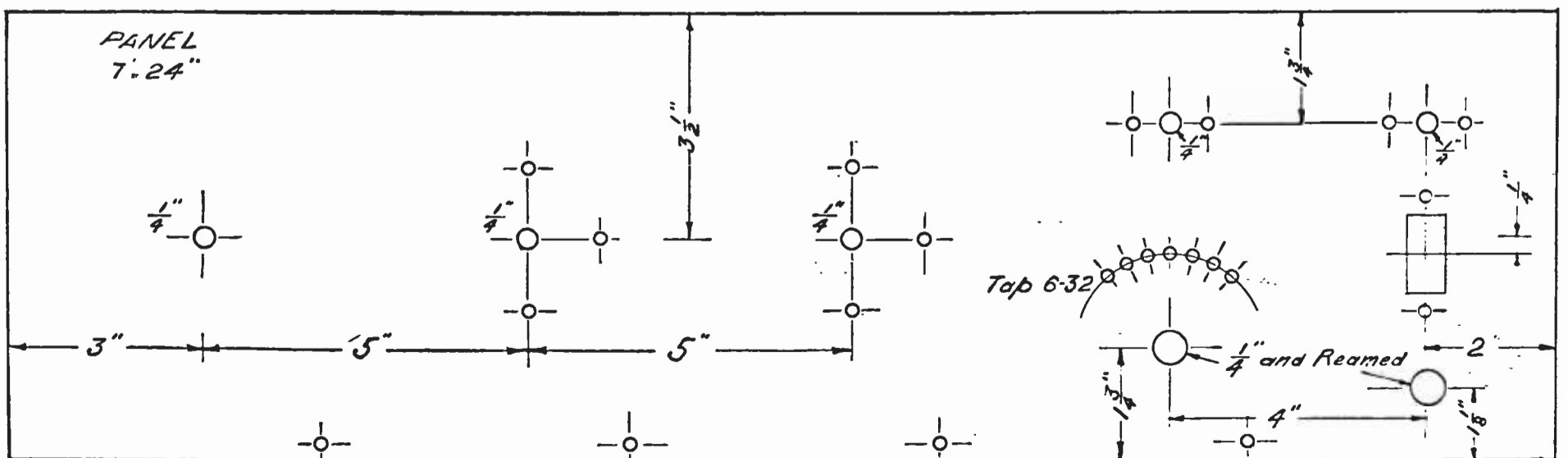

FIG. 3
The panel layout

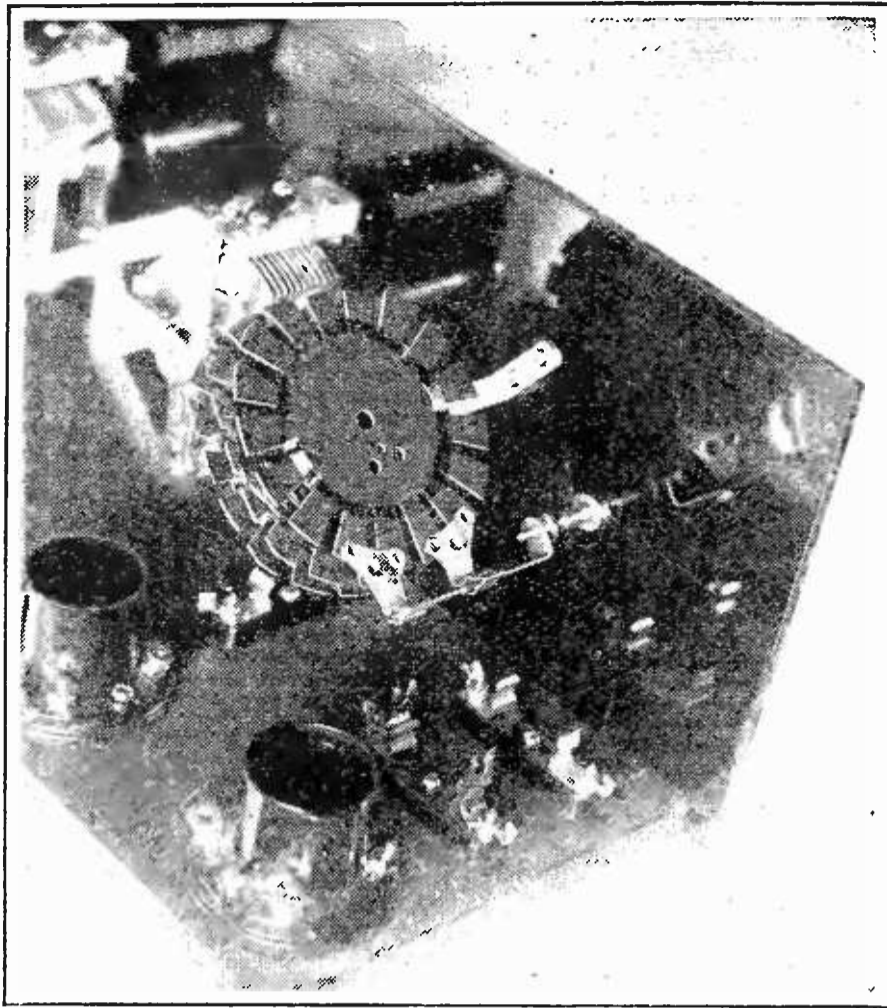

FIG. 4

Showing the manner of mounting T2 and the tickler. The commercial type of inductances have been used. The condenser mountings are also shown

THE SPECIFIC CIRCUIT

FIG. 2 shows the circuit arrangement employed by the writer. The values and constants are in every case those designated in the fundamental circuit.

The current through the amplifying filaments is adjusted by a single ten ohm rheostat and that through the detector filament by a thirty ohm rheostat.

Amplification and filaments are automa-

tically controlled by anti-capacity switch S, which is in effect two double-pole double-throw switches. When the blades are up, the first two tubes (R. F. and detector) are lighted and the output connected in the plate circuit of the reflex tube. In the center position all filaments are "off." When the blades are down (the control handle on the panel up) all tubes are lighted, the external amplifier connected and the output transferred to the plate circuit of the last tube.

MATERIALS AND PARTS

WE HAVE determined to build a truly efficient set, and we can only achieve this end by using the very best of parts. Not an item of inferior material should go into the makeup of the receiver. While the future builder need not confine himself to the trade products selected by the writer, he should be sure that his substitutes are equally efficient and reliable.

The new type Duplex variable condensers, which represent condenser efficiency rarely attained in the commercial product, were used by the author. A vernier action is supplied by Accuratune dials.

Micadon fixed condensers have been employed throughout the circuit excepting in the case of C4. These condensers can be obtained in all the designated capacities, and clip into the Daven mountings which permit the experimental variations advised in the description of the fundamental arrangement.

Five Daven mountings are used—Two condenser mountings for C2 and C3, one combina-

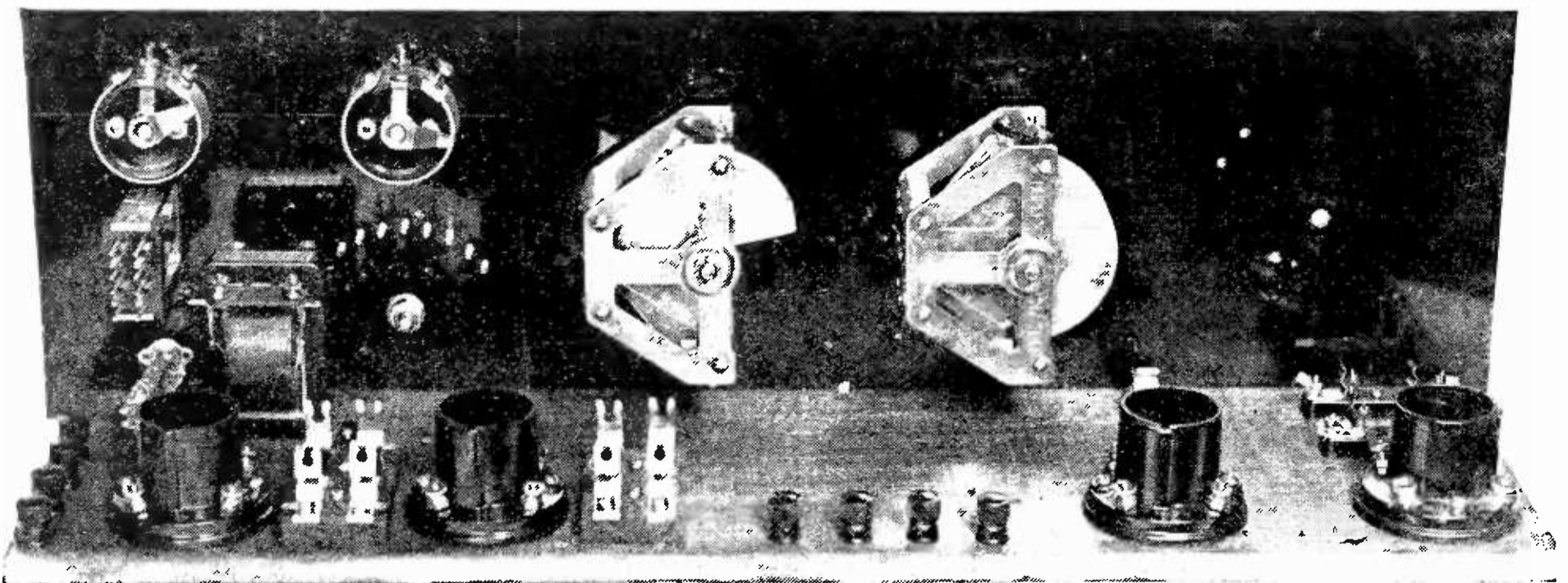

FIG. 5

The skeleton set ready for the first bit of wire and solder. The inductances have been removed, but allowance should be made, when wiring, for the space they will occupy

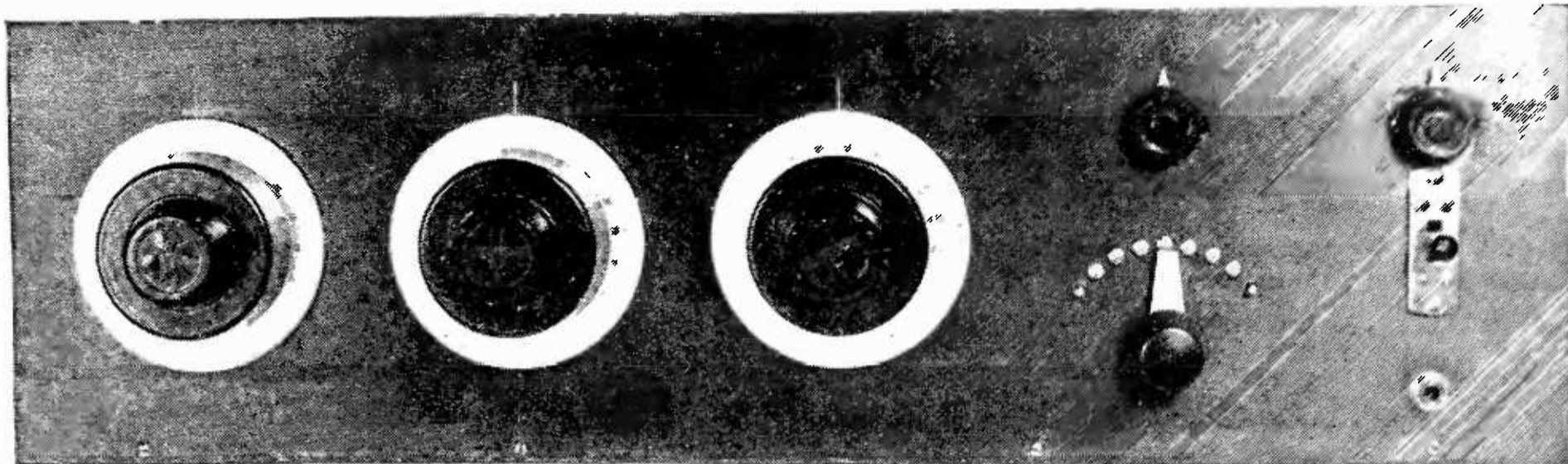

FIG. 6

Front view of the completed receiver. Truly a de luxe appearance worthy of the efficient principles which have been embodied in the design and construction

tion mounting for CR, and two resisto-couplers in the external amplifier. These mountings may be seen in photographs Figs. 4 and 5.

The Daven Improved Coupling Resistors and Daven grid leaks were also employed. These resistances, with the isolating condensers C5 and C6 clip into the resisto-coupler. (Other equally efficient coupling resistances will be found listed in THE R. B. LAB for August.)

The audio-frequency amplifying transformer is an Amertran.

Switch S is a Federal anti-capacity switch, type 1424, made by the Federal Telegraph and Telephone Company. Looking at the back of the switch, the connections should be made exactly as indicated in Fig. 2.

Na-ald sockets and General Radio rheostats maintain efficiency in their respective departments. A Carter jack and Eby binding-posts are the final touch to the deluxe equipment.

CONSTRUCTION

THE first step in building is the drilling and preparation of the panel. Consistent with our determination to use nothing but the best, bakelite is the selected material and is laid out according to Fig. 3.

All holes, excepting those otherwise designated, are drilled to pass a number eight screw. This permits a slight leeway in case of inaccuracy. The holes for the taps are drilled with a No. 35 drill and tapped for a six thirty-two thread. The taps are screwed in, no nuts being necessary behind the panel.

The rectangular hole for the anti-capacity switch is laid out according to the template furnished with the switch. The center of the switch should be $\frac{1}{4}$ inch below the center of the panel. The hole is cut out by drilling with the No. 35 drill and breaking through with a knife. The edges are filed smooth.

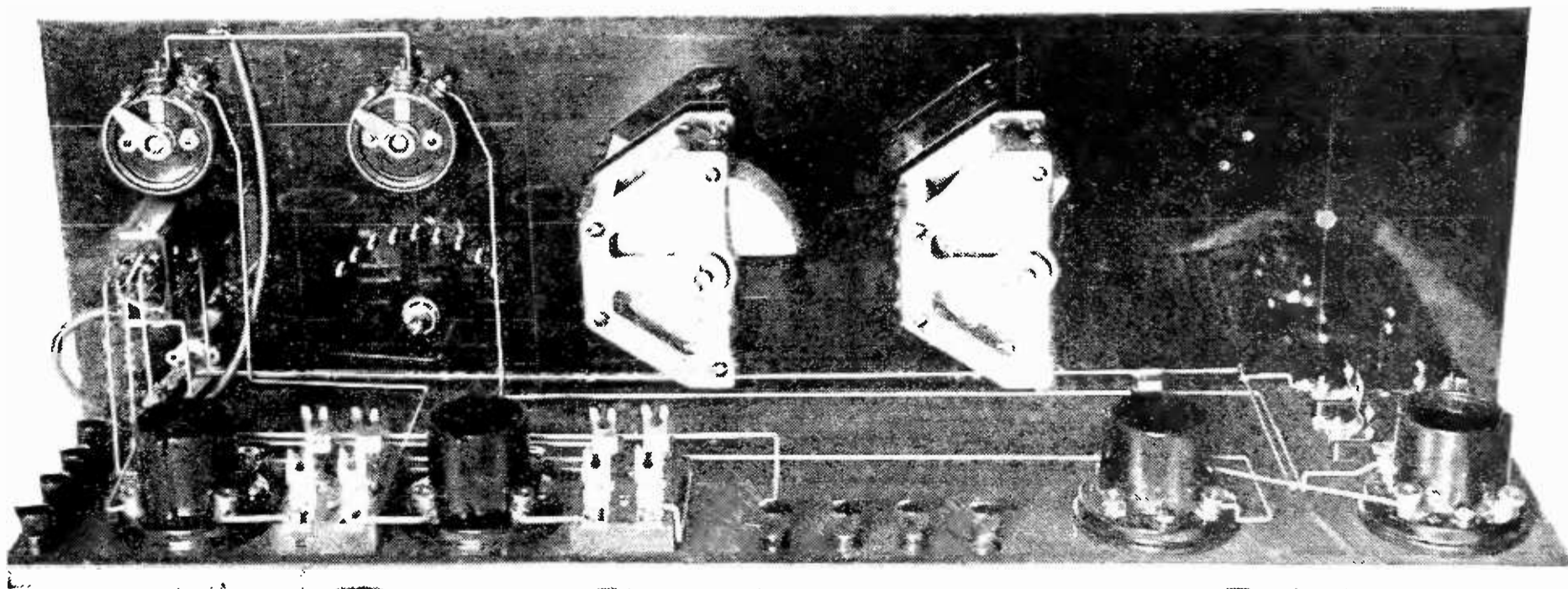

FIG. 7

The job half finished. The filaments, amplifier, and control switches are wired. After testing the filaments, the remainder of the instruments are mounted and wired

After the panel is drilled, it is grained to a beautiful linen finish and oiled. I have described this process in detail in an article on a short-wave receiver appearing in the August issue of RADIO BROADCAST. The line markers for dial settings are engraved with the ordinary square and a scribe. The lines commence one inch below the top of the panel and continue down until covered by the dial. The lines are filled in with white crayon or tailors' chalk.

The dimensions of the base are 21" x 6" x $\frac{1}{2}$ ". The binding-posts are disposed along the edges as shown in the photographs. The posts in the middle of the board are the A and B battery terminals, and those placed conveniently at the end are for C battery, antenna, and ground. No minus B battery post is provided, for in the author's laboratory the connection is made between the A and B batteries beneath the operating table. The leads from the A and C battery posts and from the antenna and ground posts are run in grooves, beneath the base board, to directly under the instruments to which they connect. This eliminates several feet of awkward exposed wiring, and the binding-posts present a more clean-cut appearance.

The mounting of the coils is a problem that the experimenter can best solve himself. The commercial inductances, though electrically efficient, are not very well designed in respect to mounting mechanics. The close-up in Fig. 4 shows the manner in which the writer has disposed of the fixed windings and variable tickler of T₂. T₁ presents less of a problem and

is easily mounted as suggested in the photographs of the completed receiver.

The first actual work of construction is the joining of panel and base and the mounting of all instruments and parts. The inductances T₁ and T₂ are then removed and the apparatus, Fig. 5, is ready for the wiring of filaments, control switch and amplifier. As this wiring proceeds, it may be advisable also to remove the audio-frequency transformer, always bearing in mind, however, the positions of the missing instruments and making allowances for them when wiring in their neighborhood.

Fig. 6 shows this wiring completed, and the filaments should be tested before proceeding further. The set is now ready for the permanent mounting of T₁, T₂ and T₃, and the final lap in wiring. Spaghetti insulation should be used sparingly and only when there exists a probable chance of wires touching.

Figs. 7, 8, and 9 are photographs of the finished receiver. Looking at the set from the rear, the tubes from right to left are: detector, R. F. reflex tube, and the two resistance-coupled amplifiers. For the most convenient wiring, the external amplifying sockets are mounted with filament posts toward the panel. The R. F. reflex socket has "P" and plus filament toward the panel, while the detector socket is mounted with minus and grid to the panel.

With a front view, running likewise from right to left, are the amplifier rheostat, the detector rheostat, the C₀ dial, C₁ dial and the tickler control.

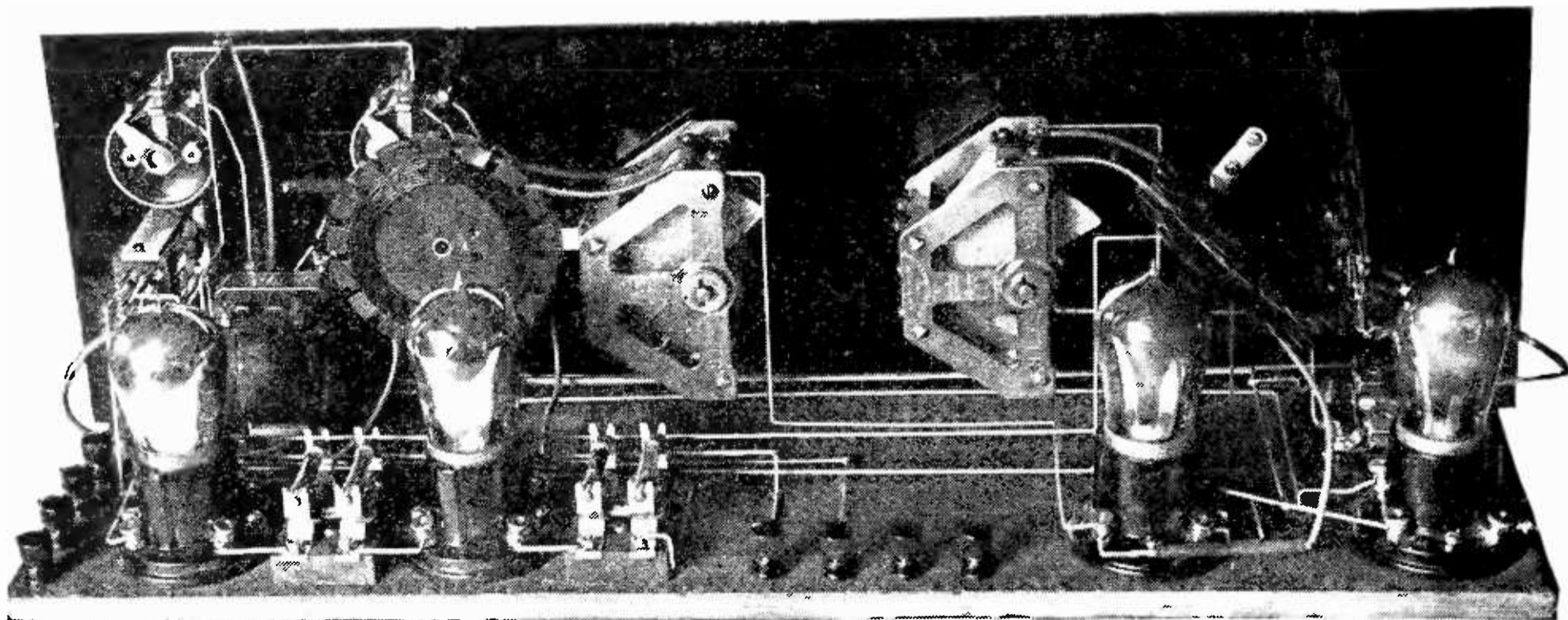

FIG. 8

From the rear. The wiring has been kept close to the base, and several long stretches wired in grooves beneath the base

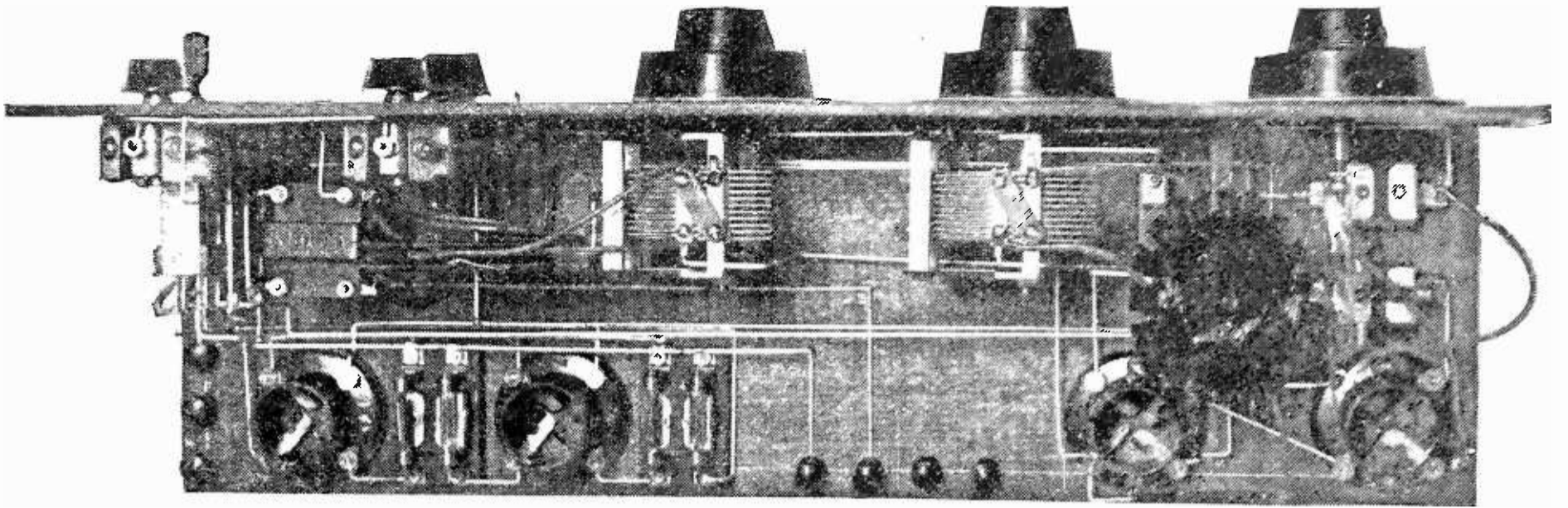

FIG. 9

Top view of the completed set.. The positions of the sockets are arranged to permit the shortest possible wiring. The resisto-couplers are shown to the left of the amplifying sockets

OPERATION

THE operation of any receiver is a knack acquired through experience rather than by following any specific instructions. It is, however, possible to point out a few principles which, if followed, may make it easier to acquire this ability.

The preliminary experiments should be those affecting stabilization of the R. F. tube and regeneration. These have been touched upon in our description of the fundamental circuit, and have been treated at greater length in the author's article already mentioned on the short-wave receiver.

The individual detector tube will greatly

determine the regeneration adjustments. Any six volt detector-amplifier tube will work satisfactorily. The author uses the UV-201-A in all sockets. The detector plate voltage, the grid leak and grid condenser and the capacity of the bypass condenser C₃ should be varied until the receiver regenerates, and on closer tickler coupling goes into oscillation without squealing at the spilling over point. The circuit should come out of oscillation at the same tickler dial reading as it goes into it.

The actual tuning is quite similar to that of the standard three-circuit regenerator. In receiving different stations, that tap on the antenna inductance should be used which permits the two condensers to "tune alike" or nearly so.

HOWARD S. PYLE has written an interesting story telling of the work and activities of the radio inspectors of the Department of Commerce, those tireless men who are doing their best to keep peace in the radio family. "Shake Hands With the R. I." will appear in an early number.

W H B

The Famous Wireless Station of a Famous Newspaper—A Now-It-Can-Be-Told Story by an Old Timer—Thrilling Days at the New York *Herald* Station, Days when the *Titanic* Sank, and Days when Neutrality was Violated and Thousands of Lives were Saved

BY R. ERNEST DUPUY

Captain, Field Artillery, United States Army

LAST winter, sitting cozily in my quarters down at Fort Sill, in the heart of Oklahoma, I heard blizzard-swathed Chicago groping for the outside world. Gripped in the clutches of the most severe storm of years, with land lines down and not a wheel turning, the city was completely cut off until radio took a hand. Even that seemed for a time useless. KYW at Chicago was reaching vainly east and west. Atmospheric conditions, however, were blocking its efforts. Then out from Nebraska came the voice of KFKX at Hastings, acknowledging KYW and working KDKA at Pittsburgh, relaying press dispatches by voice and Morse and clearing Chicago's business both east and west. And, by the way, have you ever heard prettier Morse than that chap at KFKX pounds out?

It was just one of those queer quirks of radio, that blocked direct communication from Chicago either way across the continent but left a clear belt to the southwest and south reaching down to far-off Oklahoma; one of those freaks that give the listener-in a thrill from time to time. And as I heard the voices of the night, conquering space and storm, I began recalling the many other thrills that radio had given me, directly and indirectly, since I first rubbed up against the ether waves in 1909, and began to listen to the heart throbs of the world.

It was at the famous old New York

Herald radio station at the Battery in New York City that I first made intimate acquaintance with the wireless. WHB—it was really OHX then, as old time radio operators will remember—reposed in a little wooden shack that squatted on the end of the Staten Island ferry slip. I was on the *Herald* then and a short time later was placed on duty at Ship News where from my friendship with the operators at OHX grew the desire for a receiving set of my own, which I soon satisfied. From that time on I have been an amateur, although I never took out a license and never operated a transmitting station.

HOW JAMES GORDON BENNETT USED WIRELESS

FOR the benefit of present day fans I must give some details of the old *Herald* station. The late James Gordon Bennett, owner of the *Herald*, saw the possibilities of radio from the very first. He had a Marconi set installed on the steamship *Grande Duchesse* of the Plant line to report the *Defender-Valkyrie III* races for the *America* Cup, working Sandy Hook. Here was probably the first time that radio was used for newspaper work. Mr. Bennett established a radio station as an adjunct to the *Herald's* renowned Ship News service not long afterward.

Some time prior to my coming on the *Herald*, Mr. Bennett had had a disagreement with Signor

When the Curtain is Drawn—

From past events in radio, which is so full of intensely interesting happenings, it is immensely worth while to stop, look, and read. Newcomers to radio, who are fast learning the lore of telephone broadcasting, should know that history, and extraordinarily interesting history at that, has been made in countless wireless telegraph stations ever since the inception of the art. One of the famous old American wireless stations was WHB, whose musical spark for years crashed out from the tall towers near the ferry terminal at the Battery, New York. WHB sent out press reports, and valuable weather forecasts, and exchanged messages with ships in the North Atlantic, making the name of the New York *Herald* known far and wide. Here is a story of inside history at that station—the crash of the *Titanic*, the wreck of the United Fruit *Turrialba*, and stirring wartime experiences. You will like it.—THE EDITOR.

Marconi. In 1909, the *Herald* set was a National Electric Signalling Company outfit. Later he switched to the Wireless Specialty Apparatus Company for his set and its 5 kw. spark, sending news and baseball scores, was for many years a comfort to mariners from Nova Scotia to the Caribbean and well out to sea. In fact the station was copied down in South America. Three operators kept a constant watch. The station was hand in glove with the Navy and was on particularly close terms with the Coast Guard, clearing much of their business between the cutters and Coast Guard headquarters in the Barge Office. In 1912, the call letters of the *Herald* station were changed to WHB, and WHB they remained until the station was taken out of our hands by the Navy at the outbreak of war.

From time to time I used to get thrills listening to news of the ships at sea—particularly when the Coast Guard cutters would go out into winter storms on rescue work. They cleared their business through our station and it was understood that the *Herald* was welcome to all matters of news value. When the *Republic* sank, we had our share of interesting messages and the *Titanic* disaster of course kept our station busy. The outbreak of the war in 1914, however, put all those events in the shade. But I must dwell on a few of my most important pre-war radio thrills before going on.

THE HERALD STATION—A RADIO LANDMARK

FOR instance, there was the smash of the *Turrialba* of the United Fruit Company, outside New York harbor, when old WHB handled her business and directed the Coast Guard cutter *Seneca* to the rescue. All the while the rescuers were taking off passengers, we in the radio room of WHB were listening to the bulletins that came flashing in, reporting each move. WHB had always been on good terms with the United Fruit Company, for that organization

at the breaking up of the United Wireless Company had refused to take Marconi service and had kept its own independent outfit. Their ships handled traffic with our station usually when they were within range. Those were the happy days when “wildcatting” was the rule and an operator called up any station he desired to give his business to regardless of the International conventions. The only requisite for working was that both stations could hear each other.

Then there was my first radio concert, which took place one Sunday afternoon in 1913, when the Prince of Monaco’s yacht *Hirondelle* startled all Manhattan’s radio world—a small one then—by sending out music by radio while lying at the New York Yacht Club anchorage in the Hudson river. In his yacht, the Prince had installed a clever arrangement of keys which, when pressed, changed frequencies, and gave him a series

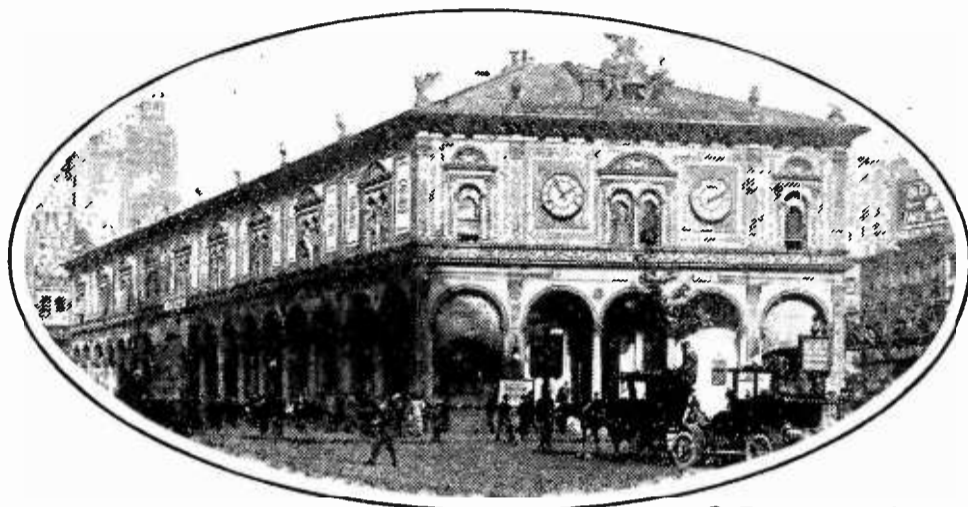

© Brown Brothers

THE NEW YORK “HERALD”

Building at Herald Square, New York. Several years ago, the newspaper sold this building to a New York clothing store and moved to another site. It is interesting to note the taxis of an earlier, and perhaps less speedy era. This office was connected to their wireless station at the Battery by a direct wire

of notes whose range was more than an octave. Using this system, he could and did broadcast a number of tunes. This was considered a remarkable performance at the time. The Lackawanna Railroad some time later brought some thrills to amateurs and professionals in radio by sending out phonograph music by means of the “flaming arc” with which the first radiophone experimenters worked.

The first real telephony through the air, however, that had anything practical about it, and that I came in contact with, was the apparatus of a Pennsylvania inventor, whose name I have unfortunately forgotten, who received permission to use our station for some of his experiments through his friendship with the late Howard C. Hillegas, then day city editor of the *Herald*. He installed a transmitting set on board the steamship *Tyler* of the Old Dominion Line and one night, when the *Tyler* was off Hatteras, called WHB. We were tremendously surprised. The skipper of the *Tyler* from his bridge talked to us so loudly that by placing the receiver against the transmitter

THE GERMAN CRUISERS "KARLSRUHE" AND "DRESDEN"

Which were lying off the United States coast in 1914 when war was declared. The *Dresden* is in the upper photograph. Many important messages from these ships were intercepted at the *Herald* station during the early months of the war. A French cruiser and several British cruisers were also off Cape Hatteras at the same time, and much radio drama was enacted between these ships, which was heard by listening commercial and amateur stations in the Eastern United States

© Underwood & Underwood

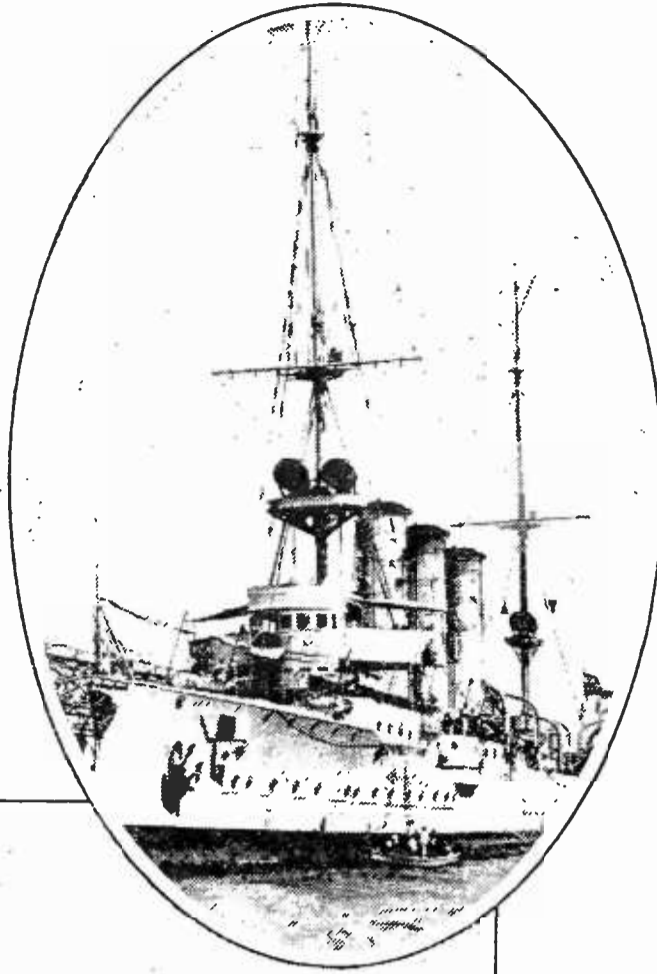
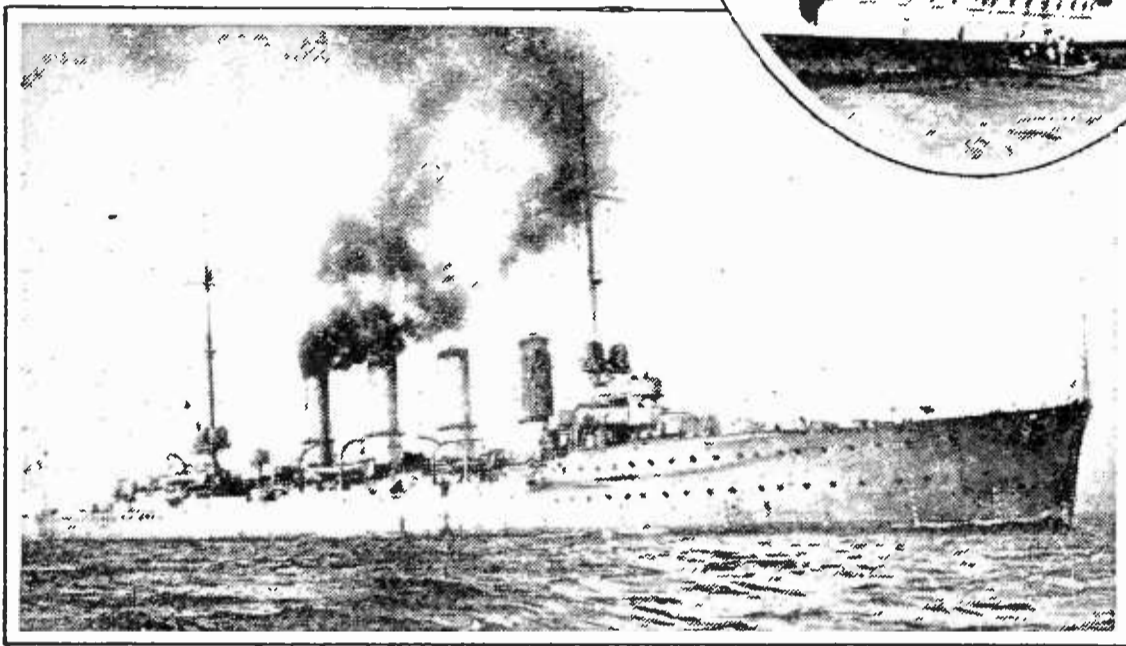

of the land line phone in the receiving office at the Battery, the captain's voice came clear and distinct to our city editor up in Herald Square. This, the first practical demonstration of the value of radio telephony that I have heard of, made a great furore at the time in radio circles.

NOW FOR THE WAR

NOW for the war stuff. From August 1, 1914, until war was declared two days later, the German lines made the most strenuous efforts to warn all their vessels on the high seas that a conflict was imminent. From Sayville, WSL, the big Telefunken station afterward shut down by the Government, went night after night a string of messages to ships of the Hamburg-American and North German Lloyd lines, all of the same tenor:—

WAR IMMINENT; MAKE FOR THE THREE MILE LIMIT

These messages were either in plain English or German, and mixed with them were all sorts of code to passenger steamships, and

both code and clear messages to the German cruisers *Karlsruhe* and *Dresden*, which, it will be remembered, were somewhere off our coasts at the time. I copied numberless messages from Sayville to vessels, both merchantmen and warships, those first four nights of August and of them all, I only remember one not addressed to a German. That was to Sir Thomas Lipton's yacht *Erin*, then escorting the *Shamrock* over for the America Cup races, informing her captain of the outbreak of war and instructing him to leave the *Shamrock* and proceed for British waters.

The code that the German vessels were receiving from Sayville at that time was a ten letter affair. For those of our readers who may be interested in code and cipher here is

one long one that I caught, to the *Dresden*:—

ADR ADR ADR DE WSL NR I WDS 25
GOVERNMENT BERLIN TO GERMAN CRUISER
DRESDEN—WSL— DESAFACADA FRIABAR-
IUM CAROTALECO HISOPIBEAS ASTYPEACUS
ALEGGISTA CUCUBEFANO EBUNDALLE ASI-
CADRAC SLAENAJIOR (word missing) IMEP-
ACITY LAPIZAIGNE GLUAPATREZ PUERCE-
GUDI HOCESANDAM ORMUZOARAN IJORTEM-
HOF BYPABULANM KATUPATOTE EYUNA-
PLUS

Some melange of words, what? And a few minutes after this was sent, I caught what I believe was the actual signal that war was declared. The message came with the usual preamble and the call letters of the *Karlsruhe*, followed by the text:—

GERMAN CRUISER KARLSRUHE—WSL—
SOHN GEBORNEN DEUTSCHLAND MODEL
RAMIFOPINO GRYPHABARD

And out of the night in response came the *Karlsruhe's* piping high frequency spark, acknowledging. And that was the last time

that the *Karlsruhe* was heard on any American radio set.

At this time, there were one French and two British cruisers lying in the vicinity of New York. Up until the third of August, they had been carrying on animated conversation, using their regular call letters, and we had become accustomed to the individualities of their sparks. With the outbreak of war they



© Brown Brothers

STATION WHB

The base of the steel tower supporting the antenna can be seen beyond the *Herald* Ship News Office where the operating room was. The inserts show the transmitting panel and the receiving table at this station. As the photographs well show, styles in radio apparatus have changed quite as rapidly as those in men's and women's dress. WHB was of great assistance during the disaster to the *Titanic*, the *Turrialba*, and other marine wrecks. Valuable press and weather information was daily sent out from this historic radio spot

changed their calls, and kept sending streams of messages in a peculiar code that consisted mostly of punctuation marks. The change in call letters meant nothing to the operators who knew their sparks, and in a Sunday special story I wrote at that time about radio and the war, I mentioned this fact and gave the new call letters of the British ships.

About two weeks later, or after that particular number of the *Herald* had had time to get overseas and be digested

in the British War Office, a frantic cable came from our London bureau, stating that the British government was accusing the *Herald* of violating neutrality and was making all sorts of dire threats to our London office. I was called upon the carpet and solemnly told (for the benefit of British officialdom, I imagined,) what a heinous offense I had committed. I gave no more British secrets away. However, I did violate neutrality later on, this time deliberately, and thereby hangs a "now it can be told" story.

HUMANE VIOLATION OF NEUTRALITY

EVERYONE remembers now, shortly before our entry into the war the German *U-53* popped into Newport, Rhode Island, one afternoon, got the latest papers and as promptly popped out again, sinking the next day a number of small craft off Nantucket lightship while American destroyers stood by and rescued her victims. She came into Newport on a Saturday afternoon, a short time after four large passenger steamships—a Cunarder, a White Star, a French liner, and an Italian—had left New York. A glance at the afternoon papers, supplemented doubtless by the reports of spies, gave her captain all the information he needed and so he quietly slipped out again and lay off Nantucket Light waiting patiently for the golden opportunity that would doubtless shower him and his crew with Iron Crosses.

When the *Herald* main office got word from Newport of the arrival of the *U-53* it was telephoned down to the Ship News Bureau as a matter of course and we proceeded to get a local end to the story, which created quite a stir in shipping circles. We were working up the story about the submarine. When over the telephone came word of her departure. There was a horse of another color. I was out in the radio station discussing the U-boat with Mor-

gan Wright, my chief operator, when the flash came. Across the sun-glinting waters of the Battery I could see in my mind's eye four great steamships sinking and their thousands of men, women, and children struggling like drowning rats in a catastrophe that would make the *Lusitania* disaster seem a mere incident. Wright and I looked at each other for an instant.

"Wright," I said; "if WHB sends out news of that U-boat's departure in to-night's press, we will be violating neutrality. Also we will be too late. Let's do it now—the responsibility is mine. Grab your key and send this—"

GERMAN U-BOAT ARRIVED NEWPORT THIS AFTERNOON AND LEFT AGAIN AT ONCE. DESTINATION UNKNOWN.

Repeat it every thirty minutes until press time and then send out the full story with your other news."

Within a minute WHB's spark was ripping through the ether and, within an hour, as I

later learned, the four liners had turned tail and were dashing for Bermuda and safety. And that is why, after waiting fruitlessly all night, the *U-53* had to content herself next morning with one of the Red Cross line boats from Nova Scotia—the *Florizel* as I remember, and some other small fry.

NEW YORK HERALD VS. UNITED STATES NAVY

SO MUCH for the actual happening. Now for the aftermath. I said nothing about the incident at the main office, for I enjoyed at the time the position peculiar for a *Herald* man of being responsible to no one but Mr. Bennett himself. In my department I was supreme. In a few days came word from the uptown office that I was wanted. I went up and found dear old Commander J. D. Jerrold Kelley, U.S.N., Mr. Bennett's crony and advisor on matters maritime—now dead like his old



FROM THE NEW YORK "HERALD"

Of Thursday, December 26, 1912. OHX was the call of the *Herald* station before the international conference which allotted call letters to the stations of every nation signatory to the conference. All the official business of the wreck of the *Turrialba* was handled by the *Herald* station

friend—and with him was a gentleman whom Commander Kelley introduced as the director of naval radio communications. He broke the news to me that the *Herald* had violated neutrality by sending out word of the departure of the *U-53* and announced that Mr. Secretary Daniels had decided that he would close up the *Herald* radio station unless we should show cause why he shouldn't. I told the naval officer I would inform Mr. Bennett, who was in town at the time, of Mr. Daniels' decision. Pending definite action he said that it had been decided to place an officer on duty at WHB as a censor, to which of course I could only agree.

I went to Mr. Bennett at once and told him the whole story, at the same time placing my resignation in his hands. He said:—

"Nothing has been printed about this, has it?"

"No, sir."

"Good. Print the whole story, with Mr. Daniels' decision, and we will let the American people judge for themselves. That's been good work, Dupuy; you did exactly what I should have desired had I known it."

Naturally I felt much relieved, for one could never know just what views Mr. Bennett would take. After all, the fact was that one of his employees embroiled the *Herald* in an official altercation.

The *Herald* played up the story the next morning for all it was worth. And, in the meantime, I had a hunch. Our operators, I found out, had been so busy that eventful night that they had omitted to copy Arlington's nine o'clock press—a matter of usual routine with WHB. I went to the Marconi Wireless Telegraph Company of America. It was only a few months previous that I had urged Mr. Bennett to drop his feud with Signor Marconi and I had shown the Marconi Company in turn that the *Herald* could provide them with a better news service than that they had been getting, with the result that in consideration

of the *Herald's* installing a Marconi set at WHB I obtained the furnishing of news service to the Marconi company. This put New York *Herald* news on Marconi vessels all over the world through our own station and the Marconi stations at Cape Cod and San Francisco. So I felt that I could enlist their help.

I asked Mr. David Sarnoff if he would obtain the radio logs of all Marconi stations, ashore and afloat that he could gather within the next few days and find out from them if NAA, the naval station at Arlington, had made any mention of the *U-53's* departure. Within a week he had the information for me. That very Saturday night NAA had sent out the news of the U-boat—too late for it to have done any good to any allied vessels. But this news was sent out within twenty-four hours of its occurring which is expressly prohibited by

the laws of neutrality. The next morning in a spread story the *Herald* announced that while Mr. Daniels was so busy regulating others, one of his own chief stations had been violating neutrality. The source of the information was not, however, made public.

OFFICIAL FEARS AND THREATS IN WASHINGTON

BEFORE ten o'clock that morning, Washington had me on the long distance telephone. It was the director of naval radio communications. He informed me that the *Herald* had libelled the Navy Department in asserting that it had violated neutrality, adding that Mr. Daniels would immediately have an order issued closing WHB so tight that it would never open again. I asked him if a careful check had been made of Arlington's business that night and he replied that he personally had inspected the station records and that neither in the press nor in any other message was there any mention made of the *U-53*.

"Well, Commander," said I, "suppose I make a bargain with you. A bargain, mind

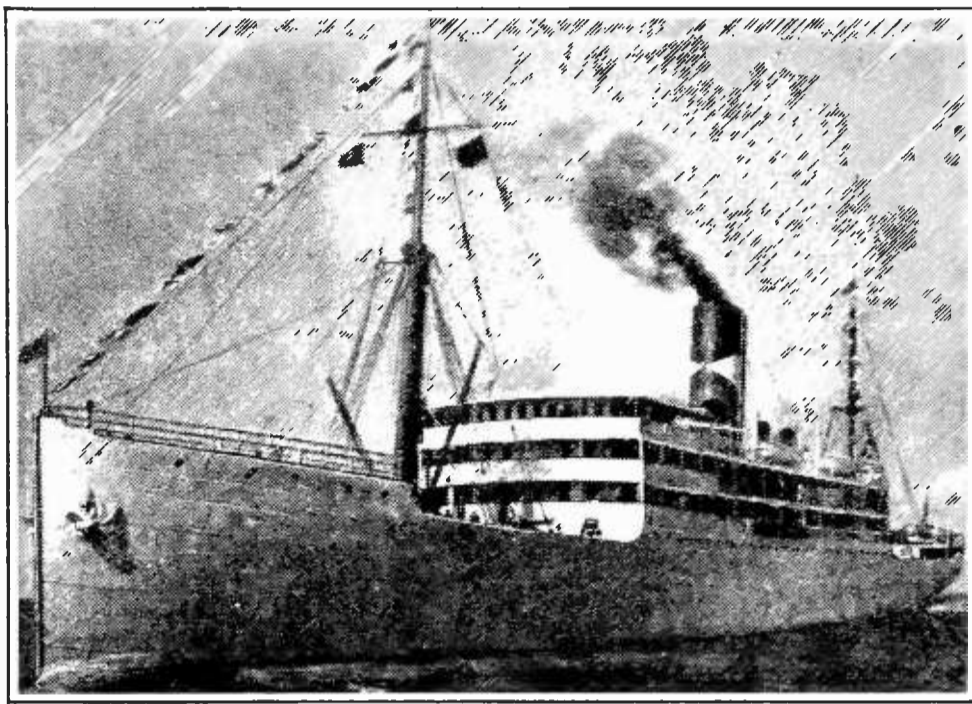

—United Fruit Company

THE SS. "TURRIALBA"

Of the United Fruit Company. The New York *Herald* wireless station WHB was practically responsible for saving this ship and her passengers when she was wrecked in December, 1912

you, not a threat. Close us up, and the New York *Herald* will publish immediately the affidavits of approximately one hundred radio operators on duty at ship and shore stations within range of NAA all affirming that NAA in its evening press that night mentioned the arrival at and departure from Newport of the *U-53*."

"Where could you get any such information?"

"Well, Commander, if I told you that you would be as wise as I am. But nevertheless it's true, and so sure as you close us up, so surely will I run the story. On the other hand, if the Navy and Mr. Secretary Daniels forget all about closing our station, the *Herald* will accept the censorship and will forget all about the story of the Navy Department violating neutrality. How about it?"

There was a silence on the line for so long that I began to think that Washington had rung off. And then:

"All right: that's a bargain."

And the incident was closed. WHB continued in service until at last the Navy took over all radio upon the outbreak of war.

I do not want my readers to gather from this that I am insinuating that the Navy Department, either directly or indirectly, was countenancing a violation of neutrality. Far from it. What had happened, of course, was that someone at NAA had slipped that message into the press stuff that night against orders, either in ignorance or more probably from motives similar to mine, and had left no record, so that when they investigated the *Herald's* story from that end, Arlington had, seemingly, a clean bill. Had the *Herald* pushed the matter and published affidavits, however, the affair would have been so embarrassing to official circles

that common sense dictated an immediate compromise, particularly as the damage was already done and the censorship of our station by a naval officer would be a sure preventive of any further trouble.

PLENTY OF ROMANCE STILL IN RADIO

LIKE most other amateurs in the vicinity of New York I watched WSL, the Telefunken station at Sayville. So did WHB. Sayville was sending continually code messages to Nauen. Even after the closing by the Navy Department of the Goldschmidt transatlantic station at Tuckerton, New Jersey, for violating neutrality, Sayville continued its work, sending now to Cartagena, Colombia, whence the messages were doubtless flashed to Berlin. This code, as I remember was now a fifteen letter affair. At last, however, through the efforts of amateurs and government agents all listening-in Sayville was caught and closed down. It was during this period that the *Providence Journal* made its sensational news beats in revealing German activities here and radio had a great deal to do with this. From the nightly messages sent by Sayville some cipher expert discovered the Boche code and from the threads thus revealed clever detectives made short work of the rest.

I have often thought of those old days of radio, while listening in to the present routine of broadcasting, and wondered if the romance had gone out of the air. After the *Shenandoah's* night adventure, however, when that storm-tossed airship was guided to safety by radio-phon, and after my own experience in hearing a storm-bound city telling its plight and linking itself to the world again through the devious channels of the ether, I have decided that the romance is still there for those who search for it.

How Radio Times Have Changed

THE article which appears below is taken from the New York *Herald* of December 26, 1912. That issue of the *Herald* was full of photographs of the survivors of the disaster to the United Fruit liner *Turrialba* and many news stories dealing with the wreck. The *Herald* station WHB, as Captain Dupuy's story brings out, had much to do with saving her passengers by radio.

This news story is especially interesting, because it shows how radio conditions have changed since "the law of 1912" (as it is always referred to now), went into effect. Especially have conditions with regard to amateur operators changed. With the formation of the American Radio Relay League, that excellently organized and managed association of amateur radio operators, the amateur has come to be

considered by those who know, as a sturdy aid to radio development. Where there have been radio difficulties, the amateur, organized as he now is, has never failed to offer his help.

While the present radio laws are generally

agreed to be by no means adequate to fit the present radio situation, those that have been in force since the unsettled days of 1912 and before, have indeed been effective in curbing many of the abuses that undoubtedly obtained during the unregulated period.—THE EDITOR.

HERALD WIRELESS AIDS THE "TURRIALBA"

Irresponsible amateur wireless operators, the bane of the commercial stations on all similar occasions, interfered materially with the wireless work between the *Turrialba* and the shore stations. All Tuesday afternoon and night the amateurs kept the air filled with their messages, sometimes trying to call the *Turrialba* and at others "jamming" the stations attempting to work by sending messages to each other.

The *Herald* wireless station cleared the *Turrialba* business, handling all messages between the wrecked vessel and the company's offices. The operators were severely handicapped by the interference of the amateurs, finding it extremely hard at times to do their work. The station at the New York navy yard also suffered by the interference of amateurs.

Since the invention of the wireless, stations attempting to work with disabled vessels have always been bothered more or less by these pirates of the air, some of whom seem to jam the air out of malicious mischievousness. This was in evidence more than ever in the *Turrialba's* case, and all of that certain clique of amateurs who bother the commercial stations about New York City were heard at work both Tuesday and last night. So bad was the interference on Tuesday, that the New York Navy station was for three hours absolutely unable to read one connected message from the disabled ship.

Under the new wireless law, which went into effect December 13, all amateur wireless stations are limited to a wavelength of 200 meters. A number of amateurs in the neighborhood of the city, who have high powered stations, have made no attempt to comply with the law, and some of them have not applied for the license, which under the law is necessary to operate a station.

W. D. Terrell, radio inspector of the New York district, as soon as the news of the disaster to the *Turrialba* became known, sent out a wireless warning to all stations, notifying amateurs to keep out entirely and commercial stations to minimize all business as far as possible until all matters connected with the steamship were cleared up. A number of amateurs paid absolutely no attention to Mr. Terrell's warning.

Mr. Abrahams, radio operator of the *Seneca*, when the revenue cutter landed here last night, said, concerning the interference, "While we were alongside the *Turrialba*, and all Tuesday night, I could hear several amateurs who have high power stations, blocking the transmission of messages between the steamship and the shore, and by the manner in which the shore messages came out to us I could tell that they were being seriously bothered at the New York end.

Officers of the *Seneca* said that the interference reminded them of the occasion that started the legislation against amateurs. On Christmas night, 1909, the *Seneca* was lying in Boston harbor with a fierce northeast gale raging outside. Suddenly a call was received stating that two vessels had just been in collision and asking for help. The message said that the ships were some distance outside. The *Seneca* at once started to get under way in the teeth of the gale when the Boston navy yard station called them, saying that the operator there knew the spark, which was that of an amateur in the city. This is only one of the many occasions when the SOS call for help has been used by an amateur with deliberate maliciousness.

—New York *Herald*
December 26, 1912

MANUFACTURERS of radio supplies are working hard to standardize their equipment. In an early number of *RADIO BROADCAST* an article by G. Y. Allen will appear, telling of the color standardization of cords used in radio connections. It will be illustrated with complete plates showing the cords and their distinctive colors.

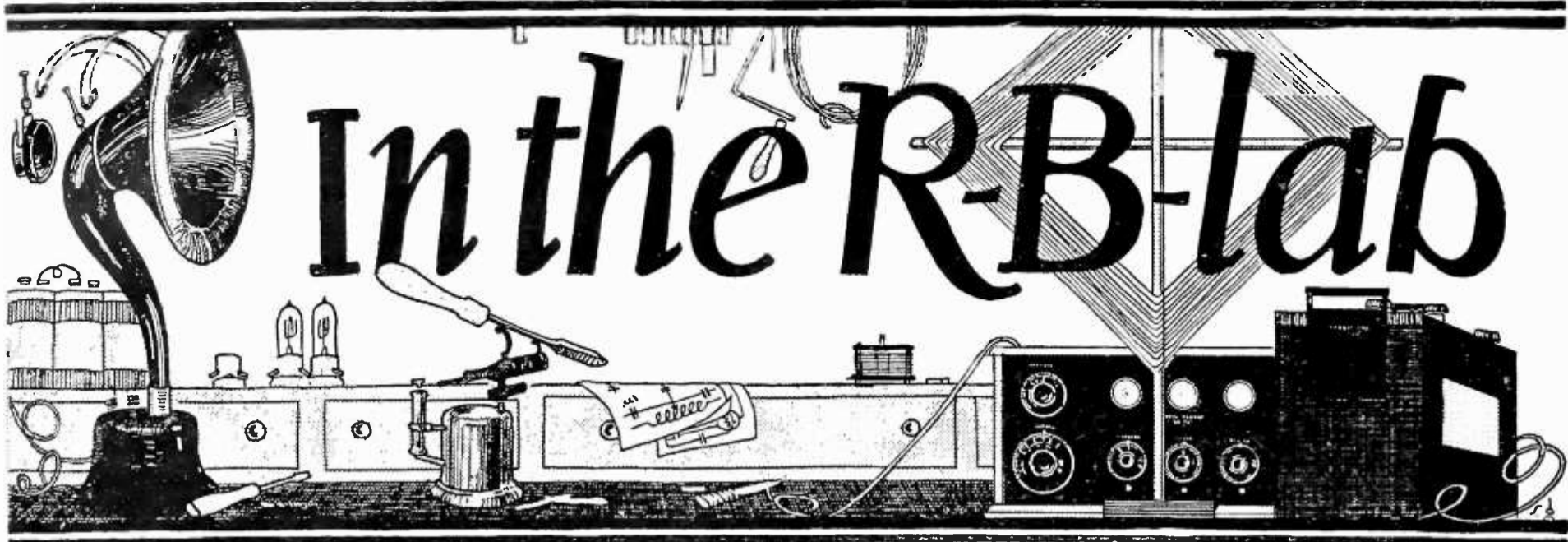

DESIGNING SMALL TRANSFORMERS

THERE are many instances where the work of the experimenter and fan would be greatly facilitated were it within his capability to design and build or rebuild small transformers.

The transformer is an important laboratory adjunct. It operates only from a current that provides the fluctuating magnetic field that is necessary for its functioning. A step-up transformer has an output potential in excess of the line voltage from which it is operated. Such transformers are used to supply high potentials for spark transmission, high voltages for C. W. sets, receiving plate-voltages through rectification, and for charging storage B batteries in high voltage groups. The step-down transformer gives a reduced potential which has wide use for A and B battery charging, bell ringing, and filament lighting. It is not very difficult to build a transformer for any of these purposes, or to redesign and alter a transformer, adapting it to a purpose other than that for which it was originally made.

The usual transformer consists of two windings, a primary and a secondary wound on a

core. Fig. 1 shows the manner of building up a "core-type" core from strips of magnetic metal. This is the most practical design of small transformers for the home construction. The voltage of the secondary varies directly with the ratio of the number of secondary turns over the number of primary turns. If the secondary has twice as many turns as the primary, its voltage will be double that applied to the latter winding. Stated in a formula, the required number of secondary turns for a desired voltage will always equal $\frac{N_p \times E_s}{E_p}$, where N_p is the number of primary turns, E_s the desired secondary voltage, and E_p the voltage of the primary.

Considering that the characteristics of the secondary will be determined by the number of turns on the transformer primary, the logical first consideration in transformer design is to determine the proper number of turns for the primary.

It can be demonstrated that a transformer operates most efficiently when the counter e.m.f. built up in the primary is equal (practically) to the applied voltage. That is, for the most efficient operation of a transformer from a 110 volt line, the primary

What the Lab Offers You This Month

—How to design and build small iron-core transformers. A simple formula for calculating the design of windings and complete instructions on building the unit which may be used in numberless ways around the amateur laboratory.

—How to build an adapter for small radio tubes, especially the Western Electric N and the Radio Corporation UV-199 types.

—A simple method for winding and counting multi-layer coils.

How to build an impromptu rectifier, which can be used on 110 volt lines, passing about $\frac{1}{10}$ ampere when charging a 45 volt B battery.

—Suggestions for building your own laboratory.

Helpful hints on radio construction and operating.

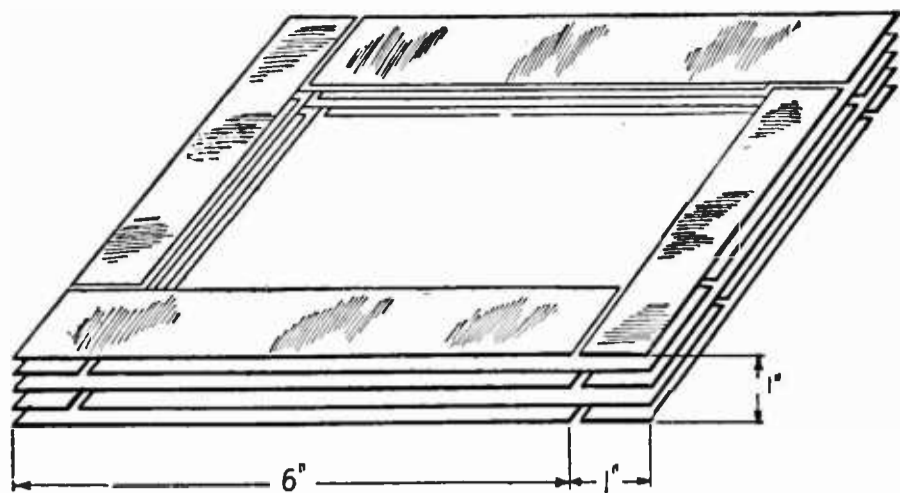

FIG. 1

The simplest way of building up a core for small transformers

winding should be such that the counter e.m.f. will also be 110 volts. Therefore, regardless of the size, and use to which the transformer will be put, the primary should always have sufficient turns to fulfill this condition.

Various considerations determine this correct amount of winding—such as the voltage, the quality of core iron or steel (the flux density) and the frequency of the current. It is all summed up in the formula—

$$N = \frac{100,000,000 \times E}{4.44 \times F \times B \times A}$$

N equals the correct number of primary turns. E is the applied voltage (usually 110). F is the frequency of the supply line (generally 60 cycles, but quite often 25 and 40 cycles). A is the cross section area of the core in square inches (the width of the winding leg times the height). B is the flux density of the core material and is measured in maxwells or lines of force per square inch. This last will vary with different grades of steel and iron. Ordinary sheet iron may be calculated as having a flux density of 33,000 lines; transformer steel, 40,000; and the flux density of some special magnetic grades between 40,000 and 50,000. If you are rebuilding a commercial transformer, you may assume a flux density of 40,000 lines.

At first glance, this may all seem rather involved. However, familiarity will show it to be quite simple. The formulas are easily applied. Let us assume that the experimenter desires to build a step up transformer for use with an S tube rectifier and filter as a B battery substitute. A maximum plate voltage of 200 is desired. Allowing for a drop of 200 volts across the rectifier and filter system, we shall need a transformer delivering 400 volts from the secondary. The transformer will be operated from a 110 volt, 60 cycle source. The experi-

menter now has several fundamental facts with which to work. They are:

$$EP = 110$$

$$F = 60$$

$$ES = 400$$

We shall assume that the experimenter has secured a commercially built core of adequate size. It is built up of steel strips two inches wide, to a height of two inches. This provides us with two additional facts, i.e.:

$$A = \text{four square inches (2 x 2).}$$

$$B = 40,000$$

We are now ready to substitute in the formula for N. Doing so, we have:

$$N = \frac{100,000,000 \times 110}{4.44 \times 60 \times 40,000 \times 4} = 258 \text{ turns of wire.}$$

This is the correct number of primary turns, or NP, and we may now substitute in the formula for the number of secondary turns, as follows:

$$Ns = \frac{Np \times Es}{Ep} = \frac{258 \times 400}{110} = 938$$

The sizes of the wires are not considered in these calculations. They are determined by the current they must carry. In the case of the transformer we are designing, the primary should be capable of passing 1.2 amperes continuously without undue heating. The secondary should be similarly capable of delivering 50 milliamperes. The primary and secondary windings should be wound respectively with No. 20 and No. 32 wires. Larger sizes may, of course, be used, but they are unnecessary and add to bulk and expense.

Transformers must be adequately insulated for the potentials which they must withstand. This applies equally to the separation of the

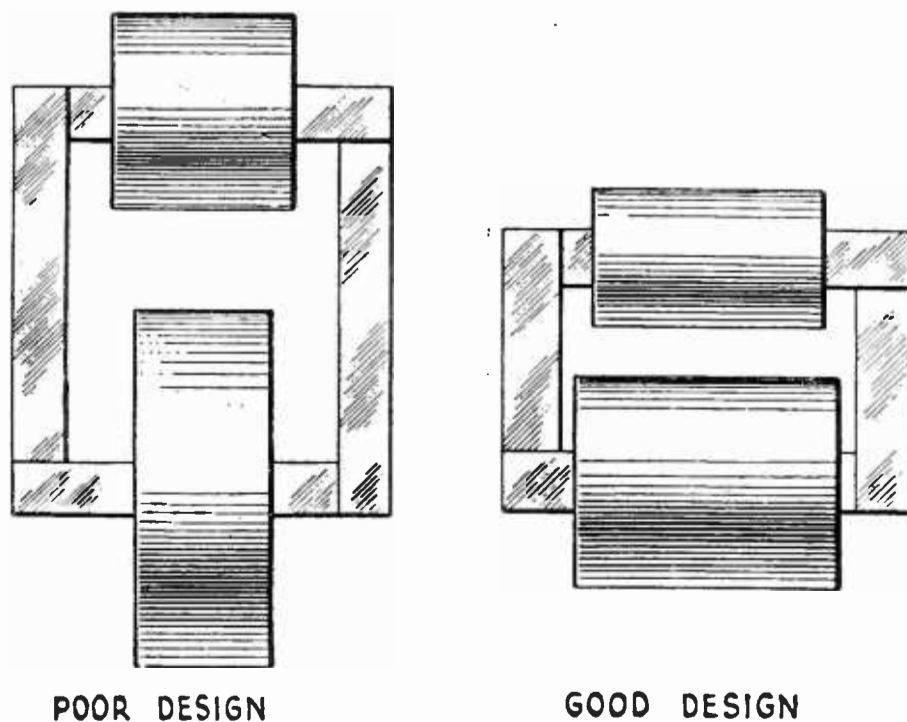

POOR DESIGN

GOOD DESIGN

FIG. 2

Showing inefficient and good transformer designs. Utilize all the practically available winding space

individual windings and the insulation of the windings from the core.

Long narrow cores should be avoided. They result in magnetic leakage and attenuation of the magnetic field. The winding legs of the core should be separated only far enough to provide sufficient space for the windings. The coils should be low and long rather than high and short. Fig. 2 shows a good and a bad example of transformer construction. Where it is convenient, the secondary may be wound over the primary with increased efficiency. In the case of two secondaries, such as the filament lighting and charging secondaries on a battery charger, the secondary delivering the highest current should be wound over the primary. However, if it is more convenient, both secondaries may be wound on the leg opposite to the primary.

The primary and secondaries should be wound on forms that will fit closely over the core which is built up inside of the windings. When the four sides of the core have been fitted together, the iron strips should be clamped firmly, eliminating leakage and vibration, and at the same time permitting

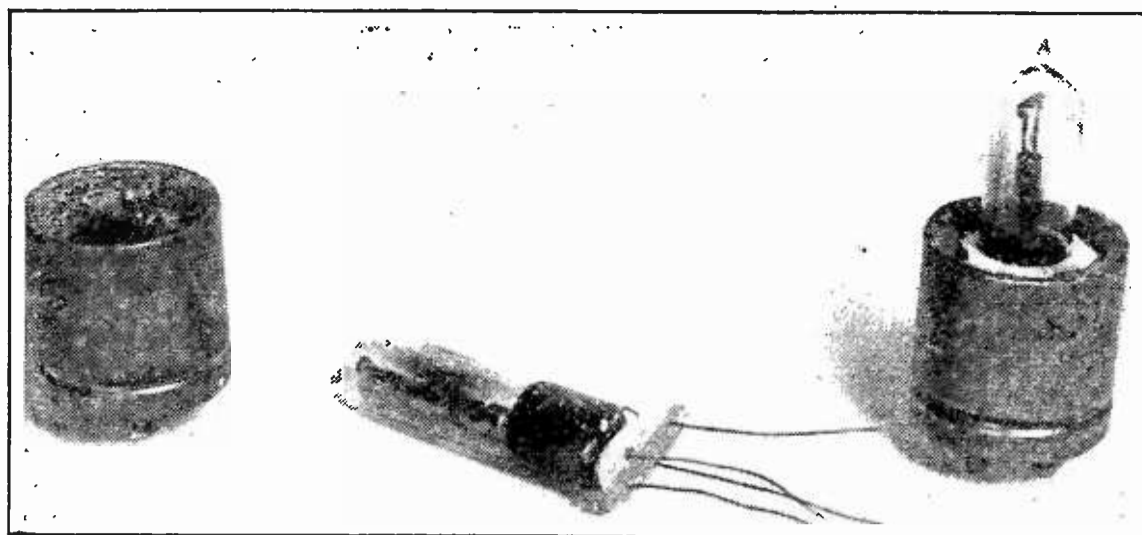

FIG. 4

The peanut tube ready for remounting—and the finished article

convenient mounting, such as suggested in Fig. 3.

AN ADAPTER FOR PEANUT TUBES

A VERY efficient and inexpensive adapter for small bulbs, such as the Western Electric N and the UV-199 tubes, fitting them into the standard six volt sockets, can be made from the bases of discarded tubes.

The burnt out or otherwise inoperative standard socket tube is broken open and the elements, glass, and cement cleaned away. The wires are removed from the base by heating the plugs with a soldering iron and pulling out the leads. The plugs, as the experimenter will observe, are small brass tubes, which should be cleaned of obstructing solder by inserting a pin while hot.

The tube is prepared for its auxiliary mounting by soldering three inch leads of approximately No. 22 wire to its own plugs. A pasteboard washer, with four holes punched in it, is slipped over the leads and pushed flat against the base of the peanut tube. The leads are then threaded down through the plugs of the large base, and the small bulb pulled up firmly into the adapter. The leads are bent over the plugs and secured with a drop of solder on the tip of each. The surplus wire is clipped.

It is, of course, necessary to run the leads from the base

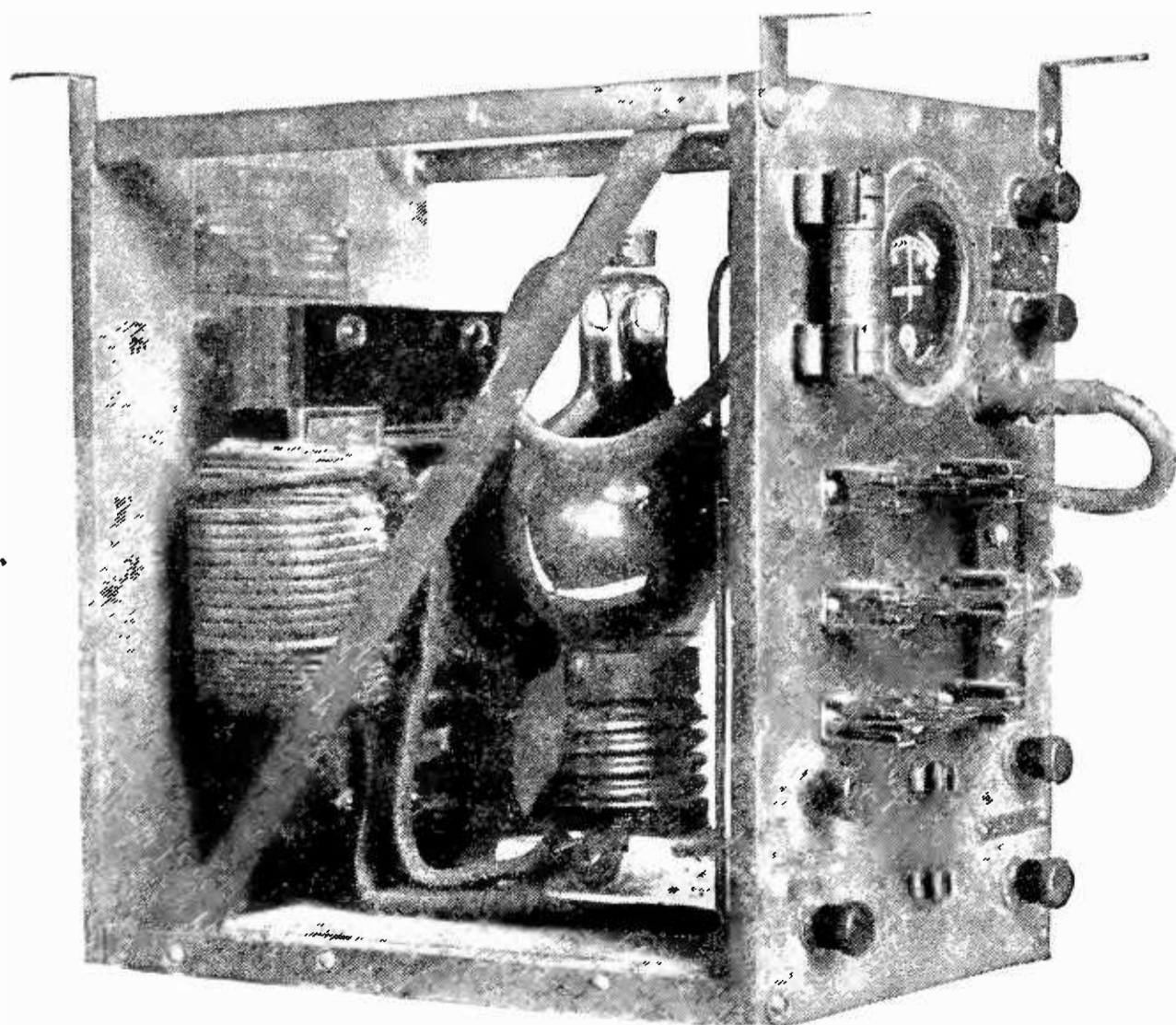

FIG. 3

A completed transformer clamped and mounted

of the tube to the corresponding connecting plugs on the exterior base. This presents no difficulty in the case of the Western Electric N tube, the base connections of which, in respect to the pin, are the same as those of Shaw base bulbs. The UV-199, however, is a different proposition, and care must be taken to effect the correct connections.

Look at the base of the UV-199, or the Cunningham C-299, with the pin up or "north." The minus filament will then be in the upper left, the plate plug in the upper right, the plus filament in the lower right, and the grid, of course, at the lower left.

A large pasteboard washer should be cut that will fit over the tube and slip snugly inside of the large base, a sixteenth of an inch or so below the top. A rim of sealing-wax is melted around the edge, finishing the job firmly and neatly.

Figure 4 shows an N tube in different stages of remounting.

WINDING AND COUNTING MULTI-LAYER COILS

THE older experimenters whose radio experiences date back to pre-broadcasting days are acquainted with the ingenious devices of the amateur operator-builder. Many of

these arrangements are being rediscovered and applied by the broadcast enthusiasts, and the amateurs' method of winding multi-layer coils will appeal particularly to the fan making his own transformers for the intermediate amplifier in a super-heterodyne receiver. The mechanical and electrical data on these transformers will be found in the April number in the Laboratory Department.

Fig. 5 shows the arrangement used by Mr. Leslie Brand, a reader of RADIO BROADCAST, for winding these coils, that dates back to the days when broadcasting was little more than a dream in the minds of Fessenden and De Forest. Mr. Brand employs a Yankee hand-drill, having a ratio of one hundred chuck turns, to thirty turns of the crank. Any other make of drill may, of course, be used with equal success.

The winding form should be designed to facilitate this semi-manual winding. The bakelite, rubber or cardboard end pieces are fastened to the spool with a nut and long bolt projecting far enough through the spool to permit firm clamping by the drill chuck.

It is not necessary to use two vises. The experimenter may secure the spool of wire in any manner his ingenuity suggests, providing it revolves free and smoothly.

The turns of the crank are counted. If,

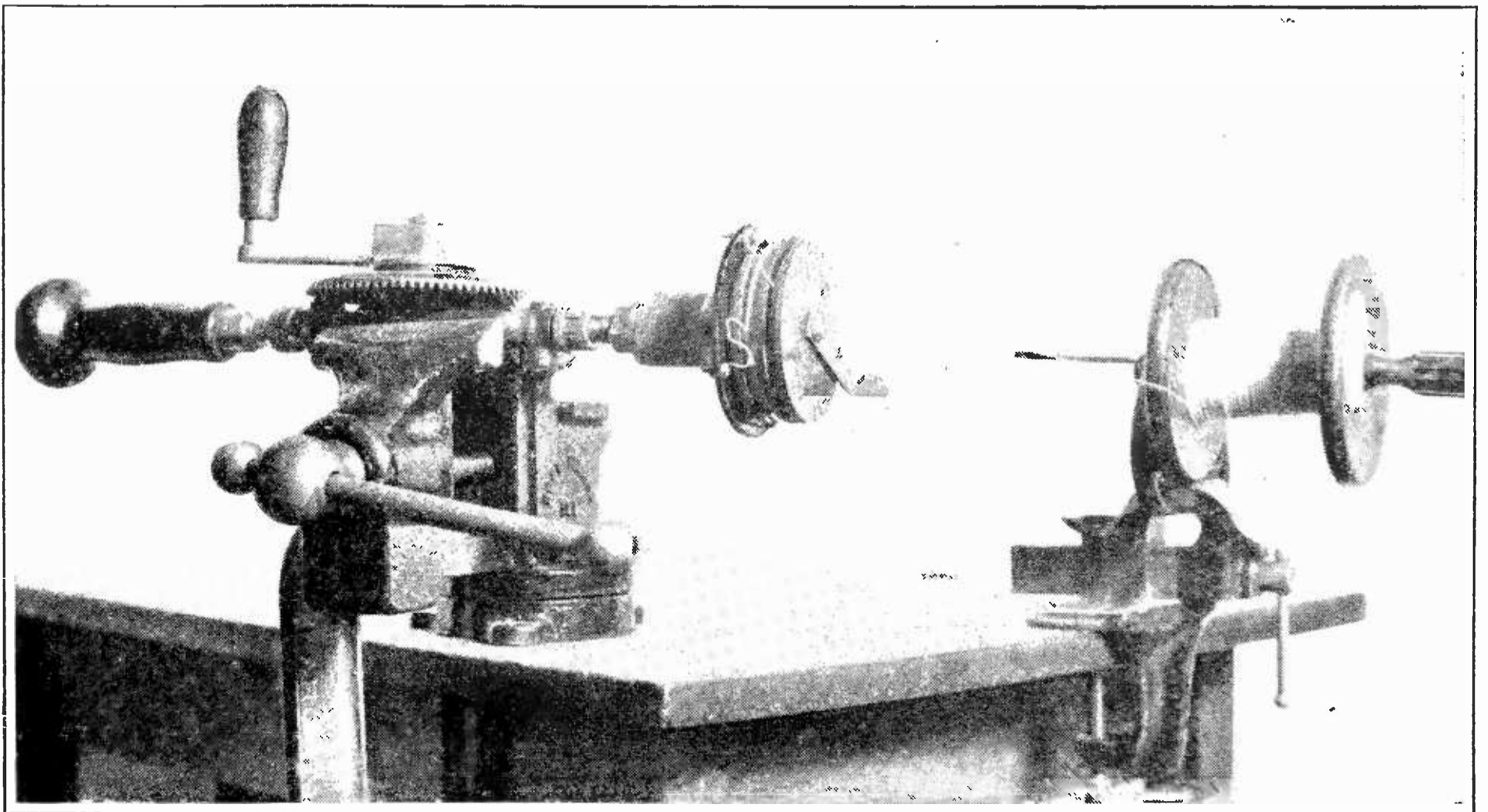

FIG. 5

A handy arrangement for winding and counting the turns in choke coils and transformers

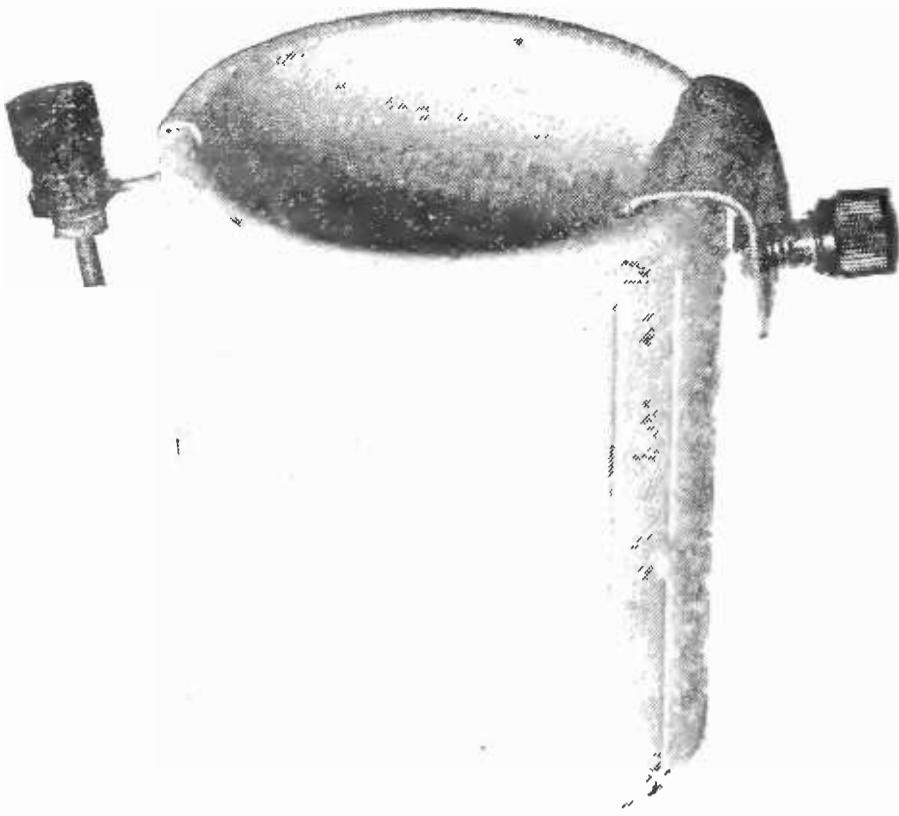

FIG. 6

An electrolytic rectifier that can be built up in a few minutes. It costs only a quarter or two and some time may help you out

using the Yankee hand-drill, it is desired to wind one thousand turns of wire, the crank is turned three hundred times. While it is possible to wind and count at the same time, it is better to call in the services of a friend for counting. This promotes accuracy, swiftness, and permits the operator to devote his attention to a neat and painstaking job.

AN IMPROMPTU RECTIFIER

THERE are many occasions when the experimenter-fan will find use for a rectifier that can be made up quickly and inexpensively. The use of a single charger for A and B batteries and the simultaneous discharge of both sources of power, is one of the several causes giving rise to this necessity. The materials for an emergency rectifier are readily found in the average lab and home. The following will be needed:

1 marmalade or similar jar. (A drinking glass will do.)

A small strip of lead (about one inch by four inches).

1 foot of aluminum wire—or a six inch strip of sheet aluminum.

A package of "20 Mule Team Borax."

The jar is three quarters filled with hot water, and as much borax dissolved as the water will take up—more technically, a saturated solution. If the borax is not at hand, your druggist will make you up fifty cents worth of

ammonium phosphate—which is a cleaner and slightly more efficient electrolyte.

The electrodes are the lead strip and aluminum wire. If the sheet aluminum is the more easily obtainable, a very narrow piece corresponding in cross section to a No. 14 wire, should be cut from it. The wire is more satisfactory than the usual sheet electrode which requires a comparatively long time for forming, whereas the wire electrode rectifies immediately. The wire should be sandpapered clean. Both elements are immersed about three inches in the solution.

The rectifier is operated from the 110 volt lines, being connected in series with an electric light bulb (preferably 100 watts) and the load—generally a B battery under charge. The aluminum electrode (positive terminal) should be connected to the plus side of the storage B battery, as per the connections in Fig. 7. This rectifier will pass in the neighborhood of one tenth ampere when charging a 45 volt battery. It cannot be used for charging A batteries.

AMMETERS FOR PULSATING CHARGING CURRENTS

ON PAGE 231 of RADIO BROADCAST for July, appears a photographic comparison of a hot-wire meter with a Jewell D.C. meter. The caption beneath the illustration unfortunately implied to some of our readers that the D.C. meter was an inaccurate instrument. Such is not the case, the D.C. meter in the photograph being a precision instrument manufactured by a very reliable concern which has specialized for many years in electrical measuring appliances.

As stated in the article in question, the D.C. meter is to be preferred to the A.C. instrument in charging circuits.

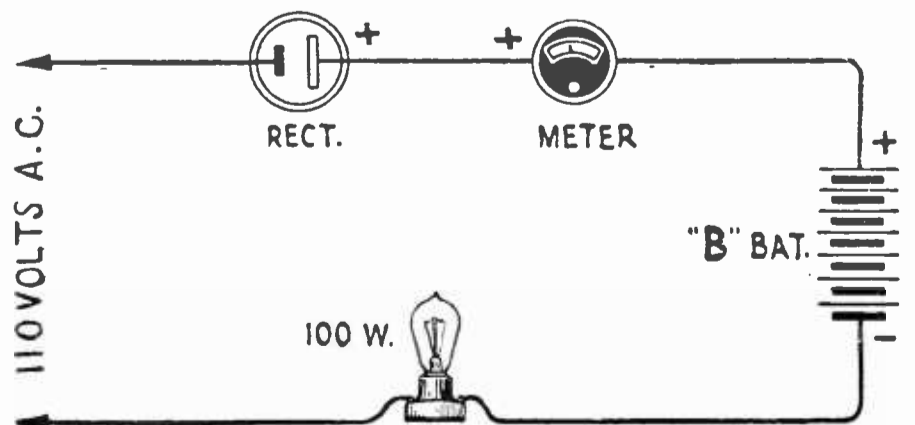

FIG. 7

The circuit for the rectifier. The aluminum electrode is the positive terminal

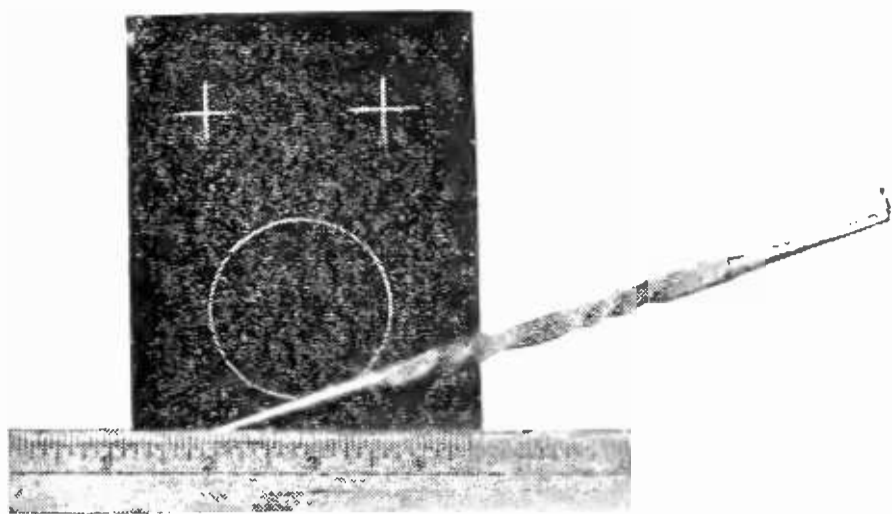

FIG. 8

The scriber—an indispensable instrument in marking and engraving your panel

BUILDING YOUR OWN LAB

OUR October suggestions for the growing laboratory are inexpensive, and so we are prodigal in our recommendation of *two* purchases. They are pictured in Figs. 8 and 9. Fig. 8 is a scriber for which there is no satisfactory substitute in laying out a panel. One end of the scriber is bent at right angles to its length to facilitate marking in tight places. The scriber sells for forty-five cents.

Fig. 9 is a screw clamp—an auxiliary vise that is held in a standard vise. It is designed to hold No. 6, 8 and 10 screws with 32 threads to an inch—the sizes most used in radio construction. It is impossible to clamp machine screws for filing and cutting in an ordinary vise without injuring the thread.

The jaws of the special vise are hardened and may be used for rethreading the screws after filing or sawing. The price of the screw clamp is \$1.50.

Both tools are made by the Stevens Company, New York City.

HELPFUL HINTS ON BUILDING AND OPERATING

NO C BATTERIES are required in the conventional resistance-coupled amplifier circuit such as described in various numbers of RADIO BROADCAST. The functioning of the resistance-coupled amplifier is, in effect, that of the application of a negative bias at audio frequency. The resistance-coupled amplifier “modulates down.” That is, if a milli-ampere-meter is placed in a plate circuit of such an amplifier, it will show a decided drop in the current when signals are being amplified. The drop will be more marked on the high notes

than on the lower frequencies. This is because the higher rate vibrations represent a more steady “bias”—the negative charges are applied to the grid more times per second.

DO NOT fasten antennas, poles, or antenna supports to brick chimneys. It is contrary to the advice of the National Board of Fire Underwriters. It weakens the structure, and under the stress of high winds, the chimney may crack. This constitutes a fire hazard that has been responsible for many serious conflagrations.

A STORAGE battery is often considered messy. It is so only when neglected. Clean your battery regularly every week, wiping all moisture from the top. When signs of corrosion appear on the positive pole, scrape and sandpaper it clean, and coat with vaseline.

DISCONNECT BOTH A and B batteries from the receiver when charging. It may not always be necessary, but it is safer.

BAKELITE is more difficult to work than hard rubber, but it will not warp, and takes a more beautiful and easy grain than the softer material.

GENUINE STATIC as yet cannot be eliminated. But a lot of so-called “QRN” comes from socket prongs, rheostats, and jacks. Look them over!

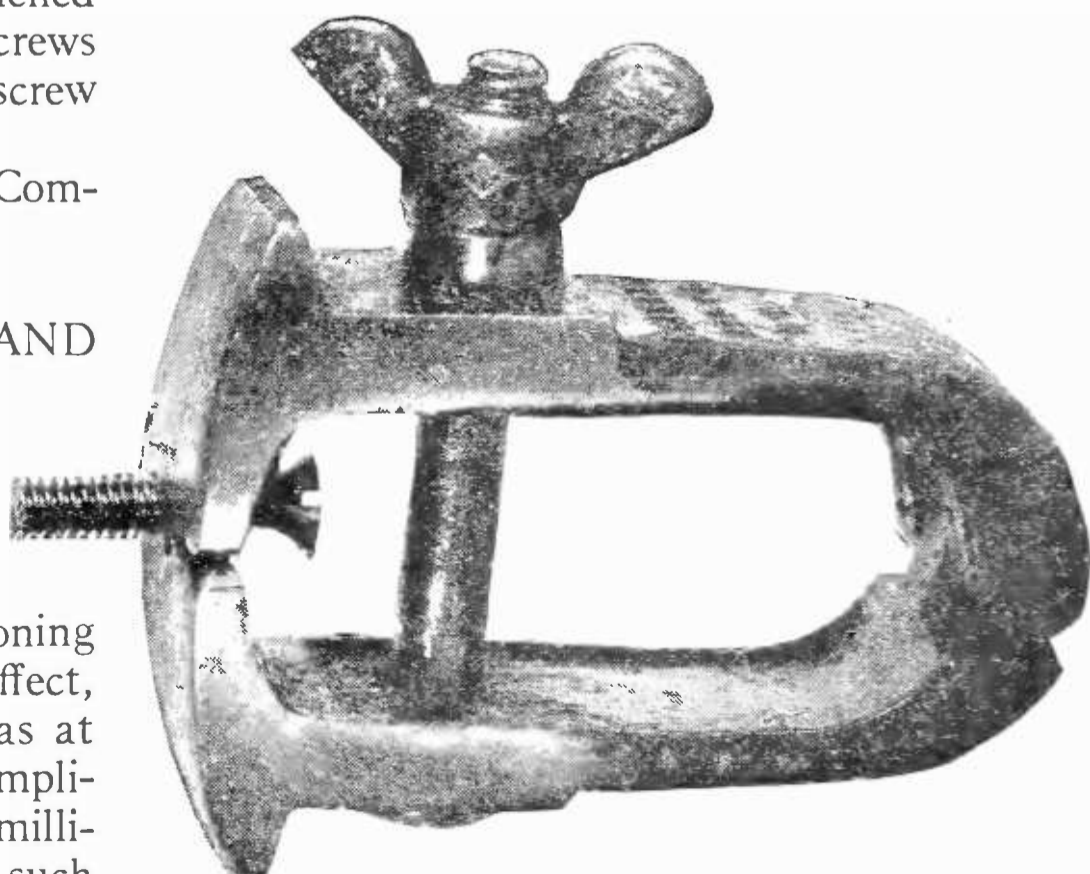

FIG. 9

A screw clamp that holds your machine screws for filing and cutting without injuring the thread. The clamp is held in a regular vise

Listening-in on the World

The Story of RADIO BROADCAST'S International Broadcasting Tests Which Will Take Place this November

BY WILLIS K. WING

RADIO listeners in America will have another wholesale opportunity this year to listen-in for broadcasting from stations in England, France, possibly Spain, Holland, and Germany when the RADIO BROADCAST International Broadcasting Tests take place during the week of November 24 to 30. Arrangements on the American continent are in charge of Arthur Lynch, editor of this magazine, and organizer of the tests. European arrangements are in charge of Hugh S. Pocock, editor of *Wireless World and Radio Review* who is coöperating with Captain A. G. D. West, who is assistant Chief Engineer of the British Broadcasting Company.

For those who did not follow the trans-atlantic tests which occurred in November, 1923, we can review the results by saying that the eight stations of the British Broadcasting Company transmitted special programs for American radio listeners, and a great number of the American and Canadian broadcasters transmitted special programs for listeners on the other side. American radio fans heard the English stations, especially 2LO, London, and 5WA, Cardiff, and 5SC, Glasgow.

American listeners with some very modest receivers found that their locations were especially good for long distance receiving and were thrilled by hearing the English programs from great distances. It is no exaggeration to say that broadcast listeners in every corner of the United States heard the foreign signals.

There were some difficulties last year for American listeners. These, in order of their importance were transmission by American stations during the time when quiet was to be preserved to listen for English programs, and interference from oscillating receivers. It is probably true that there are fewer "bloopers" in action this year than last because of the

growing sense of responsibility of the radio public.

PROSPECTS FOR THIS YEAR

ARRANGEMENTS made by this magazine for the tests this year are far more ambitious and far more complete than were those arranged for the first trans-atlantic test during the last week of November, 1923. Every broadcaster in the United States has been communicated with and without a single important exception, they have agreed to coöperate to the utmost this year, not only in transmitting special and interesting programs, but also in guarding absolute silence during the transmission hours of foreign stations.

Stations in Cuba, Porto Rico, Hawaii, will transmit as the United States and Canada unit; and it is entirely possible that Australia will enter the transmitting and receiving tests as part of the foreign group.

It is now planned that American stations will send for an hour between ten and eleven each evening of the tests, Eastern Standard Time, and the foreign stations will transmit from eleven to twelve, Eastern Standard time. This will allow a long enough time for adjusting receivers to hear the distant stations. A full band of darkness will be between all transmitting and receiving stations during the transmitting hours.

The tests this year should accomplish even more in the way of bringing the nations closer together than did the Anglo-American ones last year. There will be addresses by public men, well known on both sides of the water.

Complete announcement of the American and foreign stations participating in the tests and other details will be made through the newspapers and from the various broadcasting stations and in the December number of RADIO BROADCAST.

Oscillations and the Vacuum Tube

The Requirements and Governing Conditions for Oscillations in Tube Circuits—The Neutrodyne, the Meissner, and the Colpitts Oscillator Circuits

WHAT MAKES THE WHEELS GO 'ROUND: VII

BY WALTER VAN B. ROBERTS

THIS article is the seventh in the series by Walter Van B. Roberts which began in the March RADIO BROADCAST. These informative discussions are written to appeal to the broadcast listener who wants to know about the workings of the important units in his receiver. Mr. Roberts has quite successfully evaded the common error of technical writers who leave much unsaid or confuse what they do say with a maze of technical phraseology and turgidity of style.

While "Oscillations and the Vacuum Tube" is part of a series, it can be read comprehendingly by the reader who has not followed the previous articles.—THE EDITOR.

A BETTER method of neutralizing vacuum tube capacity is used in the neutrodyne. We have seen that the only way energy is fed back (assuming the grid circuit and plate circuit well separated or shielded from each other) is by the effect of the variations of plate potential acting on the grid through the small capacity that exists inside the tube itself between the grid and plate and the wires leading to them. Now if we could feed back to the grid another potential of exactly the same magnitude as caused by proximity of the plate, but exactly opposite in "phase", the net effect on the grid would be zero, so no energy would get back to the grid circuit. This system *wipes out at the source all tendency* to oscillate, instead of struggling to overcome the oscillations. A typical neutroding arrangement is shown in Fig. 32. The secondary of the transformer is wound in the opposite direction to the primary winding so that the potential at the upper end of the secondary is exactly opposite in phase to the potential of the upper end of the primary. Through the small capacity indicated in Fig. 32, the upper end of the secondary influences the grid in a fashion exactly equal but exactly opposite to the way the upper end of the primary influences the grid through the small capacity between the grid and plate. If the voltage on the upper end of the secondary is several times greater than the voltage variations on the upper end of the primary (and it

should be, for good amplification), then the "feed back" capacity shown (or neutralizing capacity) should be several times less than the grid-plate capacity in order that the two influences be of the same magnitude.

58. LOW CAPACITY TUBES

INASMUCH as the tendency to oscillation is greater the more the grid-plate capacity and the higher the frequency, two other lines of attack are immediately obvious. The first is to build tubes with smaller grids and plates and to keep the wires leading to them as well separated as possible. Some of the small dry cell-operated tubes represent progress along this line. The second way is to use lower frequencies to amplify. By taking advantage of the curvature of the characteristic curve of the vacuum tube it is possible to change signals coming in at a very high frequency into signals at some frequency low enough to be

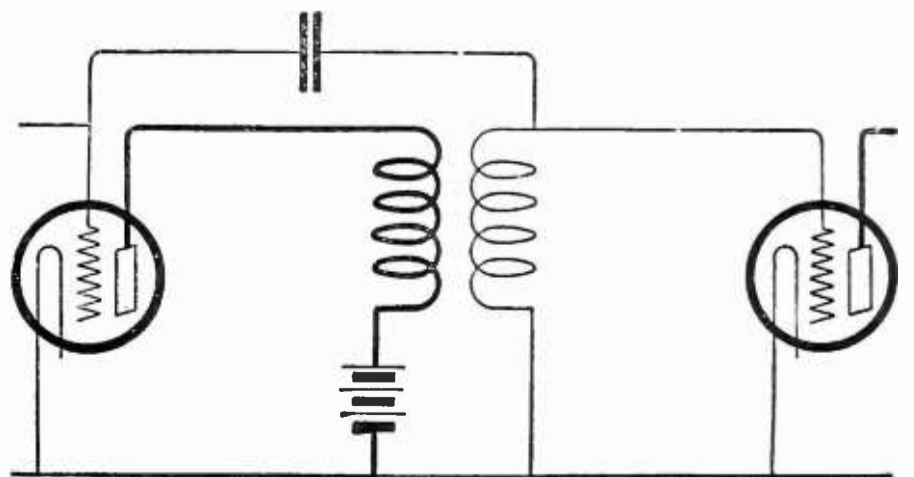

FIG. 32

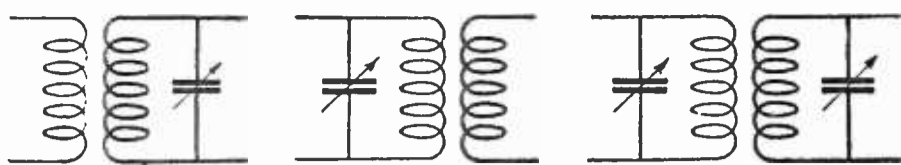

FIG. 33

more easily amplified. After amplification, these intermediate frequency currents are fed to any sort of a detector which demodulates them in the ordinary fashion, thus yielding the desired audio-frequency currents. This is the "super-heterodyne" method and will be explained more fully later on.

59. RADIO-FREQUENCY TRANSFORMERS

RADIO-frequency transformers are classified as "tuned" or "untuned." Fig. 33 shows three commonly used types of tuned transformers. A tuned transformer must be

tuned (in Fig. 33 by means of the variable condensers shown) to the frequency that is to be amplified. Thus for a particular setting of the condensers, the amplification would be great for a narrow band of frequencies but negligible for frequencies even slightly outside

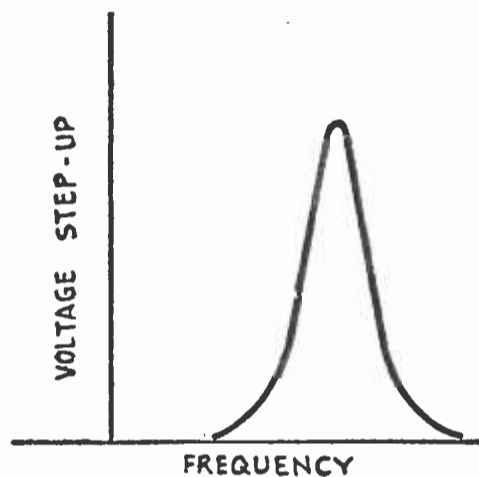

FIG. 34

of this band as shown by Fig. 34. The untuned type have no tuning adjustment, but even they work best at some particular frequency. The difference is that they work to a certain extent over a wide range of frequencies as shown by Fig. 35. This wider range is due to the introduction of resistance, or, if iron cores are used, by a combination of the advantage of the iron core with the effective resistance introduced into the transformer by the losses that occur in iron at high

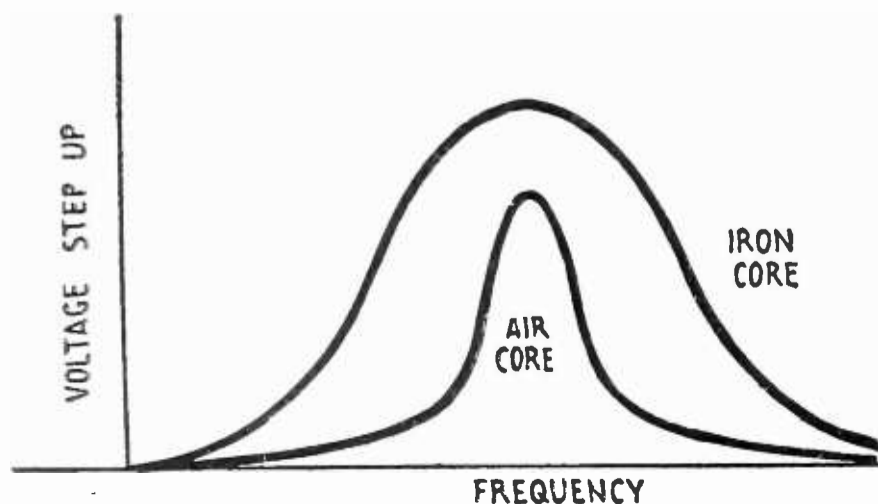

FIG. 35

frequencies. In general it may be said that when there is much resistance or anything else that causes losses, the amplification will be less than that theoretically obtainable by the use of tuned transformers. A few stages of tuned transformer-coupled amplification has the advantage of giving great selectivity, that is, amplifying only one frequency (strictly speaking, only a very narrow band of frequencies) but has the disadvantage that as each stage must be carefully tuned, it is tedious to change from one frequency to another and difficult to pick up weak signals unless the proper setting for each tuning condenser is known in advance. (In the super-heterodyne system this disadvantage disappears because the intermediate-frequency amplification is done at a fixed frequency whatever the wavelength of the station being received).

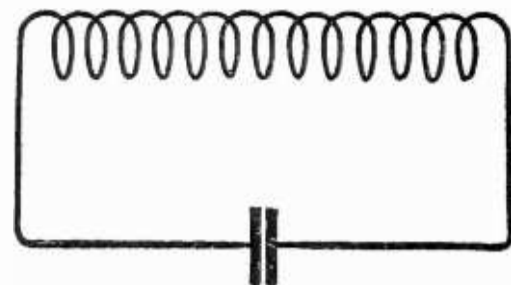

FIG. 36

60. REQUIREMENTS FOR A TUBE OSCILLATOR CIRCUIT

A MORE or less sketchy description of the setting up of oscillations was given under the paragraph on regeneration. The general conditions that have to be satisfied by any circuit in which a vacuum tube is to produce oscillations are:

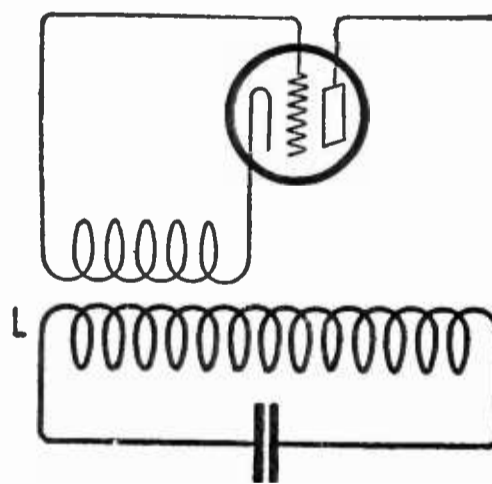

FIG. 37

(1) There must be an oscillation circuit, the natural frequency of which will largely determine the frequency of the oscillations.

(2) The grid and filament of the tube should be coupled to the oscillation circuit in such a fashion that variations of the grid potential (with respect to that of the filament) will be caused by oscillating or alternating current in the oscillation circuit.

(3) The plate must then be connected to the filament in such a fashion that the variations of plate current (which are caused by the variations of grid potential) act to increase rather than decrease the alternating current which has been assumed to exist in the oscillation circuit

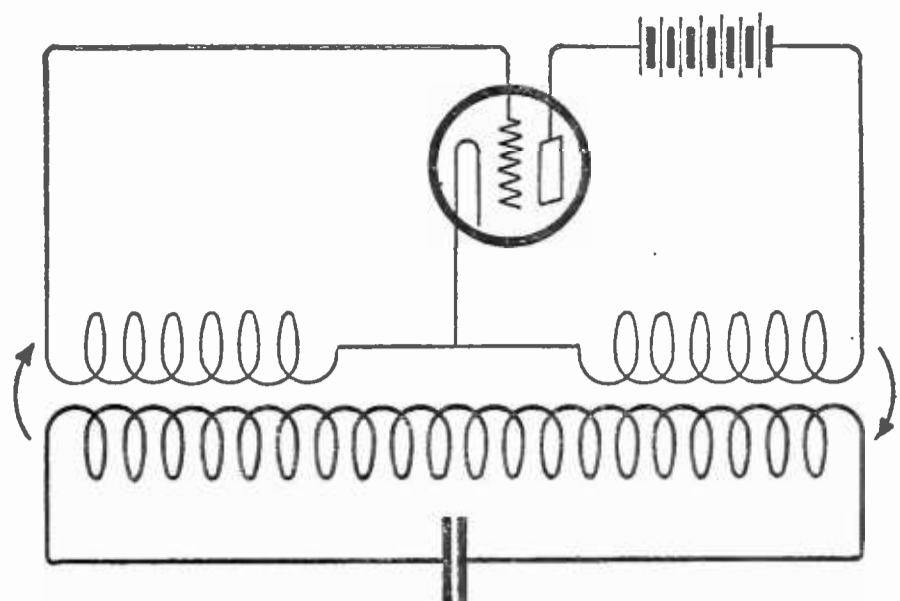

FIG. 38

and which is responsible for the variations of grid potential.

61. ANALOGY FOR AN OSCILLATOR CIRCUIT

A CLOCK is a good analogy for a vacuum tube oscillator circuit. The swinging of the pendulum corresponds to the alternating current in the oscillation circuit, and the natural frequency of the pendulum is pretty close to the frequency with which it will swing when the clock is running. Corresponding to the alternating current in the oscillation circuit operating the grid potential, we have the swinging of the pendulum operating some sort of escapement mechanism that controls the action of a spring or the falling of weights. And just as the plate current controlled by grid potential acts to keep the oscillating current going, so does the intermittent uncoiling of the spring or falling of the weights released by the escapement mechanism act to keep the pendulum swinging.

62. AN ILLUSTRATIVE OSCILLATION CIRCUIT

WE WILL build up an oscillator circuit by following our list of conditions one by one. The first condition is satisfied by the simple oscillation circuit of Fig. 36. The second condition is satisfied by Fig. 37 as the transformer type coupling between the coil L and the grid coil makes alternating current in L produce an alternating potential difference between grid and filament. The last condition is satisfied in Fig. 38 for the plate coil is assumed to be wound in such a direction that the plate current variations reinforce the current in the oscillation circuit. The flow of power is indicated by the arrows in Fig. 38. A small amount flows through the transformer coupling at the left side of the diagram to the grid and is the power input to the tube. Then

if the tube amplifies power an increased amount flows through the transformer coupling at the right, back into the oscillation circuit. The difference between these two amounts of power just takes care of the rate at which energy is being dissipated in the oscillation circuit. This is the Meissner circuit.

63. OTHER OSCILLATION CIRCUITS

FIG. 39 shows the Hartley circuit which is the same as the Meissner except that the couplings are "direct," that is, transformer type coupling has been replaced by "auto-transformer" type coupling.

In Fig. 40 we have what is usually meant by the term "feed-back" circuit. (All oscillator or regenerative circuits are really feed-back circuits of some sort). The coupling to the grid is direct while the plate circuit is coupled to the oscillation circuit by mutual inductance or transformer coupling.

Fig. 41 is exactly the reverse of the last arrangement.

Fig. 42 is the Colpitts circuit, obtained by interchanging all capacities and inductances in the Hartley circuit. The only difference is that the capacity has to be split up into two condensers in order to connect the filament in the middle of it, and a direct current path has to be provided for electrons to get from plate back to filament. The alternating current however is kept out of this path by the high reactance of the choke coil.

Fig. 43. This is the circuit used in receiving sets employing "plate-variometer" regeneration. Sometimes the tuning condenser is omitted. In any case, the circuit between the grid and filament functions as a simple inductance, and as there is no mutual inductance between the plate variometer and the grid coil, this circuit is really a Hartley circuit with no mutual inductance, the necessary capacity

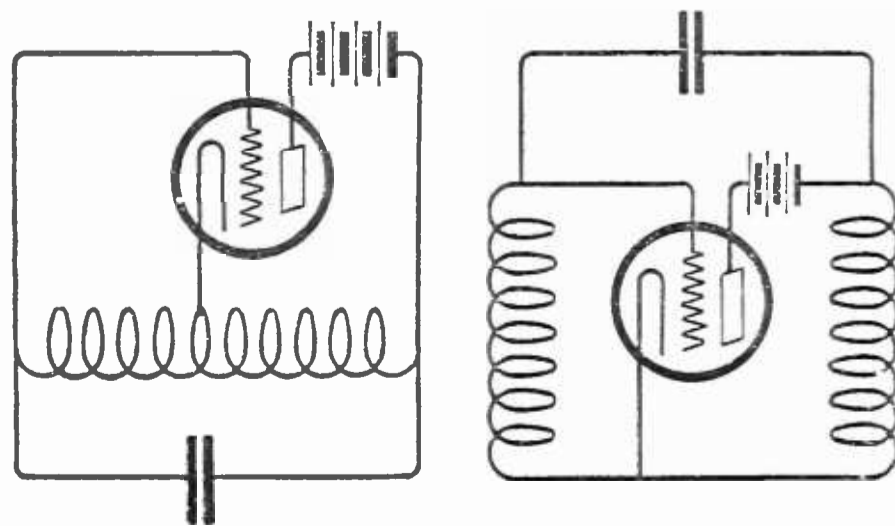

FIG. 39

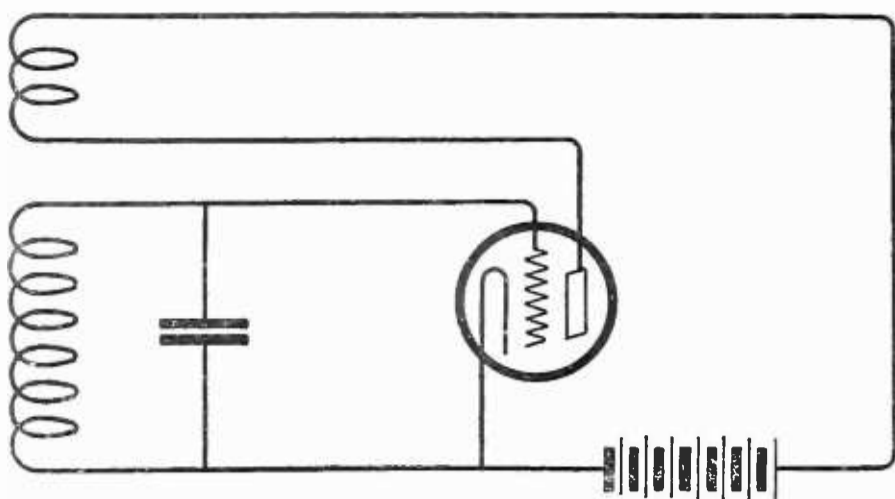

FIG. 40

being the internal grid-plate capacity shown in the conventional fashion by dotted lines.

64. RELATION OF COUPLING TO TUBE OSCILLATIONS

THE three conditions given at the outset are only qualitative. To obtain the strongest oscillations, the amount of coupling

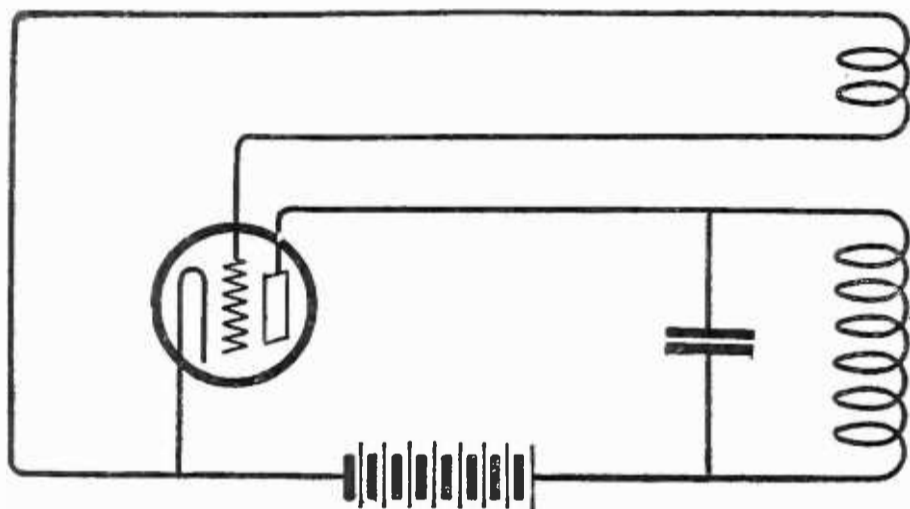

FIG. 41

between the grid circuit, plate circuit, and the oscillation circuit must be correct. If, for

example, the plate circuit is coupled too tightly to the oscillation circuit, the tube is in effect connected to an impedance greater than its own plate impedance and will work with good efficiency but less than maximum output of

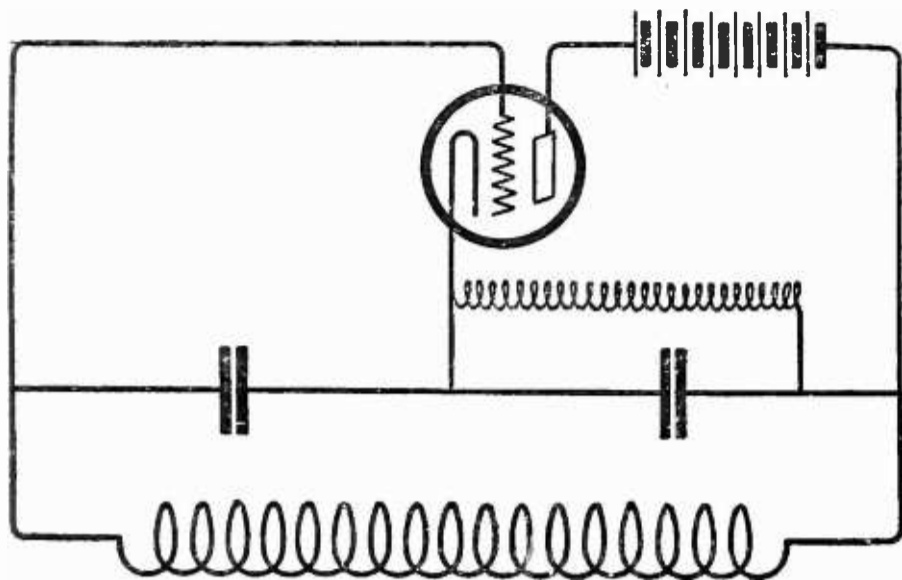

FIG. 42

power. If this same coupling is too loose, the efficiency and output will both diminish and if the coupling is less than a certain value the tube will not start oscillating at all but will merely give regeneration in case an alternating voltage of the proper frequency is applied to the grid by some outside means.

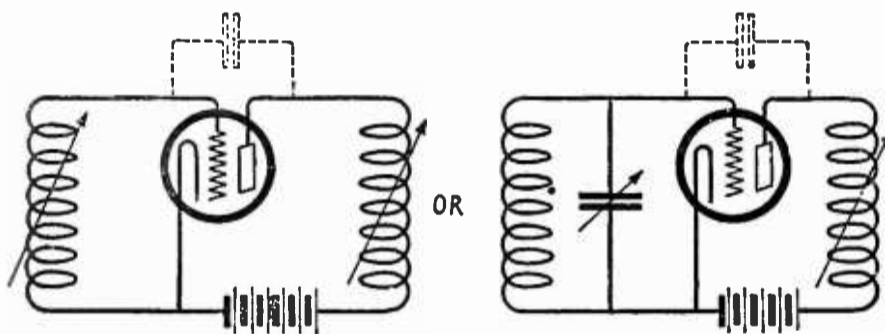
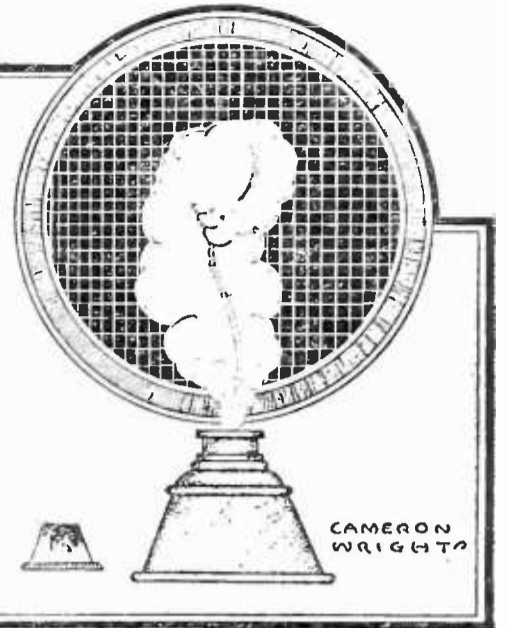

FIG. 43

NO ONE of the great numbers interested seems to know how radio — that extraordinarily effective and influential means of communication — is going to affect politics. Precedent is being set, and history being made before our very eyes in the present campaign. Mark Sullivan, one of the best known and ablest political writers in the nation, has written a highly interesting article on this subject which will appear in the November RADIO BROADCAST



WHAT Our Readers Write Us



The New Age of Fable

THE innocent searcher after radio information has his trials and his tribulations. Perhaps after he seeks he does find, more often he seeks and does not find. And sometimes when he seeks he finds fearful and wonderful facts. Casual listeners in some radio stores have overheard much technical information on radio which astounded their trained technical ears. Many radio dealers who have jumped hastily from their former mercantile pursuits, whatever they were, to radio, have not been able to make an equal mental jump to keep pace with radio theory. So it is small wonder that some owners of radio sets have their technical troubles, when one considers the kind of information they have to depend on. The following letter was written to us as a voluntary contribution to radio lore by a radio dealer, who must remain forever anonymous. We take, it must be said, if indeed that be necessary, no responsibility for the statements.

Editor, RADIO BROADCAST,
Doubleday, Page & Company
Garden City, L. I.

DEAR SIR:

What is the advantage of a vertical aerial? With a vertical aerial, there is a two fold advantage. First, because it is a good high-wave getter. Second, because a vertical aerial is not so inductant with the ground as is a horizontal aerial which tends to get worse and worse the longer it is.

With the vertical aerial, this inductance with the ground and consequent tendency to choked reception is practically overcome. This can be noticed in connection with the grid leak, which can almost be discarded, or used on very low resistance. This shows that with a vertical aerial, you are using your tubes to better advantage without having to drown them with so many megohms. It is understood, then, that this local buzzing is caused by the inductance between the horizontal aerial and the ground.

The vertical systems are the umbrella aerial, the vertical hoop aerial, and for peak reception, the balloon aerial. It has been found that this vertical antenna functions with the same intensity whether it be a fine or a heavy gauge

wire, for the reason that this vertical antenna does not lose its charge of high frequency radio currents like the horizontal aerial does.

It is remarkable the natural amplitude of such an aerial. In comparison with the regular horizontal aerial about 100 feet long and 30 feet high, the natural or initial amplitude of the respective aerials was five times as great on the vertical aerial, which was 200 feet high.

This initial amplitude without any particular "directional hard pan" is what is wanted, the same as in photography. If you have a good, full negative, you can enlarge indefinitely, but a dull or deformed negative is very difficult to enlarge.

E. S., Rhode Island.

A Good Radio Shibboleth

AN OUTSPOKEN and deadly earnest reader sent us the following letter which asks some pretty searching questions of the thoughtless broadcast listener who uses a single-circuit regenerator. We should like to hear from readers of RADIO BROADCAST whether or not they have noticed any decrease in interference from bloopers in their localities. A tabulation of the figures would be very interesting.

Editor, RADIO BROADCAST.
Doubleday, Page & Company,
Garden City, L. I.

DEAR SIR:

Here are some questions I would like to have my fellow broadcast listeners answer for their own benefit. I have made them mild, to avoid hurting their feelings, but if I had my way, those who are convicted by their answers to these questions, would all be in jail from 8 to 12 P. M. daily.

ARE YOU A JAY TUNER?

- Are you sure your set does not radiate? If so, read no further.
- When your filament or tickler is at the highest working point, do you sometimes "give her a little more," in the hope of bringing in a weak, fading, or interrupted signal?
- Do you fuss around, trying for stations you know full well are beyond your reach?
- Do you spend every evening trying to see how many stations you can tune-in, and how often you can get them?

- Do you tune-in by the whistle?
- Do you let six-year-old brother crank the dials when you get tired?
- Do you know that the sickly whine when you tune-in carelessly becomes a piercing howl in your neighbor's loud speaker? Or don't you care if it does?
- Do you know that many a would-be fan is holding off because innumerable bloopers, and jay tuners make the air hideous?
- Do you know how cheaply you can make your blooming stone-crusher into a clear-toned, selective receiver?
- Do you know that with ten cents worth of No. 22 DCC wire you can in one hour add a primary to your single-circuit receiver that will help a lot?

C. L. E., Wilkes Barre, Pa.

Radio News from Japan

27 Tatsuoka-cho
Hongo-ku, Tokyo, Japan

Editor, RADIO BROADCAST
Doubleday, Page & Company,
Garden City, L. I.

DEAR SIR:

I am a Japanese boy and I am going to a middle school of my city. I have heard often concerning to radio is very flourishing in your country from our foreigner teacher and have reads by the books.

In the Japan there is not only a broadcasting station, but the Training School Institute of Communications. Officials is broadcasting every day to a little radio fans. Radio music concert held in every places. I thought you would be interested to know about the radio in Japan.

Yours truly,
K. SUGITA.

A New World for Shut-Ins

LETTERS such as this make one feel that times are growing better for those who have to struggle along under heavy difficulties of physical shortcomings. Below is an interesting and outspoken letter on the subject which illustrates the point very nicely.

Editor, RADIO BROADCAST
Doubleday, Page & Co.,
Garden City, L. I.

DEAR SIR:

Radio is the greatest help to me, both as an amusement and an education. Being a cripple and a shut-in, I think I appreciate radio more than those who have all their strength.

Three years ago I became interested in radio through reading a radio magazine. About a year after that, I got my first receiver. It consisted of a crystal detector, phone, condenser, and a home-made loose coupler. When the secondary was pulled out all the way, it was two feet from end to end of that loose coupler. I did not have the strength to wind the coils, which had of course to be done by hand, so my father wound them for me. After it was finished, we found that the secondary would not work, so we used the primary as a one-slide tuning coil. Not being near any broadcasting station, we could not hear anything but code, but we heard plenty of that.

Then a bit later, I added a tube in place of the crystal detector. I have added a little now and then until at present I have a four-tube inverse duplex. At the age of 14, I was compelled to leave school, but have since learned

more about electricity, music, history, and other subjects by listening to the radio programs than I did from reading books.

C. M., Bradley Beach, N. J.

More Enthusiasm About the Roberts Set

THE experimenters have begun to test the claims made for the Roberts Knock-Out Two-Tube receiver, which was explained by its originator, Walter VanB. Roberts in RADIO BROADCAST for April and May. And the enthusiastic letters have begun to roll in—in no uncertain fashion. Here is an interesting one—among many such.

Editor, RADIO BROADCAST
Doubleday, Page & Co.,
Garden City, L. I.

Dear Sir:

This letter is to express my appreciation of the two articles in RADIO BROADCAST for April and May on the Roberts Two-Tube Knock-Out receiver, which I have experimented with lately at some length. I am located 17 miles southeast of Boston. Using this receiver, which I made from your circuit, I heard two stations in Chicago and WOC quite well across my 14-foot den last night, on a Music Master loud speaker. With Brandes headphones, I had to remove the receiver caps ahead of my ears when listening to WGY, WNAC, and WBZ.

In making the set, I did not follow Robert's suggestions altogether. For a primary and secondary tuner, I used a pair of unwound Kresge hub and spoke forms that sell for ten cents. I used No. 20 double covered wire because I am a firm believer in coarse gauge wire on tuners. I did not make all the taps so near the beginning because I did not see the need of tapping so much. I fixed one form permanently and arranged the other so as to draw to and fro over a latitude of three inches, I find this adjustment of value because I can use it to clear up interference as well as to put volume into reception after tuning-in a station quite clearly. The other three forms used were black fibre twenty-five cent Kresge wound spider webs from which I took all the wire and rewound. I used the brass arms Kresge sells for supporting the forms. I used a separate Bradleystat for the 201-A tube and a 30-ohm resistance for the 199 tube. Instead of neutralizing by your suggested devices, I used a small 3-plate vernier condenser bought of Kresges for fifty cents. I used a three-inch dial on it, and I wish to mention particularly that I change the setting of this dial several points one way or another with each different station received, to the great advantage of reception. This adjustment, I find, adds about twenty five per cent. clarity and volume and quite a little to distance.

Since this outfit in this irregular form works so well, I am reluctant to start on a cabinet and panel for it lest boxing the thing may reduce its volume. The set now spreads out fully twenty six inches from left to right. In the construction of the set, I used a Paragon audio transformer. I removed some wire from the tickler and then replaced it, for your number of turns seemed best for general use. My antenna is sixty feet out of doors with a thirty foot lead in the house. It is about sixty feet high at the far end.

Those who drop in to look at this receiver, seeing the crude assemblage of parts as I stuck them around experimentally on the bread board, smile at the junk pile, but their expression changes when I tune-in.

H. E. D., Hingham, Mass.



QUERIES ANSWERED

WHAT ARE THE GOVERNMENT RADIO LICENSE REQUIREMENTS?	A. F. O., Detroit, Michigan
HOW CAN I REFLEX MY AERIOLA SR. SET?	E. O. B., Boise, Idaho
WHAT ARE THE SPECIFICATIONS FOR THE UV-1716 TRANSFORMERS?	A. T. M., Miami, Florida
EXPLAIN THE REVERSE FEED BACK IN THE SUPERDYNE SET	R. D. W., Champaign, Illinois
HOW MAY A STORAGE BATTERY BE CHARGED FROM A 32 VOLT LINE?	Q. A. R., Martins Ferry, Ohio
WHAT ARE THE PARTICULARS OF THE HEAVY DUTY B BATTERY?	E. W. H., High Point, N. C.

ABOUT GOVERNMENT LICENSES

NOT A few inquiries have reached us asking for the regulations governing the application and examination for an amateur's license.

It would be well for those so interested to write to the Superintendent of Documents, Government Printing Office, Washington, D. C., for the booklet *Radio Communication Laws of the U. S.*, which sells for 15 cents. This booklet gives in full, all the details for securing this license and others more advanced, such as the experimental station license and commercial license. The International Radio Conventions and code are also included in it.

Briefly the procedure to be followed by a license applicant is as follows:

Assuming that he knows about the technical and constructional features of the transmitter to be operated he should apply to the Radio Inspector's Office in his district.

The examination covers the regulations of the International Radio Telegraphic Convention, so that calls of distress may be recognized, and the regulations concerning interference, sending and receiving signals at the rate of ten words per minute.

It is also necessary to draw a circuit diagram of the apparatus to be used for transmitting purposes.

Then, when this examination has been successfully passed, it is necessary to obtain a station license. Radio forms No. 756 and 757 are furnished for this purpose. The information required on these forms concerns the type of transmitter and antenna used, amount of input power, wavelength, etc.

Examinations for the license are held at the office of the Supervisor of Radio Department of Commerce Custom House, in the following cities:

1st Dist.	Boston, Mass.
2nd Dist.	New York, N. Y.
3rd Dist.	Baltimore, Md.
4th Dist.	Savannah, Ga.

5th Dist.	New Orleans, La.
6th Dist.	San Francisco, Calif.
7th Dist.	Seattle, Wash.
8th Dist.	Detroit, Mich.
9th Dist.	Chicago, Ill.

Amateur transmission is limited to 200 meters and below. For operating on wavelengths other than these, a special license is required.

HOW TO REFLEX THE AERIOLA, SR. AND RADIOLA TYPE RECEIVER

COMPLETE instructions for reflexing the single-circuit receiver were contained in the June issue of RADIO BROADCAST. Some of our readers have experienced a bit of trouble in making the adaption. This has been especially true of the owners of such receivers as the Aeriola and Radiola type. On account of the peculiar split windings in the tuners of these receivers it is difficult to apply the reflexit to them without affecting their over-all

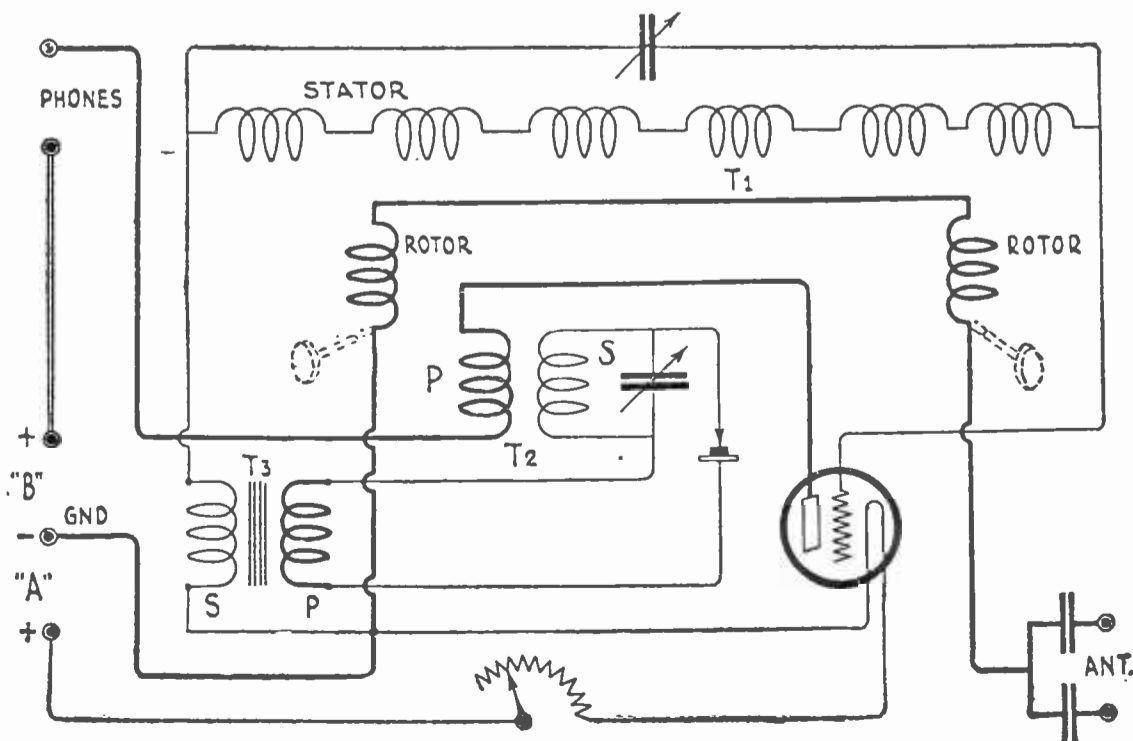

FIG. 1

efficiency. Usually the entire circuit must be torn down and the several parts re-placed so that there is no feedback or inductive relation between the tuner and radio-frequency coil units. The ordinary home-made receiver is quite easily changed over in the manner previously explained. Fig. 1 shows a circuit diagram of the Aeriola Sr. converted into a reflex receiver. A rear panel view is illustrated.

THE UV 1716 RADIO-FREQUENCY TRANSFORMER SPECIFICATIONS

MANY have asked for the construction data for winding the very scarce UV-1716 Radio-Frequency Transformers, and the following coil winding table is given.

Primary	1000 turns	No. 34 silk enamel wire
Secondary	2700 " " " " " "	" " " " " "

The coil form shown on page 493 of the April issue may be used providing the width of the slots is increased to about $\frac{3}{8}$ ".

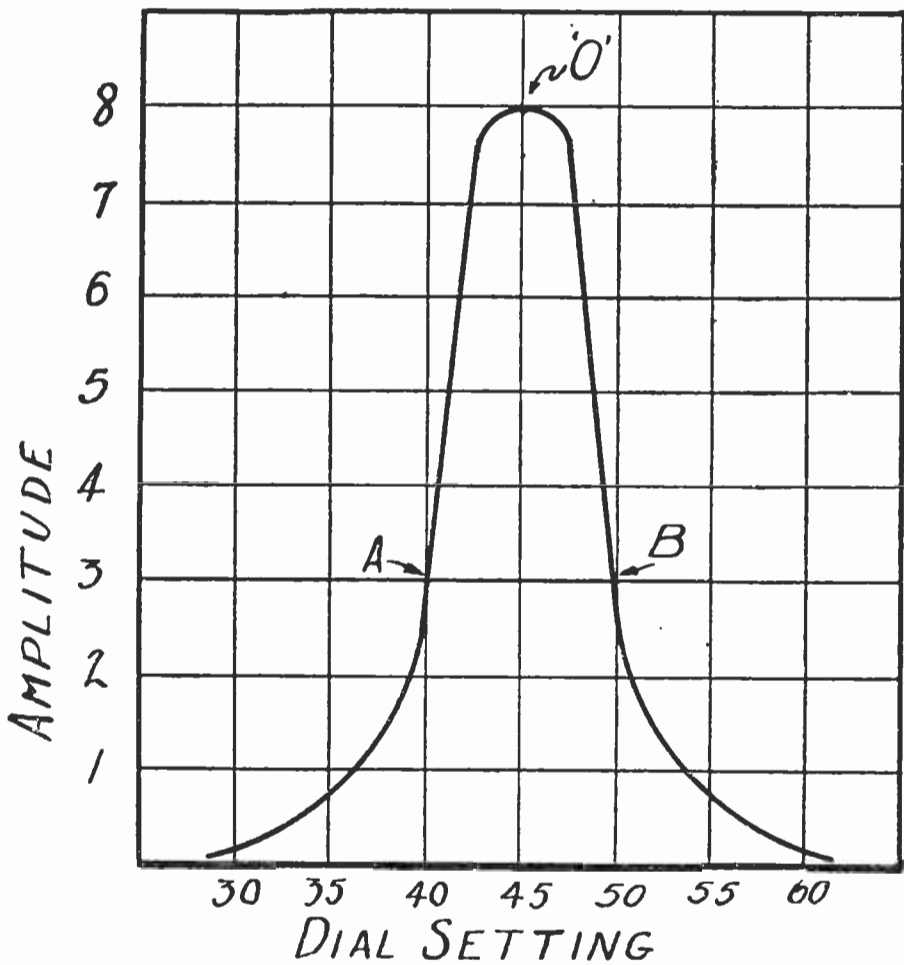

FIG. 2

EXPLAINING THE REVERSE FEED BACK IN THE SUPERDYNE

THE outstanding feature of the Superdyne is its reversed feedback control. In the ordinary regenerative set when tuning-in a station, oscillation occurs over a wide range on the tuner dial. Let us suppose it is, for example, from 40 to 50. The signal can be received clearly at about 39 but the point of greatest amplitude would be obviously at about 45. On account of the oscillator noises, it is impossible to use this point for undistorted reception. In the Superdyne, this point of greatest oscillation can be obtained, and then, by using the reverse feedback coil, this oscillation can be effectively stopped without any loss in amplitude.

Ordinarily, in the straight regenerative set we get an amplification of 3, but with the Superdyne this is increased about to 8. See Fig. 2. A and B represent the points where the oscillations begin and end respectively. O represents the point of maximum oscillation.

CHARGING STORAGE BATTERIES FROM 32-VOLT LIGHTING SYSTEM

ALL types of storage A and B batteries may be readily and successfully recharged from a 32-volt farm lighting system. Fig. 3 shows how the A and B battery may be charged merely by using the house lighting receptacles connecting with a cord and 32-volt lamp in series with the battery.

Select the socket which is most convenient for charging the battery. Screw in an attachment plug being careful that the two wires do not touch each other. Determine

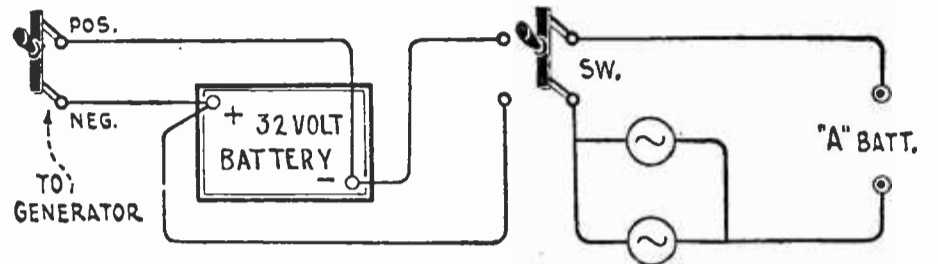

FIG. 3

the polarity of the charging wires by placing the ends of the attachment leads in a glass of water. Bubbles will form around the negative wire. If both leads show bubbles, the negative lead will give off a far greater number. After determining which is the positive and which is the negative lead, put some kind of a distinguishing mark on the negative and always use this particular socket when charging.

Properly to recharge the batteries, the positive of the charging line must go to the positive of the battery. This should be easy as you have marked your charging line, and the positive poles of the A and B batteries are also plainly marked.

When charging B batteries, use a 32-volt 25-watt lamp for the 4500 milliampere hour type and a 32-volt 15- or 20-watt lamp for the 2500 milliampere hour type. It is possible to recharge only 24 volts of B battery at one time. Therefore, a 48 volt B battery may be recharged, by charging only half or 12 cells at one time, then shifting the leads to the additional 12 cells or 24 volts. See Fig. 4.

A fully charged radio A or B battery will have a specific gravity reading of 1.275 to 1.300 and may be considered

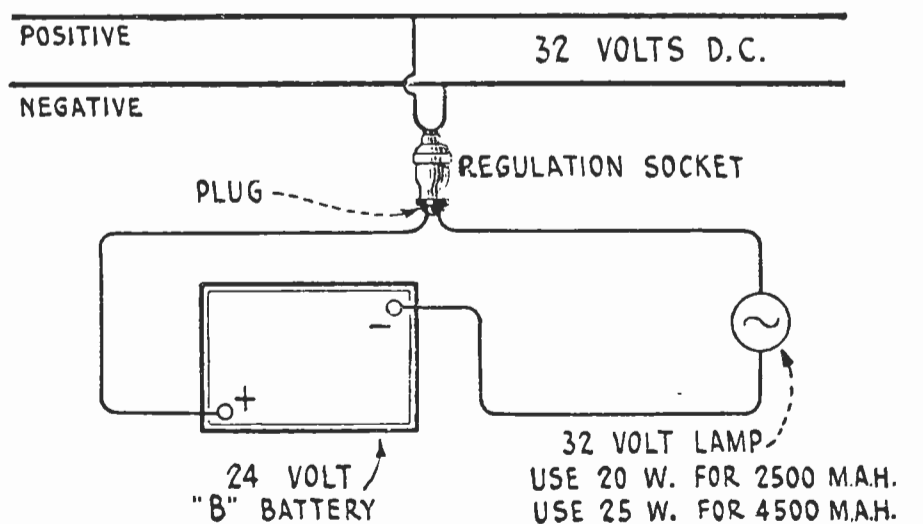
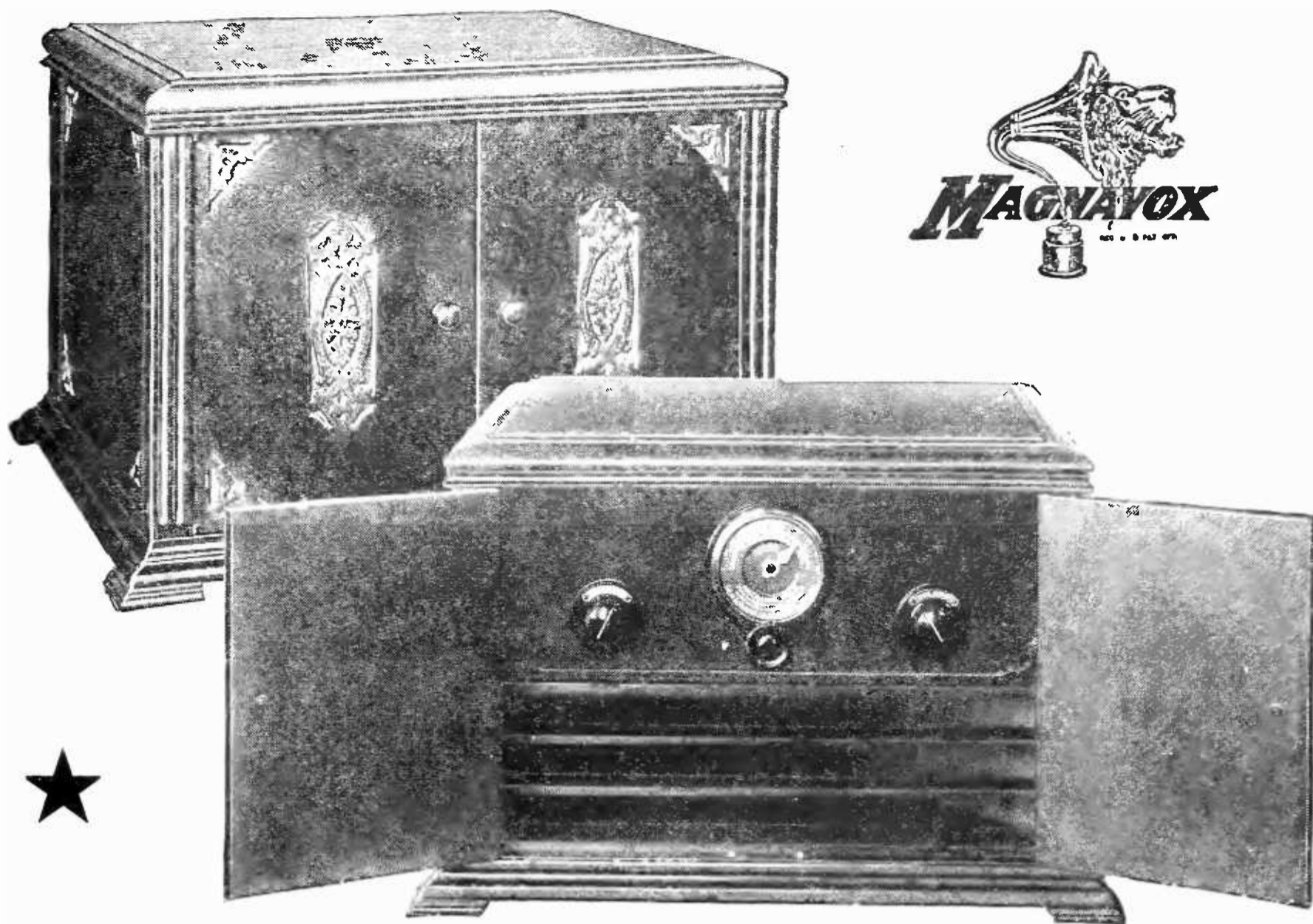

FIG. 4

discharged when it has a specific gravity reading of 1.175. For best radio results the battery should be recharged when it has a reading of 1.200.

It is possible to recharge batteries using up to 500 volts on power amplifiers and transmitters, from a 32 volt lighting system, by following the instructions with the circuit diagram in Fig. 5. Any multiple of this system may be used such as 48, 72, 96, and 120 volts.



TRF-50
(as illustrated)

A 5-tube tuned radio frequency receiver with built-in Magnavox Reproducer unit which consumes no battery. Cabinet measures: height, 14¾ in.; length, 20½ in.; depth, 18¾ in. Without tubes or batteries . . . \$150.00

TRF-5

This is identical with the above but encased in smaller cabinet without built-in Reproducer. Cabinet measures: height, 9⅝ in.; length, 20½ in.; depth, 14¾ in. Without tubes, batteries or reproducer \$125.00

MAGNAVOX

New Broadcast Receivers combining supreme efficiency, convenience and beauty

HERE at last is the perfected instrument permitting you to enjoy *simultaneously* the most desirable elements of broadcast reception.

Three decisive advantages go with the Magnavox: unequalled simplicity of control, reproduction of exceptional clearness — handsomely carved period cabinets.

Magnavox Radio Receivers, Vacuum Tubes, Reproducers, Power Amplifiers, and Combination Sets are sold by reliable dealers everywhere

THE MAGNAVOX CO., OAKLAND, CALIF.

*New York: 350 W. 31st Street San Francisco: 274 Brannan Street
Canadian Distributors: Perkins Electric Limited, Toronto, Montreal, Winnipeg*

Owing to the very low charging current needed for a B battery the efficiency of a charging plant is not lowered to any great extent by charging it from the plant storage batteries, rather than from the generator. However, a high charging current is needed for an A battery and it should only be charged while the generator is being operated to charge the plant battery. After obtaining the polarity make sure that the positive of the charging line is attached to the positive of the 6-volt storage battery as indicated on the attached diagram for charging A batteries.

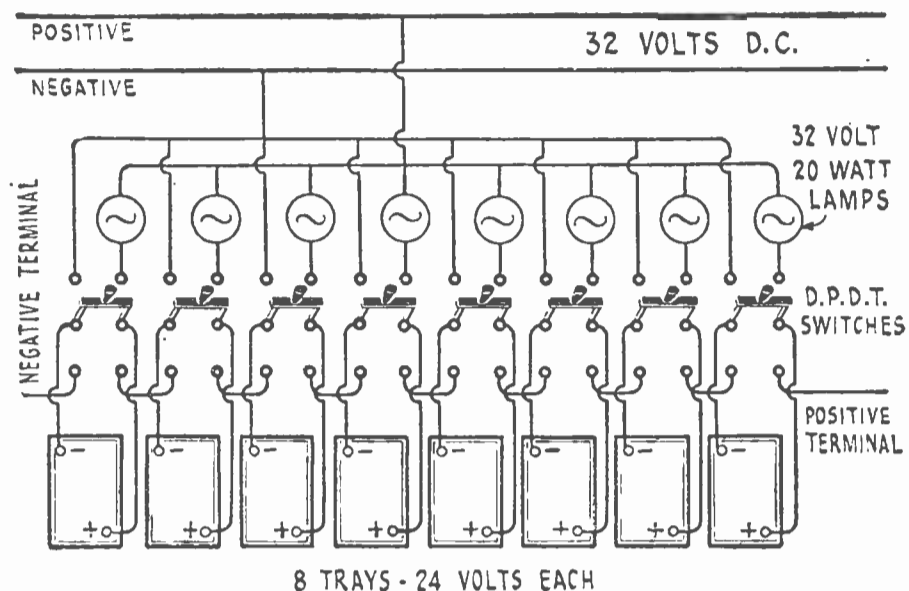

FIG. 5

B BATTERY ECONOMY

UNPLEASANT and unnecessary noises in a radio receiver may be due to static, faulty or careless wiring. And some receiver noises are directly chargeable to the B battery.

If the B battery is imperfectly connected to the receiving set, an intermittent crackling noise is sure to result in the phones or loud speaker. In any circuit which is "made and broken," a spark or arc will be set up at the point where the actual make and break occurs. Even though this loose contact in the B battery leads is slight, an abnormal amount of current will be drawn from the B battery so affected, decreasing its life and resulting in a varied voltage supply.

A B battery which has been allowed to become damp will eventually corrode and cause noises in the receiving set. Corrosion attacks the copper inter-cell connections and the zinc shells of the cells and finally eats away enough of the metal to cause imperfect and quite frequently open and short circuits.

Radio owners and purchasers will gain much by considering the type of battery best suited to their needs. Receivers employing five or more tubes draw more current in milliamperes than those having only one or two tubes. If, for instance, a battery designed for a five-tube drain is used with a receiver having two tubes, the current consumption would be lower than the manufacturer's designated rate. So the battery would not be operated at its maximum capacity and it would last much longer but its depreciation would be much greater, than a battery of smaller capacity. The National Carbon Company furnishes The Grid with the following technical suggestions:

"To secure the most service at the least expense from a B battery, it is important that a B battery be chosen which is made of cells whose size is proportional to the work to be performed. Receiving sets which require a heavy current from the B battery should be supplied with B units made of large cells.

"The number of hours a B battery will last on a receiving

set is equal to the milliampere hour capacity which the battery can deliver, divided by the current in milliamperes which the set draws from the B battery. The milliampere hour capacity of a B battery depends largely on two things, the size of the individual cells in the battery-unit and the rate at which the cells are discharged, that is to say, the current drain.

"If the current drain is too small in proportion to the size of the cells, the time required to discharge the battery will be so great that the natural depreciation, which is so characteristic of dry cells, will consume a measureable proportion of the battery's capacity, leaving less than the full amount for useful service.

"On the other hand, if the current drain is too great for this size of cells, the battery will be overloaded and this, too, results in decreasing the capacity of the battery. Between these two extremes, is a current drain at which the battery will deliver its maximum capacity. This is the normal rate of discharge for the battery. This normal rate of discharge for B batteries depends primarily on the size of cells of which the B battery is made. The larger the cells, the larger the normal rate of discharge.

"The normal rate of discharge for the customary large 45 volt B battery is from 5 to 12 milliamperes. Most multi-tube receivers and power amplifiers draw much heavier currents than this from the B battery—usually from 15 to 25 milliamperes. Consequently, the B batteries of the usual size are seriously overloaded when supplying current to these heavy-current receivers, and their life is therefore comparatively short. This makes the operating cost of such receiving sets rather burdensome.

"To provide cheaper and more satisfactory power for multi-tube receivers, battery manufacturers have developed and recently announced a special heavy duty B battery, built specifically for use on multi-tube receiving sets and power amplifiers which require 15 milliamperes or more from the B battery.

"Because of the large cells in this type unit, it is primarily a heavy current battery and therefore will not serve light current sets as economically as the usual 45 volt B battery. Sets drawing less than 15 milliamperes from the B battery can be operated more economically from the standard size 45 volt B battery."

NEUTRODYNE NOISES

WE ASSUME that the noises in question are the ones of a crackling, frying nature, differing from spasmodic static in that they are continuous in duration, varying only in intensity. Usually these noises are strongest when the neutrodyne receiver is sharply attuned to any wavelength within its range.

The causes of such noises can be summed up as follows:

1. Incorrect values of grid leak.
2. Poor or dirty contacts on socket prongs, jack blades, etc.
3. Use of too much soldering paste or acid, creating leakage paths between adjacent wires.
4. Dusty variable condenser plates.
5. Improper neutralization.

Improper neutralization is the chief cause of unpleasant and unnecessary noises in neutrodyne receivers.

It is very necessary that each of the radio-frequency stages be completely neutralized. Furthermore, it is important that they be neutralized on several wavelength settings. For this it is best to try the system on distant stations where there is small chance of receiving a broad signal.

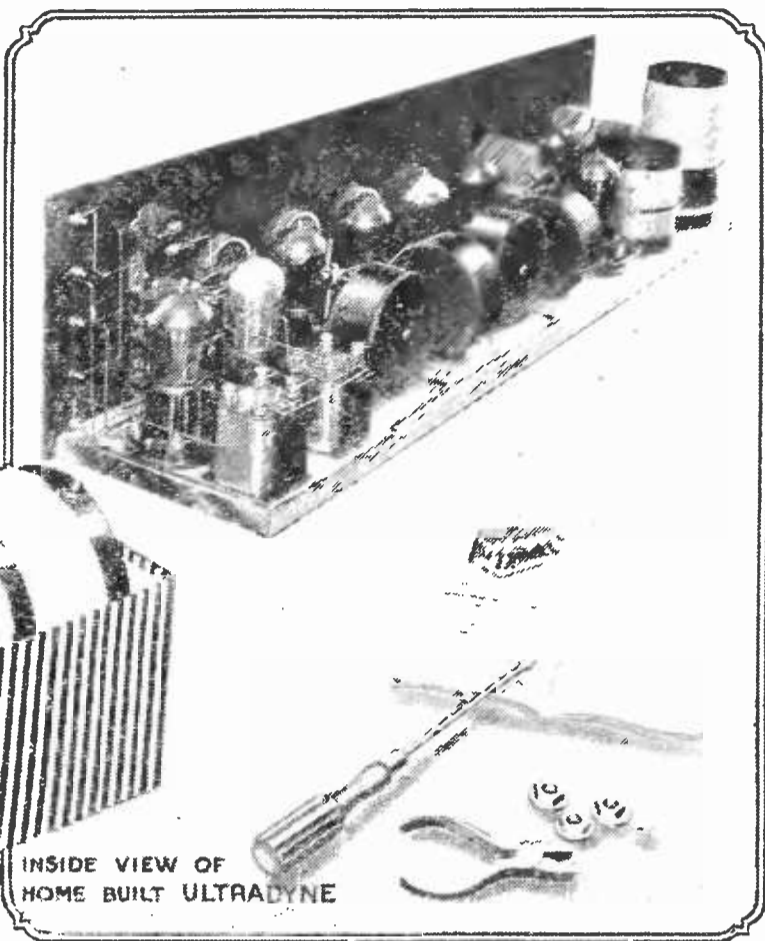

26⁰⁰

Build it with the
ULTRADYNE KIT



To protect the public, all genuine Ultra formers bear Mr. Lacault's personal monogram seal (R.E.L.) and are guaranteed so long as this seal remains unbroken.



Send for 32-page illustrated book, giving latest authentic instructions on drilling, wiring, assembling, and tuning 6 and 8 tube Ultradyne receivers.

50c

Now, the famous Ultradyne Receiver has been so simplified that anyone can successfully build it with the Ultradyne Kit. This Kit includes all the special parts required to build the Ultradyne, designed by R. E. Lacault, the inventor,—1 Type "A" Ultraformer, 3 Type "B" Ultraformers, 1 tuning coil, 1 oscillator coil, 4 matched fixed condensers.

The Ultradyne incorporates the new "Modulation System"—a decided departure from the detector arrangement of radio reception used in all other Super-Heterodynes. This "Modulation System" is the latest development of R. E. Lacault, A.M.I.R.E. Consulting Engineer of this company and formerly Radio Research Engineer with the French Radio Research Laboratories.

Even Super-Heterodyne Engineers marvel at Ultradyne performance—its unusual selectivity and great range on the loud speaker.

There is no greater receiver! Now you can build it yourself!

Write for descriptive folder.

★ **ULTRADYNE**
The Improved
SUPER-HETERODYNE
PHENIX RADIO CORPORATION

5-7 Beekman St.

New York City

★ Tested and approved by RADIO BROADCAST ★

The Progress of the "Covered Wagon"

AS THIS magazine goes to press, the RADIO BROADCAST COVERED WAGON has finished about one fifth of its transcontinental tour. Captain Jack Irwin and his radio truck traveled from New York, down through various New Jersey cities to Philadelphia and Atlantic City, and from there to Harrisburg and Altoona to Pittsburgh. The WAGON then traced its course to Cleveland and at the last writing was in Detroit.

Many radio enthusiasts in the various localities that Captain Irwin visited were greatly bothered by local interference. Local interference is indeed not a myth, as he soon discovered. While a great deal of local receiving difficulties have their origin in improper conditions in local power circuits, a great proportion of troubles certainly originate in oscillating receivers.

Letters are beginning to come in to the editorial offices from interested broadcast listeners who have talked with Captain Irwin along the route and they are unanimous in their approval of the work he is trying to do. The receivers developed in the RADIO BROADCAST LABO-

RATORY are on display on the WAGON, and they are creating a tremendous amount of interest, particularly the eight-tube superheterodyne. But when a fan reported to the crew of the WAGON that he had receiving difficulty of one sort or another, Captain Irwin and the WAGON would proceed to the spot and help "shoot" the trouble.

Radio dealers in various cities are conferring with Captain Irwin and George A. Eckweiler, technical assistant, and much radio gossip about the best ways and means to arrange window displays; they are exchanging technical information and in brief, spreading the gospel of radio.

Radio listeners, if we are to judge from the personal reactions the crew of the WAGON have reported, and also the tenor of the letters reaching this office, are much in sympathy with the purpose of Captain Irwin's trip. Power companies in various cities have shown their willingness to cooperate, and radio clubs, radio amateurs, and the radio editors of various newspapers are doing what they can to help along these efforts to improve radio enjoyment for all.

Captain Irwin will have an interesting story of his experiences next month.

Supplemental List of Broadcasting Stations in the United States

LICENSED FROM JULY 19 TO JULY 31 INCLUSIVE

CALL LETTERS	LOCATION	KILOCYCLES	WAVELENGTH	POWER (Watts)
KFAU	Boise, Idaho	1110	270	150
KFLR	Albuquerque, N. Mex.	1180	254	100
KFLW	Missoula, Mont.	1280	234	5
WABN	La Crosse, Wis.	1230	244	500
WEBI	Salisbury, Md.	1240	242	15
WFBB	Eureka, Ill.	1250	240	50
WFBG	Altoona, Pa.	1150	261	100
WOAR	Kenosha, Wis.	1310	229	50

LIST OF BROADCASTING STATIONS DELETED JULY 1 TO JULY 31

CALL	LOCATION	CALL	LOCATION
KDZI	Wenatchee, Wash.	WGAW	Altoona, Pa.
KFEZ	St. Louis, Mo.	WIAY	Washington, D. C.
KFNX	Peabody, Kans.	WJAQ	Topeka, Kans.
KFPQ	Denison, Texas	WLAV	Pensacola, Fla.
WABG	Jacksonville, Fla.	WQAL	Mattoon, Ill.
WBBJ	West Palm Beach, Fla.		

TOTALS

Number of U. S. Broadcasting Stations	543
Number of Canadian Broadcasting Stations	44
Number of Cuban Broadcasting Stations	34
Number of Mexican Broadcasting Stations	4



THIS BATTERY WILL MATERIALLY REDUCE YOUR OPERATING COSTS ON HEAVY CURRENT SETS

NEW!

Eveready Heavy Duty "B" Battery. 45 volts. Three Fahnestock Clips. Length, 8 ⁵/₁₆ inches; width, 4 ⁷/₁₆ inches; height, 7 ³/₁₆ inches; weight, 13 ³/₄ pounds.

New low price, \$4.75

New Heavy Duty 45-volt "B" Battery No. 770

Extra large cells—extra long service

FOR maximum "B" Battery economy, use this *New Eveready Heavy Duty 45-volt "B" Battery*, in the following general cases:

- 1—On all receiving sets operating at 90 volts or more, having four tubes without a "C" Battery, and all sets having five or more tubes, with or without a "C" Battery.
- 2—On all power amplifiers.
- 3—On all sets that pull heavy currents from the "B" Battery.

Under the above conditions, the *New Eveready Heavy Duty 45-volt "B" Battery* will give much longer service than the 45-volt "B" Battery of usual size.

If your receiving equipment falls under any of the above classifications, you can make a big saving in "B" Battery costs by using this *New Eveready Heavy Duty 45-volt "B" Battery No. 770*. Buy it and you get the biggest battery value on the market to-day!

Manufactured and guaranteed by
NATIONAL CARBON COMPANY, INC.
 Headquarters for Radio Battery Information
 New York—San Francisco
 Canadian National Carbon Co., Limited, Toronto, Ontario

EVEREADY
Radio Batteries
-they last longer

No. 7111
 Eveready Radio
 "A" Dry Cell
 Specially
 manufactured for
 use with dry cell
 tubes



Eveready 6-volt Storage
 "A" Battery

No. 766
 Eveready "B"
 22 ¹/₂ volts. Six
 Fahnestock Spring
 Clip Connectors



No. 772
 Vertical 45-volt, large
 size "B" Battery

No. 771
 Eveready "C" Battery
 Clarifies tone and
 prolongs "B" Battery life



No. 764
 Vertical 22 ¹/₂-volt
 "B" Battery

★ Tested and approved by RADIO BROADCAST ★

New Equipment

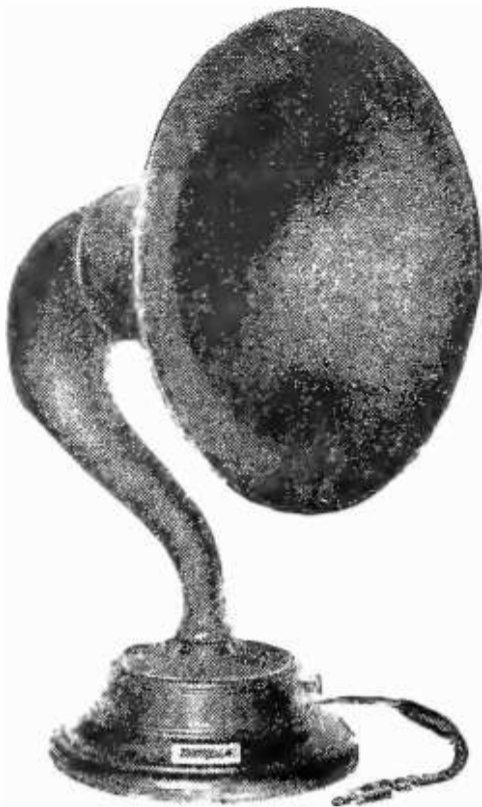

THOROLA LOUD SPEAKER

A non-power loud speaker designed by Mr. Frank Reichmann, inventor of the Thorite horn and the Thorophone loud speaker. The Thorola is very sensitive and will deliver great volume with fidelity. It uses for the first time the push-pull principle with a permanent adjustment of the diaphragm. Made by The Reichmann Company, Chicago, Illinois. Price \$25

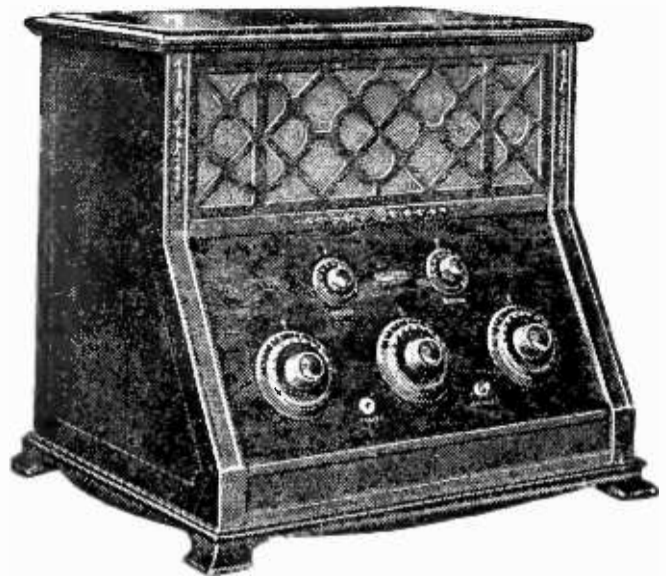

WORKRITE NEUTRODYNE

A neutrodyne receiver employing two radio-frequency, one detector, and two audio-frequency tubes. The set contains many refinements both in technical and mechanical details. One of the outstanding features of the above model, the "WorkRite Radio-King," is the built-in loud speaker. Made by The WorkRite Mfg. Co., 1810 East 30th St., Cleveland, Ohio. Price \$220

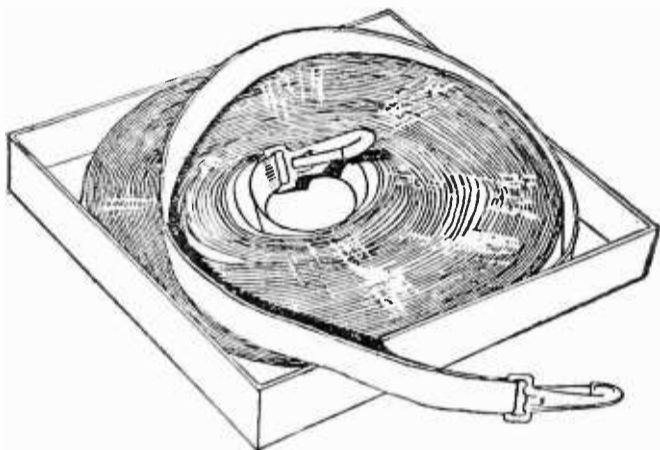

TRANSCONTINENTAL RIBBON AERIAL

A copper ribbon antenna put out in four popular lengths for broadcast reception. Made by the Acorn Radio Mfg. Co., 1806 S. Racine Ave., Chicago, Illinois



BAKER RADIO CABINET

A quality cabinet which is shipped knocked down. There are four pieces to put together requiring the insertion of but eight screws into holes already drilled. The assembled cabinet is strong and built throughout of finely finished mahogany. Made by the Baker Yacht Basin, Inc., Quincy Point, Mass. Prices range from \$4.75 to \$13.50 for cabinet sizes from 7 x 7 to 7 x 30

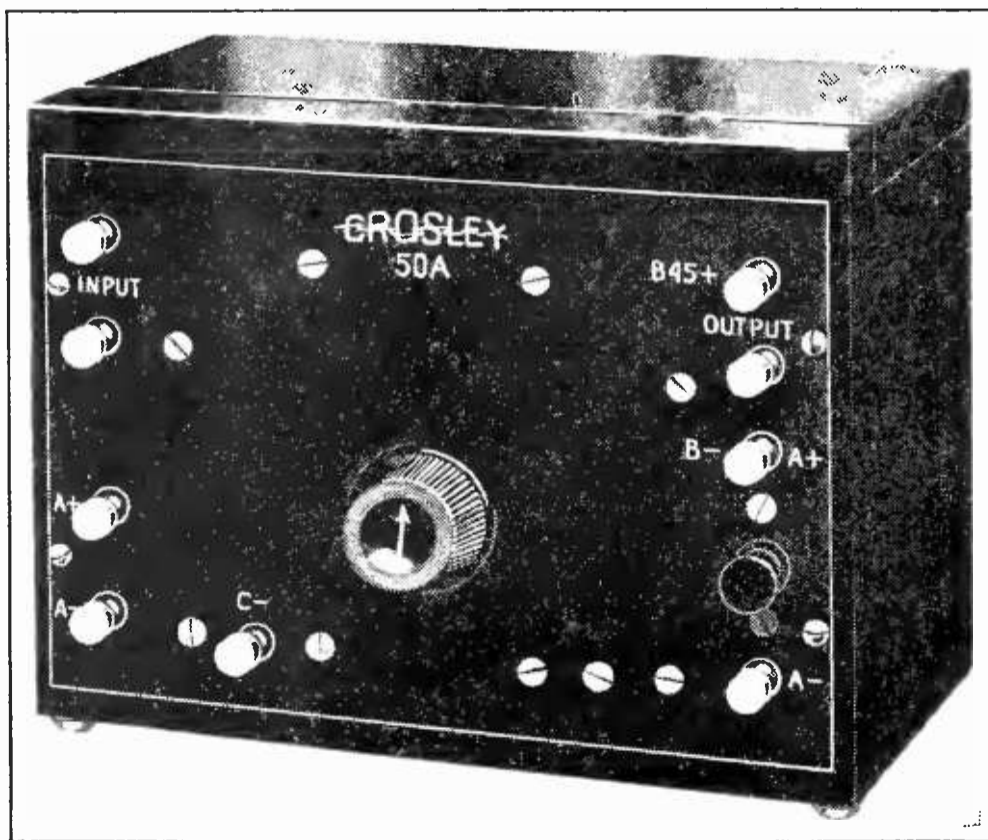

THE CROSLY AMPLIFIER

Shown here is a two stage, single rheostat controlled audio-frequency unit. This unit gives very good results when used with receivers requiring audio amplification. Made by the Crosley Radio Corp., Cincinnati, Ohio. Price \$18

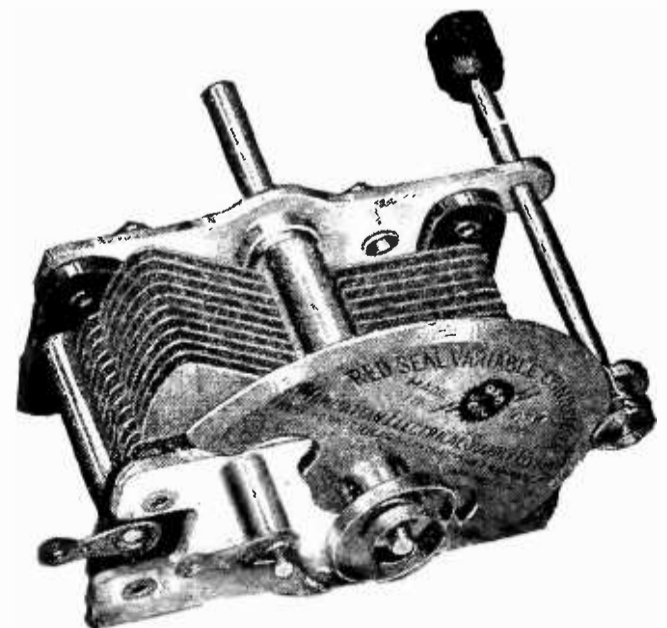

RED SEAL VARIABLE CONDENSER

A high efficiency instrument using brass plates, which are soldered to make a perfect electric joint at the plates, and "pig-tail" connections thus eliminating contact troubles. Made by the Manhattan Electrical Supply Co., Inc., 17 Park Place, New York City



FADA Radio



**FADA Neutrola Grand
No. 185/90-A**

This is the five-tube Neutrola 185-A mounted on FADA Cabinet Table 190-A. Price (less tubes, batteries, etc.) \$295.

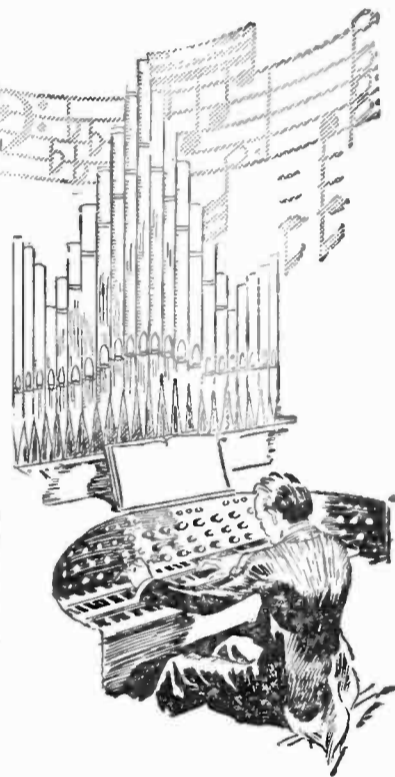
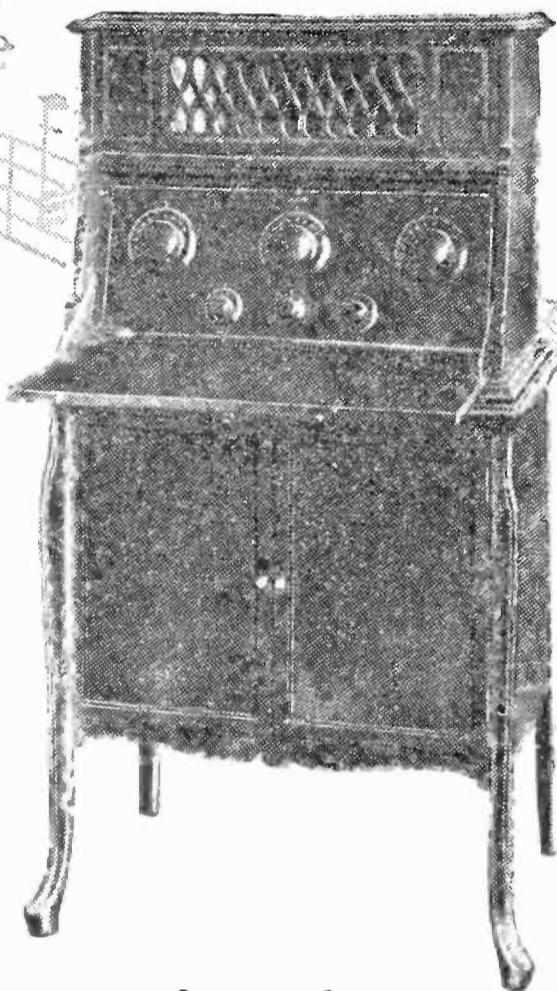

The high, sweet notes of the violin—the low, rolling bass of the organ

TONE quality—true reproduction of voice and music without distortion—is one of the outstanding features of the new FADA Neutrodyne. You hear the music just as it is played or sung.

FADA Neutrodynes can be depended upon at any time, anywhere, to give you the utmost in radio. They operate on a simple indoor or outdoor aerial and use the types of powerful tubes which give maximum results. Each bears the stamp of FADA engineering skill plus the artistry of master cabinet designers.

You who have deferred buying a radio set—waiting for someone to produce just your combination of price, performance, cabinet design and finish—need wait no longer. In the new complete line of FADA Neutrodyne receivers you can find exactly what you want.

See your dealer. He will show you a FADA Neutrodyne that will delight you—in appearance, performance and price.

You have a range from \$75 to \$295 from which to select—six models, each a remarkable value.

F. A. D. ANDREA, INC., 1581 JEROME AVENUE, NEW YORK

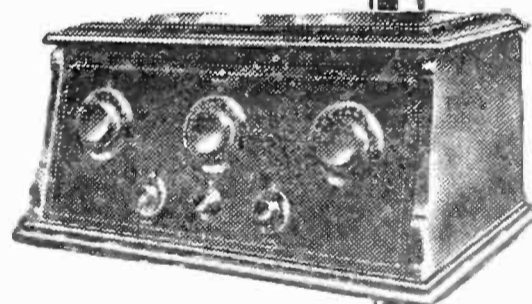

**FADA Neutroceiver
No. 175-A**

Mahogany cabinet. Inclined panel and roomy battery shelf. Five tubes. Price (less tubes, batteries, etc.) \$160.

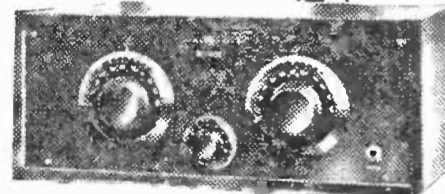

**FADA Neutro Junior
No. 195**

Three-tube Neutrodyne. A wonderful performer. Price (less tubes, batteries, etc.) \$75.



★ Tested and approved by RADIO BROADCAST ★

Among Our Authors

MYRA MAY is now in France where she is writing and traveling about. "France has French-ized all the American radio terms," she writes. "They say radio with the same 'a' as in brad, and an 'e' for the 'i.'" The French broadcasters don't run a twelve-hour-a-day show, but broadcast only during special hours. You must take your choice of what they give you, which may be anything from a lecture on roses to instruction on how to kill tigers."



MYRA MAY

CHARLES ORCHARD is associate editor of the Chesapeake and Ohio Railroad employees magazine. On reading Miss Mix's "The Listeners' Point of View" several months ago, he says that he grew interested in an angle of musical appreciation brought out by something she wrote. "Is Radio Making America Musical?" was the result.

THE PHOTOGRAPH shows McMurdo Silver wiring up one of his portable super-heterodyne receivers which he describes so ably in this number.



MCMURDO SILVER

It was taken in the RADIO BROADCAST LABORATORY at Garden City. "My life history" he says, "has been exactly like that of any other radio enthusiast. My first set used an electrolytic detector and a thread spoon tuning coil and brought in trolley car noises with very good volume—in 1912."

J. H. MORECROFT confesses that one of his favorite diversions is caring for his tribe of bees at his place in Jersey. However, we would rather mow a 3,000 foot lawn than be friendly with the bees. Professor Morecroft has just returned from a vacation and will soon resume instructing his Columbia University classes in electrical engineering.

WILLIS K. WING whose "The Case Against the Radiating Receiver" appears in this number, is a member of the editorial staff of RADIO BROADCAST. He has "sold" wireless messages in the blue-and-gold of a ship wireless operator ever since 1915. "My only claim to fame," he says, "is that I have never said 'Radio is only in its infancy.'" How odd!

THE RADIO PROGRAM directors are still making life interesting for Jennie Irene Mix, whose radio receiving studio in Toledo, Ohio is the headquarters for some of the soundest and most delightful criticism we know. "I am looking forward to some excellent and greatly improved radio programs this fall and winter," writes Miss Mix.

ZEH BOUCK, after putting his radio friends in a perfect stew of excitement and envy over his elaborately planned and advertised European vacation, disappeared from New York one day. When next heard from, he was in Atlantic City, making feeble inquiries after the inventor of the bathing suit, for what reason we won't even hazard a guess. When the cool weather of the fall comes on, radio amateurs will begin again to hear his staccato "fist" and his familiar call—2 PI.

R. ERNEST DUPUY is a captain in the Field Artillery, United States Army, now stationed at Fort Ethan Allen, Vermont. Like many of us, he started out to investigate the fascinations of radio when it was simply wireless and when one kilowatt transformers were as scarce as gold antenna wire. And again, like many of us, his interest in radio hasn't ceased. Few men could write as interesting a chapter from their experiences as Captain Dupuy has done in this issue.



CAPTAIN DUPUY

WALTER VAN. B. ROBERTS has transferred his base of operations to New York. For the time being, he has left the classic confines of his alma mater—Princeton. The next installments of this readable and helpful technical story of his are even more interesting and more helpful than those which have already been printed.

A NEW CIRCUIT DIAGRAM—READ IT!

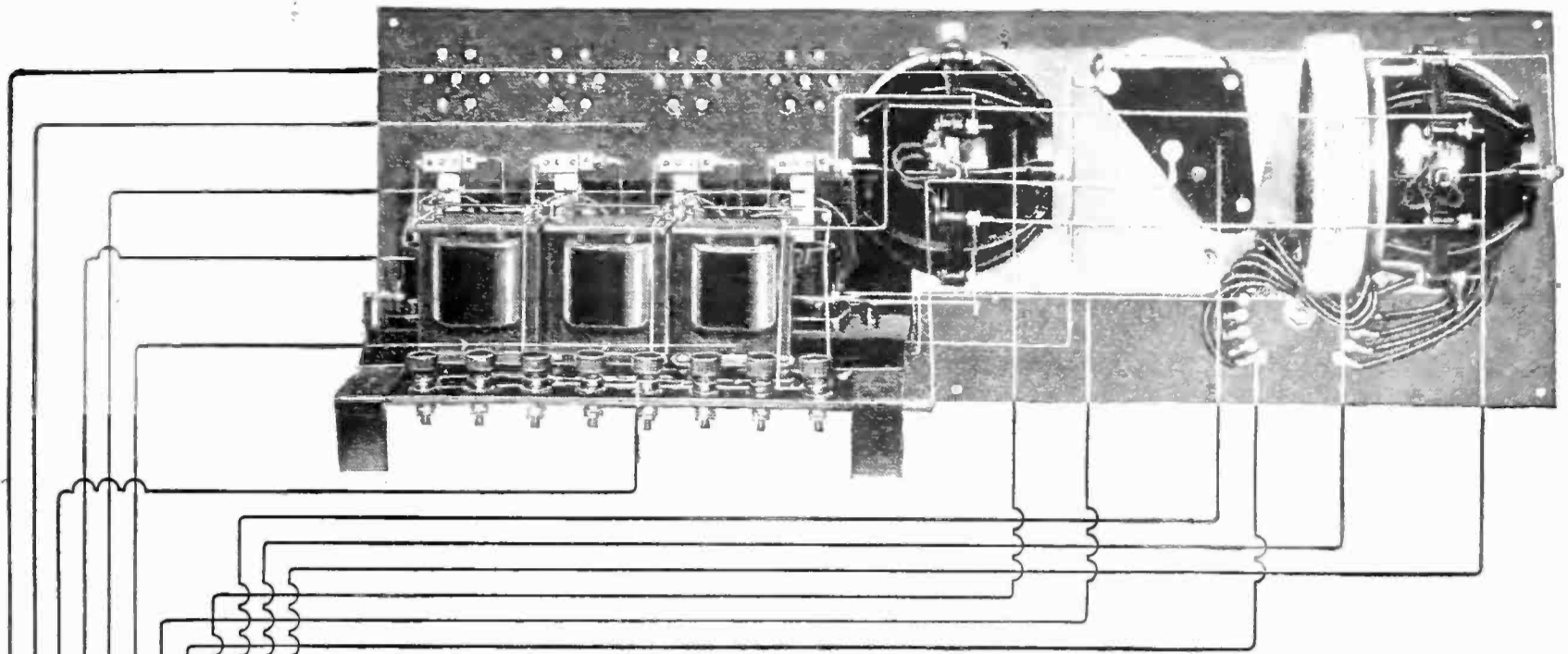

It's Not the Face of the Watch, It's the Works that Tell the Story.

1. **Variable Condenser.** Contains forty-three plates of heavy aluminum with five plate vernier for fine tuning. Mounting plates of heavy Bakelite. Ends of rotor plates bolted, preventing bending or "shorting." Large bearings make smooth easy operating.
2. **Inductance Coil.** Increases the wave range of the variocoupler to 3000 meters. Diamond wound for minimum distributed capacity. Tapped for selective tuning.
3. **Variocoupler.** Coupler shell and rotor built of solid Kellogg Bakelite, treated to avoid "distributed capacity." Many radio experts consider this the best coupler obtainable today.
4. **Variometer.** Rotor shaft accurately and permanently held in bearings. No sliding contacts. This variometer gives great added selectivity, more value.
5. **Transformers.** Designed to overcome defects of existing types and to furnish distortionless amplification of all audio frequencies. Sheet metal case heavily enameled. Primary and secondary binding posts most accessibly placed on the transformer, plainly marked.
6. **Rheostats.** Have strong, wide springs, grasping the rotor resistance on two sides with strong, positive contact. The control varies on the half turn of the coil wire on the rotor, giving vernier effect and enabling the operator to secure great selectivity, and freedom from noise and trouble.
7. **Tube Sockets.** All Bakelite. Bayonet slot reinforced with brass plate. Terminals plainly marked. Heavy springs inset into base, so they cannot touch mounting surface. With Kellogg tube sockets there is no worrying about proper connection with your lamp terminals.
8. **Binding Post Assembly.** Symphony Binding Posts connect through separate openings in the rear of the set. Each of these openings have an insulating bushing. This does away with unsightly and unnecessary wiring connections on the front panel.
9. **Bakelite Panel.** This slender, strong, highly polished panel has the equipment located upon its face in the most advantageous positions. These mountings fit most accurately drilled openings and this face equipment is a model of proper radio assembly.
10. **Aluminum Shielding.** One who has not operated a radio set cannot appreciate the importance of careful shielding and grounding. Symphony shielding is pure aluminum and ample size, correctly drilled.
11. **Circuit.** The circuit of the Symphony is controlled by the apparatus above described, and mechanically wired as indicated, produces receiving of the highest order.
12. **Contact Points.** Heavy, silver plated for minimum resistance, an instance of the fine and all important attention to details that makes for successful radio receiving.

In addition to the important, accurate and successful units pictured above, there are also the other Kellogg radio parts to complete this most efficient circuit

Jones RADIO Company

1066 W. Adams Street, Chicago, Ill.

The Symphony is manufactured under the U. S. Patent No. 1113149, Armstrong Regenerative Circuit
All parts used in the Symphony are built and guaranteed by the Kellogg Switchboard & Supply Company, manufacturers for twenty-five years of complete telephone equipment

Mr. Radio Fan,
 If your dealer does not carry Symphony receivers, send us his address. We will send you our illustrated Symphony catalog by return mail.

★
Mr. Dealer:
 Write for our bulletins and discount sheet. The Symphony will increase your profits.

★ Tested and approved by RADIO BROADCAST ★

SUPER-HET

The World's Best

By Performance

ADVANTAGES—

1. UNIFORM EFFICIENCY over the entire wavelength range of 160 to 850 meters. This means that all stations, Radiophone Broadcasting, Amateur and Commercial within this wavelength range, will be received with maximum intensity. This very desirable feature is not obtainable by any other practical method using Radio Frequency amplification.

2. SELECTIVITY by this system, greatly exceeds that obtained in all other methods of reception. Using the Model "C" with a loop in the Suburbs of New York, WOR 15 miles distant, operating on 405 meters, can be completely eliminated, and PWX 1300 miles distant, operating on 400, can be received on a loud speaker. This holds true on an average cool night. There is no telegraphic interference from 200 meter amateur stations or 600 meter ship stations.

3. SIMPLICITY to change from one station to another, there are only two dials to vary. The two dials can be calibrated for all the various stations, as there is only one best position for each station.

4. AMPLIFICATION is much greater than obtainable in any other standard receiver. Total is as follows: 1st the Heterodyne Amplification in the 1st Detector; 2nd, the Regenerative Amplification in the 1st Detector; 3rd, the 3 stages of Tuned Regenerative Radio Frequency Amplification, working at a low advantageous frequency; 4th, the second Detector action, and 5th, the two stages of low ratio distortionless audio frequency amplification.

5. RECEIVING RANGE other factors correct, the receiving range is in proportion to the effective radio frequency amplification applied. As this receiver has much greater effective radio frequency amplification than all others, the range is proportionally greater.

Complete Constructional Blue Prints Consisting of Two Sheets 50x21"

Experimenters Information Service,



WRITE FOR

★ Tested and approved by RADIO BROADCAST ★

RODYNE

Radio Receiver

NO OTHER RECEIVER
CAN EQUAL

“THE ROLLS-ROYCE OF RECEPTION”

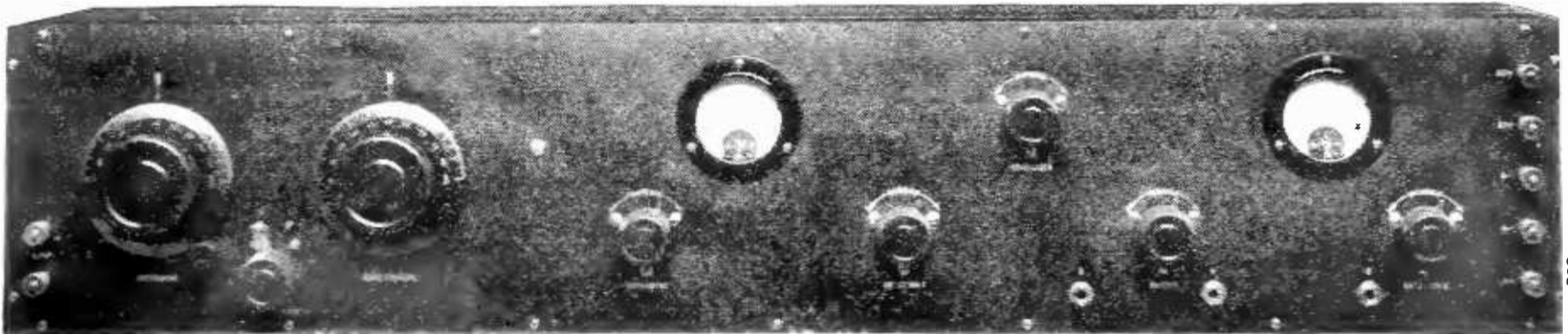

MODEL "C" SUPER-HETERODYNE

Wavelength Range 160 to 850 meters. Tubes, 2 Detectors, Oscillator, 3 Tuned Radio Frequency Amplifiers, 2 Audio Amplifiers

The Super-Heterodyne is the most efficient method of short wave radio frequency amplification known. It is used extensively by the Commercial radio companies and various governments, when it is necessary to receive over extremely long distances without interference from near-by stations.

The remarkable results are due to the Super-Heterodyne action, which is briefly as follows: the incoming signal, which may be any wave from 160 to 850, is changed through the use of a local oscillator, to a wavelength of 10,000 meters. At this wavelength an exact duplicate of the original signal is amplified at radio frequency with the very highest efficiency possible, rectified and amplified at audio frequency.

During this change a very high degree of selectivity is secured, due to the amplifier, which is designed to pass nothing but 10,000 meters. Accordingly while there may be ten or more signals in the loop, only one will be received at a time, the one that the oscillator heterodynes through the amplifier.

and Two Sheets 27x21", Our Numbers 30141-145. \$2.00 Postpaid

Designers of the Highest Class Radio Apparatus in the World

476 Broadway

NEW YORK CITY

CATALOGUE No. 64.

★ Tested and approved by RADIO BROADCAST ★

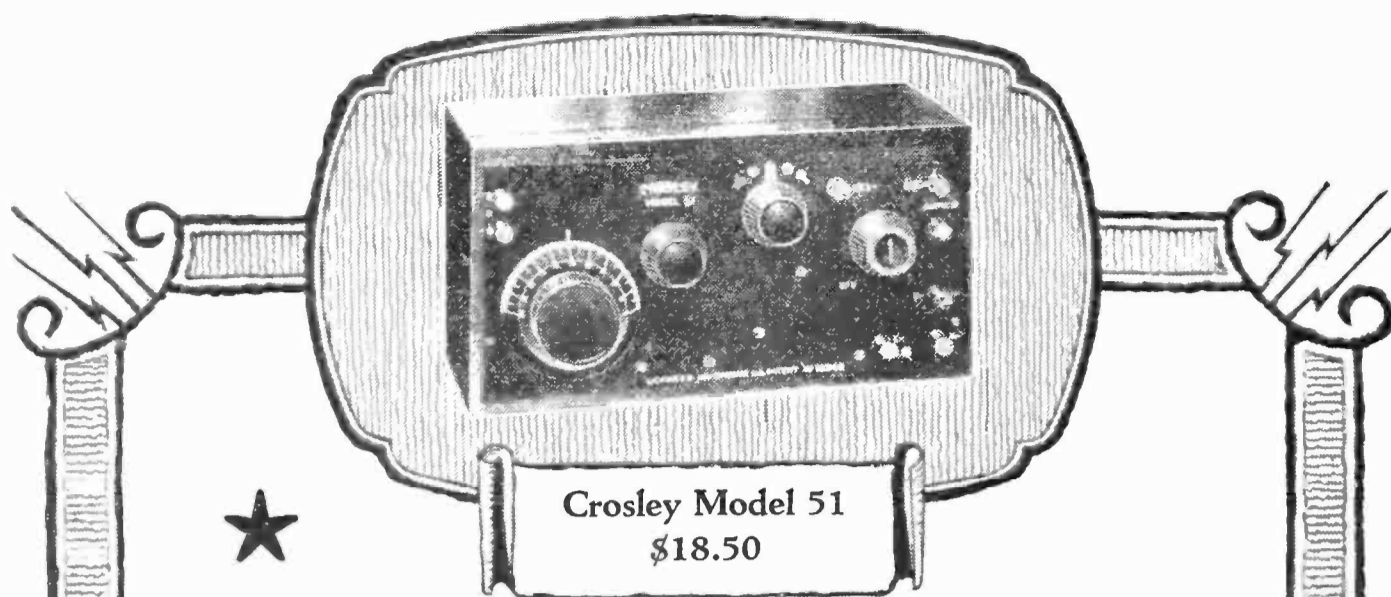

Crosley Model 51
\$18.50

A Crosley For Everyone

Priced Exceptionally Low

IT IS our ambition that everyone in the United States be enabled to enjoy the innumerable pleasures and benefits that radio provides. We have, therefore, produced in the Crosley line such an extensive assortment of Radio Receivers, at prices so reasonable, as to bring them within reach of all.

Our newest receiver the Crosley Model 51, a two tube Armstrong Regenerative set, illustrated above is indeed a triumph in radio engineering. Although it consists of detector and one stage of audio frequency amplification, it sells at the very low price of \$18.50.



CROSLY
TYPE 3-C

Crosley Type 3-C—\$110.00

A beautiful Console Model of Mahogany, adding greatly to the interior decoration of any home. It is an Armstrong Regenerative set containing the same units as the Crosley Type 3-B with the addition of a built-in loud speaker. Licensed under Armstrong U. S. Patent No. 1,113,149. Space is provided in the cabinet for housing the necessary batteries. A special mahogany stand for the Type 3-C may be had for \$25 extra.

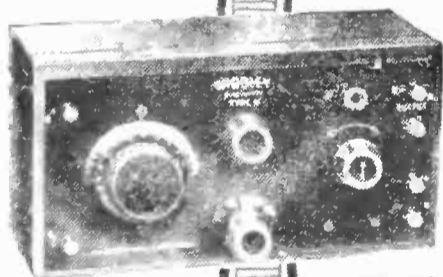

CROSLY
TYPE V

Crosley Type V—\$16.00

A one tube regenerative set, licensed under the Armstrong U. S. Patent No. 1,113,149. Actual performances of this little receiver have proven a revelation to the radio world. The Mc-Millan expedition has consistently been clearly brought in with this instrument as well as Honolulu and other far distant points.

Crosley instruments are sold by best dealers everywhere. Write for complete catalogue of Crosley receivers and parts

The Crosley Radio Corporation

POWEL CROSLY, Jr., President

Formerly

The Precision Equipment Company and Crosley Manufacturing Company

520 Alfred Street

Cincinnati, Ohio

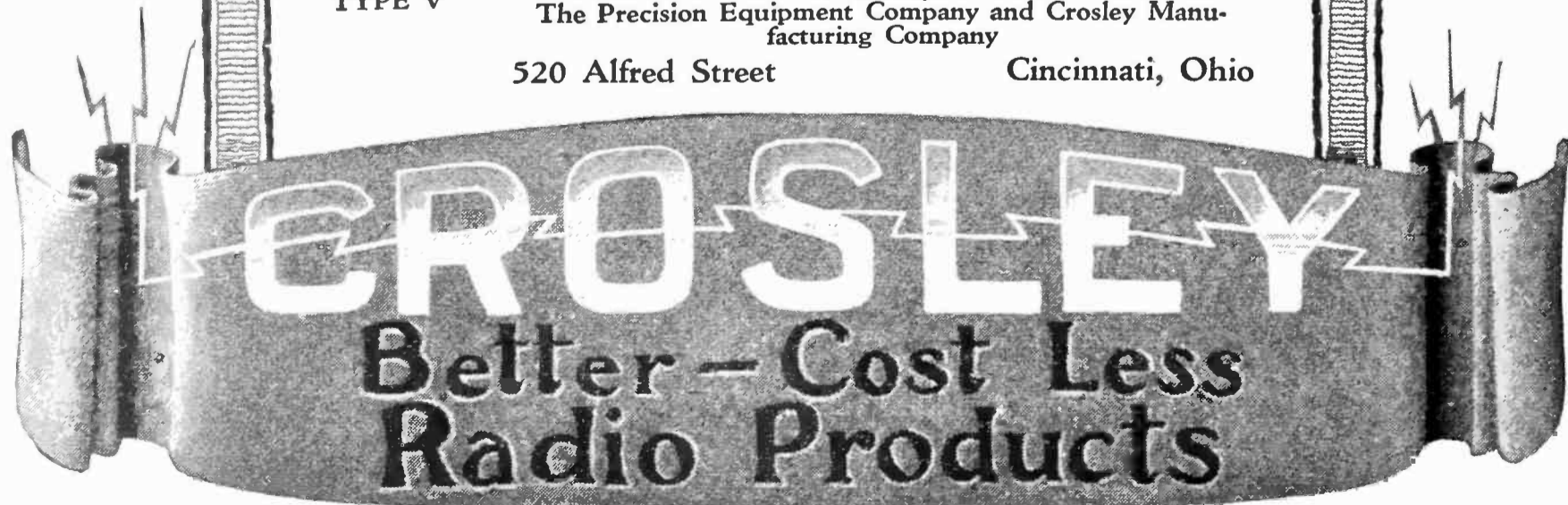

★ Tested and approved by RADIO BROADCAST ★

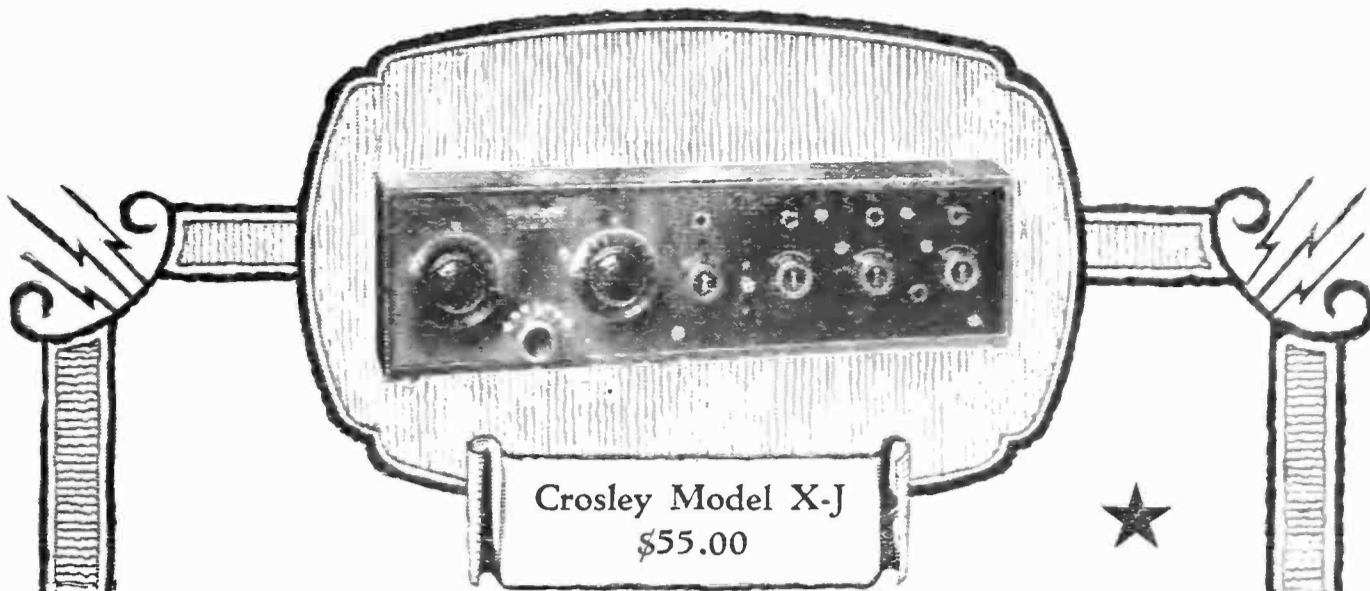

The Famous Crosley Model X-J

A Long Distance Receiver

PROBABLY the greatest single feature of this Crosley Model X-J receiver is its remarkable selectivity. It will tune through powerful local broadcasting stations and bring in distant stations clearly and with great volume. It is the most popular receiver in America to-day, we believe.

A four tube radio frequency set combining one stage of Tuned Radio Frequency Amplification, a Detector and two stages of Audio Frequency Amplification. A jack to plug in on three tubes for head phones, the four tubes being otherwise connected for loud speaker.

Crosley Type 3-B—\$42.00

This three tube regenerative receiver licensed under Armstrong U. S. Patent No. 1,113,149 combines the Crosley Type V, single tube receiver, and the Crosley two stage amplifier. In the hands of amateurs and professionals alike it has consistently out-performed sets costing a great deal more. A person hearing a broadcasting station may turn off the set by throwing switch and come back later without re-tuning.

Crosley Model VI—\$24.00

A two tube medium range receiver of exceptional merit. Consists of one stage of tuned radio frequency amplification and detector. The one stage of tuned radio frequency amplification not only amplifies the signal before it reaches the detector, enabling the detector to work more efficiently, but it also eliminates interference to a wonderful degree.

Crosley instruments are sold by best dealers everywhere. Write for complete catalogue of Crosley receivers and parts

The Crosley Radio Corporation

POWEL CROSLY, Jr., President

Formerly

The Precision Equipment Company and Crosley Manufacturing Company

520 Alfred Street

Cincinnati, Ohio

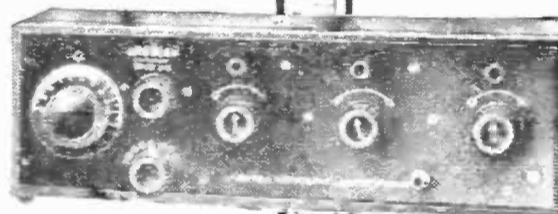

CROSLY
TYPE 3-B

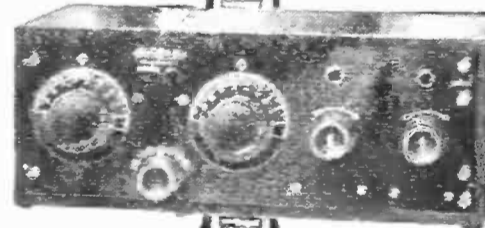

CROSLY
MODEL VI



★ Tested and approved by RADIO BROADCAST ★

"Cash In" On These Amazing

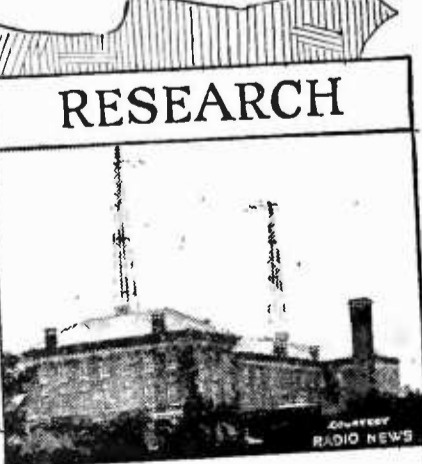
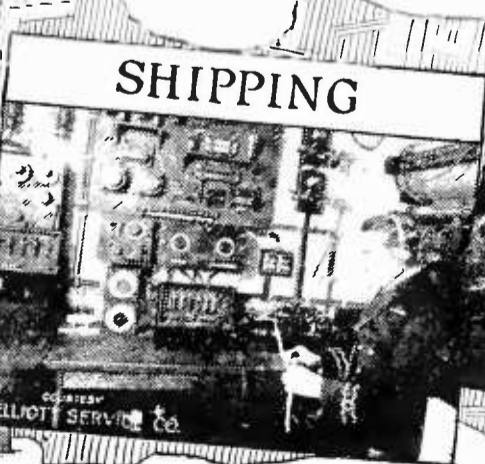
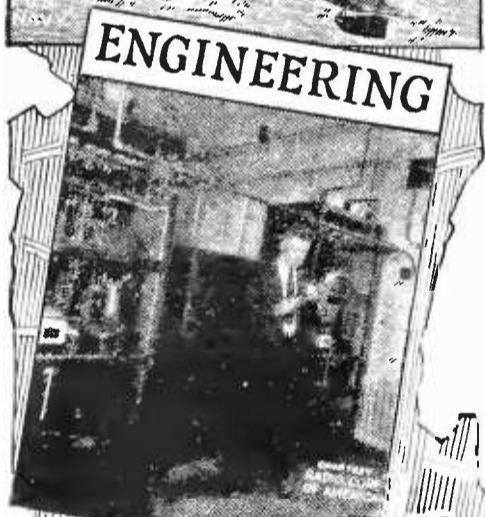
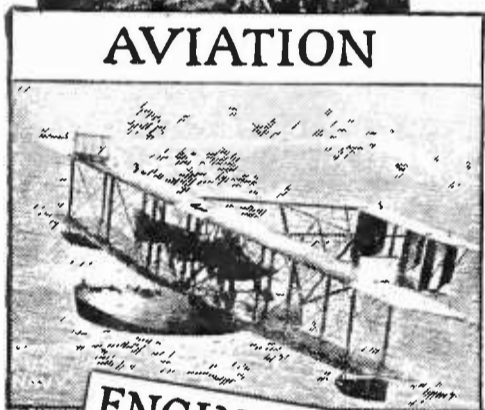

You readers of RADIO BROADCAST—you who are interested in Radio, and also interested in unusual money-making opportunities—let me send you, without the slightest cost or obligation, my new, interesting Free Book, "Rich Rewards in Radio"—a book which contains **positive proof** of the astounding opportunities in this great new industry and tells exactly how **you** can get your share of big money from it.

The pictures on this page give only the smallest indication of the scope of Radio to-day. Mail the coupon on the next page for my Free Book which gives full facts on Radio and what it can mean to you.

Earn \$75 to Over \$200 a week

You're interested in Radio—why not turn your interest into profit? Why not make big money in work you enjoy? No field to-day is growing so rapidly. No business offers such a rare variety of opportunities. Radio is a new, billion dollar industry in which thousands have already made far more money than they ever dreamed possible.

Radio can take **you** out of the rut of bare existence—into an enviable field of high salaried specialists. It can offer you unlimited opportunities for honor, wealth, power and satisfaction. It means a future filled with boundless promise!

Recognized Radio Experts In Urgent Demand

Readers of RADIO BROADCAST know in part the story of how Radio has jumped forward with leaps and bounds. You know there are broadcasting stations all over the country—that radio is used on every ship—that it is used by newspapers, government departments, business houses, banks, railroads, factories and stores. Every day, some new use for Radio is announced. And this wonderful expansion of Radio has opened up hundreds of splendid positions on land and sea—positions which you can qualify for within a few months!

New Opportunities in RADIO!

There's **big money** in this wonderful new field for you. No matter what you are doing—no matter what experience you've had, you can step in and get your share of the astonishing rewards of Radio. Big salaries, fascinating, easy work, short hours, and a wonderful future—no other field of endeavor can offer anything to compare with what Radio can mean to the men who get into this work now.

Make Radio your career. Become a radio expert now!

How We Place Graduates In Fine Radio Positions

Not a week goes by without our receiving urgent calls for our graduates. "We need the services of a competent Radio Engineer," writes a prominent radio firm. "Would appreciate your recommending any person who could fill position." "We want men with executive ability as well as radio knowledge to become our local managers," writes another firm. "We will require the services of several resident demonstrators," writes still another—and these are just a few small indications of the great variety of splendid opportunities open to our graduates!

Easy Now to Learn at Home

No previous training in electricity or radio is necessary. During your spare time at home, within an amazingly short time, you can get your National Radio Institute diploma, which is government recognized and accepted as part credit on your government license. To make the training more practical, circuits and parts for building latest receiving sets are now included **FREE** with the course.

Send for FREE BOOK

You have nothing to lose—and everything to gain. No matter what your plans for the future are—mail the coupon now for this new Free Book which tells all about the wonderful opportunities in Radio. Let it point the way to success and happiness for you. Don't delay. Mail the coupon **now**. National Radio Institute, Dept. 31EA, Washington, D. C.



E. R. Haas,
Director,
NATIONAL
RADIO
INSTITUTE
Founded 1914

I Can Qualify You as a Radio Expert in a Few Months

If you want to earn far more money than you are earning now—if you want to be your own boss—if you want a profitable business of your own—if you want to travel the world over—if you want a field of endeavor where the opportunities are unlimited—make **RADIO** your profession.

Hundreds of my students write enthusiastically of my training—and tell how it has helped them. Merle Wetzel now is making three times what he did before taking my training. Emmett Welch started at \$300 a month after graduating. Scores of others tell similar stories. Send for my Free Book which tells of the great opening in Radio, what my students are doing—what you can do. No obligation. Mail the coupon **now**.

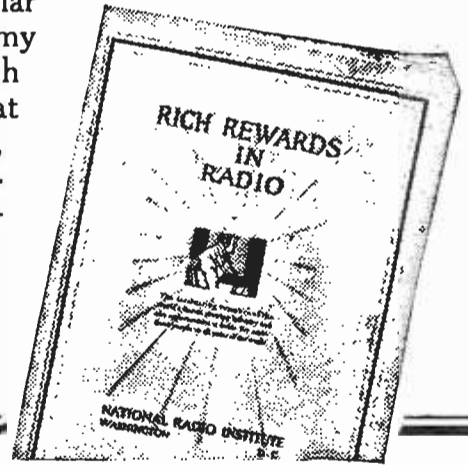

E. R. Haas, *Director*
National Radio Institute,
Dept. 31 EA, Washington, D. C.

Without any obligation on my part, please send me a **FREE** copy of your book, "Rich Rewards in Radio." Also tell me how your Free Employment Service will help me secure a position, and send me details of your special short time offer. (Please write plainly.)

Name.....Age.....

Address.....Occupation.....

City.....State.....

(Copyright of Photo)

"The Best That Money Can Buy"

"GOLD SEAL" HEADSETS

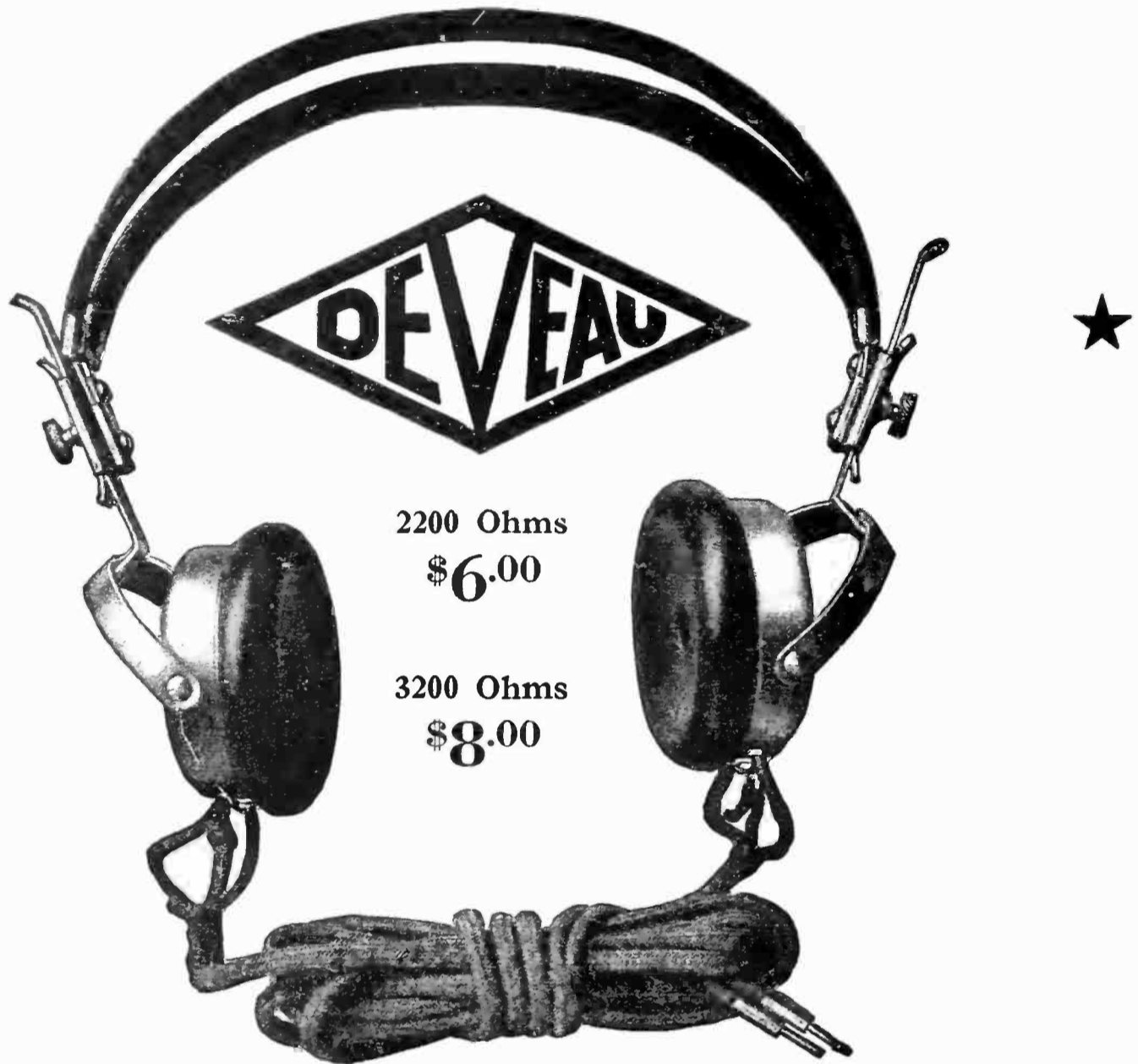

2200 Ohms

\$6.00

3200 Ohms

\$8.00

"GOLD SEAL" HEAD SETS are electrically and mechanically,—as well as from a radio standpoint,—as perfect as the highest-priced Head Set on the market,—yet, with all their perfection, they retail at only \$6.00 for 2200 Ohm and \$8.00 for 3200 Ohm.

The trade mark "DEVEAU" has stood for the highest quality in telephone apparatus for thirty years,—a guarantee that every known advantage in design and manufacturing has been taken into careful consideration.

Magnets are extra-heavy one-piece units; cups are of aluminum to keep down the weight but unlike other Head Sets, every exposed metal part of the set is finished in genuine 24-karat gold,—under a protective lacquer so that the finish will last for years; the terminals of each unit are concealed,—no contact possible with users' hands.

"DEVEAU GOLD SEAL" HEAD SETS are like a piece of fine jewelry in appearance, but with all the radio niceties that the most advanced radio enthusiast can desire. DEVEAU Units exactly match each other in tone,—each has maximum sensitivity and perfection of tone quality.

"DEVEAU GOLD SEAL" HEAD SETS are guaranteed to be electrically and mechanically perfect,—our Guarantee protects every purchaser.

STANLEY & PATTERSON 27 WARREN STREET
 23 MURRAY STREET
 NEW YORK CITY, U. S. A.

★ Tested and approved by RADIO BROADCAST ★

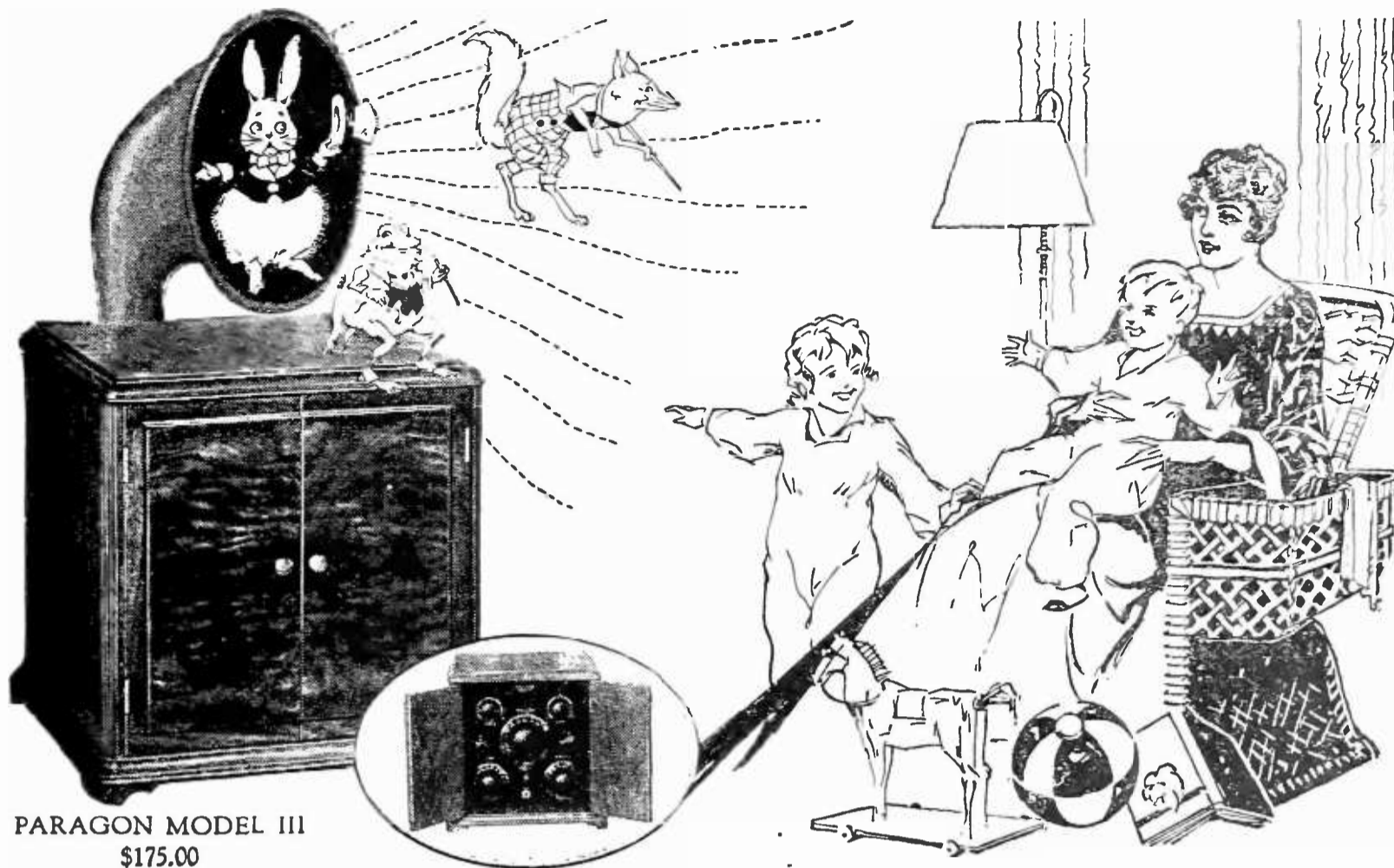

PARAGON MODEL III
\$175.00

“IT WAS PETER RABBIT—”

“... and all dressed up in his new suit to go on the journey with Reddy Fox”, comes the voice over the radio. The children sit spellbound. Mother, thankful for this few minutes' rest every evening, closes her eyes and leans back in her chair. Now the radio will take care of the children—she needn't worry.

Paragon Receivers are rich in tone value. Music, from the crash of a chord to the sob of a saxophone, is reproduced clearly just as it is played.

Voices are distinct and understandable. Static noises are reduced to the absolute minimum.

Because of Paragon selectivity and sensitivity you can tune in on and get any station you want, and hear the program without interruption or jamming from other stations.

The Paragon Model III comes in a finely finished mahogany or burled walnut cabinet which is an addition to any home. This instrument offers you the ultimate in radio enjoyment.



Write for illustrated Bulletins of Paragon Radio Receivers

ADAMS-MORGAN CO.

10 Alvin Avenue, Upper Montclair, N. J.

PARAGON

Reg. U.S. Pat. Off.

3-CIRCUIT RECEIVER

★ Tested and approved by RADIO BROADCAST ★

Read These Letters:

"Here is a list of stations received with a knock-out one-tube set, using a 301-A bulb, the night of Feb. 9th, 9 P. M. to 2 A. M.:

"PWX, WOR, WTAM, WGY, WOO, WTAV, CKAC, WJAZ, WRC, WOAW, WDAP, KYW, WFAA, WSB, WDAF, CFCN, WGR, WPAL, KFKB, KPO, KFI.

"I built this set according to plans published in the November RADIO BROADCAST. I use an adjustable crystal detector, a Bradleystat, and a vernier condenser on transformer T-1. This set is hard to beat."

A. J. HAMMERLE, 1426 Christy Ave., Louisville, Ky.

"I have written you several times about my two-tube reflex outfit which was published by you in the December issue of RADIO BROADCAST. The set is now working very much to my satisfaction, thanks to you. So far, I have received programs very clear from 35 stations; some 1,500 miles distant."

HOWARD F. ACTON, 43 Couch St., So. Norwalk, Conn.

"I think so much of the knock-out with the two steps of audio that I couldn't resist writing to you. I have built this little wonder from infancy, beginning with the one-tube reflex, then the one step, then the two-stepper. At this writing I am listening to Davenport (WOC) with grave fear of waking my little girl sleeping upstairs. I am twelve miles from Buffalo and it comes in so loud it can be heard 500 ft. away from the house, with doors closed.

"Thinking you would be interested in knowing what results were being obtained by your readers I have written you. I've tried all kinds of sets but this is the baby for me. With the greatest respect to the RADIO BROADCAST, I remain"

GEORGE STAGGERS, Snyder, N. Y.

They are but three among hundreds.

RADIO BROADCAST's knock-out receivers, designed and built in our own laboratories under the personal direction of Arthur H. Lynch has scored a real knock-out.

The first edition of the Knock-Out series was sold out in less than ten days. The second edition is now ready—more data, more photographs, more types of receivers.

Build a Knock-out Set Yourself

Everything you need to know to build a one-, two-, or three-tube knock-out receiver (not a "blooper" in the lot) and made all from parts you may secure at the nearest radio store, is contained in this book.

Here, for the first time, is bullet-proof armor to protect you against the stray shots of "trick circuits." The price is fifty cents. If you don't think the booklet is worth it, return it and we will return your money.

RADIO BROADCAST

Doubleday, Page & Co.

Garden City, N. Y.

I enclose 50 cents in payment for a copy of RADIO BROADCAST'S Knock-Out Series to be sent to

For Better Radio Reception—

Freshman Products

GUARANTEED to be mechanically perfect, scientifically accurate and built for unusual durability. Used by discriminating manufacturers and amateurs all over the world, who realize that a radio set is only as good as each individual part.

The Standard Unit for Every Tube Set

FRESHMAN

VARIABLE GRID LEAK and CONDENSER COMBINED



Permits you to adjust your circuit to any resistance you wish from zero to 10 megohms, in an unbroken range of 180 degrees.

It takes the place of a grid condenser, grid leak mounting and grid leak, and in addition permits an adjustment to the correct amount of resistance. It is the most compact, the most efficient, the most adaptable to all grid circuits, and the only one which is entirely sealed and always remains unaffected by any climatic conditions.

Base or Panel Type complete with .00025 or .0005 Freshman Condenser, \$1.00. Either Type without condenser, \$.75

"FRESHMAN" SELECTIVE

Variable Condenser

For Transmission or Reception

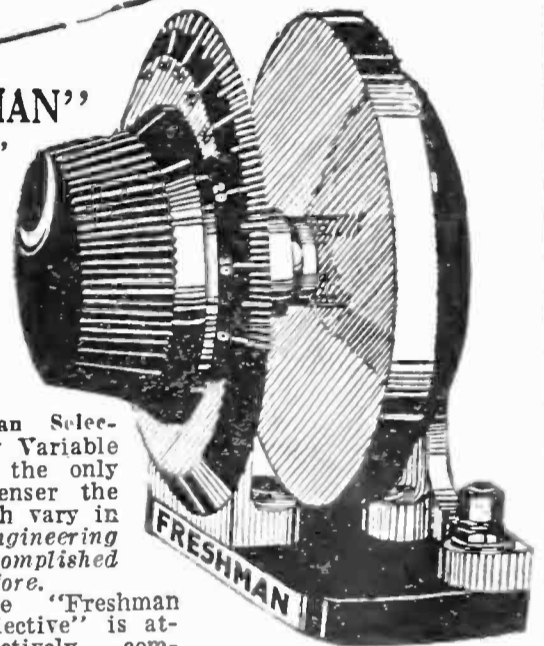

The "Freshman Selective" Mercury Variable Condenser is the only variable condenser the plates of which vary in area, an engineering feat never accomplished before.

The "Freshman Selective" is attractively compact quiet in operation and will withstand 8,000 volts without leakage or danger of short-circuiting.

.0003 MF (Equiv. to 17 pl.) } \$5
 .0005 MF (Equiv. to 23 pl.) }
 .001 MF (Equiv. to 43 pl.) } Each

All molded parts and dial of finest Bakelite.



Double Adjustable Freshman Crystal Detector

for base or panel mounting. When mounted on panel only the knob shows on the front. No more searching for the sensitive spot. Merely turn the knob as you would a dial, thus adjusting the crystal instead of the cats-whisker. Best for both Reflex and Crystal sets. Price.....\$1.50

Guaranteed Capacities

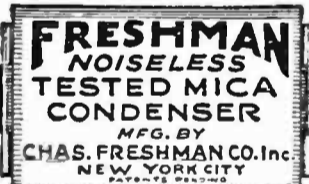

The Condenser Sensation of Modern Radio FRESHMAN NOISELESS TESTED MICA CONDENSER

Every Condenser is individually tested on high voltage for capacity, break-down and leakage. Every piece of Mica embodied in the Condenser is individually tested and examined. The new Style No. 101 is equipped with Freshman Soldering Terminals which allow 3 distinct connections with a very small amount of solder.

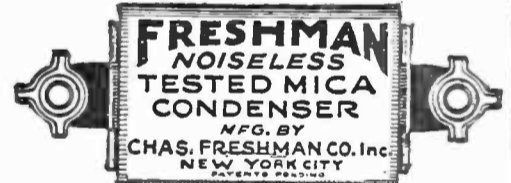

Capacity	Each	Capacity	Each	Capacity	Each	Capacity	Each
.00005	\$.35	.0003	.35	.001	\$.40	.0035	\$.70
.0001	.35	.00035	.35	.0015	.40	.004	.75
.00015	.35	.0005	.35	.002	.40	.005	.75
.0002	.35	.0006	.40	.0025	.50	.006	.75
.00025	.35	.0008	.40	.003	.60	.007	1.00
						.008	\$1.00
						.009	1.00
						.01	1.00
						.015	1.50

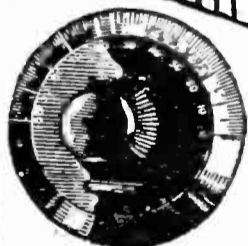

FRESHMAN Vernier Dial

A Bakelite dial with Vernier adjustment. A small rubber tired wheel through the slot in the dial permits you to set the dial to the exact point and obtain the same dial setting every time. Just the thing for Neutrodyne and Heterodyne. Price, 4 in., \$1.50 Price, 3 in., \$1

At your dealer's. Otherwise send purchase price and you will be supplied postpaid.

ANTENELLA NO OUTSIDE WIRES NEEDED

attached to any lighting socket, eliminates the inconveniences in radio, such as unsightly outdoor aerials, insulators, lightning arresters, lead-ins, etc.

ANTENELLA It is not only a real distance getter, but also overcomes static annoyances. The complete and efficient aerial.



ANTENELLA Price Only \$1.25

FRESHMAN FIX-O A fixed Grid Leak Combination, 4 in 1



Freshman Condenser Leak Mountings Freshman Grid Leak Safe-T Handle All Megohms from 1-20 to 10 megohms. Price 65c.

Write for free diagrams of Neutrodyne, Tri Flex and Super Heterodyne Circuits.

Chas. Freshman Co. Inc. Radio Condenser Products

106 Seventh Avenue New York City

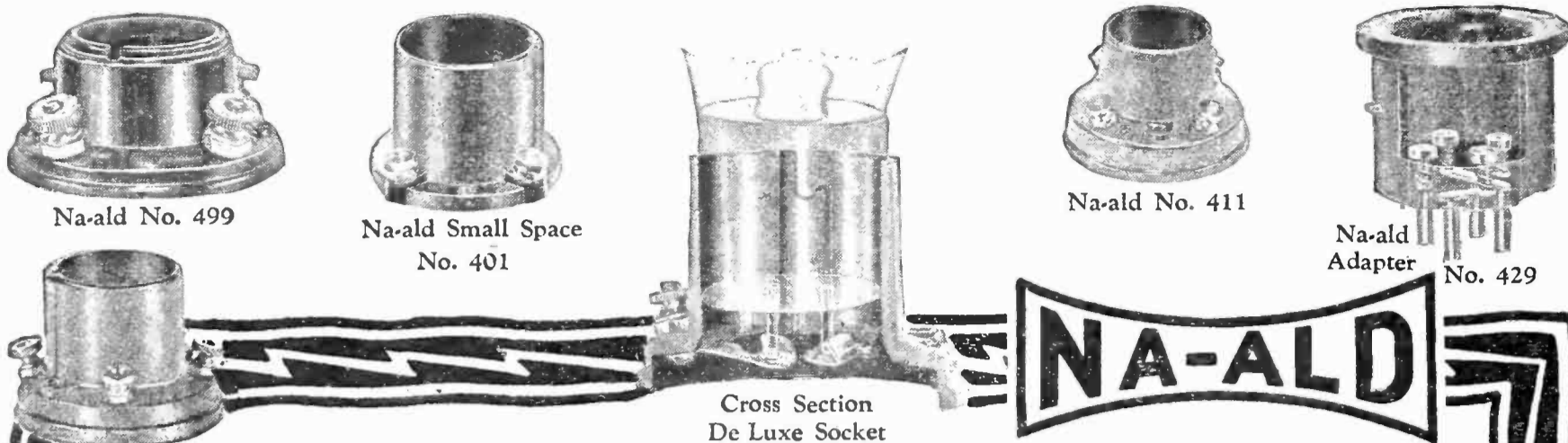

Na-ald De Luxe No. 400

IT'S THE CONTACT THAT COUNTS ★

NA-ALD SOCKETS

For 200 Tubes
 No. 400, Price 75c
 No. 401, Price 35c
 3 for \$1.00

For U. V. 199
 No. 499, Price 50c
 No. 429, Price 75c

For W. D. 11
 No. 411, Price 75c

The best radio engineering practice of to-day calls for the elimination of as much material as possible in the neighborhood of those parts of the set which carry the radio frequency current. This applies not only to metallic substances, but to insulating materials as well.

Na-ald Sockets provide for this by having uniform walls of Bakelite, giving the material its highest di-electric properties.

"Frying" noises, often attributed to B batteries, are in reality caused by poor connection. Na-ald De Luxe contacts not only press on the bottom of tube terminals but cut into the sides, automatically making a bright, perfect connection. *De Luxe is the standard for Neutrodyne and Superhetrodyne Sets.*

Send cover of Na-ald dial or socket carton or 15c for new 16 page rotogravure booklet "What to Build."

ALDEN MANUFACTURING CO. Dept. B, 52 Willow St., Springfield, Mass.

Tested and listed as standard by underwriters' laboratories

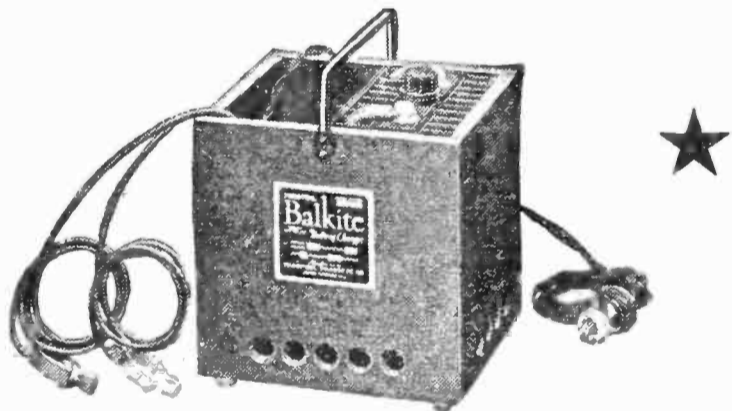

FANSTEEL Balkite PATENTS APPLIED FOR Battery Charger

Noiseless and Indestructible

A new battery charger for Radio "A" (6 volt) batteries. Entirely noiseless. Has no moving parts, requires no attention or adjustment, and cannot get out of order. No bulbs to break. Simple and unfailling in action. Can be used while the radio set is in operation. A positive economical charger for home use. Can also be used to charge "B" and automobile batteries. If your dealer can't supply you, sent direct on receipt of price. Money back guarantee.

Price \$19.50 (\$20 West of Rockies)

Dept. C5 Fansteel Products Co., Inc.
 North Chicago, Illinois



A 2c. Stamp—
 Brings this Loop on Trial

COMPARE reception on your present aerial with reception on this new IMPROVED Loop—at our expense! Put our claims of selectivity, directional capacity, sensitivity to the test on your set in your own home. 10 days in which to make every conceivable experiment. 10 days to find out all about this loop before you buy it. Unless it entirely satisfies, you may return it or have your money promptly refunded. Select your type and send C. O. D. Order NOW!

- Type A-737 (300-700 meters) 6 inches square—non-directional..... \$10
- Type A-7236 (175-1000 meters) 6 inches square—non-directional.. \$12
- Type B-2537 (300-700 meters) 18 inches square—directional..... \$20
- Type BL-2520 (200-18,000 meters) with honeycomb coil mounting.
 18 inches square—directional..... \$25

SEND FOR BULLETIN X-102

V-DE-CO RADIO MFG. CO., Dept. B, ASBURY PARK, N. J.

★ Tested and approved by RADIO BROADCAST ★

BRISTOL SINGLE CONTROL RADIO RECEIVER



Most Simple to Operate

The set for those who want results with little effort. Anyone in the family can quickly learn to operate it because technicalities and guesswork are eliminated—One Control Dial does it all.

Does Not Interfere With Your Neighbor

Other close by reception is not disturbed when you tune in with this non-reradiating Receiving Set. It gives you a comfortable sensation of freedom to be able to change from one station to another, knowing that you will not interfere with your neighbor's receiving.

Choice of Aerial or Loop

Where conditions make it difficult to install an outside aerial, as in congested sections of cities, good results can usually be had by using inside Loop. In fact, the directional feature of the Loop often brings in stations not possible with a stationary aerial.

Mounted in solid mahogany case with walnut finish, the Bristol Single Control Radio Receiver is handsome in appearance. The price is \$190.00. Bulletin AH-3013 describing this set will be mailed on request.

BRISTOL

TRADE MARK
AUDIOPHONE
REG. U. S. PAT. OFFICE



Loud Speaker

This is known everywhere as the Loud Speaker with the quality tone. Not only is the tone natural and without mechanical distortion, but is sufficiently big in volume to be easily heard in a large room or all through the house. Comes to you ready to use—no auxiliary batteries are required.

Made in three models:

Audiophone Senior.....	Price, \$30.00
Audiophone Junior.....	Price, 22.50
Baby Audiophone.....	Price, 12.50



THE BRISTOL COMPANY, Waterbury, Conn.

★ Tested and approved by RADIO BROADCAST ★

DUPLX

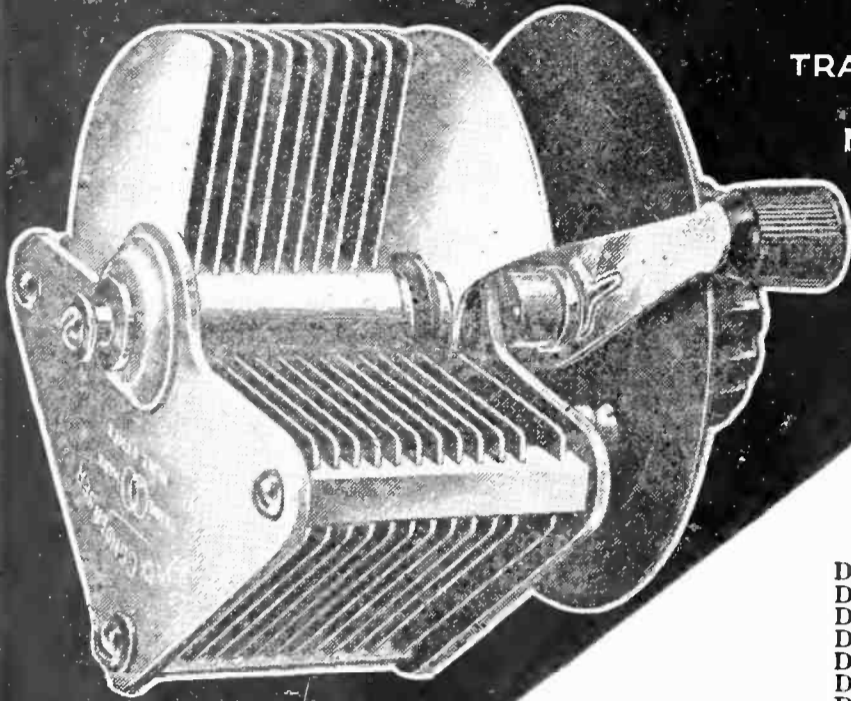

TRADE MARK
NONE OTHER

COMPACT PRECISION CONDENSER

Knob and Lever Control

Maximum-Minimum Ratio of 23 Plate Vernier 60 to 1.

Die-Cast Rotor—Milled End Posts.

SPECIFICATIONS OF ALL MODELS

Model	Total No. of Plates	Max. Cap. Mfds.	Min. Cap. Mfds.	Ratio Max.—Min.	List Price
DR-3	3	.00005	.00001	5—1	\$1.00
DR-11	11	.00024	.00001	24—1	2.00
DR-11V (Vernier)	14	.00029	.00001	29—1	2.50
DR-13	13	.00029	.00001	29—1	2.25
DR-13V (Vernier)	16	.00034	.00001	34—1	3.00
DR-17	17	.00040	.00001	40—1	2.35
DR-17V (Vernier)	20	.00044	.00001	44—1	3.25
DR-23	23	.00055	.00001	55—1	2.50
DR-23V (Vernier)	26	.00060	.00001	60—1	3.50
DR-43	43	.00103	.00002	51.5—1	3.50
DR-43V (Vernier)	46	.00115	.00002	57.5—1	4.00

PATS. PEND.

Prices on vernier including knob and lever but not the dial.

Bulletin "Taking the 'CON' Out of Condensers." Contains more facts. Write now for a copy.

We have some profitable territory open for reputable jobbers.

THE DUPLEX ENGINE GOVERNOR COMPANY, Inc.
46 Flatbush Avenue Extension, BROOKLYN, N. Y.

\$200
SELECTIVITY
for **\$8.50!**

Make Every Night Silent Night! ★

TRAP OUT THE INTERFERENCE

Selectivity—which is merely the ability to cut out interference—is the dominating difference between the very expensive sets and the moderately priced ones. Why pay \$50.00 to \$200.00 extra for increased selectivity, when for \$8.50 you can get a FERBEND WAVE TRAP which will absolutely cut out any interfering station, no matter how loud, how close by or how troublesome.

Add a Ferbend Wave Trap to Your Set

You will find it a valuable addition. It is designed and manufactured complete by us, after years of careful experimenting. It is not to be confused with imitations hastily assembled from ordinary parts. The price is \$8.50. Shipment is made parcel post C. O. D. plus a few cents postage. If you prefer, you can send cash in full with order and we will ship postage prepaid. Send us your order today.

FERBEND ELECTRIC COMPANY

19 E. South Water St.
CHICAGO
Descriptive Folder
on Request

FERBEND
Wave Trap

We guarantee that the Ferbend Wave Trap, when properly connected to any workable receiving set, will tune out any interfering station.



Use it!

To Bring In
Distant Stations
Clear and Loud.

Stops Tube Noises

Fixed Condenser
25c Extra

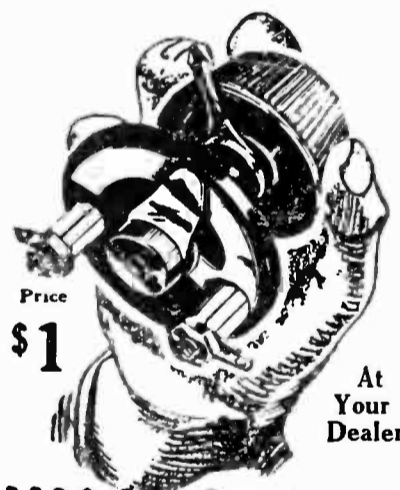
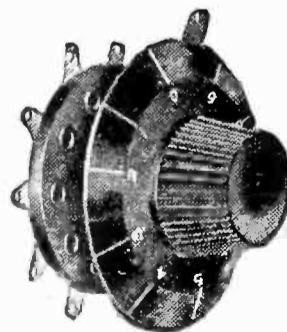

Price
\$1

At
Your
Dealer

WALNART VARIABLE GRID RESISTANCE

WALNART

Inductance Switch \$1.25
with numbered bakelite dial

One to ten positive contacts.
Only one hole required to mount.
Numbered dial shows position
of contact at all times.

Continental Bakelite Dilecto XX is used as a base for these instruments to insure positive dielectric insulation.

Write for folder describing complete Walnart Line.

Jobbers—Dealers—Manufacturers—write for discounts

WALNART ELECTRIC MFG. CO. ★

Dept. 308 1249 W. Van Buren Street Chicago

★ Tested and approved by RADIO BROADCAST ★

Clear from the skies

You can get greater clarity with a good storage battery than by any other means. If you are in any doubt about this important matter, try some friend's set that is hooked up to an Exide Battery.

It is a fascination to see how far distant a station you can tune in, but still more fascinating to get it so clearly that you actually enjoy the concert.

Two things to remember

There are two things to remember about Exide Batteries: They give uniform current over a long period of discharge. This means not only clear reception but economy.

The second thing to remember is that there is an Exide Radio Battery made for every type of tube. In addition to the "B" battery there are Exide "A's" for 2-volt, 4-volt and 6-volt tubes.

From the "midget" five-pound battery for low-voltage tubes to the larger battery for six volts, each Exide is powerful, rugged, silent, and so long-lasting that it makes for true economy.



For low-voltage tubes

Specially designed for WD-11 and UV-199 vacuum tubes, but can be used with any low-voltage tube. The two-volt Exide A Battery consists of a single cell. It will heat the filament of a WD-11 or other quarter-ampere tube for approximately 96 hours. The 4-volt A battery, having two cells, will light the filament of a UV-199 tube for 200 hours.



Exide "B" Battery

Exide

RADIO BATTERIES



For six-volt tubes

Made in four sizes—of 25, 50, 100, and 150 ampere hour capacities. Like all Exides this battery is conservatively rated. It has extra-heavy plates assuring constant potential over a long period of discharge.

And the reason is obvious

The Exide Radio Battery results from experience in the radio field dating far back of amateur radio. In fact, a majority of all government and commercial radio plants are equipped with Exide Batteries. The giant dirigible Shenandoah and the great ship Leviathan are Exide-equipped.



Go to any radio dealer or Exide Service Station and ask for Exide A and B Batteries. If your dealer cannot supply you with free booklets describing the complete Exide line of radio batteries, write to us.

THE ELECTRIC STORAGE BATTERY COMPANY, PHILADELPHIA

In Canada, Exide Batteries of Canada, Limited, 133-157 Dufferin Street, Toronto

★ Tested and approved by RADIO BROADCAST ★

Revised List of U. S., Canadian and Cuban Broadcasting Stations

This list includes all commercial broadcasting stations in the United States licensed up to March 21, 1924. Additional lists, with deletions, are printed every month in RADIO BROADCAST.

CALL LETTERS	LOCATION	(KILO-CYCLES)	WAVE LENGTH	POWER (WATTS)	CALL LETTERS	LOCATION	(KILO-CYCLES)	WAVE LENGTH	POWER (WATTS)
KDKA	East Pittsburgh, Pa.	920	326	1000	KFHJ	Santa Barbara, Calif.	833	360	100
KDPM	Cleveland, Ohio	1110	270	500	KFHR	Seattle, Wash.	1060	283	50
KDPT	San Diego, Calif.	1230	244	50	KFHS	Lihue, Hawaii	1090	275	30
KDYL	Salt Lake City, Utah	833	360	100	KFHX	Hutchinson, Kans.	1310	229	150
KDYM	San Diego, Calif.	1190	280	100	KFI	Los Angeles, Calif.	640	469	500
KDYQ	Portland, Oreg.	833	360	100	KFID	Iola, Kans.	1220	246	20
KDYW	Phoenix Ariz.	833	360	20	KFIF	Portland, Oreg.	833	360	100
KDYX	Honolulu, Hawaii	833	360	100	KFIL	Louisburg, Kans.	1280	234	30
KDZB	Bakersfield, Calif.	1250	240	100	KFIO	Spokane, Wash.	1190	252	50
KDZE	Seattle, Wash.	1110	270	100	KFIQ	Yakima, Wash.	1240	242	50
KDZF	Los Angeles, Calif.	1080	278	500	KFIU	Juneau, Alaska	1330	226	10
KDZI	Wenatchee, Wash.	833	360	50	KFIX	Independence, Mo.	1250	240	250
KDZQ	Denver, Colo.	833	360	10	KFIZ	Fondulac, Wis.	1100	273	100
KDZR	Bellingham, Wash.	1150	261	50	KFJB	Marshalltown, Iowa	1210	248	10
KFAD	Phoenix, Ariz.	833	360	100	KFJC	Seattle, Wash.	1110	270	100
KFAE	Pullman, Wash.	909	330	500	KFJF	Oklahoma City, Okla.	1190	252	20
KFAF	Denver, Colo.	833	360	50	KFJI	Astoria, Oreg.	1190	252	10
KFAJ	Boulder, Colo.	833	360	100	KFJK	Bristow, Okla.	1290	233	100
KFAN	Moscow, Idaho	833	360	50	KFJL	Ottumwa, Iowa	1240	242	10
KFAR	Hollywood, Calif.	1070	280	100	KFJM	Grand Forks, N. Dak.	1070	280	100
KFAU	Boise, Idaho	1110	270	150	KFJQ	Grand Forks, N. Dak.	1070	280	5
KFAW	Santa Ana, Calif.	1070	280	10	KFJR	Stevensville, Mont. (near)	1160	258	5
KFAY	Medford, Oreg.	1060	283	50	KFJV	Dexter, Iowa	1340	224	10
KFBB	Havre, Mont.	833	360	50	KFJW	Towanda, Kans.	1330	226	10
KFBC	San Diego, Calif.	1080	278	20	KFJX	Cedar Falls, Iowa	1310	229	50
KFBE	San Luis Obispo, Calif.	833	360	10	KFJY	Fort Dodge, Iowa	1220	246	50
KFBG	Tacoma, Wash.	833	360	50	KFJZ	Fort Worth, Tex.	1180	254	20
KFBK	Sacramento, Calif.	1060	283	100	KFKA	Greeley, Colo.	1210	248	50
KFBL	Everett, Wash.	1340	224	10	KFKB	Milford, Kans.	1050	286	500
KFBS	Trinidad, Colo.	833	360	10	KFKQ	Conway, Ark.	1340	224	150
KFBU	Laramie, Wyo.	1060	283	50	KFKV	Butte, Mont.	1060	283	50
KFCB	Phoenix, Ariz.	1260	238	10	KFKX	Hastings, Nebr.	880	341	1000
KFCF	Walla Walla, Wash.	833	360	100	KFKZ	Colorado Springs, Colo.	1280	234	10
KFCH	Billings, Mont.	833	360	10	KFLA	Butte, Mont.	1060	283	5
KFCM	Richmond, Calif.	833	360	100	KFLB	Menominee, Mich.	1210	248	5
KFCP	Ogden, Utah	833	360	25	KFLD	Franklinton, La.	1280	234	20
KFCV	Houston, Tex.	833	360	10	KFLE	Denver, Colo.	1120	268	25
KFCY	Le Mars, Iowa	1190	252	50	KFLH	Salt Lake City, Utah	1150	261	50
KFCZ	Omaha, Nebr.	1160	258	100	KFLP	Cedar Rapids, Iowa	1250	240	20
KFDA	Baker, Oreg.	833	360	5	KFLQ	Little Rock, Ark.	1150	261	20
KFDG	Boise, Idaho	1190	252	10	KFLR	Albuquerque, N. Mex.	1180	254	100
KFDH	Tucson, Ariz.	833	360	150	KFLU	San Benito, Tex.	1270	236	20
KFDJ	Corvallis, Oreg.	833	360	50	KFLV	Rockford, Ill.	1310	229	100
KFDL	Denver, Colo.	833	360	5	KFLW	Missoula, Mont.	1280	234	10
KFDO	Bozeman, Mont.	1210	248	50	KFLX	Galveston, Tex.	1250	240	10
KFDR	York, Nebr.	833	360	10	KFLY	Fargo, N. Dak.	1300	231	20
KFDV	Fayetteville, Ark.	833	360	200	KFLZ	Atlantic, Iowa	1100	273	100
KFDX	Shreveport, La.	833	360	100	KFMB	Little Rock, Ark.	1180	254	100
KFDY	Brookings, S. Dak.	833	360	100	KFMQ	Fayetteville, Ark.	1140	263	100
KFDZ	Minneapolis, Minn.	1300	231	5	KFMR	Sioux City, Iowa	1150	261	10
KFEC	Portland, Oreg.	1210	248	50	KFMS	Duluth, Minn.	1090	275	100
KFEJ	Tacoma, Wash.	833	360	10	KFMT	Minneapolis, Minn.	1300	231	5
KFEL	Denver, Colo.	833	360	50	KFMU	San Marcos, Tex.	1250	240	20
KFEQ	Oak, Nebr.	833	360	150	KFMW	Houghton, Mich.	1130	266	50
KFER	Fort Dodge, Iowa	1300	231	10	KFMX	Northfield, Minn.	1060	283	500
KFEV	Casper, Wyo.	1140	263	250	KFMY	Long Beach, Calif.	1310	229	20
KFEX	Minneapolis, Minn.	1150	261	100	KFMZ	Roswell, N. Mex.	1190	250	500
KFEY	Kellogg, Idaho	833	360	10	KFNC	Corsicana, Tex.	1280	234	20
KFEZ	St. Louis, Mo.	833	360	100	KFNF	Shenandoah, Iowa	1130	266	500
KFFB	Boise, Idaho	1250	240	10	KFNG	Coldwater, Miss.	1180	254	10
KFFE	Pendleton, Oreg.	833	360	10	KFNH	Springfield, Mo.	1270	236	20
KFFO	Hillsboro, Oreg.	1310	229	5	KFNJ	Warrensburg, Mo.	1280	234	50
KFFQ	Colorado Springs, Colo.	833	360	100	KFNL	Paso Robles, Calif.	1250	240	10
KFFR	Sparks, Nev.	1330	226	10	KFNV	Santa Rosa, Calif.	1280	234	5
KFFV	Lamoni, Iowa	833	360	100	KFNX	Peabody, Kans.	1250	240	10
KFFX	Omaha, Nebr.	1080	278	100	KFNY	Helena, Mont.	1150	261	5
KFFY	Alexandria, La.	1090	275	100	KFNZ	Burlingam, Calif.	1300	231	10
KFFZ	Dallas, Tex. (portable)	1330	226	20	KFOA	Seattle, Wash.	660	455	500
KFGC	Baton Rouge, La.	1180	254	100	KFOB	Minneapolis, Minn.	1340	224	5
KFGD	Chickasha, Okla.	1210	248	200	KFOC	Whittier, Calif.	1270	236	100
KFGH	Stanford University, Calif.	833	360	500	KFOD	Wallace, Idaho	1340	224	10
KFGL	Arlington, Oreg.	1280	234	5	KFOF	Marshfield, Oreg.	1250	240	10
KFGQ	Boone, Iowa	1330	226	10	KFOH	Portland, Oreg.	1060	283	15
KFGV	Utica, Nebr.	1340	224	10	KFOJ	Moberly, Mo.	1220	246	5
KFGX	Orange, Tex.	1200	250	500	KFOL	Marengo, Iowa	1280	234	10
KFGZ	Berrien Springs, Mich.	1120	268	250	KFON	Long Beach, Calif.	1280	234	100
KFHA	Gunnison, Colo.	1190	252	50	KFOO	Salt Lake City, Utah	1150	261	10
KFHB	Hood River, Oreg.	1070	280	5	KFOP	Dallas, Tex.	1120	268	100
KFHD	St. Joseph, Mo.	1330	226	100	KFOQ	Galveston, Texas.	1250	240	50
KFHF	Shreveport, La.	1130	266	150	KFOR	David City, Nebr.	1330	226	10
KFHH	Neah Bay, Wash.	1150	261	50	KFOT	Wichita, Kansas	1300	231	50

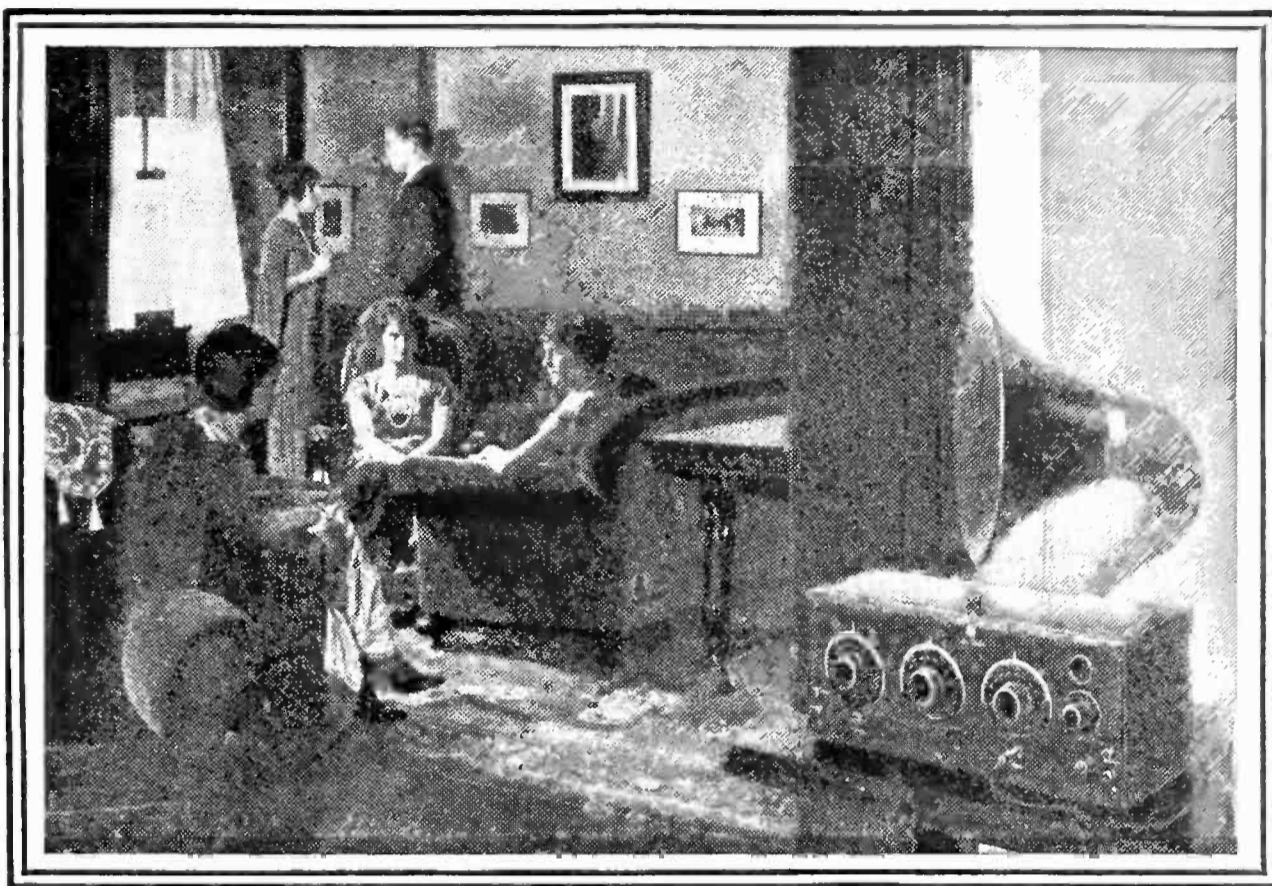

FADA "ONE SIXTY" NEUTRODYNE RADIO RECEIVER

Clarity

Radio is most enjoyable when the programs of music and other forms of entertainment are coming in sweet and clear; loud enough to be heard perfectly on the loud speaker, yet faithfully reproducing the voice of the singer or the harmonies of the orchestral instruments.

Clarity of tone is a feature that has made hosts of friends for the FADA "One Sixty" radio receiver. No matter where the station tuned in may be located—in the East, or in the West, the clarity of tone produced by the "One Sixty" is remarkably lifelike and pure. And so powerful is this wonderful receiver that the majority of broadcasting stations,

both local and distant, can be heard clearly and plainly on a loud speaker.

Quality—in design and workmanship—characterizes the FADA "One Sixty" through and through. Combining as it does the famous Neutrodyne principle with skilled FADA craftsmanship, the "One Sixty" represents a great feat of radio engineering.

In selectivity, volume, distance getting, clarity and fine appearance, the FADA "One Sixty" is unsurpassed. To hear it perform is to be convinced. It will be well worth your while to visit your dealer and see this receiver. Price \$120. This does not include tubes, batteries or phones.

F. A. D. ANDREA, INC., 1581 Jerome Avenue, New York City

FADA ★

Radio



★ Tested and approved by RADIO BROADCAST ★

Radio Broadcast

CALL LETTERS	LOCATION	(KILO-CYCLES)	WAVE LENGTH	POWER (WATTS)	CALL LETTERS	LOCATION	(KILO-CYCLES)	WAVE LENGTH	POWER (WATTS)
KFOU	Richmond, Calif.	1180	254	100	WBBN	Wilmington, N. C.	1090	275	10
KFOV	Sioux City, Iowa	1280	234	10	WBBO	Rogers, Mich.	1190	250	500
KFOX	Omaha, Nebr.	1210	248	100	WBBP	Petoskey, Mich.	1220	246	10
KFOY	St. Paul, Minn.	1330	226	50	WBBQ	Pawtucket, R. I.	1190	252	50
KFOZ	Fort Smith, Ark.	1290	233	20	WBBR	Rossville, N. Y.	1230	244	500
KFPB	Seattle, Wash.	1340	224		WBBS	New Orleans, La.	1190	250	100
KFPG	Los Angeles, Calif.	1260	238	100	WBBT	Philadelphia, Pa.	1280	234	5
KFSG	Los Angeles, Calif.	1080	278	500	WBBU	Monmouth, Ill.	1340	224	10
KGB	Tacoma, Wash.	1190	252	50	WBBV	Johnstown, Pa.	1210	248	5
KGG	Portland, Oreg.	833	360	50	WBEW	Norfolk, Va.	1360	222	50
KGN	Portland, Oreg.	833	360	100	WBBY	Charleston, S. C.	1120	268	20
KGO	Oakland, Calif.	960	312	1000	WBBZ	Indianapolis, Ind.	1320	227	50
KGU	Honolulu, Hawaii	833	360	500	WBL	Anthony, Kans.	1150	261	100
KGW	Portland, Oreg.	610	492	500	WBS	Newark, N. J.	833	360	10
KGY	Lacey, Wash.	1160	258	5	WBT	Charlotte, N. C.	833	360	500
KHJ	Los Angeles, Calif.	760	395	500	WBZ	Springfield, Mass.	890	337	1000
KHQ	Seattle, Wash.	833	360	100	WCAD	Canton, N. Y.	1070	280	250
KJQ	Stockton, Calif.	833	360	5	WCAE	Pittsburgh, Pa.	650	462	500
KJR	Seattle, Wash.	1060	283	50	WCAG	New Orleans, La.	1120	268	50
KJS	Los Angeles, Calif.	833	360	750	WCAH	Columbus, Ohio	1050	286	100
KLS	Oakland, Calif.	833	360	250	WCAJ	University Place, Nebr.	833	360	500
KLX	Oakland, Calif.	590	509	500	WCAK	Houston, Tex.	1140	263	50
KLZ	Denver, Colo.	833	360	500	WCAL	Northfield, Minn.	833	360	500
KMJ	Fresno, Calif.	1100	273	50	WCAM	Villanova, Pa.	833	360	150
KMO	Tacoma, Wash.	833	360	10	WCAO	Baltimore, Md.	833	360	50
KNT	Aberdeen, Wash.	1140	263	250	WCAP	Washington, D. C.	640	469	500
KNV	Los Angeles, Calif.	1170	256	100	WCAR	San Antonio, Tex.	833	360	100
KNX	Los Angeles, Calif.	833	360	100	WCAS	Minneapolis, Minn.	1070	280	100
KOB	State College, N. Mex.	833	360	500	WCAT	Rapid City, S. Dak.	1250	240	100
KOP	Detroit, Mich.	1050	286	500	WCAU	Philadelphia, Pa.	1050	286	100
KPO	San Francisco, Calif.	710	423	500	WCAV	Little Rock, Ark.	833	360	20
KQP	Hood River, Oreg.	833	360	10	WCAX	Burlington, Vt.	833	360	50
KQV	Pittsburgh, Pa.	833	360	250	WCAY	Milwaukee, Wis.	1150	261	250
KQW	San Jose, Calif.	833	360	50	WCAZ	Carthage, Ill.	1220	246	50
KRE	Berkeley, Calif.	1090	275	50	WCBA	Allentown, Pa.	1070	280	10
KSD	St. Louis, Mo.	550	546	500	WCBC	Ann Arbor, Mich.	1070	280	200
KSS	Long Beach, Calif.	833	360	20	WCBD	Zion, Ill.	870	345	500
KTW	Seattle, Wash.	833	360	750	WCBE	New Orleans, La.	1140	263	5
KUO	San Francisco, Calif.	833	360	150	WCBF	Pittsburgh, Pa.	1270	236	50
KUS	Los Angeles, Calif.	833	360	100	WCBG	Pascagoula, Miss. (port.)	1180	254	10
KUY	El Monte, Calif.	1170	256	50	WCBH	Oxford, Miss. (near)	1240	242	20
KWG	Stockton, Calif.	833	360	100	WCBI	Bemis, Tenn.	1330	226	100
KWH	Los Angeles, Calif.	833	360	500	WCBJ	Jennings, La.	1230	244	10
KXD	Modesto, Calif.	1190	252	5	WCBK	St. Petersburg, Fla.	1130	266	500
KYQ	Honolulu, Hawaii	1110	270	100	WCBL	Houlton, Maine	1070	280	50
KYW	Chicago, Ill.	560	536	1000	WCBM	Baltimore, Md.	1310	229	50
KZM	Oakland, Calif.	833	360	50	WCBN	Ft. Benj. Harrison, Ind.	1130	266	50
KZN	Salt Lake City, Utah	833	360	500	WCK	St. Louis, Mo.	833	360	100
KZV	Wenatchee, Wash.	833	360	50	WCM	Austin, Tex.	833	360	500
WAAB	New Orleans, La.	1120	268	100	WCX	Detroit, Mich.	580	517	500
WAAC	New Orleans, La.	833	360	400	WDAE	Tampa, Fla.	833	360	250
WAAD	Cincinnati, Ohio	833	360	25	WDAF	Kansas City, Mo.	730	411	500
WAAF	Chicago, Ill.	1050	286	200	WDAG	Amarillo, Tex.	1140	263	100
WAAM	Newark, N. J.	1140	263	250	WDAH	El Paso, Tex.	1120	268	50
WAAN	Columbia, Mo.	1180	254	50	WDAK	Hartford, Conn.	1150	261	100
WAAW	Omaha, Nebr.	833	360	200	WDAO	Dallas, Tex.	833	360	50
WABA	Lake Forest, Ill.	1130	266	100	WDAP	Chicago, Ill.	833	360	1000
WABB	Harrisburg, Pa.	1130	266	10	WDAR	Philadelphia, Pa.	760	395	500
WABD	Dayton, Ohio	1060	283	10	WDAS	Worcester, Mass.	833	360	5
WABE	Washington, D. C.	1060	283	100	WDAU	New Bedford, Mass.	833	360	100
WABG	Jacksonville, Fla.	1090	275	10	WDAY	Fargo, N. Dak.	1230	244	50
WABH	Sandusky, Ohio	1250	240	10	WDBC	Lancaster, Pa.	1160	258	50
WABI	Bangor, Me.	1250	240	100	WDM	Washington, D. C.	1280	234	50
WABK	Worcester, Mass.	1190	252	10	WDZ	Tuscola, Ill.	1080	278	10
WABL	Storrs, Conn.	1060	283	100	WEAA	Flint, Mich.	1190	250	10
WABM	Saginaw, Mich.	1180	254	100	WEAF	New York, N. Y.	610	492	500
WABN	La Crosse, Wis.	1230	244	250	WEAH	Wichita, Kans.	1070	280	50
WABO	Rochester, N. Y.	1190	252	10	WEAI	Ithaca, N. Y.	1050	286	500
WABP	Dover, Ohio	1130	266	100	WEAJ	Vermilion, S. Dak.	1060	283	100
WABQ	Haverford, Pa.	1150	261	50	WEAM	North Plainfield, N. J.	1050	286	100
WABR	Toledo, Ohio	1110	270	50	WEAN	Providence, R. I.	1100	273	100
WABS	Newark, N. J.	1230	244	50	WEAO	Columbus, Ohio	833	360	500
WABT	Washington, Pa.	1190	252	100	WEAP	Mobile, Ala.	833	360	100
WABU	Camden, N. J.	1330	226	100	WEAR	Baltimore, Md.	833	360	50
WABV	Nashville, Tenn.	1140	263	20	WEAS	Washington, D. C.	833	360	100
WABW	Wooster, Ohio	1280	234	20	WEAU	Sioux City, Iowa	833	360	100
WABX	Mount Clemens, Mich.	1110	270	150	WEAY	Houston, Tex.	833	360	500
WABY	Philadelphia, Pa.	1240	242	50	WEB	St. Louis, Mo.	1100	273	500
WABZ	New Orleans, La.	1140	263	50	WEV	Houston, Tex.	833	360	50
WBAA	West Lafayette, Ind.	833	360	250	WEW	St. Louis, Mo.	1150	261	100
WBAD	Minneapolis, Minn.	833	360	100	WFAA	Dallas, Tex.	630	476	500
WBAH	Minneapolis, Minn.	719	417	500	WFAB	Syracuse, N. Y.	1280	234	100
WBAN	Paterson, N. J.	1230	244	100	WFAF	Poughkeepsie, N. Y.	833	360	20
WBAO	Decatur, Ill.	833	360	50	WFAH	Port Arthur, Tex.	1270	236	150
WBAP	Fort Worth, Tex.	630	476	500	WFAJ	Asheville, N. C.	833	360	50
WBAV	Columbus, Ohio	770	390	500	WFAM	St. Cloud, Minn.	833	360	20
WBAX	Wilkes-Barre, Pa.	833	360	20	WFAN	Hutchinson, Minn.	833	360	100
WBAY	New York, N. Y.	610	492	500	WFAQ	Cameron, Mo.	833	360	10
WBBA	Newark, Ohio	1250	240	10	WFAT	Sioux Falls, S. Dak.	1160	258	50
WBBD	Reading, Pa.	1280	234	50	WFAV	Lincoln, Nebr.	1090	275	500
WBBE	Syracuse, N. Y.	1220	246	10	WFI	Philadelphia, Pa.	760	395	500
WBBF	Atlanta, Ga.	1110	270	500	WGAL	Lancaster, Pa.	1210	248	10
WBBG	Mattapoisett, Mass.	1250	240	100	WGAN	Pensacola, Fla.	833	360	50
WBBH	Port Huron, Mich.	1220	246	50	WGAQ	Shreveport, La.	1190	252	150
WBBI	Indianapolis, Ind.	1280	234	20	WGAW	Altoona, Pa.	1150	261	100
WBBJ	West Palm Beach, Fla.	1160	258	50	WGAZ	South Bend, Ind.	833	360	250
WBBL	Richmond, Va.	1060	283	50	WGI	Medford Hillside, Mass.	833	360	500
WBBM	Lincoln, Ill.	1330	226	200	WGL	Philadelphia, Pa.	833	360	500

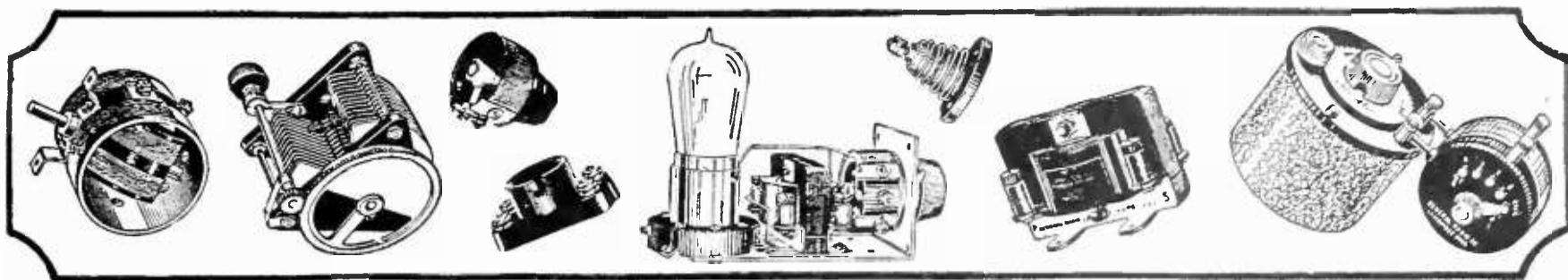

Standards of Excellence

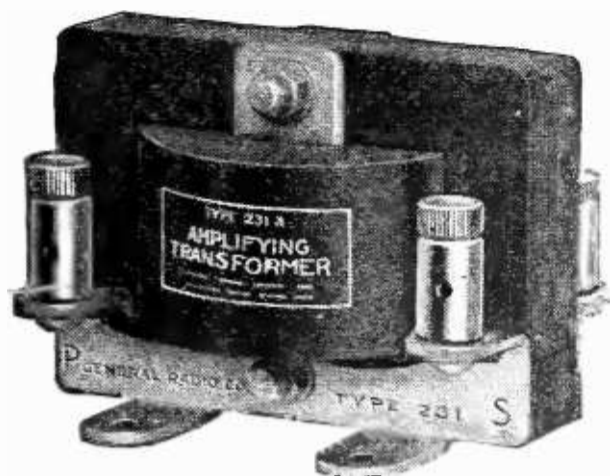

**TYPE 231-A
AUDIO TRANSFORMER**

The first closed core transformers on the market available for use in broadcast receivers were built by the GENERAL RADIO CO., nearly a decade ago.

To-day the type 231-A is the standard of excellence in transformer construction.

Thousands of these transformers are in use by fans throughout the entire radio world. They have proven a source of delight to "listeners-in" everywhere because of their volume and quality of amplification.

Many of the leading manufactured broadcast receivers are using GENERAL RADIO CO. transformers as standard equipment—because of their unflinching satisfaction.

Whether you are building a set or buying one, the question of "Quality Amplification" will be settled once and for all if you insist upon the GENERAL RADIO CO. transformers.

Winding Ratio 3.7 to 1. Impedance Ratio 10 to 1.

PRICE \$5.00



"Products of Proven Merit"

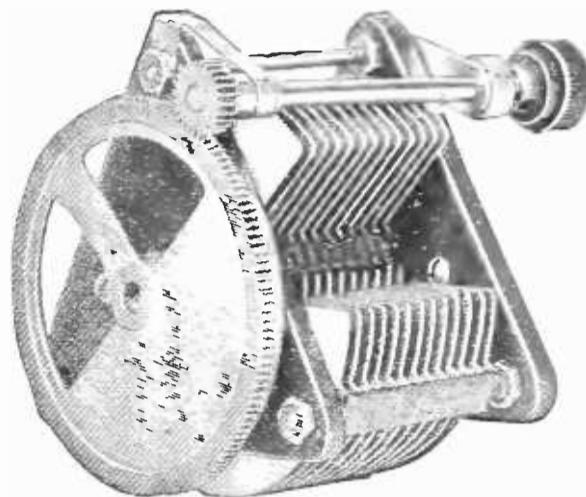

**TYPE 247-H
VARIABLE CONDENSER**

The 247-H geared variable condenser is the product of extensive laboratory research by skilled radio engineers.

In its design are incorporated features which promote the utmost electrical and mechanical efficiency.

Its method of vernier adjustment is particularly commendable.

By using the counter-balanced gear, operated by a pinion, capacity may be accurately controlled to a minute degree—thus making possible extreme selectivity.

Its bearings are smooth running and its dielectric losses are low.

Due to its critical capacity control and general over-all efficiency, the 247-H condenser is readily adaptable to use in a wavemeter and filter as well as in the receiver circuit.

Capacity of the 247-H condenser .0005 microfarad.

PRICE \$5.00

Write TO-DAY for our Instructive Folders on "Quality Amplification" and "Quality Condensers" and our new Radio Bulletin 917-B

GENERAL RADIO Co.

Manufacturers of

RADIO AND ELECTRICAL LABORATORY APPARATUS

Massachusetts Avenue and Windsor Street

CAMBRIDGE

MASSACHUSETTS

★ Tested and approved by RADIO BROADCAST ★

Radio Broadcast

CALL LETTERS	LOCATION	(KILO-CYCLES)	WAVE LENGTH	POWER (WATTS)	CALL LETTERS	LOCATION	(KILO-CYCLES)	WAVE LENGTH	POWER (WATTS)
WGR	Buffalo, N. Y.	940	319	500	WNAV	Knoxville, Tenn.	1270	236	500
WGV	New Orleans, La.	1240	242	100	WNAW	Fort Monroe, Va.	833	360	5
WGY	Schenectady, N. Y.	790	380	1000	WNAX	Yankton, S. Dak.	1230	244	100
WHA	Madison, Wis.	833	360	500	WNJ	Albany, N. Y.	833	360	55
WHAA	Iowa City, Iowa	620	484	100	WOAC	Lima, Ohio	1130	266	50
WHAB	Galveston, Tex.	833	360	200	WOAD	Sigourney, Iowa	833	360	20
WHAD	Milwaukee, Wis.	1070	280	100	WOAE	Fremont, Nebr.	833	360	20
WHAG	Cincinnati, Ohio	1350	222	100	WOAF	Tyler, Tex.	833	360	10
WHAH	Joplin, Mo.	1060	283	250	WOAG	Belvidere, Ill.	1100	273	100
WHAJ	Clarksburg, W. Va.	1160	258	15	WOAH	Charleston, S. C.	833	360	100
WHAM	Rochester, N. Y.	1060	283	100	WOAI	San Antonio, Tex.	780	385	500
WHAP	Decatur, Ill.	833	360	50	WOAN	Lawrenceburg, Tenn.	833	360	150
WHAR	Atlantic City, N. J.	1300	231	10	WOAO	Mishawaka, Ind.	833	360	50
WHAS	Louisville, Ky.	750	400	500	WOAP	Kalamazoo, Mich.	1060	283	50
WHAV	Wilmington, Del.	833	360	50	WOAR	Kenosha, Wis.	1310	229	50
WHAZ	Troy, N. Y.	790	380	500	WOAT	Wilmington, Del.	833	360	50
WHB	Kansas City, Mo.	730	411	500	WOAV	Erie, Pa.	1240	242	50
WHK	Cleveland, Ohio	1060	283	100	WOAW	Omaha, Nebr.	570	526	500
WHN	New York, N. Y.	833	360	100-500	WOAX	Trenton, N. J.	1250	240	500
WIAB	Rockford, Ill.	1190	252	50	WOC	Davenport, Iowa	620	484	500
WIAC	Galveston, Tex.	833	360	100	WOI	Ames, Iowa	833	360	100
WIAD	Philadelphia, Pa.	1180	254	100	WOK	Pine Bluff, Ark.	833	360	500
WIAF	New Orleans, La.	1280	234	10	WOO	Philadelphia, Pa.	590	509	500
WIAI	Springfield, Mo.	1190	252	20	WOQ	Kansas City, Mo.	833	360	500
WIAJ	Neenah, Wis.	1340	224	20	WOR	Newark, N. J.	740	405	500
WIAK	Omaha, Nebr.	1080	278	200	WOS	Jefferson City, Mo.	680	441	500
WIAO	Milwaukee, Wis.	833	360	100	WPAB	State College, Pa.	1060	283	500
WIAQ	Marion, Ind.	1330	226	10	WPAC	Okmulgee, Okla.	833	360	200
WIAR	Paducah, Ky.	833	360	100	WPAH	Waupaca, Wis.	833	360	500
WIAS	Burlington, Iowa	833	360	100	WPAJ	New Haven, Conn.	1120	268	10
WIAU	Le Mars, Iowa	833	360	20	WPAK	Agricultural College, N. D.	833	360	50
WIK	McKeesport, Pa.	1280	234	100	WPAL	Columbus, Ohio	1050	286	100
WIL	Washington D. C.	833	360	10	WPAM	Topeka, Kans.	833	360	100
WIP	Philadelphia, Pa.	590	509	500	WPAP	Winchester, Ky.	833	360	35
WJAD	Waco, Tex.	833	360	150	WPAQ	Frostburg, Md.	833	360	10
WJAF	Muncie, Ind.	833	360	10	WPAR	Elooit, Kansas	1270	236	10
WJAG	Norfolk, Nebr.	1060	283	250	WPAT	El Paso, Tex.	833	360	20
WJAK	Greentown, Ind.	1180	254	30	WPAU	Moorhead, Minn.	833	360	20
WJAM	Cedar Rapids, Iowa	1120	268	20	WPAZ	Charleston, W. Va.	1100	273	10
WJAN	Peoria, Ill.	1070	280	100	WQAA	Parkesburg, Pa.	833	360	500
WJAQ	Topeka, Kans.	833	360	100	WQAC	Amarillo, Tex.	833	360	100
WJAR	Providence, R. I.	833	360	500	WQAD	Waterbury, Conn.	1240	242	50
WJAS	Pittsburgh, Pa.	1190	250	500	WQAE	Springfield, Vt.	1090	275	50
WJAT	Marshall, Mo.	833	360	10	WQAF	Sandusky, Ohio	1250	240	5
WJAX	Cleveland, Ohio	770	390	500	WQAL	Mattoon, Ill.	1160	258	10
WJAZ	Chicago, Ill.	670	448	1000	WQAM	Miami, Fla.	1060	283	100
WJD	Granville, Ohio	1310	229	50	WQAN	Scranton, Pa.	1070	280	50
WJH	Washington, D. C.	1100	273	50	WQAO	New York, N. Y.	833	360	100
WJX	New York, N. Y.	833	360	500	WQAQ	Abilene, Tex.	833	360	100
WJY	New York, N. Y.	740	405	500	WQAS	Lowell, Mass.	1130	266	100
WJZ	New York, N. Y.	660	455	500	WQAV	Greenville, S. C.	1160	258	15
WKAA	Cedar Rapids, Iowa	1120	268	100	WQAW	Washington, D. C.	1270	236	5
WKAD	East Providence, R. I.	1250	240	10	WQAX	Peoria, Ill.	833	360	100
WKAF	Wichita Falls, Tex.	833	360	100	WRAA	Houston, Tex.	833	360	200
WKAN	Montgomery, Ala.	1330	226	15	WRAD	Marion, Kans.	1210	248	10
WKAP	Cranston, R. I.	833	360	200	WRAF	Laporte, Ind.	1340	224	20
WKAQ	San Juan, P. R.	833	360	100	WRAH	Providence, R. I.	1300	231	15
WKAR	East Lansing, Mich.	1070	280	500	WRAL	St. Croix Falls, Wis.	1210	248	100
WKAJ	Laconia, N. H.	1180	254	50	WRAM	Galesburg, Ill.	1230	244	100
WKAY	Gainesville, Ga.	1070	280	10	WRAN	Waterloo, Iowa	1270	236	10
WKY	Oklahoma, Okla.	833	360	500	WRAO	St. Louis, Mo.	833	360	20
WLAG	Minneapolis, Minn.	720	417	500	WRAV	Yellow Springs, Ohio	1240	242	100
WLAH	Syracuse, N. Y.	1280	234	100	WRAW	Reading, Pa.	1260	238	10
WLAJ	Waco, Tex.	833	360	150	WRAX	Gloucester City, N. J.	1120	268	100
WLAK	Bellows Falls, Vt.	833	360	100	WRAY	Scranton, Pa.	1070	280	10
WLAL	Tulsa, Okla.	833	360	100	WRAZ	Newark, N. J.	1290	233	50
WLAP	Louisville, Ky.	833	360	15	WRC	Washington, D. C.	640	469	500
WLAQ	Kalamazoo, Mich.	1060	283	10	WRK	Hamilton, Ohio	833	360	200
WLAJ	Pensacola, Fla.	1180	254	15	WRL	Schenectady, N. Y.	833	360	500
WLAW	New York, N. Y.	833	360	500	WRM	Urbana, Ill.	833	360	500
WLAX	Greencastle, Ind.	1300	231	10	WRR	Dallas, Tex.	833	360	20
WLB	Minneapolis, Minn.	833	360	25	WRW	Tarrytown, N. Y.	1100	273	150
WLW	Cincinnati, Ohio	970	309	500	WSAB	Cape Girardeau, Mo.	833	360	100
WMAB	Oklahoma, Okla.	833	360	100	WSAC	Clemson College, S. C.	833	360	500
WMAC	Cazenovia, N. Y.	1150	261	200	WSAD	Providence, R. I.	1150	261	150
WMAF	Dartmouth, Mass.	833	360	100-500	WSAG	St. Petersburg, Fla.	1230	244	10
WMAH	Lincoln, Nebr.	1180	254	50	WSAH	Chicago, Ill.	1210	248	500
WMAJ	Kansas City, Mo.	1090	275	250	WSAI	Cincinnati, Ohio	970	309	500
WMAK	Lockport, N. Y.	833	360	500	WSAJ	Grove City, Pa.	833	360	250
WMAL	Trenton, N. J.	1170	256	50	WSAL	Brookville, Ind.	1220	246	50
WMAN	Columbus, Ohio	1050	286	10	WSAN	Allentown, Pa.	1310	229	10
WMAP	Easton, Pa.	1220	246	150	WSAP	New York, N. Y.	1140	263	250
WMAQ	Chicago, Ill.	670	448	500	WSAR	Fall River, Mass.	1180	254	10
WMAV	Auburn, Ala.	1200	250	250	WSAT	Plainview, Tex.	1120	268	20
WMAW	Wahpeton, N. Dak.	1180	254	50	WSAW	Canandaigua, N. Y.	1090	275	5
WMAY	St. Louis, Mo.	1070	280	100	WSAX	Chicago, Ill.	1120	268	20
WMAZ	Macon, Ga.	1120	268	50	WSAY	Port Chester, N. Y.	1290	233	100
WMC	Memphis, Tenn.	600	500	500	WSAZ	Pomeroy, Ohio	1160	258	50
WMU	Washington, D. C.	1150	261	50	WSB	Atlanta, Ga.	700	429	500
WNAC	Boston, Mass.	1080	278	100	WSL	Utica, N. Y.	1100	273	100
WNAD	Norman, Okla.	833	360	50	WSY	Birmingham, Ala.	833	360	500
WNAL	Omaha, Nebr.	1130	266	20	WTAB	Fall River, Mass.	1210	248	10
WNAN	Syracuse, N. Y.	1050	286	100	WTAC	Johnstown, Pa.	833	360	150
WNAP	Springfield, Ohio	1090	275	100	WTAF	New Orleans, La.	1120	268	20
WNAQ	Charleston, S.C.	833	360	10	WTAG	Providence, R. I.	1160	258	10
WNAR	Butler, Mo.	1300	231	20	WTAH	Belvidere, Ill.	1270	236	10
WNAS	Austin, Tex.	833	360	100	WTAJ	Portland, Me.	1270	236	10
WNAT	Philadelphia, Pa.	833	360	250	WTAL	Toledo, Ohio	1190	252	10

"THE AIR IS FULL OF THINGS YOU SHOULDN'T MISS"



Get ready now for summer radio

A GREAT radio summer is at hand. To enjoy summer radio at its best, equip your receiver with the best batteries you can get. Put in new Eveready Radio "B" Batteries and see what wonderful, long-lived service they will give.

Made especially for radio use, Eveready "B" Batteries will operate the loud speaker at maximum volume for long or short periods, depending on how rapidly the current is taken out of them. Packed full of pep and punch and go, Eveready "B" Batteries pour out their power the moment you turn on the tubes.

Eveready "B" No. 767 is the standard amplifier "B" Battery, and gives 45 powerful, dependable, zippy volts. Five sturdy Fahnestock Clips make this big "B" Battery available for detector tube use as well—varying the voltage from 16½ to 22½ as required.

Insist on Eveready "B" Batteries, remembering that they are the product of thirty years of experience and know-how in battery making. For maximum battery economy and service buy Eveready Radio Batteries—they last longer.

Manufactured and guaranteed by

NATIONAL CARBON COMPANY, INC.

Headquarters for Radio Battery Information

New York

San Francisco

Canadian National Carbon Co., Limited

Factory and Offices: Toronto, Ontario

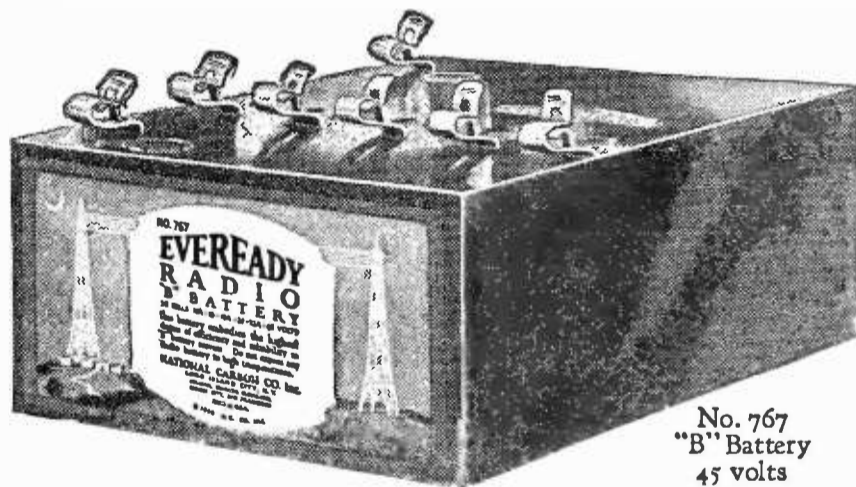

No. 767
"B" Battery
45 volts

Storage
"A"
Battery



No. 764
"B" Battery

No. 7111
Dry Cell
"A"
Battery



No. 766
"B" Battery
22½ volts



No. 771
"C" Battery



★
EVEREADY
Radio Batteries
—they last longer

Informative and money-saving booklets on radio batteries sent free on request. If you have any questions regarding radio batteries, write to G. C. Furness, Manager, Radio Division, National Carbon Co., Inc., 126 Thompson Avenue, Long Island City, N. Y.

★ Tested and approved by RADIO BROADCAST ★

Radio Broadcast

CALL LETTERS	LOCATION	(KILO-CYCLES)	WAVE LENGTH	POWER (WATTS)	CALL LETTERS	LOCATION	(KILO-CYCLES)	WAVE LENGTH	POWER (WATTS)
WTAM	Cleveland, Ohio	770	390	1000	WTAZ	Lambertville, N. J.	1060	283	15
WTAP	Cambridge, Ill.	1240	242	50	WTC	Manhattan, Kans.	833	360	1000
WTAQ	Osseo, Wis.	1180	254	100	WWAB	Trenton, N. J.	1330	226	10
WTAR	Norfolk, Va.	1070	280	100	WWAC	Waco, Tex.	833	360	50
WTAS	Elgin, Ill.	1050	286	500	WWAD	Philadelphia, Pa.	833	360	100
WTAT	Boston, Mass.	1230	244	100	WWAE	Joliet, Ill.	1320	227	500
WTAU	Tecumseh, Nebr.	833	360	10	WWAF	Camden, N. J.	1270	236	100
WTAW	College Station, Tex.	1070	280	50	WWAO	Houghton, Mich.	1230	244	250
WTAX	Streator, Ill.	1300	231	50	WWI	Dearborn, Mich.	1100	273	500
WTAY	Oak Park, Ill.	1060	283	500	WWJ	Detroit, Mich.	580	517	500
					WWL	New Orleans, La.	1070	280	100

CANADIAN BROADCASTING STATIONS

CALL LETTERS	LOCATION	(KILO-CYCLES)	WAVE LENGTH	CALL LETTERS	LOCATION	(KILO-CYCLES)	WAVE LENGTH
CFAC	Calgary, Alberta	698	430	CHCL	Vancouver, British Columbia	682	440
CFCA	Toronto, Ontario	750	400	CHCM	Calgary, Alberta	682	440
CFCF	Montreal, Quebec	682	440	CHCS	Hamilton, Ontario	732	410
CFCH	Iroquois Falls, Ontario	750	400	CHYC	Montreal, Quebec	732	410
CFCJ	Quebec, Quebec	732	410	CJCA	Edmonton, Alberta	667	450
CFCK	Edmonton, Alberta	732	410	CJCD	Toronto, Ontario	732	410
CFCL	Victoria, British Columbia	750	400	CJCE	Vancouver, British Columbia	714	420
CFCN	Calgary, Alberta	682	440	CJCI	St. John, New Brunswick	750	400
CFCO	Bellevue, Quebec	667	450	CJCM	Monti Joli, Quebec	750	400
CFCQ	Vancouver, British Columbia	667	450	CJCN	Toronto, Ontario	732	410
CFCR	Sudbury, Ontario	732	410	CJCX	Olds, Alberta	750	400
CFCW	London, Ontario	714	420	CJGC	London, Ontario	698	430
CFDC	Nanaimo, British Columbia	698	430	CJSC	Toronto, Ontario	698	430
CFQC	Saskatoon, Saskatchewan	750	400	CKAC	Montreal, Quebec	706	425
CFRC	Kingston, Ontario	667	450	CKCD	Vancouver, British Columbia	732	410
CFUC	Montreal, Quebec	750	400	CKCE	Toronto, Ontario	667	450
CFXC	New Westminster, British Columbia	682	440	CKCH	Ottawa, Ontario	690	435
CHAC	Halifax, Nova Scotia	750	400	CKCK	Regina, Saskatchewan	714	420
CHBC	Calgary, Alberta	732	410	CKCO	Ottawa, Ontario	750	400
CHCB	Toronto, Ontario	682	440	CKCX	Calgary, Alberta	682	440
CHCD	Quebec, Quebec	732	410	CKOC	Hamilton, Ontario	732	410
CHCE	Victoria, British Columbia	750	400	CKY	Winnipeg, Manitoba	667	450

CUBAN BROADCASTING STATIONS

CALL LETTERS	LOCATION	(KILO-CYCLES)	WAVE LENGTH	POWER (WATTS)	CALL LETTER	LOCATION	(KILO-CYCLES)	WAVE LENGTH	POWER (WATTS)
PWX	Habana	750	400	500	2WW	Habana	1428	210	20
2DW	Habana	1000	300	100	5EV	Colon	833	360	100
2AB	Habana	1250	240	20	6KW	Tuinucu	882	340	100
2OK	Habana	833	360	100	6KJ	Tuinucu	1090	275	100
2BY	Habana	1153	260	100	6CX	Cienfuegos	1765	170	25
2CX	Habana	937	320	10	6DW	Cienfuegos	1333	225	10
2EV	Habana	1363	220	50	6BY	Cienfuegos	1000	300	100
2TW	Habana	1300	230	20	6AZ	Cienfuegos	1500	200	10
2HC	Habana	1090	275	500	6EV	Caibarien	1333	225	10
2LC	Habana	1200	250	30	7AZ	Camaguey	1333	225	10
2KD	Habana	857	350	100	7BY	Camaguey	857	350	500
2MN	Habana	1110	270	300	8AZ	Santiago de Cuba	1250	240	20
2MG	Habana	1190	280	20	8BY	Santiago de Cuba	1200	250	100
2JQ	Habana	2000	150	10	8FU	Santiago de Cuba	1333	225	15
2KP	Habana	1500	200	10	8DW	Santiago de Cuba	1090	275	50
2HS	Habana	1666	180	20	8EV	Santiago de Cuba	1666	180	75
2OL	Habana	1035	290	10	8GT	Santiago de Cuba	1153	260	50

TOTALS

Number of U. S. broadcasting stations	575
Number of Canadian broadcasting stations	44
Number of Cuban broadcasting stations	34

THE photograph which we print this month as the frontispiece was secured through the kindness of the *Wireless World and Radio Review* (London). We are also indebted to that publication for the two drawings by Will Dare on pages four and five, illustrating the article by W. H. Cary, Jr.

For the photograph on page twenty-three of the Biggin Hill receiving station of the British Broadcasting Company, we must thank that organization.

The prize-winners in the RADIO BROADCAST DX contest will be announced in our July number, and the successful home-built and ready made receivers will be described.

“GOLDEN-LEUTZ”

SUPER-PLIODYNE 9



THE PERFECT BROADCAST RECEIVER

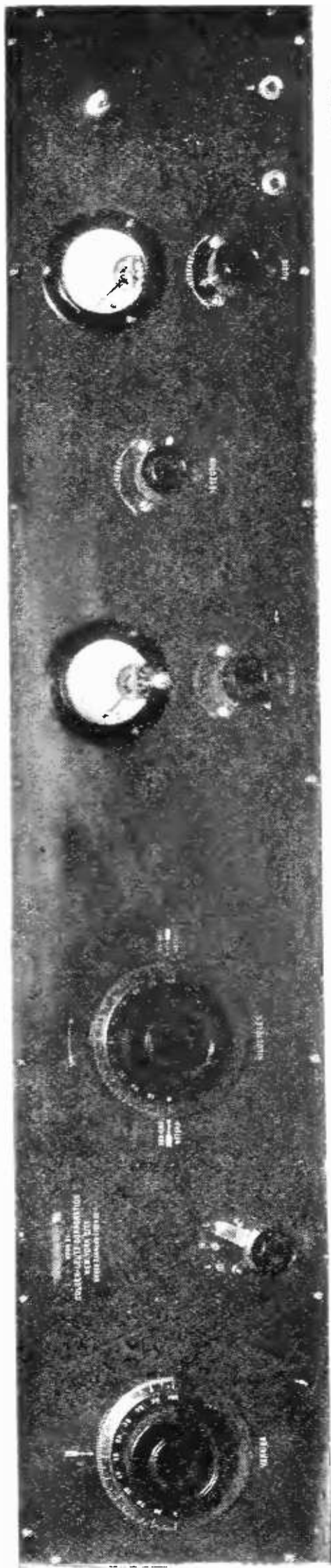

SIZE 40" x 8" x 8"

WEIGHT 65 LBS.

MANUFACTURED UNDER FARRAND LICENSE

A New Broadcast Receiver having 5 stages of Tuned Neutralized Radio Frequency Amplification, Detector and 3 stages of Audio Frequency Amplification

Built for People Who Want the Best

Complete Illustrated Catalogue and Instruction Book Mailed Upon Receipt of 25c

GOLDEN-LEUTZ INCORPORATED, 476 Broadway, New York City

★ Tested and approved by RADIO BROADCAST ★



“See! Dad
how much stronger it’s com-
ing in since you bought me

**BURGESS
RADIO BATTERIES**

SOMETIMES it’s Dad who does the buying for his radio family, but you may be sure that that youngster of his sits in on the advisory board.

In all events, whether it be the boy or his father who buys receiving set equipment, the service of Burgess Radio Batteries provides a most satisfactory and economical means to greater enjoyment of the evening’s radio entertainment.

“ASK ANY RADIO ENGINEER”

BURGESS BATTERY COMPANY

ENGINEERS - DRY BATTERIES - MANUFACTURERS
FLASHLIGHT - RADIO - IGNITION - TELEPHONE

GENERAL SALES OFFICE: HARRIS TRUST BLDG., CHICAGO
LABORATORIES AND WORKS: MADISON, WISCONSIN

BRANCHES

NEW YORK BOSTON KANSAS CITY MINNEAPOLIS
WASHINGTON PITTSBURGH ST. LOUIS NEW ORLEANS

IN CANADA

PLANTS: NIAGARA FALLS AND WINNIPEG
BRANCHES: TORONTO • MONTREAL • ST. JOHN

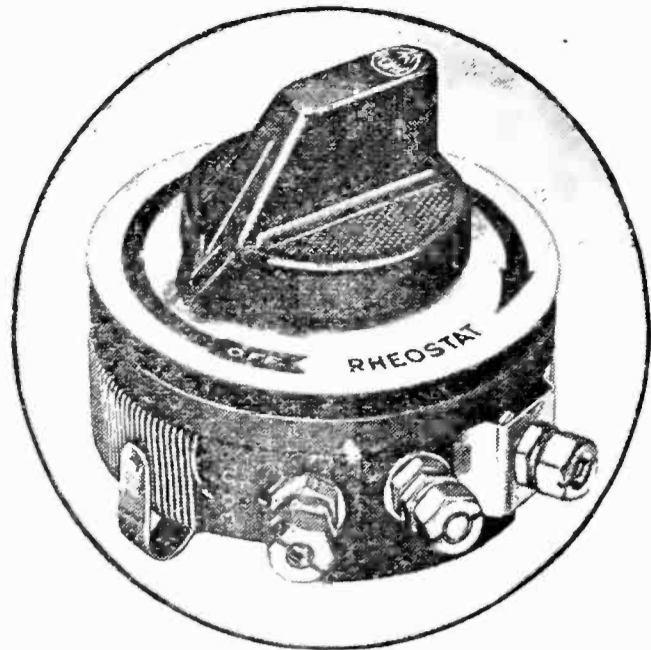

The Pacent ★
RHEOSTAT
A Favorite

The merit in the Pacent Rheostat is evidenced in its choice by leading radio authorities and its selection as standard equipment by leading set manufacturers.

It is ideal, considered from standpoints of design, operation and attractiveness of appearance. Construction in only two units simplifies installation. Fastening a single set screw insures against parts loosening or knob turning beyond its range. The Rheostat is supplied entirely complete with screws for mounting, knob and silvered dial.

Pacent Rheostats are made in a number of resistances for various needs.

Cat. No.	Resistance	Capac. Amp.	Price
85-A	6 Ohms	1.5	\$1.00
85-B	10 “	1.0	1.00
85-C	20 “	.6	1.00
85-D	30 “	.5	1.00
85-E	50 “	.3	1.00
85-F	2½ “	2.5	1.20
88	375 “	.2	1.25

Write for Catalogue B-5

PACENT ELECTRIC Co. Inc.
22 Park Place New York, N. Y.

Pacent
RADIO ESSENTIALS

★ Tested and approved by RADIO BROADCAST ★

Haynes-Griffin

RADIO SERVICE, Inc. 41 West 43rd St., N. Y. City



A. J. HAYNES
Designer of the Haynes Set

The Haynes Condenser

\$3.50

Meets every requirement — extreme low minimum capacity and maximum capacity of exactly .00023 mfd. No other condenser is exactly like it—no other achieves just the right balance between perfect selectivity and over-critical adjustment.

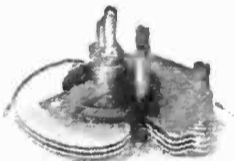

The Haynes Bank Wound Vario-Coupler

\$4.35

Furnished with only the taps you actually use and just the right number of turns on the secondary. Bank winding provides 100% efficiency on higher broadcasting wave lengths.

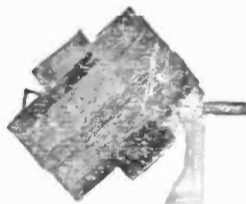

Haynes-Griffin Transformer

\$4.25

An efficient intermediate wave radio frequency transformer; uniformly tuned to a limited wave length range, and providing a degree of quietness heretofore unknown in transformers of this type. Haynes-Griffin Input Transformer also \$4.25.

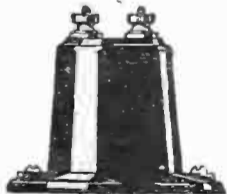

HAYNES-GRIFFIN RADIO SERVICE, Inc.

Mail Order Dept.—145 W. 45th ST., N. Y. City

Retail Store—41 W. 43rd ST., N. Y. City

Four Notable Articles on RADIO DESIGN

1: "How to Build the Haynes DX Receiver," by Laurence M. Cockaday, Technical Editor of "Popular Radio." (September, 1923 issue.) Mr. Cockaday finds the Haynes Set ideal for the average man who wants ease of operation, great selectivity, and excellent long distance reception.

2: "How to Build a Two-Stage Audio Frequency Amplifier," also by Mr. Cockaday (October, 1923 issue.) This article tells how to build the Haynes Amplifier to give loud speaker volume with the Haynes Set.

3: "A Simplified Super-Heterodyne," by A. J. Haynes (January, 1924 "Radio Broadcast"). The set described represents the result of Mr. Haynes's search for perfection after nineteen previous experimental models had been built.

4: "Shooting Trouble in the Super," also by Mr. Haynes (March, 1924 "Radio Broadcast.") Here Mr. Haynes gives many practical suggestions for meeting almost every conceivable difficulty which may develop in the super-heterodyne.

THE DEMAND FOR THESE ARTICLES IS WORLD-WIDE

In the history of radio no articles on radio design have attracted more widespread enthusiasm. Thousands of letters from all parts of the world have asked us for copies.

Through the courtesy of "Popular Radio" and "Radio Broadcast" we are able to offer them to interested experimenters at the actual cost of printing and mailing.

Simply send 4c in stamps for each article wanted. Use the handy coupon.

New York's
Largest Radio Store



Haynes-Griffin

145 W. 45th St.,
New York City

Send me articles checked below. I enclose 4c in stamps for each one wanted:

- 1: Haynes DX Receiver
- 2: Audio Amplifier
- 3: Simplified Super
- 4: Shooting Trouble

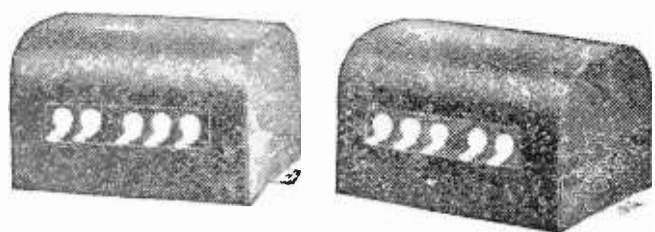

“COMO DUPLEX” TRANSFORMERS

(Push-Pull Power Type)

★
Send for Copy of—
“How to build a Power
Amplifier”

Over 10,000 replies were received from one article pertaining to power amplification using “Como Duplex” transformers—most of them are now enthusiastic users. Why not join them?

PRICE \$12.50
Per Pair

The first and best power type transformers offered the radio enthusiast. In competition COMO stands alone! We can prove it. In a competitive test embracing all push-pull transformers on the market Mr. Laurence M. Cockaday, well known Radio Engineer, finds COMO the best and therefore specifies it in his latest radio receiver—the four circuit tuner—Take advantage of Mr. Cockaday’s investigation and use COMO yourself to obtain greater Volume, better quality and freedom from tube noises that ordinary transformers produce. A great deal of the noise that is blamed on “static” is really tube noise amplified by improperly designed transformers. COMO may be used with your present amplifier, giving you more volume on weak signals that more of the ordinary amplification would kill.

Take No Chances—Use COMO
The World’s Standard Push-Pull Transformer

COMO APPARATUS COMPANY
446 Tremont Street - Boston, Mass.

The **Sodion** Tube
Non Oscillating
Non Interfering
“The Golden Rule Tube”
CONNECTICUT TELEPHONE & ELECTRIC COMPANY
MERRIDEN CONNECTICUT

Use — Price 75¢
DURHAM
Variable Grid Leak

At dealers, or postpaid
Durham & Co., 1936 Market St., Phila.

CHARGE YOUR BATTERY FOR A NICKEL ★
The Gold Seal Homcharger
Charges Radio and Auto Batteries at home overnight for a nickel. Your dealer has it. Write for FREE booklet and list of broadcasting stations.
The Automatic Electrical Devices Co.
128 West Third St., Cincinnati, Ohio

R-212
“The Best
Built Set
in America”



Licensed by J. R. M. Inc.
under Hazeltine Patents

Embodiment of the Hazeltine Neutrodyne circuit in an improved form as to neutralization, workmanship, quality, appearance and efficiency of operation.

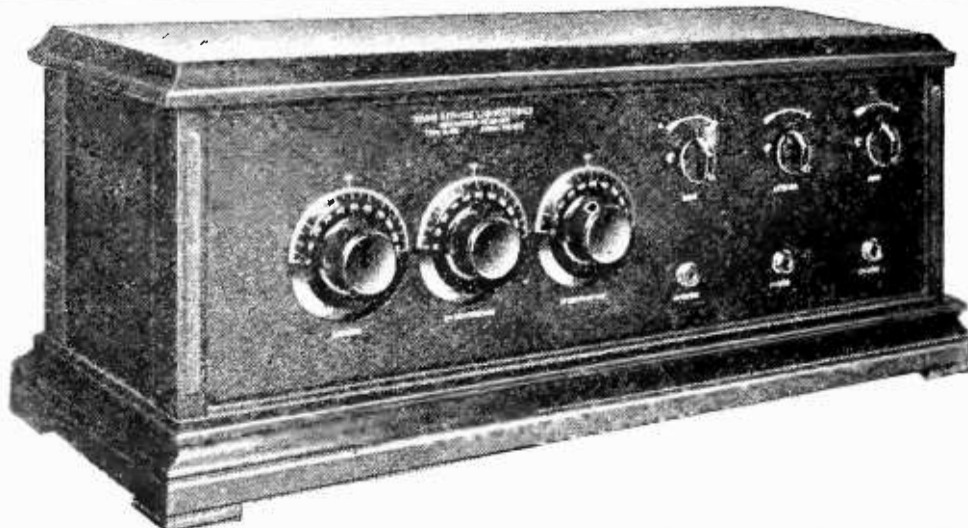

RADIO SERVICE LABORATORIES 1005 11th Ave., ASBURY PARK, N. J.

★ Tested and approved by RADIO BROADCAST ★

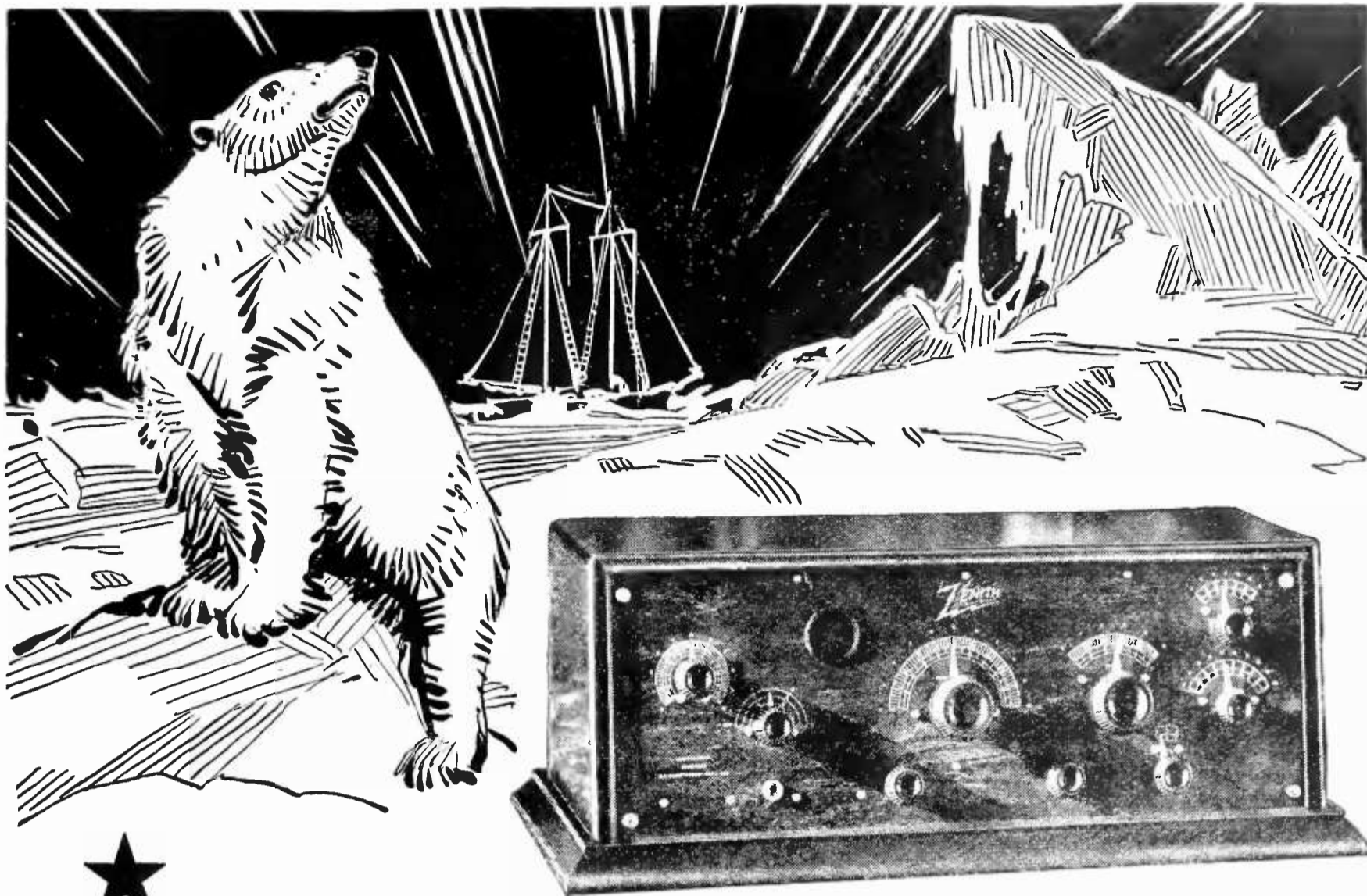

Licensed under Armstrong U. S. Patent No. 1,113,149

Eleven Degrees from the North Pole

Ice—endless miles of ice, as far as the eye can see. And frozen fast in the ice, amid the deadly stillness and the unearthly lights of the Arctic, a staunch little eighty-nine foot schooner! But Donald B. MacMillan and his band of brave explorers are not alone tonight.

Under their ice-bound hatches they listen eagerly to the news of the outside world, broadcast to them from the Zenith - Edgewater Beach Hotel Broadcasting Station, Chicago—to violins in Newark, Schenectady, Los Angeles—to singers in Atlanta—to a lively orchestra in Honolulu.

Stations in all these cities—and in several hundred others—they have readily tuned in; yet the Bowdoin tonight is only eleven degrees from the North Pole!

Out of all the radio sets on the market, Dr. MacMillan selected the Zenith exclusively—because of its flawless construction, its unusual selectivity, its dependability and its tremendous REACH.

And you can do all that Dr. MacMillan does, and more, with either of the two new models described at the right. Their moderate price brings them easily within your reach. Write today for full particulars.

Zenith Radio Corporation
McCORMICK BUILDING, CHICAGO, ILLINOIS



Model 3R The new Zenith 3R "Long-Distance" Receiver-Amplifier combines a specially designed distortionless three-stage amplifier with the new and different Zenith three-circuit regenerative tuner.

Fine vernier adjustments—in connection with the unique Zenith aperiodic or non-resonant "selector" primary circuit—make possible extreme selectivity.

2,000 to 3,000 Miles With Any Loud-Speaker

With the new Zenith 3R satisfactory reception over distances of 2,000 to 3,000 miles, and over, is readily accomplished in full volume, using *any ordinary loud-speaker*. No special skill is required. The Model 3R is compact graceful in line, and built in a highly finished mahogany cabinet **\$160**

Model 4R The new Zenith 4R "Long-Distance" Receiver-Amplifier comprises a complete three-circuit regenerative receiver of the feed-back type. It employs the new Zenith regenerative circuit in combination with an *audion detector* and *three-stage* audio-frequency amplifier, all in one cabinet.

The Zenith 4R may be connected directly to any loud-speaker *without* the use of other amplification for full phonograph volume, and reception may be satisfactorily accomplished over distances of more than 2,000 miles **\$85**

ZENITH RADIO CORPORATION,
Dept. T, 328 South Michigan Avenue, Chicago, Illinois
Gentlemen:
Please send me illustrated literature on Zenith Radio.

Name

Address.....

★ Tested and approved by RADIO BROADCAST ★

1500 MILES and More on ONE TUBE

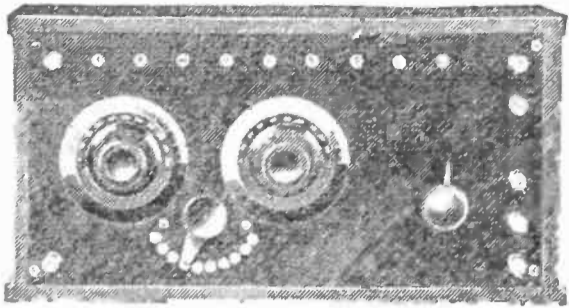

FRONT VIEW

"SHEPCO" "All Purpose" Non Radiating Receiver

TRADE MARKED—PATENTS GRANTED and PENDING

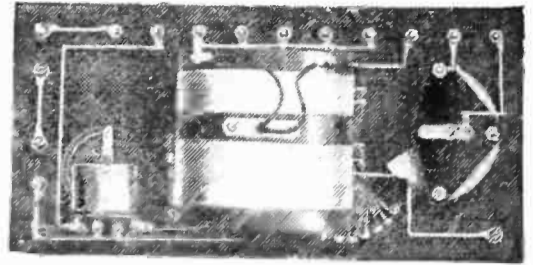

REAR OF PANEL

Thousands of Fans are doing better — A Guaranteed DX Getter

"SHEPCO" "All Wave" Jr. Non Radiating DX Coupler

PATENTS GRANTED and PENDING

Combination flat and bank wound. Eliminates use of variometers, vario-couplers and loading coils. Guaranteed to bring in distant stations loud and clear on one tube. Guaranteed wave length 150 to 1,000 Meters in single circuit. 150 to 700 Meters in triple circuit. At all dealers or sent prepaid on receipt of \$6 price

A complete one tube set mounted on genuine Bakelite panel in finely finished genuine mahogany cabinet. Equivalent to one step of audio frequency for volume. Equal to much more expensive many-tubed sets for distance and selectivity.

All Parts Genuine

Contains only best units—guaranteed genuine "SHEPCO" "All Wave" Jr. DX Coupler and genuine U. S. Tool Condenser.

Interchangeable Circuits

May be used as complete single, double, or triple circuit, single tube reflex, part of plate variometer set, plate and grid variometer set and as tuner in many other circuits. Hook-ups can be changed quickly, without tools.

Price, Without Accessories Absolute Money Back Guarantee **\$21**

At your dealers or sent prepaid on receipt of order and remittance.

SHEPARD-POTTER CO. INC.
Plattsburgh New York

Set of six efficient hook-ups with every set or sent on receipt of 10 cents in stamps to cover cost of mailing.

Two stage Audio Amplifying Unit for use with "SHEPCO" "All Purpose" or any other **\$21** set.



1/2 Actual Size

Standardize Now On These Quality Radio Parts **PREMIER**

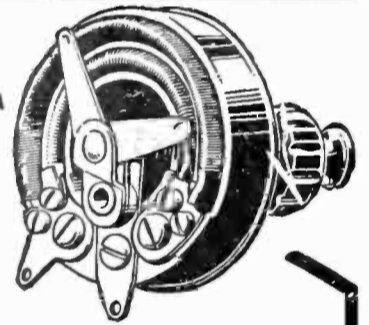

"HEGEHOG" Audio Transformers

\$3.50 The smallest, yet the most efficient Transformer ever made. Maximum reproduction value, minimum distortion, 100% shielded. Mounts anywhere—saves space in assembly. We guarantee it unconditionally. Try "Hegehog" in your next "hook-up." Ratio 1 to 3, 1 to 4, 1 to 5 \$4.50; 1 to 10 \$4.50. Write for free Bulletin No. 92, describing complete Premier list.

"MICROSTAT" Super-Vernier Rheostat

Two windings in parallel—one 6 ohms—other 40 ohms. Absolutely noiseless. Infinite control. Handles any tube. Cap. 3 amp. Bakelite moulded. Silver etched dial. The finest detector tube rheostat made—bar none. **LET US PROVE IT.** Fully guaranteed. Write for free Bulletin No. 92, describing complete Premier line.

ASK YOUR DEALER

★ **Premier Electric Company**
3812 Ravenswood Avenue CHICAGO

ASK YOUR DEALER

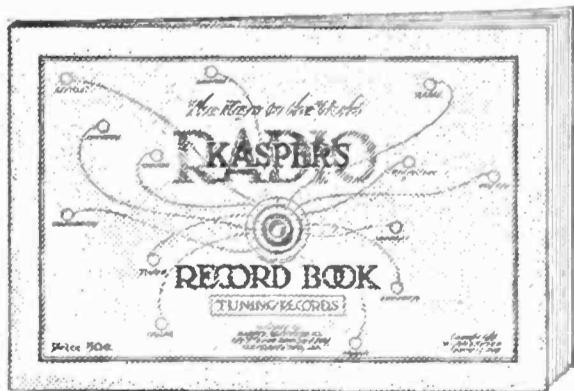

"SPIKE"

The Stations You Receive in a Kasper Radio Record Book

Then you will know where to set the Dials, Switches and Rheostats to bring them back. This book is endorsed by thousands of professional Radio Fans in all parts of the country, because it covers everything on the panel. (copyrighted) Can be used with any set. Contains up-to-date list of 1,100 Broadcasting Stations, Time of Principal Cities and instructions How to Record Stations. 24 pages, Valuable information. No set complete without one. 50c a copy, Postpaid. For your convenience enclose a one dollar bill for two copies, otherwise send Money Order for one or more. No checks nor stamps. We also furnish Kasper's "APPLAUSE CARDS" printed on stamped postal cards. 25 mailed anywhere upon receipt of 50c.

KASPER BROTHERS COMPANY, 317 Lorain Street Bank Building, Cleveland, Ohio, U. S. A.

★ Tested and approved by RADIO BROADCAST ★

Attend the Presidential Conventions !

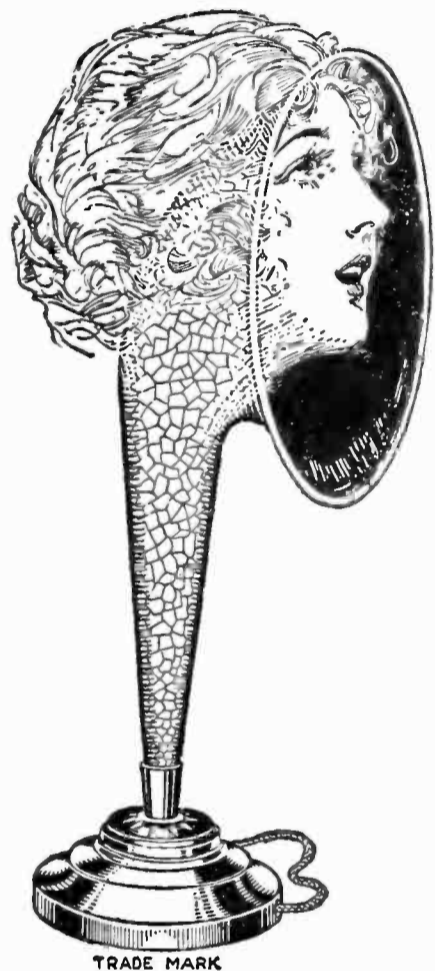

TRADE MARK

Complete \$25



Atlas Unit with
phonograph coupling \$13.50

Through the
Atlas
TRADE MARK

RADIO-REPRODUCTION
LOUD SPEAKER

HEAR the famous speakers as distinctly as though you were actually present. The ATLAS produces this marvelous illusion. Give your family and friends a real treat. Order your ATLAS Loud Speaker now.

Booklet "A" upon request

Multiple Electric Products Co. Inc.

Makers of MONOTIME LAG FUSES—MULTIPLE

2 ORANGE ST.

NEWARK, N. J.

Sole Canadian Distributors:

Marconi Wireless Telegraph Co. of Canada Ltd., Montreal, Canada.

District Offices in

Boston, Mass. Philadelphia, Pa. Baltimore, Md. Buffalo, N. Y. Rochester, N. Y.
Pittsburgh, Pa. Detroit, Mich. Chicago, Ill. St. Louis, Mo.
Denver, Col. San Francisco, Cal.

★ Tested and approved by RADIO BROADCAST ★



SELECTIVITY and VOLUME

Chelsea Parts Insure Both

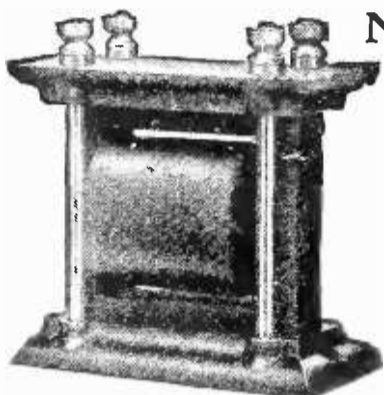

No. 50 Amplifying Transformer

Genuine bakelite insulation. Highest grade silicon steel core. Tested to 500 volts. Easy to assemble in your set. Ratio $3\frac{3}{4}$ to 1.

Price \$4.50

No. 95 Variocoupler

Stator and rotor wound on genuine bakelite tubing. Pig-tail connections to rotor and taps on stator brought to binding posts. Will give maximum results in any circuit. Panel Mounting. Price without dial, \$3.50; with dial, \$3.95.

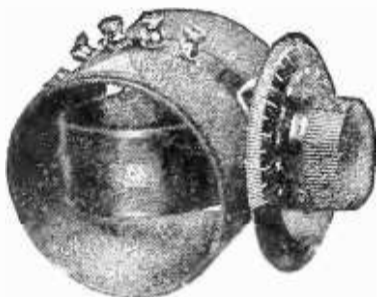

Panel Mounting Condenser

Low Loss

Genuine bakelite insulation. Pig-tail connection to rotor. Absolutely guaranteed.

No. 10—23 plate with Vernier, \$4.50.

No. 61 Moulded Socket

is moulded of genuine bakelite and has four easily accessible binding posts. Positive connection is assured at all times by the use of four heavy phosphor bronze contact springs. For 199 tubes. Price, \$0.50.



Chelsea offers a complete line of sets and parts

At your dealers or write direct



CHELSEA RADIO COMPANY
151 Spruce St. Chelsea, Mass.

COAST-TO-COAST RECEPTION *--and Beyond*

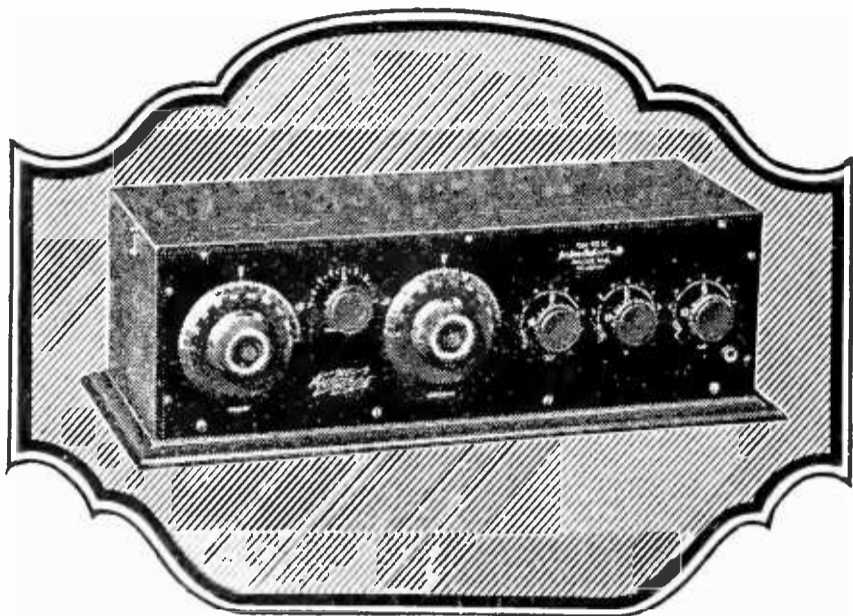

RADIODYNE

"The Voice of the Nation"

NO LOOPS - - - NO ANTENNA

With the RADIODYNE you can select broadcast programs from all parts of the country. Honolulu and London have often been picked up by operators in the central states without interference from nearby stations.

The Radiodyne is ready for operation by simply grounding to a water pipe or radiator, and throwing a few feet of wire on the floor. Uses any standard tubes—dry cell or storage battery. Extremely selective. Simple to operate—**Only two controls**—you can tune in on any program you wish—any wave length from 200 to 700 meters.

For use in apartments, boats, automobiles, railroad trains, etc., the RADIODYNE is enjoyable where other receiving sets would not be practical.

PRICE \$150.00

Write for illustrated folder which describes the RADIODYNE in detail. Every radio fan will be interested in this new type (antennaless) receiving set.

WESTERN COIL & ELECTRICAL CO.
318 5th Street :: :: Racine, Wisconsin



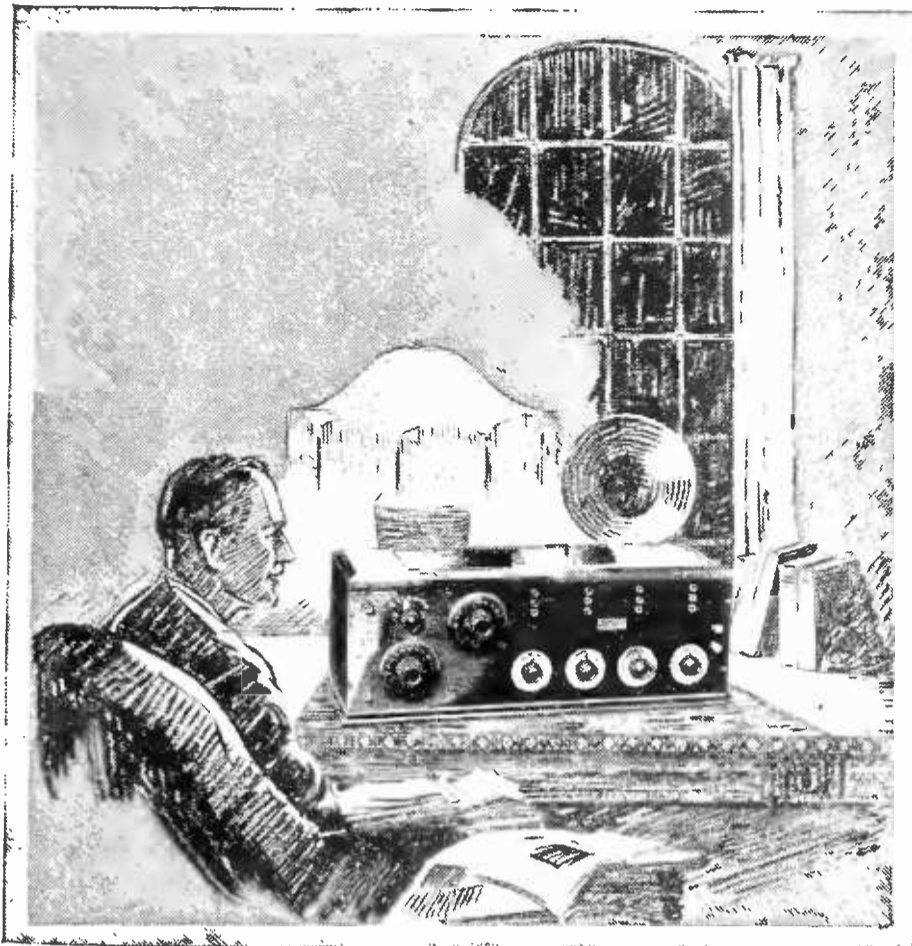

EVERY ONE CAN NOW OWN A QUALITY RADIO SET

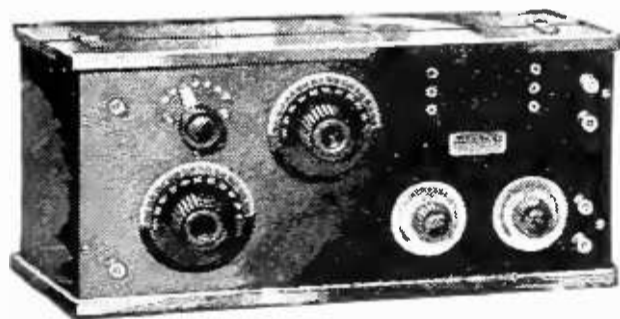

This is Model K—the much-talked-of outfit with which Mr. E. D. Elliott of Milford, New York, got London, England; Fairbanks, Alaska; La Palma, Panama; San Francisco; Los Angeles and about 122 other long distance stations.

It's a two-tube outfit that sells for only **\$29.50**

MODEL M W

Shown in the illustration at the top of the page is our 4-tube outfit that can be used with a loud speaker. It sells for only **\$54.50**

Write for bulletin.

These two Improved Miraco models make it possible for every family to own their own set—to have a choice seat for the opera or symphony or jazz concert right in their own living room.

Improvements and refinements that appear in expensive sets only—are built in each and every MIRACO. In other words, *highest quality at the lowest price* has been solely responsible for the sale of thousands of our sets that are bringing radio-joy to each and every family who own one. Users of Miraco sets report getting as many as fifty stations in one evening.

The cabinets are of solid mahogany and workmanship is unexcelled. Easy and simple to operate and always dependable. Fully **GUARANTEED** against any defects in workmanship.

Write for our new bulletin TO-DAY

DEALERS — JOBBERS. Write for proposition quickly
AGENTS. There's still some territory open
—write or wire

THE MIDWEST RADIO COMPANY
806 Main Street Cincinnati, Ohio

The Improved ★
MIRACO

RHAMSTINE★ VICTOPHONE

For All Phonographs and Loud Speaking Horns

In addition to the large diaphragm used in the Victophone, every other detail has been given the closest attention. When incorporated with your phonograph or horn, it will reproduce with the utmost volume and purest tone. No battery required to operate it. Your money back if not satisfied.

It can be furnished to fit all phonographs—the Standard Type fits the Victrola, Columbia, Jewett or Sonora. Specify make of phonograph when ordering. List price, Standard Type, \$7.50.

Order the New Victophone and test it before buying any other loud speaker

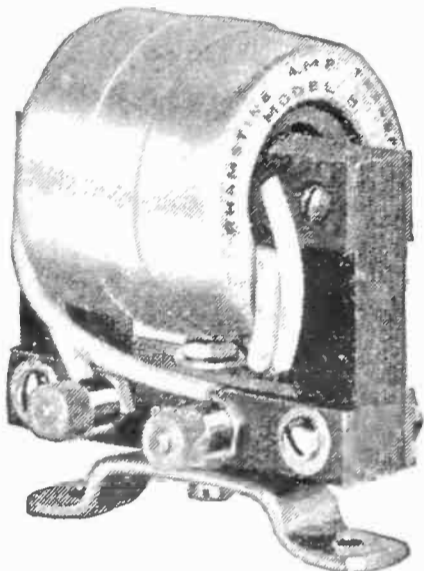

\$4.00 Postpaid

RHAMSTINE* Model B, Type 3 Amplifying Transformer

Especially Designed for Reflex Circuits, Ratio 5 to 1

Years of success in manufacturing Audio Frequency Transformers prompt the statement that you can find no better unit than the Model B. In reflex usage, the type 3—ratio 5 to 1—is highly efficient.

Order yours and secure greater range and volume with your set

Manufactured by

J. THOMAS RHAMSTINE*

506 E. Woodbridge

Detroit, Michigan

* Maker of Radio and Electrical Products

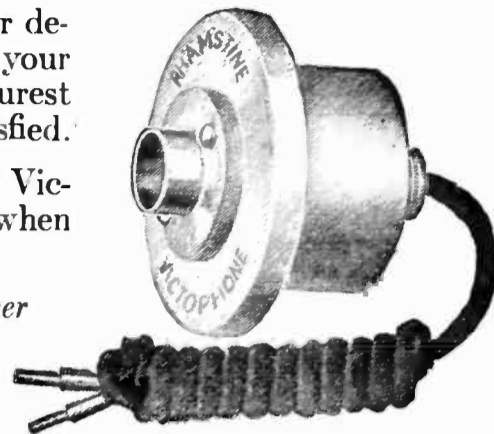

\$7.50 Postpaid
Complete with Cord

RADIO TUBE EXCHANGE

We Repair All Standard Makes of Tubes
Including

W. D. 11 or 12
U. V. 199 or C. 299
C. 11 or 12
U. V. 201A or C. 301A
D. V. 1 or D. V. 2
U. V. 200 or 201
C. 300 or 301

\$2.50



All tubes guaranteed to do the work.

RADIO TUBE EXCHANGE
200 BROADWAY NEW YORK

All Mail Orders Given Prompt Attention
Orders sent Parcel Post C. O. D.

Business Man's Dictionary And Guide to English

A complete and authoritative work for
the business office—dictionary,
letter and ad. writer, etc.

Net \$3.00

Doubleday, Page & Co.,
Garden City New York

ABSOLUTELY FREE
Thousands of
RADIO BARGAINS

You Can't Equal This Anywhere
SRACO head sets—2,000 Ohms—head
bands and cord complete. Extremely
sensitive. Write
Dept. G. for won-
derful catalogue. **\$2.98**

STANDARD RADIO CORP.
227 WEST MADISON ST. CHICAGO

Big Catalog
FREE

LEARN THE CODE AT HOME with the OMNIGRAPH

*"Just Listen—The Omni-
graph will do the teaching"*

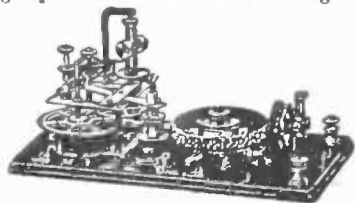

THE OMNIGRAPH Automatic Transmitter will teach you both the Wireless and Morse Codes—right in your own home—quickly, easily and inexpensively. Connected with Buzzer, Buzzer and Phone or to Sounder, it will send you unlimited messages at any speed, from 5 to 50 words a minute.

THE OMNIGRAPH is not an experiment. For more than 15 years, it has been sold all over the world with a money back guarantee. The OMNIGRAPH is used by several Depts. of the U. S. Govt.—in fact, the Dept. of Commerce uses the OMNIGRAPH to test all applicants applying for a Radio license. The OMNIGRAPH has been successfully adopted by the leading Universities, Colleges and Radio Schools.

Send for FREE Catalogue describing three models. DO IT TO-DAY.

★ THE OMNIGRAPH MFG. CO., 16K Hudson St., New York City

If you own a Radio Phone set and don't know the code—you are missing most of the fun

★ Tested and approved by RADIO BROADCAST ★

Pathé



“MINUTE MAN”

Radio Receiving Set

incorporating

Pathé Type “P” Phusiformers

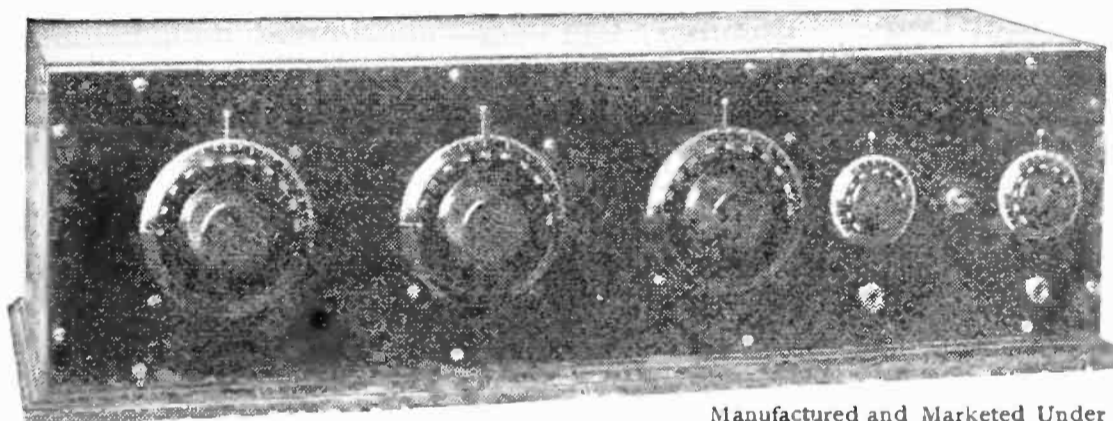

Manufactured and Marketed Under
License Agreement, Patent Pending

Price \$125.00 (tubes, batteries extra)

The new five-tube “Minute Man” was specially constructed to meet the demand for a receiving set embodying these features:

NO SQUEALS

Tune in either with a loud speaker or head phones without any squeals or rasping. At any setting of the dials there is none of this unpleasantness so prominent in many other sets.

PURE TONE

The reproduction of broadcasting by the “Minute Man” is remarkable for its clarity and sweetness of tone, increasing your enjoyment a hundredfold.

SIMPLICITY

The “Minute Man” is simplicity itself to operate. The dials can be adjusted by a child—and the set is “Fool-proof.” The dial settings are constant. A station once located can always be brought in without preliminary searching.

Genuine mahogany cabinet and panels. Gold engraved dials

FREE BOOKLET

Booklet “How to Build a 5-Tube Receiver, Using Three Phusiformers,” sent free on request. Write Dept. 205.

PATHÉ PHONOGRAPH AND RADIO CORP.
20 Grand Avenue Brooklyn, N. Y.

★ Tested and approved by RADIO BROADCAST ★

★ DUPLEx

**Series
"FR"**

TRADE MARK
NONE OTHER

Designed for grounding rotor — Wider wave band reception and transmission.

We feel that we have accomplished the supposedly impossible.

A condenser which is mechanically perfect with immeasurably small electrical losses.

Our final tests at one of the foremost universities follow with our 21 plate condenser between 400 and 530 meters.

Dial Setting	Capacity Mfds.	Resistance in Ohms Less Than	Phase Difference Less Than
100 with Vernier	.000547	.01	10 Seconds
100 without "	.000529	.01	10 "
75 " "	.000417	.01	10 "
50 " "	.000278	.01	10 "
24 " "	.000132	.01	10 "
0 " "	.000012	.01	10 "

At 1,000 cycles—resistance 10 ohms. Phase difference—10 seconds.

Some very profitable territory open for reputable jobbers. Write for booklet "Facts for Fans on Condensers."

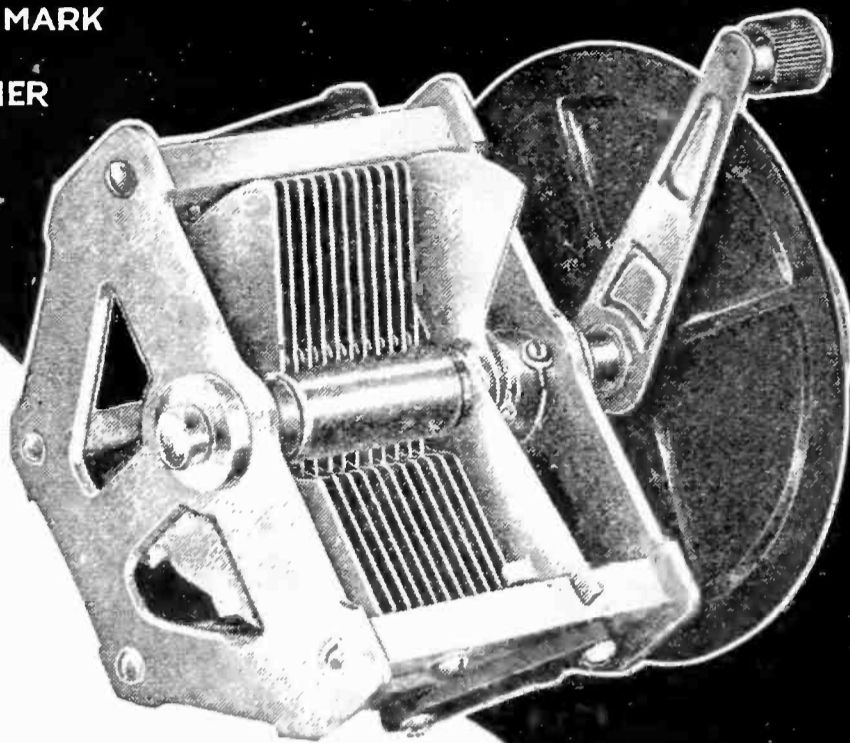

PATS. PEND.

THE DUPLEX ENGINE GOVERNOR COMPANY, Inc.
46 Flatbush Avenue Extension, BROOKLYN, N. Y.

ALL-AMERICAN Amplifying TRANSFORMERS

- are the largest selling transformers in the world
- are standard on the better sets
- are endorsed by the leading radio engineers
- are recommended by all the better dealers.

Over half a million in use and giving real satisfaction.

**THE BEST
~ PAY NO
MORE!**

Audio Freq. 3-1, \$4.50,
5-1, 10-1, \$4.75. R.F.
\$4.50. Power \$6 ea.

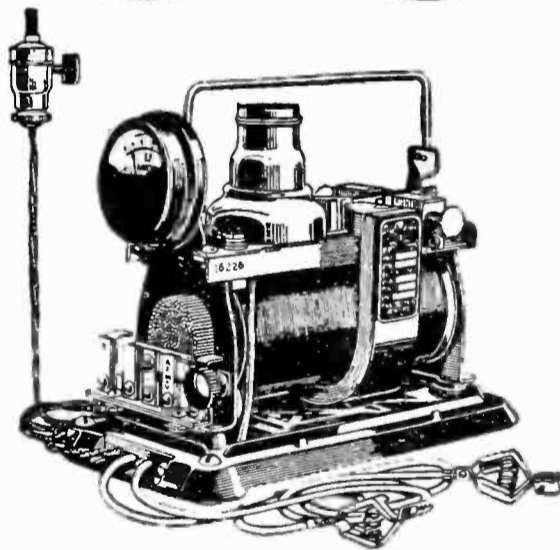

A Triply Good Buy

The type A.B.—FF charger performs three duties economically. Charges radio 2, 4, or 6 volt "A" battery, radio "B" battery up to 120 volts, and auto batteries. Average cost per charge about a nickel. Solidly built—will not get out of order. Fool-proof and simple. The first successful charger—introduced over ten years ago. Type A. B. price \$20, West of Rockies \$22; Type 6 for 6 volt A or auto batteries only, price \$15; West of Rockies \$16. B battery charging attachment, \$2.50 extra.

Write for new Bulletin on station calls, battery upkeep and wiring diagrams of basement installation of batteries. We will send dealer's name.

THE FRANCE MFG. CO.
10441 Berea Road Cleveland, Ohio

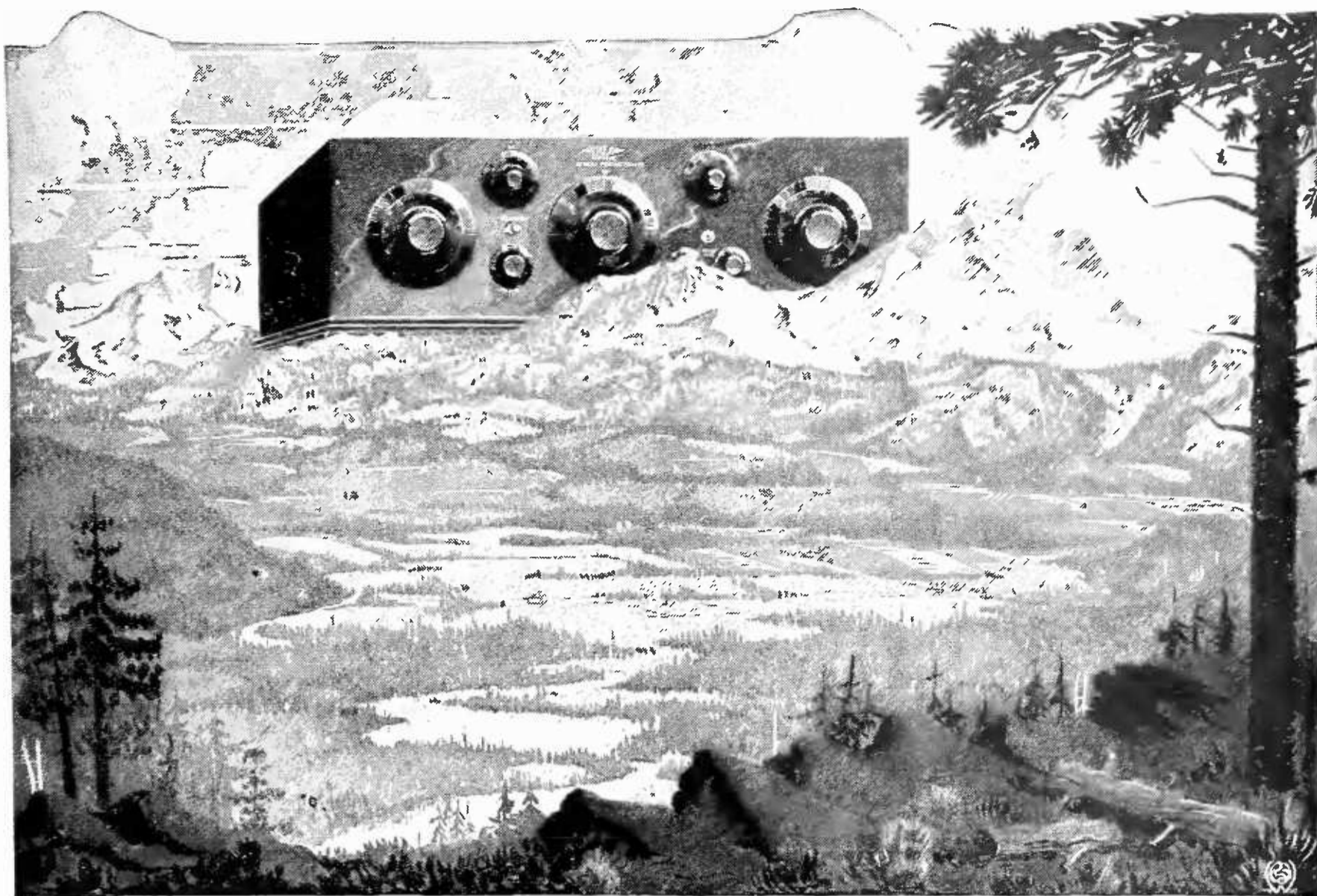

A C H I E V E M E N T

FOR ages the battle between Man and Nature has gone on. The harnessing of rivers, the bridging of oceans, the conquest of space and time,—all give evidence of Man's relentless efforts to overcome the barriers which Nature sets up to challenge his skill and ingenuity.

With the unflinching courage of pioneers, Melco attacked the last barriers of the ether, bringing the treasures of the radio art within the

reach of all. Today, the Melco receiver is supreme in its achievements.

Melco was the first to level the sinister mountains of *Interference*, *Distortion* and *Signal Losses*. By its improved design and intensive engineering, the Melco-Supreme has made distance reception the servant of the non-technical user. It has set new standards of selectivity and freedom from interference and its superb tone quality has captivated even the most critical.



AMSCO PRODUCTS, INC. ★

Broome and Lafayette Streets, New York, N. Y.



★ Tested and approved by RADIO BROADCAST ★

★ Timmons Talkers

Where a Violin is not a Flute

The tones of Timmons Talkers are so natural, rich and vibrant that they make an especial and immediate appeal to musicians. Listening to a Timmons Talker you hear a flute as a flute and a violin as a violin—you would never mistake one for the other.

A large diaphragm—3½ inches—and the “reflecting” of all sounds through two horns are responsible for the deep, pleasing naturalness of the Timmons’ tones.

But you’ll have to hear a Timmons Talker to appreciate this naturalness. In doing this we are asking you to make your loud speaker choice in your own home. Don’t make a five-minute choice, take an entire evening.

We’ll be glad to help by sending an illustration detailing how a loud speaker works. We’ll also send our folder “Volume Without Noise.”

Type A (adjustable), \$35
Type N (non-adjustable), \$25

J. S. TIMMONS, 339 E. Tulpehocken St.
GERMANTOWN PHILA., PA.

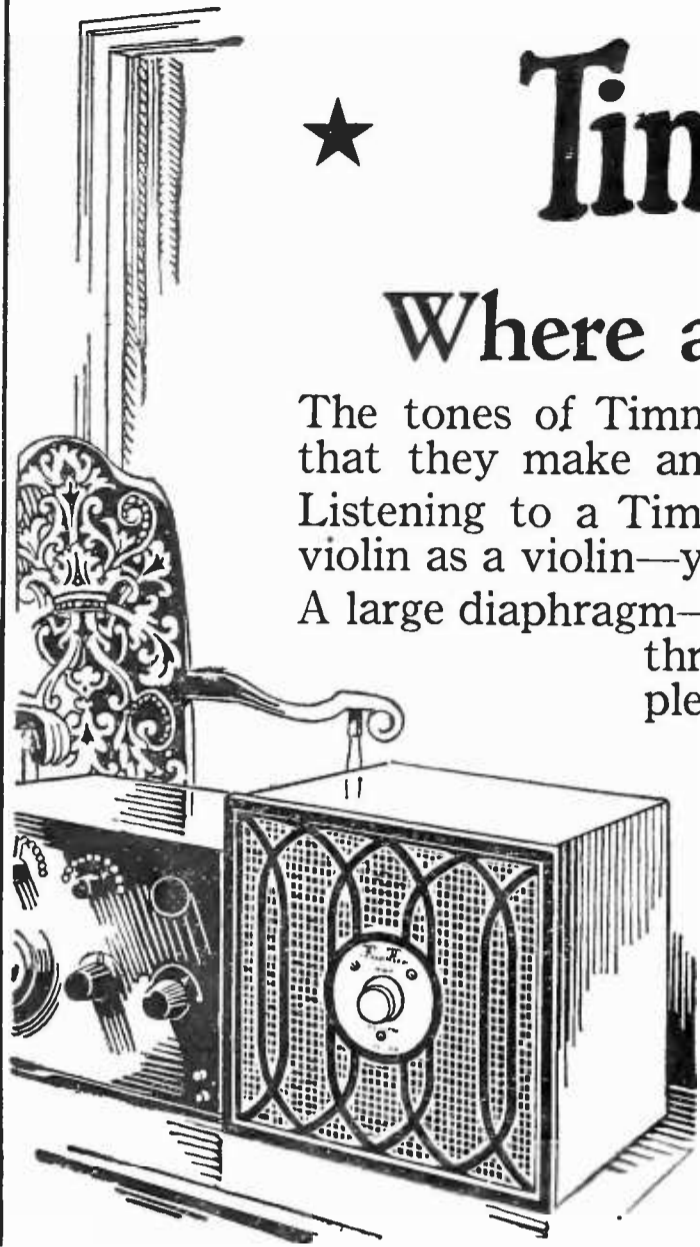

Crescent Lavite Resistances Absolutely Non-Inductive

12,000
48,000
50,000
100,000



List
\$1.50

Special resistance to order. Used in new Cockaday circuit. Dealers write for discounts.
CRESCENT RADIO SUPPLY Co. 5 LIBERTY ST., JAMAICA, N. Y.

Use INDIVIDUAL Call Cards and Radiograms with YOUR OWN Name, Address and Station



ARRL Emblem Added if Requested
MONEY REFUNDED if Not Satisfied
Cards: Red call, black printing.
High quality. 100—\$1.75; 200—\$2.75;
300—\$3.60, *postpaid*. Gov. post
cards 1 cent extra per card.

Radiograms: Same prices.
Write for INDIVIDUAL Radio Stationery and log samples and prices
Send order with check or money order Today — NOW.
RADIO PRINTERS, Dept. 85 Mendota, Illinois

STA-RITE RADIO BATTERIES SAVE YOU 60%

And Guarantee You in Writing 2 Years of Better Battery Performance
STA-RITE RADIO BATTERIES are made especially for Radio and the big saving is made possible by coming direct to you instead of thru distributors, dealers, etc. Boxes are made of oak, finished in mahogany and the plates very thick and will give a steady discharge over a long period. No premiums, just good honest battery value.

TRY TO BEAT THESE PRICES

2 Volt for W. D. 11 and 12	\$4.00	6 Volt 60 Amphr.	\$ 7.50
4 Volt for U. V. 199 Tubes	7.00	6 Volt 80 "	8.50
RADIO B. STORAGE Glass Jars, Heavy Plates— Case of 12 Cells 24 V.	4.90	6 Volt 100 "	10.00
		6 Volt 120 "	12.10
		6 Volt 150 "	14.00
		6 Volt 200 "	17.00

Get Yours Today — NOW — Send No Money

The batteries are fully guaranteed in writing and shipped subject to examination on the day your order is received. You pay on delivery or deduct 5 per cent if full cash accompanies order. You may deduct 10 per cent if two or more are ordered at one time.

STA-RITE BATTERY CO. . Dept 5 . LOUISVILLE, KY.

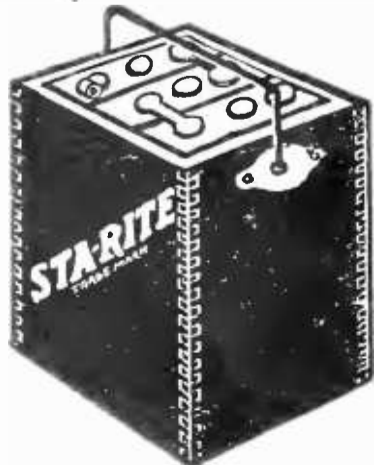

★ Tested and approved by RADIO BROADCAST ★

"Tune in" on Success

**Learn at Home
To be a Radio
Expert**

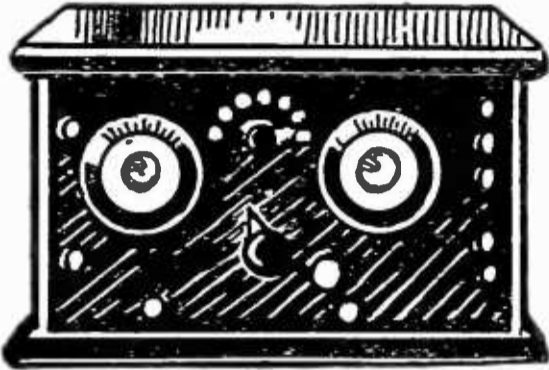

Radio Pays Big

The amazing expansion of Radio has opened thousands of wonderful new opportunities. Big salaries, easy and fascinating work, short hours and an excellent future are offered to ambitious men who enter the Radio field now.

**Free 1000
Mile Radio Outfit**

This set, when erected has a range of over 1,000 miles. The cabinet is elegantly finished in a beautiful, lustrous mahogany. You can sell it at a handsome profit if you care to, after you have completed my course. Remember, you do not pay a single penny for it.

Membership Is Valuable!

Upon completion of my course, you receive a membership in the Radio Association of America. This designates that you are a thoroughly trained Radio man. It gives you prestige and a standing in your community not otherwise possible.

Thousands of Big Pay Opportunities

My course enables you to construct, install, operate, repair and sell Radio equipment. As my representative, you can, using either your full time or spare time, take orders from your friends and neighbors. You can easily earn from \$35.00 to \$125.00 a week installing Radio sets in your locality. It is being done every day by my students. What others have done, you can do.

PROOF

Dear Mr. Mohaupt:
Your lessons are very easily digestible. To say that I enjoy them would be putting it very mildly — indeed, I crave them.
And, about the job at the Operadio Corporation; yes, I got it, thanks to you. I am learning to be an inspector at present, but I'll not stop there.
Please send me additional lessons as soon as possible.
GEO. A. GRAESSLE.

On this very day there is someone in your neighborhood who is buying a Radio Set from someone else and is having Radio work done by others. On this very day there are big pay Radio positions that are going begging. This will be repeated tomorrow and for a long time to come. Time is precious. Begin at once to get the training that will fit you to cash in on this great chance. At least investigate. Mail the coupon to get the interesting bulletin "Radio Facts."

**A. G. Mohaupt, Radio Engineer
Radio Association of America
4513 Ravenswood Ave., Dept. B5, Chicago, Ill.**

**Radio Experts Earn
\$3,000 to \$10,000 a Year**

New Radio Stations are being erected every day. Thousands of corporations are putting in private stations. Every large vessel requires its Radio Staff. From everywhere comes the urgent call for Radio Trained Men. There is almost no limit to the pay. Will you step forward and grasp this brilliant money-making chance or are you going to let days drift by and let others take in the cash?

"Learn by Doing" Method

My course is not "high-brow." It is written in plain everyday language that can be understood by any man. You need have no previous training or experience. I give you a receiving set so that I can take you through the various steps of Radio work in a practical way. You will be delightfully astonished in having made clear to you the wonderful forces of Radio that appear so mysterious to the untrained person.

FREE

I have ready for you a copy of "Radio Facts" which tells you of the latest opportunities that exist in the great field of Radio. I want you to note my "Money Back" guarantee that protects you absolutely. I also want to tell you about the big free 1,000 mile Radio Tube Set that I give away free with my course. I urge you to act at once. Fill in your name and address on the coupon and mail it to me immediately.

MAIL COUPON

A. G. Mohaupt, Radio Engr., Radio Assn. of America,
4513 Ravenswood Ave., Dept. B5, Chicago, Ill.

Please send me details of your Home Study Course—also your Free "Radio Facts" and information on how I can get a FREE 1,000 mile Radio Set.

NAME

ADDRESS

CITY..... STATE.....

ACCURATUNE

MICROMETER CONTROLS

"There's that Station"

"I have just tuned in on my Accuratune-equipped set, and with the ease of an amateur. For hours I've worked over that station with the old fashioned dials, and even vernier plate condensers. Now, with the slightest twist of the knob I pull in stations I never heard of.

"The Accuratune is not a mere dial but an actual Micrometer Control more efficient than vernier condensers or any tuning device, and far more simple to operate.

Designed for either coarse or precise tuning and to fit all standard condenser shafts. Price \$3.50

THE MYDAR RADIO COMPANY
9-D Campbell Street Newark, N. J.

Radio Ltd., Montreal, Canada
Canadian Representatives

For the Phonograph ★

The Accuratune Phonograph Attachment is applied instantly to the reproducing arm and converts your phonograph into a loud speaker. Permits the whole family to enjoy broadcast music. \$10.00.

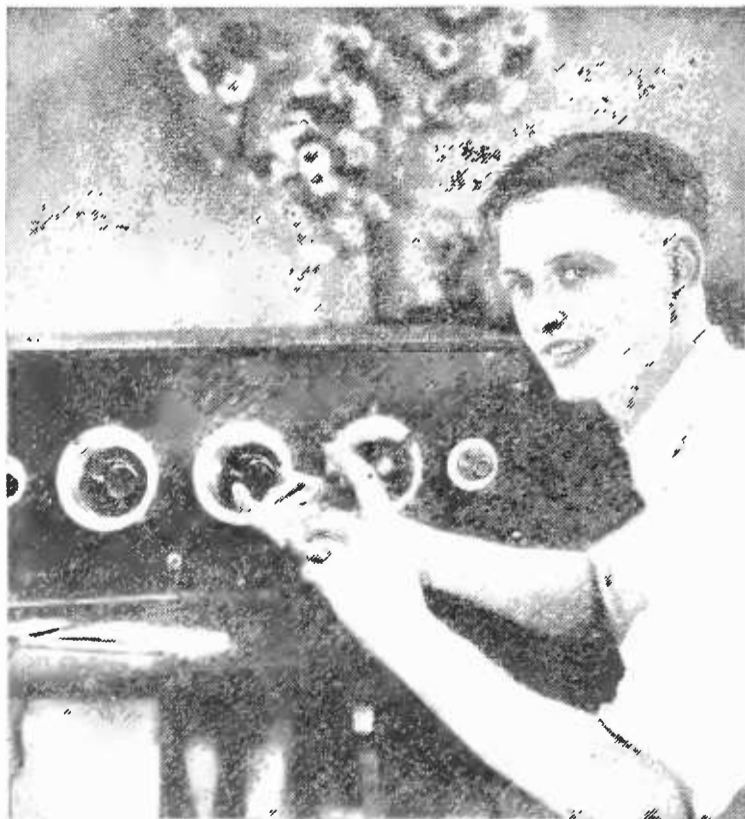

Perfectone

TRADE MARK



Here is the loud speaker that through merit has become the standard of comparison.

At your dealers, otherwise send purchase price and you will be supplied postpaid.

PERFECTONE RADIO CORPORATION
490-D BROOME STREET NEW YORK

The Lambskin Library

¶ The best works of such modern authors as Booth Tarkington, Joseph Conrad, William McFee, O. Henry and others, bound in red leather, stamped in gold, printed in clear type on good paper. Ideal books for your private shelf or for your library. Selling at *ninety cents* each, The Lambskin Library's selection represents the best bargain possible in the world of books.

At all bookstores

DOUBLEDAY, PAGE & CO.

★ Tested and approved by RADIO BROADCAST ★

The Super-Heterodyne Made Easy for Everyone!

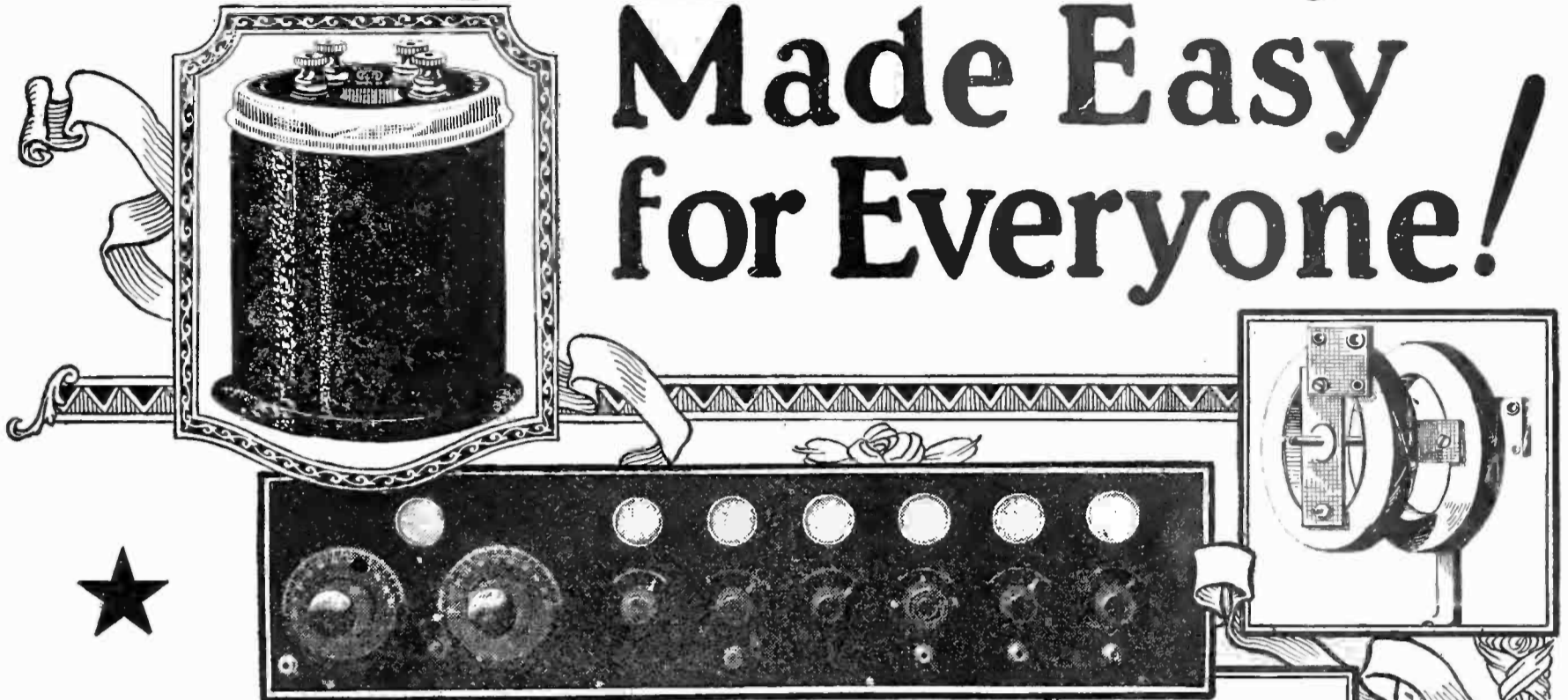

WITH the publication of *The SUPER-HETERODYNE MANUAL*, Receptrad has attained the leadership in its specialization on the Super-Heterodyne Circuit.

Whether you are an experienced builder or novice, Receptrad construction helps are so easy to follow that you are certain to achieve success when you start building.

Follow the *Manual* and your path will be easy. Results undreamed of will become commonplace in your radio enjoyment.

The Super-Heterodyne Manual \$1.50

Written by Victor Greiff, giving the fullest details and explanations on theory and practice. Includes three full size blue prints for panels, drilling, circuit, etc. The only complete and authoritative text book on the subject.

Transformer, Type 1716 \$8.50

Used in the Intermediate Frequency Amplifier. Covers frequencies from 5,000 to 25,000 meters. Self shielding. Steel core guarantees power and stability.

Oscillo-Coupler, Type SW-21 \$6.00

Covers wave-lengths between 200 and 750 meters.

Filter-Coupler, Type H-34 \$7.50

Tuned, with condensers, to 8,500 meters.

By-pass Condenser, Type C-1000 \$1.50

Special construction, capacity 1 Mfd.

Transformers, Type ATX and AT3 \$5.75

Audio, specially developed for the circuit.



Order at your dealer's

RADIO RECEPTOR CO.

(INCORPORATED)

57 BANK STREET

NEW YORK, N. Y.

★ Tested and approved by RADIO BROADCAST ★

Good soldering means good reception

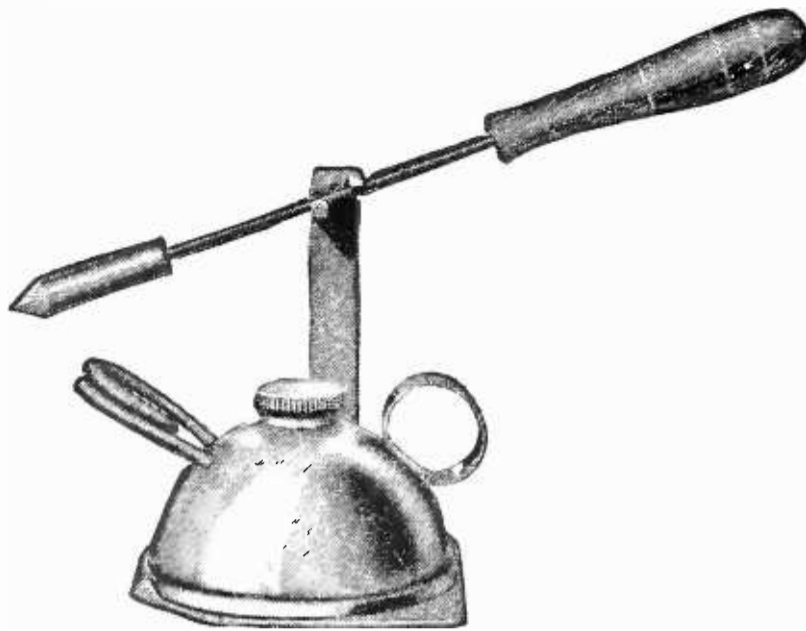

Patent applied for

"JIFFY" Blow Torch and Soldering Outfit

The Jiffy Torch is a self-blowing torch of unique design. No valves, nor pumps to get out of order. It cannot explode and develops an extreme heat of 2300 degrees F. It is unexcelled for the delicate soldering of radio, telephone and electric wiring.

Outfit consisting of Torch, copper iron, bottle of non-corrosive flux, metal stand and solder. Price \$2.00 postpaid.

Jiffy Torch only without Outfit, Price \$1.25 postpaid.

Send stamps, cash or money order to the

HANDYCAP MANUFACTURING CORPORATION

DEPT. B.

Dealers inquiries solicited

RIVERDALE, ILL.

The new

METALECTRIC Soldering Iron

Operates on any electric current with the simplicity and efficiency of a writing instrument. ★

Accepted as the logical solution to radio soldering problems by leading manufacturers and amateurs.

NOW ONLY \$3.75

Ample heat capacity

Handle always comfortable

Renewable tips

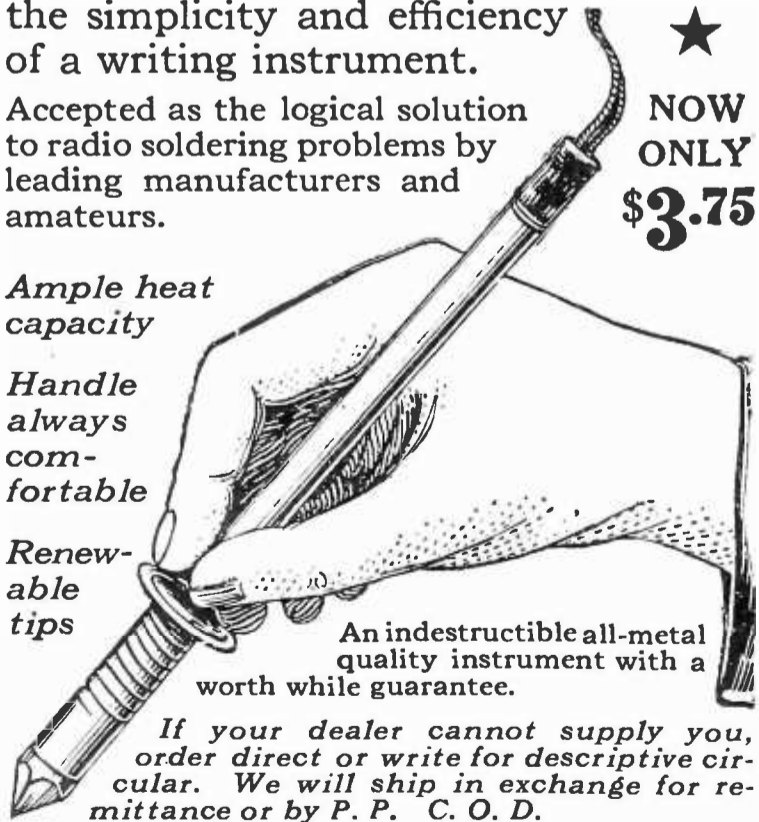

An indestructible all-metal quality instrument with a worth while guarantee.

If your dealer cannot supply you, order direct or write for descriptive circular. We will ship in exchange for remittance or by P. P. C. O. D.

POST ELECTRIC CO. MFRS.

Radio Section

30 E. 42nd St., New York

RUSONITE

FIXED DETECTOR

STONE ADJUSTER-BAKELITE BASE

GUARANTEED-PRICE \$1.25

RUSONITE PRODUCTS CORP., 15 Park Row, New York

PATENTS

Send sketch or model to-day for examination and report. *Record of Invention* blank on which to disclose your invention and NEW guide book, "How to Obtain a Patent," sent free. Promptness assured. Highest references. WRITE TO-DAY. CLARENCE A. O'BRIEN, Registered Patent Lawyer, 199-A Security Savings and Com'l Bank Bldg., directly across street from Patent Office, Washington, D. C.

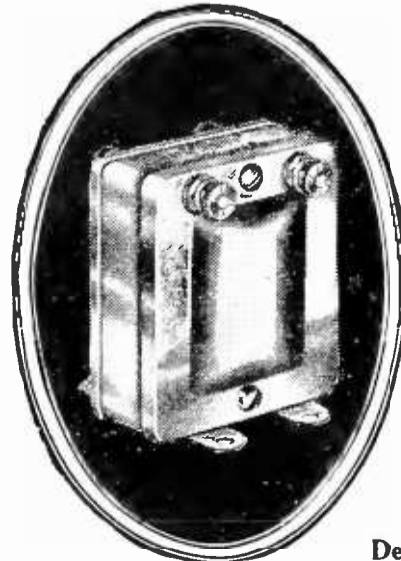

National Audio

★ Frequency Transformers

The New 6 to 1 Ratio National Transformer is for use on the first stage of amplification. Its greater ratio means increased volume, but the tone qualities that characterize the 3 1/2 to 1 ratio have been fully retained. Price of 6 to 1 ratio \$4.50 postpaid; of the 3 1/2 to 1 ratio \$4.00 postpaid.

Dealers: Write for interesting sales proposition.

National Transformer Mfg. Co.
154 Whiting Street
Dept. 513 Chicago, Illinois

★ Tested and approved by RADIO BROADCAST ★

The New
and Perfect
Variable Grid Leak
65¢



Although it is cartridge type it is different in principle from any Variable Grid Leak you have ever used before.

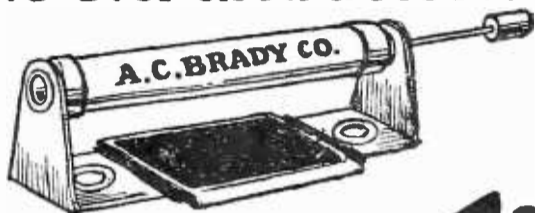

COMPLETE WITH MICA CONDENSER AND PERFECT LEAK MOUNTING \$ **1⁰⁰**

At your dealers or by mail on receipt of purchase price

A.C. BRADY CO.
Improved Radio Apparatus
108-SEVENTH AVE. NEW YORK CITY

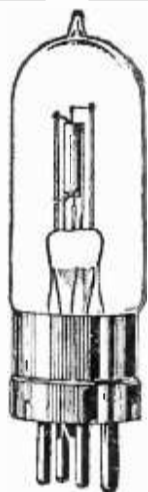

WE REPAIR RADIO TUBES

WD-11	\$3.00	DV-6-A	\$3.00
WD-12	3.00	UV-199	3.00
UV-200	2.75	C-299	3.00
UV-201	3.00	UV-201-A	3.00
C-300	2.75	C-301-A	3.00
C-301	3.00	Marconi	3.00
DV-6	3.00	Moorhead	3.00
DV-1	3.00	6v. Plain Detector	2.75
DV-2	3.00	6v. Plain Amplifier	3.00

MAIL ORDERS SOLICITED AND PROMPTLY ATTENDED TO
Dealers and Agents Write for Special Discount

H. & H. RADIO COMPANY
Clinton Hill Station
P. O. Box 22-P NEWARK, N. J.

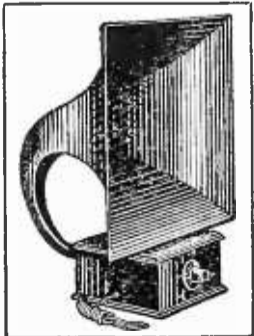

A loud speaker of the better class—combining clear, natural tones with pleasing volume. Priced at \$35.00 and worth it. Guaranteed to give complete satisfaction or money back. The Callophone is tested, and sealed. We will keep it in repair and adjustment as long as this seal remains intact.

Ask your dealer, or send direct to



THE CALLOPHONE COMPANY
of NEW YORK, Inc.
216 Mercer St. New York

\$25 for \$10

The Famous
BEL-CANTO



DIRECT FROM MANUFACTURER TO YOU

PRICE \$10.00

DELIVERED FREE TO YOUR DOOR

Sent prepaid only in the U. S. and Possessions

You cannot buy the BEL-CANTO through any dealer.

Only direct from us. We save you these three profits—DISTRIBUTOR, JOBBER and DEALER.

7 POINTS OF BEL-CANTO SUPERIORITY

1. Our own Fiber horn. Crystalline finish.
2. Our own adjustable loud speaking unit, giving a wide range of tone quality and volume without distortion.
3. The base of cast iron, weighing four pounds, eliminating top heaviness.
4. All other metal parts are of heavy cast aluminum, highly polished.
5. Complete instrument stands 22 1/2 inches high, 10-inch bell.
6. Guaranteed for one year from date of purchase against mechanical defects of any kind.
7. No auxiliary batteries required. Just plug in on second stage.

GUARANTEE

Money back any time within ten days if dissatisfied. We further guarantee to the publication carrying this advertisement that each and every speaker will be sold on the above terms and the instrument will be exactly as offered in this issue.

BEL-CANTO MFG. CO.
BENSEL-BONIS CO., Inc.

General Office and Factory
417-419-421 East 34th Street

Dept. R. B.
New York City

GENUINE ROBERTS SPIDERWEB UNITS

(TRADE MARK REG.)

Wound in accordance with Mr. Roberts specifications for the wonderful
ROBERTS CIRCUIT

This is the amazing two tube knockout circuit

A Radio Revelation

Combining the useful principles of { REGENERATION NEUTRODYNE REFLEX } In a fascinating and inexpensive simple hookup

Coast to Coast on the Loud Speaker WITH TWO TUBES

Roberts Spiderweb Units Consist of—

3 specially wound ROBERTS coils completely mounted with two dial vernier tuning control. 2 specially wound ROBERTS coils with fixed mounting } Tested—Approved and used by Mr. Roberts

Units complete ready for installation including RADIO BROADCAST'S "How to make it" instructions and hookup. **\$8⁰⁰**

TRISTAN SALES CORP. Sole Manufactures **1 Union Square, New York**



Better Tone for Your Radio!

FRANK D. PEARNE, famous Radio engineer, says TRANSCONTINENTAL RIBBON Aerials aid reception by combining maximum surface with minimum resistance. FORREST, eminent inventor, says, "I get best results by twisting Ribbon Aerial, 2 twists per 50 feet." Complete with snap hooks soldered to ends for instant attachment to insulators.

Transcontinental RIBBON COPPER AERIAL **50-Foot \$1.50**
75-Ft. \$2.25
100-Ft. \$3.00
150-Ft. \$4.50
(Trade Mark)

Clearer tone, greater volume, increased distance and selectivity guaranteed or your money refunded! Improves any set, tube or crystal. A laboratory product, with capacity, resistance and strength calculated to give better results.

Try It Without Risk! If your dealers cannot supply you, order direct from manufacturer, enclosing price. 100-foot length most generally used. Money-back guarantee protects you.

Acorn Radio Mfg. Co. 1806 S. Racine Ave. Dept. 309 CHICAGO

TRANSCONTINENTAL RIBBON AERIAL

DEALERS! Write for Special Offer!

Price 50 cents every-where

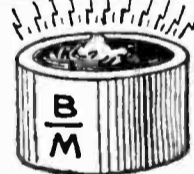

Never sold at cut prices

B-METAL

LOUD TALKING CRYSTAL

Sold only by reliable dealers and at full price. The Premier Crystal of the Radio World to-day. Ideal for REFLEX or CRYSTAL sets. Order if possible from your dealer. If he does not have it send to us for one—price 50 cents post paid.

New Jobbers' and Distributors' plan now ready

B-METAL REFINING COMPANY

525 Woodward Ave., Suite 14 DETROIT MICH.

GENUINE B-METAL

Chicago Branch 53 West Jackson Blvd
New York Branch 222 Fulton Street

★ Tested and approved by RADIO BROADCAST ★



The Meaning of the Star

THE chief danger in the development of radio is the prevalence of inferior and unsatisfactory apparatus. The demand for radio equipment that, for a time, could not be fully met by the manufacturers of standard goods, naturally flooded the market with radio sets and parts of poor design and slipshod workmanship. Many new enthusiasts turned away with disgust because of failure resulting from his so-called "bootleg" apparatus. Much of it is still offered for sale with ridiculous claims at cut prices.

To Safeguard Its Readers, RADIO BROADCAST will permit manufacturers to include a black star in the advertisements of sets, materials, parts, and accessories that have been tested by its experts and found to be worthy of indorsement. This approval will cover both design and workmanship.

The absence of the RADIO BROADCAST star will mean that the article advertised has not been offered for test and that this magazine's experts have not personally used it. The acceptance of an advertisement in itself indicates a belief in the integrity of the manufacturer. But the appearance of the star means, in addition:

Tested and Approved by RADIO BROADCAST



Loud Speaking Unit

(Phonograph Attachment) **\$6.⁵⁰**

Floating Mica Diaphragm

LOUD	NO TIN
CLEAR	NO SQUAWK
NATURAL	NO RATTLE

The new C. I. C. Loud Speaker with 20" Acoustene Fabric Horn and adjustable mica diaphragm loud speaking unit - - - - **\$16.⁰⁰**

All C. I. C. instruments carry an unconditional money back guarantee.

If your dealer cannot supply you, send your order to us. We will ship promptly by parcel post, C. O. D. postage prepaid.

**CONNECTICUT
INSTRUMENT COMPANY
STAMFORD, CONN.**

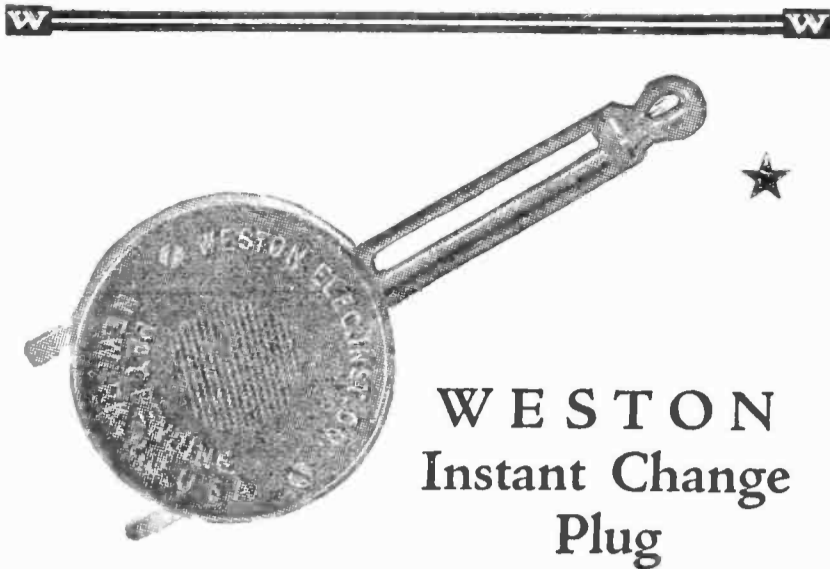

**WESTON
Instant Change
Plug**

Splendid! A quality plug you'll admire. Adds refinement to any radio set. Everyone says "It's a beauty." Change from head phones to loudspeaker in an instant. Merely press triggers to pull cables out. To connect, just shove in cables. Contact is perfect. No tools required. Step into the nearest radio shop and see it. Experts everywhere admit its superiority. Get one to-day.

Weston Electrical Instrument Co.
179 Weston Avenue Newark, N. J.



"The Crystal With a Soul"
(Reg. U. S. Pat. Office)

**THE TALK OF THE
RADIO WORLD**

"DE-TEX-IT"

COMPLETE \$1.25

A Perfect Fixed Detector

Best for Reflex and Crystal Sets

POWER—TONE—VOLUME

Catwhisker troubles eliminated. Requires no adjustment. Will not burn out.

Celerundum Crystal 50c.

Some territory still available for live jobbers.

Celerundum Radio Products Co.
170 Summer Street Boston, Mass.

*This may be the trouble
with YOUR set—*

You can probably adjust
your grid leak for higher
Detecting Efficiency

The highest efficiency can
only be obtained by adjusting
both resistor and condenser

Can You Do This ?

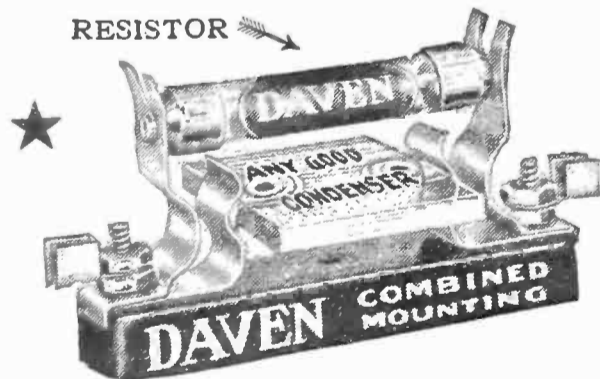

**THE DAVEN COMBINED RESISTOR-
CONDENSER MOUNTING DOES BOTH**

If your dealer cannot supply you
write

Daven Radio Company

*"Radio Resistor Specialists"
Mountings and Resistances*

13 Campbell Street Newark, N. J.



Grand Central Palace

Main and Mezzanine Floors

New York City

October 2nd to 8th inclusive, 1924

Every representative Radio firm should
have its products featured in the **THIRD
ANNUAL NATIONAL RADIO SHOW.**
A nation-wide advertising and publicity
campaign has already been launched.

For Further Details, Communicate with

American Radio Exposition Co.

522 Fifth Avenue, New York

Telephone, Vanderbilt 0068

"PROFIT SHARING WITH EXHIBITORS"

★ Tested and approved by RADIO BROADCAST ★

FAHNESTOCK'S RADIO PRODUCTS

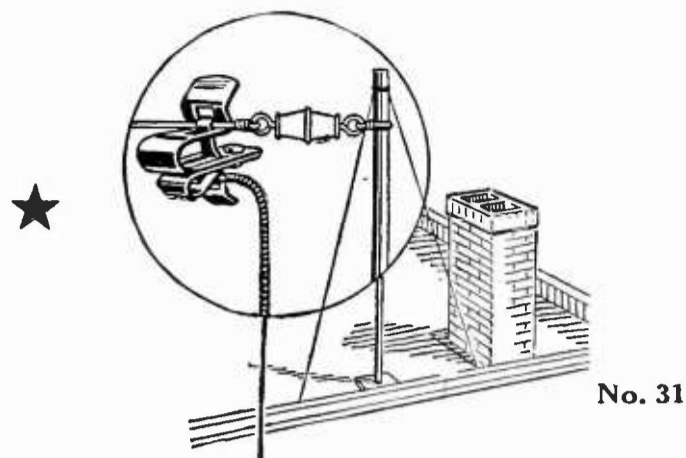

The Antenna Connector

Snap larger connector over Antenna Wire; insert Lead-in Wire into smaller clip and a perfect connection is the result.

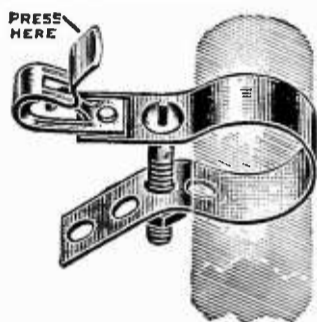

Improved Ground Clamp

Equipped with Fahnestock Patent Wire Connectors. Easily attached.

No Soldering—For Radio Use Only

Our name stamped on all products, none genuine without it
At Your Dealers

FAHNESTOCK ELEC. CO.
Long Island City, New York

JUDGMENT OF THE STORM

By Roy Mason

A novel written from the photoplay of Ethel Styles Middleton which has been produced by the Palmer Photoplay Corporation.
(\$1.50) *Doubleday, Page & Co. Garden City, N. Y.*

|| LISTEN-IN RADIO RECORD REG. U. S. PAT. OFF. THE ONLY "LISTEN-IN" BOOK

KEEP A RECORD OF STATIONS HEARD, DIAL SETTINGS, RECEIVING CONDITIONS, ETC.

Flexible cloth binding. Gold stamping. 160 pages. Printed on Bond Paper. Contains introductory article "How to Receive Radio Broadcast," by Lloyd C. Greene, Radio editor Boston *Globe*. Many Radio Hints and Tips. Complete list of Broadcasting Stations and double page map of United States.

PRICE

75 cents

At Your Dealer's
or Sent Prepaid
on Receipt of Price

**LISTEN-IN
PUBLISHING CO.**
117 MAIN ST.
CAMBRIDGE, MASS.

"Wouldn't trade my THOROPHONE

TRADE MARK REG. U.S. PAT. OFFICE

for a Rolls-Royce"

says HARRY H. HECKMAN



High
Power
Model
S-5
\$45.00

COMPARISON tells. Listen to the Thorophone and learn how perfect a loud speaker can be. Every tone, every note is given its true value. You would think speaker or musician were right before you.

Make the Thorophone your permanent loud speaker investment—you'll never want to change it. The Thorophone makes any set sound better.

Made by America's oldest manufacturers of loud speaking devices. A power horn, taking only one ampere from a 6-volt storage battery. It actually amplifies weak signals, yet handles the greatest possible volume with the same natural quality—quality that satisfies.

Write for booklet

WINKLER-REICHMANN CO.

4801 S. Morgan Street Chicago, Ill.

★ Tested and approved by RADIO BROADCAST ★

Morrison

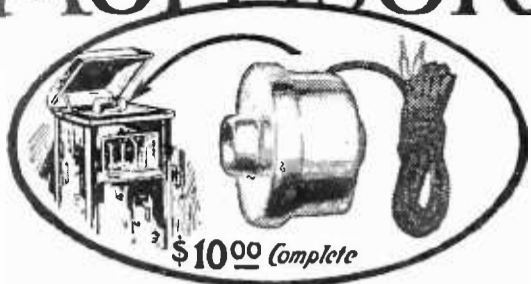

Loud Speaker ★

TO HEAR a radio concert reproduced by Morrison creates an instant desire to own one of these faithful Loud Speaking Units. For it seems like magic to hear so truly the singing quartet and the sweet-toned violin. Even with full volume no harshness nor vibration creeps in.

Then too Morrison is adjustable—turn a little dial and regulate the volume to your taste. It isn't surprising that once you own a Morrison you cannot be satisfied with less. Distant stations are unbelievably loud and clear and you can soften the tone if you wish.

Every Morrison carries a "money-back" guarantee.

**Handsomely Nickel
Plated**

\$10.00

Complete with a five foot cord

Free 2 color catalogue on request

Jobbers—Dealers

The market on Morrison is active. Our merchandising plan will interest you. Write immediately for details and discounts.

Morrison Laboratories, Inc.
347 E. Jefferson Ave., Detroit, Mich.

JUST OUT!

the type
R-100



ALL-AMERICAN ★

**LONG
WAVE**

RADIO FREQUENCY TRANSFORMER

4,000 to 10,000 Meters
(75 to 30 K.C.)

suitable for all long wave radio frequency circuits such as Reflex, Heterodyne, Ultradyne, etc. Designed by the same engineers who created the celebrated All-American Audio, Radio and Power Amplifying Transformers. Placed on the market only after long and thorough tests. Again All-Americans lead! Price.....\$6.00

All the better dealers sell The All-Americans

RAULAND MFG. CO. 2650 Coyne St. CHICAGO
Pioneers in the Industry

AMPLION



**The World's Standard
Loud Speaker**

NA-ALD

De Luxe Dials

The artistic qualities of Na-ald De Luxe dials distinguish these dials as truly beautiful. They add to the appearance of any set in which they are used.

These dials have a high gloss finish. They are moulded of Bakelite and have patented construction. Dials are matched and made in 2" 3" and 3 1/8" size.

Alden Manufacturing Company
*Largest makers of Radio sockets
and dials in the world*
Dept. B 52 Willow, St.
Springfield, Mass.

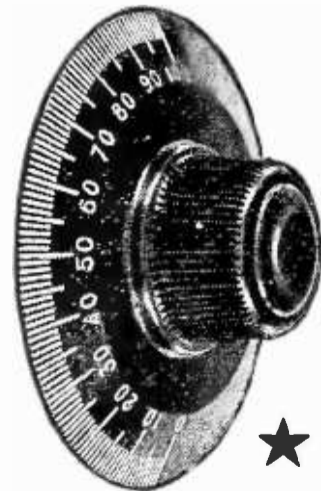

No. 3003-4
3 Inch
35c, 3 for \$1.00

★ Tested and approved by RADIO BROADCAST ★

World's Greatest BATTERY BARGAIN



Written 2 Year Guarantee
Your Proof of Satisfaction

FREE
Hydro-
meter and
"B" Bat-
tery

SAVE 50%

Thousands of RADIO BROADCAST Readers will profit by this amazing offer. They will buy the famous 2-year guaranteed, World battery at the lowest price ever quoted—They will get a hydrometer and a "B" Battery FREE. And they get the best battery built. It is "World" quality that makes possible our 2-year ironclad guarantee. It is "World" quality that makes "World" owners "tell their friends"—that's the best proof of performance any product can have.

Compare These Prices:

Special 200 Hour Rechargeable	6 Volt 60 Amp.....	\$8.50
Storage Batteries	6 Volt 80 Amp.....	10.00
2 Volt for W. D. 11	6 Volt 100 Amp.....	12.50
and 12 tubes.....	6 Volt 220 Amp.....	14.50
4 Volt for U. V. 199 tubes...	6 Volt 140 Amp.....	16.00
		\$5.00

Send No Money

You need not send a penny. Just clip this ad and attach your name and address. The battery will be shipped to you the day your order is received. When the battery arrives, inspect it—read our 2-year guarantee before you pay one penny. Convince yourself you are protected from every angle—that the World battery price saves you 50%. Get the "B" Battery and hydrometer FREE. Order to-day.

Special Offer

Clip and mail this ad with your World battery order and get this hydrometer and "B" battery free. 5% disc. for cash in full with order.

WORLD BATTERY CO.
Dept. 24, 1219 So. Wabash Ave., Chicago, Ill.



World

Spintite Wrenches

MAKE THE HEX "BEHAVE"

That's exactly what this new tool does for you—makes the hex nut "behave!" Puts an end to fussing and mussing with pliers in cramped corners.

Held securely in the hexagon head of "Spintite," a hex nut can be screwed *tight*, no matter how confined the working space.

Hollow stem goes over projecting screw-end. Ebonized handle, built to fit the finger grip, spins hex on in a jiffy. Hooking up becomes a joy with the "Spintite." You'll get greater distance and volume.

Sizes $\frac{3}{16}$ " to $\frac{3}{8}$ " 35c each. Large phone jack sizes, $\frac{7}{16}$ " to $\frac{1}{2}$ ", 65c each.

If your dealer can't supply you, send his name and write us direct.

STEVENS & CO.
Toolsmiths since 1899
377 Broadway New York

Send \$3.50 for Set 73 (professional!); 7 sizes, $\frac{1}{8}$ " to $\frac{1}{2}$ " in handsomely finished metal base.

SEND \$1. for Set 71 with three popular radio sizes

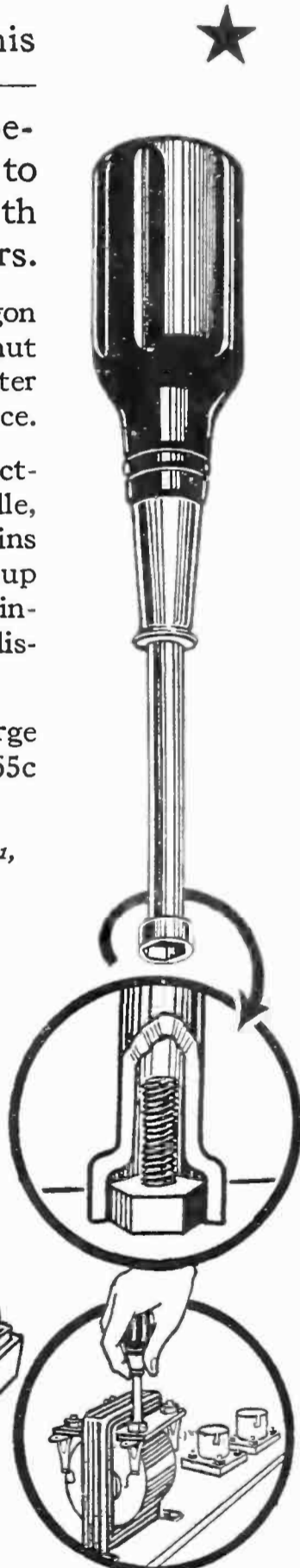
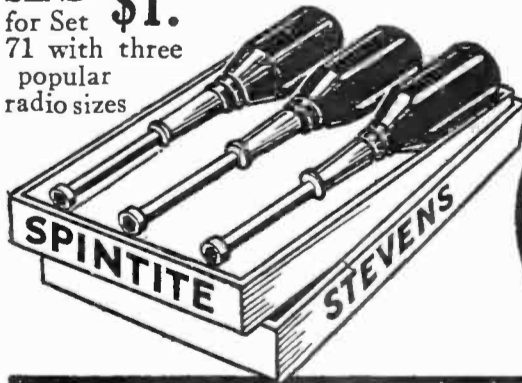

SUPERTRAN

Registered U. S. Patent Office

The Ideal Audio for NEUTRODYNES

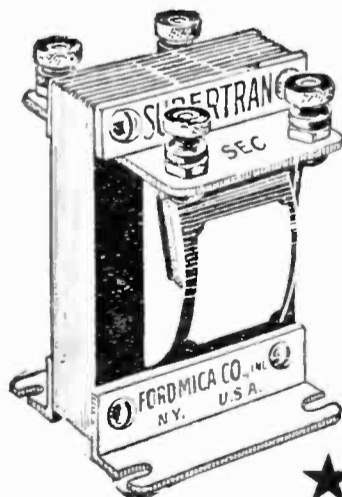

Every Neutrodyne Set requires Audio Transformers especially designed for this circuit. Build right by selecting SUPERTRANS first. Greatest volume. Least distortion.

Work equally well with all types of modern tubes.

Price \$6.00

At your dealers or by mail on receipt of purchase price.

Manufactured by
Ford Mica Company, Inc.
33 East 8th Street New York

New England Distributor
Wetmore-Savage Company, Boston

Stevens SPEED UP Tools

★ Tested and approved by RADIO BROADCAST ★



MAHOGANITE Dials that match the set

Like all other distinctive products, Mahoganite has its imitators. But these imitations are on the surface only. Mahoganite is not a surface finish. The electrical values of Mahoganite extend through the material.

The only way to assure yourself of genuine Mahoganite Panels, or Dials which match the panels is to make sure that the RADION Trademark is on every one that you buy.

21 STOCK SIZES Mahoganite and Black

6 x 7	7 x 14	8 x 26
6 x 10½	7 x 18	9 x 14
6 x 14	7 x 21	10 x 12
6 x 21	7 x 24	12 x 14
7 x 9	7 x 26	12 x 21
7 x 10	7 x 30	14 x 18
7 x 12	7 x 48	20 x 24

RADION

The Supreme Insulation

★ PANELS



Look for this stamp on every genuine RADION Panel, because of substitutes and imitations

AMERICAN HARD RUBBER COMPANY
11 Mercer Street New York

Announcement of
prize winning name
to replace "Acmedyne" ★

TELOMONIC

Well over 1000 names were suggested in the contest for a circuit name to replace "ACMEDYNE."

The judges, Charles Hardy, S. E. Bramer, R. H. Butler, H. I. Danziger, and Lester L. Jones, after careful deliberation, selected "TELOMONIC" as most expressive of this principle of tuned R. F. amplification.

The winner, Dr. M. Ohlbaum, receives a set of the essential Telos instruments for the TELOMONIC circuit.

Danziger-Jones, Inc. desires to express sincere thanks to all those who participated in this contest.

TELOS RADIO



A Pleasant Surprise Awaits the User of the A. C. H. Sharp Tuner Dials

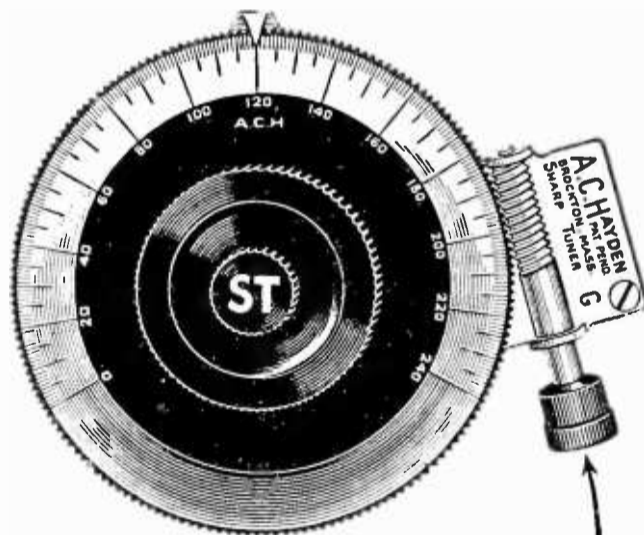

Why the A.C.H. is different

- 3 in. DIAL → ACH → 156-t0-1
- 4 in. DIAL → ACH → 215-t0-1

Will improve any receiving set, making difficult tuning easy

Money Back Guarantee

Price 3-inch size.....\$2.50 Price 4-inch size..... \$5.00
Regular fitting 5/16 shaft. 1/4 and 3/16.....5c each extra

Extra Advantage of the A C H

1. Can be attached or removed from any instrument.
2. Rough tuning same as any dial.
3. Movement so fine that the eye cannot detect but the ear can.
4. Automatically locks instrument so no jar can disturb it.
5. Dial grounded reducing the body capacity to a minimum.
6. Special dial 2 graduations where ordinarily one. ★

MAIL ORDERS SENT PREPAID IN U. S. A.

A. C. HAYDEN RADIO & RESEARCH CO.
BROCKTON, MASS., U. S. A.

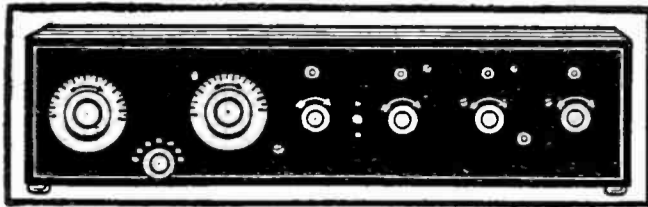

Perfect Panels

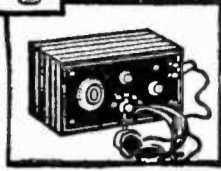

for any set, big or little!

Supreme for super-heterodyne or single circuit! No other material known possesses the many combined advantages of Bakelite-Dilecto for radio paneling!

bakelite-dilecto

(A Laminated Phenolic Condensation Material)

Once the installation is completed, Bakelite-Dilecto panels remain absolutely unchanged, no matter what abuse it is given by heat, cold, water, steam, oil, solvents, and weather elements. They do not warp, swell, shrink, crack, check, or split. Highest in dielectric strength. Surpassingly tough, yet readily machined. Your dealer can get it cut and drilled to fit your needs.

THE CONTINENTAL FIBRE CO.

Factory: Newark, Delaware

Service on Bakelite-Dilecto (also Continental-Bakelite, Conite, Contex and Vulcanized Fibre) from:

NEW YORK, Woolworth Bldg. CHICAGO, Wrigley Building
PITTSBURGH, 301 Fifth Ave. SAN FRANCISCO, 75 Fremont St
LOS ANGELES, 307 S. Hill St. SEATTLE, 1041 Sixth Av., So.

Offices and Agents Throughout the World



Coto

"Built First to Last"

"So Much Better than you claimed it to be"

So says one of the users of Coto Compact Moulded Variometer. Letters from all quarters praise this remarkably efficient variometer with the honeycomb wound stator coils. Range is 200 to 600 meters covering the broadcasting wave lengths. Type 8000. \$5.

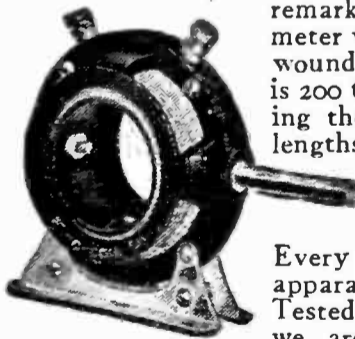

Read Our Guarantee

Every piece of Coto Radio apparatus is Laboratory Tested before shipment. So we are perfectly safe in

authorizing dealers and jobbers to guarantee you absolute satisfaction.

If your Dealer cannot supply you, send us your order and his name and address

COTO-COIL CO. 87 Willard Ave. Providence, R. I.

Los Angeles, 329 Union League Bldg.
Minneapolis, Geo. F. Darling, 705 Plymouth Bldg.
Atlanta, C. P. Atkinson, Atlanta Trust Co. Bldg.

Canada, Perkins Electric Co., Ltd.
Montreal, Toronto, Winnipeg

Do You Own a Single Circuit Set? If so it will pay you to consider

The Copp Vario-Selector



Price \$11.50

Patent Applied for

Because:

1. IT WILL CHANGE any single circuit set to a double circuit set, without rewiring and without re-building.
2. ELIMINATES RE-RADIATION.
3. GIVES SELECTIVITY to a single circuit set equal to any three circuit tuner, preserving the single circuit simplicity of tuning.

Note: The Copp Vario-Selector is NOT a Wave-Trap.

Sold through your dealer or direct.

If your dealer cannot supply you with a Vario-Selector, mail the coupon direct to us to-day.

The A-C ELECTRICAL Mfg. Co.
Dayton, Ohio

Makers of Electrical Devices for Over 20 Years

The A-C Electrical Mfg. Co., Dayton, Ohio

Gentlemen: Being unable to secure a Copp Vario-Selector from my dealer, you may send me check enclosed C.O.D. parcel post one Copp Vario-Selector, it being understood that in case I am not entirely satisfied with its operation in connection with my set, I reserve the right to return the Vario-Selector to your factory (in same condition as received by me) any time within ten days, full purchase price to be returned to me at once without further question.

Name.....

Address.....

City..... State.....

Grebe and **BAKELITE**

TRADE MARK REG. U. S. PAT. OFF.

The character of broadcast reception enjoyed by users of Grebe Radio Sets is due, in no small measure, to the extensive use of Bakelite.

The excellence of Bakelite and the dependability of its qualities is indicated by the fact that a large majority of Radio Manufacturers choose Bakelite as insulation, and for improving and simplifying the design of their sets and parts.

Bakelite combines in **ONE** material the essential properties of many. It is highly di-

electric and mechanically strong; it is unaffected by moisture, temperature or climatic changes; its color will not fade, even in strong sunlight; it will not warp, bloom or crack—but the most important property of "The Material of a Thousand Uses" in its relation to Radio is that of providing *permanently* effective insulation regardless of temperature or atmospheric conditions.

Write for a Copy of our Radio Booklet R.

Send for our Radio Map

Enclose 10c. and let us send you the Bakelite radio map. It lists the call letters, wave length and location of every broadcasting station in the world. Address Map Department.

B

BAKELITE
Condensite
REDMANOL

are the registered Trade Marks for the Phenol Resin Products manufactured under patents owned by **BAKELITE CORPORATION**

BAKELITE CORPORATION

247 Park Avenue, New York, N. Y.
Chicago Office: 636 West 22d Street

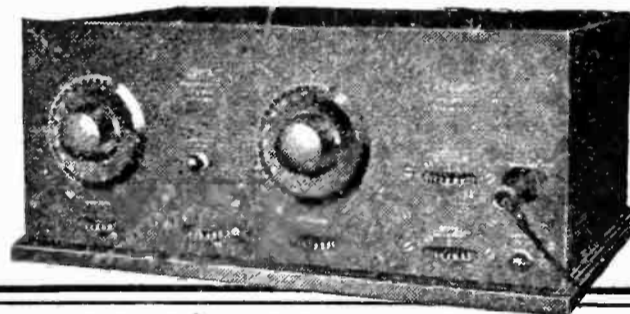
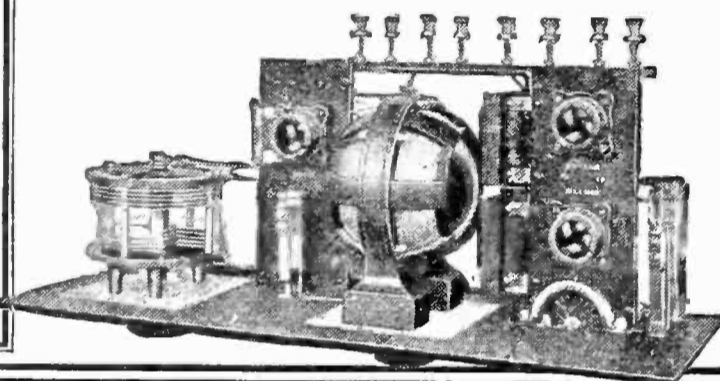

THE MATERIAL OF A THOUSAND USES

★ CARTER

Vernier Rheostat

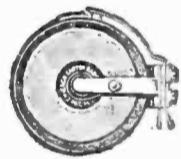

6 ohms \$1.50
20 or 30 ohms \$1.75

New original construction. Only one hole to drill, mounts like a jack. Only one control. No scraping or scratching. Vernier control all the way.

Send for illustrated catalogue



FROST-RADIO

Ask Your Neighbor



A Better Socket
At a Lower Price

THIS FROST-RADIO Shock-Absorber Socket has genuine **BAKELITE** base for panel or table mounting, sponge rubber cushion. Nickel plated metal parts. See it at your dealer's.

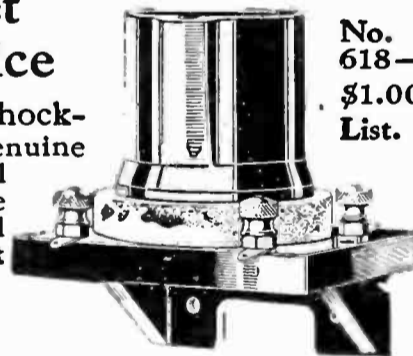

No. 618—
\$1.00
List.

HERBERT H. FROST, Inc
154 West Lake Street
Chicago : Illinois

FROST-RADIO

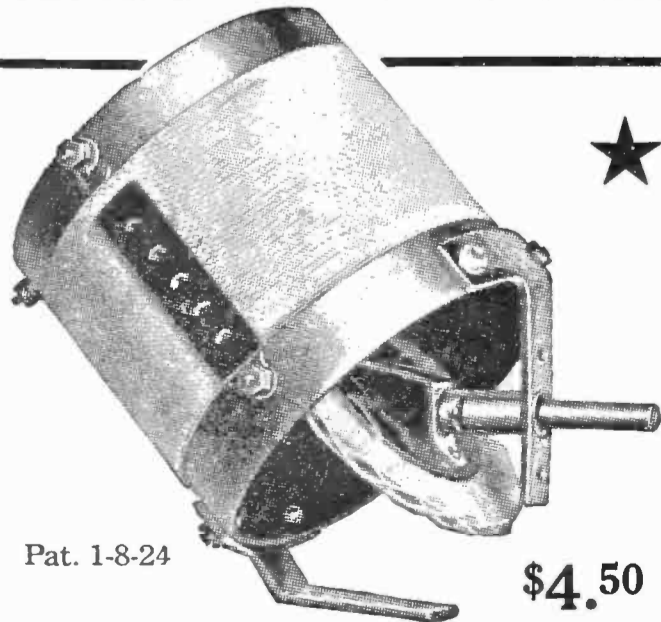

Pat. 1-8-24

\$4.50

Radio



Products

New Hartman Variocoupler

With 180° Spider Web Wound Rotor

Small, compact size saves panel space; clearer reception with minimum coupling insured. Dead shaft has no capacity effect in tuning. Pig tailed contacts; no live brackets. If dealer can't supply you, write us.

The Hartman Electric Mfg. Co.
34 East 5th St. Mansfield, Ohio

★ Tested and approved by RADIO BROADCAST ★

Save!

Trouble and Money
By equipping your radio with
**BRACH
COMPLETE RADIO
ANTENNA SET**

with famous Brach Arrester—
every part of highest grade—ap-
proved by experienced engineers
and National Board of Fire Under-
writers. You save time and money
and cut out all doubt.

At Your Dealers

L.S. BRACH MFG. CO.
NEWARK, N.J.

Branston Kit ★

No. R-99

Contains 1 Oscillator Coupler, complete with mounting brackets, bank wound inductance and adjustable coupling coil with locking device; 3 Intermediate Radio Frequency Transformers. Very sharply tuned and completely shielded; 1 Special Transfer Coupler for first or last stage of Intermediate Frequency; **\$36.50** and 1 specially designed Coupler for using Antenna



BRANSTON--GUARANTEED

This apparatus is of standard Branston Quality, rigorously tested and proved better than anything heretofore obtainable. Its efficiency and superior performance will delight you.

Our Book

"SUPER HETERODYNE CONSTRUCTION"

(One Dollar). The amateur can easily make complete and efficient Super Heterodyne Receiver that will be extremely selective, give remarkably fine quality of tone and be noticeably free from interference.

See your dealer at once, or write us to-day for all information.

CHAS. A. BRANSTON, INC.
813 Main Street Buffalo, N. Y.

Manufacturers of the famous Branston Violet Ray High Frequency Generators

In Canada—Chas. A. Branston, Ltd.
Toronto, Ontario



Your pilot over the RADIO WAVES

Whatever the radio course you have set for yourself, here is your one best guide.



JUST
OUT
—
514
PAGES

Compiled by HARRY F. DART, E.E.
Formerly with the Western Electric Co., and U. S. Army
Instructor of Radio.

Technically Edited by F. H. DOANE

THIS is what you want in a radio book. It answers your every question as it occurs to you. Look up the thorough index, turn to the page, and there you are! The most complicated facts about radio and electricity explained as easily as the most simple ones.

Everything included. Compiled by an expert formerly of the Western Electric Co., the organization that knows most about radio in the world, and edited by another famous engineer. Understood by thousands of laymen because written especially for them. Yet—and here is the real marvel of this book—the advanced amateur, constructor and experimenter also find in it the data they need for calculating the constants of transmitters, receivers and associated apparatus for all radio purposes.

SOME OF THE FEATURES: Electrical terms and circuits, antennas, battery construction and maintenance, generators and motors, vacuum tubes (really explained), many receiving hook-ups, radio and audio frequency amplification, broadcast and commercial receivers, super-regeneration, codes, license rules, etc.

Send \$1 to-day and get this 514-page I. C. S. Radio Handbook—the biggest dollar's worth in Radio. Money back if not satisfied.

-----TEAR OUT HERE-----

INTERNATIONAL CORRESPONDENCE SCHOOLS
Box 8295-B, Scranton, Penna.

I enclose One Dollar. Please send me—post-paid—the 514-page I. C. S. Radio Handbook. It is understood that if I am not entirely satisfied I may return this book within five days and you will refund my money.

Name.....

Address.....

The WORKRITE

NEUTRO-GRAND



*(Licensed under Hazeltine Patent
No. 1450080)*

Five-Tube Neutrodyne Receiver

Coast-to-coast on a built-in Loud Speaker.
Send for catalogue and complete information.

THE WORKRITE MANUFACTURING CO.
1830 East 30th St. Cleveland, Ohio
Branch Office: 536 Lake Shore Drive, Chicago

★ Tested and approved by RADIO BROADCAST ★

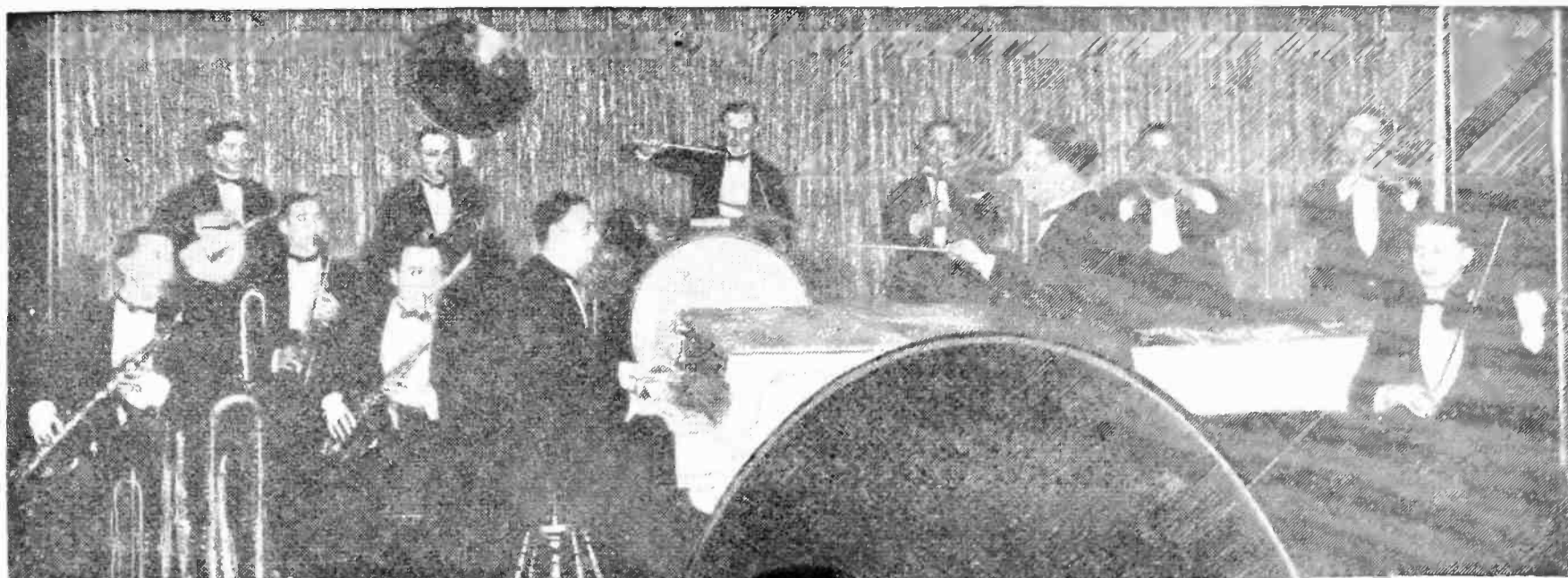

Vincent Lopez and his
Hotel Pennsylvania Orchestra

From one who knows

VINCENT LOPEZ praises and endorses the rich, clear, natural quality of MUSIC MASTER reproduction. His Hotel Pennsylvania Orchestra is heard over the radio by untold thousands.

He has enjoyed radio music—mellowed and clarified as it passes through MUSIC MASTER'S amplifying bell of selected wood. His trained ear noted instantly the faithfulness of each re-creation.

MUSIC MASTER is an enduring musical instrument. Hear it and see it at your dealer's, or have him send one to be tried and proved with your own set.

Dealers Everywhere

Music Master Corporation

(Formerly General Radio Corporation)

Makers and Distributors of High-Grade Radio Apparatus
S. W. Cor. 10th and Cherry Streets

Chicago PHILADELPHIA Pittsburgh



May I say a few words regarding the merits of the Music Master, which to my way of thinking is superlative in its field. For clearness of tone it exceeds any loud speaker which has been brought to my attention, and being directly interested in radio work I consider your product a big achievement and a valuable asset to the radio world.

Please accept my heartiest congratulations.

Sincerely yours,

Vincent Lopez

Exclusive O'keh Artist

Music Master

RADIO REPRODUCER

14-inch Model, for
the Home \$30.

21-inch Model, for
Concerts and Dancing \$35.

Connect in place of headphones. No
batteries required. No adjustments.

★ Tested and approved by RADIO BROADCAST ★

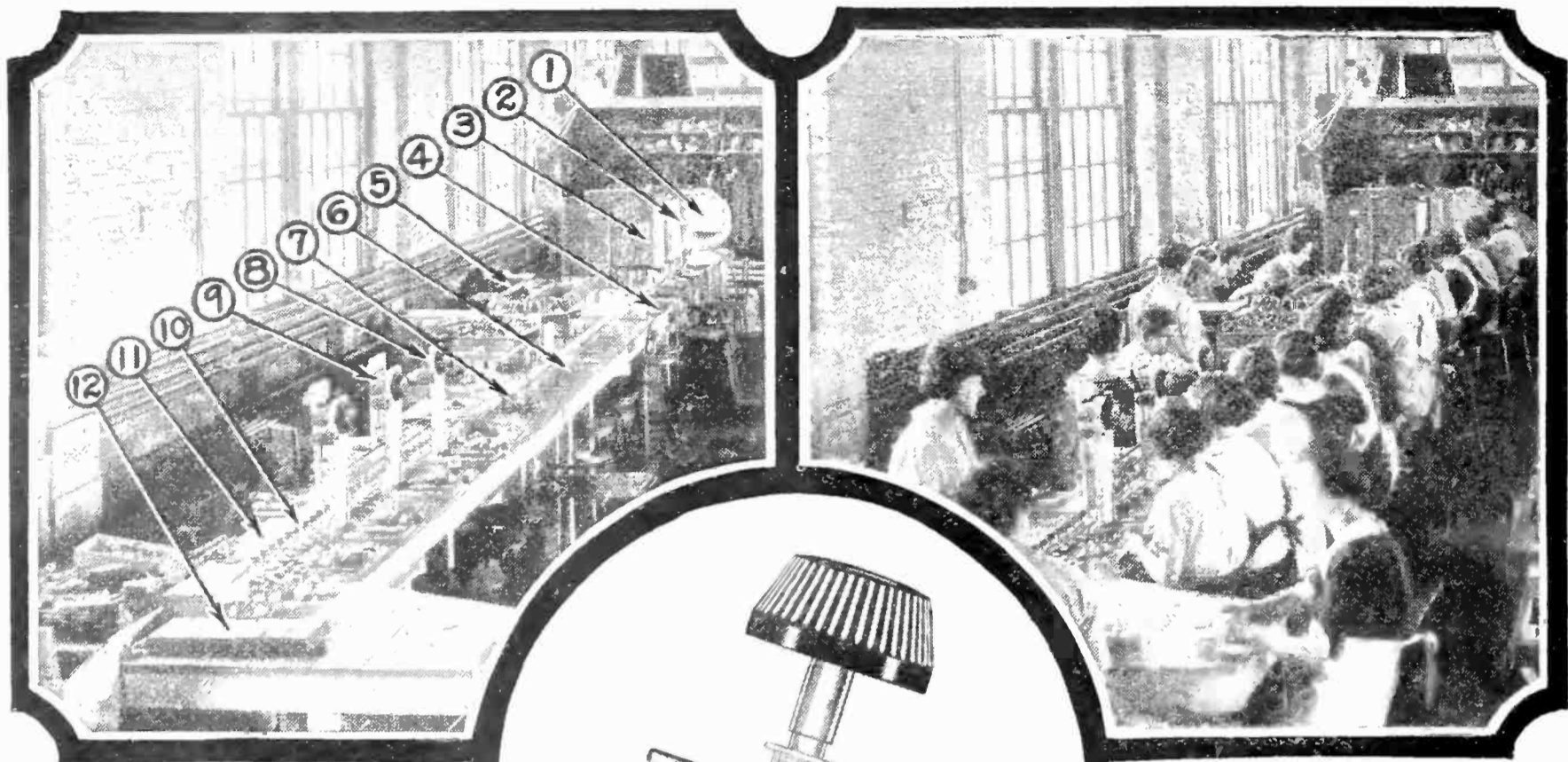

View of one production line in Bradleystat assembling department. The conveyor assembly process was developed to keep up with the increasing demand for Bradleystats and Bradleyleaks. See explanation below.

View of one production line, showing operators assembling Bradleystats and packing them in cartons for shipment. All parts are fabricated in other departments. The electric furnaces are in a separate building.

How the Bradleystat is made

FOR over twenty years the Allen-Bradley Co. has made graphite disc rheostats for battery chargers and motor starters. The experience gained during these twenty years is embodied in the most perfect filament rheostat used in radio, the Bradleystat.

Today, the Universal Bradleystat, with its two columns of graphite discs under adjustable pressure, provides unequalled control for radio tubes. Its control is absolutely noiseless, stepless and of exceedingly wide range.

Bradleystats are assembled by the most modern methods and tested rigidly before they are shipped.

The illustration above depicts the assembly process that guarantees a uniform product for the radio fan.

- | | |
|------------------------------|-----------------------------|
| 1—Cleaning porcelains | 7—Installing cover plates |
| 2—Riveting terminals | 8—Inserting adjusting knobs |
| 3—Threading terminals | 9—Six testing machines |
| 4—Inserting terminal screws | 10—Conveying Bradleystats |
| 5—Disc-filling machine | 11—Inspecting Bradleystats |
| 6—Inserting pressure springs | 12—Packing Bradleystats |

Bradleyleaks follow the same process, except for the use of different discs and the installation of condensers.

Install Bradleystats in your radio set, if you want the finest filament control obtainable. Try one, and experience new delights in radio reception.

Allen-Bradley Co.
Electric Controlling Apparatus

278 Greenfield Avenue  MILWAUKEE, Wisconsin

For Sale at All Dealers
BRADLEYSTAT \$1.85
BRADLEYLEAK 1.85
CONDENSER (.00025 mf.)35

THE ALLEN-BRADLEY CO. HAS BUILT GRAPHITE DISC RHEOSTATS FOR OVER TWENTY YEARS

★ Tested and approved by RADIO BROADCAST ★



The
Thompson
MAGNAPHONE
Reg. U.S. Pat. Office

Your receiving set can be no better, in delivered results, than the loud-speaker you use with it. The THOMPSON MAGNAPHONE is an instrument that brings out the best that is in your set—because it is specifically designed and built as a radio loud speaker, not merely adapted from other purposes.

All that you've been seeking, and haven't found elsewhere in loud-speakers, is yours with the MAGNAPHONE—the volume, the tone quality, the natural reproduction of the original performance unmarred by mechanical distortion. You'll notice the difference instantly, when you plug in a MAGNAPHONE.

Here are a few features that make the MAGNAPHONE different, and better: cone-shaped special composition diaphragm vibrating equally over its whole area; two-to-one driving armature, reducing the permissible air gap 50%; laminated magnetic pole pieces and generously large magnet. These combine in a structure which forms a loud-speaker giving results so incomparably superior that the MAGNAPHONE is the instant choice of those who demand the best.

Price \$35.00—at Good Dealers, Everywhere

Ask your dealer to demonstrate the MAGNAPHONE—compare it with any other loud-speaker, from any standpoint—and you'll admit that Thompson's 14 years' experience in radio manufacture has produced the radio reproducer that satisfies your every requirement.

Manufactured by

R. E. Thompson Manufacturing Co.

Sales Office
150 Nassau St. New York

Factory
Jersey City, N. J.

Manufacturers also of the THOMPSON BALANCED NEUTRODYNE RECEIVER. Licensed under Hazeltine Patents

★ Tested and approved by RADIO BROADCAST ★

Read This

TELEPHONE LONGACRE

KENNETH HARKNESS
256 WEST 34TH STREET, N. Y. CITY

February 25th, 1924.

Electrad Inc.
425 Broadway,
New York.

Gentlemen:

I have tested the samples of the Diode tube which you submitted and find that this tube can be used in the Harkness Circuit very satisfactorily. As a matter of fact the Diode is better than a standard three electrode tube as a rectifier in this circuit.

I have no hesitation whatsoever in endorsing the use of the Diode tube as a rectifier in the Harkness Circuit.

Cordially yours,

Kenneth Harkness

KH/AA

\$2.00

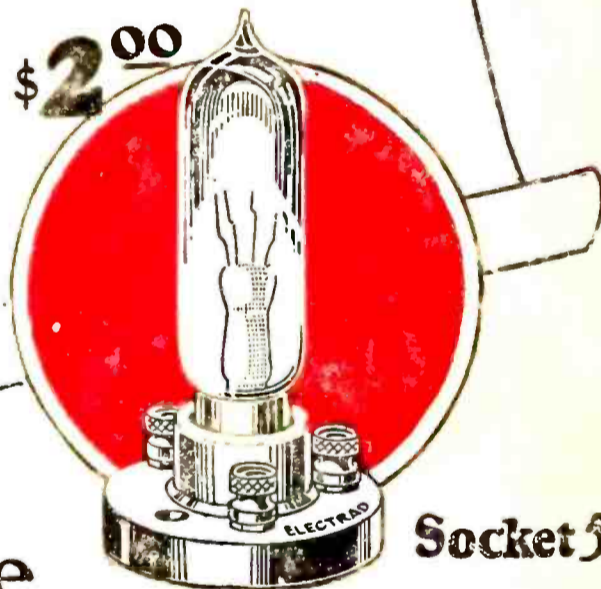

Socket 50¢

The New Diode Tube for the marvelous Harkness Reflex Circuit

Diode Tubes give you greater volume, never get out of adjustment, stabilize the circuit, and are far more sensitive than even the better grade crystals. They require no B Batteries, and will burn from 600 to 1000 hours on 1½ volt battery.

FREE! Write for our complete and detailed diagram of the Harkness Reflex Circuit and instructions for use of the Diode Tube in place of a crystal.

Electrad, Inc., Dept. 8, 428 Broadway, New York City

ELECTRAD

A Name Stamped Only on Superior Radio Products

★ Tested and approved by RADIO BROADCAST ★

THE COUNTRY LIFE PRESS, GARDEN CITY, NEW YORK