

RADIO AGE

The Magazine of the Hour

Price
25 cents

AUGUST, 1923

IN THIS NUMBER

Construction of the Four Circuit Tuner

By Frank D. Pearne

An Efficient Two-Stage Amplifier

A Simple Buzzer Transmitting Set

Complete Corrected List of Broadcasting Stations

More Good Hook-ups

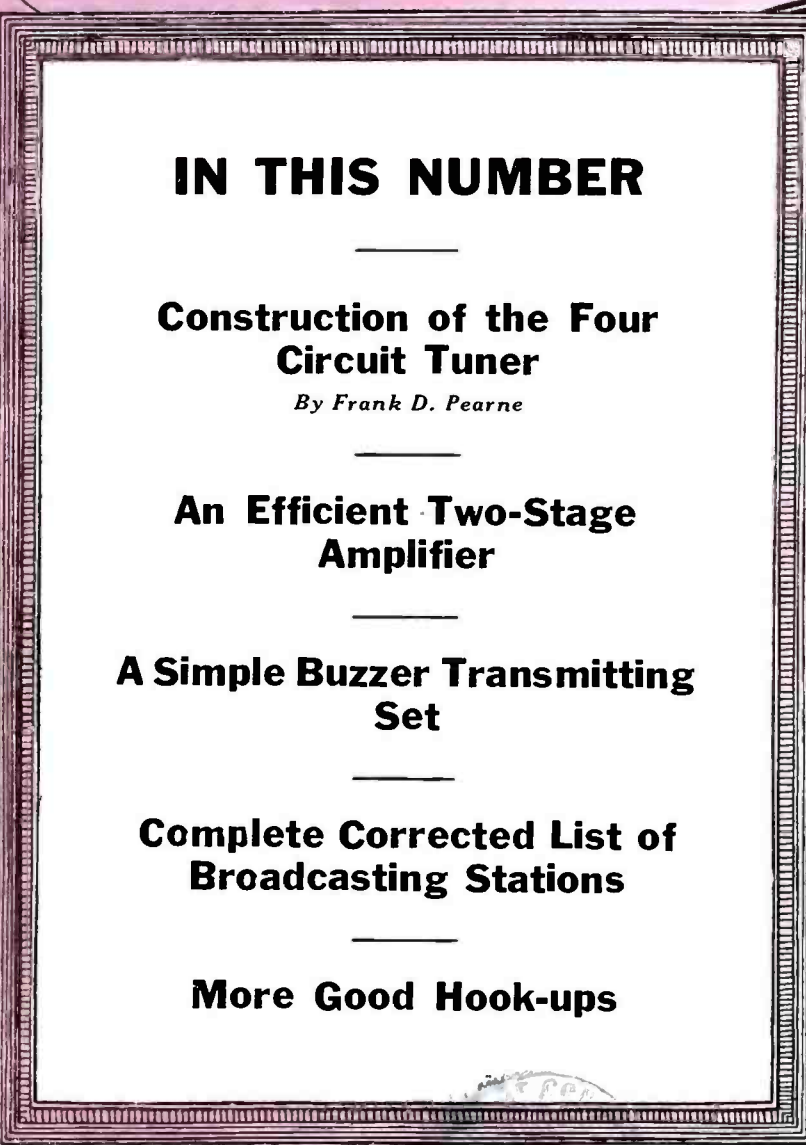
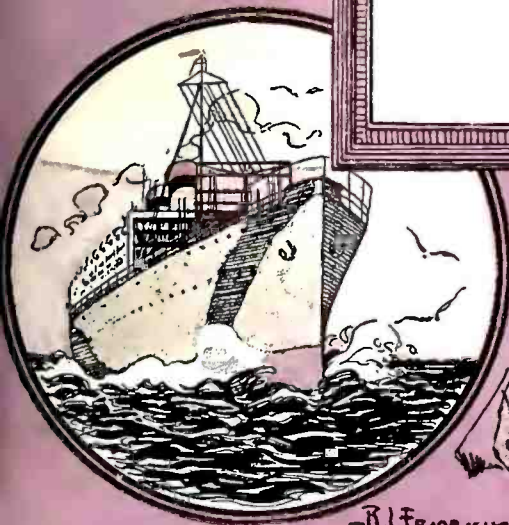
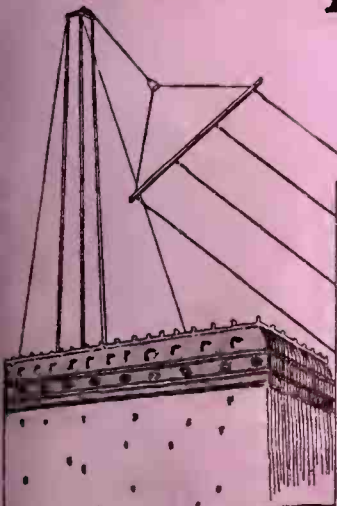

R.L. Francis

OFFICIAL NEWS MEDIUM FOR NATIONAL BROADCASTERS' LEAGUE

Reinartz Radio

How to make this distance wrecker.
How to amplify it.
How to make a Reinartz panel.

With Hook-ups

Written and Illustrated by
FRANK D. PEARNE

*Chief Instructor in electricity at Lane Technical High
School, Chicago, and famous writer on radio
construction and operation.*

Experts agree this Reinartz Hook-up
is best for average fan.

Hook-up for the Long Distance Crys-
tal Set—They are all trying it.

Get this book of the 1922-23 Season

Published by
RADIO AGE, Inc.
500 N. Dearborn Street
CHICAGO

*AT YOUR NEWSDEALERS' OR SEND MONEY ORDER
OR CURRENCY TO PUBLISHER*

—≡ Price 50 cents ≡—

While they last—This booklet and year's subscription
for only \$2

RADIO AGE

The Magazine of the Hour

Volume 2

AUGUST, 1923

Number 7

CONTENTS

	Page
Construction of the Four-Circuit Tuner..... BY FRANK D. PEARNE	3-4
How to Construct an Efficient Two-Stage Amplifier.....	5-6
A Simple Buzzer Transmitting Set.....	7
The Newest Radiotron Model, U V-199.....	8
Telephoning Over Power Lines.....	11
Thought Waves From the Editorial Tower.....	13
The Trouble Shooter—Questions and Answers, fully Il- lustrated.....	15-16-17-18
Little Things That Help.....	19
Complete list of U. S. and Canadian Broadcasting Sta- tions.....	29-30-31-32

RADIO AGE is published monthly by
RADIO AGE, Inc.

Publication office, Mount Morris, Ill.
Editorial and Advertising Offices, Boyce Building,
500 N. Dearborn St., Chicago

FREDERICK SMITH, *Editor*
FRANK D. PEARNE, *Technical Editor*
M. B. SMITH, *Business Manager*

Western Advertising Representatives:
BRUNS & WEBBER
First National Bank Building, Chicago.

Advertising Forms Close on 5th of the Month
Preceding Date of Issue.

Issued monthly. Vol. 2, No. 7. Subscription price \$2.50 a year.
Entered as second-class matter September 15, 1922, at the post office at Mount
Morris, Illinois, under the Act of March 3, 1879.

Copyright, 1923, by RADIO AGE, Inc.

For September

THERE will be an article in the September issue of this magazine that will be of intense interest and of tremendous help to all the radio receiving set operators. We suggest that you get the September issue and look out for it. It will be duly announced on the front cover and you will not miss it. We would tell more about this article for broadcast listeners but we are afraid our wide-awake contemporaries might read this and then set out to get together an inadequate and hastily prepared article on the subject in order to avoid being scooped.

By the way, the number of fans who are becoming acquainted with the superior quality of our technical articles would surprise you. We have been fortunate enough to gain a reputation for publishing well written instructions on how to make receivers and how to operate them.

Many letters come in, even during these dog days, telling us that our illustrations are the clearest and our technical discussions the most timely.

You have not forgotten that the technical editor of Radio Age is Mr. Frank D. Pearne, for twelve years the chief instructor in electricity at Lane Technical High School, Chicago. Mr. Pearne is more than an expert—he is an institution. You should see the letters he receives daily from radio fans. They have confidence in him because he knows what he is talking and writing about and he knows how to write and talk about what he knows.

Among recent subscriptions sent in we have had several for two years and a lesser number for three years. Now when a fan pays for his favorite book on radio that far in advance it shows confidence and conviction. Doesn't it?

If you want unbiased evidence on how our technical writers have been hitting the ball read the page of boosts from readers in this number. We thank you.

—THE EDITOR.

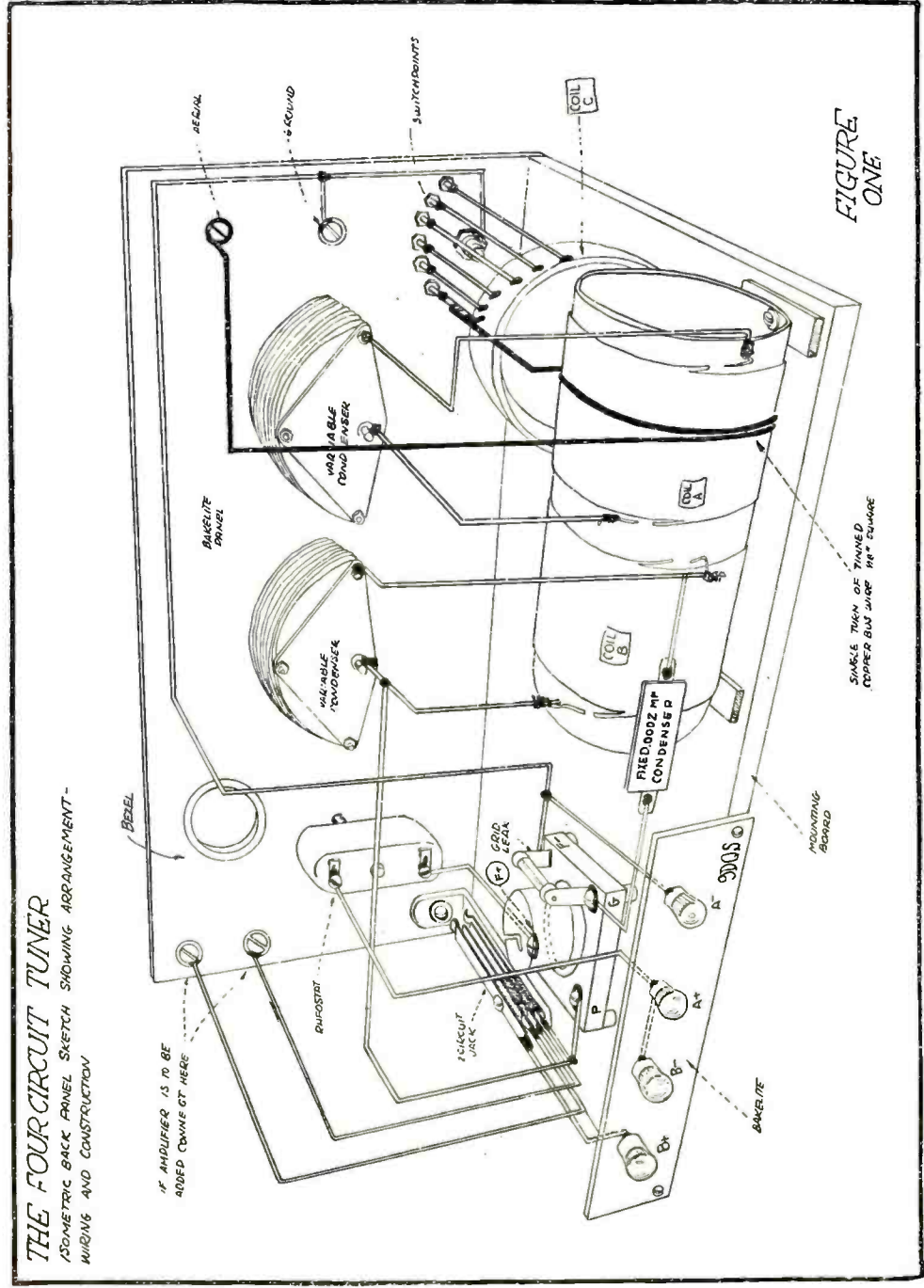

THE FOUR CIRCUIT TUNER
 ISOMETRIC BACK PANEL SKETCH SHOWING ARRANGEMENT-
 WIRING AND CONSTRUCTION

FIGURE ONE

RADIO AGE

"The Magazine of the Hour"

M. B. SMITH
PUBLISHER

PUBLISHED MONTHLY

FREDERICK SMITH
EDITOR

Construction of the Four Circuit Tuner

By FRANK D. PEARNE

ONE OF the unique contributions to the science of radio, is the four-circuit tuner, invented and developed by Laurence M. Cockaday of Station 2XK. The arrangement of this circuit is peculiar, indeed, and the advantages claimed over other circuits are first, wonderful selectivity; second, ease of operation and third, the fact that it is extremely sensitive. CW messages have been received over a distance of 3,200 miles and broadcast reception has reached the distance of 2,400 miles. This range is probably due to the manner in which the feeble impulses received upon the aerial are stepped up in the receiving transformer.

A ratio of sixty-five to one is used at this point in the circuit, which gives a very high voltage on the grid, even though that produced in the aerial may be extremely low. This high ratio is obtained by placing a single turn of square copper bus wire—in the aerial, or primary circuit—in inductive relation with a secondary coil consisting of sixty-five turns.

By referring to the drawing, Fig. 2, it will be seen that the aerial inductance consists of two coils, one of which is the single turn previously mentioned, connected in inductive relation to the coils "A" and "B," and the other, a bank-wound tuning coil used for tuning the antenna circuit. This latter coil must be placed at right angles to the others, to prevent inductive coupling.

This arrangement of the mounting is plainly shown in Figure 1. The secondary coil, "A," is connected in series with a condenser "C1" of approximately .00035 M. F. and forms a separate oscillating circuit, which is inductively connected to the oscillating circuit formed by the combination of coil "B" and

the .00035 M. F. variable condenser. This coil "B" is used as a stabilizer.

The rather unusual arrangement of this circuit as shown in Figure 2 may strike terror in the heart of the timid amateur, but if he will carefully study each detail, he will find that it is really quite simple, and that the first impression received is only due to its radical departure from the other conventional circuits. Reports received by the writer from those who have constructed the set are flattering, indeed, principally due to the absence of troubles such as body capacity, interference, and the ease with which distant stations may be brought in.

Details of Construction

The first step in the construction of the coils is to procure a tube of some good insulating material, bakelite if possible, but if this cannot be readily obtained a dry paste-board tube will do. This should be $5\frac{5}{16}$ inches in length and $3\frac{1}{4}$ or $3\frac{1}{2}$ inches in diameter. Drill two small holes just large enough to take a number 18 wire through

them, about $\frac{1}{2}$ inch apart, at a point $\frac{5}{16}$ of an inch from the end of the tube. Straight along the axis of the tube drill two more holes the same distance apart, at a point $1\frac{1}{2}$ inches from the first holes. Next drill two more holes beside the last two, about $\frac{1}{8}$ of an inch from them. At a distance of 3 inches from these holes, drill two more. These last two will come close to the other end of the tube. These holes are to be used for anchoring the ends of the coils, as shown on "A" and "B," Figure 1. Coil "B" is wound first.

This is wound between the holes which are 3 inches apart. Use No. 18 SCC. magnet wire, anchoring the starting end by threading the wire through the holes on the end of the tube. Leave an end of about 8 inches for connecting later and wind 65 turns, which will bring the end of the coil right up to the holes to be used for anchoring the ends. Cut the wire, leaving 8 inches for connecting and thread the wire through the holes to anchor the end. Now start the coil "A" in the next two holes, with the same

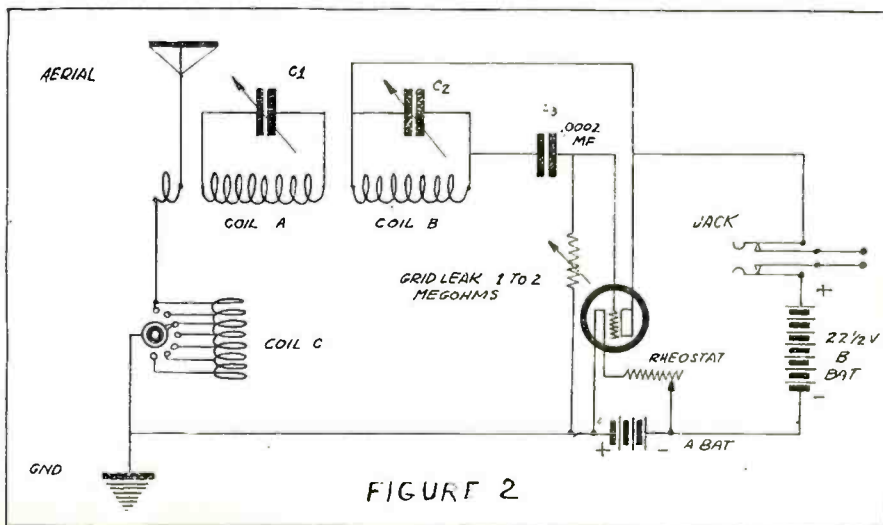

FIGURE 2

size of wire—don't forget to leave an 8 inch end—and wind 34 turns which will bring the winding up to the last two holes.

This completes the winding of the tube, with the exception of the single turn which is to be wound around coil "A" later. After making sure that these two coils are wound in the same direction, give it a good coat of shellac varnish and allow it to dry.

The next step is the winding of the bank-wound coil used for tuning the aerial, or primary circuit. This is wound on a piece of tubing of the same diameter used for the other coils. Cut off a piece of the tube, $1\frac{3}{8}$ inches in length and drill 2 holes at each end (as close as possible without breaking through the edge) to hold the ends of the coil. This coil is to be double bank-wound, and is really the only hard part of the set to construct, but after one once gets the idea of the winding, it will not be difficult. To do this right, it is a good plan to first give the tube a thin coat of shellac varnish and do the winding before it becomes very dry. Start the winding at one end in the usual way and wind two complete turns. The third turn, instead of being placed next to the second, is wound on top of these two. This will lie in the small groove, formed by the natural curvature of the wires.

Upon the completion of these three turns, the wire is brought down to the tube again and one more turn is wound on the tube. This should be placed next to the second turn. The next turn is placed on top of turns 2 and 4, etc., until 43 turns have been put in place in this manner. This should be wound with the same size and kind of wire as that used in coils "A" and "B."

This would not be so hard, were it not for the fact that taps must be taken off every so often. These taps must be brought out at the 7th, 13th, 21st, and the 31st turns, the final end of the wire acting as the tap for the 43d turn. These taps may be made by making a loop of the wire at the point where they are to be taken off and twisting it up tight against the coil. Figure 1 shows the position and method of mounting the coils in the set.

This may be varied to suit the taste of the builder, but in any event, the coil "C" must be mounted at right angles to coils "A" and "B" as shown.

After the coils are mounted and the taps from coil "C" are connected to the switch contacts, as shown

in Figure 1, the single turn of tinned copper, square bus wire is put in place and connected to the aerial binding post, and the last contact on the aerial switch. It must be remembered that the single turn of bus wire is placed around the coil having 34 turns, not the one having 65 turns. The switch lever is connected to the ground, grid leak and the positive side of the filament battery. The grid condenser, "C3" should be of the fixed mica insulated type, and the grid leak may be either a tubular leak having from one to two megohms, or of the variable type having the same resistance. The two variable condensers, "C1" and "C2," should have a capacity of approximately .00035 M. F. and are mounted on the panel and wired, as shown in Figure 1. The balance of the circuit is made of standard apparatus, which may be obtained at any radio supply store. It will be noted that Figure 1 shows the tuner only, while Figure 2 shows two connections from the inside springs of the jacks which may be connected to an amplifying unit if so desired.

If an amplifier is to be added to the tuner, the standard amplifying circuit may be employed. For the detector, UV-200 tube is recommended and if the amplifier is used, best results will be obtained with the UV-201-A tubes. The rheostat used on the detector tube should be of the vernier type, as this will be found to be one of the most sensitive adjustments in the set.

Wiring the Set

It is always a good plan to use large wire in connecting up the set. No. 14 tinned copper serves very well for this purpose, the tinned surface making it much easier to solder the joints. It is also suggested that the grid condenser be placed on the grid terminal of the socket and soldered to it. By all means solder all connections, even those where the wires connect to the binding posts, as one can never be too sure about these connections being good. The wiring may be covered with insulating tubing if desired, but this is unnecessary if No. 14 wire is used. It is, however, a good plan to use sleeving on the taps connecting the aerial switch contacts, as these wires sometimes come close together and the tubing will prevent short-circuiting. The wiring should be done in a neat manner, with all connections as short as possible.

Where Trouble Might Occur

If when the set is all wired up, it refuses to function as it should,

reverse the connections of coil "B" as it is sometimes very easy to get this part of the set connected up wrong. This however, is about the only serious trouble which might occur, but if the directions are carefully followed out the results will surprise the most skeptical.

Useful Pointers

A good way to make sure that all your connections are correct is to use a colored pencil when you are connecting your set and as you connect each wire on the set, mark out the corresponding symbol and line on the diagram you are working from. When you have finished, there will be no danger of your having left out any connections. It is a good plan to start out connecting the filament circuits of the set you are making first, and testing it by lighting the bulbs in the ordinary. If they are connected correctly, you may then proceed with the rest of the circuit.

Always hang up your phones after you are through using them, as the long cord dropping down to the floor may be stepped on and the phones dashed to the floor. When one considers how sensitive a set of headphones are, being able to detect currents of .00016 of an ampere, you will readily realize that they should be treated with care and consideration. A bad bump or drop will sometimes cause the headset to lose its magnetism or bend the diaphragm, which will result in inefficiency, which will later be laid to the set. Take care of your headset.

Did you ever know that crystals could be washed, and their sensitivity improved? Well, they can. Wash them in lukewarm water, with a stiff brush, holding them in a piece of clean silver-paper. Crystals should not be handled to excess with the bare fingers, as the fingers always have oil and grease on them no matter how clean you may wash them. If this gets on the crystal it doesn't work so well.

Short Aerials

B. O. Borgeson, of Chicago, says he hears all local stations using a ten-foot piece of wire strung from the ceiling down to his set, consisting of a short-wave three-circuit regenerative set using two stages of radio frequency, detector, and two stages of audio frequency. He uses Atwater-Kent apparatus. It makes an ideal way of receiving local concerts and programs through static and interference.

The Editor of this magazine uses about twenty feet of bell wire, strung around the picture moulding of his living room, and has to his credit a 1,000 mile range, using a Reinartz circuit with a two-stage audio frequency amplifier.

Another of our readers, Bosworth Lape, when writing in for more information on circuits, using a Reinartz hookup, tells of a one-tube reception of Omaha, Nebr., through static. Mr. Lape lives in Mansfield, Ohio, and it isn't every night that a fellow can get such good distance during the summer.

How To Construct An Efficient Two Stage Amplifier

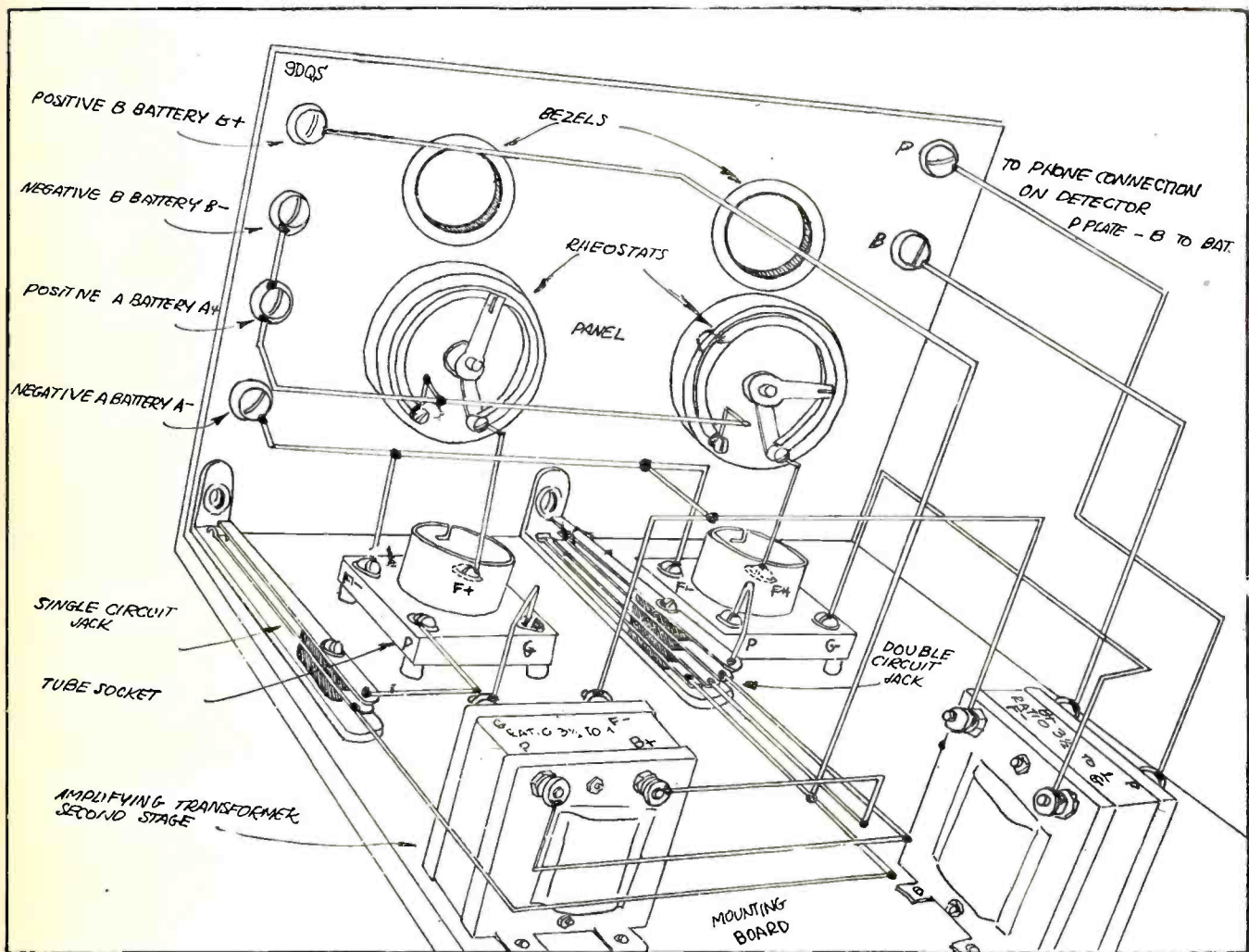

Figure 1. This shows the panel arrangement and wiring of the two stage audio frequency amplifier. Note especially the connections on the jacks.

By FELIX ANDERSON, Radio 9DQ5

A glance at the title of this article will probably convey the impression that this manuscript must have been found along with some antiquated radio literature, considering the recent trend of radio experimentation. Read the article. It is up-to-date.—The Editor.

WHEN WE stop to summarize the present developments with radio frequency, reflex and nuetrodyne systems, together with the discovery of new basic theories, it leaves us agast at the tremendous pace of radio progress.

In the wake of this progress, various circuits and systems are falling into disuse and are seldom heard of or used. Few indeed are surviving ideas.

Let us not forget the fact that among these survivors is the original audio frequency amplifier idea, a standard idea, which everybody takes for granted.

True enough—you say, but almost every BCL knows how to

construct an audio frequency amplifier—what we are just now interested in is radio frequency amplification or reflex or nuetrodyne systems.

"I have a one tube set," writes an enthusiast, "with which I am getting unusual distance, but the signal is so weak that at the best it makes difficult the reception of these long distance stations. How can I make them louder?"

The answer is simple—*audio frequency amplification*. You can use any good system, radio frequency, nuetrodyne or even reflex to advantage and get range, but where volume is necessary we make use of our old standby, AF amplification.

The writer has taken particular note of the present construction ideas and articles, and finds that nearly all are devoted to one or more of the new radical ideas now being pushed. We know there are many BCL's who wish to get volume, but don't know how and a concise, clear and detailed description of how it is accomplished will not be amiss.

The most efficient and most widely used system is the conventional two-stage transformer coupled circuit, shown in figure 2. In the characteristics of its construction, we wish to emphasize the following:

1. Flexibility—enabling the builder to connect the amplifier to his present detector unit.
2. Compactness.
3. Efficient and noiseless operation giving maximum volume, with least distortion.
4. Minimum Cost.

The following apparatus will be necessary for the construction of this amplifying unit:

- 1 panel of bakelite or formica 9 by 7 by 3-16 inches.
- 2 audio frequency transformers 3 1-2 to 1 ratio.
- 2 tube sockets.
- 2 rheostats.
- 1 double circuit jack.
- 1 single circuit jack.
- 6 binding posts.
- 2 U V 201 A amplifying tubes.
- 2 45 volt B batteries.
- 15 feet of tinned copper bus bar wire.
- 1 telephone plug.
- 1 mounting board.
- 2 panel bezels.

Cabinet and filament battery.

After the above apparatus has been purchased, the first thing to do is to lay out and drill the panel. It is not necessary to use a 9 by 7 inch panel; if the builder desires to make the amplifier in harmony with the set he already has probably the best way would be to make it in proportion to the cabinet of the detector set to which the amplifier is to be connected. We will let this rest with the judgment of the builder.

No template instructions are given as the constructor will no doubt wish to use apparatus of his or her own selection, and consequently different holes must be drilled to suit the particular apparatus one chooses.

The mounting shown in figure 1 is the arrangement the writer has found practical and harmonious.

THE TRANSFORMER. The selection of the amplifying transformer is very important considering the many makes now in use. Heretofore, the general belief was that a very high ratio transformer was necessary on the first stage of the amplifier, but test and experiments have demonstrated that at a slight sacrifice in volume by the use of a lower ratio transformer, the gain in tone and clarity is increased to a remarkable degree. In the set shown two transformers of three and one-half to one ratio, made by the National Transformer Manufacturing Company of Chicago were used with very good results.

These transformers are marked P and B plus for the primary connections, P indicating the plate of

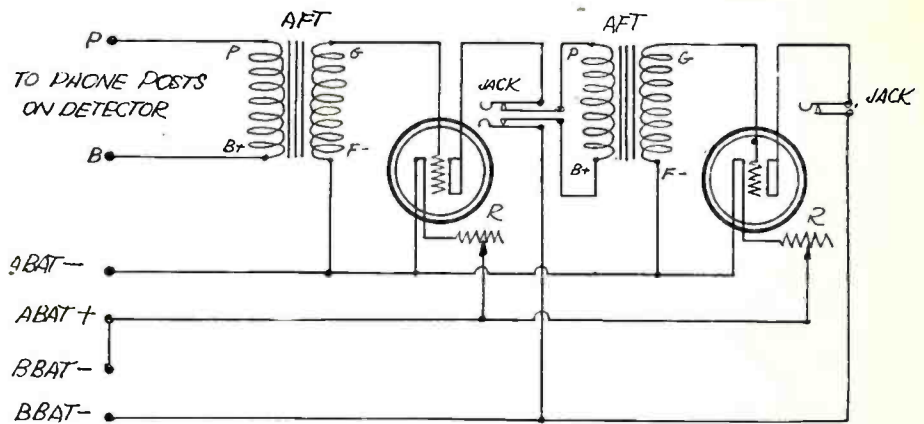

Figure 2. Circuit diagram of connections for the two stage audio frequency amplifier, showing the binding post connections.

the tube and B plus indicating the positive B battery. Secondary connections are G and F minus representing the connections to the grid of the tube and the negative filament respectively.

The F minus on the transformer must be connected to the filament negative as a negative charge is necessary on the grid when the tube is used as an amplifier.

THE BINDER POSTS shown at the upper right hand corner of the panel are connected to the output of the detector or the phone posts on this tube. These connections will have to be traced out in the detector to determine which is connected to the plate of the detector tube and which is connected to the positive B battery.

JACKS are shown in the illustrations with their connections. Four springs are shown on the first stage, and only two on the second. The use of a double circuit jack is not necessary on the second stage unless a third stage is contemplated, and which can be easily added without danger of howling if a low ratio transformer is used. If a third stage is to be added, a double circuit jack is used disregarding the two center springs entirely. The jack makes contact with a plug which when inserted into the jack spreads the two outer springs apart. When no plug is inserted these outer springs make contact with the inner ones which are connected to the primary of the transformer. When the jack is inserted the separation of the top and center springs opens the circuit, and the current travels through the phones.

THE RHEOSTATS should be of the correct design for the U V 201 A bulb, and should have a higher resistance than for the ordinary six-volt tube. The multistat, made by the Crosley Company, is very good for this purpose.

BEZELS as shown are used to

observe the tubes and their filament brilliancy when burning. They are purely ornamental, and a series of small holes drilled in a diamond formation will serve as well.

The transformer should be placed as far apart in the arrangement as possible, and should be mounted as shown with their windings running opposite to each other to counteract any undesirable inductive relation to each other.

By using a potential of from 65 to 150 volts on the plates of the tubes sufficient volume may be had to connect the set up to the phonograph or a horn using the arrangement shown in RADIO AGE for July. If a Magnavox or similar power amplifier is used, the volume will be sufficient to fill a good sized hall.

If you want a good clear loud signal use **AUDIO FREQUENCY**.

Records on Cruiser

With the Model TF tube transmitter installed on the United States cruiser, "Omaha," reliable communication was obtained up to 1,200 miles by day on C. W., and up to 1,600 miles night by ICW and voice. With the 20 kilowatt arc daylight ranges of 1,800 miles were obtained while working vessels of the United States fleet, and 2,000 miles while working shore stations.

During a single day on May 25, 1923, the Navy Department communication office handled a total of 858 messages. This was the high mark in two years' service.

Cape May Quits

The Naval Radio Traffic Station at Cape May, N. J., has been closed and abandoned. The transmitter at that station was removed to Radio Compass station at Henlopen, the latter station becoming the Compass Control station for the group composed of Cape May, Cape Henlopen and Bethany Beach. Traffic formerly handled by the Cape May station will be handled by the radio station at Philadelphia.

A Simple Buzzer Transmitting Set

By FRANK D. PEARNE

A VERY simple buzzer transmitting set, by means of which signals may be transmitted for distances of twenty-five to one hundred miles can be constructed by the amateur at a very small cost. However this is interesting only to those who have a government license, or to those who expect to have one, as it cannot be used without first taking the examination given by the government.

The principal part of this set is the coil which operates the vibrator. This is made by cutting out two fiber discs $2\frac{1}{2}$ inches in diameter and $\frac{1}{8}$ of an inch thick, with a hole one inch in diameter cut in the center of each. The core is one inch in diameter and is built up of soft iron wires $4\frac{3}{8}$ inches long. The fiber ends are forced onto the core, leaving $\frac{1}{16}$ of an inch of the core protruding through the discs. This forms the spool, which is then wound with 2,500 turns of No. 22 D. C. C. wire. The distance between the fiber ends is 4 inches.

When the winding is finished, the coil may be mounted on the base by cutting out a wooden block, with one side hollowed out to conform with the shape of the coil and a thin piece of brass bent around the coil and fastened to the base, or it may be mounted on two brass castings, as shown at "E" in the drawing. The vibrator spring is best made of phosphor bronze, or German silver, $3\frac{1}{2}$ inches long, 1 inch wide, and $\frac{1}{16}$ of an inch thick.

The lower end is bent over at right angles to allow a means of fastening it to the base. A one inch disc of iron, $\frac{1}{8}$ of an inch thick, is fastened to the vibrator spring at just the right place to come in front of the core, as shown. Two silver discs, one inch in diameter, are fastened, one to the vibrator spring and one to the adjustment screw, as shown at "S" in the drawing. These are best, when swetted on to the holding members, as they are only $\frac{1}{16}$ of an inch in thickness and any method of fastening with a screw or rivet would be awkward. Care must be used to see that the entire flat surface of these contacts meet squarely, as they carry a very heavy current

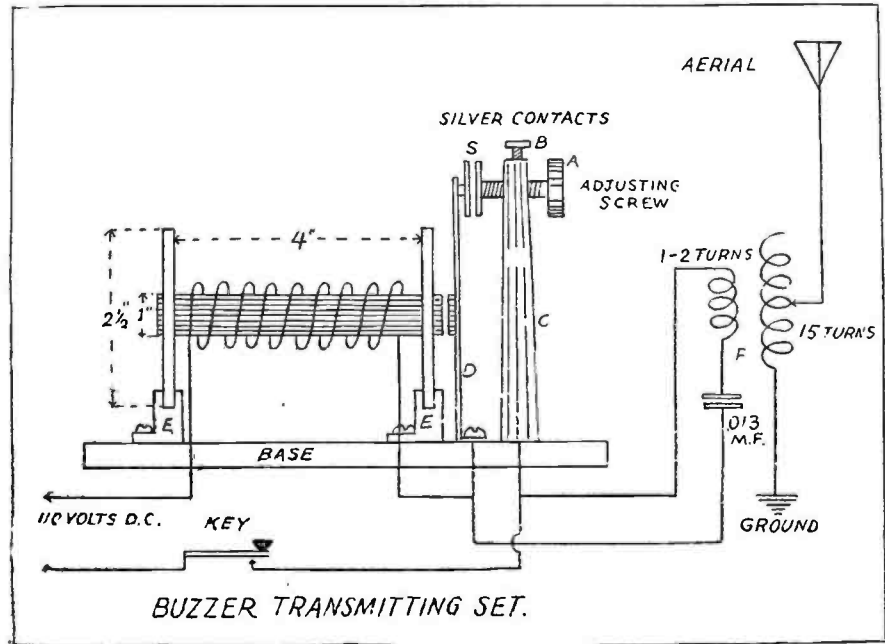

set up in the oscillating circuit. The post "C" which supports the adjusting screw "A" and contact, is made of $\frac{1}{2}$ inch brass rod, which may be straight, or turned into a fancy shape as desired. It is fastened to the base by a brass machine screw.

The oscillation transformer "F" is made by winding one coil of two turns of No. 12 bare copper wire, 10 inches in diameter and another coil of the same size wire having 15 turns, 12 inches in diameter. The small coil is placed inside of the larger, with a one inch air gap between the two. The aerial connection to the outside coil is made adjustable, by using a spring brass clip, attached to the aerial wire, which can be moved from one turn to another, for adjusting the wave length. The condenser should be of the glass or mica insulated type and should have a capacity of .013 M. F. The circuit may be easily traced from the drawing.

The oscillating circuit is formed through the small coil, condenser, vibrator spring and contact supporting post, and this much of the circuit should be wired with No. 12 wire, as it carries approximately 40 amperes. This heavy current is set up by the oscillating circuit, although the actual power consumed on a 110-volt direct current is less

than three-fourths of an ampere, so that the rest of the circuit may be wired with No. 18 copper wire.

Oakland is Active

The Oakland Tribune in California is planning to increase the power of its broadcasting station, and hopes by October to be in a position to apply for a Class B license. At present KLX is operating as a Class C station on 360 meters with a power of 250 watts. New apparatus for a 500-watt set has been ordered from the Western Electric Company, and with a 300-foot antenna, a far wider broadcasting range is planned this fall.

There are seven broadcasters in Oakland and its vicinity; two B stations and four A stations being in San Francisco, across the bay. The new G E station planned at Oakland will make a total of eight.

German Experiments

Experimental work in wired-wireless is progressing in Germany, Consul Richardson advises the Department of Commerce. Recently communication was effected between Berlin and Stolp on the Baltic coast over a 400 kilometer line. This high-frequency telephone line has been turned over to the Federal Post authorities by the firm of Lorenz A.-G. Three calls at a time were put through successfully; one on the normal wave length, another on 45 kilometer wave, and a third on a wave of 25 kilometers. Instead of cathode tubes, a special high frequency generator was used.

The Newest Radiotron, Model U V-199

By J. C. WARNER

Research Laboratory, General Electric Company

RADIOTRON UV-199 is a receiving tube of the high vacuum type which has been designed for operation on dry cells. The filament of this new tube requires only sixty milliamperes current which is supplied at a potential of 3.0 volts. Thus, the power consumed by the filament is only .18 watt.

This low current and small power consumption are made possible by the use of the new X-L tungsten filament which is being used in both the UV-199 and in the larger UV-201-A. This new filament requires much less current than the older type of tungsten filament and operates at a much lower temperature, appearing a dull yellow when lighted, while the older filaments burned at a brilliant white heat.

To illustrate the capabilities of the new filament, it is of interest to compare the UV-199 filament with that of the well known UV-201. The UV-201 filament required 1.0 ampere at 5.0 volts, that is 5 watts, and gave a total electron emission

of 7.5 to 10 milliamperes. The UV-199 filament gives the same electron emission but requires only 1-16th of the current and 1-27th of the power.

In order to operate at such a low current, it is, of course, necessary that the filament be of very small size, and in fact the UV-199 filament is only about one-fourth as thick as the average human hair. In spite of this small diameter, the filament is remarkably strong, since tungsten has about the same tensile strength as high grade steel.

The low filament current makes the UV-199 admirably suited to dry cell operation. It is always most economical to use dry cells at a low discharge rate; that is, the capacity of the cell in ampere hours is greatest if the energy is taken from the battery at a small current rate. Also, for greatest battery economy, the battery should not be discarded until the closed circuit voltage has fallen to 1.0 volt or less per cell. That is, although the voltage of a

dry cell is often thought of as 1.5 volts, this is true only at the very beginning of the life of the cell. The closed circuit voltage drops rapidly at first and then more slowly until it has reached 1.0 volt the energy contained in the battery is practically exhausted and the battery should be renewed.

The UV-199 filament is designed for operation on three dry cells in series and so takes advantage of the economy of a low current rate and the 1.0 volt per cell end point. Three six-inch cells of the ordinary general purpose type will operate one tube two hours a day for 387 hours or 193 days, two tubes 200 hours, and three tubes 125 hours. It is even possible to use flashlight cells where minimum weight and size of set are required. A small flashlight bulb requires .55 watt or three times as much power as the UV-199 filament and an ordinary tubular three-

(Continued on page 28.)



Sunday afternoon crowd in a village near Havana, Cuba, listening to its first radio program. As usual, when the camera man comes around the crowd turns to look right in the eye of the lens. U&U Foto.



Lieut. R. S. Olmstead, winner of the National Balloon race, adjusting his lightweight dry cell radio outfit, prior to the start of the race from Indianapolis. Radio rendered material service to the balloonists through the broadcasting of weather reports from five principal broadcast stations. Photo by courtesy of General Electric Company.

Radio Aids Balloon Racers

STATIC, that mysterious interference in the reception of radio signals, which is perhaps one of the greatest puzzles to radio experts today, may be confined to an atmospheric belt about the earth. At least that is the possible conclusion reached in special tests made by Ralph Upson, one of the country's most prominent aircraft engineers who was a contestant in the National Balloon race which started from Indianapolis on July 4.

Upson's balloon was equipped with a powerful lightweight radio set by the General Electric Company. For six weeks preceding the race Upson had used the set in his home and thereby became thoroughly familiar with its operation under various conditions. His experience had taught him what static sounded like, and he also learned that the air seemed particularly filled with it when there was an electrical storm in the vicinity; so much so, in fact, that one of the uses he planned for his radio outfit in the race was to detect

thunder storms before the lightning might be visible.

In his tentative report to the General Electric Company, made after the race, Upson writes:

"One of the outstanding happenings in the use of radio in the balloon race was that at altitudes of 3,000 feet and above we observed absolutely no static whatever, although we could see lightning at various points on the horizon."

Upson's chief purpose in carrying radio was to help him win the race. Five of the principal broadcast stations had arranged to send out special weather reports on upper air currents during the first night of the race and the following morning. In regard to this Upson says:

"Andrus, my aide, acted as chief radio operator. He began listening in at 8:30 o'clock the night of the race. At first he could hear nothing but code signals, concerts from various stations, and a radio drama that was being sent out from a Chicago station. For an hour, this was about all we could hear. Then

at 9:45 o'clock, central time, Andrus picked up the latter part of the weather report being broadcast from WGY in Schenectady. We heard just enough of it to make us wish we had heard the entire report. However, our disappointment was short, for a few moments later the whole report was repeated, every word being received clearly and distinctly. It was just the news we wanted.

"As a result of the information, we decided to go a little higher but not to try any high altitudes unless forced to it by thunder storms. The report gave us full confidence of reaching New York State, and possibly New England. Everything seemed so favorable that I turned in to sleep, leaving the balloon appendix partially closed. Then came the accident and you know the rest, a forced landing."

Similar outfits were installed in the three army entries in the race by the Radio Corporation of America. One of this trio, Lieutenant R. C. Olmstead, won the race.

Remote Control Broadcasting

By ROBERT J. STANTON

Assistant to the Director, Station K. Y. W.

OUTSIDE broadcasting, or transmission of speeches and music by remote control, has now reached its perfection at KYW, the radiophone broadcasting station operated by the Westinghouse Electric & Manufacturing Company, at Chicago. Remote control broadcasting means that the talk or music to be transmitted is "picked up" in a concert hall or theatre outside of the building in which the sending apparatus is installed. Before being relayed through special wires to the powerful transmitting panel in the broadcasting station, it is amplified by equipment located in the hall where it is being picked up, which insures its reaching the sending set with the same volume and audibility as heard in the hall.

Remote control broadcasting has come to be one of the important factors in radiophone service, for without it transmission of concerts played by large orchestras would be impossible, as the studios of even the largest stations are not large enough to seat a thirty-five or forty piece orchestra or band. The services of the larger churches, such as the Sunday Evening Club and Central Church of Chicago, which have choruses of a hundred voices, would also be impossible to transmit if it were not for remote control broadcasting.

The first successful remote control transmission was accomplished by KYW shortly after the station began operating, when the productions of the Chicago Civic Opera Association were broadcast direct from the stage of the Auditorium Theatre, situated approximately a halfmile from the Edison building, on the roof of which the sending equipment of KYW is located. Due to the success of the first radio transmission by remote control KYW is now known as the first radiophone station in the world to broadcast complete productions of Grand Opera, which were heard last winter in every state in the union and in Canada and Cuba.

The first step in the process of this remote control broadcasting was the installation of specially sealed telephone wire connections from the stage of the Auditorium to the transmitting panel of KYW. Three extensions were then added to these lines, which in turn were

volume music played by the orchestra during the overture.

A control switch was then installed at the right side of the theatre, fifteen rows back from the orchestra pit. By means of this switch the operator on duty at the theatre was able to cut in

the microphone before which the singers were performing, which aided him in establishing a uniformity in the volume of music being transmitted. In addition to being an expert radio engineer, it was also necessary for this man to be familiar with the action taking place in each production broadcast in order that he might know in advance if the artists were to shift their positions from the center of the stage to the right or left and whether a solo, duet, trio or full chorus was coming next.

During the broadcasting of each production, this man also was in direct communication with the operator in the station, in order that he might be immediately informed if a reduction in the volume of music should occur. If this did happen he could immediately switch in one of the other microphones and correct the trouble before the audience might discern a change.

From this beginning, the directors of KYW have gradually installed additional remote controls until at the present time there can be picked up music and speeches from ten outside sources. Special wires now connect the station with three of Chicago's leading hotels, three theatres, one newspaper office, two concert halls and a trading floor. These remote controls enable KYW to broadcast a variety of material, including commercial and financial reports, news bulletins, concerts, dance music, speeches and Grand Opera. Due to this system of outside "pickup," speeches by prominent statesmen visiting Chicago may be transmitted without the necessity of their making a special trip and second talk in the studio. The same is true of special concerts and other

(Continued on page 18.)



Remarkable cloud photograph taken by Ralph Upson during the recent championship balloon races, won by Lieut. R. C. Olmstead.

connected to three microphones, placed in the footlights on the stage, one in the middle and one on each side. A microphone also was suspended from the front of the first balcony to pick up the heavy

connected to three microphones, placed in the footlights on the stage, one in the middle and one on each side. A microphone also was suspended from the front of the first balcony to pick up the heavy

Telephoning Over Power Lines

TELEPHONING over power transmission lines became an established fact this week when executives of large power companies from various sections of the United States formally opened the new high frequency automatic telephone system just installed on the lines of the Consumers' Power Company, of Michigan. The celebration was in charge of B. E. Morrow and C. W. Tippy, officials of the Consumers' Power Company, who were first to talk over the new system. Each visitor, as he was allowed to hold conversation with the load dispatcher and operators in a power plant fifty miles distant, marveled at the extreme clearness with which conversation could be conducted.

This system has just been installed by engineers of the Westinghouse Electric & Manufacturing Company, who were also present at the opening. Only two sets are completed, these being located at Jackson and Battle Creek, Michigan. While these two cities will be able to use the apparatus, four other similar sets will be installed. In all there will be six hundred miles of transmission line utilized for telephone service when the system is completed.

This installation is a long step in advance of anything yet attempted in experiments with so-called wired wireless. Previous installations have been but adaptations of the familiar radio transmitters and receivers used in sending and receiving radio telegraph and broadcasting, and provided only one-way communication.

The system as worked out is quite flexible. Two frequencies are used.

The dispatcher's set transmits approximately 50,000 cycles and receives 60,000 cycles. The transmitter at Battle Creek transmits 60,000 cycles and receives 50,000 cycles. In effect, there are two transmitting sets and two receiving sets in service working through single telephone instruments with the result that the service is duplex and both parties may talk and listen simultaneously.

To communicate with Battle Creek, the load dispatcher at Jackson has only to lift his telephone receiver from the hook. This automatically lights the tubes and starts up the radio transmitting apparatus about half a mile away in the Jackson steam plant of the company. The dispatcher then turns the dial on his instrument to the number assigned to the Elm Street steam plant in Battle Creek. The operation of this dial sends out modulated high frequency impulses over the high tension transmission line through a sending antenna strung parallel to the power line for about 1,000 feet. These impulses are picked up on the receiving antenna at the Elm Street plant and cause a selector there to step around and stop at the proper point and, through the operation of a system of relays, rings a bell or sounds a horn in the booth of the Battle Creek station.

The Battle Creek operator unhooks his telephone receiver. This automatically starts up the transmitting radio set at Battle Creek. He then hears the Jackson voice sent out by the Jackson transmitter, and Jackson hears his voice which goes out through the Battle Creek transmitter. The two voices pass each other carried on different wave lengths, going through different transmitting radio

units, but all is tied into the two ordinary telephone instruments and controlled through them.

One of the principal difficulties which had to be surmounted in the full development of this system of communication was to neutralize the currents induced in the receiving antenna by the powerful currents in the transmitting antenna. Every radio fan knows how difficult this would be from his experience with the squeals and howls from even the small receivers in his immediate vicinity. This end is accomplished by apparatus in the balancer box at the left of the radio receiver. When properly adjusted, this balancing apparatus serves to neutralize the currents induced by the transmitting antenna in the adjacent radio receiving circuits and thus permit simultaneously the two-way communication which is an essential factor to the commercial development of high frequency telephony.

Operation of the system is so simple and so stable that it gives not the slightest hint of the months of study and experimentation that have taken place in the Westinghouse organization to combine the automatic telephone and radio elements for transmitting over lines which carry current at such tremendous pressures as to approach in volume of energy the power and effect of a bolt of lightning.

While the radio impulses which transmit the voice are carried upon the high voltage power lines, tests have shown that in event of line failure, the radio impulses jump the gaps and communication is not interrupted even when several miles of the transmission line is down.

(Continued on page 20.)

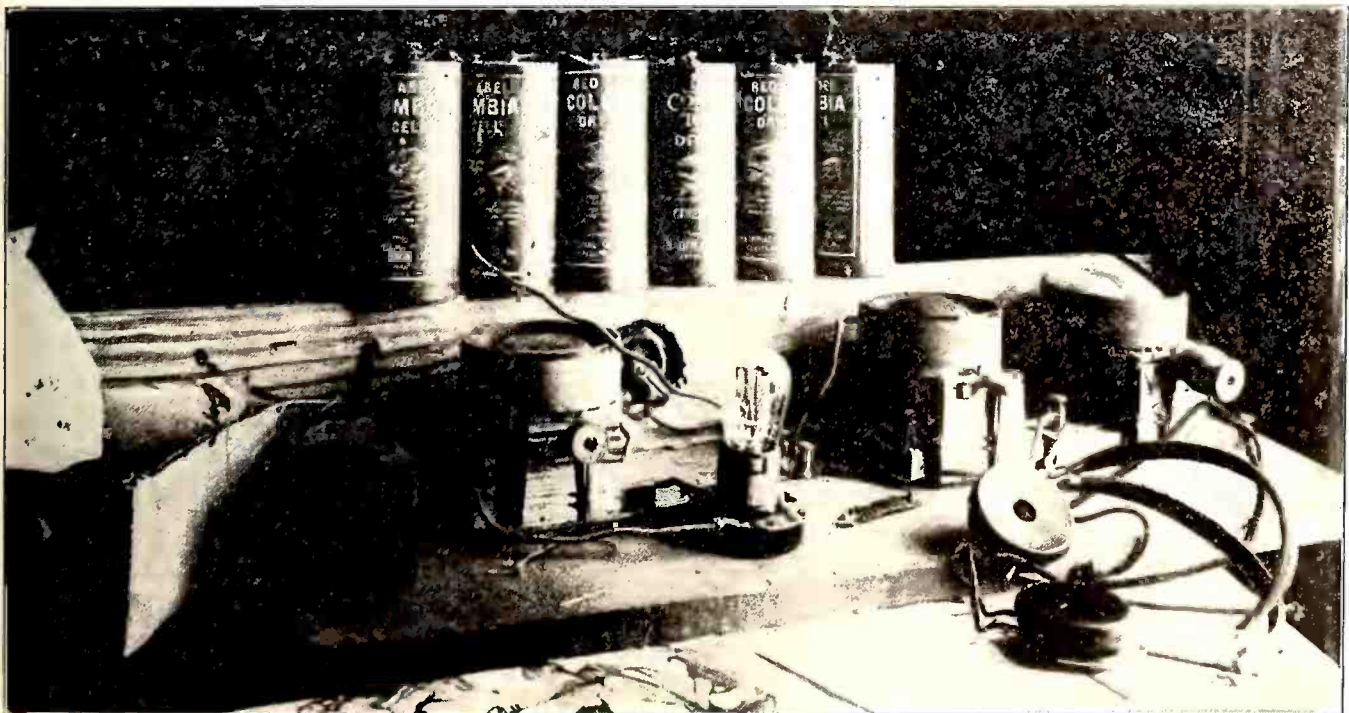

Spools and oatmeal boxes went into construction of this set, but George Stahlman of Nashville, Tenn., has picked up New York, Detroit, Fort Worth and Atlanta. In addition to getting good results, he has the satisfaction of having made his own outfit. U&U Foto.

Here's a Few Pickups of Our Own!

THERE probably is no better magazine salesman than a satisfied reader to whom we have rendered some little service or other. We take pride in saying that here is the keynote of our rapidly increasing circulation. The following extracts are taken from many letters from our readers who write in and tell us what they think of Radio Age.

Mr. E. Johnson, of 305 West 149th St., New York City, writes: "I received your diagram of the Reinartz circuit, and thank you for same. If you will forward me a subscription blank by return mail, I shall subscribe to your magazine with pleasure."

William S. Law, of Saxon Mill, Spartanburg, South Carolina, one of our regular readers who figures prominently in our "PICKUPS BY READERS" with a set constructed from instructions given in Radio Age writes: "I have just sent in my subscription for your magazine. Have been buying it every month on the stands but I do not wish to take a chance of missing a number. I think it has more helps and diagrams useful to the BCI than any other magazine."

"First of all, I wish to mention that I received the first issue of the Radio Age and find it chock-full of radio knowledge," says Mr. S. Sabo, of Quincy, Illinois. "It certainly cannot be beat."

Carl Lagergren, of Osterville, Mass., writes: "I was reading another radio magazine when the postman brought my Radio Age. The magazine I was reading contained an article on an interesting circuit but lacked detail enough for me to construct it. I wish Radio Age would print this circuit with a description of its construction, because then I know it would be made clear enough for the rank beginner to construct it."

Here's a letter from an Indiana BCL: Technical Assistant,
Radio Age:

I herewith wish to thank you for the copious information you gave me some time ago in regard to a radio circuit diagram. You sent me much more information than I had asked for and expected. As much as I would like to, I am sorry to say I am unable to subscribe to Radio Age due to the fact that the institution I am attending prohibits its students from receiving secular magazines. If no such limitation were imposed, Radio Age would be the first magazine I would subscribe for. At my home we get Radio Age regularly from our local newsdealer, and I eagerly read it during my off months. It is certainly a magazine of high caliber, full of practical information. Thanking you again for your courtesy to me, I am,

Very truly yours,
JOSEPH A. TERSTEGGE.
Saint Meinrad, Ind.

Richard F. Krouse, of Wauwatosa, Wis., says: "It gives me pleasure to be able to say that I am a subscriber to your good magazine, Radio Age."

With regard to our instructions, E. T.

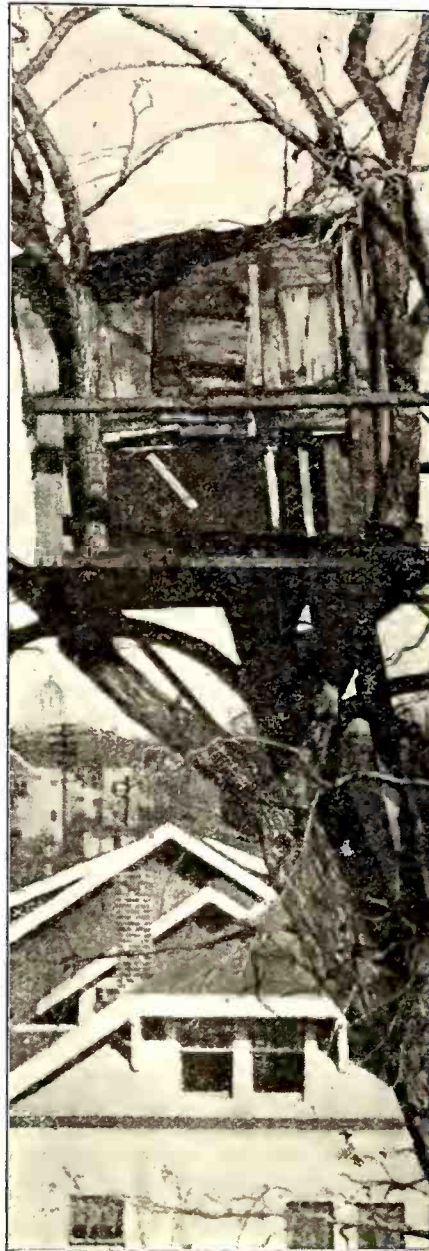

Howard Bussman, of St. Paul, Minn., has built him a tree-top laboratory where he can make all the noise and all the dirt he likes.
U&U Foto.

Siegerdt, of Chicago, writes: "I am a regular reader of Radio Age, and have constructed the W D 11 tube circuit of the March issue, and it works beautifully; in fact, better than any other circuit I have built." Mr. Siegerdt wanted information on how to further improve his set and got it.

To substantiate our first contention that a satisfied reader is a standing advertisement, we quote Mr. A. Sohval, of New York City, "I am always purchasing your publication from the stands, and whenever the opportunity presents recommend it to others."

Radio Age always welcomes constructive criticism as demonstrated in the action taken in regard to the following letter:

Radio Age:

Being a subscriber to your valuable paper, I notice the article concerning the case of a man in Dwight, Ill., who has entered suit against an amateur radio operator charging excessive interference. I would appreciate further details of this case as it progresses. Your magazine is complete in everything but one instance, which is that I think that it might be improved by adding a list of the Canadian stations, their call letters and other information to your present list of "Corrected List of United States Broadcasting Stations."

Very truly yours,

Stockton, Ill. **JOHN MAHER.**

Our issue of Radio Age immediately following the receipt of this letter contained the addition of the list of Canadian stations. Don't forget that Radio Age always welcomes suggestions of this kind, and the Editor really delights over such letters, when they contain matter showing that our readers really take so personal an interest in the magazine.

With further reference to the explicit directions and conciseness of Radio Age instructions, we print the following from a letter written by Mr. B. Magruder:

"I have tried innumerable places to get wiring illustrations of various circuits. I wish to build the Kopprasch circuit and I should like it very much if you will furnish me with a drawing or other similar data which would show the arrangement, wiring and layout of the Kopprasch circuit as clearly as that of the Erla circuit in your May issue. It was very simple to understand and I am sure I could not go wrong if I had such a plan to work from."

George W. Mayheray, of Chicago, Ill., wrote:

"Enclosed please find check for \$2 for one year's subscription to Radio Age. I am a new hand at radio and would like to construct a three-tube W D 11 set. Now I find that it would be impossible for me to construct a set from the usual instructions given, but feel confident that if I had a panel arrangement of a circuit as clear as that of the Erla circuit in the May issue I could build the circuit with ease. I think that this method of presenting circuits and ideas is a really wonderful plan for the true amateur like myself."

And you should have seen our Technical Editor, Frank D. Pearne, change his broad smile into a good-natured grin when he read this well-deserved praise, written by Mr. Mayheray:

"Mr. Pearne, you being the greatest Radio expert of today, I know you will help me as you have thousands of others. Therefore, I am thanking you in advance for much much-needed assistance in the matter of making my first attempt at radio a success."

And if you have a suggestion, or a kick, containing something of constructive nature, don't tell your wife or your cat about it. Tell us—we'll welcome the receipt of such information.

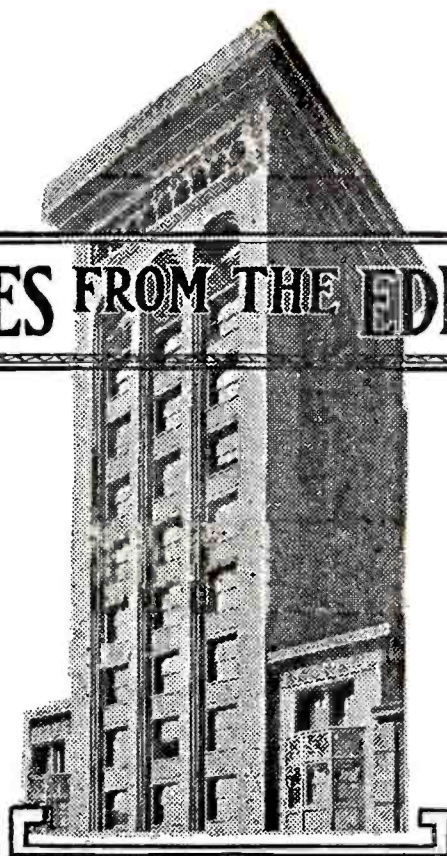

THOUGHT WAVES FROM THE EDITORIAL TOWER

THE writer has heard sufficient copyrighted music broadcast from radio stations that apparently are fighting the music combine to establish test lawsuits for the rest of time.

There have been many columns written about a suit against a big department store in New Jersey, brought by the American Society of Composers, Authors and Publishers. The suit was heralded as the first big step in the fight to settle the question as to whether the broadcasters could legally be forced to pay fees for broadcasting copyrighted music.

Great! We shall await the result of the suit with interest. Meanwhile the wide world is broadcasting copyrighted music and except for a period of non-copyrighted music in the middle west, the fans have scarcely been aware that any fight was on.

Whether it is legal or not, broadcasting stations from coast to coast are shooting the copyrighted jazz stuff out every night and it may be that the music combine is not so thoroughly convinced that broadcasting is bad for the music business as we have been so emphatically assured.

IN OTHER columns there will be found an item in this issue about how the United States Shipping Board station in England is making some distance records, reaching Panama with uniformly good results during the hot weather; also there is an item to the effect that communication between Singapore and the Christmas Islands is carried on successfully in these hot days. There is other and convincing evidence that radio is effective in hot weather if the proper equipment is used.

It is to be regretted that early in the radio game there was so much foolish discussion of static in summer. The difficulties of reception were exaggerated in publications and by word of mouth. The belief in the static bugaboo became

so general that many hard-headed business men simply refused to try to sell radio goods in the summer time, even going to the extent of ordering their purchasing departments to let the depleted stocks of equipment remain depleted, whether there was demand for equipment or not.

As a matter of fact, there is a lot of fun in radio the year 'round. It is possible to get long distance reception, if the receiving station is properly built and operated.

The only logical reason for a falling off of radio activities in the summer is that so many fans leave their homes for extended vacation outings and even when they remain at home outdoor pleasures often call them away from the radio receiving set. But that situation is met with the tendency nowadays to take a vacation radio set along and use it on the lake or in the camp.

An analysis of the situation shows that business in radio lines this summer is better than it was last summer and everything points to better business next summer than this summer.

Everybody is looking forward to the autumn months for the beginning of their promotional publicity, including advertising, and for extensive sales promotion.

It would be well for the trade to keep in mind that this summer

slump is likely to be shorter than that of last season. Publicity and advertising campaigns started in September and October will be too late to get the results that are awaiting us in the late fall and middle winter. This magazine is practicing its own preachment, having started its promotional work in July.

It is going to be a big year in radio.

ON ANOTHER page we are publishing extracts selected at random from the many letters we are receiving from fans expressing appreciation of the helpful diagrams and clear information we are publishing about making and operating radio sets. Let our hook-ups be your guide.

Mythical Static

The United States Shipping Board reports that with the two kilowatt arc and chopper installed on the steamship, "Eastern Glade," reliable night communication was accomplished on 600 meters from Durban, South Africa, to Madagascar for a period of over a month. The distance between the above mentioned places is approximately 1,200 miles.

The Shipping Board receiving station at London reports that for the past two years they have had much heavier static in winter than in summer and that although heavy static has been experienced during the past winter, receiving conditions have now greatly improved.

Your Station

Radio Age wants photographs of stations and laboratories of its readers, in order that other fellows may see what a good layout looks like. Photographs should be gloss prints and should be as clear as possible. For each photograph accepted we will pay \$1. Send them in, fellows—here's a good chance to see your station in print.

Timbuctoo Next

Radio communication between Singapore and Christmas Island was established recently, a report to the State Department advises.

Governmental Radio Activities

By CARL H. BUTMAN

WASHINGTON, D. C.—The United States Government has in operation today 885 radio stations, the Navy leading with 533 ships and 52 land stations, the Army being second, with 180 land stations.

Co-ordinating the service and equipment of these Government stations is one of the chief functions of the Interdepartmental Radio Advisory Committee, organized by Secretary Hoover soon after the first radio conference. This committee, which is composed of experts and representatives of Governmental departments taking an active part in the use of radio and broadcasting, has made a survey of the equipment and service of all Government stations, and has assigned new frequencies and wave lengths to them in accord with the recommendations of the Second National Radio Conference.

Generally it is felt today that the committee is a satisfactory clearing house for official radio activities. While broadcasting has been operated fairly satisfactorily so far, it is felt that the experience gained should form the basis of a national plan for a Governmental broadcasting system. This question members of the Committee realize, is intimately related to the 592 privately owned and operated broadcasting stations. They point out that "if radio is to become of maximum benefit to the people, the Government must continue to study the question of properly organized radio broadcasting and other services." There is a constant demand for curtailment and extension of the Government's activity and they feel that their duty is to co-ordinate those needs and execute them with maximum economy.

In the beginning the committee dealt only with broadcasting. Various problems arose which indicated the desirability of extending the scope of the work to include a wider field than radio broadcasting. This was done by Secretary Hoover to cover matters pertaining to radio communication in general. The functions of the Committee are to remain purely advisory . . . to all the participating departments in matters coming under its cognizance.

The Chairman of the Committee is Acting Assistant Secretary S. B. Davis of the Department of Commerce, who serves as the representative of that Department. The membership also includes the following representatives of the Department of Agriculture, Bureau of the Budget, Office of Chief Coordinator; Department of the Interior, Interstate Commerce Commission, Department of Justice, Department of Labor, Navy Department, Post Office Department, U. S. Shipping Board Emergency Fleet Corporation, State Department, Treasury Department, War Department.

The committee began an experimental system of "primary" broadcasting

stations for the transmission of official government news by continuous-wave (code) telegraphy, this news being available to approved privately owned broadcasting stations for re-broadcast by radio telephone. Use has been made solely of previously existing stations. Seven Post Office Department (Air Mail) stations were used at the outset, and have been replaced by the following Navy stations, working on frequencies between 50 and 65 kilocycles (between 6000 and 4600 meters); Arlington, Va., Great Lakes, Ill., New Orleans (Algiers), La., San Francisco, Calif. These primary stations accomplish the same purpose as leased wires in supplying material to the radio telephone broadcasting stations.

There is one government radio telephone broadcasting station—NAA—that at Arlington, Va. Its frequency, under the new assignments, is 690 kilocycles (435 meters). It broadcasts lectures market news, and miscellaneous information, supplied by the Departments of Agriculture, Commerce, Interior, Labor and Treasury, and also music by Government bands. The schedule includes eighteen 15-minute periods of radio telephone broadcasting daily.

Today about 100 privately owned broadcasting stations are supplied with material from several Departments and authorized to broadcast it by radio telephone.

"It is impossible to state the cost of broadcasting by Government departments because such operations have been conducted in connection with the other regular radio work of the departments,"

the committee states. The cost of conducting the broadcasting by Government stations during the past year included \$13,800 for equipment at Navy stations, including installing, alterations, power and renewals. There was no equipment charge against broadcasting by the Post Office Department stations, but the operation cost at the Post Office Department stations was approximately three cents per word. The average cost of the broadcasting from all seven Post Office stations for one day on a fifteen-hour day basis was \$53.93 or \$16,826 per year. The Committee has no estimate of the operation cost of the broadcasting from Navy stations, nor of the cost of preparing the material.

The classification of material for broadcasting is considered, and it has adopted the principle that radio broadcasting should not be used where wire telegraphy or printed publication would be as satisfactory.

Radio Gunners

It is expected that the Naval Bureau of Navigation will hold an examination for gunner—radio—about the middle of August. The Bureau will notify the service at large as soon as it is definitely settled. In all probability, requirements for this examination will be the same as those incorporated in the Bureau's manual. This is a step in advance for radio in the navy as the gunner is a warrant officer and stands next to the commissioned personnel.

Reinartz Book FREE

Reinartz Radio Book with Hook-ups—best book on best circuit—written and illustrated by Frank D. Pearne. If you want one free sign the coupon below and get the book and one year's subscription to Radio Age for \$2.00.

RADIO AGE,
500 North Dearborn St.,
CHICAGO.

Please send me FREE one of your Reinartz Radio Books and send me Radio Age for one year. I want to take advantage of this Special Offer. I enclose \$2.00.

Name.....

City.....

Street and Number....

THE TROUBLESHOOTER

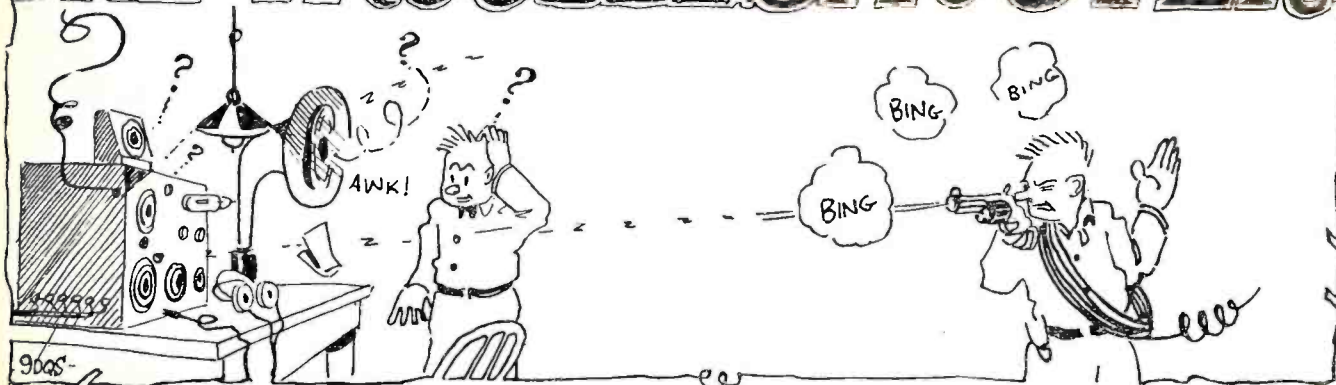

The technical department sends out many replies to questions in each day's mail. This service heretofore has been free to all but in order to assure this service to our subscribers this direct reply method hereafter must be restricted to those fans who are on our subscription list.

Fans who are not subscribers may obtain this service by enclosing 50 cents with their question and the reply will be mailed at once, accompanied by circuit diagram where illustration is needed.

All inquiries should be accompanied by self-addressed and stamped envelope.

R. C. G., Chicago, Ill.

Question: I wish to ask a few questions with regard to charging a battery. I am on a direct current for house lighting, and therefore could use the socket light for charging my storage battery but I am unable to determine exactly how much resistance I should have in the line, and the safest type to use. I have an electric toaster of 550 watts type of 5 ohms resistance, and would like to know if this would be a satisfactory resistance? How would this be connected? How long should the current be allowed to charge for an 80 ampere hour battery? How is polarity of the direct current determined? How can I tell when my battery is fully charged?

Answer: In Figure 1, I am printing the correct arrangement for charging the battery you speak of using the direct current lighting source you have. The toaster in series with several lamps of about 100 watts will sufficiently cut down the current to make it safe. The circuit should be properly fused at all times. If the battery boils violently another lamp should be added until the plates just bubble profusely. To determine when the battery is charged, I would advise that you secure a hydrometer, an instru-

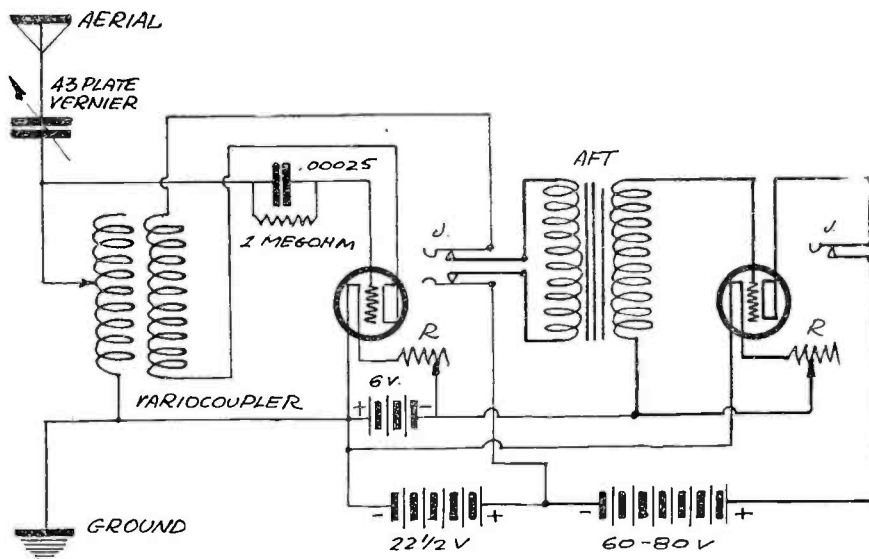

Figure 3. The single circuit regenerative set, showing the addition of one stage of AF amplification.

ment costing about seventy-five cents from your local battery station and by following the instructions accompanying the instrument you can test your battery for its gravity at any time. A fully

charged battery should read 1280. The description of a polarity indicator is described elsewhere in this issue.

T. McL., Brooklyn, N. Y.

Question: In your May edition of Radio Age, on page 21, I saw a drawing of a single tube regenerative set sent in by Harold Lee, of Fosston, Minn. I made one exactly like the drawing but am unable to get any long distance outside of WOR and WJZ both being located in Newark, N. J., about sixteen miles from here. I can get WEAJ in New York City very loud and also the two stations in Newark but no further than that. WGY I cannot get or Philadelphia, Pa., which are about 100 miles from here. Do you think an amplifying bulb would be of any assistance in getting these stations? There is a fellow near me who can get

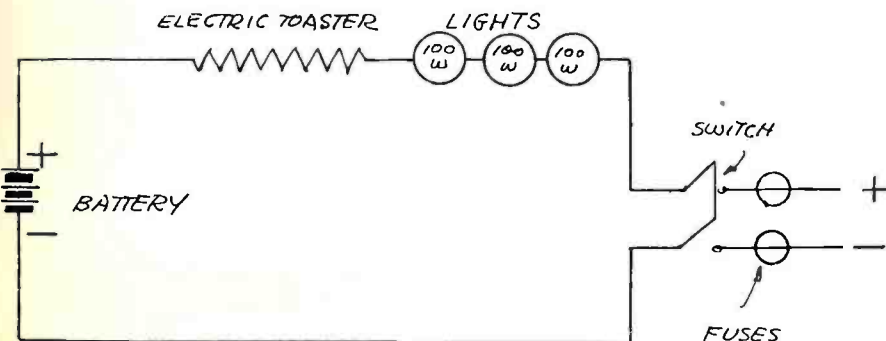

Figure 1. An arrangement using an electric toaster and a bank of 100 watt lamps in series to charge storage batteries, where direct current is available.

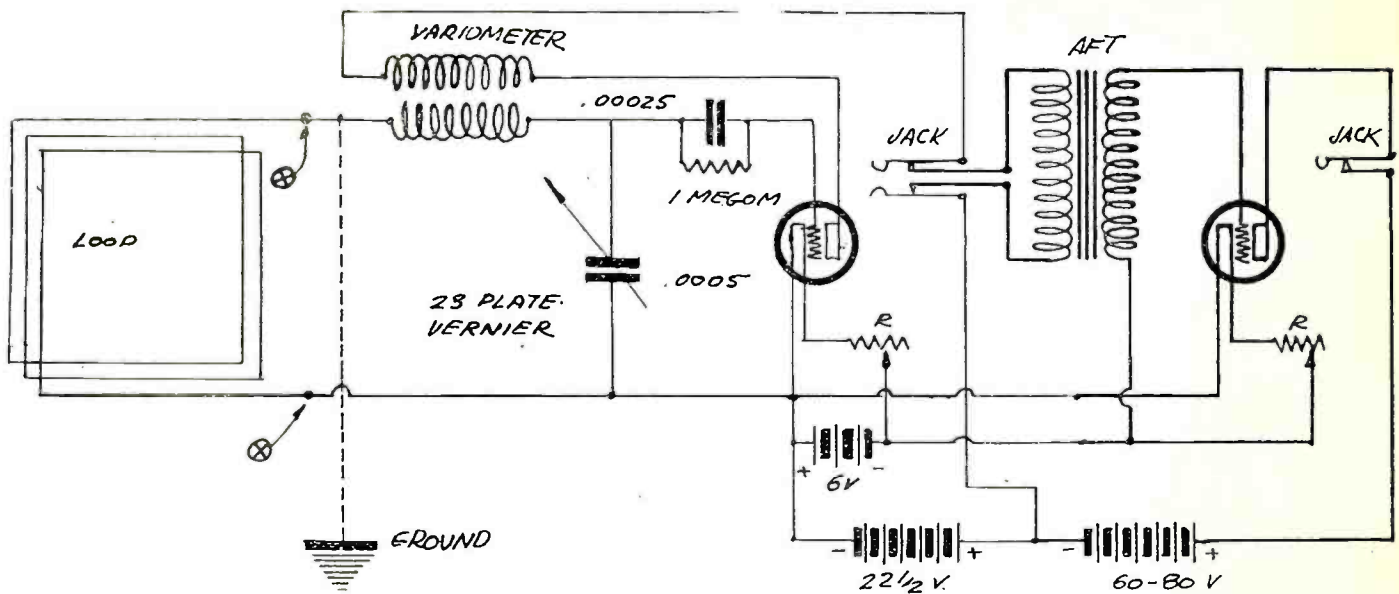

Figure 2. A simple loop circuit with one stage of AF amplification which can be converted into a regular aerial receiver by connecting an ordinary variocoupler at the points marked X.

Boston, Atlanta, Washington, D. C., etc., and he uses a one-stage amplifier along with the set. Will you kindly show how this is added?

Answer: In Figure 3, I am printing a diagram showing you how to add a one-stage amplifier to the set you have connected up. I feel confident that if you will give careful attention to the adjustment of your tube on the detector you will find that your range will increase. Probably the best way to do this is to secure another tapped B battery of 22½ volts potential and arrange it so that it is adjustable in steps of 22½ volts up to 45. You will then be able to get these long-distance stations as you wish. The set should be adjusted so that it spills over gently when the secondary of the variocoupler is turned, i. e., it should give a dull click or soft thump followed by a continuous hissing sound. If you find that the set gets the carrier waves or whistles and does not seem to be able to tune in the voice, decrease the B battery. Be sure that the filament battery is in good condition. No doubt you will also find that your set will have a better range in the fall, due to the fact that summer weather makes the reception of long distance difficult.

C. M. H., Seymour, Ind.

Question: I have a two-step amplifier, which when I first purchased it would not work and after corresponding with the manufacturer sent it in and it was repaired and returned. It worked fine for awhile, and then died again. Thought probably the transformers had gone bad and installed new ones. I am still having trouble, and would appreciate a little assistance from you. Have drawn the hookup I use, and would like to have you finish same from output of detector to output of second stage. I want to use jacks and plug. Am not familiar with the latter and would like for you to show which are open and closed.

Answer: In this issue of the magazine you will find an article on the construction of a two-stage amplifier, using jacks, which will no doubt clear up your trouble.

T. O. W., Houstonia, Mo.

Question: I am enclosing a diagram of a radiophone hookup which I am using and I would like to know how to hook one stage of radio frequency amplification to this. Would also like to have you show the detector of the circuit independently.

Answer: In Figure 4, I am showing you how to correctly add one stage of radio frequency amplification to the circuit you are now using. The detector as you ask was shown in the May issue of Radio Age.

H. R., Schenectady, N. Y.

Question: In the June number of Radio Age I noted with interest your description and drawings of the Kaufmann circuit, but am at a loss to know what size panel it will take. Was under the impression that it could be put on a panel 8 by 18 inches but notice you have the 43-plate condenser mounted directly over the Active 20-coil. This being the case, it would take a panel about 12 inches high instead of 8 inches as per the directions. The coil would take 5 inches and the condenser about 4 and with about 2 inches leeway it would make the panel pretty large. Would appreciate it very much if you could send me a template of the panel showing the correct size and spacing of the different instruments. Also note you have the 43-plate condenser mounted upside down. Is this essential?

Answer: The Kaufmann circuit can be easily mounted on the size panel as given. The Active 20-coil is not mounted directly below the condenser, but is mounted in back of it with the taps directly underneath the condenser. The coil may be set 3 or 4 inches back on the mounting board. I am sorry to say that I have on hand no template with which you could lay out the circuit. You will no doubt wish to use apparatus of your own choice, and of course the holes will have to be made in accordance with the instrument you use. The condenser is apparently mounted upside down as it has been found that this arrangement collects less dust and dirt.

B. B. J., Rock Island, Ill.

Question: Please advise just what receiving range could be obtained with the Erla circuit at this time of the year. What will the new Kaufman circuit accomplish in comparison with the Flewelling or Reinartz circuits? How are the U V 201 A tubes used? I have a perfectly good storage battery and would like to use it with this tube if the expense of additional apparatus is not too great.

Answer: Both the Erla and Kaufmann circuits are giving good results; however, will say that I am partial to the Reinartz circuit as the set for the beginner, due to the fact that it is easier to construct, least difficult to operate, and can be constructed at a minimum expense. With a Reinartz set using one tube a conservative range of 800 miles at night may be expected under favorable receiving conditions. You will not have to change the circuits at all in order to use the U V 201 A as only a special type of rheostat of higher resistance than the ordinary one is needed. If you use the tube with a regular rheostat, the knob should be turned so that the bulb barely lights. There are several small resistances on the market which can be added to the regular six ohm rheostat to make it more efficient for use with the U V 201 A.

A. C., Brooklyn, N. Y.

Question: Will you kindly print a good hookup for a set using the following apparatus in connection with a two-stage audio frequency amplifier. I have an outdoor antenna, 3 W D 11 tubes, sockets, 2 AF transformers, 2 double sockets, 2 AF transformers, 22 double circuit jacks, 1 single circuit jack, 1 variocoupler, 1 variometer, 2 variable condensers and a pair of Murdock phones.

Answer: A very efficient circuit was printed in the July issue of Radio Age, using the very apparatus you mention with the addition of a 25-turn honeycomb coil placed in the grid return circuit. If you will look back for this circuit and add to it a two-step amplifier as described in this issue, you will have a very efficient set. This circuit will give

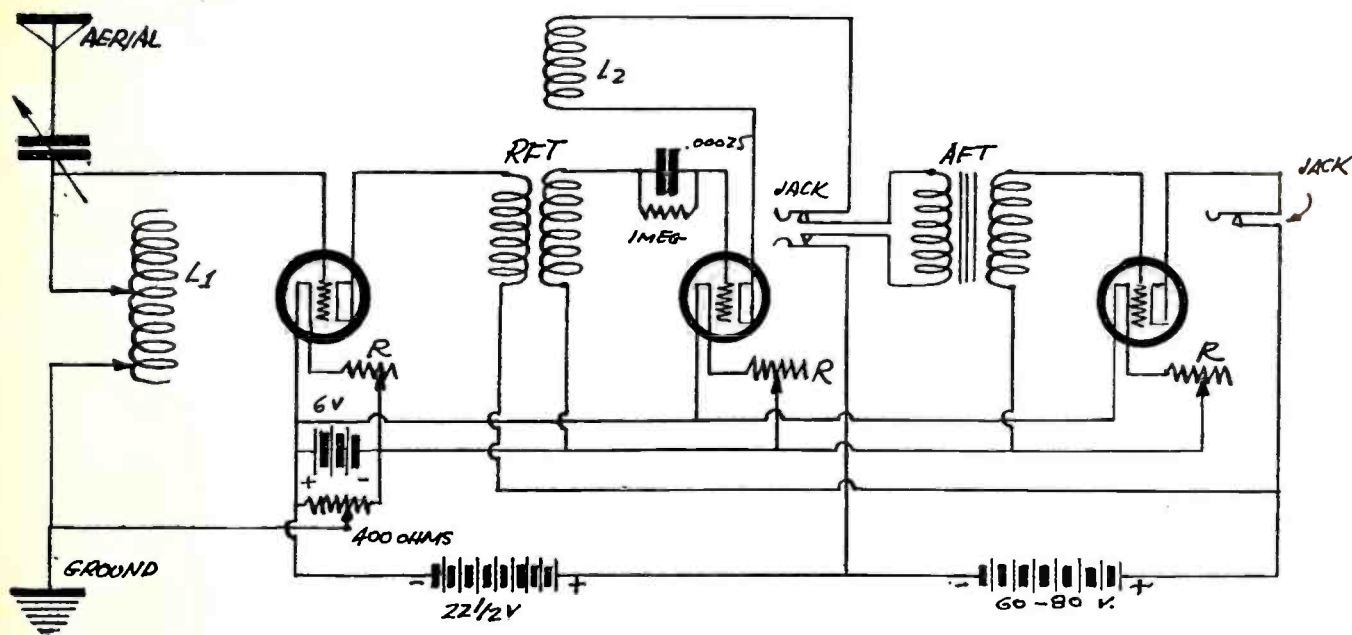

Figure 4. A single circuit regenerative circuit in connection with 1 step RF amplification and 1 step AF amplification. L 1 and L 2 are the primary and secondary of a variocoupler respectively.

ample selectivity and good range. The circuit appeared in the questions and answers section.

H. B. K., Chillicothe, Mo.

Question: Kindly print a hookup of a circuit showing one stage of audio frequency amplification in connection with a circuit using either a loop antenna or regular aerial. The set is to be used with U V 199 tubes throughout.

Answer: In Figure 2, I am printing a circuit showing a loop receiver arranged to use either an aerial of the regular type or a loop. The audio frequency amplifier is shown in darker lines. The amplifier may be constructed according to the instructions given for a two stage amplifier given elsewhere in this issue.

C. H. P., Davenport, Ia.

Question: Please send me a diagram of what you consider the best circuit using detector and 2-stage of audio amplification for use with either loop of regular antenna. I am in search of a circuit that will give me volume as well as distance, regardless of cost of building. I have a Reinartz spider web coil set, built according to your instructions and am having wonderful results with it but I am in the market for something more elaborate. This circuit is to be used for broadcast reception only.

Answer: You will want a selective, efficient circuit, such as I am printing in Figure 5. From personal experience, can say that it is yet the most efficient circuit I have used, and will give unlimited range if properly constructed. The radio frequency stage is shown to increase the range of the set, with the two stage audio amplifier, which can be con-

structed as shown elsewhere in this issue, will give plenty of volume. This circuit requires patience and skill in tuning, and you will have to adapt yourself to the noises and sounds of the set to get the best results.

J. A. O. B. Brooklyn, N. Y.

Question: In the May issue of Radio Age, you featured the Erla circuit, which I constructed according to the instructions given. I am enclosing herewith a diagram showing how I have connected the set and with which I am getting good local results but with little success on long distance stations. Is the enclosed diagram correct? Would the addition of more tubes assist in bringing about better results? I have a 75-foot aerial; would it be a good plan to put a condenser in the ground lead? I would like to have as powerful a set as possible and would like to have your opinion with reference to this.

Answer: I am mailing you a diagram which shows the limitations of your set,

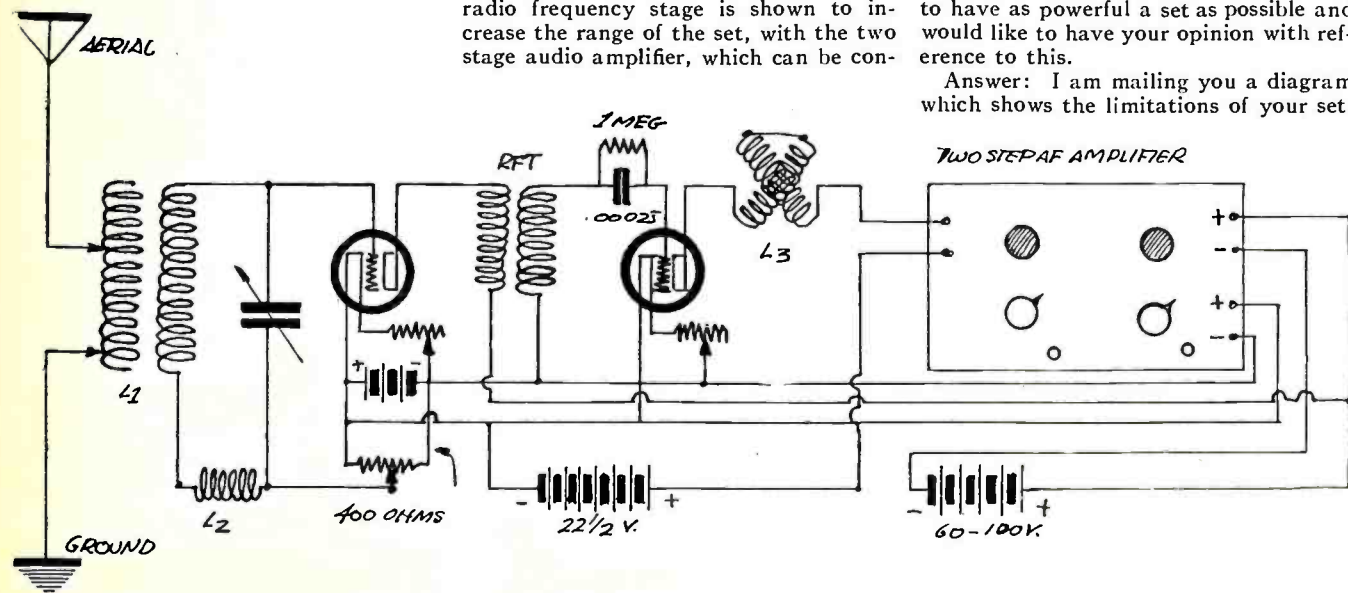

Figure 5. A simple regenerative circuit of great efficiency, 1 stage of radio frequency amplification, and two stages of audio frequency amplification. L 1 is an ordinary variocoupler, L 2 a 25 turn honeycomb coil, and L 3 a variometer, The drawing illustrates the use of the audio frequency amplifier described in this issue.

due to reversed transformer connections. It is important that you have these connections correct. On your diagram you indicate the connections from the G on the reflex transformer going to the positive of the AF transformer, and the A on the reflex transformer connected to the P on the AF transformer which is incorrect. Correct connections are G of the reflex transformer to P on the AF transformer, and F— on the reflex transformer to B+ on the AF transformer. The correction of this error will greatly improve the efficiency of your set. Would advise that you shorten your antenna down to about 50 feet and forget about inserting a condenser in the ground lead.

J. N., Chicago, Ill.

Question: I have constructed my set in accordance with the hookup in your booklet, "Reinartz Radio." On the antenna I have a 23-plate condenser and on the ground an 11-plate. I use a Schoonover coil and am able to get local stations loud enough on the detector tube so that they can be heard all over the room by using an adapter on my victrola. However, I have not been able to get out-of-town stations even with one step of audio frequency, although I have friends who get distant stations loudly on the Reinartz sets with only a detector tube. I have therefore tried to add a step of radio frequency to see if this would bring in the distant stations. I have an Erla A B 1 transformer mounted in a bulb socket and am using a C 301 A tube as a radio frequency amplifier. The addition of this apparatus has not helped the situation a bit. All I get now is a humming sound and weak signals from local stations. I can turn off the radio frequency tube or even remove it from its socket, and still get these weak signals. Please explain this.

Answer: Inasmuch as several of our readers are asking about this circuit, I am printing in Figure 6 the correct connections for the addition of a one-step radio frequency amplifier together with a step of audio frequency which should give very good results if connected as shown. The humming sound you speak of is called a beat note, and is caused by the radio frequency tube oscillating, rectifying the signal instead of amplifying it. Probably the reason you can hear signals without the RF stage working is due to the fact that this part of the circuit acts as a condenser and passes the signal on to the detector without actual contact.

A. S., Chicago, Ill.

Question: I have a crystal set made up as per enclosed drawing received from you, and have had very good success with it. However, since change in wavelengths, I have been unable to pick up KYW station, which before the change came in loudest of all. Can you suggest any change in this set to enable me to again receive this station?

Answer: I am mailing you a diagram with suggested additions and changes, which I trust will enable you to again receive this station as you did before.

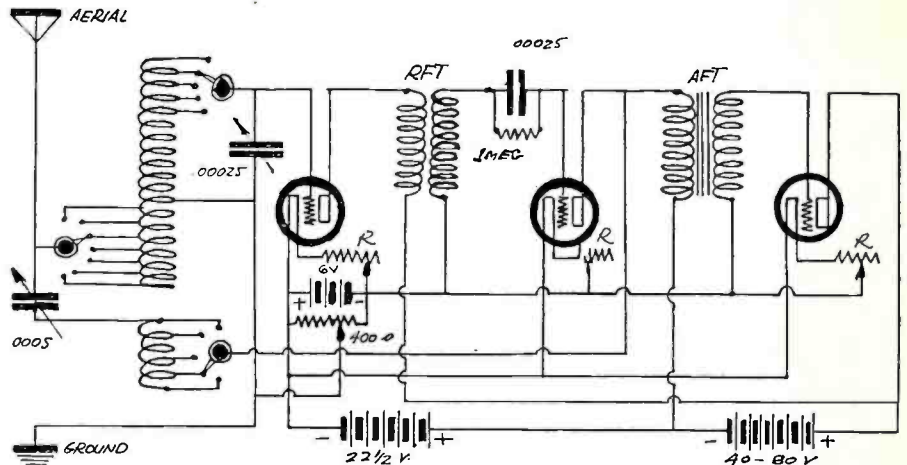

Figure 6. Many of our readers are contemplating the addition of radio frequency to their Reinartz sets. This circuit shows about the most efficient arrangement yet found.

Would advise that you carefully note the time at which this station is transmitting, as the change in wave length has affected the transmitting of this station very much with regard to range and signal strength. Improvements are being made and it will shortly become normal. You will have to tune lower than before, as their wave is now around 347 meters.

W. R. B., Odenton, Md.

Question: I recently purchased a wireless specialty receiver from the Navy Department but it has proven unsatisfactory and so I want to change the hookup. The apparatus is connected as enclosed drawing shows. Provision is made for both crystal and tube detector. What changes will be necessary to make this set efficient?

Answer: Your drawing shows a 43-plate condenser across the secondary of the variocoupler which is incorrect. Substitute a 23-plate in its place. It may be that this set was designed for use on waves of from 600 meters and up. This would be detrimental for tuning short waves. Investigate and see if the coils used for primary, secondary and tickler have more than 75 turns for primary and secondary and if the tickler has more than 100 turns. If it has it may be necessary to remove about 25 turns from each one of them. The July issue contains the hookup you should use for the tube set, in the questions and answers section.

Mexican Fair

The recent radio fair, held in Mexico City, aroused considerable interest, and there has been an increase in sales of radio telephone apparatus. Some low-priced German equipment is now coming on the market, the Department of Commerce has been advised.

Remote Control Broadcasting

(Continued from page 10.)

music. This system also enables KYW to give a complete broadcasting service to millions of radio listeners in the United States and its neighboring territory.

Boulevard Concerts

Le Matin, the well-known Parisian daily, is operating a concert radio receiving set in front of its office on a popular boulevard, where crowds gather to listen to news, concerts and statistics from fourteen amplifying horns. The amplifiers are sufficiently loud to be heard over the terrific traffic noises, Consul Ives reports from Paris.

The public listening-in station was installed by the Soci t  Francais Radio Electrique which broadcasts two concerts daily on 1,780 meters. Other broadcasting is done by the Eiffel Tower on 2,600 meters, and the Superior School of the telegraph and telephone service of the government on 450 meters.

No provision for a royalty to broadcasters has been made in France, beyond the payment of an annual fee of ten francs to the French Postal Service by owners of wireless receiving sets. The Eiffel Tower radiations are sent out for the general public, and the Superior School broadcasts are carried on in the interest of education and experimentation. The Soci t  Francais Radio Electrique, however, states that it obtains its remuneration by the sale of the "Radiola" receiving sets adapted to the broadcasting system used by the Soci t , explaining that in order to receive its wireless concerts properly it is essential that a "Radiola" set be used. The assertions of the company are corroborated by private set owners who say that other receiving sets are unsuitable for the company's broadcasts, concerts being heard very indistinctly with other sets, if at all.

Listening-in is becoming popular in France, it is reported, although not as extensively as in the United States. Anyone may own a receiving set there, but transmitting outfits must be licensed by the government. French receiving sets are advertised for sale as low as 250 francs each. No specific import duties are prescribed for complete radio receiving sets, but the different parts are dutiable separately.

Most of the French broadcasts are on long wave lengths, except those of the Superior School.

Little Things That Help

Polarity Indicator

A simple polarity indicator can be constructed by taking two pieces of copper wire which are not insulated, and inserting them into a diluted solution of sulphuric acid and water. If the acid is not handy the plain water will often serve the purpose. The two wires are placed in the solution and are connected to the source of potential to be tested. As the current flows through the wires and solution, there will be noted small bubbles of gas rising from the wires. This indicates the decomposition of water into hydrogen and oxygen. Water being composed of these two gases separates into their respective values, of hydrogen two parts and oxygen one. It will be noticed that one of the

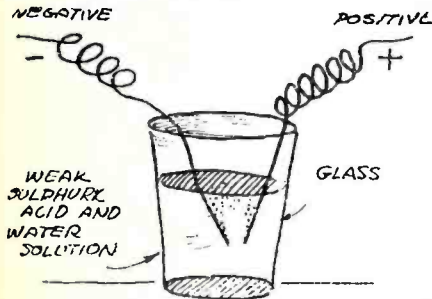

Figure 1. This arrangement is probably the simplest method of finding polarities of batteries, currents, etc.

wires gives more bubbles than the other. THE HYDROGEN IS THE NEGATIVE POLE OF THE SOURCE AND THE OXYGEN THE POSITIVE. Or saying it in a different way, the wire giving the most bubbles is the negative and the lesser of the two is the positive. Try it on your B battery.

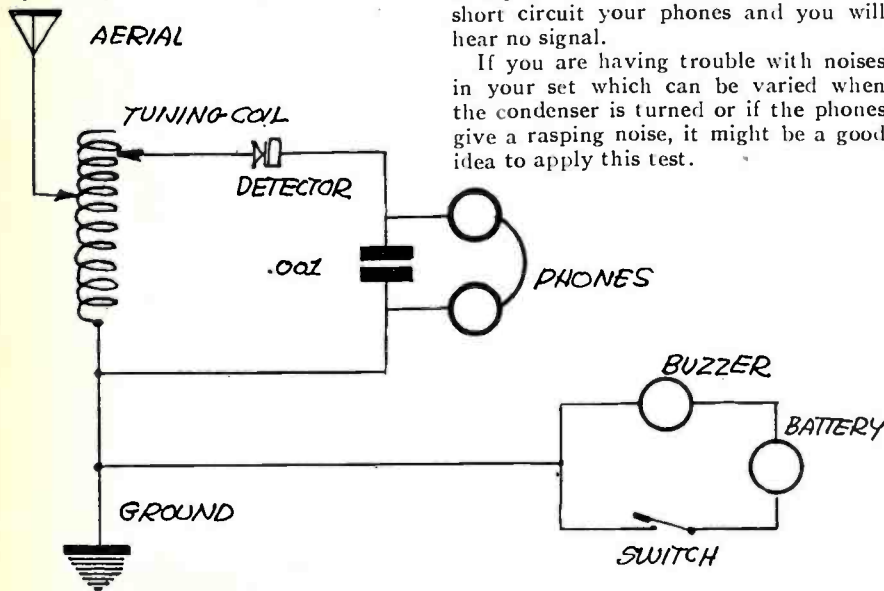

Figure 3. If you are having trouble with scraping, rasping noises in your set, which are amplified by turning the condenser knob, try this test on them. It can also be used for testing breaks in coils, and for loose connections.

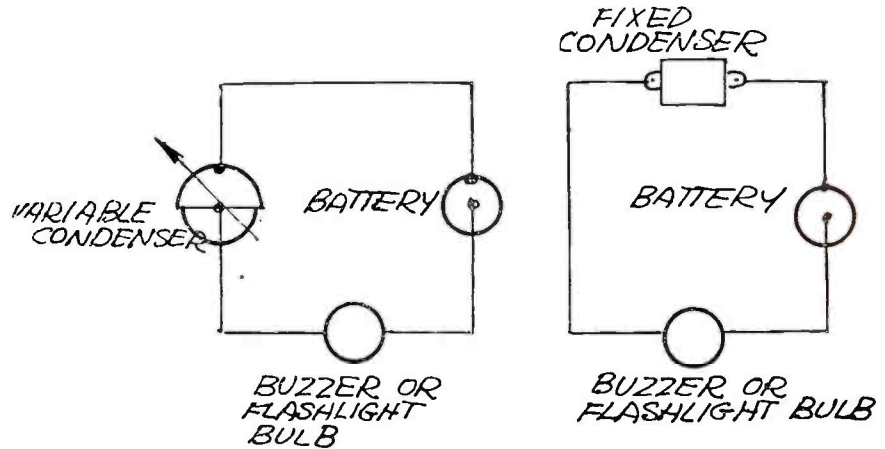

Figure 2. Our crystal set users will welcome this suggestion for testing out their crystals. The connection on the buzzer should run to the ground post on the receiving set.

Simple Test for Condenser Short Circuits

Procure a dry cell and an ordinary flashlight battery and touch it to the terminals of the fixed condenser, as in figure 2. If the condenser is defective, the bulb will light. This applies to fixed condensers and variable condensers as well. To test a variable condenser, the connection is made to the rotary and stationary plates respectively. The plates are then turned, and the bulb is watched. If the condenser plates touch or are shorted, the bulb will light indicating faulty spacing.

This test is essential where the condenser is to be shunted across the B battery and filament as in the Grimes circuit, or where a large capacity condenser is connected across the B battery. If a phone condenser is defective it will short circuit your phones and you will hear no signal.

If you are having trouble with noises in your set which can be varied when the condenser is turned or if the phones give a rasping noise, it might be a good idea to apply this test.

Testing Crystals

An easy and well-known method for testing crystals is possible by the simple use of an ordinary buzzer, a dry cell and a switch. The instruments are connected as in Figure 3, and are used to find the "hot spot" on crystals.

The buzzer is connected to the dry cell and switch in series, and the switch is closed. The buzzer sets up a series of oscillations, which if the detector is properly adjusted will be heard in the phones.

This will dispel all doubt as to whether the crystal you are using is sensitive or not.

New Trouble Finding Chart

A very clever idea for clearing up various troubles in the radio receiving set, is the new Trouble Finding Chart, produced and copyrighted by the Benson Melody Company, 190 North State Street, Chicago, Ill.

This chart has all the troubles known to radio sets listed on one side, and their causes listed on the other. A series of lines extending from each particular case of trouble mentioned, ends in the explanation of what will cause that certain trouble, making it possible for the beginner to solve his own trouble problems without the advice of an expert.

This fills a long felt want in the radio field, as it covers anything which may happen in the set and it is bound to be very popular, not only with the beginners, but also with the fan who has advanced to the expert stage.

NOTICE

Notice is hereby given to all whom it may concern that John Doll, formerly employed in the circulation department of Radio Age, is no longer associated with the publication.

Power Wires in Telephony

(Continued from page 11.)

This feature of the high frequency telephone system gives it a marked advantage for load dispatching over the conventional wire circuit telephone system.

Communication between Jackson and Battle Creek has demonstrated that even lightning storms, which will interrupt service momentarily on the transmission lines, have no effect upon communication by high frequency telephony.

When the system is extended all the outlying sub-stations will use the same transmitting and receiving frequencies or wave lengths as Battle Creek. That is, the dispatcher will be able to talk with any station merely by dialing the proper call number on his desk phone. Under this arrangement outlying stations would not be able, under normal conditions, to talk with each other, but by going a step farther in working out the intricate system of relays and wave-changing switches, any sub-station operator, by dialing the number ten on his phone will automatically cut in a spare set of tuning condensers for receiving and change his transmitting wave length so that, in action, his set then will operate just the same as the load dispatcher's set in Jackson and he can talk with any or all other stations. Another detail of the installation is the arrangement of extra selectors at the various substations through which the dispatcher, by dialing a general call number on his telephone, will ring all substations on the system and be able to transmit emergency orders simultaneously to all substation operators.

The high frequency apparatus, or the radio units of the system, are located at the various terminal stations. Two antenna wires are strung for a short distance on the towers which support high tension power lines. One of these is a sending antenna and one used exclusively for receiving. The antenna wire is given about twelve feet clearance from the power line wire. The upper or transmitting antenna is connected to the transmitting set and the lower antenna to the receiving set.

High frequency currents are generated by a 250 watt vacuum tube similar to those used in broadcasting stations. This tube operates on 2,000 volt direct current. This high frequency current flows into the transmitting antenna and instead of being broadcast through the air, it induces, by electrostatic and electro magnetic induction, corresponding high frequency current in the adjacent power line and this high frequency energy, superimposed upon the energy transmitted normally by the power line, is carried on the power line to the receiving station where, by induction, it is led into the receiving set through the receiving antenna. This unit is an ordinary long wave, coupled circuit radio receiver. It is equipped with a detector and one-step amplifier.

The high frequency currents generated by the 250 watt vacuum tube type oscillator are modulated by a second 250 watt

vacuum tube to the grid of which the voice frequencies developed by the microphone are applied. A 50 watt vacuum tube is interposed between the relatively weak microphone circuit and the grid of the 250 watt modulator tube for the purpose of amplifying the voice frequencies.

The largest broadcasting radio stations, such as WWJ, the Detroit News, that has been heard over a radius of thousands of miles, use transmitting sets of 500 watts capacity. Some idea of the energy required to operate the Consumers' Power Company high frequency telephone system may be gleaned from the fact that its transmitters have a capacity of 250 watts, just half the size of WWJ and larger than many of the other important broadcasting sets with which Michigan amateurs are familiar.

Radio Drama

A turn of the dial gains you admission to the radio drama. Tune your radio set to station WGY and at least one evening a week you will hear an entire play, sometimes a comedy drama, a farce or melodrama.

For nearly a year now the General Electric Company station at Schenectady, N. Y., has been offering dramas by radio one night a week and during that period the little group of actors making up the WGY players has had the largest audiences ever before accorded dramatic offerings. Just how large that audience is is difficult to estimate. There are at least 2,000,000 radio sets in the country and of that number 1,500,000 are almost nightly within range of WGY. Many of these sets have loud speakers or extra phones enabling groups to listen-in. The number of people who have heard the WGY players in the continuous run of forty-three weeks is anybody's guess.

Edward H. Smith and a half dozen actors were engaged, about a year ago, to produce Eugene Walter's play, "The Wolf," at WGY. It was something entirely new; it was contended by many that the radio audience would be unable to follow the play with any degree of interest because of the absence of scenery and because they could not see the players. Voice alone, it was contended, would not be sufficient to put over dramatic climaxes.

From the very first the radio drama was a success. Letters veritably poured into the station, asking for more. Mr. Smith, formerly an actor and director on the professional stage, was engaged to produce one show a week.

This work was undertaken in a serious and thorough manner and for months many of the greatest successes of the stage have been going into the air, reaching untold thousands who, but for radio, would never have had an opportunity of hearing the plays. During the past winter when farmers in many parts of the country were snowed in, cut off from the mails, the village, and in many cases their nearest neighbors, radio programs went out to relieve their loneliness. The farmer, the woodsman,

the keeper of the lighthouse along the Atlantic coast, were enthusiastic in expressing their appreciation of the dramas.

Mr. Smith and his players have pioneered in the art of the radio drama; they have had to develop a new technic. It was found necessary to make occasional changes in play manuscripts, especially where a climax depended upon sight for its appreciation. The entrance to or departure from a room by one of the characters had to be indicated by sound, as a closing door. A bell helps somewhat in announcing a newcomer to the invisible stage. Various sound devices were created to produce atmosphere. A telegraph key and an imitation of an engine whistle helped in a railway station scene; storms were simulated by devices similar to those used on the stage.

The performer was greatly handicapped at first because he had depended a great deal upon the presence of his audience. Facial expressions were no help to interpretation; strong emotion could be conveyed only by vocal tone. To help the performer to a realization that his work was heard and appreciated WGY requested the radio audience to write their "applause" and this they have done by the thousands. The actor finds inspiration for his work in applause, not of hands clapping, but in written words.

A Broadcast Freak

With nearly 600 radio broadcasting stations in the air, many of them at the same time, it is not unusual for an operator to pick up two or three stations at the same time. Then begins the delicate task of tuning out all but the desired station, a task frequently impossible and always trying to the temper.

It is most unusual, however, for a fan to secure dual reception and discover that both stations are playing the same tune in the same key and tempo.

This occurred Tuesday evening, May 22, at 8:21 o'clock. A Providence, R. I., radio fan recently wrote WGY, the Schenectady station of the General Electric Company, that he had heard the Radio Four sing "Dixie" from WGY at the same time that WEAN, the station of the Shepard Company in Providence, was sending out a phonograph record of "Dixie," a banjo solo with piano accompaniment. Part of the letter follows:

"Just once you faded out and WEAN was playing a banjo solo with piano accompaniment, 'Way Down South in Dixie.' What was our surprise to hear your minstrels come in on the same song, in the same key and same tempo and together the two companies, so many miles apart, finished the verse and chorus."

The log of WGY showed that the Radio Four had sung "Dixie" on the night and at the time given by the correspondent and R. F. Shepard, Vice President of the Shepard Company has reported that his station broadcasted the same number at that time.

Factors That Have Made Radio Broadcasting Possible

By S. M. KINTNER

Manager Research Division, Westinghouse Electric & Manufacturing Company

IN THE early days of radio, more than 20 years ago when it was called wireless, there was a man in Pittsburgh working on the development of an idea which, when it was perfected, completely revolutionized the art.

The Marconi system, the one then in use, was founded upon a device termed a coherer, which was generally acclaimed as the most marvelously sensitive mechanism ever conceived by man. It was generally said, and by those best qualified to speak, to be *the essential element* which made the "wireless telegraph" possible. Yet in the face of all of this praise of the coherer, the so-called "*electric eye*," this Pittsburgh man clung to his idea which called for no less radical a move than the complete abandonment of this so-called indispensable part.

The coherer was a trigger device which was tripped by the received signals and required resetting before it could operate again.

This resetting required time and limited the rate at which messages could be received. It had another defect more serious than its slowness, in that all signals sounded alike.

A signal from a nearby station was no louder than from one much more distant. With such a device radio telephony was unthinkable. In fact, I have recently been told by the man who was then the examiner of wireless inventions in the United States Patent Office that he had told his friends that "no one would ever be able to telephone by wireless methods."

The Pittsburgh man set himself the task of making a radio receiver which was constantly in condition to receive and which gave a response in proportion to the amount of the received energy.

He succeeded in producing several such devices all capable of meeting his requirements. We then noticed that he could distinguish different transmitting stations by slight difference in their spark sounds. With his detector he used telephone receivers to make manifest the received signals, whereas the Marconi system employed telegraph sounders.

This observation suggested that there was some constant difference

in the radiation of one station from another that gave it character and made it distinguishable like the voice of a particular individual.

If then the radiation could transmit such characteristic spark tones, all waves being developed by spark discharge at that time, why was it not possible to transmit any tone if only the way of controlling the radiation could be determined?

The Pittsburgh man to whom this experience relates was not long in devising a simple way of proving his theory. He simply placed an ordinary telephone microphone in the antenna of his transmitting station, which was arranged to give several thousand sparks per second, and while his assistant talked into the microphone, R. A. Fessenden, the Pittsburgh man, listened at his receiver and heard the first words ever transmitted by radio telephone.

Pittsburgh, then, is the birthplace of radio telephony, both as to the instrumentalities and the applica-

tion in this newest and greatest field in which it has been employed, broadcasting. To R. A. Fessenden, then a professor in the University of Pittsburgh, came the idea which revolutionized the radio art and led directly to his invention of the radio telephone: to H. P. Davis, Vice President of the Westinghouse Co., came the vision of broadcasting which led to the creation of KDKA and the many others following it.

Pittsburgh is justly proud of her record of accomplishments in radio but those responsible for the accomplishments realize that still more is needed to place radio broadcasting on a plane where it will render the service of which it is capable.

The channel of Communication that carries voice consists of electromagnetic waves, which can be thought of as like water waves in shape and exist in what is termed the ether. The ether, scientists tell us, permeates all space and is the means, by wave motion again, by

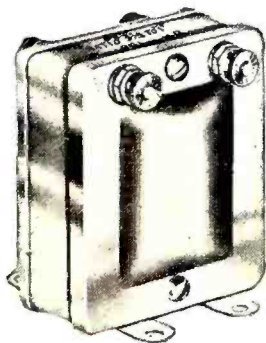

TESTED AND APPROVED
BY RADIO AGE
INSTITUTE

When building your radio set, remember that National Transformers mean perfect amplification—that they give the most efficient service under every condition—on all sets.

National Transformers function perfectly on the Cockaday circuit. This recently discovered circuit is described in this issue of Radio Age by Mr. F. D. Pearne, who has tested the National and given it his personal endorsement.

NATIONAL TRANSFORMER MANUFACTURING CO.

154 WHITING STREET

CHICAGO, ILL.

Bring in
Distant Stations
Clear and Loud
WITH
NATIONAL
AUDIO TRANSFORMERS

Price \$4.00
postpaid

National Transformers are not only at their best on the Cockaday, but they are equally as effective for use in Reinartz, Neutrodyne, Reflex, Flewelling, Inverse Duplex and other recently developed circuits. Can be used with all types of tubes on the market.

If your dealer cannot supply, order direct mentioning name of dealer. We guarantee satisfaction.

which the light from the distant stars is brought to the earth. Light waves and electro-magnetic waves used in radio are alike aside from their length. They both travel outward from an exciting source at the same speed, 186,000 miles per second, almost $7\frac{1}{2}$ times around the earth in a second of time. Every second of time more than 800,000 waves leave the radio antenna and rush outwards with their inconceivable speed. They rush past the receiving antenna and in so doing give up a small part of their energy, which manifests itself as a minute electric current which surges to and fro in step with the onrushing waves. If the antenna is properly in tune the currents set up will be much larger than if it is not. This difference may have a ratio of the order of 100 to 1. If the receiving antenna is located very near to a transmitting station the strength of the "out of tune" currents may be sufficient to be distinctly heard. This accounts for the interference that is sometimes caused.

To return for a moment to the transmitting station which can be pictured as a continuous emitter of waves, and see how those waves are modified to convey the sounds it is desired to transmit, let us take a single tone—high C—of the soprano. That tone is made by 1,024 vibrations per second in the air. If then the intensity of the antenna radiation is varied 1,024 times per second and caused to change from a maximum to a minimum at a regular rate, the current in the receiving antenna will also vary in a corresponding manner, when this received current is passed through the necessary appliances and finally gives its indication in the telephone receiver, 1,024 vibrations of the diaphragm results and the tone high C is reproduced. What is true of one tone is equally true of others and of combinations of others and in this manner a voice controls the rate of energy emission from the station by varying the intensity of the waves, and the waves, without changing in the number per second sent out, are delivering the message.

The oscillating currents set up in the receiving antenna cannot be applied directly to the telephone for they are of too high a frequency to give any response. Remember the sound frequency is conveyed by the *variation of the radiated wave intensity* at the sound frequency. For convenience the radio art has adopted the terms radio frequency and audio frequency as terms indicating certain ranges of current or wave frequencies. An audio frequency is

one within the audible limit, which, for most ears, is below 15,000 complete oscillations per second. Radio frequencies are all frequencies above the audible limit. All radio waves used in transmitting, excepting a very few from some of the transoceanic high powered radio telegraph stations are of radio frequency.

Remembering now that the currents set up in the receiving antenna have the same frequency as that of the waves producing them and that they are of radio frequency, that is, above the audible limit, it is apparent that something must be done to convert them to a usable form, before applying to the telephone receiver. This change is made by what is termed the detector. This device, a crystal or a tube, permits currents to pass in one direction but not in the other. By collecting all of the current pulses that pass and storing them in a condenser, from which they are drawn by the telephone receiver, it becomes possible to detect the variation in the rate of energy arrival. That is the swelling and shrinking in intensity of the radiated waves, as produced by the sound waves being transmitted, causes a corresponding swelling and shrinking of the charge in the condenser, and of the current in the telephone receiver withdrawing it, and gives a reproduction of the originating sound.

That is the essential idea of radio telephony. The important elements needed to practice it, which we now look upon as essential, will give way, as the art develops, to improved appliances and methods, just as Marconi's coherer and system was abandoned for the Fessenden form of detector and system of operation, the one now being used.

Service in Denmark

Radiotelephone connection between Copenhagen and the island of Bornholm in the Baltic Sea, heretofore poorly equipped with means of communication, is now an accomplished fact, Trade Commissioner Sorensen reports. Radiotelephony between the two points is now open to the public. The radio circuit, which consists of the four stations: Amager, Lyngby, Hammeren and Ronne Radio, is based on the Poulsenarc system, manufactured by the German firm, Lorenz. The installation permits of communications in either direction simultaneously. The radio is connected with the ordinary Copenhagen telephone system, so that any subscriber may ask for a number on Bornholm Island and get connection. The cost for a call is 3.50 crowns for a three-minute period.

Helps Amateurs

Washington, D. C.—The Department of Commerce has authorized a broader band of wave-lengths for general and restricted amateur radio stations, and created a new class of amateur operator's license to be known as "Amateur Extra-First-class."

The new regulations sent to all district supervisors of radio provide that licenses will be issued permitting the use of any type of transmitter—CW, Spark, AC-CW, ICW, unfiltered CW and phone—with the restriction that when using pure CW they are authorized to use wave lengths from 150 to 200 meters and when using spark, AC-CW, ICW, unfiltered CW and phone the wave lengths from 176 to 200 meters only can be used. The types of transmitters must be specified in the application and the license.

Special amateur radio station licenses will be issued permitting the use of pure continuous wave transmitters only, authorizing the use of wave lengths from 150 to 220 meters.

For the purpose of application to amateur stations, pure CW is defined as follows: A system of telegraphing by continuous oscillations in which the power supply is substantially direct current as obtained from (1.) a generator, (2.) a battery, or (3.) a rectifier with an adequate filter. A filter is not deemed adequate if the supply modulation exceeds five per cent.

General restricted and special amateur stations are not permitted to use a transformer input exceeding one kilowatt, or equivalent of this power based upon watt input to plates if tubes are used. Where input rating of tube is not specified by manufacturer this rating will be considered as double the manufacturers output rating.

On licenses issued for amateur stations you will include the following: "This station is not licensed to transmit between the hours of 8 and 10:30 p. m., local standard time, nor Sunday mornings during local church services."

Special amateur stations must be operated by persons holding an extra first grade amateur operator's license, or a commercial first-class operator's license, or a commercial extra first-class operator's license. Applicants must also meet the requirements of Regulations 63.

A new class of amateur operator's license is hereby established to be known as "Amateur Extra First Grade." Licenses of this grade will be issued to persons passing the required special examination with percentage of at least seventy-five and code speed in sending and receiving at least twenty words a minute, five characters to the word; who have had at least two years' experience as a licensed radio operator; and who have not been penalized for violation of the radio laws subsequent to the date of these regulations.

The chains of habit are too weak to be felt until they are too strong to be broken.

Naval Radio Service Increases Efficiency

(By Washington Radio News Service)

Washington, June 11.—The Naval Communication Service in the past three months has made gigantic strides in the efficiency of its service, chiefly through educating its untrained personnel. Courses of radio instruction, in addition to the regular schools at Great Lakes, Norfolk and San Francisco, have been prepared and the results are "very gratifying," a recent report states. Today the 1200 radio men stationed ashore are receiving intensive training in fleet communication, so that they will be familiar with sea operation. Today the personnel of the Communication Service of the Navy is in better shape than in any other branch of the service, officers of the Communications Service state.

A survey of the radio personnel situation just completed by the Navy, shows that there are 2443 radio men on duty, and that vacancies in the three higher rates exist. Following examinations held in May, 170 radio men were promoted to higher rates, fifteen of them becoming Chief Radiomen. There was still a shortage of 562 men in the service.

Opportunities in the Naval Service are good for young men, communication experts point out, citing a recent case where a young man of 20, who held the rate of First Class Radioman, was persuaded to remain in the service, because at 32 he would be eligible for transfer to the Reserve with a regular income of \$75 to \$80 a month. No such an opportunity awaited a young man in ordinary business pursuits, it was explained. This young man is now enroute to sea duty in the Mediterranean.

Service Improves.

Discrepancies in transmission of messages by the Navy has been decreased markedly during the past six months. During a recent period of supervision, five Atlantic stations had no errors, while the only two out of the other seven had over one tenth of a word in a thousand wrong. Manipulation has improved greatly, operators are better instructed in procedure and are most attentive, the report states.

In an effort to decrease governmental radio interference, a special committee composed of members of the Interdepartmental Advisory Committee on Radio, has made a study of wave frequencies used by the Government and recommended certain changes to the Department of Commerce. In view of this, Secretary Denby of the Navy has requested that a complete survey of all Government radio activities be now undertaken by this committee, so that complete cooperation and co-ordination may be had.

Commander S. C. Hooper, in charge of Radio Engineering in the Navy, it is reported, will become Fleet Radio Officer under Admiral Coontz, when the latter assumes command of the U. F. Fleet early in August.

Wartime Radio

As an instance of the work of former amateurs, who served in the Signal Corps during the war, it is said that seventy-three per cent of the 400 radio men engaged in intelligence work were ex-amateurs. Not a single "leak" occurred in the service, which intercepted 73,000 enemy messages and recorded 175,000 bearings on enemy radio stations. The country and the Signal Corps is greatly indebted to these amateurs for their war work.

Although little was known of the work of the radio intelligence section of the army during or since the war, it was one of the most spectacular. Radio direction finders were placed all along the lines, at a distance of about five miles from the actual front and spaced about twelve miles apart. These receiving sets located the enemy stations in operation, recorded their bearings by means of directional coils, not unlike modern radio compasses, and forwarded the bearings to headquarters where they were plotted on maps. The reports from any American radio observers enabled the staff to keep an accurate check on practically all the German stations all the time.

Other radio receiving stations at army headquarters, intercepted and copied all enemy code messages, and telegraphed them back to general headquarters where code experts worked them out, giving the staff valuable information as the movements or intentions of the enemy.

On one occasion, when the Germans were planning a big offensive, the code all along the line was suddenly changed. The old code, known by the Americans for some time became valueless. But one German officer could not decipher a long message sent him in the new code and asked his commander to repeat it in the old one. This was done and as the American intercepting stations copied both messages, the staff of experts at headquarters soon had a fair solution of the new code, which they eventually worked out in its entirety. The repetition of the message in both codes was more than they hoped for, and when the new code was transmitted to the French and British headquarters, the American radio intelligence service was credited with a big "scoop."

Many times, it is recorded, enemy messages were intercepted, decoded, and rushed to the troops at a threatened front in time for them to prepare for the projected attack.

Wonderful results were also accomplished by our advance listening-in stations in front line dugouts and trenches, with amplifiers, the wires radiating to grounds in no-man's land. Sometimes they were actually tied in on enemy phone lines. These stations picked up enemy phone conversations by induction, enabling our operators to copy orders and messages.

Few things are impractical in themselves; and it is for want of application, rather than means, that men fail of success.—[Rochefoucauld.

"UNITED"
Radio Instruments
Will Multiply the Joy
of your Radio Evenings



Our new million dollar plant with its unequalled equipment of precision tools and our staff of trained radio experts have enabled us to develop condensers and transformers which offer

1. Finer tuning, under more perfect control.
2. Clearer reception, from any distance.
3. Welcome freedom from discordant noises.

"United" Audio-frequency Amplifying Transformer

Magnetically shielded, Ratio 5 to 1, Price \$4.50

"United" Variable Condensers
with new Vernier Dial Adjuster

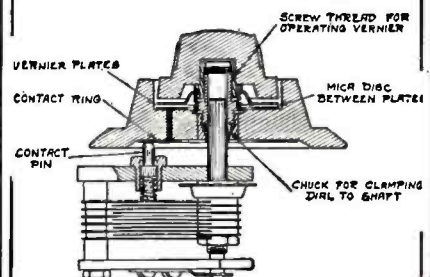

43 plate \$6.50	5 plate \$5.00
23 plate 6.00	3 plate 4.75
11 plate 5.50	Postpaid

Try your Dealer First, if he does not carry the line, remit to us and give us his name and address.

UNITED
Mfg. & Distributing Co.

9705 Cottage Grove Ave., CHICAGO, ILL.

NEW YORK OFFICE
50 Church St., New York, N. Y.

SAN FRANCISCO OFFICE
709 Mission St., San Francisco, Cal.

New Radio Books

COVERING Details on how to operate a set, how to build a set, principles of vacuum tubes, radio hook-ups etc. Standard and up-to-date Radio books; practical books for the practical man. Each written by an authority and in a manner that makes them easily understood.

Ideas for the Radio Experimenter's Laboratory, by M. B. Sleeper.....	\$0.75
Radio Hook-Ups by M. B. Sleeper.....	.75
Radio Design Data by M. B. Sleeper.....	.75
Construction of New Type Trans-Atlantic Receiving Set by M. B. Sleeper.....	.75
Construction of Radiophone and Telegraph Receivers for Beginners by M. B. Sleeper.....	.75
How to Make Commercial Type Radio Apparatus by M. B. Sleeper.....	.75
Wireless Telegraphy and Telephony Simply Explained by A. P. Morgan.....	1.50
Experimental Wireless Stations by P. E. Edelman	3.00
A B C of Vacuum Tubes Used in Radio Reception by E. H. Lewis.....	1.00

Any of these books will be sent prepaid to any part of the world on receipt of price. Remit by Draft, Postal Order, Express Order or Registered Letter.

For Sale by

Radio Age, Inc.

500 N. Dearborn Street

Chicago, Ill.

Radio Camping

By VELMA CARSON

Westinghouse Electric & Manufacturing Company

It takes one more paddle to go canoeing nowadays than it used to. Besides the one for propelling the boat there must be a paddle for catching concerts.

And besides a girl, some cushions, a camera, and a lunchbasket the young man takes along a small radio receiving set. They come now in small boxes with a handle and are as easy to carry as any of the aforementioned prerequisites to the successful canoe trip.

He puts the set between himself and the girl in the bottom of the boat, places the extra paddle perpendicularly against the back of the seat and has her lean on it to hold it secure. Then he attaches one wire to the upright end of it for an aerial and trails the other wire in the water to ground his circuit. They put on the head phones. He tunes in to the nearest station and paddles off to the shadiest nook he can find.

Imagine this canoe on a moonlight night away off down the river and an unseen orchestra playing, "Melody of Love!"

If there is any time in the world that a person is in the mood for good music it is at the end of a long, thrilling day exploring in the woods or doing any of the relaxing things that are a part of camp life.

Even the rattly-bang piano player with a one-sided repertoire, or the banjo picker who knows eight old songs, or the sixteen-year-old with a thin voice and ukelele have always been welcome in a summer camp. Well, if the man who can improvise on a mouth organ has had his share of appreciation out in the woods, the radio, with its diverse programs, is sure to be listed right along with the iron skillet when the question comes up concerning camping paraphernalia.

The business man who wants to hide himself from business annoyances, the telephone, newspapers, and other people can still get the news of the day and satisfy his curiosity about the baseball scores.

If mother does not care about too much strenuous hiking and swimming she can be sure of having entertainment while she rests in camp. The children can be kept occupied at the awful hour of bedtime, and the young people can have dance music without the trouble of importing a victrola or a piano. Besides if one is to go into wilds sufficiently wild these cumbersome instruments are practically impossible.

One group of Camp Fire Girls learned the joy of doing interpretative dancing in their bare feet on grassy slopes near their camp in the North woods by radio last summer. They also studied the art of telling stories from the "Dreamtime Lady."

It is no small help in any camp to get the weather report and river conditions.

"Humoresque" goes beautifully with bacon and eggs and does not detract in the least from the chirp of crickets.

In Czechoslovakia

The manufacture, sale, storage, and importation of radio telephone and telegraph equipment in Czechoslovakia is only permitted under license from the state, says Trade Commissioner H. L. Groves in a report to the Department of Commerce. The Ministry of Commerce in cooperation with the Ministry of Posts and Telegraphs are authorized to grant licenses for this purpose. The Ministry of Posts and Telegraphs also supervises and controls the manufacture, sale and storage of radio equipment and cooperates with the Ministry of Commerce in the granting of licenses.

Up to the present time only one company, "Radioslavia," has obtained a license for the manufacture of radio equipment in Czechoslovakia. It has not yet started production. This company is understood to be affiliated or closely connected with the French Company "Societe Francaise Radio-electrique." A German Company—"Gesellschaft fur Drahtlose Telegraphie, System Telefunken"—is said to be promoting a company with Czechoslovak capital for the purpose of exploiting German wireless patents, but it has not yet been granted the necessary license.

The attitude of the Ministry of Posts and Telegraphs toward the granting of licenses to transmit as well as to receive radio messages is said to be favorable in the following instances:

- (1) Technical High-schools, for scientific purposes.
- (2) Industrial establishments which have obtained special licenses from the Ministry of Commerce to manufacture radio equipment.
- (3) Ships and aircraft.
- (4) Electric power stations, waterworks, and other establishments of public utility, under special conditions.
- (5) Companies which have been authorized by the state to broadcast matter of general interest, such as news-statements, exchange reports, agricultural reports, concerts, lectures, etc.

Licenses for the operation of receiving sets only will be granted to institutions, companies, and those regularly taking the reports transmitted either by the State Telegraph Office or by companies authorized by the state to transmit such messages.

Random Reports

Recent reports from the Navy Department indicate a very considerable amount of interference from mush and harmonics at all points within 200 miles of Pearl Harbor. Current transformer circuits will be installed on the Honolulu transmitters of the navy within the near future, which will eliminate this interference it is hoped.

Naval experts admit that arcs and spark transmitters create a considerable amount of interference in their vicinity, unless special circuits are installed to reduce such interference. Transmitters of these types are being modified as rapidly as funds permit. On arc transmitters current transformer or similar circuits are being installed and spark transmitters are being replaced by tubes.

New RCA Official

F. P. Guthrie, until recently head of the radio division of the Shipping Board, has been appointed district manager for the Radio Corporation, with headquarters in Washington, D. C. Mr. Guthrie has followed radio for years. During the war he served as a commissioned officer in the Naval Communication service. It is understood that he will have charge of the corporation's new broadcasting station, soon to be opened in Washington, as well as the commercial work.

A. H. Morton, who has been in charge of the corporation's commercial station here for some time, has been transferred to New York, where he will take up organization duties in that district.



Make Your Set The Sensation of Your Town!
with

The **RADIOXOR**

*Simple
Inexpensive
Certain*

Can be attached any set, operating head phones or loud speaker, crystal or Vacuum Tubes, Loop, Plug or Outdoor Aerial.

*Send Your Name
address and type of set
on a post card for
details*

Selling like wildfire, so act promptly. Orders filled in order of receipt.

WILLART SALES CO.

WORLDS TOWER BUILDING
110 W. 40th Street
NEW YORK CITY

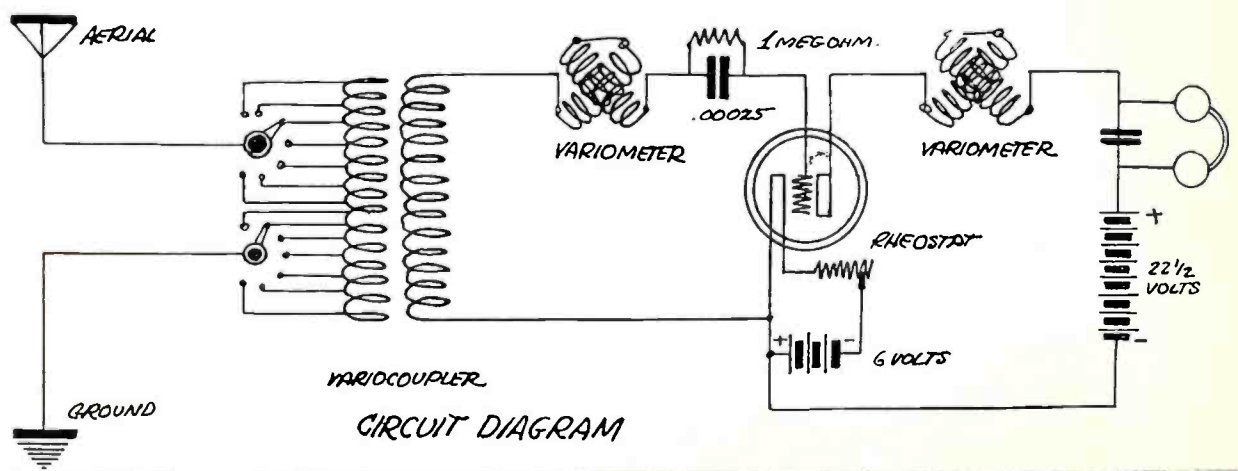
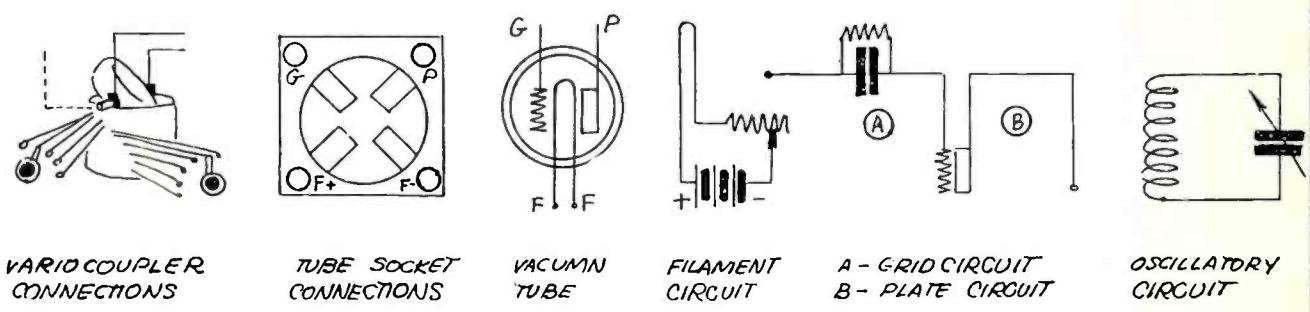
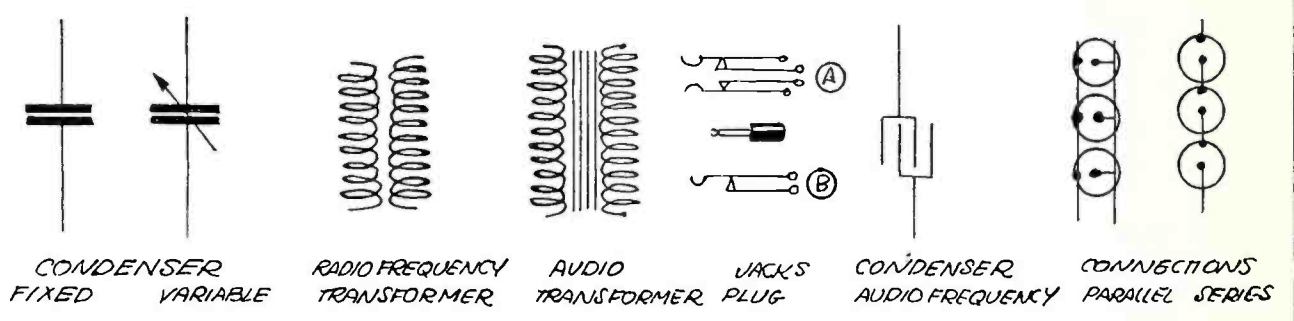
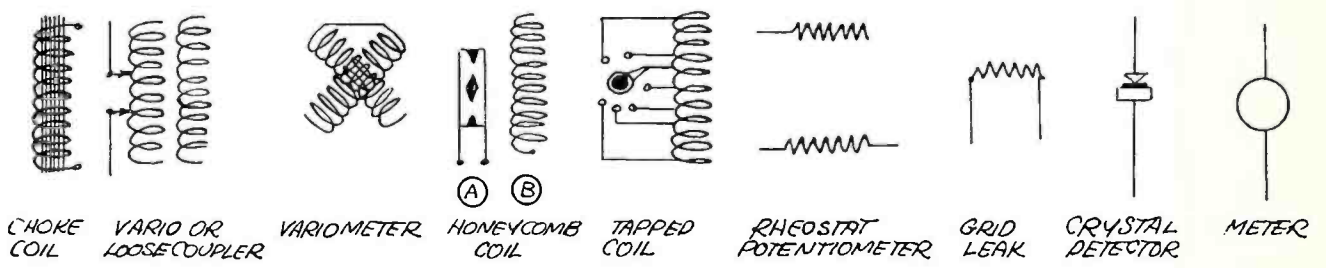
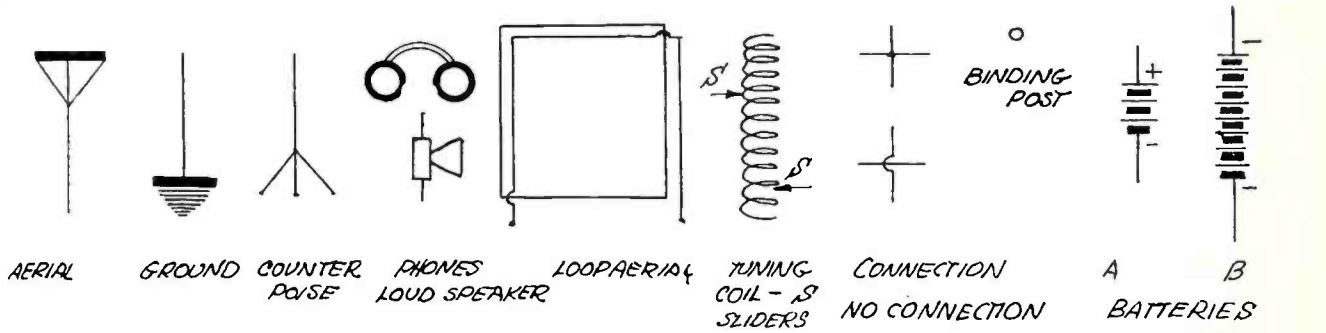

Inter-American Communication Conference Proposed

An official resumé of the activities of the Fifth International Conference of American States, held at Santiago, Chile recently, cites the recommendation for an Inter-American Electrical Communication Commission and a communications conference.

"Inter-American Electrical Communication: The first part of this resolution recommends to the American States, as an essential part of the public service, the supervision of international electrical communication and also domestic electrical communication insofar as it affects or forms part of the system of international communication. As a part of this resolution provision is made for the establishment of an Inter-American Electrical Communications Commission to consider the cooperation which may be established between the American States regarding electrical communications, and to prepare a convention which shall establish equitable proportional rates and uniformity of rules governing Inter-American Electrical Communications; this commission to be called at a place and date to be determined by the Governing Board of the Pan American Union. The conclusions of this Commission shall be submitted to the Governing Board of the Pan American Union in order that they may in turn be submitted to the States belonging to the Pan American Union."

Short Waves in Beam

F. W. Dunmore and F. H. Engel, radio experts of the Bureau of Standards, state that for point-to-point radio communication, there are two important ways of reducing interference; that is, to direct the waves radiated from the transmitting stations in a narrow beam toward the receiving station, and to use short wave lengths which are not at present employed.

Experiments have recently been conducted at the Bureau of Standards on transmitting apparatus, employing electron tubes, which transmits a directed beam of radio waves, and employs waves as short as ten meters. This system offers substantial relief from interference difficulties, and also has the military applications. The apparatus has been used for communication by both radiotelegraphy and radiotelephony.

In the experiments, a reflector was used, consisting of short parallel vertical wires, arranged on a frame shaped like a parabola. This reflector acts much as an ordinary mirror would for light waves. The radio waves are, in fact, the same kind of waves as light waves, but of considerably longer length. Forty vertical wires were used and the generating set with its small antenna was placed at the focus of the parabola. Each wire was tuned separately to ten meters by adjusting its length. It was found that about seventy-five per cent of the radiated energy could be confined within an angle of about seventy-five degrees.

This apparatus is described in Scientific Paper, No. 469, of the Bureau of Standards, entitled, "Directive Radio Transmission on a Wave Length of Ten Meters." Copies may be obtained from the Superintendent of Documents, Government Printing Office, Washington, D. C., for ten cents.

New Station Idea

The Chesapeake and Potomac Telephone Company has given Washington another broadcasting station. It is a class B station with an individual wave length which will reach to all corners of the nation. This company, which is a member of the American Telegraph and Telephone Company, has started the erection of the second of the Bell-system broadcasting stations, and plans to duplicate in power and quality the New York station, WEAf.

A unique feature is that the new plant will be a public service station; that is, it will be operated without profit and may be leased or chartered by other interests for periodic broadcasting at a rate equivalent to the proportional cost of operation.

It is understood that a local broadcasters' association may be organized and the operating time of the station divided to care for its members. This, it is believed, will save small operators considerable money in comparison to the costs of installation and upkeep of private broadcasting stations. Certain hours of any schedule would be reserved by the telephone company for the transmission of matter of public interest, such as presidential addresses, congressional debates and governmental information. Important concerts broadcast from WEAf in New York, may be sent by land line to Washington, and broadcast simultaneously from the new station, officials say.

The electrical equipment is the product of the Western Electric Company, and was installed under the direction of C. & P. and A. T. & T. Co., engineers. The station is located on the telephone building, 725 Thirteenth Street, the towers being erected on the roof.

Send \$1.00 to Radio Age, 500 N. Dearborn Street, Chicago, and receive this instructive radio periodical for six months. Regular subscription price is \$2.50 a year.

CLASSIFIED ADVERTISEMENTS

Six cents per word per insertion, in advance. Name and address must be counted. Each initial counts as one word. Copy must be received by the 5th of month for succeeding month's issue.

HELP WANTED

Ambitious men and women 18 up wanted for U. S. Government Permanent Jobs. \$95 to \$192 Month. Paid summer vacation. Short hours. Pleasant work. Common education sufficient. Experience unnecessary. Write today sure for free list of positions obtainable. Franklin Institute, Dept. W115, Rochester, N. Y.

PATENTS AND TRADEMARKS

"Patents and Trade-Marks," 64-page Book free. Excellent References. 23 years' experience. Robb, Robb & Hill, 1413 Hanna Bldg., Cleveland, Ohio, 952 McLachlen Bldg., Washington, D. C.

SUBSCRIPTION AGENTS

We want representatives in every community to obtain subscribers for Radio Age. Excellent opportunity for radio enthusiasts to make good money quickly. Write Radio Age, Inc., 64 West Randolph Street, Chicago, Ill.

BOOKS

If you have not bought your Reinartz Book, fully illustrated with hook-ups and clear description of how to make this popular circuit, send \$1.50 in money order or check and we will send you the booklet "Reinartz Radio" and place you on the subscription list of Radio Age for six months. Address Radio Age, 500 N. Dearborn Street, Chicago, Ill.

RADIO OUTFIT AND SUPPLIES

Radio Solder for construction and repairing radio outfits. Three six inch bars 25c postpaid. Hamilton Lead Company, Hamilton, Ohio.

CHARGE YOUR BATTERY
(RADIO OR AUTO)
at HOME for a NICKEL
The HOMCHARGER
POPULARLY PRICED—PAYS FOR ITSELF
SEND FOR THE AUTOMATIC ELECTRICAL DEVICES CO.
FREE BOOK 146 W THIRD ST. CINCINNATI, OHIO



LEARN RADIO
Here's your opportunity. Radio needs you. Win success in this fascinating field. Trained men in demand at highest salaries. Learn at home, in your spare time.
Be a Radio Expert
I will train you, quickly and easily, to design, construct, install, operate, repair, maintain, and sell all forms of Radio apparatus. My new methods are the most successful in existence. Learn to earn \$1,800 to \$10,000 a Year
FREE Wonderful, home-construction, tube receiving set, of latest design.
Write for "Radio Facts" free. Engineer Mohaupt.
American Electrical Association
Dept. 607 4513 Ravenswood Ave., Chicago

Radio Trouble Finding Chart
Locates Immediately
The Troubles in Your Radio Set
25c
SIMPLE, EASY and PRACTICAL
Dealers write for discount
BENSON MELODY CO.
190 N. State St., Chicago, Ill.
Manufacturers of Melody Portable and Power Speakers
Service Dept. Work at Reasonable Price. Radio Distributors

The Newest Radiotron, Model U V-199

By J. C. WARNER

Research Laboratory, General Electric Company

(Continued from page 8.)

cell battery will operate a single UV-199 tube one hour per day for a month. This combination makes it possible to build a portable radio set containing a tube detector, complete with batteries and phones, and weighing only five or six pounds.

Another interesting comparison gives an idea of the low filament consumption. We usually think of the power consumed in the plate circuit of a vacuum tube as being very small, and this is quite true, but in some cases, the UV-199 may use more power in the plate circuit than in the filament. For example, the plate current at 80 volts may be 2.5 milliamperes, making a plate power consumption of .2 watt, while the filament power is only .18 watt.

The life of an X-L tungsten filament is usually terminated, not by actual burnout, but by a decrease in electron emission. This decrease is not gradual during the life of the tube, but occurs suddenly, close to the end of life, and is indicated by a marked increase in the voltage required on the filament to give good results.

In spite of the reduction of filament current in the UV-199, the other electrical characteristics of the tube have not been sacrificed in the least. In fact, the UV-199 is a better detector and amplifier than the UV-201. The amplification constant averages 6.25 for the UV-199 compared with 6.0 for the UV-201. The plate impedance at 40 volts is about 18,000 ohms for the UV-199 and 20,000 for the UV-201. These figures, which in themselves are perhaps of little interest to you, simply mean that the UV-199 is a somewhat better amplifier than the UV-201 and in the usual audio frequency amplifier circuit will give nearly 50% more power for the same input voltage.

It is, of course, not to be expected that the UV-199 should give as great power amplification as the UV-201-A. The UV-201-A is a larger tube, having large electrode surfaces and requiring greater filament energy and naturally is capable of supplying large power amplification. However, it does not have the advantage of dry battery operation except in limited cases.

As a detector, the UV-199 functions very well in any of the usual circuits and is particularly well adapted to use in single tube sets where small size and weight are de-

terminations of the UV-199 are exceptionally small and for this reason this tube is an excellent radio frequency amplifier and little trouble is experienced with undesired oscillations.

In common with all vacuum tubes and in fact almost any sort of electrical apparatus, to obtain best results it is necessary to observe a few simple precautions. These are described in detail on the instruction sheet furnished with each tube so that it is only necessary to mention a few of them briefly here.

Of first importance perhaps is the injunction to take care that the plate battery does not become connected to the filament by accident. The UV-199 filament requires such a low voltage for normal operation that the twenty to eighty volts of the plate battery will burn it out instantly, and unless one is looking at the tube the burnout may occur so quickly that he does not know what has happened. A ten watt Mazda lamp placed in series with the plate battery will prevent any such accidental burnout.

Instructions as to proper filament, plate and grid voltages are important. Do not forget that if you are operating a single tube from three dry cells, you must have a thirty ohm rheostat in series with the filament, and if you are using a six volt battery you must have about sixty ohms in series. Otherwise, the filament voltage will be excessive and will shorten the life of the tube.

When the tube is used as a radio frequency amplifier or as a detector, the plate voltage should be not more than 45. For audio frequency amplification the plate voltage may be increased to 80, but in this case a grid battery should be used to prevent distortion and also to limit the plate current and so prolong the life of the "B" battery. The correct connections for the detector and amplifier tubes and the location of the grid battery are clearly shown on the instruction sheet. This also shows the arrangement of the contact pins in the base. The arrangement is not the same as in the UV-200, UV-201 and UV-201-A, the change having been made in order to bring the grid and plate terminals on opposite sides of the socket and to make possible very short leads between tubes and transformers.

The UV-199 and UV-201-A are

by the colored or silvered appearance of the bulb. There is often a considerable variation in the amount of coating, but this has no detrimental effect on the action of the tube.

The X-L filament has made possible one other important improvement which appears in both the UV-199 and UV-201-A. This is the almost complete elimination of tube noises. It is true that the term "tube noise" is often used to cover everything from loose connections to howling due to improper circuit adjustments, but true tube noises may be divided into two classes. First, a sort of crackling which resembles some forms of static, and second, a steady hissing or roaring noise. The crackling noise is characteristic of high temperature filaments and is obviously absent in tubes containing X-L filaments. The hissing noise is due to the presence in the tube of traces of gas and since X-L filament tubes utilize an extremely high vacuum, this source of noise is greatly reduced. This high vacuum also serves to maintain uniform operating characteristics throughout the entire life of the tube.

Domestic Phenol

The manufacture of phenol will soon be under way in a plant now being constructed by the Bakelite Corporation.

This enterprise is the direct result of the protection afforded by the new tariff. American consumers have always been dependent upon a foreign source of supply for this commodity and today are paying abnormally high prices due to a general European shortage and an insufficient domestic production. Phenol, an essential ingredient in the manufacture of high explosives, was manufactured in the United States in a large way during the war—the foreign supply being, of course, strictly embargoed by every belligerent country—but since then the industry went out of existence for lack of tariff protection.

The Bakelite Corporation will manufacture a surplus beyond its own needs and to this extent American consumers will be assured of a supply at as moderate prices as conditions will permit, in conformance with the Corporation's announced policy.

Phenol (carbolic acid) is used for the manufacture of synthetic resins, largely used in the radio industry, also for dyes, for pharmaceutical preparations, for disinfectants and many other purposes. It is absolutely essential not only to industry and the public health, but most important of all for the national defense

Complete Corrected List of U. S. and Canadian Broadcasting Stations

Complete Each Issue

THE list of broadcasting stations on these pages is brought up to date each month by additions of new stations and deletion of those which have suspended operation. The list is the product of a vast volume of correspondence and its completeness is due in large measure to the assistance of our special news service in Washington, D. C. Suggestions, corrections and additional data will be welcomed from readers. Broadcasters: Send in your program schedules.

IXAD, Pawtucket, R. I. 1000 miles: Special license experimental; Standard Radio & Electric Co.
KDKA, E. Pittsburg, Pa.; Class B station Westinghouse Elec. & Mfg. Co.
KDOW, Steamship America, New York.
KDPM, Cleveland, Ohio; Westinghouse Elec. & Mfg. Co.
KDYL, Salt Lake City, Utah; news music, entertainment, Telegram Publishing Co.
KDYM, San Diego, Cal.; Savoy Theatre; 252 meters 100 watts.
KDYQ, Portland, Ore.; Oregon Inst. Technology.
KDYS, Great Falls, Mont.; Class B, Great Falls Tribune.
KDYX, Phoenix, Arizona; Smith Hughes & Co.
KDYX, Honolulu, T. H.; 12:15 to 1:15 p. m., stock reports and weather; 6:30 to 7:30 p. m., music, lectures; Sunday, 11 a. m. to 12:30 p. m., sermons; Honolulu Star-Bulletin, Ltd.
KDZB, Bakersfield, Calif.; Frank E. Siefert.
KDZE, Seattle, Wash.; Rhodes Co.
KDZF, Los Angeles, Calif.; Automobile Club of Southern California.
KDZI, Wenatchee, Wash.; Electric Supply Co.
KDZK, Reno, Nev. Wednesday 8 to 9 p. m.; Friday 8 to 9 p. m. Musical and news features; Nevada State Journal, Nevada Machinery & Electric Co.
KDZQ, Denver, Colo. Pyle & Nichols, 1247 Broadway.
KDZP, Bellingham, Wash.; 261 meters, 50 watts; Bellingham Pub. Co.
KFAD, Phoenix, Ariz.; Class B, McArthur Bros. Mercantile Co.
KFAE, Pullman, Wash.; State College of Washington.
KFAF, Denver, Colorado; George S. Walker, Western Radio Corporation; musical programs, news items, etc., daily except Tuesday and Sunday, 8 to 9 p. m.; mountain standard time.
KFAJ, Boulder, Colo.; University of Colorado.
KFAN, Moscow, Idaho; Electric Shop.
KFAT, Butte, Mont.; Standard P. Co.
KFAQ, San Jose, Calif.; City of San Jose.
KFAR, Studio Lighting Service Co., Hollywood, California 280 meters, 200 watts.
KFAT, Eugene, Ore. Monday, Wednesday and Saturday 8 to 9 p. m. Music; Sunday 8:30 to 9:15 Church Services; Pacific Radio Co.
KFAU, Boise, Idaho; Class B, Boise High School.
KFVB, Venice, Calif.; Able Mining Co.
KFAW, Santa Anne, Calif.; Class B, Radio Den.
KFAY, Central Point, Ore.; W. J. Virgin Milling Co.
KFBB, Havre, Mont.; F. A. Buttrey & Co.
KFBC, San Diego, Calif.; W. K. Ashill.
KFBE, San Louis Obispo, Calif.; R. H. Horn.
KFBG, Tacoma, Wash.; First Presbyterian Church.
KFBK, Sacramento, Calif.; Class B; daily 8 to 4 p. m. and 6 to 8:30 p. m.; Sunday and Thursday 8 to 9 p. m.; Kimball-Upson Co. and Sacramento Union.
KFBL, Everett, Wash.; Leese Bros.
KFBU, Thomas, Bishop, N. S., Laramie, Wyo.; 283 meters, 50 watts.
KFCB, Salem, Ore.; F. S. Bartin.
KFCF, Walla Walla, Wash.; Frank A. Moore.
KFCG, Billings, Mont.; Elec. Service Station.
KFCI, Colorado Springs, Colo.; Colorado Springs Radio Co.
KFCL, Los Angeles, Calif.; Los Angeles Union Stock Yards.
KFCM, Richmond, Calif.; Richmond Radio Shop.
KFCO, Casper, Wyo.; Motor Service Station.
KFCP, Ogden, Utah, Ralph W. Flyers.
KFCY, Houston, Tex.; Fred Mahaffey, Jr.
KFCZ, The Mars, Ia.; Western Union College.
KFDG, Omaha, Neb.; Omaha Central High School.
KFDA, Baker, Ore.; Adler's Meats Store.
KFDB, San Francisco, Calif.; Mercantile Trust Co.
KFDC, Spokane, Wash.; Radio Supply Co.; 283 meters; 10 watts.
KFDD, St. Michael Cathedral, Boise, Idaho. 252 meters, 10 watts.
KFDO, Bozeman, Mont.; Everett H. Cuttins.
KFDP, Des Moines, Ia.; Hawkeye Radio & Supply Co.
KFDQ, San Francisco, Calif.; John P. McKee.
KFDU, Lincoln, Neb.; Nebraska Radio & Elect. Co.; 240 meters; 20 watts.
KFDV, Fayetteville, Ark.; Gilbreth & Stinson.
KFDY, Brookings, S. D.; South Dakota State College of Agriculture and Mechanical Arts.
KFDL, Denver, Colo.; Knight Campbell Music Co.
KFDJ, Corvallis, Ore.; Oregon Agr. College.
KFDM, Spokane, Wash.; Radio Supply Co.
KFDF, Casper, Wyo.; Wyoming Radio Corp.
KFDR, York, Nebraska; Bullock's Hardware & Sporting Goods.
KFDX, Shreveport, La.; First Baptist Church.
KFDZ, Minneapolis, Minn.; Harry O. Iverson.
KFEC, Portland, Ore.; Mier & Frank Co.
KFED, Tacoma, Wash.; Guy Grant.
KFEL, Denver, Colo.; Winner Radio Corp.
KFEP, Denver, Colo.; Radio Footprint Co.
KFEQ, Oak Nebraska; J. L. Scroggin.
KFEK, Oak, Nebraska; J. L. Scroggin.
KFFR, Kirk, Jim, Sparks, Nev.; 228 meters, 10 watts.
KFER, Ft. Dodge, Iowa; 231 meters, 10 watts; Auto Electric Service Co.
KFFG, Baton Rouge, La.; 254 meters, 263 meters; 100 watts.
KFFH, Minneapolis, Minn.; 261 meters, 100 watts Augsburg Seminary.
KFEY, Kellogg, Idaho; Bunker Hill & Sullivan Mining & Construction Co.
KFFZ, Dallas, Texas; 226 meters, 20 watts; A. G. Bernes Amusement Co.
KFEZ, St. Louis, Mo.; American Society of Mechanical Engineers.
KFFA, San Diego, Calif.; Dr. R. C. Shelton.
KFFE, Bendleton, Ore.; Eastern Oregon Radio Co.
KFFG, Hillsboro, Ore.; Dr. H. Smith.
KFFP, Moberly, Missouri; First Baptist Church.
KFFQ, Colorado Springs, Colo.; Markheffel Motor Co.
KFFV, Lamona, Iowa; Graeland College.
KFFW, Omaha, Neb.; 278 meters, 350 watts; The McGraw Co.
KFFX, Alexandria, La.; 275 meters; 100 watts; Pincus & Murphy Inc.
KFGG, Baton Rouge, La.; 254 meters, 10 watts; Louisiana State University.
KFGV, Chickasha, Okla.; 248 meters, 20 watts; Chickasha Radio & Elect. Co.
KFGF, Mt. Vernon, Wash.; Boothenan, Stevens & Co.
KFGH, Stanford Univ., Calif.
KFGJ, St. Louis, Mo.; 266 meters, 100 watts; Nat'l Guards Missouri 138 Infantry.
KFGK, Arlington, Oregon; Arlington Garage.
KFGP, Cheney, Kansas; 229 meters, 10 watts; Cheney Radio Company.
KFGQ, Boone, Iowa; 226 meters, 20 watts; Grant Hardware Co.
KFGV, Union, Nebraska; 224 meters, 10 watts; Haldbreder Radio Supply Co.
KFGX, Orange, Texas; 250 meters; 500 watts; First Presbyterian Church.
KFGY, Baudette, Minn.; 224 meters, 15 watts; Gjelhay's Radio Shop.
KFGZ, Berrien Springs, Mich.; 268 meters, 10 watts; Emmanuel Missionary College.
KFHA, Gunnison, Colo.; Colorado State Normal School.
KFHB, Hood River, Oregon; P. L. Boardwell.
KFHD, St. Joseph, Mo.; 226 meters, 19 watts; Dlx Electric Co.
KFHE, Shreveport, La.; 266 meters, 150 watts; Central Christian Church.
KFHR, Seattle, Wash.; Star Elect & Radio Co.; 270 meters; 100 watts.
KFHH, Neah Bay, Wash.; Ambrose McCue.
KFHI, Wichita, Kansas; 224 meters, 20 watts; Charles V. Dixon.

KFHJ, Santa Barbara, Calif.; Fallon Co.
KFHL, Okaloosa, Ia.; 227 meters, 10 watts; Penn College.
KFHP, Kearney, Neb.; Radio Bug Products Co.; 246 meters; 10 watts.
KFHQ, Curtis Bros. Hardware Store, Los Gatos, Calif.; 242 meters, 5 watts.
KFHS, Dow, Clifford J., Lihue, Hawaii, 275 meters, 30 watts.
KFHT, Nelson, Robert Washington, Hutchinson, Kansas; 239 meters, 50 watts.
KFHU, Sateren, M. G., Mayville, N. D.; 261 meters, 50 watts.
KFHY, MoEwan, R. S., Trinidad, Col.; 242 meters, 50 watts.
KFID, Iola, Kansas, 246 meters, 20 watts; Ross Arbuckle's Garage.
KFIQ, Yakima, Wash.; 224 meters, 50 watts; Yakima Valley Radio Broadcasting Association.
KFI, Los Angeles, Calif.; radius covers entire U. S. and Canada; Daily, 6:45 to 11 p. m. Sunday 10 to 11 a. m., 4 to 4:30 and 8 to 11 p. m.; entertainment and educational features; station operates three remote control stations; Earle C. Anthony, Inc.
KFII, St. Louis, Mo.; 214 meters, 10 watts; Franklin W. Jenkins.
KFIF, Portland, Ore.; Benson Tech. Student Body.
KFIC, Denver, Colorado; 224 meters, 15 watts; Phillip Laskowitz.
KFIJ, Platte, S. D.; Sidney I. Thorean; 236 meters; 5 watts.
KFIK, Gladbrook, Ia.; Gladbrook Electric Co.; 234 meters; 20 watts.
KFIO, Spokane, Wash.; North Central High School; 252 meters; 50 watts.
KFID, Greeley, Colo.; Weld County Printing & Publishing Co.; 238 meters; 100 watts.
KFIH, Denver Park Amusement Co.; Lakeide, Colo.; 226 meters, 10 watts.
KFIU, Alaska Elect. Light & Power Co., Juneau, Alaska, 226 meters, 10 watts.
KFV, Gridley, Calif.; The Freeborn Shop.
KFIV, Broyles, V. H., Pittsburg, Kansas; 240 meters, 20 watts.
KFIZ, Reorganized Church of Jesus Christ of Latter Day Saints, Independence, Kans.; 240 meters, 50 watts.
KFJ, Spokane, Wash.; Doer-Mitchell Elec. Co.
KGB, Tacoma, Wash., Sunday: 5 to 7:30; Daily: 7 to 9 p. m. (except Thursday) News, Sport bulletins, lectures, entertainment, weather, tide tables, bedtime stories, etc.; Tacoma Daily Ledger station operated by the William A. Mulline Electric Co.
KGG, Portland, Ore.; Hallock & Watson Radio Service.
KGN, Portland, Ore.; Northwestern Radio Mfg. Co.
KGO, Altadena, Calif.; 2500 miles, every Saturday 8 to 9:30 p. m. Musical program;
KGU, Honolulu, Hawaii, Walkiki Beach, Marlon A. Mulrone; Honolulu Advertiser.
KGV, Portland, Ore.; Oregonian Pub. Co.
KGY, Lacey, Wash.; St. Martin's College, (Rev. S. Ruth).
KHJ, Los Angeles, Calif.; Daily except Sunday: 12:30 p. m. to 1:15 p. m. news and concerts; 7 to 7:30 p. m. Children's Half Hour; 8 to 9:30 p. m. De Luxe program of music, news and educational features; Sunday: 10 to 11 a. m. Scripture reading, sermon, prayer and sacred musical program; Pacific time: Times-Mirror company.
KHQ, Seattle, Wash.; Louis Wasmer.
KIJ, Stockton, Calif.; C. O. Gould.
KIS, Los Angeles, Calif.; Bible Inst. of Los Angeles.
KIB, Pasadena, Calif.; J. J. Dunn & Co.
KID, Tucson, Ariz.; Univ. of Arizona.
KIN, Monterey Electric Shop, Monterey, Calif.; 261 meters, 10 watts.
KIS, Oakland, Calif.; Warner Bros.
KIX, Oakland, Calif.; Tribune Pub. Co.
KIZ, Denver, Colo.; Class B, 485, Reynolds Radio Co.
KJAZ, Mecon, Ga.; Mercer University.
KJC, Redkey, Calif.; Lindsay-Worthill Co.
KJF, Fresno, Calif. Max. 2576 Miles; Musical program. San Joaquin Light & Power Corp.
KMO, Tacoma, Wash., Love Electric Co.; Tacoma Times.
KNJ, Roswell, New Mexico; 1000 miles; Every evening at 8; news, weather reports, stock market, concerts and sermons; Roswell Public Service Co.
KNT, Aberdeen, Wash.; North Coast Products Co.
KNV, Los Angeles, Calif.; Radio Supply Co.
KNW, Los Angeles, Calif.; Electric Lighting Supply Co.
KOB, State College, N. Mex.; time signals and weather reports 12 noon and 10 p. m. mountain time; music and lectures Monday, Wednesday and Friday, 7:30 to 8:30 p. m.; New Mexico College of Agriculture and Mechanical Arts.
KOE, Spokane, Wash.; Spokane Chronicle.
KOP, Detroit, Mich.; Detroit Police Dept.
KOG, Modesto, Calif.; Modesto Evening News.
KOH, San Francisco, Calif.; Hale Bros.
KOI, Berkeley, Calif.; Univ. of California.
KQP, Hood River, Oregon; Apple City Radio Club.
KQV, Pittsburgh, Pa.; Doubleday-Hill Elec. Co.
KQW, San Jose, Calif.; Ches. D. Herrold.
KRE, Berkeley Daily Gazette, Berkeley, Cal.; 278 meters, 50 watts.
KSD, San Jose, Calif.; O. A. Hale & Co.
KSB, St. Louis, Mo.; 1700 miles; grain, livestock, cotton, New York stocks, poultry and butter market, metal market, official weather and news at 9:40, 10:40, 11:40, 12:40, 1:40, 2:40 and 4 p. m.; 8 to 10 p. m. 400 meters, musical end other features; Pulitzer Publishing Co., St. Louis Post Dispatch.
KSS, Long Beach, Calif.; Frost & Dean Radio Research Lab.
KSU, Wenatchee, Wash.
KTV, Seattle, Wash., First Presbyterian Church.
KUO, San Francisco, Calif., Examiner Printing Co., San Fran. Examiner.
KUS, Los Angeles, Cal. 500 miles; setting up exercises daily, 7 to 7:30 a. m. and 12:00 noon to 12:30 p. m.; concert, 65 voices, 8 to 8:45 p. m. Wednesdays end Fridays; City Dye Works.
KUY, Del Monte, Calif., Coast Radio Co.
KWG, Stockton, Cal. Daily Market reports, music and news 4 to 5 p. m.; Wireless 3 to 8 p. m. Sunday; Tuesdays and Fridays, music, 8 to 9 p. m. Portable Wireless Telephone Co.
KWH, Los Angeles, Calif., Los Angeles Examiner.
KXD, Modesto, Calif., Herald Publishing Co.
KYQ, Honolulu, T. H., The Electric Shop.
KYW, Chicago, Ill., Westinghouse Elec. & Mfg. Co., 345 meters.
KZM, Oakland, Calif., Western Radio Inst., Preston D. Allen.
KZN, Salt Lake City, Utah, The Deseret News.
KZF, Wenatchee, Wash., Wenatchee Battery & Motor Co.
KOF, Anacostia, D. C., U. S. Navy Dept.
PWX, Havana, Cuba, Cuban Telephone Co.
WABD, Dayton, Ohio; 288 meters, 16 watts; Parker High School.
WAI, Dayton, Ohio, McCook Field, U. S. Army.
WAAB, New Orleans, La., Yeldomus Jensen.
WAAC, New Orleans, La., Tulane Univ.
WAAD, Cincinnati, Ohio, Ohio Mechanics Inst.
WAAF, Chicago, Ill., Chicago Daily Drivers Journal.
WAAE, St. Louis, Mo., St. Louis Chamber of Commerce.
WAAH, St. Paul, Minn., Commonwealth Electric Co.
WAAK, Milwaukee, Wis., Gimbel Bros.
WAAI, Minneapolis, Minn., Minnesota Tribune Co. & Anderson-Beemish Co.

(Continued on next page.)

Complete Corrected List of U. S. and Canadian Broadcasting Stations

- WAAM, Newark, N. J., 300 miles; musical and code, every week day 11 to 11:55 a. m., 8 to 9 p. m.; Wednesday evenings 8 to 9; I. R. Nelson Company.
- WAAN, Columbia, Mo., Univ. of Missouri.
- WAAP, Wichita, Kans., United Elec. Co.; Otto W. Taylor.
- WAAR, Greenwich, Conn., New England Motor Sales Co.
- WAAS, Decatur, Ga., Georgia Radio Co.
- WAAT, Jersey City, N. J., Jersey Review.
- WAAX, Omaha, Neb., Omaha Grain Exchange.
- WAAY, Emporia, Kans.; Daylite 100 miles; nite 500-1000 miles; each Tuesday and Thursday from 7 to 8 p. m. Acknowledge all communications at 7:15 p. m. The Hollister Miller Motor Co.
- WABA, Lake Forest, Ill.; 266 meters, 100 watts; Lake Forest College.
- WABB, Harrisburg, Pa.; 266 meters, 10 watts; Dr. John B. Lawrence.
- WABC, Anderson, Ind.; 299 meters, 10 watts; Fulvinder-Grimes Battery Co.
- WABD, Dayton, Ohio; 286 meters, 10 watts; Parker High School.
- WABE, Washington, D. C.; 283 meters, 50 watts; Y. M. C. A.
- WABF, Mt. Vernon, Ill.; 234 meters, 250 watts; Mt. Vernon Register-News Co.
- WABG, Jacksonville, Fla.; Arnold Edwards Piano Co. 248 meters; 10 watts.
- WABM, Doherty, P. E. Saginaw, Mich.; 251 meters, 100 watts.
- WABO, Lake Avenue Baptist Church, Rochester, N. Y.; 252 meters, 30 watts.
- WABI, Bangor, Me.; Bangor Railway and Elect. Co.; 240 meters; 50 watts.
- WABJ, South Bend, Ind.; The Radio Laboratories; 240 meters; 50 watts.
- WAJT, Marshall, Me.; Kelly-Vawter Jewelry Co.
- WAKO, Yankton, S. D.; Yankton College.
- WABH, Sandusky, Ohio; 234 meters, 100 watts; Lake Shore Tire Co.
- WAAA, W. Lafayette, Ind., Purdue University.
- WBAD, Minneapolis, Minn., Sterling Elec. Co. & Journal Printing Co.
- WBAE, Peoria, Ill., Bradley Polytechnic Inst.
- WBAF, Muncie, Ind., Fred M. Middleton.
- WBAE, Bridgeport, Pa.; Diamond State Fibre Co.
- WBAM, New Orleans, La.; I. B. Benson.
- WBAN, Paterson, N. J., Wireless Phone Corp.
- WBAD, Decatur, Ill.; 100 miles; occasional music; sermons; James Millikin Univ.
- WBAP, Fort Worth, Tex.; 4000 miles; Markets and News; Feature concert Monday to Friday inclusive; 9:30 p. m. to 10:45 p. m. Central Time; Quiet nights Saturday and Sunday. The Star-Telegram.
- WBAA, South Bend, Ind., Myron L. Harmon.
- WBAB, Hamilton, Ohio; Republican Publishing Co.
- WBAV, Columbus, Ohio; Erner & Hopkins Co.
- WBAW, Marietta, Ohio; Marietta College; 216 meters; 100 watts.
- WBAZ, Wilkes-Barre, Pa.; John H. Stenger, Jr.
- WBBA, Newark, O.; 240 meter, 20 watts; Newark Radio Lab.
- WBBC, Sterling, Ill.; 229 meter, 50 watts; Sterling Radio Equipment Co.
- WBBD, Reading, Pa.; Barbey Battery Service; 224 meters; 50 watts.
- WBDE, Anthony, Kans.; T. & H. Radio Co.; 261 meters; 100 watts.
- WBS, Newark, N. J.; Radius 500 ml.; Musical and Educational, week days; 10:30 to 11 a. m.; 1:00 to 1:15 p. m.; 2:15 to 2:30 p. m.; 7:30 to 8:30 p. m.; Sundays: 9 to 10:30 a. m.; 1 to 3 p. m.; D. W. May, Inc.
- WBT, Charlotte, N. C. 1200 miles; 11: a. m. weather report 485; 4:30 p. m. mechanical music; 8 p. m. Market Report; 8:30 Tuesday and Friday regular concert; 7:30 p. m. Sunday, Church Southern Radio Corp.
- WBU, Chicago, Ill., City of Chicago.
- WBZ, Springfield, Mass., Westinghouse Elec. & Mfr. Co.
- WCAD, St. Lawrence University, Canton, N. Y.; 280 meters, 50 watts.
- WCAE, Pittsburgh, Pa.; 12:36 news and reports; 3:30 weather reports; 4:15 Closing Market reports; 7:30 Late news and lecture; 8:30 musical programs; Kaufmann Baer Co.
- WCAO, New Orleans, La., Daily States Pub. Co.
- WCAH, Columbus, O., Daily program 11:30 to 12:30; Every Tuesday evening at 7, musical program; C. A. Entekin Electric Co.
- WCAI, San Antonio, Texas, Southern Equipment Co.
- WCAJ, Univ. Place, Neb., Nebraska Wesleyan University.
- WCAK, Houston, Texas, Alfred P. Daniel.
- WCAL, Northfield, Minn., St. Olaf College.
- WCAM, Villanova, Pa., Villanova Univ.
- WCAO, Baltimore, Md., Sanders & Stayman Co.
- WCAP, Chesapeake & Potomac Tel. Co., Washington, D. C.; 460 meters, 500 watts.
- WCAR, San Antonio, Texas, Alamo Radio Elec. Co.
- WCAS, Minneapolis, Minn., Wm. H. Dunwoody Industrial Inst.
- WCAT, Rapid City, S. Dak., South Dakota School of Mines.
- WCAU, Philadelphia, Pa.; 1000 miles; Daily 10:30 a. m. to 2:30 p. m.; 5:30 p. m.; regular concert 10 to 12 noon; Tuesdays, Fridays, Saturdays; Durham & Co., Inc.
- WCAV, Little Rock, Ark., J. C. Dice Elec. Co.
- WCAW, Omaha, Neb., Woodmen of the World.
- WCAX, Burlington, Vermont, University of Vermont.
- WCAY, Milwaukee, Wis., Kesselman O'Driscoll Co.
- WCBA, Allentown, Pa., Chas. W. Halmbach; 280 meters; 5 watts.
- WCBB, Greenville, S. C.; 240 meters, 100 watts; K. & K. Radio Supply Co.
- WCBD, Voliva, Wilbur Glenn Zions, Ill.; 315 meters, 500 watts.
- WCE, Minneapolis, Minn., Findley Elec. Co.
- WCK, St. Louis, Mo., Stix Baer & Fuller.
- WCM, Austin, Texas, Univ. of Texas.
- WCK, Detroit, Mich., Detroit Free Press.
- WCDA, Lindbergh, Kan., Central Kansas Radio Supply.
- WCDAE, Tampa, Fla., Tampa Daily News.
- WCDF, Kansas City, Mo.; Kansas City Star; 411 meters; 500 watts. Regular concerts on Mon. Wed. and Fri. nights from 8 to 9:30. Concerts from 3:30 to 4:30 p. m. each afternoon except Sun. Baseball scores 3:25, 4:00, 4:30, 5:00, and 5:50 p. m. Marketgram and weather forecast 5:55 nightly, except Sun. Educational features and musical program 6 to 7 o'clock each night except Sunday. "Nighthawk" Frolic, Coon Sanders orchestra at the Hotel Bluebeach nightly except Sun. 11:45 p. m. 10 to 1 a. m.
- WDAG, Amarillo, Texas, K. Laurence Martin.
- WDAG, Brownsville, Pa., Hartman-Riker Elec. & Mach. Co.
- WDBF, Phillips, Robert G., Youngstown, Ohio; 261 meters, 50 watts.
- WDAH, El Paso, Tex.; Trinity Methodist Church.
- WDAJ, Ervins Bl. Co., Parson's, Kan. 258 meters, 15 watts.
- WDAI, Syracuse, N. Y., Hughes Electrical Corp.
- WDAN, Hartford, Conn., Hartford Courant.
- WDAL, Jacksonville, Fla., Florida Times Union.
- WDAO, Dallas, Texas, Automotive Elec. Co.
- WOAP, Chicago, Ill., markets, and concerts 860; Daily on all business days: 9:30 a. m. receipts and shipments; estimated cash lots; local weather report; opening futures market in wheat, corn, oats, rye, barley, pork, lard and ribs. 10 a. m. Future quotations, live stock receipts and prices; 10:30 a. m. futures quotations; 11 and 11:30 a. m. same; 12 noon, future and cash grain prices; 12:30 and 1 p. m. futures quotations; 1:20 p. m. closing futures quotations and high and low for day. Cash grain prices. Gross bids for cash grain to arrive. 6 p. m. closing quotations; news items. On Saturdays closing prices at 12:05 p. m. instead of 1:20 p. m. Visible supply chances sent when posted. Regular concert schedule 10 p. m. Tuesdays, Thursdays and Saturdays. Sunday evenings 9 p. m. and 10 p. m. Chicago Board of Trade official station.
- WDAF, Philadelphia, Pa.; Lit Brothers.
- WDAS, Worcester, Mass., Samuel A. Walte.
- WDAU, New Bedford, Mass., Slocum & Kilburn.
- WDAZ, Centerville, Iowa; First National Bank 268 meters, 100 watts.
- WDAY, Fargo, N. D.; 244 meters, 50 watts; Fargo Radio Service Co.
- WDM, Washington, D. C., Church of the Covenant.
- WDT, New York, N. Y., Ship Owners Radio Service.
- WDL, Tuscola, Ill., James L. Bush.
- WEAA, Fallain & Lathrop, Flint, Mich.; 280 meters; 150 watts.
- WEAB, Fort Dodge, Iowa, Standard Radio Equip. Co.
- WEAD, Atwood, Kans., Northwest Kansas Radio Supply Co.
- WEAG, Blacksburg, Va., Virginia Polytechnic Inst.
- WEAF, New York City, N. Y., Western Electric Co.
- WEAK, Edgewood, R. I., Nichols-Hineline-Bassett Lab.
- WEAH, Wichita, Kans., Wichita Board of Trade and Lander Radio Co.
- WEAI, Ithaca, N. Y., Cornell University.
- WEAJ, Vermillion, S. Dak., University of South Dakota.
- WEAK, St. Joseph, Mo., Julius B. Abercrombie.
- WEAM, North Plainfield, N. J., Borough of N. Plainfield.
- WEAN, Shenandoah, Va., The Shenandoah R. Co.; 273 meters, 100 watts.
- WEAO, Columbus, Ohio, Ohio State University.
- WEAP, Mobile, Ala., Mobile Radio Co.
- WEAQ, Berlin, N. H., Y. M. C. A.
- WEAR, Baltimore, Md., Balt. American & News Pub. Co.
- WEAS, Washington, D. C., The Hecht Co.
- WEAU, Sioux City, Iowa, Davidson Bros. Co.
- WEAY, Houston, Texas, Will Horwitz, Jr.
- WEAZ, Waterloo, Iowa, Donald Redmond.
- WEB, St. Louis, Mo., The Benwood Co., Inc.
- WEV, Houston, Texas, Hurlburt-Sull Elec. Co.
- WEW, St. Louis, Mo., St. Louis Univ.
- WEW, St. Louis, Mo., Market and weather reports at 9 a. m., 10 a. m. and 2: p. m.; no other regular program; St. Louis University.
- WEY, Wichita, Kansas, Cosradio Co.
- WFAA, Dallas, Texas, A. H. Belo & Co.
- WEAB, Syracuse, N. Y., C. F. Woese.
- WFAC, Superior, Wis., Superior Radio Co.
- WFAP, Poughkeepsie, N. Y., H. C. Spratley Radio Co.
- WFAG, Waterford, N. Y., Radio Engineering Lab.
- WFAM, Port Arthur, Texas, Elec. Supply Co.
- WFAN, Asheville, N. C., Hi-Grade Wireless Instrument Co.
- WFAP, Brentwood, Mo., Domestic Electric Co.
- WFAM, St. Cloud, Minn., Granite City Elec. Co. and Times Pub. Co.
- WFAN, Hutchinson, Minn., Hutchinson Electric Service Co.
- WFAQ, Cameron, Mo., Cameron Radio Co. and Mo. Wesleyan College.
- WFAT, Sioux Falls, S. Dak.; also Argus-Leader.
- WFAV, Lincoln, Neb., Univ. of Neb. Dept. of Elec. Engineering.
- WFI, Philadelphia, Penn., also Strawbridge & Clothier.
- WGAC, Brocton, N. Y., Orpheum Radio Stores Co.
- WGAD, Ensenada, Porto Rico, Spanish-American School of Radio-telegraphy.
- WGF, Des Moines, Iowa, 300 miles; Musical and entertainment Tuesday and Friday 7:30 p. m.; Church Services Sunday at 6 p. m. or 7:45 p. m. as announced; Special programs as announced Register and Tribune.
- WGAI, Shenandoah, Iowa, W. H. Gass.
- WGAL, Lancaster, Pa.; Lancaster Elec. Supply Co. 248 meters; 10 watts.
- WGAN, Pensacola, Fla., Cecil E. Lloyd.
- WGAQ, Shreveport, La., Glenwood Radio Corp.
- WGAR, Fort Smith, Ark., Southwest American.
- WGAU, Wooster, Ohio; 226 meters, 20 watts; Marcus G. Limb.
- WGAU, Savannah, Ga., B-H Radio Co.
- WGAW, Altoona, Pa., Ernest C. Albright.
- WGAX, Washington Court House, Ohio, Ohio Radio Elec. Co.
- WGAY, Madison, Wis., North Western Radio Co.
- WGAZ, South Bend, Ind., South Bend Tribune.
- WGI, Medford Hillside, Mass., Am. Radio & Research Corp.
- WGL, Philadelphia, Pa., Thos. F. J. Rowlett.
- WGM, Atlanta, Ga., Atlanta Constitution.
- WGR, Buffalo, N. Y., Federal Tel. & Teleg. Co.
- WGV, New Orleans, La., Interstate Elec. Co.
- WGY, Schenectady, N. Y., General Elec. Co.
- WHA, Madison, Wis., Univ. of Wis.
- WHA, Iowa City, Ia.; 500 miles; 8:30 p. m. Monday, instruction; Tuesday, concert; Wednesday, popular lecture; Friday, University News; public lectures and concerts irregularly; State University of Iowa.
- WHAB, Galveston, Texas, Clark W. Thompson (Fellman's Dry Goods Co.)
- WHAC, Waterloo, Iowa, Cole Bros. Elec. Co.
- WHAD, Marquette Univ., Milwaukee, Wis.; 280 meters, 100 watts.
- WHAG, Cincinnati, Ohio, Univ. of Cincinnati.
- WHAH, Joplin, Mo.; radius, 1384 ml.; Concerts, markets, weather, etc. Tuesday and Thursday evenings; 8 to 10; Daily except Sundays: 10 a. m. to 2 p. m.; Saturday night special; 11 to 12:30; Radio Supply Co.
- WHAI, Des Moines, Iowa, Radio Equip. & Mfr. Co.
- WHAJ, Bluefield, W. Va., Bluefield Daily Telegraph and E. K. Kitts.
- WHAK, Clarksburg, W. Va., Roberts Hdwe. Co.
- WHAL, Lansing, Mich., Lansing Capitol News.
- WHAM, Rochester, N. Y., Daily-Weather reports 2:40 p. m.; Organ 2:45, 5:00, 8:45; Orchestra 3:00, 7:00; Bed-time stories, Sport results, Business reports and market reports, the latter on 485 meters, 7:15 p. m.; Sunday-Radio Channel Service, 8:15 p. m.; University of Rochester.
- WHAO, Savannah, Ga., Frederick A. Hill; every evening 8 to 9; Saturday nights, 12:30 to 1:30 a. m.
- WHAP, Decatur, Ill., Dewey L. Otta.
- WHAQ, Washington, D. C., Semmes Motor Co.
- WHAR, Paramount Radio & Elect. Co., Atlantic City, N. J.; 231 meters, 15 watts.
- WHAS, Louisville, Ky., Courier Journal and Louisville Times Co.
- WHAV, Wilmington, Del., Wilmington Elec. Spec. Co.
- WHX, Des Moines, Iowa; 300 miles; 5:45 p. m. to 6:15 p. m. Daily; 8:00 p. m. to 10 p. m. Wednesday evenings; Central Standard time; Iowa Radio Corp.
- WHAY, Huntington, Ind., Huntington Press.
- WHAZ, Troy, N. Y., Rensselaer Polytechnic Inst.
- WHB, Kansas City, Mo., Sweeney Auto & Tractor School.
- WHC, Monticello, W. Va., W. V. University.
- WHK, Cleveland, Ohio, Warren R. Cox.
- WHN, Ridgwood, N. Y., Times Printing & Pub. Co.
- WHU, Toledo, Ohio, Wm. B. Duck Co.
- WHAB, Joslyn Automobile Co., Rockford, Ill.; 252 meters, 50 watts.
- WHAC, Galveston, Texas, Galveston Tribune.
- WHAD, Ocean City, N. J., Ocean City Yacht Club.
- WHAF, New Orleans, La.; G. A. DeCortin, 10 Marlborough Gate; 234 meters, 10 watts.
- WHAG, Norfolk, Neb.; 200 miles News and Markets 12:15, 3:30 and 5:30 p. m. The Huse Publishing Co. The Norfolk Daily News.
- WHAH, Newton, Iowa, Continental Radio & Mfg. Co.
- WHAI, Springfield, Mo., Heer Stores Co.
- WHAJ, Neenah, Wis., Fox River Valley Radio Supply Co.
- WHAK, Omaha, Neb.; 7:45 a. m. livestock receipts; 9:10 a. m. Livestock receipts and opening hog market; 1:15 a. m. rainfall and temperature report and weather forecast for Nebraska and Iowa. Livestock market; 12 m. cattle, hog and sheep market; 1:50 p. m. rainfall and temperature report and weather forecast for Nebraska and Iowa; market detail; 3:50 p. m. complete market reports and estimated receipts for next day; Daily Journal-Stockman.
- WHAL, Milwaukee, Wis., School of Engineering.
- WHAP, Springfield, Mass., Radio Development Corp.
- WHAR, Marion, Ind., Chronicle Pub. Co.
- WHAS, Paducah, Ky., Mutual 3:30 to 4 p. m. and 7 to 8 p. m. except Sundays.
- WHAT, Paducah Evening Sun; Albert Bennett, operator.
- WHAS, Burlington, Iowa, Hawk-Eye Home Elec. Co.
- WHAT, Tarkio, Mo., Leon T. Noel.
- WHAU, Le Mars, Iowa, Am. Trust & Savings Bank.
- WHAV, Binghamton, N. Y., N. Y. Radio Lab.
- WHAW, Rainnaw, Mich., Rainnaw Radio & Elec. Co.
- WHAY, Neenah, Wis.; 224 meter, 100 watts; Fox River Valley Radio Supply Co.
- WIK, McKeessport, Pa., K. & L. Fleck Shop.
- WIL, Washington, D. C., Continental Elec. Supply Co.
- WIP, Philadelphia, Pa., Gimbel Bros.
- WIZ, Cincinnati, Ohio, Cino Radio Mfg. Co.
- WIAB, Lincoln, Neb., American Radio Co.
- WIAD, Waco, Texas, Jackson's Radio Engrng. Lab.
- WIAP, Muncie, Ind.; 1800 miles; 7:30 to 8 Monday, Wednesday, Friday evening, 6:30 to 7 p. m. Saturday, music; 8:30 to 9 a. m. every afternoon, News; 10:30 to 12 M. Sundays, Church service. Smith Electric-Muncie Press.

(Continued on next page.)

Complete Corrected List of U. S. and Canadian Broadcasting Stations

WJAI, Dayton, Ohio 260 miles; Sunday 8:40, 9:15 Religious; Wednesday 9:15, 9:45 Entertainment; Friday 9:15 to 9:45 Entertainment. Y. M. C. A.

WJAK, Stockdale, Ohio, White Radio Lab.

WJAM, Cedar Rapids, Ia.; D. C. Perham, 268 meters, 20 watts.

WJAN, Peoria, Ill.; 280 meters, 100 watts; Daily except Sunday: 9 a. m. Peoria Livestock; 9:15 a. m. Special Weather Information; 11:30 a. m. weather, opening livestock and market quotations; 1:30 p. m. Closing livestock and markets, official weather information; talk to women by Phyllis Ann; Monday and Tuesday, government agrigrams; 5:30 p. m. baseball reports during season; Tuesday, Thursday and Saturday, special concerts as announced at 9:15 p. m.; One musical number precedes each broadcasting. Peoria Evening Star.

WJAP, Duluth, Minn. 1500 miles; Sunday 11 a. m., 12:30 p. m. Church Service and organ recital; First Methodist Church, Rev. Chas. N. Pace, Pastor, Monday 8 p. m. to 9 p. m. musical; Thursday 8 p. m. to 9 p. m. musical; Kelley Duluth Co.

WJAO, Topeka, Kans., Calmar, Okla.

WJAP, Providence, R. I., The Outlet Co., J. Samuels & Bros.

WJAS, Pittsburgh, Pa., Pittsburgh Radio Supply House.

WJAT, Marshall, Mo., Kelley-Vawter Jewels Co.

WJAX, Cleveland, Ohio, Union Trust Co.

WJAZ, Chicago, Ill., Chicago Radio Lab.

WJD, Granville, Ohio; 229 meters, 50 watts; Richard Harris Howe.

WJH, Washington, D. C., Radio City.

WJX, New York, N. Y., De Forest Radio Telephone & Teleg. Co.

WJZ, New York, Radio Corp. of America; Aeolin Hall, 455 meters.

WKAA, Cedar Rapids, Ia.; Daily; weather reports, crop reports, government reports; Mondays, Thursdays and Saturdays; music; H. F. Paar.

WKAC, Lincoln, Neb.; Star Publishing Co.; 275 meters; 100 watts.

WKAD, Looft, Charles, East Providence, Ill.; 240 meters, 10 watts.

WKAF, Wichita Falls, Texas, W. S. Radio Supply Co.

WKAN, Montgomery, Ala., Alabama Radio Mfg. Co.

WKAQ, Cranston, R. I., Dutton Electric Co.

WKAQ, San Juan, Porto Rico, Radio Corp. of Porto Rico.

WKAR, Michigan Agri. College, East Lansing, Mich., 230 meter, 100 watts.

WKAS, Springfield, Mo., L. K. Lines Music Co.

WKAV, Laconia, N. H., Laconia Radio Club.

WKAW, Beloit, Wis.; 242 meters, 10 watts; Turner Cycle Co.

WKAX, Bridgeport, Pa., J. Samuels & Bros.; 231 meters; 15 watts.

WKAY, Gainesville, Ga., Brown College.

WKC, Baltimore, Md., J. M. Zamolski Co.

WKY, Oklahoma City, Okla., Oklahoma Radio Shop.

WLZ, Fairfield, Ohio, U. S. Army.

WLAC, Raleigh, N. C., N. C. State College.

WLAC, Minneapolis, Minn., Cutting & Walsh Radio Corp.

WLAI, Syracuse, N. Y., Samuels & Woodworth.

WLAI, Waco, Texas, Waco Electric Supply Co.

WLAK, Bellows Falls, Vt., Vermont Farm Machine Co.

WLAL, Tulsa, Okla., Tulsa Radio Co.

WLAN, Houston, Me., Putnam Hdwe. Co.

WLAP, Louisville, Ky., W. Y. Jordan.

WLAQ, Kalamazoo, Mich., A. E. Schillings.

WLAT, Burlington, Iowa, Radio Specialty Co.

WLAV, Pensacola, Fla.; program, 8 to 9 p. m.; The Electric Shop.

WLAW, New York, N. Y., New York Police Dept.

WLAX, Greencastle, Ind., Greencastle Community Broadcasting Station.

WLAY, Fairbanks, Alaska, Northern Commercial Co.

WLAZ, Warren, Ohio, Hutton & Jones Elec. Co.

WLB, Minneapolis, Minn., Univ. of Minn.

WLW, Cincinnati, Ohio, Crosley Mfg. Co.

WMA, Anderson, Ind., Arrow Radio Lab.

WMAA, Oklahoma City, Okla., Radio Supply Co.

WMA, Memphis Commercial Appeal; Memphis, Tenn.

WMAE, Cazenovia, N. Y.; J. Edw. Page; 261 meters; 50 watts.

WMAE, Rockport, Mo., Atchinson County Mall.

WMAE, Dartmouth, Mass., Bound Hills Radio Corp.

WMAH, Lincoln, Neb., General Supply Co.

WMAI, Kansas City, Mo., Drivers Telegram.

WMAK, Lockport, N. Y., Norton Lab.

WMAI, Trenton, N. J., 100 miles; 7:30 to 9 p. m. Mondays and Thursdays, musical programs, lectures etc.; Trenton Hardware Co.

WMAN, First Baptist Church, Columbus, Ohio; 286 meters; 20 watts.

WMAN, Columbus, Ohio, First Baptist Church.

WMAP, Easton, Pa., Utility Battery Service.

WMAQ, Fair Store Building, Chicago; 4:35 to 5 p. m. daily; 7 to 7:30 p. m. Monday, Wednesday, Friday and Saturday; 7 to 8 p. m. Tuesday and Thursday; 9:15 to 10 p. m. daily; Chicago Daily News, and Fair Department Store.

WMAV, Auburn, Ala., Polytechnic Inst.

WMAW, Wahpeton, N. D., Wahpeton Elec. Co.

WMAV, St. Louis, Mo., 600 miles; Religious services Sunday, 11 a. m. and 8 p. m.; Tuesday at 7 p. m.; Kingshighway Presbyterian Church.

WMAZ, Macon, Ga., Mercer University.

WMA, Cincinnati, Ohio, Precision Equipment Co.

WMAI, Paramount Radio Corp., Duluth Minn.; 266 meters, 25 watts.

WMAI, Washington, D. C., Doleider-Hill Electric Co.

WMAI, Bowling Green, Ky., Park City Daily News.

WMAI, Boston, Mass.; Monday 4 to 5 p. m. (silent at night) Tuesday 4 to 5 p. m. and 7 to 8:30 p. m. Wednesday 4 to 5 p. m. 9:30 to 11 p. m. Thursday 4 to 5 and 7 to 8:30 p. m. Friday 4 to 5 and 8 to 9:30 p. m. Saturday 4 to 5 and 9:30 to 11 p. m. The Shepard Stores; J. J. Fanning, announcer Samuel Curtis, operator. 278 meter, 100 watts.

WMAI, Norman, Okla., Okla. Radio Engineering Co.

WMAI, Omaha, Neb., R. J. Rockwell.

WMAI, Syracuse, N. Y., Syracuse Radio Telephone Co.

WMAI, Springfield, Ohio, Whittenberg College.

WMAI, Charleston, S. C., Charleston Radio Elec. Co.

WMAI, Austin, Texas, Radio Corp.

WMAI, Philadelphia, Pa., 1000 miles; Talks, Radio information, music, Chapel Service, Wednesday 7:30 p. m.; Saturday 7:30 p. m.; Sunday 2:30 and 4:30; Every day 12:15, 1 p. m. Lentz Bros. Co.

WMAI, Knoxville, Tenn., People's Tel. and Tel. Co.

WMAI, Baltimore, Md., Sblpowners Radio Service.

WMAI, Fortness Monroe, Va., Henry Kunzman.

WMAI, Yankton, S. Dakota; 244 meters, 100 watts; Dakota Radio Apparatus Company.

WNI, Albany, N. Y., Sblpowners Radio Mfg. Co., Inc.

WNO, Jersey City, N. J., Wireless Telephone Co. of Hudson Co., N. J.

WNOA, Ardmore, Okla.; radius 1,500 miles; Tuesday and Friday: musical and educational programs; Dr. Walter Hardy; station operated by G. H. Reitz.

WNOA, Lima, Ohio, Maus Radio Co.

WNOA, Fremont, Neb., Medland College.

WNOA, Tyler, Texas, Tyler Commercial College.

WNOA, Charleston, S. C., Palmetto Radio Corp.

WNOA, San Antonio, Tex.; 385 meters; Southern Equipment Company; Programs Daily; 10:30 a. m. Opening markets, U. S. weather forecast, crop reports, road reports, cotton reports, money market, livestock quotations and news bulletins, daily except Sun. 12:15 p. m. Livestock quotations, produce markets, and news bulletins. 3 p. m. Closing markets, cotton reports, grain and market futures and news bulletins. 7 p. m. Complete baseball scores from American National and Texas leagues, final reports on markets, and news bulletins. Daily except Sun. 9:30 to 10:30 p. m. Concerts. Thurs. 7:30 to 8:30 p. m. Musical and Community Programs. Sunday 11:00 a. m. Church Services; 5:00 to 6:00 p. m. Concerts.

WNOA, Parsons, Kans., Erving's Electrical Co.

WNOA, Frankfort, Ky., Collins Hardware Co.

WNOA, Webster Groves, Mo., Wm. E. Woods.

WNOA, Lawrenceburg, Tenn., James D. Vaughan.

WNOA, Omaha, Neb., 100 miles; Woodmen of the World.

WNOA, Portsmouth, Virginia; Portsmouth Kiwanis Club.

WNOA, Kenesha, Wis., Henry P. Lundskog.

WOS, Jefferson City, Mo., Missouri State Marketing Bureau; 441 meters, 500 watts; first fifteen minutes of every hour from 8 a. m. to 2 p. m.; markets and music at 5 p. m. Monday, Wednesday and Friday nights, 8 to 9:30 concerts. No Sunday program.

WQAT, Wilmington, Del., Boyd Martell Hamp.

WQAV, Erie, Pa., Pa. Nat'l Guard.

WQAW, Trenton, N. J., Franklin J. Wolff.

WQAW, Omaha, Neb., 100 miles, Woodmen of the World.

WQAZ, Stanford, Texas, Penick Hughes Co.

WQBB, Greenville, O.; 240 meters, 100 watts; K. & K. Radio Supply Co.

WCCB, Davenport, Ia. time signals, 10:55 a. m.; weather 11 a. m.; 360 meters, 11:05 opening market quotations, agrigrams; 12:00 noon, chimes concert; 2:00 p. m. closing stocks and markets; 3:30 p. m. educational talk; 5:45 p. m. chimes concert; 6:35, sandman's visit; 7:00 musical program; 8 p. m. lecture; Sunday, religious and musical and religious features, 9 a. m. to 10 p. m.; Palmer's School of Chiropractic.

WOL, Ames, Ia., Iowa State College.

WOK, Pine Bluff, Ark., concerts Tuesday and Friday evenings beginning at 8; Sunday, 11:00 a. m. service and sermons from churches at 11 a. m. and 7:30 p. m., Arkansas Light & Power Co.

WOO, Philadelphia, Pa., John Wanamaker.

WOO, Kansas City, Mo., Western Radio Co.

WOR, Newark, N. J., L. Bamberger & Co.

WOW, Omaha, Neb., B. B. Wood.

WPA, Fort Worth, Texas, Fort Worth Record.

WPAB, State College, Pa.

WPAC, Okmales, Okla., Donaldson Radio Co.

WPAD, Chicago, Ill., Wisbold & Co.

WPAF, Council Bluffs, Iowa, Peterson's Radio Co.

WPAG, Independence, Mo., Central Radio Co.

WPAH, Waupaca, Wis., Wisconsin Dept. of Markets.

WPAJ, New Haven, Conn., Doolittle Radio Corp.

WPAK, Fargo, N. D., North Dakota Agricultural College.

WPAK, Columbus, Ohio, Superior Bag & Tel. Equip. Co.

WPAM, Topeka, Kans., Averbach & Gustel.

WPAP, Winchester, Ky., Theo. D. Phillips.

WPAQ, Frostburg, Md., General Sales & Eng. Co.

WPAQ, Wilmington, Del., Radio Installation Co., Inc.

WPAH, Beloit, Kans., R. A. Ward.

WPAH, Amsterdam, N. Y., J. & M. Electric Co.

WPAH, El Paso, Texas, Superior Radio Co.

WPAU, Moorhead, Minn., Concordia College.

WPAZ, Charleston, W. Va., Dr. John B. Keck.

WFG, New Lebanon, O., Nushawg Poultry Farm; 234 meters, 50 watts.

WPI, Clearfield, Pa., Electric Supply Co.

WQAW, Washington, D. C.; Catholic University of Am.; 236 meters; 50 watts.

WSAC, Clemson College, S. C.; Clemson Agriculture College.

WQAB, Fairport, Pa., 150 miles; 10:30 p. m. every evening. Horace A. Beale, Jr.

WQAB, Springfield, Mo., Southwest Missouri State Teachers' College.

WQAC, Amarillo, Texas, E. B. Gish.

WQAD, Waterbury, Conn., Whittall Electric Co.

WQAE, Moore Radio News Station, Springfield, Vermont; 275 meters, 50 watts.

WQAF, Sandusky, Ohio, Sandusky Register.

WQAH, Lexington, Ky., Brock-Anderson Elect. Eng. Co.

WQAI, Ann Arbor, Mich., Ann Arbor Times-News.

WQAJ, Columbus, Ohio, Superior Radio Co.

WQAL, Cole County Tel. & Tel. Co., Mattoon, Ill.; 258 meter, 10 watts.

WQAM, Miami, Fla., Electrical Equipment Co.

WQAN, "The Voice of Anthracite," 280 meters, 150 watts; Scranton Times, Scranton, Pa., musical and informative programs three daily; 12:30, 4:30 and 7:30 p. m. except Sunday. Music news, weather forecasts and reports baseball scores, market quotations, evening bedtime stories. Special musical programs by vaudeville and other artists on Tuesday and Friday evenings at 8 p. m.

WQAO, New York, N. Y., Calvary Baptist Church.

WQAP, Lincoln, Neb., Am. Radio Co.

WQAO, Abilene, Texas, West Texas Radio Co.

WQAR, Muncie, Ind., Press Publishing Co.

WQAS, Lowell, Mass.; Prince-Walter Company.

WQAT, Westhampton, Va.; Radio Equipment Corp.

WQAV, Huntington & Curry, Inc., Greenville, S. C.; 253 meters, 15 watts.

WQAW, Scranton, Pa., Scranton Times.

WQAW, Washington, D. C.; Catholic University of America; 236 meters; 50 watts.

WQAX, Peoria, Ill.; Radio Equipment Co.

WQAY, Hastings, Neb., Gaston Music & Furniture Co.

WQAZ, Greensboro, North Carolina; Greensboro Daily News.

WRAA, Houston, Texas, Rice Institute.

WRAA, Savannah, Ga.; Savannah Board of Public Education.

WRAA, Marion, Kansas, Taylor Radio Shop.

WRAF, Laporte, Ind.; 224 meters, 10 watts; Radio Club, Inc.

WRAH, Providence, R. I.; Stanley N. Read.

WRAI, St. Croix Falls, Wis.; Northern States Power Co.

WRAI, Carthage, Ill., Robert E. Compton & Carthage College.

WRAI, Grover, Waldo C., La Crosse, Wis.; 234 meters, 100 watts.

WRAI, Burlington, Iowa; 229 meters, 20 watts; Black Hawk Electrical Co.

WRAI, St. Louis, Mo., Radio Service Co.

WRAI, Winter Park, Fla.; Winter Park Electric Construction Co.

WRAI, David City, Neb.; J. C. Thomas; 226 meters; 20 watts.

WRAS, McLeansboro, Ill.; Radio Supply Co.

WRAU, Amarillo, Texas, Daily News.

WRAV, Yellow Springs, O., Antioch College.

WRAV, Good, Horace D. Reading, Pa.; 238 meters, 10 watts.

WRAV, Flexon's Garage, Gloucester City, N. J.; 268 meters, 50 watts.

WRAV, Scranton, Pa.; radius 400 mi.; Sunday Chapel service; Wednesday Selective Musical program, 8:15 to 10; Saturday; 8:15 to 11; Radio Sales Corp., 280 meters, 100 watts.

WRAZ, Radio Shop of Newark, Newark, N. J. 233 meters, 50 watts.

WRK, Hamilton, Ohio, Doron Bros. Elec. Co.

WRL, Schenectady, N. Y., Union College.

WRM, Urbana, Ill., Univ. of Ill.

WRP, Camden, N. J., Federal Inst. of Radio Telg.

WRR, Dallas, Texas, City of Dallas, Police and Fire Signal Dept.

WRW, Tarrytown, N. Y.; Tarrytown Radio Research Lab; 275 Meters; 50 watts.

WSAA, Marietta, O., B. S. Sprague Electric Co.

WSAB, Cape Girardeau, Mo., Southeast Mo. State College.

WSAC, Clemson College, S. C.; Clemson Agricultural College.

WSAG, Davis, Lonon N. J.; 268 meters, 10 watts.

WSAH, Chicago, Ill.; A. C. Leonard, Jr.; 248 meters, 500 watts.

WSAJ, Grove City, Pa., Grove City College.

WSAK, Daily News, The, Middleport, Ohio; 258 meters, 20 watts.

WSAL, Brookville, Ind.; Franklin Electric Co.

WSAN, Allentown Radio Club, Allentown, Pa.; 229 meters, 10 watts.

WSAP, New York City; Seventh Day Adventist Church.

WSAQ, Davis, Lonon N. J.; 268 meters, 10 watts.

WSAR, Doughty, Weich Elect. Co., Fall River, Mass.; 254 meters, 10 watts.

WSAT, Plainview Elect. Co., Plainview, Texas; 263 meters; 20 watts.

WSB, Atlanta, Ga., Atlanta Journal.

WSL, Utica, N. Y., J. & M. Fleck Co.

WSY, Birmingham, Ala., Alabama Power Co.

WTAB, Fall River Daily Herald, Fall River, Mass.; 248 meters, 10 watts.

WTAC, Johnston, R. I., Traffic Co.

WTAS, Elgin, Ill.; 275 meters, 500 watts; Chas. E. Erbstein.

WTAU, Tecumseh, Neb., Buegy Battery & Elec. Co.

WTAU, College Station, Texas; Ag'ltie & Mech. College; 254 meters; 50 watts.

WTG, Manhattan, Texas, Kans. State Agri. College.

WTP, Bay City, Mich., Ra-Do Corp.

WTP, New York, N. Y., Signal Corps, U. S. Army.

WTAO, Waco, Tex.; 80 miles; Weather forecast 11 a. m. daily; musical concerts, daily, 1:30 p. m. and on Wednesday and Saturday evenings at 8; Sanger Bros.

WTD, Philadelphia, Pa., Wright & Wright, Inc.

WWA, Laredo, Texas, Worman Bros.

WWS, Daily News Print Co., Canton, Ohio; 268 meters, 200 watts.

WWI, Dearborn, Mich., Ford Motor Co.

WWJ, Detroit, Mich., Evening News.

(Continued on next page.)

Complete Corrected List of U. S. and Canadian Broadcasting Stations

Canadian Stations

CFAC, Calgary, Alta., Can. Western Radio Co., Ltd.
 CFCA, Toronto, Ont., Can. Toronto Star.
 CFCB, Vancouver, B. C., Can. Marconi Co.
 CFCE, Halifax, N. S., Can. Marconi Co.
 CFCF, Montreal, P. Q., Can. Marconi Co.
 CFCN, Iroquois Falls, Ont., Can. Abitibi Power & Paper Co., Ltd.
 CFCI, Walkerville, Ont., Can. Motor Products Corp.
 CFCN, Calgary, Alta., Can. W. W. Grant Radio, Ltd.
 CFCX, London, Ont., Can. The London Advertiser.
 CFFC, Fort Frances, Ont., Can. International Radio Develop. Co.
 CFTD, Toronto, Ont., Can. The Bell Telephone Co.
 CFYO, Vancouver, B. C., Can. Victor Wentworth Odium.
 CFZC, Montreal, Que., Can. Can. Westinghouse Co., Ltd.
 CHBC, Calgary, Canada, W. W. Grant Radio, Ltd. (Morning Albertan.)
 CHCA, Vancouver, B. C., Can. Radio Corp. of Vancouver, Ltd.
 CHCB, Toronto, Can. Marconi Co.
 CHCC, Edmonton, Alta., Can. Can. Westinghouse Co., Ltd.
 CHCF, Winnipeg, Man., Can. Radio Corp. of Winnipeg, Ltd.
 CHCQ, Calgary, Alta., Can. Western Radio Co., Ltd.
 CHCS, London, Ont., Can. London Radio Shoppe.
 CHCX, Montreal, Que., Can. B. L. Silver.
 CHCZ, Toronto, Ont., Can. Globe Printing Co.
 CHCC, Vancouver, B. C., Can. Can. Westinghouse Co., Ltd.
 CHVC, Toronto, Canada, Metropolitan Motors Co.
 CHXC, Ottawa, Ont., Can. J. R. Booth, Jr.
 CHYC, Montreal, Que., Can. Northern Elec. Co.

CJBC, Montreal, Que., Can. Dupuis-Freres.
 CJCA, Edmonton, Alta., Can. Edmonton Journal, Ltd.
 CJCB, Nelson, B. C., Can. James Gordon Bennett.
 CJCD, Toronto, Can., T. Eaton, Co.
 CJCE, Vancouver, B. C., Can. Vancouver Sun.
 CJCF, Kitchener, Ont., Can. News Record, Limited.
 CJG, Winnipeg, Canada, Manitoba Free Press.
 CJCH, Toronto, Ont., Can. United Farmers of Ontario.
 CJCI, St. John, N. B., Can. McLean, Holt & Co., Ltd.
 CJCN, Toronto, Ont., Can. Simons, Agnew & Co.
 CJCS, Halifax, N. S., Can. Eastern Telephone & Telegraph Co.
 CJCV, Calgary, Alta., Can. Edmund Taylor.
 CJGC, London, Ont., Can. London Free Press.
 CJNC, Winnipeg, Man., Can. Tribune Newspaper Co.
 CJSC, Toronto, Ont., Can. Evening Telegram.
 CKAC, Montreal, Can. La Presse.
 CKCB, Winnipeg, Man., Can. T. Eaton Co., Ltd.
 CKCD, Vancouver, B. C., Can. Vancouver Daily Province.
 CKCE, Toronto, Ont., Can. Can. Ind. Telephone Co.
 CKCK, Regina, Sask., Can. Leader Pub. Co.
 CKCR, St. John, N. B., Can. Jones Elec. Radio Co., Ltd.
 CKCS, Montreal, Que., Can. The Bell Telephone Co.
 CKCZ, Toronto, Ont., Can. Westinghouse Co., Ltd.
 CKKC, Toronto, Ont., Can. Radio Equipment & Supply Co., Ltd.
 CKOC, Hamilton, Ont., Can. Wentworth Radio Supply Co., Ltd.
 CKQC, London, Ont., Can. Radio Supply Co.
 CKZC, Winnipeg, Man., Can. Salton Radio Eng. Co.

Radio in War

International rules for the control and operation of radio in time of war, as propounded by the Commission of Jurists at The Hague, were announced by the Department of State recently.

These regulations, in the preparation of which Captain Samuel W. Bryant, United States Navy, and Colonel George S. Gibbs, United States Army, assisted American Commissioners Moore and Washburn, provide substantially that in time of war the working of non-telligerent radio stations shall continue to be organized, as far as possible, in such manner as not to disturb the services of other radio stations. Belligerent and neutral powers may regulate or prohibit the operation of radio stations within their jurisdiction.

The erection or operation by a belligerent power of radio stations within neutral jurisdiction constitutes a violation of neutrality on his part as well as on the part of the neutral power.

A neutral power need not restrict or prohibit the use of radio stations located within its jurisdiction, except to prevent the transmission of information destined for a belligerent concerning military operations and except as further prescribed. All restrictive or prohibitive measures taken by a neutral power shall be applied impartially by it to the belligerents.

Belligerent mobile radio stations within a neutral state must abstain from all use of their radio apparatus. Neutral governments are bound to prevent such use.

The transmission by radio by a vessel or an aircraft, whether enemy or neutral, when on or over the high seas, of military intelligence for the immediate use of a belligerent is deemed a hostile act and will render the vessel or aircraft liable to be fired upon. A neutral vessel or neutral aircraft which transmits, when on or over the high seas, information destined for a belligerent concerning military operations shall be liable to capture. The Prize Court may condemn the vessel or aircraft, if it considers that the circumstances justify condemnation. Liability to capture of a neutral

vessel or aircraft on account of the acts referred to is not extinguished by the conclusion of the voyage or flight on which the vessel or aircraft was engaged at the time, but shall subsist for a period of one year after the act complained of.

In case a belligerent commanding officer considers that the success of the operation in which he is engaged may be prejudiced by the presence of vessels or aircraft equipped with radio installations in the immediate vicinity of his armed forces or by the use of such installations therein, he may order neutral vessels or neutral aircraft on or over the high seas; to alter their course to prevent their approaching the armed forces under his command; or to not make use of their radio transmitting apparatus while in the immediate vicinity of such forces.

A neutral vessel or aircraft, which does not conform to such direction, exposes itself to the risk of being fired upon. It will also be liable to capture, and may be condemned by the Prize Court.

Neutral mobile radio stations shall refrain from keeping any record of radio messages received from belligerent military radio stations, unless such messages are addressed to themselves. Violation of this rule will justify the removal by the belligerent of the records of such intercepted messages.

Belligerents are under obligations to comply with the provisions of international conventions in regard to distress signals and distress messages so far as their military operations permit. Nothing in these rules shall be understood to relieve a belligerent from such obligation or to prohibit the transmission of distress signals, distress messages and messages which are indispensable to the safety of navigation. The perversion of radio distress signals and distress messages prescribed by international conventions to other than their normal and legitimate purposes constitutes a violation of the laws of war and renders the perpetrator personally responsible under international law.

Acts not otherwise constituting espionage are not by reason of their involving

violation of these rules. Radio operators incur no personal responsibility from the mere fact of carrying out the orders which they receive in the performance of their duties as operators.

How to Ship

At a general meeting of the Electrical Jobbers' Association, held at Hot Springs, the following recommendations were presented by the Radio Committee, and unanimously adopted by the Association:

That manufacturers of radio materials supply their distributors with standard size, 8 1-2 by 10 inch price and data sheets.

That defective tubes and radio materials returned to manufacturers, where such returns are permitted, be credited rather than replaced in the interest of economy by the elimination of handling small shipments, as in most cases the distributor has already made replacement or adjustment with the dealer.

That manufacturers pack and ship receiving sets in individual cartons or crates of sufficient strength to permit reshipment in original package.

That all manufacturers of receiving sets of value of \$25 or more, supply these sets with a serial number to facilitate the tracing of lost or stolen sets, and that the serial number and catalog number appear on the outside of the container where it will show to the best advantage in stocking on distributors' and dealers' shelves, and further recommends that manufacturer, distributor and dealer use serial numbers on their invoices.

That all portions of inside of instruments depending on the strength of the panel for support be reinforced by extra individual support of such unit so mounted to prevent breakage by rough handling.

That the present practice of allotting radio materials on which the demand exceeds the supply be changed to conform to the practice of manufacturers of other lines handled by distributors, thereby rewarding the distributors who create business and placing supplies where the demand is most urgent and with a view to discouraging speculation.

RADIO AGE INSTITUTE

To insure 100% value to readers of advertisements, as well as 100% value to the advertisers themselves, radio equipment is now being tested and endorsed by the

RADIO AGE INSTITUTE
500 NORTH DEARBORN STREET
CHICAGO, ILLINOIS

No charge is made for testing and approval, and all merchandise will be returned as soon as possible, transportation expenses to be paid by the manufacturer. Lists of makers of approved radio goods will be published from time to time.

SERVICE DEPARTMENT FOR READERS

Please remember that Radio Age has one of the best radio instructors in the United States, who is ready to answer any technical question. This costs subscribers nothing.



A Gold Mine!

Over three hundred pages of fully illustrated instructions on how to build and operate sets! Truly a treasure trove for the home radio experimenter!

Written by experts, diagrammed by experts, tested and proved by experts. And all so simple and clear that the beginner can understand.

Reinartz circuits, with instructions on how to make them and amplify them.

Long Distance crystal sets. How to hook 'em up. How to make the aerials do their darndest.

Kopprasch circuits, Armstrong circuits, readers' circuits on which they have made distance records.

How to make battery chargers. How to make transformers, coils, condensers, variocouplers, loading coils, dry-cell circuits, audio-frequency amplifiers, one-tube loop aerial sets, two-circuit crystal detectors.

Ten issues of RADIO AGE "The Magazine of the Hour," the experimenters' guide.

**In One Volume---Cloth Bound---Gold Lettered
with one year's subscription to Radio Age!**

All for \$4.00 Postpaid

Send money order or check now.

RADIO AGE, Inc.

500 North Dearborn Street
CHICAGO