

# Popular Radio

25¢

JUNE • 1927 •

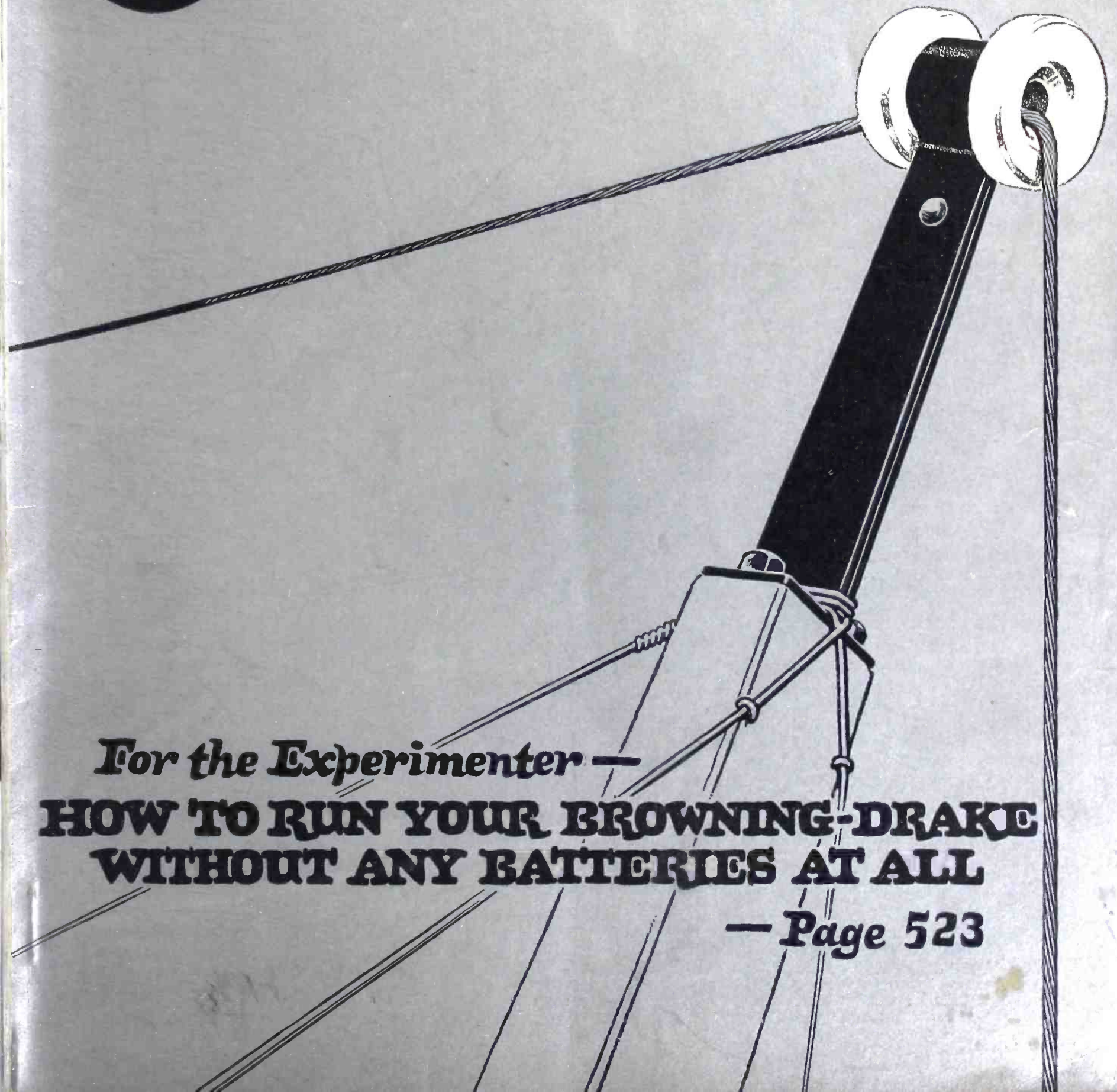

*For the Experimenter —*  
**HOW TO RUN YOUR BROWNING-DRAKE  
WITHOUT ANY BATTERIES AT ALL**

— Page 523



## Do you watch the “danger spots”

What are the critical points in a set, that everything else depends on? The tubes, of course.

There is no set cheap enough to warrant careless tube buying. Genuine Radiotrons get something more out of even the poorest set.

And there is no set so expensive that tube quality doesn't matter. For, nothing short of genuine RCA Radiotrons can get the great music and remarkable performance that a really fine set is capable of. They're the very heart of the whole performance!

*Bring your storage battery set up-to-date with  
a power RADIOTRON UX-171 or UX-112  
a detector RADIOTRON UX-200-A  
and RADIOTRONS UX-201-A for all-round quality*  
*Bring your dry battery set up-to-date with  
a power RADIOTRON UX-120  
and RADIOTRONS UX-199 for all-round quality.*

### A WATCHMAN ON THE INSIDE

THE SILVER COLOR inside a genuine Radiotron UX-199 and UX-201-A is a chemically active substance always on the lookout.

How it gets there is an important story. It is caused by the sudden evaporation of a bit of chemical inside the tube, to make the most nearly perfect commercial vacuum still more complete! But, after three methods of exhaust are applied to your Radiotron, there may still float about in it a few atoms of air or gas. They may be invisible to the finest microscope, but they get in the way of perfect reception. The silver color in the tubes, however, is an active film that attracts and holds these air atoms—keeps them away from the vital parts of the tube—makes it work better—last longer.

When you are buying a tube of the silvery type, and want to make sure of the efficiency of that inside watchman, just be sure to get a genuine RCA Radiotron. The mark is on the bottom.



RADIO CORPORATION  
OF AMERICA

New York Chicago  
San Francisco



# RCA Radiotron

MADE BY THE MAKERS OF THE RADIOLA

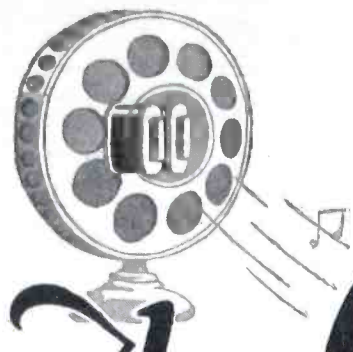

# The Coils the thing!

## that makes Radio

### From Microphone to Loud Speaker

No radio unit is any better than its coil for the coil is the vital part of all radio apparatus.

Coils in the microphone and all the way down the line to the loud speaker determine the volume, the selectivity, the distance, and, most important of all, the tone qualities. Coils cannot be too well made—the wire in them cannot be too good—the insulation cannot be too perfect.

The best radio apparatus in the world, made by the most successful radio manufacturers, is equipped with Dudlo layer wound coils. These manufacturers know from experience that it is *unprofitable* to attempt to wind their own coils and *unwise* to experiment on doubtful sources of supply for parts so highly specialized and so important as their coils.

By standardizing on Dudlo wire and coils, you can avoid all worry as far as these units are concerned.



*Dudlo coils are wound to manufacturers' specifications. The Dudlo Engineering Laboratories are at the service of any radio manufacturer to assist in designing the proper coil for certain purposes—samples submitted without obligation.*

# DUDLO

**DUDLO MANUFACTURING CORPORATION, FORT WAYNE, INDIANA**

56 EARL STREET  
NEWARK, N. J.

160 NORTH LA SALLE STREET  
CHICAGO, ILL.

4153 BINGHAM AVE.  
ST. LOUIS, MO.

274 BRANNAN ST.  
SAN FRANCISCO, CALIFORNIA

# Popular Radio

EDITED by KENDALL BANNING



FOUNDED 1911

VOLUME XI

June, 1927

NUMBER 6

## CONTENTS

(Cover design by Frank B. Masters)

Winged Faces Joined to Winged Words  
FRONTISPIECE.....PAGE 518

What Shall We Do with Television?  
Television is an accomplished fact—but how will man use it? This article makes many interesting forecasts as to the possible uses that may be made of this latest child of radio science  
By *Thomas Elway*.....PAGE 519

How to Build a Power-Pack  
for Browning-Drake Receivers  
Complete details for operating the Browning-Drake receiver without the use of any batteries at all, as told by the inventors themselves—  
*Glenn H. Browning and  
Dr. Frederick H. Drake*....PAGE 523

The "Secrets" of the Hypnotist by Radio  
An explanation of the "mysteries" involved when the radio hypnotist casts his spell through the ether  
By *E. E. Free, Ph.D.*.....PAGE 528

"Squeals"—What They Are and  
How to Stop Them  
By *E. G. Fracker*.....PAGE 530

"This Is Station WAIL Calling"  
By *Mabel Wheeler*.....PAGE 533

Popular Radio Circuits  
INSTALLMENT NO. 10:  
The Lincoln Superheterodyne Receiver  
The Aero-Dyne Receiver  
*The Technical Staff*.....PAGE 534

The New and Remarkable  
"40th Fly-Power Relay"

A relay device resembling a radio vacuum valve that will operate on one-billionth of a watt  
By *E. E. Free, Ph.D.*.....PAGE 536

The Biggest Radio Vacuum Valve  
in the World  
By *W. T. Meenam*.....PAGE 538

How to Get Quality Amplification  
NUMBER 3: How to build a low-frequency amplifier that uses impedance and transformer coupling  
*The Technical Staff*.....PAGE 541

Just a Dash-Board of Reception  
At last a radio installation for an automobile that is practical and is an integral part of the car  
By *Laurence M. Cockaday*....PAGE 543

How to Assemble the RGS Receiver  
Complete constructional details for assembling a receiver that has remarkable qualities of selectivity and amplification over the whole waveband  
By *Joseph Calcaterra*.....PAGE 546

Your Laboratory Tools  
ARTICLE NO. 3: The uses and the operation of the small wood-turning lathe  
By *Lowell Madden, Jr.*.....PAGE 549

The First Scientific Evidence of the  
Existence of the "Radio Ceiling"  
By *Uthai Vincent Wilcox*....PAGE 552

What's New in Radio  
*The Technical Staff*.....PAGE 554

## DEPARTMENTS

In the World's Laboratories.....*E. E. Free*..... 560  
Star Program Features of the Month..... 564  
With the Experimenters.....*Richard Lord*.. 582  
Broadcasts..... 594

VOLUME XI

JUNE, 1927

NUMBER 6

Published monthly by Popular Radio, Inc., 627 West 43rd St., New York, N. Y.; telephone number, Chickering 1906; Douglas H. Cooke, President and Treasurer; Kendall Banning, Vice-President; Laurence M. Cockaday, Secretary; Emma A. Harm, Asst. Treasurer. Price, 25 cents a copy; subscription, \$3.00 a year in the U. S., Canada and all countries within the domestic postal zone; elsewhere, \$3.50 a year, payable in advance. The International News Company, Ltd., No. 5 Bream's Bldg., London, E. C. 4, sole distributors in England. Entered as second-class matter April 7, 1922, at the Post Office at New York, N. Y., under the act of March 3, 1879. Additional entry at Jamaica, L. I., N. Y. Copyright 1927, and title registered as a trade-mark by Popular Radio, Inc. Copyright in Great Britain by Popular Radio, Inc., 6 Henrietta St., Covent Garden, W. C., London, England. For advertising rates, address Popular Radio, Inc., 627 West 43rd St., New York; or 225 North Michigan Ave., Chicago. Printed in U. S. A.

JOHN V. L. HOGAN, Contributing Editor

LAURENCE M. COCKADAY, Technical Editor

E. E. FREE, Ph.D., Contributing Editor

# Raytheon Leads



Raytheon BA  
350 m. a.  
(Half size)

Raytheon's leadership in the rectifier field is demonstrated again by the announcement of these sensational new rectifiers, worthy to take their places alongside Raytheon Types B and BH.



Raytheon A  
2 1/2 amps.  
(Actual size)

## Light Socket A-B-C Power With One Rectifier

By this amazing rectifier, Raytheon BA-350 m. a., the final great step in the development of radio power is accomplished. Compact, built-in A-B-C power, without accessories, becomes a fact.

Soon a specially selected group of leading radio manufacturers will announce their newest receivers, using Raytheon BA-350 m. a. Standard 201-A tubes are used, and all batteries, chargers, accessories, and outside power equipment are eliminated.

Raytheon BA-350 m. a., the crowning accomplishment of the Raytheon Research Laboratories, has at last given the radio world a practical, proven solution to the problem of simple light socket receiver operation.

## A Revolutionary Scientific Achievement

In High Current, Low Voltage Rectification Raytheon A-2 1/2 amps. is revolutionary in principle, in construction, in performance. It is an unbreakable metal cartridge, compact and simple, without liquids or filaments.

Above all, it is The Efficient Rectifier. Its operating cost over the period of a year, compared with that of other types of rectifiers designed for similar uses, will show a cash saving of many dollars.

Raytheon A-2 1/2 amps. was invented by Monsieur André of La Radiotechnique in Paris, and developed by the Raytheon Research Laboratories with his cooperation.

Battery chargers and A power units using this remarkable rectifier will bear the same seal of approval that distinguishes all Raytheon-equipped power devices.

## RAYTHEON MANUFACTURING COMPANY

Cambridge, Massachusetts



Only manufacturers whose units have been tested and approved by Raytheon may use this seal on their products.

### New Prices

Type B . . .	\$4.50
Type BH . . .	6.00
Type BA . . .	7.50
Type A . . .	4.50

# Raytheon

The Heart of Reliable Radio Power

# A PAGE WITH THE EDITOR

THE next issue of POPULAR RADIO (for July) will contain announcements of very special interest and value to radio experimenters and broadcast listeners alike—announcements of new radio receivers and of new radio accessories that will be available during the coming season.

\* \*

THE July issue will be, in effect, a special "What's New in Radio" number, prepared for the information and guidance of the readers of POPULAR RADIO.

\* \*

FOR many weeks the Technical Staff of POPULAR RADIO has been in touch with inventors and manufacturers, collecting information about their new and improved apparatus, and testing the advance models in the POPULAR RADIO LABORATORY.

\* \*

THE data obtained in this comprehensive survey has not only revealed many of the surprises that are in store for the fan, but augurs a radio season that will exceed all that have gone before.

\* \*

No previous year has shown such a varied advance in the radio art, nor offered as much of real value to the experimenter or listener, in the form of receiving sets, of loudspeakers, and of parts, as will the season that formally begins the middle of June with the opening of the Radio Manufacturers' Association's exhibit in Chicago on June 13th.

\* \*

AND the apparatus of outstanding merit will be pictured and described in the forthcoming July issue of POPULAR RADIO—which no real fan can afford to miss.

\* \*

FIVE years ago, when radio broadcasting burst upon an amazed and delighted public and everyone hastened to buy and assemble radio apparatus, the talking machine industry all but turned up its toes and died.

\* \*

FOR the public spent its money on its new toy—and for the moment laid its old toy aside.

\* \*

BUT the talking machine industry slowly began to awaken to the fact that the radio art, and the electrical engineers and experimenters who were developing it, were placing at the disposal of the talking machine industry new apparatus and new scientific principles of sound reproduction that could be put to its own practical use.

With this discovery the resuscitation of the talking machine industry began.

\* \*

By the aid of the microphone, electrically recorded talking-machine discs made their appearance—an enormous improvement over the old mechanically recorded discs.

\* \*

THE new line of 1927 models of talking machines, based upon new principles of sound reproduction developed by the radio experts, has classified the old-fashioned talking machine with the one-horse shay.

\* \*

THE use of low-frequency amplification systems—another contribution by the radio experts—has made possible a quality of tone and volume of sound that has given the talking machine an importance that was never before attainable by the old method.

\* \*

AND now the hour is approaching when the talking machine and radio will be literally as well as figuratively united—through the medium of a newly developed little device known as an "electrical pick-up" that may be attached to the ordinary talking machine (in place of the usual mechanical "recorder") and which is connected by a wire directly to the radio receiver itself, or better still, to an independent amplifier.

\* \*

BY means of this remarkable little instrument (that will eventually be on the market at a price within the reach of all) a quality and volume of reproduction is possible that is exactly the same as that of the \$1,000 talking-machine equipped with low-frequency amplifiers—an instrument that is capable of filling a large auditorium with sound!

\* \*

This "electrical pick-up" device (and there are several variations of it that are now awaiting attention in the Patent Office) opens up a new era in the musical arts. And it will be described in the coming (July) issue of POPULAR RADIO.

\* \*

THE advent of this instrument will place at the disposal of radio and talking-machine fans generally a quality of music reproduction that has heretofore been reserved for the exclusive few. And it opens up new markets to the manufacturers of radio apparatus and talking-machine records as well.

\* \*

ONE of the interesting and significant results of a recent survey made by The National Broadcasting Company revealed that whereas three years ago 75 per cent

of the radio fans expressed a desire for jazz, only 5 per cent express that desire now.

\* \*

THAT the demand for jazz is decreasing is an opinion that is apparently based upon substantial evidence—by questionnaires from listeners as well as data furnished by music publishers and others. Many, if not most people, believe that this gradual change augurs well for the radio fan, the radio industry, and for the musical art.

\* \*

OUT in Grand Rapids, however, there is an incorrigible fan who just plumb won't stand for this conclusion, and who has discontinued his subscription to POPULAR RADIO because it has published what he designates as "editorial criticism of broadcasting jazz music."

\* \*

STILL, once we knew a man who complained to the House Committee of his club that "the hot water was too hot!"

\* \*

MR. UTHAI VINCENT WILCOX, who contributes this article, "The First Scientific Evidence of the Existence of the Radio Ceiling," is a Washington, D. C., newspaper correspondent who contributes articles occasionally to the leading magazines. He is one of a group of four correspondents who are keeping in touch with the scientists and experimenters in the National Capital for the benefit of the readers of POPULAR RADIO.

\* \*

"SQUEALS"—What They Are and How to Stop Them," which appears on pages 530-532 of this issue, was contributed by Mr. Edward G. Fracker, one of the radio experts of the Bell Telephone Laboratories. Mr. Fracker is one of the old-timers in radio; he entered the Government service back in the old "spark" days, and later continued his research work with the Westinghouse Company in the development of radio receiving apparatus.

\* \*

JOSEPH CALCATERRA, who contributes the article on the RGS receiver, has been engaged in radio and its allied activities since his early youth. His journalistic work began as Information Editor—and later as Radio Editor—of *Popular Science Monthly*. For three years he contributed a series of daily radio articles to the United Feature Syndicate. He is widely known to radio fans and experimenters.

*Kendall Banning*  
Editor, POPULAR RADIO.

## For better reception — Copper Shielding

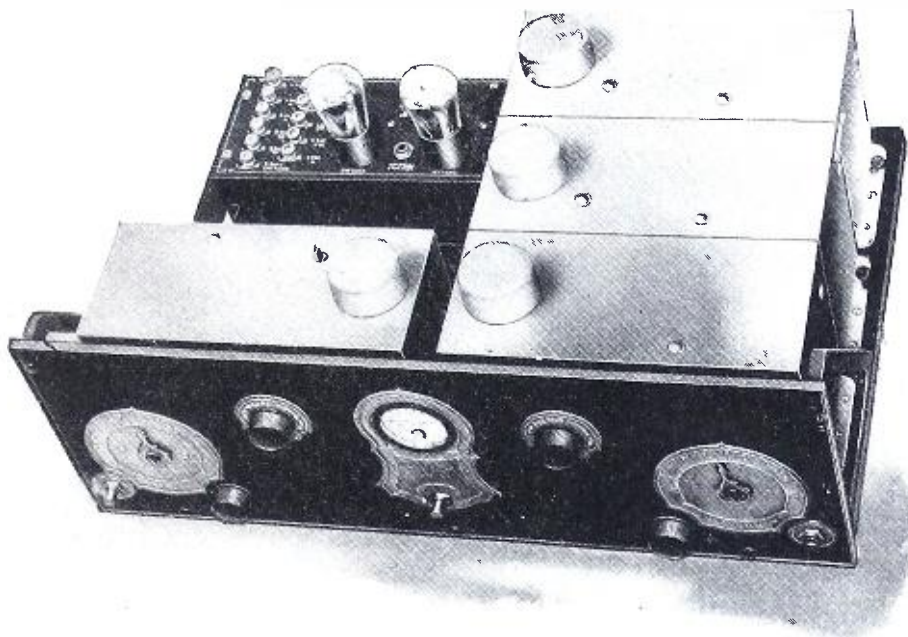

This Stromberg-Carlson six-tube Neutrodyne set, No. 601, is completely shielded with sheet Copper

Write for our new book on  
Copper Shielding. There is  
no cost or obligation.

Copper shielding gives  
closer selectivity and  
finer tone quality.

Sheet Copper combines  
higher conductivity  
with easy working  
qualities.

**COPPER & BRASS**  
RESEARCH ASSOCIATION  
25 Broadway — New York

*Insist on hearing* **R.G.S.** *this receiver*

## The R. G. S. RECEIVER

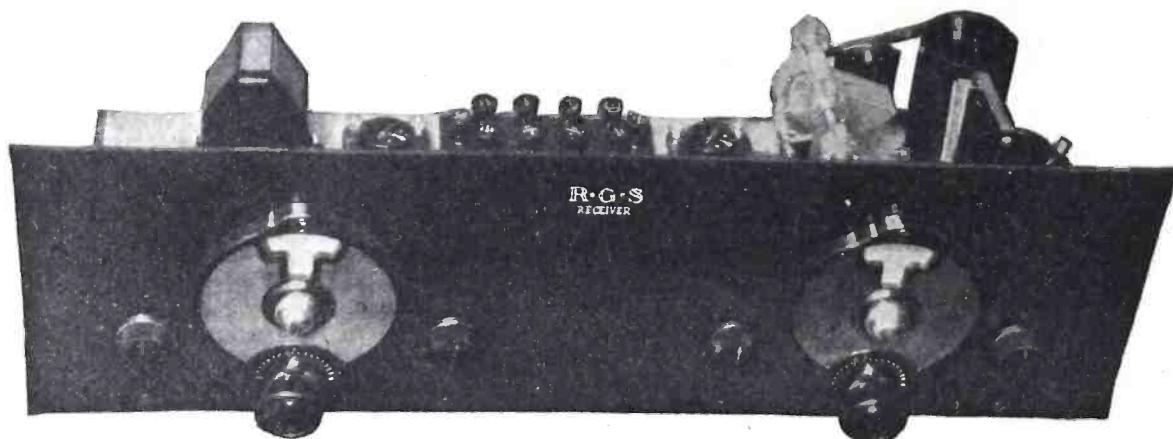

1. Four tubes, CX-371 in last stage.
2. Two dials—nearest possible approach to tuning efficiency.
3. Equal selectivity on the upper half as well as on the lower half of the dial without being at all critical at any point.
4. Selective enough to pierce barrage of "local" stations in most congested broadcast areas such as New York City, Chicago, San Francisco.
5. Sensitive enough to "bring-in" St. Louis, Denver, Miami Beach, Havana, Chicago and even San Francisco through New York City "locals".
6. Straight line radio frequency amplification.
7. Straight line volume control.
8. Tonal quality comparable to, if not superior to, any \$300.00 set.
9. Enough volume to blast a Western Electric Cone.
10. With Cunningham Power Tube in the last stage, draws but 19 1/2 milliamperes.
11. Antennae control.
12. Scientifically selected and closely co-ordinated apparatus. (National Co., Samson Electric Co., DeJur Products, A. H. Lynch, Inc., Sangamo Electric Co., Central Radio Laboratories, Inc., Grimes Radio Engineering Co., Inc., Acme Wire Co., Westinghouse Mi-Carta, H. H. Eby Co., etc.)
13. R. G. S. Receiver adaptable to any good standard cabinet. (List of names on request.)
14. Following accessories for best results: Cunningham Radio Tubes, Eveready Batteries, Western Electric Cone.
15. Sold two ways: (1) Complete kit of parts, \$69.70; (2) Completely assembled by latest laboratory methods, (without cabinet or accessories), \$79.70.

**\$79.70**

Assembled by Latest  
Laboratory Methods  
Without Accessories  
or Cabinet



**\$69.70**

Complete Kit of  
Parts  
Without Accessories  
or Cabinet

**R. G. S. SALES DIVISION**

Grimes Radio Engineering Co., Inc.

STATEN ISLAND . . . . . NEW YORK

DEALERS:—Write for Complete Merchandising Proposal.

**BUILT FOR MODERN**  **BROADCAST CONDITIONS**





Garo

### The Progressive Policy of POPULAR RADIO

*"I have always had a great regard for POPULAR RADIO. Its moderate yet progressive policy, and its carefully maintained quality, both commend it to me. It is doing a good job!"*

*Loeb C. Deutschmann*  
PRESIDENT, TOBE DEUTSCHMANN COMPANY.



Bell Telephone Laboratories

### Winged Faces Joined to Winged Words

*On April 7, 1927, the American Telephone and Telegraph Company demonstrated television, both by telephone and by radio. As Mr. Walter S. Gifford, President of the Company, talked by telephone with Secretary Herbert Hoover, in Washington, he saw within the hooded frame in front of him a moving image of Mr. Hoover, painted in the glow of a neon lamp. The transmitted electric signals represented small units of Mr. Hoover's countenance, illuminated successively by a rapidly-moving spot of light at Washington. Energized by these signals, the neon lamp at New York reproduced each spot of light and shade so rapidly that the result blended into a smoothly-moving picture. At Mr. Gifford's left is Mr. F. B. Jewett, Vice President of the American Telephone and Telegraph Company. At the left is Dr. Herbert E. Ives, head of the group of engineers who are responsible for the development.*

# Popular Radio



VOLUME XI

June, 1927

NUMBER 6

## WHAT SHALL WE DO WITH TELEVISION?

Some people think that science is moving too fast for mankind to keep up. Television is its latest marvel—foreshadowed by the experiments of Jenkins, Baird and others already described in POPULAR RADIO, now accomplished in still a different way. Will television be a useful aid to mankind or an annoyance or merely a scientific toy?

By THOMAS ELWAY

THE age of television is upon us. Even before the remarkable demonstration presented by Dr. Herbert E. Ives and his associates of the Bell Telephone Laboratories on April 7, 1927, the experiments of Jenkins, Baird, Alexander and others had already made it probable that science would soon offer methods for "seeing" by radio or over the wires.

The Ives process puts the seal of certainty on this probability.

It is true that there are some present limitations. For example, all processes of television so far proposed involve the necessity of breaking up the image to be transmitted into a large number of smaller units, for each of which a separate signal must then be sent over the television link. To obtain the requisite speed for these small image units, Dr. Ives uses a moving spot of brilliant light, which spot passes rapidly over the scene to be transmitted. Necessary as a concession to speed, this device carries the limitation that the object to be viewed must be moderately simple and must be fairly close to the transmitter.

In Dr. Ives' tests the face of Mr. Hoover and other faces were seen distinctly over the wire. A scene from a

play or the view out of a window could not have been transmitted. The moving light spot would not have reached, for example, the slopes of a distant mountain, to carry their image into the wire.

Mr. Baird's method of obtaining his unit images by a series of separate viewing tubes\* avoids this difficulty but falls into others due to the small amount of light provided for each unit and the consequent slower speed.

No present television process can be considered perfect, but that is no reason for pessimism. Improvements will come; perhaps totally new processes will be discovered. The age old dream of the writers of fiction to "see at a distance" or through walls or around obstacles will be granted to us very soon at the hands of the master magicians of modern science.

The question for those of us who are not members of this magical fraternity which serves us nowadays so usefully is this: What are we to do with television now that we are to have it?

When the telephone was first invented many men of ability, including scientists as well as the individuals of more "practical" outlook, inspected it with

interest but regarded it as nothing but a scientific toy. That it could have practical utility was, to their minds, a piece of the wildest optimism on the part of Professor Bell. Everyone knows now how utterly wrong these pessimists were. It is doubtful whether any scientific invention of the past century has revolutionized business and living as completely as has the little electromagnetic vibrator with which Professor Bell and Mr. Watson conducted their historic conversation a half century ago.

Is television destined to be equally revolutionary? Or is it to be merely another scientific toy which university laboratories can play with and which the occasional wealthy amateur of science can use to entertain his after-dinner guests?

Admitting that to give a final answer to these questions would be the business of a seventh son and not of a mere observer of scientific progress, it may be interesting, none the less, for the mere observer to try to foresee some of the things which a successful process of television may permit us to do; some of the revolutions, great or small, with which we are apt to be confronted now that the inventors have presented the

\* See Mr. Baird's own description in POPULAR RADIO for November, 1926, pages 649-650.

world with a successful distance-seeing device.

It is possible to think of uses of television which would not be universally popular. In families where argument exists about Papa's taste in neckties a television apparatus at the haberdasher's, over which Mama could inspect Papa's prospective purchase before it was an accomplished fact, might be welcomed by one side of the family less enthusiastically than by the other side. It is to be suspected, also, that the installation in club rooms of television apparatus connectable to the members' firesides will be forbidden under suitable penalties in many sets of by-laws and house rules. A complaint often made, nowadays, by critics of modern civilization is that privacy has vanished. The famous Tyrant of Syracuse who installed a listening tube within his prison to hear what his victims said of him has been

excelled by modern dictaphones and telephones. Television would give us the possibility of secret eyes as well as secret ears. Detectives would like this; criminals would not. As for the great mass of us who are not ordinarily of either persuasion, opinions would vary, doubtless, with the circumstances.

The possibility of television where it is not wanted need not concern us, however, as much as its possibility where it is wanted. We must remember, too, that there are two essentially different varieties of television, just as there are two varieties of telephonic communication.

One of these varieties is analogous to radio broadcasting. At some central station there will be prepared and broadcast the signals corresponding to visible things. Any persons desiring to see them will merely install the proper varieties of receiving apparatus and sit

down and look. It is this procedure which has been begun in London by the well-known television experimenter, Mr. J. L. Baird.

The other variety of television is that demonstrated by Dr. Ives and the American Bell telephone system. It may be called the "link" system and is analogous to the present telephone system.

If you wish to talk to a friend halfway across the continent, the telephone company establishes for you a line or lines of wire connected, through many switchboards and exchanges, from your telephone to the instrument of your distant correspondent. It now becomes possible, although not quite so convenient, to establish a visual linkage of this variety between any two stations equipped with the proper apparatus. It is obviously possible to arrange this same linkage through radio channels.

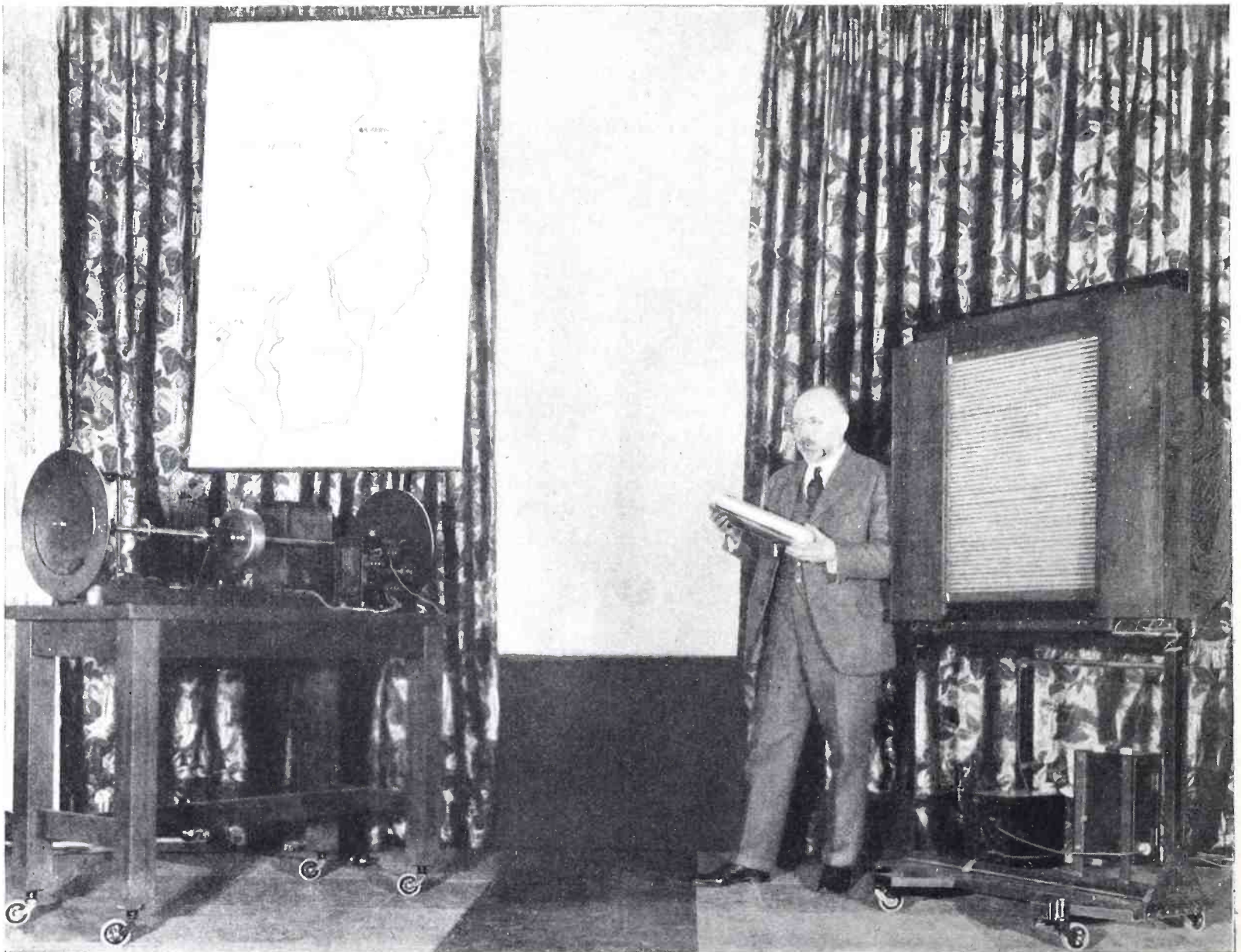

Bell Telephone Laboratories

### The Radio "Eye" and One Form of Its Neon Lamps

*Dr. Herbert E. Ives, its inventor, is holding one of the large photoelectric cells which he uses to pick up light reflected from the sitter's face by the moving light-spot of the television transmitter. The electric signal thus produced is transmitted, amplified and used to illuminate the proper spot on the neon tubes in the frame at Dr. Ives' left. The successive glowing spots along these neon tubes reproduce the picture, as if on a screen. At Dr. Ives' right is the laboratory apparatus used in developing the system. Holes in the two spinning disks keep the light-spot of the transmitter and the eye of the viewer focussed on corresponding spots of the sitter's face and of the image.*

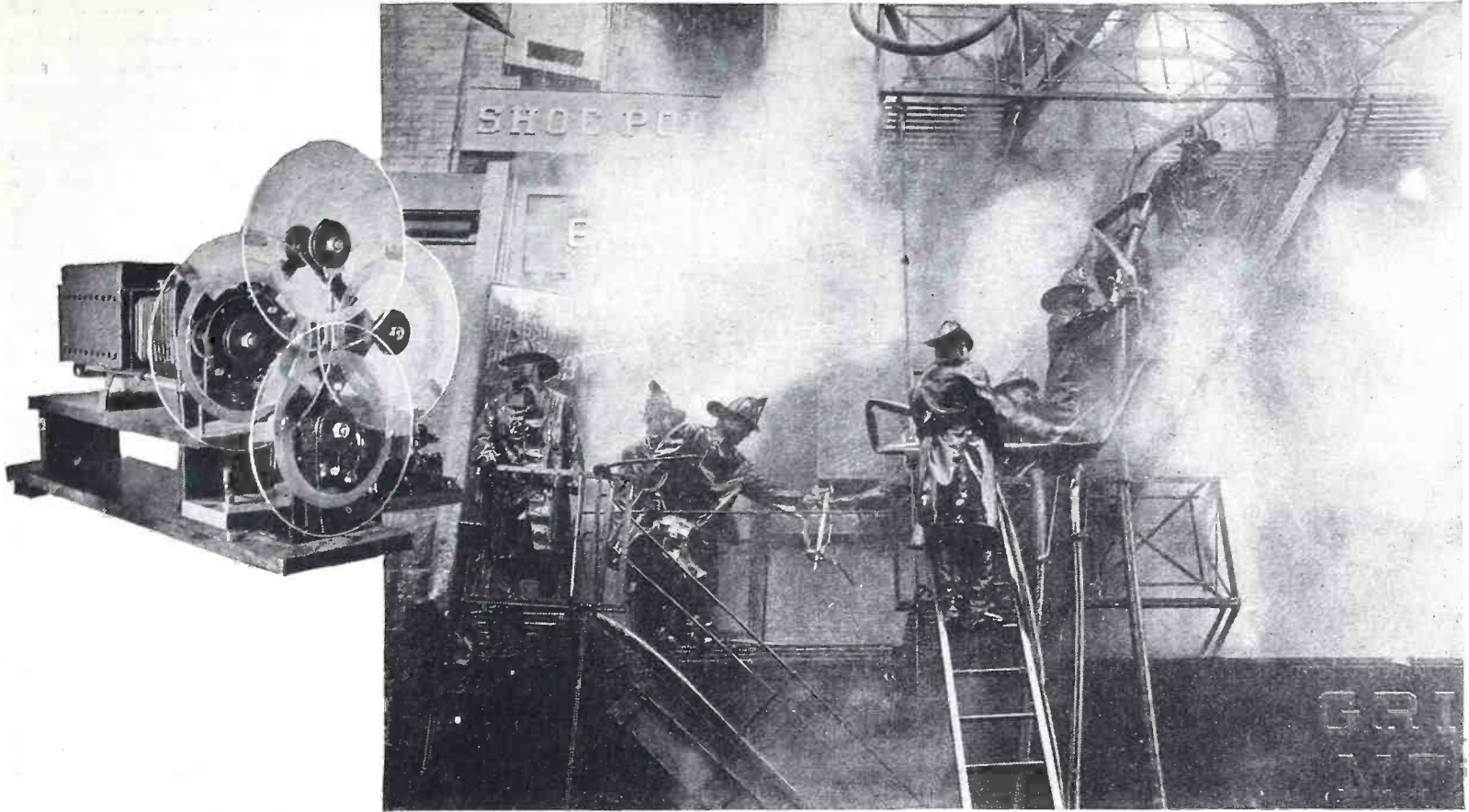

Brown Bros.

## News Events May Be Projected on the Walls of Our Homes

*Television transmitters, operated by experienced cameramen, may broadcast the world's doings direct from the scenes of action. Although no present process of television can yet "report" news events in pictures, it is not impossible that some day a machine may broadcast such spectacular events as this.*

Venturing once more to usurp the prerogatives of the prophetic seventh son, let me suggest that this establishment of television linkage is apt to be not only the first real success of television but the chief permanent utility of that accomplishment.

The police departments of our various cities now enjoy a periodic institution called the "line-up." At convenient intervals criminals or suspected criminals who have fallen foul of the dragnet are lined up for inspection by members of the detective force. In some cities a truly dramatic note is added by the fact that the sleuths are masked; the intention being, of course, to prevent the criminals acquiring such familiarity with the features of their enemies as might make trouble for some unfortunate crime-detector later on.

"Not being a bird," said Sir Boyle Roche, "I cannot be in two places at once." Detectives suffer from a similar handicap. If a sleuth from one city wishes to inspect the catch of criminals in another city there is but one thing for him to do; he must get on the train and go. Meanwhile he will miss the catches from his own fishing grounds. To overcome this handicap our crime-detecting experts have devised such expedients as formalized descriptions, finger-prints, Rogues' Gallery photographs, and the like. No doubt these are

useful, although it may be questioned whether any living criminal could possibly look as thuggish as do virtually all of the official photographs.

But how much better it would be if it were possible for the New York detective force to view each morning the line-ups in Chicago and Boston and Washington and Philadelphia, the distant cities enjoying, at the same time, an inspection of New York City's catch? Dr. Ives' machines now make this possible. If someone compelled me to select one particular use of television which was apt to be first in practical importance, I think that this is the one I would choose.

Next in importance will be, perhaps, the ability of experts to inspect objects or persons at a distance. It is already becoming customary for physicians to be consulted by telephone on behalf of distant patients. Some months ago the experts of the Bell Telephone Laboratories sent the heart-beat of a patient in Atlantic City over the wire to Chicago and got back again in a few minutes the Chicago expert's diagnosis of what was troubling the defective pump. As I write this article the newspapers carry an account of a patient in New Orleans consulting his physician in Paris by means of the transatlantic radio phone.

Now that it is possible to combine with this long-distance ear a similar exten-

sion for the eyes of the diagnostician, the handicap of distance on the medical specialist will virtually vanish. If some rich man in San Francisco feels that he will die without the aid of some specialist in New York it will no longer be necessary to hire a special train and to clear the track for the physician or for the patient. Some one of the admirable hospitals of the California city will be linked by television and by telephone to a similar examining room on the Atlantic. With the patient in one room, surrounded by physicians and nurses to do what the consultant may ask, and with the consultant listening and watching from three thousand miles away, such aid as the expert might be able to render will be supplied enormously more cheaply and (what is still more vital) enormously more quickly than could be done now even by every use of rapid railways and of still more rapid aircraft.

Again with the caution which should animate every amateur prophet, I am inclined to believe that this use of television in the art of healing will join its use in criminology as among the first and most important services of the inventions which are now assured.

Commercially, the use of television is apt to lag a bit behind its employment in matters of medicine or crime—matters which concern things so much more

important than money. But even in commerce there are possible utilizations which seem promising and which may be developed rapidly. Many buyers from other portions of the United States make journeys each year to New York City. Others travel to still more distant centers, as the fashion experts congregate each year in Paris. The possibility of these trips and of the amusements which they are considered to require constitute, I understand, the most sacredly-guarded perquisites of being a buyer. If television interferes, this will be one of the places where television engineers will get themselves disliked.

I fear, however, that this is inevitable. It is obviously far cheaper, far quicker and much more convenient to inspect a new line of crockery or furniture by a combination of telephone and television than it is to make a trip for that purpose. Admittedly, the inspection will not be quite so perfect; there will be less opportunity for negotiation and there may be other disadvantages. Not all commercial purchases will be made by television, even if the art becomes as cheap and convenient as the telephone. But undoubtedly there exists here a commercial possibility which the experts in television will not fail to cultivate. And if we can but arrange to broadcast by television some of the cabaret shows which buyers are said to find so necessary as stimulants to their imagination, perhaps all of us can stay home

more and do our own buying with equanimity.

Far more important than any of these commercial opportunities for television are some which are less likely to be undertaken in the beginning for the reason that they are important only to the scientists, who are always poor; these involve the possibility of sending the receiving eye of a television machine into places where the living human eye finds it inconvenient to venture.

Suppose, for example, that Dr. T. A. Jagger, the distinguished and adventurous scientist whose job it is to keep watch on the volcanoes of the Hawaiian Islands, decides that one of his temperamental fire-spouters is about to erupt. Not even Dr. Jagger, for all his proven courage and self-sacrifice, would be willing to remain within the crater while the eruption was happening. It would be useless to do so, for he could never return with the record of things seen.

But suppose that Dr. Jagger installed, in some convenient niche close to the point of danger, the transmitting eye of a television machine. Seated safely in his laboratory miles away, with his seismographs and other instruments conveniently at hand, the Doctor could watch each stage of progress of the eruption until it became so utterly violent that the apparatus was destroyed. At the sacrifice of one television transmitter, costing perhaps a few hundreds or even a few thousands of dollars, it

would be possible to obtain information concerning volcanic eruptions which, it is true, a human eye might see but which no human brain could survive to record and bring back.

There exist, also, places on earth which we cannot visit, not so much because they are dangerous as because they are inaccessible. Perhaps the most interesting of these is the bottom of the deep sea, five or six miles below the waves. Great vessels equipped with powerful dredging apparatus and manned by scientific experts have brought up from these abysmal depths a few samples of very curious creatures. Some of these depth-dwellers wear little lanterns, equipped with light like that of the fire-flies. Thus they find their way around and lure their food. On the sea bottom there walk some curious crab-like creatures equipped with long legs like stilts. Scientists imagine that these stilts are necessary because the sea bottom is covered with a thick layer of slime which is never disturbed. Ordinary short-legged creatures would sink into this mire and die.

It is improbable that a living man will ever be able to visit these great depths of the sea. The pressure of the water there reaches the enormous total of nearly twelve tons to the square inch. The living creatures who inhabit this strange realm of life are permeable to the water, so that the pressure goes right through them and is without effect. This

(Continued on page 579)

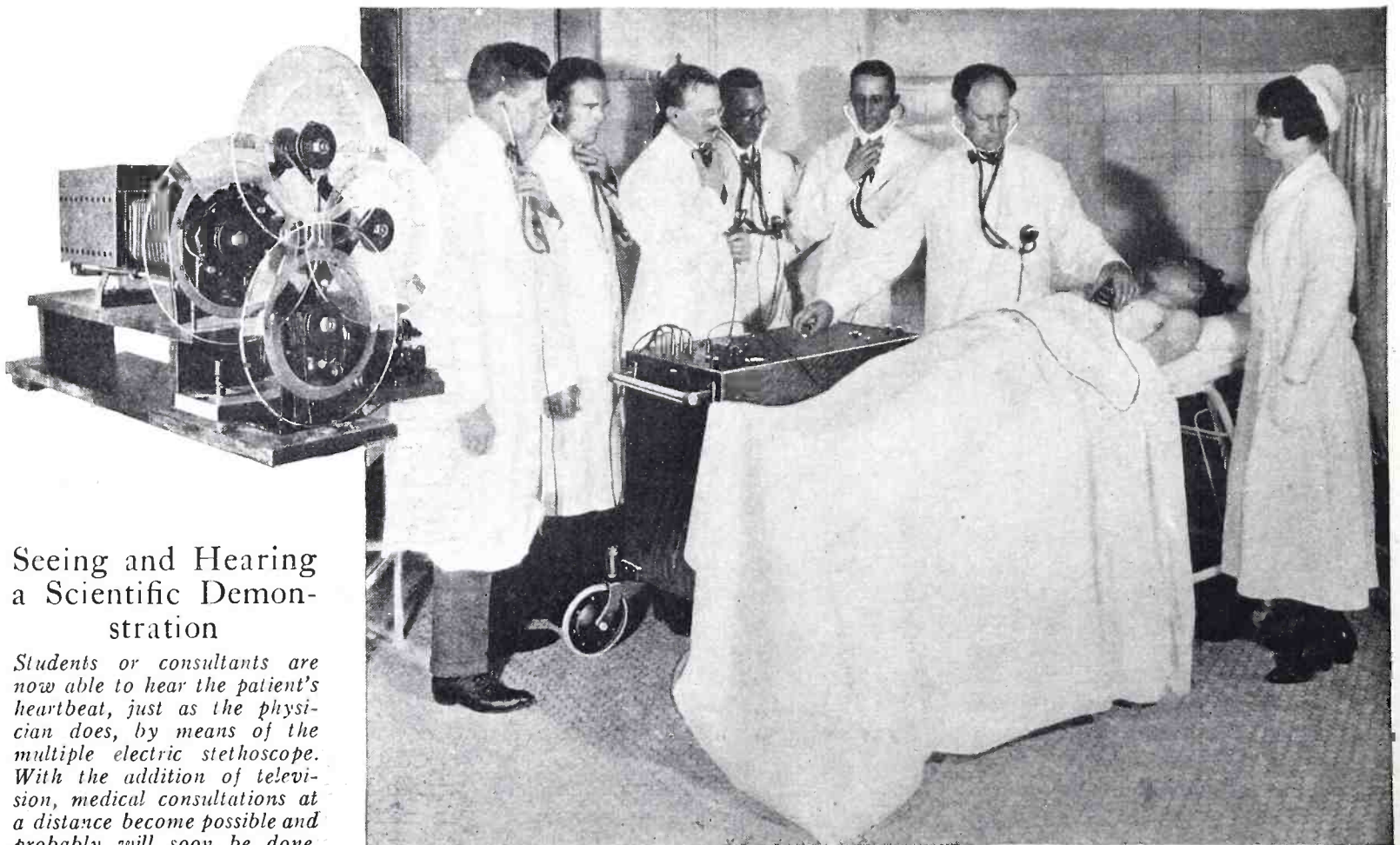

### Seeing and Hearing a Scientific Demonstration

*Students or consultants are now able to hear the patient's heartbeat, just as the physician does, by means of the multiple electric stethoscope. With the addition of television, medical consultations at a distance become possible and probably will soon be done.*

Brown Bros.

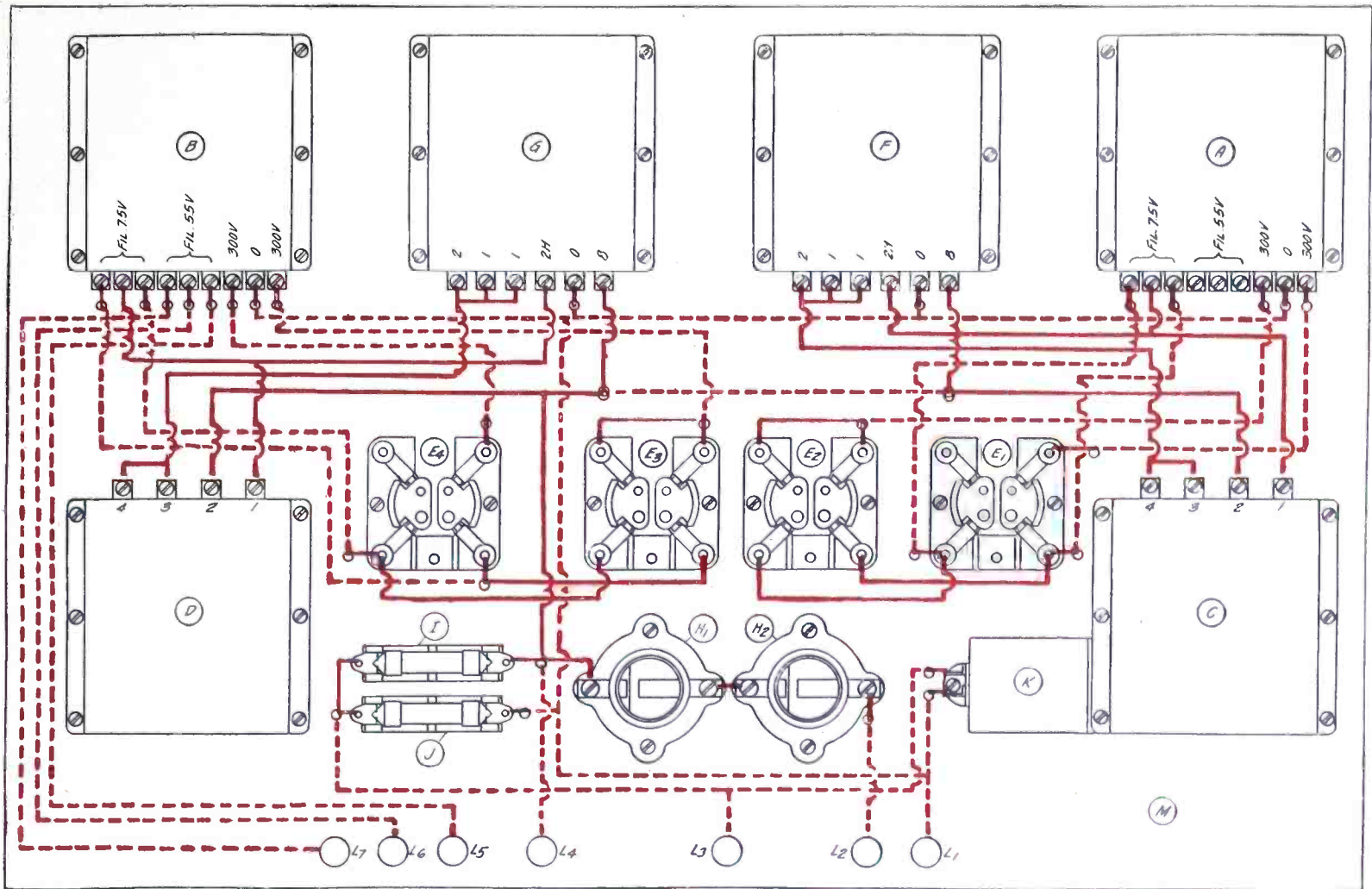

A PICTURE WIRING DIAGRAM OF THE "ABC" POWER-PACK  
 FIGURE 1: In this chart the instruments are outlined in BLACK; the solid RED lines indicate the wiring to be done above the baseboard and the dotted RED lines the wiring to be done under the baseboard.

HOW TO BUILD

# A Power-Pack for Browning-Drake Receivers

Here is a new way to operate your Browning-Drake set without *any batteries at all* by means of series filament wiring on standard valves. Four rectifier valves are employed to furnish a current of 250 milliamperes, so that the "A," "B" and "C" voltages in a five-tube set may be obtained directly from the 110-volt, 60 cycle AC current lighting lines.

By GLENN H. BROWNING and DR. FREDERICK H. DRAKE

COST OF PARTS—Not more than \$101.00

HERE ARE THE PARTS USED IN THE LABORATORY MODEL OF THE POWER-PACK—

- A and B—National power transformers;
- C and D—National filter choke coils, type 80;
- E1, E2, E3 and E4—Airgap UX-type sockets;
- F and G—Tobe high-voltage B block;
- H1 and H2—Benjamin porcelain cleat receptacles, No. 9401;

- I—Tobe high-current resistor, 7,500 ohms, equipped with any approved resistance mounting;
- J—Tobe high-current resistor, 5,000 ohms, equipped with any approved resistance mounting;
- K—Tobe paper condenser, 400 volts, 4 mfd.;

- L1, L2, L3, L4, L5, L6 and L7—Any approved binding posts (Eby posts illustrated);
- M—Wooden baseboard, 11 3/8 by 20 3/4 by 1/2 inch;
- N1 and N2—Wooden strips to support the baseboard, 3/4 by 3/4 by 11 1/8 inches.

AS every broadcast listener knows, there are now several methods of operating a radio receiver by merely plugging in on the electric lighting lines for the necessary power.

Some of these methods are eminently

satisfactory—and some are not so good.

There are a number of reasons for the failure of some of these methods.

The most successful and therefore the most common method of operating the receiver from the light socket involves

the use of a storage battery in combination with a suitable trickle charger for the "A" supply, while the "B" supply is obtained from a "B" power-pack. The only attention that the listener need give to this combination is to supply the stor-

age battery with distilled water occasionally.

Another form of alternating current "A" supply used with a "B" power-pack consists of a rectifier combined with a filter system to convert the alternating current to direct current. The initial cost of this apparatus is practically the same as that of a storage battery with a trickle charger. Generally, however, this method is not as satisfactory.

A third method of obtaining power from the light lines involves the use of UX-199 type valves that take a filament current of only .06 of an ampere (60 milliamperes). The filaments may be connected in series and the current from the output of the "B" power-pack may be passed through them. This method really does operate entirely from the light current without the use of batteries, but it has one serious draw-back: the plate current drawn by ordinary sets varies somewhat in its values. The plate current passes through the filaments of the UX-199 type valves and if it happens to increase much above 60 milliamperes, the vacuum valves become "flashed" or paralyzed in a short time. A milliammeter may, of course, be used and an adjustment made from time to time. In fact, a meter is an essential part in this type of a receiver if satisfactory operation is to be obtained for any length of time. This method is not to be altogether

condemned, even though it is not entirely satisfactory with the present 60 milliamper valve.

Another method suggested to the writers by Mr. Milton B. Sleeper incorporates the principle of filtering a rectified current of 250 milliamperes to supply the filaments of UX-201-a type valves.

This idea has been tried at various times, only to reveal that the apparatus necessary was ordinarily too bulky and expensive. Mr. Sleeper's solution to this problem, however, was to filter two currents of 125 milliamperes separately with two filter systems, to combine the output, and thus obtain the necessary current for operation with UX-201-a type valves. A number of manufacturers make power transformers and filter chokes which are built to pass 80 milliamperes and most of these will pass 125 milliamperes without serious overloading.

This method has drawbacks: one of them is the initial cost; on the other hand, it does away with the disadvantages due to line voltage variation, for a variation of 10 milliamperes means little when compared to the 250 milliamperes which are taken by the filaments of the tubes. It also allows the use of the more powerful UX-201-a type valves in the low-frequency amplifier as well as a sensitive

UX-200-a type valve for the detector. These tubes, with a UX-171 type valve for the last stage, make a desirable combination, no matter what type of power supply is used. As the UX-171 type tube takes 500 milliamperes, its filament should be heated from a step-down winding on the power transformer.

Taken all in all, the new "ABC" power-pack when used in conjunction with the standard Browning-Drake receiver will give excellent results and will always be ready for operation with practically no upkeep worries, adjustments or renewals.

*How to Construct the Power-pack*

First of all, prepare the baseboard, M, as shown in Figures 1 and 2. It should be cut to a size of 11-3/8 by 1/2-inch. Across the bottom of each end a 3/4-inch strip of wood should be fastened to raise the bottom of the baseboard off the table when in operation. These may be attached as shown in Figure 3.

Next, mount the power transformer, B, in the position indicated in Figure 1. Then mount the two condenser blocks, F and G, and the second power transformer, A. These are all mounted in a line and spaced evenly, as shown in Figures 1 and 2.

Next, mount the two filter chokes, C and D, at opposite ends of the board, as shown in Figure 1. The four sockets, E1, E2, E3 and E4, should then be

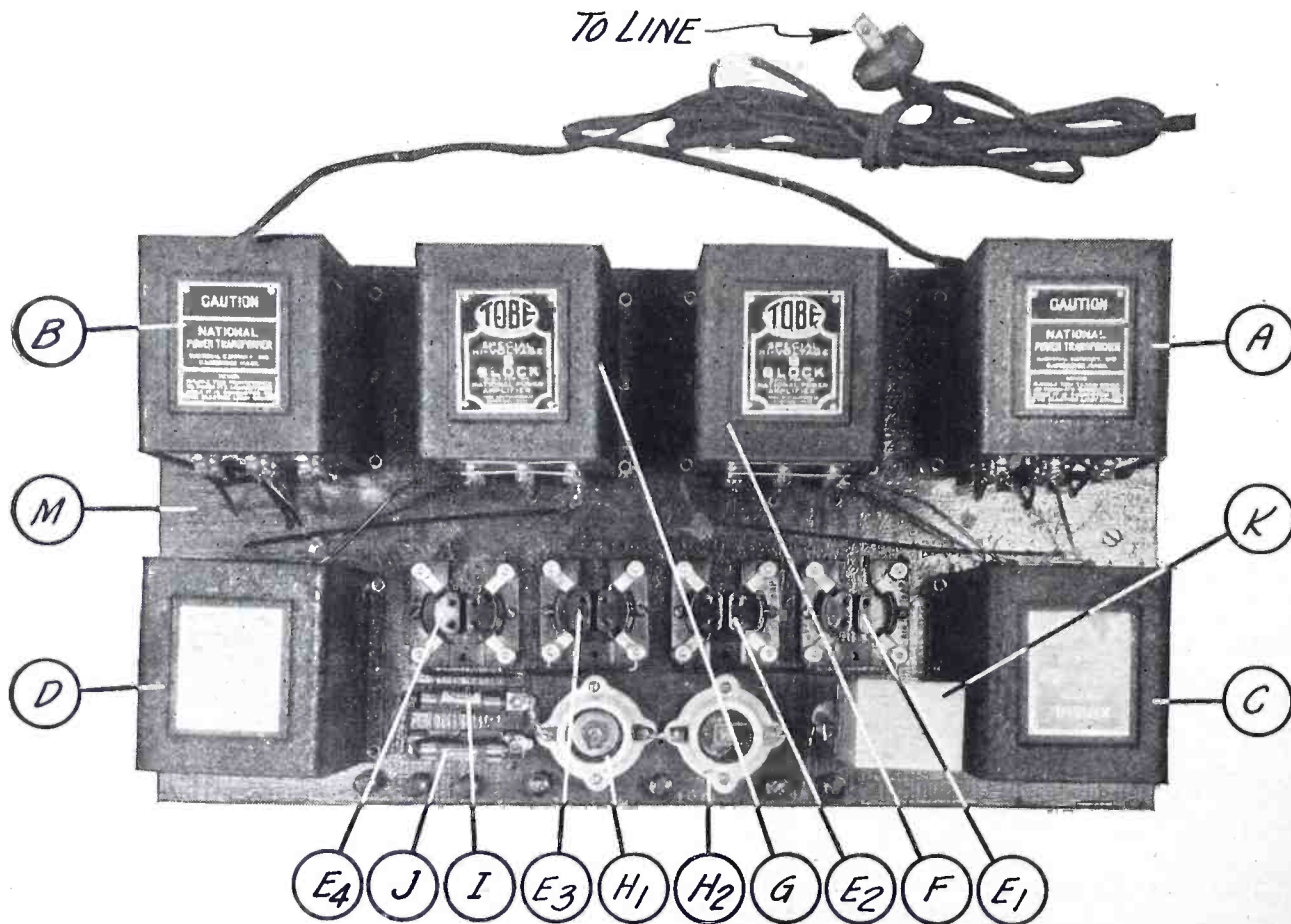

A VIEW OF THE "ABC" POWER-PACK FROM ABOVE

FIGURE 2: This view shows the neat layout of the instruments of the power-pack. The high-voltage blocks, A and B, are plainly marked. Other parts are designated with letters that correspond with the text and the list of parts at the beginning of the article.



mounted in a row in the space between the two filter chokes. The mountings for the two resistances, I and J, may next be attached to the baseboard. Then mount the two lamp receptacles, H1 and H2. The last instrument to be attached is the condenser, K, whose position is shown in Figure 1.

As there is no critical adjustment of the locations of the components of this apparatus, no measurements have been given in the drawings; as long as the parts are placed in approximately the positions indicated, operation will be found satisfactory.

*How to Wire the Unit*

In wiring the unit all that is necessary is to follow the picture wiring diagram in Figure 1. In this figure the colored lines represent the wiring and the black lines the outlines of the instruments. Where the colored lines are dotted they indicate connections beneath the base, M. The small circles outlined in black through which the colored line goes indicate the spots where a hole should be drilled in the base-board and the wires led through.

The experienced fan who is interested in the theoretical circuit may consult Figure 7 which gives the electrical circuit symbolically.

The diagrams are so simple that a further discussion is unnecessary. For wiring, use either solid insulated bus wire or a flexible wire, such as "Cel-site."

*How to Change over the Browning-Drake Receiver*

In order to rearrange the circuit of the receiver described in the April, 1927, issue of POPULAR RADIO for operation with the ABC power-pack, only a few minor changes need to be made, provided that the constructor has wired the receiver according to the directions given in the earlier article. Here are the changes to be made:

1. Connect the filaments of the first four vacuum valves, F1, F2, F3 and F4, shown in Figures 4 and 6, in series. Include in this series connection the lights for the dials.

2. Connect the 33-ohm resistance, T, and the 30-ohm rheostat, V, in parallel with the first vacuum valve, F1. A drop of solder should be attached to the 30-

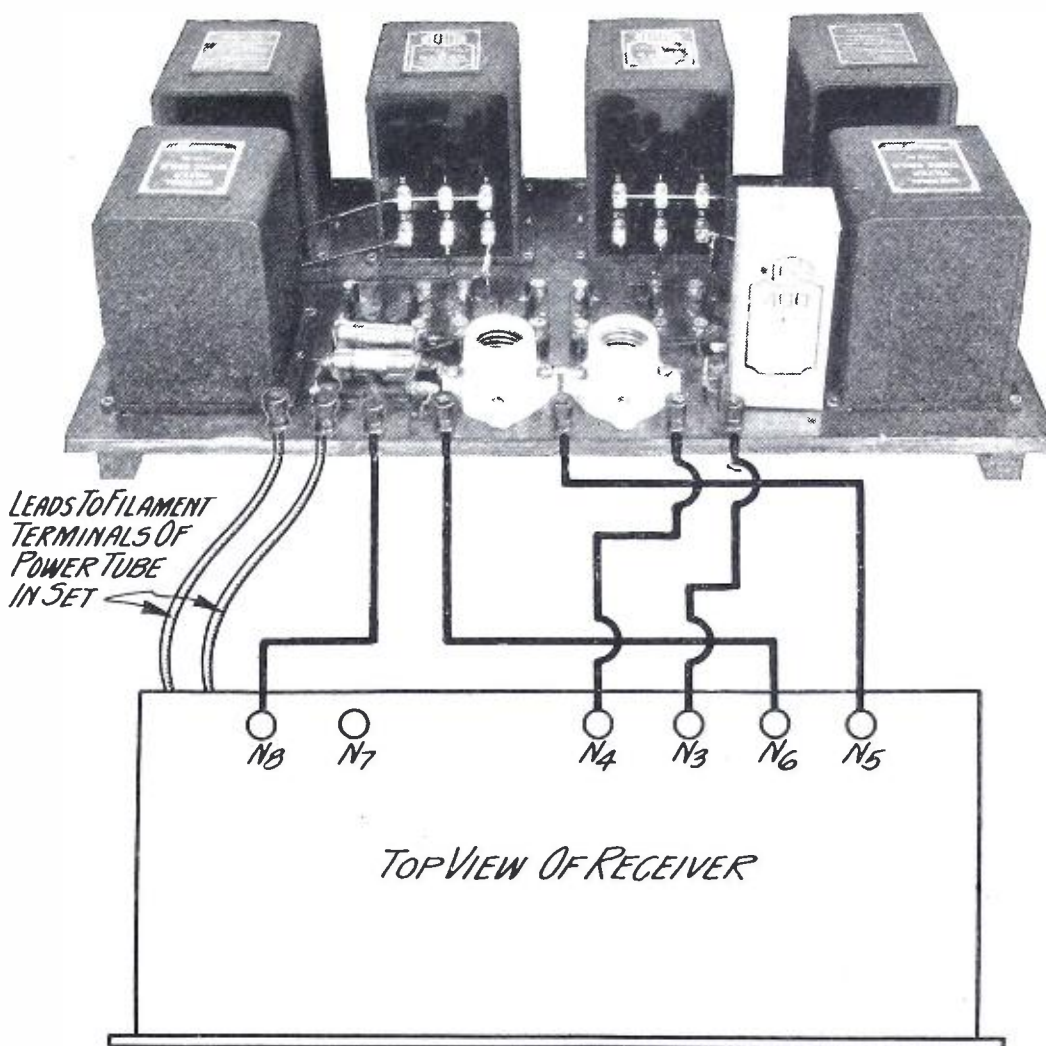

HOW TO HOOK UP THE TWO UNITS

FIGURE 3: This picture shows the connections between the receiver and the new power-pack. Four UX-216-b valves must be placed in the vacuum-valve sockets. Also place a 50-watt electric light bulb in the left-hand porcelain socket, shown in front part of the power-pack above, and a 25-watt electric light bulb in the right-hand porcelain socket.

ohm rheostat so that it can never be turned completely "off." This rheostat then acts solely as a volume control except that decreasing the resistance now will decrease the volume; with the other arrangement it increased the volume.

3. Remove the 1¼-ampere automatic filament control, U, from its mounting and in its place insert an Aerovox 2,000-ohm Lavite resistance. Rewire this unit as shown in Figures 4 and 6.

4. Disconnect the filament of the last vacuum valve, F5, and solder on two long leads that can go directly to the 5½-volt winding of one of the power transformers of the power-pack.

5. Eliminate condensers, K1 and K3, from the circuit.

All of these connections and changes

are clearly shown in Figures 4 and 6 and if the builder follows directions carefully he will find no trouble in wiring up.

The method of hooking up the new power-pack to the receiver is indicated very clearly in Figure 3.

These changes may be made in less than an hour by the average set-builder. The operation and tuning of the receiver follow exactly the same methods as before described, except that the receiver should be always turned "on" and "off" by means of a switch in the 110-volt, 60 cycle AC line; otherwise valves may be damaged by high-voltage surges.

The writer has found this method an interesting and practical solution of the problem of operating a receiver without the use of "A," "B" or "C" batteries.

The list of parts given on page 523 includes the exact instruments used in the unit from which these specifications were made up. The experienced amateur, however, will be able to pick out other reliable makes of instruments which have been approved by POPULAR RADIO which may be used with good results. But we recommend that the novice follow the list, as the diagrams in this article will tell him exactly where to bore the holes and exactly where to place the connections. If instruments other than the ones listed are used, the only change that will be necessary will be the use of different spacings for the holes that are drilled in the sub-base for mounting the instruments. To any reader who has difficulty in obtaining any of the parts which are necessary in making up these model receivers and power units, POPULAR RADIO SERVICE BUREAU, 627 West 43rd Street, New York City, will gladly assist in seeing that his requirements are promptly supplied.

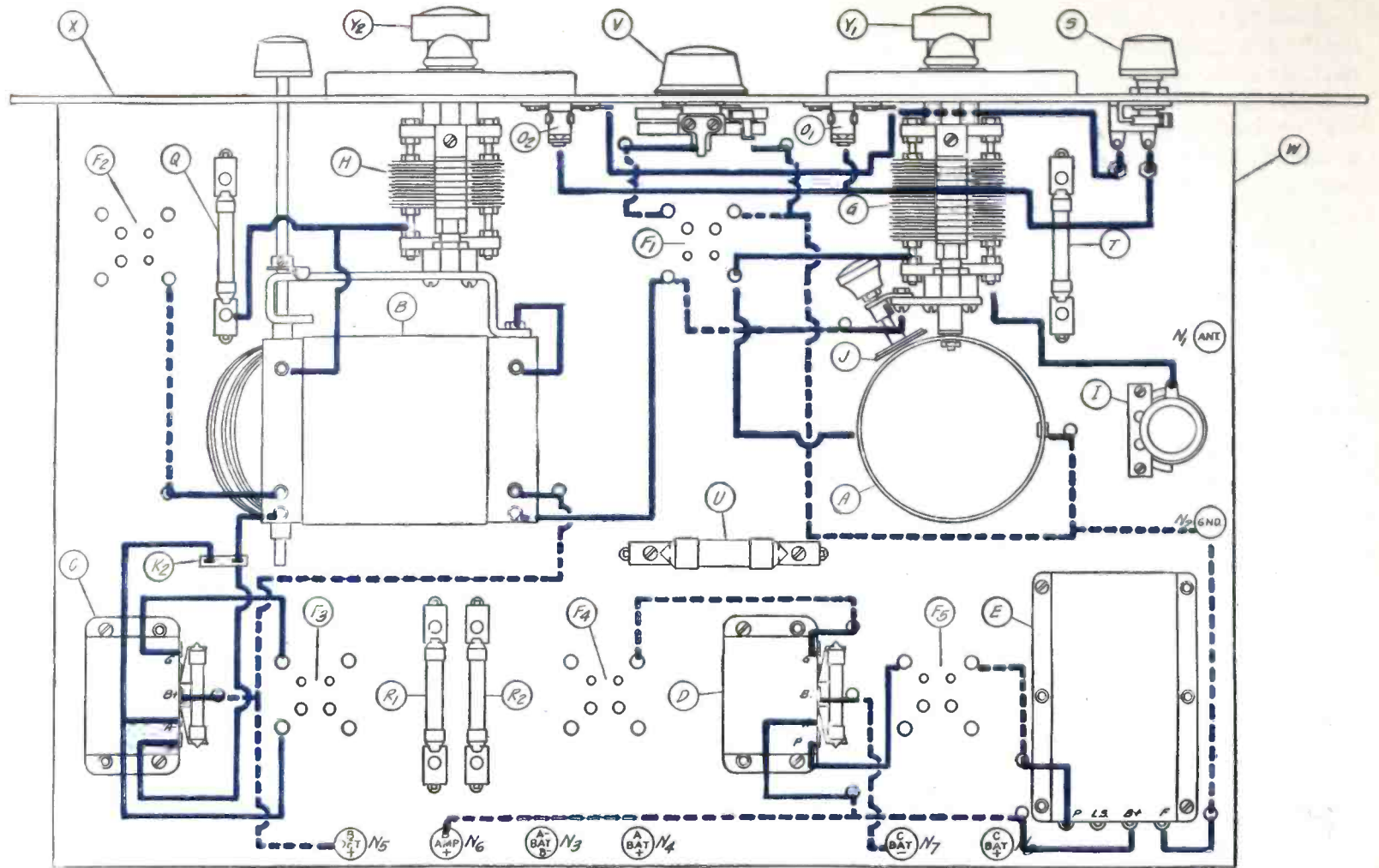

THE PICTURE WIRING DIAGRAM FOR THE TOP OF THE REVISED BROWNING-DRAKE RECEIVER

FIGURE 4: This drawing gives the changes in the wiring of the standard Browning-Drake receiver, described in the April issue of POPULAR RADIO, to permit its use with the power-pack described in this article. The changes may be easily made within an hour. The solid BLUE lines indicate the wires above the panel; small holes outlined in BLACK show where these wires go through the panel; dotted BLUE lines indicate the continuation of the wiring under the panel.

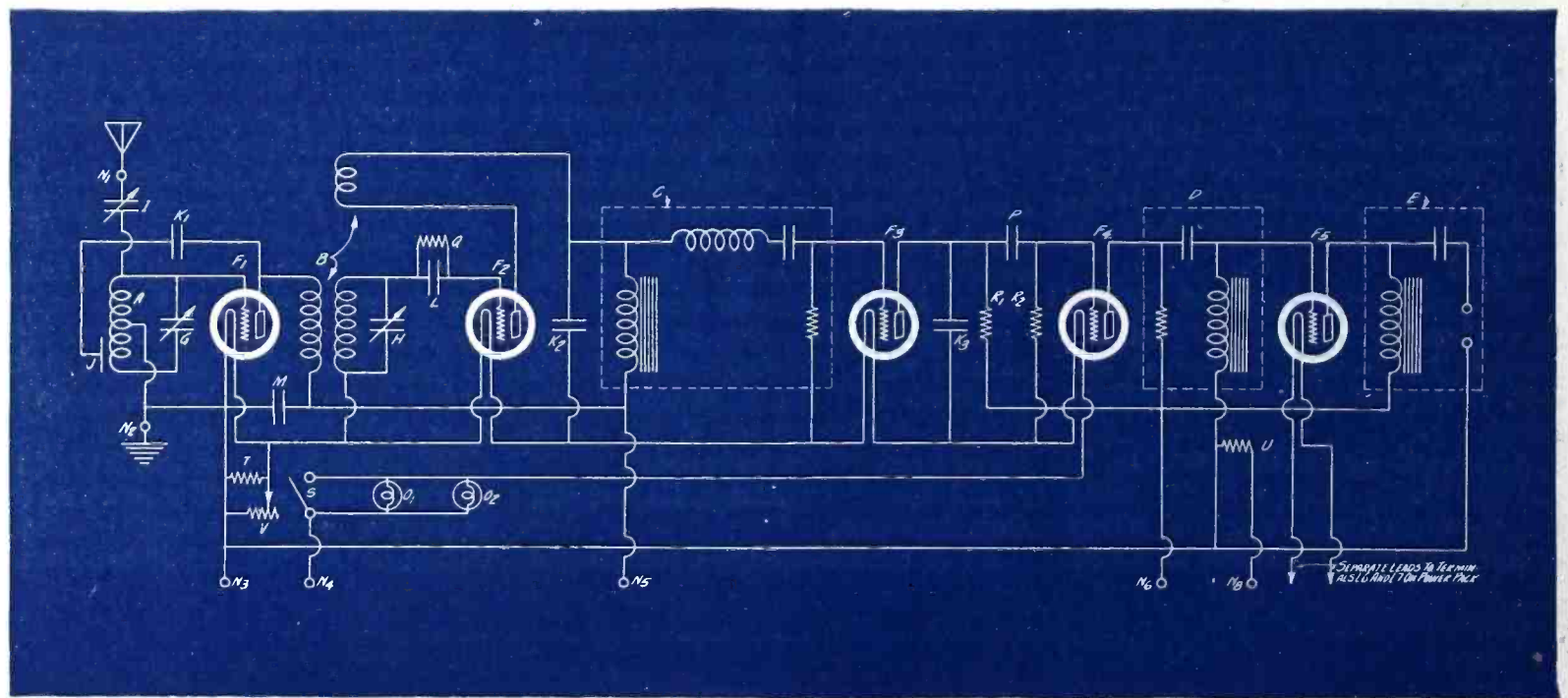

THE SCHEMATIC DIAGRAM OF THE REVISED BROWNING-DRAKE CIRCUIT

FIGURE 5: Here is the electrical circuit of the Browning-Drake receiver as wired up for operation with the "ABC" power-pack. A comparison of this diagram with the schematic diagram of the standard Browning-Drake receiver in the April issue of POPULAR RADIO will show that the changes do not affect the electrical characteristics of the circuit.

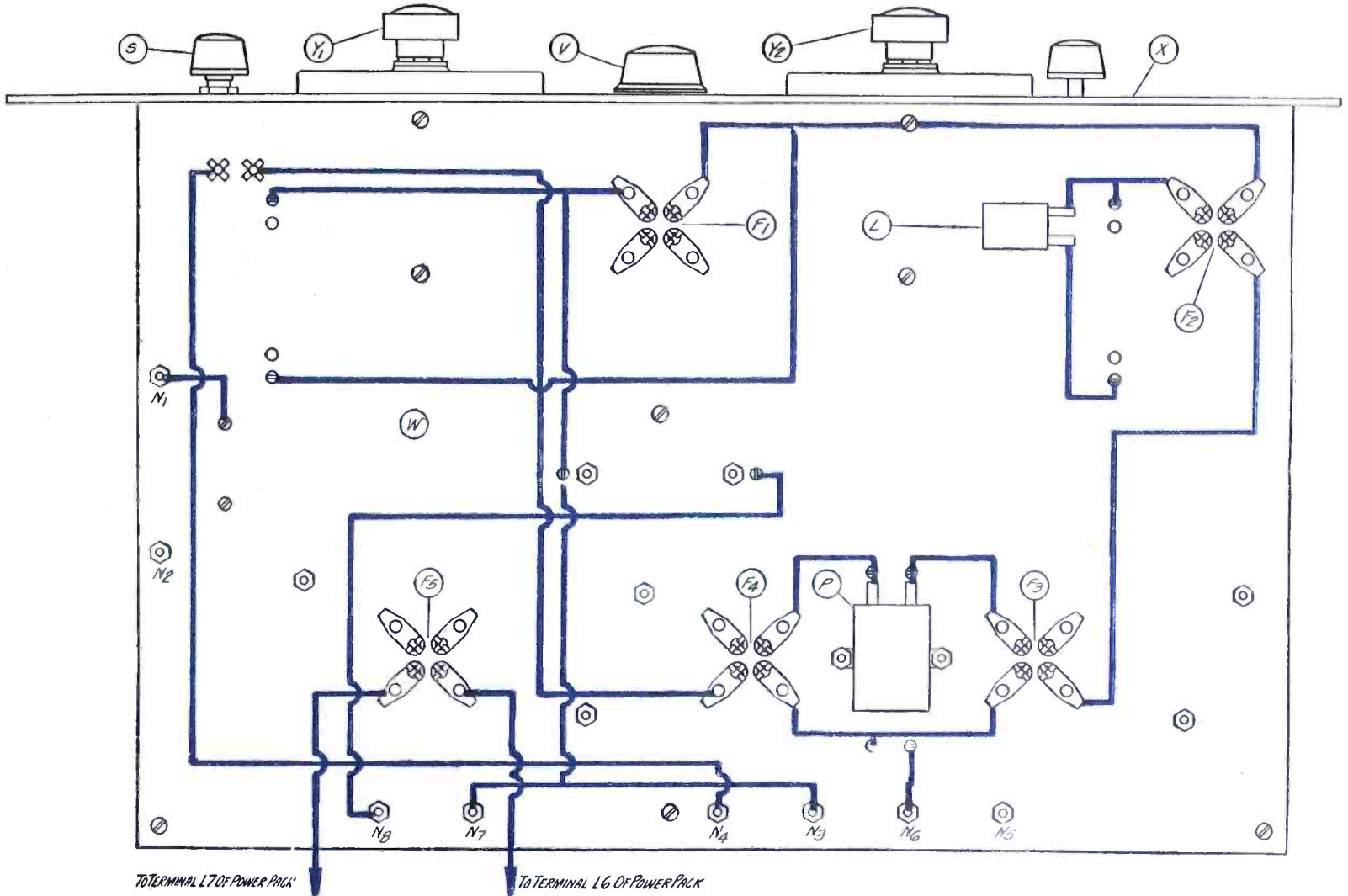

THE REVISED WIRING DIAGRAM FOR THE BOTTOM SIDE OF THE BROWNING-DRAKE RECEIVER

FIGURE 6: In this diagram the BLUE lines indicate the wiring to be done on the under side of the Browning-Drake receiver shown in FIGURE 4.

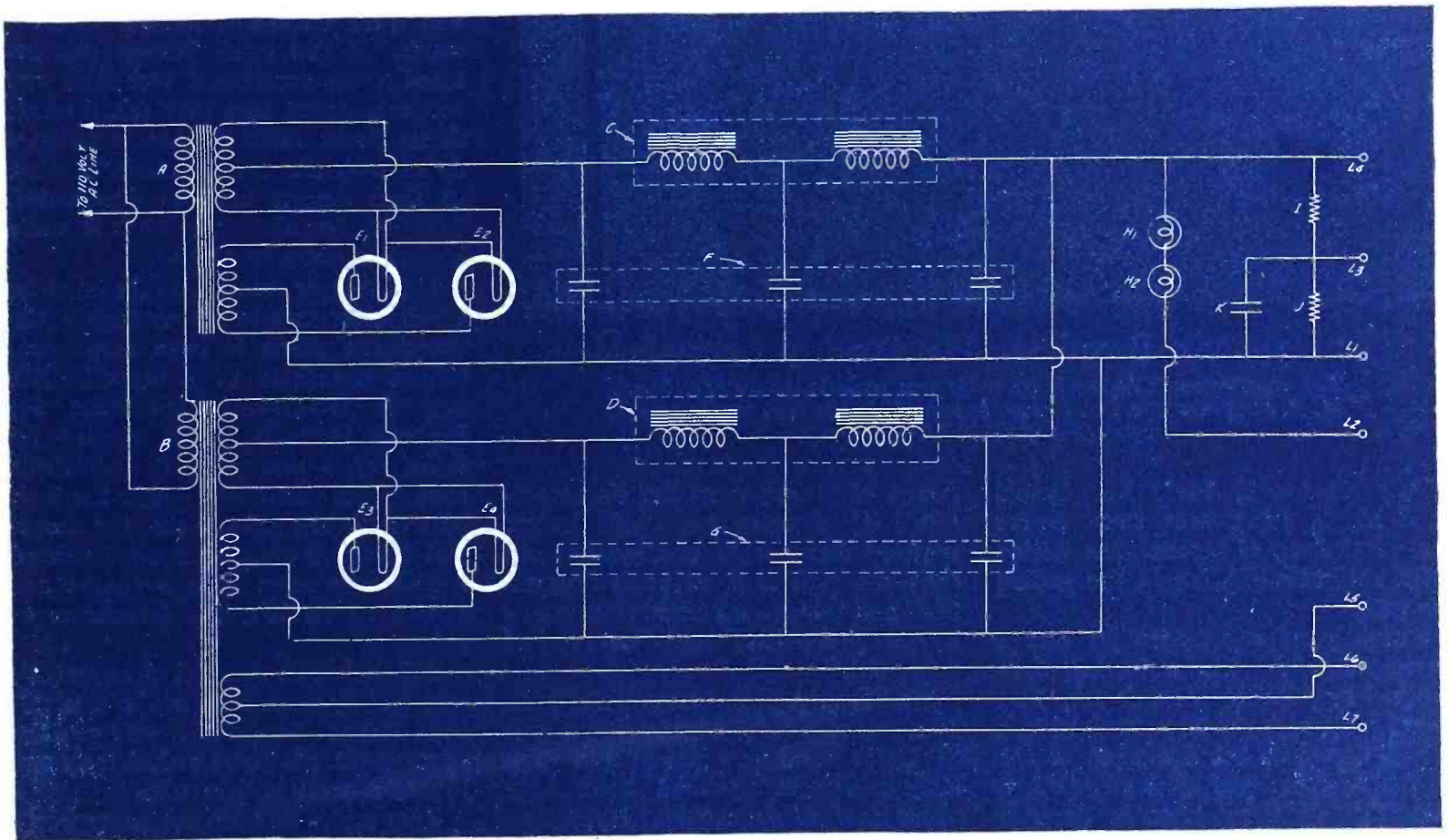

THE SCHEMATIC DIAGRAM OF THE POWER-PACK

FIGURE 7: Here is the electrical circuit which the "ABC" pack employs to furnish the power for the Browning-Drake receiver. Notice the two separate filter systems employed.

# The "SECRETS" OF THE



## The Hypnotist Broadcasts His Spell in Springfield—

*The experiment in hypnosis by radio was undertaken by Mr. Gerald M. P. Fitzgibbons, a well-known hypnotist, in the broadcasting studio of station WBZ in Massachusetts.*

ON March 9, 1927, Mr. Gerald M. P. Fitzgibbons stood before the microphone of broadcasting station WBZ at Springfield, Mass., and evoked the past.

Thirty years ago hypnosis was a household word. The world had been shocked by "Trilby," first of the "best sellers," the saga of the pathetic artist's model, beautiful but frail, and of the all too magnetic eyes of the mysterious Svengali. In every town in America amateur Svengalis tried to follow the instructions in booklets labeled, "How to Be a Hypnotist"; itinerant practi-

tioners of the art astonished the attendants at Chautauquas and lecture courses; dinner-table conversation was enlivened with such words as "suggestion" and "animal magnetism" as it now is with "vibrations" and "waves" and "electrons."

The Spanish War came and went. The pocket puzzle, Pigs-in-clover, and the Ouija board were laid to rest. The tandem bicycle vanished before the newly invented automobile. Hypnotism lost the favor of the fickle public and psycho-analysis, trailing wisps of foggy language called "complexes" and "sup-

*The significance of the successful tests to cast spells via the microphone and science's answer to the question, "Can the broadcast listeners be hypnotized by radio?"*

By E. E. FREE, Ph.D.

pressions," came to take its place.

Now Mr. Fitzgibbons has brought hypnosis back, if only for a day. His experiment over the wave of WBZ was an experiment in radio hypnosis.

Standing at the microphone, he spoke over the ether the words intended to induce the hypnotic spell. Listening at the Hotel Brunswick, in Boston, were three men. Two of these men the hypnotist had expected; the third man was present without prearrangement.

Two physicians, Dr. A. Warren Stearns and Dr. Clarence A. Bonner, both of Boston, were present to observe the experiment. The two subjects present by prearrangement passed under the hypnotic influence when the magic words came over the radio, although not with a perfection fully satisfactory to the physicians. The third man, present without Mr. Fitzgibbons' knowledge, was quite unaffected by the hypnotic words. A few other persons who listened to the experiment over their own receivers report that they felt drowsy; as no doubt radio listeners sometimes do at programs even more interesting, so these reports may be disregarded. The first recorded experiment in radio hypnosis came to an end.

If newspaper reports and the inquiries which have come to me are typical, the experiment seems to have been considered something of a marvel. Not only is it deemed astonishing for hypnotic influence to be exerted by radio, but a proportion of individuals seem to feel that a new danger has been let loose on the radio world—the danger that the minds of listeners may be seized suddenly by some radio hypnotist and carried off by him into foolishness or worse.

This last is as nonsensical as was the supposed hypnotic influence of Svengali over Trilby. No person with a mind worth stealing is going to lose it to any hypnotist, radio or otherwise.

Even minds that are not really worth carrying away are perfectly safe from this attack, for it is recorded that idiots are among the few kinds of people

# HYPNOTIST BY RADIO

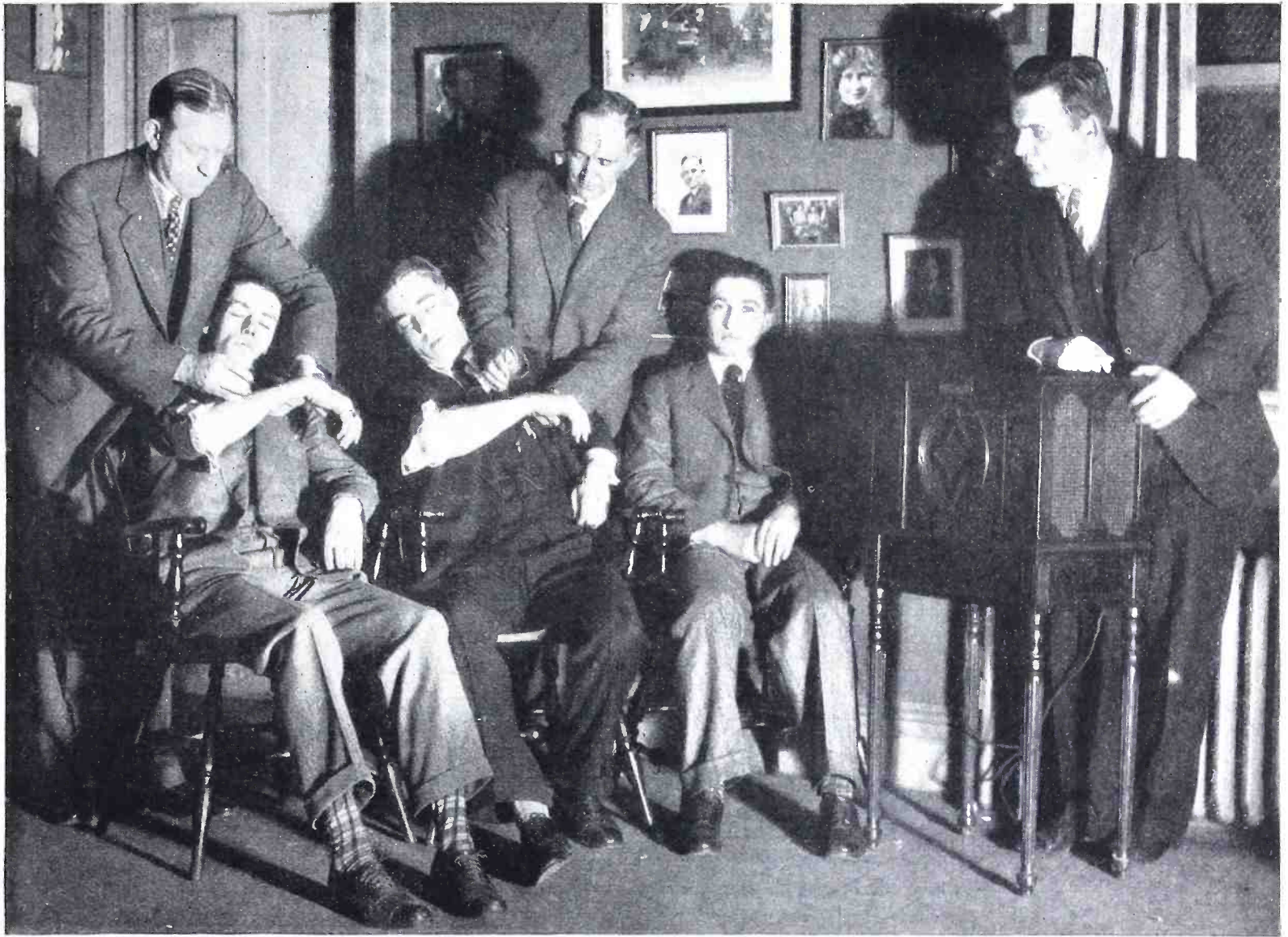

Henry Miller

## —and Hypnotizes Two of the Three Subjects in Boston

*In station WBZA, two experimenters (both of whom had been previously cast under spells by Mr. Fitzgibbons) responded to the hypnotist's suggestions; the third experimenter did not. In the picture above Dr. C. A. Bonner and Dr. A. Warren Stearns are sticking needles into the two subjects to test the extent of the hypnosis.*

seldom hypnotizable, even with their own consent.

Nor is the experiment of radio hypnotism any special marvel except as all mental phenomena are really marvelous when one digs deeply enough into them. Any psychologist familiar with the facts of hypnotism could have predicted that the Springfield experiment would come out exactly as it did. The persons formerly hypnotized by Mr. Fitzgibbons and expecting to have it happen to them again would drop off to sleep. Other persons, not prepared by previous hypnotism or by expectation, would be immune.

While I can find no record of a previous instance in which the signal to drop asleep was passed from hypnotist to subject by radio, that is merely because no one thought of using it. Hypnotists have sent such sleep messages by letter and by telegram, by the word of

mouth of other persons, even by such purely impersonal signals as the striking of a clock or the whistle of the postman. As long as forty years ago the French psychologist, Liégeois, sent his subject into the hypnotic state by speaking to him over the telephone from a distance of several miles; truly a marvelous feat, the French telephone being what it still remains, but wonderful telephonically, not hypnotically.

There is not the slightest difficulty about producing hypnosis at a distance provided two conditions exist: one is the willingness of the subject, the other is that that subject shall have been hypnotized previously by the same hypnotist and shall have been prepared by him for the later event.

The still more marvelous-seeming feat of causing a subject to fall asleep spontaneously at a certain hour or signal, without any action at all by the

hypnotist, is equally a commonplace of the hypnotic operating room. It is done by what is called post-hypnotic suggestion.

Everyone is familiar, even now when it is less often a means of public entertainment than it used to be, with the procedure of ordinary hypnosis. The hypnotist makes a few passes, murmurs a few words or gently strokes the subject's head. The subject falls into a deep sleep in which he is blind, deaf and senseless to all outside *stimuli* except those coming from the hypnotist.

The hypnotist says: "You are falling in an elevator."

The subject instantly shows every sign of severe fright. On the signal of the hypnotist, the subject will swim ridiculously on the dry floor or growl like a bear or eat paper for ice-cream or accept anything else that the hypno-

(Continued on page 572)

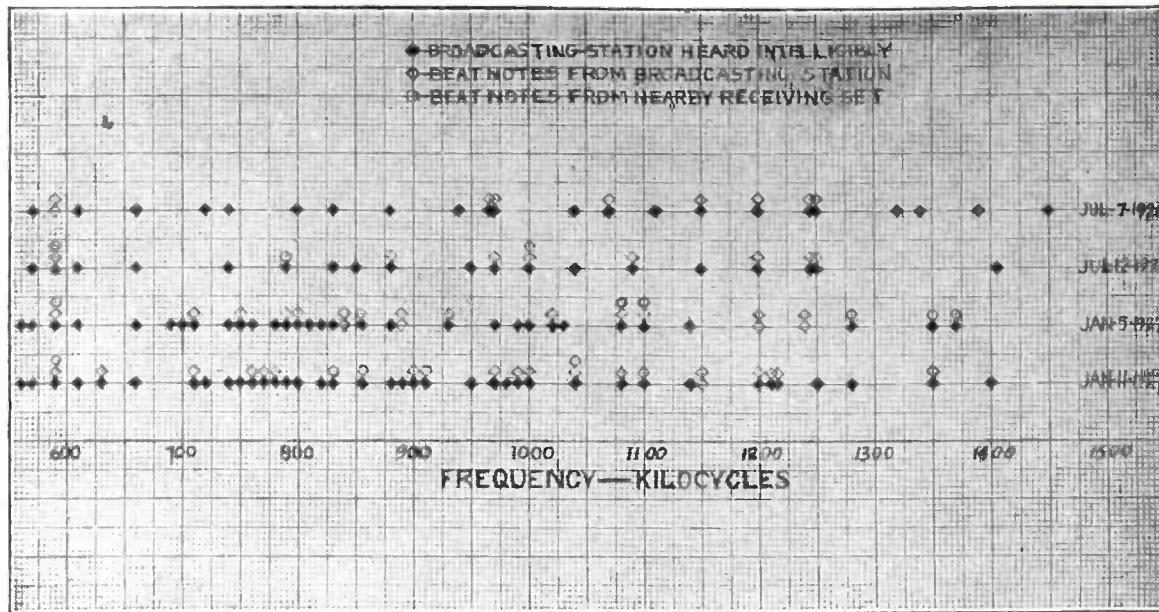

Bell Telephone Laboratories

## A COMPARISON BETWEEN SUMMER AND WINTER INTERFERENCE

FIGURE 1: The first two horizontal lines of designations were made in July, 1926, the last two in January, 1927. Although the number of stations heard during the winter tests was greater than the number heard in the summer tests, due to better reception conditions, the amount of interference also increased.

# “SQUEALS”

## What They Are and How to Stop Them

*Practical information that every set owner should have on how to free broadcast reception from one of the preventable annoyances.*

By E. G. FRACKER

THE greatest afflictions of the broadcast listener are static, spark stations and squeals.

Static is absent or slight most of the time.

Government regulation of wavelengths and schedules has reduced the amount of spark interference.

But during most of the listening hours we are annoyed by a range of noises extending throughout the entire range of frequencies that are audible to the human ear, such as might be produced by a hungry pig family of all ages. And it is with such noises, commonly referred to as “squeals,” that we are concerned in this article.

In the pioneer broadcasting days the air was not cluttered up, because but few transmitting and receiving sets were in use. Transmitters operated at widely separated frequencies and crystal detectors were used for receiving. This was detrimental to the propagation of squeals.

Now, however, with the lid off the range of frequencies assigned by the government for broadcasting, the air is burned up nightly by a go-as-you-please competition of hundreds of sta-

tions. Although the majority retain the frequencies originally allotted, many have become shifters. The comparatively few crystal sets are practically extinct; they have given way to the more versatile vacuum-tube receivers. Nearly every listener knows that these present day conditions are responsible for the squeals which are his worst radio affliction.

Assuming that the listener's set is incapable of producing these unwanted noises, all his disturbances will be picked out of the air.

An attempt is made to pick up a distant station by setting the dials to positions which previously have brought it in satisfactorily, but nothing is heard but a steady whistle. This is due to the operation of another station differing only a few thousand cycles in carrier-frequency from the desired station, the pitch of the whistle being equal to the difference in frequencies. This is what may be expected when the transmission from both stations is received with approximately equal intensity.

If the station to which the set is tuned be received with greater intensity, it may be possible to distinguish what is being

transmitted, but the whistle will be heard so long as the current from the weaker station is sufficient to actuate the detector.

This difference in intensity may be due to the power used for transmission, distance from receiver, intervening atmospheric and land conditions or the tuning of the receiver.

The production of the audio-frequency current which causes this whistle is due to the same property of the detector tube which enables it to change the component frequencies produced by modulation into speech-frequency currents similar to those which originate at the microphone.

To generalize, when any two currents of slightly different frequencies, such as carrier currents from two broadcasting stations, are passed through the detector, they are resolved into a current at a third frequency equal to the difference of the original frequencies, which is the pitch of the tone heard.

This tone is sometimes referred to as a “beat-note” and the combining action producing it is called “heterodyning.”

It is possible, on some receiving sets, to receive with good volume two or more stations of different carrier-frequencies

without hearing beat-notes. This occurs when the frequencies differ by more than the highest audible frequency. Conditions at the receiving set are generally responsible for this. The circuits are not sufficiently selective, either inherently or because of inefficient manipulation. The degree of selectivity also depends on whether the receiver is located near broadcasting stations. In such districts a completely shielded, highly selective circuit is of advantage.

Another external source of squeals is the oscillating receiving set, due to the heterodyning of its oscillating currents with the high-frequency currents radiated by broadcasting transmitters.

The receivers that may be expected to cause disturbances are regenerative receivers, receivers that have radio-frequency amplifiers improperly arranged to prevent oscillation, and super-heterodyne sets in which considerable energy is transferred from the oscillator circuits to the loop or antenna.

All these types may be considered as low-power transmitting stations, as they annoy in much the same manner as a heterodyning broadcasting station. However, the beat-notes produced by receivers are generally variable as a result of changes in the circuit constants and may be identified by this characteristic.

In general, it may be said of oscillating receivers that the extent of their offense is governed by their distance from the listener's receiver and the closeness of coupling between their antenna and oscillating circuits. We should be thankful that they rarely inflict unearthly wails upon other receivers without wailing likewise themselves. Although measures may be employed whereby they may be made self-immune, the less said about these measures the better, lest they be used for revengeful purposes—which would only make matters worse. Besides, kind words and constructive criticism have already proved their worth in

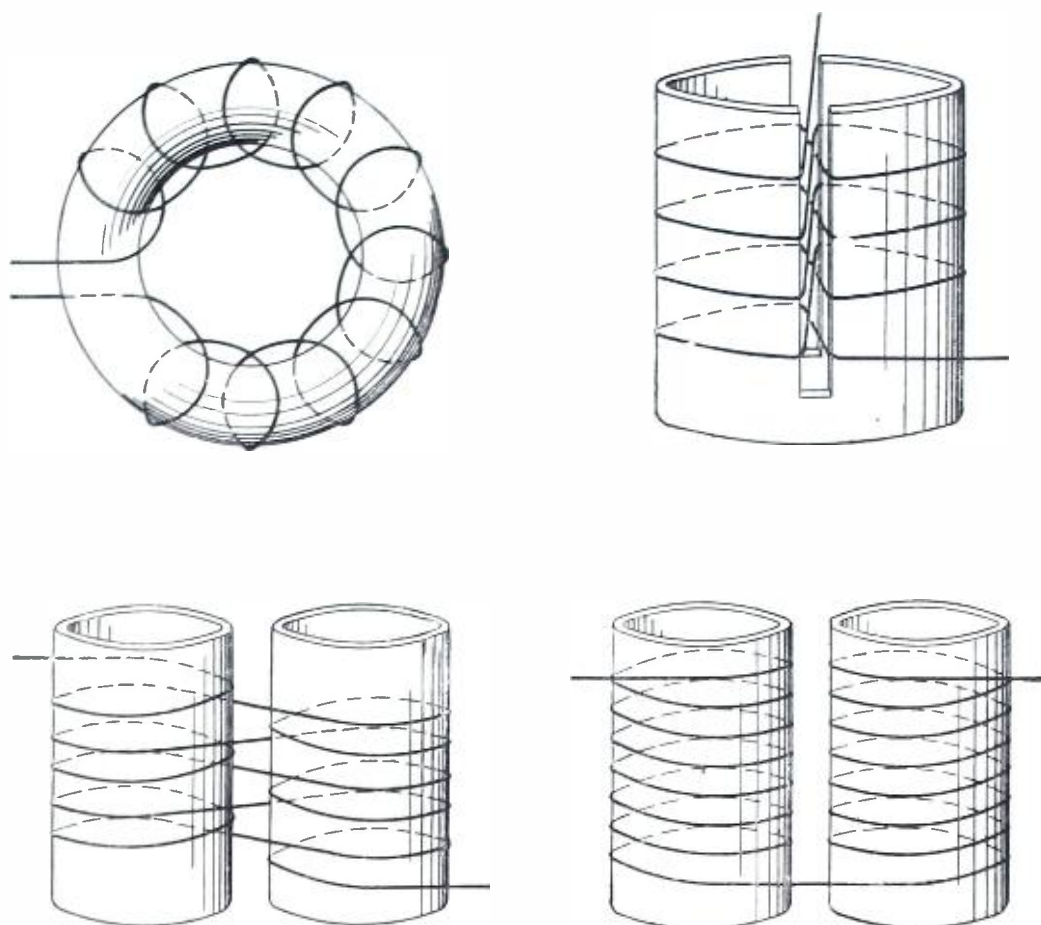

COILS WITH LIMITED FIELDS

FIGURE 2: The coils shown here tend to withhold the electrical fields within the dimensions taken up by the windings themselves. At the top left is shown the toroid coil which has a self-contained field. At the right is the "Figure 8" coil wound on a single slotted tube; on the bottom left is a "Figure 8" coil wound on two tubes; at its right is a so-called binocular coil with the windings in reversed direction on the two tubes.

eliminating many nerve-racking receivers. Set a good example by using a receiver that reproduces with the utmost fidelity possible; it will be worth more than one hundred 3,000-mile squealers in its ability to furnish high-class entertainment instead of punishment to all members of the family and friends.

Another source of external squeals, which is but rarely heard, takes the form of telegraphic dots and dashes.

Some of the high-power, long-wave tel-

egraph stations are responsible for them. Although the frequencies at which they transmit are far below those of the broadcasting band, their power is so great that it is possible to receive currents at harmonics of their fundamental frequencies, at a few points on the dial where broadcasting stations are tuned in, and the heterodyning of the harmonic-frequency currents with the broadcasting carrier-frequency currents causes beat-notes to be heard.

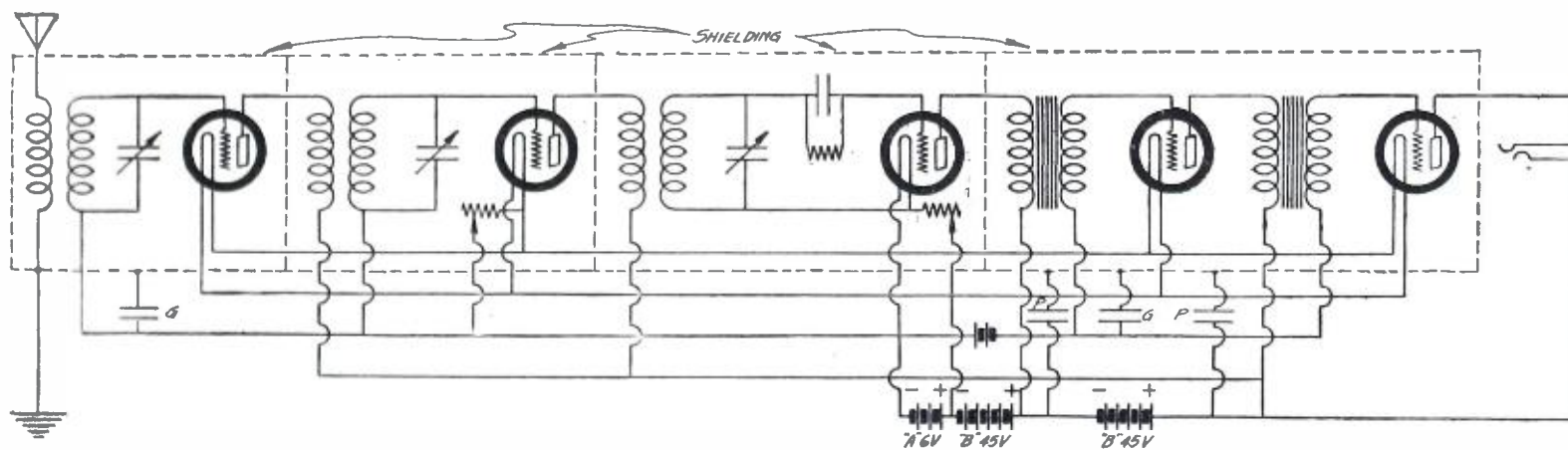

SOME OF THE METHODS USED FOR PREVENTING SQUEALING

FIGURE 3: Make the leads from the grid to the coils and from the plate to the coils as short as possible; employ interstage shielding for each stage of high-frequency amplification; include the low-frequency amplifier in a stage shield; use as many by-pass condensers as are indicated across the batteries and filament circuits.

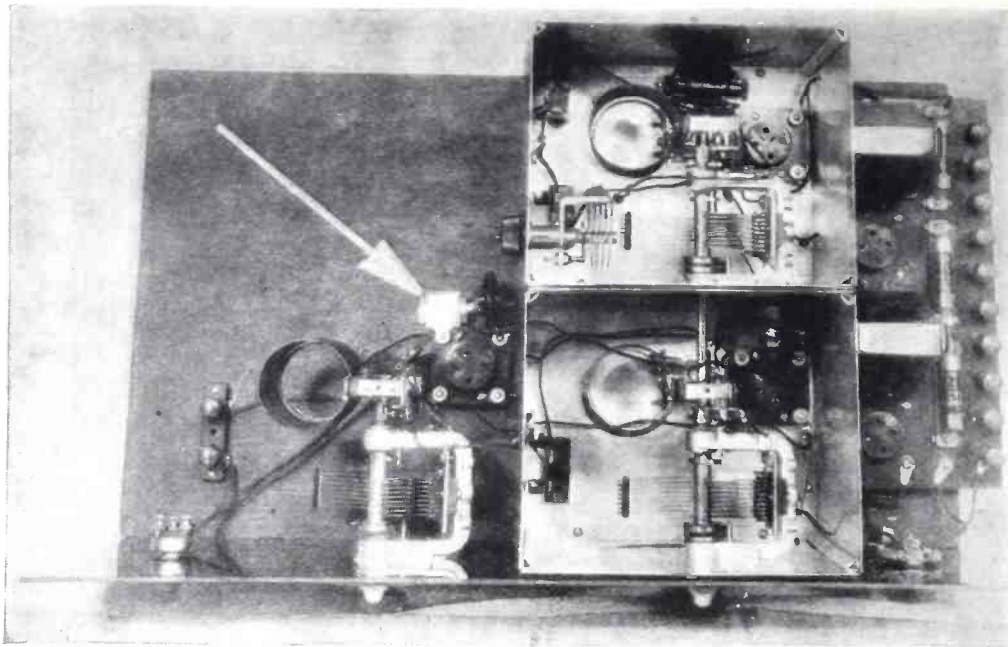

#### HOW A NEUTRALIZING CONDENSER IS USED TO DIMINISH SQUEALING

FIGURE 4: In this picture, which is a reproduction of the Hi-Q receiver, the white arrow points to one of the neutralizing condensers. It is used to balance the tube capacity, thus preventing feedback and the consequent oscillation or squealing that would be obtained without the neutralizing condenser.

An idea of the extent and nature of the various squeals heard may be gained from Figure 1, which shows observations which were made between 9 P. M. and 11 P. M. during four nights.

The first two observations show conditions during last July. The fact that fewer receiver squeals were present on one night was due to the heat and humidity, which tended to discourage all desire for dial manipulation. The two lower observations indicate the revolutionary conditions that existed in January. Allowing for more stations being received because of the more favorable winter atmospheric conditions, it shows that many stations have changed their wavelengths upward.

This congestion between 300 and 400 meters, although objectionable in some respects, is responsible for one worthwhile improvement; it has largely discouraged the desire to hunt for distant stations, which were frequently located by setting the receiver in a state of oscillation. This is indicated by the small number of receiver squeals heard in January, the height of the open season for DX hunter.

Very little progress can be made in eliminating these squeals of external origin. Their volume may be reduced and some may be eliminated by using highly selective receiver circuits. However, if too great a degree of selectivity be obtained, distortion will result from incomplete reception of the side bands.

A receiver tuned to 1,000 kilocycles and having a resonance curve as shown at A, Figure 5, will receive about 50 per cent as much from either a 993 or

1,007 kilocycle station as from a 1,000 kilocycle station, assuming equal input to the receiver at resonance in each case.

With the receiver modified so that its resonance curve is as shown at B with the current maintained the same as before for the 1,000 kilocycle station, the current from the other stations will be reduced to approximately 20 per cent and

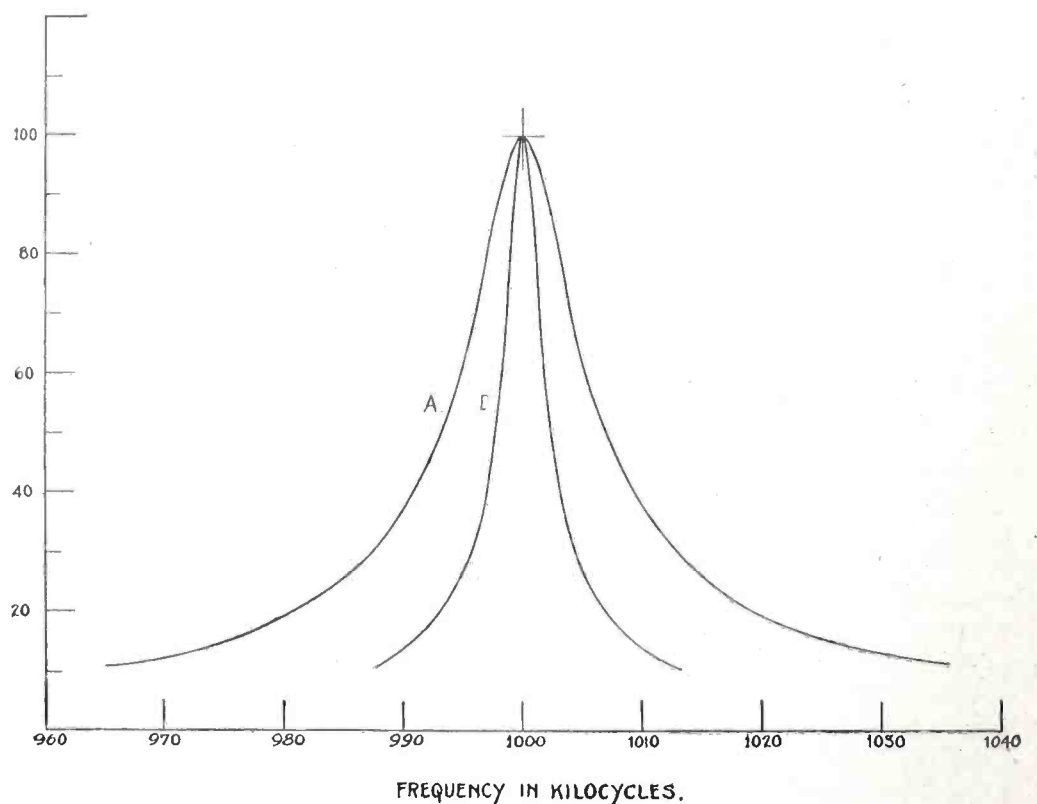

#### A COMPARISON OF A SHARP AND BROAD RESONANCE CURVE

FIGURE 5: The tuning curve shown at A includes a wider band of frequencies than the one shown at B. A receiver with a curve similar to B will not be affected by interfering stations to as great an extent as the one with a curve similar to that shown at A. Greater selectivity may be obtained by reducing the resistance of the high-frequency tuning circuits.

the beat-notes from these stations will be correspondingly reduced in volume. Greater selectivity in a receiver may be obtained by reducing the resistance of the radio-frequency circuits including the antenna circuit and by reducing the coupling to the antenna.

With the squeals that originate within the listener's receiver it is a different matter. They can always be eliminated, although more time is often required to do this than to build the receiver. A sustained audio-frequency tone is generally due to radio-frequency oscillations in the receiver or to feedback at audio-frequencies, often referred to as "singing." A beat-note from a receiver oscillating at only one frequency can be heard only when another oscillating current is present, such as from an incoming signal. If heard without the presence of an incoming signal, the set may be singing at two slightly separated radio-frequencies or else at an audio-frequency.

In radio-frequency amplifier sets, the utilization of interstage transformers makes a potential oscillator of each radio-frequency tube circuit, due to the coupling through the tube capacity which permits an interchange of energy between the grid and plate inductances (as shown in Figure 7) unless some means is adopted to prevent oscillation. This may be accomplished by reducing the plate in-

(Continued on page 574)



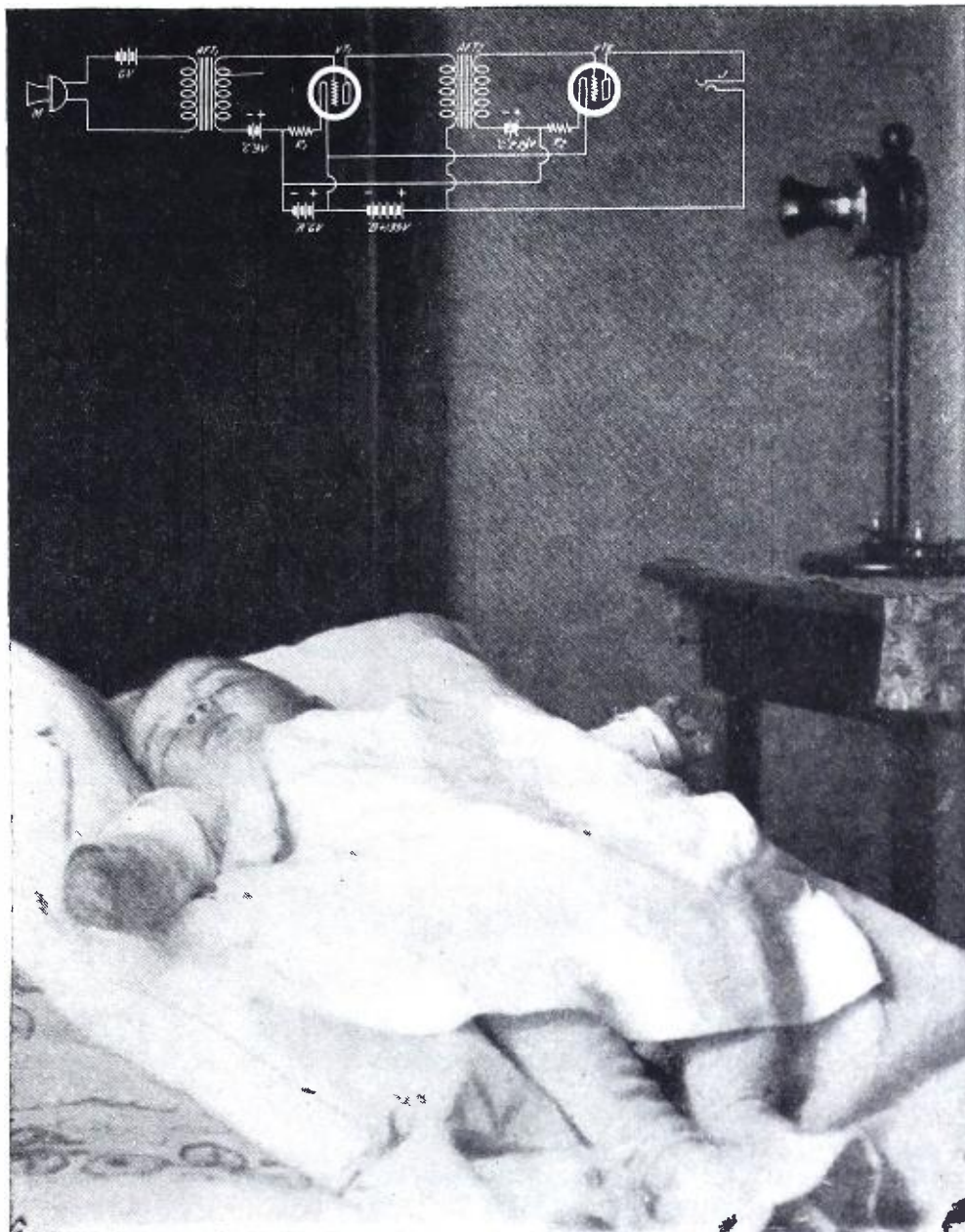

**A TIP FROM ONE RADIO FAN**

*Here is a practical, labor-saving suggestion for the household that contains a baby—and a mother who has housework to do.*

# “This Is Station WAIL Calling”

By MABEL WHEELER

HERE IS A LIST OF PARTS REQUIRED FOR THIS HOOK-UP—

- |  |   |   |
|--|---|---|
| Microphone;                              | 2 rheostats or automatic filament controls; | 1 UX-112 type valve;                                      |
| 2 high-grade low-frequency transformers; | 1 filament switch;                          | 1 UX-171 type valve (in the last stage of amplification); |
| 2 open-circuit jacks;                    | Bakelite panel, 7 by 14 inches;             | Proper length of No. 16 bell wire.                        |
| 2 UX type sockets;                       | Baseboard, 8 by 12 inches;                  |   |

**O**UT in Indianapolis there lives a young lady—ten months old, to be precise—who has a private broadcasting station all her own. Also, she does all of the broadcasting herself. Her warbling is not for the general public, however; only members of her own family and guests get the benefits of the broadcaster's treble voice.

The special call letters of the station are, according to the family, WAIL, but they are not registered.

The small broadcaster's name is Patricia Jenkins.

It all came about in this manner:

Miss Patricia has her bed in the nursery on the second floor of her

home. When the rest of the family were downstairs talking, or listening to the radio or the piano, it used to be impossible to hear the baby cry when she wakened from her naps. So Mrs. Herbert Jenkins, the baby's mother, or Mrs. Charles Pickerill, the baby's grandmother, used to make numerous trips up the stairs on false alarms, thinking they heard the baby's cries.

Finally Mr. Jenkins decided that all this bother should be eliminated, so he conceived the idea of broadcasting Pat's cries through the house. He installed a microphone (later replaced by a telephone transmitter), so that each wail from Pat's crib would be broadcast

through the house. Two stages of amplification were used, and a loudspeaker was installed downstairs.

Now even the gentlest wail of Patricia comes rushing out from the speaker like the roar of a lion; her every cough or sigh is wafted loudly and clearly to the family below.

Now mother and grandmother go about their work without a tremor of nervousness. For they know that her waking will be instantly made known to them above all other noises.

The diagram of the circuit used is shown in the accompanying illustration and the list of parts necessary to duplicate this device is given above.

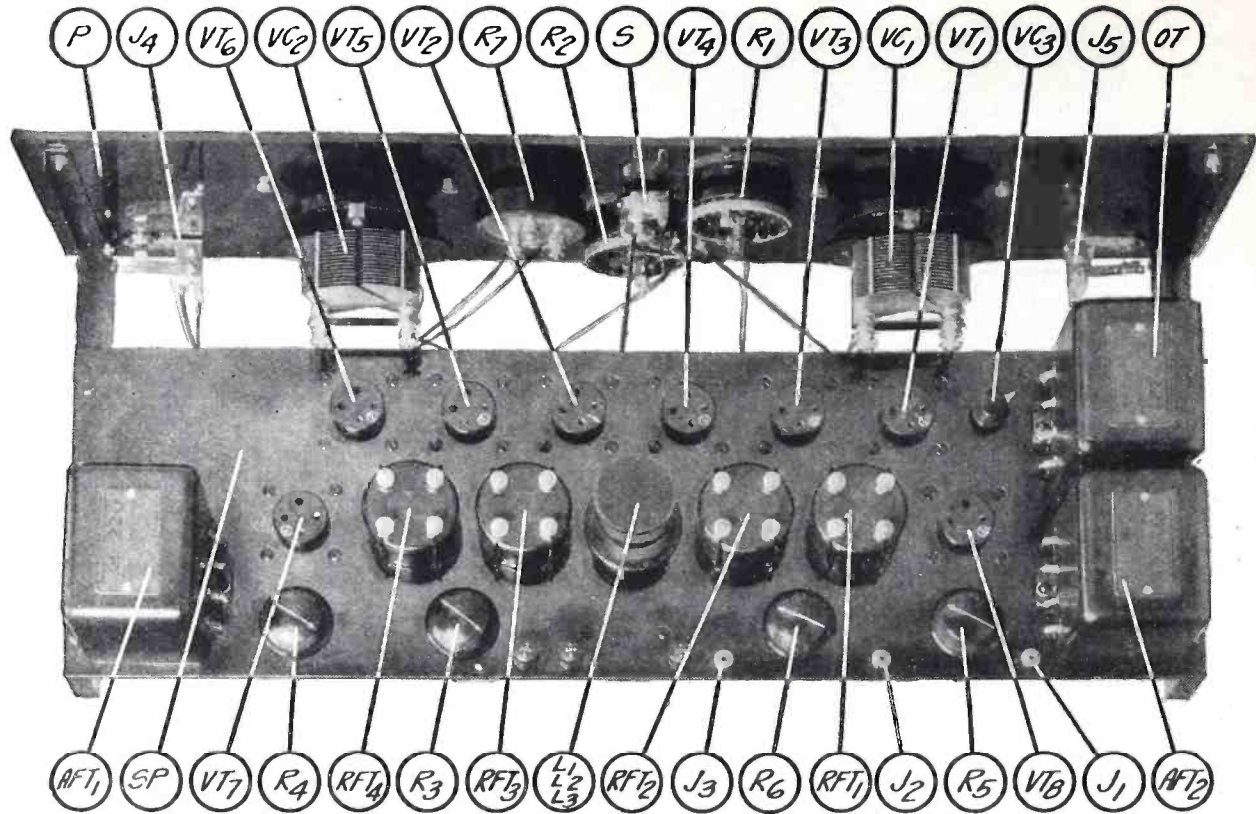

### The Lincoln Superheterodyne Receiver

*Stations come in at only one setting of the dials in this new superheterodyne receiver; extraneous noises have been reduced to a minimum by its design. The low-frequency amplifier is excellent; it is followed by an output filter to keep heavy currents out of the reproducer. The set is easy to tune and is ideally suited for use with a power-pack.*

# Popular Radio Circuits

INSTALLMENT NO. 10

## THE PARTS THAT ARE RECOMMENDED FOR USE IN THIS RECEIVER ARE—

- |   |   |  |
|---|---|--|
| <p>RFT1, RFT2, RFT3 and RFT4—Lincoln long-wave, air-core, high-frequency transformers;</p> <p>AFT1 and AFT2—S-M low-frequency transformers, type 220;</p> <p>OT—S-M output transformer, type 221;</p> <p>VC1 and VC2—Remler 360-degree type variable condensers, .0005 mfd.;</p> <p>VC3—Chelton midget condenser, No. 850;</p> <p>VT1, VT2, VT3, VT4, VT5, VT6, VT7 and VT8—Benjamin skeleton sockets No. 9044;</p> | <p>L1, L2 and L3—Lincoln-fixt inductance (oscillator coil);</p> <p>GL—Tobe condenser, .00025 mfd., with grid-leak mounting.</p> <p>GC—Durham grid-leak, 2 megohms;</p> <p>C1—Tobe condenser, .5 mfd.;</p> <p>C2 and C3—Tobe condenser, .006 mfd.;</p> <p>C4—Tobe condenser, .00025 mfd.;</p> <p>J1, J2 and J3—Yaxley jacks, No. 416;</p> <p>J4—Yaxley double-circuit jack, No. 3C;</p> <p>J5—Yaxley open-circuit jack, No. 701;</p> <p>S—Yaxley switch, No. 10;</p> | <p>R1, R2, R3, R4 and R5—Yaxley rheostats, 20 ohms, No. 120K;</p> <p>R6—Yaxley rheostat, 6 ohms, No. 16K;</p> <p>R7—Centralab variable resistance, 200,000 ohms;</p> <p>P—Composition panel, 7 by 24 inches;</p> <p>SP—Composition sub-panel, 7 by 23 inches;</p> <p>2 S-M dials, type 801;</p> <p>1 Yaxley cable connector plug, and battery cable, No. 660;</p> <p>1 Lincoln loop.</p> <p><b>COST OF PARTS: Not over \$103.00.</b></p> |
|---|---|--|

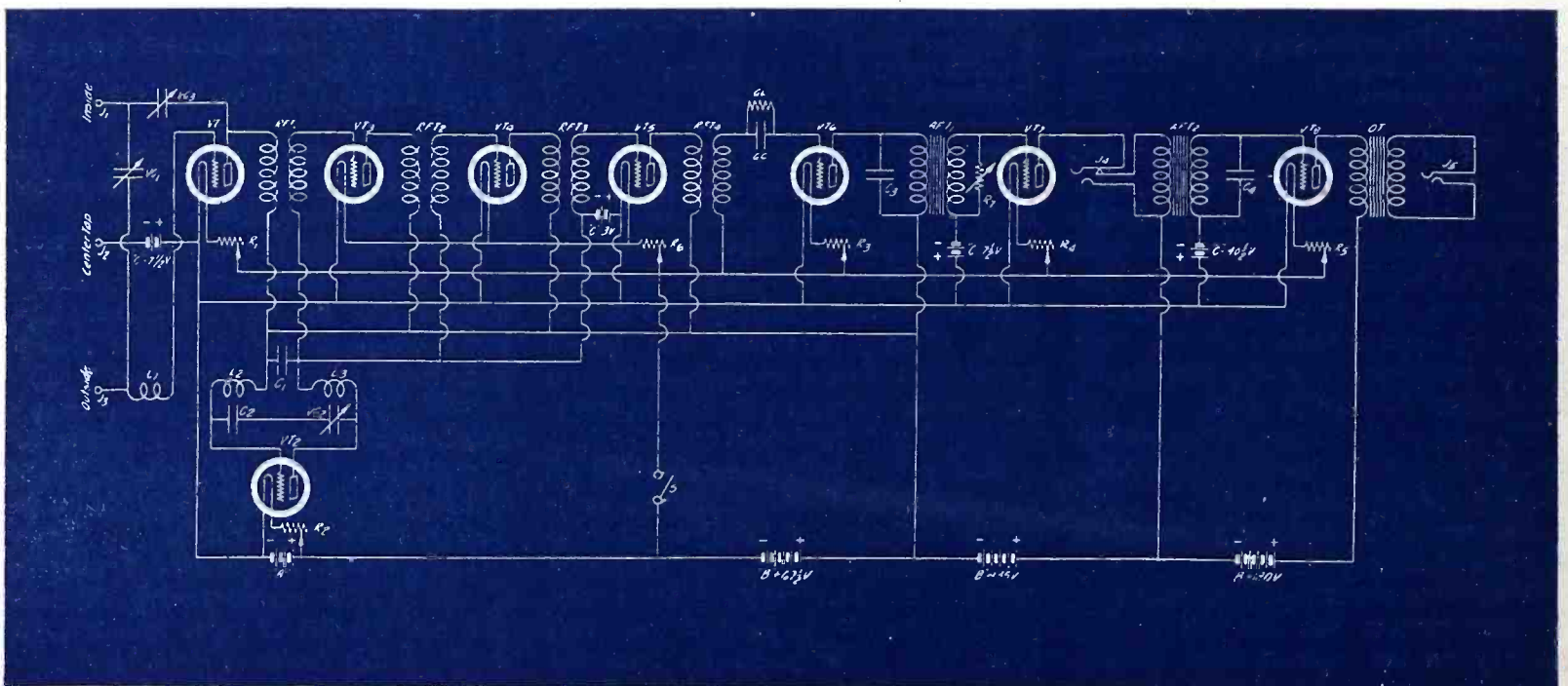

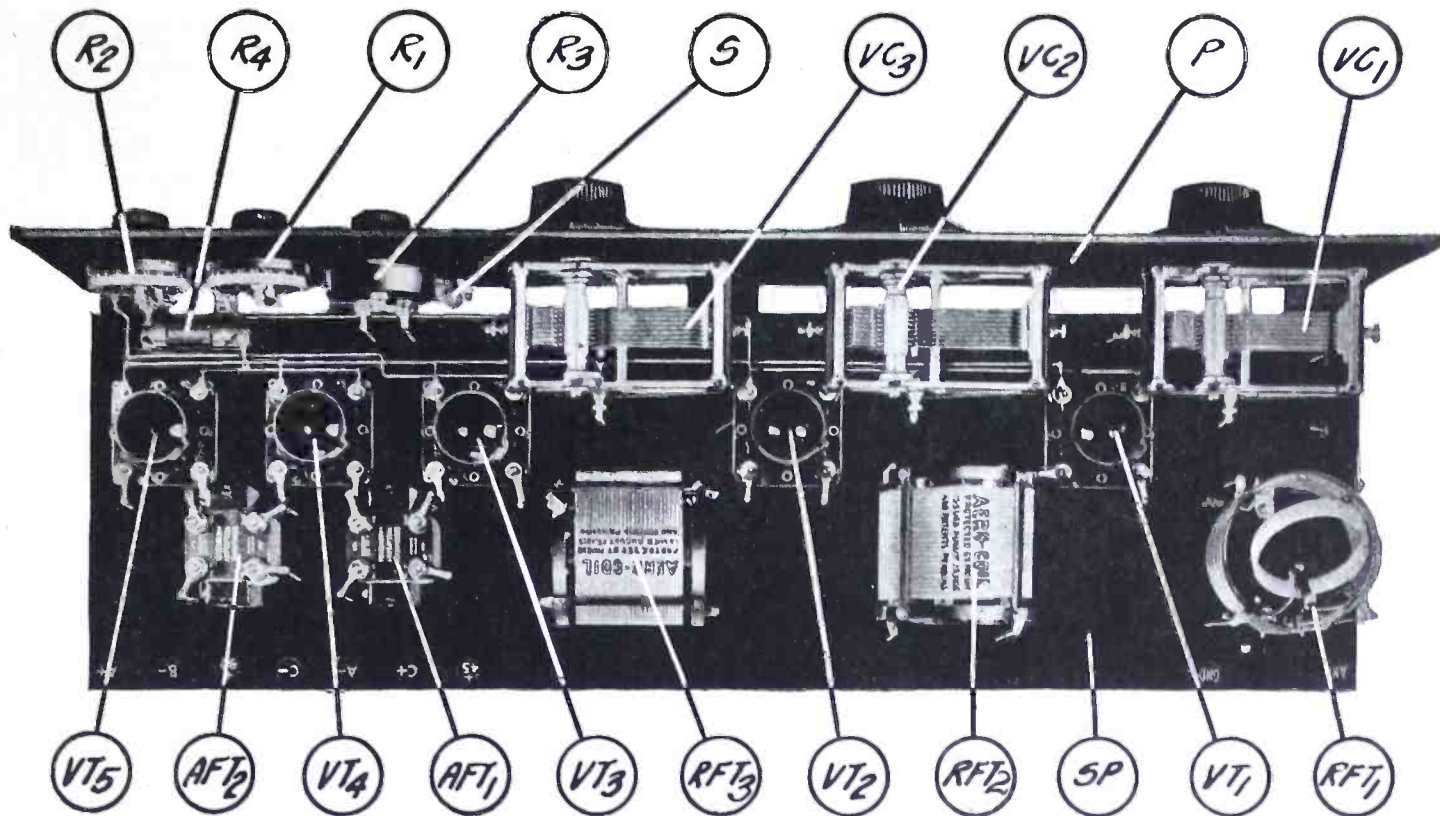

### The Aero-Dyne Receiver

*This receiver comprises two stages of tuned high-frequency amplification, a tuned vacuum-tube detector stage and a two-stage, transformer-coupled, low-frequency amplifier. The high-frequency amplifier contains efficiently designed coils, and the results obtained with this arrangement should satisfy any set constructor as to selectivity, distance and sensitivity. A variable high resistance in the plate circuit of the first two vacuum valves provides a good means for controlling volume and oscillation. UX-201-a type valves may be used throughout.*

#### THE PARTS THAT ARE RECOMMENDED FOR USE IN THIS RECEIVER ARE—

- RFT1, RFT2 and RFT3—Aero coil set, type TRF-120;
- AFT1 and AFT2—Thordarson low-frequency transformers, ratio 3½ to 1;
- VC1, VC2 and VC3—Karas Orthometric variable condensers, .00037 mfd.;
- VT1, VT2, VT3, VT4 and VT5—Benjamin cushion sockets, No. 8645;
- J1—Yaxley two-circuit jack, No. 2A;
- J2—Yaxley open-circuit jack, No. 1;
- GL—Dubilier grid-leak, 2 megohms;

- S—Yaxley battery switch, No. 210 (with pilot light);
- R1—Yaxley rheostat, 20 ohms, No. 120K;
- R2—Yaxley rheostat, 15 ohms, No. 115K;
- R3—Centralab variable resistance, zero to 200,000 ohms;
- R4—Amperite, No. 112 or Daven ballast, ½ ampere;
- C1—Dubilier fixed condenser, 1 mfd.;
- C2—Dubilier mica fixed condenser, .001 mfd.;

- GC—Dubilier mica grid condenser, .00025 mfd. (with grid-leak clips);
- P—Formica panel, verichromed and drilled, 7 by 28 by 3/16 inches;
- SP—Composition sub-panel, 7 by 27 by 3/16 inches;
- 3 sub-panel brackets;
- 3 Kurz-Kasch "Aristocrat" port dials, 4-inch diameter, No. 567;
- 9 Eby binding posts.

COST OF PARTS: Not over \$71.00.

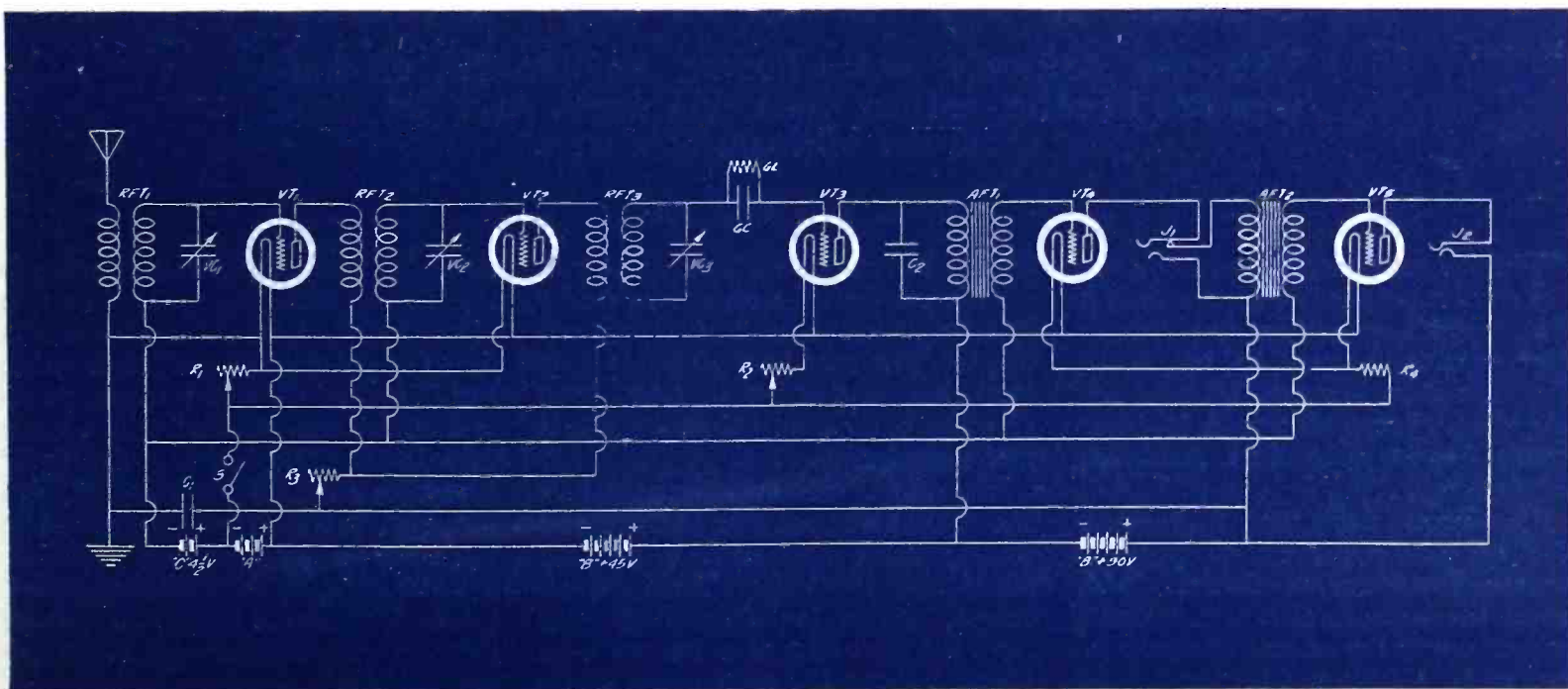



Westinghouse

#### A DROP OF WATER THAT RINGS A BELL

*A drop of water running down the two wires into the glass in the center of the picture will cause the grid-glow relay to operate and will ring a bell. By changing the connections slightly, the action of a burglar in picking up the silver on which Mr. Knowles' hand rests could be made to sound the alarm. The relay itself, looking not unlike a rectifier tube, is on top of the inverted drinking glass just in front of Mr. Knowles.*

## THE NEW AND REMARKABLE "40th Fly-Power Relay"

This new electronic device has an amplification of more than one hundred million times, and works on a current of about one billionth of a watt.

By E. E. FREE, Ph.D.

**T**HE familiar electrons of our vacuum tubes are used in a new way in the astonishingly sensitive "grid-glow relay" recently invented by Mr. D. D. Knowles, of the Research Laboratory of the Westinghouse Electric & Manufacturing Company, at East Pittsburgh, Pennsylvania.

So delicate is this remarkable device that the energy necessary to operate it equals, Mr. Knowles calculates, only about one billionth of a watt, which is approximately the amount of energy expended by a fly in walking the distance

of one fortieth of an inch up a wall.

Although devised with an eye mainly on its possible uses in electrical engineering, the new relay may prove to have interesting applications in radio, some of which possibilities POPULAR RADIO is now investigating.

The relay is contained in a glass bulb not unlike a vacuum tube and possesses three metallic electrodes: a grid, an anode and a cathode. These are arranged, however, in the reverse direction from the electrodes of a vacuum tube. Figure 2 shows the arrangement of the

elements. The cathode, corresponding to the filament, is the outer one and consists of an open aluminum cylinder one inch in diameter and one and one-fourth inches long. Inside this is the anode, which is a nickel wire shielded with a glass tube, except at its very tip. The "grid" is another wire, also glass shielded, and with its upper end bent over the tip of the anode, so that a distance of exactly one thirty-second of an inch separates them. The tube is filled with neon or argon or some other inert gas, under very low pressure.

In operation, an alternating potential of about 440 volts, at the usual 60 cycles, is impressed between the cathode and the anode. The grid is left "floating"—not connected to anything. As experts in electronic devices will perceive at once, this produces an accumulation of negative charge on the grid, which stops any passage of current between the anode and the cathode.

Suppose, now, that this accumulated charge on the grid is led away by touching the grid wire or in any other way. Current will then pass between the cathode and anode, being self-rectified as it passes. Any electric leakage from the grid circuit serves, therefore, as a very minute signal to start the much larger current through the tube itself. The "amplification" of this action (not quite the same, of course, as the amplification of an ordinary radio tube) reaches the enormous ratio of one to about one hundred million.

If the wire connected to the grid enters a gas flame (see Figure 1), the leakage of electrons into the flame will be sufficient to discharge the grid and to start the tube current. Leakage from the grid into water, such as might be caused by a rainstorm, is equally efficacious. The relay will serve, therefore, as a detector either of fire or of flood. By reversing the connections, it may be used to sound a danger signal if the fire in a stove or furnace goes out. If the grid is connected to a sheet of tinfoil underneath a jeweler's display tray, the capacity effect of a thief's hand stretched out to carry off some apparently unprotected article will cause sufficient leakage to start the relay and give the alarm. In an especially ingenious application worked out by Mr.

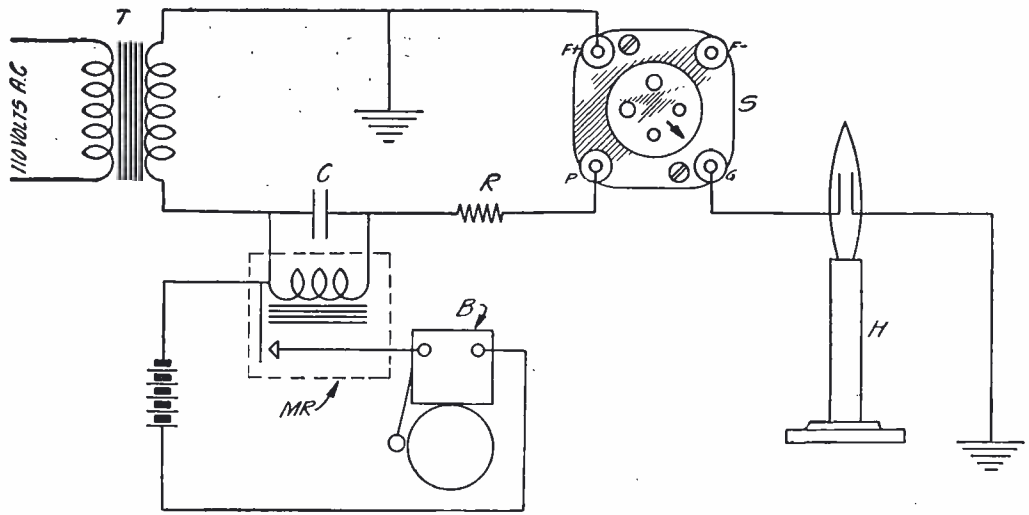
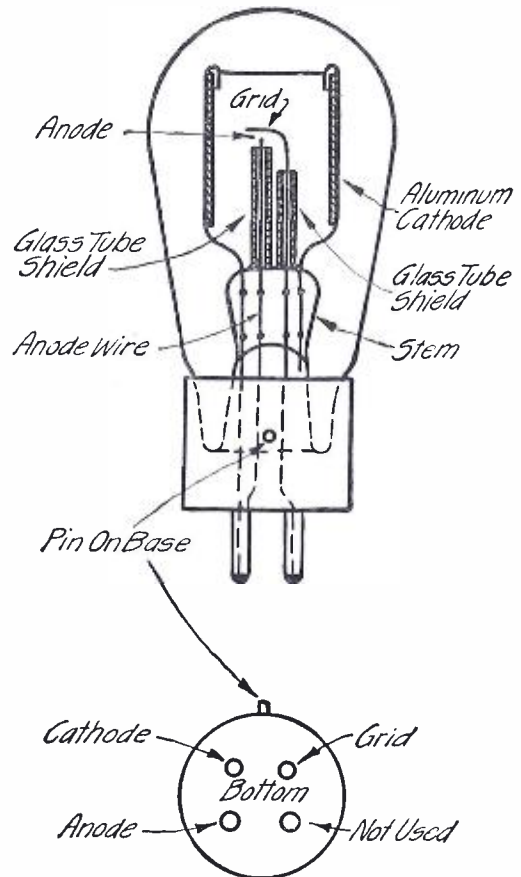

FIGURE 1: This hook-up shows the connections of the grid-glow relay when acting as a detector of flame. The transformer produces 440 volts alternating current between the anode and cathode of the relay. The grid of the relay is connected with a wire projecting into the flame. Ions in the flame permit the charge to leak off this grid to the ground wire and allow the relay tube to operate. If the flame goes out, the leakage ceases and the tube current stops. The relay circuit may be arranged to ring the signal bell either if the flame starts or if it goes out.

Knowles, the capacity of the body of someone who stops in front of a store window is made to start the window lights or to operate electric circuits displaying a series of signs inside the window, starting a revolving display machine, or otherwise amusing the inlooker, all quite automatically.

FIGURE 2: The aluminum cylinder which forms the cathode is connected to one terminal of a standard radio-tube base and the anode wire to another. The grid wire comes out to the grid terminal of the base, the fourth terminal remaining unconnected.



## It Happens in the Best of Sets

### A Monologue That Every Fan Will Recognize

"OH, hello, Smith! Come in, you're just in time; we were getting WAQW just a while ago—that's Omaha, you know. I'll get some good station for you in a jiffy—this radio certainly is a jim-dandy—best ever.

"I think I hear someone now. . . . Let's see, that ought to be KHJ. . . . I'll have him in just a minute; sometimes, you know, it's a trifle hard getting tuned in. There's so many on the air—it's hard tuning them all out. . . . Um, guess they're not on to-night. . . . Well, I'll try someone else. Let's see, now, what's doing at . . . Oh, mother, is WLZB on the air to-night?

"I think it is; let's see, what is their wavelength? . . . You know, Bob, I've sure been having a wonderful time with this radio—yes, indeed—best in the country; wonderful range, volume, all that sort of thing. And so simple, too; easy to handle. . . . Ah, here's someone. . . . No, I guess not; thought I heard someone then. . . .

"That's funny; don't seem to be anyone on the air to-night. . . . What time is it? The air ought to be full of 'em. Wonder if London's trying to get through to-night? . . . H'm, let's look at these tubes; well, they seem to be all right. . . . The aerial seems to be in

the correct position. . . . That is funny. H'm.

"What? Going already? Why, Bob, I haven't had anyone yet; you *must* hear someone. . . . I'll have them in just a minute. Why, you've just come over—and you came to hear it. Well, if you *must*, I suppose you must, but do drop in again, Bob, by all means. . . . Good night!

"H'm now let's see . . . what is wrong with this confounded thing, anyway? . . . Whoa! Gee whiz, I forgot to turn on the switch. . . . Oh, Bob; say, *Bob*—HEY!"

—FRANK ROMANO.

# The Biggest Radio Vacuum

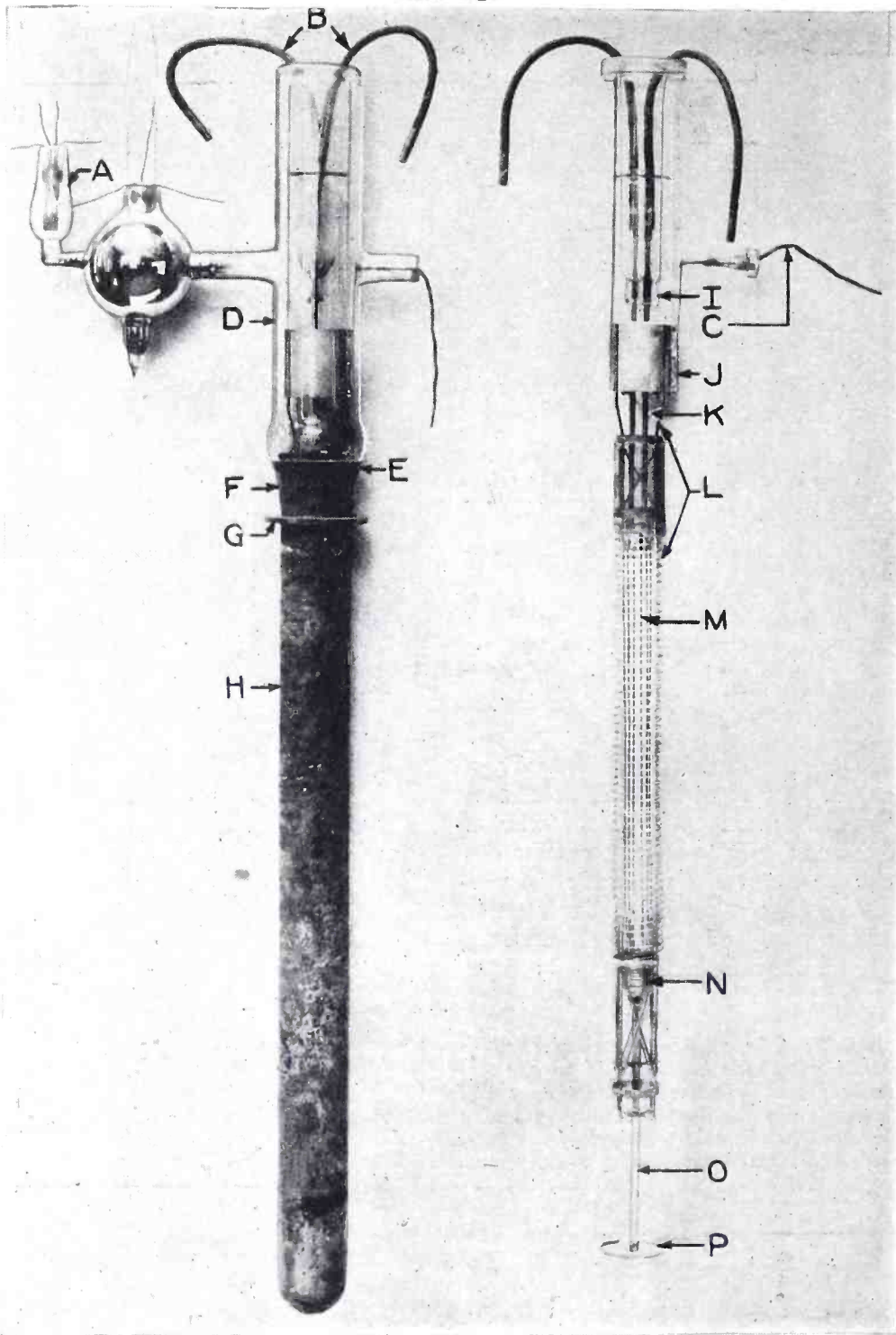

General Electric

## TWO VIEWS OF THE 100-KILOWATT VALVE

At the left is an outer view of the valve; the picture at the right shows the elements inside of the tube. A is the ionization gauge; B, the filament leads; C, grid lead; D, the high-tension bushing; E, the glass junction to the copper anode; F, the anode seal; G, the securing flange; H, the anode proper; I, the filament pinch seal; J, the grid clamp; K, the inner filament leads; L, the tungsten grid; M, the filament wires; N, the filament support; O, the quartz support, and P, the spacer disk.

AND now comes the colossal 100 kilowatt tube (or "valve," as it is properly called)—the greatest of the gigantic valves to bear the designation of "the grandfather of all valves."

Picture a valve that stands nearly two feet higher than the average man; that weighs a hundred pounds, and that is 400,000 times as powerful as the ordinary valve in a radio receiver, and you

will get an approximate idea of this newest product of the radio laboratory.

For the past few weeks the high-powered transmitter of WGY, at Schenectady, N. Y., has been using this transmitting vacuum valve, thus marking the first practical use of a valve of this size by any broadcasting station. It takes the place of eight 20 kilowatt valves in WGY's transmitter.

With such a transmitting valve available, engineers of the General Electric Company will be able to carry on their investigations in broadcasting on higher powers than have ever before been possible.

Up to the present time 50 kilowatts in the antenna has been known as "super-power," but with valves of an output of 100 kilowatts at hand, investigations will be possible up to 500 kilowatts or more. The 100 kilowatt vacuum valve is used as a high-frequency amplifier, fulfilling in the transmitter a use comparable with the high-frequency stages in most receivers. In the receiver a very weak, high-frequency oscillation is picked up by the antenna. This excites the high-frequency amplifier valve which amplifies the power or signal. In the transmitter, the output of one 20 kilowatt valve is amplified by the 100 kilowatt valve.

In the development of the 100 kilowatt valve the research laboratory had to devise an entirely new structural design to provide necessary strength and durability. Outside of its water jacket the new valve stands five feet high and two thirds of this height consists of the copper envelope, which is four inches in diameter. The envelope serves a double purpose, for it not only contains the elements of the tube but is itself the anode or plate.

The upper portion of the valve is made of glass through which protrude the insulated filament leads and the grid lead. The glass bulb is twenty-two inches long and four inches in diameter and it is sealed to the spun out end of the copper anode cylinder in such a way that the junction of glass and copper is mechanically strong and vacuum tight.

Two copper cables of a size capable of carrying a current of several hundred amperes act as leads and are connected to tungsten rods which in turn pass through a "pinch" seal terminating as inner filament leads at the filament ends. Three lengths of tungsten wire, each about 16 inches long, connect to each of the inner leads, forming six parallel filament spans. These pass within the grid and meet at a common point at the filament spring suspension in the lower end of the valve.

The grid, within the copper envelope, is cylindrical and has an overall length of three feet, five inches. The grid frame is a most ingenious structure of molybdenum and tungsten. Bracing, such as is commonly used in steel bridge and tower construction, provides maximum strength with a minimum of

# Valve in the World

By  
W. T. MEENAM

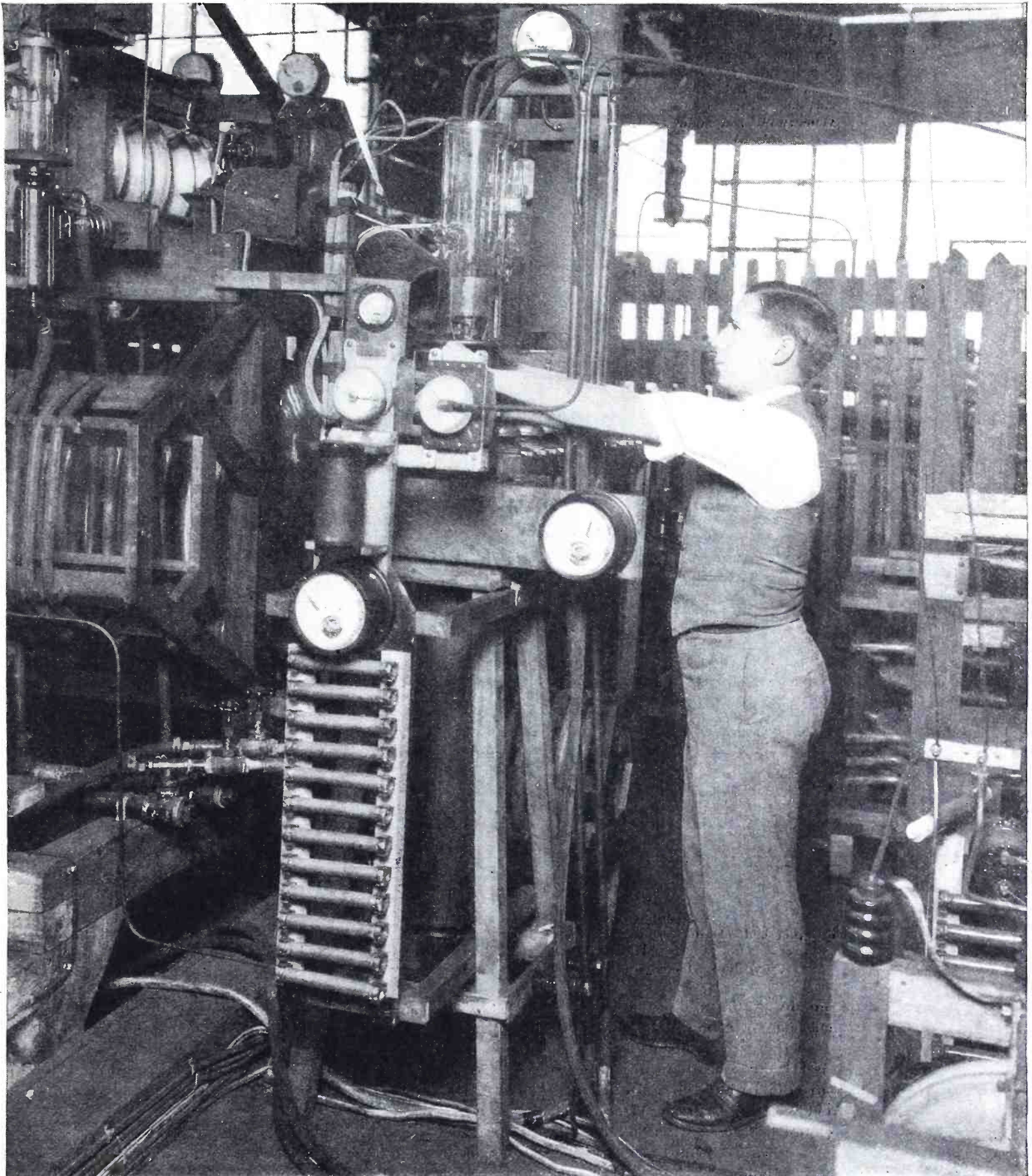

General Electric

## THE GIANT VALVE IN USE AS A TRANSMITTER

*In the center of the picture may be seen the new monster valve, with part of the accompanying apparatus for its control. It generates high-frequency oscillations of the most powerful order of any that have ever been propagated by a single tube.*

metal. Sufficient rigidity and strength are necessary in this construction to prevent short circuiting from sagging.

To guard against failure due to large

pressure increases in the valve, a pressure gauge or, more properly, an ionization gauge is used on the 100 kilowatt valve. This gauge takes the form of

a special three-element vacuum valve.

This gauge operates on the principle of the ratio of ionization by collision with electrons to the amount of gas present.

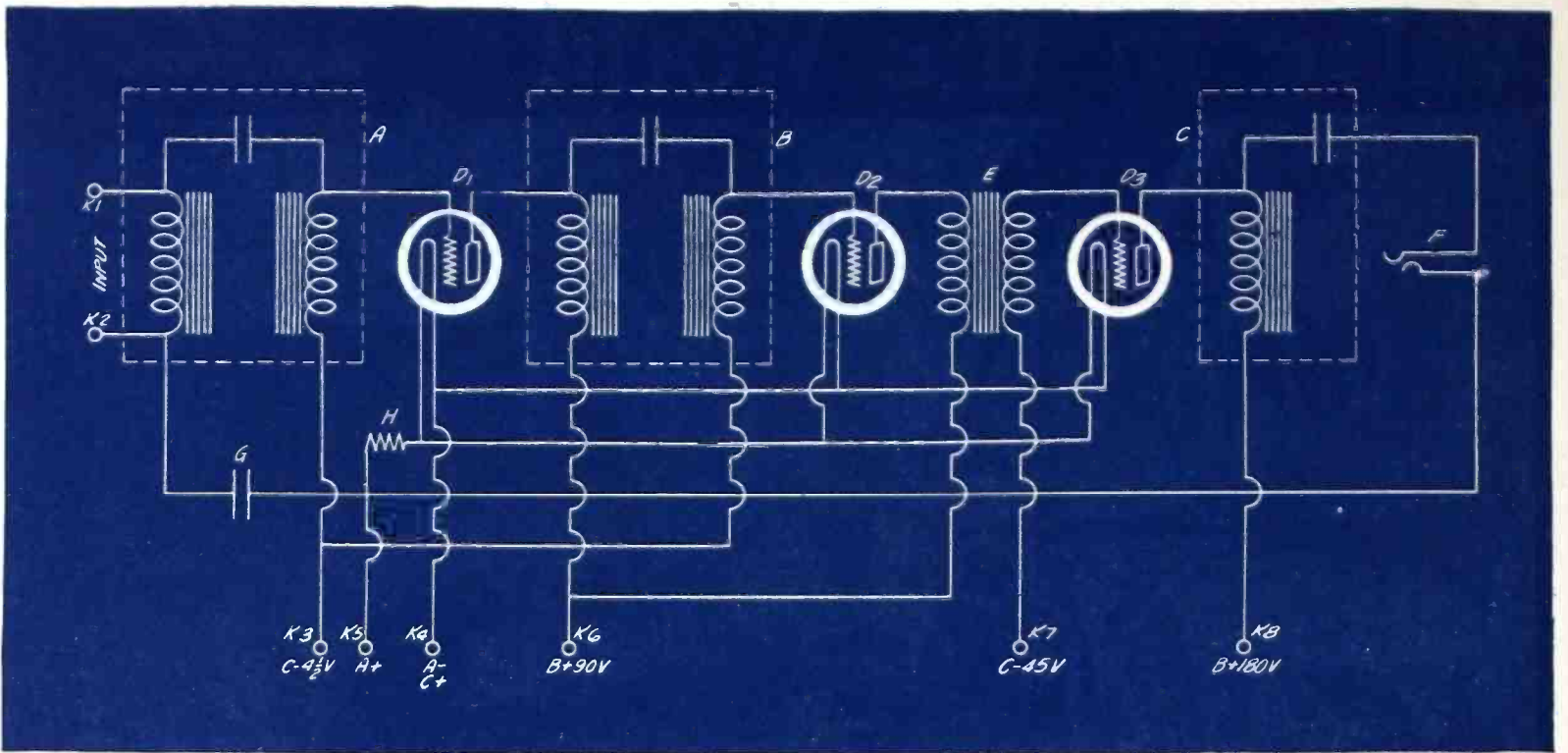

THE SCHEMATIC WIRING DIAGRAM

FIGURE 1: In the electrical circuit employed in this amplifier unit the first two stages of amplification contain two separate units that include two low-frequency chokes and a coupling condenser; the third stage is a regular transformer-coupled stage with a low-ratio transformer. The output contains a filter unit consisting of a choke and a suitable high-voltage condenser. To keep the direct current from the windings of the reproducer, two regular tubes are used in the first and second stages, with a power tube in the last stage.

The list of parts given on page 541 includes the exact instruments used in the laboratory model of this receiver. The experienced amateur, however, will be able to pick out other reliable makes of instruments which have been approved by POPULAR RADIO and which may be used with good results. But we recommend that the novice follow the list, as the diagrams in this article will tell him exactly where to bore the holes and exactly where to place the connections. If instruments other than the ones listed are used, the only change that will be necessary will be the use of different spacings for the holes that are drilled in the sub-base for mounting the instruments. To any reader who has difficulty in obtaining any of the parts which are necessary in making up these model receivers, POPULAR RADIO SERVICE BUREAU, 627 West 43rd Street, New York City, will gladly assist in seeing that his requirements are promptly supplied.

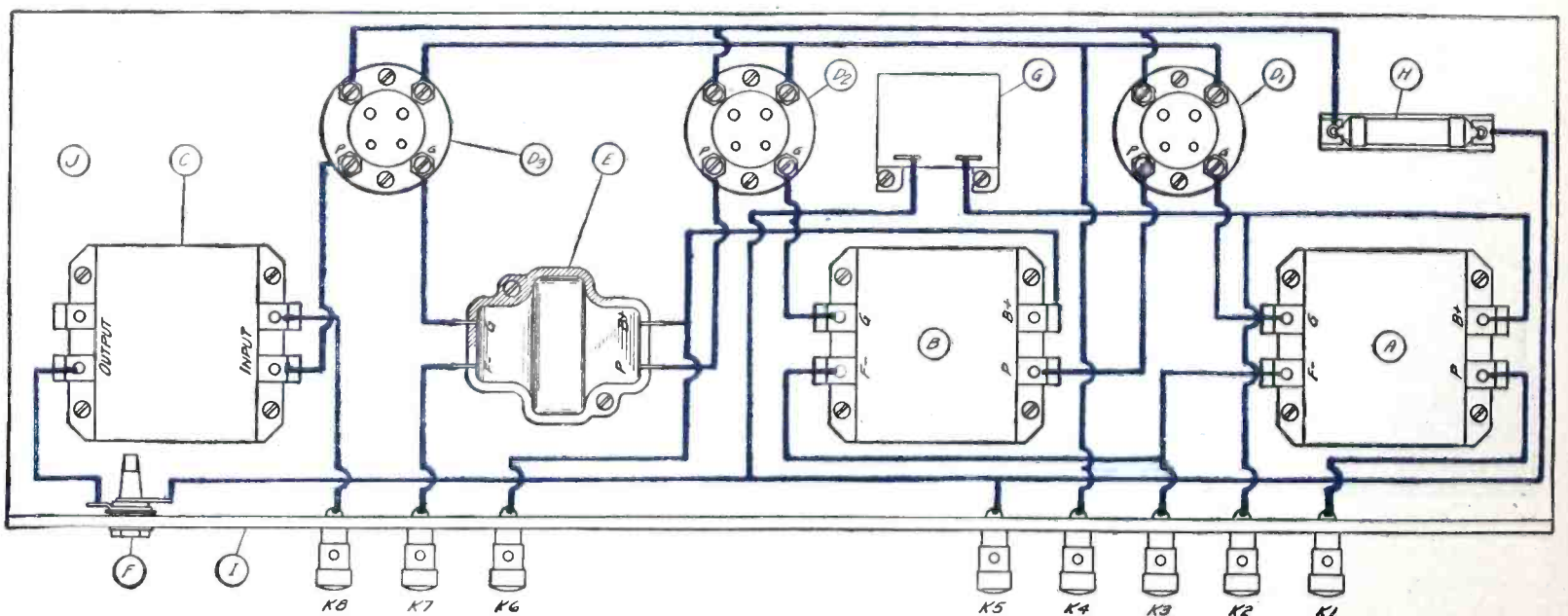

HOW TO WIRE THE UNIT

FIGURE 2: This diagram gives the general layout of the instruments in this unit, with the exact electrical connections to be made. The instruments are outlined in black; the blue lines indicate the wiring. As there are no critical positions for the instruments, exact spacing on the baseboard is not necessary. If this diagram is followed by the constructor, there will be no trouble in getting the unit to function properly.



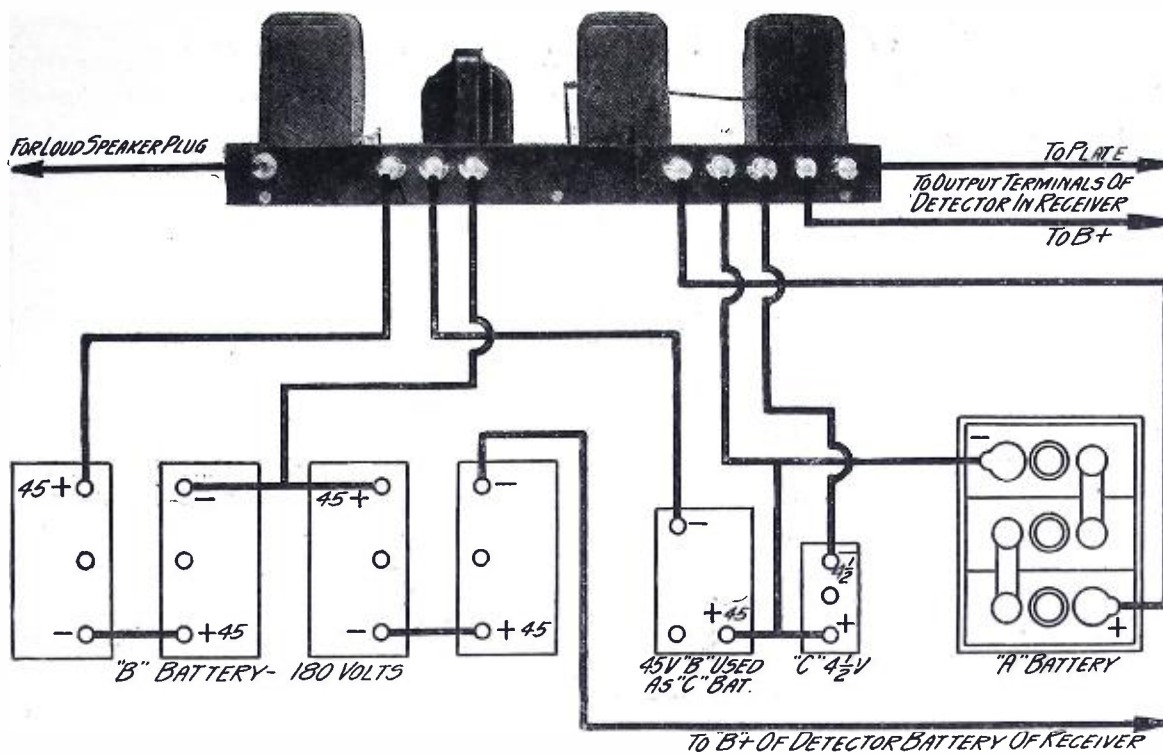

HOW TO HOOK UP THE NEW AMPLIFIER

FIGURE 3: This diagram shows how the amplifier is put into action. In the lower part are the connections with the "A," "B" and "C" batteries. The leads to the reproducer and to the detector circuit are shown in the upper corners.

# How to Get Quality Amplification

NUMBER 3: Here are the constructional details for building a low-frequency amplifier that you can use just as successfully with your old receiving set to better the quality of amplification as with your new receiver. It employs two stages of double impedance coupling and one stage of transformer coupling with an output filter.

By THE TECHNICAL STAFF

COST OF PARTS: Not more than \$32.00

HERE ARE THE PARTS THAT WERE USED IN THE LABORATORY MODEL OF THIS UNIT—

- A and B—General Radio double-impedance couplers, type No. 373;
- C—General Radio speaker filter, type No. 387-A;
- D1, D2 and D3—General Radio sockets, type No. 349;
- E—General Radio low-frequency transformer, type No. 285, ratio 1-2.7;

- F—Carter short jack, No. 1;
- G—Tobe paper output-filter condenser, 2 mfd.;
- H—Elkay equalizer, type 1, for use with four UX-201-a type valves equipped with mounting;
- I—Bakelite binding-post strip, 1½ by 16 by 3/16-inch;

- J—Wooden baseboard, 6 by 16 by ½-inch;
- K1, K2, K3, K4, K5, K6, K7 and K8—X-L push posts, lettered as follows: Two marked, "C" battery minus (—), "A" minus (—), "A" battery positive (+), "B" 90 positive (+), "C" battery minus (—), Amp. "B" positive (+), respectively.

THIS new amplifier is especially designed to bring out the low tones of speech and music with exceptional volume; at the same time it preserves an equal amplification over the middle range of audible frequencies as well as the upper range.

The amplifier pack consists of two stages of double impedance-coupled amplification followed by one stage of low-ratio transformer-coupled amplification equipped with an output filter consisting of a suitable choke and high-voltage condenser unit.

This amplifier may be incorporated in place of the old-fashioned amplification scheme in any old receiver to bring the quality of reproduction up to date, or it may be used with a new model that the experimenter is building in his home.

The model described was designed especially for this purpose by the staff of POPULAR RADIO EXPERIMENTAL LABORATORY, and it has been fully tested out and its outstanding features noted.

The schematic wiring diagram of the circuit used in the amplifier pack to be described is shown in Figure 1.

### How to Construct the Unit

To build the amplifier pack, cut the baseboard, J, to the proper size, 6 by 16 by ½-inch. Then prepare the binding-post strip, I, as shown in Figures 2 and 4. The dimensions for the binding-post strip are 1½ by 16 by 3/16-inch.

The eight binding posts, K1, K2, K3, K4, K5, K6, K7 and K8 and the jack, F, are then fastened to this strip in the order shown in Figure 2.

Now the various instruments, including the couplers and the transformers, the sockets, filament resistor and the out-

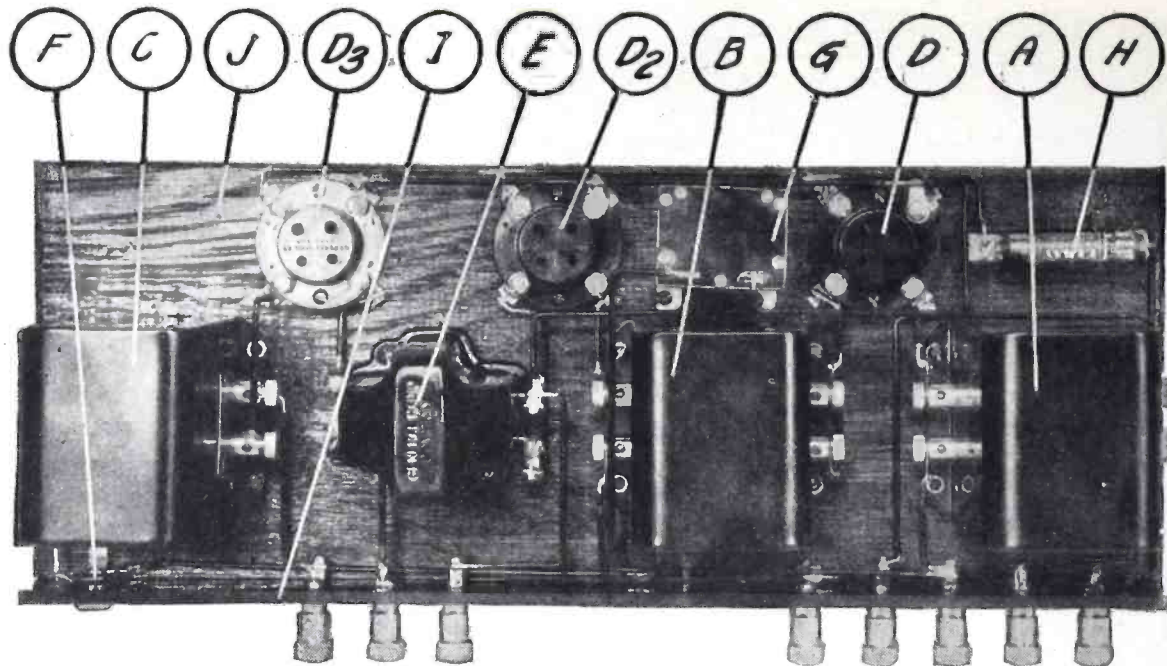

A VIEW OF THE AMPLIFIER FROM ABOVE

FIGURE 4: In this illustration the arrangement of the apparatus mounted on the baseboard is clearly shown. The eight binding posts are mounted on a connection block that runs the whole length of the baseboard.

put filter, may be mounted on the baseboard, J. Next attach the binding-post strip, I, to the baseboard by means of three strong wood screws inserted through the strip and into the edge of the baseboard.

The wiring should be done exactly as shown in Figure 2; this carries out the wiring scheme given in the schematic drawing in Figure 1.

When the wiring is completed, the unit is ready to be installed.

In Figure 3 is shown the method for connecting the unit to the batteries and to the detector circuit of the set with which the amplifier pack is to be used.

Insert two UX-201-a type valves in sockets D1 and D2, and insert a UX-171 type valve in the socket D3, which is the power stage.

When the vacuum valves have been placed in their respective sockets, the amplifier pack is ready for use. It

should be used with a high quality reproducer that is capable of reproducing all the tones, both high and low, that the amplifier furnishes. The reproducer is plugged into the amplifier pack by means of a phone plug inserted into the jack, F.

The receiver with which this unit is used may be tuned in the usual manner and the quality of reproduction will be found to be almost astonishing in its clarity and great volume.

## DISTRIBUTION of BROADCASTING STATIONS of the UNITED STATES

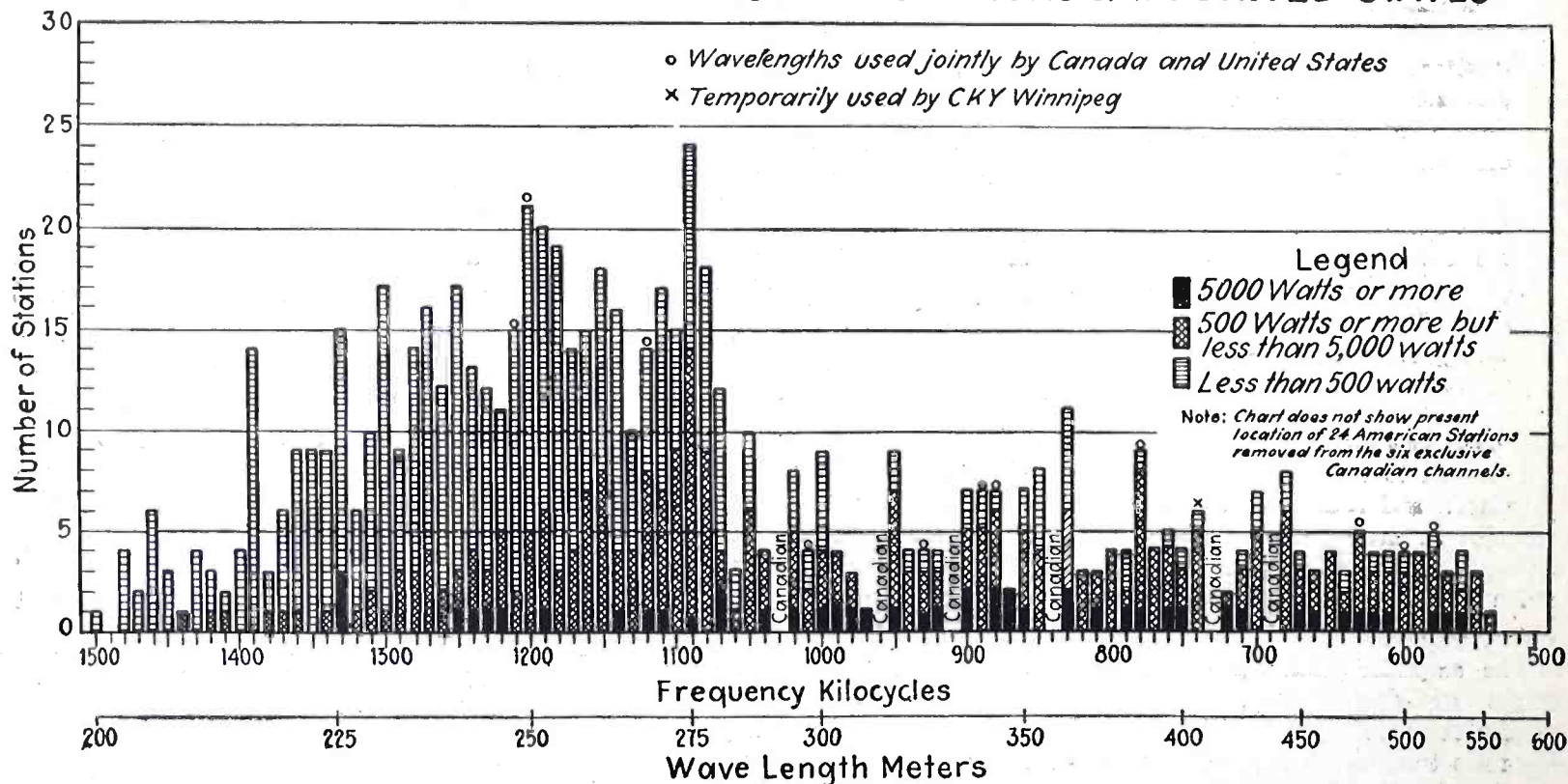

This chart shows the latest figures on the number of American broadcasting stations operating on the various broadcasting wavelengths; it also shows the location of the spectrum of the eighteen channels that are now being used by Canadian stations (six of which are exclusive and twelve of which are shared with American stations).

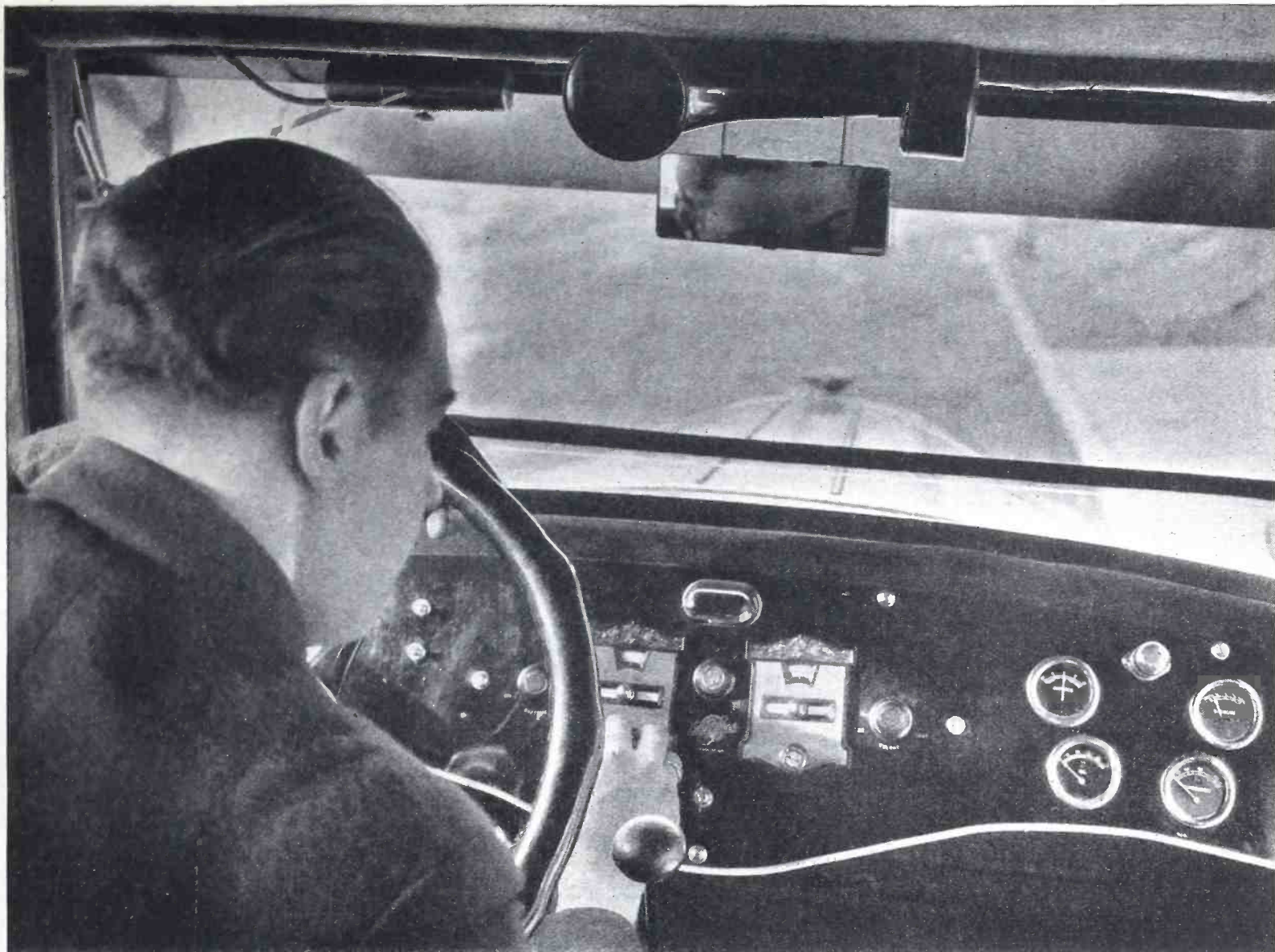

From a photograph made for POPULAR RADIO

### A RADIO RECEIVER THAT YOU TURN ON LIKE THE HEADLIGHTS OF YOUR CAR

FIGURE 1: The tuning controls are an integral part of the dash-board, and are within easy reach of the driver. The reproducer may be seen at the top of the windshield.

# Just a Dash-Board of Reception

Here is an ingenious and highly compact radio installation that provides for a receiver hidden behind the control board of your motor car, an antenna concealed in the top, batteries installed behind the seat—and a miniature loudspeaker set up over the mirror.

By LAURENCE M. COCKADAY

**I**F C. A. Duryea, the inventor and driver of the first "horseless carriage," had known of radio back in 1892, he probably would have started experimenting then with the installation of a receiving set in his historic motor car.

Ever since radio broadcasting's earliest days the idea of radio as an accessory to the automobile has persisted, and although there have been many more or less successful attempts to reach a practical solution (such as the use of portable sets, sets installed on the running board, sets installed in a carrier trunk at the

rear of the car and numerous other makeshifts), only recently has a practical installation been developed for the radio fan who is also a motorist.

This new type of installation, which has been developed especially for motor work, is the outcome of long experiment and research by William Heina, the designer. He has finally developed a receiver sensitive enough to work inside the steel body of any type of automobile.

This novel installation consists of three stages of high-frequency amplification with three tuned circuits, and

operates by two dials. Two stages of low-frequency amplification produce enough volume to operate the loudspeaker. The set is contained in a heavy steel cabinet of small dimensions and is installed back of the dashboard with the two controls easily within the driver's reach, as shown in Figure 1.

The receiver in no way interferes with either the room in the car or the controlling mechanism, from a driver's standpoint.

The dashboard that carries the radio set is made up in standard designs for va-

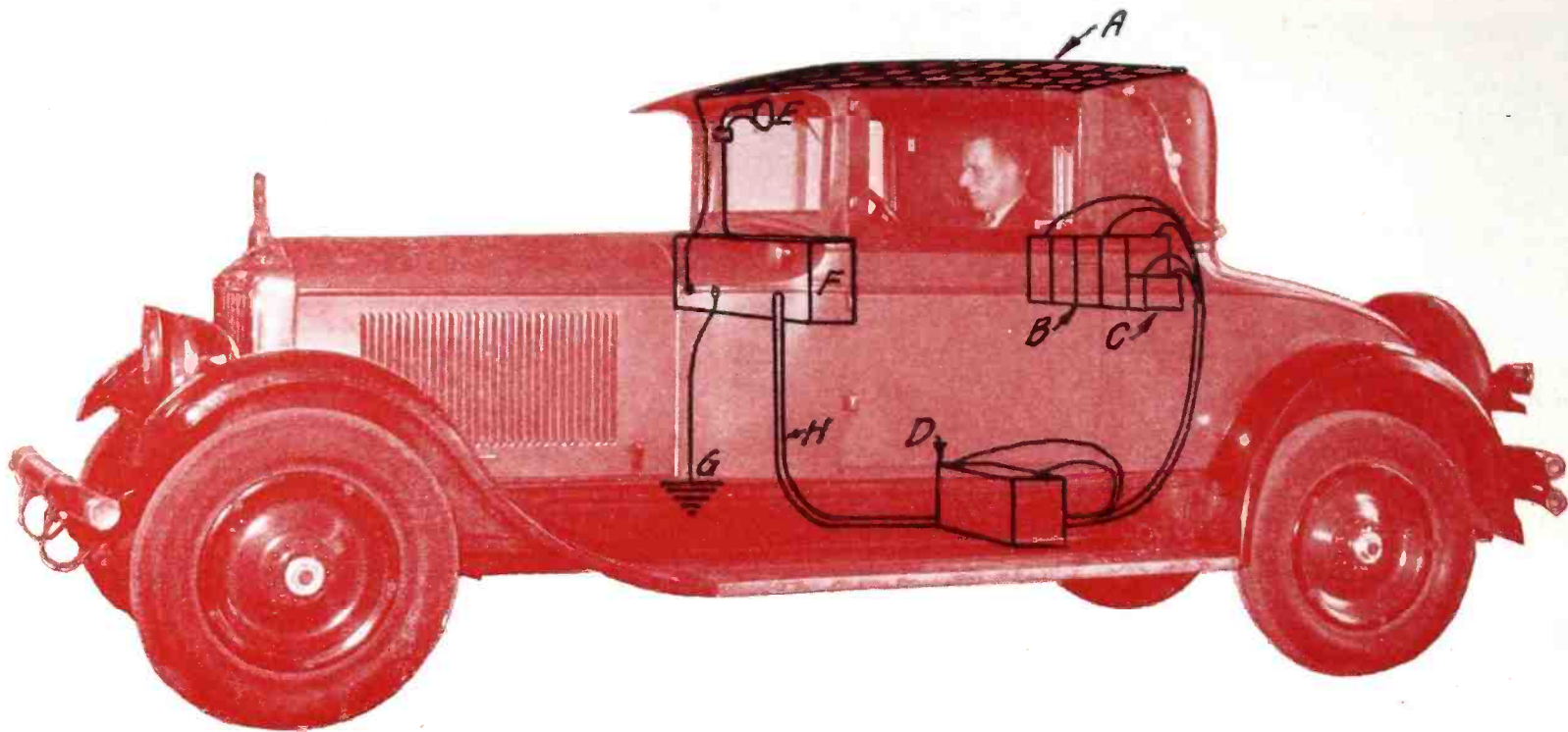

HOW THE NEW SYSTEM IS INSTALLED

FIGURE 2: The antenna, A, consists of a copper mesh erected between the outer and inner upholstery of the top of the car. The "B" and "C" batteries are installed in any convenient compartment, in this case in the back of the seat. The "A" battery, D, is the automobile storage battery used in starting and lighting; E is the loudspeaker; F, the set proper; G, the grounding, which is made on the chassis; and H is the armored cable that connects the battery to the set.



From a photograph made for POPULAR RADIO

INSTALLING THE "B" BATTERY

FIGURE 3: This picture shows how the "B" batteries may be fastened snugly in place underneath the front seat of a five-passenger touring car. Three standard sized "B" batteries are used.

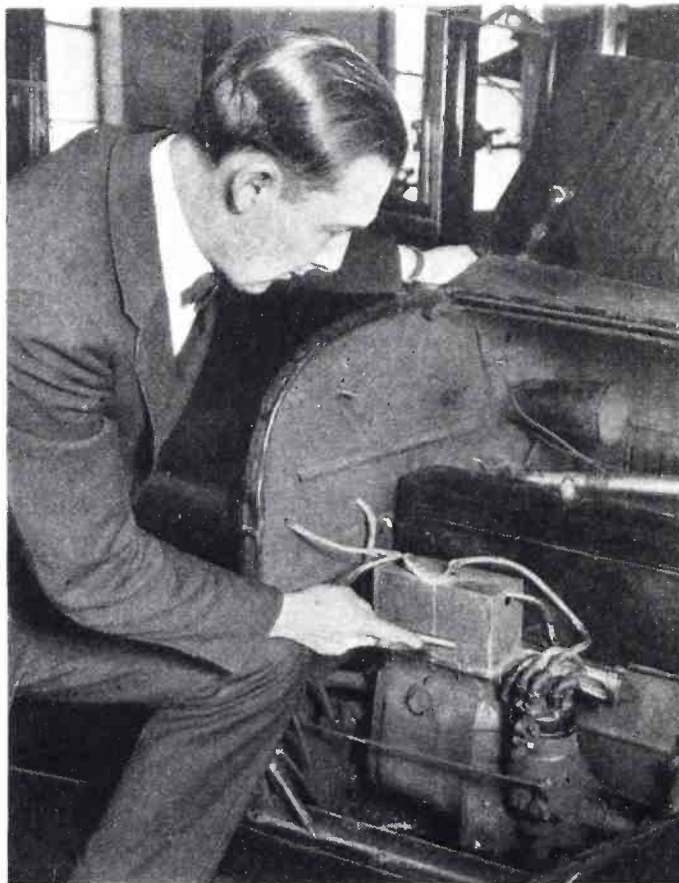

From a photograph made for POPULAR RADIO

ELIMINATING INTERFERENCE BY SHIELDING

FIGURE 4: The man in the picture is pointing at the copper shielding on the ignition coil. Notice also the copper shielding covering the wires leading to the coil.

rious types of cars, and the whole set, including the aerial, loudspeaker and "B" batteries, may be installed within two or three days' time. The appearance of the car remains exactly the same as before, with no exposed wires or accessories other than the small loudspeaker that is shown above the mirror in Figure 1.

In preparing an installation of this type, a small capacity antenna, consisting of a strip of copper mesh, is installed in between the outer and inner coverings of the top and the lead-in wire is brought down through the sides of the body where it will be out of the way and invisible.

In Figure 5 is shown an antenna installation in process of construction. The inner upholstery has been loosened and the copper mesh is being applied, after which the inner upholstery will be put back. The antenna thereafter will be an integral part of the car, but it will be out of sight and out of the way. An antenna of this type is non-directional and reception will be equally good with the car pointed in any direction. This is an advantage over the loop type of antenna for a car.

The "B" batteries used in the receiver are installed either in one of the seat compartments or in the luggage carrier or package compartment. They are fastened securely so that they cannot bounce around or rattle and are connected to a special battery cable manufactured for the purpose and covered with a metal sheath.

The car battery is used for the "A" battery. A typical battery installation is shown in Figure 3.

In actual demonstrations the author has found the receiver to be entirely satisfactory for reception up to 100 miles either during the day or at night, and on a number of occasions distances up to



From a photograph made for POPULAR RADIO

#### HOW THE ANTENNA IS HIDDEN IN THE TOP

FIGURE 5: *The copper wire screen used for the capacity pick-up is attached in between the outer and inner upholstery of the roof, so that when once installed it is out of the way, as well as out of sight; no visible wires are left hanging.*

1,000 miles have been received in the evening. In Figure 2 is shown a diagrammatic assembly of the receiver installed in the author's car.

One of the hardest problems to eliminate, in an installation of this type, is the electrical motor noise caused by the ignition and accompanying wiring.

In Figure 4 is shown a method for cutting down such interference. It consists of a shielded compartment for the coil and shielded wires running to the distributor head and to the spark plugs. This shielding, of course, must be grounded to the frame of the car, which

is also used as a ground for the receiver.

During the summer vacation hours this type of receiver will be an especial boon to the motorist, as it may be used to keep him in touch with the world when he is off on a pleasure trip. The car may be parked anywhere and programs received from city stations with ease.

For a vacationist at his country home a loudspeaker extension cord may be run from the garage into the cottage and a loudspeaker installed right in the living room. It may be tuned to the best station and will serve for dance music or other forms of broadcast entertainment.

## A Remarkable Music-Making Appliance

In the July issue of POPULAR RADIO will appear an article that will be of immense interest to music lovers, to owners of radio receivers and of phonographs alike. The article will tell how to convert any phonograph into an electrically operated music-making device of the highest order. The article will give all of the details of the changes that are necessary to obtain reproduction from the phonograph that in both quality and volume is every bit as good as the finest radio reproduction—because radio principles are used in it.

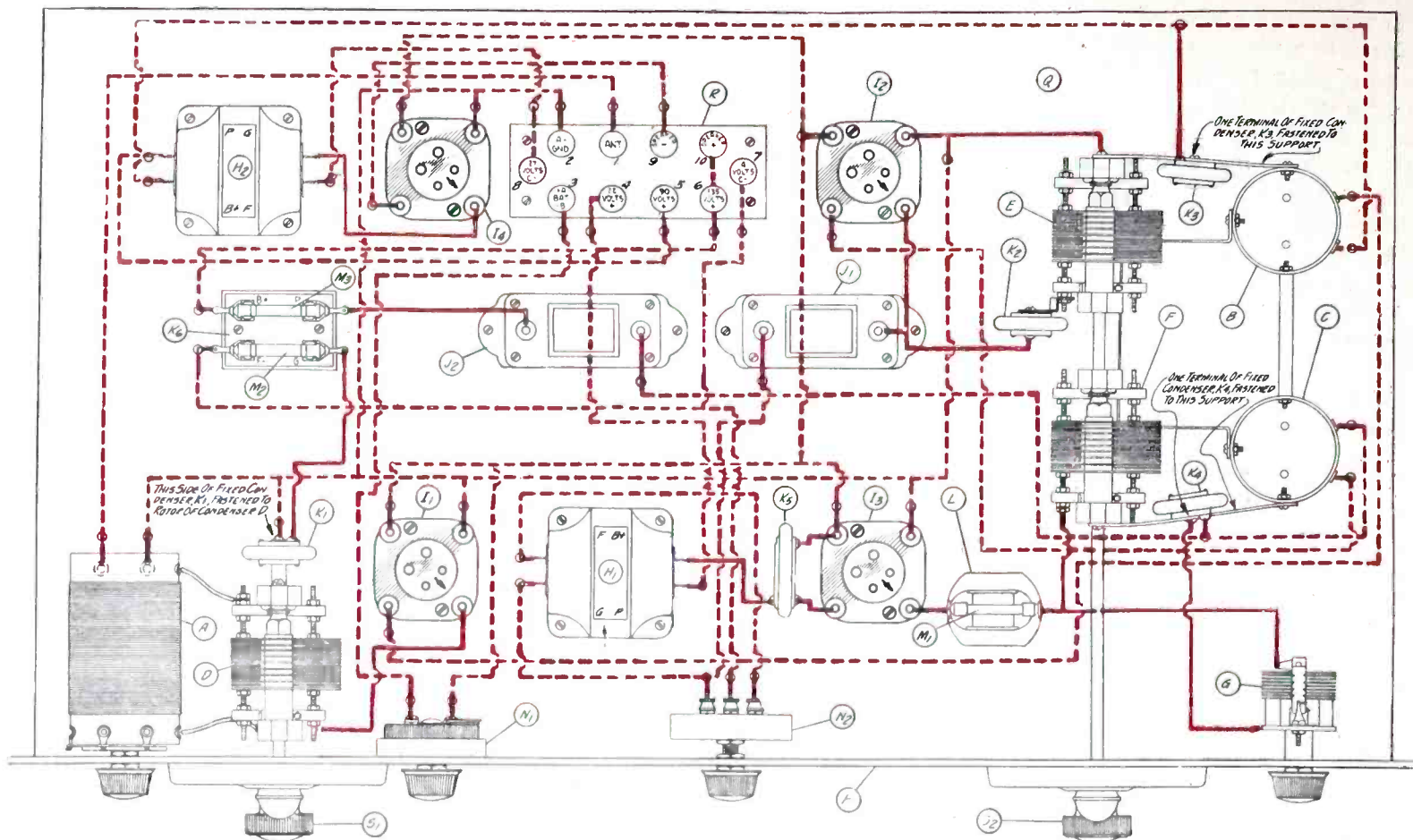

THE PICTURE WIRING DIAGRAM

FIGURE 1: In this drawing all the parts that are mounted on the panel and on the base-board are drawn in BLACK lines. All of the wiring that is in view on top of the panel is shown in heavy RED lines and the wiring beneath the panel is indicated in dotted RED lines. The BLACK circles show where the wires go through the panel.

HOW TO ASSEMBLE

# The RGS RECEIVER

This is the second of a series of articles on the assembly and operation of popular kits of parts that may be obtained for building really good radio receivers. The series differs from the "How-to-build" articles, in that the sets described have been designed outside of the POPULAR RADIO Experimental Laboratory, by commercial engineers. The sets that are selected for description, however, have been carefully tested in the POPULAR RADIO Laboratory and will be chosen for their outstanding features and all-around efficiency.

By JOSEPH CALCATERRA

COST OF PARTS—Not more than \$70.00

HERE IS THE LIST OF PARTS NECESSARY FOR THE CONSTRUCTION OF THE RECEIVER—

- |  |  |  |
|--|--|--|
| A, B and C—National RGS coils;                                 | J2—Grimes filter choke;  | M3—Lynch metallized resistor, .025 megohm;                   |
| D, E and F—National RGS variable condensers;                   | K1 and K2—Sangamo fixed condensers, .00025 mfd.;                       | N1—De Jur rheostat, 2 ohms;                                  |
| G—Hammarlund midget variable condenser;                        | K3, K4 and K5—Sangamo fixed condensers, .001 mfd.;                     | N2—Centralab variable modulator, 250,000 ohms;               |
| H1—Samson low-frequency transformer, 2 to 1 ratio, type HW-A3; | K6—De Jur resistance mounting, complete with coupling condenser;       | P—Westinghouse-Micarta RGS panel;                            |
| H2—Samson low-frequency transformer, 6 to 1 ratio, type HW-A3; | L—Sangamo fixed condenser, .00025 mfd., with grid-leak mounting clips; | Q—Wooden baseboard, 9 by 20 by 1/2 inch;                     |
| I1, I2, I3 and I4—Benjamin sockets, No. 9040;                  | M1—Lynch metallized grid-leak, 2 megohms;                              | S1 and S2—National Velvet Vernier dials, type "B";           |
| J1—Grimes grid choke;  | M2—Lynch metallized resistor, 1 megohm;                                | 10 Eby binding posts and composition connection block strip; |
|  |  | 25 feet Acme flexible Celatsite wire.                        |

THE RGS receiver is the outcome of one man's confidence in the fundamental soundness of the "inverse-duplex" principle of amplification.

Long after others had discarded the idea of reflex amplification, David

Grimes continued to experiment with his own pet circuit, popularly known as the "IDS circuit."

The new RGS circuit is the result of thousands of actual laboratory experiments made by Mr. Grimes and his as-

sistants over a period of three years.

When he started on his experimentation, Mr. Grimes made the following list of desirable characteristics that a receiving circuit should have before it could win his approval:

1. Adequate selectivity;
2. Good tone quality, without loss of volume;
3. Equal selectivity over the whole wavelength range;
4. Equal amplification over the whole wavelength range;
5. Straightline volume control;
6. Sensitivity;
7. Adaptability to all antenna sizes;
8. Adaptability to all localities;
9. Ease of construction and operation.

The experiments which followed were conducted with the object of finding ways and means of incorporating these features in the new receiver.

The circuit finally developed to meet these requirements is shown in Figure 3.

Sharp selectivity over the whole wavelength range was obtained through the use of tuned high-frequency circuits and by the application of a new principle discovered by accident during the course of the experiments. It was found that the use of a resistance-coupled low-frequency stage of amplification, using the resistance coupler, K6, introduced what seemed to be at first a very undesirable factor. The coupling condenser of the resistance coupler provided a high-frequency feedback between the plate circuit of the second high-frequency valve and the grid circuit of the first high-frequency valve. This feedback could be made either to aid or oppose, depending on the polarity of the primary winding of the third high-frequency transformer, C. If it was aiding, the feedback produced oscillations which made the circuit unstable; while if it was made to oppose, the loss sustained reduced the efficiency of the circuit. In an effort to eliminate the effect, a filter choke coil, J2, was introduced as shown in Figure 3. This seemed to help materially in prevent-

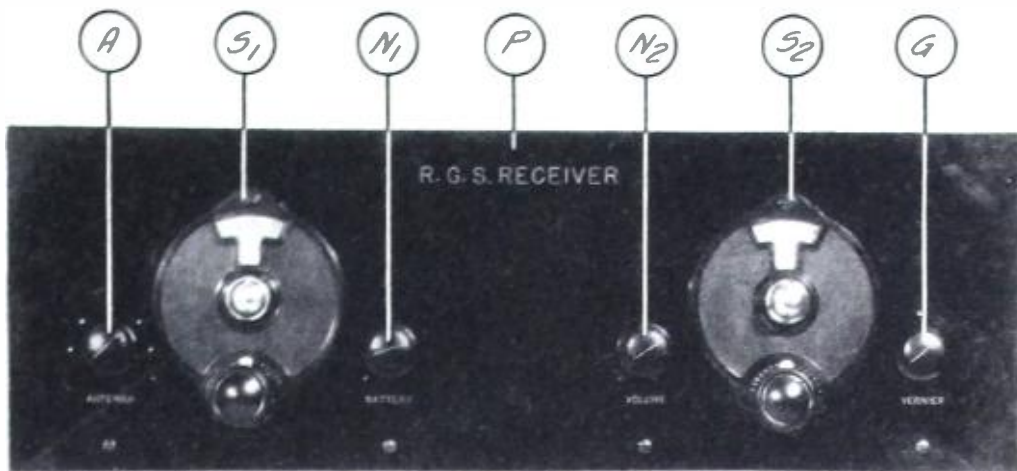

A FRONT VIEW OF THE RGS

FIGURE 2: The various controls on the panel of the new receiver are marked with letters that correspond with the list of parts given at the beginning of this article and with the data in the text.

ing instability or loss of efficiency.

While experimenting to determine the smallest choke coil that could be used to advantage, so as to save unnecessary construction expense, Mr. Grimes discovered to his surprise that with a certain value of inductance and resistance for this choke and the coils of the high-frequency transformers connected for aiding feedback, practically no reinforcement was obtained at the low wavelengths around 200 meters, but that the reinforcement increased as the receiver was tuned to the higher wavelength settings up to around 550 meters.

The result was an automatic means of increasing amplification as the wavelength was increased without instability at the short waves. By a curious coincidence, it was found that this not only gave equal amplification over the whole wavelength range, but also provided equal selectivity over the wavelength range—a condition not obtainable by the usual methods that have been adopted to get equal amplification for all wavelengths.

In operation, the signal energy is amplified at high frequencies in turn by vacuum valves, I1 and I2; after this, rectification or detection takes place in the detector valve. The low-frequency energy is transferred, by means of the low-frequency transformer, H1, into the grid circuit of vacuum tube I2 for the first stage of low-frequency amplification. The schematic diagram of the electrical arrangement may be seen at Figure 3.

It is then transferred by means of the resistance coupler, K6, into the grid circuit of valve I1 for the second stage of low-frequency amplification. Finally it is passed through the transformer, H2, to valve I4, which serves as the last low-frequency amplifier.

We have, therefore, the equivalent of two stages of high-frequency amplification, a vacuum valve detector and three stages of low-frequency amplification, using four vacuum tubes instead of six.

The use of a resistance-coupled low-frequency stage, sandwiched in between the two transformer-coupled stages, pro-

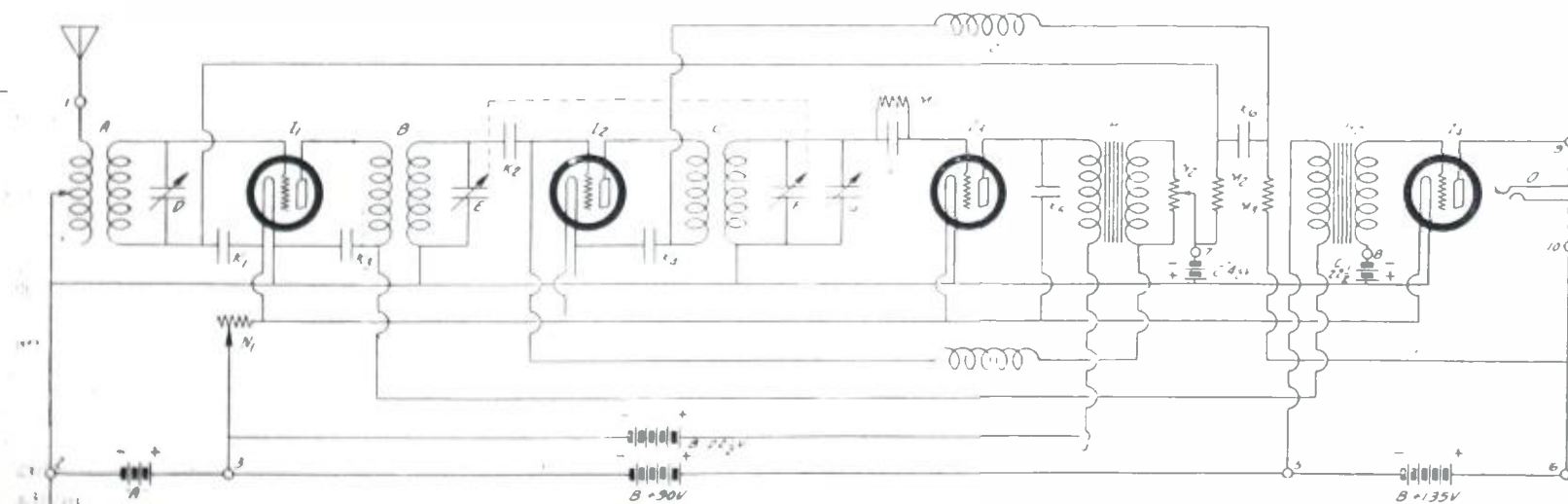

THE SCHEMATIC DIAGRAM OF THE ELECTRICAL CIRCUIT

FIGURE 3: In the theoretical wiring of the RGS receiver, notice the peculiar connection of the choke coil, J2, shown at top of diagram, which is so designed that it makes the amplification obtained uniform over the whole band of frequencies covered by the receiver.

duces excellent tone quality. The howling due to resonance and feedback effects, usually encountered when a number of transformer stages are cascaded, is eliminated by the resistance stage.

A 250,000-ohm potentiometer across the secondary of the first low-frequency transformer gives an even variation of volume from minimum to maximum and also provides very good quality by preventing overloading of the audio tubes by strong local signals.

The use of a separate "B" battery for the detector prevents howling from coupling effects as the batteries become run down. A tap switch on the antenna coil of the first high-frequency transformer, A, permits increasing or shortening of the electrical length of the antenna. Taps are provided at the second, fourth, eighth, sixteenth and thirty-second turns of the primary winding; this feature makes it easy to adapt the receiver for use on different sizes of antennas and for varying distances from broadcasting stations. It also makes it possible to vary the degree of selectivity and provides a means of controlling the energy input to the detector circuit to avoid overloading the detector tube.

A special isolating circuit consisting of a grid choke, J1, and a fixed condenser, K2, is used to isolate the tuning condenser circuits of condensers E, F and G from the low-frequency circuits of transformer H1, thus eliminating the body capacity effects usually found in unshielded receivers.

Variable condensers E and F are ganged together for simplified operation

and a small auxiliary tuning condenser, G, is provided for fine tuning.

A 2-ohm rheostat, N1, gives a fine adjustment of filament voltage for all vacuum valves.

Valves of the UX-201-a type are used for the first high-frequency and second low-frequency valve, I1, and for the second high-frequency and first low-frequency tube, I2. A UX-200-a type valve should be used as the detector, on account of its sensitivity with volume and noiseless operation on distant stations. This type of valve usually requires a few minutes before it warms up, but it will then give reception with remarkable sensitivity. A UX-171 type power valve should be used for the last valve, I4. This type of tube will give full volume without distortion or overloading. High "B" battery voltages are sometimes recommended when this valve is used, but excellent results will be obtained with 135 volts of "B" battery. A negative grid bias is provided for all the amplifier valves, thus increasing battery and valve life and also eliminating distortion and overloading.

*How to Build the Receiver*

The construction of the receiver is a simple matter. The parts are easily mounted on the drilled panel and the wood baseboard. While it is possible to get good results even though the location of the parts is changed, best results with a minimum expenditure of time and effort will be obtained by following the layout shown in Figures 1 and 4.

After all the parts are mounted, you can proceed with the wiring of the re-

ceiver, using the flexible wire provided with the kit. All the grid connections and most of the plate connections should be made on the top side of the baseboard, Q, to keep the leads short and avoid interaction and pickup. Most of the rest of the wiring can be done by running the longer leads through the baseboard and along the under side. In running the leads, work on the principle that a straight line is the shortest distance between two points.

The exact wiring of the instruments in the receiver, and the connections for the antenna, ground, reproducer and batteries are clearly shown in Figure 1, and do not require any further explanation.

*How to Operate the Receiver*

While the operation of the receiver is a simple matter, a few pointers will prove of value in getting maximum efficiency in tuning.

The pointers on the antenna, battery and volume control knobs (see Figure 2) should be set to the dots on the panel when the knobs are turned as far as they will go in a counter-clockwise direction. The pointer on the vernier knob should be set to the dot when the rotor plates of the condenser are half out. The tuning condenser dials, S1 and S2, should be set to the "100" position when the rotor plates are all in mesh with the stator plates of the condensers.

To get the set into operation, turn all the knobs so that the pointers point directly up toward the top of the panel. Then tune in a local station having a wavelength of about 400 meters. Loosen

*(Continued on page 573)*

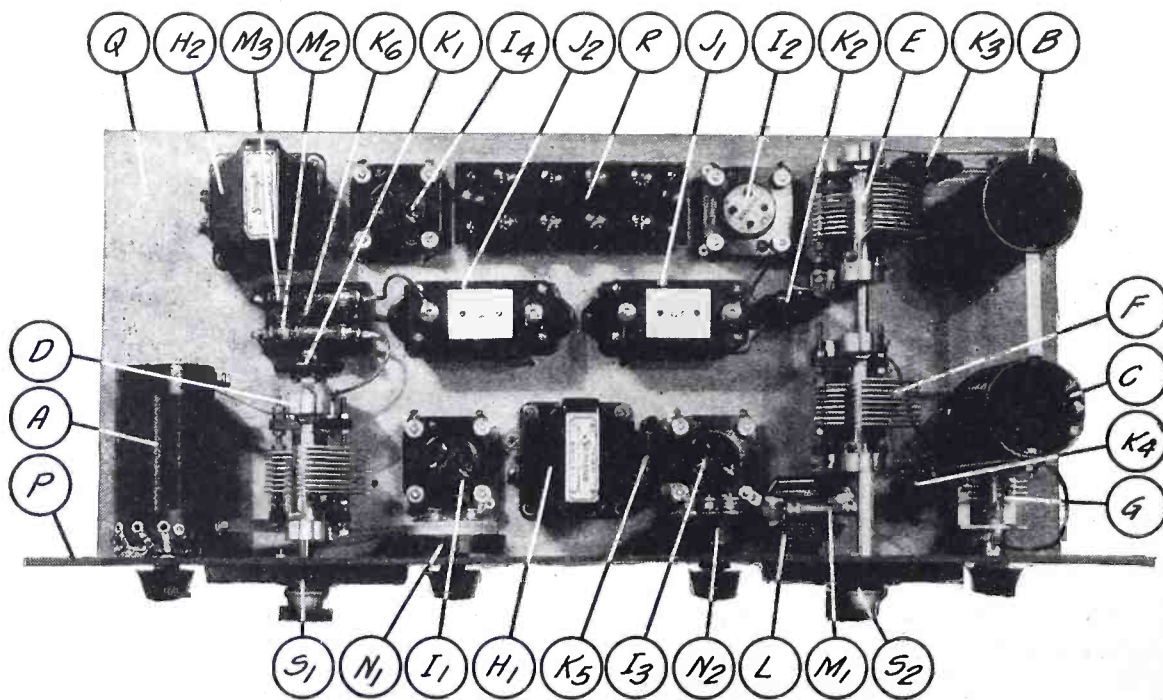

A VIEW OF THE SET FROM ABOVE

FIGURE 4: This shows the general arrangement of the apparatus on the baseboard and on the front panel. The neat arrangement makes for ease of assembly and also simplifies the wiring of the instruments.



**Q** This series of articles is designed for the particular benefit of the home experimenter—for the radio fan who wants to increase his efficiency and add to his pleasure by the correct use of the common laboratory tools.

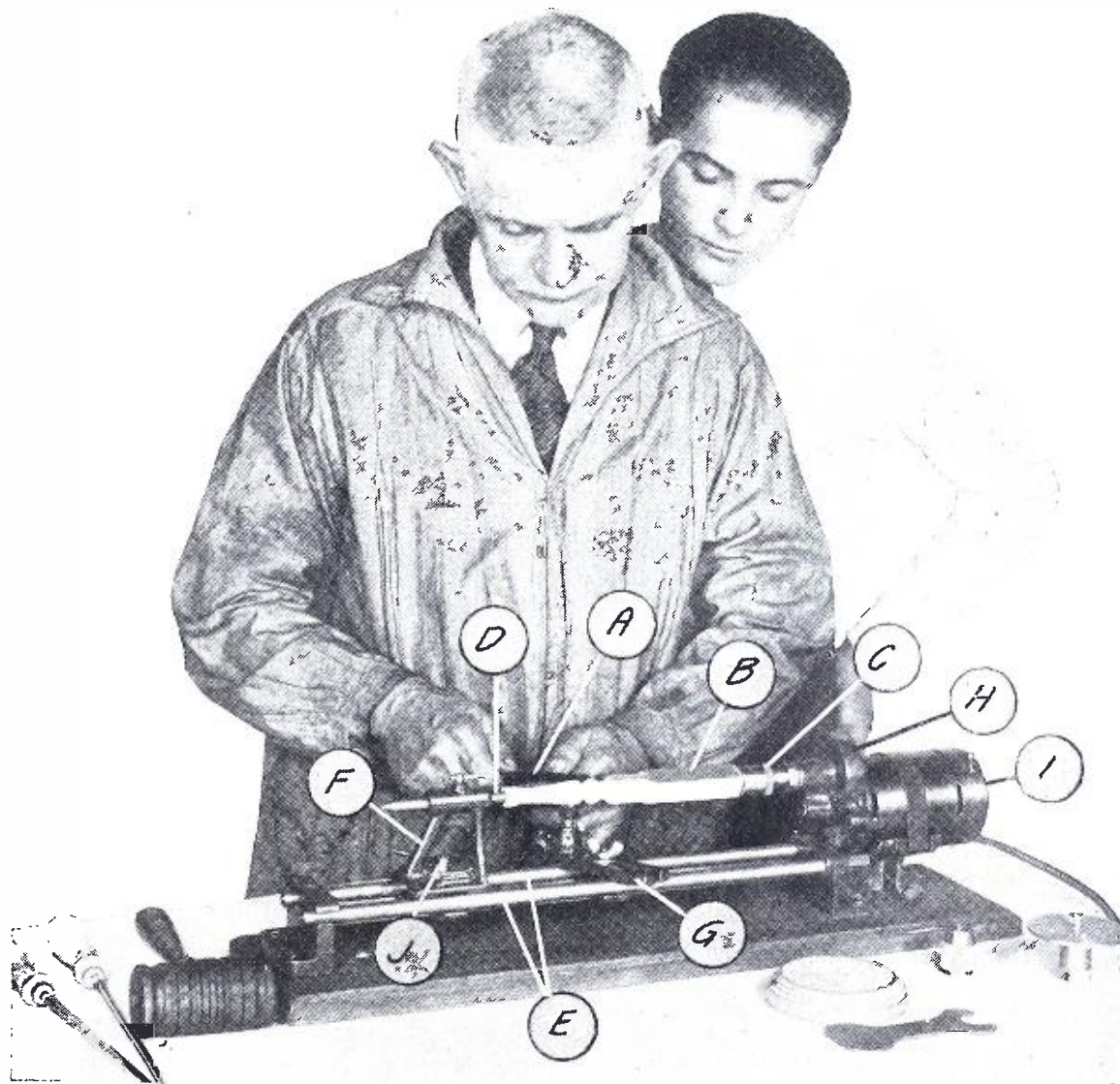

From a photograph made for POPULAR RADIO

**THE LATHE IS EASY TO OPERATE—ONCE YOU GET THE “FEEL” OF THE CUTTING TOOLS**

*This compact little lathe (shown above doing a turning job), may easily be mounted on your regular work bench and still leave plenty of room for other tools. I is the electric motor, H the gear case, C the spur center, B the work being turned, A the hand-cutting tool, D the dead center, G the tee-rest, F the tail stock casting, J the clamping nuts, and E the bed rods.*

# Your Laboratory Tools

ARTICLE NO. 3

No radio experimental laboratory is complete without some sort of lathe—which is capable of doing an astounding number of jobs. Here, for example, are some practical pointers on the use of a light, power-driven, compact and easy-to-operate lathe that is peculiarly suited to the needs of the amateur.

By LOWELL MADDEN, JR.

**D**URING the past two years there have appeared on the tool market a variety of light, power-driven lathes that offer to the home experimenter amazing possibilities in power machinery.

Equipped with such a tool, the ingenious experimenter who dabbles in

mechanics may give expression to his creative urge in a number of different ways. For example, he can make decorative radio cabinets; he can turn wood into all sorts of fancy shapes; he can saw bakelite; he can drill, polish, turn light metal and, indeed, do a dozen

other laboratory chores that are well beyond the capacity of hand tools.

For after all, a lathe is nothing but a “powerized” combination of hand tools which affords greater output and greater accuracy.

The particular machine that we are

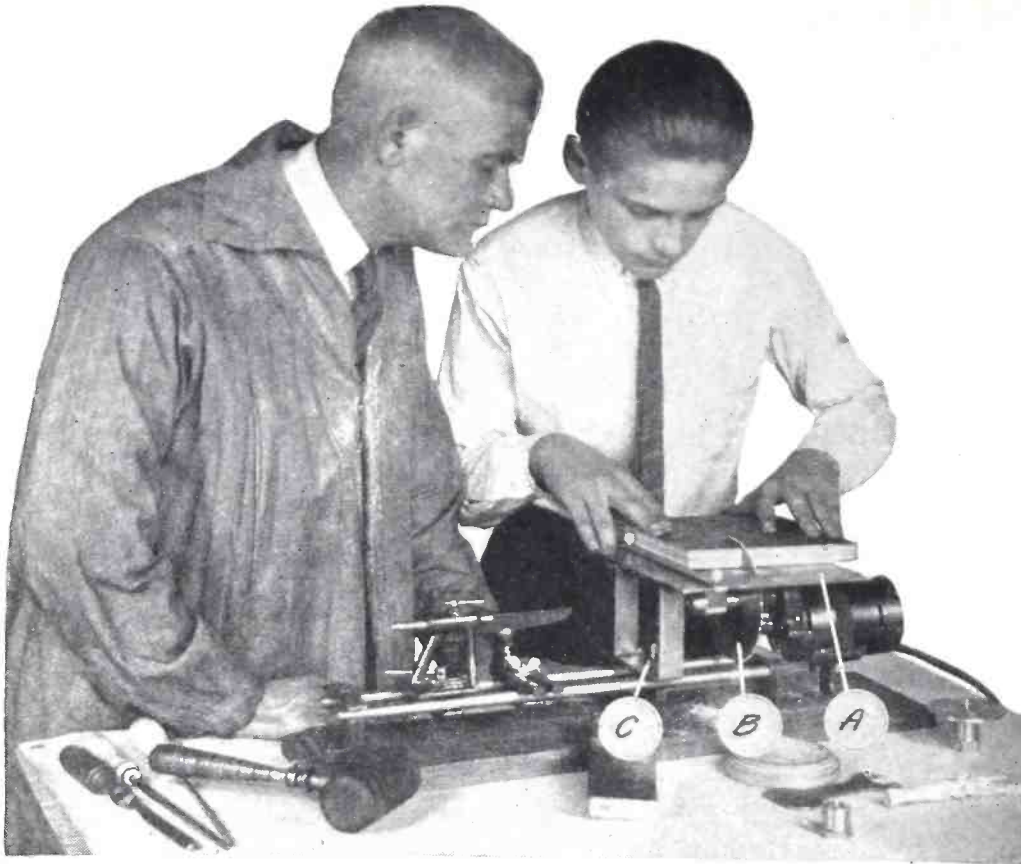

From a photograph made for POPULAR RADIO

#### FASTER AND MORE ACCURATE

FIGURE 1: Sawing wood at high speeds with a lathe takes much of the hard work out of building a radio cabinet—and in addition, it makes a better job. The average experimenter will have no trouble in turning out, with the aid of this lathe, many times the amount of work he could do by hand. A is the saw table, B the saw, and C the saw table clamping nut.

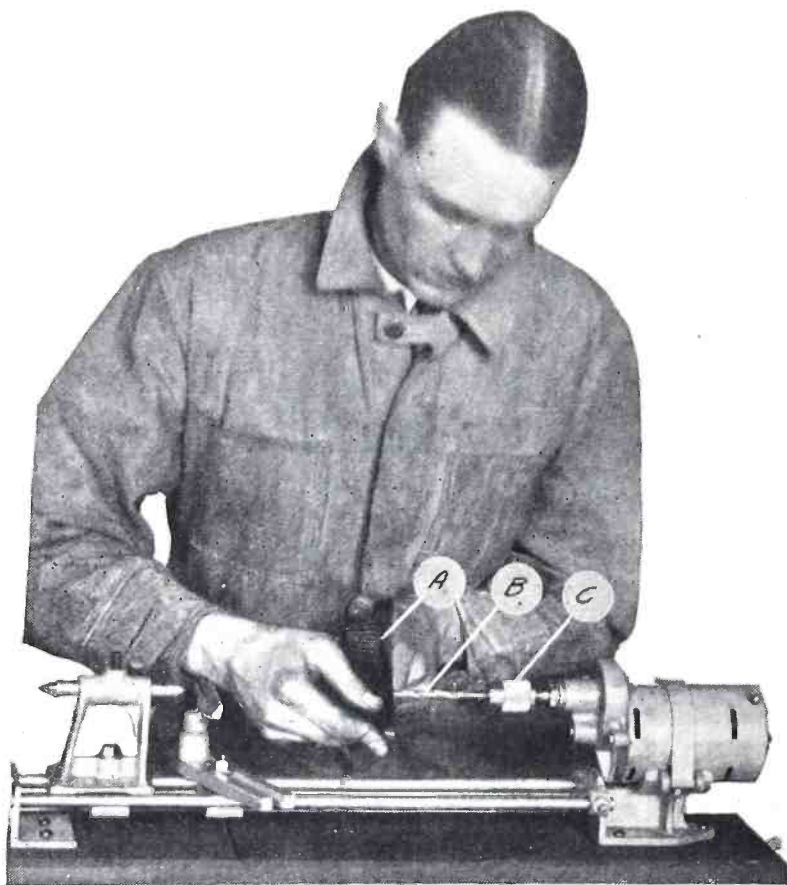

From a photograph made for POPULAR RADIO

#### POWER AT THE PLACE YOU NEED IT

FIGURE 2: With the lathe turning the drill, the experimenter can give his whole attention to the work he is doing, and so avoid ragged or crooked holes. In this picture the operator is resting his wrist on the tee-rest; this gives him a steadier grip on the work. The drill chuck is shown at C, the drill at B, and the work at A.

considering in this instalment is known as the Speedway lathe. It is an example of the tendencies in design at present being followed by a number of light tool manufacturers. Technically, it is known as a "motor in the head lathe," for that is the proper name of the big factory lathes that are driven by electric motors mounted on the live spindle.

In this particular instance, the live spindle of the lathe is the spindle of the motor itself, operating through a small train of gears. As the motor is a high-speed device, the gears are used to reduce this speed and to deliver more power to the work.

A feature of this particular tool is the detachable motor, which is held in position at the end of the lathe bed by a metal strap. Once detached and provided with its special handle, the motor immediately becomes available as a hand power drill. Not only this, but it can also be pressed into service as a portable polishing and grinding tool; a special arbor is used in this instance.

The bed of the lathe is made up of two rods of cold-rolled steel, upon which slides the tail-stock. Other attachments, such as the tee-rest and saw table, may be fixed in position by the use of clamping nuts.

This lathe is admirably suited to small wood-turning jobs, for it has sufficient speed and ample power for all work of this sort—provided that the operator is not in too great haste and does not jam his turning tool.

That the reader may have a better insight into the manipulation of the tool, let us take, as a project a simple turning job, that of cutting out and trimming up a base for a candlestick.

To do this particular job, we shall need what is known as a "screw center."

This is like a small face plate provided with an ordinary wood screw attached to its exact center. A flat piece of wood to be turned is cut out (as illustrated in Figure 5) and is attached to the face plate in the manner shown. The first part of the operation involves turning the piece down to the proper diameter; to do this the tee-rest will have to be adjusted so that the operator may manipulate his tool over the periphery. The tee-rest proper should be adjusted so that it is approximately in line with the center of the revolving piece. This having been done, the operator is ready to begin the actual work of turning.

Those who have some knowledge of wood turning will naturally wonder why the dead center is not brought up in position for a job of this nature. In a case of this kind, the operator must use his best judgment. If the piece of

wood being turned is thin or has a thickness of, let us say, less than an inch, he runs the risk of splitting it if he jams the dead center into place. In the case of a piece of two-inch stock being turned, the problem would be altogether different and the operator might find it advisable to run the dead center up into place. In this particular job it is advisable to do without it.

Professional wood turners are equipped with all sorts, sizes and shapes of hand turning tools, but the amateur operator, especially when he is beginning, will find it possible to get along with two turning tools—a skew and a gouge.

For the kind of work immediately at hand—the turning down of the piece of wood to a definite diameter—the gouge may be used.

The beginner is cautioned to proceed slowly until he becomes acquainted with the “feel” of the tool and until he discovers the real cutting capacity of the motor. He can start out with a light cut and gradually increase it until he senses the critical speed. In taking this cut, the tool should be gripped rather tightly and brought to the proper position on the tee-rest. As the cutting proceeds the operator should learn to work the tool from right to left, taking off a cut of the proper depth on each movement.

After the piece is trimmed down to the proper diameter, the workman may continue to put the proper molding on the edge. It is always best to have this sketched out on a piece of paper. As a general rule, improvised turning, like improvised music, does not work out successfully or artistically. The actual turning is followed by severe application of sandpaper, starting out with a fairly coarse grade and working down to a light grade.

In turning out such a thing as a leg for a radio cabinet, a slightly different practice would be followed. To offset the danger of splitting, the screw center is replaced by a spur center. This spur center is provided with sharp projections that pierce the wood, thereby permitting the power from the lathe spindle to be delivered to the work. A special spur center for this use is part of the standard equipment of the lathe. Naturally, the tail-stock center must be employed on a piece of work of this nature. A few drops of oil should be put on the wood where the tail-stock center engages it. If this is not done the friction caused by the revolving wood may be so great as to heat the tail-stock center to a point where it will become soft, and no careful mechanic wants a soft lathe center.

(Continued on page 580)

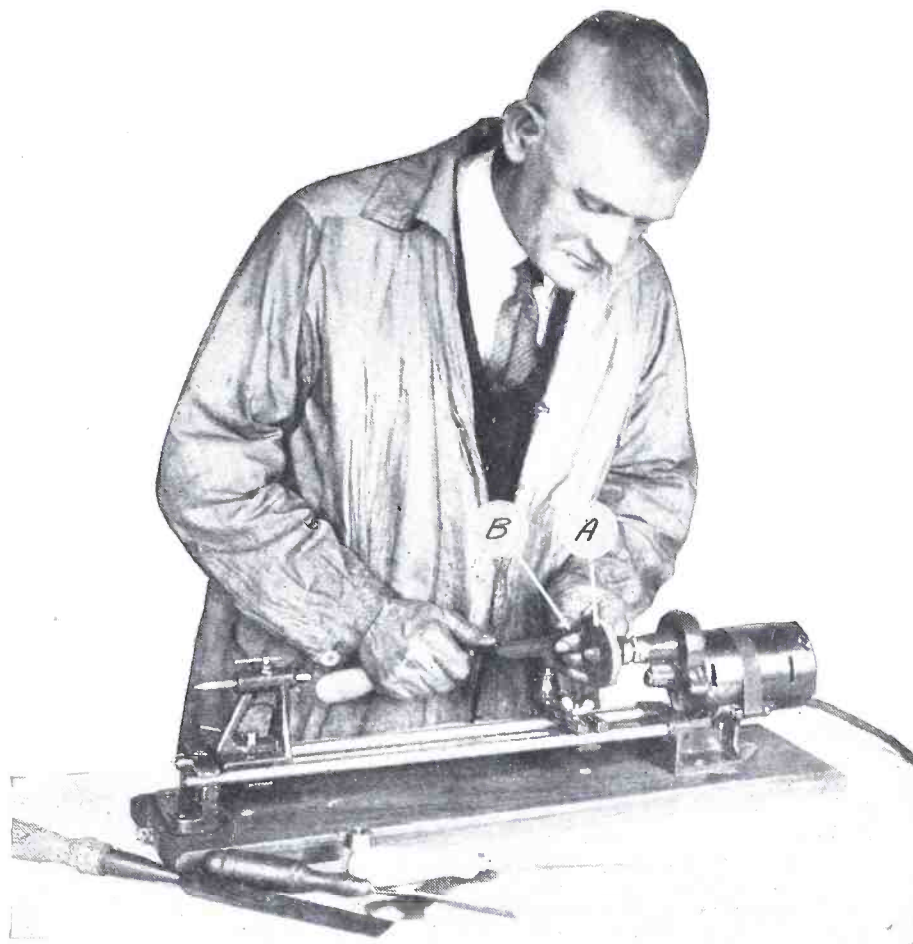

From a photograph made for POPULAR RADIO

IT HELPS TO KEEP THE TOOLS IN SHAPE

FIGURE 3: A power-operated grinding wheel permits two-fisted sharpening of tools—the best way to get keen edges. The lathe requires sharp tools to produce good work; blunt tools will frequently jam and cause injury to both the machine and the work. The grinding wheel is shown at A and the tool to be sharpened at B.

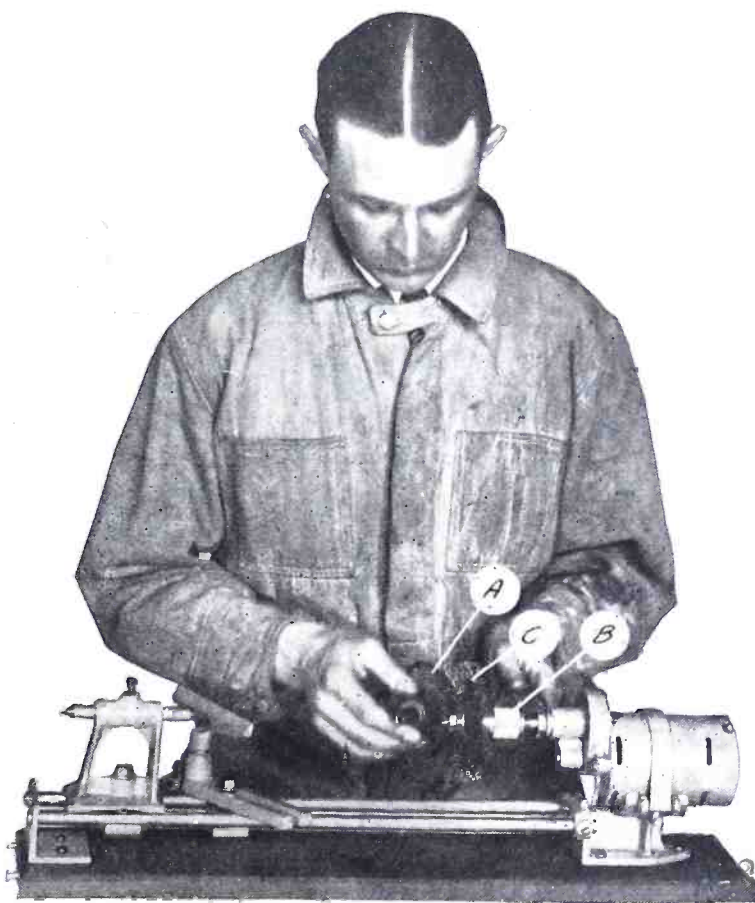

From a photograph made for POPULAR RADIO

AN EASY WAY TO MAKE THINGS SHINE

FIGURE 4: The lathe with a wire brush attachment will make metal work as bright in finish as manufactured articles. B is the chuck holding the wire wheel C, and A is the work, a metal casting being polished prior to lacquering. Buffer wheels for fine polishing work can also be used with the lathe.

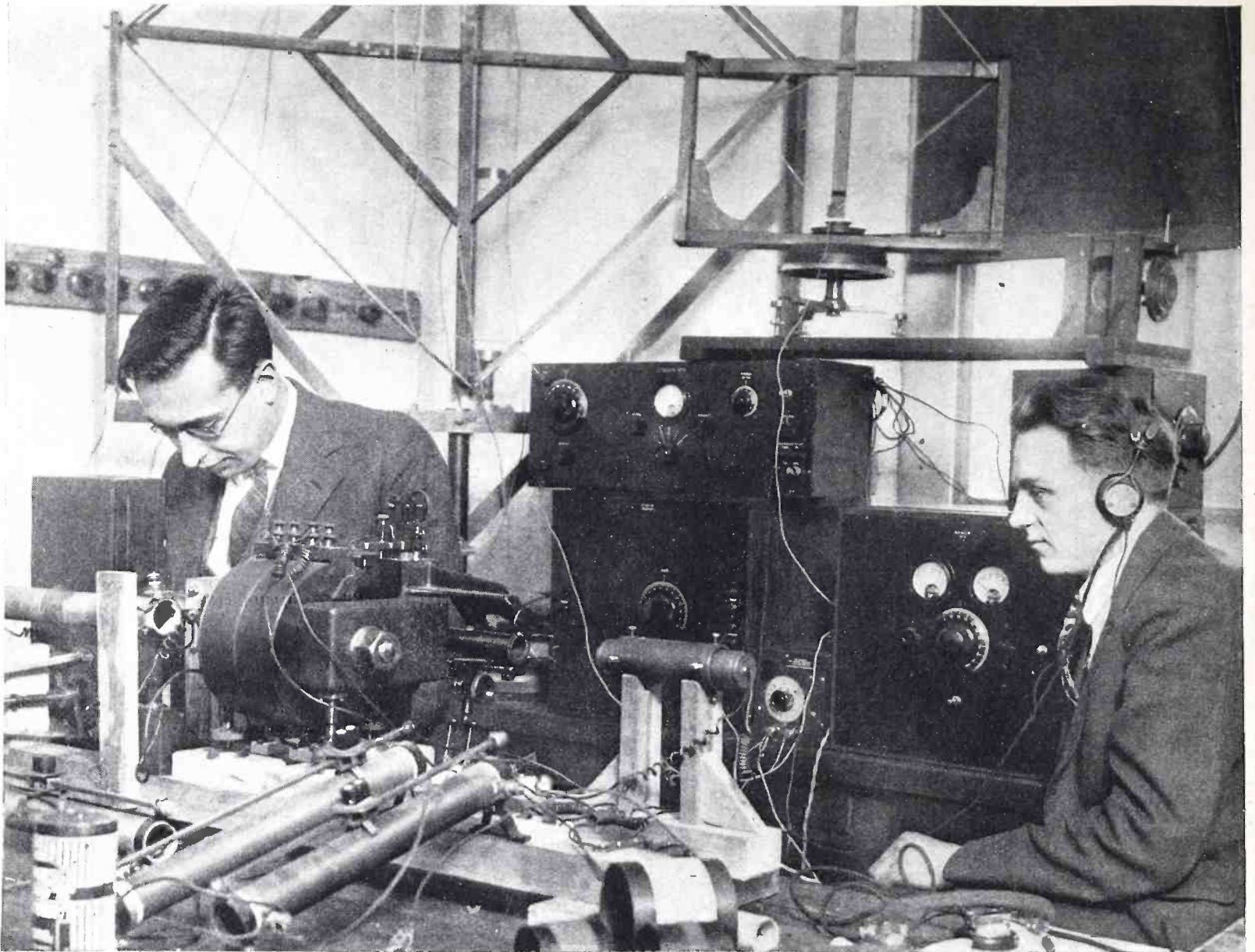

Underwood &amp; Underwood

#### HOW THEY LOCATED THE HEAVISIDE LAYER ABOVE THE EARTH

*Here are Dr. G. Breit (left) and Dr. M. A. Tuve (right) with part of the apparatus with which they obtained scientific evidence of the existence of the Kennelly-Heaviside layer and located its position in the earth's blanket of air. Their researches establish many theories about this phenomenon.*

## THE FIRST SCIENTIFIC EVIDENCE OF THE EXISTENCE OF *The "Radio Ceiling"*

Readers of POPULAR RADIO are familiar with the theory that there is a blanket of air at some undetermined distance above the earth and that this blanket acts as a reflector of radio waves; the April issue contained the latest data on this interesting subject. Since then, however, two scientists have collected what is probably the first evidence—evidence so convincing as to constitute proof of the existence and location of this layer. Here it is.

By UTHAI VINCENT WILCOX

**F**OR nearly a quarter of a century it has been supposed that there is a layer in the upper air that serves as a good conductor of magnetic energy. It has been believed that the layer contains free ions and electrons which may have emanated from the sun, and that

it is the presence of these that makes it a good conductor.

Now come Dr. Breit and Dr. M. A. Tuve, of the Department of Terrestrial Magnetism of the Carnegie Institution of Washington, D. C., to demonstrate for the first time that such a layer

exists. They have measured its effective height above the earth and learned somewhat of how it affects transmission.

It had long been suggested that if there were such a layer, the upper portions of a given radio wave would move through the earth's atmosphere at a

greater velocity than the lower portions of the same wave, which move where conductivity is not so good. In consequence, it was thought, the top of the wave front would be accelerated beyond that of the lower part, causing the wave to bend forward and ultimately bringing it to the earth.

Ocean waves toppling over forward as they approach the beach crudely illustrate what was thought to be one effect of this conducting layer in the upper air. According to theory, the layer acted as a "ceiling," bending or reflecting radio waves back to earth.

The investigators reasoned that if this theory were correct, then a receiver at a given point on the earth's surface would record at least two pulses for every pulse at the sending station. One of these would reach it by a direct horizontal path through the air; the other would travel by way of the "ceiling," reaching the receiving station as an "echo" or "reflection." They reasoned further that if this were the case, then the reflected wave, since it traversed a greater distance, would reach the receiver a little later than the direct wave, and that this difference in time might be measured.

To test these assumptions the investigators set up a receiving station, R (shown in the diagram at the bottom of this page), eight miles from the transmitting station, T. Interrupted trains of waves were sent from T, each train having a duration of about 1/1000 of a second. At the receiving end the signals were detected, amplified and recorded by photographing the tracings made by an oscillating marker.

The photographic records showed conclusively that under certain circumstances each signal was registered twice, and that, in accordance with the assumption, there was an appreciable interval of time between them.

In this manner, through a series of experiments extending over many months, a technique was developed which enabled the investigators to demonstrate experimentally that a transmitted signal, depending upon conditions, reached the receiving station by two paths; the direct path, TR, and the path by way of the "ceiling," TLR. Furthermore, knowing the distance between stations and knowing the retardation of the reflection and the speed of radio waves, the height of the layer was readily computed and found to be about 100 miles, though it appeared to rise and fall during the period observed within a range of from 50 to 130 miles.

Although these experiments do not tell whether radio waves are actually reflected or refracted by the layer, they

(Continued on page 581)

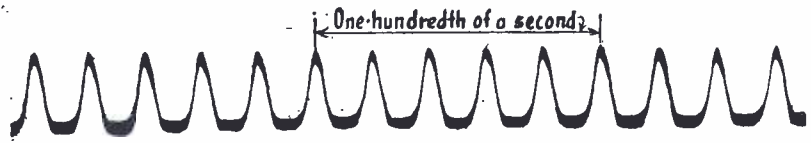

DIRECT WAVES — NO REFLECTIONS

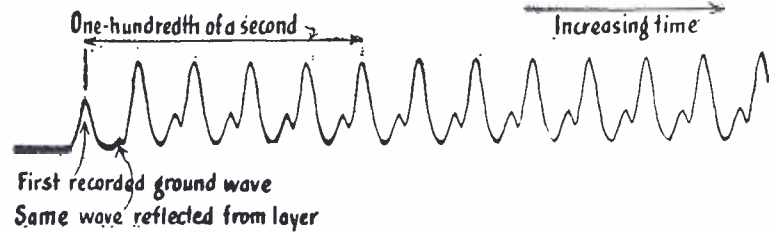

DIRECT WAVES AND SINGLE REFLECTIONS

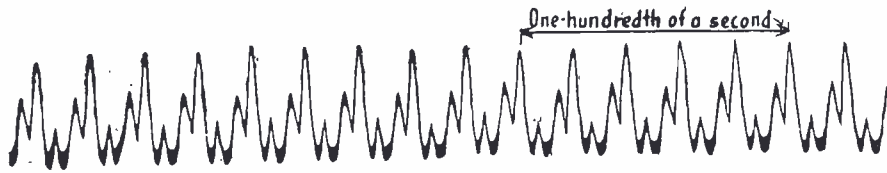

DOUBLE REFLECTIONS

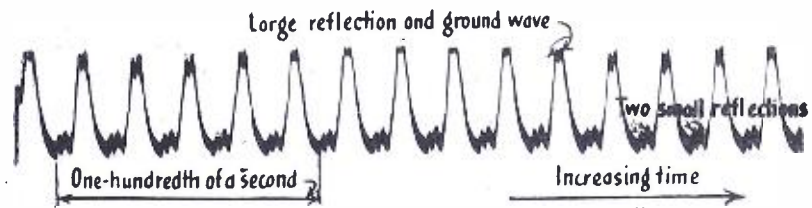

"MULTIPLE REFLECTIONS"

HOW RADIO WAVES ARE REFLECTED FROM THE UPPER AIR

A comparison of three lower wave-trains with the one at the top shows how waves reflected from the Kennelly-Heaviside layer differ from direct waves. The highest projections are made by direct waves; the smaller projections are caused by reflection.

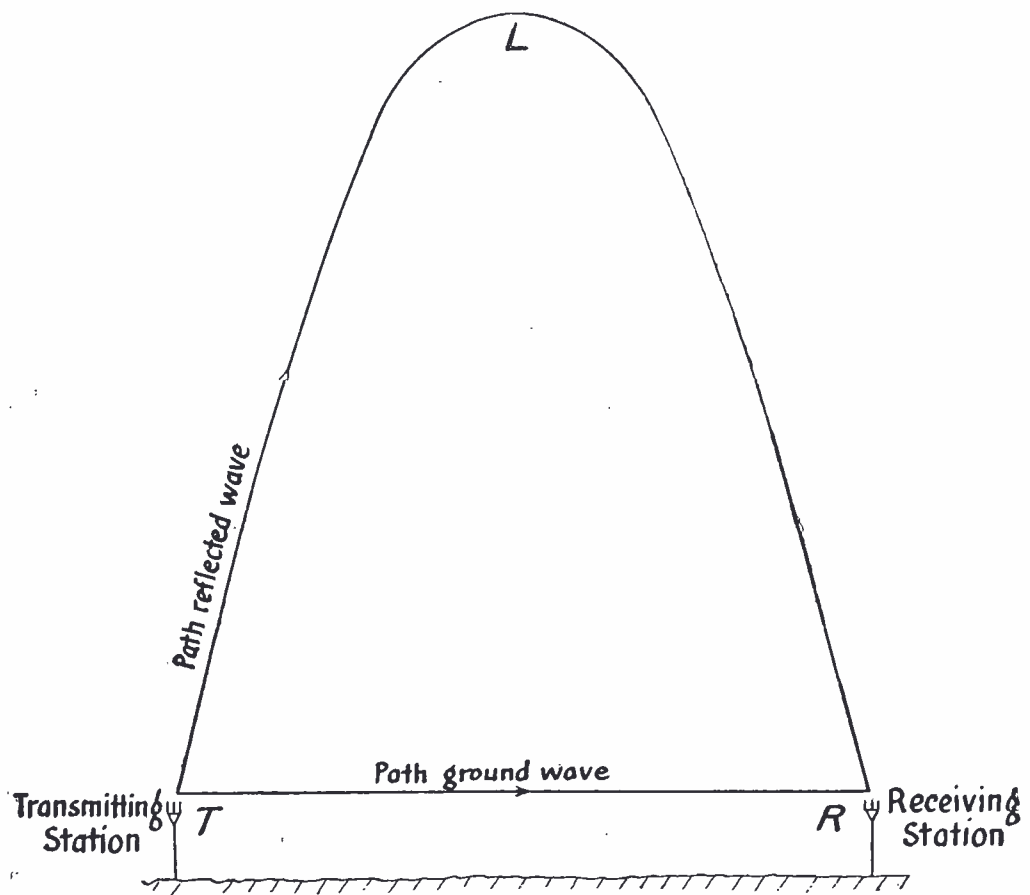

HOW THE REFLECTING LAYER WAS LOCATED

The waves that went to the upper air and were reflected, following the path TLR, reached the receiver R later than the waves that took the direct path TR. Knowing the speed of radio waves, it was a simple matter to determine the height of the reflected layer.



Henry Miller

### A NOVEL "RADIO PILLOW"

A radiophone concealed in what appears to be an ordinary small cushion for the divan is one of the season's novelties that is amusing the radio fans of Europe; the above picture shows Claire Rommer, the German film star, listening in.

# What's New in Radio

Conducted by

THE TECHNICAL STAFF

Inventors, experimenters, manufacturers and readers generally are invited to keep the Technical Staff of POPULAR RADIO informed of all new apparatus that is of their own creation or that comes to their attention; if the apparatus passes the tests of the POPULAR RADIO LABORATORY it will be duly recorded in this Department for the information and benefit of all.



### A Special Valve for High-Frequency Amplification

*Name of instrument:* "Ceco type K special radio-frequency valve."

*Description:* This new vacuum tube is similar in appearance to the standard UX-201-a type valve. The filament draws  $\frac{1}{4}$  ampere at 5 volts and the plate voltage used may be anywhere from 67 to 140 volts. The valve is especially designed for use as a high-frequency amplifier and may be used for this purpose in most receivers. Its purpose is to increase the sensitivity of the receiver. Its characteristics are somewhat different from those of the UX-201-a type valves and for this reason it should not be used in manufactured neutrodyne receivers, unless facilities are available for re-balancing the neutralizing equipment of the receiver.

*Usage:* As an amplifier valve in the high-frequency stages of a receiver.

*Outstanding features:* Provides increased sensitivity in the high-frequency amplifier. Good construction. Long life.  
*Maker:* C. E. Mfg. Co., Inc.

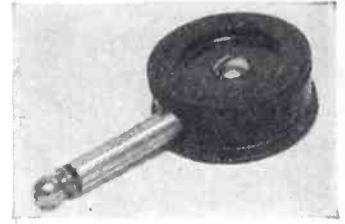

### A Handy Phone Plug

*Name of instrument:* "Twistit" phone plug.

*Description:* This plug consists of a composition body with a metal shaft and tip well insulated from one another. Two holes are provided in the edge of the body, into which the phone tips are inserted, after which a twist of one of the sides of the composition body anchors the tips firmly. To withdraw the tips, the side of the body is twisted in the opposite direction and withdrawn.

*Usage:* As a plug for use in making connections with a jack.

*Outstanding features:* Provides a positive grip on the tips of the reproducer or headphone cord. Eliminates strain on cord when removing tips from plug, because when loosened the gripping action is completely eliminated.

*Maker:* Kirkman Engineering Corp.

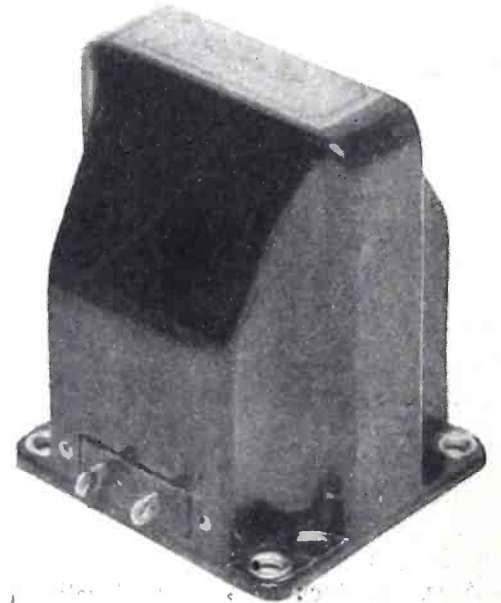

### A High-grade, Low-frequency Amplifier Coupling Unit

*Name of instrument:* Dual impedance unit.

*Description:* This dual impedance is entirely enclosed in a neat metal case with a flanged base, in which are provided the necessary screw holes for mounting the instruments. The four terminals project through the steel case and are mounted on composition insulating strips.

*Usage:* As a coupling unit in a double-impedance, low-frequency amplifier circuit.

*Outstanding features:* Rigid construction. Convenient arrangement of terminals. Neat appearance. Compact. Excellent quality of reproduction when used in conjunction with standard vacuum tubes.

*Maker:* Samson Electric Co.

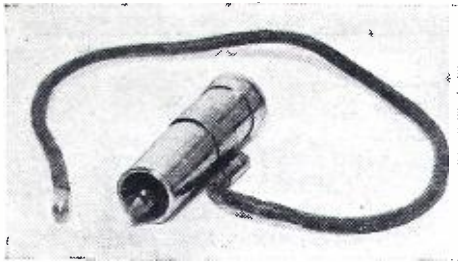

### An Accessory That Gives a Check on the "A" Battery

*Name of instrument:* "Ga-jit" "A" battery tester.

*Description:* This device consists of a nickel-plated metal tube inside of which is an electromagnet with a counterweighted plunger. To this plunger is attached a calibrated metal scale. There are two pointed terminals on the device that are to be touched to the two terminals of the storage battery to be tested. When the instrument is connected across the storage battery, the magnetic action draws the plunger and the calibrated scale upward and causes part of the scale to project through the top of the metal case. The distance that the scale projects out of the case is determined by the voltage of the battery under test. It is this latter fact that explains the operation of the device. A fully charged battery has a high voltage and will force the plunger all the way out, while a partly discharged battery with a lower voltage will force the plunger only part of the way. Thus the scale is calibrated to show "low," "medium" and "high."

*Usage:* To test the charge condition of a 6-volt storage "A" battery.

*Outstanding features:* Provides accurate indication of the state of charge of a storage battery. Eliminates the necessity for using a hydrometer and does not even require that the battery cells be opened. Handy.

*Maker:* General Instrument Corp.

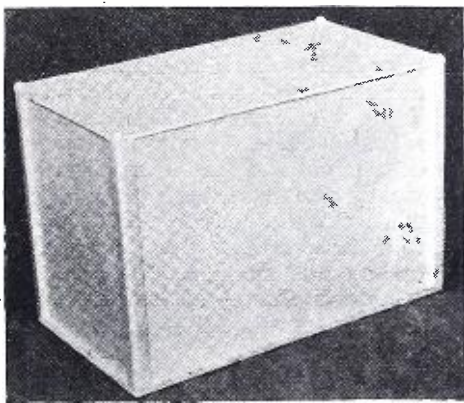

### Knock-down Shields Made in All Sizes

*Name of instrument:* Shields for high-frequency amplifiers.

*Description:* These shields may be obtained in knock-down form, and may be purchased to make up into complete shields of any desired size. The shield consists of four corner posts which are slotted to accommodate the sides and ends of the shields. These posts may be obtained cut to any length, and the sides, ends, top and bottom sheets

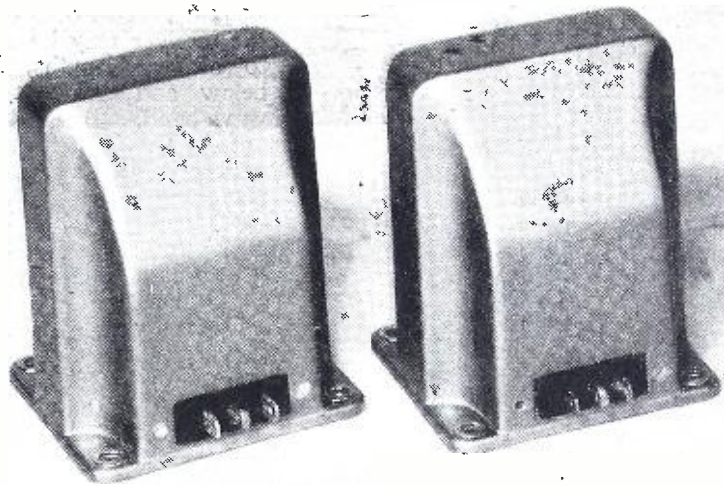

### This Coupling Combination Will Increase Volume and Reduce Distortion

*Name of instrument:* Push-pull coupling units for low-frequency amplifier.

*Description:* These two coupling units consist of well-designed and constructed windings and cores of suitable characteristics, entirely inclosed in neat metal housings that are finished in burnished copper. The "input" unit consists of a primary winding and two secondary windings. The latter are connected in series and three terminals are brought out. The two secondary windings provide the input circuits for the two vacuum valves used in each stage of the push-pull type of amplification. The output unit is identical with the input unit in appearance, except that it has only three terminals instead of five. It consists of two impedance coils con-

nected in series. Each of these impedance coils furnishes a path for the direct current from the "B" battery to the plate of one of the valves. The alternating current is shunted through the windings of the reproducer. Each of these units measures  $3\frac{1}{8}$  by  $2\frac{1}{2}$  by  $2\frac{7}{8}$  inches.

*Usage:* As the coupling units for use with the push-pull type of amplification, in which two valves are used in a single stage of amplification to reduce distortion and prevent unsymmetrical overloading. It is especially recommended for use in the last low-frequency stage.

*Outstanding features:* Good design and proportioning of electrical values. Takes up no more room than an ordinary amplifying transformer and an output transformer, except for the space required by the extra vacuum tube.

*Maker:* Samson Electric Co.

may also be obtained in any size required. The sheets and corner posts are all of aluminum. The sheets are approximately  $\frac{5}{64}$  of an inch thick while the corner posts are made in approximately  $\frac{1}{4}$ -inch angles. To assemble a shield, the four corner posts are mounted in a vertical position on the bottom sheet, by means of four screws which pass through the bottom and up into threaded holes in the ends of the corner posts. The sides and ends of the shields then slide down into position in the slots of the corner posts. The box is completed by mounting the top sheet in the same manner as the bottom, *i.e.*, by means of four screws which pass into the top ends of the corner posts. Partial shields of any size or shape may be made through the use of only two or three corner posts, with as many side sheets as may be required.

*Usage:* To enable the home constructor to make up stage shields for a high-frequency amplifier of any desired size.

*Outstanding features:* Aluminum used is of a thickness proven by tests to be the most practical for shielding purposes. Neat in appearance. Easy to assemble. Easy to drill and cut with ordinary tools. Provides good shielding. Component parts may be obtained in any specified size, to be made up into partial or complete shields to fit the requirements of the user.

*Maker:* Aluminum Company of America.

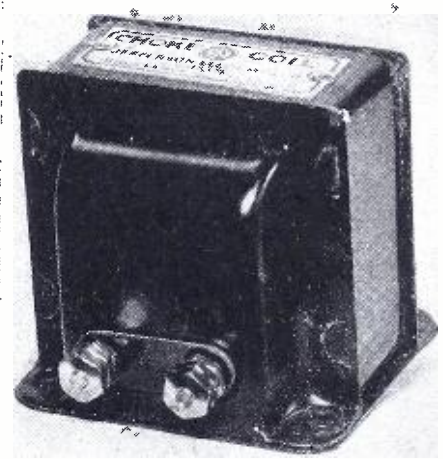

### An Inductance That Helps Reproduction

*Name of instrument:* Choke coil.

*Description:* This unit consists of an iron-core choke coil inclosed in a metal case. A small inset terminal panel of insulating material is provided. The entire unit is small and measures  $2\frac{1}{4}$  by  $2\frac{3}{8}$  by  $2\frac{3}{4}$  inches. It has a rated inductance of 30 henries at no load.

*Usage:* In conjunction with a 4 microfarad by-pass condenser, as an output filter to shunt the high-voltage direct current around the reproducer windings.

*Outstanding features:* Adequate inductance. Protects the loudspeaker. Compact.

*Maker:* Jefferson Electric Mfg. Co.

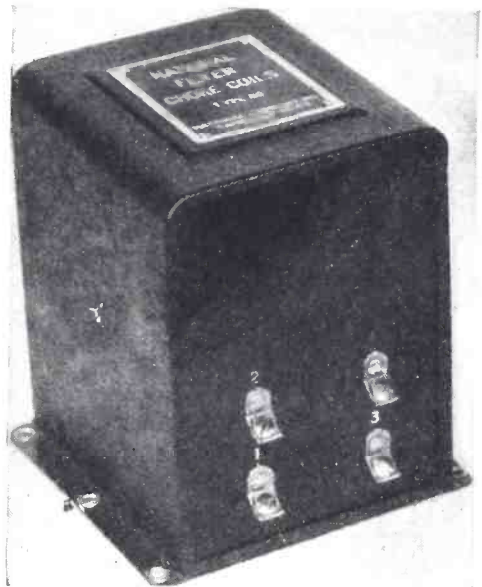

### A Choke That Requires Little Installation Space

*Name of instrument:* Filter-choke coils.

*Description:* This unit is inclosed in a pressed-metal case. It consists of two iron-core choke coils designed for use in the filter circuit of "B" power-packs where the current does not exceed 80 milliamperes. Separate terminals are provided on the composition panel at one end of the case for the two choke coils within. The two coils can therefore be used singly or in series, as desired.

*Usage:* As the smoothing inductance for use in conjunction with high-capacity condensers as the filter of a "B" power-pack to eliminate the hum which would ordinarily be present in a receiver which drew its plate supply from the house-lighting lines through a rectifier.

*Outstanding features:* Small size. Neat appearance. Matches the other "B" power-pack units made by this same company. Can be used as the filter choke in any circuit which requires a high inductance with a current-carrying capacity not exceeding 80 milliamperes.

*Maker:* National Company, Inc.

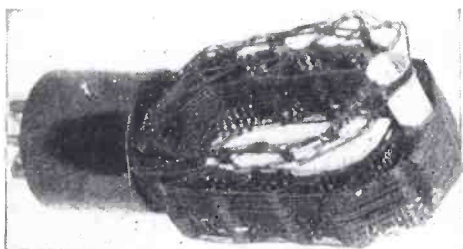

### Plug-in Coils for All-Wave Receivers

*Name of instrument:* Plug-in coil.

*Description:* This is a self-supporting coil with an air core. The coil consists of a primary and a secondary winding, with provision made for varying the coupling by moving the primary away from the secondary by means of a short length of dowel rod (as shown in the illustration). The coil is permanently mounted on a composition base similar to those used on vacuum tubes. The terminals are connected to the four prongs at the bottom of this base. To use these coils, a receiver is equipped with standard vacuum valve sockets which

serve as the receptacles for the coils. By plugging in coils of different sizes, the receiver may be made to respond to all wavelengths, including those below and above the broadcasting wave band.

*Usage:* As the inductances in a receiver which is intended for reception on all wavelengths.

*Outstanding features:* Efficient coil windings. Provide variable couplings between circuits. Firmly mounted. Permit the use of ordinary vacuum-valve sockets for coil mountings. Enable the receiver in which these coils are used to cover all wavelengths.

*Maker:* Washburn Mfg. Co.

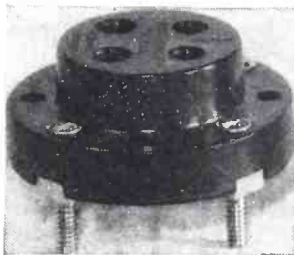

### This Valve Socket Simplifies Sub-Panel Wiring

*Name of instrument:* Vacuum-tube socket.

*Description:* This socket is molded of bakelite and is equipped with phosphor-bronze spring contacts. The connection terminals are riveted to the bakelite frame and every precaution has been taken to prevent the spring contacts from working loose. The terminal binding posts extend downward so that the socket may be mounted on the top of a sub-panel with the four terminals projecting through the sub-panel and securely fastened to it by means of four nuts provided with the socket. All wiring of connections may then be made underneath the sub-panel.

*Usage:* As a valve socket in receivers in which the sockets are to be mounted on a sub-panel and the wiring is to be done underneath.

*Outstanding features:* Firm and lasting contacts. Riveted construction. High quality insulation. Permits all wiring to be done beneath the sub-panel of the receiver.

*Maker:* Klosner Radio Corp.



### A Heavy-Weight Cap to Eliminate Microphonic Valve Noises

*Name of instrument:* Vacuum valve vibration repressor.

*Description:* This valve cap is molded from soft lead. It is approximately  $\frac{1}{4}$  of an inch thick at the top but tapers

down on the sides to a thin edge. This edge is easily bent with the fingers and when the cap is in place these edges may be bent to conform with the shape of the tube. This insures a snug fit of the cap.

*Usage:* To be placed on vacuum valves to eliminate mechanical vibration which causes howling.

*Outstanding features:* Molded in one piece. Polished exterior. Extremely heavy with correspondingly good repressor action. Stops howling in a low-frequency amplifier.

*Maker:* Mertz Specialty Co.



### A Good Filter Condenser for "B" Power-Packs

*Name of instrument:* Filter condenser block.

*Description:* This condenser block, known as the Tobe BH filter block, consists of an aluminum finished metal container in which are carried all of the condenser capacities required for the filter in any "B" power-pack which delivers 300 volts or less through a rectifier type BH valve. These condensers are of the "paper" type, and, after being placed in the metal "can," are completely sealed in with an insulating compound. This makes the assembly impervious to moisture and dust and also lends rigidity. The metal case also serves as a shield when properly grounded. There are four terminals at the lower edge of one side of the case. This condenser block simplifies the construction of power-packs because it reduces the amount of space required for mounting the condensers and eliminates much of the wiring that would be necessary if individual condensers were used. The capacities provided by the block are 4, 4 and 6 microfarads. The unit is designed to operate with any DC operating voltage up to 300 volts.

*Usage:* Provides all filter capacities for a power-pack which uses the BH type rectifier valves.

*Outstanding features:* Well constructed. Neat and compact. Conveniently located terminals. Will withstand high working voltage. Saves space, time and effort in the construction of a "B" power-pack.

*Maker:* Tobe Deutschmann Co.



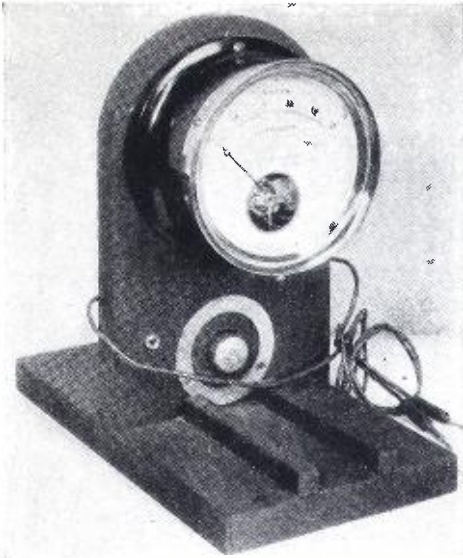

### A Practical Battery-Testing Device for Dealers

*Name of instrument:* "ABC" battery tester.

*Description:* This device consists of a combination voltmeter five inches in diameter, mounted on a wooden stand and base. It is so designed as to facilitate attachment to the dealer's counter or to the laboratory table. It is equipped with a large, visible scale. Two rubber-covered wires are provided for testing the "B" and "C" batteries. For testing dry-cell batteries, an automatic arrangement is used, whereby the battery is placed on the two wooden strips on the base and is pushed against the metal ring and button shown in the illustration. The meter functions as an ammeter for testing dry cells, but for "B" and "C" battery testing it functions as a voltmeter with a range of 0-50 volts.

*Usage:* For testing "B" and "C" batteries and also dry-cell "A" batteries.

*Outstanding features:* Convenient to use. Large and easily readable scale. Fool-proof, in that "B" and "C" batteries cannot be connected to the circuit provided for testing 1-1.2-volt dry cells.

*Maker:* Burton-Rogers Co.

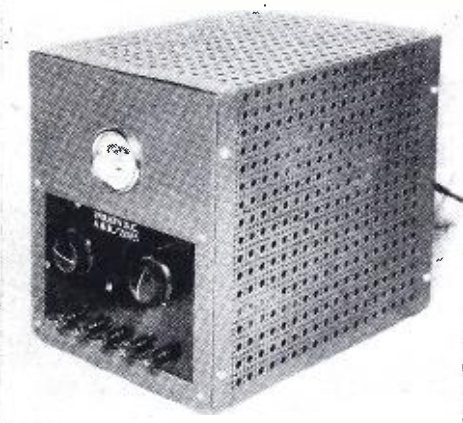

### A Power-Pack Operating on DC Lighting Lines

*Name of instrument:* Varion DC power-pack.

*Description:* This is a well-constructed power-pack. It contains the necessary choke coils, condensers and resistances for the filter, all mounted on a composition base and inclosed in a ventilated metal housing. On the outside

of the case, at one end, is an insulating panel which carries the output terminals and the control knobs for varying the filament voltage and the detector plate voltage. Immediately above this panel is a voltmeter with a scale which reads up to 8 volts. This permits an exact adjustment of the filament supply voltage. The meter is connected across the filament terminals and shows the exact filament voltage supplied to the receiver. The unit supplies an adjustable detector plate voltage and fixed voltages for the high-frequency amplifier, and high voltage for the last low-frequency amplifier stage. This latter voltage is almost equal to the line voltage, usually slightly less than 110 volts.

*Usage:* To eliminate all batteries and supply all necessary filament and plate voltages for the operation of any radio receiver from the direct-current lighting lines.

*Outstanding features:* Eliminates all batteries. Reliable in operation. Completely inclosed. Well ventilated. Contains a voltmeter to permit exact adjustment of filament supply voltage. Neat appearance.

*Maker:* Morison Electrical Supply Co.



### A Double-Impedance Coupling That Gives Lifelike Reproduction

*Name of instrument:* Double-impedance coupling unit.

*Description:* This unit consists of two impedance coils and a fixed condenser. These three units are included in a single metal case. All internal connections are made before the instrument case is sealed. Four external connection terminals are provided in the form of binding posts near the bottom of the case, which is flanged and eyeletted for mounting screws. The impedance coil and the condenser values are so selected as to provide high amplification at the very low frequencies.

*Usage:* To provide intervalve coupling in the low-frequency amplifier portion of a radio receiver.

*Outstanding features:* Provides high amplification at all frequencies, especially at the extremely low frequencies that are neglected by many low-frequency coupling devices. The appearance and terminal arrangement of these units

are much like those of low-frequency transformers and they are connected into a circuit in the same way. They are, therefore, ideal for use as a substitute for poor transformers in re-vamping an old receiver. Neat in appearance. Efficient.

*Maker:* General Radio Co.

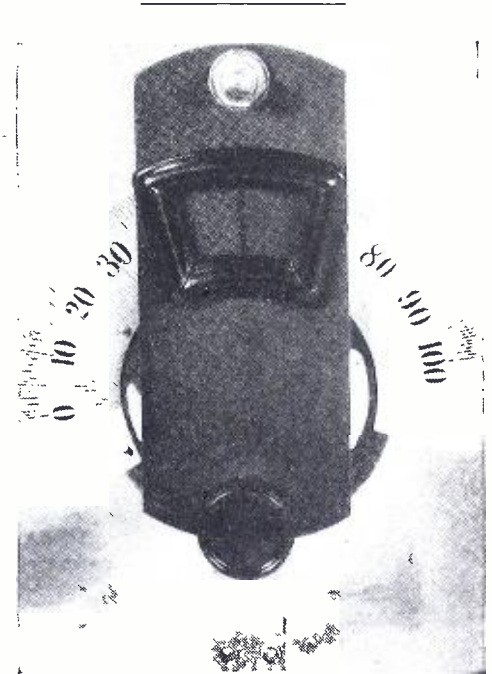

### An Illuminated Tuning Control

*Name of instrument:* Illuminated tuning control and pilot light combination.

*Description:* This device consists of an adjustable metal framework on which the instrument to be controlled is mounted. This framework may be mounted directly on the rear of the receiver panel. A celluloid dial rotates behind the panel but is visible from the front of the receiver through a small, rectangular, beveled window. This scale, which is calibrated in degrees, rotates with the moving section of the condenser or other tuning unit and both are controlled by a small tuning knob on the panel just below the window. The knob provides a vernier control with a ratio of approximately 8 to 1. A small lamp is mounted just behind the calibrated scale in such a position that a beam of light will be shown through the translucent scale. This makes it easy to read the indicator settings, even in the dark. The lamp also serves as a pilot light, in that it may be connected to the circuit in such a way that it is turned "on" and "off" with the receiver. Where it is not desired to take advantage of this feature, the separate, small switch, that is mounted on the framework of this instrument may be used to turn the lamp "on" and "off."

*Usage:* As a tuning control to be mounted on the panel of a radio receiver.

*Outstanding features:* Provides good vernier control. Neat in appearance, when mounted on a panel. Has self-contained switch or may be operated automatically by the filament-control switch of the receiver. Plainly calibrated scale. Illuminated from within. Template is furnished to simplify the drilling of the panel for the installation of this device.

*Maker:* Pilot Electric Mfg. Co., Inc.



Underwood &amp; Underwood

### A New Radio-equipped Automobile

A receiving set installed on the dashboard is one of the latest things in automobile accessories; it is compactly and conveniently arranged so that the driver may tune in as he rides—if he is a steady driver. The loudspeaker may be seen, installed just above the windshield.



### This Unit Keeps Your Storage Battery Charged at All Times

**Name of instrument:** Trickle charger for storage "A" batteries.

**Description:** This device consists of a transformer and an electrolytic rectifier. The transformer case and the rectifier base are molded in one piece. The glass rectifier jar sets down into this base and is held firmly in position by a heavy metal conductor which extends from the rectifier to one of the output binding posts of the transformer case. A non-acid electrolyte is used in the rectifier. The unit will charge a storage battery at approximately a .6 ampere rate.

**Usage:** To be connected to a storage battery at all times when the receiver is not in use. This provides a small con-

tinuous charge, which will keep the battery constantly in good condition. **Outstanding features:** Compact size. Neat appearance. The use of a glass container for the rectifier permits the operator to see at a glance when additional water is required.

**Maker:** France Mfg. Co.

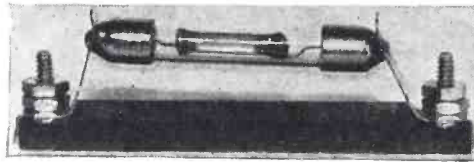

### A Fixed Resistance That Is Sealed in a Vacuum

**Name of instrument:** Fixed high resistance unit.

**Description:** This resistor, which is known as the Tobe "Tipon" Loewe resistance, consists of a glass tube which is coated with a resistance material, the resistance of the units depending on the density of the coating. The connecting wires are sealed in the glass tube and the resistance coating extends out on to these wires, thus insuring perfect contact. The entire assembly is inclosed in another and larger glass tube and the air is evacuated, thus providing a vacuum container for the resistance which protects the resistance element from atmospheric moisture, oxidation and deterioration. This precaution results in a constant resistance value and noiseless operation. Silver-plated metal ends are mounted on the glass container to insure good external contact when this unit is used with any standard type of resistance mounting. These resistances are made in various sizes, ranging from 10,000 to 10,000,000 ohms.

**Usage:** As resistance units for resistance-coupled amplifiers, grid-leaks, or other

purposes where the current does not exceed one watt.

**Outstanding features:** Permanent resistance values. Close ratings of resistance values. Resistance sealed in a vacuum.

**Maker:** Tobe Deutschmann Co.



### This Grid-Leak Helps to Eliminate So-Called "Tube Noises"

**Name of instrument:** Fixed resistor.

**Description:** The resistor element of this device is unique in that it is fused into glass. The resistance element itself is made up of a closely set material, which furnishes an uninterrupted path for the flow of current and which has much more permanent characteristics than had many of the older type of grid-leaks which made use of a crystalline formation in the resistance element. The small glass tube into which the resistance element has been fused is completely inclosed in a larger glass tube which is equipped with metal caps at each end. The ends of the resistance terminates in these caps. This resistor is installed in the same manner as any of the cartridge-type grid-leaks—by slipping into a standard mounting.

**Usage:** As a grid-leak or for any other purpose where a fixed resistor of values from 500 to 10,000,000 ohms are required.

**Outstanding features:** Stable characteristics. Noiseless in operation. Well made. Guaranteed accurate within 5 per cent of rated value.

**Maker:** Amsco Products, Inc.

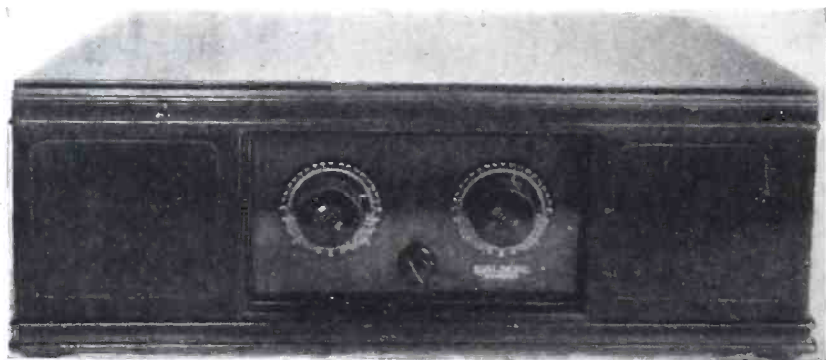

### A New Receiver That Operates Entirely From the Lamp Socket

**Name of instrument:** Walbert Model 26-PT Receiver for lamp socket operation.

**Usage:** For the reception of broadcast programs.

**Outstanding features:** Absolute freedom from AC hum. Operates from any line voltage between 110 and 125, and frequencies from 50 to 60 cycles. Requires no upkeep attention. Excellent tone quality and selectivity. Pleasing appearance. Easy to operate. Requires only the push of a button to place in operation. May be logged. Dial settings for a given station always remain the same with this receiver.

**Description:** Nothing could be more simple or fool-proof than the installation and operation of this receiver.

There are no batteries to bother with. In installing the receiver in the home it is only necessary to place the seven AC valves in their sockets, connect the antenna and ground wires to their binding posts, insert the tips of the reproducer cord into two small jacks, provided inside of the receiver for this purpose, and insert the power plug into the nearest lamp socket. The receiver is then "all set to go." Thereafter pressing one button starts the receiver, and pressing another turns it off!

Tuning is accomplished by means of two knobs on the front panel of the

(Continued on page 576)

## A Receiver That Is "Different"

*Name of instrument:* Leutz Universal Transoceanic "Phantom" receiver.

*Description:* The radio public has become so accustomed to have its receivers inclosed in mahogany and walnut cases that a receiver not thus housed comes as a shock to many. The "Phantom" receiver strikes a new note in external design, in that it is housed in a dull-finished, natural-color aluminum case with all tuning and other controls set in contrasting black.

To many radio enthusiasts this arrangement is attractive. However, to those who prefer the more usual form of housing for the receiver, special cabinets of wood may be obtained from the manufacturer.

It has been the manufacturers' intention to provide in this set extremely high efficiency, and to include nothing that does not make toward this end.

The greatest possible leeway has been provided to permit the owner to adapt this set to his needs. Any type of power valve may be used in the last low-frequency stage. Any sort of "B" power may be used—dry "B" batteries, storage "B" batteries, or a "B" power-pack. The tuning may be limited to as many or as few controls as desired—anywhere from one to five, as will be explained later. Any sort of an antenna may be used—loop, indoor or outdoor. The receiver is equipped with plug-in coils to cover the broadcast waveband, and other coils may be obtained which will permit the receiver to cover all wavelengths from 35 meters up to 3,600 meters.

The receiver consists of four stages of tuned high-frequency amplification, a vacuum valve detector and four stages of low-frequency amplification. This requires the use of nine valves in all. Each of the high-frequency amplifier stages is shielded separately and the complete low-frequency amplifier is totally shielded from the rest of the receiver. The aluminum case serves as part of this extensive shielding system, and also provides practically total shielding for the entire receiver against all outside disturbances.

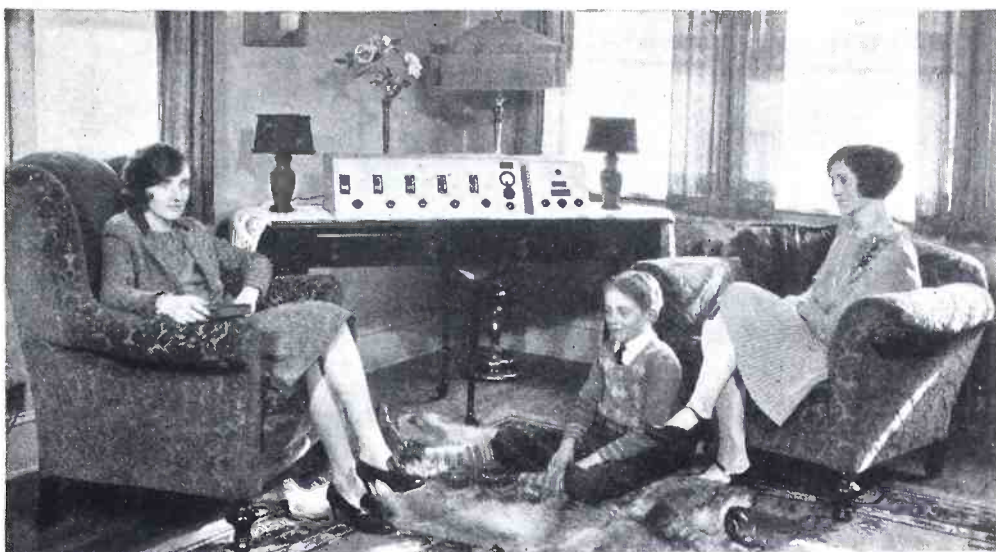

### THE "PHANTOM" IN OPERATION

*Here is this novel receiver operating with the Leutz "B" power-pack—which may be seen to the right of the set. The dull metal finish of the set is a new departure in cabinet design.*

Each high-frequency stage is provided with a variable tuning condenser, as is the detector circuit. Thus there are five tuning condensers in all, and each is operated by a tuning control which projects through the front of the receiver. A novel feature of this arrangement, however, lies in the fact that the rotors of these five condensers are provided with hollow shafts. These shafts are all in line, and a metal rod is slipped through them. By tightening the set screws in the shafts the rotors of the condensers can be made fast to this common shaft so that they will turn together as a single unit. This means that the receiver can be made to operate by a single control, providing all rotors are tightened on the common shaft. Then, if any one of the tuning controls on the panel is turned, all of the condensers will turn with it and all circuits will be tuned at the same time. In actual practice it is usually considered best to operate the first condenser separately because the values of its circuit vary according to the values of the antenna to which the set is connected. The other four condensers can be tied together to operate from a single control, thus mak-

ing the receiver a two-control outfit. Small auxiliary adjustment knobs are provided on the front of the receiver to adjust the capacities of three of these circuits so that the tuning controls can be brought into exact synchronism with the fourth.

It is not essential, however, that the condensers be coupled together. Tuning with the five separate controls is not nearly so much of a problem as it would appear at first glance. When a given station is exactly tuned in it will be found that all but the first dial show almost exactly the same setting. That is, if a certain station tunes in at a given setting on the second control dial, the third, fourth and fifth dials will all show within one or two degrees of the same reading.

A voltmeter and switch is mounted at the right-hand end of the receiver panel. This voltmeter is one of the attractive features of the receiver, as it will measure every voltage used in the receiver. For instance, if the switch is set on point No. 1 the meter will show the filament voltage applied to the four high-frequency amplifier valves. Point No. 2 gives the detector filament voltage. Point No. 3 shows the "C" voltage applied to the grids of the first three low-frequency amplifier valves. Point No. 4 gives the "C" voltage of the power valve. Point No. 5 shows the voltage applied to the plate of the detector valve and points Nos. 6, 7 and 8 show the plate voltages applied to the high-frequency valves, the first three low-frequency valves and the power valve, respectively.

This voltmeter therefore not only permits the proper filament voltage to be maintained (by means of the two rheostat controls on the receiver front), but also provides an easy check on the other voltages used. This simplifies the proper voltage adjustments where a power-pack provided with variable outputs is used to supply the high voltages. It also serves as a quick check on the voltage of batteries, if batteries are used for the operation of the set.

This receiver will provide best all-around results, of course, when an outdoor antenna is used. In congested areas the length of an antenna

*(Continued on page 578)*

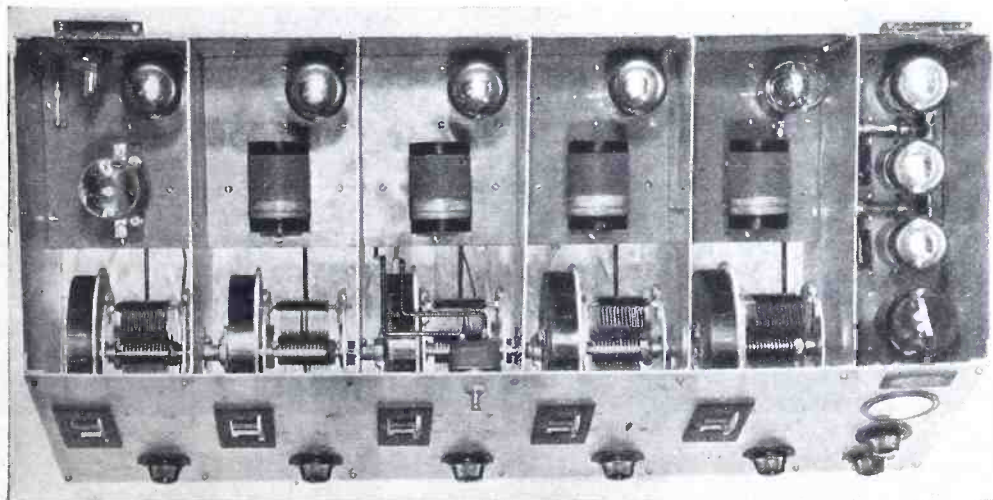

### THE SHIELDED COMPARTMENTS OF THE RECEIVER

*At the right are the four low-frequency stages in one compartment. The four high-frequency and the detector stages, each in a separate compartment, are seen to the left of the low-frequency compartment. Note also the common shaft for the rotors of the tuning condensers.*



## IN THE WORLD'S LABORATORIES

CONDUCTED BY DR. E. E. FREE

### A New Use for Vacuum Tubes

ALTHOUGH vacuum tubes are usually operated in radio under alternating-current conditions, whether used as amplifiers, oscillators or detectors, it is well known that a direct current will pass through a tube when the filament is heated and when a positive voltage is maintained on the plate. This direct current is affected by the grid voltage much as are the more usual alternating currents which we ask our receiving tubes to handle. Indeed, it is by measuring the direct current which passes under these uniform conditions that we obtain the familiar "characteristic" curves indicating the relations between grid voltage, plate current and other characters for any selected tube.

The vacuum tube is really a direct-current instrument as well as one for alternating current. It is merely that practical considerations arising from the nature of radio have conspired to emphasize the oscillatory properties of the

tube and to minimize its behavior toward direct potentials.

Important steps toward the enlargement of this relatively neglected direct-current field have been taken in a recent paper by Professor Nicholas Minorsky of the Moore School of Electrical Engineering at the University of Pennsylvania.\* Professor Minorsky connected a series of vacuum tubes, with the output of one communicating to the grid of the next, all being supplied with adjusted direct-current plate potentials from points along a potentiometer. When the characteristics of tubes and circuits are related to each other in the proper fashion (for the details of which Professor Minorsky's paper must be consulted) the final tube of the series possesses a peculiar kind of instability by virtue of which a small change of grid potential on the first tube causes the

\*"Phenomenon of Direct-Current Self-Excitation in Vacuum Tubes and its Applications," by Nicholas Minorsky. *Journal of the Franklin Institute* (Philadelphia), volume 203, pages 181-209 (February, 1927). POPULAR RADIO is indebted to Professor Minorsky for some additional information concerning his investigations.

plate current through the final tube to alternate between a high value and a value which is virtually zero. The tube series acts, therefore, as a direct-current amplifier.

Professor Minorsky's term for this action is the "contact effect," which emphasizes the similarity of the action to that of any contact device, such as a switch. By applying a small additional voltage (in the proper direction) to the grid of the first tube a relatively large current may be "turned on" through the plate circuit of the final tube, much as though a switch, previously open, had been closed. As always, the electronic changes inside the tubes are virtually without inertia. Accordingly, the combination acts as an inertialess switch or relay, thus extending to certain direct-current problems this same quick-acting relay principle which is already the secret of many successes of the vacuum tube in alternating-current technique. To close an ordinary switch or an ordinary relay takes both time and energy. The vacuum-tube "contact" device "closes" vastly more rapidly and with much less consumption of power.

One practical application of the device has already been made. This is in the regulation of the voltage of direct-current dynamos. The standard method of doing this uses some variety of voltage-operated relay which will start or break the current passing through a special, additional field-coil of the dynamo, in agreement with the fall or rise of the voltage which the dynamo is delivering. Too low a delivered voltage operates the relay, closes the circuit of the auxiliary field coil, and thus increases the magnetic forces in the dynamo, bringing the voltage back where it belongs.

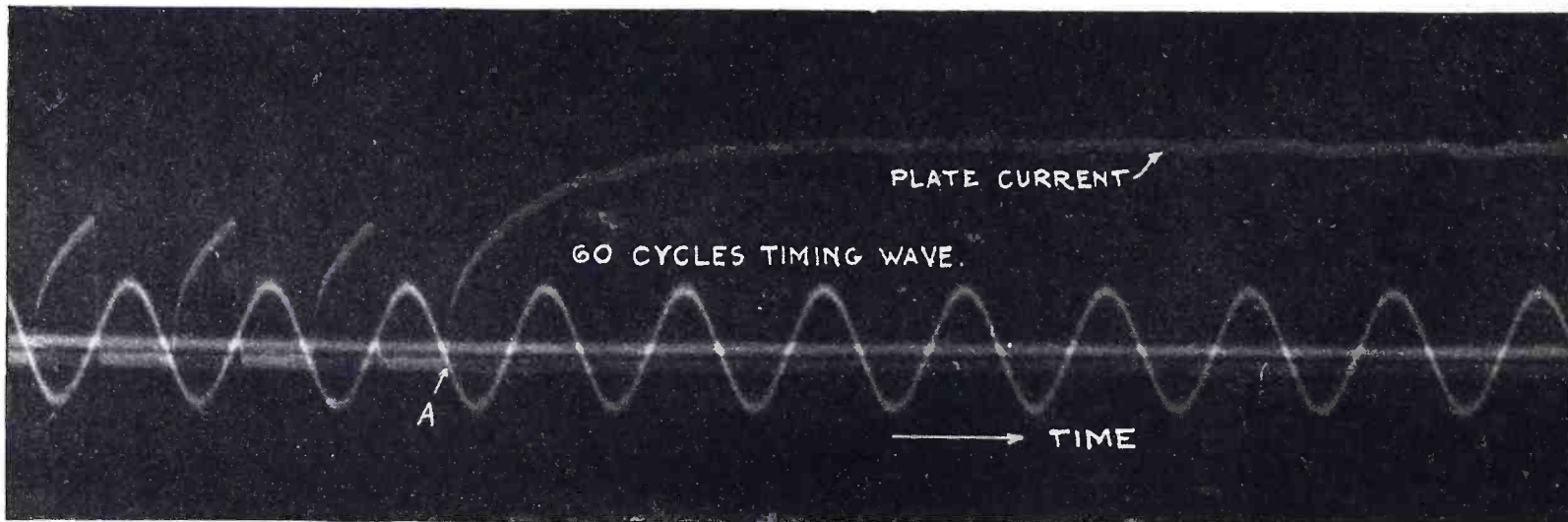

Courtesy of Professor Minorsky

#### HOW A VACUUM-TUBE CIRCUIT WORKS AS A DIRECT-CURRENT RELAY

This oscillograph record was made by the series of vacuum tubes, put together by Professor Nicholas Minorsky, to operate as a relay to make or break a direct current. The regular wavy line is the timing wave, at 60 cycles a second. The curve marked "plate current" indicates how quickly the vacuum-tube relay "closed," permitting the plate current to rise, after the starting signal was given to the first vacuum tube of the series.

The time of this starting signal is indicated by the letter "A."

Relays now used for this purpose are mechanical, being operated by some electromagnetic effect of the altered voltage. Although reasonably satisfactory, they have some lag, they absorb some energy and they possess mechanical contact points which may burn out or require adjustment.

Professor Minorsky has applied his new vacuum-tube device to this problem. He reports that it operates excellently, uses very little power, is without inertial lag and does away with the difficulties due to contact points. The "contacts" are the electrons in the tube, not any metallic points or plates.

Professor Minorsky's work is not so much a contribution to radio as one from radio. An instrument developed and perfected largely by the radio industry is shown to have promise of large importance for branches of electrical engineering which have seemed quite remote from oscillators or receivers.

### Somersaults in the Transformer

EVERY radio fan knows that operation of the familiar iron-core transformers such as we use in our audio-frequency amplifiers involves a rapid alternation of the magnetic forces in the iron-filled throats of these instruments. It is not so well known that these magnetic forces are related to some of the most intimate and important properties of the atoms of iron, as distinct from atoms of other kinds of matter. These facts belong in the science of magnetism, a science which is much less well known to the average radio experimenter than it ought to be.

Twenty years ago the magnetism of iron was very much of a mystery. It is still impossible to claim that all of the mystery has disappeared, but some of it has and the experts who are at work in this field are rapidly dispelling the remnants of ignorance which still remain. Modern theories assume, with ample evidence for the assumption, that the manifestations of magnetic forces on the part of alloys of iron are due essentially to the fact that each tiny atom of iron in the alloy is itself a minute magnet.

Everyone who has experimented at all with electric currents and with magnetic forces knows that the passage of a current of electricity through a circular coil of wire will generate a magnetic force acting along the axis of the coil. This is the so-called magnetizing current, and an arrangement in which a direct current flows through a succession of turns of wire wound in a solenoid, constitutes the familiar electro-magnet. When it is remembered that an atom of

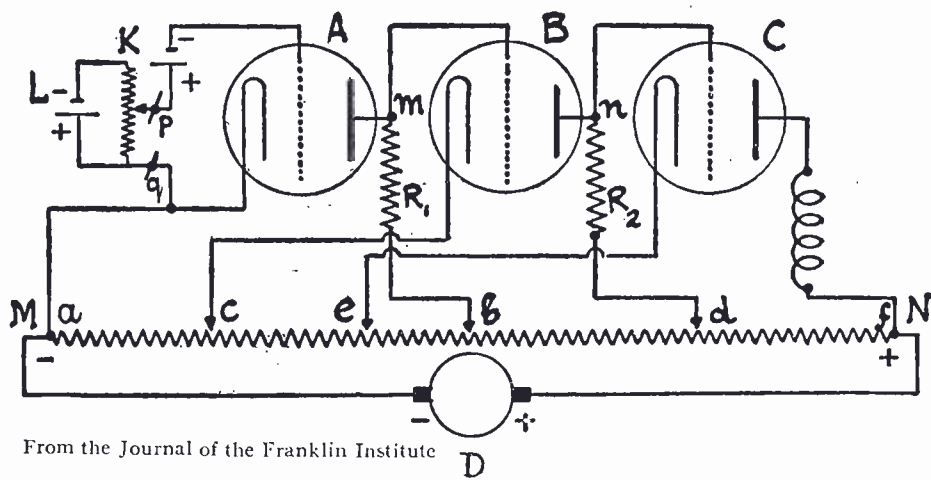

From the Journal of the Franklin Institute

#### PROFESSOR MINORSKY'S DIRECT-CURRENT AMPLIFIER

The series of vacuum tubes, all supplied with plate voltages from the potentiometer and dynamo, will deliver a large direct current in the plate circuit of the third tube, marked "C," in response to a small signal initiated by the subsidiary circuit at "L" and applied to the grid of the first tube, marked "A." The device has been applied to the regulation of the voltage produced by direct-current dynamos.

matter consists essentially of a number of electrons revolving around the atomic nucleus as planets revolve around the sun, it is easy to see that these continual revolutions of the electric charges which constitute the electrons resemble the much larger revolutions of the electric current through the coils of an ordinary electro-magnet.

Each electron orbit ought to be capable, therefore, of acting as a tiny electro-magnet and of producing a magnetic force extending outward from the atom, just as the magnetic force of an electro-

magnet extends outward from the two ends of the coil.

Although we are still unable to unravel all of the details of the electron orbits inside the atom of iron, there is good ground for the belief that these orbits are so arranged in space as to discharge, outside of each atom, a significant amount of this magnetic attraction. In the case of atoms such as those of copper or silver, which are not notably magnetic, the most plausible assumption is that the electron orbits in these atoms are arranged differently; presumably in such fashion that the magnetic force due to one electron orbit is canceled by an opposing magnetic force due to another electron orbit, in which the electron moves, perhaps, in the reverse direction.

According to this theory, if a piece of iron is "magnetized" so that it attracts another piece of iron, affects the compass needle, and so on, it means atomically that a majority of the atoms inside the piece of iron are turned in directions sufficiently parallel to make the individual magnetic forces reinforce each other.

On the other hand, when we have a piece of iron which is not magnetized we need not assume that the atoms of this non-magnetic iron have lost their individual doses of magnetism. The more reasonable assumption is that the atoms in the non-magnetic iron are arranged at random, with the directions of their magnetic forces in conflict, thus neutralizing each other in so far as any external magnetism is concerned.

It is an obvious corollary of these ideas that when a non-magnetic piece of iron is magnetized this involves, in the atomic world, a turning around of the atoms inside the iron.

Imagine yourself standing on a platform before a great crowd of people. If



Bell Telephone Laboratories

#### MAGNETS OBEY HIM

Dr. L. W. McKeegan, of the Bell Telephone Laboratories, has added important facts to our knowledge of the somersaults of atoms in iron alloys as a result of his work with permalloy, the iron-nickel alloy used for cores in submarine cable and for other purposes.

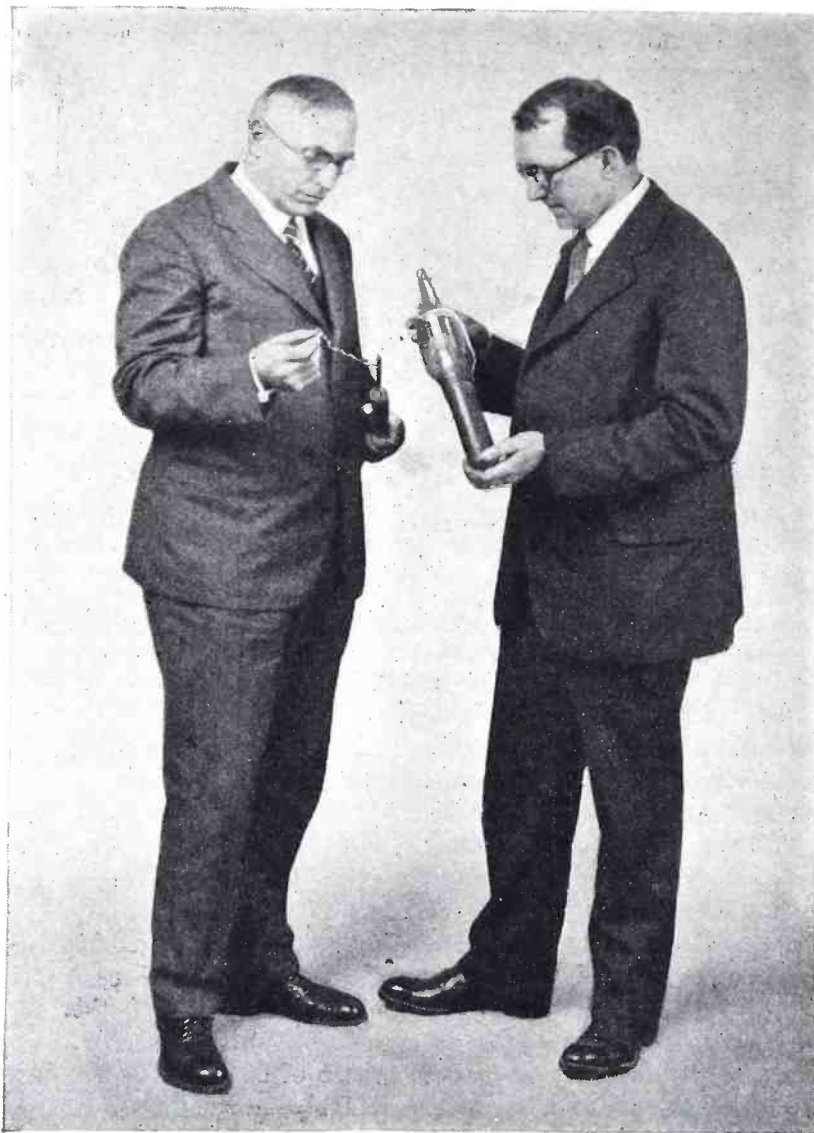

Bell Telephone Laboratories

#### HONORED FOR TWO KINDS OF COMMUNICATION

*Two physicists of the Bell Telephone Laboratories have received the John Scott Medal recently for services to communication; one for aiding messages under the sea, the other for help to messages traversing the ether. At the left is Mr. G. W. Elmen with a strip of the magnetic metal, permalloy, used to "load" cables and permit them to carry submarine messages faster than is possible otherwise. At the right is Mr. William G. Housekeeper holding one of the high-power vacuum valves which he perfected for trans-Atlantic radio telephone communication.*

the meeting has not been brought to order and if the members of the crowd are faced entirely at random, some facing in one direction and some in another, you will see from the platform merely the vast black crowd of human individuals. Suppose now that the chairman raps his gavel to call the meeting to order. Instantly, all the individuals turn around (if necessary) so that everyone is facing in a single direction. There then appears to your eye a vast sea of human faces, replacing the former indistinguishable mob.

What happens when a piece of iron is magnetized may be likened to this. The magnetizing force turns around the majority of the atoms so that all of their magnetic forces, corresponding to the people's faces, point in the same direction.

When the phenomena are viewed in this way, it is obvious that certain phys-

ical changes not concerned with magnetism may be involved.

To return to our illustration of the crowd of people; if the people are packed very tightly together and if then some stimulus forces them to face in one direction, there will be a good deal of friction as one individual bumps his neighbor in the ribs or is stepped on by his neighbor's feet. The crowd will actually get warmed a little, physically as well as metaphorically.

The same thing happens in a bar of iron when it is magnetized.

The atoms interfere a trifle with each other as they turn around. The iron develops a little heat. Some of the energy of the magnetizing force is absorbed. The bar may actually change a little in length or volume, due to the rearrangement of the atoms.

This last effect, technically known as "magnetostriction," has recently been

studied illuminatingly by Dr. McKeehan of the Bell Telephone Laboratories.\*

As all students of radio now know, Mr. G. W. Elmen, of these same laboratories, invented some time ago the remarkable new alloy called "permalloy." This permalloy possesses what is called in physical terminology an extremely high magnetic "permeability." This permeability corresponds, roughly, to ease of magnetization. It is reasonably accurate to say that permalloy is more easily magnetized, other things being equal, than even the best pure iron. Before Mr. Elmen's invention, this was regarded as an impossibility, the current magnetic theories indicating that pure iron was itself a more easily magnetizable substance than any alloy which could be made from it. Accordingly, Mr. Elmen having seriously cracked the then-existing magnetic theory, Dr. McKeehan set out to discover the reason for this disaster and, if possible, to repair the theory.

The clue to this repair turned out to be in the magnetostriction of the permalloy, the change of length or volume which samples of permalloy disclose when magnetized or demagnetized. Experiments show that this change, in the case of permalloy, is very small. Accordingly, in line with the theory of the tiny atomic magnets which must be turned around during magnetization, Dr. McKeehan concludes that the combination of iron atoms and nickel atoms produces an atomic structure in which the iron atoms can be turned around more readily, with less change in the volume of the material, with less friction and interference during the turning and, accordingly, with the high "magnetic permeability."

Dr. McKeehan's work thus provides not only an explanation of some of the peculiar properties of permalloy, but also another group of facts supporting the modern magnetic theory as above described.

In case of a transformer in a radio amplifier, every alternation of the oscillating current must be accompanied by a reversal of the magnetic forces in the iron core. This means that a large proportion of the atoms of iron inside the core are turning active somersaults, one for each reversal of the electric current. This continual somersaulting is not to be done without difficulty. Friction occurs between the atoms. Energy is lost. This is the energy which appears as "core loss" in transformer discussions and which may act, if the current in-

\* "A Physical Background for Permalloy," by L. W. McKeehan. *Bell Laboratories Record* (New York), volume 3, pages 105-107 (December, 1926). "Magnetostriction," by L. W. McKeehan. *Journal of the Franklin Institute* (Philadelphia), volume 202, pages 737-773 (December, 1926).

volved is large, to heat up the core of the transformer.

In the case of transformer cores, the effort of the designer is to procure alloys of iron in which the back and forth somersaults of the atoms occur as easily as possible, so that the loss of energy on each alternation of the current will be a minimum. There exist, however, many electro-magnetic problems in which the object is just the reverse of this. For example, in devices that employ permanent magnets, a familiar instance being the ordinary radio headphone, the effort is to make the "somersaulting" of the atoms as difficult as possible, so that when a piece of iron is once magnetized it will remain in that condition as long as possible.

For this purpose, it is now customary to employ alloys of iron with the metal cobalt; these alloys have been found to retain the magnetism more successfully than other known materials. From the viewpoint of atomic theory, these alloys are believed to be so constituted that, when the atoms have once been turned mainly in a single direction they will not turn around again easily or under the action of ordinary forces.

It is obvious that this theory of the tiny atomic magnets in alloys of iron helps to explain many other magnetic properties of these alloys, as, for example, the tendency of iron to lose its magnetism when heated or when subjected to repeated mechanical vibration.

It is possible to knock much of the magnetism out of the magnet of a telephone receiver by dropping the receiver on the floor. What happens, we believe, is that the shock loosens some of the atoms sufficiently to make them turn a partial or complete somersault, getting out of the magnetic alignment to which they previously conformed. The effect is somewhat the same as would be the effect of a mild earthquake shock on the crowd of people watching the chairman on the platform. Undoubtedly many of the human atoms would turn around in other directions to see what the earthquake shock meant. The orientation—the human "magnetism"—of the crowd would be lost.

### A "Radio Motor"

THE fact that small plates cut from crystals of quartz can be set into violent oscillation when subjected to the voltage alternations of radio currents is now familiar to everybody; this, indeed, is the fact which underlies the use of these so-called "piezo-electric" crystals to control the frequencies of transmitters or to produce the most accurate kinds of wavemeters.

It is also well-known that sound waves

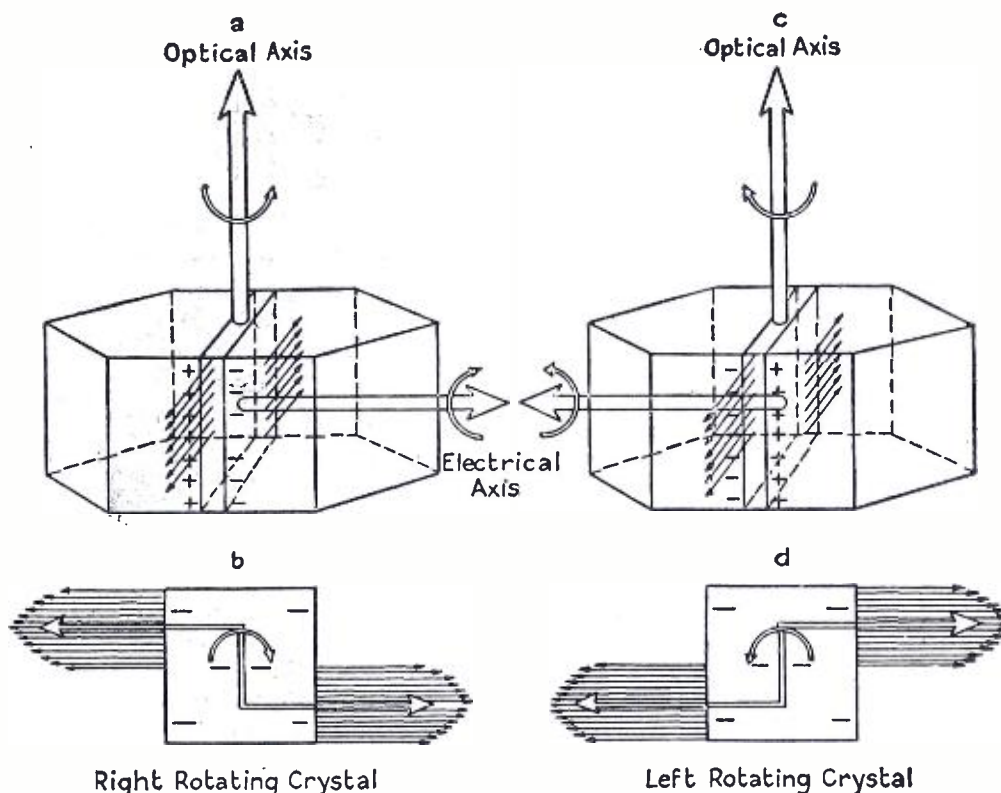

From the Proceedings of the Institute of Radio Engineers

### QUARTZ PLATES FOR THE RADIO MOTOR

By means of these diagrams, Dr. A. Meissner illustrated to the Institute of Radio Engineers how plates of quartz cut from natural quartz crystals may be set into rotation by being subjected to alternating electrostatic stresses. The forces which move these small "radio motors" are believed to be due to tiny winds created by the vibration of the quartz plates in the air, as is shown by the diagrams above.

can be produced by setting such crystals into vibration. The high-frequency, inaudible sound waves first investigated by Professor Langevin in France during the war and since studied so spectacularly by Professor R. W. Wood and Mr. Alfred Loomis, are produced in this way. One method of producing beams of under-water sound waves for determining the depth of the sea makes similar use of these vibrating quartz plates driven by audio-frequency currents.

At the meeting of the Institute of Radio Engineers in New York City on March 2, 1927, Professor W. G. Cady read a paper\* by Dr. A. Meissner, the well-known engineer of the Telefunken Company, in Berlin, in which he described an interesting "radio motor" which can be constructed on the basis of this vibratory effect. A quartz plate, properly cut from a crystal and properly energized by a radio circuit, may be set into rapid rotation in its metal container or may even be inspired to jump entirely out of this container, so violent may be the motion imparted to it. If the quartz plate is mounted on a nearly frictionless spindle, like the mounting for the balance wheel of a watch, it will rotate rapidly around this axis and may even be persuaded to yield a very small amount of

power, although not enough to cause the electric-motor industry any fear for its future business.

Dr. Meissner believes that the forces acting on a quartz plate so arranged are due to acoustic reactions between the plate and the air. The surfaces of the plate are vibrating rapidly back and forth, as the crystal shrinks and swells a trifle in the direction of the one of its crystal axes which corresponds to the particular frequency at which it is vibrating. This vibration of the quartz surface sets the adjacent air into a similar vibration. That is how the sound waves are sent out when a quartz crystal is used as a generator of sound.

The air is not, however, a perfectly elastic medium. At high frequencies of vibration the air molecules fail to respond perfectly to the rapid back-and-forth swings of the surface of the crystal. This produces, Dr. Meissner believes, actual currents of air blowing away from sides or corners of the crystal; indeed, these miniature winds can be demonstrated with light wind-vanes, sensitive flames and the like. It is also possible to show that the winds are a little off center on the crystal plate. Accordingly, they produce a twisting force which sets the crystal into rotation. The radio oscillations produce a vibration, the vibration produces winds, the winds turn the "radio motor."

(Continued on page 586)

\* "Piezo-Electric Crystals at Radio Frequencies," by A. Meissner. To be published in the Proceedings of the Institute of Radio Engineers (New York). Cited from reprint distributed at the meeting of the Institute, March 2, 1927.



Here is POPULAR RADIO'S selection of the "star" broadcast features that are scheduled as regular weekly events for the month beginning May 16—program numbers of outstanding merit that are selected on the basis of intrinsic worth, as well as upon their importance as determined by the large audiences reached by powerful single stations and by the chain stations that now cover the country. Every radio fan has—or should have—a receiver good enough to tune in on most of the features that are listed.

(THE PROGRAMS GIVEN HERE ARE SCHEDULED ACCORDING TO EASTERN STANDARD TIME; FOR BROADCAST LISTENERS LIVING IN LOCALITIES THAT USE DAYLIGHT SAVING TIME, THE TIMES OF PERFORMANCE ARE AN HOUR LATER THAN EASTERN STANDARD TIME.)

**Mondays**

**ROXY AND HIS GANG;** 7.30 P. M.; 110-piece symphony orchestra, with soloists; WJZ, WBZ, WBZA, KDKA, KYW, WRC, WSB, WHAS, WSM.



Roxy, with the crowning achievement of all, broadcasting for one and one-half hours. Roxy exercises the talent of the musical staff of the world's greatest theatre. This great weekly festival always includes the world's largest organ, the world's largest theatre symphony and one of the country's largest broadcasting chains. Roxy's broadcasting takes the form of a series of musical surprises. Douglas Stanbury, a young Canadian tenor, is Roxy's star tenor soloist. He is the fiancé of Mlle. Maria Gambarelli.

**HIRE'S HARVESTERS;** 8.00 P. M.; instrumentalists; WEA, WEEL, WGR, WLIT, WRC, WCAE, WTAM, KSD, WCCO.

This group is now engaging in another "musical tour of the world." Although musical tours have long ceased to be novel, Hire's Harvesters are able to attract and hold listeners.

**WILLYS-OVERLAND SYMPHONY;** 8.30 P. M.; symphonic music and soloists; WJZ.



Henry Hadley, with a "hand-picked" orchestra recruited from the ranks of the great New York Philharmonic Orchestra. This feature has recently been augmented by the addition of the Willys-Overland Mixed Quartet. This is essentially a music-lovers' feature, although it at times deals in such trifles as "No, No, Nanette" and "Tea for Two."

**RECORD BOYS;** 9.00 P. M.; songs and humor; WJZ, WBZ.



The funniest negro talk on the air. This is really an A-1 comedy program, provided by a trio of old-time performers who know how to merchandise songs. Al Bernard, Frank Kamplain and Sammy Stept are the performers.

**A. AND P. GYPSIES;** 9.00 P. M.; classical and semi-classical music; WEA, WEEL, WJAR, WDAF, WRC, WSSH, WTAM, WLIT, WWJ, WCAE, WSAI.



A stimulating musical organization assisted by John Barnes Wells, lyric tenor. Mr. Wells (shown at the left) is not only a tenor of note, but an instructor and authority on singing. Harry Horlick is the director of the orchestra.

**BARRERE LITTLE SYMPHONY;** 9.00 P. M.; ensemble; classical selections only; WABC.



George Barrere, the director of this ensemble, is one of the greatest musicians appearing regularly on the air; he is the first flutist of the New York Symphony. He performs the seemingly impossible in playing the flute and conducting the orchestra at the same time. This organization is a real favorite with the musical enthusiasts of New York.

**WBAL ENSEMBLE;** 9.00 P. M.; chamber music; WBAL.



The WBAL Ensemble is a hand-picked musical organization, made up of wood-winds and strings, under the direction of Robert Lula, shown at the left.

**RUUD LIGHT OPERA;** 9.30 P. M.; orchestra and soloists; WJZ, KDKA, WBZ.

Erva Giles, soprano, and Frank Munn, tenor, are the stars of this feature. These brilliant performers are supported by the Ruud Light Opera Orchestra, under the capable directorship of Walter Henschen. The Ruud organization has been unusually successful in popularizing light opera material.

**LIDO VENICE DANCE ORCHESTRA;** 10.10 P. M.; jazz music; WEEL.

Jacques Renard takes his position somewhere among the good dance orchestra leaders of the country. He has been supplying music for this period for the last year, and it is said that his audience has grown to great size.

**B. A. ROLFE'S DANCE ORCHESTRA;** 11.00 P. M.; jazz numbers; WEA.



B. A. Rolfe was one of the first orchestra leaders to leave the camp of wild syncopation and he is at present the leader of the movement for well-mannered and well-behaved jazz. Rolfe was at one time the leader of a classical ensemble.

**WBAL DANCE ORCHESTRA;** 11.00 P. M.; dance music; WBAL.

WBAL tries its hand at syncopation. Baltimore dances to this orchestra regularly.

**CORNADA ORCHESTRA;** 1.00 A. M.; dance music; KMOX.

KMOX stirs the midnight air with St. Louis' idea of a rousing good dance orchestra.

**Tuesdays**

**DINNER CONCERT;** 6.30 P. M.; classical and semi-classical music; WGY.

Middle New York's finest contribution to evening music—the dinner music supplied by the Hotel Ten Eyck Concert Ensemble.

**WBAL DINNER MUSIC;** 6.30 P. M.; chamber music; WBAL.

**GEORGE OLSEN'S STROMBERG-CARLSON ORCHESTRA;** 8.00 P. M.; dance music; WJZ, WBZ, KDKA, KYW.



George Olsen and a special orchestra that has been assembled to meet better the limitations of broadcasting. Olsen has signed a year's contract to broadcast exclusively for the Stromberg-Carlson Mfg. Corp.; he used to broadcast from the grill room of the Pennsylvania Hotel in New York.

**EDISON ENSEMBLE;** 8.00 P. M.; classic and popular music; WRNY.





# New!

You don't have to be  
water boy to this  
battery charger



The Thordarson Battery Charger R-175 employs the Raytheon Rectifying Cartridge, guaranteed as above.

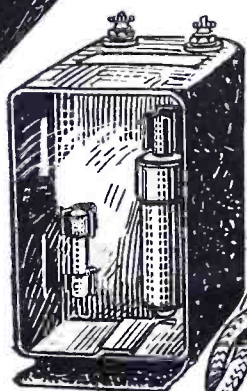

## THORDARSON BATTERY CHARGER R-175

Radically new,—sound in principle,—proven in performance.

The Thordarson Battery Charger makes its bow as a welcome relief to the army of butlers to thirsty battery chargers.

**Dry**—As dry as they make 'em. In fact, the rectifying element is contained in a moisture-proof cartridge.

**Silent**—No vibrating parts. Current is rectified through a patented electro-chemical process.

**Safe**—There is no hazard to rugs or woodwork, for there is no acid to spill. The tubes of the set are safe, even if turned on when charger is in operation.

**Compact**—Fits into battery compartment easily. Only 2 3/4" wide, 5 3/4" long and 4 3/4" high, overall.

**Efficient**—This charger is always ready for service. No overhauling required. Rectifying element can be replaced in thirty seconds.

**Guaranteed**—The rectifying unit is guaranteed for 1,000 hours' full-load operation, or approximately one year's normal service. The Transformer will last indefinitely.

Charging Rate - 2 amperes

For Sale at Good Dealers Everywhere  
or direct from factory

Price Complete, \$12.50

THORDARSON ELECTRIC MANUFACTURING CO.  
Transformer Specialists since 1925  
WORLD'S OLDEST AND LARGEST EXCLUSIVE TRANSFORMER MAKERS  
North and Kingsbury Streets - Chicago, Ill., U.S.A.

**GRAND OPERA PROGRAM; 9.00 P. M.; soloists and instrumentalists; WJZ, KDKA, KYW.**

Genia Zielinska, soprano; Devora Nadworney, contralto; Guiseppi de Benedetto, tenor, and Nino Ruasi, basso; with the heavy stuff from the great operas. This is largely an Italian quartet and naturally takes its music very seriously.

**EVEREADY HOUR; 9.00 P. M.; varied program; WEA, WEEL, WFI, WCAE, WGR, WWJ, WOC, KSD, WJAR, WCCO, WTAM, WGN, WSAI, WTAG, WRC, WGY, WHAS, WSM, WSB, WMC.**



The Eveready Hour has in the last six months ascended to true greatness, both in program making and in execution; any fair critic of broadcasting will be forced to include it in the ten best features on the air. It is usually a program with a distinct trend in the direction of continuity. Virginia Rea is the coloratura soprano of this group.

**EDUCATIONAL PROGRAM; 9.00 P. M.; lectures; WLWL.**  
One of a precious few real good educational programs, featuring professors of the various colleges and universities located within the bounds of New York City.

**JUBILEE SINGERS; 9.00 P. M.; female quartet; WBAL.**  
Sob numbers for those who like them. They are very well sung, however.

**SAM 'N' HENRY; 9.00 P. M.; negro comedy; WGN.**  
A consistently funny duet of darky songs and darky lingo.

**MUNICIPAL BAND; 10.00 P. M.; Baltimore City Band; WBAL.**  
The pride of Baltimore exposes its musical wares to the fans of the United States. This band, under the direction of Nelson C. Kratz, is used for all official occasions in Baltimore.

**BRIDGE INSTRUCTION; 10.00 P. M.; WEA, WEEL, WCSH, WTAG, WJAR, WGR, WCAE, WTAM, WFI, WWJ, WSAI, WGN, WOC, WCCO, KSD, WRC, WGY.**



A description of bridge as it is played by the patriarchs of the game. The plays are announced by Graham MacNamee.

**DON AMAIZO; 10.00 P. M.; violinist; WJZ, KDKA, KYW, WCCO.**



Cooking oil romanticism delivered by Col. C. T. Davis. Those who have patience enough to listen to the wordy and flowery descriptions of the exploits of Don Amaizo will be amply repaid by the violin selections. Although it is not generally known, the dashing Don Amaizo is none other than Godfrey Ludlow, shown at the left.

**ARROWHEAD INN ORCHESTRA; 10.30 P. M.; dance music; WGBS, WIP.**

One of New York's many dance orchestras played in a famous road-house at the gateway to Broadway.

**PENNSYLVANIA GRILL; 10.30 P. M.; dance music; WJZ.**  
Roger Wolfe Kahn, precocious son of the renowned Otto, in what used to be George Olsen's shoes. However, young Mr. Kahn seems to be holding up to the traditions of the Pennsylvania grill room. This feature is an exceptionally reliable source of good dance music.

### Wednesdays

**DINNER CONCERT; 6.45 P. M.; chamber music; WSM.**  
A small ensemble with good talent and good intentions. Only the classics are played.

**RADIO NATURE LEAGUE; 7.30 P. M.; nature talks; WBZ.**



Thornton Burgess, and other naturalists, in lectures full of absorbing interest for those who love the open spaces.

**STEINDAL STRING QUARTET; 7.30 P. M.; semi-classical music; KMOX.**

A small organization with good talent devoting itself to the masters.

**KATZ AND HIS KITTENS; 8.00 P. M.; dance orchestra; WQJ.**  
One jazz orchestra able to raise its head above the several million other orchestras in Chicago.

**IDENT'S NO. 1 AND NO. 2; 8.30 P. M.; the Mitchel Brothers, banjo and piano; WJZ, WBZ, KDKA, KYW.**



John and Bill Mitchel enter the crooning contest with good success. While these performers will never give music lovers musical indigestion, their act is bright and sparkling enough to interest the popular song fan.

**DAVIS SAXOPHONE OCTETTE; 8.30 P. M.; popular and classic music; WEA, WEEL, WJAR, WLIT, WRC, WCAE, WTAM, WSAI, WCSH.**

Eight saxophones under the perfect control of Clyde Doerr, who opens his program with the spirited "Davisax" march.

**REMINGTON BAND; 8.30 P. M.; typical band selections; WGY.**



A big band from a little town broadcasting from one of the great American stations. This band is made up of the employees of the Remington Typewriter Co. at Iliion, N. Y.; its conductor is Edwin L. Daniels.

**IPANA TROUBADOURS; 9.00 P. M.; dance music; WEA, WEEL, WGR, WRC, WCAE, WWJ, WLIB, KSD, WCCO, WDAF, WGY.**



Bombastic troubadour music and dance numbers molded into perfect shape under the guidance of Sam Lapin's baton.

**MAXWELL HOUR; 9.00 P. M.; orchestra and soloists; WJZ, WBZ, KDKA, KYW, WHAS, WSB, WMC, WSM.**

Great moments in music supplied by a famous orchestra and a famous director. Shilkret's Maxwell Ensemble has never won a blue ribbon simply because blue ribbons have never been offered to air performers.

**RCA RADIOTRONS; 10.00 P. M.; songs and comedy; WJZ, WBZ, KDKA, WEBB.**

A brilliant program built around the talent of the Shannon Quartet: Andy Sanella, saxophonist; Sammy Herman, xylophonist, and L. T. Priest, comedian. This is one of the best variety features on the air.

**FISHER'S DANCE ORCHESTRA; 10.00 P. M.; dance music; KFI.**  
Ray Fisher is the big gun in dance music in the West, where Lopez is just a legend.

**SMITH BROTHERS; 10.00 P. M.; humorous songs; WEA, WTAG, WGR, WRC, WCAE, WWJ, WSAI, KSD, WOC, WCCO, WDAF.**



The personified "Trade Marks" of a great cough-drop manufacturer. "Mark" and "Trade" sing foolish little ditties with a great deal of success. Their parts are taken by two Rutgers College students, "Scrappy" Lambert and Billy Hillpat.



**HAGAN'S DANCE ORCHESTRA; 11.00 P. M.; dance program; WOR.**  
A newcomer whose stock has appreciated in value since the first week. Hagan has no style of his own, but he plays other styles remarkable well.

**JADE ROOM DANCE ORCHESTRA; 11.00 P. M.; dance music; WTAM.**  
Emerson Gill, with an orchestra which is helping to make the "Sixth City" famous.

**KFI MIDNIGHT FROLIC; 3.00 A. M.; varied program; KFI.**  
Big-time vaudeville circuits supply the talent for this stimulating hour of music.

### Thursdays

**PALAIS ROYAL ORCHESTRA; 6.00 P. M.; dance music; WEEL.**  
Boston's idea of a rousing good dance organization.

**MEYER DAVIS ORCHESTRA; 7.00 P. M.; dance music; WGBS.**  
Davis is always mentioned along with Lopez, Olsen, and the rest of New York's best.

**ORGAN RECITAL (Fred Weaver); 7.30 P. M.; classical and semi-classical selections; WBAL.**  
Just the kind of organ music that most people like to hear.

**CONCERT ENSEMBLE; 7.35 P. M.; chamber music; WGN.**  
This is a rare thing in Chicago—good chamber music.

**CHATEAU SOURIER CONCERT; 7.45 P. M.; chamber music; CNRM.**  
Chateau Sourier is Montreal's greatest hotel, and this concert is supplied by its dining-room ensemble.

**WBAL ENSEMBLE; 7.45 P. M.; chamber music; WBAL.**  
Something you'd like to listen to after a hard day at the office.

**CLICQUOT CLUB ESKIMOS; 9.00 P. M.; banjo ensemble; WEA, WEEL, WCCO, WGN, WCAE, WGY, WJAR, WTAG, KSD, WOC, WGR, WFI, WWJ.**



Harry Reser, with a snappy dance orchestra made up principally of banjos. Each evening's entertainment is usually marked by some unique departure from conventional music-making.

**FULLER ORCHESTRA; 9.30 P. M.; popular music; WGHP.**  
No. 2 on the list of Chicago dance orchestras.

**GOODRICH SILVERTOWN ORCHESTRA AND SILVER MASKED TENOR; 10.00 P. M.; popular music; WEA, WEEL, WCCO, WGN, WCAE, WJAR, WTAG, KSD, WOC, WGR, WFI, WWJ, WSAI, WCSH, WADC, WHAS, WSB, WSM, WMC.**

The return to the air of the Goodrich Silvertown Cord Orchestra and the Silver Masked Tenor after playing a thirty-week engagement on the B. F. Keith vaudeville circuit.

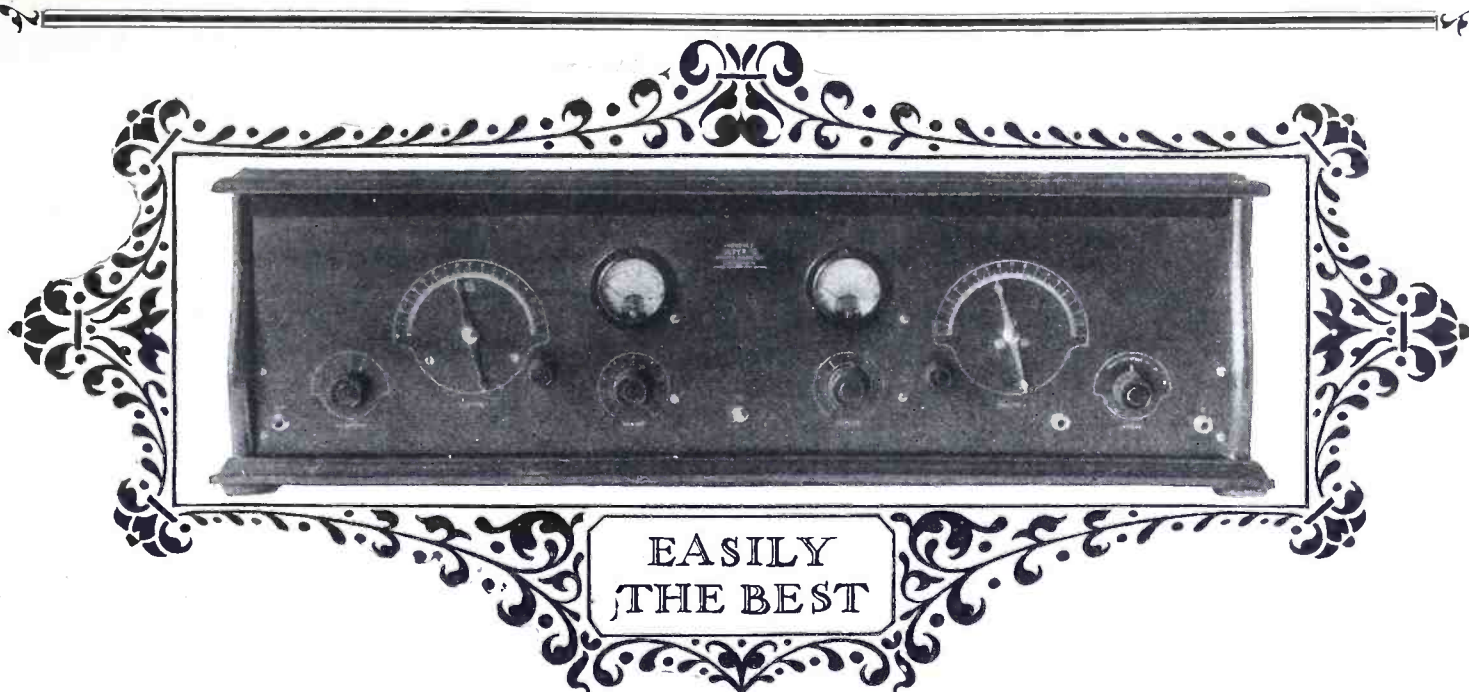

# The New Custom-Built 10 Tube Model SUPER-10 SPECIAL

This is the greatest receiving set ever built by Norden-Hauck Engineers. Nothing equals it for sheer performance, quality and distinction. Absolutely nothing has been omitted to provide supreme radio reception—a new standard previously unknown.

The SUPER-10 SPECIAL is the response to your demand for radio perfection, expressed in an individual hand built Receiving Set. Every detail bespeaks the master craftsman. Thus those who would add the final touch of luxury and distinction, may gratify their desire in the Special Super-10. It is for those who want and can afford the best.

**EXTRA POWER**—Guaranteed Selectivity—absolutely faithful reproduction at any desired volume—and marvelously easy to operate.

Of course the SUPER-10 SPECIAL may be operated either from house current or batteries. The Norden-Hauck Model 500 HI DUTY Power Unit has been designed particularly for the SUPER-10 SPECIAL or any other receiver requiring large current capacity, numerous voltage taps and controls up to 525 volts for the new 210 Power Tube. Upon request attractive illustrated literature which has been prepared on the SUPER-10 SPECIAL and Power Unit will be gladly mailed to you without cost or obligation.

The Standard Super-10 has not been discontinued or superseded by this Special model.

Complete constructural Blue Prints and parts are obtainable for the SUPER-10 SPECIAL, STANDARD SUPER-10 and the MODEL 500 POWER UNIT.

## NORDEN-HAUCK, INC.

Marine Building

ENGINEERS

Philadelphia, Pa.

----- For Your Convenience Use the Attached Coupon. -----

NORDEN-HAUCK, INC.  
Marine Building, Philadelphia, Pa.

I enclose \$..... for which send me, postpaid, items checked below:

- |   |  |
|---|--|
| <input type="checkbox"/> Complete constructural Blue Prints for the SUPER-10 SPECIAL @ \$2.00.  | <input type="checkbox"/> Complete constructural Blue Prints for the MODEL 500 POWER UNIT @ \$1.00. |
| <input type="checkbox"/> Complete constructural Blue Prints for the SUPER-10 STANDARD @ \$2.00. | <input type="checkbox"/> Illustrated literature on the SUPER-10 SPECIAL.                           |

Name..... Address.....

## Fridays

**HOTEL BRETTON HALL ORCHESTRA**; 6.30 P. M.; *chamber music*; WOR.

An old standby of the one who prepares these little comments. Not perfect, just good.

**KING EDWARD HOTEL ORCHESTRA**; 6.35 P. M.; *chamber music*; CNRT.

Those residing in northern New York will do well to tune this in. Such good music is difficult to find.

**MIXED QUARTET**; 7.30 P. M.; *male voices*; WBAL.

Just a nice little quartet singing little ditties that quartets are always expected to sing.

**HAPPINESS BOYS**; 7.30 P. M.; *songs and jokes*; WEA.F.



Billy Jones and Ernest Hare in a half-hour of foolishness and song. Although their humorous supply often becomes a bit "mossy," their songs are unfailingly fresh and original—and they enjoy their own act as genuinely as do their audiences.



**GOLDMAN BAND**; 8.00 P. M.; *wide range of selections*; WEA.F, WEEI, WGR, WLIT, WRC, WCAE, WTAM, WWJ, WSAI, WOC, WCCO, WGY, KVOO, WFAA, WOAF, WLIB.



Edwin Goldman's famous symphony in brass is an outfit that is always worthy of a Red Seal record. Goldman's repertoire is usually one of wide variety, running all the way from brilliant modern marches to Tschaiakowsky and Beethoven. Perhaps the best of the bands that are now broadcasting.

**MARKEL'S SOCIETY ORCHESTRA**; 8.00 P. M.; *dance music*; WJZ, WBZ, KDKA, KYW.

What New York's best society uses when it wants to dance. Markel's Society Orchestra means just that—nothing more and nothing less.

**ROYAL HOUR**; 8.30 P. M.; *orchestra and soloists*; WJZ, WBZ, KDKA, KYW.

Joe Green and his Royal Music Makers have been supplying Grade "A" music since chain broadcasting was a pup.

**TRAYMORE CONCERT ORCHESTRA**; 9.00 P. M.; *chamber music*; WPG.

One of the Atlantic City hotel ensembles fills a half-hour of WPG's time. This is the dining-room organization of one of the best hosteries.

**LA FRANCE ORCHESTRA**; 9.30 P. M.; *popular orchestral music*; WEA.F, WGR, WLIT, WOC, WCAE, WTAM, WWJ, KSD, WDAF, WMAG.



Anna C. Byrne, with a group of 33rd-degree musicians, specializing in the classics and semi-classics. No small orchestra on the air has a more enviable record.

**ARMCHAIR HOUR**; 10.00 P. M.; *vocal and instrumental music*; WJZ, WBZ.



WJZ "fills in" with studio talent. Keith McLeod on the vibraphone, Godfrey Ludlow on the violin and a quartet made up of announcers supply the entertainment. Marley Sherris (at the left) is one of the performers before the Mike.

**WHITTAL ANGLO-PERSIANS ORCHESTRA**; 10.00 P. M.; *classical and semi-classical music*; WEA.F, WEEI, WJAR, WTAG, WGR, WLIT, WTAM, WCAE, WWJ, WCCO, WDAF, KSD, WOC, WGN, WGY.

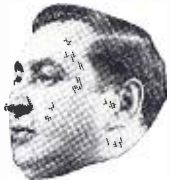

This ensemble comes dangerously close to measuring up to the highest standards. They have, since the inception of this feature, been an unfailing source of classical music, well chosen and well played. The organization is under the direction of Mr. Louis Katzman.

**PENNSYLVANIA GRILL**; 10.30 P. M.; *dance music*; WJZ.

One of two weekly "appearances" of Roger Kahn and his very popular jazz band. Mr. Kahn has many dance orchestras operating under his name, but this is the only one he directs personally.

**DANCE ORCHESTRA**; 11.00 P. M.; *dance music*; KDKA.

## Saturdays

**JACQUES RENARD'S ORCHESTRA**; 6.45 P. M.; *dance music*; WEEI.

Rip-snorting dance music from a young French director with American ideas. He's very popular up Boston way.

**ARCADIA BALL ROOM ORCHESTRA**; 7.45 P. M.; *dance music*; WGBS.  
One of the many, many good dance orchestras playing regularly for New York broadcasters.

**HOTEL CHELSEA CONCERT**; 9.30 P. M.; WPG.

Good enough for one of the best hotels in Atlantic City.

**BENJAMIN FRANKLIN ORCHESTRA**; 10.05 P. M.; *chamber music*; WIP.

One of a very few sources of good music in the Quaker City.

**ARCADIA DANCE ORCHESTRA**; 12.00 P. M.; *dance music*; KMOX.  
St. Louis makes a bid for midnight popularity.

**COLORADO ORCHESTRA**; 12.30 P. M.; *dance music*; KOA.

KOA enters the midnight competition for listeners to dance music.

## Sundays

**ROXY SUNDAY PROGRAM**; 2.00 P. M.; *vocal and instrumental numbers*; WJZ, WBZ, WBZA, KYW, WRC.

Roxy in a real surprise grab-bag program; even the studio staff is not informed as to the nature of the program until the last minute. As an index of the character of this program, it might be said that Roxy recently strolled into the studio with Carrie Jacobs Bond, Evelyn Herbert and Margaret Anglin.

**BEDFORD Y.M.C.A. MEN'S CONFERENCE**; 4.00 P. M.; *Dr. S. Parkes Cadman*; WEA.F, WEEI, WCSH, WTAG, WCAE, WSAI.



Popular philosophy for those who like their Sunday religion in light doses. Dr. S. Parkes Cadman is perhaps the best known divine in the country, due largely to his broadcasting activities and to his widely syndicated newspaper articles.

**CROSLY RADIO FEATURE** (alternate weeks); 5.30 P. M.; *varied program*; WEA.F, WEEI, WJAR, WTAG, WGN, WFI, WRC, WCSH, WCAE, WTAM, WWJ, WSAI, KSD, WDAF, WHAS, WSM, WSB, WMC, WGY.

The Crosley Radio Corporation makes its contribution to broadcasting with a varied musical program. After a day of heavy preaching, it comes as welcomed relief.

**PARK V. HOGAN ORGAN RECITAL**; 7.00 P. M.; *organ and vocal*; WJZ.

For over three years Park Hogan has been playing for New York's greatest station. Isn't that sufficient endorsement?

**THE CAPITOL GRAND ORCHESTRA** (and Major Bowes' family); 7.20 P. M.; *symphonic music and soloists*; WEA.F, WEEI, KSD, WRC, WWJ, WJAR, WCAE, WTAG, WHAS, WSB, WSM, WMC.



As the publicity man writes, "A galaxy of stars," in a two-hour program full of solid entertainment. This organization, obviously to meet the new Roxy competition, has increased the strength of its grand orchestra by fourteen men, bringing the total up to ninety-four. Thus, it takes its place as the second largest symphony orchestra on the air. The Capitol Grand Orchestra and the Baby Grand Studio Orchestra are under the direction of David Mendoza, a young Spaniard, not yet in his thirties. Mendoza was at one time the first fiddle in the orchestra under the Roxy régime. The impresario is Major Edwin Bowes.

**DELLA ROBBIA CONCERT**; 7.45 P. M.; *chamber music and solos*; WOR.

A nice little Sunday evening concert from a nice little broadcasting station and a nice little hotel. This concert offers great relief to an afternoon filled with all sorts of hymn tunes and exhortations.

**COOK'S TOURS**; 8.30 P. M.; *travelogue with music*; WJZ.

Although one of the oldest commercial features on the air, Cook's travelogues are still immensely popular with the radio audience. It is well-deserved popularity, however, for these travelogues, with their musical background, have been consistently good.

**AMBASSADOR CONCERT**; 9.10 P. M.; *chamber music*; WPG.

A great Atlantic City hotel gets a little well-deserved publicity.

**ATWATER KENT HOUR**; 9.15 P. M.; *star soloists*; WEA.F, WEEI, WFI, WCCO, WTAM, WGN, WCAE, WGR, WOC, WTAG, WWJ, KSD, WRC, WSAI, WGY, WHAS, WSB, WMC.



The moguls of operatic music in an ambitious effort to produce the outstanding event in weekly broadcasting. Except on rare occasions, vocal numbers are solos. The conductor of the orchestra is Mr. Niccolai Berezowsky.

**COLLIER HOUR**; 9.30 P. M.; *variety program*; WJZ, KYW, WBZ, KDKA.

The Collier Hour involves good music, story-telling and educational discussions. All of this is ingeniously arranged and presented with amazingly good showmanship and continuity.

## Centralab Station Selector



**BIGGEST Dollar's Worth in Radio.** Tunes out short wave interference, increasing selectivity of any set (not using loop) on stations close to local, except same wave length stations. Not a wave trap. No adjustments. At dealer's or send us dollar bill. Money-Back Guarantee. Satisfaction guaranteed.

## Centralab Modu plug



**GIVES** old receivers the improved tone volume control of latest, best sets. Replaces present speaker plug. Tune in with dials. Then modulate to any degree on Modu Plug alone (between speaker and set). Reduces interfering noises. Attaches without tools. Nothing else like it. Cord or Jack Type, \$2.50 at dealers, or mailed C. O. D. Parts manufacturers for 69 makers of leading standard sets.

Central Radio Laboratories  
17 Keefe Ave. Milwaukee, Wis.

**Centralab**

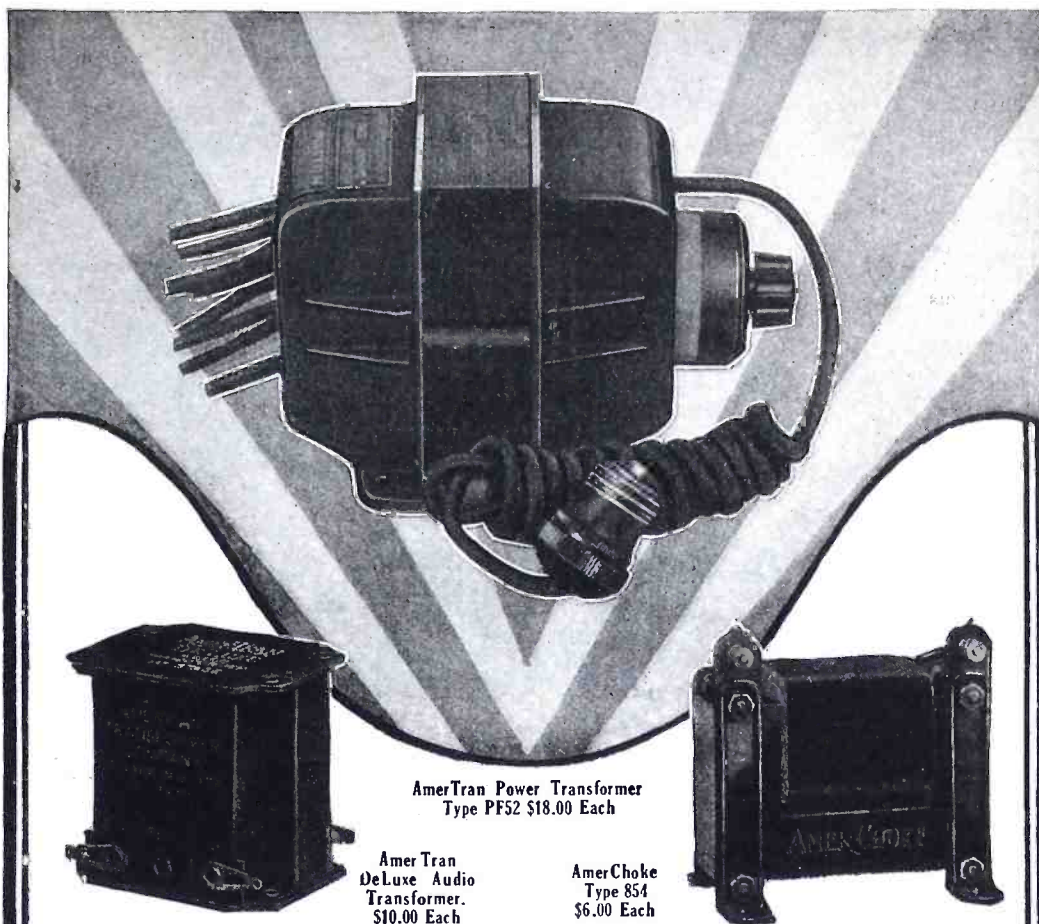

AmerTran Power Transformer  
Type PF52 \$18.00 Each

AmerTran  
DeLuxe Audio  
Transformer.  
\$10.00 Each

AmerChoke  
Type 854  
\$6.00 Each

# BETTER RADIO NEEDS THESE QUALITY AMERTRAN UNITS

You wouldn't consider a cheaply built engine in a \$3,000 car—

Then why spend money for a good loudspeaker and good tubes for use in the new set you are building and put into it poorly designed, inefficient audio transformers?

AmerTran DeLuxe transformers are so perfected that they cause tubes to amplify with all their natural fullness. Lesser transformers cannot equal the AmerTran DeLuxe for dependable volume and tone quality. Properly installed, they result in uniform reception over the entire useful audible range.

There is no question about the AmerTran DeLuxe. Time and again it has proved to the satisfaction of engineers and laboratory workers that it is the truly outstanding audio transformer. Finest results with modern speakers and tubes are easily obtainable, and comparison will convince you that the AmerTran DeLuxe sets an entirely new standard of audio amplification.

### Battery Elimination

The AmerTran Power Transformer Type PF52, AmerChoke Type 854, and the AmerTran Resistor Type 400 are recommended for the construction of a highly efficient high voltage plate supply. Through slight changes in your set, you may replace all batteries with an unexcelled source of reliable power. Write for information on building this apparatus—also free booklet, "Improving the Audio Amplifier."

## THE AMERICAN TRANSFORMER CO.

178 EMMET STREET

NEWARK, N. J.

"Transformer Builders for Over 26 Years"

Sold only at authorized  
**AMERTRAN**  
DEALERS

Statement of the ownership, management, circulation, etc., required by the act of Congress of August 24, 1912, of POPULAR RADIO, published monthly at New York, N. Y., for April 1, 1927, State of New York, County of New York.

Before me, a Notary Public in and for the State and county aforesaid, personally appeared Douglas H. Cooke, who, having been duly sworn according to law, deposes and says that he is the Publisher of the POPULAR RADIO and that the following is, to the best of his knowledge and belief, a true statement of the ownership, management, etc., of the aforesaid publication for the date shown in the above caption, required by the Act of August 24, 1912, embodied in section 411, Postal Laws and Regulations, printed on the reverse of this form, to wit: 1. That the names and addresses of the publisher, editor, managing editor, and business managers are: Publisher, Douglas H. Cooke, 627 West 43d Street, New York City, N. Y.; Editor, Kendall Banning, 627 West 43d Street, New York City, N. Y.; Managing Editor, Kendall Banning, 627 West 43d Street, New York City, N. Y.; Business Manager, E. A. Harm, 627 West 43d Street, New York City, N. Y. 2. That the owner is: POPULAR RADIO, Inc., whose stockholders are: Douglas H. Cooke, 627 W. 43d Street, New York City; Kendall Banning, 627 West 43d Street, New York City; Laurence M. Cockaday, 627 West 43d Street, New York City; Theodora W. Cooke, 59 Beechmont Drive, New Rochelle, N. Y. 3. That the known bondholders, mortgagees, and other security holders owning or holding 1 per cent or more of total amount of bonds, mortgages, or other securities are: NONE. 4. That the two paragraphs next above, giving the names of the owners, stockholders, and security holders, if any, contain not only the list of stockholders and security holders as they appear upon the books of the company but also, in cases where the stockholder or security holder appears upon the books of the company as trustee or in any other fiduciary relation, the name of the person or corporation for whom such trustee is acting, is given; also that the said two paragraphs contain statements embracing affiant's full knowledge and belief as to the circumstances and conditions under which stockholders and security holders who do not appear upon the books of the company as trustees, hold stock and securities in a capacity other than that of a bona fide owner; and this affiant has no reason to believe that any other person, association, or corporation has any interest direct or indirect in the said stock, bonds, or other securities than as so stated by him. Douglas H. Cooke, Publisher. Sworn to and subscribed before me this 1st day of April, 1927. Sadie M. Nilan, Notary Public, Queens County. (My commission expires March 30, 1928.)

## Schedules of Dinner-Hour and Dance Programs of Special Note

★ Programs of Dinner-Hour Music <i>(Eastern Standard Time)</i>			★ Programs of Dance Music <i>(Eastern Standard Time)</i>		
FEATURE	STATION	TIME	FEATURE	STATION	TIME
Palmer House Victorians	<b>WEBH</b>	7:15 P. M.; <i>daily except Sundays.</i>	Colorado Orchestra	<b>KOA</b>	12:15 P. M.; <i>Saturdays.</i>
Hotel Andrew Jackson Concert	<b>WSM</b>	7:15 P. M.; <i>Tuesdays; 6:45 P. M.; Wednesdays and Thursdays.</i>	Packard Six Orchestra	<b>KFI</b>	1:00 A. M.; <i>Monday mornings.</i>
Neopolitans	<b>WTAM</b>	6:00 P. M.; <i>Wednesdays and Thursdays.</i>	Coronado Orchestra	<b>KMOX</b>	1:00 A. M.; <i>Mondays, Tuesdays, Wednesdays, Fridays, Saturdays.</i>
Emerson Gill's Orchestra	<b>WTAM</b>	6:00 P. M.; <i>Fridays.</i>	Arrowhead Inn Dance Orchestra	<b>WGBS, WIP</b>	10:30 P. M.; <i>Tuesdays and Saturdays.</i>
Bem's Little Symphony	<b>KGO</b>	9:00 P. M.; <i>daily except Saturdays.</i>	McDonald Recording Orchestra	<b>WGBS, WIP</b>	10:30 P. M.; <i>Thursdays.</i>
Katz and His Kittens	<b>WQJ</b>	8:00 P. M.; <i>daily except Sundays and Mondays.</i>	Van Horn Dance Hour	<b>WPG</b>	10:30 P. M.; <i>Fridays.</i>
Hotel Tuller Concert	<b>WGHP</b>	7:00 P. M.; <i>daily except Sundays.</i>	Casino Dance Orchestra	<b>WPG</b>	11:30 P. M.; <i>Saturdays and Mondays.</i>
WBAL Dinner Concert	<b>WBAL</b>	6:30 P. M.; <i>Mondays, Tuesdays, Thursdays and Fridays.</i>	Silver Slipper Orchestra	<b>WPG</b>	11:30 P. M.; <i>Tuesdays.</i>
Joe Rine's Orchestra	<b>WEEI</b>	6:05 P. M.; <i>Mondays, Wednesdays and Thursdays.</i>	Golden Pheasant Orchestra	<b>WTAM</b>	10:15 P. M.; <i>Sundays.</i>
Jack Renard's Orchestra	<b>WEEI</b>	6:45 P. M.; <i>Saturdays.</i>	Emerson Gill Orchestra	<b>WTAM</b>	10:00 P. M.; <i>Mondays and Wednesdays.</i>
Mack's Collegians	<b>KFI</b>	9:30 P. M.; <i>Saturdays.</i>	Far East Orchestra	<b>WTAM</b>	11:00 P. M.; <i>Thursdays.</i>
Ray Fisher's Orchestra	<b>KFI</b>	10:00 P. M.; <i>Wednesdays.</i>	Jade Room Orchestra	<b>WTAM</b>	11:30 P. M.; <i>Fridays.</i>
Concerts from Atlantic City Hotels	<b>WPG</b>	7:25 P. M.; <i>daily except Sundays.</i>	Simovar Orchestra	<b>WENR</b>	1:00 A. M.; <i>Thursday, Friday and Saturday mornings.</i>
Special Dinner Programs	<b>WBZ</b>	7:00 P. M.; <i>daily.</i>	Midshipmen Orchestra	<b>KGO</b>	12:30 P. M.; <i>Thursdays.</i>
KDKA Little Symphony	<b>KDKA</b>	6:00 P. M.; <i>Tuesdays, Thursdays.</i>	Katz and His Kittens	<b>WQJ</b>	11:00 P. M.; <i>Saturdays, Tuesdays, Wednesdays, Thursdays and Fridays.</i>
Coronado Orchestra	<b>KMOX</b>	7:00 P. M.; <i>Sundays.</i>	WBAL Dance Orchestra	<b>WBAL</b>	11:00 P. M.; <i>Mondays, Tuesdays, Thursdays and Fridays.</i>
Organ Recital	<b>KMOX</b>	7:00 P. M.; <i>daily except Sundays.</i>	Renard's Orchestra	<b>WEEI</b>	10:05 P. M.; <i>Mondays.</i>
Drake Concert	<b>WLIB</b>	8:00 P. M.; <i>Tuesdays, Thursdays and Saturdays.</i>	Joe Rine's Orchestra	<b>WEEI</b>	10:05 P. M.; <i>Wednesdays.</i>
Drake Concert	<b>WGN</b>	7:35 P. M.; <i>daily except Sundays.</i>	Nighthawks	<b>WBBM</b>	1:00 A. M.; <i>Mondays; 12:00 P. M.; Tuesdays and Thursdays.</i>
Brown Palace Orchestra	<b>KOA</b>	8:30 P. M.; <i>daily except Thursdays.</i>	Vincent Carr Orchestra	<b>WIP</b>	10:05 P. M.; <i>Saturdays.</i>
Benjamin Franklin Orchestra	<b>WIP</b>	6:10 P. M.; <i>Tuesdays, Wednesdays, Thursdays and Saturdays.</i>	Vanderbilt Dance Orchestra	<b>WOR</b>	11:35 P. M.; <i>Tuesday.</i>
McDonald's Orchestra	<b>WIP</b>	6:10 P. M.; <i>Mondays and Fridays.</i>	Cass Hogan's Orchestra	<b>WOR</b>	11:00 P. M.; <i>Wednesdays and Saturdays.</i>
Bretton Hall String Quartet	<b>WOR</b>	6:30 P. M.; <i>Tuesdays and Fridays.</i>	Fletcher Henderson's Orchestra	<b>WOR</b>	11:00 P. M.; <i>Fridays.</i>
Dinner Concert	<b>WJW</b>	6:00 P. M.; <i>except Saturdays and Sundays.</i>	Kentucky Serenaders	<b>KYW</b>	11:30 P. M.; <i>Saturdays.</i>
Jack Jacobs Orchestra	<b>WOR</b>	6:15 P. M.; <i>Mondays, Wednesdays, Thursdays and Saturdays.</i>	Roger Kahn's Orchestra	<b>WJW</b>	10:30 P. M.; <i>Tuesdays.</i>
Twilight Musical	<b>WAIU</b>	7:00 P. M.; <i>Mondays, Tuesdays and Wednesdays.</i>	B. A. Rolfe's Orchestra	<b>WEAF</b>	11:00 P. M.; <i>Mondays.</i>
			Goodrich Zippers	<b>WEAF</b>	10:00 P. M.; <i>Thursdays.</i>
			Johnny Johnstone's Orchestra	<b>WJZ</b>	10:30 P. M.; <i>Thursdays; 10:50 P. M.; Saturdays.</i>

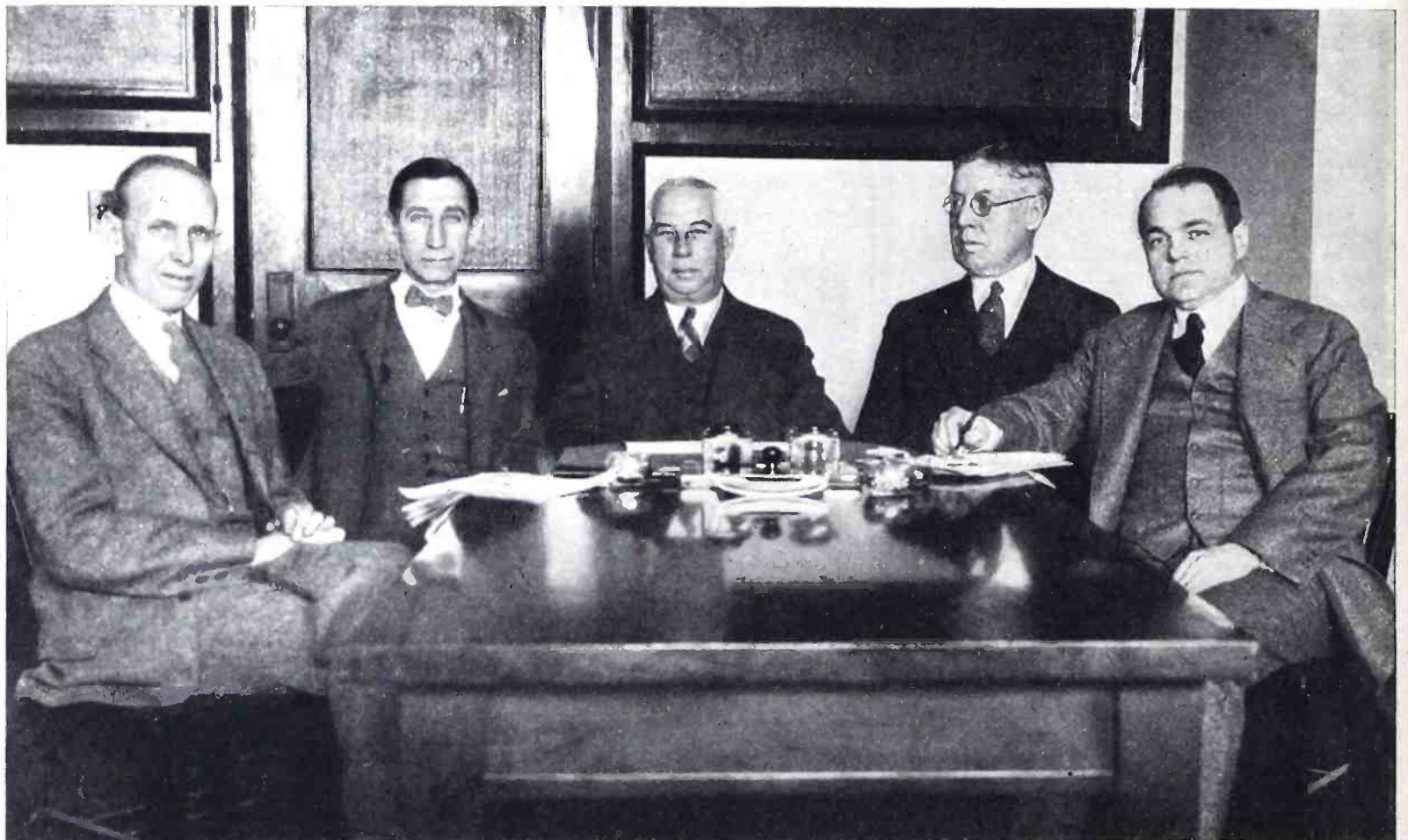

Henry Miller

### The First Full Session of the New Radio Commission of the U. S. Department of Commerce

The arrival from abroad of Rear Admiral W. H. G. Bullard, several weeks after his appointment as Chairman, did not halt the work of this body, which proceeded to its task of bringing order out of the ethereal chaos with commendable promptness and efficiency, under temporary leadership. The members shown above, from left to right, are Henry A. Bellows, Eugene O. Sykes, W. H. G. Bullard, John F. Dillon and Orestes H. Caldwell.



Experts in the POPULAR RADIO Laboratory with measuring apparatus arranged for loudspeaker tests.

## HOW THE POPULAR RADIO LABORATORY HELPS YOU TO BUY GOOD LOUDSPEAKERS

**A** CONFUSING number of factors enter into the intelligent choice of a loudspeaker, and the layman, unless he is provided with the rare natural gift of a hypercritical ear and an innate "engineering sense," runs the risk of making a selection that will eventually prove unsatisfactory. The speaker of his choice may have sounded well in the dealer's store; it may have been well and artistically made, but he failed to properly judge the factors of the case. Some speakers, for instance, sound better on certain receivers; receivers that have electrical characteristics matching the characteristics of speakers of certain types.

What is the impedance of the speaker you have purchased or intend to purchase? Does it match the output impedance of the vacuum tube used? What is the resonance curve? Does it respond to the lower frequencies as well as the high ones? Will it, after a month or so of constant use, show a tendency to chatter on the crescendos? Is the parchment too hygroscopic? Does the speaker create

extraneous noises that are believed, wrongly, to originate in the receiver with which it is used?

These are some of the many important questions that the POPULAR RADIO Laboratory answers for those who purchase loudspeakers advertised in its columns. Testing a speaker involves something more than merely listening to it. Days or even weeks may be required to properly determine whether or not a loudspeaker meets the high standards set by the engineering staff of POPULAR RADIO. Consequently, speakers approved by the Laboratory and advertised in the columns of the magazine may be purchased with the assurance of satisfactory performance, affording both the proper volume and a high degree of quality.

This is but one of the many services that POPULAR RADIO extends to its readers. As far as possible, it guarantees the purchasers of apparatus advertised in its columns against disappointment and loss. For over three years it has given of its time, money and resources, that its readers could buy with confidence and safety.

[[ A list of tested and approved loudspeakers may be had by addressing a stamped, self-addressed envelope to the Service Department, 627 West 43rd Street, New York City. ]]

Buy with Confidence Series No. 2

**POPULAR RADIO, INC., 627 W. 43rd St., NEW YORK CITY**

# Here's Work That is Almost ROMANCE!

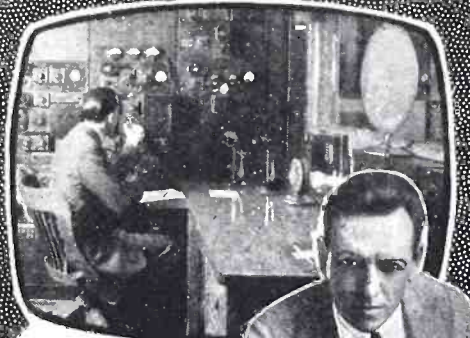

## EARN BIG MONEY in RADIO

Get into the great new BIG-Pay Industry—Radio. If you're earning a penny less than \$50 a week, clip coupon now. Send for 64-page FREE BOOK. Be a Radio Expert and draw down big money for this easy, fascinating work. Positions everywhere. Need for Radio Experts in every community. Short hours. BIG PAY. Free book gives all the facts.

### Learn Quickly and Easily at Home

Skilled Radio Engineers will show you how to qualify, quickly and easily at home, for Radio's fine jobs. We train you completely and thoroughly. Hundreds of N. R. I. trained men are today holding down good big jobs in the Radio field. Hundreds of opportunities now awaiting the trained man. FREE EMPLOYMENT SERVICE. Many other big features. Get the facts—CLIP COUPON.



"My charges for consultation \$2.50 per hour. All success due to you."  
R. W. Blackhill, Brooklyn.



"Radio a gold mine—your course worth thousands."  
A. R. Herke, Winnipeg.

### Get This Free Book!

Send coupon below for FREE BOOK—"Rich Rewards in Radio." Read for yourself. No previous experience needed. Common schooling enough. WRITE NOW.



### Big Receiving Outfit Furnished

Materials for building up-to-date receiving sets, and to construct 50 well-known Radio circuits included to help you learn. An UNEQUALLED OFFER. Other special features now being offered, so Act Quick!

NATIONAL RADIO INSTITUTE  
Dept. F-86, Washington, D. C.

## MAIL COUPON

National Radio Institute,  
Dept. F-86, Washington, D. C.

Without obligating me in any way, please send me your free book, "Rich Rewards in Radio," also complete information on your practical, home-study Radio course.

Name.....

Address.....

Town.....State.....

## The "Secrets" of the Hypnotist by Radio

(Continued from page 529)

tist tells him to do or to believe.

To produce the after effects of post-hypnotic suggestion the hypnotist simply impresses on the mind of the subject some order to be carried out later on. He may say, for example, "in fifteen minutes you will go out to the news-stand and buy a copy of POPULAR RADIO."

Sure enough, when the allotted time has passed, the subject, who has been awakened in the meantime, will take his hat and depart on the errand mentioned, usually not quite knowing why he does so but feeling an irresistible impulse to the act.

This makes the feat of radio hypnotism very simple. The hypnotist needs merely to say to his subject, already hypnotized some hours ahead of the experiment:

"At eight o'clock tonight I shall speak to you over the radio and say 'sleep'; you will then instantly pass into a hypnotic sleep from which you will awake ten minutes later."

At the appointed hour the word "sleep" is spoken and the post-hypnotic suggestion takes its course. The magic word need not be "sleep"; it can be "buttons" or "abacadabra" or anything. All that is necessary is some signal for which the path has already been prepared by the previous hypnotic suggestion. Even that previous suggestion is unnecessary if the hypnotist and the subject are accustomed to working together. I know a hypnotist who needs merely to wave his hand at one of his subjects in order to send that subject into the hypnotic sleep. One word, in person, by telephone or by radio, would be equally efficacious.

The feat of Mr. Fitzgibbons involves, therefore, facts already quite well-known to experts on hypnotism. Nor is this expertness something which only Yogis or Mahatmas possess. Any physician or physiologist, acquainted with the workings of the human body, can learn the trick of hypnotism in a dozen hours. He may not qualify so soon in understanding the psychological meanings of hypnotic reactions; indeed, there are many of these reactions which are still not understood by anybody; but the mere performance of the hypnotic act is a secret soon grasped and easily practiced. Centuries ago, when the phenomena of hypnotism were first discovered by the famous French charlatan, Mesmer, from whose name "mesmerism" comes, they were believed to be related to dark secrets of "animal magnetism." That delusion is long dispelled. We now know that hypnotism merely reflects some little-used, but quite normal, powers of the human mind.

These powers are in the mind of the

subject, not the mind of the hypnotist.

The thinking part of the human brain consists of about nine billion little gray cells, forming the so-called gray matter which is spread in a layer about one-sixth of an inch thick over about one and one-half square feet of the brain's outer surface. Connecting these gray cells with one another are billions of tiny separate fibers, like telegraph wires. These form the inner, white part of the brain. Thinking consists, in some way not yet completely understood, of the passage of messages back and forth from some gray cell to other ones. Sense impulses, like things seen by the eyes, are sent into the gray cells over the nerves; thus the process of thinking is started.

Although the explanation of hypnotism in terms of these thinking gray cells in the brain is still far from complete, it is possible to say that it consists of some sort of a block against the kind of thinking which ordinarily corrects mistakes and keeps us from doing ridiculous things. Were I to tell you, for example, that you are alone in the middle of the Atlantic Ocean and must instantly swim for shore, you refuse to get excited or to begin swimming. You can look around you and see for yourself that you are not in the middle of the Atlantic or of any ocean. Your own thinking corrects the mistake which I tried to tell you. It tells you, instead, that I am a liar.

To the hypnotized subject this kind of correction of what he is told by the hypnotist becomes impossible.

By some block of the white-fiber telegraph wires connecting his gray cells, he is prevented from doing any such corrective thinking at all. He is forced to think only what the hypnotist tells him. This is what is called "suggestion" and it is by no means confined to hypnosis. When someone works up a mob to the point of fury and unreason; when an orator sways his audience to believe (temporarily at least) something which they will presently reject; when some emergency like a fire or earthquake rouses individuals to acts of daring from which they would ordinarily shrink and which they may forget a few moments later—all those are instances of a mental condition like that which the hypnotist produces.

When any speaker over the radio is impressive enough to persuade you of something, he has really been practicing on you a kind of "radio hypnotism."

Without your consent, no one can practice more.

There are still many marvels which prevent our full understanding of hypnotism, but there are neither marvels nor dangers in the carriage of the hypnotizing stimulus by radio.



# SET BUILDERS

Write us before you build

**BEFORE** you build, get our prices on the parts you are planning to use.

We handle only brand new apparatus—standard makes that are fully guaranteed. **QUANTITY** sale of **QUALITY** parts explains our low prices. Compare with others and see why thousands of fans look to us as radio headquarters.

All the latest kits, accessories and parts—a million dollar radio stock to choose from.

## CHICAGO SALVAGE STOCK STORE

Dept. PR 509 S. STATE STREET  
CHICAGO, ILL.

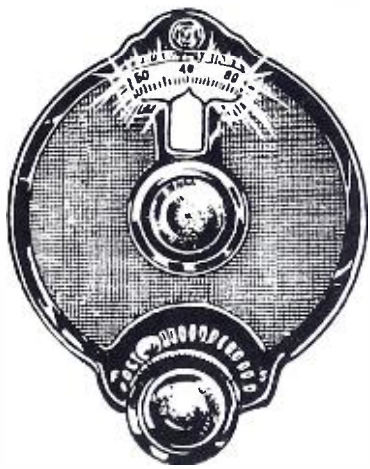

## NEW LIGHT on Fine Tuning

The Illuminated Dial  
National Velvet-Vernier  
Type C

More widely used in carefully engineered sets than ever before. Its brilliant, indirectly-lighted scale, lasting beauty, variable-ratio of 6-1 to 20-1, and ease of attachment are responsible for its deserved popularity SPECIFIED for the SC-II.

Send for Bulletin 116 L-6

NATIONAL COMPANY INC.  
W. A. READY, Pres. Cambridge, Mass.

Be Sure You Get the Genuine

# NATIONAL

RADIO PRODUCTS

## How to Assemble the RGS Receiver

(Continued from page 548)

the set-screw on the rotor of condenser E and adjust the tuning condensers till the station is tuned in best. When this is done, tighten the set-screws on the rotors of all the condensers.

You will now find that any station may be tuned in by adjusting the condenser dials. The setting of the vernier knob, G, is not critical, as it is set directly to the dot on the panel in most cases, but maximum tuning efficiency may be obtained by a slight readjustment of this knob.

When first put into operation, the detector valve is apt to make the set noisy and may sometimes produce a howl. A slight readjustment of either the battery or volume knobs, or both, will usually eliminate noises. If the volume control is turned too far in a clockwise direction, a choking noise will result; this can be eliminated by turning the knob back slightly in a counter-clockwise direction.

The antenna knob serves to increase or decrease the electrical length of the antenna. The two-turn setting is at the "9 o'clock" position; the 32-turn setting is at the "3 o'clock" position.

Shortening the electrical length of the antenna gives greater selectivity and better distance at the short waves, but less distance at the long waves.

Increasing the electrical length of the antenna broadens the tuning and decreases the distance at short waves; but increases the distance at long waves. Any adjustment made in the electrical length of the antenna requires a slight readjustment of the first tuning condenser, D.

When tuning in lower wavelength stations, better results will be obtained if the vernier knob is adjusted to the left of the "12 o'clock" position, while on the higher wavelength stations better results will be obtained if the knob pointer is adjusted to the right of the "12 o'clock" position. At every wavelength in between there is a "best" adjustment, but this adjustment is not critical.

For best results on loud local stations, reduce the electrical length of the antenna and increase the volume control. These adjustments decrease the input without reducing volume and prevent overloading the detector valve. Any decrease in volume through cutting down the antenna length is compensated for by increasing the volume control.

A little practice with the controls will show you the settings that give the best results. Do not be too impatient the first time you try to tune in. Log all your local stations first and then you can determine the approximate settings to bring in the distant stations.

ASK . . ANY . . RADIO . . ENGINEER



## This is the Burgess Radio "A" Battery

A SPECIALLY designed "A" battery for radio service. There is nothing like it in its field.

Proportioned to permit ease of handling and convenience of cabinet assembly and storage, you may expect this new Burgess creation to give you the length of service and dependability under all conditions for which all products of Burgess are noted.

If you are using the ordinary type of No. 6 "A" battery, we suggest that you learn for yourself from the Burgess Radio "A" the measure of service you have a right to expect.

Ask Any Radio Engineer

BURGESS BATTERY COMPANY  
GENERAL SALES OFFICE: CHICAGO

Canadian Factories and Offices:  
Niagara Falls and Winnipeg



# BURGESS

## RADIO BATTERIES

28 Leading Radio Engineers Specify  
Hammarlund Products In Their Newest Receivers

HAMMARLUND MANUFACTURING COMPANY  
424-438 W. 33rd Street, New York

For Better Radio  
**Hammarlund**  
PRECISION  
PRODUCTS

Write for illustrated literature describing Hammarlund Precision Products for all of the popular circuits.

Ask us for a list of the latest models of receivers for which Hammarlund Products are officially specified



### Your Source of Supply

Manufacturers find the newest approved features—in Audio transformers, B Power and Power Amplifier transformers and chokes—designed by Dongan, builders of radio parts, exclusively.

This is the season to secure the maximum service from our engineering staff.

Complete information on Power Units for the new 350-400 MA Tubes. Several types, mounted or unmounted.

DONGAN ELECTRIC  
MANUFACTURING COMPANY  
2983-3001 Franklyn St. Detroit, Mich.

TRANSFORMERS of MERIT for FIFTEEN YEARS

### "Squeals"

(Continued from page 532)

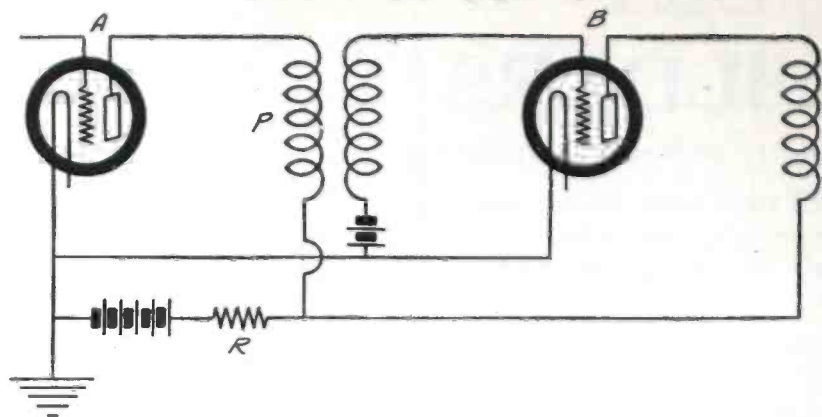

#### YOUR BATTERIES MAY CAUSE HOWLING

FIGURE 6: This diagram shows how resistance in "B" batteries will tend to produce coupling between the two tube circuits, A and B. The resistance, R, which may be the resistance of the batteries, is included in the plate circuit of both valves, A and B, and any variation in the current from one will produce a drop across the resistance, R, and thus cause a varying voltage across the other valve-plate circuit. This may cause unwanted oscillations.

ductance, adding resistance in the grid or plate circuit, using reversed inductive feedback, or by using neutralizing capacities.

The first two methods tend to reduce the amount of amplification obtainable. The most common method is the use of neutralizing capacities. In addition, it is necessary to prevent coupling between the radio-frequency transformers, such as by placing them so that no mutual inductance exists between them, by using some form of "Figure 8" or toroidal coils (Figure 2), which have localized fields or by shielding the coils electrostatically from one another. It is also necessary that the grid and plate leads and the connections in the high-frequency circuits be kept short and well

separated from the other leads and the current carrying parts of the apparatus to which they are not connected.

Some form of feedback is always responsible for singing in the audio-frequency section of a receiver. It may be electrostatic, electromagnetic, mechanical or due to coupling through a resistance common to several tube circuits.

The arrangement of the parts in the input and output circuits so as to allow but little capacity between them, and the reduction of the grid and plate leads to the shortest lengths possible, will reduce electrostatic coupling. The designations on audio-frequency transformers as provided by the manufacturer should be followed in making connections, as this has an important bearing on the prevention

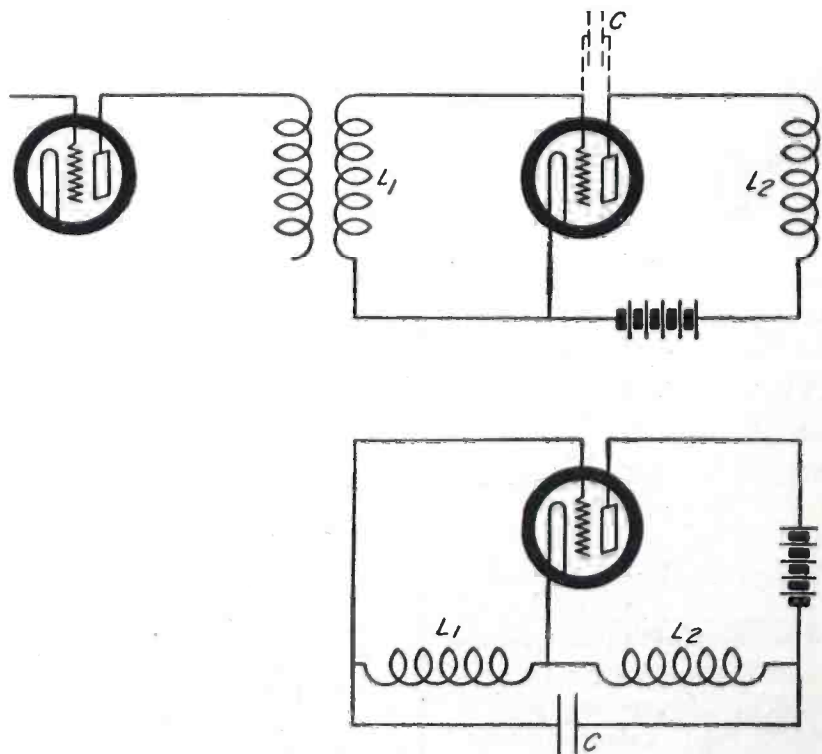

#### HOW A HIGH-FREQUENCY STAGE MAY OSCILLATE

FIGURE 7: The capacity between the grid and plate of the vacuum valve used as a high-frequency amplifier is indicated at C. A re-arrangement of this diagram has been made below showing that this circuit is, in effect, an oscillating circuit with a grid and a plate coil coupled through this capacity, C. That is the reason why high-frequency amplifiers oscillate unless they are neutralized or stabilized in some other manner.

# FREE Simplified BLUE PRINTS

You can have your choice of any one set of POPULAR RADIO Simplified Blueprints with your new or renewal subscription for POPULAR RADIO, accompanied by remittance of \$3.00. These Blueprints will make it possible for you to build a tested and approved set. You, as a reader of POPULAR RADIO, know the many entertaining, interesting and instructive articles that are published each month. We promise that throughout the coming months POPULAR RADIO will hold more and more of interest for Radio Fans.

### Ease, Economy and Accuracy in Construction

Simplified Blueprints make it possible for anyone, without previous knowledge of radio, to construct a highly efficient radio receiver. These Blueprints consist of 3 diagrams as follows:

#### Panel Pattern

This Blueprint is the EXACT size of the actual set. So accurate that you need merely lay it on your panel and drill as indicated. No scaling or measuring to do, no danger of ruining the panel through faulty calculation.

#### Instrument Layout

Here again you have an actual size print of each instrument and binding post and its exact location both on the panel and within the cabinet.

#### Wiring Diagram

The unusual feature of this Blueprint is that it is an actual size picture diagram of the finished set. Each instrument and other parts appear in exact size and the wires are so clearly traced from one contact to another that you can connect all terminals accurately without even knowing how to read a hook-up diagram.

Set No. 18—"The Improved Raytheon Power-Pack" (as described in the May, 1926, issue of POPULAR RADIO).

Set No. 22—"The LC-27 Broadcast Receiver" (as described in the October, 1926, issue of POPULAR RADIO).

Set No. 23—"The LC-Senior Power-Pack" (as described in the November, 1926, issue of POPULAR RADIO).

Set No. 24—"The LC-Intermediate Power-Pack" (as described in the December, 1926, issue of POPULAR RADIO).

Set No. 25—"The LC-Junior Power-Pack" (as described in the January, 1927, issue of POPULAR RADIO).

Use coupon below; indicate which set of Blueprints you want.

**POPULAR RADIO**  
Dept. 49

627 West 43rd Street New York City

POPULAR RADIO, Dept. 49  
627 West 43rd Street, New York City

Enclosed is my remittance of \$..... in full payment for subscription, with Blueprints as checked below, FREE.

- Set Number 18     Set Number 23  
 Set Number 22     Set Number 24  
 Set Number 25

Name.....  
Street.....  
City..... State.....

of interstage coupling. It is always a wise policy to ground the transformer cores. In amplifiers intended for high amplification, it is generally necessary to enclose one or more stages in a metal shield.

Stray fields of transformers or retardation coil may provide coupling which will induce voltages in phase with the input voltages and thus cause singing. This may be prevented by using closed core coils, adjacent coils being placed at right angles to each other so that coupling between them is reduced to a minimum.

Where grid or plate voltages for more than one stage are obtained from the drop of potential across a resistance, the resistance should be shunted by a large capacity by-pass condenser. The same applies to batteries used to supply more than one stage with grid or plate potentials. In each case the condenser should be connected so as to provide a low impedance path to ground at the low potential end of the grid and plate circuits. The effect of a resistance common to more than one plate circuit is explained in Figure 6.

A general idea of the points to follow in arranging and wiring a receiver so as to make it howl-proof is given in Figure 3.

Singing from mechanical feedback may result when the vibration of the loudspeaker sets up a mechanical vibration of the tube elements, which commonly starts at the detector tube, causing a periodic variation of its plate current, which is amplified and reproduced in the loudspeaker. A repetition of this cycle continues until a sustained howl is produced, its tone being resonant to the mechanical period of vibration of the tube elements. The easiest applied remedy is to place as much distance as possible between the loudspeaker and the set; or, when the speaker is of the horn type, merely rotating it so as to direct its output away from the set will often eliminate the howling.

Should all these measures fail or if it is not desirable to change the position of the loudspeaker, the detector tube, and often the amplifier tubes also, should be equipped with vibration-proof sockets.

A receiving set free of all internal causes of squeals will be capable of accomplishing the utmost from a quality standpoint, within its circuit and apparatus limitations, but the external sources of squeals will still exist for some time. To obtain the minimum amount of disturbance it will be necessary to use discrimination in selecting stations for entertainment. Adjustments can be made that reduce the volume received from nearby high-power stations to a level that is ample and at the same time reduce the level of interfering transmitting and receiving stations to practical inaudibility.

# Imagine an air-column 48" long

...concealed  
in a cabinet  
only 18" long

YET that is exactly what has been accomplished in the Amplion Patrician. A 48" air-column amplifier is assembled with the world-famous Amplion unit in a mahogany cabinet 18" x 12" x 9".

That is the reason why this splendid instrument has such a wide range of resonant, natural tone — mellow.

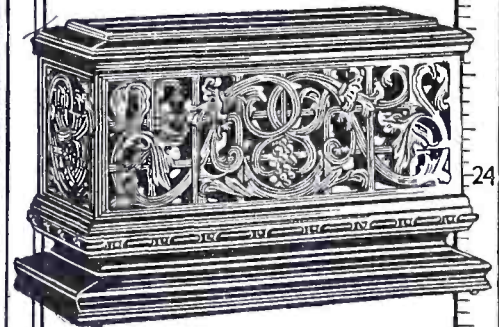

## AMPLION PATRICIAN

AA18 . . . . \$50

Hand-carved mahogany grille on all four sides, giving a non-directional reproduction.

OTHER AMPLIONS:

Amplion Cone  
AC12 . . . . \$30

Amplion Grand  
AC15 . . . . 135

Other models as low as \$12

Write for illustrated literature giving full details of the Amplion line.

The Amplion Corporation  
of America

Dept. X, 280 Madison Avenue  
New York City

The Amplion Corporation  
of Canada, Ltd.  
Toronto, Ont.

# AMPLION

# SALES!

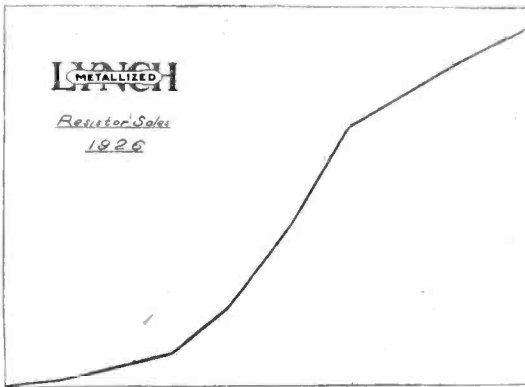

April May June July August September October November December

**T**HERE is much truth in the old adage: "Figures don't lie." The above graph showing our ever-increasing sales is proof positive of the true merit of the Lynch Metallized Resistor.

## Endorsed and Used by Leading Manufacturers

Crosley, Ferguson, Gilfillan, Grimes Engineering Corporation, The National Company and other leaders in the industry use the Lynch Metallized Resistor and other products. These manufacturers realize that "the proof of the pudding is in the eating."

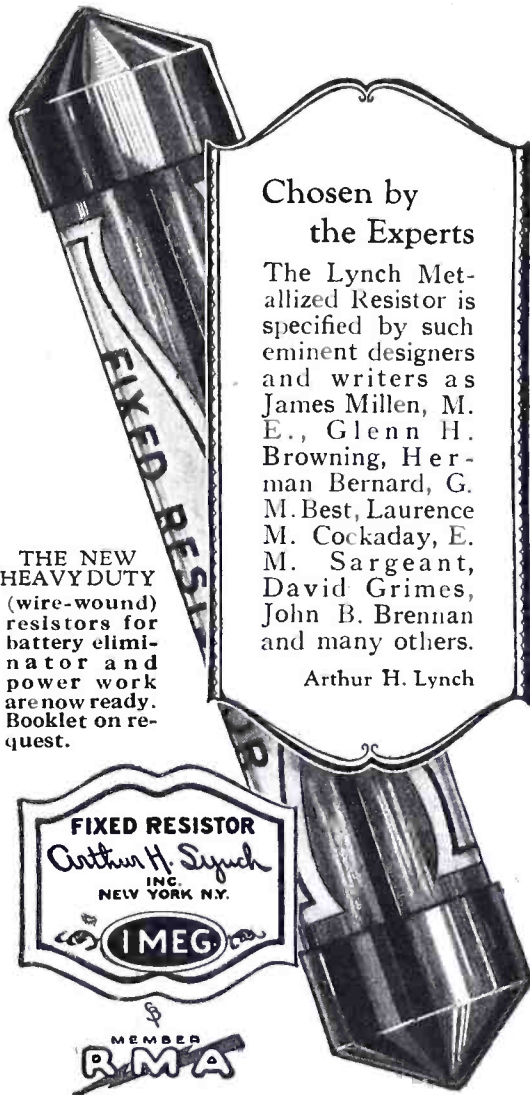

### Chosen by the Experts

The Lynch Metallized Resistor is specified by such eminent designers and writers as James Millen, M. E., Glenn H. Browning, Herman Bernard, G. M. Best, Laurence M. Cockaday, E. M. Sargeant, David Grimes, John B. Brennan and many others.

Arthur H. Lynch

THE NEW HEAVY DUTY (wire-wound) resistors for battery eliminator and power work are now ready. Booklet on request.



ARTHUR H. LYNCH, Inc.  
General Motors Bldg., Broadway &  
58th Street, New York, N. Y.

# LYNCH

## METALLIZED

### FIXED RESISTORS

## What's New in Radio

(Continued from page 558)

receiver; the volume of reproduction may be regulated as desired by means of the third knob.

In addition to the simple installation and operation requirements of this set, there is an additional advantage in the fact that the receiver requires absolutely no upkeep attention. There are no batteries, chargers or electrolytic rectifiers to require the addition of water from time to time. Nor is there anything that requires further adjustment. So far as the owner of the receiver is concerned he will never have occasion to even raise the cover of the receiver until such time as a vacuum valve may wear out. But even this should not occur until the receiver has been in operation at least 1,000 hours, and probably not until after several thousand hours.

The instrument presents a beautiful appearance. It is entirely enclosed in a sturdy walnut cabinet of the table-mounting type which is 30 inches long, 11 inches high and 17 inches deep. This is finished in warm brown tones with an attractive arrangement of panels and borders for variety. The small panel which carries the tuning controls is of metal, finished to match the rest of the cabinet. It is placed in the center of the front wall of the cabinet but is recessed a distance of about one inch, thus breaking up the monotony of the large front surface. The calibrated tuning scales are stamped directly on this metal panel and the pointers on the two tuning knobs revolve over these scales.

This receiver may be placed on any convenient table, or may be used with a special stand to match the receiver which is put out by the manufacturer. The top of the cabinet is hinged at the back and raises up to disclose the interior of the receiver. It will be noticed that the radio unit itself is built up on a large composition sub-panel. This accommodates five of the vacuum valves or tubes, and the other parts of the receiver with the exception of the three tuning condensers which are mounted on a heavy metal sub-panel, that is parallel with, and just behind, the front control panel. The use of this metal panel for the mounting of the condensers helps to maintain their rigidity, and permits the coupling together of two of the condensers for operation by a single control.

The power supply equipment and the power amplifier valve are mounted on a separate composition sub-panel at the left-hand end of the interior of the cabinet. The power-pack and the receiver proper are therefore entirely separate units, but are inclosed in the same cabinet.

Shielding of the power-pack is provided by the metal cases which inclose its component parts. Shielding is also provided for the coils in the receiver proper, in the form of large, burnished copper "cans" which inclose the individual coils.

The receiver makes use of five vacuum valves; but the output of the receiver proper goes to the large power-amplifier valve which is located in the power-pack. In all, therefore, the receiver is a six-tube affair. The five valves in the receiver unit are of the McCullough AC type. These are special vacuum valves, so designed as to operate with an alternating-current

filament supply, instead of the direct-current supply required by ordinary valves. These five tubes are used to provide two stages of high-frequency amplification, a vacuum valve detector, and with the power tube in the power-pack, three stages of low-frequency amplification. The coupling in these stages is provided by two double impedances and one low-ratio transformer. The use of a UX-210 type valve in the last stage eliminates the possibility of overloading and guarantees the best of tone quality, together with tremendous volume. The use of the McCullough AC valves eliminates all necessity for direct-current filament supply for filament lighting. While the power amplifier valve is a standard type, alternating current can always be used for supplying the filament of the valve used for this purpose. The AC filament-supply current is provided through a small step-down transformer which is included in the power-pack. This reduces the line voltage to the voltage requirements of these valves.

The high-voltage supply for the plates of the valves must be direct current, of course. This is obtained by means of a step-up transformer, the output of which is rectified and then filtered by means of the equipment contained in the power-pack. A standard UX-216-b type rectifier valve is used. The AC filament supply for this rectifier valve and also for that of the UX-210 type power-amplifier tube is obtained from the step-down winding on the power transformer.

As comparatively high voltages are developed in the power-pack, especially in the plate supply for the power-amplifier valve, all "live" parts are inclosed in covers, or are insulated, so that there is not the slightest danger of a person coming into accidental contact with these parts.

Precautions have been taken in the design to prevent possible damage to the reproducer resulting from the comparatively heavy current that flows in the plate circuit of the power amplifier valve, in which circuit the reproducer is connected. An output has been included in this circuit which keeps the direct current out of the reproducer windings and permits only the low-frequency, modulated current to pass through the windings.

The tone quality in this receiver is remarkably realistic. The same fine quality is obtained regardless of the adjustment of the volume control on the receiver panel. But by means of this control, the volume may be reduced to just the degree at which it is most pleasing to the operator. There is no hum to mar the reproduction, such as is encountered in some AC-operated receivers.

The selectivity is also excellent, providing a suitable antenna is used. In cities it will usually be found best to use an antenna not longer than 60 feet, including the lead-in wire. Out of town, where there are no nearby broadcasting stations a longer antenna may be used. In homes where alternating-current, house-lighting supply is not available this receiver cannot be used. The manufacturer, however, makes a similar receiver for operation with batteries to take care of such conditions.

Maker: Walbert Mfg. Co.

## WORLD Radio Units Save You 50%

"A" Current

From  
Your  
Light  
Socket

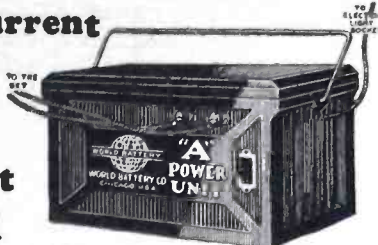

World  
"A" POWER UNIT

Automatically provides even, unvarying "A" current from the moment you throw on your set switch. Finer reception, uninterrupted by "fade-outs" and "screeches." Absolutely noiseless. Assures full tone quality from your set and wider D X range. A marvelous improvement—at less than half the cost of any similar equipment. Shipped complete, subject to inspection, on receipt of price—or C. O. D. if you wish.  
25 Amp. Unit for sets of 4 tubes or less—\$12.75  
60 Amp. Unit for sets of 5 tubes or more—\$15.75  
5% discount if cash in full is sent with order.

**\$12.75** Complete

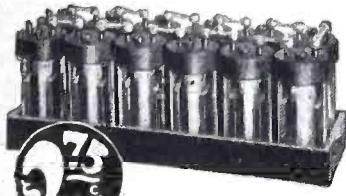

Clearest  
Truest "B"  
Power with  
World Radio  
Storage

"B" Batteries 12 Cell  
24 Volt

Sturdy construction. SOLID RUBBER CASE protection. Recharged for almost nothing. Endorsed and listed as standard by Radio News Lab., Pop. Radio Lab., Pop. Sci. Inst. Standards, Lefax, Inc. and other famous institutions. Just state number wanted, and we will ship same day order is received by express, C. O. D., subject to examination. 5% discount for cash with order.  
Extra Offer: 4 Batteries in series (96 volts) \$10.50.

**WORLD BATTERY COMPANY**

1219 S. Wabash Ave., Dept. 77, Chicago, Ill.  
Set your radio dials at 288.3 meters for the  
World Storage Battery Station W S B C.  
Variety—New Talent—Always Interesting.

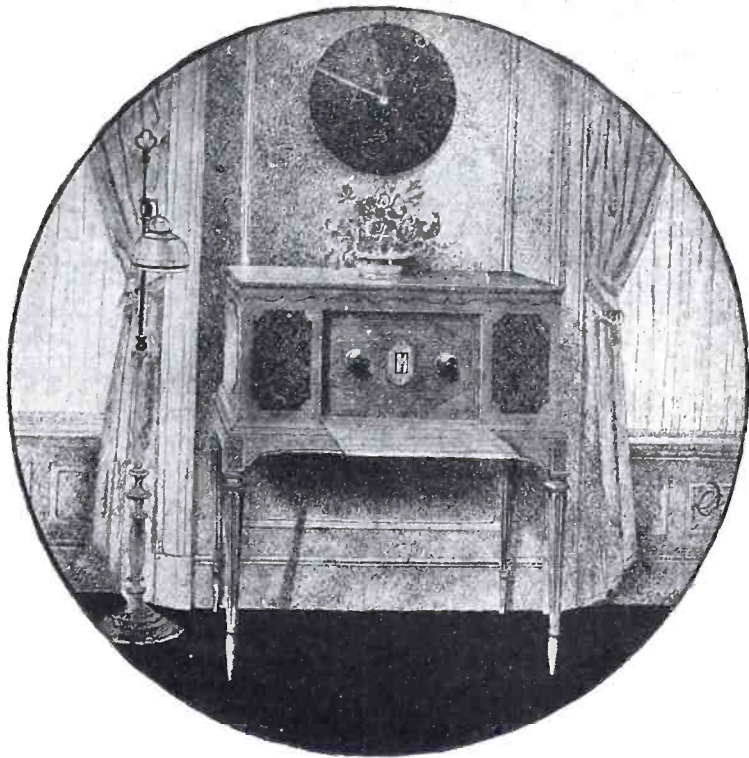

# MU-RAD

Announces a new Super-Six  
All Electric Receiver

[ Striking innovations and remarkable reception feature this new set ]

A NEW and even better Mu-Rad, beautifully encased in cabinets of two-toned walnut decorated with burl panel effects, is now at your disposal. A Mu-Rad that you can operate with or without batteries, with *only one* tuning control, an indoor antenna if desired and every improvement that modern radio engineering can devise. You will be amazed at the extreme selectivity, the faithful tonal qualities, the volume range and the remarkable distance attainable from this new and unusual radio. Hear the Mu-Rad at your earliest opportunity. You will enjoy radio reception that has outperformed all competition in every radio test, since the birth of the industry.

- No A B C batteries
- No electrolyte
- One tuning control
- One volume control
- Indoor antenna operation
- Extreme selectivity
- Ultimate in tone quality
- Volume to meet any requirement
- A go-getter on distance
- Unusually easy operation

A good name  
**N'A-ALD**  
in radio

Use Power tubes  
for good quality  
at full volume

Simply adapt to your set with

**Connectoralds**

(Reg. U. S. Pat. Off.)

The use of a Power Tube in the last audio will very greatly improve your tone quality. No change in set wiring is necessary when Connectoralds are used.

For UX 171 and UX 112 Tubes, Na-Ald 112 Connectoralds are recommended for maximum volume with storage battery sets. These tubes will deliver without distortion several times the volume of the regular 201A. Price \$1.50.

For UX 120 Tubes in UV 201A sockets, the Na-Ald No. 120 Connectorald should be used. To convert a storage battery set to dry batteries with ample loud speaker volume, use a UX 120 tube in the last audio stage with the 120 Connectorald and UX 199 tubes with 419X Adapters in the other sockets. Price \$1.25.

For the UX 120 Tube in UV 199 sockets, ample loud speaker volume without distortion is obtainable from any set equipped for UV 199 tubes by means of the UX 120 or equivalent tube, with the Na-Ald No. 920 Connectorald. The tube is raised slightly, but provides for its use in most sets with limited headroom. Price \$1.25.

For UX 120 tubes in the UV 199 sockets of the Radiola Superheterodyne Semi-Portable and Radiola Super VIII. These excellent Superheterodynes will deliver ample volume for loud speaker operation when equipped with the UX 120 used with the Na-Ald No. 420 Connectorald. Price \$1.25.

**ALDEN MANUFACTURING CO.**  
Dept. 323-C Springfield, Mass.

**MUR-AD RADIO CORPORATION**

ASBURY PARK

Dept. P.

NEW JERSEY



## MODEL "C" CHEST

Cabinets in stock—have piano hinge—and grooved front, the top rail being removable. Made in walnut with popular hand rubbed high light effect finish. Illustration shows gold-line wood panel to match.

Panel size	Price 10" deep	Price 12" deep	Panels to match
7x18"	\$15.00	\$17.00	\$1.26
7x21"	17.00	*18.50	1.47
7x24"	19.00	21.00	1.68
7x26"	†21.00	23.00	1.82
7x28"	23.00	25.00	1.96
7x30"	23.00	25.00	2.10

\* For HiQ and Browing Drake Receivers.  
† For Victoreen Receiver.

### Walnut Infradyne Cabinet

for 7x30" panel, and 10x34" baseboard.

**\$26.00**

### LC-27 Cabinets

Mahogany or Walnut with baseboard.

**\$18.00**

WRITE FOR trade proposition and folder showing complete LC-27 Line and other Radio Furniture.

## CORBETT CABINET MFG. COMPANY

St. Marys, Pennsylvania

# New!

The Latest Addition to the "CE Co" Family

## TYPE "K" Radio Frequency Tube

Price, \$3.00

# CECO

TYPE "K"

will pep up your set, increase volume, improve the tone, clarify distant reception



**Makes a Good Receiver Better**

Write for Complete Data Sheet

C. E. MFG. CO. Inc. . . . PROVIDENCE . R. I.

## Whats New In Radio

(Continued from page 559)

should be around 75 feet. Out in the country this may be increased to any length desired. However, good results can be obtained with an indoor antenna. For those who prefer to use a loop antenna, provision is made whereby the first coil (antenna coil) can be pulled out and a strip equipped with plugs inserted in its place. The loop is then connected to the terminals provided on this strip.

The recommended valve equipment consists of 5 UX-201-a type valves for the four high-frequency stages and the first low-frequency stage; an old UX-200 (not 200-a) type valve for the detector; 2 hi-mu valves for the second and third low-frequency stages and a power valve for the last low-frequency stage. The three different types of valves specified for use in the low-frequency amplifier are made necessary by the use of a combination of transformer-coupled and resistance-coupled amplification. The power valve selected for use in the last stage is determined by the plate-supply voltage available. The best results and greatest volume are obtained by using a UX-210 type valve here, but this requires a "B" power-pack that will deliver at least 350 volts. The second choice is the UX-171 type power valve which operates with a 180-volt "B" power-pack. If dry cell "B" batteries are the only available source of high voltage, then the

UX-112 or the UX-201-a type valves can best be used because of their lower current consumption.

The use of the Leutz "B" power-pack is recommended with this receiver because it is designed to meet its special requirements. It provides three adjustable output voltages for the detector, high-frequency and intermediate low-frequency plate supplies and fixed voltages for the grid bias and plate supply of the power valve. This "B" power-pack is designed for use only where the house-lighting supply is 100 to 125 volts at 50 to 60 cycles.

The selectivity of this receiver may be judged by the fact that with the use of an outdoor antenna over 150 feet in length (the only one available at that time), it was found possible to separate WPG, the Atlantic City station, from WMSG, a New York station, while operating the receiver within approximately three miles of the latter. The wavelength difference between these two stations is only three meters. If they were any closer in wavelength they would heterodyne with one another.

*Usage:* For the reception of broadcast programs.

*Outstanding features:* Extreme volume of reproduction. Fine tone quality. Sensitivity to extremely weak signals. A high degree of selectivity. Totally shielded. Excellent workmanship.

*Maker:* C. R. Leutz Co.

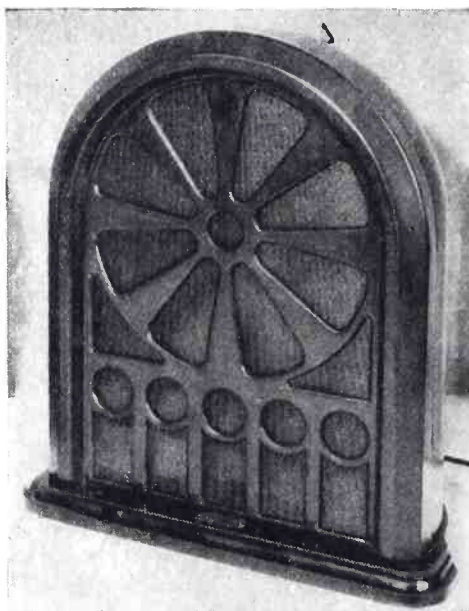

## A Unique Reproducer With a Metal Resonance Chamber

*Name of instrument:* Cone-type reproducer.

*Description:* This loudspeaker consists of an electric actuating mechanism and a free-edge cone, completely inclosed within an all-metal housing. An output transformer is included in the instrument to permit its use with receivers that include a power valve with high plate voltage for the last low-frequency stage. The metal housing is bowl-shaped in the back and serves as a resonance chamber, in addition to affording complete protection for the more delicate cone unit. The front of the case is a metal grill, backed up with wire gauze.

*Usage:* As the reproducer for use with any radio receiver.

*Outstanding features:* Excellent tone quality. Sturdy construction. Neat appearance. Moderate price.

*Maker:* All-American Radio Corp.

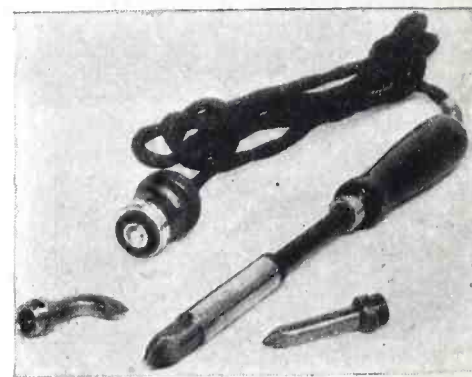

## A Soldering Iron for Radio Constructors

*Name of instrument:* Electric soldering iron.

*Description:* This is a "single-heat" device which has much to recommend it for the use of the set builder. It consists of a heater element of special alloy, incased in a porcelain compound, which in turn is inclosed in a nicked tubular case. The tips are screwed into one end of this case; the other end is attached to a black, oxidized-metal tube which extends through the wooden handle and contains the wires leading to the heater element. Where the wire comes out of the end of the handle it is protected by an "anti-kink" spring. The equipment includes three tips of different shapes to satisfy different requirements. Tips can be changed in a fraction of a minute. An extension cord and double attachment plug are provided with the instrument.

*Usage:* For any soldering work that requires the use of a light iron.

*Outstanding features:* Operates on 110-volt alternating or direct current. Draws only 75 watts. Spring protects cord from wear and breakage, thus preventing short-circuits.

*Maker:* Adroit Tool Co., Inc.



## TUBE EQUALIZER SYSTEM

**Use Any Combination of Tubes**

No rewiring. Just insert Equalizers to match the different voltages. Self-adjusting. Made for every tube. 50c; mounted, 75c.

Elkay Suppressors choke squealing. 75c; mounted, \$1

Langbein-Kaufman Radio Co. (Dept. R)  
62 Franklin St.  
New Haven, Conn.



## What Shall We Do With Television?

(Continued from page 522)

would not be true for a surface dweller like man. Any man-containing steel tank, like the caissons used by divers near the surface, would be flattened to a pancake instantly by the pressure at the sea bottom. If we are ever to study with any adequacy the life and the living conditions on the bottom of the sea, it will have to be done in some other fashion than by sending any adventurer down to make a report.

A motion picture camera, equipped with its own light-producing apparatus and built strongly enough to withstand the external twelve tons to the square inch, is a distinct possibility, but a better possibility is television. With an electric eye at the bottom end of six miles of steel cable a scientist could sit comfortably in the cabin of his laboratory ship and watch by the hour the antics of those stilt-walking crabs and those lantern-carrying fish five thousand fathoms beneath his feet.

All of these possibilities which I have been amusing myself by imagining deal with the second variety of television; the variety employing definite links between one place and another. In my continued capacity of temporary prophet I am of the opinion that it will be some of these things which are first developed. Television broadcasting, for all that it was tried before the other system, seems to me much less likely to reach the first practical success.

When it does come it will depend, not upon the mere perfection of a process of television, but upon the development of some cheap form of television receiver, preferably some form which can be attached to ordinary radio receivers.

It has now come to be admitted, even by the most erudite and professional of musicians, that radio broadcasting is gradually producing an improvement in the public taste in music and in the public's knowledge of the great melodic works. The broadcasting of television would make it possible to do the same for that other fraction of the fine arts, painting and sculpture.

While this broadcasting of great art is perhaps the largest possibility in this direction, it is by no means the only one. Travel by television is a possibility. Airplane views of great spectacles, like the Grand Canyon or Niagara Falls, are possible without danger and without providing the thirty-million-odd airplanes which would be necessary to give our whole population a chance to see the show. Subjects which are taught in the universities by a combination of eye and ear (as, for example, experimental science is taught) could be broadcast by television and radio, losing little or nothing of their original vividness.

Television, when we have perfected it, will be very much worth having.

## Better than ever!

# The NEW Mayolian

"B" SUPPLY

### Type 614

## The "B" Without a Buzz

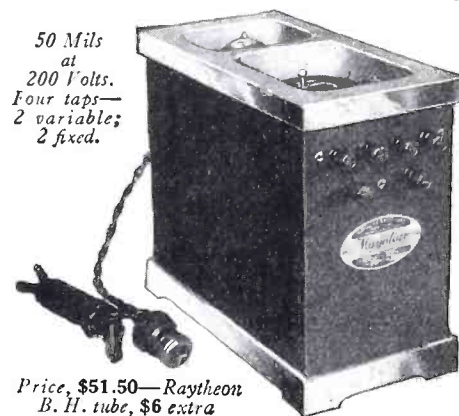

50 Mils at 200 Volts. Four taps—2 variable; 2 fixed.

Price, \$51.50—Raytheon B. H. tube, \$6 extra

THE latest achievement of Mayolian Engineers—Type 614—will not hum or "motor-boat" with resistance-coupled or other receivers. Its high capacity filter ably takes care of the most severe fluctuations in current drain of any of the modern types of receivers. High-powered, uniform, noiseless!

More than four years of research and pioneering in battery elimination have led to the development of several types of Mayolian B Units, an A & B Eliminator, A Charger, Tone Filter; chokes, transformers and condensers.

The "Laboratory-Built" standards of Mayolian have earned for its products the endorsement and approval of Raytheon and other pre-eminent manufacturers and engineers in the radio industry.

*Write us for literature*

## MAYOLIAN CORPORATION

1668 Webster Ave., New York, N. Y.

*Pioneers in Battery Elimination*



*The Power of Niagara—  
The Quiet of an Arctic Night*

## The POPULAR RADIO Atlas and Log

will give you a list of all the NEW Broadcasting Stations with wavelengths and other necessary information

### A Complete Atlas and Station Log

The "POPULAR RADIO International Radio Atlas and Log" will supply you with full information regarding broadcasting stations of the United States and Canada.

This most useful and practical Atlas consists of 16 pages, size 12" x 15", printed on good paper, from clear type in two colors and contains a complete series of double page maps, including—The World—The United States—Canada—North and South America, showing location of principal broadcasting, leading commercial and governmental radio stations.

### SPECIAL FREE OFFER

You may have a copy of the "POPULAR RADIO International Radio Atlas and Log" free, with POPULAR RADIO for (8) eight months

## For Only \$2.00

Pin \$2.00 in bills to the coupon below.

If you are a subscriber to POPULAR RADIO your subscription will be extended eight months.

Date.....

POPULAR RADIO, Dept. 42A,  
627 West 43rd St., New York City.

Enclosed is my remittance of \$2.00 for which you are to enter my subscription (extend my subscription) for (8) eight months for POPULAR RADIO and send FREE a copy of the "POPULAR RADIO International Radio Atlas and Log."

Name.....

Address.....

City..... State.....

**Now  
You can build the  
kind of a radio you  
have always wanted**

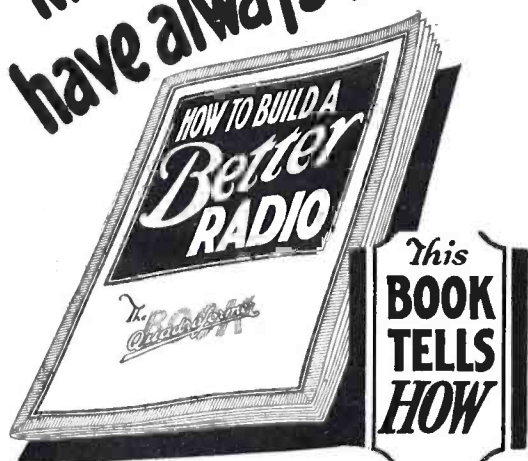

No matter whether you want to improve a set you now have or build a new one - get this book first. Tells how to build the latest one, two and three dial receivers - 5 to 7 tubes.

**10¢ PREPAID**

**GEARHART-SCHLUETER, Fresno, Cal.**

**CARTER**

New  
**RESISTORS**

For  
**Power Operated Sets**

The advent of socket operated sets using A. C. current from the socket brought a new demand for resistance.

Carter Resistors are the answer to this demand and have met with instant success.

Again Carter originality is displayed in these new products. See them at your dealer's.

Send for illustrated folder of circuit suggestions.

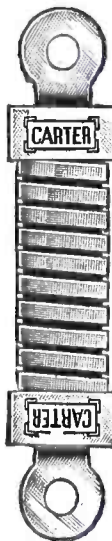

Full Size

In Canada: Carter Radio Co., Ltd., Toronto  
**CARTER RADIO CO.**  
CHICAGO

**Your Laboratory Tools**

(Continued from page 551)

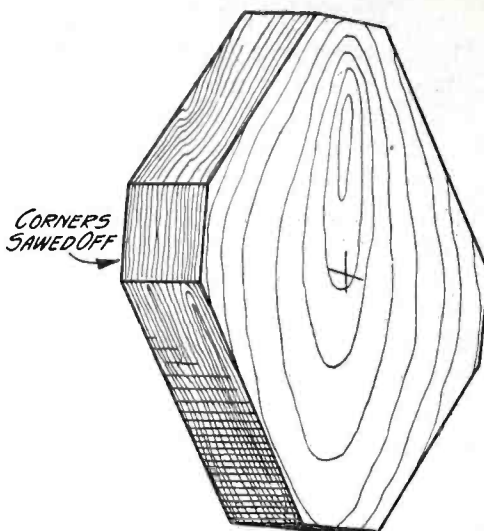

**RIGHT WAY TO TURN FLAT WORK**

FIGURE 5: By sawing the corners off a flat piece of work to be turned, the turning operation is hastened and the danger of splitting avoided. Before turning, be sure that the corners of the wood do not touch the lathe bed.

Now just a word about attaching the screw center or the spur center into the special chuck.

Two wrenches are provided for this purpose; one wrench is used to prevent the live spindle from revolving, while the second wrench is used to tighten the centers. One of these wrenches will also have to be used to hold the live spindle while a drill is being inserted in the drill chuck.

At this point a word of precaution will not come amiss. In turning out pieces such as shown in Figure 5, the mechanic will do well to make sure that the edges of the piece will clear the bed of the lathe. Otherwise the piece may strike the bed, break and injure the operator.

Light drilling jobs can be accomplished with the tool as illustrated in Figure 2. The work is held in the end and pressed against the cutting point of the drill. Unless the lips of the drill are ground off especially for cutting brass, the operator who is unaccustomed to the action of a cutting drill should take care to see that the work is not snatched out of his hand at the point where the drill breaks through. In the case of small drills, the drill would naturally break; the larger drills, however, will not do this—they will either bend or pull the work out of the operator's hands. Just before a drill breaks through cast iron or brass, the operator should release some of the pressure and permit the drill to "ease" its way through the final stages of the cut.

In Figure 1 we see the power lathe being used with its sawing attachment. Here, it will be noticed, a special table has been attached to the bed of the lathe and a circular saw placed on the live spindle. An adjusting saw guide is also attached to the table.

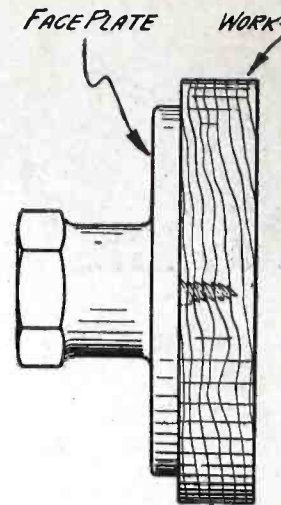

**THE USE OF THE FACE PLATE**

FIGURE 6: Flat pieces of wood for coil ends are best worked up by the use of the face plate with a screw center. The screw that holds the work to the plate can be seen projecting through the hollow hub of the plate into the wood.

It is obvious that the operator must be careful with his fingers in using this attachment. He should also have some respect for the little motor, especially when he has a lot of cutting to do.

Although representing a great deal of power in a small space, this little motor will become hot if heavily overworked for long periods of time. Even when worked normally it will cut twenty times faster than a man can saw, to say nothing of the accuracy possible.

The grinding operation, for which a small special arbor and grinding wheel are provided, is illustrated in Figure 3.

With this attachment the operator may keep his wood-cutting tools, drills and chisels sharp. For those who are unaccustomed to the ways of the shop, it may be said that drills should not be sharpened too rapidly. Nothing loses its hardness so rapidly through overheating as a drill, and once made soft by being "burned" on a grinding wheel, a drill becomes practically useless except for working with wood and extremely soft metals.

In Figure 4 the operator is shown using a wire brush. This is a brush made with steel wire bristles and it is used in cleaning off metal surfaces. Some idea of other uses to which it may be put can be had from the suggestion that when used with the motor and independently of the lathe it is especially helpful in cleaning the underside of automobile mud-guards.

The clever mechanic will find a great many other uses for this little lathe. He can wind coils with it; he can cut and polish bakelite or he may, by rigging up different gadgets, accomplish a wide range of different operations. For after all is said and done, no tool will do work that is beyond the range of the mind of the man who uses it.



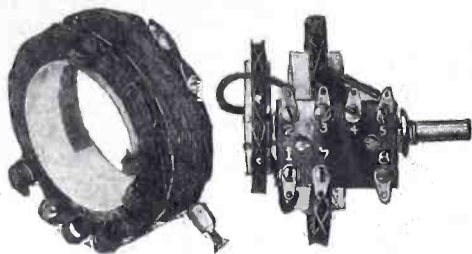

Sickles Coil Set No. 18A for Roberts

**COIL PRICES**

- No. 30 Shielded Transformer... \$2.00 each
- No. 24 Browning-Drake..... 7.50 Set
- No. 18A Roberts Circuit..... 8.00 "
- No. 25 Aristocrat Circuit..... 8.00 "

There are Sickles Diamond Weave Coils for all Leading Circuits.

**The F. W. Sickles Co.**  
134 Union Street  
SPRINGFIELD, MASS.

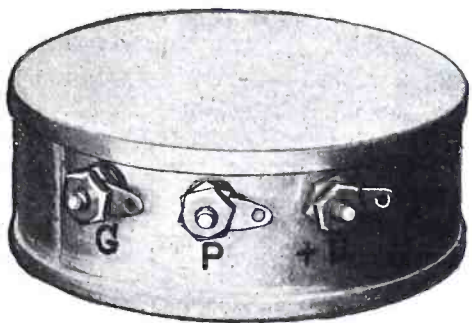

Shielded Tuned Radio Transformer, No. 30

**The "Radio Ceiling"**

(Continued from page 553)

do explain some of the peculiarities of transmission.

"Fading," for example, which is one of the chief sources of irritation to the radio fan, is seen to be due not alone to interference between ground and reflected waves, but to changes in the height of the layer and in its effectiveness as a reflecting surface. The measurements obtained by the investigators showed that these changes are often very sudden; they also indicated that variations may take place with the season and with the time of day, the layer probably being at a greater height in fall than in summer and in the afternoon than in the morning.

Again, the character of the reflecting or refracting surface would naturally affect the quality of the reflected waves. A bumpy or corrugated surface would tend to produce "multiple reflections," causing interference, confusion and even "fading" where waves happen to neutralize one another.

For a long time scientists have been trying to learn what the forces really are which surround the earth, circulate within its interior and penetrate its atmosphere. Gradually progress is being made. It is now clear, for example, that the earth itself is surrounded by a magnetic field. It has also been shown that the sun has a magnetic field similar to that of the earth. It is probable that all celestial bodies are surrounded by such fields. Indeed, it has been suggested that every large rotating mass, such as the earth, is an electro-magnet that causes magnetic force in a manner not yet determined. Verification of the existence of a conducting layer in the upper air is another notable step forward in man's effort to understand and master the physical forces which surround him.

The existence of this layer has additional significance in the possibility that its movements in the earth's magnetic field may induce electric currents which, in turn, may have far-reaching effects. Again, the motion of the layer as a whole may affect the condition of the lower atmosphere, producing important changes in electric pressure.

The experiments here described were made with the cooperation of the Naval Research Laboratory, the Radio Corporation of America, the American Telephone and Telegraph Company, the Westinghouse Electric and Manufacturing Company, and the Bureau of Standards. The possibilities of the importance of the ionization of the upper atmosphere were pointed out first by Professor A. E. Kennelly, of the United States, and later, among others, by Oliver Heaviside, of England.

For this reason the layer is frequently called the "Kennelly-Heaviside layer."

**Bradleystat**

PERFECT FILAMENT CONTROL

For noiseless, smooth filament control and maximum range, ask your dealer for the Bradleystat. This well-known

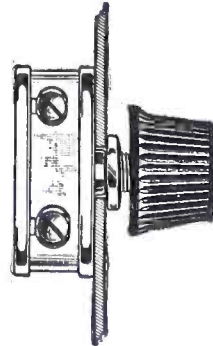

graphite disc rheostat can be used for ALL TUBES, without change of connections. The bakelite knob is removable, if desired.

The one-hole mounting makes the Bradleystat easy to install.

**Bradleyleak**

THE PERFECT GRID LEAK

With a range from 1/4 to 10 megohms, the Bradleyleak offers a variation of adjustment that adapts it to any tube or any circuit. A small grid condenser can be attached direct to its terminals. One-hole mounting.

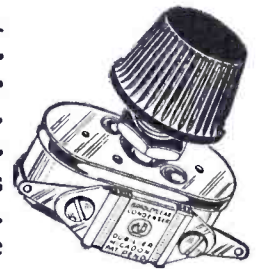

**Bradley-Amplifier**

Resistance-Coupled PERFECT AUDIO AMPLIFIER

For perfect tone quality, use resistance coupling, and for convenience and reliability, ask your dealer for a Bradley-Amplifier. Ready to install in your radio set.



Mail this coupon to

ALLEN-BRADLEY CO.  
276 Greenfield Ave., Milwaukee, Wis.

Please send me your folders on Allen-Bradley radio devices, including the Bradley-Amplifier.

Name.....

Address.....

**YAXLEY**  
APPROVED RADIO PRODUCTS

**Radio Convenience Outlets**

No longer need radio reception be confined to one room — nor need battery wires be a tangled, unsightly mass strewn about the set. With the neat and efficient Yaxley Radio Convenience Outlets you can enjoy your favorite programs in any room in the house. Your batteries can be placed in the basement, closet or any out-of-the-way place and wires brought to set from Convenience Outlet with cable and plug that keeps wires together in an attractive way. Plug cannot be inserted incorrectly. Yaxley Radio Convenience Outlets are easily installed in any standard switch box.

- No. 135—For Loud Speaker. \$1.00
- No. 137—For Battery Connections..... 2.50
- No. 136—For Aerial and Ground..... 1.00

At your dealer's. If he cannot supply you, send his name with your order to

**Yaxley Mfg. Co.**  
Dept. P  
9 So. Clinton St.  
Chicago, Ill.

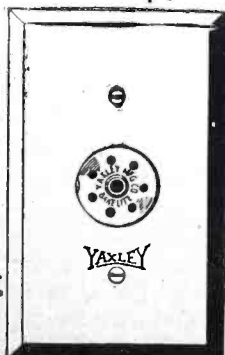



Tune quickly—adjust accurately—eliminate distracting noises—get correct tube oscillation—with X-L VARIO DENSERS in your circuit.

Designers of all latest and best circuits specify and endorse.

**MODEL "N"**—Capacity range 1.8 to 20 micro-micro farads. Micrometer adjustment assures correct oscillation control in all tuned radio frequency circuits. Neutrodyne, Roberts 2-tube, Browning-Drake, Silver's Knockout, Interflex circuit, Quadraformer, World's Record Super-9, B. T. Power-6, R. B. Lab. Circuit, etc. Price, \$1.00.

**MODEL "G"**—For Cockaday, Oliver Lodge N. Loftin-White, Nankin Ultra-5 circuits, filter and intermediate frequency tuning in super-heterodyne and positive grid bias in all sets. Capacity range, Model G-1 .00002 to .0001 Mfd. Model G-5 .0001 to .0005 Mfd. Model G-10 .0003 to .001 Mfd. Price each with grid leak clips \$1.50.

**X-L PUSH POST**—Push it down with your thumb, insert wire, remove pressure, wire is firmly held. Vibrations will not loosen, releases instantly. A push post that excels in appearance, action, service and convenience. Price 15c.



**PUSH POST PANEL**—7 push posts mounted on black insulating panel with permanent white markings. Soldering lugs, raising bushings, screws for mounting, etc. in box complete. Price \$1.50.



X-L Push Post Panel

FREE wiring diagrams showing use of X-L units in the new LOFTIN-WHITE constant coupled radio frequency circuit, and in other popular hook-ups. Send for yours today.

**XL Radio Laboratories**  
2422 Lincoln Ave., Chicago, Ill.



Trade Mark Reg'd U. S. Pat. Office

**VERITAS RESISTORS**



2 WATT—A NEW SIZE

We announce a new 2-watt Veritas Resistor, intended for all usual grid-leak and resistor uses where the radiation requirements do not exceed 2 watts, and intended to replace old type resistors and grid leaks in which the resistance element is separately enclosed within a glass tube, and which are only 1/10 to 1/20 as able to carry current safely. In spite of much greater value, 2-watt Veritas Resistors sell for no more than the old style. They stand up in service, are accurate, changeless and can be soldered, too, without damage.

The TOBE 5-watt Veritas Resistor is still part of the Veritas line. In addition we now present to the Radio Public a 10-watt resistor with all the excellent Veritas characteristics and suitable for use in large B-Eliminators and Power-Supply units. Send for catalogue L-6.

**Tobe Deutschmann Co.**  
Engineers and Manufacturers of Technical Apparatus  
Cambridge, Mass.



## WITH THE EXPERIMENTERS

CONDUCTED BY RICHARD LORD

### "Stereophonic Reception"

EVEN with the most perfect of loudspeakers, it is not possible to get exactly the same musical effect from the reproduction as would be obtained if the listener were seated in a hall listening directly to the performance. The same observation applies to a phonograph.

The reason for this is not far to seek. In a concert hall the sound reaches the listener from practically every angle, due to reflections from the walls, roof and various objects within the building. These complex reflected sound waves are picked up by the listener's ears, but, due to the fact that he has *two* ears, the impression transmitted to his brain is somewhat different from that which he would receive if he had but one ear, on account of what might be termed "phase difference."

This phase difference is caused by the distance between the ears. Sound waves from the right will reach the right ear a small fraction of a second before they affect the left ear, and *vice versa*.

This state of affairs results in giving us the effect of hearing from several points at once, so that when we are listening to an orchestra in a hall we get a

sense of perspective; all the instruments in the orchestra combine and blend to give us the desired effect.

This effect is further assisted by the fact that the orchestra is spread out over a relatively considerable area.

When listening to a broadcast reproduction of the same performance, however, the effect is totally different. Even if the loudspeaker and its associated amplifier are perfect, the effect still seems to be "flat." It is like the difference between looking at a photograph through a stereoscope and then looking at it without the aid of such an instrument.

This is one of the artistic faults of broadcasting, and it is due primarily to the fact that the microphone has, by virtue of its design and construction, but one ear.

Several microphones may be used, but they will not greatly improve the situation, because all their outputs have to travel over a single circuit only, in order to reach the broadcast listener, *i.e.*, the ether. (In the case of the phonograph, of course, the medium of transmission is the record.)

Thus, up to the point of reproduction by the loudspeaker, there is no phase difference between the various sound

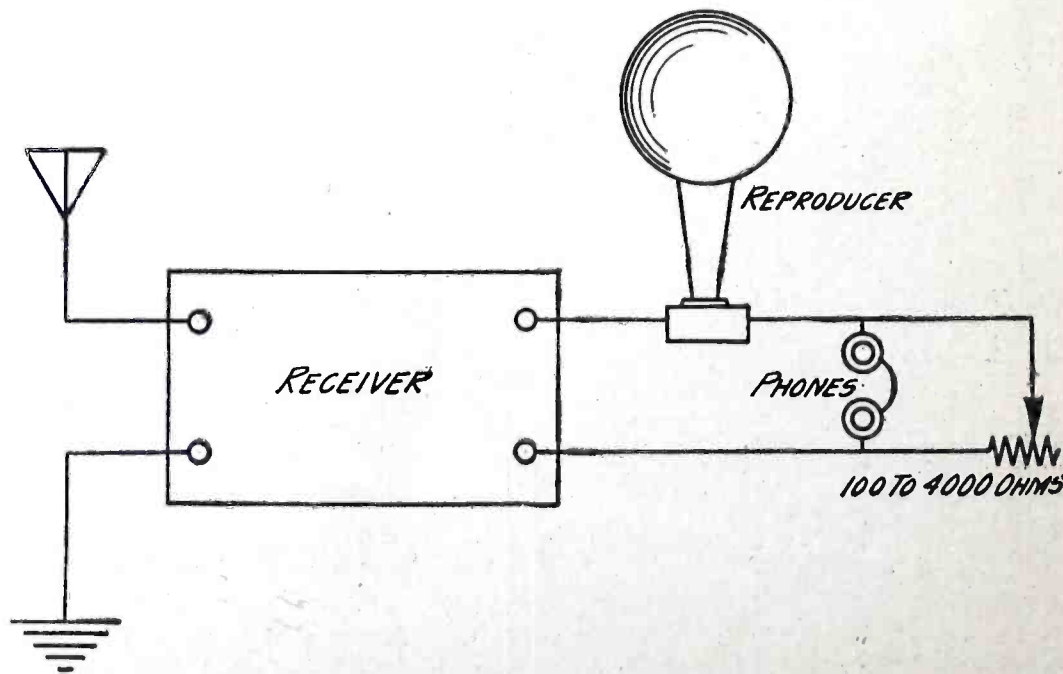

THE WAY TO GET "SOLID" SOUND

FIGURE 1: By means of the variable resistance shown at the right of the diagram, the volume of sound from the headphones is balanced with that from the loudspeaker. The two reproducers sounding together gives the "stereophonic" effect.

# Put a Power tube

( $\frac{1}{4}$  amp. ZP 201-A)

## in Every socket—



without  
re-wiring  
your set

Radio's sensational development has seen nothing more startling than the new ZP 201A, oxide filament,  $\frac{1}{4}$  amp. Power Tube—the Zetka Process power tube for every stage.

Now, for the first time, can power tubes be used in every socket of your set. Now you can enjoy *real* power, and *without changing a single wire!*

Replace your old 201A's with a set of these new ZP 201A's and enjoy the most startling achievement in tube history.

There is appreciable current saved, both A and B—it is not necessary to hook up additional C's—but—what

an improvement in tone, in volume, in sensitivity.

Only \$2.50 each at your nearest dealer puts a complete Power Tube set well within your radio budget. And then only you'll enjoy real radio satisfaction—with power tubes of longer life, that increase in efficiency as you use them.

*Ask your Zetka dealer to show you the Zetka Weston meter test. You'll want nothing but Zetka thereafter.*

YOUR SET DESERVES THIS FINER EQUIPMENT  
PRICES NO HIGHER

# ZETKA

The Clear Glass Tube

ZETKA LABORATORIES, INC.  
73 WINTHROP STREET NEWARK, N. J.

## Re-inforced Construction makes possible "UNCONDITIONAL GUARANTEE"

### Sunlight CRUSADER RADIO TUBES

Now you can buy tubes with a definite assurance that you will get the service for which you pay. Our sweeping guarantee for one year sees to that.

And furthermore, you get better reception, because our special design and re-inforced construction tends to eliminate microphonic noises. Yet they cost no more than ordinary tubes!

*Descriptive folder on request*

**THE SUNLIGHT LAMP CO.**  
NEWTON FALLS, OHIO



## "8 hour" SERVICE on any Kit or Parts

The most complete stock of QUALITY KITS and PARTS in the CENTRAL WEST enables us to offer this unheard of service. Only GENUINE parts specified by designers are used—NO SUBSTITUTIONS—All quality Parts and Kits are stocked—even those not listed below. Any item advertised in this issue obtainable here at quoted prices. WESTERN READERS are now assured of quicker service. Send your orders for quality merchandise and pleasing, rapid service.

R. G. S. Receiver	\$69.70
Low Frequency Amplifier	31.65
Browning-Drake Power Pack	100.15
New Browning Drake	85.45
Pre-Selector Receiver	33.20
Hammarlund-Roberts Hi-Q	63.05
Varion Power Pack	55.00
Silver Shielded Six	95.00
S-C II Receiver	60.35
L-C 27 Receiver	85.20
L-C 27 Senior Power Pack	65.00
L-C 27 Intermediate Power Pack	47.50
B-T Power Six	78.13
New Remler Infradyne	112.35
Karas Equamatic	89.24
New Samson (Cotton) Super	135.00
Clough Super	80.85
Chicago Daily News Receiver	46.30
Centralab Tone Amplifier	16.00
CeCo Tubes (as advertised)	1.75 up
S-M 652 Reservoir "B" (Less Tubes)	34.50

Send only \$5.00 with your order and we will ship within 8 hours any kit or part on the market—you pay balance upon delivery, plus small mailing charges. All Delivery Charges PREPAID on any kit, anywhere in the U. S., IF certified check or money order for full amount accompanies order. Prices on complete wiring of kits gladly given. SEND IN YOUR ORDER—we Guarantee real service and merchandise.

**Austin-White**  
**RADIO**  
125-7 SO. MARKET ST., CHICAGO, ILL.



Courtesy of the Bakelite Corporation

### "A CAPACITY EQUAL TO THAT OF THE EARTH"

*Here is a view in a large manufacturing plant whose monthly output of fixed condensers has a total capacity that equals that of the earth, considering it as one gigantic fixed condenser. The small condensers shown in this picture are made of bakelite, mica and tinfoil.*

waves; or rather, instead of two sets of sound waves, slightly out of phase with one another, there is but one set.

The music of a full orchestra thus reaches the radio listener from but one definite point in space, which is unnatural. For really natural reproduction, not only is the phase difference itself essential, but it must also constantly vary so as to give the impression of hearing from several points at once—the different points where the instruments are placed.

The echo effects present in a large hall must also be taken into consideration, as has lately been successfully done at 2LO, London, where a special room is set aside for the production of an echo effect.

At first sight the difficulties in the listener's path seem to be insurmountable. To correct the transmission two separate transmitters and receivers would be necessary, which, of course, is impractical.

However, it is quite practicable for the listener to produce a phase difference at the receiving end, the results of which will give an extremely pleasing effect; this may be arranged in a few minutes without the necessity of altering the set in any way, or adding any complicated apparatus.

Given a receiver capable of good loudspeaker reproduction, all we require is a pair of headphones and a resistance variable between about 100 and 4,000 ohms. The hook-up is given in Figure 1, and is simplicity itself.

The station should be tuned into maximum strength on the phones, which, by the way, should not fit too tightly on the head. The loudspeaker is then moved away from the listener till a slight echo effect becomes apparent. About 10 or 15 feet ought to suffice.

The variable resistance should then be used to regulate the strength in the phones till their effect upon the ear is approximately equal to that of the reproducer. A marked improvement in the

quality of reproduction will then be apparent, due to the phase difference introduced by the distance between the loudspeaker and the phones.

The essential point is that the intensity of the sound that reaches the ear from both sources should be as nearly equal as possible. Hence the advisability of wearing the phones loosely.

This phase difference varies in extent with the frequency of the reproduced sounds, and it is this constantly varying phase difference which produces the stereophonic effect so superior to ordinary reproduction, for the sound waves appear to reach the ears of the listener from all directions at once, just as they do in the concert hall.

Much has been done in England to secure this phase difference at the transmitter, by means of the echo room already referred to. In this room, which is bare, a loudspeaker reproduces the program from the studio. This speaker is supplied by a separate microphone set alongside the broadcasting microphone, and it has its own amplifier. In the echo room there is also a third microphone, set some distance away from the loudspeaker. The output of this microphone is superimposed upon that of the studio microphone, and the two outputs have a phase difference which can be regulated by varying the distance between the echo-room microphone and the loudspeaker.

By means of this combination extremely realistic reproduction can be obtained, even from a draped studio performance. The engineers responsible for the development of the method claim that they can pick up an open-air band and broadcast it as if it were playing in a large, echoey hall!

This same principle of the introduction of phase difference can also be applied to a phonograph and suggests a line of research for the phonograph industry.

Two distinct reproducing systems are

necessary, complete with sound boxes and horns of similar characteristics. Two needles are placed in the same groove of the record, one about 2½ to 3 inches behind the other, according to the character of the music. By this means surprisingly realistic reproduction may be obtained.

—A. DINSDALE.

### What Condensers Are Doing for Man

THE Leyden jar has formed the basis of one of the principal means of harnessing electrical energy so that it will perform the many tasks set for it by man. At first this important device served as a mere toy; it was used in the beginning to send an electric shock through a chain of soldiers or monks for the amusement of royalty. The Leyden jar (named after the town in Holland where it was first made known to the public), is the foundation of the fixed condenser.

Until recently the Leyden jar served its purpose as a condenser with little improvement over the original types. It was most familiar as part of the doctor's X-ray machine.

As radio came into more general use, the development of the condenser grew apace; today condensers are made in a variety of forms—variable and fixed, with air, paper, or mica dielectrics—and they range in size from tiny devices one inch square for radio receivers, to the larger units for high-tension transmission lines, encased in bakelite, and porcelain tubes the diameter of a gallon jug.

Condensers as they are used today help to smooth out the rough spots in the flow of electricity. As potential store-houses of electrostatic energy, they are used to break the gap in the starting and stopping of elevators and other kinds of motor-operated machinery where there are electrical contacts.

In power transmission they serve in a number of ways. They perform an interesting service by permitting the use of high-tension power lines for telephoning. Variation in the capacity of the condensers permits the sending and receiving of a number of messages at once, without interference. Condensers are also employed to drain telephone lines of undesirable high-frequency currents. Instead of this form of energy being re-radiated into the ether, the condensers carry off the interference to the ground.

The combination of condenser units to effect varying capacities is another of the unique features of these controlling devices. Automatic railway signals are operated through the use of such condensers to insure the safe operation of our railway systems.

Were it not for the condenser, radio would be a lost art, for in tuning there must be some means of adjusting the receiving instrument to the frequency set up by the sending station. This is nearly always accomplished by the condenser.

—S. P. HOLLINGSWORTH.

# \$75 A WEEK BUILDING RADIO SETS

—in your spare time

JOIN the Radio Association of America. Learn how to build and repair radio sets. The Association will train you—start you out in business if you wish. Be the radio "doctor" of your community. \$3 an hour upwards easily made. Radio offers you a big money-making opportunity right now.

### Earns \$500 in Spare Hours

"I have at last found myself," writes Lyle Follick, Lansing, Michigan. "I have already made over \$500 building radio sets after working hours." Werner Eichler, Rochester, N. Y., writes, "I have made over \$50 a week in my spare time."

Our members are starting radio stores, increasing their salaries, securing better positions, earning big money for the most enjoyable kind of spare-time work.

### What a Membership Means

A membership in the Radio Association of America gives you the most up-to-date and thorough training in the Science of Radio.

You're taught how to build and repair all

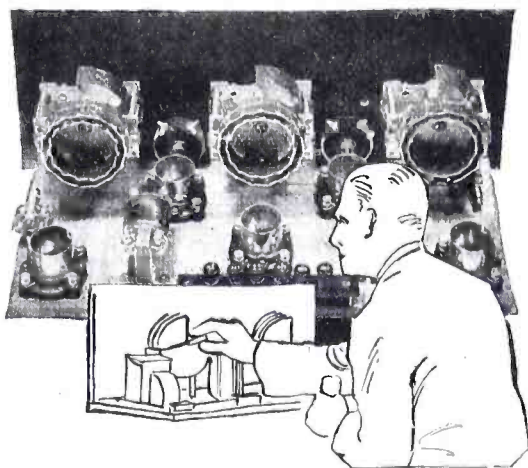

kinds of sets. You receive the privilege of buying parts at wholesale prices.

You're helped to make money.

### Join the Association Now

If you're interested in Radio for either pleasure or profit, join the Association without delay, because we have a plan whereby your membership may not—need not—cost you a cent. Only a limited number of these memberships are acceptable. Write now for details. Write before it's too late.

This Association has prepared a beautiful book that gives figure-facts regarding the profit possibilities of the Radio Industry, the purpose of the Association, and the details of the Special Membership Plan.

### Mail This Coupon

RADIO ASSOCIATION OF AMERICA

Dept. PR-6---4513 Ravenswood Ave., Chicago

Send me your book and details of your Special Membership Plan.

Name.....

Address.....

City..... State.....



**DON'T** let this happen to **Your Set**

### The Next Storm May Do It

Provide the protection the National Board of Fire Underwriters demand. It takes but a few minutes to attach a

### WIRT LIGHTNING ARRESTER

It is the approved air-gap type, heavily insulated with Bakelite to withstand high voltage. A Bakelite "petticoat" provides added protection by draining off water and keeping out dust. Metal parts are brass. Nothing to rust or wear away. Will last a lifetime.

Terminals are extra heavy, and designed for connecting to aerial without cutting wire.

At all dealers for \$1.25 each. Get one today, for tomorrow — well — you never can tell.



**WIRT COMPANY**

5243 Greene Street Philadelphia, Pennsylvania

## F. D. Pitts Company INCORPORATED

219A Columbus Ave. Boston, Mass., U. S. A.

**Merchandising Radio Since 1919**

DEALERS—send for large and profusely illustrated catalog on the products of scores of nationally advertised radio manufacturers.

Wholesale Exclusively

**"Pioneers in the Distribution of Radio"**

# play safe

Much of the success of the Socket Power Unit or Receiver depends on the variable resistor.

Don't experiment—use **CLAROSTAT**, the greatest variable resistor. It covers the entire range, has a current carrying capacity of 20 watts and is sturdily constructed with laboratory precision.

**WARNING!** Beware of imitations. Every genuine **CLAROSTAT** has the name etched on the case. Look for it.

Have you a copy of "THE GATEWAY TO BETTER RADIO"? 32 pages of interesting reading on every phase of radio.

Send 25c in stamps or coin

American Mechanical Labs., Inc.  
285 North 6th St., Brooklyn, N. Y.

Send 25c for 32 page illustrated book



**CLAROSTAT**

## "World's Finest 3-Ft. Cone or Roll-Type" Loud-Speaker "ENSCO" KIT ONLY \$10 Assemble in Less Than an Hour

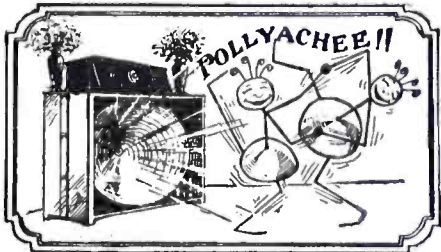

Complete parts furnished in kit form. We guarantee this speaker the equal of any manufactured cone speaker considering price.

With this **THREE FOOT CONE SPEAKER** you hear all the tones. It brings out the true depth and beauty of orchestral and instrumental music. Can be operated softly for living room music or full volume for dancing, and without trace of distortion.

Kit includes famous "ENSCO" cone unit, the only direct drive, distortionless unit for large cones; Alhambra Fonotex for big cone, with brass apex, two Blue Prints showing cabinet, stand, or roll-type construction. All necessary instructions for assembling.

Buy this wonderful speaker under our absolute guarantee. **Your money back** if you are not convinced that it is the finest reproducing medium. It works on any set, with ordinary Tubes or with Power Output.

### ORDER COUPON—SEND NO MONEY

Write your name plainly as indicated below, then mail and complete kit will be forwarded to you. Just pay postman \$10.00 upon delivery.

Name.....

Address.....

**ENGINEERS' SERVICE CO.**  
25 CHURCH ST. Desk Z NEW YORK CITY

## In the World's Laboratories

(Continued from page 563)

### Another Chance for Radio Tests of the Sun

AMERICAN radio enthusiasts will remember the extensive tests of the effect of the sun's shadow on radio waves which were made in the United States during the total eclipse of the sun in January, 1925. It was these tests which furnished one of the first sure pieces of evidence concerning the Heaviside Layer and the part played by this upper level of our atmosphere in radio matters.

Last year there was another total eclipse of the sun, but it happened to be visible only in the Indian Ocean, on the east coast of Africa and in parts of the islands of the western Pacific Ocean. This region being ill-provided with radio stations or with listeners, few radio tests were made and no further important facts seem to have come to light.

On June 29, 1927, there will be still another total eclipse of the sun. This one, fortunately for science, will be total in thickly settled countries well provided with radio listeners and with broadcasting stations.

The eclipse begins, in early morning by local time, about four hundred miles southwest of the British Isles. At about five thirty, A. M., Greenwich Time, the eclipse sweeps across England in a northeasterly direction, from North Wales and Liverpool to Hartlepool, a port on the North Sea. A little later the eclipse will be total at Stavanger, in southwestern

Norway, will sweep northward along the whole length of that country and will then traverse the portion of the Arctic Ocean north of Asia, perhaps the least populous ocean of the world. In the later afternoon, still according to local time, the eclipse will be visible as a total one in parts of eastern Siberia, where it will be enjoyed, we imagine, by no one except the Eskimos. At sunset, the eclipse ends in the Northern Pacific Ocean, just south of the Aleutian Islands.

The eclipse will be visible, as a partial eclipse only, in parts of Alaska and in Greenland. This continent will have no glimpse of it as a total one and even the partial eclipse will be invisible in the thickly-settled portions of our side of the world. The favorable points for observation will be in England and in Norway, and expeditions from many astronomical observatories in all parts of the world will be stationed at vantage points along this portion of the path. Extensive plans are being made in England for public observation of the eclipse, along the lines carried out so successfully for the American eclipse of 1925 by Professor Ernest W. Brown, of Yale University, and his assistants. It is planned, also, to enlist British radio fans in repeated tests of the effect of the passage of the sun's shadow on radio transmission.

It is probable that the effects of the eclipse on radio will be, in some degree,

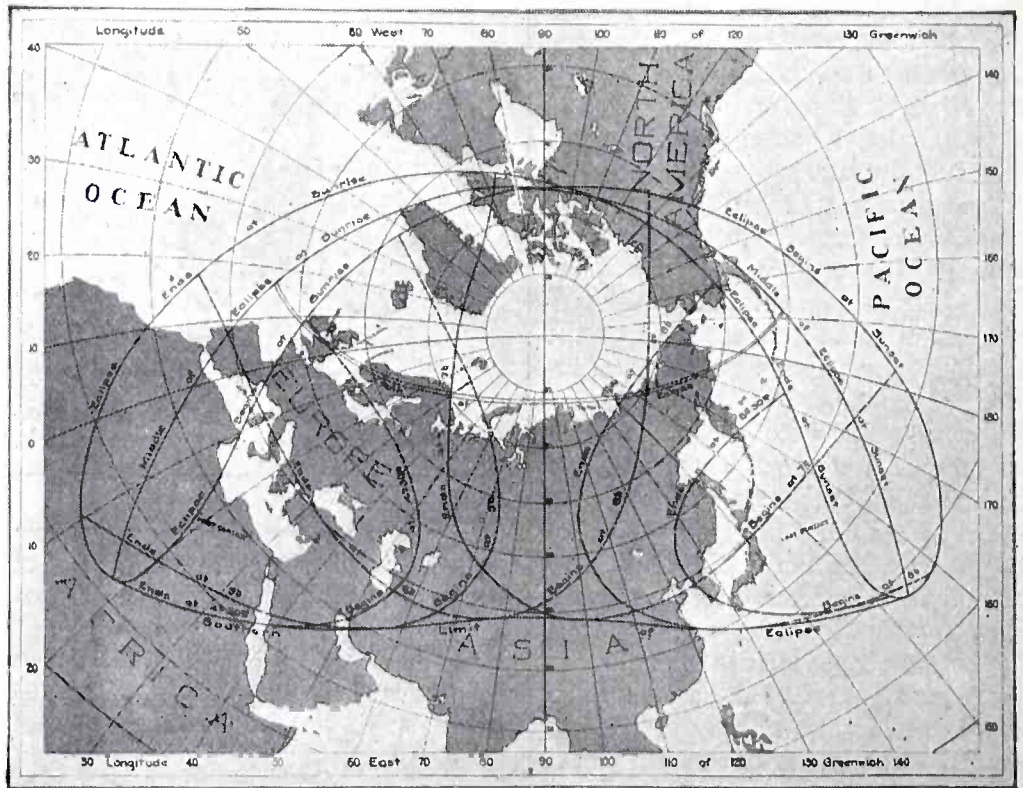

From the Nautical Almanac, 1927

### WHERE THE SUN WILL OFFER ANOTHER RADIO EXPERIMENT

This map, prepared by the astronomers of the United States Naval Observatory, shows the parts of the earth which will be shaded, totally or partially, by the moon's shadow during the total eclipse of the sun on June 29, 1927. The narrow double line, marked "Path of Total Eclipse," indicates the only places which will see the sun totally obscured.

# Build Your LC-27 Receiver

with the aid of  
**Popular Radio**  
SIMPLIFIED  
Blue Prints

*Easy, Quick and Accurate*

This receiver embraces the 14 points of an ideal radio receiver to meet the demands of the average man's requirements.

1. A quality of reproduction that is as nearly perfect as possible;
2. A cabinet designed to blend harmoniously with the finest surroundings;
3. Consistently good performance with a minimum of care and attention, once the set is installed;
4. A tuning control so simple that any one may operate the set without special instruction;
5. A selectivity adequate to eliminate interference from stations on adjoining wavelengths;
6. An ability to operate on any type of antenna or with no antenna at all;
7. A capacity to operate on house current or batteries, as desired;
8. Adequate shielding of parts;
9. A power amplifier and output filter to supply volume without distortion;
10. A construction that provides for the use of nationally known tubes and parts that are easily obtainable in any locality;
11. A non-regenerative circuit;
12. A simple construction with a minimum of adjustments;
13. A sensitivity adequate to provide good reception of distant programs;
14. A fool-proof construction.

By using POPULAR RADIO Simplified Blueprints in building your LC-27 Receiver, you can save time, eliminate the possibility of error, and make your set exactly like the laboratory model.

If your local dealer cannot supply you with Blueprints of the LC-27 Receiver, they will be sent post-paid upon receipt of \$1.00.

A full description of this Receiver, with detailed directions for building, was published in the October, 1926, issue of POPULAR RADIO. Send 35 cents for a copy.

We also have Blueprints of The LC-Senior Power-Pack, The LC-Intermediate Power-Pack and The LC-Junior Power-Pack which were designed to operate The LC-27 Receiver.

**POPULAR RADIO**

Service Bureau 44-B

627 West 43rd Street New York City

world-wide; as the effects of the 1925 eclipse seemed to be. Accordingly, amateurs who are working in America during the hours of the eclipse should record carefully any unusual observations which come to their attention. As this note is written it appears unlikely that any organized effort will be made to obtain American observations, but the editor of this Department will be glad to forward any incidental observations to the European scientists who are in charge of the observations there.

The American hours corresponding to the occurrence of the eclipse in Europe and Asia are as follows: The partial shadow will first strike the earth, in the Atlantic Ocean and in northeastern Africa, at about 11.30 P. M. on the evening of June 28, Eastern Standard Time. Totality will begin, in the Atlantic, about an hour later. The sweep of the shadow over the British and Scandinavian radio stations will last from approximately 12.20 A. M. on the morning of July 29 until about ten minutes later. The duration of totality at any one point on this part of the eclipse path will be only 24 seconds. By about 1.30 A. M., Eastern Standard Time, the total phase of the eclipse will have reached the Aleutian Islands and ended. The partial phase of the eclipse will end at about 2.30 A. M.

Mathematical details of the eclipse path, times and similar matters are printed in the Nautical Almanac for 1927, published by the United States Naval Observatory and for sale by the Superintendent of Documents, Washington, D. C., at one dollar a copy. For facts about eclipses in general any good textbook of astronomy may be consulted; that by Professor E. A. Fath, published by the McGraw-Hill Book Company, New York City, is good, as is also the new edition of Young's Astronomy, edited by Professor Henry Norris Russell, of Princeton University, and published by Ginn & Company, Boston.

## The Theory of Antennas

RADIO engineers interested in the more fundamental (and mathematical) theories of the science should not miss a discussion of the space characteristics of radio antennas published recently by Captain William H. Murphy of the Signal Corps of the United States Army.\* Captain Murphy applies to the characteristics of receiving antennas the general electrostatic equations for electric fields in space.

Perhaps the most interesting parts of his discussion are those dealing with the directional characteristics of receiving antennas and with the displacements of phase angle which may occur.

\* "Space Characteristics of Antennæ," by William H. Murphy. *Journal of the Franklin Institute* (Philadelphia), volume 203, pages 289-311 (February, 1927).

**SM**

## Push-Pull for Power

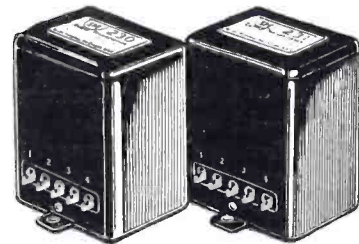

Two new audio frequency transformers have just been released by the Silver-Marshall laboratories, which, used with two 112 or 171 type tubes, will provide greater power output without overload distortion than the most powerful 210 amplifiers heretofore used.

One 230 and one 231, with two 171 tubes, will give *greater* undistorted power output with but 180 volts than a 210 tube operated at 400 volts or more!

Type 230 input transformer may be used as a 3:1 or 6:1 ratio audio transformer, or as a 3:1 push-pull input transformer. Its characteristics are very similar to those of the famous 220—effective primary inductance 100 henries, with falling curve from 30 to 5,000 cycles.

Type 231 output transformer may be used as a push-pull output transformer, or to obtain accurate matching of output impedance of all standard power tubes when used as an ordinary output transformer. Its characteristics are similar to the popular 221, plus an additional primary winding.

Price, either type, \$10.00

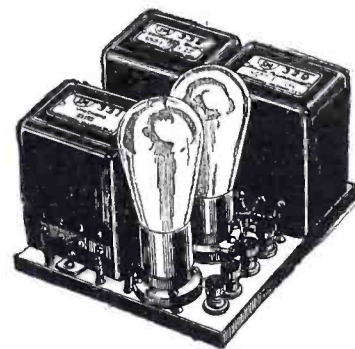

The S-M 652 Reservoir B will supply practically constant power to any set, 45 milliamperes at 90 volts, 10 milliamperes at 45 volts, and ample current for power tubes on the 180 volt tap. It will not "motor-boat," "hum," or "putt" even on resistance coupled amplifiers. Price \$34.50.

**SILVER-MARSHALL, Inc.**

844 WEST JACKSON BLVD.  
CHICAGO, U. S. A.

# ask us another

Q.—Who is the largest manufacturer of radio parts in the world?

A.—Pilot Electric Manufacturing Company, 323 Berry Street, Brooklyn, N. Y.

Q.—Name 3 distinguishing characteristics of Pilot parts.

A.—1—Absolute precision.  
2—Absolute uniformity.  
3—Lowest priced.

Q.—How does Pilot manage to combine absolute precision with low prices?

A.—By production on a scale never before attempted.

Q.—Why is Pilot's manufacturing method unique?

A.—Raw materials only enter the receiving dept. All Pilot parts made complete in the Pilot factory.

Pilot parts are sold by all Kress and Kresge stores and by leading radio dealers everywhere.

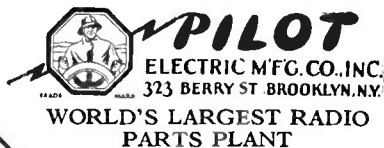

## Are Radio Waves Injurious to the Blood?

THAT having radio "get into the blood" may actually be more than a mildly derisive figure of speech is the interesting, although somewhat ill-supported, suggestion made in a recent article by Mr. Bernard Leggett, Radiologist of the East London Hospital for Children, in London, England.\*

As is usual among the medical profession, the title of radiologist does not refer to any item of radio (which Englishmen call "wireless" anyway) but indicates that Mr. Leggett is an X-ray expert, charged with the care and operation of the hospital's outfit for this useful surgical accessory.

Mr. Leggett's discussion of the possible effects of radio or other electric oscillations on the blood of human individuals begins with the field which he knows best, that of the much shorter ether waves of the X rays. The dangerous effects of these rays upon the human body are well known, as are also the somewhat analogous effects, dangerous or beneficial, of the next longer waves of the ultraviolet rays. Mr. Leggett points out, also, that it has been observed by many workers with X rays that changes in the composition of the blood have been observed not infrequently in persons who work much with X-ray apparatus.

Physicians set great diagnostic value, nowadays, upon the exact percentage of red blood corpuscles in the blood, upon the proportions of different kinds of corpuscles among the other, or "white," corpuscles, and so on. Blood tests are made frequently, not only upon invalids but upon well persons who observe the sensible precaution of obtaining periodic physical examinations. Workers with X rays have been found to show, more frequently than is normal, blood changes which cannot be other than injurious to health.

When such injuries have been observed they have usually been ascribed to undue exposure to the X rays themselves, in spite of the precautions taken in all modern X-ray laboratories to protect the workers from these radiations. Mr. Leggett suggests, however, that the true cause may be some hitherto unsuspected effect of the high-frequency oscillations, closely resembling radio waves, which are produced and emitted by the transformers and other apparatus used to produce the high-voltage currents which operate the X-ray tubes. If so, he goes on, the same effects ought to be perceptible among electricians who spend much time in the neighborhood of powerful alternating-current generators or motors, and still more among the persons similarly employed with radio apparatus.

\*"Radiological Blood Changes," by Bernard Leggett. *British Journal of Actinotherapy* (London), March, 1927, pages 24-25.

# SANGAMO MICA CONDENSERS



## CAPACITIES and PRICES

0.00004	} 40c.	0.001	} 50c.
0.00005		0.0012	
0.00006		0.0015	
0.00007		0.00175	
0.00008		0.002	
0.0001		0.0025	
0.00012		0.003	} 60c.
0.00015		0.0035	
0.000175		0.004	
0.0002			
0.00025		0.005	70c.
0.0003		0.006	85c.
0.00035		0.007	90c.
0.0004		0.0075	95c.
0.0005		0.008	\$1.00
0.0006		0.01	1.15
0.0007		0.012	1.20
0.0008		0.015	1.25

With Resistor clips, 10c extra

SANGAMO ELECTRIC COMPANY  
SPRINGFIELD, ILLINOIS

# Greatest Receiver Ever Developed

In the latest issue of the *Citizens Radio Call Book*, there is a descriptive article regarding the *New Camfield Super-Selective Nine* Receiver. This circuit is considered by experts as the greatest receiver ever developed. An outstanding achievement is the simultaneous increasing of both selectivity and sensitivity to a point heretofore considered impossible.

## CAMFIELD'S Super-Selective Nine

The *Super-Selective Nine* offers to set builders unusual opportunities, for here is a circuit that will meet every requirement for the very best in radio reception. Another feature that will appeal to the radio public is the turning of a switch on the panel, which converts this set from a 5-tube, two-control receiver for local stations, to a nine-tube super-selective and super-sensitive circuit, capable of tuning through powerful local stations and receiving distant ones on a ten Kilocycle separation of frequency.

Write today for book on this wonder circuit and have the facts before you. Use the handy coupon below. Send 25c. today—now.

Camfield Radio Mfg. Co.  
357-364 E. Ohio Street,  
Chicago, Ill.



Camfield Radio Mfg. Co.  
357-364 E. Ohio St., Chicago, Ill.

Enclosed find 25 cents for booklet, "Camfield's Super-Selective 9."

Name.....

Address.....

# YOUR RADIO PROBLEMS SOLVED

It is possible that your individual problem has been covered in an issue of POPULAR RADIO, and so as an aid to you we endeavor to keep a supply of back numbers in stock. The condensed index below gives a few of the subjects that have appeared recently: look this list over and if the information you want is covered, we will be pleased to supply back numbers at 35c. a copy.

### December, 1926

- Uncle Sam's New Short-Wave Net.
- How Circuit Resistance Affects Selectivity.
- POPULAR RADIO Circuits.
- How to Build the LC-Intermediate Power-pack.
- Inside Information on New Radio Receivers.

### January, 1927

- How to Build the New KH-27 Receiver.
- To Start and Stop Your Set Automatically.
- POPULAR RADIO Circuits.
- The Quack Doctors of Radio.
- How to Build the LC-Junior Power-pack.

### February, 1927

- The Coming of the "RADIO UNIVERSITY."
- How to Get Quality Amplification.
- How to Build and Use a Portable Test-Board.
- How to Assemble the All-Amaz Senior Three-tube Reflex Receiver.
- What's New in Radio.

### March, 1927

- How to Build the Univalve Receiver.
- POPULAR RADIO Circuits.
- How to Increase the Range of Ammeters and Voltmeters.
- How to Build Your Own 36-Inch Cone Loudspeaker.
- What's New in Radio.

## POPULAR RADIO

Dept. 48

627 W. 43d St., New York

mail  
Coupon  
Now



Do electricians show such effects?

Mr. Leggett admits that he does not know. He has never known, he says, any electrician of distinctly lethargic temperament. Instead, persons of this profession seem to incline to nervousness. These are admittedly mere guesses. No facts are known either way.

It is obviously foolish to get in the least excited about these suggestions, so long as they are mere suggestions, without definite facts to back them up. Nevertheless, it is possible to record a hearty second to Mr. Leggett's suggestion that the matter be put to the test by making a series of blood tests of a large number of persons whose occupations compel them to associate closely with machines emitting powerful alternating electric waves. It would be no great task to make some hundreds of such tests on, for example, the dynamo tenders of some large power company, discovering whether or not these much electrified individuals differ from the mass of the population in any recognizable character of the blood. It is to be hoped that someone will undertake such a test.

### Do "Polar Fronts" Affect Radio Waves?

ALTHOUGH there have been innumerable discussions of the relationship between weather and radio, with almost as many proposed theories as there have been theorists, the matter is still impenetrably obscure. That is what gives interest to a recent discussion of the so-called "polar front" theory of weather, as applied to American weather.\*

This theory, developed by the famous Norwegian meteorologist, Bjerknes, for the weather of North Europe, assumes that most of the changes of weather which occur in our temperamental northern climes are related to the arrival of great masses of cold air from the neighborhood of the North Pole. These blocks of air are supposed to mix but little with the warmer air farther south, except along the margins of the blocks. They are almost like icebergs in the air.

The margin, where much mixture does occur, is the "front" of the polar air mass; hence the "polar front" designation of the theory. Storms and temperature changes and other weather vagaries are due, the Norwegian school of meteorologists insists, to the violent air circulation which is produced along this front. It is like the boiling wall of water at the front of a flood.

This, in rough outline, is the theory—a theory now increasingly popular among professional students of meteorology.

Captain Reginald Bureau, of the

\* "Application of the Polar Front Theory to a Series of American Weather Maps," by Carl-Gustaf Rossby and Richard Hanson Weightman. *Monthly Weather Review* (Washington, D. C.), volume 54, pages 485-496, with seven maps (December, 1926; issued February 26, 1927).

First in the Field  
Specializing in  
Cockaday Kits

## S. HAMMER RADIO CO., 303 Atkins Ave. Brooklyn, New York

Cockaday Sets Now Made Easier to Build by Our New "Ready-to-Wire" Plan  
**50% of Your Time, Work and Worry SAVED!**

All you need do is to connect bus-bar according to diagram, solder and your set is finished. These Kits are sent to you completely mounted, and assembled on a Veneered Mahogany baseboard and genuine bakelite panel, drilled and engraved. Genuine parts used as listed below; exactly as used in Mr. Cockaday's Laboratory Model. COMPARE OUR OFFER!

### LC-27 BROADCAST RECEIVER SENIOR AND INTERMEDIATE POWER PACKS

- 1 Hammarlund mid-line dual condenser, .00275 mfd. \$7.50
- 1 Hammarlund mid-line single condenser, .00275 mfd. 4.65
- 1 Precision Duo-Octoform coil set comprising one antenna coupler and two inter-stage couplers. 10.50
- 1 Amertran De Luxe first-stage transformer 10.00
- 1 Amertran De Luxe second-stage transformer. 10.00
- 1 Amerchoke #854. 6.00
- 1 Dubilier or Tobe 4 mfd. Filter condenser. 5.50
- 1 Dubilier filter condenser, 1 mfd. 3.60
- 1 Mar-Co illuminated control scale 0 to 100 3.50
- 2 Mar-Co small controls, scale 0 to 50 and 50 to 0. 1.50
- 1 Carter Battery Switch. .65

- 1 Samson radio-frequency choke coil #85. \$1.50
- 3 Aerovox. mica fixed condensers, .00025 mfd. 1.05
- 1 Durham or Daven Resistor 4 meg. .50
- 1 Lynch Grid Leak Mounting. .35
- 1 Carter Gem Jack. .25
- 1 Carter variable resistance, 0-10,000 ohms. 2.00
- 12 Eby binding posts. 1.80
- 5 Benjamin UX Sockets. 3.75
- 1 Amperite No. 1. 1.10
- Mechanical Kit, consisting of aluminum shields, binding post strip, decorated panel and Tait brackets. 12.50

READY-TO-WIRE KIT PRICE **\$85<sup>20</sup>**

### Build Your BALSAMWOOD Speaker From the DURA-BALSAM-KIT

Price With Unit \$14.00

Price Without Unit \$8.00

### HAMMARLUND-ROBERTS HI-Q RECEIVER

- 3 Sets of Hammarlund AutoCouple Coils. \$10.00
- 3 Hammarlund Mid-line Variable Condensers. 14.25
- 1 Hammarlund Jr. Variable Condenser. 1.80
- 1 Sangamo Condenser with clips .00025 mfd. .40
- 1 Durham resistor, 2 megohms. .50
- 1 Sangamo Fixed condenser, .001 mfd. .50
- 2 Samson low-frequency transformers. 10.00
- 1 Carter Snap Jack, No. 1. .25
- 1 Carter combination battery switch and 10 ohm midget rheostat, No. M-10-S. 1.00
- 2 Amperites No. 1A. 2.20

- 1 Amperite No. 112. \$1.10
- 1 Carter "Imp" antenna switch No. 12. .70
- 3 Benjamin sockets No. 9040. 2.25
- 2 Benjamin sockets without bases No. 9049. 1.00
- 2 Marco Vernier Dials No. 192. 5.00
- 10 Binding posts. 1.50
- 1 Hammarlund-Roberts foundation unit. 10.50
- 1 Fixed resistance, 2 ohms. . . . .
- 2 Hammarlund Equalizer Condensers. . . . .

PRICE INCLUDED IN ABOVE UNIT  
READY-TO-WIRE KIT, PRICE **\$63<sup>05</sup>**

The Above Kits Can Also Be Obtained Completely Wired to Specifications Write for our interesting special circular which we have prepared on the LC-27 Receiver and above Kits

DEALERS: WRITE FOR SPECIAL DISCOUNTS

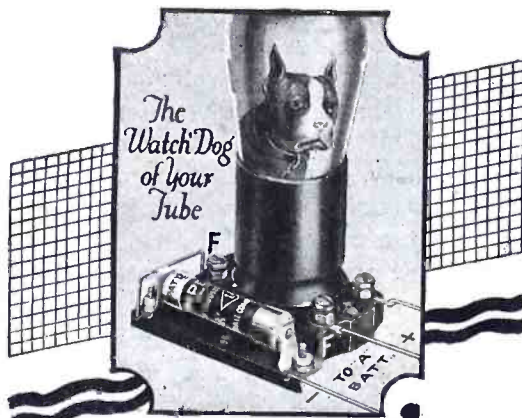

# Getting FULL Tube Value

PERFORMANCE and life is what you pay for in a tube. Amperite alone insures getting both. Controls filament current automatically. Simplifies wiring. Eliminates hand rheostats. Identify by the name. Accept nothing else.

**FREE—The Radial Book.** Gives season's most popular Hook-Ups, and invaluable Construction Data. Send for it today to Dept. PR-6.

Radial Co., 50 Franklin St., New York

Price \$1.10 mounted (U.S.A.)

Sold Everywhere



## AMPERITE

REG. U.S. PAT. OFF.  
The "SELF-ADJUSTING" Rheostat

## A VITROHM RESISTOR



FOR RAYTHEON and Q R S

350 m.a. ABC units

Vitrohm 507-62 is ready for immediate delivery to consumer, dealer, jobber and manufacturer.

This new Ward Leonard Resistor is wire-wound, with both resistance wire and terminal contacts protected by a fused-on coating of vitreous enamel. Special pre-aged resistance wire guarantees accuracy of rating when installed and permanence of this accuracy regardless of length of service.

Vitrohm 507-62

For all 350 m. a. Current Supply Units. 4760 ohms total resistance; tapped for —40, —22, —9, —4½, +22, +45, +67, +90, +135, +157 and +180 volts.

Approved by Raytheon and Q R S

Laboratories

Price, with mounting brackets, \$8.75

7135-B  
Ward Leonard Electric Company  
MOUNT VERNON NEW YORK



**demand**  
**AEROVOX**

**FILTER CONDENSER  
BLOCKS**

For Working Voltages of 200, 300,  
400, 600 and 1000 Volts D. C.

Flexible leads for connections eli-  
minate all possibilities of leakage  
from soldering.

AEROVOX WIRELESS CORPORATION  
60-72 Washington Street  
Brooklyn, N. Y.

French radio service, has applied this polar front theory to radio conditions in Europe, tracing much of the static and other disturbances encountered in France and Switzerland to the electric changes which accompany the violent agitation of the air along such a polar front. Neither in weather science nor in radio has the polar front theory been worked out in detail for American conditions. The paper referred to above is a good beginning from the meteorological side. Now is the time for some radio enthusiast to undertake experiments on the radio side.\*

\*To such prospective enthusiasts there is to be recommended the comprehensive and admirable monograph on meteorological physics, entitled "The Physics of the Air," by Dr. W. J. Humphreys, of the United States Weather Bureau, published by the Franklin Institute, Philadelphia, Pa., at a price of six dollars.

**Why a Magnetic "B" Battery  
Eliminator is Improbable**

For over fifty years it has been known that when thin plates of the element bismuth are placed in intense magnetic fields an electric current flowing simultaneously through such bismuth plates is deflected to one side in a fashion which makes it possible to obtain a very small difference of voltage between one edge of the bismuth and the other.

This is the effect known, after its discoverer, as the "Hall effect."

Last year Professor Palmer H. Craig, formerly of the University of Cincinnati, published results indicating that the electromotive forces thus obtainable might be much larger than previous investigators had supposed.† Some months later Professor Craig, then at Mercer University, inspired newspaper dispatches claiming that it is possible to make use of this effect to obtain considerable voltages, probably useful for radio purposes.

Physicists familiar with the Hall effect and with the difficulty of measuring with accuracy the small voltages which this phenomenon is competent to produce were sceptical of Professor Craig's suggestion and further announcements of its success do not seem to have appeared. Instead comes an experimental paper by Dr. C. W. Heaps, of the Rice Institute, who has repeated Professor Craig's earlier work and finds himself unable to confirm it.§ The voltages found by Professor Craig are far too large to be real, Dr. Heaps believes. Perhaps there was some leakage in the apparatus or some other error.

And so another illusory hope of using some little-known physical effect to get rid of radio batteries departs, not much lamented, to its grave of obscurity.

† "The Hall Effect in Bismuth with Low Magnetic Fields," by Palmer H. Craig. *The Physical Review* (Minneapolis, Minn.), volume 27, pages 772-778 (June, 1926).

§ "The Hall Effect in Bismuth with Small Magnetic Fields," by C. W. Heaps. *The Physical Review* (Minneapolis, Minn.), volume 29, pages 332-336 (February, 1927).



Delano, Paris

**A FRENCH LOUDSPEAKER**

*This device, which the inventor, M. Felipe Saldana, is demonstrating, is said to attain unusually good quality by several novelties of construction, including a membrane of a synthetic organic compound*

**A New French Loudspeaker**

A LOUDSPEAKER capable of developing unusual volume, yet of relatively small size, has been invented by a Parisian engineer, Mr. Felipe Saldana. The movement is of the usual electromagnetic type, a magnetized armature being caused to vibrate in synchronism with the electric oscillations. The novelty of the Saldana instrument consists in two things: the system for transmitting the armature vibration to the diaphragm and the material of which this diaphragm is made.

The transmitting system consists of several metallic rods, all attached to the armature and to the diaphragm, instead of the usual single rod. The object is to prevent any selective resonance or selective transmission by the rod itself, due to its own natural period of vibration. The system of several rods is said to insure undistorted transmission of all audio frequencies from the armature to the diaphragm.

The diaphragm consists of a sheet of synthetic material said to be a compound of cellulose with an organic acid; evidently a material of the type of the cellulose acetate used for airplane wing dope or for certain kinds of motion picture film. Materials of this type are now made in sheets of various thicknesses, but the substance has not previously been tried, so far as known, for diaphragm material. As employed in the new Saldana instrument it is said to give a less distorted reproduction than any other diaphragm material yet used.

It is generally admitted that the materials now used for loudspeaker diaphragms are far from satisfactory. Metals are ideal, except that none of them are light enough. Experimentation with organic membrane materials such as that employed by Mr. Saldana should be encouraged.

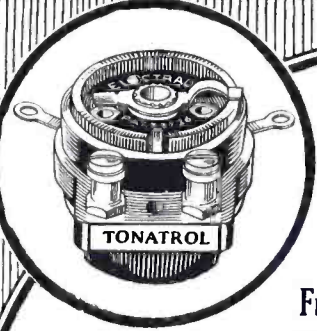

U. S. Patent  
No. 1593658  
July 27, 1926

**NOW!**  
From a Whisper  
to Full Volume

**"Tonatrol"**  
a true tone and volume control

The most efficient and perfect instrument ever invented for controlling tone and volume! Enables you to regulate volume evenly from the softest music to the most powerful reverberating tones.

"TONATROL" is a smart addition to any set. Very neat in design and made of genuine Bakelite. Easy to install.

TONATROL — Standard Volume Control—Price . . . . \$1.50  
TONATROL — Type W S (with filament switch)—Price . . . \$2.00

Write for free installation booklet for the correct way to control volume.

At your dealers.

175 Varick Street, Dept. 43  
New York, N. Y.

**ELECTRAD**

# SUMMER IS HERE

## Build the "Town and Country" Portable Receiver with Simplified Blue Prints

The "Town and Country" Portable Receiver, developed by the POPULAR RADIO LABORATORY and described in the July, 1926, issue, marks a decided advance in portable receiver design. While not a "vest pocket" receiver, the new "Town and Country" is small enough to be taken along on a motor boat or train trip. Efficiency has not been sacrificed for the sake of compactness.

The receiver uses six UX-199 tubes and one UX-120 power tube. Operating on a loop, tone quality is guaranteed by the use of a fundamentally correct circuit, high-class transformers and cone-type speaker.

The "Town and Country" Portable Receiver is mounted in a special mahogany cabinet with a drop front and is equipped with a carrying handle. All equipment, including the folding loop, cone loud-speaker, batteries and connecting cable, is installed in a suitcase. Connections from the equipment to the set are made by means of jacks and plugs.

By using POPULAR RADIO Blue Prints in building your "Town and Country" receiver, you can save time, eliminate the possibility of error, and make your set exactly like the laboratory model.

If your local dealer cannot supply you with Blue Prints of this set, they will be sent post-paid upon receipt of \$1.00 per set.

### POPULAR RADIO

Service Bureau 44-D

627 W. 43rd St., New York City

## A New Fact About Hearing

THE peculiarities of the human ear are so important to the successful use of radio and are so well known to radio experts that much interest attaches to the recent discovery of Dr. Stacy R. Guild, of the University of Michigan that the basilar membrane in the ear of guinea pigs is an exceedingly variable anatomic structure.\* The basilar membrane will be recalled as that short ladder-like strip of tissue coiled up inside the spiral portion of the ear of man and of other vertebrates. It is generally assumed that nerve fibres attached to the different "rungs" of this living ladder form the mechanism by which we recognize the pitches of different tones. This theory assumes that the rungs of the ladder increase in length gradually and uniformly, from one end of the ladder to the other.

Dr. Guild finds by examination of the ears of many guinea pigs that this is not true. Instead, the ladder seems to vary in width irregularly from one end to the other. Furthermore, the character of the ladder varies greatly in different animal individuals.

\*"The Width of the Basilar Membrane," by Stacy R. Guild. *Science* (Lancaster, Pa.), volume 65, pages 67-69 (January 21, 1927).

## A New Name for the Heaviside Layer

FEW radio theories have aroused more controversy than that of the Heaviside Layer, the upper region of our atmosphere which is supposed to be electrically conductive and to have such important effects on radio. Not only had the existence of this famous Layer been hotly denied and as hotly affirmed, but the halls of radio societies have resounded to equally vociferous arguments concerning its correct name. The existence of this Layer appears to have been suggested independently by Mr. Oliver Heaviside and by Professor Kennelly.

Now appears a new candidate for the name. In a letter to the London scientific periodical, *Nature*, Dr. Charles Chree, the distinguished British expert on terrestrial magnetism, asserts that neither Mr. Heaviside nor Professor Kennelly first had the idea of the Layer, but that it was mentioned first by Dr. Balfour Stewart in his article on terrestrial magnetism in the ninth edition of the *Encyclopædia Britannica*, written about 1882.\* Dr. Chree gives the references as sections 121 and 134 of this article. Dr. Stewart's reason for assuming the existence of the conducting layer high in the atmosphere was the existence of certain daily changes in earth magnetism, which changes are most easily explained by assuming tides raised by the sun and moon in the electrified material of the Heaviside region.

\*"Wireless Communication and Terrestrial Magnetism," by C. Chree. *Nature* (London), volume 119, pages 82-83 (January 15, 1927).

**Dealers  
attention!**  
**Free**  
UP TO DATE  
LIST of  
WHOLESALE PRICES

The May list of radio specials is now ready.

12-hour shipments.

Due to Walthal's famous purchasing power, you can get those hard-to-get items that set-builders demand. More different makes, a more complete line of items than is carried by any other distributor in the United States.

We carry full lines, such as All-American, Thordarson, AmerTran, Balkite, Tungar, Westinghouse, Ward Leonard, and every well-known make.

**WALTHAL**  
ELECTRIC CO. INC.  
WHOLESALE SERVICE

MAIL COUPON TODAY

WALTHAL WHOLESALE SERVICE,  
61 Cortlandt Street,  
New York City.

Please rush to me your up-to-date wholesale price lists. This does not obligate me in any way.

Name.....

Address.....

City..... State.....

## Use These Coils and Improve Any Radio Receiver

### AERO COIL SUPER-SENSITIVE INDUCTANCE UNITS



Tuned Radio Frequency Kit

**\$12.00**

This Aero Coil Tuned Radio Frequency Kit will positively improve the performance of your receiver. It is the basic reason for the splendid performance of the 5-tube Aerodyne Receiver described in this issue of POPULAR RADIO. Special patented Aero Coil construction eliminates radio frequency losses. You will notice instantly a tremendous improvement in volume, tone and selectivity.

This kit consists of three matched units. The antenna coupler has a variable primary. Uses .00035 condenser. Coils are uniformly air spaced. No dope is used. Consequently they tune into resonance on a "knife's edge."

### FREE with Each Kit

Eight-page color circuit, layout and instruction sheet for building the super-sensitive 5-tube Aerodyne Receiver, described in this issue, packed with each kit. Extra copies, 75c each. Instructions include insert showing how to wire up for a power tube if desired.

Get these coils from your nearest dealer. If he can't supply you, order direct from the factory.

**AERO PRODUCTS, INC.**  
Dept. 104 1772 Wilson Ave.  
CHICAGO, ILLINOIS

## The News of Mars

AS USUAL, the recent near approach of the planet Mars to the earth produced a group of reported radio signals supposed to emanate from that interesting member of our solar family. As before, however, none of these supposed Martian radiograms possesses the slightest real indication of having come from the planet or of representing anything more mysterious than the miscellaneous clicks, crashes, squeaks and what-not which commonly animate our long-suffering ether.

Sensitive radio receivers, erected in England for the announced purpose of listening to Mars, obtained, as they did two years ago, an assortment of unusual and unexplainable noises. Inasmuch, however, as such unexplainable noises may be obtained without difficulty in much less sensitive radio receivers erected anywhere on earth, neither the astronomers nor the radio engineers are inclined to place any great reliance upon the British reports. An assortment of "psychic" gentlemen have also announced the receipt of direct messages sent to them from Mars telepathically or in similarly mysterious fashions. Naturally, scientists are disinclined to consider these reports otherwise than as material for amusement.

The real scientific investigations which have been conducted during the past six months in many of the world's great astronomical observatories have not yet been computed and announced except in a few instances. The planet Mars has been in unusually favorable position during 1926 for accurate astronomical observations. The distance sep-

arating it from the earth was slightly greater than at its last near approach in 1924. However, the planet this year was higher above the horizon, for northern observers, a fact which greatly facilitated telescopic observations.

Up to the date of writing this note, the only important Martian discovery announced by the world's observatories is the definite proof of the fact that the darker and lighter markings on the planet's surface are subject to change from time to time. One instance of this has been announced by Dr. E. M. Antoniadi, the experienced Martian observer of the Meudon Observatory, near Paris.\* Other changes, affecting different parts of the planet from those observed by Dr. Antoniadi, have been recorded by Dr. W. H. Steavenson, also an experienced observer and the Martian specialist of the great Royal Observatory of Great Britain at Greenwich.†

Dr. Antoniadi and Dr. Steavenson agree that the darker markings on Mars alter from year to year both in size and in position, these alterations being of exactly the character which they would disclose were the darker markings composed of vegetation. It is now coming to be accepted generally by astronomers that this is the explanation of the Martian dark areas. The changes observed this year are due, on this theory, to

\*Dr. Antoniadi's observations are referred to in a note entitled "News of Mars and of Jupiter" in *La Nature* (Paris), number 2740, supplement page 113 (October 9, 1926). Further observations at Meudon are summarized by M. Jarry-Desloges in "Contribution to the Study of the Planet Mars" (in French), *Comptes Rendus de l'Académie des Sciences* (Paris), volume 183, pages 1025 to 1026 (November 29, 1926).

†"Mars in 1926," by W. H. Steavenson. *Nature* (London), volume 118, pages 666-667 (November 6, 1926).

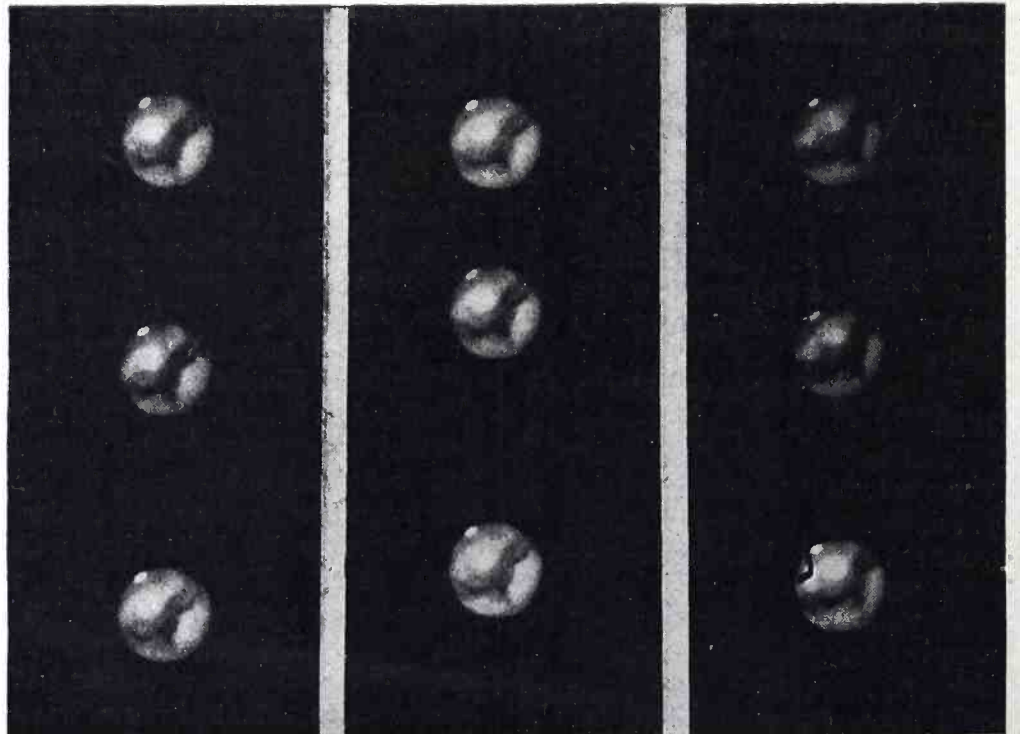

Yerkes Observatory

### MARS HAS LIFE—BUT PROBABLY NO RADIO

The darker and lighter markings on the surface of Mars are well shown in these reproductions of photographs made a few hours apart by the late Professor E. E. Barnard, using the great 40-inch telescope of the Yerkes Observatory. Changes in these markings observed during the present approach of Mars have convinced astronomers that the planet harbors living vegetation. There is no evidence of intelligent beings who might be trying to reach us by radio.

alterations in the average tracks of storms or in the prevailing directions of moisture-bearing winds. Such climactic changes would result, quite obviously, in the development of the areas of vegetation in somewhat different shapes and sizes.

It is probable that the combined observations of Mars during 1924 and 1926 will result in the definite acceptance by astronomers of the theory that Mars possesses, at the least, forms of life similar to our vegetation. Whether or not Mars harbors, in addition to this vegetation, anything that could be called animal life, or that could be considered similar to terrestrial intelligence, is still very much an open question. Still more doubtful is any possibility that Mars might be occupied by creatures acquainted with radio and either willing or able to attempt communication with us. Those radio enthusiasts who received this year, out of the trackless ocean of ether, the supposed mysterious signal "M" are, we fear, more the victims of their own enthusiasm than of any Martian scientist.

### A Voice Against Railway-Train Radio

AN argument which deserves consideration in connection with the numerous recent proposals for the use of radio on railway trains is urged by Dr. J. H. Morecroft in his well-known department "The March of Radio," in a recent issue of *Radio Broadcast*.\* Dr. Morecroft is not favorably impressed by the desirability of this extension of radio. Admitting that safety, as well as the convenient operation of trains, makes it desirable for some means of communication to be provided between the engineer and the rest of the train crew, Dr. Morecroft urges that this should be accomplished by means of wire lines, plugged together at the car couplings, instead of by radio.

The objection to radio is the possibility of interference with other radio operation and the general jamming of an ether already too full of radio impulses. A telephone system with detachable plugs at each car-end, in the same general manner as is now used for the air-hose, impresses Dr. Morecroft as being more suitable for this particular purpose. Although this Department has previously advocated the use of radio for railway train communication, it must be admitted that Dr. Morecroft's argument deserves careful consideration. His system retains, however, one important disadvantage now existing, and which a radio system might be arranged to cure. This is the impossibility of communication between the dispatcher's office, or other officials along the line, and the moving train.

### The Relation of Ether Waves to Psychic Phenomena

SIR OLIVER LODGE has been for years a consistent advocate of the idea, none too popular among the rank and file of scientific men, that the universe contains non-material mysteries which it is the business of science to investigate.

That the so-called "psychic" phenomena, if real, are in this field is one of Sir Oliver's beliefs; that the much-disputed ether is closely related to these phenomena he has several times suggested. Referring, in a recently published letter\*, to a certain mysterious, although disputed, power of divination supposed to be possessed by gifted individuals, Sir Oliver says:

"There is an etherial environment too; and it may be that that is the home of the subconscious, in the same sense as matter is the home of the conscious part of our minds.

"I am myself inclined," he continues, "to think that we shall find ourselves more directly or immediately concerned or connected with the ether than we are with matter, in spite of the fact that matter looms so large to our familiar senses."

Most scientific men would be sceptical of the idea. Even the existence of the ether is doubted.

Nevertheless, Sir Oliver's ideas are always interesting. In the past, many of them, especially in radio, have proved to be true.

\* "The Dowsing or Divining Rod," by Oliver Lodge. *Nature* (London), volume 119, page 387 (March 12, 1927).

### A New Biography of Electrons

THE lives and loves of atoms and electrons have become so important in many radio devices besides the vacuum tube that any new summary of the rapidly advancing knowledge in this realm of physics has its proper place in every radio library. For about two years Dr. Karl K. Darrow, of the Bell Telephone Laboratories, has been contributing to the publications of the telephone industry articles describing current advances in atomic physics and related fields. Some of these articles have now been collected, revised and expanded into a book which every physicist will find of interest.† Dr. Darrow has an unusual gift of clear and interesting expression without the sacrifice of accuracy. It is unfortunate that limitations of space prevented the inclusion in the new book of some of Dr. Darrow's papers dealing with radio waves and their close relatives.

† "Introduction to Contemporary Physics," by Karl K. Darrow. Published by D. Van Nostrand Company, New York City. 449 pages, 1926, \$6.00.

# VARION

## Current Supply Unit

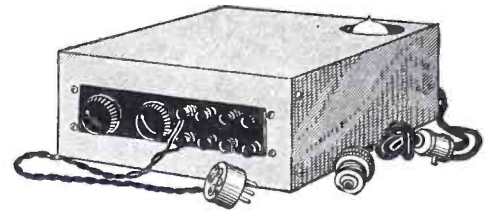

The parts making up the Varion Kit are manufactured by these leading manufacturers:

AMERICAN TRANSFORMER CO.  
CENTRAL RADIO LABORATORIES  
H. H. EBY MANUFACTURING CO.  
SANGAMO ELECTRIC CO.  
WARD LEONARD ELECTRIC CO.

200 volts output at 60 m. a. drain. 2 C-bias voltages, one variable from 0-45 volts. A-current for 171 power tube available if desired. 16 mfd. of condensers assures reserve energy necessary for good reproduction.

At 100 m. a. drain, Varion passed the Raytheon Laboratories standard hum test.



Raytheon B H Rectifier



Centralab Heavy Duty Resistor



Eby Ensign Binding Posts

## COMPONENT PARTS

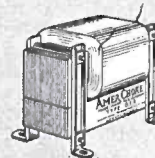

AmerTran Amerchoke #854

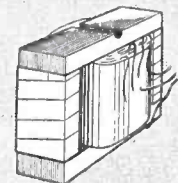

AmerTran Special Transformer, designed exclusively for Varion Current Supply Unit



Sangamo Wound Condenser Block

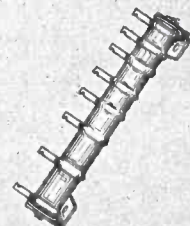

Ward Leonard Vitreous Enamelled Permanent Resistor

APPROVED BY RAYTHEON LABORATORIES

\* "Where Short Waves Are Not Needed," *Radio Broadcast* (Garden City, N. Y.), volume 10, page 149 (December, 1926).

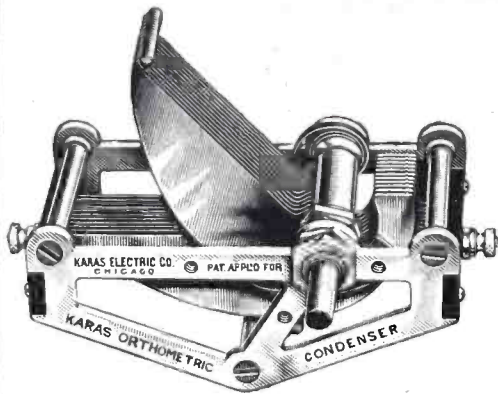

## KARAS ORTHOMETRICS SPECIFIED FOR THE AERODYNE RECEIVER

THREE Karas .00037 Mfd. 17 Plate Orthometric Variable Condensers are specified by the Aero people for use in constructing the super-sensitive 5-Tube Aerodyne Receiver. This famous receiver has won a unique place for itself because of its remarkable performance and extreme selectivity under the most adverse conditions. Distant stations can be brought in through the heaviest kind of a local barrage; tuning is remarkably sharp.

The Aerodyne not only is an easy receiver to build, but it also is extremely easy to tune. The wide, even separation of wave lengths afforded by Karas Orthometrics makes tuning a pleasure. These condensers actually eliminate crowding from every part of the dials. Every point on the dial from 1 to 100 thus becomes a separate broadcasting wave length. For Orthometrics are strictly straight frequency line variable condensers. Each station is equally separated from its adjoining stations in both directions by 10 kilocycles, exactly as wave lengths are allocated by the Government.

### Precision Built—the Karas Way

Orthometric Condensers have die-stamped solidly braced plates and frames of finest quality brass, and both rotor and stator plates are soldered at every contact point. Frame and rotor plates are grounded to eliminate body capacity. Rotor is held in cone bearings which permit easy, smooth action, yet with permanent alignment. Hard rubber dielectrics placed well outside of the effective electrostatic field eliminate absorption losses. Tests have shown that Orthometrics have no measurable losses—and resistance has been reduced to the absolute zero point within the limits of modern engineering.

### Order Orthometrics for Your Aerodyne Today

Your dealer carries Orthometrics or can get them for you. If he is out of stock and you are in a hurry you may order direct from this advertisement by filling out and mailing the coupon. SEND NO MONEY. Merely hand the postman the price of the condensers plus a few cents postage. Start building your Aerodyne NOW.

**KARAS ELECTRIC CO.**  
1025 Association Building  
CHICAGO

Karas Electric Co.,  
1025 Association Building, Chicago.  
Send me 3 Karas 17 plate .00037 mfd. Orthometric Condensers, price \$6.75 each, for which I will pay postman \$20.25, plus postage, upon delivery.

Name.....  
Address.....  
City..... State.....  
(We prepay postage when cash accompanies order.)



## BROADCASTS

### An Important Short-Wave Patent

WHILE our national law makers were fighting over the Radio Bill and while the newly-created Radio Commission was giving serious thought to the question of who should be allotted wavelengths, Dr. Reginald A. Fessenden, of Boston, Mass., of "heterodyne" fame and a distinguished radio scientist, was recently granted patent No. 1,617,240 for a method of using wavelengths between 1 meter and 50 meters for directive signaling, a waveband which undoubtedly is being accorded serious interest by members of the "Radio Group."

Dr. Fessenden states that his invention has for its object greater reliability of operation and the elimination of errors and disturbances.

During the years 1899-1918, Fessenden made many hundreds of experiments on methods of radio signaling on wavelengths varying from a few centimeters to more than six thousand (6000) meters. An account of these experiments, including the results obtained, was published by him, and will be found in the *Proceedings*

of the American Institute of Electrical Engineers, November, 1899, and July 1908; *The Electrical Review*, London, May 11th and 18th, 1906, and February 15th, February 22nd and March 1st, 1907, and *The Electrician*, London, February 15th and 22nd, 1907, and December 19th, 1919.

Shortly after 1914, in connection with problems relating to aeroplane and submarine signaling where high masts, and therefore long wavelengths, could not be used, Dr. Fessenden investigated his records on the lower wavelengths—those between 300 meters and a few centimeters. As the use of wavelengths of a few centimeters was considerably worse than the use of wavelengths of 300 meters, he wished to know at exactly what point the diminution of efficiency began to occur.

To his great surprise, he discovered—what had hitherto been unsuspected by himself, and apparently by everyone else—that there was a good and efficient band of wavelengths lying between 50 meters and 1 meter.

He had, in the course of his experiments—and so, no doubt, had others—used wavelengths lying in this band, of

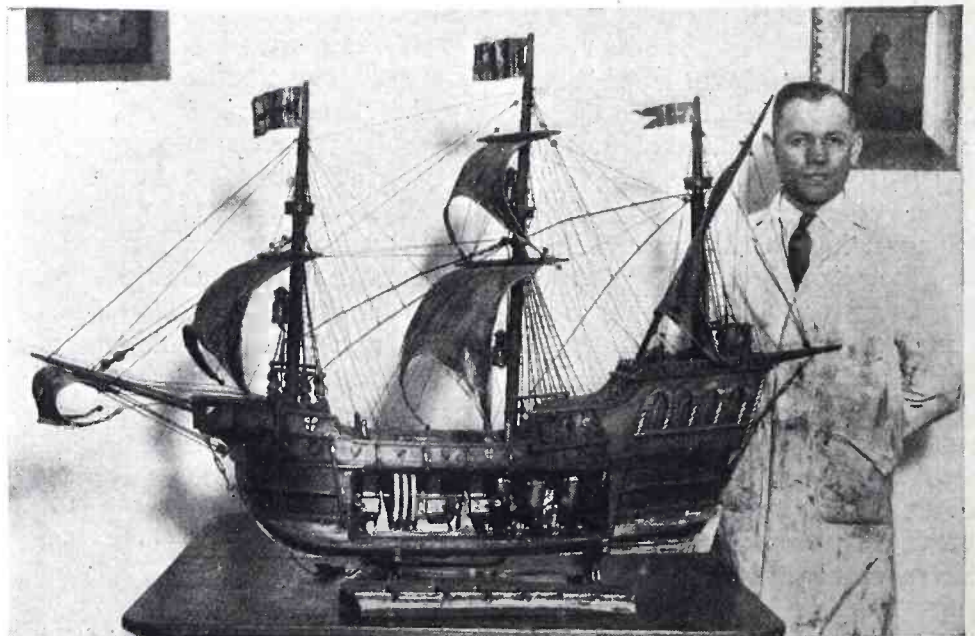

Keystone

### THE CRAFTSMAN'S SKILL COMBINES WITH THE RADIO ART

How a radio receiver may be encased in a work of art is evidenced in this beautiful model of Columbus' flagship SANTA MARIA, within which a complete five-tube receiving set is installed. Mr. Karl Bauer, seen at the right, is the experimenter who created this unique set.

the order of 5 meters, but had never made the discovery of their extra efficiency, having attributed this efficiency to accidental variations; and it was not until the mass of results collected between 1899 and 1918 were tabulated and compared that he made the discovery.

The results could not be published at the time, as early in 1915 he received orders from both the United States Navy Department and from the War Department to the effect that inventions that have military uses should not be communicated by him to anyone except to certain designated officials, and the orders were that such secrecy must be maintained until the instructions were canceled "by competent authority." These orders were not canceled until several years after the close of the war.

The reason why this particular band is "transparent" is not known definitely by him, and so far no explanation has been given which has been accepted by scientists generally. There are no doubt a number of reasons, but whatever they may be, it is now certain, from the many recorded results of investigations made since he first disclosed the fact, that Dr. Fessenden's results are correct and that there is a band of wavelengths which is abnormally favorably to transmission and which is of the order of 5 meters.

The three claims allowed to Dr. Fessenden are as follows:

1. The method of obtaining increased transmission efficiency in directional radio signaling which comprises transmitting the signals by electric waves shorter than 50 meters in length and longer than 1 meter in length, such waves having a relatively high transmission characteristic whereby said signals are transmitted with much less disturbance by injurious atmospheric effects.

2. The method of obtaining increased transmission efficiency in directional radio signaling which comprises transmitting the signals by means of electric waves, of a band of wavelengths characterized by a high transmission efficiency, said band of wavelengths lying between 50 meters and 1 meter in length.

3. The method of obtaining increased transmission efficiency in directional radio signaling which comprises transmitting the signals on those wavelengths between 50 meters and 1 meter which effect a high transmission efficiency.

—WM. G. H. FINCH.

\* \*

### Broadcast Station Changes Not Reported This Month

DUE to the fact that all licensing and relicensing of broadcasters was held up during April, pending the decision of the Federal Radio Commission, no reports of broadcast changes can be made in this issue of POPULAR RADIO. The reports will begin again as soon as the Commission begins issuing licenses.

## Is your receiver up to the 1927 Standard of Tone Quality?



Type 285  
Audio Transformer  
285D (1 to 3 ratio)  
285H (1 to 6 ratio)  
PRICE \$6.00 each



Type 373  
Double Impedance Coupler  
Price \$6.50 each

A great many broadcast receiving sets in operation to-day are not up to the 1927 standard of tone quality. Yet, in other respects, such as sensitivity and selectivity they are reasonably efficient. If you are operating a receiver which answers this description, here are two suggestions for improving your audio amplifier, so that you may enjoy better radio reproduction without buying or building a new receiver:

1. Replace your old audio amplifier units by two General Radio Type 285 Transformers. A Type 285D (1 to 3) is recommended for the first stage, and a Type 285H (1 to 6) for the second:
- or Substitute for your present amplifier a combination consisting of two stages of double impedance coupled and one stage of transformer coupled amplification. This combination requires two General Radio Type 373 Double Impedance Couplers and one Type 285D Transformer.
2. Use a UX-171 or CX-371 tube in the last audio stage. This tube will effect an improvement in tone quality due to the greater volume it will produce without overloading. When this tube is used, however, a device such as the Type 367 Output Transformer or Type 287A Speaker Filter is required to protect the loudspeaker from the flow of direct current.

Diagrams of the above mentioned amplifier circuits and folders fully describing the Type 285 Transformers, Type 373 Double Impedance Coupler, Type 367 Output Transformer, and Type 387A Speaker Filter will be sent upon request.

General Radio Co., Cambridge, Mass.

**GENERAL RADIO**  
**PARTS AND ACCESSORIES**

TRUPHONIC STANDARD  
AMPLIFYING TUBES ARE  
DESIGNED ESPECIALLY FOR  
TRUPHONIC AUDIO AMPLIFICATION—  
AN H. P. DONLE DEVELOPMENT.

IN USING THIS MOST EFFICIENT  
FORM OF AMPLIFICATION—WHETHER  
BUILT INTO YOUR SET BY THE  
MAKER OR AS A SEPARATE UNIT—  
THE HIGHEST EFFICIENCY IS  
REACHED BY THE USE OF THESE  
TUBES.

LITERATURE ON THIS AND OTHER PRODUCTS  
SENT ON REQUEST

THE DONLE-BRISTOL CORPORATION  
56 CAMBRIDGE STREET  
MERIDEN—CONNECTICUT—U. S. A.



**Marvelous Townsend "B" SOCKET Power Unit**  
**Replaces "B" Batteries**

**Complete only 4.95**  
 \$1.00 down Balance C.O.D.

Enjoy greatly improved reception and forget unreliable "B" Battery nuisance. Every part in the Townsend "B" Socket Power Unit is made and assembled in our own factory. That is why we can give you a high grade instrument at a startlingly low price, with a real guarantee of money back if not satisfied. Delivers up to 100 volts on any set, on direct or alternating current—any cycle. Full tone, clarity and volume. Just read these enthusiastic endorsements.

London, Ont., Canada.  
 I am very well pleased with your Eliminator. Since using it I have had many more stations and greater distance.  
 —C. E. Bond.

Dewey, Okla.  
 I am more pleased with your Eliminator than I was with batteries.  
 —B. E. Doureton.

Renovo, Penn.  
 I have received the Townsend Eliminator and it works fine.  
 —Clarence Witchey.

Great Barrington, Mass.  
 I have given your Eliminator a good test and find it very good.  
 —H. M. Miles.

Tested and approved by America's leading Radio authorities—Radio News and Popular Radio Laboratories.

**ORDER TODAY!**

Simply fill out the coupon and slip it into an envelope with only \$1.00 and mail at once. Your Townsend "B" Socket Power Unit will be sent promptly. Deposit only \$3.95 plus postage with the postman. Try out for 10 days—then if not delighted with improvement in reception, return it to us and purchase price will be refunded.

**TOWNSEND LABORATORIES**  
 713 Townsend St. Dept. 19 Chicago, Illinois

**10 Days FREE TRIAL**  
 You are the Judge!  
**Attach only \$1.00 to this Coupon!**  
**SEND TODAY**

TOWNSEND LABORATORIES.

713 Townsend St., Dept. 19  
 Chicago, Ill.

Gentlemen: Attached find \$1.00. Kindly send at once Townsend "B" Socket Power Unit, C. O. D., for \$3.95, plus postage, on guaranteed 10-day free trial.

Name.....

Address.....

City.....State.....

**Broadcasting Stations Warned Against Quacks**

QUACKS are turning to radio as a new and modern means of extracting money from the gullible, it is indicated in a warning sent to broadcasting stations throughout the country by the National Better Business Bureau and its affiliated local bureaus. These advices have done much to protect the listener-in from inspired promotions. A recent warning sent to Washington, D. C., broadcasting stations by the local bureau is directed against a western cancer institution which has been criticized by medical associations as a "quackery." This institution has recently appealed to radio stations in the country for space on the air. Reports received here indicate that the promoters are meeting with very little success, due largely to the notices sent out and to the caution exercised by radio station managers to protect their unseen audience.

**A Radio Medical Code for the Sea**

AN international radio medical code to aid doctorless ships at sea in the diagnosis and treatment of diseases is being prepared by the American Code Company, in collaboration with steamship lines and New York medical men. The passing of medical advice from shore to ship and from ship to ship, first practised by the Seaman's Church Institute, has grown to such an extent that some universally understandable code is needed to make this sort of communication easy and exact. According to F. A. Hall, a representative of the American Code Company, the outline of

a book to be used in treating diseases in accordance with advice received by the code has been prepared.

**Labor Opposes Air Property Rights**

"ORGANIZED labor is unalterably opposed to property rights on the air, maintaining that this new medium of communication and entertainment must be developed and utilized for the benefit of all the people and not as a source of profit for corporation, private or political interest." This is the substance of an address delivered before the Federal Radio Commission by Edward M. Nockles, representing the labor cooperative broadcasting station WCFL. Mr. Nockles maintained that the medium of radio communication—the ether—was not the product of capital or labor, but a "God-given" natural resource; hence its use should be determined by the great body of radio listeners, and not by any moneyed group of promoters or advertisers.

**The Decline of Interest in the Broadcasting of Jazz**

IN answer to a questionnaire sent to broadcast fans three years ago, according to Mr. Frank A. Arnold, director of development of the National Broadcasting Company, 75 per cent of those who answered expressed a preference for jazz. In answer to a similar questionnaire sent out recently, only 5 per cent expressed a preference for this form of broadcast entertainment. The answers indicated a marked inclination toward programs made up of classical and semi-classical music and educational features.



Keystone

**GERMAN OPERA FOR A GERMAN PFENNIG**

Radio does all the work for this 1927 model of Berlin organ grinder; all he need do is tune in his portable receiver on a good broadcast program and then stand by while the coins drop. It may not be as romantic as the old hand organ, but it's a great deal easier—on the organ grinder and on the audience.



## For the Beginner FREE HAND BOOK with Popular Radio

Kendall Banning, Editor, and Laurence M. Cockaday, Technical Editor of POPULAR RADIO, have compiled a book that will prove to anyone that he can build a set which will give distance, selectivity and tone volume, and at the same time a very definite basic knowledge of radio.

### BUILD YOUR OWN SET AND SAVE MONEY

In "How to Build Your Radio Receiver," you will find complete specifications, construction diagrams, photographs and instructions for building all of the following sets:

- A \$5 Crystal Set
- The Haynes Single-Tube Receiver
- A Two-Stage Audio-frequency Amplifier
- The Cockaday 4-Circuit Tuner
- A 5-Tube Tuned Radio-frequency Receiver
- The "Improved" Cockaday 4-Circuit Tuner
- The Regenerative Super-Heterodyne Receiver

### ADVISORY SERVICE ALSO FREE

POPULAR RADIO maintains a big modern laboratory with a trained staff of investigators under the personal supervision of Mr. Cockaday. This Laboratory is always available through our Technical Service Bureau to answer, free to subscribers, by personal letter, any problems you encounter which are not answered in either the "Handbook" or the magazine.

### SPECIAL BOOK OFFER

You can secure a copy of "How to Build Your Radio Receiver" FREE and have all the privileges of the Technical Service Bureau without additional expense, if you will send a remittance of \$3.00 in full payment of 12 months' subscription for POPULAR RADIO. (Or as an alternative, you may have the book and privileges of the Technical Service Bureau with POPULAR RADIO for 7 months only—for \$2.00. A two dollar bill will do.)

Remember you take no chance—we will refund your money in full if you are not more than satisfied.

## POPULAR RADIO

Department 35

627 West 43rd Street, New York

## FREE SIMPLIFIED BLUE PRINTS

You know how helpful, interesting and practical POPULAR RADIO is. You fully appreciate that at \$3.00 a year it is a real bargain. Consequently, you should find it easy to convince one, two or more of your friends, who are not now subscribers, of the unusual value when any one of these sets of Simplified Blueprints is offered free with their twelve months' subscription for POPULAR RADIO at the regular price of \$3.00. In addition to the Blueprints given to your friends we will allow you one set free for each new subscription you send us with a \$3.00 remittance. Five new subscriptions and remittance of \$15.00 would entitle you to five sets free.

Only one set of Blueprints free with a renewal subscription whether your own or a friend's.

POPULAR RADIO, INC., Dept. 35

627 West 43rd Street, New York City

Enclosed is my remittance of \$..... covering ..... annual subscription for POPULAR RADIO (names on sheet attached). Send me set(s) checked below.

- |                                     |                                     |
|-------------------------------------|-------------------------------------|
| <input type="checkbox"/> Set No. 18 | <input type="checkbox"/> Set No. 24 |
| <input type="checkbox"/> Set No. 22 | <input type="checkbox"/> Set No. 25 |
| <input type="checkbox"/> Set No. 23 | <input type="checkbox"/> Set No. 26 |
| <input type="checkbox"/> Set No. 27 |                                     |

Name.....

Address.....

Foreign postage 50c extra. No extra for Canada.

## Transoceanic Calls Heard

THE following stations were received and logged at the amateur station of J. Mousset (EF-8JMS) at 14 Rue de Beaune, Paris, France, with a cage antenna, 8 by 6 meters, and a Bourne low-loss receiver:

- U-10R—Nov. 9, 1926; signal strength R-4; calling CQ on 41 meters; good note; no interference or fading;
- U-1AAR—Nov. 9, 1926; signal strength R-6; calling CQ on 40 meters; good note; no fading;
- U-9XL—Nov. 12, 1926; signal strength R-6; calling IDA on 41 meters; good note; no fading;
- U-9GEW—Nov. 12, 1926; signal strength R-8; calling CQ on 39 meters; good note; no fading;
- U-2GS—Nov. 13, 1926; signal strength R-4; calling CQ on 40 meters; good note; no fading;
- U-2NZ—Nov. 13, 1926; signal strength R-7; calling CQ on 40 meters; good note; no fading;
- U-8SF—Nov. 13, 1926; signal strength R-7; calling CQ on 40 meters; good note; no fading;
- U-3JO—Nov. 13, 1926; signal strength R-5; communicating with F-8YOR on 42 meters; good note; no fading;
- U-4IC—Nov. 13, 1926; signal strength R-5; calling U-4TX on 40 meters; good note; no fading;
- U-8ADM—Nov. 13, 1926; signal strength R-4; calling CQ on 41 meters; good note; no fading;
- U-3AU—Nov. 14, 1926; signal strength R-4; calling CQ on 42 meters; good note; no fading;
- C-3AFO—Jan. 17, 1927; signal strength R-7; good note on 40 meters; no fading;
- C-3ADC—Jan. 17, 1927; signal strength R-4; good note on 40 meters; no fading;
- C-3ACI—Jan. 21, 1927; signal strength R-3; good note on 40 meters; no fading;
- C-3AFB—Jan. 24, 1927; signal strength R-5; good note on 39 meters; no fading;
- C-3AEA—Feb. 2, 1927; signal strength R-2; weak signals with fading;
- C-3AM—Feb. 3, 1927; signal strength R-5; good note on 40 meters; no fading;
- C-3BH—Feb. 7, 1927; signal strength R-8; very fine, strong note on 37.3 meters; no fading;
- C-3AGB—Feb. 11, 1927; signal strength R-2; calling on 39.8 meters; weak signals accompanied by fading.

THE amateur station of Russell S. Morton (U-3CEC), using an antenna and counterpoise and a three-circuit regenerative detector set with one stage of low-frequency amplification, logged station OA-2YJ, April 10, 1927. Signal strength R-3; rectified AC note; very bad static.

## A Radio Slander Law

It is reported that Congressman Dickstein of New York will introduce at the next session of Congress an amendment to the 1927 Radio Law to prevent the broadcasting of matter known to be false or defamatory to any individual, organization, race or religious belief.

## The Official BROWNING-DRAKE KIT SET



THE life of the average radio design offered to the home builder has been a few months. Rarely has a design endured over a year without undergoing radical changes. Browning-Drake's popularity has increased with every passing year, ever since its presentation in the summer of 1924. Three years have elapsed, yet no radical changes or improvements in the Browning-Drake design have been necessary to maintain its popularity.

This April, a standard design known as the Official Browning-Drake Kit Set, incorporating refinements to take care of present broadcasting conditions and make the set adaptable to power units and "B" eliminators, was presented to the radio public. This Official Kit Set is now standard on the market.

To obtain the rare Browning-Drake performance, be sure you get the Official Browning-Drake Kit, Foundation Unit, Neutralizer and Resistance Cartridge, products of the Browning-Drake Corporation, together with the approved parts of associate manufacturers, which are handled by reputable radio dealers. Get your parts TODAY and build the Official Browning-Drake Kit Set.

DEALERS: Twice as many Browning-Drake Kits are sold as those designed for any other set. We will be glad to forward the name of our nearest jobber.

Browning-Drake Corp.  
Brighton Mass.

**BROWNING-DRAKE**  
RADIO

# Leutz-Universal Transoceanic

— A Powerful Nine Tube Receiver —

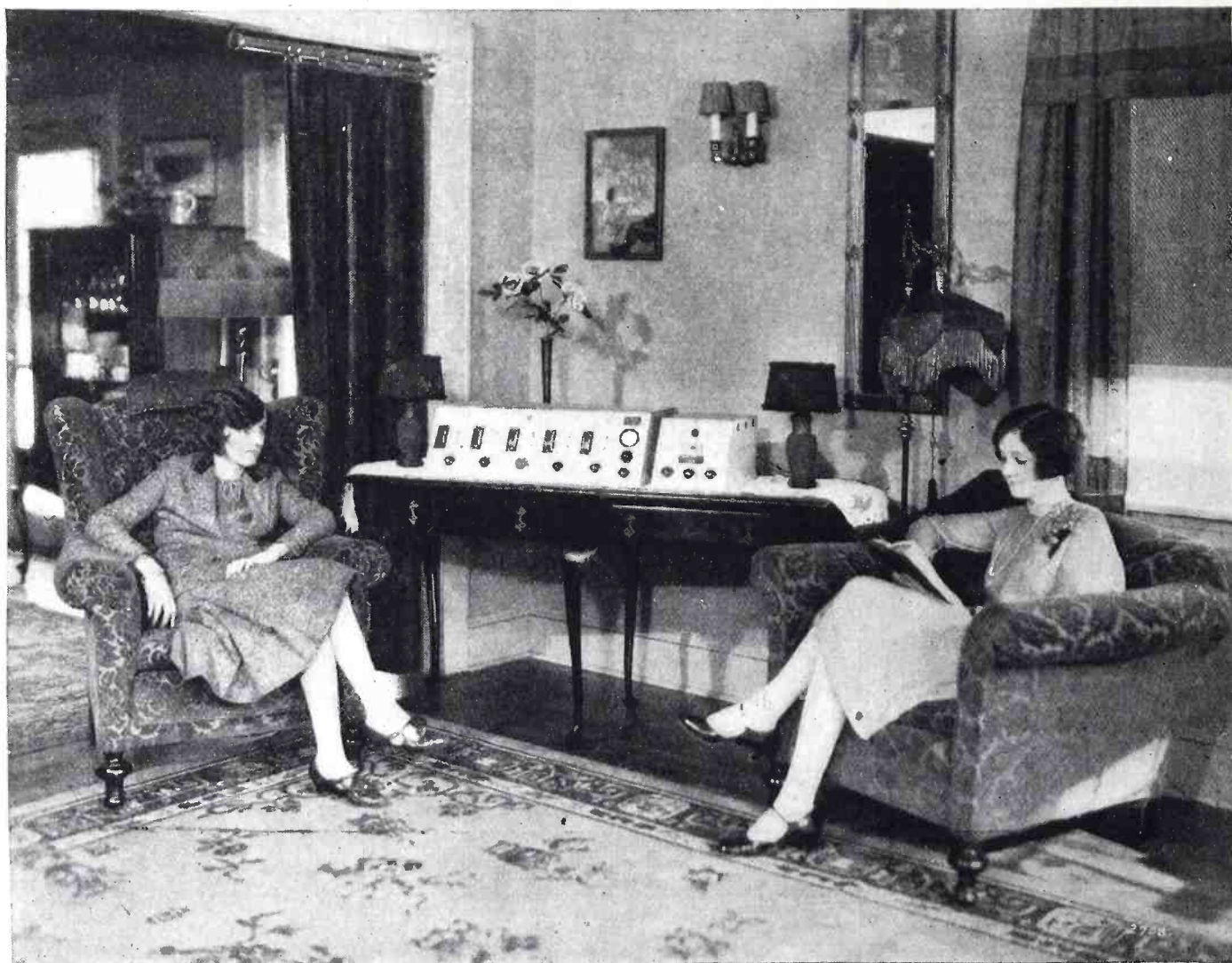

*Table Installation Universal Transoceanic and Current Supply*

Universal Transoceanic Receivers have now been shipped to every State in the Union, every Province of Canada, and to Mexico, Ecuador, New Zealand, Australia, Spain, Portugal, Italy and many other foreign countries.

Reports from customers fully substantiate our broad claims in every respect.

New literature covering this model is now being mailed to our regular mailing list.

We will be glad to send you a copy upon request.

**C. R. LEUTZ, Inc.**

**6th and Washington Aves., Long Island City, New York, U.S. A.**

**CABLE: EXPERINFO**

*Snap a switch*

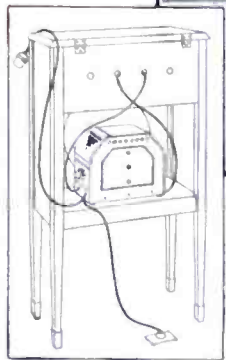
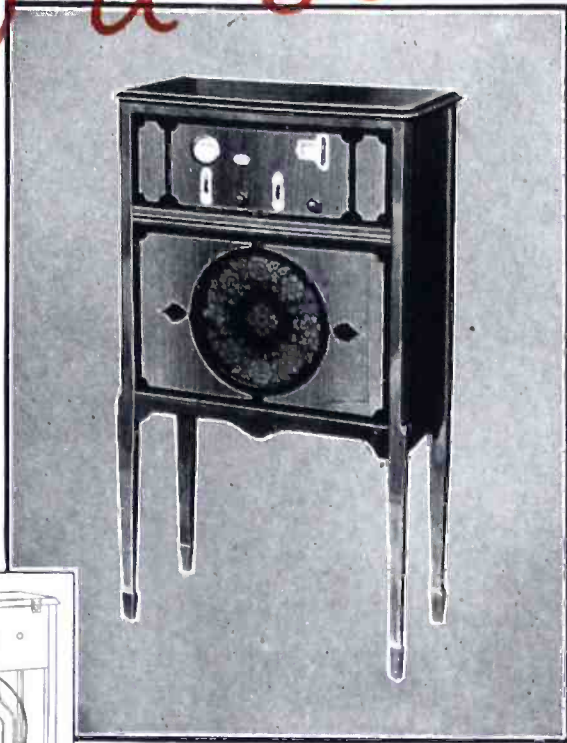

The 6 tube Console pictured above stands 40 inches high—contains skillfully engineered shielded circuit—single drum dial control. Musicone built in. Price without tubes and power unit—\$95.

- No more batteries
- No battery charger to watch
- No batteries to water
- No failure of the power plant just as you sit down to a fine program
- No upsetting the house to have the radio serviced
- No apologies to make to callers that the batteries have just run down
- No batteries to recharge
- No batteries to renew

## A B and C Power from the light socket for the latest model Crosley A C Radios

This power unit weighs 13 lbs., stands 9 inches high and is 4 inches wide and requires no more attention than a vacuum cleaner or an electric iron. It transforms mechanically ordinary 110 volt 60 cycle house current into smooth, quiet radio energy. *No interfering hum!*

Price \$50

Crosley radios especially designed to use this battery eliminator are the 6 tube AC-7, a neat table model of the famous Crosley single drum control receiver selling at \$70, and the 6 tube console model AC-7-C pictured above at \$95.

*Prices slightly higher west of the Rocky Mountains.*

Crosley Musicones \$9.75 and \$14.75. Write Dept. 16 for descriptive literature.

**THE CROSLLEY RADIO CORPORATION**

Cincinnati, Ohio.

Powel Crosley, Jr., Pres.

Crosley sets are licensed under Armstrong U. S. Patent No. 1,113,149 or under patent applications of Radio Frequency Laboratories, Inc., and other patents issued and pending.

TO SET

**CROSLLEY**  
 BETTER ... COSTS LESS  
**RADIO**

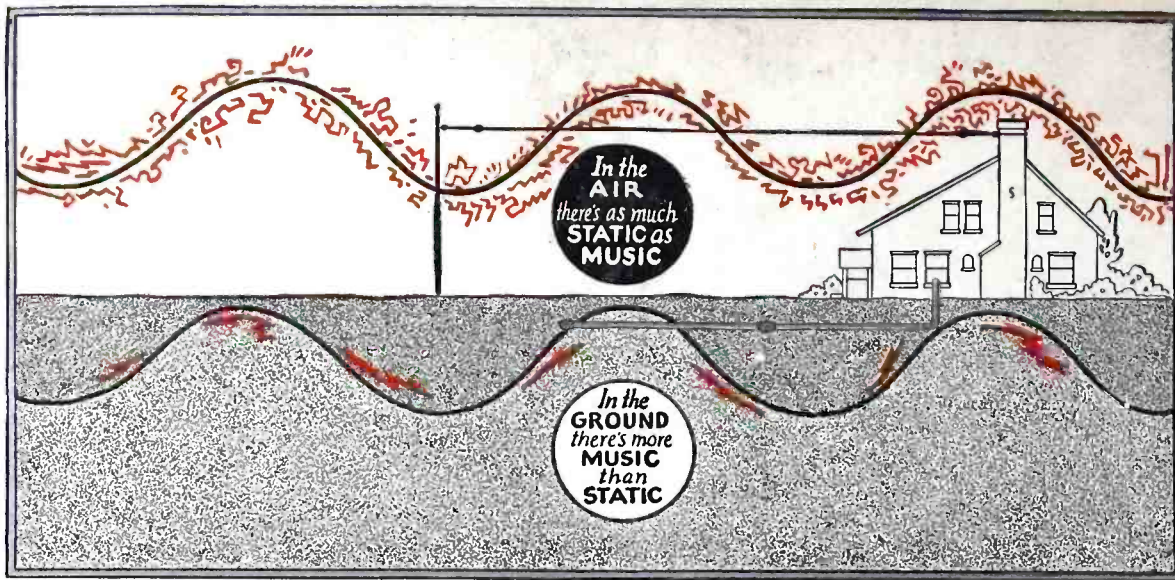

# Use **STATIC-FREE** Ground Waves Get Distance Loud and Clear all Summer

**SUBANTENNA**—new underground Antenna System astounds listeners and laboratories with loud, clear reception on hot summer nights when old style aerial brings in unwanted noise

**I**MAGINE the intense pleasure of bringing in your favorite distant station loud and crystal clear—right thru summer's curtain of static and noise! But you don't have to be content with merely imagining it. Real DX in summertime—real big volume—amazing clarity—much better selectivity—all these are now available to you—and, with your present set. Simply connect your set to **SUBANTENNA**—the marvelous new underground antenna system that uses filtered ground waves instead of noisy air waves.

**Read PROOF that SUBANTENNA is the Greatest New Thing in Radio**

### Static Is No More

"I have received the Subantenna. My grandson installed it. **STATIC IS NO MORE.** Am well satisfied. I can tune in stations I never could coax out of the air even though I had a long aerial."—A. E. F., Kans.

### Better Selectivity—No Static

"It has always been impossible for me to eliminate the Drake Hotel. I was told that Subantenna would enable me to do this. Although skeptical, in view of many similar claims made by other manufacturers of radio accessories, I had one of the Subantennas installed. The results have been most satisfactory, in that I have not only been able to

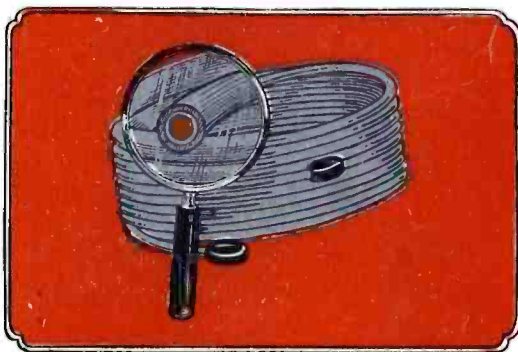

get every station in Chicago of any consequence, when the Drake was on the air, but out-of-town stations as well. In addition I am able to report that static, which was a source of much annoyance before, has been entirely eliminated so far as I am able to observe."—R. L. P., Chicago.

### Michigan Gets California

"I have had KFI California several times and go all over U. S. A. to Portland, Maine. You have the goods. It is far better for volume and tone on loud speaker than outside aerial."—C. J. S., Mich.

### Why SUBANTENNA Makes Every Night a Good Radio Night

In summer *air*, the ratio of static strength to signal strength favors static. The "noise" is so much greater than the broadcast signal that it sometimes hides the

music you wish to hear. That's why you don't get distance in the summertime. But, when you use **SUBANTENNA**, the situation is just reversed. For, in the ground, the ratio of static strength to signal strength favors the latter. In fact, there is so little static in the ground that the broadcast signal easily dominates it, with the result that you don't hear the static. Radio research men have long known this fact, but no device had ever been perfected by which ground waves could be used. Now, however, you have **SUBANTENNA**—a great new device which makes radio, for the first time, an all year 'round pleasure.

### Eliminates Lightning Risk

Not only will **SUBANTENNA** give you loud, clear reception in summer—not only will this remarkable invention better the selectivity of your set—but it also completely eliminates the lightning hazard. With **SUBANTENNA** you can go right on listening in during the most severe electrical storm without fear of attracting lightning or damaging your set.

## FREE TRIAL

### Make This Convincing Test

Install **SUBANTENNA**. Leave your old aerial up. Select a bad night when DX is almost impossible with the ordinary aerial. Make a comparison station for station, connecting first your aerial, then **SUBANTENNA**. If from stations that are just a mess of jumbled noise with the old aerial, you don't get reception that rivals local in sweetness and clarity the instant you switch the **SUBANTENNA**, this test won't cost you even a single penny. Send coupon at once for scientific explanation of **SUBANTENNA** and for particulars of **GUARANTEE** and **FREE TRIAL OFFER**. Send **COUPON NOW!**

# SUBANTENNA

**Underground Antenna System**

**CLOVERLEAF MFG. CO.**

2714 W. CANAL STREET

CHICAGO, ILLINOIS

## CLIP AND MAIL AT ONCE

Cloverleaf Mfg. Co.,  
2714-W Canal St., Chicago.

Tell me all about **SUBANTENNA**, your unqualified, unconditional guarantee and your **FREE TRIAL OFFER**.

Name.....

Address.....

Listen to **SUBANTENNA** Static Eliminators over **KYW Chicago** 536 meters every Wednesday night 7:30 to 8 P. M. Central Daylight Saving Time