

Popular Radio

25¢

MARCH
1926

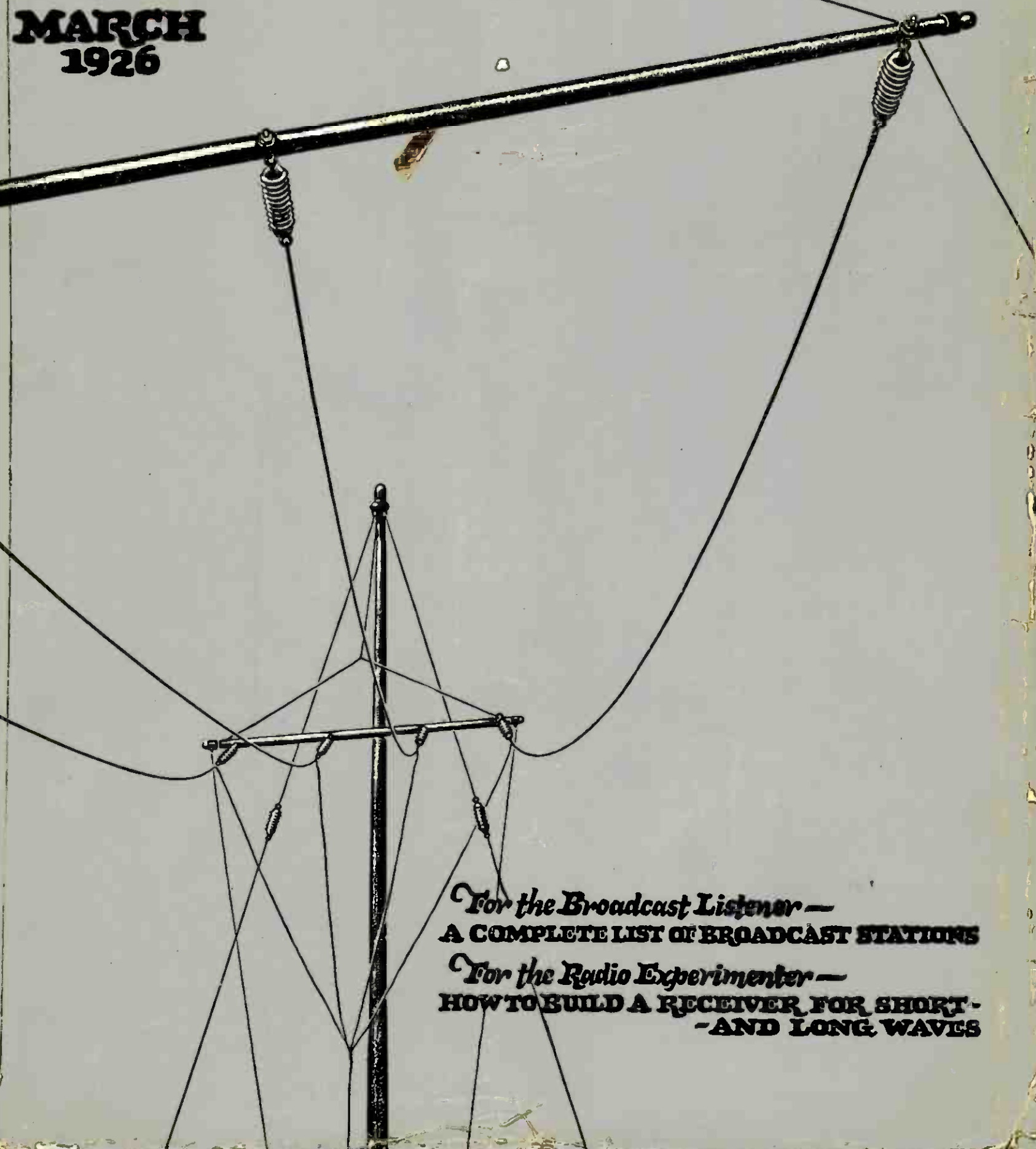

For the Broadcast Listener —
A COMPLETE LIST OF BROADCAST STATIONS
For the Radio Experimenter —
**HOW TO BUILD A RECEIVER FOR SHORT-
-AND LONG WAVES**

130,000 times better

One of the great steps forward in the development of the Radiotron was the evolution of the X-L filament.

When you tune in to clear reception, do you know that a stream of electrons leaping from a glowing filament is the current which, translated into sound, you hear as a fine symphony, a jazz orchestra, a clever story?

The more electrons thrown off at a given temperature, the longer the tube lasts, and the longer the batteries last. The X-L filament in Radiotrons UV-199 and UV-201-A throws off, at operating temperature, 130,000 times as many electrons as an ordinary tungsten filament. In one sense, therefore, the X-L filament is 130,000 times better!

And this filament means stability, too—and silent operation. And it keeps its efficiency practically to the end of its life.

Watch for the RCA mark on every tube you buy, and know that you have the latest, most perfected tube, as well as the most accurately made.

Radiotron UV-199

is the standard tube for dry battery sets. UX-199 is exactly like it, but has a new base.

Radiotron UV-201-A

is the standard tube for storage battery sets. UX-201-A is exactly like it, but has a new base.

RADIO CORPORATION OF AMERICA
New York Chicago San Francisco

RCA Radiotron

MADE BY THE MAKERS OF RADIOLAS



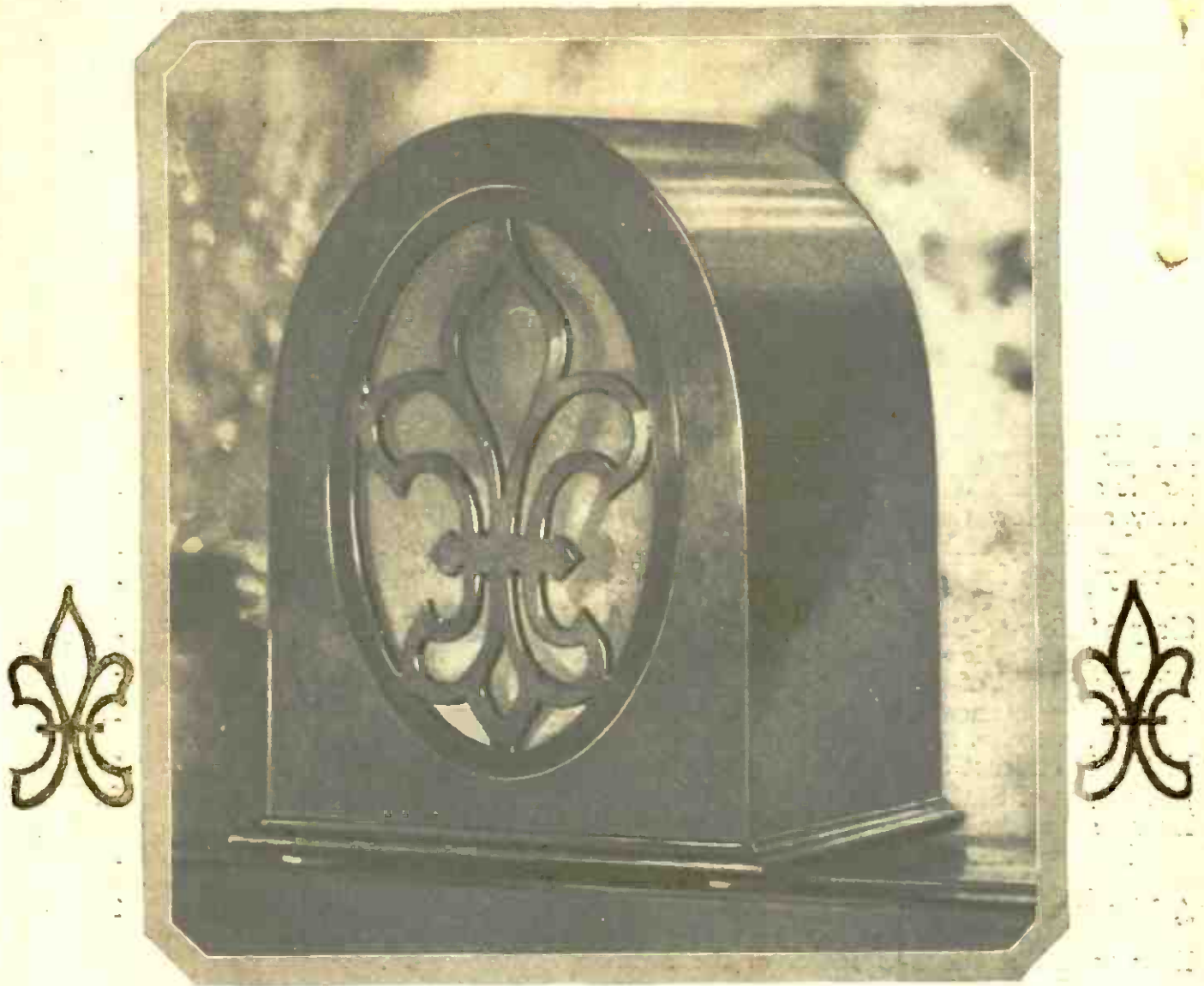

Brandes Cone Speaker

A truly decorative bit of furniture concealing a speaker of remarkable qualities—faithful, natural. Low and high notes gain new charm. Greater volume. A deluxe product, the result of 17 years of research and experience in radio acoustics.

Brandes

experts in radio acoustics since 1908.

All apparatus advertised in this magazine has been tested and approved by POPULAR RADIO LABORATORY

POPULAR RADIO

EDITED by KENDALL BANNING



FOUNDED 1911

CONTENTS for MARCH, 1926

VOLUME IX	(Cover design by Frank B. Masters)	NUMBER 3
A Phenomenon in Radio Reception.....	FRONTISPIECE	
A New Theory of Wave Transmission.....	<i>E. F. W. Alexanderson</i> ..	Page 207
Radio as a Life Work.....	<i>Pierre Boucheron</i>	213
Why and How the Milliammeter Increases the Efficiency of Your Set.....	<i>Maurice M. Osborne</i>	220
Handy Tools for Radio Fans.....	<i>The Technical Staff</i>	223
No. 10: The Scriber		
Simple "How-to-Build" Articles for Beginners... ..	<i>Laurence M. Cockaday</i>	224
No. 15: How to Build a Three-tube Four-circuit Tuner		
The New Lord of the Ether.....		229
What "Inductance" Really Is.....	<i>Oliver Lodge</i>	232
Article No. 15		
List of Broadcast Stations in the U. S.....		236
53 Sources of Static.....		242
How to Get the Most Out of Your Ready-made Receiver.....	<i>S. Gordon Taylor</i>	243
No. 10: The Thompson Minuet Receiver, Model R-81		
A Measurement Chart.....	<i>Raoul J. Hoffman</i>	255
No. 14: For Simple Calculation of the Inductance of Toroid Coils		
How to Build the S-C Receiver for Short and Long Waves.....	<i>McMurdo Silver and Laurence M. Cockaday</i> ..	258
DEPARTMENTS		
In the World's Laboratories.....	<i>E. E. Free</i>	272
The Broadcast Listener.....	<i>Raymond F. Yates</i>	280
In the Experimenter's Laboratory.....	<i>Laurence M. Cockaday</i> ..	285
The Raytheon Plate Supply with the Four-circuit Tuner.....		
Record Every Experiment.....		
The 8-tube Reflex Superheterodyne Receiver.....		
Listening In.....	<i>Lloyd Jacquet</i>	288
What's New in Radio Apparatus.....	<i>The Technical Staff</i>	292
Broadcasts.....	<i>J. Andrew White</i>	296

VOLUME IX

MARCH, 1926

NUMBER 3

Published monthly by Popular Radio, Inc., 627 West 43rd St., New York, N. Y., telephone number, Chickering 1906; Douglas H. Cooke, President and Treasurer; Kendall Banning, Vice-President; Laurence M. Cockaday, Secretary; Joseph T. Cooney, Asst. Treasurer. Price 25 cents a copy; subscription \$3.00 a year in the U. S., Canada and all countries within the domestic postal zone; elsewhere \$3.50 a year, payable in advance. The International News Company, Ltd., No. 5 Bream's Bldg., London, E. C. 4, sole distributors in England. Entered as second class matter April 7, 1922, at the Post Office at New York, N. Y., under the act of March 3, 1879. Copyright, 1926, and title registered as a trade-mark by Popular Radio, Inc. Copyright in Great Britain by Popular Radio, Inc., 6 Henrietta St., Covent Garden, W. C., London, England.

Printed in U. S. A.

LAURENCE M. COCKADAY, *Technical Editor*

E. E. FREE, Ph.D., *Contributing Editor*

JOHN V. L. HOGAN, *Contributing Editor*

For advertising rates address

E. R. CROWE & COMPANY, INC.

New York: 25 Vanderbilt Avenue

Chicago: 225 North Michigan Avenue

Grebe
"Colortone"

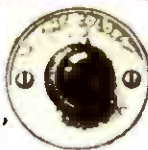

Flexible Unit Control



A

B

The high-wave reception range of the Grebe dial (B)—from 550 down to 240 meters—equals the practical tuning range of the usual receiver. The low-wave range of the Grebe dial (A) provides additional reception down to 150 meters.



Grebe
Binocular Coils
Ref. U. S. Pat. 06
and
Low-wave
Extension
Circuits

Always Well in Advance

THE Synchrophase, as usual, is fully a year in advance of other receivers. This is due to those Grebe developments which have contributed so much to the improvement of radio reception. As past experience will show, these advances may be adopted, perhaps next year, on sets of other manufacturers.

So, in buying a Synchrophase now, you are assured of a receiver well in advance of others, and a quality of reception which they will take some time in equalling, if ever.

*A demonstration by your dealer
will convince you.*

A. H. Grebe & Co., Inc., 109 West 57th St., N. Y.

Factory: Richmond Hill, N. Y.

Western Branch: 443 So. San Pedro St., Los Angeles, Cal.

This company owns and operates stations WAHG and WBOQ; also low-wave re-broadcasting stations, mobile WGMU and marine WRMU.

It is written:

"It is foolish to try to graft a bamboo shoot on a cherry tree."

The adding of Grebe developments to other receivers does not put Synchrophase quality into them. Only Grebe can do that.

C. A. Carter



All Grebe apparatus is covered by patents granted and pending.

The GREBE SYNCHROPHASE

TRADE MARK REG. U.S. PAT. OFF.



The Synchrophase is also supplied with battery base.

PAGES WITH THE EDITOR

JUST as this number of POPULAR RADIO was about to go to press the Editor received four letters upon a subject of importance both to the readers of this magazine as well as to the publishers.

ALL four letters came from a distance. One was from a group of members of the Liverpool Wireless Society of England; one from Mr. Walter Munn of Southampton, Eng.; one from Mr. H. M. Thompson of Vancouver, B. C., and one from Mr. Arthur E. Anderson of Duluth, Minn. And all of them asked, in effect, "Why doesn't POPULAR RADIO *always* publish the constructional details of coils, transformers, condensers and other parts that are specified in the How-to-build series of articles?"

"How," they ask, "can we build the sets if we are located where the parts you specify are not obtainable, and if you do not tell us how to build the parts themselves?"

THESE questions are so pertinent, and they so directly affect the interests of readers and publisher alike, that the Editor is taking this opportunity of sharing his reply with all our readers.

IN the earlier constructional articles of the "How-to-build" series, POPULAR RADIO told its readers how to build their own coils and certain other radio parts. It did so because in those days manufacturers had not yet produced and secured wide distribution for the special parts that were required for the successful operation of the sets described—most of which (like the Four-circuit Tuner, for example) were conceived and developed in the POPULAR RADIO LABORATORY.

BUT the *average* experimenter, it was found, has neither the facilities, time nor ability to make these parts himself. And (with the exception of those few amateurs who have had wide experience) the results were unsatisfactory. So the experimenter generally blamed the set—instead of the inefficient home-made part that was really responsible for the trouble.

INDEED, nearly all of the difficulties that in the earlier days led to correspondence between the experimenters and the Service Bureau of POPULAR RADIO were directly traceable to this source.

THIS trouble, however, began to diminish as soon as the radio industry became better organized and undertook to manufacture special coils, special transformers, special condensers and other special parts that were required for the successful operation of these sets.

It is, therefore, with the purpose of serving the best interests of the largest number of ex-

perimenters, and of enabling them to build and assemble their own sets in exact conformity with the experimental sets that are developed and tested in the POPULAR RADIO LABORATORY, that has made not merely advisable, but necessary the use of parts that are obtainable through the ordinary trade channels.

ONLY in this way, experience has shown, can the average experimenter build or assemble a receiver that will function with exactly the same characteristics as the successful experimental set in the laboratory.

IN order to aid our readers in obtaining such parts, the Service Bureau has been co-operating with manufacturers and dealers throughout the country so that the radio parts used in the model receivers in the "How-to-build" articles will be available to experimenters at the time the issues of POPULAR RADIO reach their hands. This activity of POPULAR RADIO Service Bureau now constitutes one of its most valuable services to its readers.

FOR the benefit of those of our readers who live abroad or in localities where these parts are not obtainable, the Service Bureau offers personal assistance. Upon request, it will inform readers concerning the prices of the parts that are specified and will purchase them and ship them upon receipt of remittance or C. O. D. For this service no additional charge is made to subscribers.

BUT while this service is meeting the needs of most of our readers, there still remains a small group of highly proficient amateurs who have both the desire and the ability to make their own parts.

IN some cases this experienced amateur is capable of making the parts from detailed specifications. To him POPULAR RADIO will furnish, whenever possible, the data he needs—sometimes in the form of a footnote to the "How-to-build" article, sometimes in the form of a personal letter.

BUT in some cases POPULAR RADIO cannot conscientiously recommend that even its most experienced readers undertake to build the special parts. For instance:

THE coil required for the successful operation of the LC-26 receiver (described in the December 1925 issue) is wound on a special form of moulded hard rubber with a specified dielectric constant for the moulding material. It is wound on a regular coil winder with a regular spacing throughout in order to produce a unit of specified inductance and of specified capacity, and the job is done with such exactitude that these values (which include the radio-frequency resistance), *vary less than one per cent.*

(Continued on page 6)

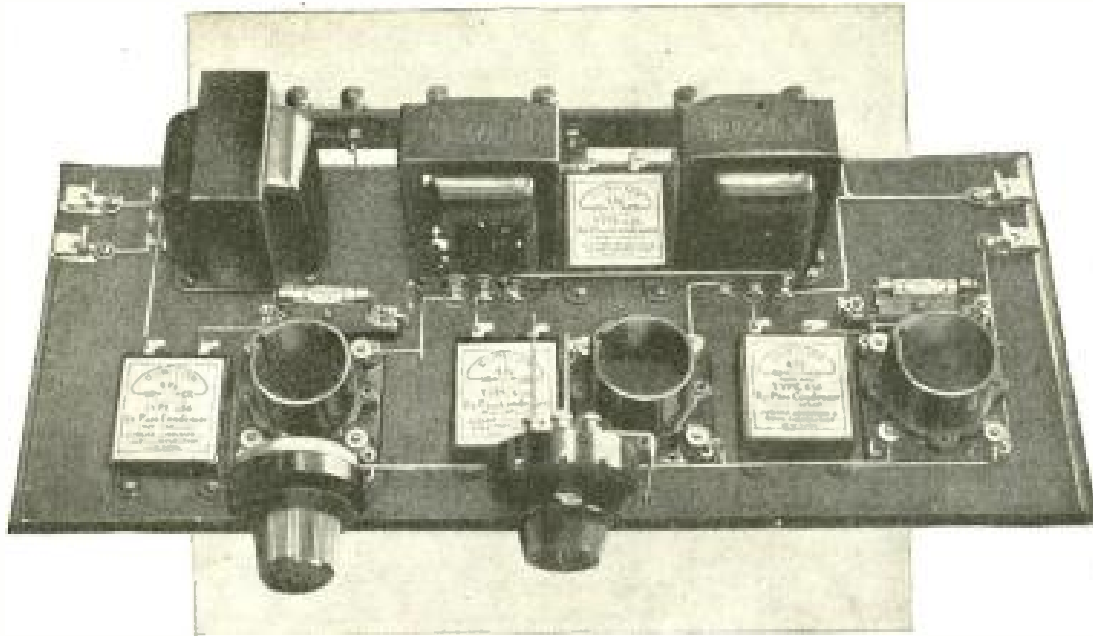

Distortionless Amplification

In impedance coupled Amplifiers (which evenly amplify all the notes in the musical scale) as well as in most of the latest developments in audio amplification, fixed condensers and grid leaks are essential elements of the hook-up.

Unless the accuracy and reliability of these parts is above question, the results from the unit will prove disappointing.

The set-builder who uses *Dubilier By-Pass Condensers* and the silent *Dubilier Metaleak* in constructing this unit, works with the assurance that comes from the use of parts whose performance has been tested and guaranteed by the best known manufacturer of condensers in the world.

Dubilier

CONDENSER AND RADIO CORPORATION

4377 Bronx Boulevard, New York, N. Y.

PAGES WITH THE EDITOR

(Continued from page 4)

It is highly unlikely that any amateur can make such a part himself—at least not a part that would function properly in the LC-26 set.

UNDER the circumstances the editors of POPULAR RADIO do not believe that they would best serve the interests of the great bulk of its readers to recommend that such attempts be made.

Just how to render the greatest value to the greatest number of readers is, of course, the earnest desire of the editors of this magazine. If any of our readers can suggest more practical methods than are now observed for meeting the particular editorial problem that has been presented by the four readers who are quoted at the head of this department, they will confer a real favor not only upon our remotely situated readers who have difficulty in buying

or making radio parts, but also upon the editors who are seeking to fill their wants.

"I VALUE the material published in POPULAR RADIO. It is my personal opinion that your magazine is one of the very best published in this country. I believe I am in a position to judge, at least to a certain extent, as to the value of such popular scientific journals; as I have been engaged in public educational work in public schools, normal schools and private schools for some twelve or more years."

—F. J. KARRER, Seattle, Wash.

Kendall Banning
Editor, POPULAR RADIO

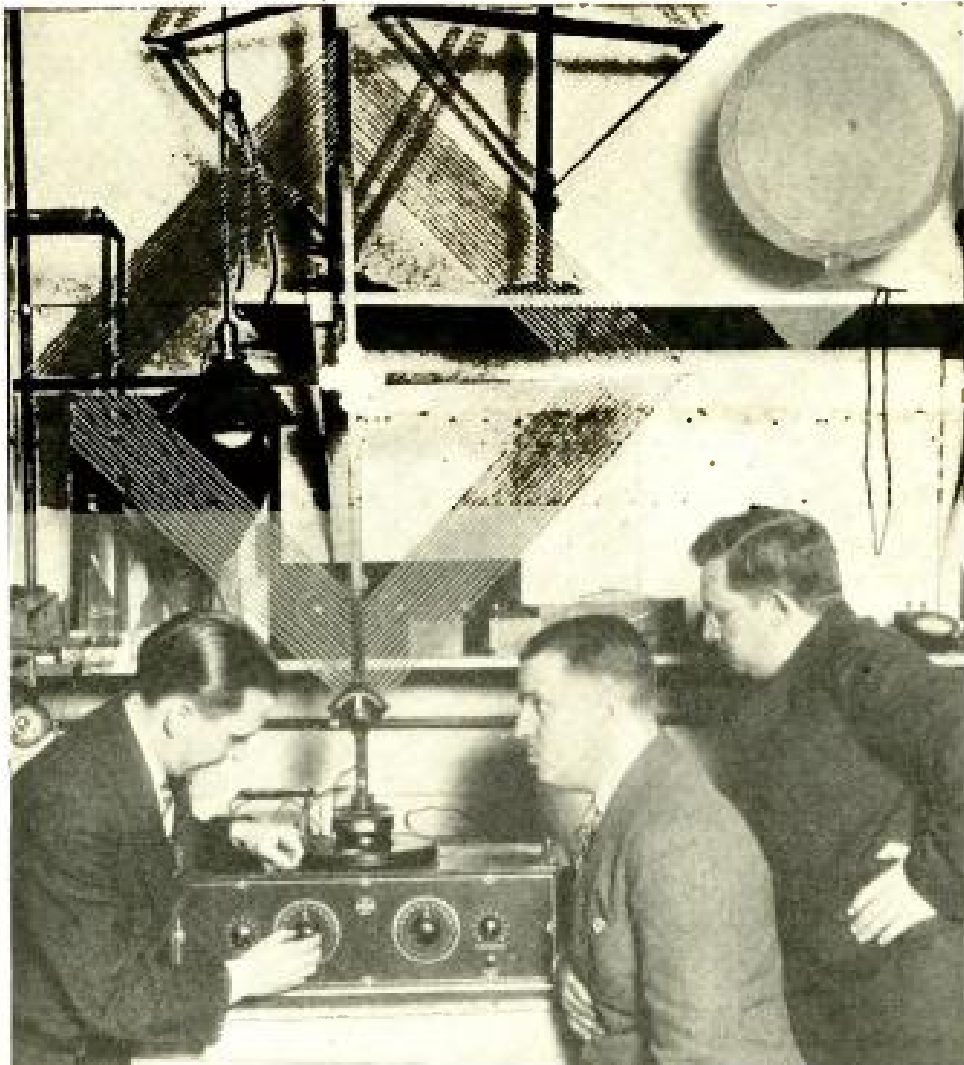

From a photograph made for POPULAR RADIO

A UNIQUE ALL-ALUMINUM RECEIVER

Here is the Eight-tube Superheterodyne Reflex receiver that was described in the January 1926 issue of POPULAR RADIO. It is remarkable in that all the metal parts employed in the receiver (except the rheostat windings) have been replaced with aluminum parts—even down to the foil used as condenser plates in the mica fixed condenser. The builder, Mr. Richards, has been demonstrating the set at radio shows; he is shown here demonstrating it in the POPULAR RADIO LABORATORY.

Perhaps you, too, can cut your
 "B" battery costs in half
 Just follow the chart. It gives you
 the secret of "B" battery economy

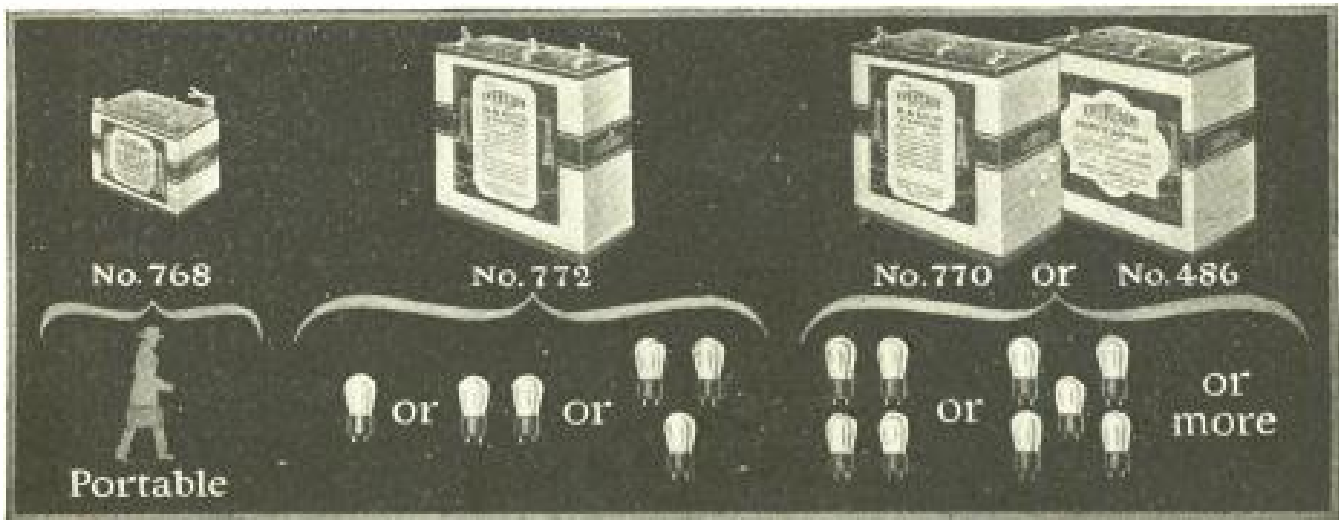

THOUSANDS of people have made the discovery that Eveready "B" Batteries, when used in the proper size and with a "C" battery*, are the most economical, reliable and satisfactory source of radio current.

On sets of one to three tubes, Eveready "B" Battery No. 772, used with a "C" battery, will last a year or longer, usually longer. On sets of four and five tubes, either of the larger Heavy Duty Eveready Batteries No. 770 or No. 486, used with a "C" battery*, will last eight months or more.

These figures are based on the average use of receivers, which a country-wide survey has shown to be two hours daily throughout the year. If you listen longer, of course, your batteries will have a somewhat shorter life, and if you listen less, they will last longer.

Here is the secret of "B" battery satisfaction and economy:

With sets of from 1 to 3 tubes, use Eveready No. 772.

With sets of 4 or more tubes, use either of the Heavy Duty Batteries, No. 770, or the even longer-lived Eveready Layerbilt No. 486.

Use a "C" battery on all but single tube sets.

Evereadys give you their remarkable service to the full when they are correctly matched in capacity to the demands made upon them by your receiver. It is wasteful to buy batteries that are too small. Follow the chart.

In addition to the batteries illustrated, which fit practically all of the receivers in use, we also make a number of other types for special purposes. There is an Eveready Radio Battery for every radio use. To learn more about the entire Eveready line, write for the booklet, "Choosing and Using the Right Radio Batteries," which we will be glad to send you on request. This booklet also tells about the proper batteries for the new power tubes. There is an Eveready dealer nearby.

*NOTE: In addition to the increased life which an Eveready "C" Battery gives to your "B" batteries, it will add a quality of reception unobtainable without it.

Manufactured and guaranteed by
NATIONAL CARBON COMPANY, INC.
 New York San Francisco
 Canadian National Carbon Co., Limited, Toronto, Ontario

EVEREADY
Radio Batteries
-they last longer

Tuesday night means Eveready Hour—9 P. M., Eastern Standard Time, through the following stations:
 WEAF—New York WBAI—Cincinnati
 WJAR—Providence WEAR—Cleveland
 WEEI—Boston WJL—Detroit
 WTAG—Worcester WGN—Chicago
 WFI—Philadelphia WOC—Davenport
 WOR—Buffalo WCCO—Minneapolis
 WCAB—Pittsburgh KSD—St. Paul
 KGO—San Francisco, 8 P. M.
 Pacific Coast Time

Profitable Representation

is dependent upon confidence between the manufacturer and the dealer.

A dealer's faith in the factory he represents is aided by familiarity with the manufacturer's policies.

The fundamental policies of Kolster Radio are based upon sound merchandising principles of proven worth.

Kolster Radio is technically correct and thoroughly guaranteed.

Dealers are given exclusive territory and protection against price decline and obsolescence.

These policies are simple and effective. They are and must be the basis of good merchandising.

We have popularized Kolster Radio through dominating space and sincere copy in The Saturday Evening Post and in newspapers throughout the country. The name Kolster is familiar to every radio prospect.



Kolster Six, dual control, loud speaker enclosed, space for batteries. One of five beautiful models, of which there are two Eights and three Sixes. Each is housed in a cabinet of rare charm, designed by leading authorities.

The Kolster franchise is a valuable asset to dealers. It is an acknowledgment of Kolster's faith in the dealer. It is his assurance of assistance, protection and profit.

We invite interested dealers to communicate with us concerning the Kolster franchise for reliable dealers.

FEDERAL TELEGRAPH COMPANY
(of California)

Room 1077, Woolworth Building, New York City

KOLSTER RADIO

All apparatus advertised in this magazine has been tested and approved by POPULAR RADIO LABORATORY



A Notable Service Rendered with Distinction

"EVERY year of our work with radio has brought a greater appreciation that it is one of the most progressive forces ever known. To observe, to announce and to explain this progress so that mankind can benefit to the fullest degree from it is a notable service. POPULAR RADIO is performing this great task with distinction."

A. ATWATER KENT
ATWATER KENT MANUFACTURING COMPANY



From a photograph made for POPULAR RADIO

A Phenomenon in Radio Reception That Has Led to a New Theory of Wave Transmission

Here is an ordinary vertical loop direction-finder that is tuning in at the maximum amplitude the signals which are being transmitted from the horizontal wave antenna shown in the background—despite the fact that the loop is AT RIGHT ANGLES to the direction of transmission.

Popular Radio

VOLUME IX

MARCH, 1926

NUMBER 3



A NEW THEORY OF WAVE TRANSMISSION

All of the theories of "radio waves" heretofore propounded fail to explain certain radio phenomena. In the course of his researches into these mysteries in his extensive field laboratory, the author of this article—who is one of the world's foremost scientists—developed a new theory that he has illustrated with a simple and novel mechanical model. This new theory, which accounts for fading and the erroneous results met with in direction-finding and which throws light on the little-understood "horizontal radio wave," is put forth for the first time in this article that has been prepared exclusively for POPULAR RADIO.

By E. F. W. ALEXANDERSON

THE earliest radio literature describing the experiments of Hertz makes it plain that even at that date the possibility of polarization of radio waves was realized by this pioneer discoverer. Then this subject fell into complete neglect so far as practical radio technique is concerned. When it again came to our attention recently during our research work on short waves it was through an accident. And it came as unexpectedly as a new discovery.

What we are now trying to do is to formulate a conception of what the radio wave consists of and how it travels. We have too long been satisfied with mathematical symbols that have no definite physical meaning. This has limited our vision in understanding wave propagation and some of the most important radio phenomena remain unexplained.

We are therefore approaching the sub-

ject from two angles. One is the classical theory of light radiation in the ether; the other is the electromagnetic theory as we know it in electrical engineering.

Both of these theories have their difficulties and their shortcomings.

The only positive knowledge we have of electricity is the electronic theory. We know that the electron is the smallest element of matter. We know its mass, its electric charge and we know how fast it travels. But we do not know what magnetism really is. As a matter of fact we have good reason to believe that *there is no distinct force that can be called a magnetic field and there is no ether in the old sense.** If there were an ether what is the relation between the electron and the ether and between the ether and magnetism.

* See "There Are No Ether Waves" by the late Dr. Charles P. Steinmetz. POPULAR RADIO for July, 1922, pages 161-166.

The best picture we can form is to assume that each electron has its own ether attached to it. But why call this medium ether?

Dr. Michael I. Pupin has very appropriately said "why not just call it electricity?" This explanation was given by him in an inspiring lecture delivered in Schenectady to the memory of Dr. Steinmetz. According to this new theory a complete electron consists of a nucleus and an aurora of electricity extending through the universe. If a nucleus vibrates, the aurora tries to follow; but it cannot follow immediately, so the motion progresses in the form of waves in the electric medium. Thus the relativity of light

velocities is easy to understand because each source of light carries with it its own track on which it travels.

This electric medium is material; it has mass and elasticity. We can thus form a mechanical conception of wave motion. But what, then, is magnetism?

The answer is, it is simply the velocity or kinetic energy of the electric medium. This sounds reasonable enough, but how about a solenoid magnet?

The electrons circulate around in the coil and carry with them the electric medium like a flywheel. When the current is constant, the flywheel runs at a constant speed and consumes no energy except the frictional losses which may be

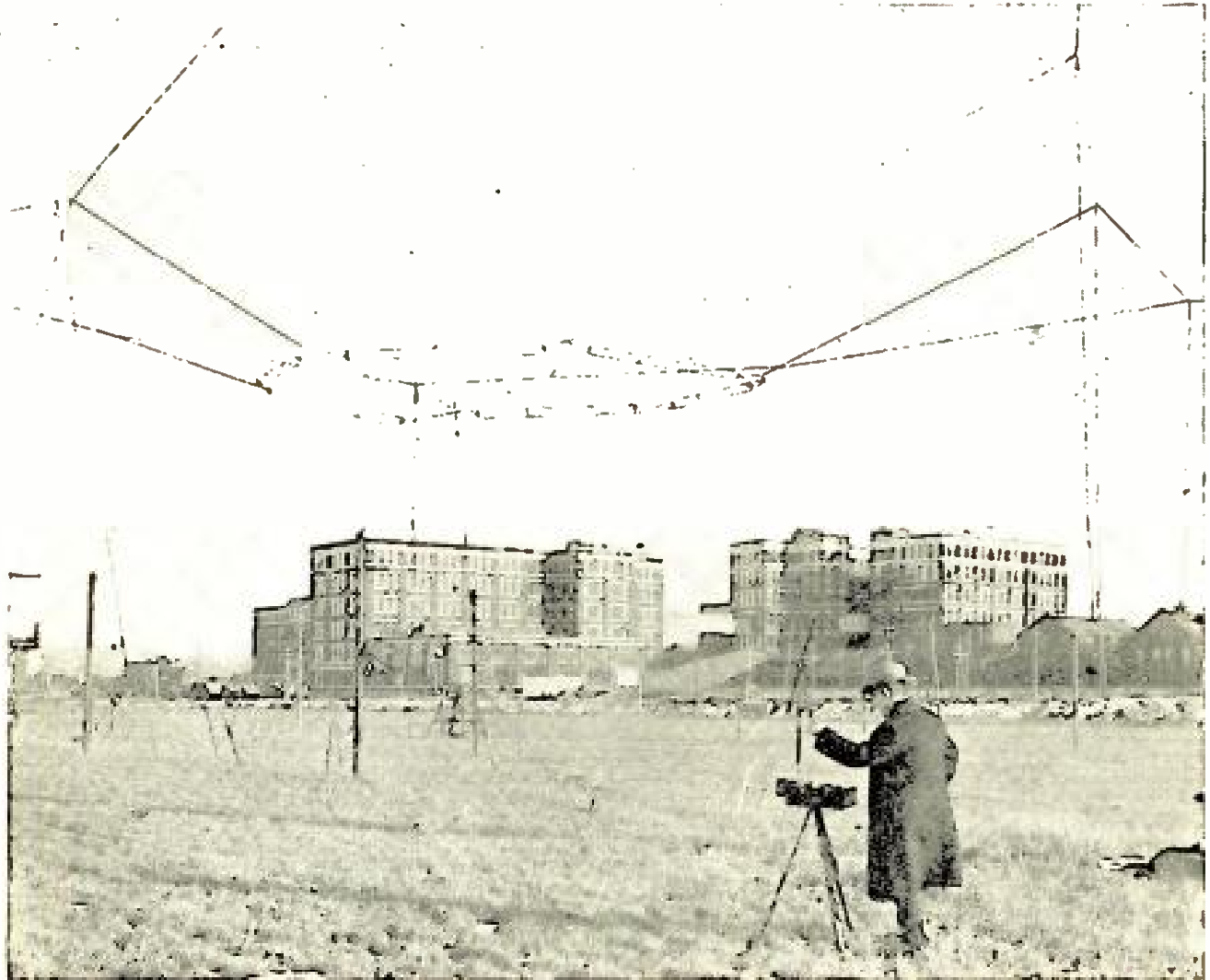

From a photograph made for POPULAR RADIO

A PHENOMENON IN RECEPTION THAT IS NOT EXPLAINED BY FORMER THEORIES

The operator of the vertical-loop direction-finder here has the loop pointed directly at the transmitting antenna. In this position he would normally get a maximum deflection on the galvanometer that is incorporated in the receiver in the small box mounted on the tripod, yet the meter registers zero.

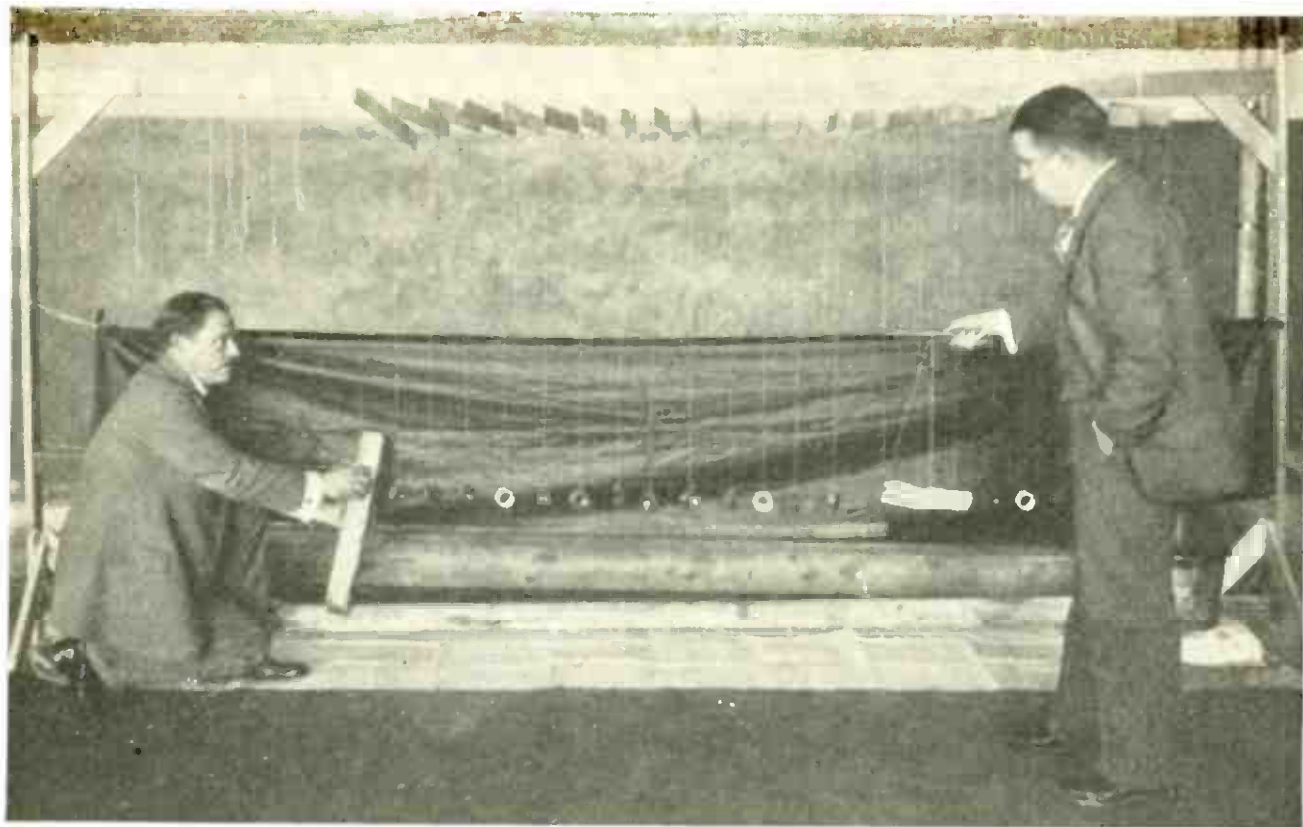

From a photograph made for POPULAR RADIO

AN EXPLANATION OF "FADING" ON A MECHANICAL MODEL

The model consists of balanced weights hung on strings that are fastened to individual rocker arms; they are tied together by rubber bands in a horizontal direction, to reproduce the field stresses in the wave. At the left Mr. Alexanderson is shown about to start the weights into a wave motion for demonstrating to the Technical Editor of POPULAR RADIO, by means of a paper weight tied to a string and running over a small glass rod held by the visitor, that at certain points there will be no indication of wave motion by the paper weight detector. This is a mechanical analogy which demonstrates the twisting plane of polarization and also a certain kind of radius.

said to be the resistance losses in the copper wire. But when we start it and stop it we have to deal with the kinetic energy and we know that inductance has all the characteristics of kinetic energy. Furthermore, if we now run the flywheel back and forth rapidly, by reversing the current, the mass of the distant portions cannot follow immediately and elastic strains are set up in the medium which therefore carries away energy in the form of wave motion. The elastic forces are electromotive forces. The magnetic field is velocity.

This mechanical analysis can be carried still further. Thus a change in magnetic field may be said to be a change of velocity of the medium. But change in velocity is acceleration and is accompanied by forces of mass reaction (inertia). These mass reactions are equal to the elastic forces that produce acceleration. Our old

magnetic theory tells us that a change of magnetic field produces an electromotive force and our mechanical theory of the electric medium tells us that the elastic electromotive force, acting upon the mass, produces changes of velocity which are equivalent to changes of magnetism.

So, you see, the two theories check and we can afford to forget, for the time being, that there is a magnetic field.

The advantage of this reasoning is that we can express our theory in a mechanical model. For study of more complicated phenomena this is very helpful. Such phenomena as linear or elliptic polarization and change in plane of polarization can thus easily be visualized.

One example of the use of the mechanical model for studying wave propagation is an experiment which was made to study a phenomenon which has been often observed but never before satisfactorily

explained. What I refer to are the false indications of a direction finder which are sometimes very pronounced.

The following are some of the factors which we desire to correlate by a logical explanation. It has been known almost since the beginning of transatlantic communication with long waves that measurements of direction of wave propagation with rotating loops show peculiar irregularities at the time of sunset. This phenomenon has become known especially from the work of Dr. L. W. Austin and Dr. A. Hoyt Taylor. The apparent deviation in direction of wave propagation which they reported were at times so great that it was feared that the installation of the Beverage antenna on Long Island

might at times be rendered inoperative by these changes in direction of the wave. No such effects were, however, observed. Here it should be noted that the observations which showed these irregularities were made with a loop rotated around a vertical axis, whereas the Beverage antenna is a horizontal wire one wavelength long.

Another peculiarity of the observations of radio waves known among aviators is the fact that direction finder bearings on an airplane are correct only if the plane flies in the line towards the observing station. If the airplane flies at right angles, the direction finder gives false orientation as high as 45 degrees or more. It is also known that this false orientation is

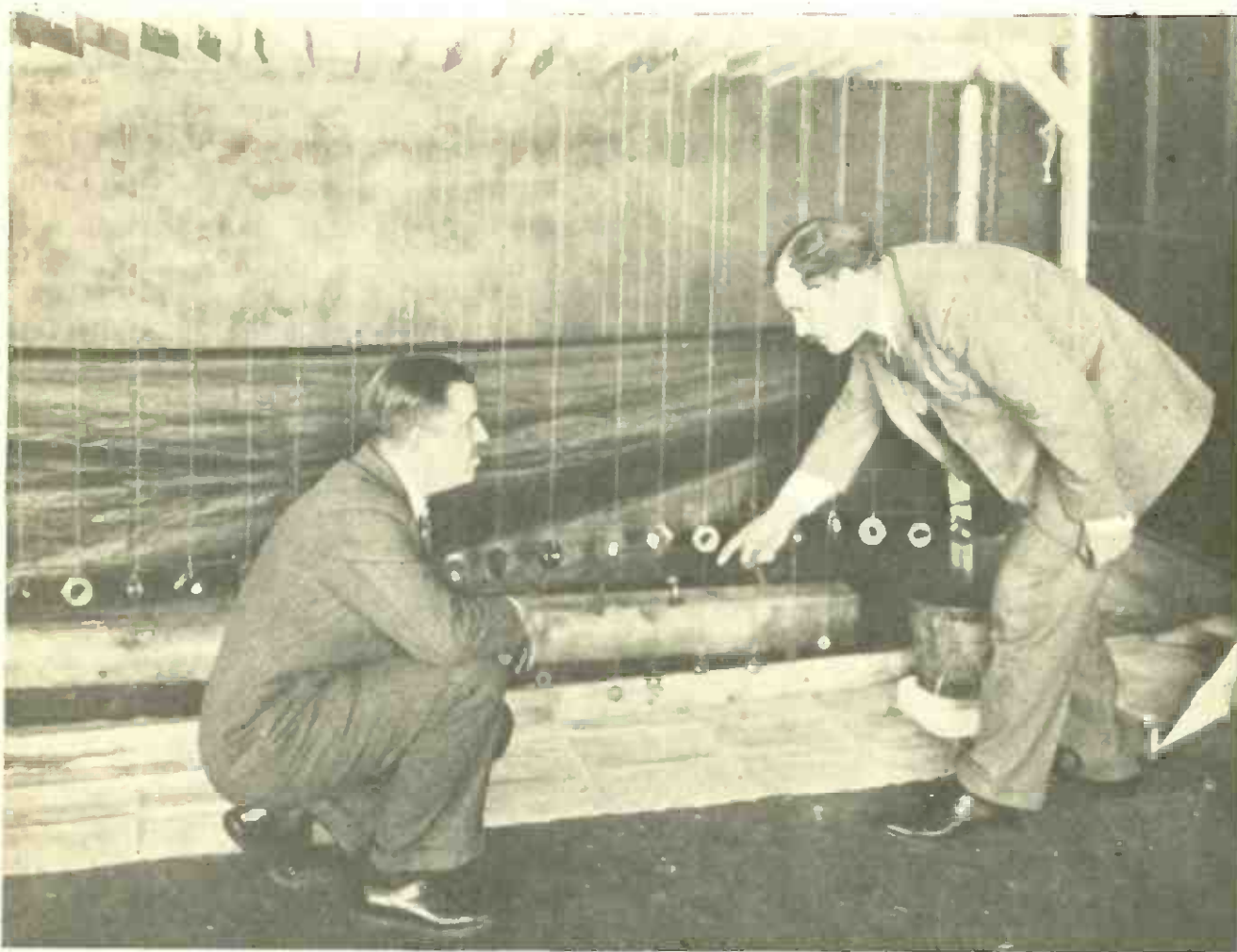

From a photograph made for POPULAR RADIO

HOW A RADIO WAVE PRODUCES GROUND CURRENTS AT A DISTANCE FROM THE TRANSMITTER

The smaller set of weights (at which Mr. Alexanderson is pointing) represents earth currents that are set up by the radio waves which are represented by the large upper weights. When the apparatus is set in motion, a regular wave-form is set up in the lower set of weights by the action of the upper set of weights operating through the rubber bands.

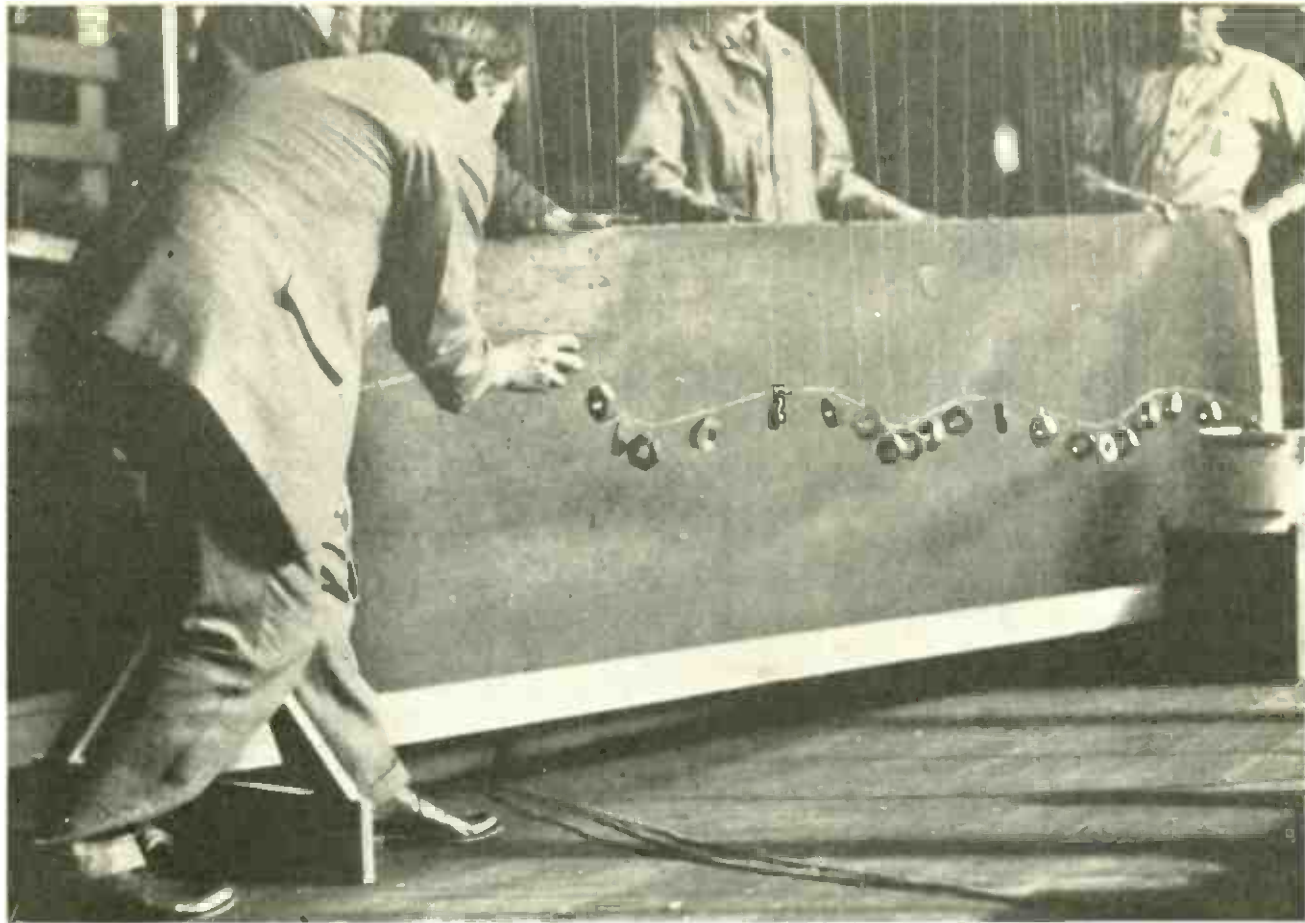

From a photograph made for POPULAR RADIO

A DEMONSTRATION OF THE "CORKSCREW WAVE"

The author is here shown setting up a corkscrew wave motion by means of his mechanical "analogy machine." Notice how the rubber bands govern the motion of the whole wave; they have the same effect upon the separate weights as the elastic transmission medium would have upon the electrons in a radio wave itself.

greater if the antenna is trailing horizontally. It is, therefore, attempted to keep the antenna as vertical as possible by a weight.

A third set of observations has been brought out through the research work in Schenectady on horizontally-polarized waves radiated by a horizontal loop. Measurements with a direction-finder receiver usually give bearings approximately at right angles to the place where the station really is, but sometimes it gives no direction indication at all. Other measurements indicate that the direction of wave propagation is almost straight vertical. The observation that the wave appears to come straight down from above suggested an explanation that wave components radiated directly upwards had been reflected straight down by the Kennelly-Heaviside layer. This explanation seems however less likely in view of

the other facts to be considered.

Putting all these facts together it seems now that the old observations on the long wave, the airplane and our recent work on the horizontal loop can all be explained as a characteristic behavior of the horizontally polarized wave.

In all three cases the wave *appears* to come in from the side, but actually it does not. When in the third case there is no direction indication whatever, and the wave appears to come in from above, this is also an illusion.

The question is: what does really happen?

This is the problem on which the experiment with the mechanical model can throw some light.

We must for this purpose return to the idea that the radio wave is a mechanical wave motion in the elastic electric medium. In the mechanical model the

weights represent the mass and the rubber bands the elasticity of this medium and the vertical as well as horizontally-polarized wave can easily be reproduced. But when we are to imitate a wave motion over the surface of the earth, we must also in some way imitate the presence of the earth. The earth is a conductor and therefore the elastic strains represented by the rubber bands cannot exist in the earth. Displacement currents in the electric medium can, on the other hand, induce conduction currents in the earth. These conduction currents are moving electrons which may be represented by weights which are not tied together by rubber bands in the horizontal plane, whereas they are electrically associated with the electric medium above. To imitate this condition, weights were hung by vertical rubber bands so that they were elastically associated by the wave medium but not connected to each other. Now if a horizontally-polarized wave is sent forth through this system, it is found that the wave motion is propagated to the vertically suspended weights producing elastic strains in the vertical rubber bands.

We must remember that the elastic strains represent electromotive forces and these elastic strains so produced are of the same character as if they were a part of a vertically propagated wave motion. Actually no such wave motion exists and these electromotive forces are only the electromotive forces which induce currents in the ground. If we now assume that we set up a receiving antenna in the form of a vertical loop with its plane at right angles to the wave motion, the primary wave motion does not induce any currents in the loop. However, the secondary electromotive forces which induce currents in the ground are in the plane of this loop and do tend to induce such currents in the loop.

We have thus been led by the mechanical theory of wave motion to attribute certain well-known phenomena to ground currents caused by horizontally polarized waves. It is, however, possible to come

to the same result with the electromagnetic theory and give a better quantitative treatment of this problem with the help of mathematics.

Looking upon the problem in this way, we will assume that a horizontally polarized wave travels parallel to the earth. The electromotive forces and the displacement currents are horizontal and the magnetic lines of force are vertical. Thus the magnetic lines terminate in the ground. The magnetic lines are sweeping away from the radiator like alternate north and south poles of magnets pointed into the earth. According to the laws of magnetic induction these sweeping magnetic poles will produce eddy currents in the ground which in their turn induce currents in a direction-finding loop. An apparent orientation is therefore found at right angles to the direction of wave propagation.

If this theory is correct, it should be found that false indications of the direction finder and the apparently vertical wave propagation can be observed only in the proximity of "ground." Thus if observations are made in airplanes high enough over the ground, the horizontally polarized wave should show a horizontal plane of polarization with a true direction of propagation.

It is hoped that with the co-operation of the government such observations may be made. If such tests give the results predicted it may be concluded with reasonable assurance that the peculiar phenomena of false indication of direction finders which have been known for some time may be explained as a normal characteristic, indicating the presence of horizontally-polarized waves. This theory also explains why the existence of horizontally-polarized waves has so long been neglected because it has been shown that a horizontally-polarized wave can be received on a vertical loop but not on a horizontal loop. It will also give us greater confidence in the use of the mechanical theory of wave motion for explaining other phenomena of wave propagation.



Kadel & Herbert

THE UNIVERSITIES TRAIN ENGINEERS FOR THE RADIO INDUSTRY
The demand for experts is being met in part by technical schools and universities where courses in electrical engineering are preparing technical men for positions with business corporations. Such engineers usually earn from \$2,500 to \$7,500 a year in salary; some consulting engineers have earned as high as \$100,000 a year.

Radio as a Life Work

Where the opportunities lie for the experimenter who wants to earn his living in this new field of science and industry

By PIERRE BOUCHERON

THERE are at present some excellent opportunities in both the commercial and engineering fields of radio—with perhaps a slight preference for the first.

The engineer who spends a lifetime in research, designing and experimental work is likely to follow a very ethical pathway. In many instances the lure of money or profit in his profession is somewhat distasteful, and, providing his income is sufficient to take care of his

immediate needs, he is usually satisfied with his lot.

The commercial man, on the other hand, is apt to view things in a different light. His training and qualifications are concerned with chasing the almighty dollar. It is his job to make sales for his company; for that reason, the viewpoint of the commercial man is closely associated with money-making and he is apt to apply the same principle to the matter of salaries and com-

missions. The commercial side of any industry is consequently often more profitable than the engineering end.

This article is not concerned with the commercial radio man.

Whether or not a man chooses the engineering side of radio as a profession is, after all, a matter of individual temperament and disposition.

As a matter of fact, there are many engineers who have branched into the commercial end of radio, and there are likewise men starting in commercial capacities, who later find engineering more suited to their individual ambitions.

Radio engineering does not require very many men, but the few who are required must be good. There is, however, a growing need for operating men, particularly at high-powered land stations. By "operating men," is meant not so much telegraph operators as men who are well versed in the fundamentals of radio and who have a fair technical training as well as a practical one—transmitting and receiving engineers for example, and men who are trained in the installation, operation and care of high power transmitting and receiving apparatus, and who are telegraphers as well.

Radio as it is today has branched out considerably into many sub-divisions. An important development of recent years has been transoceanic radio telegraphy. This country has made active progress in transoceanic communication and a number of radio stations have been erected on both the Atlantic and Pacific coasts, which are designed for high-powered long-distance transmission and reception. In this field, therefore, there is need, and probably always will be, of men capable of handling the operating details of these high power equipments.

What are the duties of transmitting and receiving engineers at high power stations?

The transmitting engineer at a high

power station may aptly be called a shift engineer. His duties correspond somewhat to those of an engineer at a central power plant and the experience he gains here may come to him in good stead should he later engage in regular power-station work.

In addition to this, he has the advantage of being in close touch with the latest applications resulting from modern scientific discoveries in engineering practice. Of late, radio has struck a new cord; and its principles are rapidly finding uses in all manner of allied engineering such as telephony and telegraphy.

It is the duty of a shift engineer to keep the apparatus moving. He must see to it that the power supply is constant, that the cooling system connected with the efficient operation of the high frequency alternators is in working order, that the remote control system is operating at such speed that 50 or more words a minute may be possible at any moment. Incidentally, the speed control of high-frequency alternators must be very accurate and the methods which have been devised to accomplish this are novel and instructive from an engineering point of view.

The problems of the receiving engineer are somewhat similar but on a smaller scale. The battery supply must be kept quiet and constant and the receiving equipment must ever be in a highly effective working order. These factors are of great importance in reception.

The receiving engineer is perhaps more in touch with the immediate development of radio than anyone else, as it is necessary for him to secure the facilities for handling as great an amount of traffic as possible with the apparatus available. The work, therefore, calls for considerable ingenuity.

The man who has a good electrical engineering training and who has devoted a certain amount of time to amateur radio experimentation naturally has the

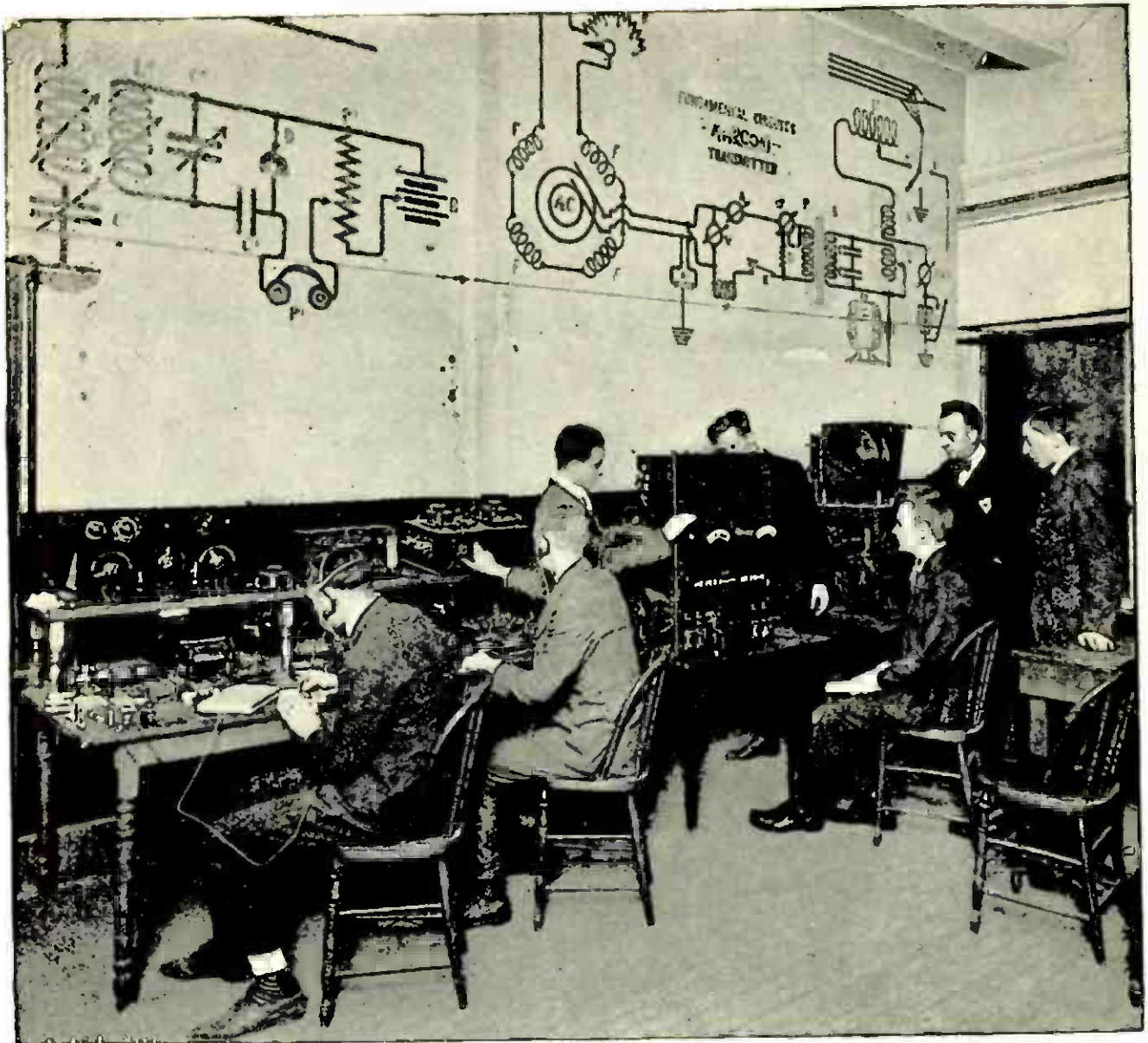

Radio Corporation of America

HOW RADIO OPERATORS ARE INSTRUCTED

Amateurs as well as "fans" without technical knowledge are turned into radio operators in radio courses that are conducted by private institutions and by some few business corporations. A ship's operator earns from \$1,000 a year to \$1,800 with board.

advantage in such work. There are many electrical students who are amateurs, with such training and as electrical engineering has been foremost in their minds, radio has occurred to them as a possible career.

There is a good future for competent radio engineers; men who have considerable experience and who understand the problems involved in making radio fool-proof. In fact, there are today many serious difficulties to be overcome. Here are some of them:

As many tropics-bound ship operators

know, we have in radio a strong negative factor in the masterful and ever present "static" which also bears the less popular name of "strays." These atmospheric electrical disturbances cause objectionable noises in the receiving telephones of the operator. For this reason, parts of messages are often mutilated. In fact, when static is very severe (as during heavy electrical storms), radio reception often has to be abandoned for lengthy and costly periods. This problem is probably the most important one that requires solu-

tion today. It was discovered a short time ago that static waves seem to travel largely from a particular direction which is frequently different to the incoming radio signals. The final elimination of static is a problem that is not going to be solved overnight; it will rather be a gradual process. It will probably be a long chain of personal achievements of many engineers when finally static will be entirely controlled or eliminated.

A scheme to overcome static has been employed which may aptly be termed the "dodging" method. In this case there are possibly three separate transoceanic receiving stations located at various points along the coast each separated by a distance of 400 or 500 miles. The plan is for each of these stations to receive the incoming signals and simultaneously transmit them over a land line to a central receiving point, such as New York. The method of reception at the central point may be any recording method which will permanently register the signals on paper tape. The central receiving operator thus has three tapes passing his line of vision which record the same message. As in most cases static is of local origin, it is assumed that only one of the stations will be affected at one time and that the other two will receive the signals without mutilation. Thus, if one of the tapes shows static interference, there remain two others for checking purposes.

Another problem which requires solution is that of making radio communication secret so that transmitted signals cannot be intercepted by either competing organizations or by foreign governments, who may, by following the simple expedient of setting up receiving installations, "listen-in" and copy what is going on in the ether.

Another problem in radio is that of perfecting a reliable calling system for use primarily on board vessels. At present it is necessary for an operator

to be constantly "listening-in" in order to know whether anyone is calling him.* Some interesting developments in this direction have been made by our English colleagues, but they have plenty of room for perfection.

High speed radio telegraphy has been receiving attention and several systems are known to work satisfactorily. But these are practically useless when static is very severe. For that reason, there is need of a certain amount of development in high speed transmission and reception, so that the transmission and reception of international messages can be made a profitable one for those engaged in it.

A recent development has been the so-called "wired-wireless" experiments in which radio is made use of in long distance wire telephony and telegraphy. Effective multiplexing is made possible by the use of radio waves which are guided by wires. In fact from six to ten simultaneous channels of communication are sometimes available on a single wire line. These experiments indicate that we may reasonably look forward to transoceanic cable telephony.

Radio direction finding is proving invaluable in maritime circles, but it has not reached perfection by any means. Here too there is need of radio engineers who will specialize in direction-finding work exclusively.

An appliance which has well nigh revolutionized the radio world, with special emphasis on radio telephone broadcasting, is the vacuum tube. The vacuum tube today is truly the "heart of radio." It has the unique characteristic of performing all the essential functions of generating and modulating the high-frequency power of the transmitting station, and it may also be used to receive, rectify, and amplify the received power at the receiving station. Not only does it prove excellent in radio telegraphy but is exceptionally well adapted for radio telephony.

* See POPULAR RADIO for June, 1924.



Radio Corporation of America

WHERE THE "COMMERCIAL TRAFFIC WORK" OF RADIO IS CARRIED ON

With the constant increase in the number of radiograms and the building of new radio-telegraph stations throughout the world, the demand for help is growing proportionately. Men who handle the routine message work in such a trans-atlantic radio-telegraph operating room as shown above, usually get from \$1,500 to \$2,700 a year.

We have, therefore, in the vacuum tube another angle of radio which will require specialized attention by competent electrical engineers of the future. The vacuum tube is not only used in radio but it has found its way to advantage in ordinary wire telephony and other electrical uses which makes us realize that electrical engineering is closely associated with radio engineering.

In fact, one cannot be a good radio engineer without being well founded in electrical principles.

As an illustration of how closely radio is associated with wire telephony and telegraphy, it may be recalled that the American Telephone and Telegraph Company gave a demonstration before

the International Communication Conference, who were able to listen to conversation going on between a ship in the Atlantic and a small island in the Pacific. In this instance, radio was linked with the regular land telephone lines and necessitated the combined co-operation of radio, electrical and communication engineers.

Another illustration was the duplex radio telephone feat between the S. S. *America* and the Deal Beach radio telephone station, accomplished by the combined engineering skill of the Radio Corporation of America, the American Telephone and Telegraph Company, the Western Electric Company and the General Electric Company.



Ewing Galloway

THE RADIO FAN WHO IS "HANDY WITH TOOLS" USUALLY
STARTS IN A FACTORY JOB

If he has inventive talent, his career will lead upward indefinitely. Mechanics usually start in at such work at about \$1,100 a year; a skilled mechanic may get from \$1,800 to \$3,100 a year, and inventors sometimes get in addition a share in the proceeds of their inventions.

But perhaps the most important and far-reaching opportunity in radio is radio broadcasting.

The ether in and near large cities that are served by broadcasting stations is literally packed with music, lectures, news, children stories, market and weather reports and what not. Radio telephone development is responsible for this tremendous interest. Recent estimates of the number of radio broadcast enthusiasts place this figure at approximately three million!

Men and boys who a few months ago did not know a vacuum tube from an electric lamp are today holding neighbors spellbound with their glib radio vernacular. Parents are beginning to look upon their radio amateur sons in a new light—as future Edisons and DeForests and Marconis. A great many youths are naturally gravitating toward radio as a profession; they need help and timely advice.

Meanwhile, however, man, woman and child want to hear "the voices from the air." They need apparatus for this—apparatus that is effective. Already the radio public is beginning to discriminate. There is, therefore, an excellent chance for the conscientious engineer who wishes to see broadcasting and amateur radio a part of every day activity. As radio progresses, there will be need of more exact methods in the designing and manufacture of apparatus. Moreover, these factors will necessitate careful consideration by future radio engineers.

The broadcasting and amateur side of radio is one which today plays a very important part in general radio development. In fact, amateur radio has contributed in a great degree to the general progress of the science.

A leading radio engineer recently emphasized the need of good radio men. He thought that radio as a commercial and professional possibility had been

given altogether too much publicity and that its future had been painted in too glowing colors. For that reason he thought there were too many men attracted to it who were not especially equipped either by inclination or education to take up radio as a profession, and would ultimately retard rather than advance the art.

This engineer carefully gleans every patent which is directly or indirectly connected with radio that is issued by the United States Patent Office. His conclusions are that there is probably only one out of every 1,000 patents issued which is really of any value to the development of radio. The 999 remaining patents are so called "paper patents" and are practically worthless. Incidentally, they reflect the lack of knowledge and experience which these would-be inventors hold. Many of these documents have been prepared by men who have a vague and hazy idea of radio fundamentals. In short, there is too much negative activity connected with radio and there is need of some real constructive and really worth while work along these lines.

It would seem, therefore, that if any competent electrical engineer is contemplating specializing in radio the field is open to him for recognition providing that he is willing to keep his feet on the ground and "lay off" on radio

dreams and impossibilities. There is, of course, nothing to stop an electrical man from pursuing a strictly electrical career and at the same time resort to radio as a hobby whereupon he may by due process of experimentation and research strike something of real importance and benefit to the art.

There is a growing number of universities and colleges in this country that have recognized the value of radio by making it part of their regular engineering courses. Some of these are Columbia University, Cornell, Rensselaer Polytechnic Institute, Yale, Harvard, Massachusetts Institute of Technology, Pennsylvania State College, Polytechnic Institute of Brooklyn and several other education institutions.

The most practical way to learn radio properly is to become first an electrical engineer or at least to become well-grounded in electrical principles through amateur experimentation or intensive training at a good radio institute. In this way the student may acquire enough radio knowledge to enter the service of one of the several large radio companies in one of their branches, such as designing, construction work, manufacturing, operation or maintenance.

The men who are today well known in radio circles and who have fared well are those who have followed these or similar lines.

A New Power Amplifier Unit

In the April issue of POPULAR RADIO will appear the first complete description of a new unit that will be the forerunner of many audio-frequency amplifying devices of the future. The article will describe a power amplifier unit that will provide straight audio-frequency amplification with a minimum of distortion. The unit comprises one stage of transformer-coupled audio-frequency amplification and it will supply the A, B, and C voltages to the power amplifier tube in the last stage; it will also supply B and C voltages for the first stage of amplification and will supply the B current for any set with which it is to be used. When added to any set that employs one, two or three tubes, it will give reproduction of that lifelike tone quality and volume that will enable the filling of a large hall or auditorium with concerts.



Kadel & Herbert

A RECEIVER THAT IS WELL EQUIPPED WITH METERS

By mounting the milliammeter directly on the panel of the radio receiver the operator has an indication at all times that the vacuum tubes are functioning properly. The instrument is indicated by an arrow.

WHY AND HOW THE MILLIAMMETER INCREASES

The Efficiency of Your Set

To keep you advised of the drain on your "B" batteries, to show you whether there is distortion in your audio-frequency amplifier and to act as a warning signal in case any other circuits in the receiver go wrong—these are the functions of this instrument.

By MAURICE M. OSBORNE

A DIRECT-CURRENT milliammeter is an electrical measuring instrument which looks and is built like a voltmeter but which measures rate of current flow or consumption instead of its voltage or pressure. It makes this measurement in milliamperes (thousandths of an ampere) and is used in radio for indicating the rate of current flowing from the "B" battery through the plates of the vacuum tubes.

Few set owners or builders have not at some time or other been appalled by the unexpectedly rapid running-down of their "B" batteries through excessive drain. This is particularly so in the case of sets that employ high "B" voltage on the audio-frequency amplifiers and without grid-biasing means ("C" batteries).

The "B" battery current can flow only when the filament of a tube is lighted. Turning the "A" current on the tube-

filament heats it. As soon as it has sufficient voltage impressed upon it and the temperature has risen to a critical point, the heated filament begins to emit electrons or tiny negative charges of electricity. These electrons start to flow to the tube plate, which is charged positively from the "B" battery, and therefore attracts them. The grid of the tube may be disconnected and there will still be this flow of "B" current, as long as filament and plate are properly wired to the "A" and "B" batteries.

Now the grid acts like a shutter on the flow of electrons, being wide open and permitting a large flow when it is charged positively and more and more closed to the electron flow as it becomes charged more and more negatively. The "B" current flow may be increased by connecting the positive side of a grid battery to the grid and it may be decreased by the opposite means.

This is why the use of grid biasing or "C" battery economizes "B" battery current.

The most generally useful position of the milliammeter in the radio set is on the minus "B" lead, between the set and the battery. To connect, attach the binding post of the meter marked (+) to the "B" negative post on the set, with a short insulated wire. Attach the "B" negative lead from the battery to the other post on the meter. The meter will now show the total amount of "B" battery current that is being used at any time. To safeguard the meter from excessive current from accidental short circuits caused by dropping a screwdriver into the set, or making an incorrect connection, a 10 watt, 110 volt lamp may be connected in series with the meter.

The meter should show no reading when the "A" battery is turned off. If it does, there is a short-circuit somewhere. This is the first useful purpose of the milliammeter—it detects even very minute short-circuits in the radio set. If such a reading appears, with the "A" battery switched off, the position of the

short-circuit should be tested for with a voltmeter, keeping one side of the meter attached to the "B" negative lead and exploring with the other lead from the meter.

It is far safer to remove all of the tubes when this is being done, to remove the danger of burning out tubes.

The milliammeter will immediately show a reading, which for a five-tube set may be as high as 20 to 40 milliamperes, if there are no "C" batteries used and the "B" voltage is high on the audio-frequency tube plates. But such a high "B" battery current is entirely unnecessary and may be at least halved by the proper use of "C" or grid-biasing batteries, with an improvement in faithfulness of reproduction at the same time.

If the set does not use "C" batteries, they may be installed as follows:

All the battery-cable leads should be disconnected at the batteries, to avoid danger of short-circuits, when working around the set. Then the wiring should be disconnected from the binding post marked "filament" or "—" of each of the audio-frequency transformers.

Assuming that there are two audio-frequency amplifying tubes, each with a transformer and each with about 90 volts of "B" battery on the plate, the set should have one or two 4½-volt "C" batteries. The negative side of one each of these "C" batteries should be connected with a short wire to the transformer binding post marked "filament" and the wire which was taken off the transformer should be connected to the positive binding post of the "C" battery, thus connecting the "C" positive to the "A" negative. Flexible leads with Fahnestock clips should be used and the "C" batteries should be placed in the back of the cabinet, behind the tubes.

Then the batteries may be connected and the set tuned.

The experimenter will note an immediate reduction in the reading in the milliammeter and an improvement in quality of reproduction.

For still greater improvement, four 45-volt batteries may be used instead of two 45-volt "B" batteries. A voltage of 90, or two "B" batteries may be put on the plate of the first audio tube (first after the detector), and a voltage of 180, or four full "B" batteries, on the plate of the last tube. A grid battery of $4\frac{1}{2}$ volts may be used on the first tube grid and a small $22\frac{1}{2}$ volt "B" battery with taps at $16\frac{1}{2}$, $18\frac{1}{2}$, 21 volts for the second tube grid-battery. The experimenter may try different grid biases on this last tube; probably about 18 volts will be good, but the best bias is determined by ear.

Still further improvement will result from the use of another tube in parallel with the last tube. This may be done by installing a new socket beside the last tube—and connecting grid to grid, plate to plate, "A" positive to "A" positive and "A" negative to "A" negative with short leads of insulated wire.

Although the ear is the final judge of perfection of reception, it is a condition of distortionless amplification that the needle of a milliammeter in the "B" negative line will show no movement whatever while the set is operating. With insufficient voltage on the plates of the tubes in a trans-

former-coupled audio-frequency amplifier, the milliammeter reading will increase with a loud signal. If there is not enough "C" battery voltage, the reading will decrease on loud notes. Increasing the grid biases will correct this condition. If the milliammeter needle varies its position continually and over a wide range when signals are being received, there is sure to be distortion. The grid biases and "B" battery voltages should be adjusted so that the milliammeter needle remains absolutely still at all times that signals are being received.

The milliammeter will show with the above recommended high plate voltages, not one bit more current used than with the lower and less satisfactory voltages. The grid-batteries have reduced the current used.

If a "C" battery or grid connection breaks, abnormal current flow shows up the defect. If tubes go dead, a drop in the reading immediately points to the trouble. A leaky tube with a poor vacuum will be indicated by its abnormal draw of "B" current.

The experimenter should make a friend and adviser of his milliammeter. He will never regret it and will find it to pay in added enjoyment of programs.

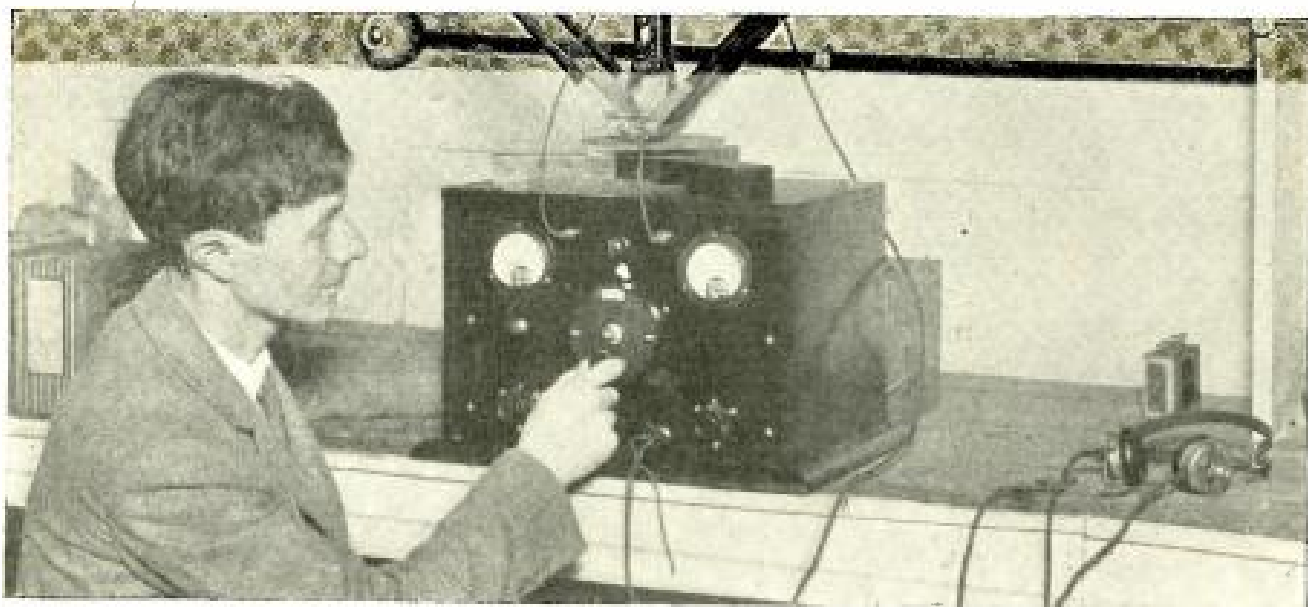

FROM a photograph made for POPULAR RADIO

**THE SINGLE-CONTROL SUPERHETERODYNE IS EQUIPPED WITH BOTH
A VOLTMETER AND A MILLIAMMETER**

A plate milliammeter is so necessary in adjusting the receiver to obtain the best results that it is included as an essential part of it.

Handy Tools for Radio Fans: No. 10



From a photograph made for POPULAR RADIO

THE SCRIBER

A device for laying out the centers in drilling panel holes

AN instrument of this kind with a strong sharp point is always useful in the experimenter's workshop or laboratory for drawing lines on the back of panels or for laying out the centers of the instruments. It must not be confused with the center punch as it should never be struck with a hammer to make a deep hole. It is only used to make a slight pin prick at the place where the center punch will later enlarge the hole to start to drill.

The instrument is usually finished as shown in the photograph, with a knurled surface and a small knob at one end for applying greater pressure.

The preceding suggestions in this series were SIDE-CUTTING PLIERS, SCREW-DRIVERS, THE HYDROMETER, THE BATTERY-TESTING VOLTMETER, THE FILE, THE JACK KNIFE, THE ELECTRIC SOLDERING IRON, THE SOCKET WRENCH and THE HAND DRILL.



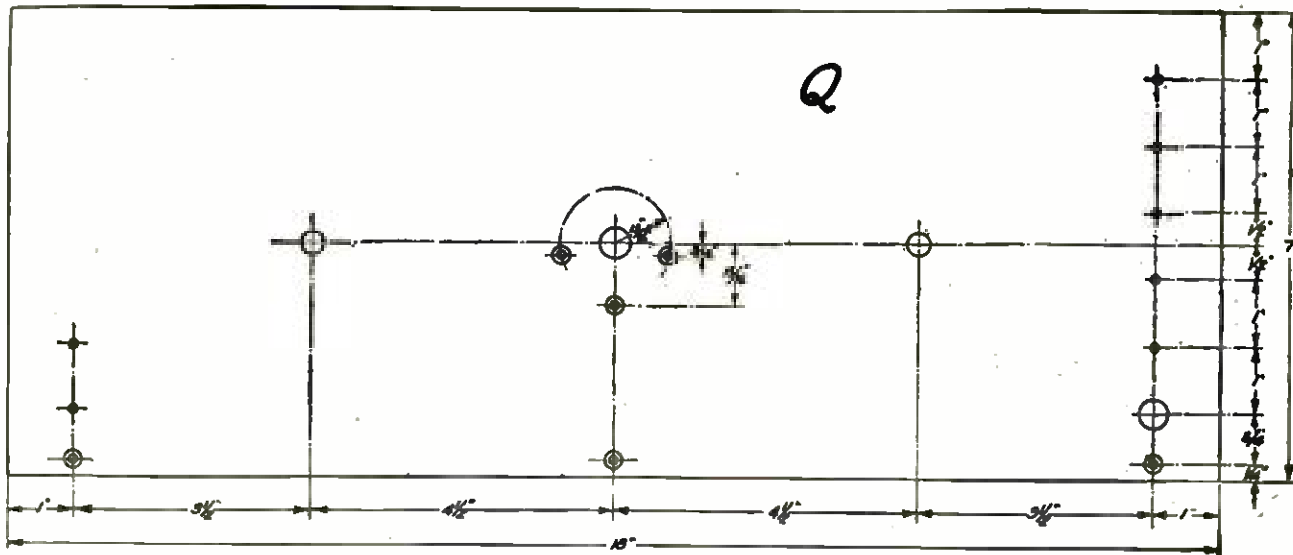

THE DRILLING PLAN FOR THE PANEL

FIGURE 1: This drawing shows exactly where holes should be drilled in the panel for mounting the instruments. The holes which are outlined with a double circle should be countersunk. Always start drilling the holes in the panel with a small drill—one-sixteenth is a good size.

Simple "How to Build" Articles for Beginners No. 15

How to Build a Three-tube Four-circuit Tuner

By LAURENCE M. COCKADAY

COST OF PARTS: *Not more than \$42.50*

APPROXIMATE RANGE: *1,000 miles*

HERE ARE THE ITEMS WITH WHICH THE
LABORATORY MODEL WAS BUILT—

A, B, C and D—primary, secondary stabilizer and antenna load coils of the Precision Octaform four-circuit coil set;
E and F—two sections of the Lombardi dual SLF variable condenser, .00035 mfd.;
G—Aerovox mica fixed condenser, .00025 mfd.;
H and I—Perry audio-frequency transformers;
J—Bradley leak;
K—Jones seven-point inductance switch;

L—E-Z-stat, 6 ohms;
M—Amperite No. 112;
N1—Benjamin Cle-Ra-Tone standard socket;
N2 and N3—Na-ald De Luxe socket No. 400;
O—Yaxley open-circuit filament lighting jack;
P—Gee-Haw vernier dial;
Q—panel, 7 by 18 inches;
R—Baseboard 6¾ by 16¾ inches;
Seven Eby binding posts.

THIS model receiver, which has been added to this series of simple sets for the beginner, utilizes the principle of the four-circuit tuner as it was first produced. That is, it consists of a detector and two stages of transformer-coupled amplification.

The set is not as costly as the five-tube

receivers but it is extremely efficient and selective and in addition produces a fine tone quality which is due to the quality of reproduction obtained in the amplifier.

It incorporates one great improvement over the old four-circuit tuner in that both of the condensers are coupled together on one shaft in accordance with

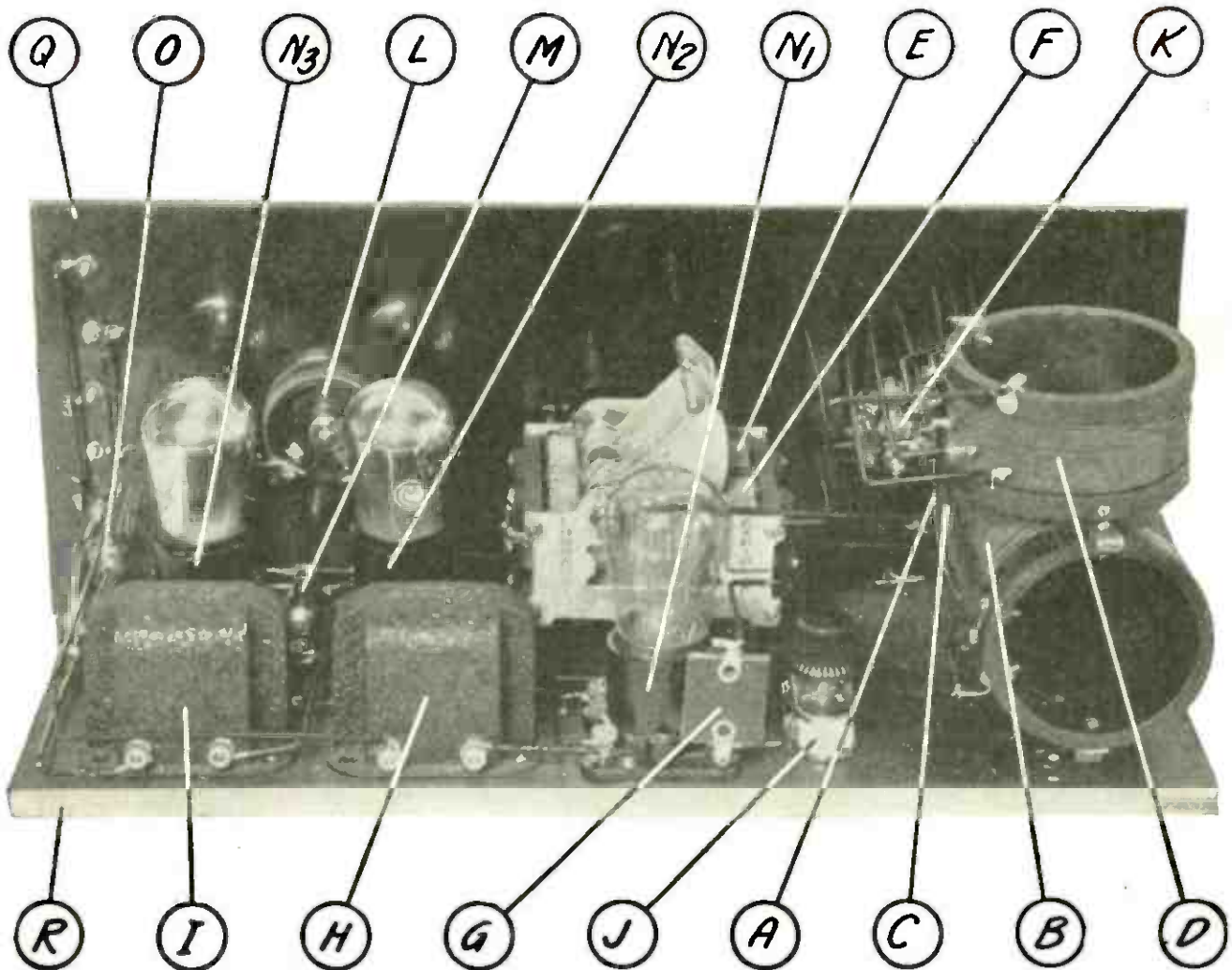

A VIEW OF THE SET FROM THE REAR

FIGURE 2: This picture diagram shows the general arrangement of all the instruments.

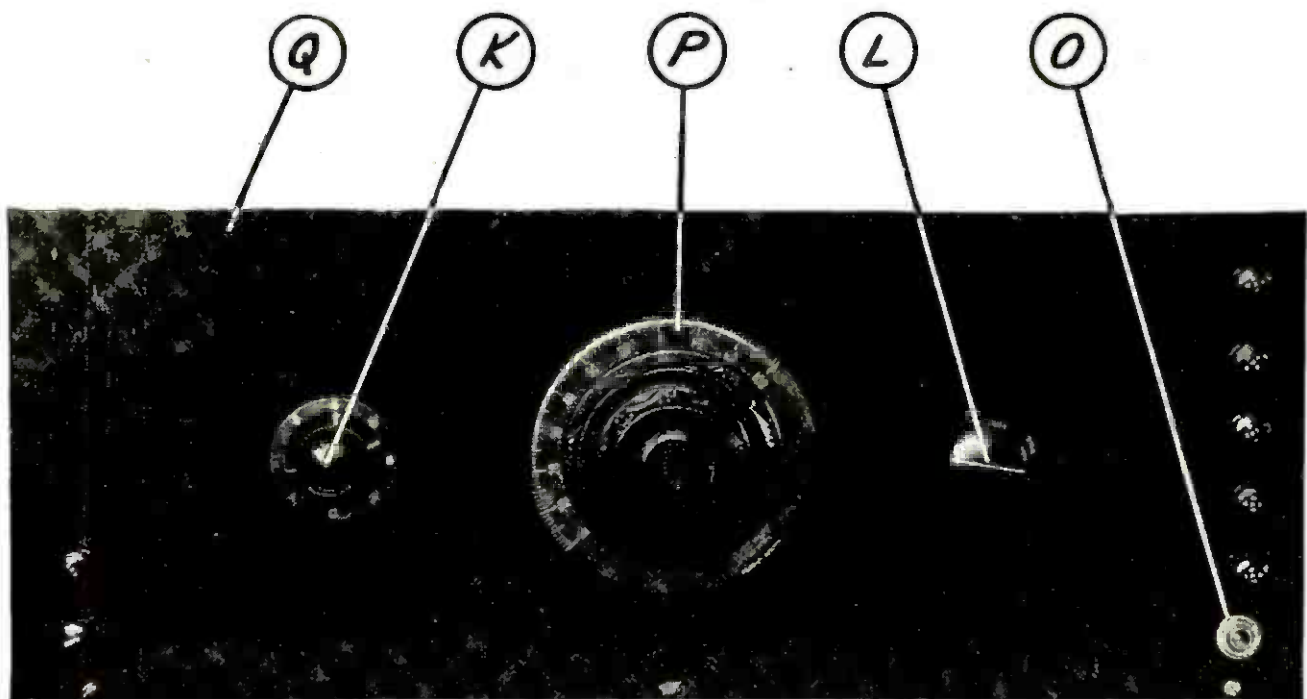

THE PANEL ARRANGEMENT

FIGURE 3: A front view of the panel is shown here. The lettering used here, as in the other illustrations, corresponds exactly with that in the list of parts.

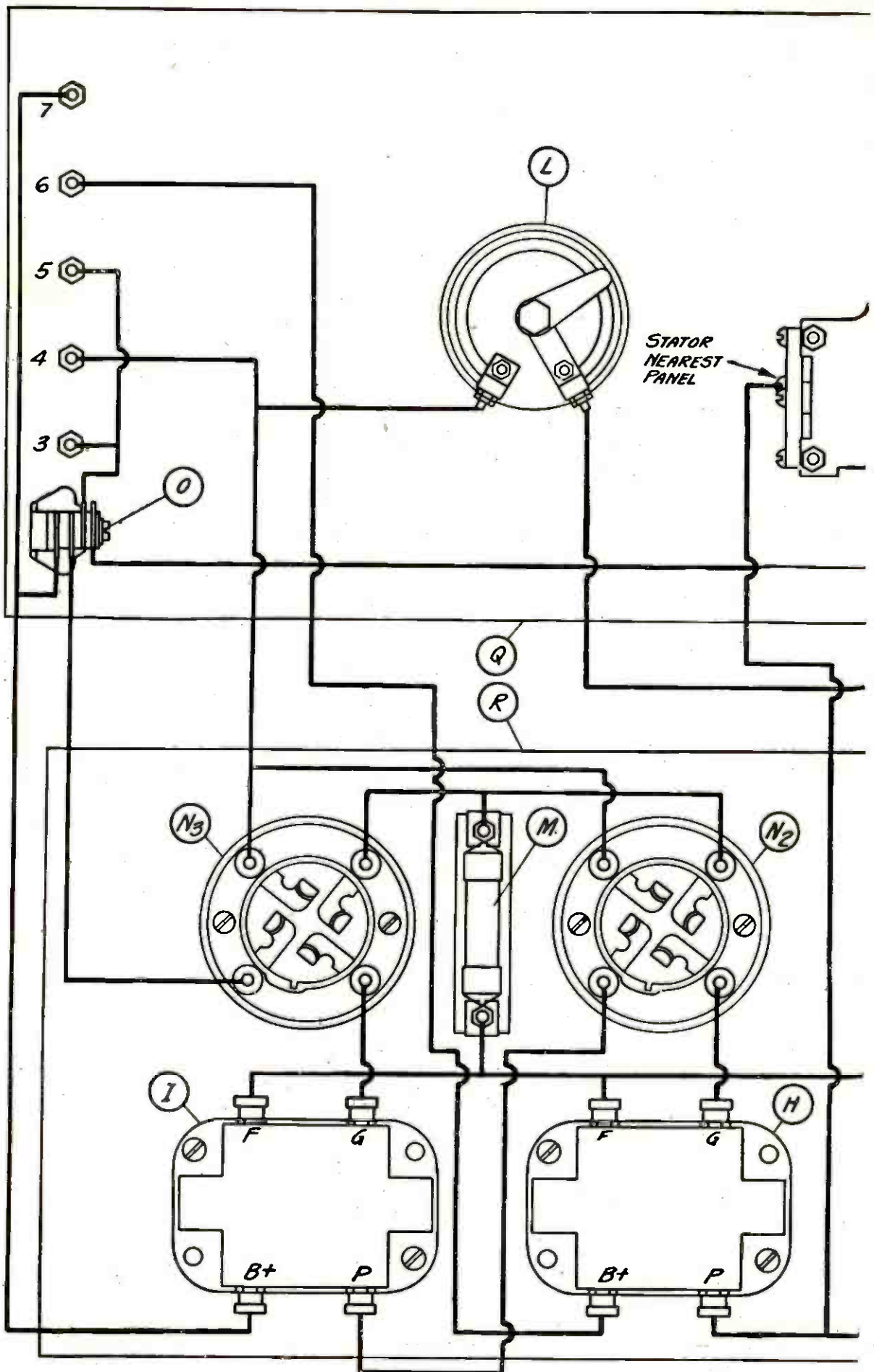
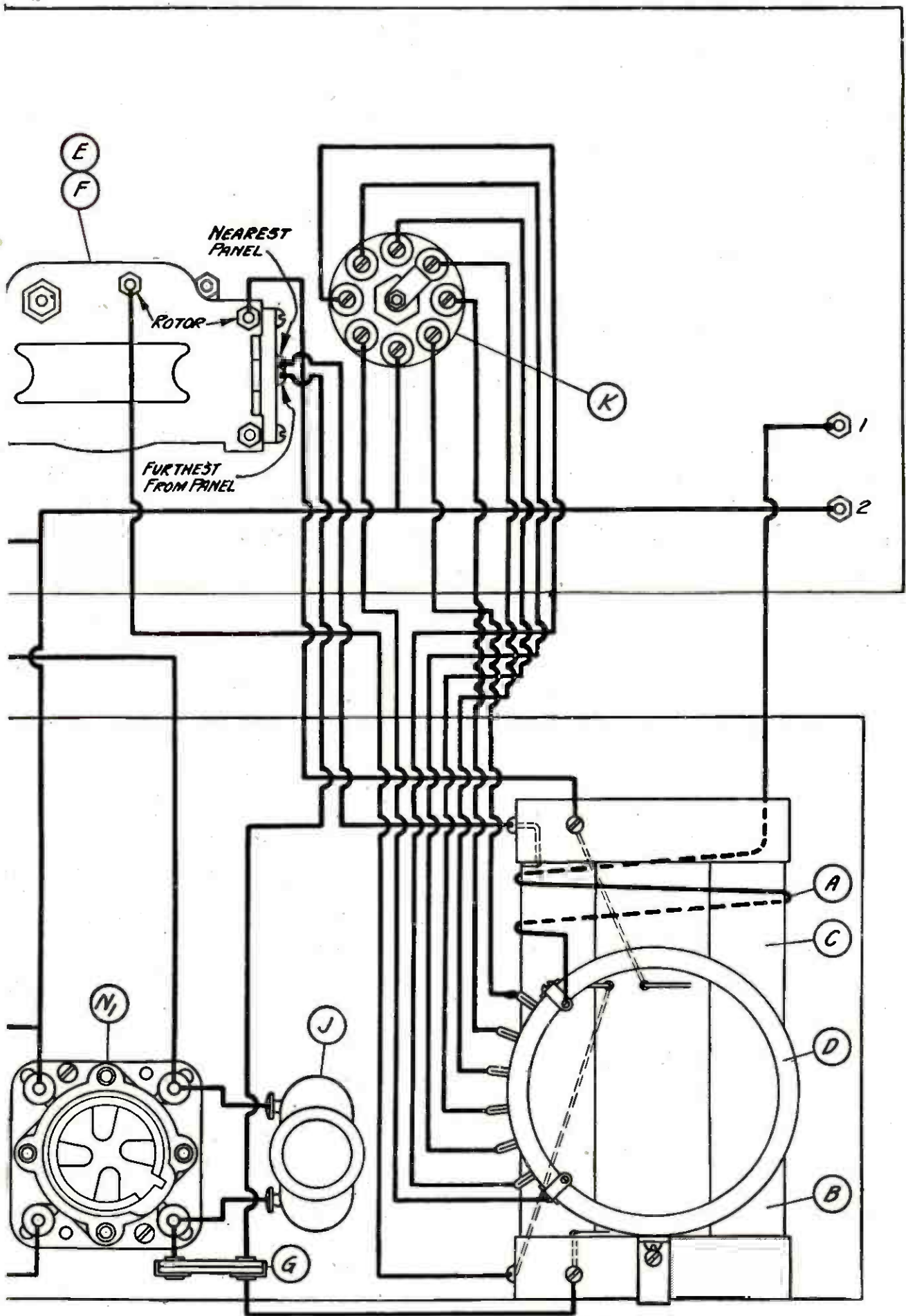

FIGURE 4: A picture diagram that gives the connections between the various rectangle represents the baseboard, while the instruments are drawn as nearly as



instruments of the receiver. The upper rectangle represents the panel and the lower possible in the positions in which they will appear.

the modern trend towards simplification of tuning. Another improvement is the employment of a simple inductance switch that does away with many holes in the panel and with the hard work of drilling them.

This receiver will be found easy to operate, and with it the beginner should be able to bring in distant stations on a loudspeaker.

The set operates from a six-volt storage battery and two 45-volt "B" batteries and is, of course, regenerative. However the coupling between the oscillating circuit and the antenna circuit is so loose that radiation is practically eliminated.

The unit that is described here was built and carefully tested in the POPULAR RADIO LABORATORY.

Take this issue of the magazine to a radio store and ask the dealer to supply you with the parts necessary to build the receiver, which are listed at the head of this article.

Then take the parts home and drill the panel Q as shown in Figure 1 which gives the size of the panel and the correct spacing for all the holes that are used to mount the instruments and binding posts.

Next mount the instruments in their correct positions on the panel and baseboard as shown in Figure 2. When this is done, wire up the instrument with standard round bus wire as indicated in Figure 4.

When you have finished wiring up, connect the antenna, ground and batteries to

the binding posts in the following manner:

Connect the antenna lead wire to binding post 1 with the ground wire running to binding post 2. Connect the two 45-volt "B" batteries in series and connect the positive 90-volt terminal to binding post 3. Connect the positive 22½-volt tap to binding post No. 4. Connect the negative terminal of the "B" battery to binding post No. 5.

Then connect the 6-volt "A" battery across binding posts 6 and 7 with the positive terminal connected to post No. 6 and the negative terminal connected to post No. 7.

Insert in socket N1 a UX-200 detector tube and place two UX-201-a tubes in the two remaining sockets. Place the loudspeaker plug in the jack O and the two amplifier tubes should immediately light up to the correct brilliancy.

Finally adjust the rheostat L so that the detector tube burns with the correct brilliancy and rotate the dial P until the stations are picked up.

The best selectivity and volume will be obtained by rotating the inductance switch knob K to the right number.

The correct type of antenna to use with this receiver is a single wire or a double wire 100 to 150 feet long.

If the set is built correctly, as shown in the diagrams and pictures, the operator will find, after he becomes familiar with tuning, that he will get good reception on the loudspeaker from stations which are up to about 1000 miles away.

A Storage Battery Charger That You Can Make at Home

In the April issue of POPULAR RADIO will appear another article of the simple "how-to-build" series. It will describe a storage battery charger that may be made at home by even an inexperienced radio fan at a cost of only a few dollars. This unit will operate directly from the AC lighting lines and will provide the experimenter with a reliable means for keeping his storage battery fully charged and ready for operation at all times.

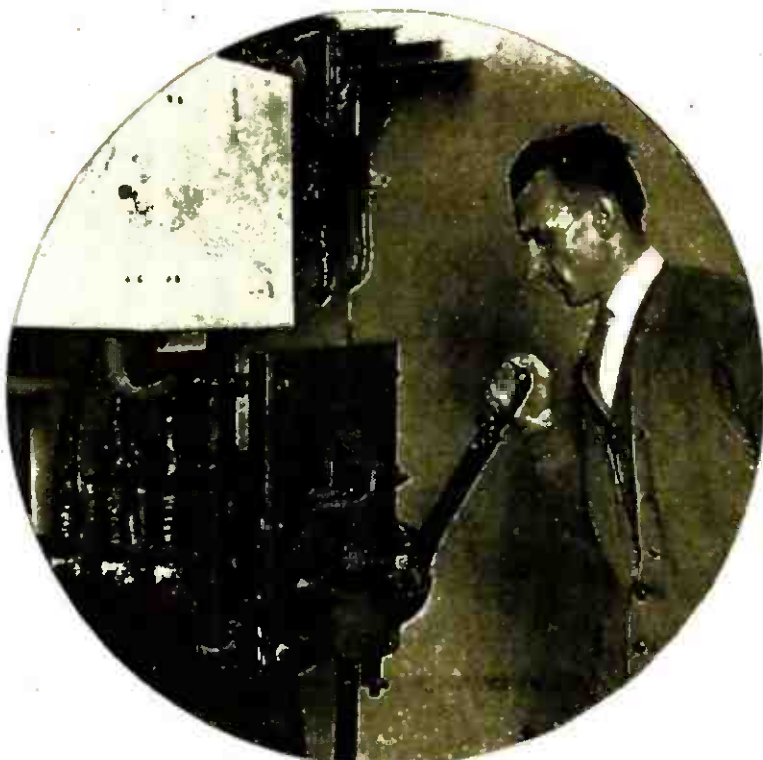

The master switch that controls the current of 4300 volts potential which enters the station from the power plant. It is the only switch in the station which is set by hand.

The New Lord of the Ether

Some of the unique features of the most powerful broadcasting station in America—2XAR, located at Bound Brook, New Jersey.

From photographs made by Kadel & Herbert.

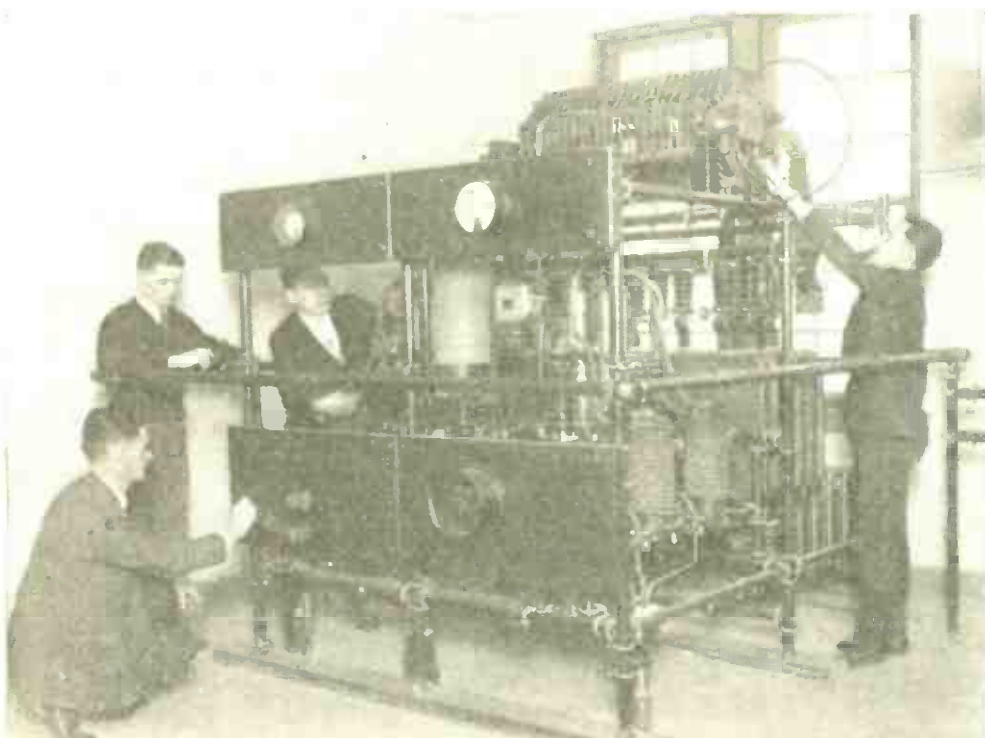

One of the oscillators of the 50-kilowatt transmitter which make the new Bound Brook station one of the most powerful broadcasters. The coiled tubing which supplies water to the huge water-cooled tubes is here shown.

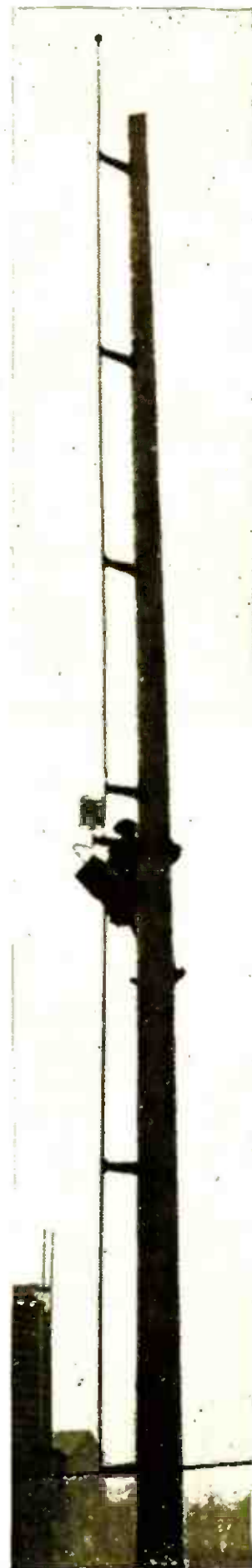

The upright short-wave antenna; half-way up is the antenna coil.

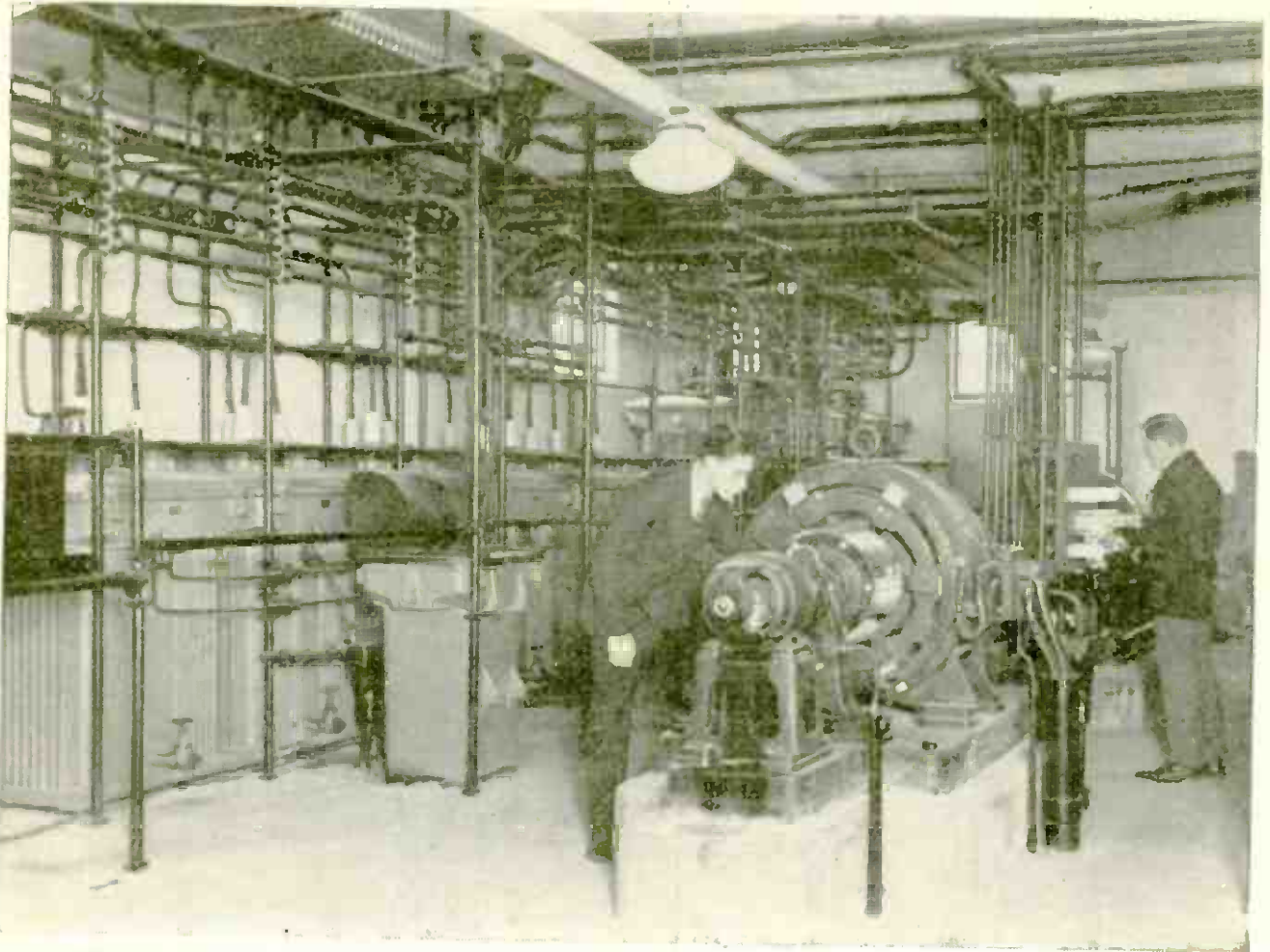

The transformer room where the outside current of 4300 volts potential is reduced to 2300 volts. One of the two motor generators is shown above.



Four of the 64 ten-kilowatt tubes that are used in the station. The water-cooling jackets and tubing are here shown.

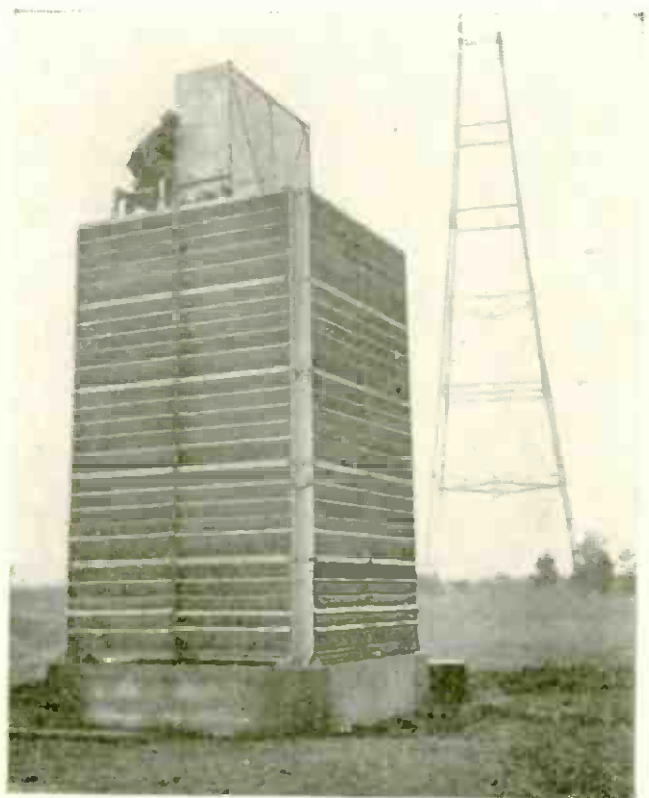

The huge water cooler which cools 100 gallons of water a minute. This water is kept constantly in circulation.

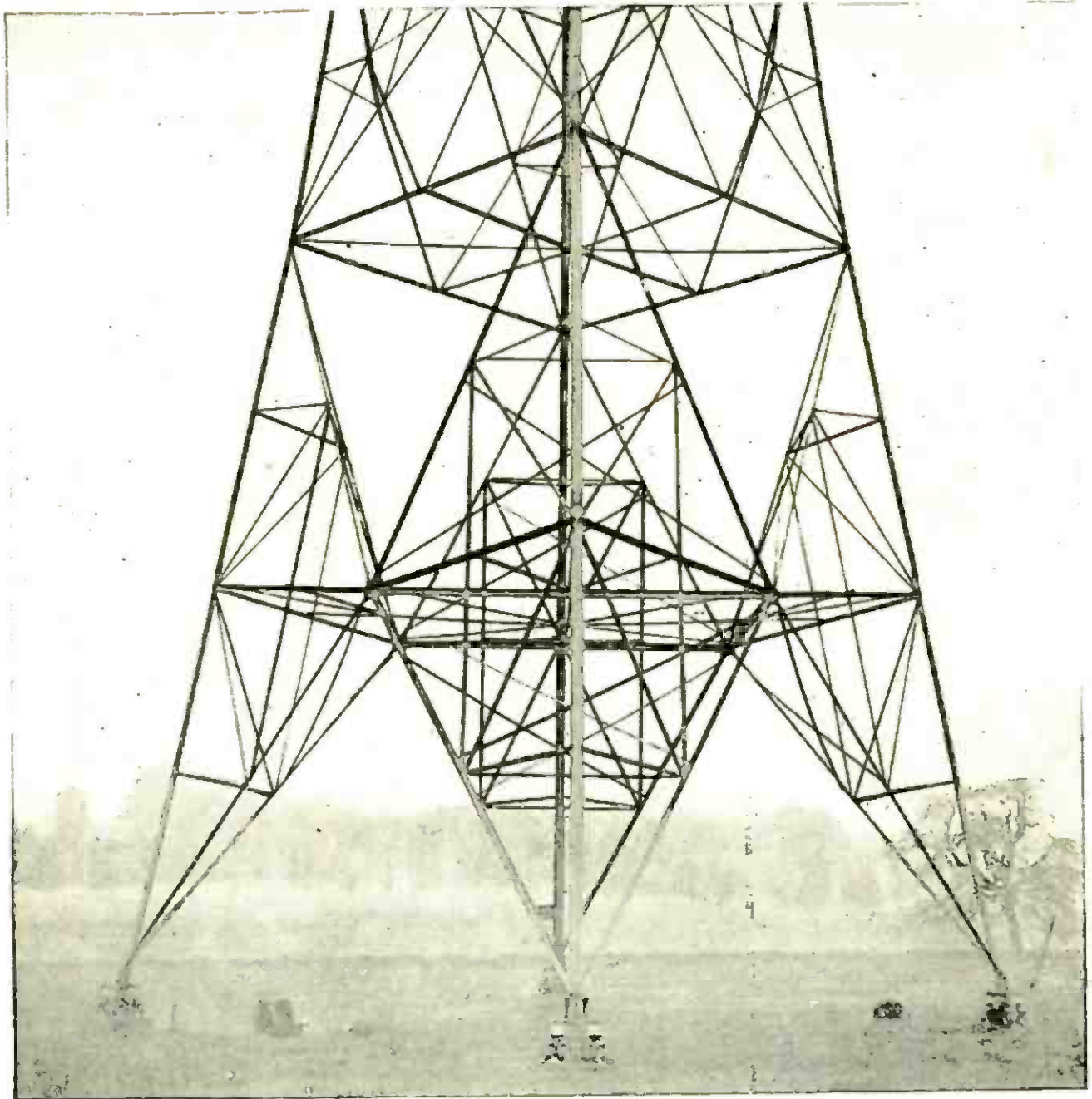

The steel network at the base of one of the two 400-foot towers which support the antenna. Notice how the feet of the tower are insulated from the ground.

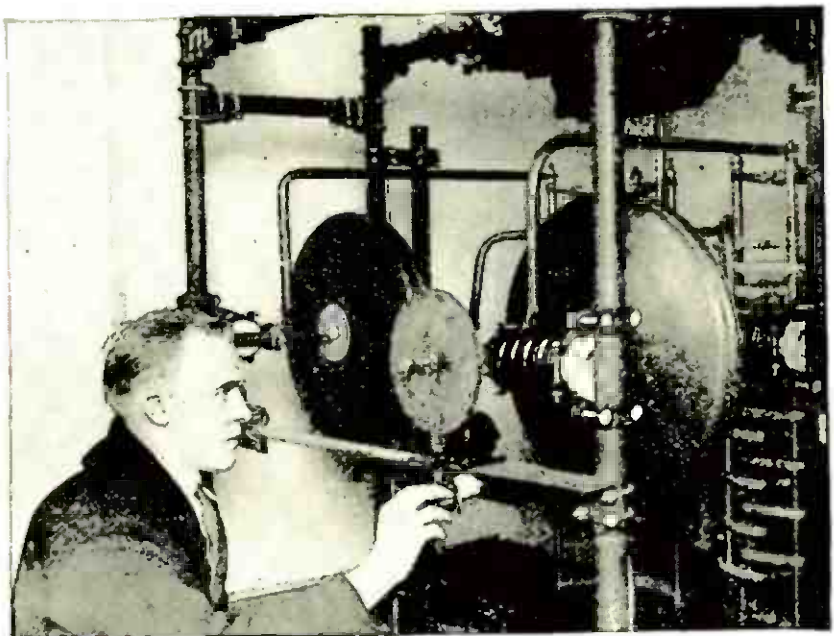

A pair of vernier air condensers which are used to sharpen the antenna tuning. They are operated automatically by the tiny electric motor placed between them.

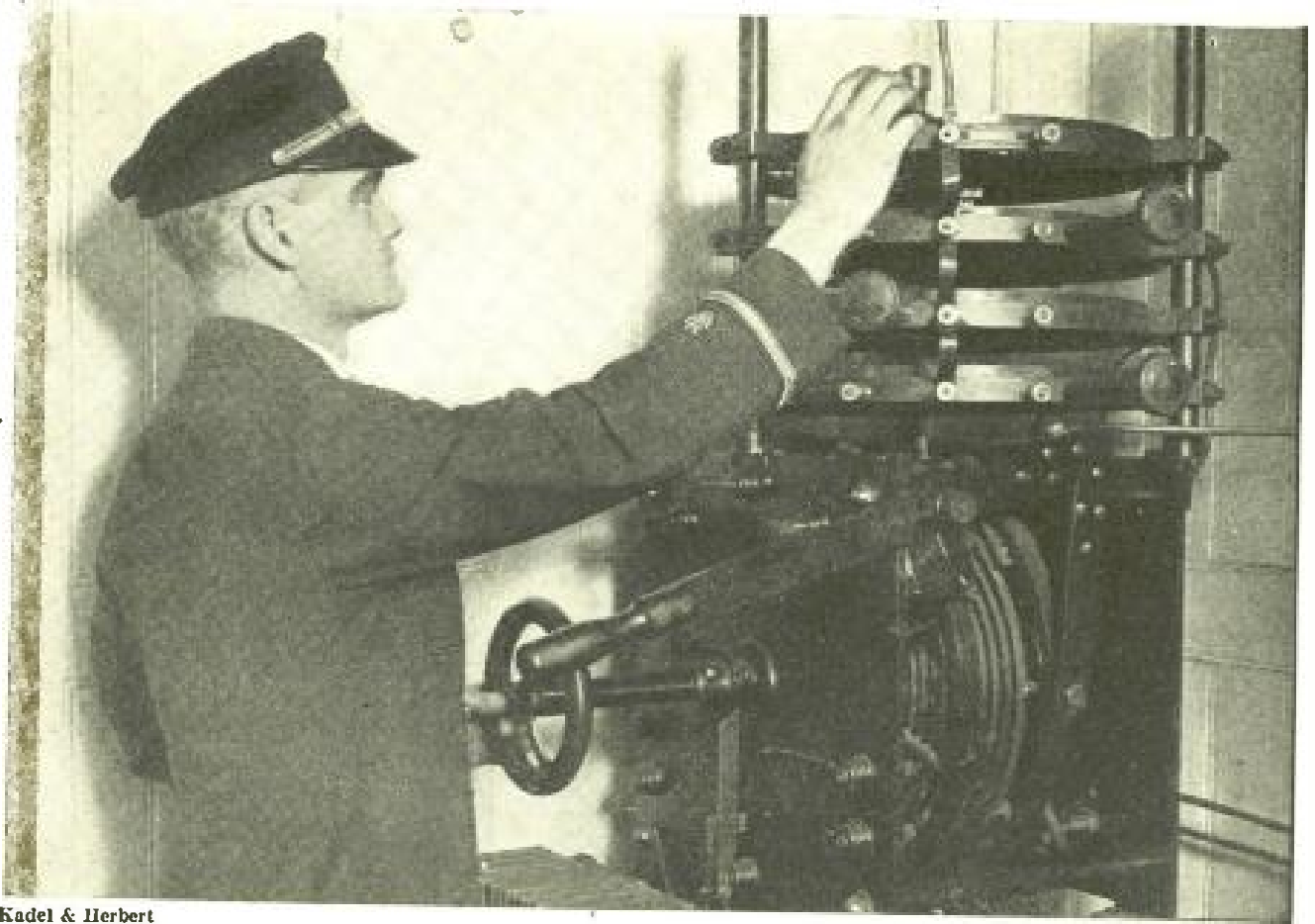

Kadel & Herbert

HOW A TRANSMITTING INDUCTANCE IS USED

The ship's operator in this picture is shown adjusting the variable "pancake" inductances of a quenched spark transmitter.

What "Inductance" Really Is

Article No. 15

Some of the main facts underlying the use of induction in modern electrical apparatus and some of the interesting phenomena that accompany the working of electrostatic and electromagnetic induction are told in this article.

By SIR OLIVER LODGE, F.R.S., D.Sc., LL.D.

"INDUCTION" is a general name that was first employed by Faraday to indicate any electromagnetic or electrostatic action across space; that is through the ether only, as opposed to "conduction" through matter.

When a charged body is brought near a conductor, it is said to act inductively on that conductor. If the conductor is insulated, its potential is thereby raised by

an amount proportional to the charge and inversely as the distance of that charge.

Electrostatic Induction

An insulated conductor thus acted upon inductively not only has its potential raised so that it can give off a spark similar in sign to that of the inducing body, but it has its own charges redistributed. The charge of the opposite sign is at-

tracted towards the neighborhood of the inducing charge and a charge of similar sign is repelled, so that it has opposite charges at its two ends and is said to be polarized. If it is grounded the repelled charge escapes and an extra supply of the attracted sign is supplied sufficient to neutralize its potential and reduce it to zero in spite of the continued neighborhood of the inducing charge.

For instance, if a positively charged sphere is brought into a room, the floor, walls, ceiling, tables and all neighboring objects are charged inductively and negative electricity may be removed from any of them. If the hand of an operator is brought near the inducing charge that hand at once acquires an opposite charge.

In other words, electrons crowd into it from the earth and face the inducing positive charge until, if the hand be brought near enough and the potential of the in-

ducing charge is high enough, the opposite charges rush together disruptively, breaking down the insulation of the air and causing the momentary evolution of heat and light called a spark.

If instead of a flat surface a pointed body is brought near the charge, the electrons crowding on to that point are able to break down the air at a considerable distance, giving however not a spark but a luminous glow (brush discharge). In other words, they electrify the air in the immediate neighborhood; which then, no doubt, moves towards the charged body and rapidly discharges it. In this way, what is called "an electric wind" (ionization) may be produced, which may drive a small paper-mill, or by its action on the point may propel that backwards, if it is free to move.

When an elongated insulated conductor is subjected to induction and then broken

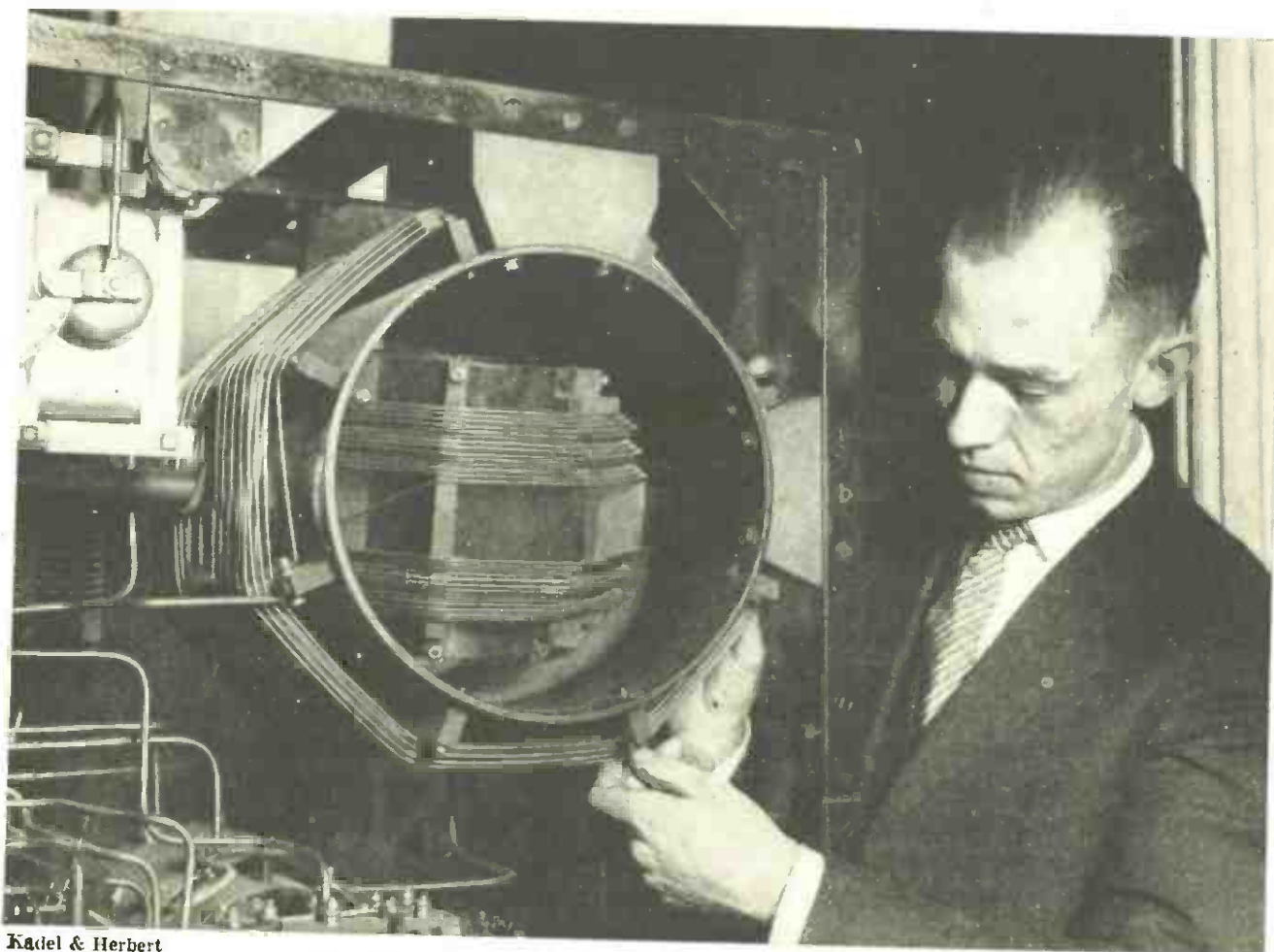

Kadel & Herbert

A CONTINUOUSLY VARIABLE INDUCTANCE

The apparatus shown in this illustration is called a variometer. It consists of two coils of wire—an outer coil and an inner coil which is rotatable in inductive relation to the outer one. It is used in this case for transmitting.

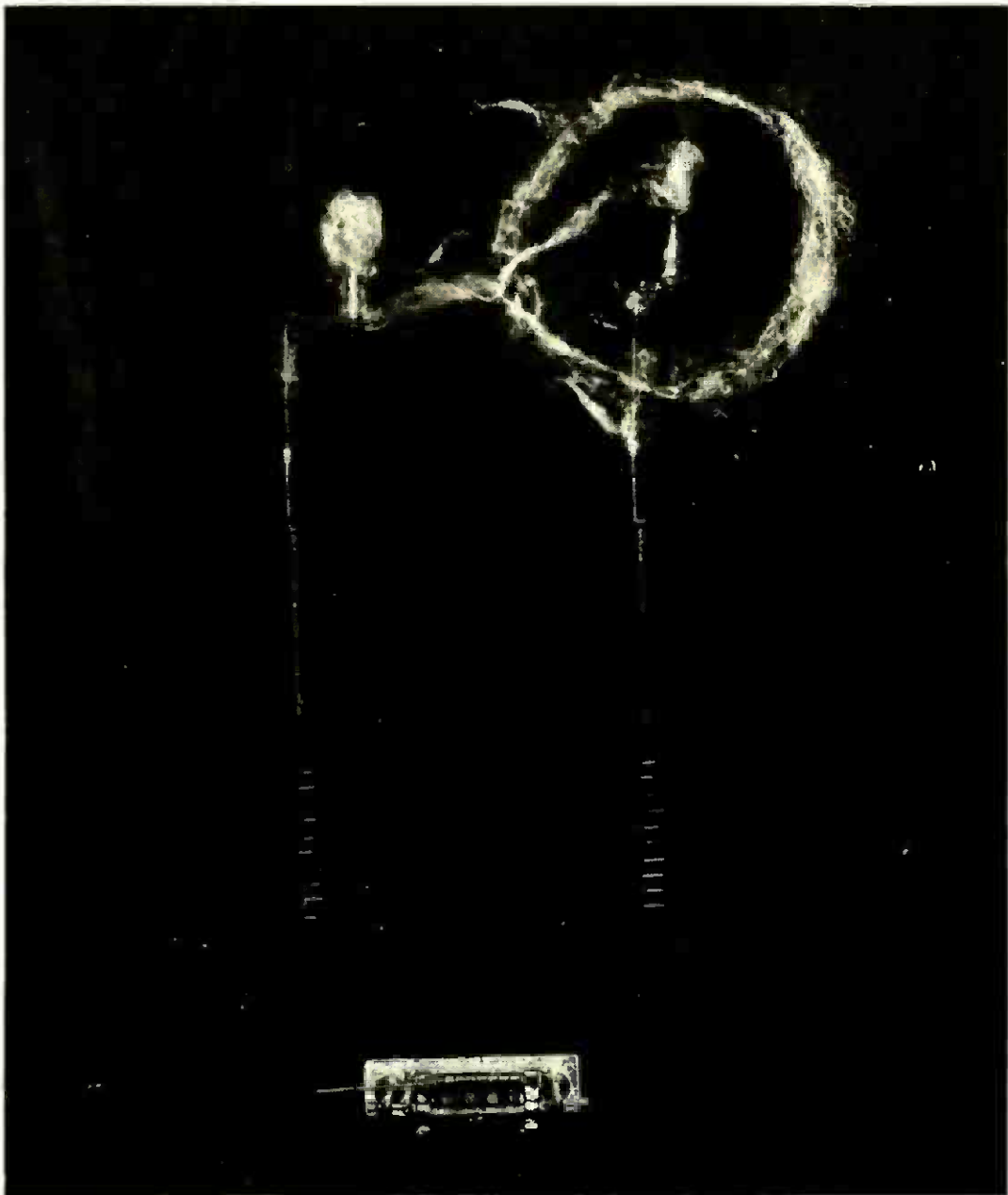

Courtesy of Joseph G. Brand

THE TESLA-LOUDIN INDUCTANCES

This apparatus also makes use of electromagnetic induction. The brushing discharge shown around the glass bulbs of the bent wires is produced by the use of the phenomenon known as induction.

in half or separated (by previous arrangement) into two portions, one half *will be charged negatively*, while the other half *will be charged positively*.

The two charges may be separated to any distance by what might be called "convection," though this term is more usually applied to the automatic carrying of charges by the atoms of matter, instead of to their artificial conveyance by hand or other means of locomotion.

Magnetic Induction

When one end of a long magnet, that

is to say a magnetic pole, is brought near a piece of iron it too is acted on inductively and is said to be polarized.

If, for instance, the inducing pole is a north pole the piece of iron will have a south pole at the near end and a north pole at the far end. But if it is now broken in half these poles cannot be separated. New poles appear at the break and each half is a complete magnet. And the same will occur for as many pieces as are broken off.

This is an important distinction between magnetism and electricity. It may

be said that whereas electric lines of force terminate on conductors, one end being positive, and the other end negative, magnetic lines of force never terminate but are always closed curves. However, when they quit the air and enter iron or steel, the change in what is called "magnetic permeability" or more simply, the change of material, causes poles to appear at the boundary. And these poles appear wherever there is a boundary.

Moreover, there is no ordinary conduction for magnetism, as there is for electricity, and a magnet cannot be discharged by touching it. Steel magnets may be magnetized by induction, and if the steel is hard they will retain the magnetism imparted. That is to say, the material does not allow the lines of force produced in it to subside again. A portion may subside but a portion is retained.

The retained portion is called "permanent magnetism."

It can, however, be got rid of in several ways. It partly subsides if the steel is rapped violently, as by the blows of a hammer. It also subsides to some extent with the lapse of time. It diminishes also if the steel is heated: at a certain temperature it disappears altogether. At a red-heat iron becomes insusceptible to magnetism. Nickel loses its susceptibility at a much lower temperature. Cobalt retains it to a white-heat.

Concerning the nature and cause of these differences, and indeed the reason for the susceptibility of iron and other magnetic substances, some progress has been made, but there is much still to be discovered. At present, in an elementary treatment, we must ascertain and accept the facts. Hard steel is not easily magnetized; but when it is magnetized it remains in a magnetized state, especially if the bar is long and thin. A short stout bar is quite unsuitable for a permanent magnet. If such a bar magnet is wanted, it should be made of thin bars separately magnetized and then riveted or clamped together.

Electricity may be conveyed from one body to another by conduction, but magnetism can only be transmitted by induction and the two opposite poles can never be separated. The poles of every magnet are equal in strength; though if they are of different size, one may be more concentrated than the other.

All the lines of force from every portion of the north pole curve round to a corresponding portion of the south pole and then continue through the steel or iron completing the magnetic circuit. Such a circuit is sometimes called "open"—meaning that it has an air-gap; in the case of a bar magnet a wide and diffuse air-gap. It may be technically closed, or short circuited, by a piece of iron or "keeper" so that the stray field in the air can be reduced to insignificance. But all magnetic circuits are really closed in one material or another.

The same statement may be made for "current" electricity, for when a current flows it must flow in a complete circuit. But if a dielectric or insulator is interposed in that circuit, then the circuit is completed, not by conduction, but by electric displacement. That is, it is completed in an elastic manner like the stretching of a membrane across a pipe, which would be displaced by the flow of water until it either bursts or stops the flow and causes an elastic recoil or discharge. That is just what happens in a condenser, though the displacement is not of a mechanical and obvious kind. The electric flow is checked and driven back again when the propelling force is removed and the external metallic circuit completed.

Some dielectrics are much more easily "burst" than others. Glass, bakelite, hard rubber and even liquid insulators, such as oil are able to stand a considerable strain. Air is burst more easily. Induction always precedes a spark; and it is electrostatic induction which chiefly operates in condensers as against electromagnetic induction in transformers.

Broadcasting Stations in the U. S.

(Corrected as of January 20, 1926)

Call Letters	Location	Wave-length	Location	Wave-length	Call Letters	Wave-length	Location	Call Letters
KDKA	East Pittsburg, Pa.	309.1	AGRICULTURAL COL., N. D.	275	WPAK	202.6	Big Bear Lake, Cal.	KFXB
KDLR	Devils Lake, N. D.	231	AKRON, O.	258	WADC	202.6	Elisabeth, N. J.	WIBS
KDYL	Salt Lake City, Utah	246	ALBUQUERQUE, N. M.	254	KFLR	202.6	Evanston, Ill.	WEHS
KDZB	Bakersfield, Cal.	209.7	ALBUQUERQUE, N. M.	250	KFVY	205.4	Brooklyn, N.Y.	WFRL
KFAB	Lincoln, Neb.	340.7	ALLEN TOWN, PA.	254	WCBA	205.4	Flagstaff, Ariz.	KFXV
KFAD	Phoenix, Ariz.	273	ALLEN TOWN, PA.	229	WSAN	205.4	Logan, Utah	KFXD
KFAF	San Jose, Cal.	217.3	ALTOONA, PA.	278	WFBG	205.4	Oxnard, Cal.	KFYF
KFAJ	Boulder, Col.	261	AMARILLO, TEX.	263	WDAG	205.4	Providence, R. I.	WCBR
KFAU	Boise, Ida	282.8	AMES, IA.	270	WOI	205.4	San Pedro, Cal.	KFVD
KFBB	Havre, Mont.	275	ANDERSON, IND.	246	WEBD	205.4	Utica, N. Y.	WIBX
KFBC	San Diego, Cal.	224	ANDERSON, IND.	218.8	WHBU	206.8	Joliet, Ill.	WJBA
KFBK	Sacramento, Cal.	248	ANITA, IA.	273	KFLZ	206.8	Oakland, Cal.	KFWM
KFBL	Everett, Wash.	224	ASHEVILLE, N. C.	254	WABC	206.8	Wooster, O.	WA1 W
KFBS	Trinidad, Col.	238	ASTORIA, ORE.	246	KFJI	208.2	Los Angeles, Cal.	KNRC
KFBU	Laramie, Wyo.	270	ATLANTA, GA.	270	WDBE	209.7	Bakersfield, Cal.	KDZB
KFCB	Phoenix, Ariz.	238	ATLANTA, GA.	270	WGST	209.7	Chicago, Ill.	WSBC
KFCF	Walla Walla, Wash.	256	ATLANTA, GA.	428.3	WSB	209.7	New Bedford, Mass.	WIBH
KFDD	Boise, Ida	278	ATLANTIC CITY, N. J.	275	WHAR	209.7	New York, N. Y.	WBNY
KFDJ	Corvallis, Ore.	282.8	ATLANTIC CITY, N. J.	299.8	WPG	209.7	Providence, R. I.	WCWS
KFDM	Beaumont, Tex.	315.6	AUBURN, ALA.	248	WAPI	209.7	Santa Maria, Cal.	KFXC
KFDX	Shreveport, La.	250	AUSTIN, TEX.	231	KUT	211.1	Avalon, Cal.	KFWO
KFDY	Brookings, S. D.	273	AVALON, CAL.	211.1	KFWO	211.1	Lewisburg, Pa.	WJBQ
KFDZ	Minneapolis, Minn.	231	BAKERSFIELD, CAL.	209.7	KDZB	211.1	Upland, Cal.	KFWC
KFEC	Portland, Ore.	248	BALTIMORE, MD.	246	WBAL	212.8	Portland, Ore.	KFWV
KFEL	Denver, Col.	254	BALTIMORE, MD.	275	WCAO	212.8	Portland, Ore.	KQP
KFEQ	Oak, Neb.	268	BALTIMORE, MD.	229	WCBM	212.8	Richmond Hill, N. Y.	WWGL
KFEY	Kellogg, Ida.	233	BALTIMORE, MD.	254	WFRB	212.8	Washington, D. C.	WMAL
KFFP	Moberly, Mo.	242	BANGOR, ME.	240	WABI	214.2	Joliet, Ill.	WCLS
KFGH	Stanford University, Cal.	270	BATAVIA, ILL.	275	WORD	214.2	Joliet, Ill.	WKBB
KFGQ	Boone, Ia.	226	BAY CITY, MICH.	261	WSKC	214.2	Oklahoma City, Okla.	KEXR
KFH	Wichita, Kan.	268	BAY SHORE, N. Y.	215.7	WRST	214.2	St. Louis, Mo.	KFWF
KFHA	Gunnison, Col.	252	BEAUMONT, TEX.	315.6	KFDM	215.7	Bay Shore, N. Y.	WRST
KFHL	Oskaloosa, Ia.	240	BEAUMONT, TEX.	227	KFXM	215.7	Chicago, Ill.	WBBZ
KFI	Los Angeles, Cal.	468.5	BEEVILLE, TEX.	248	KFRB	215.7	Chicago, Ill.	WIBJ
KFIF	Portland, Ore.	248	BELLEFONTAINE, O.	222	WHBD	215.7	Chicago, Ill.	WIBM
KFIO	Spokane, Wash.	266	BELOIT, WIS.	268	WEBW	215.7	Chicago, Ill.	WKBQ
KFIQ	Yakima, Wash.	256	BERKELEY, CAL.	256	KRE	215.7	Denver, Col.	KFXJ
KFIU	Juneau, Alaska	226	BERRIEN SPRINGS, MICH.	285.5	WEMC	215.7	Harrisburg, Pa.	WPRO
KFIZ	Fondulac, Wis.	273	BIG BEAR LAKE, CAL.	202.6	KFXB	215.7	Logansport, Ind.	WHBL
KFJB	Marshalltown, Ia.	248	BIRMINGHAM, ALA.	248	WBRC	215.7	North Bend, Wash.	KFQW
KFJC	Junction City, Kan.	218.8	BISMARCK, N. D.	248	KFYR	215.7	Philadelphia, Pa.	WHBW
KFJF	Oklahoma City, Okla.	261	BOISE, IDA.	282.8	KFAU	217.3	Chicago, Ill.	WFKV
KFJI	Astoria, Ore.	246	BOISE, IDA.	278	KFDD	217.3	Holy City, Cal.	KFQU
KFJM	Grand Forks, N. D.	278	BOONE, IA.	226	KFGQ	217.3	Homewood, Ill.	WOK
KFJR	Portland, Ore.	263	BOSTON, MASS.	242	WBZA	217.3	San Jose, Cal.	KFAF
KFJY	Fort Dodge, Ia.	246	BOSTON, MASS.	261	WDBR	218.8	Anderson, Ind.	WHBU
KFJZ	Fort Worth, Tex.	254	BOSTON, MASS.	348.6	WEEI	218.8	Buffalo, N. Y.	WJBP
KFKA	Greeley, Col.	273	BOSTON, MASS.	250	WNAB	218.8	Flushing, N. Y.	WIBI
KFKU	Lawrence, Kan.	275	BOSTON, MASS.	280.2	WNAC	218.8	Junction City, Kan.	KFJC
KFKX	Hastings, Neb.	288.3	BOULDER, COL.	261	KFAJ	218.8	Manhattan, Kan.	KFVB
KFKZ	Kirksville, Mo.	226	BRISTOW, OKLA.	374.8	KVOO	218.8	Olympia, Wash.	KFRW
KFLR	Albuquerque, N. M.	254	BROOKINGS, S. D.	273	KFDY	218.8	Red Bank, N. J.	WJBI
KFLU	San Benito, Tex.	236	BROOKLYN, N. Y.	205.4	WFRL	220	Logansport, Ind.	WIBW
KFLV	Rockford, Ill.	229	BROWNSVILLE, TEX.	278	KWWG	220	Oakland, Cal.	KFUU
KFLX	Galveston, Tex.	240	BUFFALO, N. Y.	244	WEBR	220	Parkerburg, Pa.	WQAA
KFLZ	Anita, Ia.	273	BUFFALO, N. Y.	319	WGR	220	San Francisco, Cal.	KJBS
KFMQ	Fayetteville, Ark.	299.8	BUFFALO, N. Y.	218.8	WJBP	222	Bellefontaine, O.	WHBD
KFMR	Sioux City, Ia.	261	BURLINGAME, CAL.	226	KFOB	222	Culver, Ind.	WHBF
KFMW	Houghton, Mich.	263	BURLINGTON, IA.	254	WIAS	222	Elkins Park Pa.	WIBG
KFMX	Northfield, Minn.	336.9	BURLINGTON, VT.	250	WCAX	222	Norfolk, Va.	WBBW
KFNF	Shenandoah, Ia.	263	CAMBRIDGE, ILL.	242	WTAP	222	Poynette, Wis.	WIBU
KFOA	Seattle, Wash.	454.3	CAMBRIDGE, O.	234	WEBE	222	Rock Island, Ill.	WHBF
KFOB	Burlingame, Cal.	226	CAMDEN, N. J.	236	WFBI	222	St. Petersburg, Fla.	WIBC
KFOJ	Moberly, Mo.	242	CAMP LAKE, WIS.	231	WCLO	222	Takoma Park, Md.	WBE3
KFON	Long Beach, Cal.	233	CANTON, N. Y.	263	WCAD	224	Cape Girardeau, Mo.	KFVS
KFOO	Salt Lake City, Utah	236	CANTON, O.	254	WHBC	224	Charlotte, N. C.	WJBG
KFOR	David City, Neb.	226	CAMP GIRARDEAU, MO.	224	KFVS	224	Everett, Wash.	KFBL
KFOT	Wichita, Kan.	231	CARTERSVILLE, MO.	258	KFPW	224	Iowa City, Ia.	KFQP
KFOX	Omaha, Neb.	248	CARTHAGE, ILL.	236	WTAD	224	Laconia, N. H.	WKAV
KFOY	St. Paul, Minn.	252	CAZENOVIA, N. Y.	275	WMAC	224	Monmouth, Ill.	WBBU
KFPL	Dublin, Tex.	252	CEDAR RAPIDS, IA.	278	KWCR	224	Ogden, Utah	KFU
KFPM	Greenville, Tex.	242	CEDAR RAPIDS, IA.	268	WJAM	224	Paterson, N. J.	WODA
KFPR	Los Angeles, Cal.	231	CHARLESTON, S. C.	268	WBY	224	San Diego, Cal.	KFBC
KFPW	Cartersville, Mo.	258	CHARLOTTE, N. C.	275	WBT	226	Boone, Ia.	KFG
KFPY	Spokane, Wash.	266	CHARLOTTE, N. C.	224	WJBG	226	Burlingame, Cal.	KFOB
KFOA	St. Louis, Mo.	261	CHATTANOOGA, TENN.	256	WDOD	226	Chicago, Ill.	WBB1
KFOB	Fort Worth, Tex.	263	CHICAGO, ILL.	535.4	KYW	226	Chicago, Ill.	WIBO
KFOP	Iowa City, Ia.	224	CHICAGO, ILL.	278	WAAF	226	David City, Neb.	KFOR
KFOU	Holy City, Cal.	217.3	CHICAGO, ILL.	226	WBBM	226	Harrisburg, Ill.	WEB
KFQW	North Bend, Wash.	215.7	CHICAGO, ILL.	215.7	WBBZ	226	Hollywood, Cal.	KFQZ
KFOZ	Hollywood, Cal.	226	CHICAGO, ILL.	266	WBCN	226	Juneau, Alaska	KFIU
KFRB	Beaville, Tex.	248	CHICAGO, ILL.	370.2	WEBH	226	Kirksville, Mo.	KFKZ
KFRG	San Francisco, Cal.	288	CHICAGO, ILL.	266	WENR	226	Nashville, Tenn.	WDAD

Call Letters	Location	Wave-length	Location	Wave-length	Call Letters	Wave-length	Location	Call Letters
KFRU	Columbia, Mo.	499.7	CHICAGO, ILL.	217.3	WFKB	226	New York, N. Y.	WEBL
KFRW	Olympia, Wash.	218.8	CHICAGO, ILL.	302.8	WGN	226	New York, N. Y.	WEBM
KFSG	Los Angeles, Cal.	275	CHICAGO, ILL.	233	WHBM	226	Seymour, Ind.	WFBE
KFUL	Galveston, Tex.	258	CHICAGO, ILL.	215.7	WIBJ	226	South San Francisco, Cal.	KFWI
KFUO	St. Louis, Mo.	545.1	CHICAGO, ILL.	215.7	WIBM	227	Beaumont, Tex.	KFXM
KFUP	Denver, Col.	234	CHICAGO, ILL.	226	WIBO	227	Cleveland, O.	WDBK
KFUR	Ogden, Utah	224	CHICAGO, ILL.	215.7	WKBG	227	Fort Wayne, Ind.	WOWO
KFUS	Oakland, Cal.	256	CHICAGO, ILL.	258	WLTS	227	Welcome, Minn.	KFVN
KFUT	Salt Lake City, Utah	261	CHICAGO, ILL.	447.5	WMAQ	229	Allentown, Pa.	WSAN
KFUU	Oakland, Cal.	220	CHICAGO, ILL.	250	WMBB	229	Baltimore, Md.	WCBM
KFVD	San Pedro, Cal.	205.4	CHICAGO, ILL.	258	WPCC	229	Clay Center, Neb.	KMMJ
KFVE	St. Louis, Mo.	240	CHICAGO, ILL.	447.5	WQJ	229	Grove City, Pa.	WSAJ
KFVG	Independence, Kan.	236	CHICAGO, ILL.	268	WSAX	229	Marshfield, Wis.	WGBR
KFVH	Manhattan, Kan.	218.8	CHICAGO, ILL.	209.7	WSBC	229	Pasadena, Cal.	KPPC
KFVI	Houston, Tex.	240	CHICKASHA, OKLA.	252	KOCW	229	Richmond, Va.	WBBL
KFVN	Welcome, Minn.	227	CHICO, CAL.	251	KFWH	229	Roanoke, Va.	WDBJ
KFVR	Denver, Col.	244	CINCINNATI, O.	258	WAAD	229	Rockford, Ill.	KFLV
KFVS	Cape Girardeau, Mo.	224	CINCINNATI, O.	422.3	WKRC	229	Taunton, Mass.	WAIT
KFVW	San Diego, Cal.	246	CLARINDA, IA.	242	KSO	231	Austin, Tex.	KUT
KFVY	Albuquerque, N. M.	250	CLAY CENTER, NEB.	229	KMMJ	231	Camp Lake, Wis.	WCLO
KFWA	Ogden, Utah	261	CLEARWATER, FLA.	266	WGHB	231	Deville Lake, N. D.	KDLR
KFWB	Hollywood, Cal.	252	CLEVELAND, O.	227	WDBK	231	Ellsworth, Me.	WHBK
KFWC	Upland, Cal.	211.1	CLEVELAND, O.	389.4	WEAR	231	Harrisburg, Pa.	WHBG
KFWF	St. Louis, Mo.	214.2	CLEVELAND, O.	273	WHK	231	Los Angeles, Cal.	KPPC
KFWH	Chico, Cal.	254	CLEVELAND, O.	389.4	WTAM	231	Minneapolis, Minn.	KFDZ
KFWI	South San Francisco, Cal.	226	COLDWATER, MISS.	254	WREC	231	Montgomery, Ala.	WIBZ
KFWM	Oakland, Cal.	206.8	COLLEGE STATION, TEX.	270	WTAW	231	San Jose, Cal.	KQW
KFWO	Avalon, Cal.	211.1	COLLEGEVILLE, MINN.	236	WFBJ	231	Streator, Ill.	WTAX
KFWU	Pineville, La.	238	COLORADO SPRINGS, COL.	250	KFXF	231	Webster, Mass.	WHBE
KFWV	Portland, Ore.	212.6	COLUMBIA, MO.	499.7	KFRU	231	Wichita, Kan.	KWTF
KFXB	Big Bear Lake, Cal.	202.6	COLUMBUS, O.	293.9	WAIU	231	Wilkes-Barre, Pa.	WHRE
KFXC	Santa Maria, Cal.	209.7	COLUMBUS, O.	293.9	WEAO	233	Chicago, Ill.	WHBM
KFXD	Logan, Utah	205.4	COLUMBUS, O.	278	WMAN	233	Kellogg, Ida.	KFFY
KFXE	Colorado Springs, Col.	250	CORVALLIS, ORE.	282.8	KFDJ	233	Kingston, N. Y.	WDBZ
KFXH	El Paso, Tex.	242	COUNCIL BLUFFS, IA.	278	KOIL	233	Long Beach, Cal.	KFON
KFXJ	Denver, Col.	215.7	CRANSTON, R. I.	440.9	WDFW†	233	Memphis, Tenn.	WHHQ
KFXM	Beaumont, Tex.	227	CRETE, ILL.	344.6	WLSI	233	New York, N. Y.	WQEQ
KFXR	Oklahoma City, Okla.	214.2	CULVER, IND.	222	WHBH	233	St. Louis, Mo.	KMOX
KFYX	Flagstaff, Ariz.	205.4	DALLAS, TEX.	475.9	WFAA	234	Ypsilanti, Mich.	WJIB
KFYF	Oxnard, Cal.	205.4	DALLAS, TEX.	246	WRR	234	Cambridge, O.	WEBE
KFYJ	Houston, Tex.	238	DARTMOUTH, MASS.	440.9	WMAF	234	Denver, Col.	KFUP
KFYR	Bismark, N. D.	248	DAVENPORT, IA.	483.6	WOC	234	Flint, Mich.	WFDF
KGO	Oakland, Cal.	361.2	DAVID CITY, NEB.	226	KFOR	234	Forty Wayne, Ind.	WHBJ
KGTT	San Francisco, Cal.	234	DAYTON, O.	275	WSMK	234	Fresno, Cal.	KMJ
KGU	Honolulu, Hawaii	270	DEARBORN, MICH.	266	WWI	234	La Salle, Ill.	WJBC
KGW	Portland, Ore.	491.5	DECATUR, ILL.	270	WBAO	234	Philadelphia, Pa.	WFBD
KGY	Lacey, Wash.	246	DECATUR, ILL.	270	WJBL	234	Providence, R. I.	WGBM
KHJ	Los Angeles, Cal.	405.2	DEERFIELD, ILL.	238	WHT	236	San Francisco, Cal.	KGTT
KHQ	Spokane, Wash.	273	DENVER, COL.	254	KFEL	236	Camden, N. J.	WFBI
KJBS	San Francisco, Cal.	220	DENVER, COL.	234	KFUP	236	Carthage, Ill.	WTAD
KJR	Seattle, Wash.	384.4	DENVER, COL.	244	KFVR	236	Collegeville, Minn.	WFBJ
KLDS	Independence, Mo.	440.9	DENVER, COL.	215.7	KFXJ	236	Evansville, Ind.	WGBF
KLS	Oakland, Cal.	250	DENVER, COL.	266	KLZ	236	Independence, Kan.	KVVG
KLX	Oakland, Cal.	508.2	DES MOINES, IA.	322.4	KOA	236	Kansas City, Mo.	KWKC
KLZ	Denver, Col.	266	DETROIT, MICH.	270	WGHP	236	Madison, Wis.	WIBA
KMA	Shenandoah, Ia.	252	DETROIT, MICH.	256	WMBC	236	Nashville, Tenn.	WCBQ
KMJ	Fresno, Cal.	234	DETROIT, MICH.	352.7	WVJ	236	New York, N. Y.	WRMU
KMMJ	Clay Center, Neb.	229	DEVIL'S LAKE, N. D.	231	KDLR	236	Richmond Hill, N. Y.	WBOQ
KMO	Tacoma, Wash.	250	DUBLIN, TEX.	252	KFPL	236	Richmond Hill, N. Y.	WGMU
KMOX	St. Louis, Mo.	233	EAST LANSING, MICH.	285.5	WKAR	236	Salt Lake City, Utah	KFOO
KMTR	Los Angeles, Cal.	238	EAST PITTSBURG, PA.	309.1	KDKA	238	San Benito, Tex.	KFLU
KNRC	Los Angeles, Cal.	208.2	ELGIN, ILL.	275	WCEE	238	Decrfield, Ill.	WHT
KNX	Hollywood, Cal.	336.9	ELGIN, ILL.	302.8	WLIB	238	Houston, Tex.	KFYJ
KOA	Denver, Col.	322.4	ELIZABETH, N. J.	202.6	WIBS	238	Los Angeles, Cal.	KMTR
KOB	State College, N. M.	348.6	ELKINS PARK, PA.	222	WIBG	238	Petoskey, Mich.	WBPP
KOCH	Omaha, Neb.	258	ELLSWORTH, ME.	231	WHBK	238	Phoenix, Ariz.	KFCB
KOCW	Chickasha, Okla.	252	EL PASO, TEX.	242	KFXH	238	Pineville, La.	KFWU
KOIL	Council Bluffs, Ia.	278	EL PASO, TEX.	268	WDAH	238	Reading, Pa.	WRAW
KPO	San Francisco, Cal.	428.3	ESCANABA, MICH.	256	WRAK	238	St. Petersburg, Fla.	WHBN
KPPC	Pasadena, Cal.	229	EVANSTON, ILL.	202.6	WEHS	238	Trinidad, Col.	KFBS
KPRC	Houston, Tex.	296.9	EVANSVILLE, IND.	236	WGBF	240	Bangor, Me.	WABI
KPSN	Pasadena, Cal.	315.6	EVERETT, WASH.	224	KFBL	240	Galveston, Tex.	KFLX
KQP	Portland, Ore.	212.6	FALL RIVER, MASS.	254	WSAR	240	Houston, Tex.	KFVI
KQV	Pittsburg, Pa.	275	FALL RIVER, MASS.	266	WTAB	240	New York, N. Y.	WHAP
KQW	San Jose, Cal.	231	FARGO, N. D.	261	WDAY	240	Oakland, Cal.	KTAB
KRE	Berkeley, Cal.	256	FAYETTEVILLE, ARK.	299.8	KFMQ	240	Oakland, Cal.	KZM
KSAC	Manhattan, Kan.	340.7	FLAGSTAFF, ARIZ.	205.4	KFYX	240	Oskaloosa, Ia.	KPHL
KSD	St. Louis, Mo.	545.1	FLINT, MICH.	234	WFDF	240	Owosso, Mich.	WSMT
KSL	Salt Lake City, Utah	299.8	FLUSHING, N. Y.	218.8	WIBI	240	Rapid City, S. D.	WCAT
KSO	Clarinda, Ia.	242	FONDULAC, WIS.	273	KFIZ	240	St. Louis, Mo.	KFVE
KTAB	Oakland, Cal.	240	FORT DODGE, IA.	246	KPJY	240	Scranton, Pa.	WGBI
KTBI	Los Angeles, Cal.	293.9	FORT WAYNE, IND.	234	WHBJ	240	Trenton, N. J.	WOAX
KTBR	Portland, Ore.	263	FORT WORTH, TEX.	254	KFJZ	242	Winter Park, Fla.	WDBO
KTCL	Seattle, Wash.	305.9	FORT WORTH, TEX.	263	KFQB	242	Boston, Mass.	WBZA
KTCS	Hot Springs, Ark.	374.8	FORT WORTH, TEX.	475.9	WBAP	242	Cambridge, Ill.	WTAP
KTNT	Muscataine, Ia.	256				242	Clarinda, Ia.	KSO
KTW	Seattle, Wash.	454.3				242	El Paso, Tex.	KFXH
KUO	San Francisco, Cal.	250				242	Grand Rapids, Mich.	WEBK

Call Letters	Location	Wave-length	Location	Wave-length	Call Letters	Wave-length	Location	Call Letters
KUOM	Missoula, Mont.	244	FREEPORT, N. Y.	244	WGBB	242	Greenville, Tex.	KFFM
KUSD	Vermillion, S. D.	278	FRESNO, CAL.	234	KMJ	242	Moberly, Mo.	KFFJ
KUT	Austin, Tex.	231	FULFORD-BY-THE-SEA, FLA.	278	WGBU	242	Moberly, Mo.	KFOP
KVOO	Bristow, Okla.	374.8	GALESBURG, ILL.	254	WFBZ	242	Oxford, Miss.	WCBH
KWCR	Cedar Rapids, Ia.	278	GALESBURG, ILL.	244	WRAM	242	Philadelphia, Pa.	WABY
KWG	Stockton, Cal.	248	GALVESTON, TEX.	240	KFLX	242	Plainfield, Ill.	WWAE
KWKC	Kansas City, Mo.	236	GALVESTON, TEX.	258	KFUL	242	Superior, Wis.	WEBC
KWKH	Kennonwood, La.	261	GLOUCESTER CITY, N. J.	268	WRAX	244	Buffalo, N. Y.	WEBR
KWSC	Pullman, Wash.	348.6	GRAND FORKS, N. O.	278	KFJM	244	Denver, Col.	KFVR
KWWG	Brownsville, Tex.	278	GRAND RAPIOS, MICH.	256	WBDC	244	Freeport, N. Y.	WGBB
KYW	Chicago, Ill.	535.4	GRAND RAPIOS, MICH.	242	WEBK	244	Galesburg, Ill.	WRAM
KZM	Oakland, Cal.	240	GREELEY, COL.	273	KFKA	244	Minneapolis, Minn.	WAMD
WAAD	Cincinnati, O.	258	GREENTOWN, INO.	254	WJAK	244	Missoula, Mont.	KUOM
WAAF	Chicago, Ill.	278	GREENTOWN, INO.	242	KFFM	244	Pomeroy, O.	WSAZ
WAAW	Omaha, Neb.	278	GROVE CITY, PA.	229	WSAJ	244	Yankton, S. D.	WNAX
WABC	Asheville, N. C.	254	GUNNISON, COL.	252	KFHA	246	Anderson, Ind.	WEBD
WABI	Bangor, Me.	240	HAMILTON, O.	270	WRK	246	Astoria, Ore.	KFJI
WABO	Rochester, N. Y.	278	HAMILTON, O.	252	WSRO	246	Baltimore, Md.	WBAL
WABQ	Haverford, Pa.	261	HANOVER, N. H.	256	WDCH	246	Dallas, Tex.	WRR
WABR	Toledo, O.	263	HARRISBURG, ILL.	226	WEBQ	246	Fort Dodge, Ia.	KFJY
WABW	Wooster, O.	206.8	HARRISBURG, PA.	275	WBAK	246	Lacey, Wash.	KGY
WABX	Mt. Clemens, Mich.	246	HARRISBURG, PA.	231	WHBG	246	Milwaukee, Wis.	WSOE
WABY	Philadelphia, Pa.	242	HARRISBURG, PA.	215.7	WPRC	246	Mt. Clemens, Mich.	WBAX
WABZ	New Orleans, La.	275	HARRISON, O.	422.3	WLW	246	Salt Lake City, Utah	KDYL
WAOC	Akron, O.	258	HARTFORD, CONN.	475.9	WTIC	246	San Diego, Cal.	KFWA
WAFD	Port Huron, Mich.	275	HASTINGS, NEB.	288.3	KFKX	246	Springfield, Vt.	WQAE
WAGM	Royal Oak, Mich.	258	HAVERFORD, PA.	261	WABQ	246	Weirton, W. Va.	WIBR
WAHG	Richmond Hill, N. Y.	315.6	HAVRE, MONT.	275	KFBB	249	Auburn, Ala.	WAPI
WAIT	Taunton, Mass.	229	HOBOKEN, N. J.	340.7	WMCA	249	Beeville, Tex.	KFRB
WAIU	Columbus, O.	293.9	HOLLYWOOD, CAL.	226	KFQZ	248	Birmingham, Ala.	WBRC
WAMO	Minneapolis, Minn.	244	HOLLYWOOD, CAL.	252	KFWB	248	Bismark, N. D.	KFYR
WAPI	Auburn, Ala.	248	HOLLYWOOD, CAL.	336.9	KNX	248	Johnstown, Pa.	WGBK
WARC	Medford, Mass.	261	HOLY CITY, CAL.	217.3	KFQU	248	Lancaster, Pa.	WGAL
WBAA	West Lafayette, Ind.	273	HOMWOOD, ILL.	217.3	WOK	248	Marshalltown, Ia.	KFJB
WBAK	Harrisburg, Pa.	275	HONOLULU, HAWAII	270	KGU	248	New Bedford, Mass.	WNBH
WBAL	Baltimore, Md.	246	HOT SPRINGS, ARK.	374.8	KTHS	248	Omaha, Neb.	KFOX
WBAO	Decatur, Ill.	270	HOUGHTON, MICH.	263	KFMW	248	Portland, Ore.	KFEC
WBAP	Fort Worth, Tex.	475.9	HOUGHTON, MICH.	263	WWAO	248	Portland, Ore.	KFFP
WBAX	Wilkes-Barre, Pa.	256	HOUSTON, TEX.	240	KFVI	248	Sacramento, Cal.	KFBK
WBBL	Richmond, Va.	229	HOUSTON, TEX.	238	KFYJ	248	St. Louis, Mo.	WEW
WBBM	Chicago, Ill.	226	HOUSTON, TEX.	296.9	KPRC	248	St. Louis, Mo.	WMA Y
WBPP	Petoakey, Mich.	238	INDEPENDENCE, MO.	236	KFVG	248	Springfield, O.	WC SO
WBBR	Rossville, N. Y.	273	INDEPENDENCE, MO.	440.9	KLDS	248	Stockton, Cal.	KWG
WBBS	New Orleans, La.	252	INOIANAPOLIS, INO.	268	WFBM	248	West Palm Beach, Fla.	WIOD
WBBW	Norfolk, Va.	222	IOWA CITY, IA.	224	KFQP	250	Albuquerque, N. M.	KFVY
WBBY	Charleston, S. C.	268	IOWA CITY, IA.	483.6	WSUI	250	Boston, Mass.	WNAB
WBBZ	Chicago, Ill.	215.7	ITHACA, N. Y.	254	WEAI	250	Burlington, Vt.	WCAX
WBCN	Chicago, Ill.	266	JACKSONVILLE, FLA.	336.9	WJAX	250	Chicago, Ill.	WMBB
WBOC	Grand Rapids, Mich.	258	JAMESTOWN, N. Y.	275	WOCL	250	Colorado Springs, Col.	KFXF
WBES	Takoma Park, Md.	222	JEFFERSON CITY, MO.	440.9	WOS	250	Knoxville, Tenn.	WFBC
WBNY	New York, N. Y.	209.7	JOHNSTOWN, PA.	256	WHBP	250	Oakland, Cal.	KLS
WBOQ	Richmond Hill, N. Y.	236	JOHNSTOWN, PA.	248	WGBK	250	Oak Park, Ill.	WGES
WBRC	Birmingham, Ala.	248	JOHNSTOWN, PA.	268	WTAC	250	Oil City, Pa.	WBBA
WBRE	Wilkes-Barre, Pa.	231	JOLIET, ILL.	214.2	WCLS	250	Philadelphia, Pa.	WIAB
WBT	Charlotte, N. C.	275	JOLIET, ILL.	206.8	WJBA	250	Philadelphia, Pa.	WNAT
WBZ	Springfield, Mass.	333.1	JOLIET, ILL.	214.2	WKBB	250	Philadelphia, Pa.	WWAD
WBZA	Boston, Mass.	242	JUNCTION CITY, KAN.	218.8	KFJC	250	San Francisco, Cal.	KUO
WCAC	Manchester, Conn.	275	JUNEAU, ALASKA	226	KFIU	250	Scranton, Pa.	WQAN
WCAD	Canton, N. Y.	263	KANSAS CITY, MO.	236	KWKC	250	Shreveport, La.	KFDX
WCAE	Pittsburg, Pa.	461.3	KANSAS CITY, MO.	365.6	WDAF	250	Tacoma, Wash.	KMO
WCAJ	University Place, Neb.	254	KANSAS CITY, MO.	365.6	WHB	250	Tulsa, Okla.	WLAL
WCAL	Northfield, Minn.	336.9	KANSAS CITY, MO.	278	WOQ	252	Chickasha, Okla.	KOCW
WCAO	Baltimore, Md.	275	KELLOGG, IOA.	233	KFEY	252	Dublin, Tex.	KPFL
WCAP	Washington, D. C.	468.5	KENNONWOOD, LA.	261	KWKH	252	Gunnison, Col.	KFHA
WCAR	San Antonio, Tex.	263	KINGSTON, N. Y.	233	WDBZ	252	Hamilton, O.	WSRO
WCAT	Rapid City, S. D.	240	KIRKSVILLE, MO.	226	KFKZ	252	Hollywood, Cal.	KFWB
WCAU	Philadelphia, Pa.	278	KNOXVILLE, TENN.	250	WFBC	252	Minneapolis, Minn.	WRFM
WCAV	Burlington, Vt.	250	KNOXVILLE, TENN.	268	WNOX	252	Newark, N. J.	WNJ
WCBA	Allentown, Pa.	254	LACEY, WASH.	246	KGY	252	Newark, N. J.	WGCP
WCBD	Zion, Ill.	344.6	LACONIA, N. H.	224	WKAV	252	New Orleans, La.	WBBS
WCBE	New Orleans, La.	263	LAMBERTVILLE, N. J.	261	WTAZ	252	Orono, Me.	WGBX
WCBH	Oxford, Miss.	242	LANCASTER, PA.	258	WDBC	252	Raleigh, N. C.	WRCO
WCBM	Baltimore, Md.	229	LANCASTER, PA.	248	WGAL	252	St. Paul, Minn.	KFOY
WCBQ	Nashville, Tenn.	236	LANSING, MICH.	285.5	WREO	252	Shenandoah, Ia.	KMA
WCBR	Providence, R. I.	205.4	LAPORTE, IND.	224	WRAF	252	Syracuse, N. Y.	WFBL
WCCO	St. Paul-Minneapolis, Minn.	416.4	LARAMIE, WYO.	270	KFBU	252	Toledo, O.	WTAL
WCEE	Elgin, Ill.	275	LA SALLE, ILL.	234	WJBC	254	Albuquerque, N. M.	KFLR
WCLO	Camp Lake, Wis.	231	LAWRENCE, KAN.	275	KFKU	254	Allentown, Pa.	WCBA
WCLS	Joliet, Ill.	214.2	LAWRENCEBURG, TENN.	282.8	WOAN	254	Asheville, N. C.	WABC
WCSSH	Portland, Me.	256	LEWISBURG, PA.	211.1	WJBQ	254	Baltimore, Md.	WFBR
WCSSO	Springfield, O.	248	LINCOLN, NEB.	340.7	KFAB	254	Burlington, Ia.	WIAS
WCSS	Providence, R. I.	209.7	LINCOLN, NEB.	275	WFAV	254	Canton, O.	WHBC
WCX	Pontiac, Mich.	516.9	LOCKPORT, N. Y.	266	WMAK	254	Chico, Cal.	KFWH
WOAD	Nashville, Tenn.	228	LOGAN, UTAH	205.4	KFXD	254	Coldwater, Miss.	WREC
WDAE	Tampa, Fla.	273	LOGANSPORT, IND.	215.7	WHBL	254	Denver, Col.	KFEL
WDAF	Kansas City, Mo.	365.6	LOGANSPORT, IND.	220	WIBW	254	Fall River, Mass.	WSAR
WOAG	Amarillo, Tex.	263	LOS BEACH, CAL.	233	KFON	254	Fort Worth, Tex.	KFJZ
WOAH	El Paso, Tex.	268	LOS ANGELES, CAL.	468.5	KFI	254	Galesburg, Ill.	WFBZ

BROADCAST STATIONS IN THE UNITED STATES

Call Letters	Location	Wave-length	Location	Wave-length	Call Letters	Wave Length	Location	Call Letters
WDAY	Fargo, N. D.	261	LOS ANGELES, CAL.	231	KFPR	254	Greentown, Ind.	WJAK
WBOC	Lancaster, Pa.	258	LOS ANGELES, CAL.	275	KFSG	254	Ithaca, N. Y.	WEAI
WBDE	Atlanta, Ga.	270	LOS ANGELES, CAL.	405.2	KHJ	254	Norman, Okla.	WNAD
WDBJ	Roanoke, Va.	229	LOS ANGELES, CAL.	238	KMTR	254	Osseo, Wis.	WTAQ
WDBK	Cleveland, O.	227	LOS ANGELES, CAL.	208.2	KNRC	254	St. Petersburg, Fla.	WJBB
WDBO	Winter Park, Fla.	240	LOS ANGELES, CAL.	293.9	KTBI	254	University Place, Neb.	WCAJ
WDBR	Boston, Mass.	261	LOUISVILLE, KY.	399.8	WHAS	256	Berkley, Cal.	KRE
WDBZ	Kingston, N. Y.	233	LOUISVILLE, KY.	275	WLAP	256	Chattanooga, Tenn.	WDOD
WDCH	Hanover, N. H.	256	MACON, GA.	261	WMAZ	256	Detroit, Mich.	WMBC
WDOD	Chattanooga, Tenn.	256	MADISON, WIS.	535.4	WHA	256	Escanaba, Mich.	WRAC
WDRC	New Haven, Conn.	268	MADISON, WIS.	236	WIBA	256	Grand Rapids, Mich.	WBDC
WDWF	Cranston, R. I.	440.9	MANHATTAN, KAN.	218.8	KFVH	256	Hanover, N. H.	WDCH
WDZ	Tuscola, Ill.	278	MANHATTAN, KAN.	340.7	KSAC	256	Johnstown, Pa.	WHBP
WEAF	New York, N. Y.	491.5	MANSFIELD, CONN.	275	WCAC	256	Muscatine, Ia.	KTNT
WEAI	Ithaca, N. Y.	254	MARSHFIELD, WIS.	229	WGBR	256	Oakland, Cal.	KFUS
WEAM	North Plainfield, N. J.	261	MARSHALLTOWN, IA.	248	KFJB	256	Portland, Me.	WCOS
WEAN	Providence, R. I.	270	MASON, O.	325.9	WSAI	258	Richmond, Va.	WRVA
WEAO	Columbus, O.	293.9	MEDFORD, MASS.	261	WARC	256	Sycamore, Ill.	WJBN
WEAR	Cleveland, O.	389.4	MEMPHIS, TENN.	278	WGBC	256	Walla Walla, Wash.	KFCF
WEAU	Sioux City, Ia.	275	MEMPHIS, TENN.	233	WHBQ	256	Washington, D. C.	WRHF
WEBC	Superior, Wis.	242	MEMPHIS, TENN.	499.7	WMC	256	Wilkes-Barre, Pa.	WBAX
WEBD	Anderson, Ind.	246	MIAMI, FLA.	263	WQAM	256	Yakima, Wash.	KFIQ
WEBE	Cambridge, O.	234	MIAMI BEACH, FLA.	384.4	WMBF	258	Akron, O.	WADC
WEBH	Chicago, Ill.	370.2	MILWAUKEE, WIS.	275	WHAD	258	Carterville, Mo.	KFPW
WEBJ	New York, N. Y.	273	MILWAUKEE, WIS.	261	WKAF	258	Chicago, Ill.	WLTS
WEBK	Grand Rapids, Mich.	242	MILWAUKEE, WIS.	246	WSOE	258	Chicago, Ill.	WPCC
WEBL	New York, N. Y.	226	MINNEAPOLIS, MINN.	231	KFDZ	258	Cincinnati, O.	WAAD
WEBM	New York, N. Y.	226	MINNEAPOLIS, MINN.	244	WAMD	258	Galveston, Tex.	KFUL
WEBQ	Harrisburg, Ill.	226	MINNEAPOLIS, MINN.	263	WHAT	258	Lancaster, Pa.	WDBC
WEBR	Buffalo, N. Y.	244	MINNEAPOLIS, MINN.	278	WHDI	258	New York, N. Y.	WRNY
WEBW	Beloit, Wis.	268	MINNEAPOLIS, MINN.	252	WRHM	258	Omaha, Neb.	KOCH
WEBZ	Savannah, Ga.	263	MISSOULA, MONT.	244	KUOM	258	Omaha, Neb.	WNAL
WEEI	Boston, Mass.	348.6	MOBERLY, MO.	242	KFFP	258	Rochester, N. Y.	WHEC
WEHS	Evanston, Ill.	202.6	MOBERLY, MO.	242	KFOJ	258	Royal Oak, Mich.	WAGM
WEMC	Berrien Springs, Mich.	285.5	MONTGOMERY, ALA.	231	WIBZ	261	Bay City, Mich.	WSKC
WENR	Chicago, Ill.	286	MOOSEHEART, ILL.	370.2	WJJD	261	Boston, Mass.	WDBR
WEPI	Newark, N. J.	263	MT. CLEMENS, MICH.	246	WABX	261	Boulder, Co.	KFAJ
WEW	St. Louis, Mo.	248	MT. PROSPECT, ILL.	322.4	WJAZ	261	Fargo, N. D.	WDAY
WFAA	Dallas, Tex.	475.9	MUSCATINE, IA.	256	KTNT	261	Haverford, Pa.	WBQ
WFAM	St. Cloud, Minn.	273	NASHVILLE, TENN.	236	WCBQ	261	Kenonwood, La.	KWKH
WFAP	Lincoln, Neb.	275	NASHVILLE, TENN.	226	WDAD	261	Lambertville, N. J.	WTAZ
WFBC	Knoxville, Tenn.	250	NASHVILLE, TENN.	292.8	WSM	261	Macon, Ga.	WMAZ
WFBD	Philadelphia, Pa.	234	NEWARK, N. J.	263	WEPI	261	Medford, Mass.	WARC
WFBE	Seymour, Ind.	226	NEWARK, N. J.	252	WGCP	261	Milwaukee, Wis.	WKAF
WFBG	Altoona, Pa.	278	NEWARK, N. J.	252	WNJ	261	Norfolk, Va.	WTAR
WFBH	New York, N. Y.	273	NEWARK, N. J.	405.2	WOR	261	North Plainfield, N. J.	WEAM
WFBJ	Camden, N. J.	236	NEW BEDFORD, MASS.	209.7	WIBH	261	Ogden, Utah	KFWA
WFBK	Collegeville, Minn.	236	NEW BEDFORD, MASS.	248	WNBH	261	Oklahoma City, Okla.	KFJF
WFL	Syracuse, N. Y.	252	NEW HAVEN, CONN.	268	WDRC	261	St. Louis, Mo.	KFQA
WFBM	Indianapolis, Ind.	268	NEW ORLEANS, LA.	268	WJBO	261	Salt Lake City, Utah	KFTU
WFBP	Baltimore, Md.	254	NEW ORLEANS, LA.	275	WABZ	261	Sioux City, Ia.	KFMR
WFBZ	Galesburg, Ill.	254	NEW ORLEANS, LA.	252	WBBS	261	State College, Pa.	WPSC
WFDF	Flint, Mich.	234	NEW ORLEANS, LA.	263	WCBE	263	Amarillo, Tex.	WDAG
WFI	Philadelphia, Pa.	394.5	NEW ORLEANS, LA.	270	WOWL	263	Canton, N. Y.	WCAD
WFKB	Chicago, Ill.	217.3	NEW ORLEANS, LA.	319	WSMB	263	Fort Worth, Tex.	KFQB
WFR	Brooklyn, N. Y.	205.4	NEW ORLEANS, LA.	275	WWL	263	Houghton, Mich.	KFMW
WGAL	Lancaster, Pa.	248	NEW YORK, N. Y.	209.7	WBNY	263	Houghton, Mich.	WWAO
WGBB	Freeport, N. Y.	244	NEW YORK, N. Y.	491.5	WEAF	263	Miami, Fla.	WQAM
WGBC	Memphis, Tenn.	278	NEW YORK, N. Y.	273	WEBJ	263	Minneapolis, Minn.	WHAT
WGBF	Evansville, Ind.	236	NEW YORK, N. Y.	226	WEBL	263	Newark, N. J.	WEPI
WGBI	Scranton, Pa.	240	NEW YORK, N. Y.	226	WEBM	263	New Orleans, La.	WCBE
WGBK	Johnstown, Pa.	248	NEW YORK, N. Y.	273	WFBH	263	New York, N. Y.	WSDA
WGBM	Providence, R. I.	234	NEW YORK, N. Y.	315.6	WGBS	263	Portland, Ore.	KTBR
WGBR	Marshfield, Wis.	229	NEW YORK, N. Y.	240	WHAP	263	Portland, Ore.	KFJR
WGBS	New York, N. Y.	315.6	NEW YORK, N. Y.	361.2	WHN	263	San Antonio, Tex.	WCAR
WGBU	Fulford-by-the-Sea, Fla.	278	NEW YORK, N. Y.	405.2	WJY	263	Savannah, Ga.	WEBZ
WGBX	Orono, Me.	252	NEW YORK, N. Y.	454.3	WJZ	263	Shenandoah, Ia.	KFNF
WGCP	Newark, N. J.	252	NEW YORK, N. Y.	288.3	WLWL	263	Toledo, O.	WABR
WGES	Oak Park, Ill.	250	NEW YORK, N. Y.	526	WNYC	263	Yellow Springs, O.	WRAY
WGHB	Clearwater, Fla.	266	NEW YORK, N. Y.	233	WOKO	266	Chicago, Ill.	WBCN
WGHP	Detroit, Mich.	270	NEW YORK, N. Y.	361.2	WQAO	266	Chicago, Ill.	WENR
WGMU	Richmond Hill, N. Y.	236	NEW YORK, N. Y.	236	WRMU	266	Clearwater, Fla.	WGHB
WGN	Chicago, Ill.	302.8	NEW YORK, N. Y.	258	WRNY	266	Dearborn, Mich.	WWI
WGR	Buffalo, N. Y.	319	NEW YORK, N. Y.	263	WSDA	266	Denver, Col.	KLZ
WGST	Atlanta, Ga.	270	NEW YORK, N. Y.	270	WJAG	266	Fall River, Mass.	WTAB
WGY	Schenectady	379.5	NORFOLK, NEB.	222	WBBW	266	Lockport, N. Y.	WMAK
WHA	Madison, Wis.	535.4	NORFOLK, VA.	261	WTAR	266	Spokane, Wash.	KFIO
WHAD	Milwaukee, Wis.	275	NORMAN, OKLA.	254	WNAD	266	Spokane, Wash.	KFPY
WHAM	Rochester, N. Y.	278	NORTH BEND, WASH.	215.7	KFQW	266	Wilmington, Del.	WHAV
WHAP	New York, N. Y.	240	NORTHFIELD, MINN.	336.9	KFMX	269	Beloit, Wis.	WEBW
WHAR	Atlantic City, N. J.	275	NORTHFIELD, MINN.	336.9	WCAL	268	Cedar Rapids, Ia.	WJAM
WHAS	Louisville, Ky.	399.8	NORTH PLAINFIELD, N. J.	261	WEAM	268	Charleston, S. C.	WBBY
WHAT	Minneapolis, Minn.	263	OAK, NEB.	268	KFEQ	268	Chicago, Ill.	WSAX
WHAV	Wilmington, Del.	266	OAKLAND, CAL.	220	KFUU	268	El Paso, Tex.	WDAH
WHAZ	Troy, N. Y.	379.5	OAKLAND, CAL.	256	KFUS	268	Gloucester City, N. J.	WRAX
WHB	Kansas City, Mo.	365.6	OAKLAND, CAL.	206.8	KFWM	268	Indianapolis, Ind.	WFBC
WHBA	Oil City, Pa.	250	OAKLAND, CAL.	361.2	KGO	268	Johnstown, Pa.	WTAC
WHBC	Canton, O.	254	OAKLAND, CAL.	250	KLS	268	Knoxville, Tenn.	WNOX

Call Letters	Location	Wave-length	Location	Wave-length	Call Letters	Wave Length	Location	Call Letters
WHBD	Bellefontaine O.	222	OAKLAND, CAL.	508.2	KLX	268	New Haven, Conn.	WDRC
WHBF	Rock Island, Ill.	222	OAKLAND, CAL.	240	KTAB	268	New Orleans, La.	WJBO
WHBG	Harrisburg, Pa.	231	OAKLAND, CAL.	240	KZM	268	Oak, Neb.	KFEQ
WHBH	Culver, Ind.	222	OAK PARK, ILL.	250	WGES	268	San Francisco, Cal.	KFRG
WHBJ	Fort Wayne, Ind.	234	OGDEN, UTAH	224	KFUR	263	Wichita, Kan.	KFH
WHBK	Ellsworth, Me.	231	OGDEN, UTAH	261	KFWA	268	Worcester, Mass.	WTAG
WHBL	Logansport, Ind.	215.7	OIL CITY, PA.	250	WHBA	270	Ames, Ia.	WOI
WHBM	Chicago, Ill.	233	OKLAHOMA CITY, OKLA.	261	KFJF	270	Atlanta, Ga.	WDBE
WHBN	St. Petersburg, Fla.	238	OKLAHOMA CITY, OKLA.	214.2	KFXR	270	Atlanta, Ga.	WGST
WHBP	Johnstown, Pa.	256	OKLAHOMA CITY, OKLA.	275	WKY	270	College Station, Tex.	WTAW
WHBQ	Memphis, Tenn.	233	OLYMPIA, WASH.	218.8	KFRW	270	Decatur, Ill.	WBAO
WHBU	Anderson, Ind.	218.8	OMAHA, NEB.	248	KFOX	270	Decatur, Ill.	WJBL
WHBW	Philadelphia, Pa.	215.7	OMAHA, NEB.	258	KOCH	270	Detroit, Mich.	WGHP
WHDI	Minneapolis, Minn.	278	OMAHA, NEB.	278	WAAW	270	Hamilton, O.	WRK
WHEC	Rochester, N. Y.	258	OMAHA, NEB.	258	WNAL	270	Honolulu, Hawaii	KGU
WHK	Cleveland, O.	273	OMAHA, NEB.	526	WOAW	270	Laramie, Wyo.	KFBU
WHN	New York, N. Y.	361.2	ORONO, ME.	252	WGBX	270	New Orleans, La.	WOWL
WHO	Des Moines, Ia.	526	OSKALOOSA, IA.	240	KFHL	270	Norfolk, Neb.	WJAG
WHT	Deerfield, Ill.	238	OSSEO, WIS.	254	WTAQ	270	Providence, R. I.	WEAN
WIAD	Philadelphia, Pa.	250	OWOSSO, MICH.	240	WSMH	270	Stanford University, Cal.	KFGH
WIAS	Burlington, Ia.	254	OXFORD, MISS.	242	WCBH	273	Anita, Ia.	KFLZ
WIBA	Madison, Wis.	236	OXNARD, CAL.	205.4	KFYF	273	Brookings, S. D.	KFDY
WIBC	St. Petersburg, Fla.	222	PARKESBURG, PA.	220	WQAA	273	Cleveland, O.	WHK
WIBG	Elkins Park, Pa.	222	PASADENA, CAL.	229	KPPC	273	Fondulac, Wis.	KFIZ
WIBH	New Bedford, Mass.	209.7	PASADENA, CAL.	315.6	KPSN	273	Greeley, Col.	KFKA
WIBI	Flushing, N. Y.	218.8	PATERSON, N. J.	224	WODA	273	New York, N. Y.	WFBH
WIBJ	Chicago, Ill.	215.7	PETOSKEY, MICH.	238	WBBP	273	New York, N. Y.	WEBJ
WIBM	Chicago, Ill.	215.7	PHILADELPHIA, PA.	242	WABY	273	Phoenix, Ariz.	KFAD
WIBO	Chicago, Ill.	226	PHILADELPHIA, PA.	278	WCAU	273	Rossville, N. Y.	WBFR
WIBR	Weirton, W. Va.	246	PHILADELPHIA, PA.	234	WFBD	273	St. Cloud, Minn.	WFAM
WIBS	Elizabeth, N. J.	202.6	PHILADELPHIA, PA.	394.5	WFI	273	St. Louis, Mo.	WIL
WIBU	Poynette, Wis.	222	PHILADELPHIA, PA.	215.7	WHBW	273	St. Louis, Mo.	WSBF
WIBW	Logansport, Ind.	220	PHILADELPHIA, PA.	250	WIAD	273	Spokane, Wash.	KHQ
WIBX	Utica, N. Y.	205.4	PHILADELPHIA, PA.	508.2	WIP	273	Tampa, Fla.	WDAE
WIBZ	Montgomery, Ala.	231	PHILADELPHIA, PA.	394.5	WLIT	273	Tarrytown, N. Y.	WRW
WIL	St. Louis, Mo.	273	PHILADELPHIA, PA.	250	WNAT	273	Urbana, Ill.	WRM
WIOD	West Palm Beach, Fla.	248	PHILADELPHIA, PA.	508.2	WOO	273	West Lafayette, Ind.	WBAA
WIP	Philadelphia, Pa.	508.2	PHILADELPHIA, PA.	250	WWAD	275	Agricultural College, N.D.	WPAK
WJAD	Waco, Tex.	352.7	PHOENIX, ARIZ.	273	KFAD	275	Atlantic City, N. J.	WHAR
WJAG	Norfolk, Neb.	270	PHOENIX, ARIZ.	238	KFCB	275	Baltimore, Md.	WCAO
WJAK	Greentown, Ind.	254	PINEVILLE, LA.	238	KFWU	275	Batavia, Ill.	WORD
WJAM	Cedar Rapids, Ia.	268	PITTSBURG, PA.	275	KQV	275	Cazenovia, N. Y.	WMAC
WJAR	Providence, R. I.	305.9	PITTSBURG, PA.	461.3	WCAE	275	Charlotte, N. C.	WBT
WJAS	Pittsburg, Pa.	275	PITTSBURG, PA.	275	WJAS	275	Dayton, O.	WSMK
WJAX	Jacksonville, Fla.	336.9	PLAINFIELD, ILL.	242	WWAE	275	Elgin, Ill.	WCEE
WJAZ	Mount Prospect, Ill.	322.4	POMEROY, O.	244	WSAZ	275	Harrisburg, Ia.	WBAK
WJBA	Joliet, Ill.	206.8	PONTIAC, MICH.	516.9	WJR†	275	Havre, Mont.	KFBB
WJBB	St. Petersburg, Fla.	254	PORT HURON, MICH.	275	WCX	275	Jamestown, N. Y.	WOCL
WJBC	La Salle, Ill.	234	PORTLAND, ME.	256	WAFD	275	Lawrence, Kan.	KFKU
WJBG	Charlotte, N. C.	224	PORTLAND, ORE.	248	WCSH	275	Lincoln, Neb.	WFVU
WJBI	Red Bank, N. J.	218.8	PORTLAND, ORE.	248	KFEC	275	Los Angeles, Cal.	KFSG
WJBK	Ypsilanti, Mich.	233	PORTLAND, ORE.	248	KFIF	275	Louisville, Ky.	WLAP
WJBL	Decatur, Ill.	270	PORTLAND, ORE.	263	KFJR	275	Mansfield, Conn.	WCAC
WJBN	Sycamore, Ill.	256	PORTLAND, ORE.	212.6	KFWV	275	Milwaukee, Wis.	WHAD
WJBO	New Orleans, La.	268	PORTLAND, ORE.	491.5	KGW	275	New Orleans, La.	WABZ
WJBP	Buffalo, N. Y.	218.8	PORTLAND, ORE.	212.6	KQP	275	New Orleans, La.	WWL
WJBQ	Lewistown, Pa.	211.1	PORTLAND, ORE.	263	KTBR	275	Oklahoma City, Okla.	WKY
WJJD	Mooseheart, Ill.	370.2	POYNETTE, WIS.	222	WIBU	275	Pittsburg, Pa.	KQV
WJR	Pontiac, Mich.	516.9	PROVIDENCE, R. I.	205.4	WCBR	275	Pittsburg, Pa.	WJAS
WJY	New York, N. Y.	405.2	PROVIDENCE, R. I.	209.7	WCWS	275	Port Huron, Mich.	WAFD
WJZ	New York, N. Y.	454.3	PROVIDENCE, R. I.	270	WEAN	275	Sioux City, Ia.	WEAU
WKAQ	Milwaukee, Wis.	261	PROVIDENCE, R. I.	234	WGBM	275	South Bend, Ind.	WSBT
WKAR	San Juan, P. R.	340.7	PROVIDENCE, R. I.	305.9	WJAR	278	Altoona, Pa.	WFBG
WKAU	East Lansing, Mich.	285.5	PULLMAN, WASH.	348.6	KWSC	278	Boise, Ida.	KFDD
WKAU	Laconia, N. H.	224	RALEIGH, N. C.	252	WRCO	278	Brownsville, Tex.	KWWG
WKBB	Joliet, Ill.	214.2	RAPID CITY, S. D.	240	WCAT	278	Cedar Rapids, Ia.	KWCR
WKBE	Webster, Mass.	231	READING, PA.	238	WRAW	278	Chicago, Ill.	WAAF
WKBG	Chicago, Ill.	215.7	RED BANK, N. J.	218.8	WJBI	278	Columbus, O.	WMAN
WKRC	Cincinnati, O.	422.3	RICHMOND HILL, N. Y.	315.6	WAHG	278	Council Bluffs, Ia.	KOIL
WKY	Oklahoma City, Okla.	275	RICHMOND HILL, N. Y.	236	WBOQ	278	Fulford-by-the-Sea, Fla.	WGBU
WLAL	Tulsa, Okla.	250	RICHMOND HILL, N. Y.	236	WGMU	278	Grand Forks, N. D.	KFJM
WLAP	Louisville, Ky.	275	RICHMOND HILL, N. Y.	212.6	WWGL	278	Kansas City, Mo.	WOQ
WLBL	Stevens Point, Wis.	278	RICHMOND, VA.	229	WBBL	278	Memphis, Tenn.	WGBC
WLIB	Elgin, Ill.	302.8	RICHMOND, VA.	256	WRVA	278	Minneapolis, Minn.	WHDI
WLIT	Philadelphia, Pa.	394.5	ROANOKE, VA.	229	WDBJ	278	Omaha, Neb.	WAAW
WLS	Crete, Ill.	344.6	ROCHESTER, N. Y.	278	WABO	278	Philadelphia, Pa.	WCAU
WLSI	Cranston, R. I.	440.9	ROCHESTER, N. Y.	278	WHAM	278	Rochester, N. Y.	WABO
WLTS	Chicago, Ill.	258	ROCHESTER, N. Y.	258	WHEC	278	Rochester, N. Y.	WHAM
WLW	Harrison, O.	422.3	ROCKFORD, ILL.	229	KFLV	278	Stevens Point, Wis.	WLBL
WLWL	New York, N. Y.	288.3	ROCK ISLAND, ILL.	222	WHBF	278	Tuscola, Ill.	WDZ
WMAC	Cazenovia, N. Y.	275	ROSSVILLE, N. Y.	273	WBBR	278	Valparaiso, Ind.	WRBC
WMAF	Dartmouth, Mass.	440.9	ROYAL OAK, MICH.	258	WAGM	278	Vermillion, S. D.	KUSD
WMAK	Lockport, N. Y.	266	SACRAMENTO, CAL.	248	KFBK	280.2	Boston, Mass.	WNAC
WMAL	Washington, D. C.	212.6	ST. CLOUD, MINN.	273	WFAM	282.8	Boise, Ida.	KFAU
WMAN	Columbus, O.	278	ST. LOUIS, MO.	261	KFQA	282.8	Corvallis, Ore.	KFDJ
WMAQ	Chicago, Ill.	447.5	ST. LOUIS, MO.	545.1	KFUO	282.8	Lawrenceburg, Tenn.	WOAN
WMAY	St. Louis, Mo.	248	ST. LOUIS, MO.	240	KFVE	292.8	Nashville, Tenn.	WSM
WMAZ	Macon, Ga.	261	ST. LOUIS, MO.	214.2	KFWF	285.5	Berrien Springs, Mich.	WEMC

†This station is operated under two call signs.

BROADCAST STATIONS IN THE UNITED STATES

Call Letters	Location	Wave-length	Location	Wave-length	Call Letters	Wave Length	Location	Call Letters
WMBB	Chicago, Ill.	250	ST. LOUIS, MO.	233	KMOX	285.5	East Lansing, Mich.	WKAR
WMBC	Detroit, Mich.	256	ST. LOUIS, MO.	545.1	KSD	285.5	Lansing, Mich.	WREO
WMBF	Miami Beach, Fla.	384.4	ST. LOUIS, MO.	248	WEW	288.3	New York, N. Y.	WLWL
WMC	Memphis, Tenn.	499.7	ST. LOUIS, MO.	273	WIL	288.3	Hastings, Neb.	KFKX
WMCA	Hoboken, N. J.	340.7	ST. LOUIS, MO.	248	WMAY	293.9	Columbus, O.	WAIU
WNAB	Boston, Mass.	250	ST. LOUIS, MO.	273	WSBF	293.9	Columbus, O.	WEAO
WNAC	Boston, Mass.	280.2	ST. PAUL, MINN.	252	KFOY	293.9	Los Angeles, Cal.	KTBI
WNAO	Norman, Okla.	254	ST. PAUL-MINNEAP., MINN.	416.4	WCCO	296.9	Houston, Tex.	KPRC
WNAL	Omaha, Neb.	258	ST. PETERSBURG, FLA.	238	WHBN	299.8	Atlantic City, N. J.	WPG
WNAT	Philadelphia, Pa.	250	ST. PETERSBURG, FLA.	222	WIBC	299.8	Fayetteville, Ark.	KFMQ
WNAX	Yankton, S. D.	244	ST. PETERSBURG, FLA.	254	WJBB	299.8	Salt Lake City, Utah	KSL
WNBH	New Bedford, Mass.	248	SALT LAKE CITY, UTAH	246	KDYL	302.8	Chicago, Ill.	WGN
WNJ	Newark, N. J.	252	SALT LAKE CITY, UTAH	236	KFOO	302.8	Elgin, Ill.	WLIB
WNOX	Knoxville, Tenn.	268	SALT LAKE CITY, UTAH	261	KFUT	305.9	Providence, R. I.	WJAR
WNYC	New York, N.Y.	526	SALT LAKE CITY, UTAH	299.8	KSL	305.9	Seattle, Wash.	KTCL
WOAI	San Antonio, Tex.	394.5	SAN ANTONIO, TEX.	263	WCAR	309.1	East Pittsburgh, Pa.	KDKA
WOAN	Lawrenceburg, Tenn.	282.8	SAN ANTONIO, TEX.	394.5	WOAI	315.6	Beaumont, Tex.	KFDM
WOAW	Omaha, Neb.	526	SAN BENITO, TEX.	236	KFLU	315.8	New York, N. Y.	WGBS
WOAX	Trenton, N. J.	240	SAN DIEGO, CAL.	224	KFBC	315.8	Pasadena, Cal.	KPSN
WOC	Davenport, Ia.	483.6	SAN DIEGO, CAL.	246	KFWV	315.8	Richmond Hill, N. Y.	WAHQ
WOCL	Jamestown, N. Y.	275	SAN FRANCISCO, CAL.	268	KFRC	319	Buffalo, N. Y.	WGR
WOOA	Paterson, N. J.	224	SAN FRANCISCO, CAL.	234	KGTT	319	New Orleans, La.	WSMB
WOI	Ames, Ia.	270	SAN FRANCISCO, CAL.	220	KJBS	322.4	Denver, Col.	KOA
WOK	Homewood, Ill.	217.3	SAN FRANCISCO, CAL.	428.3	KPO	322.4	Mt. Prospect, Ill.	WJAZ
WOKO	New York, N. Y.	233	SAN FRANCISCO, CAL.	250	KUO	325.9	Mason, O.	WSAI
WOO	Philadelphia, Pa.	508.2	SAN JOSE, CAL.	217.3	KFAF	331.1	Springfield, Mass.	WBZ
WOQ	Kansas City, Mo.	278	SAN JOSE, CAL.	231	KQW	336.9	Hollywood, Cal.	KNX
WOR	Newark, N. J.	405.2	SAN JUAN, P. R.	340.7	WKAQ	336.9	Jacksonville, Fla.	WJAX
WORD	Batavia, Ill.	275	SAN PEDRO, CAL.	205.4	KFVD	336.9	Northfield, Minn.	KFMX
WOS	Jefferson City, Mo.	440.9	SANTA MARIA, CAL.	209.7	KFXC	336.9	Northfield, Minn.	WCAL
WOWL	New Orleans, La.	270	SAVANNAH, GA.	263	WEBZ	340.7	Hoboken, N. J.	WMCA
WOWO	Fort Wayne, Ind.	227	SCHENECTADY, N. Y.	379.5	WGY	340.7	Lincoln, Neb.	KFAB
WPAK	Agricultural College, N. D.	275	SCRANTON, PA.	240	WGBI	340.7	Manhattan Kan.	KSAC
WPCC	Chicago, Ill.	258	SCRANTON, PA.	250	WQAN	340.7	San Juan, P. R.	WKAQ
WPG	Atlantic City, N. J.	299.8	SEATTLE, WASH.	454.3	KFOA	344.8	Crcte, Ill.	WLS
WPRC	Harrisburgh, Pa.	215.7	SEATTLE, WASH.	384.4	KJR	344.8	Zion, Ill.	WCBD
WPSC	State College, Pa.	261	SEATTLE, WASH.	305.9	KTCL	348.6	Boston, Mass.	WEEL
WQAA	Parkesburg, Pa.	220	SEATTLE, WASH.	454.3	KTW	348.6	Pullman, Wash.	KWSC
WQAE	Springfield, Vt.	246	SEYMOUR, IND.	226	WFBE	348.6	State College, N. M.	KOB
WQAM	Miami, Fla.	263	SHENANDOAH, IA.	263	KFNF	352.7	Detroit, Mich.	WWJ
WQAN	Scranton, Pa.	250	SHENANDOAH, IA.	252	KMA	352.7	Waco, Tex.	WJAD
WQAO	New York, N. Y.	361.2	SHREVEPORT, LA.	250	KFOX	381.2	New York, N. Y.	WHN
WQJ	Chicago, Ill.	447.5	SIoux CITY, IA.	261	KFMR	361.2	New York, N. Y.	WQAO
WRAF	Laporte, Ind.	224	SIoux CITY, IA.	275	WEAU	361.2	Oakland, Cal.	KGO
WRAK	Escanaba, Mich.	256	SOUTH BEND, IND.	275	WSBT	365.6	Kansas City, Mo.	WDAF
WRAM	Galesburg, Ill.	244	SOUTH SAN FRANCISCO, CAL.	226	KFWI	365.6	Kansas City, Mo.	WHB
WRAW	Yellow Springs, O.	263	SPOKANE, WASH.	266	KFIO	370.2	Chicago, Ill.	WEBH
WRAW	Reading, Pa.	238	SPOKANE, WASH.	266	KFPY	370.2	Moosheart, Ill.	WJJD
WRAX	Gloucester City, N. J.	268	SPOKANE, WASH.	273	KHQ	374.8	Bristow, Okla.	KVOO
WRBC	Valparaiso, Ind.	278	SPRINGFIELD, MASS.	333.1	WBZ	374.8	Hot Springs, Ark.	KTHS
WRC	Washington, D. C.	408.5	SPRINGFIELD, O.	248	WCSO	379.5	Schenectady, N. Y.	WGY
WRCO	Raleigh, N. C.	252	SPRINGFIELD, VT.	246	WQAE	379.5	Troy, N. Y.	WHAZ
WREC	Coldwater, Miss.	254	STANFORD UNIVERSITY, CAL.	270	KFGH	384.4	Miami Beach, Fla.	WMBF
WREO	Lansing, Mich.	285.5	STATE COLLEGE, N. M.	348.6	KOB	384.4	Seattle, Wash.	KJR
WRHF	Washington, D. C.	256	STATE COLLEGE, PA.	261	WPSC	389.4	Cleveland, O.	WEAR
WRHM	Minneapolis, Minn.	252	STEVENS POINT, WIS.	278	WLBL	389.4	Cleveland, O.	WTAM
WRK	Hamilton, O.	270	STOCKTON, CAL.	248	KWG	394.5	Philadelphia, Pa.	WFI
WRM	Urbana, Ill.	273	STREATOR, ILL.	231	WTAX	394.5	Philadelphia, Pa.	WLIT
WRMU	New York, N. Y.	236	SUPERIOR, WIS.	242	WEBC	394.5	San Antonio, Tex.	WOAI
WRNY	New York, N. Y.	258	SYCAMORE, ILL.	256	WJBN	399.8	Louisville, Ky.	WHAS
WRR	Dallas, Tex.	246	SYRACUSE, N. Y.	252	WFBL	405.2	Los Angeles, Cal.	KEHJ
WRST	Bay Shore, N. Y.	215.7	TACOMA, WASH.	250	KMO	405.2	Newark, N. J.	WOR
WRVA	Richmond, Va.	256	TACOMA PARK, MD.	222	WBES	405.2	New York, N. Y.	WJY
WRW	Tarrytown, N. Y.	273	TAMPA, FLA.	273	WDAE	416.4	St. Paul-Minneapolis, Minn.	WCCO
WSAI	Mason, O.	325.9	TARRYTOWN, N. Y.	273	WRW	422.3	Cincinnati, O.	WKRC
WSAJ	Grove City, Pa.	229	TAUNTON, MASS.	229	WAIT	422.3	Harrison, O.	WLW
WSAN	Allentown, Pa.	229	TOLEDO, O.	263	WABR	428.3	Atlanta, Ga.	WSB
WSAR	Fall River, Mass.	254	TOLEDO, O.	252	WTAL	428.3	San Francisco, Cal.	KPO
WSAX	Chicago, Ill.	268	TRENTON, N. J.	240	WOAX	440.9	Cranston, R. I.	WDWFT
WSAZ	Pomeroy, O.	244	TRINIDAD, COL.	238	KFBS	440.9	Dartmouth, Mass.	WLSI
WSB	Atlanta, Ga.	428.3	TROY, N. Y.	379.5	WHAZ	440.9	Dartmouth, Mass.	WMAF
WSBC	Chicago, Ill.	209.7	TULSA, OKLA.	250	WLAL	440.9	Independence, Mo.	KLDS
WSBF	St. Louis, Mo.	273	TUSCOLA, ILL.	278	WDZ	440.9	Jefferson City, Mo.	WOS
WSBT	South Bend, Ind.	275	UNIVERSITY PLACE, NEB.	254	WCAJ	447.5	Chicago, Ill.	WMAQ
WSDA	New York, N. Y.	263	UPLAND, CAL.	211.1	KFWC	447.5	Chicago, Ill.	WQJ
WSKC	Bay City, Mich.	261	URBANA, ILL.	273	WRM	454.3	New York, N. Y.	WJZ
WSM	Nashville, Tenn.	282.8	UTICA, N. Y.	205.4	WIBX	454.3	Seattle, Wash.	KTW
WSMB	New Orleans, La.	319	VALPARAISO, IND.	278	WRBC	454.3	Seattle, Wash.	KFOA
WSMH	Owosso, Mich.	240	VERMILLION, S. O.	278	KUSD	461.3	Pittsburg, Pa.	WCAE
WSMK	Dayton, O.	275	WACO, TEX.	352.7	WJAD	468.5	Los Angeles, Cal.	KFI
WSDO	Milwaukee, Wis.	246	WALLA WALLA, WASH.	256	KFCF	468.5	Washington, D. C.	WCAP
WSRO	Hamilton, O.	252	WASHINGTON, D. C.	468.5	WCAP	468.5	Washington, D. C.	WRC
WSUI	Iowa City, Ia.	483.6	WASHINGTON, D. C.	212.6	WMAL	475.9	Dallas, Tex.	WFAA
WTAB	Fall River, Mass.	266	WASHINGTON, D. C.	468.5	WRC	475.9	Fort Worth, Tex.	WBAP
WTAC	Johnstown, Pa.	268	WASHINGTON, D. C.	256	WRHF	475.9	Hartford, Conn.	WTIC
WTAD	Carthage, Ill.	236	WEBSTER, MASS.	231	WKBE	483.6	Davenport, Ia.	WOC
WTAG	Worcester, Mass.	268	WEIRTON, W. VA.	246	WIBR	483.6	Iowa City, Ia.	WSUI
WTAL	Toledo, O.	252	WELCOME, MINN.	227	KFVN	491.5	New York, N. Y.	WEAF

Call Letters	Location	Wave-length	Location	Wave-length	Call Letters	Wave Length	Location	Call Letters
WTAM	Cleveland, O.	389.4	WEST LAFAYETTE, IND.	273	WBAA	491.5	Portland, Ore.	KGW
WTAP	Cambridge, Ill.	242	WEST PALM BEACH, FLA.	248	WIOD	499.7	Columbia, Mo.	KFRU
WTAQ	Oaseo, Wis.	254	WICHITA, KAN.	231	KFOT	499.7	Memphis, Tenn.	WMC
WTAR	Norfolk, Va.	261	WICHITA, KAN.	268	KFH	508.2	Oakland, Cal.	KLX
WTAW	College Station, Tex.	270	WILKES-BARRE, PA.	256	WBAX	508.2	Philadelphia, Pa.	WIP
WTAX	Streator, Ill.	231	WILKES-BARRE, PA.	231	WBRE	508.2	Philadelphia, Pa.	WOO
WTAZ	Lambertville, N. J.	261	WILMINGTON, DEL.	266	WHAV	516.9	Pontiac, Mich.	WJR†
WTIC	Hartford, Conn.	475.9	WINTER PARK, FLA.	240	WDBO	526	Des Moines, Ia.	WXC
WWAD	Philadelphia, Pa.	250	WOOSTER, O.	206.8	WABW	526	New York, N. Y.	WHO
WWAE	Plainfield, Ill.	242	WORCESTER, MASS.	268	WTAG	526	Omaha, Neb.	WNYC
WWAO	Houghton, Mich.	263	YAKIMA, WASH.	256	KFIQ	535.4	Chicago, Ill.	WOAW
WWGL	Richmond Hill, N. Y.	212.6	YANKTON, S. D.	244	WNAX	535.4	Madison, Wis.	KYW
WWI	Dearborn, Mich.	266	YELLOW SPRINGS, O.	263	WRAV	545.1	St. Louis, Mo.	WHA
WWJ	Detroit, Mich.	352.7	YPSILANTI, MICH.	233	WJBK	545.1	St. Louis, Mo.	KFUO
WWL	New Orleans, La.	275	ZION, ILL.	344.6	WCBD	545.1	St. Louis, Mo.	KSD

†This station is operated under two call signs.

NOTE TO BROADCAST LISTENERS: The above list of broadcasting stations will be brought up to date and the changes will hereafter be published in each number of POPULAR RADIO. Preserve the list given herewith and mark the alterations upon it as they are printed in succeeding issues.

53 Sources of Interference

In the Receiver Itself or in the Apparatus Connected to it:

1. An improperly tuned receiver.
2. A loose connection in the receiver or broken wires in the headphone or loud-speaker cord.
3. A defective grid leak.
4. A defective tuning condenser—a momentary shorting of condenser plates.
5. A fixed condenser with defective insulation.
6. Discharged or weak batteries.
7. Loose connections at the batteries.
8. "B" battery eliminators; (in the electrolytic type under certain conditions).
9. A bad socket.
10. A bad tube.

From Apparatus in the Same House with the Receiver—or in a Neighbor's House:

11. Vacuum cleaners.
12. Sewing machine motors or any commutator motor.
13. A violet-ray machine.
14. Ozonators.
15. Door bells and buzzers.
16. Switching of lamps or other electrical devices.
17. Electrical heating pads with thermostat control.
18. Oil burners that use spark ignition; (certain types).
19. Washing machines with split-phase type of motor—if the starting switch is defective.
20. Battery chargers of the vibrating type.
21. Battery chargers of the electrolytic type; (under certain conditions).

22. Elevator controllers and motors of the commutator type.
23. Bad contact in switch, fuse, socket, or other device.
24. Hum caused by having radio receiver or its wiring near lighting wires.

From Outside Sources:

25. Atmospheric static.
26. Regenerative receivers.
27. Sign flashers.
28. Commercial wireless (code) stations.
29. Amateur wireless stations.
30. Induction coils.
31. Electric street cars.
32. Defective rail bonds on street railway systems.
33. Heterodyning of broadcasting stations.
34. Overlapping of broadcasting stations.
35. Telephone ringers.
36. Induction from telephone and telegraph lines.
37. Motion picture machines that use arc lamps.
38. Motors and generators of the commutator type.
39. Electric welding apparatus.
40. X-ray machines.
41. Static machines.
42. Static produced by belts.
43. Electrical manufacturing processes.
44. Induction from high potential circuits.
45. Arcing wire in trees and other grounded objects.
46. Leaking insulators on power circuits.
47. Defective lightning arresters on power circuits.
48. Loose street lamps in sockets.
49. Bad contacts in switches.
50. Lightning arresters.
51. Smoke or dust precipitators.
52. Defective transformers.
53. Defective street light rectifiers.



From a photograph made for POPULAR RADIO

THE THOMPSON MINUET UNDER TEST IN THE LABORATORY

FIGURE 1: The receiver was also put into operation at specially chosen points in and near New York City in order to reproduce actual operating conditions as far as possible.

HOW TO GET THE MOST OUT OF YOUR READY-MADE RECEIVER

No. 10: THE THOMPSON MINUET RECEIVER MODEL R-81

This series of articles explains the theory, operation, equipment and care of standard receiving sets

This series does not indorse the product of any manufacturer nor make comparisons between receivers. The sets already described include: No. 1, the Eagle Neutrodyne; No. 2, the Radiola Superheterodyne; No. 3, the Melco Supreme Receiver; No. 4, the Crosley Trirdyn; No. 5, the De Forest Reflex; No. 6, the Atwater Kent; No. 7, the Grebe Synchrophase Receiver; No. 8, the Freed-Eisemann Receiver; No. 9, the Garod Neutrodyne Type V Receiver.

By S. GORDON TAYLOR

EXPLANATION OF SYMBOLS IN FIGURE 1—

RFC1—Antenna coupling coil;
RFC2 and RFC3—Radio-frequency coupler coils;
VC1, VC2 and VC3—Variable condensers;
VT1, VT2, VT3 and VT4—UX-199 type vacuum tubes;
VT5—UX-120 type amplifier vacuum tube;
AFT1 and AFT2—Audio-frequency amplifying transformers;

R1—Filament rheostat controlling VT1 and VT2;
R2—Filament rheostat controlling VT3, VT4 and VT5;
R3—Grid-leak resistance;
C1, C2, C3 and C4—Fixed condensers;
C5 and C6—Neutralizing condensers;
S1—Battery switch.

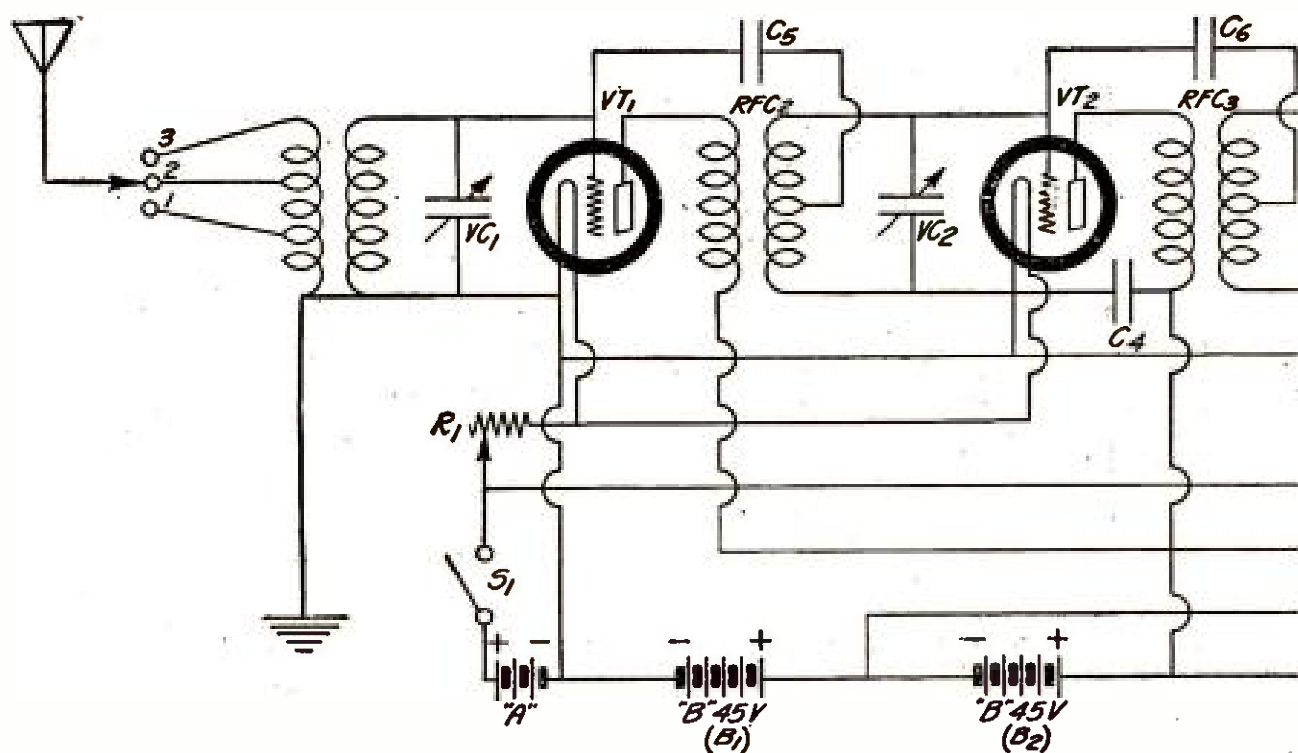

THE WIRING DIAGRAM OF THE RECEIVER

FIGURE 2: This schematic drawing together with the text should give the novice a general understanding of how the receiver works. The lettering used is identical with that employed in the other illustrations and in the list of parts.

THIS five-tube receiver is of the tuned-radio-frequency type and employs the neutrodyne method of preventing oscillation in the radio-frequency amplifier. The theory of neutralization used in this type of receiver has already been described in detail in previous articles of this series.*

Construction of the Receiver

This receiver, when it is put into operation, is entirely self-contained. The loudspeaker, tuning control units and the receiver proper as shown in Figures 3, 4 and 5 are all mounted on the battery box and sub-panels while space is provided within the cabinet for all batteries, "A," "B" and "C." All the connecting wires are therefore concealed within the cabinet with the exception of those which lead to the antenna and ground.

Access to the battery compartment and the rear connection block is gained from the rear of the receiver, by the removal of the grill. This is accomplished by

turning the knob at the top and pulling the grill out and up.

The variable tuning condensers are mounted on a metal subpanel and are mechanically coupled together by means of wires and pulleys so that they are operated from a single major tuning control at the front. In this way the three tuned circuits are controlled by a single tuning knob which swings in a calibrated arc around the circumference of the loudspeaker cone.

It is impossible, however, in this type of receiver to tune three circuits with a single control and have each one tuned to absolute accuracy. The slight variation involved is not noticeable to any extent in the case of reception from local broadcasting stations but it does become noticeable when an effort is made to bring in distant stations where extremely fine tuning is necessary.

To take care of this variation the manufacturer of this receiver has provided "compensator" controls on the front of the receiver. By means of these controls the slight readjustment of the

* Those who wish to familiarize themselves with this theory are referred to the articles of this series which appeared in POPULAR RADIO for December, 1924, and August, 1925.

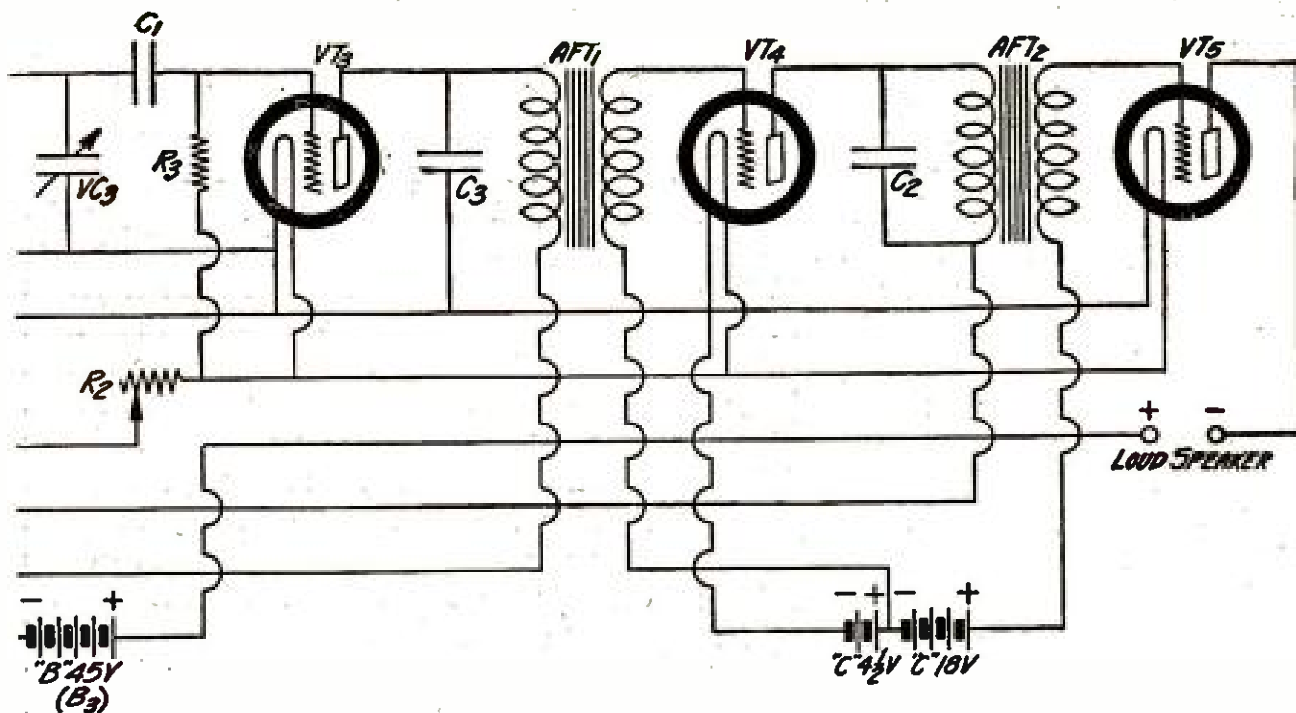

settings of VC1 and VC3 may be made. Thus these two circuits may be brought into exact resonance with the other circuit. The result of this arrangement is a single-control receiver for local reception but with the added refinement of compensator adjustments for sharp tuning.

There are also two knobs on the panel which control the battery current supply to the tube filaments. The one at the right is used to adjust the current to the detector and audio amplifier tubes. When this is once set for maximum results it need not be varied except that it should be advanced somewhat as the voltage of the "A" battery drops through age. The filament knob at the left serves to control the volume of sound by varying the amount of current flow through the filaments of the radio-frequency amplifier tubes. By the use of this control any desired degree of volume may be obtained.

How the Receiver Works

When radio signals are intercepted by the antenna there is a flow of radio-frequency current through the coil which is connected in the antenna-ground circuit, i. e., the primary of RFC1. By means of electromagnetic induction this energy is transferred to the secondary of the antenna coupler RFC1.

The amount of energy transferred in this manner depends upon the ratio of turns in these two coils and the degree of coupling between them. If the energy transfer is too great the tuning, which is controlled by the condenser VC1 shunted across the secondary coil, will be broad when a large antenna is used. This condition may permit two broadcasting stations on different wavelengths to be heard at the same time.

To eliminate this possibility the antenna coil in this receiver is provided with three taps, marked 1, 2 and 3 in Figure 2. If a short antenna is used with the receiver the connection to the tapped part of this coil is made to binding post number 3, which provides the maximum energy transfer to the secondary coil. In other words, a small antenna picks up comparatively little energy from the ether and all of this energy may be used to advantage.

A larger antenna, however, may pick up too much energy. Therefore it should be connected to binding post 1 or 2 which provides fewer turns of the antenna coil in the circuit with the result that the coupling between the two coils is "loose" and there is a comparatively smaller transfer of energy.

Let us assume, for the purpose of illustration, that the energy of the incoming signal has been successfully transferred to

the secondary coil of RFC1. It is then necessary to tune this circuit by means of VC1. This must be done because this circuit will accept only energy of the same frequency, or wavelength, as that to which the circuit is tuned. If the secondary is tuned to 300 meters, for instance, the resistance that this circuit offers against the flow of energy is low if the received energy has a frequency of 1,000,000 cycles a second, corresponding to a 300 meter wavelength. The resistance is high to other frequencies, however.

It may be considered then that this tuned secondary circuit accepts signals of the same wavelength to which it is tuned and rejects all others. It follows, of course, that by varying the adjustment of VC1 this circuit may be made an "acceptor" of signals of any wavelength within the range of the circuit (in this receiver the range is approximately 200 to 600 meters), while at the same time serving as a "rejector" of all signals of wavelengths higher or lower than that to which the circuit is tuned.

The secondary of RFC1 is connected to the grid and filament of VT1, as shown in the diagram, Figure 2. Thus the energy put into this coil from the antenna coil is impressed across the grid and filament of the vacuum tube.

Through the amplifying action of the tube the energy taken out of the amplifier tube will be greater than that put into it. The added electrical energy is supplied by the high voltage "B" battery and is taken out across the plate and filament of the tube.

When an impulse of energy is impressed on the grid of the tube, this element acts as a throttle, allowing a corresponding impulse of electrical energy to be drawn from the "B" battery through the plate circuit of the tube. Thus an energy flow is set up in the primary of RFC2 because this coil is connected between the "B" battery and the plate of the tube.

It is evident then that the signal energy which was intercepted by the antenna

circuit and transferred to the secondary circuit of RFC1 will be duplicated in the primary circuit of RFC2 but it will, of course, be larger because of the amplification properties of the tube.

This increased energy is transferred to the secondary of RFC2, if the latter is tuned to the same wavelength. It is then impressed on the grid circuit of the second radio-frequency amplifier tube where further amplification is provided. Thus extremely weak signals intercepted by the antenna are built up so that by the time they are impressed upon the grid of the detector tube, through RFC3, they have a respectable amount of strength. This of course means that the receiver is much more sensitive to weak signals from distant stations than would be the case if a radio-frequency amplifier were not used.

Up to this point all the energy has remained in the form of radio-frequency currents. Radio-frequency energy, however, cannot be made audible by inserting a loudspeaker or headphone in the circuit. It is first necessary to change the form of the current to so-called "audio-frequency." In other words the radio-frequency must be reduced to one within the range of the human ear. This is accomplished by means of the detector tube which has what might be called a semi-rectifying action. The result is that the output of the detector tube practically amounts to a direct current which fluctuates according to the vibration or frequency of the voice or music which is being received.

If headphones were connected in the plate circuit of the detector tube in place of the primary coil of AFT1, these vibrations or frequencies would become audible reproductions of the sounds which were originally broadcast.

In order to make the use of a loudspeaker possible, however, it is necessary to build up the strength of these audio-frequency currents. This is accomplished by the use of two stages of audio-frequency amplification.

The process is the same as that of the radio-frequency amplifier except that the

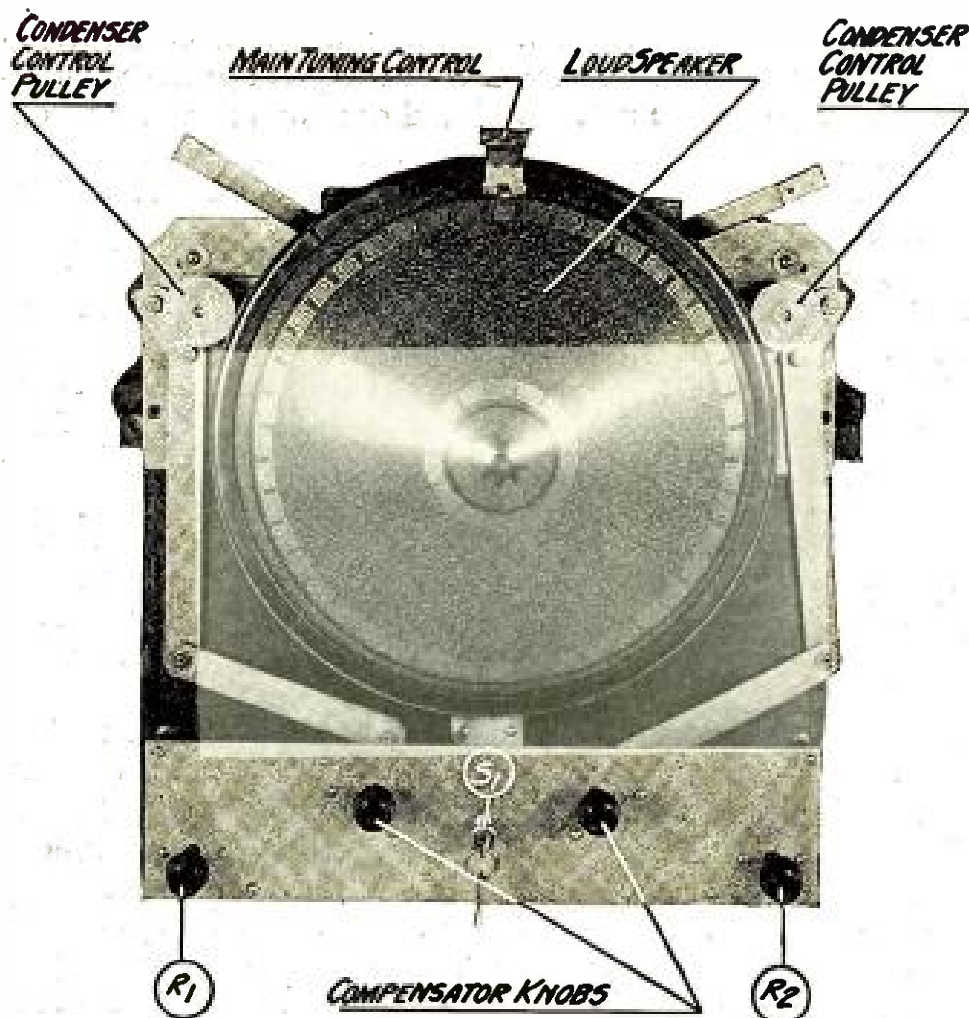

A FRONT VIEW OF THE RECEIVER, WITH THE CABINET REMOVED

FIGURE 3: The pulleys which control the two condensers VC_1 and VC_3 are shown in this picture. The single control at the top also operates the third condenser, VC_2 . The receiver is completely assembled and wired before it is placed in the cabinet.

coupling coils (audio-frequency transformers) are of a different type which requires no tuning because they pass nearly all audio-frequency currents with equal facility.

Antenna and Ground

As has been stated, there is a definite limit to the amount of signal energy that can be effectively transferred from the antenna circuit to the receiver. If there is too great an energy transfer the tuning becomes broader, with the result that two stations broadcasting on different wavelengths may be heard at one time. To a certain extent the three connections provided on the antenna coupling coil may be used to adjust the signal strength to suitable proportions. However there are other conditions that should be considered.

If the receiver is located close to powerful broadcasting stations the antenna will pick up a great deal of energy—perhaps so much that even with the antenna connected to the first tap on the antenna coil the energy transfer will be too great unless a small antenna is used. On the other hand, if the nearest broadcasting station is 50 or 100 miles distant it may be possible to use a much larger antenna, even when it is connected to taps 2 or 3 on the antenna coil. Because of the greater distance the signals have to travel, in this latter case, they are naturally comparatively weak when they reach the receiving antenna and therefore the signal energy impressed on the grid circuit of the first tube will be sharp in tuning.

The logical conclusion is that a small antenna should be used if the receiver is

to be located within a few miles of a powerful broadcasting station. When there are no nearby stations the antenna may be much larger.

Actually these conclusions are borne out by facts, with the result that an antenna between 60 and 75 feet in length is recommended where there are high power broadcasting stations within a distance of about 30 miles from the receiver. Where the nearest stations are at a greater distance than this a larger antenna may be used—anywhere from 100 to 150 feet in length—depending on the distance.

Previous articles of this series have gone into detail regarding the installation of antennas and ground connections. It does not seem necessary to go over this ground again, especially since the instruction booklet which is furnished with this receiver by the manufacturer covers this subject with great thoroughness. It should suffice to offer an illustration of an ideal antenna arrangement, Figure 6, with the suggestion that it be followed as closely as conditions may permit.

The Vacuum Tubes to Use

This receiver is designed to operate with dry-cell tubes exclusively. As indicated in the list of symbols at the head of this article, UX-199 type tubes are used for the radio-frequency amplifier, detector and first audio amplifier tubes. For the second audio amplifier tube a UX-120 type of tube is used.

If desired, the UX-199 type may be used in all five sockets but the increased volume with the use of a UX-120 tube in the last audio stage is so great as to make the substitution of a UX-199 tube impractical. Therefore the only combination to be discussed here will be that which uses a UX-120 as indicated above.

What Batteries to Use

Dry-cell batteries alone are used to operate this receiver. This includes the "A" battery, which supplies the filament lighting current; the "B" battery, which supplies the high voltage to the tube plate

circuits, and the "C" battery, which supplies the proper grid-bias to provide the maximum volume and tone quality in the audio-frequency amplifier.

The "A" battery is made up by connecting six ordinary dry cells as shown in Figure 7. By connecting batteries in series their total current is equal to that of only one battery, but their total voltage is equal to the sum of their individual voltages. Therefore, since dry cells are rated at $1\frac{1}{2}$ volts each two connected in series would provide a 3 volt supply.

The UX-199 type of tube operates on three volts but it is necessary to use three dry cells in series to operate these tubes. This is because the voltage of the batteries drops slightly after they have been in use a short while so that two of them in series would not supply an adequate voltage for any length of time. Therefore three dry cells are connected in series to provide suitable voltage, even after their initial voltage has dropped somewhat.

When dry cells are connected in multiple (parallel) their total voltage remains the same as that of a single battery but their current (life) is greatly increased. In some cases, where the current drain is fairly large two batteries connected in multiple will have considerably more than twice the life of a single battery. In such cases it is of course more practical to use two batteries, thus connected, than one.

For lighting the filaments of this receiver, it is therefore recommended that both of these methods of connection be used. This arrangement is shown in Figure 7. The six dry cells are divided into two groups of three each. The three batteries in each set are connected in series, providing a total voltage of $4\frac{1}{2}$ for each set. The two sets are then connected in multiple making the total output voltage $4\frac{1}{2}$ but more than doubling the current life.

In selecting dry cells for use in lighting the filaments of this receiver it is recommended that preference be given to batteries which are made expressly for radio use. The ordinary batteries commonly

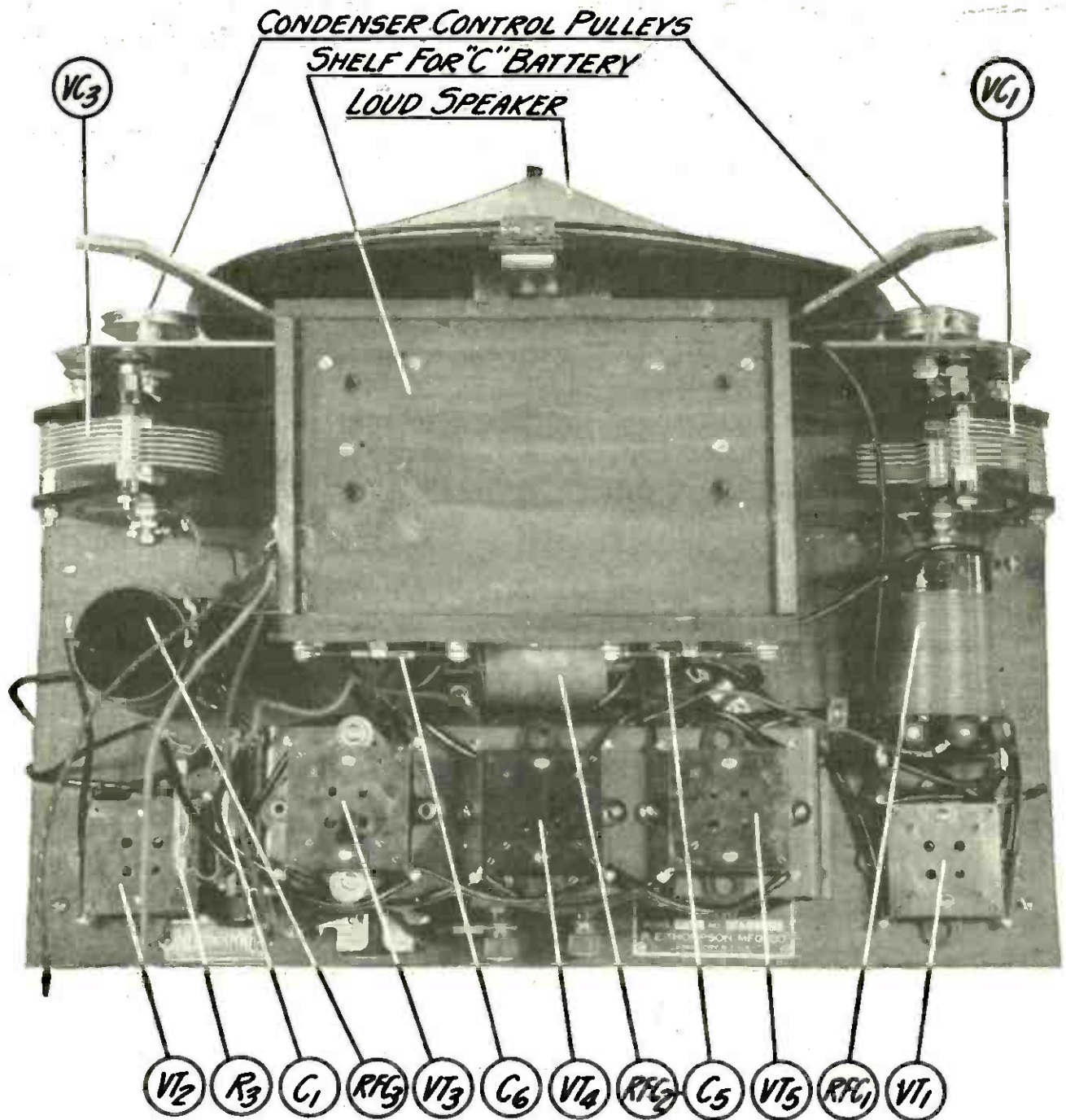

A TOP VIEW OF THE RECEIVER

FIGURE 4: The greater part of the assembly of the set, as shown here, is mounted on the top of the battery box. VC2 is hidden by the "C" battery shelf.

used for operating doorbells will not function as satisfactorily as radio dry cells which are so designed as to provide maximum efficiency when subjected to current drains such as those required for operation of vacuum tubes.

The life of a set of six standard radio dry cells, connected to the Thompson receiver, as shown in Figure 7, should approximate 80 to 100 hours of use. This means that if the receiver is used an average of two hours per day, one set of

these batteries should last about a month and a half.

A small pocket voltmeter may be used to test the batteries from time to time, to determine their condition. A new battery should register $1\frac{1}{2}$ volts when the voltmeter is connected across its terminals.

As the batteries become worn their voltage drops until they do not provide ample voltage to operate the receiver. When the voltage drops to .9 volt per cell the batteries should be replaced with new. It is

a good idea to purchase a new set of batteries when the voltage of the old has dropped to 1 or 1.1 so that the new ones will be on hand when the time comes for their installation.

For the high voltage supply it is possible to use "B" batteries of either the dry or storage type, or one of the devices now on the market which make it possible to obtain the proper voltage supply direct from the house lighting lines. The source most commonly used, of course, is the dry-cell "B" battery. This consists of a number of small dry cells, similar to flash light cells, which are assembled into sealed blocks containing either 15 or 30 cells each, representing total voltages of $22\frac{1}{2}$ and 45 respectively.

Like the dry cells used for lighting the filaments, these batteries must be replaced with new ones when they become worn out. Their condition may be tested with a small voltmeter, as in the case of the dry cell "A" batteries, but in this case the voltmeter should be capable of reading up to 50 volts. The most practical arrangement is to purchase a voltmeter with a double scale; one with a maximum of two or three volts, for use in measuring the voltage of the "A" batteries and the other with a maximum of 50 for measuring the voltage of the individual blocks of the "B" battery. "B" batteries should be replaced when the voltage of a single 45

volt block drops to 34, or a $22\frac{1}{2}$ volt block drops to 17.

The approximate life of a set of dry cell "B" batteries used with this receiver is shown in the tabulation given below.

Study of the circuit diagram will show that the first 45 volt battery, designated as "B1" is connected in the circuits of all five tubes, while "B2" is connected in the circuits of only four—VT1, VT2, VT4 and VT5. The current drain of the tube VT3 is so slight as to be of little importance, so it may be considered that the current drain on batteries "B1" and "B2" is approximately equal. "B3," however, is connected in the circuit of VT5 only and is therefore subjected to a much lighter drain than are the other two batteries. It is therefore advisable to switch the batteries around about once a month. Thus, at the end of three months, each battery will have served one month in each of the three positions in the circuit and each will therefore have been subjected to the same drain. If this suggestion is not followed, it will be found that the first two batteries will run down much faster than the third.

Some difficulty will be found in using the storage type of "B" batteries with this receiver because the space provided in the cabinet is not sufficient. However, if there is no objection to mounting the storage batteries outside of the cabinet,

TABLE OF ESTIMATED "B" BATTERY LIFE WITH THE THOMPSON RECEIVERS

Amount of use daily	"B1"	"B2"	"B3"	ALL, IF INTER-CHANGED MONTHLY
2 hours	148 days	148 days	388 days	190 days
3 hours	91 days	91 days	288 days	124 days
4 hours	61 days	61 days	228 days	86 days

This approximation of the life of the "B" batteries used with the Thompson receiver is calculated from the actual current drain figures divided into the known ampere hour capacity of standard makes of "B" batteries. It will be noted that if the batteries are not changed around monthly, as suggested in the text, "B1" and "B2" will run down almost three times as rapidly as "B3." By interchanging the batteries monthly, however, the life of all will be approximately equal and it will be a more simple matter to keep the battery voltage checked up.

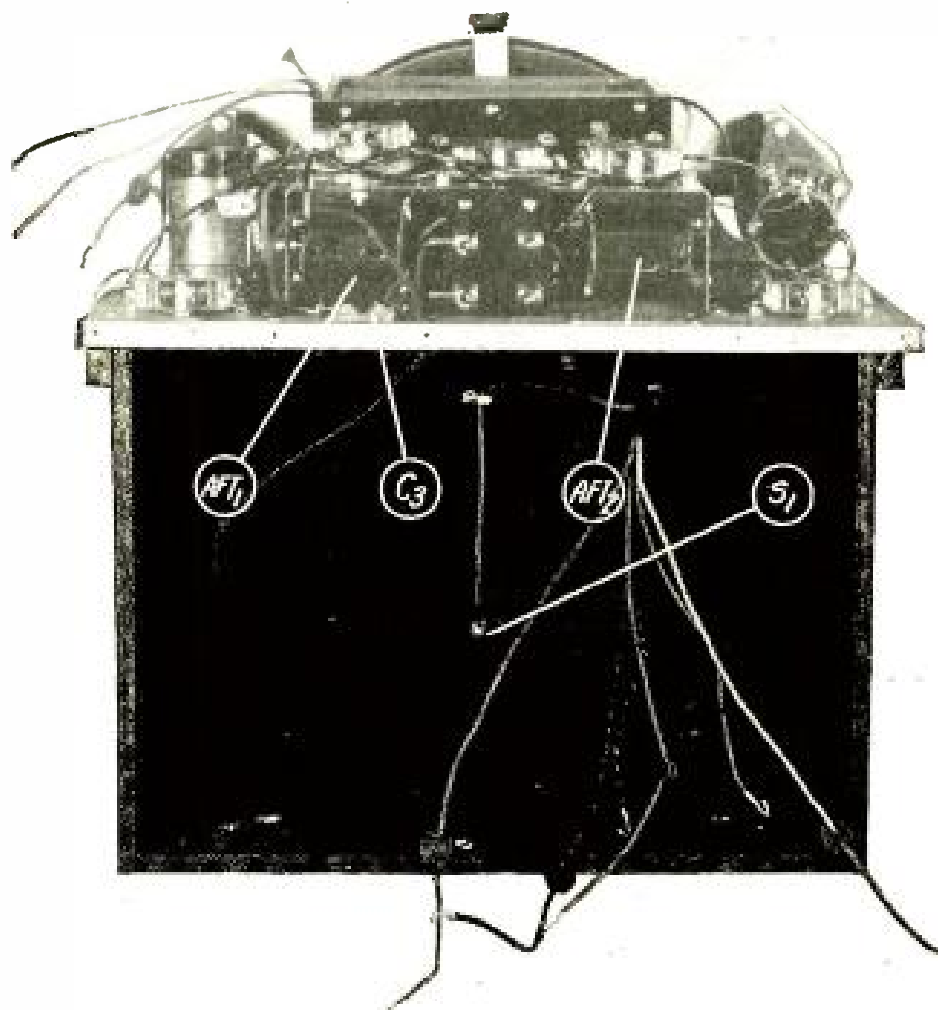

A REAR VIEW OF THE SET WITHOUT ITS CABINET

FIGURE 5: *The space provided for the batteries is here shown. When the cabinet is in place the batteries may be reached by removing the grill at the rear. The battery arrangement is given in Figure 7.*

their use will be found entirely practical.

The first cost of such batteries is higher than that of the dry cell type. However, storage "B" batteries may be recharged when they run down and will function for years with only an occasional charging. A charger which makes it possible to recharge storage batteries from the electric light line may be purchased for a few dollars, and will enable the owner to charge his batteries at home.

If it is desired to use a "B battery eliminator" one should keep in mind the dimensions of the battery cabinet in the receiver and it is by all means advisable to require a demonstration of the device in conjunction with this particular receiver before the purchase is made. This is especially important because many of the devices which furnish the high volt-

age plate supply direct from the electric light lines will not function satisfactorily unless several feet away from the receiver.

A 22½-volt "B" battery serves as the "C" battery for this receiver. Heretofore receivers required only about 4½ volts of "C" battery but with the advent of the new power tubes, such as the UX-120, higher "C" battery voltages are required. This is fortunate because otherwise the current drain on the "B" batteries where the voltage is over 100 would be excessive.

The "C" battery serves not only to cut down the current drain on the "B" batteries, but also to improve the tone quality of reproduction.

The "C" battery is subjected to practically no current drain and for that rea-

son its life in the receiver is approximately equal to its shelf life, which is the term used to designate the life of a battery which is not used but which gradually deteriorates and loses strength because of age.

The estimated life of the "C" battery is in excess of 18 months. When its voltage has dropped to 17 it should be replaced.

The Operation of the Receiver

After the batteries, antenna and ground have been connected to the receiver, as shown in Figure 7, it is a simple matter to put it in operation. The five vacuum tubes should be inserted in their sockets, making sure that the UX-120 type tube is placed in the socket marked VT5 in Figure 4. It is also advisable at first, to connect the wire running to the antenna coupler coil to the middle one of the three binding posts mounted on the rear end of this coil.

The filaments of the vacuum tubes are lighted next by inserting the key in the battery switch S1 and turning a quarter turn to either side. The rheostat knobs R1 and R2 are then each turned half way on. At this setting their pointers will point directly upward. With these two operations accomplished, the filaments of the five tubes should glow dimly, and the receiver is in readiness for reception.

The two compensating knobs should then be set at zero and the main tuning control moved slowly over its scale until a broadcast station is heard. The main control may be left at the setting where the signal is loudest.

The compensating knobs should then be adjusted in an effort to make the signal still louder. When this has been done the receiver is tuned to exact resonance with the broadcasting station.

At this point the two knobs R1 and R2 should be readjusted. As they are turned to the right they allow greater

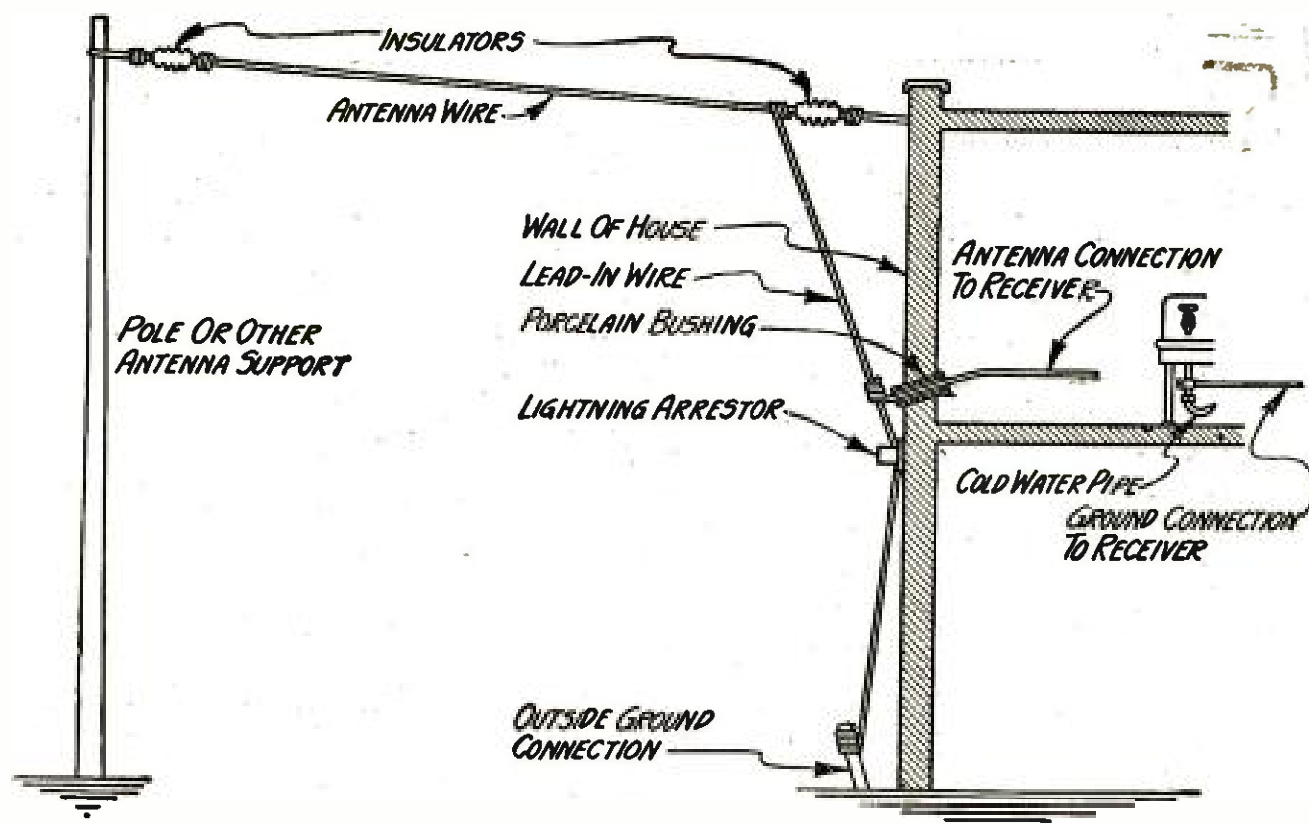

AN EXCELLENT ANTENNA ARRANGEMENT

FIGURE 6: The design of the antenna is necessarily governed, in most cases, by the roof or yard space available. However, many of the ideas suggested by this illustration may be used to advantage in any antenna installation. The best length for the antenna will depend in each case on the interference conditions.

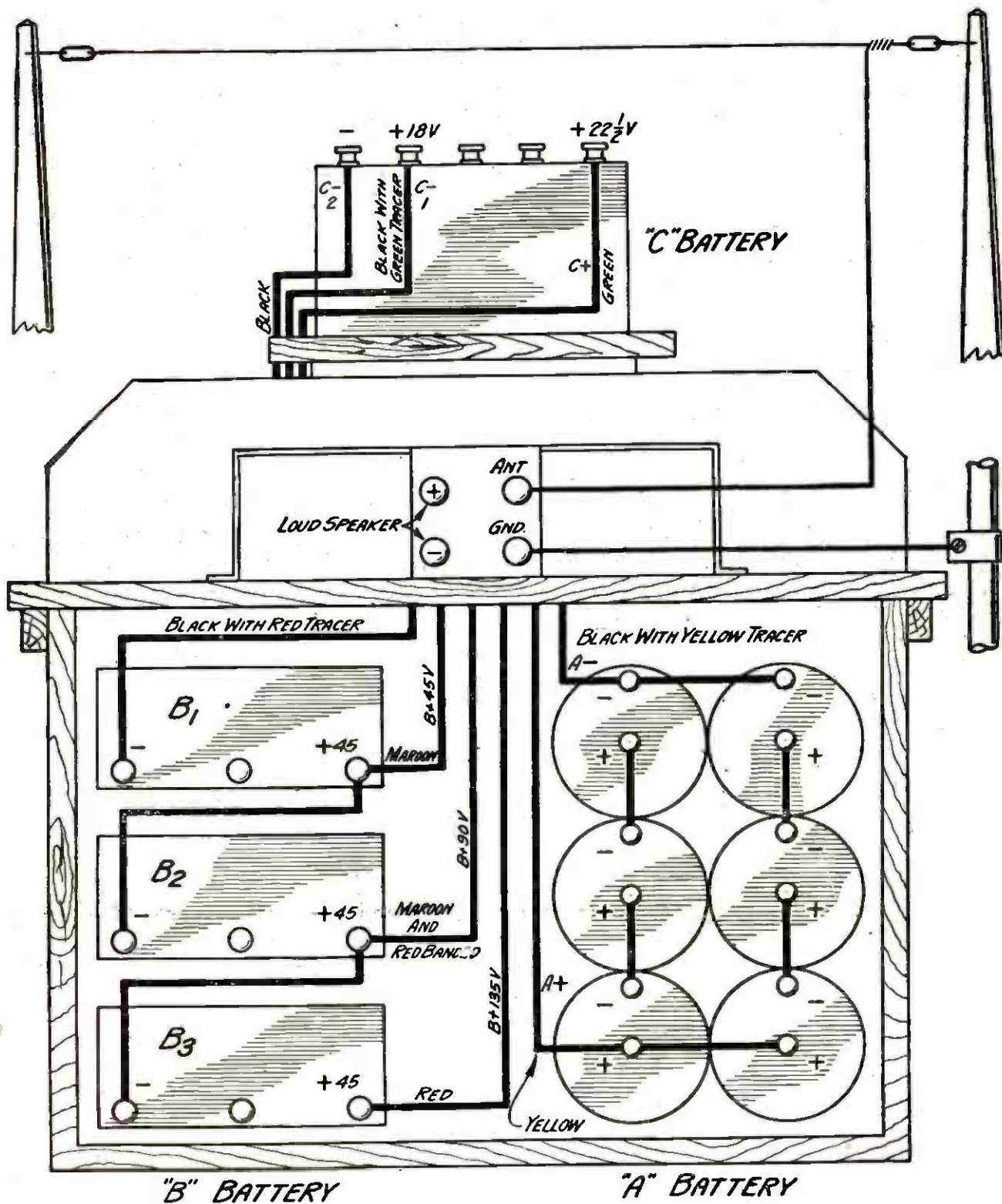

THE CONNECTION CHART

FIGURE 7: This diagram gives the wiring of the batteries, antenna, ground and loud-speaker. The arrangement of the "A," "B" and "C" batteries is also shown.

current to flow to the filaments of the tubes. With this increased current there will be an increase in volume of received signals up to a certain point. Above this point increasing current will not increase signal strength but will shorten the life of the tubes.

The proper setting of the knobs R1 and R2, therefore, is the lowest one which will provide maximum volume of signals. If maximum volume is not needed, in the case of reception from local stations, it can be cut down to any desired degree by turning the knob R1 backward (left).

When the compensator knobs are set for maximum effectiveness for one broadcasting station they will need little attention unless the wire running to the antenna coupling coil is changed to another terminal. In that case a new setting for them will be necessary. This new setting, however, will hold good for all stations so long as the connection to the antenna coil is not changed.

After practicing tuning for a short time, it is well to try changing the connection to the antenna coil from one terminal to another until all three have been tried. Then leave the connection on the terminal which provides the greatest signal strength but which still retains ample selectivity to make possible the reception of any station without interference from another. After the best connection has once been found there is no necessity for

again changing it unless a change is made in the antenna.

How to Chart the Receiver

When a station has once been tuned in it can always be brought in again at the same setting of the main tuning control (and the compensating controls). For this reason a notation of the dial setting should be made for each new station.

Thereafter when it is desired to tune in a certain station it is necessary only to refer to these notations to find the proper setting for the tuning control.

These notations may be made in tabular form and new stations added as they are tuned in. If desired, the stations can later be arranged on a new chart, listed in alphabetical order or in any other arrangement which is convenient to the operator of the receiver.

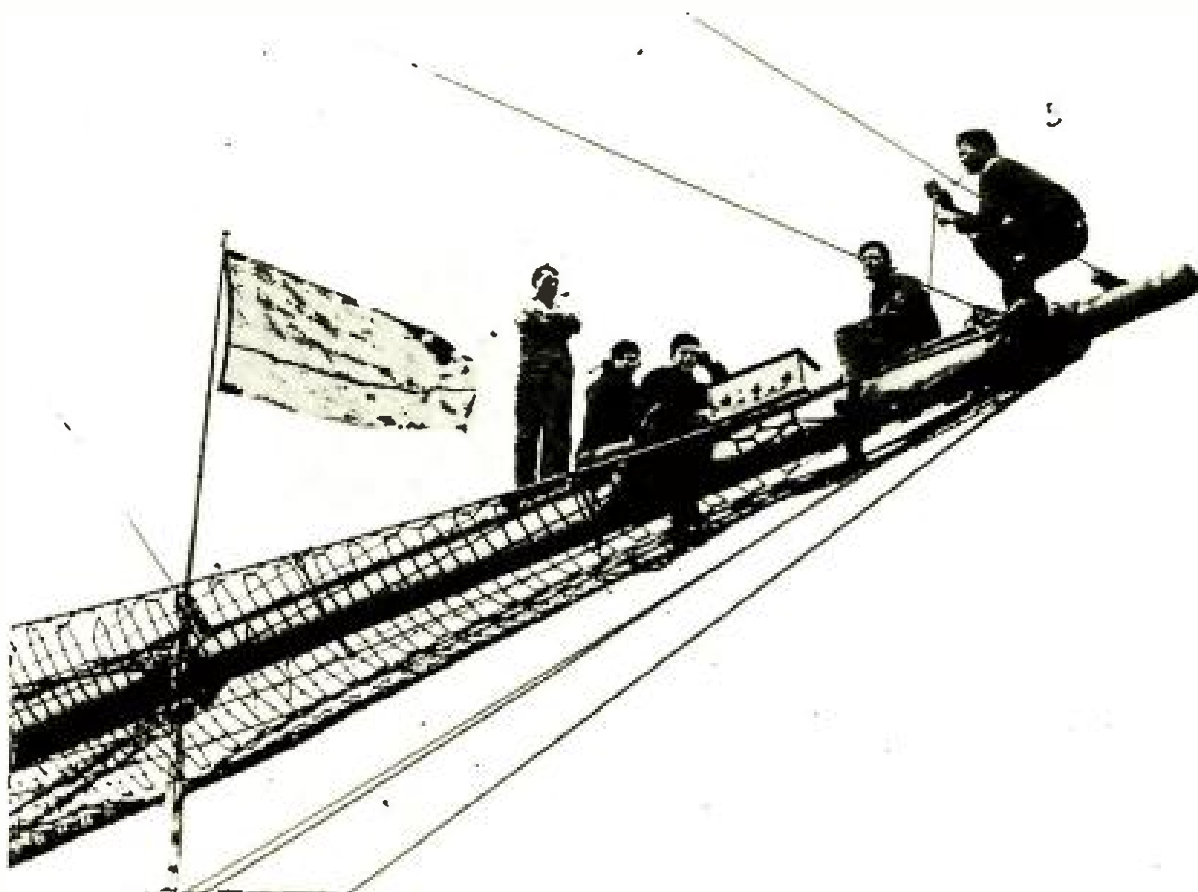

Kadel & Herbert

"LIFE ON THE ETHER WAVE"

The best point of radio reception on board a vessel is the bowsprit—if the cadets of the New York State schoolship NEWPORT are to be believed. Radio fans of an experimental turn of mind may care to check up on this conclusion—and on the other hand, they may not!

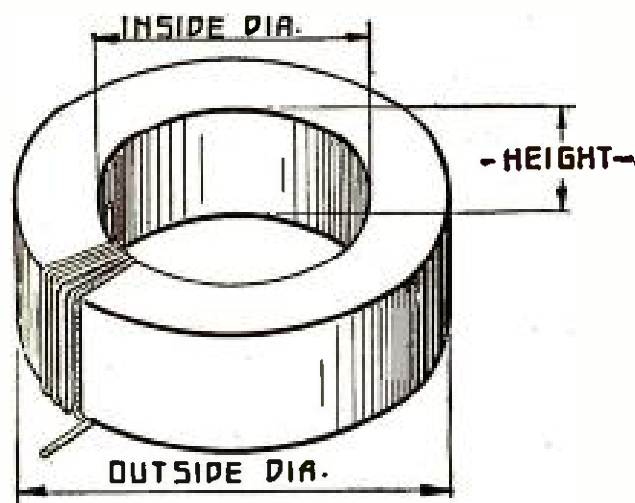

THE TYPE OF COIL TO BE MEASURED

FIGURE 1: The toroid shape of winding, shown in the diagram above, that consists of a circular winding of square cross section may be easily calculated for inductance as explained in the following article.

A MEASUREMENT CHART

FOR SIMPLE CALCULATION OF INDUCTANCE OF TOROID COILS

ARTICLE No. 14

By RAOUL J. HOFFMAN, A.M.E.

THE trend of development in recent coil design has been somewhat toward the confinement of the magnetic field within the coil in order to eliminate radiation, inductive coupling between stages, and a freedom from outside interference.

The ordinary coil, the solenoid, as used today, has a larger external field which is the main cause of picking up outside energy from nearby stations.

A coil wound around a ring has a completely self-contained magnetic field, and is called a toroidal coil, also known under the popular name as the "doughnut coil."

The simplest form for winding a toroidal coil is a ring with a rectangular cross-section, for which the inductance follows the equation:

$$L = .0117 n^2 h \log_{10} O.D./I.D.$$

wherein L denotes the inductance in microhenrys, n the total number of turns,

h the thickness or height of the coil, O.D. the outside diameter and I.D. the inside diameter; all dimensions in inches.

For ready calculations the above formula is represented by a chart as shown in Figure 2.

Figure 1 shows the general design to be calculated.

Using a certain size of wire to be wound on a single layer on a given inside diameter there is a maximum number of turns possible.

Looking at the chart in Figure 1, we find on scale No. 1 the inside diameter of the coil, on scale No. 2 the double silk covered wire and on scale No. 3 the single silk over single cotton covered wire; by connecting scale No. 1 with scale No. 2 or scale No. 3 we find the line intersecting scale No. 4 at the maximum number of turns possible.

Example: To find the inductance of a toroidal coil having a height of 1.5 inches an outside diameter of 4 inches and an inside diameter of 2 inches using

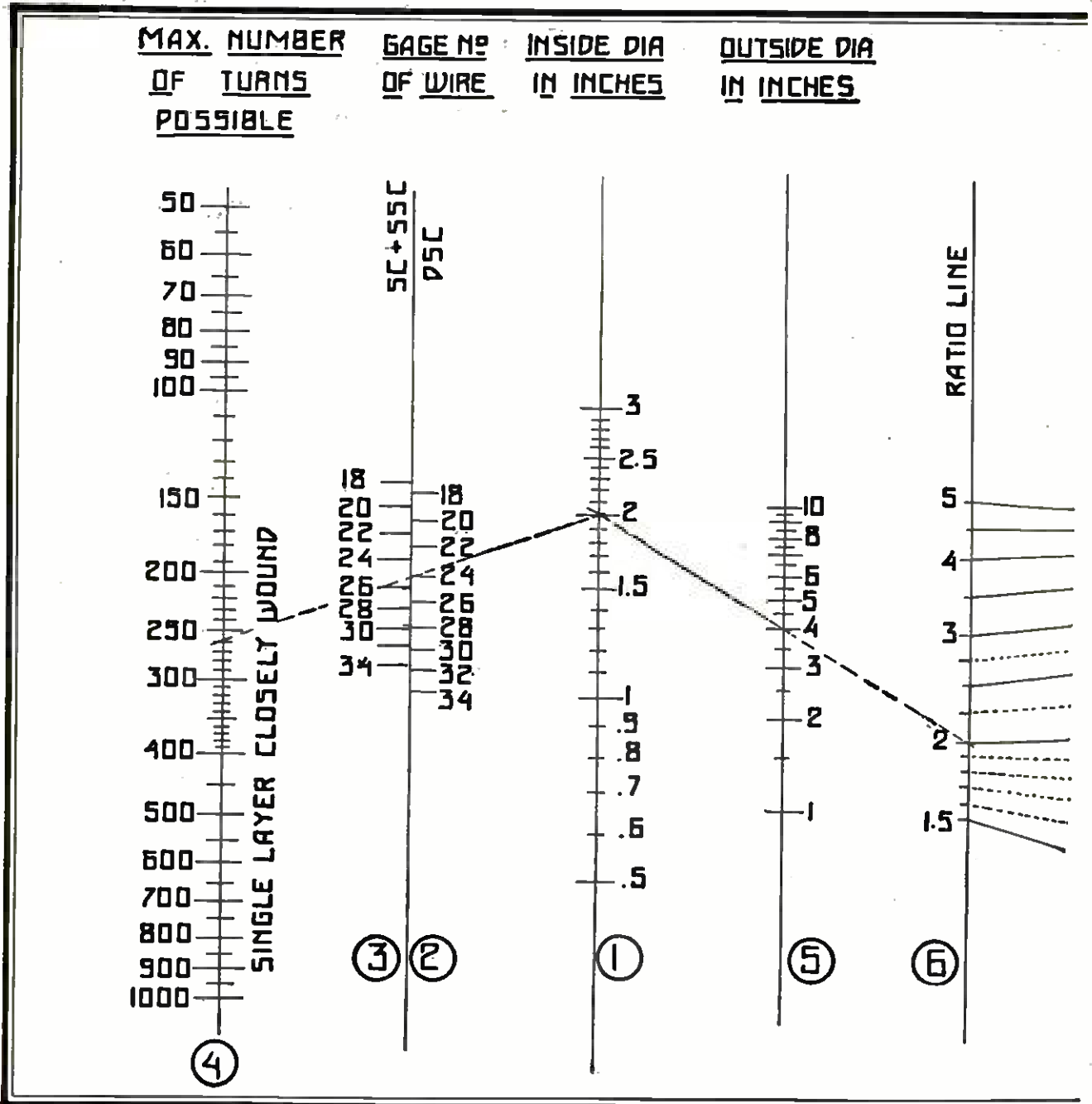

THE CHART THAT HELPS YOU TO DESIGN THE TOROID COIL
 FIGURE 2: By means of this simplified chart the amateur experimenter may design his toroid coils to any inductance value that he desires to use in his receiving set. The chart takes into consideration the number of turns of wire necessary, kind of wire, the inside and outside diameters of the toroid and the height of the windings for obtaining a coil of a certain specified inductance value.

No. 24 D.S.C. wire. Connect 2 on scale No. 1 with 24 on scale No. 2 you will find the line intersecting 260 on scale No. 4 which is the maximum number of turns possible for a single layer.

Then connecting 2 on scale No. 1 with 4 on scale No. 5, you will find the line intersecting 2 on scale No. 6 which gives

the ratio of the outside and inside diameter; taking the same ratio number on the conversion line No. 7 and connecting it with 1.5 on scale No. 8, then connecting the intersection point on the reference line No. 9 with 260 on scale No. 10 you will find the inductance on scale No. 11 to be 360 microhenrys.

Q The next MEASUREMENT CHART of this series will enable the experimenter to figure out the inductance of the circular section toroid coil.

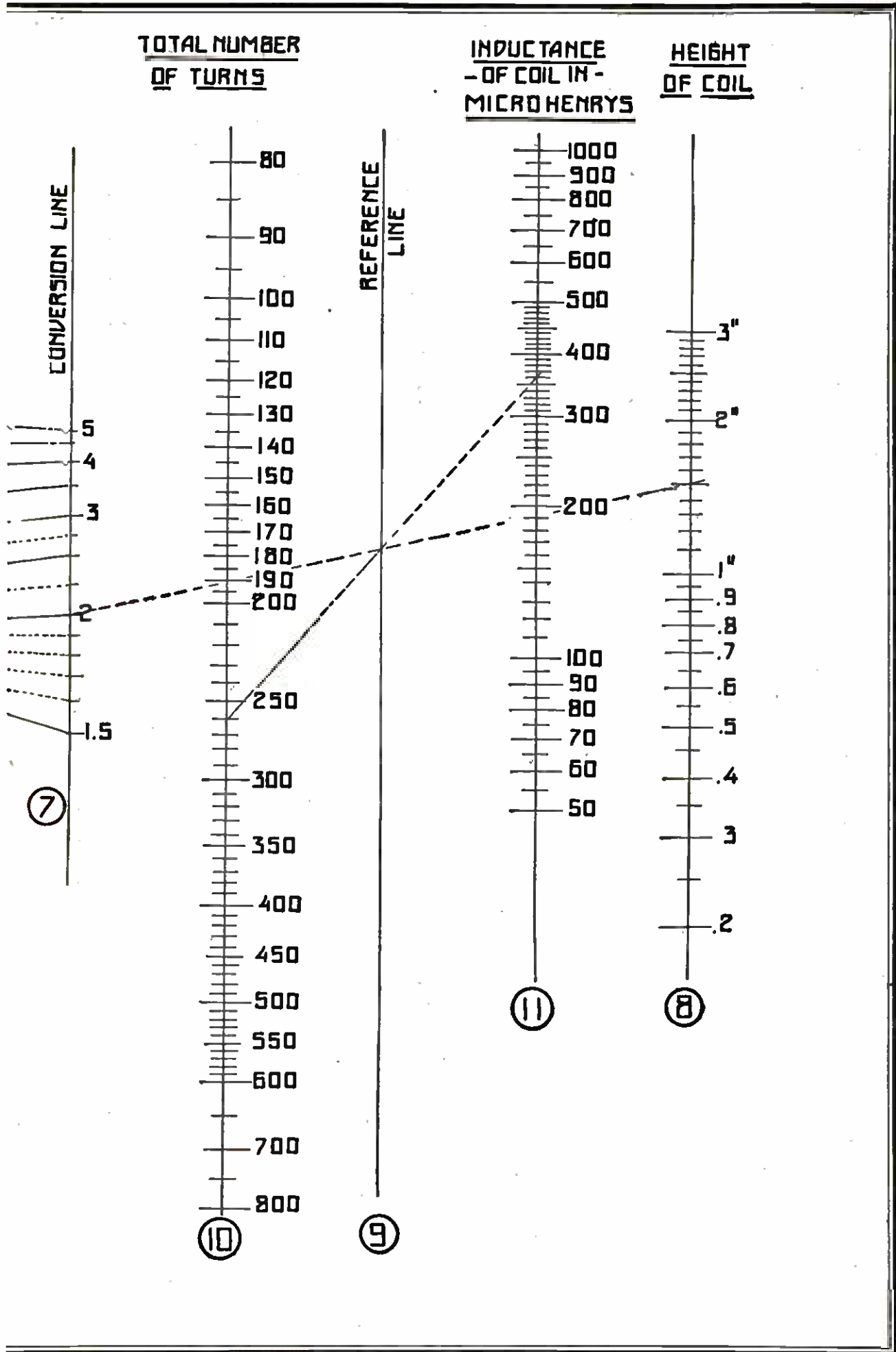

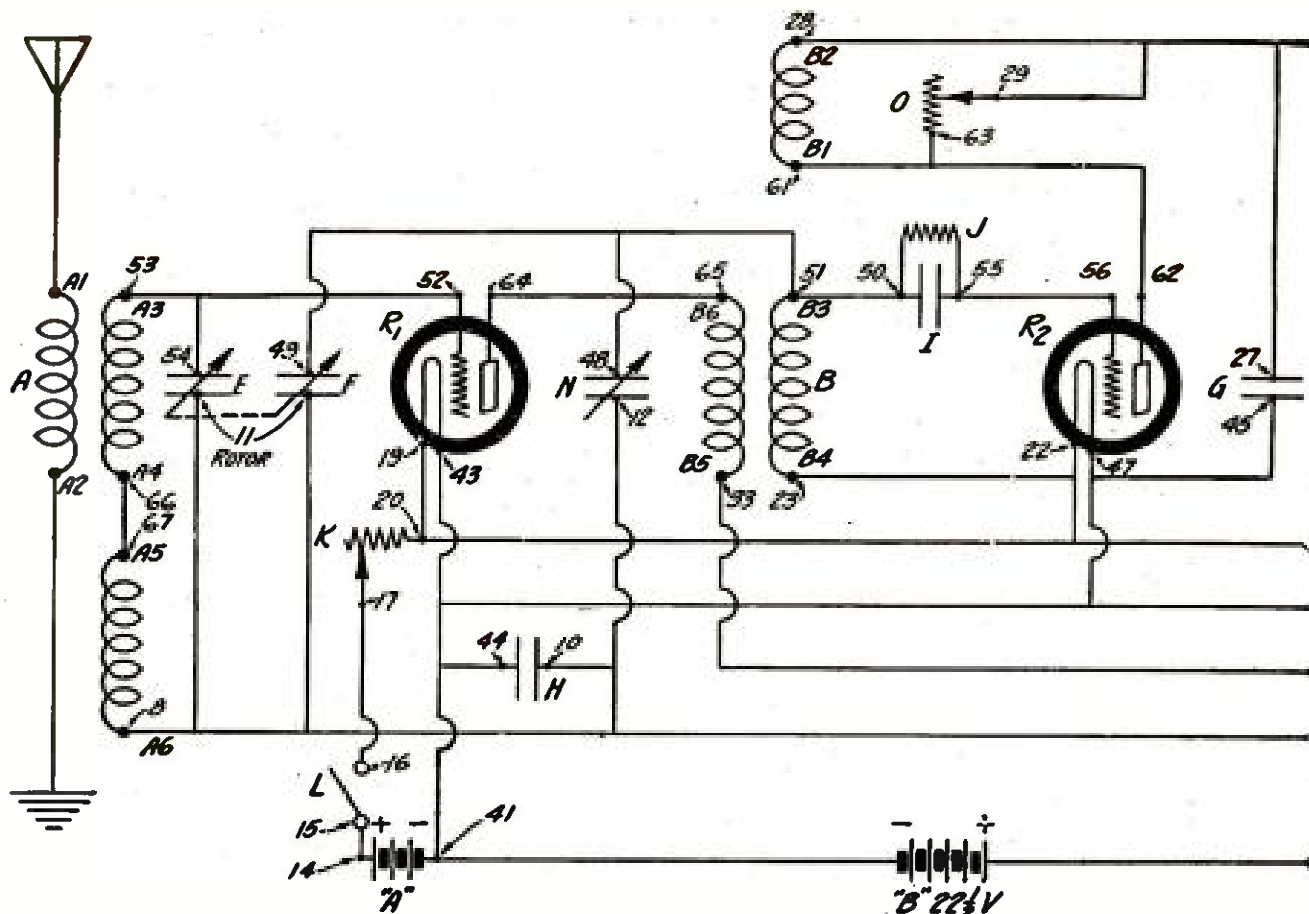

HOW TO BUILD THE S-C RECEIVER

—for short and long waves

This new receiver covers wavelength ranges from 50 to 550 meters. This is the first time that a description of a receiver employing radio-frequency amplification with a regenerative detector for use over such wide frequencies has ever been described in any magazine. One exceptional feature of this receiver is that the wiring is done in advance, in the form of a "harness," and the whole receiver may be built in less than an hour. The qualities of volume, tone, distance reception and selectivity are exceptionally good.

By McMURDO SILVER and LAURENCE M. COCKADAY

COST OF PARTS: *Not more than \$57.00.*

RECEIVING RANGE: *Coast to coast.*

HERE IS A LIST OF THE PARTS USED IN THE LABORATORY SET—

- | | |
|--|--|
| <p>A and B—S-M antenna coil No. 110A and detector coil No. 114A equipped with two No. 515 coil sockets;</p> <p>C and D—Thordarson No. R-200 transformers;</p> <p>E and F—S-M SLF variable condensers No. 316 equipped with one vernier dial No. 801;</p> <p>G—Polymet mica fixed condenser, .002 mfd.;</p> <p>H—Polymet mica fixed condenser, .005 mfd.;</p> <p>I—Polymet mica fixed condenser equipped with grid leak clips, .00015 mfd.;</p> <p>J—Polymet grid leak, 2 megohms;</p> <p>K—Yaxley rheostat No. 16K, 6 ohms;</p> <p>L—Yaxley battery switch No. 10;</p> | <p>M1—Yaxley jack, type No. 1;</p> <p>M2—Yaxley jack, type No. 2;</p> <p>N—S-M Type No. 340 variable condenser, .000025 mfd.;</p> <p>O—Centralab variable resistance, No. 25 M.S.R.;</p> <p>P—Poster drilled and engraved front panel, 7 by 18 inches;</p> <p>Q—Poster drilled and engraved sub-panel, 6½ by 17 inches;</p> <p>R1, R2, R3 and R4—S-M tube sockets, type No. 510;</p> <p>S1 and S2—No. 540 mounting brackets;</p> <p>T—Hardwood cabinet for 7 by 18 inch panel;</p> <p>U—Belden S-C connecting harness.</p> |
|--|--|

THE HOOK-UP FOR THE NEW S-C RECEIVER

FIGURE 1: Notice that all of the symbols for the instruments bear designating letters which reappear in the list of parts and throughout the text and the following illustrations; this eliminates the possibility of mistakes in construction and wiring up

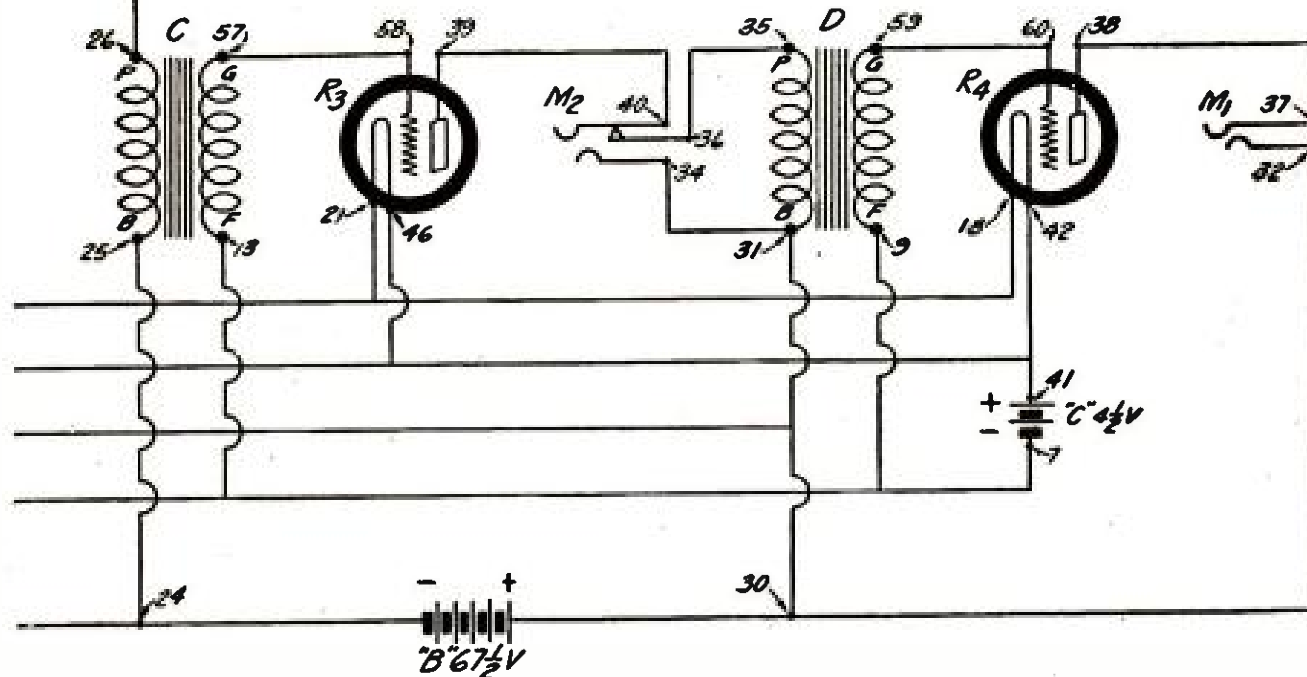

The list of parts given here includes the exact instruments used in the laboratory set, from which these specifications were made up. The experienced amateur, however, will be able to pick out other reliable makes of instruments of similar characteristics and equal efficiency. But if the novice follows this list, the diagrams in this article will tell him exactly where to bore the holes and exactly where to place the connections. If instruments other than the ones used in the original model are used, the only change that will be necessary will be the use of different spacings for the holes that are to be drilled in the panel for mounting the instruments.

THE development of the S-C receiver was undertaken by its designers with a number of definite ends in view. Possibly first was the development of a receiver for the home builder which would cover the entire wavelength band from 50 to 500 meters. Another important consideration was that the receiver should represent a far better dollar for dollar operating value than would any other design for this large wavelength band in points of selectivity, distance, range and tone quality, with four tubes.

It would be well for a moment to consider some of the special points incorporated in this design, in order that the prospective builder and experimenter may decide for himself whether or not it will satisfy him.

The first feature of the design is the absence of a multitude of tuning controls. All wavelength adjustment for tuning is done by a single dial, thus simplifying the operation of the receiver to a point where the absolute novice can operate it with the assurance of far more than average results. This feature is accomplished through the use of two standard condensers which are so designed that they lock into each other and thus permit of control from a single

master dial. Needless to say, their design must be extremely accurate in order that any circuit variations will not affect the tuning of the receiver throughout its entire wavelength range other than to an extent which may be compensated for by a midget condenser which is employed for this purpose. This minor adjustment is not one that has to be made for each station tuned in, but rather, it is a single adjustment made initially in balancing the circuit. The substantially straight-line-frequency curve of the condensers used results in extremely easy tuning, as the low-wave stations may be so easily separated with no sacrifice in selectivity on the longer wavelength stations.

The wide tuning range of the receiver is accomplished by the use of special low-capacity, plug-in coil units. Thus, with two standard A type inductances, the wavelength range is from 190 to 550 meters. The range with two type B inductances is from 90 to 210 meters; the range with two type C inductances is from 50 to 110 meters. For the higher wavelengths used in European broadcasting two type D inductances will give a range from 550 meters to 1,200 meters. The type E coils will cover from 1,200



From a photograph made for POPULAR RADIO

TESTING OUT THE FINAL MODEL

FIGURE 2: *The authors are here shown putting the final model of the new receiver through its paces. They have checked up on its selectivity and tone quality as well as its distance-getting capacity and the amount of "B" battery consumption, before giving it their approval.*

meters to 1,800 meters.* Due to the design of these coils, which are wound upon ribbed-bakelite tubing, the losses are extremely low.

The reader doubtless realizes that seldom is an all-wave design practical, yet in this particular receiver it has not only been made practical but it is perhaps the first time that radio-frequency amplification has been employed over such a wide range and with such satisfactory results.

The audio-frequency amplifier of this receiver represents another exceptional bit of engineering work on transformer design. A new type of

* In the list of parts only the type A coils are listed.

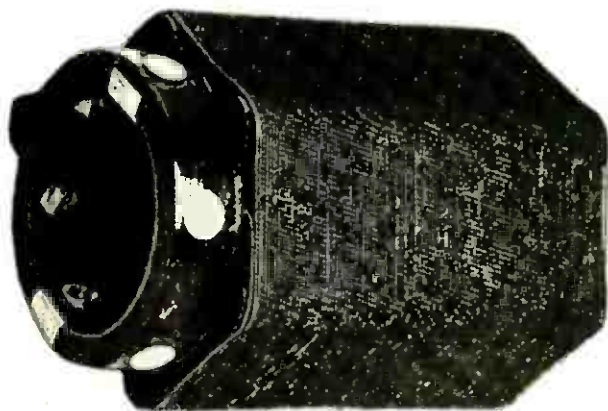

FIGURE 3: *The type of interchangeable coil used in the receiver.*

power transformer, heretofore available only in receivers costing from \$500 to \$2,500 or more, is used. These transformers have practically a straight-line-frequency curve from 40 to 7,000 cycles. They are designed also for handling comparatively high powers without distortion.

Another feature never before seen in home-constructed experimental receivers is the use of a wiring "harness" which simplifies the wiring to a point where anyone can assemble the receiver in less than an hour. This wiring "harness" or cable contains all the wiring in various colors, cut to the right lengths and assembled in one cable as shown in Figure 12. All low-potential leads, including battery connections, are contained in the cable so that it is merely necessary to compare the colors of the leads with the information given in the diagrams and connect the proper ones where they project from the cable to the instrument terminals that are numbered with the same numbers as marked in the photographs and drawings. The high potential leads of the grid and plate circuits of the radio-frequency amplifier and the detector are separate from the cable but supplied with it—cut to the proper length, with the ends scraped and tinned. Thus the wiring in this case is merely a simple process of pushing the ends of the cable through the holes in the base-board and soldering them to instrument lugs or fastening them under the binding posts. This cable method of wiring is extremely efficient, for all the low-potential leads are grouped together and as a result, coupling to undesired parts of the circuit is reduced to a practical minimum.

The circuit design is the standard four-tube circuit that employs one stage of tuned-radio-frequency amplification with variable coupling between the antenna and the grid circuit of the radio-frequency tube, a regenerative detector, with a resistance regeneration control and two stages of power-transformer amplification. Little more need be said of it, for in a recent survey of popular interest, it was found that this general circuit design was the most popular in the estimation of the home set-building public. The selectivity, sensitivity and quality of reproduction in this new receiver really is in excess of that of many five or six-tube receivers now available. While the S-C receiver does not represent the absolute limit of sensitivity or selectivity that may be realized by employing twice as many tubes in a carefully built receiver, it does represent the best dollar-for-dollar value available to the home-builder for a four-tube receiver, on account of its extreme flexibility and wide usage. The circuit design for the new receiver is shown in Figure 1.

Parts Used in Building the Set

In all of the diagrams used in this article, each part bears a designating letter; in this way, the prospective builder of a set may easily determine how to mount the instruments in the correct places and connect them properly in the electric circuit.

The same designating letters are used in the text and in the list of parts at the beginning of the article. (See page 258.)

How to Construct the Set

After procuring all the instruments and materials for building the set, the amateur should prepare the panel P, (shown in Figures 4, 5, 6, 7, 8, 9 and 10).

First of all, cut the panel to the correct size, 7 by 18 inches. Then square up the edges smoothly with a file. The centers for boring the holes (which are necessary for mounting the instruments) should be laid out on the panel as shown in Figure 11. A convenient method for doing this is to lay out all center holes on a piece of paper the same size as the panel; then the piece of paper may be fastened on the panel and the centers marked directly on the panel by punching through the paper with a sharp, pointed instrument.

If all the holes to be drilled are first started with a small drill, one-sixteenth of an inch in diameter or less, they may be more nearly centered.

The holes outlined with a double circle should be countersunk, so that the flat-head machine screws used for fastening the instruments are flush with the panel. All the rest of the holes are straight drill holes. Sizes for the diameters of these holes have not been given, but the builder will readily decide what size hole is necessary by measuring the diameter of the screws and shafts of the instruments that must go through the holes.

When the panel is drilled the builder may give it a dull finish by rubbing the face of the panel

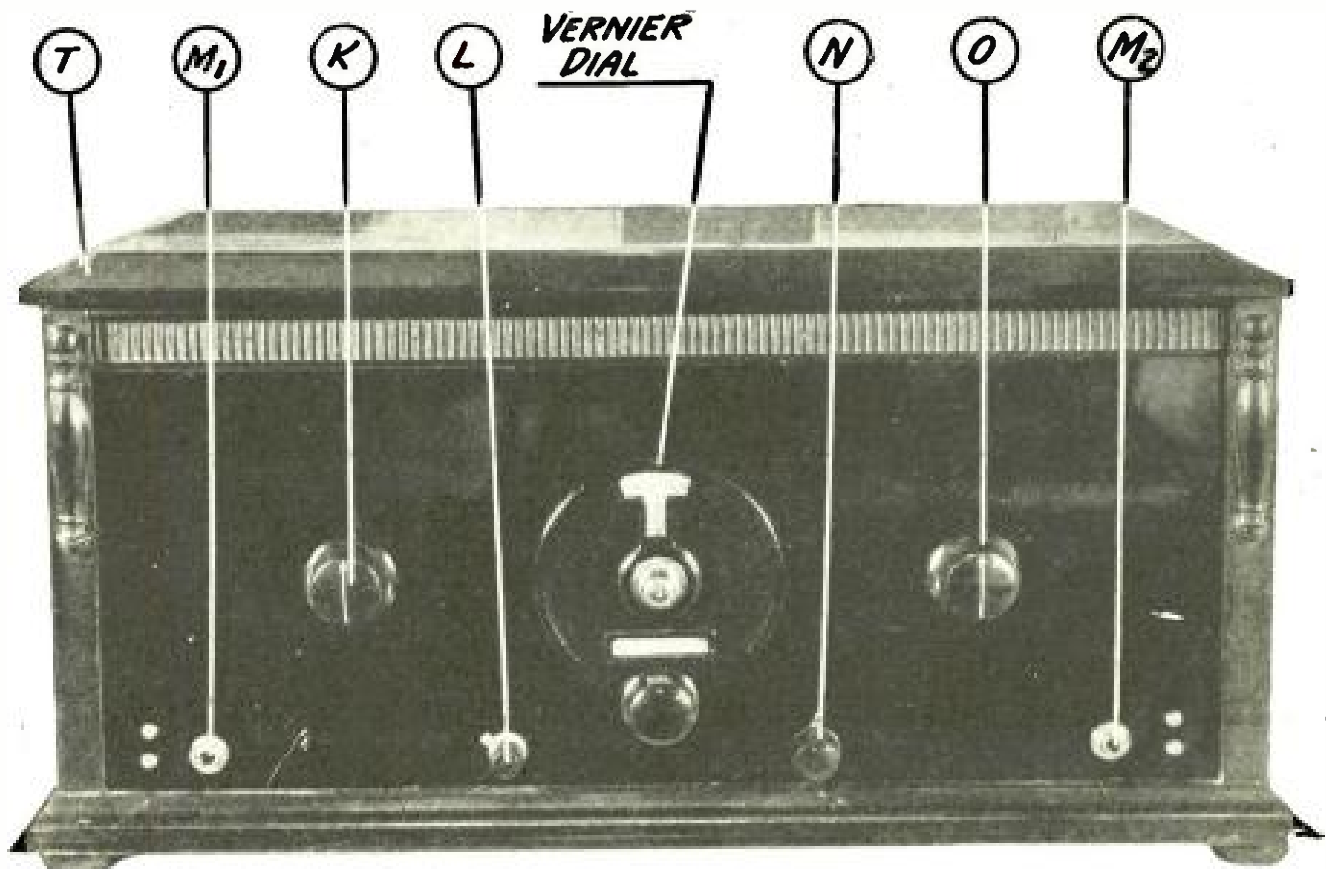

THE FRONT VIEW OF THE RECEIVER

FIGURE 4: As the dials and knobs are marked with letters which correspond to the instruments to which they are attached, the prospective operator will have no trouble in locating the various tuning controls, as they are explained in the instructions for tuning.

lengthwise with fine sandpaper until it is smooth. This process should be repeated, except that light machine oil should be applied during the second rubbing. Then rub the panel dry with a piece of cheesecloth. A permanent dull finish will be the result. Or, the panel may be left with its original shiny-black finish, if care has been exercised, so that it has not been scratched during the drilling.

After the panel has been prepared the experimenter is ready to mount the instruments upon it.

If the specified drilled and engraved panel is bought, of course, this work will be unnecessary, as the drilling and finishing are already done by the manufacturer of the panel.

The sub-base Q may be prepared or bought already drilled as the experimenter may prefer. The drilling plan for this sub-base is also shown in Figure 11.

First of all, mount the coil sockets for the coils A and B in the proper places and fasten them to the baseboard Q with three screws to each instrument, as shown in Figures 5, 6, 7 and 8. It will be found that they fit exactly on the drilled panel. The proper positions for them are indicated in Figure 6, as determined by the position of the notches on the inner side of the socket rings. These are indicated in the photograph by arrows.

Next, mount the four tube sockets R1, R2, R3 and R4 in their correct positions as shown in Figures 5 and 6. They are fastened to the sub-base Q with a single screw to each instrument. Sockets R1 and R2 should be placed with the line

that indicates the pin facing towards the back of the set and sockets R3 and R4 should be set with the straight line indicating the pin facing the front of the set. This is indicated in Figure 6 by small white line.

Next, mount the transformer C at the left-hand side of the sub-base and transformer D at the right-hand side of the sub-base (looking from the rear). The secondary terminals marked G and F should face in toward their respective sockets as may be seen in Figure 6. These large transformers should be mounted with four machine screws and nuts to each instrument.

Next, turn the sub-base upside down and mount the three condensers, G, H, and I in their proper positions by means of two screws and nuts through the holes in each instrument, as shown in Figure 9.

Then, insert the grid leak J in the clips on the condenser I.

The next job will be to mount the two variable condensers, E and F, on the sub-base Q by means of two screws fastened through the sub-base up into the casting of the condensers themselves. This is also shown in Figure 6. Notice that the shaft of the condenser farthest from the main panel P is slipped into the bushing of the shaft of the front condenser where it is held fast by set screws.

The next job will be to mount the two brackets S1 and S2 one at either end of the bottom side of the sub-panel Q. These are fastened in place

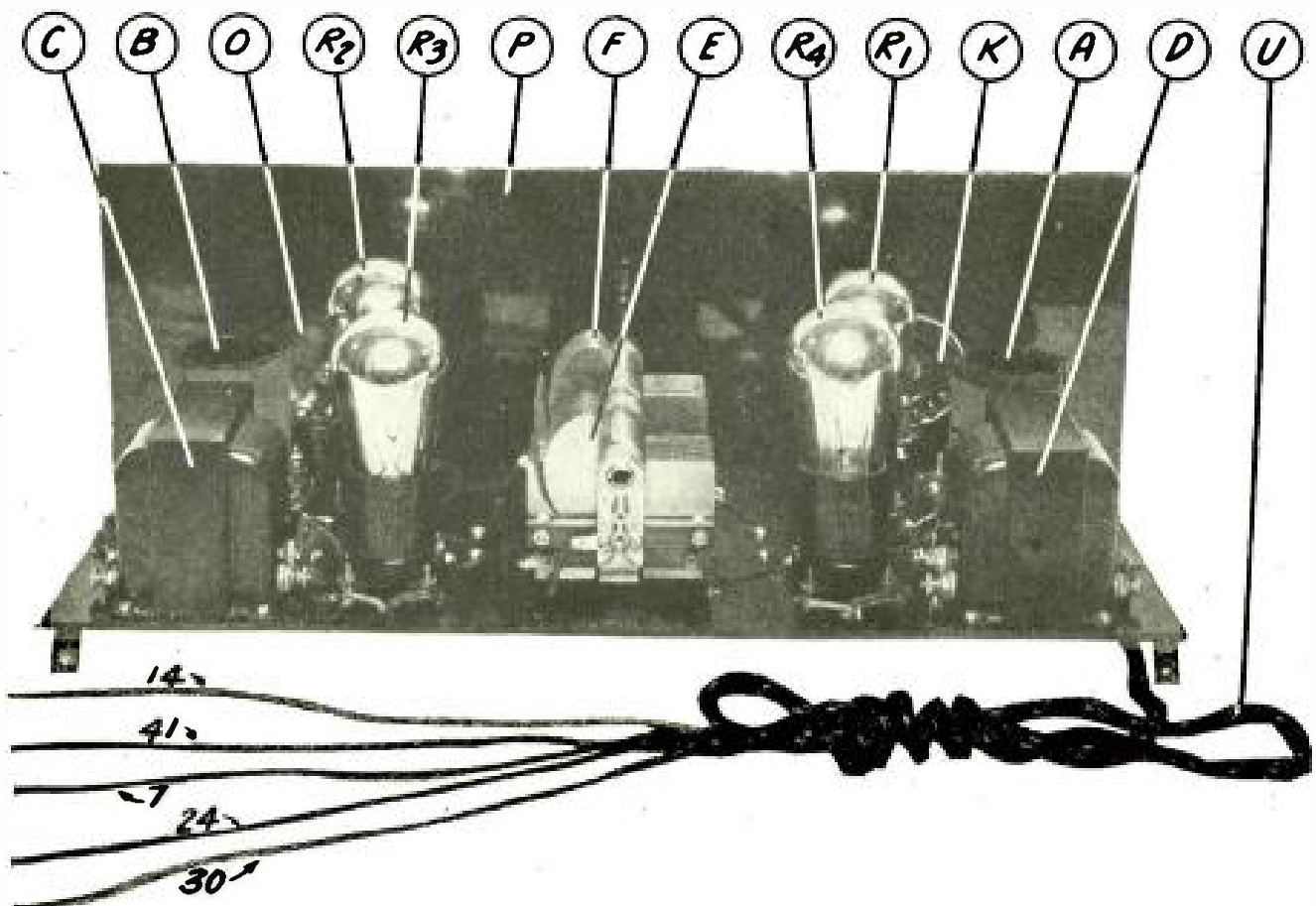

VIEW OF THE SET FROM THE REAR

FIGURE 5: This picture shows the general arrangement of all the instruments as they are fastened to the panel or base.

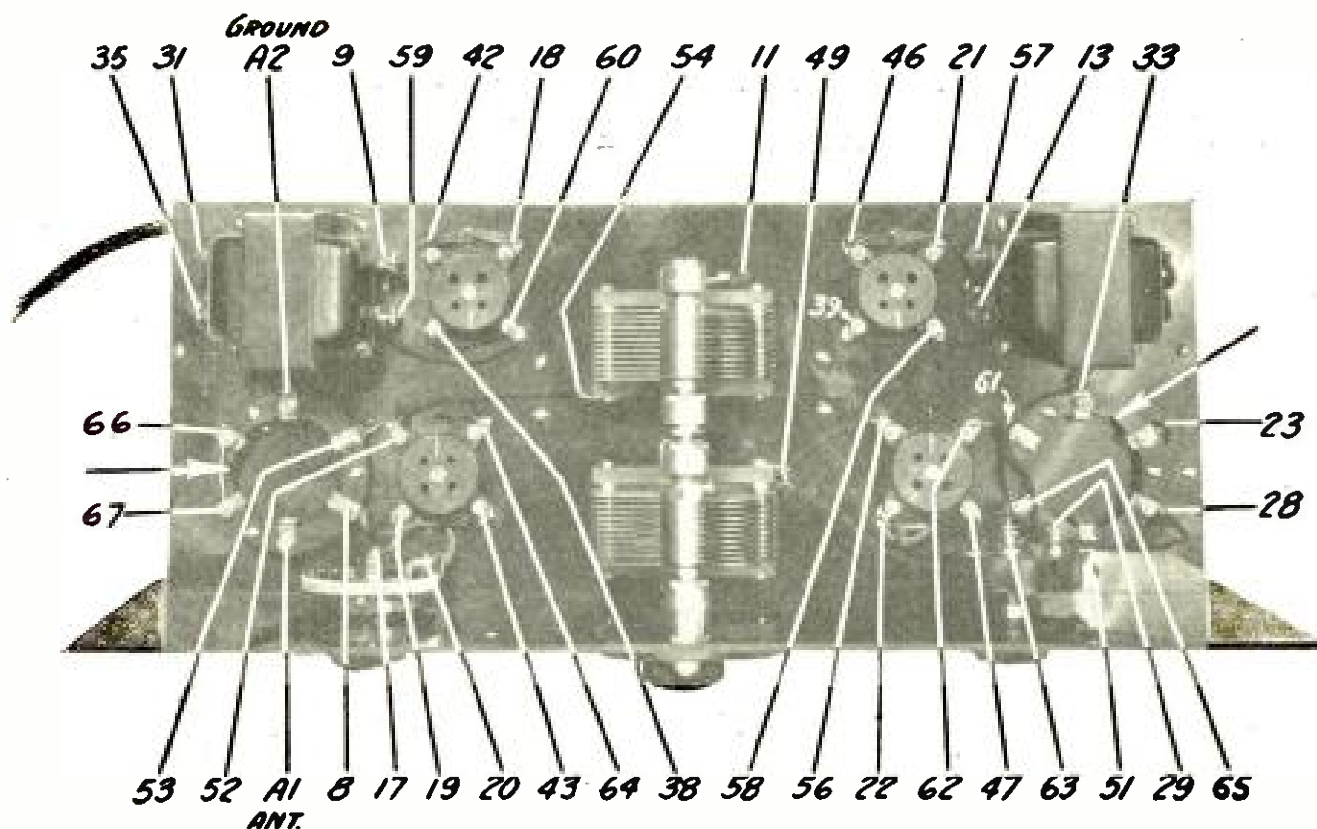

VIEW OF THE SET FROM ABOVE

FIGURE 6: This diagram will help you in your wiring, as it shows the terminals of the various instruments. They are designated by numbers that correspond with the numbers given in the text and with those that are attached to the various colored wires in the "harness" as indicated in Figure 12. (For instance, No. 35 wire in the harness would attach to the 35 terminal on the transformer D).

with two screws and bolts to each bracket.

Next, mount the rheostat K on the right-hand end of the main panel P (looking from the rear). This is fastened with a single large nut on the shaft in the front of the panel. The indicating knob should then be attached to the shaft, as shown in Figures 4 and 5.

Then do the same thing with the 25,000 ohm resistance O at the left-hand end of the panel, as shown in the same Figures.

Now mount the two jacks, M1 and M2, in the proper position, as shown in Figures 4 and 9; and also mount the switch L and the midget variable condenser N, as shown in the same two Figures.

You are now ready to slip on the main panel over the shaft of the variable condenser and attach the four screws through the front of the main panel into the two brackets, S1 and S2 to make a firm assembly of both of the units P and Q. Then fasten the large nut on the shaft of the condenser F. This finishes the construction work and the set is now ready to be wired.

How to Wire the Set

By means of the novel S-C harness, the wiring of this set is practically all done in advance for the experimenter. Place the receiver "upside down" with the panel facing towards the builder.

Then take the connecting harness U that is illustrated in Figure 12 and hold it in your hands with the four battery connections numbered 7, 30, 24, 14 and 41 on the right. Then poke the first wires, which consist of a single maroon-and-red wire, No. 35, and a double red wire, No. 31,

through the hole at the extreme upper right-hand corner of the sub-panel Q as you look down upon it.

Next solder the single brown wire, No. 37, to the right-hand terminal of the jack M1 as you look down upon it. Consult Figures 6, 9 and 11 frequently when doing the wiring up, as a check on your procedure. Then solder the double red wire, No. 32, to the left-hand terminal of the same jack. Next poke the double black wire, No. 9, through the adjacent hole in the sub-panel; and then poke the double black wire, No. 8, through the first right-hand hole in the sub-panel Q nearest the jack.

Then insert the yellow wire No. 19 and 20, the red-and-yellow wire, No. 17, and the double black-and-yellow wire, No. 43, in a group through the hole which is located near the hole for the No. 8 wire.

Then solder the single red-and-yellow wire, No. 16, to the terminal of the switch L which is nearest the sub-panel Q and also solder the yellow wire, No. 15, to the remaining terminal of this switch.

Next insert the double black-and-yellow wire, No. 42, and the double yellow wire, No. 18, through the hole which is out near the top edge of the sub-panel Q.

Then insert the short brown wire, No. 38, through the small hole in the sub-panel Q which lies right near the cable at that point. Next solder the double black-and-yellow wire, No. 44, to the far side of the condenser H. Then solder the triple black wire, No. 10, to the near side of the same condenser.

Now insert the black wire, No. 11, through the adjacent hole towards the top edge of the sub-panel Q. Then solder the double black wire, No. 12, to the right-hand terminal of the midget condenser N.

The next job will be to solder the double black-and-yellow wire, No. 45, to the far side of the condenser G. The maroon wire, No. 27, should then be soldered to the near terminal of the same condenser. Next insert the brown wire, No. 39, through the small hole in the sub-panel Q which lies near the far side of the condenser G. The double black-and-yellow wire, No. 46, and the double yellow wire, No. 21, should now be inserted through the large hole which is near the outer edge of the sub-panel Q at this point. Then insert the black wire, No. 13, through the adjacent hole in the sub-panel Q at this point.

Now proceed to insert the single black-and-yellow wire, No. 47, and the double yellow wire, No. 22, through the large hole in the sub-panel Q, which lies nearest to the left-hand side of the small midget condenser N.

The next wire is a red wire, No. 33, and it should be poked through the small hole in the panel which lies near the right side of the end of the jack M2. Then solder the double red wire,

No. 34, to the bottom right-hand terminal that lies nearest the sub-panel Q. The black-and-red wire, No. 36, should be soldered to the left-hand terminal of this same jack and the remaining brown wire, No. 40, should be soldered to the right-hand terminal of this jack, which is nearest the builder.

Next insert the yellow wire, No. 23, through the small hole in the sub-panel Q that is near the left-hand side of the end of the jack M2. The maroon wire, No. 28 and 29, should be inserted through the hole in the lower left-hand corner of the sub-panel Q that lies nearest the main panel P. The double maroon wire, No. 26, and the single maroon wire, No. 25, should then be inserted through the large hole in the upper left-hand corner of the sub-panel Q.

Next take the large separate maroon wire, No. 64 and 65, and solder one end of it to the terminal marked P of the socket R1. Slip it through the adjacent hole in the sub-base, towards the bottom side, and run along the bottom of the sub-panel Q and up through the small hole that is adjacent to the terminal B6 on the coil-socket B where it should be soldered.

Then, take the multiple black wire, No. 48, 49, 50 and 51, and solder it to the left-hand

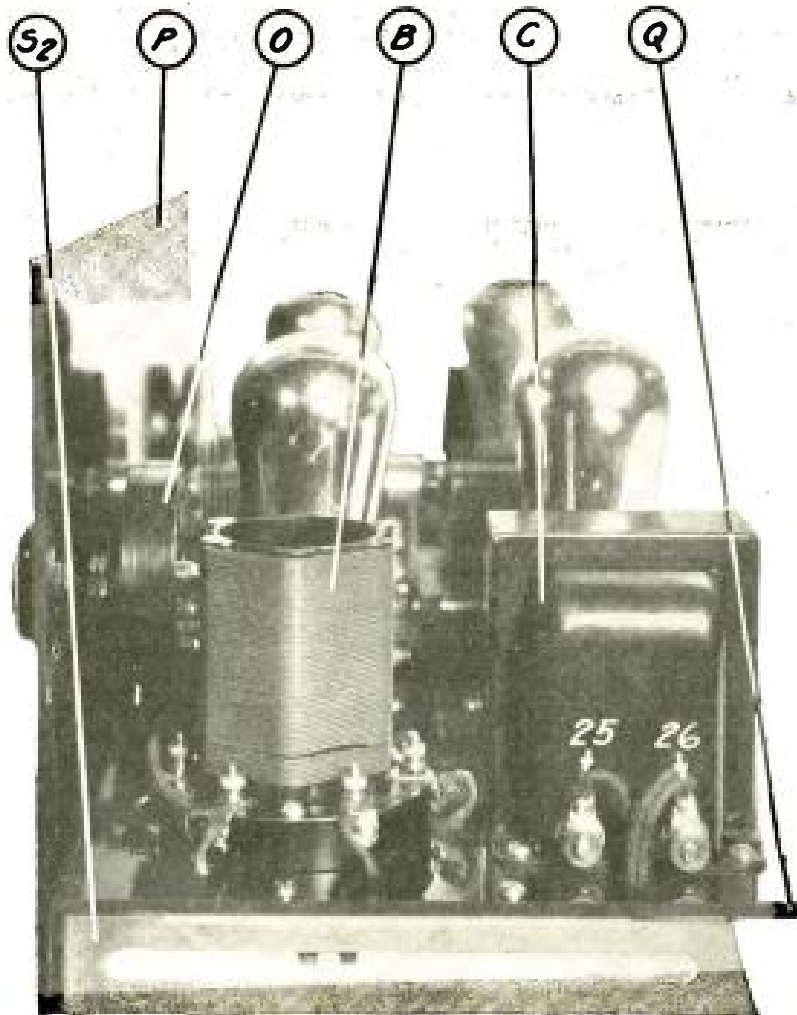

VIEW OF THE RECEIVER AS SEEN FROM THE RIGHT END

FIGURE 7: This shows the manner in which the sub-panel is fastened to a metal bracket and how the whole assembly is connected with the main panel. The general scheme for mounting the transformer and the coil is also given.

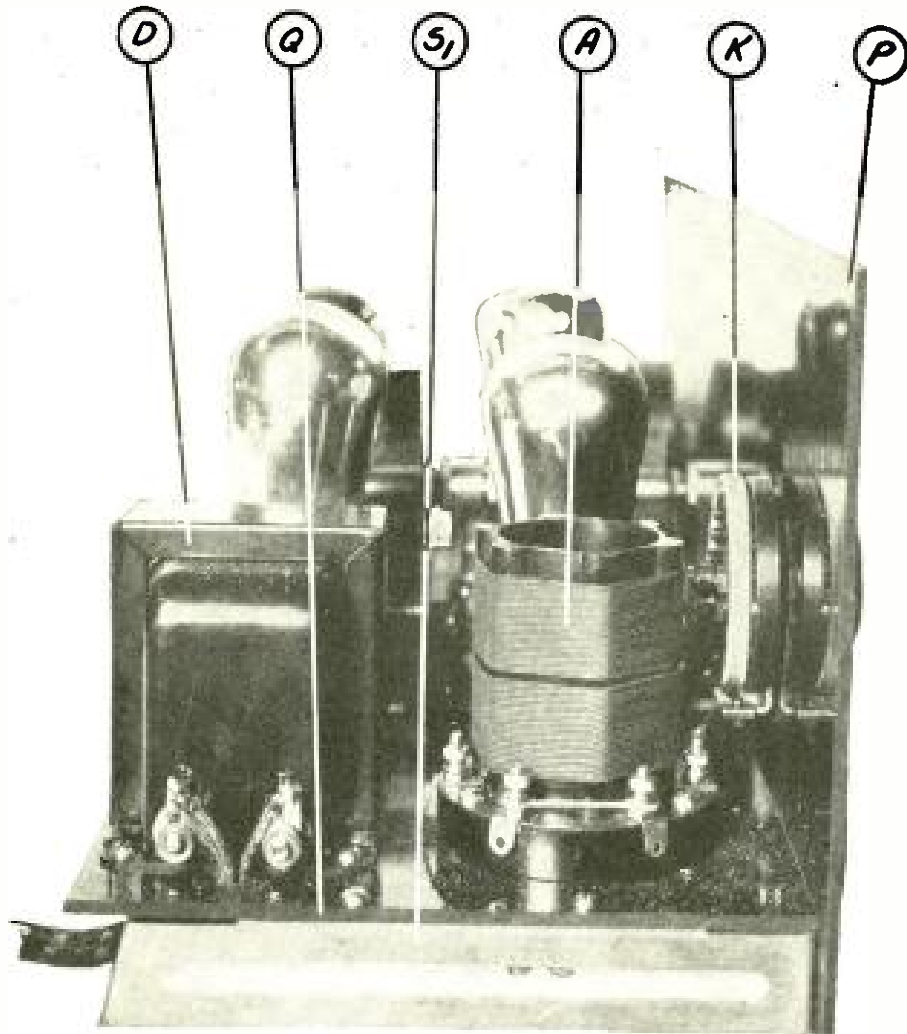

VIEW OF THE RECEIVER AS SEEN FROM THE LEFT END -

FIGURE 8: This illustration shows the other end of the receiver and indicates the method of mounting the remaining coil and transformer and also the rheostat. Notice, in the left end lower corner, how the wiring cable comes out of the back of the receiver near the bracket and underneath the sub-panel.

terminal of the midget condenser N, as you look down upon it with the set upside down. Then run the connection, No. 50, over to the near end of the condenser and grid leak I and J, respectively.

Then insert the remaining ends, No. 49 and 51, of this wire through the small hole which will be found in the sub-panel Q at the left-hand side of this same condenser. Then turn the set the other way up and solder connection No. 49 to the left-hand terminal on the stator of the condenser F, which is adjacent to this hole. Then run the remaining terminal, No. 51, of this same wire over to the terminal B3 on the coil-socket B and solder it fast.

This completes all the wiring that runs to terminals below the sub-panel Q.

Now take the small black wire, No. 55 and 56, and attach one end of it to the terminal G on the tube socket R2 and run it over to the screw that attaches to the remaining terminal of the condenser I and the grid leak J. (This is one of the screws that holds this condenser on to the bottom of the sub-panel Q. It is the opposite terminal to the one you have already connected wire No. 50 to.)

Next, take the short black wire, No. 57 and

58, and run it between the terminal G of socket R3 and terminal G of transformer C. Then connect the small black wire, No. 59 and 60, between the terminal G of socket R4 and the terminal G of transformer D.

Then pick out the black wire, No. 52, 53 and 54, and connect the long bare end to terminal A3 of coil-socket A and connect this same end to the terminal marked G on socket R1. The remaining end, which is No. 54, should be connected to the nearest stator terminal of condenser E.

Next take the maroon wire, No. 61, 62 and 63, and connect the large bare end to terminal P on socket R2 and terminal B1 on socket coil B. Then run the opposite end of this wire, which is No. 63, to the lower right-hand terminal of the resistance O.

Then, connect terminals A4 and A5, on coil-socket A, with a black wire, No. 66 and 67.

This completes the wiring of the separate pieces on the top of the panel and you are now ready to connect up the rest of the cable ends which were previously projected upward through the holes in the sub-base Q.

Start connecting this up in the following manner:

Connect the double black wire, No. 8, to the

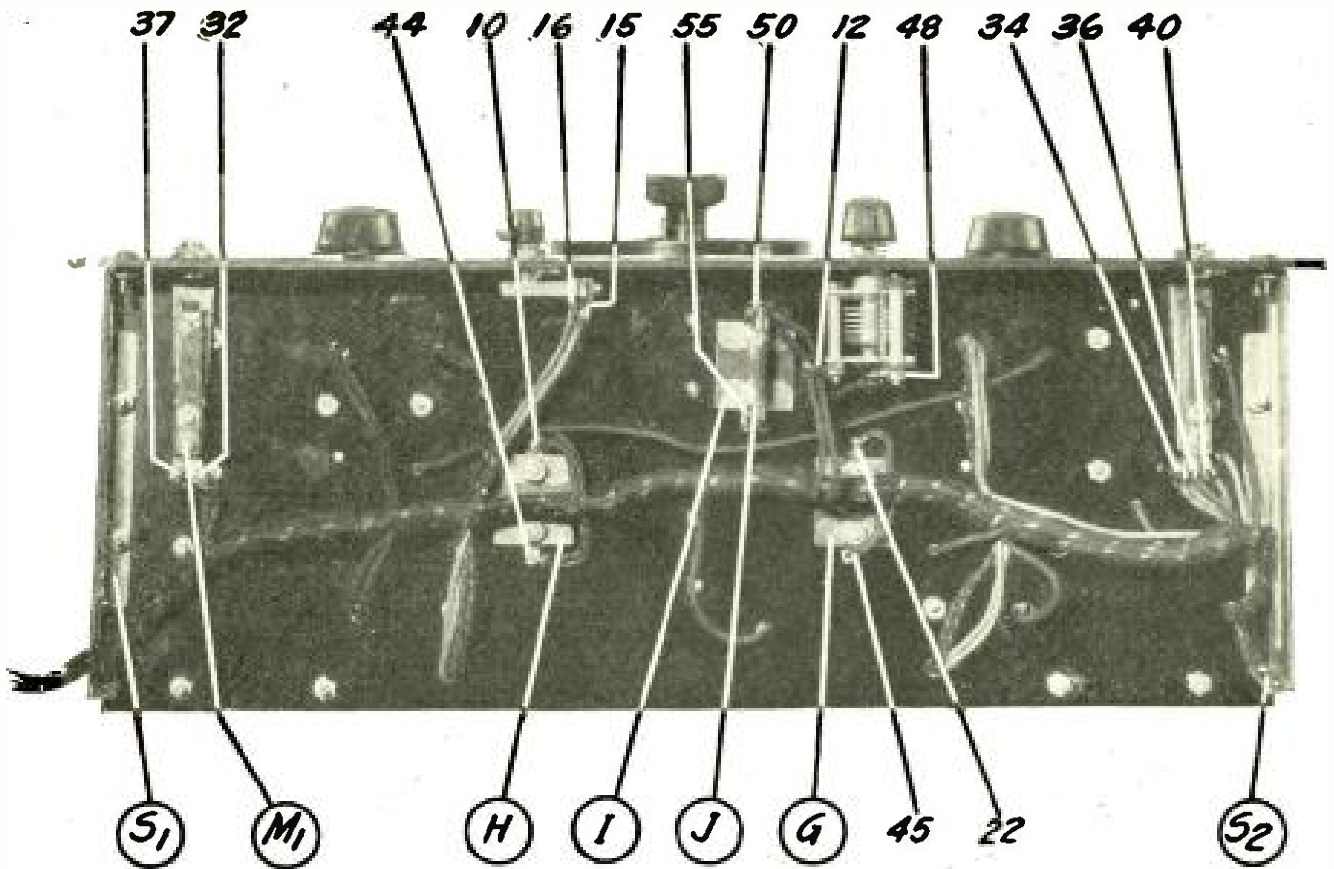

VIEW OF THE RECEIVER FROM UNDERNEATH

FIGURE 9: This diagram will be found of help in wiring up, as it shows the connections for the terminals of the "harness" below the sub-base. They are numbered with designating numbers that refer to the instrument terminals as well as to the colored wires themselves.

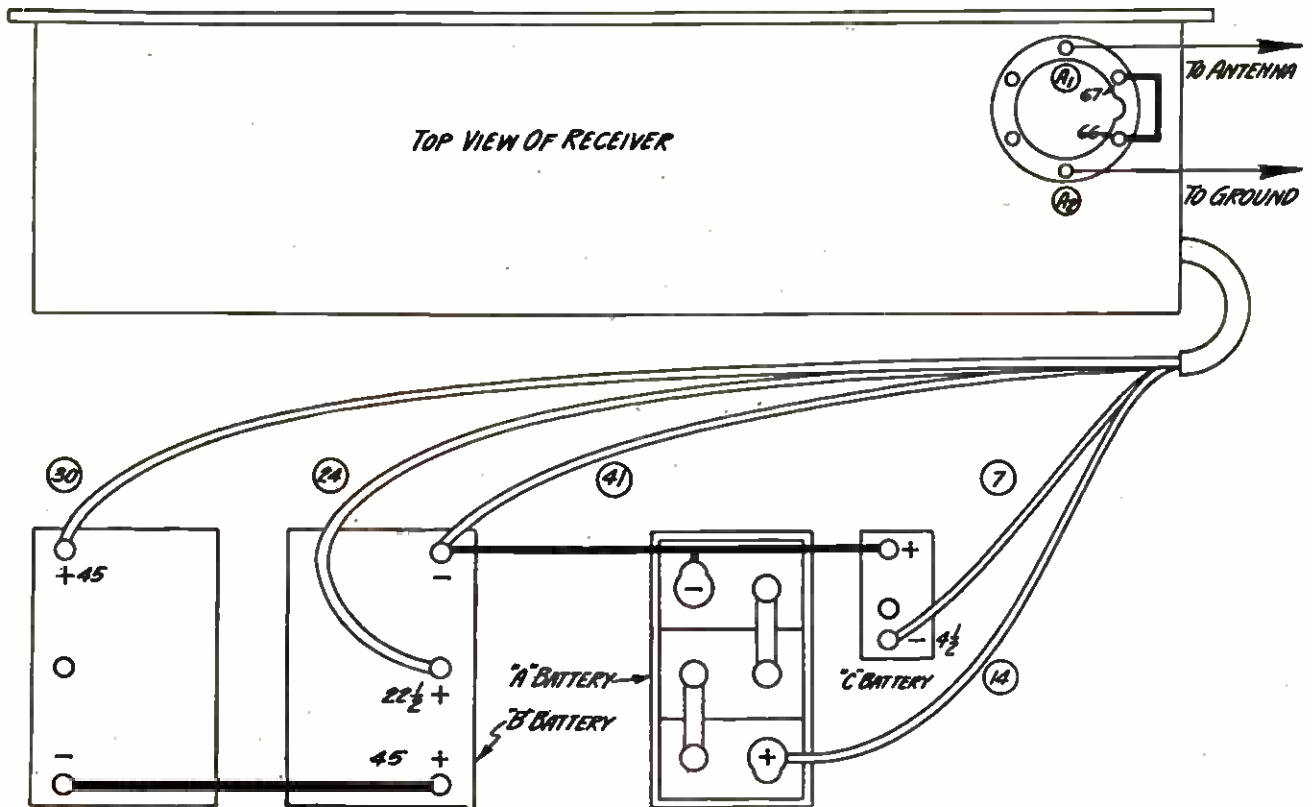

HOW TO HOOK-UP THE BATTERIES AND THE AERIAL AND GROUND

FIGURE 10: This drawing prevents the builder from making mistakes in connecting the batteries to the terminals of the "harness" or battery cord. Follow these instructions and the set will be hooked up correctly because the terminals shown here and in the "harness" diagram in Figure 12 are marked with the same numbered designation.

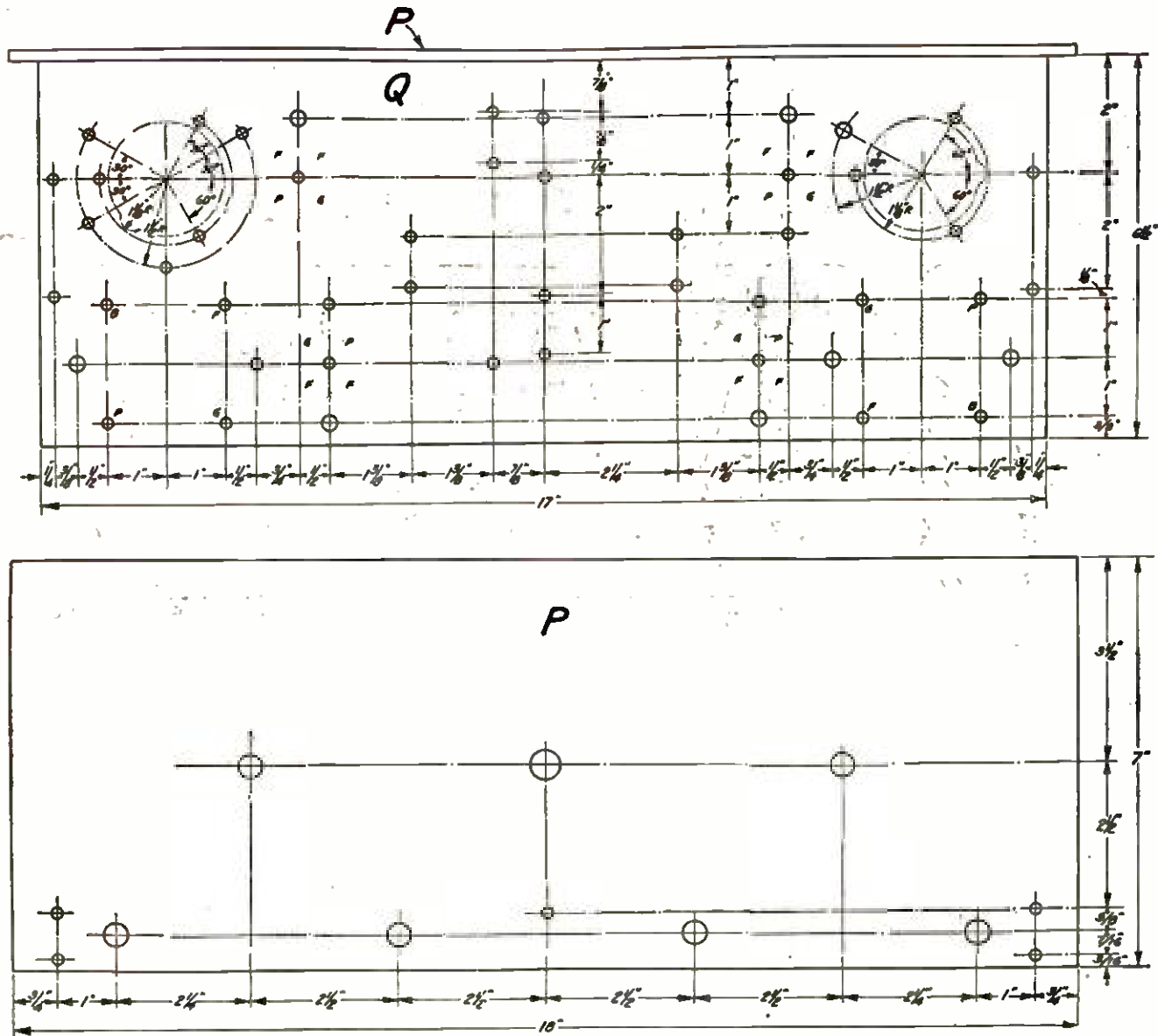

THE DRILLING PLANS

FIGURE 11: The top drawing gives the drilling dimensions for the sub-panel Q and lower drawing gives the drilling dimensions for the main panel P. These drawings show where to drill the holes for mounting the instruments and for the holes in the sub-base that the wires are inserted through. The correct spacings are given for all the holes.

terminal A6 on the coil-socket A. Then connect the single yellow wire, No. 19 and 20, to the right-hand terminal F of socket R1, and to the bottom terminal of rheostat K. Then, connect the single red-and-yellow wire, No. 17, to the left-hand terminal of the rheostat K. Next connect the double black-and-yellow wire, No. 43, to the left-hand terminal F of socket R1.

Next connect the single brown wire, No. 38, to the terminal marked P of socket R4. Then connect the double yellow wire, No. 18, to the left-hand terminal marked F of socket R4. Also connect the double black-and-yellow wire, No. 42, to the right-hand terminal of socket R4. Then connect the double black wire, No. 9, to the terminal marked F on transformer D. All of these wires will be found coming through the sub-base Q at holes adjacent to the instrument terminals, just where you previously placed them. Next connect the single red-and-black wire, No. 35, to the terminal marked P of transformer D. Then connect the double red wire,

No. 31, to terminal marked B on transformer D.

The next wire to be connected is the single black wire, No. 11, which should be connected to the common rotor terminal for condensers E and F.

The next job will be to connect the double black-and-yellow wire, No. 46, to the right-hand F terminal of socket R3. Connect the double yellow wire, No. 21, to the left-hand F terminal of the same socket. Then solder the single brown wire, No. 39, to the terminal marked P on the same socket.

The next task will be to connect the single black wire, No. 13, to the terminal F on transformer C. Then connect the double maroon wire, No. 26, to the terminal marked P of this same transformer. Connect the single maroon wire No. 25, to the remaining terminal marked B of this transformer.

Now connect the double yellow wire, No. 22, to the right-hand F terminal of socket R2. Then connect the single black-and-yellow wire, No. 47,

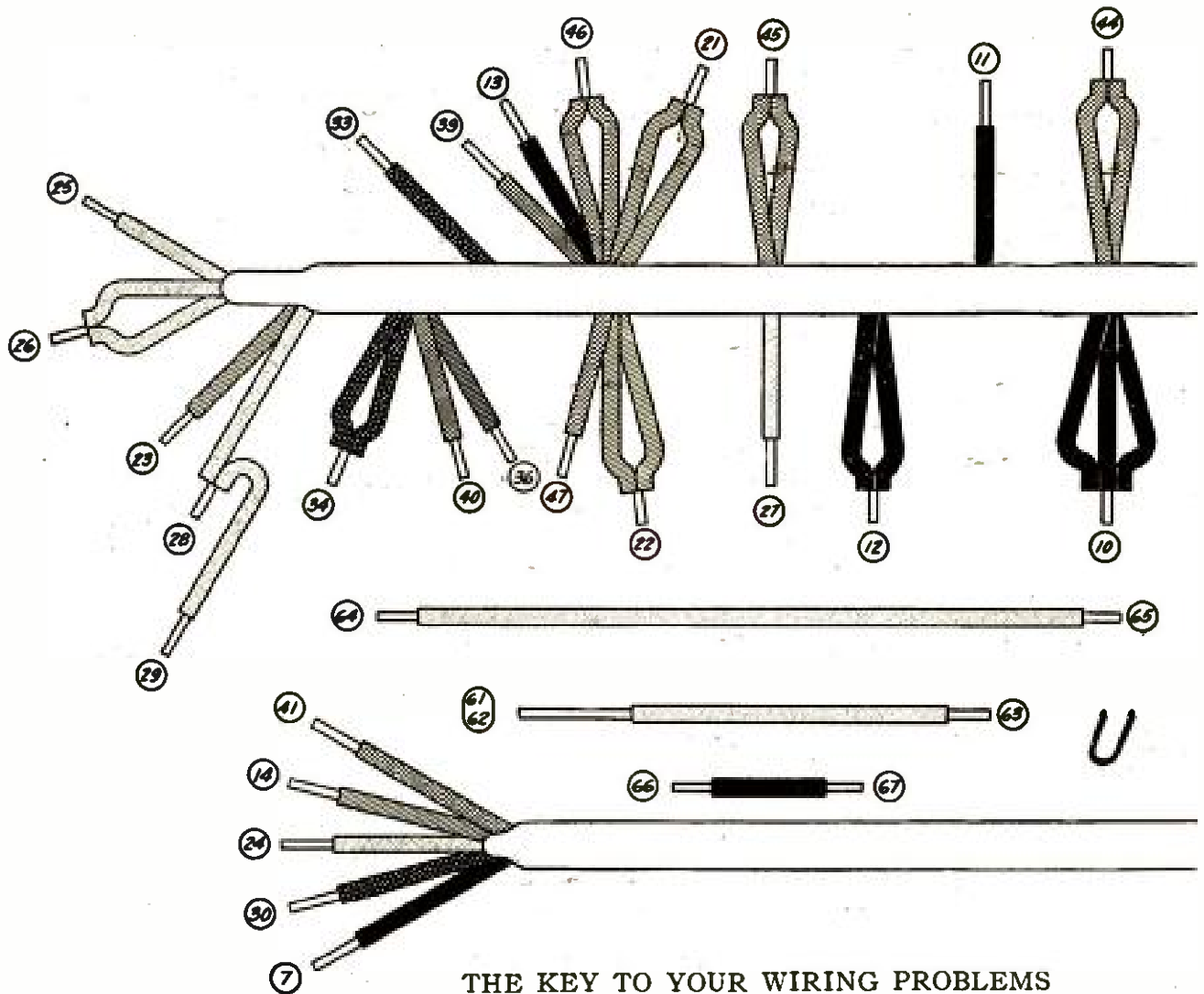

THE KEY TO YOUR WIRING PROBLEMS

FIGURE 12: This drawing shows in diagrammatic form the "harness" for the new S-C receiver. All of the wires are numbered with the same numbers as the terminals that they go to; on the receiver parts themselves. The legend printed at the left gives an indication of the various colors that you will find in the harness. The smaller wires that are separate from the harness you will find in the same package with the harness itself. These are used for plate and grid connections.

LEGEND

Maroon	
Yellow	
Red	
Brown	
Black	
Red With Black Tracer	
Black With Yellow Tracer	
Yellow With Red Tracer	

to the left-hand terminal of this same socket.
 Another connection that may now be made is to solder the single red wire, No. 33, to terminal B5 on the coil-socket B. The single yellow wire, No. 23, may now be soldered to terminal B4 on the same coil-socket.
 The last connection which must be made before the job is finished is the maroon wire and this should be fastened with terminal No. 28 connected to terminal B2 on the same coil-socket. At the other end of this wire will be found connection point No. 29 which should go to the left-hand, bottom terminal of the resistance O.

This completes the wiring and you are now ready to install the receiver.

How to Install the Set

Before placing the set in the cabinet, which may be any standard cabinet for a 7 by 18 inch panel, the tuning dial (No. 801) should be attached to the gang condenser. The dial should be examined first to make sure that the indicator plate, visible through the aperture at the top, is reading on the "zero-to-100" scale rather than the "200-to-zero" scale, which is on the opposite side. This can easily be adjusted properly by merely loosening the nickel-plated center stud holding the indicator disk in place. This disk will drop out if the control knob of the dial is pulled away from the center slightly. The indicator disk may then be turned so that its "zero-to-100" side will be visible through the aperture. It can be pushed into place by merely moving it in its cavity in the dial housing. Pulling the control knob away from the center will cause the indicator disk to drop

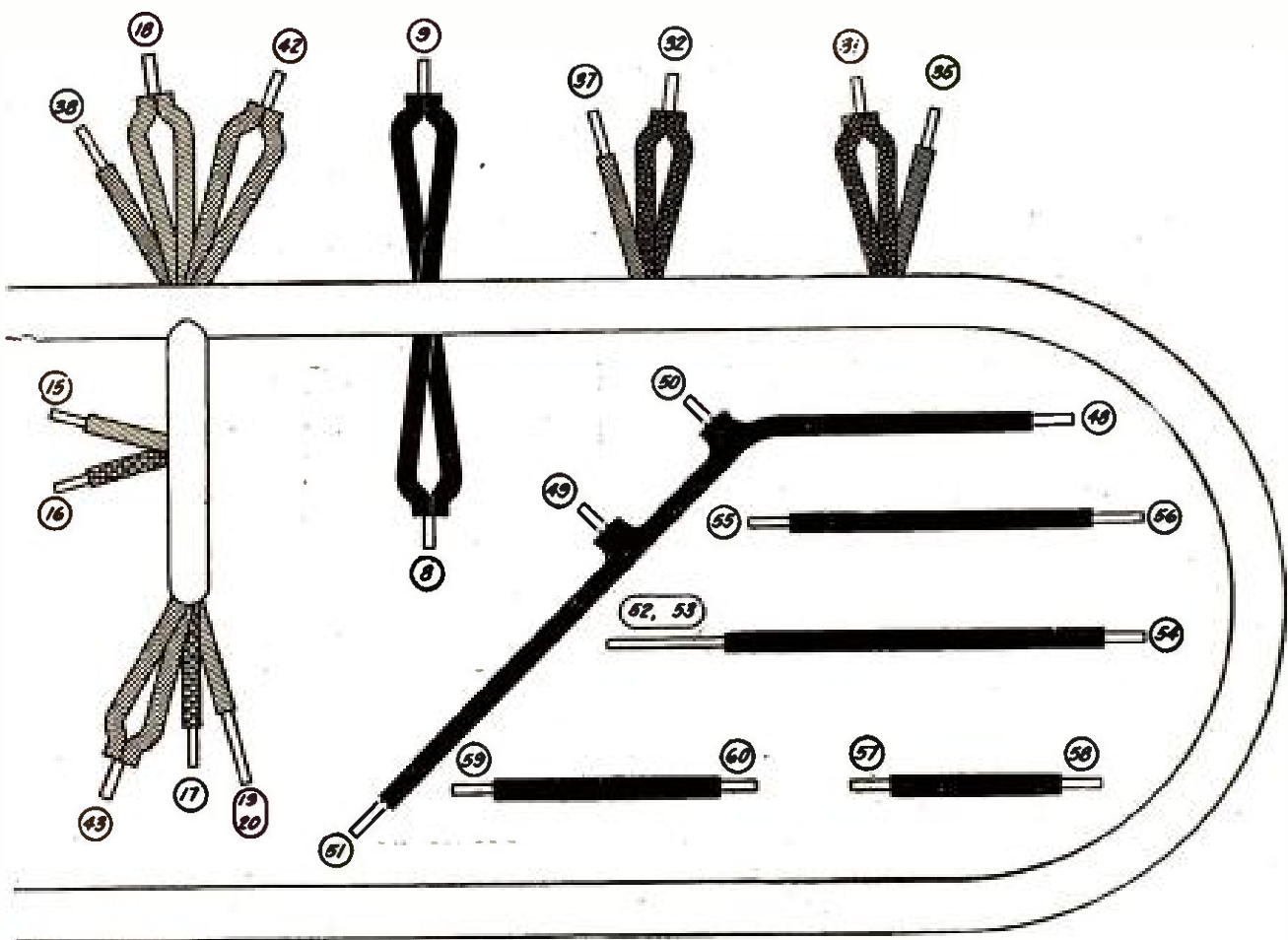

down and engage with the small friction-drive stud of the control-knob mechanism. The nickle-plated center stud may then be screwed up tight and the dial is ready for use. It should then be placed over the condenser shaft at the center of the panel in such a fashion that the small locking pin of the dial, located below the control knob, will fit into the small hole intended for it in the panel, which will prevent the dial from turning. Both condensers should be turned so that their plates are entirely interleaved and so that when viewed from the front, the edges of the rotor plate section are just even with the top edges on the left-hand side of the stator plate sections, where they are not cut away. The condensers may be easily locked together by means of the set screws found at the rear end of the rotor bushing of the front condenser F. The dial is then locked to the condenser shaft by tightening up the set screw in the nickle-plated center piece, being sure that the dial reads zero against its indicating mark when both condensers are entirely interleaved. Should it be found that the two condensers, when locked together, move stiffly, the rear bearing of the front condenser F should be loosened up by unlocking the lock nut, giving the bearing sleeve one turn counter-clockwise so that it will not bear against the rear of the rotor-plate bushing, and relocking the nut on this bushing against the condenser frame. In this way only three bearings will be actually in use for the two condensers—more than are actually necessary for good mechanical operation.

The knobs on the rheostat K and the volume-control resistance O should be tightened up on

the instrument shafts with a small screw-driver so that the heads of the arrows will fall directly over the contact arms that are visible at the rear of the instruments.

The small balancing condenser, below at the right of the control dial, should have its plates turned *all the way in* and the pointer screwed up on the shaft until it points straight to the right. Then the small knobs supplied with this condenser should be screwed up until it locks the pointer in this position. Thus the pointer will be at the left when the plates are entirely "out" and at the right when the plates are entirely interleaved.

Then the set may be put into the cabinet and fastened in place. A hole should be drilled in the back of the cabinet for the battery-end of the cable, so that the batteries can be connected.

Connect the batteries and the aerial and ground connections exactly as shown in Figure 10. Next insert in the four tube-sockets, R1, R2, R3 and R4, four UX-201-a tubes, or you may insert three UX-201-a tubes in sockets R1, R2, and R3 and one UX-112 in socket R4, for greater volume.

Be sure that the pins on the tubes are turned towards the small lines on the socket as indicated in Figure 6, by the white lines.

To become acquainted with the set, it will be best to start now to tune in a few local stations. Turn the switch L so that the filaments light up when the rheostat K is rotated in a clockwise direction. Then insert the loudspeaker plug in jack M1 or the phones in jack M2 for tuning.

In preliminary tuning of the receiver, the balancing condenser should be turned entirely to the

A Tuning Chart to Adjust to Your Own Set

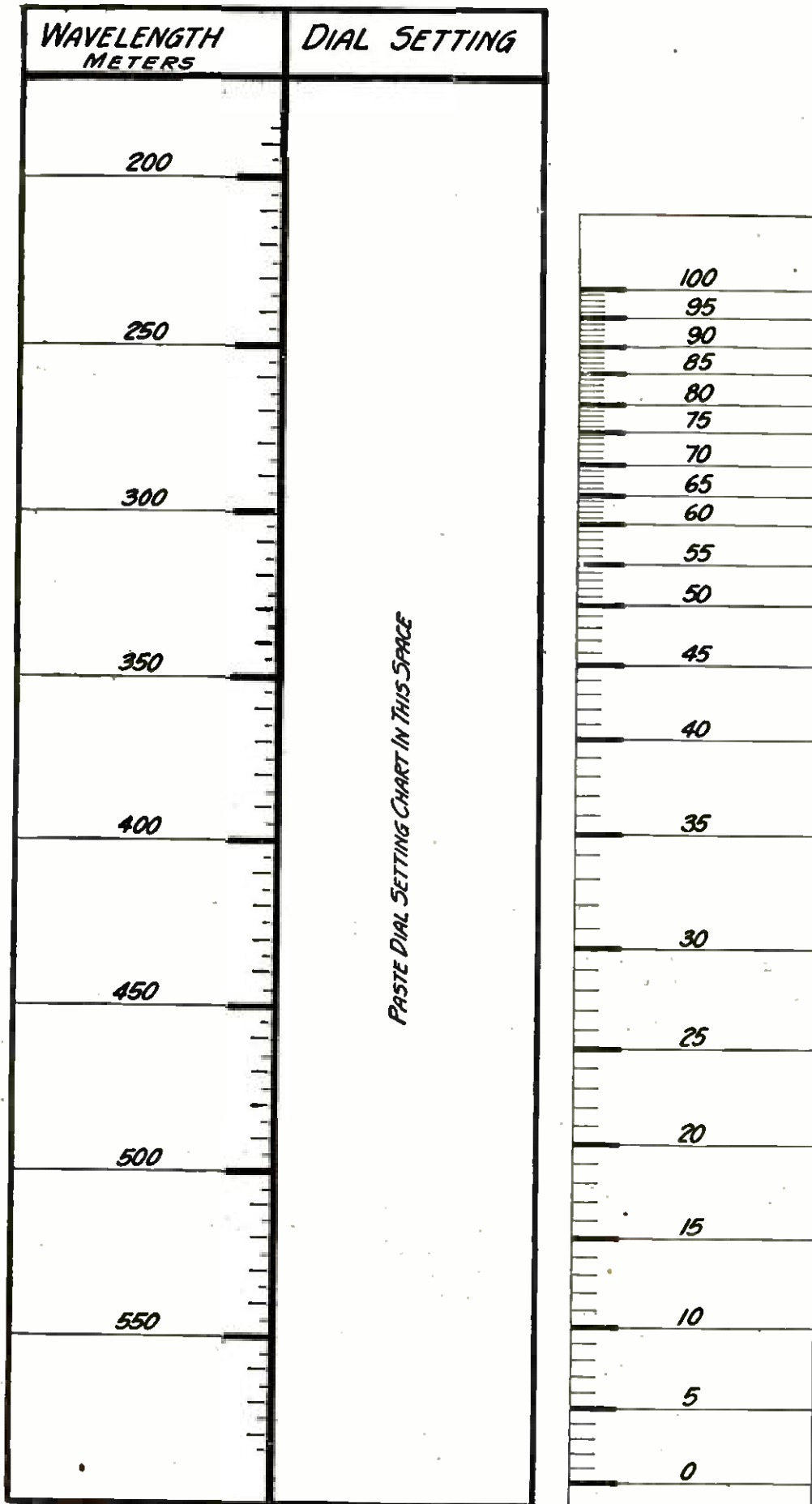

FIGURE 13:

Cut out the chart at the left and paste it on a piece of thin, stiff, white bristol paper. Then cut out the small chart at the right. It should be pasted in position on the blank space on the right side of the main chart underneath the heading "dial setting." To get it in exactly the right position, tune in a station of around 350 to 400 meters and find out what setting it comes in on on your dial. For instance, a station on 405 meters would come in somewhere near 30 to 35 on your dial according to the variation of the condenser in the set. If it comes in at 32 (say), paste the wavelength part of the chart in place so that 405 meters on the wavelength scale is exactly opposite 32 on the dial setting scale. Then all the other stations will tune in approximately as indicated by the completed chart.

left and all tuning should be done with the large center dial. If it is noticed that stations appear to come in at two points on the central dial, say from one-half to two degrees apart, this can be overcome by adjusting the small balancing condenser from left to right until the stations come in at only one sharply defined point. If adjusting the balancing condenser does not overcome this difficulty, then the set-screw that locks together the two tuning-condenser rotor assemblies, should be loosened and their position with relation to each other changed in such a fashion that when the rear condenser E is so set that its rotor-plate edges are on a line with the left edges of its stator plates, the rotor-plate edges of the front condenser F will be slightly below, say not over one-eighth of an inch at their periphery, the left edges of the front condensers' stator plates.

After this adjustment has been once made, all the tuning will be done with the main dial and the resistance O will be used to control regeneration. Turning this resistance in a clockwise direction will increase regeneration and turning it in the opposite direction will decrease regeneration.

The two inside rotatable coils in the coil units A and B should be adjusted for maximum signal strength, with the proper degree of selectivity, and for the proper amount of regeneration that can be controlled by the resistance O.

The rotor of the coil A should be reversed a few times until the best signal strength and the best selectivity is obtained. This can be done by inserting the finger down into the coil and turning the small rotor a little bit at a time until the correct setting is found.

The same applies to the regenerator tickler mounted inside of coil B. This should be rotated until it is in the right position and until the

maximum signal strength is obtained, with a smooth control of regeneration. In Figure 13 is given a tuning chart that will show approximately where to set the dial for various wavelengths. Once a station is located its volume may be improved by setting the control O for the best signal strength.

It is recommended that a cone-type of loud-speaker be used with the set. In the final analysis, results are the deciding factor in whether a receiver design will be popular and will continue to be regarded with favor. On the night of December 28, at the home of Mr. Laurence M. Cockaday in a residential section of New York City, between nine and ten o'clock, some 34 stations were logged with the four tubes, on a loud-speaker, without the use of headphones. Slightly later, when KFI came on, this station approximately 2800 miles away was brought in, to a crowded metropolitan area, with sufficient volume to be heard throughout two good-sized rooms.

The adaptability of the general design, assembled as it is on a 7 by 18 inch bakelite panel and a 7 by 17 inch bakelite sub-base, is astonishing. It may be placed in any type of console cabinet or any other standard enclosure or, it may even be put in a portable case, since the receiver will operate with a small antenna—or with a long one with equal selectivity—say, anywhere from 20 to 150 feet. If it is desired to receive the lower wavelengths, the short-wave coil sets should be installed in place of the two that are given in the list of parts accompanying this article. The tuning with these, however, remains the same for any wavelength range.

The set is easily put together in less than an hour and will be found to be extremely selective, with great sensitivity, and fine tone quality.



Kadel & Herbert

THE "FIRST PRIZE RADIO DRAMA" IS PRODUCED

A few months ago station WGBS of New York offered a prize for the best play written for production before the microphone. The winning script was entitled "Sue 'Em," and it was recently given first presentation by the Provincetown Players in the studio of WGBS and was simultaneously broadcast from WIP and WGY.



IN THE WORLD'S LABORATORIES

CONDUCTED BY DR. E. E. FREE

Does the Moon Affect Radio?

IN the early days of broadcasting there was a common opinion that distant reception was related in some way to the phases of the moon. Most radio engineers put this down as superstition, although there were a few enthusiasts who took the matter seriously enough to keep records which proved (as might have been expected) to indicate nothing very definite. In those days distant reception was more or less a happy accident anyway. Any effects which the moon may have had on distant radio were covered up by other variables.

It seems, however, that one British amateur has been keeping careful records more recently. The results are reported in a recent note by Mr. W. J. Turberville-Crewe,* who suggests that other observers do likewise. The one series of records available suggests that distant reception is better when the moon is on the wane than when it is increasing.

Curiously enough, there are at least two ways in which the moon actually might influence the behavior of radio waves. One of these is by some magnetic action. The other is by the action of moonlight on the ionization of the atmosphere.

The magnetic field of the earth is not an invariable thing. On the contrary there are well known alterations in the intensity and direction of the magnetic forces with the hour of the day, the day of the month, and the like. Some of these variations are believed to be due to the sun, to the seasons and other factors but when all such have been eliminated there remain some variations which can be correlated only with the moon. The latest student to examine these lunar magnetic effects reports that they may be best explained as due to a tide created by the moon in the atmosphere of the earth, thus displacing the ionized zone which we call the Heaviside Layer.† Undoubtedly, this would somewhat affect radio as well as earth magnetism.

*"Wireless, the Moon and the Barometer." by W. J. Turberville-Crewe. *Experimental Wireless* (London), vol. 2, page 901 (November, 1925).

Moonlight, too, would have an effect somewhat similar to the effect of sunlight, although proportionately weaker. It would tend to ionize the upper air, thus affecting once more the properties of the Heaviside region. Furthermore, the light of the moon is partly polarized light. Its vibrations tend to be all in one plane instead of in all possible planes, as is the case with sunlight. There is some evidence that polarized light is a more effective ionizer than is ordinary light of the same intensity.

All in all, the suggestion of Mr. Turberville-Crewe may be heartily seconded. A number of carefully kept diaries, showing the measured intensity of reception of selected distant stations as related to the position and phase of the moon might yield some interesting information.

†"The Lunar Diurnal Magnetic Variation at Greenwich and other Observatories;" by S. Chapman. *Philosophical Transactions of the Royal Society* (London), vol. 225, pages 49-91 (April 17, 1925).

Solving Antenna Problems by Small-Scale Models

THE problem of how much energy will be radiated by the antenna of a broadcasting station or by any other transmitting antenna is not only one of the most important of practical radio problems; it is also one of the most difficult to solve. The radiation is specified, of course, by the general laws of electro-magnetic fields, but unfortunately the mathematic expressions for the complicated antenna systems now in vogue are so involved and difficult that only a very few cases have yielded, so far, to the analytic skill of the mathematicians. And to experiment extensively upon the properties of actual, full-size antenna systems involves the long-continued use of installations which are urgently needed, in most cases, for commercial use.

Thus arises the desirability of being able to experiment on radiation from small-size model antenna systems. That this is possible has been suggested by many radio engineers. Over three years ago an actual investigation was begun

by Professor J. Tykocinski-Tykociner of the University of Illinois. The results of this investigation are now published in detail* and constitute an interesting and useful chapter of radio research.

The investigation depends upon the principle, which Professor Tykociner establishes both theoretically and experimentally, that the behavior of an antenna system is practically the same so long as the ratio between its linear dimensions and the wavelength of the oscillations used is constant. For example, a three-foot antenna of a certain design, energized by a three-meter wave, will behave like a three-hundred-foot antenna of the same design energized by the three-hundred-meter wave of a broadcasting station. The small antenna may be used to test the radiation or other properties. Conclusions thus obtained may then be applied to the design or operation of the larger system used with ordinary waves.

*Preliminary reports were made before scientific meetings in 1923 and 1924. The full report is entitled, "Investigation of Antennae by Means of Models," by J. Tykocinski-Tykociner, published as Bulletin number 147 of the Engineering Experiment Station of the University of Illinois, Urbana, Ill., 60 pages, issued May 25, 1925, price 35 cents. We are indebted to Professor Tykociner for the photographs reproduced herewith.

Professor Tykociner's experiments have been carried out, in the main, with model antennas energized with waves between three meters and six meters in wavelength. These waves were produced by vacuum-tube circuits showing considerable ingenuity in arrangement but not essentially different in principle from other circuits arranged for the generation of ultra-short waves. The radiation from the model antenna systems and the losses and other features of such systems were measured, also, according to methods now in standard use for waves within this same high-frequency range.

There is an instrumental novelty, however, in the form of a new variable condenser, designed for extremely short waves and which is said to obviate many of the well-known difficulties in using ordinary condensers with waves shorter than ten meters. The new condenser consists of two fully circular plates each of which is broken, along a diameter, by a small offset, like the step of a stair. When the rotor plate is rotated, the proportion of the two plates which is farther apart by the amount of the offsets is increased or decreased, thus altering the capacity by a small amount and without as much disturbance from the body capacity of surrounding objects as is inevitable with condensers of

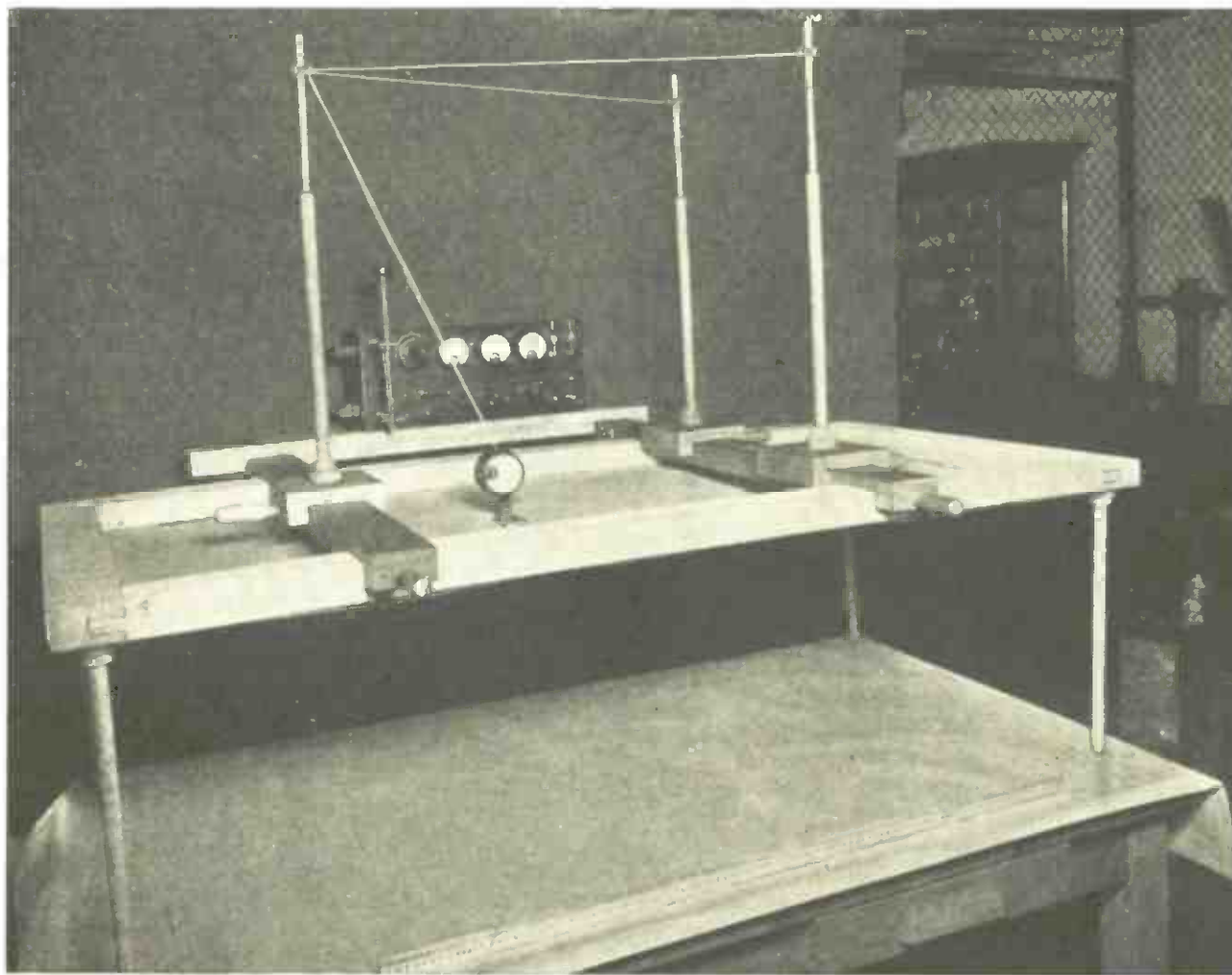

A SMALL-SCALE MODEL OF A FLAT TOP ANTENNA

By this model and others like it Professor Tykociner, of the University of Illinois, has been able to study the properties of different antenna systems without building complete full-size antennas. Very short waves are used, so that the small antenna will behave as does a large antenna using longer waves.

more usual design. The wavemeter used with the apparatus consists of one of these condensers mounted with an inductance consisting of a single loop of brass strip.

The whole system of short-wave generator, instruments and model antennas has proved valuable, Professor Tykociner reports, both in radio instruction to students and in the practical study of antenna problems. It is probable, too, that it would prove useful as equipment for fundamental researches in wave radiation and propagation. Amateur experimenters searching for new worlds to conquer in radio research are recommended to study Professor Tykociner's experiments and to consider building some similar small-scale models of their own.

Mine Finding by Science

THE hope that radio waves might be put to practical use in exploring the rocks of the earth and in finding valuable minerals or veins of precious ore has been disappointingly slow of fruition.*

*For an account of some possibilities, see: "Finding Mines by Radio," POPULAR RADIO for September, 1924, pages 238-245.



AN ANTENNA LABORATORY

Here is where Professor Tykociner (seated at the desk) and his assistant, Mr. L. P. Garner, have carried out their studies with model antenna systems.

This possible application of radio is still in the stage of discussion and hopes. The difficulty appears to be that much fundamental scientific work must first be done merely for its own sake and without hope of immediate reward. No one has been found to do this. It is easier—and more profitable—to construct some complicated and impressive modification of the old-fashioned, and useless, divining rod.

However, there does appear to be important progress in the use of another method of underground exploration, that by gravity. Geologists have known for many years that the force of gravity at the earth's surface is not everywhere the same. Some parts of the earth appear to be underlain by heavier rocks, other parts by lighter rocks. The differences are slight, far too slight to be detected by ordinary scales. Nevertheless, they can be detected by delicate instruments, especially by a device known as the Eötvös balance. The use of this balance is slow and laborious but it is possible by its aid to map the intensity of gravity over any desired part of the earth's crust.

It has been found that such a gravity map supplies a certain amount of data of value in inferring the existence of underground mineral deposits.† For example, salt has a lower density than most rocks. Above a salt deposit there will be a slight decrease of gravity. And, since salt is sometimes associated with a certain kind of oil deposit, this fact may be useful in prospecting for oil. The method is now in use and has proven of some value although in this case, as with the radio methods, the need is for much additional scientific information before practical application can be direct and perfect.

It is a pity that among the hundreds of organizations and individuals who annually spend millions in searching for new mines none can be found to undertake the scientific study of the radio possibilities. There could be no guarantee of financial profits. Profits often dodge the scientific pioneers and find a lodging elsewhere. But there would be, at least, the consciousness of having done a worth-while job for radio science.

†The Eötvös balance and other modern devices for scientific prospecting are described briefly in a recent article entitled "Buried Treasure," by Albert G. Ingalls, *The Scientific American* (New York), vol. 133, pages 392-393 (December, 1925).

What Pushes a Wheelbarrow?

SIR Oliver Lodge is unique among scientific men in his gift for finding the picturesque phrase. He has done it again. In the Norman Lockyer Lecture on "The Link between Matter and Matter," delivered before the British Science Guild on November 16, 1925, he urged upon the scientists there assembled the fundamental profundity and importance of so simple a question as that of what pushes a wheelbarrow.

"I am going to suggest," he said, "that the pressure of light may have to be taken into account before the most ordinary operations of daily life, even the propulsion of a wheelbarrow, are properly explained."*

*The lecture was reported in the London and the New York newspapers of November 17, 1925. A portion of it is summarized in "Hypothesis about Push or Contact Force," by Sir Oliver Lodge, *Nature* (London), vol. 116, pages 869-871 (December 12, 1925).

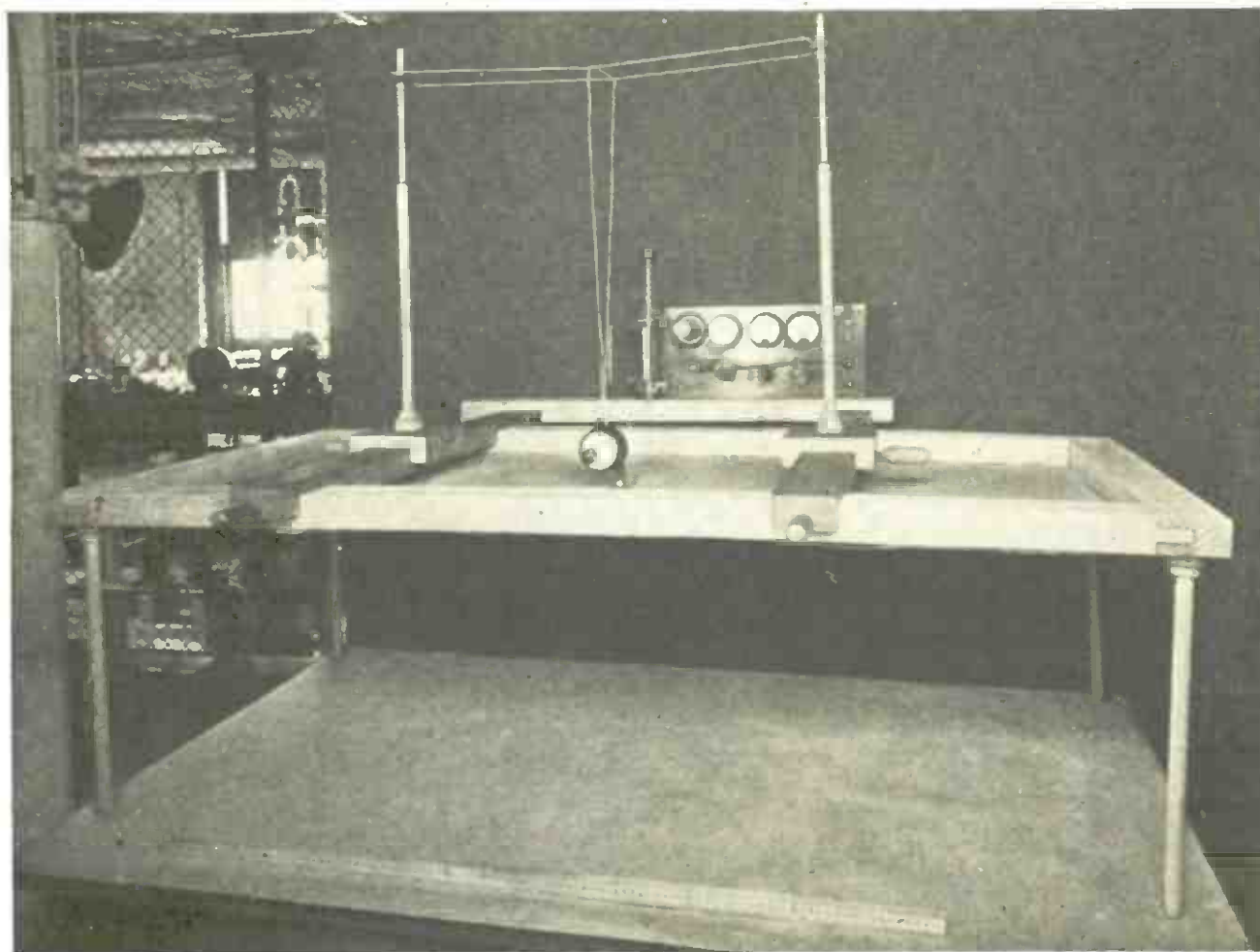

ANOTHER SMALL-SCALE ANTENNA MODEL

This photograph shows the model of a T-shape antenna, the drive being from the center. The mathematical equations for the operation of most shapes of antennas are difficult to solve; some are impossible. For such antenna systems a little advance work with models may save much trouble after the antenna is erected.

Under ordinary circumstances the pressure of light is a very tiny force. It required, indeed, the most delicate and laborious physical experiments to prove its existence.† Only with very minute particles, like those driven backward in the tails of comets by the sunlight, does the pressure of radiation become sufficient to influence the movements of bodies in our ordinary world. But all this may be very different, Sir Oliver suggests, when we deal with the world of very tiny dimensions close to atoms.

One of the great mysteries of physics is the mystery of what keeps atoms apart. When you push a wheelbarrow, to continue Sir Oliver's striking illustration, the atoms of your hands do not actually touch the atoms of the wheelbarrow handles. If these did really touch they would always thereafter stick together, unless, indeed, they mutually blew up and vanished. The very fact that atoms continue to exist proves that they do not touch each other so closely that the moving electrons inside them interfere with each other.

What keeps them apart? What is it that transfers the pushing force from your hands to

the wheelbarrow handles, even while the individual atoms of the two are still relatively far apart? Sir Oliver suggests that it may be the pressure of radiation.

We know very little about the radiation given off by atoms but one fact of which we do feel fairly sure is that radiation, for example the emission of light, is a symptom of atomic trouble. When an electron shifts its position inside an atom, light may be given off. When an atom disrupts, X rays or gamma rays or some other radiation may be given off. It is possible, Sir Oliver thinks, that when two atoms come too close together this near approach initiates some kind of profound change in the internal electron orbits and that this change, in its turn, produces a momentary radiation of light or of some other ether wave which radiation is intense enough to keep the atoms from further approach merely by virtue of the pressure of light.

All of this takes place, of course, in the very tiny spaces in and near the atom. None of it is perceptible to our coarser senses, except as the resultant cumulative effect is made evident in such interactions as the ability of our hand to push successfully against a wheelbarrow. It is curious that we push things only by the aid of light rays but it may easily be true.

†For an account of the discovery see: "Why the Sun Makes Possible Long-Distance Wireless," POPULAR RADIO, vol. 1, pages 249-255 (August, 1922).

New Tests on Amplifiers

CAREFUL scientific tests of the exact performance of radio instruments are so rare that each new piece of work is of importance. One has just appeared as a product of the program of the Radio Research Board, in Great Britain, carried out at the National Physical Laboratory.* Methods have been developed for the testing of the amplification and input impedance of audio-frequency and radio-frequency amplifiers, employing vacuum tubes. A few preliminary tests have been made, also, on the causes and occurrence of distortion in audio-frequency amplifiers. All radio experimenters interested in precise testing methods should consult the paper.

*"The Performance of Amplifiers," by H. A. Thomas. Paper delivered before the Institution of Electrical Engineers, London, December 2, 1925. The paper will appear in full in the *Proceedings* of that Institution.

The Wind of Ether Past Our Earth

THE American Association for the Advancement of Science, an organization comprising the majority of the active research workers of the United States, holds an annual meeting in the week of Christmas and New Year's. For the past three years an anonymous friend of the Association has provided a prize of one thousand dollars, to be awarded for the most important contribution presented before the annual meeting. This year the meeting was held at Kansas City, Missouri, and the annual prize was awarded for a paper which has great interest for the radio public.

The paper was by Professor Dayton C. Miller, of the Case School of Applied Science, at Cleveland, Ohio. Its subject was the complete report of Professor Miller's important and surprising experiments on the actual detection of the ether by physical means.*

These experiments are based, it will be remembered, on the idea that if the ether is a real thing there must be a vast wind of ether blowing through and past our earth as it swings along through space. Imagine an airplane flying through the air. As everyone who has been in an airplane knows, there is a wind of tremendous force blowing past the airplane so long as it is in flight. There is no difficulty in detecting this. Indeed, the existence of this wind constitutes one of the most uncomfortable features of flying.

As soon as the physicists had formulated any idea of the ether at all it occurred to them that there ought to be a similar wind of ether past the moving earth. We would not detect it, they agreed, as the ether probably permeates all material things, including our bodies. It would blow right through us, as the wind blows through a fence of chicken wire. But it ought to be possible, scientists agreed, to detect this wind of ether by physical experiments. Many such experiments were tried. All of them failed, including the famous Michelson-Morley experi-

*Professor Miller's preliminary report of these experiments has already been noted in this Department. "Two Important Experiments on the Ether and Relativity," POPULAR RADIO for September, 1925, pages 286-287.

ment which is one of the chief foundations of the Einstein theory of relativity. The failure of these ether-wind experiments is one of the main reasons why a fraction of the scientists have followed such men as Steinmetz in the conclusion that the ether is an illusion and does not exist at all.

Professor Miller was never of this group. He has persisted in experimental effort to detect the ether wind. At last, after nearly forty years of work, he believes that he has succeeded. In barest outline, his method involves the measurement of the speed of light in different directions. Light travels in the ether (if there is any ether) and the speed of light ought to be affected by the speed of the ether itself, relative to the observer. If a wind of ether is blowing past the observing station, the speed of light across this wind ought to be a little different from its speeds with or against the wind.

Professor Miller's experiments have been carried out on Mount Wilson, in California, where the great astronomical observatory is located. A variation of the speed of light has been found, just as was predicted. The amount of this variation corresponds, Professor Miller reports, with the position of the earth in its orbit; that is, with its direction of motion relative to the direction of the supposed ether wind of space. All of the data, including over one hundred thousand observations, agree with the hypothesis that there actually is an ether wind blowing past the top of Mount Wilson where the tests were made.

The fact that this wind was not detected by the earlier experiments, made close to sea level, is probably due, Professor Miller believes, to the fact that the part of the ether close to the earth is more or less dragged along with the earth as it moves. Think again of the flying airplane. Inside the structure of this machine there is little or no perceptible wind. The air there is dragged with the plane. Close to the outside of the plane the wind is perceptible but relatively weak. This air is partially dragged with the plane. You must reach out a foot or two from the fuselage before you feel the full strength of the wind that is actually blowing past.

It is just so, Professor Miller thinks, with the earth. Inside the earth the ether is largely dragged along with it. Close to the surface the drag is still considerable. One must climb a fairly high mountain before the wind of ether becomes fast enough, relative to the earth, to be detected by physical apparatus which we know how to build.

From Professor Miller's figures it has been possible, also, to calculate the speed and direction of the motion of our whole solar system relative to the ether. Again the analogy of the airplane will help to make this clear. Suppose that there is no wind, really, so that the wind which the aviator perceives comes entirely from the motion of his airplane. Suppose, further, that the aviator cannot see the ground or determine in any other way the nature of his motion through space. But grant him a set of wind-measuring instruments which tell him the amount and direction of his movement through the air. Then, by the simple device of circling about a little and reading his wind instruments, he can



From a drawing made for POPULAR RADIO by Arthur T. Merrick

OUR EARTH AND ITS WIND OF ETHER

If space is filled with ether, as many scientists still believe, the motion of the earth and of the solar system must create a great wind of ether blowing past our globe. Professor Miller believes that he has detected this "etheric wind," as is described on the preceding page. Inside the earth and close to its surface the wind is believed to be less fast, the ether being dragged along, partially, with the earth.

determine how fast and in what direction he is moving relative to the air stream.

Professor Miller has done this for the earth. The movement of the earth in its orbit provides the necessary circling. The ether-wind measurements provide the rest of the data. The conclusion is that our entire solar system is flying through the ether at the tremendous speed of 120 miles a second in the direction of the constellation Draconis. Or, what is the same thing, the ether wind is blowing past our system with this speed and in the reverse direction.

If these results of Professor Miller stand the test of repetition and criticism they will constitute, it is safe to say, the most important piece of physical work since the discovery of

radioactivity. They amount to a proof that the ether is real. Our theories of radio waves, of light, of gravitation and of most other physical fundamentals must take this fact into account. We must search for the nature of the ether. Is it composed of tiny flying particles? Is it a continuous medium, like a jelly? Does the electron consist of condensed ether or is it a vacuum in the ether? We will no longer be able to evade these problems by the assumption that the ether is merely a device for thinking, without actual physical existence.

As yet, not all the physicists agree with Professor Miller. They suspect that some error may have crept, unnoticed, into his observations. Only one thing will determine this—the inde-

pendent repetition of the experiments. It is to be hoped that this will be undertaken immediately by competent experts. Meanwhile, the award of the Association's prize to Professor Miller is an indication that the Committee of Award, which included Professor K. T. Compton, one of our most competent physicists, considers the new experiments as worthy of the utmost respect.

More Experiments with Oscillating Crystals

THE crystal oscillators invented last year by the Russian radio engineer, Mr. O. V. Lossev,* have continued to attract the attention of European investigators. It is reported that circuits based on this phenomenon are becoming popular in Russia† and three British investigators have recently published the results of tests with similar hook-ups.§ One of these British investigators, Captain H. J. Round, is so well-known as a competent radio engineer that his results have unusual interest.

It is quite possible, the Captain reports, to maintain oscillations in a circuit containing a crystal of zincite and a source of electric energy, the contact of the zincite and the cat-whisker serving as the generator of the oscillations. However, such oscillators are instable and delicate and sensitive points on the zincite crystal are hard to find, much harder than sensitive points on the ordinary galena crystals used for reception. Pure, crystalline zinc oxide (zincite is the impure zinc oxide found in nature) is even better than natural zincite. The conclusion implied by Captain Round's results is that the Lossev oscillators do not offer, at present, any advantage over the familiar tube oscillators, although they may be worth the attention of experimenters.

*See "The New Crystal Oscillators," POPULAR RADIO for November, 1924, page 507.

†"The Oscillating Crystal," by C. Nicolaieff. *Popular Wireless* (London), vol. 7, pages 45-46 (September 5, 1925).

§"New Facts About Oscillating Crystals," by H. J. Round and N. M. Rust. *The Wireless World* (London), vol. 17, pages 217-218 (August 19, 1925).

"Practical Crystal Oscillator," by L. L. Barnes. *The Wireless World* (London), vol. 17, pages 275-279 and 331-334 (September 2 and 9, 1925).

Do Millikan Rays from Spiral Nebulas Cause Air Ions?

THAT rays of the new ultra-short variety recently discovered by Professor Millikan* may originate in spiral nebulas billions of miles away in space and that these rays may be responsible, in large part at least, for the phenomena of our Heaviside Layer are the suggestions offered in a recently published letter by Dr. J. H. Jeans, the distinguished British astronomer and physicist.†

The source of the Millikan rays is likely to be, Dr. Jeans agrees, some profound atomic transformation such, for example, as the union and resultant annihilation of an electron with a positive nucleus or proton. It has long been suspected by the astronomers that this actually takes place in the interiors of the hotter stars, possibly of all stars, and that it is responsible in part at least for the supply of energy which the stellar suns pour out so lavishly into space. In the case of an ordinary star, Dr. Jeans points out, the very high-frequency rays detected by Dr. Millikan could not escape from the star in any quantity, even if they were generated within it. The matter of the star itself would be opaque to them. The only radiation which escapes is that originating near the surface of the star. This constitutes ordinary starlight.

"On the other hand," Dr. Jeans writes, "there are astronomical bodies which are transparent to ordinary light and probably also to high-frequency radiation. The most obvious examples are the irregular nebulas, such as the Orion nebula and the shells of the planetary nebulas, but the most important to cosmical physics are the spiral nebulas. * * * These nebulas must be almost completely transparent to newly generated radiation, so that practically the whole of the radiation they generate will escape into space without any change of wavelength. Space must be filled with such radiation, and its penetration into our atmosphere would seem to provide a natural explanation of the highly-penetrating radiation recently investigated by Millikan."

*The discovery of these rays by Dr. Millikan was described in this Department last month, POPULAR RADIO for February, 1926, pages 162-163.

†"Highly-Penetrating Radiation and Cosmical Physics," by J. H. Jeans. *Nature* (London), vol. 166, page 861 (December 12, 1925).

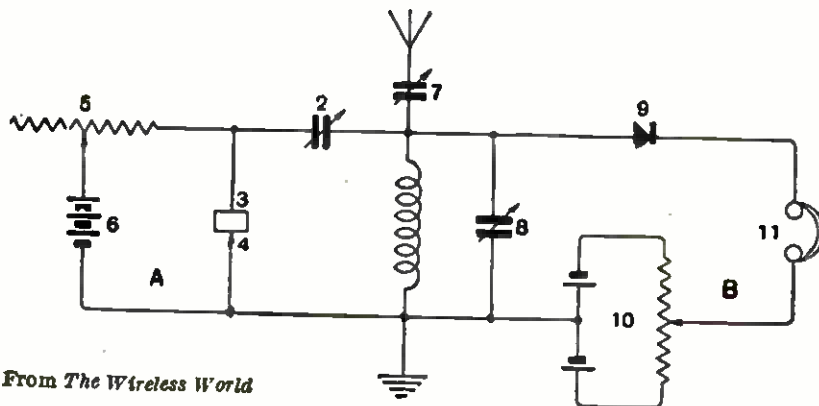

From *The Wireless World*

CAPTAIN ROUND'S CIRCUIT FOR CRYSTAL AMPLIFICATION

Circuit B is an ordinary crystal detector one. The amplifying circuit is marked A and contains the zincite oscillating crystal 3-4, a .0002 microfarad condenser (marked 2), a resistance variable in small steps up to 12,000 ohms and a battery of from 30 to 40 volts. The antenna circuit is tuned by the two low-loss condensers marked 7 and 8.



The University of Chicago

PERHAPS THIS IS A SOURCE OF MILLIKAN RAYS

Diffuse, cloud-like nebulas are suggested, together with the more familiar spiral nebulas as possible sources of the newly-discovered very short rays from space. The two cloud nebulas shown here were photographed by Professor Barnard in the constellation of Cygnus, the Swan. The streak is the trail of a meteor which happened to cross the sky while the exposure was being made.

Calculations of the probable rate of generation of the Millikan radiation in the spiral nebulas and the probable intensity of such radiation reaching the earth agree reasonably well, Dr. Jeans goes on to say, with the observed facts, both the facts recently disclosed by Dr. Millikan and the facts of ionization in the earth's atmosphere.

It is these latter facts which are especially important for radio theory. The action of the ultra-short rays on matter is extremely severe. Atoms are disrupted; electrons are shot out at speeds approaching the speed of light. Exposure of living creatures to intense beams of the Millikan rays for a few seconds would probably result in immediate death. The atoms of the air at high levels above the earth's surface are so exposed to these ultra-short rays arriving from space. Many of these atoms will be ionized; ionization consisting, you remember, in the ejection of one or more electrons from the atom

so that the atom itself is left with a positive charge.

This production of negative charges (the ejected electrons) and of positive charges by ionization is what creates, we believe, the Heaviside region of the upper air which region is so important in modern theories of long-distance radio transmission.* If Dr. Jeans is right in his suggestions it may well be that transatlantic radio is possible at all only because of atomic explosions which create ultra-short radiation in vast spiral nebulas more than a hundred thousand light-years away, for that is now the astronomer's estimate of the usual distance of such objects.

Seldom has science presented us with a more vivid conception of the grandeur of the universe.

*For an account of the effects of air ionization on radio transmission see: "How the Air Affects Radio," POPULAR RADIO for September, 1925, pages 199-206, and "How Earth Magnetism Affects Radio Waves," by H. W. Nichols and J. C. Schelleng, POPULAR RADIO for October, 1925, pages 309-316.



Kadel & Herbert

A PRINCE PERFORMS BEFORE "MIKE"

Between the motion picture that brings the royal presences before the eyes of their subjects, and the radio which brings the royal voices into their subjects' ears, it is becoming more and more necessary for kings and princes to play their parts by acquiring both the presence and the voices of skilled actors. Prince Wilhelm of Sweden is here shown broadcasting some of his own poems.

The BROADCAST LISTENER

*Comments on radio programs, methods and technique
—from the point of view of the average fan*

By RAYMOND FRANCIS YATES

A Year's Supply of Holiday Hymns

UNLESS you are a great body for Christmas carols (no, we're not exactly crazy about them) you probably got enough of them during the recent season to carry you well into the New Year. Since Xmas hymns and the like take a position near the end of our personal scale of entertainment, we took on enough carol material during the recent high tide to last us way, way into 1929. If it should happen that not a single broadcaster should use any Xmas song stuff during the week of December 25, 1926 (that's a highly speculative thought, isn't it?) our present supply would still be fresh and crisp. That's how the big Xmas programs of the broadcasters scored up here.

We have it from a pretty reliable source (the big throat lozenge people tipped us off) that thousands and thousands of members of quartets spent the entire month of January repairing the damage that 4,562 renditions of "Silent Night" had done to their voices. The records held by "At Dawning" and "By the Waters of Minnetonka" were easily broken and our statistical

department is now busy re-arranging its records. According to present figures, "Silent Night" tops the list, with "At Dawning" second. Vincent Lopez is also reported making a fine showing with "Wildflower." We already know where a little Lopez money may be had.

* * *

A Group of Real Creative Radio Artists

IF WE were going to spend five thousand dollars a night on the radio, seeking out the haughty *virtuosi* of the musical world would be one of the very last things that we should do. We are of the opinion that a radio show can be given a full five-quart sound by the use of many other tricks.

If we were asked (probably we never shall be asked) to mention the organization making the greatest contribution to radio theatricals we should immediately put down the Eveready artists. Here is an intelligent effort to improve the art. Since its very first program, the Eveready organization has attempted to pile up new experience and it is responsible for more new effects and schemes than a Hotel Commodore full of studio impresarios.

Will Radio Have a Sex Problem?

NOWADAY our Broadway shows are not complete unless some wild-eyed butter and egg man is chasing a Mrs. Babbitt around her Louis XVth bedroom. The sex garbage of every court procedure is dramatized with Howitzer headlines in our newspapers and our movies do little more than depict the loose sex ethics of what is to our directors the Hispano-Suiza stratum of society. The sex language in our novels is as plain as the story of Little Red Riding Hood and characters are incessantly calling themselves or other people dirty names.

With all of this odoriferous stuff going down the chute to public consumption, we should feel pretty happy in the thought that radio is still a virgin source of entertainment, free from the Hearst-McFadden-Woods-De Mille notion of heavy appeal. If radio goes sex, this country will in ten years make the Roman debauchery look like a sorority dance. A few stations have at times been a little "fresh" but in general the record of radio has been delightfully clean and free from anything with a pink appearance.

* * *

A Novel in Fifteen Minutes by Radio

THAT wholly ingratiating litterateur, Cosmo Hamilton, believes that we are approaching the day when novelists will compress their plots into a fifteen-minute volume for radio presentation.

Mr. Hamilton, it seems, has decided that the age of reading has passed and that this lazy human race will in the near future want its reading matter poured into its ears in fifteen-minute doses. Mr. Hamilton recently tried the idea from WJZ with a literary minuet he called "Sons and Mothers." Our Intelligence Department has not as yet had the time necessary to fully investigate the results of this pioneer move but in the absence of this material we are going to take a chance in saying that the thing came pretty close to being a flop, even though Mr. Hamilton did succeed in obtaining a front page story in the *New York Times*. It has been whispered around that Mr. Hamilton was more interested in getting on the front page of the *Times* than he was in convincing the world that ninety-thousand page novels would soon go the way of celluloid collars and Mah Jongg.

* * *

Why Thousand-dollar-a-night Voices Sound That Way

THOSE who have religiously followed these little diamond studded paragraphs have probably noticed our poignant criticism concerning the appearance of so many musically inclined Joneses and Smiths on the air. Here again the virus of doubt has entered our system and we are about (not quite, but *about*) ready to admit that Sadie Jones who comes to the studio with a Ford and galoshes impresses us almost as much as her silver-slipped sister who arrives with her limousine, photographer and publicity man. We have asked ourselves frankly and honestly if we really can notice anything existing between

the voice of Sadie and Gabriella that could be called a whale of a difference. We confess publicly and unashamed that, as far as the radio is concerned at least, the heavy efforts of practically all of Sadie's expensive sisters entirely elude our sense of musical appreciation. Perhaps we can save a little of our grace by admitting that we do detect a difference in technique, but the question of voice quality finds us sitting on the old board fence. This will probably be a big disappointment to those who have thought right



© Goldensky Studios

RE-SOUNDING THE TOCSIN OF FREEDOM

Perhaps the fear that Americans, deluged with prohibition laws, censorship and other restrictive legislation, might forget the spirit of liberty that fired their forefathers inspired station WIP to broadcast the ringing of this liberty bell on New Year's Eve. Mrs. Freeland W. Kendrick, the wife of the mayor of Philadelphia, sounded its tones—gently, with a tiny rubber mallet.

along that we were a musical connoisseur with highfalutin ideas.

When we came to this big decision, we were thinking of Johnny Fish in Penn Yan, N. Y. Johnny built his own "two tuber" from the Woolworth-Kresge supply base and he has something which he thinks in his Penn-Yan way is pretty nice. And let us tell you that you can see the aerials of thousands of Johnny's counterparts from the windows of the Sixth and Ninth Avenue "L's." On Johnny's radio set a voice is a voice and hardly that. The quality of a voice, in Johnny's ears depends solely upon the label you put on it. If you say it is Sadie, it is "punk" but if you say it is Gabriella, it is "great"—largely because the name sounds expensive. Let the announcer say that such-and-such a voice is one of the accessories of the Metropolitan Opera House and all of the Johnnies in the country will sit enthralled before their horns.

What we have been trying to tell you, Dear Reader, in case you have been unable to find out, is that 95 out of every one hundred radios reproduce badly. So badly in fact, that any registration of real art in singing is usually impossible. Of course, there is some solace in the knowledge that we have so many goofs in this country who fall for foreign-sounding names and Rhinestone headbands.

* * *

The Problem of Announcers Again

Just as this Department was beginning to feel that it had the announcing situation well fixed and that all of our little big men in the studios-

knew exactly what we thought of them, a few high school girls sent Mr. Norman Brokenshire (WJZ) some silly mash notes, and now we have another very bad case on our hands.

Mr. Brokenshire has never made what you could call a staggering hit with us for we have felt that this young man was always pretty sure that it was Mr. Brokenshire speaking and that Mr. Brokenshire was a very erudite person. If we sat down to write a column that read like Mr. Brokenshire talks we should sooner or later expect to be exposed.

We don't know what there is about the radio that makes announcers feel so important and makes them want to talk like millionaire graduates of Oxford. Mash-notes is about the only solution that we have. The cheapest and saltiest ham that ever played the lead in that stirring drama, "Way Down East," probably felt the same way when the high-school girls of Little Falls wrote to tell him what a perfectly wonderful guy he was.

It is not in the heart of this department to write to Mr. Brokenshire to tell that we know that he is not as ritzy or as blasé as he would try to have us believe.

We cannot close this exposé without registering another protest. We wish Mr. Brokenshire would stop trying to be funny. Sometime ago this young man asked the orchestra for which he was announcing to play "A Cup of Coffee, A Sandwich and You." When he turned to "the boys" and asked them to "coffee up, coffee up, now," this sour old thing rolled off an oath that was nothing short of scandalous.

That shows what kind of a listener to good humor we are.



Underwood & Underwood

IT'S NOT ALWAYS WORK IN THE WORKHOUSE

Radio furnishes entertainment for the inmates of the Southwark Workhouse in England. An old phonograph horn has been pressed into service as a loudspeaker.



Pacific & Atlantic

SPREADING A POLICE ALARM THROUGH THE ETHER

When this set of bells (which is tuned to selected frequencies) is rung into the microphone of station WHO of Des Moines, Iowa, it causes a white light to flash in specially constructed receivers placed in all police stations. In this way a police alarm may be spread and descriptions of criminals broadcast the moment a crime is reported.

The whole State of Iowa is covered by this system.

A Silent Night in New York?

WHEN the news that the Chicago listeners were out on some sort of a strike came, (that does sound foolish, doesn't it) we thought that the sloppy broadcasting in the Chicago district was responsible for it. We confess that we cannot quite apply the same theory to a communication now laying on our desk signed by some mysterious "Citizens Radio Committee" and announcing the beginning of a movement to bring about a silent night in Greater New York. Like the Chicago affair, the movement is supposed to represent the wailing of thousands and thousands of injured listeners who, caring not a *durn* about what the majority may desire, set out to inveigle the broadcasters into the belief that nothing but a silent night will save the radio business from positive ruin. As in the case of prohibition and a dozen other evils growing from like sources, it is the noisy and cranky minority that carries its point.

We publish herewith, part of the letter received from this "vast" and peevish body (which appears suspiciously like the efforts of a single person floating under a self-appointed Executive-Chairmanship):

"Dear Sir:

"Like every American institution, the broadcasting station is a product of public opinion, a reflection of popular desire. A broadcasting station, if it is to function properly and perform a real service, must supply what its patrons desire and in a satisfactory manner, not what its sponsors believe is proper. The only barometer of the public's opinion is the verdict of the listener.

"In the silent night controversy the real reasons, purposes and benefits are:

"First of all, the listeners; they are the ones who, through the purchase of their sets and parts, made the industry what it is today. They have spent millions of dollars for apparatus which has given the industry the wherewithal to develop the science.

"These listeners are spending thousands of dollars in telegrams, phone calls and letters to encourage the station and make for the betterment of radio, and every fair-minded station realizes that it must please the listeners if it is to have a large regular happy and satisfied audience.

"There are many other reasons why the listeners' wishes should be satisfied. They certainly have their rights which should be respected. Silent night is not being requested for the express purpose of eliminating interference of one station with another; that is a matter for the United States Government, which is ably handling the matter.

"It is not a matter that requires technical tests, as some have suggested, nor is it a matter of teaching the fans how to tune their sets as some others have suggested. That is being taken care of and the fans are rapidly learning the art.

"When several stations in a certain area, being within the magnetic field of each other, are broadcasting at the same time, a general interference is set up, which prevents a great many in that area from cutting through for DX stations with any kind of satisfactory program. If the wave band of any one of these stations is close to that of a DX station, then it is almost impossible for many to bring in

the distant stations, and if they do get it, reception is marred or spoiled. Therefore, those without 'supers' should be considered.

"The solution of the problem seems to hinge on the selfishness of different factions among the listeners in and the broadcasting stations. Those with 'super' sets receive out-of-town stations seven nights a week, while those owning less efficient sets merely ask for one night, Friday, after 7 P. M.

"I have spoken to several owners of broadcasting stations with regard to advertising programs. I do not want them to misunderstand my statements. Every broadcasting station is an advertising medium and it makes no difference to the listener if everything they broadcast is paid for, for they realize that no one is going to invest the money necessary to install a station and operate it just for the fun of it or the pleasure the public will get out of it. It would be unreasonable to think this. It is a business proposition with the stations, and we hope everyone will be able to make a great profit on the investment.

"I want it understood that the Citizens' Radio Committee, sponsoring this drive for a silent night, is in no way antagonistic to the broadcasting stations. It has on every occasion offered its cooperation and assistance to them in every way possible, for that is the very purport of its platform. Some stations have realized this and expressed their thanks to us.

"The listeners do not want to be unfair or unreasonable. All they ask is the co-operation of the stations, to consider the privileges they are entitled to.

"The majority must govern, selfishness cannot be considered.

"Respectfully, and 73s

"JOEL J. MICHAELS,

"Executive Chairman."

A radio receiver becomes a mere toy in the hands of a certain class of listeners. They care nothing about the merit of the local performances; they are animated by some sort of a kid passion to reach out and see how many stations they can log. In the average case they manage to catch nothing but the call letters but, in their kidlike enthusiasm they call that radio reception. Ask an engineer who knows his business (and be mighty careful whom you ask these days) and he will tell you that perfect radio reception is impossible over a distance of 100 miles. He will tell you further that music loses its edge and beauty. It becomes "thin" and the tendency toward distortion in the average receiver is great.

We are that type of body known as a stay-at-home when it comes to radio, for, if we do say it ourselves, we turn a frightfully critical ear toward our cone. Distance means no more to us than the saving of cigar bands or marbles, and yet it may come to pass that the kindergarten class of radio listeners will win out, and we shall have to spend one evening a week at the movies. The plan for the silent night does not sound 100 percent American to us and

we believe that we shall turn the entire matter over to the Klu Klux Klan.

It is inconceivable that anyone but a clique of cranks could feel that a silent night in New York would be an ingratiating asset to the radio art. It is odd, isn't it, to see the will of the minority spending its force here and there without regard for consequences and certainly without respect for the rights of the majority. We take it that the little boys who started this movement have not stopped to give a thought to the hundreds of thousands of people outside of New York City, who depend night after night upon the Metropolitan stations for their entertainment. And what would our whimpering laddy-bucks say if they should gain their point (God forbid!) and they go out to search for distances only to find that their boy friends in several other large cities have noised the broadcasting off the air? It is not difficult to see that this long-distance fishing game will defeat itself in time but it seems that it is up to us to prepare an ABC treatment on the subject so that all the members of the Radio Boy Scouts will surely understand.

* * *

What Percentage of Light Music Does a Program Need?

WHEN our publicity boys at the radio studios get hard up for ideas, they sit right down and pound off about four and one half gallons of literary near-beer dealing with the big, vital subject of "Jazz vs. Classical Music." These heavy manuscripts usually start out like this:

"King Jazz is slipping," or, if the studio happens to be in the jazz market, "Jazz is holding its own with the listeners of the United States."

This and the subject of radio movies can pass the guard of any editor from the *New York Times* to the *Oshkosh Record*.

There was a day, and not long ago, when this department talked nasty about jazz—calling it by some presumably funny name. That just shows how silly and inconsistent you can be if you don't watch yourself all of the time. Here we are just waking up after four years of being Bached, Schuberted, MacDowellled and Wagonered to a point where we are simply as limp as a rag—the music has been so heavy that 98 per cent of our energy has been consumed in digesting it. There has been little left to enjoy save the fact that we have been listening to the masters. When we started out with this business of listening to the masters *via* the air we had no use for Bell-ans charcoal tablets but now, we confess, we are quite worried about our condition.

If it had not been for Mr. Bernie and Mr. Lopez (even with his high "Wildflower" record) we should have had almost a miserable time with the radio. We are in our present licked condition, willing to go on record as saying that the jazzists of this country did a big thing for broadcasting when they prevented it from falling entirely into the hands of our Size 1, Series E musical high-brows in the studios.

After all, this old world wants a little salt with its pepper, a little soda with its liquor, a little sugar with its vinegar and a little calves' liver with its bacon.



IN THE EXPERIMENTER'S LABORATORY

CONDUCTED BY LAURENCE M. COCKADAY

The Raytheon Plate Supply With the Four-circuit Tuner

It does not seem to be generally understood that the Raytheon Plate Supply Unit (described in the November issue of POPULAR RADIO) can be used with the Four-circuit Receiver with Resistance-coupled Amplifier, which was described in the October, 1924, issue. This combination is entirely practical, as is here explained.

When "B" batteries are used to supply the plate voltage of this receiver, it is necessary to use a separate 22½-volt "B" battery for the detector. This is necessary because the negative side of the detector "B" battery is connected back to the "A" battery through the potentiometer winding in the "Dubl-Wundr." This is the arrangement used for varying the plate voltage on the detector tube, by simply rotating the knob of the potentiometer, thus providing the exact adjustment of the plate voltage for maximum sensitivity. If three 45-volt blocks of "B" battery are used to provide the necessary 135 volts for the amplifier tubes and a tap is taken off at 18 volts for the detector, trouble will result because the negative side of this "B" battery is connected to both the detector "B-" and the amplifier "B-" posts on the receiver. Inside of the receiver these two posts are connected to the slider of the potentiometer (Dubl-Wundr) and to the positive side of the "A" battery respectively. In effect the slider is thus connected to the positive side of the "A" battery. It is therefore evident that when this slider is moved toward the negative side of the "A" battery, thus decreasing the resistance between the slider and the negative end of the potentiometer winding, the "A" battery will be short-circuited through this part of the potentiometer resistance. If the slider is moved all the way to the negative side of the resistance winding there will be a direct short-circuit of the "A" battery, or if moved to within a few turns of the negative end, there will be little resistance in the circuit and a sufficiently large current will flow through these few turns to burn them out. In this latter case, of course, the potentiometer will be ruined.

If the negative terminal of the common "B" battery is connected only to the amplifier "B-" terminal of the receiver, and not to the detector "B-" terminal, no advantage will be gained from the potentiometer and the receiver will not have maximum sensitiveness or volume.

For these reasons it is evident that the Raytheon Plate Supply Unit cannot be used to supply both the detector and amplifier of this receiver if its negative terminal is connected to both negative "B" terminals of the receiver. However, when this unit is used there are two ways of getting around this trouble. The first is to use a single 22½-volt "B" battery for the detector as before, but to use the Raytheon Unit for the amplifier voltage. This is perhaps the best plan because it practically eliminates "B" battery worry inasmuch as the current drain on the detector "B" battery is so low that the life of the battery should be in the neighborhood of a year.

If it is desired to dispense with the "B" battery entirely results practically equal to the above may be obtained by connecting the negative terminal of the Raytheon Unit to the amplifier "B-" terminal of the receiver, *but not to the detector "B-" terminal*. Then connect the positive detector terminal of the Raytheon Unit to the detector "B+" terminal of the receiver, and the high voltage positive terminal of the unit to the amplifier "B+" terminal of the receiver. As explained above, this makes the potentiometer ineffective but the Bradleyohm variable resistance provided in the Raytheon Unit serves the same purpose as the potentiometer.

The use of a separate "B" battery for the detector and the Raytheon Unit for the amplifier has the advantage that finer variation of the detector plate voltage can be obtained by means of the potentiometer. There is the added convenience that the potentiometer control knob on the panel of the receiver is more accessible than that of the Bradleyohm. For local reception maximum sensitivity is not necessary and therefore frequent adjustment of the potentiometer is not required but when tuning in distant stations—for the DX fan—the potentiometer provides the better arrangement.

—S. GORDON TAYLOR

Record Every Experiment!

WHILE I was recently examining the Patent Office old records, I noticed that inventions "come in bunches," so to speak. The first patent on a steamboat, for instance, was issued to Robert Fulton in 1809; within a few years many other inventors followed with various improvements and the Patent Office was deluged with applications for steamboat patents. The bicycle craze, which extended over about ten years, resulted in hundreds of bicycle improvement patents being issued during that period. And so the story continued through the new era of telegraph, telephone, automobiles, locknuts, vacuum sweepers and many other inventions.

Today we are in the radio era. Hundreds of applications for patents on radio apparatus are being received every month by the Patent Office. Many of the inventors will be made rich; others will waste much time, considerable money—and will meet with disappointment.

Millions of dollars have been made from simple inventions, so simple in fact that almost every person who afterward saw them wondered why they also had not thought of the same things.

The radio industry, however, presents a different situation from many of the past subdivisions of new discoveries. No man can tell absolutely whether or not a great majority of electrical experiments will prove successful, except by actual test. In other words an inventor of radio electrical improvements must necessarily carry on numerous experiments, never knowing whether the results will prove good or bad.

All of us who have attended technical schools will remember the tedious and apparently foolish and unnecessary requirement of keeping an

accurate and detailed laboratory record, irrespective of how unimportant the experiments appeared to be. It is true that considerable time is consumed in doing this, but every experimenter should establish an iron-clad rule, never to proceed with an experiment, regardless of its apparent simplicity, without first preparing a neat note book, with the page correctly dated, and make the required sketches and the notes of the accomplishments as the results are affected.

The reason this should be done is that practically all valuable patents are at one time or other adjudicated in the courts. In other words, the strength of the patent will be thoroughly tested by persons or firms who want to manufacture the product without paying a license fee. Litigation is almost inevitable. Moreover, some individual may infringe the patent and it may be necessary for the inventor to prove priority rights. In either case the note book evidence is very important, and has been known to have sufficient weight to win a suit.

Only recently a great battle between Armstrong and De Forest was decided in one of our higher courts. Previously a lower court decided that Armstrong was the inventor of the regenerative circuit, but the last decision was rendered in favor of De Forest, and as the records of the trial show, his notebook was an important exhibit. In it was a sketch of the circuit, together with a written description of the obtained results. This page also bore the date of the experiment.

Many persons are carrying on experiments daily with various radio circuits and numerous applications for patents on improvements of radio apparatus are being filed. It therefore



From a photograph made especially for POPULAR RADIO

HOW THE PRACTICAL EXPERIMENTER DOES HIS WORK

Laboratory work which deals with new developments would never have any practical result if the data which are gained were not carefully recorded. The engineer shown in this illustration is determining tube characteristics and recording his results in the form of tables which will be made into curves for future reference.

behooves every inventor to establish his date of priority.

The great battle between Dr. Bell and Elisha Gray, in the celebrated telephone patent case, was decided in favor of Dr. Bell, even though both of these men filed their papers in the Patent Office a few hours apart on the same day. But Dr. Bell satisfactorily proved to the Court that he was the real inventor. That is the only reason he was awarded the patent. That decision meant \$40,000,000 to him. And it is not an overestimate of the amount of money which he received from royalties on the patent.

As yet the radio industry is in its infancy. The future holds in store many wonderful and presently inconceivable improvements in radio apparatus. Experiments will prove profitable to many. Practically everything that is known of radio today was discovered by an apparently unimportant experiment. Therefore any experimenter who owns a radio set, whether it is a small crystal set or a complicated and expensive heterodyne, has as good a chance of making a valuable discovery as those who already have done so. So he should keep a detailed record of every change in the wiring and arrangement of the circuits, so that if new and beneficial results are accomplished it will be no trouble to reperform the experiment. And above all, a complete record is on file for future reference, if it is needed to assist in establishing the inventor's rights against some other inventor who may have successfully performed the same result within a short period afterward.

—LEO T. PARKER

The 8-tube Reflex Superheterodyne Receiver

IN cases where it is desired to use this receiver to reproduce broadcasting with great volume, as in a hall or large room, the use of the new power tube UX-112 in the last stage of audio amplification will give rather surprising results. Such a tube is better able to handle the large amount of energy put into the last tube in this receiver, than is the UV-201-a type.

When using the UX-112 for this purpose it is not necessary to make any change in the wiring of the circuit. Simply remove the UV-201-a tube and replace it with the UX-112. A sep-

arate rheostat is not needed. It is a good plan, however, to connect a "C" battery in the grid return of this tube. This is easily accomplished by breaking the connection from the grid leak 06 (see diagram in descriptive article on this receiver in POPULAR RADIO for January, 1925) to the "A" battery circuit, and inserting a 4½ volt "C" battery. The positive terminal of the "C" battery is connected to the -A circuit and the negative terminal to the grid leak.

In addition to better and louder reproduction of signals, this arrangement will eliminate the howl which is discussed in the following paragraphs, without the necessity for using the variable grid leak.

When the "B" batteries used with this receiver start to run down a howl frequently develops if the loudspeaker is placed close to the receiver. Or this may even be true in some cases with fresh "B" batteries. In the latter case the trouble lies in a so-called "microphonic" tube in either the detector or one of the audio-amplifier sockets, or perhaps from the failure to use a vibrationless socket for the detector tube.

When changing tubes around does not eliminate the howl, it is fair to assume that the howl is the result of partly run down "B" batteries. Sometimes the howl has been known to start when the batteries had dropped to about 39 volts, whereas the useful life of the battery should be until the voltage drops to about 34 volts per 45-volt block.

The remedy for the howl is to connect a variable grid leak such as the Bradleyleak across the resistance 06 (see illustrations of constructional article in the January, 1925, issue of POPULAR RADIO) which is the grid leak of the last audio amplifier tube. With the set in operation, this variable leak is adjusted to a point where the howl stops and the signals are clear and undistorted.

This adjustment will cut the volume slightly, but under ordinary conditions the volume produced by this receiver is able to stand such a reduction.

Incidentally, this variable leak provides an excellent volume control because by decreasing the resistance of the leak sufficiently the signal strength can be cut down almost to a whisper.

—S. GORDON TAYLOR

Three Hundred Million Miles an Hour

This is not the speed of any rifle bullet or even of a runaway comet. Such things are far slower. Yet this astounding speed exists. It exists right here on earth. It is the speed of some of the tiny electrons inside the atoms of matter. These marvelous speeds of atomic rotation, transcending all ordinary human experience, will be described in the next issue of POPULAR RADIO by Dr. E. E. Free.



LISTENING IN

PRACTICAL pointers from experimenters and broadcast listeners. What helpful hints can YOU offer to your fellow fan? Readers are invited to address their letters to the editor of this Department.

CONDUCTED BY LLOYD JACQUET

How I Made a Low-Loss Terminal

I MADE a low-loss terminal for my newest Cockaday receiver from material on hand in the shop. (See Figure 1.)

A piece of glass rod, such as is used in bathrooms provided the body of the job, while brass strips supplied the means of supporting the clips to which connections were made and soldered.

Heavy brass brackets fitted around the ends of the rod provided the supports. These were drilled, so that the entire assembly could be screwed on to the board.

As many of the brass strips as there were terminals may be used. Small nuts and bolts

serve to tighten up on them so that they will not work loose upon the glass rod.

Although I used Fahnstock clips for the connectors, the wires may easily be soldered directly on to the strips. This terminal is neat, and because glass is used, the insulation is practically perfect.

—E. M. BACKMAN, Sharon, Pa.

* * *

A Station Card-Index

STATIONS have changed their locations and data so often, that their wavelengths have been a subject of periodical correction in my call book. This document became so inaccurate with time, that I decided to install a semi-

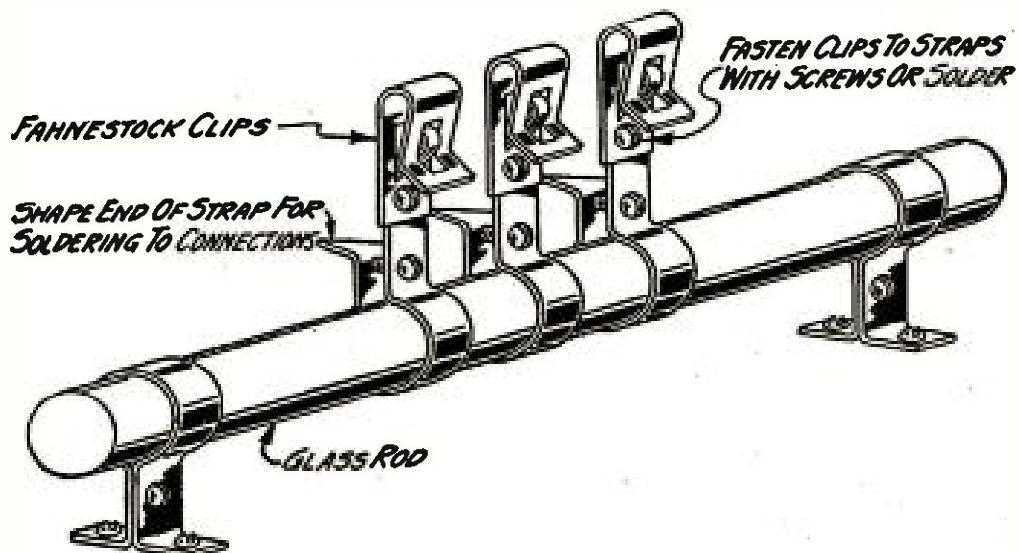

A DIAGRAM OF A SIMPLE LOW-LOSS TERMINAL

FIGURE 1: The low-loss terminal which is illustrated here may be cheaply assembled from a glass rod and a few brass strips. The insulation is practically perfect.

permanent recording system which could be easily kept up to date.

This led me to devise the card system, which was placed in a filing box. This gave me new information about stations at an instant's notice, and provided me with an easily corrected record.

I had several hundred cards run off by a printer, containing the major heads. Ordinary small filing cards were used and all the information that the average fan wants—or at least, all I wanted—was carried on them.

I then proceeded to fill in the station call letters and the information that I had at hand regarding them. These I filed alphabetically by call letters, beginning with the "K" series.

At regular intervals, I indicated the alphabetical arrangement, such as KDKA, KFI, WEA, WOK and so on. A regular small filing cabinet contained the five hundred or so cards required.

—S. KESSLER, *New York, N. Y.*

* * *

A Remedy for Soft Tubes

ALTHOUGH soft tubes require somewhat critical "B" battery voltages, I find that I can get good results from an old tube of this type. As I cannot get fine regulation of plate voltage from the "B" battery which I have, I introduce a small non-inductive resistance in the plate circuit of the tube. (See Figure 2.)

This resistance, which need not be more than 100 ohms with a battery voltage of 22.5, is placed in series with the "B" battery. By regulating this resistance, I get the best operating plate voltage, and can leave the filament adjustment without change for the entire evening.

—PAUL BARRETT, *Baltimore, Md.*

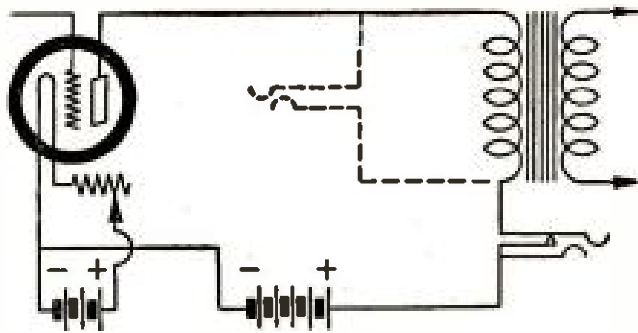

HOW TO CHECK LOUDSPEAKER PERFORMANCE

FIGURE 3: Either an open circuit jack or a single closed circuit jack may be used to test the various stages from the detector circuit to the loudspeaker. The loudspeaker need not be cut off while the phones are in circuit.

How I Made My Loudspeaker Perform Properly

It has been a habit for radio fans to tune in with headphones for long distance reception and then, increasing the power, to switch on the loudspeaker. The results were not always as expected.

I ran into this idea while looking for trouble in my five-tube receiver. After testing the audio-frequency amplifier, in which I suspected a fault to lie, I found that everything was all right. But it was from the detector that poor results were coming. I inserted a jack in series with the primary winding of the transformer and the "B" battery, as shown in Fig. 3.

This was a closed-circuit jack, and when I inserted the phones I could hear the broadcasting

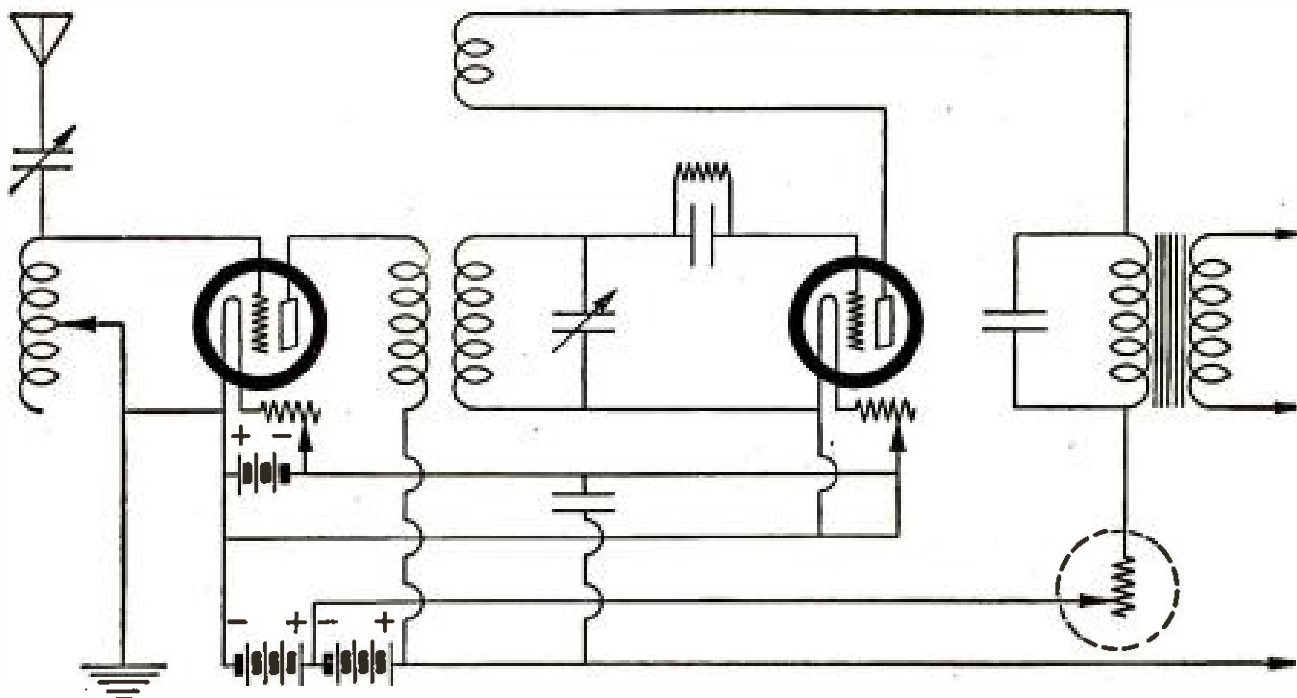

HOW TO CONTROL THE PLATE VOLTAGE OF A CRITICAL TUBE

FIGURE 2: To do this, a small non-inductive resistance is placed in the plate circuit of the tube. This schematic diagram indicates where the insertion should be made.

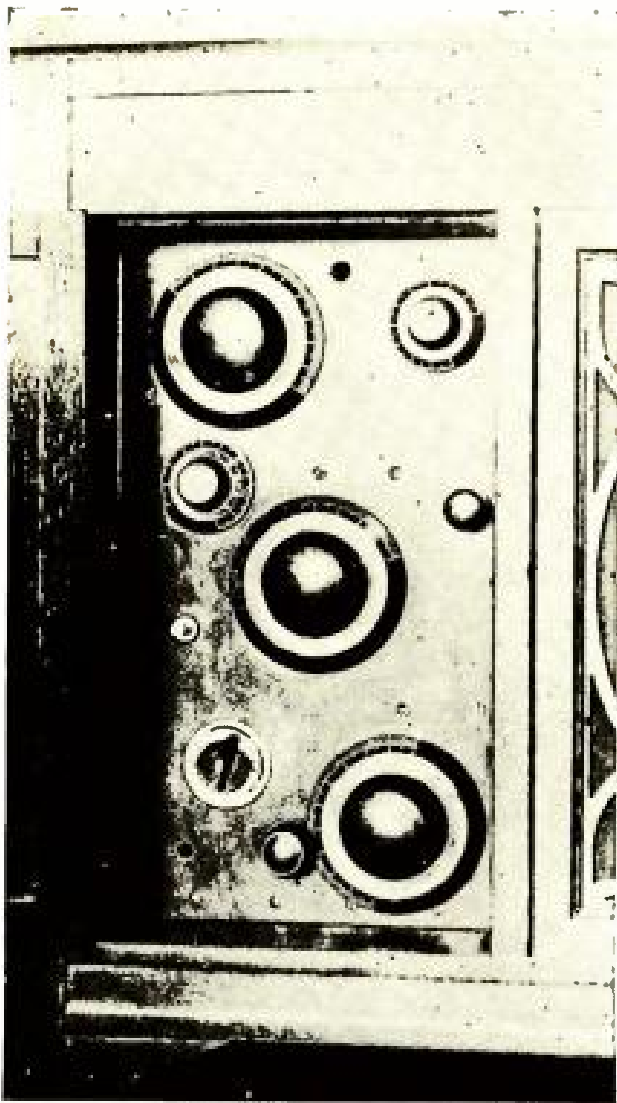

THE PANEL OF THE CONSOLE RECEIVER
 FIGURE 4: The diagonal arrangement of the three condenser dials shown here make it possible to obtain maximum spacing of the units.

which was also reproduced in the loudspeaker at the end of the audio-frequency amplifier. This idea helped me greatly in tuning in with the long distance stations and gave me an absolute check upon my audio amplifier and speaker.

It is not necessary to disturb the wiring of the receiver at all to locate this jack. It occurred to me that an open-circuit jack could be connected across the primary winding, as shown in the diagram. In fact, I have equipped all of my stages with this arrangement, so that I can find any trouble almost instantly.

In one case (the first) the jack will place the headphones in series with the transformer winding, and in the second, the headphones will be in parallel. In either case the loudspeaker may be kept going while the phones are in use.

—IRVING MULLER, Woodhaven, L. I.

How I Built a Radio Set in a Console

ALTHOUGH space is at a premium in the record compartment of the average phonograph, it is

possible, nevertheless to build into it a five-tube set. (See Figures 4 and 6.)

Here is how I did it:

I placed the main tuning dials diagonally across the panel, which insured maximum spacing of the tuning units—a great advantage in radio-frequency tuning.

I provided extra lengths of wire so that the entire unit, which is built on the panel, may be pulled out for inspection or repair. The two radio-frequency tubes are mounted on the small base-shelves of their own. The detector and the first audio tube are on the large shelf to the right, and the last audio tube is placed on the base-board.

Assembly need not be cramped, if proper care is taken in the location of the apparatus beforehand. Of course, it is necessary to study out the effect that the panel layout will have on the balance of the phonograph furniture before anything at all is attempted.

—HUGH G. BERSIE, Chicago, Ill.

* * *

Home-Made Brackets

I WAS greatly handicapped in the finishing of my McLaughlin Receiver by not being able to secure the necessary brackets which hold the panel at an angle to the wooden base.

However, it was a pleasant "job" to make a pair which served the purpose and it enhanced the appearance of the set considerably.

I secured a square foot of heavy brass, about one sixteenth of an inch thick. Having drawn the right size bracket specifications on a piece of drawing paper, I cut it out with a sharp pointed knife, making a duplicate. One of these

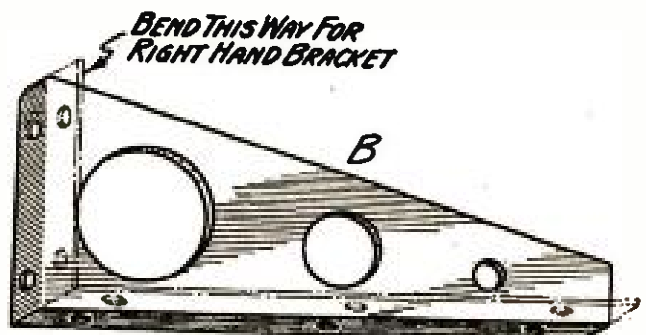
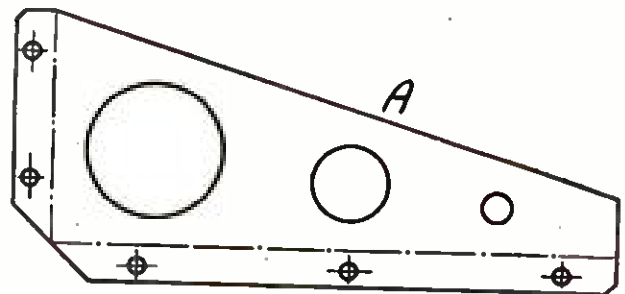

THE PATTERNS OF THE BRACKETS
 FIGURE 5: "A" is the pattern for the completed bracket. The drawing "B" shows the edges bent for a left-hand bracket. The dotted lines show how the edges are bent for a right-hand bracket.

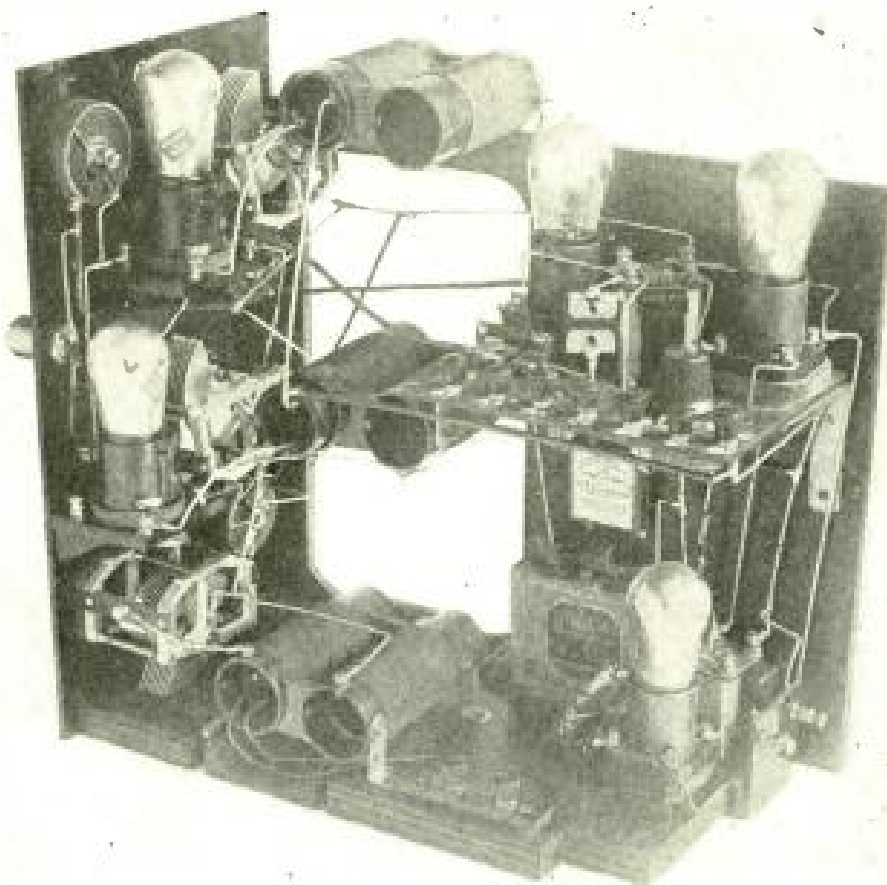

A VIEW OF THE INTERIOR OF THE RECEIVER

FIGURE 6: *This unique arrangement of apparatus was forced by the limited space in the record compartment of the phonograph for which the receiver was designed. The two radio-frequency tubes have been mounted upon small base-shelves supported by the main panel, while a side panel supports much of the remaining apparatus. Extra lengths of wire have been provided so that the panel unit may be pulled out for inspection or for repairs.*

drawings was for the right-hand side, and the other for the left-hand side.

It was easy to locate the two patterns on the brass, and they were outlined with a sharp point on the metal. With a heavy pair of shears, or better yet, a small metal saw, the units were cut out. Then, sections in the shape of holes or triangles were drilled and filed away, as shown in Figure 5.

Sufficient material was left on two sides, which were to be bent over, after drilling. This operation was done with the vice and a wooden mallet.

Cheap, strong and handsome brackets for any use can be built in this way.

—ROBERT CONWAY, *New Orleans, La.*

* * *

Hints for Using the Soldering Iron

WHEN the inveterate radio constructor starts on a job, it is usually of the marathon type and he does not leave his shop until the batteries are connected and the tubes inserted in the newest radio acquisition.

The electric soldering iron is generally the tool that suffers in this procedure. It is continuously being heated for a period of two to five hours; and it shows all the effects of hard use when all of the wiring is finally completed.

Not only must the builder watch the iron, turn it off when it is getting too hot, turn it on again before it becomes too cold, but he must tin it, keep it clean and generally devote as much time to keeping it in condition as to the actual soldering itself.

Here is how the problem was solved in my work shop:

I have a line with plug receptacles located at convenient intervals along the working bench. Near the switchbox, which is off to one side, there is a socket into which I placed a 75-watt electric light bulb. This bulb is connected in series with the line.

This bulb allows sufficient current to pass through to the electric soldering iron to keep it at just the right temperature. I never have to watch its temperature, and the tinning process does not have to be repeated except occasionally.

Of course, other devices besides the soldering iron may be operated from the plug sockets. My small electric drill also connects to the plug, as well as a small motor which runs a buffer, coil-winder and drilling arrangement. The installation is comparatively inexpensive and its saving in temper alone is worth the trouble. It can be installed by the radio fan builder himself at the cost of very little time and trouble.

—DAVID LAY, *New York, N. Y.*



WHAT'S NEW IN RADIO APPARATUS

THIS department is conducted by POPULAR RADIO LABORATORY for the purpose of keeping the radio experimenter and the broadcast listener informed concerning the newest inventions and the approved developments in radio equipment. Only such apparatus as has been tested and endorsed by the Laboratory is noted in these columns.

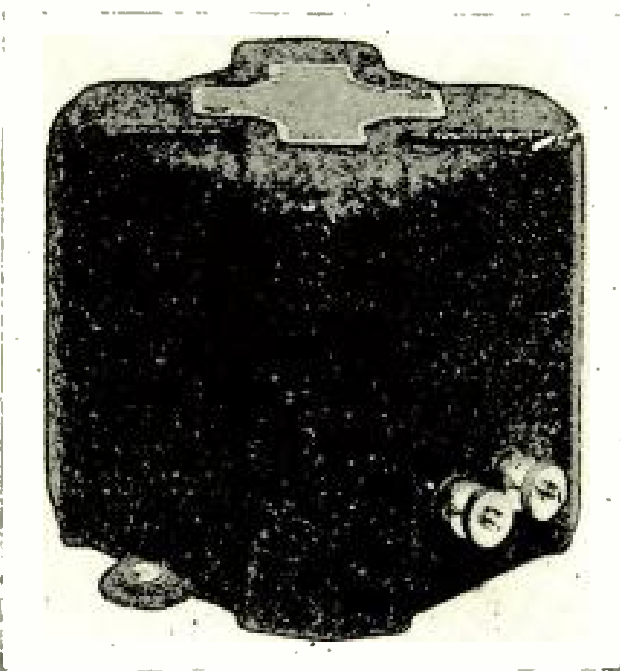

A NEW TRANSFORMER WITH UNUSUAL CORE DESIGN

Name of instrument: Audio-frequency transformer.

Description: This transformer contains four sections of core which are arranged in a cross-shaped pattern when looking at the transformer from the top. They are really four separate square-shaped cores which almost totally surround the coil windings. The transformer has a high value of primary inductance and is pleasingly efficient over a large band of audio frequencies. It is furnished in a metal case with binding posts brought out for the necessary terminals.

Usage: In an audio-frequency amplifier as an interstage coupling unit.

Outstanding features: Large core area. Improved amplification at the lower frequencies. Neat appearance.

(Further details furnished on request)

A NEW VERNIER KNOB

Name of instrument: Knob and dial.

Description: An ingenious application of two ring gears of different ratios in which one of the gears forms a tilting table arrangement. The small inner knob of this instrument is attached to a rotating slider which presses one portion of the top gear enmeshed with the lower gear. Upon revolution of this small knob the difference in the ratios of the two ring gears causes the dial to revolve extremely slowly in accordance with the difference of the number of teeth of the two gears. In this case, a ratio of 100 to 1 is produced.

Usage: With a tuning unit in a set.

Outstanding features: Neat appearance. Extremely smooth vernier action without back-lash. Provides direct gearing as well as vernier gearing.

Maker: (Further details furnished on request.)

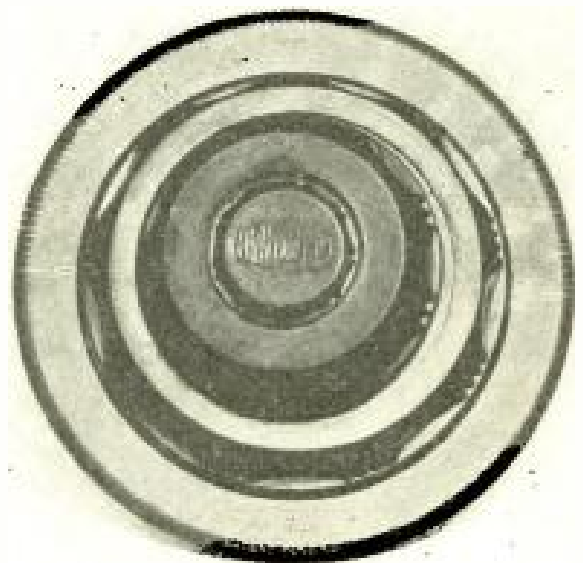

Apparatus Approved by Popular Radio

This list of apparatus approved by the POPULAR RADIO LABORATORY will be continued as a part of the WHAT'S NEW IN RADIO APPARATUS department until all instruments, parts and complete sets have been included. The listing is alphabetical by manufacturer's name and the installment in this issue includes the letters C through E.

AERIALS

Silver-Tone antenna; Colonial Brass Co.
Tinned "Copperweld" antenna wire; Copperweld Steel Co.
Ducon lamp socket aerial; Dubilier Condenser & Radio Corp.
Lamp socket antenna; Electrad, Inc.
Indooraerial; Electrad, Inc.

AMPLIFIERS

Super amplifier; Daven Radio Corp.

AUDIO-FREQUENCY TRANSFORMERS

Cardwell transformers; Allen D. Cardwell Mfg. Co.
Chelsea amplifying transformer; Chelsea Radio Co.
Como Duplex transformer; Como Apparatus Co.
Coto audio-frequency transformer; Coto Coil Co.
Globe audio-frequency transformer; Coyne Radio Service
Day-Fan audio transformer; Dayton Fan & Motor Co.
Superadio amplifier unit; De Witt-La France Co., Inc.
Equi-flux audio transformer; James C. Doran & Sons
Dymac audio transformers; Electrical Products Mfg. Co.
Erla audio transformer; Electrical Research Labs.
Essex audio transformer; Essex Mfg. Co.

BATTERIES

"Ace" "A" and "B" batteries; Carbon Products Co.
Flashlight batteries; Champion Carbon Mfg. Co.
Storad "A", "B" and "C" batteries; Cleveland Engineering Labs. Co.
Copper Giant "A" battery; Copper Giant Battery Co.
"Diamond" "B" battery; Diamond Electric Specialties Corp.
Radio-primary battery; Thos. A. Edison, Inc.
Exide "A" and "B" batteries; Electric Storage Battery Co.

BATTERY CHARGERS AND RECTIFIERS

Storad "B" battery charger; Cleveland Engineering Labs. Co.
Esco battery charger; Electric Specialty Co.
Exide rectifier; Electric Storage Battery Co.

BATTERY ELIMINATORS

Dongan "B" eliminator; Dongan Electric Mfg. Co.
Epom "B" battery eliminator; Epom Corp.

BINDING POSTS

"Dixie" engraved binding post; Dixie Supply Co.
Eby binding post; H. H. Eby Mfg. Co.

CRYSTAL DETECTORS

A-1 Galena crystal; California Radio Minerals
A-1 catwhiskers; California Radio Minerals
Carborundum stabilizing detector unit; Carborundum Co.
"Carco" crystal variometer receiving set; Carter Mfg. Co.
"De-tex-it"; Celerundum Radio Products Co.
"Maxitone" crystal; Century Products Co.
Radio reflex crystal; Century Products Co.
"Skylark" detector tip; V. L. Chamberlain
"Clearco" radio crystals; Clearco Crystal Co.
Rasla fixed detector; Davidson Radio Corp.
Universal radio crystal detector; Electric City Novelty & Mfg. Co.
Pyratek fixed crystal rectifier; Erisman Laboratories

DIALS

Cardwell Equitrol; Allen D. Cardwell Mfg. Co.
Day-Fan knobs and dials; Dayton Fan & Motor Co.
Erla dials; Electrical Research Labs.
E-Z-Toon radio dials; E-Z-Toon Radio Co.

FIXED CONDENSERS

Daven Leakecondenser; Daven Radio Corp.
Special coupling condenser, type A; Daven Radio Corp.
Fixed condenser; Tobe C. Deutschmann.
Micadons; Dubilier Condenser & Radio Corp.
Dubilier filter condenser; Dubilier Condenser & Radio Corp.
Erla fixed condensers; Electrical Research Labs.

GRID-LEAKS AND RESISTANCES

Centralab adjustable grid-leak; Central Radio Labs.
Centralab radiohm (non-inductance variable resistance); Central Radio Labs.
Crescent Lavite resistance; Crescent Radio Supply Co.
C-H variable grid-leak; Cutler-Hammer Mfg. Co.
C-H resistances; Cutler-Hammer Mfg. Co.
Resistors and grid-leaks; Daven Radio Corp.
Grid-leaks; De Forest Radio Co.
Resistor leak mounting; Daven Radio Corp.
Resisto-coupler; Daven Radio Corp.
Precision resistors; Daven Radio Corp.
Resistance unit; Dubilier Condenser & Radio Corp.
Durham grid-leaks; Durham & Co.
Fil-ko-leak; DX Instrument Co.
Fil-ko-resistor; DX Instrument Co.
Lavite resistances; Eastern Coil Corp.
Double grid-leak mountings with condenser clips; Electrad, Inc.
Double grid-leak mountings without condenser clips; Electrad, Inc.
Single grid-leak mountings without condenser clips; Electrad, Inc.
Single grid-leak mountings with condenser clips; Electrad, Inc.
Single mountings with condenser clips only; Electrad, Inc.
Royalty resistances; Electrad, Inc.

HEADPHONES

"Callophone" headset; Callophone Co. of New York.
"Camco" Cannon-Ball headset; Cannon & Miller Co., Inc.
Headset; Connecticut Instrument Co.
Coryphone headset; Chas. Cory & Son.
Crosley headphone; Crosley Radio Corp.
Cyclone headset; Cyclone Radio Receiver Corp.
De Forest radiophones; De Forest Radio Co.
Dictograph headset; Dictograph Products Corp.
Edson phones; Edson Radio Sales Co.
Eisemann headset; Eisemann Magneto Corp.

INSULATORS

Insulators; Circle F. Mfg. Co.
Pyrex insulators; Corning Glass Works.

JACKS

Carter "Hold-Tite" jack; Carter Radio Co.
Carter portable jack; Carter Radio Co.
Receptacle jack; Carter Radio Co.
"Cico" bakelite jack; Consolidated Instrument Co. of America, Inc.
Radjo jacks; Electric City Novelty & Mfg. Co.

KITS

Telos kit; Danziger-Jones, Inc.
Daven resistance-coupled amplifier kits; Daven Radio Corp.
"R.D.X." Reflex receiver kit; Durrant Radio, Ltd.
DXL tuned R.F. kit; D.X.L. Radio Corp.
Resistance-coupled amplifier kit; Electrad, Inc.
Erla Superflex Cir-kit; Electrical Research Labs.

LIGHTNING ARRESTERS

"Little Joe" lightning arrester; Circle F. Mfg. Co.
"Fil-Ko" lightning arrester; DX Instrument Co.
Lightning arresters (indoor and outdoor); Electrad, Inc.

"Keystone" lightning arrester; Electric Service Supplies Co.
Essex lightning arrester; Essex Mfg. Co.

LOOPS

"Calvert" loop; Calvert Specialty Co., Inc.
Carter new loop aerial; Carter Radio Co.
D. T. W. Collapsible Loop; Tobe C. Deutschmann
Eria loop; Electrical Research Labs.

LOUDSPEAKERS

"Cellophone" loudspeaker; Cellophone Co. of New York.
"Camco" loudspeakers; Cannon & Miller Co., Inc.
"Temple" reproducer; Chicago Signal Co.
Loudspeaker; Columbia Radio Corp.
"Madera" clearspeaker; Compressed Wood Corp.
"C.I.C." loudspeaker; Connecticut Instrument Co.
Coryphone loudspeaker; Chas. Cory & Son.
Crosley Musicone; Crosley Radio Corp.
Cyclone loudspeaker; Cyclone Radio Receiver Corp.
De Forest loudspeaker; De Forest Radio Co.
Dexter loudspeaker; Dexter Metal Mfg. Co.
Dictograph loudspeaker; Dictograph Products Corp.
Charmitone loud singer; Dual Loudspeaker Co.
Excellone loudspeaker; Excellone Radio Sales Co.

MISCELLANEOUS ACCESSORIES

"Gem" radio fuse; Chicago Fuse Mfg. Co.
"Temple" comparator; Chicago Signal Co.
Kester rosin-core radio solder; Chicago Solder Co.
Nestor Bend-Rite; Consolidated Instrument Co. of America, Inc.
Telephone receiver cords; Crescent Braid Co.
Premier 20 foot extension cord with plug; Crescent Braid Co.
Tufglass battery tray; Russell B. Cressman.
Crowe metal marker; Crowe Name Plate & Mfg. Co.
Cuno radio electric match; Cuno Engineering Corp.
C-II Radioloc; Cutler-Hammer Mfg. Co.
Sentinel radio fuses; Davis Electric Co.
De Forest coil mounting; De Forest Radio Co.
A.C. transformer; Dongan Electric Mfg. Co.
Dongan choke; Dongan Electric Mfg. Co.
Window Pane lead-in connector; D.S. DuBois.
Audio transformer, battery charger and battery eliminator coils; Dudlo Mfg. Co.
"Nokorode" soldering paste; M. W. Dunton Co.
Durham base; Durham & Co.

Easy seat cushion; Easy Seat Sales Agency.
Eby binding post strips; H. H. Eby Mfg. Co.
Bezels; Electrical Research Labs.
Solderless connectors; Electrical Research Labs.
Essex radio soldering fluid; Essex Mfg. Co.
Binding post name plates; Etching Co. of America

PANELS

"Bakelite-Dilecto" panels; Continental Fibre Co.
Crowe metal panel; Crowe Name Plate & Mfg. Co.
"Celeron" radio panel; Diamond State Fibre Co.

PHONE PLUGS

Carter One-way plug; Carter Radio Co.
Carter Tu-way plug; Carter Radio Co.
Carter "Imp" plug; Carter Radio Co.
Cico 2-way plug; Consolidated Instrument Co. of America, Inc.
Cico automatic plug; Consolidated Instrument Co. of America, Inc.
Eby phone plugs; H. H. Eby Mfg. Co.

PHONOGRAPH ATTACHMENTS

"C.I.C." phonograph attachment; Connecticut Instrument Co.

POTENTIOMETERS

Carter vernier control potentiometer; Carter Radio Co.
Centralab potentiometer; Central Radio Labs.
"Cico" bakelite potentiometer; Consolidated Instrument Co. of America, Inc.
C-H potentiometer; Cutler-Hammer Mfg. Co.
Day-Fan potentiometer; Dayton Fan & Motor Co.
Potentiometer; De Forest Radio Co.
Potentiometer; Eisemann Magneto Corp.
Potentiometer; Electrical Research Labs.

POWER AMPLIFIERS

De Luxe amplifier; Daven Radio Corp.

RADIO CABINETS

"Corbett's" radio cabinets; Corbett Cabinet Mfg. Co.
Adjustable consoles, tables and enclosures; Detroit Woodcraft Corp.
Vulcawood (cabinet material); Diamond State Fibre Co.
Adapto radio cabinet; L. R. Donehue Corp.
Eagle console cabinet; Eagle Radio Co.

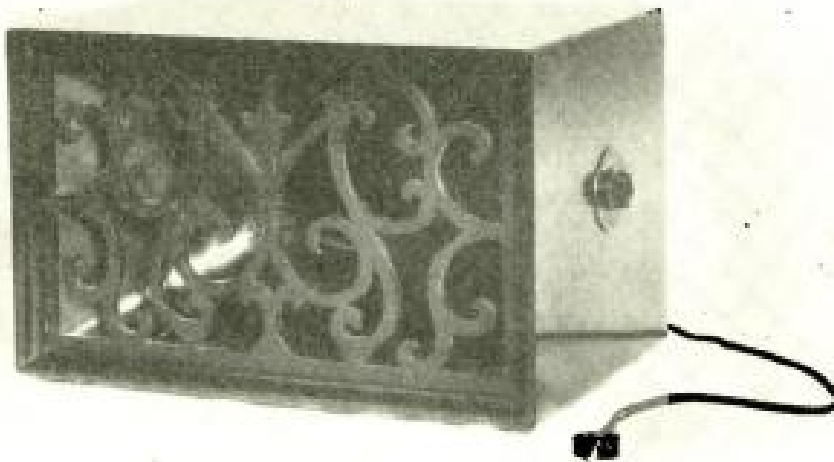

A HIGH QUALITY CABINET SPEAKER

Name of instrument: Cabinet reproducer.

Description: This new reproducer is equipped with a long horn of special shape and a variable reproducing unit. The adjustment for this unit is on the right side of the cabinet, which is finished in highly polished mahogany. The cabinet is equipped with a cord for attaching to the radio receiving set itself. The con-

struction of both the unit and the horn shape is such that the cabinet speaker produces the low tones and the high tones with a natural mellow quality.

Usage: In connection with a radio receiving set as a reproducer.

Outstanding features: Neat appearance. Good tone quality. Very fine appearance.
(Further details furnished on request)

RADIO-FREQUENCY TRANSFORMERS

Cardwell "Toro-Tran"; Allen D. Cardwell Mfg. Co.
 "Carco" neutroformer; Carter Mfg. Co.
 Celco intermediate-frequency amplifying transformer;
 Central Engineering Labs.
 Tuned-intermediate-frequency transformer; Como Ap-
 paratus Co.
 Coto radio-frequency transformer; Coto Coil Co.
 Harper Metaloid; Cribben Radio Corp.
 Day-Fan radio-frequency transformer; Dayton Fan &
 Motor Co.
 De Roy phusiformer; De Roy Radio Corp.
 Superadio radio-frequency amplifier unit; De Witt-La
 France Co., Inc.
 Dubilier Duraltran; Dubilier Condenser & Radio Corp.
 Low-loss radio-frequency transformer; Eastern Coil
 Corp.
 Eisemann radio-frequency transformer; Eisemann Mag-
 neto Corp.
 Radjo low-loss radio-frequency transformer; Electric City
 Novelty & Mfg. Co.
 Erla transformers and balloon circloid radio-frequency
 coupler; Electrical Research Labs.

RECEIVING SETS

"Cardwell" receiver; Allen D. Cardwell Mfg. Co.
 Chelsea receiver; Chelsea Radio Co.
 Clear-o-dyne receiver; Cleartone Radio Co.
 Goldcrest Cleartone receiver; Cleartone Radio Co.
 Cleartone "90" receiver; Cleartone Radio Co.
 Crosley receivers; Crosley Radio Corp.
 "Teledyne" receiver; Cutting & Washington Radio Corp.
 "Towne & Country" receiver; Cutting & Washington
 Radio Corp.
 C & W receiver; Cutting & Washington Radio Corp.
 Cyclone radio receiver; Cyclone Radio Receiver Corp.
 Day-Fan receivers; Dayton Fan & Motor Co.
 De Forest receivers; De Forest Radio Co.
 Dexter DX-5 receiver; Dexter Metal Mfg. Co.
 Dynergy radio set; Dynamotive Radio Corp.
 Eagle neutrodyne; Eagle Radio Co.
 Echophone V-3, F5 and portable; Echophone Radio, Inc.
 Eisemann receivers; Eisemann Magneto Corp.
 Erla knockdown receiver; Electrical Research Labs.
 De Luxe Heteroplex receiver; Elvin Radio Co.
 Gold Medal receiver; Eureka Outlet Co.
 Superheterodyne receivers; Experimenters Information
 Service, Inc.

RHEOSTATS

Vernier rheostat; Carter Radio Co.
 Carter "Imp" rheostat; Carter Radio Co.
 Centralab rheostats; Central Radio Labs.
 Cico rheostat; Consolidated Instrument Co. of America,
 Inc.
 C-H rheostat; Cutler-Hammer Mfg. Co.
 Day-Fan rheostat; Dayton Fan & Motor Co.
 De Jur 1-hole rheostat; De Jur Products Co.
 Fil-ko-stat; DX Instrument Co.
 Eagle revolving resistor rheostat; Eagle Radio Co.
 Rheostat; Electrical Engineering Equip. Co.
 Erla Precision rheostat; Electrical Research Labs.

SOCKETS AND ADAPTERS

Camfield "Bull Dog Grip" socket; Camfield Radio Mfg.
 Co.
 V. T. socket; Circle F. Mfg. Co.
 Coto tube socket; Coto Coil Co.
 C-H socket; Cutler-Hammer Mfg. Co.
 Sockets; De Forest Radio Co.
 Duray All-Glass viralon socket; Duray Radio Corp.
 Eby cushion socket; H. H. Eby Mfg. Co.
 Universal socket; Electric City Novelty & Mfg. Co.
 Erla socket; Electrical Research Labs.
 Essex socket; Essex Mfg. Co.

SWITCHES

Carter "Imp" switch; Carter Radio Co.
 Carter inductance switch; Carter Radio Co.
 Carter jack switch; Carter Radio Co.
 Carter Dialite; Carter Radio Co.
 Celco indicating switch; Central Engineering Labs.
 Centralab battery switch; Central Radio Labs.
 "C.I.C." lock "A" battery switch; Connecticut Instru-
 ment Co.

Cico battery switch; Consolidated Instrument Co. of
 America, Inc.
 C-H switches; Cutler-Hammer Mfg. Co.
 De Forest switches; De Forest Radio Co.
 Multiple switch; Eagle Radio Co.
 Radjo switches; Electric City Novelty & Mfg. Co.
 Arkay cam switch; Essex Mfg. Co.

TESTING INSTRUMENTS

Cell-O-Meter; Cellokay Mfg. Corp.
 SOS hydrometer; Chaslyn Co.
 Dongan high-resistance voltmeter; Dongan Electric Mfg.
 Co.

TOOLS AND EQUIPMENT

"Reachit" wrench; Kaufman & Clough Co.
 Coburn "Unitool"; Coburn Tool Co.

TUBES

"Ceco" vacuum tube, type 201-a; C. E. Mfg. Co.
 Power amplifier tubes E & F; C. E. Mfg. Co.
 Cleartron model C.T. 199; Cleartron Vacuum Tube Co.
 Hi-constron vacuum tube; Cleartron Vacuum Tube Co.
 "Sodium" tubes; Connecticut Telephone & Electric Co.
 Magnatron detector tube; Connewey Electric Labs.
 Rex. tubes for "B" eliminator; Connewey Electric Labs.
 Cunningham tubes; E. T. Cunningham, Inc.
 Daven tubes; Mu-6 and Mu-20; Daven Radio Corp.
 De Forest audions; De Forest Radio Co.
 Protect-o-tube; Don Mac Co.
 Diode detector tube; Electrad, Inc.
 Everest "World Top" tube; Everest Mfg. Co.

TUNING INDUCTANCE UNITS

Radio-frequency tuner; Chelsea Radio Co.
 Antenna tuning unit; Chelsea Radio Co.
 Coto compact moulded variometer; Coto Coil Co.
 Coto compact moulded variocoupler; Coto Coil Co.
 Coto honeycomb coil; Coto Coil Co.
 Day-Fan variometers; Dayton Fan & Motor Co.
 Day-Fan variocouplers; Dayton Fan & Motor Co.
 Day-Fan detector unit; Dayton Fan & Motor Co.
 De Forest honeycomb coil; De Forest Radio Co.
 Variometer; De Forest Radio Co.
 Eastern coupler; Eastern Coil Corp.
 Three-circuit tuner; Eastern Coil Corp.
 Low-loss coils; Eastern Coil Corp.
 Cockaday coils (silk wound); Eastern Coil Corp.
 Variometer; Eisemann Magneto Corp.
 Variocoupler; Eisemann Magneto Corp.
 Verni-tuner; Electrad, Inc.
 Short-Wave coil; Electric City Novelty & Mfg. Co.
 Radjo low-loss 180 three-circuit tuner; Electric City
 Novelty & Mfg. Co.
 Duo-lateral coils; Electric Products Mfg. Co.
 Pall Mall variocoupler; Essex Mfg. Co.

VARIABLE CONDENSERS

"Cardwell" condensers; Allen D. Cardwell Mfg. Co.
 Chelsea variable condenser; Chelsea Radio Co.
 Straight-line wavelength condenser; Chelsea Radio Co.
 Chelton "Special" condenser; Chelton Electric Co.
 Connecticut condenser; Connecticut Telephone & Elec-
 tric Co.
 Coto variable condenser; Coto Coil Co.
 Crest convertible condenser; Crest Radio Corp.
 Rasla Sivate-Lyme frequency condenser; Davidson Radio
 Corp.
 Variable condenser; De Forest Radio Co.
 Superadio condenser; De Witt-La France Co., Inc.
 Duplex condensers; Duplex Condenser & Radio Corp.
 DXL condenser, model C; DXL Radio Corp.
 Eagle condenser; Eagle Radio Co.
 Eisemann condenser; Eisemann Magneto Corp.
 Erla Miniloss condenser; Electrical Research Labs.
 Elraco Precision condenser; Elgin Radio Corp.

WIRE

Bus wire, square and round; Edward N. Cook Plate Co.
 "Blue Ribbon" battery cable; Crescent Braid Co.
 Enameled, cotton-covered, silk-covered bus bar, magnet
 and aerial wire; Dudlo Mfg. Corp.
 Skware flex bus wire No. 12; Essex Mfg. Co.

Q THE article "How to Build and Operate a Low-power Transmitter" (which was crowded out of this issue), will appear in POPULAR RADIO for next month—April.

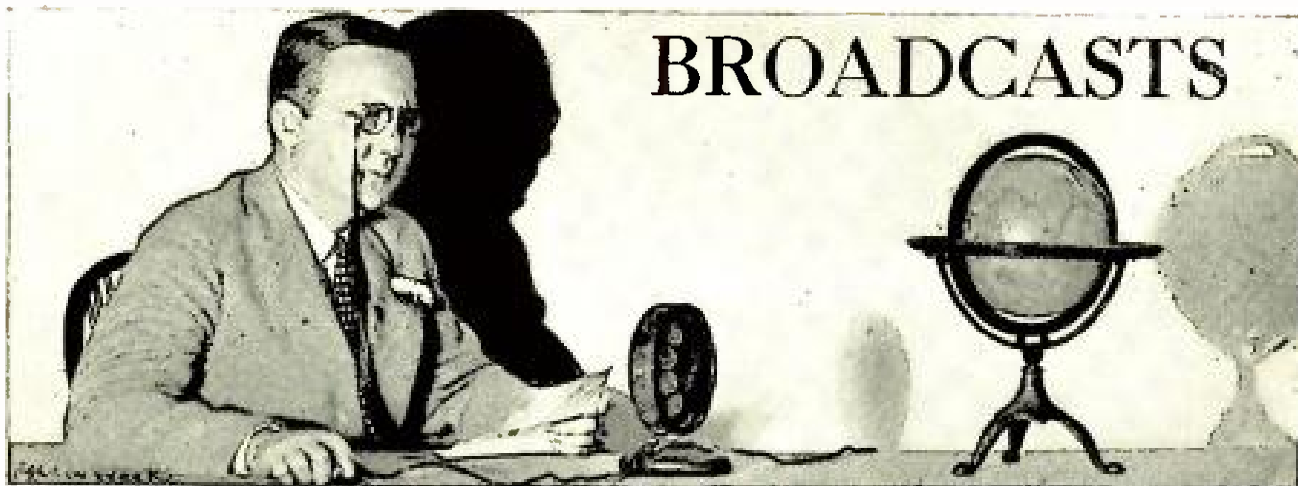

BROADCASTS

CONDUCTED BY J. ANDREW WHITE

In this department the Dean of Broadcasters—whose voice is known to millions of broadcast listeners—records items of interest and value to all radio fans everywhere.

Broadcasting College Courses to Farmers

THE announcement that an expert has been named to take over control of the radio activities of the Department of Agriculture brings to mind the fact that Secretary Jardine himself, while still president of the Kansas State Agricultural College, was one of the early broadcasters of agricultural extension work. It is beyond question that a systematic development of a definite service will carry pleasure and profit beyond calculation into the homes of the farm families; and the cooperation of federal, state and local agencies as planned in the new program gives promise of realizing the hope that cold and formal lectures will be shelved and that regular classroom instruction by radio will be instituted, with students regularly registered and examined and given full credit for work performed. This was the development of agricultural broadcasting foreseen by William A. Wheeler, member of the Interdepartmental Radio Board, in recommending specific reservations within the broadcast bands of wavelengths for dissemination of agricultural material. Adoption was secured for the resolution which carried the recommendation, so the day should not be far distant when it will be possible for all the major agricultural colleges in the country to make their courses available to the entire farm population instead of reaching, as now, a comparatively small percentage of the folks they are designed to help.

* * *

Jazzing the Deaf by Radio

BITTER opponents of jazz are faced with a counter-claim now that the pronounced rhythm of this class of music emphasized by beating of the drums and piercing notes of the "hot" cornet playing have humanitarian value—that through certain strains vibrations are set up which enable the deaf to hear. This information has been conveyed to Paul Ash, orchestra leader and radio star of KYW, in letters from several

women who explain that these are the only sounds they have been able to hear and that they enjoy the jazz music although otherwise deaf. A famous ear specialist of Chicago has become interested in the subject, it is reported, and is conducting a series of tests to determine the possibilities of utilizing this means of "bone conduction" of sound so that those who have lost normal hearing may through radio have the pleasures of music. When the unique investigation has been completed the renowned specialist promises the issuance of a report and a test program over the air is to be given with deaf persons asked to "listen in" and to report what they "hear."

* * *

Warnings by Wireless

WHEN a dozen or so tributaries hereafter are inclined to go on a rampage, and flood or deposit ice break-ups into swollen streams feeding into the Ohio River the serious changes thus brought about will be known immediately to navigators, shippers, farmers and others along a 1,000 mile stretch from Pittsburgh to Cairo. Daily radio broadcasts of the weather and a report of the river and its stages form the basis of the new and useful report which has been added to the varied forms of service originating at WLW.

* * *

Radio Service to Newspapers

ONE of the first impediments to the selection of whatever might be thought useful to air entertainment programs was the opposition encountered by pioneer broadcasters from the news gathering agencies which furnish the newspapers of the country with countless items daily. In the earliest days of broadcasting news bulletins were a regular feature; then in most instances they were dropped out only to reappear within the last year or so in various forms and increasing volume. The restrictions of the earlier days having been gradually lifted, it is interesting to note that this has been largely because radio has

proved to be of inestimable aid to the great system of news distribution in times of emergency. A number of instances might be cited, but the public is more or less familiar with these and will be more interested to learn of the latest arrangement made to provide the protection of radio for newspaper readers in the Rocky Mountain territory. This has been brought about by completion of plans with KOA, by which that station at Denver in cooperation with the United Press Association will flash the big news events of the day if landwire communication becomes blocked during severe storms or is crippled through blizzards or washouts. The news is to be read into the microphones at stated intervals and editors all over the territory will be equipped to take down the items in shorthand.

* * *

The Pending Radio Legislation

READERS have indicated a considerable interest and some degree of confusion in their minds as to the radio legislation proposed for the present session of Congress. While it cannot be anticipated what changes may take place between the time this is written and when it appears in print, the situation, briefly stated, is this:

There are two bills before Congress providing for the proper policing of the ether, as desired by the Department of Commerce. One is sponsored by Representative White of Maine; and a similar bill has been introduced in the Senate by Dill of Washington. Chairman of committees of both branches of the legislative bodies abandoned the original intention of arranging for joint hearings but arrangements were made for the convenience of witnesses to appear before both bodies at practically the same time. It is thought that most of those who will appear in each instance will be called, as the principal purpose of the hearings will be to give supplementary information and to answer the questions of the committeemen who may desire slight modification or amendment of the bills as drawn. As the bills stand at this writing both cover the legislative requirements as outlined by the recent National Radio Conference, except that they do not establish fees for licensing stations and operators, or give any mention to the recommendation to place a ban on oscillating receivers.

* * *

How Europe Is Regulating Its Broadcasters

EUROPEAN regulations affecting broadcasters are being developed along lines very similar to those recommended for adoption in the United States. At a conference of engineers at Geneva a 10 kilocycle separation was urged for allocation of wavelengths within the bands most familiar to listeners, and a separation of 20 kilocycles between the transmitting channels of the long wave stations. In the effort to clear up interference overseas the drastic recommendation was included to set aside requests for allocation of any of the channels between 300 and 500 meters, and that no consideration be given to applications for such licenses from new stations except in very special cases. This parallels the recommendation made by our own conference at

Washington. It means of course that Europe has plenty of stations and that newcomers should be made to accept whatever is open below 300 meters and above 500 meters. Furthermore, applications are to be considered in the light of the length of service rendered by the station, the number of listeners it serves, its range, and how



Pacific & Atlantic

MAKING THE OCEAN'S FLOOR HIS STUDIO

With a specially constructed microphone and a radio receiver inside of his helmet, Herr Rarmstorf, the famous diver, went to the bottom of the North Sea near Heligoland to broadcast a talk to the fans of Europe. Here he is just beginning his descent to his lonely studio

it fits in with the necessity of having several stations serving a multiplicity of listeners speaking different languages. Judged by the foregoing requirements, however, it was decided that priority rights must be established as there are not sufficient channels to serve all future needs between 200 and 600 meters. At some later date consideration is to be given to the bands below 200 meters. Incidentally, the bothersome operators of oscillating receivers abroad escape also, no action being taken against regenerative receiving sets.

* * *

The New "Community Concerts" by Radio

SINCE Cincinnati blazed the way with its series of twenty community concerts through WSAI three other cities have seen the value of setting their community favorably before the horde of radio listeners. St. Louis has followed the praiseworthy example and so has Davenport, Iowa, with San Antonio, Texas, considering the matter seriously. And now a State has fallen in line, with the announcement by Governor M. E. Trapp of Oklahoma to set aside a day to be known as "The Voice of Oklahoma Day" in an effort to raise a \$100,000 fund to establish a radio station to present the charms of that particular section of the southwest. That this useful movement is growing cannot be but a cause for congratulation, for, as expressed by the Chairman of the Cincinnati Chamber of



Pacific & Atlantic

A BOTTLE OF RADIO MUSIC

Even empty whiskey bottles have a use, finds Victor La Force—if you can get your radio receiver inside of one. He built a complete crystal receiver in this bottle within seven hours.

Commerce, Edward J. Hoff, those in charge of the pioneer effort along this line will be only too happy to assist others and advise them in the light of experience, which may be summed up in this extract from his statement to the San Antonio committee: "We know the pitfalls; we know the objections that will be met with; we know the difficulty of raising money to pay the bills; we know that if you don't raise sufficient money, you can't put on high class programs; we know that if you don't put on high class programs your advertising would be against you rather than for you."

* * *

What Re-broadcasting Does for the Fan

THERE is no small degree of pleasurable excitement in picking up the music and speech from stations in foreign lands, and more of such thrills are coming to us regularly with the rapid development of re-broadcasting and superpower. As we await the day, however, when such reception will be merely an incident in the program of each night, there is a slight shock for an American who picks up a London broadcast announcement and finds the casual statement in print, that: "The Radio Revel, to be held by the B.B.C. and the Faculty of Arts at Olympia, will include dance music from Berlin, Amsterdam, Paris, Brussels, San Sebastian, Madrid, New York and Pittsburgh."

* * *

The Best Location for DX Reception

BRANDAMORE's claim of being the prize location for long distance reception, which was heralded far and wide in the press not so long ago, has suffered a severe setback with the disclosure that a railway telegraph operator located at the small Pennsylvania town has admitted his reception of distant radio stations on an ordinary telephone line was a hoax. For two years Earl Davidson mystified experts who were sent to investigate the phenomena. It was quite common for the employees of the railroad to lift the telephone receiver to report a train and pickup a radio program being broadcast from Atlanta, San Francisco and occasionally from stations overseas. A concealed radio set connected to the telephone lines by means of a device worked out by Davidson, details of which he did not disclose, lay at the bottom of the mystery which has now been cleared up. Davidson lost his job as the result of the hoax.

* * *

The Radio Play Contest

THE Hoover Cup, a silver trophy, is to be given to the winner of the radio play contest along with the \$500 cash prize originally put up by WLS to create for the radio drama the equivalent of the scenario in motion pictures. The contest closed on February 1 with the announcement that the committee of judges is headed by Stuart Walker and the others to pass upon the plays submitted are Augustus Thomas, playwright; George Arliss, actor; and James O'Donnell, Bennet, dramatic critic.



Harris & Ewing

A RADIO SET MADE TO RECEIVE STATIC

This apparatus tunes in on all the static it can find while all other receivers are doing their best to avoid it. It is the static recorder employed by the Bureau of Standards at Washington to find out the main characteristics of this type of interference, especially the wavelengths upon which it operates.

The Broadcasting of Copyrighted Music

THE long standing controversy between radio and musical interests about which I wrote some months ago as one affecting the public in the matter of whether or not radio listeners would continue to hear new and good music on the air, was the subject of a three-day discussion at the Fourth Annual Radio Conference at Washington. The basis of disagreement is the copyright law and although the sessions were hectic, no agreement was reached between the broadcasters and the Society of Authors, Composers and Publishers. Both sides agreed that there is only one solution to the problem, but since neither seemed willing to advance that solution except in private, and recommended to the conference that legislation be enacted to settle the question, the whole matter was tabled by recommendation of Secretary Hoover, who asked that further effort be made toward reconciliation. The music interests asked for payment each time a number is broadcast, payment to be on the basis of the record made of the daily renditions at each station with periodical settlement of the required fee as compensation to the music society. The amount of bookkeeping involved was thought to be an obstacle to adoption of this system, but there was no opposition to the plan on the part of the National Association of Broadcasters; the spokesman for that organization, Paul

Klugh, however, insisted that the music interests would not consider such a proposal unless forced to do so by Congressional action. Although this method of payment was considered to be the logical plan upon which both sides could get together, no action was taken, and although a long fight is thought to be in prospect it seems only a matter of time when agreement upon this sensible solution will be reached.

* * *

Italy Adds to the Ethereal Choir

THE projected station at Milan, Italy, will be similar to 2LO at London, equipped to broadcast with 12 kilowatts, on 384 meters. It is being erected by the owner, the Union Radiofinica Italiana.

* * *

Radio Sets for the Blind

THE worthy purpose of providing radio sets for the blind, the campaign for which it was my great privilege to open with a microphone introduction of the remarkable Helen Keller, more than a year ago, goes on apace with Boy Scouts in forty-eight states installing free of charge the two-tube outfits provided by the American Foundation for the Blind for afflicted persons who cannot afford to purchase a set. Within three months joy has been brought to 650 homes through this work, thus multiplying by seven the resolution of the boys to do a good turn daily.

On the Trail of Old Man Static

THERE is still no explanation of why radio reception should be stronger in winter, when static electricity leaps out of one's hair or sparks out of the rug at one's feet, and weak in summer when there are apparently no static charges about us. This is the view held by J. K. Smith of the Stewart-Warner corporation, under whose direction an investigation of "fading" on a scale never before attempted has been carried on through twenty observation stations. Readings taken every two minutes during the period of the tests are to be charted and the results averaged and plotted on a map similar to that issued by the Government Weather Bureau. A comparison of fading and static curves with those of the weather map should be of value in determining the effect of weather on radio reception, for reception in the year past failed to follow the accepted rules. There were clear cold nights when it was impossible to hear stations 500 miles distant, and there were warm, wet nights entirely free from static and perfect for broadcast reception from distant points.

* * *

Linking the Home Telephone to Radio

A NUMBER of times within my recollection word has been received from some radio fan telling how he connected up his radio set and gave the neighbors on his party telephone line a treat; in fact, these reports are received with such regularity that the latest one from Guy Oglesby of Colony, Oklahoma, has added interest only because the connections were made with twenty farmers, instead of three or four. Quite a different matter, however, is the report received from R. A. Nevin of Hiawatha, Kansas, and made public by KOA. It appears to be a regular thing there for the telephone officials to provide radio loudspeaker service to widely scattered subscribers, an arrangement about which Mr. Nevin

makes this comment: "This system is ideal except that we take what the operator gives us. On the whole, however, he gives us the best."

* * *

How Zanesville Reduces Interference

THERE is a ten dollar fine coming to the resident of Zanesville, Ohio, who uses a vibratory battery charger during the periods of broadcast reception, which is designated as between the hours of six in the evening through to five in the morning, in an ordinance recently passed, designed to keep the ether free from local interference.

* * *

Sweden Profits from Broadcasting

SWEDEN is making money out of broadcasting. The Telegraph Administration came to the close of the year with a net profit of more than 150,000 crowns and the broadcasting company which divides things up with the Government also reports large profits. More than 120,000 licenses were taken out by the Swedish fans and it is proposed that a reduction in the license fee is in order for 1926. The revenue from licenses is divided fifty-fifty between the Telegraph Administration and the broadcasting company, but of the other income the radio company receives 75 percent.

* * *

The "Coming International Radio Conference"

AT least sixty countries will be represented at the great International Radio Conference to be held at Washington within a few months, for the State Department has already received three score acceptances to its invitation to participate.



Kadel & Herbert

A RADIO SET WITH A TWO-METER RANGE

This loop transmitter and receiver is one of the most efficient sets used by the U. S. Army, although it can only operate between 72 and 74 meters. On this short wavelength range, however, it can receive ten different stations $\frac{1}{8}$ of a meter apart. The loop antenna is enclosed in a metal frame.



The Jewett Cone

IT Tunes!

Good Radio reception must be tuned. Receivers do need dials.

But Tuned Reproduction is something new. Many a speaker lacks even an adjustment to fit the power of its receiver.

This new Jewett Cone tunes, over a wide, sweeping range—to the receiver, to the volume of the broadcasting station, and to the exact tone you best enjoy.

You'll be simply amazed at the result.

Low notes you never before heard over your Radio! Richness, balance and volume that reveal merits hitherto unsuspected in your receiver!

By all means, hear this revolutionary reproducer!

Compact, highly decorative and supremely efficient—Immune to dampness, tear or puncture—Standard replacement for obsolete horns and old style cones—Price \$19.50.

JEWETT RADIO & PHONOGRAPH COMPANY

5668 TELEGRAPH ROAD

Factories: Allegan, Michigan — Pontiac, Michigan

PONTIAC, MICHIGAN

In Canada: Jewett Radio-Phonographs, Ltd., Walkerville, Ontario.

Export Sales Office:
116 Broad Street,
New York, N. Y.

JEWETT

Send for this New

S Four

No choicer group of radio products has ever been embodied in a single radio receiver. Not only are these manufacturers nationally known and accepted as the leaders in radio design and construction, but they have developed for the S-C receiver many new features which will create a new standard in reception throughout the radio world.

Represented Manufacturers:

Belden Mfg. Co.
S-C Wiring Harness

Central Radio Laboratories
Centralab Resistance

Polymet Mfg. Corporation
Fixed Condensers, Leak and Leak Clips

Silver-Marshall, Inc.
Variable Condensers, Coil Sockets, Coils, Tube Sockets, Vernier Dial, Mounting Brackets

Thordarson Electric Mfg. Co.
Equipformer Audio Transformers

Poster & Co.
Drilled and Processed Front Panel and Drilled Sub-Panel

Yaxley Mfg. Co.
Rheostat, Jacks, Switch

The outstanding receiver development of the season, combining the genius of two of the most distinguished radio engineers. A receiver for the home builder that will represent for several seasons greater value than any other design available.

Here is a receiver that will represent to the home set builder a greater dollar for dollar value for years to come than any other design now available.

Consisting of one stage of tuned radio frequency amplification, a regenerative detector and two stages of audio amplification, it is the most popular circuit that has been developed in the past two years.

In addition to this, several outstanding features place the design in a position far in advance of anything available or yet announced. Unlimited

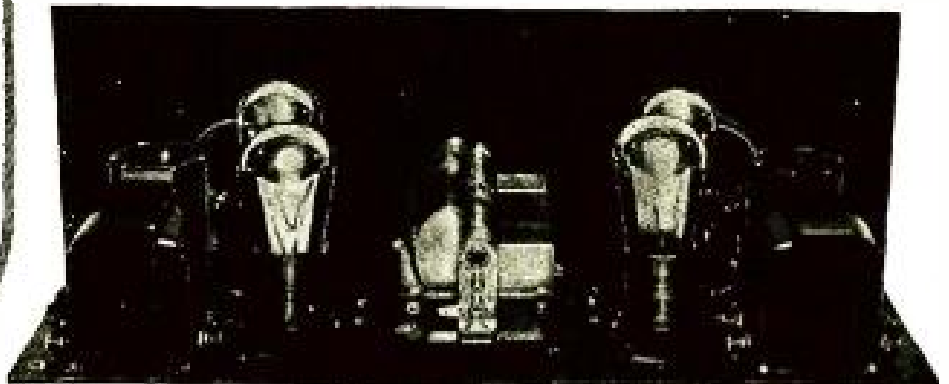

All apparatus advertised in this magazine has been tested and approved by POPULAR RADIO LABORATORY

C

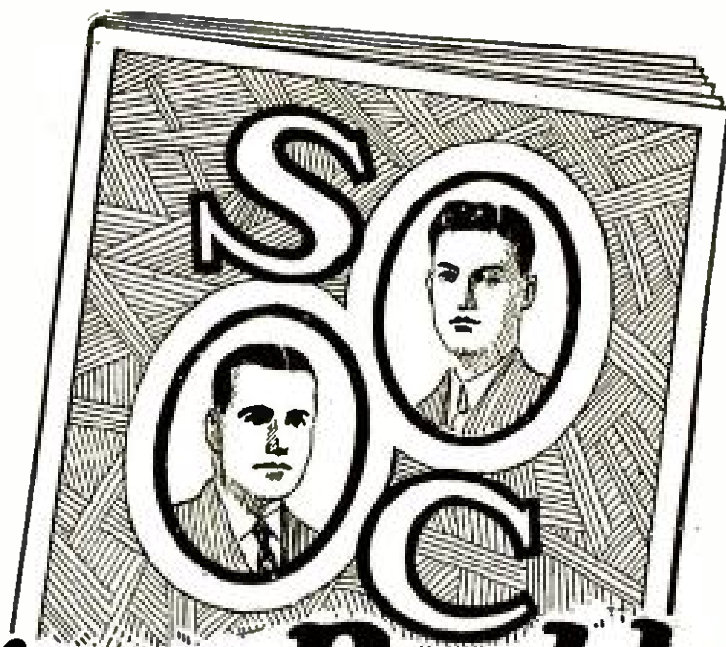

Tube Receiver Booklet

wave-length range, with interchangeable antenna and detector coils; a marvelously improved audio transformer; a special self-contained wiring harness; but one tuning or station selector control, are special features.

Over-all design is rugged and solid. Adapted to practically any standard cabinet, any standard tube, any battery or eliminator source of supply, outdoor antenna or loop.

Only a screw driver and pair of pliers necessary to build this set. The set can be built at an extremely low cost and parts are readily available at all radio dealers.

Get the hand-book at your radio dealer's, or clip the coupon and send with 25 cents to

S-C Merchandising Company
 105 So. Wabash Avenue, Chicago

S-C Merchandising Company
 105 So. Wabash Avenue, Chicago

Herewith please find 25 cents for which send me the hand-book of the new S-C Four-Tube Receiver.

NAME.....

ADDRESS.....

Read these Startling FACTS

Single Control—One tuning or station selector control.

Selectivity—Equal to that of laboratory super-heterodynes and superior to that of most five and six-tube receivers, permitting consistent distance reception through from five to fifteen powerful local stations operating simultaneously.

Sensitivity—In practically all cases will go below the noise level and tests indicate that a consistent range of 1,000 to 2,500 miles may be expected.

Quality—Two new-type Thordarson power amplifying transformers with a substantially flat frequency characteristic over a range of 40 to 6,000 cycles.

Volume—Ample for loud speaker operation for stations 1,500 to 2,500 miles distant under favorable conditions.

Flexibility—Through the use of interchangeable coils, wave-length range is practically unlimited.

Wiring—Carried in a special harness. Each wire is of exactly right length and of special color. No soldering needed unless preferred by the builder.

Logging—Tuning dial provided with direct reading logging space.

S SC FOUR-TUBE RECEIVER C

SM

SC



Type 316 Condenser, .00035 Mfd. for single or gang control. Brass plates, die cast frame. Price, \$5.75.



Type 801 Universal Vernier Dial, Ratio 14.5:1. Fits any standard condenser right or left, 180 or 360° movement. Price, \$2.50.



Interchangeable Coils for any wavelength. Standard Sizes, \$2.50. Type 515 Coil Socket, \$1.00.

Behind the S C Receiver there is an unusual story. A story of two men enlisting the aid of seven unexcelled engineering organizations—the pick of the industry—for an unusual purpose. Not to find the answer to a problem—for the answer is the ideal receiver—but to devise ways and means of duplicating ideal requirements day-in-day-out—of duplicating in actual practice, theoretically perfect operation.

They did it! With the S C Receiver. In a single stroke they combined single control . . . unlimited wavelength range . . . tuned radio frequency amplification . . . regeneration . . . unequalled quality of reproduction, and a simplicity of assembly positively astounding.

“THE KEY TO THE S C RECEIVER” tells the whole story. Send 25c. for this Booklet today!

Silver-Marshall, Inc.

112 S. Wabash Ave., Chicago.

Type 510 All-Bakelite Socket for UX Tubes, 50c.

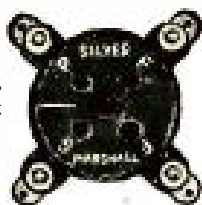

Type 340 Compensating Condenser, .000025 Mfd. with knob, \$1.50.

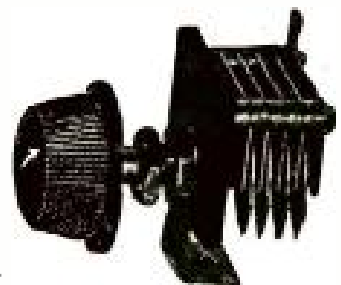

S SC FOUR-TUBE RECEIVER **C**

Woodcraft enclosures for the New SC Receiver

The keynote of the S-C 4-tube Receiver is simplicity—simplicity of construction and simplicity of operation. Just as there never was a more simple set to build or to use there never has been devised a cabinet which lends itself so admirably to any size or position of the panel.

A Woodcraft Cabinet is a fitting receptacle for the S-C Receiver and the combination will produce a reception instrument and piece of furniture of which you will be proud for years.



**RADIO-ENCLO
CONSOLETTA
(Unison)**

Woodcraft Cabinets are adaptable to all the popular circuits. They may be used with the B-T Counterphase, the Hammarlund-Roberts, the LC-26, the Universal, and the Browning-Drake, as well as with the new S-C 4-tube Receiver.

The panel opening in all Woodcraft models is adjustable up to a maximum of 30" x 10". It is also possible to mount the panel to tilted or perpendicular position in each model.

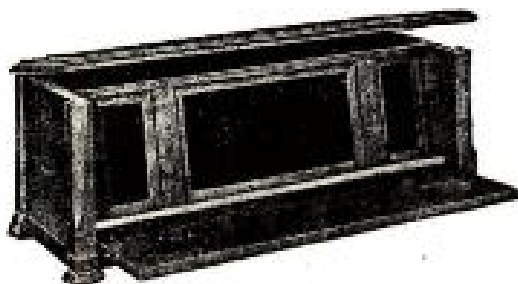

**RADIO-ENCLO
(Open Front)**

Inside clearance
10" x 10".

To repair set
simply remove
the front filler
blocks, etc.

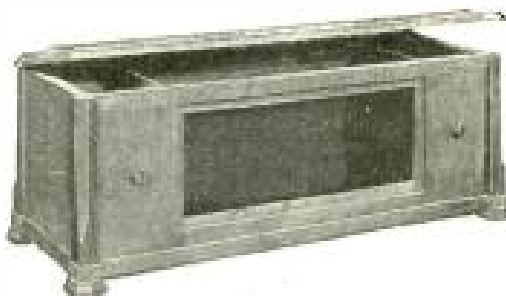

**RADIO-ENCLO
(Closed Front)**

The Woodcraft is by no means a makeshift. It is built of genuine dark walnut with five coats of lacquer rubbed to a piano satin finish. Many two-tone, carved and inlaid effects, make Woodcraft models more beautiful than you may imagine. The panels are completely surrounded by a 3/4" two-tone bevel.

If you are a fan who builds new sets frequently, Woodcraft offers you an exclusive advantage. Because of the exclusive Woodcraft design (Broad patents pending) it is possible to make quick changes in panel size and position instantly without screw holes, cutting, etc.

Built by the
**DETROIT WOODCRAFT
CORPORATION**

Write for circular,
prices, etc., to
Dept S
4611 Woodward Ave.
Convention Hall
Detroit, Mich.

Sales and Adv. Dept's
4611 Woodward Avenue
Convention Hall
Detroit Mich.

S SC FOUR-TUBE RECEIVER C

YAXLEY
APPROVED RADIO PRODUCTS

Used in the S-C
Four Tube Receiver

Radio Jacks

These jacks have springs of genuine phosphor bronze. Pure silver self-cleaning contact rivets. One nut mounting. All bakelite insulation: low dielectric loss. Spring terminals tinned for soldering. Fit any standard radio plug.



No. 1 —Open Circuit..... Each, \$0.50
No. 2A—Two Circuit..... .60



Air-Cooled Rheostat

Scientifically designed to give the most perfect results. Smooth as silk in operation. Has a very fine adjustment, feeding current slowly and evenly. The resistance unit is suspended in air. This permits an even rise in temperature and does away with excessive heating. Furnished complete with bakelite knob.

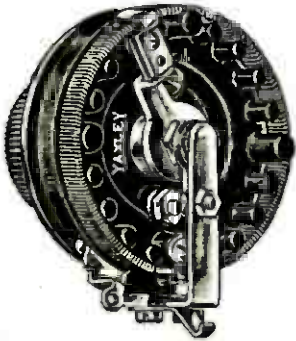

No. 102K—	2 Ohms	Each
No. 13K—	3 Ohms	
No. 16K—	6 Ohms	
No. 110K—	10 Ohms	
No. 115K—	15 Ohms	
No. 120K—	20 Ohms	
No. 125K—	25 Ohms	
No. 130K—	30 Ohms	
No. 140K—	40 Ohms	

(Etched Dial Plate 15c. extra)

Midget Battery Switch

The most efficient filament control switch made. Never gets out of order. One nut mounting. Hard rolled phosphor bronze springs. Pure silver contacts. Quick make and break. Furnished complete with "Off" and "On" plate, as illustrated.

No. 10..... Each, \$0.50



Get the S-C Instruction Book and Yaxley Radio Parts at all Radio Dealers.

Yaxley Manufacturing Company
Dept. P, 217 No. Desplaines St., Chicago, Ill.



in the Better Sets

—you'll find Centralab Controls as standard for oscillation and volume controls. The Centralab Radiohm (shown above) provides perfect control of oscillation. It is USED IN THE NEW S-C CIRCUIT because of the same inherent quality, smooth, noiseless variation, and long life that has prompted sixty-six radio set manufacturers to use it in this year's models. Holds that sensitive regenerative position immediately preceding the oscillation point, without distortion or loss of selectivity. Think what a boon to clear, true-tone reception.

Regardless of the circuit you may use, a Centralab Radiohm or Modulator of proper resistance will improve your control of tone and volume. Retail at \$2—at your dealer's, or mailed direct.

Write for literature describing this and other patented Centralab Radio controls.

CENTRAL RADIO LABORATORIES
17 Keefe Ave. Milwaukee, Wis.



S SC FOUR-TUBE RECEIVER **C**

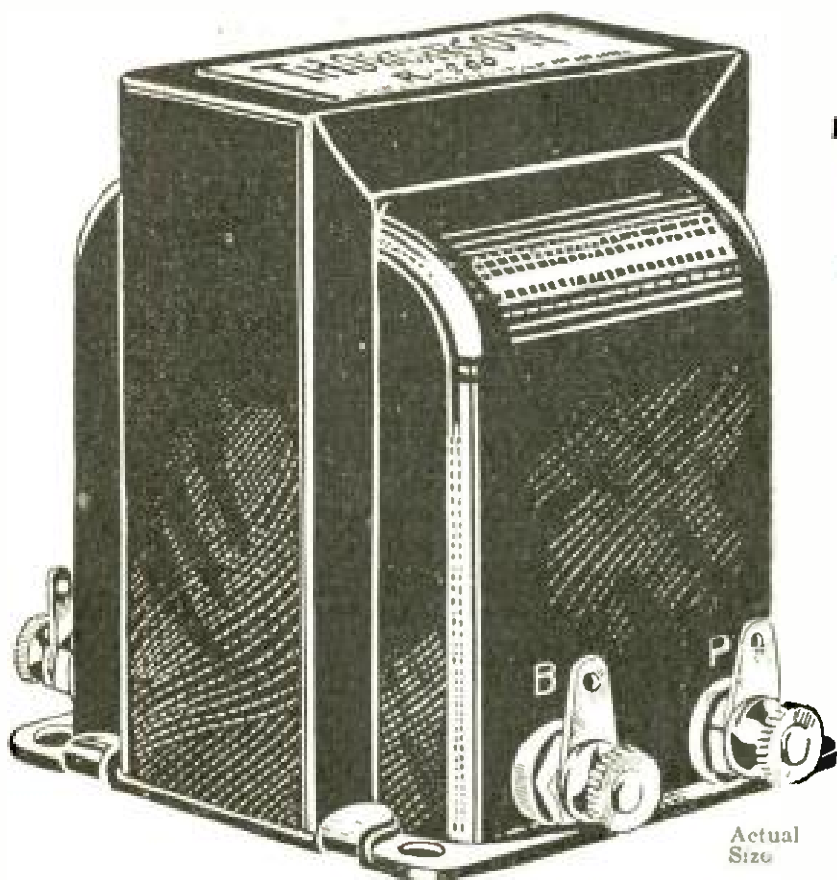

Here is the New
THORDARSON
R-200

used in the
S-C Receiver

Price **\$ 8** each

A Big New Audio Frequency Transformer

—Guaranteed by Thordarson

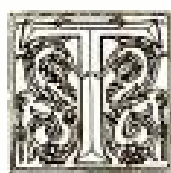

THIS big new Thordarson R-200 contains a super-size layer-wound square coil. The much larger magnetic circuit, so provided, minimizes core losses (a leading cause of distortion in powerful receivers). If your present transformers distort voices and instruments when you desire full volume, if they blur the low notes, if they are lacking in genuine musical quality, replace them with a pair of these big new Thordarson R-200's. Ideally adapted for all two-stage amplifiers. If dealer is not yet supplied, order from us. Write for fully descriptive literature.

Other Thordarson Transformers

Autoformers (All Frequency Amplifiers), \$5 each. Regular Super Audio Frequency Transformers in either sub-panel or top mounting type: 2-1, \$5; 3½-1, \$4; 6-1, \$4.50. Power Amplifying Transformers, \$13 the pair. Inter-stage Power Amplifying Transformers,

\$8. For Raytheon B-eliminators: R-195 Transformer, \$7; R-196 Choke, \$5. All Thordarson products are unconditionally guaranteed. Shipped direct upon receipt of price, if dealer cannot supply.

THORDARSON ELECTRIC MANUFACTURING CO.
Transformer specialists since 1895
WORLD'S OLDEST AND LARGEST EXCLUSIVE TRANSFORMER MAKERS
Chicago, U.S.A.



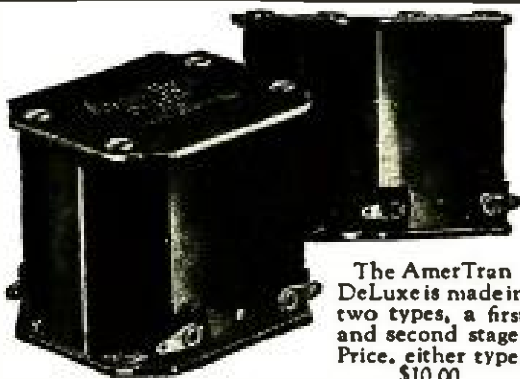

The AmerTran DeLuxe is made in two types, a first and second stage. Price, either type, \$10.00.

A New Standard of Excellence in Audio Amplification

The realism of this new audio transformer is outstanding. Realism of this kind results from the uniform amplification of the fundamental tones of the lower register. The AmerTran DeLuxe makes possible the natural reproduction of not only the Overtones, but all of the transmitted Fundamental tones.



AmerTran Power Transformer type PF-45, Price \$15.00. type PF-52, Price \$18.00.

The AmerChoke type 854 is a choke coil or impedance of general utility. Price \$6.00.



A Good Audio Amplifier

Requires enough plate and grid bias voltage on its tubes to prevent them from being overloaded by the signal voltage.

The AmerTran PF-45 or PF-52 with the half wave high voltage rectifying tubes now available and suitable condensers and resistances—together with three AmerChokes Type 854 will furnish these proper voltages. This combination will give real quality loudspeaker volume. AmerTran Power Transformers also supply A. C. filament current for the last audio tube.

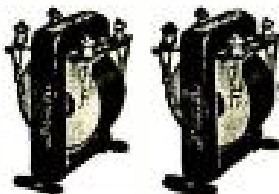

AmerTran Audio Transformers type AF6 (turn Ratio 5) and AF7 (turn ratio 3½) are the leaders in their class. Price, either type, \$5.00.

Write for booklet describing these and other AmerTran Products—with recommendations on their use. It's free on request. All prices are F. O. B. Newark, N. J.

AMERICAN TRANSFORMER CO.
178 Emmet Street, Newark, N. J.
"Transformer builders for over twenty-five years"
Sold Only at Authorized AmerTran Dealers.

CABINET FOR LC-26 RECEIVER



With piano hinge, lid stay and splined mounting board.
Prices: Genuine American Walnut.....\$17.00
Genuine Mahogany 17.00
Mahogany or Walnut Finish..... 14.50

McLAUGHLIN CABINET—panel 10" x 14½"
Walnut or Mahogany\$12.00
Mahogany Finish..... 9.60

HAMMARLUND ROBERTS CABINET
With piano hinge, sloping front and fancy line grooves.
Walnut or Mahogany\$14.00
Mahogany Finish..... 11.50

Cabinets for all popular circuits carried in stock. Shipping charges prepaid.

CORBETT'S CABINETS have been preferred for several years by quality set builders and are unquestionably superior in design and finish. They are backed by our guarantee to please you. Carefully hand rubbed piano finish. Well packed for shipment.

WRITE FOR CATALOG showing attractive models for all sizes of radio cabinets, consoles and tables. Jobbers and Dealers write for discounts.

CORBETT CABINET MFG. COMPANY
St. Marys, Penna.



12-Cell—24 Volt Storage 'B' Battery
Positively given free with each purchase of a WORLD "A" Storage Battery. You must send this ad. with your order. WORLD Batteries are famous for their guaranteed quality and service. Backed by years of successful manufacture and thousands of satisfied users. Equipped with Solid Rubber Case, an insurance against acid and leakage. You save 50 per cent and get a

2-Year Guarantee Bond in Writing
WORLD Battery owners "tell their friends." That's our best proof of performance. Send your order in today.

Solid Rubber Case Radio Batteries
6-Volt, 100-Amperes \$11.25
6-Volt, 120-Amperes 13.25
6-Volt, 140-Amperes 14.00

Solid Rubber Case Auto Batteries
6-Volt, 11-Plate \$11.25
6-Volt, 13-Plate 13.25
12-Volt, 7-Plate 18.00

SEND NO MONEY Just state battery wanted and we will ship day order is received, by Express C. O. D. subject to your examination on arrival. **FREE "B" Battery** included. Extra Offer: 5 per cent discount for cash in full with order. Buy now and get a guaranteed battery at 50 per cent saving to you.

Approved and Listed as Standard by Leading Authorities including Radio News Laboratories, Popular Science Institute of Standards, Popular Radio Laboratories, Radio Broadcast Laboratories, Radio in the Home, and Lefax, Inc.

WORLD BATTERY COMPANY
1219 So. Wabash Ave., Dept. 3 CHICAGO, ILL.

World For AUTO and RADIO
STORAGE BATTERIES



MOBILE - WEAVER - WASH - WES - HULL - RAY - RAY - WOOD - RAY

A New Loud Speaker Principle

—gives you all the thrill of the first row orchestra

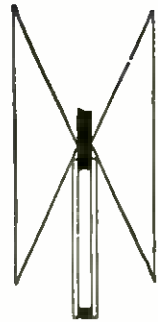

Above is section of the new Acme Free-Edge Cone loud speaker, showing the two free-edge cones.

Now you can get the full joy of radio. Those thin, tinny piano notes, those muffled, nose-holding singers' voices—mere shadows of the living, thrilling originals — are gone forever.

Now by a new principle, that of the "double free-edge cone," the new Acme loud speaker gives you volume reproduction of the human voice and all musical instruments with faithful exactness. It fills and rounds out, puts life, fire, reality into the shadowy phantom voices you have been so accustomed to hearing.

Clear as if You Sat in the "Bald Headed" Row

At home in an arm chair, you can now sit back and enjoy broadcasting as fully as if you were in the famous "bald headed" row. Whether you listen to an operatic selection, or a roaring, howling prize-fight, you get every sound,

every slightest variation of expression that is picked up and broadcast by the microphone. No tense straining to

make out muffled voices—no disappointment. You hear the natural voice speaking—not a megaphone.

After 5 years' effort and the testing of 256 different experimental models, the new Acme "double free-edge cone" loud speaker gives you front row seats at any broadcast entertainment.

One Program Tells the Story

Go to any authorized Acme dealer. Have him tune in on your favorite station. After you have heard one program you'll appreciate far better than words can describe, this new Acme Loud Speaker. Acme Apparatus Company, pioneer radio and transformer engineers and manufacturers, Cambridge, Mass., U. S. A.



The Acme "double free-edge cone" loud speaker. Puts back into the "shadow voice" the living, recognizable, individualistic tones of each speaker. Round model (shown) \$25.



The Acme "double free-edge cone" loud speaker. Puts back into the "shadow voice" the living, recognizable, individualistic tones of each speaker. Cabinet model (shown) \$35.

ACME ~for amplification



TIMBRETONE

REG. U.S. PAT. OFF.

Mindful of the part the Radio Public has played in the past four years and of the confidence placed in Timbretone, we take this opportunity of thanking our many friends.

We have tried to please. We have earnestly striven for the attainment of our aim,—“TIMBRETONE, THE NEAREST APPROACH TO SPEAKER PERFECTION POSSIBLE.” We are still at it;—and we are not going to quit until we have done what we set out to do.”

We have associated with us the firm of Sanford Bros. who have been in business over 25 years and we are proud of the fact that they selected *Timbretone* as the speaker they wanted to represent in the selling field.

The combination means for you—QUALITY—DEPENDABILITY—& SERVICE.



ADDRESS THE NEAREST OFFICE

SANFORD BROS.

CHICAGO
30 W. Walton Pl.

CHATTANOOGA, TENN.
615 Broad St.

SEATTLE, WASH.
Am. Bank Bldg.

SAN FRANCISCO, CAL.
311 Minna St.

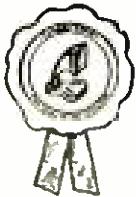

FACTORY

TIMBRETONE MFG. CO., HOOSIC FALLS, N. Y.

22½ Volt
un-acid
everlasting
rechargeable
“B”

Storage
Battery

\$2.95

includes
chemical



45 volts \$5.25, 90 volts \$10.00, 112½ volts \$12.50, 135 volts \$14.75, 157½ volts \$16.80. Truly the biggest buy today. Easily charged on any current including 32 volt systems. Any special detector plate voltage had. Tested and approved by leading authorities such as POPULAR RADIO laboratories. Over 3 years sold on a non-red tape 30 day trial offer with complete refund if not thoroughly satisfied. Further guaranteed 2 years. Knock-down kits at greater savings. Complete “Hawley” “B” Battery charger \$2.75. Sample cell 35c. Order direct—send no money—simply pay the express-man cost on delivery. Or write for my free literature, testimonials and guarantee. Same day shipments.

B. HAWLEY SMITH, 315 Washington Ave.,
Danbury, Conn.



ANTENNA TO SET



TO PROTECTIVE SPARK

ENTIRELY NON-CONDUCTIVE

No. 248

E-5941
Underwriters App.

“Little Joe” Lightning Arrester

Especially designed for Radio Work. Made of Porcelain, small, neat, rugged and serviceable. Can be suspended on antenna or fastened to wall.

Ask Your Dealer

M’f’d by CIRCLE F MFG. CO.
Trenton, New Jersey



The "ORTHOPHASE"

R. J. Griffith's Push-Pull Radio Frequency Circuit

Described in the February issue of POPULAR RADIO

Uses

HAMMARLUND

Straight-Line Frequency
CONDENSERS

Made in All Standard Capacities

Distributes Stations Equally Over the Dials

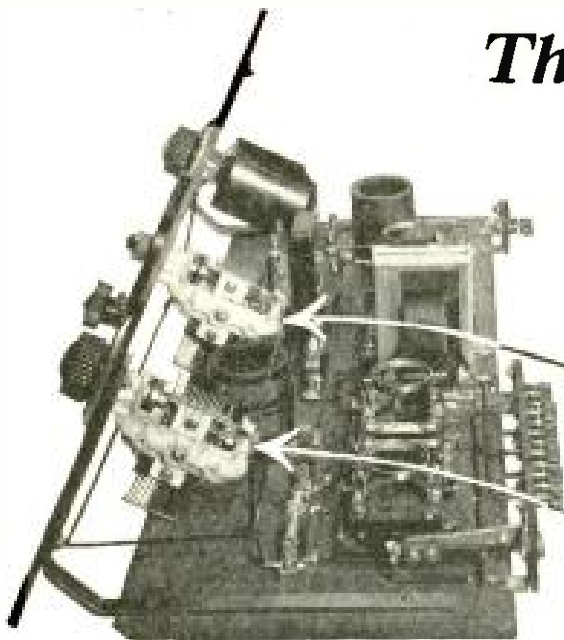
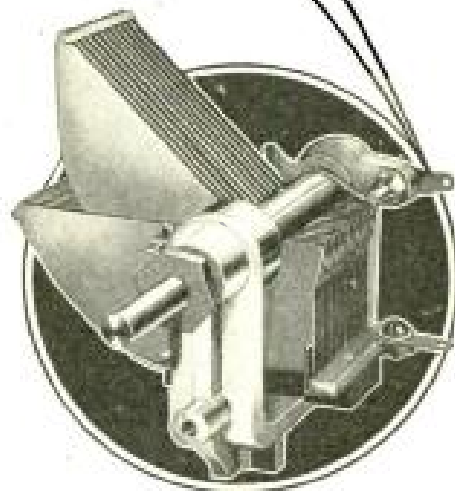

DESIGNERS of new circuit adaptations are extremely careful of the materials they use.

They can ill afford to sponsor any but the best and dare not take chances when presenting a new idea to the radio public for the first time.

During the past year, there have appeared many new circuit arrangements for which Hammarlund Precision Products were specified.

Not because some other good make might not have worked satisfactorily, but because Hammarlund quality insured success.

R. J. Griffith's remarkable push-pull radio-frequency receiver is one of the first of the 1926 developments to employ Hammarlund Precision Products.

Write for Hammarlund Descriptive Literature

HAMMARLUND MANUFACTURING CO.

424-438 W. 33rd Street, New York City

For Better Radio
Hammarlund
PRECISION
PRODUCTS



Here's Work That is Almost ROMANCE!



Many **EARN**
\$50. to \$250.
a week in **RADIO**

Get into the great new BIG-Pay Industry—Radio. If you are earning a penny less than \$50 a week, clip coupon now. Send for AMAZING FREE BOOK. Be a Radio Expert, and draw down big money for the easiest and most fascinating work in the world. Positions everywhere. Need for Radio Experts in every community. Short hours. BIG PAY. Free book gives all the facts.

Learn Quickly and Easily at Home
Master Radio Engineers will show you how to qualify, quickly and easily at home, for Radio's fine jobs. We guarantee to train you successfully. Every day N. R. I.-trained men are taking good places in the Radio field. Thousands of openings now awaiting the trained man.
FREE EMPLOYMENT SERVICE. Many other big features. Get the facts—**CLIP COUPON.**

Get This Free Book

Send coupon below for **FREE BOOK**—“Rich Rewards in Radio.” Read for yourself. No previous experience needed. Common schooling enough. **WRITE NOW.**

Receiving sets, from simplest kind to thousand mile receiver, included to help you learn. An **UNEQUALLED OFFER.** Other special features for limited time only, so **ACT QUICK!**

NATIONAL RADIO INSTITUTE
Dept. CT-8, Washington, D. C.

MAIL COUPON

National Radio Institute, Dept. CT-8, Washington, D. C. Without obligating me in any way please send me your free book, “Rich Rewards in Radio,” also complete information on your practical, home-study Radio course.

Name.....
Address.....
Town..... State.....



“My charges for consultation, \$2.50 per hour. All success due to you.” R. W. Blackhill, Brooklyn.



“Radio a gold mine—your course worth thousands.” A. R. Herke, Winnipeg.

for
radio aerials
—**COPPER**
wire

COPPER combines the essential qualities of—

resistance to corrosion,
tensile strength,
high conductivity.

COPPER & BRASS
RESEARCH ASSOCIATION
25 Broadway, New York

when
you have done everything
to your set and yet you
don't get *Results* - try

AEROVOX

FIXED CONDENSERS

*Tested and approved by M. I. T., Yale, Radio News, Popular Radio and Popular Science. Used by over 200 of America's leading set manufacturers.

Made in all capacities. Also manufacturers of Grid Leaks, Resistors, Resistofomers and Rheostats.

Accuracy plus Quality
Results

AEROVOX WIRELESS CORPORATION
489-491-493 Broome St., New York City
Branch Offices:
Chicago, Ill. 53 W. Jackson Blvd.
Cincinnati, Ohio 304 Palace Theatre Bldg.
Boston Mass. 104 Portland St.
Los Angeles, Cal. 324 No. San Pedro St.

One Tuning Control ~ Calibrated in Meters!

THIS has been accomplished in the Ferguson Model "Eight" without the slightest sacrifice in the efficiency for which Ferguson Receivers have long been famous.

After choosing your program from the evening newspaper, simply turn up its wavelength on the indicator and in comes your station, clear and true!

Three stages of perfectly matched audio enable you to enjoy full loud speaker volume on even the distant stations.

Go to your Authorized Ferguson Dealer and examine the super-craftsmanship of a Ferguson, noting the graceful dignity of the cabinet. Then, hear a comparative demonstration—experience the unrivaled ease of operation—the true tone fidelity—and you will know why the Ferguson has been universally acknowledged to be "The Gold Standard of Radio Receivers."

J. B. FERGUSON, INC.
41 East 42nd Street • New York, N.Y.

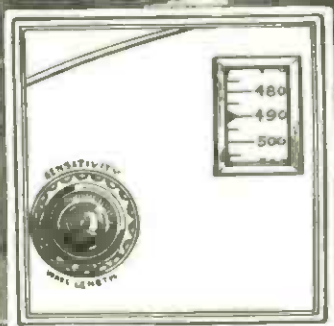

Ferguson

J.B. INCORPORATED

The Gold Standard of Radio Receivers

Prigony

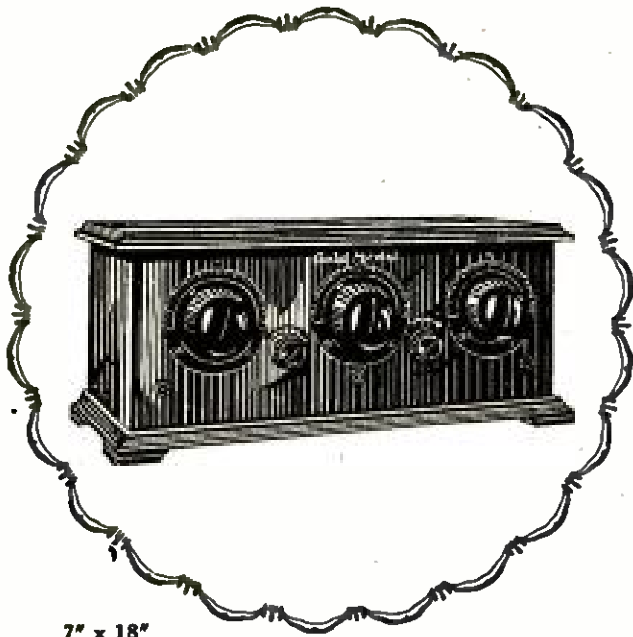

7" x 18"
A Beautiful
Wooden Cabinet

ONLY
\$25

A

Fit for the home of a king—
built for the home of
moderate means.

\$60 Receiver for \$25

The Gold Medal 5-tube tuned radio frequency receiver "that stormed the country!" Manufactured to sell at \$60, now \$25.

Distance, volume, and good tone quality. Guaranteed to operate or money refunded. Send \$25 by money-order or certified check and this fine receiver will be sent express prepaid. Tubes, batteries and speaker extra.

GOLD MEDAL RADIO CORP.

1036 Longwood Ave.

New York City



it's in the Tube

Your receiving set can be no better than its tubes. CECO Tubes give maximum results in clarity of tone, rich volume and long life.

Our charted tests (results confirmed by laboratories of national reputation) PROVE CECO TUBES SUPERIORITY—as detectors, as amplifiers.

Buy CECO Tubes whether your set takes one tube or eight. Now ready! CECO Tubes with new type Long PRONG BASES. Also, power amplifier tubes, E (Dry Cell Type), F (Storage Battery), for last stage of Audio Frequency. Ask your radio dealer.

C. E. Mfg. Co., Inc.
702 Eddy St., Providence, R. I.

CECO
TUBES

Jo-day
-in every
good set!



A turn of the Tuning Dial—that's all!

And presto! The AMPERITE self-adjusting rheostat control does the rest. Tones so clear, voices so distinct, volume so good, you simply are amazed. Tubes deliver as never before when under these seemingly magical influence of AMPERITE individual control. No guessing. Less wiring. Permits of any type or combination of tubes. Specified in all popular construction sets. Price, \$1.10.

There is an AMPERITE for every tube

Write for free hook-ups

Radiall Company

Dept. P.R.-3, 50 Franklin St., N. Y. City

AMPERITE

REG. U.S. PAT. OFF.
The "SELF-ADJUSTING" Rheostat



Unfailing Radio Power from the LIGHT SOCKET with Balkite Radio Power Units

Balkite Radio Power Units give unfailing, uniform current for both circuits from the light socket. One very popular Balkite installation, especially for heavy duty sets where reserve "A" power is required is with the Balkite Battery Charger and Balkite "B." Here the noiseless, high-rate Balkite Battery Charger at \$19.50 is ideal. If your battery should be low, you merely turn on the charger and operate the set. Balkite "B" at \$35 eliminates "B" batteries entirely and supplies plate current from the light socket.

Balkite light socket equipment

Another very popular Balkite installation is with the Balkite Trickle Charger and Balkite "B." The Balkite Trickle Charger at

\$10 converts your "A" battery into an automatic "A" power unit that provides "A" current from the light socket, so that both circuits operate from the lighting circuit. This installation enables you to convert your present receiver into a light socket set.

Noiseless—No bulbs— Permanent

All Balkite Radio Power Units are permanent pieces of equipment, entirely noiseless, have no bulbs, nothing to break, replace or get out of order. Their current consumption is very low. All operate from 110-120 volt AC current, with models for 50, 60 and other cycles. All are tested and listed as standard by the Underwriters' Laboratories.

Sold by radio dealers everywhere. Prices slightly higher West of the Rockies and in Canada.

FANSTEEL Balkite Radio Power Units

BALKITE BATTERY CHARGER • BALKITE TRICKLE CHARGER • BALKITE "B" • BALKITE "B" II

Manufactured by FANSTEEL PRODUCTS COMPANY, Inc., North Chicago, Illinois

Sole Licensees in the United Kingdom: Messrs. Radio

Accessories Ltd., 9-13 Hythe Rd., Wellesden, London, N. W. 10

All apparatus advertised in this magazine has been tested and approved by POPULAR RADIO LABORATORY

TEAR OUT

Radio Institute of America
322-A Broadway, New York City

Please send me full information about your Home Study Course of radio instruction.

I am interested in the complete course, including code instruction, which qualifies for the U. S. Gov't Commercial or Amateur Radio License.

I am interested in the technical course for radio dealers, jobbers and salesmen.

Name

Address

.....

A Shortage of Trained Radio Men!

We can't supply trained radio operators to the shipping companies fast enough!

You can't get better radio training than that offered by Radio Institute of America. Courses planned and Supervised by RCA secure you your 1st Class Commercial Radio Operator's License. And an immediate position awaits every graduate.

Moreover you can study at home in spare time.

The coupon will bring you complete information.

RADIO INSTITUTE OF AMERICA

Formerly Marconi Institute
Established in 1909

322-A Broadway, New York City

More Profits for the PROFESSIONAL Set Builder

WE have an unusually interesting proposition to make to the man who is now building (or has the ability to build) radio receiving sets for resale.

This is a real opportunity. Write to-day for full information.

Gearhart-Schlueter Radio Corp.

714 Voorman Ave.
Fresno, California

DON'T WAIT!



PEP UP THAT SET NOW WITH X-L RADIO PRODUCTS

Just install them in your receiver and hear them speak for themselves
Endorsed by POPULAR RADIO LABORATORY and other leading radio authorities in all the latest circuits

Model "N" Vario Denser

Capacity range 1.8 to 20 micro-micro-farads, for balance in Roberts two tube, Browning-Drake, McMurdo Silver's Knockout, Neutrodyne and tuned radio frequency circuits.
Price \$1.00

Model "G" Vario Denser

For the Cockaday circuits, filter and intermediate frequency tuning in super-heterodyne and positive grid bias in all sets.

G-1- .0002 to .001 MF.
G-5- .0001 to .0005 MF.
G-10- .0003 to .001 MF.

Price Each With Grid Leak Clips, \$1.50

X-L Push Post

A binding post that really does excel in looks, action, service and convenience. Just push it down—insert wire—cannot jar loose from vibration. No screwing or danger of shearing off wires. Furnished attractively plated with soldering lug and necessary markings.

Price Each 15 Cents



X-L RADIO LABORATORIES
2422 Lincoln Ave. CHICAGO



Complete Radio Panels in the Most Attractive Designs

DESIGNS and decoration in any art style may be applied to Formica panels by the Veri-Chrome process. This year will see the introduction of new decoration of remarkable attractiveness.

The Veri-Chrome process, patented and controlled by the Formica Insulation Company is proving so much more adaptable from the production point of view; it is producing panels of so much finer appearance, that it promises to supersede other methods of panel decoration and marking.

Because of its permanent finish and immunity to atmospheric and other conditions, Formica provides the most lasting and desirable front for a radio set. It is evidence of the highest quality.

Completely decorated panels are offered amateur set builders who put together certain well known kits: Bremer Tully, Counterphase, Nameless and No. 1; Best's Superheterodyne in two sizes, 7x20 and 7x26, Browning Drake kit of the National Co., and the Marco Browning Drake Kit.

Write for prices and literature.

THE FORMICA INSULATION CO.
4641 Spring Grove Avenue, Cincinnati, O.

FORMICA

Made from Anhydrous Bakelite Resins
SHEETS TUBES RODS

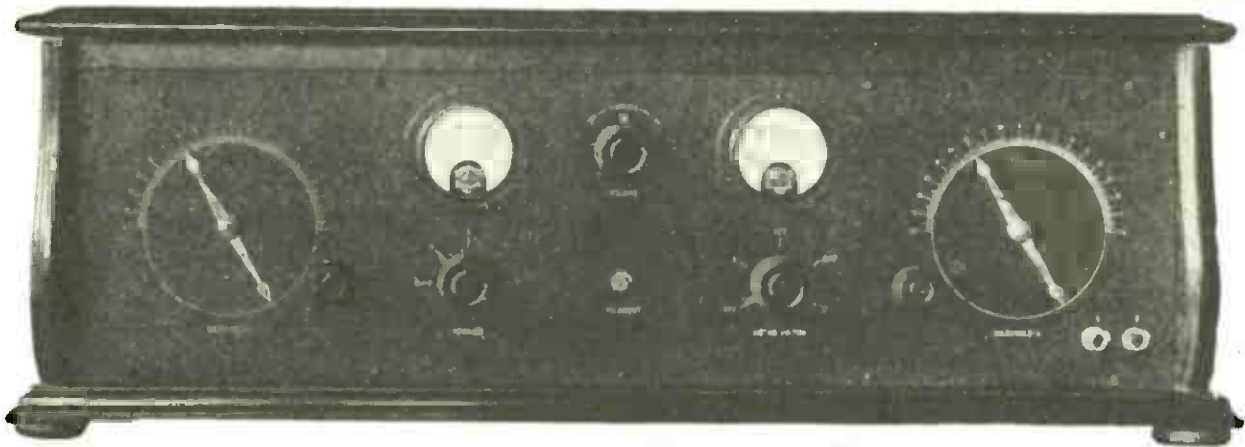

The Best in the World

No Batteries

are required even to operate the most powerful 10-tube receiver.

We have experimented with many types of "Eliminators" and now recommend without qualification the

Model A Power Unit

One Customer Telegraphs:

"Receiver assembled, performing like a thoroughbred."

The Amateur or Experimenter with his ultra-modern high-powered receiver is years ahead of Commercial Radio.

It is significant that unsolicited testimonials are constantly being received from even the far corners of the earth, where Norden-Hauck Engineers have furnished the finest radio apparatus known to the art today.

Quotations gladly furnished on radio parts and apparatus having non-infringing uses.

Write for Literature

NORDEN-HAUCK, INC.

Engineers

1617 Chestnut Street, Philadelphia, Penna.

FIXED RESISTORS

Micamold

REG. **FIXED CONDENSERS**

"Made of Mica and Moulded in genuine Bakelite"

With Micamold Resistors and Condensers you need no clips or mounts—just solder direct to the terminals, thus eliminating point or loose contact and accidental dislodgment of the units.

Micamold Products are moulded in genuine Bakelite and guaranteed within 5% of calibrations and constant in value. They are noiseless, moistureproof and indestructible.

At all good Radio Stores

MICAMOLD RADIO CORP.
Flushing and Porter Aves., Brooklyn, N.Y.

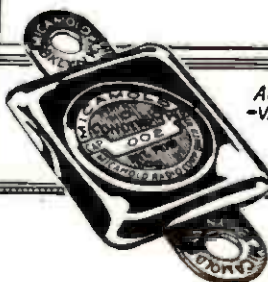

ACCURACY GUARANTEED
-VALUES REMAIN CONSTANT

MOULDED UNDER PRESSURE OF 50 TONS



KORACH

Tuned Loop
Multiple Switch Board Tuner
Directional
Base Compass for Logging
Collapsible

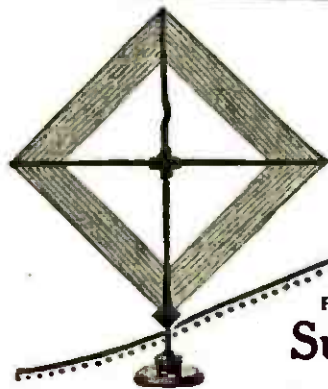

For those who demand
Superior Results

Leads the march toward perfect radio reception under all conditions. Not merely a "loop" but an ingenious arrangement of mechanical skill designed for superior results. L. M. Cockaday, using this loop, reached out across the Atlantic to audibly hear many trans-continental Stations.

Selectivity Plus Distance

unheard of with common loop aerials. The Korach excels on all sets designed for loop reception. Priced at \$12.50 and for sale by all good dealers. Full particulars sent for 2c stamp and name of local dealer.

KORACH RADIO CO.

20 E. JACKSON BLVD. Dept. 10 CHICAGO, ILL.

Dealers and Jobbers: Write today for attractive proposition

THE KORACH JUNIOR

A modification of the "Senior" but possessing all its important features - - - \$10.00

Let the Pure Tones Through



Make Your Old Set A 1926 Model!

The Daven Super-Amplifier used with any set or circuit carries through the full, clear tones of the broadcasting station programs. If you prefer to assemble the Amplifier, obtain the Daven 3-stage Kit, which includes all parts except sockets.

PURE tones, beautifully clear and full, go out from the broadcasting station. They reach your detector still pure and clear. But what then?

From the detector your amplifying apparatus operates. Distortion arises unless you take advantage of a method of amplifying that far-sighted manufacturers and thousands of set builders are now adopting—Resistance Coupled Amplification. Resistance Coupling is not new, but *Resistance Coupling with real volume amplification is new.* It is the most approved method of letting pure tones through.



The new Daven Special Coupling Condenser Type "A", for Resistance Coupled Amplification, sold separately and also included in all Daven Amplifiers, Kits and Resisto-Couplers. For greater volume and better quality.

The Daven Super-Amplifier costs little. It is easily and conveniently installed in any set made. Buy it complete to save hook-up labor. For those preferring to assemble, the Daven 3-stage Kit gives all the necessary parts except sockets. You will join hundreds of others who have written to thank us for the improvement Daven has given.

Write us today for The Resistor Manual, an authoritative book on Resistance Coupled Amplification, 25c at good dealers, 30c by mail.

DAVEN PRODUCTS ARE SOLD ONLY BY GOOD DEALERS

"The Sine of Merit"

DAVEN RADIO CORPORATION

Resistor Specialists

Newark

Reg. U. S. Pat. Off.

New Jersey



The new Daven High MU Tube Type MU-20, used with the Daven Super-Amplifier, gives 50% more volume—6 volt, 1/4 ampere. A Daven Power Tube Type MU-6 in the last or output stage helps any set regardless of the method of amplification—6 volt, 1/2 ampere.



THE RESISTOR MANUAL is the handbook of Resistance Coupled Amplification. At your dealer's 25c. By mail postpaid 30c.

CLIP THIS COUPON

DAVEN RADIO CORPORATION
153 Summit Street, Newark, New Jersey

Please send me the following on Resistance Coupled Amplifications
Check One

- Resistor Manual. 30c is enclosed.
- Complete Catalog (free).

Name.....

Address.....

For Dealers: Send your letterhead and we will have our nearest distributor communicate with you.

THE BIG LITTLE THINGS OF RADIO

All apparatus advertised in this magazine has been tested and approved by POPULAR RADIO LABORATORY



It says
“Stop”
 and lightning won't harm
 your set

The National Board of Fire Underwriters specify that an approved Radio Lightning Arrester *must* be used with all out-door aerial installations.

Protection is easy. Insure your insurance and save your set with a **WIRT LIGHTNING ARRESTER** (listed as standard by the Underwriters Laboratories). The cost is a trifle.

THE WIRT LIGHTNING ARRESTER is an approved air gap type, made of bakelite giving ample insulation, with brass terminals moulded in bakelite, far enough apart so that there is no leakage. A "petticoat" of bakelite shields the arrester from water and dust. Handsome and rigid. Lasts a lifetime. Easy to install. Full directions on box.

When you install your **WIRT LIGHTNING ARRESTER**, get a **WIRT INSULATOR** and prevent leakage along your lead-in wires. It keeps the wire at the proper distance, provides perfect insulation, and prevents wear and tear on the wire by preventing sagging and swaying.

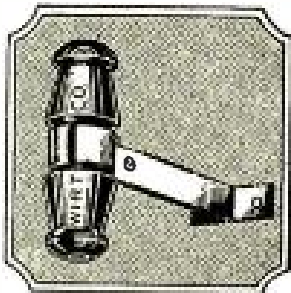

THE WIRT LIGHTNING ARRESTER IS LISTED AS STANDARD BY THE UNDERWRITERS LABORATORIES.

WIRT LIGHTNING ARRESTER.....\$1.00
WIRT INSULATOR..... .35

Sold by leading Radio dealers

WIRT COMPANY
 PHILADELPHIA PENNSYLVANIA
 Makers of Dim-A-Lite

Steinite LOW LOSS Interference Eliminator

No Radio Set Complete Without It

Now you can select stations at will, cut out interference and undesired stations—tune in loud and clear. **Wonderful results with any tube or crystal set using any kind of aerial except loop antenna.** Partially absorbs static.

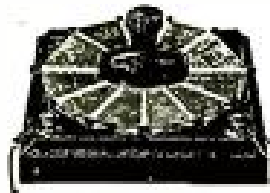

\$1 Amazing Results, Better Reception Guaranteed or We Refund Your Dollar. Send Order Today. Post-paid

Select Stations At Will

Try this Interference Eliminator on your set—no tools—nothing to add—attached in 2 minutes to aerial. Doesn't disturb present log. Directions easy to follow. Two big banks testify to our reliability. Order today—dollar bill will do—we take the risk—money back if you say so.

STEINITE LABORATORIES
 301 Radio Building, ATCHISON, KANSAS
 Five Tube Set - \$29.75

Write for complete Steinite Radio literature—it's FREE. Most beautiful and least expensive radio sets in America.

Premier B Battery Cabinet

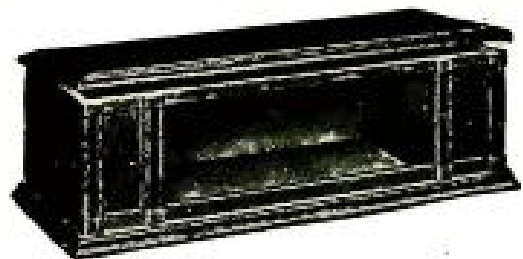

Our Premier B Battery Cabinet is a beautiful piece of furniture. The B battery compartment will take any type B battery. The space of each B battery compartment is 4 1/2" wide, 8 1/2" high and 10" deep.

No.	For Panel	Deep	Genuine Walnut
718-10	7 x 18	10"	\$18.50
721-10	7 x 21	10"	19.00
724-10	7 x 24	10"	19.50
726-10	7 x 26	10"	20.00
728-10	7 x 28	10"	21.00
730-10	7 x 30	10"	22.00

F.O.B. Waukesha, Wis.

The tops of these cabinets are figured walnut, the ends and B battery panels are select walnut, all 5 ply veneer. The bases are built up of massive molding. Nickel plated piano hinges and lid holders. The material and finish in these cabinets will equal the best furniture obtainable.

WE MAKE 9 STYLES OF CABINETS FOR 14 SIZES OF PANELS. Send for our 1925-26 line of cabinets at "Factory to User" prices.

Utility Cabinet Company

Phone 721

Waukesha, Wisconsin

Announcing RADIO CENTER

FOR the first time in the history of the industry, radio manufacturers can now enjoy year-round demonstration and sales facilities of unequalled attractiveness in the heart of the world's greatest radio market—New York City.

Sound-proof booths of special construction—a location where unusual clarity of reception can be had from any of the well-known broadcasting stations—every facility for the efficient transaction of business—conference rooms—a radio laboratory—these are but a few of the unique advantages provided at Radio Center.

Occupying two floors of more than twenty thousand square feet in the famous Bush Building, 42nd Street, Radio Center is superbly situated for all-round accessibility—and its patrons enjoy the unequalled Bush Terminal Distribution service.

Radio Center is the big move of the year—directed by men of wide experience in successful co-operative merchandising, and backed by ample financial strength.

The demand for space is already large—the time to investigate is NOW—call in person if you possibly can—write, or better still, wire for a copy of the Radio Center Book.

RADIO CENTER, INC.

S. Herbert Mapes, President

BUSH BUILDING

130 West Forty-second Street
New York City

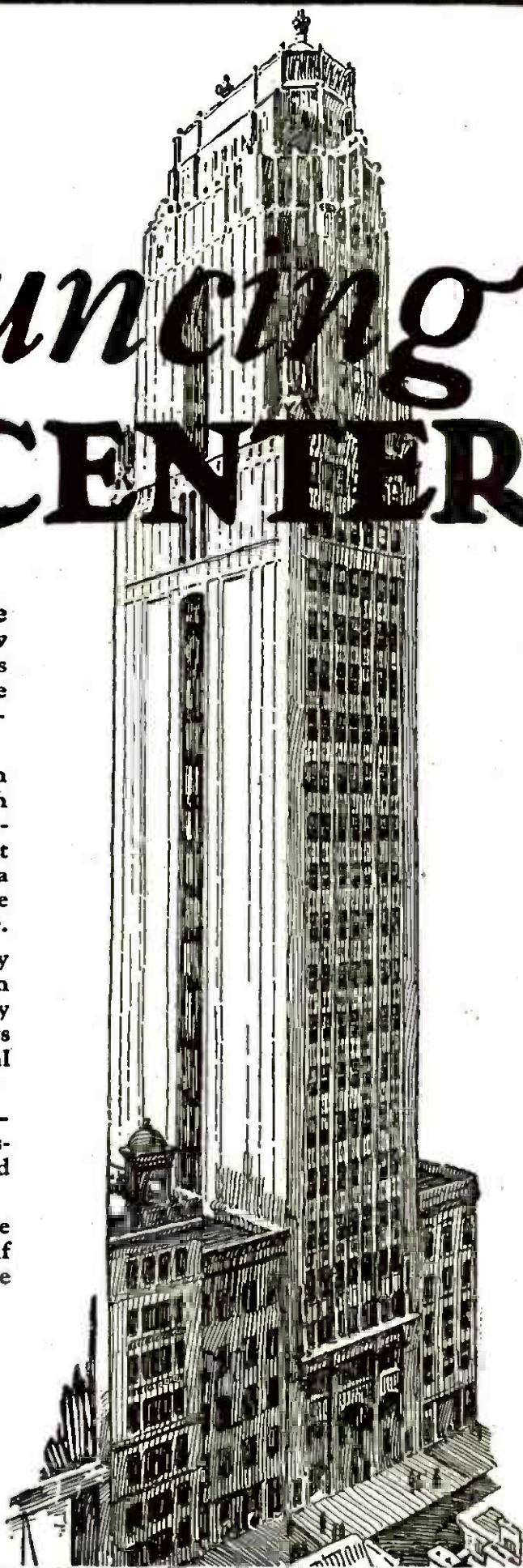

AMPLION

Product of
38 Years'
Experience



For Better Radio
Reproduction

"I have listened to many loud speakers, but never to any music which can compare with that reproduced by the Amplion. The sound is clear, sweet and well modulated. It brings in clearly instruments in bands and orchestras that were lost in other speakers. Through my Amplion I enjoy my radio to a degree I had never thought possible."

You will be as appreciative as this gentleman, once you hear your set through an Amplion. Creation of the originators and oldest makers of loud speaking devices—Alfred Graham & Co., London, England—The Amplion leads in popularity throughout the world.

Enjoy an Amplion demonstration at your dealer's. Six models, including phonograph units, equipped with cords and panel plugs, \$12 up. Write for the "Amplion Pedigree."

**THE AMPLION CORPORATION
OF AMERICA**

Suite X, 280 Madison Ave., New York City
Chicago Branch: 27-29 N. Morgan St.
Burndept of Canada, Ltd., Toronto

New!

Every Radiola 25 or 28 Owner
Should Have This
Tube Saver and
Aid to Better Reception

If your set is a Radiola 25 or 28 you can obtain the best results only by correct adjustment—measuring your tube filament voltage to exactly 3.0 volts.
Get the new Sterling Voltmeter especially designed for Radiolas 25 and 28. Handy—no leads to fuss with—plugs right into the set. Save tubes, betters reception.
Ask your R. C. A. dealer or write our factory for details

PRICE \$7.50

Sterling

R25-28 Filament Voltmeter

THE STERLING MANUFACTURING CO.
Dept. G Cleveland, Ohio

Every Radio Fan
should have this book
JUST OUT—514 PAGES

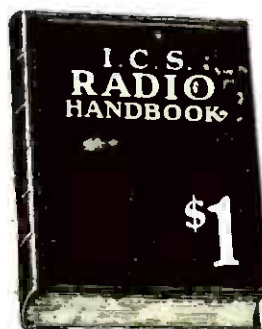

Compiled by
HARRY F. DART, E.E.
Formerly with the Western Electric Co., and U. S. Army Instructor of Radio.

Technically edited by F. H. Doane
NO MORE need you turn from book to book, hoping to find what you want. It is all here, in 514 pages crammed full of every possible radio detail. Written in plain language, by engineers for laymen. 100,000 sold.

IT EXPLAINS: Electrical terms and circuits, antennas, batteries, generators and motors, electron (vacuum) tubes, many receiving hook-ups, radio and audio frequency amplification, broadcast and commercial transmitters and receivers, super-regeneration, codes, etc.

Send \$1 today and get this 514-page I. C. S. Radio Handbook
—the biggest value in radio today

INTERNATIONAL CORRESPONDENCE SCHOOLS
Box 8252-G, Scranton, Penna.

I enclose One Dollar. Please send me—post-paid—the 514-page I. C. S. Radio Handbook. It is understood that if I am not entirely satisfied I may return this book within five days and you will refund my money.

Name.....

Address.....

Check here and enclose \$1.50 if you wish the De Luxe edition bound in Leatheroid.

RADIO 'RITHMETIC



Multiply distance by adding a *RECTIGON*

A SIMPLE solution for so big a result! Want band music? Try KDKA. Jazz? Theatricals? Maybe you'll find it at WBZ, KYW or KFKX. What your local stations won't provide can be obtained easily from somewhere else.

How well you receive radio entertainment depends upon the condition of your batteries — *and that's up to you.* With a Westing-

house Rectigon on the job both your "A" and "B" batteries can be kept fully alive to the greatest possibilities of your set.

And it's easy as can be. Just snap on the leads and turn on the current. There's no muss or fuss; no acids; no chemicals, and no noise. The Rectigon more than pays for itself within a short time.

WESTINGHOUSE ELECTRIC & MANUFACTURING CO.

SOUTH BEND, IND.

The Westinghouse Rectigon Battery Charger

No storage-battery radio is complete without a **RECTIGON.**



© 1928.
W. E. & M. Co.

Westinghouse manufactures, also, a complete line of Micarta radio panels, Micarta tubes and instruments.



Sickles Coil Set No. 24 for Browning-Drake Circuit. Price \$7.50.

SICKLES

DIAMOND-WEAVE COILS

(Trade Mark registered Aug. 4, 1925)

For Browning-Drake, Roberts, Craig, Aristocrat and Hoyt Circuits

(Patented Aug. 21, 1923)

The Sickles No. 18 A coil combination is designed specifically for the Roberts Reflex and other reflex circuits using neutralized radio frequency amplification, combined with regeneration controlled by a movable tickler.

The No. 25 coil combination is built for the Aristocrat Circuit, and it will also work admirably in all of the universal circuits using tuned radio frequency amplification, neutralized by the Rice Method and combined with regeneration.

Send for descriptive catalog

The F. W. Sickles Co.

134 Union Street

SPRINGFIELD, MASS.

COIL PRICES

No. 18A Roberts Circuit	\$ 8.00 set
No. 24 Browning-Drake	7.50 set
No. 20 Craig Circuit	4.50 set
No. 19 Acme Reflex	4.50 set
No. 8 Knockout Reflex	4.00 set
No. 21 Hoyt Circuit	10.00 set
No. 25 Aristocrat Circuit	8.00 set

—a distinct innovation in the capacity unit field

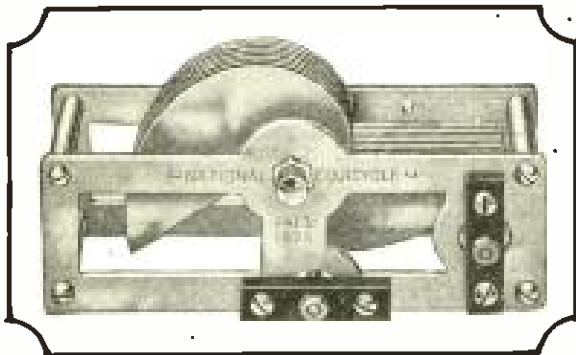

The New NATIONAL EQUICYCLE Condenser

(Patented Feb. 10, 1925)

The latest development in straight line frequency control as applied to NATIONAL CONDENSER design.

Increases range of rotation from 180° to 270°, permitting more precise adjustment and sharper separation of stations. And accomplishes this without gears, cams or levers.

It has the same electrical efficiency and mechanical ruggedness that have always characterized NATIONAL DX Condensers. Prices:

Made in Two Sizes	With Dials	Without Dials
.0005	\$7.00	\$5.00
.00025	7.50	5.50

Get the genuine. Insist upon NATIONALS. Your dealer appreciates your patronage and will gladly get them for you. Write for Bulletin 111 PR.

NATIONAL COMPANY, INC.

W. A. READY, President

110 Brookline Street Cambridge, Mass.

Wonderful Volume with Clearness AMPL-TONE



\$3.00

Phonograph makers have spent years perfecting the acoustic properties of their phonographs. Use an AMPL-TONE Unit and make a real Loud Speaker in an instant or use it in your horn and get better results.

After all, speakers are as good as their unit. We make a real unit at a real price. Money gladly returned if you are not entirely satisfied.

The UNION FABRIC CO.
DERBY, CONN.

Makers of the Excellent French AMPL-TONE Headset
Please send me an AMPL-TONE Unit for which I enclose \$3.00.

Name

Address

State

The Mystery Receiver

CHARLES LEUTZ'S LATEST EPIC



THE UNIVERSAL SUPER-8

LICENSED UNDER HOGAN PAT. 1,014,002

*Tunes all Wavelengths from 35 to
3600 Meters*

The Universal Super 8, "The Mystery Receiver," is an improved design of the Universal Plio 6, but does not by any means supersede the Universal Plio 6, which is still continued and which is the leading broadcast receiver in its sphere. The Universal Super 8, however, is an advancement in that while it retains all the salient features of the Universal Plio 6, adds some new desirable features, making it the highest grade set possible to produce

- (1) Meters are provided to read the battery voltages.
- (2) A special antenna coupling circuit is provided to reduce interference and static.
- (3) Geared verniers are provided on the tuning controls.
- (4) Metallic shieldings provided at points deemed advisable.
- (5) Seven tubes are used to give still greater volume and fine tone musical reproduction.
- (6) All the important component parts are encased in a metal container, and factory sealed to prevent any damage and to prevent competitors from copying the new features.
- (7) We believe it is impossible to trace the circuit and design by taking this receiver apart outside of our factory.

The exact function of the seven tubes of the Universal Super 8 is not revealed at this time as the manufacturers desire to keep all details a secret until full patent protection is afforded. Full operating instructions are supplied with each Universal Super 8, however. Patents are applied for covering some of the features of the Universal Super 8.

Either the old or the new type tubes are used in the Universal Super 8, and special provision is made for bias batteries, specified by some tube manufacturers.

Obviously this receiver will not be made on a large production scale, due to the time needed in building each one individually. Orders are now being taken on a custom-made basis as each set is laboratory tested in Long Island by an expert radio engineer to insure its perfection.

It is believed that the new design embodied in the Universal Super 8 gives the finest musical reproduction, tune, selectivity, audibility and maximum range that can be obtained by any receiver using seven tubes. Judging from the interest in our other multiple tube receivers, we believe the demand for this new design is going to tax our capacity the year around, and, as above stated, orders are now being taken in rotation. Prices quoted on application.

This receiver is not regenerative and is not a super-heterodyne.

WRITE OR WIRE

GOLDEN - LEUTZ INC.

VAMOS BUILDING

6th & Washington Aves. Long Island City, N. Y.

Cable "Experinfo"

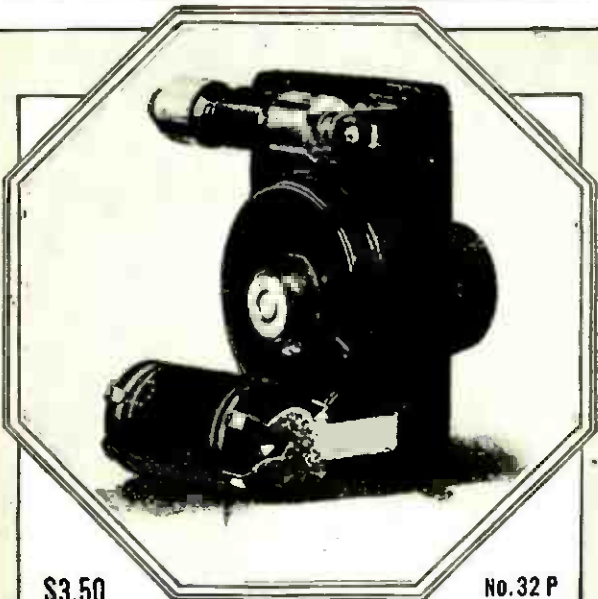

\$3.50
IN U. S.
(WITHOUT DRY CELL)

No. 32 P

Banish Detector Troubles with The Carborundum Stabilizing Detector Unit

BY a turn of the knob on the stabilizer you adjust the detector impedance to best suit operating conditions.

You can materially reduce the detector circuit damping, thus giving increased selectivity—sharper tuning.

With this stabilizing unit you get the most efficient rectification—resulting in increased sensitivity—greater volume.

It's a simple device that solves all detector troubles.

Comes equipped with genuine, fixed Carborundum Detector. An ordinary flash-light cell for booster voltage completes the unit.

You can get the fixed, permanent Carborundum Detector alone for \$1.50

YOUR DEALER OR DIRECT
Send for Descriptive Circular Showing Hookups

THE CARBORUNDUM COMPANY
NIAGARA FALLS, N. Y.

New York Chicago Boston Philadelphia
Cleveland Detroit Cincinnati
Pittsburgh Milwaukee Grand Rapids



"A Better Condenser"

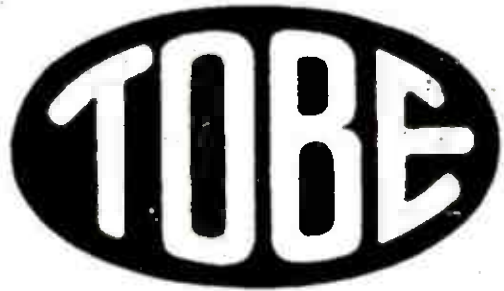

The TOBE DEUTSCHMANN High-Voltage Bi-Pass Condenser in its silvered, shielded metal case is designed for all usual by-pass work in radio receiving-sets, and for construction of "B" eliminators of the Raytheon and other types.

0.10 Mfd.....	\$0.60	0.5 Mfd.....	\$0.75
0.25 Mfd.....	0.70	1.0 Mfd.....	0.90
		2.0 Mfd.....	\$1.75

We announce a new TOBE High-Voltage Filter Condenser for strictly filter uses, for power amplifiers and other high-tension work up to 750 volts. Each of these is individually tested and stamped with date of test. Accuracy is guaranteed to within 5% of rating. Put up in heavy metal cases and recommended for precision work. Prices are the same as our former list on filter-condensers.

The new TOBE "B" BLOCK is out, for "B" eliminator construction, with one 8 Mfd., two 2 Mfd., and two 1 Mfd. condensers in one case. Saves \$2.50 over cost of separate units.—saves space.—saves wiring.

Send for free eliminator diagrams

TOBE DEUTSCHMANN CO.
Cornhill, Boston, Mass.

FREE RADIO CATALOG

WRITE for a copy of our NEW 100-Page Radio Catalog — Parts, Accessories—Kits—Sets—Everything for the Fan.

DEPT. PR

CHICAGO SALVAGE STOCK STORES

509 S. State Street CHICAGO, U. S. A.



Health and happiness through radio



Each morning, young and old everywhere are adding to their store of health by doing the setting-up exercises broadcasted from many stations. Each evening radio adds to their pleasure and happiness through the dance programs.



In developing receiving sets that make the benefits of radio broadcast reception practical for everyone, radio engineers have found Bakelite to be superior for a great variety of radio parts—particularly those that are vital to clear reception and true tonal quality.

Bakelite is the preferred material for panels, dials, knobs, condensers, tube sockets and tube bases, plugs, rheostats and for

other radio devices including speakers. In fact, 95% of radio set and parts manufacturers use Bakelite as they have found that its permanently high insulation value, its strength, its lasting color and finish, its immunity to injury through exposure to heat or moisture, make it superior for radio use.

It is always best to make sure that the radio set or parts that you buy are Bakelite insulated.

Write for Booklet 28

BAKELITE CORPORATION
247 Park Avenue, New York, N. Y.
Chicago Office: 636 West 22nd St.
BAKELITE CORP. OF CANADA Ltd.
163 Dufferin St., Toronto, Ontario, Can.



BAKELITE

REGISTERED U. S. PAT. OFF.



THE MATERIAL OF A THOUSAND USES

"The registered Trade Mark and Symbol shown above may be used only on products made from materials manufactured by Bakelite Corporation. Under the capital 'B' is the numerical sign for infinity, or unlimited quantity. It symbolizes the infinite number of present and future uses of Bakelite Corporation's products."

All apparatus advertised in this magazine has been tested and approved by POPULAR RADIO LABORATORY

“and even the distant stations now come in loud and clear”

A UX POWER TUBE

will increase volume and clarity in YOUR set, too!

REWIRING UNNECESSARY

NOTE: Both the UX-120 tube, which has been designed to increase volume and clarity in all dry battery sets and the UX-112 tube designed to increase volume and clarity in storage battery sets, can be easily applied to any set by the use of a Na-Ald Adapter or Connectorald as shown below.



How to Improve Sets Equipped with UV-199 Tubes
To increase volume and clarity in sets using UV-199 tubes, use the UX-120 tube in the last stage. Easily fitted to the UV-199 socket with a Na-Ald No. 920 Connectorald which also provides cables for attaching necessary extra B and C batteries. Price, \$1.25.

How to Switch to Dry Batteries Without Sacrificing Volume or Quality

A UX-120 tube for the last stage with UX-199 tubes in the other sockets provides with dry cells, results previously obtained only with storage batteries. Fit UX-120 tube to the UV-201-A Socket with Na-Ald Connectorald No. 120. Cables provided for attaching extra B and C batteries. Fit UX-199 tubes in all other sockets with Na-Ald No. 419-X adapters. Price, No. 120, Connectorald, \$1.25; No. 419-X Adapter, 35c.

How to Improve Storage Battery Sets

Volume and clarity can be increased in storage battery sets by using the UX-112 tube in the last stage. Easily fitted to the UV-201-A socket with Na-Ald No. 112 Connectorald which provides cables for attaching necessary extra B and C batteries. Price, \$1.25. Mail coupon below for complete adapter information covering use of new tubes in all sets.



No. 120 Connectorald
Dept. C 13
Springfield, Mass.

All Na-Ald Sockets, Dials and Adapters are protected by patents. Many patents pending.

ALDEN MANUFACTURING COMPANY



ALDEN MFG. CO.,
Dept. C 13, Springfield, Mass.
Please send me complete information on how to increase volume and clarity in any set by the use of the new tubes.

Name.....
Street.....
City..... State.....

PROVED BY PERFORMANCE!



TRF Kit
\$12.00

AERO COILS

This season—thousands more fans found the answer to complete radio satisfaction thru Aero Coils. Selectivity! Distance! Power! All these—to a degree not yet even approached by any other inductances. And simply because the Aero Coil is patented—both in principle and in construction. Any set—any circuit is greatly improved by substituting these wonder inductances for those you are now using. At your dealers.

Write for free Aero Booklet!

- CT-80 Three Circuit Tuner..... \$8.00
(Variable Primary)
- TRF-110 Radio Frequency Regenerative Kit..... 11.00
- WT-40 Wave Trap Coll..... 4.00
- OS-55 Oscillator..... 5.50
- AX-45 Antenna Coupler..... 4.50
(Variable Primary)

AERO PRODUCTS, INC.

217 N. Desplaines St.

Chicago

Get This Big Western Radio Catalog

NEW
1925-1926
EDITION

DEALERS, send for our big live catalog. Contains nationally advertised high quality sets, kits and parts. Use your letterhead.



Western Radio MFG CO.
134 W. Lake St. Chicago, Ill.

The PERRY TRANSFORMER is used in the new 3-Tube Four Circuit Tuner as designed by Mr. Cockaday



PERRY engineers have finally succeeded in developing a new transformer incorporating an adequate core to prevent saturation. This new development plus several simplified steps in transformer design enables you to produce all the actual tones that the ear can hear from the lowest to the highest, with a transformer at a moderate price. And you hear the actual tones, not the harmonics. An organ is an organ and a piccolo is a piccolo with a Perry in your set.

Perry transformers can be used in practically every circuit. If you are building a new receiver or if you have an old one that does not give you satisfactory reproduction, you will find that installation of these new transformers will remedy the old trouble of distortion and small volume.

Perry transformers may be used in pairs, or used alone followed by one or two stages of resistance-coupled amplification. Ratio $3\frac{1}{4}$ to 1. Price each \$6.

PERRY WIRE WORKS

Manufacturers of Transformers, Rheostat and Potentiometer Windings
YONKERS NEW YORK

Attractive propositions open for jobbers.

DEALERS — Write for discounts and information.

THE BIG
NEW

TRANSFORMER

Perry

INTERESTING DATA

The curve shown at the right is reproduced from an actual curve made in testing the Perry Transformer. You will note that it is almost a straight

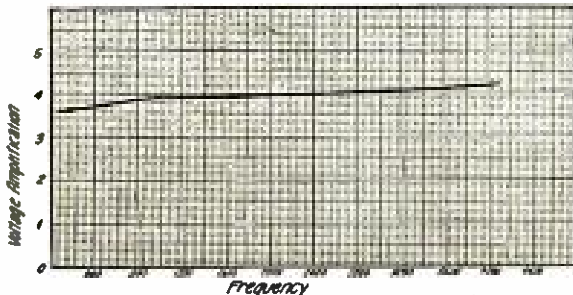

FOR THE ENGINEER

line from 40 cycles to 4000 cycles. You get the actual tones, high or low, almost to the limit of human hearing.

Protects



against leaks and losses

THE utmost possible protection against leaks and losses in the circuit is afforded by Radion—*The Supreme Insulation*.

Radion Panels reduce surface leakage and dielectric absorption to a minimum. Their beautiful surface finish adds to the attractiveness of any set. Radion Dials match their beauty of finish and help to get close tuning. Radion Sockets reduce capacity effects.

Radio dealers have the complete line of Radion low-loss parts. Manufacturers will find it to their interest to write us for prices on moulded parts. Send for catalog.

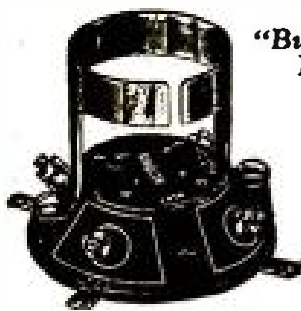

No. 2 Radion Socket for new UX tubes, with collar adapter for old-type tubes. No. 4 same as No. 2, without collar adapter, for new UX tubes exclusively.

FREE Booklet,
"Building Your Own Set"
Mailed on Request

**AMERICAN
HARD RUBBER
COMPANY**
Dept. B 15
11 Mercer St.
New York City

Chicago Office:
Conway Building

Pacific Coast Agent:
Goodyear Rubber Co.
San Francisco
Portland

RADION

The Supreme Insulation

Made to order exclusively for radio purposes



Cat. No. 251B.
.00035 Mfd. Max..
Price \$3.50
Cat. No. 251C.
.0005 Mfd. Max..
Price \$4.50

Supreme Selectivity!

THIS TRUE Straight Line Frequency Condenser—perfected by Pacent Engineers—will amazingly improve the selectivity of any set. Sturdily built. Electrically and mechanically right—meeting all requirements of low loss design. Mount this real Straight Line Frequency Condenser in your set **TONIGHT** and experience the joy of quick, certain tuning!

AT YOUR DEALER or
Write for booklet "Pacent Radio Essentials"

Pacent Electric Company, Inc.
91 Seventh Ave., New York City

Hoyt

RADIO ROTARY METER



Price
\$24.00

This unique meter will do all testing necessary on Radio receiving sets, tubes, batteries and battery eliminators. It furnishes the experimenter and Radio dealer with a single instrument with five different ranges, reading from as low as $\frac{1}{4}$ mil-ampere or 1.8 volt to 7.5 milamperes or 150 volts. Operation is simple and accident-proof.

BURTON-ROGERS CO.
26 Brighton Ave. Boston, Mass.
National Distributors



DON'T APOLOGIZE

WHAT a feeling that is,—isn't it? All the neighbors and the wife gathered round to hear you make good on that crack—that you got "MIAMI" last night. ¶ And you work and sweat and pray with a net result of many squaks, a few whistles and finally hear a few remarks, from your local broadcasting station ten miles away, for the relief of the suffering South Sea Islanders. It's awful. ¶ Good Tubes are the answer to many radio troubles—the great majority of the sets are good—the hookup in most cases is very simple—but you must rely on your tubes to do the work—and that's where Sylvania comes in. ¶ Sylvania Tubes are Good Tubes—no higher in price—they are excelled by none in quality, performance and life. ¶ Try this better tube—it will please you as it has thousands of others—and amaze you, too, with the results you will get.

At your dealers or write us direct.



Sylvania

Radio Tubes



SYLVANIA PRODUCTS COMPANY
Emporium, Pennsylvania

"THERE'S A SYLVANIA FOR EVERY TUBE APPLICATION"

All apparatus advertised in this magazine has been tested and approved by POPULAR RADIO LABORATORY

Another WESTON Radio Contribution



Model 506 Voltmeter and Universal Bi-Polar Switch

FOR *unusual* radio results, for economy and for positive set control, we announce this unique Weston combination of panel Voltmeter and Switch.

Just a twist of the Bi-Polar Switch and you instantly and accurately make a complete electrical check on your radio set regardless of make!

Obvious operating advantages lie in quick and positive knowledge of all voltage conditions as read on this double scale (140/7 volts) Voltmeter.

By placing a Weston Model 506 Voltmeter and a Multi-Point Switch on the panel of your set you insure the use of tubes at proper filament voltages, you can constantly check battery conditions and get the best results.

Typical of its value is its use on a five-tube neutrodyne—you can regulate the filament voltages of: the Radio Frequency Tubes, Detector Tube, the First and Second Audio Frequency Tubes, and check the voltage of the "A" and "C" Batteries, the detector "B" and Amplifier "B" Batteries.

Weston quality Radio Instruments lead in the radio field as in every other electrical outlet in commerce, industry and research. The name Weston is a guarantee of quality and satisfaction.

For complete information on this new 506 and switch combination write for Circular "N"

Western Electrical Instrument Corporation
115 Weston Avenue, Newark, N. J.



THE PARTS

the dealer sold you—

You can blame them, your circuit or static. But most frequently

RECEPTION TROUBLES

are caused simply by a bad connection. A dirty untinned soldering iron *cannot fail* to make a bad joint.

The iron can be properly cleaned only by the chemicals in

SOLDERCAKE

grooved, always ready to use.

Dealers—You can insure your reputation by selling this necessary Soldercake to every customer. Write now for our helpful proposition.

Fans—25c and your dealer's name will bring this cake postpaid to you.

C. de P. FIELD CO. 110 East 42nd Street
NEW YORK CITY
(Estab. 1860)

Build Your LC-26

With the Aid of

Popular Radio Blue Prints

It is Easy, Quick and Accurate

The LC-26 is the ideal all-around receiver, combining unusually fine tone quality, selectivity and distance-getting ability, with simplicity of construction and operation. It operates on any antenna from 10 feet to 200 feet long, indoors or out.

In tests at Washington, D. C., the LC-26 brought in over 40 stations in one night, the farthest away being KGW, Portland, Oregon.

At Chicago, Ill., the LC-26 brought in KFI, Los Angeles, every night for a week, and over 60 other stations. WEA, New York, was heard clearly at eleven o'clock in the morning. At New Haven, Conn., it brought in WMBF, at Miami Beach, Florida, at 4:00 p.m., as well as New York stations for which New Haven is a dead spot.

All reception on the LC-26 is on the loudspeaker, as it has no phone connection.

By using POPULAR RADIO Blue Prints in building your LC-26, you can save time, eliminate the possibility of error, and make your set exactly like the laboratory models (see page 52).

If your local dealer cannot supply you with Blue Prints of the LC-26, they will be sent postpaid on receipt of \$1.00 per set.

A full description of the LC-26, with detailed directions as to how to build it, was published in December, POPULAR RADIO.

POPULAR RADIO

Service Bureau 34-A

627 West 43d Street, New York

New "AMSCO" Products

*The choice of
Leading Radio Engineers*

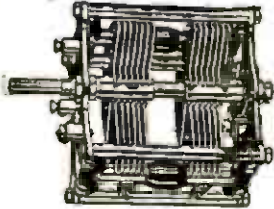

AMSCO SIAMESE CONDENSERS

Used by William H. Preiss in his "Straight 8" Receiver, R. E. Lacault in his "Ultra-dyne," L. M. Cockaday in his "L. C. 26" Receiver, and specified by Lester L. Jones for single control receivers.

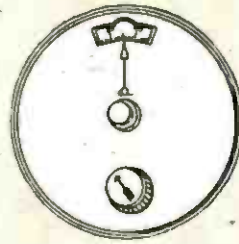

DE LUXE MODEL AMSCO VERNIER DIALS

Now finished in gold, silver, and jet. Free acting-forward or backward, fast or slow, without momentum or backlash. Gives finesse to fingers.

FOR STRAIGHT-LINE AMPLIFICATION



AMSCO RESISTANCE COUPLERS

The perfected instruments for straight-line amplification. All frequencies within the voice and music ranges, from the highest treble to the lowest bass, are augmented equally, giving true tone reproduction without distortion.

Investigate Amsco Resistance Couplers, Grid Gates and Resistors.

It Clicks into Contact

AMSCO UNIVERSAL SOCKET



All standard UX and CX radio tubes snap in with a click that assures positive contact.

Patented Amsco construction fully enclosed in genuine Bakelite. One hole mounting. They save space.



AMSCO PRODUCTS, INC.
Broome & Lafayette Sts., New York

THESE CIRCUITS HAVE PROVED SUCCESSFUL!

Here are the outstanding circuits of the year.
One of them will suit your particular need.

THE COCKADAY LC-26 RECEIVER

1 General Radio Type 269 Variometer with knob	\$5.30	1 Bradley leak 1/4 to 10 Megs.	\$1.85	1 Cabinet, Mahogany or Walnut Finish	\$14.50
1 General Radio Rheostat Type 214A, 7 Ohms.	2.25	3 Bradley units 1/4 meg.	2.25	1 Hardwood Baseboard.	.50
1 Precision Octoform Coil Set.	5.50	1 Bradley unit 1/2 meg.	.75	4 Small Brass Brackets.	.20
1 Amco Double Condenser No. 1814	6.25	3 Amperites 1A.	3.30	2 Large Brass Brackets.	.15
1 Micamold Condenser .00015 mfd.	.35	1 Amperite No. 112.	1.10	1 Antenna Connection Block 1 x 2 Inches.	.15
1 Micamold Condenser .00025 mfd.	.35	5 Benjamin Standard Sockets.	5.00	1 Battery Connection Block 1 x 9 Inches.	.25
2 Daven Resisto-Couplers with 1 mfd. condensers.	3.00	1 Carter Single Circuit Jack.	.70		
1 Amertran DeLuxe 1st Stage Transformer	10.00	2 Carter No. 2 Jack Switches	2.00		
		8 Eby Binding Posts.	1.20		
		1 Fynur Vernier Dial.	3.50		
		1 Drilled and Engraved Panel.	7.50		
				Blueprints for LC-26.	\$1.00
					\$77.90

Complete parts for the Raytheon Plate Supply Unit--\$41.10

HAMMARLUND - ROBERTS

1 Special Foundation Unit (Drilled and Engraved Panel and Sub-Panel; Metal Brackets and Wire)	\$9.40
2 Rawland Lyric Transformers	18.00
1 Hammarlund Midret Condenser	1.10
2 Hammarlund .0005 S. L. F. Condensers	10.00
1 Set Hammarlund-Roberts Coils	6.00
2 Naal Super DeLuxe 4 in. Dials	1.40
8 Naal De Luxe Sockets	3.75
1 Naal K3843 1 3-4 in Dial	1.25
4 Amperites 1A	4.00
6 Pra. Union Phone Tip Jacks	1.35
1 Carter 25 Ohm Imp. Rheostat	1.00
1 Carter Imp. Battery Switch	.85
1 Carter Single Circuit Jack, No. 101	.70
1 Dubilier Type 640G .00025 Condenser	.50
1 Dubilier Type 640 .002 Condenser	.45
1 Dubilier Type 640 .006 Condenser	.45
1 Durham Resistor	.40
	\$60.85

Special designed mahogany cabinet for this kit \$10.00

New!
ALL PARTS FOR THE
General Radio Universal \$44.80

WHOLESALE RETAIL

MORISON

Electrical Supply Co. Inc.

15 East 40th Street, New York City

McLAUGHLIN SINGLE CONTROL RECEIVER

Complete Parts — \$113.30
D. T. W. Loop — \$25.00
True Blue Tubes — each \$3.50

C. O. D. Mail Orders promptly and accurately filled. Dealers and setbuilders—Write for information.

GET LONDON? NEW HETRO - MAGNETIC

One of the most powerful radio receivers in existence, built by a pioneer radio scientist, employing the new hetro-magnetic principle.

The first three tubes give you six stages of amplification, three magnetic coils for each tube or eleven sets of transformer parts.

Instead of selling through dealers for \$100 or over and tying up our merchandise—we are offering this set direct to readers of Popular Radio at \$45, after most thorough test by The Popular Radio Laboratory.

Large circular describing set clearly and giving complete description of its novel features, its remarkable record in performance, sent on request.

Sets are sold on a 10-day trial.

COAST TO COAST RECEPTION
GUARANTEED

MERCURY ELECTRIC CORP.
2032 Grand Ave. New York

CARTER

"DIALITE"

"IMP"

Pilot Switch



\$1.75 Complete With 6 Volt Lamp



\$1.50 Complete With 6 Volt Lamp

Gives you light right over dials. Only one hole to mount. Can be used as combination Dialite and "A" Battery Switch. Current consumption negligible.

Quarter turn "A" Battery Switch which shows by red light when tubes are burning. Saves run down battery by forgetting to turn off set. Attractive. Current consumption negligible.

See them at your dealers. Write for illustrated folder.

In Canada—Carter Radio Co., Limited, Toronto





Model R Receiver:
Rauland-Lyric-
equipped. Price
\$90 (East of the
Rocky Mountains)

Beauty and Permanence

Listeners Marvel—

at the wealth of enjoyment awaiting but a touch of the fingers.

Women Are Delighted—

with the tasteful stateliness of the Model R cabinet, as much as with the neatness of its battery accommodations.

Engineers Voice Approval—

of the rigid spot-welded steel chassis, protecting from damage every part of a set that stands as a notable example of the completely manufactured rather than the merely assembled radio receiver.

Service Men Commend—

the thoroughness with which every part has been made proof against the interruption of its service, so far as human ingenuity can devise.

Dealers Are Enthusiastic—

over the excitement created everywhere by this unique receiver and the uniform satisfaction felt by its users.

Buy "Solid Value" in Your Radio

The leading wholesaler of radio apparatus in your community has probably been, for years, an ALL-AMERICAN Authorized Distributor. ALL-AMERICAN Guaranteed Radio Products are being shown everywhere by responsible and reliable dealers.

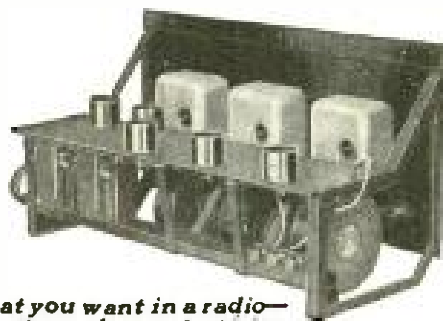

All that you want in a radio—
natural tone, sharp selectivity,
straight-line-frequency tuning
(360°) unaffected by position
of the fingers, extreme
sensitiveness, permanence.

ALL-AMERICAN RADIO CORPORATION, E. N. Rauland, Pres., 4211 Belmont Ave., Chicago, U. S. A.

OWNING AND OPERATING STATION WENR—266 METERS

ALL-AMERICAN
Pioneers in the Radio Industry

All apparatus advertised in this magazine has been tested and approved by POPULAR RADIO LABORATORY



A New and Finer Quality of Reception Raytheon Tube-B Eliminator

Using

DONGAN

B-Power Units

Transformers



509 Full Wave
\$7.00 List

Also — Transformers and
Chokes for R. C. A. and
Cunningham Tubes.

Chokes



514 20 henry
\$5.00 List

Raytheon Tubes

\$6.00 List

Check or money orders filled
at once—build your own and
enjoy consistent, quiet and
economical radio.

Thousands of fans who have built their own B-Eliminators, using Raytheon Tubes and Dongan Transformers and Chokes, have found an almost unbelievable improvement in reception. Smooth, uninterrupted plate supply perfects the quality of all signals and greatly clears up and gives added strength to DX work—the ideal equipment for the International Tests.

Dongan B-Power Units are essential parts to the construction of this remarkable new Eliminator. Complete instructions make it easy to build your own. Tubes and Dongan parts at most good dealers. For interesting details write for information at once.

Manufacturers

For B-Eliminator and Receiving Set manufacturers, Dongan offers a complete line of B-Power Units, Audio Transformers, A.C. Tube Step-Down Transformers and Voltmeters. Information or engineering cooperation at your request.



DONGAN ELECTRIC MANUFACTURING CO.
2983-3001 Franklin Street Detroit, Mich.

TRANSFORMERS OF MERIT FOR FIFTEEN YEARS

RESULTS HAVE PROVEN

THE PRECISE SYNCRODENSER has been the choice of the discriminating SET BUILDER for many months, and has proven conclusively its ideal characteristics for the elimination of interference on the lower wavelengths, with greatly increased efficiency in any type of receiver.

IN accordance with the PRECISE policy of adding improvements which has always kept their products months in advance of the radio art, we are pleased to announce at this time the improved Syncrodenser with nickel plated brass frame, and gold plated brass plates, rigid construction, with accuracy before unheard of in commercial condensers.

SELECT PRECISE and be sure of the best in radio. RESULTS WILL PROVE IT.

.0005 Mfd. \$4.50

00035 Mfd. \$4.00

Write for
complete
data on the
new im-
provements.

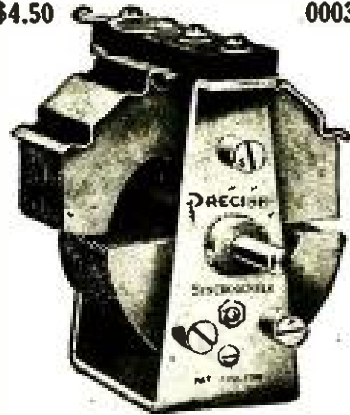

We have the
most com-
plete line of
radio and
audio trans-
formers.

PRECISE MANUFACTURING CORPORATION
Rochester, N. Y.

A Great Message

and an interesting PROPOSITION
mailed FREE upon request to every
RADIO-CONSUMER

No matter what you intend to buy in the line of Radio you cannot afford to do so before writing for our proposition which is an entirely new idea in buying direct for the Consumer, thereby enabling us to sell all Standard Radio Receivers, Parts, Knockdown Kits, and Accessories at a considerably great saving to the Radio Consumer. To those that Time and Money is of any Value at all, our Proposition will be of exceptional value.

All the LATEST advertised KNOCKDOWN KITS are furnished by us COMPLETE ready to WIRE with all SPECIFIED PARTS and POSITIVELY NO SUBSTITUTIONS unless so requested.

THE NEW S-C 4-TUBE RECEIVER
Complete kit of parts exactly as used in the Laboratory Model, is now ready for delivery.

WRITE FOR OUR PROPOSITION NOW
Buy After, and save plenty of Your Hard Earned Money and Valuable Time.

CONSUMERS SERVICE CO.
Direct Buyers for the Consumer
140 Liberty St. New York City, N. Y.

It's Easy to Build A Powerful Set

Using the New and Improved FRESHMAN "TRF" Low Loss Kit



Straight Line Wave Length Condensers With Low Loss Self Balanced Coils

These are the identical units which have made the FRESHMAN MASTERPIECE factory built Receivers the World's Greatest Radio Sets

\$9.50

Complete instructions for building this powerful five tube receiver, written in plain everyday English, together with actual size schematic wiring diagram are furnished with every FRESHMAN "TRF" Kit.

Sold by Authorized Freshman Dealers Only!

CHAS. FRESHMAN CO., INC.

Freshman Building, New York
2626 W. Washington Blvd., Chicago

All apparatus advertised in this magazine has been tested and approved by POPULAR RADIO LABORATORY

First in the Field
Specializing in
Cockaday Kits

S. HAMMER RADIO CO., 303 Atkins Ave. Brooklyn, New York

Cockaday Sets Now Made Easier to Build by Our New "Ready-to-Wire" Plan
50% of Your Time, Work and Worry SAVED!

All you need do is to connect bus-bar according to diagram, solder and your set is finished. These Kits are sent to you completely mounted, and assembled on a Veneered Mahogany baseboard and genuine bakelite panel, drilled and engraved; in a solid Mahogany Cabinet. Genuine parts used as listed below; exactly as used in Mr. Cockaday's Laboratory Model. **COMPARE OUR OFFER!**

"THE S-C RECEIVER"

- | | | | |
|--|--------|---|------|
| 2 S-M antenna coils No. 110A and detector coil No. 114A with 2 No. 515 coil sockets..... | \$7.00 | 1 Polymet gridleak, 2 megohms..... | .25 |
| 2 S-M SLF variable condensers No. 316 with 1 vernier dial No. 801..... | 13.75 | 1 Yaxley rheostat, No. 16K, 6 ohms..... | 1.35 |
| 4 S-M tube sockets, type 510..... | 2.00 | 1 Yaxley battery switch No. 10..... | .50 |
| 2 Thordarson S-C power transformers..... | 16.00 | 1 Yaxley jack, type No. 1..... | .50 |
| 1 Polymet mica fixed condenser, .002 mfd..... | .40 | 1 Yaxley jack, type No. 2..... | .60 |
| 1 Polymet mica fixed condenser, .005 mfd..... | .60 | 1 Centralab variable resistance, 25,000 ohms..... | 1.50 |
| 1 Polymet mica fixed condenser clips, .00015 mfd..... | .45 | 1 S-M midget condenser, No. 340, .000025 mfd..... | 1.50 |
| | | 2 S-M mounting brackets..... | .70 |
| | | 1 Belden S-C connecting harness..... | 4.00 |

Total (including drilled and engraved Bakelite panel 7 by 18 inches; drilled and engraved sub-panel 6½ by 17 inches) **\$55.10**

READY-TO-WIRE KIT, PRICE, . . \$59.50
WIRED COMPLETE In Genuine Mahogany Cabinet **.. \$75.00**

UNASSEMBLED KITS IN STOCK

THESE KITS IN STOCK

SHUNT PLATE FEED UNIT, NEW ORTHOPHASE RECEIVER, RAYTHEON PLATE SUPPLY UNIT, McLAUGHLIN SINGLE CONTROL SUPERHETRODYNE

Cockaday's New LC-26 Receiver

- | | | | |
|--|--------|--|--------|
| 1 General Radio Variometer type 269 with rheostat knob..... | \$5.30 | 3 Bradleyunits, ¼ megohm.... | \$2.25 |
| 1 General Radio Rheostat type 214-a, 7 ohms, with rheostat knob..... | 2.25 | 1 Bradleyunit ¼ megohm.... | .75 |
| 1 Precision Octavoform coil set..... | 5.50 | 3 Amperite No. 1a..... | 3.30 |
| 1 Amsco Double Unit Condenser No. 1814..... | 6.25 | 1 Amperite No. 112..... | 1.10 |
| 1 Micamold fixed Condenser .00015 mfd..... | .35 | 5 Benjamin standard "Cle-tone" sockets..... | 5.00 |
| 1 Micamold fixed Condenser .00025 mfd..... | .35 | 1 Carter single-circuit jack No. 101..... | .70 |
| 2 Daven resisto-couplers (new type)..... | 3.00 | 2 Carter Jack switches No. 2..... | 2.00 |
| 1 Amertran DeLuxe transformer, first stage..... | 10.00 | 8 Eby binding posts..... | 1.20 |
| Bradleyleak ¼ to 10 meg..... | 1.85 | 1 Fynur vernier control knob and dial..... | 3.50 |
| | | 1 Universal decorated panel, 8 x 22 inches..... | 7.50 |
| | | 4 Small brass brackets..... | |
| | | 2 Bakelite Connection Blocks 1 x 2 plus 1 x 9..... | |
| | | 2 Large Brass Brackets..... | .35 |

READY-TO-WIRE KIT, PRICE, . . \$62.50
WIRED COMPLETE In Genuine Mahogany Cabinet **\$77.00**

UNASSEMBLED KITS IN STOCK

HAMMARLUND ROBERTS! KITS IN STOCK

WRITE FOR BOOKLET about these Parts and Kits. Also for Free Radio Catalog

Transportation Prepaid. One-third must accompany all C. O. D. orders. Not insured unless insurance charges included

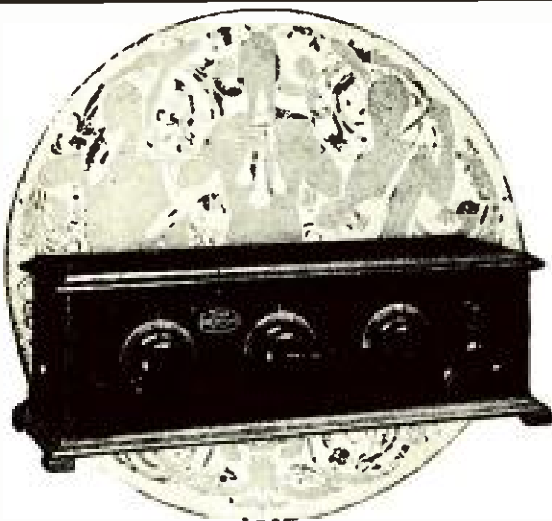

ARBORPHONE

A New Conception of Good Radio

No matter what experience you have had with radio you've a new thrill coming when you listen to Arborphone performance the first time.

Clear reception—even on D X work—is the outstanding quality that endears Arborphone to thousands of owners all over this country. Mother, sister or any member of the family can get plenty of stations on the Arborphone. An expert isn't required to operate this remarkable simplified receiver.

By all means buy now before trying out the Arborphone at your dealer's. No value in radio to equal it. Let us send you a copy of our new and interesting radio book.

\$55.00

Dealers
The sales plan back of this wonderful set assures you a splendid year 'round business. Ask for details—by mail or wire. \$60.00 in Rocky Mt. and Pacific Coast States.

MACHINE SPECIALTY COMPANY
317 S-Main Street I Ann Arbor, Michigan
"All You Could Ask of a Radio"

COMO

VARIABLE-RATIO AUDIO-TRANSFORMER



3 Ratios:—4 to 1, 6 to 1, 8 to 1, all in one high-grade audio transformer. The primary taps allow a choice of the best turns—ratio for each stage of amplification, and can be also used for volume-control. Built by COMO, a pioneer in Radio and a maker of radio-products of recognized quality.

At All Good Dealers

\$6.00

Send for descriptive pamphlet V

COMO APPARATUS CO., INC.
Kelley Street Manchester, N. H.

CARDWELL

CONDENSERS

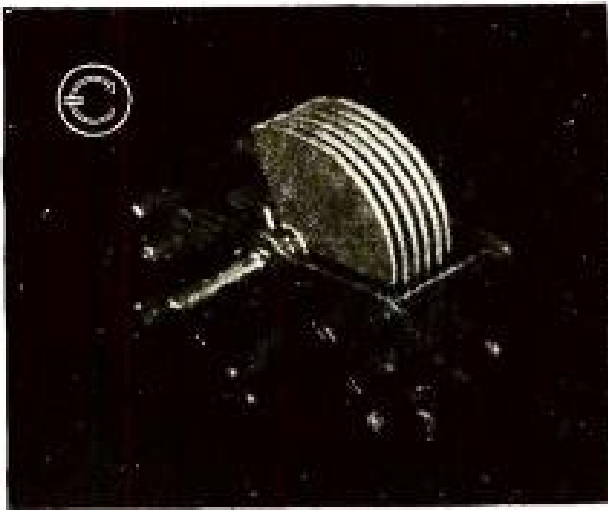

The new Type E taper plate Cardwell has been universally greeted by editors and engineers as the logical answer to the demand for straight frequency tuning.

Semi-circular plates, far heavier than ever used before, assure absolutely permanent calibration, and it will mount entirely behind a four inch dial. Its depth back of the panel is under three inches.

The price for the .00035 mfd. size is \$4.75. Other sizes are priced proportionately.

The Allen D. Cardwell Mfg. Corp.
81 Prospect Street, Brooklyn, N. Y.

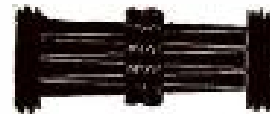

Write for catalogue. If your dealer can't supply you, order direct from us.

"THE STANDARD OF COMPARISON"

All apparatus advertised in this magazine has been tested and approved by POPULAR RADIO LABORATORY



ACME WIRE RADIO PRODUCTS



Celatsite Wire

Celatsite is a tinned copper bus bar wire with a non-inflammable "spaghetti" insulation in five colors. Supplied in 30 inch lengths.

**Flexible
Varnished "Spaghetti"**

A perfect insulation tube for all danger points in set wiring. Costs little more and is worth a lot more than the cheaper substitutes offered. Black, yellow, red, green, brown, for wires No. 10 to No. 18. 30 inch lengths.

Celatsite Battery Cable

For connecting A and B Batteries (or current supply) to radio set. Silk braid covering 5 flexible Celatsite wires—5 feet long—a different color for each terminal. Prevents messy wiring and "blown" tubes. Adds greatly to the appearance of your set.



Enameled Antenna Stranded

The best outdoor antenna you can put up. 7 strands of enameled copper wire; maximum surface for reception. Enameling prevents corrosion and consequent weak signals. 100, 150 or 200 foot coils, boxed.



Loop Antenna Wire

You can make a good loop with Acme wire made of 65 strands of fine copper wire, green silk covered. Flexible; non-stretching, neat.

Flexible Celatsite Wire

Flexible stranded wire for "point to point" and sub-panel wiring—latest method of wiring sets. 5 colors, black, yellow, green, red and brown, one for each circuit. 25 ft. coils.



Send for Folder.

**THE ACME WIRE CO., Dept. P
New Haven, Conn.**

Burns



*Clarity
Volume
Beauty*

PRICES
Three Finishes
\$22.50 \$25.00
\$30.00

FOR REAL ENJOYMENT

Use the BURNS Loud Speaker on your receiving set. Produces utmost in volume and clarity of tone. Reaches full range of musical scale—equal to hearing the original production.

At your dealers or direct
American Electric Company
State and 64th Streets, Chicago

LOMBARDI

STRAIGHT LINE CONDENSERS

Frequency and Wave Length

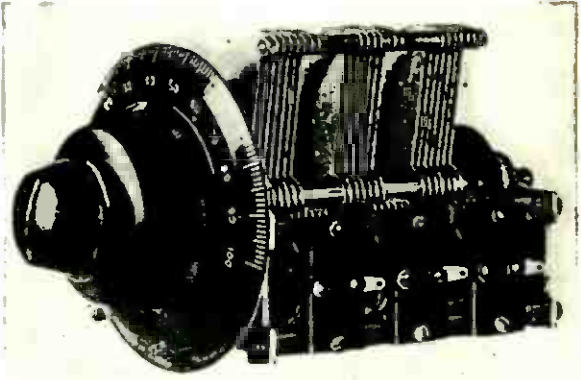

Are real precision instruments, fit for the highest grade of Radio Sets. Their substantial and careful design is immediately apparent to anyone who knows Radio. Patented ball and taper-bearing shaft and watch spring pig tail insure permanent accuracy. Made in both single and multiple units. Multiple units licensed under Hogan patents.

Manufacturers and home set builders write for full descriptive matter.

LOMBARDI RADIO MFG. CO.
67 Minerva St. Derby, Conn.

Big Demand for New Circuits

The New S. C. Receiver
L. C. 26 Broadcast Receiver

Orthophase Receiver
General Radio Universal Receiver

We Have All the Hard-to-Get Complete

STANDARD PARTS

Either in Kit Form or Separately for All Popular Circuits

SEND YOUR ORDER NOW!

STANDARD PARTS FOR LATEST S. C. RECEIVER

	Total		Total
2 S-M antenna coils: Nos. 110A and detector coil No. 114A, equipped with 2 No. 515 coil sockets	\$7.00	1 Polymet mica fixed condenser, equipped with gridleak clips, .10005 mfd	\$.45
2 S-M Sif variable condensers No. 316, equipped with 1 vernier dial No. 801	13.75	1 Yaxley rheostat, No. 16K, 6 ohms	1.35
4 S-M tube sockets, type 510	2.00	1 Yaxley battery switch No. 10	.50
2 Thordarson S-C power transformers	16.00	1 Yaxley jack, type No. 1	.50
1 Polymet mica fixed condenser, .002 mfd	.40	1 Yaxley jack, type No. 2	.60
1 Polymet mica fixed condenser, .005 mfd	.60	1 Centralab variable resistance, 25,000 ohms	1.50
1 Polymet gridleak, 2 megohms	.25	1 S-M midget condenser, No. 340, .000025 mfd	1.50
		2 S-M mounting brackets	.70
		1 Belden S-C connecting harness	4.00

Complete Parts

(Including Drilled and engraved front panel, 7 by 18 inches
Drilled and engraved sub-panel, 6 1-2 by 17 inches)

\$55.

We guarantee immediate Delivery

Cabinet for this set \$9.50 extra

SETS WIRED TO ORDER \$10. EXTRA

General Radio Universal Receiver

Complete parts including bakelite
Drilled and Engraved Panel.

\$49.30

Circular describing this circuit prepaid upon the receipt of 10 cents to cover postage charges.

SETS WIRED TO ORDER \$10. EXTRA

Mr. Laurence Cockaday's L. C. 26 Receiver

PARTS USED BY MR. COCKADAY IN BUILDING HIS LABORATORY SET

	List Price
1 General Radio variometer, type 269, equipped with rheostat knob	\$5.40
1 General Radio rheostat, type 214c, 7 ohms, equipped with rheostat knob	2.25
1 Precision Octaform coil set	5.50
1 Ameco special double unit condenser No. 1814, each section .0003 mfd	6.25
1 Mico mold fixed condenser, .00015 mfd	.36
1 Mico mold fixed condenser, .00025 mfd	.36
2 Daven resisto-couplers (new type which incorporate 1 mfd. condenser in base)	3.00
1 Amertran DeLuxe transformer, first stage	10.00
1 Amertran 1-4 to 10 meg	1.85
3 Bradley units, 1-4 megohm	2.25
1 Bradley unit, 1-2 megohm	.75
2 Amperites No. 1a	3.20
1 Amperite No. 112	1.10
5 Benjamin standard "Clore-tons" sockets	6.00
1 Carter single circuit jack, No. 101	.70
2 Carter Jack switches, No. 2	2.00
8 Eby binding posts	1.20
1 Fyner vernier control knob and dial	3.50
4 Small brass brackets	
1 Antenna connection block, 1 x 2 inches	.80
1 Battery connection block, 1 x 9 inches	
2 Large brass brackets	

Complete Parts (including 1 Bakelite drilled and engraved Panel 8 x 22) \$59.75

Orthophase Receiver

1 General Radio Variometer No. 269	\$5.00
1 Precision Orthophase-Coil Set No. 300	7.50
2 Hammarlund S. L. F. Condensers	5.00 ea.
1 Aerovox Fixed Condenser, .00015	.35
1 Amertran 5-1 Audio Transf.	5.00
1 Pacent Super-Audioformer	7.50
1 Daven Resisto-Coupler	1.50
1 Durham .25 Resistance	.40
1 Durham .5 Resistance	.40
1 Rasla Fixed Crystal	1.25
1 Daven Grid Leak Holder	.35
1 Amperite No. 1A (1-4 Ampere)	1.10
1 Amperite No. 1 (1 Ampere)	1.10
4 Benj. Universal Sockets	.75 ea.
1 Carter No. 103 Jack	.90
1 National Velvet Vern. Dial	2.50
2 Century 3-inch dials	2.00
1 Drilled & Engraved Panel 8 x 22 Bakelite	4.25
7 Eby Binding Posts	.15 ea.
Small Brass Brackets: Antenna Block 1	
2 Insul. Batt. Conn. Block 1 x 9	.85
Large Plain Brackets	
Total	\$56.50

1 Corbett Cabinet 8 x 22 inches, including Baseboard for above set \$17.00

WHOLESALE AND RETAIL

HEINS & BOLET, 44 PARK PLACE, NEW YORK

Mail Orders Shipped the Same Day They Are Received

Dealers!

Here Is the Book
To Go By
When You
Go To Buy

Radio's biggest book of "dealer values." It features and illustrates all standard, high grade lines—the sellers and money-makers! Sets, parts, accessories, cabinets—**EVERYTHING IN RADIO—PROMPT DELIVERY**

We carry a large and complete stock at all times. Orders shipped on same day received.

Immediate Delivery

The "S-C" Receiver

The newest circuit to win approval of critical radio enthusiasts, designed by **MESSRS. SILVER and COCKADAY**

ALL PARTS IN STOCK NOW

2 S-M antenna coils, Nos. 110A and detector coil No. 114A equipped with 2 No. 515 coil sockets.	\$7.00
2 S-M SLF variable condensers No. 316, equipped with 1 vernier dial No. 801.	13.75
4 S-M tube sockets, type 510.	2.00
1 No. 619 Keel Unit (consists of front and rear panel, brackets, harness, screws, etc.)	11.00
2 Thordarson S-C power transformers.	16.00
1 Polymet mica fixed condenser, .002 mfd.	.40
1 Polymet mica fixed condenser, .005 mfd.	.60
1 Polymet mica fixed condenser, equipped with grid-leak clips, .00015 mfd.	.45
1 Polymet gridleak, 2 megohms.	.25
1 Yaxley rheostat, No. 16K, 6 ohms.	1.35
1 Yaxley battery switch No. 10.	.50
1 Yaxley jack, type No. 1.	.50
1 Yaxley jack, type No. 2.	.60
1 Centrafah variable resistance, 25,000 ohms.	1.50
1 S-M midget condenser, .000025 mfd.	1.50
	\$57.40

WRITE FOR DEALER'S DISCOUNT

Special: Prices & Discounts Factory-Built-L-C-26 Receiver

This is the genuine, original L-C-26 circuit factory built and thoroughly tested and guaranteed by experts. An excellent, high grade item. Subject to Regular Dealer's Discount.

\$77.50
LIST PRICE

COMPLETE S-M-"SILVER-SIX" PARTS FOR

The popular selling circuit on the market now. Cash in on the publicity.

CATALOG Contains complete information discounts & PRICES

HAMMARLUND-ROBERTS

ALL PARTS IN STOCK IMMEDIATE DELIVERY

ALL PARTS IMMEDIATE DELIVERY

DEALERS—The catalog contains complete information, prices AND DISCOUNTS

ULTRADYNE

McLAUGHLIN'S Single Control Super

RAYTHEON PLATE SUPPLY UNIT

WHOLESALE RADIO SERVICE CO.

Wholesale Distributors Radio Apparatus Dept. 326

6 CHURCH ST., N. Y. C.



Recommended by
RICHARD J. GRIFFITH
FOR
**ORTHOPHASE
RADIO
RECEIVERS**



THE recognition of the **RASLA FIXED DETECTOR** as the standard is again indicated in its selection by **Richard J. Griffith** in his article, "How to build the new Orthophase Radio Receiver," in **Popular Radio**, February.

\$1.25

at your dealers or direct

While other detectors have come and gone, the **RASLA** has remained the standard for years. Even extremely large current will not burn it out or injure its sensitivity. Its guaranteed durability is especially remarkable. But most important of all, it achieves almost a 25% increase in sensitivity! At your dealers, or direct \$1.25 postpaid.

FREE—Rasla Circuit Diagrams sent on request.

Davidson Radio Corporation
134 Livingston St., Brooklyn, N. Y.

Faradon



Since 1907

FARADON QUALITY CONDENSERS

have been furnished to satisfy the exacting requirements of many

IMPORTANT USERS

U. S. Army, U. S. Navy, Bureau of Standards, General Electric Co., Radio Corp. of America, Tropical Radio Telegraph Co., Westinghouse Electric & Mfg. Co., and Western Electric Co. are some of the large Faradon users.

FARADON

can be confidently relied upon for thoroughly satisfying service. Our Engineering Staff, on request, will co-ordinate fully to meet your particular requirements.

"Fit out with Faradon"

Wireless Specialty Apparatus Co.
JAMAICA PLAIN, BOSTON, MASS., U. S. A.

Electrostatic Condensers for all Purposes

Faradon

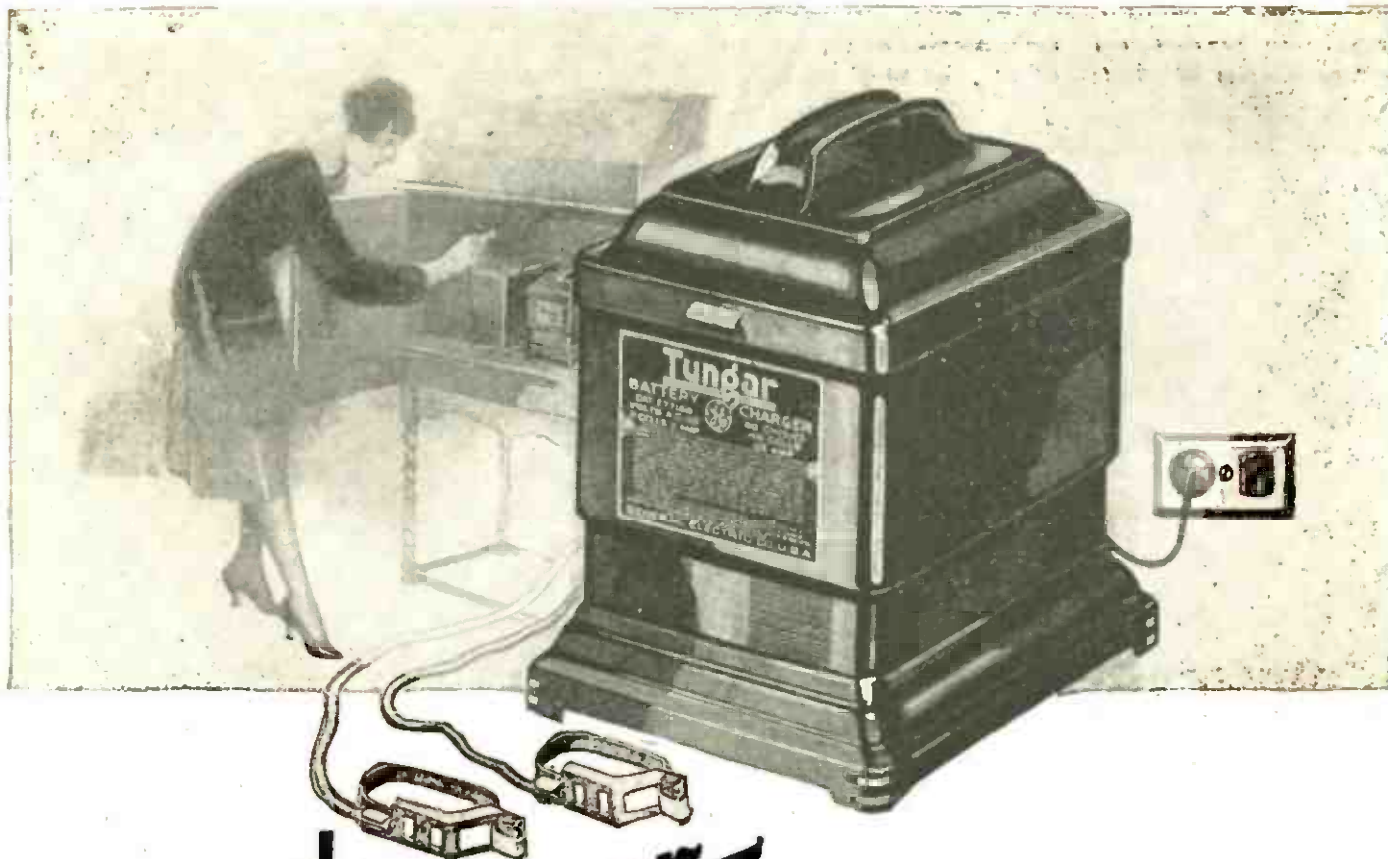

With Tungar— an overnight charge for a dime/



It can't blow out Radiotrons if left hooked to set while charging.

Does not disturb radioreception in neighborhood.

It is complete—charges 2-4-6 volt "A" or 6-12 volt auto batteries, or 24-96 volt "B" batteries in series

Especially adaptable to permanent installation in cabinet with switch control.

Five ampere size \$28.00 (East of Rockies)

Two ampere size \$18.00 60 cycles - 110 volts

Merchandise Department
General Electric Company
Bridgeport, Connecticut

Two clips for your battery and a plug for your house current—that's all. And the steady, quiet Tungar charges your batteries overnight.

Just about a dime's worth of current and two minutes of work. So simple!

It's the no-fuss, easy-to-use charger—for all batteries.

Tungar

REG. U.S. PAT. OFF.

BATTERY CHARGER

Tungar—a registered trademark—is found only on the genuine. Look for it on the name plate.

GENERAL ELECTRIC

All apparatus advertised in this magazine has been tested and approved by POPULAR RADIO LABORATORY

SIMPLIFIED BLUEPRINTS MAKE IT EASY TO BUILD A SET

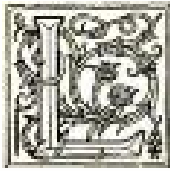

LAURENCE M. COCKADAY has personally supervised the preparation of *Simplified Blueprints* of eight of POPULAR RADIO'S most popular circuits. Each set consists of at least three separate *Actual Size* Blueprints; first a Panel Pattern; second, an Instrument Layout; and third, a Picture Wiring Diagram all simplified in the fullest sense of the word *because*

The Panel Pattern can be laid on the panel and all holes drilled as indicated. No scaling to do and so accurate there is no danger of ruining the panel through faulty calculation.

The Instrument Layout placed on the sub-base permits you to indicate by pinpricks the exact location of every screw.

The Picture Wiring Diagram gives every instrument in exact size and position with every wire clearly indicated from one contact to the other. With no knowledge of radio symbols you can assemble every part and complete your wiring with no chance of error.

Priced at \$1.00 per Set of Three Prints

Set No. 4—"Cockaday Four-Circuit Tuner with Resistance-Coupled Amplifier" (five tubes, distortionless, two dials, automatic vacuum tube control, as described in the October, 1924, issue of POPULAR RADIO).

Set No. 6—"The Cockaday 8-tube Super-heterodyne Reflex Receiver" (eight tubes, two tuning dials, loop, non-radiating, distortionless, as described in January, 1925, issue of POPULAR RADIO).

Set No. 11—"5-Tube Tuned Radio-Frequency Receiver with Simplified Control" (as described in August, 1925, issue of POPULAR RADIO).

Set No. 12—"8-Tube Superheterodyne with Single Control" (eight tubes, two straightline variable condensers, as described in October, 1925, issue of POPULAR RADIO).

Set No. 13—"Ratheon Plate Supply Unit" (a really dependable method for obtaining a "B" source of supply as described in November, 1925, issue of POPULAR RADIO).

Set No. 14—"The LC-26 Broadcast Receiver" (as described in December, 1925, issue of POPULAR RADIO).

Set No. 15—"The Orthophase Receiver" (a circuit development using a new principle in radio-frequency amplification, making a receiver with great sensitivity, combined with sharp tuning and ease of operation, as described in February, 1926, issue of POPULAR RADIO).

Set No. 16—"The S-C All-Wave Receiver" (equipped with inter-changeable coils so that it has practically an unlimited wavelength range, covering all wavelengths from 50 to 550 meters, as described in March, 1926, issue of POPULAR RADIO.)

Full constructional and parts details for these Receiving Sets will be found in the issue of POPULAR RADIO indicated. Back issues of POPULAR RADIO will be furnished at the rate of 35c a copy

Popular Radio

627 West 43d Street

Dept. 34

New York City

POPULAR RADIO, Inc., Dept. 34
627 West 43d St., New York City Date.....

Enclosed is my remittance of \$....., for which kindly send me Blueprint Set (s) consisting of Panel Pattern, Instrument Layout and Wiring Diagram as checked below:

Set Number 4 Set Number 11 Set Number 13 Set Number 15
 Set Number 6 Set Number 12 Set Number 14 Set Number 16

Name.....
Address.....
City..... State.....

DEALERS

Write for terms on these fast selling Blueprints. An attractive Display Chart free with orders.

All apparatus advertised in this magazine has been tested and approved by POPULAR RADIO LABORATORY

Send for this RADIO BOOK FREE

1926 Catalog of RADIO BARGAINS

Save 1/3 to 1/2



The World's Largest Exclusive Radio Mail Order House Will Send You This Wonderful Book FREE

64 illustrated pages containing thousands of bargains in radio sets, semi-finished sets and radio kits of all styles, sizes and approved circuits. 5-tube sets as low as \$29.50. Beautiful models of the very latest designs and types. Elaborate console models with loud speakers built right in cabinets of genuine mahogany and walnut. All sets guaranteed. Coast to coast receiving range. Also contains everything in radio supplies, including batteries, chargers, loud speakers, transformers, condensers, rheostats and any other parts you may want for improving your set or building a new one. Guaranteed saving to you of 1/3 to 1/2.

AMERICAN RADYNOLA 5 TUBE SET

\$29.50

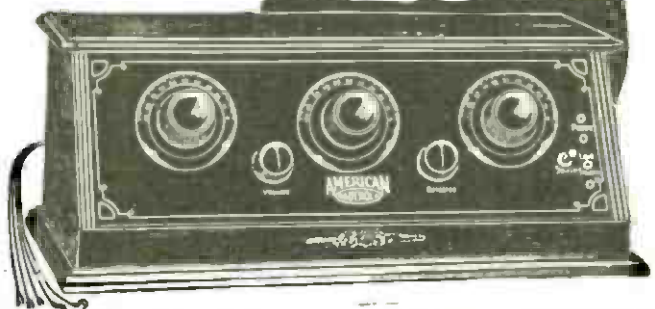

The Biggest 5-Tube Value on the Market

Positively the world's greatest 5-tube radio bargains. Regular \$75.00 value. Our large quantity production enables us to sell this set for only \$29.50, fully built and wired in beautiful mahogany cabinet of latest design with sloping Bakelite panel of Satin finish, handsomely etched and engraved as illustrated. Constructed of the finest low-loss condensers, coils and sockets. Bakelite baseboard panel and dials. Price for set only. **\$29.50** Transportation charges extra, shipping weight 25 lbs.

This set with all accessories, including the famous American Bell loud speaker with adjustable unit, 2-45 volt "B" batteries, one guaranteed 100 Ampere Hour, storage "A" battery, cable for battery connection, 5-201A tubes, Aerial and ground equipment, and everything complete ready to set up and operate. Nothing else to buy. Price **\$59.75** Transportation charges extra. Shipping weight 100 lbs.

Order Direct from This Page! Save About One-Half!

Order direct from this page. Save 1/3 to 1/2. Our guarantee protects you. Money cheerfully refunded if you are not satisfied. Write your order and prices plainly. Send post office money order or bank draft for full amount to insure safety. Refer to any bank or commercial agency regarding our reliability.

SEMI-FINISHED 5-TUBE RADIO FREQUENCY SET

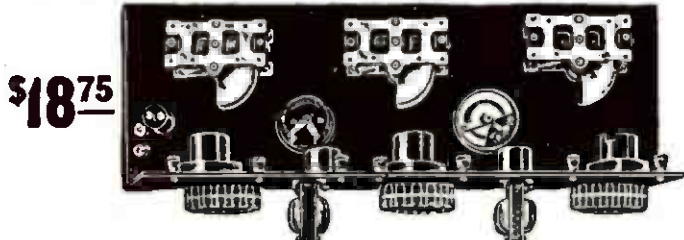

\$18.75

This special offer is astounding the radio world. Coast to coast reception on loud speaker. Low loss condensers and sockets. Highest quality transformers. Bakelite rheostats. All wiring concealed under Bakelite baseboard. 7x18 panel—fits into any standard 7x18 cabinet. Complete instructions for operating. Guaranteed saving to you of \$50.00. Price of set all mounted, \$18.75. Cabinet of same model as American Radynola pictured above \$5.65 extra.

SEMI-FINISHED 8-TUBE SUPER-HETERODYNE

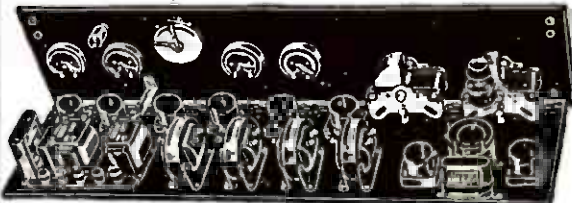

\$43.75

World's Famous 8-tube super heterodyne. Fully mounted on panel and baseboard. Comes completely assembled ready to wire and operate. We have testimonials from thousands of builders of this set. Some have received foreign stations on loop aerial. Unsurpassed in volume and tone quality. Low-loss straight line frequency condensers, vernier dials, finest quality rheostats. Matched Columbia long waved transformers. Requires only three screws for attaching panel and baseboard and set is ready to operate. 7 x 30 panel. Price of set only \$43.75.

Requires following accessories to complete this set: 7x30 cabinet, 8-201A tubes for storage battery operation or No. 199 tubes for dry cell operation. 100 Ampere hour storage battery, 2-45V "B" batteries, loud speaker, center tapped loop aerial. All these items are listed in our catalog at a tremendous saving.

Complete Parts for Best 45 Kilocycle Super-Heterodyne Genuine Remler Parts **\$49.50**

You must have our catalog no matter what set or kit you want. Our line is complete and includes all popular sets, such as Superheterodyne, Neurodyne, Ultradyne, Reinartz, Regenerative, Radio Frequency, Browning-Drake, Super-Heterodyne Reflex and all other latest circuits. Kits, sets and parts manufactured by all well known manufacturers such as Frost, Howard, Baldwin, Brandes, Western Electric, Columbia and others.

Our semi-finished sets come with all parts mounted on panel and baseboard ready for wiring. Do not fail to send for our catalog. Remember—we are the largest exclusive radio mail order dealers in the world and carry the best of everything in radio. We save you 1/3 to 1/2 on the following kits. Detailed descriptions appear in our catalog.

Catalog includes list of broadcasting stations, general radio information and facts about our free service division. Write for it today.

NEUTRODYNE
Genuine licensed Neurodyne kit of parts, come fully assembled on the panel and baseboard with complete instructions, ready to wire. Price, **\$29.75**

COCKADAY
3-tube Cockaday kit of parts, fully assembled on panel and baseboard, ready to wire. Price, **\$15.85**

FOUR TUBE BROWNING-DRAKE AND COCKADAY'S NEW LC 26 CIRCUIT PARTS ARE IN OUR CATALOG.

Complete Parts for Cockaday Resistance Coupled and 5-tube set at prices that will astound you. Also complete parts for AC Kit.

RANDOLPH RADIO CORPORATION

159 N. Union Ave. Dept. 264 Chicago, Illinois

YOUR INDIVIDUAL PROBLEM SOLVED

POPULAR RADIO, with which is combined *The Wireless Age*, maintains for the benefit of its readers a Technical Service Bureau and Laboratory, under the personal supervision of Laurence M. Cockaday which will, without charge, answer by personal letter any question, problem or request for information submitted by a subscriber. This service is, however, also available to readers, other than subscribers, at the very nominal rate of 50 cents the inquiry.

In writing please confine your questions to one general

November, 1923

- The 100 Best Hook-ups (Part 1).
- Receiving without Antennas.
- How to build the New Regenerative Super-heterodyne Receiver (Part 1).
- How to build a combination Short and Long-wave Receiver.

December, 1923

- How to select your Radio Parts.
- The 100 Best Hook-ups (Part 2).
- How to Read a Diagram (Part 1).
- How to build an efficient Crystal Receiver.
- How to build the Super-heterodyne Receiver (Part 2).

January, 1924 (Out of Stock)

(A Reprint of Mr. Cockaday's article describing the DX Regenerative Receiver may be had for 25 cents.)

February, 1924

- How to add "Push and Pull" amplification to the 3 tube Cockaday 4-Circuit tuner.
- The original 4-Circuit Tuner as a Portable Set with Loop.
- The 100 Best Hook-ups (Part 4).
- How to build a 3-tube Reflex Receiver.

March, 1924

- Hoffman Transformer Measurement Chart
- The 100 Best Hook-ups (Part 5).
- How to build an Amateur Transmitter.
- A 3-tube Reflex Receiver (Part 2).

April, 1924

- How to build a Simplified Neutrodyne Receiver.
- The 100 Best Hook-ups (Part 6a).
- How NOT to Tune the Single Circuit Receiver.
- A Novel Substitute for "B" Batteries.

May, 1924

- A Compact Radio Kit for a Spring Hike.
- How to Get the Maximum Radio-frequency Amplification.
- 100 Best Hook-ups (Part 6b).
- Where Interference Comes In.
- How to Make an Audio-frequency Amplifier that Does Not Distort.

June, 1924

- How to Install a Receiver on your Boat.
- The 100 Best Hook-ups (Part 7).
- How to Build a Regenerative Receiver for Use with an Indoor Antenna.
- How to Make a Two-Slide Tuner.

July, 1924

- How to Avoid Local Interference.
- How "Resistance" Affects Radio Circuits.
- An Ideal Set for Summer-time Reception.
- 100 Best Hook-ups (Part 8).
- How to Do Your Soldering Correctly.
- How to Build the POPULAR RADIO Portable.

August, 1924

- How to build a single dry-cell tube, four-circuit tuner.
- How to build a two tube reflex receiver.
- Helpful hints for the broadcast listener.

September, 1924

- How to build a single dry-cell tube reflex receiver.
- How to build a multi-wave tuner.
- How to improve broadcast reception.

October, 1924

- How to build the (Cockaday) Four Circuit Tuner with a Resistance-coupled Amplifier.
- How to Select a Ready-made Receiver.
- How to Build a Detector-amplifier.
- A Radio Set to Pack in Your Suitcase.
- Harnessing the Radio and the Movie.

November, 1924

- How to Locate Interference from Power Lines.
- Cockaday Article for Beginners.
- How to Build a Low-loss Tuner for Short-wave Reception.
- The New Type of Superheterodyne.

December, 1924

- How to Build a Non-radiating 7-tube Superheterodyne Receiver.
- Cockaday Article for Beginners.
- How to Get the Most Out of Your Ready-made Receiver.

January, 1925

- How to Build the Cockaday 8-tube Superheterodyne Reflex Receiver.
- How to Improve Broadcast Reception.
- Cockaday Article for Beginners.

February, 1925

- How to Get on a Radio Program.
- A Loudspeaker for a Crystal Set.
- How to Build a 4-tube Reflex Receiver with the New Sodium Detector.
- Cockaday Article for Beginners.

March, 1925

- How to Build the Improved DX Regenerative Receiver.
- Factors that Govern the Capacity of Condensers.
- What "Induction" Means to Your Set.
- A Five Meter Vacuum-tube Transmitter and Receiver.

April, 1925

- Single Control Receivers.
- How to Improve Broadcast Reception. VI: Increasing the Selecting Power of Your Receiver.
- How to get the Most out of Your Ready-made Receiver.
- Quartz Crystal as a New Wavelength Standard.

May, 1925

- Factors That Affect Antenna Capacity.
- How to Wire Your Home to Have Radio in Every Room.
- Handy Tools for Radio Fans, The Hydrometer.
- How to Build the "Portable Town and Country Receiver."

subject, writing on one side of the paper only, and enclose a self-addressed and stamped envelope.

It is possible that your individual problem has been covered in an issue of POPULAR RADIO, and so as an aid to you we endeavor to keep a supply of back numbers in stock. The condensed index below gives a few of the subjects that have appeared recently, look this list over and if the information you want is covered, we will be pleased to supply back numbers at 35c. a copy.

June, 1925

- New Development in Vacuum Tubes.
- How to Build a Five-tube A-C Receiver.
- How to Draw Up Your Own Tuning Chart.
- Watt's Law in a Nutshell.
- "What Set Shall I Buy?" First Installment.

July, 1925

- The Best 101 Hook-ups.
- "What Set Shall I Buy?" Second Installment.
- Broadcast Stations in the United States.
- What's New in Radio Apparatus.

August, 1925

- "Motion Pictures" by Ether Waves.
- A New Type of Hornless Loudspeaker.
- How to Build a 5-Tube Radio-Frequency Set with Simplified Control.
- Trouble Shooting.
- Hints for Amateurs.

September, 1925

- How the Air Affects Radio.
- When You Turn Your Dials.
- Useful Charts for Amateurs.
- Call Letters That Have a Past.
- Broadcasts.

October, 1925

- How Earth Magnetism Affects Radio Waves.
- How to Improve Broadcast Reception.
- What Makes a Low-loss Coil?
- How to Build the New 8-Tube Superheterodyne with a Single Control.

November, 1925

- Radio's Newest Instrument—the Photoelectric Cell.
- How to Build the Raytheon Plate Supply Unit.
- New Methods of Calibrating Your Receiver.
- Practical Pointers About Transformers.
- Multi-layer Coils.

December, 1925

- How to Build The New LC-26 Receiver.
- How to Improve Broadcast Reception.
- What Every Radio Experimenter Should Know About Condensers.
- "Truthful Reproduction." How to Get It from Your Set.
- Radio that Runs on a Beam.

January, 1926

- How to Get the Most Out of Your LC-26 Receiver.
- Some New and Useful Facts About Coils.
- When Your Set Won't Work.
- Straight-Line-Frequency Condensers.
- What's New in Radio Apparatus.

February, 1926

- How to Reduce Distortion in Amplification.
- Some Stunt Sets.
- Important Kinks in Wiring.
- How to Cut Down Your "B" Battery Bill.
- Hints for Amateurs.

Popular Radio

627 West 43d Street

Dept. 38

New York City

S SC FOUR-TUBE RECEIVER C

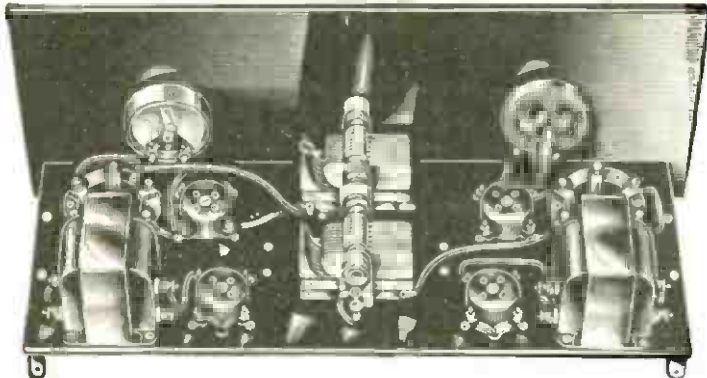

S-C 4-TUBE RECEIVER

Here are the parts for the famous S-C 4-tube receiver, exactly as used in the Laboratory Model. Four tubes, Regenerative detector. Single dial control. One stage of radio frequency and two stages of audio frequency. Coils are mounted in sockets and can be interchanged. The feature of this circuit is that it can be tuned in from 50 to 1500 meters, by changing coils, and with special coils, up to 2500 meters. Special wiring harness simplifies building to the nth degree. No bus wire needed. Each terminal is plainly marked for easy and quick connection. Anyone can connect this circuit. The Super set to build.

Equipped with the famous R T 200 Thordarson transformers, heretofore privately built for the most extensive sets.

The parts used in the Laboratory Model will be supplied. Order them or any others you may be interested in direct from this advertisement, enclosing remittance. We are the country's oldest specialty radio house, and supply over 100,000 radio fans with parts. We guarantee satisfaction. Prompt shipment and careful handling of your order. List price.....\$58.85

PARTS USED IN THE S-C 4-TUBE RECEIVER

2	# 316 Silver-Marshall .00035 Condensers.....	\$11.50
2	515 " " " " " " " " " " " " " " " "	2.00
1	110A " " " " " " " " " " " " " " " "	2.50
1	114A " " " " " " " " " " " " " " " "	2.50
4	510 " " " " " " " " " " " " " " " "	2.00
1	" " " " " " " " " " " " " " " "	2.50
1	113-P " " " " " " " " " " " " " " " "	1.50
1	Pr. " " " " " " " " " " " " " " " "	.70
2	S-C Thordarson Power Transformers # 200.....	16.00
1	Yaxley 6 ohm rheostat.....	1.35
1	# 1 " open circuit Jack.....	.50
1	# 2A " two " " " " " " " " " " " " " " "	.60
1	" " " " " " " " " " " " " " " "	.50
1	Centralab Resistance, 25,000 ohm.....	2.00
1	Belden Wiring Harness.....	4.00

1	Polymet .00015 condenser with leak clips.....	.45
1	" " .002 " " " " " " " " " " " " " " " "	.40
1	" " .005 " " " " " " " " " " " " " " " "	.60
1	" " 2 megohm leak.....	.25
1	7 x 18 Drilled and processed Front Panel.....	4.50
1	" " Sub-panel.....	2.50
Total.....		\$58.85

ADDITIONAL ACCESSORIES RECOMMENDED

1	IV 2512—7 x 18 Cabinet.....	\$8.95
4	IV 1530—201A tubes.....	6.20
1	IV 1592—100 AMP. storage battery.....	9.85
2	IV 1553—B Batteries.....	5.10
1	IV 6062—Cone Speaker.....	21.95
Total Net.....		\$52.05

COCKADAY'S L. C. 26 Complete Parts \$62.15

RAYTHEON TUBE B-ELIMINATOR Complete Kit \$39.50

SILVER-THORDARSON Kit \$31.95

HAMMARLUND-ROBERTS Complete Parts \$57.50

McLAUGHLIN 8 TUBE SUPER Complete Parts \$82.50

OTHER FAMOUS CIRCUITS

Here are a few sample bargains from the Barawik Catalog:
 Complete parts for Remler-Best 8-tube Super... \$48.45
 Complete parts for B-T Counterphase 6..... 63.50
 Complete parts for Silver-Super Autodyne..... 62.50
 Complete parts for Hazeltine Neutrodyne..... 29.25
 Complete parts for Browning-Drake circuit..... 32.25
 Guaranteed 201A type Tubes..... 1.15
 Guaranteed 45-v. large B batteries..... 2.55

Order direct from this ad or get a free copy of our complete catalog of everything in radio.

FREE RADIO GUIDE

NEW 1926 EDITION NOW READY

Barawik's New 1926 Radio Guide presents, in concise form, the famous radio circuits you have read about, such as: New S-C 4-Tube Receiver, Cockaday's L. C. 26, Radio Broadcast's Aristocrat and Universal, Silver-Marshall circuits, Hammarlund-Roberts, Raytheon "B" Supply, Hanscom circuits, Branstons kits, Victoreen kits, etc. Besides, it illustrates and describes sets, kits, accessories and parts that are needed by every set builder, fan, novice or beginner. As a catalog and guide, it is invaluable; and it shows you how you can save big sums in the very things you need, or it helps you to decide what set will best meet your needs and your pocketbook.

It shows the newest straightline condensers, low-loss coils, vernier dials, tubes, cone speakers, A and B current supply, batteries and everything from a crystal to the expensive complete DeLuxe console receiver—and one, two, three, five and eight-tube sets—at startlingly low prices. Whether you just want supplies for your present set or desire new one, here you can secure them at a guaranteed saving.

Fill in the coupon now for your free copy or drop us a postal or letter. Do this before you send another cent for anything in radio—now, while this announcement is before you. You'll be well repaid. Also please include name of radio fan or fans who would be interested.



MAIL THIS COUPON NOW →

The Barawik Co.

102-104 So. Canal St., Chicago, Ill.

BARAWIK CO., 102-104 So. Canal St.,
 Send me my copy, free, of your new Radio
 log and Builder's Guide.

Chicago
 Cata-

Name.....
 Address.....
 Friend.....
 Address.....

HOW YOU CAN GET SIMPLIFIED BLUEPRINTS FREE

You can have your choice of any one of eight POPULAR RADIO Simplified Blueprints with your new or renewal subscription for POPULAR RADIO, accompanied by remittance of \$3.00. These Blueprints will make it possible for you to build a tested and approved set, while POPULAR RADIO for 12 months will keep you in touch with the progress being made in radio.

You, as a reader of POPULAR RADIO, know the many entertaining, interesting and instructive articles that are published each month. Every issue some new item is sure to attract your attention. We promise that throughout the coming months POPULAR RADIO will hold more and more of interest for Radio Fans.

Ease, Economy and Accuracy in Construction

Simplified Blueprints were prepared under the personal supervision of Laurence M. Cockaday. They make it possible for anyone, without previous knowledge of radio, to construct a highly efficient radio receiver. Each set of Blueprints consists of 3 prints as follows:

Panel Pattern

This Blueprint is the EXACT size of the actual set. So accurate that you need merely lay it on your panel and drill as indicated. You can readily appreciate the convenience of this Blueprint. No scaling or measuring to do, no danger of ruining the panel through faulty calculation.

Instrument Layout

Here again you have an actual size print of each instrument and binding post and its exact location both on the panel and within the cabinet. Even the cabinet structure is clearly shown.

Wiring Diagram

The unusual feature of this Blueprint is that it is an actual size picture diagram of the finished set. Each instrument and other parts appear in exact size and the wires are so clearly traced from one contact to another that you can connect all terminals accurately without even knowing how to read a hook-up diagram.

Full constructional and parts details for these Receiving Sets will be found in the issue of POPULAR RADIO indicated. Back issues of POPULAR RADIO will be furnished at the rate of 35c a copy.

POPULAR RADIO
Department 39
627 West 43d Street, - New York

There Are Simplified Blueprints for the Following Sets:

- Set No. 4—"Cockaday Four-Circuit Tuner with Resistance-Coupled Amplifier" (five tubes, distortionless, two dials, automatic vacuum tube control, as described in the October, 1924, issue of POPULAR RADIO).
- Set No. 6—"The Cockaday 8-tube Superheterodyne Reflex Receiver" (eight tubes, two tuning dials, loop, non-radiating, distortionless, as described in January, 1925, issue of POPULAR RADIO).
- Set No. 11—"5-Tube Tuned Radio-Frequency Receiver with Simplified Control" (as described in August, 1925, issue of POPULAR RADIO).
- Set No. 12—"8-Tube Superheterodyne with Single Control" (eight tubes, two straightline variable condensers, as described in October, 1925, issue of POPULAR RADIO).
- Set No. 13—"Raytheon Plate Supply Unit" (a really dependable method for obtaining a "B" source of supply as described in November, 1925, issue of POPULAR RADIO).
- Set No. 14—"The LC-26 Broadcast Receiver" (as described in December, 1925, issue of POPULAR RADIO).
- Set No. 15—"The Orthophase Receiver" (a circuit development using a new principle in radio-frequency amplification, making a receiver with great sensitivity, combined with sharp tuning and ease of operation, as described in February, 1926, issue of POPULAR RADIO.)
- Set No. 16—"The S-C All Wave Receiver" (equipped with interchangeable coils so that it has practically an unlimited wavelength range, covering all wavelengths from 50 to 550 meters, as described in March, 1926, issue of POPULAR RADIO.)

Use coupon below; indicate which set of Blueprints you want.

POPULAR RADIO, Dept. 39
627 West 43rd Street, New York City

Enclosed is my remittance of \$..... in full payment for subscription, with Blueprints as checked below, FREE.

<input type="checkbox"/> Set Number 4	<input type="checkbox"/> Set Number 13
<input type="checkbox"/> Set Number 6	<input type="checkbox"/> Set Number 14
<input type="checkbox"/> Set Number 11	<input type="checkbox"/> Set Number 15
<input type="checkbox"/> Set Number 12	<input type="checkbox"/> Set Number 16

Name.....

Street.....

City..... State.....

Light to see — power to hear

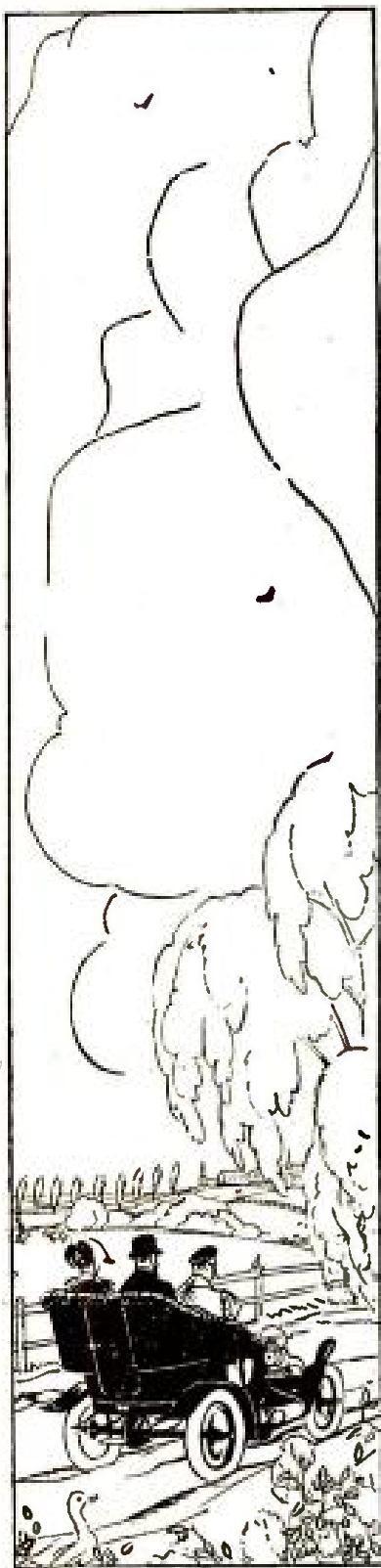

WHEN you buy a Prest-O-Lite Storage "A" or "B" Battery for your set, you are not only saving money because of the low cost but you are buying radio batteries that are made by a company with over twenty years of manufacturing experience.

Prest-O-Lite maintains the world's largest electrochemical research laboratories. From these laboratories have come the wonderfully efficient Prest-O-Lite Radio Batteries. Made especially for radio, they deliver their rated capacities at full power.

Ask for Prest-O-Lite Radio Batteries. They may be purchased from \$4.75 and up. It is no longer necessary to take chances with batteries of unknown make. You will find Prest-O-Lite dealers within earshot of your own loud speaker.

THE PREST-O-LITE CO., INC.
INDIANAPOLIS, IND.

New York San Francisco

In Canada: Prest-O-Lite Company of
Canada, Ltd., Toronto, Ontario

Send for free booklet

"What every owner of a radio should know about storage batteries" is a little booklet which every radio fan will find interesting and helpful. It is full of hints that will bring surprising radio results—and save you money.

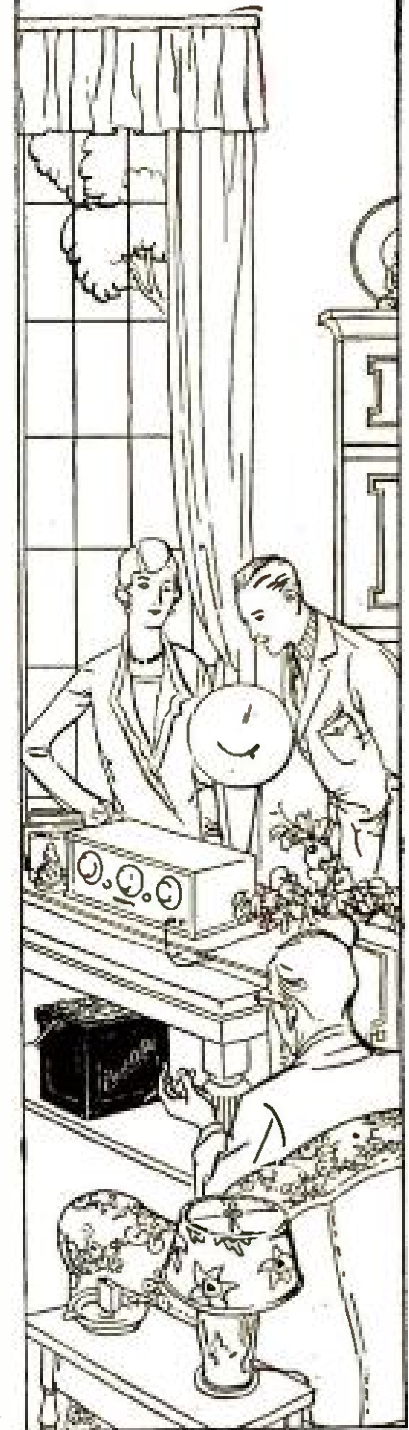

Designed especially for Radio

Prest-O-Lite

STORAGE BATTERIES FOR
MOTOR-CARS AND RADIO



MYERS TUBES



Get Out of the Fog

Myers Tubes make an instantaneous improvement in the clarity, volume, distance and quality of reception from any Radio Set.

The Tube is the Voice of the Circuit

MYERS Tubes are real Radio Tubes—not modified incandescent lamps. They are made by pioneer Radio Tube designers, for Radio purposes exclusively. Compact, precisely correct, free from dead spaces and clumsy dimensions. Finest performance, finest appearance.

Special internal geometry gives highest mutual conductance and largest factor of amplification, resulting in maximum performance when used in either transformer, impedance or resistance coupled circuits.

Unbreakable in normal use. Double-end electrode supports. Absolutely non-microphonic. Perfectly uniform. No matching necessary.

Marvelous Clarity

Internationally preferred by amateurs and experts. Made with standard four-prong base, or double-end, in types Myers 01-A, Myers 01-X, Myers 99, Myers 99-X.

List price, any type \$2.50.

Fully protected by patents pending and issued in the United States and Foreign Countries.

At Your Dealers

Myers Radio Tube Corporation
Cleveland, Ohio

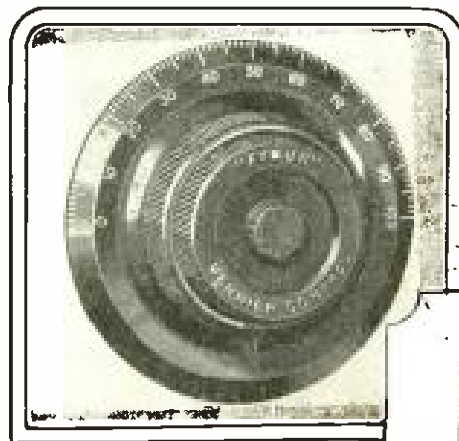
Price
\$3.50

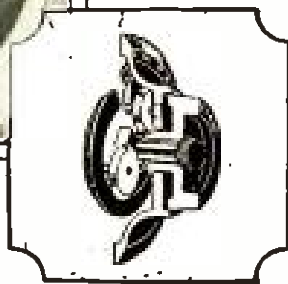

The Best Dial for the Finest Tuning

There's no backlash nor lost motion in the Fynur Dial. It's absolutely accurate—durable—and very simply constructed. It's the finest dial you can buy for distance tuning or for separating low wavelength stations. Dual control. No gears. Operates by traction. Will fit any standard $\frac{1}{4}$ " shaft.

If your dealer cannot supply you, write to us
AUGUST GOERTZ & CO., INC.
270-286 Morris Ave. Newark, N. J.

FYNUR VERNIER CONTROL

Now in its second successful year

The MOLLIFORMER "B" UNIT REPLACES "B" BATTERIES

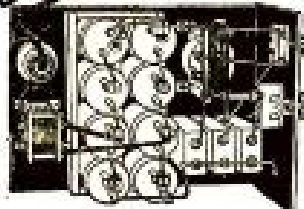

No Hum—No Acids—No Tubes

MODEL F W 4

This is the completely assembled MOLLIFORMER "B" UNIT designed especially for 5 or 6 tube receivers requiring no more than 100 volts on the amplifiers. The MOLLIFORMER employs improved electrolytic full wave rectifier. Low in cost and exceptionally low in operation.

MODEL F W 4—PRICE
Completely assembled \$24.50

BUILD IT YOURSELF

You can build your own MOLLIFORMER "B" UNIT in less than an hour and save money. The Kits listed below include all the essential parts necessary to assemble the unit complete.

PRICE
Complete Kit MODEL F W 4— 39 cycle A-C \$17.00
Complete Kit MODEL F W 8— 60 cycle A-C 22.50
25 and 40 cycle transformers \$2.00 additional

Kits include Rectifiers. Parts sold separately if desired.
DEALERS—Write for discounts.

C. E. JACOBS, Sole Mfr.

2812 N. Kedzie Ave. CHICAGO

SANGAMO Mica Condensers in intermediate sizes



IMPROVE
TONE
RANGE
AND
VOLUME

It is accuracy, not luck, that makes one receiver sweeter and more powerful than another that is almost its twin. Especially condenser accuracy, for the closer you come to absolute accuracy at these critical parts, the more wonderful your receiver will be. The cost of accurate condensers is small—the effect is immense.

Now you can get Sangamo Mica Condensers in capacities in between the usual stock sizes so you can build with greater accuracy than ever before. They are guaranteed to be accurate, and they always stay accurate, being solidly molded in bakelite. Neither heat, cold, moisture, pressure nor acid fumes will affect their capacity, because bakelite seals the delicate parts against all outside influences.

Capacities in microfarads and prices

0.00004	} 40c.	0.001	} 50c.	
0.00005		0.0012		
0.00006		0.0015		
0.00007		0.00175		
0.00008		0.002		
0.0001		0.0025		
0.00012		0.003		} 60c.
0.00015		0.0035		
0.000175	0.004			
0.0002	} 70c.	0.005	} 70c.	
0.00025		0.006		
0.0003		0.007		
0.00035		0.0075		
0.0004		0.008		95c.
0.0005		0.01		\$1.00
0.0006		0.012		1.15
0.0007		0.015		1.20
0.0008		0.015		1.25

With Resistor clips. 10c. extra

Also Sangamo By-Pass Condensers

1/10 mfd. 30c.	1/2 mfd. 90c.
1/4 mfd. 80c.	1 mfd. \$1.25

Sangamo Electric Company Springfield, Illinois

RADIO DIVISION, 50 Church Street, New York

SALES OFFICES—PRINCIPAL CITIES

For Canada—Sangamo Electric Co. of Canada, Ltd., Toronto.
For Europe—British Sangamo Co., Ponders End, Middlesex, Eng.
For Far East—Ashida Engineering Co., Osaka, Japan

FOR CLEAR, QUIET "B" POWER



RADIO Storage "B" Battery

12 Cells 24 Volts Lasts Indefinitely—Pays for Itself

Economy and performance unequalled before. Recharged at a negligible cost. Delivers unflinching power that is clear, pure and quiet. Approved and listed as standard by leading Radio Authorities, including Pop. Radio Laboratories, Pop. Sci. Inst., Standard, Radio News Lab., Lafax, Inc., and other important institutions. Equipped with Solid Rubber Caps, an insurance against acid and leakage. Extra heavy glass jars. Heavy rugged plates. Order yours today!

SEND NO MONEY Just state number of batteries wanted and we will ship day order is received. Extra offer: 4 batteries in series (96 volts), \$10.50. Pay expressman after examining batteries. 5 per cent discount for cash with order. Mail your order now!

WORLD BATTERY COMPANY
1219 So. Wabash Ave., Dept. 77 Chicago, Ill.
Makers of the Famous World Radio "A" Storage Battery
Prices: 6-cell, \$10.50; 12-cell, \$18.00; 18-cell, \$25.50; 24-cell, \$33.00.
All equipped with Solid Rubber Caps.

World STORAGE BATTERIES

Set your Radio Dial at 210 meters for the new 1000 watt World Storage Battery Station, WBBB, Chicago. Watch for announcements.

WBAK—WBAF—WGN—WWS—HCU—KGO—KFAF—WJW—KOP

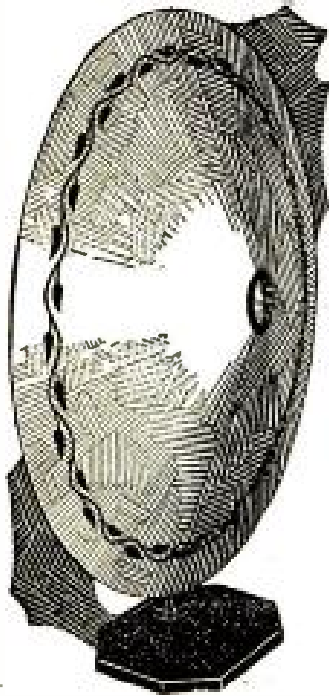

Make Your Own Cone Loud Speaker —and Save \$25⁰⁰

(All Parts Supplied)

Why pay \$35 or more for a cone loud speaker when you can easily assemble a splendid super-sensitive one at home with the complete parts we send you—and save \$25?

With the parts we send you is a special complete cone unit, blue print and simplified directions for assembling. Even if you don't know the first thing about radio, the directions are so clear that you can easily set up this wonderful speaker in a few interesting hours. Don't confuse this cone with the small-size ones being sold by other manufacturers. Stands eighteen inches high, complete in every detail. Not only unmatched for beauty, but reproduces both music and voice with faultless accuracy. Yet the cost is amazingly low—

you pay only \$10 for this remarkable instrument—the most approved form of loud speaker known. We can offer you this big saving because the cost of labor in assembling and packing of the cone is a big item, and our method of selling also eliminates all jobbers' and dealers' profits.

SEND NO MONEY

Simply send name and address and the complete outfit will be sent you by return mail. When postman brings package, deposit with him only \$10.00 in full payment. If you aren't more than delighted—if you're not absolutely convinced that you have a cone speaker equally as fine as any \$35 cone sold—simply return the parts within ten days and your money will be instantly refunded. Never before has a better radio bargain been offered. You would pay at least \$35 for a cone speaker of equal quality anywhere. Act at once. Write NOW!

Scientific Radio Laboratories
254 West 34th St. Dept. 33 New York City

C-O-N-V-E-R-T-E-D-!-!

Your Four Circuit Tuner converted into the latest Cockaday Receiver or accepted as part payment on an LC-26.



Does your eight tube superheterodyne:

- (1) Cover efficiently 175-560 meters
- (2) Give good quality and volume
- (3) Exclude extra repeat points
- (4) Allow long B battery life

?

If not, then you should write us for quotation on modifications that will correct these deficiencies.



The METROPOLITAN LABORATORIES

86-88 West Broadway, New York City

"The Best Is the Cheapest"

IMPROVED LOPEZ LOW LOSS TUNER

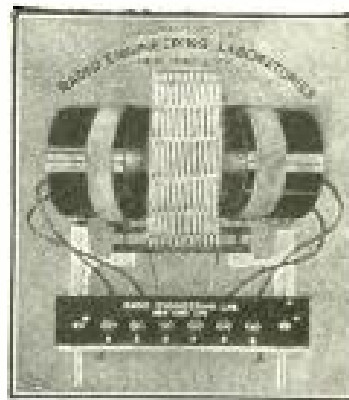

The Improved Lopez Tuner has two wavelength ranges using one .0005 mfd. tuning condenser. Allows greater separation between stations.

LOW RANGE —150 to 400 METERS
HIGH RANGE—220 to 600 METERS

ABSOLUTELY MOISTUREPROOF

Coils wound with triple cotton covered paraffined wire. Every contact is positive. There are no spring or friction contacts.

Improved Tuner—Price, \$10.00

RADIO FREQUENCY COIL

of similar construction as the Lopez Tuner Secondary, with necessary antenna tap, used with a .0005 mfd. variable condenser.

Coil and Mountings—Price, \$2.00

A highly efficient 4-Tube Set may be constructed with the Lopez Tuner and the R. F. Coil.

Constructional data on the new 3 and 4-Tube Sets now ready for distribution.

RADIO ENGINEERING LABORATORIES

25 Thames St.

New York, N. Y.

"The Low Loss Coil Pioneers"

A RADIO CABINET OF BEAUTY AND ELEGANCE DIRECT TO YOU AT LOWEST COST

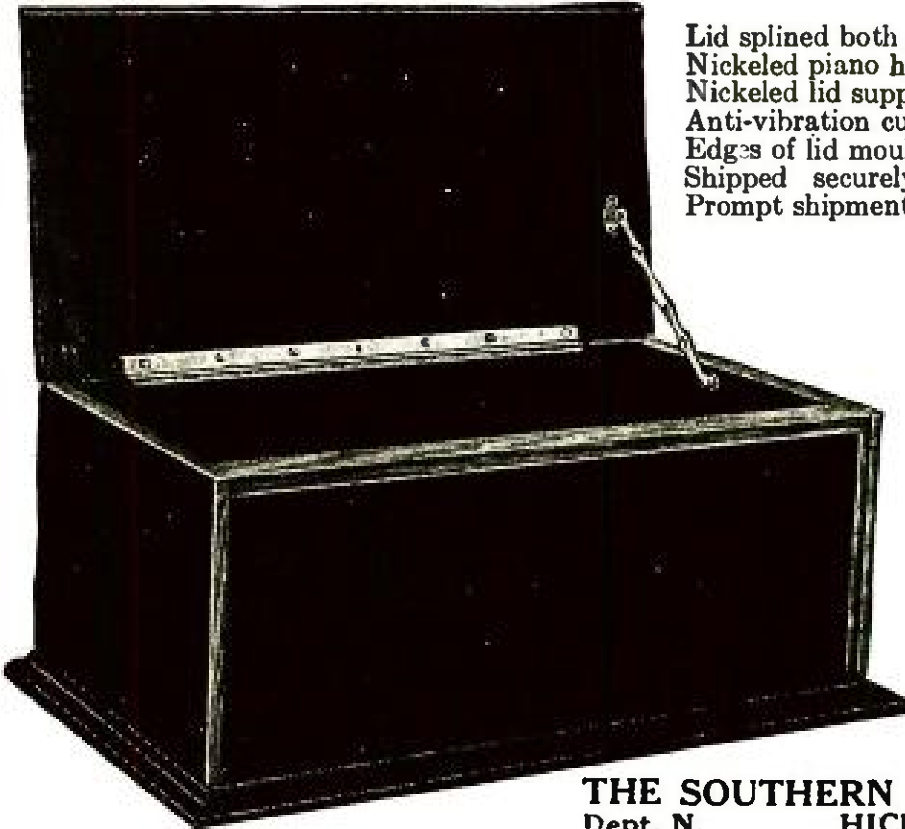

Lid splined both ends to prevent warping.
Nicked piano hinge—Full length.
Nicked lid support of artistic design.
Anti-vibration cushion feet (not visible in cut).
Edges of lid moulded to match bottom.
Shipped securely packed in strong carton.
Prompt shipment. Big stock for holidays.

	Hardwood, Rubbed Mahogany Finish	Solid Black American Walnut
7 x 18 x 7 1/2 or 10 in. deep	\$3.50	\$5.00
7 x 21 x 7 1/2 or 10 in. deep	3.75	5.25
7 x 24 x 7 1/2 or 10 in. deep	4.00	5.50
7 x 26 x 7 1/2 or 10 in. deep	4.75	6.25
7 x 28 x 7 1/2 or 10 in. deep	5.50	7.00
7 x 30 x 7 1/2 or 10 in. deep	6.00	8.00

Add 25c. for "E-Z" Fone plug.

CASH WITH ORDER or C. O. D.
if 1/4 of price is sent with order.

Prices F. O. B. Hickory, N. C.

Order express shipment, often
cheaper than mail and much safer
from damage.

FREE WITH EACH CABINET
a glued-up stock non-warping 1/2-
inch BASEBOARD.

Free Catalogue.

THE SOUTHERN TOY COMPANY, INC.
Dept. N. HICKORY, NORTH CAROLINA

*For Clear Reception
and Quality Tone Use*

HEATH'S RESISTANCE- COUPLED AMPLIFIER

This wonderful 3-stage Amplify-
ing Unit gives remarkable quality
of tone, free from distortion, and
satisfying in its naturalness.

*If your Dealer cannot supply you—
Order Direct From*

HEATH RADIO & ELECT. MFG. CO.
206-8-10 FIRST STREET
NEWARK, N. J.

THINK MAN! THINK!!

You can now make an **Electric Light Socket Radio Receiver** out of any battery-operated set, radio circuit or parts, and eliminate forever all A. B. and C. batteries, chemicals, charges, continuous trouble, upkeep expense, disappointments, and save easily \$75 a year.

Anyone—you, your battery-charging, electrical and radio service man or dealer—can make it in short time at reasonable expense. Thousands are now doing it and thousands of Powerolas are now in the homes.

It will be as good as **POWEROLA**, the famous 5-tube no-battery electric radio (universal for A. C. or D. C.) now demonstrated and sold by your local electric light company, radio, electrical or music dealer, and tested and endorsed by Popular Radio, Radio Broadcast, Radio News and all highest and leading authorities, and engineers, as being powerful, practical, perfect, dependable and constant in performance.

REMEMBER—YOU DON'T HAVE TO JUNK OR THROW AWAY YOUR OLD SET OR PARTS. THEY CAN NOW BE MADE INTO AN UP-TO-DATE ELECTRIC RADIO, THE LATEST AND BEST IN RADIO PERFECTION AND PLEASURE.

Send \$1.00 and we will mail you booklet containing new and hitherto unpublished diagrams, information and literature, showing how to make any old or new radio set, circuit and parts into an Electric Radio.

Powerola Radio Corporation
1841 Broadway, N. Y. City



“The Kid
Himself!”

JUDGE, JR.

Who Runs the “HIGH HAT” Column
Every Week in Judge

“TAKES THE AIR”

Every Thursday at 7 P. M.
at Station WJZ

“HE’S A KNOCKOUT!”

Judge for Yourself

COILS FOR EVERY POPULAR RADIO RECEIVER

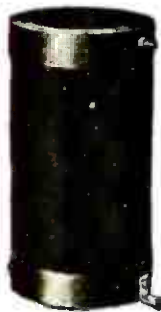

PRECISION OCTAFORM COIL

A new type of inductance used in the Cockaday LC-26 Receiver. The only coil that can be used in this set. Price \$5.50.

PRECISION RF COUPLERS

With the patented octaform shape, having 90% air core. Price \$2.50 each.



INDUCTO COUPLER

McLaughlin recognized the superiority of Precision Coils when he recommended the Inducto Coupler for his One-Control Superheterodyne. For use where a split winding coil is desired. Price \$1.85.

PRECISION ANTENNA COUPLER

For the McLaughlin One-Control Super. May be used when an outdoor aerial is desired with a Super. Price \$3.50.

COCKADAY COIL \$5.50 (New Octaform Base)

The fact that this coil was used in the 4-Circuit Tuner as designed by Mr. Cockaday, is significant recognition of the accuracy and efficiency of Precision Coils.

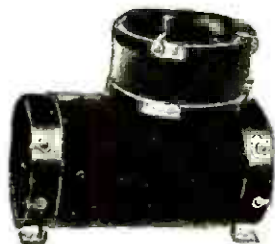

WE SPECIALIZE IN COCKADAY KITS

Sets designed by Mr. Cockaday have always proved so successful and the demand has been so great that it is often difficult to get all the parts for their construction. We specialize in Cockaday Kits. Complete parts exactly as used in Mr. Cockaday's Laboratory Models. Our buying department has exceptional facilities for getting all the parts for these Cockaday Kits. Write us.

COCKADAY LC-26 KIT

1 General Radio variometer, type 269, equipped with rheostat knob.....	\$5.30	3 Amperites No. 1a.....	\$3.30
1 General Radio rheostat, type 214-a, 7 ohms, equipped with rheostat knob.....	2.25	1 Amperite No. 112.....	1.10
1 Precision Octaform coil set.....	5.50	5 Benjamin standard "Cle-tone" sockets.....	5.00
1 Amisco special double unit condenser No. 1814 each section .0003 mfd.....	6.25	1 Carter single-circuit jack, No. 101.....	.70
1 Micamold fixed condenser, .00015 mfd.....	.35	2 Carter Jack switches, No. 2.....	2.00
1 Micamold fixed condenser, .00025 mfd.....	.35	8 Eby binding posts.....	1.20
2 Daven resisto-couplers (new type which incorporates 1 mfd. condenser concealed in base).....	3.00	1 Fynur vernier control knob and dial.....	3.50
1 Amertran DeLuxe transformer, first stage.....	10.00	1 Universal decorated panel, 8x22 inches.....	7.50
Bradley leak, 1/4 to 10 meg.....	1.85	Blueprints.....	1.00
3 Bradley units, 1/4 megohm.....	2.25	4 Small brass brackets.....	
1 Bradley unit, 1/2 megohm.....	.75	1 Antenna connection block, 1x2 inches.....	
		1 Battery connection block, 1x9 inches.....	1.75
		2 Large brass brackets.....	
		Screws and buss wire.....	
		Solid Walnut Cabinet.....	17.00
		Total.....	\$81.90

COCKADAY "B" ELIMINATOR KIT

1 Raytheon tube.....	\$6.00	1 Benjamin cleat receptacle, type 9401.....	\$3.35
1 Acme transformer.....	7.00	1 Bradleyohm No. 10—100,000 ohms.....	2.00
2 Acme henry choke coils.....	10.00	1 Bradley unit resistance—7,500 ohms.....	.75
2 Tobe shielded, high voltage paper condensers, 2 mfd.....	3.50	1 Electrad resistance mounting.....	.35
2 Tobe shielded, high voltage paper condenser, 4 mfd.....	7.50	1 Hardwood baseboard, 7x20 inches.....	.50
1 Tobe shielded, high voltage paper condensers, 1 mfd.....	1.25	1 Composition binding post strip, 1x7 inches.....	.25
2 Tobe shielded, high voltage paper condensers, .1 mfd.....	1.40	1 Pair small brass brackets.....	.20
1 Federal socket, type 16.....	1.00	Total.....	\$42.05

PRECISION COILS AND KITS ARE ABSOLUTELY GUARANTEED

Send money order today or we will ship C.O.D. upon receipt of your order anywhere in the U. S. A. Dealers—Write for information about the complete Precision Line.

PRECISION ORTHOPHASE COILS

Designed especially for the new Orthophase Receiver described in February Popular Radio. Price per set of three, \$7.50.



PRECISION AUTODYNE COUPLER

Used in the Superheterodyne Reiflex Receiver described in January 1925 issue of Popular Radio Price \$3.50.



PRECISION COIL CO., INC.
209 Centre Street, New York, N. Y.

Make Your Radio Set More Efficient With Allen-Bradley Radio Devices

IT matters not whether you are building a receiver or own a factory-built set, in either case you can make your set more efficient by using Allen-Bradley Radio Devices in many parts of the receiver. In addition to the various devices for filament control, grid leak and potentiometer control, there also are the Bradley-switch and the Bradleyner which are easily installed. The one-hole mounting makes installation quick and easy.

TO bring your set up-to-date, replace your old condensers with Bradleydensors and thereby enjoy the selectivity of straight-line-frequency tuning. The condenser is extremely compact and will not interfere with any other parts on your panel. Don't forget the Bradley-Amplifier for perfect audio amplification. This efficient amplifier is a complete unit ready for immediate use in your set. Try Allen-Bradley Devices tonight and hear the difference!

Insist on Allen-Bradley Products Sold In Distinctive Checkered Cartons



Bradleystat
PERFECT FILAMENT CONTROL



Bradleyleak
THE PERFECT GRID LEAK



Bradleyohm
PERFECT VARIABLE RESISTOR

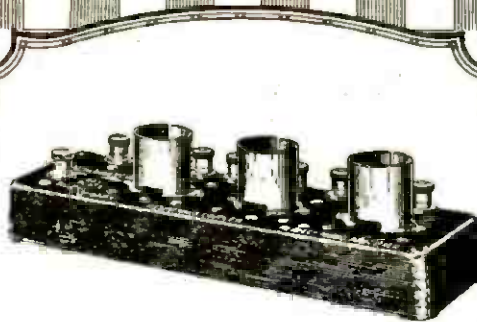

Bradley-Amplifier
Resistance-Coupled
PERFECT AUDIO AMPLIFIER



Bradleyometer
THE PERFECT POTENTIOMETER



Bradleyswitch
PERFECT BATTERY SWITCH



Bradleyunit
Amplifier Resistors

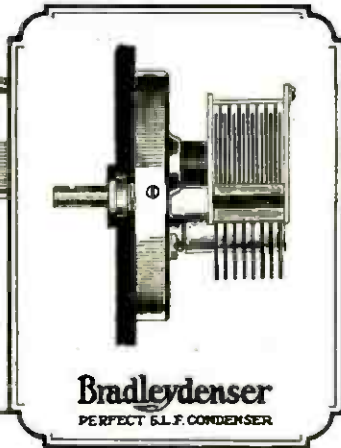

Bradleydensor
PERFECT G.L.F. CONDENSER



Bradleyunit
PERFECT POWER RESISTOR

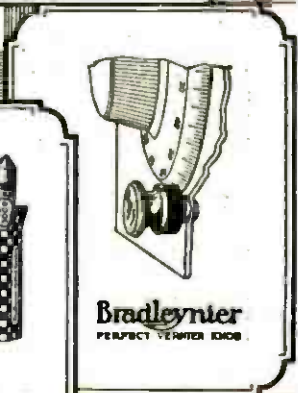

Bradleyner
PERFECT TUNER KNOB



Allen-Bradley Company,
276 Greenfield Ave., Milwaukee, Wis.

Please send me, immediately, your latest literature describing the entire Allen-Bradley line.

Name.....

Address.....

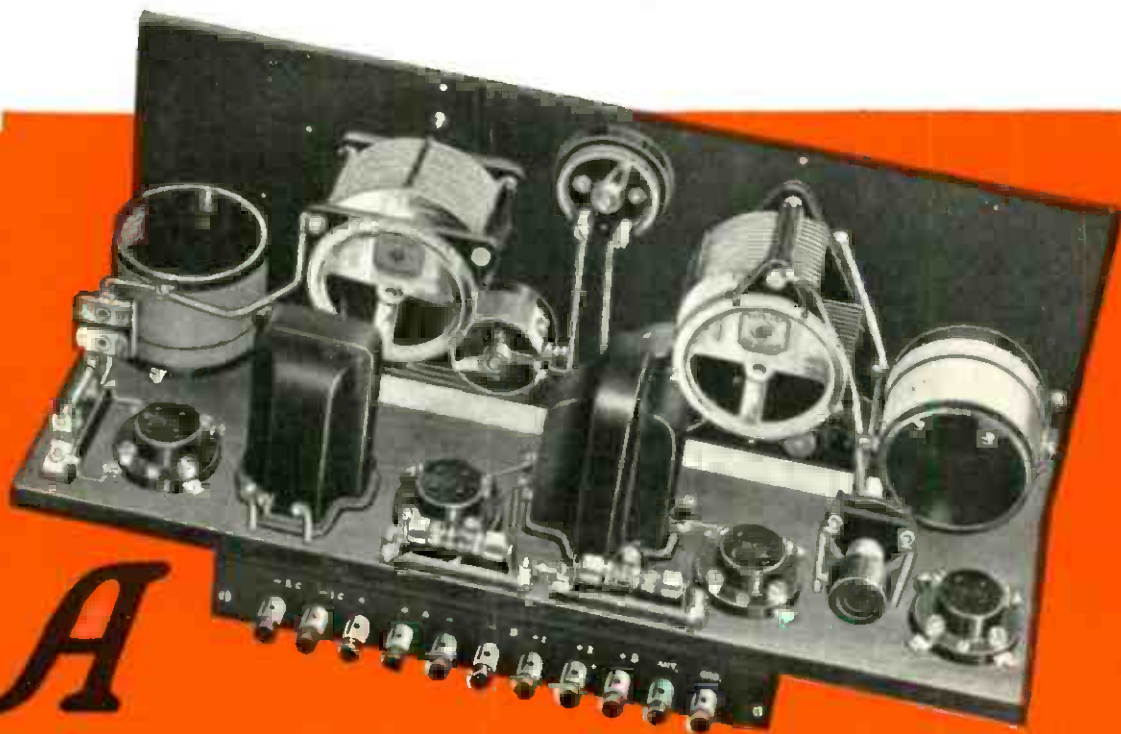

A Masterpiece in Radio Technique

*Exemplifying All the Refinements
of Modern Receiver Design*



*This Booklet is FREE
to Set-Builders*

ASK your dealer for free booklet containing diagrams, templates, list of parts, and complete instructions for building the "UNIVERSAL." If he is unable to supply information and parts, write to Dept. "UNIVERSAL," General Radio Co., Cambridge 39, Mass.

THE Radio Broadcast "UNIVERSAL" has been designed by Arthur H. Lynch to include every popular improvement of receiver design that is practicable for home construction.

The experiences and skill of Radio Engineers, Radio Editors, and amateur set-builders throughout the United States are summarized in this receiver.

While the circuit itself is not new in principle, it is slightly different in its application, and embodies the latest refinements of the radio art.

From a standpoint of performance, simplicity, and economy of construction and operation, the "UNIVERSAL" is unrivaled.

To the set-builder who expects real results from his set we give our assurance that he will get them from a properly built "UNIVERSAL."

The RADIO BROADCAST
UNIVERSAL
FOUR TUBE RECEIVER

GENERAL RADIO

INSTRUMENTS

"Behind the Panels of Better Built Sets"



The mark of quality whether you buy or build. Insist upon C-H radio products for highest efficiency in your new set.

“That’s Not Only a Beautiful Set, Fred; It Has Been Carefully Designed — Those Sockets Prove It!”

A list of some of the prominent radio manufacturers using C-H Products

Acme Apparatus Co.
 American Bosch Magneto Co.
 Crosley Radio Corporation
 Dayton Fan & Motor Co.
 Dictagraph Products Co.
 Dubilier Condenser & Radio Corp.
 Electrad, Inc.
 Froed-Eisemann Radio Corp.
 Garod Corporation
 Gilfillan Bros., Inc.
 Harding Mfg. Co.
 Howard Radio Co.
 King Electric Mfg. Co.
 Kodel Radio Corporation
 Malone-Lemmon Laboratories
 Glenn L. Martin Co.
 Wm. J. Murdock
 Pfanstiehl Mfg. Co.
 Philadelphia Storage Battery Co.
 Signal Electric Co.
 Silver-Marshall Co.
 R. E. Thompson Co., Inc.
 J. S. Timmons
 Workrite Mfg. Co.
 Zenith Radio Co.

YOU can always tell a carefully designed set by its parts—any radio set manufacturer will tell you so.

That’s why you find so many sets on the market today with C-H sockets, rheostats and switches. For manufacturers know by careful testing the advantages that hundreds of thousands of radio fans have found in C-H features through years of “building their own”

C-H Low Loss Sockets, for instance, settle once and for all one of the most annoying of all set troubles—loose contacts at the tube prongs. In C-H sockets each tube prong is firmly held in the one piece, *silver-plated*, double grip contacts. Jarring of the set or corrosion cannot alter the perfect contact. They are easily wired and give a finished appearance to any set.

So whether you buy or build—look for the C-H trade mark. It is a guarantee of satisfaction.

THE CUTLER-HAMMER MFG. CO.

Member Radio Section, Associated Manufacturers of Electrical Supplies
MILWAUKEE, WISCONSIN



The New C-H UX Socket

for the new UX tubes. Same C-H one piece, low loss **SILVER** plated, double grip contacts as in the C-H original low loss socket with the **ORANGE** shell. Heat proof Thermoplax body—terminals cannot loosen under heat of soldering iron.

Spring washers under binding posts prevent loosening of hex nuts and assure tight connections. The hex nuts are slotted to permit tightening with screw driver or wrench.

The lugs at the end of the contacts are designed for easy soldering and may be bent down for under wiring.

CUTLER-HAMMER

Buy Your Radio Parts by Name