

Popular Radio

Edited by **KENDALL BANNING**

AUGUST · 1925



**— In this Issue —
How to Build a
5-Tube Radio Fre-
quency Receiver
with Simplified
Control.**

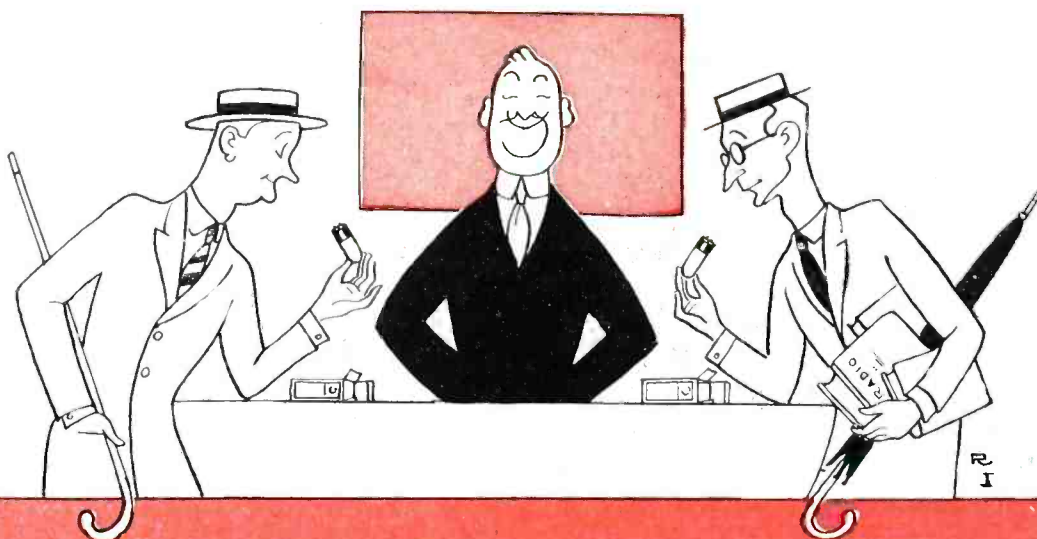

It isn't a
genuine
UV-199
unless
it's a
Radiotron

The familiar names WD-11, WD-12, UV-199, UV-200 and UV-201-A rightfully belong to Radiotrons only. To be sure of quality, it is important to look carefully at the base of every tube you buy to see that it carries the name Radiotron and the RCA mark as proof that it is a *genuine* Radiotron.



Radio Corporation of America

Chicago

New York

San Francisco



Radiotron

AN RCA PRODUCT

A new by **Brandes**

Listen for the low tones; listen for the high tones. Suddenly you'll realize how much *more* you hear through a Brandes. New rounded fullness in the low register—new clarified lightness in the high.

It took the Brandes Laboratories two years to develop this speaker. Two years of earnest research which are now rewarded by the supreme quality of their product. And the horn has grace and simple beauty. It is antique bronze in finish—but gold in *tone!*

The new Brandes Speaker (Type H) may well be the standard by which all others can be judged. And this is merely one way of saying, hear them all before you make your choice.

Price \$18

*Slightly more west of the Rockies
and in Canada*

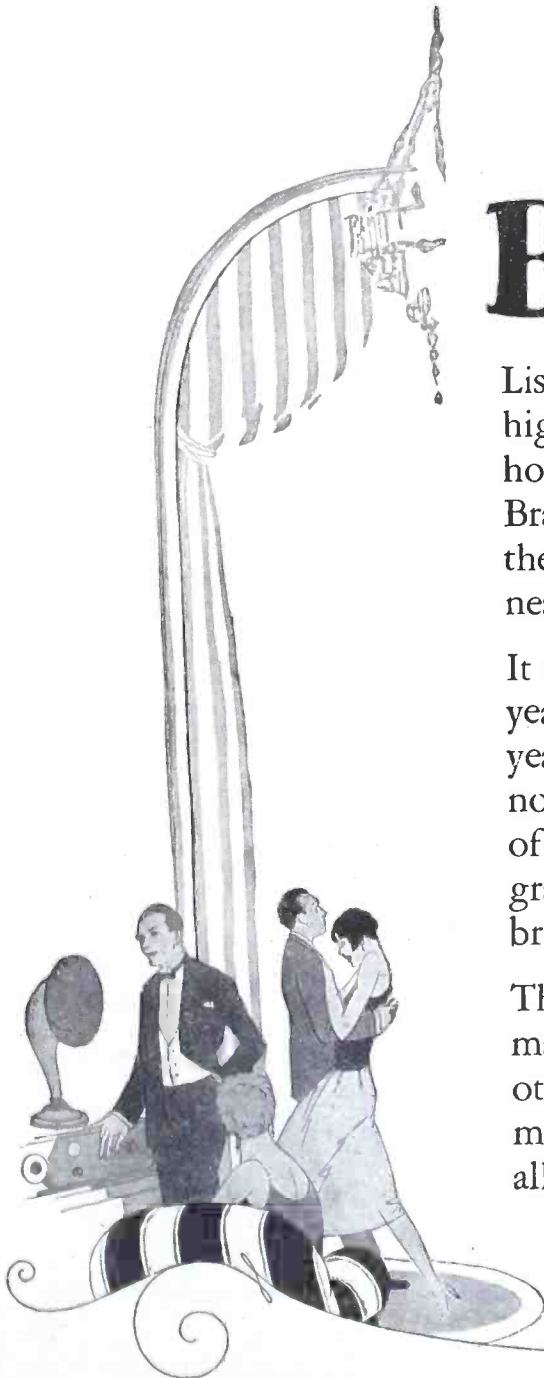

© Copyrighted by C. Brandes, Inc., 1925

All apparatus advertised in this magazine has been tested and approved by POPULAR RADIO LABORATORY

POPULAR RADIO

EDITED by KENDALL BANNING



CONTENTS for AUGUST, 1925

(Cover design by Frank B. Masters)

VOLUME VIII

NUMBER 2

An Unusual Automobile "Extension" for Broadcasting.....	FRONTISPIECE
Riding to Riches by Radio.....	Ralph E. Renaud.....Page 99
Part I	
"Motion Pictures" by Ether Waves.....	Charles Allen Herndon..... 107
Men Who Made Radio.....	114
Eighth Installment	
How to Get the Most Out of Your Ready-made	
Receiver.....	S. Gordon Taylor..... 116
No. 7: The Grebe Synchronphase	
A New Type of Hornless Loudspeaker.....	W. T. Meenam..... 128
A Mobile Radio Relay Station.....	David Lay..... 130
How to Build a 5-Tube Radio Frequency Set with	
Simplified Control.....	Albert G. Craig..... 136
"What Set Shall I Buy?".....	150
Important Trifles in Radio.....	Raymond Francis Yates..... 154
The Grid-leak	
The Atom.....	William Bragg..... 159
Article No. 1	

DEPARTMENTS

What Readers Ask.....	Laurence M. Cockaday..... 164
In the World's Laboratories.....	E. E. Free..... 168
Trouble Shooting.....	S. Gordon Taylor..... 176
The Broadcast Listener.....	Raymond Francis Yates..... 180
With the Inventors.....	William G. H. Finch..... 184
Broadcasts.....	David Lay..... 188
What's New in Radio Apparatus.....	The Technical Staff..... 191
Hints for Amateurs.....	Albert G. Craig..... 195

VOLUME VIII

AUGUST, 1925

NUMBER 2

Published monthly by Popular Radio, Inc., 627 West 43rd St., New York, N. Y., telephone number, Chickering 1906; Douglas H. Cooke, President and Treasurer; Kendall Banning, Vice-President; Laurence M. Cockaday, Secretary; Joseph T. Cooney, Asst. Treasurer. Price 25 cents a copy; subscription \$3.00 a year in the U. S., Canada and all countries within the domestic postal zone; elsewhere \$3.50 a year, payable in advance. The International News Company, Ltd., No. 5 Bream's Bldg., London, E. C. 4, sole distributors in England. Entered as second class matter April 7, 1922, at the Post Office at New York, N. Y., under the act of March 3, 1879. Copyright, 1925, and title registered as a trade-mark by Popular Radio, Inc. Copyright in Great Britain by Popular Radio, Inc., 6 Henrietta St., Covent Garden, W. C., London, England.

Printed in U. S. A.

LAURENCE M. COCKADAY, *Technical Editor*
 E. E. FREE, Ph.D., *Contributing Editor* JOHN V. L. HOGAN, *Contributing Editor*

For advertising rates address

E. R. CROWE & COMPANY, INC.

New York: 25 Vanderbilt Avenue

Chicago: 225 North Michigan Avenue



Binocular Coils

Selectivity

—the most important function of a radio set

Sensitivity—yes.

Clarity of tone—surely.

But *selectivity*—that is the true test of performance.

The extreme selectivity of the Grebe Synchronphase has been made possible by the *Binocular Coils* which, because they have no field, are unaffected by impulses from undesired stations. They keep the set automatically balanced against such interference.

These Binocular Coils are exclusively Grebe, as are also the *Grebe S-L-F* (straight line frequency) *Condensers* and *Grebe Volume Control* which are outstanding features of the Synchronphase.

Ask your dealer to demonstrate these features or write us

A.H. Grebe & Co., Inc., Van Wyck Blvd., Richmond Hill, N.Y.
Western Branch: 443 So. San Pedro St., Los Angeles, Cal.

The

GREBE

This Company owns and operates stations WAHG, WBOQ; also mobile and marine low-wave re-broadcasting stations.

SYNCHROPHASE

—TRADE MARK—



The true worth of a machine lies not in its appearance but in its performance.

Doctor H.A.



All Grebe apparatus is covered by patents granted and pending.

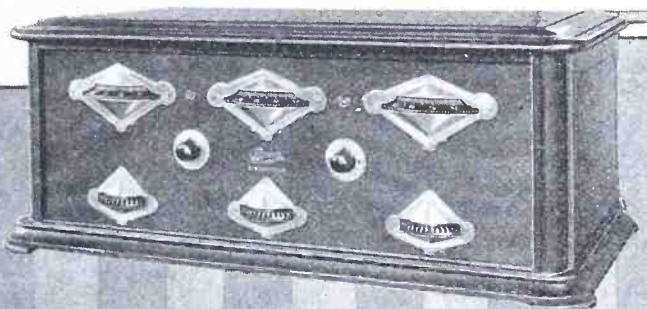

Also supplied with base for batteries

All apparatus advertised in this magazine has been tested and approved by POPULAR RADIO LABORATORY

PAGES WITH THE EDITOR

The Wireless Age to Be Combined with POPULAR RADIO

BEGINNING with the September number—published August 20—the oldest and one of the best and most widely known radio magazines in the world, *The Wireless Age*, will be consolidated with POPULAR RADIO.

* * *

THE consolidation marks the most important single advance that POPULAR RADIO has yet made in the publishing field, and establishes this combined magazine as the oldest, as it has been the most authoritative radio periodical, and one of the most widely circulated radio monthly magazines in the world.

* * *

To the strength of POPULAR RADIO will now be added the editorial resources of *The Wireless Age*—including not merely such material considerations as valuable contributions and a large list of subscribers, but also long established contacts with the world of science—contacts to which the successful career of *The Wireless Age* has been largely due. These assets now merge with this magazine.

* * *

THIS consolidation, however, will not otherwise alter the editorial policy of POPULAR RADIO, *nor affect the absolute independence of action that has marked this magazine from its beginning.*

* * *

The Wireless Age, the pioneer magazine in the radio field, was established in 1911 under the name of *Marconigraph* by the Marconi Wireless Telegraph Company of America. One year later the name of the magazine was changed to *The Wireless Age*.

* * *

FROM 1911 to 1923 *The Wireless Age* was edited by J. Andrew White, who built up the publication from a 16-page pamphlet to a 100-page magazine. Dur-

ing that period it has recorded every activity in the radio field, from the original Marconi experiments across the Atlantic and the pioneer wireless installation on shipboard to amateur activities everywhere. In recent years it has featured predominantly the broadcasting phase of radio, and it was to devote himself to this that its editor, Mr. White, gave up his editorial duties. Today Mr. White is perhaps the most popular sports announcer in the country.

* * *

WHEN the Marconi Wireless Company of America was taken over by the Radio Corporation of America in 1919, the publication of *The Wireless Age* was in turn taken over by The Wireless Press, Inc., a subsidiary company of the Radio Corporation of America. This subsidiary company was headed by General James G. Harbord, President of the Radio Corporation of America.

* * *

As the Radio Corporation of America has grown and its activities vastly developed, it finally reached the point where it concluded that it should concentrate in its highly specialized sphere and to dispose of its magazine interests entirely. So after careful consideration, the directors of The Wireless Press, Inc., selected POPULAR RADIO as the magazine that is best equipped to fulfill the obligations of *The Wireless Age* to its friends and readers.

* * *

WITH the next issue, therefore, this magazine will greet its largely increased army of subscribers and readers under the title of

POPULAR RADIO
with which is combined
The Wireless Age

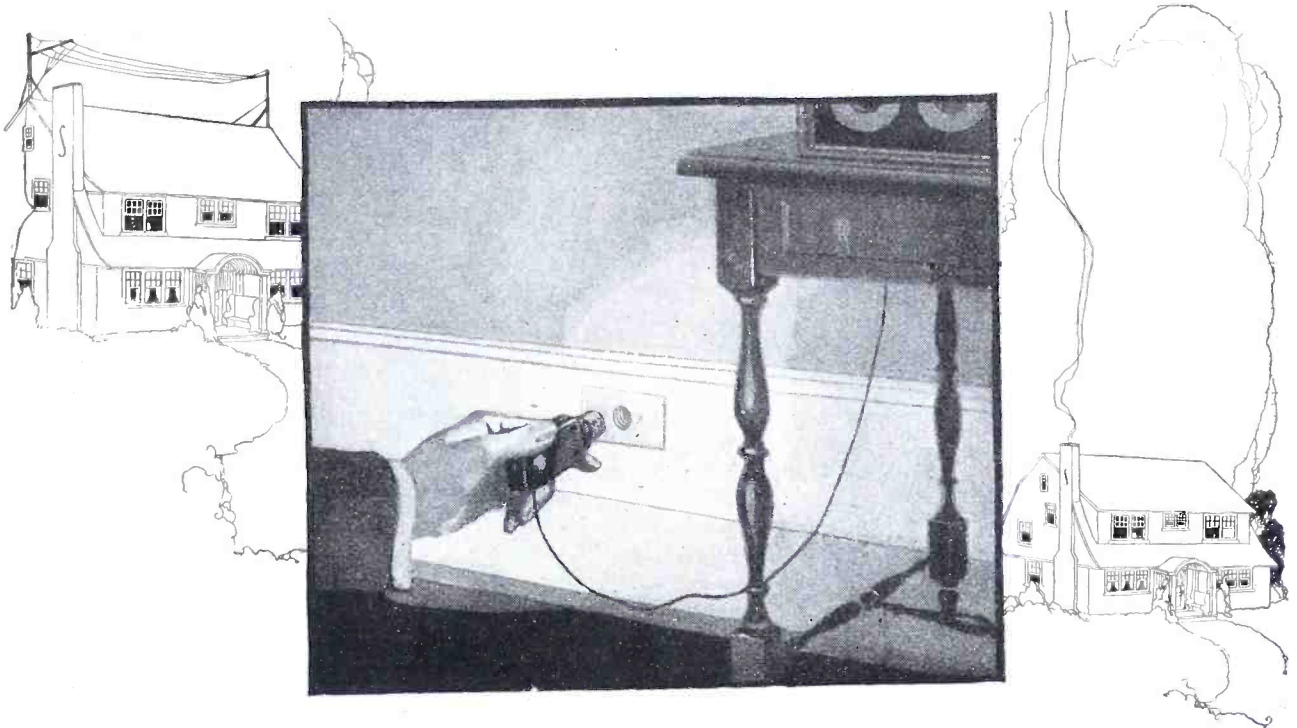

The \$1.50 Ducon— and no antenna!

A small Ducon screwed into a light socket—or a cumbersome, unsightly aerial? Surely a Ducon! It's so inexpensive—so easy to use—so sure in its results.

Take home a Ducon today—and hear tonight's best programs!

The Ducon is sold by all reliable dealers. Try one for five days. If it is not thoroughly satisfactory, your money will be refunded.

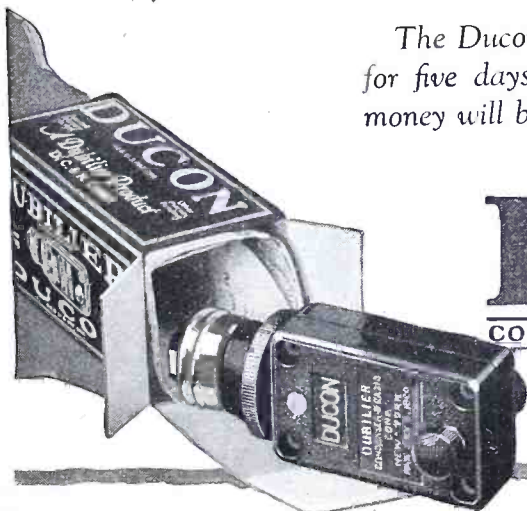

Dubilier

CONDENSER AND RADIO CORPORATION

All apparatus advertised in this magazine has been tested and approved by POPULAR RADIO LABORATORY

PAGES WITH THE EDITOR

(Continued from page 4)

SIR WILLIAM BRAGG, who contributes to this number of POPULAR RADIO the first of a series of articles on the atom, is not only one of the most distinguished scientists in the world, but one who is peculiarly gifted in the art of presenting scientific information in terms that the layman can easily understand. As evidence, turn to page 159.

THE exclusive American serial rights of this series of articles have been obtained by POPULAR RADIO by special arrangement with *The Illustrated London News*, in whose name the copyright on the drawings has been reserved.

"IN your feature *What Set Shall I Buy?* in the June issue, you give the cost of our Model 20 Receiver as \$100 'complete,'" writes Mr. F. W. Kulicke of the Atwater-Kent Manufacturing Co. of Philadelphia. "On account of this," he continues, "one of our dealers in Fitchburg writes that one of his customers refuses to pay because he thinks that the \$100 includes complete equipment for installing. . . . In order to avoid similar misunderstandings, we suggest that you give the price of \$100 as being 'less equipment.'"

THE suggestion is hereby adopted and carried into effect. In some unexplained way the phrase "less equipment" was omitted from the price as published in our June issue—with resultant complications.

IN the July number of POPULAR RADIO appeared a short item, "Radio Interference from Clouds of Steam." It has elicited an interesting commentary by Mr. A. Neal of Pando, Colo., who writes:

"SOME years ago, in a railroad station where I was located, a string of several telegraph wires passed diagonally across and over the main track less than fifty feet from the office end of the depot. You are no doubt familiar with a telegraph switchboard; a ground strap is located across the tops of the wire straps and separated from them by only about the thickness of a piece of heavy writing paper. This is a lightning protection for the instruments.

"OCCASIONALLY I noticed that a heavy freight locomotive, passing under these wires and working hard, caused a stream of static to jump across the gap between the ground and wire straps; it continued during the time the smokestack was directly and nearly directly under the wires and sounded like a miniature machine gun in action.

"AT the time I attributed this action to some freak condition of the atmosphere. Now I am wondering if it was not caused by excessive moisture in the exhausted steam. Because of condensed steam in the cylinders a locomotive sometimes exhausts quantities of

very small drops of water, drops so small that the soot-laden stains they leave on everything that gets in the way are about the size of a pin-head.

"MORE recently in an office where the wires (including a dispatcher's telephone circuit) were brought to the office in a cable about the tracks, I noticed that an engine standing or passing under this cable while 'popping off,' that is, while steam was escaping through the safety valve, produced a peculiar interference in the phone; it sounded something like a series of two-toned vibrations. Steam escaping through a safety valve generally does so with an unpleasant intermittent movement; 'popping off' gives a very good idea of the sound.

"I MENTIONED this action of the phone to the train dispatcher one day, and he told me that sometimes he knew from noises in his phone, when a train was passing a certain point where the wires crossed over the track between two certain stations of his district.

"PERHAPS other readers of POPULAR RADIO, located in railroad offices, particularly those that use telephones, have noticed interference from passing trains."

WHEN the feature "100 Best Hook-ups," which ran serially in POPULAR RADIO last year, was revised and brought up to date for publication in its entirety in the July issue—in response to the demands of our readers—it bore the somewhat modified title of "101 Best Hook-ups."

It was not until the July number had gone to press that the Editor was informed that a year preceding, Mr. M. B. Sleeper, the well-known radio expert, had published an excellent pamphlet under the title "101 Receiving Circuits."

THAT POPULAR RADIO should have selected the specific number "101" without knowledge of Mr. Sleeper's use of the same numeral, was entirely a coincidence. But as Mr. Sleeper is shortly to publish a revised edition of his pamphlet, the Editor is glad of the opportunity to credit Mr. Sleeper with the prior use of the numeral "101"—and to extend to our readers Mr. Sleeper's assurance that the new edition will be better than the old one!

IN the next issue Mr. John V. L. Hogan will contribute a timely article on "How to Improve Broadcast Reception"—written for the specific purpose of advising the broadcast listener.

Kendall Ranning
Editor, POPULAR RADIO

**EVEREADY HOUR
EVERY TUESDAY
AT 8 P. M.**

Eastern Standard Time

For real radio enjoyment, tune in the "Eveready Group."

Broadcast through

WEAF	New York
WJAR	Providence
WEEI	Boston
WFI	Philadelphia
WGR	Buffalo
WCAE	Pittsburgh
WEAR	Cleveland
WSAI	Cincinnati
WWJ	Detroit
WCCO	{ Minneapolis
WOC	{ St. Paul
	Davenport

*Eveready
Columbia
Ignitor
"A" Battery
The
proven
dry cell
for all
radio
dry cell
tubes
1½
volts*

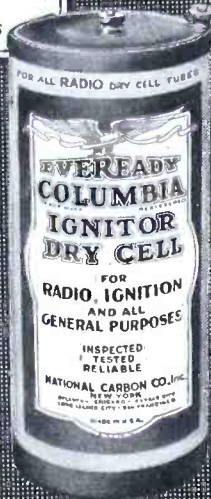

PREFERRED

It is no accident that more Eveready Radio Batteries are purchased by the radio public than any other radio batteries.

Such complete and voluntary endorsement can lead to but one conclusion—for best reception and longest life, Eveready Radio Batteries lead the field.

You can prove this for yourself by hooking Eveready Radio Batteries to your set. You will find that they deliver a steady, vigorous stream of power that lasts longer. It is Eveready economy that has created such an overwhelming preference for Evereadys. There is an Eveready dealer nearby.

Manufactured and guaranteed by

NATIONAL CARBON COMPANY, Inc.
New York San Francisco

Canadian National Carbon Co., Limited
Toronto, Ontario

EVEREADY Radio Batteries

-they last longer



*No. 772
45-volt
Large
Vertical
Price
\$3.75*



*No. 767
45-volt
Large
Horizontal
Price
\$3.75
With
variable
taps*

All apparatus advertised in this magazine has been tested and approved by POPULAR RADIO LABORATORY

Cunningham RADIO TUBES

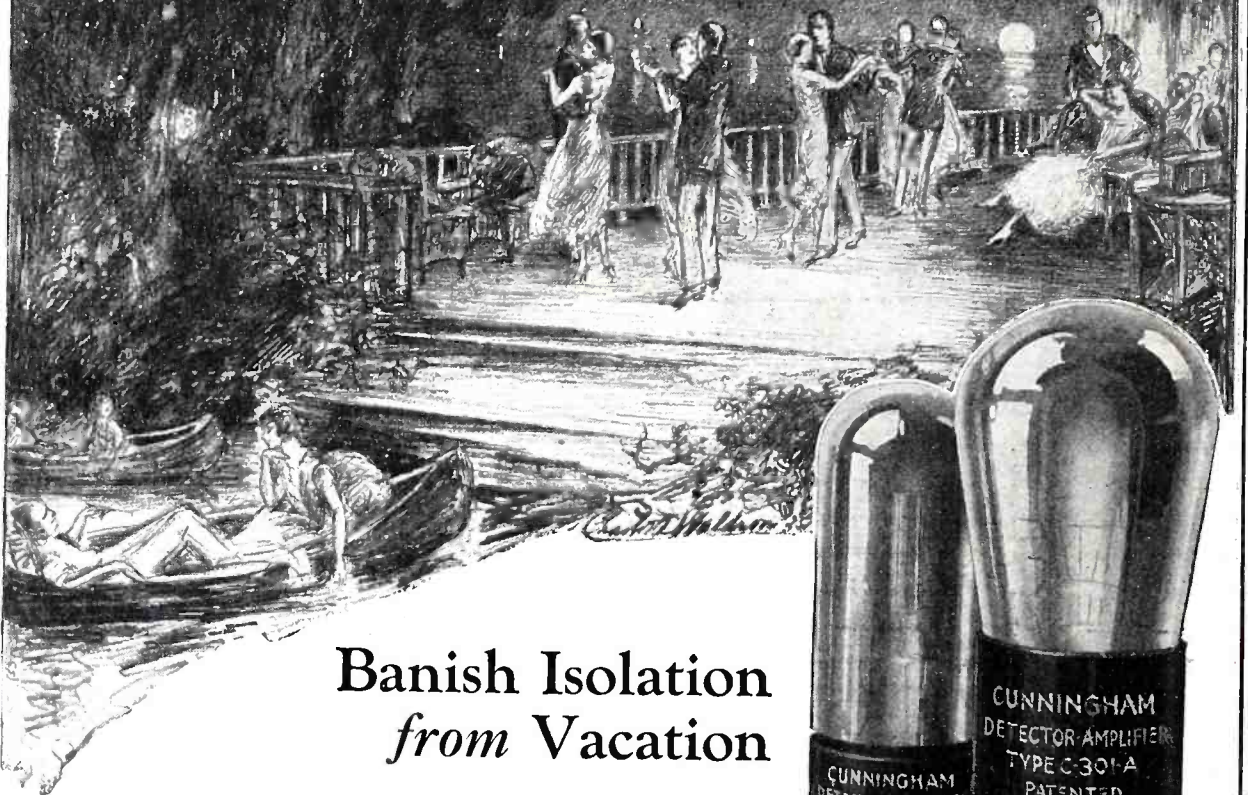

Banish Isolation from Vacation

TRANSLATE a mid-summer night's dream, a fairy fantasy, into the gay reality of dance—of song—of haunting melody.

In the back-country, among the towering, snow-capped peaks, over the placid summer sea, the ether is a-thrill with those same magic impulses that soar and dip above the city's crowded streets.

For real summer enjoyment you cannot do without radio. For full enjoyment of radio you cannot do without Cunningham Radio Tubes.

E. J. Cunningham Inc.

CHICAGO HOME OFFICE: 182 Second Street, SAN FRANCISCO NEW YORK

PATENT NOTICE: Cunningham Tubes are covered by patents dated 2-18-12, 12-30-13, 10-23-17, 10-23-17, and others issued and pending.



Since 1915—

Standard for
All Sets

TYPES C301A, C300, C299,
C11, C12.

In the Orange and Blue
Carton.

All apparatus advertised in this magazine has been tested and approved by POPULAR RADIO LABORATORY



POPULAR RADIO is a medium of expression
of the skill of the radio amateur

"I read POPULAR RADIO often and with great enjoyment. I find it an excellent expression of the ingenuity and skill of the amateurs who have done so much to advance the radio art."

E. W. Allerton

CHIEF CONSULTING ENGINEER,
RADIO CORPORATION OF AMERICA



From a photograph made for POPULAR RADIO

An Unusual Automobile "Extension" for Broadcasting

THE use of the short-wave transmitter installed on an automobile for relaying events in the field back to the main broadcasting station for ultimate re-transmission on a regular wavelength is a feature that will do much to extend the facilities for broadcasting. In this picture, Mr. Al Grebe is shown demonstrating such an installation to the engineering staff of POPULAR RADIO. (See page 130.)

Popular Radio

VOLUME VIII

AUGUST, 1925

NUMBER 2



Riding to Riches by Radio

PART I

Stock in some radio enterprises is sound and is destined to increase in value; stock in other radio concerns is worthless. As a part of its service to its readers, POPULAR RADIO points out, in this series of two articles, what the difference between the two really is—and how to find it before you invest. The author of this article is neither an investment expert nor a radio shark. He is merely an inquiring reporter in a comparatively new field. And as such he desires to hold up a not too solemn finger for the benefit of those who have not provided themselves with facts.

By RALPH E. RENAUD

IN all the past twelve thousand years of civilization, commercially considered, there has been nothing quite so startling as the growth of the radio industry.

Five years ago radio telephony, as it is understood today, wasn't a business at all. It was a mere scientific prospectus.

Last year radio concerns took in a million dollars a day.

Late in 1920 Westinghouse erected a broadcasting station. Since then the yearly figures of sales growth read like an exercise in geometrical progression: 1920, \$2,000,000; 1921, \$5,000,000; 1922, \$60,000,000; 1923, \$120,000,000; 1924, \$350,000,000. Nothing like that had ever been heard of before. It made the statisticians gasp. The motor industry, now the first in the United States, turned over \$3,168,588,146 last year and hatched out 3,617,602 cars. But it had been incubating thirty years. Moving pictures also reeled off their profits into astronomical figures,

but the days of the infant nickelodeon industry were long ago. Within the life of a good, healthy lawsuit radio has become the world's foremost indoor sport. And in its present mood, be it at Boyle's Thirty Acres, Coogan's Bluff, or fishing for DX right beside the old fireside, the world will pay anything for its sport.

Just what is the commodity for which all this money is being turned loose? In essence it is energy in the smallest conceivable quantities, electromagnetic waves so weak they have to be measured by the microampere. If all the energy picked up last night by all the receiving sets of the world were concentrated into a single impulse it wouldn't drive an electric locomotive from the Pennsylvania Terminal to Manhattan Transfer. It wouldn't even start it.

Yet the United States alone paid a million dollars a day for its share of that infinitesimal fly-power!

By the time we began to put up our

new calendars radio sales had already doubled those of kodak and sporting goods. The industry had nudged into a position beside shipbuilding, chemicals and leather. Naturally the inevitable consequences of such increase had not escaped the attention of the public. And, lest this introduction to a discussion of radio stocks be dismissed as a roseate come-on, let us add right here that the public has not escaped the consequences.

The first radio stocks lay fallow on the market. A few discerning souls who had sense enough to buy the right ones are now commuting in airplanes. Then a prize fight, with its clanging gong of destiny, was broadcast, and sets, home-made or shop-sold, began to invade the hitherto sacred privacy of the American home. Every other set-owner whispered to himself, "Say, this is going to be good! There ought to be money in this!" He repeated it, more confidently to his friends and neighbors. It was perfectly apparent that to the manufacturers the receiving set was proving an Aladdin's lamp. Pretty soon there were thousands who wanted to horn in on the profits.

The tom-toms were already beating for them. The witch-doctors had begun the ghost-dance and the snake-oil was bottled. About two years ago radio stocks blossomed like dandelions after a spring rain. Then they began to act very much as the airplane stocks are acting today. In other words, they started to airplane. Paper millions in stocks were floated, some good, mostly bad. In much of the literature there was the rankest sort of misrepresentation or, what amounts to the same thing, unwarranted enthusiasm. The majority of the hundred or so radio companies which have offered stock to the public in the past few years have not only retired from business but are so poorly (or well) remembered that there is no bid for their stocks.

Spurlos versenkt!

Still, it is quite possible to find radio and affiliated stocks. It would not be overstating the case to say the woods are

full of them. There are now approximately fifty-one radio, communication, and electrical equipment stocks which would be recognized with varying degrees of cordiality by a respectable broker. These range from the patrician General Electric, batting around 300, to Jones Manufacturing, at a dollar and a quarter.

Of the actual radio stocks, there are not more than a dozen listed, only one (Radio Corporation of America) being listed on the Stock Exchange. The unlisted market offers another dozen or so which can't or won't meet the listing requirements. These are the "over the counter stocks." Beyond and outside even the unlisted market a not too vigorous search will uncover additional alleged radio stocks. It is there that the bargains can be picked up for twenty-five or thirty cents. But even Woolworth isn't dealing in these.

The head of the financial department of a great New York newspaper tells me that in his opinion there are only about six of the strictly radio stocks which can justly be called good. Probably less than this number have real investment merit. As he phrased it, "The others are either a tremendous speculation or rank swindles." Perhaps, after we examine the patent situation, as we shall, we may conclude he is an optimist, at that.

What, then, is the matter with the radio stocks? All have beautifully engraved certificates, and most have acquired pleasant salesmen who do not hesitate to say a few kind and tactful words about them. To find at least part of the answer, suppose we select a few of the companies and scrutinize them a little more closely than their salesmen would care to do.

Exhibit A must be exhumed from the graveyard of radio flops—companies, so to speak, which have passed into the great beyond where there are no margins or giving of margins. But it was a whiz-bang of a little concern while it lasted. It had a name which strongly suggested the General Electric Company. But the resemblance ended with the nomenclature. There were also some honored names

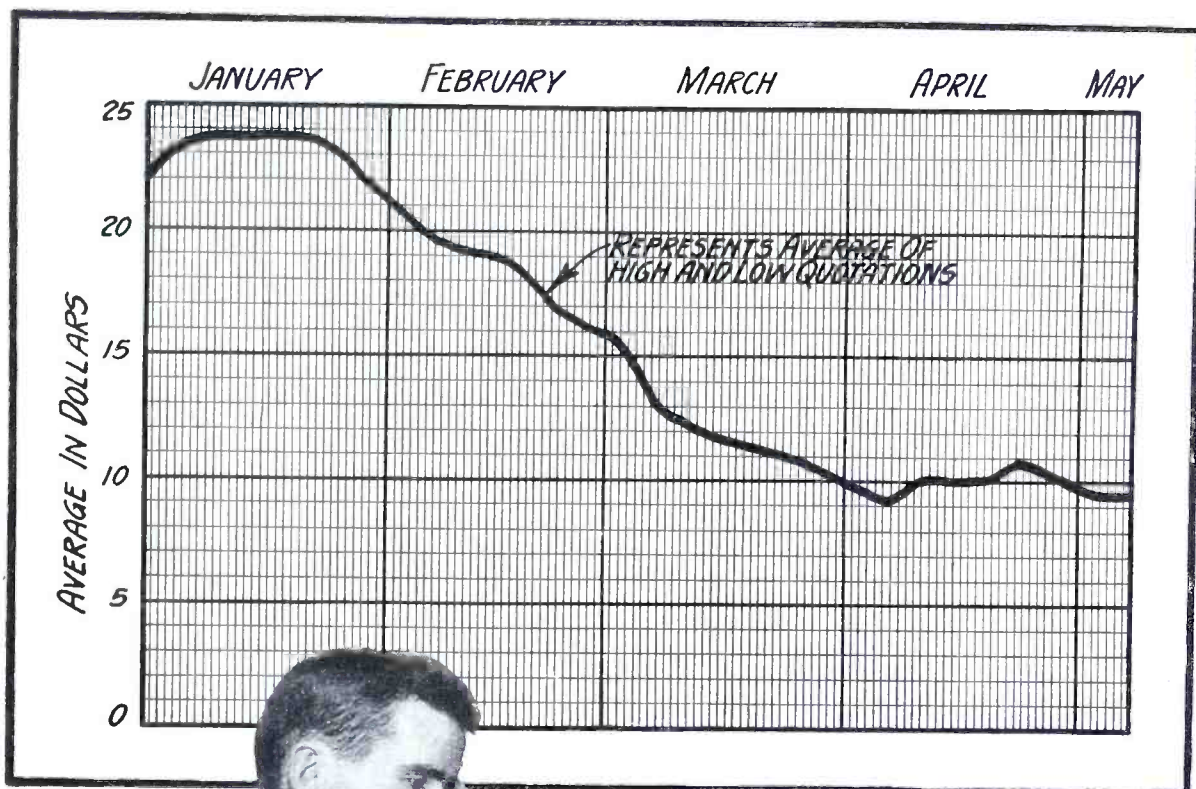

WHAT MAKES RADIO STOCKS DECLINE?

Before you invest, read this article and find out where the real values are—and how to discover them.

Brown Bros.

among the Board of Directors—sons of presidents, and things like that. But it is only fair to add that a number of these resigned as soon as they heard they were elected, and others withdrew while the going was good.

Never at any time in its career did the corporation have any capital whatsoever. But it promptly broke out into a capital stock issue of \$5,000,000 worth of shares—150,000 shares of 8 percent preferred stock at a par value of \$10 and 3,500,000 shares of common at a dollar. As stated, the company had no capital, as none of the

amateur financiers who organized it really yearned to put any money into it. But it would be unjust to say it had no assets. It possessed two ringing slogans, "Strike While the Iron is Hot," and "Ride to Riches with Radio."

At an early stage of the proceedings a George Randolph Chesterish promoter, well upholstered in the customary fur coat, arrived on the scene like a fairy godmother, informed all and several to quit worrying, and announced that he proposed to take over the entire direction of affairs. The hypnotized officers seem

to have let him get away with it. Thereupon it was broadcast that negotiations were under way to market the whole manufacturing output of several going concerns. They put it just that way, oh, so cagily!—"negotiations were under way." But somebody neglected to sign any contracts. The sales catalog showed impressive half-tones of factories at Woodside, N. J., Newark, N. J., and Kearney, N. J. The catalog did not assert outright that these busy factories were the property of the corporation. Neither did it state the truth that the only connection between corporation and factories was an occasional small order. But the general impression left on the reader was to the effect that these pictured factories were merely small Jersey samples of numberless thriving plants controlled by the company throughout North America and contiguous territory.

The catalog said, nay, it almost sang, that:

"This corporation
 Manufactures its own goods.
 Assembles its own parts.
 Retailers direct to the public.
 Wholesales direct to the jobber.
 Eliminates the middleman.
 Sells for cash in advance only.
 Has no funded debt.
 Has no notes, no bonds outstanding.
 Has no dead assets.
 Can therefore realize practically everything instantaneously for cash."

At the time the public was thus invited to "Ride to Riches with Radio" this company had manufactured nothing, assembled virtually nothing, and sold nothing. It had become nothing but a scheme to peddle stock. Of course, they didn't do it quite so successfully as Jimmy Elliott, of Phonofilm fame, and his high-powered band of diplomaed go-getters. They had no picture of President Coolidge to aid them. But they did very well—so well, indeed, that in a little while the entire Board of Directors decided to "Strike While the Iron is Hot" and quit, leaving the promoter-sales-manager in charge of a company without officers, a sales organization and a flossy name. The stock-

holders, of course, were left clutching the bag. As a matter of fact, it is of record in this case that long after an agreement had been made under pressure to cease all stock sales, the sales of stock nevertheless continued. But let us leave Exhibit A before we get tangled in the ramifications of grand larceny.

The second case, or, if you like, Exhibit B, falls into a different category. It is dryer reading and requires the ability to draw commonsense conclusions from elementary figures—a faculty which few purchasers of stock seem to have developed. This company also has some well-known names back of it and is listed at present on the Curb, where many good little stocks go the minute they are weaned.

The balance sheet filed with the Curb last September shows:

ASSETS	
Cash on hand, or subject to our withdrawal	\$38,000.00
Accounts receivable	25,000.00
Advances to subsidiary companies.....	12,000.00
Patents	1,250,000.00
Investments	
Stock in subsidiary companies (without goodwill valuation).....	38,352.06
Tools, drawings, patterns (estimated) ..	50,000.00
	<hr/>
	\$1,413,352.06
LIABILITIES	
Accounts payable	
(Accrued organization expenses)...	\$5,000.00
Capital stock	
(Authorized 250,000 shares, no par value)	1,408,352.00
	<hr/>
	\$1,413,352.06

Particular attention is hereby directed to that item of "Patents" set down as \$1,250,000.00. There really are some patents, beside an Armstrong license, consisting of several radio and automotive devices. No one can say they are not worth that much and anybody can say they are. But that item is certainly called on to do a man-sized job of balancing. Incidentally, the factory of this concern, turned out, on investigation, to occupy a space of 100 by 100 feet in a West Side loft building. Admission was refused. Apparently there were about twenty people at work. The set produced is said to be a good one.

Now then, let us look at another bal-

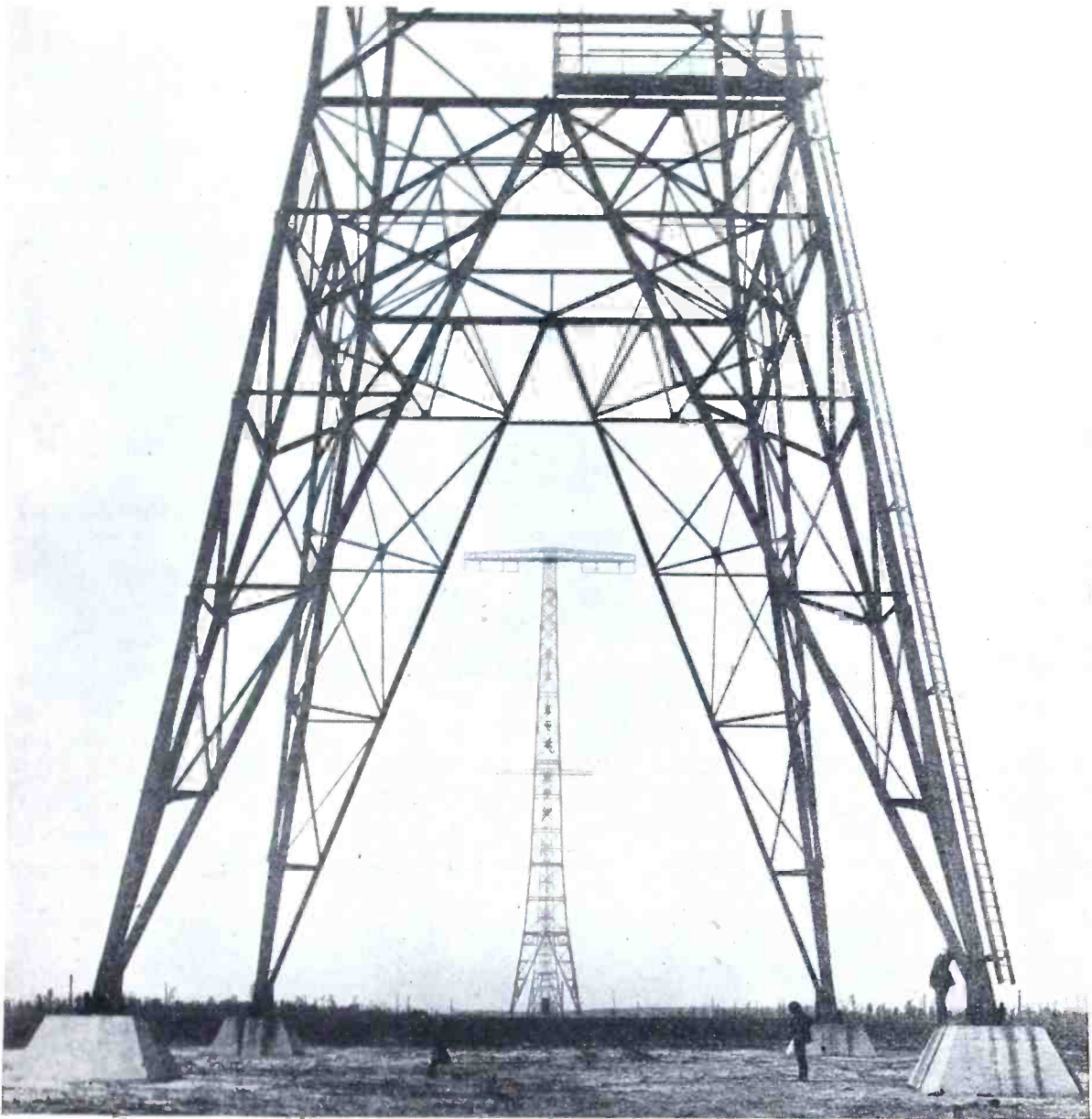

Radio Corporation of America

PROPERTY VALUES PLUS MONOPOLY RIGHTS AFFECT STOCK HOLDINGS

The value of holdings in the Radio Corporation of America partly rests upon its monopoly of transatlantic commercial radio communication, backed by costly equipment. This picture shows some of the radio towers on its Long Island plant.

ance sheet issued by the same concern and submitted to the public. This one is prefaced by an inconspicuous note and is as follows:

ASSETS

After giving effect to present financing	
Cash on hand.....	\$591,184.91
Accounts receivable.....	1,960.94
Inventories.....	22,840.19
Tool equipment.....	24,520.03
Furniture and fixtures.....	162.00
Patents, development and patent rights.....	920,630.28
Deferred charges.....	1,870.00
Organization expenses.....	9,000.00
Total assets.....	\$1,572,168.35

LIABILITIES

Accounts payable and trade acceptances.....	\$9,668.35
Net worth of capital stock.....	1,562,500.00
	<hr/>
	\$1,572,168.35

If this balance sheet be compared with the first the patent item seems to have shrunk, due, no doubt, to the lapse of time—and the item of cash on hand to have swelled enormously, from \$38,000, as a matter of fact, to \$591,184.91. But there is no real discrepancy. The little note at the beginning of the second statement,

"After giving effect to present financing," explains everything. You see, the cash is only on hand "after giving effect to present financing," or, to put it a bit more crudely, when the stock is sold.

Sometimes these unobtrusive prefatory notes are overlooked by hurried investors, though they are indulged in by the Street's "best people." Incidentally, the stock of this concern at this writing is worth approximately a fifth of what it was offered for—or rather, it is quoted for a fifth of what it was offered for.

The third case shows what may happen to holders of a premier radio stock, admittedly sound, who fail to watch their step. There are two villains to this piece—Mr. Ginsberg and Mr. Hassenpfeffer, let us call them, chiefly because these appellations are so unlike their own names. At the time Radio Corporation of America changed its capital stock structure, and offered one share of the new A stock for every five shares of the original issue, Mr. Ginsberg, having procured a list of R. C. A. stockholders, conceived a brilliant idea. He circularized all these peo-

ple, offering to act as their agent for purposes of transfer and hinting at some four times their present return on the stock. His plan was a simple one. He proposed to put up each share as margin, thus purchasing additional shares, and gamble on the stock going up, which it did, furiously.

But our Mr. Ginsberg, unfortunately, was not like Cæsar's wife. In fact, his reputation was so little above suspicion that legitimate brokers could scent him from afar. So it was necessary for Mr. Ginsberg to transact his business with a broker of standing similar to his own, a Mr. Hassenpfeffer, already mentioned as among those present. The Ginsberg circular appeal had brought out a considerable amount of the stock which he deposited with Mr. Hassenpfeffer, directing the latter to proceed as outlined above and incidentally slipping to the extent of placing all the stock in his own name.

Now Mr. Hassenpfeffer believed he had inside information about R. C. A. He decided to gamble for a drop in the bucketshop, as it were, and promptly sold the stock at the market. Meanwhile the stock

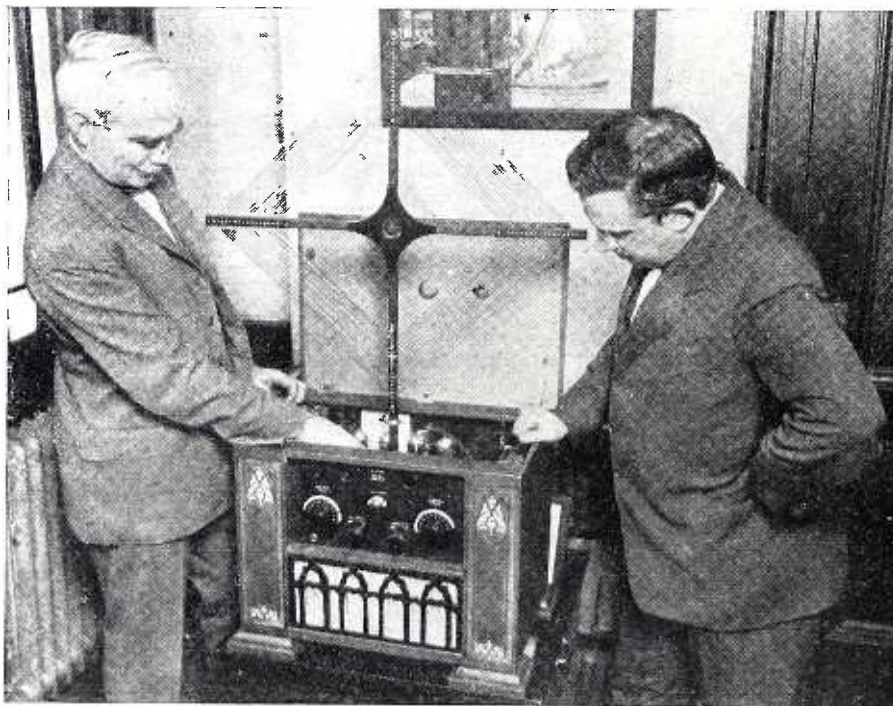

De Forest Radio Co.

MANY STOCK VALUES REST ON PATENT RIGHTS

On the radio inventions of Dr. Lee de Forest (at the left) extensive industrial properties have been built. But the value of the stock in them is dependent upon certain patent rights that are in litigation.



Kadlca Herzet

AN INVENTOR WHOSE PATENTS HAVE INVOLVED LEGAL COMPLICATIONS THAT BEAR UPON STOCK VALUES

Dr. Marius C. A. Latour (seated), a noted French inventor, after assigning various patent rights and licenses to radio corporations, became engaged in litigation when it developed that the Hazeltine Corporation had bought control of the Latour Corporation.

continued to rise steadily, and Mr. Ginsberg, the optimist, cheerfully licked his lips. When the market price had skyrocketed to an altitude at which he felt he could no longer afford to wait he called on Mr. Hassenpfeffer for his profits. Mr. Hassenpfeffer blandly informed him that there weren't any, adding as an afterthought, that there wasn't even any stock. Well, well! You can readily imagine how embarrassing this proved to poor Mr. Ginsberg. The merest prod of the toe revealed that Mr. Hassenpfeffer was financially flat on his back, and Mr. Ginsberg's clients were clamoring for a settlement.

To one of these, whose loss was a small matter of \$4,000 and whose real name isn't Mrs. Gull, he wrote consolingly, thus:

"Dear Mrs. Gull:

"The house with which we were carrying radio stock has not rendered us an accounting yet, and it seems as if they are in some sort of difficulty and we are trying to adjust these

matters in order to get the money coming to you from the sale of the stock.

"We have taken the matter up with the authorities here who have worked with us on this account and expect to have results after Thursday, the day on which the matter comes up for discussion.

"Will you kindly have a little patience until that time?"

"Very truly yours,

"S. L. Y. GINSBERG."

There was a certain modicum of truth in this letter. The house with which Mr. Ginsberg was carrying the stock was, beyond a doubt, "in some sort of difficulty." And he had indeed taken the matter up with the authorities, or *vice versa*, as the case may be. He has been compelled by subpoena from the Attorney General's office to appear and show cause why he should not be prosecuted under the Martin Act. Will the stockholders get their money back? . . . Yes, we have no bananas.

These examples explain the vicissitudes of particular stocks. But to explain what

has happened to all the radio stocks, without exception, the state of the industry itself must be examined.

In many ways last year radio was under forced draught. It was a political year, and politics called on the art of broadcasting for the first time. Many people believed that it was necessary to own a receiving set to follow the campaign properly. Then came the Democratic convention in Madison Square Garden, with its thrilling story of embattled giants and howling mobs vibrating day and night across the ether for almost three weeks. The stentorian lungs of Governor Brandon booming into the microphone that "Ala-baaaaam-a casts twenty-four votes for Oscar W. Underwood!" did a million times more to advertise radio than all its paid press agents. The public went mad-dog on radio and remained so up to and including December 25.

Then the overburdened Christmas tree broke down.

It must have been apparent to all who read the advertisements in the daily papers during the past six months that something untoward was happening in the radio industry. Evidence accumulated showing that a good many of the twenty-one hundred manufacturers were in trouble. Department stores burst into a rash of double-page announcements that they were prepared to sell standard sets for half price. Prices were slashed everywhere, in one way or another. General Harbord, at the last meeting of the Radio Corporation stockholders, estimated that 325,000 receiving sets had been thrown on the market.

So, it is clear today that radio is suffering from colic—too many green apples. The industry, stimulated by the fiercest production rivalry of record, turned out a bumper crop of receiving sets. The public was asked to eat them green. And the public process of digestion simply

broke down. This painful reaction occurred just when radio was experiencing its natural seasonal decline, unchecked this year by the stimulating tonic of politics. For it is only wisdom to admit that interest in radio is as seasonal as it is in motoring or golf.

The stock market is a prosaic place, but all these conditions were promptly reflected therein. The stock market has a way of being intolerably prompt. Radio stocks began to slide rapidly down hill. In many cases, of course, it was merely a case of water seeking its own level. Speculators operating among the radios on margin were wiped out like so many chalk marks. It is said that at the time the slide began there had been at least one share of radio stock sold for every receiving set used in the United States. That would mean about 3,000,000 shares. During the period of inflation the increase had been extraordinary, in one case a gain of 400 percent. But proportionate to the time involved the drop was even more impressive. One stock lost 80 percent.

Julius G. Berens, in a compilation of twenty radio stocks, showed that the difference between the high of 1925 and the low toward the end of May was something like \$82,775,000 out of a total market value of \$179,664,000.

Yet it isn't all unhealthy, this process of deflation. Applied to the radio industry as a whole, and especially to its mirror in the stock market, these timely reducing exercises will develop a sounder and less flabby body. Only the fittest in the field will survive. The "gyps" will be pinched out. There will be bankruptcies, liquidation and receiverships. This is painful to all concerned. But perhaps the most excruciating, because undeserved agony, will be experienced by those who have never learned to distinguish between an investment and a contribution to charity

But how *does* one learn?

The next installment of this article will tell how to distinguish between good radio stocks and poor ones. It will appear in POPULAR RADIO next month—September.



HOW THE MOVING IMAGE APPEARS ON THE SCREEN

The pictures projected upon the screen by the "teloramaphone," in their present early state of development, show figures in silhouette only.

"Motion Pictures" by Ether Waves

The home radio movie has arrived. We have now reason to hope that we will eventually sit at home and watch the world series exactly as it is played and hear the umpire and the crowd at the same time. People in the most isolated sections of the country will attend distant Fourth of July celebrations, or perhaps, the next presidential inauguration by radio, and see and hear more of it than if they were in the crowd in front of the speaker's stand."—C. FRANCIS JENKINS.

By CHARLES ALLEN HERNDON

COMING events cast their shadows before."

As this is written, I have just come from a shadow-show in the Washington suburban home of C. Francis Jenkins.

The figure that produced the shadows was on a motion picture film being projected in the inventor's laboratory in Washington. It was separated from the screen by six miles of city and suburban streets and houses.

While the little crowd of neighbors and friends watched a small screen which formed a panel in the receiving set, there suddenly appeared on it the silhouetted figure of a girl. There was no scenery. The details of the dancing figure were not shown. But the shadow-like figure moved—it danced. And those who were present seemed to realize that, simple silhouette though it was, it was really

dancing at the wedding of the motion pictures with radio.

When you think of the great super-feature motion picture play with its thousands of actors, its elaborate sets and its faithful reproduction of infinite minute details, this simple silhouette of a lone dancer may seem disappointingly crude. But even the wonderful motion picture industry had its crude beginnings.

In fact, the first feature film (which was presented to the public at Richmond, Ind., in 1894, and projected from the first machine of the type now in general use throughout the world) also merely depicted a solitary dancer. That dancer of 1894 was probably directly responsible for the subject of the radio movie of 1925; for the inventor who made that first machine and gave that first motion picture performance was this same C.

Francis Jenkins, who has now married the movie to radio.

Ever since then, he has devoted much of his time to inventing improvements on motion picture apparatus, including a slow-motion picture camera which takes 4,000 pictures a second. When the radio came in, however, he turned enthusiastically to the problem of sending and receiving pictures by wireless. He worked out the only system so far devised for sending typewritten and other matter and receiving similar messages on the same machine at the same time and also the only system of sending radio pictures from a flat surface to a flat surface.

But ever since Mr. Jenkins succeeded in sending such still pictures in this country, or since M. Edouard Belin in France or Prof. Arthur Korn in Germany performed similar experiments abroad, imaginative persons have confidently predicted that some day motion pictures would be sent by radio. As the motion picture is just a series of still pictures showing successive phases of action, it did not take much mental daring to make the forecast. The prophets were, however, rather vague as to just when this newest wonder would start or just how it could be brought about.

It is easier said than done. In order to

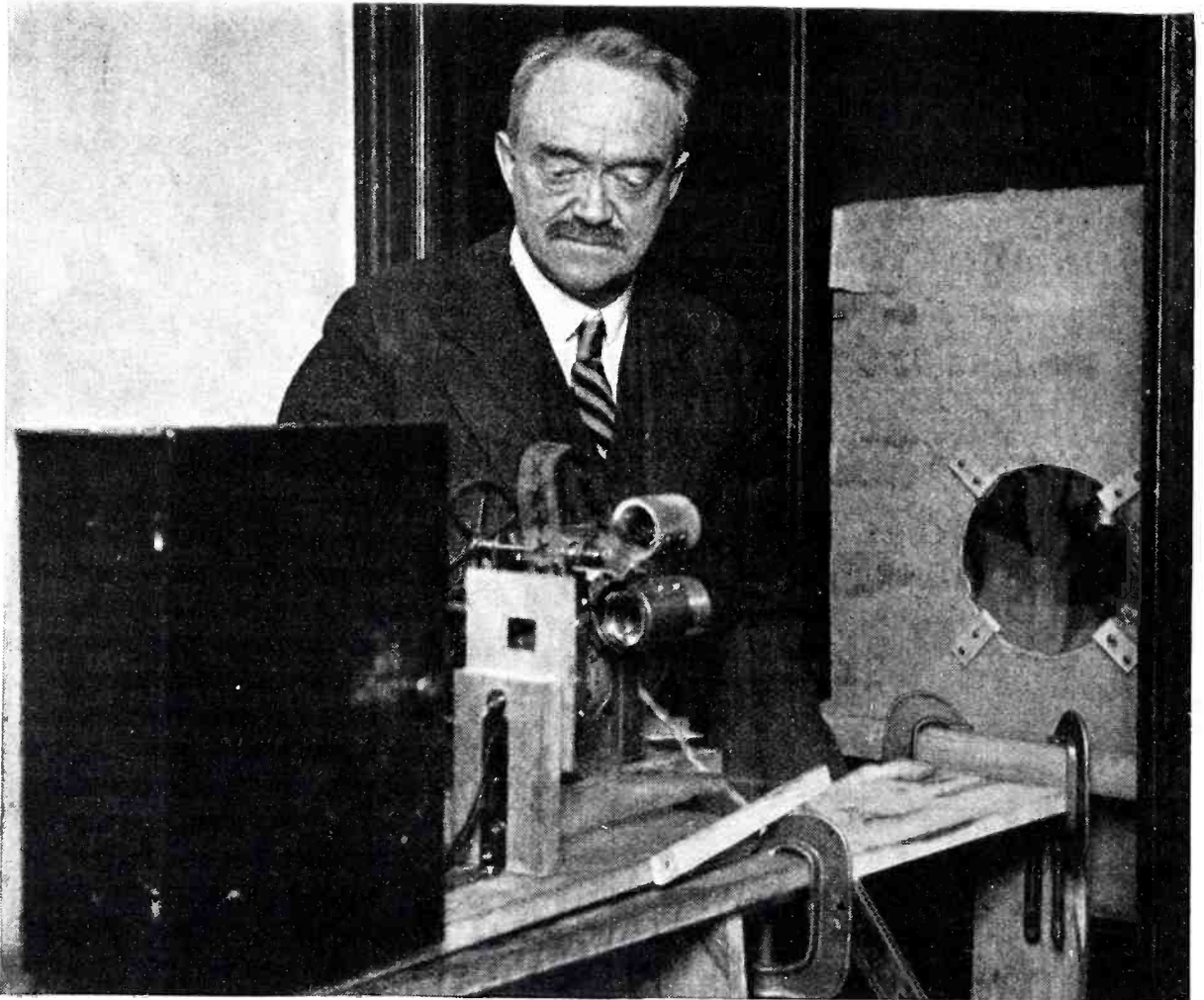

From a photograph made for POPULAR RADIO

THE FIRST MOTION PICTURE MACHINE

This machine—operated by its inventor, C. F. Jenkins—uses standard motion picture films. The changing pictures on the film are imaged on the flat surface of the large plano-convex lens at the right, which is held in place in the screen by four pieces of wood. The lens which projects these pictures onto the larger lens is the lower one of the two small cylinders directly in front of the inventor.

obtain the illusion of motion in a motion picture at least sixteen complete pictures must be projected every second. In order to send one complete still picture giving fine details by radio, it requires about six minutes by the best system now in use.

Six minutes seems short when you remember that the radio picture is knocked down, as it were, and then built up piece by piece at the receiving station. The lights and shades which make up the photograph must be translated into variations in an electric current, which in turn must be translated back again into lights and shades which make up the reproduction at the receiving end.

All systems of sending pictures by wire or wireless are based on the photo-

electric or light sensitive cell. That is, certain substances used in these cells have the peculiar property of permitting current to flow through them more readily when they are illuminated than when they are in the dark. They act as electric valves. By simply varying the amount of light that reaches them, the current passing through them can be varied correspondingly.

In the Jenkins apparatus for sending still pictures, for instance, the picture is placed in an ordinary stereopticon or magic lantern and its image is projected across the room so that one tiny corner of it strikes a hole in a box in which there is a thallium sulphide cell. If that tiny corner happens to be a shaded portion

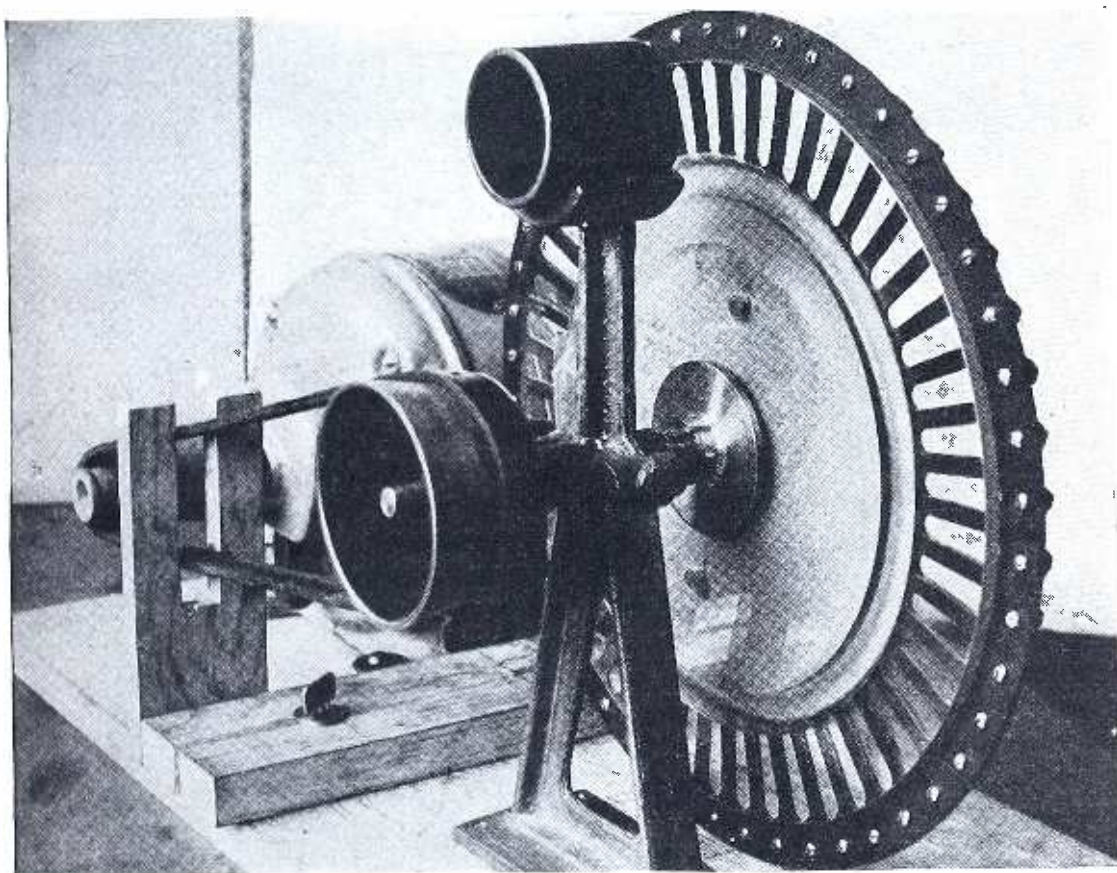

From a photograph made for POPULAR RADIO

THE LATEST PRISMATIC DISC

The source of light is located in the round black box. This light is projected in succession by each lens located in the small openings around the periphery of the wheel onto a small motion picture screen. As the lenses rotate, each draws a line of light across the screen, but as the circular prism behind the lenses is constantly changing the angle between its faces, each line is drawn just under the last one until the picture is complete. Thus, for each revolution of the prismatic wheel one picture is placed upon the screen and as the disc rotates at a speed of 900 times each minute there are fifteen pictures a second produced on the screen.

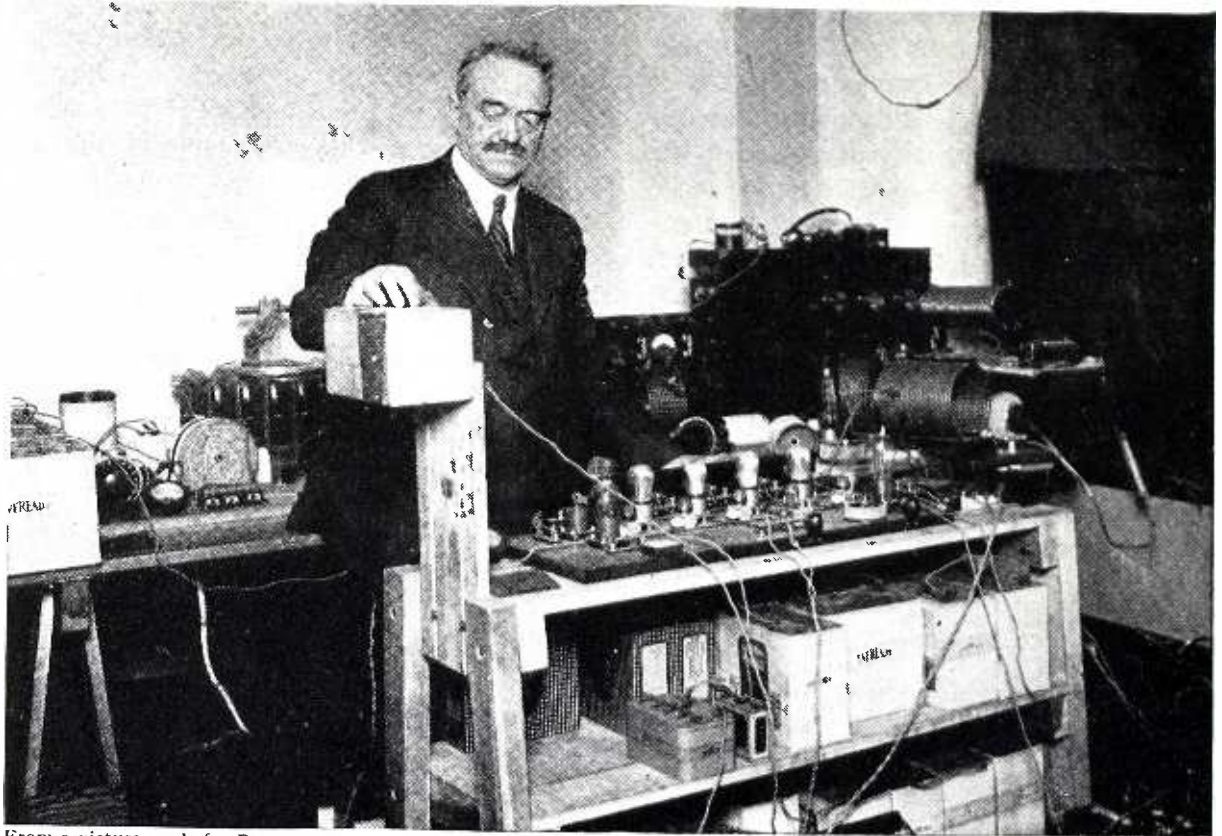

From a picture made for POPULAR RADIO

THE RADIO UNITS FOR THE MOVING PICTURE TRANSMITTER

The inventor has his hand placed on the small square box that contains the light-sensitive cell which converts the pictures into electrical impulses for transmission by radio. This, when attached to the apparatus shown on page 108, will transmit moving picture films and when used in conjunction with the apparatus on page 112 will transmit pictures of living subjects.

of the picture, only a weak current can pass through the cell. If that little piece of the image represents a light part of the picture, a strong current is permitted to pass through the cell.

In order to send a picture, each part of it must be brought in front of the light cell, so that the variations in its lights and shades will produce corresponding variations in the current which pass on to the broadcasting apparatus and are picked up at the receiving station. At the receiving station, the variations in the radio waves produce variations in the light of an electric lamp.

The chief feature which distinguishes the Jenkins method of transmitting pictures from other methods is in the way these changes in the light are distributed on the photographic plate at the receiving end and the way the image of the original

is brought piece by piece in front of the light sensitive cell at the sending end.

This is done by an ingenious arrangement of moving glass discs.

At the sending end a set of these discs is placed between the projecting lantern and the box containing the light sensitive cell. The edges of these discs are of varying thickness so that each part of the circumference of the discs acts as a different prism to bend at different degrees the light coming from the lantern. When these overlapping glass discs are placed in motion, the net result is the shifting of the entire projected image, slice by slice, across the light sensitive cell.

Beautiful half-tone photographs are picked into hundreds of pieces in this way in six minutes and broadcast piece by piece. At the receiving station a sim-

ilar set of glass discs is placed between the lamp controlled by the incoming waves and the photographic plate. The spinning of this set of discs at exactly the same rate as the set at the sending end distributes the flashes of light on the plate so that an exact reproduction of the original photograph is built up line by line.

One picture in six minutes is, however, a long way from sixteen pictures in one second. To send movies it is necessary to tear down and build up the pictures nearly six thousand times that fast. Obviously, since the speed at which such a picture is sent is determined by the rate at which the image is shifted in front of a single light sensitive cell, the glass discs which shift the image must be tremendously speeded up.

This Mr. Jenkins did. But with the

arrangement of discs used for the still pictures, he could not get enough speed. So he devised a new disc, the edges of which are set with a number of tiny lenses, and with it sliced the image up much faster. But even this disc could not carry the image past the light-sensitive cell fast enough to send a complete picture in one-sixteenth part of a second.

Speed, more speed—vastly more speed—was needed. The disc could not be forced to make up the difference without danger of flying to pieces. It was necessary to jazz up other parts of the process.

By multiplying the number of light-sensitive cells, Mr. Jenkins found that he could multiply the speed obtained by his disc. Instead of trying to send the entire image slice by slice from top to bottom, past a single light cell, he decided to project it against a box with four holes

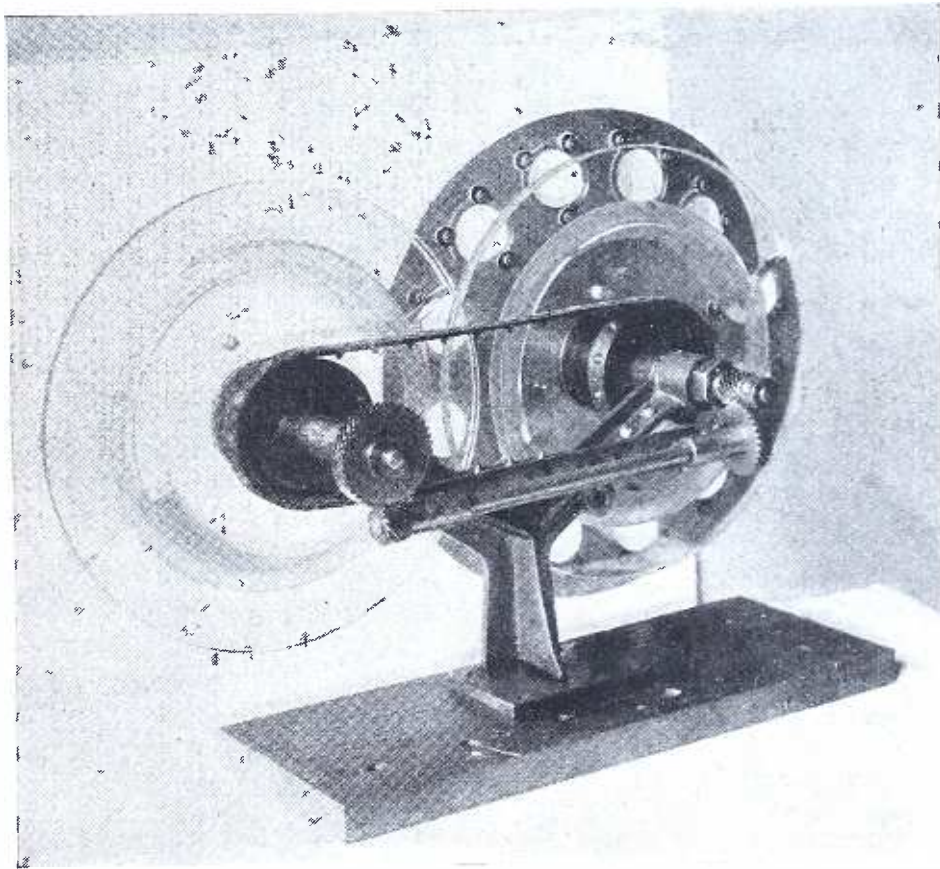

From a photograph made for POPULAR RADIO

A DOUBLE DISC MACHINE

This model uses a double disc arrangement instead of a single wheel. The principle of operation is entirely the same as that explained in the caption of the machine shown on page 109. The two discs are used to throw a pencil of light across the screen in shifting lines until a whole picture is built up.

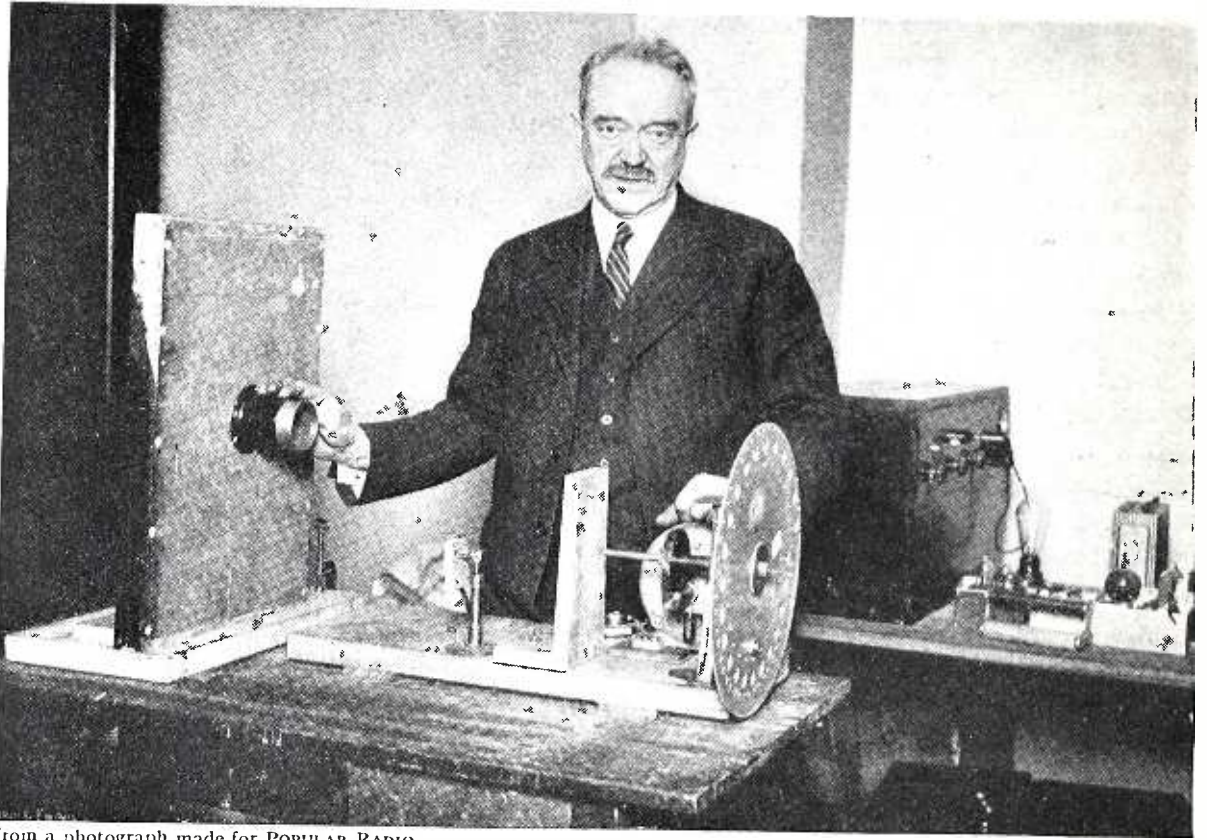

From a photograph made for POPULAR RADIO

THE TRANSMITTER FOR LIVING MOTION PICTURES

The large lens in the mask at the left images the picture of the moving object through the tiny lenses of the rotating wheel onto a large lens similar to that shown in the photograph on page 108. This literally cuts up the image of the moving object in a series of 15 or 16 pictures each second, thus preparing a series of pictures which can be converted to electrical impulses by the light sensitive cell shown in the wooden box on page 110.

in it leading to four separate light-sensitive cells. By this arrangement, while one-quarter of the image is being carried past one light cell, the other three-quarters are also being carried piece by piece past the other three light cells. The image is in this way picked to pieces in four places at once. The resulting current variations are distributed and broadcast as modulations on the one radio carrier wavelength in much the same way that four or more telegraph messages are sent over one wire at the same time.

But even multiplying the speed four times that obtained by the disc alone was not enough. Mr. Jenkins decided to get still greater speed by sending the pictures in larger pieces. Beautiful half-tone photographs must be sent in hundreds of very fine slices or pieces in order to bring out all the fine details. Pictures requiring less detail can be sent in larger pieces.

As the silhouette is the simplest form of the human figure, it can be sent in the largest pieces.

The inventor, therefore, devised his "teloramaphone," as he has named it, to show silhouette pictures built up in four sections at once out of forty-eight pieces.

In this way he has achieved the seemingly impossible task of sending sixteen complete pictures a second by radio. So rapidly are these pictures built up as white silhouettes on a black background on the little screen of the teloramaphone that the mechanics of the thing is hardly noticeable. Yet these pictures are built up before your very eyes as you watch the screen. It is not a photographic process like the sending of still pictures has been. The little silhouettes are completely formed by spots of light from four small electric lamps, one for each quarter of the picture, flashing with lightning-like rapid-

ity and shifted on the screen by a revolving disc similar to the one at the sending station and tuned to the same speed with it.

In order to bring the silhouettes out clearly, the greatest contrast between light and dark was needed. Ordinary metal filament incandescent lamps could not be used, because the wires in them stay white hot between rapid pulsations of current. What was needed was a light which would go out the instant the current went off. Finally, after many experiments, Prof. D. M. Moore's glow lamp was adopted. Instead of a wire filament, this little electric lamp has a little well of gas which becomes incandescent when the current goes on, but instantly loses its incandescence when the current stops.

These glow lamps had to be manufactured in the desired size to furnish a spot of light of the proper proportions to build up the silhouette in the required time. In making a detailed photograph, these little lamps with smaller diameter gas wells are used. As other parts of the apparatus are speeded up still further, the smaller lamps can be substituted for those used to make the silhouettes and pictures can be built up in more and smaller pieces. As the smaller pieces are used greater detail will be brought out.

But that is in the future. What is here now is the Jenkins teloramaphone.

The teloramaphone as at present designed looks not unlike the usual large tube-set receiving cabinet. In fact, it is that and something more; for it contains a panel in which is a dark screen behind which flash the spots of light which are built up into the white silhouette upon a dark background.

On the same antennas which now catch the audible broadcast, we may soon receive the spoken and acted play as well as played and acted music. When the music is not to our ear, we can shut off the sounds and in the quiet of our home watch "the magic shadow shapes that come and go."

There on the little screen before us, we

may find relief from the complexities of modern life in dainty, simple little white-shadow plays presented with a directness and vigor practically unknown in our more detailed photo and spoken drama today.

At least that is what we can expect if we can judge by the past. In Europe the silhouette drama was once a leading form of entertainment. In the twelfth and thirteenth centuries, the "shadow theater" produced actors which became renowned. Even down to 1850, the silhouette maintained a certain vogue; but in the latter part of the preceding century, the shadow theater probably reached its greatest popularity. Special plays were written for performance on its stage. In Paris, especially, it became the rage in high society.

Yet in all the shadow shows from King Tut's time on, the spectators had to go to the show. By the teloramaphone revival of the old art of pantomime, the show will come to the spectator. Radio waves will bring into homes throughout the country plays and dances. Bedtime stories will not only be illustrated, but told entirely in silhouette action without interfering with father reading the newspaper.

Some people, no doubt, will prefer the trip to the corner theater in order to see more detailed motion pictures. Yet there is also promise in this apparatus for them. The silhouette movie may reasonably be expected to repeat the history of those silhouette paper cut-outs and paintings on glass so popular in great-grandfather's day. As they were the pioneers for the cheap photograph, so the four-cell teloramaphone may be the pioneer not only of detailed movies but of radio vision.

For the motion picture film used at the broadcasting station is even now merely a convenience. Shadows of the moving hands or other things inserted between the light and the photo-electric cell are transmitted just as easily as the silhouette on the film. To get away from mere shadows, the teloramaphone process only has to be speeded up sufficiently.



The MEN WHO

8th Installment

The Creator of a Modulation System

E. H. COLPITTS has been identified with radio research and practice for a number of years, during which time he developed a modulation system. His most outstanding contribution to radio science has been the invention of the Colpitts oscillator which has been of great importance in the development of radiotelephony.



The Inventor of a Tikker

WITH the advent of the arc transmission system it became necessary to devise a means of breaking up the continuous-wave train transmitted from a sending station so that it could be made audible at the receiving end. **CHARLES L. LOGWOOD** invented a device known as the "tikker" which was similar to that invented by Dr. Austin. He also developed some important oscillating circuits.

DeForest Radio Co.



The Designer of a Transmitting Arc

E. L. CHAFFEE is identified with radio science through his researches in electric oscillations IN VACUO and in regeneration. His most outstanding contribution was the Chaffee arc and his gap that was used in conjunction with the arc in radiotelephone work.

MADE RADIO

The Inventor of a Neurodyne System

THE *neurodyne* system of radio-frequency amplification, so-called because it prevents feedback through the amplifier and thus eliminates radiation, was invented in 1922 by PROFESSOR L. A. HAZELTINE. This *neurodyne* system was first worked out "on paper" by mathematics and was then applied to the construction of a receiver.



Bachrach

He Invented a Regenerative Circuit

A REGENERATIVE circuit which is notable for its flexibility was invented by A. MEISSNER of Germany. This circuit embraces a feedback system and magnetic coupling between the load circuit and the plate circuit of the tube. The feedback system in the Meissner circuit does not depend upon the voltage drop across a reactance in the load circuit as it does in some of the other systems. It has proved particularly applicable for radio installations on aircraft.



The First Man to Signal by an Electrostatic System

A. FREDERICK COLLINS, an English inventor, after experimenting with systems of wireless signalling, developed in 1900 an electrostatic system which carried speech a distance of about eight miles. He is credited in some British circles with being one of the inventors of the radiotelephone.

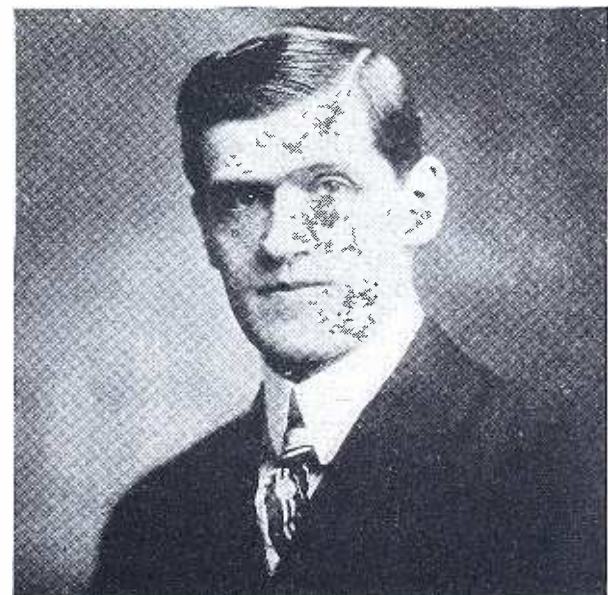

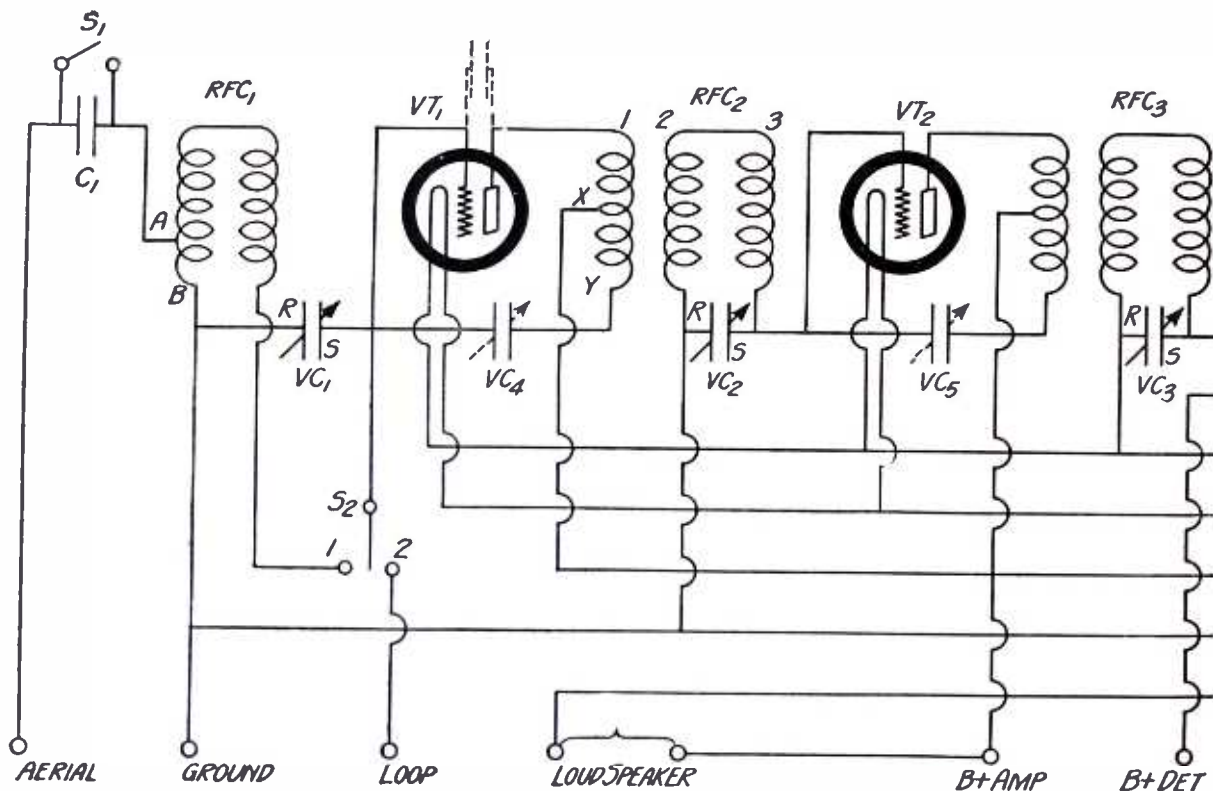

HOW TO GET THE MOST OUT OF
YOUR READY-MADE RECEIVER

NO. 7: THE GREBE SYNCHROPHASE RECEIVER

This series of articles explains the theory, operation, equipment and care of standard receiving sets

This series does not indorse the product of any manufacturer or make comparisons between receivers. The sets already described include: No. 1, the Eagle Neutrodyne; No. 2, the Radiola Superheterodyne; No. 3, the Melco Supreme Receiver; No. 4, the Crosley Trirdyn; No. 5, the De Forest Reflex; No. 6, the Atwater Kent.

By S. GORDON TAYLOR

THE Grebe Synchronphase receiver is of the tuned-radio-frequency type and makes use of the neutralization method for preventing oscillation in the radio-frequency amplifier portion.

An oscillating condition of the vacuum tubes in a radio-frequency amplifier usually prevents—or at least distorts—reception.

The feed-back in the circuits of a tube results from magnetic coupling between coils in the output and input circuits of the tube and also from the

coupling effect of the capacity between the tube electrodes. The former type of coupling is known as "inductive coupling," while the latter is called "capacitative coupling."

In the Grebe receiver the effect of inductive coupling is practically eliminated by the use of a special type of coils, known as "binocular" coils.

This name was derived from the shape of the coil, a picture of which is shown in Figure 3. With this arrangement any inductive coupling from an-

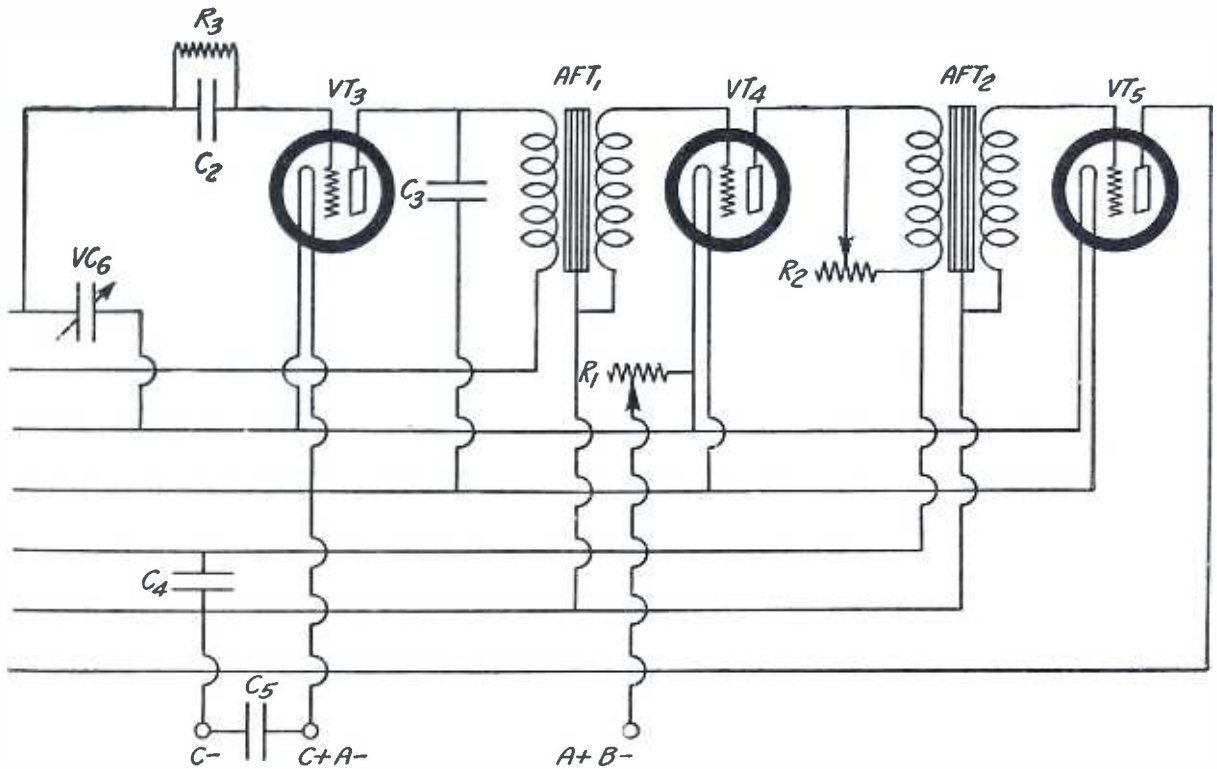

WIRING DIAGRAM OF THE GREBE SYNCHROPHASE RECEIVER

FIGURE 1: The designating letters refer to parts described in the text and also shown in the other figures.

other part of the circuit will affect both halves of the coil but in opposite directions; therefore, the induced energy in one half will oppose the induced energy in the other half. And inasmuch as the induced energy is equal in the two halves, the resulting energy flow for the entire coil is zero. Thus the undesirable inductive coupling is eliminated.

In the wiring diagram, Figure 1, coils 2 and 3 of the coupler RFC represent the two halves of the binocular coil. Coil No. 1 of this coupler is the primary coil and is connected in the plate or output circuit of the first tube while coils 2 and 3 are in the grid or input circuit of the second tube. Coil No. 1 cannot be seen in Figure 3 as it is placed inside of coil 2.

The capacitive coupling is eliminated in this receiver by means of the neutralization method. As was explained before, a condenser inserted across the plate and grid circuits of a

vacuum tube results in a tendency for some of the energy to flow from the plate circuit back to the grid circuit, in which case the tube becomes a miniature generator of radio-frequency currents; in other words, it reaches a condition of oscillation, thus interfering with its functioning as an amplifier.

In the radio-frequency amplifier a condenser is not actually inserted between these two circuits, but unfortunately the opposing surfaces of the grid and plate of the vacuum tube act as such a tiny condenser. Inasmuch as these two elements are indispensable to a vacuum tube used as an amplifier, some means must be found of combating the tendency to oscillate. To do this another circuit is added and so arranged that its current-flow tendency is opposed to that from plate to grid.

In Figure 1, the capacity which causes the trouble is shown by dotted lines at VT1. The neutralizing circuit consists of the coil X-Y and the condenser VC4.

How the Receiver Works

The signals from a broadcasting station are intercepted by the antenna and are brought to the receiver through terminal No. 1. From here they pass on through condenser C1, or switch S1 if the latter is closed. This condenser is provided to adapt the receiver to oversized aerials. By allowing the incoming signals to pass through this condenser the same effect is obtained as would result from using a smaller antenna. With a normal antenna the switch S1 is closed, thus short circuiting C1 and allowing the signal to pass on without going through the condenser.

The signal energy then flows into the

coil of RFC1 at A and passes through a few turns to B which is connected to the ground.

The coil A-B is part of the entire coil of RFC1, and therefore a flow of energy through coil A-B induces a similar current in the entire coil by conductive coupling. This whole coil is the secondary of the coupler and is connected in the grid circuit of the first radio-frequency amplifier tube, VT1. It is tuned to resonance with the incoming signal by means of the variable condenser VC1. The connection to the grid of the tube may easily be followed down through the switch S2 (which must be connected to point 1 when an

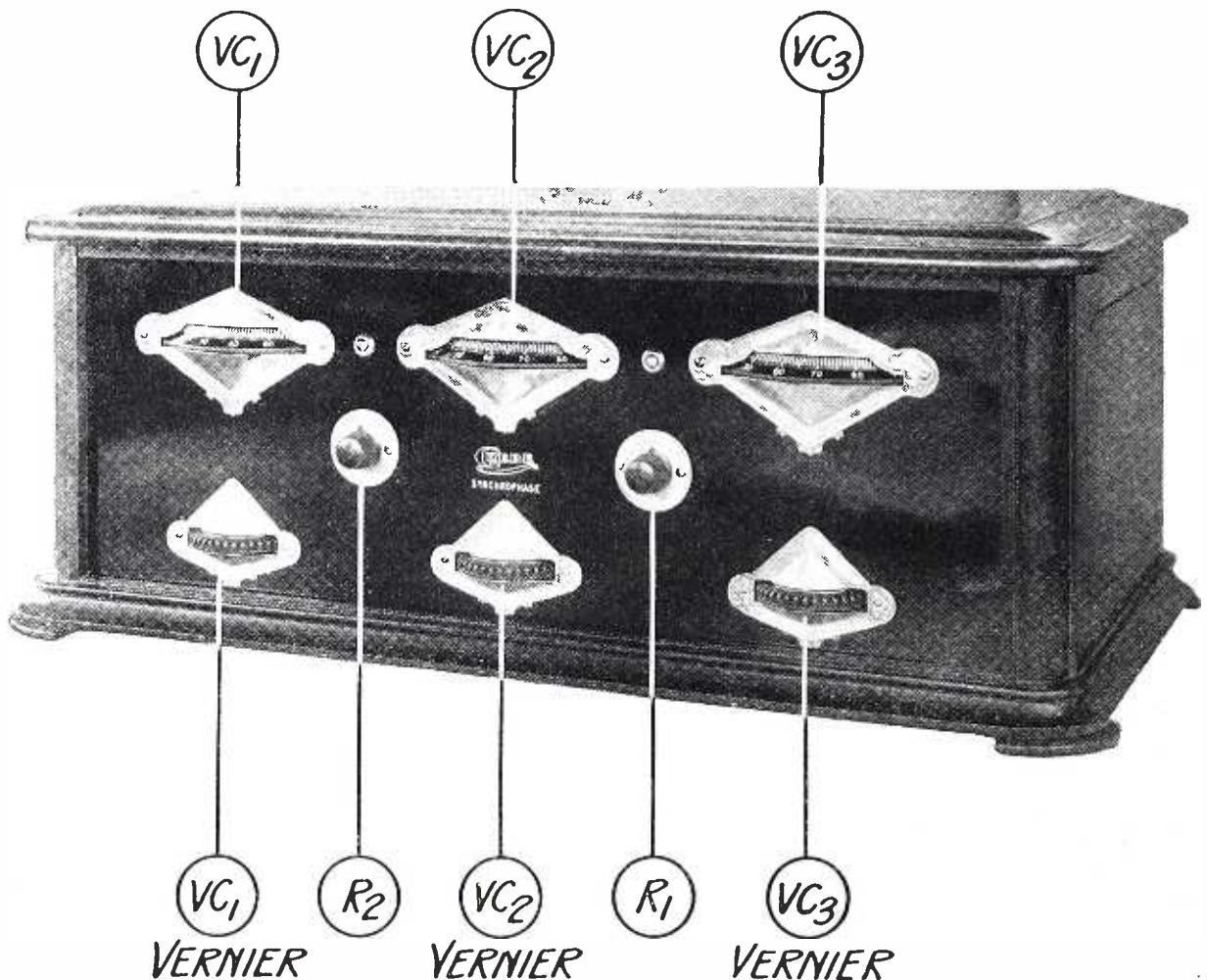

THE PANEL VIEW OF THE RECEIVER

FIGURE 2: Tuning is accomplished with the three upper controls, and the three lower controls which permit extremely small variations for sharp tuning. The left-hand knob controls the volume and is usually set on point 4 or 5 unless extreme volume is desired, when it is set on 6. The other knob controls the filament current and is usually set at 4.

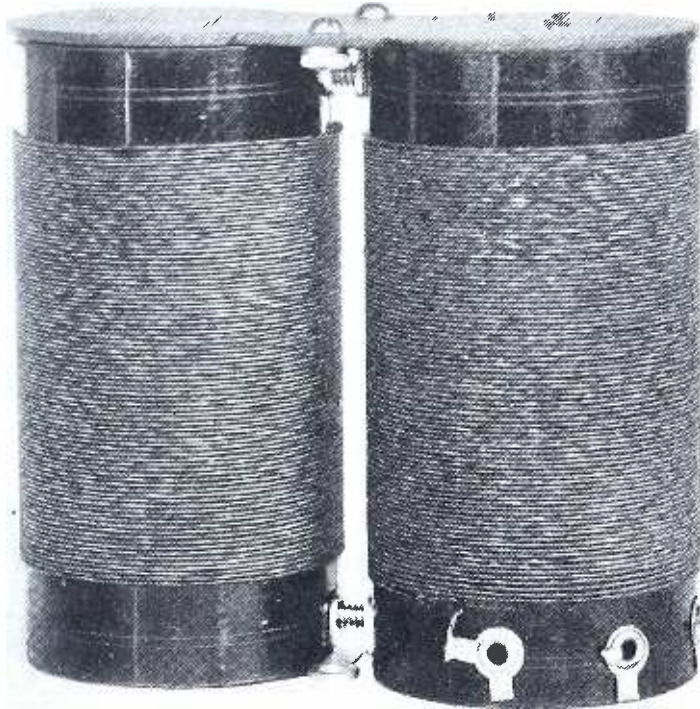

THE GREBE BINOCULAR COIL

FIGURE 3: *By winding the coil in two connected parts its magnetic field is limited and is little affected by stray currents from other parts of the circuit.*

outdoor antenna is used) and from there to the grid.

When a loop antenna is used it is connected to the terminals marked "Ground" and "Loop." In such a case, the coil RFC1 is not used. The loop acts not only as an antenna but also as a coupler coil. By connecting the loop as explained, and throwing S2 to point 2, the signals picked up by the loop are impressed on the grid of the tube as before, and the loop is tuned by means of the condenser VC1.

The signals impressed on the grid of VT1 result in amplified signal energy flowing in the plate circuit of this tube. The additional energy required for the amplified signal is obtained from the high-voltage "B" battery which connects to the plate of the tube through point X of the primary of coupler RFC2.

By the process of electromagnetic induction the energy flowing through this primary sets up a similar flow of energy through the secondary coil which con-

sists of coils 2 and 3. This secondary coil is also tuned to resonance with the incoming signal by means of condenser VC2 and the signal is impressed on the grid of the second radio-frequency amplifier tube VT2. Here it is further amplified in the same manner as before and passed on to VT3 through the coupler RFC3.

Up to this point the signal has been twice amplified but is still in the form of an alternating current of too high a frequency to be audible to the human ear. The next step, therefore, is to change its form to make it audible, and this is the function performed by VT3 which is called the detector tube. The condenser C2 and the grid-leak R3 are provided to aid in this rectifying action.

The purpose of radio-frequency amplification is to increase the sensitivity of the receiver; therefore, if headphones could be connected in the output circuit of VT3 signals would be audible, even from distant broadcasting stations.

Having provided ample sensitivity,

the next requirement is to increase volume to make possible the use of a loudspeaker. It is for this purpose that the audio-frequency amplifier, consisting of VT4 and VT5 is used. The coupler coils used are different from those used with the first and second tubes but their function and circuits are much the same. The energy in the detector plate circuit passes through the primary of the coupler (audio-frequency transformer) AFT1 and induces a current flow in the secondary which is impressed on the grid of VT4. The signal is then amplified through the action of vacuum tube VT4, is passed on to VT5 in the same way and is there again amplified. From VT5 it passes to the loudspeaker.

In the case of signals received from nearby broadcasting stations the volume in the loudspeaker would be too great for comfort in an ordinary room so the variable resistance R2 is provided to permit reduction of volume to a desired degree.

Construction of the Receiver

The general construction of the receiver is clearly shown in the accompanying illustrations. The set is intended for use with external "A," "B" and "C" batteries and with either an outdoor, an indoor or a loop antenna.

All of the parts are made by the Grebe Company, and are especially designed for this receiver.

One feature of the three large variable condensers used for tuning lies in the fact that they are of the so-called "straightline-frequency type." With the ordinary type of condenser the low-wave broadcasting stations come so close together on the lower part of the condenser dials that it is sometimes difficult to separate them and the tuning of such stations is extremely critical. With the Grebe type of condensers, however, this difficulty is partially avoided. The spacing on the dials between low-wave stations is greatly increased while spacing between the higher-wave stations (where great spacing is not needed) is

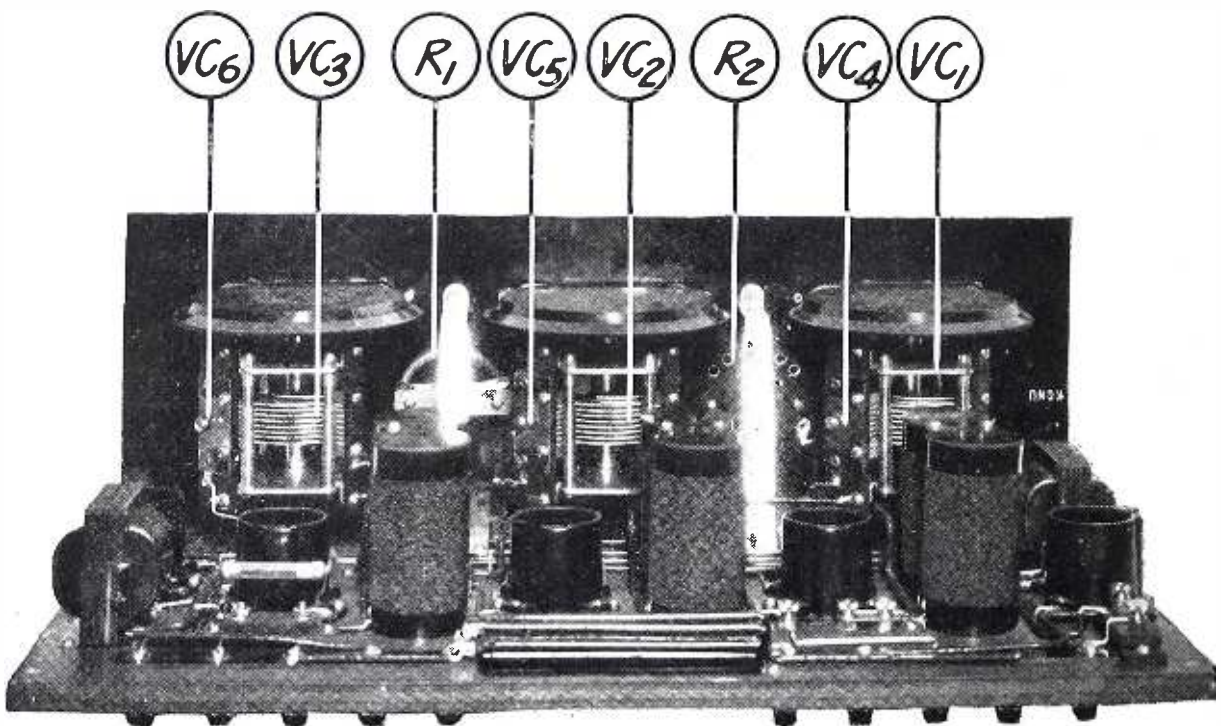

THE REAR VIEW OF THE "WORKS"

FIGURE 4: The instrument layout is here clearly shown. The designating letters are the same as those shown in Figure 1. The balancing condensers VC4 and VC5 are in plain view here; the use of them is explained in the text.

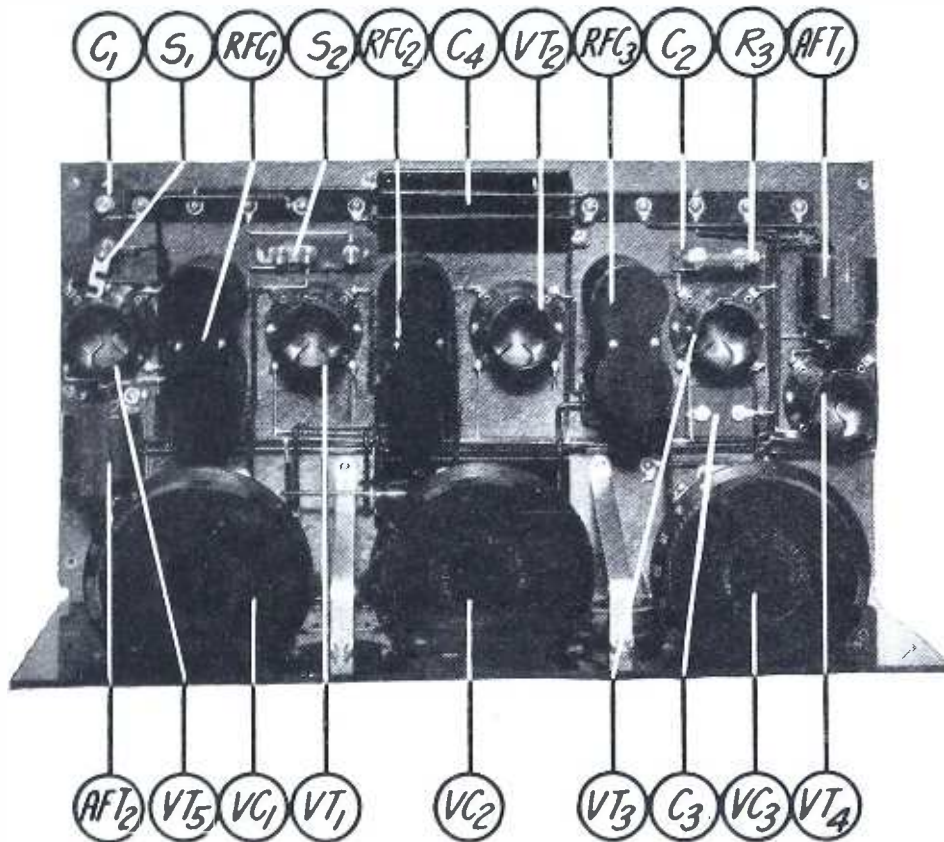

ANOTHER INSIDE VIEW

FIGURE 5: *The instruments which are not mounted on the panel are all on a sub-base, so that the whole set may be removed from the cabinet for inspection or repair. Experimenters are not advised to attempt such removal unless it is absolutely necessary, however; even then it is better for the novice to leave such work to the dealer or the manufacturer.*

decreased. In effect this spreads the entire broadcast waveband evenly over the whole scale on the dials, thus simplifying the tuning process.

The design of the neutralizing condensers VC4 and VC5 also facilitates obtaining maximum results from the receiver. Neutralizing condensers are usually adjusted and sealed before a manufactured receiver leaves the factory. Difficulty is sometimes encountered where this is the case because tubes, other than those used when the receiver was adjusted, may have different internal capacities, thus making the neutralizing circuit only partially effective. In the case of the Grebe receiver the owner of the receiver can readjust his own neutralizing capacities to take care of any variations in his own tubes. Instructions for this neu-

tralizing adjustment will be given later.

A condenser, VC6, is provided to permit synchronizing the dial settings of the condensers VC2 and VC3. By once adjusting VC6 these two variable condensers can be made to tune just alike for a given wavelength, therefore a given broadcasting station may be tuned in with both of these condensers set at exactly the same reading.

The type and layout of controls on the panel are such as to permit operation of the three tuning controls at the same time. The controls for condenser VC2 and VC3 can be moved simultaneously with the thumb and first finger of the right hand, while the control of VC1 is being moved with the left hand. This eliminates some of the difficulty in tuning encountered in many receivers which have three controls.

The Antenna and Ground

Almost any antenna is suitable for use with the Synchronphase receiver. A wire strung around the picture moulding will give good results, especially if it runs through three or four rooms in nearly a straight line, rather than around the four sides of one or more rooms. Better results will, of course, be obtained with an outdoor antenna, which may be anywhere from 50 to 200 feet in length. Probably the best all around arrangement is a single wire about 100 feet in length including the lead-in. The layout of such an antenna is shown in Figure 6. A longer antenna will produce greater volume and distance but will have a tendency to broaden tuning thus resulting in interference between stations operating on nearly the same wavelength. In any event the condenser C1 and switch S1 help to take care of this, as explained above.

A short antenna will not produce quite as much volume on distant stations nor will it permit reception from such great distances as will the 100 foot wire. However, a short outdoor antenna (or an indoor antenna) picks up less static and this is naturally an important consideration for even local reception during the summer.

The ground connection may be made to a cold water pipe or any other pipe system, which connects with the ground—with the exception of gas pipes. Hot water pipes or steam radiators usually provide suitable ground connections but gas pipes are usually insulated from the ground by rubber washers in the pipeline near the meter.

If no pipelines are available in the house a quantity of copper wire buried in moist ground or dropped into the water of a well or cistern will serve. In any case a good electrical connection should be made to the ground line

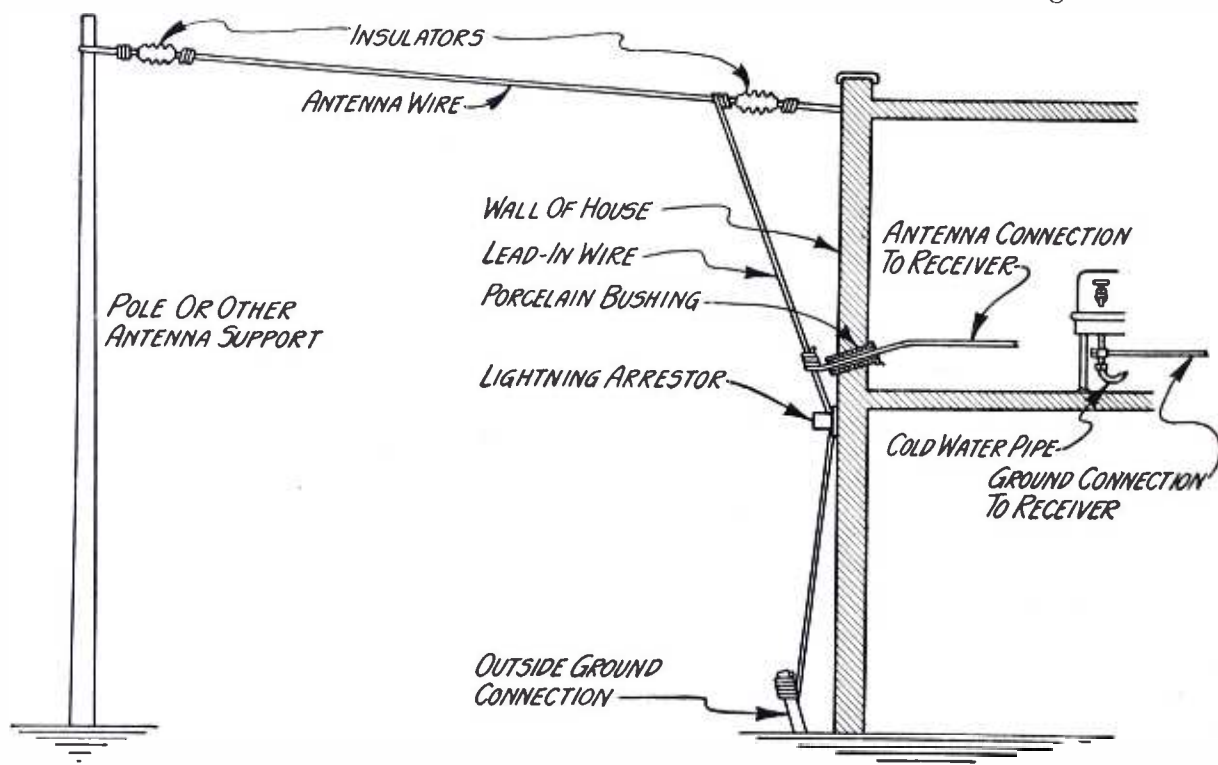

A SUGGESTION FOR THE ANTENNA LAYOUT

FIGURE 6: The design of the average antenna is necessarily governed by physical conditions such as yard space-limitations. Regardless of conditions many of the ideas incorporated in antenna illustrated in this figure may be used to advantage. The antenna for use with the Grebe receiver should preferably be about 100 feet in length, measured between insulators, although good results are obtainable with shorter spans.

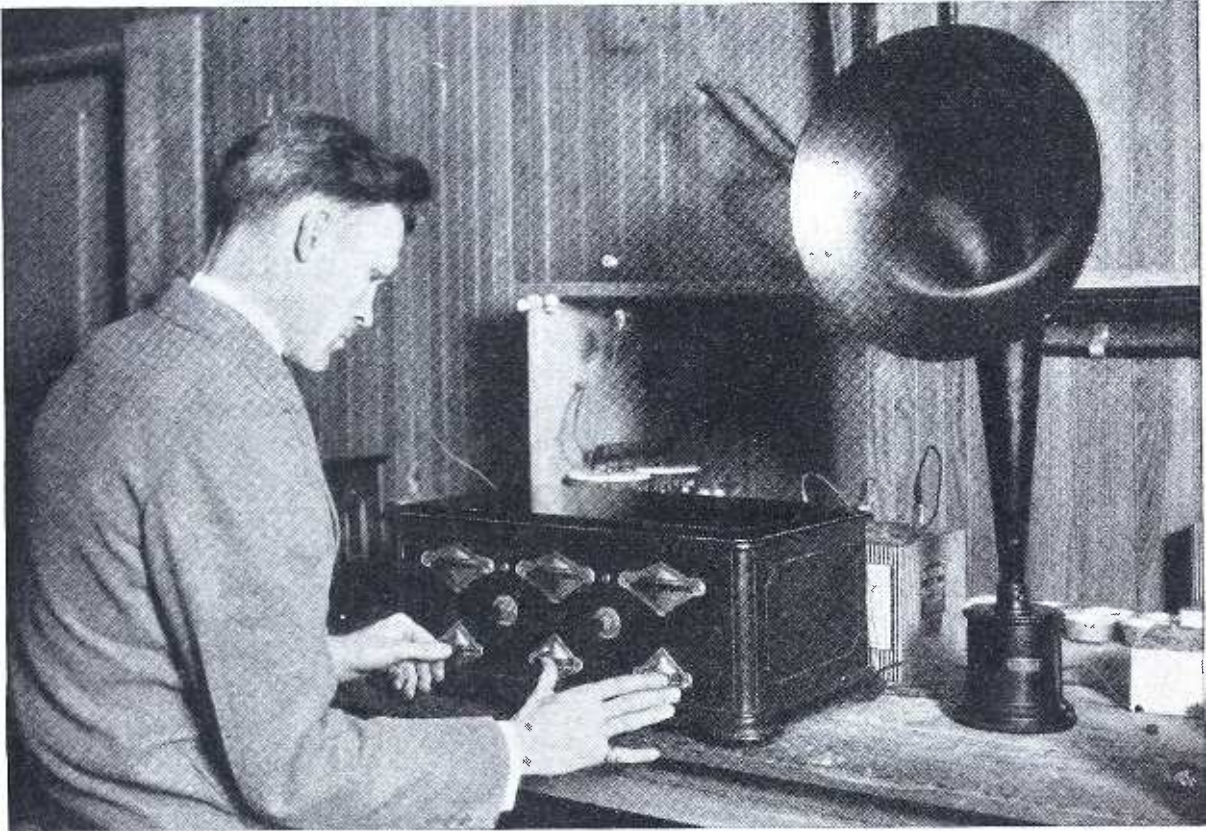

From a photograph made for POPULAR RADIO

TWO HANDED OPERATION OF THE THREE TUNING CONTROLS

Here the author demonstrates the method of tuning the three dials simultaneously, thus eliminating the necessity for a third hand.

selected. If it be a pipe any paint or other coating on the pipe should be filed off until the pipe is bright and shiny at the point where connection is to be made and connection made by means of a regular ground clamp.

If for any reason the use of an antenna is not practical, a small loop antenna may be used. This is connected to terminals 2 and 3 (Figure 7).

A lightning arrester may be connected as shown in Figure 6.

What Vacuum Tubes to Use

This receiver is designed to use vacuum tubes of the UV-201-a type throughout. These may be the UV-201-a, the C-301-a—or the De Forest DV-2. These are all "hard" tubes which require the use of a storage "A" battery for filament-current supply, and consume approximately $\frac{1}{4}$ ampere each. The use of a "soft" detector tube, such

as the UV-200, is not recommended. A special model of this receiver is on the market for use with dry-cell tubes—one which is especially designed for operation with these tubes. Satisfactory results will not be obtained if dry-cell tubes are used with the model described in this article.

What Batteries to Use

This receiver uses three separate types of batteries—the "A," "B" and "C" batteries.

The "A" battery must be of the storage type. This storage battery may have a rated ampere-hour capacity of between 75 to 150. A battery charger is also desirable so that the battery may be charged at home, thus avoiding the inconvenience of carting the battery to a neighboring charging station; or the expense of having the battery called for and delivered by the charging station.

Connections for a battery charger are shown in Figure 7, for use where the house is equipped with alternating current for lighting.

In the case of a direct-current house supply it is important that the polarity of the current first be determined. This may be done by holding the two ends of the leads (from a light socket) a half-inch apart and dipping them into a cup of water to which a half teaspoonful of salt has been added. Bubbles will rise from one of the wires when the current is turned on, and this wire is the negative (—) side of the line. In making this test there is no danger provided insulated wire is used and the hands are not allowed to come in contact with the bare ends of the wires. Connections for a bank of lamps (to be used for the charging resistance with direct-current supply) are shown in Figure 8. No other apparatus is needed for charging from direct-current mains.

It is essential that a hydrometer be obtained also, to determine when it is in need of recharging. When the hydrometer shows a reading of 1,185 it is an indication that the battery needs charg-

ing. A reading of approximately 1,285 indicates a fully-charged battery. Actually a fully discharged battery will give a reading of about 1,150 but it should never be allowed to run down to this point as the battery is quite likely to be injured.

The "B" battery consists of four 22½ volt batteries, or two 45-volt units. In either case the total voltage required is 90. Large size batteries (either 22½ or 45-volt units) are desirable because their life is approximately 16 times that of the small size of the same voltage; and the initial cost is only about twice the cost of the others. The new extra large "Heavy Duty" batteries are recommended, however, as they offer still greater economy. This is made clear in the table on page 126.

Storage "B" batteries may also be used. In fact the use of them will reduce the battery upkeep cost in the long run and the service obtained from them, provided they are given an occasional charge, will be as satisfactory as that obtained from batteries of the dry-cell type.

Charging equipment for such batteries may be purchased for a small sum

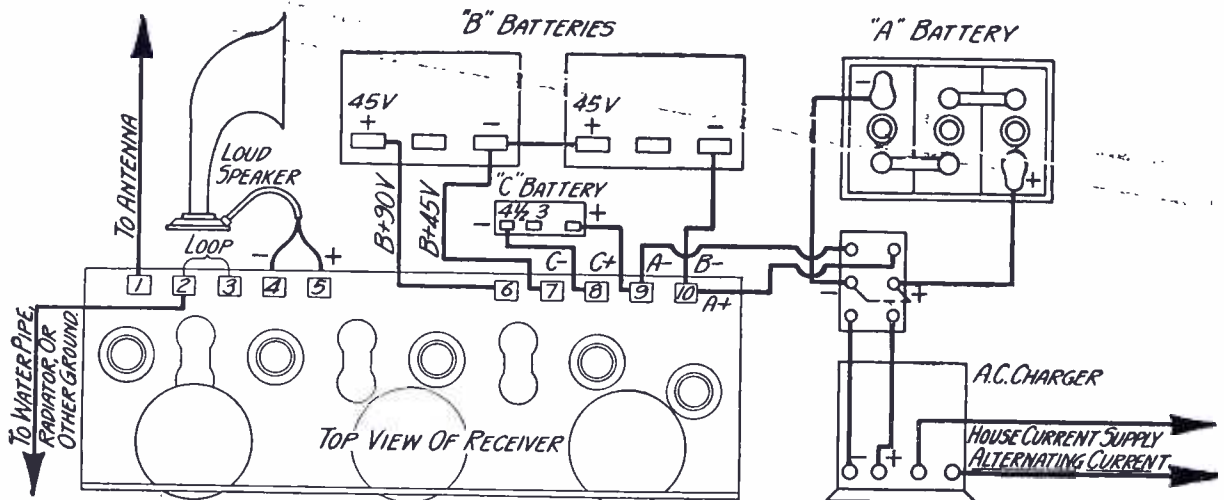

CONNECTIONS FOR THE COMPLETE EQUIPMENT

FIGURE 7: In addition to the connections for the batteries, loudspeaker, antenna and ground, connections for the battery charger are shown. A switch is incorporated in the "A" battery circuit. When thrown to the up position the battery is connected to the receiver and when thrown down connects to the charger; there is then no danger of starting the charger while the battery is still connected to the receiver.

TO "A" BATTERY CONNECTIONS OF RECEIVER

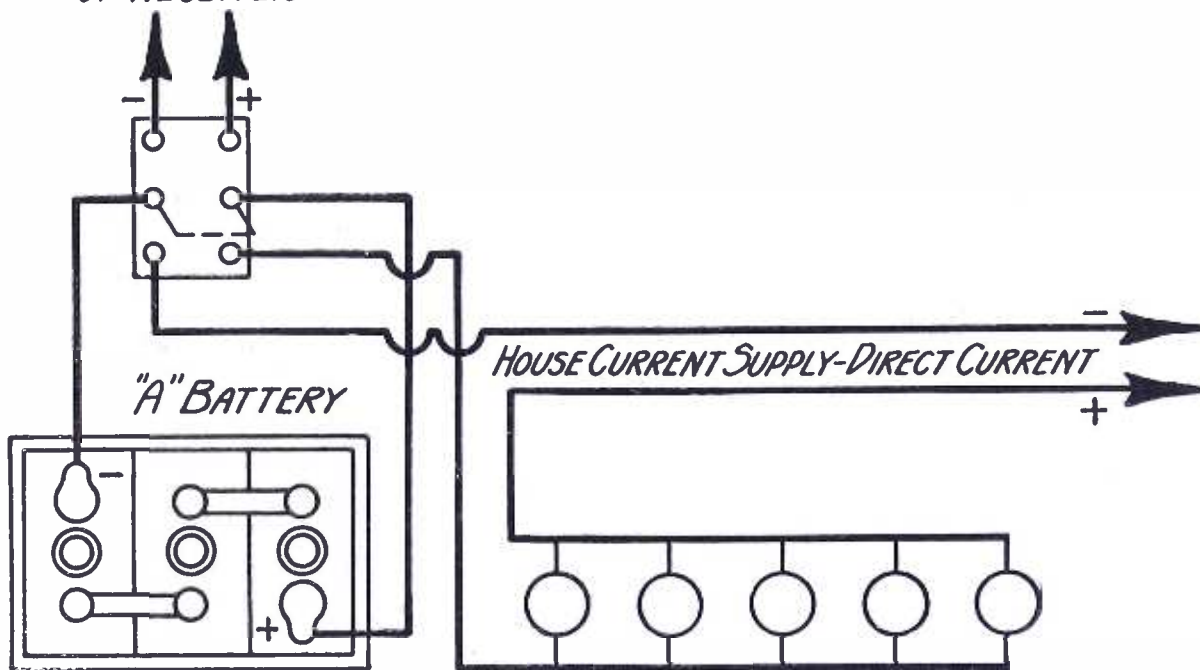

CHARGING THE "A" BATTERY FROM DIRECT CURRENT HOUSE SUPPLY

FIGURE 8: In this case no charger is needed. Only resistance is required and this is furnished by the use of five ordinary 100 watt lamps connected as shown. If desired a special charging resistance may be purchased to use in place of the lamps.

and where the house supply is alternating current an attachment may be purchased to permit the regular "A" battery charger to be used for charging the storage "B" batteries also.

The "C" battery is of the dry-cell type and consists of a regular $4\frac{1}{2}$ volt unit sold for this use. There is practically no current consumed from this battery and its life is therefore long. It will be good until it just naturally dies of old age. It will very likely last a year.

The Operation of the Receiver

The connections for the batteries, antenna, ground and loudspeaker are shown in Figure 7. These connections are all self-explanatory, with the possible exception of the connections to the terminals marked 1, 2 and 3 in Figure 7. When an outdoor or indoor antenna is used, it is connected to terminal No. 1. When a loop antenna is used, however, its two ends are connected to terminals

2 and 3 and terminal No. 1 is left unconnected. In either case the ground is connected to terminal No. 2. When an outdoor or indoor antenna is used the switch S2 is swung around so as to make contact with point No. 1 (the left-hand point looking down on the receiver from the top). When a loop antenna is used this switch arm is connected to point No. 2.

After the receiver has been connected up in accordance with the above, turn the "volume increase" knob to point 6 and the "filament increase" knob to zero. Next insert the five vacuum tubes in their sockets and turn the "filament increase" knob to 4. This will light the tubes and the receiver is then ready for operation.

To tune in a station the dial settings shown in the tuning chart below will be approximately correct for all receivers of this type and model. The best plan is to select a powerful nearby station which is known to be in operation at the

Average hours use per day	"Large" size batteries			"Heavy Duty" batteries		
	2	3	4	2	3	4
("C" battery voltage)						
4½ volts	222 days	144 days	105 days	388 days	259 days	194 days
3 "	154 "	93 "	63 "	275 "	173 "	121 "
1½ "	120 "	70 "	47 "	220 "	131 "	91 "

This table shows the effect of the "C" battery on the life of the "B" batteries. Greatest economy in operation is obtained when using 4½ volts of "C" battery. The table also shows the much longer life of the "Heavy Duty" type "B" batteries.

time. Then consult the chart to ascertain the dial settings for that station. If that particular station is not shown on the chart, set the dials for the station shown, with a wavelength nearest to that of the station which you desire to tune in. If the receiver is in operation in Los Angeles, for instance, and KHJ of that city operating on 404 meters is the station which you wish to tune in, set the dials as shown on the chart for station WOR which operates on 405 meters. These dial settings will be nearly correct for KHJ; only a slight variation will bring in the desired station.

After one station has been tuned in in this manner, it will be a simple matter to tune in others. The three dials should be moved in unison, manipulating the left-hand dial with the left hand, the other two with the thumb and forefinger of the right hand. This movement should be slow, as it is an easy matter to slip over stations, especially if they be distantly located. When another station is heard readjust each of the three dials slightly to bring it in with maximum volume.

After this tuning process has been practiced a short time it will be well to investigate some of the refinements of tuning. First of all, try different settings of the "volume increase" knob while a station is tuned in. Points 3, 4 or 5 usually provide plenty of volume on all but distant stations. In a large hall, or in receiving distant stations point 6 is useful, otherwise it will give too much

volume for comfort in an ordinary room.

Next try interchanging the tubes from one socket to another. One tube will sometimes work better in the third socket than in the fourth, etc. The best combination can be determined in a few minutes and the tubes may be left permanently in the positions in which they give the best results.

These receivers are carefully balanced before they leave the factory, but when the purchaser of the receiver puts it into operation he may find that it oscillates or whistles when he tries to tune in stations in the lower or higher wavelengths.

Where this condition is found it will be necessary for the owner to rebalance the receiver himself, or take it to his dealer to have it done. It is not a difficult task, however, and it is to facilitate this process that the adjusting screws on condensers VC4 and VC5 are provided.

If it is found that the receiver oscillates only when high-wave stations are tuned in the screw on VC4 should be turned slightly in the clockwise direction, keeping the signal tuned in in the meantime. A small screw-driver with a wood handle is recommended for this purpose. This screw should be adjusted in this direction a little at a time until the oscillation ceases.

If oscillation takes place only on the low-wave stations, an adjustment should be made on condenser VC5, in the same manner described for VC4.

In some cases it may even be found

that the receiver oscillates to a certain extent on all wavelengths. In such a case the balancing process is somewhat different. The receiver should be left all connected in readiness for reception, with the tubes turned on. The second and third dials from the left are then set at 40, and the left-hand dial at 100. Dial No. 2 is then rotated between 30 and 50. At some point a click will probably be heard. If not, turn the screw of VC5 in an anticlockwise direction until a click is heard as dial No. 2 is rotated back and forth from 30 to 50. Then turn the screw in a clockwise direction until the click disappears, and approximately a quarter turn beyond this point. This finishes the balancing of VC5.

Next set all dials at 40 and adjust balancing condenser VC4 in the same manner just described, but this time rotating the left-hand dial back and forth between 30 and 50.

There may still be slight signs of oscillation on the high waves, or possibly the low waves. If so a small adjustment of the balancing condensers as described first will remedy the trouble.

Finally it is well to know that the "C" battery voltage used has a strong influence over the life of the "B" batteries and therefore over the upkeep cost of the receiver. The tabulation above demonstrates that the life of the "B" batteries is much greater when the "C" battery voltage is $4\frac{1}{2}$ than when it is $1\frac{1}{2}$ or 3. On the other hand, it is sometimes found that the tone quality and reproduction of the receiver improve somewhat with a decrease of "C" bat-

tery voltage from $4\frac{1}{2}$ to 3. This evidently is not always the case, but where it is found to be so, it is up to the operator to decide whether tone quality or maximum economy is the more important consideration.

Charting the Receiver

Tuning will be simple if a record sheet is kept, on which are recorded the dial settings for each station as it is tuned in for the first time.

A record of a few stations is shown below, in the form of a convenient chart. The antenna used when this chart was made up was a short one and there was no occasion to make use of the condenser C1. If a long antenna is used it will be necessary at times to connect C1 into the circuit no doubt. For that reason it will be well to add another column to the chart to note whether or not S1 is open or closed when the dial settings for each station are recorded. This is done because the setting of the dial of VC1 varies slightly according to whether S1 is open or closed.

<i>Wave-length</i>	<i>Station</i>	VC ₁	VC ₂	VC ₃
526	WNYC	90	91	90
509	WIP	87	88	87
492	WEAF	83	83	83
475	WEEL	80	80	80
468	WCAP	78	78	78
455	WJZ	74	74	74
405	WOR	64	64	63
394	WLIT	62	62	62
379	WGY	59	59	59
360	WHN	54	54	54
344	WCBD	49	49	49
333	WBZ	46	46	46
315	WGBS	41	41	41
300	WPG	36	36	36

"In the Experimenter's Laboratory"

BEGINNING in the next issue—for September—POPULAR RADIO will publish a new and essentially helpful department that will be conducted by the Technical Staff of the POPULAR RADIO LABORATORY for the particular benefit of the radio amateur and for the broadcast listener who is interested in experimental work and who seeks to attain better results from his radio equipment—and who may thus profit from the constant experimental work of a skilled and experienced staff of experts.



General Electric

THE INVENTORS AND THEIR NEW UNIT

The working mechanism of the vibrating cone loudspeaker is here shown in the hands of its co-designers. In the background is shown another instrument fully set up in a cabinet.

A New Type of Hornless Loudspeaker

By W. T. MEENAM

THE ordinary loudspeaker usually approaches true reproduction only within a limited frequency range. Low notes are usually shattered; they are lost almost entirely or else they are produced only as overtones.

Here is a new device, developed by Chester W. Rice and Edward W. Kellogg, which utilizes a vibrating cone to set up the air waves and gives faithful reproduction from the deepest organ notes to the highest violin harmonics.

Sound is, of course, produced by vibrations which are sent through the air as pulsations. The more vibrations a second, the higher is the pitch of the sound. In the usual telephone receiver the sound is produced by vibrations of a metal diaphragm which is affected by the varying strength of an electromagnet behind it.

This type of reproducer is satisfactory for headphones, as the air gap between the diaphragm and the eardrum through which distance the sound vibrations must travel is small, and diaphragm vibrations of small amplitude are sufficient. For loudspeaker operation, however, the telephone unit must be more powerful and is usually coupled with a horn. It will be found that such an arrangement does not always reproduce both high and low notes with the same precision, and it is usually the low notes which are slighted.

To radiate low notes more effectively there must be more air moved with each swing of the diaphragm. The loudspeaker may be thought of as an air pump. If an air pump which will give a large movement of air with each stroke is desired, a large piston area and

a long stroke should be used. The telephone receiver type of speaker is not suited to the purpose of obtaining a long stroke, first, because the movable iron will strike the poles of the magnet if it swings far, and second, because it is in an unstable position and with the very flexible diaphragm support which is essential for the long stroke, there is not enough stiffness to hold the iron away from the magnet poles.

In the new hornless loudspeaker, the familiar moving-coil type of drive is employed. If a copper wire is placed between the poles of a magnet, the wire will be pushed sidewise when a current is sent through the wire.

The wire is wound into a coil, and as it moves parallel to the faces of the magnet poles instead of toward and away from them, there is no limit to the distance it can move. The varying currents from the radio set are passed through an amplifier to the moving coil. The strength of the magnetic force on the

coil of copper wire varies with this current, and the coil is thus caused to vibrate. In this device the moving coil is attached to a diaphragm, consisting of a paper cone about six inches in diameter, the outer edge of which is supported by a membrane of thin rubber.

An important feature of this new hornless loudspeaker is the baffle board which surrounds the diaphragm and which serves as the front of the cabinet.

The baffle does not itself radiate sound, but it prevents air from circulating between the front and back of the diaphragm.

The cabinet contains, in addition to the speaker itself, a rectifier and amplifier, power for the operation of which is taken from the alternating-current lighting circuit. The amplification obtained from this new device is sufficient to produce, in the case of local stations, clear loudspeaker signals from a crystal receiver, provided that the latter gives clear headphone reception.

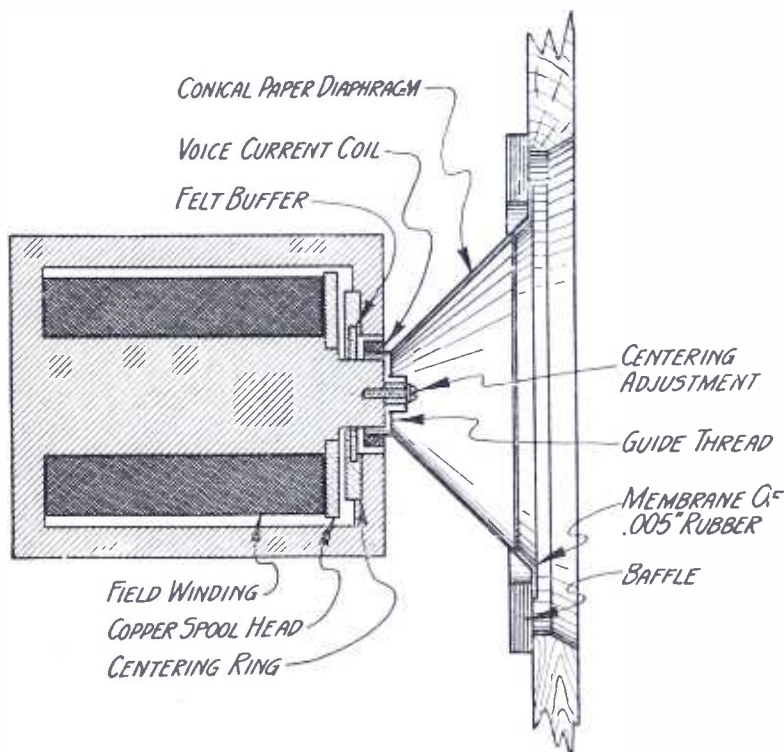

THE WORKING PRINCIPLE OF THE UNIT

This diagram shows the various parts included in the design and the general mechanical arrangement. Notice that the voice-current coil which furnishes movement to the conical, paper diaphragm moves back and forth in a horizontal position at right angles to the magnet.

A MOBILE

The advent of the practical, motorized short-wave relay station into the realm of broadcasting marks the beginning of a new era. With its aid, a description of any outdoor event, no matter where located, may be transmitted through a regular broadcasting station.

By DAVID LAY

HERETOFORE ordinary broadcasting has been confined to events which have taken place directly in the broadcasting studio or events that have been picked up by means of a specially installed telephone line direct to the location where the event is taking place.

It is true that in a few instances (such as the broadcasting of the recent total eclipse and the broadcasting of the race between the motorboat *Baby Gar II* and the Twentieth Century Limited) that the original signals were picked up from a mobile station located in an airplane.

The chief problem in this latter method of broadcasting was to devise a connecting link between the event being described and the large high power broadcasting station operating on a regular wavelength.

The best solution to this problem lies in the use of portable short-wave pick-up stations working in conjunction with the regular broadcasting stations.

Such a mobile station, the call letters of which are WGMU, has already been placed in operation by A. H. Grebe and Company. It is an ideal short-wave relay installation, operating on 63 meters in conjunction with station WAHG (the main station of the same company) which operates on 316 meters.

A description of this mobile pick-up

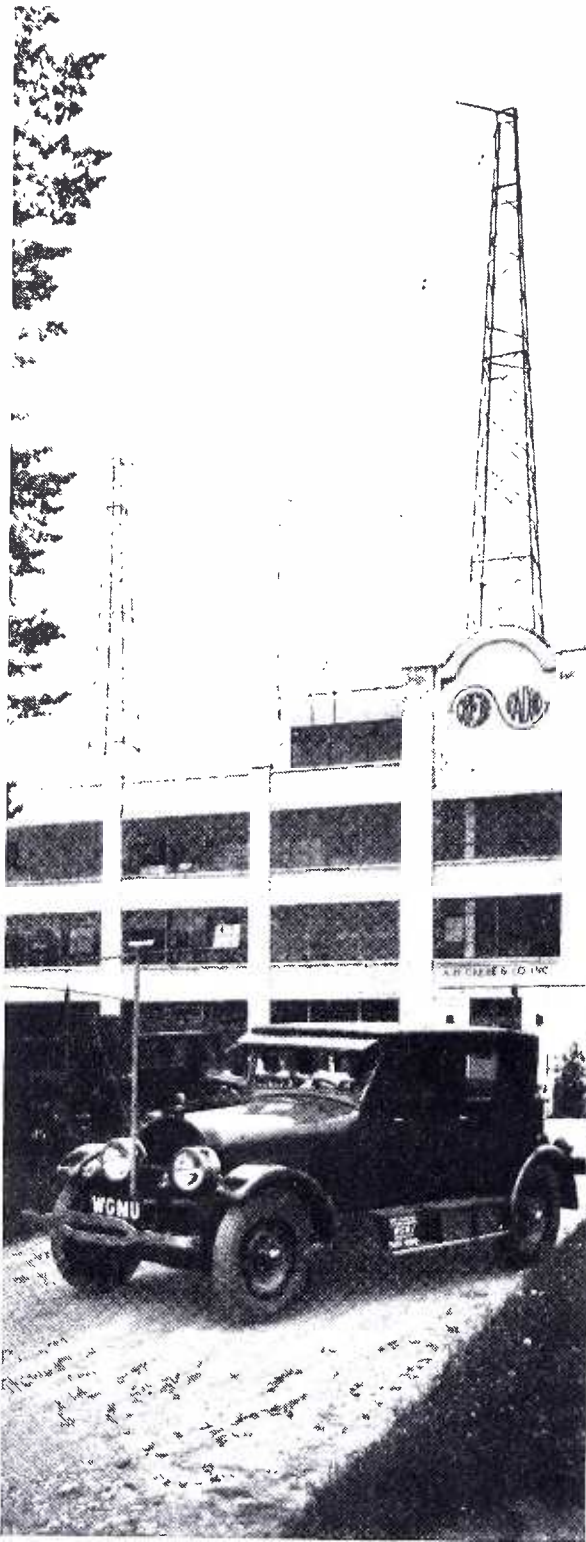

From a photograph made for POPULAR RADIO

THE NEW TYPE OF "RADIO REPORTER"

FIGURE 1: *The short-wave transmitter on a motor car leaving the main broadcasting station for a trip to the locality of a distant event; the description of the event will be relayed back to the main station and put on the air through the large antenna.*

RADIO RELAY STATION

station is of interest to the radio fan for it clears up the "mystery" of this type of broadcasting.

There are four essential links in the chain from the event to the listener.

First, the signal is broadcast by mobile station WGMU on a wavelength of 63 meters.

Second, it is picked up by a special short-wave receiver which operates a loudspeaker.

Third, by placing the microphone of WAHG near the above loudspeaker, the signal from the short-wave pick-up station is re-broadcast on a normal wavelength.

Fourth, it is received by the broadcast listener.

In this article only the apparatus used in bringing the signal up to the microphone of the main station, WAHG, is described as the reader is no doubt familiar with the regular broadcasting station. These two links of the chain are the short-wave transmitter and the short-wave receiver.

The Grebe short-wave transmitter, WGMU, is installed complete on an automobile but, at the same time, the whole seating capacity of the car is reserved for the station operator and other passengers. The transmitter proper is



From a photograph made for POPULAR RADIO

A SHORT-WAVE TRANSMITTER IN ITS CARRYING CASE

FIGURE 3: The staff inspects the transmitting apparatus. The designations show A, the transmitter; B, the wave-meter and C, the portable microphone control. The case containing this instrument folds up, thus protecting it from dust and dirt.

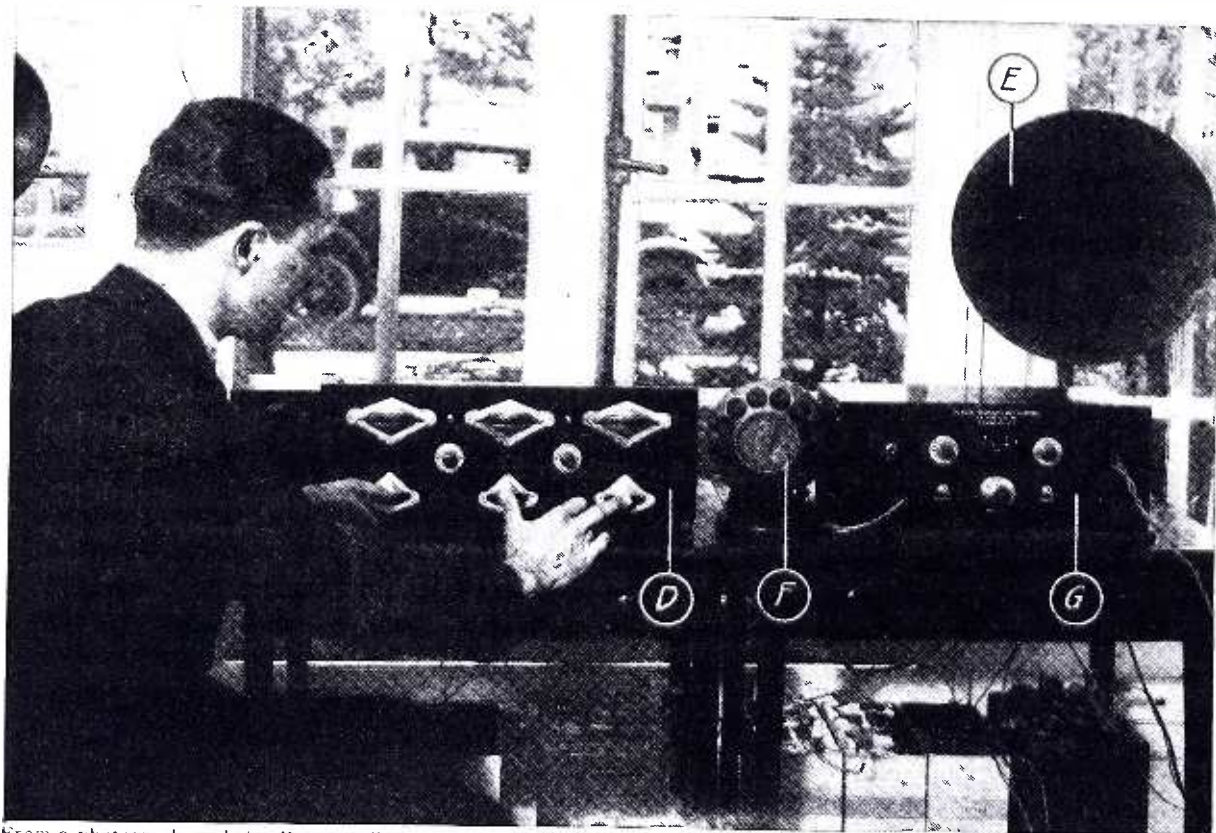

From a photograph made for POPULAR RADIO

THE SHORT-WAVE RECEIVER

FIGURE 4: The four instruments shown in this photograph are D, a short-wave receiver; E, the loudspeaker; G, the speech amplifier; F, microphone. The receiver picks up the signal from the mobile station and it is made audible through the loudspeaker, picked up by the microphone F and strengthened by the amplifier G.

carried in a case on the rear of the car in the same manner as the regular automobile trunk is carried, while power for operation of the mobile station is furnished by storage batteries on the running board of the car. (See Figure 1 and the frontispiece for views of the mobile station ready for traveling and set up for operation; also Figure 3 for a closer view of the transmitter.)

The transmitter (shown as A in Figure 3), is a standard vacuum tube type which uses four fifty watt vacuum tubes just as the larger broadcasting stations might use four two hundred and fifty watt tubes. Two additional speech amplifying tubes of a smaller variety are used to strengthen the signal before it reaches the transmitting tubes proper. Storage batteries are used to light the filaments of the vacuum tubes and also to drive

a motor generator set which furnishes the 1,500 volt supply for the plate circuit of the transmitting tubes. This motor generator is mounted on springs in a compartment directly under the transmitter. The plate supply for the speech amplifying tubes is furnished by three large size 45 volt "B" batteries.

The antenna is carried just above the roof of the car when running or for short distance work, but it can be raised by means of extension poles to give the transmitter additional broadcasting range. The ground wire is carried to the frame of the car which acts as a counterpoise.

The small panel (shown as B in Figure 3) is a wavemeter which makes it a simple matter for the operator to keep his transmitter on the correct wavelength. It might be mentioned here

that the wavelength of 63 meters is one of those set aside by the government for this class of relay work.

The portable microphone control (shown as C in Figure 3) is an essential part of the transmitting equipment when broadcasting is to be done at some distance from the car. This cabinet may be carried to the scene of the broadcasting, as it is connected back to the car with an extension cable. Microphones are provided for the broadcaster and for the announcer and there is one stage of vacuum tube amplification to insure the signal reaching the transmitter on the car with sufficient strength.

The short-wave receiver which operates in conjunction with mobile transmitter WGMU is a standard Grebe Synchronphase with the coils rewound for the shorter wavelength required. In Figure 4 it is shown as D together with the loudspeaker E which it operates.

The microphone of station WAHG is indicated as F and it is placed in about the position shown rather than directly in front of the loudspeaker of the short-wave receiver. As the particular microphone of station WAHG shown in

Figure 4 is located in Mr. Grebe's home, the signal is sent through the amplifier G before it is transmitted by wire to station WAHG.

A complete test and demonstration of the satisfactory operation of mobile station WGMU was carried out by the technical staff of POPULAR RADIO as follows: The mobile station was run to an isolated point, approximately twenty miles out on the Long Island Motor Parkway, and there put in operation as shown in the frontispiece. We could now talk back to the operator of the short-wave receiver (see Figure 4) and we gave instructions to put our voices on the air through station WAHG. We were now broadcasting from station WAHG, but we had no check on just what was being sent out.

The car in the background (in the frontispiece) supplied this check, as it contains an ordinary receiving set such as any broadcast listener would use. As soon as this receiver was tuned to WAHG the loudspeakers on the running board reproduced everything which we spoke into the microphone. Thus the signal had made a trip back to WAHG on a

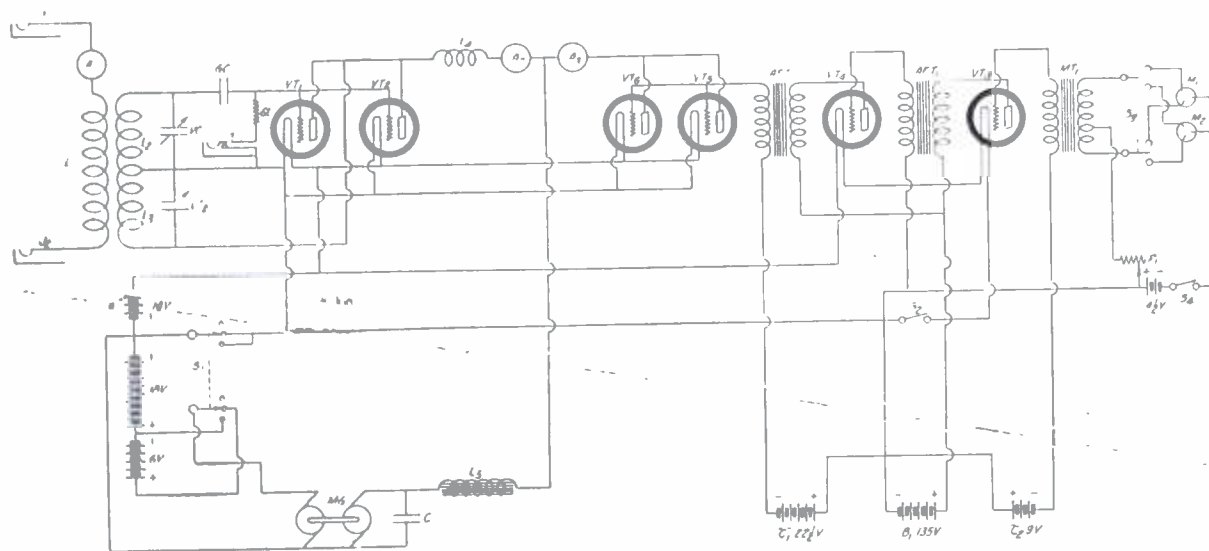

THE CIRCUIT DIAGRAM FOR THE TRANSMITTER

FIGURE 5: This diagram shows the general electrical connections for the microphone circuit, the speech amplifier, the modulator tubes and the short-wave oscillator tubes. The two jacks, J1 and J2 are connected to the short antenna and to the frame of the car, which act as the antenna and counterpoise respectively.

wavelength of 63 meters and a return trip to the receiving car on a wavelength of 316 meters.

A pick-up station such as WGMU can be used as a relay from any point to which an automobile can be driven. The same type of station installed on a launch can be used to relay descriptions of aquatic events. On an airplane it would serve in the same manner for bird's-eye descriptions of races and such events. Thus much closer contact with current events is possible by radio than would have been dreamed of a few years ago.

For some of the technical details of the transmitter that are of interest to the more rabid fans, consult Figure 5 for a complete wiring diagram of the transmitter and Figure 6 for a panel view of the transmitter with the instruments marked by the same designating

letters used in the schematic diagram. The circuit used is a modified Hartley circuit with separate grid and plate tuning for the oscillator tubes. Heising modulation is employed.

Two fifty-watt vacuum tubes VT1 and VT2 are operated in parallel as oscillators. The grid circuit of these tubes consists of the inductance L2, the tuning condenser VC1, the .002 mfd. grid condenser GC, the 10,000 ohm grid leak GL and the jack J3, the latter to insert a key for continuous wave work. The plate circuit of these tubes consists of the inductance L3, the tuning condenser VC2, the radio-frequency choke L4, the plate-current milliammeter A2, the 1,500-volt generator of the motor-generator MG and the filter system which is a 30-henry choke L5 and a 3-mfd. condenser C. Switch S1 provides an "off" position, also high and low-

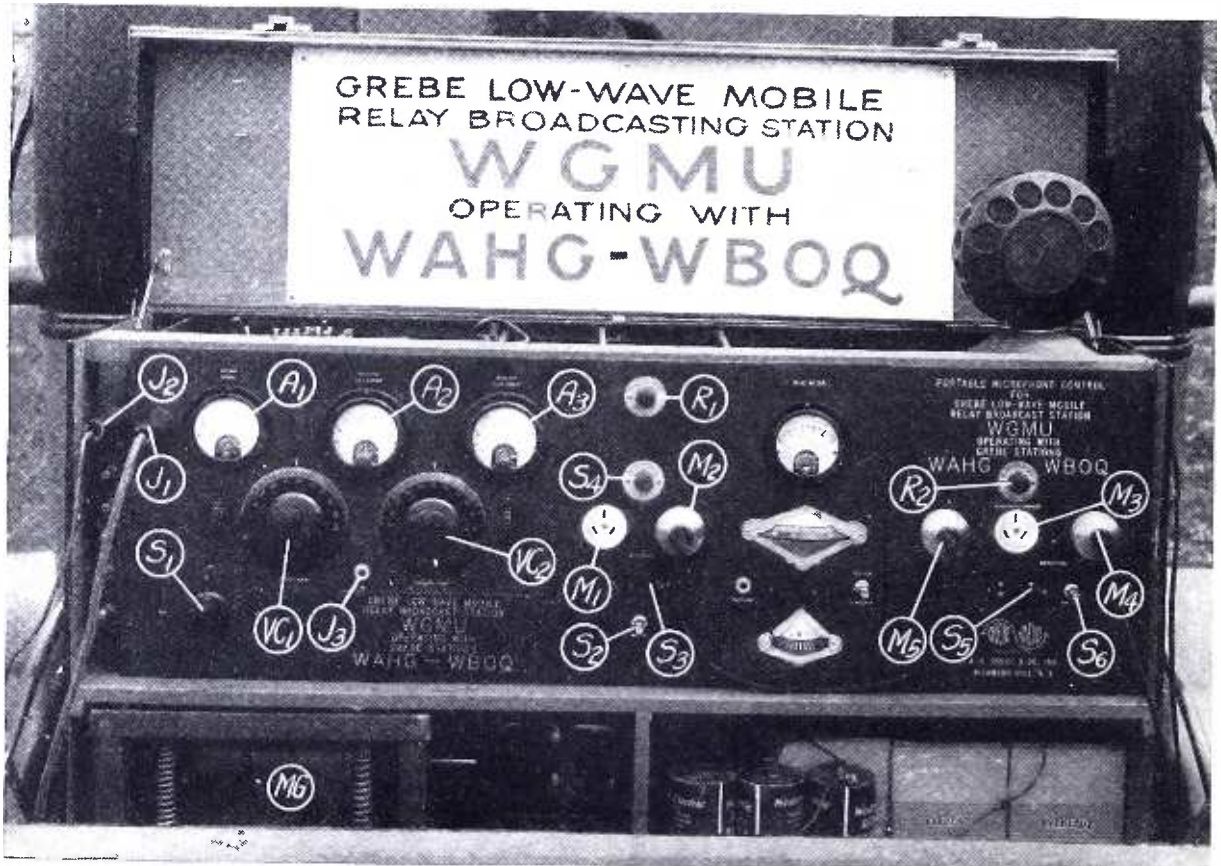

From a photograph made for POPULAR RADIO

A CLOSEUP OF THE SHORT-WAVE TRANSMITTER

FIGURE 6: This picture gives a detailed view of the transmitting oscillator panel, the wave-meter and the microphone control panel. The various designations drawn in the photograph tell in the text exactly what each instrument is.

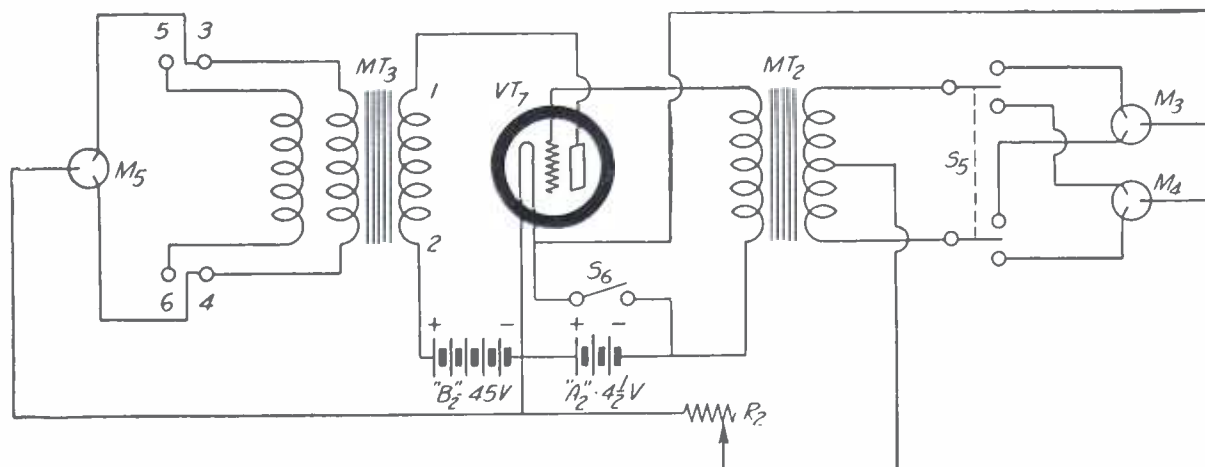

THE DIAGRAM OF THE MICROPHONE CONTROL.

FIGURE 7: The electrical connections for the microphone receptacles, the transformers and the vacuum tubes that are employed for picking up the signal and supplying it with the proper strength to the transmitter located at the rear of the motor car.

power positions by changing the voltage on the driving motor of the motor-generator-unit.

The microphone circuit consists of microphone receptacles M1 and M2, microphone changeover switch S3, cutoff switch S4, a $4\frac{1}{2}$ -volt battery, rheostat R1 and the primary of modulation transformer MT1. Instead of the secondary of the modulation transformer acting directly on the modulator tubes, the voice-frequency current is passed through two stages of amplification, consisting of vacuum tube VT3, audio-frequency transformer AFT1, vacuum tube VT4 and audio-frequency transformer AFT2 together with the necessary batteries. The grid circuit of the fifty-watt modulator tubes VT5 and VT6 contains the secondary of transformer AFT2 and a $22\frac{1}{2}$ -volt "C" battery. The modulator tubes receive their plate current from the same 1,500-volt generator as the oscillator tubes but it passes through the plate milliammeter A3 instead of A2.

The filaments of all the tubes in the transmitter are lighted by the 10-volt storage battery A1. Those of the small speech-amplifier tubes VT3 and VT4 are connected in series and provided with a cutoff switch S2.

The antenna circuit of the transmitter

consists of the antenna jack J1, the antenna ammeter M1, the inductance L1 and the counterpoise jack J2.

Refer to Figures 6 and 7 for the details of the portable microphone control. The microphone circuit embraces the microphone receptacles M3 and M4, the microphone changeover switch S5, the primary of the modulation transformer MT2, the rheostat R2, the $4\frac{1}{2}$ -volt battery and the cutoff switch S6.

The secondary of the modulation transformer works through one stage of amplification, consisting of VT7 with its necessary batteries, into the primary of modulation transformer MT3. Either the high-ratio secondary (terminals 5 and 6) or the low-ratio secondary (terminals 3 and 4) of this transformer may be connected to the output receptacle M5. This latter receptacle is connected by flexible cable to either microphone receptacle M1 or M2 of the transmitter.

This covers fairly thoroughly the design and operation of an ideal short-wave relay installation.

With the growing use of mobile pick-up stations of this type, located on automobiles, airplanes, launches, trains or ocean-going steamships there will be no single spot left in the future on the land, in the air or on the sea from which a broadcast program may not originate.

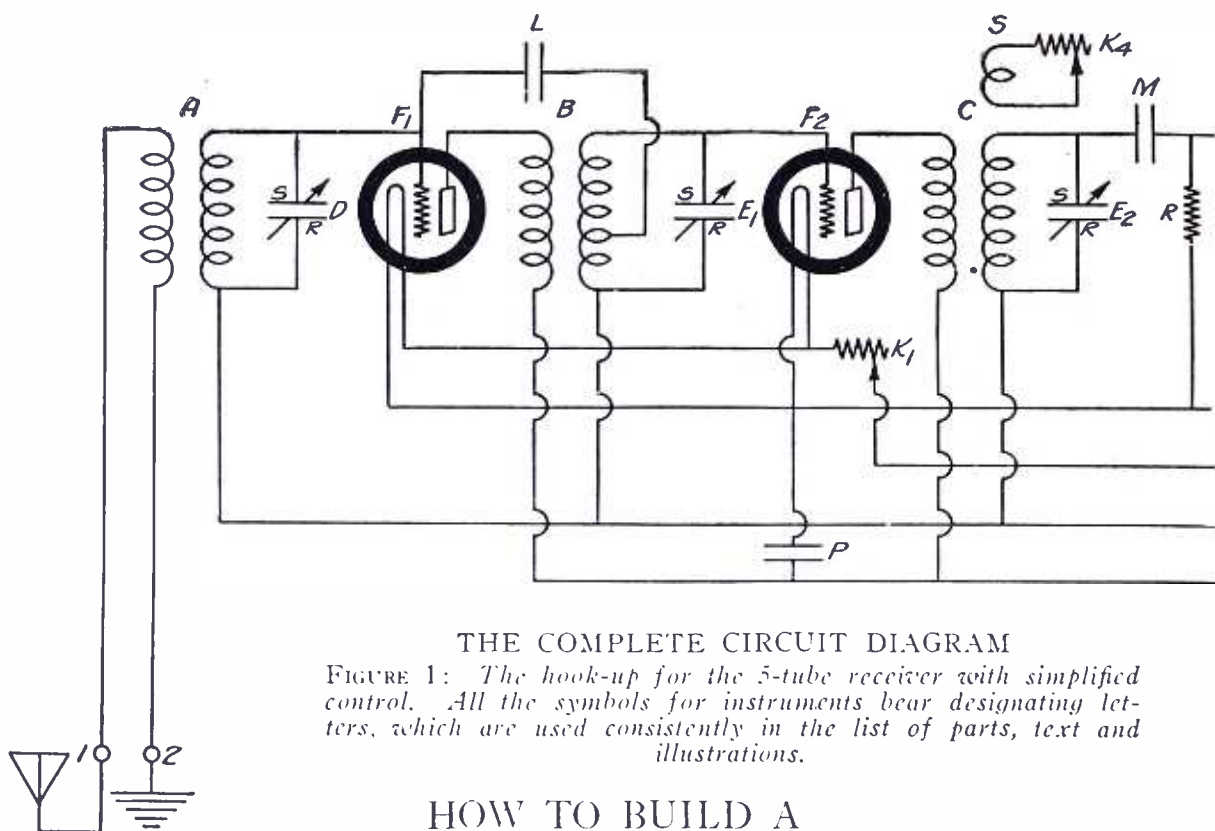

THE COMPLETE CIRCUIT DIAGRAM
 FIGURE 1: The hook-up for the 5-tube receiver with simplified control. All the symbols for instruments bear designating letters, which are used consistently in the list of parts, text and illustrations.

HOW TO BUILD A 5-Tube Radio Frequency Set —with Simplified Control

The set here described is particularly recommended because it will not radiate—even though it uses regeneration. Operation has been simplified by using a minimum of panel controls. A special type of amplification has been used to give distortionless reproduction.

By ALBERT G. CRAIG

COST OF PARTS: Not more than \$65.00

RECEIVING RANGE: Up to 2,000 miles

HERE ARE THE ITEMS YOU WILL NEED—

- | | |
|---|--|
| A, B and C—Aero Coil low-loss tuning inductance and two radio-frequency transformers; | L—X-L Vario Denser, Model N; |
| D—Lombardi straight-line frequency variable condenser, .00035 mfd.; | M—Sangamo mica fixed condenser, .00025 mfd.; |
| E—Lombardi straight-line frequency double variable condenser, .00035 mfd. capacity for each half; | N—Sangamo mica fixed condenser, .002 mfd. |
| F1, F2, F3, F4 and F5—Benjamin standard sockets; | O—Dubilier micadon, type 640, .02 mfd.; |
| G—Rauland-Lyric audio-frequency transformer; | P—Dubilier by-pass condenser, 1. mfd.; |
| H—Thordarson audio-frequency transformer ratio 6 to 1; | Q—Daven resistance mounting; |
| I—Thordarson audio-frequency transformer, ratio 3½ to 1; | R—Daven resistance unit, 5 megohms; |
| J—Carter last-stage filament control jack, No. 103; | S—Loop around radio-frequency transformer C; |
| K1, K2, K3 and K4—Bradleystats; | T—composition panel, 7 by 24 inches; |
| | U—hardwood sub-base, 9⅞ inches by 23 inches; |
| | V—antenna binding post strip; |
| | W—battery binding post strip; |
| | X—small brass brackets; |
| | Y—cabinet; |
| | machine screws; wood screws; bus wire. |

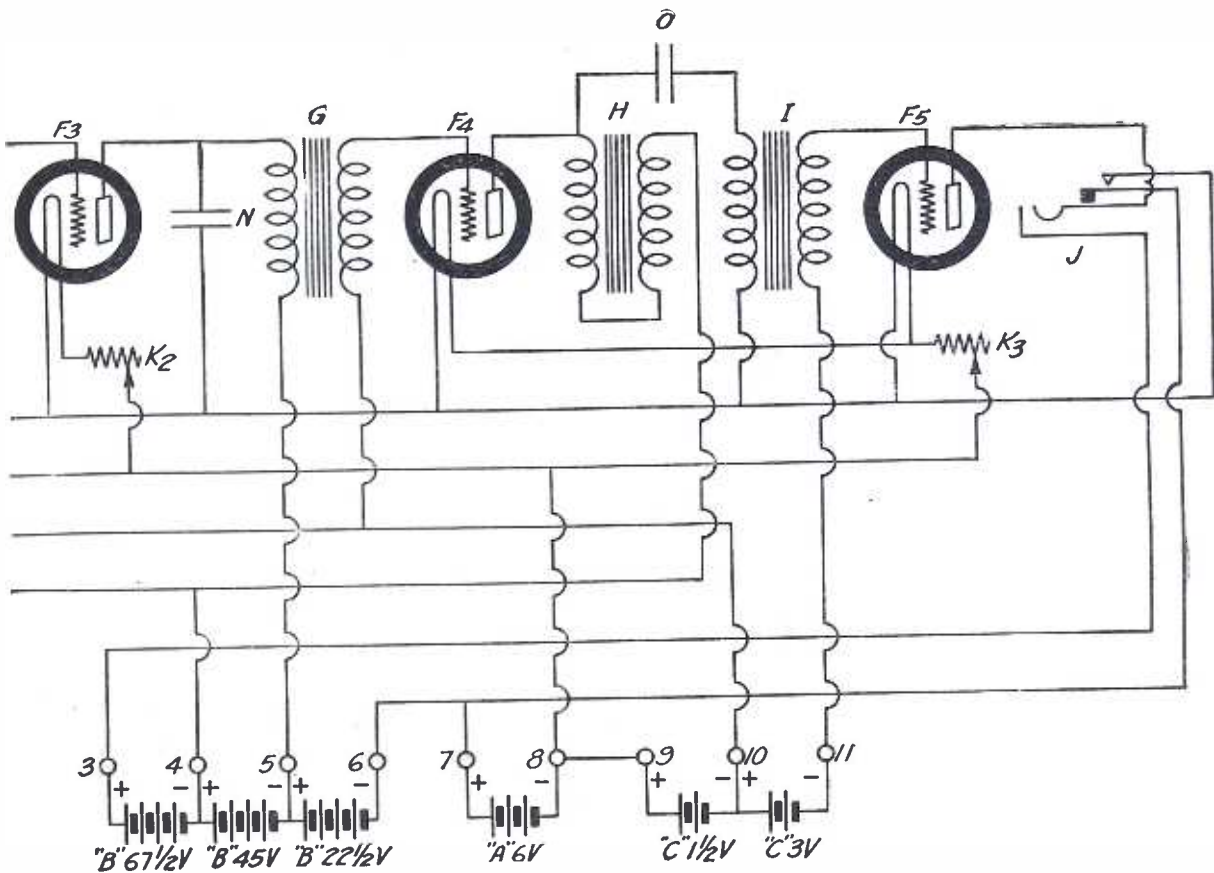

THIS receiving set was designed with three essential requirements always in mind. First, it must be simple to control. Second, it must not radiate. And third, it must give quality reproduction.

An important step toward easier tuning was made possible by the commercial development of the multiple condenser. By using a single condenser for the tuning inductance and a two unit multiple condenser (that is, two condensers on the same shaft) for the two radio frequency transformers, the number of wavelength controls was reduced from three to two, or the maximum number which one person can move simultaneously.

All of the variable condensers in this set are the straight line frequency type, which change the frequency to which the circuit is tuned uniformly as the dial is rotated. As the broadcasting station wavelengths are assigned with uniform frequency differences between them, this means that they will be separated equally on the tuning dials. With the ordinary condenser it will be noticed that the low wavelength stations seem to be crowded

together while there is more space than necessary between the high wavelength stations.

Three filament rheostats have been employed, one for the two radio-frequency tubes, one for the detector and one for the two audio-frequency tubes, but all of these rheostats have been placed within the set as their adjustment is not critical, and it is just as well to remove the temptation to turn them continuously. All tube filaments are lighted by inserting the loudspeaker plug in the single filament control jack.

This receiving set has been made non-radiating by neutralizing the grid-plate capacity of the first radio frequency tube, but at the same time the sensitivity of the receiver to weak signals has been increased considerably by providing a variable regeneration control over the second radio frequency tube. An absorption loop around the second radio-frequency transformer, with a Bradleystat for varying the absorption effect, worked out to give an easy control over regeneration.

To test the receiver for radiation, the

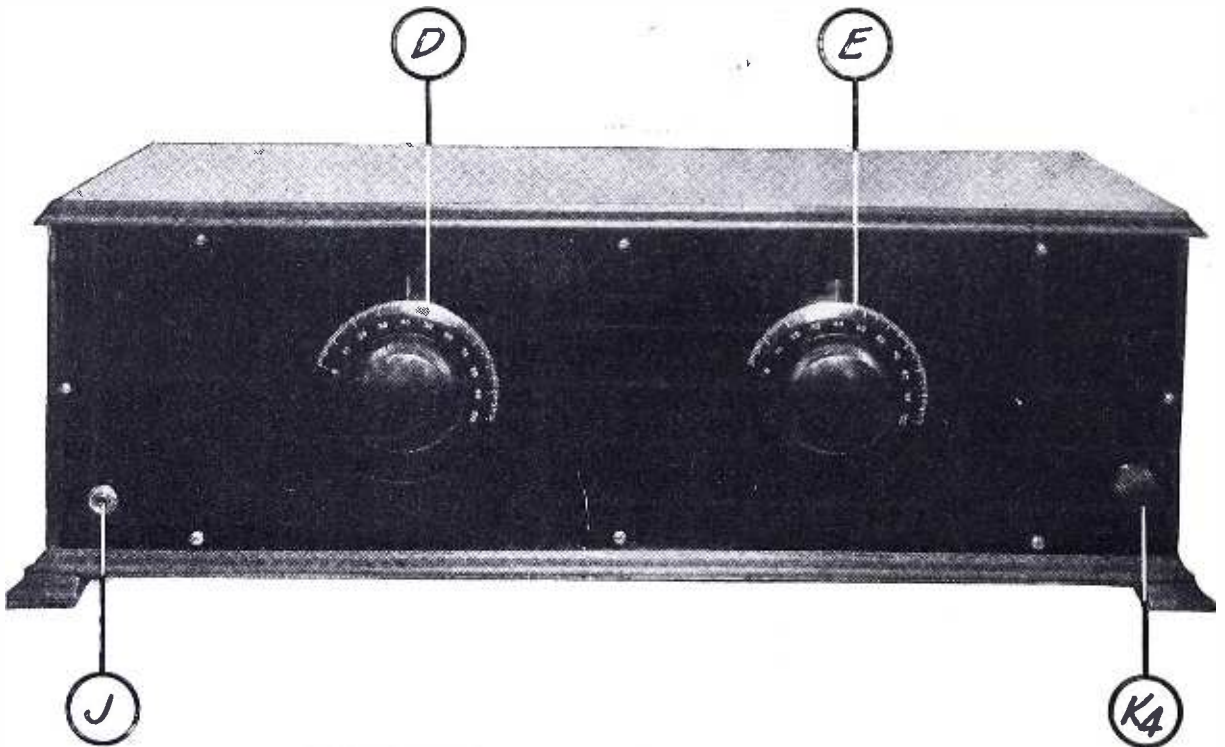

THE PANEL VIEW OF THE RECEIVER

FIGURE 2: This gives an idea of how the set looks from the front. As the dials and knobs are marked with letters which correspond with the instruments to which they are attached, the prospective operator will have no trouble in locating the various controls as they are explained in the instructions for tuning.

second radio-frequency tube was made to oscillate and heterodyne with a certain broadcasting station. At the same time a second set across the laboratory was tuned to the same broadcasting station and the program was received with no trace of a whistle from the first set.

A special type of amplification has been chosen which gives, in effect, the quality of choke coil amplification with the

voltage step-up (for greater volume) of transformer-coupled amplification. Because suitable choke coils are not generally available commercially, one audio-frequency transformer has been utilized as a choke coil by connecting the two windings in series and a second audio-frequency transformer used for its regular purpose as a voltage step-up device.

This receiver was tested on antennas

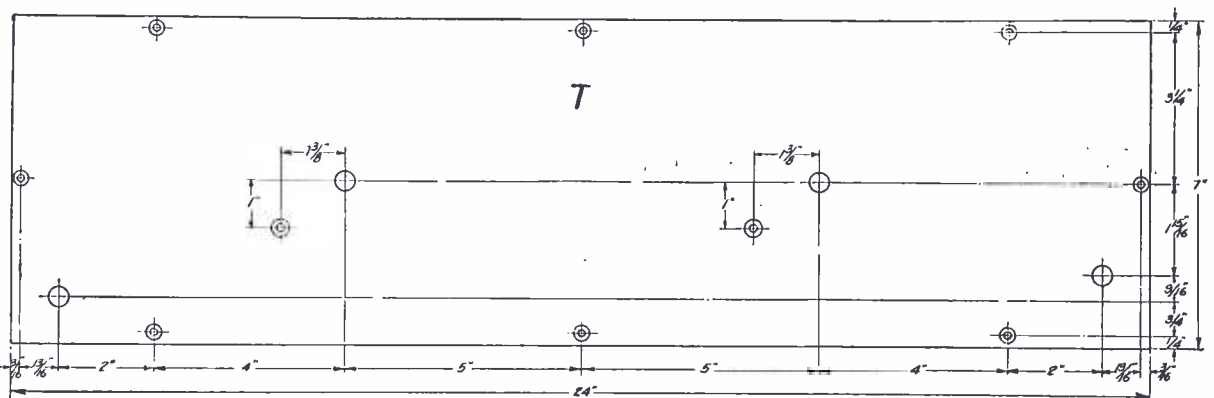

THE DRILLING PLAN FOR THE PANEL

FIGURE 3: Where to drill the holes for mounting the instruments. The holes outlined with a double circle should be countersunk. Always start drilling holes in the panel with a small drill; one-sixteenth inch is a desirable size.

which varied in length from 10 to 150 feet. On the local New York stations good volume and excellent selectivity were obtained on the shortest antenna while the distance possibilities were increased as the antenna was lengthened. A good average length of antenna would be 75 feet.

The schematic diagram of Figure 1 will give a good conception of the circuit that is employed.

Parts Used in Building the Set

In all the diagrams in this article each part bears a designating letter; in this way, the prospective builder of a set may easily determine how to mount the instruments in the correct places and connect them properly in the electric circuit.

The same designating letters are used in the text and in the list of parts at the beginning of the article.

Q The list of parts there given includes the exact instruments used in the set from which these specifications were made up. The experienced amateur, however, will be able to pick out other reliable makes of instruments which may be used with equally good results. But we recommend that the novice fol-

low the list, as the diagrams in this article will tell him exactly where to bore the holes and exactly where to place the connections.

If instruments other than the ones listed are used, the only change that will be necessary will be the use of different spacings for the holes that are to be drilled in the panel for mounting the instruments.

How to Construct the Set

After procuring all the instruments and materials for building the set, the amateur should prepare the panel T (shown in Figures 2, 3 and 4).

First, cut the panel to the correct size, 7 by 24 inches. Then square up the edges smoothly with a file. The centers for boring the holes (which are necessary for mounting the instruments) should be laid out on the panel as shown in Figure 3. A convenient method of doing this is to lay out all center holes on a piece of paper the same size as the panel; then the piece of paper should be pasted on the panel and the centers marked directly on the panel by punching through the paper.

The holes outlined with a double circle should be countersunk, so that the flat-head machine screws used for fastening the instruments are flush with the panel. All the rest of the holes in the panel are straight drill holes. Sizes for the diameters of these holes have not been given, but the builder will

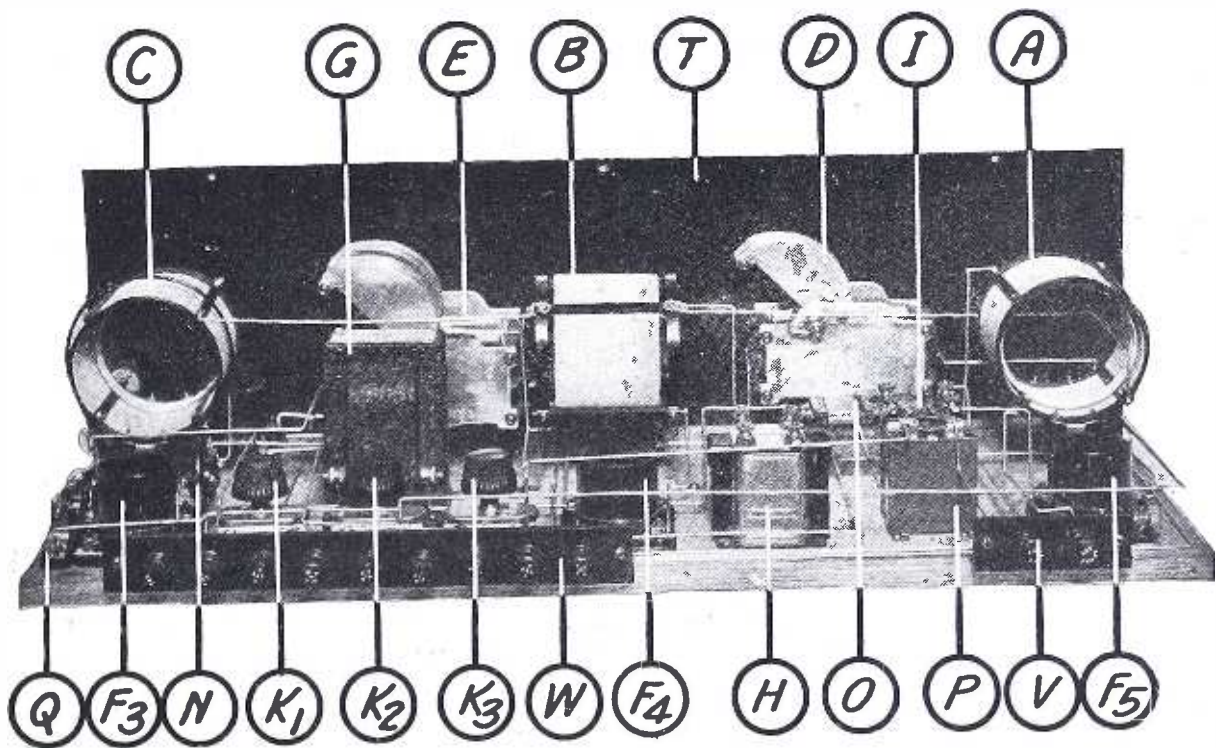

VIEW OF THE SET FROM THE REAR

FIGURE 4: This picture shows the general arrangement of all the instruments fastened to the panel or base. The exact locations for the instruments are shown in Figure 5.

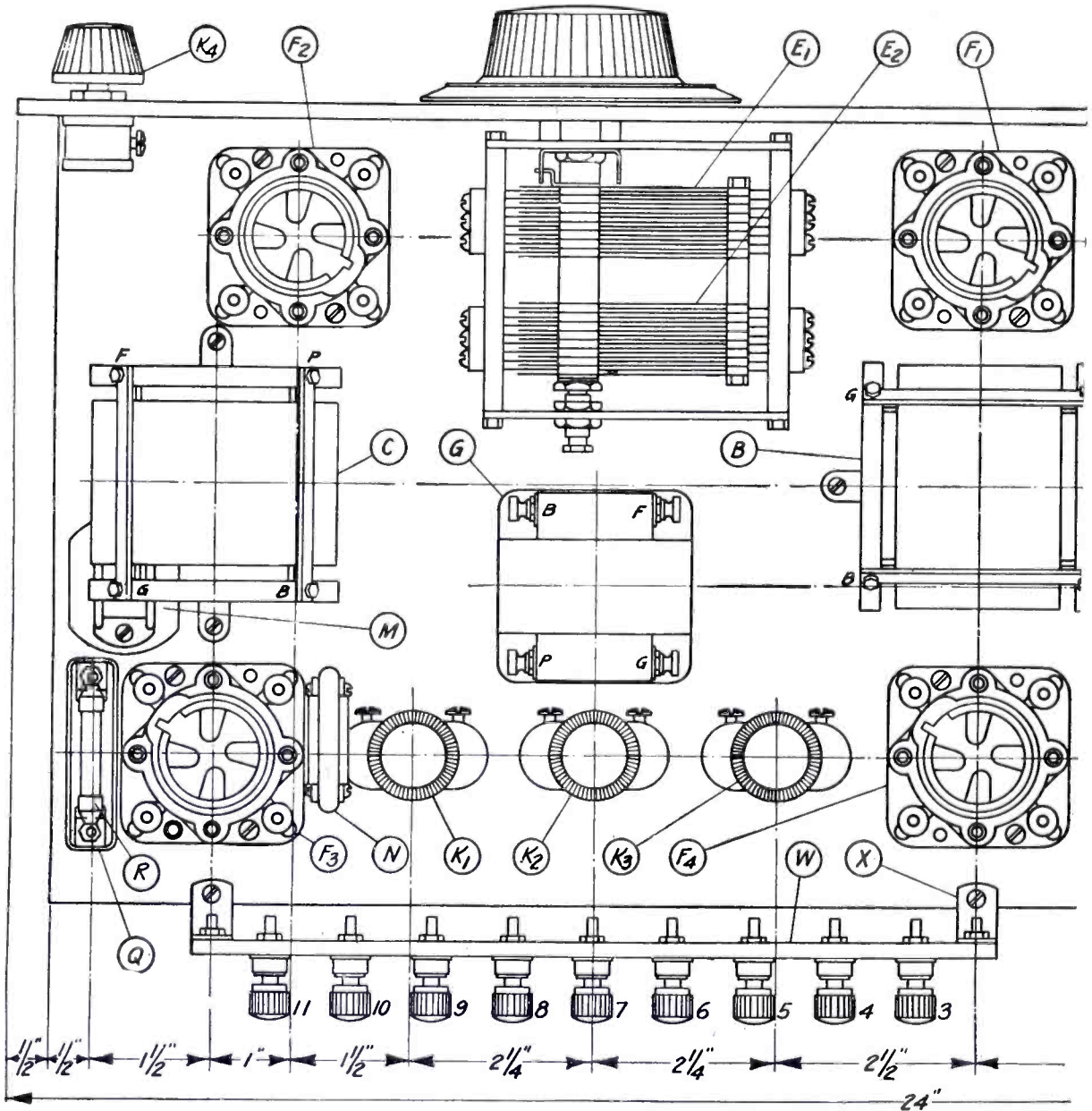

THE WORKING DRAWING FOR CONSTRUCTION

FIGURE 5: Here are shown the correct positions for the instruments which are mounted on the base. The positions are given, center to center, for all instruments.

readily decide what size hole is necessary by measuring the diameters of the screws and shafts of the instruments that must go through the holes.

When the panel is drilled, the builder may give it a dull finish by rubbing the face of the panel lengthwise with fine sandpaper until it is smooth. This process should be repeated, except that light machine oil should be applied during the second rubbing. Then rub the panel dry with a piece of cheesecloth. A permanent dull finish will be the result. Or the panel may be left with its original shiny-black finish, if care is exercised so that it is not scratched during the drilling.

The sub-base U (see Figures 4 and 5)

should be cut to size $9\frac{7}{8}$ by 23 inches. If a piece of $\frac{1}{2}$ -inch hardwood, surfaced on both sides, can be obtained the work of squaring up the edges will be a minimum.

Make up the composition antenna binding post strip V, the battery binding post strip W and also the four small brass brackets X, if these cannot be purchased. (See Figure 8 for detailed dimensions of these parts.)

Complete specifications for constructing the cabinet Y are shown in Figure 10. It may be made out of $\frac{1}{2}$ -inch hardwood such as mahogany, walnut or oak, and finished to suit the taste of the builder. Or the cabinet may be purchased from your radio dealer as it is a standard size. In the latter case it will only be

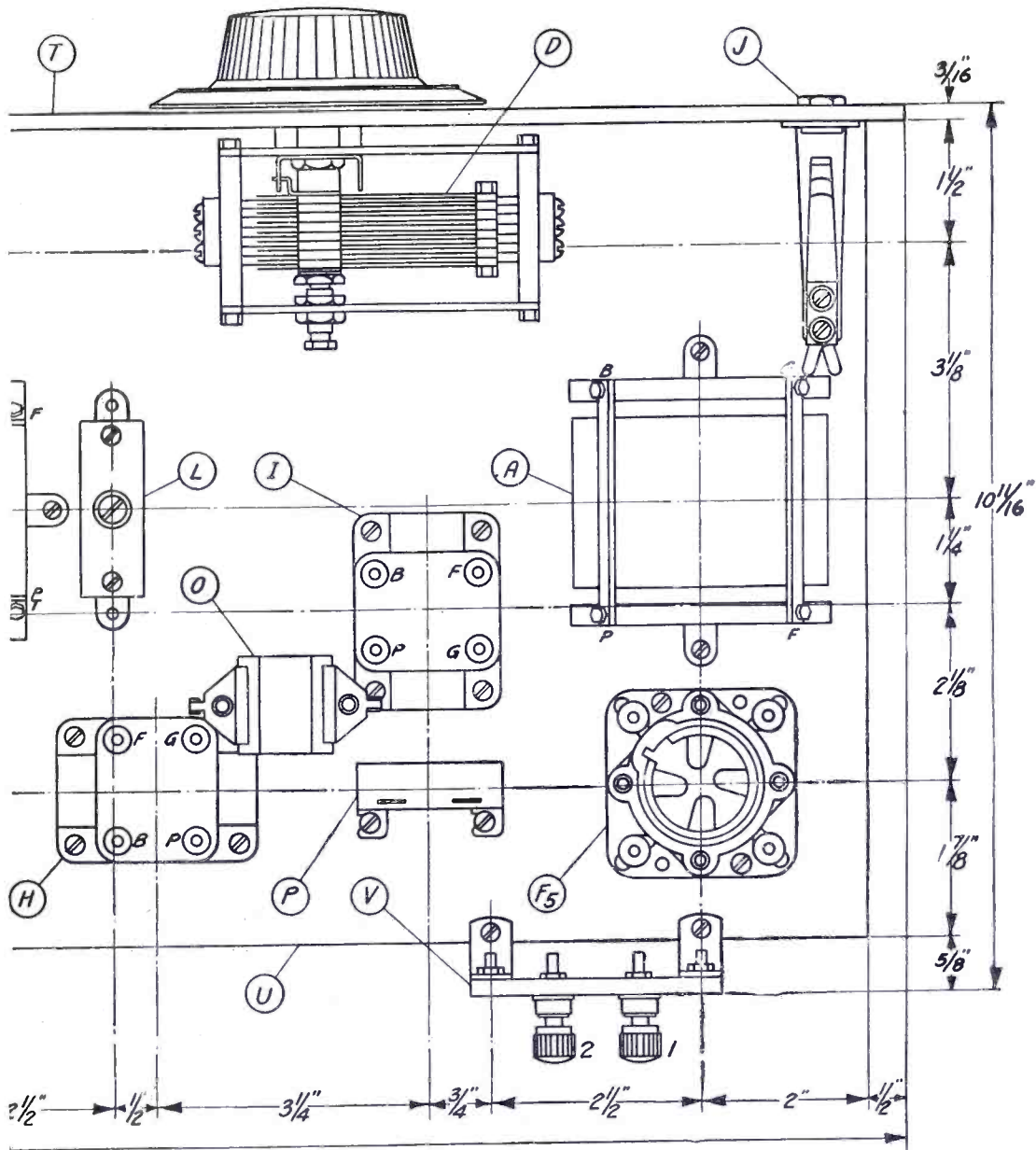

necessary to cut the slots in the back of the cabinet for the binding post strips.

Preliminary to mounting the parts of the set fasten the panel T at right angles to the sub-base U with wood screws driven through the panel holes into the edge of the sub-base. (See Figures 4, 5, 6 and 7.)

Beginning with the base-mounted instruments, fasten the sockets F1, F2, F3, F4 and F5 to the sub-base with wood screws in the positions shown in Figures 4 and 5. Note the positions of the socket slots from Figure 5.

By means of two wood screws through the metal eyelets, fasten the neutralizing condenser L to the base as shown in Figure 5. The metal terminal which comes straight out of the bakelite case should be towards the rear of the set.

Mount the three audio-frequency transformers G, H and I according to Figures 4 and 5. The plate and grid terminals of G are towards the rear of the set; the positive "B" and plate

terminals of H are towards the rear of the set and the plate and grid terminals of I are towards the rear of the set.

Using fine wood screws, mount the three rheostats K1, K2 and K3 on the sub-base with the terminal towards the rear of the set. Note the exact positions from Figures 4 and 5.

Fasten the bypass condenser P to the sub-base as shown in Figures 4 and 5.

Fix the resistance mounting Q in position beside socket F3. (See Figures 4, 5 and 7.)

Prepare the tuning inductance A and the two radio-frequency transformers B and C for mounting by attaching the small supporting brackets furnished with these coils. Mount the tuning inductance A, which is the coil with only four soldering terminals, with the terminals marked F and P towards the rear of the set. (See Figures 4, 5 and 6.) Mount the radio-frequency transformer B with the ter-

minals marked B, T and P towards the rear of the set. (See Figures 4 and 5.) Mount the radio-frequency transformer C with the terminals marked B and G towards the rear of the set. (See Figures 4, 5 and 7.)

Assemble the eleven binding posts on panels V and W and fix these two binding post panels to the sub-base by means of the four small brass brackets X. Note the positions of these binding post strips from Figures 4 and 5.

Starting on the panel, mount the jack J with the frame down in the lower left-hand corner of the panel according to Figures 5 and 6.

Now, fasten the regeneration control K4 in the lower right-hand corner of the panel, noting that the terminals are turned inward. (See Figures 5 and 7.)

Finally, mount the two variable condensers D and E on the panel. The correct positions are shown in Figures 4 and 5. Attach dials to these condensers.

How to Wire the Set

When wiring, it should be remembered that all connections from the high-voltage side of the transformers and coils (that is to say the side next to the vacuum tubes) should be

kept about 1/2-inch away from the other wiring and should not run parallel to other wires for any considerable distance.

Use tinned-copper bus wire throughout. All connections should be bent into the proper shape and then soldered in place.

Start wiring the filament-lighting circuit according to Figures 1 and 9. The main positive and negative filament bus wires run along the rear of the set between the sockets and binding post strips and along the front of the set between the sockets and the panel. Connect the positive terminals of sockets F1, F2, F3, F4 and F5 together and continue the wire to the top terminal of jack J. Run a wire from the second terminal of jack J (counting from the top) to the negative "B" battery binding post (No. 6) and to the positive "A" battery binding post (No. 7).

Connect the positive "C" battery binding post (No. 9) and the negative "A" battery binding post (No. 8) to the right-hand terminals of rheostats K1 and K2 and to the left-hand terminal of rheostat K3. Now, connect the left-hand terminal of rheostat K1 to the negative terminals of sockets F1 and F2. Join the left-hand terminal of rheostat K2 and the negative terminal of socket F3. Next, run

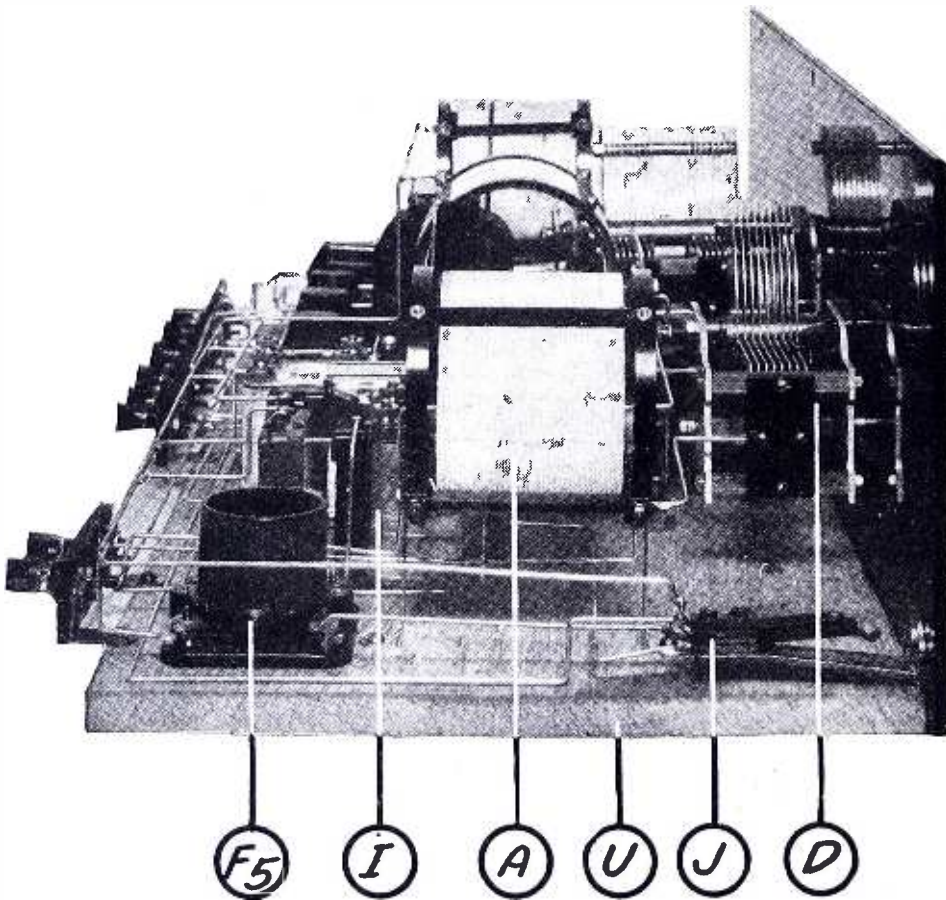

VIEW OF THE SET FROM THE LEFT

FIGURE 6: This illustration shows the general manner of mounting the tuning inductance and its condenser, the jack, the last socket and the antenna binding post strip.

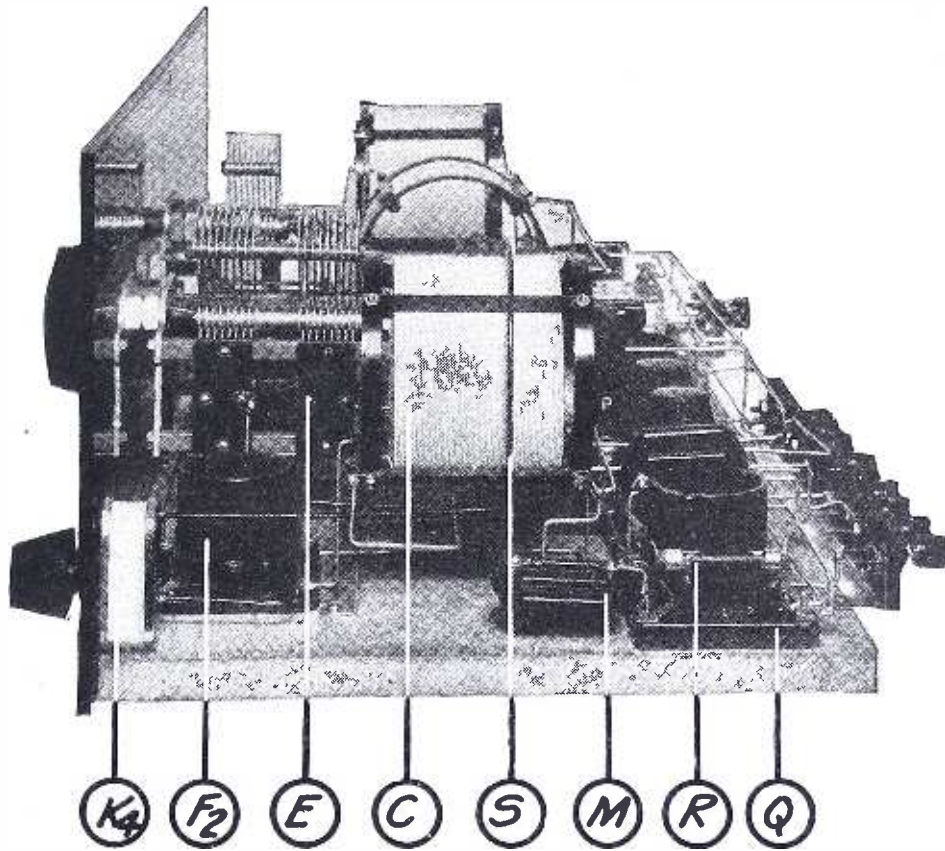

HOW THE SET LOOKS FROM THE RIGHT

FIGURE 7: This end view indicates the manner of mounting the last radio-frequency transformer, the grid-leak, the grid-condenser, the battery binding post strip and the regeneration control which consists of a single turn of insulated wire around the radio-frequency transformer and a rheostat connected to the ends of the single turn.

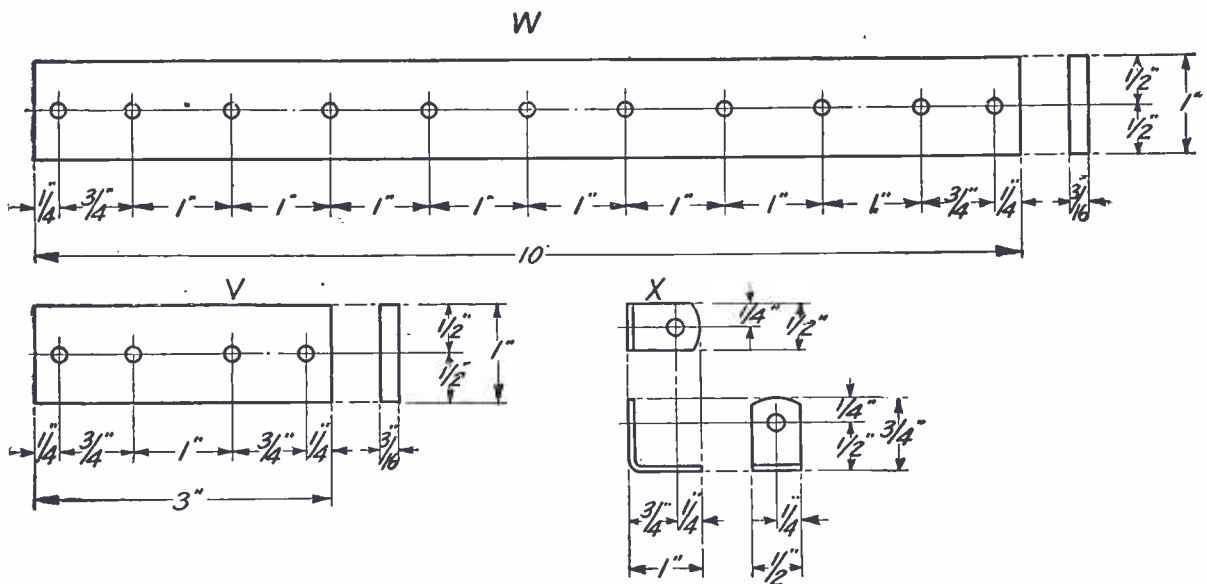

DETAILS OF THE CONNECTION BLOCKS AND THE SMALL BRASS BRACKETS

FIGURE 8: This drawing gives the necessary data for making the insulating strips on which the binding posts are mounted. It also gives the dimensions for the small brass brackets that are used to fasten the strips to the base.

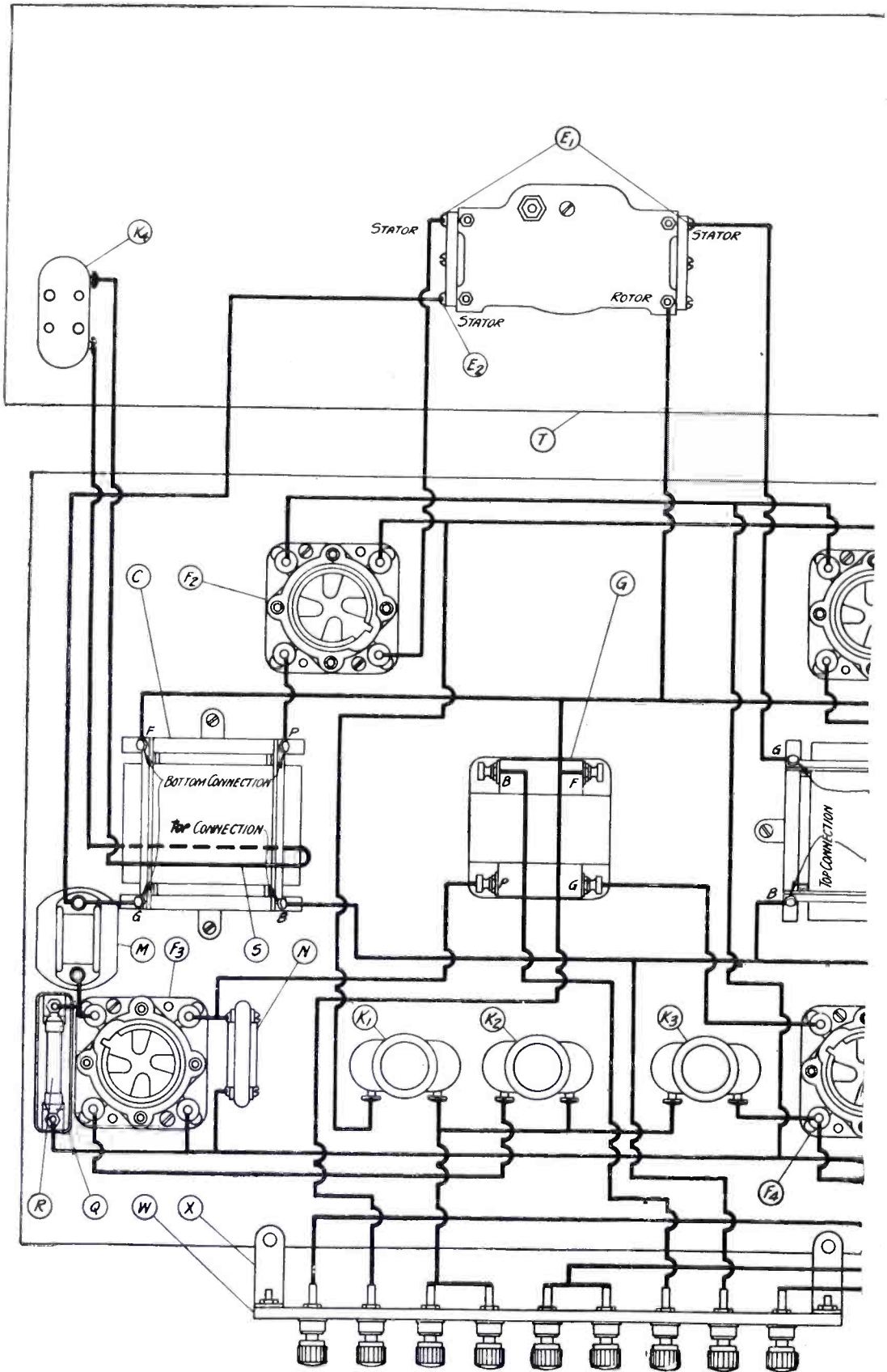

THE WORKING PLAN FOR

FIGURE 9: The upper rectangle represents the panel, and on it the instruments are drawn just as they appear. The lower rectangle represents the base; the instru-

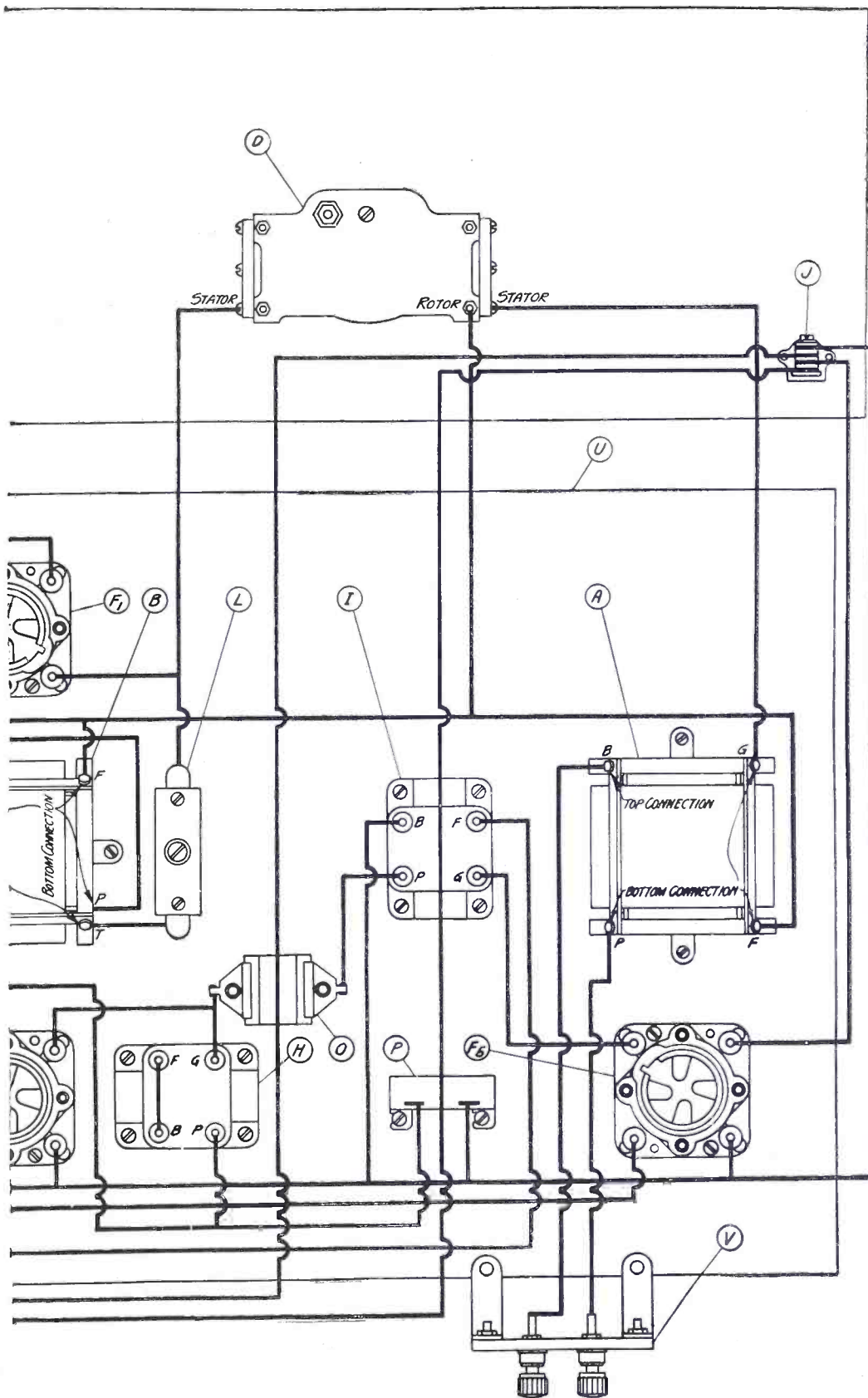

CONNECTING UP THE INSTRUMENTS

ments are drawn in approximately the positions they would have when seen from above. The heavy black lines show the way to wire up the mounted instruments.

a wire from the right-hand terminal of rheostat K3 to the negative terminals of sockets F4 and F5.

Now, connect the terminal marked P on the tuning inductance A to the antenna binding post (No. 1). Connect the terminal marked B on the same coil to the ground binding post (No. 2).

Join the terminal marked G on the tuning inductance A to the stationary plates of condenser D. Also connect the stationary plates of condenser D, the grid terminal of socket F1 and the nearest terminal of the neutralizing condenser L.

Next connect the terminals marked F on tuning inductance A, on radio-frequency transformers B and C, on audio-frequency transformer G with the rotary plates of condensers D and E and continue the wire to the negative "C" battery binding post (No. 10).

Join the plate terminal of socket F1 and the terminal marked P on the radio-frequency transformer B.

Now, connect the terminals marked B on radio-frequency transformers B and C, the plate binding post of audio-frequency transformer H, the nearest terminal of condenser P and the positive "B" battery binding post (No. 4). Join the remaining terminal of bypass condenser P to the wire connecting the positive socket terminals.

Join the terminal marked G on the radio-frequency transformer B to the stationary plates of section E1 of the multiple condenser.

Also connect these same stationary plates of E1 to the grid terminal of socket F2. Connect the terminal marked T of radio-frequency transformer B to the open terminal of neutralizing condenser L.

Now join the plate terminal of socket F2 and the terminal marked P on the radio-frequency transformer C.

Connect the stationary plates of section E2 of the multiple condenser, the terminal marked G on the radio-frequency transformer C, and one terminal of the grid condenser M. Join the other side of the grid condenser M, the adjacent terminal of the grid-leak mounting Q and the grid binding post of socket F3. Connect the remaining terminal of the grid-leak mounting to the wire joining the positive socket terminals. Insert the grid-leak R in its mounting. (See Figure 7 for the position of the grid condenser.)

Place a single turn of insulated bus wire around radio-frequency transformer C and connect its ends to the two terminals of the regeneration control K4. (See Figures 4, 5 and 7 for the placing of this loop.)

Next, connect the plate terminal of socket F3 with the plate terminal of audio-frequency transformer G and with one side of the condenser N. Connect the other side of condenser N to the wire joining the positive socket terminals. Join the terminal marked B on transformer G to the positive "B" battery detector binding post (No. 5).

Connect the terminal marked G on trans-

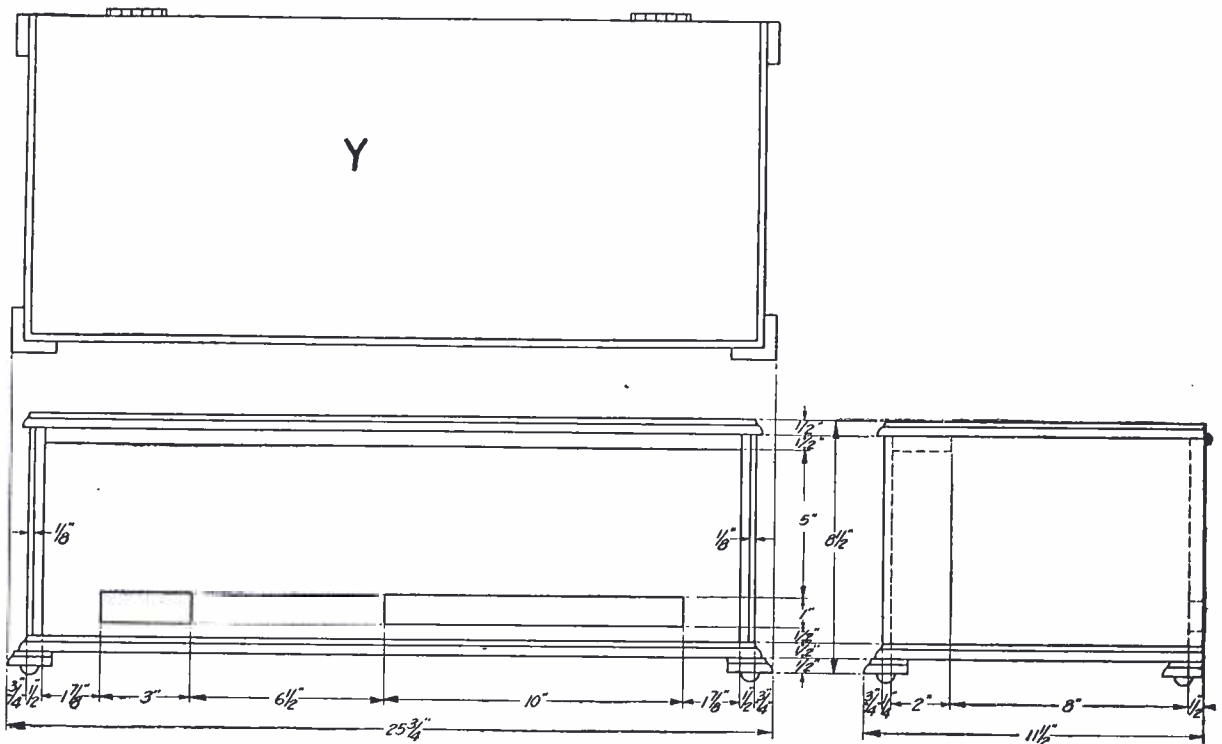

THE DIMENSIONS FOR THE CABINET

FIGURE 10: This diagram (which gives the top, front and side measurements for the cabinet) may be turned over to a competent cabinet maker who can build a cabinet from these directions so that it will fit the set correctly.

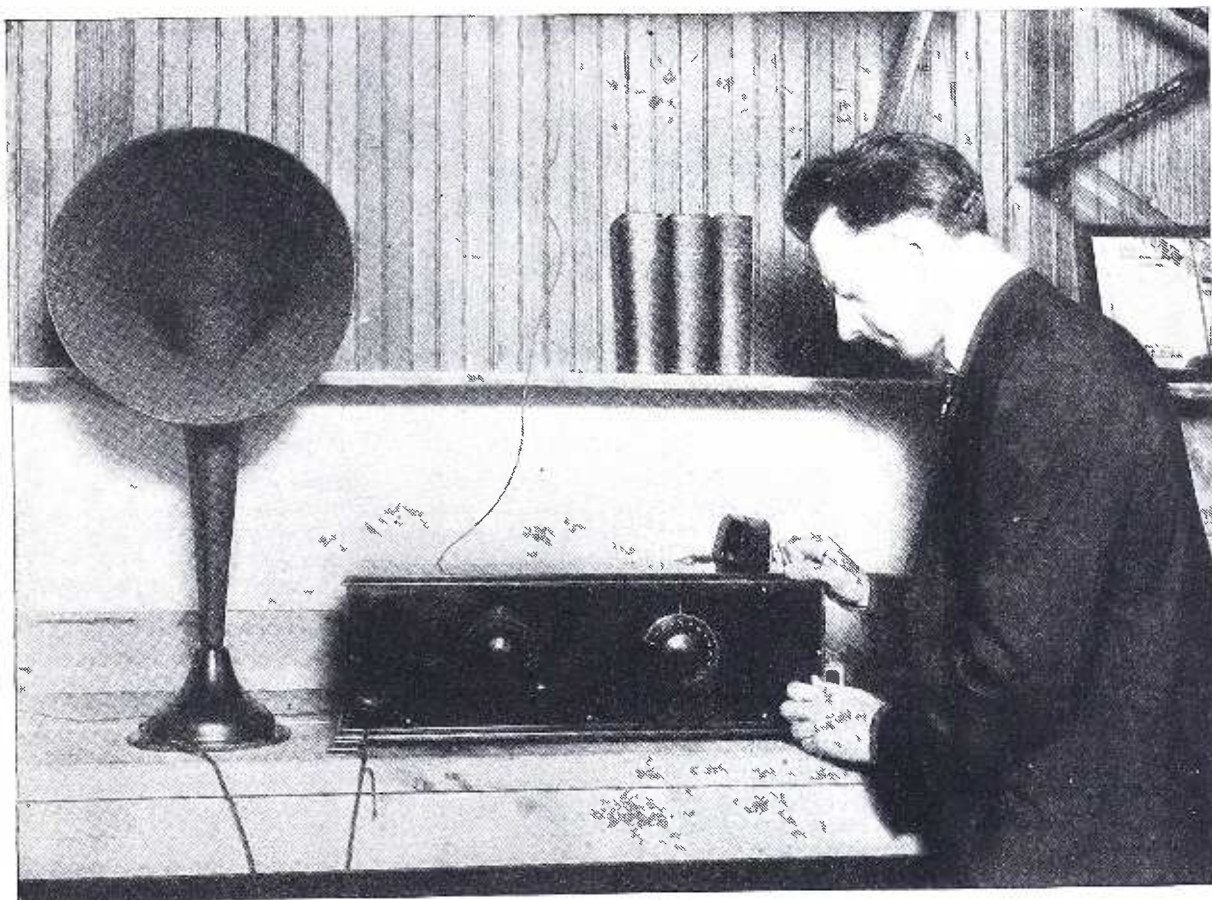

THE RECEIVER WORKING ON A TEN-FOOT ANTENNA IN THE LABORATORY TEST

No difficulty was experienced in getting good loudspeaker reception on the local broadcasting stations with very short antennas. Under these conditions the regeneration control is the main factor in bringing the signal up to loudspeaker volume. It is also useful in increasing volume from distant stations when using longer antennas.

former G to the grid binding post of socket F4.

As transformer H is to be used as a choke coil, join the negative filament and positive "B" binding posts together. Connect the plate terminal of socket F4, the grid binding post of transformer H and one side of condenser O. See Figures 4 and 5 for the position of condenser O. Join the other side of condenser O and the plate binding post of audio-frequency transformer I. Connect the positive "B" binding post of transformer I to the wire joining the positive socket terminals.

Now join the grid binding post of transformer I and the grid terminal of socket F5. Run a wire from the negative filament binding post of transformer I to the negative "C" battery binding post (No. 11).

Connect the plate terminal of socket F5 to the third terminal of jack J. Finally, connect the bottom terminal of jack J to the positive amplifier "B" battery binding post M (No. 3).

The set should now be completely wired.

How to Install the Set

After the set has been completely wired, place it in the cabinet and fasten with wood

screws through the holes provided at the edges of the panel.

The antenna panel and the binding post panel will now fit into the slots in the back of the cabinet and will come approximately flush with the back of the cabinet.

Attach the antenna lead-in wire to binding post No. 1 (the first one on the right, looking at the rear of the set). Connect the ground wire to binding post No. 2. Connect the "A," "B" and "C" batteries according to the diagram of connections given in Figure 11.

Turn the adjusting screw of the Vario Denser L counter-clockwise until the tension on the screw is released, indicating minimum capacity. The minimum capacity of this condenser is approximately correct for a 201-a tube and will serve as a trial setting.

Insert five UV-201-a or C-301-a in the five sockets F1, F2, F3, F4 and F5. Insert the loudspeaker plug in jack J and turn up the rheostats K1, K2 and K3 until all five tubes are lighted to the ordinary brilliancy.

The set is now ready for use.

Operating Data

The regeneration control K4 should be

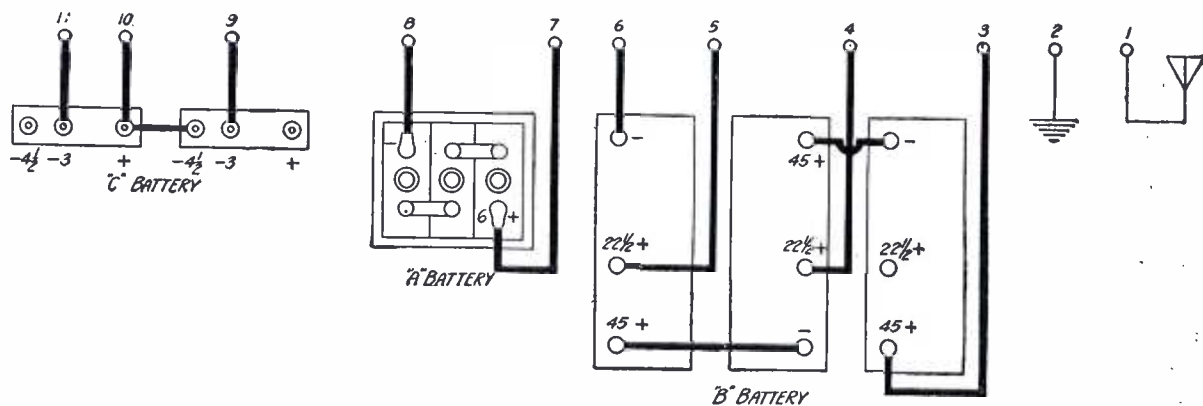

THE CONNECTIONS TO THE BINDING POST PANELS

FIGURE 11: This drawing will prevent you from making mistakes in connecting to the terminals at the back of the receiver. If you follow these instructions, the set will be hooked up correctly as the terminals shown in the wiring diagram are marked with designations that correspond with the numbers given here.

turned clockwise to the stop position, as its use may be studied better after some station has been tuned in.

The tuning chart of Figure 12 was made up from the laboratory set and should be approximately correct for other sets which have been made up with the same apparatus. Therefore we will use this chart as a starting point. Select the most powerful local broadcasting station and find its wavelength in the newspaper; from this same wavelength at the bottom of the tuning chart run a vertical line up to the curve for condenser D, then run a hor-

izontal line over to the left margin of the chart and read the dial setting for condenser D. Use the curve for condenser E in the same manner and find the dial setting for condenser E. Use these dial settings and find out whether the local station selected is audible or not. If it is, merely adjust each condenser separately until the station is received with the best volume.

If difficulty is experienced in picking up a station, move condenser D slightly off the setting indicated by the chart and slowly rotate condenser E about the chart setting. Repeat

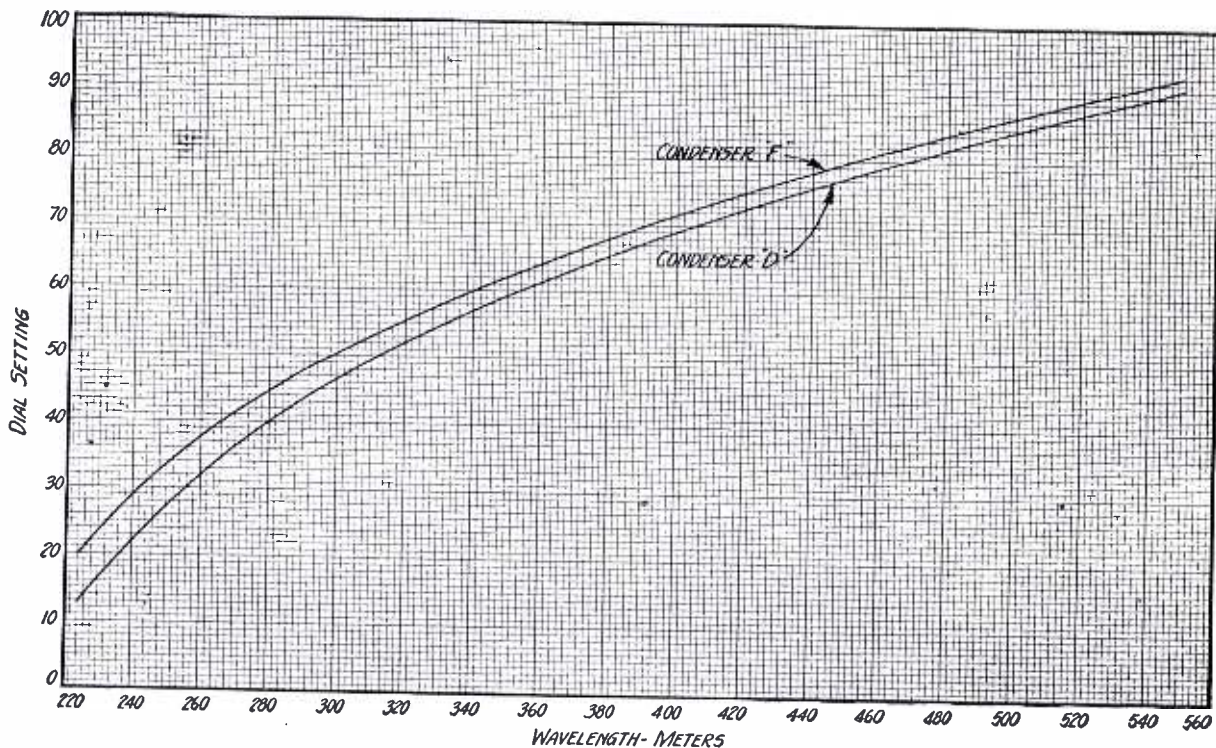

THIS TUNING CHART TELLS YOU HOW TO SET THE DIALS

FIGURE 12: This chart gives the dial settings of the two tuning condensers for the broadcasting wavelengths. Your set should tune approximately the same as the laboratory set if the same apparatus is used.

this process, moving condenser D in small steps, until a station is picked up. Adjust the condensers for greatest volume.

Now the filament rheostats K1, K2 and K3 can be adjusted and left until a drop in storage battery voltage requires a new setting (this should be very seldom if the storage battery is kept well charged). Turn the rheostats down (counter-clockwise) one at a time, until the signal decreases sharply in strength; then turn the rheostats back up slightly. There will be found an adjustment such that turning the rheostats up does not markedly increase the signal strength, but turning them down does decrease it very much. This is the best setting for the rheostats.

To set the neutralizing condenser L, tune in a good strong signal to work on. Remove the first radio-frequency tube from socket F1; run a thin strip of paper down the inside of the socket and over one of the filament prongs; then replace the vacuum tube. It should not light now because of the paper between the tube contact and the socket contact. With a

sharpened stick vary the neutralizing condenser L until the original signal is received with minimum strength; this indicates that the grid-plate capacity of the first radio-frequency tube has been neutralized. Phones are good for this adjustment. It may be necessary to vary the tuning condensers slightly during the balancing process.

Now the regeneration control K4 can be tested out; its effect will be more marked if a weak signal is being received or if a local station is being received weakly on a short antenna. Gradually turn the control knob K4 counter-clockwise and notice the signal grow in strength; this will continue until the second radio-frequency tube starts to oscillate, which indicates that you have gone too far. However, the set does not radiate and disturb your neighbors, since the first tube is neutralized and prevents the oscillation from reaching the antenna.

After the receiving set has been adjusted it can be turned off and on by removing and replacing the loudspeaker plugs.

Nine Tips for Summertime Reception

1. DON'T try to pick up long distance in midsummer. Be satisfied to enjoy the good programs from the nearer stations.
2. DON'T be disappointed if an occasional storm interferes with your summer radio evening.
3. If you want louder signals, use a longer antenna, more tubes, higher plate voltage, more sensitive loudspeakers and more careful tickler and receiver adjustment.
4. A PLEASANT signal filling a moderate size room should be enough to give satisfaction. It is wasteful to insist on tremendous signals which generally are less pleasant than moderate signals.
5. IF your local station comes in too loudly and drowns others out, a smaller aerial will help in tuning him out, with a small condenser connected between aerial and ground. And if all measures to get rid of the local station fail, why not enjoy his concerts?
6. FOR the longer waves above 450 meters, use a condenser connected between the aerial and ground terminals of your set.
7. READ POPULAR RADIO. It helps you to know how your set works and keeps you up to date in radio. Information of this sort is an aid in getting the concerts loud and clear.
8. ASK your radio dealer for advice; he can probably tell you what you want to know and will be glad to do so. The manufacturer of your set is also willing to help you get the desired results from its use.
9. Do not throw away the direction sheets or booklet that came with your set and with the tubes. Read all such material carefully now and then, and follow the suggestions which are given. If you have lost the direction sheets write to the dealer or manufacturer for another copy. The direction sheets answer most of the questions which have been puzzling you and preventing you from getting the best out of your set.

“What Set Shall I Buy?”

A LITTLE more than a year ago there were only a very few ready-made sets on the market. Today there are about 140, ranging from small and inexpensive crystal receivers, which sell for as low as four or five dollars, to elaborate superheterodynes that run into the hundreds. Those that have been approved by the POPULAR RADIO LABORATORY will be pictured each month until the series is completed. They will be accompanied by brief but specific and authoritative data concerning them—as a helpful guide to the broadcast listener and to the prospective listener who is thinking of selecting the receiver that will best meet his special needs as well as the limitations imposed by his purse.

Operadio Convertible Receiver

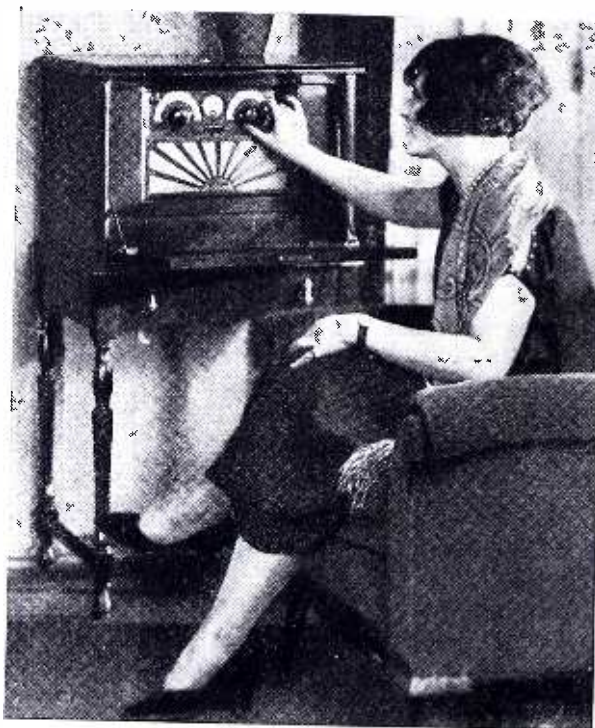

This receiver may be taken out of the cabinet and carried with you on your vacation. It is equipped with a handle and cover.

MANUFACTURER'S NAME; The Operadio Corp.
MODEL; Portable 1925 Operadio
NUMBER OF TUBES; six
TYPE OF TUNING; tuned radio frequency
TYPE OF DETECTOR; vacuum tube
RANGE ON PHONES; 3,000 miles (9,000 mile record)
RANGE ON LOUDSPEAKER; 3,000 miles (9,000 mile record)
COMPLETE COST; \$189.00
ANTENNA RECOMMENDED; self-contained loop
KIND OF TUBES FOR R. F.; 199 type
DETECTOR TUBES; 199 type
AUDIO TUBES; 199 type
TYPE OF "A" BATTERY; six 1½-volt dry cells
TYPE OF "B" BATTERY; four 22½-volt dry cells
DETECTOR "B" VOLTAGE; 45 volts
WAVELENGTH RANGE; 250 to 600 meters
NUMBER OF TUNING CONTROLS; two
"A" BATTERY CURRENT CONSUMED; approx. .03 amperes
"B" BATTERY CURRENT CONSUMED; .180 amperes per cell

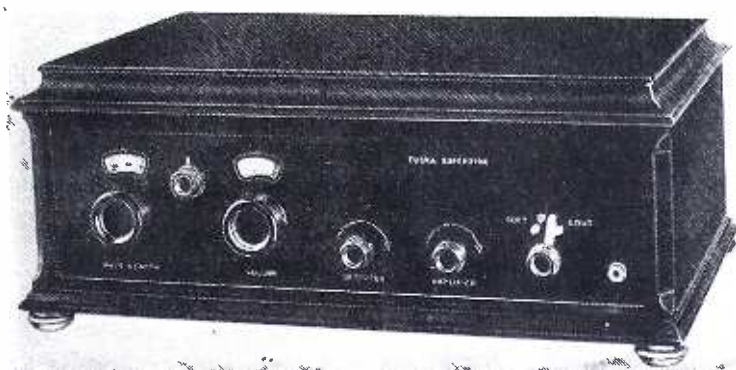

A self-contained four-tube Superdyne with a unique tuning dial. As the knobs are turned the numbers, indicating the setting of the tuning condensers, pass under a hairline. The set is equipped with a loud and soft adjustment.

Tuska Superdyne

- | | |
|--|--|
| MANUFACTURER'S NAME; The C. D. Tuska Co. | DETECTOR TUBE; UV-200 |
| MODEL NUMBER; 305 Superdyne | AUDIO TUBES; UV-201-a |
| NUMBER OF TUBES; four | TYPE OF "A" BATTERY; 6-volt storage |
| TYPE OF TUNING; 1 RF with regenerator | TYPE OF "B" BATTERY; any standard |
| TYPE OF DETECTOR; vacuum tube | DETECTOR "B" VOLTAGE; any standard |
| RANGE ON PHONES; 3,000 miles | WAVELENGTH RANGE; broadcast range |
| RANGE ON LOUDSPEAKER; 3,500 miles | NUMBER OF TUNING CONTROLS; three |
| COST COMPLETE; \$85.00 | "A" BATTERY CURRENT USED; 1½ amperes |
| ANTENNA RECOMMENDED; outdoor | "B" BATTERY CURRENT USED; 7 milliamperes |
| KIND OF TUBES FOR R. F.; UV-201-a. | |

Auto Indicator Pocket Receiver

- MANUFACTURER'S NAME; Auto Indicator Co.
 MODEL; Standard "B" Model Pocket Radio
 NUMBER OF TUBES; one
 TYPE OF TUNING; rheostat and condenser
 TYPE OF DETECTOR; non-regenerative
 RANGE ON PHONES; 1,000 miles
 RANGE ON LOUDSPEAKER; not specified
 COST COMPLETE; \$32.50
 ANTENNA RECOMMENDED; 75 to 100 feet No. 14 copper wire
 KIND OF TUBES FOR R. F.; none
 DETECTOR TUBE; UV-199 or C-299
 AUDIO TUBES; UV-199 or C-299
 TYPE OF "A" BATTERY; dry cell
 TYPE OF "B" BATTERY; dry cell
 DETECTOR "B" VOLTAGE; 22½ volts
 WAVELENGTH RANGE; 200 to 700 meters
 NUMBER OF TUNING CONTROLS; three
 "A" BATTERY CURRENT USED; 06. ampere
 "B" BATTERY CURRENT USED; less than .5 milli-ampere

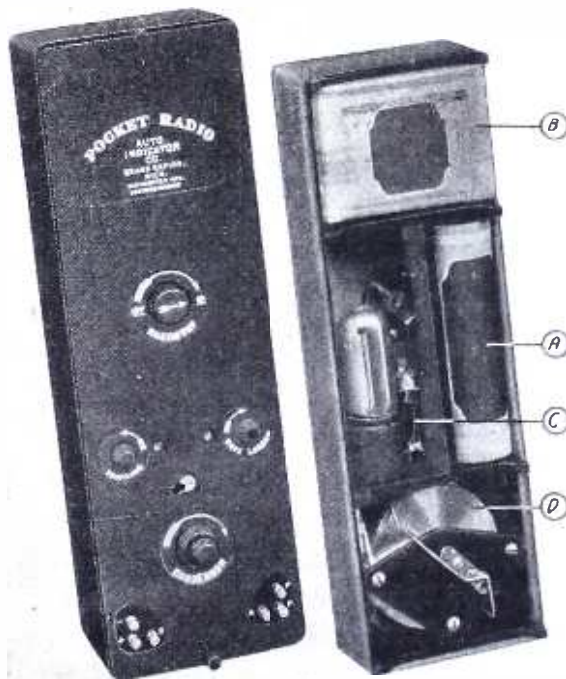

A single-tube portable receiver fully equipped with batteries.

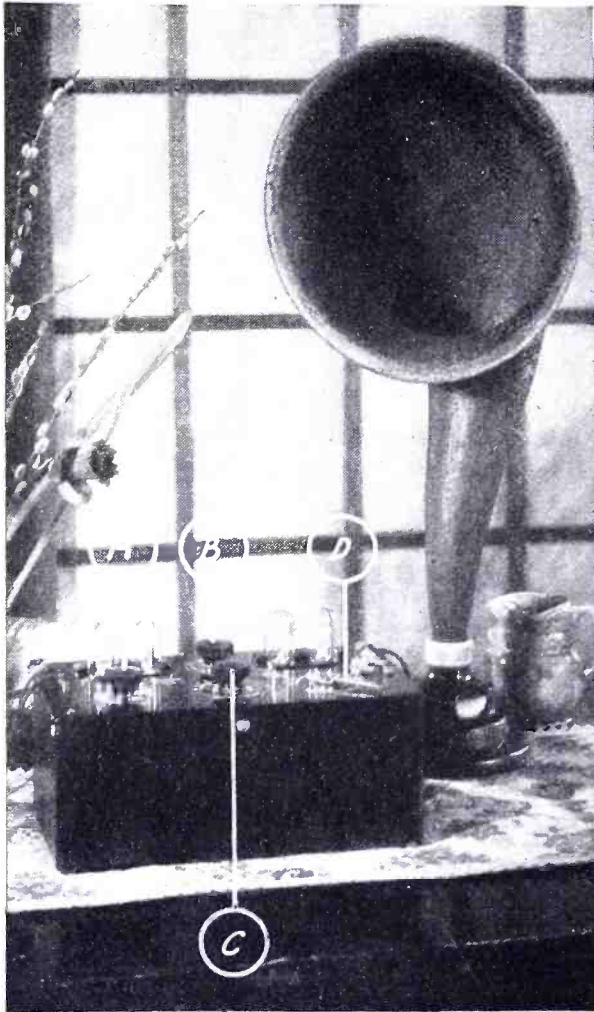

A is the regenerative control, B and C are the rheostats, and D is the tuning control.

The Radiola III-A

MANUFACTURER'S NAME; Radio Corporation of America
 MODEL; Radiola III-A
 NUMBER OF TUBES; four
 TYPE OF TUNING; *See below
 TYPE OF DETECTOR; WD-11 Radiotron, regenerative
 RANGE ON PHONES; none specified
 RANGE ON LOUDSPEAKER; none specified
 COST COMPLETE; \$90.00
 ANTENNA RECOMMENDED; outdoor, 50 to 150 feet
 KIND OF TUBES FOR R. F.; none
 DETECTOR TUBE; one WD-11 Radiotron.
 AUDIO TUBES; one WD-11 for 1st stage A. F., and two WD-11 for 2nd push-pull stage A. F.
 TYPE OF "A" BATTERY; 4 to 6 dry-cells in parallel, 1.5 volts
 TYPE OF "B" BATTERY; 90-volt dry-cells
 TYPE OF "C" BATTERY; 45-volt dry-cells
 DETECTOR "B" VOLTAGE; 20 to 45 volts
 WAVELENGTH RANGE; 195 to 640 meters
 NUMBER OF TUNING CONTROLS; one
 "A" BATTERY CURRENT USED; 1 ampere
 "B" BATTERY CURRENT USED; no load = 6 milliamperes; full load = 7 milliamperes.

Federal Receiver No. 141

MANUFACTURER'S NAME; Federal Telephone Mfg. Corp.
 MODEL NUMBER; type 141
 NUMBER OF TUBES; five
 TYPE OF TUNING; variable capacity
 TYPE OF DETECTOR; hard or soft tube
 RANGE ON PHONES; none specified
 RANGE ON LOUDSPEAKER; none specified
 COST; \$150.00 (not complete)
 ANTENNA RECOMMENDED; not less than 200 mmf. nor more than 2,000 mmf. measured at 600 meters
 KIND OF TUBES FOR R. F.; hard tube
 DETECTOR TUBE; hard or soft tube
 AUDIO TUBES; hard tubes
 TYPE OF "A" BATTERY; 6 volts
 TYPE OF "B" BATTERY; 90 volts
 DETECTOR "B" VOLTAGE; 20 volts

WAVELENGTH RANGE; 200 to 600 meters
 NUMBER OF TUNING CONTROLS; two
 "A" BATTERY CURRENT USED; 1.25 amperes
 "B" BATTERY CURRENT USED; 10 to 15 milliamperes

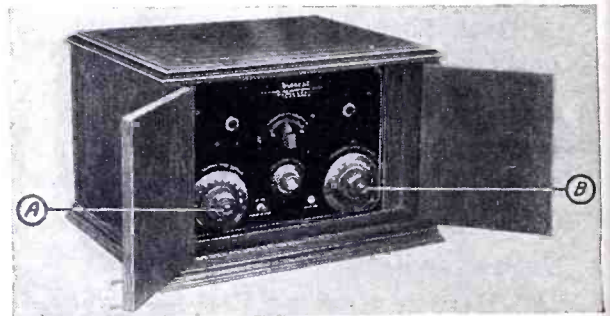

In this receiver, antenna tuning is accomplished with dial A and secondary tuning with dial B, making a simple adjustment

Special Crystal Set

MANUFACTURER'S NAME; The A. H. Miller Radio Co.

NUMBER OF TUBES; none

TYPE OF TUNING; capacity

TYPE OF DETECTOR; crystal detector

RANGE ON PHONES; fifteen to twenty-five miles

COST COMPLETE; \$1.79

ANTENNA RECOMMENDED; 100 feet

WAVELENGTH RANGE; 200 to 600 meters

NUMBER OF TUNING CONTROLS; one

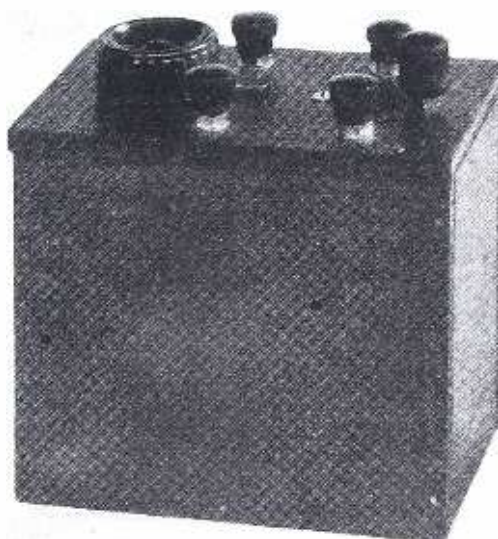

A simple crystal set that can be attached to a temporary antenna and ground in a few moments.

Pfanstiehl Overtone Receiver

MANUFACTURER'S NAME; Pfanstiehl Radio Co.

MODEL NUMBER OR NAME; Pfanstiehl Overtone

NUMBER OF TUBES; five

TYPE OF TUNING; tuned radio frequency (Pfanstiehl non-oscillating system)

TYPE OF DETECTOR; 201-a

RANGE ON PHONES; 3,000-5,000 miles

RANGE ON LOUDSPEAKER; 2,000-3,000 miles

COST COMPLETE; \$140.00; plus equipment, \$225.00 approximately

ANTENNA RECOMMENDED; outdoor (or indoor wire beneath moulding)

KIND OF TUBES FOR R. F.; 201-a

DETECTOR TUBE; 201-a

AUDIO TUBES; 201-a

TYPE OF "A" BATTERY; any

TYPE OF "B" BATTERY; any

DETECTOR "B" VOLTAGE; 22½ volts

WAVELENGTH RANGE; 200-575 meters

NUMBER OF TUNING CONTROLS; three

"A" BATTERY CURRENT USED; 1.25 amperes

"B" BATTERY CURRENT USED; 10 to 15 milliamperes

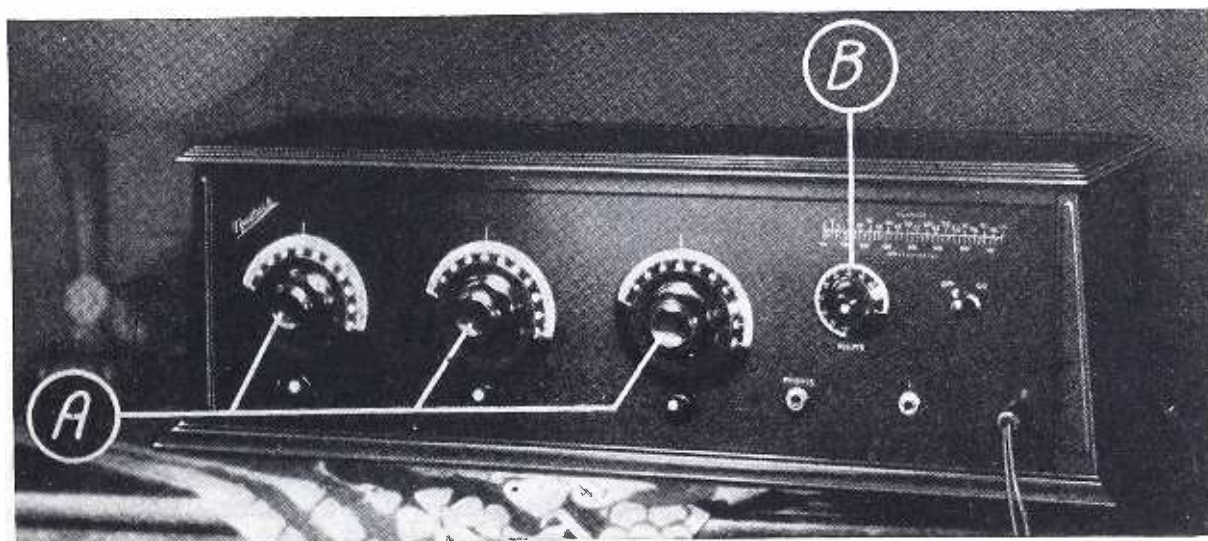

A five-tube tuned-radio-frequency receiver that is exceptionally easy to operate. The three tuning dials, A, are set at approximately the same values in tuning and the volume control, B, is adjusted for the desired strength of signals.

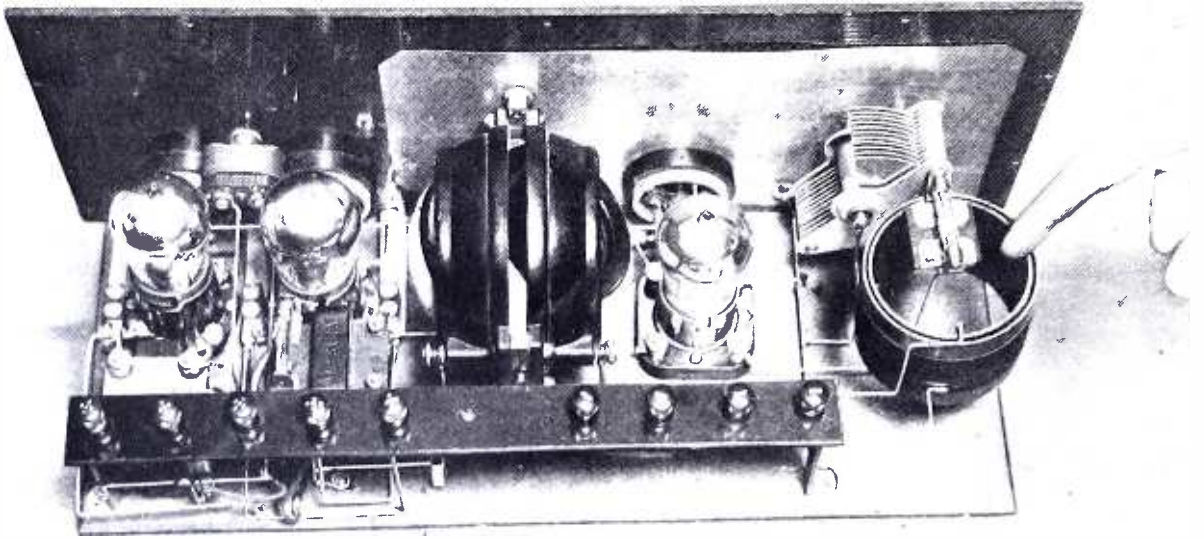

Kadel & Herbert

HOW A GRID-LEAK IS MOUNTED IN A RADIO RECEIVER

A grid-leak and a grid-condenser are shown at the right in the picture near the man's finger. If this grid-leak were not of the proper resistance, it would destroy the selectivity of the set, decrease signal strength and cut down reception range.

Important Trifles in Radio

The Grid-leak

What it is, how it works—and the vital part it plays in your receiving set

By RAYMOND FRANCIS YATES

THE physical insignificance of a device is no indication of its importance. Tiny rivets hold the Woolworth Building together, and safety pins have prevented many disasters.

The little grid-leak, until recently, has been the neglected child of the radio set simply because its appearance does not demand respect. Ask the average fan what it does and he will reply:

"Well, a grid-leak is a—a—resistance which—which—causes a leakage."

Very simple, indeed. A grid-leak is simply a grid-leak.

To become familiar with the function of the grid-leak, let us consider Figure 1.

Here we see an ordinary receiving circuit that has connected to the vacuum tube grid a grid-leak and a grid condenser. Let us assume that the circuit

B is tuned to the same wavelength as the antenna circuit A. Oscillations will then be set up in B and this will be connected to the grid with the vacuum tube by way of the condenser. Therefore, the grid will become alternately positive and negative; and each time the grid becomes positive, the electron current will be decreased. Consequently during each wave train the grid will gain a negative charge.

Now, this negative charge is both good and bad. It is good if we control it and bad if we allow it to reach a point that is too high.

We must remember that the little electrons, which are shot off the glowing filament of the tube, are negative in nature and when the grid becomes negative the electrons are forced back to

the filament. When negative meets negative repulsion always takes place. Two negative charged bodies always repel each other. Therefore, we must not allow the grid to become too negative if we wish to operate our radio receiver at its most efficient point.

At the end of each wave train this negative charge should leak off through the condenser or through the glass walls of the tube itself. This should happen before the next wave train comes along, and it is to insure such a result that a high resistance is inserted across the grid condenser. This high resistance is called the grid-leak.

The importance of grid-leaks grows daily. The day of calling a pencil mark on a piece of cardboard a grid-leak is past. Our more sensitive circuits demand a very carefully regulated resistance of constant value and a grid-leak of constant value is a mean thing to make.

Grid-leaks are made by depositing a colloidal carbon ink upon a small strip of paper. So difficult has been the task of making these grid-leaks with an accurate resistance that only one or two manufacturers have the courage to guarantee that their grid-leaks are accurate within 10 percent. The resistance of grid-leaks changes with age, following it appears, as far as physicists know, the same law that holds true for cheese, of which the taste improves with age.

A grid-leak made today will have a resistance three months from now somewhere between $\frac{3}{4}$ and $\frac{1}{2}$ its original value.

The resistance of grid-leaks is measured in megohms. A megohm is a million ohms. $\frac{1}{10}$ th of a megohm is then 100,000 ohms and $\frac{1}{2}$ of a megohm is 500,000 ohms. The one megohm type is most used, but I do not mention this as a recommendation.

Too many fans choose their grid-leaks

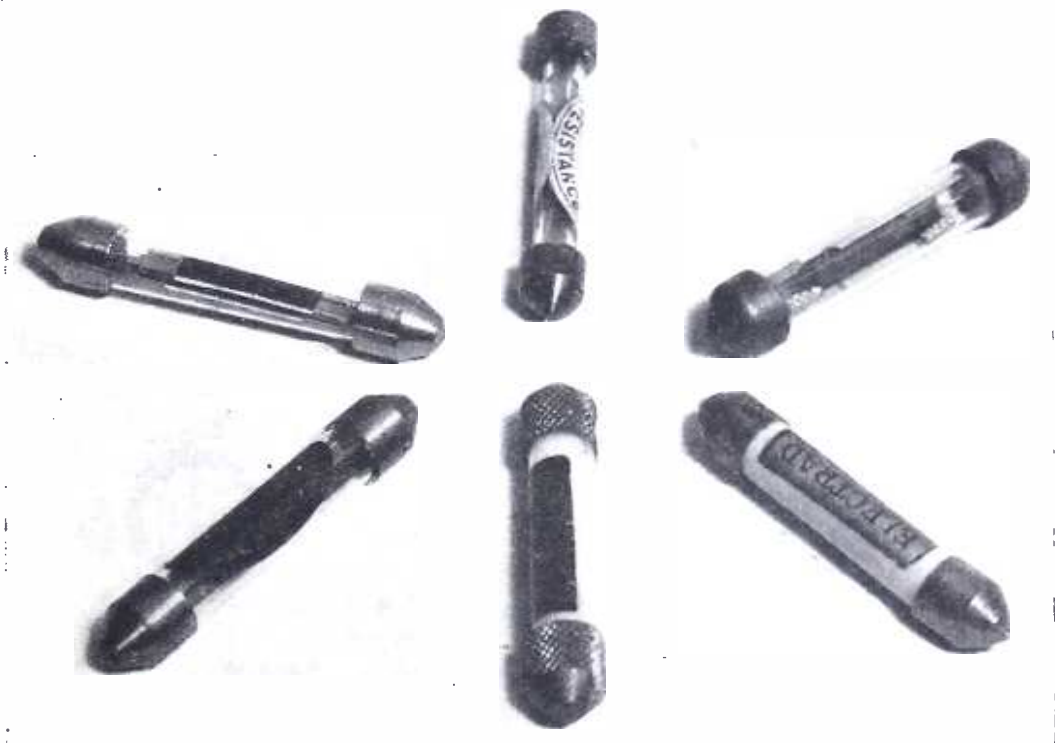

From a photograph made for POPULAR RADIO

HOW GRID-LEAKS ARE CONSTRUCTED

Grid-leaks are usually made of a strip of insulating material that has been impregnated with some substance containing a carbon or graphite base and hermetically sealed in a glass tube. This construction insures a constant value of resistance that, under other conditions, would be subject to change by atmospheric effects.

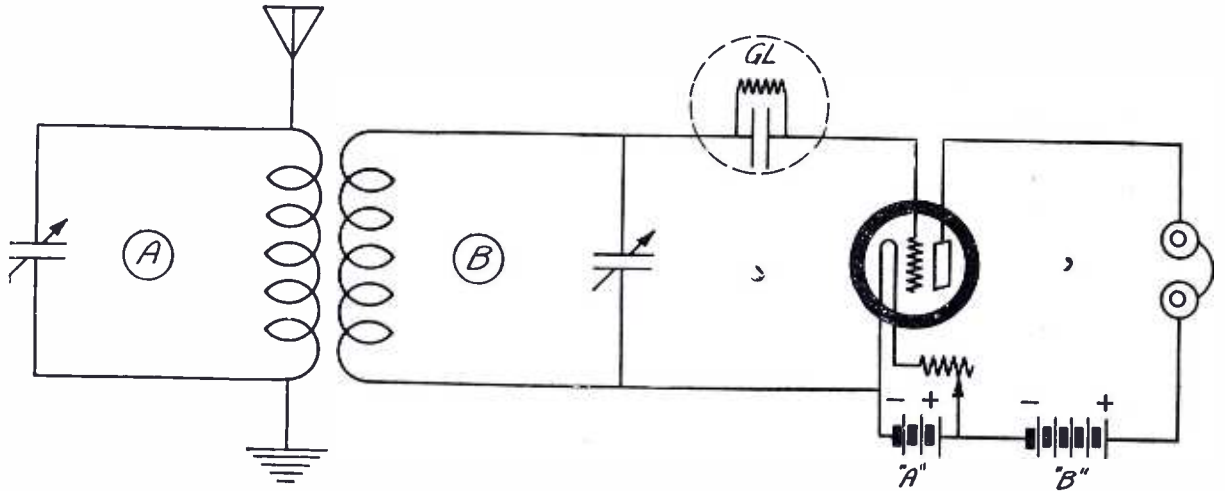

HOW GRID-LEAKS ARE USED IN A RADIO RECEIVING CIRCUIT

FIGURE 1: This conventional receiver hook-up shows one of the connections for the grid-leak which acts as a throttle upon the flow of electrons from the grid of the vacuum tube.

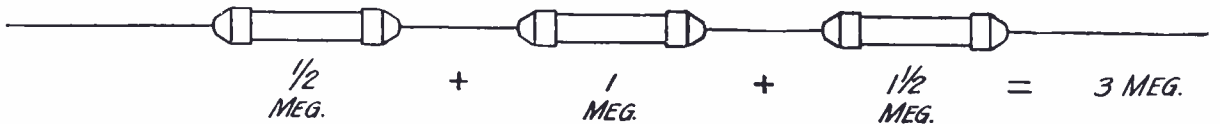

HOW TO FIGURE COMBINED RESISTANCES IN SERIES

FIGURE 2: Grid-leaks connected in series as shown in the diagram have a resistance that is equal to the sum of their individual resistances.

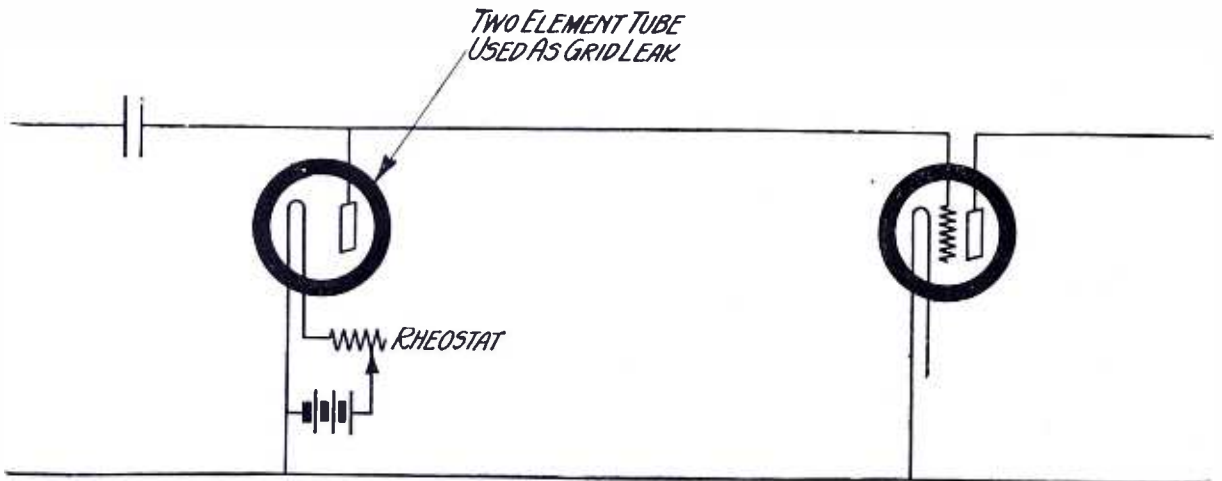

A SUBSTITUTE FOR A GRID-LEAK

FIGURE 3: How a two-element tube, preferably one of the old Fleming valves, may be connected in a receiving circuit to perform the function of a variable grid-leak.



From a photograph made for POPULAR RADIO

VARIABLE GRID-LEAKS OF STANDARD TYPES

Some types of variable grid-leaks are built so that pressure upon a substance varies its conductivity or so that a plunger passes through a loosely-packed, highly resistant substance. In another type a contact slides over a surface that is completely impregnated with a substance like graphite. There is besides a unique grid-leak that contains a high resistant liquid which makes contact on a large or small area of metal terminals as the grid-leak is turned in its contact springs.

on the hit and miss principle. They figure that as long as they have a grid-leak in the circuit or an apology for one, their obligation to this particular part of the outfit is fulfilled, yet, the operating efficiency of many an outfit has been ruined through an unhealthy grid-leak.

No set rule can be given for the use of grid-leaks. Resistances that range all the way from 1/10th to five megohms are used. If we have a pet circuit and want to make sure that we are employing a grid-leak of the proper resistance, there is only one thing to do and that is to cut and try. But one cannot cut and try, if one only has a single grid-leak. If we buy three grid-leaks, one with a resistance of 1/2 megohm, one of one megohm and one of 1 1/2 megohms, there is a possibility that we may arrange these in a combination of just the necessary resistance. When these resistances are connected in series as

illustrated in Figure 2, we add them up to determine the total resistance. Thus the following formula would hold true:

$$R = R_1 + R_2 + R_3$$

When we connect in series, we always add the resistance. Now, if we wish to obtain a lower resistance, we connect the grid-leaks in parallel for which arrangement the following formula holds true:

$$1/R = 1/R_1 + 1/R_2 + 1/R_3$$

We see it is possible to juggle our three little grid-leaks around so that we can obtain rather a wide range of resistances.

What is the most perfect form of grid-leak?

There is such a thing, yet some of us would probably guess all night before we should hit upon it.

Who would imagine that a perfect grid-leak is a two-element vacuum tube?

When the filament of a two-element tube is cold and no current is passing through it, the resistance of the space between the filament and the plate is infinite. If current is allowed to pass through the filament, the resistance of this space can be changed all the way from infinity to a few thousand ohms. Therefore, a two-element vacuum tube with a battery and rheostat is the most dependable form of variable grid-leak, and the best way of using this variable grid-leak is shown in Figure 3. Of course the average bug will not care to go to this trouble, but for the real radio "crank," I cannot think of anything that will surpass this arrangement for bringing results.

Who would think that a grid-leak would cause circuit noises? But a poor grid-leak will do exactly that. Grid-leaks, aside from being non-inductive and non-capacitative should also be non-microphonic. When tiny carbon particles are brought together they are

bound to be microphonic unless they are properly treated. The least movement of these particles due to mechanical disturbance or to temperature effects will alter the resistance of the grid-leak and we will get a registration in the phones. For this reason grid-leaks must be made of the very best materials and thoroughly protected from moisture and other disturbing effects. If we build our own pencil-line grid-leaks, it will be wise to soak them in paraffine after the connections are made.

Right here it is well to give a word of warning about the connections. Small clamps of copper are best to use, since much of the trouble in grid-leaks results from poor contact.

This is an appreciation of the lowly grid-leak. Let us remember that it is quite an important thing after all which demands the respect of the set owner just as much as its more aristocratic brothers and sisters, the condensers, coils, vacuum tubes and headphones.



Pacific & Atlantic

RADIO BROADCASTER USES PLANE TO KEEP APPOINTMENT

Art Gillham, known to radio fans as the "Whispering Pianist," has been working on such a crowded schedule while touring the West that he found it necessary to use an airplane in his jumps. A portable organ and a microphone were sent to the air field at San Francisco, where he did his broadcasting with the plane waiting to carry him to his next stop.

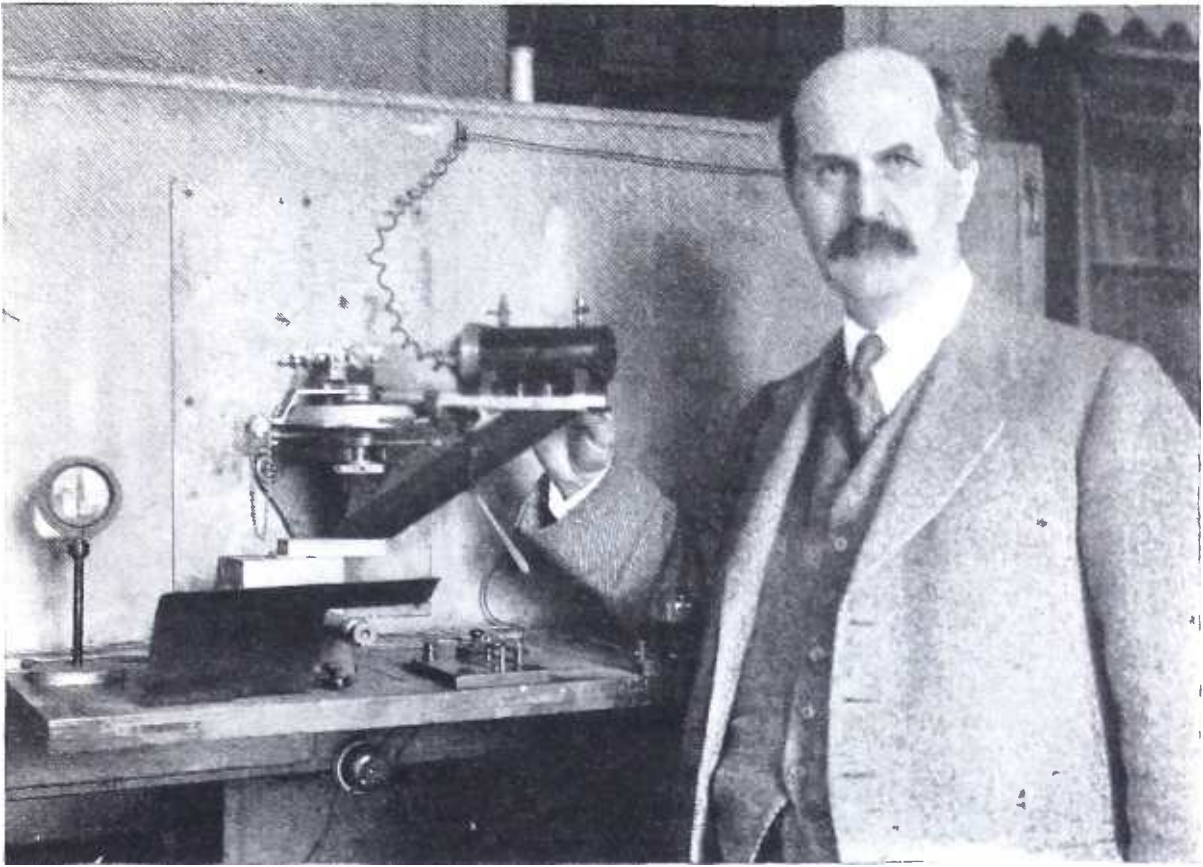

Hoppé, London

THE AUTHOR IN HIS LABORATORY

The atom plays such a vital part in the drama of radio that POPULAR RADIO has turned to one of the world's foremost authorities for a series of short popular articles on this subject that every radio fan should know about. Sir William Bragg of England is the Fullerian Professor of Chemistry at the Royal Institution and Director of the Darcy-Faraday Research Laboratory.

The ATOM

ARTICLE NO. 1

Scientists tell us that the entire universe is made up of only ninety different kinds of atoms. Tremendous power is believed to lurk within these minute and constantly moving particles. To solve the age-old mysteries that lurk within them and to harness their energy has now become one of science's greatest problems.

By SIR WILLIAM BRAGG, K.B.E., D.Sc., F.R.S., M.R.I.

TWO thousand years ago, Lucretius, the famous Latin poet, wrote his treatise, "*De Rerum Natura*"—"Concerning the nature of things." He maintained the view that earth and water and air and all things were composed of innumerable small bodies or corpuscles, each too small to see, and all in rapid motion. He tried to show that these suppositions

were enough to explain the properties of material things.

There was a rival set of views, according to which there would be no evidence of structure, however closely things were looked into.

If, for example, the water in a bowl were divided into drops, and each of these into smaller drops, and so on *ad*

infinitum, the minutest portion would still have all the properties of water. On the view of Lucretius, if sub-division were carried out sufficiently, one would come at last to the individual corpuscles or atoms: the word atom being taken to have its original meaning—that which cannot be cut.

There is a mighty difference between the two views. On the one, there is nothing to be gained by looking into the structure of substances more closely, for, however far we go, we come to nothing new. On the other view, the nature of things as we know them must depend on the properties of the atoms of which they are made. It becomes a matter of the highest importance and the greatest interest to find out, if we can, what the atoms are like.

Fortunately, at least for those who love to inquire into the ways of Nature, the view maintained by Lucretius turns out to be the closer to the truth.

Lucretius had, however, no conception of the modern form of the atomic theory, the form which has made possible the tremendous advance of the last century in chemistry and physics. He did not realize that there are atoms of a limited number of sorts in the world, and that all the atoms of one sort are alike. That idea is comparatively new; and it makes the whole matter much simpler. We have to examine the properties of a few sorts of atoms only, not those of an infinite number of different individuals.

There are some ninety sorts of atoms, of which the whole world is made and all that is in it, and the universe, as far as we know it. Some kinds of atoms are used freely; others very sparingly. The marvel is that the atoms are not only the elements of construction, but also everything required for the building. They are not only the bricks; they are also the cement and the tools and the plan, for no other material is found be-

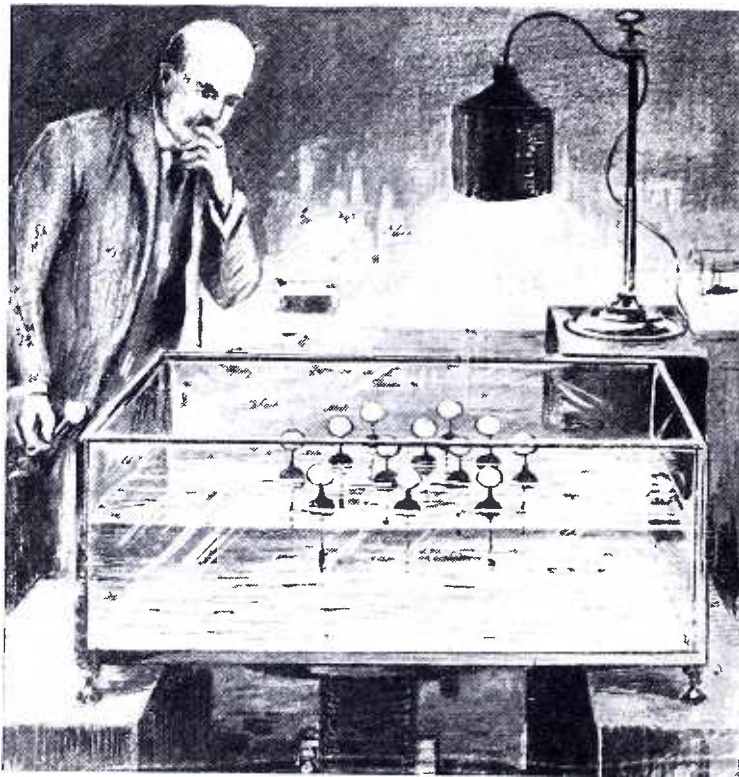

A HINT AT ATOMIC ACTION

FIGURE 1: Ping-pong balls, when mounted on floating magnets which are controlled by a sunken master magnet, will tend to arrange themselves in a definite pattern. Science believes that atoms in a molecule do something of the same sort.

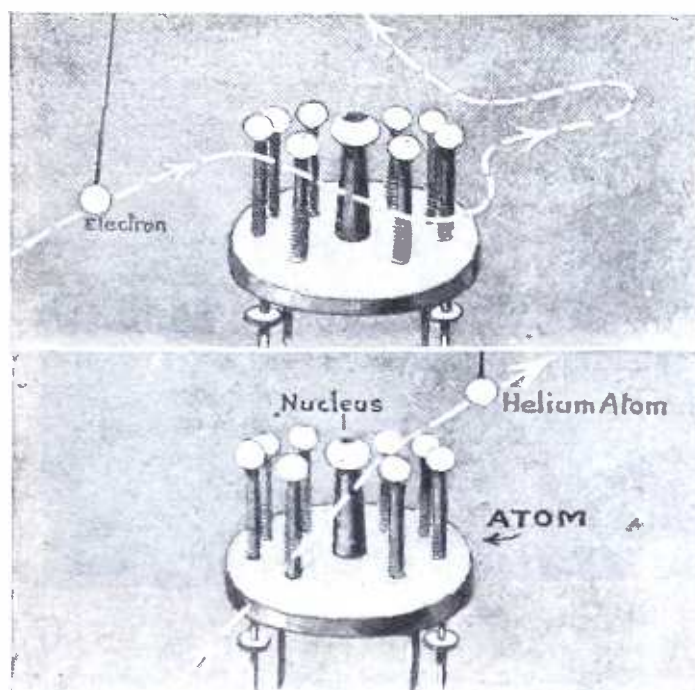

HOW AN ELECTRON IS REPELLED BY AN ATOM

FIGURE 2: *A slowly moving electron fails utterly in its effort to penetrate an atom; the dotted line in the upper drawing shows the nature of its erratic course. A helium atom, flying into another atom, and moving too close to the nucleus, is sharply deflected from a direct line as is indicated in the lower figure. Only the great speed at which an electron moves makes it possible for it ever to force its way into an atom.*

side them. We are, of course, considering material things only.

We therefore are bound to ask what the atoms are like, and what inner structure they have to account for the fact that they may be combined in such infinite variety. We have a better understanding of the atom than Lucretius; our wonder is correspondingly deeper.

In the last quarter of a century or so, two new agencies have helped us to see more closely into the constitutions of the atom itself: they are our studies of radioactivity and of X rays.

We may say that there were three broad principles, each well established, which were the basis of scientific advance before the last period set in.

The first of these was the grouping of atoms into different kinds, as already explained.

The second recognized the existence of forces drawing the atoms together, as exemplified in any solid or liquid, and even in ages, though in that case their

detection is difficult.

The third asserted that all atoms were in constant motion, even when they were the constituents of a body which seemed perfectly quiet, such as a table, or a piece of paper.

This idea is fundamental to all modern science, pure and applied; it is involved both in the most abstruse theoretical researches and in every industrial process. Although the recognition of heat as the consequence and equivalent of motion was often obscured by other theories, yet there have always been men who held sound views on the point. One of these was Hooke, a famous scientist of the seventeenth century.

"Heat," he says, "is nothing else but a very brisk and vehement agitation of the parts of a body . . . whereby the parts of a body are made so loose that they become fluid. . . . Let us suppose a dish of sand set upon some body that is very much agitated . . . on a very stiff drumhead, which is vehemently or very nimbly beaten with the drumsticks. By this means the sand in the dish . . . becomes a perfect

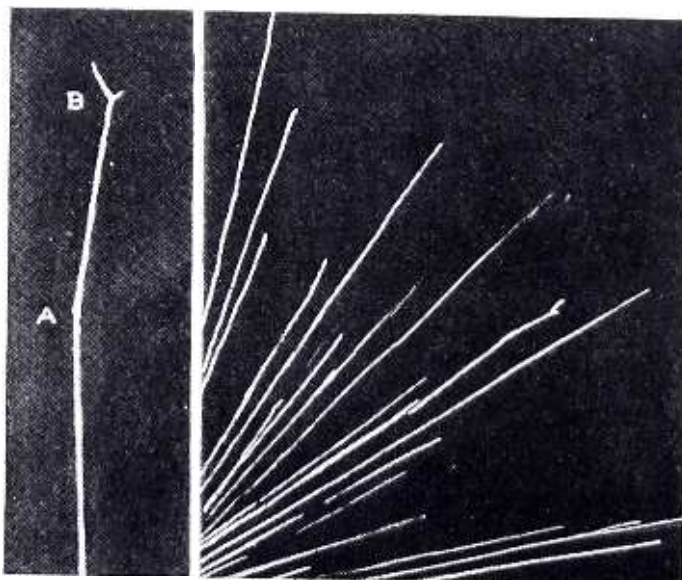

EXPLODING RADIUM SHOOTS OUT HELIUM

FIGURE 3: *After living a perfectly normal life, radium suddenly explodes and sends out a helium atom—flying like a shot from a gun at the surprising speed of about 100,000 miles a second. The diagram shows, at A and B the two points of deflection as the helium drives through other atoms.*

fluid; and ye can no sooner make a hole in it with your finger but it is immediately filled up again and the upper surface of it levell'd. Nor can you bury a light body, as a piece of cork under it, but it presently emerges or swims as 'twere on the top; nor can you lay a heavier on the top of it, as a piece of lead, but it is immediately buried in sand and (as 'twere) sinks to the bottom."

The motions of the atoms act contrariwise to their mutual attractions; the former tend to keep them apart, the latter to draw them together. When the former are supreme, the substance is a gas; when the latter, a solid. The liquid state is intermediate, as will be explained later.

We now come to the contributions which we owe to radioactivity.

In order to account for the fact that a solid body very strongly resists compression, we have been accustomed to suppose that each atom occupies a certain volume, and that there is a considerable difference between the volumes of the different kinds. For instance, potassium is lighter than water, while diamond is more than three times as heavy as the latter. We know, too, that the potassium atom is more than three times as heavy as the carbon atom which is the sole

constituent of the diamond. The former must, therefore, be much more bulky than the latter. If we suppose, for want of better knowledge, that the atom is spherical, we can calculate the relative sizes of the two spheres.

Each atom has, so to speak, a domain into which all our efforts at compression cannot force another atom to enter. Radium shows us, nevertheless, that, under circumstances beyond our power to bring about by the greatest exertion of pressure, one atom can not only penetrate another, but can actually pass right through without permanent injury to either. For a moment two atoms occupy the same space.

A radium atom is like any other, all its life. But its life ends; and the death involves a cataclysm of a most surprising nature. For one or two thousand years the radium atom goes about its business in a normal way; and then explodes suddenly, dividing itself into two portions, one large and one small. The latter goes off like the shot from a gun, and its velocity is about 100,000 miles a second; so that, if unchecked, it would reach the moon in two seconds and a half. Nevertheless, it is brought to rest

in two or three inches in the open air; and in a much shorter distance in any solid material. Its arrest is due to loss of energy in driving *through* the hundreds of thousands of atoms which it meets. The projectile is actually an atom of helium, the lightest atom except hydrogen.

If one atom goes straight through another, when the speed is so great, and cannot be forced into it by more ordinary means, we are led to picture the atom as a domain occupied by some sort of inhabitants who are able to keep out another set when they are not moving too fast. A number of soldiers might occupy a certain piece of territory, and an approaching army might under normal circumstances be unable to enter. But if the second army came at the rate of, say, a hundred miles a second, the first army might not even know their territory had been penetrated; unless, of course, two soldiers happened to collide!

Or we may illustrate the point by means of the models shown in Figure 2.

A number of magnets stand on end in a circle, each mounted on a spring. A magnet suspended at the end of a long card is made to approach the circle gently. If the polarities of the magnets are rightly arranged, the swinging magnet will recoil and try vainly, at various points, to enter in. If, however, it is drawn back far enough, so that it comes at the circle with a rush, it will go through. It will set the standing magnets quivering on their springs, just as, in fact, the parts of an atom are known

to be set in motion in the analogous case.

It is found that we must further elaborate the idea of the atom's structure by supposing that the mass of the atom is centered in a nucleus *positively electrified*. Around this are arranged a number of "electrons," *negatively electrified and all alike*.

We have now made it resemble a miniature solar system.

The upper half of Figure 2 shows what happens if an electron—not moving too fast—encounters an atom. The lower half shows a helium atom, a nucleus only, because in its excessive speed it actually loses its two satellite electrons going through an atom it has met, and going so near the nucleus that it is sharply deflected; as at *A* and *B* in Figure 3. At *B* can even be seen a minute track like a spur where the atom that has been driven into too directly has been pushed off to one side.

The electrons of an atom are arranged in some order about the nucleus, and when we try to picture to ourselves how this may be we sometimes make use of the model shown in Figure 1. Here a number of floating magnets are arranged so as to repel each other, while they are all drawn towards a center provided by a strong magnet underneath the tank in which they float. Obviously a regularity of arrangement will ensue, but the model claims no exactness of analogy. It is pretty to put the magnets in the corner of the tank, and watch them move into their places in a stately fashion.

The RADIO GROUCH

JUDGING from the amount of public squeaking there is on the air, some of the stations ought to lay in a supply of broadcaster oil.

I DON'T mind having my morals improved within reason, but sometimes I think there are too many transmissionaries to the heathen.

THE radio, I hear, is now permanently established as a feature of political campaigns, but I notice that there are still a lot of politicians who stick to the good old party wire.

—HOWARD BRUBAKER

WHAT READERS ASK

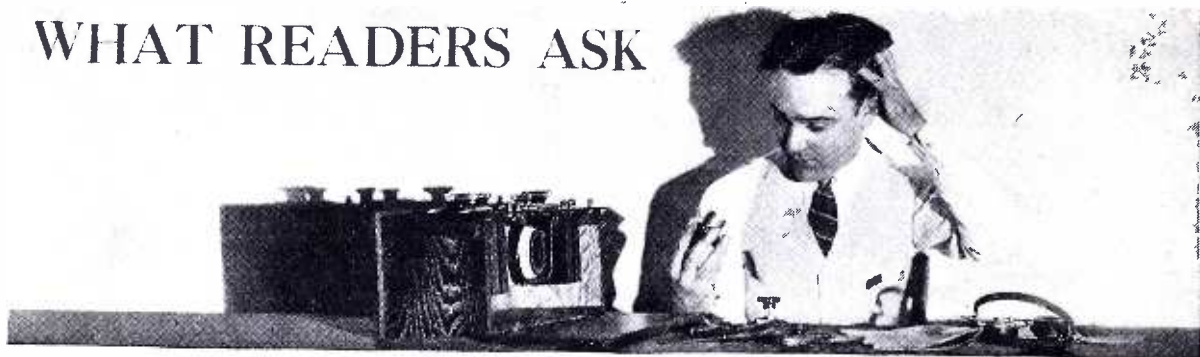

CONDUCTED BY LAURENCE M. COCKADAY

In justice to our regular subscribers a nominal fee of fifty cents per question is charged to non-subscribers to cover the cost of this service, and this sum must be inclosed with the letter of inquiry. Subscribers' inquiries should be limited to one question or one subject.

How to Add Two Stages of Audio-frequency Amplification to a Crystal Tuner

QUESTION: Please show me how to add two stages of amplification to a crystal set that consists of a variocoupler with a series variable condenser in the antenna circuit and a shunted variable condenser connected across the secondary coil. I am interested only in local programs for clear reception and I want to use this on a loudspeaker or occasionally on the phone.

R. J. CARROLL

ANSWER: The circuit that we have prepared for you is shown in Figure 1. The parts that you will need in building this simple set are shown in the following list:

L1 and L2—primary and secondary coils of variocoupler;
 VC1 and VC2—variable condensers, .0005 mfd.;
 DET—crystal detector;
 C—mica fixed condenser, .0005 mfd.;
 AFT1 and AFT2—audio-frequency amplifying transformers;
 R1 and R2—filament rheostats, 5 ohms;
 TEL—telephones or loudspeaker.

You will need two WD-12 or C-12 tubes and sockets for this receiver. If these are used the "A" battery should consist of three 1½-volt dry-cell batteries connected in parallel. This receiver should give you very clear reception on local signals.

Straight Panels or Slanting Panels for Radio Receivers?

QUESTION: Which do you think is the most convenient type of panel to use on

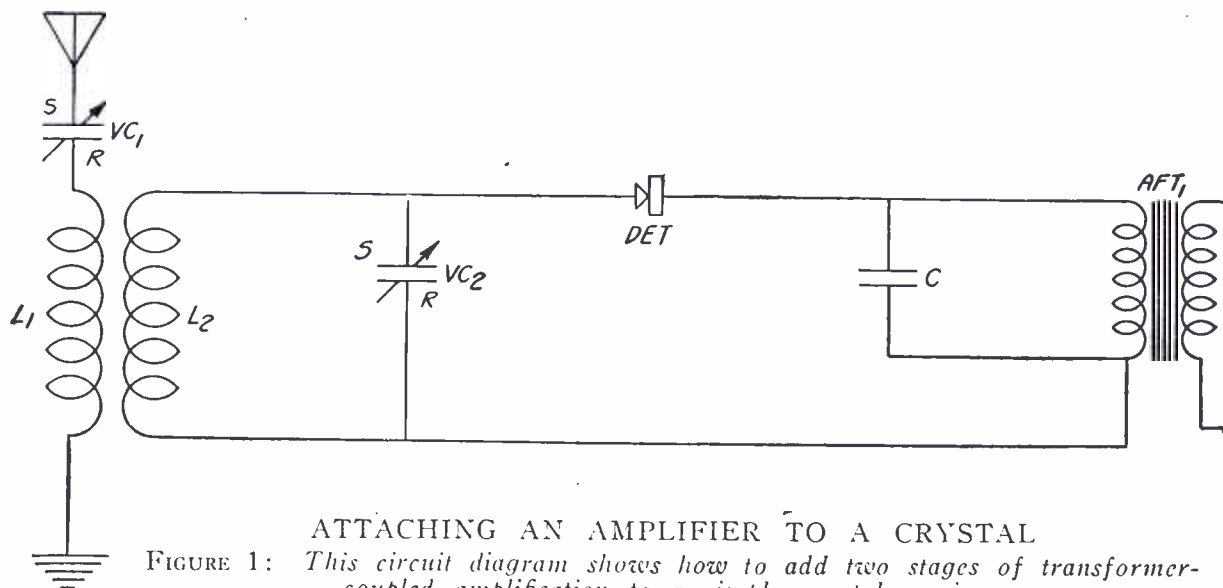

a radio receiving set—the straight vertical type or the slanting panel that faces the eye of the operator?

S. SIEHMS

ANSWER: We prefer the sloping panel from the standpoint of ease of operation of a radio receiving set. The panel should be at right angles to the line of vision of the operator when he sits at a comfortable arms-length from the radio receiving set. Using a radio table of standard height and sitting on a chair (also of standard height) with the arms bent in a comfortable position and the hands on the dials, it will be found that a panel with a slope backward of 25 degrees will just meet this condition, giving the operator a clear view of the dials and the dial settings without straining his arms, his neck or his eyesight.

Connection Wire to Use

QUESTION: What kind of bus wire do you believe to be more suitable for wiring up a home-built radio receiving set?

T. RAMOS

ANSWER: Use a round bus wire of about No. 12 gauge. This can be bent in the desired shape necessary when connecting the various instruments with the least effort and it makes a good looking job. When wires cross a small piece of spaghetti tubing may be used to act as an insulator against possible short circuits, but on the whole we would advise that the tubing is used extremely sparingly.

The "Town and Country" Receiver as a Permanent Set-up

QUESTION: Will Mr. Taylor's "Town and Country" portable receiver (described in POPULAR RADIO for May, 1925) be suitable for operation in my

apartment house (which is of steel construction) for all-year-round use? I have studied the article describing this set and it appeals to me very much as I am unable to use an outdoor antenna. I do not need a portable set, however, and I am wondering if this receiver will be satisfactory for all-year-round use in such a location.

D. TUSKA

ANSWER: This receiver should give you fine results in this location where you cannot put up an outdoor antenna. We recommend its use for any purpose whether in town or in the country.

The Size of Rheostats for the WD-12 Tube

QUESTION: What is the proper size of rheostat to use with the WD-12 type of tube operating on an ordinary radio dry-cell battery?

R. TIETJEN

ANSWER: Use a rheostat of 5 or 6 ohms resistance.

Radio-frequency Added to the Regenerative Receiver

QUESTION: Is it possible to add a stage of radio-frequency to a regenerative receiver in order to cut out radiation?

F. HAXTON

ANSWER: Yes, this is a practical scheme. If the radio-frequency tube contains the familiar neutralization method of eliminating feedback, the question of radiation is solved.

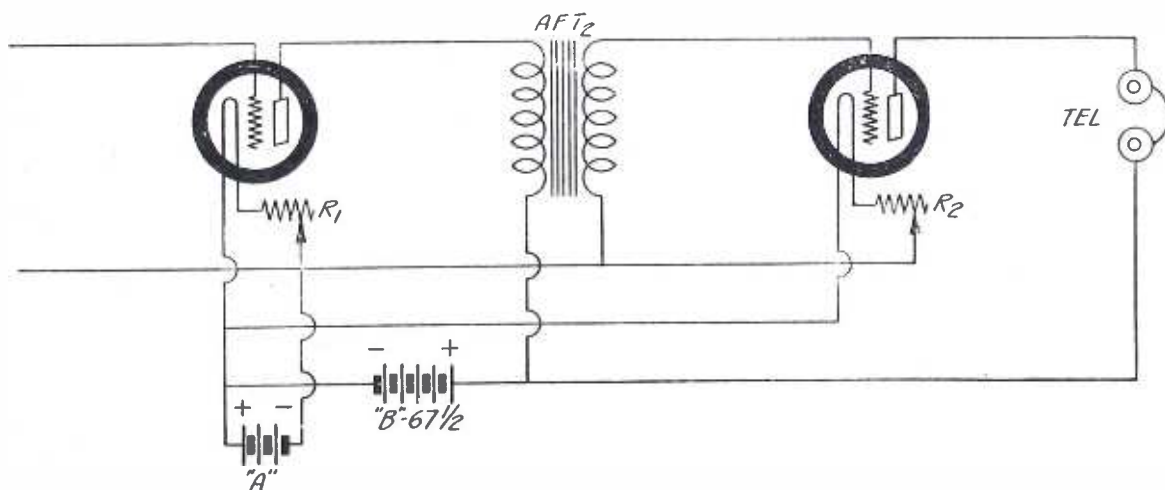

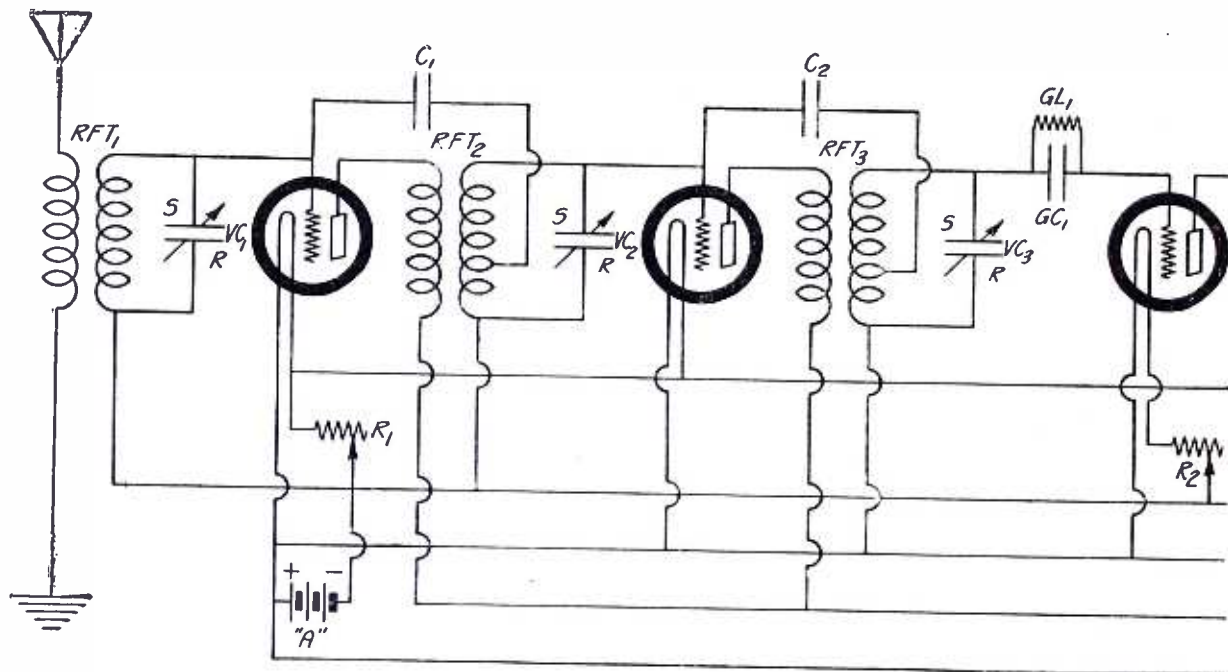

A NEUTRODYNE WITH ONE STAGE OF TRANSFORMER-COUPLED AND ONE STAGE OF IMPEDANCE-COUPLED AMPLIFICATION

FIGURE 2: This circuit shows the electrical connections for a standard neutrodyne receiver employing two stages of neutralized radio-frequency amplification, vacuum tube detector, one stage of transformer-coupled audio-frequency amplification and a single stage of impedance-coupled amplification.

An Efficient Neutrodyne Receiver

QUESTION: Will you kindly give me a wiring diagram for a neutrodyne receiver that employs two stages of radio-frequency, vacuum tube detector and one-stage of transformer-coupled audio-frequency amplification and one-stage of impedance coupled amplification? I would like to use the standard UV-201-a vacuum tube throughout except that I want to use a UV-200 tube for the detector.

JOHN TUTT

ANSWER: In figure 2 you will find a circuit diagram that shows the connections for a receiver of the type you require. The parts that you will need for building this set are the following:

- RFT1, RFT2 and RFT3—standard neutrodyne radio-frequency couplers;
- VC1, VC2 and VC3—variable condensers, modified straightline wavelength, .00035 mfd.;
- C1 and C2—neutrodon compensating condensers;
- GL1—variable grid-leak;
- GL2—fixed grid-leak, $\frac{1}{4}$ megohm;
- GC1—mica fixed condenser, .00025 mfd.;
- GC2—mica fixed condenser, .006 mfd.;
- C3—mica fixed condenser, .0005 mfd.;
- R1—filament rheostat, 6 ohms;

- R2—filament rheostat, 6 ohms;
- AFT1 and AFT2—audio-frequency amplifying transformers;
- J1 and J2—double-circuit jacks;
- J3—single-circuit jack.

The first two and the last two tubes should be either C-301-a tubes or UV-201-a tubes, or any of the standard makes of "hard" vacuum tubes of this general type. The third tube (the detector tube) should be a UV-200 tube or a C-300 tube. All the tuning is done with the three condensers, VC1, VC2 and VC3, the two small variable condensers, C1 and C2 being used to neutralize the circuit.

The transformer, AFT2 is used only as an impedance, the primary being left open and the secondary terminals being connected to the two inner terminals of the jack, J2.

Condensers for Filter Circuits in "B" Eliminators

QUESTION: Do you recommend the use of the Dubilier bypass condenser in the filter circuits of "B" eliminators?

R. NORDSTRUM

ANSWER: We do not recommend the use of this instrument. It may operate for a short time but it will eventually break down and cause a short circuit of the apparatus. This does not mean that this instrument is an inferior one. The Dubilier Condenser & Radio Corporation advise against the use of this apparatus for such purposes.

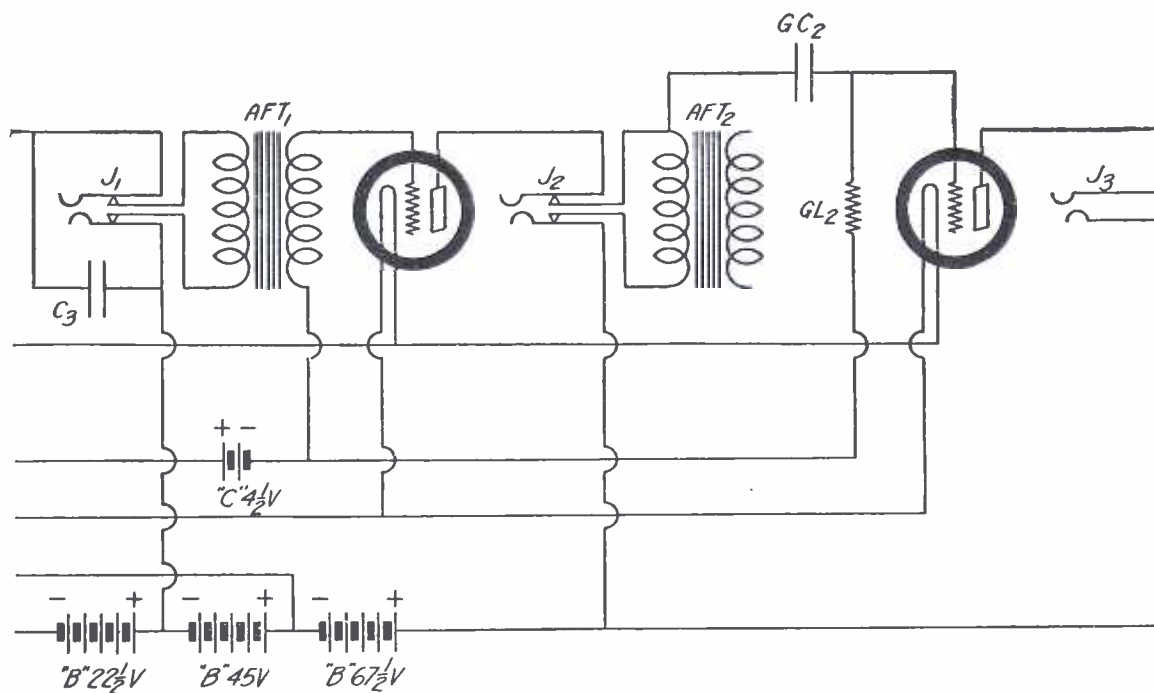

Binding Posts on the Panel or at the Rear of the Set

QUESTION: Which do you deem the advisable method for constructing a receiver—to incorporate the binding posts directly on the front panel or to place them on a strip at the rear of the radio set?

JERRY LAUTERBACH

ANSWER: We recommend that you use a small panel at the rear of the set for the antenna, ground, and battery connections. This keeps any stray voltages away from the operator's hands and also helps to eliminate body capacity from the antenna circuit.

A Fuse for the "A" Battery Circuit

QUESTION: Recently my storage battery leads happened to touch each other, with resultant violent sparking and heating of the leads. How can I prevent a recurrence of this trouble?

A. FRAZIER

ANSWER: Get a fuse block with a single six

ampere fuse such as is used for electric light wiring. Put it in series in one of the "A" battery leads by disconnecting one wire from the storage battery and changing it to one terminal of the fuse block; then connect the other terminal of the fuse block back to the vacant binding post of the storage battery. Now, the fuse will blow in case of a short circuit.

The Hot Wire Ammeter

QUESTION: What kind of inexpensive ammeter can be used for measuring either alternating or direct current? I would like to measure the current when my alternating current charger is charging my storage battery, and also the direct current when vacuum tubes are lighted from the storage battery.

F. HUTCHINSON

ANSWER: The small hot wire type of ammeter should suit your purpose. This style meter measures the current indirectly as the current serves only to heat a thin wire or strip in the meter, just as it would heat the wires in a toaster or other electric appliance. The expansion of the hot wire due to heating is transferred to the needle of the meter by a lever system and thus the amount of heating (and the current causing it) are measured.

Useful Charts for Amateurs

Nine information and computation tables for the guidance of experimenters who design or build receiving sets—in POPULAR RADIO for September.

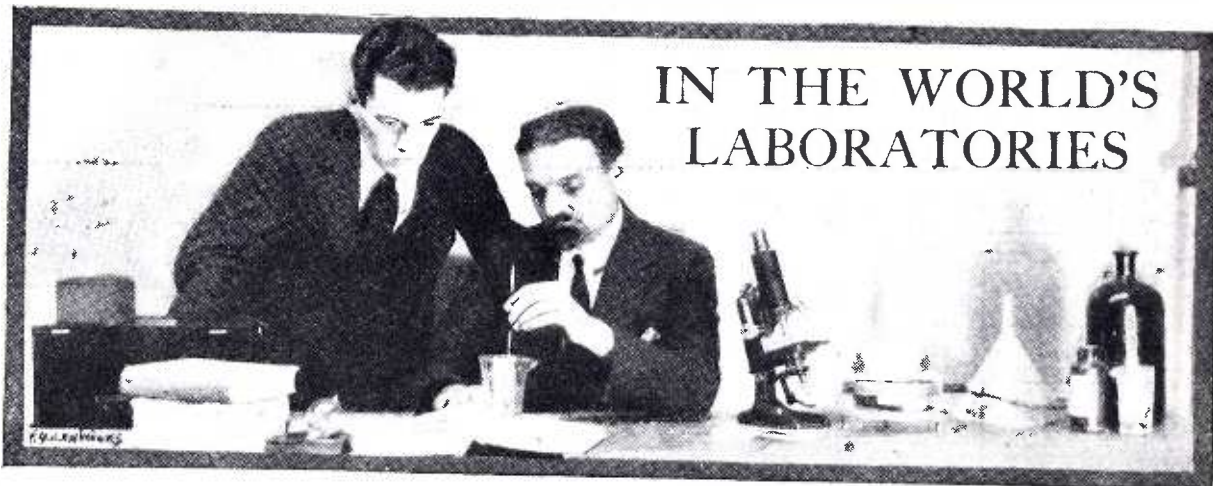

IN THE WORLD'S LABORATORIES

CONDUCTED BY DR. E. E. FREE

New Theories of Ether Waves

READERS of this department are already familiar with the idea that ether waves may not be waves at all but tiny particles like bullets of light. These supposed particles are called *quanta*; the theory which imagines them to exist is called the quantum theory. If they are

real at all they must be extremely tiny. Electrons would be millions of times larger.*

There are many facts which favor this quantum theory. One, for example, is what physicists call the photo-electric effect. Certain metals, notably the metal potassium, have the property of giving off electrons when light falls on them. This was the basis of the famous "hearing starlight" experiments of General Ferrié and M. Jouaust. A ray of light from the star fell on a small potassium cell. This gave off electrons. The electric charges thus produced were magnified by amplifiers and made audible.

Now when one measures very accurately the speed of the electrons thus given off from potassium (or other metals) under the action of rays of light it is found that this speed is constant for a definite kind of light regardless of how strong the light is. A still more startling experiment can be performed with X rays. If a stream of rapidly moving electrons is directed against a metal plate X rays are given off by the plate. That is how the usual X-ray tubes work. The wavelength of the X rays produced depends upon the speed of the bombarding electrons.

Now let the X rays thus produced fall on another metal plate. Electrons are set free, for the photo-electric effect works with X rays just as it does with the longer waves of visible light. Now comes the surprise. The electrons set free from the illuminated metal plate have the same speed (with certain small and explainable variations) as had the electrons that produced the X rays in the beginning. This is true even when the source of the X rays and the plate on which they fall are far apart, so that the X rays are greatly enfeebled by the distance.

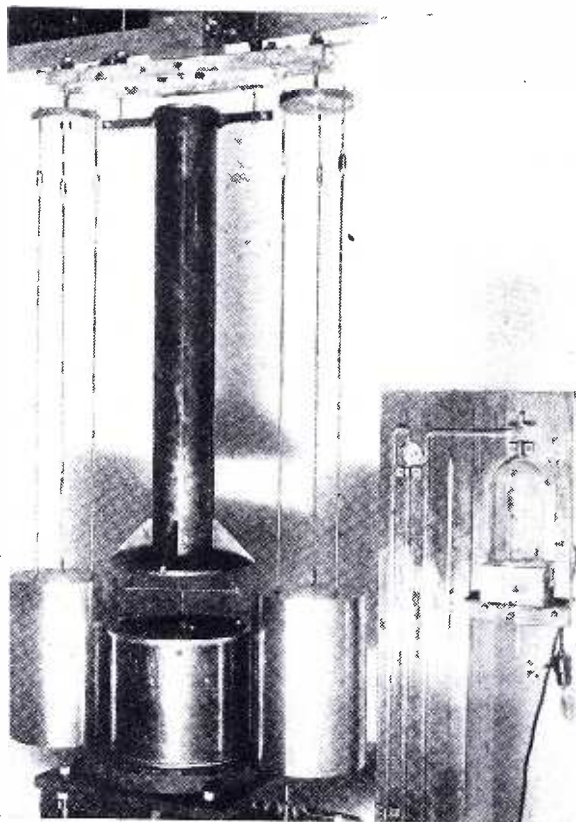

Pacific & Atlantic

WHAT IS GRAVITATION?

New theories of ether waves have prompted renewed attack on the mysterious cause of gravitation. The Bureau of Standards is using this apparatus to weigh the earth.

*For brief accounts of the quantum theory see "Are Ether Waves Composed of Minute Particles?" in this department of POPULAR RADIO for February, 1924, pages 207-209; "Is There a Universe Still Smaller than Electrons?" POPULAR RADIO for July, 1924, pages 82-83; "Ether Waves that Move in 'Squirts,'" POPULAR RADIO for March, 1925, pages 291-292; "Another Theory of Particles Smaller than Electrons," POPULAR RADIO for May, 1925, page 483.

The really remarkable character of this result is apparent from a vivid illustration which we owe to Sir William Bragg. Suppose, he says, that a plank falls off a ship in the harbor of New York City and makes a tiny wave in the ocean. Suppose, then, that this wave crosses the ocean, becoming continually feebler by mere spreading of the wave-front, and enters the harbor of Liverpool. And then suppose that a plank floating in the harbor there instantly jumps up to the deck of a ship. That would be truly remarkable. Yet that is exactly what happens in the sequence of moving electron, X ray and emitted photo-electron, as described above.

It has been quite impossible, so far, to explain this result on the basis of the wave theory of ether waves. The wave would be far too feeble, at a distance, to eject an electron with the same energy as was possessed by the electron which started the wave. But on the theory of light bullets, or quanta, this is all quite clear. The energy of the "wave" would be concentrated in single bundles—the quanta. If one of these quanta happened to hit the plank in Liverpool the plank would jump with the same energy that started off the quantum in the beginning.

That is part of the case for quanta. It is typical of the other arguments. There are some facts like this, most of them discovered only recently, which can be explained easily enough on the idea of light particles but which will not fit at all into the older idea of ether waves.

On the other hand there are some facts which the wave theory explains well but which the quantum theory will not explain at all. Among these are the facts of what is called interference, facts well known for years in the science of optics and which are finding radio application, nowadays, in modern theories of fading.

At present we are in the position of having two mutually contradictory theories of ether

radiation—light, X rays, radio waves and the rest. Each theory fits some facts and refuses to fit others. Yet all the facts, no matter how contradictory, are demonstrably true.†

There have been numerous attempts to reconcile these two theories. One of them is due to Dr. Nils Bohr, of atomic fame, and two of his collaborators.‡ They imagine atoms to be radiating ether impulses all the time. Normally this radiation is imperceptible. Only when the radiation of an atom changes from one kind of radiation to another do we perceive anything; either a light ray or some X rays or a radio wave or some other radiation.

Another suggestion, made originally by no less an authority than Professor Albert Einstein and quoted with approval by Sir Oliver Lodge§ has been repeated recently by the distinguished English astronomer and mathematician, Dr. J. H. Jeans.|| According to this theory the apparent ether wave is unreal and represents merely the places in space at which the flying quanta have a high probability of acting on the atoms or electrons of matter. A third suggestion, made by Sir Joseph Thomson,

†One of the best recent summaries of this conflict between the wave theory and the quantum theory is "Some Contemporary Advances in Physics—VII. Waves and Quanta," by Karl K. Darrow, *Bell System Technical Journal* (New York), vol. 4, pages 280-326 (April, 1925).

‡"The Quantum Theory of Radiation," by Nils Bohr, H. A. Kramers and J. C. Slater, *The Philosophical Magazine* (London), vol. 47, pages 785-802 (May, 1924); also published (in German) in *Die Zeitschrift für Physik* (Berlin), vol. 24, heft 2, pages 69-87 (1924). Dr. Slater has recently amplified the theory somewhat in "A Quantum Theory of Optical Phenomena," *The Physical Review* (Cornell, N. Y.), vol. 25, pages 395-428 (April, 1925).

§See POPULAR RADIO for February, 1924, pages 207-209.

||"Electric Forces and Quanta." Lecture before the Institution of Electrical Engineers, London, February 5, 1925; published in *Nature* (London), vol. 115, number 2888, supplement, pages 361-368 (March 7, 1925).

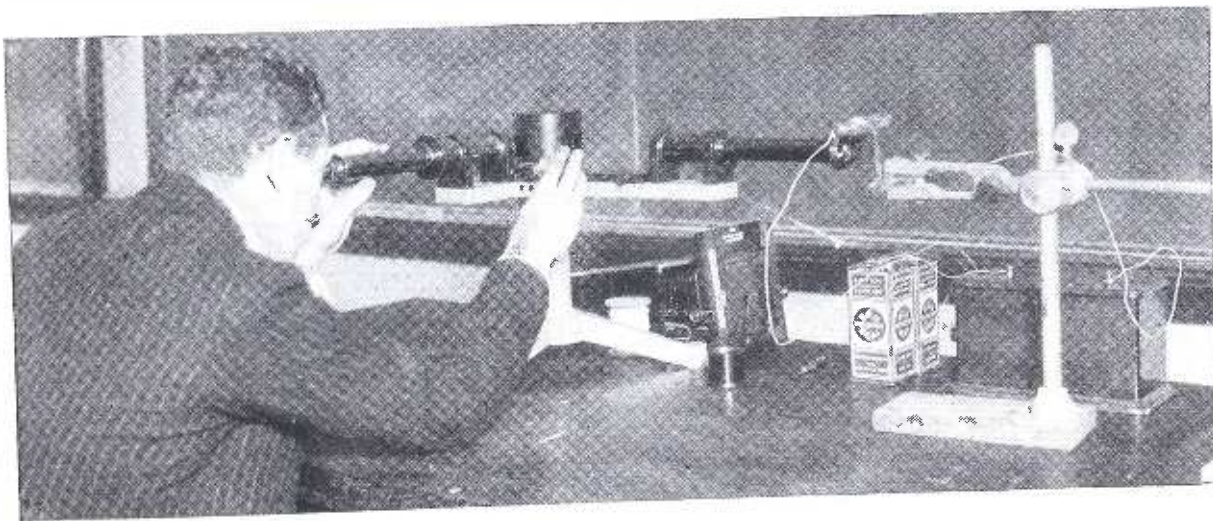

Brown Brothers

STUDYING ETHER WAVES IN THE LABORATORY

This form of spectroscope is used for visual study of the light rays sent out by electrified atoms in the small glass tube at the right. For more precise work a photographic plate is attached to the instrument, replacing the eye of the observer.

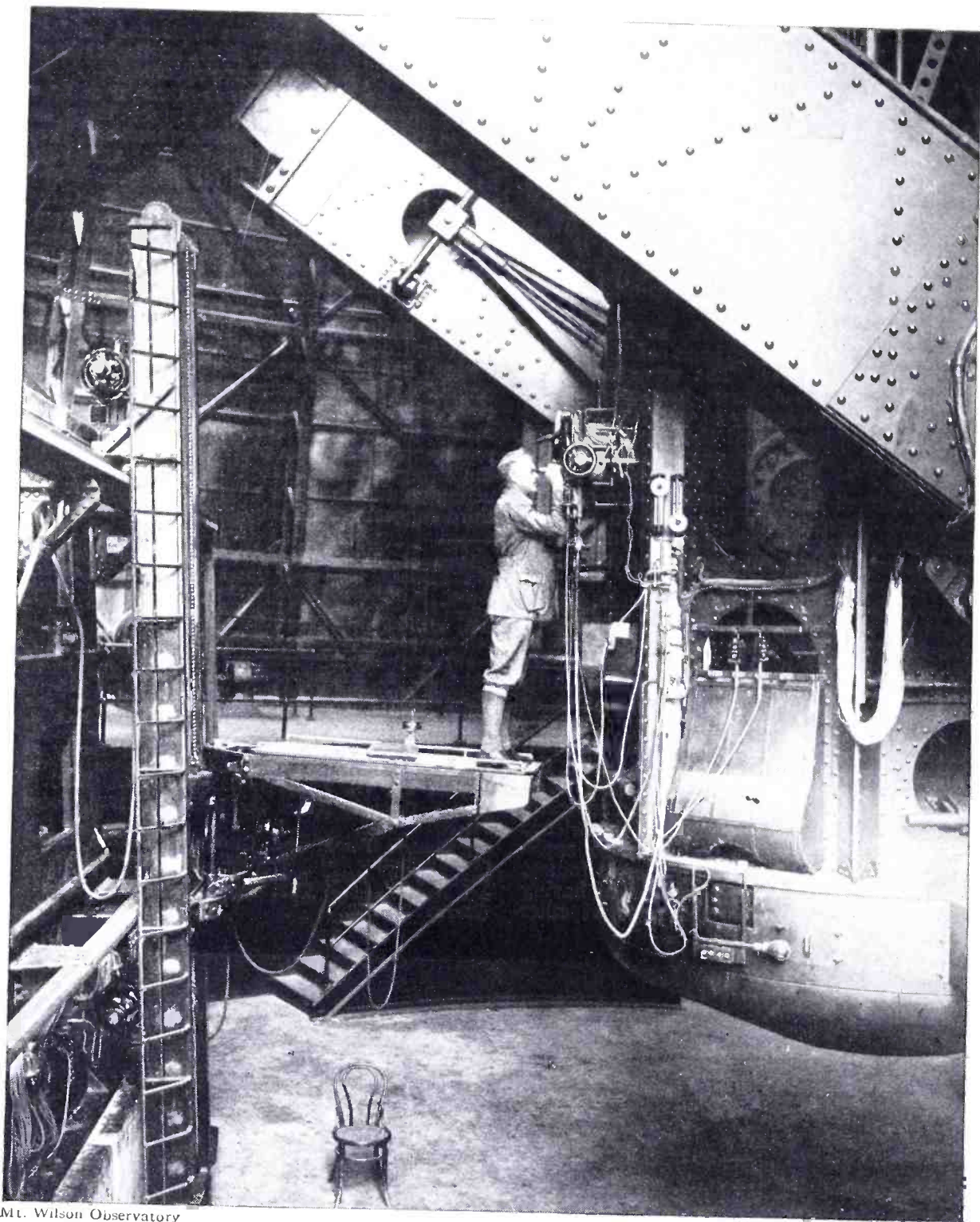

Mt. Wilson Observatory

LIGHT WAVES FROM MILLIONS OF MILES AWAY

Standing at the focus of the great telescope at Mount Wilson, Cal., Mr. Francis G. Pease is measuring the size of the distant variable star called Mira. This star shrinks and swells in a regular cycle. The measurements are made by interference, one of the phenomena very difficult to explain by the quantum theory.

contemplates the simultaneous emission of both ether waves and quantum particles.¶

But more appealing than any of these—at

¶"A suggestion as to the Structure of Light," by Sir J. J. Thomson, *The Philosophical Magazine* (London), vol. 48, pages 737-746 (October, 1924).

least to the radio engineer—is a suggestion made by Louis, Duke de Broglie, a French nobleman who has been for several years a persistent student of the quantum evidence.*

*This idea was first suggested to the French

He suggests that radiation may consist of individual, very tiny quanta, inside each of which there is going on some kind of periodic phenomenon characterized by a definite frequency. One might think of it, for example, as being a periodic motion of the electric and magnetic forces inside the tiny quantum.† A simple mechanical analogy would be a spherical ball which alternately shrunk and expanded along its axis, taking alternately the shape of an egg and of an onion.

While we are in the habit of speaking glibly of "waves" in the ether, we really have no evidence that any such things exist. What we do have evidence for is *frequencies*; some kind of phenomenon that recurs at regular intervals. This is especially true in radio; radio-fre-

quencies mean much more to us than radio "waves." The suggestion of the Duke de Broglie gives us these frequencies plus the idea of compact particles or "bullets" of energy.

As yet these new theories have been applied mainly to the facts of light and of X rays. Radio engineers will watch with interest their extension to the lower frequencies.

More Atoms Consent to Be "Stripped"

IN POPULAR RADIO for August, 1924, Dr. R. A. Millikan, distinguished American physicist and now president of the California Institute of Technology, described the remarkable experiments of himself and Dr. Bowen, in "stripping" off one or more of the electrons from the outer structure of atoms.* All atoms consist, you remember, of a central nucleus around which revolve a greater or lesser number of electrons, much as planets revolve around the sun. By using very hot

Academy of Sciences nearly two years ago; see the *Comptes Rendus de la Academie des Sciences* (Paris), vol. 177, pages 507-510 (September 10, 1923) and pages 548-550 (September 24, 1923). It is now presented in more detail in an article in the *Annales de Physique* (Paris) for January-February, 1925, abstracted in *Nature* (London), vol. 115, page 549 (April 11, 1925).

†This suggestion was made by Mr. Edmund C. Stoner in an address before the (Cambridge (England) Philosophical Society on January 1, 1925, printed in the *Proceedings* of that Society, vol. 22, pages 577-594 (March 12, 1925).

*"Do Electrons Play or Loaf," by Robert A. Millikan. POPULAR RADIO, vol. 6, pages 109-116 (August, 1924).

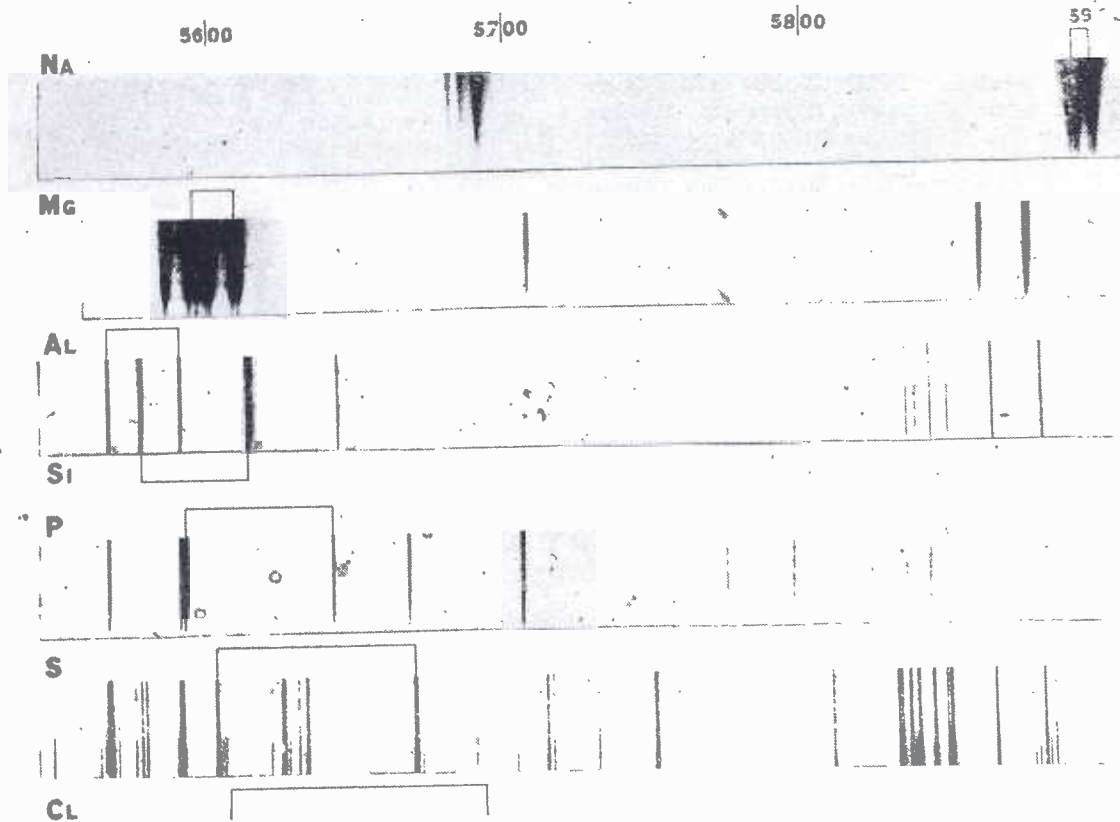

Courtesy of the Physical Review

WHAT THE SPECTRA OF STRIPPED ATOMS LOOK LIKE

The corresponding pairs of spectrum lines for the different atoms are indicated by the small brackets drawn above and below the photographed spectra. The top strip is the spectrum of sodium, the two crucial lines being marked at the right-hand end. Below, in order, are the spectra of stripped atoms of magnesium, aluminum, silicon, phosphorus, sulphur and chlorine, the last being indicated by brackets alone.

electric sparks passed through a crowd of gaseous atoms of various kinds, Drs. Millikan and Bowen knocked off successively the first, second, third and up to the sixth electron from such atoms as that of nitrogen. The result was a series of important new facts about the properties and structure of these atoms.

Dr. Millikan and Dr. Bowen have now extended these experiments to additional kinds of atoms, including some which have as many as seventeen planetary electrons and from which as many as seven of these electrons have been stripped off by the hot-spark method.†

The chief importance of this fact is that it is possible, by this process, to produce a series of partially stripped atoms which differ from each other only in the mass of their respective nuclei. For example, the atom of chlorine, the poison gas first used by the Germans during the war, contains normally seventeen electrons. When seven of these are gone the resulting atoms have ten. Similarly, the normal atom of sulphur has sixteen electrons. Taking six from it leaves, as before, an atom with ten electrons. Finally, the atom of phosphorus has fifteen electrons and can be made to lose five, so that it, too, retains but ten.

We have then obtained, you perceive, a series of stripped atoms—chlorine, sulphur and phosphorus—each of which has ten planetary electrons. But these atoms still possess their original central nuclei and these nuclei have different masses, or, in common language, different “weights.” By examining the light sent out by such stripped atoms, the

†“The Series Spectra of the Stripped Atoms of Phosphorus, Sulphur and Chlorine,” by I. S. Bowen and R. A. Millikan. *The Physical Review* (Corrying, New York), vol. 25, pages 295-305 (March, 1925).

so-called spectra of the atoms, it is possible

to learn much concerning the conditions and orbits of the remaining ten electrons, as well as some things about atomic behavior in general. Measurements of such spectra by Dr. Millikan and Dr. Bowen have supplied substantial confirmation of the famous atomic theories of Dr. Nils Bohr.‡

Do Cold Waves Disturb Radio Transmission?

THAT there is “clearly a relation between air temperature and the intensity of radio signals” is the interesting conclusion expressed recently by the *Monthly Weather Review* in its account of a report of Mr. L. W. Austin to the International Union of Scientific Radio Telegraphy.*

As a part of the work of this Union, records were kept during parts of 1923 and 1924 of the field strength at the receiving station at the Bureau of Standards, Washington, D. C., of several American radio stations of relatively high power, chiefly WII at New Brunswick, N. J., and WGG at Tuckerton, N. J. A considerable variability of the received field strength was noticed during the cold waves of January 22 and 27, 1924, and during the previous moderate cold of January 7 and 15.

“It is too early,” the report continues, “to give any definite explanation of the variations observed. Their cause is evidently atmospheric and the connection with the cold waves of January suggests either that the part of the atmosphere concerned in the variations lies much below the Heaviside surface.”

‡The Bohr theories were described in POPULAR RADIO for April, 1924, pages 319-327, and for December, 1924, pages 546-553.

*“Air Temperature and the Intensity of Radio Signals,” a review in the *Monthly Weather Review* (Washington, D. C.), vol. 52, page 590 (December, 1924).

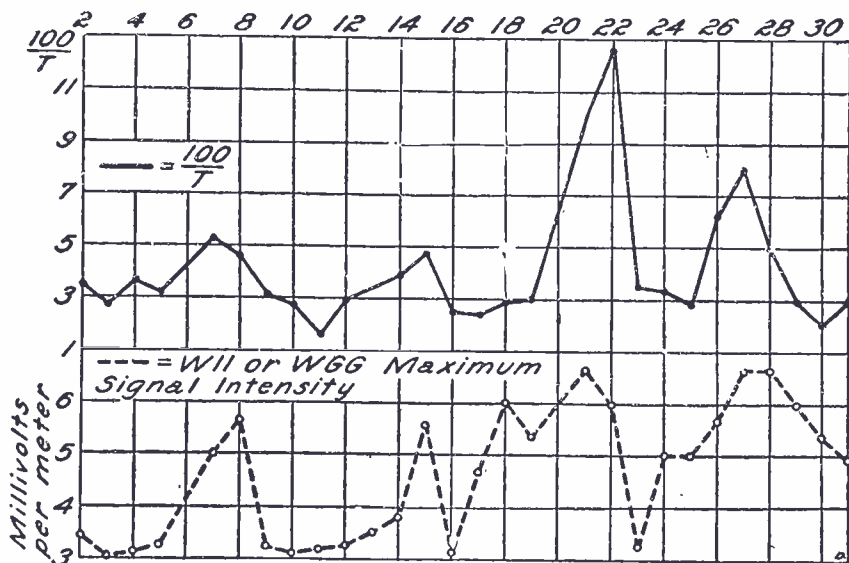

HOW RADIO TRANSMISSION MATCHED THE COLD WAVES

These two curves, taken from Dr. Austin's report, show a surprising correspondence. Temperature is above; radio signal strength is below. The data are for January, 1924.

Static from Volcanoes

DURING the month of May, 1924, the great volcanic vent of Halemaumau in the Hawaiian Islands displayed a series of explosive spasms more marked than any recorded since the Islands were discovered by the whites. As an incident of these explosions vast clouds of dust were sent up on several occasions for a mile or more into the air. The United States Government now maintains near the volcano a special observatory and a recent report of this observatory is devoted to the May eruptions.*

One feature of this report has considerable radio interest. This is the curve showing the relation between the explosive activity of the volcano and the number of electric storms. There is a clear parallelism. The more explosions, the more storms.

This agrees with the observation often made during volcanic eruptions that lightning can be observed to play through and around the vast clouds of ejected dust. Presumably the friction of the dust particles on each other generate static electricity which is responsible, in turn, for the electric disturbances. A volcanic dust cloud is probably a remarkably successful manufactory of radio static and if the radio fans in Hawaii happened to be tuned in during the eruptions of Halemaumau it is probable that they heard the eruption as well as saw it.

* "Volcanic Conditions in May: Seismic Sequences of the Eruption," by R. H. Finch. United States Department of Agriculture, *Monthly Bulletin of the Hawaiian Volcano Observatory* (Honolulu, Hawaii), vol. 12, pages 38-55 (May, 1924).

The Mystery of the Atomic Sun

THE three things in the universe about which we know the least are just these three things which are most fundamental—the three things out of which everything that we know is made. They are the electron, the proton and the "disturbance in space" which we call ether waves.

Matter is made—as everyone knows nowadays—of atoms. Atoms are made of electrons and protons. The protons and some of the electrons form the central nucleus of each atom, the atomic "sun." Other electrons revolve around this nucleus much as the earth and the other planets revolve around the central sun of our solar system. From this atom ether waves go out, at times, as pulses of light. On the other hand, ether waves in the form of light or X rays or even radio waves, can sometimes affect the atom, even to disrupting it. This is the modern picture of the universe, a picture already sufficiently familiar to the readers of POPULAR RADIO.*

Concerning the number, arrangement and motions of the electron planets in the atom we already have a great deal of information. We are learning much, also, about the relations of these electron motions to ether waves, to the

* See for example, "Bohr's New Theory of Atoms," POPULAR RADIO for April, 1924, pages 319-327, and "Broadcasts from Atoms," POPULAR RADIO for December, 1924, pages 546-553.

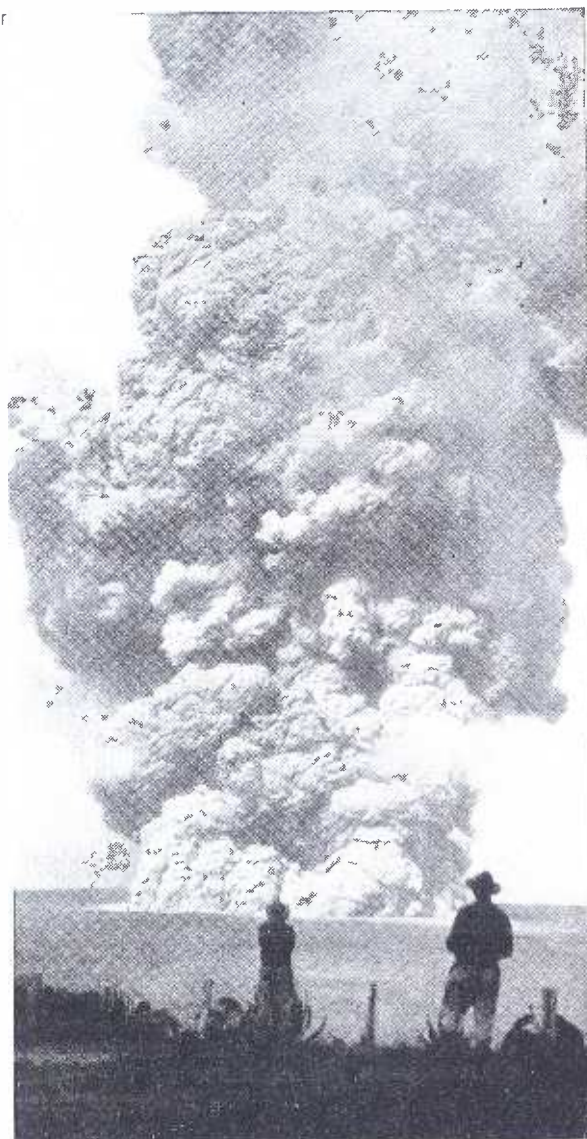

Courtesy "Scientific American"

ANOTHER STATIC FACTORY

This view of a recent eruption in Hawaii shows the tremendous quantity of dust, all of it more or less electrified, which is shot into the air by volcanic activity.

so-called spectrum lines with which the different atoms identify themselves in the light that they send out. But about the other essential part of the atom, its central sun or nucleus, our ignorance remains virtually complete.

Therein lies the importance of an address made recently before the Franklin Institute, in Philadelphia, by Sir Ernest Rutherford in which Sir Ernest describes what has been learned, most of it by himself and his associates, about the disintegration and transmutation of the chemical elements.†

An instance of natural disintegration is radium, the atoms of which fly apart once in a

† "The Natural and Artificial Disintegration of the Elements," by Professor Sir Ernest Rutherford, *Journal of the Franklin Institute* (Philadelphia), vol. 198, pages 725-744 (December, 1924).

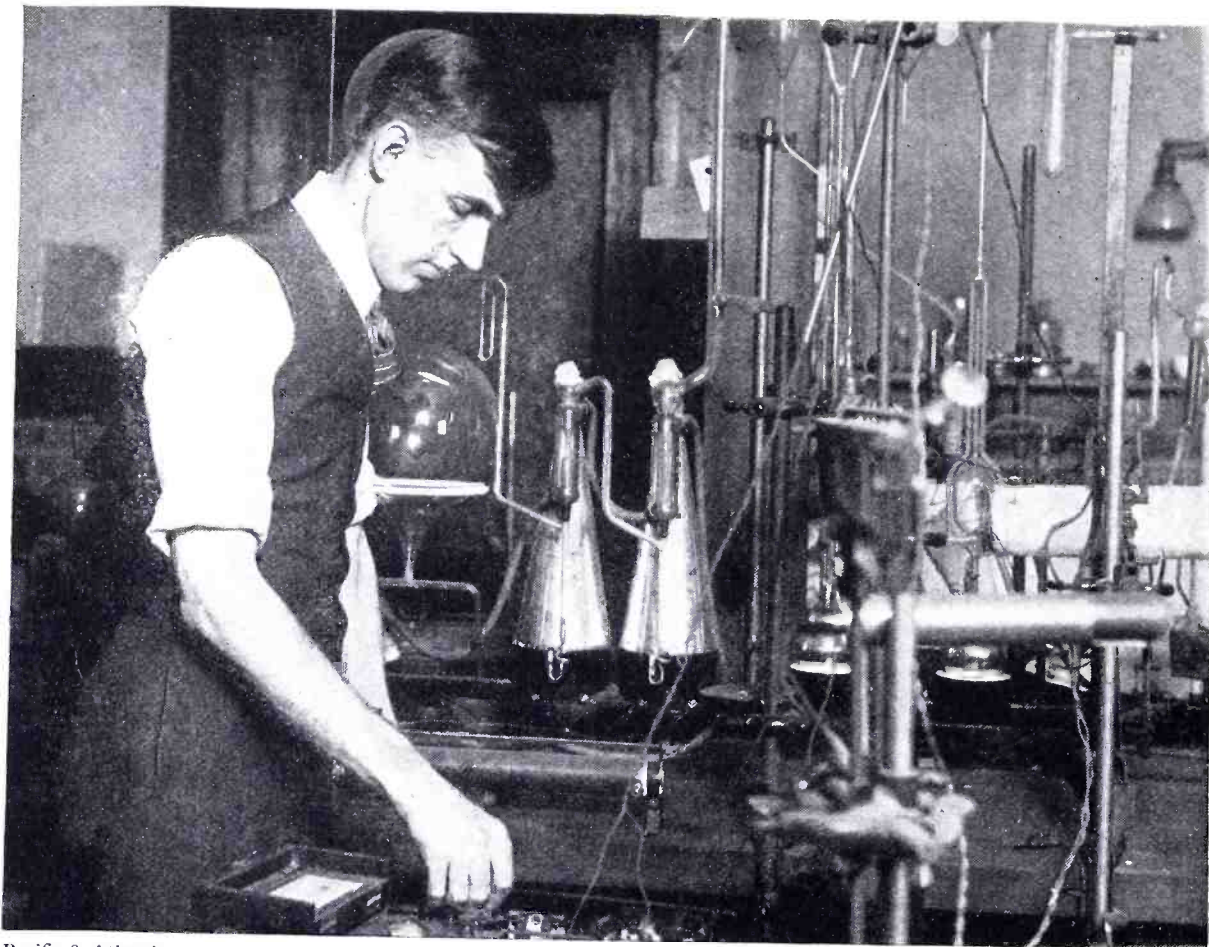

Pacific & Atlantic

AN AMERICAN INVESTIGATOR OF ATOMIC MYSTERIES

Dr. F. S. Mohler, of the United States Bureau of Standards, is one of the American scientists who has been working actively on the facts of atomic structure, especially on the relations of the atoms to the production of light spectra and of other varieties of ether waves.

while, ejecting electrons and other particles with explosive violence. Artificial disintegration of other atoms has been accomplished by Sir Ernest by bombarding them with the fast-moving, very tiny "alpha-particles" shot out by radium and by elements like it. All these facts have been noted in this department.

In his Philadelphia address Sir Ernest summarizes the evidence obtained from these various lines of investigation and proceeds to apply it to the elucidation of that most mysterious problem of what the central suns of the atomic systems are like. In the atom of aluminum, for example, there are a total of 27 electrons and 27 positive particles or protons. All of the protons and 14 of the electrons are crowded together in the atomic sun or nucleus; the other 13 electrons revolve around this nucleus as planets might. The nucleus contains, then, a total of 41 particles, protons and electrons. Nevertheless it is so small, Sir Ernest reports, that its outside diameter cannot be as much as a trillionth of a centimeter, the maximum value being, in figures, 4×10^{-13} cm. This is about one twenty-five-thousandth of the diameter of the aluminum atom as a whole.

If one imagines, therefore, an aluminum

atom enlarged so that it is a kind of complicated solar system the outer orbits of which are a mile across, all the protons and half of the electrons will be concentrated in a small central sphere about two feet in diameter. It is the nature of the forces active within this relatively tiny central sphere—the nucleus—that constitutes the greatest present problem of atomic physics.

It is probable, Sir Ernest believes, that these forces within the nucleus are somewhat different from the ordinary electric attractions which control the movement of the planetary electrons and of the larger electric forces which we are familiar with in electrical engineering. There is evidence that the potentials within the nucleus may exceed 2,000,000 volts and that the usual laws for the attraction of unlike charges and the repulsion of like charges may break down.

More important still, there is reason to suspect, Sir Ernest concludes, that an electron and a proton may sometimes unite into a more or less stable combination, forming a sort of monogamous unit which he calls a "neutron." Out of such neutrals, arranged in various ways inside the atomic nucleus, the nuclei of all the

various chemical elements may be imagined to be built up.

It is probable that the aggregate of neutrons or of other particles inside the atomic nucleus must be thought of as in vigorous motion, rather than being merely stuck together as though glued each to each by electric attraction. Inside the nucleus, as outside it, the atom is essentially a fragment of motion.

We have been astonished in the past two decades at the succession of discoveries which disposed of the former idea that atoms were mere inert bits of matter, replacing this idea with the concept of the rapid and complicated planetary motion of the outer electrons. The atomic sun, when we thought of it at all, we have passed by as probably merely a clump of protons and electrons. This, it appears, is as far from the truth as was the earlier idea of inert atoms. Inside the nucleus, too, there is a vast and continual activity.

Ultra-short Waves from a Mercury Arc Lamp

READERS of POPULAR RADIO will remember the remarkable experiments of Nichols and Tear in the production of very short radio waves, which experiments Dr. Nichols himself presented to our readers.* By this work the part of the ether-wave series assigned to heat waves and to infra-red light was linked for the first time with the series of electric ether waves like those used in radio.

After the publication of this work in 1923 Dr. Nichols and Dr. Tear continued the experiments. Dr. Nichols was reading a report of them to the National Academy of Sciences, in Washington, when he was taken with the heart attack which caused his sudden death. The complete report of the later work has now been prepared for publication by Dr. Tear.†

Specialists will find in the new paper some additional details of apparatus and methods not contained in the earlier, preliminary publications of the work. To the radio fan the most interesting new fact is the isolation of electric waves—essentially radio waves—from the “light” sent out by a mercury-vapor arc lamp, the same general kind of lamp as is used by photographers and motion picture producers to provide an intense bluish light.

The light of such mercury lamps contains a number of bright lines in the visible part of the spectrum. Dr. Nichols and Dr. Tear filtered out this visible light by means of opaque screens. They got rid, also, of the invisible radiation lying in the well-known infra-red region, the radiation consisting of waves only slightly longer in wavelength than the waves of visible red light. There was a residue of radiation. This was detected and measured by methods similar to those employed for the very

short radio waves and which were described by Dr. Nichols in his paper in POPULAR RADIO.

The result is the detection of mercury-lamp rays having wavelengths as long as .42 millimeter. Since the previous work (since repeated) had led to the discovery of true radio waves as short as .22 millimeter, it is apparent that the mercury lamp has been made to yield ether waves clearly within the true radio range. Thus we have another definite proof of the essential identity of radio waves and light waves.

It is worth noting, too, that the ether wave series no longer provides any gaps to be filled—in imagination—by new and mysterious kinds of radiation. Such unknown “rays” have been dragged in many times to explain facts not yet understood.

It remains possible, of course, that there exist waves still shorter than the gamma rays from radium. Very long radio waves are equally possible. Both ends of the series are perhaps extensible. But there are now no unknown gaps in the middle of it.

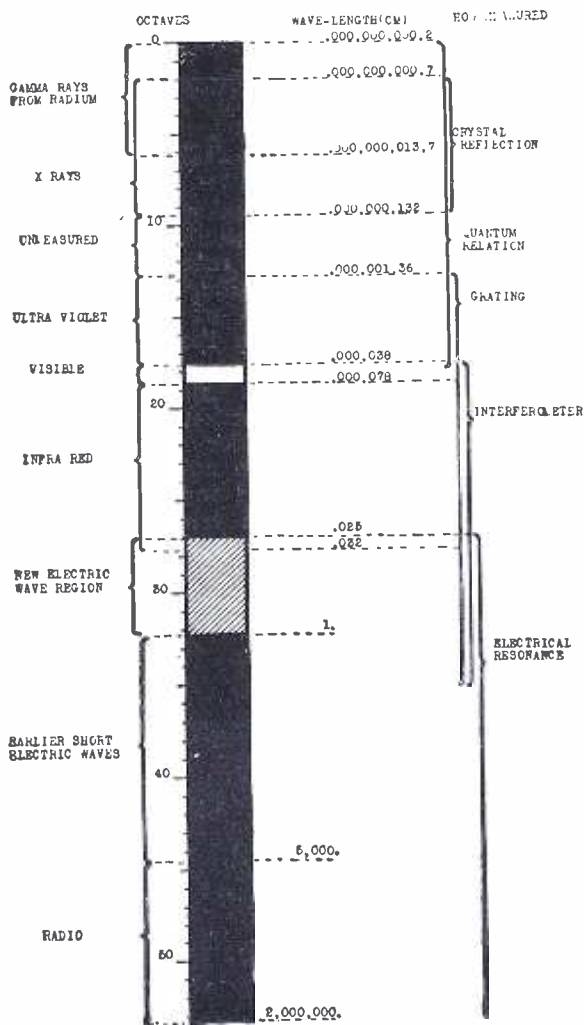

Nela Research Laboratories

THE COMPLETE ETHER-WAVE SERIES

All the gaps in the ether-wave series have now been filled, as is indicated by this diagram prepared by Dr. Tear.

* "The Shortest Radio Waves Ever Produced by Man," by Ernest Fox Nichols. POPULAR RADIO, vol. 4, pages 22-29 (July, 1923).

† "Joining the Infra-red and Electric-wave Spectra," by E. F. Nichols and J. D. Tear. The Astrophysical Journal (Chicago), vol. 61, pages 17-37 (January, 1925).

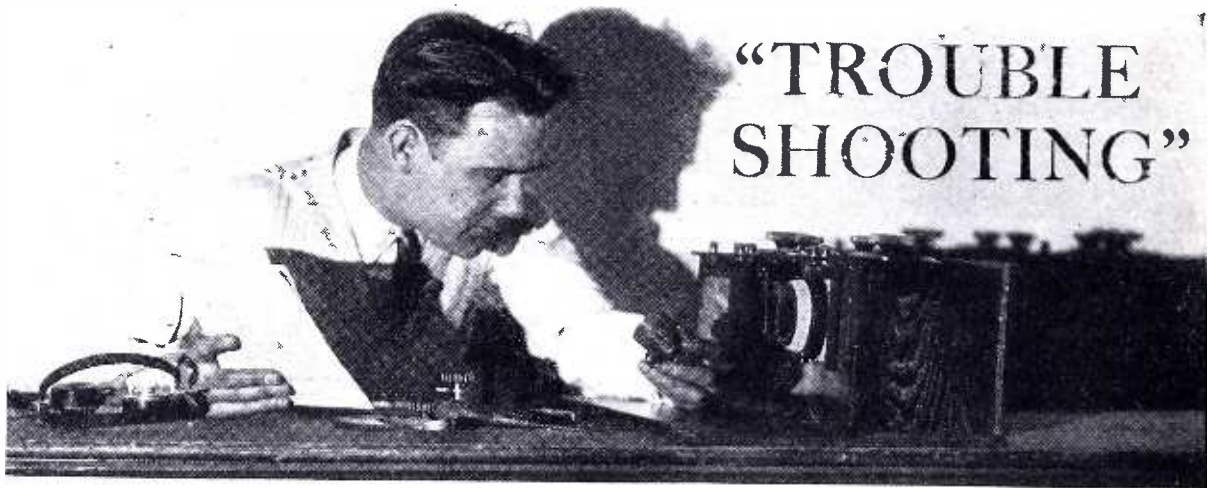

CONDUCTED BY S. GORDON TAYLOR

EVERY radio receiver requires a careful balancing of all of its parts if the best results are to be obtained. Two receivers made from exactly the same design may give widely different results, owing to variations in the parts used, the skill of the experimenters and the location of the receiver. This department is conducted for the special benefit of readers who have built the radio receivers described in POPULAR RADIO and who want to profit from the experience of others in operating them—to learn the little kinks that get the maximum results.

Another Amplifier Combination

IN the "Trouble Shooting" department of the June issue the connections were shown for combining the crystal receiver and the one-stage dry-cell tube amplifier which were described in the series of "How-to-build" articles for beginners, in the June and February, 1925, issues.

The beginners' article elsewhere in this issue covers the construction of a two-stage resistance-coupled amplifier which also uses dry-cell tubes. Inasmuch as this new amplifier is especially designed for use in conjunction with a single-stage transformer-coupled amplifier, it works out exceptionally well when added to the combination described in the "Trouble Shooting" department last month.

The combination of these three units will provide good loudspeaker volume of exceptional clarity. The crystal detector is noted for its faithful and distortionless reproduction; and the resistance-coupled amplifier has a similar reputation. For best results, however, it is advisable to use one stage of transformer-coupled amplification between the detector and the resistance-coupled amplification.

In Figure 1 is shown a picture of these three units combined. To effect the combination a slight change was made in the single-stage transformer-coupled amplifier. Binding posts were installed along its right-hand edge to correspond with those at the left. Then by bridging connecting wires directly

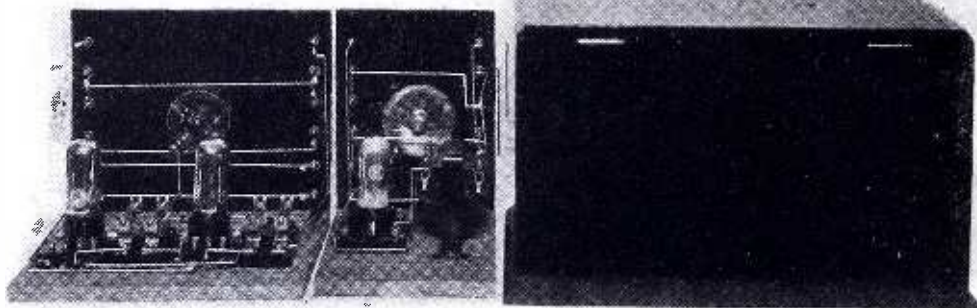

THE REAR VIEW OF THE CONNECTED UNITS

FIGURE 1: A front view of the combination is shown in Figure 2. Excellent loudspeaker volume of high quality is obtained from this combination of units.

across from one unit to another all are connected to the "A" battery and amplifier "B" batteries. It is then necessary to connect the batteries only to the right-hand end of the last unit as shown. Figure 3 shows the connections for the middle unit after the suggested change has been made in its wiring. The new wiring, which has been added, is shown in dotted lines. The connection between units, and from the end unit to the batteries, are made clear in Figure 2.

In case it is desired to use these two amplifiers with a receiver that has a vacuum tube detector instead of a crystal detector, the connections between the amplifier units, and from

these to the batteries, remain the same. In addition, however, the two lower left-hand binding posts of the first amplifier unit are connected across to the two "A" battery binding posts on the detector unit. In that case the binding post on the detector unit which is to be connected to the positive connection of the "B" battery should be made direct to the 22½-volt tap of the "B" battery and not to the "B+" binding post of the amplifier unit. If the "B—" connection of the detector unit is connected to the negative side of the "A" battery, as in the case of some detector units, it will be necessary to use a separate 22½-volt "B" battery for the detector.

Single Control and the Four-circuit Receiver

THE following communication from Mr. J. C. Fitzgerald of Oshkosh, Wis., undoubtedly will be of interest to many whose thoughts are straying in the direction of single-control receivers. Mr. Fitzgerald writes:

"In order to be abreast of the times one must have a single-control radio receiver. For obvious reasons the four-circuit re-

ceiver lends itself most readily to this method of control. In order to make such a receiver it is necessary only to use Remler condensers of .0005 and .00035 microfarad capacity instead of the Cardwell condensers specified in the October number of POPULAR RADIO.

"Remove the shaft from one of them (this will determine the position of the

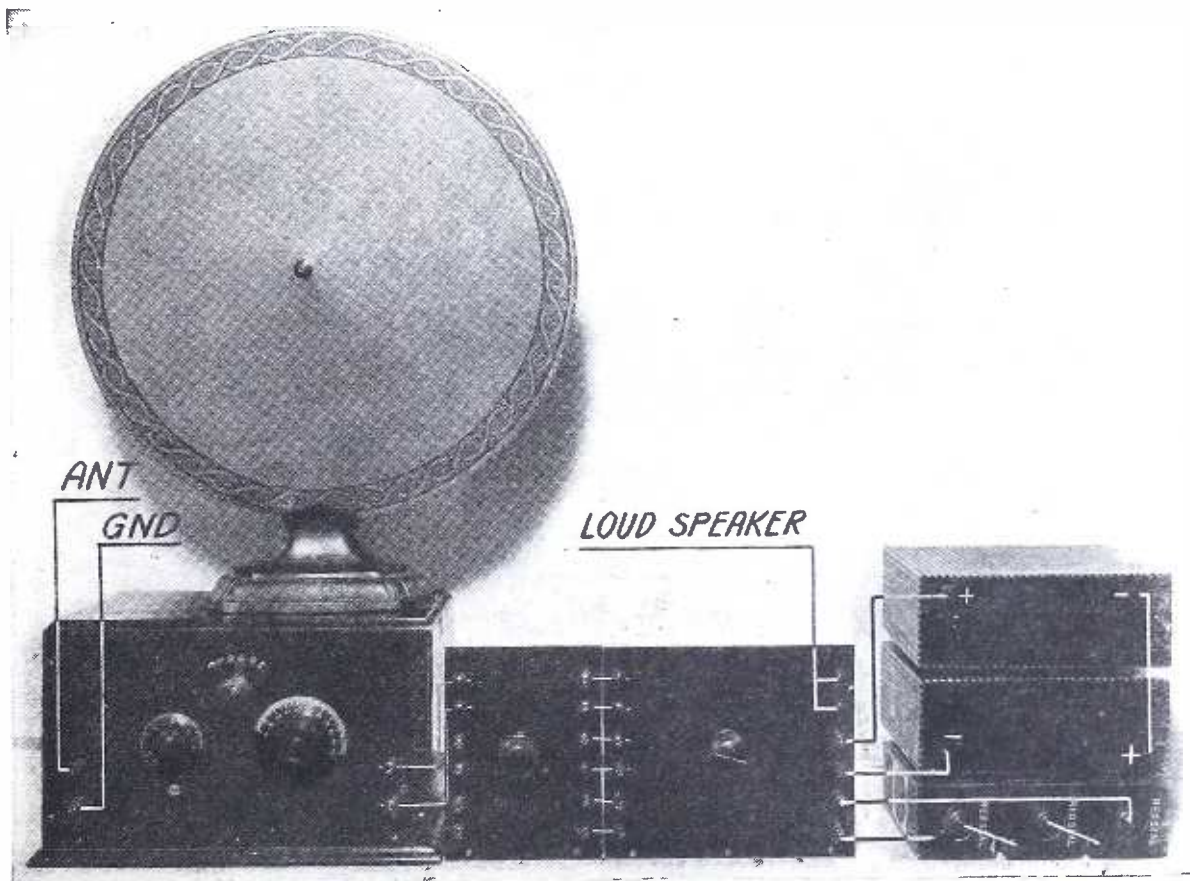

OBTAINING LOUDSPEAKER RESULTS FROM A CRYSTAL TUNER

FIGURE 2: The units described in the series of "Simple How-to-Build" articles can be combined to produce the results of large receivers. Here is a combination made up of a crystal receiver, (POPULAR RADIO, June, 1925), a one-tube, transformer-coupled amplifier (described in February, 1925, POPULAR RADIO) and a two-tube resistance-coupled amplifier (described on page 14 of this issue).

All the connections are clearly shown in the picture.

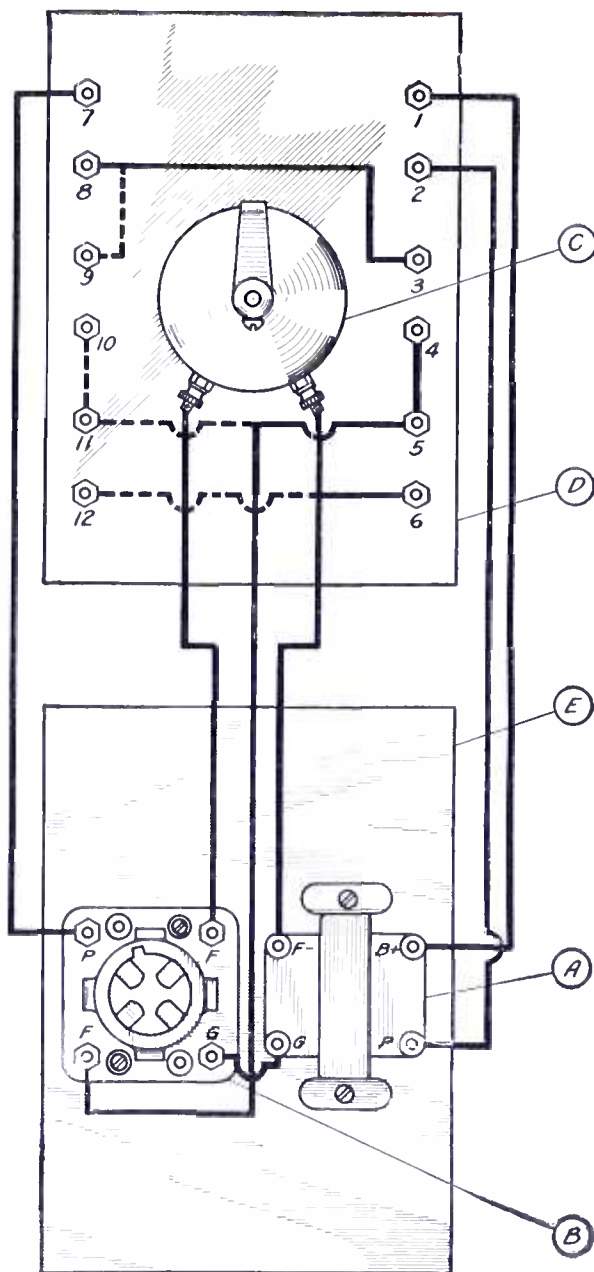

CHANGES IN THE PICTURE WIRING DIAGRAM

FIGURE 3: This drawing shows the single tube transformer-coupled amplifier with the four extra binding posts. The added connections are shown in dotted lines and the original connections in heavy black lines.

dial on the panel. Take your choice as to which shaft to remove), and mount the two on a piece of $\frac{1}{4}$ -inch thick hard rubber or other composition about 4 inches by 6 inches in such a manner that their protruding composition gears intermesh. They should be so arranged on this sub-panel that they make an angle of about 135 degrees one to the other. This will provide plenty of clearance between the plates of the two condensers when they

are set at their minimum capacity, i.e., when the plates are all the way out.

"A little care is necessary to mesh the gears so that the plates of the two condensers are set exactly alike. When the condensers have been properly fastened to the small sub-panel, the whole assembly can be fastened to the main panel by means of three or four flathead bolts so placed that the heads are concealed by the dial. A 6-volt, .3 ampere Walbert 'Panelite' in series with the 'A' battery switch, and placed directly above the dial, provides excellent light for tuning and shows when the set is turned on.

"With this condenser arrangement no vernier dial is necessary. The regular Remler dial rotated through three hundred and sixty degrees provides for fine tuning. The selectivity, volume, sensitivity, and tone quality are at least as good as when other condenser arrangements are used.

"By studying the accompanying photographs, it will be noted that the Bradley-ohms are mounted on a shelf behind the panel. This shelf is supported by brackets fastened to the baseboard. It will also be noted that a universal Bradleystat is used to control the filament of the last audio tube. This enables one to use different tubes without the bother of changing amperites. A 216-a tube seems to be best in this stage. The jack was omitted from the first stage of this receiver because it is in use in a locality that has no big broadcasting station within a radius of 200 miles. The jacks in the last two stages are of the filament control type.

"The new Sodian tube (type D-21), used as a detector in this set seems to give as much volume and better tone quality than the usual UV-200 and uses only $\frac{1}{4}$ ampere current.

"The two turns of 'A' coil shown in the pictures are shorted so they are in effect only one turn.

"A small fixed condenser in multiple with the last $\frac{1}{2}$ megohm resistance sometimes stops a high-pitched whistle that occasionally bothers in the last stage of four-circuit tuners. This trouble is sometimes due to mechanical coupling between loudspeaker and set. In the set pictured the loudspeaker unit, as well as the horn, rests on pieces of sponge rubber so as to minimize the transmission of mechanical vibration to the set."

This single-control tuning arrangement suggested by Mr. Fitzgerald is an entirely practical one—especially as the four-circuit tuner is particularly adaptable to the single-control principle. Some of the other changes mentioned by Mr. Fitzgerald may also prove helpful to owners of four-circuit receivers.

The use of the Sodian tube (D-21) as a detector in this circuit has given satisfactory results in some cases but in others does not

seem to work out well. Also, the use of a lower resistance in the grid circuit of the last tube—either .25 or .1 megohm—will usually

eliminate any whistle there may be when the fifth tube is used. This remedy is considered better than the use of a fixed condenser.

The Five-tube AC Receiver

(This set was described in POPULAR RADIO for June, 1925)

THE current supply for the heaters of the five tubes is obtained from the 110 volt AC house lighting lines, through a small step-down transformer. Such transformers are designed to deliver the specified output voltage on 110 volt input, and will continue to deliver sufficient output voltage even though the input voltage, or the voltage of the lighting lines, may be somewhat less than 110. However, if the line voltage is too low the output voltage will also be too low for proper operation of the AC tubes. In some localities, for instance, the line voltage may not be more than 100 or 102 volts, and in such cases it is quite probable that the transformer will not deliver sufficient voltage to operate the tubes at maximum.

In view of these conditions it is essential that the transformer used with the AC receiver be capable of delivering proper output voltage regardless of how much the line voltage may vary from 110.

A further condition required in the transformer is that the voltage variation between taps be small. Transformers which have a variation of one volt or more between taps are not suitable. The voltage should be vari-

able in steps of about one-quarter volt.

The transformer mentioned in the article in the June, 1925, issue (Dongan type B-Special Transformer) has proved satisfactory for use with these AC tubes. It is capable of taking care of line voltages from 100 to 120 or even lower or higher than this. The tap switch which is mounted on the transformer includes five taps to vary the output voltage in steps of approximately two-tenths of a volt. Three output terminals are also provided on this transformer instead of two as shown in the June issue.

Where the line voltage is 110 or lower the leads from the tubes are connected to the two outside output terminals on the transformer. If the line voltage is higher than 110 the leads from the receiver are connected to the left hand and center terminals of the transformer (with the output terminals toward the observer).

In most cases a voltmeter suitable for measuring alternating current voltage will not be available, but the proper connections to the transformer can be determined by trial. If the output voltage is too high the receiver will tend to oscillate. On the other hand, too low voltage will result in decreased volume and probably an audible hum.

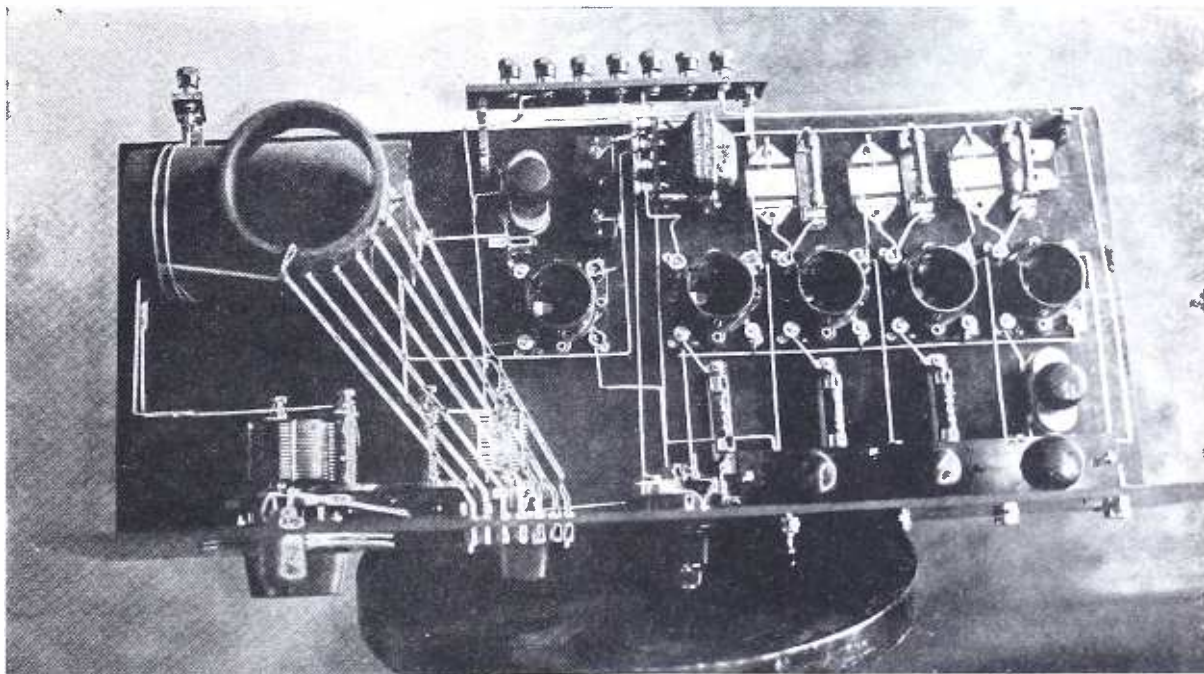

HOW THE TWO VARIABLE CONDENSERS ARE MESHED TOGETHER

FIGURE 4: *The baseboard layout is almost identical with that of the four-circuit receiver with resistance-coupled amplifier described in POPULAR RADIO for October, 1924. The only variations from the original receiver are in the arrangement of the Bradleyohms and the variable condensers.*



International

REGULAR BROADCASTING MAKES ITS OFFICIAL DEBUT IN THE FLOWERY KINGDOM

The "radio craze" swept over Tokyo, Japan, with the inauguration of regular broadcasting late in March. This snapshot shows some of the crowd that collected about the loudspeakers that were set up in front of the more progressive shops.

The BROADCAST LISTENER

*Comments on radio programs, methods and technique
—from the point of view of the average fan*

By RAYMOND FRANCIS YATES

WHILE writing flattering paragraphs sprayed with Chypre is several hundred meters from being our oyster, we are really not as bad as some of our readers try to make us out. God knows, there is not a vestige of egg on our vest, we do not use a skullcap or a snuff-box and the knees and seat of our trousers are far from being shiny. The trouble is, it seems, that too many people take us seriously thinking that we are putting on a superior critical air with the avowed intent of showing the broadcasting industry that it is a very rank and a very junky affair.

As a matter of fact, that is a long way from our aim.

In the first place, who are we to dispute the artistic sense and theatrical judgment of our keen, studious and very alert directors of the radio? A lot of nerve we have to question the talent of the great big minds back of broadcasting. The very thought of it makes us feel weak

and mean. What we are really trying to do, Dear Reader, and what we will do, if you will laugh a little with us instead of writing very saucy letters about our sarcasm, is to make ourselves ridiculous by attempting to criticise something that is safely out of the zone of our esthetic sensibilities. It is our most sincere ambition to be another Merton of the Movies in the field of radio criticism and if we want to suffer through the mental anguish and the sacrifices that this entails, all's well and good. That's our business. Keep right on writing your nasty letters if you must, our cross is not too heavy to bear!

* * *

Honors to WJZ

ANY broadcaster that will install a portable transmitter on a yacht in an effort to supply its listeners with the steaming hot news of a boat race, is, to our way of thinking, an in-

stitution dedicated to public good. During the Cornell-Princeton-Pennsylvania races, WJZ was Johnny-on-the-Spot with a small radiator (radio type) placed on an Elco cruiser in the care of Major Andrew White. While the voice was a trifle mushy, the effort was essentially a pioneering one, and deserves nothing but sincere praise.

* * *

Rating the Announcers

THE professors of New York University set out on a classical piece of research when they called together all of the New York station announcers to study their voices scientifically and to give them each a ticket telling them just where they stood on the scale of acoustic importance. The exhaustive data which they recently laid before the studio managers, were accumulated by the aid of a phonographic recorder into which each young man poured his silver voice for future reference.

It is said that Mr. McNamee won the contest by four-tenths of a point, which means very little to this gray old head.

Brokenshire, who patronizes thousands daily from WJZ and who, had the contest been based on vocal cocksureness, would have put all competitors to shame, was a very close second. Mr. Granlund (NTG, WHN), this department is sorry to report, made a very poor showing, pulling up to about seventh place.

Even the professors of N. Y. U. should know that you cannot expect too much of a phonograph record.

We have no desire to demonstrate sympathy with the aims of the learned men who designed and executed this unique contest. The results, though painstakingly gathered, amount to so much twaddle to this reckless old dumb-bell. When somebody tells us that Mr. McNamee has a frequency superiority of four-tenths of a point over Mr. Brokenshire we find it difficult to prevent ourselves from lapsing into a prolonged fit of laughter which would be strictly against the doctor's orders. We can appreciate Nurmi doing a hundred yards in 9.16 but when Mr. Brokenshire is said to do a "Good night" in 86.9 (the meaning of this figure is still a total mystery) we feel like curling up in some cozy little corner and purring ourself to sleep.

We cannot help but believe that our experimentally inclined professors made a serious mistake in this matter. The announcing material with which we have to work runs so low in grammatical and vocal efficiency that it is pure nonsense to compare one announcer with the other. One might just as well compare the cackle of a white leghorn with a pullet or the bark of a fox terrier with its miserable brother, the pomeranian. If several hundred new voices had been tested and labelled (not that the testing and labelling means a great



Kadel & Herbert

"AND THEN JOHNNY WOODCHUCK SAID—"

The days of summertime radio are upon us, and more receivers than ever are now being operated in camps, where the voices of the city penetrate when the day's work is over. These fair vacationists are tuning in on a cot-time story.

deal) there might have been found a large number of persons who could express themselves more pleasantly, more feelingly and more intelligently than any one of our present announcers. If announcing is to be improved, experimental material must come from without, not from within.

* * *

Why Newspapers Are Wary of Broadcast Artists

THE American Newspaper Publishers Association, always wary of the radio business, has recently decided that newspaper columns will remain closed to those who advertise on the air. No matter how beautifully the Eveyready Trio or the Goodrich jazz band plays, and no matter how badly the readers of any particular paper desire to distinguish these music makers from all the rest of the orchestras and trios listed, no effort will be made to extend this service.

The greatest object of any newspaper, we have always been told by the big publishers, is that of giving service to its readers. Of course, we have always known that this is largely distilled bunk and that the sole object of any paper is that of landing the big national contracts. Service to the reader is carried

only to the point necessary to hold the patronage of the largest number of people possible.

National baseball is the biggest advertised industry in the United States, but our newspapers do not seem to object to turning over tons and tons of white space daily to help fill the pockets of the baseball magnates. Radio is not the greedy user of space that baseball is, but our publishers, those great big-hearted fellows who burn with the desire to be of service to their fellow men, seem to begrudge every square inch of type space devoted to the subject.

The decision of the N. A. P. A. to omit the names of orchestras, unless they are paid to publish them, really shows just how much is thought of the "reader first" ideal to which so many of our publishers hold—for business reasons.

* * *

WE quote from the *Visitor*, a religious publication circulated in the city of Providence, R. I.:

"May we hope to be pardoned for expressing a very personal opinion of America's wishy-washy, good-goody man, one Roxy? In things that are blatant and banal he is the supreme offender. How can a man be

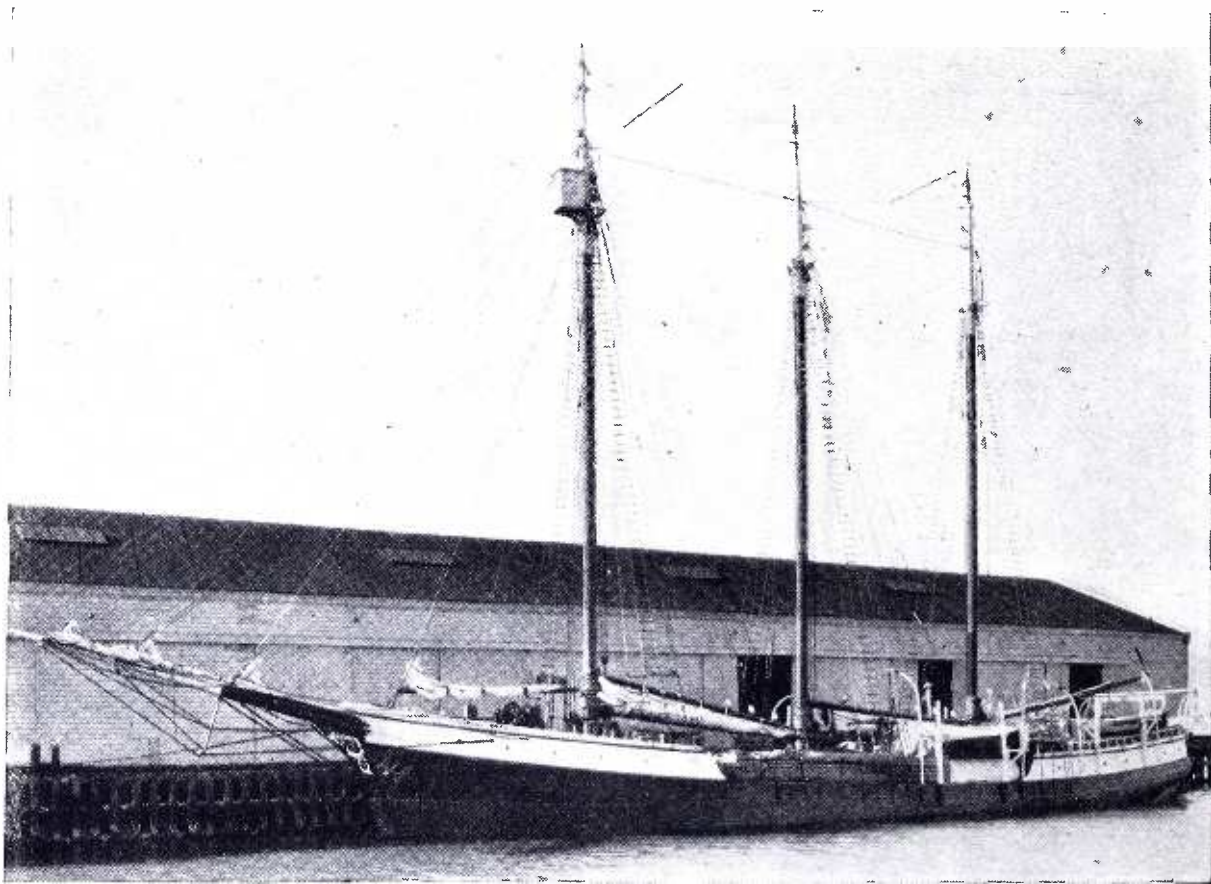

RADIO EMBARKS ON SCIENTIFIC EXPEDITIONS

One of the real services rendered by radio has been to arouse public interest in the activities of explorers. Like the MacMillan expedition, this little vessel, the CHARLES BOWER, is keeping the fans in touch with its adventures in the far north, by means of its transmitting apparatus.

expected to sleep nights having listened to his foolish sentimentality? How on earth is it possible for anyone to stomach Roxy's idiotic blessings and benedictions. We always see Roxy the alert business man behind his words. We have tried our best to throw the mantle of charity over this piously-inclined entertainer, but we never turn from the radio without a picture of Roxy's leer."

When an idle musier in type aims a squirt of nasty ink at Roxy, we usually get pretty well boiled up over it. As might be expected from most religious bigots, it seems that the ordained have a monopoly on blessings and benedictions and that should anyone outside God's hand-picked followers communicate an honest blessing to his fellow men, he must be a shameless hypocrite and a soothsayer. Just remember this, because if you have not got a holy license to wish a friend well, you must be purveying your kindness for business reasons.

That the writer of this malicious item never turns from the radio "without a picture of Roxy's leer" admits very little for so pious a gentleman. Where is his tolerance, his professed Christianity? Where is his optimism; his well wishing? We could go ranting like this for a dozen pages, but that would be a silly thing to do. If we exploded every time we read the bigoted effusions of minds in religious strait-jackets, we should be kept pretty busy nowadays. Perhaps it would be just as well to permit J. Frank Chase (Mr. Chase sent us the clipping), Secretary of the New England Watch and Ward Society, to come to the defense of Roxy. The letter says in part:

"In a Metropolis where recently thirteen plays were claimed to be questionable and where scarcely a theater has escaped the scrutiny of censoring, 'Roxy' manages perhaps the largest theater in the world with three packed houses a day, and each performance 'as clean as a hound's tooth.' Nothing offensive, nothing suggestive, nothing morally tainted, has ever, so far as I know, been witnessed at the Capitol, and yet it is a financial success and that in a city where it is claimed a 'classy show' is the only one which pays.

"The writer of the offending article calls Roxy in the face of that miracle America's wishy-washy, good-goody man. I say Roxy is a proven genius—he is doing in his field in a fine, clean, manly way a miraculous piece of work. That man who can amuse his fellows with clean, wholesome recreation is a great public benefactor.

"But he makes money out of it."

"Well, suppose he does. It is better than making money out of the filthy. The man who can make clean things pay today is a supergenius, if theatrical managers are sound in their contentions.

"As to his 'foolish sentimentality,' that opinion indicates the writer is lacking in humanity and has lost the milk of human kindness. The sentiment of Roxy is the manly, gentle type that a man feels when he speaks of 'Mother.'



Kadel & Herliert

A "NON-BREAKABLE" VACUUM TUBE
A demonstration of the new $\frac{1}{4}$ -ampere bulbs that are designed to reduce the losses due to breakage by radio fans.

"I have been a constant radio fan and have yet to hear Roxy utter any weakly sentimental stuff. In fact, he eschews such stuff. Perhaps his conversation with his artists may be what is alluded to. If so, I may say that all his artists highly respect and esteem him. He is the kind of big brother that awakens the intensest loyalty. Recently when a new member sang her first song, it was plain that she had stage fright and wasn't doing herself justice. It was wonderful to hear him restore her confidence by an encouraging word: 'Now relax and be yourself, and try another one,' and I imagine there was a pat on the shoulder, but when she sang at once again the miracle had been accomplished, and the tones were fine, firm and very true and correct. Roxy has the genius to discover merit and develop it by kindness.

"But it is not artistic merit alone he develops. He has the genius to keep all around him ambitious to be true and noble. A medical friend of mine who visited New York a few days ago commented on the artificiality of New York women with their paint and powder, but he said 'I went to the Capitol and met Roxy's girls and found them different from other Broadway girls.'



WITH THE INVENTORS

CONDUCTED BY WILLIAM G. H. FINCH

This department will keep you in touch with the latest inventions of interest on which patent rights have been granted, and which are significant contributions to radio art.

A Neutralized Tuned Radio-frequency Receiver

RECEIVERS that employ two or more stages of radio-frequency amplification that involve the use of two or more circuits tuned to the incoming frequency, and arranged so that each of two plate circuits has a tuned circuit that is associated with it either by coupling or direct connections, sometimes produce undesirable reactions or self-oscillations. This tendency toward self-oscillation is due largely to capacity coupling in the tubes themselves.

John Scott-Taggart of London, England proposes, in the patents, Nos. 1,524,580 and 1,524,581, to eliminate this evil by the proper use of condensers that are connected in the circuits as shown in Figures 1, 2, and 3. These condensers produce a reverse reaction effect that neutralizes the tendency of the radio-frequency amplifier to generate oscillations, thereby eliminating the "squealing" that might otherwise result.

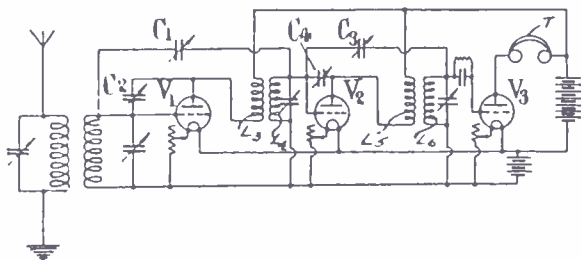

THE NEUTRALIZED TUNED RADIO-FREQUENCY CIRCUIT

FIGURE 1: Scott-Taggart's "neutrodyne" or neutralized tuned radio-frequency. C_1 , C_2 , C_3 and C_4 are neutralizing condensers.

Vacuum Tubes in Transatlantic Cable Reception

THIS invention covers a system for receiving and for definitely and sharply discriminating between signals in the form of current impulses or waves varying in amplitude.

In numerous telegraph signaling systems intelligence is conveyed by code impulses differing from each other and arranged in various combinations to represent letters of the alphabet. These impulses are distinguished from each other by the employment of code combination impulses that differ in potential. If the live impedance is substantially constant, these impulses also differ to the same degree in current strength. At the receiving station, in order that the impulses may be translated into observable form or recorded, it is necessary to provide apparatus which will discriminate between impulses varying in current strength.

This patent, No. 1,514,753, was issued to Peter I. Wold of Schenectady, N. Y. and the circuit for it appears in Figure 4. This diagram shows how cable service has to depend on radio apparatus for best operation.

Because of slight variations in the line impedance and in the electrical characteristics of the line, impulses differ in current strength when impressed upon the line at the transmitting end, reach the receiving apparatus somewhat distorted and the actual difference in current strength between succeeding impulses may be insufficient to enable the ordinary receiving apparatus to translate or record them in intelligible signals. This is a big factor in transatlantic cable communication.

This difficulty can be eliminated by this invention and discrimination between signaling impulses is made certain by interposing between the usual recording and translating devices at the receiving station and electrical network in the nature of a marginal relay. This device responds, not in direct proportion to the strength of the received current, but discrim-

inates between small variations in current strength and substantial differences besides.

A network having a stepped characteristic is provided by utilizing a number of vacuum tubes connected in parallel, each of which is arranged to pass currents between certain definite limits of current strength.

receiving apparatus on a slidable sub-base which is supported in suitable grids upon the base proper of the cabinet, resulting in quick and easy positioning and access to the apparatus mounted thereon. The patent is number 1,527,896 and was granted to Samuel L. Miller of Chicago.

A Novel Variable Condenser

CARL A. HELLMANN of Washington, D. C. has invented a novel variable condenser (Patent No. 1,525,778) wherein a useful variation of capacity may be had over an angle of rotation exceeding 180 degrees and approaching as near to 360 degrees as may be desired in any particular case.

Another feature of this condenser is that it has several distinct ranges of capacity, which may be readily selected for service by mechanical or electrical means, or by both together.

A Convenient Design for a Radio Receiver Cabinet

PATENT No. 1,528,473 issued to Joseph B. Edwards of Chicago relates to a cabinet which will permit its top, rear or front part to be removed independently of the other to permit access to the various pieces of apparatus mounted in same.

This type of cabinet construction should prove popular among those experimentally inclined because of the ease with which one can quickly make an inspection or any changes desired.

A Handy Radio Cabinet

A NEW style of construction for a radio cabinet has been patented to cover mounting the

A New Modulation System

A NEW radio phone modulation system is disclosed on patent No. 1,528,047, issued to Frank Conrad of Pittsburgh, Pa.

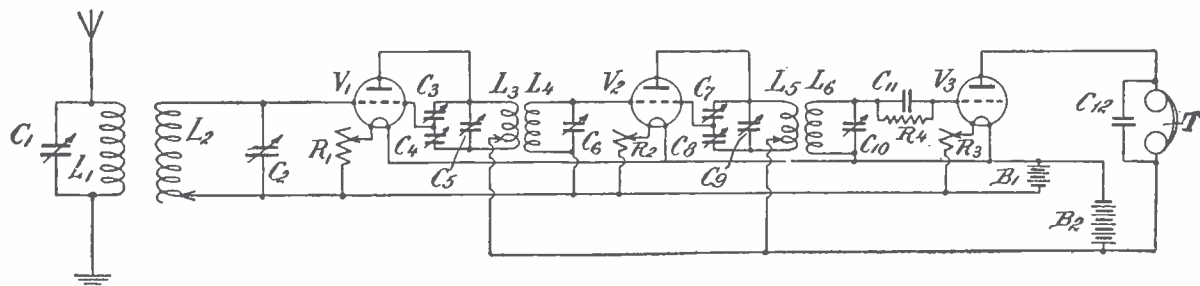

FIGURE 2: Another modification of Taggart's invention, showing positions of the various neutralizing condensers in an inductively coupled radio-frequency amplifier circuit.

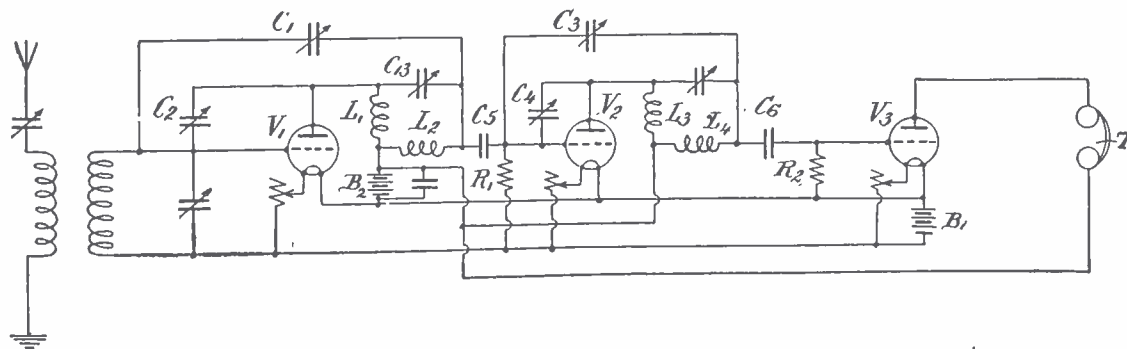

FIGURE 3: A modified circuit arrangement in which the tubes are capacitatively rather than inductively coupled.

A Novel Grid Condenser

A NEW patent discloses a method of employing the base of a tube in such a manner that the base forms an integral part of the grid condenser and at the same time provides a convenient means for connecting the grid condenser in the grid circuit. Figures 5 and 6 show how the dielectric material 13, such as mica, is held in place by the metal element of the condenser in the form of a copper band 10 which is clamped around the tube base by the means of a bolt and nut. This patent was granted to Robert C. Pitard of Jackson, Miss. under the number 1,523,893.

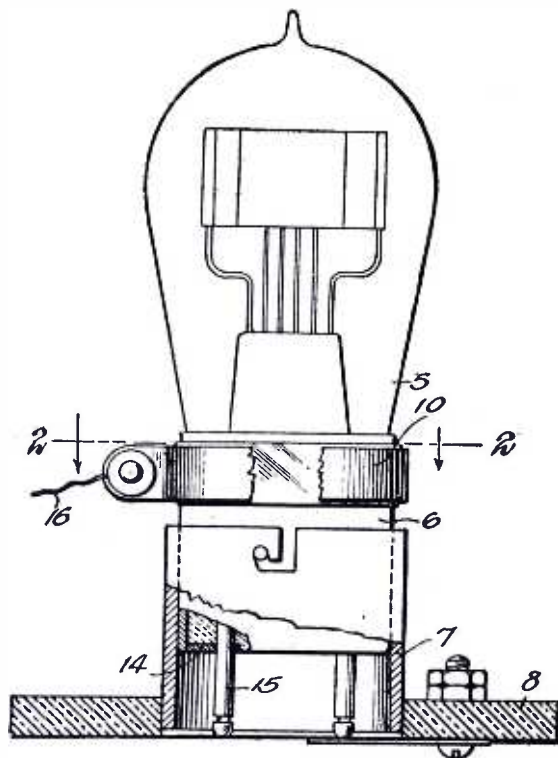

FIGURE 5: A view partly in elevation and partly in section of a grid condenser showing how the base of a vacuum tube is employed as one of the elements of the condenser.

A New Radio Transmission Idea

IN patent No. 1,468,250, S. O. E. T. Trost of London, England, suggests a scheme for impressing two oscillations on the antenna in such manner that they are opposite in phase. They therefore neutralize each other. Modulation consists in varying the phase of one of the oscillations so that the neutralization is no longer perfect. Thus a signal is sent out.

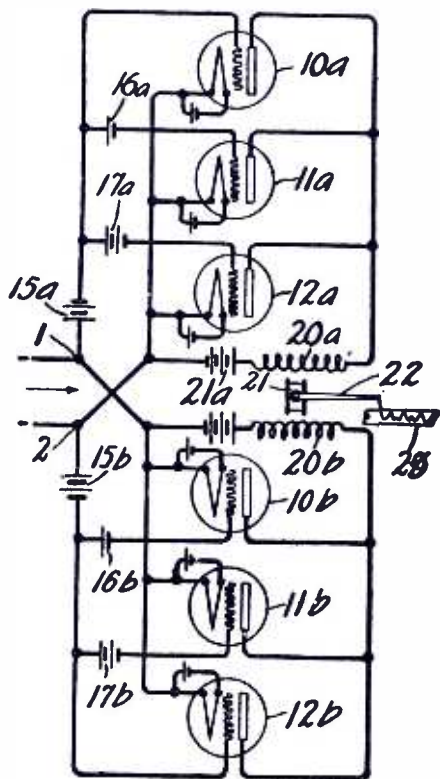

FIGURE 6: Peter I. Wold's method for definitely and sharply discriminating between received signals.

A Short Range Radio System

THIS patent, No. 1,470,088, is a suggestion for the use in radio signalling of much longer waves than any now employed, waves the frequencies of which approach those of ordinary alternating currents. Frequencies of 500 to 1,000 cycles are suggested, corresponding to wavelengths of 600,000 to 300,000 meters. It is claimed by the inventor, Fritz Lowenstein of New York, that these very low-frequency waves have utility in signalling over short distances, as for example, between the ships of a fleet at sea, and that they do not travel far enough to produce interference at a distance or to be readable by distant enemy stations.

The New Birch-Field Receiver

THE illustration on page 187 is that of a four-tube receiver embodying the new Birch-Field tuning unit, patent No. 1,488,310, designated "A" (Figure 7).

In radio receiving sets generally and more particularly in the less expensive sets, considerable difficulty is encountered in the reception from stations at a distance and even in stations close by, due among other things to a lack of sharp tuning capabilities in the parts of such sets, and among the more important objects of the invention is the provision of a receiving set which, while simple in construction and operation and inexpensive in cost, is

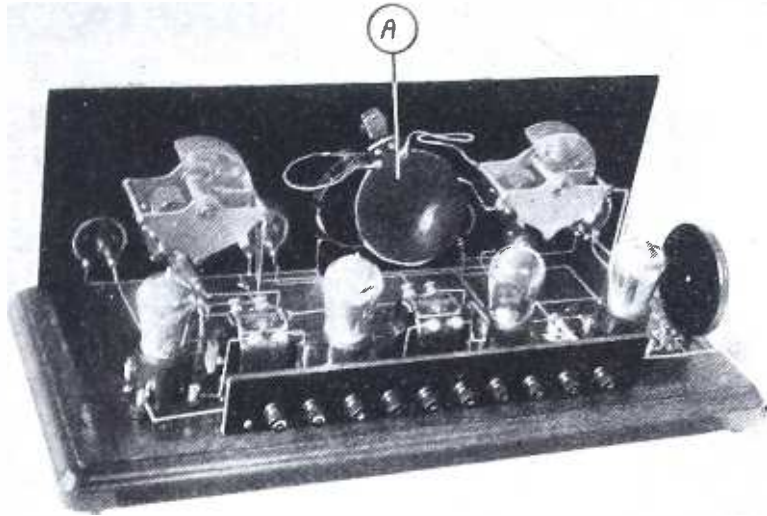

THE RECEIVER WITH THE NEW INDUCTANCE UNIT

FIGURE 8: *The coil unit shown at A permits the variation of coupling between the primary and secondary from the outside of the cabinet, which has been removed for the photograph.*

nevertheless capable of very sharp and quick tuning and very efficient detuning.

Where such receiving apparatus employs the inductive relationship of two induction members such as coils, it is obvious that the efficiency of the inductance will be dependent upon the extent to which the secondary cuts the lines of force about the primary, and this is a prime consideration in the mounting of induction members.

The inductance members "A" are so related and associated that the secondary may be positioned in any desired portion of the field

associated the inductance or tuner units which permit a variation of their relative positions in more than one plane, and more particularly to permit of such variation by the operation of but one control; and permitting of angular variation of the inductance there between; and in a plurality of planes, one or more of the pancake type inductances are employed.

Such a structure provides a method of obtaining high efficiency, simplicity and sharpness in tuning at very low cost.

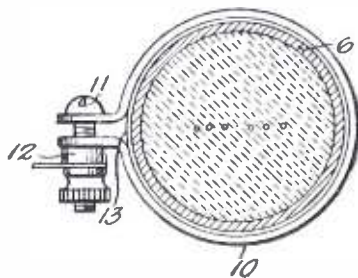

FIGURE 7: *A top view of the drawing of Figure 5, in which 6 is the tube base, 10 is a metallic band and 13 is a band of dielectric material.*

about the primary; the provision of inductance members so associated as to permit of their variation in position relatively to each other, so as to give maximum inductance, thereby resulting in rapid and sharp tuning, which is due to the way Birch-Field has mounted and

Radio Picture Transmission

C. FRANCIS JENKINS, of Washington, D. C., in another of his patents (No. 1,533,422) discloses an apparatus for the transmission of photos, maps, and photo-messages by radio, and has for its principal object a construction permitting continuous operating at high speed over an extended period. Another object is to secure a high degree of efficiency of the incoming radio signals, with as nearly perfect modulation as can be attained.

A New Method for Manufacturing Condensers

A PATENT was granted to W. R. Respass of Staten Island, for a method of manufacturing condensers, patent No. 1,533,611, in which the metallic plates of a condenser are coated with a dielectric film.

A Method of Eliminating the "B" Battery

For several months the POPULAR RADIO LABORATORY has been working on the development of a "B" battery eliminator. The subject will be shortly treated in a constructional article in a near issue of this magazine.

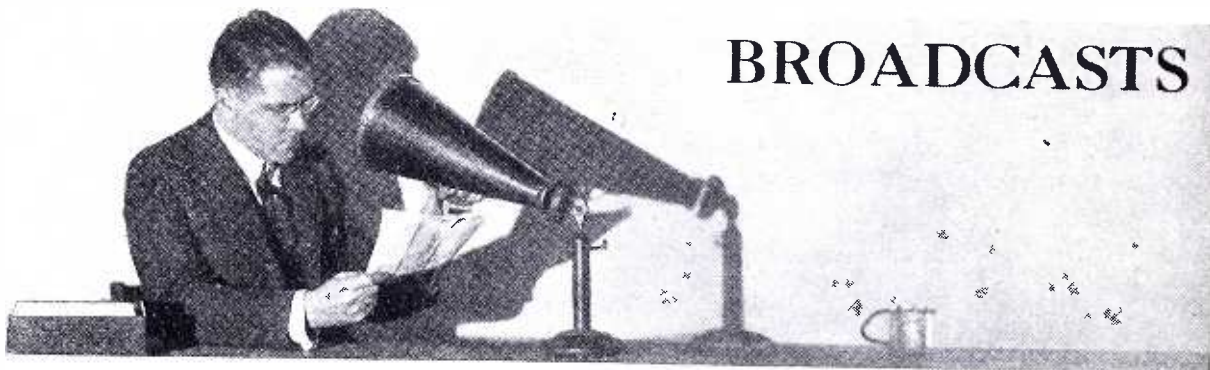

BROADCASTS

CONDUCTED BY DAVID LAY

ITEMS of general interest that you ought to know; bits of useful information that every radio fan ought to know.

Radio vs. Barroom Stories

THE placing of radio receiving sets in British "pubs"—as the English call their cafés, has received official commendation from a magistrate in Cornwall. An application for installing a radio receiving set in a public bar came to the attention of a magistrate who, in passing upon it, said that it was desirable that radio sets be installed in pubs, on the grounds that it would be far better for people who came to drink to listen to the educational matter broadcast than to sit about telling barroom stories.

* * *

Insurance Company Broadcasts "Health"

A RADIO "gym" has been opened by the Metropolitan Life Insurance Company in New York City, and from it setting-up exercises are broadcast daily through stations WEAJ, New York City, WCAP, Washington and WEEI, Boston. The exercises go on the air at 6.45 A.M. for one hour. They are divided into three separate classes of twenty minutes each, beginning at 6.45, 7.05 and 7.25 o'clock. This early morning program is supported by the distribution of exercise charts and other literature that is designed to give a full measure of health value to the broadcasting. The exercises are conducted to music and timed to a cheerful tempo.

* * *

Peru Starts Broadcasting

RADIO broadcasting was started in Peru in March. The first station to be built in that country is at Lima; it is a duplicate of the famous London station 2LO, that was located at Marconi House. The Peruvian station's call is OAB and its transmitting wave 360 meters. About a thousand radio receiving sets have already been shipped to Lima from the United States.

Sweden Gets the Fan Fever

SINCE the first of the year, when daily radio broadcasting service from the new stations in Gothenburg and Palmo in Sweden were started, four thousand fans have taken out licenses in Gothenburg alone. It is reported that about 11,000 crystal receiving sets, 30,000 headsets, 4,000 tubes and almost 1,000 complete receiving sets, together with a large quantity of parts of all kinds, which amount to almost \$300,000, were sold in a couple of months in Gothenburg.

* * *

Theatrical Managers and Broadcasters End Fight

THEATRICAL managers in England have agreed to give up their fight against broadcasting, on the condition that the company restrict their theatrical broadcast to twenty-six per year. In addition the British Broadcasting Company agrees never to broadcast first nights. It is also agreed that the portions of a play that are broadcast shall not take up more than twenty-five minutes in all. This may be taken all at once, or split up among the various acts.

* * *

What Parisian Fans Pick Up

BROADCASTING is carried on in the Paris district by the Eiffel Tower, the Société Française Radio-Electrique and the Superior School of the Postal, Telegraph and Telephone Services of the French Government, reports John Farr Simons, of the American Consulate in Paris to POPULAR RADIO. The wavelength used by the Eiffel Tower is 2,650 meters; the principal items broadcast are weather reports, stock exchange news and a radio concert every evening. The wavelength used by the Société Française Radio-Electrique is 1,750 meters, which broadcasts two radio concerts, one in the afternoon and the other in the evening. The Superior School broadcasts on a wave of 458 meters; its program includes educational subjects and an evening concert.

Weather Forecasts by Radio

HERE is a list of the radio stations in the United States and territories which are broadcasting the official weather forecasts in co-operation with the United States Weather Bureau at Washington, as compiled by B. Francis Dashiell. As the weather forecast for the State in which the listener resides is

almost always the only one desired, it is necessary merely to tune in for the nearest station that broadcasts for the State—setting the radio receiver at the indicated wavelength at the scheduled broadcasting time. All time used is local for the station indicated. The list is alphabetically arranged by cities, giving the stations, wavelength and local broadcasting time; the time stated is Standard Time.

LIST OF STATIONS THAT BROADCAST WEATHER FORECASTS

City	State	Station	Wavelength	Time of Broadcasting
Altoona,	Pa.	WFBG	278	10.30 P.M.
Ames,	Ia.	WOI	270	9.45 A.M. and 9.30 P.M.
Atlanta,	Ga.	WSB	428	11.55 A.M. and 10.00 P.M.
Auburn,	Ala.	WSY	250	12.00 Noon.
Austin,	Tex.	WCM	268	10.30 A.M. and 4.00 P.M.
Baltimore,	Md.	WCAO	275	12.00 Noon.
		WCBM	229	10.00 P.M.
		WGBA	254	2.00 P.M.
Boise,	Ida.	KFAU	275	3.15 P.M.
Boston,	Mass.	WGI	261	5.30 P.M.
		WNAC	280	11.00 A.M.
Breckenridge,	Minn.	KFUJ	242	9.30 A.M. and 3.30 P.M.
Buffalo,	N. Y.	WGR	319	10.45 A.M.
Canton	N. Y.	WCAD	263	11.00 A.M.
Charlotte,	N. C.	WBT	275	11.00 A.M.
Chicago,	Ill.	WAAF	278	10.30 A.M.
		WGN	370	9.00 A.M. and 10.25 P.M.
		WLS	345	9.00 A.M. and 10.00 P.M.
		KYW	535	1.00 P.M. and 11.30 P.M.
Cincinnati,	O.	WLW	422	10.30 A.M.
Cleveland,	O.	WEAR	389	11.00 A.M. and 3.00 P.M.
Columbia,	Mo.	WAAN	254	12.00 Noon.
Columbus,	O.	WBAV	294	11.30 A.M.
		WEAO	294	12.30 P.M.
Dallas,	Tex.	WFAA	476	10.30 A.M.
		WRR	261	12.00 Noon and 5.45 P.M.
Davenport,	Ia.	WOC	484	1.00 P.M. and 9.00 P.M.
Denver,	Col.	KLZ	283	8.30 A.M. and 7.55 P.M.
		KOA	322	1.00 P.M.
Des Moines,	Ia.	WHO	526	9.30 A.M. and 12.00 noon.
Detroit,	Mich.	WCX	517	10.15 A.M.
		WWJ	353	11.25 A.M.
Devils Lake,	N. D.	WDLR	231	12.00 noon.
Evansville,	Ind.	WGBF	217	11.15 A.M.
Fargo,	N. D.	WDAY	244	10.30 A.M.
		WPAK	275	10.50 A.M.
Fond du Lac,	Wis.	KFIZ	273	4.00 P.M.
Fort Worth,	Tex.	WBAP	476	11.00 A.M. and 9.30 P.M.
Fresno,	Cal.	KMJ	248	8.15 A.M.
Galveston,	Tex.	KFLX	240	10.30 A.M.
Grand Rapids,	Mich.	WBDC	256	12.15 P.M.
		WEBK	242	10.00 A.M.
Havre,	Mont.	KFBB	275	12.30 P.M.
Honolulu,	T. H.	KGU	360	7.30 P.M.
Hot Springs,	Ark.	KTHS	375	9.45 A.M. and 9.30 P.M.
Houghton,	Mich.	WWAO	244	11.00 A.M.
Houston,	Tex.	WEAY	360	11.00 A.M. and 9.00 P.M.
Indianapolis,	Ind.	WFBM	268	10.15 A.M.
Jefferson City,	Mo.	WOS	441	11.00 A.M.
Kansas City,	Mo.	WDAF	366	5.55 P.M.
		WHB	366	10.30 A.M. and 3.00 P.M.
La Crosse,	Wis.	WABN	244	9.00 A.M. and 1.30 P.M.
Lafayette,	Ind.	WBAA	273	9.50 A.M.
Lancaster,	Pa.	WDBC	258	11.45 A.M.
Lansing,	Mich.	WKAR	285	12.00 noon.
		WREO	285	9.00 P.M.
Lincoln,	Neb.	WCAJ	275	10.30 A.M.
		WFAV	275	11.00 A.M.
Lockport,	N. Y.	WMAK	466	11.00 A.M.
Los Angeles,	Cal.	KFI	467	5.30 P.M.
		KHJ	404	12.30 P.M. and 8.00 P.M.
Louisville,	Ky.	WHAS	400	4.50 P.M.
Madison,	Wis.	WHA	535	12.00 noon.

City	State	Station	Wavelength	Time of Broadcasting
Manhattan,	Kans.	KSAC	341	12.00 noon.
Memphis,	Tenn.	WMC	500	10.30 A.M. and 9.30 P.M.
Milwaukee,	Wis.	WCAV	266	10.15 A.M.
		WHAD	275	11.00 A.M.
Minneapolis,	Minn.	WCCO	416	10.30 A.M. and 10.00 P.M.
Mobile,	Ala.	WEAP	263	12.00 noon.
Moorhead,	Minn.	WPAU	258	11.00 A.M.
New York,	N. Y.	WAHG	316	12.00 noon and 10.45 P.M.
		WEAF	492	12.00 noon.
		WIIN	361	10.30 A.M. and 11.00 P.M.
		WNYC	526	10.30 P.M.
		WJZ	454	10.00 P.M.
Norfolk,	Neb.	WJAG	270	12.15 P.M.
Norfolk,	Va.	WTAR	261	6.00 P.M.
Norman,	Okla.	WNAD	254	2.00 P.M. and 9.15 P.M.
Oakland	Cal.	KGO	299	1.30 P.M. and 6.45 P.M.
		KLX	510	7.15 P.M.
Orange	Tex.	KFGX	250	11.45 A.M.
Omaha,	Neb.	WIAK	278	10.20 A.M. and 1.30 P.M.
		WOAW	526	10.00 P.M.
Osseo,	Wis.	WTAQ	254	12.15 P.M.
Peoria,	Ill.	WJAN	273	10.30 A.M.
Philadelphia,	Pa.	WIP	508	1.30 P.M. and 6.00 P.M.
		WOO	508	11.30 A.M. and 10.00 P.M.
Phoenix,	Ariz.	KFAD	360	5.30 P.M.
Pittsburgh,	Pa.	KDKA	309	12.30 P.M. and 10.00 P.M.
Portland,	Ore.	KFEC	248	12.00 noon and 6.00 P.M.
		KGW	485	11.30 A.M. and 7.30 P.M.
Providence,	R. I.	WEAN	270	11.10 A.M. and 5.40 P.M.
		WJAR	306	12.00 noon and 4.00 P.M.
Raleigh,	N. C.	WFBO	252	12.30 P.M. and 3.00 P.M.
Rapid City,	S. D.	WCAT	240	10.30 A.M. and 1.30 P.M.
Rochester,	N. Y.	WHAM	278	2.55 P.M.
Saginaw,	Mich.	WABM	261	9.15 A.M. and 5.00 P.M.
St. Louis,	Mo.	WEW	248	11.00 A.M.
		KSD	545	10.00 A.M. and 10.00 P.M.
Salt Lake City,	Utah	KDYL	306	7.00 P.M.
San Antonio,	Tex.	WOAI	395	10.30 A.M. and 12.15 P.M.
San Juan,	P. R.	WKAQ	341	9.00 A.M. and 9.00 P.M.
Schenectady,	N. Y.	WGY	380	11.45 A.M.
Scranton,	Pa.	WQAN	250	12.30 P.M. and 4.00 P.M.
Seattle,	Wash.	KFOA	450	8.15 P.M.
		KFOX	233	7.00 P.M.
		KJR	384	7.30 P.M.
Shenandoah,	Ia.	KFNF	266	12.00 noon and 9.45 P.M.
Sioux City,	Ia.	WEAU	275	10.15 A.M.
Syracuse,	N. Y.	WFBL	252	1.00 P.M.
Springfield,	Mass.	WBZ	331	10.00 P.M.
State College,	N. M.	KOB	349	11.55 A.M. and 9.45 P.M.
Stevens Point,	Wis.	WLBL	278	9.45 A.M. and 12.30 P.M.
Storrs,	Conn.	WABL	275	12.00 noon.
Tampa,	Fla.	WDAE	273	5.00 P.M.
Trenton,	N. J.	WOAX	240	11.00 A.M. and 12.15 P.M.
Washington,	D. C.	NAA	435	10.05 A.M. and 10.05 P.M.
		WRC	469	10.00 P.M.
Wichita,	Kans.	WEAH	268	10.40 A.M.
Yankton,	S. D.	WNAX	244	10.00 A.M.

Building Sets Is Popular in Holland

Most radio fans in Holland prefer to build their own sets, according to recent reports from Amsterdam and consequently few purchasers of complete sets are to be found in the Netherlands. Dutch amateurs prefer the "three honeycomb-coil system," few using variometers or variocouplers. The Dutch have licensed six broadcasters; a tax of 100 florins a year is levied for an hour a week of broadcasting. The Government itself, however, plans to erect a station, but listeners in of the Netherlands may still listen to radio concerts from British, German, French, Belgian and Swiss stations. The recent formation of a dealers association is expected to aid in popularizing radio in Holland.

Permits to Buy Sets

POLISH radio regulations are reported to be so severe and complex that dealers are required to demand official permits of customers before they can sell complete receiving sets or loudspeakers. Despite the regulations and a sales tax of 20 percent on imported apparatus, radio has become a craze in Poland. Receiving set licenses are granted to only citizens of age, and fees are levied upon listeners by the government and by the broadcasters.

* * *

Anti-antenna Ordinance

BECAUSE of the various objections raised against antennas on roofs by Berlin chimney sweeps, a city ordinance has been passed to the effect that all radio equipment over roofs within the city limits must come down.



THIS department is conducted by POPULAR RADIO LABORATORY for the purpose of keeping the radio experimenter and the broadcast listener informed concerning the newest inventions and the approved developments in radio equipment. Only such apparatus as has been tested and endorsed by the Laboratory is noted in these columns.

AERIALS

Spring aerial and counterpoise; Mack Co.

AUDIO-FREQUENCY TRANSFORMERS

"Marle" audio-frequency transformer; Marle Engineering Co.

"Mar-Co" audio-transformer; Martin-Copeland Co.

Maxum" audio-frequency transformers; Maxum Radio & Electric Co.

"Se-Ar-De" amplifying transformer; R. Mitchell Co.

Audio-frequency transformer; Modern Electric Mfg. Co.

Push-pull transformers; Modern Electric Mfg. Co.

"National" audio-frequency transformer; National Transformer Mfg. Co.

Audio-frequency transformer; New York Coil Co.

BATTERIES

"Red Seal" dry batteries; Manhattan Electrical Supply Co.

"Eveready" storage "A" batteries; National Carbon Co., Inc.

"Eveready" dry-cell "A" "B" and "C" batteries; National Carbon Co., Inc.

"Novo" "B" batteries; Novo Mfg. Co.

"B" BATTERY ELIMINATORS

*Mayolian B-Supply; Mayolian Radio Mfg. Co.
Mayolian A.C. transformer unit (for eliminator);*

*Mayolian Radio Mfg. Co.
Mayolian D.C. filter unit (for eliminator);
Mayolian Radio Mfg. Co.*

BINDING POSTS

"Read 'em" binding posts; Marshall-Gerken Co.

CRYSTAL DETECTORS

*"DX-Alena" crystal; G. Everett Marsh, Inc.
Miller-B-Metal crystal; A. H. Miller Radio Co.*

Miller-B-Metal battery crystal; A. H. Miller Radio Co.

Miller-B-Metal fixed detector; A. H. Miller Radio Co.

Argentite crystal; Mineral Products Co.

"M.P.M." crystal; M. P. M. Sales Co.

"Arlington" NAA crystal detector; Newman-Stern Co.

NAA meter tested crystal; Newman-Stern Co.

DIALS

Knobs and dials; R. Mitchell Co.

4" "Accuratune" dial; Mydar Radio Corp.

"Accuratune" micrometer control; Mydar Radio Corp.

FIXED CONDENSERS

Fixed condenser; New York Coil Co.

GRID-LEAKS AND RESISTANCES

"Mar-Co" resisto coupler; Martin-Copeland Co.

"Mar-Co" variable grid-leak; Martin-Copeland Co.

Resistance mountings; Leslie F. Muter Co.

A FIXED CARBORUNDUM CRYSTAL

Name of instrument: Crystal detector.

Description: This instrument contains a carborundum crystal in permanent adjustment. The crystals themselves are mounted inside the glass cylinder with two brass caps holding the terminals at either end. The terminals are brought out to binding posts with a thumbnut on each terminal for fastening in the circuit of the receiving set.

Usage: In any receiver that employs a crystal detector for rectification.

Outstanding features: Compact. Needs no adjustment. Long life.

Maker: The Carborundum Co.

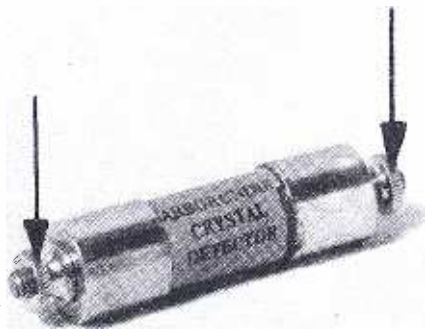

A detector that needs no adjustment.



A toroid coil equipped with soldering lug terminals

Resistances; Leslie F. Muter Co.
 Mr.-Im-Co grid-leak; Michigan Elec. & Mfg. Co.
 Variable grid-leak; New York Coil Co.

HEADPHONES

"Red Seal" headset; Manhattan Electrical Supply Co.
 "Repeater" phones; Moss-Schury Mfg. Co.
 "Mozart-Radiocirc" headset; Mozart-Grand Co.
 "Murdock" phones; Wm. J. Murdock Co.
 "Red-Head" phones; Newman-Stern Co.

INSULATORS

Antenna-lead-in insulator; Leslie F. Muter Co.
 Bakelite hot-moulded insulator; W. G. Nagel Electric Co.

JACKS

"Mar-Co" shur-grip jacks; Martin-Copeland Co.
 Non-solder jack; Metro Electric Mfg. Co.
 Jack; Wm. J. Murdock Co.

KITS

8-tube Superheterodyne kit; Moskowitz & Herbach.
 "National" Regenaformer kit; National Co., Inc.
 Kit for Roberts' circuit; J. Nazeley Co.
 Superheterodyne kit; New York Coil Co.

LIGHTNING ARRESTERS

Guardian Arrester; Leslie F. Muter Co.
 Lightning Arrester No. 200; Leslie F. Muter Co.

LOOPS

"Red Seal" Map-loop; Manhattan Electrical

A HANDY WIRE CUTTER

Name of instrument: Cutting pliers.

Description: A well-made hand instrument for cutting wires made of very fine quality steel with smooth running bearing and convenient hand grip. There are no rough edges on the tool to irritate the hands.

Usage: In the laboratory or workshop for cutting wire in constructing or installing radio apparatus.

Outstanding features: Handy size. Good permanent cutting edges. Smooth action. Smooth finish. Light weight.

Maker: Winchester Repeating Arms Co.

A NOVEL RADIO-FREQUENCY TRANSFORMER

Name of instrument: Radio-frequency transformer.

Description: This transformer is wound in a semi-toroid form and consists of two windings, primary and secondary, connected in the plate circuit of one tube and the grid circuit of the following tube respectively. The turns are wound so that the outer edge of the turns is in a single layer and the sides and the inner edges are shifted regularly out of place, one above and one below the adjacent turns. This construction of winding gives a rigid winding and at the same time limits the external magnetic field to the smallest physical dimensions.

Usage: In a radio-frequency circuit as an inter-stage coupling unit.

Outstanding features: Toroid shape. Low external fields. Neat appearance.

Maker: Allen D. Cardwell Mfg. Corp.

Supply Co.

"Marion" folding loop aerial (with compass); Marion Electrical Mfg. Co.

Supportena folding loop; J. Nazeley Co.
 Portena folding loop; J. Nazeley Co.

LOUDSPEAKERS

"Magnavox" reproducers; Magnavox Co.

"Manhattan" loudspeaker; Manhattan Electrical Supply Co.

"Morrison" loudspeaker; Morrison Laboratories, Inc.

"Mozart" loudspeaker; Mozart-Grand Co.

"Atlas" loudspeaker; Multiple Electric Products Co., Inc.

"Murdock" loudspeaker; Wm. J. Murdock Co.
 "Music Master" loudspeaker; Music Master Corp.

"National" Dual amplifiers; National Transformer Mfg. Co.

MISCELLANEOUS ACCESSORIES

"Malone-Lemmon" Control-o-meter; Malone-Lemmon Products.

Points; Marshall-Gerken Co.

"Switch" lever; Marshall-Gerken Co.

"Mar-Co" multi-connector; Martin-Copeland Co.

"Bull Dog" mast seat; Mast Seat Mfg. Co.

"Mitchell" battery connector; R. Mitchell Co.

"Mitchell" antenna tensionator; R. Mitchell Co.

Mounting plates; R. Mitchell Co.

Brackets; R. Mitchell Co.

Moon radio log; Moon Radio Corp.

Morrison toner; Morrison Laboratories, Inc.

"Mu-Rad" B-Radiator; Mu-Rad Laboratories, Inc.

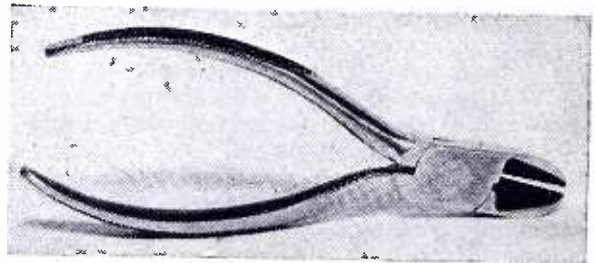

Cutting pliers that are useful in wiring up a set

A SUBSTANTIALLY CONSTRUCTED SOCKET

Name of instrument: Vacuum-tube Socket.

Description: A socket for standard tubes constructed completely of bakelite with four connection fingers of phosphor bronze and terminals, including in one piece the fingers and soldering lugs. The top of the socket is held in a small circular flange of nickel plated brass which prevents the edge from breaking out.

Usage: For mounting standard makes of vacuum tubes.

Outstanding features: High conductivity. Good contact. Neat appearance. Compact.

Maker: Walbert Mfg. Co.

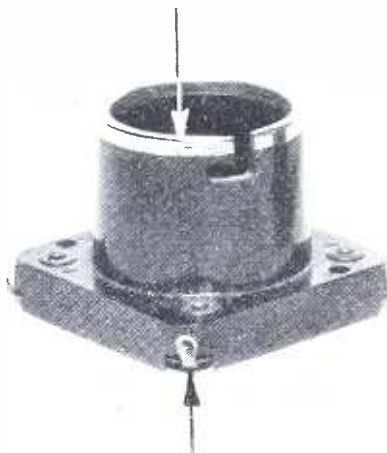

Equipped with reinforcing metal band and soldering lugs.

"Mu-Rad" Recto-Filter; Mu-Rad Laboratories, Inc.

Instant Adjustable Ground clamp; Leslie F. Muter Co.

All-Radion products; New York Hard Rubber Turning Co.

Bakelite form for spider-web coil; J. Nazeley Co.

2-stage R. F. amplifier; Norden-Hauck, Inc.

PANELS

Panel; Marshall-Gerken Co.

PHONE PLUGS

"Mar-Co" switch plug; Martin-Copeland Co.

"Mar-Co" multi-plug; Martin-Copeland Co.

Automatic shock-proof phone plug; Leslie F. Muter Co.

PHONOGRAPH ATTACHMENTS

"Red Seal" phonograph attachment; Manhattan Electrical Supply Co.

Phonograph attachment; Morrison Laboratories, Inc.

"Atlas" phonograph attachment; Multiple Electric Products Co., Inc.

"Accuratune" phonograph attachment; Mydar Radio Corp.

POTENTIOMETERS

Armorclad potentiometer; Martin-Copeland Co.

POWER AMPLIFIERS

"Magnavox" power amplifiers; Magnavox Co.

RADIO CABINETS

Solid mahogany cabinet; Nassau Cabinet Co.

RADIO-FREQUENCY TRANSFORMERS

"Marle" radio-frequency transformer; Marle Engineering Co.

"Maxum" radio-frequency transformer; Maxum Radio & Electric Co.

Reflex transformer; Modern Electric Mfg. Co.

Superformer; Moskowitz & Herbach.

"National" radio-frequency transformer; National Transformer Mfg. Co.

Radio-frequency transformer; New York Coil Co.

Intermediate-frequency transformer; New York Coil Co.

Self-balanced R.F. transformer; Nolte Mfg. Co.

RECEIVING SETS

"Magnavox" broadcast receivers; Magnavox Co.

"Magnavox" combination sets; Magnavox Co.

"Marshall" receivers; Marshall Radio Products, Inc.

"Marwol" A1 receiver; Marwol Radio Corp.

"Mercury" receiver; Mercury Radio Products Co.

Metrodyne Super-five receiver; Metro Electric Co.

"Michigan" receiver; Michigan Radio Corp.

"Miraco" receiver; Midwest Radio Corp.

Miller-B-Metal crystal set; A. H. Miller Radio Co.

Mohawk 5-tube receiver; Mohawk Electric Corp.

"Moon" "Satterlee antennaless" receiver; Moon Radio Corp.

"Moon" Ultra-Five receiver; Moon Radio Corp.

"Mozart" Baby Grand; Mozart-Grand Co.

"Mu-Rad" receiver; Mu-Rad Laboratories, Inc.

"Murdock" neutrodyne receiver; Wm. J. Murdock Co.

"Somerset" receiver; National Air-Phone Corp.

C-10 Navy Model Superheterodyne; Norden-Hauck, Inc.

Improved regenerative superheterodyne receiver; Norden-Hauck, Inc.

Standard loop superheterodyne receiver; Norden-Hauck, Inc.

Superheterodyne C-7 (experimenters); Norden-Hauck, Inc.

RHEOSTATS

Marshall-stat; Marshall Electric Co.

Rheostat; Marshall-Gerken Co.

"Mar-Co" rheostat; Martin-Copeland Co.

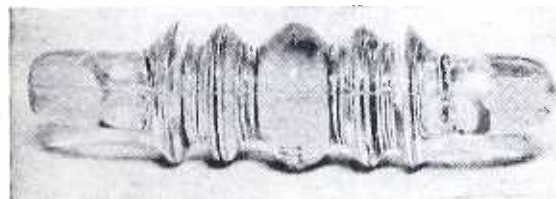

A glass insulator molded in a single piece.

A NEW GLASS INSULATOR

Name of instrument: Antenna insulator.

Description: This insulator is constructed entirely of a single piece of glass moulded into a form that includes four thin flanges and a larger center flange. The insulator is strong and its construction limits leakage to a low value even in bad weather.

Usage: For insulating outdoor antenna wires.

Outstanding features: Compact. Light weight. Strong.

Maker: M. M. Fleron & Son, Inc.

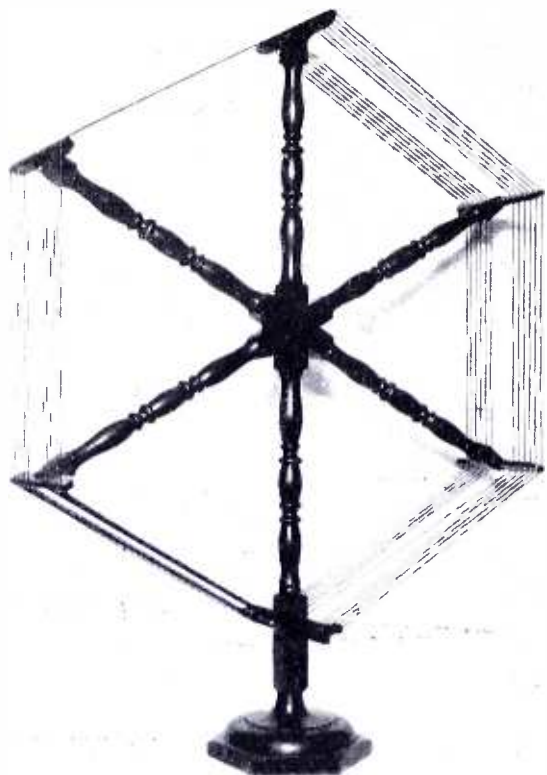

This loop more nearly approaches the cylindrical coil shape than the square type.

SOCKETS AND ADAPTERS

"Thorobred" socket; Marshall-Gerken Co.
 "Mar-Co" sockets; Martin-Copeland Co.
 Double contact tube socket; Mazda Radio Mfg. Co.
 Antenna adapter for standard loop superheterodyne receiver; Norden-Hauck, Inc.

SWITCHES

"Mar-Co" switches; Martin-Copeland Co.
 Kee-lock switch; Metro Electric Mfg. Co.
 "Se-Ar-De" automatic selector switch; R. Mitchell Co.
 "Mac-kontrol"; Mack Company.
 Switches; Leslie F. Muter Co.

TESTING INSTRUMENTS

Radiometer; R. Mitchell Co.
 Dry cell tester; W. G. Nagel Electric Co.
 Ammeter; W. G. Nagel Electric Co.
 High resistance voltmeters and voltmeters; W. G. Nagel Electric Co.

A HEXAGON SHAPED LOOP

Name of instrument: Loop antenna.

Description: A collapsible loop antenna that is supplied for final assembly by the experimenter. It contains three turned wooden arms which fit together and a special wooden base. The amateur winds the wire on the loop and connects it to the two binding post terminals that are furnished.

Usage: As an antenna pick-up device for multitube receivers.

Outstanding features: Well finished appearance. Good directional selectiveness. Easy to set up. Good appearance.

Maker: R. B. Scribner Co.

TUBES

"Magnavox" vacuum tube; Magnavox Co.
 A-C radio tube; McCullough Sales Co.
 "Myers" tube; E. B. Myers Co., Ltd.
 Eveready vacuum tube, type 201-a; Herman A. Nussbaum Sales Co.
 "Nutron" solodyne tube; Nutron Mfg. Co.
 Matched tube; Nutron Mfg. Co.

TUNING INDUCTANCE UNITS

180-degree variocoupler; Manhattan Electrical Supply Co.
 Control-o-meter; Malone-Lemmon Products.
 Variometers; Marshall-Gerken Co.
 "Mar-Co" tuner; Martin-Copeland Co.
 "Cockaday" coils; McConnell Cable & Specialty Co.
 "Se-Ar-De" coupler; R. Mitchell Co.
 "Precision" selector; Moskowitz & Herbach.
 Roberts units; J. Nazeley Co.
 Oscillator coupler; New York Coil Co.
 Journal filter tuner coils; Nolte Mfg. Co.
 Journal one knob set coil; Nolte Mfg. Co.
 Wave trap filter coil; Nolte Mfg. Co.

VARIABLE CONDENSERS

"Red Seal" variable condensers; Manhattan Electrical Supply Co.
 "Mar-Co" super-vernier condenser; Martin-Copeland Co.
 "Mar-Co" neutralizing condensers; Martin-Copeland Co.
 Variable condenser; Mignon Electric Mfg. Corp.
 "Se-Ar-De" condenser; R. Mitchell Co.
 "National" condenser; National Co., Inc.
 Grounded variable low-loss condenser; New York Coil Co.
 Selector variable condenser; with self-balanced coils attached; New York Coil Co.
 "Niagara" Mignon condenser; Niagara Sales Corp.

The Government Should not Censor the Ether

"THE character of the matter sent out must be left to the stations themselves and they, in turn, must be governed by the wishes of their listeners. The public will unquestionably turn to the station from which it gets the most worthwhile material, and, in any event, interference by the Government in the character of programs would inevitably mean censorship. It would become the negation of the fundamentals of free speech and free dissemination of information."

—HERBERT HOOVER

U. S. Secretary of Commerce

HINTS FOR

AMATEURS



CONDUCTED BY ALBERT G. CRAIG

"B" Battery Eliminators

THERE are now on the market a number of devices for furnishing plate current to radio receiving sets from the alternating-current and direct-current lighting lines. A "B" battery eliminator for direct current needs no rectifier. All that is necessary is some form of resistance device to bring the voltage down to a value suitable for use on the detector and amplifying tubes. In addition to this is necessary a filter circuit designed to eliminate any voltage variations in the supply current so that no hum will be discerned when the set which uses such a supply is connected to the telephones or loudspeaker. In some of these devices an electrolytic rectifier is used and in some a vacuum-tube rectifier is used. Some devices rectify both halves of the cycle and some of them only rectify a half wave. The full-wave rectifier is desirable. The rectifiers that use standard UV-201-a tubes should never be overloaded. In other words, if a multi-tube set is attached to such a device employing, say, two UV-201-a tubes, the current drawn through these tubes as rectifiers may be too great for the normal filament emission and this will cause the tube to deteriorate rapidly. It is, therefore, imperative when using rectifiers of this type with this type of tube, that a set should contain not more than five tubes and it should be equipped with "C" batteries to limit the total plate

energy required for operation in order to make the tubes last a suitable length of time.

If this is not done the filament emission of the tubes will fall off rapidly and they will be worthless in about 250 or 300 hours of operation. This is usually a serious trouble experienced when the uninitiated radio set user tries to operate a multi-tube set on such a device.

Be sure that you limit the total plate current in your receiver with "C" batteries properly arranged so that you do not overload the tubes in the "B" eliminator no matter what design it may be and then you will get proper results from the eliminator itself.

Straight-line-frequency Condensers

THERE is a great call at the present time for so-called straight-line-frequency condensers although there is not at the present time (and never will be) any such instrument. This is because it is impossible to make a variable condenser that will have a straight-line-frequency characteristic with all types of coils used in radio. The ultimate reason for this is that all coils used in radio have some distributed capacity varying from a relatively small amount to quite a large value and this fixed shunt capacity across the variable condenser shifts the capacity across the circuit and throws out the

frequency curve from a straight-line characteristic. Therefore, even a condenser especially designed for use with a theoretically perfect coil with zero distributed capacity would not give a straight-line-frequency curve with any type of coil now on the market. Any specific condenser which claims to be a straight-line-frequency condenser is so only with *one specific type of coil* for which the condenser has been designed to operate in conjunction with. In other words, manufacturers will find that they will have to design a coil to go with their straight-line condensers in order to be able to substantiate their claim that their condenser is a straight-line-frequency condenser and this same condenser, when used with a coil of different distributed capacity, will show a curve for the frequency characteristic instead of a perfectly straight-line. When buying such a condenser be sure that you also obtain the coil that the condenser was calculated to operate with, if you desire an absolutely straight-line characteristic.

The Application of Simplified Control to Tuned Radio-frequency Receivers

ELIMINATING one or two dials from the ordinary triple control tuned radio-frequency receiver can be accomplished by employing some of the double or triple unit variable condensers now on the market. The use of this simplified unit will enable much quicker and more accurate setting of the dial with a considerable improvement in the results obtained from the receiver. A multi-unit condenser to be employed satisfactorily should have matched units, that is, all of the separate capacity units should be so fixed on the shaft that the capacity of all three will be the same (or practically so) for any setting of the main dial. This is important when a triple unit condenser is used for

the receiver. An easier combination, and one that is probably more practical, would be the use of a single condenser for tuning of the antenna circuit and a double unit for tuning simultaneously the two succeeding circuits. Be sure to obtain a multi-unit condenser of this type that is matched within at least five percent variation.

One Stage of Radio-frequency

THE addition of a single radio-frequency tube to an ordinary receiver or one of the regenerative type will enable the user to tune considerably sharper with his present set and at the same time to increase his distance range.

Particularly is this single tube an improvement when used with a closely coupled regenerative receiver. Its function in this case would also include the prevention of radiation by the regenerative receiver. This is especially true if the single stage of radio-frequency amplification is neutralized by one of several closely allied methods of the bridge principle.

The Application of Varnish to Radio Coils

IN general, the use by the amateur of varnish or shellac in coils should be avoided. This is because the amateur or radio fan seldom has access to the right kind of varnish or knows how to apply it.

Certain forms of high-grade varnish have been found (when applied in extremely thin coats) to increase the distributed capacity of a coil only slightly, and the losses incurred through this increase have been found to be less than the losses due to leakage through the coil when left dry in a humid atmosphere.

In some cases using a varnish of the right kind, the over-all resistance at radio frequencies has been unexpectedly found to be reduced by the application.



Coming!

Factories of this Company are in quantity production of the new Jewett Receiver. Deliveries have begun.

These facts are supremely significant. For this new Jewett constitutes beyond question, *the longest recent forward step toward perfect Radio Reception.*

In fundamentals, and in details, the Jewett is emphatically *new.*

Its tuning element is *new.*

Its method of audio amplification is *new.*

Its beauty of line and finish is *new* and distinctive.

Originality that can come only from genius—young, untrammled, triumphant—such will be your confident verdict.

Make no Radio investment until you have seen this new Jewett and listened to the marvel of its performance!

The Jewett will be marketed in a beautiful cabinet of the new Clairmount Mahogany, at a price far below any receiver of comparable performance.

“THERE IS NO SUBSTITUTE FOR THE BEST”

JEWETT RADIO & PHONOGRAPH COMPANY

5668 TELEGRAPH ROAD

PONTIAC, MICHIGAN

Factories: Allegan, Michigan—Pontiac, Michigan

In Canada:

Jewett Radio-Phonographs, Ltd.
Walkerville, Ontario

Export Sales Offices:

16 Broad St., New York City

The Jewett Receiver

All apparatus advertised in this magazine has been tested and approved by POPULAR RADIO LABORATORY

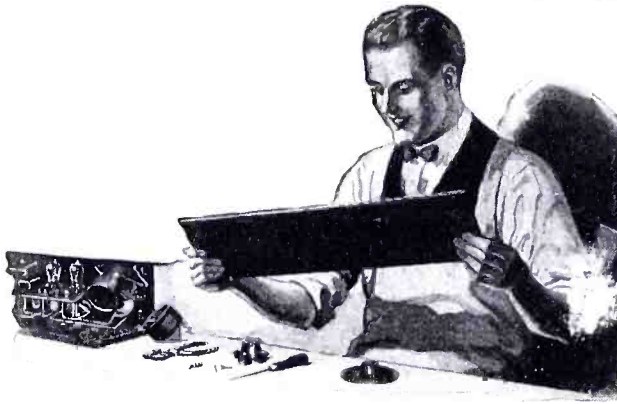

Developed by engineers for radio *only*

*Why this special panel
material gives better results*

IN THE early days of radio development, our engineers realized that ordinary insulation good enough for a hundred other uses was not good enough for radio. So they developed Radion—a super-panel material designed for radio use exclusively.

Radion has, by test, highest insulation characteristics. It has a high-polished finish which keeps out dirt and moisture, guarding against short circuits that often reduce good reception. Radion is the easiest material to cut, drill and saw. 18 stock sizes, black and Mahoganite. Ask for it by name.

*Send for booklet
"Building Your Own Set"*

For 10 cents we will send you our booklet, "Building Your Own Set," giving wiring diagrams and directions for building the most popular circuits.

AMERICAN HARD RUBBER COMPANY
Dept. B8, 11 Mercer St., New York City
Chicago Office, Conway Building
Pacific Coast Agent: Goodyear Rubber Co.
San Francisco, Portland

RADION

The Supreme Insulation

PANELS

Dials, Sockets, Binding Post Panels, etc.

AMERICAN HARD RUBBER COMPANY
Dept. B8, 11 Mercer St., New York City
Please send me your booklet, "Building Your Own Set," for which I enclose 10 cents, (stamps or coin).

Name

Address

City State

We've Mapped the Air FOR YOU!

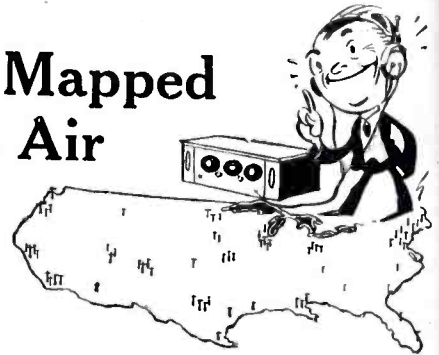

HERE'S a marvelous new way to chart your radio exploits—a beautiful Air Map, printed in three colors, with every station clearly marked and Time zones outlined! Size, 28 x 34 inches.

There's no limit to the useful and amusing ways you can use Collier's new Radio Map of the U. S. and Canada. With its help

You can find out INSTANTLY how far away any station is

If you use a directional aerial, you can point the loop exactly toward the station you want to get. The map also outlines the radio districts, and gives an alphabetical list of *all* stations and their operators. Thousands have already been sold. Get yours *to-day!* At your news stand or radio dealer's, only 25 cents—or just mail a quarter to us.

P. F. COLLIER & SON COMPANY
260 Park Avenue, NEW YORK CITY

Musical Quality, DX Re- ception, Selectivity and Noise Elimination

is improved to an unusual degree
by the use of

**New York Coil Company's
Precision Mica Fixed Condensers**



Used by the leading set manufacturers.

Our "Selector" Variable Condensers, Mounted and Unmounted Audio Transformers and B Battery Eliminator Condensers, are leaders.

NEW YORK COIL CO.
338 Pearl St. New York City

Pacific Coast: Marshank Sales Co.
926 Ins. Exch. Bldg., Los Angeles, Calif.

All apparatus advertised in this magazine has been tested and approved by POPULAR RADIO LABORATORY

ULTRA-LOWLOSS CONDENSER



CAP. .0005 mfd.

\$5.00

Unusual Features Increase Receiving Efficiency

IN LESS than six months the Ultra-Lowloss Condenser has proved its right to leadership by greatly simplified design, greater tuning efficiency, and radically different operating results—not only in the eyes of scientific and engineering men, but with the buying public as well.

These are the predominating Ultra-Lowloss features: (1) Single insulation strip reduces leakage losses materially, (2) Monoblock mounting with plates cast into block reduces series resistance and assures positive contact, (3) Minimum of metal of high resistance material in the field and frame reduces eddy current losses, (4) Cutlass Stator Plates produce a straight line wavelength curve—separating stations evenly over the dial. Each degree on a 100 degree scale dial represents approximately $3\frac{1}{2}$ meters over the broadcast wave length range.

This even separation applies to both high and low wavelengths! Simplifies tuning materially!

The Ultra-Lowloss Condenser is a recent development of R. E. Lacault, E. E., originator of the famous Ultradyne receiver.

Design of Lowloss Coils furnished free with each Condenser for amateur and broadcast wavelengths showing which will function most efficiently with the Condenser.

At your Dealer's. Otherwise, send purchase price and you will be supplied postpaid.

ULTRA-LOWLOSS CONDENSER

Write for Descriptive Folder.

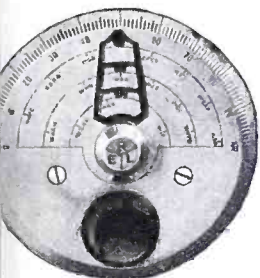

Simplifies radio tuning. Dial record a station on the dial—thereafter, simply turn the finder to your pencil mark and get that station instantly. Easy—quick to mount. Eliminates fumbling, guessing. Furnished clockwise or anticlockwise in gold or silver finish. Gear ratio 20 to 1.

Silver \$2.50.
In gold finish, \$3.50.

ULTRA-VERNIER
TUNING CONTROL



R. E. Lacault

To manufacturers who wish to improve their sets

I will gladly consult with any manufacturer regarding the application of this condenser to his circuit for obtaining best possible efficiency.



PHENIX RADIO CORPORATION

116 East 25th Street

New York

All apparatus advertised in this magazine has been tested and approved by POPULAR RADIO LABORATORY

MADE with absolute precision, the perfect balance of Marathon Tubes insures the best reception.

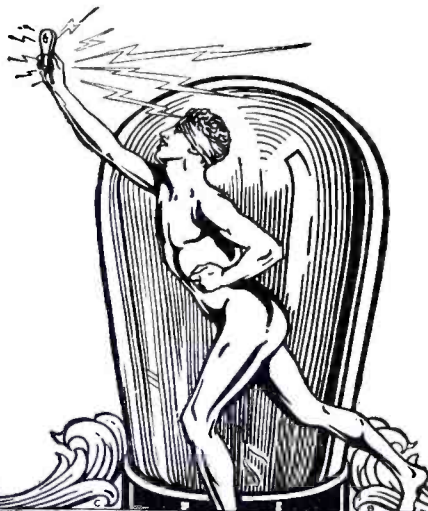

ALL that the name implies. In the orange-and-blue carton with the Marathon Runner. Every tube guaranteed.

MARATHON
A TRIUMPH IN RADIO TUBES

TRADE MARK

Manufactured by NORTHERN MFG. CO., Newark, N. J.

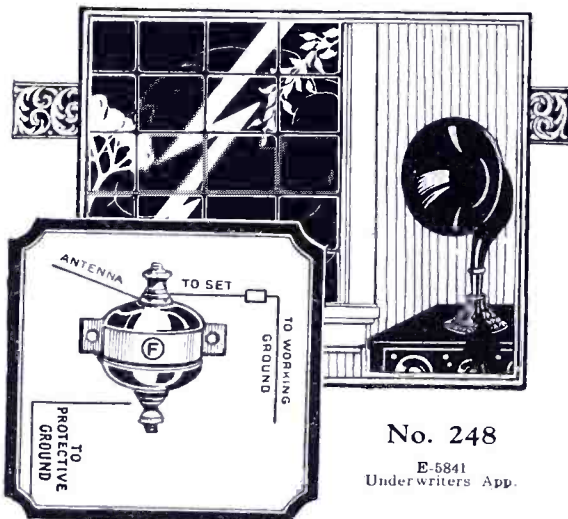

No. 248

E-5841 Underwriters App.

**“Little Joe”
Lightning Arrester**

Especially designed for Radio Work. Made of Porcelain, small, neat rugged and serviceable. Can be suspended on antenna or fastened to wall.

Ask Your Dealer

M’f’d by **CIRCLE F MFG. CO.**
Trenton, New Jersey

The name RATHBUN on any radio product is a pledge of good faith to every purchaser.

Every product bearing this name is honestly made for satisfactory performance. And that more than any other factor should govern the selection of radio equipment.

RATHBUN MANUFACTURING CO., Inc.
Jamestown New York



Build this phenomenal new radio in 45 minutes



The revolutionary Erla Circloid-Five Factory-Bilt Kit—as you receive it.

Price \$49.50

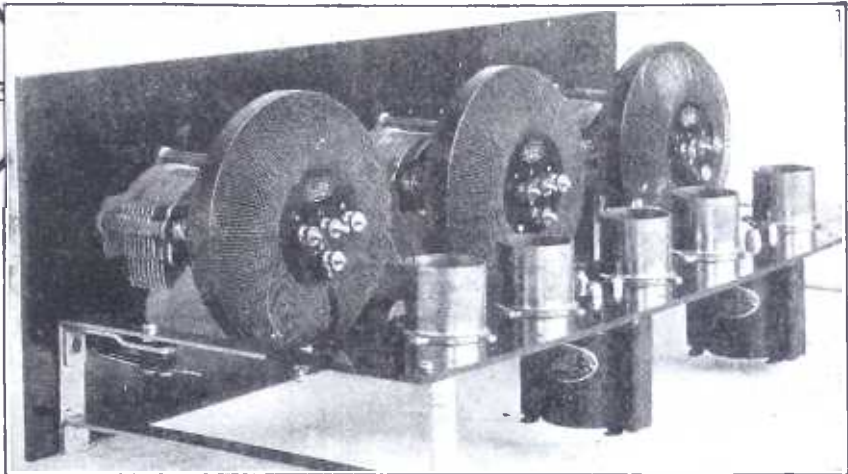

This new type kit is factory assembled. Ready cut, flexible, solderless leads make it ridiculously easy to wire. Amazing new inductance principle brings results hardly thought possible. Send for book, *Better Radio Reception*.

NOW anyone can build the finest of receivers in only a few minutes. No more wire bending or soldering. Merely attach a few ready cut, flexible eyeletted leads and the job is done. We guarantee that the finished set is unsurpassed even by the costliest factory-built receiver.

But most amazing is the new inductance principle incorporated in this last word in kits—called the Erla Circloid principle of amplification.

Four vital improvements result from this great discovery, which are not found in ordinary sets.

1. Greater Distance: Erla * Balloon *Circloids have no external field, consequently do not affect adjacent coils or wiring circuits. This enables concentration of proportionately higher amplification in each stage, with materially increased sensitivity and range.

2. More Volume: Increased radio frequency amplification made possible by Erla Balloon Circloids gives concert volume to distant signals inaudible with receivers of conventional type.

3. Increased Selectivity: Erla Balloon Circloids have no pick-up quality of their own. Hence only signals flowing in the antenna circuit are amplified. Static is greatly reduced for this reason.

4. Improved Tone Quality: The self-enclosed field of Erla Balloon Circloids eliminates stray feed-backs between coils and consequently does away with mashing of signals and distortion. Tone is crystal clear and perfectly lifelike.

Write for free information on kit—also book

See how 45 minutes of fun will give you the newest and most nearly perfected set known to radio science. Easy as A-B-C to finish. Examine it at any Erla dealer's, or send the coupon for full information, illustrations and diagrams *free*. Also ask for remarkable new book, "Better Radio Reception," describing the sensational new Circloid principle. Enclose 10c for mailing and postage on book.

ELECTRICAL RESEARCH LABORATORIES
2533 Cottage Grove Ave., Chicago

**Trade Mark Registered.*

ELECTRICAL RESEARCH LABORATORIES,
2533 Cottage Grove Ave.,
Chicago, U. S. A.



Send me free information on kit. Enclose 10c for postage for book "Better Radio Reception."

This sign identifies authorized Erla distributors. All are equipped to give complete radio service.

Name.....

Address

City..... State.....

Dealers *Exclusive franchises, are available to high class dealers in localities still open. Write or wire immediately.*

All apparatus advertised in this magazine has been tested and approved by POPULAR RADIO LABORATORY

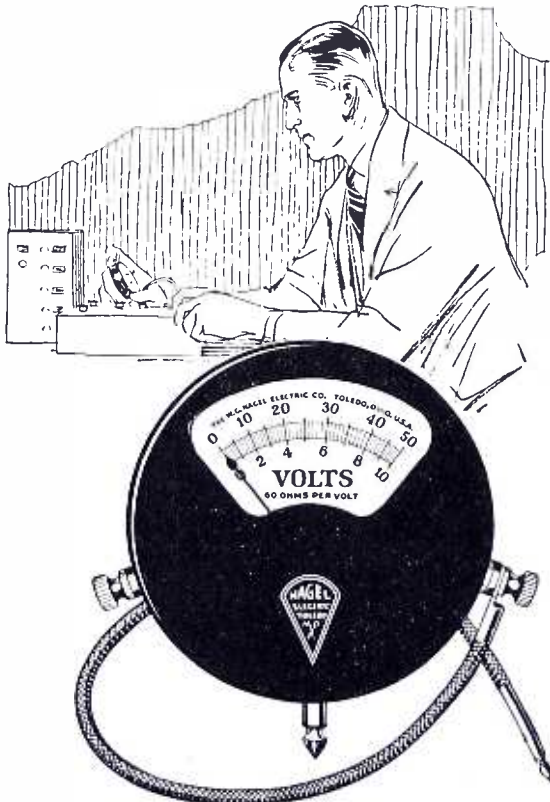

No. 23—For use with "B's" and for "A's" in place of hydrometers

Make sure of this before you test

60 Ohms per volt is high resistance! It is considered standard for voltmeters. The cheaper the instrument, the lower the resistance and the greater the danger of draining your batteries. "60 Ohms per volt" appears on the dial of Nagel Voltmeters. It is the symbol of protection. Drop in at your dealer's or write The W. G. Nagel Electric Co., 513 Hamilton Street, Toledo, Ohio.

NAGEL

Manufacturers of

**DRY CELL TESTERS · AMMETERS
HIGH-RESISTANCE VOLTMETERS
and VOLTAMMETERS · BAKELITE
HOT MOULDED INSULATIONS**

New and Improved



\$5⁵⁰

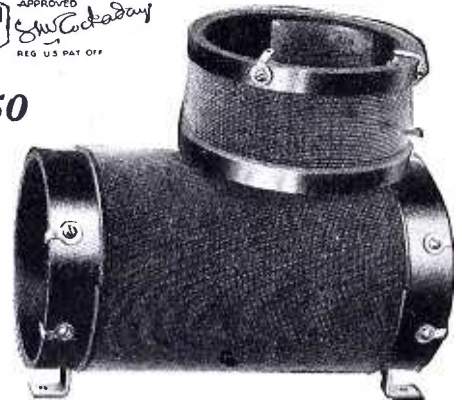

Authorized Cockaday Coil!

No more loose winding—special new feature holds coil windings fast. Built throughout of moulded hard rubber, not affected by atmospheric conditions. Wound with No. 18 D. S. C. copper wire.

The only coil specified by L. M. Cockaday in his New Four Circuit Tuner with Resistance Coupled Amplification because it meets all his specifications. Described in October POPULAR RADIO as Cockaday Precision Coil. Hundreds have substituted this quality coil for those of inferior make and are amazed at the improved reception, selectivity and general D-X results.

At your dealers, otherwise send purchase price and you will be supplied postpaid

In Canada \$7.75. Canadian Distributor, Perkins, Ltd. Montreal—Toronto—Winnipeg

PRECISION COIL CO., Inc.
209-B Centre St., New York City

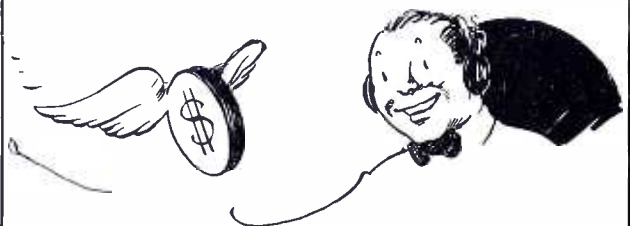

Here it is! listen! Hommel Broadcasting:

Business static hurts your cash register as much as weather static hurts reception.

Now, listen in carefully.

The HOMMEL Dealer Service Department was developed for the one particular purpose to help alleviate business "static". That Department is vitally concerned in furthering your interests—as a Hommel Dealer.

We work shoulder to shoulder with our dealers—not in competition with them. We wholesale only and carry only the most reputable radio equipment. All user inquiries and orders resulting from our national advertising are forwarded promptly to our local dealer.

We can't help you unless you ask us to. Write today for Hommel's Encyclopedia of Radio Apparatus 266-P. It's free and will help you.

LUDWIG HOMMEL & CO
929 PENN AVENUE ———— PITTSBURGH, PA.

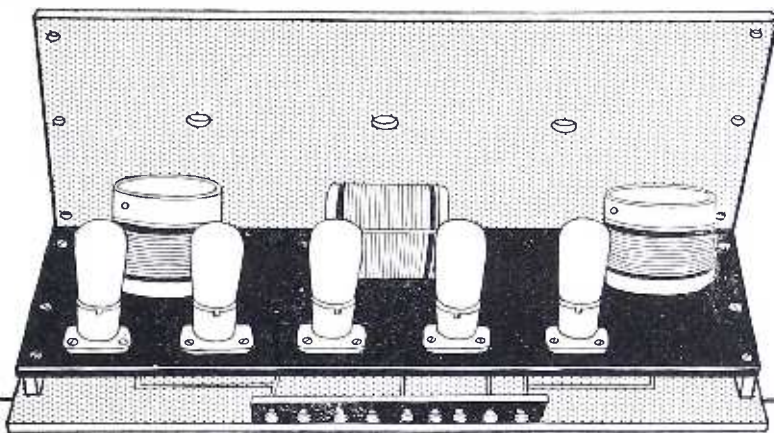

FORMICA *Base Panels*

THE use of Formica base panels in a radio set is becoming almost universal practice with set makers, and with amateurs who do the better work.

It makes the leads shorter and the wiring more efficient. If it is desired to avoid soldering, the base panel may be used to greatly reduce the number of soldered joints.

The appearance of the set is much neater and finer. And the structure is so much stronger that such a set can be dropped from a counter or store shelf and nothing will happen to it.

It is essential that a base panel be made of mechanically strong material that will not warp and distort—so that coils will not be thrown out of alignment—and the operation of the set made less efficient.

Formica is used by 125 leading manufacturers of radio sets.

Write for booklet, "What Formica Is."

THE FORMICA INSULATION COMPANY

4641 Spring Grove Avenue, Cincinnati, Ohio

SALES OFFICES

50 Church Street.....New York, N. Y.
 9 South Clinton St.....Chicago, Ill.
 516 Caxton Bldg.....Cleveland, Ohio
 327 Cutler Bldg.....Rochester, N. Y.
 422 First Avenue.....Pittsburg, Pa.
 6 Beacon Street.....Boston, Mass.
 55 Calle Obispo.....Habana, Cuba

1026 Second Avenue.....Minneapolis, Minn.
 725 Bulletin Bldg.....Philadelphia, Pa.
 708 Title Building.....Baltimore, Md.
 585 Mission Street.....San Francisco, Cal.
 419 Ohio Building.....Toledo, Ohio
 309 Plymouth Bldg.....New Haven, Conn.
 Whitney Central Bldg.....New Orleans, La.

FORMICA

Made from Anhydrous Bakelite Resins
SHEETS TUBES RODS

Hear the Formica Orchestra over WLW every Tuesday evening from 9 to 10 Central Standard Time.

All apparatus advertised in this magazine has been tested and approved by POPULAR RADIO LABORATORY



Scientific Research for Radio Manufacturers

Radio Manufacturers are constantly faced with scientific problems due to the discovery of new principles and the necessity for keeping their product in the front rank in Radio's rapid advance.

Kalmus, Comstock & Wescott, Inc., offers to the Radio Industry resources, equipment, and trained scientific skill necessary to solve these problems.

We maintain a staff of highly trained scientists and engineers with years of practical experience in the various fields of industrial research.

Our Laboratories, personnel and experience are available to Radio Manufacturers for a reasonable compensation. It will pay you to write for complete information.

KALMUS, COMSTOCK & WESCOTT Inc.

110-114 BROOKLINE AVE. Industrial Research Engineers. BOSTON, MASSACHUSETTS

The Red Stripe
A Radio Guide Line

For your protection, throughout the center of every Dilecto radio panel is a Red Stripe. You can see it along the edge of every panel.

If you buy or build a set Look for the Red Stripe—and you'll be sure of the finest, strongest radio panel that can be made. Dilecto is a Phenolic condensation material.

THE CONTINENTAL FIBRE COMPANY
Factory: Newark, Delaware

Service on Dilecto, Conite, Contex and Vulcanized Fibre from:

New York, 250 Park Ave. Chicago, Wrigley Bldg.
San Francisco, 75 Fremont St. Los Angeles, 307 S. Hill St.
Seattle, 1041 Sixth Ave., South
Pittsburgh, Farmers Bank Bldg.

Dilecto



\$3.25 COD RADIO Storage "B" Battery

12 Cells 24 Volts Lasts Indefinitely—Pays for Itself
Economy and performance unheard of before. Recharged at a negligible cost. Approved and listed as Standard by Leading Radio Authorities, including Pop. Radio Laboratories, Pop. Sci. Inst. Standards, Radio News Lab., Leafax, Inc. and other important institutions. Equipped with Solid Rubber Case, an insurance against acid and leakage. Extra heavy glass jars. Heavy, rugged plates. Order yours today!

SEND NO MONEY Just state number of batteries wanted and we will ship day order is received. Extra Offer: 4 batteries in series (96 volts), \$12.75. Pay expressman after examining batteries. 5 per cent discount for cash with order. Mail your order now!

WORLD BATTERY COMPANY
1219 So. Wabash Ave., Dept. 77, Chicago, Ill.
Makers of the Famous World Radio "A" Storage Battery
Prices: 6-volt, 100 Amp. \$11.25; 120 Amp. \$13.25; 140 Amp. \$14.00
All Equipped with Solid Rubber Case

World FOR STORAGE BATTERIES RADIO

KDKA - WFAF - WGN - WJS - KHJ - KGO - KFAF - WJY - KOP

All apparatus advertised in this magazine has been tested and approved by POPULAR RADIO LABORATORY

Announcing the Balkite Trickle Charger at \$10 and the new Balkite "B" at \$35



U. S. Patent
May 27, 1924

Balkite Trickle Charger

Charges both 4 and 6 volt Radio "A" batteries. Will furnish more current than is used by 6 dry cell tubes, if used only while the set is in operation. If allowed to "trickle" charge continuously will also furnish enough current for 8 storage battery tubes. Size 5 1/2 in. long, 2 1/4 in. wide, 5 in. high. Operates from 110-120 AC 60 cycle current.

Manufacturers are offering switches which turn on Balkite "B" and turn off the charger when you turn on your set. This makes the current supply for both circuits automatic.

Price \$10

West of Rockies, \$10.50

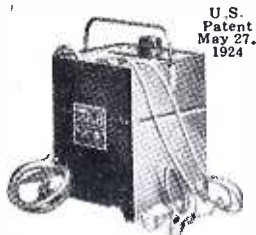

U. S. Patent
May 27, 1924

Balkite Battery Charger

The most popular battery charger on the market. It can be used while the radio set is in operation. Charging rate 2.5 amperes. Operates from 110-120 AC 60 cycle current. Special model for 50 cycles.

Price \$19.50

West of Rockies, \$20

The Balkite Battery Charger is today the most popular charger on the market. It is the only charger commonly used while the set is in operation. Balkite "B" II is also well known. It replaces "B" batteries entirely and supplies plate current from the light socket.

We now announce the Balkite Trickle Charger at \$10. This low-rate charger is especially adapted to use with sets of relatively low "A" current requirements—dry cell sets and storage battery sets with few tubes. Owners of dry cell sets can now make a very compact and economical installation with a Balkite Trickle Charger and a low capacity storage battery of the type offered by battery manufacturers this fall.

We also announce the new Balkite "B" at \$35. This new model will serve sets of five tubes and less. It fits in your present "B" battery compartment.

Noiseless—No bulbs—Permanent

All Balkite Radio Power Units are entirely noiseless in operation. They have no moving parts, no bulbs, and nothing to adjust, break or get out of order. Each is a permanent piece of equipment with nothing to replace. They require no other attention than the infrequent addition of water. They require no changes or additions to your set. They are guaranteed to give satisfaction.

Manufactured by

FANSTEEL PRODUCTS COMPANY, Inc.
North Chicago, Illinois

FANSTEEL Balkite Radio Power Units



U. S. Patent
May 27, 1924

Balkite "B"

Eliminates "B" batteries. Supplies plate current from the light socket. Operates with either storage battery or dry cell tubes. Keeps "B" circuit always operating at maximum efficiency. Requires no attention other than adding water about once a year.

Will serve any set of 5 tubes or less. Occupies about same space as 45 volt dry "B" battery. Operates from 110-120 AC 60 cycle current.

Price \$35



U. S. Patent
May 27, 1924

Balkite "B" II

Same as the new Balkite "B" but will fit any set including those of 10 tubes or more. Operates from 110-120 AC 60 cycle current. Special model for 50 cycles.

Price \$55

Tested and Listed as
Standard by
Underwriters'
Laboratories

BALKITE BATTERY CHARGER BALKITE TRICKLE CHARGER BALKITE "B" BALKITE "B" II

All apparatus advertised in this magazine has been tested and approved by POPULAR RADIO LABORATORY

BURGESS RADIO BATTERIES

Quality at Every Price

Cabinet or table space many times determine the size and type of radio batteries selected by the user.

Burgess manufactures a battery for every radio circuit and tube. Your choice of any one of many types involves no sacrifice of economy or service hours. The value and quality of Burgess Radio Batteries are constant — your satisfaction assured.

"Ask Any Radio Engineer"



One of several sizes of Vertical 'B' Batteries.

Burgess 'C' Batteries improve reception economically.



Standard Burgess Radio No. 6 'A' Battery. "Over Twice the Life."



Burgess block shape 'B' Batteries are made in numerous types and voltages.

BURGESS BATTERY COMPANY

Engineers DRY BATTERIES Manufacturers
Flashlight - Radio - Ignition - Telephone
General Sales Office: Harris Trust Bldg., Chicago
Laboratories and Works: Madison, Wis.

In Canada: Niagara Falls and Winnipeg



RESISTOR
No. 105
+
CONNECTING
LINKS
+
MICADON
=
COUPLER
No. 104

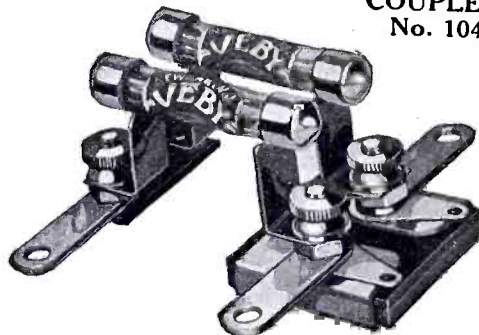

SIMPLE—EFFICIENT SOLDERLESS ECONOMICAL MOUNTS DIRECTLY ON SOCKETS FOR RESISTANCE COUPLED AMPLIFIER RESISTANCE COUPLER

COMPLETE (less Micadon) \$1.25

Manufactured by

VEBY RADIO COMPANY

Makers of

QUALITY RADIO RESISTORS

141 WASHINGTON ST.,

NEWARK, N. J.

Our King Type Cabinet



Our cabinets are made of carefully selected lumber. They are beautifully finished and hand rubbed. The workmanship is of as high grade as in the best furniture. If not entirely satisfied with cabinets received from us, money will be refunded. Black walnut cabinets have piano hinges and lid holders. Imitation walnut cabinets have regular hinges, no lid holders. Send for circular showing our De Luxe Type, also our Beauty Type.

No.	For Panel	Deep, In.	Imitation Walnut	Genuine Walnut
King 621	6 x 21	7	\$4.60	\$6.80
King 714	7 x 14	7	4.20	6.70
King 718	7 x 18	7	4.35	6.80
King 721	7 x 21	7	4.90	7.40
King 724	7 x 24	7	5.35	8.00
King 726	7 x 26	7	5.80	8.50
King 728	7 x 28	7	6.60	10.00
King 730	7 x 30	7	7.00	11.00
King 71810	7 x 18	10	5.70	9.00
King 72110	7 x 21	10	6.25	9.50
King 72410	7 x 24	10	6.70	10.00
King 72610	7 x 26	10	7.25	10.50
King 72810	7 x 28	10	8.00	12.00
King 73010	7 x 30	10	8.20	12.50
King 836	8 x 36	10	8.75	12.00
King 840	8 x 40	10	9.25	12.50
King 921	9 x 21	10	7.50	9.25
King 924	9 x 24	10	8.50	10.50

F. O. B. WAUKESHA, WIS.

UTILITY CABINET COMPANY

Waukesha

Phone-721

Wisconsin

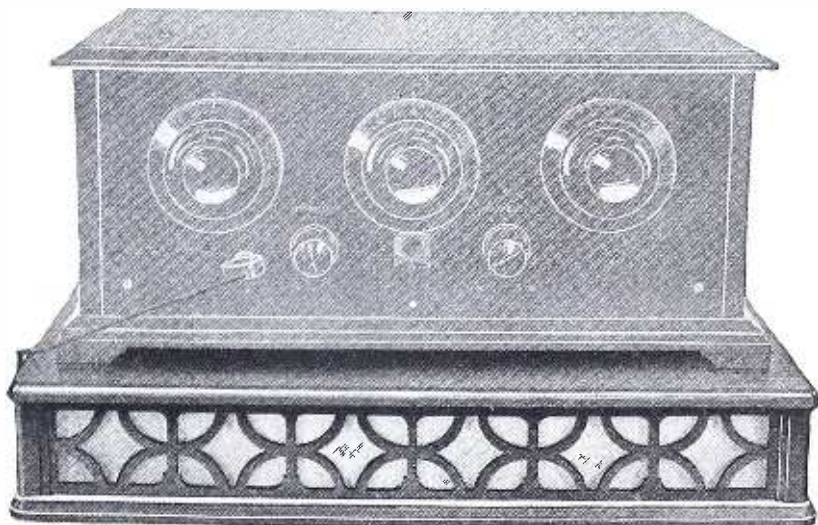

The New **TIMBRETONE**

REG. U.S. PAT. OFF.

“Beauty is MORE than skin deep.”

In the new **TIMBRETONE** you have not only the “Beauty” of appearance but also the “Beauty” of Quality and Performance.

The size and shape permits it to be used either as a base to your cabinet or on top of the set and when so used carries the idea of one complete radio unit.

As a loudspeaker it's a beauty!

List Price in U. S. (east of Mississippi) **\$30.00**

Dealers and Jobbers—Write for advance information



Made in Hoosick Falls, N. Y.
by the Timbretone Mfg. Co.

**"pep up" your radio
for good summer reception**

**JEFFERSON
TUBE REJUVENATOR
keeps tubes like NEW**

ALL radio tubes weaken with use—especially in summer when burned at higher voltage. Keep your radio tubes efficient this summer with the Jefferson Tube Rejuvenator. Attach to a convenient electric light socket—in your own home—"bring back" each tube in 10 minutes!

Repeat once a month—note how it improves reception; **DOUBLES** and **TREBLES** tube life. Quickly pays for itself thru saving tubes and batteries. A home rejuvenator for tubes is just as essential to satisfactory radio reception as a charger for storage batteries. Completely restores paralyzed or exhausted tubes. At leading stores selling radio. If your dealer can't supply you, send \$7.50 to

Jefferson Electric Mfg. Co., 501 So. Green Street, Chicago, Ill.

Makers of Jefferson Radio, Bell Ringing and Toy Transformers; Jefferson Spark Coils for Automobile, Stationary and Marine Engines; Jefferson Oil Burner, Ignition Coils and Transformers.



For
**HOME
Use**



Patent Pending

\$7.50

\$10 in Canada



Takes large or small tubes—
201-A, 301-A, UV-199, C-299



FREE!

To Each Purchaser of a **WORLD 6 V. Auto or Radio BATTERY**

12-Cell—24 Volt Storage 'B' Battery

Positively given free with each purchase of a **WORLD "A"** Storage Battery. You must send this ad. with your order. **WORLD** Batteries are famous for their guaranteed quality and service. Backed by years of successful manufacture and thousands of satisfied users. Equipped with *Solid Rubber Case*, an insurance against acid and leakage. You save 50 per cent and get a

2-Year Guarantee Bond in Writing
WORLD Battery owners "tell their friends." That's our best proof of performance. Send your order in today.

Solid Rubber Case Radio Batteries
6-Volt, 100-Amperes . . . \$11.25
6-Volt, 120-Amperes . . . 13.25
6-Volt, 140-Amperes . . . 14.00

Solid Rubber Case Auto Batteries
6-Volt, 11-Plate . . . \$11.25
6-Volt, 13-Plate . . . 13.25
12-Volt, 7-Plate . . . 16.00

SEND NO MONEY Just state battery wanted and we will ship day order is received, by Express C. O. D. subject to your examination on arrival. **FREE** "B" Battery included. **Extra Offer:** 5 per cent discount for cash in full with order. Buy now and get a guaranteed battery at 50 per cent saving to you.



Approved and Listed as Standard by Leading Authorities including Radio News Laboratories; Popular Science Institute of Standards; Popular Radio Laboratories; Radio Broadcast Laboratories; Radio in the Home; and Lefax, Inc.

WORLD BATTERY COMPANY
1219 So. Wabash Ave., Dept. 3 CHICAGO, ILL.

World For **AUTO** and **STORAGE BATTERIES** **RADIO**



KDKA - WFAF - WGN - WLS - KHL - KGO - KFAF - WJY - KOP

AMPLION

The World's Standard Loud Speaker
Alfred Graham & Company, London, England, Patentees.

Long tone travel with gradual amplification provided by the non-resonating, dragon-shaped tone conduit.

Adjustment for "tuning" the Amplion "Floating Diaphragm" electro-magnetic unit to your set.

Rubber bushings insulate horn and unit from tone conduit.

Hinged base permits tilting horn to any desired angle.

Thirty years have perfected and made it the finest reproducer. The originators and oldest makers of loud speakers created the Amplion. Hear it—in comparison!—and learn why it is the world's largest seller. Six models, \$13.50 up. Write for literature and dealer's name.

THE AMPLION CORPORATION of AMERICA
Executive Offices: Suite X, 280 Madison Ave., New York
Canadian Distributors: Burndep't of Canada, Ltd.
130 Richmond Street W., Toronto

KING IN RADIO

A complete line—that's "King in Radio"

KING-HINNERS neutrodyne is neutrodyne *plus*. Offered in table type, table type with loud speaker built in and the elaborate console model, each one a masterpiece of the cabinet maker's art. These receivers embody features which stand out above all competition—special tube arrangement, tapped antenna coil, voltmeter, push-pull volume control and dozens of others, all unique.

Then there is the King Five Broadcast Receiver which embodies tone, selectivity, distance, volume and beauty at prices which anyone can afford.

These receivers represent the two circuits which have been proven best by popular demand.

Knock-down kits and a full assortment of parts complete the line.

"KING IN RADIO" products are backed by the King reputation—twenty years in the making of precision parts plus fifteen years of radio research, an eight acre plant, a world-wide sales organization.

A national advertising campaign just getting under way will bring "KING IN RADIO" to the attention of more than twenty million possible radio buyers—Saturday Evening Post, Country Gentlemen, leading radio publications and newspapers backed by direct mail.

Write for our new Catalog showing the "King in Radio" line.

KING QUALITY PRODUCTS, INC., Buffalo, N. Y.

BRANCHES: CHICAGO — KANSAS CITY — BRIDGEBURG, ONT.

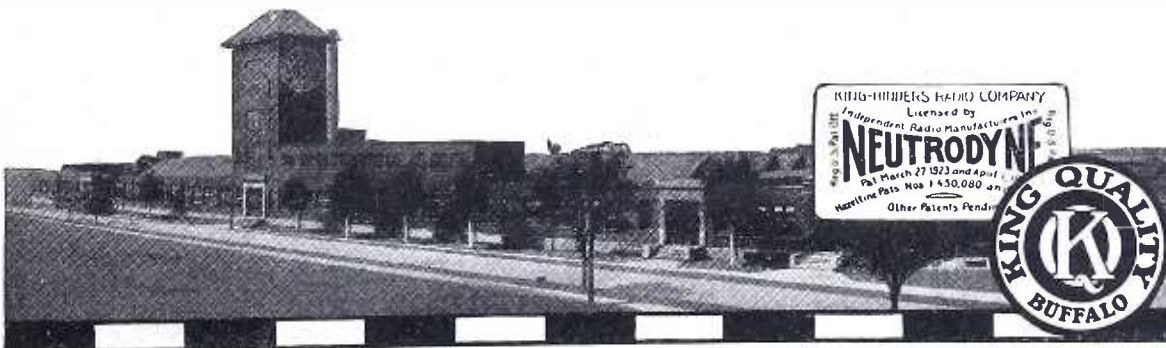

KING-HINNERS RADIO COMPANY
Licensed by
NEUTRODYNE
Independent Radio Manufacturers Inc.
Pat. March 27 1923 and April
Nashville Pats. Nos. 1,430,000 and
Other Patents Pending



All apparatus advertised in this magazine has been tested and approved by POPULAR RADIO LABORATORY

The Highest Class Receiver in the World

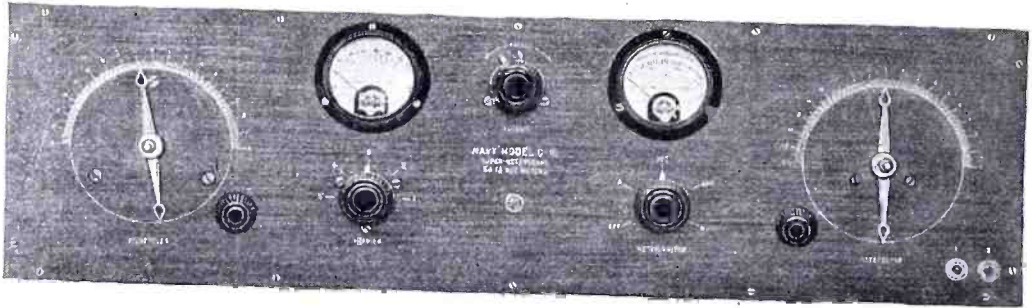

Navy Model C-10 Super-Heterodyne

For any Circuit

Prompt shipment can be made on tested, standard apparatus of the following manufacture:

E. I. S., Inc.
General Radio
Willard
Benjamin Electric
Allen Cardwell
Dubilier **Formica**
Western **Magnavox**
Jewell **Amer Tran**
Western Electric
Radio Corporation
Music Master **Acme**
Cutler Hammer **Frost**
Federal **Kellogg**

Wavelength range 50-600 meters with removable Coils. Dimensions 28 in. x 8 in. x 8 in. Only two major tuning adjustments. Total amplification almost 2,000,000 times.

A high powered 10-tube Broadcast Receiver capable of receiving over 3,000 miles under favorable conditions, and having a degree of selectivity far in advance of others.

We believe the Navy Model C-10 represents final superiority over any receiver now being manufactured or even contemplated for broadcast reception.

Illustrated descriptive matter gladly mailed upon request. Write direct to

NORDEN-HAUCK, INC.

Engineers

1617 Chestnut St., Philadelphia, Pennsylvania

EBY PATENTED BINDING POSTS

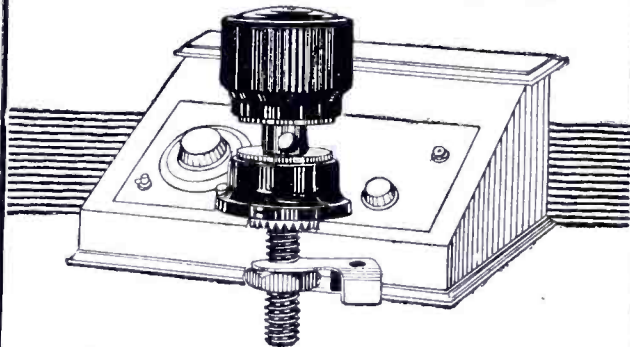

Standard Equipment On 150 Manufacturers' Sets

Unvarying, built-in superiority made them select EBY posts. They are *your* logical choice, too.

Furnished either plain or engraved in twenty-five different markings and the base of every post is clearly marked EBY.

The Tops Don't Come Off

15c — At All Dealers — 15c

The H. H. EBY MFG. CO., Phila., Pa.

AP COILS & COILS

TOROIDALS

Set Manufacturers

We are equipped with Automatic Machinery and are in a position to manufacture Precision wound, toroidal coils on forms to manufacturers' specifications. Reliable set manufacturers are invited to submit specifications.

ACME PRODUCTS CO

107 W. Canton St.

Boston, Mass.

All apparatus advertised in this magazine has been tested and approved by POPULAR RADIO LABORATORY

GENERAL RADIO

Transformers

bring out
all the
Refinements
of
Tone Quality

USE A 6 to 1 RATIO
IN THE FIRST STAGE
AND A 2 to 1 IN THE SECOND

\$ 6 each



Two Ratios—New Prices

The better loudspeakers today are capable of reproducing music with all its truest refinements of tone quality. Consequently a higher standard of transformer design is necessary to deliver to the loudspeaker the desired volume with a purity of tone that makes radio reception delightfully natural.

In designing the General Radio Type 285 transformers great stress has been laid upon tone quality—yet volume has been increased to a very marked degree.

Due to the special design of the core and adjustment of the coil turns these transformers are capable of high and even am-

plification of all tones common to speech, instrumental and vocal music.

In spite of the pronounced superiority over other transformers they sell at a popular price.

Enjoy music in its unmodified form—as pure, full and natural in tone as it enters the microphone at the studio of the broadcasting station. Use a 6 to 1 ratio in the first stage and a 2 to 1 in the second.

Ask to see them at your local dealers' or write for our descriptive folder 285-P showing Amplification curves and wiring diagrams.

GENERAL RADIO Co

Cambridge, Mass.

“Behind the Panel of Better Built Sets”

All apparatus advertised in this magazine has been tested and approved by POPULAR RADIO LABORATORY

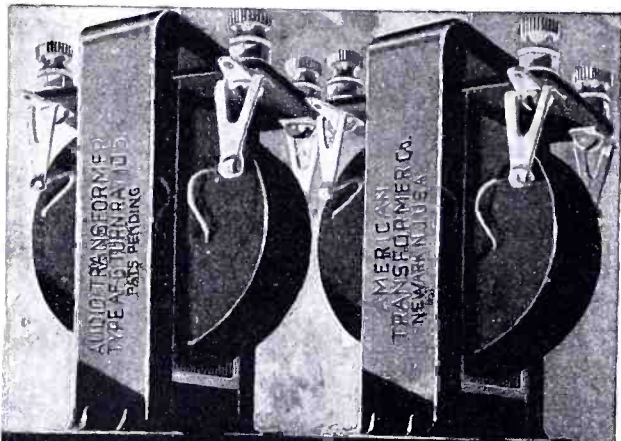

Better Than Required!

The AmerTran isn't made to sell where price and cheapness displace value and quality.

It is a safe product of long standing. Correct scientific design, and the recognition of exact operating conditions are the requirements the AmerTran meets—truthfully.

Better than required construction means dependable, efficient audio amplification—the only kind you really want to pay for.

Buy AmerTrans by the Pair!

AmerTran is made in two types, one quality—AF6, ratio 5:1 and AF7, ratio 3½:1. Price either model, \$7.00 at your dealer's.

AMERICAN TRANSFORMER COMPANY

175 Emmet St., Newark, N. J.

"Transformer builders for over 24 years"

AMERTRAN

TRADE MARK REG. U.S. PAT. OFF.

Another Achievement!



\$5.00
per
set

PRECISION R. F. COUPLING UNIT

May be used as a transformer for coupling two tubes in a circuit as a radio frequency amplifier. Specified for use with the McCulloch AC Tube, as described in June Popular Radio. Designed for present broadcast range in conjunction with a standard .0005 mfd. variable condenser. The coupler consists of a compact primary winding to be connected to plate circuit of one tube and a split secondary winding, half on each side of the primary, to be shunted with the tuning condenser and connected in grid circuit of following tube.

The design is such that an amplifier built with this apparatus makes possible extremely sharp tuning with maximum signal strength and stability of operation.

Made by the makers of the famous Cockaday Coil.

At your dealers, otherwise send purchase price, and you will be supplied postpaid

Precision Coil Company, Inc.
209-B Centre St., New York City



DUPLEX

DUPLEX STANDARD "None better made"

Conform to Bureau of Standards specifications. Rugged construction assures permanent alignment.

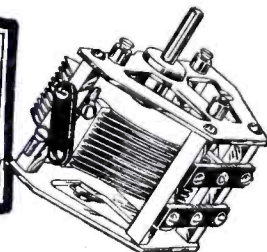

DUPLEX MATCHED CONDENSERS

ALWAYS READ ALIKE



ONLY ONE NUMBER TO LOG

Or eliminate logging—Dial by call letters or wave lengths. Specially tested and guaranteed. Matched, packed and sealed, to remain unopened until used. Literature on request.

DUPLEX CONDENSER & RADIO CORPORATION
50 Flatbush Ave. Extension, Brooklyn, N. Y.

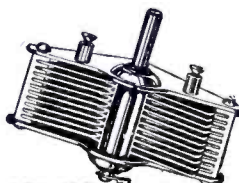

DUPLEX JUNIOR "Best at the price"

A good, low-priced condenser. Die-cast rotor. Bakelite insulation. Many other features.

CONDENSERS

All apparatus advertised in this magazine has been tested and approved by POPULAR RADIO LABORATORY

Music Master Receiving Sets

A Logical Development

Music Master

*Resonant Wood
Insures Natural
Tone Quality*

TYPE 300

Five Tubes. Connect with standard bell or cabinet type MUSIC MASTER Reproducer or with specially designed art model reproducer illustrated. Great selectivity, extraordinary volume, wonderful tone quality. Solid mahogany cabinet, beautifully ornamented, brown mahogany art satin finish. \$300
Price

MUSIC MASTER Reproducer Model XII, Drum Type. Specially designed art model illustrated. \$35
Price

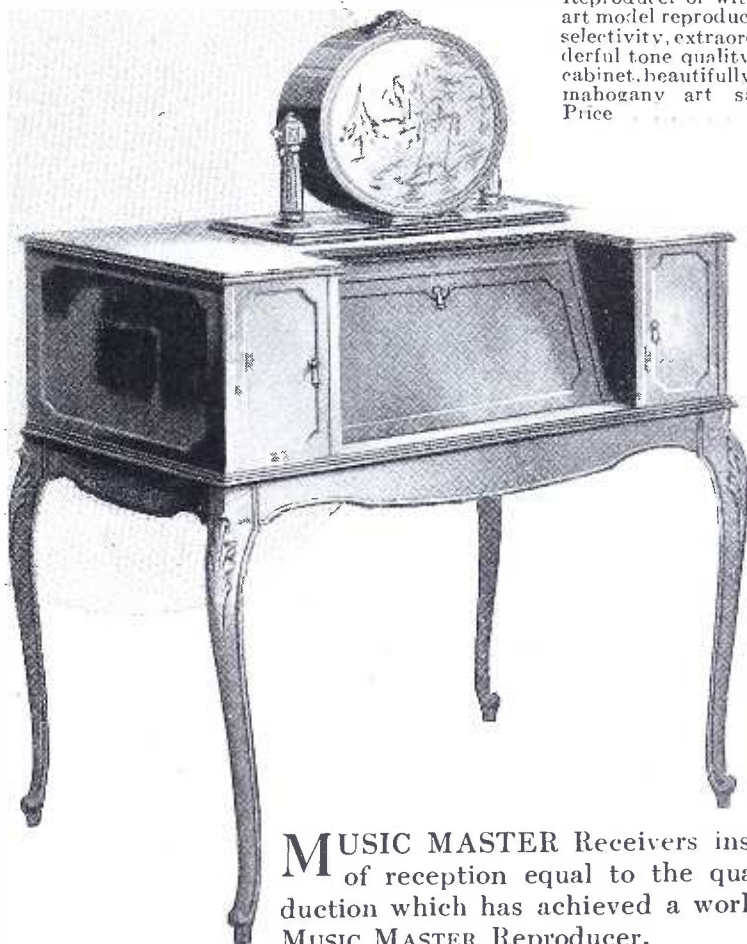

*Canadian
Prices
Slightly
Higher*

MUSIC MASTER Receivers insure efficiency of reception equal to the quality of reproduction which has achieved a world-standard in MUSIC MASTER Reproducer.

Combining the proved powers of MUSIC MASTER reception and the demonstrated supremacy of MUSIC MASTER reproduction in one splendid radio ensemble of supreme efficiency, MUSIC MASTER reasserts its pre-eminence as the *Musical Instrument of Radio*—there IS no substitute.

Authorized dealers everywhere are ready to demonstrate radio as you have always wanted to hear it. See Music Master—hear—compare—before you buy ANY radio set.

Music Master Corporation

Makers and Distributors of High-Grade Radio Apparatus
CHICAGO PHILADELPHIA, 128-130 N. Tenth St. MONTREAL
NEW YORK Canadian Factory: Kitchener, Ontario PITTSBURGH

*Ten Models \$50 to \$460
Guaranteed Unconditionally*

*Sold by Authorized Music Master
Dealers Everywhere*

MUSIC RADIO MASTER PRODUCTS

All apparatus advertised in this magazine has been tested and approved by POPULAR RADIO LABORATORY

Parts for a Thousand and One Hookups Always Obtainable at Morisons!!!

And you will also get — Morison service, expert advice, high quality, fair prices

COCKADAY'S 8-TUBE SUPER-REFLEX RECEIVER

(See January Popular Radio)

- 1 General Instrument Low-Loss Condenser (isolanite insulation) .001 mfd. \$5.00
 - 1 General Instrument Low-Loss Condenser (isolanite insulation) .001 mfd. 6.50
 - 1 Set of 4 Matched Haynes-Griffin Intermediate Transformers 20.00
 - 1 Precision Autodyne Coupler 3.50
 - 1 Karas-Harmonic Audio-Frequency Transformer 7.00
 - 1 Amplex Grid-leak .0005 mfd. 1.25
 - 1 Benjamin Cle-rane Socket 1.00
 - 7 Federal Sockets No. 16 ea. \$1.20 8.40
 - 1 Patent Double Circuit Jack60
 - 1 Patent Single Circuit Jack 1.50
 - 2 Na-aid 4 inch Dials No. 3043 ea. .75 1.50
 - 1 Amco 2 Ohm Rheostat 1.35
 - 1 Amco Potentiometer 400 Ohms 1.50
 - 2 Daven Resisto coupler mountings ea. \$1.00 2.00
 - 1 Daven Grid-leak Mounting35
 - 2 Daven Resistor .5 Megohms ea. 50 1.00
 - 1 Daven Resistor .5 Megohms 50
 - 1 Daven Resistor .25 Megohm 1.00
 - 1 Daven Resistor .25 Megohm ea. 50 1.00
 - 1 Radion Panel 7x24 ins. 3.00
 - 2 .0001 N. Y. Coil Mica Condensers ea. 3570
 - 4 .006 N. Y. Coil Mica Condensers ea. 75 3.00
 - 1 .00025 N. Y. Coil Mica Condenser with Grid-leak Mounting45
 - 1 Duratran Radio-Frequency Transformer 4.00
 - 1 Walbert A Battery Switch50
 - 1 Baseboard 9 3/8 x 22 3/4 x 1 1/2 ins75
 - 1 Connection Block 1 x 9 x 3-16 ins25
 - 7 Eby Binding Posts ea. 15 1.05
 - Material for making brackets25
 - 1 Korach Tuned Loop 16.50
 - 1 Mahogany Cabinet 12.50
- \$103.90**

TOWN AND COUNTRY RECEIVER

(See May Popular Radio)

- 1 Remler Variable Condenser .00035 \$5.00
 - 1 Amco 20-Ohm Rheostat 1.25
 - 1 Amco 400-Ohm Potentiometer 1.50
 - 2 Cutler-Hammer Battery Switches ea. 60 1.20
 - 1 Adams Jack No. 50170
 - 1 Adams Jack No. 50180
 - 1 Dubilier .00025-.601 Condenser45
 - 1 Dubilier .00025-.601 Condenser35
 - 1 Daven 4 meg. Resistance50
 - 6 Benjamin No. 199 Sockets ea. \$1.00 6.00
 - 3 Dubilier Duratrans ca. 4.00 12.00
 - 2 Patent Audioformers No. 26 ca. 5.00 10.00
 - 9 Eby Binding Posts ea. .15 1.35
 - 1 7 x 18 Radion Panel25
 - 1 Brass Strip for Brackets15
 - 1 Hard Rubber Strip 1 x 9 ins.25
 - 1 Baseboard 7 x 16 3/450
 - 1 Lengths Bus Bar50
 - 15 Lengths Bus Bar ea. .0230
 - 1 7 x 18 Cabinet 7.50
 - 1 Hoyt Bezel Hole 0-6 Voltmeter 3.00
- \$65.35**

McCULLOUGH AC 5-TUBE RECEIVER

(See June Popular Radio)

- 1 General Radio Variometer No. 269 \$5.00
 - 2 Precision R. F. Coupling Units 5.00
 - 2 Hammarlund .0005 10.00
 - 5 Federal Sockets No. 16, 1.20 ea. 6.00
 - 1 General Radio Audio Transformer No. 285 7.00
 - 1 Daven Mtg. No. 41 1.00
 - 2 Dubilier .003 Cond. No. 601 ea. .75 1.50
 - 1 Daven Resistor .25 Meg.50
 - 1 Daven Resistor 4 Meg.50
 - 1 Daven Resistor .5 Meg.50
 - 1 Dubilier Condenser .00025 No. 601-G45
 - 1 Dubilier Condenser .00015 No. 60135
 - 1 Dubilier Condenser .0001 No. 60135
 - 1 Patent Jack No. 61 S. C.50
 - 1 Radion Panel 7 x 24 3.00
 - 1 Baseboard 9 3/8 x 22 3/475
 - 1 Antenna Binding Post Strip15
 - 1 Battery Binding Post Strip25
 - 1 Cabinet 7 x 24 12.50
 - 3 4 inch Kurs Kash Dials 3.00
 - 1 Dongan Transformer 6.00
 - A. C. Leads 1.50
- \$65.80**

McCullough AC Tubes \$6.00 each

Ask for any Parts you can't get
WHOLESALE RETAIL



15 East 40th Street, New York City

Establish connections with Morison now before the fall rush begins. C O D Mail Orders filled promptly.

WRITE TODAY!

**JUST ONE LAZY TUBE
MAY BE TO BLAME FOR
LACK OF VOLUME OR FAILURE
TO GET DISTANT STATIONS!**

*This Simple
Tube Tester
Quickly Reveals
Many Troubles
Which Might Other-
wise Take Hours to Find.*



THE success or failure of any set often hinges on the quality of one tube. This tube may "glow" like the others and still be a poor amplifier. A tube that is good today may be poor tomorrow.

The only way to know true conditions is to check the tubes with a scientific instrument. The Sterling Home Tube Tester will show you in less than half a minute whether a tube is good, fair or poor.

Act now—the sooner you get your Sterling Tube Tester the sooner your trouble vanishes.

THE STERLING MANUFACTURING CO.
Cleveland, Ohio, Dept. C.

Price \$8.50



Ask for interesting bulletin on tube testing. It's free.

Steinite LOW LOSS Interference Eliminator

What Every Radio Owner Needs

Tested and approved by the Popular Radio Laboratory Over 36,000 Sold First 6 Weeks. Now you can select stations at will, cut out interference and undesired stations—tune in loud and clear. Wonderful results with tube or crystal sets of any make using any kind of aerial except loop antenna.

Reduces Static

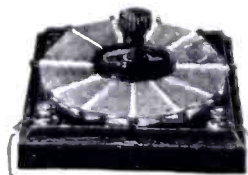

\$1 Postpaid
Amazing satisfaction. Better reception guaranteed or your money cheerfully refunded.

Select Stations At Will

Put this interference eliminator on your set—that's the test—no tools attached in two minutes to aerial. Doesn't disturb present log. Directions easy to follow. No additional tubes or batteries. Two big banks testify to our reliability. Order today—dollar bill will do—we take the risk—money back if you say so.

**STEINITE LABORATORIES
Manufacturers**

134 Radio Building, ATCHISON, KANSAS

Write for complete radio literature—it's FREE. Steinite sharp tuning summer sets. Most beautiful and least expensive radic sets in America.

Jobbers—Dealers: Write today for full description and prices Steinite nationally known popular price radio sets, interference eliminator, and long distance crystals.

All apparatus advertised in this magazine has been tested and approved by POPULAR RADIO LABORATORY

DAVEN TUBES

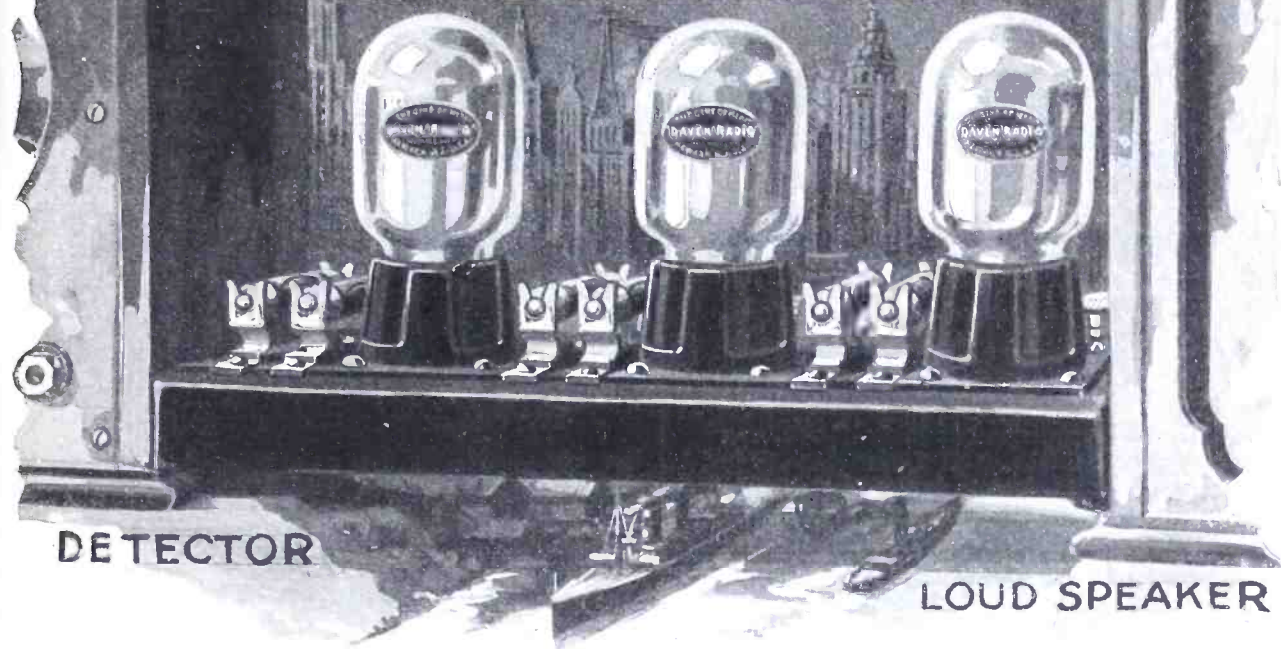

The Bridge to Amplification Without Distortion

Daven engineers were pioneers. They blazed the way for others to follow. They designed and built the first Resistance Coupled Amplifier offered the public. They found resistance coupling in an experimental stage. They perfected it.

Daven Resistance Units, Amplifier Kits and Super Amplifiers are accepted by the foremost authorities in Radio as standard. The Daven Super Amplifier, for use in any known set or circuit, is priced at \$15.00.

A NEW TUBE BY DAVEN

To meet the exacting requirements of Resistance Coupled Amplification the Daven Radio Corporation has created a new product—the DAVEN HIGH MU VACUUM TUBE, Type MU 20. It is designed for one specific purpose only—to increase the amplification of the Daven Resistance Coupled Amplifier so as to exceed that of ordinary audio frequency coupling.

The Daven High Mu is a 6 volt $\frac{1}{4}$ ampere tube with an amplification constant of 20. The price is \$4.00.

DAVEN PRODUCTS ARE SOLD ONLY BY GOOD DEALERS.

"The Sine of Merit"

DAVEN RADIO CORPORATION

Resistor Specialists

NEWARK

Reg. U. S. Pat. Off.

NEW JERSEY



Resistor Manual

Manufacturers of high grade sets are turning to Resistance Coupled Amplification in increasing numbers. The authority on Resistance Coupled Amplification is *The Resistor Manual*. You can buy it at your dealer's, price 25c; or we will send it postpaid on receipt of 35c.

All apparatus advertised in this magazine has been tested and approved by POPULAR RADIO LABORATORY



**All the Precision
Rigidity
Selectivity**

**for which D X L is famous
found in Model C**

the NEW
**Single End Plate
CONDENSER**

FOR the first time the permanent qualities found in high priced double end plate condensers are accomplished in Model C, the new Single End Plate Condenser by D X L.

Leading engineers pronounce Model C a marvel of design and workmanship. Great economy in materials and manufacture brings this remarkable condenser within the reach of Receiver manufacturers who want quality.

Performance in all types of sets, built up with D X L Model C's, is vastly improved.

The first glance or long tests will convince you of the quality of Model C. Sturdy and selective.

SET MANUFACTURERS

Priced attractively on contracts. Inquire at once before output is absorbed. Our engineers at your disposal.

JOBBERS

Electros ready for catalogs. A complete line of quality condensers. D X L Products are absolutely guaranteed.

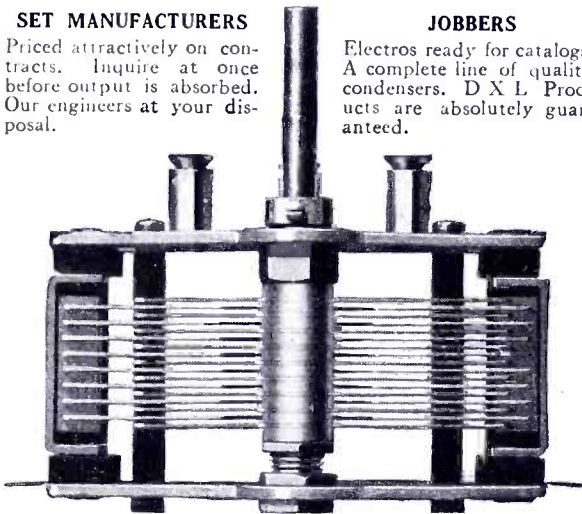

TRADE **DXL** MARK

RADIO CORPORATION

5767 Stanton Ave., Detroit, Mich.



**THERE'S
A
REASON!**

The fine, clear tone and volume of the Kellogg Symphony Reproducer is due to the Kellogg unit with the magnetic diaphragm control.

This exclusive Kellogg principle has produced wonders in the accurate reproduction of voice and music; piano music is unusually fine, the lowest tones of the saxophone to the highest of the violin are as clear as a bell, the soprano voice can really be admired.

Observe the rigid construction of this unit, the exactness of every detail, the size of the magnets. The *unit is the reason.*

See one at your dealers today.

Kellogg Switchboard & Supply Co.
1066 W. Adams St., Chicago, Ill.

With every Kellogg radio part, Use—Is The Test



KIC-O
STORAGE 'B' BATTERIES

**"B" ELIMINATOR
SIMPLICITY**

**PERMANENT
ALKALINE STORAGE
BATTERY RECEPTION**

KIC-O MULTI-POWER UNITS operate from your lighting line and eliminate the replacing of dry cell "B" batteries... usually saving their cost in the first six to twelve months of service on Neutrodyne and Super Heterodyne sets.

Its RECHARGER is attached to back.

Guaranteed Two Years

PRICES
MULTI-POWER UNITS
(Complete)

130 volt P. U. . . . \$43.50
100 volt P. U. . . . \$35.00
100 volt C. U. . . . \$32.50

Power—**E**conomy—**P**erformance
Unexcelled for better Radio.
Backed by years of research.

WRITE NOW FOR SPECIAL FREE TRIAL OFFER! DEALERS! EVERYBODY!

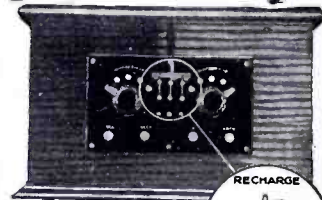

Kimley Electric Company, Inc.
2667 Main Street
Buffalo, N. Y.



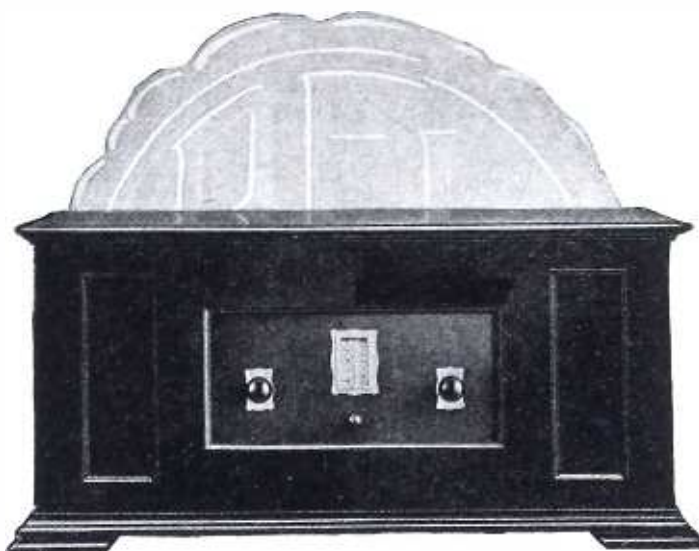

RECHARGE
RECEIVE

All apparatus advertised in this magazine has been tested and approved by POPULAR RADIO LABORATORY

Announcing the Results of an Ideal

THREE YEARS ago a group of men organized the Radio Frequency Laboratories, Inc., because they believed in the future of the radio industry. One result has been the development of a broadcast receiving system which is unique in its combination of power with simplicity.

This new receiver is believed to be a near approach to the ideal home radio equipment. It employs a novel high frequency amplifier and filter system which opens an entirely new range of possibilities in radio reception.

The usual complication of tuning dials gives place to a single illuminated selector. The uncertain hunt for stations and wave-lengths is eliminated, since this selector carries a permanent wave-length scale which is accurate under all operating conditions.

A group of well-known and substantial manufacturers will make available to the radio public the RFL receiver—certain models of which will appear on the market during the present year. Further announcements later.

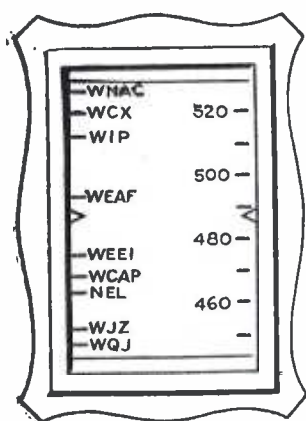

**Illuminated
Station Selector operated
by knob at right of panel.
Volume control at left.**

**RADIO FREQUENCY LABORATORIES, Inc.
Boonton, New Jersey**

All apparatus advertised in this magazine has been tested and approved by POPULAR RADIO LABORATORY

The New UNIVERSAL PLIO 6

Tunes All Wavelengths
Within Distance Range of This Receiver



AUSTRALIA		
2FC	Sydney	1100 meters
3LO	Melbourne	1720 meters
5MA	Adelaide	850 meters
BELGIUM		
BAV	Brussels	1100 meters
CZECHO-SLOVAKIA		
PRG	Prague	1800 meters
OKP	Kbely	1150 meters
DENMARK		
OXE	Lungby	2400 meters
FRANCE		
FL	Eiffel Tower	2600 meters
GERMANY		
LP	Berlin	2370 meters
POZ	Nauen	2800 meters
ENGLAND		
5XX	Chelamsford	1500 meters
2LO	London	365 meters
HOLLAND		
PA5	Amsterdam	1050 meters
PCFF	Amsterdam	2000 meters
ITALY		
ICD	Rome	470 meters
SPAIN		
EBX	Cartagend	1200 meters
SWITZERLAND		
HB2	Lausanne	850 meters
HB1	Geneva	273 meters
UNITED STATES		
KDKA	Pittsburgh	64 meters
WGY	Schenectady	390; 38 and 109 meters

And all other Broadcasters

LITERATURE READY

SEND
COUPON
NOW

GOLDEN-LEUTZ, INC.
476 Broadway, New York City

Name.....
Address.....
City..... State.....

LAST
A S I T
T I T E

the
centered
terminal

Lastite
is Radio's only
perfect, permanent
Contact.

This fact is of the utmost interest to all Manufacturers, and all set builders, who seek to eliminate a prevailing fault of radio circuits - the common nut-and-lug connection that after a time works loose.

If your intention is to permanently sustain the precise functions of your apparatus, by having it in dependable circuits, you will find the Lastite is preeminently necessary.



Manufacturers and Distributors,
write or telegraph for samples

William Stevens Co.,
27 Hammatt Road, Roslindale, Mass.

PATENT APPLIED FOR

Send for
FREE Bulletin 94

Whether you plan to build or to buy a receiving set, it will pay you to know something about the "insides" of radio. This booklet gives you the "inside dope" on some of the recent inventions embodying the latest ideas of radio engineers. In this bulletin is full information about the

Premier "HEGEHOG"
Audio Transformer

Ratios 1 to 3, 1 to 4 and 1 to 5, \$3.50 Ratio 1 to 10, \$4.50

This light weight audio transformer has earned a place in the very front rank for its remarkable volume, and pure, natural tone. It is 100% self shielded against foreign noises.

It cuts the space requirements for audio transformers in two. Ideal for neat and compact wiring, and for portables.

FREE HOOK-UP DIAGRAMS also sent on request. All popular types. Address

PREMIER ELECTRIC CO.

3807 RAVENSWOOD AVE., CHICAGO

PREMIER
Quality Radio Parts



All apparatus advertised in this magazine has been tested and approved by POPULAR RADIO LABORATORY



The original Type 285 Transformer, Ratio $4\frac{1}{2}$ to 1. Distortionless, due to 100% balance between impedance and magnetic field. Uniformity guaranteed. Price, \$5.00.

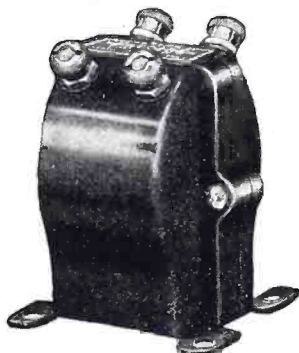

Eclipse, Ratio $2\frac{1}{2}$ to 1. Three audio stages are made practical by these transformers. Price, \$4.00. Comet, Ratio $3\frac{1}{2}$ to 1. Encased same as above. A fine low-priced transformer of popular ratio. Price each, \$3.25.

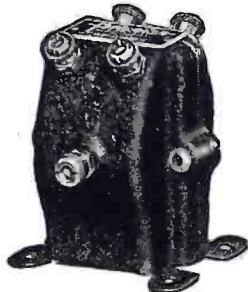

Push and Pull Set. No.800(Input). No. 801 (Output). Power amplifying transformers giving precision results because laboratory matched. Price per pair, \$11.00



Super-Multiformer, No. 1700. Read main text for description. 4 stages long wave R. F. intermediate amplifier (45K.C). Improves all "Supers." Price, \$20.00.

Instruments of Laboratory Precision At Commercial Prices

PRECISE instruments are designed and perfected by the use of measuring, weighing and testing equipment which we believe is not excelled by any equipment other than that of the Bureau of Standards. But the Precise Manufacturing Corporation has applied to the laboratory the same principles of economy and efficiency usually applied only to the factory. The resulting remarkable uniformity, splendid finish and better performance of Precise Products at their reasonable price is making Precise standard among discerning set builders and among dealers who value their trade. Precise Products are unqualifiedly guaranteed.

The present Precise transformer line meets practically every need of ratio, application and price. A new transformer is soon to be announced which will make the line absolutely complete.

In Radio Frequency too, Precise Excels The SUPER-MULTIFORMER

The absolute matching of the four 45 K. C. stages of the SUPER-MULTIFORMER is the marvel of radio engineers, all superheterodyne owners and experimenters who have tried it with any of the standard "super" hook-ups.

Write for Booklet on the McLaughlin One Control "Super"

This exhaustive treatise with full construction details and designs was printed to sell at one dollar. Owing to the growing interest in long wave intermediate radio frequency amplifiers we are mailing it for the small price of 25c. Get your copy at once before it is out of print.

Look for the Announcement of the New Precise Synchrodenser next month It's Revolutionary

PRECISE MANUFACTURING CORPORATION ROCHESTER, NEW YORK

BRANCHES

53 W. Jackson Blvd., Chicago
821 Market St., San Francisco
Eastern Sales Office—Niagara Sales Corp., 3-5 Waverly Place, N. Y. City
Southern Representatives—Saal Products Sales, Inc., 35 Warren Street, New York City
CANADIAN DISTRIBUTORS
Perkins Electric, Ltd.
Toronto, Montreal, Winnipeg

PRECISE TRANSFORMERS

All apparatus advertised in this magazine has been tested and approved by POPULAR RADIO LABORATORY

At Last a Twin Bulb Charger



\$14 LIST (without bulbs)
East of the Rockies

Absolutely Quiet

The New Twin Bulb Handy Charger is absolutely noiseless. It will charge "A" batteries, any voltage from 2 to 12 Volts and "B" batteries from 24 to 120 volts. The two bulbs double the speed of the average bulb charger giving a speed to the Handy of 4 to 5 amperes per hour to a six Volt Battery.

TWIN BULB HANDY CHARGER

Speed—4 to 5 Amperes
"A" Batteries 2—12 Volts
"B" Batteries 24—120 Volts

The New Twin Bulb Handy Charger is fire-proof. Even if allowed to run for several days there is no danger of fire or overcharging the battery. It requires no care when in or out of use.

A Full Wave Charger

The New Twin Bulb Handy Charger employs the advanced "Push-Pull" principle, using both halves of the AC wave, thus obviously making it a highly efficient charger.

See your dealer for a demonstration today or write us for literature.

INTERSTATE ELECTRIC CO.
4339 Duncan Ave., St. Louis, Mo.

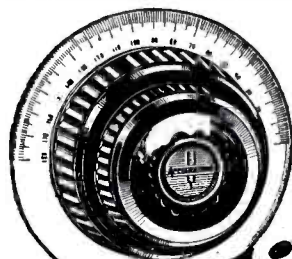

Pat. April
21-25
Other
Patents
Pending

Essential for summer tuning

In summer, when static is apt to prove most active, the uncanny precision of the Accuratune, geared for coarse or fine tuning on an 80 to 1 ratio, is particularly appreciated. It tunes in stations clearly and strongly, and tunes out interference effectively, all as a matter of course.

MYDAR RADIO CO.
5 CAMPBELL ST. NEWARK, N. J.

ACCURATUNE
REGISTERED GEARED 80:1 U.S. PAT. OFF.

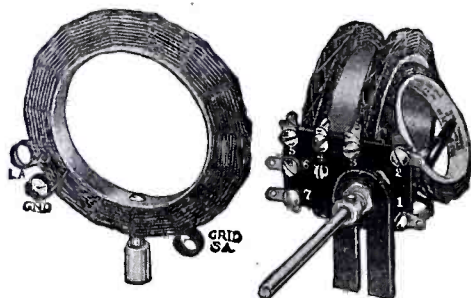

Coil Set No. 24 for Browning-Drake Circuit

SICKLES Diamond Weave Coils

(Patented Aug. 21, 1923)

*For Browning-Drake, Roberts, Craig,
and Hoyt Circuits*

Sickles Coils for the famous Browning-Drake Circuit are the latest Sickles achievement in efficient design for a particular use. They are priced at \$7.50 a set.

The New No. 18 A Coils for any Roberts Circuit are absolutely standard equipment. They are priced at \$8.00 per set.

Coil Set No. 20, at \$4.50, is for use specifically with the New Reflex Receiver designed by Albert G. Craig using the Sodian detector.

Coils for the Hoyt Circuit at \$10.00 a set for the Knock-out Reflex Circuit at \$4.00 a pair, and the Tuned Radio Frequency coils at \$2.00 each are other standard Sickles Coils. We manufacture also for manufacturers special requirements.

Send for descriptive catalog

The F. W. Sickles Company
339 Worthington St., Springfield, Mass.

All apparatus advertised in this magazine has been tested and approved by POPULAR RADIO LABORATORY

PROFESSIONAL SET BUILDERS!

and
dealers who build sets

WE will shortly begin a series of newspaper advertisements, featuring the work of individuals and dealers who build sets using Cardwell Condensers.

If you build to specification or from original design, it will be to your interest to communicate with us immediately.

Ask for details of plan. Be sure to give name of your jobber.

**ALLEN D. CARDWELL
MANUFACTURING CORP.**

81 Prospect Street, Brooklyn, N.Y.

FOR UNIVERSAL USE

Either A. C. or D. C. 110 Volts

Any Cycle

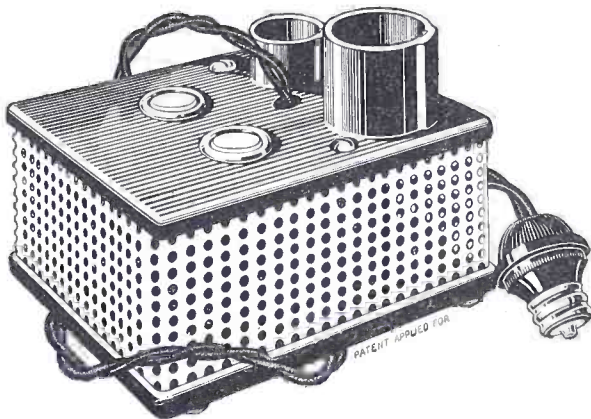

\$7.50

**BURTON & ROGERS
TUBE
FLASHER**

For 201A or 199 Type Tubes

HERE is a device, so simple that a child can operate it, and yet so effective that

NO RECEIVING SET IS COMPLETE WITHOUT ONE

It brings back to full efficiency your radio tubes that have begun to fail. It prevents run-down tubes from running down good tubes in the same set. It needs no attention—should last a lifetime.

When your tubes start to fail

FLASH 'EM

1. Connect device to any 110 volt lamp socket, A. C. or D. C.
2. Insert tube.
3. Press button opposite tube for exactly 45 seconds.
4. Release button and allow tube to glow for 10 minutes.

Unless the tube is entirely gone, this treatment will restore its radio qualities.

WRITE FOR PARTICULARS OR
ASK YOUR DEALER

BURTON & ROGERS MFG. CO.
755 Boylston St., Boston, Mass., U. S. A.

BIG MONEY!

\$3,000 to \$10,000 a year

Want to make big, easy money? Learn how to install, operate, repair, construct and sell Radios. Write now for facts about the amazing opportunities for Radio experts, and our special offer of a FREE 1000-mile receiving set, and how you can quickly train at home by mail.

Be a Radio Expert

No previous experience necessary. Anyone with ordinary education can now learn Radio quickly under our simplified home-study plan. We need men right now to represent our Association. Be the Radio expert in your neighborhood. Get your share of the big profits. Hundreds about you want Radios and advice how to operate. You can earn enough money right from the start to pay for course. Nothing difficult about it. Low cost and easy terms.

FREE
1,000-MILE
Receiving Set

Don't miss this big special offer to supply FREE all parts necessary to construct a high-grade 1000-mile receiving set. You can sell this set alone for practically the entire cost of the course. Send for the facts now. Find out all about this big-pay field. Address

Radio Association of America
4513 Ravenswood Ave., Dept. 58 Chicago, Ill.

for
**Finer
Tuning**

CHELTEN

**Low Loss
Midget
Vernier**

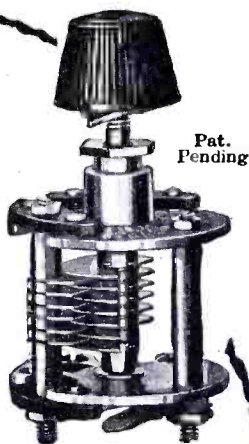

Pat.
Pending

Bridge meas. max. cap.
.000045 Mfd. Frequency
meas. max. cap. **\$1.50**
.000027 Mfd.

Use a plain condenser for rough tuning—then reach the peak of resonance by the fine adjustment possible only with the Chelten Midget. Takes up only 1 3/8" space. Used also as a stabilizer in most radio circuits. Remember, the Chelten is the original midget variable condenser. All others are imitations.

At Your Dealer's—or Sent Direct by Parcel Post

**CHELTEN ELECTRIC COMPANY
PHILADELPHIA**

SIMPLEX

Efficient devices bearing this name have made it one of the best known in radio. For instance—

Simplex SR-5 Receiver—a distance getter of full volume and clear tone at \$57.00.

Simplex 180° DX Tuner—much sharper than 90° coils. Spiral wound molded rotor.

Simplex 180° Variocoupler—especially well adapted to radio frequency circuits.

It's Lightning Arrester Time

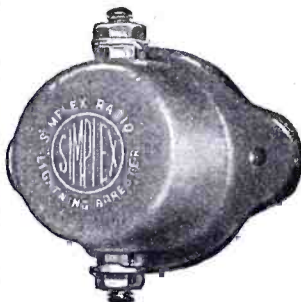

The Simplex gives complete safety. Air gap sealed in glazed porcelain housing. Weather proof. Listed as standard by National Board of Underwriters.

At your
Dealer's

\$1.50

**SIMPLEX RADIO CO., Mfrs.
1013-15 Ridge Ave., Philadelphia, Pa.**

"The Tube with a SENSIBLE GUARANTEE"

SUPERTRON
A SERIAL NUMBER GUARANTEE

PROTECTION!



An "unlimited," "unconditional," etc., guarantee with all kinds of promises is not sound—that's nonsense.

Specific limitations with means of identification is the only kind of guarantee that can be sound—that's sensible.

Each Supertron tube is serial numbered and wrapped in a guarantee certificate bearing a corresponding number for your protection.

Buy Supertron Fearless!
The dealers guarantee them fearlessly!

**PUBLIC DEMAND \$2.00
PRICE**
ALL TYPES

Supertron Mfg. Co., 32 Union Square, New York
Export Div., M. Simons, 220 B'way, N. Y.

BLUEPRINTS FREE

Your choice of any set of famous Popular Radio Simplified Blueprints sent absolutely free.

You know how helpful, interesting and practical POPULAR RADIO is. You fully appreciate that at \$3.00 a year it is a real bargain. Consequently you should find it easy to convince one, two or more of your friends, who are not now subscribers, of the unusual value when any one of these seven sets of Simplified Blueprints (described on page 42) is offered free with their twelve months' subscription for POPULAR RADIO at the regular price of \$3.00.

In addition to the Blueprints given to your friends we will allow you one set free for each new subscription you send us with a \$3.00 remittance. Five new subscriptions and remittance of \$15.00 would entitle you to five sets free.

Only one set of Blueprints free with a renewal subscription whether your own or a friend's.

POPULAR RADIO, INC., Dept. 83,
627 West 43d Street, New York City

Enclosed is my remittance of \$ covering annual subscription for POPULAR RADIO (names on sheet attached). Send me set(s) checked below.

- Set No. 4
- Set No. 6
- Set No. 7
- Set No. 8
- Set No. 9
- Set No. 10
- Set No. 11

(See page 42 for description of Sets)

Name

Address

Foreign postage 50c. extra. No extra for Canada.

McLAUGHLIN ONE-CONTROL SUPER

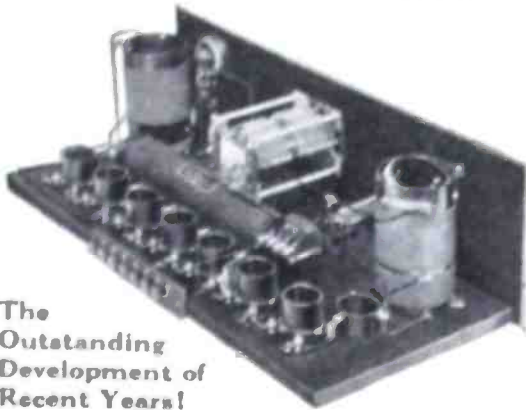

The
Outstanding
Development of
Recent Years!

Now Being Built in All Parts
of the World

Think of it! A real 7-tube Super having only one dial to turn over the entire broadcast range. Selectivity so sharp as to bring in two and sometimes three stations within one degree of the dial, and without a particle of interference. Powerful Pre-lac No. 1700 Super A transformer makes necessary only one stage of audio amplification for satisfactory loud speaker home volume. Tone quality of music absolutely life-like—no distortion. A great distance getter. Distant stations usually have about same volume as locals under normal conditions. All "official" instruments and parts are laboratory quality, including Low Loss coils, non-microphonic socket strip, automatic filament control jacks, etc. Easily and rapidly assembled from U-NI-Dial official McLaughlin Kit.

Descriptive Bulletin on Request

U-NI-DIAL RADIO CO.

35 Greenwood Ave. East Orange, N. J.

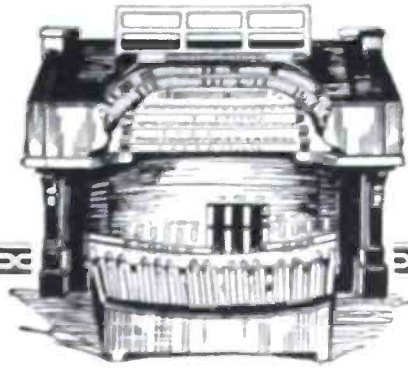

Majestic Roll of the Mighty Organ

Mighty tones from the noblest of musical instruments do not tax the resources of Rauland-Lyric. Accurately designed for faultless amplification, this instrument faithfully transmits all organ tones—from those of the piccolo stop down even to the lowest of the open diapason.

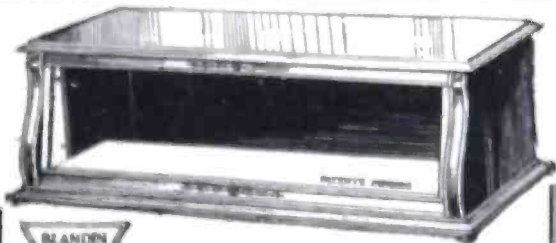

You'll Like This Duplex

One cabinet—
Any panel size, 7x26, 7x24, 7x21 or 7x18".
Depth 10". Room for all dry batteries.
Either straight or sloping panel—grooves,
no screws.

Solid mahogany. Latest lacquer hand-rubbed finish. Entire lid raises. Full length piano hinge. Folding lid supports. Felt covered feet. Extra 1/2" mounting board.

The new Blandin Console is ready for you.

Write for Duplex and Console illustrated price lists. Dealers, write your jobber.

Blandin
Radio Cabinets

Built by
BLANDIN
1500-16th St.
Racine, Wis.

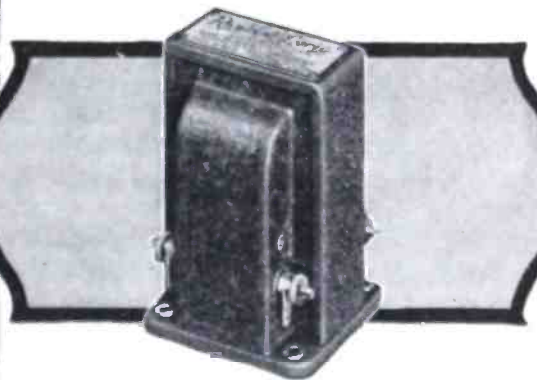

Rauland-Lyric is a laboratory-grade audio transformer designed especially for music lovers. The price is nine dollars. Descriptive circular with amplification curve will be mailed on request. All-American Radio Corporation, 4201 Belmont Ave., Chicago.

Rauland-Lyric
AN
ALL-AMERICAN
TRADE MARK
TRANSFORMER

The Choice of Noted Music Critics

NOT HURT

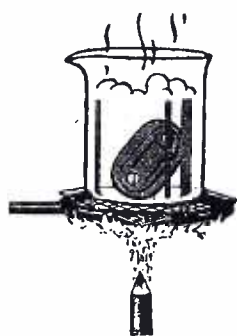

by boiling
or freezing



Sangamo Mica Condensers

An engineer engaged in research work for a large company needed condensers that would stand severe use and stay accurate.

So he took a Sangamo mica condenser and kept it in boiling water for several hours. Then he had it frozen into a cake of ice. When tested afterward, he found no change in the capacity. Even this severe treatment had no effect upon its accuracy! Your receiver will work far better with condensers that are accurate—and stay accurate.

Sangamo condensers are approved by every nationally recognized radio laboratory. They are guaranteed to be accurate within 10 per cent. of marked capacity and to sustain that accuracy. Soldering does not change the capacity. Neither does dampness nor salt air.

Their neat appearance appeals to those who are particular about good workmanship; solidly molded in smooth brown bakelite, all corners rounded, ribbed for mechanical strength, and decidedly easy to solder.

Made in all capacities from .00005 to .01 mfd. Prices are moderate. Supplied with resistor clips for 10 cents extra.

Good radio stores carry Sangamo Mica Condensers or can get them quickly from jobbers. Insist!



Sangamo Electric Company
Springfield, Illinois

RADIO DIVISION, 50 Church Street, New York

SALES OFFICES—PRINCIPAL CITIES

For Canada—Sangamo Electric Co. of Canada, Ltd., Toronto.

For Europe—British Sangamo Co., Ponders End, Middlesex, Eng.

For Far East—Ashida Engineering Co., Osaka, Japan

1320-6

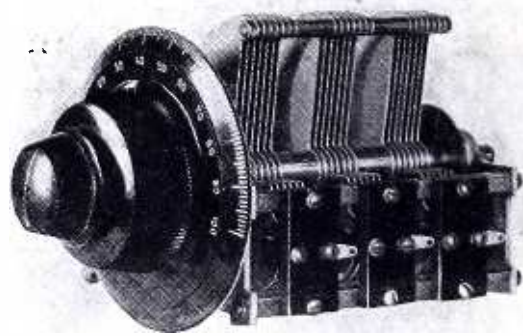

LOMBARDI STRAIGHT LINE CONDENSERS

(Wavelength or frequency rotor plates)

No Backlash—Geared Vernier—Pat. Pending
Separates the Short Wave Stations
In Multiple or Single Units
High Electrical and Mechanical Precision
Adjustable Ball and Taper Bearings
Watchspring Pigtail on Rotor

ADVANCED DESIGN

No Compromise With Quality

FOR MANUFACTURERS
HOME SET BUILDERS

LOMBARDI RADIO MFG. CO.

67 Minerva Ave., Derby, Conn.

Multiple Condensers

Licensed Under Hogan Patent

The LARGEST RADIO STORES in AMERICA



Hook-ups!

All the latest and best Kits in our new

RADIO CATALOG

FREE

Just Out! Our new 1925, ninety-six page Radio Catalog including all the best and latest Kits, Parts and Accessories. Also our new 32 page bargain section—write for your FREE copy to-day!

Save Money! We buy up manufacturers' jobbers, and dealers surplus and bankrupt stocks—but only brand-new fully guaranteed, nationally advertised apparatus. Our enormous buying power permits us to pay spot cash and get rock-bottom prices—even way below manufacturer's costs. That's why our catalog is crammed with thousands of wonderful Radio Bargains.



509 So. State St., CHICAGO, ILL., Dept. P. R. 6

All apparatus advertised in this magazine has been tested and approved by POPULAR RADIO LABORATORY

Niagara Produces Another Wonder!



ARAGAIN Radio Receiver

THE SET THAT NEEDS NO EXCUSES

Combining extreme selectivity and exceptional tonal quality with ample undistorted volume, easily controlled.

It is a precision instrument, thoroughly tested before leaving the factory.

Some good territory still available for responsible Distributors. Write for details.

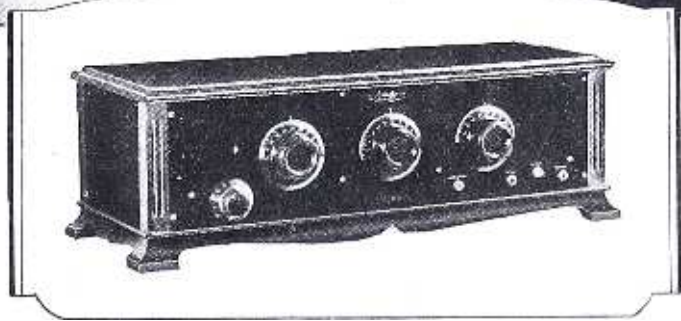

The ARAGAIN receiver illustrated is built by experienced craftsmen to a standard that will appeal to those who value quality based on sound engineering principles. It is the receiver of no regrets.

\$180.00 f. o. b. Niagara Falls

Autometal Corporation, 311 Falls St., Niagara Falls, N. Y.

INQUIRE
AT
YOUR DEALER'S
ABOUT THE
NEW TYPES
OF
U. S. TOOL
CONDENSERS



U. S. TOOL
COMPANY, INC.
AMPERE, N. J.

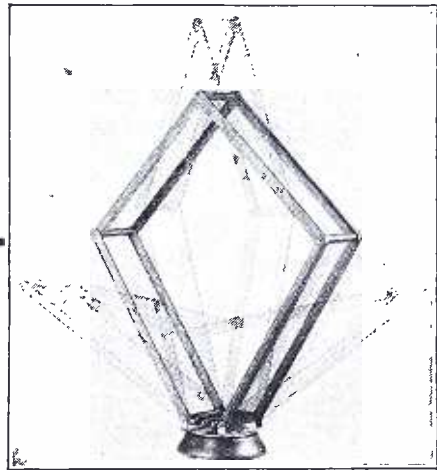

REG. U. S. PAT. OFF.
Infringements Vigorously Prosecuted

folds to any position THE AALCO LOOP *with wires always taut*
The newest addition to the line of quality Radio Accessories. Made of the highest grade materials throughout in a new and masterly design. Specifications: Length—24 inches, Normal Ht.—30 inches, Wave length range 120 to 600 meters. PRICE \$15.00

The "AALCO"

Is different both in appearance and operation. You will find that this new loop adds to the performance of your set. If your Dealer cannot supply you send money order, and we will ship direct.

JOBBERS

Write for our proposition

AALCO RADIO LABS.
6336 Cottage Grove Ave., CHICAGO

All apparatus advertised in this magazine has been tested and approved by POPULAR RADIO LABORATORY

The "WINDHAM" WIRE FORMER

A Handy Tool for Electricians, Radio Fans and Mechanics



This rugged little tool not only makes accurate loops or eyes for No. 4, 6, 8 and 10 screws but will make either sharp or easy radius right angle bends and the sharp cutter will cut the toughest wire as well.

It is drop forged of the very best steel and carefully tempered in oil.

Dealers and Jobbers send for full information Desirable territory still open

Retail Price \$1.25

THE GOYER COMPANY
Willimantic Connecticut



Keep up to the World with the

LIBERTY Sealed Five
News • Opera • Markets
National Events
Athletic Scores
Latest and Best in Music



Manufactured by

LIBERTY
TRANSFORMER CO., INC.
123 N. Sangamon St. CHICAGO, ILL.

FREE SIMPLIFIED BLUEPRINTS FREE

YOU CAN HAVE YOUR CHOICE OF ANY ONE OF SEVEN SETS

You can have your choice of any one of seven POPULAR RADIO Simplified Blueprints with your new or renewal subscription for POPULAR RADIO, accompanied by remittance of \$3.00. These Blueprints will make it possible for you to build a tested and approved set, while POPULAR RADIO for 12 months will keep you in touch with the progress being made in radio.

You, as a reader of POPULAR RADIO, know the many entertaining, interesting and instructive articles that are published each month. Every issue some new item is sure to attract your attention. We promise that throughout the coming months POPULAR RADIO will hold more and more of interest for Radio Fans.

Ease, Economy and Accuracy in Construction

Simplified Blueprints were prepared under the personal supervision of Laurence M. Cockaday. They make it possible for anyone, without previous knowledge of radio, to construct a highly efficient radio receiver. Each set of Blueprints consists of 3 prints as follows.

Panel Pattern

This Blueprint is the EXACT size of the actual set. So accurate that you need merely lay it on your panel and drill as indicated. You can readily appreciate the convenience of this Blueprint. No scaling or measuring to do, no danger of ruining the panel through faulty calculation.

Instrument Layout

Here again you have an actual size print of each instrument and binding post and its exact location both on the panel and within the cabinet. Even the cabinet structure is clearly shown.

Wiring Diagram

The unusual feature of this Blueprint is that it is an actual size picture diagram of the finished set. Each instrument and other parts appear in exact size and the wires are so clearly traced from one contact to another that you can connect all terminals accurately without even knowing how to read a hook-up diagram.

Set No. 4—"Cockaday Four-circuit Tuner with Resistance-coupled Amplifier" (five tubes, distortionless, two dials, automatic vacuum tube control) as described in October, 1924, POPULAR RADIO.

Set No. 6—"Cockaday 8-Tube Super-heterodyne Reflex Receiver" as described in January, 1925, POPULAR RADIO.

Set No. 7—"Craig 4-Tube Reflex Receiver with Sodian Detector Tube" as described in February, 1925, POPULAR RADIO.

Set No. 8—"Cockaday Improved DX Regenerative Receiver" (four tubes, distortionless, automatic filament control) as described in March, 1925, POPULAR RADIO.

Set No. 9—"The Portable Town and Country Receiver" (six tubes, three stages of transformer-coupled, radio-frequency amplification, loop antenna) as described in May, 1925, POPULAR RADIO.

Set No. 10—"The 5-Tube A-C Receiver" (five A-C tubes, two stages of tuned-radio-frequency amplification) as described in June, 1925, issue of POPULAR RADIO.

Set No. 11—"5-Tube Tuned Radio-Frequency Receiver with Simplified Control," as described in August, 1925, POPULAR RADIO.

Use coupon below; indicate which set of Blueprints you want.

POPULAR RADIO

Dept. 89

627 West 43rd Street

New York City

POPULAR RADIO, Dept. 89

627 West 43rd Street, New York City

Enclosed is my remittance of \$..... in full payment for subscription, with Blueprints as checked below, FREE.

- | | |
|--|--|
| <input type="checkbox"/> Set No. 4—Cockaday Four-circuit Tuner with Resistance-coupled Amplifier. | <input type="checkbox"/> Set No. 8—Cockaday Improved DX Regenerative Receiver. |
| <input type="checkbox"/> Set No. 6—Cockaday 8-Tube Super-heterodyne Reflex Receiver. | <input type="checkbox"/> Set No. 9—"The Portable Town and Country Receiver." |
| <input type="checkbox"/> Set No. 7—Craig 4-Tube Reflex Receiver with Sodian Detector Tube. | <input type="checkbox"/> Set No. 10—"The 5-Tube A-C Receiver." |
| <input type="checkbox"/> Set No. 11—5-Tube Tuned Radio-Frequency Receiver with Simplified Control. | |

Name.....
Street.....
City..... State.....

All apparatus advertised in this magazine has been tested and approved by POPULAR RADIO LABORATORY

Obsolete

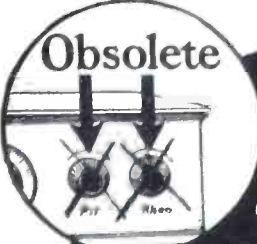

Take the
"GUESS"
Out of Tube
Control

With **\$ 1.10**
Everywhere

Amperite automatically controls tube current, eliminates hand rheostats, filament meters, guessing and all tube worry. Simplifies wiring, tuning and operation. Permits the use of any type of tube or any combination of tubes. Tested and used by more than 50 set manufacturers and in every popular construction set

RADIALL COMPANY

Dept. P.R.-11, 50 Franklin St., New York City

Write for
FREE
Hook-ups

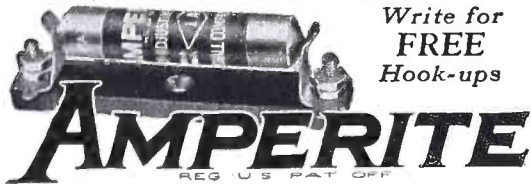

AMPERITE
REG. U.S. PAT. OFF.

The "SELF-ADJUSTING" Rheostat

"Use EMPIRE-TRONS and Hear the Difference"

EMPIRE-TRONS

RADIO TUBES

Not an Experiment

Built to the most exact and rigid requirements and have passed the most exhaustive tests, to prove their efficiency.

Lasting Qualities

Tests conducted recently, on an average run of **Empire-trons**, showed them still functioning perfectly after being in continuous operation 1200 hours, and without manifesting any signs of paralyzing—*these are facts!*



Each tube is a model of perfection.

Finest mechanical construction.

Tested in our Factory

Made in U. S. A.

Bakelite Bases

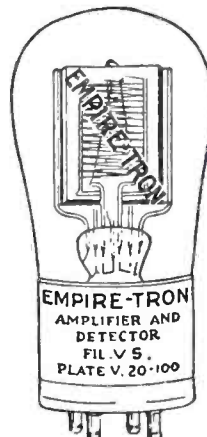

Type '99 also supplied with '01A base

Our Guarantee

Dealers are authorized to replace any EMPIRE-TRONS not giving satisfactory performance, through manufacturing defects, if returned to us within 60 days from date of purchase. Our policy is a protection to dealers and users, alike.

Approved by "Popular Radio" and "Radio News" Laboratories. Accepted by leading manufacturers as "standard."

EMPIRE-TRONS represent a superior Quality Tube, sold at a price to meet competition, but giving larger profits to dealers.

*Choice Territorial Rights
Are Open
Write for full particulars*

**AMERICAN-INTERNATIONAL
TRADING CO.**

24-26 Stone St., New York
Cable address "Stanmarks"

"Use EMPIRE-TRONS for perfect Radio Reception"

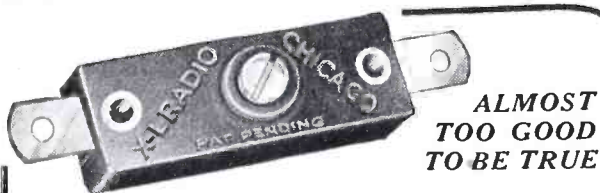

**ALMOST
TOO GOOD
TO BE TRUE**

X-L VARIO DENSERS

SPECIFIED BY ALBERT G. CRAIG

For Easier Balance and Tuning
More Stability

Greater Distance Volume and Clarity
IN HIS

FIVE TUBE RADIO FREQUENCY RECEIVER
With Simplified Control

ENDORSED BY LAURENCE M. COCKADAY

MODEL N—Capacity range 1.8 to 20 micro-micro-farads, for balance in Roberts two tube, Browning-Drake, McMurdo Silver's Knockout, Neutrodyne and tuned radio frequency circuits. Price \$1.00

MODEL G—Two capacity ranges, .00016 to .00055 and .0003 to .0015 Microfarads, for the Cockaday circuits, filter and intermediate frequency tuning in super-heterodyne and positive grid bias in all sets. Price \$1.50

**X-L RADIO LABORATORIES
2422 Lincoln Ave. CHICAGO**

Positively Necessary for
Super-Heterodyne
Filter
Tuning

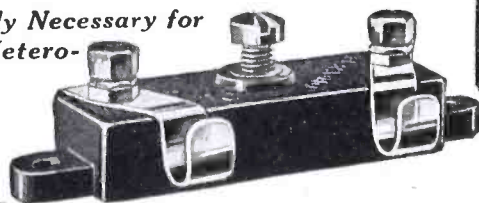

All apparatus advertised in this magazine has been tested and approved by POPULAR RADIO LABORATORY

"Take No Chances—Use Como"
COMO DUPLEX

The World's Standard Push Pull Transformer



PRICE \$12.50 per pair

For maximum volume without distortion

What Prominent Writers on Radio Subjects say About Como.

Lewis B. Hagerman, Technical Editor, *Chicago Post*: "Actual Tests show this transformer to be far superior to any others of similar makes."

R. J. Robbins, *New York Sun*: "After consideration of several well-known makes of push pull transformers which are available 'COMO DUPLEX' was selected as most satisfactory."

C. White, *Radio World*: "'COMO DUPLEX' is infinitely superior—most other push pull transformers seem to be ordinary transformers with a center tap brought out as a makeshift."

E. P. Gordon, *Open Road*: "A system of audio-amplification which is becoming increasingly popular. Its use . . . will give surprising results in both quality and volume, and is thoroughly recommended by this department."

NEED WE SAY MORE?

COMO APPARATUS COMPANY

Manchester, New Hampshire

For Sale at Leading Dealers



At your dealer
\$1.25

WANT more stations?
 JOIN the "Dis-tance-getters"—
 Replace your dials with

WALBERT UNIVERNIER

WALBERT MFG. CO., CHICAGO

POPULAR RADIO FOR 5 MONTHS

Send a Dollar Bill With the Coupon Below

We want more subscriptions, and so we will enter your subscription for 5 months, if you will fill out the coupon below, wrap a \$1.00 bill around it and mail it to us promptly.

This offer should interest the casual reader, the newcomer into the ranks of radio fans and all POPULAR RADIO readers who are not now subscribers. *This offer is only open to new subscribers.*

DO YOU WANT TO BUILD A SET?

You will get more out of Radio when you build your own set. POPULAR RADIO has made it possible for the beginner, with no previous knowledge of radio, to build any type of receiving set desired with the assurance of getting perfect results.

"HOW TO BUILD YOUR RADIO RECEIVER"

The most complete and authoritative collection of material on Receiver Construction yet published in book form. All working details given; lists of parts required; complete hook-ups and circuit diagrams. (See page 44.)

TUNE-IN ON ONE OF THESE

You may have a copy of "How to Build Your Radio Receiver" FREE with a 7 months' subscription to POPULAR RADIO for \$2.00. Or your subscription for POPULAR RADIO for 12 months and your copy of "How to Build Your Radio Receiver" both for \$3.00.

SIMPLIFIED BLUEPRINTS

POPULAR RADIO'S latest aid to receiving set builders show in ACTUAL SIZE every detail of the construction of 7 popular sets. (See page 42.)

Subscribe to POPULAR RADIO for 12 months and you may have your choice of any one set of Simplified Blueprints, at the regular subscription price of \$3.00.

POPULAR RADIO

627 West 43d Street

New York City

POPULAR RADIO, Dept 87
 627 West 43rd Street, New York City.

Enclosed is remittance of \$.... as payment, in full, of subscription offer for POPULAR RADIO as checked below.

- 5 months for \$1.00 (new subscription only).
- 7 months and "How to Build Your Radio Receiver" for \$2.00.
- 12 months and "How to Build Your Radio Receiver" for \$3.00.
- 12 months and Set of "Simplified Blueprints" No. for \$3.00.
- 24 months for \$5.00.

NAME

ADDRESS

CITY STATE

All apparatus advertised in this magazine has been tested and approved by POPULAR RADIO LABORATORY

A RADIO CABINET OF BEAUTY AND ELEGANCE DIRECT TO YOU AT LOWEST COST

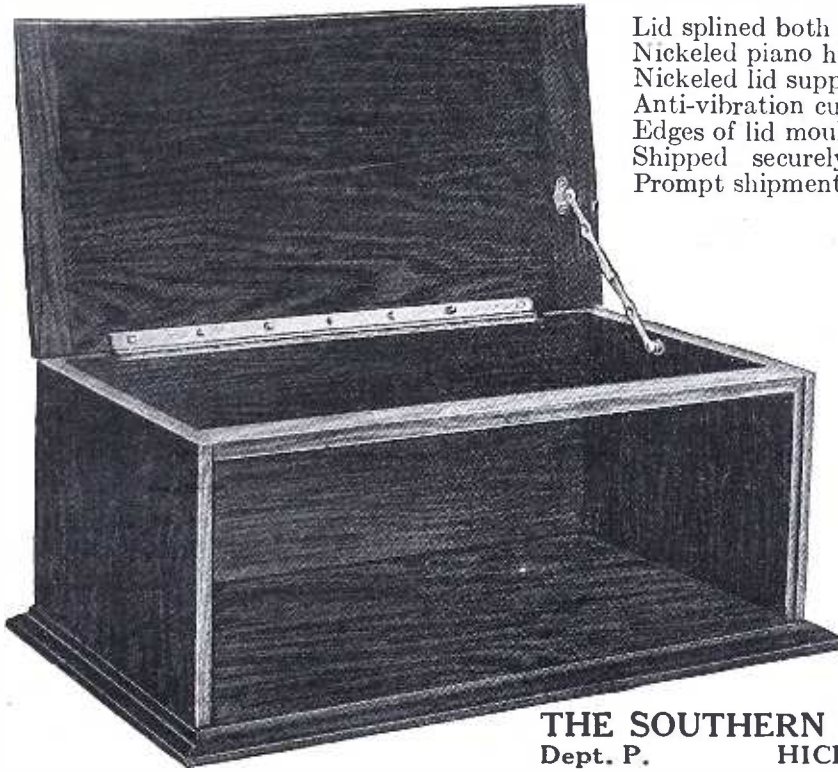

Lid splined both ends to prevent warping.
Nicked piano hinge.
Nicked lid support of artistic design.
Anti-vibration cushion feet (not visible in cut).
Edges of lid moulded to match bottom.
Shipped securely packed in strong carton.
Prompt shipment.

	Hardwood, Rubbed Mahogany Finish	Solid Black American Walnut
7 x 18 x 7 1/2 or 10 in. deep	\$3.50	\$5.00
7 x 24 x 7 1/2 or 10 in. deep	4.00	5.50
7 x 26 x 7 1/2 or 10 in. deep	4.75	6.25
7 x 28 x 7 1/2 or 10 in. deep	5.50	7.00
7 x 30 x 7 1/2 or 10 in. deep	6.00	8.00

CASH WITH ORDER or C. O. D. if 1/4 of price is sent with order.
Prices F. O. B. Hickory, N. C.
Order express shipment, often cheaper than mail and much safer from damage.

FREE WITH EACH CABINET a glued-up stock non-warping 1/2-inch BASEBOARD.

Free Catalogue.

THE SOUTHERN TOY COMPANY, INC.
Dept. P. HICKORY, NORTH CAROLINA

that secret door and what it means

A stage in the secret process of impregnation

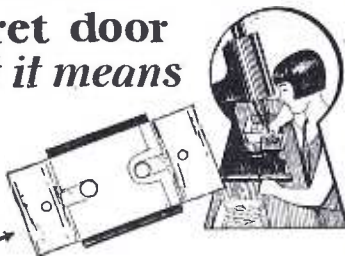

It protects the secret of our process of **Impregnation**. Impregnation makes **Aerovox Tested Fixed Mica Condensers** accurate. It fixes the layers of tin foil and mica into a homogeneous unit that will not be affected by moisture or temperature changes.

Aerovox builds up to a precise capacity. No other manufacturer does this. Aerovox is endorsed by Radio News, Popular Radio, Professor Wheeler of Yale and many leading set manufacturers.

Made in all capacities. Write for particulars of our complete line including Resistors, Rheostats and Grid Leaks.

AEROVOX
(AEROVOX)

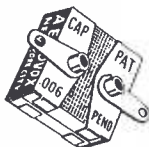

Chicago Office:
53 W. Jackson Boulevard

AEROVOX WIRELESS CORP.
491 Broome St New York City

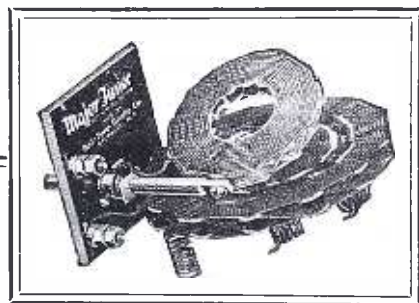

Have you met

Major Tuner

Reg. U. S. Pat. Office.

MAJOR TUNER will end those "interference blues." A set built with the **MAJOR TUNER** gets only one station at a time—the one you want to get and no other.

MAJOR TUNER is the most advanced form of three circuit Low-Loss tuner. It is packed with complete picture wiring diagrams and full instructions.

(If your dealer cannot supply you, write us.)

BEL-TONE RADIO CO. **\$4**
161 Jamaica Ave., Brooklyn, N. Y.

ANYONE CAN BUILD A SET WITH SIMPLIFIED BLUEPRINTS



LURENCE M. COCKADAY has personally supervised the preparation of *Simplified Blueprints* of seven of POPULAR RADIO'S most popular circuits. Each set consists of three separate *Actual Size* Blueprints; first a Panel Pattern; second, an Instrument Layout; and third, a Picture Wiring Diagram all simplified in the fullest sense of the word **because**

The Panel Pattern can be laid on the panel and all holes drilled as indicated. No scaling to do and so accurate there is no danger of ruining the panel through faulty calculation.

The Instrument Layout placed on the sub-base permits you to indicate by pinpricks the exact location of every screw.

The Picture Wiring Diagram gives every instrument in exact size and position with every wire clearly indicated from one contact to the other. With no knowledge of radio symbols you can assemble every part and complete your wiring with no chance of error.

Priced at \$1.10 per Set of Three Prints

Set No. 4—"Cockaday Four-Circuit Tuner with Resistance-Coupled Amplifier" (five tubes, distortionless, two dials, automatic vacuum tube control, as described in the October 1924 issue of POPULAR RADIO).

Set No. 6—"The Cockaday 8-tube Super-heterodyne Reflex Receiver" (eight tubes, two tuning dials, loop, non-radiating, distortionless, as described in January 1925 issue of POPULAR RADIO).

Set No. 7—"The Craig 4-Tube Reflex Receiver with the New Sodian Detector" (four tubes, two tuning dials, short antenna, non-radiating as described in February 1925 issue of POPULAR RADIO).

Set No. 8—"The Improved Cockaday D.X. Regenerative Receiver" (four tubes, one tuning dial, one

regeneration dial, short or long indoor or outdoor antenna, resistance coupled amplification as described in March 1925 issue of POPULAR RADIO.)

Set No. 9—"Portable Town and Country Receiver" (six tubes, three stages of transformer, coupled, radio-frequency amplification, loop antenna, tuned by variable condenser as described in May 1925 issue of POPULAR RADIO.)

Set No. 10—"5-Tube A-C Receiver" (five "McCullough" A-C tubes, two stages of tuned radio frequency amplification, as described in June 1925 issue of POPULAR RADIO).

Set No. 11—"5-Tube Tuned Radio-Frequency Receiver with Simplified Control" (as described in August 1925 issue of POPULAR RADIO).

Full constructional and parts details for these Receiving Sets will be found in the issue of POPULAR RADIO indicated. Back issues of POPULAR RADIO will be furnished at the rate of 35c a copy

Popular Radio

627 West 43d Street

Dept. 84

New York City

POPULAR RADIO, Inc., Dept. 84
627 West 43d St., New York City Date.....

Enclosed is my remittance of \$..... for which kindly send me Blueprint Set (s) consisting of Panel Pattern, Instrument Layout and Wiring Diagram as checked below:

Set Number 4 Set Number 8
 Set Number 6 Set Number 9
 Set Number 7 Set Number 10
 Set No. 11

Name.....
Address.....
City..... State.....

DEALERS

Write for terms on these fast selling Blueprints. An attractive Display Chart free with orders.

All apparatus advertised in this magazine has been tested and approved by POPULAR RADIO LABORATORY



Special for Set Manufacturers

Thirty-eight Set Manufacturers are using Dongan Quality Radio Parts. No matter what your requirements in audio transformers and volt-meters Dongan will assure the best performance.

Dongan Type B AC-Tube Transformers for AC Tube Receivers were the first on the market and are standard. Get complete data for building AC Sets.

Transformers and Chokes for B-Eliminators

DONGAN ELECTRIC MANUFACTURING CO.

2983 Franklin Street

Detroit, Michigan

Type S
Audio Transformer
Special quality in this hand-some mounted transformer. Attractive prices.



Type CSB
Audio Transformer
One of 35 types exclusively for set mfrs. Performance equal to any.

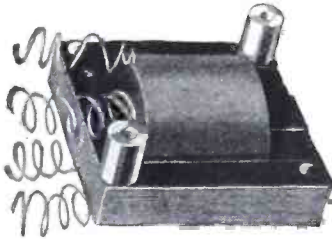

Type N
Voltmeter
One of 5 types. Range 0-7, 0-50, 0-100 volts. A guaranteed, high grade instrument

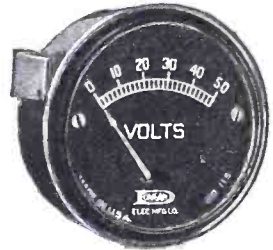

"Transformers of Merit for 15 years"

Craig 5-Tube Radio Frequency Set

All parts exactly as specified by Mr. Craig except that we supply the new improved Keystone Air Coils, one of the finest, most efficient low-loss coils. They make any set work better.

7x24-inch drilled panel and handsome genuine walnut cabinet, elegantly finished.

Complete Kit, **\$59.50**

LOW PRICES ON OTHER KITS

Cockaday 5-tube A. C. Receiver.....	\$47 50
Cockaday 8-tube Superhetrodyne.....	74 50
Cockaday 5-tube 4 Circuit.....	67 00
4-Tube Browning Drake.....	35 00
Best Superhetrodyne-Remler parts.....	52 50
Model L ₂ Ultradyne Kit with all parts.....	59 50
5-Tube Bremer Tully Nameless All Genuine Low-loss parts.....	42 50
Pressley Superhetrodyne Kit, Genuine Sangamo parts.....	69 50

Parts all exactly as specified and of same brands or equal quality brands as in original specifications.

BARAWIK COMPANY
102 S. Canal St. Chicago, Ill.

with the \$100 Guarantee



Absolutely warranted to protect your set from lightning, with a guarantee to pay you \$100 or repair your set, should it be damaged through any fault of the

FIL-KO-ARRESTER.

Listed as standard under the re-examination service of National Board of Fire Underwriters.

If your dealer has none, send his name with remittance to Dept. PR-325

DX Instrument Co.
Harrisburg, Pa.



Instruction Book

and

Radio Manual FREE

with

Popular Radio

Build Your Own

Aside from the feature of economy, there is the thrill and satisfaction that comes from building your own receiving set. Instead of being a mere "dial-twister" you will necessarily have a very definite basic knowledge of what radio is all about after constructing a set.

Thousands of sets have never been constructed because of the atmosphere of mystery that has enveloped the whole subject of radio. Kendall Banning, Editor, and Laurence M. Cockaday, Technical Editor of POPULAR RADIO, through their close contact with the great radio public sensed this and compiled a book that will convince the veriest beginner that technical training is not essential. If you have a little time to devote to a most fascinating pastime, send for a copy of "How to Build Your Radio Receiver" and discover how simple and easy set building really is. This famous book has made it so.

Free Advisory Service

POPULAR RADIO is full of helpful suggestions as well as instructive and entertaining articles on radio and allied scientific phenomena. This information is supplemented by an advisory service that is free to all subscribers. Any problem you encounter that is not answered in the book or magazine will be answered by personal letter if you will submit it to the Technical Service Bureau. For this purpose a big modern, laboratory with a trained staff of investigators under Mr. Cockaday's personal direction is always at your service.

A Valuable Combination

For the next thirty days we will give you a copy of "How to Build Your Radio Receiver," FREE and enroll you for all privileges of the Technical Service Bureau at no further expense, on receipt of your remittance of \$3.00 in payment for a 12 months' subscription for POPULAR RADIO. (As an alternative offer, if you wish the combination with POPULAR RADIO for 7 months only—send but \$2.00). In any event, you run absolutely no risk as we will refund in full if you are not more than satisfied with your purchase.

POPULAR RADIO Dept. 85,
627 West 43d Street,
New York City.

Offer expires
Aug. 20, 1925

Enclosed remittance of \$3.00 is payment in full for a 12 months' subscription for POPULAR RADIO and copy of "How to Build Your Radio Receiver" FREE.

Name.....

Address.....

City..... State.....

Check here and remit \$2.00 if you prefer POPULAR RADIO for 7 months only in combination with "How to Build Your Radio Receiver."

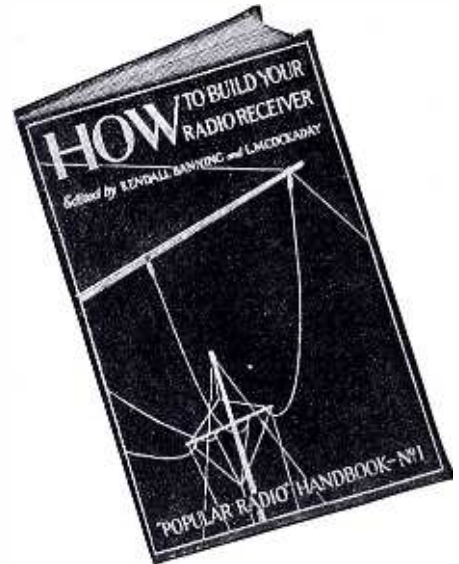

In "How to Build Your Radio Receiver" you will find complete constructional diagrams, specifications, photographs and instructions for building the following sets. Each has been selected as representative of its circuit because in laboratory tests it proved the best for distance, selectivity, tone volume, simplicity of construction, ease in tuning, reliability and all-around satisfaction.

A \$5 CRYSTAL SET

The simplest up-to-date set for local broadcast reception. Approximate range, 15 miles, though distances up to 400 miles are not extraordinary. Gives clear signals on headset without distortion. No operating cost whatever.

THE HAYNES SINGLE TUBE RECEIVER

An efficient set that may be made by a novice at an approximate cost of only \$15 for parts. Simple to tune, selective, good audibility. Long distance range up to 1,000 miles on earphones. Six-volt storage battery and 22½-volt "B" battery required, or may be adapted for dry cells and dry cell tubes.

A TWO-STAGE AUDIO-FREQUENCY AMPLIFIER

This instrument may be added to any set, crystal or tube, to strengthen the received signals, so that they will operate a loud-speaker. It is easy to construct, efficient and inexpensive, costing only \$15 for parts. Operates on the same "A" battery that is used on the vacuum-tube detector unit.

THE COCKADAY 4-CIRCUIT TUNER

A 3-tube set, famous for its high selectivity and beautiful tone. So neat and compact that it may be kept in a bureau drawer. Cost of parts about \$40. Receiving range approximately 1,500 miles on a loud-speaker. Operates on a 6-volt storage battery and two 45-volt "B" batteries, or may be adapted to dry cells and dry cell tubes.

A 5-TUBE TUNED RADIO-FREQUENCY RECEIVER

Two stages of tuned radio-frequency amplification, detector, and two stages of audio-frequency amplification are here employed so that the possibility of "oscillation and re-radiation" is eliminated. The set can be operated on a loop antenna and may be built at a cost of only \$90 for parts. Six-volt storage battery and two 45-volt "B" batteries required. Range about 1,000 miles on loop or indoor antenna and 2,500 to 3,000 miles on an outdoor antenna.

THE "IMPROVED" COCKADAY 4-CIRCUIT TUNER

Probably the most important contribution yet made to the equipment of the radio fan. A compact 5-tube set with a receiving range of over 3,000 miles. Cost of parts about \$95. Wave length range from 150 to 675 meters. Automatic tuning and power amplification. Maximum volume of sound, excellent reproduction and no interference. Requires a 6-volt "A" battery, three 45-volt "B" batteries, one 22½-volt "B" battery and a 9-volt "C" battery.

THE REGENERATIVE SUPER-HETERODYNE RECEIVER

More sensitive, more selective and more simple to tune than any other 6-tube receiver yet developed. A three-section 6-tube set employing the Haynes Single Tube Receiver as tuner. May be further extended to a four-section, 8-tube set by the addition of the two-stage audio-frequency amplifier. The cost of parts approximates \$100. Range of 3,000 to 4,000 miles on a loud-speaker. Has been called the "Rolls-Royce" of radio receivers.

POPULAR RADIO
627 West 43d Street, New York City

All apparatus advertised in this magazine has been tested and approved by POPULAR RADIO LABORATORY

First in the Field
Specializing in
Cockaday Kits

S. HAMMER RADIO CO., 303 Atkins Ave. Brooklyn, New York

Cockaday Sets Now Made Easier to Build by Our New "Ready-to-Wire" Plan
50% of Your Time, Work and Worry SAVED!

All you need do is to connect bus-bar according to diagram, solder and your set is finished. These Kits are sent to you completely mounted and assembled on a Veneered Mahogany baseboard and genuine bakelite panel, drilled and engraved; in a solid Mahogany Cabinet. Genuine parts used as listed below; exactly as specified by Mr. L. M. Cockaday. COMPARE OUR OFFER!

5 Tube New A C Receiver

- 1 General Radio Variometer, No. 269
- 2 "Precision" R. F. Coupling Units
- 2 Hammarlund condensers, .0005 mfd.
- 3 Kurz-Kasch 4 inch dials
- 5 Federal Sockets, No. 16
- 1 General Radio A. F. Transformer, No. 285
- 1 Dongan Special Step-Down Transformer, Type B
- 1 Daven Resisto-Coupler mountings
- 2 Dubilier Mica, fixed condenser, .006 mfd.
- 1 ea. Daven resistor, 1/4 megohm, 1/2 megohm
- 1 Daven grid-leak, 4 megohms
- 1 Dubilier fixed condenser, .00025 mfd.—clips
- 1 Dubilier Mica fixed condenser, .00015 mfd.
- 1 Dubilier Mica fixed condenser, .0001 mfd.
- 1 Patent single circuit jack
- 1 Genuine Bakelite Panel Drilled and Engraved 7 x 24"
- 1 Veneered Baseboard
- 1 Antenna Binding Post Strip
- 1 Battery Binding Post Strip, small brass brackets, A C Leads, Binding Posts, etc.

READY-TO-WIRE KIT PRICE, . . . \$52.50
UNASSEMBLED KIT PRICE, . . . Write Us
WIRED COMPLETE In Genuine Mahogany Cabinet, including Dongan Transformer and 5 McCullough A C Tubes \$79.50

McCullough A C Radio Tubes in Stock

8 TUBE NEW COCKADAY SUPERHETERODYNE REFLEX RECEIVER KIT

- 1 General Instrument .0005 Condenser (Isolantite Insulation) \$5.50
- 1 General Instrument .001 Condenser (Isolantite Insulation) 6.00
- 1 Haynes Griffin input transformer (new type) 5.00
- 3 Haynes Griffin intermediate transformers (new type) 15.00
- 1 Precision Autodyne Coupler 3.50
- 1 Karas Harmonik Audio Frequency Transformer 7.00
- 1 Amplex Grid-Denser .0005 1.25
- 1 Benjamin Cle-ra-tone Socket 1.00
- 7 Federal Sockets No. 16 8.40
- 1 Patent Double Jack60
- 1 Patent Single Jack50
- 2 Na-Aid 4 inch Dials 1.50
- 1 Amso Rheostat 2 Ohms 1.35
- 1 Amso Potentiometer 400 Ohms 1.50
- 1 Daven Grid-leak Mounting . . . \$.35
- 2 Daven Resisto - Coupler Mountings 2.50
- 2 Daven Resistors .5 Megohms 1.00
- 1 Daven Resistor 5 Megohms .50
- 1 Daven Resistor .005 Megohms 1.00
- 2 Daven Resistors .25 Megohms 1.00
- 2 New York Mica Condensers .0001 Mfd.70
- 4 New York Mica Condensers .006 Mfd. 3.00
- 1 New York Mica Condenser .00025 with clips 45
- 1 Duratran Radio Frequency Transformer 4.00
- 1 Walbert "A" Battery Switch .50
- 7 Eby Binding Posts 1.40
- 1 Sub-Panel 1 x 9 Genuine Bakelite15
- 1 Baseboard (Hardwood) 35
- 1 Genuine Bakelite Panel, Drilled and Engraved 3.00

READY-TO-WIRE KIT PRICE \$74.50
WIRED COMPLETE IN GENUINE MAHOGANY CABINET, INCLUDING KORACH LOOP. \$110.00

COCKADAY'S Authorized ANTENNA COUPLER for the 8 Tube Super-Het for use with outdoor aerial **\$2.00**

WRITE FOR CIRCULAR about these Parts and Kits. Also for Free Radio Catalog

Transportation Prepaid. One-third must accompany all C. O. D. orders. Not insured unless insurance charges included

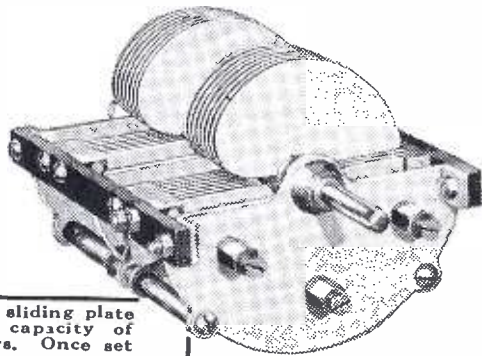

Patented sliding plate equalizes capacity of condensers. Once set always set.

CONTINENTAL LO LOSS

New UNITROL Condenser for single control sets

(Licensed under the Hogan Patents)

Manufactured by the makers of the famous Continental Lo Loss Junior condenser and recommended by G. M. Best, Arthur Lynch, McMurdo Silver and other radio authorities.

If your dealer can't supply you with Continental Condensers write—

Condenser Headquarters

GARDINER & HEPBURN, INC.
611 Widener Bldg., Philadelphia, Pa.

Oh boy KESTER
Rosin Core
Radio SOLDER

Sure is Safe and Simple
APPROVED BY RADIO ENGINEERS
A GENUINE SOLDER
CHICAGO SOLDER COMPANY
4221 Wrightwood Av., Chicago, U.S.A.

Originators and World's Largest Manufacturers of Soft Fluxing Solder
YOUR DEALER CAN SUPPLY YOU

All apparatus advertised in this magazine has been tested and approved by POPULAR RADIO LABORATORY

LET COCKADAY TELL YOU THE ANSWER

POPULAR RADIO maintains for the benefit of its readers a Technical Service Bureau and Laboratory, under the personal supervision of Laurence M. Cockaday which will, without charge, answer by personal letter any question, problem or request for information submitted by a subscriber. This service is, however, also available to readers other than subscribers, at the very nominal rate of 50 cents the inquiry.

In writing please confine your questions to one general

November, 1922

- Sir Oliver Lodge on ether waves.
- How to add a Vacuum Tube to your crystal set.
- The most popular transmitting aerial.
- How to make a novel varlocoupler.

December, 1922 (Out of stock)

January, 1923 (Out of stock)

(A Reprint of Mr. Cockaday's article describing the DX Regenerative Receiver may be had for 25 cents.)

February, 1923 (Out of stock)

March, 1923 (Out of stock)

April, 1923 (Out of stock)

May, 1923 (Out of stock)

A reprint of Mr. Cockaday's original 4-Circuit Tuner will be found in POPULAR RADIO'S HANDBOOK. See page 60.

June, 1923

- How the Microphone Transmitter Works.
- How to Build a Good Single Tube Receiver.
- How to Make a Crystal Detector Stand.

July, 1923

- The ratio in size between your antenna and your coil.
- Useful facts about ear-phones.
- How to make a dry-cell tube Regenerative Set.
- How to keep up your storage battery.

August, 1923 (Out of stock)

A reprint of the Tuned Radio Frequency Receiver will be found in POPULAR RADIO'S HANDBOOK. See page 60.

September, 1923

- How to get a radio license.
- How weak signals are regenerated.
- How to make a battery charging rectifier.
- How to build the Haynes DX receiver.

October, 1923

- Practical hints for Coil Calculations.
- How to make a Two-stage Audio-frequency Amplifier.
- Ten good rules for Broadcast Listeners.
- How to make a simple Honeycomb Receiver.

November, 1923

- The 100 Best Hook-ups (Part 1).
- Receiving without Antennas.
- How to build the New Regenerative Super-heterodyne Receiver (Part 1).
- How to build a combination Short and Long-wave Receiver.

December, 1923

- How to Select your Radio Parts.
- The 100 Best Hook-Ups (Part 2).
- How to Read a Diagram (Part 1).
- How to build an efficient Crystal Receiver.
- How to Build the Super-heterodyne Receiver (Part 2).

January, 1924 (Out of Stock)

(A Reprint of Mr. Cockaday's article describing the DX Regenerative Receiver may be had for 25 cents.)

February, 1924

- How to add "Push and Pull" amplification to the 3 tube Cockaday 4-Circuit tuner.
- The original 4-Circuit Tuner as a Portable Set with Loop.
- The 100 Best Hook-ups (Part 4).
- How to build a 3-tube Reflex Receiver.

March, 1924

- Hoffman Transformer Measurement Chart.
- The 100 Best Hook-ups (Part 5).
- How to Build an Amateur Transmitter.
- A 3-tube Reflex Receiver (Part 2).

April, 1924

- How to Build a Simplified Neutrodyne Receiver.
- The 100 Best Hook-ups (Part 6a)
- How NOT to Tune the Single Circuit Receiver.
- A Novel Substitute for "B" Batteries.

May, 1924

- A Compact Radio Kit for a Spring Hike.
- How to Get the Maximum Radio-frequency Amplification.
- 100 Best Hook-ups (Part 6b).
- Where Interference Comes In.
- How to Make an Audio-frequency Amplifier that Does Not Distort.

June, 1924

- How to Install a Receiver on your Boat.
- The 100 Best Hook-ups (Part 7).
- How to Build a Regenerative Receiver for Use with an Indoor Antenna.
- How to Make a Two-Slide Tuner.

July, 1924

- How to Avoid Local Interference.
- How "Resistance" Affects Radio Circuits.
- An Ideal Set for Summer-time Reception.
- 100 Best Hook-ups (Part 8).
- How to Do Your Soldering Correctly.
- How to Build the POPULAR RADIO Portable.

August, 1924

- How to build a single dry-cell tube, four-circuit tuner.
- How to build a two tube reflex receiver.
- Helpful hints for the broadcast listener

September, 1924

- How to build a single dry-cell tube reflex receiver.
- How to build a multi-wave tuner.
- How to improve broadcast reception.

October, 1924

- How to Build the (Cockaday) Four Circuit Tuner with a Resistance-coupled Amplifier.
- How to Select a Ready-made Receiver.
- How to Build a Detector-amplifier.
- A Radio Set to Pack in Your Suitcase.
- Harnessing the Radio and the Movie.

subject, writing on one side of the paper only, and enclose a self-addressed and stamped envelope.

It is possible that your individual problem has been covered in an issue of POPULAR RADIO, and so as an aid to you we endeavor to keep a supply of back numbers in stock. The condensed index below gives a few of the subjects that have appeared recently, look this list over and if the information you want is covered, we will be pleased to supply back numbers at 35c. a copy.

November, 1924

- How to Locate Interference from Power Lines.
- Cockaday Article for Beginners.
- How to Build a Low-loss Tuner for Short-wave Reception.
- The New Type of Superheterodyne.

December, 1924

- How to Build a Non-radiating 7-tube Superheterodyne Receiver.
- Cockaday Article for Beginners.
- How to Get the Most Out of Your Ready-made Receiver.

January, 1925

- How to Build the Cockaday 8-tube Superheterodyne Reflex Receiver.
- How to Improve Broadcast Reception.
- Cockaday Article for Beginners.

February, 1925

- How to Get on a Radio Program.
- A Loudspeaker for a Crystal Set.
- How to Build a 4-tube Reflex Receiver with the New Sodon Detector.
- Cockaday Article for Beginners.

March, 1925

- How to Build the Improved DX Regenerative Receiver.
- Factors that Govern the Capacity of Condensers.
- What "Induction" Means to Your Set.
- A Five Meter Vacuum-tube Transmitter and Receiver.

April, 1925

- Single Control Receivers.
- How to Improve Broadcast Reception, VI: Increasing the Selecting Power of Your Receiver.
- How to get the Most out of Your Ready-made Receiver.
- Quartz Crystal as a New Wavelength Standard.

May, 1925

- Factors That Affect Antenna Capacity.
- How to Wire Your Home to Have Radio in Every Room.
- Handy Tools for Radio Fans. The Hydrometer.
- How to Build the "Portable Town and Country Receiver."

June, 1925

- New Development in Vacuum Tubes.
- How to Build a Five-tube A-C Receiver.
- How to Draw Up Your Own Tuning Chart.
- Watt's Law in a Nutshell.
- "What Set Shall I Buy?" First Installment.

July, 1925

- The Best 101 Hook-ups.
- "What Set Shall I Buy?" Second Installment.
- Broadcast Stations in the United States.
- What's New in Radio Apparatus.

Popular Radio

627 West 43rd Street

Dept. 88

New York City

All apparatus advertised in this magazine has been tested and approved by POPULAR RADIO LABORATORY

Why POPULAR RADIO specifies AERO COILS

in the new 5-tube simplified control

T. R. F. set designed by Albert G. Craig



THE U. S. Bureau of Standards' base for calculating dielectrics is AIR—the best dielectric. The first reason, therefore, that Aero Coils make the most efficient inductance system is that their dielectric is 95% air! This characteristic, made possible by a patented construction, so greatly diminishes the high frequency resistance of Aero Coils that they tune into resonance on a "knife's edge" and actually use the energy which other types of inductance waste.

Still sharper selectivity, more power, and still greater sensitivity result from the patented Aero Coil construction because it permits the windings to be dopeless and to be uniformly and properly air spaced, thereby lowering to an amazing minimum the distributed capacity of this super-efficient inductance.

When shunted with a good .00035 variable condenser, Aero Coils will tune

below 200 and above 550 meters. Never before such range, never before such selectivity, power, sensitivity, volume, or clarity. Build Mr. Craig's wonderful 5 tube set with Aero Coils—or use this inductance system in any kind of tuned radio frequency receiver or wherever an inductive coupling is required. At your dealer's or, in case your dealer cannot supply you, direct from the factory. \$3.50 each or \$10.50 the set of three with brackets and circuit diagram.

"Knife-like Selectivity"
Much More Volume
Absolute Clarity
Amazing Sensitivity
Tunes Below 200 Meters and Above 550 Meters

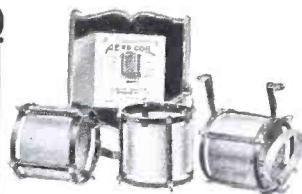

BUILD a Super-Powered Set Like These Fans Did

"Last night, December 26th, between 8 and 12 P.M., I received the following stations with the Chicago stations working full blast: WGR, WBCN, KDKA, WEAJ, WHB, KGO, WTAY, WTAS, WHAS, WDAF, WFAA, WCX, WOAW, KYW, WOO, WNAC, WBAP, WSB, CNRC, WEBH, WDAR, WCAP, WJJD, WGN, WMAQ, WLS, WQJ, WLW, WREO, WBZ."

H. H. HYLER,
854 Cornelia Ave.,
Chicago, Ill.

"I brought in four Pacific Coast stations the first night the set was in operation. These are KGO, KPO, KHJ, and KNX. Tuning is needle sharp and, therefore, very selective. Anyone who wants to build a real set should use these coils. The results will surprise them"

FRANK O. MYERS,
134 Chapman Ave.,
Elkhart, Ind.

"I have used and tested every type of radio frequency coil on the market, but I have never experienced the success with any of them that I have with Aero Coils. The quality is of the highest, the volume greater step for step, and the reaching power away above anything which is on the market. With the circuit shown on your circular, I have pulled in stations from Montreal to Mexico City, Seattle, Portland, and all the Atlantic, Gulf and most of the Pacific stations."

GEORGE H. LEVERETT,
Telephone & Telegraph Engineer,
5833 W. Circle Ave.,
Chicago, Ill.

"I am able to tune in the following stations any night in my location, which is two miles from WQJ, three miles from WEBH, three miles from WGN, four miles from KYW and WMAQ: WBZ, KOA, WSAI, KFI, WCAP, WCAE, WLW, WGN, WMAK, KHJ, WCX, WOC, KFKX, WTAM, CKCK, KDKA, WTAS, KFKB, WHAS, WMC, WFAA, WBAP, WGR, WWJ, WEAJ, WORD, WOR, KPO, KGU, CFCA, KGO."

VERNAN A. WATTS,
3038 Broadway,
Chicago, Ill.

AERO PRODUCTS, Inc.
 Successors to HENNINGER RADIO MFG. CO.
 217 N. Des Plaines St. Dept. 38 Chicago
 Pacific Coast Representative S. A. WINSOR, 1221 W. 16th St., Los Angeles

All apparatus advertised in this magazine has been tested and approved by POPULAR RADIO LABORATORY

Bradleystat

REGISTERED U.S. PAT. OFF.
PERFECT FILAMENT CONTROL
 for ALL Tubes
 without change of connections



Buy your Bradleystat from nearest dealer

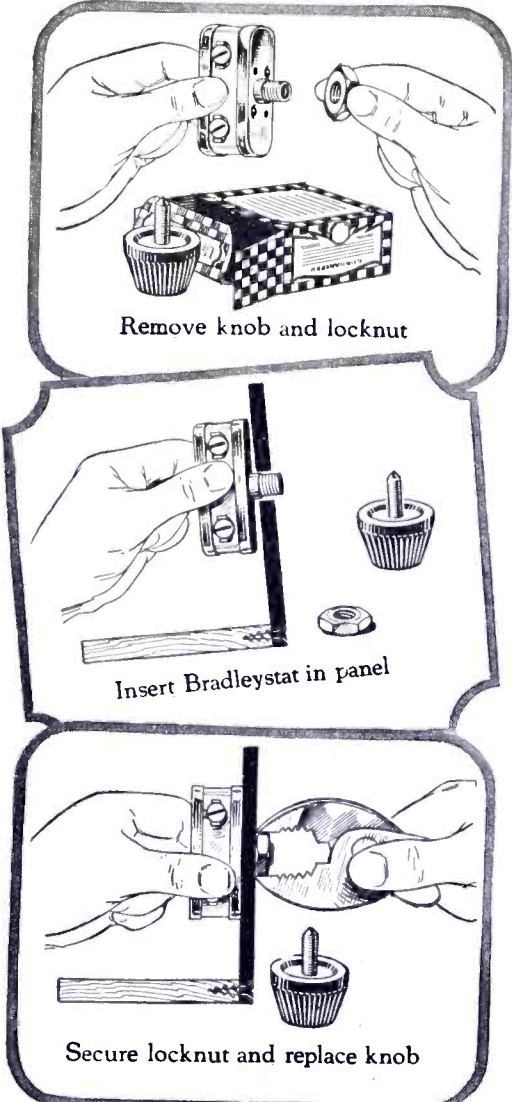

Improve Your Radio Set with noiseless filament control

THE present trend in radio receivers is toward greater refinement in tone quality, selectivity, and simplicity of control. This accounts for the growing popularity of the Bradleystat and other Allen-Bradley perfect radio devices. The graphite disc construction eliminates the scratchy, noisy operation obtained with wire rheostats, and it provides an unequaled range of control for all tubes.

The "one-hole mounting" and the small size of the Bradleystat permits quick and easy substitution for other rheostats.

Try a Bradleystat, tonight, and enjoy the silent, perfect control that makes tuning a pleasure.

Allen-Bradley Co.
 Electric Controlling Apparatus

276 Greenfield Ave.  Milwaukee Wis.

Manufacturers of graphite disc rheostats for over twenty years

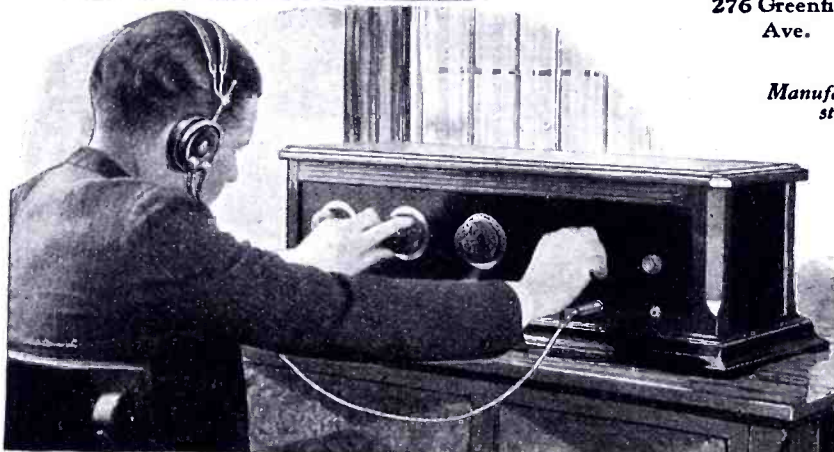

Allen-Bradley Co.
 276 Greenfield Avenue
 Milwaukee, Wis.
 Please send me your latest literature on the Allen-Bradley line of radio devices.

Name.....
 Address.....

All apparatus advertised in this magazine has been tested and approved by POPULAR RADIO LABORATORY

The Wonder of Radio!



Crosley owns and operates station WLW, Cincinnati, the first remotely controlled super-power broadcasting station.

CROSLLEY 50 One tube set



2-Tube Crosley 51

Same as wonderful Crosley 50 with additional tube amplifier. Local and nearby stations on loud-speaker always and distance up to 1500 miles under average conditions. Much greater range with head phones.

Special Sloping Front 2-Tube Crosley 51

Same as model 51, with cabinet holding all dry A and B batteries. \$23.50.

2-Tube Crosley 51 Portable

The Crosley 51 in a black leatherette case, with nickel trimmings. Space for batteries. \$23.50.

Crosley Musicone

A marvelous new development of loud-speaking principles. Diffusion of sound creates perfect reproduction of all tones. \$17.50.

3-Tube Crosley 52

A larger set for those who want greater reception range on the loud-speaker. Operates on three tubes, using wet or dry batteries. Consistent loud-speaker range 1500 miles or more.

Special Sloping Front

3-Tube Crosley 52

Cabinet contains dry A and B batteries. Same efficient detection and reception as regular 52. \$35.

3-Tube Crosley 52 Portable

Same as other 52 models, but in a black leatherette case. Easily carried. All batteries inside. \$35.

Prices quoted above do not include accessories. Add 10 per cent west of Rocky Mountains.

This is the latest refinement of the marvelous set that enabled Leonard Weeks of Minot, N. D. to catch the messages of MacMillan's North Pole expedition when sets costing ten times as much failed.

In this set Crosley has developed the famous Armstrong regenerative circuit. This circuit does with one tube what it takes three tubes to do in others.

This set will bring in stations from all over the country. It is simple and easy to operate. With accessories the total cost should be under \$25.00. Crosley keeps the cost down with his "radio-for-the millions" ideas in production.

Recent letters from enthused owners of the Crosley one-tube 50 report good reception at these distances:

Mrs. J. E. Martin at East Palestine, O. hears KGO at Oakland, Calif.
O. W. Bryant at Sunset, Texas get WLW at Cincinnati, KDKA at Pittsburgh and Hollywood, Calif.
L. R. Pratt, Hammond, Ind. hears 5NO, New Castle, England.
Eugene Barnhouse at Brookfield, Mo. hears Montreal and Winnipeg, Canada.
Paul J. Hall at Osceola, Neb. hears 2LO at London, England.

Crosley manufactures receiving sets which are licensed under Armstrong U. S. Patent No. 1,113,149, and priced from \$14.50 to \$65, without accessories.

The Crosley Radio Corporation

Powel Crosley, Jr., President

816 Sassafras Street, Cincinnati

PRESS OF WILLIAM GREEN, NEW YORK

The Sensation of the Season

MODEL 5-F-5

New and Improved **FRESHMAN MASTERPIECE**

Five Tube
Tuned Radio
Frequency

Full Throated
Loud Speaker
Built In



Encased in as fine a heavy 5 ply solid,
genuine mahogany cabinet as ever
graced any radio set.

\$60.

Every part embodied is newly constructed
resulting in greater efficiency and finer
tone quality. The illustration shows our
new straight line wave length, low loss
condenser and vernier device, permitting
the reception of stations over a wave
length from 190 to 550 meters.

For Sale By Authorized Freshman Dealers Only

Chas. Freshman Co. Inc.
Radio Receivers and Parts
FRESHMAN BUILDING
240-248 WEST 40TH ST.-NEW YORK, N.Y.
CHICAGO OFFICE — 327 S. LA SALLE ST.

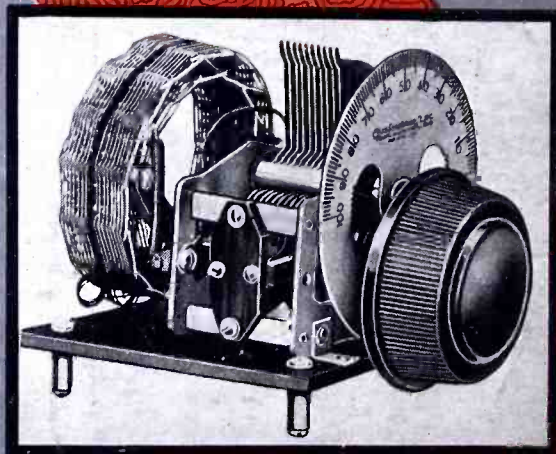

*Vernier feature assures greater
selectivity and sharper tuning.*